

The
American Annual
of Photography

THE EASTMAN KODAK COMPANY



1922





THE GETTY CENTER LIBRARY





Digitized by the Internet Archive
in 2018 with funding from
Getty Research Institute

ANSCO CAMERAS

TASTES in hand cameras vary, and are "subject to change without notice." Therefore the Ansco Company manufactures to meet the demands of amateur photographers seventeen different models in a total of forty-four choices of lens and shutter equipment, to the end that everyone may find in the Ansco line the best camera possible to meet his needs within the means at his command.

Ansco cameras are divided into the following five groups or classes:

- (1) The regular Folding Ansco series.
- (2) The Ansco Speedex series.
- (3) The Ansco Junior series.
- (4) The Ansco Vest-Pocket series.
- (5) The Buster Brown series (the Ansco box cameras.)

In the Folding Ansco group there are three sizes, the No. 1A ($2\frac{1}{2} \times 4\frac{1}{4}$), the No. 3 ($3\frac{1}{4} \times 4\frac{1}{4}$), and the No. 3A ($3\frac{1}{4} \times 5\frac{1}{2}$). With all three there is a choice between the Ansco Rapid Symmetrical Lens, U. S. 4, an

objective of excellent defining power, supplied with either Bionie or Ilex General shutter, and the Modico Anastigmat Lens, F 7.5, a lens made especially for Ansco cameras and remarkable for its definition, flatness of field, and freedom from astigmatism—the Modico

being supplied in either Capax or Ilex General shutter. Features of the Ansco Folding series are the self-masking or exact-radius finder, the Ansco thumb-focusing device, which permits quick changing of

the focus and instant locking of the focus at any distance figure, and the Ansco spool-holding device, which holds the film taut at all times and ejects the exposed roll neatly into the hand when the spool-pins are released. Special features of the No. 3 and No. 3A Folding Ansco which will appeal to readers of the American Annual are the exceptionally convenient rising, falling, and sliding front; the double focusing scale, which permits scale-focusing with either plates or films; and the



Ansco Cameras, especially when used with the fast Ansco Speedex Film, are facile tools for obtaining pictorial results. Summer snapshot, $\frac{1}{2}$ second at F11.3.

ANSCO CAMERAS

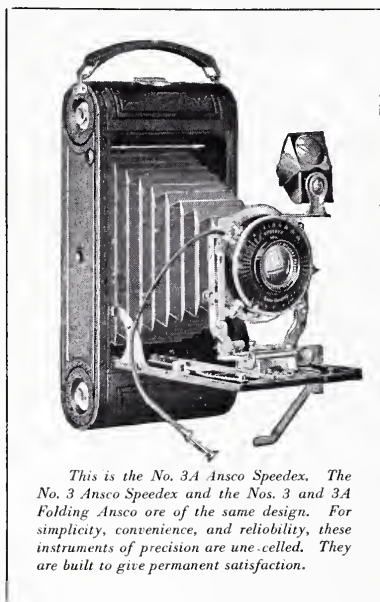

This is the No. 3A Anseo Speedex. The No. 3 Anseo Speedex and the Nos. 3 and 3A Folding Anseo are of the same design. For simplicity, convenience, and reliability, these instruments of precision are unequalled. They are built to give permanent satisfaction.

unique Combination Back which is supplied as an extra. This combination back has a self-hooded ground glass which need not be removed for the insertion of the holder, and it will take *either* plateholder or film-pack holder.

The price of the No. 1A and of the No. 3 Folding Anseo is, with Symmetrical lens, \$23, and with Modico lens \$28. The corresponding prices of the No. 3A are \$27 and \$32—truly fine value for the money.

The Nos. 1A, 3 and 3A Anseo Speedex are really the Nos. 1A, 3, and 3A Folding Anseo raised to a higher power. The design is the same, but the lens is the Anseo Anastigmat, speed F 6.3, in either Speedex Optimo or Flex Aeme shutter, permitting a

range of automatically controlled exposures from one to 1/300 second, besides Bulb and Time, and the cameras are covered with genuine Persian morocco instead of seal-grain leather. These models make a splendid permanent equipment of wide range and reliability. The prices are \$51 for the No. 1A, \$52.50 for the No. 3, and \$64 for the No. 3A.

Anseo Junior cameras have not so many refinements as the regular Folding and Anseo Speedex series, but are thoroughly reliable and efficient, are well finished, with genuine leather covering, and make good pictures easily. They are supplied in the No. 1A, No. 2C, and No. 3A sizes, at prices ranging from \$16 to \$27. There is also a convenient Anseo V-P Junior, 2 $\frac{1}{4}$ x 3 $\frac{1}{4}$, which sells for \$12, \$13.50, and \$18.50, according to lens and shutter. The last-named price applies when equipped with Modico F 7.5 Anastigmat lens in Extraspeed Bionic shutter, which permits speeds of 1/10, 1/25, 1/50, 1/100, and 1/200 second, besides Bulb and Time.

Besides the Anseo Vest-Pocket Junior, there are three other vest-pocket cameras in the Anseo line. The amateur photographer wishing a hand camera of miniature dimensions for more or less constant use—to seize those pictorial opportunities that present themselves during the business day, on his travels, or on hikes and climbs, hunting trips, and the like—could make no greater mistake

ANSCO CAMERAS

than to overlook these efficient little machines. There are many thousands of them in use, and the unsolicited letters of enthusiastic praise which we receive from their owners (people who *know* cameras and are exacting in their requirements) would make a volume big enough to keep any printer happy. These cameras are the kind of thing that gets an increasing vogue through friendly tips passed along the line by users.

The Anseo Vest-Pocket No. 2 and the Anseo Vest-Pocket Speedex No. 3 are of the same size and make the same size of picture, $2\frac{1}{4} \times 3\frac{1}{4}$. They are, however, quite different in design. The No. 2 has a direct-extension front, quickly op-

erated, very positive, and very rigid. Focusing is done by means of a milled wheel behind the lens plate, lens and shutter racking in or out as this wheel is turned. This operation may be performed without losing sight of the image in the finder. Out-of-focus negatives are a rare occurrence with the Anseo V-P No. 2, although it is built essentially for quick action. It is a beautiful little camera, strikingly fine in its appearance and its finish, smooth in all its workings, and built to stand the test of rough-and-ready usage through an indefinite period of years. The shutter is the Extraspeed Bionie, and a choice is offered between the Modico Anastigmat, F 7.5, and the Anseo Anastigmat, F 6.3, each of $3\frac{1}{2}$ inches focal length. Both models have the Anseo depth-of-focus scale inside the lens-cap. With Modico Anastigmat the price is \$22.50; with Anseo Anastigmat, \$27.50.

The Anseo Vest Pocket Speedex No. 3 is higher-priced than the No. 2, being of a more expensive let-down platform construction. In fact, no expense has been spared to make this the most exquisite little machine of its type available to those who wish the best picture-making tools obtainable. Its distinguishing features are so many that to describe them here would exceed the limits of space, but a special folder explaining and illustrating all details will be sent to anyone on request, or may be had of Anseo dealers. Readers of the Annual should

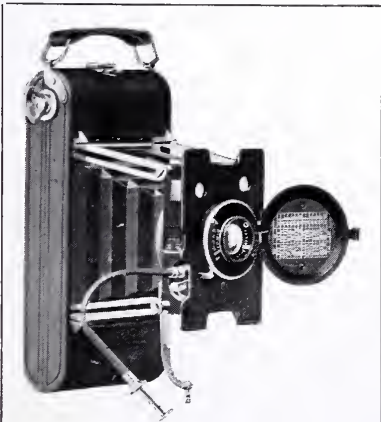

Problem: Make a $2\frac{1}{4} \times 3\frac{1}{4}$ camera of the direct-extension type. Make it small, strong, durable, rigid, sure in action, extra-speedy in operation, and productive of clear crisp negatives under widely varying conditions of light, subject, and use. And keep the cost down to meet the means of the large number. Result: The Anseo Vest Pocket No. 2, \$22.50 and \$27.50.

ANSCO CAMERAS

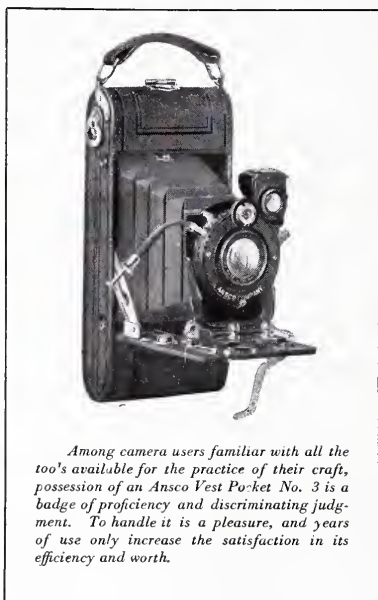

Among camera users familiar with all the too's available for the practice of their craft, possession of an Anso Vest Pocket No. 3 is a badge of proficiency and discriminating judgment. To handle it is a pleasure, and years of use only increase the satisfaction in its efficiency and worth.

see this folder, whether interested now or not. Prices are \$36, \$41, \$56, and \$80, with, respectively, Modico F 7.5 Anastigmat, Anso F 6.3 Anastigmat, Anso F 4.5 Anastigmat, and B. & L. Tessar F 4.5. In each case the shutter is the Acme Speedex, giving Time, Bulb, and automatically controlled exposures from one to 1/300 second.

The Anso Vest-Pocket No. 0, smallest of the vest-pocket series, takes pictures $1\frac{5}{8} \times 2\frac{1}{2}$. Like the No. 2, it has a single-arm direct-extension system, rapid, positive, and rigid, and in this case self-opening. The No. 0 is correct in design, con-

struction, and equipment, the kind of miniature camera which the expert can use without discovering that points important to him have been neglected. It is furnished with fixed focus at \$9 and \$10.50, and with focusing device and Modico F 7.5 or Anso F 6.3 Anastigmat in Bionic Extraspeed shutter at \$20 and \$25.

The Box Buster Browns are made in four sizes, $2\frac{1}{4} \times 3\frac{1}{4}$, $2\frac{1}{2} \times 4\frac{1}{4}$, $2\frac{7}{8} \times 4\frac{7}{8}$, and $3\frac{1}{4} \times 4\frac{1}{4}$. They range in price from \$2.50 to \$4.50, and are remarkably good box cameras, substantially constructed of well-seasoned wood, with neatly rounded edges and a covering of the best imitation leather. A Buster Brown is just the thing for the beginner, and if Anso Speedex Film is used in it the snapshot range will be appreciably wider than readers of The Annual would naturally expect with any box camera.

The foregoing comment suggests a further word as to film. Any reputable roll film can be used with good success in Anso cameras—with better success, we maintain, than in cameras of other makes,—but the photographic enthusiast who has not used the new Anso Speedex Film has a pleasant surprise in store for him. This film has wide latitude and very fine quality and gradation, and its extra speed is an advantage in hand-camera photography. The results will please you.

ANSCO COMPANY, Binghamton, N. Y.

November 1, 1921

GOERZ

Lenses and Cameras



Goerz Lenses:

Dagor F:6.8

The universal lens for amateur and professional.

Dogmar F:4.5

The ultimate high speed lens.

Goerz Cameras:

Rollfilm Tenax

Light and compact
 $1\frac{1}{8} \times 2\frac{1}{2}$, $2\frac{1}{4} \times 3\frac{1}{4}$,
 $3\frac{1}{4} \times 4\frac{1}{4}$.

High Speed Ango

For experienced photographers: $3\frac{1}{4} \times 4\frac{1}{4}$, 4×5 , 10×15 cm., 5×7 . Stereo 10×15 in.

All Goerz Plate Cameras can be used with Film-packs also

THE same care and precision in manufacture that has made the name "Goerz" the synonym for highest grade in lenses has made Goerz Cameras second to none.

The Goerz "Dagor" Lens is the universal lens for photographic purposes. The "Dogmar" is the ultimate high speed lens, free from coma and flare.

Goerz cameras are light, strong, rigid, and accurately constructed.

Whether lens or camera, if it's a Goerz, it's the best you can buy.

Ask Your Dealer

C. P. Goerz American Optical Company

317K East 34th Street, New York City

Distributors in the U. S. A. for
Sendlinger Optical Glass Works, Berlin
Manufacturers of Optical Glass of every
description.

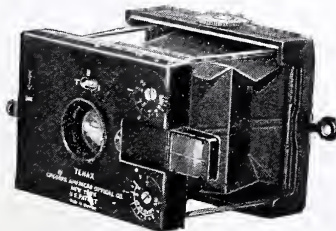

Pocket Plate Tenax

Extremely light and small,
but for finest work: $1\frac{3}{4} \times 2\frac{3}{8}$,
 $2\frac{1}{2} \times 3\frac{1}{2}$. Stereo $1\frac{3}{4} \times 4\frac{1}{4}$.

**EMBOSS YOUR PRINTS, STATIONERY,
BOOKS, ETC., AND**

Protect Your Checks with

ROOVERS EMBOSSERS

They will instantly and beautifully emboss your name,
address, initial, initials in succession, etc., on paper placed
between the jaws by simply pressing the handles.

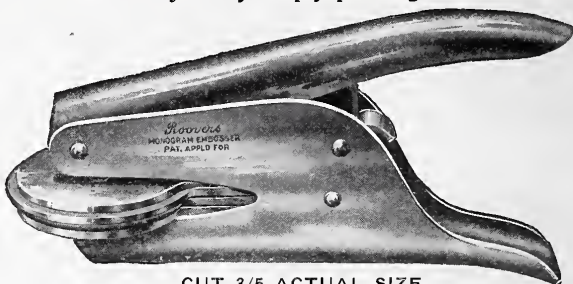

CUT 3/5 ACTUAL SIZE

MADE OF STEEL, NICKEL PLATED. LIGHT IN WEIGHT.

FOLLOWING ARE PRINTS OF SOME OF THE STYLES.

GEORGE B. ENDICOTT *R. F. Kirkland*
87 SEVENTH AVENUE *The Breakers*
BROOKLYN, N. Y. GOLD SPRING, N. Y.



E. A. H. **BΦΣ**
A. E. N. **H. F. M. W.**

Write for embossed circulars showing many styles of embossing with prices and particulars.

ROOVERS BROTHERS

100 Schermerhorn St., Brooklyn, N. Y., U. S. A.



VELOSTIGMAT F:4.5

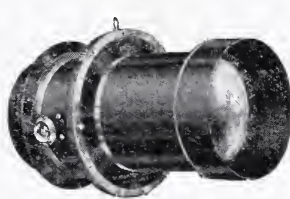

VITAX PORTRAIT F:3.8

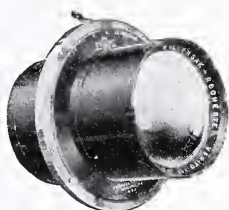

VERITO SOFT-FOCUS
F:4

LENSES and SHUTTERS

for every purpose

—for amateurs and professionals, for pictorialists and commercial photographers, for hand cameras and studio outfits are included in the

WOLLENSAK

line of products. Over a dozen different lenses, in focal lengths from 2" to 26", with a variety of shutter mountings are described in our literature. Ask your dealer or us for free booklets on "Studio Lenses," "Commercial Lenses," and "Amateur Lenses."

SELECT YOUR LENS AND SHUTTER FROM
THE COMPLETE LINE

Wollensak Optical Company

Rochester

N. Y.

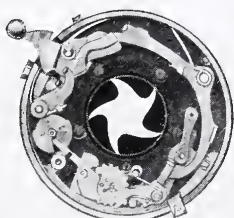

BETAX, GAMMAX & DELTAX—Shutters of "Xact Xposure"

No Complex Gears—No Uncertain Pumps

HOUSH
SUPREME
QUALITY
ALBUM

*Buy a HOUSH ALBUM
and stick your pictures in it with*

nobuc

You cannot beat this combination

MORE THAN A MILLION

Housh Albums

Are Now in Use

For twenty years these beautiful albums have been made uniformly good.

If your dealer does not handle the Housh line, please write for our price list. Perhaps you can induce him to order just the Housh Album you want.

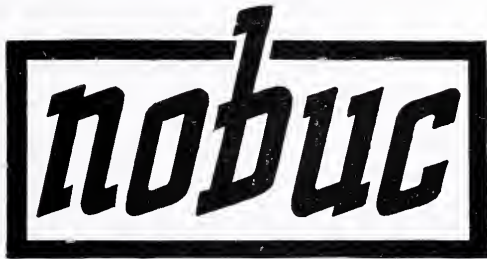

TRADE MARK REG. U. S. PAT. OFFICE

is a CLEAN, STAINLESS, NON-BUCKLING, NON-WRINKLING adhesive, especially prepared for mounting Photographs FLAT, without any unusual preparation or trouble.

For Sale by Dealers.

THE HOUSH COMPANY, Manufacturers
7-17 E. Concord Street, Boston, Mass.

THE ROYAL FOREGROUND GRADED FILTER

(Patented April 14th, 1911)

The Latest and Greatest Improvement in Ray Filter

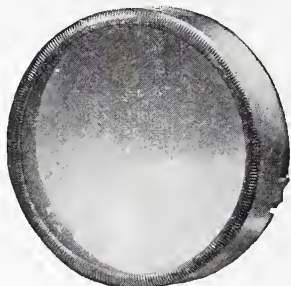

STYLE A

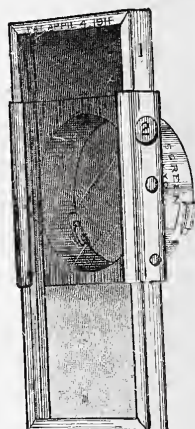

STYLE B

The only Ray Screen ever invented that will give an even, equal exposure to both sky and foreground, and produce a perfect cloud effect instantaneously with ordinary plates.

The Royal Foreground Ray Screen is so constructed that the color, which is a strong orange yellow at the top, is gradually diminished until perfect transparency is attained at the bottom. The practical effect of the gradual blending of color is to sift out or absorb the powerful chemical rays from the clouds and sky, which pass through the strongly colored top of the filter, without perceptibly decreasing the weak illumination of the reflected light from the foreground, which comes through the transparent or colorless lower part of the screen in full intensity.

The reason that daylight cloud pictures are rare is that the strength of the illumination from the sky is many, many times that of the partially absorbed and reflected light from objects on the ground.

If a correct exposure is given to the clouds, then the landscape is badly under-exposed; if the correct exposure is given to the landscape, then the clouds are literally burnt up from over-exposure, and no matter how contrasty they may have appeared to the eye, an unscreened photograph shows only a blank white sky.

The Royal Foreground Ray Screen is also very useful for subjects which are more strongly illuminated on one side than on the other, as in photographing by the light of a side window or in a narrow street. By simply turning the dark side of the foreground screen toward the bright side of the object a good, even exposure will result.

STYLE A slips over the front of the lens the same as a lens cap, and may be instantly attached or removed.

No.	Diameter, Inches	Price
0A	$\frac{3}{8}$	\$2.00
1A	1 5-16	2.25
2A	(for box cameras)	2.00
3A	1 7-16	2.25
4A	1 $\frac{1}{2}$	2.50
5A	1 $\frac{3}{4}$	2.75
6A	2	3.00
7A	2 $\frac{1}{4}$	3.50
8A	2 $\frac{3}{4}$	4.00
9A	2 $\frac{3}{4}$	4.50
10A	3	4.75
11A	3 $\frac{1}{2}$	5.50
12A	3 $\frac{1}{2}$	6.00
13A	4	7.00
14A	4 $\frac{1}{2}$	8.00

STYLE B is mounted in a sliding frame so as to bring a filter in front of any desired depth of color in front of the camera lens.

No.	Diameter, Inches	Price
1B	1 5-16	\$4.00
3B	1 7-16	4.00
4B	1 $\frac{1}{2}$	4.50
5B	1 $\frac{3}{4}$	5.50
6B	2	6.00
7B	2 $\frac{1}{4}$	6.75
8B	2 $\frac{3}{4}$	8.00
9B	2 $\frac{3}{4}$	8.75
10B	3	9.50
11B	3 $\frac{1}{4}$	10.75
12B	3 $\frac{1}{2}$	12.00
13B	4	14.00
14B	4 $\frac{1}{2}$	16.00

GEORGE MURPHY, Inc.,

57 East Ninth Street

NEW YORK

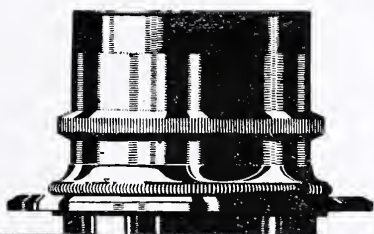

CARL ZEISS

Photographic Lenses

Made exclusively by the Zeiss Works at Jena, Germany. Write for Catalogue P. 226.

HAROLD M. BENNETT, *U. S. Agent*, 153 W. 23rd St., New York

Ica Victrix

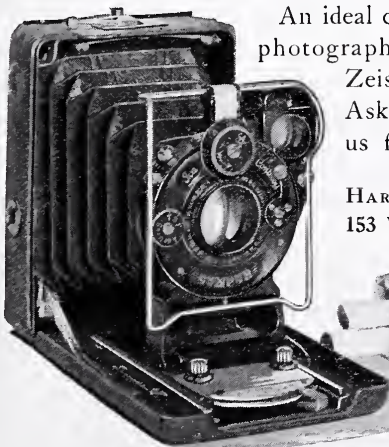

An ideal companion for the pictorial photographer. Furnished with Carl Zeiss Lens and Compur Shutter. Ask your dealer about it or write us for the new Ica catalogue.

HAROLD M. BENNETT, *U. S. Agent*
153 West 23rd Street, New York

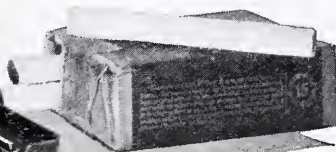

The Standard Photographic Magazines of America

The
PHOTOGRAPHIC
· JOURNAL ·
· of AMERICA ·
(Formerly Wilson's)

For the advanced and scientific photographer. The Standard Photographic Magazine of America for the past 59 years. \$2.00 per year in U. S. and Canada. Foreign postage, 75 cents extra. 20 cents the copy.

THE
CAMERA

The recognized practical magazine for the amateur and general photographer for the past 25 years. Profusely illustrated and handsomely printed. Every issue really is a work of art. \$2.50 per year in U. S. and Canada. Foreign postage, 75 cents extra. 25 cents the copy.

BULLETIN OF
PHOTOGRAPHY

The authority for the professional photographer for the past 14 years—the weekly business paper for the business photographers. Practical articles by practical writers. 32 pages every week. \$2.00 per year in U. S. and Canada. Foreign postage, \$1.00 extra. 5 cents the copy.

FRANK V. CHAMBERS, Publisher
636 S. Franklin Square, Philadelphia, U. S. A.

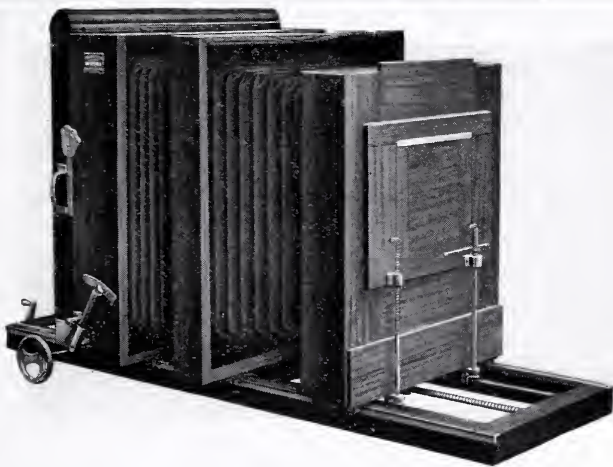

The WESEL Camera

For Photo-Engravers, Photo-Lithographers
and Rotary Gravure Printers

ASIDE from embodying numerous exclusive features that make for efficiency and economy in operation, the Wesel Camera *is built to last*. Materials and workmanship are of the kind that guarantee permanent satisfaction. And that's what you want—particularly with a Camera.

There are two different models in three standard sizes. Write for illustrated and descriptive catalog and compare the Wesel Camera with any other Camera of its type on the market.

We manufacture complete equipment for Photo-Engravers, Electrotypers and Stereotypers—also equipment and supplies for printers.

Put your problems up to men who understand your problems. Consult Wesel.

F. WESEL MANUFACTURING COMPANY

72-80 Cranberry Street,

Brooklyn, N. Y.

Chicago Office: 1654 Monadnock Bldg.

Tennant & Ward's List

of "worth while" books on photography

WALL'S DICTIONARY OF PHOTOGRAPHY

Tenth Edition, 1920. Revised to date and largely rewritten by F. J. Mortimer. 700 pages; 2,000 references. Cloth: postpaid \$5.

PHOTOGRAPHY MADE EASY—AS EASY AS A B C

By R. Child Bayley. 261 pages. Stout paper covers \$1.50

THE ART OF RETOUCHING NEGATIVES AND FINISHING PRINTS IN BLACK AND WHITE AND COLORS

By R. Johnson. 10th revised edition by Bruce and Braithwaite. 90 pages; illustrated; postpaid \$2.50.

THE PHOTOGRAPHIC RESEARCHES OF FERD. HURTER AND VERO C. DRIFFIELD

A Memorial Volume, edited by W. B. Ferguson and republishing all their original pages with a Bibliography of Later Work. 374 pages. Illus. Cloth \$9.

PHOTOGRAMS OF THE YEAR 1921

An International Illustrated Review of the World's Progress in Pictorial Photography. Reports of the Great Exhibitions, a Critique and 86 Plates. Ready in January. Stiff paper covers \$2.50. Cloth, \$3.50 postpaid.

PENROSE'S ANNUAL 1922

The Process Year Book and Review of Graphic Arts. Volume 23. Edited by W. Gamble. With 88 plates in color, gravure and other methods. Ready in January. Postpaid \$5.

PRACTICAL PHOTO-MICROGRAPHY

The Principles and Methods Plainly Explained for Beginners. A common-sense book. By Geo. West. 160 pages; with 8 plates, table, etc. Postpaid \$2.50.

BROMOIL, BROMOIL TRANSFER AND OIL PRINTS

By James A. Sinclair, Fred Judge and other experts. Practical Working Methods. Illustrated. Postpaid \$1.

PHOTOGRAPHING FLOWERS AND TREES

With an essay on "The Decorative Use of Natural Forms." By J. Horace McFarland. Illustrated. 50 cents.

PHOTO-MINIATURE SERIES

Monographs on Photography. Edited by John A. Tennant. No. 184: Soft Focus Lenses; No. 183: Color Photography; No. 182: The Studio, its Design and Equipment. Send for list of titles. Per Copy 40 cents. Per year \$4.

THE "BIG SIX" SERIES

Popular Photographic Handbooks. Cloth, 60 cents.

Send for General Book List, Free. We can supply any photographic book published—at the publisher's price.

TENNANT AND WARD, Publishers
103 Park Avenue **New York**

All Phones
Main 2912

Theatrical
(Stage Work)
Banquets
Newspapers
Magazines
Advertisers
Etc.

FRANCIS P.
BURKE

COMMERCIAL PHOTOGRAPHERS

106 N. LA SALLE STREET

156 W WASHINGTON ST.

OPPOSITE CITY HALL

CHICAGO

Sept. 26, 1921

Exteriors and
Interiors
Landscape
Machinery
Automobiles
Buildings
Architectural
Advertising
Prints in Quantity
Copy and Enlarging

The National Engineering & Refining Co.,
Rapid City,
South Dakota.

Gentlemen:

Your check, in the sum of \$16.25, received today. I must say that I am indssd pleased with the returns from my hypo settlements.

I must confess that after five years of continuous efforts in trying to solve why my returns have not been better, I now have the satisfaction of knowing it is altogether with the firm you deal with. You may rest assured that in the future my efforts will be greater and all shipments will be sent direct to the National Engineering & Refining Company.

Yours truly,

F. P. Burke

THIS SAME

NATIONAL ENGINEERING & REFINING CO.

EVOLVED

NECO PRECIPITANT

THE COMPOUND THAT HAS MADE THE SAVING
OF ALL

THE SILVER IN WORN-OUT HYPO

SO EASY

SO QUICK

SO ECONOMICAL

THAT

THE RETURNS FROM WORN-OUT HYPO HAVE BECOME A SUBSTANTIAL ITEM ON THE PHOTOGRAPHER'S DEPOSIT SLIP. A REAL PROFIT.

Try NECO side by side with any other method of saving this silver. Compare your NET RETURNS from our refinery and the VERDICT will be NECO EVERY TIME.

STOCK HOUSES FROM COAST TO COAST CARRY NECO IN STOCK. 5 lbs. will recover all the silver in 160 gallons worn-out hypo at 1¼c per gallon.

SAMPLE SENT UPON REQUEST.

NATIONAL ENGINEERING & REFINING CO.
RAPID CITY

SO. DAK.

Rough & Caldwell Company

ARTISTS AND DESIGNERS OF
PHOTOGRAPHIC BACKGROUNDS



ROUGH & CALDWELL

BACKGROUND. 7021

No. 7021

8 x 8.....\$25.60 8 x 10.....\$32.00
8 x 8 x 7.....\$34.00

An Artistic Background is the greatest aid to Studio Portraiture. An Artistic Background is a satisfaction to the photographer and a pleasure to his client.

Our Catalogue and twelve photographs of designs now ready.

New Designs shown in photographs every few months.

We are now supplying the **FLATTED OIL BACKGROUND**. Flatted Oil Grounds are indestructible, rolling without cracking, impervious to dampness or wet, and specially suited for Resort trade, where exposure cannot be avoided.

If you desire a Background, write us and state style desired, and we will send catalogue and submit photographs for inspection.

ROUGH & CALDWELL CO.

57 East Ninth Street

New York City



The Kalosat Lens

The Kalosat series of lenses are recognized today by the foremost pictorial and professional photographers as the fastest lenses offered to American photographers.

While giving soft diffused effects, they nevertheless retain definition and full color values.

They appeal to all serious workers who require atmosphere, chromatic values and softness without loss of perspective or speed.

Series I-F 4.5 and series II-F 6.3 Kalosat Lenses are constructed of a single element of quartz, transparent to all of the valuable light rays in the spectrum, including ultra-violet.

Mounted in the finest brass mountings or can be fitted in your present mountings. Special fittings of shutters and mount to suit your particular requirements.

Send for our booklet "K" which tells how the Kalosat lenses will improve your photography.

HANOVIA LENS LABORATORIES

Newark, N. J.

For the man  *who cares*

The lens that inspires

Make Your Prints in Colors (40 Shades)

An Explanatory Diagram Showing the Various Stages in the Production of AUTOTYPE CARBON PHOTOGRAPHS

The Production of an Autotype Carbon Photograph

HOW IT IS DONE

A
The Coated Surface of Exposed Carbon Tissue (Pigmented Gelatine).

B
Single Transfer Paper.

C
Soak A and B in cold water, bring coated surfaces together in contact and squeegee.

D
Place the adherent tissue and transfer paper between blotting boards for a few minutes. Next immerse in warm water, until the colored gelatine begins to ooze out at the edges.

E
Strip off the tissue backing paper and throw it away.

F
A dark mass of colored gelatine is left on the transfer paper. This remains in the warm water and the gelatine surface is sprinkled over until the picture gradually makes its appearance.

G and H
Continue until completed.

I
The picture is now placed in an alum bath (five per cent) to harden the film and discharge the bichromate sensitizing salt. A rinse in cold water completes the operation.

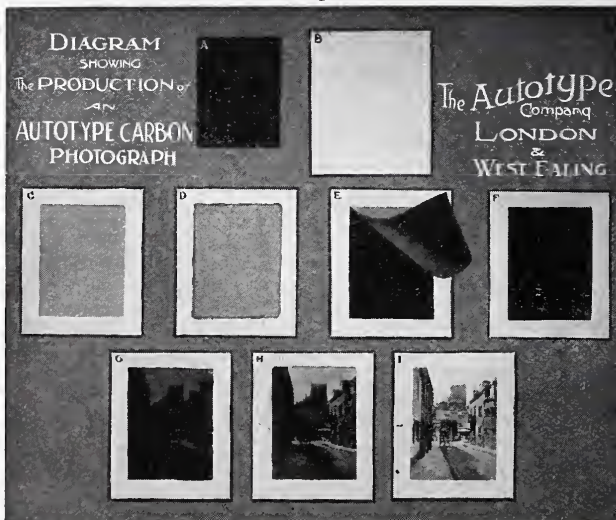

TRIAL SETS OF CARBON PRINTING MATERIALS

In order to combat the erroneous notion, somewhat prevalent amongst Amateur Photographers, that a trial of the Carbon Process necessarily entails the expenditure of a considerable sum on costly apparatus, we have decided to introduce trial sets of the absolutely essential materials.

PRICES OF TRIAL SETS

No. 1 Outfit for 5 x 7.....	\$1.75	Postpaid
No. 2 Outfit Complete for 5 x 7.....	5.75	"
No. 4 Outfit Complete for 8 x 10.....	8.00	"

American Agents, GEORGE MURPHY, Inc., 57 East 9th St., New York
Send for Booklet



ILEX

THE

Perfect Shutter

Three Essentials of a Photographic Shutter Accuracy, Reliability, Invariability

All these are embodied in the Ilex. Their construction is such that it cannot be otherwise. Built like, and with the same care, as a high grade watch, ILEX shutters are so perfect that they seldom, if ever, need adjustment or repair, after being fitted to cameras.

ILEX SHUTTERS ARE NOT AN EXPERIMENT. They have stood the test for over a decade and the thousands of satisfied and enthusiastic users in all sections of the globe are proof of our assertion of Superiority.

ILEX ACME LENSES

although new in length of time on the market, have already won for themselves an enviable reputation, and have been very highly endorsed by experts of all leading camera manufacturers of the country, to whom we have submitted samples. Our complete line embraces the following:

- Ilex Acme Portrait—F.3.8
- Ilex Acme Portrait—F.5
- Ilex Acme Anastigmat—F.4.5
- Ilex Acme Anastigmat—F.6.3 Conv.
- Ilex Acme Anastigmat—F.6.3 and F.7.5
- Ilex Acme F.8 Symmetrical

and Wide Angle and Soft Focus Lenses.

These lenses when fitted to an ILEX shutter, give the user a combination which is unequaled.

FULL PARTICULARS ON THE EQUIPMENT

in which you are interested, or on our complete line, can be obtained from your photographic dealer or direct.

Booklet on Request.

ILEX OPTICAL COMPANY
Rochester, N. Y.

Chemical Cleanliness

is a large factor in securing perfect negatives and prints.



Hard Rubber Trays, Fixing Baths, Plate Lifters, Stirring Rods, Funnels, Etc.

can be kept absolutely clean.

BECAUSE—Hard rubber is not affected by, nor can it contaminate any photographic chemical solutions. Most violently active acids and the strongest alkalis do not even etch its surface. Therefore Hard Rubber equipment is positively and permanently safe. This fact is becoming widely appreciated by professionals, advanced amateurs and photo engravers.

Write for information.

American Hard Rubber Company
11 Mercer Street
New York, U. S. A.



WHERE LILLIES GROW.

William Ludlum.

The American Annual of Photography 1922

VOLUME XXXVI

Edited by Percy Y. Howe



NEW YORK

THE AMERICAN ANNUAL OF PHOTOGRAPHY, INC.

MCMXXI

(TRADE MARK REGISTERED)

Copyright, 1922, by
THE AMERICAN ANNUAL OF PHOTOGRAPHY, INC.,
NEW YORK.

FEDERAL PRINTING CO., NEW YORK

THE GETTY CENTER
LIBRARY

P R E F A C E

HE industrial world, due to re-action from war conditions, has been greatly disturbed during the present year, consequently we are unable to report any remarkable advance in the photographic art.

The contributed articles and illustrations in this, our thirty-sixth volume, are by leading workers, both amateur and professional, at home and abroad. The variety of subjects, and individuality of treatment, demonstrate the wide field now covered by photography, and we hope will be of great interest to our readers.

I wish to thank all who have assisted in the preparation of this book, especially those whose contributions we have been compelled to omit through lack of space.

Material for the 1923 edition should be sent to 422 Park Hill Avenue, Yonkers, N. Y., prior to August 1st, 1922.

PERCY Y. HOWE, Editor.

TABLE OF CONTENTS

Contributed Articles

The Year's Work. By Carrol B. Neblette.....	9
Soft Focus vs. Anastigmat Lenses. By A. H. Beardsley.....	22
The Photographing of Maps to Scale. By J. H. Prideaux.....	32
Stereoscopic Photography. By Charles F. Rice.....	38
Bromoil Results. By Chas. H. Partington.....	46
Kallitype. By James Thomson.....	62
Camera Clubs and Pictorial Photographers. By Louis F. Bucher.....	68
Photography As Applied to Radiography. By S. A. Schwarz.....	74
Desensitizing. By Henry F. Raess.....	94
Zoo Photography. By Arthur H. Farrow.....	100
The Bromide Print. A Means Not an End. By Wm. Alexander Alcock....	106
The Sun in the Picture. By Horace Sykes.....	110
Taking the Dark Out of the Dark-room. By August Krug.....	116
Then and Now. By C. H. Claudy.....	120
The Multiple Gum Process. By Francis Orville Libby.....	124
Shutters and Their Speeds. By J. A. Ernest Zimmerman.....	136
One Way of Developing Roll Film. By H. V. Schieren.....	138
Laws of Art Versus Individual Taste. By Sigismund Blumann.....	142
Outdoor Portraiture. By Paul L. Anderson.....	146
Night Photography. By Sophie L. Lauffer.....	156
Lantern Slide Painting. By Marcus G. Lovelace.....	160
The Optics and Mechanics of Enlarging. By A. Lockett.....	168
In Old Kingston, N. Y. By Wm. H. Broadwell.....	178
Photographic Methods of Testing Developers. By J. I. Crabtree.....	184
Snapping State Capitols. By George Steele Seymour.....	216
On Cultivating the Habit of Observation. By Wm. S. Davis.....	222
The Miniature Camera for Exhibition Work. By T. W. Kilmer.....	228
Writing for Photographic Magazines. By Frederick C. Davis.....	232
Photographing Oriental Art Bits and Bric-a-Brac. By Dr. R. W. Shufeldt	238
Photography in Research and Science. By Arthur G. Eldridge.....	242
More About Photographic Lenses. By Carl W. Atkinson.....	246
Photography in Biological Work. By B. F. Lutman.....	256
Photographing Birds' Nests. By Hugo H. Schroder.....	266
The Single Slant Light. By George D. Jopson.....	268
American Annual Formulary.....	274
United States Weights and Measures.....	283
English Weights and Measures.....	284
Metric System of Weights and Measures.....	285
Conversion of Metric Into English Measure.....	286
Chemical Elements	287
Table of Comparative Speed Numbers.....	287
Thermo Development	288
Table for Calculating Distances in Enlarging and Reducing.....	289
Table of Distances for Use in Focusing.....	290
Length of Studio.....	290
Uniform System for Stops.....	291
American Photographic Societies.....	292

Index to Subjects

PAGE	PAGE		
Acid Fixing Bath.....	276	Lantern Slides.....	265
Adhesive for Labels.....	280	Length of Studio.....	290
Amidol Formula.....	274	Lenses.....	22, 42, 246
Anastigmat Lenses.....	22	Lenses, Cleaning.....	281
Autochromes.....	40, 280	Lighting.....	268
Azol Formula.....	276	Maps, Photographing.....	32
Bird Photography.....	266	Mctol.....	274, 275
Blackening for Brass.....	281	Metric System.....	285
Blackening Mixture.....	281	Microscopic Photography.....	243
Bleacher.....	50	Monomet Formula.....	275
Blue Print Paper.....	277	Moonlight Effects.....	282
Bromide Paper.....	106, 278	Mounting.....	282
Bromoil.....	46, 106	Multiple Gum Process.....	124
Calendar.....	8	Night Photography.....	156
Cameras.....	228	Nude Photography.....	142
Camera Clubs.....	68, 292	Para-Amidolophenol Formula.....	275
Carbon Process.....	279	Paste.....	282
Carbo Process.....	108	Photography in Biological Work.....	256
Cleaning Bottles.....	281	Photographing Birds' Nests.....	266
Clearing Stains.....	281	Photographing Bric-a-brac.....	238
Comparison of F. Values.....	282	Photographing Colored Objects.....	258
Comparative Plate Speed Numbers.....	287	Photographic Magazines.....	232
Composition.....	142	Photography in Science.....	243
Conversion of Metric System.....	286	Pictorial Photography.....	46
Darkroom.....	116	Plate Speeds.....	287
Desensitizing.....	14	Platinum Paper.....	279
Developers.....	10, 184, 274	Portraiture.....	142, 146
Development.....	82, 138	Poison and Antidotes.....	282
Diamidophenol.....	274	Polished Surfaces.....	282
Dye Impression Process.....	10	Printing-out Papers.....	280
Elements, The.....	287	Pyro Formula.....	275
English Weights.....	284	Reduction.....	277
Enlarging.....	48, 168, 289	Rodinal Formula.....	276
Exposure.....	111, 135, 282	Radiography.....	74
Farmers' Reducer.....	277	Safe Lights.....	46, 282
Ferrous Oxalate Formula.....	274	Salted Paper.....	280
Film to Remove.....	281	Sepia Toning.....	278
Film Tank.....	10	Short Stop.....	276
Firelight Effects.....	281	Shutter Speeds.....	135
Fixing Baths.....	52, 276	Single Slant Light.....	268
Flatten Prints.....	282	Societies, List of.....	292
Focusing Table of Distances.....	290	State Capitols.....	216
Fog.....	200	Stereoscopic Photography.....	38, 261
Ground Glass Substitute.....	281	Studio, Length of.....	290
Gum Bichromate.....	279	Table of Distances.....	289
Gum Process.....	124	Tank Developing.....	275
Hardeners.....	276	Testing Developers.....	184
Hydrochinon Formula.....	274, 276	Test for Hypo.....	282
Hypo Test.....	282	Thermo Development.....	288
Intensification.....	277	U. S. Diaphragms.....	291
Kallitype.....	62, 279	U. S. Weights.....	283
Lamps.....	116	Weights and Measures.....	283, 285
Landscape Photography.....	111, 120, 178, 216, 222	X-Ray Plates.....	10
Lantern Slide Painting.....	160, 265	Zoo Photography.....	100

Index to Authors

	PAGE		PAGE
Alcock, William Alexander.....	106	Libby, Francis Orville.....	124
Anderson, Paul L.....	146	Lockett, A.....	163
Atkinson, Carl W.....	246	Lovelace, Marcus G.....	160
Beardsley, A. H.....	22	Lutman, B. F.....	256
Blumann, Sigismund.....	142	Neblette, Carrol B.....	9
Broadwell, Wm. H.....	178	Partington, Chas. H.....	46
Bucher, Louis F.....	68	Prideaux, J. H.....	32
Claudy, C. H.....	120	Raess, Henry F.....	94
Crabtree, J. I.....	184	Rice, Charles F.....	38
Davis, Frederick C.....	232	Schieren, H. V.....	138
Davis, William S.....	222	Schwarz, S. A.....	74
Eldridge, Arthur G.....	243	Seymour, George Steele.....	216
Farrow, Arthur H.....	100	Shroeder, Hugo H.....	266
Jopson, George D.....	268	Shufeldt, Dr. R. W.....	238
Kilmer, T. W.....	228	Sykes, Horace.....	111
Krug, August.....	116	Thomson, James.....	62
Lauffer, Sophie L.....	156	Zimmermann, J. A. Erncst.....	135

Index to Illustrators

	PAGE		PAGE
Alcock, Wm. Alexander, 107, 109, 110, (Insert),	248	Fink, Leonid.....	45
Astrella, Louis.....(Insert)	104	Fleckenstein, Louis F.....	120
Anderson, Paul L.....	147, 149, 155	11, 51, (Insert)	120
Berkey, Irving.....	49	Gardner, Jared.....	205
Bill, J. Anthony.....	131	Gilroy, Ed. L.....	73
Bucher, Louis F.....	69	Gill & Son.....	259
Baker, Lawrence.....	95	Goetz, Louis F.....	141, 145
Beals, Jessie Tarbox.....(Insert)	88	Harding, G. H. S.....	255
Broadwell, Wm. H.....	179, 181, 182, 183	Harting, G. W.....	15, 87
Brown, E. J.....	230	Henry, Eugene P.....	59, (Insert), 160
Carlyle, Thomas.....	114	Hitchin, A. L.....	20
Carter, F. William.....	237	Johnson, Belle.....(Insert)	72
Champlain Studio.....	93	Jopson, George D.....	269, 271, 273
Cohen, Edgar A.....	209	Jones, Meyers R.....	247
Coit, Richard M.....	39	Kattelman, Carl H.....	71
Conkling, O. C.....	79	Kilmer, T. W.....	229, 231
Cooke, Helen W.....	21	Kimberly, G. P.....	29, 43
Crabtree, J. L.....	191, 192, 194, 197, 201	Krug, August.....	116, 117, 119
Davis, Wm. S.....	222, 223, 224, 227	Laity, Warren R.....	263
Detlefsen, Dr. F.....	187	Lauffer, Sophie L.....	157, 159
Doutt, Chas. W.....	226	Libby, Francis Orville.....	125, 133
Eickemeyer, Rudolf.....	17, 199	Lockett, A.....	169, 170, 171, 172, 173
Ellis, Wm. Shewell.....(Insert)	9	Ludlum, Wm.....(Insert facing Page 1)	1
Eitel, Theodore.....	175	Macnaughton, Wm. Elbert (Insert)	168
Eldridge, Arthur G.....	243, 244, 245	Matthews, Kate.....	195
Farrow, Arthur H.....	101, 103	Maurer, Oscar.....	235
		Mehling, Mrs. Standiford.....	177

Index to Illustrators

	PAGE
Meservy, Chas. D.....	134
Mettee, Holmes I.....	123
McFarlin, A..... (Insert)	136
Montgomery Robert B.....	32
Neyman, Percy.....	31, 143
Pardoe, Dr. J. H.....	35
Partington, Chas. H.....	40, 53, 55, 61
(Insert).....	192
Petrocelli, Joseph..... (Insert)	128
Porterfield, W. H. (Inserts) 24, 96,	33
Prideaux, J. H.....	99
Proskauer, Julien J.....	56
Randall, Lawrence C..... (Insert)	38
Rice, Chas F.....	189
Rodgers, Dr. C. F.....	213
Reece, Jane.....	138, 140
Schieren, H. V.....	75, 77, 83, 91
Schwarz, S. A.....	163
Schweickart, Peter J.....	167
Settgas, Wm. C.....	217, 219, 221
Seymour, George Steele.....	238, 239, 241
Shufeldt, Dr. R. W.....	

	PAGE
Shroeder, Hugh H.....	30, 267
Smith, Kate..... (Insert)	64
Snyder, Charles L.....	151
Steele, Louis F..... 47, (Insert)	232
Stockton, A. J.....	139
Squier, P. F.....	19
Sweet, L. D..... 23, (Insert)	152
Sykes, Horace.....	113, 115
Taylor, R. B. M..... (Insert)	224
Thonson, James.....	63, 67
Tylei, Edna M..... (Insert)	288
Vail, Floyd.....	37
Wakeford, C. E..... (Insert)	256
Webb, Mrs. Sidney V.....	27
Weber, E. F.....	144
Weis, A. J..... (Insert)	184
Whitehead, John M.....	13
Willard, Stephen H.....	81
Winston, Gilmer.....	251
Ziegenfuss, Dr. W. E.....	36
Zimmermann, J. A. E.....	136, 137

Index to Advertisers

	PAGE
Anseo Company.....	Insert before i
American Hard Rubber Co.....	xvi
American Journal of Photography, The.....	xxvi
American Lead Pencil Co.....	xxvii
American Photographic Publishing Co.....	xxx, xxxi
Archinal, Adam.....	xxxii
Bass Camera Co.....	xxxiii
Bennett, Harold M.....	vii
Bosworth, Morris F.....	xxxiii
British Gelatine Works, Ltd., The.....	xxxiv
Camera Craft.....	xxiv
Central Camera Co.....	xxii
Central Dry Plate Co.....	xxvi
Chambers, Frank V.....	viii, xxxv
Cohen's Exchange, Abe.....	xxix
Eagle Pencil Co.....	xxiv
Eastman Kodak Co.....	Fourth Cover, xvii-xxi
Engel Mfg. Co.....	xxxii
Gilbert Supply Company.....	xxxiv
Goetz, C. P. American Optical Co.....	i
Gundlach Manhattan Optical Co.....	xxviii
Guide to Nature, The.....	xxxii
Hadaway, Tom.....	xxii
Hammer Dry Plate Co.....	xxiii
Hanovia Lens Laboratories.....	xii
Harris & Co., Ralph.....	xxxiii
Harvey, G. L.....	xxiv
Higgins & Co., Chas. M.....	xxvi
Hoschke, Fred A.....	xxxiv
Housh Company, The.....	iv, v
Ilex Optical Co.....	xv
Johnston, J. W.....	xxxv
Keasbey, Frederick W.....	xxviii
Kittredge Co., R. W.....	xxv
Lewis, J. L.....	xxxiii
Leto Photo Materials Co.....	xxxix
Murphy, Inc., George.....	Second and Third Covers; vi, xiv, xxxvii-xl
National Engineering & Refining Co.....	xi
Neuman, Robert.....	xxxiv
New York Camera Exchange.....	xxxvi
O'Neill Photo Co.....	xxvi
Parallax Reflector Co.....	xxxiii
Roovers Brothers.....	ii
Rough & Caldwell Co.....	xii
Sagamore Chemical Co.....	xxv
Tennant & Ward.....	x
Wesol Manufacturing Co., F.....	ix
Willoughby, Chas. G.....	xxiv
Wollensak Optical Co.....	iii

REFERENCE CALENDAR FOR THREE YEARS

1921

							1921																	
	S	M	T	W	T	F	S		S	M	T	W	T	F	S		S	M	T	W	T	F	S	
Jan.	..	1	2	3	4	5	6	May	1	2	3	4	5	6	7	Sept.	1	2	3	
	2	3	4	5	6	7	8		8	9	10	11	12	13	14		4	5	6	7	8	9	10	
	9	10	11	12	13	14	15		15	16	17	18	19	20	21		11	12	13	14	15	16	17	
	16	17	18	19	20	21	22		22	23	24	25	26	27	28		18	19	20	21	22	23	24	
	23	24	25	26	27	28	29		29	30	31		25	26	27	28	29	30	..		
	30	31		
Feb.	..	1	2	3	4	5	..	June	..	1	2	3	4	..	Oct.		
	6	7	8	9	10	11	12		5	6	7	8	9	10	11		2	3	4	5	6	7	8	
	13	14	15	16	17	18	19		12	13	14	15	16	17	18		9	10	11	12	13	14	15	
	20	21	22	23	24	25	26		19	20	21	22	23	24	25		16	17	18	19	20	21	22	
	27	28		26	27	28	29	30	..		23	24	25	26	27	28	29		
		30	31		
Mar.	..	1	2	3	4	5	..	July	1	2	..	Nov.	..	1	2	3	4	5	..		
	6	7	8	9	10	11	12		3	4	5	6	7	8	9		6	7	8	9	10	11	12	
	13	14	15	16	17	18	19		10	11	12	13	14	15	16		13	14	15	16	17	18	19	
	20	21	22	23	24	25	26		17	18	19	20	21	22	23		20	21	22	23	24	25	26	
	27	28	29	30	31		24	25	26	27	28	29	30		27	28	29	30	
		31		
April	1	2	..	Aug.	..	1	2	3	4	5	6	Dec.	1	2	3
	3	4	5	6	7	8	9		7	8	9	10	11	12	13		4	5	6	7	8	9	10	
	10	11	12	13	14	15	16		14	15	16	17	18	19	20		11	12	13	14	15	16	17	
	17	18	19	20	21	22	23		21	22	23	24	25	26	27		18	19	20	21	22	23	24	
	24	25	26	27	28	29	30		28	29	30	31		25	26	27	28	29	30	31		

1922

							1922																
	S	M	T	W	T	F	S		S	M	T	W	T	F	S		S	M	T	W	T	F	S
Jan.	1	2	3	4	5	6	7	May	..	1	2	3	4	5	6	Sept.	1	2
	8	9	10	11	12	13	14		7	8	9	10	11	12	13		3	4	5	6	7	8	9
	15	16	17	18	19	20	21		14	15	16	17	18	19	20		10	11	12	13	14	15	16
	22	23	24	25	26	27	28		21	22	23	24	25	26	27		17	18	19	20	21	22	23
	29	30	31		28	29	30	31		24	25	26	27	28	29	30	
	
Feb.	1	2	3	4	..	June	1	2	3	..	Oct.
	5	6	7	8	9	10	11		4	5	6	7	8	9	10		1	2	3	4	5	6	7
	12	13	14	15	16	17	18		11	12	13	14	15	16	17		8	9	10	11	12	13	14
	19	20	21	22	23	24	25		18	19	20	21	22	23	24		15	16	17	18	19	20	21
	26	27	28		25	26	27	28	29	30	..		22	23	24	25	26	27	28
		29	30	31	
Mar.	1	2	3	4	..	July	1	..	Nov.	1	2	3	4	..	
	5	6	7	8	9	10	11		9	10	11	12	13	14	15		5	6	7	8	9	10	11
	12	13	14	15	16	17	18		16	17	18	19	20	21	22		12	13	14	15	16	17	18
	19	20	21	22	23	24	25		23	24	25	26	27	28	29		19	20	21	22	23	24	25
	26	27	28	29	30	31	..		30	31		26	27	28	29	30	
	
April	1	..	Aug.	1	2	3	4	5	Dec.	1	2
	2	3	4	5	6	7	8		6	7	8	9	10	11	12		3	4	5	6	7	8	9
	9	10	11	12	13	14	15		13	14	15	16	17	18	19		10	11	12	13	14	15	16
	16	17	18	19	20	21	22		20	21	22	23	24	25	26		17	18	19	20	21	22	23
	23	24	25	26	27	28	29		27	28	29	30	31	..		24	25	26	27	28	29	30	
	30		31	

1923

							1923																	
	S	M	T	W	T	F	S		S	M	T	W	T	F	S		S	M	T	W	T	F	S	
Jan.	..	1	2	3	4	5	6	May	1	2	3	4	5	Sept.	1	
	7	8	9	10	11	12	13		6	7	8	9	10	11	12		2	3	4	5	6	7	8	
	14	15	16	17	18	19	20		13	14	15	16	17	18	19		9	10	11	12	13	14	15	
	21	22	23	24	25	26	27		20	21	22	23	24	25	26		16	17	18	19	20	21	22	
	28	29	30	31		27	28	29	30	31	..		23	24	25	26	27	28	29		
		30		
Feb.	1	2	3	June	1	2	..	Oct.	..	1	2	3	4	5	6	
	4	5	6	7	8	9	10		3	4	5	6	7	8	9		7	8	9	10	11	12	13	
	11	12	13	14	15	16	17		10	11	12	13	14	15	16		14	15	16	17	18	19	20	
	18	19	20	21	22	23	24		17	18	19	20	21	22	23		21	22	23	24	25	26	27	
	25	26	27	28		24	25	26	27	28	29	30		28	29	30	31	
		
Mar.	1	2	3	..	July	..	1	2	3	4	5	6	7	Nov.	1	2	3
	4	5	6	7	8	9	10		8	9	10	11	12	13	14		4	5	6	7	8	9	10	
	11	12	13	14	15	16	17		15	16	17	18	19	20	21		11	12	13	14	15	16	17	
	18	19	20	21	22	23	24		22	23	24	25	26	27	28		18	19	20	21	22	23	24	
	25	26	27	28	29	30	31		29	30	31		25	26	27	28	29	30	..		
		
April	1	2	3	4	5	6	7	Aug.	1	2	3	4	..	Dec.	1	
	8	9	10	11	12	13	14		5	6	7	8	9	10	11		2	3	4	5	6	7	8	
	15	16	17	18	19	20	21		12	13	14	15	16	17	18		9	10	11	12	13	14	15	
	22	23	24	25	26	27	28		19	20	21	22	23	24	25		16	17	18	19	20	21	22	
	29	30		26	27	28	29	30	31	..		23	24	25	26	27	28	29	
</																					



William Shewell Ellis.

The American Annual of Photography · · 1922

THE YEAR'S WORK

By CARROL B. NEBLETTE

HE growth of photography has been rapid indeed. When we compare the many forward steps that have taken place, the many processes that have come and gone giving way to methods of superior results and wider applications, and then think that all of this progress has been accomplished in somewhat less than a century, it seems certain that photography is something that the world needs and something that has a large future. For only those discoveries or inventions have such rapid progress which fulfill some urgent world demand, and whatever the world demands must have a future.

Probably no other discovery excepting the invention of printing, and the reduction of metals from their ores, has contributed so much to the advancement of mankind. Photography undoubtedly fills a large and increasing place in the modern world, and of its future few will care to question that it will be of even greater value than it now is. After the thought of the many advances that have been made in the past in the science of photography, the next question that comes to the mind is "What progress is being made now?" To answer this query in a short and popular manner is the purpose of this article.

Owing to the disturbances in the industrial world during the past year the novelties in apparatus have been few. Notable among the new apparatus introduced in the past year has been the Imperial Impex plate for X-Ray workers, the

Carbine film developing tank, and among the new working methods the Dye Impression process, and the new developer D50. As a brief account of these will be of interest I append a short outline of the methods, and a description of the apparatus.

The Imperial Impex plate for X-Ray workers should greatly advance the growing interest that is being taken in this line of work, as it will greatly facilitate the photographing of very difficult subjects. This plate consists of a fast X-Ray emulsion coated on the surface with an intensifying screen composed principally of calcium tungstate. The phospherence property of the layer in close contact with the emulsion has the effect of shortening the required exposure to a considerable degree. Experiment has shown that the new plate is from fifteen to thirty times the speed of the regular X-Ray plate depending on the manner the new plate is used. Owing to the greater speed of the new plate shorter exposures may be given which will enable the worker to attempt muscular movement which has heretofore been attended with great danger to the patient and the operator. The new plate met with the approval of the principal workers in England, and is rapidly making a name for itself.

The Carbine film tank which was introduced by the firm of Butcher & Sons, of London differs from the other existing methods of daylight tank developing apparatus in that it requires neither changing box, nor apron. The tank is built in the form of a tube into which the developer is poured through an opening at the top. The roll of film is attached to a holder at the top of the tank, the end of the spool is connected with the plunger, and when the same is pressed down the film is unrolled within the tank, so that the developer has complete access to the whole surface of the emulsion.

Among the most interesting as well as the most valuable of the new processes, is the new Dye Impression process introduced early in 1920. The new process of negative making allows of much shorter exposures than the ordinary and the production of prints of almost any color in full daylight. None of the processes following the development of the negative require a darkroom. Briefly the outline of the process is as follows: The developed plate after fixation is immersed



PORTRAIT.

LOUIS FLECKENSTEIN.

in a "preparing bath" for the purpose of rendering the silver image impermeable to certain dyes. When this has been completed the negative is placed in a "dye bath" in which the shadows of the negative absorb the dye in proportion to their strength, while the high-lights having been rendered impermeable to the action of the dye by the first bath refuse to take up the dye and we therefore possess a dyed plate which only needs to be squeegeed to a prepared paper in order to secure a print in any color, depending on the dye used to color the negative. After all the prints desired have been made the dye is removed from the negative, and the same may be stored away until more prints are desired when the process is repeated. The materials necessary for the process, which is very economical, are furnished by the patentees—Dye Impression Photos, Ltd., London, England.

The only new developer introduced during the year which has attracted much attention is D50. The developing properties of D50 which is a mixture of some new chemical compounds of the phenolic type, was first called to the attention of photographers by Mr. John H. Gear, Hon. F.R.P.S., in the British Journal of Photography for May 27, 1921. The keeping properties of D50 according to Mr. Gear represent a decided advance over any other known developing agent. Mr. Gear states that he has successfully used a solution of D50 that has stood in an open tray for one week. He also claims for it greater energy than most developers in ordinary use, and freedom from a tendency to cause fog. Tests conducted by Mr. Gear with Dr. Adolphe Abrahams, F.R.P.S., the famous authority on high speed photography, seem to prove the especial value of the new agent for short exposures.

Mr. Gear recommends the following formula:

Solution A.

D50 Concentrated solution.....240 minims
 Water to make..... 10 Oz.

Solution B.

Sodium Sulphite Dry.....200 Grains
 Sodium Carbonate Dry.....125 "
 Potassium Bromide 5 "
 Water to make..... 10 Oz.

An important advance in the research work of the year



A DREAM OF THE RAPLOCH.

JOHN M. WHITEHEAD.

which cannot help but have a large influence on future working methods is the discoveries of methods of reducing the sensitiveness of plates so as to allow them to be developed in a brighter light. The remarkable desensitizing properties of phenolsafranine was first noted by Dr. Lупpo-Cramer. On Jan. 3, 1921, Mr. Raymond E. Crowther published in *The British Journal* an account of his trials with the same, and very shortly afterward the Ilford Plate Co. put a compound called Desensitol on the market. Considerable attention has been paid not only to the scientific aspects of the matter, but also to its practical application. The first is by no means settled. Dr. Lупpo-Cramer considers desensitization as an oxidation phenomenon. M. Lumiere also found that the most effective desensitizers were mild oxidants. However the restoration of the original sensitiveness upon washing out the dye indicates that no permanent change results. Lately M. Lumiere and Seyewetz (*B. J.* June 10th and 24th) have published a paper recording extensive experiments on the subject. There appears to be no way of determining what dyes will act as desensitizers without actual test. Phenolsafranine is the best desensitizer according to M. Lumiere, as its action extends evenly through the entire spectrum, while those of many other of the dyes examined are selective in action. An editorial in the *B. J.* suggests that it is within the range of possibility that an orthochromatic plate which does not require a screen may be produced by this method. Whatever may be the future developments of the process it is certain that it has come to stay, and that it is an advance of considerable importance to the practical photographer. As most of the American magazines have published accounts of the practical working of the method I will refer the reader to any of the following articles: *American Photography*, June 1921, page 328, *Camera Craft*, April, 1921, page 111, *Photo Era*, May, 1921, page 243, which is a reprint of the article of January 3 in the *B. J.*

The production of panchromatic sensitiveness with mineral salts by Capstaff of the Eastman Research Laboratory has opened up a new field for exploration which may develop into an extremely profitable one. Film bathed in a two per cent solution of sodium bisulphite, and followed by washing from five minutes to thirty hours, showed increasing sensitiveness



HOWARD GILES—ARTIST.

G. W. HARTING.

to the red. Without the bisulphite bath washing in water confers little or no sensitiveness. The addition of an alkali increases the sensitiveness, while soluble bromides diminish the action. The effect is due apparently to the sulphurous content of the bisulphite. No satisfactory theory has yet been found. Messrs. Capstaff and Bullock attribute it to a partial reduction of the silver salt to colloidal silver.

Mr. F. F. Renwick has also found that potassium iodide and sodium and potassium cyanide have the same effect. In the Photo Journal January, 1921, he states that a very dilute (1-50,000) solutions of the former are sufficient to render the plate markedly red sensitive. Renwick considers that the action is due to a change within the silver-bromide-iodide grain rather than anything akin to ordinary sensitizing by dyestuffs.

Increasing the speeds of panchromatic plates by treatment with ammonia is the subject of some valuable experiments by Samuel M. Burka. It was found that bathing commercial panchromatic plates in a solution of 25cc. ethyl-alcohol, 75cc. water and 3ccs. ammonia water (20% NH_3) for 4 minutes at 18 degrees centigrade and drying rapidly, increased the sensitiveness to white light 100% in nearly all cases, while the sensitiveness to red was extended 100 or more Angstrom units. In some few cases the speed in the red was increased 400%. If plates are bathed without the alcohol the speed is still greater, but the keeping quality is impaired. With the addition of alcohol plates treated with ammonia are usable after a week, but the fog rapidly increased. The method is expected to be of considerable advantage for aerial photography where high speed together with red sensitiveness is required. (Published in Journal of Franklin Institute and B. J. of Photo., August 6, 13 and 20, 1920.)

In the Hurter and Driffeld Memorial lecture delivered before the Society of Chemical Industry Mr. Frank Forster Renwick, F.R.P.S., advanced a new theory of the latent image. He considers that in our highly sensitive plates we are dealing with crystalline silver bromide in which something else than gelatine, some highly unstable form of colloidal silver exists in solid solution, and that it is this dissolved silver which first undergoes change on exposure to light. The function of ripening he explains so as to produce this colloidal silver in



A Foggy August Morn

its most sensitive state. (Reprinted B. J., July 23 and 30, 1920.)

The three most important scientific works of the year in the English language are the H. and D. Memorial volume, *The Silver Bromide Grain of Photographic Emulsions*, and *The Fundamentals of Photography*.

The first is published by the Royal Photographic Society of Great Britain and contains a reprint of all of the famous papers of the researches of Hurter and Driffield. The same is edited by W. B. Ferguson, K.C.B., Hon. F.R.P.S., who contributes an excellent summary of the early work of the two experimenters, and also a most complete bibliography of later work on the same subject.

The monograph on the Silver Bromide Grain is the first of a series of publications on the theory of photography to be published by the Eastman Research Laboratory. It is a highly scientific and comprehensive study of the silver grain. While of great value to the scientist, and of undoubted value to research workers, it is of little value to the ordinary worker.

The Fundamentals of Photography is a little textbook in simple language from the pen of Dr. C. E. K. Mees, and is quite an agreeable change from the mathematical complexity of much of his former work. The little book explains in a simple way with the aid of many charts and figures the principal operations of photography. Our only wish is that Dr. Mees might go on for several more pages in the same way for the advantage of those above the amateur stage.

The closing months of the year of 1920 were marked by the death of one of the greatest of scientific workers in photographic research. Although he had not been much to the fore during the past few years on account of rheumatism, the importance of his work grows from day to day, and there is no other man who has contributed so much to the advancement of photography in all of its branches as Sir William de Wiveslie Abney, K.C.B., Hon. F.R.P.S., F.R.A.S., F.R.S., etc. His principal works are:

Instruction in Photography	Action of Light in Photography
Treatise on Photography	Color Measurement and Mixture
Photography with Emulsions	Trichromatic Theory of Color



RESTING.

P. F. SQUIER.

and large numbers of papers to societies and the periodical press. It is to be hoped that these will be collected into one or two volumes by the Royal Photographic Society as a memorial volume. In discussing the work of Abney in the Royal Photographic Society's Journal, Mr. W. B. Ferguson says: "The great work done by Abney for the science and art of photography during the last sixty years can only be estimated by those who have the ability to understand and the industry to read through numerous papers and communications to the photographic and scientific periodical press. Of great scientific insight and breadth of views imbued with the true spirit of research and of indefatigable industry, he was not only an able experimenter, but moreover possessed the power of communicating to others in a clear and intelligible manner the bearings of the results of his experiments. The advancement of Photography owes much to him, and a study of his scientific papers extending over a period of sixty years will show in how many points the present position of photo science is due to the work of Sir William Abney."



THE REFECTORY.
WHITEFRIARS MONASTERY, COVENTRY.

A. L. HITCHIN.



A LETTER TO SANTA CLAUS.

HELEN W. COOKE.

SOFT-FOCUS VS. ANASTIGMAT LENSES

By A. H. BEARDSLEY

ET me say at the outset that I have no intention to begin a controversy, nor shall I attempt to act as arbiter. My purpose will be to take the attitude of the inn keeper in "Silas Marner" who, prevented many a broil by remarking firmly to those who were disposed to violence, "Gentlemen, you're *both* right, and you're *both* wrong, and the *truth* lies a'tween you!" By placing a few facts—as I know them—before the reader, I may render some service to the end that soft-focus and anastigmat lenses may be better understood and valued.

In my opinion there is a definite place in photography for the soft-focus and the anastigmat lens. One cannot supplant the other. Each serves its particular field exclusively. There may be cases where there is an overlapping and consequent confusion with regard to the exact dividing line; nevertheless, each type of lens is indispensable to the photographer who would express his best in photographic science and art.

The popularity of the soft-focus lens, once confined to the professional or advanced amateur-photographer, is now arousing the interest of the average camerist to such an extent that a word on the subject may be of value. Without a doubt, the soft-focus lens has come to stay. By its intelligent use, the worker can obtain effects that cannot be had in any other way without manipulation of a character too technical for the average camerist to attempt. The earlier types of soft-focus lenses were so constructed that even the professional photographer was compelled to make a special study of its use, but today such strides have been made by several manufacturers, that a soft-focus lens requires no more study than a high-grade anastigmat in order to obtain results. Of course, whether these results meet the individual requirements of the camerist is a question that he alone can determine.

Paradoxical as it may seem, a soft-focus lens requires



AN OLD FENCE.

L. D. SWEET.

careful focusing. That is, there is a point where the "softness" or diffusion reaches its most pleasing effect without becoming too "fuzzy" or positively out of focus in appearance. When soft-focus lenses were first placed upon the market, many photographers were unable to understand why they could not obtain the same effect by simply putting their anastigmat lenses slightly out of focus. At first glance, it might appear to the novice that there was no difference; but subsequent study and critical inspection revealed the fact that a soft-focus lens produced a roundness and atmospheric quality that was not paralleled by the "out-of-focus" anastigmat. Naturally, there was then, and is now, considerable discussion with regard to this point; but the fact remains that the soft-focus has come to make a long stay, and we shall have to accept it as an important link in the chain of photographic apparatus upon which we depend to help us express ourselves pictorially.

Sometimes, it may be said that the average amateur enters photography "where angels fear to tread". In the opinion of those of ripe photographic experience, to give a beginner a soft-focus lens might be likened to giving a stick of dynamite to a child. However, those of long experience notwithstanding, there are many beginners who have been successful with a soft-focus lens before being able to make a clear-cut picture with an anastigmat lens. Personally, it would seem to me that any beginner should master a rapid rectilinear or anastigmat lens before he attempts to use a soft-focus lens. In my opinion, he requires the technical experience and preparation that he receives by mastering "sharp" lenses; but to say that it is impossible for a beginner to use a soft-focus lens successfully until he can use an anastigmat lens, is to court contradiction. Hence, I would not care to go on record as saying that it cannot be done; but should anyone ask my opinion, I should favor the mastery of the "sharp" lens first.

Without a doubt, the soft-focus lens is ideally adapted to the requirements of the camerist who yearns to express himself in an original manner. But here let me ask how he is to know what he does or does not want unless he has had prior experience with other lenses? Let us assume that a beginner is given a new camera fitted with a soft-focus lens. How is



SOLEMN WATCHES OF THE NIGHT.

W. H. Porterfield.

he to apply the rules and suggestions of his instruction-book? From the moment that he makes the first exposure, he is working along lines that are not covered by the one book that is of greatest service to him in his tyro-days. Mind, I am not saying that it cannot be done; but it seems to me that the average beginner has troubles enough without inviting them. Let us assume once more that he does make excellent pictures and becomes master of his equipment. What is he to do when he wishes to use an outfit equipped with a good anastigmat lens?

My reason for mentioning soft-focus lenses is with the desire to be of some service to those of my readers who may be contemplating an entrance into photography via the soft-focus-lens route. By all means, enter photography; but remember that it is the successful beginner that gets the most *out* of photography. Although I endorse and would promote the use of the soft-focus lens, I would not care to do so in cases where it might result in the beginner becoming discouraged and giving up photography altogether—to the direct loss of all concerned.

It will be well for the beginner to study the soft-focus lens and to use one *after* he has been graduated up to it by thorough work and the mastery of "sharp" lenses. He will enjoy the soft-focus lens, and he may do better with it than he thinks; but first let him be a master of photographic rudiments. It will pay him a thousandfold in the end.

The anastigmat lens won its way by sheer merit until today no camera is conceded to be of very great efficiency without one. However, it has been brought to such a state of perfection that, in some cases, it has overreached itself and produces a "wiry", cold sharpness that repels rather than attracts the beholder. It is this very perfection of sharpness and covering-power that is responsible for the soft-focus lens. However, as often happens among reformers, those who fathered the first soft-focus lenses went to extremes and were responsible for pictures that were as unnatural as they were absurd. This situation gave rise to as many attempts to obtain soft definition with an anastigmat as there are recipes to make home-brew. To-day, the makers and most users of soft-focus lenses are "back to normal". That is, they are

responsible for pictures that have the required diffusion, but still contain the basic strength of the anastigmat lens.

This transition-period is responsible for two schools of pictorial photography—one that accepts nothing artistic that is not diffused, and the other that demands critical definition. Between these extremes there are many minor schools that adopt such parts of the two main schools as suit individual requirements.

I believe that it is safe to say that today a "sharp" picture may be considered to be artistic as readily as one that is diffused. In short, the two schools appear to have come to the conclusion that each is an asset to photography, and that neither can hope to oust the other from the field.

It seems to me that the entire question of soft-focus vs. anastigmat lenses should be brought down to the basic truth that both are needed in photography, and that the decision with regard to which is superior be left to the requirements of the work in hand, and not to an arbitrary opinion or school. In short, here we have two excellent tools which we should learn to use intelligently to express pictorially our best interpretation of a given subject. Usually, we should not select a soft-focus lens to photograph a railroad-engine for a catalog-illustration. However, there might be a case where a diffused picture of the same engine surrounded by a cloud of steam and smoke might lend itself beautifully to the requirements of an intelligent and trained pictorialist. It would be poor judgment, in my opinion, to decide in favor of either type of lens without first determining which would do the best work for the subject in hand. Remember that these lenses are tools to use, at will, to help us get the best possible results. Every photographer who can afford it should have both—not one or the other. The soft-focus and anastigmat lens may be made to work together harmoniously and to the betterment of photography. The day should be passed when the photographer is compelled to choose one or the other because of his mistaken allegiance to any school, or clique of amateur or professional photographers.

It is possible to make a picture with an anastigmat lens and to enlarge it with a soft-focus lens or vice versa. Why should it be considered photographically unethical to do so?



MRS. SIDNEY V. WEBB.

It is the *result* that we are after. The lens that helps us most to obtain the result is the lens to use either for the original negative or the enlargement. The trouble with many of us is that we lean too heavily upon the opinions and experiences of others. In a way, Camera Clubs are to blame for the desire to ask some one else before making a decision with regard to a lens or a printing-process. Mind you, I believe thoroughly in photographic comradeship as it is found in so many Camera Clubs today; but although I would advise any amateur or professional photographer to consider carefully the opinions and experiences of others, nevertheless, I would suggest that final decisions be made by the man most concerned, viz.: the photographer himself. Let him stand firmly on his own photographic feet. Let him use the lens or process that will enable him to express best the pictorial idea within him. If it be a soft-focus lens, well and good. If it be an anastigmat lens, well and good. When all is said and done, the responsibility for failure or success rests with the camerist himself.

There are several standard soft-focus lenses on the market even as there are a number of standard anastigmat lenses. There are various types that are designed to produce special results. This is true of anastigmat lenses. When it comes to the matter of making a selection, the choice of a soft-focus lens is just as important as in the case of an anastigmat lens. In short, a soft-focus lens—its selection and use—must be taken fully as seriously as in the case of a high-grade anastigmat. As I have said already, neither lens will do the work of the other; but both are needed to complete the photographer's equipment.

Even among the staunchest supporters of the soft-focus lens there is a difference of opinion as to how diffused a picture may be and still be considered artistic and beautiful. Followers of the anastigmat lens are often confronted with the problem of how sharp a picture may be without losing its claim to true art. In fact, the deeper we enter the subject the more involved does it become, and the more convinced do I become that there is a tremendous amount of energy being wasted in discussion that might well be put to the use of *both* the soft-focus and anastigmat lens. The more that we



A FROSTY MORNING.

G. P. KIMBERLY.

learn about these two types of lenses the more pleasure we shall have out of photography, and the greater variety of pictures shall we be enabled to enjoy.

In conclusion, let me say that there should be no more *versus* between the soft-focus and the anastigmat lens. Neither is in a position to supplant the other. Hence, let us face the fact that both are becoming indispensable and that both are ideally adapted to supplement the work of the other. Let us waste no more time in the attempt to decide which is best; but rather let us find new ways and means to make each type of lens help photography to become a greater science and a more beautiful art than ever before. Let us be glad that a new tool has been placed in our hands rather than thwart its purpose by ill-considered "snap" judgments. The anastigmat lens has made good. The soft-focus lens is making good. Let us remember that there were people who decried the steam-engine, electric light and telephone. Now all three work together in harmony to make this world a better place to live in. Soft-focus and anastigmat lenses are at our disposal to make photography a greater power in the commercial and artistic life of the world. Let us make the most of them, and let us be glad that they are helping us to reach higher and truer standards in the science and art of photography.



MOURNING DOVE NEST.
(See Page 266).

HUGO H. SCHRODER.



INGEBORG LA COUR.
Interpretative Dancer.

PERCY NEYMANN

THE PHOTOGRAPHING OF MAPS TO SCALE

By J. H. PRIDEAUX



At times the amateur photographer is called from his pictorial work to a more serious and painstaking branch of photography—the reduction of maps to a known scale. In very large plants this is a simple matter because they have every facility for doing this work with the least possible trouble, but to the amateur who has only a view camera, this involves a serious amount of work, if he is to do the work accurately.

Some years ago the writer was called upon to reduce a goodly number of mine maps to a scale of from 100 feet to the inch to 1000 feet to the inch, a ten times reduction, for the purpose of illustrating the maps in a report.

It was practically impossible to collect the maps to a central point, as it was imperatively necessary that the maps remain in the offices of the various companies. If the maps had been allowed to go out the proper installation of the necessary apparatus could have been made permanent, as to the setting of camera in relation to the easel for this reduction, and the whole operation simplified.

Failure to get the original maps involved going to the Engineering Departments, rig up an easel of about 10 by 12 feet for the tacking up of the maps to be photographed. These maps were in some cases of very great dimensions necessitating the use of many plates to complete the property lines.

A view camera 11" x 14" was employed, fitted with an anastigmat lens of good make, long extension bellows, equipped with rising and falling front and swing back. The ground-glass was centered both vertically and horizontally, and on these center lines divisions of one inch were marked (Figure 1). The easel was also divided in the same manner vertically and horizontally, the divisions being ten inches



A WOODLAND BROOK.

Robert B. Montgomery.

apart. As this reduction was to be a ten times the one inch divisions on the ground-glass had to coincide with the 10 inch division on the easel.

In order to get clear cut negatives a process plate was used, and in some cases where the maps were in colors the necessary plate and color screen were employed.

Practically all the maps were made on tracing cloth which made the use of the process plate imperatively necessary. However, a blue print was sometimes photographed, in this

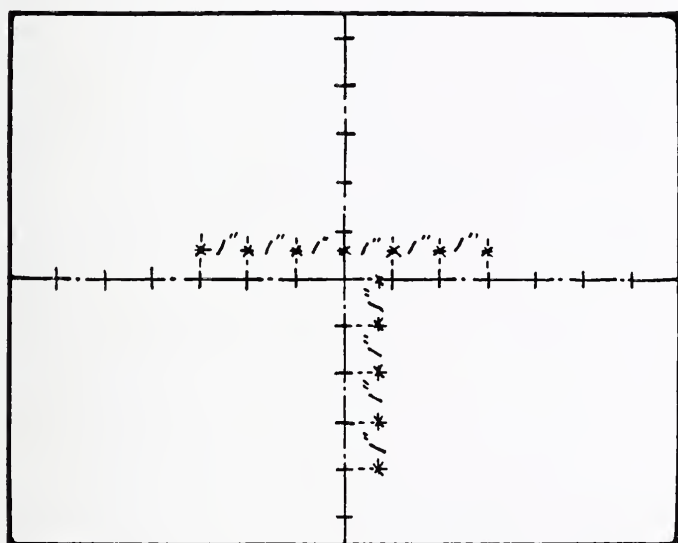

Figure 1.

Ground Glass Divisions.

case a trichromatic plate was used with an orange red screen, giving excellent results.

In all cases the lens was stopped down to a $F/64$ opening, giving an exposure of about two minutes as a maximum, the time of course being greatly dependent upon the light conditions. With the use of a trichromatic plate, and the orange red screen, the time was necessarily lengthened.

The camera was set on a stout tripod on a center line with the easel, and the lines centered on the ground-glass with those on the easel until all divisions were in line with each

other. In this case a 12-inch focus lens was used, and in the first set up to photograph to the required scale it was necessary to make a calculation for distance from easel to lens, from the formulæ: times reduction \times lens focus, plus lens focus. For example, a scale of 100 feet to one inch to 1000 feet to the inch, thus a $1/10$ reduction \times 12" (lens focus) plus 12' lens focus, gave 132" from lens to drawing, and the draw of the camera was found by dividing this 132" by $1/10$ th, which gave 13.2/10 inches.

To facilitate the work a table was constructed to readily find the distance when other scales were used on the maps to cover a certain area, as follows:

Reduction to	Reduction	Dimensions of Map Covered	Dimensions of Plate	Lens to Drawing	Draw of Camera
200 ft.	$\frac{1}{2}$	21.0 in. \times 27.0 in.	13.5 in. \times 10.5 in.	36 in.	18.0 in.
300 ft.	$\frac{1}{3}$	31.5 in. \times 40.5 in.	13.5 in. \times 10.5 in.	48 in.	16.0 in.
400 ft.	$\frac{1}{4}$	42.0 in. \times 54.0 in.	13.5 in. \times 10.5 in.	60 in.	15.0 in.
500 ft.	$\frac{1}{5}$	52.5 in. \times 67.5 in.	13.5 in. \times 10.5 in.	72 in.	14.4 in.
600 ft.	$\frac{1}{6}$	63.0 in. \times 81.0 in.	13.5 in. \times 10.5 in.	84 in.	14.0 in.
700 ft.	$\frac{1}{7}$	94.5 in. \times 73.5 in.	13.5 in. \times 10.5 in.	96 in.	13.7 in.
800 ft.	$\frac{1}{8}$	84.0 in. \times 108.0 in.	13.5 in. \times 10.5 in.	108 in.	13.5 in.
900 ft.	$\frac{1}{9}$	94.5 in. \times 121.5 in.	13.5 in. \times 10.5 in.	120 in.	13.3 in.
1000 ft.	$\frac{1}{10}$	105.0 in. \times 135.0 in.	13.5 in. \times 10.5 in.	132 in.	13.2 in.
1200 ft.	$\frac{1}{12}$	126.0 in. \times 162.0 in.	13.5 in. \times 10.5 in.	156 in.	13.0 in.
1500 ft.	$\frac{1}{15}$	157.5 in. \times 202.5 in.	13.5 in. \times 10.5 in.	192 in.	12.8 in.
2000 ft.	$\frac{1}{20}$	210.0 in. \times 270.0 in.	13.5 in. \times 10.5 in.	252 in.	12.6 in.

By consulting this table if using a 11" \times 14" plate and 12" focus lens, it can readily be seen the dimensions of a map to be covered by a given size plate, the approximate distance from lens to drawing and the draw of the camera. Of course the use of a different focus and plate will necessitate the re-calculation of this table, which can readily be done by using the formulæ as given.

When a map was too large to be covered by one plate the map was marked with a line top and bottom so as to act as cutting lines for the proper joining together of the two pieces, these lines appearing on both plates.

As to development of the plates and paper used the formulæ of the maker was used as to developer, and as the reproductions were to be used for calculations a glossy paper was used of high contrast.

The above illustrates very clearly the use of the apparatus you may have at hand to photograph to a given scale should anyone be called upon to do this branch of work. Of course, where the necessary apparatus is fixed in a special room, where a specialty is made of this branch of the art, the work is

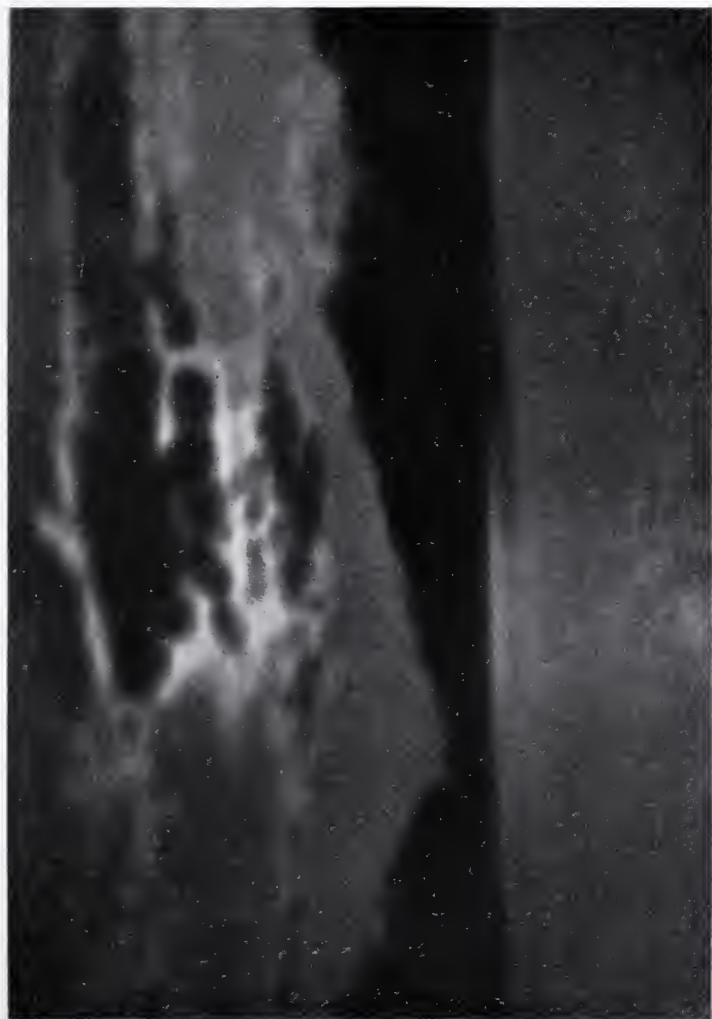

SUNSET.

DR. J. B. PARDOE.

greatly simplified, but not having the proper facilities the foregoing is of value to the amateur.

The accuracy of the reproductions of these maps were so that the necessary calculations were made from them instead of from the bulky 100 feet to the inch blue prints furnished for calculation purpose.

As the mine workings in the beds did not extend over the entire property, only being shown where worked, it was necessary to make an outline property map showing all corners. A pantograph reduction was made for check purposes, and when the photographic prints were laid on this outline the corners were found to coincide very accurately.

Another interesting piece of work was suddenly thrust upon me when I was called upon to enlarge a section of one of the United States Topographical maps, the enlargement to be $3.15/100$ times greater than the original to fit a certain scale map. In this I was handicapped by not having a large enough enlarging lantern to take in the full size section. A copy was made of smaller dimensions than the original, this was then placed in the enlarging lantern and enlarged to $4.82/100$ times, bringing it to the size of map required. The map was made in four sections, the negative having been divided so that one section could be enlarged at a time until all four sections were printed, the sections were then put together making the complete map, a test for accuracy was made and all points were found to coincide to a nicety.

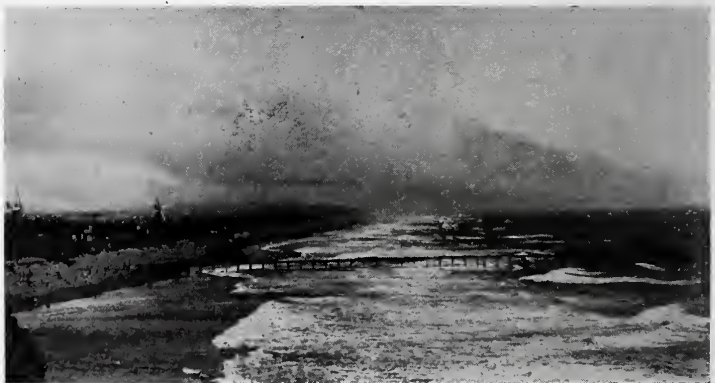

GENTLE BREAKERS.

DR. W. E. ZIEGENFUSS.



RUSSIAN IMMIGRANT.

FLOYD VAIL, F.R.P.S.



Illustrating article "Stereoscopic Photography," by Charles F. Rice.

STEREOSCOPIC PHOTOGRAPHY

By CHARLES F. RICE



HOTOGRAPHY as it is usually done, with a single-lens camera, is one-eyed photography. Stereoscopic photography is two-eyed photography. And there is a vast difference.

Did you ever watch a one-eyed man light a pipe or cigar? He can't tell except by "trial and error" whether he is holding the match in the right place or not. His single vision allows but for two dimensions—width and height—but no depth or distance. So with photography, the ordinary single-lens sort reduces everything to a single plane—the surface of the print—and the picture enables us to judge the distance of objects therein only in the most general way, by their relative size, by convergence and divergence of parallel lines, by lights and shadows, and by what is called aerial perspective.

Now stereoscopic methods supply photographs with the third dimension, depth or distance. The two-lens camera sees things as our two eyes do, and the finished stereograph viewed through a stereoscope shows the scene as our eyes would see it—every object at its proper distance and standing out with a roundness that is so realistic as to be positively startling when seen for the first time. The appearance is not that of a picture on a plane surface, but is as if we were actually looking at the scene itself, except for color. The



CATHEDRAL ARCHES.

RICHARD M. COIT.

Autochrome supplies color, so that the stereoscopic Autochrome is the nearest counterfeit to nature that we can get by photography and is as much more perfect than the single black and white print as—well, there is no comparison at all.

Most people, and this includes many photographers, do not understand the stereoscopic principle. It depends on the fact that the left eye does not see exactly the same view that the right eye does, because the eyes are about two and a half inches apart and to that extent each has a different viewpoint from the other. This makes a considerable difference with objects that are close at hand, and less and less difference as the distance increases. Sight along the edge of a foot-rule as you would along a gun-barrel—right eye open, left eye closed. Now, without changing the position of the rule, close the right eye and open the left. See the difference? On the other hand, if you're looking at a church steeple a mile away, it looks just the same to one eye as it does to the other.

Say you're walking along the sidewalk and approach the corner of a building. If the building is on the right, you can see farther round the corner with the left eye than with the right. If the building is on the left—vice versa. It is this "seeing round the corners" that makes the objects in stereoscopic photographs stand out with such great roundness and relief.

I'm sure you have all made outdoor portraits where the finished print showed a tree growing right out of the victim's head! This would be quite impossible in the stereoscopic photograph. The tree might be in line with the subject's head in one photograph, but not in the other; and in the combined view as seen through the stereoscope the tree would stand back where it belongs, without in the least interfering with any nearby object.

My brother photographers of the one-eyed camera must realize that if what I have said so far is true, stereoscopic photography is not so bound down by limitations in choice of subject as is one-eyed photography. That is actually the case. Almost every scene or subject that looks good to your two eyes will make an attractive stereoscopic photograph. And you all know how far from being so that is in the case of the single-lens camera.



CHP
1920

ROADSIDE HOME.

Chas. H. Partington.

I have in mind to illustrate this point a woodland view I ran across the other day. Grass in the foreground, beyond that and down a steep bank a brook, the farther shore some forty feet distant, overhanging branches, brook disappearing in trees and bushes in the distance, sun peeping through in spots. Looked very, very pretty to the eye—no, I should say *two* eyes. To one eye, or in a single photograph, the view was a meaningless jumble of grass, trees, reflections, etc. But in the stereo, what a difference! Everything appeared at its proper distance. You could see that the water just beyond the grass was really six or eight feet lower. You could see right through the overhanging branches. The brook wound back until lost to sight among the receding trees. And you've no idea how wet the water looked!

Stereoscopic photography used to be popular in this country, immensely so. Every family had a stereoscope and collection of views on the parlor table. A veteran professional photographer was telling me only the other day what a big and profitable branch of his practice stereo work used to be. Why it went out of vogue, I don't know; but it did, and it is only comparatively recently that some attempt has been made to revive stereoscopic photography in this country. I say in this country, for apparently in Europe the practice has kept right on and has been improved and perfected, so that now there are many models of English, French and German stereo apparatus, some of them very efficient indeed. Compared with these there are only three or four stereoscopic cameras now made by American manufacturers. These are efficient cameras, too, without a doubt; but are of different size and style from the European models and therefore not altogether comparable with them.

The old parlor table stereoscope accommodated a double photograph that just about covered a mount $3\frac{1}{2} \times 7$ inches. That is, the individual print was $3\frac{1}{2}$ inches square, and this is still the standard stereo size in this country. In continental Europe, however, smaller sizes are customary— 45×107 millimetres, or approximately $1\frac{3}{4} \times 4\frac{1}{4}$ inches; and 6×13 centimetres, or approximately $2\frac{1}{2} \times 5\frac{1}{4}$ inches. Both of these sizes are standard, over there, with the 45×107 millimetres in the lead.

Two and a half inches, or a little more, it varies somewhat, is the measurement between the pupils of a normal person's two eyes. It follows that for easy viewing of photographs in the stereoscope there should be just about $2\frac{1}{2}$ inches separation between the corresponding edges of the twin prints—that is between the left edge of the left print and the left edge of the right print, and between the right edge of the right print and the right edge of the left print; or between the two images of the same point in the view as presented in the two prints. This separation is of course impossible with prints which individually exceed $2\frac{1}{2}$ inches in width. The European apparatus conforms to the rule, the American does not.

A very great advantage of the smaller sizes of stereo cameras is that they employ short focus lenses. The advantage is in the great depth of focus (or field) possessed by the short focus lens. The fabled "universal focus" is desirable in stereo photography—that is, one would like everything in front of the lens, both near and far, to be in needle-sharp focus at the same time—and the shorter focus your lens is the nearer you come to accomplishing this impossible requirement.

Lenses of the viewing apparatus (stereoscope) should be of approximately the same focal length as the lenses in the camera. Thus, the old-fashioned American stereoscope made for the $3\frac{1}{2} \times 7$ size, is not most suitable for the little 45×107 millimetres views which are taken with lenses of about $2\frac{1}{2}$ inches focal length.

Paper prints are the commonest form of stereoscopic photographs. Glossy paper is preferable because it shows fine detail the best. Transparencies on glass (similar to lantern-slides) are more effective than paper prints—they will show even finer detail, and because the light shines through them instead of merely on the surface, there is a sparkle and brilliancy impossible to attain in a paper print. Autochromes, which are glass transparencies in natural colors, are the most effective of all stereographs, and a well-done stereoscopic Autochrome viewed through the proper sort of stereoscope is almost as good as looking at the scene itself; even better, perhaps, in a sense, because you can study every detail at



G. P. KIMBERLY.

OLD LETTERS.

leisure of what in the actual scene was but a fleeting impression.

Certain rules have to be observed in stereoscopic photography. The camera has to be level, from left to right. It may be pointed up or down a little, at the risk of distorting vertical lines, without harming the stereoscopic effect. But the top of the camera must not incline to left or right. If it does, the resulting stereograph will be an "eye-twister." It will hurt your eyes trying to look at it through the stereoscope. Paper prints may be trimmed to make the crooked straight, but correction is possible only to a very limited degree in the case of transparencies on glass.

As you look at a stereoscopic negative so that the picture is right side up—and right is right, and left is left—the individual negative at the left is that which was exposed through the right-hand lens of the camera, and vice versa. Therefore, if a print is made from the entire negative, with a single exposure, the print will have to be cut in two and its halves transposed, left for right. Or the same course may be followed as in making glass transparencies—the left-hand negative is printed on the right-hand end of the transparency plate, then the negative and positive plates are shifted for the second exposure which prints the right-hand negative on the left end of the transparency. A special form of printing frame may be bought which facilitates printing in this manner. The stereoscopic Autochrome has to be cut apart and its halves transposed and bound up with a cover-glass.

No other special precaution nor procedure is necessary in stereoscopic photography. There is no obstacle (except perhaps cost of apparatus) which need deter any earnest amateur from attempting this most fascinating branch of photography. Because the stereo camera is practically two cameras in one, with twin lenses and shutters, it is about twice as expensive as a single camera of similar optical equipment. That, of course, is natural and unavoidable. I don't know of any really first class stereo camera that sells for less than \$50, and they range from that to \$200 or more. But the results are worth it.



THE WILD FLOWER.

LEONID FINK

BROMOIL RESULTS

By CHAS. H. PARTINGTON



THE increase of interest in pictorial photography in the United States was well manifested in the past year at various exhibitions, and shows great promise for this branch of art in the future. Pictorial work with the camera offers a wide range of subjects whose beauty of light, shade and general effect is increased to a great extent by the proper print medium. Wonderful results are obtained in many cases by straight printing or enlarging, but there are times when some control is not only desirable but imperative. Many things can be done to the negative to bring the desired results by resorting to controlled development, intensification, reduction, retouching, pencil work on tissue paper, etc. All have their advantages, but in most instances are uncertain or troublesome, and this fact leads us to search for a different method.

Having run the gauntlet of photography for more than twenty years and consequently passing through many stages of its development, the writer, after considering the matter for some time, decided to give "Bromoil" a trial. Text books and magazine articles on the subject were read and re-read and included writings by experienced and well-known workers. The variations in procedure of different authorities, especially where one condemned what the other recommended, was surprising, and the only thing to do was get busy to decide the how and why for one's self. The results of numerous experiments are given in the following paragraphs, and while details may seem many, as well as the process somewhat complicated, the reader is earnestly requested to give this printing medium a trial. After a few prints are made the simplicity of the work will assert itself, and the beauty of the finished picture will be well worth the effort.

The Negative.

Stress has been laid upon the kind of negative required, but the writer finds that any that will make a respectable



NEAR THE SUMMIT OF MT. BLANC.

LOUIS J. STEELE.

print by contact or enlargement will be satisfactory for Bromoil. In cases where the negative is extremely thin with no deep shadows or heavy high-lights and which produces a print gray in tone, it will be difficult to produce a Bromoil. Extreme care and patience will produce a successful result, but a beginner is not urged to try such a print until experienced to some extent.

The Paper.

The general opinion regarding this material is that all grades or makes with the exception of Platino-Matt can be made to give good results, but even this surface will be found suitable by proper handling. Heavy, double weight stock is recommended, due to the fact that it will retain the most moisture. Thin papers are very liable to dry out before inking is completed, resulting in uneven, patchy work. Of all the grades or makes tried, my own choice is P. M. C. No. 8. This is a heavy weight buff stock with a surface and thickness of gelatine very much suited for inking.

Papers such as Royal Bromide produce a very pleasing result, as the surface is entirely different from the P. M. C. The coating, however, does not seem to stand the brush treatment as well and unless care is used the gelatine is easily broken.

Portrait Bromide is a tough surface paper and is inclined to ink with a flat, dead result. The print, if made to prevent this effect and inked with a hard medium, will resemble gum work.

The Enlargement.

The enlargement is made the same as though no Bromoil was to be considered. The depth of tone and gradations should be the same as for regular work. If no attempt at control is made when inking the print, all the original quality can be held. With straight inking all gradations will appear, provided no part of the previous procedure was neglected.

Development.

After exposure the print should be developed in either Metol-Hydrochinon or Amidol made up to the formula provided by the manufacturers. Amidol is preferred, as it contains no carbonate of soda which, in some cases may



WORK, WORK, WORK, BUT HAPPY.

IRVING BERKEY.

weaken the gelatine and prove troublesome in warm weather. Amidol produces a blue-black image and seems to develop to a better depth which consequently gives an excellent relief for inking.

Development should not be forced nor checked, but the exposure should be such as to produce a full scale of gradations and stop. Checking development due to over-exposure may be suitable for an ordinary enlargement, but for Bromoil the silver must be completely reduced without fogging the highlights.

Fixing After Development.

For this part of the work there are different ideas and it is evident that some are without foundation. One article stated that it makes no difference whether a plain or acid bath is used, another simply mentions a fixing bath with no reference regarding its composition, while a third statement was decisive that an acid bath could not be tolerated.

Not wishing to get poor results the writer used a plain bath and on account of not rinsing thoroughly after development, the hypo-solution soon discolored and the prints were stained. Since then the fixing bath contains an acid hardener, besides the fact that the prints are put through an acid bath to check the action of the developer completely. The strength of the hypo is one to four and the acid hardener one to sixteen. The complete bath is exactly the same as recommended by manufacturers of developing papers. The acid checking bath is $1\frac{1}{2}$ oz. to 32.

The Bleacher.

Many bleaching bath formulæ are in existence, and it is doubtful in the writer's mind if they produce any different results. It is advisable to use a bath of good strength, as final results depend upon complete action. A satisfactory formula is given which produces first class results. Prints will bleach in 45 to 60 seconds, and should be allowed to remain for at least five minutes to make the action certain. This solution can be used repeatedly until exhausted, which is noticeable as its action gets slower. Sediment will form and this should be filtered out as it very often leaves marks on the print. These marks are easily removed by absorbent



FAMILY GROUP.

LOUIS FLECKENSTEIN.

cotton under water, but it is best not to touch the gelatine surface in any manner.

The Acid Bath.

The use of the acid bath has been discarded by the introduction of a special bleacher originated in England. As it is not always convenient to get the imported article, besides it being much more expensive than the making of your own solution, it is better to use the acid.

This bath removes all color of the bleacher stain and tends to make the gelatine absorbent, which is quite an advantage in inking. Sulphuric Acid (C. P.) is used, and while it is very strong it can be handled with sufficient care to prevent trouble. If gotten on the clothes it leaves a red mark that is impossible to remove and in contact with the skin burns quickly. In mixing with water always add the acid slowly with constant stirring. *Never add water to acid* as an explosion will result, due to instant generation of steam, and acid will be scattered broadcast.

Final Fixing Bath.

This bath is also mentioned in other cases as being plain, acid, etc. An acid hardener bath at this stage has a tendency to toughen the gelatine and is not recommended. The addition of sulphite of soda only produces the best results. This fixing bath is weak and need be no stronger than one to ten.

Washing.

Washing after first development and fixing should be thorough, and the same applies after bleaching and fixing. Prints handled over in twelve changes of water is a more certain process than running water.

Drying.

For Bromoil work it is very important that prints dry evenly, or white blotches will appear when ink is applied. To lay the paper flat at any stage of drying is sure to leave shallow pools of water which will take longer to evaporate than the balance of the surface, and in most cases a circle of white will be the result. Patches that refuse the ink are also caused by not keeping the paper moving and completely submerged at all times no matter whether in plain water or chemical



Figure 1.

Illustrating article "Bromoil Results," by Chas. H. Partington.

solutions. Papers that float, such as Royal Bromide, must be watched at all times to prevent this trouble.

At any stage of drying the paper should be drained, placed face up on clean blotters and surface dried by dabbing with a clean cloth. For this purpose a handkerchief that has been washed several times serves very well. Dab off the surplus water lightly as too rough a treatment may damage the surface.

Condensed Operations and Formulæ.

The enlargement is exposed the same as if Bromoil was not considered and developed in the following:

Water	12 oz
Sodium Sulphite (anhydrous).....	180 grains
Amidol	35 grains
Potassium Bromide (saturated).....	5 drops

After development pass print through an acid short stop as follows:

Water	32 oz
Acetic Acid (28%)	1½ oz

Rinse in clean water and fix for ten minutes in

Water	16 oz
Hyposulphite of Soda	4 oz
Acid Hardener	1 oz

For convenience the acid hardening solution is given herewith:

Water	5 oz
Sodium sulphite (anhydrous)	1 oz
Acetic acid (28%)	3 oz
Common alum	2 oz

After the prints are washed they can be dried and bleached later, or put at once into the following solution which acts quickly:

Water	30 oz
Copper sulphate (blue vitriol).....	600 grains
Potassium bromide	300 grains
Potassium bichromate	30 grains

Bleaching action should be continued at least five times as long as it takes to eliminate the deepest shadows. The bath costs very little and can be used until the action gets too slow.



Figure 2.

Illustrating article "Bromoil Results," by Chas. H. Partington.

After bleaching is completed rinse in running water, and place for five minutes in the following acid bath:

Water 20 oz

Sulphuric Acid (C. P.)..... 1 oz

After another brief rinsing fix for ten minutes in

Water 20 oz

Sodium sulphite (anhydrous) 1 oz

Hyposulphite of soda 2 oz

After a thorough washing, the prints can be dried for future inking or inked at once. The question of drying after first fixing as well as the fixing after the bleacher is used, is given great concern in some articles. One statement applies that seventy-five per cent of Bromoil failures are due to not drying the print between operations. This has been proven to have no foundation, as the writer has produced the same results in inking, whether dried at different stages or not. The advantage of not drying is that no prolonged soaking in water is necessary to raise the relief.

After the bleaching, fixing and washing is completed the print can be inked at once, provided the relief is sufficient and this can easily be determined by draining and examining. The proper effect is easily noticeable as the highlights are raised and the shadows sunk. If the relief is not sufficient, a ten minute soaking in water of 115° F. will produce the desired result. Warmer water is not necessary, and an excessive temperature may make the gelatine too weak for brush action. The temperature given is almost necessary if print has been dried after bleaching unless the worker has several hours to waste soaking the print in water from 70° to 80°. Some articles denounce high temperatures, but the writer finds them an advantage.

The Inking Pad.

A stout sheet of glass somewhat larger than the print should be provided as well as four to six sheets of clean, lintless blotter. The latter should be soaked in water and laid one on the other upon the glass and the surplus water removed by light action of a squeegee roller.

The Ink.

The ink used is such as made for lithograph work and is in most cases imported from England. It is manufactured



"FAST FALLS THE EVEN-TIDE." Lawrence C. Randall.

expressly for Bromoil work, and can be procured in both hard and soft grades, and in various colors. The unsettled conditions, due to the war have made it difficult to obtain ink, and the writer decided to take up the matter with manufacturers in the United States.

Details of the process and samples of foreign inks were submitted to The Ault & Wiborg Co., of Cincinnati and they proceeded to make an ink which worked very well. The efforts of this firm demand appreciation, and their very obliging manner and willingness to help proved an advantage. Special colors are made to order even in small tins of two ounces, and the cost is far below the foreign product. Stiff or soft inks are made as requested, and a color or density once established can be duplicated any time. Any one taking up this work, or having had experience, will do well to get in touch with this manufacturer for any particular ink desired.

Inking the Print.

The print is drained and laid upon the wet pad and surface dried by dabbing lightly with a clean soft cloth or handkerchief. When this is done the relief should stand out boldly and if not very much in evidence, the print should be soaked again.

The ink should be applied to a clean plate of glass of ample size (about 8 x 10"). A lump as large as a pea is sufficient for several 10 x 12" prints and should be spread in a thin layer by means of a palette knife. The amount of ink mentioned should be spread over an area of about 2 x 7" and the balance of the glass used for dabbing off the excess on the brush.

The brushes used should be of the stag-foot shape so as to permit presenting a full surface to the print when held at an angle. Straight face brushes will do as well, but as they must be held vertical they tend to hinder inspection of the work as it progresses. The manipulation of this form of brush is also tiresome, and therefore it is better to use the slant type made especially for the purpose.

These tools are specified by numbers and a No. 10 is about 7/8" in diameter. The greater the number, the larger the diameter and for prints about 10 x 12" the worker should pro-

vide one of each No. 5, No. 7, No. 10 and No. 14. The necessity of having about ten or twelve brushes, whether of the same size or not, is generally recommended in order that dry ones may always be on hand for "hopping" or removing surplus ink. Two or three extra brushes in addition to the inking one are sufficient, as they can be cleared of ink by rubbing on clean paper when necessary.

To properly ink the print it is imperative that the brush be very lightly charged on the tips of the hairs only. Excess ink may be removed by dabbing on a clean section of the glass leaving just enough on the brush to show on the skin when drawn across the hand. Remember that you are inking a paper print and not painting a house. It is far better to apply too little ink than too much, and there is no excuse for applying color merely for the fun of removing it again.

To apply the ink after brush is charged, hold it at the extreme tip with the thumb, first and second fingers. This gives a springy and soft action and with strokes about five or six per second the ink should take readily. Dab straight toward the print surface and don't drag, as in painting or the color will not be forced into the gelatine. This dragging action may also break the coating and ruin the print. It is preferable to start inking in the upper left-hand corner and work diagonally until ending in the lower right, but no definite rule need be followed. Any procedure that will ink the print evenly is satisfactory. The brush should be freshly charged repeatedly by dabbing on the glass, as the main thing is to apply the ink lightly but in the same density.

Much has been put in print regarding the application of ink to the print, and a great deal could be added in this article, but owing to the fact that the writer found this operation of Bromoil to vary with instructions, it may be best for the readers of the *Annual* to determine their own method. A few notes on results obtained and reference to Figure 1 (Page 53) will give a few ideas of what brushwork will accomplish.

The section denoted by "A" has been pigmented with a heavily charged brush and no attempt made to change the result. This blocks the shadows and increases the glare of the highlights, thereby giving a soot and whitewash effect of extreme contrast. A better result would have been

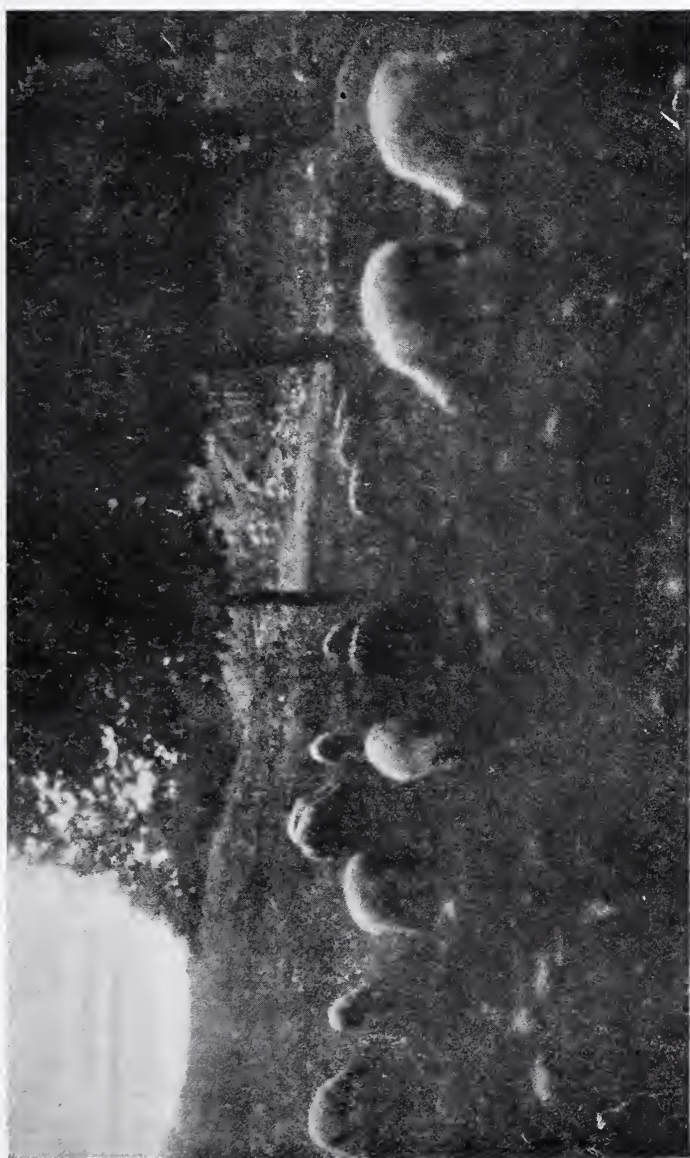

EVEN-TIDE.

EUGENE P. HENRY.

obtained by using less ink and a quicker action of the brush.

At "C" the result of a brush not having enough ink is illustrated. This gives not only a soft effect, but very flat as well. There is no snap or life as at "B".

Applying ink as heavily as at "A" was done at "D" also and "hopping" resorted to. This is done with a dry brush held about one inch above the print, then dropped and allowed to rebound when it is caught and dropped again. This action can be very quick and soon removes the excess ink from the surface. A more convenient method is to attach a stiff steel wire to the brush about ten inches long and at right angles to the handle which affords a means of quick tapping of the brush. Hopping will produce a grain effect and contrast, but if the action is too severe the gelatine surface will be ruined. The trees at section "E" were hopped in order to lighten the tones and produce the effect of distance. The sky has not been inked at all except for the slight overlap at the roof of the cabin.

The portion at "F" shows the surface as it appears when first inked and a partly blank surface not touched at all. This part was included in the illustration merely to show the smudgy effect when ink is first applied. At "G" the print has been inked with a properly charged brush and slightly hopped to clear away the flat appearance.

Figure 2 is the completed picture inked to suit the ideas of the maker. Such things as softer ink, a heavily charged brush, no hopping, etc., would give entirely different results, and therefore the effect of the final print is all in the hands of the worker. A comparison of this illustration with the first one should give an idea of what can be accomplished. Figure 3 is an example of Bromoil for sunlight and shadow effects and this medium produces a result that is many times more effective than a straight bromide. The real beauty of a Bromoil print is the inked surface and texture. Half tone illustrations are not able to show this process to advantage and therefore those who have never seen a print of this kind have missed much. The process is not in the least expensive and is well worth a trial. A few disappointments may be encountered at the beginning, but a reasonable amount of care and patience will soon bring success.



Figure 3.

Illustrating article "Bromoil Results," by Chas. H. Partington.

KALLITYPE

By JAMES THOMSON

N years past my methods of working with my own formulae have been fully described in the photographic magazines and recorded in the British Journal of Photography Almanac, "Epitome of Progress." Inasmuch as I have done no experimenting along kallitype lines for the last few years I have really nothing new to offer.

To offset this it has been urged by Mr. Sigismund Blumann (who not long ago sent me some really beautiful kallitype examples done on thin paper) that there are new workers in the field to whom kallitype as a mode of pictorial expression is not known.

To do full justice to such a subject requires more space than I at present have at my disposal. In the "Formulary" at the back part of the present volume (Page 279) my kallitype formula for black and white effects may be found, and is as follows: Distilled water, 1 ounce; citrate of iron and ammonia (brown), 25 grains; ferric oxalate (Merck's or Malinckrodt's), 15 grains; chloride of copper, 8 grains; oxalate of potassium, 33 grains; nitrate of silver, 15 grains; oxalic acid, 15 grains; gum arabic, 10 grains; 5% bichromate of potassium solution to suit (4 to 10 drops). There are a half dozen variations of this formula (to suit special needs), but by modifying, it may be made to answer for any quality of negative, dense or otherwise. For example: All that is necessary when too vigorous is to dilute with distilled water. On the other hand, contrast may be had by adding more bichromate solution, by using a stronger developer, or by using a few additional grains of the iron.

When from undiscoverable cause the formula refused to produce prints up to the mark I have saved the day by adding to the sensitizer some 10 drops of platinum solution. The success of this experiment started a new line of thought, the result being a new and less complicated formula, which, in

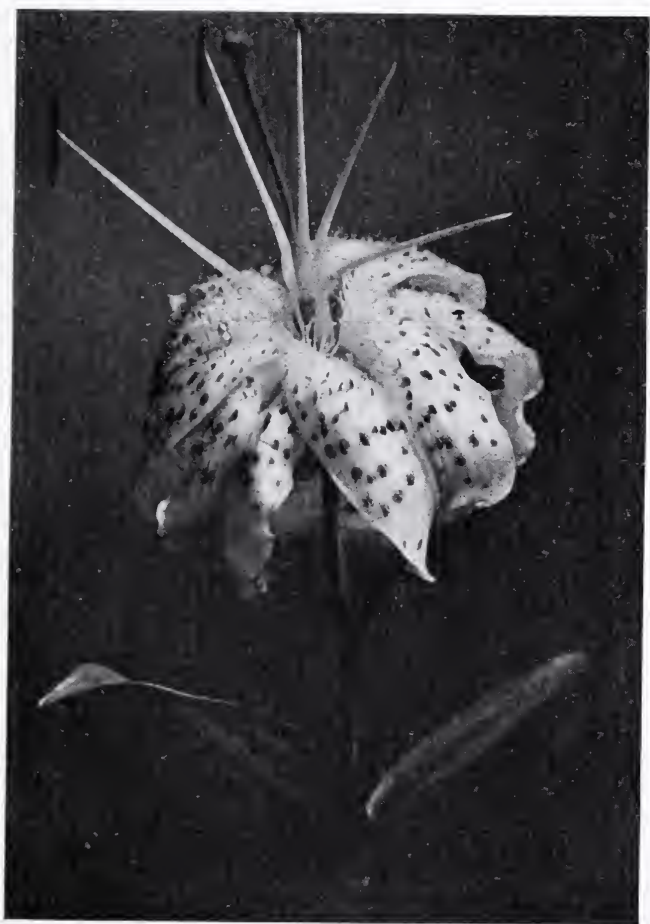

Illustrating article "Kallitype," by James Thomson.

the hands of the novice, is less likely to give trouble. As a matter of fact, I personally for years have used no other. The formula is as follows: Distilled water, 1 ounce; citrate of iron and ammonia (green scales), 20 grains; ferric oxalate, 20 grains; oxalate of potassium, 18 grains; gum arabic, 10 grains; platinum solution 10 drops; bichromate solution from 4 to 10 drops. This forms a clear solution that ordinarily requires no filtering. Put aside for twenty-four hours before using, then shake thoroughly.

When ferric oxalate is in prime order excellent blacks are obtainable, but in any event good browns are possible. Browns of purple cast are resultant of a preponderance of ammonia iron citrate over the ferric oxalate.

As regards the No. 1 formula care must be exercised in compounding. Place the ounce of water in a dark bottle and add the chemicals in the order given. Turn bottle upside down once or twice and put away for twenty-four hours to soak. Now, shake well and filter by placing a wad of absorbent cotton in a glass funnel and pouring over it the solution sediment and all. This done, take the wad, fold it and squeeze back all liquid, rejecting only the gritty particles. This sensitizing medium is of the nature of an emulsion, it being necessary to retain the brown sediment in order to get full printing capacity, the gritty particles alone being rejected.

Coating may be done with a flat camel-hair rubber-bound brush, or a flexible pad made of sheet celluloid folded once and covered with cotton flannel as described in Photo Miniature No. 47. A thin even coating repeated if necessary is essential. Rough paper may require but a single coat, but smooth may require two. Experience can alone determine that phase of the matter.

In order to get velvety depth and richness of deposit a good surface of sizing is necessary. Strathmore water color paper which I use for particular work requires thus to be sized. With ledger papers one may do without sizing, but richer prints will follow the application of arrowroot. For small dimensions writing papers can be employed, Japanese tissue and wedding card bristol are others that are useful. Some most artistic effects have been had with cream-laid Old Hampshire linen paper. Some very unusual effects have been



THE LOVE STORY.

Kate Smith.

had by using tinted writing papers, buff, pink, pale green, pale blue and the like. As a matter of fact good results have been had on the commonest of paper stock, even on cover paper, but of course for lasting effects only pure linen papers should be used.

Underprint—say there is a face in the composition—then only the more prominent features should show, detail of skin, eyes, mouth and the like not appearing at all. Take from the frame and immerse in the developer which is prepared as follows: Distilled water, 1 ounce; silver nitrate, 40 grains; citric acid (crystallized), 10 grains; oxalic acid, 10 grains. When thoroughly dissolved filter through fine linen or muslin. *To develop use a porcelain tray.*

This is a stock solution, and to each dram used take and dilute with seven drams of water. Immerse the print face down, immediately turning over to break bubbles. The image quickly flashes up, but print may remain in bath a trifle longer, development completed, rinse and immerse in weak hypo for five minutes: Water 32 ounces; hypo 50 grains. Wash for half an hour.

Impure whites will follow where fixation has been insufficient.

For a size we may employ arrow-root, 2 to 5 grains to the ounce of water. Beat up in a little cold water; add the remainder of the water hot and bring to a boil when it will lose its cloudy appearance. A porcelain-lined vessel should be used, and the size strained through cheesecloth.

Small sheets may be sized by immersion, afterwards suspending by a corner to dry.

The platinum solution may be prepared as follows: Take 15 grains chloro-platinite of potassium and dissolve in 1 ounce of water. Add 2 drams 50% phosphoric acid and water to make 2 fluid ounces. Distilled water should be used.

When a kallitype or platinum printing formula fails to give satisfactory results the fault is usually in the ferric oxalate, which is a chemical prone to spoil on the shelves of the dealer, and sold in such condition. In prime order ferric oxalate comes in glistening greenish-brown scales which rattle when the bottle is shaken. When powdery and matted together there has been a change from the *ferric* to the *ferrous* condi-

tion, which renders it worthless for our purpose. To test any doubtful solution add ferricyanide of potassium, when if any ferrous salt be present it will strike a blue precipitate, but if ferrous salt be only slightly present the ferrocyanide of potassium (red prussiate) will restore it again. My own plan is to pour out a little of the solution on a white plate, and add a few drops of red prussiate solution, when, if suitable to use, the color is green, whereas, when totally spoiled it is blue, the Turnbull's blue of the blue-print.

Buy ferric oxalate in ounce bottles and keep such bottles in an air-tight preserving jar.

Slightly over-printed pictures can be reserved for toning with uranium which has a reducing effect and furnishes colors all the way from rich brown to red chalk.

While kallitype cannot compare with platinotype in lasting qualities, it is the equal in appearance to that beautiful process the basis of each being the iron salts.

It has been unfortunately true that kallitype prints, made in accordance with the original formula of the inventor, have had poor lasting qualities due no doubt to the imperfection of the mode of fixation. Not a print made by me with the original formula but what in the course of a few years gave indication of deterioration. On the other hand, prints made by the "Thomson" formula as much as a dozen years ago, have, so far as the eye can detect, faded not at all. One hung in strong light for that length of time is seemingly as brilliant as when made.



Illustrating article "Kallitype," by James Thomson.

CAMERA CLUBS AND PICTORIAL PHOTOGRAPHERS

By LOUIS F. BUCHER



One will dispute the fact that America is well equipped with pictorial photographers. On the other hand, it may surprise you to read that the U. S. A. is woefully lacking in the very means of producing excellent camera workers; I mean that of Camera Clubs or Photographic Societies. It is true that we have a splendid organization, composed of many of the country's best workers. It is a sort of Alumni of the photographic field, an association the greater part of whose members are finished workers. It is also true that there are about forty other organizations many of which are struggling along in an attempt to "promote and cultivate the art and science of photography". Among these forty or so organizations are several that are doing much to accomplish their purpose. The membership of these societies ranges from fifteen members to as high as five hundred. A small club membership is sometimes due to so-called exclusiveness and sometimes to the inability to interest others. But progressiveness is the dominant factor in enrolling large numbers.

From these facts one can readily see that our country is far behind in the matter of photographic societies. This is the more apparent to anyone who has become familiar with the activities of our English cousins who can proudly boast of a society in every town of any size. And you must remember that the area and population of the British Isles are small compared to those of the United States.

While I have no accurate knowledge in proof of my statement, I venture to say that only a small percentage of the pictorial workers of America are members of any local camera organization. By "pictorial workers" I mean those whose names are usually seen in the Salon catalogs. Now the question why? From my own experience, I believe that the entire fault does not lie with the pictorial worker. Some



THERE'S ONE.

LOUIS F. BUCHER.

of the clubs are to blame in that they have discouraged the advanced worker from joining their forces by being too ready to classify him as "professional", or, as is often the case, because of just plain jealousy. It is logical to assume that the majority of workers in any Camera Club consists of those who give little thought to the really serious side of photography, and the majority can be the means of making or breaking the club by its condemnation of camera work that "is way above their heads". They cannot appreciate it. But that does not mean that it is not good work, nor that it should be called or classified as professional. In fact, I am firmly of the belief that professionals, in the true sense of the word, should be encouraged to join forces with the amateur. Of course such workers would not care to, and should not be expected to compete in club competitions with the amateurs, at least not with the beginners, for that would discourage the latter. It is my opinion that Camera Clubs will find professional photographers willing and eager to lend a hand in the advancement of photography, for they realize that the future professional will be a graduate from the school of amateur experience.

Another fault to be found with the organization of Camera Clubs generally is the lack of the sense of personal responsibility. Executives are oftentimes chosen because they are "good fellows", rather than because of ability to direct the club and to plan properly for its management. That holds good also of committee chairmen. It is considered to be an *honor*, and that is why many accept, giving little thought to the duties and responsibilities of the position. If you ever have had any correspondence with them, you know what I mean. Now why should that condition exist in these enlightened days. A voice from the dark says that it is because they all work without pay and do not have to work if they do not want to. True! But if that spirit actuates them they should relinquish the job and let some one else take it, for surely there is some person in the organization who would make good. The officials of fraternal organizations, with few exceptions, are not paid. You will find officers and committeemen in such orders taking great pride in the growth of their society. Now let's bring such a condition



SAN DIEGO EXPOSITION, SAN DIEGO, CAL. CARL H. KATTELMANN.

to pass in the photographic world. When the day comes that Camera Clubs and Photographic Societies are conducted and managed on a businesslike basis, with a thought for all and malice toward none, the pictorial photographers will be *seeking* membership; eager to help in promoting and cultivating the art and science of photography. And it should be so to-day. The Camera Club should not be too big for the pictorial photographer, nor the pictorial photographer too big for the club. Harmony should reign; with the club seeking the aid of the advanced worker and the latter in turn, offering his assistance to the local club. If the community is so unfortunate as not to have an organization, the pictorial workers should see that one is immediately founded.

Let you and me dream for a moment. In our dream we see a photographic organization in every town of any size in the U. S. A. John Paul Edwards is the president of one in Sacramento; O. C. Reiter heads one in Pittsburgh; the destinies of the Buffalo organization are in the hands of W. H. Porterfield; A. F. Kales has charge of that in Glendale, Calif., while T. O. Sheckell officiates at Salt Lake City. At Cincinnati, Seattle, Chattanooga, New Orleans, Dallas, Memphis, and all other big cities now without an organization, in our vision, flourishing clubs are pictured. Our dream continues and we find that they are all members of a national organization, conducting Interchanges of high-grade prints and lantern slides. Many one-man exhibits by the best workers of America are circulating among these clubs. One of the many Salons now held has been recognized as *The Annual Salon* and has the indorsement of this national organization. Other Salons are of course held. Every owner of a camera of any kind belongs to the Camera Club in his community and is endeavoring to earn the honor of being called a P. P., meaning Pictorial Photographer, of course. Affiliation with this national association carries with it that spirit of good-fellowship and cooperation which is part of every individual member and every club. The dealers, manufacturers, importers, and magazines are lending a hand. In fact, we see a national convention held for general discussion and for the election of officers. In fact, our dream pictures this convention as being held in the city in which the



Belle Johnson.

annual salon is being shown. At this convention and the salon we see the latest in photographic equipment and the best in photography.

Some dream, and yet it can be realized if the pictorial photographers everywhere and the Camera Clubs and Societies get together. In the absence of a club, let one be founded. Aye, let us do this. Let the new year see the formation of many new clubs and a great increase among photographic workers in America. To help this good work along a brochure has been published and is being distributed by the Associated Camera Clubs of America, under the title "The Camera Club, Its Organization and Management". It will be sent free upon application to the association, at 878-880 Broad Street, Newark, New Jersey. Over two hundred and fifty applications for this booklet were received within the month after its issuance. This augurs well for the realization of our dream. Let us see what we really can do when beginners, novices, amateurs, advanced amateurs, pictorial photographers and professionals get together in their own community and nationally, form a club or join that one already in existence, and work for the advancement of the art and science of pictorial photography.



PATIENCE.

EDW. L. GILROY.

PHOTOGRAPHY AS APPLIED TO RADIOGRAPHY

By S. A. SCHWARZ

O the alchemist of the sixteenth century belongs the honor of having first perceived a definite change that took place in silver chloride (AgCl) known to them as Luna Carula, upon exposure to light. They interpreted this change which was a decided darkening, as a species of transmutation of metals. It was Scheele, a Swedish chemist (in 1777), who investigated the properties of silver and proved the actual changes that took place in this chemical decomposition.

Scheele found that upon exposing silver chloride to the action of light beneath water, a substance was dissolved which upon application of silver nitrate (AgNO_3) gave once more silver chloride, in the form of a heavy black precipitate. He further proved that upon adding ammonia in some form or other, the black precipitate was changed into an insoluble residue which upon examination was found to be pure metallic silver.

Subsequent experiments by Thomas Wedgewood, Sir Humphry Davy, Dr. Wollaston, Niepce and Daguerre demonstrated the possibility of coating a highly polished surface with Nitrate of Silver and upon this surface producing an image by means of the rays of light.

The silver plate which Daguerre used as a support for the sensitive coating of his then famous Daguerrotype was soon replaced by a glass plate coated with albumen which acted as a vehicle for the silver salts. Later the albumen was replaced by a collodion emulsion which in turn was soon supplanted by a coating of gelatine. This last process is still in use at the present day.

Generally speaking the emulsion or sub-stratum is evenly spread over the plate and when it has sufficiently hardened the sensitive salts are introduced. The chemicals used in



7
FOOT OF CHILD. SPACES SHOWING AREAS NOT YET
OSSIFIED.

Illustrating article "Photography as Applied to Radiography," by S. A. Schwarz.

order to render the emulsion sensitive to the actinic rays of light are the following:

Ag NO₃ = Silver Nitrate.

KBr = Potassium Bromide.

KI = Potassium Iodide.

In the making of the plate the following reaction takes place



and



Upon exposure to light the plate undergoes certain chemical changes which are invisible and remain so until the plate is developed, that is to say the latent image is brought to the surface.

The first plate (glass) which had an emulsion on it, was the wet plate, and was first used practically by Schoenbein, a Swiss chemist. The vehicle employed for the purpose of carrying the sensitive coating was ordinary cotton dissolved in nitric and sulphuric acids better known as collodion. This plate after having been coated with collodion was immersed in a silver bath and both exposure and development were carried on while the plate was still wet.

Various experiments lead Schoenbein to the conclusion that the developing agent which best reduced the haloid acted upon by light to metallic silver was a ferrous sulphate solution (Fe SO₄). After development the plate was immersed in a strong solution of potassium cyanide, which dissolved all the free silver not acted upon by the light. Owing to its highly poisonous quality potassium cyanide was soon replaced by sodium thiosulphate commonly known as hypo which produced the same chemical action as potassium cyanide.

The chemical reaction which takes place in the process of development may be expressed as follows:

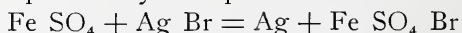

this reaction depositing pure metallic silver Ag upon the surface of the plate.

In the process of fixation using hypo as the chemical medium the following reaction takes place:—

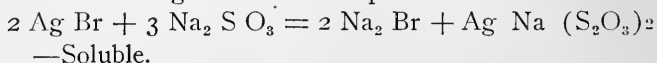

A practical test of the chemical reaction as well as the



FRACTURE OF FIBULA SHOWING DISPLACEMENT AND
OVER-RIDING OF FRAGMENTS.

Radiograph Taken Through Cast.

Illustrating article "Photography as Applied to Radiography," by S. A. Schwarz.

reduction to metallic silver may readily be performed as follows:

Take 25 cc of nitrate of silver in solution. To this add an equal amount of water. In a separate container dissolve a few grains of Metol, Pyro or any of the commonly employed developing agents. Upon mixing the two liquids a heavy black precipitate is formed which is pure metallic silver.

A simple chemical experiment which readily illustrates the reducing power of Hypo may be performed as follows:

To a solution of 50 cc of nitrate of silver add 25 cc of a saturated solution of sodium chloride (common kitchen salt). Immediately a heavy white precipitate—silver chloride—is formed. If Hypo is added 5 cc at a time while stirring the silver chloride it will be seen that the latter gradually disappears—goes into solution.

In modern days when the keeping quality of a plate is one of its greatest assets we find that the collodion or wet plate is readily pushed aside by the dry plate, which besides having greater keeping qualities has the added features of speed and latitude.

The sensitive coating of the dry plate in accordance with Abney (Treatise on Photography) is prepared as follows:—

Pot. Iodide	0.3 gr.	in 35 cc of water
Pot. Bromide	8.7 " "	40 " " "
Nelson No. 1 Gelatine....	2.0 "	" " " "
Silver Nitrate	11.4 " "	15 " " "
Heinrich Gelatine	10.0 "	" " " "
or Nelson No. 1 Gelatine.	6.0 "	" " " "

It may be said here that the ingredients as given above are almost universally used by all plate manufacturers of today varying only the ratio of the ingredients so as to insure greater or less speed.

The plates employed in Radiography are divided into two distinct groups—single and double coated.

The single coated plate as its name implies has only one gelatine coating, which carries the sensitive salts. For general work this probably is the most popularly known and the most universally employed plate. In work where greater penetration is required, and where owing to a prolonged exposure the possibility of halation is greatly increased, the double



O. C. CONKLING.

coated plate will be found more advantageous. This plate is coated with two distinct emulsions—the first one, or the one nearest to the glass, being the absorbing emulsion. It consists of a surface which is very slow, and as its name implies its function is to absorb the light before it reaches the glass, thus preventing secondary radiation and its natural consequence halation.

This emulsion when dry in turn is coated with another thinner and faster sensitized mixture, which takes care of the weaker rays which strike the surface of the plate.

In order to facilitate the handling of the plates, and above all keep all metallic substances away from it, the plates as a rule are loaded in double envelopes. One the inner is black and the second the outer orange red. Probably the simplest, and at the same time the safest, method of handling and loading these envelopes is to place them on the table in pairs red first and black on top with the flaps of the envelopes down. The plate is now inserted into the black envelope first which in turn is then inserted into the red. Care should at all times be taken that the pasted portion of the envelope does not become superimposed upon the emulsion side of the plate. This loading of envelopes is to be carried on in a room illuminated by a ruby or safe-light. As not every ruby light may be considered safe, it will be found advisable to test the one in use before exposing any plates to its rays. A simple yet effective test is to expose say half of an ordinary plate to the light coming from the lamp. This is done while the other half of the plate is held between the leaves of a book. If upon development the plate shows no darkening in the portion which was exposed to the ruby light, the lamp may be considered safe; if on the other hand a dark area appears upon development, it will be a sure indication of the fact that the ruby lamp should by no means be regarded as a safe illuminant of the dark-room, but should be made so. The introduction of a few sheets of orange or ruby fabric will as a rule remedy this evil, and render the lamp quite safe.

As already stated the most universally adopted method of exposure for plates or films—the latter having been placed upon the market quite recently) is to have them in double envelopes of red and black light proof material. This method



THE FATE OF THE WILLOW.

STEPHEN H. WILLARD.

proved a rather serious handicap especially when exposures of exceedingly short duration were required.* Such exposures when made were as a rule hopelessly undertimed and practically rendered valueless for diagnosis. In order to overcome this decidedly serious drawback intensifying screens are employed. These screens may be composed of different chemical constituents such as zinc sulphide, calcium tungstate or platinocyanide of potash, mounted in an aluminum frame or cassette very much resembling the ordinary printing frame. The X-Ray plate after having been carefully dusted is placed in the dark-room, into this cassette, emulsion side in contact with the screen. The cassette is then closed and is ready for exposure. In order to take the radiograph the cassette containing the plate is placed in apposition to the patient in such a way that the ray will pass through the glass side of the plate to the screen, the latter becoming fluorescent intensifies the plate and permits of a much shorter exposure. As it is an exceedingly difficult matter to get the screen free of all grain, it will be found that its granular surface at times is reproduced on the plate causing the texture of the emulsion to show certain irregularities which are likely to interfere with definition.

Storing of Plates.

Owing to the intensely strong penetrating power of the X-Ray more than the usual precautions for storing of the sensitized materials are to be observed. Experience has proven that a large lead lined box is about the safest, most economic as well as convenient way. In addition to the protection against the ray care should be taken not to store the plates where they may be attacked by the fumes of such chemicals as acetic acid, ammonia, nitric or sulphuric acid, as their action upon the sensitive surface of the plate may prove quite detrimental.

Development.—Chemistry:

After the light sensitive material has been exposed to the action of the ray for a short time a chemical change takes place which remains latent until the emulsion is subjected

* Especially in stomach plates where peristaltic waves are to be considered and exposures of 1/10 of a second are required to stop motion.



NORMAL KNEE-JOINT SHOWING FOREIGN BODY IN KNEE
JOINT (TIP OF NEEDLE).

Illustrating article "Photography as Applied to Radiography," by S. A. Schwarz.

to the action of an oxidising or reducing agent more commonly known as a developer. Its action consists in removing the bromine from the sensitized surface leaving behind a deposit of black metallic silver which forms the image.

The most popular reducing agent is Metol, or any one of its substitutes taken from the Paramidophenol group, being either a sulphate or a chloride. This developer catering solely to detail does not by itself make a suitable compound, as it does not impart density to the negative. The addition of Hydrochinone will assist us greatly in overcoming this difficulty. There are very few developers which can successfully be employed without the addition of other chemicals. Developers in order to act properly must be in alkaline solution, the strength of the developer depending vastly upon the amount of alkaline present. The greater the reduction potential i. e., the more rapid the action of the developer the less alkali will be required. Hydrochinone offers a splendid example of the above instance. It is in many cases used with caustic alkalis, while other developing agents require only weaker carbonated alkali. Let us for a moment investigate more carefully the action of the alkali and what takes place if such alkali are added in the wrong ratio. The presence of too much alkali in the developer has the tendency to produce chemical fog or veil. A condition which renders the plate more or less dense in the high lights and only partially transparent in the shadows. A plate of this character is termed flat, or non-contrasty. If on the other hand too little of the alkali is present the developer will act too slowly, thus producing an unsatisfactory negative which as a rule due to prolonged development will show discoloration as well as traces of light fog.

The alkalis used in development are of two kinds: The caustic and the carbonated alkalis. The former are not used as frequently as the latter which are salts of carbonic acid (H_2CO_3) as they are not as rich in alkalis as the carbonates. Of the carbonates employed perhaps sodium carbonate is the most popular. It is marketed in two forms, either crystals or in anhydrous (dehydrated). If sodium carbonate is re-crystallized from an over saturated solution each part of

sodium carbonate will absorb in the process of re-crystallization 10 parts of water and should be expressed as follows:



It is for this reason that when sodium carbonate is employed in crystalline form to compound the developer a greater quantity of the chemical must be used. If on the other hand the soda is heated to between 85 and 98 degrees Fahrenheit so as to expel all the water, the dried crystal ground to a fine powder, we obtain the dehydrated soda, a chemical of far greater strength as well as keeping qualities.

We have found that a tray containing a developing solution after having been exposed to air will gradually turn brown and then black. This chemical change or oxidization is due to the fact that the developing agent or rather its ingredients have a great affinity for the oxygen of the air. A pure developing agent in solution, either Pyrogallic acid or Metol will within a very short time turn dark and thus be rendered entirely useless. In order to minimize this possibility another chemical substance having the same or greater affinity for oxygen is introduced. This chemical will absorb an equal amount of oxygen from the air, prolong the life of the solution and thus fulfill the duties of a preservative. To accomplish this a certain amount of sodium sulphite $\text{Na}_2 \text{SO}_3$ is added to the developer. As this chemical may also be obtained in crystalline as well as anhydrous form the same conditions are to be observed as in the case of the carbonate. It has been found advisable to introduce into all developers a small quantity of potassium bromide K Br which acts as a restraining agent, permitting the high lights to acquire density without clogging the shadows.

We have thus found the composition of a developer as follows:—

1. Metol—The developing (oxidizing) agent.
2. Sodium Sulphite—The preservative.
3. Hydrochinone—A second reducer to obtain contrast.
4. Sodium Carbonate—The alkali acts as accelerator.
5. Potassium Bromide—Restrainer.

Technique of Development :

The chief causes of failure in development are:—

1. Lack of cleanliness.

2. Unsafe light.
3. Careless manipulation.

No. 1. Taking these in order as enumerated it will be found advisable never to use a dish which has been emptied of its contents until it has been carefully washed in hot water and some abrasive soap, after which it should be rinsed in a weak solution of nitric acid.

The same trays and tanks or dishes should always be used for the same purpose, and labeled with that end in view. Keep all beakers, graduates and other accessories scrupulously clean, as the chemicals used in photography have destructive tendencies towards each other.

No. 2. A good test for the safe-light has already been given in one of the previous paragraphs (Page 80).

No. 3. A great many plates are rendered absolutely useless owing to the careless handling they receive at the hands of the operator, either before, during or after completion of development. A great deal of the discomfort and annoyance resulting from the above may be avoided if the plates or films are handled with care, being particularly careful not to touch the sensitive surface with the fingers.

Process of Development:

Development which must be carried on in the dark-room can be accomplished in two distinct ways. Either by tray or tank. Both ways are good, give splendid results, and have attained a widespread popularity. In hospitals where the departments of radiography and photographic research are two of the most important divisions the development of all plates and films coming from the X-Ray department is carried on in large tanks. Some of these tanks hold 25 gallons of solution and accommodate from 24 to 36 14 x 17 plates. In places where the quantity of the plates is large, tray development becomes practically impossible. The technique of development does not differ from ordinary development to any great extent excepting that the process is carried quite a good bit further. This is especially the case in bone lesions where a good bit of density as well as detail is wanted. After the plate is fully developed it is washed for a few minutes, and is then inserted into a bath of acid hypo. Here the unexposed silver is dissolved and the negative



IN CHILMARK.

G. W. HARTING.

rendered transparent. After fixation is completed the plates are washed for one hour in running water and then hung up to dry.

It might not be amiss to mention here a few of the most common causes of failure and perhaps suggest remedies for them.

1. Plate slow in starting—Developer too cold or plate undertimed.
2. Lack of detail in the shadows—Wrong exposure, not enough time.
3. Plate flashes up within a few minutes—Greatly overtimed.
4. Mottled plate—Developer not agitated.
5. Finger marks—Careless handling.
6. Frilling—Developer too warm, or too alkali.
7. Unevenly developed plate—Not flooded evenly at beginning.
8. Blisters—Uneven temperature of the various solutions used. Acid hypo too strongly acid.
9. Pinholes and spots—Plates not dusted before loading.
10. Round white spots—air bells—Caused by carelessly inserting plate into developer.
11. Negative yellow or otherwise discolored—Impure sodas, or old developer.
12. Dense negatives—Overtimed.

The following are the remedies suggested for the above errors:

1. Have the developer as near normal temperature as possible, that is to say 65 degrees F.
2. Increase your exposure.
3. Diminish the exposure.
4. Rock tray or employ a mechanical rocking device.
5. At no time touch the emulsion surface of the plate with hands.
6. Keep solution at the proper temperature, reduce sodium carbonate.
7. Make sure of covering the plate evenly with the developer.
8. Have solutions and wash water as nearly the same degree of heat as possible.



JUST IN FROM THE GARDEN.

Jessie Tarbox Beals.

9. Dust plates carefully before loading into envelopes and also before development.
10. Insert the plate into the developer so as to cover it completely with one sweep. Keep tray in motion.
11. Do not use a cheap grade of chemicals, and do not try to economize by using the developer too long.
12. Do not carry development too far.

The after treatment of the negatives in radiography does not differ in any way from the after treatment of negatives in ordinary photography. Intensification, reduction, enlarging as well as reducing involve the same processes, and further details pertaining to it may readily be obtained from any book on photography.

Probably the most difficult phase of radio-photography is the determination of the proper exposure. In ordinary photography we have only to consider the intensity of the light and this can readily be obtained. Knowing the speed of the lens as well as of the plate or film employed we in most cases are enabled to produce a fairly satisfactory negative. Not so in radiography. Besides knowing the intensity of the ray it is quite essential to also know its penetrating power, the distance of the tube from the plate, (this distance is measured from the target of the tube) thickness of the body to be radiographed. Thus owing to so many factors which enter the determination of the exposure its correctness is a rather difficult problem to solve. From time to time we may run across some formulæ which upon substitution of the proper factors will give a final result which in a measure would be the correct exposure. These formulæ may have some merit, but experience has taught that they are not absolutely reliable.

Before taking up one of these formulæ and discussing the same, it might not be amiss to acquaint ourselves somewhat with the various factors which enter such a formula. To begin with, the current in an X-Ray tube circuit, is measured by units called milli-ampères, which is one thousandth of an ampère, and is usually read directly from an instrument called the milli-ammeter, in series with the circuit.

The second item is the voltage, or the pressure of the current, and is measured by the distance which an electric

spark will jump to short circuit an X-Ray tube. The back-up as this distance is commonly called will approximately be 20,000 volts to jump one inch between fairly sharp points. Additional voltages are as follows:—

35,000	volts	to	jump	2	in.
45,000	“	“	“	3	“
55,000	“	“	“	4	“
65,000	“	“	“	5	“
70,000	“	“	“	6	“

As a rule there is a direct reading voltmeter in parallel with the circuit from which the direct voltage or pressure may readily be determined. Still it has been found advisable to check these readings by actually measuring the spark gap. In addition to the above factors the intensity of the X-Ray plays a very important part in the determination of the length of the exposure. It has been found that the intensity of the X-Ray varies inversely as the square of the distance from the target; thus if the tube is two feet from the plate upon doubling this distance we reduce the intensity of the ray to one quarter. Similarly if the distance is tripled the intensity will be one-ninth of the original intensity. Hence the complete exposure of a radiograph may be given in terms of inches of spark gap (back-up), milli-ampères of current, seconds of time and inches of distance. If the parts to be radiographed are of uniform size and thickness for a great length of time, the distance and spark-gap being the same, the average exposure may be expressed in terms of milli-ampère-seconds and time: E = Exposure; M. A. = Milli-Ampères; S = Seconds Time. Or

$$E = M. A. S. \text{ in seconds.}$$

It has further been found the reaction produced on a photographic plate by the X-Ray varied directly as the current and the time, i. e., an increase in either one of these factors will cause a proportionate increase in the photographic reaction. Let us for example assume that for a given negative a correct result is obtained by having the tube at a certain distance from the body, the back-up and the milli-ampères all correctly computed. The same result may be obtained by giving an exposure of half the time provided we double the milli-ampères, and so on any desired time may be obtained



STONE IN THE KIDNEY.

Illustrating article "Photography as Applied to Radiography," by S. A. Schwarz.

provided we make a proportionate increase in the milli-
amperage.

Taking a concrete example let us assume the following:
Conditions:—

Distance = 20 inches

M. A. = 20

Spark = 3 inches

Correct exposure time = 12 sec. Required: The expos-
ure time if the distance is changed to 15 inches, no other
factors being changed.

$$12 : X = 20^2 : 15^2$$

The product of the means being equal to the product of the
extremes we have:—

$$400X = 12 \times 225$$

Solving for X we have:—

$$X = 6\frac{3}{4} \text{ seconds.}$$

Problem No. 2.

What would be the correct exposure if the current were
doubled?

Taking the original example as given above we have:
Since doubling the current doubles the intensity of the ray
the time requirement for the exposure will only be one half,
in other words the correct exposure will be 6 seconds.

In conclusion it may be said that although these various
formulæ and other methods will to a certain degree help
the Roentgenologist to determine roughly the time of exposure,
yet in this field as well as any other field of photography,
the truly successful operator is he who obtains his results
from continued practice and experience.



DOROTHY.

CHAMPLAIN STUDIO.

DESENSITIZING

By HENRY F. RAESS



IN the fall of 1920 Dr. Lueppo-Cramer electrified the photographic world by announcing that he had discovered a method whereby he could develop panchromatic plates (or emulsions) by weak candle light. This appeared so revolutionary as to be almost unbelievable. The Doctor made no secret of his work, but generously published it to the world. The discovery was partly due to an accident. It appears that a dry plate manufacturer occasionally was annoyed with spots on some of his plates. The same emulsion on films caused no trouble. Microscopic examination showed that the spots consisted of a black dust particle surrounded by a light field. Moistening a spot with sulphuric acid and observing it under the microscope the black spot was seen to become ruby red. This indicated that the particle was some coloring matter (or dye stuff). But the origin of this still remained a mystery. The polishing and coating machines were examined. Changes were made in the clothing of the personnel, and even the latter were changed where they were directly connected with the coating of the plates. But still the spots persisted.

Dr. Lueppo-Cramer was responsible for their elimination, and as he said they gave him no rest in the day and no sleep at night. It was customary to pile the plates ready for coating in lots of fifty and put them into a cardboard box. After coating the upper plate always showed the spots, but not the other forty-nine. Examining the cover showed that a strip of black calico was glued to the inside and this was then covered with white paper. The plates had gradually worn away the paper in places leaving the cloth bare. Minute particles of this cloth settled on the plate and caused these spots. And this coloring matter was then the first desensitizer. The strange behavior of the dye stuff led Dr. Lueppo-Cramer to try the action of solutions of a number of dyes on plates after exposure and before and during development. He found that



LAWRENCE BAKER.

THE SUNLIT ROAD.

the sensitiveness of the emulsion to light had been very much reduced and a much brighter light could be used during development.

Phenosafranine gave the best results. One part of this red dye was dissolved in two hundred parts of ethyl alcohol and distilled water added to make solution 1 to 2000 (about four grains per pint) and 5 c.c. added to 100 c.c. of developer (about two drams in five ounces). After placing the plate in this mixture for one minute the development can be finished in bright yellow light, or even by candle light at six feet. Even panchromatic plates can be so developed. The dye being red it was thought that possibly it acted as a screen. Other dyes were tried including blue, and it was found that also some of the latter possessed this property although not so pronounced. Further investigation showed that the dyes had a chemical action on the emulsion and so caused the reduction in sensitiveness.

Instead of adding the phenosafranine to the developer it can also be used as a preliminary bath before development. The importance of this method of development will be appreciated by those who have to work with panchromatic emulsions as heretofore it was necessary to carry out all manipulations with panchromatic plates until they were fixed; in either total darkness or in a certain green light which emitted rays between about 5100 A. U. and 5400 A. U. This is in the blue-green region of the spectrum and is the so called "safe light," but it takes some time for the eye to become accustomed to it as it is very weak. But even this "safe light" will soon cause fog with some emulsion, so it must be used with care. The reason for the comparative insensitiveness of panchromatic emulsions to this region of the spectrum is that the majority of the panchromatic sensitizers in use show but little absorption for this color, and so an insufficient amount of light is transmitted to effect the emulsion.

But this was not Dr. Lueppo-Cramer's first work along these lines. He had noticed as early as 1901 that the sensitiveness of plates was greatly reduced when in certain developers, especially those belonging to the paramidophenol class. Plates could be developed in these developers in a light so bright that when hydrochinone was substituted they were hopelessly

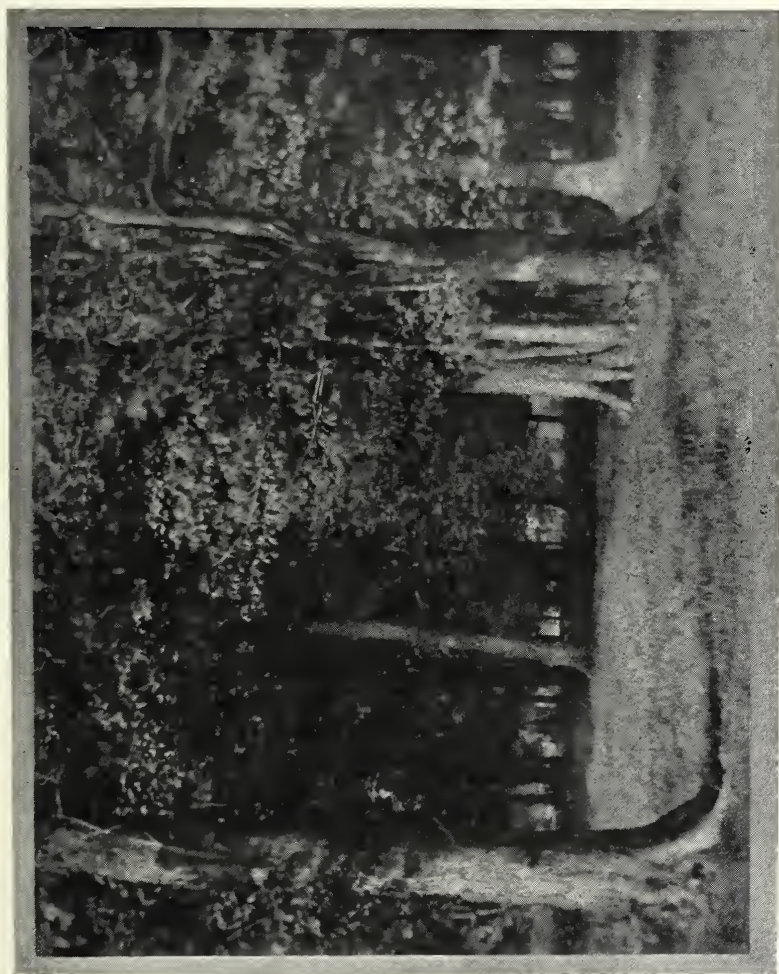

INTO THE DEEP WOOD.

W. H. Porterfield.

fogged. Later Dr. Lueppo-Cramer found that aqueous solutions of certain developing agents had a similar but far stronger action in reducing the sensitiveness. At the present time diamidophenol hydrochloride (Amidol) and triamidobenzol hydrochloride are the only substances possessing this property to a practical degree that are not dye stuffs.

The most effective was a 0.05 per cent. solution of Amidol in distilled water without any other admixture. The plate after exposure was placed in the above solution for one minute in darkness and then developed with one of the usual developers excepting glycine which caused a dichroic fog. Another plate having the same exposure but not treated was placed in the developer at the same time and both developed in bright yellow light. The plate which had not been treated became badly fogged, while the other remained clear. Orthochromatic plates showed but little difference between the treated and untreated plates; they both rapidly fogged. The above experiments were repeated by the writer, using lights of three different luminosities. A ruby light such as used for developing the average fast plate, an orange light used for developing "gas light" papers, and a bright yellow light which would not be safe even for the slowest developing papers. The developer was a metol-hydro, as used by the writer for all his photographic work with plates and papers excepting line work. The developer is so adjusted that it requires seven minutes at 65 degrees Fahrenheit to properly develop a fast plate. A 0.05 per cent (about two grains in seven ounces) solution of Amidol in distilled water was used as a preliminary bath. Fast and medium speed plates, ortho and panchromatic plates were tried. The latter were first tested for red sensitiveness as all so-called panchromatic emulsions are not always so. In all cases two plates were exposed and for the same length of time. One plate was then bathed for one minute in the Amidol solution in darkness and then, slightly rinsed. Both plates were then placed in the developer about two feet from the light. The treated fast and medium speed plates remained clear but the others became badly fogged when using the bright yellow light. The treated ortho plates remained clear in the orange light but fogged in the bright yellow light,

and the panchromatic plate fogged in the red light unless treated.

The phenosafranine solution made as above was then tried. All plates, even the very red sensitive emulsion, remained clear in the bright yellow light after allowing the solution to act for one minute in darkness. The results were the same whether the phenosafranine was used as a preliminary bath, or added to the developer. In conclusion, we would say this: the phenosafranine method is far more practical than the Amidol, as it was found that the action of the developer on the Amidol treated plates had been so greatly accelerated that unless the emulsion was very fresh a considerable chemical fog was produced even when the plate was developed in darkness. Dr. Lueppo-Cramer's statement that the presence of sulphite in the Amidol solution destroyed the latter's peculiar property of desensitizing was verified. In some cases the phenosafranine has a tendency of slightly staining the gelatine a reddish color, especially if it is used as a preliminary bath.

While the stain is not objectionable, it can be easily removed by placing the plate after fixing and washing a short time for a few minutes in a strong solution of alum containing a small quantity of pure hydrochloric acid and washing again. The presence of the phenosafranine in the developer does not cause any deterioration in either fresh or used developer even after some months. In other words, it is perfectly safe to add the dye to the stock developer.



PONTIFICAL HIGH MASS.

JULIEN J. PROSKAUER.

ZOO PHOTOGRAPHY

By ARTHUR H. FARROW



FROM the days of childhood pictures of wild animals have interested most of us. There are few amateur photographers who have not yearned for an opportunity to make animal studies. But all of us cannot go to foreign lands, and the gratification of portraying wild animals in their native haunts comes to about one photographer in thousands—the rest have to depend upon animals in captivity for their subjects.

The Zoo has a particular fascination for young and old, but it makes an especial appeal to the amateur photographer as a prolific field rich in possibilities for interesting pictorial studies. Close to the delight of seeing strange animals and birds lies the joy of making pictures of them. If there is one place where the camera can be utilized at all seasons of the year, a place where it can easily be made a source of pleasure and profit, that place is the Zoological Park.

There is also a sporting element attached to this branch of photography that is particularly appealing to every red-blooded individual.

Scattered throughout this broad land of ours are a number of excellent Zoological Parks of which we can well be proud. The largest and most representative, perhaps, is the one at Bronx Park, New York City, but the amateur photographer who aspires to take pictures here is doomed to disappointment. As one is about to pass through the turnstile at the entrance he is greeted with a conspicuous sign giving notice that "No cameras are allowed".

One is at a loss to understand just why the management persists in this policy of prohibiting the use of cameras, in spite of vigorous protests, but, unfortunately for us, the fact remains that they do.

My impression is that the main purpose of a zoological collection is an educational one; to further the study of natural



A WINTER SCENE IN THE DEER PADDOCK.

Illustrating article "Zoo Photography," by Arthur H. Farrou.

history and to enable the lover of birds and animals to become better acquainted with representative foreign and domestic species. One would think if this were really the case, everything would be done to encourage an interest in this direction, and what better means is there for furthering this interest than that which the camera affords of making lasting photographic records of the denizens of the Zoo.

I have been to the Bronx Park Zoo many times, but have always come away disappointed at not being able to use the camera. Of course, small cameras are smuggled in and exposures made surreptitiously with them, but this kind of photographic work is not satisfactory, and one does not get any real pleasure from it.

If the reason for prohibiting the cameras is a mercenary one, (and it is the only one I can think of), why not charge a nominal fee, say fifty cents, for a permit to take pictures? This would be willingly paid by serious workers, and the revenue derived would more than offset any loss occasioned through the non-purchase of picture postcards and illustrated literature.

Happily for camera devotees, this deplorable policy is the exception and not the rule at other Zoological Parks in this country. At most of them no restriction whatever is placed upon the use of hand cameras. In fact, one is permitted to photograph as much as one likes, providing the animals are not molested or unnecessarily disturbed or annoyed.

During the past few months the writer has been a frequent visitor at the excellent Zoo at Cincinnati, Ohio, and here one can photograph to one's heart's content, and facilities are afforded for the purchase of films and other photographic supplies.

Zoo photography is intensely interesting work and will well repay the time and effort devoted to it, but even with all restrictions regarding the use of the camera removed, one must not think it is an easy matter to obtain good pictures. It is not; difficulties will be encountered that will tax the energy of the most enthusiastic. A considerable amount of ingenuity is required to obtain worth-while pictures. It is to be understood that just to point the camera at the subject



MR. PELICAN OBLIGINGLY POSES.

Illustrating article "Zoo Photography," by Arthur H. Farrow.

and make the exposure is not all that is necessary if successful photographs are desired.

The main essentials for success are, a good lens, a quick eye, and as much attention to composition and other details as the case will allow. Great patience and careful observation must be devoted to securing effective poses, good lighting and appropriate backgrounds.

Animals in captivity are very restless and continually on the move. To obtain successful pictures of them one must combine patience with quickness to seize the most favorable moment for making the exposure. A long-focus lens, or even a telephoto, will often be found useful in dealing with creatures difficult to approach at close quarters, or such as are small. A very low viewpoint is often an advantage, but care must be taken that no near foreground objects obscure the actual object.

Most of the popular makes of hand cameras are adapted for the purpose. The best outfit that can be purchased is none too good, although not absolutely necessary. Much good work can be done with a camera such as the ordinary amateur uses. Of course, the Graflex is well fitted for the work; but it has the disadvantage of being cumbersome and conspicuous, and the price is prohibitive for the average worker. After mature consideration and from practical experience, I have come to the conclusion that an Ansco Speedex No. 3, fitted with an F/4.5 lens, is an ideal instrument for this particular work. It is a real pocket camera, extremely simple in operation and extraordinarily efficient. The large aperture anastigmat lens enables one to make snapshots under the most unfavorable conditions, and the full measure of such occasions will be encountered in serious Zoo photography. The $2\frac{1}{4}$ in. x $3\frac{1}{4}$ in. size picture is about the smallest that can be adequately used in the album. It is well adapted for making lantern slides, and the correctly-timed negative enlarges satisfactorily.

Zoo subjects are particularly effective when rendered in the form of stereoscopic pictures, but like the Graflex, a stereoscopic camera is rather bulky and somewhat limited in its use in this field of endeavor.

Sometimes it is an extremely easy matter to make a good



STILL LIFE STUDY.
CHRIST OR MAMMON.

COPYRIGHT, MARCH 1921. LOUIS ASTRELLA

photograph of a bird or an animal, then again it may prove to be the most difficult and exasperating task to get just what one wants. The only thing is not to be discouraged by failures—one will get plenty of them—but keep on trying until success is achieved. If one desires to obtain a representative collection of Zoo pictures it will be necessary to make many visits. The habits and characteristics of the various subjects must be studied. The better acquainted one gets with the animals, the keepers and conditions, the possibilities and limitations, the better chance for success.

The most desirable, perhaps, of all Zoo subjects are the great cats—lions, tigers, leopards, but the likelihood of securing good pictures of them is very uncertain. About the only way is to place the lens of the camera through the bars of the cages, but it is only on rare occasions a satisfactory picture can be secured in this manner. There are times, however, when the animals are using their outdoor cages, and when the light is favorable, that this can be done. Make friends with the keepers and usually a way will be found to get the picture you want.

The water-fowl, pelicans, swans and ducks, are always attractive and usually very accessible. If one watches carefully and waits patiently for interesting and characteristic poses, opportunities will occur for making pleasing studies. The cages in which small animals and birds are confined are usually made of fine meshed wire. A fact that is not generally known is that one or two wires directly across the front of the lens does not make any appreciable difference in the resultant picture, providing the wires are right up against the lens and do not cast any image on the plate or film. Thus, a fairly large mesh does not do any real harm.

In making your visits to the Zoo, avoid crowded days. Select a time when there is likely to be few visitors. Experience will teach which hours are best for different subjects. Some subjects can be best secured in the morning, others later in the day. A lot depends on the position of the cages.

I hope that this comparatively new field in which very little really serious work has been done will be accorded consideration by amateur photographers, especially those who are also nature lovers.

THE BROMIDE PRINT—A MEANS NOT AN END

By WILLIAM ALEXANDER ALCOCK, L.I.B.

O the great majority of casual photographers, who regard the bromide enlargement as the Ultima Thule in photography (and I am afraid they constitute the great army of those who keep the photographic stock-houses busy) it will perhaps be news that many serious pictorialists are ever seeking ways to improve and modify the result which this process gives.

In my contribution to the last issue of this *Annual*, I adverted at some length to the bromoil process, a process which in the hands of the enthusiast is hard to equal, and almost impossible to excel. But to many who have tried it discouragement and failure have been the portion. To such I say try again, and perhaps a few suggestions in the matter of working details may be of assistance.

Try the following developer:

Water	20 oz.
Sulphite of soda (Anhydrous).....	$\frac{3}{4}$ oz.
Amidol	50 grs.
Potassium Bromide.....	10 grs.
Bi-Sulphite of soda.....	50 grs.

Use the developer immediately after it has been compounded and use fresh developer for each print. If an 11 x 14 print be soaked in water for forty-five seconds before development, an ounce of the foregoing solution will be ample.

Expose the print so that it begins to appear in the developer in about 30 seconds and develops fully in four minutes. Rinse the print. Fix it for ten minutes in the following bath, freshly compounded:

Water	20 oz.
Hypo	2 oz.
Sodium bisulphite	200 grs.

After fixing wash for ten minutes and dry the print.

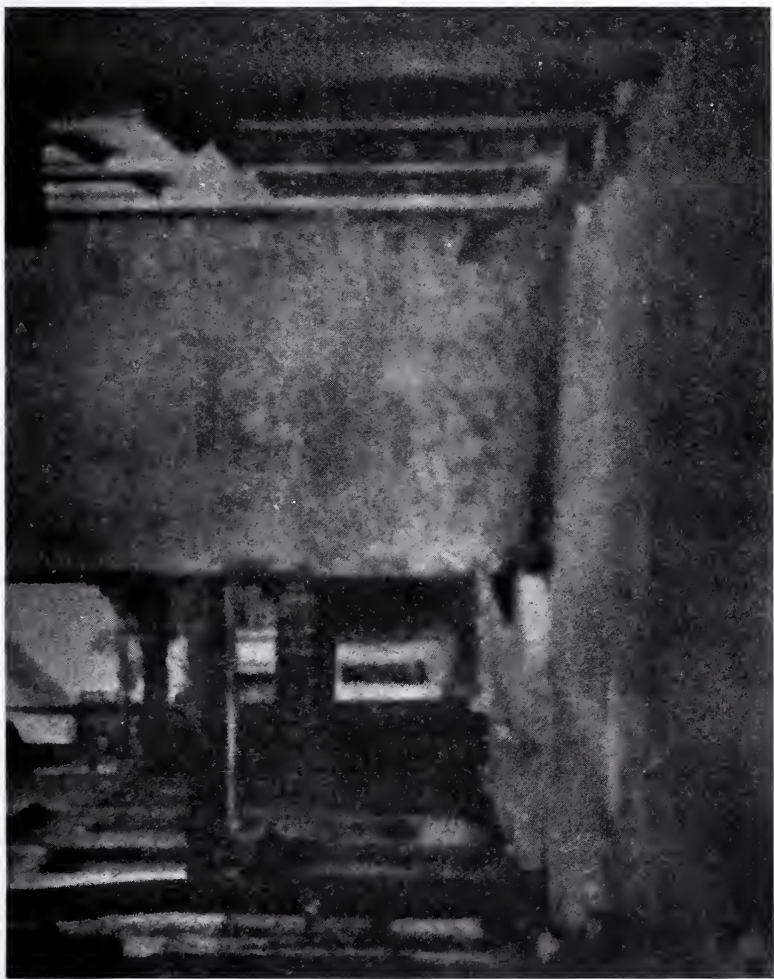

AN ANCIENT AMERICAN THOROUGHFARE.
Bronze.

WILLIAM ALEXANDER ALCOCK.

It may be bleached at any time within reason, and I have found that I have no difficulty in inking a print one year old at the time of bleaching.

There are numerous—almost innumerable—formulae for the bleach. The S. H. Williams bleacher, which can be bought in the supply-houses and only needs to be diluted to one-third of its strength, is as good as any and saves work. It has the additional advantage of requiring no sulphuric acid bath after bleaching, the print being fixed for five minutes in a 5% hypo bath, washed for ten minutes and dried. It is then ready for soaking and will keep indefinitely.

A very pleasing and exceedingly interesting method of after treatment of a bromide print is to make a bromoil transfer. This is done by making a bromoil print in the manner above indicated and then super-imposing on the bromoil a sheet of good paper such as Michallet or Whatman, or one of the Japan Paper Company papers, passing the two sheets through a wringer and peeling them apart, when the image will be found to have transferred itself from the bromide paper on to the other. This gives a print closely approximating a lithograph and enables one to dispense with the usually undesirable heavily coated gelatine surface of the bromide print. I have found that a wooden wringer—a mangle—made by the American Wringer Company, gives equally as good results as does an expensive etching press, while in addition it is a very useful household appliance.

The space at my disposal prevents me from doing more than touch the high spots.

I should like to dwell upon carbro, a very simple method by which a carbon print may be made from a bromide, but the full details of working this process have been published by the Autotype Company and may be obtained from George Murphy, Inc., New York, the American agents.

A very charming method of modifying a bromide print is to give it a gum coating, not as with platinum by registering and printing, but by chemical action alone. This process was worked out by Mr. T. H. Greenall, and described by him in our British contemporary, *The Amateur Photographer*, in the issue of February 12, 1919.

This comparatively unknown process is simple and inex-



A LONELY VIGIL.
Palladium Print.

WILLIAM ALEXANDER ALCOCK.

pensive and is described in detail in Wall's Dictionary, Tenth Edition. The worker who is seeking the unusual will do well to investigate this method of treatment.

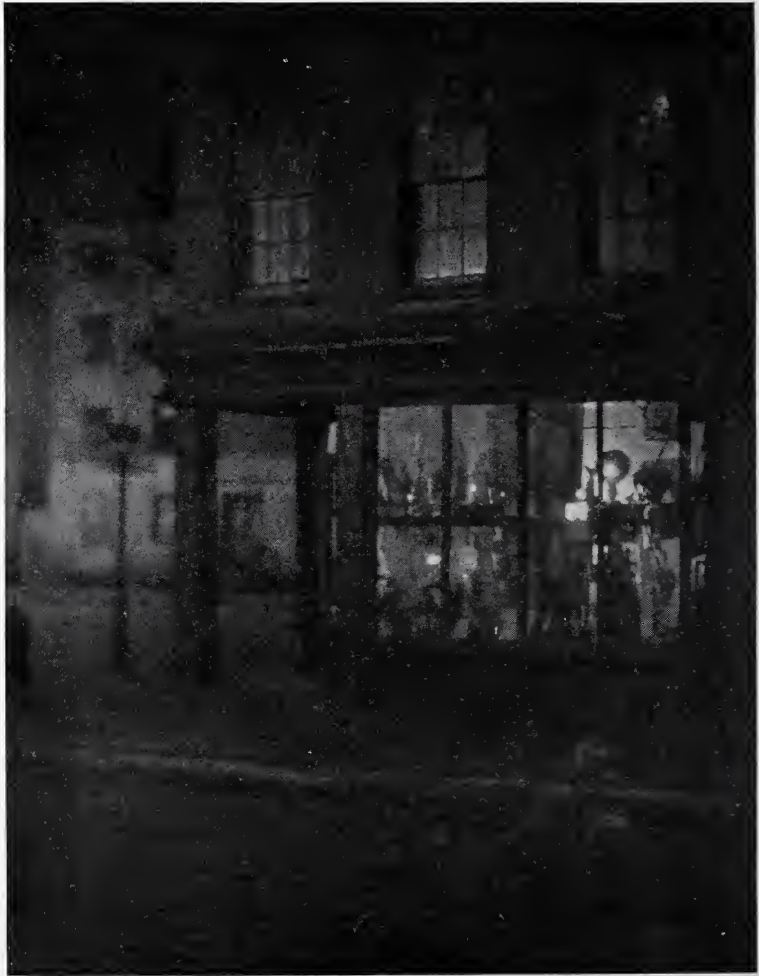

JUNK FOR SALE.

WILLIAM ALEXANDER ALCOCK.

THE SUN IN THE PICTURE

By HORACE SYKES

WHEN I first learned to make photographs—that is, how to manipulate the camera, develop plates, and make satisfactory prints—the novelty of the various processes, the charm of the ground-glass, and the fascination of seeing the image appear from nothingness, lured me on at first and absorbed me. I made photographs literally by the roll and by the pack. I immortalized absolutely everything from the back-yard fence to my best girl's family.

At length this sort of thing became burdensome to my pocket-book. My interest began to wane. I grew tired of simply multiplying prints. I reached a stage where I found myself looking over great bunches of old photographs and wondering why I ever took them, what on earth I saw in that old stump patch or pile of rocks to induce me to waste a film on it. Eventually the simple mechanical and chemical manipulations ceased to absorb me as they had done. I reached a point where I longed to make more than just ordinary snapshots.

I noticed that some photographs were more greatly admired than others, that some prints had a far more lasting interest. As I sorted out and culled, some prints seemed to continually find their way back among the chosen, and I began to realize that they possessed something that the others did not. They were different. The fact that they were pictures, while the others were merely photographs, began to manifest itself and I commenced to seek the reason why.

It was at this point that I began to grope about and reach out for that something which makes photographs into real pictures. I commenced to study pictures that pleased me, and to attempt to analyze recognized pictures by other photographers. At first the thing seemed hopeless, but presently I discovered one fact that became a great help to me. The fact

that any unusually attractive aspect or mood of nature is equally attractive in a picture. Accordingly I began to watch for the unusual and to attempt to photograph it. This led me to do many bold and daring things photographically speaking, to take some desperate chances. I remember that when I once told a photographer friend of the old cut and dried type, that I contemplated taking pictures with the image of the sun in them, he advised me not to be so foolish.

I did not take his advice, and I was not altogether foolish either, although my first efforts were far from successful, or are my present efforts always so. I have, however, made many good sun pictures, found it to be a very interesting as well as different subject, and will reveal a few of the things I have learned about it.

There is a great difference in the behavior of lenses when it comes to working head on into the sun. There are comparatively few that will render an image that is clear and free from spots, rainbows, etc., due to the reflections from the internal glass surfaces. It is my observation that in general the cemented lenses are superior to the air space lenses in this respect.

The next thing I learned was that there is not much difference between the various makes of plates and films in doing this class of work. What I consider my very best sun picture, "Sun and Sea" (Figure 1), was taken on a cheap single coated plate. I cannot say that I have found double-coated or other non-halation plates to be of any great advantage.

It required a long time for me to learn that the ray filter is of little value. I am quite sure that it actually spoiled some of my exposures that would otherwise have been successful.

It is the subject matter itself, the condition or quality of the light, the condition of the atmosphere and sky that are the controlling factors. I have learned that the lens and plate cannot, as a practical thing, record successfully extremes of light which are greater than the eye can comfortably discern. In other words, if the sun is partly obscured by smoke, haze, fog, clouds, or the deep color of sunset so one can look at it with the unaided eye without discomfort the plate can record it without becoming mussed up with halation and lens reflections. Success depends therefore not



SUN AND SEA.

Figure 1.
Illustrating article "The Sun in the Picture," by Horace Sykes.

so much on the equipment or methods as on close observation of the subject, and making the exposure at the critical moment.

The matter of exposure should also be mentioned. The natural thing to do is underexpose. Because of the apparent intensity of the light one will naturally shorten the time. It must be remembered that the lens sees only the shadow side of what is before it, and that a fairly full exposure is necessary. My most successful exposures have been from a twenty-fifth to a hundredth part of a second at an average stop of F 6/8.

I use only tank development for both plates and films, and believe it to be one of the essentials in this fascinating work. My prints and enlargements are made in the usual manner. For the sake of brevity I have not attempted to tell all I know about this interesting subject. The fact is I learn something new almost every time I attempt it. I have given a few brief hints which I hope will encourage and help others to start.

I wish to state in concluding that the two illustrations (Figures 1 and 2) are the result of simple straight photography. Neither the negative nor the print has been faked in any way.



ANCHORED.

THOMAS CARLYLE.



DECEMBER EVENING. Figure 2.
Illustrating article "The Sun in the Picture," by Horace Sykes.

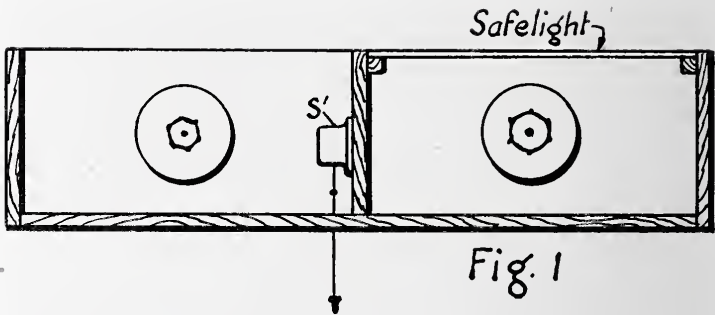

Illustrating article "Taking the Dark Out of the Dark-Room," by August Krug.

TAKING THE DARK OUT OF THE DARK-ROOM

By AUGUST KRUG

NOT so many years ago the average dark-room was a place of Stygian blackness: a feeble red light faintly illuminated a space about the size of an eight-by-ten tray and in addition probably exhaled an asphyxiating odor, due to a combination of burning paint and half-consumed kerosene. The electric dark-room light is now universal, and explosions no longer interrupt the peaceful quiet as we develop our plates: but "inefficient" is the mildest word that can be applied to most of the lamps.

This article will tell about a lamp which was made and installed in our dark-room. It has aroused the wonder of all who have seen it; the invariable query is, "But can it be safe?" It is. Portrait films are developed by its light; every object in the room can be distinctly seen; solutions can be made up in any part of the room, which is sixteen feet square; newspapers can be read comfortably by its light, and it is so soft that there is no eye-strain after an all-day session in the dark-room. In fact, we are thinking seriously of not calling it the "dark-room" any more.

Of course, it is an indirect light, because no direct source of illumination could do all that. The light box is suspended



THE PORTAL.

AUGUST KRUG.

from the center of the ceiling, hanging down about eighteen inches. The ceiling and part of the side walls are kalsomined white, the remainder, about five feet up from the floor, is painted chocolate color, being easier to clean and not showing pyro stains. The ceiling becomes the source of light, an area of about eight square feet sending well diffused illumination over the whole room.

The drawing (Figure 1) shows the construction of the box. It is divided by a vertical partition through the center, giving two boxes of equal capacity. It is lined with tin or galvanized iron painted and enameled white. Three lights are installed, two of these go in the side which is later covered with the safelight, one being installed at each end, the other goes into the white-light side. The safelight used is determined by the character of work done: the Wratten No. 2 is suitable for most.

The unique feature of the light is that it can instantly be changed from red to white or from white back to the safe-light, simply by pulling on the cord which hangs pendant from the box. Turning on one light automatically turns off the other, and the process can be repeated indefinitely. The main control switch, which turns the light on and off, is situated near the dark-room entrance, and of course works independently of the other switches.

The switches marked S and S' in the drawing (Figure 2) are what are known as 'pull chain switches', and they are connected up as shown in the wiring diagram. They are arranged so that one is "off" while the other is "on". The chains are made of equal length, and tied together at the ends with a single cord, which is then led through the bottom of the box. It may have a radiant tip if desired. It is suggested that the switches be located in the white light side of the box, so that adjustments can be made without difficulty. There is, of course, no reason why a different kind of safelight should not be installed over what we have termed the "white-light" side of the box: as, for instance, one of clear yellow glass for use when printing gaslight papers.

Our equipment consists of a 200-watt type C mazda lamp in the white light side, and two ordinary 100-watt tungstens in the safelight side. It is not possible to use gas filled lamps

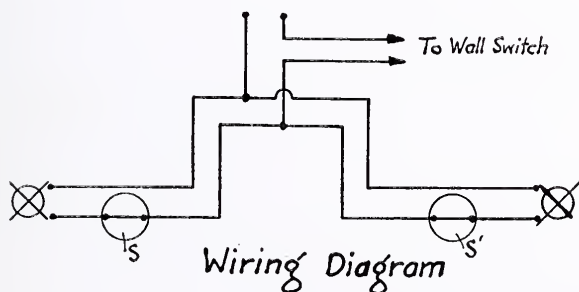
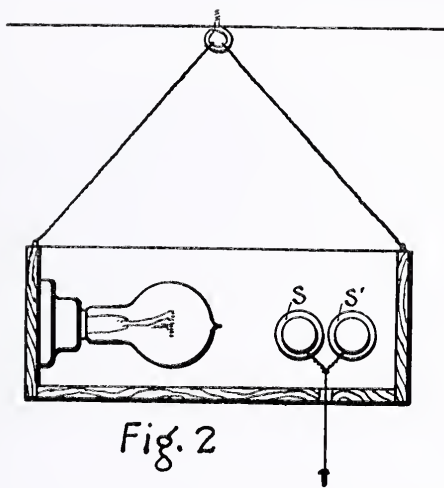

Figure 2.

in this side, on account of the heat generated. Perhaps the wattage mentioned would be excessive for smaller rooms, but it is a comfort to be able to work in a room in which everything is distinctly visible.

Exact dimensions are not given, because the worker who decides to make himself one of these lights must figure them out for himself. Nor have I prepared the customary itemized cost-sheet, showing how economically it can be made, believing that the comfort gained by the use of the light cannot be measured in terms of dollars and cents. When you have taken the dark out of your dark-room, you will like the result so much that you, too, will want to pass the idea on to others, as I have tried to do.

THEN AND NOW

By C. H. CLAUDY



YOU are invited to take a walk with me . . . a photographic walk. We are going picture hunting, you and I, to see what of beauty or of interest we can pick up.

Only first we are going to turn the clock back forty-eleven years.

While I lug our portable camera, which weighs only sixty pounds, out on the porch, do you go to the barn and get the travelling dark room. It is nicely mounted on a push cart. I'll have the hired girl bring out a few buckets of water to put in it, and also get the tripod and the plates and holders. And don't forget the kerosene.

All set? Let's go. Isn't it nice and light. Two healthy girls could push this nice light little push cart around the landscape. It's only a few hundred pounds on wheels, a few pounds of glass and chemicals, some water, a nice little camera about as big as an egg crate and a lens which looks like a cross between a French 75 shell and a thermos bottle.

Really, it's nothing . . . look at the artist. He has to carry an easel and canvass and paints and brushes and a camp stool, and when he gets where he is going he has to spend all afternoon at the job, and *then* he doesn't get anything, much. While we . . . say, how is that? Look at that stream, and those overhanging trees; man, I know you are hot, but why stop to mop your face when you can look at a landscape like *that?*

Now, do you set up the tripod, and I'll give you a lift with the camera, and then you focus and I'll prepare the plates. You see, I'm willing to do the hot work. Sticking head and shoulders into the little dark-room, and being all fastened in with a tight cloth bag tied around my waist, is hot, but who minds a little discomfort like that? The kerosene dark-room lamp is hot and smelly, too . . . you didn't forget to bring the kerosene, did you?

I dare say I speak in a somewhat smothered voice, due to



BETH BERI AS "THE GYPSY."

Louis Fleckenstein.

my being all prisoned up. "You pretty nearly ready? I am . . ."

I come out, somewhat hot and little disheveled. But my precious wet plate is very wet indeed, and you are all ready, thank goodness, and so we proceed to make the picture, giving several seconds exposure. Then I wish on you the job of developing the plate. You find it hot and smelly and muggy in there, but as you are progressing you begin to shout at me: . . . "Hi, Carl. This is a wonderful negative. Most remarkable detail and absolutely perfect exposure . . ."

It is true. We have made a perfectly bully negative. And it has only taken us an hour or so of light, easy work. All we have to do is to pack up the outfit and move it some more dusty miles, and prepare another wet plate and set up and take down a nice little light camera which weighs a ton at the end of the trip, and when we come home in the evening we'll have three or four wonderful pictures.

"Look at that drawing," you say. "What about your old artist *now*? Isn't science *wonderful*? Think of being able to do all this in an afternoon, and with only the little labor we had."

It is true . . . it is, or rather was, wonderful. But let's jump back to 1921.

If you go for a photographic walk with me you slip into your pocket a V. P. K. or carry a Three A in your hand, dangling . . . maybe you allow yourself the luxury of a case and strap. Me? I carry a panoram, just so we won't both shoot the same sort of views. In your pocket are two or three rolls of film, weighing altogether almost as much as a nice red apple you have in the other pocket. When we make pictures we use a fence post, tree stump or old box, if we have to have a tripod, but usually we don't. The E. K. people make the little screw dingus that helps us attach our instrument anywhere, but we make most of our pictures in from a twenty-fifth to a hundredth of a second.

We don't know anything about travelling dark-rooms. We never saw one, either of us. I have seen wet plates prepared, in a photo engraving plant . . . you perhaps hardly know what "wet plate" means. We don't have to bother with plates, wet or dry . . . we don't have any plate holders. We know not the

focussing cloth. Our entire outfit is so small and light that we get footsore, if footsore at all, from the miles we travel, not from the weight we tote.

When we return, we develop our roll of film in a tank while we eat supper, and still we don't bother with lamps of any kind, let alone smelly kerosene ones. At the end of the day you have sixteen perfect little pictures and I six or eight long panoramic pictures taking in a view of a hundred and some degrees each.

It's a long, long way from forty eleven years ago. The big lens has become little. The huge camera has shrunk to one which goes in the pocket. The tripod is a tiny fixture, the dark-room has gone, the glass plate has been changed into film, its wet emulsion dried and rolled up into a little cylinder which goes into the pocket.

Let us give credit where credit is due. Our ancient forbears who followed Daguerre builded better than they knew . . . for in spite of what would be to us today insuperable difficulties, they brought before a waiting world so much of the wonder and romance of photography that the waiting world expressed itself as willing and ready to pay for that same romance if it could be made a little more portable.

Then the kodak, roll film, the developing tank, the modern lens, manufacturing methods which reduced the price of the whole to within the range of the most modest pocketbook, and a system of sensitive-product distribution which makes it possible to buy film anywhere in the world . . . and we have modern photography.

What? Well, I'll say I haven't told the half. Our forebears printed slowly and with difficulty on home-made albumen paper . . . we do it by lamp light in a moment. They either made their own chemicals or waited weeks to get an order through to a stockhouse . . . we have ours served pure and cheap at any supply store. They had to identify their negatives by notes . . . we make our notes *via* autographic film at the same time we make the negative. They knew only one method of enlarging . . . to photograph the photograph. We use V. P. negatives in an inexpensive enlarger and print enlargements at home as fast and as good as contact prints. They used a cap . . . we have an automatic shutter.

No, there isn't any moral. Only, some day when the shutter won't work or the negatives are not properly exposed, or you lose a roll from carelessness, or the cat walks over your pet print and you start in to say just what you think, remember what you and your forbears did in the name of photography and give thanks, instead of lurid lambastings, that you live in an age where photography is not only a magic and a wonder but a convenience.

Did you ever stop to think why "you press the button and we do the rest" does not make its former advertising appeal? It's because "the rest" is so easy, so pleasant and so fascinating that we refuse to pay some one to have all that fun for us which we might have for ourselves.



THE PICKET FENCE.

HOLMES I. METTEE

THE MULTIPLE GUM PROCESS

By FRANCIS ORVILLE LIBBY



AMONG photographers the making of prints by the superimposing of two or more layers of pigment on a piece of paper by the Gum Bichromate or Multiple Gum process has always been a sort of "Never Never" land of photographic printing, a mysterious process used and known by only a chosen few. I am going to try to show you that this should not be the case and that "Gum" is the simplest of all the so-called controlled processes for the serious worker with pictorial aspirations to use.

To begin with I want to say a few words about the results to be obtained in comparison with other methods of printing. I am not going to compare Gum with Bromide because the latter, fine as the results produced by this medium are, lacks the opportunity for control, and expression of individuality, which a process to be suited to the needs of the pictorialist should have. Platinum renders gradations in the highlights better than any other process, but is not so susceptible to control as Gum and does not give so rich a black as can be obtained with some other processes. Hand coated platinum with several printings is much better. The Carbon Process is rather laborious to handle and difficult in hot weather, but gives a beautiful richness in the shadows, and detail that is hard to equal, but is not nearly as easy to modify in contrast, either locally or totally, as Gum.

The Advantages of Gum Are:

1. Your choice of color and texture of paper support are practically unlimited.
2. Modifications of relative values are made more easily than in any other medium except Oil and Bromoil and as easily as in these.
3. The possibilities of modification of total contrast are unlimited.



YANKEE DOODLE.

FRANCIS ORVILLE LIBBY.

The Disadvantages of Gum Are:

1. That it is difficult and almost impossible to get exactly the same result on duplicate prints.
2. The process on account of its great flexibility appears difficult at the beginning. This apparent difficulty I hope to prove to you is not very real.
3. The rendition of very fine and intricate detail is almost impossible on account of the looseness of texture in a Gum print but this is rather an advantage than otherwise, as it tends to give a breadth to the picture it might not otherwise have.

Gum is not a process to be used in small sizes of pictures, but rather for the production of exhibition pictures, and those in which you desire to express something more than the limitations of the lens and plate have allowed you to get on your negative. It is a process for the impressionist, not the realist, and is for the man who has an idea to put in permanent form, an interpretation of some beautiful mood of nature, rather than for the man who is content to reproduce simply the facts as they lie before him.

Whistler, the painter, used to say that "Nature was never wholly perfect," but be that as it may, Art is certainly nature seen through the artist's eyes and interpreted through his temperament and individuality. The use of the Gum process will not make a picture for you, but if you have your story to tell, it will do its part and enable you to put it on paper in a permanent and beautiful form.

To begin with, the materials you will need: Paper of all sorts can be used, but probably the easiest to work and the most satisfactory in the long run, are the good grades of drawing and charcoal papers. I have made prints on tissue of various sorts, but unless I am after some particular effect for which it would not be suitable, I now use almost wholly the rough and smooth Arnold Drawing Papers, which are very satisfactory. The rough for very broad effects and the smooth for detail and delicacy. Practically all papers are best sized before coating with the sensitizing mixture as this will give you purer highlights, and for this you will need something to fill the pores of the paper. There are a number of things

that can be used, but my preference is for a gelatine size which I mix as follows:

Rub 6 gr. of Thymol in a mortar with 30 to 60 minims of 90% Alcohol until dissolved.

Add this to 20 oz. of water in a wide mouthed bottle.

Add 1 oz. Nelson's Shredded Gelatine.

Let it stand one hour or more and then dissolve in a water bath of not over 120 degrees and filter through muslin. Your size is now ready and will keep indefinitely and can be used any time by warming it up in a water bath. When I size I add to about an ounce of the size 10 or 12 drops of a saturated solution of Chrome Alum. This hardens the Gelatine and it will not dissolve if you should find it necessary to use hot water later on in developing the print.

Besides this you will need two other solutions:

One of Gum Arabic 2 oz. water 3 oz. and to each ounce of the gum solution should be added two or three drops of a 40% solution of Formaldehyde as a preservative. This I compound by putting the Gum Arabic in a piece of cheesecloth and suspending it in the water in a wide-mouthed vessel. It will dissolve in about two days.

The other is the sensitizing solution and it may be either a solution of Potassium, Ammonium or Sodium Bichromate. I have tried them all but have finally fixed on the following as by far the most satisfactory:

1½ oz. Ammonium Bichromate and 400 gr. Manganese Sulphate to 10 oz. water.

The addition of the Manganese Sulphate seems to have a tendency to hold the pigment to the paper and render it less likely to flake with a light printing.

All our preparations are now made and we are ready to start our printing. First, some evening we warm up the Gelatine size until it is liquid and then laying the paper we are going to use on a newspaper, or other clean surface, we brush the face of it with the liquid working first one way and then the other. Any good sized brush will do, and it is not necessary to be very particular except to be sure that the paper is all covered and the coating fairly uniform. Mark the back of the sheet and lay it flat on the floor or hang it up to dry.

This sizing is a quick job and from fifteen to twenty large pieces of paper can be coated in half an hour. After sizing, the paper can be put away until needed and is ready to use any time.

To print, take a piece of your sized paper and coat it with a mixture of Gum Solution, 1 dram, and Bichromate Solution, 2 drams, or one part to two parts, to which has been added pigment of whatever color you desire. The above proportions are right for the ordinary negative or straight print, but if you need more contrast use less Bichromate and add enough water to make up. If you require a flatter result add more Bichromate, keeping the solution of Gum and Sensitizer the same.

For pigment you may use many things: Moist water colors are good and the finely ground dry pigments such as can be bought at any painters' supply house are excellent. The only thing you must be sure of is that your color is not in the nature of a dye but is a true pigment, otherwise it will stain your paper and not remain on the surface as it should. For a few cents you can buy enough color to last you for a year. After trying everything I could find that I had heard of I have finally settled down to the use almost wholly of but a few kinds of pigment: Carter's Velvet Black, a show card color, for brown and warm black, Lamp Black where a colder black is desirable, Prussian Blue and Devoe's Dark Blue, another show card color for night effects or to modify the blacks. The Prussian Blue is a very strong brilliant color, a powder, and should be used sparingly and very thoroughly mixed, otherwise it has a tendency to streak, also the moist Oleo colors made by A. Sartorius, are particularly good.

With the above colors it is possible to get a great deal of variety, and they are about all you will need unless you want to experiment and try to produce prints in their natural colors. This I do not think desirable as Photography is essentially a monochromatic art. In Gum it is not easy to get a true black. The tendency with all the blacks is toward a brown. This is particularly true with the Ivory black and with this color you will obtain a very rich effect by leaving the Bichromate stain in the paper. If you desire to remove this stain it can be very easily done at any time by a bath of

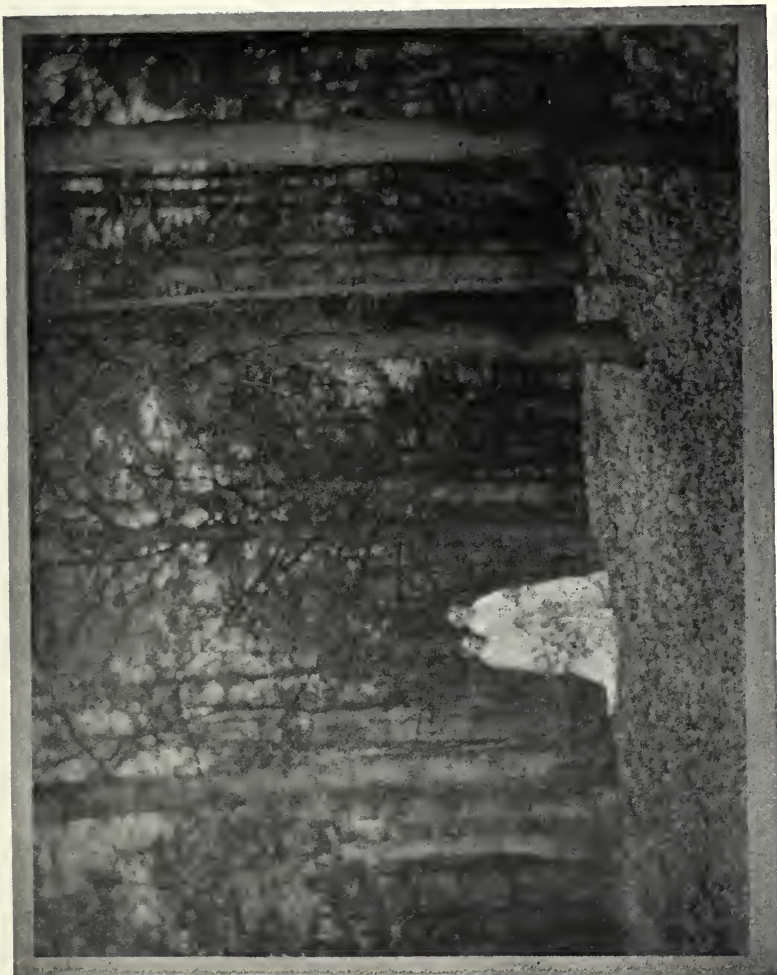

W. H. Porterfield.

AS IN THE DAYS OF PLATO.

1 oz. of Alum to 20 oz. of water, or better still, a small quantity of Sodium Bisulphite in water, it is not necessary to be particular about the amount. I put two or three teaspoonfuls in a tray with about 60 oz. of water. However, if you use the alum bath before the last printing is made, you will find it has a tendency to shrink the paper. For applying the sensitizing mixture to the paper you should have a flat bristle brush about two inches wide, preferably set in rubber, though this is not necessary if you are careful in washing the brush after using, the bristles should be soft and fine but springy. A camel's hair brush is not good at all as it is too soft. This brush you will use in coating the paper, and you should also have what is called a Flat Badger Blender to smooth the coating and prevent brush marks and inequalities. The coating should be done with a moderately full brush going over the paper first one way and then across. The Blender is used holding it vertically above the paper and brushing rapidly to and fro just touching the tips of the hairs to the paper. There is a knack about coating, but it is not at all difficult after a little practice. The first coating is, on some papers, particularly the smooth surfaced ones, the hardest to get smooth and even, but slight variations in the evenness of the first coating, unless too bad can be easily taken care of in later printings. With rough papers or papers with a surface such as charcoal papers have, the coating is very easy. The coating may be done in the light of an ordinary room as the Bichromate is not sensitive until dry, but after coating the paper should be hung up in the dark to dry thoroughly, which will take twenty minutes or half an hour. Do not try to keep the sensitized paper too long before printing. The sooner it is printed after coating the better, as the Gum has a tendency to become insoluble if kept too long. This is also true after printing and it is best when possible to coat, print and develop the same day.

Your negative is all ready of course, so we can proceed to the printing: I use paper negatives wholly and have made them on P.M.C. Bromide No. 2 paper. Lately I have found another paper that I think will be even better, as it has less grain, none apparently; it is Artura Carbon Black Studio Special. With a negative of fair density and contrasts on

this paper the printing time will run from 10 to 30 minutes depending on the season of the year, and what you desire to get in your printing. If your negative has considerable contrast and you want to get a tint in the highlights, make your first printing long with a thin coating and build up the shadows in subsequent printings by giving shorter exposure and letting the highlights wash off after you have gotten them where you want them. I prefer fairly short printings myself, as I like to be able to start development just as soon as my paper has soaked long enough to be limp. If you have made an error in printing and given a very much too short exposure, so that the pigment comes off very unevenly or in places where you do not want it to come off, it is usually best to take a brush and remove all the coating, and on the other hand, if you have very much over printed and the pigment does not start at all after prolonged soaking quite often you can save the print by adding a little Ammonia to the water which you will find has a very marked softening effect on the coating. A weak solution of Sulphuric Acid in water is also good at times.

The amount of pigment which should be added to the Gum and Bichromate varies with the result you desire to obtain and somewhat with the pigment you are using. To 1 dram of Gum and 2 drams of Bichromate you will find 10 to 12 minims of, say the Velvet Black about right. This color is liquid being mixed with water and Glycerine. When the paper is coated it should appear a rather light, yellowish brown. In later printings you can use more pigment and it should but rarely be necessary to make more than four printings to get a scale ranging from the deepest blacks to white.

Print in direct sunlight and try an exposure of twenty minutes in the middle of the day. Be careful not to expose the paper to too strong a light when putting it in the frame or removing it as it is quite sensitive. The paper after exposure will show you quite a clear image if your coating has been light, but while it is possible to judge quite accurately by this image whether your printing is sufficient it requires practice and experience, so at first you had best simply expose for a certain length of time and then develop the print, and one or two trials will quickly give you the correct printing time.



J. ANTHONY BILL.

The whole principle of Gum Printing can be very simply stated. It is, that a colloid, in this case Gum Arabic which has been rendered more or less insoluble by the action of light on a sensitive salt such as Ammonium Bichromate holds the pigment on the surface of the paper in a greater or lesser degree depending on the extent to which the Gum has become insolubilized, hence the development of a print consists in washing off the pigment which has not become attached to the paper by the light action. A printed piece of paper may be developed automatically by immersing it in water, face downward, and leaving it until the pigment has washed off the paper. I do not advise automatic development, however, as working this way one has no opportunity for personal control and modifications of the image and values, which of course it is necessary for the pictorial worker to have. As I said before, print until after soaking in water until limp the color will begin to leave the paper upon the application of a stream of water. I use a short length of rubber hose attached to the faucet and start development with a moderately full, smooth flowing stream of cold water. The force of the stream and the volume of water to use is dependent on the action of the print. Sometimes you may need to use hot water and sometimes a spray will help. Nearly always you will need to use brushes and the most useful are a large round Camel's hair brush, a medium sized sable and a very small fine sable and two bristle brushes, one small and the other about one-half inch wide. The bristle brushes are necessary when you have to take the pigment off clean. When you have gotten your print to a satisfactory point, hang it up to dry.

I have said that multiple gum printing was the simplest of the controlled processes for the pictorial worker to use and this I believe to be a fact. However, for the very reason that it is capable of so much variation and control, though you will find that if you will adopt the method I have endeavored to outline you can produce prints at once, you will also find that you will not necessarily get the finished result just as you may desire to have it. That, however, will shortly come with practice and experience. Form a mental image of the picture you desire to produce before you start and work with that in mind all the time, and before you know it



"I WILL LIFT UP MINE EYES UNTO THE HILLS."

FRANCIS ORVILLE LIBBY.

you will find the process your obedient servant and that you can produce pictures instead of mere records of a pretty view. Birge Harrison says, "Nature, however beautiful, is not art. Art is natural beauty interpreted through human temperament," and Anderson says that "The aim of the artist must always be to arouse some emotional mood or sentiment." Bear these two sayings in mind. They are worth much thought and study and if upon consideration you find you agree with them, then you will want a process to work with that will not hamper you in the free expression of your ideas, such a process is Multiple Gum printing and I recommend it to your attention.



DAFFODILLS.

CHARLES D. MESERVEY.

SHUTTERS AND THEIR SPEEDS

By J. A. ERNEST ZIMMERMANN, B.S.



ARTICLES published from time to time in our photographic periodicals claiming that the shutter speeds $1/25$, $1/50$, $1/100$ are one and the same, seem to be accepted as trustworthy by most photographic workers as well as the novice of the art. If these speeds are practically the same, why do manufacturers label them thus?

The author could never understand such misrepresentation of facts as these and accordingly tested the shutter speeds of his apparatus. The work carried out and conclusions, arrived at in his own private laboratory, have led to the discovery that the three shutter speeds, which are apt to vary minute, fractional, parts of a second on one side or the other of the recorded speeds, are different and not of the same speed as asserted by various writers and authors. The process of these investigations, as conducted by means of a swinging pendulum of definite length through a short arc, is too intricate to be treated and published in the *Annual*. A different method, therefore, had to be devised which should prove and show the variance of the three speed conditions.

Selecting a cloudy but bright day, the experiment, which everyone can perform with a plate camera except the box type, was carried out. A reproduction of the negative which was obtained accompanies this article (Figure 1).

The author employed an 8 x 10 view camera, with grooves for holding opaque slides, cut in the side edges of the reversible back. This arrangement permitted him to obtain four different exposures on one plate, or Eastman flat film, by simply moving the opaque slides from one side to the other. Instead of using an apparatus with removable back and slides, a camera that does not possess this can be used as follows: A piece of heavy opaque paper—the size of the opening when the back is removed—is used. Cut one-fourth of the entire paper away, making right angles with the edges. This can

be used as the mask to obtain the four desired exposures to show whether the speeds are the same or whether the same vary. The four or three variant exposures should correspond to the method of analysis as outlined below.

From the reproduction given—which has been numbered from 1 to 4 to facilitate the pursuance of this analysis—it will readily be seen that number 1 is approximately one-half as dense as number 2; also number 3 is four times as dense as



No. 1. $1/100$ sec. exposure No. 3. $1/25$ sec. exposure.
 No. 2. $1/50$ sec. exposure. No. 4. $1/5$ sec. exposure.

Figure 1.

number 1 and twice as dense as number 2. Number 1 received the exposure marked $1/100$; number 2 the exposure marked $1/50$; number 3 exposure $1/25$ and number 4 exposure $1/5$. One easily notices since number 2 is twice as dense as number 1, and that speed $1/100$ was used for 1 and speed $1/50$ for 2, that these speeds are in the ratio of 1 to 2, i.e., that $1/100$ is twice as fast as $1/50$. The same can be shown and proved with number 3 which is one-fourth as rapid as number 1, and one-half as fast as number 2. Number 1 compared with number 4 shows that it is twenty times the speed, the density of which was determined by means of a microscope as well as



A. McFarlin.

by the light law of inverse squares which gave the result of 19.83 times the intensity of number 1.

It is hoped by the author that the foregoing proofs will be convincing evidence to those who have been in doubt as to the misstatements of articles published and issued from time to time. If the readers of the *Annual* cannot accept the veracity and the proofs as herewith given, they only need to employ the foregoing analysis of the methods of exposures to convince themselves and obtain their own proofs.

The camera employed for this investigation was procured from the Conley Camera Co. It was fitted with their shutter and a F8 rapid rectilinear lens working at 12½ inches. The negative was made on Eastman Commercial Orthonon Film.



Correct exposure.

Illustrating article "Shutters and Their Speeds," by J. A. Ernest Zimmermann.

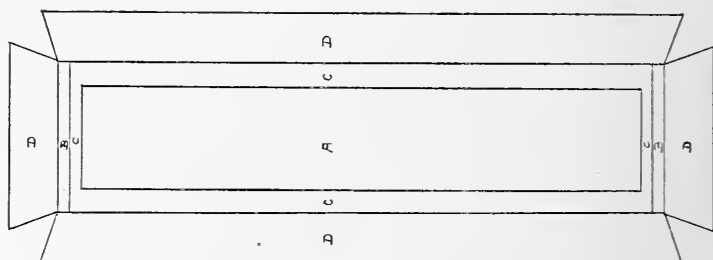

Figure 1.

Illustrating article "One Way of Developing Roll Film," by H. V. Schieren.

ONE WAY OF DEVELOPING ROLL FILM

By H. V. SCHIEREN



OME of us still cling to the "watch it as you go" method of development, and if there is anything more pesky and messy to handle in this way, than the average roll film, the writer has yet to find it. Casting about for some means of managing these long, unruly strips of wet celluloid, the use of a shallow tray with a glass bottom suggested itself.

After a little experimenting such a tray was evolved and it has proved a great boon, taking care of a long roll of film, and making development as easy as with a glass plate. My tray is made to fit the $4\frac{1}{4} \times 3\frac{1}{4}$ Graflex Roll Holder film, but trays can be made to take any size film, and no set rule can be given as to how big the tray should be, as it all depends on the size of the film you use. Make the tray just large enough so that the film fits snugly in it.

Lay off on a piece of fairly heavy and stiff cardboard, a diagram like Figure 1. With a sharp knife cut out the long strip down the center marked A in the diagram. This will be the slit through which you will watch the progress of development. Procure two small strips of thin wood (cigar box-wood) and cement one at each end with water-proof cement, B-B in the diagram. These strips are put in so that the ends of the film may be pinned to them with glass headed pins during development.



MORNING.

ARTHUR J. STOCKTON.

Cut a piece of glass the exact size of the bottom of the tray so that it will make a tight fit against the edges of the wood strips. Cement the glass to the cardboard all along the edge at C-C-C-C, in the diagram, and let the whole thing dry under pressure for several hours. When dry cut out the diagram on the outer lines, score the bottom with a sharp knife, and bend up the sides, D-D-D-D, to form the sides of the tray. Bind the corners inside and out with Dennison's heavy muslin glued tape, and bind all edges with the tape. Run a strip of tape along the bottom of the tray so that it projects over the glass a little, and can be seen from the inside through the glass. This will insure a water-tight joint. Let the tray dry thoroughly for at least twelve hours, and then give it a couple of coats of acid proof paint, being sure to let each coat dry well before applying the next.

To use the tray the film is first soaked in cold water until limp. Have the inside of the tray thoroughly wet and lay the film face up, pinning the ends to the wooden strips, at each end, pour on the developer and develop in the usual way.

When it is desired to see how development is progressing, pour the developer into a graduate and hold the tray up to the dark-room light, and the image can be plainly seen through the glass bottom. If a red light can be arranged on a low shelf or table, the image can be easily viewed.

After development the film may be washed in the tray and the hypo bath poured in, or these operations may be carried on in another receptacle. The glass bottom stiffens the tray and makes it quite strong so that it will stand hard usage. Made of cardboard the trays are light and can be easily handled, the writer having developed over three dozen rolls of film in one of them with no signs of wear.

Figure 2 shows the finished tray.

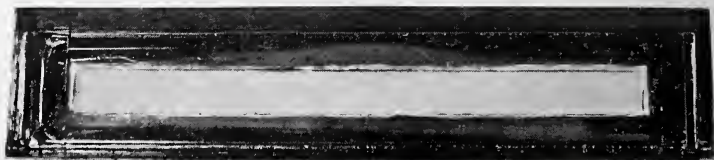

Figure 2.

Illustrating article "One Way of Developing Roll Film," by H. V. Schieren.



THE LIGHT OF THE CROSS.

LOUIS A. GOETZ.

Illustrating article "Laws of Art Versus Individual Taste," by Sigismund Blumann.

LAWS OF ART VERSUS INDIVIDUAL TASTE

By SIGISMUND BLUMANN



SPeaking of music, the lover of Jazz has been heard too often saying, "I don't know anything about music but I know what I like". With all due respect to the otherwise nobler animal who speaks thus, let it be considered that the hog knows nothing of fine eating but he, too, knows what he likes and it is swill. Individual taste is frequently confounded with originality. There is no connection. A hundred individuals are more likely to enjoy what is inferior to one whose trained senses and judgment qualify him to prefer the good.

Adages and epigrams have been made in good faith which seem to serve whatever purpose. The devil has quoted scripture, "Rules are made for the common mind: Great minds are above them". Are they indeed! "Genius knows no laws". Fly not like the eagle, little mind, or you may be shot for a goose. Fads are the ephemeral attempts to escape rules and they last for a day. But the arts of Greece have given Rodin his schooling. Praxiteles is still the master.

The rules of Art are not made arbitrarily and intended to curb individuality. They are arrived at by experience, and mature, patient study and consideration. They are based on laws of nature: Basic and fundamental. Hogarth's line of beauty is not a formula but a psychological phenomenon. Curves please because men have been created with a sense of ease and enjoy the smooth traverse of round lines and resent the violence of angles. Balance (not mathematical symmetry) is a quality within us not established by the will of man.

So in photography it behooves us to study well every law of Art, to master every application thereof, to adapt each to our form of expression, and if God has been so good as to make us great enough, to add to these laws with demonstrations of our own.



HO! CHARON!

Illustrating article "Locus of Art Versus Individual Taste," by Sigmund Blumann.

PERCY NEYMANN.

Unlike religion, which hath many creeds, Art has but one,
"To hold the mirror up to Nature", and while
 "To him who in the love of Nature
 Holds communion with her visible forms
 She speaks a various language,"

we must never forget that it is Nature which speaks and not our own exalted self that makes the thunder roar, or the streams purl, or the breezes whisper.

The human form divine is divine when it conveys to us the beauty Divinity put upon it. When it is merely a naked body it is only carnal, ugly, obscene and calling it a Study in the Nude cannot make it an exemplar of Art.

When distorted trees and curdled skies manufactured by reticulated films and cotton batting are smudged on paper, we may say a new Art has arrived but there is no new Art. Though the bodies of men change and earth itself passes through its mutations, the primal force, the unit of origin, the first creative edict that started the universe shall be as it was at the beginning. And we who worship Art and love her, not as a pose or an affectation, but deeply and reverently, shall find we are doing something very near to worshipping the Supreme Power that made all things according to law.



RUSTIC BRIDGE.

E. F. WEBER.



THE ATHLETE.

LOUIS A. GOETZ.

Illustrating article "Laws of Art Versus Individual Taste," by Sigismund Blumann.

OUTDOOR PORTRAITURE

BY PAUL L. ANDERSON



ABOUT eighty years ago, D. O. Hill, a Scotch painter, became interested in photography, and worked more or less in that medium for several years. He does not seem to have left a high reputation as a painter, his work being, apparently, pretty rather than powerful, but had he given his attention to portraiture instead of, chiefly, to landscape, it is at least possible that he would have taken high rank among painters, for his photographic portraits show him to have owned a fine sense of composition and values, and a keen appreciation of character. Indeed, it is safe to say that the camera portraits made by Hill have never yet been surpassed by any photographer, and have rarely been equalled, a fact which is all the more surprising when we consider the difficulties against which he had to struggle.

Photography was then in its infancy. Lenses were uncorrected, and slow; the sensitive substance used for negative making was paper, crudely sensitized, and requiring long exposures; and the printing mediums available were so crude that it is only with the development of such processes as photogravure and gum-platinum that the full merit of Hill's work has been appreciated. In consequence of the primitive character of Hill's materials, his exposures ranged in the neighborhood of four or five minutes, and to secure full exposure even with this long time he was obliged to pose his sitters out of doors, generally in a full blaze of direct sunlight.

With the development of faster lenses and more rapid plates photography, so far as portrait work is concerned, became an indoor sport, and when some unthinking copy-cat built him a studio with a north sky-light the path first traveled by Hill deteriorated into a little-used trail; gradually the conviction grew among photographers that the place to do portrait work was in a studio, and it was many years before the daring amateur rushed in where more experienced workers feared to



OUTDOOR PORTRAIT.

PAUL L. ANDERSON.

tread, and proved that equally good—and often better—portraits could be produced in home surroundings. Even yet there is a feeling against doing portrait work outdoors, and the writer has heard a well-known photographer declare flatly that it was impossible to produce satisfactory portraits in an outdoor light.

It is by no means impossible to do so; Hill proved this conclusively, and a few more recent workers have added to his original demonstration, but it remains somewhat more difficult. It is, however, unquestionably the case that in many instances outdoor portraiture shows a quality which is utterly unobtainable indoors, and is therefore more satisfying. The writer does not mean to claim that all portrait work should be done outdoors; the home and the studio both furnish satisfactory settings, and magnificent work has been done in both places, but he does mean to say that it is a mistake for camera workers to confine themselves within four walls and under a roof when making portraits.

When working outdoors the photographer finds certain advantages and certain disadvantages as compared to indoor practice. The disadvantages may be enumerated briefly, the most conspicuous one being the fact that the background and surroundings vary; the uniformity which exists in the studio, permitting the photographer to concentrate his attention on the sitter, is lost, and a more alert mind is required to correlate the sitter with the surroundings. Also, the background is often beyond control, and can be varied only by moving to another spot. The light is also beyond control, so that the worker must modify his ideas and his attitude to meet the illumination, instead of changing the light to suit his ideas. And the clothing suitable for outdoors is not always that appropriate to either home or studio, so that a certain expression of the sitter may be impossible.

But as so often happens in photography, disadvantages bear somewhat of the flavor of advantages; the good and the bad are so inextricably mingled that we cannot say definitely, "such-and-such a thing is undesirable." The very conditions which require an alert and open mind develop thereby a sensitiveness, an appreciation, which would otherwise be lacking, and result in a freshness and spontaneity that is rarely seen in



OUTDOOR PORTRAIT.

PAUL L. ANDERSON.

studio work, the variety of surroundings contributing in no small measure to this effect. That is, the changing conditions help in two ways: directly in the setting; and indirectly, in the photographer's mental attitude. The quality of the light also may help, for an outdoor light, especially if direct sunlight, gives a snap and life which cannot be secured indoors except at the expense of naturalness; the use of spotlights and secondary lighting will give it, to be sure, but it then becomes difficult to preserve unity and harmony, and the effect is not that of a figure bathed in sunlight. So, too, with the clothing. Furs are more convincing when seen against a background of snow and sky than when worn indoors; a riding habit is more at home outdoors than in the studio; and a light summer garment harmonizes better with a background of trees than with the painted background of the studio.

So we find that in enumerating the disadvantages we have also named most of the advantages, but one remains, and that no inconsiderable one, especially when working with children. The greater strength of the outdoor light permits of conspicuously shorter exposures than are possible indoors, with the result that children may be photographed at play, in action, thus securing a natural effect which far surpasses even the best of studio work. Stronger light is an advantage, too, with adults, since the use of color-sensitive plates in conjunction with a ray-filter becomes a possibility, and a convincing quality of roundness, together with perfect texture rendering, results, this being not easily attained in the studio, and even when it is so attained, it is generally at the expense of other qualities.

Now as to working methods. The very flexibility of outdoor work precludes any positive instructions; there are no rules in art. Each worker must determine for himself just what he will do, selecting clothing, arrangement, pose, lighting, to express what he wishes to say; the alert mind must be, precisely, alert, and it is not so easy to fall into a rut as in studio work. But a few suggestions may at all events be given.

It is not, in general, well to have the sitter facing directly toward the sun, or even at such an angle that direct rays fall on the eyes, for in such circumstances most persons will squint. The writer has, however, seen a portrait by Coburn



THE STORM KING.

CHARLES L. SNYDER.

in which the sitter was turned almost squarely toward the sun—but her eyes were shaded by a broad-brimmed hat. The contrast between the fully illuminated lower face and the shaded forehead was very striking, and the portrait was eminently successful; of course, full exposure and soft development were required to retain the values. Still, it is generally better to have the sitter turned so that the direct light comes slightly from behind, the general illumination being reflected from the sky or from some nearby object; the effect of relief obtained by means of the resulting halo on the figure is noteworthy—and natural. As in studio work, a secondary or reflected light should explain itself; few things are more irritating than the double light so popular among the motion picture workers, where aluminum screens are used to throw light into shadows, the effect being usually overdone. The writer has seen a motion picture in which this had been carried to such an extreme that in an outdoor scene, in full sunlight, the catchlights in the eyes came from below. The careful and sincere worker, however, need hardly be warned against such absurdities.

As for settings, any place will do. A porch, a brook, an orchard, a pergola, the side of a house, the open sky; all these have been used, and well used, for backgrounds. It is simply a matter of keeping one's eyes open and selecting a setting which will harmonize with the thought one wishes to express, and it cannot be too strongly emphasized that no place should be rejected because of preconceived ideas; each should receive consideration, not on its character, but strictly on its merits as an arrangement in black and white. It is, of course, necessary that the surroundings shall not compete in interest with the sitter, but this is equally true of indoor work. Still, the caution may perhaps not be out of place, since there is greater danger of such an occurrence outdoors than in, the ordinary surroundings being more varied. Whether the background is foliage, flowers, or any other varied subject, the definition should be such as to prevent its deteriorating into a collection of meaningless blobs of light, and this brings us to another matter of importance, the lens.

A soft-focus lens is desirable in all portrait work; sharp definition, however valuable in scientific photography, is dis-



THE FONT.

L. D. Sweet.

tinctly out of place in portraiture. The writer does not mean to advocate the extreme blurriness seen in some pseudo-artistic portrait and genre photographs, but the definition of an anastigmat does not correspond to that of the eye. A famous scientist once remarked that if an optician should give him so poor an instrument as the human eye, he would reject it scornfully. This is true enough, so far as it goes; the normal eye is subject to all the errors of an uncorrected lens with the exception of astigmatism, and many eyes own that fault as well. It is true that the eye possesses certain advantages over any lens, such as automatic focusing, automatic diaphragming, and the power of rotation, which makes it, in effect, an extreme wide-angle instrument, but the fact remains that it does not give precise definition, and an objective which does this cannot correctly represent the subject as the eye sees it. Therefore, a certain amount of softness of definition is desirable, and, in general, the softness may be slightly exaggerated above that given by the eye, not only without offense, but even with positive pleasure; sharp outlines are offensive to the cultivated observer. A further advantage of the soft-focus lens is that the subject may be harmonized with the background in a more satisfactory manner; the fact that neither one is sharply drawn tends to bring the two into better relation, making the subject seem appropriately placed in the surroundings. Still further, a soft-focus lens does not incline so much as a corrected one to give the distressing blobs of light referred to. And if the work be done in full sunlight, a good soft-focus lens, properly used, renders the shimmering, vibrating quality of the light as no corrected lens can ever do.

As regards the camera, the best one is that to which the worker is accustomed, though for the portraiture of children a reflecting instrument of the Graflex type is very desirable. Negatives made with such a camera will probably require enlarging, but this is no disadvantage, and the advantages are great. In fact, the writer does practically all of his portrait work, both indoors and out, with an instrument of this kind.

Plates should, in general, be used, as they are more generally satisfactory than films, possessing a finer quality, and those of the non-halation type are almost imperative; otherwise, the quality of foliage against the sky, of distant, illumi-

nated landscape, and even of the figure itself, will suffer. And in most cases color-sensitiveness is to be desired, for the ordinary plate has a tendency to flatten the subject. This may be desirable when a poster effect is sought, but for most portraiture full rendering of color values is preferable. The writer's choice of plates falls on a backed or a double-coated panchromatic, but a double-coated orthochromatic will do admirable work; in fact, many of the writer's best negatives were made on the latter type of plate. It should be borne in mind that a color-sensitive plate, used without a ray-filter, possesses hardly any appreciable advantage over an ordinary one, and that if the filter is not correctly adjusted to the plate the result may be even worse, so far as color rendering is concerned, than if no filter were used.

Most outdoor portraits will be printed in a relatively high key. The general effect of outdoors is luminous, and to print in the full scale or in a low key is to destroy this effect. To be sure, a low key will at times be used, but in the main the case is as stated. Further, except for special effects, usually in an extremely high key, a warm print on a cream tinted stock will give the best result; sometimes a very delicate light gray will be best, but not as a rule. Consequently, the printing medium should be one which best renders this effect, and for straight prints there is none which equals platinum. The lustre of carbon fits it better for strong indoor effects, with large masses of dark; it is difficult to secure clear, pure highlights in gum; and most bromide and gas-light papers utterly lack the charming surface texture of platinum. Next to platinum comes a good matt-surface bromide—and there is no third. If, however, the worker wishes to be able to modify results at will, emphasizing a light here, lowering a shadow there, and, in short producing a work of art rather than a mere mechanical representation of the subject, no other process can compare with oil or bromoil. The oil-pigment processes are the most flexible of any yet devised for photographic use; color, values, even line itself, may be varied at will, and the surface texture of the print may vary from the precise, dry texture of gas-light, to the loose texture of a gum print on rough paper. We may have the dull surface of platinum or the lustre of carbon; we may even vary the texture in different portions

of the print. Briefly, there is no other process which offers so many advantages as oil, the sole drawback being the comparative slowness of production. But if one lion is better than a hundred jackals, we may fairly say that one fine print is better than a hundred mediocre ones, and we will choose oil for the rendering of our negatives.

So the photographer, whether amateur or professional, who takes up outdoor portraiture for the first time will find himself led to a most delightful experience, provided he will remember two things. First, not every subject can be rendered outdoors; and, second, he must approach literally every subject with an open mind, free from preconceived ideas. Given these two facts, and the technical skill to handle his instruments, there is every reason for him to expect a higher percentage of pleasing results than if working in either the home or the studio.



OUTDOOR PORTRAIT.

PAUL L. ANDERSON.

NIGHT PHOTOGRAPHY

By SOPHIE L. LAUFFER



HE amateur photographer is apt to think of night photography of street scenes, buildings, etc. as too difficult for him to attempt. He is depriving himself of one of the most interesting phases of pictorial photography. True, the amateur must have unending patience, endurance, and especially good nature. People *will* stop, look, smile knowingly, pass on; Street urchins *will* be pests standing in front of the lens, getting into the picture. All you have to do is pretend that you are making an exposure and they will pass on leaving the field to you. You will invariably come across the young man who knows it all and will insist upon giving advice. Take it, thank him, and he will pass on self satisfied with "all the good he has done."

You will find it very beneficial and time saving in the end if you spend two or three evenings walking around looking for pictures that will lend themselves to night rendering. Wandering around aimlessly with the heavy apparatus needed is more than discouraging. Having chosen some half dozen or so likely subjects, you start out another evening with the proper equipment.

A view camera is absolutely essential as seldom does one take a scene which does not contain a building or other structure, and what is worse than faulty architecture? A little precaution at the beginning will encourage one to do more of this kind of work. A good substantial tripod is needed. Wind, storm, rumbling vehicles all are to be thought of. A large rubber focusing cloth will be helpful for focusing and in case of storm. As for films or plates, I have found portrait films have given me the best results, especially when the black paper that comes between them is placed in the holder.

Much has been said about the lens, and I hope that I will not shock the reader when he hears that I have always used



AN ANCIENT LANDMARK.
Gum Palladium.

SOPHIE L. LAUFFER.

a soft focus lens of two elements. The rear element used alone and stopped down to F/6 or F/8 has given the best results. The barrel acts as an excellent hood. At night one does not see every detail, then why not use a lens of the soft focus type?

Relative to exposure, take an evening before starting on your real expedition, go a short distance from home and make three or four exposures of the same scene, varying the time from one-half minute to fifteen minutes. Experience is the best and only teacher.

Select that point of view which will have the lights evenly distributed. Glaring lights should be avoided. A cap is to be preferred when making the exposure. Each time a lighted vehicle passes, cap the lens, otherwise streaks are produced across the plate.

When developing, aim for the softness, the mellowness of night. A developer of the Azol or Rodinal type has proven most successful for this. If there be much halation this can be remedied if the negative, while still wet, is rubbed lightly with a piece of absorbent cotton saturated with alcohol. A paper that will give a good warm black renders night effects best. A gum print, using a little brown pigment with the black, gives excellent results. Palladium (warm black) with a thin coating of gum gives the soft mellowness of night better than anything else I know of.



A CANAAN EVENING.
Kallitype.

SOPHIE L. LAUFFER.

LANTERN SLIDE PAINTING

By MARCUS G. LOVELACE, Mus. Doc.

ANTERN slides to my mind are one of the most beautiful forms of the photographic image, and when properly colored are even superior to the plain slide. I have heard many people express preference for the hand colored slide to the Autochrome or Paget, although the writer cannot agree with them on this point, for to my mind there is no form of photograph that will compare with a good color plate.

Many miles of direction have been written about the coloring of lantern slides, but with one exception I have never seen any that were really practical. Most people use water colors. While it is possible to use them so that they do not look like the terrible things we see in the theatres announcing "The Perils of Pekin in 5 reels, with George Manleigh, and Lovine Sweet," it is not often that they are anything but a warning to young slide painters.

Nothing is more pleasing to the beginner than to get his color eight shades too dark, using some of the various aniline colors and then try to get the color out. It can be done,—sometimes. Usually your slide is spoiled. With the use of oil colors all these troubles are avoided, and there is really only one difficulty to contend with—what this is I will explain at length.

For materials, I am going to give specific names, as I have found that all brands of paint do not work the same, and some will not work at all. Get enough colors—life is too short to spend time mixing shades all the time. The outfit that I am giving here will only cost three or four dollars at the most, and will paint upward of a million slides—easily.

The colors I use are—"Windsor & Newton Transparent Oil Colours"—a special color made for transparent work. Get the following colors—Gamboge, Chinese Orange, Mars Yellow, Alizarin Crimson, Crimson Lake, New Blue, Prussian Blue, Brown Pink, Italian Pink, Burnt Sienna, Vandyke Brown.



THE REAPER.

Eugene P. Henry.

For medium to mix them with I must acknowledge my indebtedness to Mr. Alfred H. Saunders, for a formula given in the *Annual* some years ago and which I reprint here. It is the best medium I know, and I have tried them all, or nearly all.

Transparent Gold Size, 4 parts.

Pure Linseed Oil, 2 parts,

And pure Turpentine, 1 part.

Get these from a dealer in Artists' materials, or you will not get linseed oil or turpentine, but some villainous compound which will ruin your work. Mix these well and you are ready.

Dust is the prime enemy of the slide painter—guard against it as a plague by whatever means is necessary. Do not paint by daylight—use a light of the same color as the one by which it will be shown, or as near as possible. A nitrogen filled bulb—a white one—is first rate—then use a piece of opal glass, not ground but opal for an easel. Put it at an angle of about 45 degrees and your easel is ready. For a palette nothing is better than another piece of glass, not opal but clear, prepared as follows. Arrange your colors in a row, all reds together, all blues together, etc., then take a brush and put a small dab of each color (mixed with a little of the medium given above) on the top edge of the glass. After they are all on make a list and paste it on the back of your palette, so that it can be read from the front. By merely looking at the row of colors on the top edge of your palette, you will know what color you want to put out, and use. This may seem a small item, but after painting slides awhile it will be found very valuable as a time saver.

Brushes are a big item. If they are good you will have little trouble in doing good work, but if they are poor, they are an endless nuisance, as a hair from a brush ruins a slide if left on and usually you will spoil the slide if you try to remove the hair.

The brushes used are called flat top, camel's hair, china painters shaders, round, in quills. That is the full name and Devoe and Reynolds make an excellent grade. Get some handles for them when ordering. You will need about four—ranging from an eighth to a little more than a quarter of an

inch in diameter. They are round stubby brushes like a short cylinder of hair, but when filled with color they will fan out until they will draw a line as fine as a hair. *Do not try* to use the ordinary pointed water color brush if you want success.

The most difficult thing to learn in slide painting is the operation called *fingering*. It is not possible to put large tints on a slide by means of a brush. Streaks will show in spite of all that can be done to prevent them. Large tints are put on in this way. A small amount of color is put on the palette and mixed with a little medium. It is then painted on the slide and then fingered. This is done by polishing the second finger of the right hand with a piece of pumice stone, under water, until the finger is smooth as glass, taking care not to rub until finger is raw. Dry the finger and then finger as follows. Start at the bottom of the tint to be fingered and dab with the ball of the finger that has been polished. Roll the finger as you do so, so that each dab is a short roll of the finger on the smooth part. Do not dab without rolling the finger, it's a waste of time. Do not drag the finger, the paint will smear. Dab lightly, do not press heavily. Roll the hand from the thumb side *toward* the little finger. Each dab must overlap the last one made, and the pressure must be even.

Much depends on the consistency of the paint. If the mixture of paint and medium is too thin—that is, there is too much medium—the mixture will remain in little mottled puddles after each finger dab. If the mixture is too stiff or too dry, you will have prints of the finger at each dab. When the paint and medium is working right, and is just dry enough, each dab will leave a little mark which will run together and as *fingering* goes on will gradually form an even tint. Note the two conditions—1st: If paint and medium mixture is too thin, it will leave little puddles of paint after it, like foot prints on a wet floor. 2nd: If mixture is too thick, it will stick to finger and leave imprints of the finger on the slide.

This may seem a little unnecessary attention to detail, but *fingering* a slide is one of the most important things, if not the *most* important of the whole process—without it it is hardly possible to paint any kind of a slide whatsoever.

If you do not succeed at first—and it's almost certain you



IN BOSTON HARBOR.

PETER J. SCHWEICKART.

won't—have some benzole handy, wash the slide off and you are ready to try it again.

Now for a slide—get a seascape if possible, it's easiest, and proceed as follows. Take a small quantity of Prussian Blue on the palette and mix with a little medium. Take your slide and paint it all over with this color. Lay your brush down and start to finger the color even, watching for the faults I have just told you of. You may have to wash the slide off four or five times, but it will not be hurt if you are careful. Read the directions on fingering again. Finger from left to right along the bottom edge, wipe the finger clean, and start to finger the next section higher, being sure that the upper rows of dabs always overlap the one below it, and wiping finger clean at end of a row of dabs. You must learn to finger an even tint before you can do anything else, so have patience and after a little without any change in your method of working, you will find that you can put on a tint as smooth as can be. Remember what was said about the paint being too thin or too dry, keep trying, and soon it will be easy.

Suppose that you have had good luck the first time, and you have an even blue shade all over the slide. If it is too light you should have used a darker color to start with— if it is too dark the original color should have been lighter. If it is too dark, keep on fingering and wiping. If it is too light dab on some more color and finger again. When the color is the right shade take a chamois stump (from a dealer in artists' materials) and wipe out all the places where you do *not* want blue—for instance, in a seascape—wipe out your beach, flecks of foam, boats, etc., leaving the blue over the sky and sea. Do *not* use cloth or anything but chamois, or you will have lint on the slide which ruins it. Wipe the stump clean with benzole and a rag, and it will last a long time. Remember if you spoil the slide in wiping out blue where it is not wanted, wash the whole slide with benzole and paint it again. Should you run over the edge, say, of a sail or a whitecap, and take some of the sky away, it can be fingered with a little care and blended so that it will not be necessary to paint the whole slide over.

After the blue is put on, and all detail where you will use other colors is wiped clean, put the slide into a tin box, say

about 8 x 10 by 2—made without solder, and with a tight fitting lid. This is called the stove, and is for drying the paint hard. The slide must be heated to about 200° for several hours in order to bake the paint dry and hard, which must be done between each painting. 200 to 250 Fahrenheit for about three hours is enough—too *much* heat will cause paint to turn brown.

When slides are cool, go ahead and paint in your detail, as much as possible, taking care that wherever one color goes over another the first one is baked before the other is put on. After you have painted your first slide, put it in the lantern and learn your mistakes. It will probably be too dense, too dark, have dust on it, hairs from the brush, etc., so do not be discouraged, just make it over again.

Many people like to blend a sky from a deep blue at the top to a fine red at the bottom—why, I don't know but it is done and this is the way it is done with oil colors. Start at the horizon with a sweep of Crimson lake, above that a strip of Prussian blue or New Blue then above that a sweep of Vandyke brown.

Now start at the bottom and finger, blending them together and the trick is done. Another combination of this sort is Italian pink, then Prussian blue, then Vandyke brown above that.

In painting waves, water, etc., coat entirely with blue, fingered on, and then put on light touches or coats of yellow and brown in order to make the green shades wanted. Grass is better made this way than by mixing colors. I would advise the slide painter to buy a few oil colored slides such as the "Raft of the Medusa by Gericault," and it will teach you more of what a well fingered sky and sea should look like than pages of description could ever do. In putting in clouds they should be wiped clean of paint in this way. Take a small piece of chamois skin, and roll up into a small cylinder—wipe out the clouds with a circular motion and then finger smooth so that the sky blends into the clouds in order to avoid the "Hole in the sky" effect that is all too common.

I am not going to attempt to tell you what colors to mix to make definite shades as the *Annual* is too limited in size to let me have fifty or sixty pages. The object of the glass palette

with the sample colors on the top is to enable you to see what the colors look like when light shines through them, and with a little practice one can get shades that will fit any picture. An artist friend tells me that with the colors I have mentioned in the list a man could paint any picture that has ever been painted, so there you are.

Another word and I am done—oil colors are as permanent as can be made. Any water colors suitable for slides will (in time) bleach out when used in a powerful lantern. Why spend time to make them if they will bleach out in a short time? I am sure that anyone seeing a good oil slide will never use any more water colors, and I can assure you that if you will practice the above given directions faithfully, you cannot help but succeed. I dislike giving rules exceedingly, but possibly these brief rules will help the young painter.

1st—Put in your largest tint or your blue first—that which must be fingered and then bake dry.

2nd—Put in your reds next, and your yellows last, baking after each one.

3rd—You can paint all over a slide with all sorts of colors, without baking in between each application, if they do not touch each other. Small detail in various parts of a slide, such as a large group, can be painted all at the same painting, if you don't let separate colors touch each other.

4th—Never try to paint over a color until it has been baked dry. It cannot be done.

5th—You will save time by following these directions exactly and by trying the slides in the lantern until you get a good idea of how dense they ought to be—it is impossible to judge by the eye until you have had considerable experience.

6th—Much time is saved by painting several slides at once—putting in all that is possible on each and then baking them all at once. Painting single slides, except at first is a terrible time-killer. It takes no longer to paint a dozen slides with oils than with water colors, except that all of one color is put in at once with oils, and with water colors you paint the slide with all the colors at once.



BRONX RIVER, N. Y.

WM. C. SETTGAS

THE OPTICS AND MECHANICS OF ENLARGING

By A. LOCKETT

HE essential factors for securing a truthful enlarged reproduction of any photograph, as far as the formation of the image is concerned, are: (1) Uniform lighting; (2) the suitability of the enlarging lens, or objective; (3) the correct fixing and adjustment of the objective; and (4) the perfect parallelism of negative and bromide paper. The first two are optical factors, the third is partly optical and partly mechanical, while the fourth is wholly mechanical. These points are most conveniently dealt with in turn, though in many respects interdependent.

Firstly, with regard to uniform lighting. If using a daylight box-form enlarger, care must be taken to point it at a clear sky. Clouds may cause unevenness should the negative be thin, in which case it is advisable to hold a piece of ground-glass a few inches above the enlarger. If employing an adjustable enlarging camera, one should see that the outside inclined white reflector is quite clean and receives an unobstructed light. Sometimes part of the reflector is shadowed by its nearness to the building, or by a projection overhead. A point often overlooked is that the reflector should be large enough to fill the whole view-angle of the lens when the camera is at the shortest extension likely to be wanted. Thus, in Figure 1, the dotted lines give the angle included by the lens A, at a given short distance from the negative B. They demonstrate how, at that extension, the reflector C is too small and will not light the whole negative evenly, although it will do so when the camera is racked out further, for a smaller-size enlargement. This will be especially apparent with a thin negative, or when making an enlarged negative from a transparency. For the same reason it is important to see that the opening in the window shutter D is sufficiently large, according to its distance from the negative.



PECONIC BAY.

Wm. Elbert Macnaughton.

When the window faces the sky, or has an open expanse in front, it is often better to cover the aperture with fine ground-glass or tracing paper, omitting the reflector. The negative should not be too close to the diffusing medium, or the grain may be focused.

With an enlarging lantern having a compound plano-convex condenser it is a much more complicated matter to get even lighting. The brightest part of the arc, incandescent filament, mantle, or lamp flame, as the case may be, has to be brought on to the common axis of the condenser and

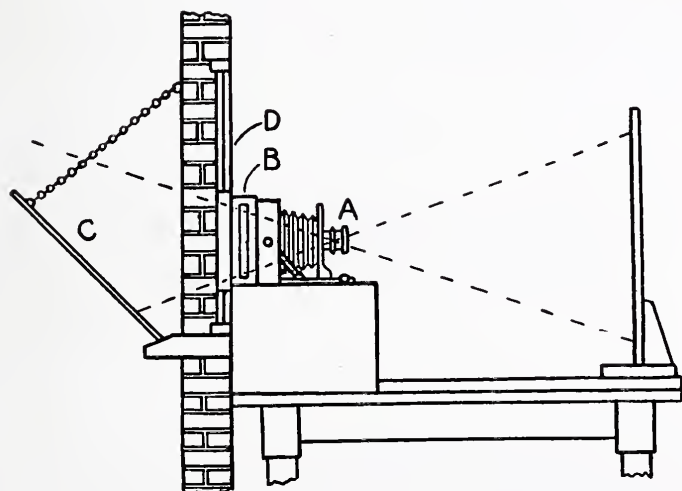

Figure 1.

objective, and adjusted at just the right distance from the condenser, which varies with the amount of enlargement. Theoretically, the conditions are as illustrated by Figure 2, where it will be seen that the illuminant A is placed at such a distance from the condenser BC as to converge the beam of light into the center of the objective D; while, at the same time, the objective itself is in such a position with respect to the negative E as to project a sharply-focused image of the desired size on to the easel F.

Ignoring, for simplicity, the exact nodal points, this means that the distances AB and CD are conjugate foci of the

condenser, while the distances ED and DF are conjugate foci of the objective. In practice, however, such an adjustment has to be deviated from, owing largely to the condenser being poorly corrected and having no precise focus. The best lighting is found to be obtained when, the negative having been removed, an image of the light-source is formed on a white card temporarily held a little way in front of the objective.

Since the position of the illuminant has to be altered for every variation in the scale, or ratio, of the enlargement, one should first roughly focus the latter to the desired size on the easel, without paying much attention to the lighting. The negative should then be withdrawn, and the lamp alone

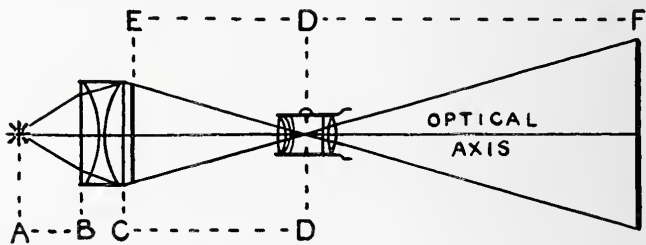

Figure 2.

moved, adjusting its distance and centrality till the easel is brightly and evenly lit. Lastly, the negative is re-inserted and sharply focused, noting that this does not again render the lighting uneven, and, if it does, once more very slightly shifting the lamp.

An up-to-date cinematograph operator, by the way, would refuse to employ a compound plano-convex condenser, owing to the large amount of spherical aberration. Photographers might find it worth while trying whether the Herschel, or meniscus and bi-convex pattern, would not be as superior for enlarging as it is acknowledged to be for motion-picture purposes.

In the writer's opinion, however, uniform artificial lighting is more readily obtained by using a silvered reflector, either spherical, parabolic, or of the parallax kind, and doing away with the condenser altogether. The lamp A (Figure 3)

should be in the focus of the reflector B, so as to throw the light in an approximately parallel beam on to a piece of flashed opal C, placed about an inch behind the negative D. This method is especially suitable with nitrogen-filled bulbs. It is also very convenient for using objectives of different foci, as may sometimes be wished, which cannot be done with the ordinary condenser unless the negative stage is movable.

Another excellent system of artificial illumination, applicable to one's own camera or to any daylight enlarger, is to employ a dull white surface as a reflector, either flat or bent to an ellipsoid or paraboloid curve. Burners or electric lamps are arranged at each side so that their combined diffused light is reflected to the negative, whereas direct light is

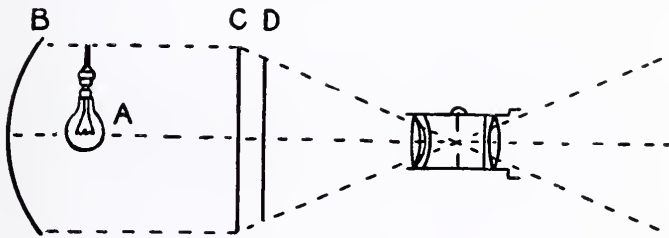

Figure 3.

screened off. This is an extremely efficient method, and shares with reflected or diffused daylight the great merit of not showing up retouching or scratches, so familiar a drawback when enlarging with a condenser and an unshielded light.

We now come to consider the nature and quality of the objective. The selection depends somewhat on the kind of lighting. With daylight, the aperture is not important, save that a small stop evidently prolongs the exposure, especially when the scale of enlargement is carried beyond a modest size. Enlarging lanterns, however, are generally fitted with portrait lenses of the Petzval type, having Waterhouse stops and focusing by a rack and pinion. Its large aperture apart, this kind of lens is by no means the best for the purpose. It suffers slightly from curvature of field, that is, the center and margins of the picture are not in equally sharp focus at the same time, with the largest diaphragm. Hence, a midway

position has to be selected, and a stop then inserted to give greater sharpness.

A point which often gives rise to confusion is exactly what happens when stopping-down the objective in enlarging. This will be better understood by remembering that the diaphragm has two distinct functions; firstly, to improve definition and increase depth of focus, and, secondly, to regulate the amount of light that passes, thereby adding to or reducing the exposure. Now, in daylight enlarging, or with artificial light when a diffuser or a white reflector is placed behind the negative, the stops act normally; that is, an aperture half the size or area of another will need approximately four times the exposure. When using a condenser alone, however, the conditions are no longer similar, but depend on

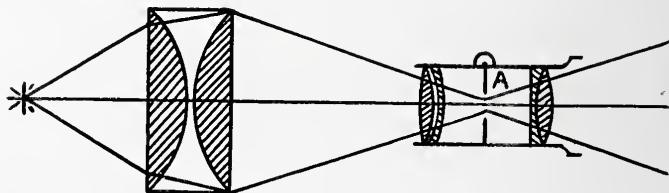

Figure 4.

the extent to which the beam of light is converged in the objective.

Thus, with a "point" light-source, such as an arc lamp, the beam is converged to a slender compass in the lens, so that the whole of it readily passes through a comparatively small stop, as seen at A, in Figure 4. It is, therefore, evident that there will be no difference, as regards exposure, between the small stop and a larger one, since the beam remains the same; the only difference, if any, will be in the definition. With a large light-source, however, such as an incandescent mantle, the beam will occupy greater space in the lens, and require a wider aperture for its unimpeded passage, as seen at B, in Figure 5. Hence, it is plain that stopping-down will cut off some of the light, besides probably giving uneven illumination. It will also be noted, in Figure 5, that the diameter of the objective is barely sufficient to admit the beam. A large light-

source, then, not only needs a rapid lens for the best results, but one of adequate diameter.

All things considered, a large-aperture anastigmat is far superior to the Petzval objective. Its field is perfectly flat, and the definition uniformly sharp from center to margin, even with the full opening. One of more moderate aperture will, of course, answer with a small light-source. Such lenses can be obtained to order in focusing mounts or jackets, and a metal iris diaphragm should be stipulated. Some lanterns have a fine-adjustment screw to the front, which renders unnecessary any provision for focusing on the lens.

With regard to the focal length, a short focus has the advantage that the distances from lens to easel need not be so great, also the depth of definition is superior should it be

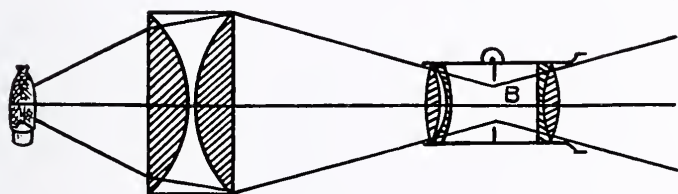

Figure 5.

required to tilt the negative and easel in curing distortion. If a portrait lens is being used, however, a somewhat longer focus is advantageous, since, owing to the narrow angle at which the beam of light enters, the central portion only of the lens is brought into service.

The focal length of the condenser and of the objective must, in any case, be mutually suitable. A handy rough rule to remember is that the best focus for the objective will be about equal to the diameter of the condenser, or within $\frac{1}{2}$ in. less or more than the diameter. Thus, a condenser $5\frac{1}{2}$ in. in diameter, as used with $3\frac{3}{4}$ in. by $4\frac{1}{4}$ in. negatives, needs an objective of from 5 in. to 6 in. focus.

Coming to the correct fixing and adjustment of the objective, it is important that the optical axis of the latter should be perpendicular to both the negative and bromide paper. In a fixed-focus box enlarger this is a practical certainty, and it

may also be expected in adjustable daylight enlarging cameras of sufficiently rigid make. Unfortunately, the same cannot always be asserted of enlarging lanterns, especially those of an old-fashioned pattern, or that have been much in use. Now and then one comes across an instance where the extension frame is weak or insufficiently supported, with the result that the weight of the objective is able to bend it appreciably downwards. Sometimes it is even found that the lens-board is not mounted at a true right-angle to the extension frame, or is warped, so as to give a distinct twist to one side.

Another essential occasionally lost sight of is that the axis of the condenser and objective should coincide. Many lanterns are now fitted with a rising and falling movement of the lens-board, and this may give trouble unless used with discretion.

We now arrive at the fourth factor, parallelism. To obtain an accurate and undistorted enlargement, it is ordinarily indispensable that the plane of the negative should be parallel with that of the easel, both being perpendicular with the axis of the objective. Many cases of uneven definition may be traced to some carelessness or structural fault in these respects. Thus, the carrier may have its rebate wrongly cut, so as not to be parallel with the outside surface, or it may be unprovided with spring clips, so that the negative is loose. A very trifling shift of the negative will have a considerable effect on the focus. A displacement of the easel is not injurious to the same extent, but even that may interfere with uniform sharpness. The easel may be untruly mounted or not properly level, especially if home-made, for, simple as it seems, to obtain (and retain) a really flat surface is not at all an easy matter. The performance of an altogether unexceptionable enlarger is often thrown quite out of true by a clumsily-constructed makeshift easel.

An exception to the foregoing rule of parallelism must, of course, be made when it is desired to correct the slanting upright lines of an architectural negative, due to its having been taken with the lens out of the horizontal, and with neglect to use the swing-back. In such circumstances, it is usually possible to get the lines right again by tilting the negative and the easel, many of the more expensive enlarging outfits



THEODORE EITEL.

being furnished with adjustments for this purpose. After any occasion of using these, great care should always be taken that the negative-holder and easel are again returned to the exact vertical—indeed, there ought properly to be some automatic device to check them in that position, or to show at a glance that they are in it.

Enlargements are frequently rendered uneven in sharpness from the mere fact of the paper not remaining flat when pinned up. A glass-fronted easel is, therefore, much the best. It should be seen that the glass is free from defects.

If the easel has grooves cut at the base to run on inverted-V rails, particular attention is needed that these grooves are truly perpendicular to the easel when the latter is upright, otherwise it will be given a sideways twist, a tilt forwards or backwards, or possibly both. Perhaps the fault may be so slight as to escape casual notice, and yet sufficient to affect the definition in part of the enlargement.

It is quite possible to shift the easel when fixing the paper, and it will not do to rely too much on a weighty base, though, obviously, this is desirable. The easel might with advantage be provided with some kind of clamping screw, to render shifting impossible.

In conclusion, the probability of vibration must not be overlooked, for a very little of that will go a long way to destroy sharpness. And vibration, it may usefully be remembered, is quite compatible with great apparent rigidity of construction. That is to say, a seemingly light and fragile apparatus may actually be firmer and steadier, owing to scientific design, than one much more solid-looking and heavily-built.



MRS. STANDIFORD-MEHLING.

IN OLD KINGSTON, N. Y.

By WILLIAM H. BROADWELL



HAVING previously been over this ground I decided a more extensive trip to obtain photographs of some of the many historical places would prove both interesting and profitable. Accordingly I loaded my car with photographic materials, plus a very simple camping outfit, and started off one morning for the Catskill mountains.

I followed the well-known Catskill highway to Kingston. Making my way in a leisurely manner I reached a point half way between Kingston and Saugerties where I found a nice secluded spot, pitching my tent and camping for the night. I did this so as to reach Saugerties in the early morning when the light would be most suitable to photograph an old house I had passed several times before, but always when the light was wrong. This time I was obliged to make the exposure during a rain—however the light was perfect. It is the oldest house along the Hudson river, remaining in the possession of the original family. It is over 200 years old, and the only one I know of which has the original smoke-house still standing.

Continuing on I made my way through Catskill and Jefferson. Each of these towns contain many old houses of great interest. On through East Windham to Gilboa; the latter a place of the past because this town is now uninhabited and will soon be under the waters of a large reservoir. Here I made a number of beautiful landscapes. Just one view to show the possibilities—Manorkill Falls (Figure 1, Page 182), one of the feeders of the new reservoir. Then on as far as Grand Gorge, returning to Kingston.

The town of Kingston was founded in 1610 by Hollanders, who established a trading post; Norwegians, Dutch, French, English and Germans came later. In 1652 a permanent settlement was made. At that time the whole region went under



OLD SENATE HOUSE.
Figure 2.
Illustrating article "In Old Kingston, N. Y.," by William H. Broadwell.

the name "The Esopus." It became Kingston when this section came under the control of the British.

Of the many old houses still standing, probably the most interesting as well as picturesque is the one built in 1676 by Wessel Tenbroeck and known as the "Senate house" (Figure 2). This is now a museum owned by the state. It was here the first state senate met until the burning of Kingston, in 1777, by the British. It is on the main highway.

The next most interesting is the old academy (Figure 3), founded in 1774, now occupied by a newspaper plant. Here was educated the first Governor of New York, Gov. Clinton, as well as other prominent men—Vanderlyn, the artist, Thos. DeWitt, D.D., Livingston, Van Rensselaer and many others.

Kingston is one of the few old places that really make you forget the present and live again in the past. Wherever you go some old house looms up before you, all in a perfect state of preservation. The Tappen house, wherein lived Christopher Tappen, the patriot and statesman; the Elmendorf house, onetime tavern; the Sleight house, now owned and occupied by the D. A. R. Col. Abraham Hasbrouck, Generals James and George Clinton.

One of the views made there is not historical at the present time but will soon become so. This is the chain ferry from Rondout to Kingston Point (Figure 4). This antiquated ferry is owned and operated by an influential resident, and is a highly paying proposition during the height of the touring season. It is scarcely more than a cable's length from shore to shore—no ferry-house on either side—is operated by a chain by which the boat is pulled across by its own power. The boat's capacity is six average size automobiles, and tourists are obliged to wait in turn often two hours or more before they can get aboard the boat. On each side of the creek leading from the landings are long, steep and dangerous roads.

This view was taken under trying conditions. In order to get in all I wished to make a record picture, I was obliged to take it against the light. I wanted first, the boat, then the landings on both sides in order to show the shortness of the ferry, and, finally, a part of the hilly road on the far side with automobiles awaiting their turn to cross.

I was informed that this summer would see the last of this



Figure 3.

FIRST NEW YORK STATE ACADEMY.

Illustrating article "In Old Kingston, N. Y.," by William H. Broadwell.

famous ferry, as a bridge was being built to take care of the traffic using that road at the present time, and would be in operation within a year.

Views of this sort are the kind that all photographers historically inclined should be on the watch for to photograph and preserve for posterity. I am glad to learn that many have followed my advice on the matter as published in the *Annual* for 1911, page 45, and many in all parts of the country are now making records of just such subjects. Let the good work go on.

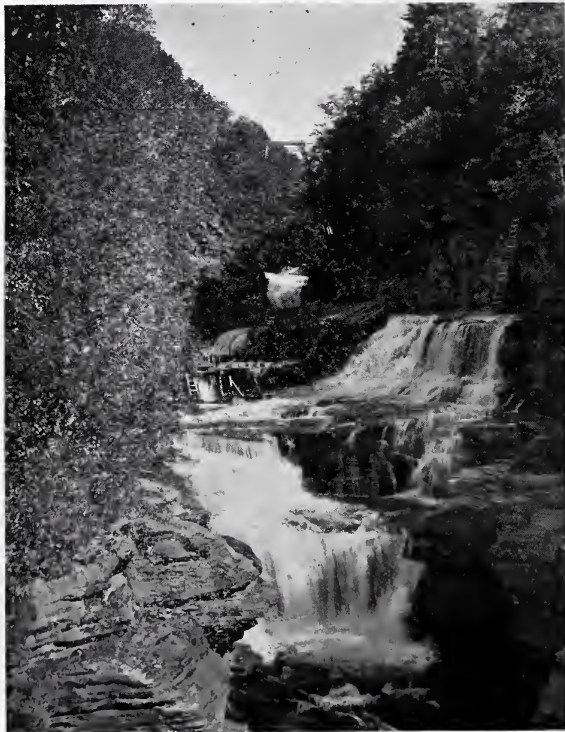

Figure 1.

MANORKILL FALLS, N. Y.

Illustrating article "In Old Kingston, N. Y.," by William H. Broadwell.



Figure 4.
THE OLD FERRY, KINGSTON TO RONDOUT, N. Y.
Illustrating article "In Old Kingston, N. Y.," by William H. Broadwell.

PHOTOGRAPHIC METHODS OF TESTING DEVELOPERS

By J. I. CRABTREE

Research Laboratory, Eastman Kodak Company, Rochester, N. Y.



ONE of the many problems assigned to the Photographic Department of the Research Laboratory of the Eastman Kodak Company is the working out of better-developing formulæ, which involves the testing of developers submitted from outside sources. Years of experience in this connection has shown that only a surprisingly small number of different developing formulæ are necessary to successfully develop every type of emulsion, and that in spite of the numerous developing agents of varying chemical composition at present available, pyro, Elon, and hydroquinone still remain unequalled though para-amidophenol, glycin, methyl-o-amidophenol, and diamidophenol are useful for special purposes.

Instead of adhering strictly to the manufacturer's published formulæ almost every photographer has his own pet formula with a reputation in many cases entirely undeserved, because the formula was not compared with the manufacturer's formula under equally favorable conditions. These remarks apply also with regard to developing agents. Some photographers use developing agents of unknown composition with supposedly mysterious properties, although careful comparative tests would undoubtedly prove that the developing agents in question are no better than the standard known developers.

In this article it is the object of the author to explain how by simple tests the photographer may judge the merits of any developing agent or developing formula with accuracy.

Two methods of testing are possible:

1. The absolute method, by means of which the various properties of a developer are expressed numerically, and
2. The comparative method, whereby the developer to be tested is compared side by side and under identical conditions with a standard developer.



A. J. Weis.

The first method is obviously the ideal one, because if we can measure the properties of a substance and express them in numbers, then we really know something about that substance. Without the necessary apparatus, however, it is not possible for the photographer to express his various tests numerically, but by comparing a developer side by side with a standard, he is usually in a position to judge the merits of the developer with sufficient accuracy for all practical purposes.¹

Classification of Developers.

In photographic practice, the word "developer" is used synonymously with a developing agent—a complete developing solution ready for use—and a developing formula, so that developers may be classified as follows:

1. Developing agents.
 - a. Composition known.
 - b. Composition unknown.
2. Developers ready for use.
 - a. Composition known.
 - b. Composition unknown.
3. Developing formulæ.

1-a. In order to test a developing agent of known composition, say hydroquinone, it should be compared with a known pure sample of the same developing agent, by compounding a standard developing formula with both chemicals and then comparing the two developers so obtained.

A suitable standard developer formula is the following:

	<i>Metric</i>	<i>Avoirdupois</i>
Developing agent.....	5 gms.	75 gr.
Sodium sulphite (E. K. Co.)...	50 gms.	1 2/3 oz.
Sodium carbonate (E. K. Co.) .	25 gms.	375 gr.
Potassium bromide.....	1.5 gms.	20 gr.
Water to.....	1 liter	32 oz.

1-b. A developing agent of unknown composition is compounded according to the above formula and compared with a known developing formula used for average work. Such a developer, known as MQ-25,² is prepared according to the

(1) Chemical methods of testing developing agents have been fully described by H. T. Clarke (Jour. Ind. Eng. Chem., Nov. 1918).

(2) The suffix 25 means that 25% of the total developing agent consists of Elon. See "A Simplified Method of Writing Developing Formulæ", by C. E. K. Mees, Brit. Jour. Phot., 1917, p. 535.

above formula, using 1.25 gms. of Elon and 3.75 gms. of hydroquinone as the developing agent.

2. A ready-for-use developer is compared with MQ-25 or with a known satisfactory developer.

3. The behavior of a developer prepared according to a new formula is compared with that of the best previously known formula for the particular purpose in question.

The Emulsion to be Tested.

Since the behavior of a photographic material towards developers is usually independent of the support on which the sensitive emulsion is coated, we will refer only to the action of developers on emulsions.

We cannot comprehensively speak of the properties of a developer without referring to the emulsion which is developed, and, vice versa, when speaking of the properties of an emulsion, we refer to them in connection with a particular developer.

Most developing formulæ are particularly adapted for particular classes of emulsions and should be compared on representative emulsions in such classes as follows:

Negative emulsions	{ NC film. Commercial film Process film.
Positive emulsions	{ Positive motion picture film. Seed Lantern plates.
Paper emulsions	{ Velox. Bromide and Artura Iris.

Mixing the Developer

When compounding test developers from the solid developing agent, it is important to weigh out the various ingredients very carefully in order to insure an accurate comparison. Instead of weighing out small quantities of potassium bromide it is more accurate to measure out the required volume of a 10% solution.

Since a developer which gives bad chemical fog is useless, and since more developers are rejected on account of fog than for any other defect, it is important that the rules of mixing developers be carefully observed so that no fogging agents are produced during mixing. As a general rule, the sulphite should be dissolved first, each chemical thoroughly dissolved



WILLOWS.

DR. F. DETLEFSEN.

before the next one is added, and the developer mixed at as low a temperature as possible; otherwise, the developer will give fog even if prepared from the purest chemicals. A report on a developer incorrectly mixed is absolutely worthless, because there is no way of telling whether the fog was inherent in the developer or was a result of incorrect mixing.

To mix the standard formula on page 185 proceed as follows:

Dissolve the sulphite in about 300 cc. or 10 oz. of luke warm water; then add the Elon or hydroquinone or both, and allow to cool. Meanwhile, dissolve the carbonate in 300 cc. of luke warm water, add the bromide, and cool. Now add the carbonate solution to the sulphite solution and add cold water to make 32 oz. or 1 liter.³

Sensitometric Methods.

When we expose a plate or film in a camera focused on a landscape, we impress upon the emulsion areas of light of varying sizes and of varying brightness. After development the negative consists of areas of varying sizes and varying opacity or density, the relation of the density of a given area to the intensity of the light producing it for the particular emulsion depending upon the developer and the time of development.

The density of any particular portion of a negative is a measure of its capacity for stopping light and is proportional to the total mass of silver comprising that portion. It can be measured by chemical analysis but much more readily by an optical instrument by comparison with a standard density. In the case of an average amateur negative the density of the shadows will average 0.25 to 0.4 and the density of the highlights from 1.2 to 1.8. One way of comparing the behavior of two developers is to expose two films in a camera on the same subject, giving the same exposure, develop them side by side and compare the densities of corresponding areas of the shadows, middle tones and high lights of the resultant negatives. This method is not entirely satisfactory because very few areas of uniform density are large enough to permit of measurement and it is not possible to place any two areas which received the same exposure side by side so as to compare the densities visually.

(3) See "How to Prepare Photographic Solutions", by J. I. Crabtree (Brit. Jour. Phot., 1919, p. 365); also, "Chemical Fog", (Amer. Ann., 1919, p. 20)



F. A. CHURCHILL.
Artatone Print.

DR. C. F. RODGERS.

It is much more simple, therefore, to expose a negative in steps of gradually increasing exposures so as to correspond with the shadows, middle tones and high lights of a subject and use these graded test strips in place of actual camera exposed films because the developed strips may be placed side by side and a comparison made of the densities of steps which received identical exposures.

How to Expose a Step Negative.

When measuring the characteristics of a developer in absolute units, it is necessary to use a standard light source and a special rotating disk or drop shutter for obtaining the graded exposures, but for comparison purposes it is simply necessary to give the test emulsion about 6 different steps in exposure, the lowest step being given such an exposure that after development the step will be just visible. The exact ratio of the exposures of the various steps is not important but should be of the order 1, 2, 4, 8, and 16.

To prepare a number of test strips, proceed as follows:

Take a 5 x 7 or 8 x 10 sheet of the film coated with the particular emulsion to be tested (see page 186), place in a printing frame, and cover with an opaque card. Now, make a preliminary test to ascertain the distance from the exposing light so that an exposure, say of 2 seconds, is required to produce a just visible deposit on the film when developed in the standard developer for an average time. Then, place the frame containing the sheet of film to be exposed at this determined distance from the light source, and shift the card so as to expose a strip of the film in the frame for 16 seconds. Then expose new steps after the expiration of 8, 4, 2, and 1 seconds respectively. The last step should be unexposed so as to serve as a fog test strip. The various steps have, therefore, received exposures of 0, 2, 4, 8, 12, and 32 seconds respectively (Figure I). Now, cut the film lengthwise along the dotted lines so as to give a number of graded test strips.

A quicker method than the above, if a large number of test strips have to be prepared, is to expose an 8 x 10 or 5 x 7 sheet of film as above, and develop this without cutting along the dotted lines. This graded strip negative can then be used as a master negative for printing test strips, the printing ex-

posure being so adjusted, as described above, that the least exposed step is just visible after development.

For purposes of comparing developers, the exact ratio of the exposures for the various steps is unimportant, though it is not advisable to make the ratio of successive exposure steps greater than the power of 2.

In some cases it is sufficient to make comparative tests on

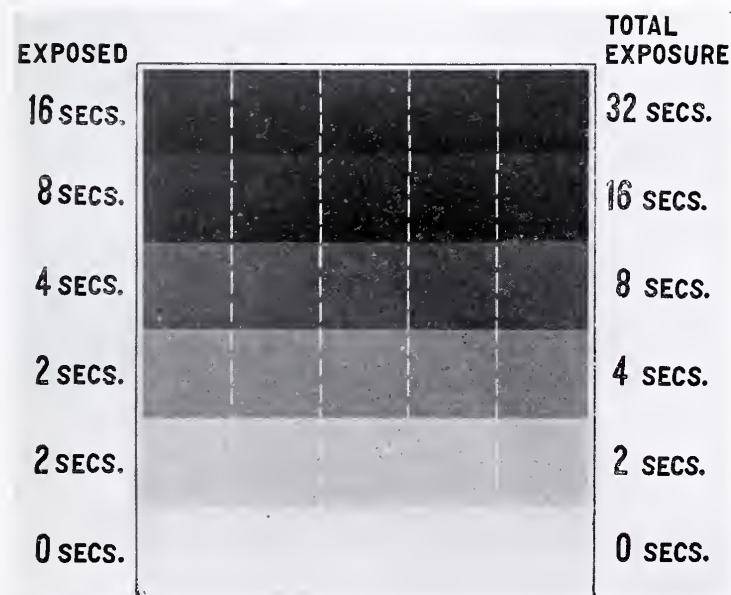

Figure 1.

Method of Exposing Test Film and Cutting Into Graded Test Strips.

strips of film which received only one step in exposure, which are known as "flashed strips." To prepare a number of flashed strips expose one half of a large sheet of film so that after development the density will be a little less than unity. This would correspond to a middle tone of an average negative, and objects should be just visible on looking through the flashed half of the developed film. The unexposed half serves for the fog test. The large sheet should then be cut lengthwise so as to give a number of test strips which all received the same exposure.

The Use of Graded and Flashed Test Strips.

Flashed strips give only a comparative measure of the maximum density produced by the developers. When comparing two similar developing agents for purity or when comparing contrast developers, flashed strip tests usually supply all of the information required. If developers are to be compared for detail rendering power and for contrast, then graded strips should always be used.

How to Interpret Test Strips After Development.

After development, the graded test strips will appear as in Figure 2. The lowest step, *a*, is a measure of the fog produced by development, since this step did not receive any exposure.

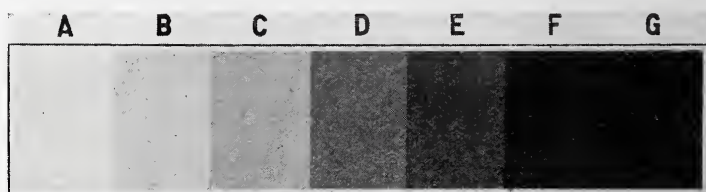

Figure 2.
A Step Negative As It Appears After Development.

Always think of the first step, *b*, and the last step say, *g*, as corresponding to the shadows and highlights in the subject photographed, the intermediate steps corresponding to the various tones of the subject. The density of *b* is a measure of the detail giving power of the developer, while the difference between *g* and *b* gives the density contrast. In the case of developers required to render a minimum exposure, say for high speed photography, the difference in density between *a* and *b* should be as great as possible with enough difference between *b* and *g* to give a sufficiently contrasty print, but with a developer intended for, say, line work, the density of *a* should be as low as possible; that is, the developer should be free from fog, while that of *b* and *g* should be as great as possible.

Factors to be Considered when Comparing Developers.

An ideal developer is one which will develop rapidly, give good contrast and shadow detail without producing chemical



HIGH SEAS.

Joseph Petrocelli.

fog, and which will deteriorate only slowly; that is, if it has good keeping qualities. Other factors are of less importance. The specifications of ideal developers for various purposes, of course, differ. For instance, if the most is to be secured from an under-exposed negative, it should be developed in a tray with a developer containing caustic alkali, this developer keeping active for only a very short time. In the case of amateur finishers' and motion picture film laboratories, a developer is required which will develop a normally exposed negative in from 5 to 15 minutes, but the developer must also keep in active condition for 2 or 3 weeks.

In order, therefore, to enable the reader to interpret the results of his tests, it is necessary first to study the various characteristics of a developer as follows:

I. THE DEVELOPING POWER

When we speak of "developing power," we are using a somewhat vague term in an attempt to sum up several characteristics of the developer in one word. An accurate description of a developer cannot be given briefly, because one developer may be very powerful as regards giving extreme contrast regardless of time, while another may be very energetic and give a normal negative quickly, but is incapable of giving extreme contrast. We may consider "developing power," therefore, as being made up of the following factors:

(a). *Time of Appearance of the Image.*

Every photographer has observed that after placing the negative in the developer, the time required for the first signs of the image to appear varies with different developers. The time of appearance is not an exact measure of the speed of development, because this depends also on the rate of diffusion of the developer and reaction products in and out of the gelatine film, though as a rule with a rapid working developer the time of appearance is short.

With a developer of the Elon type, the time of appearance is very short, but the image subsequently builds up slowly. With hydroquinone the time of appearance is much longer, but the image then builds up rapidly. The difference in behavior of these two developers is illustrated in Figure 3.

Graded strips which had received the same exposure were

developed in an all Elon developer (MQ-100) and in an all-hydroquinone (MQ-0) developer side by side and a strip removed from each developer at regular time intervals. After 1 minute all the steps were visible on the Elon strip but only the heavier exposures or highlights were visible on the hydroquinone strip. At the end of two minutes, the lower tones corresponding to the shadows in a photograph were just vis-

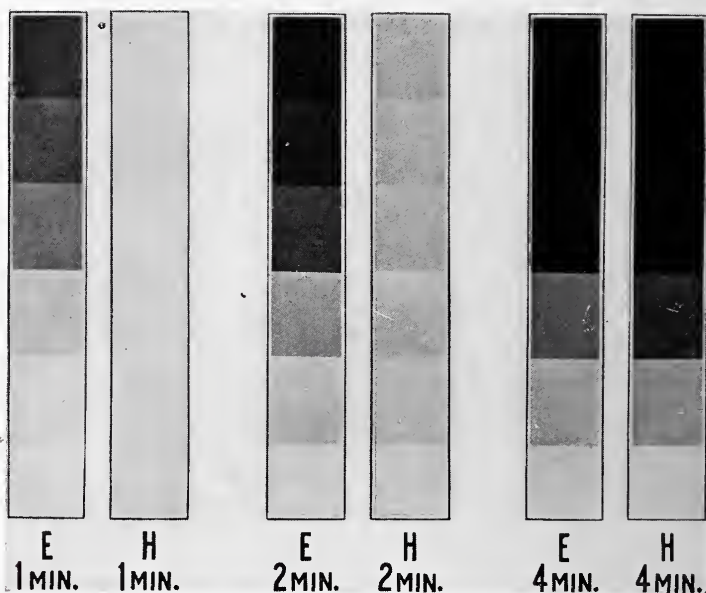

Figure 3.

Developed Graded Strips Showing the Difference in Behaviour Between Elon and Hydroquinone.

ible on the hydroquinone strip, but at the end of 4 minutes both strips looked almost alike.

When using developers of the Elon type, if the image is examined by inspection, the photographer is apt to remove the film from the developer too soon, because he is misled by the rapid appearance of the image, though from the above it is seen that to secure the same density contrast, it is necessary to develop for almost the same time. We say, therefore, that Elon has a high development factor and hydroquinone a low



DAWN.

KATE MATTHEWS.

one, the development factor, or Watkins factor, being equal to the total time of development divided by the time of appearance of the image.

When comparing two developer samples, say hydroquinone, by testing developers prepared from them according to the same formula, the time of appearance of the image is inversely proportional to the percentage of pure developing agent in the samples. With other developers it is a rough measure of the detail rendering power; that is, if the image flashes up quickly and the negative is not over-exposed, then we are reasonably sure that all the shadow tones will be developed out.

(b). *The Rate of Development after the Image Appears.*

Development consists in reducing the exposed grains of silver bromide contained in the emulsion to metallic silver. All the grains do not commence to develop at the same time, because they are distributed throughout a more or less thick layer of gelatine, but the rate at which the grains develop as a whole depends on the number of unexposed grains remaining to be developed. Therefore, as development proceeds and the number of undeveloped grains remaining become smaller, a fewer number of grains develops in each minute until finally it is not worth while to prolong development, because the unexposed grains then commence to be reduced to silver at a greater rate than the remaining exposed grains.

The growth of the image as a result of the development of the silver bromide grains is referred to as the growth of density, and in the case of a graded strip negative the density of the middle steps increases in the same proportion, but the lower and higher steps do not grow quite so fast. Figure 4 represents a cross section of a strip negative developed for, say, 1 minute. The difference between the lowest and highest steps (ab) or density contrast is very small. On prolonged development each step has increased in density, and the density contrast (cd) is much greater than (ab).

The density contrast of a negative is governed both by the difference in brightness between the high lights and shadows of the subject and by the degree of development of the negative. In order therefore to maintain the density contrast of a batch of negatives as constant as possible, films exposed on a flatly lighted subject should be fully developed, but those ex-

posed on a contrasty subject should be developed to a less extent.

Density contrast should be carefully differentiated from *general density*. An over-exposed and under-developed negative will have good density in the shadows, but the highlights will not be much more dense; that is, the negative as a whole will look dense but the density contrast will be small. The *maximum density contrast* is the greatest density contrast

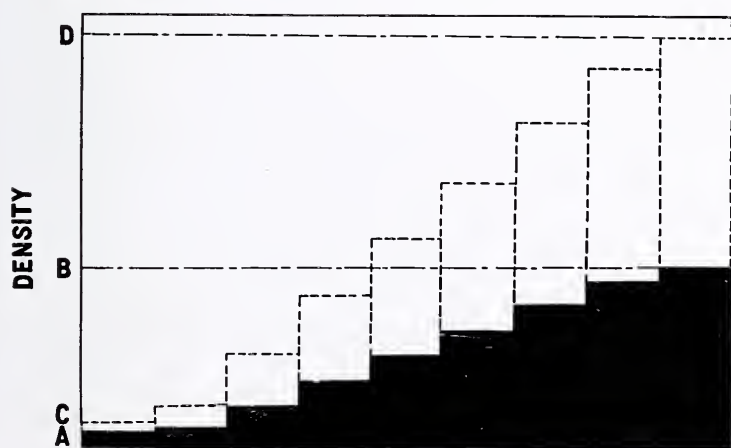

Figure 4.

Showing the Growth of Density of the Image During Development.

obtainable by prolonged development until fog begins to form at a greater rate than the image.

As regards maximum density contrast and speed of development, developers fall into four classes as follows:

(a) High maximum contrast and high speed of development; that is, the negative rapidly obtains great general density and contrast. In terms of the step negative (Figure 2, page 192), the density of *b* is fairly high and the density difference *g-b* is great also. Developers of this type are Elon-hydroquinone or pyro developers in combination with caustic alkali.

(b) Low maximum contrast and high speed of development. Elon developers are of this type; that is, the image flashes up but fails to build up general density. In terms of the step

negative, the density of b is fairly high, but the difference $g-b$ is comparatively small.

(c) High maximum contrast and low speed of development. Hydroquinone is a typical developer in this class; that is, the image appears slowly and development proceeds fairly slowly, but good density and contrast are finally obtained.

(d) Low maximum contrast and low speed of development; that is, the image appears slowly and development proceeds slowly, so that good contrast is never obtained.

(c) The Power of the Developer to Render Visible a Minimum Exposure.

For most photographic work this property of the developer is perhaps the most important. Contrast in a negative is not so important nowadays in view of the large variety of printing media of varying contrasts to take care of negatives of varying contrast. Referring to the step negative (Figure 2, page 192), the detail giving power of the developer is measured by the difference between the density steps a and b . This is obviously the greater the less the fogging power of the developer. The detail giving power is usually lowered by the addition of potassium bromide, which addition is analogous to cutting off the same amount of density from each step.

The relative effect of bromide on density is greater on the first step than on the last, and this is why when testing a developer it is advisable to omit the bromide from the test formula. With some very energetic developers, however, it is advantageous to add a certain amount of bromide because in some cases bromide restrains fog more than the image. In other words, suppose that in 5 minutes without bromide step b had a density of 0.4 and then fog commenced to form. In the next 5 minutes, suppose a fog density of 0.2 was formed and the total density of b only grew to 0.5. The effective density contrast is, therefore, 0.3. Now, suppose the addition of potassium bromide cut down the density of step b to 0.45 and cut the fog down to 0.05. Then the density contrast or effective density of b is 0.4, showing the advantage of adding bromide.

2. CHEMICAL FOG

When comparing developers, we are only concerned with developer fog and not with fog inherent in the emulsion. De-

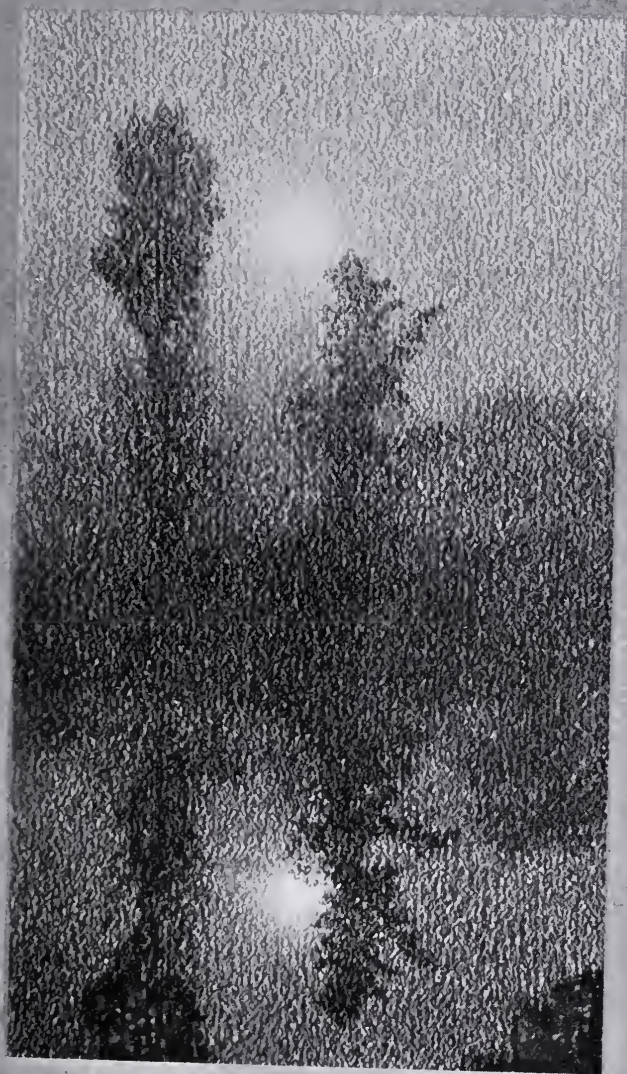

A Fine Morning

RE
Vr.
1921

veloper fog is caused by impurities or oxidation products of the developing agent formed during mixing. The importance of careful mixing of developers for test purposes is therefore apparent (See page 186 "Mixing the Developer").

Interesting facts about fog are that the fog layer is not distributed evenly over the entire image, but is thinner in the highlights because in those places where more image is developed, more potassium bromide is formed as a reaction product of development which therefore restrains the fog adjacent to the denser portions.

The absolute amount of fog depends on the volume of developer used. A film developed in a small volume of developer will have slightly less fog than if developed in a large volume, because in the former case the concentration of the bromide produced during development is greater.

Practical Determination of Fog.

Fog measurements are usually made by determining (a) the time required for fog to become just visible, and (b) the total fog density formed when development is complete.

(a) I. It has been found that a slow positive emulsion such as a lantern slide emulsion or motion picture positive emulsion, although very free from fog is very sensitive to the presence of impurities in the developer, and these emulsions are therefore very suitable for fog tests.

To make the test, first immerse one half of the unexposed film in the developer and then, after one minute, completely immerse the film. Fog will therefore appear on the first half sooner than on the second half, and the time for the dividing line to become visible is taken as the fogging point.

(b) II. The total fog density is given by the density of the end or unexposed portion of the developed graded strip (Figure 2, page 192). After the fog once appears its rate of growth is proportional to the time of development, that is, if the fog appears in two minutes and reaches a density of say, 0.2 in 4 minutes, then the fog density in six minutes will be around 0.4.

The total fog formed after developing to an average contrast is usually proportional to the time of appearance of the fog, though as seen from the curve in Figure 5, it is possible that two developers in five minutes, say, might give the same fog, but in three minutes the fog densities might be quite dif-

ferent. It is important, therefore, to consider both the time for fog and the total fog formed when development is complete.

Without a density measuring instrument the fog is most easily judged by laying the film, emulsion side down, on a sheet of white paper. With positive emulsions, such as lantern slides and motion picture positive film, no fog is permissible, but in the case of negatives, a very slight veil invariably forms by the time sufficient contrast is gained.

If a developer, which is otherwise satisfactory, gives excessive fog, the effect of the addition of a little potassium bromide should be tried before rejecting the developer. In the case of

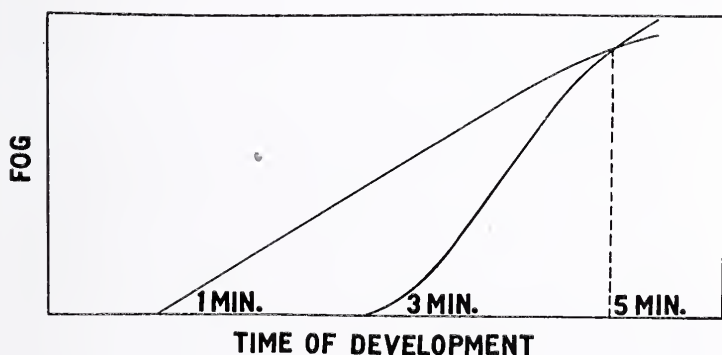

Figure 5.

Curves Showing the Rate of Growth of Fog During Development.

an energetic developer of the caustic-elon-hydroquinone type, bromide exerts a greater restraining action on the fog than on the image, so that increasing amounts of bromide should be tried up to, say, five grams per liter, noticing carefully the effect on the lowest density and the density contrast of the graded test strip. If the fog is reduced to practical limits, and the density of the lowest step is not diminished to an extent equal to the original fog density, and if the density contrast is likewise not diminished, then the fog has been effectively eliminated.

3. LIFE OF THE DEVELOPER

The active life of a developer is determined by

(a). The time required for the developer to oxidize by virtue

of contact with the air, and, therefore, become useless either as a result of exhaustion or because of fog resulting from the oxidation products of the developer.

(b). The useful work which the developer will perform; that is, the number of films or prints developed when the solution is used continuously.

(a). The resistance of a developer to aerial oxidation is called the "keeping power" and is determined by measuring, say, 500 cc. or 16 oz. of developer into an open tray, allowing this to stand at room temperature, and making graded strip tests at frequent intervals, preferably daily. Before making the daily tests, the volume of developer should be brought up to the original five hundred cc. with water, so as to compensate for loss by evaporation.

The keeping test should always be made in comparison with a standard, known developer.

As the developer becomes oxidized, it usually turns dark brown in color, though the rate at which a developer darkens in color is no criterion of the rate of exhaustion, because some developers darken slightly the first day of exposure and do not darken further on keeping, though the developer might be totally exhausted on the third day. An unused MQ (Elon hydroquinone) developer which on standing in a closed bottle turns slightly yellow and opalescent should be regarded with suspicion.

Keeping power is of great importance in the case of developers intended for use in tanks such as in motion picture and amateur finishing work. It is of less importance for tray development.

If the developer refuses to develop after standing in an open tray for two or three days at 70° F., it is useless for tank work. In the case of a developer with good keeping properties, the maximum density on the test graded strip will usually drop to about one half in three or four days when applying the above test.

(b). The *useful* work test is made by exhausting the developer by developing a number of films or prints for a definite time in a definite volume of developer and noticing the time of appearance of the image and the point at which a change in color or a weakening of the image occurs.

In practice, while the developer is being exhausted by virtue of developing the image, it is also being exhausted by aerial oxidation as a result of agitation, so that a strict exhaustion test could only be made by the impractical method of surrounding the developing tray or vessel with an atmosphere of an inert gas, say nitrogen, so as to prevent aerial oxidation.

The only final life test, therefore, is to exhaust the developer under actual working conditions.

If the developer oxidizes rapidly an exhaustion test is not of much value, so that the keeping test should always be made first, and then an exhaustion test made if the developer appears promising.

4. COLOR OF IMAGE

The color of the image is of most importance when developing paper prints and motion picture positive film. As a rule, Kodolon gives a grayish, hydroquinone a black, and Amidol a blue-black image.

Tests for color should always be made by cutting the test strips from a single sheet of film or paper, so as to insure that the tests are made on the same emulsion.

In the case of a negative, the color is of less importance, because the quality of the negative is determined by the final print which it produces. The only colored negative images met with in practice are those given by pyro. Elon-hydroquinone images are termed "neutral deposits."

With pyro, the yellow stain, which is an oxidation product of pyro, may be distributed uniformly over the image, in which case the effect is the same as if a yellow filter had been placed over the negative; i.e., it increases the printing exposure. The stain may also consist of image stain, in which case each developed grain of silver is combined with more or less oxidation product stain, so that the pyro stained image is composite and consists of a neutral silver image and a yellow stain image, the latter image, therefore, adding to the contrast.⁵ It is for this reason that a yellow stained pyro negative gives a more contrasty print than an apparently similar negative developed in a non-staining developer. When comparing negatives developed with pyro, therefore, always compare prints made from the negatives and not the negatives alone.

(5) See article on "Stains on Negatives and Prints," *Amer. Ann.*, 1921, p 204.

For negative work, a developer is to be preferred which gives a fairly colorless deposit, because in the case of a pyro stained image the quantity of stain depends on so many factors, such as the time and temperature of the developer, the time of rinsing, the nature of the fixing bath, the time of washing, etc., that it is almost impossible to control the quality of the pyro stained negatives obtained. When judging two developers, one of which gives a neutral deposit, and the other a pyro stained image, providing the two developers compare favorably as regards the capacity for rendering detail, fog, contrast, and keeping power, the developer which gives the neutral deposit or non-stained image is to be preferred.

MISCELLANEOUS FACTORS FOR COMPARISON

(a). *Effect of Dilution.* In many cases it is desirable to be able to dilute a developer so as to secure a certain contrast in a definite time, though, contrary to a popular notion, prolonged development with a weak developer does not always give better results than shorter development, say 5 minutes, in a stronger developer, and in many cases the results are inferior.

Pyro behaves normally on diluting up to three or four times; that is, the time of development is inversely proportional to the dilution, or if one volume of developer is diluted with, say, two volumes of water, in order to secure the same contrast the negatives should be developed for three times as long. The fog values for equal contrasts are likewise approximately equal.

A dilute developer, however, oxidizes more rapidly than one which is more concentrated, the rate of oxidation being roughly proportional to the sulphite concentration. Sodium sulphite at strengths higher than 10% to 15% oxidizes more or less slowly, but very rapidly at strengths below this. This is very apparent with developers intended for use with a reel and tank outfit. If the developer contains 10% to 15% of sodium sulphite, very little fog forms on churning up the developer, but if the developer is diluted with only 50% of water, fog may begin to form very rapidly.⁶

With Elon-hydroquinone the time of development is roughly inversely proportional to the dilution up to a dilution of one to three, though there is a tendency for the weak developer to give

⁶ See Article "Chemical Fog" (*Amer. Ann.* 1919, p. 20).



JARED GARDNER.

more fog than the stronger developer when developing to a given contrast. Beyond a certain dilution prolonged development does not increase contrast, because fog grows at a greater rate than the image.

A glycin developer will withstand more dilution than any other known developer and still behave rationally, and for this reason glycin has long been a favorite developer for tank work.

(b). *Effect of Temperature.* With developers such as hydroquinone, development proceeds very slowly at low temperatures, so that a developer of this type, as compared with an Elon-hydroquinone developer tested under arctic conditions would prove very unsatisfactory. For tropical work, a developer is required which will not cause undue swelling of the gelatine or excessive fog.

(c). *Alkalinity.* A developer which is strongly alkaline shortens the life of the acid fixing bath because the acid in the latter is rapidly neutralized by the alkali in the developer carried over by the films and prints, and under such conditions the films and prints are likely to become stained.⁷

Excessive alkali also tends to soften the gelatine film, so that, other factors being equal, a developer containing a minimum of alkali is to be preferred.

(d). *Cost.* The cost of the developer per unit of work performed is calculated by dividing the total cost of the developer (including labor) by the total area of the films and prints developed measured in square feet. A developer which is more expensive as regards chemicals but which has a long life is often cheaper in the long run because the extra cost of chemicals is more than offset by the saving of labor and perhaps tie-up involved when mixing a new batch of developer.

(e). *Physical and Chemical Properties.* The solubility, color, and crystalline form are of importance. A developing agent which is readily soluble in cold water and is white and crystalline is always to be preferred.

Developers of the monomethyl paraminophenol type are readily precipitated by a solution of sodium sulphite, which in many cases makes it impossible to prepare the developer in the highly concentrated form.

⁷ See Article on "Stains on Negatives and Prints" (*Amer. Ann.* 1921, p. 204).

PRACTICAL EXAMPLES

The following examples illustrate the methods of presenting reports on the various types of developers:*

1. Report on a Sample of Hydroquinone.

The sample was compared with a known pure sample of hydroquinone by first compounding the following MQ₀ formula with each sample:

	<i>Metric</i>	<i>Avoirdupois</i>
Developing Agent.....	5 gms.	75 gr.
Sodium Sulphite (E. K. Co.)..	75 gms.	2½ oz.
Sodium Carbonate (E. K. Co.)	25 gms.	375 gr.
Potassium Bromide.....	1.5 gms.	20 gr.
Water to make.....	1 liter	32 oz.

Sheets of flashed motion picture positive film were developed in each developer side by side at 70° F., and keeping tests made by exposing the developer for 24 hours in an open tray, taking care to dilute the developer to the original volume before testing each day in order to compensate for evaporation.

	<i>Sample</i>	<i>Standard</i>
Time of Appearance....	65 seconds	65 seconds
Time of Appearance after 24 hours.....	165 seconds	160 seconds
Density in 6 minutes....	1.94	2.00
Density after 24 hours..	0.85	0.86
Time for fog at 70° F..	11 minutes	12 minutes

The above results show that the sample consists of practically pure hydroquinone. Although the sample contains a trace of colored impurity which produces a little fog, this would be negligible in practice.

2. Report on a Sample of Elon Substitute.

The sample was compared with pure samples of Elon and Kodelon (paraminophenol hydrochloride) by compounding the MQ₀ formula and testing on sheets of flashed motion picture positive film, as follows:

<i>Developing Agent</i>	<i>Time of Appearance</i>	<i>Time for Fog at 70° F.</i>	<i>Density in 6 Minutes</i>	<i>Fog</i>
Elon	7 seconds	10 minutes	0.75	0.05
Sample	14 seconds	6 minutes	0.62	0.05
P. A. P.....	30 seconds	16 minutes	0.49	0.03

*In the absence of a density measuring instrument the photographer can visually compare densities with sufficient accuracy by placing the two graded or flashed strips side by side and examining the density of corresponding steps when looking through them against a uniformly illuminated light source such as a uniform sky. The lowest densities are best compared by laying down on a sheet of white paper.

From the above it is seen that the sample stands about half way between paraminophenol and Elon in its photographic behavior. (Since the sample was so remote from Elon, it was unnecessary to make further tests).

3. Report on the Developing Agent "X".

The developing agent "X" submitted consisted of light gray flakes, which were readily soluble in water and very readily precipitated by sodium sulphite. Preliminary experiments having shown that the developer behaved in a manner very similar to Elon, it was required to determine whether the developer became exhausted at a greater rate than Elon. Developers were, therefore, compounded with equal weights of Elon and the sample "X," according to the MQ₀ formula (Page 207), and sheets of flashed motion picture positive film developed in each developer for 7 minutes at 70° F. The films were developed consecutively without loss of time so as to eliminate as far as possible errors due to oxidation of the developer, and the time of appearance noticed in each case. The results were as follows:

	<i>1st Sheet</i>		<i>10th Sheet</i>		<i>20th Sheet</i>	
	<i>Time of</i>		<i>Time of</i>		<i>Time of</i>	
	<i>Appearance</i>	<i>Density</i>	<i>Appearance</i>	<i>Density</i>	<i>Appearance</i>	<i>Density</i>
Elon ...	5 seconds	2.5	12 seconds	1.5	40 seconds	0.98
Sample X	5 seconds	2.2	16 seconds	1.4	56 seconds	0.90

From the above tests it is seen that the sample X compares favorably with Elon as regards its photographic behavior although the color of the silver image produced was decidedly bluer than that given by Elon.

REPORTS ON DEVELOPING FORMULÆ

For practical purposes developing solutions may be divided into five classes as follows:

1. *Developers for average work.*
 - a. Negative developers (tray and tank).
 - b. Paper developers.

Tests on these developers should include developing power, life, color of image, fog, etc.

2. *Developers for under-exposed negatives.*

These developers should be tested against the following formula, which is the best present known formula for under-exposure work:



AUTUMN ASPENS.

EDGAR A. COHEN.

	<i>Metric</i>	<i>Avoirdupois</i>
Sodium sulphite.....	60 gms.	2 oz.
Elon	16 gms.	250 gr.
Hydroquinone	16 gms.	250 gr.
Caustic soda.....	10 gms.	150 gr.
Potassium Bromide.....	10 gms.	150 gr.
Water to.....	1 liter	32 oz.
Then add Wood or Denatured Alcohol	50 cc.	

If this developer gives too much contrast, reduce the negative with ammonium persulphate.

Preliminary tests should be made on flashed film, giving such an exposure that a just visible deposit is given by the above developer, in, say, 3 minutes. If the formula to be tested compares favorably with the above, a final test should be given by cutting a camera exposed film in two and developing one-half in each developer.

3. *Contrast Developers.*

- a. Short life type.
- b. Long life type.

The best contrast developer known to date is the following:*

	<i>Metric</i>	<i>Avoirdupois</i>
Solution A.		
Sodium Bisulphite.....	25 gms.	375 gr.
Hydroquinone	25 gms.	375 gr.
Potassium Bromide.....	25 gms.	375 gr.
Water to make.....	1 liter	32 oz.
Solution B.		
Caustic Soda.....	45 gms.	1½ oz.
Water to.....	1 liter	32 oz.

Use equal volumes of A and B.

This developer will not keep, so that for tank work a comparison should be made with the formula given in the report below, which has much better keeping qualities, but does not give as much contrast as the formula above.

The following example illustrates the method of testing contrast developers:

Report on a Process Developer Formula for Tank Work.

The formula submitted was compared with the Eastman

*See "Elementary Photographic Chemistry" p. 48. (Obtainable gratis from the Eastman Kodak Company.)

process Elon-hydroquinone tank developer, the formula for which is as follows:*

	<i>Metric</i>	<i>Avoirdupois</i>
Sodium Sulphite.....	75 gms.	2½ oz.
Elon	1 gm.	15 gr.
Hydroquinone	9 gms.	135 gr.
Potassium Carbonate.....	25 gms.	375 gr.
Potassium Bromide.....	5 gms.	75 gr.
Water to make.....	1 liter	32 oz.

Tests were made on flashed process film, developing for 5 minutes at 70° F., and the tests repeated at intervals, until on standing in open trays the developers were exhausted. The results were as follows:

	<i>1st Day</i>		<i>2nd Day</i>		<i>4th Day</i>		
<i>Developer</i>	<i>Density</i>	<i>Fog</i>	<i>Density</i>	<i>Fog</i>	<i>Density</i>	<i>Fog</i>	
Test Formula....	1.14	.05	.74	.05	.00	.00	Developer reddish brown
Eastman Formula	1.62	.09	1.43	.06	1.03	.04	Developer slightly yellow

The above results show that the developer submitted is inferior as regards developing and keeping power to the Eastman formula.

4. *Ultra Rapid Developer for Recording Paper.*

With many scientific recording instruments the record is made by means of a beam of light reflected from a mirror on to a traveling band of photographic paper. It is often necessary to develop this record almost instantaneously, and for this purpose the following formula is recommended:

	<i>Metric</i>	<i>Avoirdupois</i>
A. Sodium sulphite.....	15 gms.	225 gr.
Elon	10 gms.	150 gr.
Hydroquinone	10 gms.	150 gr.
Sodium sulphite.....	60 gms.	2 oz.
Water to.....	1 liter	32 oz.

Then add 50 cc. of wood or denatured alcohol to keep the Elon and hydroquinone in solution. The sulphite is added in two portions to facilitate solution of the Elon.

B. Caustic soda.....	25 gms.	375 gr.
Water to.....	1 liter	32 oz.

Use equal volumes of A and B.

*See "Booklet Reproduction Work With Films" p. 10. (Obtainable gratis from the Eastman Kodak Company.)

When comparing a new formula with the above, tests should be made on flashed sheets of paper and preference given to the developer producing the greatest density in the shortest time providing the keeping properties are satisfactory.

5. *Deep Tank Developers for Motion Picture Film Work and Amateur Finishing.*

Satisfactory developing formulæ in this class are more difficult to work out than any other developing formulæ because deep tank developers must fulfill so many conditions, as follows:

(a). The developer should give a negative of fixed contrast in a given fixed time. An average time for developing motion picture negative and positive film is five minutes, and fifteen minutes for amateur finishing. The time fifteen minutes is convenient because it takes about ten minutes to load a new rack with films. The time of development is easily adjusted by diluting the developer or making it more concentrated.

(b). The keeping properties should be satisfactory as regards growth of fog with age, non-staining properties, and exhaustion. After the developer has been used for some time, the concentration of potassium bromide, which is formed as a result of conversion of the silver bromide emulsion to metallic silver, increases so that if the developer contains much hydroquinone, which is very sensitive to bromide, shadow detail in the negative is lost. Pyro, Elon, and Ortol are less sensitive to bromide and should therefore predominate in a negative developer. Pyro oxidizes rapidly and gives stain unless an excess of sulphite is added, which in turn tends to produce fog. For motion picture positive work the effect of the accumulated potassium bromide is of less importance, since this can be compensated for by increasing the printing exposure.

In tank work, as the developer becomes exhausted as a result of performing useful work, it is customary to increase the time of development by about one minute per day so as to maintain a constant contrast of the negatives.

Tank developers should be given a thorough exhaustion test by developing camera exposed or flashed films in a deep glass tank containing about half a gallon of solution, a sufficient number of films being developed daily so as to correspond to an average daily run in a fifty or one hundred gallon tank,



STUDY.

JANE REECE.

Graded strip tests should also be made daily and developed to a given density contrast, the density of the lowest steps which are a measure of the detail giving power being carefully noted.

(c). The alkalinity should not be excessive; otherwise, the acid fixing bath soon becomes neutral as a result of the neutralization of the acid by the alkali in the developer carried over by the films.

The following example illustrates the method of testing tank developer.

Report on a Deep Tank Developer Formula for Amateur Finishers.

The formula submitted was tested against the standard formula by first developing flashed sheets of NC film for 15 minutes at 70° F, the tests being repeated after allowing the developers to stand in open trays over night and diluting to the original volume to compensate for evaporation. The results were as follows:

	<i>1st Day</i>		<i>2nd Day</i>	
	<i>Density</i>	<i>Fog</i>	<i>Density</i>	<i>Fog</i>
Test Formula. . . .	1.50	.32	1.40	1.30
Standard Formula	1.06	.20	0.20	0.15

This preliminary test showed that the developer submitted has excellent keeping qualities, so that further exhaustion tests were made by developing the equivalent of five hundred rolls of film per day in fifty gallons of developer for a period of five days. Daily tests were made on graded strips noticing carefully the lowest density and the density contrast. The results were as follows:

	<i>1st Day</i>				<i>5th Day</i>			
	<i>Densities</i>		<i>Density</i>		<i>Densities</i>		<i>Density</i>	
	<i>2nd</i>	<i>6th</i>	<i>Con-</i>	<i>Fog</i>	<i>2nd</i>	<i>6th</i>	<i>Con-</i>	<i>Fog</i>
	<i>Step</i>	<i>Step</i>	<i>trast</i>		<i>Step</i>	<i>Step</i>	<i>trast</i>	
Test Formula.	0.31	1.60	1.29	0.14	.11	1.21	1.10	0.10
Standard Formula.	0.30	1.20	0.90	0.13	.20	1.01	0.81	0.13

The above results show that although the test formula has excellent keeping properties, as the developer becomes exhausted it loses its power of rendering shadow detail. The developer costs twice as much as the standard formula, but the cost per unit of work is less, since its active life is greater.

Precautions to Be Observed When Testing Developers.

1. Make all tests on film having the same emulsion number.

2. The flashed strips or exposed graded strips must all receive *the same exposure*, especially when making keeping tests at daily intervals. To insure this the exposing lamp should be placed in circuit with a volt meter, and the voltage maintained constant at, say, 110 volts. It is also advisable to adjust the time of exposure so that the exposure required is at least 20 seconds either by varying the distance of the printing frame from the light source, or by placing one or two sheets of opal glass between the lamp and the exposing frame. If an error of one second is made in exposing, the error will then be only five per cent, while if the exposure given is two seconds and an error made of only one-half second the effective error would be twenty-five per cent.

3. The developers to be compared must be at *the same temperature*.

Tests at daily intervals in order to be strictly comparative should be made at the same temperature, although the temperature usually varies only slightly from day to day. Unless a thermostat is available it is better to make the tests at room temperature (which should be stated) providing the temperature of all the test developers is the same, rather than attempt to adjust the temperature to a standard temperature.

4. *The degree of agitation of the developer* relative to the film when making the tray and tank tests *should be constant*, because when the film or developer is agitated the developer in contact with the surface of the film is frequently renewed and the development is much more rapid than when the film and developer are stationary. Handling of the test strips is much facilitated by pinning across a wooden frame with the aid of glass push-pins.

5. When making the exhaustion tests the sheets of film used for exhausting the developer should be half flashed, that is, one-half of the sheet should be unexposed so as to represent an average exposed negative. An average rate of exhaustion is the equivalent of ten sheets of 8 x 10 film per gallon of developer per day for five or ten successive days.

As each successive daily test is made there is a loss of developer from evaporation and from absorption by the gelatine film. In the tanks are covered the loss by evaporation will be negligible.

SNAPPING STATE CAPITOLS

By GEORGE STEELE SEYMOUR



HE collecting mania is strong in man. Whether one be a Japanese and collect male and female ceremonial dolls, or an American and collect picture post cards, it is the same passion. The owner of a camera—a tyro—an amateur with a turn for accumulating negatives, will find his efforts running along certain lines, and so will be established his field for photograph collecting.

I once held to the mistaken notion that a camerist need not snap familiar objects, on the ground that better pictures of them could be bought ready-made. Thus I missed many negatives for which uses have later arisen. When one is far away and suddenly wishes a picture of the bronze palmetto tree at Columbia, S. C., or the totem pole at Tacoma, Wash., it makes no difference that the tourist in those respective localities is overwhelmed by a profusion of them.

My career as a collector of state capitols is thus divided sharply into two periods; the early, characterized by an avoidance of the obvious (due to an overplus of theory and underplus of experience), and the present, in which the proximity of a dome leads automatically to the click of the shutter.

State capitols are difficult subjects, since you must see them from the same point of view from which everyone else sees them, and originality of treatment is almost impossible. Nearly all of them are abundantly domed. At Madison, Wis., the shining white dome dominates a three-cornered structure—three wings radiating from it. The dome is similar to that of the capitol at Washington—the only closer resemblance that I know of is the one at Sacramento. My camera visited Madison on a sunny Sunday, but on the tenth floor of a near-by office building a room was found open, and from the window of this room our view was taken. The anastig-



STATE CAPITOL,
MADISON, WIS.

GEORGE STEELE SEYMOUR.

mat brought out nicely all the fine details, though the view is, of course, without any artistic pretensions.

In "quaint, historic Sante Fe," the field proved more favorable. Down the romantic lane habited by the Mexican maiden, an air of mystery is lent to the undersized building with its unmistakably tinnish dome. The tin dome maker must once have been popular, for at Salem, Oregon, we come across him again. Its neighbor, Olympia, however, resisted his enchantment, and Washington State has adopted as her capitol a brown stone building that would pass creditably for a union station.

Some states have spent millions in the effort to make their official headquarters a focus of art and talent. St. Paul boasts an architectural gem; Harrisburg, with all its reputed graft, is ornately decorated. New York has erected a French chateau on the top of a steep slope—a most unreasonable location, from a photographer's way of thinking. The only way I know of to get it upright on a film is to take it sidewise down Eagle Street. Beacon Hill is famous, and the golden dome at the head of Park Street needs no more introduction than does the replica of a cod-fish that hangs over the Speaker's desk.

Custom seems to have established the dome as a widespread, though not universal, feature of capitology. Certain capitol buildings of the middle west—Lansing, Springfield, Topeka, Lincoln, Denver—are almost duplicates of one another. Possibly some portable house builder or large mail-order concern could let us into the secret of this uniformity. The dome at Des Moines covers much that is of interest—an especially fine law library, for one thing, and a notable wall particularly a museum of transportation in the basement, painting of the coming of the pioneers, for another—but including an immense Conestoga wagon or prairie schooner, with its brown hood spread, just as it used to "cross the prairies as of old." It is an inspiring sight.

But the domeless capital is by no means unknown. Albany I have mentioned. In Baton Rouge is to be found a much earlier French chateau, in, I grieve to report, not nearly such good repair. The crenellated towers set high on the bank of the Mississippi make a picturesque view provided one is far

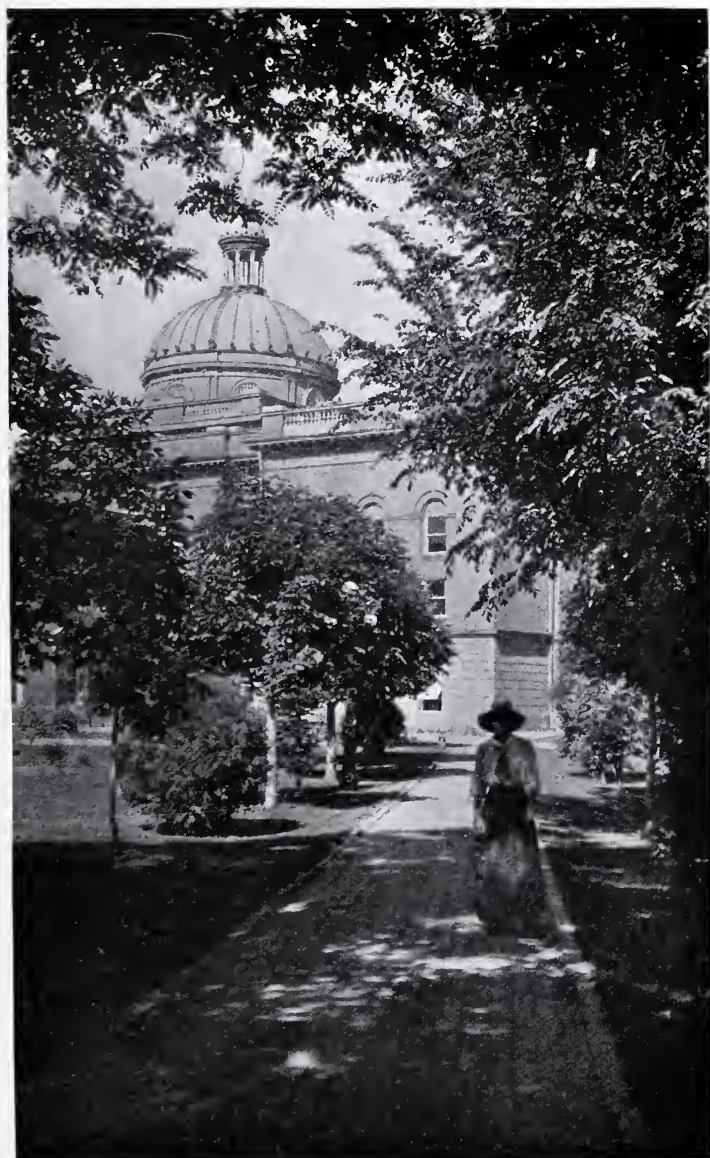

STATE CAPITOL,
SANTA FE, NEW MEX.

GEORGE STEELE SEYMOUR.

enough distant to be oblivious to the loosened tiles and chipped plaster. On the bank of the Kennebec stands another domeless capitol, though Maine has provided her legislative house with the conventional up-hill site. Delaware has a fine modern colonial structure, of the type of Bullfinch, towered instead of domed. Nashville still uses the antique towered meeting-house of earlier days, while Richmond legislators meet in a Greek temple which does not seek to reflect architecturally the face of its great neighbor upon the Potomac.

History dwells deep in some of these ancient agoras. One cannot fail to feel reflective beside the tall columns of the building at Montgomery that sheltered the first congress of the Confederacy. The graceful Georgian state house upon the Severn, in a town as yet undiscovered by railroads, upholds the dignity of its founder, Lord Baltimore, amid surroundings as old and dignified as itself. A statue of Roger B. Taney stands guard over it. In Concord, the statue and memory of Franklin Pierce, favorite son of New Hampshire, protects a building of the conventional type; while in Columbia, the honor of South Carolina is properly set off against an extremely made-to-order structure by the bellicose Wade Hampton in bronze. An effect of greater modernity is achieved in Indianapolis, where Benjamin Harrison stands guard before a state capitol that is not located on a hill and into the building of which many other novel features have entered.

Strangest in its antecedents is the domed palace at Austin, located in spacious grounds at the end of an avenue flanked by statues of prominent citizens. The government of Texas, finding itself in need of an official residence and lacking the million dollars or so needed to build one, contracted with an eastern syndicate for the erection of its capitol and paid for the same with a small empire of the public lands. When you look on the map of Texas and see a great stretch of country in the western part of the state where railroads have not yet entered, that is the so-called "capitol land grant." Who can say whether or not the deal was a wise one?

These are but a few of the memories awakened by my packet of negatives from state capitols.



STATE CAPITOL,
BATON ROUGE, LA.

GEORGE STEELE SEYMOUR.



Figure 3.

THE WILLOW SCREEN

*Illustrating article "On Cultivating the Habit of Observation,"
by William S. Davis.*

ON CULTIVATING THE HABIT OF OBSERVATION

By WILLIAM S. DAVIS



ONE of the most valuable—indeed essential—assets for the photographer is the power of accurate and keen observation of the multiplicity of elements constantly met with. Many people who possess good eyesight and a normal allotment of "grey matter" go about their daily tasks with only sufficient knowledge of the aspect of objects and persons to recognize acquaintances and surroundings on sight. This limited perception, which precludes an understanding of the more subtle changes constantly taking place and the reasons therefor, is not due to inability to comprehend more, but purely to undeveloped powers of observation, these being in



Figure 2.

BY THE RUSH FRINGED BANK

*Illustrating article "On Cultivating the Habit of Observation,"
by William S. Davis*



Figure 1.

IN APRIL

*Illustrating article "On Cultivating the Habit of Observation,"
by William S. Davis.*

need of cultivation before it is possible to enjoy to the fullest the beauty, and varied aspects, of whatever material is presented to the eye.

No matter how far a pictorialist may choose to depart from a literal rendering of facts it is necessary to have an understanding of such matters as details and forms of natural objects, and what changes are to be expected from differences in lighting, etc. before it is possible to select and reject intelligently from the mass of material open to choice, since even the most imaginative idea must, if it is to be rendered



EVENING IN THE PARK.

R. B. M. Taylor.

clear to the spectator, be expressed by means of familiar forms which serve as symbols.

Nature is in a continual state of flux, every leaf and blade of grass slowly but surely undergoing changes which ultimately become visible to the most casual observer, while even those objects which are supposed to remain in a static condition are greatly altered in outward aspect according to the time and conditions under which they are seen.

One of the best ways to stimulate the habit of observation known to the writer is to select some subject of easy access and watch the variety of transformations which will occur from such causes as change of season, angle of lighting at different hours of the day and night, atmospheric conditions ranging from clear sunshine to fog, rain, and driving snow, and of course the alteration in grouping of lines and masses to be noted from various viewpoints.

While the habit of visual observation should be cultivated until it ceases to be a conscious effort it is a decided help to supplement this with camera or sketch-book. Even though one may not possess real skill with the pencil the effort of trying to draw an object will tend to increase the keenness of observation, since one must really see a detail distinctly before it can be drawn, and this causes much to be noted which might otherwise be overlooked. For this reason sketch-book notes are of educational value to the photographer, who sometimes falls into the habit of simply studying the general aspect of a prospective subject, knowing that the lens will record all the detail. The result of such carelessness is not infrequently brought home when the print is made and distracting elements claim attention which were quite unnoticed in the original at the time the exposure was made.

By way of illustrating these notes four studies are presented (selected from a much larger number) of a single group of willows located upon the margin of a small pond. "In April" (Figure 1) presents the subject before the foliage appeared, the diffused lighting quite characteristic of a mild spring afternoon lending tonal softness to the rendering. "By the Rush Fringed Bank" (Figure 2) was made in June from a standpoint considerably to the left, and lower, than the first, while "The Willow Screen" (Figure 3) shows the

trees as they appear from a point on the shore directly back of them, with a suggestion of water appearing beyond. In Figures 2 and 3 an effort was made to utilize in a decorative manner the pattern formed by the spots of foliage and spacing of the tree-trunks. The fourth study, "A Winter Afternoon" (Figure 4), shows the material from almost the same angle as the springtime study, but nearer the trees, and somewhat lower, the difference in effect between them being due to the presence of snow and greater space occupied by the trees in the winter composition.



CHARLES W. DOUTT.



A WINTER AFTERNOON

Figure 4.

*Illustrating article "On Cultivating the Habit of Observation,"
by William S. Davis. (Page 222.)*

THE MINIATURE CAMERA FOR EXHIBITION WORK

By T. W. KILMER



ONE of the greatest helps to me is to know the various methods employed by photographic workers in making and printing their entries for exhibition work.

Take the last American Salon at Pittsburgh as an example: John Paul Edwards makes his work in such and such a manner, Porterfield does so and so, Louis Fleckinstein works this way. They all have their peculiar methods of procedure to produce the finished result.

Many use the 8 x 10 and the 11 x 14 camera, many pictorialists employ smaller instruments. Personally the small camera appeals to me from the standpoint of weight. I use for most of all my exhibition work (out door work) a small Icarette film camera, taking films $2\frac{1}{4}$ inches square. As I am called here and there in my professional duties, the little Icarette is always with me. Sometimes I use a K₃ filter, but mostly not. I get my clouds by stopping down. The lens is an anastigmat of F7. It is my aim to produce on the film a sharp, clear picture of what I see. This small, sharp negative is then enlarged, either in its entirety or portions of it, upon a smooth semi-matt paper. Personally I use Artura extra heavy. I enlarge always up to 8 x 10.

These 8 x 10 prints are worked up as follows: Take a drop or two of megilp, add to it five or six drops of turpentine, place a piece of cloth over your finger and mix these together. Have two tubes of water color, one of ivory black and the other of white. To fix up a bald-headed sky—touch the cloth (after mixing the megilp and turpentine) to a little ivory black, rub smooth on the bottom of a white dish or glass plate, and then rub over the entire sky with your finger covered by the cloth. After this has set, say for five or ten minutes, fold a clean piece of cloth over your finger and rub out places on the sky, representing clouds, blend



Illustrating article "The Miniature Camera for Exhibition Work," by T. W. Kilmer.

these together. By a little practice all types of skies may be put in. Shadows in the landscape may be accentuated by use of the ivory black.

In the same way planes of the picture may be separated by using the white for the distance. By using black or white on a small stump you can modify your original print in many ways to improve its pictorial value. When the 8 x 10 print is worked up to suit you, place it on an easel and copy it with a soft focus lens up to any size negative you wish. Personally I use an 11 x 14 commercial film and a Verito lens. With the finished large negative you may print in any medium you wish. My exhibition prints of late have all been multiple gums.

By the use of the small camera we may make many exposures at small expense. Let me finish by saying that the greatest help to me is in placing every film I make in the enlarging lantern and studying its pictorial possibilities when viewing it many times enlarged upon the screen.



E. J. BROWN.



Illustrating article "The Miniature Camera for Exhibition Work," by T. W. Kilmer. (Page 228.)

WRITING FOR PHOTOGRAPHIC MAGAZINES

By **FREDERICK C. DAVIS**

NY one who is a practical amateur or professional photographer is eligible to write for photographic magazines. These various publications are constant buyers of articles which are of interest to photographers; and while their rates of payment are not as high as could be wished, the remuneration is satisfactory. No great literary ability nor extensive photographic experience is necessary in order to write something acceptable for these magazines, but the article must be practical and helpful. The writer must have had photographic experience, be it as a vocation, as an avocation, or as a hobby.

Needless to say, general encyclopædic recasts—such as “How Photography was Discovered”—are not wanted; nor are dissertations on the relative beauties of photographs and oil-paintings; nor any material whatever rewritten from reference books. Articles instructing how to make new apparatus, how to adapt old photographic appliances to new uses, how to save money when making photographs, how to obtain new effects, how to do any practical thing useful to the photographer—such as that is what is wanted. The editors of these magazines like live and interesting informative articles by persons who know from experience whereof they write.

Three years of experience in writing for photographic magazines has taught me one vital thing: if you are interested in the practical phases of photography, write practical articles, and not essays on pictorial composition; and if you are artistically inclined to accept photography as a new means of pictorial expression, write articles that consider the art of photography, and not any telling how to make enlarging-cameras or ruby-lamps. (These two subjects, by the way, have been overworked.) William S. Davis, who is one of the most frequent contributors to photographic magazines, is by profession an



WHENCE AND WHITHER.

Louis J. Steele.

artist, so he logically writes articles from a pictorial standpoint; whereas I, having done commercial and illustrative and press work, write wholly from the practical angle. It is necessary to write of the things on your own side of the fence.

Following is a list of prominent photographic publications, with the needs of each outlined, with a list of typical titles from some, and with perhaps a word or two here and there of personal observation. Certain magazines such as Abel's Photographic Weekly (Cleveland) and the Bulletin of Photography (Philadelphia) use articles of interest to professional photographers only.

American Photography, 428 Newbury Street, Boston, Mass. Frank R. Fraprie, Editor, Arthur Hammond, Associate Editor. Monthly. This magazine uses articles treating almost every phase of photography. Its needs, like those of other photographic magazines, are so general in its line that it seems no one sort of practical article is more favored than another. It is desirable, though, that articles on ordinary photographic subjects be not too long; also that the subject be covered thoroughly, and not too argumentatively. Not more than three or four illustrations should accompany any one article. These restrictions I have found in personal experience. Matter accepted for publication is paid for on publication at the rate of \$3.00 per printed page, which averages about one-half cent per word.

A list of representative titles of articles showing the sort of matter this magazine prints:

Enlarging on Gaslight Paper.	Making an Enlarging Apparatus.
Photographing in the Home.	Photographing Interiors.
Finishing Efficiency.	Far Eastern Art and its lessons.
Angle of View and Wide Angle Lenses.	Notes on Marketing Prints.
Photographing Athletic Events.	
Tropical Photography.	

The Camera, 636 Franklin Square, Philadelphia, Penna. Frank R. Chambers, Editor. Monthly. This magazine prefers articles telling how to make things. Literary efforts that get nowhere are at a discount. Articles of interest to practical workers are preferred to be of about 1,000 words long. "Reports in two or three weeks." Pays on acceptance at about one-half cent per word or slightly higher.

Representative titles from The Camera :	Management of Lines in Com- position.
Use and Abuse of the Soft Focus Lens.	Control in Development. Figures in the Landscape.
Improving the Printing Qual- ity of Negatives.	Correct Exposure.

Camera Craft: Claus Spreckels Building, San Francisco, California. Monthly. This publication does not pay for unsolicited manuscripts. A great many able writers and ardent photographers feel willing to give, without pay, the benefit of their experience and ability to fellow enthusiasts. These have generally filled the pages, apparently with satisfaction to Editor and Reader. Contributions are always welcomed and, meeting standards and policy, are published.

Photo-Era Magazine: Publication-office, Wolfeboro, New Hampshire; Boston office, 367 Boylston Street, Boston 17, Mass. Wilfred A. French, Ph.D., Managing Editor; A. H. Beardsley, Associate Editor and Publisher. Monthly. This publication uses articles on photographic subjects that are scientific, practical or that describe interesting parts of the world for the tourist-photographer to visit. Articles are solicited from practical photographers only. Manuscripts are reported on within two weeks and payment is made upon acceptance, at the rate of \$3.75 per printed page. The smaller type used in printing *Photo-Era Magazine* compensates for the seemingly higher rate. The rate is really about one-half a cent per word, the same as other photographic magazines pay. A few representative titles of articles printed in *Photo-Era Magazine* are:

Balance by Shadow in Pictorial Composition.	
Photographic Greeting Cards.	The Cheapest Printing Pro- cess.
Mounting Prints.	
Push-the-button Retouching.	The Big Question—Exposure.
The Quartz-Meniscus Lens.	Repairing Broken Negatives.
How to know your best photo- graphs.	Insects in Comic Photography.
The Enemy—Dust.	The Camera in The Wind- ward Islands.
Cob-web Photography.	Selling Your Photographs.

Photo-Miniature, 103 Park Avenue, New York, John A. Tennant, Editor. Monthly. This is a series of monographs



FOREST RANGERS IN CALIFORNIA.

OSCAR MAURER.

on photography issued in the form of a monthly magazine. Each issue contains a monograph, dealing exhaustively with some one photographic subject, of from 10,000 to 15,000 words. Before submitting manuscript for this publication, write to the editor asking whether the subject is acceptable, and be sure that your information is cast in the form usually shown in its pages. Manuscripts are reported on in ten days. A clear, concise, and practical survey of the subject is indispensable in monographs intended for this publication. \$50.00 is paid on acceptance for suitable monographs.

Kodakery: Eastman-Kodak Company, Rochester, New York. Monthly. Articles for *Kodakery* must be written for the amateur, and should not exceed 1,000 words. This magazine is small, and is mailed free-of-charge to anyone who purchases an Eastman camera made for amateurs. It is maintained as an advertisement, which fact should be a valuable hint to the writer. Manuscripts are reported on in one week and payment is made on acceptance at a rate fixed accordingly with the value of the contribution.

It is evident that the foregoing magazines do not use small photographic items of a hundred words or so. However, *Popular Mechanics* (Chicago) in its Shop Notes and Amateur Mechanics' department uses many original and novel items of about one hundred words, paying on acceptance rates varying from \$1.00 to \$7.50 and even more for acceptable material, depending on the value of the contribution. The average price is about \$3.00.

Illustrated World (Chicago) buys the same sort of material, paying on acceptance at rates varying between \$1.00 and \$2.00 for each item. Address the Handy Mechanics Department.

Popular Science (New York) is usually overstocked with photographic articles, but when they buy they pay from \$1.00 up for each, the average being \$2.50 for items illustrated with photographs. Address such articles to the Practical Workers Department.

Other magazines which occasionally use photographic articles are *Browning's Magazine* (New York), *International Studio* (New York), some art-magazines, as well as various home-publications which now and then use articles telling how to make better photographs.



COAST NEAR MONTEREY, CALIF.

F. WILLIAM CARTER.



Figure 3.

Illustrating article "Photographing Oriental Art Bits and Bric-a-brac,"
by Dr. R. W. Shufeldt.

PHOTOGRAPHING ORIENTAL ART BITS AND BRIC-A-BRAC

By R. W. SHUFELDT, M. D.



ALL of the objects to be described in the present article form a part of my private collection. They came from various sources, and some of them have been in my possession for over fifty years. One day I conceived the idea of photographing the pieces here reproduced; and as the photography of such bric-a-brac draws a bit on one's taste and skill, it occurred to me that an account of my success in this matter might be of interest to the readers of the *Annual*, especially if accompanied by an historical sketch of the material, as well as a short description of each piece.

In Figure 1 we have a most interesting object that came from China—I think from the city of Shanghai—and is probably the work of a native; it has been in my possession since about 1865, so its exact history has, to some extent, faded



Figure 2.

*Illustrating article "Photographing Oriental Art Bits and Bric-a-brac,"
by Dr. R. W. Shufeldt.*

from my memory. Whoever the artisan may have been, he evidently intended to produce a piece worth the while, for it is no less than fourteen inches in height, carved out entirely of one piece of some hard wood. Whether it represents a Buddha, or some Chinese lady of rank, or other female personage, I am unable to say. Some student and expert in this line of Oriental art can best pass upon that point. That it is intended to represent Buddha, I doubt very much. The face, hands, and feet have been painted a deep red color, while all the drapery is heavily overlaid with gilt and that to a very considerable thickness. This has kept wonderfully well when we consider the age of this piece and the traveling it has done. As will be observed, the pose is a seated one, but not a conventional Buddha attitude, for the right leg is raised, and it is only the left that is in contact with the seat for its entire outer side. In the left hand is held a black roll of what appears to be some document or other, as its ends are painted to represent the rolling. As will be seen in the photograph, the seat, whatever it may be intended to represent, is a lofty and most elaborate affair, curiously carved and painted in a deep black, with a few blotches here and there of a bright green, especially near the base. Two ledges have been formed by the carver at the back of this seat—one on the right hand side to hold a green vase from which a flame seems to be issuing, while the other is a rest for a white bird—possibly a cockatoo.

To make an effective picture of a figure of this sort, it demands to be photographed directly from in front, as it is from this point alone that this ancient and attractive piece can be appreciated. On direct lateral view there are but two points best seen, and these are the profile of the person, and the fact that the elaborate top of her seat or throne arches far over her head, its outermost point being in about the same plane with one an inch in advance of her left knee. The back of this piece is flat and uncarved.

A very remarkable piece of pottery of Japanese manufacture is shown in Figure 2, it being a "chocolate-pot," and was probably made for the export trade. The spout, lid, and upper half of the handle of this vessel is glazed, and of a mottled sap green color, the rest being dull and unglazed and



Figure 1.

*Illustrating article "Photographing Oriental Art Bits and Bric-a-brac,"
by Dr. R. W. Shufeldt.*

of a dark Prussian green, marked all over with Japanese characters, as though done with a blunt pinpoint. About an inch above the bottom there is a small, raised, white slab of china, pointed above and rounded below, upon which a hair-line character is traced, which may be the trade-mark of the maker. On the outer left-hand side of this pot are two figures of men in alto-relievo, probably engaged in playing some game or other; they stand on ledges raised above the outer surface of the vessel, evidently placed there for their especial accommodation. The opposite side is plain; hence, in photographing such an object, it should be turned so that the spout and handle show up well, to let us see as much as possible of the two figures that lend such a remarkable interest to the piece as a whole.

The beautiful little teapot shown in Figure 3 is of Chinese make, of a pale green color, and a piece of "trick china"; it holds about two small cups of tea; and when a stranger is served, he or she is very apt to wonder how it was filled, as it has no lid, and no opening at the top, while the spout is very small. To let the secret out, I may say that the opening is in the bottom and stoppered with a very small cork. The Chinese think this is very cute and a great joke!

The block seen in the same figure with the teapot is of wood, two and a half by one and a half inches in size, and one inch thick. Upon it are two raised Chinese characters. This was my father's personal card-plate for his visiting cards in China, when he commanded one of our warships in the Asiatic station. It was left to the taste of the owner as to what color ink to use and what kind of paper, and there were places in Shanghai where the printing was done and the "cards" ordered.



Figure 1. Comparison of Structure From Different Regions of a Copper Alloy (Microscopic).
Illustrating article "Photography in Research and Science," by Arthur G. Eldridge.

PHOTOGRAPHY IN RESEARCH AND SCIENCE

By ARTHUR G. ELDRIDGE

WITHIN the past few years there has been an increasing use of photography in research work and in science for industrial purposes as well as educational. The still camera and the motion camera combined with the microscope are far reaching in their application, giving us indisputable evidence, and making records superior to any possible description or other methods of recording.

In the field of metallurgy there has been great advancement in recent years in the knowledge of metals and in improved products, much of which is due to Microscope Photography. This makes it possible to record the results so that a comparative study may be made (Figure 1). A properly prepared specimen placed under stress in a special stressing machine may be photographed in motion through the microscope, showing the action of the crystals, the failure and breakdown of the metal under excessive load (Figure 2).

This work has led to investigation on a large scale of the fatigue and failure of various kinds of steel for important

uses. The metallurgist in studying the heat treatment of metals makes photomicrographs of the results in a long series of specimens, revealing the effects of the treatment on the structure and composition which can not be indicated by chemical analysis.



Unstressed.

During Stress.

During Stress.

Figure 2. Progressive Stages in the Failure of Wrought Iron Under Repeated Bending Stress.

In biology the functioning of organs, the movements of corpuscles in arteries and veins and their reactions to parasitic organisms may be shown clearly by motion pictures (Figure 3). Studies of the effect of rotation on the semicircular canals of animals and nystagmus of the eye in humans have

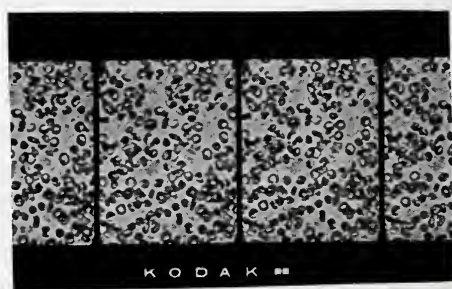
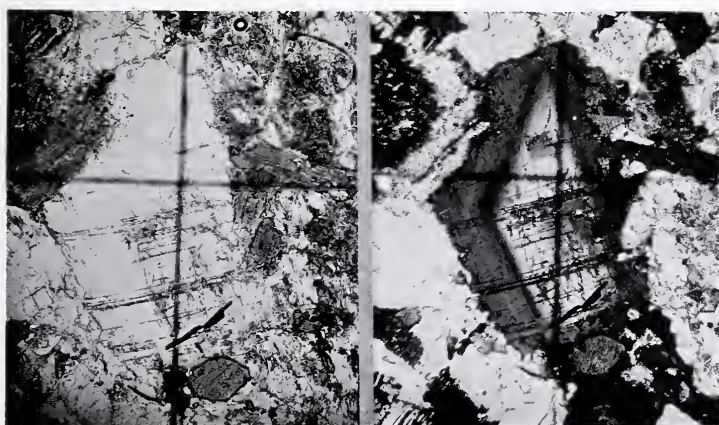

Figure 3. Corpuscles in Motion Showing Their Form and Change of Shape as They Pass Through the Capillaries.

proven to be of value. By reducing or increasing the nominal speed of taking we may see things hidden from the unaided eye.

We may pass beyond the range of visibility to the ultra violet region and record photographically some things we would never see because within the range of visible light certain substances do not differentiate from their surroundings.

Slow motion pictures of athletic performances are of great value for instructional purposes in athletic coaching. It takes one a long time to find out by eye what happens in the quicker motions of discus throw, ball pitching or tennis. Film a perfect performance once and it may be repeated indefinitely without losing "form."



Ordinary Light. Polarized Light.
Figure 4. Structure in Rock Section Revealed by Polarized Light.
Identical Area in Each Photograph. (Microscopic.)

In the field of geology, industrial development of mineral deposits may hinge on what the microscope reveals. The camera will record what the scientist sees for the illustration of his report. A case in hand gave proof of the presence of certain minerals when photographed in polarized light, while other methods of determination had given a negative answer. (Figure 4).

From these few illustrations we can see that photography is a potent tool of science, recording where nothing else can record; giving in a flash a faithful reproduction of intricate structure where hours of labor at drawing could not interpret; telling quickly the facts where chemical analysis or physical examination would fail.

MORE ABOUT PHOTOGRAPHIC LENSES

By CARL W. ATKINSON



IN response to the request of the Editor, the writer will attempt to follow up the article "Photographic Lenses, Types and Uses" in last year's *Annual*, taking up some of the subjects in more detail.

In that article we traced the progress of photographic optics from the beginning through the various stages; the single achromatic lens, the rectilinear, the Petzval, and lastly, we briefly mentioned a few of the modern types of anastigmat lenses. In this number, we shall briefly review a part of last year's sketch, especially that part referring to the various aberrations, and go into a bit more detail in the discussion of types of anastigmats.

The six aberrations we mentioned were (1) Chromatic aberration; (2) Central Spherical aberration; (3) Distortion; (4) Symmetrical Spherical aberration of oblique pencils (astigmatism); (6) Curvature of field. Other aberrations exist but they only appear in objectives of exceedingly large diameter.

Chromatic aberration, though the first fault to be corrected (chronologically speaking) is still extremely troublesome owing to the fact that glass does not disperse all parts of the spectrum equally, and it is quite impossible to correct any lens for all colors. The ordinary photographic lens of short or medium focal length is quite well enough corrected for any reasonable purpose, but in the huge telescope this variation of the foci of various colors may be a matter of inches and prove very troublesome indeed—particularly when it is desired to photograph with them.

In microscope objectives it is possible to use fluor spar and obtain almost complete elimination of this troublesome error, but perfect pieces of fluor spar are never found of size sufficient for use in photographic lenses, so that recourse must be had (when especially fine color correction is imperative) to



JOY.

Hand Coated Platinum on Japanese Vellum.

MYERS R. JONES.

a variety of glass which contains calcium fluoride. This glass possesses to some degree the dispersive peculiarities of fluor spar, but is not nearly so effective.

Spherical aberration of direct pencils can be corrected so completely that in the paraxial zone (or even an angle of perhaps ten or even fifteen degrees) the image will bear enlargement until diffraction breaks it down, i. e. "The standard of definition is equal to the theoretical diffraction image." This standard of definition can be more easily obtained if larger angles than those named are not demanded, but in many of the modern lenses not only an angle of sixty degrees or more must be covered, but also they are required to work at relative apertures far greater than were deemed practicable in former years.

This condition frequently makes necessary the sacrifice of some of the fine central definition in order to obtain fair marginal correction; some modern anastigmats lack much of the fine central quality of a rectilinear by the best makers. Some ultra rapid anastigmats do not give images of really critical sharpness and will shift focus when stopped down, making it really necessary to focus with the stop to be used in making the exposure; this is caused by the fact that perfect correction for central spherical aberration (of direct pencils) has been sacrificed to attain marginal definition, speed or both.

Distortion was fully covered in the 1921 *Annual*, so that no further mention need be made of it here.

Astigmatism and coma have long been the *bete noir* of good lenses, and they are most difficult to explain because no drawing can be made to properly illustrate them.

Paul L. Anderson in his book "Pictorial Photography" gives perhaps the best definition and illustration of astigmatism in print today. We quote:

"Astigmatism is that defect in which bundles of rays passing obliquely through the lens near the margin are converged, not to points, but to straight lines. Each such bundle is converged to two straight lines at different distances from the lens and at right angles to each other, or, rather, it is converged to a line, and after passing the point of convergence it diverges again to another line. Astigmatism is difficult to illustrate graphically, but may be understood by anyone who will



AN OLD FASHIONED GIRL.

William Alexander Alcock.

roll up a truncated cone of paper and pinch the small end to a straight line, afterward pinching the cone to another straight line at right angles to the first and at some distance from the end. The straight lines represent the projection of a point of the object, whereas if the lens were free from astigmatism this projection would be represented by rolling the paper so as to form a complete cone, the small end being a true point. It should be noted that astigmatism appears only at the margins of the field, so will not be noticeable if the lens is of great focal length relatively to the plate used. The practical result of astigmatism is to render it impossible to focus simultaneously on vertical and horizontal lines in the same plane and lying near the edges of the field, so that if the image of a tree, for instance, comes close to the edge of the plate the trunk will be sharp and the branches blurred, or vice versa, but it will not be possible to get both sharp at once, except by using a small diaphragm."

Coma is an unsymmetrical error which increases greatly as the lens diameter grows larger in proportion to the focal length; it therefore is the arch enemy of rapid lenses. A certain amount of it can be camouflaged by scattering it over the entire field; this is frequently done, and the only way it is noticeable is that the resulting negatives are grey and hazy in appearance—they lack "sparkle" or "snap."

It is possible to correct a single element for coma, and the well-known Cooke and Heliar lenses were designed to eliminate the error by this means; each of the three elements is free from coma. Other lenses have been constructed which are remarkably free from this error. Dr. Rudolph practically eliminated it in his original design of the F/6.3 Tessar, while several of the most famous of modern designers have made great strides toward absolute correction of it.

Complete correction of curvation of field is at present, and will be, impossible as long as opticians are compelled to use spherical curves as lens surfaces. No way has ever yet been devised for the successful grinding of ellipsoidal surfaces with the accuracy necessary for photographic objectives.

The development of aeroplane photography has caused great steps to be taken in overcoming curvatures, since absolute flatness of field over an angle of about forty-five degrees is an

essential to successful work of this character and too, it must be obtained in very large aperture lenses. Some of the very newest lenses of this type are wonderfully well corrected.

The term "Anastigmat" may be truthfully applied to any objective in which is attained good correction for astigmatism, central spherical aberration and curvature. Good correction for chromatic error is assumed and usually attained. The best optical firms produce lenses of this type which are not only well corrected for these errors, but are also very free from other and equally serious defects.

A very excellent type of anastigmatic objective may well be termed the "Protar type" since the Protar by Carl Zeiss was the first objective of that design, and is still one of the very finest of the various convertible anastigmats.

Each element of the "Protar type" is composed of four elements cemented together to form a very perfect single lens which is in itself a complete anastigmat working at $F/12.5$. The doublet is, of course, equally excellent in its performance, works at from $F/6.3$ to $F/7.7$, and at small apertures, covers about 85 degrees. The outstanding feature of this type is the readiness with which different singlets may be combined to obtain doublets of different focal length; a set of three or four of the single elements making possible a selection of six or ten focal lengths.

Several lenses of the "Protar type" are made today, each having its individual claims for superiority, and the writer is glad to remark that nearly all of them are of high excellence. The only real disadvantage of the construction lies in the fact that, owing to the deep curves and numerous elements, it is very costly to produce.

Another type of lens which was and is deservedly popular has three cemented elements in each half. The complete lens gives an excellent image over (at small stops) about ninety degrees; its usual aperture is about $F/6.8$, and it can be relied upon to do excellent work under any conditions when its speed is sufficient.

As compared with the preceding type, the latter has a somewhat wider angle, but not quite so flat a field; the cost is less but it is much less readily combined in sets and the singlets do



GILMER WINSTON.

not perform as perfectly unless stopped down to (in most cases) $F/16$.

Many lenses of the triple cemented type are produced, and those by the really reliable makers are of high excellence.

Another type of lens is composed of two symmetrical elements, each of which consists of two cemented meniscus elements whose concave surfaces face the diaphragm. It usually has a very flat field of about 65 degrees, within which angle the definition is extremely critical at an aperture of about $F/6.3$. At small stops this angle is somewhat increased. It costs somewhat less to produce than many types, and slight variations of glass are easily compensated by varying the separation of the elements.

A rather unique type of lens we will term the "Cooke type," since the Cooke lens is the most prominent example of it. It is composed of three single elements which are separated by air spaces; the front and rear element are double convex, while the central lens is a double concave, more powerful than either of the positives. Each element is free from coma in itself, and the curves and separations are so designed as to give very fine correction for the other errors. The image is, therefore, very sharp and, by reason of its perfect coma correction, very brilliant.

Several modifications of the original design have appeared, giving lenses which are intended for different purposes.

One of the most successful and widely modified lens designs (among unsymmetrical lenses) is that of the "Tessar type." It is composed of two uncemented elements in the front combination and two cemented behind the diaphragm. It was originally designed to work at $F/6.3$ to cover an angle of about 65 degrees. Within these limitations of speed and angle, it is almost unsurpassable.

It has been widely copied and modified with more or less success, the first modification having been made by the original designer. This was an $F/4.5$ Tessar, which at the time of its introductions was easily the best $F/4.5$ anastigmat on the market, inasmuch as its image showed fewer optical errors than any of its predecessors. It is still in a class with the very finest of ultra rapid objectives—a class which is above criticism and no one of which, perhaps, is superior in every

way to the others. Most of these, too, are of the Tessar type.

This article would scarcely be complete without a brief description of telephoto lenses, which have been developed greatly within the past decade.

Telephotography has long been practiced and deserves greater popularity not only on account of its possibilities in the way of obtaining large images of distant objects, but also on account of the very perfect perspective obtained by its use.

The forerunner of the telephoto lens was called the "Orthoscopic Lens," and consisted of a positive front combination with a negative rear. It gave a long focal length with a short bellows extension (as do all telephoto lenses) and was, for a time, very popular. It proved, however, not to be orthoscopic, as it gave marked distortion, and soon disappeared from the market.

J. H. Dallmeyer experimented for a long time with a lens similar to the "Orthoscopic," except that varying sizes of image were made possible by altering the separations of the positive and negative elements, thus altering the focal length. Failing to eliminate serious distortion he gave up this design in favor of a fully (centrally) corrected positive lens, and a negative element constructed as a doublet similar to a rectilinear. This largely obviated distortion at the expense of at least doubling the number of glass-to-air surfaces in the complete combination.

For several years Dallmeyer's plan was used by the various opticians except for the fact that they made a cemented singlet negative, instead of a symmetrical doublet. For architectural work these lenses are most excellent, since the positive element may well be one of the cemented triplet or of the Protar type, which can be used for medium or wide angle work, independent of the negative lens.

Such combinations are necessarily very slow, and for work demanding quick exposures one must either use very rapid positive or one of the two types to be described.

While it is not in the province of this article to give an elaborate description of telephotography, perhaps a few words of explanation may be of use: In telephotography the rays emerging from the positive element and the image thereby magnified to a degree depending on the distance between and

relative focal length of the two. It is quite evident therefore that (1) the central part only of the image formed by the positive is used (since the rest would be off the plate) and therefore the central corrections of that element must be perfect for the errors are magnified; (2) Since the image is spread over a larger area it is less powerful in its action on the plate. A positive lens working at $F/4$ gives a telephoto combination working at $F/8$ at $2X$; $F/12$ at $3X$ etc.

A few years since, several lenses appeared on the market which allowed telephoto snapshots. They were almost identical with the "Orthoscopic" in principle though far better corrected. They gave a $2X$ magnification with ordinary and negative aberrations were well balanced. They worked at speeds which varied from $F/9$ to $F/5.4$ and proved a great boon to press photography.

The call for a variable focus telephoto lens with speed caused Dallmeyer and Voightlaender to fit lenses of the Petzval type with telephoto attachments, but their great weight and bulk has been an objection.

At last Zeiss produced a cemented quadruplet which worked at $F/3$, and mounted this in an adjustable mount with a negative element. This was a distinct step in the right direction, and it was perfect enough that some of these lenses are still in use. It made possible a snapshot outfit of reasonable bulk, which could be used to photograph subjects theretofore impossible.

There are several lenses of this type on the American market today which are very successful. They are light enough to work on a reflecting camera, and so well corrected as to do fine work at their full aperture, which is quite rapid enough for anything except the highest speed work.

In conclusion may the writer venture to state that were he selecting an outfit for "all around work" he would choose a "set" of lenses of the Protar type or a cemented triplet type lens. For hand camera work one of the $F/6.3$ Tessar type would prove exquisite. For speed work there is a wide range of ultra rapid objectives to choose from, and they vary widely in their characteristics as applied to the different requirements of the photographer.



SOLITUDE.

G. H. S. HARDING.

PHOTOGRAPHY IN BIOLOGICAL WORK

By B. F. LUTMAN

HE following notes make no claim whatever to originality of method used; they have been gathered from various sources, and many of them are well known to biologists who make use of the camera for recording some of their observations. At the present time almost every botanist and zoologist uses the camera at some time or other for such a purpose since it offers such a quick and convincing means for recording evidence. The methods here suggested, however, are ones that have been tested out and found successful in quite a number of years of experience with botany and photography, and while they are fragmentary and unconnected, they may at least serve to call attention to some materials or procedures that are not as widely known as they might be. The author frankly recommends certain products—not because they are necessarily the only ones or maybe even the best—but for the reason that they have given results with him in the particular work for which he wished to use them.

Lenses. A lens, good, bad, or indifferent, some one has said, is worth just about what you paid for it. A high priced lens for photographic work like a good microscope objective means good workmanship, and is backed by the advertising, and by the reputation of a reliable firm. There is, however, one factor that adds greatly to the price of many of the lenses known as anastigmats. This is what is known as speed. The aim of the modern lens maker is to produce a lens that will work at very short exposures in poor light, or will catch rapidly moving objects in good light. This means that the lens has a large aperture, and large aperture lenses do not have depth of focus; it is optically impossible to have both at the same time.

But the biologist does not need speed one time in a thousand. So, unless the laboratory lens is to be used surreptitiously for pictures of the baby at home, or of auto races,



AN OLD FARM HOUSE.

C. E. Wakeford.

its wide aperture and resultant speed is useless. A rectilinear will, in most cases, do just as well as a high priced anastigmat since they will both have to be stopped down to a small aperture to secure depth of focus, and at these small openings the results obtained could not be distinguished even by an expert. A lens of the speed known as F/6.8 will answer all requirements. Fine definition and a brilliant image are the real measure of a lens for scientific purposes. The author is strongly prejudiced in favor of the cemented type of lens, and has used a Voigtlander Collinear Series III and a B. & L. Plastigmat for years with better success than with the air space lenses. Nearly all, if not all, of the cheap anastigmats are of the latter construction. The advantage of the cemented lenses is that they work against the sunlight without flare and give a brilliant image. A lens of as short a focal length as possible is of advantage in giving depth of focus. A seven or seven and a half inch lens on a 5 x 7 plate or a five or five and a half inch on a 4 x 5 plate, would be my recommendation.

Shutter. Reliability is the test of a shutter for scientific work. Speed, as with lenses, is not essential. The Compound, Volute, or Optimo shutters answer all requirements, but my choice would be a Volute since it gives timed exposures up to three seconds.

Camera. The majority of scientific men have settled on the 5 x 7 camera as the proper size for indoor, or for not too extensive field work. Its advantages are in the medium price of the plates, the camera is not too large to carry, and in the size being just right for the page of the ordinary average book or bulletin. Two points are to be considered in buying a camera: a rigid front for the shutter and lens and a long bellows. The bellows should be at least sixteen inches long.

In addition to the 5 x 7 camera, which, with its case and six loaded plate holders will weigh ten or twelve pounds, a smaller pocket camera that can be taken on field trips and excursions is advisable, and is the instrument that will be used nine times out of ten for work outside the laboratory. A roll film camera $2\frac{1}{4} \times 3\frac{1}{4}$ is the best choice for this sort of work; it is convenient; it is small enough to go into the

pocket; the films can be obtained anywhere; the pictures are large enough for contact prints and as large as can be made into lantern slides by contact. For real work such a camera should have tripod sockets and some means for focusing.

Second hand apparatus. When funds, either laboratory or personal, are scarce, second-hand lenses and cameras may be had that have lost little except the newness of the leather, or the brightness of the nickel trimmings together with about a third of the original price. Of course, if money is no consideration, it is as well to buy new equipment, but a little shopping among the reliable second-hand dealers will often bring up just the sort of an instrument that you want. There are a number of such firms now where the purchaser can be assured of fair treatment.

Photographing colored objects. The average biological worker falls back on ortho or isochromatic plates for bringing out differences in the intensities of greens and yellows in plants or animals. These plates will answer most needs, as they are sensitive to these two colors when used with a yellow or orange filter of proper density. The photography of colored flowers presents a lot of new problems, however, as does the proper rendering of the various shades produced in plant diseases. In some cases a panchromatic plate is absolutely essential for success. The Eastman Kodak Co. have a pamphlet on "Color plates and filters for commercial photography" that may be had without cost, and Dr. C. E. K. Mees, the scientific director of the company, has written a small and very understandable book "The Photography of Colored objects" that is invaluable to any one interested in getting proper color renderings in plants, or in any other object for that matter. The latter book sells for about fifty cents and is obtainable from any dealer. The Wratten Panchromatic plate and the Wratten filters, also Eastman Commercial Panchromatic film are made by the Eastman Company. They will do the work as well as anything on the market at the present time since they are sensitive to all of the colors, even red, but must be used with the proper light filter.

Photographing stained sections or stained objects. It is often difficult to get sufficient contrast from stained sections with the ordinary plates even those that claim to be iso- or



GILL & SON.

orthochromatic. The writer has even fallen back on process plates since they gave more contrast. Blue or purple stains are always the hardest to handle, and these tones are very common in sections stained with the so-called triple stain. The Eastman Company makes a plate for this special purpose known as the Wratten M. This plate is panchromatic, and so must be developed either in darkness or with a green safe light. It is backed, a great advantage in getting a brilliant negative. The emulsion is a slow one but as rich in silver as a process plate. No special difficulty is experienced from the development in the dark as a few trial exposures will usually give the right time. Or a special screen for the dark-room light may be obtained from the same company. The proper light filter must be used for the dye with which the sections are stained. The Eastman Company have a booklet on the subject "Photomicrography" which may be had for the asking. The absorption bands of the various stains, and the effect of the proper light filter on the time of exposure, have all been worked out and are presented in tabular form. My method for introducing the light filter may be new. For low magnifications, a B. & L. or Spencer Lens daylight lamp is placed under the microscope substage, the daylight glass being removed and a piece of white frosted glass substituted. The mirror is useless and must be first removed from the instrument. The light from these lamps is sufficient for medium magnifications. The Wratten filters (two inches square) are bound up between two plates of glass (lantern slide covers) and placed on the lamp. The light which reaches the stained object is colored. The advantage of this method is that the light filter if placed at any other point may cause optical troubles especially after it has been enclosed between glass. It is necessary to enclose these filters in this manner, or to buy them enclosed, as they are only stained pieces of gelatin and are readily soiled by the fingers.

Cut Films. Some years ago, it was possible to obtain several makes of cut films which could be slipped into special holders and then loaded into the ordinary dark slide. They had two great advantages over the glass plates in that they were non-breakable, of light weight, and small bulk when stored. It has been estimated that they have one tenth the

weight of dry plates and occupy one sixth the amount of storage space. Scientific negatives, especially those taken in the field, have often to be sent by mail to be developed, and the non-breakable quality is appreciated if the views are highly important ones that may be almost impossible to obtain a second time.

The cut films went out of fashion for a number of years, but the Eastman Company has recently taken them up in this country, and is pushing them under the slogan, "Cut films will replace glass dry plates as the dry plates replaced the old wet plates." The Portrait film put out by this company was the only type obtainable for several years but today, the same company puts out Commercial, Commercial Ortho, and Process films, all at the same price and Panchromatic films at a slightly higher price. The Commercial Ortho is especially fine for biological work where small differences in color is to be represented, but for most work the Portrait film is entirely satisfactory. The superiority of the Commercial Ortho comes out when the subtle differences between the plants that have been treated with different types of fertilizers is attempted in a photographic manner. The shades of green, green-yellow, and bluish green are perfectly clear to the eye, but are exasperatingly elusive on a photographic plate. The Portrait films can usually be obtained from dealers in fair sized towns, but only in the size purchased by the commercial portrait photographer, i. e., the 5 x 7. The price of cut-films, it may be said, is about the same as for first class glass plates of the same type.

Stereophotography. Ten or fifteen years ago, the stereo photograph was often the only object of art in many homes. The movies have killed off popular interest in double pictures, but they still have a place in scientific work. The immense advantage that stereographs have over the ordinary single print is that they give objects in all their three dimensions while the latter at its best only gives two dimensions, length and breadth, and suggests a third dimension by the distribution of light and shade. The medical profession and the animal anatomists have recognized the advantage of stereographs for dissections to show the structure of the body as laid open by the scalpel and scissors. They have been used

also to give a life-representation of certain diseases; one of the elaborate atlases on skin eruptions being put out with all of the illustrations in the form of double stereophotographs. There are many places in botanical work where the stereo picture is superior to the single picture, but the attention of the writer has been directed to it principally because of its applicability to plant diseases in which the whole plant, or some part of it, is distorted. Mosaic of potato foliage is one of the new potato troubles that causes a lot of worry to growers in the North, especially those who ship their tubers for seed. The peculiar crinkling of the foliage is characteristic, but can be brought out much better in a stereo print than in a single one. In fact the stereograph is almost as good as seeing the disease itself.

The American stereo cameras (Century, Premo, Conley, Korona, etc.) are plate cameras of the 5 x 7 size and can be used for any other work where a single large print is desired by removing in a few minutes the pair of lenses and the internal septum and attaching a single lens. A broad front (known as a stereo front) and broad bellows are the only differences between this form of camera and an ordinary one of the same size. A pair of rectilinear lenses of about 5 inches focus in a stereo shutter completes the outfit. The Eastman Kodak Co. puts out a stereo roll film camera which is very convenient for field work but offers the disadvantage, as do all roll film cameras, that it is impossible to focus on a ground-glass. The stereo prints are just as easy to make and mount as ordinary ones, and there is nothing complicated or mysterious about the whole process. If you have never tried stereo photography, you will be fascinated by it as a means of representing in a picture all that we see in nature except the color, and it is possible to add even this attraction if Autochrome plates are used.

Line drawings from photographs. The line drawing is often preferable to the photograph for purposes of reproduction. The only successful cheap method of reproducing a photograph is by means of a half-tone, and this type of plate only prints well on a fairly smooth paper. It prints at its best and approximates the photograph itself on a glossy, highly calendered, printing paper but such a paper is today very



IN DOCK

WARREN R. LAITY.

expensive and cannot be used for bulletins that are to be printed by tens of thousands for free distribution. A simple method of changing photographs into line drawings has been followed for years by the U. S. Department of Agriculture and is essentially as follows:

A clean, clear negative of any size, is best as it has to be used for enlargement. The negative is put into an enlarging lantern and a large print, say 8 x 10 or 11 x 13 made from it. This print must be on a paper that does not have a glossy surface; Enlarging Cyko or Artura Carbon Black work equally well. The dry print is gone over in outline with Higgin's India ink. The objects are all gone over in ink on this print, care must be used to see that everything of importance in the photograph is represented in ink. Shading is represented either by lines or cross-hatching. The print furnishes the background, shading and everything—no special artistic skill is necessary—and a little practise will soon show just what must be reproduced in the ink to make the line drawing look lifelike when the photograph has all disappeared.

The next proposition is to get rid of the photographic image entirely. This is done in a bleaching solution. Prints may be bleached in a strong solution of Farmer's reducer. This reducer is made up of potassium ferricyanide and hypo and bleaches rather slowly. A fairly strong solution of the ferricyanide should be used to hasten matters. A bleach which will work equally well and is used by many photographers is a four per cent solution of potassium cyanide to which is added a little iodine in a potassium iodide solution (10% c. c. of a 1/3% of iodine in a 1% potassium iodide in water to 90cc. of the potassium cyanide solution). There seems to be no particular advantage in this combination over Farmer's reducer and the highly poisonous character of the potassium cyanide itself and even of its fumes makes extreme care necessary in handling it.

Before placing the prints into this solution for bleaching, the writer has always found it best to have them bone dry. The easiest way to do this is to lay the print for a few minutes on the steam radiator after the last ink work has been completed on it. The ink will stick tenaciously to the paper and not be dissolved in the above solution, but the print must not

be touched, and the washing which follows the bleaching (10 - 15 minutes) must be carried on in such a way that the stream of water will not strike the print directly. Do not touch the print until it is completely dry when it will be found that the ink will not be easily removable. This method will lend itself to converting photographs of any sort into line drawings. One of the most successful lot of prints ever seen by the author was a series of microphotographs of wood tissues changed to line drawings.

Lantern slides. Lantern slides are always necessary at times. Most amateur photographers have a knowledge of the ordinary bromide slide for whose manipulation a regular dark room and a red light is essential. An English slide, the Wellington S. C. P., imported by Ralph Harris and Co. of Boston, is in many ways easier to handle, and for certain purposes is much superior. It is a reflection on American dry plate makers that they have not put a similar product on the market. The mystical letters, S. C. P. mean Slow Contact Printing and indicate that the slide has an emulsion similar to that of Cyko or Velox paper, and not like that of bromide paper. No dark-room is necessary for this lantern plate development and the time of exposure is approximately the same as that of Cyko. The Cyko developer works well with it although the makers give a very different formula. This lantern plate is especially fine for line drawing copied from books, giving good, clear black lines and for contact prints from small snap-shot negatives that are of indifferent quality. It is possible to get lantern slides from any negative that will give a passable print on Cyko, Azo or Velox. It is needless to say, of course, that these slides are too slow for making lantern slides by reduction; they are only intended for contact prints.

PHOTOGRAPHING BIRDS' NESTS

By HUGO H. SCHRODER



PHOTOGRAPHING birds' nests is a very fascinating branch of Nature photography and offers a great many possibilities for artistic results. When photographing birds we have to expose rather hurriedly to get our subject, but with their nests we have plenty of time to compose the view on the screen.

The camera to be used for photographing birds' nests should have a bellows extension of at least twice the focal length of the lens used. $3\frac{1}{4} \times 4\frac{1}{4}$ and 4×5 cameras are well suited for this work, as they give contact prints of good size, and good quality negatives can always be enlarged to any desired size. The $3\frac{1}{4} \times 4\frac{1}{4}$ camera is ideal for the photographer who is interested in lantern slides, as this size plate is right for making slides by contact printing. The camera should be equipped with a ground-glass screen.

A rectilinear lens of the convertible type will do very well for photographing nests and eggs, and also for photographing young birds in the nest in good light. The convertible lens is to be preferred, as it enables the photographer to use the camera at some distance from the nest where it is located on the outer branches of trees.

A tilting top tripod is needed for nests on the ground, or in low bushes. However, the ordinary tripod will do as well if equipped with a ball and socket head such as the Optipod.

The best results in photographing birds' nests are obtained on calm days when the sky is slightly overcast. A small stop and plenty of exposure is needed in order to bring out the delicate markings of the eggs, and to show the material from which the nest is constructed. When the nest is in direct sunlight it can be shaded by using the focussing cloth, or interposing the body between the light and the nest.

Always photograph nests *in situ* so as to obtain natural results. Show as much as is possible of the nest surround-

ings together with the detail of its construction. When the nest is hidden among the foliage do not trim away any branches or leaves that are necessary to shelter it from sun or rain, but tie these out of the way while making the exposure. Be sure to leave the surroundings as you found them so as to protect the nests from the elements and from observation. Nests left exposed are often destroyed by various animals and snakes. The small boy is often the cause of nests being destroyed, or deserted, by being too inquisitive, or from a desire to make an egg collection. Do not keep the birds from the nest too long as the eggs may be chilled by any unnecessary delay.

Some birds will permit the photographer to secure pictures of them while on or near the nest, and when bringing food to their young. The camera may be set up near the nest, and the exposure made from the hiding place of the photographer, by means of a thread attached to the shutter release, or an extension tube with a large bulb. A series of photographs may often be secured showing the nest with eggs, young birds in the nest, the mother bird on the nest and the parents bringing food to their babies. Such a series will give the photographer a pictorial history of the birds and their home life.



CATBIRDS' NEST IN GRAPEVINE.

HUGO H. SCHRODER.

Illustrating article "Photographing Birds' Nests," by Hugo H. Schroder.

THE SINGLE SLANT LIGHT

By GEO. D. JOPSON



THE problem that is not a problem and still is a problem with a photographer is light. A contradictory statement? Not quite! Go to a convention. Better still, go calling on brother photographers and talk light to them, and you will find that you are higher up a tree than what you were before you started, for each man has his pet hobby about light.

All will agree that in order to successfully make photographic pictures light is absolutely essential. A photograph can be made by any kind of a pure white light whether produced as a result of the rays of the sun, or by certain artificial means; but for the purpose of producing technically perfect lightings certain rules must be adhered to and followed, especially in the construction of a light for portraiture.

As we are considering a light for the professional portrait photographer I will adhere to construction of light for portraiture, groups and such photographic work that may come to the all-round portrait photographer, and will deal with daylight and the so-called "skylight."

Having had experience with top and side lights, some tops—and possibly I can say all tops—being put in at a haphazard guess, and now working with a single slant of my own designing I will say—and to make the saying emphatic will use a slang expression—I would not go back to a top and side *on a bet*. To commence with the working of a single slant is more economical. There is only one light to curtain, and its workings is simplicity in itself. In the adjusting and re-adjusting of the curtains for the purpose of obtaining special light effects there is only one-half of the labor required.

A single slant light should be installed so that the rays of light will fall at a forty-five degree angle. To obtain this desirable angle of light rays the following rule is quite a safe one to follow, and is the one I followed in installing my light.



Figure 1.
Illustrating article "The Single Slant Light," by George D. Jopson.

The light being eight feet wide, ten feet high and four feet above the floor, I measured into the studio fourteen feet from the light; then at that fourteen feet point imagined a person five feet tall. By taking five feet it equalized between a sitting and standing figure, then drew a forty-five degree angle from the top of the five-foot figure towards the light, after which the light was slanted in to meet the forty-five degree line. By that method the top of light leaned into the studio just four feet.

The glazing of the light is ribbed glass—twenty ribs to the inch. I have heard photographers condemn ribbed glass, but personally I prefer it. The light works softer—being free from the sharp wiry effects that a plain glass is apt to give. I have heard the question arise—in fact used to ask the question myself—can a group be made successfully by a single slant, the person at the extreme distance being equally as well lighted as the person near the light? I will answer by stating that I have far better success in lighting groups than I ever did have with a top and side light. To prove my argument I submit in Figure 1 a group made about Dec. 10th, 1920. To commence with I wish to say that this group is not submitted as an example of grouping for you or any photographer to emulate, nor are any of the photographs. These are just tests of the light, and if the light had been controlled for effects the pictures would be useless as a demonstration of a single slant light.

I have selected this group on account of the conditions under which it was made. It represents "The Big Brothers Class" of the Methodist Church. Time was set for the group; every one on time except two who came strolling in a full half-hour late with the usual excuses. You photographers who make groups can understand. You have all been there. Comments and explanations would be superfluous, so will say that as a few of the others had another appointment there was just seven minutes left in which to perform the work. I know that that little sawed off, hammered down fellow in the center is bad, but he is the pastor, and was wanted there with the officers on either side of him. Well! why dwell—I grouped (?) them and shot off three 8x10 plates in about five minutes. The real reason for selecting this picture to illustrate group



Figure 2.

Illustrating article "The Single Slant Light," by George D. Jopson.

work is that it was made with *light full open* with the man on the left within three feet of the light, and the man on the right sixteen feet away. No holding back locally or faking in any way, but a straight print from a straight negative—a hurriedly made group, if badly composed still evenly lighted.

Having informed you that my light is a direct north one will add that Figure 2 was posed at east end, and Figure 3 at west end of light. These two pictures were specially made with the light wide open to illustrate this article. No screens of any description were used—absolutely no effort made to control the light—just using the light as I received it without modification. If I should submit prints to illustrate this article that were made from carefully studied negatives where the light had been controlled with the curtains, and further accentuated with the use of head and side screens, the illustrations would be of little or no value. What the photographer who is contemplating a new light desires to know is—what will your light do, not what can you do with your light. When a light performs well wide open it certainly will perform better in the hands of an intelligent photographer who thoroughly understands light and shade and its proper distribution on the face or figure, which is accomplished by means of the intelligent manipulation of shades and screens.

If you are installing a new light or contemplating the installing of one, by all means make a thorough investigation of the single slant, and if you are convinced, "believe me," you will never regret it.



Figure 3.

Illustrating article "The Single Slant Light," by George D. Jopson.

American Annual Formulary

In the following section we have gathered together a typical collection of Formulae and Tables, which will assist the photographer in his every-day work. It will be noticed that makers' formulae are omitted. These can best be obtained by direct application to the makers. The appended formulae are selected from the working methods of practical photographers.—Editor.

TRAY DEVELOPERS FOR PLATES AND PAPERS

Amidol. (W. M. Keck).—Amidol, 20 grains; sodium bisulphite (dry), 40 grains; sodium sulphite (dry), 60 grains; potassium bromide (powdered), 1 to 3 grains; water, 4 ounces. For all kinds of developing paper. Expose so that the development will be complete in twenty to thirty seconds. The tone is a blue black.

Amidol Universal Developer. (W. A. Alcock).—Water, 20 ounces; sulphite of soda (dry), $\frac{3}{4}$ ounce; Amidol, 50 grains; potassium bromide, 10 grains; citric acid, 20 to 40 grains. Splendid developer for papers intended for bromoil. Expose so that the image first shows in thirty seconds and develop for four minutes. Gives good tones in hot or cold hypo alum, and nice soft negatives. Splendid in hot weather as minimizes danger of frilling owing to lack of carbonate.

Diamidophenol. For Paper (Edwin Loker).—Water, 20 ounces; sodium sulphite (anhydrous), $1\frac{1}{2}$ ounces; sodium bisulphite, 10 drams; bromide potassium, 10 grains. To use, take 2 ounces and add 6 grains diamidophenol.

Ferrous Oxalate. For Papers (M. G. Lovelace).—No. 1. Hot water, 1000 CC. Dissolve ferrous sulphate, 250 grams; add slowly sulphuric acid, 3 CC. No. 2. Potassium oxalate (neutral), 250 grams; potassium bromide, 1 gram; hot water to make 1000 CC. Add $\frac{1}{2}$ part of No. 1 to 4 parts of No. 2. After development wash in acetic acid stop bath.

Hydroquinone. (Max Gartner).—Solution No. 1. Water, distilled, 20 ounces; hydroquinone, 160 grains; sodium sulphite (anhydrous), 2 ounces citric acid, 60 grains; potassium bromide, 40 grains. Solution No. 2, water, distilled, 20 ounces; caustic soda (sticks), 160 grains. For use take No. 1 one part, No. 2 one part, and water two parts.

Hydrochinon.—For over-exposure plates to obtain contrasty negatives (B. H. Allbee).—No. 1, water, 8 ounces; sulphite of soda (anhydrous), $\frac{1}{2}$ ounce; hydrochinon, 80 grains. No. 2, water, 8 ounces; carbonate of soda (dry), 1 ounce; potassium bromide, 40 grains. Take equal parts of No. 1 and No. 2. Temperature, 70 degrees.

Metol (H. W. Hales).—Metol, 60 grains; warm water, 16 ounces; sulphite of soda (anhydrous), $\frac{1}{2}$ ounce; carbonate of soda (dry), $\frac{1}{2}$ ounce. Dissolve metol in warm water, then add the sulphite and carbonate in order named. Cool. Can be used repeatedly. For developing papers add a few drops of 10 per cent. solution of bromide of potassium.

Metol-Hydroquinone for Orthochromatic Plates.—Water, 20 ounces; metol, 14 grains; potassium metabisulphite, 18 grains; hydroquinone, 56 grains; sulphite of soda (anhydrous), 1 ounce; carbonate of soda (dry), $1\frac{3}{4}$ ounces. Use 1 drop of a 10 per cent. potassium bromide solution to each ounce only if necessary.

Metol-Hydroquinone. For Paper (M. Gartner).—Water, distilled 32 ounces; metol, 15 grains; sulphite of soda (anhydrous) 1 ounce; hydroquinone, 60 grains; sodium carbonate (dry) 6 drams (for contrast use 1 ounce); bromide of potassium, 5 grains. Dilute this stock solution with an equal amount of water.

Developer for Commercial Work. (Max Gartner).—Water, distilled, 100 ounces; Ortol, $\frac{1}{2}$ ounce; hydroquinone, 2 ounces; sulphite of soda, anhydrous, 8 ounces; carbonate of soda, anhydrous, 12 ounces; bromide of potassium, $\frac{1}{4}$ ounce. For plates use full strength.

Para-Amidophenol. (M. G. Lovelace).—Dissolve 150 grains sulphite soda (anhydrous) in 800 CC. hot water; add 20 grains para-amidophenol; dissolve 8 grains lithium hydrate in 100 CC. water, and add until precipitate formed is dissolved; then add water to make 1000 CC.

Pyro. For Prints (M. G. Lovelace).—No. 1 Pyro, 12 grains; sulphite soda (anhydrous), 80 grams; potassium ferrocyanide, 2 grams; water, 500 CC. No. 2 Sodium hydrate, 4 grams; water, 500 CC. To use, one part each with water 2 parts. Add 3 drops saturated solution bromide of potassium to every 400 CC. of developer.

Pyro. For Night Subjects (Robert Dykes).—Stock solution—Pyro, 1 ounce; potassium bromide, 60 grains; potassium meta-bisulphite, 50 grains; distilled water to make 12 ounces. No. 1. Take stock solution 3 ounces, add 2 ounces boiled water. No. 2. Sulphite soda (anhydrous), 1 ounce; carbonate soda (dry), 1 ounce; water (boiled) to make 20 ounces. For use, 4 drams No. 1 to 5 drams No. 2 in 16 ounces of water.

Pyro. For Overtimed Plates (J. D. Elliott).—Sulphite soda, 40° solution, 4 ounces; water, 4 ounces; pyro, 10 grains. Immerse plates in this solution for 20 minutes in the dark; then add to above solution $\frac{1}{2}$ drachm carbonate soda, 20° solution. When image appears add one more drachm of the carbonate soda solution.

Pyro. (W. M. Keck).—Pyro, 20 grains; sodium carbonate (dry), 40 grains; sodium sulphite (dry), 60 grains; water, 16 ounces. For either tray or tank development. Time six minutes.

Pyro Tray Film Developer. (J. E. Carson).—No. 1 solution, boiled water or rain water, 8 ounces or 240 C.C.s.; potassium metabisulphite, 60 grains or 3.55 grams; pyro, 120 grains, or 7.10 grams. No. 2 stock solution; boiled or rain water, 8 ounces, or 240 C.C.s.; sulphite soda anhydrous, 328 grains, or 21 $\frac{1}{2}$ grams; carbonate soda, 219 grains, or 14 $\frac{1}{4}$ grams. For developing use half ounce or 15 cubic centimeters of each solution, and four ounces or 120 C.C.s water. Develop for five minutes at 65 degrees.

Pyro-Metol. For plates (H. M. Long).—A. Water, 22 $\frac{1}{2}$ ounces; metabisulphite, 2 dram; metol, 60 grains; pyro, 1 ounce. B. Water, 16 ounces; sulphite soda (anhydrous), 2 ounces. C. Water, 16 ounces; carbonate soda (dry), 1 ounce. Normally used 1 ounce of each stock to 16 of water.

TANK DEVELOPERS FOR NEGATIVES

Metol-Hydro (Frew).—Water, 12 ounces; metol, 7 $\frac{1}{2}$ grains; sulphite soda (anhydrous), 274 grains; hydroquinone, 30 grains; carbonate soda (anhydrous), 150 grains; bromide potassium, 2 grains. For use to each ounce of above add 4 ounces of water; temperature, 65 degrees; time, 12 minutes.

Monomet-Hydro-Pyro (John Boyd).—Monomet, 4 grains; hydroquinone, 4 grains; pyro, 4 grains; metabisulphite potassium, 4 grains; carbonate of soda, dessicated, 40 grains; sulphite of soda (anhydrous), 60 grains; bromide of potassium, 1 grain; water, 4 ounces. For tank development use 28 ounces of water. Development 20 minutes at 65 degrees.

Pyro (George D. Jopson).—No. 1. Water, 16 ounces; meta-bisulphite of potash, 70 grains; pyro, 1 ounce; bromide potassium, 8 grains. Mix in order given. No. 2. Sulphite soda, 60° test. No. 3. Carbonate soda, 40° test. To use, mix 2½ ounces of No. 1, 2 and 3 in rotation, add 57 ounces of water. Develop 20 minutes at 65°.

Rodinal or Azol.—Water, 60 ounces; rodinal or azol, 1 ounce; temperature, 65 degrees; time, 25 minutes.

DEVELOPERS FOR LANTERN SLIDES

Hydroquinone (B. H. Allbee).—No. 1. Hydroquinone, 150 grains; metabisulphite potash, 10 grains; bromide potassium, 50 grains; water, 20 ounces. No. 2. Sulphite of soda (anhydrous), 1 ounce; caustic soda, 100 grains; water, 20 ounces. Take equal parts of No. 1 and No. 2.

Hydroquinone. One Solution for Warm Tones (A. H. Farrow). Hydroquinone, 1 dram; sulphite of soda (anhydrous), 2 drams; carbonate of soda (dry), 4 drams; bromide of potassium, 20 grains; water, 12 ounces.

Hydroquinone. For Colder Tones (B. H. Allbee).—No. 1. Hydroquinone, 60 grains; sulphite of soda (anhydrous), 1 ounce; citric acid, 10 grains; bromide potassium, 10 grains; water, 10 ounces. No. 2. Carbonate of soda (dry), 1 ounce; water, 10 ounces. Use equal parts.

FIXING BATHS AND HARDENERS

Fixing and Hardening Bath. For Plates, Films and Papers. (W. A. Alcock).—In hot weather, hypo, 1 lb.; epsom salts, 1 lb.; water, 100 oz. In cold weather, hypo, 1 lb.; epsom salts, ½ lb.; water, 100 oz.

Acid Fixing Bath (Carbutt).—Sulphuric acid, 1 dram; sodium hyposulphite, 16 ounces; sulphite of soda (anhydrous), 2 ounces; chrome alum, 1 ounce; warm water, 64 ounces. To prepare the bath, dissolve the hypo in 48 ounces of water, the sulphite of soda in 6 ounces; mix the sulphuric acid with 2 ounces of the water and pour slowly into the sulphite solution and then add to the hypo solution. Dissolve the chrome alum in 8 ounces of water; add to the bulk of the solution and the bath is ready for use.

Fixing Bath for Lantern Slides (B. H. Allbee).—Sulphuric acid, 1 dram; hypo, 16 ounces; sulphite of soda (anhydrous), 1 ounce; chrome alum, 1 ounce; water, 64 ounces.

Plain Fixing Bath.—Dissolve 1 pound of sodium hyposulphite in 2 quarts of water, or 4 ounces of the hypo in a pint of water, according to the bulk of the solution required.

Hardener for Fixing Bath (Beach).—Water, 40 ounces; sulphite of soda (anhydrous), 3 ounces; powdered alum, 16 ounces; acetic acid, 40 ounces. Add in the order given and shake well until dissolved. Of the above add 16 ounces to each gallon of hyposulphite of soda solution, testing 70 to 80 degrees.

Hardening Negatives.—Immerse them for a few minutes in formalin, 1 ounce; water, 30 ounces.

Short Stop, removes developer stains; renders an acid fixing bath unnecessary when making D. O. P. or bromide prints, and destroys stains on both prints and fingers. (J. E. Carson).—Potassium metabisulphite, 1 ounce or 30 C.C.s.; water, 32 ounces, or 960 C.C.s. When thoroughly dissolved add 10 drops C. P. sulphuric Acid. This bath should have a light sulphur dioxide odor after standing awhile. If not, add acid drop by drop until odor appears.

INTENSIFICATION

Intensifier, One Solution (F. M. Steadman).—No. 1. Bichloride of mercury, ½ ounce; water, 10 ounces. No. 2. Iodide of potassium,

5 drams; water, $1\frac{1}{2}$ ounces. Add to No. 1. No. 3. Hyposulphite of soda, 1 ounce; water, $2\frac{1}{2}$ ounces. Add to the previous mixture. This clears the solution when it is ready for use for local intensification. For tray intensification add more water to slow its action.

Intensifying with Red Ink (E. M. Cohen).—Soak the negative well. Put teaspoon of red ink into tray of water and rock until mixed. Immerse negatives face up till well and evenly colored, then without washing put in drying frame. If left in solution too long will be over dense, in which case several trays of clear water will eliminate some of the color.

The intensification is permanent without the danger of negative going bad, as is the case when mercury is used.

Intensifier—Mercuric Chloride Process.—No. 1. Mercuric chloride, 200 grains; bromide of potassium, 120 grains; water, $6\frac{1}{2}$ ounces. No. 2. Sulphite of soda (anhydrous), 1 ounce; water, 4 ounces. The well-washed negative, free from hypo, must be thoroughly bleached in No. 1; well washed; and then blackened in No. 2. After blackening it is well washed again.

REDUCTION

Reducer, Single Solution (F. M. Steadman).—Red prussiate of potash, size of pea; hyposulphite of soda, six times that volume; water, 6 ounces (for local reduction, $1\frac{1}{2}$ ounces.) When reduced wash thoroughly.

Reducer—Ammonium Persulphate.—Ammonium persulphate, 15 grains; water, 1 ounce. The solution should be made just before use. The negative must be perfectly free from hypo or it will be stained by the persulphate. When the desired reduction has been reached, transfer the negative without washing to a 10 per cent. solution of anhydrous sodium sulphite. Wash finally for 15 or 20 minutes.

Reducer—Farmer's.—Dissolve 1 ounce of potassium ferricyanide in 9 ounces of water and make up to 10 ounces, forming a 10 per cent. solution. Label this poison. Thoroughly wet the negative to be reduced. Take enough fresh plain hypo fixing bath for the purpose, and add to it enough of the ferricyanide solution to make it a light straw color. The negative to be reduced is immersed in this solution, when it will be seen to lose density. Rock the tray to insure evenness of action. This reducer can also be used for local treatment.

PRINTING PROCESSES

Blue Prints

Blue Printing Sensitizing Formulæ (Brown).—A. Dissolve 110 grains ferric ammonium citrate (green) in 1 ounce of water. B. Dissolve 40 grains of potassium ferricyanide in 1 ounce of water. These two solutions are made up separately. They are then mixed together and kept in a stoneware bottle, but the single solution should always be filtered before use. The mixture will retain its good qualities for months if kept from the light.

(Millen).—Potassium ferricyanide, 1 ounce; ammoniac citrate of iron, $1\frac{1}{2}$ ounces; distilled water, 10 ounces. Mix thoroughly and filter. The solution should have a deep wine color and dry on the paper a lemon-yellow. If the solution is green and has a precipitate, the ammonio-citrate is old and spoiled. The mixture should be kept from the light.

Bromide Paper

Bromide Paper Developers: Hydroquinone-metol. No. 1. Water, 10 ounces; hydroquinone, 52 grains; potassium metabisulphite, 18 grains; sulphite of soda (anhydrous), 5 drams; carbonate of soda,

1¼ ounces. No. 2. Water, 10 ounces; metol, 30 grains; carbonate of soda, 5 drams; sulphite of soda (anhydrous), 5 drams. One or two drops of a potassium bromide 10 per cent. solution added to 1 ounce of the mixed developer will increase contrast and keep the whites pure. Equal parts of 1 and 2 give excellent prints from a normal negative; one part of 1 and two of 2 give gray prints with maximum half-tone and gradation; two parts of 1 and one of 2 give vigorous prints from soft delicate negatives.

Amidol for rich blacks (freshly prepared). Distilled (or boiled) water, 4 ounces; sulphite of soda (anhydrous), 45 grains; amidol, 10 to 15 grains. Add a drop of 10 per cent. bromide solution to each ounce of developer.

Sepia Tones: Hypo Alum.—Hyposulphite of soda, 5 ounces; ground alum, 1 ounce; boiling water, 70 ounces. Dissolve the hypo in the water, and then add the alum slowly. A milk-white solution results which should be decanted when clear. It is not used until cold (about 60° Fahr.).

Sepia Tones: Sulphide of Sodium.—The fixed and washed print is treated with one of the following solutions: (1) Potassium ferricyanide, 10 grains; potassium bromide, 10 grains; water, 1 ounce; or (2) potassium ferricyanide, 20 grains; sodium chloride (common salt), 30 grains; water, 1 ounce. The image will be bleached by either of these solutions in a few minutes, the whitish appearance of the deposit being caused by its change into a salt of silver. After 5 minutes in running water apply the sulphuretted solution: Dissolve 3 ounces of sodium monosulphide in 15 ounces of water; boil the solution for about 10 minutes, filter off the black precipitate formed, and when cooled make up to 25 ounces with water. To tone take of the sulphide solution 1 ounce and add water 12 to 20 ounces.

Red Tones: Copper.—Dissolve 100 grains of ammonium carbonate in 2 ounces of water, and in this solution dissolve 10 grains of sulphate of copper. Then add 20 grains of potassium ferricyanide. A clear, dark green solution results which gives a red-chalk tone in about 3 minutes. Tone until the deepest shadow is converted, and then wash the print for 10 minutes.

Green Tones: Vanadium.—Bleach print in the following: Potassium ferricyanide, 10 grains; ammonium carbonate, 100 grains; water, 1 ounce. Wash well and apply: Ferric chloride, 2 grains; vanadium chloride, 2 grains; ammonium chloride, 4 grains; hydrochloric acid, 5 minims; water, 1 ounce.

Blue Tones: Iron.—Bleach print in: Potassium ferricyanide, 10 grains; ammonium carbonate, 100 grains; water, 1 ounce; then tone in ferric chloride, 5 grains; hydrochloric acid, 5 minims; water, 1 ounce.

To prevent blistering on bromide paper (P. L. Anderson).—Immerse after fixing and before washing from 10 to 15 minutes in water, 10 ounces; formaldehyde, 1 ounce. A 10 per cent. solution of chrome alum will do equally well.

To make bromide paper translucent (P. L. Anderson).—Lay the paper negative face down on a blotter and paint thinly with the following mixture. Give three coats. Turpentine, 3 ounces; powdered resin, 1 ounce; gum elemi, 1 ounce; paraffine wax, ½ ounce. Heat with stirring until it begins to boil. Allow to cool slightly and add turpentine, 3 ounces.

Carbon Tissue

Carbon Tissue, Sensitizer for (Bennett).—Potassium bichromate, 4 drams; citric acid, 1 dram; strong ammonia water, about 3 drams; water, 25 ounces; dissolve the bichromate and citric acid in hot water, and add sufficient ammonia to change the orange color of the solution to lemon-yellow. Sensitize for 90 seconds; reducing the water softens

the gradation in the print; increasing it to 30 ounces gives more vigor.

Carbon Lantern Slides.—Prepare the glass by coating with the following preparation: 180 grains of Nelson's Gelatine No. 1, in 20 ounces water. Add 10 grains bichromate of potash. Dry and allow the plate to be exposed to light for a couple of days to make the coating thoroughly insoluble. Sensitizer for tissue: 1 per cent. to $1\frac{1}{4}$ per cent. solution of bichromate of potash. Immerse 2 minutes. Print deeply; expose twice as long as ordinary paper print. Develop in hot water as usual.

Gum Bichromate

Gum Bichromate (Casper Millar). A.—Gum arabic, $1\frac{1}{4}$ ounces; water, $3\frac{1}{2}$ ounces; salicylic acid, 4 grains.

B.—Chrome alum, 45 grains; water, $3\frac{1}{2}$ ounces. Grind A and B with water and pigment, brush over paper, dry and store.

Suggested formula.—A. 2 ounces; B, $1\frac{1}{2}$ drams; carbon black, 10 grains; sensitize for 2 minutes in 5 per cent. bichromate solution.

Kallitype

Kallitype Sensitizer for Black Tones (J. Thomson).—Distilled water, 1 ounce; ferric oxalate (Merck's or Mallinckrodt's), 15 grains; citrate of iron and ammonia (brown scales), 25 grains; chloride of copper, 8 grains; oxalate of potassium, 35 grains; oxalic acid, 15 grains; silver nitrate, 15 grains; gum arabic, 10 grains. For greater contrast add 1 to 10 drops 5 per cent. bichromate of potassium solution.

Developer: Stock Solution.—Distilled water, 1 ounce; silver nitrate, 40 grains; citric acid, 10 grains; oxalic acid, 10 grains. Filter. Normal developer 1 dram stock solution and 7 drams of water.

Platinum Papers

Platinum Sensitizer (P. L. Anderson).—Stock solutions: I. Water, hot, distilled, 2 ounces; ferric oxalate, 240 grains; oxalic acid, 16 grains. II. Water, hot, distilled, 2 ounces; ferric oxalate, 240 grains; oxalic acid, 16 grains; potassium chlorate, 4 grains. III. Water, distilled, 19 drams; potassium chloroplatinite, 219 grains ($=\frac{1}{2}$ ounce). Keep in amber glass bottles or in the dark. For use take: I, 22 mm.; II, 0 mm.; III, 24 mm. Gives very soft prints. Or, I, 12 mm.; II, 10 mm.; III, 24 mm. Results about the same contrast as a P. O. P. print. Or, I, 0 mm.; II, 22 mm.; III, 24 mm. Gives extreme contrast.

Above quantities sufficient for a 10 x 12 sheet of ordinary paper. Very smooth requires less and very rough more, up to 25 per cent. additional. Apply with a soft fitch or camel-hair brush, allow to surface dry, and make bone-dry over a stove or gas jet. Should dry in not less than five or more than ten minutes.

Platinum: Sensitizing Gold Bath and Sepia Papers. A.—Chloroplatinite of potassium, 15 grains; distilled water, 90 minims.

B.—Ferric oxalate, 21 grains; oxalic acid, 2 grains; distilled water, 183 minims. For cold bath paper, mix A and B, and add 15 minims of water. For sepia paper mix A and B and add 15 minims of a 5 per cent. solution of mercuric chloride. The addition of a few grains of potassium chlorate to any of the above gives increased contrast in the print. From 140 to 170 minims of solution are sufficient to coat a sheet of paper 20 x 26 inches.

Platinum Prints: to Intensify. A.—Sodium formate, 45 grains; water, 1 ounce.

B.—Platinum perchloride, 10 grains; water, 1 ounce.

C.—For use, take 15 minims each of A and B to 2 ounces of water. Immerse prints until sufficiently intensified, then remove and wash.

Platinum Prints to Distinguish from Bromide.—Soak the print in saturated solution of mercuric chloride; a platinum print will not change; a bromide print will bleach.

Salted Papers

Salted Paper Prints: Sensitized with the following: Silver, 480 grains Troy; water, 11 ounces. Dissolve and pour off 2 ounces, and to the 9 ounces left add strong aqua ammonia to form a precipitate and redissolve the precipitate, then add the remaining 2 ounces which will form another precipitate; to this add 9 drops of nitric acid C. P. Apply this to the paper with a tuft of cotton.

Any good toning bath will give good results, such as—Chloride aluminum, 80 grains; bi-carbonate soda, 360 grains; water, 48 ounces. When mixed this will form a flaky hydrate which will settle to the bottom. It can be strained through clean washed muslin. To prepare a small bath for toning, take 12 ounces of the stock solution and add sufficient gold to tone in 8 to 10 minutes. The gold solution must be neutralized with bi-carbonate soda before adding to the above bath. When the prints reach the desired tone throw them into a bath of salt water, made of water, 1 gallon; table salt, 1 ounce.

Printing Out Papers

Gold Toning (B. H. Allbee).—No. 1, 10 per cent. solution sulphocyanide of potassium; No. 2, 15 grains chloride of gold in 7½ ounces of water; No. 3, 10 per cent. solution phosphate of soda; No. 4, saturated solution borax. Take No. 1, 1 dram, water, 8 drams; No. 2, 4 drams; No. 3, 1 dram; No. 4, 2 drams. In this put print in dry. Toning should be complete in two minutes. Wash as usual.

Gold Toning.—For blue-black tones, for slight strengthening, and for converting rusty black into pure black. Soak prints in warm water, lay on warm glass, brush over glycerine and blot off. Pour on few minims of solution of gold chloride (1 grain per dram), and rapidly brush in all directions. When toned, rinse, and sponge back and front with: Metol, 50 grains; sodium sulphite, 1 ounce; potassium carbonate, ½ ounce; water, 20 ounces. Tone in daylight. Do not tone sepias or old prints in this solution.

Gold Toning—To Give Black Tones (A. B. Klugh).—Solution A. Sodium thiosulphate (hypo), 40 grams; water, 100 cc. Solution B. Lead nitrate, 5 grams; acetic acid, glacial, 5 cc.; water, 50 cc. Add to solution A enough of B to produce a slight milkiness. Filter and add 25 cc. of a 1% solution of gold chloride. Print deeply and tone until a warm black is produced.

MISCELLANÆ

Adhesive for Labels.—Soak 1 part of the best glue in water until thoroughly swollen, add a little sugar candy, 1 part of gum arabic and 6 parts of water. Boil with constant stirring over a spirit lamp until the whole gets thin. Coat sheets of paper with it; let dry and cut up into convenient sizes.

Autochromes.—*Sensitizing to get more speed* (M. G. Lovelace).—In complete darkness bathe plates in the following solution: Distilled water, 66 cc.; ethyl alcohol, pure, 90 deg., 33 cc.; dye solution, 2 cc.; ammonia, .30 cc. The dye solution is a mixture of pinachrome, pina verdol and pinacyanol, 1 part of each in 1000 of alcohol. Bathe plates for five minutes and dry away from dust. These plates require a special filter the formula being: Hard gelatine, 3 gms.; distilled water, 100 cc.; filter yellow K, 1 per cent. solution, 2.5 cc. Use 1 cc. to each 10 square centimeters of surface. These plates have about five times the speed and it is possible to make snap shots with them if a lens working at F/4.5 and F/5.6 is used.

Blackening Mixture.—Dissolve a 4-ounce stick of licorice in 8 ounces of water with the aid of gentle heat. When dissolved rub into the mixture 1 ounce of burnt sienna in powder, using the back of a spoon for this purpose. When cold, bottle for use.

Blackening Brass.—Make two solutions: Copper nitrate, 200 grains;

water, 1 ounce. Silver nitrate, 200 grains; water, 1 ounce. Mix the solutions; clean the article well; dip it in the solution for a moment; withdraw it; dry it; and heat it strongly.

Black, Dead, for Wood.—Shellac, 40 parts; borax, 20 parts; glycerine, 20 parts; water, 500 parts. When dissolved, add 50 parts aniline black.

Cleaning Greasy Bottles.—Wash with benzine, or permanganate of potassium, to which has been added some hydrochloric acid.

Bottles that have contained resinous substances, wash with potash or soda and rinse with alcohol. Bottles that have contained essences, wash with sulphuric acid, then with water.

Clearing Stained Negatives.—Dissolve $\frac{1}{8}$ ounce of pulverized alum in 20 ounces of water and add 1 dram of sulphuric acid. Immerse the stained plate in this solution for a few minutes; remove plate, wash and then set in the rack to dry.

Film: to Remove from Glass: Make two solutions. A.—Sodium fluoride, 6 grains; water, 4 ounces.

B.—Sulphuric acid, 6 drops; water, 1 ounce. Place the negative in solution A for 2 minutes and then place directly in solution B. After another 2 minutes lift the film with the finger from one corner of the plate. It will soon leave the glass.

Firelight Effects on Developing Paper (H. S. Hood). No. 1.—Water, 5 drams; copper sulphate, 10 per cent. solution, 15 minims; ammonium carbonate, 10 per cent. solution. Add till precipitate first formed is redissolved.

No. 2.—Water, $4\frac{1}{2}$ ounces; potassium ferricyanide, $\frac{6}{10}$ drams. Mix separately and add No. 2 to No. 1. The print will turn bright red. Wash well.

Ground Glass: Substitutes for. 1.—Paraffine wax makes an excellent substitute for ground glass if the latter should get broken. Iron the paper onto a sheet of plain glass. It is more transparent than the focusing screen and the image will appear clearer; hence, in exposing allowance must be made for the difference in illumination.

2.—Resin dissolved in wood alcohol and blown over the glass; this must not be scratched; it gives a very fine-grained ground glass effect.

3.—White wax, 120 grains; ether, 1 ounce.

Ground Glass Varnish: Sandarac, 90 grains; mastic, 20 grains; ether, 2 ounces. Dissolve the resins in the ether and add benzole $\frac{1}{2}$ to $1\frac{1}{2}$ ounces.

Lens: to Clean.—The lens should always be kept free from dust or other impurities. To clean it, spread upon a table a clean sheet of paper; take the lens apart, and with a camel-hair brush dust each of the combinations on both sides. If the surfaces of the lenses are very dirty and have lost their polish, make up the following: Nitric acid, 3 drops; alcohol, 1 ounce; distilled water, 2 ounces. Dip a tuft of filtering cotton in this solution, rub each side of the lens, then polish with an absolutely clean chamois. Clean the lens tube before replacing the lenses, each of which should be finally dusted with a camel-hair brush.

Moonlight Effects on Developing Paper (H. S. Hood).—Immerse in water, 5 ounces; ferric ammonium citrate, 12 grains; potassium ferricyanide, 12 grains; nitric acid, $\frac{2}{5}$ drams. Prints will assume a blue color. Wash until whites become clear.

Mounting Without Cockling (W. S. Davis).—Coat back of dry print with as strong a solution of warm gelatine (pure table gelatine will do) as can be spread easily. Allow to dry, then attach to mount by dampening the amount with water, then lay print in desired position; cover with a sheet of bond or smooth paper, and apply a warm flat iron until the gelatine melts. Very effective for thin mounting material, as there is no cockling if the mount contains just the right amount of water.

Paste, Starch (A. Lomax).—Powdered starch, 1 ounce; cold water, 12 ounces. Mix smooth with a glass rod, heat to boiling point. Boil half a minute stirring all the time. Use cold.

Poisons and Antidotes.—Administer the antidote as soon as possible. If a strong acid or alkali, or cyanide of potassium, has been swallowed, lukewarm water in large quantities should be swallowed at once. Where strong acids or alkalies have not been swallowed, rid the stomach of the poison by vomiting; for this purpose take 25 grains of zinc sulphate in warm water.

Polished surfaces: to Photograph.—Smear the surface with soft putty so as to deaden the reflections. Photograph the article against a black background, and stop off all reflections, allowing the light to come from one direction only. To photograph hollow cut glassware fill with ink or aniline black water dye. Before photographing machinery deaden the bright parts with putty.

Safe Light for Panchromatic Plates.—Take old dry plates and coat with the following: Water, 10 ounces, tartrazine, 75 grains; patent blue A, 75 grains; naphthol greens, 75 grains; sulphuric acid, 30 minims. Stain the plates as deeply as possible. Use two plates.

Stains: to Remove from the Hands.—Developer stains: solution of citric or oxalic acid. Silver nitrate stains: Water, 4 ounces; chloride of lime, 350 grains; sulphate of soda, 1 ounce. Apply with a brush.

Tarnished Daguerreotypes, to Restore.—Remove the silvered plate from the case and place it, image uppermost, under a box lid or other protector from dust, etc. Put a small piece of potassium cyanide into a graduate and pour over it 1 or 2 ounces of water. Hold the daguerreotype by the corner with a pair of pliers, rinse it in clear running water, then pour over it the weak cyanide solution (a 3 per cent. solution is usually employed), and return it to the graduate. Repeat this operation several times until the discoloration quite disappears. Wash well in running water, and then, before the surplus water has time to collect in tears upon the image, begin to dry the plate gradually over a spirit lamp, holding the plate in an inclined position so that it will dry from the uppermost corner. The secret of success is in the use of pure water for the final washings and the drying of the image without check or the formation of tears.

Test for Hypo: Potassium permanganate, 2 grains; potassium carbonate, 20 grains; distilled water, 40 ounces. Soak the plate or print to be treated in water for one hour, then remove and add to the water a few drops of the above solution, which will turn a greenish yellow or brown if the water is not free from hypo.

To Flatten Double-weight Prints (George D. Jopson).—A—9 ounces boiling water; $\frac{1}{2}$ ounce gelatine. B—3 ounces boiling water; $\frac{1}{2}$ drachm alum. C—2 drachms oil of cloves. Mix and strain through cheese cloth while hot. To use take a little from the stock and place in a cup. Place cup in hot water until backing is dissolved. Apply very thin to back of print with soft cloth or a tuft of cotton.

COMPARISON OF VALUES COMPILED BY CHAS. LE B. GOELLER

Taking for a standard f.8 as unit of measurement.
Speed increased. Opening twice as fast.

f:8 = 1	Twice as fast as	f:11.3	exposure	1 sec.
7.5 = $1\frac{1}{8}$	“	as	10.6	“ 0.88 sec.
6.8 = $1\frac{3}{8}$	“	as	9.6	“ 0.725 “
6.3 = $1\frac{3}{5}$	“	as	8.8	“ 0.625 “
6. = $1\frac{7}{9}$	“	as	8.5	“ 0.5625 “
5.6 = 2.	“	as	8	“ 0.5 “
4.5 = $3\frac{1}{6}$	“	as	6.3	“ 0.3125 “

UNITED STATES WEIGHTS AND MEASURES
According to Existing Standards

LINEAR

	Inches	Feet	Yards	Rods	Fur's	Mi.
12 inches = 1 foot.	12 =	1				
3 feet = 1 yard.	36 =	3 =	1			
5.5 yards = 1 rod.	198 =	16.5 =	5.5 =	1		
40 rods = 1 furlong.	7,920 =	660 =	220 =	40 =	1	
8 furlongs = 1 mile.	63,360 =	5,280 =	1,760 =	320 =	8 =	1

SURFACE—LAND

	Feet	Yards	Rods	Roods	Acres
144 sq. ins. = 1 sq. ft.					
9 sq. ft. = 1 sq. yd.	9 =	1			
30.25 sq. yds. = 1 sq. rod.	272.25 =	30.25 =	1		
40 sq. rods = 1 sq. rood.	10,890 =	1,210 =	40 =	1	
4 sq. roods = 1 acre.	43,560 =	4,840 =	160 =	4 =	1
640 acres = 1 sq. mile.	27,878,400 =	3,097,600 =	102,400 =	2,560 =	640

VOLUME—LIQUID

	Gills	Pints	Gallon	Cub. In.
4 gills = 1 pint.	32 =	8 =	1 =	231
2 pints = 1 quart.				
4 quarts = 1 gallon.				

FLUID

Gallon	Pints	Ounces	Drachms	Minims	Cubic Centimetres
1 =	8 =	128 =	1,024 =	61,440 =	3,785,435
	1 =	16 =	128 =	7,680 =	473,179
		1 =	8 =	480 =	29,574
			1 =	60 =	3,697

16 ounces, or a pint, is sometimes called a fluid pound.

TROY WEIGHT

Pound	Ounces	Pennyweights	Grains	Grams
1 =	12 =	240 =	5,760 =	373.24
	1 =	20 =	480 =	31.10
		1 =	24 =	1.56

APOTHECARIES' WEIGHT

lb.	$\frac{3}{4}$ Ounces	$\frac{3}{4}$ Drachms	$\frac{\text{D}}{3}$ Scruples	gr.	Grains	Grams
1 =	12 =	96 =	288 =	5,760 =	373.24	
	1 =	8 =	24 =	480 =	31.10	
		1 =	3 =	60 =	3.89	
			1 =	20 =	1.30	
				1 =	.06	

The pound, ounce, and grain, are the same as in Troy weight.

AVOIRDUPOIS WEIGHT

Pound	Ounces	Drachms	Grains (Troy)	Grams
1 =	16 =	256 =	7,000 =	453.60
	1 =	16 =	437.5 =	28.35
		1 =	27.34 =	1.77

ENGLISH WEIGHTS AND MEASURES

APOTHECARIES' WEIGHT

20 Grains	=	1 Scruple	=	20 Grains.
3 Scruples	=	1 Drachm	=	60 Grains.
8 Drachms	=	1 Ounce	=	480 Grains.
12 Ounces	=	1 Pound	=	5,760 Grains.

FLUID MEASURE

60 Minims	=	1 Fluid Drachm
8 Drachms	=	1 Fluid Ounce
20 Ounces	=	1 Pint
8 Pints	=	1 Gallon

The above weights are usually adopted in formulas.

All Chemicals are usually sold by

AVOIRDUPOIS WEIGHT

27 $\frac{1}{32}$ Grains	=	1 Drachm	=	27 $\frac{1}{32}$ Grains
16 Drachms	=	1 Ounce	=	437 $\frac{1}{2}$ Grains
16 Ounces	=	1 Pound	=	7,000 Grains

Precious Metals are usually sold by

TROY WEIGHT

24 Grains	=	1 Pennyweight	=	24 Grains
20 Pennyweights	=	1 Ounce	=	480 Grains
12 Ounces	=	1 Pound	=	5,760 Grains

NOTE.—An ounce of metallic silver contains 480 grains, but an ounce of nitrate of silver contains only 437 $\frac{1}{2}$ grains.

UNITED STATES FLUID MEASURE

Gal.	Pints.	Ounces.	Drachms.	Mins.	Cub. In.	Grains.	Cub. C.M.
1	= 8	= 128	= 1,024	= 61,440	= 231.	= 58,328.886	= 3,785.44
	1	= 16	= 128	= 7,680	= 28.875	= 7,291.1107	= 473.18
		1	= 8	= 480	= 1.8047	= 455.6944	= 29.57
			1	= 60	= 0.2256	= 56.9618	= 3.70

IMPERIAL BRITISH FLUID MEASURE

.	Pints.	Ounces.	Drachms.	Mins.	Cub. In.	Grains.	Cub. C.M.
1	= 8	= 160	= 1,280	= 76,800	= 277.27384	= 70,000	= 4,543.732
	1	= 20	= 160	= 9,600	= 34.65923	= 8,750	= 567.966
		1	= 8	= 480	= 1.73296	= 437.5	= 28.398
			1	= 60	= 0.21662	= 54.69	= 3.550

METRIC SYSTEM OF WEIGHTS AND MEASURES

MEASURES OF LENGTH

DENOMINATIONS AND VALUES		EQUIVALENTS IN USE
Myriameter.....	10,000 meters.	6.2137 miles.
Kilometer.....	1,000 meters.	.62137 mile, or 3,280 ft. 10 ins
Hectometer.....	100 meters.	328. feet and 1 inch.
Dekameter.....	10 meters.	393.7 inches.
Meter.....	1 meter.	39.37 inches.
Decimeter.....	1-10th of a meter.	3.937 inches.
Centimeter.....	1-100th of a meter.	.3937 inch.
Millimeter.....	1-1000th of a meter.	0.394 inch.

MEASURES OF SURFACE

DENOMINATIONS AND VALUES		EQUIVALENTS IN USE
Hectare.....	10,000 square meters.	2.471 acres.
Are.....	100 square meters.	119.6 square yards.
Centare.....	1 square meter.	1,550. square inches

MEASURES OF VOLUME

DENOMINATIONS AND VALUES			EQUIVALENTS IN USE	
NAMES	No. of Liters	CUBIC MEASURES	DRY MEASURE	WINE MEASURE
Kiloliter or stere.....	1,000	1 cubic meter.	1.308 cubic yards.	264.17 gallons.
Hectoliter....	100	1-10th cubic meter.	2 bu. and 3.35 pecks.	26.417 gallons.
Dekaliter....	10	10 cubic decimeters.	9.08 quarts.	2.6417 gallons.
Liter.....	1	1 cubic decimeter.	.908 quart.	1.0567 quarts.
Deciliter....	1-10	1-10th cubic decimeter.	6.1023 cubic inches.	.845 gill.
Centiliter....	1-100	10 cubic centimeters	.6102 cubic inch.	.338 fluid oz.
Milliliter....	1-1000	1 cubic centimeter.	.061 cubic inch.	.27 fl. drm.

WEIGHTS

DENOMINATIONS AND VALUES			EQUIVALENTS IN USE
NAMES	Number of Grams	WEIGHT OF VOLUME OF WATER AT ITS MAXIMUM DENSITY	AVOIRDUPOIS WEIGHT
Millier or Tonneau.....	1,000,000	1 cubic meter.	2204.6 pounds.
Quintal.....	100,000	1 hectoliter.	220.46 pounds.
Myriagram.....	10,000	10 liters.	22.046 pounds.
Kilogram or Kilo.....	1,000	1 liter.	2.2046 pounds.
Hectogram.....	100	1 deciliter.	3.5274 ounces.
Dekagram.....	10	10 cubic centimeters.	.3527 ounce.
Gram.....	1	1 cubic centimeter.	15.432 grains.
Decigram.....	1-10	1-10th of a cubic centimeter.	1.5432 grain.
Centigram.....	1-100	10 cubic millimeters.	.1543 grain.
Milligram.....	1-1000	1 cubic millimeter.	.0154 grain.

For measuring surfaces, the square dekameter is used under the term of ARE; the hectare, or 100 ares, is equal to about $2\frac{1}{2}$ acres. The unit of capacity is the cubic decimeter or LITER, and the series of measures is formed in the same way as in the case of the table of lengths. The cubic meter is the unit of measure for solid bodies, and is termed STERE. The unit of weight is the GRAM, which is the weight of one cubic centimeter of pure water weighed in a vacuum at the temperature of 4 deg. Cent. or 39.2 deg. Fahr., which is about its temperature of maximum density. In practice, the term cubic centimeter, abbreviated c.c., is generally used instead of milliliter and cubic meter instead of kiloliter.

THE CONVERSION OF FRENCH (METRIC) INTO ENGLISH MEASURE

1 cubic centimeter	=	17 minims			
2 cubic centimeters	=	34 "			
3 "	=	51 "			
4 "	=	68 "	or 1 dram	8 minims	
5 "	=	85 "	" 1 "	25 "	
6 "	=	101 "	" 1 "	41 "	
7 "	=	118 "	" 1 "	58 "	
8 "	=	135 "	" 2 drams	15 "	
9 "	=	152 "	" 2 "	32 "	
10 "	=	169 "	" 2 "	49 "	
20 "	=	338 "	" 5 "	38 "	
30 "	=	507 "	" 1 ounce	0 dram	27 minims
40 "	=	676 "	" 1 "	3 drams	16 "
50 "	=	845 "	" 1 "	6 "	5 "
60 "	=	1014 "	" 2 ounces	0 "	54 "
70 "	=	1183 "	" 2 "	3 "	43 "
80 "	=	1352 "	" 2 "	6 "	32 "
90 "	=	1521 "	" 3 "	1 "	21 "
100 "	=	1690 "	" 3 "	4 "	10 "
1000 "	=	1 liter =	35 "	1 "	40 "

THE CONVERSION OF FRENCH (METRIC) INTO ENGLISH WEIGHT

The following table, which contains no error greater than one-tenth of a grain, will suffice for most practical purposes.

1 gram	=	15 $\frac{2}{5}$ grains.			
2 grams	=	30 $\frac{4}{5}$ "			
3 "	=	46 $\frac{1}{5}$ "			
4 "	=	61 $\frac{4}{5}$ "or	1 dram	1 $\frac{4}{5}$ grain
5 "	=	77 $\frac{1}{5}$ ""	1 "	17 $\frac{1}{5}$ grains
6 "	=	92 $\frac{3}{5}$ ""	1 "	32 $\frac{3}{5}$ "
7 "	=	108 ""	1 "	48 "
8 "	=	123 $\frac{2}{5}$ ""	2 drams	3 $\frac{2}{5}$ "
9 "	=	138 $\frac{4}{5}$ ""	2 "	18 $\frac{4}{5}$ "
10 "	=	154 $\frac{2}{5}$ ""	2 "	34 $\frac{2}{5}$ "
11 "	=	169 $\frac{4}{5}$ ""	2 "	49 $\frac{4}{5}$ "
12 "	=	185 $\frac{1}{5}$ ""	3 "	51 $\frac{1}{5}$ "
13 "	=	200 $\frac{3}{5}$ ""	3 "	20 $\frac{3}{5}$ "
14 "	=	216 ""	3 "	36 "
15 "	=	231 $\frac{2}{5}$ ""	3 "	51 $\frac{2}{5}$ "
16 "	=	247 ""	4 "	7 "
17 "	=	262 $\frac{2}{5}$ ""	4 "	22 $\frac{2}{5}$ "
18 "	=	277 $\frac{4}{5}$ ""	4 "	37 $\frac{4}{5}$ "
19 "	=	293 $\frac{1}{5}$ ""	4 "	53 $\frac{1}{5}$ "
20 "	=	308 $\frac{3}{5}$ ""	5 "	8 $\frac{3}{5}$ "
30 "	=	463 ""	7 "	43 "
40 "	=	617 $\frac{1}{5}$ ""	10 "	17 $\frac{1}{5}$ "
50 "	=	771 $\frac{3}{5}$ ""	12 "	51 $\frac{3}{5}$ "
60 "	=	926 ""	15 "	26 "
70 "	=	1080 $\frac{1}{5}$ ""	18 "	0 $\frac{1}{5}$ "
80 "	=	1234 $\frac{3}{5}$ ""	20 "	34 $\frac{3}{5}$ "
90 "	=	1389 ""	23 "	9 "
100 "	=	1543 $\frac{1}{5}$ ""	25 "	43 $\frac{1}{5}$ "
1000 "	=	1 kilogram =	32 oz., 1 dr.,	12 $\frac{2}{5}$ gr.	

THE ELEMENTS:
THEIR NAMES, SYMBOLS, AND ATOMIC WEIGHTS
OXYGEN STANDARD.

Compiled by **HENRY F. RAESS.**

1915

Aluminum...Al	27.10	Holmium....Ho	163.50	Rhodium....Rh	102.90
Antimony...Sb	120.20	Hydrogen....H	1.008	Rubidium...Rb	85.45
Argon.....A	39.88	Indium.....In	114.80	Ruthenium..Ru	101.70
Arsenic....As	74.96	Iodine.....I	126.92	Samarium...Sa	150.40
Barium....Ba	137.37	Iridium....Ir	193.10	Scandium...Sc	44.10
Bismuth...Bi	208.00	Iron.....Fe	55.84	Selenium...Se	79.20
Boron.....B	11.00	Krypton....Kr	82.92	Silicon.....Si	28.30
Bromine...Br	79.92	Lanthanum..La	139.00	Silver.....Ag	107.88
Cadmium...Cd	112.40	Lead.....Pb	207.10	Sodium.....Na	23.00
Caesium...Cs	132.81	Lithium....Li	6.94	Strontium...Sr	87.63
Calcium...Ca	40.07	Lutecium...Lu	174.00	Sulphur....S	32.07
Carbon....C	12.00	Magnesium..Mg	24.32	Tantalum...Ta	181.50
Cerium....Ce	140.25	Manganese..Mn	54.93	Tellurium...Te	127.50
Chlorine...Cl	35.46	Mercury....Hg	200.60	Terbium...Tb	159.20
Chromium..Cr	52.00	Molybdenum.Mo	96.00	Thallium...Tl	204.00
Cobalt....Co	58.97	Neodymium..Nd	144.30	Thorium...Th	232.40
Columbium.Cb	93.50	Neon.....Ne	20.20	Thulium...Tm	168.50
Copper....Cu	63.57	Nickel.....Ni	58.68	Tin.....Sn	119.00
Dysprosium Dy	162.50	Niton.....Nt	222.40	Titanium...Ti	48.10
Erbium....Er	167.70	Nitrogen...N	14.01	Tungsten...W	184.00
Europium..Eu	152.00	Osmium.....Os	190.90	Uranium...U	238.50
Fluorine...F	19.00	Oxygen.....O	16.00	Vanadium...V	51.00
Gadolinium.Gd	157.30	Palladium...Pd	106.70	Xenon.....Xe	130.20
Gallium...Ga	69.90	Phosphorus..P	31.04	Ytterbium...Yb	173.50
Germanium.Ge	72.50	Platinum....Pt	195.20	Yttrium....Yt	89.00
Gluclium...Gl	9.10	Potassium...K	39.10	Zinc.....Zn	65.37
Gold.....Au	197.20	PraseodymiumPr	140.60	Zirconium...Zr	90.60
Helium....He	3.96	Radium.....Ra	226.40		

TABLE OF COMPARATIVE PLATE SPEED
NUMBERS

H & D	Watkins P No.	Wynne F No.	H & D	Watkins P No.	Wynne F No.
10	15	24	220	323	114
20	30	35	240	352	120
40	60	49	260	382	124
80	120	69	280	412	129
100	147	77	300	441	134
120	176	84	320	470	138
140	206	91	340	500	142
160	235	98	380	558	150
200	294	109	400	588	154

The above Watkins and Wynne numbers are equivalent to the H and D, only when the latter is determined in accordance with the directions of Hurter and Driffield, that is with pyro-soda developer and using the straight portion only of the density curve.

To convert H and D into Watkins: Multiply H and D by 50 and divide by 34. For all practical purposes the Watkins P number is $1\frac{1}{2}$ times H and D.

To convert Watkins into Wynne F Nos.: Extract the square root and multiply by 6.4.

The above methods have been approved by the Watkins Meter Company and the Infalible Exposure Meter Company.

THERMO DEVELOPMENT

Reprinted by permission from Thermo Development Chart, published by the American Photographic Publishing Company, Boston 17, Mass.

Degrees Fabr.	T. C. 1.9.				T. C. 2.6			
	Min. Tray	Min. Tank	Min. Tray	Min. Tank	Min. Tray	Min. Tank	Min. Tray	Min. Tank
80	3 $\frac{1}{2}$	12	1 $\frac{1}{2}$	7 $\frac{1}{2}$				
78	3 $\frac{3}{4}$	13	2	8 $\frac{1}{2}$				
76	3 $\frac{3}{4}$	14	2 $\frac{1}{4}$	9 $\frac{1}{2}$				
74	4	15	2 $\frac{1}{2}$	10 $\frac{1}{2}$				
72	4 $\frac{1}{4}$	16	2 $\frac{3}{4}$	11 $\frac{1}{2}$				
70	4 $\frac{1}{2}$	17	3	13				
68	5	18 $\frac{1}{4}$	3 $\frac{1}{4}$	14 $\frac{1}{2}$				
66	5 $\frac{1}{4}$	19 $\frac{1}{2}$	3 $\frac{1}{2}$	16				
64	5 $\frac{3}{4}$	21	4	18				
62	6 $\frac{1}{4}$	22 $\frac{1}{2}$	4 $\frac{1}{2}$	20				
60	6 $\frac{1}{2}$	24	5	22				
58	7	26	5 $\frac{1}{2}$	24 $\frac{1}{2}$				
56	7 $\frac{1}{2}$	28	6	27				
54	8	30	6 $\frac{1}{2}$	30				
52	8 $\frac{1}{2}$	32	7 $\frac{1}{2}$	33				
50	9 $\frac{1}{4}$	34	8 $\frac{1}{2}$	37				
48	10	37	9 $\frac{1}{2}$	41 $\frac{1}{2}$				
46	10 $\frac{1}{2}$	40	10 $\frac{1}{2}$	46				
44	11 $\frac{1}{2}$	43	11 $\frac{1}{2}$	51 $\frac{1}{2}$				
42	12 $\frac{1}{4}$	46	12 $\frac{1}{4}$	57				
40	13 $\frac{1}{4}$	49	14 $\frac{1}{2}$	63				

TABLE OF DEVELOPMENT SPEEDS
ANSKO FILM, MS. BARNET—Super-speed
 Ortho, M; Extra Rapid Ortho, MS. Red Seal, M; Red Diamond, MS; Self-screen Ortho, MS;
CENTRAL—Special XX, S; Special, M; Comet, M; Colormon, MQ; Panortho, MQ; CRAMER—
 Crown S; Anchor, MQ; Banner X, S; Inst. Iso, MQ; Med. Iso, MQ; Commercial Isonon, MQ;
 Portrait Isonon, M; Trichromatic, MQ; Spectrum, MQ; Slow Iso, MQ; Contrast, VVQ. **ENSIGN FILM, MS. HAMMER—Special Extra Fast, MS; Extra Fast, M; Aurora Extra Fast, MS; Ortho Extra Fast, M; Ortho Nonhal., M; Fast, MQ; Slow, VQ. Ortho Slow, VQ. ILFORD—**
 Monarch, VS; Zenith, VS; Special Rapid, VS; Rapid Chromatic, M; Ordinary, Q. **IMPERIAL—Flash Light, M; Special Sensitive, MQ; Ortho-**

chrome S.S., MQ; Special Rapid, S; Orthochrome S.R., MS; Non-filter, MQ. **KODAK—**Speed Film, S; N.C. Film, S; Portrait Film, S. **MARION—Record, S; P.S.; MS. PAGET—XXX M; XXXXX, MS; Swift, S; Ex. Spec. Rap., S; Ortho. Ex. Spec. Rap., MQ; Pancho Ord, Q; Pancho. Color, VQ; Spec. Rap., S; Hydra Pancho, MQ; Hydra Rapid, MQ; PREMIO FILM PACK—S, SEED—Graflex, MQ; 30 Gilt Edge, MS; 26 X, MS; 23, MQ; L Ortho, MQ; Non-halation, MQ; Panchromatic, VQ. **STANDARD—Extra, Orthonon, MQ; Polychrome, MQ. STANLEY—59, M; Commercial, MQ. WELLINGTON—Extreme, S; Xtra Speedy, MS; Film, MS; Iso Speedy, M; Portrait Speedy, M; Anti-Screen, M; Speedy Spec. Rap., M; Ortho Process, M; Wratten—Pancho, MQ; Process Pancho, Q.****

WATKINS THERMO PYRO-SODA T. C. 1.9	
a. Potassium metabisulphite.....	80 gr.
Pyro	160 gr.
Sodium sulphite, dry.....	1 oz.
Water to make.....	10 oz.
b. Sodium carbonate, dry.....	2 oz.
Potassium bromide.....	40 gr.
Water to make.....	10 oz.
MODIFIED THERMO M. Q. T. C. 1.9	
a. Potassium metabisulphite.....	60 gr.
Metol	30 gr.
Hydrochinon	90 gr.
Water to make.....	20 oz.
b. Sodium sulphite, dry.....	1 oz.
Sodium carbonate, dry.....	1 $\frac{1}{2}$ oz.
Water to make.....	20 oz.
MODIFIED THERMO D. Q. T. C. 2.6	
a. Potassium metabisulphite.....	60 gr.
Duratol	30 gr.
Hydrochinon	90 gr.
Water to make.....	20 oz.
b. Sodium sulphite, dry.....	1 $\frac{1}{2}$ oz.
Sodium carbonate, dry.....	2 oz.
Water to make.....	20 oz.

INSTRUCTIONS.—Look up the Development Speed of the plate or film and mix the developer as directed for that class, USING WATER WHICH HAS STOOD IN THE ROOM LONG ENOUGH TO ATTAIN ROOM TEMPERATURE. In safe ruby light (or total darkness) place the plate in the tray, flow it with developer, cover the tray light-tight, and note the time. We recommend handling plates in total darkness and using white light while they are covered. Now observe the temperature of the room and consult the Table of Temperatures, where the correct time for development will be found opposite the degree and under the Temperature-Coefficient of the developer in use. The tray may be rocked now and then during development, but the plate should not be removed from the solution until the time is up. Then turn out the white light and rinse and fix the plate by safe light or in a covered tank.

If the first trial does not give the right printing quality to suit your requirements, classify the plate one class nearer VS for more or one class farther from VS for less contrast.

DILUTION OF DEVELOPER.—	VVQ	VQ	Q	MQ	M	MS	S	VS
Watkins Thermo Pyro-Soda.....	1	1 $\frac{1}{2}$	1 $\frac{3}{4}$	2 $\frac{1}{4}$	3	4	5	6 $\frac{3}{4}$
Modified Thermo M.-Q.....	1 $\frac{1}{2}$	2	2 $\frac{3}{4}$	3 $\frac{1}{2}$	4 $\frac{1}{2}$	6	8	10
Modified Thermo Duratol.....								
drams of each stock to be diluted to make total volume 3 ounces for tray or 10 ounces for tank development.								
Kodinal (Citol, Azol, Certinal) ..	20	26	35	45	60	80	105	135
minims solution to be made up to 3 ounces for tray or 9 ounces for tank. T. C. 1.9.								

Dilution of Dev.	VVQ	VQ	Q	MQ	M	MS	S	VS
Metabisulphite grs.								
Potass.....	1.68	2 $\frac{1}{2}$	3.	4.	5.	6.8	9.	12.
Metol.....	.84	1 $\frac{1}{4}$ or 2 $\frac{1}{4}$	1 $\frac{3}{4}$ or 3	2.	2 $\frac{1}{2}$ or 5	3.4	4 $\frac{1}{2}$ or 9	6 or 12
Hydrochinon..	2.52	1.68 3 $\frac{1}{2}$	2 $\frac{1}{2}$ 4 $\frac{1}{2}$	3	6.	10.2	16.8 13 $\frac{1}{2}$	24 or 18
Sod. Sulphite..	12.5	16 $\frac{1}{2}$	22.	28.	37.	50.	66.	82.
Sod. Carbonate	18.75	24 $\frac{1}{2}$	33.	42.	55.	70.	99.	123.
Water.....	30 $\frac{5}{8}$	30 $\frac{5}{8}$	30 $\frac{5}{8}$	30 $\frac{5}{8}$	30 $\frac{5}{8}$	30 $\frac{5}{8}$	30 $\frac{5}{8}$	30 $\frac{5}{8}$

*For flashlight pictures equal parts of Hydrochinon and Eikonogen give softer effects.

N.B.—A single portion of developer should be used for only one plate, but the used developer (except pyro) should be saved for paper. If fog occurs, add to each ounce of water used for diluting, 7 $\frac{1}{2}$ to 10 grs. dry sulphite.



BETSEY.

Edna Leighton Tyler.

TABLE FOR CALCULATING DISTANCES IN ENLARGING OR REDUCING

From *The British Journal Photographic Almanac*

Focus of Lens Inches	Times of Enlargement and Reduction							
	1 Inch	2 Inches	3 Inches	4 Inches	5 Inches	6 Inches	7 Inches	8 Inches
2.....	4 4	6 3	8 2 $\frac{2}{3}$	10 2 $\frac{1}{2}$	12 2 $\frac{2}{5}$	14 2 $\frac{1}{3}$	16 2 $\frac{2}{7}$	18 2 $\frac{1}{4}$
2 $\frac{1}{2}$	5 5	7 $\frac{1}{2}$ 3 $\frac{3}{4}$	10 3 $\frac{1}{3}$	12 $\frac{1}{2}$ 3 $\frac{3}{8}$	15 3	17 $\frac{1}{2}$ 2 $\frac{9}{10}$	20 2 $\frac{2}{7}$	22 $\frac{1}{2}$ 2 $\frac{3}{16}$
3.....	6 6	9 4 $\frac{1}{2}$	12 4	15 3 $\frac{3}{4}$	18 3 $\frac{3}{5}$	21 3 $\frac{1}{2}$	24 3 $\frac{3}{7}$	27 3 $\frac{3}{8}$
3 $\frac{1}{2}$	7 7	10 $\frac{1}{2}$ 5 $\frac{1}{4}$	14 4 $\frac{2}{3}$	17 $\frac{1}{2}$ 4 $\frac{3}{4}$	21 4 $\frac{1}{5}$	24 $\frac{1}{2}$ 4 $\frac{1}{12}$	28 4	31 $\frac{1}{2}$ 3 $\frac{9}{10}$
4.....	8 8	12 6	16 5 $\frac{1}{3}$	20 5	24 4 $\frac{4}{5}$	28 4 $\frac{2}{3}$	32 4 $\frac{4}{7}$	36 4 $\frac{1}{2}$
4 $\frac{1}{2}$	9 9	13 $\frac{1}{2}$ 6 $\frac{3}{4}$	18 6	22 $\frac{1}{2}$ 5 $\frac{3}{5}$	27 5 $\frac{2}{5}$	31 $\frac{1}{2}$ 5 $\frac{1}{4}$	36 5 $\frac{1}{7}$	40 $\frac{1}{2}$ 5 $\frac{1}{16}$
5.....	10 10	15 7 $\frac{1}{2}$	20 6 $\frac{2}{3}$	25 6 $\frac{1}{4}$	30 6	35 5 $\frac{5}{6}$	40 5 $\frac{5}{7}$	45 5 $\frac{5}{8}$
5 $\frac{1}{2}$	11 11	16 $\frac{1}{2}$ 8 $\frac{1}{4}$	22 7 $\frac{1}{3}$	27 $\frac{1}{2}$ 6 $\frac{4}{5}$	33 6 $\frac{1}{2}$	38 $\frac{1}{2}$ 6 $\frac{5}{12}$	44 6 $\frac{2}{7}$	49 $\frac{1}{2}$ 6 $\frac{3}{16}$
6.....	12 12	18 9	24 8	30 7 $\frac{1}{2}$	36 7 $\frac{1}{5}$	42 7	48 6 $\frac{6}{7}$	54 6 $\frac{3}{4}$
7.....	14 14	21 10 $\frac{1}{2}$	28 9 $\frac{1}{3}$	35 8 $\frac{3}{4}$	42 8 $\frac{2}{5}$	49 8 $\frac{1}{6}$	56 8	63 7 $\frac{7}{8}$
8.....	16 16	24 12	32 10 $\frac{2}{3}$	40 10	48 9 $\frac{3}{5}$	56 9 $\frac{1}{3}$	64 9 $\frac{1}{7}$	72 9
9.....	18 18	27 13 $\frac{1}{2}$	36 12	45 11 $\frac{1}{4}$	54 10 $\frac{4}{5}$	63 10 $\frac{1}{2}$	72 10 $\frac{2}{7}$	81 10 $\frac{1}{8}$

The object of this table is to enable any manipulator who is about to enlarge (or reduce) a copy any given number of times to do so without troublesome calculation. It is assumed that the photographer knows exactly what the focus of his lens is, and that he is able to measure accurately from its optical center. The use of the table will be seen from the following illustration: A photographer has a *carte* to enlarge to four times its size, and the lens he intends employing is one of 6 inches equivalent focus. He must therefore look for 4 on the upper horizontal line and for 6 on the first vertical column and carry his eye to where these two join, which will be 30-7 $\frac{1}{2}$. The greater of these is the distance the sensitive plate must be from the center of the lens; and the lesser, the distance of the picture to be copied. To *reduce* a picture any given number of times, the same method must be followed; but in this case the greater number will represent the distance between the lens and the picture to be copied, the latter that between the lens and the sensitive plate. This explanation will be sufficient for every case of enlargement or reduction.

If the focus of the lens be 12 inches, as this number is not in the column of focal lengths, look out for 6 in this column and multiply by 2, and so on with any other numbers.

**TABLES OF DISTANCES AT AND BEYOND WHICH ALL OBJECTS
ARE IN FOCUS WHEN SHARP FOCUS IS SECURED ON
INFINITY**

Focal Length of Lens in Inches	Ratio marked on Stops													
	f/4	f/5.6	f/6	f/7	f/8	f/10	f/11	f/15	f/16	f/20	f/22	f/32	f/44	f/64
	Number of feet after which all is in focus													
4	33	24	22	19	17	13	12	9	8	7	6	4	3	2
4½	38	27	25	21	19	15	14	10	10	7	7	5	3½	2½
4¾	42	30	28	24	21	17	15	11	11	8½	7½	5½	4	3
5	47	34	31	27	24	19	17	12	12	9½	8½	6	5	3
5½	52	36	35	30	26	21	19	14	13	10½	9½	6½	5½	3½
5¾	57	40	38	33	28	23	21	15	14	11½	10½	7	5½	3½
6	63	45	43	36	31	25	23	17	15	12½	11½	7½	6	4
6½	68	50	46	38	34	27	25	18	17	13½	13	8½	6½	4
6¾	75	54	50	42	38	30	28	20	19	15	14	9	7	4½
7	81	58	54	46	40	32	29	22	20	16	15	10	7½	5
7½	87	62	58	50	44	35	32	23	22	17½	16	11	8	5½
7¾	94	67	63	54	47	38	34	25	24	19	17	12	8½	6
8	101	72	68	58	51	40	37	27	25	20	18	12½	9	6
8½	109	78	73	62	54	44	39	29	27	22	20	13½	10	6½
8¾	117	83	78	64	58	47	42	31	29	24	21	14½	10½	7
9	124	90	83	71	62	50	45	33	31	25	22	15½	11	7½
9½	132	96	88	76	68	52	48	36	32	28	24	16	12	8
9¾	141	100	94	80	71	56	51	37	35	29	25	17½	12½	8½
10	150	104	100	84	76	60	56	40	38	30	27	19	13½	9
10½	156	111	104	89	78	63	57	42	39	32	29	20	14	10
11	168	120	112	96	84	67	61	45	42	34	31	21	15	10½
11½	180	127	116	101	90	71	65	47	45	35	32	22	16	11
11¾	190	133	125	107	95	75	68	50	47	37	34	24	17	12
12	197	141	131	113	99	79	72	52	50	39	36	25	18	12½
12½	208	148	140	120	104	83	75	55	52	42	38	26	19	13

If sharp focus is secured on any of the distances shown, then with the stop indicated all objects are in focus from half the distance focused on up to infinity.

LENGTH OF STUDIO

REQUIRED FOR LENSES OF DIFFERENT FOCAL LENGTHS FROM 6 TO 8 FEET IS ALLOWED FOR THE CAMERA AND OPERATOR

From "Photographic Lenses" by BECK and ANDREWS

Focus of Lens	Size	Kind of Portrait	Length of Studio	Dist. of Lens from Object
Inches			In Feet	In Feet
	6	Carte de Visite 3¼x4¼	Full Length	18 to 20
7½	Carte de Visite	Full Length	22 to 25	14 to 15
		Full Length	24 to 28	17 to 19
		Bust	10 to 15	5
8½	Carte de Visite	Full Length	20 to 23	12 to 13
		Bust	12 to 17	7
9½	Cabinet and smaller groups	Full Length	25 to 30	17 to 18
		Bust	13 to 20	8
11	Cabinet and 5x7 groups	Full Length	32 to 40	23 to 24
		Bust	14 to 20	7
		Full Length	20 to 25	13
14½	Cabinets, panels and 6½x8½ groups	Full Length	14 to 20	7
		Bust	14 to 20	7
		Full Length	25 to 30	14
19	10x12 portraits or groups	Bust	14 to 20	7
		Full Length	25 to 30	14
24	16x20 portraits or groups	Full Length	14 to 20	8
		Bust	14 to 20	8

"UNIFORM SYSTEM" NUMBERS FOR STOPS FROM

$$\frac{f}{1} \text{ TO } \frac{f}{100}$$

In the following table Mr. S. A. Warburton calculated the exposure necessary with every stop from $\frac{f}{1}$ to $\frac{f}{100}$ compared with the unit stop of the "uniform system" of the Photographic Society of Great Britain. The figures which are underlined show in the first column what $\frac{f}{a}$ must be in order to increase the exposure in geometrical ratio from $\frac{f}{4}$, the intermediate numbers showing the uniform system number for any other aperture.

f	U. S. No.	f	U. S. No.	f	U. S. No.	
1	<u>$\frac{1}{16}$</u>	15	14.06	58	210.25	
$1\frac{1}{4}$.097	16	16	59	217.56	
1.414	<u>$\frac{1}{8}$</u>	17	18.06	60	225.00	
$1\frac{1}{2}$.140	18	20.25	61	232.56	
$1\frac{3}{4}$.191	19	22.56	62	240.25	
2	<u>$\frac{1}{4}$</u>	20	25.00	63	248.06	
$2\frac{1}{4}$.316	21	27.56	64	256	
$2\frac{1}{2}$.390	22	30.25	65	264.06	
2.828	<u>$\frac{1}{2}$</u>	22.62	32	66	272.25	
$2\frac{3}{4}$.472	23	33.06	67	280.56	
3	.562	24	36.00	68	289.00	
$3\frac{1}{4}$.660	25	39.06	69	297.56	
$3\frac{1}{2}$.765	26	42.25	70	306.25	
$3\frac{3}{4}$.878	27	45.56	71	315.06	
4	1	28	49.00	72	324.00	
$4\frac{1}{4}$	1.12	29	52.56	73	333.06	
$4\frac{1}{2}$	1.26	30	56.25	74	342.25	
$4\frac{3}{4}$	1.41	31	60.06	75	351.56	
5	1.56	32	64	76	361.00	
$5\frac{1}{4}$	1.72	33	68.06	77	370.56	
$5\frac{1}{2}$	1.89	34	72.25	78	380.25	
5.656	2	35	76.56	79	390.06	
$5\frac{3}{4}$	2.06	36	81.00	80	400.00	
6	2.25	37	85.56	81	410.06	
$6\frac{1}{4}$	2.44	38	90.25	82	420.25	
$6\frac{1}{2}$	2.64	39	95.06	83	430.56	
$6\frac{3}{4}$	2.84	40	100.00	84	440.00	
7	3.06	41	105.06	85	451.56	
$7\frac{1}{4}$	3.28	42	110.25	86	462.25	
$7\frac{1}{2}$	3.51	43	115.56	87	473.06	
$7\frac{3}{4}$	3.75	44	121.00	88	484.00	
8	4	45	126.56	89	495.06	
$8\frac{1}{4}$	4.25	45.25	128	90.50	90	506.25
$8\frac{1}{2}$	4.51	46	132.25	91	517.56	
$8\frac{3}{4}$	4.78	47	138.06	92	529.00	
9	5.06	48	144.00	93	540.56	
$9\frac{1}{4}$	5.34	49	150.06	94	552.25	
$9\frac{1}{2}$	5.64	50	156.25	95	564.06	
$9\frac{3}{4}$	5.94	51	162.56	96	576.00	
10	6.25	52	169.00	97	588.06	
11	7.56	53	175.56	98	600.25	
11.31	8	54	182.25	99	612.56	
12	9.00	55	189.06	100	625	
13	10.56	56	196.00			
14	12.25	57	203.06			

American Photographic Societies

This list is compiled from information received from an inquiry form sent to the societies during the latter half of 1921. It includes many societies not given in the 1921 Annual, but falls short of completeness as a record of the photographic societies of America. Secretaries of societies not here listed are urged to send us particulars of their organization so that the list may be fully representative of society activities.—Editor.

- ALLENTOWN CAMERA CLUB—Allentown, Pa. Headquarters, 708 Hamilton St. *President*, George E. Phillips; *Vice-President*, L. H. Cutten; *Secretary*, R. B. Hernandez, 1326 Chew St., Allentown, Pa. Member Associated Camera Clubs of America.
- AMERICAN INSTITUTE PHOTOGRAPHIC SECTION—New York City. Headquarters, 322-324 West 23d Street. Established March 26, 1859. Stated meetings, first and third Mondays of each month. No meetings during Summer months. *Chairman*, Oscar G. Mason; *Vice-Chairman*, Robert A. B. Dayton; *Treasurer*, James Y. Watkins; *Secretary*, John W. Bartlett, M.D., F.R.P.S., 149 West 94th Street.
- ASSOCIATED CAMERA CLUBS OF AMERICA—Headquarters, 878-880 Broad Street, Newark, N. J. *President*, Julius F. Graether, Newark Camera Club; *Secretary*, Louis F. Bucher, Newark Camera Club; *Treasurer*, Henry C. Brewster, Newark Camera Club; *Western Vice-President*, Todd Hazen, Oregon Camera Club; *Southern Vice-President*, George H. Rowe, Photographic Club of Baltimore; *Central Vice-President*, Dr. Maclay Lyon, Kansas City Camera Club; *Eastern Vice-President*, J. L. Hanna, Columbia Photographic Society, Philadelphia. Motive—Closer affiliation of Camera Clubs, Annual Exhibits, Interchanges of Prints and Slides, as well as ideas, and literature. Membership September 1, forty-two clubs. Association organized May 1, 1919.
- BERKSHIRE PHOTOGRAPHIC SOCIETY—Headquarters, care of A. W. Jacobs Studio, 30 North St., Pittsfield, Mass. Member Associated Camera Clubs of America.
- BOULDER CAMERA CLUB—Care of University of Colorado, Boulder, Colo. *President*, Severance Burrage.
- BOSTON CAMERA CLUB—Boston, Mass. Established 1881. Incorporated 1886. Membership, 75. *President*, P. Hubbard; *Secretary*, John H. Thurston, 50 Bromfield Street.
- BOSTON YOUNG MEN'S CHRISTIAN UNION CAMERA CLUB—Boston, Mass. Headquarters, 48 Boylston Street, Boston. Organized, 1908. *President*, Herbert B. Turner; *Vice-President*, Louis Astrella, 26 Quincy Street, Roxbury; *Treasurer*, F. Chester Everett; *Secretary*, Ernest Gustavsen, 234 Hyde Park Ave., Forest Hills. Meetings first Tuesday each month at club rooms, 48 Boylston Street. Member Associated Camera Clubs of America.
- BROOKLYN INSTITUTE OF ARTS AND SCIENCES, PHOTOGRAPHIC SECTION—Headquarters, Academy of Music Building, Lafayette Ave., Brooklyn, N. Y. Organized 1886. Membership 75. Meetings for general discuss on and criticism the second Monday each month except July and August. Courses in Rudiments of Photography, Advanced Photography, Pictorial Photography, Loan Exhibitions. Annual exhibit of the Department in May. Demonstrations of the various processes every third Friday evening. *President*, Wm. Elbert Macnaughton; *Vice-President*, Wm. Alexander Alcock; *Secretary*, Sophie Louisa Lauffer, 157 Bainbridge St.; *Treasurer*, J. Halstead Patterson.
- BUFFALO CAMERA CLUB—Buffalo, N. Y. Headquarters, Kinne Building, corner Main and Utica Streets. Annual election of officers, fourth Tuesday in April; regular meeting nights, second and fourth Tuesdays of each month. *President*, F. W. Cowell; *Vice-President*, N. G. Sherk; *Secretary*, Charles L. Peck, 1101 Elmwood Avenue. Member Associated Camera Clubs of America.
- CALIFORNIA CAMERA CLUB—San Francisco, Cal. Headquarters, 833 Market St., San Francisco, Cal. Established March 18, 1890. Incorporated April 5, 1890. Membership 437. Date of meeting second Tuesday, monthly.

Monthly print exhibitions and illustrated lectures. *President*, Edward H. Kemp; *Secretary*, Wm. C. Mackintosh. Member of other clubs are cordially invited to visit our rooms when in San Francisco. Member Associated Camera Clubs of America.

CAMERA CLUB OF DETROIT—Headquarters, 7849 Walnut St., Detroit, Mich. *Temporary Chairman*, Orville P. Laughlin.

THE CAMERA CLUB—New York. Headquarters, 121 West 68th St., Established in 1884 and incorporated in 1896 upon consolidation with the New York Camera Club, 121 West 68th St. Membership 245. Annual meeting first Thursday after the first Monday in January. *President*, J. Henry McKinly; *Secretary*, Monroe W. Tingley.

"CAMERADS"—New Brunswick, N. J. Headquarters, corner Church and George Streets. Established April 24, 1890. *Secretary*, Harvey Iredell; D.D.S., Lock Box, 34 New Brunswick.

CAMERA CLUB OF WATERBURY—Waterbury, Conn., P. O. Box 712. Organized Sept. 1919. Meets Monday evenings at the Y. M. C. A. Room 10, 136 West Main St. *President*, Arthur H. Ganung; *Secretary*, Hollis M. French. Member Associated Camera Clubs of America.

CAMERA PICTORIALISTS OF LOS ANGELES—Los Angeles, Cal. Headquarters, Room 31, Walker Auditorium. Association formed for strictly pictorial work; the holding of an annual International Salon; and for the good of the cause generally. Membership limited to twenty. Meeting, first Monday of month. *Director*, Louis Fleckenstein; *Secretary*, Perry N. Moerdyke.

CAPE ANN CAMERA CLUB—Headquarters, Gloucester, Mass.

CAPITAL CAMERA CLUB—Washington, D. C., 638 I Street, N. W. Founded May 1, 1891. Annual meeting, first Thursday in January. *President*, Frederick L. Pittman; *Vice-President*, G. W. Anderson; *Secretary*, George M. Miller, 638 I St., N. W.; *Treasurer*, J. H. Weimer; *Librarian*, Miss Lucy Powell. Date of annual exhibition, March. Member Associated Camera Clubs of America.

CENTRAL Y. M. C. A. CAMERA CLUB—Headquarters, 1421 Arch Street, Philadelphia, Pa. Club organized 23 years ago. Meetings, third Monday in month. *President*, Bernard B. Wolff; *Vice-Presidents*, Geo. S. Gassner, J. F. Jackson; *Secretary*, S. K. Taylor; *Financial Secretary*, S. R. C. Cooper. Membership, 75.

CHICAGO CAMERA CLUB, Chicago, Ill. Headquarters, 31 W. Lake Street. Established February 14, 1904. Incorporated February 19, 1904. Meetings every Wednesday. *President*, Leroy T. Goble; *Vice-President*, James E. Mead, Jr.; *Secretary*, Alvin R. Born, 7744 Oglesby Ave.; *Treasurer*, Gilbert B. Seehausen. Member Associated Camera Clubs of America.

CHICAGO PHOTO FELLOWS—Chicago, Ill. Organized September 8, 1909. Membership, 8. *Correspondent*, F. M. Tuckerman, 1109 Railway Exchange, Chicago.

CLEVELAND PHOTOGRAPHIC SOCIETY—Cleveland, Ohio. Headquarters, The Towers, 6106½ Euclid Ave. Established June 7, 1913. Permanent organization effected at meeting of June 18. Incorporated October 9, 1920. Meetings every Wednesday. *President*, W. W. Webber; *Vice-President*, C. H. Shipman; *Financial Secretary*, Max E. Reuter; *Corresponding Secretary*, H. G. Cleveland. Member Associated Camera Clubs of America.

COLUMBIA PHOTOGRAPHIC SOCIETY—Philadelphia, Pa. Headquarters, 2526 North Broad Street, Philadelphia. Established 1889. Incorporated July 3, 1894. Membership, 80. Business meeting first Monday of each month; other Mondays, lectures or demonstrations. Member of Associated Camera Clubs of America. *President*, Daniel Fritz; *Vice-President*, Theo. D. Mitchell; *Treasurer*, C. F. Davis, 701 Eldridge Avenue, West Collinswood, N. J.; *Secretary*, A. I. Bond.

DARKROOM CLUB—Milwaukee, Wis. Organized January 1921. Meets every third Friday of each month. Meetings held at home of the president, 730 55th St. *President*, B. C. Demium; *Vice-President*, John H. Becker; *Secretary-Treasurer*, Albert L. Goerlitz, 749 27th Street.

DARTMOUTH CAMERA CLUB—Headquarters, 7-8 Robinson Hall, Hanover, N. H. Organized, 1915. Membership, 30. *President*, A. R. Steiner. All communications addressed to Prof. Leland Griggs, Hanover, N. H. Member Associated Camera Clubs of America.

DALLAS CAMERA CLUB—Dallas, Texas. Organized July 20, 1921. *President*, Jno. R. Minor, Jr.; *Vice-President*, L. B. Eidson; *Secretary*, H. B. Thevenet, Sr.

DETROIT CAMERA CLUB—Detroit, Mich. Headquarters, 32 Adams Ave. West. *Secretary*, Dr. Preston M. Hickey.

ELMIRA CAMERA CLUB—Elmira, N. Y. Headquarters, 116 Baldwin Street, Elmira. Established, 1902. Membership, 30. Meets first Wednesday each

- month. *President*, C. G. Leonardi; *Secretary-Treasurer*, E. Radeker Stancliff, 240 Lake Street. Member Associated Camera Clubs of America.
- ELYSIAN CAMERA CLUB—307 Washington St., Hoboken, N. J. Established 1902. Date of meeting first Friday of each month. Membership 54 Active, 7 Associate, 8 Honorary. *President*, Albert Harrass; *Vice-President*, Adolph Geiger; *Secretary*, J. Henry Wendt, 805 Washington St., Hoboken, N. J. Member Associated Camera Clubs of America.
- GILD OF PHOTOGRAPHERS OF THE SOCIETY OF ARTS AND CRAFTS OF BOSTON, MASS.—*Dean*, Herbert B. Turner; *Secretary and Treasurer*, Ralph Osborne; *Councillors*, Miss Lois L. Howe, Alton H. Blackinton. Organized February 18, 1916. Meetings held at members' studios.
- GRAND RAPIDS CAMERA CLUB—Member Associated Camera Clubs of America. Headquarters, 2 Central Place, where demonstrations and inspiration meetings are held each Thursday evening from September to June inclusive, with occasional field days during the Summer months. *President*, Prof. H. C. Doane; *Vice-President*, J. O. Rogers; *Treasurer*, A. Steenhagen; *Secretary*, Miss Loa G. Winegar. Member Associated Camera Clubs of America.
- INDIANAPOLIS CAMERA CLUB—Headquarters, 406 Rauh Bldg., Indianapolis. Member Associated Camera Clubs of America.
- INTERNATIONAL PHOTOGRAPHIC ASSOCIATION—San Francisco, Cal. Founded 1908. *President*, F. B. Hinman, Evergreen, Col.; *General Secretary*, A. E. Davies, 1327 Grove St., Berkeley, Cal.; *Stereoscopic Album Director*, James B. Warner, 413-415 Claus Spreckels Building, San Francisco, Cal.; *Director Post Card Division*, John Biesman, Hemlock, Ohio; *Director Lantern-Slide Eastern Division*, Arthur H. Farrow, 51 Richelieu Terrace, Newark, N. J.; *Director Lantern-Slide Western Division*, A. E. Davies, 1327 Grove Street, Berkeley, Cal. *State Secretaries*: California—A. E. Davies, 1327 Grove St., Berkeley. Colorado—H. E. High, 1023 Champa St., Denver. Idaho—Eugene Clifford, 902 9th Ave., Lewiston. Iowa—Harry B. Nolte, Algona. Kansas—H. H. Gill, Hays City. Louisiana—Samuel F. Lawrence, 1247 Oakland Street, Shreveport. Mississippi—George W. Askew, Jr., 211 34th Ave., Meridian. Missouri—J. F. Peters, Room 210 Union Station, St. Louis. New York—Louis R. Murray, 927 Ford Street, Ogdensburg. Oregon—F. L. Derby, La Fayette. Texas—Emmett L. Lovett, care Southern Electric Company of Texas, Wichita Falls. *Album Directors*: Alabama—Richard Hines, Jr., Barton Academy Bldg. Mobile. Colorado—O. E. Aultman, Pleased Bldg., Trinidad. Connecticut—Harry E. Carpenter, 389 Remington Ave., Bridgeport. Florida—Capt. E. S. Coutant, Lock Box 73, Stuart. Georgia—L. O. Surles, P. O. Box 434, Cuthbert. Idaho—Eugene Clifford, 902 9th Ave., Lewiston. Illinois—George A. Price, Box 286, Champaign. Iowa—C. W. Parker, Mapleton. Maryland—E. G. Hooper, 218 East 20th Street, Baltimore. Massachusetts—John Mardon, 10 High Street, Boston. Michigan—W. E. Ziegenfuss, M. D., 171 Richton St., Detroit. Minnesota—Leonard A. Williams, 622 2nd Avenue South, St. Cloud. Mississippi—George W. Askew, Jr., 211 34th Ave., Meridian. Missouri—Wharton Schooler, R. F. D. No. 2, Eolia. New York—Charles F. Rice, P. O. Box 517, Mamaroneck. North Dakota—Jas. A. Van Kleeck, 619 Second Ave., North Fargo. Ohio—J. H. Winchell, R. F. D. No. 2 Painesville. Pennsylvania—L. A. Sneary, 2822 Espy Ave., Pittsburgh. South Dakota—C. B. Bolles, L. B. 351, Aberdeen. Texas—J. B. Oheim, P. O. Drawer M. Henrietta. Utah—John C. Swenson, A. B. Provo. West Virginia—William E. Monroe, Box 298, Point Pleasant.
- KANSAS CITY CAMERA CLUB, 1919-1920—Suite 501, Bryant Building, Kansas City, Mo. Organized 1914. Club meets second Monday of each month. Annual Exhibition in November. *President*, Chas. H. Stearns; *Vice-President*, Wm. Pitt; *Secretary-Treasurer*, Dr. Maclay Lyon. Member Associated Camera Clubs of America.
- KODAK PARK CAMERA CLUB—Kodak Park, Rochester, N. Y. Organized Jan. 6, 1920. Meetings held bi-monthly. *President*, Harris Tuttle; *Vice-President*, W. L. Farley; *Secretary*, Howard A. Sauer, Kodak Park; *Treasurer*, Irwin Ward. Member Associated Camera Clubs of America.
- LOWELL Y. M. C. A. CAMERA CLUB—Lowell, Mass. *Secretary*, I. C. Shappee.
- MOLINE Y. M. C. A. CAMERA CLUB—Headquarters, Moline, Ill.
- MONTREAL AMATEUR ATHLETIC ASSOCIATION CAMERA CLUB—Montreal, Canada. Headquarters, M. A. A. Building, 250 Peel Street. Organized May 1, 1906. *President*, F. H. J. Ruel; *Vice-President*, W. S. Wier; *Hon. Secretary*, Walter G. D. Boronow; *Treasurer*, R. E. Melville. Exhibitions: Annual, April; Local, November.
- NEWARK CAMERA CLUB, INC.—878-880 Broad Street, Newark, N. J. Organized 1888. Incorporated 1910. Meetings, second and fourth Mondays in each month. Motto, "SOMETHING OF INTEREST EVERY MONDAY NIGHT." *President*, J. Raymond Boyle; *Vice-President*, Lyman Lee;

- Secretary*, Edwin Wick; *Treasurer*, Henry C. Brewster. Membership now 200 active. Member and organizer of Associated Camera Clubs of America. Visitors Welcome.
- NEW BRITAIN CAMERA CLUB**—Organized 1892. *President*, W. B. Rossberg; *Vice-President*, H. P. Richards; *Secretary-Treasurer*, Paul A. Stahl, 260 Corbin Avenue, New Britain, Conn. Meets first and third Tuesdays, 173 Main Street. Member Associated Camera Clubs of America.
- NEW HAVEN CAMERA CLUB**—17 Broadway. Organized 1911. Membership, 35. *President*, Thomas G. Bowers; *Vice-President*, Benjamin H. Walden; *Secretary*, William R. Frisbie, 55 Lyon St., (N. H.); *Treasurer*, J. Geo. Blunden. Meetings held every Thursday. Business meetings, first Thursday in the month. Member Associated Camera Clubs of America.
- NONDAGA PHOTOGRAPHIC CLUB**—35-36 Grand Opera House Building, Syracuse, N. Y. Organized 1920. Membership 49. Meetings first and third Fridays in each month. Motto: "A live wire club." *President*, Ralph R. Scobey; *Vice-President*, Wm. J. Chorley; *Secretary*, Prof. Frederick W. Simpson, 529 Garfield Ave.; *Treasurer*, Prof. T. L. Hankinson. Member Associated Camera Clubs of America.
- ORANGE CAMERA CLUB**—East Orange, N. J. Headquarters, Main and Clinton Streets. Established March 21, 1892. Incorporated May 19, 1893. Membership, 115. Date of meetings, first and third Saturdays of each month, except July, August and September. *President*, Robert M. Crater; *Secretary*, C. Russell Powelson, Main and Clinton Streets, East Orange, N. J. Member Associated Camera Clubs of America.
- OREGON CAMERA CLUB**—Portland, Oregon. Headquarters, F'fth Floor Elks' Building. Established 1895. Incorporated 1903. Membership, 100. Date of annual meeting, second Tuesday in January. *President*, H. W. Sherrard; *Secretary*, E. C. Churchill. Date of annual exhibit, early in Spring. Member Associated Camera Clubs of America.
- PHOTOGRAPHIC CLUB OF BALTIMORE CITY**—Baltimore, Md. Headquarters, 329 Park Avenue. Established 1885. Incorporated 1890. Membership, active, 50. Meetings, first Tuesday in month. *President*, A. Gustafson, Baltimore; *Secretary*, A. H. Goldsborough, Baltimore. Member Associated Camera Clubs of America.
- PHOTO FELLOWS CLUB**—Vancouver, Canada. Headquarters, 650 Granville Street. *Secretary-Treasurer*, Lieut. J. Green, R. N. V. R.
- PHOTOGRAPHIC SOCIETY OF PHILADELPHIA**—Philadelphia, Pa. Headquarters, 1615-1617 Sansom Street. Established November, 1862. Incorporated April, 24, 1885. Membership, 95. Date of meetings: Members, second Wednesday. *President*, Dr. Collier F. Martin; *Secretary*, E. A. McKinley, 1615 Sansom Street; *Treasurer*, H. F. A. Starr. Date of members' annual exhibition, March. Member Associated Camera Clubs of America.
- PICTORIAL PHOTOGRAPHERS OF AMERICA**—New York City. Headquarters, National Arts Club, 119 East 19th Street. Meetings first Monday evening in each month from October to June. *President*, Clarence H. White; *Vice-President*, Dr. A. D. Chaffee; *Hon. Vice-Presidents*, Gertrude Kasebier, Prof. Chas. F. Chandler; *Treasurer*, Dr. Chas. H. Jaeger; *Recording Secretary*, Jerry D. Drew; *Corresponding Secretary*, Margaret Watkins. Member Associated Camera Clubs of America.
- PITTSBURGH ACADEMY OF SCIENCE AND ART (PHOTOGRAPHIC SECTION)**—Pittsburgh, Pa. Headquarters, Carnegie Institute, Schenley Park. Organized January 23, 1900. Membership, 100. Meetings, second and fourth Tuesdays in each month at Carnegie Institute. *President*, O. C. Reiter, 2424 Penn Avenue; *Vice-President*, M. C. Rypinski; *Secretary-Treasurer*, Chas. K. Archer, 1412 Carnegie Bldg., Pittsburgh, Pa.; *Lantern-Slide Director*, P. F. Squier, 483 Campbell Street, Wilkinsburg, Pa.; *Print Director*, S. A. Martin, 1011 Heberton Avenue, Annual salon, Carnegie Art Gallery, March. Address all communications to Chas. K. Archer, Secretary, 1412 Carnegie Bldg., Pittsburgh, Pa.
- PITTSBURGH PHOTOGRAPHIC SOCIETY**—Pittsburgh, Pa. Headquarters, North Side Community House. Established June, 1921. Membership, 25. *President*, Charles W. Douth; *Secretary*, John Allen; *Treasurer*, M. P. Beers.
- PITTSBURGH SALON OF PHOTOGRAPHIC ART**—Pittsburgh, Pa. Under auspices of Photographic Section of the Academy of Science and Art. Membership consists of the leading pictorialists in the United States. *President*, O. C. Reiter, 2424 Penn Avenue, Pittsburgh, Pa.; *Secretary*, Charles K. Archer, 1412 Carnegie Bldg., Pittsburgh, Pa. Salon held Carnegie Institute, March. Last day of entry, February 10.
- POLYTECHNIC CAMERA CLUB**—Polytechnic Institute of Brooklyn, 99 Livingston St., Brooklyn, N. Y. Organized May 15, 1921. Meets second and fourth Tuesdays, 12.30 p. m. *President*, Joseph R. Fisher, 1555 74th St.; *Secretary*, Edward Breiteirser, 2703 Bainbridge Ave., Bronx, N. Y.

- PORTLAND CAMERA CLUB PHOTOGRAPHIC SECTION OF THE PORTLAND SOCIETY OF ART—Portland, Me. Headquarters, L. D. M. Sweat Memorial, Spring, corner High Street. Established 1899. Membership, 86. Date of meetings, every Monday evening. *President*, E. Roy Monroe; *Vice-President*, Roger P. Jordan; *Secretary-Treasurer*, William T. Starr. Date of annual exhibition, in March. Member Associated Camera Clubs of America.
- POSTAL PHOTOGRAPHIC CLUB—Headquarters, Washington, D. C. Established December, 1888. Membership, 40. Date of meetings, no regular meeting. *President*, Charles E. Fairman; *Secretary*, Ernest L. Crandall, 1331 Newton Street, N. E., Brookland, Washington, D. C. Albums circulate among members monthly, except August and September.
- READING CAMERA CLUB—Reading, Pa. Headquarters, 610 Court St. Established 1913. Meetings first and third Thursdays of each month. Quarterly exhibits for members only. Annual exhibit early in March. *President*, H. N. Mucher; *Secretary*, J. Trate Gerhard, 752 9th St. Reading. Member Associated Camera Clubs of America.
- SALT LAKE CITY CAMERA CLUB—Salt Lake City, Utah. *Secretary*, Thomas O. Sherkell.
- SAN DIEGO Y. M. C. A. CAMERA CLUB—San Diego, Cal. Organized January, 1920. *President*, Homer C. Miller; *Vice-President*, Ivor N. Lawson Jr.; *Secretary-Treasurer*, Y. M. C. A., San Diego, Cal.
- SOUTHERN CALIFORNIA CAMERA CLUB—213 Columbia Bldg., 313 W. 3rd St., Los Angeles. Membership 140. *President*, Ralph G. Hawkins; *Vice-President*, Claude Williams; *Secretary*, Frances Purdy. *Board of Governors*, R. M. Weed, Orrie Pauline Close, W. L. Jennings. Member Associated Camera Clubs of America. Send notices public exhibitions, eontests and salons.
- ST. LAWRENCE CAMERA CLUB—Ogdensburg, N. Y. Headquarters, 74 Caroline Street. Established 1900. Membership, 10. Date of meetings, at the call of the *Secretary*. *President*, Arthur L. Jameson; *Secretary*, John N. Brown, 74 Caroline Street.
- ST. LOUIS CAMERA CLUB—St. Lou's, Mo. Organized February 12, 1914. Devoted to the interest and advancement of the art of photography. Meetings every first and third Thursdays at 8 p. m., Barr Branch Library, Jefferson & Lafayette Aves. *President*, Oscar C. Kuehn; *Vice-President*, E. W. Lidaker; *Secretary*, A. W. Prasse, 3149 Shenandoah Avenue, St. Louis. Member Associated Camera Clubs of America.
- TRENTON PHOTOGRAPHIC SOCIETY—Headquarters, 209 East State St., Trenton, N. J.
- UTAH CAMERA CLUB—Salt Lake City, Utah. *President*, Geo. I. Reeves; *Secretary*, Thomas O. Sheckell, 1411 Walker Bank Bldg.
- WASHINGTON Y. M. C. A. CAMERA CLUB—Washington, D. C. Headquarters, Central Y. M. C. A. Building. Membership, 32. *President*, Myron F. Myers; *Secretary*, Miss Elizabeth N. Brownley, 908 Que St., N. W.
- WESLEY CAMERA CLUB—Headquarters, Bell Theatre Buildng. Organized April 6, 1912. Meeting the first Monday of each month. *President*, W. A. Drewelow; *Vice-President*, Halvor Flom; *Secretary and Treasurer*, Lawrence Burke (Wesley, Iowa).
- WILKES-BARRE CAMERA CLUB—Headquarters, 131 West Main St., Wilkes-Barre, Pa. Member Associated Camera Clubs of America.
- YONKERS CAMERA CLUB—Yonkers, N. Y. Headquarters, Hollywood Inn Building. *President*, W. R. Cronk; *Vice-President*, Wm. Beck; *Secretary*; Elijah F. Munn; *Librarian*, C. B. Carling; *Trustees*, F. W. Woche, Wm. S. Mitchell, Geo. Stengel. Member Associated Camera Clubs of America.



Achievement

The making of fine lenses is no longer a mysterious art locked in the minds of old world craftsmen.

Through its staff of optical mathematicians, through its Research Laboratory and by means of testing apparatus of the utmost exactitude, the Kodak company has again proved that we here in America can equal the world in the scientific production of instruments of precision.

The production of the Kodak Anastigmat lens is a distinct achievement—not merely in the fact that it is at least the equal of the finest anastigmats made anywhere in the whole world, but in the further fact that through the use of scientific, specialized machinery of the utmost accuracy it is made and sold at a price which is bringing the anastigmat advantages to hundreds of thousands of amateurs who have not hitherto felt that they could afford a lens of the finest quality.

*Send for the free booklet "About Lenses".
It contains interesting information that you ought to have.*

The **KODAK**
ANASTIGMATS
f.7.7 f.6.3 and f.4.5

Eastman Kodak Company
Rochester, N. Y.

Eastman View Camera No. 2

Seven by Eleven



A sturdy, portable camera that makes 7x11 pictures—a proportion that is particularly pleasing for groups, architectural subjects and landscapes.

A large sliding front board permits the lens to be centered on either half of the film when two 5 x 7 exposures are desired. The swing is of unusual latitude—in every respect it is a superior camera, in an increasingly popular size.

The price, with case and one Eastman Film Holder... \$63.18

EASTMAN KODAK COMPANY

ROCHESTER, N. Y.

All Dealers

The *Special* Kodaks



WHILE every photographic convenience practical in a pocket camera is incorporated in the *Special* Kodaks, the feature that immediately stamps them as cameras of a superior sort is their lens and shutter equipment.

The Lens: The Kodak Anastigmat lens $f.6.3$ is Eastman-made from formula to finish. It has the speed that you want sometimes, and the qualities of flatness of field and definition (sharpness) that you want always. The Kodak Anastigmat $f.6.3$ is the lens for better pictures.

The Shutter: A full-jeweled watch is accurate to the second. The Kodamatic shutter, Eastman-made throughout, is accurate to $1/200$ of a second. With automatic exposures as fast as $1/200$ of a second and intermediate speeds down to $1/2$ second as well as time and "bulb" action, any amateur is equipped for any picture in the hand camera field.

The *Special* Kodaks equipped as above
range in price from \$50.00 up.

At your dealer's

EASTMAN KODAK COMPANY

ROCHESTER, N. Y., *The Kodak City*



The Graflex Camera



SHOWS you in the focusing hood a brilliant full negative size image, right side up, of the subject before the camera. As you advance toward or recede from the subject, you control the changing composition. Accurate focus is maintained by a slight movement of the focusing pinion—no measuring or guessing of distances.

The Graflex Focal Plane Shutter, with its range of instantaneous exposures of from $\frac{1}{10}$ to $\frac{1}{1000}$ of a second and the adjustments for time and retarded automatic exposures, makes it possible to secure not only good speed pictures but it makes easier the photographing of landscapes, marine views, portraits, architectural subjects and interiors.

The Graflex catalogue free at your dealer's or by mail

EASTMAN KODAK COMPANY

Folmer & Schwing Department

ROCHESTER, N. Y.

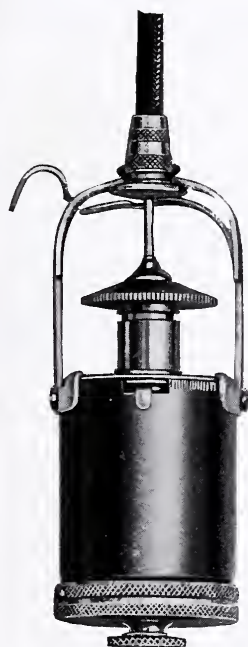

*You can
make pictures
of you*

Attached to the cable release, the Kodak Self Timer trips the shutter after you have taken your position in front of the lens. Plenty of time to pose for your own picture— $\frac{1}{2}$ second or one minute as you like—within this range the interval is under your control—plenty of time to rejoin the group.

THE PRICE

Kodak Self Timer, \$1.25

EASTMAN KODAK COMPANY

ROCHESTER, N. Y.

At your dealer's

CAMERAS—KODAKS—LENSES and SUPPLIES

(new or used)

at record-breaking prices. Write for copies of our

Latest Catalog and Bargain Book

and convince yourself. Hundreds of "good as new" bargains listed in our Bargain Book. Right now is the best time to pick up a Bargain in the photographic line. We buy—sell and trade. A trial of 10 days is granted on every item we sell. If at the end of that time you are not satisfied with your purchase you may return same for something else, or we will refund your money.

CENTRAL CAMERA CO.

124 So. Wabash Ave., Dept. AA-1 Chicago, Ill.



Hypo Eliminator

For Professional, Amateur and Photo finishing plants. THE GREAT TIME AND WATER SAVER. With a 4 oz. bottle of Hypo thousands of negatives and prints may be completely washed in 8 minutes without any after effects.

Simple, Economical and Efficient

Manufactured by MARION & CO., LONDON, ENGLAND

If your local dealer cannot supply you a 4 oz. bottle will be promptly mailed you on receipt of money order to the amount of 60c.

CIRCULAR ON REQUEST

A LIBERAL PROPOSITION AS A SIDE LINE TO SALESMEN REPRESENTING RELIABLE PHOTO STOCK HOUSES.

Address all inquiries to

TOM HADAWAY

U. S. Agent

235 Fifth Ave.

Dept. H

New York City

Forward Orders to Montgomery, N. Y.

J. L. LEWIS

522 SIXTH AVE.

NEW YORK

Specialties

Seltona Paper

Barnet Plates

Barnet Papers

Aldis Lens, F/3

Bromoil Materials

Sinclair Lens Hoods

Send for Catalogue

None but the finest chemicals, the purest silver, the most expert handling and a rigid system of supervision enter into the making of

HAMMER PLATES

That's why they are uniform, reliable and unsurpassed.

Special Brands for Special Needs

Hammer's Special Extra Fast (Red Label) and Extra Fast (Blue Label) plates for field and studio work, and Hammer's Extra Fast Orthochromatic and D. C. Orthochromatic plates for color values



HAMMER DRY PLATE COMPANY

Ohio Ave. and Miami St.

St. Louis, Mo.

If It's
Photographic



You'll Find It
at Willoughby's

You're sure to find it here—in the World's Largest Camera Supply House. Special Equipments, Imported Cameras and Lenses. Enlargers and printers. Everything for the amateur and professional.

Write for latest bulletin and price-list. Call when in New York.

Charles G. Willoughby, Inc., 110 West 32d Street, New York

No. 2 Harvey Exposure Meter

BEST Cloudy Days
For Exteriors or Interiors
All Cameras.

Your Dealer or G. L. Harvey
105 S. Dearborn St., Chicago. \$2.00
Costs no more than 2 Spoiled Roll Films

CAMERA CRAFT

Claus Spreckels Bldg.,

San Francisco, Cal.

Practical and informative for amateur, commercial and portrait photographers.

Its advertising pages keep you up-to-date.

To be enlarged January 1st, 1922 and subscription price raised to \$1.50. Up to that date we will accept subscriptions at **\$1.00 per year** for one or more years.

Canadian postage 25 cents

Foreign postage 50 cents

Sample on request

EAGLE "MIKADO"



Pencil No. 174



For Sale at your Dealer

Made in five grades

ASK FOR THE YELLOW PENCIL WITH THE RED BAND

EAGLE MIKADO

EAGLE PENCIL COMPANY, NEW YORK

“AGFA”

*Photographic
Products*

American Distributors:

Sagamore Chemical Company, Inc.
213-215 Water Street New York

ALL METAL

RWK

PATENTED

PHOTO-PRINTER

FOR PLATES AND FILMS

Produces results economically at operator speed.
For Professional, Amateur and Commercial Photographers.

Has two clamps, one that operates by hand for holding negative and MASK in relative positions, the other operates automatically with pressure cover and holds print paper in place, thus producing prints that require no trimming. For any size negative up to full capacity.

Size $6\frac{1}{2} \times 8\frac{1}{2}$ ins. **\$8.50** Delivered with
Weight 7 Pounds Bulbs in U. S. A.

Ask your dealer. Facsimile folder upon request.
We have new models, sizes 8x10 and 11x14, and
will be pleased to furnish information upon request.

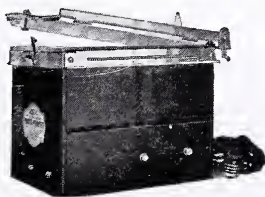

MODEL "C"

MANUFACTURED BY

R. W. KITTREDGE CO.
812 W. SUPERIOR STREET, CHICAGO, ILL.

Central Plates

Recognized as the standard plate for Professional, Commercial and Amateur Photography.

The Home of Standardized Plates

Central Dry Plate Co.

New York

St. Louis

San Francisco

The Portable Skylight

will make Photography by Flash Light a pleasure to you and your customers. An adjustable light for Home and Studio Work. Available at all times. Good Home Portrait Operators make \$300 to \$500 per month. The Better Class Customer demands Home Portrait Photos. Are you going to fill this demand or let some one else do it?

A few orders pay for an outfit. Price for Outfit Complete \$45. Adjustable Reflector, \$12; Spark Metals, 2 for 25c., 12 for \$1.00. New Front Cloths, \$1.75. All repairing taken care of promptly. Send for Descriptive Literature and how to make money at Home Portraiture. At your Dealer or direct from

O'NEILL PHOTO CO.

O'Neill, Nebraska

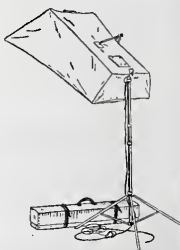

For the Amateur and Professional Photographer

PHOTO-ERA MAGAZINE

The American Journal of Photography

Wolfeboro, New Hampshire, U. S. A.

A photographic magazine that for twenty-three years has stood for the best in photography. Send for sampl. copy.

Subscription price, \$2.50; Canadian, \$2.85; Foreign, \$3.25.



HIGGINS'

PHOTO MOUNTER
PASTE and

Are the Finest and Best Inks and Adhesives

Emancipate yourself from the use of corrosive and ill-smelling inks and adhesives, and adopt the HIGGINS INKS AND ADHESIVES. They will be a revelation to you, they are so sweet, clean, well put up and withal so efficient.

At Dealers Generally

Chas. M. Higgins & Co., Mfrs., 271 Ninth Street, Brooklyn, N. Y.

BRANCHES: CHICAGO, LONDON

DRAWING INKS
ETERNAL WRITING INK
ENGROSSING INK
TAURINE MUCILAGE
DRAWING BOARD PASTE
LIQUID PASTE
OFFICE PASTE
VEGETABLE GLUE



*The largest selling Quality
pencil in the world*

VENUS PENCILS

For bringing out the soft tones of a photograph, deepening the shadows and emphasizing the high lights — VENUS Pencils are known in studios thruout the world as perfect tools.

17 Black Degrees
6B Softest to 9H Hardest
and 3 copying

Plain Ends, per doz., \$1.00
Rubber Ends, per doz., 1.20

VENUS

Artist Pencil

No. 849

Delights the soul of a re-
toucher. No sharpening — al-
ways full length. In 16 de-
grees from 5B to 9H, with
a correspondingly marked
holder for each degree. Sep-
arate refill leads in boxes of 6.

No. 849 Venus Pencil, .45 ea.
No. 842 Refill Leads,
.60 box of 6

*At stationers and stores
throughout the world.*

American Lead Pencil Co.
220 Fifth Ave., Dept. Pk. New York
and London, Clapton, Eng.



We are pleased to announce that
DUNN "THE LENS MAN"

Is now conducting a New York Office for the

Struss Pictorial Lens

Mfd by Fred'k W. Keasbey, Box 303, Morristown, N. J.

Mr. Dunn will have on hand a full line of SPL's, also complete sets of Ray Filters specially made to screw on the rear of SPL barrels. There will also be on display an exhibit of the work done with SPL by leading Pictorialists and Professionals. New York and Eastern Dealers can obtain prompt shipment of Lenses and Service in Special elements and markings.

Lenses sent on trial through your Dealer if you will send his name. Write for Free Booklet.

New York Office:
22 East 30 St.

Great Britain:
2 Roger Place, Skinner Lane,
Leeds



Turner-Reich

Convertible Anastigmat Lenses F:6.8
Equal Diffusion Portrait Lenses F:4
Ultrastigmat Cine Lenses F:1.9
Korona Hand Cameras
View and Home Portrait Cameras
Folding Studio Stands
Korona Panoramic View Cameras
for films and plates
5x12 7x17 8x20
Pancratic Telephoto Lenses

Send for our catalogue



Gundlach-Manhattan Optical Company
835 Clinton Ave., S. Rochester, N. Y.

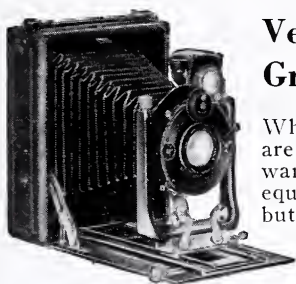

Vest Pocket Camera, or Graflex—

Whatever your needs may be, you are certain to find just what you want in Cohen's ample stocks, at unequalled prices. Not cameras alone, but Lenses, Shutters, Auxiliaries and Photographic Supplies of every description. Visit us when in New York.

Ica, Goerz and Graflex Cameras
Kodaks—Carl Zeiss Lenses—Binoculars

PROMPT ATTENTION TO ALL MAIL INQUIRIES

ABE COHEN'S EXCHANGE

*Kodaks, Graflex and
Foreign Cameras
Anastigmat Lenses.*

**113 Park Row
NEW YORK**

*Microscopes,
Binoculars
and Field Glasses*

**The premier
selftoning paper**

Seltona
LETO

A collodion paper that prints quickly and renders with absolute fidelity every quality possessed by the negative. Simply fixing produces the most delightful tones of singular purity and charm. Simple modifications en-

able the worker to get a range running from dark brown through purple to blue. Beginners, advanced workers and professionals find Seltona a never failing ally, responsive to their every need.

Sole Manufacturers:

The Leto Photo Materials Co. (1905), Ltd.

Roman Wall House

1, CRUTCHED FRIARS, LONDON, E.C.3.

PHOTOGRAPHIC

PRACTICAL PHOTOGRAPHY

The aim of the Editors in publishing this series is to give in each volume the practical information needed to master a definite branch of photographic work. Useless, impractical theories are not included, the whole purport of the series being to give up-to-date, usable information that will be immediately helpful in the field or workroom. Illustrations are used wherever necessary to make the text entirely clear, but not solely because of their artistic value. Whether in paper or cloth binding, the size will be uniform—handily fitting the pocket. In paper, per copy, 50 cents, or \$4.50 by subscription for twelve numbers. In cloth, per copy, \$1.00, or \$9.00 by subscription for twelve numbers.

No. 1. The Secret of Exposure.—If exposure is correct, all other steps in the making of a good negative are purely mechanical. This number discusses exposure thoroughly and gives a complete system, with full directions, for obtaining correct exposure under all conditions, using any plate on the American market.

No. 2. Beginners' Troubles.—This number contains an enormous amount of practical help for every worker, novice or expert. Its primary purpose is to show the cause of common failures, but in general it is a manual of photographic work dealing with the production of a perfect negative and a print from it.

No. 3. How to Choose and Use a Lens.—Every successful worker must know what his lens can do and how it may be used to best advantage. This number explains the particular qualities of each type of lens now used in photography and deals particularly with the more modern types, their differences and relative advantages.

No. 4. How to Make Prints in Colors.—The desirability of making prints in colors led to the publishing of this number, a careful choice of the best methods being made for the guidance of our readers. The toning of a standard black and white print to every possible hue is explained, while the special manipulating processes and the latest developments in natural color photography are clearly described.

No. 5. How to Make Enlargements.—No worker who advances beyond the plane of the tyro can produce consistently satisfying results without an enlarger. This volume tells the why of the enlarging process, and follows it with full and clear information regarding the practical side of enlarging, including the construction and use of different types of enlargers.

No. 6. How to Make Portraits.—Making portraits in the home is a branch of photography of interest to every owner of a camera. This volume tells in detail how to make portraits of your family and friends, which will be more satisfactory to you than the conventional portrait made in a studio. You need no other source of information than this book to make portraits of any size, by contact or enlarging methods.

No. 7. How to Make Lantern Slides.—An exhibit of slides from your own negatives is a treat for your family and friends. In this volume the subject of slide making is thoroughly covered. Slides in black and white, toned or in natural colors can be made by any camera user. A copy of this book will tell you how to make them.

No. 8. The Elements of Photography.—An elementary manual for the beginner, giving a concise but thorough description of the fundamentals of photography with film and plate cameras.

No. 9. Practical Retouching.—This manual, designed to cover the whole practice of retouching negatives, combines the practical experience of five skilled workers in this line, each of whom has written exhaustively on the subject. The resulting manuscript covers every phase of the work, including the use of retouching machines.

The books of this series may be had from dealers in photographic supplies, news stands, booksellers or the publishers. Remittance may be made by money order or check.

American Photographic Publishing Co.

264 Camera House

Boston, Mass.

LITERATURE

Your Success in Photography

Every reader of this book is seriously interested in the success of his photographic efforts. Of this we feel assured—otherwise he would not be reading it to secure information that brings successful results. Information! That is the secret of good results—backed by experience. Information must be up-to-date, authentic, and to be valuable the useless facts must be weeded out from the practical "meaty" matter, and the net result presented to the reader. This is what the Editors are doing in our monthly magazine AMERICAN PHOTOGRAPHY.

For more than thirty years this magazine has served the American photographic public, and endeavored to be all that its name implies—the standard American photographic magazine. It covers the whole field of photography for amateur, professional and commercial workers, publishing each month forceful articles on the best current practice and latest advances in each of these classifications. The monthly departments include two monthly Competitions, with criticism of pictures; "Shop Notes;" "Exchange List," for the exchange of prints; "Reader's Forum," for the general correspondence of readers; "The Market Place," listing the most recent information as to firms buying pictures; "Notes and News" of clubs, new material, books and manufacturing activities. In short, we publish a reader's magazine, and in addition place our Editorial Staff at the service of our friends, to help them with perplexing problems. This means you!

Does a magazine published along such lines meet your ideas of good service? We think it does, for we try to put ourselves in our readers' positions when we consider a change in the makeup of the magazine. Join our steadily increasing circle of readers and friends. The subscription price is but \$2.50 per year, including personal Editorial help when you need it. Send your subscription to-day and look forward to twelve numbers of the best photographic literature that you have ever read.

Optics for Photographers

Translated from the original by

HANS HARDING, PH.D.

By FRANK R. FRAPRIE, S.M.,
F.R.P.S.

The writer of this book starts with the fundamental laws of the propagation of light, and carefully and logically carries the reader through the principles of geometrical optics to a complete explanation of the action of all types of photographic lenses, and a description of their qualities and defects. Only the simplest mathematics is used, and this sparingly. The book is brilliantly worked out, and is indispensable in the photographic library, being the only modern and comprehensive work on the subject in English. The author is the calculator and inventor of a well-known series of high-grade anastigmat lenses; he has the happy facility of expressing himself in such clear, simple language that no one will have the least difficulty in understanding his exposition of the subject. Bound in red cloth, \$2.50.

Chemistry for Photographers

WM. R. FLINT.

This is the most practical book on photo-chemistry yet published. Before taking up the study of photo-chemistry the author defines, and illustrates with experiments, the basic types of chemical action which are encountered in a study of photo-chemistry. Thus the man who has never studied chemistry is in a position to understand the pages which follow. Subsequently, the reader considers: light and chemical reaction, photo-chemistry of silver salts; the chemistry of development; the chemistry of the fixing process; after-treatment of the negative; printing processes with silver, iron and chromium salts; and the chemicals of photography—every chapter involving a photo-chemical treatment of the subject. Bound in red cloth, \$2.50.

American Photographic Publishing Co.

264 Camera House

Boston, Mass.

PLAUBEL

Cameras and Lenses

Peconette Roll Film 6 x 6 cm.
 Peconette Roll Film 6 x 9 cm.
 Makina Plate—Film 4.5 x 6 cm.
 Makina Plate—Film 6.5 x 9 cm.
 Makina Stereo 4.5 x 10.7 cm.
 Precision Peco Plate—Film 9 x 12 cm.
 Precision Peco Plate—Film 10 x 15 cm.
 Special Plate Cameras 6.5 x 9 and 9 x 12 cm.

Anticomar F-3, F-4.2, F-4.5
 Triple Orthar F-5.4, F-6.8
 Doppel Orthar F-6.3, F-6.8
 Satz Orthar F-6.3, F-6.8
 Wide Angle Orthar F-9
 Pecosigmat F-6.8
 Anastigmat Tele—Peconar F-3, F-4.5, F-5.
 F-6.

ADAM ARCHINAL, U. S. Agent
 Plaubel & Co., Frankfurt a/m, Germany

1409 Broadway, N. Y. C.

Catalog sent on request.

Of Especial Interest to Nature Photographers

THE GUIDE TO NATURE

Edward F. Bigelow, Managing Editor

Published by THE AGASSIZ ASSOCIATION, ARCADIA, Sound Beach, Conn.

A Profusely Illustrated Monthly Magazine Devoted
 to Commonplace Nature with Uncommon Interest.

Subscription, \$1.50 per Year Single or Sample Copy, 15c.

PHOTOGRAPHS WANTED

I will buy good photographs taken in Hawaiian Islands, Japan, Philippine Islands, China, Manchuria, Korea, French Indo-China, Straits Settlements, Dutch East Indies, India, Ceylon, Arabia, Egypt and the countries touching the Mediterranean.

I want the points of interest, native costumes, sports, dances and strange customs, methods of transportation, child life and other interesting and unusual views. Also scenes on shipboard or train between these countries. Also want views from the oil fields of the world.

A short description required with each view and publication rights. Do not send prints, but write me letter telling what you have and state the size and price of glossy prints.

MORRIS F. BOSWORTH

Post Office Station E, Box 116, Cleveland, Ohio, U. S. A.

10 Buys
 Millions $\frac{1}{100}$
 Billions
 in use
 to day



Engel
"Art Corners"

NO PASTE NEEDED

Use them to mount your kodak pictures, post cards, clippings in albums. Made in Square, Round, Oval, Fancy and Heart shape, of black, gray, sepia and red gummed paper. Slip them on corners of pictures, then wet and stick. **QUICK, EASY, ARTISTIC.** No muss, no fuss. At photo supply, drug and stationery stores. 10 cts. brings full package and samples from



ENGEL MFG. CO., Dept. AA, 4711-17 N. Clark St., CHICAGO

Bass Complete Camera Service

Graflex Kodaks Motion
Picture Apparatus New and
Used

Studio Lights, Laboratory
and School Equipment,
Spencer Microscopes.

Liberal Trades

The Bass selling method is
the Golden Rule Method.
Catalogues Free. Advise us
of your wants.

Bass Camera Company

Graflex Headquarters of America
109 N. Dearborn St., Dept. L
Chicago, Illinois

Wellington

Plates & Papers Supreme Quality

Wellington Photo-
graphic Hand Book, 136
Pages, Bound and Illus-
trated, 35c Postpaid.
Contains an article of in-
struction on the popular
Bromoil Process.

*Wellington Price-list sent
on request.*

Manufactured by
Wellington & Ward
Elstree, Herts, England
Sole U. S. Agents
RALPH HARRIS & CO.
26-30 Bromfield St.,
Boston, Mass.

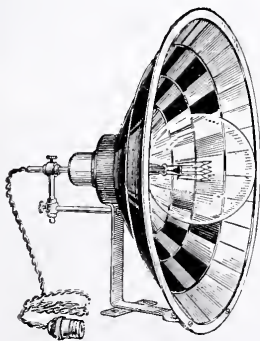

GRAY'S Parallax Reflecting Condensers

Constant increase in the demand by
regular customers—including the
U. S. Government—is proof-positive
of the value of Parallax for making
large photos from small negatives.
Ask your dealer.

PARALLAX is a Complete Enlarging Con-
denser, mounted, with adjustable lamp
holder and wired socket for incandescent
electric lamps. In Series C all of the mir-
rors are silvered.

Number and Series	Number of Mirrors	Largest Negative Covered	Largest Nitro Lamp	Price Without Lamp
12E	61	5x7	300 watts	\$15.00
15E	93	7x9	500 "	30.00
19E	98	8x10	1,000 "	40.00
9C	30	4x5	200 "	8.00
11C	30	5x7	200 "	10.00
13C	36	8x10	300 "	18.00
20D	7	Illuminator	1,000 "	30.00

PARALLAX REFLECTOR CO.
MANUFACTURERS

MIDLAND PARK

NEW JERSEY

Modern Photography Needs a Perfect Flash Light for Home Portrait and Studio Work

The Poynter Lamp is the result of years' experimenting by a practical Photographer. The Lamp is guaranteed to be absolutely safe and reliable. For farther information write to

ROBERT NEUMANN

Manufacturer and Distributor

1401-1411 Plum St.,

Cincinnati, Ohio

LANTERN SLIDES in NATURAL COLORS

An easy method based on the tri-color system, giving slides of greater transparency than single-plate methods and with correct color rendition. Suitable for amateurs.

Price \$1.00 Postpaid

FRED A. HOSCHKE

601 BELMONT AVE

SPRINGFIELD, MASS.

SIMEONS' PHOTOGRAPHIC GELATINE

is the best for

DRY PLATE PAPER and FILM

EMULSIONS

THE BRITISH GELATINE WORKS, LTD.

17, Wilson Street, London, E.C.2.

Telephone—1701 Clerkenwell

Cablegrams—"Jellify, London"



Gilbert Electric Retoucher

"The Little Speedster"
For Negatives and Prints. Speeds up your retouching. Does expert work. Saves time. Saves money. Costs little to run. Will soon pay for itself. THIS DEVICE gives the "touch" by automatic double vibration produced by an oscillating vibrator. Patented U. S. and Canada. *Geo. G. Holloway* says:

"One of the best inventions Photography has had the good fortune to meet with; most useful." New model much improved, quiet and efficient.

GILBERT SUPPLY COMPANY, Independence, Iowa

JOHNSTON'S

Made in
U. S. A.

Snow White Ink

Known
Abroad

A Standard Preparation for Photo Users

Equally serviceable with Pens, as a White Ink; with Brushes, as a White Water Color; with Air Brushes, as a Spray. Will not powder nor rub off. Remains white, when fairly protected.

For Dark Surfaces of Photo Albums or Photo Mounts, Borders or Ornamentations.

For Numbering, Lettering and Signatures.



½ ounce jar, 25c

Flows readily from pens.

For Films, Negatives as an Opaque with Pens, Brushes, or Air Brushes.

It writes White and it prints White. No waste. Always Good.

At Better Photo Supply Dealers Generally

Or direct from

J. W. JOHNSTON

New Arts Bldg.,

Dept. AA,

Rochester, N. Y.

The Commercial Photographer

By L. G. ROSE

*Including Price Lists for Commercial Work
in Two Large Cities*

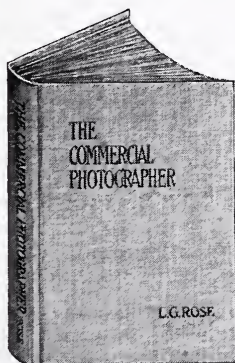

A work by a thoroughly competent and widely experienced commercial photographer of the highest reputation.

Every phase of Commercial Photography is treated with a view for presentation of the essentials. The various appliances discussed, best methods of exposure, illumination and graphic presentation to ensure a successful outcome.

It is a book essentially for the commercial man and meets every requirement. Profusely illustrated with examples of work of varied kind.

The book will be found of pertinent interest not only to the trade photographer but also to the specialist. The application of photography is considered in its bearings upon the commercial man, the architect, the tradesman, the physician, the lawyer and the scientist, by one who has had very extensive experience in the different kinds of work required.

148 Pages. 85 Illustrations.

Price \$4.00 per copy; Postage 15c extra.

At Your Dealers or Direct from the Publisher

FRANK V. CHAMBERS, 636 S. Franklin Square
PHILADELPHIA

SPECIAL BARGAIN

Subject to Prior Sale

50—3.B Model Burke & James Enlarging Lanterns equipped with 750 Watt Special Concentrated Nitrogen Lamp, also Acetylene Burner. These machines were specially made for the U. S. Government and has the special feature of a revolving negative holder.

Regular price fitted with 9 in. condensing lenses, \$146.00; OUR PRICE—\$75.00.

Ingento Focusing Platforms for the A-3 Model Enlarger. Regular Price, \$22.50; OUR PRICE—\$12.50.

Special on Hess-Ives Cameras

These are box cameras, similar in construction to the Telescopic Graflex, but without hood, covered with finest quality grain leather, and includes ground glass, 2 tripod sockets and one plate holder:

Size $3\frac{1}{4}$ x $4\frac{1}{4}$, equipped with a fixed focus single achromatic lens and T. I. B. Shutter. Former Price \$25.00; OUR PRICE \$6.00.

Same size, equipped with Rapid Symmetrical Lens in focusing mount and Wollensak Auto Shutter working from 1/100 second to 1 second. Former Price \$35.00; OUR PRICE \$10.00.

Size $3\frac{1}{4}$ x $5\frac{1}{2}$, same specifications. Former Price \$45.00; OUR PRICE \$12.50.

Film pack adapters for these cameras can be supplied at the following prices:

$3\frac{1}{4}$ x $4\frac{1}{4}$	\$1.25
$3\frac{1}{4}$ x $5\frac{1}{2}$	\$2.00

New York Camera Exchange
109 Fulton Street, New York City

IF correct exposure was a matter of heat instead of light, would you guess, would you use a table of average temperatures, or would you use a thermometer that gave you the exact information you wanted at the time and under the actual conditions prevailing?

The **WYNNE INFALLIBLE HUNTER METER** measures the actinic or photographic value of the light just as the true and tested thermometer measures heat. It does still more—it resolves these factors into units of correct exposure, at any stop and for any plate or film, by a slight turn of a dial. Like a small, thin Hunter case watch, it is as handsome as it is convenient and exact.

Price, \$3.50. Postpaid—Send for One To-day

State whether you wish for "F" or U. S. stop system. Circulars on request.

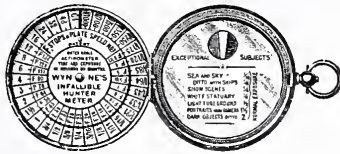

Elmendorf's Lantern Slide Colors

We are glad to announce that we can again supply these sets complete with all the colors listed below.

They are prepared by Dr. Elmendorf, whose Wonderfully Colored Lantern Slides are famous the World Over.

TEN COLORS

No. 1 Light Yellow, No. 2 Dark Yellow, No. 3 Orange, No. 4 Rose, No. 5 Vermilion, No. 6 Brown, No. 7 Maroon, No. 8 Gold Green, No. 9 Blue, and No. 10 Violet.

Price, Per Set, \$1.50

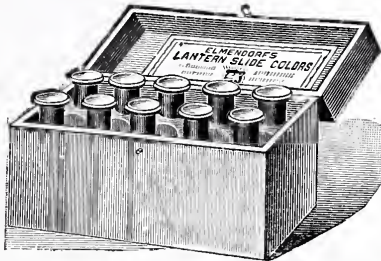

American Agents, **GEORGE MURPHY, Inc.**, 57 East 9th Street, New York
Send for a copy of our Sundries Catalogue—It's Free

OUR LENS DEPT.

Before you Buy, Sell or Exchange your lens, write me at Murphy's.
HOWELL, THE LENS MAN

A Few Suggestions

For Studio and Home Portraiture

Ross X Press—Vilostigmat Sec. II. Vitax—B & L 1c Tessars.
Cooke Portrait.

For Group View

Ross Homocentric F 5.6, F 6.3, F 6.8.
Ross Compound Homocentric F 6.8 Convertible Vilostigmat—Sec. I, F 6.3 (Convertible). Vilostigmat—Sec. IV, F 6.3.

For Soft Focus Work

Verito—Spencer-Portland-Struss Lenses.

For Telephoto Naturalist Work

Ross Telecentric Lenses. The telephoto lens for the short focus camera.



Write about these or many other lenses we have on hand at very attractive prices.

All lenses are sold on a trial basis, i. e., returnable in 10 days at full price paid if not suited to your requirements.

George Murphy, Inc.

Lens Dept.

57 East 9th Street, New York

THE STERN DRYER

Note — When you stop the motor you automatically turn off the gas, thus making it impossible to burn the belt, a feature not found on any other dryer.

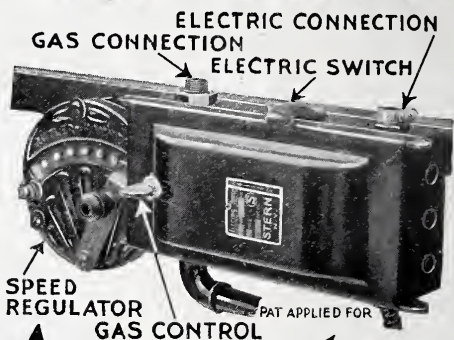

Will positively dry double or single weight prints in one revolution and will continue to dry them for the entire 24 hours of the day.

There are no
Crawling Belts
Springs
Weights
Lacings
Chains
to get out of
order.

All gearing connected direct and is Foolproof.

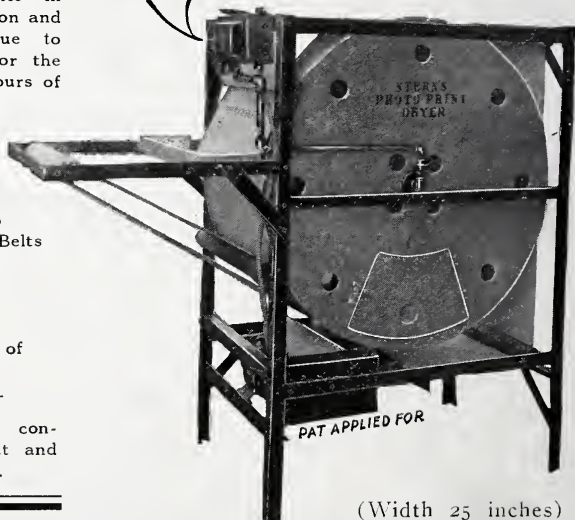

(Width 25 inches)

This Machine will more than pay for itself in One Season, in Time and Help Saved. No more waiting for the Last Batch to Dry. It will be ready by the time the previous batch is trimmed and sorted. Its Narrow Width allows it to pass through doorways where many other dryers cannot pass.

(Send for Circular with full description)

When ordering, please state what current you use, either alternating or direct

Gas Heat.....	F. O. B. New York—	Price
Electric Heat.....	F. O. B. New York—	250.00

GEORGE MURPHY, Inc.

57 East Ninth Street, New York

Lares Master Projection Printer

For Enlarging, Copying and Reducing

Entirely different and superior to any other ever placed on the market. Should be part of the equipment of every Studio, Finishing Plant, Copying House and Photo Engraver.

Occupies only 26 inches square of floor space and no special wiring is required, no extra fits, holders and discs to handle, as the machine is fitted with Lares Pattern Mask, which is adjustable to all sizes.

Is always ready to work and never in the way.

No special lenses are required. Any lens having focal length of 8 inches or less may be used.

Prints any kind of tinted border on any size picture in one printing. No mark to slip, no guesswork, no waste of material and time. You see it all and it prints it all with one exposure and one light, including the desired background from any other background negative, giving any degree of softness or sharpness to the background or tinted border or white margin around the tint.

No trouble to vignette enlarged or reduced pictures; will also give tinted vignettes to match the background in the negative.

Lares Master Projection Printer makes plain prints up to 18x22, from 8x10 plates or films or smaller, and reduces to locket or postage stamp size. Background printed in if desired.

Lares Master Projection Printer will print tinted borders on any picture from the locket size up to and including 2x30 paper. Each picture has a beautiful tinted border or embossed effect and a background printed in or vignetted, all with one exposure.

No trouble to change from one size to another, thereby giving the customer a variety of sizes and shapes from the same negative, which will enable the owner to make real profits from his enlarging, copying, etc., therefore this is an ideal addition to any Studio, Finishing Plant, etc.

The Machine is fitted with a unique device which enables the photographer to give his prints line screen and diffused effect, either separate or both at the same time.

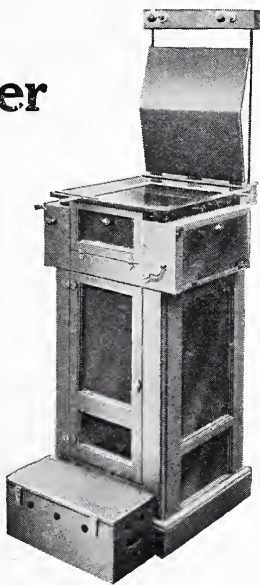

Lares Projection Printers are made to use in everyday work. They are made of the very best material, and with ordinary care will last a lifetime.

The Light Box is made of metal throughout and is properly ventilated to prevent heating when in continuous use. It is fitted with brackets for Cooper-Hewitt F. M. Tube, which with proper care will last for an indefinite time; also receptacles for four 250-watt Nitrogen short bulbs. However, the preference is given to the Cooper-Hewitt outfit by the inventor, being more rapid than the Nitrogen lamps.

FOR COPYING—As well as being a printer, this machine will make reduced or enlarged negative from any picture or drawing. The soft light falling at every angle upon the picture eliminates the possibility of wrinkles or the grain of the paper being shown. Thus the best possible results are obtained in the negative.

Uses Any Lens—8-Inch Focus or Less

Outfit without lamp or lens. \$407.50
Cooper-Hewitt F. M. Tube
Auxiliary (special), f. o.
b. Hoboken, N. J. 58.00
250 C. P. Short Bulbs (stere-
opticon), each 4.50

GEORGE MURPHY, Inc., 57 E. Ninth St., New York

GORDON

Corner-Pocket

Sepia Brown Cover—Sepia Brown Insert
Sepia Brown Cover—Fawn Insert
Olive Gray Cover—Olive Gray Insert



A beautiful folder of heavy two-toned stock embossed in a handsome leather finish.

The edges of folder and insert are artistically feathered and give it a rich appearance.

Size No.	For Print or Picture	Per 100	500 Lots Per 100
46	4x 6	\$9.00	\$8.50
58	5x 8	\$10.75	\$10.25
70	7x10	\$13.75	\$13.25
71	7x11	\$15.50	\$15.00
104	10x14	\$25.00	\$24.00

GEORGE MURPHY, Incorporated

57 East Ninth Street

New York City

Send for Copy of Our Mount Catalogue

Reliefs - Relief Colour Paint

American Grayson Co. Inc.

Sandusky New York







GETTY CENTER LIBRARY



3 3125 00615 3304

