

LOADER, SCOOP TYPE, D.E.D., 4 WHEEL DRIVE, PNEUMATIC TIRES,
 HINGED FRAME STEER, W/FORKLIFT FRONT MOUNTED,
 HYDRAULIC OPERATED, 10,00 LB CAPACITY (EATON
 YALE & TOWN, TROJAN MODEL 3000M) W/ENGINE
 CUMMINS MODEL C-180-CI

Reference: LO 5-3805-243-12-1 and C9100-IL

Intervals are based on normal hours of operation. Adjust to compensate for abnormal operations and severe conditions. During inactive periods, sufficient lubrication must be performed for adequate preservation.

Clean fittings before lubricating.

Relubricate after washing or fording.

Clean parts with SOLVENT, dry-cleaning, or with OIL, Fuel, Diesel. Dry before lubricating.

Lubricate points indicated by dotted arrow shafts on both sides of equipment.

Drain gearcases when hot. Fill and check level.

FOLD

FOLD

LUBRICANT ● INTERVAL

INTERVAL ● LUBRICANT

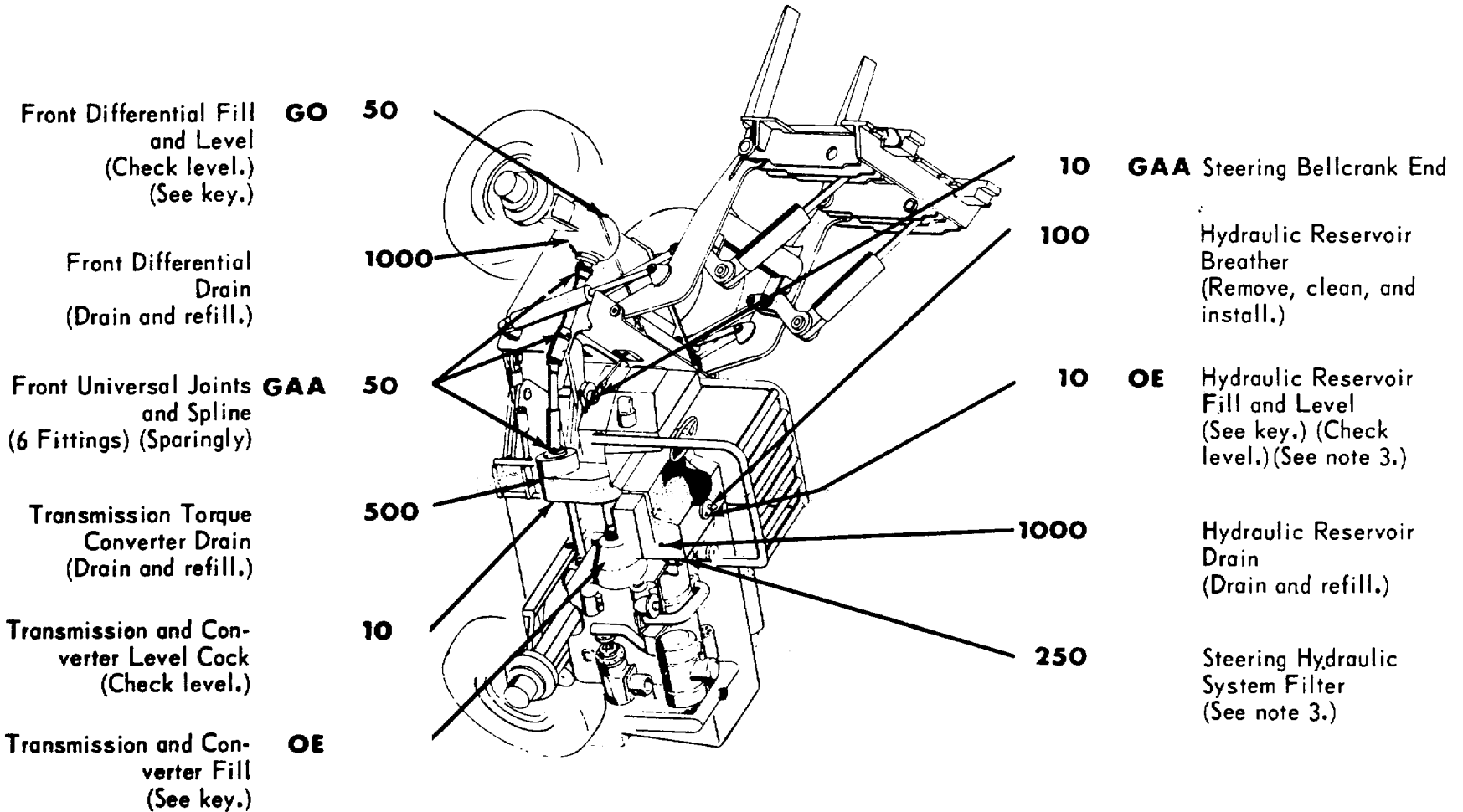

LUBRICANT • INTERVAL

INTERVAL • LUBRICANT

Lift Arm Pivots **GAA 10**
 Main Pivots **GAA 10**
 Steering Cylinder **GAA 10**
 Pivot
 Axle Cradle Pivots **GAA 10**
 Rear Differential Drain
 (Drain and refill.) **1000**

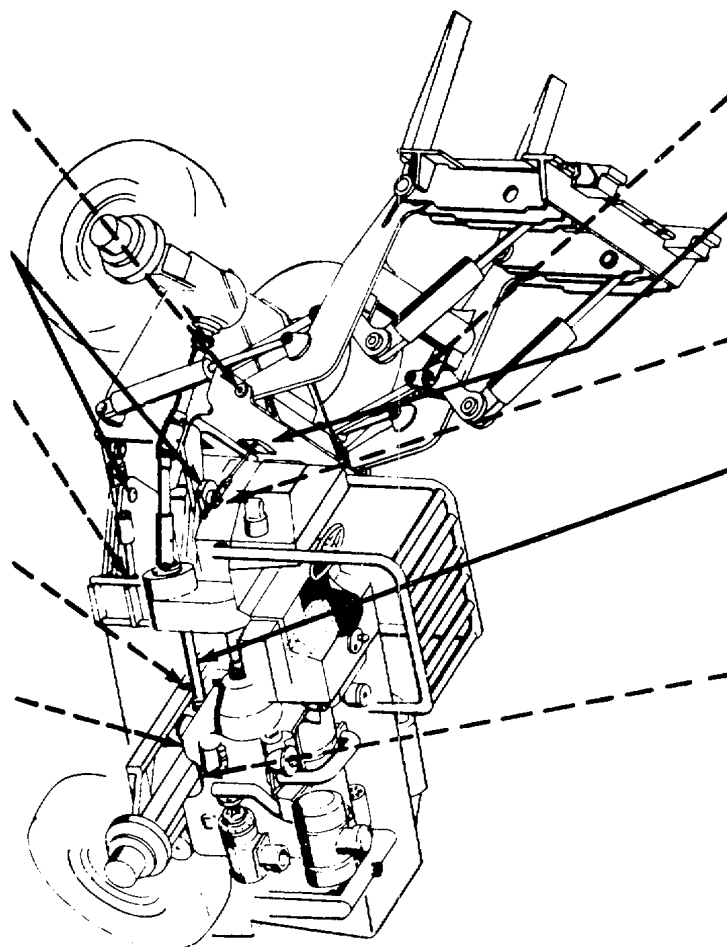

10 GAA Bellcrank Pivot
10 GAA Steering Rod End
10 GAA Steering Tie Rod
**500 GAA Transmission Control
 Lever Linkage**
**50 GO Rear Differential Fill
 and Level
 (Check level.)
 (See key.)**

FOLD

FOLD

-KEY-

LUBRICANTS	CAPACITY	EXPECTED TEMPERATURES			INTERVALS
		Above +32°F	+ 40°F to -10° F	0°F to -65°F	
OE -OIL, Engine, Heavy Duty Oil Can Points					Intervals given are in hours of normal operation.
Transmission and Converter	24 qt	OE 10	OE 10	OES	
Hydraulic Reservoir	200 qt				
OES -OIL, Engine, Sub-zero					
GO -LUBRICATING OIL, Gear					
Front Differential	24 qt	GO 90	GO 90	GOS	
Rear Differential	24 qt				
GOS -LUBRICATING OIL, Gear, Sub-zero					
GAA -GREASE, Automotive and Artillery		ALL TEMPERATURES			

NOTES:

1. FOR OPERATION OF EQUIPMENT in PROTRACTED COLD TEMPERATURES BELOW -10°F. Remove lubricants prescribed in the key for temperatures above -10°F. Relubricate with lubricants specified in the key for temperatures below -10°F

2. OIL CAN POINTS. Every 50 hours lubricate handbrake, control lever linkage, and all exposed adjusting threads with OE.

3. HYDRAULIC SYSTEM. Every 100 hours remove breather, wash in solvent, blow dry and reinstall. Every 250 hours remove steering system return filter element, clean housing, and install new element. Every 1000 hours of operation drain and clean hydraulic reservoir, install new element, fill system, operate equip for 5 minutes, check for leaks, check oil level and bring to full mark.

4. LUBRICANTS: The following is a list of lubricants with the Military Symbols and the applicable specification numbers.

OE-MIL-L-2104 OES-MIL-L-10295
 GO-MIL-L-2105 GOS-MIL-L-10324
 GAA-MIL-G-10924

Copy of this Lubrication Order will remain with the equipment at all times; instructions contained herein are mandatory.

BY ORDER OF THE SECRETARY OF THE ARMY:

OFFICIAL:
 KENNETH G. WICKHAM,
 Major General, United States Army,
 The Adjutant General.

HAROLD K. JOHNSON,
 General, United States Army,
 Chief of Staff.

LO 5-3805-243-12-2 DISTRIBUTION: To be distributed in accordance with DA Form 12-25, Section II, Organizational Maintenance Requirements for Earth Moving Equipment Leaders.

This fine document...

Was brought to you by me:



[Liberated Manuals -- free army and government manuals](#)

Why do I do it? I am tired of sleazy CD-ROM sellers, who take publicly available information, slap “watermarks” and other junk on it, and sell it. Those masters of search engine manipulation make sure that their sites that sell free information, come up first in search engines. They did not create it... They did not even scan it... Why should they get your money? Why are not letting you give those free manuals to your friends?

I am setting this document FREE. This document was made by the US Government and is NOT protected by Copyright. Feel free to share, republish, sell and so on.

I am not asking you for donations, fees or handouts. If you can, please provide a link to liberatedmanuals.com, so that free manuals come up first in search engines:

<A HREF=<http://www.liberatedmanuals.com/>>Free Military and Government Manuals

– Sincerely
Igor Chudov
<http://igor.chudov.com/>