



---

# Application Protocol 227 Validation Report

## Version 1.0

---

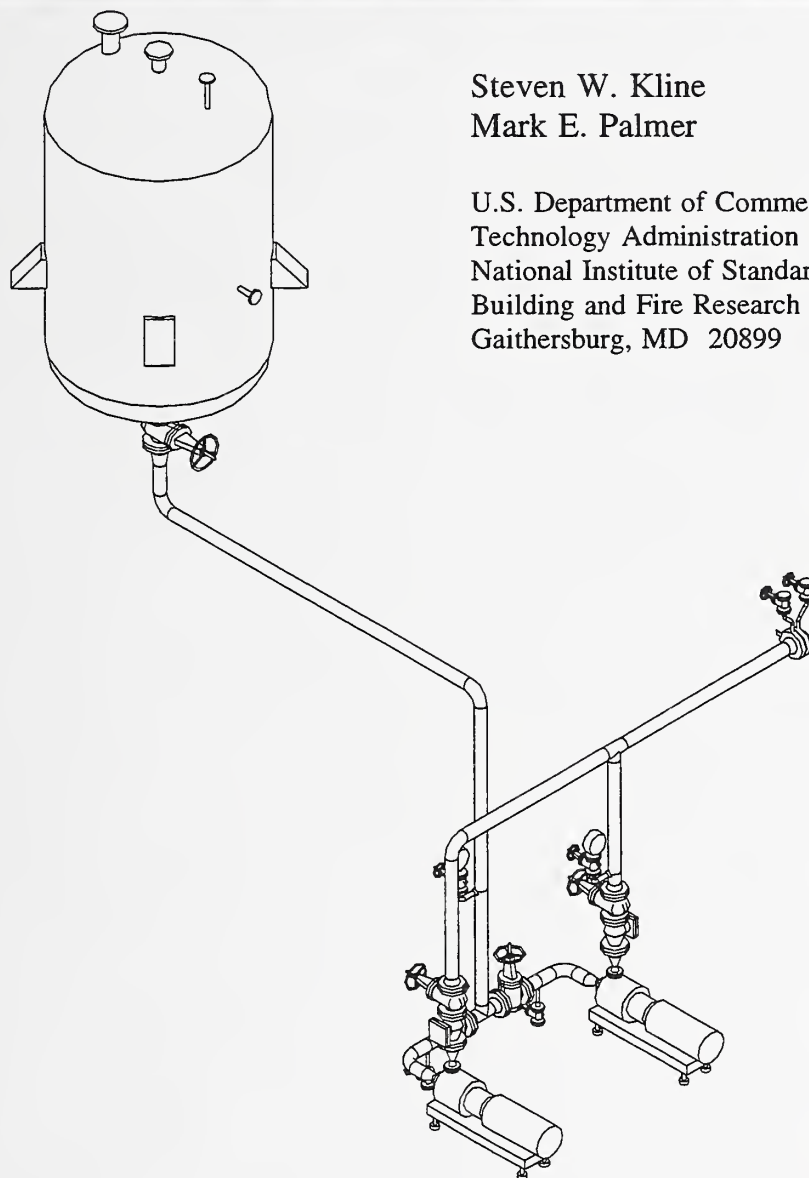

Steven W. Kline  
Mark E. Palmer

U.S. Department of Commerce  
Technology Administration  
National Institute of Standards and Technology  
Building and Fire Research Laboratory  
Gaithersburg, MD 20899



United States Department of Commerce  
Technology Administration  
National Institute of Standards and Technology



# Application Protocol 227 Validation Report Version 1.0

---

Steven W. Kline  
Mark E. Palmer

U.S. Department of Commerce  
Technology Administration  
National Institute of Standards and Technology  
Building and Fire Research Laboratory  
Gaithersburg, MD 20899

August 1996



**U.S. Department of Commerce**  
Michael Kantor, *Secretary*

**Technology Administration**  
Mary L. Good, *Under Secretary for Technology*

**National Institute of Standards and Technology**  
Arati A. Prabhakar, *Director*



## ABSTRACT

Part 227 of ISO 10303, *Plant Spatial Configuration*, specifies an application protocol (AP) for the exchange of spatial configuration information of process plants. This includes shape characteristics, spatial arrangement characteristics, and design and fabrication information for piping system components, and functional and stream information for piping and HVAC (heating, ventilating, and air conditioning) systems. Also included are shape and spatial arrangement characteristics of other related plant systems that impact the design and layout of piping systems.

This report describes the plan for validating AP 227 and the results of various review and validation tasks. This report has individual sections describing the validation of the major components of the Application Protocol: scope and requirements evaluation, application reference model validation, integrated resources interpretation, application interpreted model validation, and conformance requirements evaluation.

The validation process has been completed in parallel with the development of the application protocol. Thus, the completion of sections of this document has been dependent on whether the analogous part of the AP 227 document had been completed. This is, therefore, a living document that will be updated periodically as the AP 227 document is updated. This version of the validation report is based on the Committee Draft (CD) version of AP 227.

## PREFACE

Industry and government require comprehensive and reliable information exchange mechanisms to effectively integrate computer-aided (CAx) systems and evolving information technologies. Subcommittee Four (Industrial data and global manufacturing programming languages) of the International Organization for Standardization (ISO) Technical Committee 184 (Industrial automation systems and integration), ISO TC184/SC4, is preparing ISO 10303, a set of international standards titled *Industrial automation systems and integration - Product data representation and exchange*. The set of proposed standards is informally known as STEP (STandard for the Exchange of Product model data).

ISO 10303 will provide a neutral mechanism for describing product data throughout the life cycle of a product, independent of any particular CAx system. ISO 10303 is suitable for file exchange and for implementing, sharing, and archiving product databases. The development of ISO 10303 is based upon the use of information models, a framework for product data modelling, formal data specification languages, and an architecture that separates information requirements from implementation methods.

A fundamental concept of STEP is the definition of application protocols (APs) as the mechanism for specifying information requirements and for ensuring reliable communication. An **application protocol** is a Part of ISO 10303 that defines the context, scope, and information requirements for designated application(s) and specifies the resource constructs used to satisfy these requirements. The scope of an AP is defined by the type of product, the supported stages in the life cycle of the product, the required types of product data, the uses of the product data, and the disciplines that use the product data. Additionally, an AP enumerates the conformance requirements for conformance testing of implementations of the AP.

Part 227 of ISO 10303, *Plant Spatial Configuration*, specifies an AP for the exchange of spatial configuration information of process plants. This document constitutes the validation report of the review and validation tasks associated with the validation of the CD version of AP 227. This report has individual sections describing the validation of the major components of the AP: scope and requirements evaluation, ARM validation, integrated resources interpretation, AIM validation, and conformance requirements evaluation.

## ACKNOWLEDGMENT

The following individuals contributed to the development of this document:

Diane Craig  
Susan Jones  
Kathy Tan  
Alan Wilson

P.D.I.T., Inc.  
Merck & Company, Inc.  
NIST  
Computervision



# Validation Report for ISO/CD 10303-227

Contents	Page
ABSTRACT .....	iii
PREFACE .....	iv
ACKNOWLEDGMENT .....	v
1 Introduction .....	1
2 Definitions and abbreviations .....	1
2.1 Definitions .....	1
2.1.1 application .....	1
2.1.2 application activity model (AAM) .....	1
2.1.3 application interpreted construct (AIC) .....	2
2.1.4 application interpreted model (AIM) .....	2
2.1.5 application object (AO) .....	2
2.1.6 application protocol (AP) .....	2
2.1.7 application protocol validation .....	2
2.1.8 application reference model (ARM) .....	2
2.1.9 catalogue .....	2
2.1.10 component .....	2
2.1.11 conformance class .....	2
2.1.12 connection .....	2
2.1.13 construct .....	2
2.1.14 data .....	2
2.1.15 data exchange .....	2
2.1.16 equipment .....	2
2.1.17 functional .....	3
2.1.18 information .....	3
2.1.19 information model .....	3
2.1.20 instrument .....	3
2.1.21 insulation .....	3
2.1.22 integrated resource .....	3
2.1.23 interpretation .....	3
2.1.24 physical .....	3
2.1.25 pipe .....	3
2.1.26 plant .....	3
2.1.27 plant item .....	3
2.1.28 process flow diagram .....	3
2.1.29 product .....	3
2.1.30 product data .....	4
2.1.31 site .....	4
2.1.32 test model .....	4
2.1.33 unit of functionality .....	4
2.1.34 usage scenario .....	4
2.1.35 validation .....	4
2.2 Abbreviations .....	4



3	AP Validation Plan	5
3.1	Overall Method	5
3.2	Validation Workshops	6
3.3	Overlap with other APs	9
4	Scope and Requirements Evaluation Report	10
5	ARM Validation Report	10
5.1	AAM to ARM Correspondence	10
5.2	Population of ARM with Data	22
5.2.1	Relational Database Data Population	22
5.2.2	Overview of Usage Scenarios	23
5.3	Computervision Prototype	24
5.3.1	History	24
5.3.2	Description of Prototype	24
5.3.3	Implementation of Prototype	25
5.3.4	Conclusions	25
6	Integrated Resources Interpretation Report	25
6.1	Introduction	25
6.2	Workshops	25
6.3	Requirements Changes	26
6.4	Interpretation of Application Objects and Assertions	26
6.5	Application Interpreted Constructs	26
6.6	AIM Specializations	26
7	AIM Validation	27
7.1	ARM to AIM Correspondence	27
7.2	Population of AIM with Data	27
7.3	Results of Parsing the AIM EXPRESS Schema	28
8	Conformance Requirements Evaluation Report	28
9	Pilot Implementation Results	28
9.1	PlantSTEP Demonstration Project	28
9.1.1	Introduction	28
9.1.2	Scenario	29
9.1.3	Approach	32
9.1.4	Demonstration File Data Population	32
9.1.5	Implementation	34
9.1.6	Results	34

# Validation Report for ISO/CD 10303-227

## Annexes

A	Engineering Data Matrices	36
B	Summary of Process Plant Test Model Library	62
B.1	Introduction	62
B.2	Summary of Process Plant Test Models	65
B.2.1	Purpose	65
B.2.2	Process Plant Example Models Summary	65
B.3	Process Plant Model Examples	66
B.3.1	PPE1	66
B.3.2	PPE2	71
C	Summary of Original Twenty Three Usage Scenarios	77
D	Bibliography	79

## Figures

1	PlantSTEP Demonstration Project Scenario	29
B.1-1	Process Plant Integrated View	64
B.3.1-1	Simple Piping Arrangement - Perspective View	68
B.3.1-2	Tank	69
B.3.1-3	Pump	70
B.3.2-1	A-0: Redesign of Piping System in IDEF0	74
B.3.2-2	A0: Redesign Piping System Using AP 221/AP 225/AP 227 in IDEF0	75
B.3.2-3	Modified Piping Arrangement - Perspective View	76

## Tables

1	AP Review and Validation Methods	5
2	Validation Workshops	6
3	AAM ICOM to ARM UoF/Entity Mapping	11
4	ARM Entity Coverage	12
A.1	Functional Mapping Matrix - Equipment	37
A.2	Functional Mapping Matrix - Piping Components	50
A.3	Functional Mapping Matrix - HVAC	57
A.4	Functional Mapping Matrix - Structural, Civil, and Architectural	59

## 1 Introduction

ISO 10303 is an International Standard for the computer interpretable representation of product data. The objective is to provide a neutral mechanism capable of describing product data throughout the life cycle of a product, independent of any particular system. The nature of this description makes it suitable not only for neutral file exchange, but also for data sharing, data archiving, and implementation of product databases.

A fundamental concept of ISO 10303 is the definition of application protocols (AP) as the mechanisms for specifying information requirements and for ensuring reliable exchange. An Application Protocol is a part of ISO 10303 that defines the context, scope, and information requirements for designated applications and specifies the constructs of the Integrated Resources used to satisfy these requirements.

This report describes the plan for validating AP 227 [1], and the results of various review and validation tasks. The validation was done using:

- source data from companies' operations for confirmation of requirements;
- source data to populate application reference model (ARM) tables;
- examples provided by experts from different companies and countries as the basis for validating the ARM and the application interpreted model (AIM) and for creating AP 227 exchange files;
- periodic reviews and validation by industry and peer organizations.

This report has individual sections describing the validation of the major components of the Application Protocol: scope and requirements evaluation, ARM validation, integrated resources interpretation, AIM validation, and conformance requirements evaluation.

The validation process has been completed in parallel with the development of the application protocol. Thus, the completion of sections of this document has been dependent on whether the analogous part of the AP 227 document had been completed. This is, therefore, a living document that will be updated periodically as the AP 227 document is updated. This version of the validation report is based on the Committee Draft (CD) version of AP 227.

## 2 Definitions and abbreviations

### 2.1 Definitions

For the purposes of this validation report, the following definitions apply:

**2.1.1 application:** a group of one or more processes creating or using product data [2].

**2.1.2 application activity model (AAM):** an IDEF0 [3] model that describes the activities and processes that use and produce product data in a specific application context.

## Validation Report for ISO/CD 10303-227

**2.1.3 application interpreted construct (AIC):** a logical grouping of integrated resource constructs that is shared by two or more AIMS.

**2.1.4 application interpreted model (AIM):** a model of selected integrated resources which are constrained, specialized or completed to satisfy the information requirements of the application reference model. The AIM shall be defined in EXPRESS and EXPRESS-G (a graphical subset of EXPRESS) [4].

**2.1.5 application object (AO):** an atomic element of an application reference model that defines a unique application concept and contains attributes specifying the data elements of the object [2].

**2.1.6 application protocol (AP):** a part of ISO 10303 that specifies an application interpreted model satisfying the scope and information requirements and constraints of a specific application [2].

**2.1.7 application protocol validation:** the process of evaluating a candidate AP and its components, e.g., ARM and AIM, to determine whether these satisfy the specified scope and requirements for the AP.

**2.1.8 application reference model (ARM):** a model that specifies conceptual structures and constraints used to describe the information requirements of an application. The ARM shall be documented in a formalized modelling language such as EXPRESS [4], IDEF1X [5], or NIAM [6]. Each information requirement has a normative definition.

**2.1.9 catalogue:** a list of things or a document that contains a list of things.

### NOTES

1 - A catalogue may be a list of symbols or of plant items and their properties and features.

2 - A catalogue may be either an electronic or printed document.

**2.1.10 component:** a plant item that may be part of another plant item.

**2.1.11 conformance class:** a subset of an application protocol for which conformance may be claimed [2].

**2.1.12 connection:** an association between two plant items that results from a physical joining. A connection has both physical and functional properties. The properties describe both the physical nature of a connection and the functional capability that it provides.

**2.1.13 construct:** a data modelling structure that represents the semantics of a concept.

**2.1.14 data:** a representation of information in a formal manner suitable for communication, interpretation, or processing by human beings or computers [2].

**2.1.15 data exchange:** the storing, accessing, transferring, and archiving of data [2].

**2.1.16 equipment:** a plant item that carries out an operation on the process material. An equipment has both physical and functional properties.



NOTE - An equipment may be treated as a single item for the purpose of design, acquisition, or operation.

**2.1.17 functional:** descriptive adjective which, when applied to an item, refer to a set of characteristics, properties, or traits of the item. "Functional" refers to the actions, activities, or capabilities, that the item provides or may provide to fulfill a purpose.

**2.1.18 information:** facts, concepts, or instructions [2].

**2.1.19 information model:** a formal model of a bounded set of facts, concepts, or instructions to meet a specified requirement [2].

**2.1.20 instrument:** a plant item that is an individually identifiable item or combination of items that is part of a system which monitors or controls the systems in a process plant.

NOTE - Instruments include items such as control valves, sensors, and gauges.

**2.1.21 insulation:** a volume of material that provides resistance to the flow of heat, electricity, or sound.

**2.1.22 integrated resource:** a part of ISO 10303 that defines a group of resource constructs used as a basis for product data [2].

**2.1.23 interpretation:** the process of adapting a resource construct from the integrated resources to satisfy a requirement of an application protocol. This may involve the addition of restrictions on attributes, the addition of constraints, the addition of relationships among resource constructs and application constructs, or all of the above [2].

**2.1.24 physical:** descriptive adjective which, when applied to an item, refer to a set of characteristics, properties, or traits of the item. "Physical" refers to shape and material characteristics such as weight, size and location and orientation of the item.

**2.1.25 pipe:** a plant item that is hollow and approximately cylindrical, that may have a constant cross-section along its length, and that conveys fluid, vapor, or particulate flow.

**2.1.26 plant:** an assembly of one or more plant systems and plant items that is intended to perform a chemical, physical or transport process. A plant is identified as a single unit for the purposes of management and ownership. A plant has both physical and functional properties.

**2.1.27 plant item:** a physical object or volume of space that is, or may be, a part of a process plant. If it is a volume of space, it may or may not contain other objects. A plant item has both physical and functional properties.

**2.1.28 process flow diagram:** a schematic representation containing the aggregation of the results of a process design activity. A process flow diagram shows the arrangement of the equipment selected to carry out the processes, the stream connections, stream flow rates and compositions, and the operating conditions.

**2.1.29 product:** a thing or substance produced by a natural or artificial process [2].

## Validation Report for ISO/CD 10303-227

**2.1.30 product data:** a representation of information about a product in a formal manner suitable for communication, interpretation, or processing by human beings or by computers [2].

**2.1.31 site:** an area of land on which one or more process plants is or may be situated.

**stream:** a flow of something past a point along a path.

NOTE - This is assumed to be at a frozen point in time. The 'something' that flows along a path includes materials, signals, energy, information, etc.

**2.1.32 test model:** a specification of an example product model, e.g., design and surface finish specification for a gear, which is structured to support the incremental testing of the information models of an AP, e.g., ARM, AIM, and implementations of the AP. The test model shall include sufficient detail to populate the relevant objects, attributes, relationships and assertions of an information model.

**2.1.33 unit of functionality:** a collection of application objects and their relationships that defines one or more concepts within the application context such that the removal of any component would render the concepts incomplete or ambiguous [2]. UoFs are a mechanism for modularising the information requirements of the AP into primary concepts. The UoFs are also used as modules for defining conformance classes.

**2.1.34 usage scenario:** a specification of a sequence of industry events which create, access, modify, or exchange some portion of the product data considered for inclusion in the scope of an application protocol. The usage scenario includes the description of the types of information used in the events, the tasks and objectives of each event, and the roles executed by software tools and humans during or after the events.

**2.1.35 validation:** the process of evaluating a system or component to determine whether it satisfies specified requirements.

## 2.2 Abbreviations

For the purposes of this validation report, the following abbreviations apply:

AAM	application activity model;
AIC	application interpreted construct;
AIM	application interpreted model;
ANSI	american national standards institute;
AP	application protocol;
ARM	application reference model;
ASME	american society of mechanical engineers;

B-rep	boundary representation;
CAD	computer-aided design;
CD	committee draft;
CSG	constructive solid geometry;
ICAM	integrated computer aided manufacturing;
ICOM	inputs, controls, outputs, or mechanisms;
IDEF0	ICAM definition language 0
IDEF1X	ICAM definition language 1 extended
IS	international standard
ISO	international organization for standardization
P&ID	pipng and instrumentation diagram;
PFD	process flow diagram;
PPE	process plant example;
PPEAM	process plant engineering activity model;
STEP	standard for the exchange of product model data
UoF	unit of functionality.

### 3 AP Validation Plan

#### 3.1 Overall Method

Table 1 below summarizes the approach employed in validating AP 227.

**Table 1 - AP Review and Validation Methods**

	Relevant Portion of AP	Method	Completion Status
1	Scope and Requirements	ISO Meeting Agreement	Complete
		Validation Workshops	Complete



**Table 1 - AP Review and Validation Methods (concluded)**

	Relevant Portion of AP	Method	Completion Status
2	ARM	AAM to ARM Mapping	Complete
		Validation Workshops	Complete
		Mapping of Process Plant Examples	Complete
3	Mapping Table	Interpretation Review	Complete
4	AIM	Validation Workshop	Complete
		Mapping of Process Plant Examples	Complete
		EXPRESS Parser	Complete
5	Conformance Requirements	Industry Assessment	In process

### 3.2 Validation Workshops

The structure and content of validation workshops will vary during the development of the AP. A validation workshop may include discussions and agreements at an ISO meeting or a walk-through of a reference model with industry representatives and domain experts who did not participate in the development of the AP component. The validation workshops that have been held are summarized in Table 2 below.

**Table 2 - Validation Workshops**

Organization	Meeting Location	Date	AP 227 Version	Topic
<i>PlantSTEP</i>	Houston, TX, USA	11 May 1994	n.a.	Review and approval of usage scenarios
ISO TC184/SC4/WGs	Davos, Switz.	16-19 May 1994	n.a.	Review and approval of scope and project
ISO TC184/SC4	Davos, Switz.	20 May 1994	n.a.	Review and approval of scope and project
<i>PlantSTEP</i>	Boston, MA, USA	1 August 1994	July 1994	Review and approval of scope
<i>PlantSTEP</i>	San Francisco, CA, USA	29-31 August 1994	August 1994	AAM/ARM mapping and ARM validation
<i>PlantSTEP</i> , <i>PISTEP</i> , and <i>ProcessBase</i>	Paris, France	6-7 September 1994	August 1994	ARM review; Aps 221, 225 & 227 Harmonization

Table 2 - Validation Workshops (continued)

Organization	Meeting Location	Date	AP 227 Version	Topic
EPISTLE Plenary	Paris, France	8-9 September 1994	August 1994	Scope and ARM review
<i>PlantSTEP</i>	San Antonio, TX, USA	28-29 September 1994	September 1994	ARM validation
IPO and ISO TC184/SC4/Wgs	Greenville, SC, USA	17-20 October 1994	October 1994	ARM review
<i>PlantSTEP</i>	Wilmington, DE, USA	2-3 November 1994	October 1994	ARM validation
<i>PlantSTEP</i>	Overland Park, KS, USA	29 November - 1 December 1994	November 1994	ARM validation
Japan STEP Center and ENAA	Tokyo, Japan	20-21 December 1994	N367	ARM review
<i>PlantSTEP</i> and Daratech Plant Design Conference	Cambridge, MA, USA	17 January 1995	N367	Broader review by industry
IGES/PDES Org.	Newport Beach, CA, USA	24 January 1995	N367	Group 1 review and comments
<i>PlantSTEP</i> , PISTEP, and ProcessBase	London, UK	6-7 February 1995	N367	Aps 221, 225 & 227 requirements harmonization
EPISTLE	London, UK	10 February 1995	N367	Group 1 review and comments
<i>PlantSTEP</i>	Gaithersburg, MD, USA	28 February - 2 March 1995	February 1995 (AP Clause 4 & ARM V9)	AIM/ARM review and validation
<i>PlantSTEP</i>	Long Beach, CA USA	13 March 1995	February 1995	AIM/ARM review and validation
ISO TC184/SC4/Wgs	Sydney, Australia	20-23 March 1995	March 1995	ARM and AIM review
<i>PlantSTEP</i> , EPISTLE	Long Beach, CA, USA	10-12 April 1995	April 1995	AP 221 harmonization workshop
<i>PlantSTEP</i>	Sommerset, NJ, USA	18-20 April 1995	April 1995	ARM/AIM validation workshop



Table 2 - Validation Workshops (continued)

Organization	Meeting Location	Date	AP 227 Version	Topic
<i>PlantSTEP</i>	Long Beach, CA USA	1-2, 5 May 1995	April 1995	AIM/ARM review and validation
<i>PlantSTEP</i>	Kingsport, TN, USA	16-18 May 1995	May 1995 (ARM V10)	AP validation workshop
<i>PlantSTEP</i>	Long Beach, CA USA	8-9 June 1995	May 1995	AIM/ARM review and validation
<i>PlantSTEP</i> , EPISTLE	London, UK	13-15 June 1995	June 1995	AP review and harmonization with AP 221
ISO TC184/SC4/WGs	Washington, D.C., USA	26-30 June 1995	n.a.	AP 221/227 terminology harmonization
<i>PlantSTEP</i>	Long Beach, CA USA	19-21 July 1995	June 1995	AIM/ARM review and validation
<i>PlantSTEP</i>	Long Beach, CA USA	24-28 July 1995	June 1995	AIM/ARM review and validation
<i>PlantSTEP</i>	Long Beach, CA USA	2-4 August 1995	June 1995	AIM/ARM review and validation
<i>PlantSTEP</i>	Gaithersburg, MD, USA	15-16 August 1995	August 1995 (all clauses and ARM V11)	AAM, ARM, and AIM validation workshop
IPO	Kansas City, MO, USA	17-18 September 1995	N441	CD qualification workshop
<i>PlantSTEP</i>	Gaithersburg, MD, USA	10-12 October 1995	N442	Implementation workshop
<i>PlantSTEP</i>	Exton, PA, USA	14-16 November 1995	N442	Demonstration project workshop
<i>PlantSTEP</i>	Long Beach, CA, USA	4-7 December 1995	N442	Implementation and demonstration project workshops
ISO TC184/SC4/WGs	Dallas, TX, USA	21-26 January 1996	N442	AP 221/227 conformance class discussion
<i>PlantSTEP</i>	Long Beach, CA, USA	20-22 February 1996	N442	Demonstration project workshop

**Table 2 - Validation Workshops (concluded)**

Organization	Meeting Location	Date	AP 227 Version	Topic
<i>PlantSTEP</i>	Houston, TX, USA	20-21 March 1996	N442	Conformance class workshop
<i>PlantSTEP</i>	Gaithersburg, MD, USA	1-2 May 1996	N442	CD comment resolution workshop
<i>PlantSTEP</i>	Gaithersburg, MD, USA	4-5 June 1996	N442	Demonstration project workshop
A/E/C Systems	Anaheim, CA, USA	18 June 1996	N442	Demonstration of AIM implementation
<i>PlantSTEP</i> , EPISTLE	Cambridge, UK	11-12 July 1996	N442	CD comment resolution workshop

### 3.3 Overlap with other APs

The following APs support the representation and exchange of process plant information:

- AP 221: Functional data and their schematic representation for process plant;
- AP 227: Plant spatial configuration;
- AP 231: Process Engineering Data: Process Design and Process Specifications of Major Equipment.

Since the initiation of AP 227, the project teams for these three APs have worked to harmonize requirements and ensure that the APs provide the necessary data sharing capabilities. To this end, AP 227 has developed a usage scenario for the redesign of a piping system (see Process Plant Example 2 in annex B) for the purpose of investigating, solving, and demonstrating data sharing of process plant information with the use of the three APs.

As part of this AP harmonization strategy, the committee draft for comment (CDC) versions of AP 221 and AP 227 were distributed for international review as a combined packet. The AP projects have met several times since the CDC package was issued to review and resolve the comments received from the CDC review. They have also met to review and resolve comments received from the CD version of the AP.

Additionally, the AP 227 project is continuing to monitor and review the development of other APs that may be useful to AP 227 and the process plant industries. These include:

- AP 212: Electrotechnical Plants;
- AP 217: Ship Piping.

- AP 225: Structural building elements using explicit shape representation;

## 4 Scope and Requirements Evaluation Report

This AP project had the benefit of starting with the activity models that had been developed by pdXi and Pat Harrow and the enterprise summary model, funded by PISTEP, commonly referred to as the Process Plant Engineering Activity Model (PPEAM). These models have received extensive input and review by industry and provided a viable foundation for the AAM for AP 227.

The AP 221 and AP 227 process plant AP projects and the Process Plant AP Planning Project agreed at their January 1994 meeting to use the PPEAM as a summary of relevant enterprise activities and a reference for describing the scope of the APs to business managers. In order to complete the task of formal identification of data flows and shared data, more rigorous activity modeling of relevant processes and activities was required.

Through a combination of industry reviews and the development of usage scenarios for high priority (usually high value added) activities, the AP 227 AAM reached stability. The scope of AP 227 was initially proposed at a workshop hosted by NIST in October 1992. Following numerous additional workshops and discussions with industry, international consensus on the scope of AP 227 was established in May 1994. This consensus on the value and boundaries of the scope has been reinforced at all of the validation meetings listed in Table 2.

## 5 ARM Validation Report

### 5.1 AAM to ARM Correspondence

An analysis to ensure correspondence of in scope and out of scope data flows of the AAM with the ARM was completed early in the AP development process. Twenty three usage scenarios, detailed in annex C, were developed early in the AP development process by *PlantSTEP* domain experts to evaluate the AAM and identify requirements. These twenty three scenarios were used to establish the AAM to ARM correspondence. The in-scope activities of these scenarios were analyzed for detailed data requirements. Industry experts developed "Engineering Data Matrices" (refer to annex A) for the in-scope activities. These results were used to assess the coverage and completeness of the ARM and the correspondence from the AAM to the ARM.

An additional analysis of the correspondence between the in scope data flows of the AAM and the ARM was completed using the CD version of AP 227. This analysis mapped the in scope and partially in scope (noted by a \*) inputs, controls, outputs, or mechanisms (ICOMs) identified in Annex F of the AP document to ARM UoFs and entities identified in clauses 4.1 and 4.2, respectively, of the AP document. The AAM ICOMs and their corresponding ARM UoFs and entities are shown in Table 3. The results of this analysis indicated that all of the in scope and partially in scope ICOMs were covered by one or more ARM entities.



Table 3 - AAM ICOM to ARM UoF/Entity Mapping

AAM ICOM	ARM UoF	ARM Entity
Change Request Change Request, Design Change Request, Plant Change Request, Procedure Change Request, Supplier List	Change_information	All entities in the UoF
Equip Chars, Functional Equip Chars, Perf Equip Chars, Process Equip Chars, Reqd. Equip List Equipment ID	Equipment_characterization	All entities in the UoF
	Piping_component_characterization	All entities in the UoF
Codes* Corporate Standards* Design Basis* Guidelines/Requirements* Owner Requirements* Project Specific Procs/Std/Gdlns/ Specs/Codes* Regulations/Regulatory Requirements* Safety System Spec* Specs & Stds*	Connector	Piping_connector Piping_connector_service_characteristic
	Equipment_characterization	Equipment
	Piping_component_characterization	Piping_size_description Pressure_class Schedule
	Piping_system_functional_characterization	Piping_specification Piping_system Piping_system_line Stream_design_case
	Plant_characterization	Piping_system
	Plant_item_characterization	Construction_material Design_project Functional_design_view Material_specification_selection Physical_design_view Piping_system_component Required_material_description Specification_item_family Structural_component
Line Sched/list	Piping_system_functional_characterization	Line_piping_system_component_assignment Piping_system_line
Matl Reqmts	Plant_item_characterization	Material_specification_selection Material_specification_subset_reference
Plant	Plant_characterization	Plant

**Table 3 - AAM ICOM to ARM UoF/Entity Mapping (concluded)**

AAM ICOM	ARM UoF	ARM Entity
Plant Items	Plant_item_characterization	Plant_item
Plant Perf Reqmts	Plant_characterization	Functional_plant Plant Plant_process_capability
Site Information*', Existing	Site_characterization	Site
Status**'	Change_information Shape	Change Plant_item_interference_status
Stream Data	Piping_system_functional_characterization	Stream_design_case Stream_phase
System Design, Prelim System Layout System Layout/Design System Layout/Design, Preliminary	Piping_system_functional_characterization	All entities in the UoF
	Plant_characterization	All entities in the UoF
	Plant_item_characterization	All entities in the UoF
	Site_characterization	All entities in the UoF
Vendor Data	Equipment_characterization Plant_item_characterization	Equipment Catalogue_definition Catalogue_item

The analysis also indicated that the scope of the AP described by the ARM exceeds that of the AAM in that not all of the entities defined in the ARM map back to an AAM ICOM. A listing of the ARM entities is provided in Table 4. This listing shows whether an ARM entity is related to an AAM ICOM, and if not, what UoF it is part of. The results of this review show that all the ARM entities that are not mapped from an AAM ICOM are related to representation of an item (advanced\_csg\_-representation, piping\_design\_csg\_representation, and wireframe\_and\_b\_rep\_geometry UoFs), shape of an item (shape UoF), or the connections between items (connection and connector UoFs). The results also show that 72.5% of the ARM entities are related to an AAM ICOM.

**Table 4 - ARM Entity Coverage**

Reference Note	ARM Entity
4	b_rep_element
1	blank
1	blind_flange
2	block
1	breakline



Table 4 - ARM Entity Coverage (continued)

Reference Note	ARM Entity
1	building
1	bushing
6	butt weld
1	cable_support
1	catalogue_definition
1	catalogue_item
1	catalogue_item_substitute
1	change
1	change_approval
1	change_delta
1	change_item
1	change_life_cycle_stage
1	change_life_cycle_stage_sequence
1	change_life_cycle_stage_usage
1	changed_line_assignment
1	changed_line_branch_connection
1	changed_line_plant_item_branch_connection
1	changed_line_plant_item_connection
1	changed_line_to_line_connection
1	changed_material_specification_selection
1	changed_piping_system_line
1	changed_piping_system_line_segment
1	changed_piping_system_line_segment_termination
1	changed_planned_physical_plant
1	changed_plant
1	changed_plant_item
1	changed_plant_item_collection
1	changed_plant_item_connection

Table 4 - ARM Entity Coverage (continued)

Reference Note	ARM Entity
1	changed_plant_item_connector
1	changed_plant_item_design_view
1	changed_plant_item_shape
1	changed_plant_process_capability
1	changed_plant_system
1	changed_reference_geometry
1	changed_required_material_description
1	changed_sited_plant
1	changed_sub_plant_relationship
4	circular_ellipsoid
1	compressor
2	cone
4	conic
1	connected_assembly
5	connection_definition
6	connector_definition
1	construction_material
1	coupling
1	cross
2, 3	csg_element
4	curve
2	cylinder
1	design_project
7	detail_shape
1	ducting_component
4	eccentric_cone
4	eccentric_cylinder
3	eccentric_pyramid

Table 4 - ARM Entity Coverage (continued)

Reference Note	ARM Entity
1	eccentric_reducer
1	eccentric_swage
1	elbow
1	electrical_component
6	electrical_connector
1	electrical_system
5	electricity_transference
1	engine
7	envelope_shape
1	equipment
1	equipment_breaching
1	equipment_trim_piping
1	expander_flange
2	extrusion
1	facet
1	faceted_terrain_model
6	female_end
1	fitting
1	flange
6	flanged
6	flanged_end
5	flexible_connection
5	fluid_transference
4	free_form_curve
5	functional_connection_definition_satisfaction
5	functional_connection_occurrence_satisfaction
6	functional_connector
6	functional_connector_definition_satisfaction



**Table 4 - ARM Entity Coverage (continued)**

Reference Note	ARM Entity
6	functional_connector_occurrence_satisfaction
1	functional_design_view
1	functional_plant
1	functional_plant_item_satisfaction
1	functional_plant_satisfaction
1	furnace
1	gear_box
1	heat_exchanger
3	hemisphere
1	hierarchical_assembly
1	hvac_component
1	hvac_system
1	inline_equipment
1	inline_instrument
1	insert
1	inside_and_thickness
1	installed_physical_design_view
1	instrument
1	instrumentation_and_control_component
1	instrumentation_and_control_system
1	insulation
7	interfering_shape_element
1	jacketed_piping
1	lap_joint_flange
1	lap_joint_stub_end
1	lateral
4	line
1	line_branch_connection

**Table 4 - ARM Entity Coverage (continued)**

Reference Note	ARM Entity
1	line_branch_termination
1	line_less_piping_system
1	line_piping_system_component_assignment
1	line_plant_item_branch_connection
1	line_plant_item_branch_connector
1	line_plant_item_connection
1	line_plant_item_connector
1	line_plant_item_termination
1	line_to_line_connection
1	line_to_line_termination
5	load_transference
1	location_in_building
1	location_in_plant
1	location_in_site
5	locked_orientation_connection
6	male_end
1	manufacturing_line
1	material_specification_selection
1	material_specification_subset_reference
1	mitre_bend_pipe
1	offline_instrument
1	olet
1	orifice_flange
1	orifice_plate
7	outline_shape
1	outside_and_thickness
1	paddle_blank
1	paddle_spacer

Table 4 - ARM Entity Coverage (continued)

Reference Note	ARM Entity
6	physical_connector
1	physical_design_view
1	pipe
1	pipe_bend
1	pipe_cap
1	piping_component
1	piping_connector
1	piping_connector_service_characteristic
1	piping_size_description
1	piping_specification
1	piping_spool
1	piping_spool_assignment
1	piping_system
1	piping_system_component
1	piping_system_line
1	piping_system_line_segment
1	piping_system_line_segment_termination
1	planned_physical_plant
1	planned_physical_plant_item
1	plant
1	plant_item
7	plant_item_centreline
1	plant_item_collection
5	plant_item_connection
5	plant_item_connection_occurrence
5	plant_item_connector
6	plant_item_connector_occurrence
1	plant_item_definition



**Table 4 - ARM Entity Coverage (continued)**

Reference Note	ARM Entity
1	plant_item_design_view
7	plant_item_geometric_origin
1	plant_item_instance
4	plant_item_interference
1	plant_item_interference_status
1	plant_item_location
7	plant_item_shape
1	plant_item_weight
1	plant_process_capability
1	plant_system
1	plant_system_assembly
1	plant_volume
4	point
1	point_terrain_model
4	polygon
1	pressure_class
1	pressure_vessel
1	process_ducting
1	project_design_assignment
1	pump
2	pyramid
1	reducer
1	reducing_flange
3	reducing_torus
4	reference_geometry
1	relative_item_location
1	required_material_description
1	reserved_space



Table 4 - ARM Entity Coverage (continued)

Reference Note	ARM Entity
1	ring_spacer
1	route
1	schedule
1	segment_insulation
6	service_operating_case
7	shape_interference_zone_usage
7	shape_representation
7	shape_representation_element
7	shape_representation_element_usage
1	silo
1	site
1	site_feature
1	sited_plant
1	slip_on_flange
6	socket
1	socket_weld_flange
2	solid_of_revolution
1	spacer
1	specialty_item
1	specification_item_family
1	spectacle_blind
2	sphere
3	square_to_round
1	straight_pipe
1	stream_design_case
1	stream_phase
1	structural_component
6	structural_load_connector

**Table 4 - ARM Entity Coverage (continued)**

Reference Note	ARM Entity
1	structural_system
1	sub_plant_relationship
1	support_component
1	support_constraints
1	support_usage
1	support_usage_connection
3	surface
1	survey_point
1	swage
1	swept_bend_pipe
1	system_space
1	tank
1	tee
1	terrain_model
6	threaded
1	threaded_flange
2	torus
1	train
3	trimmed_block
2	trimmed_cone
3	trimmed_cylinder
2	trimmed_pyramid
2	trimmed_sphere
2	trimmed_torus
3	tube
1	turbine
1	union
1	unit

**Table 4 - ARM Entity Coverage (concluded)**

Reference Note	ARM Entity
1	valve
4	vector
1	weld_neck_flange
4	wire_and_surface_element
1	wye

NOTES

- 1 - ARM entities that are related to AAM ICOMs
- 2 - Advanced\_csg\_representation UoF entities
- 3 - Piping\_design\_csg\_representation UoF entities
- 4 - Wireframe\_and\_b\_rep\_geometry UoF entities
- 5 - Connection UoF entities
- 6 - Connector UoF entities
- 7 - Shape UoF entities

## 5.2 Population of ARM with Data

### 5.2.1 Relational Database Data Population

As part of the assessment of the ARM and the coverage provided by Process Plant Example (PPE) Models 1 and 2 described in annex B, a relational database was created based on ARM Version 11. To develop the database schema from the ARM, the ARM IDEF1X [5] model was loaded into the ERwin<sup>(TM)</sup> modeling software. ERwin has the capability to generate a database schema for several different relational databases from an IDEF1X model. For the purposes of this assessment, the relational database used was Oracle<sup>(TM)</sup> Version 7.0.16.

During the process of generating the Oracle database tables from the IDEF1X model schema, the following errors were identified:

- Several entity names were too long. Oracle requires a unique name that is less than 27 characters long. All entity names were shortened to fit into this constraint.
- Several entity and attribute names conflicted with Oracle reserved words. Conflicts included 'insert', 'union', 'group', 'current', and 'date'. Entity and attribute names were modified to eliminate the conflict.

- The table for entity 'survey\_point' was not created, since it did not have any attributes. An open issue will be added to the issues log to modify the ARM to add the appropriate attribute(s) to this entity.

In order to populate the Oracle database, data was derived from a training model provided by DuPont Corporation. This training model is theoretical and does not reflect an actual design since all values and geometry exist only to support the model and are not based on fact. However, the model is considered to be representative of an actual chemical process plant.

The Oracle database was loaded with piping and equipment data from the portion of the training model that corresponds to PPE 2 described in annex B. Shape, geometry, and location data for a tank and two pumps were extracted from the model and loaded into the database. This portion of the data provides coverage of approximately 6% of the model.

## 5.2.2 Overview of Usage Scenarios

As part of developing the ARM, the AP 227 project defined ten specific tasks that the AP must support. These tasks include:

- references to codes, specifications, and standards;
- references to stream data;
- plant arrangement (placement of space occupying elements);
- configuration management of plant items and piping system information;
- spatial design of piping systems, including:
  - pipe routing and component placement;
  - placement of pipe supports.
- connectivity and topology checks;
- material and connection compatibility;
- interference checking;
- bill of materials for piping and piping components;
- fabrication and assembly of piping.

This set of tasks have been used as a baseline for assessing data requirements. Industry experts completed functional mapping matrices which identified the types of data required for the above tasks (see annex A for examples of this input). Matrices for the following domains were completed and used to validate the ARM during development:

- mechanical equipment;



## Validation Report for ISO/CD 10303-227

- piping;
- HVAC;
- structural, civil, and architecture.

The AP project team developed ARM mapping matrices for industry experts to populate with source data as another validation mechanism.

In addition to the tasks listed above, the AP project developed five usage scenarios prior to starting the ARM. These five scenarios are decompositions of activities within the AP 227 AAM and are documented with the AAM. The five usage scenarios are:

- layout plant piping system;
- procure a plant component;
- exchange of information between construction management, design engineering, and the plant owner;
- revamp (redesign) of a plant;
- exchange of a boiler design between plant design engineer and the boiler fabricator.

## 5.3 Computervision Prototype

### 5.3.1 History

Computervision<sup>(TM)</sup> (CV) decided to utilize AP 227 ARM Version 10 as a component object model to implement a prototype 3D graphical piping application on their new PELORUS<sup>(TM)</sup> object oriented architecture. This decision was made because first, there was a need to develop a piping prototype and second, this would allow CV to test the implementation of a STEP compliant application.

### 5.3.2 Description of Prototype

The prototype piping application utilized an interactive menu and point digitize to route a pipeline with pipes, elbows and valves. By this method a user could create a graphical representation of a complex pipeline containing multiple components.

The piping components were displayable in any view (e.g. plan, section, isometric) and in any of the three ARM representations (envelope, outline, detail). The piping components could be interference checked against other components or geometry. The attributes of the piping components could be reported in a menu to the use.

### 5.3.3 Implementation of Prototype

CV created a C++ class library corresponding to the main trees in the ARM and integrated this class library with the PELORUS classes (e.g. graphics, geometry, user interface) to produce the prototype.

CV started with the main ARM elements `plant_item` and `plant_item_shape`. CV then added object methods to these classes for the actions: create, display, interference check, edit, delete and report. CV created C++ classes corresponding to the ARM elements `pipng_system_component` and subtypes `pipe`, `elbow` and `valve`. These classes had fields corresponding to the ARM elements and overloaded methods<sup>1</sup> where necessary.

CV then implemented a C++ class for the ARM elements `plant_item_connector` and `plant_item_connection` to provide for the inter-connectivity of the piping components. CV also created C++ subclasses corresponding to the ARM elements `explicit_shape`, `envelope_shape`, `outline_shape` and `detail_shape`. These classes again had fields corresponding to the ARM elements and overloaded methods where necessary.

Finally, all the classes were compiled to produce the prototype piping application. This prototype covered an estimated 70% of the ARM through the use of virtual classes. About 20% of the ARM was actually tested by the prototype.

### 5.3.4 Conclusions

The prototype piping application was very successful. CV determined that the ARM provides a sound structure for the implementation of a 3D CAD application. The ARM also provides a complete and accurate describe the piping components' attributes and geometric shapes.

## 6 Integrated Resources Interpretation Report

### 6.1 Introduction

This section of the validation report describes the interpretation of the ARM of AP 227. It summarizes the logic for the interpretation of the information requirements found in AP 227 and the rationale for rules added to the AIM. These information requirements are organized in the alphabetical order of the information requirements in Clause 4 of the AP 227 document.

### 6.2 Workshops

Several workshops were held to perform the interpretation of AP 227. These are detailed in Table 2. Changes to the interpretation were necessary because of modifications to the ARM and to the application protocol requirements during the harmonization with AP 221.

---

<sup>1</sup> Overloaded methods refer to the use of multiple method instances that share a common name and provide a common operation on different argument types. A method is a function that is defined for a particular object type.

### 6.3 Requirements Changes

The requirements of AP 227 were modified as a result of harmonization with AP 221. Meetings held to harmonize the two APs are detailed in Table 2. This document will be updated to reflect changes to the information requirements (i.e., application objects that were removed, added, or renamed).

### 6.4 Interpretation of Application Objects and Assertions

Clause 5.1 of AP 227 provides a mapping table that shows how each application object maps to one or more AIM constructs.

During the interpretation of the AP 227 ARM, several areas of the model were evaluated. Issues were raised where the model did not clearly specify the requirements as described by the project development team.

The model did not clearly and consistently handle the functional and physical views of plant items. In some areas of the model, these views were combined whereas in other areas they were distinct. The line definition is purely functional in nature. Connectors are both physical and functional. The line segment termination and termination connection area was modified to clarify transition between the functional line segment and the functional or physical connector.

The area dealing with change was modified slightly to clarify the types of information needed, for example, what dates are relevant. The types of fittings were rearranged; artificial supertypes for fittings that contain common data were removed.

The usage of shape elements either in the definition of the shape of an item or the definition of an interference zone was clarified.

### 6.5 Application Interpreted Constructs

The requirements of AP 227 were not satisfied by any of the existing AICs. Since this is the first AP to be interpreted in the area of process plants, new AICs may be identified for future incorporation into AP 227 when another AP with similar requirements is interpreted.

### 6.6 AIM Specializations

Several specializations of the **product\_definition** entity were created in AP 227 for the distinction of the type of plant system as defined in the ARM.

Several specializations of the **group** entity were created in AP 227 for the classification of piping components, connections, and connectors. Piping components are classified by their type as defined in the ARM. Connections are classified by their freedom of motion and function. Connectors are classified by their function and end types.

Since none of the existing AICs satisfied the geometry requirements, specializations of the **shape\_representation** entity were created in which to place these constraints.



Specializations of the **shape\_aspect\_relationship** entity were created for each of the types of connection defined in AP 227. These specializations constrain the type of termination and the item that is connected.

For connections, a specialization of the **shape\_aspect** and the **shape\_aspect\_relationship** entities was created. This entity is a subtype of **shape\_aspect\_relationship** because it must relate the two connectors that form the connection. It is a subtype of **shape\_aspect** because the connection as a whole is part of the definition of another object.

## 7 AIM Validation

### 7.1 ARM to AIM Correspondence

The constraints in the AIM were written to satisfy the cardinality constraints of the attributes and assertions defined in the ARM. Global rules were written in the short form to constrain the constructs from the integrated resources where a local rule could not be defined in a specialization.

The **approval\_requires\_approval\_date\_time** rule enforces the required **approval\_date** attribute in the **Change\_approval** object in the ARM. The **approval\_requires\_approval\_person\_organization** rule enforces the required approver attribute in the **Change\_approval** object in the ARM.

The **change\_action\_requires\_date** rule enforces the required date attribute of the **Change** object in the ARM. The **change\_item\_requires\_creation\_date** rule enforces the required **creation\_date** attribute in the **Change\_item** object in the ARM. The rule ensures that every assignment of a change has a creation date. The **change\_item\_requires\_id** rule enforces the required **change\_item\_id** key attribute in the **Change\_item** object in the ARM. The rule ensures that every item that is changed has an identification.

The **change\_life\_cycle\_stage\_usage\_requires\_approval** rule enforces the **Change\_life\_cycle\_stage\_usage** to **Change\_approval** assertion in the ARM. The rule ensures that every approval is assigned to exactly one **Change\_life\_cycle\_stage\_usage**. The **Change\_life\_cycle\_stage\_usage\_requires\_stage** rule enforces the **Change\_life\_cycle\_stage** to **Change\_life\_cycle\_stage\_usage** assertion in the ARM. The rule ensures that every **Change\_life\_cycle\_stage\_usage** assigns changes for exactly one **Change\_life\_cycle\_stage**. The **versioned\_action\_request\_requires\_change\_action** rule enforces the **Change** to **Change\_life\_cycle\_stage\_usage** assertion in the ARM. The rule ensures that every **Change\_life\_cycle\_stage\_usage** assigns exactly one **Change**.

### 7.2 Population of AIM with Data

Based on sample populations of the AIM, modifications to the interpretation were required. The **plant\_item\_definition** entity was replaced by two global rules: **product\_definition\_context\_name\_constraint** and **product\_definition\_usage\_constraint**.

The **product\_definition\_context\_name\_constraint** rule restricts the allowable names of the **product\_definition\_context** entity to those identified during interpretation. Within AP 227, things may be physical or functional, a definition or an occurrence, defined in a catalogue, or a **pipingspool**. The **product\_definition\_usage\_constraint** rule enforces several assertions in the ARM. It enforces that each

physical occurrence is related to at most one physical definition as required by the `plant_item_`-`definition` to `planned_physical_plant_item` assertion.

### 7.3 Results of Parsing the AIM EXPRESS Schema

The short and long form of the AIM EXPRESS schema is provided in Clause 5.2 and annex A of AP 227, respectively. A syntax review of the schema provided in the pre-CD qualification version of the AP using Dataprobe Version 2.1 found no errors. Additional reviews of the CD version of the AP using Fedex and ST-Developer identified minor syntax errors and three entities that were used but not declared in the schema. These errors were fixed.

## 8 Conformance Requirements Evaluation Report

Clause 6 of AP 227 contains a description of the ten conformance classes identified for the AP. Conformance to a class is distinguished by the support of a particular usage class and by the geometric representation of shapes. All conformance classes include information concerning change, plants, plant items, and connectors.

The conformance classes are divided into four usage groups:

- Functional/logical definition and connectivity of piping system lines;
- Plant layout and arrangement information of plant systems;
- Detailed design information of a plant and plant systems; and
- Piping fabrication and installation information.

The version of the conformance classes contained in the CD version of AP 227 is currently being reviewed for its utility, practicality, understandability, and coverage of requirements.

## 9 Pilot Implementation Results

### 9.1 *PlantSTEP* Demonstration Project

#### 9.1.1 Introduction

The DuPont "TRD" CAD training model was chosen to be the basis for the *PlantSTEP* demonstration project model. The demonstration project focused on a section of the model which included 4 lines, 2 pumps, 1 tank, and a variety of piping components. A representation of this portion of the TRD training model is provided by PPE 2 in annex B. The objectives of the demonstration project were to:

- Illustrate the practical use of *PlantSTEP*'s ISO 10303 Application Protocol in the context of a set of high-value business transactions.
- Accelerate the initial set of implementations of AP 227 through coordinated collaborative vendor-focussed project.

- Validate the usefulness of AP 227 for its intended scope.
- Assist *PlantSTEP* members in planning for the implementation of STEP.

### 9.1.2 Scenario

The scenario employed in the demonstration project is the representation and transfer of data via an AP 227 STEP neutral file between the various design life-cycle phases. Data used in the scenario was limited to the design domain in order to implement a practical demonstration. Focus was on spatial design considerations of the design only, excluding clash management. No detailed engineering analysis (e.g., pump sizing, pipe stress calculations) was included.

The demonstration project scenario assumes that an owner/operator initiates conceptual or front end design of a process plant and is utilizing one or more design contractors for detailed design. The design contractor interfaces with the fabricator who deals primarily with pipe fabrication. Equipment vendors supply data on equipment, which is used by both the owner/operator and the contractor to

The design life-cycle

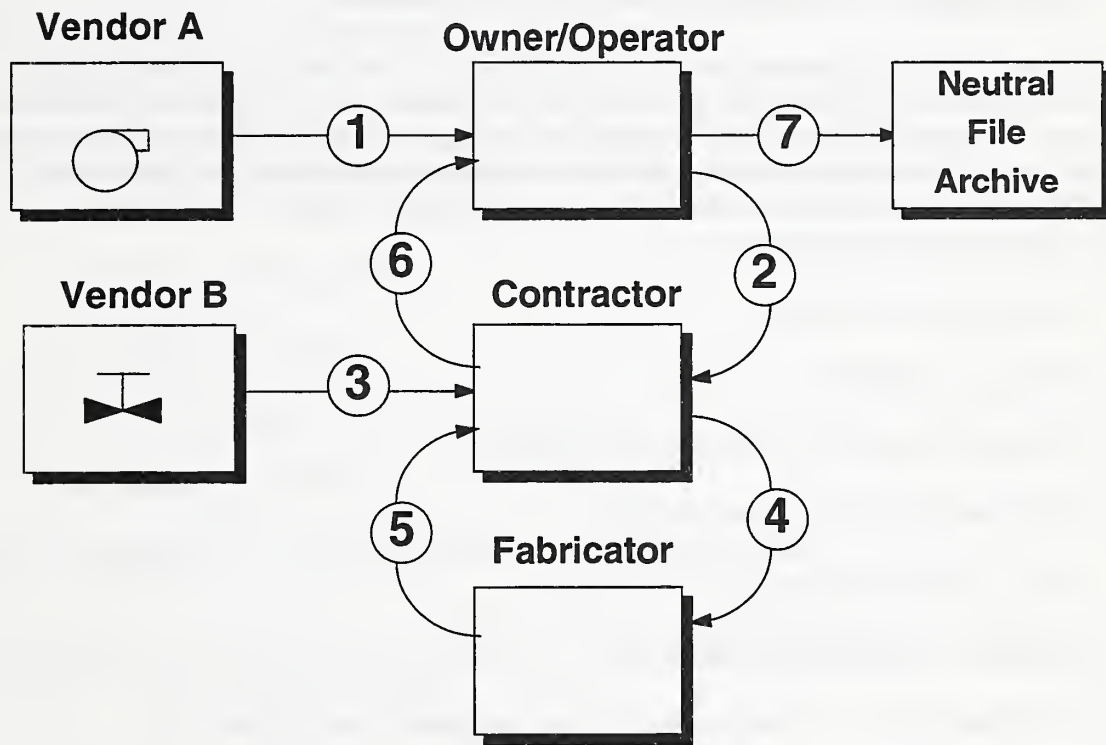

Figure 1 - PlantSTEP Demonstration Project Scenario

data transfers involved in the demonstration project are described below. Data transfers via neutral file



## **Validation Report for ISO/CD 10303-227**

exchange are represented by circled numbers in Figure 1 and in the text below as number in parentheses, e.g., (1).

### **9.1.2.1 Exchange # 1 - Vendor A (Pump Supplier) to Owner/Operator**

In this exchange, a vendor supplies data on a pump to the owner/operator who initially locates it in the 3D model. The owner/operator receives a file that contains:

- Identification of the pump and its materials;
- Weights;
- Connector orientation and position;
- Shape of the pump;
- References to applicable specifications.

### **9.1.2.2 Exchange # 2 - Owner/Operator to Contractor**

In this exchange, the owner/operator initiates the requirements for the process plant design scenario. Preliminary layouts of major equipment (tank and pumps in this scenario) based on a site/world coordinate system are initiated by the owner/operator, including data received from vendors (1). These preliminary layouts are transferred to the contractor for completion of the final design. For the purposes of the demonstration project, the owner uses a different CAD system than the contractor. The contractor receives a file that contains:

- Basic siting and layout data;
- All major equipment;
- Functional connectivity and equipment (P&ID-like);
- Piping specifications and owner catalogue;
- Shape of the major equipment;
- References to applicable specifications.

### **9.1.2.3 Exchange # 3 - Vendor B (Valve Supplier) to Contractor**

In this exchange, another vendor supplies valve information to the contractor to be used in detailed design and arrangement of the piping system. The contractor receives a file that contains:

- Multiple valves in a catalogue;
- Identification of the valve and its materials;

- Weights;
- Connector orientation and position;
- Shape of the valve;
- References to applicable specifications.

#### **9.1.2.4 Exchange # 4 - Contractor to Fabricator**

In this exchange, the contractor provides a transfer of data to the fabricator who is then able to utilize this data for pipe fabrication and spooling. The pipe fabricator receives a file that contains:

- 3D model of the piping system (shape\_relationships, connections, connectors);
- Specifications for all items;
- Exchange subsets.

#### **9.1.2.5 Exchange # 5 - Fabricator to Contractor**

In this exchange, the fabricator passes back to the contractor any data from it's activities which need to be preserved long term in the design data. Data which might originate with the fabricator are such things as shop welds (for spooling) if this detail is not provided by the contractor, and fitting changes made (e.g., fabricated bends instead of separate fittings). The contractor receives a file that contains:

- 3D model of the piping system;
- Specifications for all items;
- Identification of spools;
- Identification of field welds.

#### **9.1.2.6 Exchange # 6 - Contractor to Owner/Operator**

In this exchange, the owner/operator receives the completed design back into it's CAD system via data transfer from the contractor in order to maintain the 'as-built' data associated with the facility. The owner/operator receives a file that contains:

- 3D model of the piping system;
- Specifications for all items;
- Identification of spools;
- Identification of field welds;



## Validation Report for ISO/CD 10303-227

- Relationships to all source data from the owner file (#2).

### 9.1.2.7 Exchange # 7 - Archival Storage

In this exchange, the owner/operator archives data for long term preservation and upgrade purposes. The owner/operator stores a file that contains:

- All pertinent design data;
- Identification of all changes;
- Identification of blockpoint release status;
- Approvals.

### 9.1.3 Approach

The demonstration project had at its core a set of test data. The actual test case included the piping and instrumentation connectivity, piping component selections, location, and positioning and physical shape of part of a piping system. Appropriate subsets of the test data were exchanged between the various participants in the demonstration scenario.

The full set of test case data was put into the STEP neutral file format. The full set of data was then divided into overlapping subset populations for the seven exchange points in the scenario. Each participant in the scenario then implemented the capability to read the incoming file (if appropriate) and generate the outgoing file (if appropriate) for their scenario.

### 9.1.4 Demonstration File Data Population

The first part of the demonstration project was the development of the data needed for the demonstration and the creation of a neutral format exchange file containing this data. A technical team studied the model and listed the type of plant items found in the model. Using this list, they located the ARM entities and attributes that were needed for these plant items, and tried to match the model data available to the information that the ARM required. While matching this data to the ARM, domain experts were called upon to locate additional data needed, to clarify some ARM definitions, and to specify the intended use of certain entities and attributes.

Using the list of ARM entities and attributes, the team looked at the mapping table to determine which AIM entities were needed. Using this mapping table and the data, AIM entities, data, and prescribed values were added to the demonstration exchange file. During this process, some issues were raised about the inconsistencies of the mapping table which were later corrected. For the different plant\_items in the model, the advanced\_csg\_representation, connection, equipment\_characterization, piping\_component\_characterization, piping\_design\_csg\_representation, piping\_system\_functional\_characterization, plant\_characterization, shape, and wireframe\_and\_b\_rep\_geometry UOFs were completely created for the plant items in the model. In addition, the connector, plant\_item\_characterization, site\_characterization UOFs were approximately 50% completed.

From the population exercise, various issues were brought up asking for a clarification of an ARM definition and the intention of certain relationships. The main issues identified were:

- The `orifice_flange_entity` is missing an `end_3_connector`.
- There is no ARM entity for the classification of gaskets and nipples.
- A Clarification of `end_1`, `end_2`, and `end_3` connectors is needed. Designers and vendors use this description in two different ways. A rule should be used to describe the desired intent.
- In what cases is a `piping_size_description` used with a `piping_system_component` and a `piping_connector`. For example, for a 7.62 cm x 7.62 cm tee, do you use one `plant_item_-connector` for the component to describe that all connectors are 7.62 cm? Rules are recommended so there is no variability in an exchange file.
- A distinction should be made between an electronic and paper catalogue.
- Through the ARM and AIM, there seems no attribute or entity to hold information about more than one catalogue. Previous catalogue references should be kept in order.
- Should the occurrence of a component refer to the version of a plant or the version of the `plant_item_definition`? Does the file contain multiple versions of a file or is any exchange considered to denote a new version? What qualifies for a new version number?
- A clarification of a `skirt_outside_diameter` of an olet is needed within the ARM definition.
- Field and shop weld information are not currently stored. If they are part of the scope, they should be added.
- AP 227 says that the `plant_item_weight.weight_value` "specifies a measure of the mass of a `plant_item`". The name is inconsistent with the definition, although the AIM does give two names for this attribute: `weight_value` and `mass_value`.
- `Piping_specification` needs to carry an attribute `corrosion_allowance`. This is a fundamental property used to determine the details within the specification and is used for on-the-fly calculations when placing components. `Corrosion_allowance` needs to be transferred explicitly (with units) even though it may also be a part of the service description.
- Service limits (upper and lower temperatures and pressures) for a piping specification/piping system do not seem to be addressed in the ARM.
- Mitred bends should contain an attribute `bend_radius` and indicate the number of mitres.
- Information about branch reinforcing is missing. Is this part of the scope?
- The `coating_reference` and `heat_tracing_type` under `piping_system_component` should be renamed to `coating_reference_override` and `heat_tracing_type_override` to indicate that they are only to be used to indicate an exception for that component from the data in the associated `piping_system_line_segment` value, thus avoiding duplicated data.

## Validation Report for ISO/CD 10303-227

After the main data file was created, subsets of the main file were created to match the first five exchanges outlined above, and subsets of those five exchanges were created to accommodate a minimal implementation of the application protocol for initial demonstrations.

### 9.1.5 Implementation

The second part of the demonstration project was the implementation of a portion of the AP, and test it using the demonstration file. This tested whether systems could use the data that was stored, understand how to retrieve the information, and test if the information required in the exchange file was adequate and appropriate.

Implementors began work to understand the ARM, mapping table, AIM, and exchange files. After reviewing this material and beginning to implement the geometry of the AP, the following issues were noted:

- The connect points of a connector are given in global coordinates where the location of a `plant_item` is also given in global coordinates. Instead, should the `plant_item` be in global, while the locations of the connectors are assumed relative to that location.
- The AIM allows different types of geometry (CSG, Wireframe, B-Rep) to be combined within the same file. This should be stricter to accommodate different vendor capabilities.
- In the AIM, many entities have name, description, or ID fields which are not directly mapped to the ARM. A follow-up document or user's guide should suggest what values are needed there or should require that these items be left blank.
- A nominal size should not be mapped to a unit since the size is a key for a table and not an actual unit.
- Following from an ARM question, mass is converted to weight to get the `weight_value`, but `mass_units` are still used because there is no `weight_unit` within the integrated resources. A clarification is needed in AP 227 or in ISO 10303-41 [7] to know how a value of weight can be correctly described.

In addition, the implementors' work helped to correct the demonstration file. During the implementation phase, the implementor's noticed some differing interpretations of the AIM, and some ARM entities which were incorrectly mapped, so corrections and additions were made to the main demonstration file and the subsets files as needed.

### 9.1.6 Results

#### 9.1.6.1 Demonstration File Population

Through this population exercise, various issues were raised regarding attributes missing in the ARM, some improvements needed of definitions in the ARM, and a need to clarify or document the intended use of some ARM entities and relationships. Through this exercise, the team tested whether the AP could store the information within the scope of the AP, and tested the boundaries of the project. By



creating the file that involved pieces of 12 of the 13 UOFs, the work proved that the AP contains information that is useful to many scenarios within the design phase of a plant.

### 9.1.6.2 Implementation

The implementation of the demonstration model began with the work towards a demonstration at the A/E/C Systems show, but will be followed-up afterwards. Currently 3-4 implementors have developed either a read or write interface to understand the exchange file. There were two scenarios in the demonstration.

In Scenario A of the demonstration, System 1 output a file containing information about two pumps and their location. System 2 read in the file, displayed the two pumps, added a tank, and some piping, and output an exchange file containing this new information. System 3 read in System 2's file and displayed this piping system.

In Scenario B of the demonstration, System 1 output a file of geometric information, and plant item classifications. System 3 read in the file and displayed the information.

The successful demonstration of these two scenarios at the A/E/C Systems show showed that basic plant identification data and geometric descriptions could be successfully passed using AP 227.



## Annex A

### Engineering Data Matrices

Data matrices for mechanical equipment, piping components, HVAC components, and structural, civil, and architectural components are provided below.

Data categories identified with a 'N' contain data considered as needed or necessary for the engineering design process. Data categories identified with a 'W' contain data that is wanted or desired.

Table A.1 - Functional Mapping Matrix - Equipment

EQUIPMENT TYPE	DATA: N = NEEDED W = WANTED						
	PRODUCT ID (N)	SPATIAL (N)	BASIC ENGR (N)	STREAM (N)	DETAILED ENGR (W)	REGULATORY (W)	PROCUREMENT (W)
Pump	Tag or ID Number Descriptor	Spatial Envelope Dimensions (Pump, Motor Driver, and Base Plate) Shaft C.L. Orientation Shaft C.L. Coordinates Elev of Bottom of Base Plate or Support Points Support Point Coordinates Connection C.L. Coordinates (At Face of Connection) Connection C.L. Orientation Connection Shape Coupling Face Coordinates (at Shaft C.L.) Operations Space Envelope Dimensions & Orientation Maintenance Space Envelope Dimensions & Orientation Insulation Dimensions	Pump Type and Description Pump Materials of Construction Driver Tag or ID Number Driver Type Reference Specifications Fluid Service Name Fluid Pumped Design Temperature Design Suction Pressure Design Discharge Pressure Operating Temperature Operating Suction Pressure Operating Discharge Pressure Pipe Pipe Connection ID Pipe Pipe Connection Type Pipe Connection Size Pipe Connection Rating Pipe Connection Material Pipe Connection Details (insertion depth, thread depth, etc.) Pipe Connection Movements Pipe Connection Allowable Loads Weight Insulation Requirements Special Considerations for Spatial Location or Piping Design (e.g., Utilities Requirements, Vent and Drain Req'mts)	Stream ID Stream Description Stream Properties: Vapor Fraction Temperature Pressure Flow Molecular Weight Density (Liquid & Vapor) Viscosity Surface Tension Vapor Specific Heat Ratio Vapor Compressibility Stream Constituents  Note: More than one case may exist for Stream Properties and Stream Constituents (e.g., Normal Operating, Design Operating, Mechanical Design, Upset).	Case Pressure Rating Impeller Material Seal Type Special Seal Data Driver Type Driver Power Source Data Overpressure Protection Requirements Minimum Flow Requirements Exposure Design Data (Wind, Earthquake, Sand, Etc) Paint Requirements		Requisition Number P.O. Number Vendor Name Schedule Milestone Dates

Table A.1 - Functional Mapping Matrix - Equipment (continued)

EQUIPMENT TYPE	DATA: N = NEEDED W = WANTED					REGULATORY (W)	PROCUREMENT (W)
	PRODUCT ID (N)	SPATIAL (N)	BASIC ENGR (N)	STREAM (N)	DETAILED ENGR (W)		
Compressor	Tag or ID Number Descriptor	Spatial Envelope Dimensions (Compressor, Motor Driver, and Base Plate) Shaft C.L Orientation Elev of Bottom of Base Plate or Support Points Support Point Coordinates Connection C.L. Coordinates (At Face of Connection) Connection C.L. Orientation Connection Shape Coupling Face Coordinates (at Shaft C.L.) Operations Space Envelope Dimensions & Orientation Maintenance Space Envelope Dimensions & Orientation Insulation Dimensions	Compressor Type and Description Materials of Construction Driver Tag or ID Number Driver Type Reference Specifications Fluid Service Name Fluid Compressed Design Suction Temperature Design Suction Pressure Design Discharge Temperature Design Discharge Pressure Operating Suction Temperature Operating Suction Pressure Operating Discharge Temperature Operating Discharge Pressure Pipe Pipe Connection ID Pipe Connection Type Pipe Connection Size Pipe Connection Rating Pipe Connection Material Pipe Connection Details (insertion depth, thread depth, etc.) Pipe Connection Movements Pipe Connection Allowable Loads Weight Insulation Requirements Vent Requirements Special Requirements for Spatial Location or Piping Design For Reciprocating: Distance Piece Vent Requirements Rod Packing Vent	Stream ID Stream Description Stream Properties: Vapor Fraction Temperature Pressure Flow Molecular Weight Density (Liquid & Vapor) Viscosity Surface Tension Vapor Specific Heat Ratio Vapor Compressibility Stream Constituents  Note: More than one case may exist for Stream Properties and Stream Constituents (e.g., Normal Case, Upset Case)	Case Pressure Rating Seal Type Special Seal Data Driver Power Source Data Overpressure Protection Requirements Minimum Flow Requirements Exposure Design Data (Wind, Earthquake, Sand, Etc) Number of Stages Paint Requirements Driver Speed Gearbox Input Speed Gearbox Output Speed Lube Oil System Type Lube Oil System Cooling Duty Lube Oil System Pump Data	Requisition Number P.O. Number Vendor Name Schedule Milestone Dates	

Table A.1 - Functional Mapping Matrix - Equipment (continued)

EQUIPMENT TYPE	DATA: N = NEEDED W = WANTED					REGULATORY (W)	PROCUREMENT (W)
	PRODUCT ID (N)	SPATIAL (N)	BASIC ENGR (N)	STREAM (N)	DETAILED ENGR (W)		
Turbine	Tag or ID Number Description	Spatial Envelope Dimensions (Turbine and Base Plate) Shaft C.L. Orientation Shaft C.L. Coordinates Elev of Bottom of Base Plate or Support Surfaces Support Point Coordinates Connection C.L. Coordinates (At Face of Connection) Connection C.L. Orientation Connection Shape Data Connection ID Coupling Face Coordinates Operations Space Location, Orientation, Dimensions Maintenance Space Location, Orientation, Dimensions Insulation thickness	Turbine Type and Description Materials of Construction Reference Specifications Energy Source Fluid Design Temperature Design Inlet Pressure Operating Temperature Operating Inlet Pressure Operating Exhaust Pressure Pipe Connection ID Pipe Connection Type Pipe Connection Size Pipe Connection Rating Pipe Connection Material Pipe Connection Details (insertion depth, thread depth, etc.) Pipe Connection Movements Pipe Connection Allowable Loads Weight Insulation Requirements Special Requirements for Spatial Location or Piping Design	Stream ID Stream Description Stream Properties: Vapor Fraction Temperature Pressure Flow Molecular Weight Density (Liquid & Vapor) Viscosity Surface Tension Vapor Specific Heat Ratio Vapor Compressibility Stream Constituents  Note: More than one case may exist for Stream Properties and Stream Constituents (e.g., Normal Case, Upset Case)	Case Pressure Rating Seal Type Special Seal Data Driver Power Source Data Overpressure Protection Requirements Minimum Flow Requirements Exposure Design Data (Wind, Earthquake, Sand, Etc) Paint Requirements Driver Speed Gearbox Input Speed Gearbox Output Speed Lube Oil System Type Lube Oil System Pump Data	Requisition Number P.O. Number Vendor Name Schedule Milestone Dates	



Table A.1 - Functional Mapping Matrix - Equipment (continued)

EQUIPMENT TYPE	DATA: N = NEEDED W = WANTED						PROCUREMENT (W)
	PRODUCT ID (N)	SPATIAL (N)	BASIC ENGR (N)	STREAM (N)	DETAILED ENGR (W)	REGULATORY (W)	
Pressure Vessel	Tag or ID Number Description	Spatial Envelope Dimensions Centreline Orientation Centreline Coordinates Bottom Tangent Line Elev. (Vertical Vessel) Tangent Line Coordinates (Horizontal Vessel) Support Point Coordinates Base Ring Diameter (Vertical Vessels) Bottom of Base Ring Elevation (Vertical Vessels) Platform Elevation Platform Orientation Platform Envelope Dimensions Platform Penetration Location and Size Ladder Orientation Ladder Spatial Envelope Dimensions Connection C.L. Coordinates (At Face of Connection) Connection C.L. Orientation Connection Shape Data Connection ID Attachment Location Coordinates Attachment Orientation Attachment Envelope Dimensions Attachment Connection Point Coordinates Operations Space Location, Orientation, Dimensions Maintenance Space Location, Orientation,	Pressure Vessel Type and Description Materials of Construction Fluid Service Names Design Temperature Design Pressure For Each Fluid: Operating Temperature Operating Pressure Cyclic Operating Data Pipe Pipe Connection ID Pipe Connection Type Pipe Connection Size Pipe Connection Projection Pipe Connection Rating Pipe Connection Material Pipe Connection Details (insertion depth, thread depth, etc.) Pipe Connection Movements Pipe Connection Allowable Loads Vessel Weight (Erection, Empty, Operating, Hydrotest) Insulation Requirements Support Data Load per support Support configuration Special Requirements for Spatial Location or Piping Design	For Each Stream: Stream ID Stream Description Stream Properties: Vapor Fraction Temperature Pressure Flow Molecular Weight Density (Liquid & Vapor) Viscosity Surface Tension Vapor Specific Heat Ratio Vapor Compressibility Stream Constituents  Note: More than one case may exist for Stream Properties and Stream Constituents (e.g., Normal Case, Upset Case)	Overpressure Protection Requirements Exposure Design Conditions (Wind, Earthquake, etc.) Design Codes Fabrication Requirements (Heat treatment, etc.) Nozzle schedule (listing) with all pertinent information Design Pressure and Temperature Internals Data Trays Packing Separation Painting Requirements Platform Data		Requisition Number P.O. Number Vendor Name Schedule Milestone Dates

Table A.1 - Functional Mapping Matrix - Equipment (continued)

EQUIPMENT TYPE		DATA: N = NEEDED W = WANTED					REGULATORY (W)	PROCUREMENT (W)
PRODUCT ID (N)	SPATIAL (N)	BASIC ENGR (N)	STREAM (N)	DETAILED ENGR (W)				
Heat Exchanger	Spatial Envelope Dimensions Centreline Orientation Centreline Coordinates Support Point Coordinates Platform Elevation Platform Orientation Platform Envelope Dimensions Platform Penetration Location and Size Ladder Spatial Envelope Ladder Spatial Envelope Dimensions Connection C.L. Coordinates (At Face of Connection) Connection C.L. Orientation Connection Shape Data Connection ID Attachment Location Coordinates Attachment Orientation Attachment Envelope Dimensions Attachment Connection Point Coordinates Operations Space Location, Orientation, Dimensions Maintenance Space Location, Orientation, Dimensions Insulation Thickness	Heat Exchanger Type and Description Materials of Construction Fluid Service Names HOT SIDE Design Temperature/Range Operating Temperatures Operating Pressures Cyclic Design Data COLD SIDE Design Temperature/Range Design Pressure/Range Operating Temperatures Operating Pressures Cyclic Design Data Connection C.L. Coordinates (At Face of Connection) Connection C.L. Orientation Connection Shape Data Connection ID Attachment Location Coordinates Attachment Orientation Attachment Envelope Dimensions Attachment Connection Point Coordinates Operations Space Location, Orientation, Dimensions Maintenance Space Location, Orientation, Dimensions Insulation Thickness	For Each Stream: Stream ID Stream Description Stream Properties: Vapor Fraction Temperature Pressure Flow Molecular Weight Density (Liquid & Vapor) Viscosity Surface Tension Vapor Specific Heat Ratio Vapor Compressibility Stream Constituents Note: More than one case may exist for Stream Properties and Stream Constituents (e.g., Normal Case, Upset Case)	Overpressure Protection Requirements Exposure Design Conditions (Wind, Earthquake, etc.) Design Codes Fabrication Requirements (Heat treatment, etc) Internals Data Trays Packing Separation Etc Painting Requirements Platform Data			Requisition Number P.O. Number Vendor Name Schedule Milestone Dates	

Table A.1 - Functional Mapping Matrix - Equipment (continued)

EQUIPMENT TYPE	DATA: N = NEEDED W = WANTED					REGULATORY (W)	PROCUREMENT (W)
	PRODUCT ID (N)	SPATIAL (N)	BASIC ENGR (N)	STREAM (N)	DETAILED ENGR (W)		
Tank	<p>Tag or ID Number Description</p>	<p>Spatial Envelope Dimensions Centreline Orientation Centreline Coordinates Support Point Coordinates Base Ring Diameter Bottom of Base Ring Elevation Platform Elevation Platform Orientation Platform Envelope Dimensions Platform Penetration Location and Size Ladder Orientation Ladder Spatial Envelope Dimensions Connection C.L. Coordinates (At Face of Connection) Connection C.L. Orientation Connection Shape Data Connection ID Attachment Location Coordinates Attachment Orientation Attachment Envelope Dimensions Attachment Connection Point Coordinates Operations Space Location, Orientation, Dimensions Maintenance Space Location, Orientation, Dimensions Insulation Thickness</p>	<p>Tank Type and Description Materials of Construction Fluid Service Names Design Temperature Design Pressure For Each Fluid: Operating Temperature Operating Pressure Cyclic Operating Data Pipe Pipe Connection ID Pipe Connection Type Pipe Connection Size Pipe Connection Projection Pipe Connection Rating Pipe Connection Material Pipe Connection Details (insertion depth, thread depth, etc.) Pipe Connection Movements Pipe Connection Allowable Loads Tank Weight (Erection, Empty, Operating, Hydrotest) Insulation Requirements Support Data Load per support Support configuration Special Requirements for Spatial Location or Piping Design</p>	<p>For Each Stream: Stream ID Stream Description Stream Properties: Vapor Fraction Temperature Pressure Flow Molecular Weight Density (Liquid &amp; Vapor) Viscosity Surface Tension Vapor Specific Heat Ratio Vapor Compressibility Stream Constituents</p> <p>Note: More than one case may exist for Stream Properties and Stream Constituents (e.g., Normal Case, Upset Case)</p>	<p>Overpressure Protection Requirements Exposure Design Conditions (Wind, Earthquake, etc.) Design Codes Fabrication Requirements (Heat treatment, etc.) Nozzle schedule (listing) with all pertinent information Internals Data Trays Packing Separation Etc Painting Requirements Platform Data</p>	<p>Requisition Number P.O. Number Vendor Name Schedule Milestone Dates</p>	



Table A.1 - Functional Mapping Matrix - Equipment (continued)

EQUIPMENT TYPE	DATA: N = NEEDED W = WANTED						
	PRODUCT ID (N)	SPATIAL (N)	BASIC ENGR (N)	STREAM (N)	DETAILED ENGR (W)	REGULATORY (W)	PROCUREMENT (W)
Silo	Tag or ID Number Description	Spatial Envelope Dimensions Centreline Orientation Centreline Coordinates Support Point Coordinates Base Ring Diameter Bottom of Base Ring Elevation Platform Elevation Platform Orientation Platform Envelope Dimensions Platform Penetration Location and Size Ladder Orientation Ladder Spatial Envelope Dimensions Connection C.L. Coordinates (At Face of Connection) Connection C.L. Orientation Connection Shape Data Connection ID Attachment Location Coordinates Attachment Orientation Attachment Envelope Dimensions Attachment Connection Point Coordinates Operations Space Location, Orientation, Dimensions Maintenance Space Location, Orientation, Dimensions Insulation Thickness	Silo Type and Description Materials of Construction Fluid Service Names Design Temperature Design Pressure Operating Temperature Operating Pressure Cyclic Operating Data Pipe Pipe Connection ID Pipe Connection Type Pipe Connection Size Pipe Connection Projection Pipe Connection Rating Pipe Connection Material Pipe Connection Movements Pipe Connection Details (insertion depth, thread depth, etc.) Pipe Connection Allowable Loads Silo Weight (Erection, Empty, Operating, Hydrotest) Insulation Requirements Support Data Load per support Support configuration Special Requirements for Spatial Location or Piping Design	For Each Stream: Stream ID Stream Description Stream Properties: Vapor Fraction Temperature Pressure Flow Molecular Weight Density (Liquid & Vapor) Viscosity Surface Tension Vapor Specific Heat Ratio Vapor Compressibility Stream Constituents  Note: More than one case may exist for Stream Properties and Stream Constituents (e.g., Normal Case, Upset Case)	Overpressure Protection Requirements Exposure Design Conditions (Wind, Earthquake, etc.) Design Codes Fabrication Requirements (Heat treatment, etc) Nozzle schedule (listing) with all pertinent information		Requisition Number P.O. Number Vendor Name Schedule Milestone Dates



Table A.1 - Functional Mapping Matrix - Equipment (continued)

EQUIPMENT TYPE	DATA: N = NEEDED W = WANTED					PROCUREMENT (W)
	PRODUCT ID (N)	SPATIAL (N)	BASIC ENGR (N)	STREAM (N)	DETAILED ENGR (W)	
Furnace	Tag or ID Number Descriptor	Spatial Envelope Dimensions Natural Centreline Orientation and Coordinates Support Point Coordinates Platform Elevation Platform Orientation Platform Envelope Dimensions Platform Penetration Location and Size Ladder Orientation Ladder Spatial Envelope Dimensions Connection C.L. Coordinates (At Face of Connection) Connection C.L. Orientation Connection Shape Data Connection ID Attachment Location Coordinates Attachment Orientation Attachment Envelope Dimensions Attachment Connection Point Coordinates Operations Space Location, Orientation, Dimensions Maintenance Space Location, Orientation, Dimensions Insulation Thickness	Furnace Type and Description Materials of Construction Fluid Service Names HOT SIDE Design Temperature/Range Design Pressure/Range Operating Temperatures Operating Pressures Cyclic Design Data AIR SIDE Design Temperature/Range Design Pressure/Range Operating Temperatures Operating Pressures Cyclic Design Data AIR SIDE Design Temperature/Range Design Pressure/Range Operating Temperatures Operating Pressures Cyclic Design Data Pipe Design Data Pipe Pipe Connection ID Pipe Connection Type Pipe Connection Size Pipe Connection Projection Pipe Connection Rating Pipe Connection Material Pipe Connection Details (insertion depth, thread depth, etc.) Pipe Connection Movements Pipe Connection Allowable Loads Furnace Weight (Erection, Empty, Operating, Hydrotest) Insulation Requirements Support Data Load per support Support configuration Special Requirements for Spatial Location or Piping Design NOTE: Furnaces may have mechanical equipment such as fans or waste heat	For Each Stream: Stream ID Stream Description Stream Properties: Vapor Fraction Temperature Pressure Flow Molecular Weight Density (Liquid & Vapor) Viscosity Surface Tension Vapor Specific Heat Ratio Vapor Compressibility Stream Constituents  Note: More than one case may exist for Stream Properties and Stream Constituents (e.g., Normal Case, Upset Case)	Overpressure Protection Requirements Exposure Design Conditions (Wind, Earthquake, etc.) Design Codes Fabrication Requirements (Heat treatment, etc.) Nozzle schedule (listing) with all pertinent information Internals Data Trays Packing Separation Etc Painting Requirements Platform Data Burner Safety Management System Description/Code Backfire/Spark Protection Requirements	Regulation Number P.O. Number Vendor Name Schedule Milestone Dates

Table A.1 - Functional Mapping Matrix - Equipment (continued)

DATA: N = NEEDED W = WANTED							
EQUIPMENT TYPE	PRODUCT ID (N)	SPATIAL (N)	BASIC ENGR (N)	STREAM (N)	DETAILED ENGR (W)	REGULATORY (W)	PROCUREMENT (W)
Engine	Tag or ID Number Description	Spatial Envelope Dimensions (Engine and Base Plate) Shaft C.L. Orientation Shaft C.L. Coordinates Elev of Bottom of Base Plate or Support Points Support Point Coordinates Connection C.L. Coordinates (At Face of Connection) Connection C.L. Orientation Connection Shape Coupling Face Coordinates (at Shaft C.L.) Operations Space Envelope Dimensions & Orientation Maintenance Space Envelope Dimensions & Orientation Insulation Dimensions	Engine Type and Description Materials of Construction Reference Specifications Vendor Name Fluid Service Names For Fluid and Exhaust Services: Design Temperature Design Suction Pressure Design Discharge Pressure Operating Temperature Operating Suction Pressure Operating Discharge Pressure Pipe Pipe Connection ID Pipe Pipe Connection Type Pipe Connection Size Pipe Connection Rating Pipe Connection Material Pipe Connection Details (insertion depth, thread depth, etc.) Pipe Connection Movements Pipe Connection Allowable Loads Weight Insulation Requirements Special Requirements for Spatial Location or Piping Design	Stream ID Stream Description Stream Properties Vapor Fraction Temperature Pressure Flow Molecular Weight Density (Liquid & Vapor) Viscosity Surface Tension Vapor Specific Heat Ratio Vapor Compressibility Stream Constituents  Note: More than one case may exist for Stream Properties and Stream Constituents (e.g., Normal Case, Upset Case)	Overpressure Protection Requirements Exposure Design Conditions (Wind, Earthquake, etc.) Design Codes Fabrication Requirements (Heat treatment, etc) Nozzle schedule (listing) with all pertinent information Painting Requirements Platform Data Backfire/spark Protection Requirements		Requisition Number P.O. Number Schedule Milestone Dates

Table A.1 - Functional Mapping Matrix - Equipment (continued)

EQUIPMENT TYPE	DATA: N = NEEDED W = WANTED						
	PRODUCT ID (N)	SPATIAL (N)	BASIC ENGR (N)	STREAM (N)	DETAILED ENGR (W)	REGULATORY (W)	PROCUREMENT (W)
Gearbox	Tag or ID Number Description Connection ID	Spatial Envelope Dimensions Shaft C.L.'s Orientation Shaft C.L.'s Coordinates Elev of Bottom of Base Plate or Support Points Support Point Coordinates Coupling Face Coordinates (at Shaft C.L.'s) Operations Space Envelope Dimensions & Orientation Maintenance Space Envelope Dimensions & Orientation Insulation Dimensions	Gearbox Type and Description Weight		Gear Service Rating Design Reference Code Coupling and Shaft Data Diameter in/out Type of Shaft preparation Coupling Type Lube Oil System Design		Requisition Number P.O. Number Vendor Name Schedule Milestone Dates

Table A.1 - Functional Mapping Matrix - Equipment (continued)

EQUIPMENT TYPE	DATA: N = NEEDED W = WANTED						
	PRODUCT ID (N)	SPATIAL (N)	BASIC ENGR (N)	STREAM (N)	DETAILED ENGR (W)	REGULATORY (W)	PROCUREMENT (W)
Process Ducting	Tag or ID Number Description	Spatial Envelope Dimensions Support Point Coordinates Connection C.L. Coordinates (At Face of Connection) Connection C.L. Orientation Connection Shape Data Connection ID Attachment Location Coordinates Attachment Orientation Attachment Envelope Dimensions Attachment Connection Point Coordinates Operations Space Location, Orientation, Dimensions Maintenance Space Location, Orientation, Dimensions Insulation Thickness	Duct Type and Description Reference Specifications Fluid Service Names Design Temperature Design Pressure Operating Temperature Operating Pressure Materials of Construction Material Thicknesses Weight For Pipe and Duct Connections: Connection ID Connection Type Connection Size Connection Rating Connection Material Connection Details (insertion depth, thread depth, etc.) Connection Movements Connection Allowable Loads Insulation Requirements Special Requirements for Spatial Location or Piping Design	Stream ID Stream Description Stream Properties: Vapor Fraction Temperature Pressure Flow Molecular Weight Density (Liquid & Vapor) Viscosity Surface Tension Vapor Specific Heat Ratio Vapor Compressibility Stream Constituents  Note: More than one case may exist for Stream  Properties and Stream Constituents (e.g., Normal Case, Upset Case)			Requisition Number P.O. Number Vendor Name Schedule Milestone Dates



Table A.1 - Functional Mapping Matrix - Equipment (continued)

EQUIPMENT TYPE	DATA: N = NEEDED W = WANTED					REGULATORY (W)	PROCUREMENT (W)
	PRODUCT ID (N)	SPATIAL (N)	BASIC ENGR (N)	STREAM (N)	DETAILED ENGR (W)		
Materials Handling System	Tag or ID Number Description Connection ID	Spatial Envelope Dimensions Support Point Coordinates Connection C.L. Coordinates (At Face of Connection) Connection C.L. Orientation Connection Shape Data Connection ID Attachment Location Coordinates Attachment Orientation Attachment Envelope Dimensions Attachment Connection Point Coordinates Operations Space Location, Orientation, Dimensions Maintenance Space Location, Orientation, Dimensions Insulation Thickness	Type and Description Reference Specifications Fluid Service Names Design Temperature Operating Pressure Operating Temperature Materials of Construction Weight Connection ID Connection Type Connection Size Connection Rating Connection Material Connection Details (insertion depth, thread depth, etc.) Connection Movements Connection Allowable Loads Insulation Requirements Special Requirements for Spatial Location or Piping Design	Stream ID Stream Description Stream Properties: Vapor Fraction Temperature Pressure Flow Molecular Weight Density (Liquid & Vapor) Viscosity Surface Tension Vapor Specific Heat Ratio Vapor Compressibility Stream Constituents Note: More than one case may exist for Stream Properties and Stream Constituents (e.g., Normal Case, Upset Case)			Requisition Number P.O. Number Vendor Name Schedule Milestone Dates

Table A.1 - Functional Mapping Matrix - Equipment (concluded)

EQUIPMENT TYPE	DATA: N = NEEDED W = WANTED						
	PRODUCT ID (N)	SPATIAL (N)	BASIC ENGR (N)	STREAM (N)	DETAILED ENGR (W)	REGULATORY (W)	PROCUREMENT (W)
Miscellaneous	Tag or ID Number Descriptor	Spatial Envelope Dimensions Support Point Coordinates Connection C.L. Coordinates (At Face of Connection) Connection C.L. Orientation Connection Shape Data Connection ID Attachment Location Coordinates Attachment Orientation Attachment Envelope Dimensions Attachment Connection Point Coordinates Operations Space Location, Orientation, Dimensions Maintenance Space Location, Orientation, Dimensions Insulation Thickness	Equipment Type and Description Reference Specifications Fluid Service Names Design Temperature Design Pressure Operating Temperature Materials of Construction Weight Connection ID Connection Type Connection Size Connection Rating Connection Material Connection Details (insertion depth, thread depth, etc.) Connection Movements Connection Allowable Loads Insulation Requirements Special Requirements for Spatial Location or Piping Design	Stream ID Stream Description Stream Properties: Vapor Fraction Temperature Pressure Flow Molecular Weight Density (Liquid & Vapor) Viscosity Surface Tension Vapor Specific Heat Ratio Vapor Compressibility Stream Constituents Note: More than one case may exist for Stream Properties and Stream Constituents (e.g., Normal Case, Upset Case)			Requisition Number P.O. Number Vendor Name Schedule Milestone Dates

**Table A.2 - Functional Mapping Matrix - Piping Components**

DATA: N=NEEDED W=WANTED									
PIPING TYPE	PRODUCT ID (N)	SPATIAL (N)	BASIC ENGR. (N)	STREAM (N)	DETAILED ENGR.	Constr Data	Regulatory (W)	Procurement	Oper/Maint.
System	System Name (Code) System Description	n/a	Service (Fluid Content)						
Line	Line ID (Line Number)	Route Begin Location End Location	Design Pressure Design Temperature P&ID Reference Flow Direction(s) (@ connect points)	Flow Rate (#/HR) Density (#/CF) Viscosity Fluid Type Specific Gravity	Piping Material Specification (Carbon Steel per ASTM A106 Grade B) Normal Operating Temperature (degrees F) - (330 F) Normal Operating Pressure (psig) - (69.00)				
Spool	Spool Number	Configuration (Shape) Installed Location Orientation	Field or Shop Fabricated Piece Mark Field Weld Locations		Spool Release Sheet Reference Overall Dimensions - Fit in RR Box Car, Flat bed truck, thru plant construction openings? Field weld locations do not fall on support point, close to wall, in floor between levels. Spool Weight	Work Pkg ID Install Status	Marking (N stamp)	Required Delivery Date Fabrication Shop ID Fabrication Status	

Table A.2 - Functional Mapping Matrix - Piping Components (continued)

DATA: N=NEEDED W=WANTED									
PIPING TYPE	PRODUCT ID (N)	SPATIAL (N)	BASIC ENGR. (N)	STREAM (N)	DETAILED ENGR.	Constr Data	Regulatory (W)	Procurement	Oper/Maint.
Pipe	Unique ID Component Type (Pipe)	Shape Location Orientation Connect Data	Nominal Size I Material Category (CS, SS) Schedule/Wt/Wall (Sch 40s) Connection Type (Butt Weld) Class (Spec ID) - (HBD) Engineering Status (Hold, Prelim, IFC)		Material Specification (Carbon Steel per ASTM A106 Grade B) Dimensional Standard (Per ANSI B36.10) Coating (Hot Dipped Galvanized) Lining (Polyvinylidene Chloride Lined) Heat Tracing (Steam or Electric) Insulation Type (Mineral Wool) Insulation Thickness Units of Issue (Double Random Lengths) End Prep (Beveled both ends) Maximum Allowable Stress Minimum Wall Thickness (for Bent Pipe) Ovality Allowance (3%) Weight Per Foot	Work Pkg ID Install Status	Marking (N stamp) per ASME Section III Class 1)	Stock Code Material Requisition ID Purchase Order ID Required Delivery Date Supplier Purchasing Status	
Fitting (1-sized) (Cross) (Cap) (Plug) (Nipple) (Coupling) (Union) (Tee, I-szd Branch) (Elbows and Bends) - The above for fittings plus	Unique ID Component Type	Shape Location Orientation Connect Data	Nominal Size I Material Category (CS, SS) Rating (Class 300) Schedule I (Sched 40, 80, etc.) Connection Type (BW, SW, etc.) Class (Spec ID) - (HBD) Engineering Status (Hold, Prelim, IFC) Bend Radius (LR, SR, 3D, 5D )		Material Specification (Carbon Steel per ASTM A234 WPB) Dimensional Standard (Per ANSI B16.9) Coating (Hot Dipped Galvanized) Lining (Polyvinylidene Chloride Lined) Heat Tracing (Steam or Electric) Insulation Type (Mineral Wool) Insulation Thickness Weight Bend Angle	Work Pkg ID Install Status Ovality Allowance (3%)	Marking (N stamp) per ASME Section III Class I) Minimum Wall Thickness (for Bends)	Stock Code Material Requisition ID Purchase Order ID Required Delivery Date Supplier Purchasing Status	



Table A.2 - Functional Mapping Matrix - Piping Components (continued)

DATA: N=NEEDED W=WANTED									
PIPING TYPE	PRODUCT ID (N)	SPATIAL (N)	BASIC ENGR. (N)	STREAM (N)	DETAILED ENGR.	Constr Data	Regulatory (W)	Procurement	Oper/Maint.
Fitting (2-sized) (Reducer) (Swage) (Reducing Elbow) (Reducing Insert) (Bushing)	Unique ID Component Type	Shape Location Orientation	Nominal Size 1 Nominal Size 2 Material Category (CS, SS) Rating (Class 300) Schedule 1 (Sched 40, 80, etc.) Schedule 2 (Sched XS, XXS, etc.)		Material Specification (Carbon Steel per ASTM A234 WPB) Dimensional Standard (Per ANSI B16.9) Coating (Hot Dipped Galvanized) Lining (Polyvinylidene Chloride Lined) Heat Tracing (Steam or Electric) Insulation Type (Mineral Wool)	Install Status	Marking (N stamp per ASME Section III Class 1)	Stock Code Material Requisition ID Purchase Order ID Required Delivery Date Supplier Purchasing Status	
Branches (Reducing Tee) (Laterals) (Weldolet) (Sockolet) (Elbowlet) (Sweepolet) (Latrolet) (Stub-in) (Threadolet) (Nipolet) (Bossolet) (Wye)			Connection Type 1 (BW, BLE, etc.) Class (Spec ID) - (HBD) Connection Type 2 (THRD, PSE, etc.) Class (Spec ID) - (HBD) Engineering Status (Hold, Prelim, IFC) Branch Angle (Laterals, Stub-in, Latrolet)		Insulation Thickness Reinforced or Unreinforced Branch Connection Weight				
Fitting ('N'-sized) (Reducing Tees -3 sized)	(Same as 2-sized fittings plus)		Nominal Size 'N'						

Table A.2 - Functional Mapping Matrix - Piping Components (continued)

DATA: N=NEEDED W=WANTED									
PIPING TYPE	PRODUCT ID (N)	SPATIAL (N)	BASIC ENGR. (N)	STREAM (N)	DETAILED ENGR.	Constr Data	Regulatory (W)	Procurement	Oper/Maint.
Flanges (Reducing Flange) - All the above for Flanges plus	Unique ID Component Type	Shape Location Orientation Connect Data	Nominal Size 1 Material Category (CS, SS) Flange Rating (Class 300) Schedule 1 (Sched 40, 80, etc.) Class (Spec ID) - (HBD) Connection Type (BW, SW, etc.) Flange Type (Weld-Neck, Slip-on, etc.) Facing Type (RF, FF) Engineering Status (Hold, Prelim, IFC) Straddle (Do bolt holes straddle CL) Orifice Connection Type (SC, SW, etc.) Length (Long Weldneck)		Material Specification (Carbon Steel per ASTM SA105) Dimensional Standard (Per ANSI B16.5) Coating (Hot Dipped Galvanized) Lining (Polyvinylidene Chloride Lined) Heat Tracing (Steam or Electric) Insulation Type (Mineral Wool) Insulation Thickness Face Finish (Smooth 125/250 Ra Facing) Weight Nominal Size 2	Install Status	Marking (Per MSS SP 25)	Stock Code Material Requisition ID Purchase Order ID Required Delivery Date Supplier Purchasing Status	
Mechanical Connector (Victaulic Connection) (Grayloc Connector)	Unique ID Component Type	Shape Location Orientation Connect Data	Nominal Size 1 Maximum Working Pressure (rating)		Vendor ID ( Victaulic) Manufacturer Catalogue Model Number Pipe Ends Separation (gap) Weight				

Table A.2 - Functional Mapping Matrix - Piping Components (continued)

DATA: N=NEEDED W=WANTED									
PIPING TYPE	PRODUCT ID (N)	SPATIAL (N)	BASIC ENGR. (N)	STREAM (N)	DETAILED ENGR.	Constr Data	Regulatory (W)	Procurement	Oper/Maint.
Valve (Relief/Angle Valve) - All the above for Valves plus	Valve Tag ID Unique ID	Shape (Body and Operator) Location Orientation Connect Data	Nominal Size 1 Valve Type (Gate, Globe, Check, etc.) Operator Type (Handwheel, Chain, Motor) Rating (Class 600) Connection Type (Flanged, BW) Material Category (CS, SS) Chain Length (for Chain operated only) Engineering Status (Hold, Prelim, IFC) Angle/Construction Nominal Size 2 Rating 2		Vendor ID (Pacific Valves) Valve Body Material (2.1 1/4 Cr 1/2 Mo Alloy Stl per ASTM A182 Gr F11 Class 2) Stem Type (Extended Stem for Low Temperature Service) Internals Type (Solid Plain Wedge, Welded or Integral Seats) Valve Trim (API 600, Trim 8 (13Cr HB 300 Min & H F Stellite 6 or Equal HB 350 Min) Valve Packing (Graphoil Packing, Braided Top & Bottom Rings, Flex. Middle Rings) Valve Code (API 602, OS&Y, Bolted Bonnet) Operator Actuation Type (Electrical, Pneumatic, etc.) Motor Operator Manufacturer and Catalogue Model Number	Install Status	Marking (N stamp per ASME Section III Class 1)	Stock Code Material Requisition ID Purchase Order ID Required Delivery Date Supplier Purchasing Status	
In-Line Instrument (Flow Element) (Orifice Plate) (Flow Meter Run)	Instrument ID	Shape Location Orientation Connect Data Tap Orientation	Instrument Type Plate Thickness (orifice plate) Bore Diameter		Vendor ID, Model Number Orifice Flange Tap Size Differential Flow Data Required Straight Length Upstream/downstream (meter run) Weight	Install Status		Stock Code Material Requisition ID Purchase Order ID Required Delivery Date Purchasing Status	

Table A.2 - Functional Mapping Matrix - Piping Components (continued)

DATA: N=NEEDED W=WANTED									
PIPING TYPE	PRODUCT ID (N)	SPATIAL (N)	BASIC ENGR. (N)	STREAM (N)	DETAILED ENGR.	Constr Data	Regulatory (W)	Procurement	Oper/Maint.
Specialty Item (Steam Trap) (Expansion Joint) (Strainers) (Eyewash) (Safety Shower) (Cleanout) (Sample Cooler) (Air Eliminator) (Flexible Connector) (Fire Monitor)	Item ID (Equip No.) Item Description Unique ID	Shape (External Geometry) Location Orientation Connect Data	Pressure Rating Nominal Size Material Category (CS, SS) Connection Type Engineering Status (Hold, Prelim, IFC)		Data Sheet ID Data Sheet Pertinent Info (Design/Dim Stds, Stress, Temp, Press, etc.) Manufacturer's Name Model Number Serial Number Special Requirements Weight	Install Status	Marking (N stamp per ASME Section III Class 1)	Stock Code Material Requisition ID Purchase Order ID Required Delivery Date Supplier Purchasing Status	
Gasket (Modeled) (Some CAD systems support modeling of gaskets)	Unique ID	Shape Location Orientation Connect Data	Nominal Size 1 Facing Type (Full Face) Class (Spec ID) - (HBD) Gasket Thickness		Material Specification (Neoprene per ASTM D 1330) Dimensional Standard (Per ANSI/AWWA C111/A21.11)	Install Status		Stock Code Material Requisition ID Purchase Order ID Required Delivery Date Supplier Purchasing Status	



Table A.2 - Functional Mapping Matrix - Piping Components (concluded)

DATA: N=NEEDED W=WANTED									
PIPING TYPE	PRODUCT ID (N)	SPATIAL (N)	BASIC ENGR. (N)	STREAM (N)	DETAILED ENGR.	Constr Data	Regulatory (W)	Procurement	Oper/Maint.
Implied Material (Gaskets - not modeled) (Bolts/Studs/Nuts) (Victaulic Clamps/Bolts)	Unique ID - Implied Parent ID of Implied Rule (This rule assumes a rule defines the number and type of components to be generated)	Location (of Implied Parent)	Nominal Size 1 of Implied Parent Comtype of Implied Parent Bolt Table Ref. (RF 150LB Flgd Joint) (Assumes a table of std. bolt-up requirements exist)		Number of Bolts Required for Joint Bolt Type (Machine Bolt, Stud Bolt) Number and type of nuts/washers required (2 Heavy Hex nuts per ANSI B18.2) Bolt dimensions - Diameter/Length Dimensional Standard Material Specification (Alloy Steel per ASTM A193 B7) Tensile Strength				
Support/Hanger	Hanger/Support Number Unique ID	Geometric Shape Location Orientation of Support Point(s)	Support Type (Anchor,guide, etc.) Attachment Type (Welded, Clamp, Shoe) Engineering Status (Hold, Prelim, IFC) Hanger Detail Sheet Number		Allowable Loads/Forces Data Hanger Parts List (Rod, Clevis, Clamp, Jamb Nut, Extension Piece, Bracket) Model Numbers of Parts in Hanger Parts List Calculation Sheet ID Stress Iso Dwg Number Stiffness Matrix Displacement and Displacement Limits	Install Status	Marking (N stamp per ASME Section III Class I)	Supt Data Sheet ID Supplier Purchasing Status	
Interference	Interference ID	Location Type	ID Interfering Comp 1 ID Interfering Comp 2 ID Interfering Comp 'N'		Reviewed By Justified (Allowable, etc.?)				

Table A.3 - Functional Mapping Matrix - HVAC

DATA: N = NEEDED W = WANTED									
HVAC TYPE	CATEGORY	CLASS	PRODUCT ID (N)	SPATIAL (N)	BASIC ENGR. (N)	STREAM (N)	DETAILED ENGR. (W)	REGULATORY (W)	PROCUREMENT (W)
System	Process Supply Return		System ID Description		Flowrate Temperature Pressure Velocity Insulation Specification (ref)	AIR (HVAC) Composition (ref) Stream Number (ID)			
Duct	Straight Flexible		Component ID	Geometry Data Location Orientation Connections Connection Orientation	Section Type Size Material Thickness		Insulation		
Flow Control	Damper Screen Ventilation Valve	Fire Air	Component ID Description	Geometry Data Location Orientation Connections	Section Type Size Material Thickness				
Fitting	Entry Exit Transition Flexible Connection Elbow Junction  Ogee Joint  Cap	Tee Wye Lateral Cross Tapoff  Flange Coupling Connector	Component ID Description	Geometry Data Location Orientation Connections	Section Type(s) Size(s) Material(s) Thickness(es)				

Table A.3 - Functional Mapping Matrix - HVAC (concluded)

DATA: N = NEEDED W = WANTED									
HVAC TYPE	CATEGORY	CLASS	PRODUCT ID (N)	SPATIAL (N)	BASIC ENGR. (N)	STREAM (N)	DETAILED ENGR. (W)	REGULATORY (W)	PROCUREMENT (W)
Distribution Box			Component ID Description	Geometry Data Location Orientation Connections	Section Type Size Material Thickness				
Equipment	Heater Cooling Coil Fan Coil Fan	Centrifugal Axial	Component ID Description	Geometry Data Location Orientation Connections Connection Locations Connection Orientations	Section Type Size Material Thickness Weight Capacity Motor Horsepower				

Table A.4 - Functional Mapping Matrix - Structural, Civil, and Architectural

TYPE	DATA: N = NEEDED W = WANTED								
	CATEGORY	CLASS	PRODUCT ID (N)	SPATIAL (N)	BASIC ENGR. (N)	STREAM (N)	DETAILED ENGR.	REGULATORY (W)	PROCUREMENT
<b>STRUCTURAL</b>									
Steel Member	Columns Beams Braces  Plates	Gussets Bases	Unique ID	Spatial Envelope Dimensions Exact section Nodes Coordinates Orientation Origin Coordinates Length Load Location Points Exact Shape Holes Location and Shape	Material Section ID Design Code Fire & Safety Code Load Type (pipe and equip) Load Magnitude	N/A	Out of Scope		Out of Scope
Concrete Members	Columns Beams Piers Slabs Foundations Walls			Same as Steel Members	Same as Steel Members				
<b>CIVIL</b>									



Table A.4 - Functional Mapping Matrix - Structural, Civil, and Architectural (continued)

TYPE	DATA: N = NEEDED W = WANTED									
	CATEGORY	CLASS	PRODUCT ID (N)	SPATIAL (N)	BASIC ENGR. (N)	STREAM (N)	DETAILED ENGR.	REGULATORY (W)	PROCUREMENT	
Roadways Terrain Landscape Railways Walks Fences  Environmental Data			Unique ID      N/A	Spatial Envelope Dimensions Location and Orientation  N/A	Road Width Road Maximum Load  Wind Data Storm Data Frost Line Seismic Classification Seasonal Temperature Extremes Seasonal Humidity Extremes	N/A    N/A	Out of scope  Out of scope		Out of scope   Out of scope	
ARCHITECTURAL										

Table A.4 - Functional Mapping Matrix - Structural, Civil, and Architectural (concluded)

TYPE	DATA: N = NEEDED W = WANTED									
	CATEGORY	CLASS	PRODUCT ID (N)	SPATIAL (N)	BASIC ENGR. (N)	STREAM (N)	DETAILED ENGR.	REGULATORY (W)	PROCUREMENT	
Non-structural Building Elements	Walls		Unique ID	Spatial Envelope Dimensions Orientation Origin Coordinates Holes location and shape	Material Design Code Fire and Safety Code Building Code Specification Reference  Same as Walls	N/A	Out of scope		Out of scope	
	Doors		Unique ID	Same as Walls						
	Flooring System		Unique ID	N/A	Material Specification Reference Fire and Safety Code					
	Roofing		Unique ID	Same as Walls	Same as Walls					
	Lighting		Unique ID	Spatial Envelope Dimensions Orientation Origin Coordinates	Same as Walls  Electrical Code					
	Ceiling System		Unique ID	Same as Walls	Same as Walls					

## Annex B

### Summary of Process Plant Test Model Library

#### B.1 Introduction

ISO 10303 is an International Standard for the computer-interpretable representation and exchange of product data. The objective is to provide a neutral mechanism capable of describing product data throughout the life cycle of a product, independent from any particular system. The nature of this description makes it suitable not only for neutral file exchange, but also as a basis for implementing and sharing product databases, and archiving.

AP 221 of ISO 10303 specifies the data structures for the exchange of process plant functional data and its 2D schematic representation. The core of the functional data is the identification and description of the equipment and components within the plant. The functional data defines the composition of the set of equipment and components into systems and sub-systems, and defines connectivity.

AP 225 of ISO 10303 specifies the data structures for the exchange of building structure designs using explicit shape representations. Designs of building structures specify the shape and properties of the structural elements and how the elements are assembled to form the structure. The application protocol addresses the building structure design requirements that support all stages of the life cycle of a building, including design, construction, and maintenance.

AP 227 of ISO 10303 specifies the data structures for the exchange of spatial configuration information of process plants. This spatial configuration information includes the shape, material, and physical arrangement of the piping system components as well as the shape and physical arrangement information for related plant systems that impact the design and layout of the piping systems. The application protocol addresses the piping system information requirements that support the design, fabrication, and maintenance of the piping system.

AP 228 of ISO 10303 specifies the systems which provide heating, ventilation, and air conditioning (HVAC) and is applicable to all buildings using these services. These systems provide the space conditions required to support the activities that take place within buildings. The scope of this application protocol covers the whole project life and includes the HVAC system topology, energy analysis, system networks, detailed design, tendering, planning and information for the commissioning and operation stage.

AP 230 of ISO 10303 is concerned with the steel frame of buildings and similar structures - the system with the function of transmitting the applied loads on the components of the building, including their dead load, to the ground. A key feature will be the close integration of the information concerned with structural analysis, member and connection design, and detailing for fabrication and erection.

AP 231 of ISO 10303 specifies the exchange, archival storage, and sharing of chemical process engineering and design information. This will include the design of chemical processes, process simulations, stream characteristics, unit operations, and design requirements for major process

equipment. The scope of this project includes the information provided in process flow diagrams (PFDs). The PFDs are commonly used as the basis for detailed process design and the development of Piping and Instrumentation Diagrams (P&IDs).

The eventual implementation and use of these data exchange standards by industrial companies, teams and vendors requires that these standards be consistent. Information expressed and implemented in one AP must be compatible and, where appropriate, consistent with similar information expressed in other APs. The AP projects' industrial sponsors recognize the need to have a near-term capability that also provides for long-term inter-operation and sharing of data over the life cycle of the process plant. The AP 227 project team is working with the other process plant AP project teams to harmonize terminology and concepts where appropriate to support these needs.

Initially, a suite of process plant test models and corresponding test cases are being developed to assess the utility and correctness of process plant application reference models, application interpreted models, and proposed application protocols. Eventually, this suite of test models will also be used to assess prototype implementations of APs 221, 225, 227, 228, 230, and 231, and for interoperability assessments.

The process plant test models are theoretical and do not reflect an actual design since all values and geometry exist only to support the test models. They are being derived from the "TRD" training model provided by DuPont Corporation. Details of each test case are provided in clause 3 of this annex. This document will be updated as specifics (model description, test objectives, success criteria, etc.) of each test case are developed.

These test models, when combined, will form an integrated view of an area in a process plant. This integrated view is shown on Figure B.1-1.



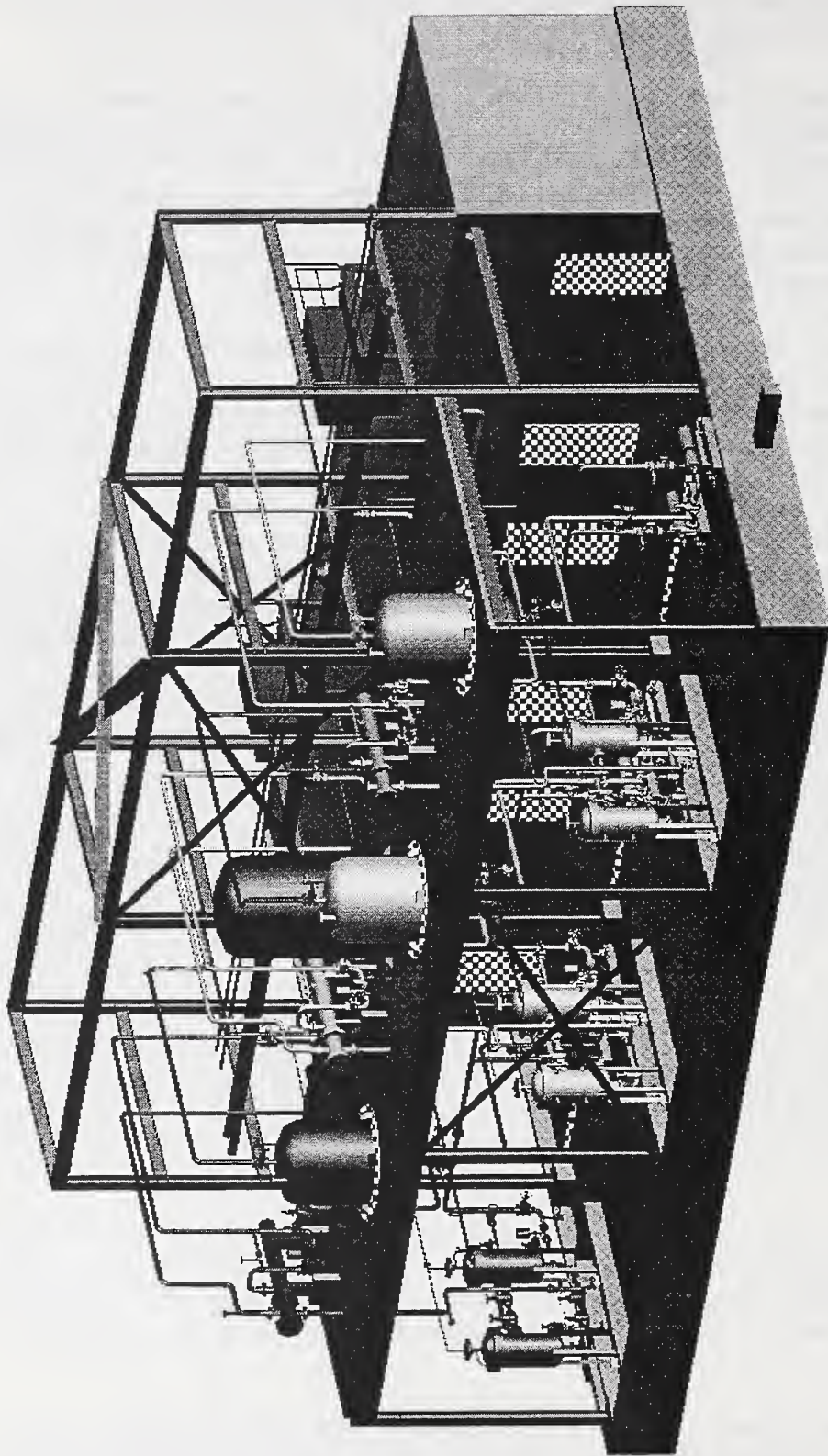

**Figure B.1-1 - Process Plant Integrated View**

## B.2 Summary of Process Plant Test Models

### B.2.1 Purpose

Provide a public domain library of process plant models and corresponding test cases for assessing the utility and correctness of process plant application reference models and proposed application protocols.

### B.2.2 Process Plant Example Models Summary

PPE1:	Simple Piping Arrangement - 3 pipe lines, 1 reserved space, 1 in line equipment
PPE2:	Modification to PPE1 (PPE2.1 = P&ID; PPE2.2 = 3D model) - addition of 1 auxiliary pump and 2 pipe lines
PPE3:	Equipment Spatial Configuration - 2 pieces of equipment with connecting pipe lines
PPE4:	Complex Piping Spatial Configuration - 3 piping systems, multiple reserved spaces, soft and hard clashes
PPE5:	Mechanical Spatial Configuration
PPE6:	Structure Spatial Configuration
PPE7:	HVAC and Electrical Spatial Configuration
PPE8:	Instruments & Controls and Architecture Spatial Configuration
PPE9:	PPE2.2 + PPE3
PPE10:	PPE5 + PPE6 + PPE7 + PPE8
PPE11:	PPE9 + PPE10
PPE12:	PPE4 + PPE11

## B.3 Process Plant Model Examples

### B.3.1 PPE1

Plant Example Title: Simple 3D Piping Arrangement

Date of Last Edit: 28 October 1996

Summary Description: PPE1 consists of the simple piping arrangement shown on Figure B.3.1-1. Included in this arrangement are 3 pipe lines, and 2 inline pieces of equipment (tank and pump). This piping arrangement will be modeled in various 3D CAD systems in order to baseline the ability of each system to identify the known discrepancies in the arrangement.

Notes: This example will include a version for each class of geometry specified in AP 227.

Test objectives:

- TO1: check existence of all components
- TO2: check completeness of component descriptions
- TO3: check accuracy of elevations
- TO4: check continuity of pipe lines
- TO5: check interferences (soft and hard clashes)
- TO6: check material compatibility

Detailed Description (refer to Figure B.3.1-1:

- |     |                  |   |
|-----|------------------|---|
| 1.  | Equipment        | Tank, 10.16 cm flanged nozzle, dimensions as shown in Figure B.3.1-2.   |
| 2.  | Piping component | Valve, 10.16 cm, 67.5 kg, flanged, raised face, 2.54 cm insulation.     |
| 3.  | Piping component | Flange, 10.16 cm, weld neck, 67.5 kg, raised face, 2.54 cm insulation.  |
| 4.  | Piping component | Reducer, 10.16 cm to 7.62 cm concentric, butt weld, 2.54 cm insulation. |
| 5.  | Pipe             | 7.62 cm, butt weld, 2.54 cm insulation.                                 |
| 6.  | Piping component | Elbow, 7.62 cm, 90 degree, butt weld, 2.54 cm insulation.               |
| 7.  | Pipe             | 7.62 cm, butt weld, 2.54 cm insulation.                                 |
| 8.  | Piping component | Elbow, 7.62 cm, 90 degree, butt weld, 2.54 cm insulation.               |
| 9.  | Pipe             | 7.62 cm, butt weld, 2.54 cm insulation.                                 |
| 10. | Piping component | Weldolet to 2.54 cm branch line, butt weld, 2.54 cm insulation.         |
| 11. | Piping component | Elbow, 7.62 cm, 90 degree, butt weld, 2.54 cm insulation.               |
| 12. | Piping component | Flange, 7.62 cm, weld neck, 67.5 kg, raised face, 2.54 cm insulation.   |

## Validation Report for ISO/CD 10303-227

- |     |                  |  |
|-----|------------------|--|
| 13. | Piping component | Valve, 7.62 cm, flanged, raised face, 2.54 cm insulation.                          |
| 14. | Piping component | Flange, 7.62 cm, weld neck, 67.5 kg, raised face, 2.54 cm insulation.              |
| 15. | Pipe             | 7.62 cm, butt weld, 2.54 cm insulation.  |
| 16. | Piping component | Weldolet to 1.27 cm branch line, butt weld, 2.54 cm insulation.                    |
| 17. | Piping component | Elbow, 7.62 cm, 90 degree, butt weld, 2.54 cm insulation.                          |
| 18. | Pipe             | 7.62 cm, butt weld, 2.54 cm insulation.  |
| 19. | Piping component | Reducer, 7.62 cm to 3.81 cm eccentric, butt weld, flat on top, 2.54 cm insulation. |
| 20. | Piping component | Flange, 3.81 cm, weld neck, 67.5 kg, raised face, 2.54 cm insulation.              |
| 21. | Equipment        | Pump, flanged nozzles, dimensions as shown in Figure B.3.1-3.                      |
| 22. | Piping component | Flange, 2.54 cm, weld neck, 67.5 kg, raised face, 2.54 cm insulation.              |
| 23. | Piping component | Reducer, 2.54 cm to 7.62 cm concentric, butt weld, 2.54 cm insulation.             |
| 24. | Piping component | Flange, 7.62 cm, weld neck, 67.5 kg, raised face, 2.54 cm insulation.              |
| 25. | Piping component | Valve, 7.62 cm, flanged, raised face, 67.5 kg, check, 2.54 cm insulation.          |
| 26. | Piping component | Valve, 7.62 cm, flanged, raised face, 67.5 kg, globe, 2.54 cm insulation.          |
| 27. | Piping component | Flange, 7.62 cm, weld neck, 67.5 kg, raised face, 2.54 cm insulation.              |
| 28. | Pipe             | 7.62 cm, butt weld, 2.54 cm insulation.  |
| 29. | Piping component | Elbow, 7.62 cm, 90 degree, butt weld, 2.54 cm insulation.                          |
| 30. | Pipe             | 7.62 cm, butt weld, 2.54 cm insulation.  |
| 31. | Piping component | Orifice flange, 7.62 cm, 135 kg, 2.54 cm insulation.                               |
| 32. | Piping component | Orifice plate, 7.62 cm.  |
| 33. | Piping component | Orifice flange, 7.62 cm, 135 kg, 2.54 cm insulation.                               |

Special Features of Piping Arrangement: None



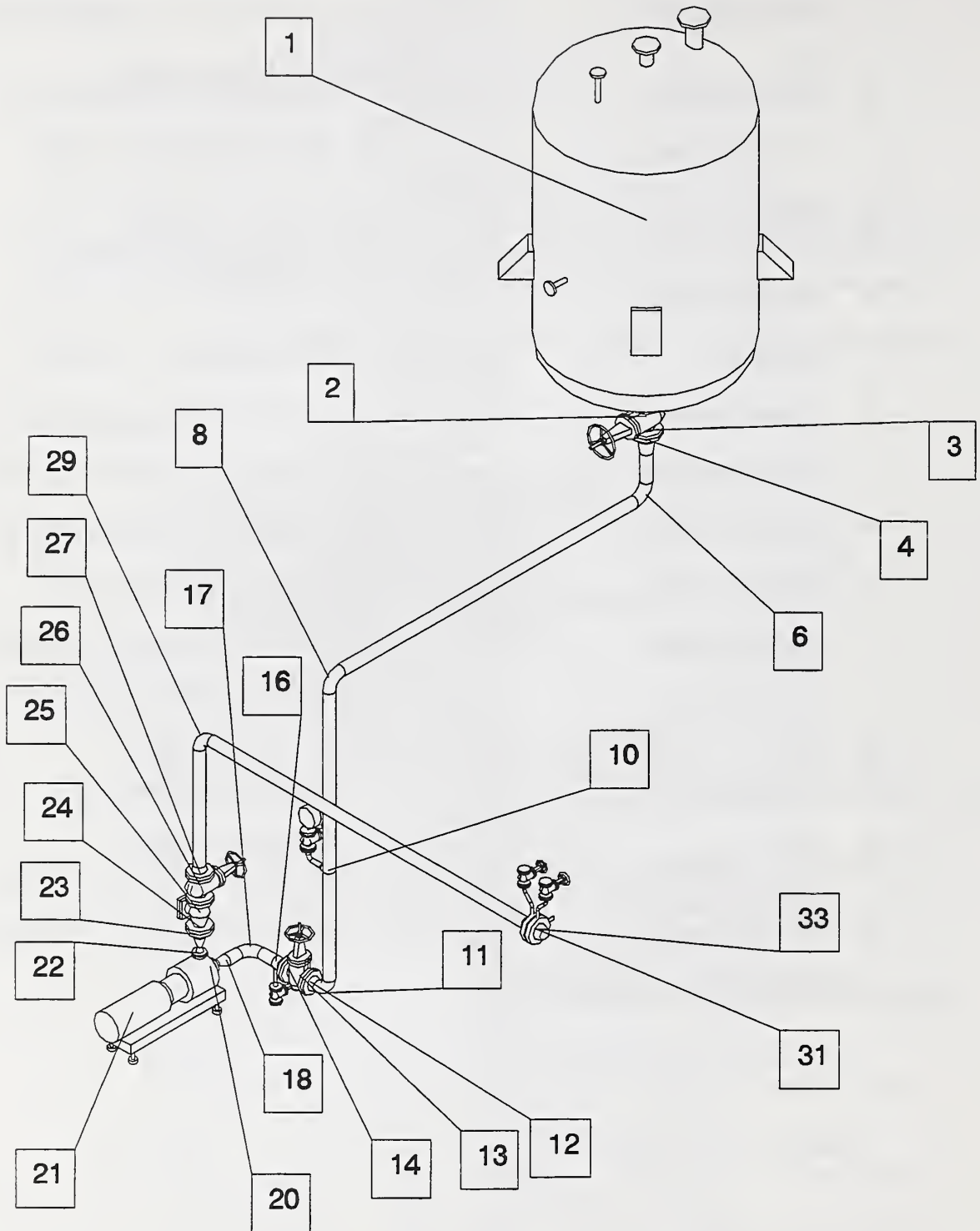

Figure B.3.1-1 - Simple Piping Arrangement - Perspective View

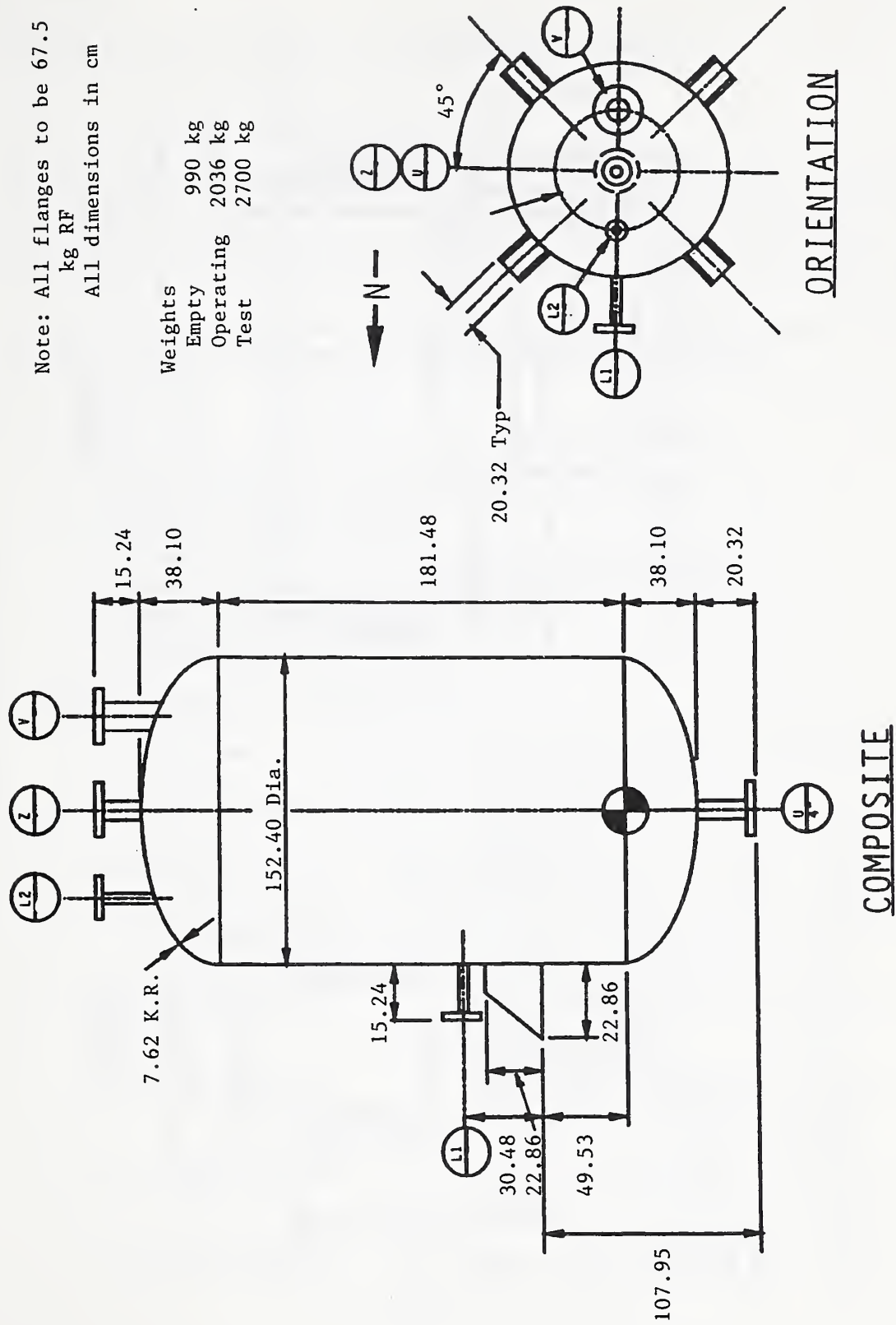

Figure B.3.1-2 - Tank

Note: All flanges to be 67.5 kg RF  
 All dimensions in cm

Weights

Empty N/A  
 Operating N/A  
 Test N/A

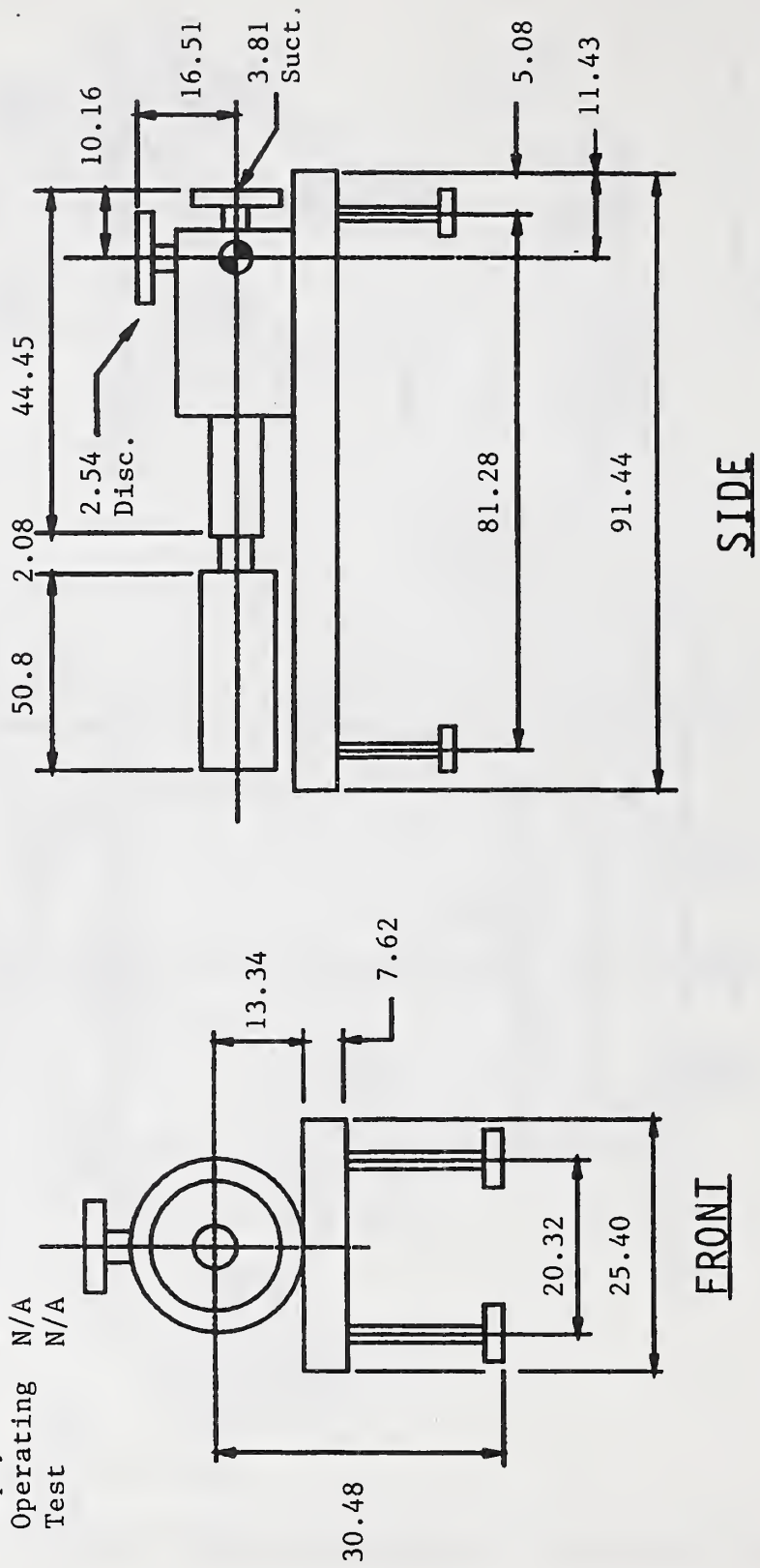

Figure B.3.1-3 - Pump

## B.3.2 PPE2

Plant Example Title: Modification of Simple 3D Piping Arrangement

Date of Last Edit: 28 October 1996

Summary Description: Once the base case model has been established for the 3D CAD system, the testing will proceed to PPE2. PPE2 is a modification of the PPE1 test case. The scenario for PPE2 consists of a modification of the original piping arrangement to add an auxiliary pump and 2 pipe lines so that the new pump can be used if the existing pump is removed from service. Also, a motor removal area for the existing pump (PPE1) and new pump will be added.

The different activities associated with combining the original design information in PPE1 with the PPE 2 modification information are shown on Figures B.3.2-1 and 3.2-2.

Test Objectives:

- TO1: Check existence of all new/modified components
- TO2: Check accuracy of elevations
- TO3: Check continuity of pipe lines
- TO4: Check the ability to remove the existing pump motor
- TO5: check completeness of new/modified component descriptions
- TO6: check interferences (soft and hard clashes)
- TO7: check material compatibility

Detailed Description (refer to Figure B.3.2-3):

- |     |                  |   |
|-----|------------------|---|
| 1.  | Equipment        | Tank, 10.16 cm flanged nozzle, dimensions as shown in Figure B.3.1-2.   |
| 2.  | Piping component | Valve, 10.16 cm, 67.5 kg, flanged, raised face, 2.54 cm insulation.     |
| 3.  | Piping component | Flange, 10.16 cm, weld neck, 67.5 kg, raised face, 2.54 cm insulation.  |
| 4.  | Piping component | Reducer, 10.16 cm to 7.62 cm concentric, butt weld, 2.54 cm insulation. |
| 5.  | Pipe             | 7.62 cm, butt weld, 2.54 cm insulation.                                 |
| 6.  | Piping component | Elbow, 7.62 cm, 90 degree, butt weld, 2.54 cm insulation.               |
| 7.  | Pipe             | 7.62 cm, butt weld, 2.54 cm insulation.                                 |
| 8.  | Piping component | Elbow, 7.62 cm, 90 degree, butt weld, 2.54 cm insulation.               |
| 9.  | Pipe             | 7.62 cm, butt weld, 2.54 cm insulation.                                 |
| 10. | Piping component | Weldolet to 2.54 cm branch line, butt weld, 2.54 cm insulation.         |
| 11. | Piping component | Tee, 7.62 cm, butt weld, 2.54 cm insulation.                            |
| 12. | Piping component | Flange, 7.62 cm, weld neck, 67.5 kg, raised face, 2.54 cm insulation.   |



## Validation Report for ISO/CD 10303-227

13. Piping component Valve, 7.62 cm, flanged, raised face, 2.54 cm insulation.
14. Piping component Flange, 7.62 cm, weld neck, 67.5 kg, raised face, 2.54 cm insulation.
15. Pipe 7.62 cm, butt weld, 2.54 cm insulation.
16. Piping component Weldolet to 1.27 cm branch line, butt weld, 2.54 cm insulation.
17. Piping component Elbow, 7.62 cm, 90 degree, butt weld, 2.54 cm insulation.
18. Piping component Reducer, 7.62 cm to 3.81 cm eccentric, butt weld, flat on top, 2.54 cm insulation.
19. Pipe 3.81 cm, butt weld, 2.54 cm insulation.
20. Piping component Flange, 3.81 cm, weld neck, 67.5 kg, raised face, 2.54 cm insulation.
21. Equipment Pump, flanged nozzles, dimensions as shown in Figure B.3.1-3.
22. Piping component Flange, 2.54 cm, weld neck, 67.5 kg, raised face, 2.54 cm insulation.
23. Piping component Reducer, 2.54 cm to 7.62 cm concentric, butt weld, 2.54 cm insulation.
24. Piping component Flange, 7.62 cm, weld neck, 67.5 kg, raised face, 2.54 cm insulation.
25. Piping component Valve, 7.62 cm, flanged, raised face, 67.5 kg, check, 2.54 cm insulation.
26. Piping component Valve, 7.62 cm, flanged, raised face, 67.5 kg, globe, 2.54 cm insulation.
27. Piping component Flange, 7.62 cm, weld neck, 67.5 kg, raised face, 2.54 cm insulation.
28. Pipe 7.62 cm, butt weld, 2.54 cm insulation.
29. Piping component Weldolet to 2.54 cm branch line, butt weld, 2.54 cm insulation.
30. Piping component Tee, 7.62 cm, butt weld, 2.54 cm insulation.
31. Pipe 7.62 cm, butt weld, 2.54 cm insulation.
32. Piping component Orifice flange, 7.62 cm, 135 kg, 2.54 cm insulation.
33. Piping component Orifice plate, 7.62 cm.
34. Piping component Orifice flange, 7.62 cm, 135 kg, 2.54 cm insulation.
35. Piping component Flange, 7.62 cm, weld neck, 67.5 kg, raised face, 2.54 cm insulation.
36. Piping component Valve, 7.62 cm, flanged, raised face, 2.54 cm insulation.
37. Piping component Flange, 7.62 cm, weld neck, 67.5 kg, raised face, 2.54 cm insulation.
38. Pipe 7.62 cm, butt weld, 2.54 cm insulation.
39. Piping component Weldolet to 1.27 cm branch line, butt weld, 2.54 cm insulation.
40. Piping component Elbow, 7.62 cm, 90 degree, butt weld, 2.54 cm insulation.

41.	Piping component	Reducer, 7.62 cm to 3.81 cm eccentric, butt weld, flat on top, 2.54 cm insulation.
42.	Pipe	1-1/5.08 cm, butt weld, 2.54 cm insulation.
43.	Piping component	Flange, 3.81 cm, weld neck, 67.5 kg, raised face, 2.54 cm insulation.
44.	Equipment	Pump, flanged nozzles, dimensions as shown in Figure B.3.1-3.
45.	Piping component	Flange, 2.54 cm, weld neck, 67.5 kg, raised face, 2.54 cm insulation.
46.	Piping component	Reducer, 2.54 cm to 7.62 cm concentric, butt weld, 2.54 cm insulation.
47.	Piping component	Flange, 7.62 cm, weld neck, 67.5 kg, raised face, 2.54 cm insulation.
48.	Piping component	Valve, 7.62 cm, flanged, raised face, 67.5 kg, check, 2.54 cm insulation.
49.	Piping component	Valve, 7.62 cm, flanged, raised face, 67.5 kg, globe, 2.54 cm insulation.
50.	Piping component	Flange, 7.62 cm, weld neck, 67.5 kg, raised face, 2.54 cm insulation.
51.	Pipe	7.62 cm, butt weld, 2.54 cm insulation.
52.	Piping component	Elbow, 7.62 cm, 90 degree, butt weld, 2.54 cm insulation.
53.	Pipe	7.62 cm, butt weld, 2.54 cm insulation.

Special Features of Piping Arrangement:

1. New pump will be located within the motor removal area for the existing pump for verification of interference checking capability.

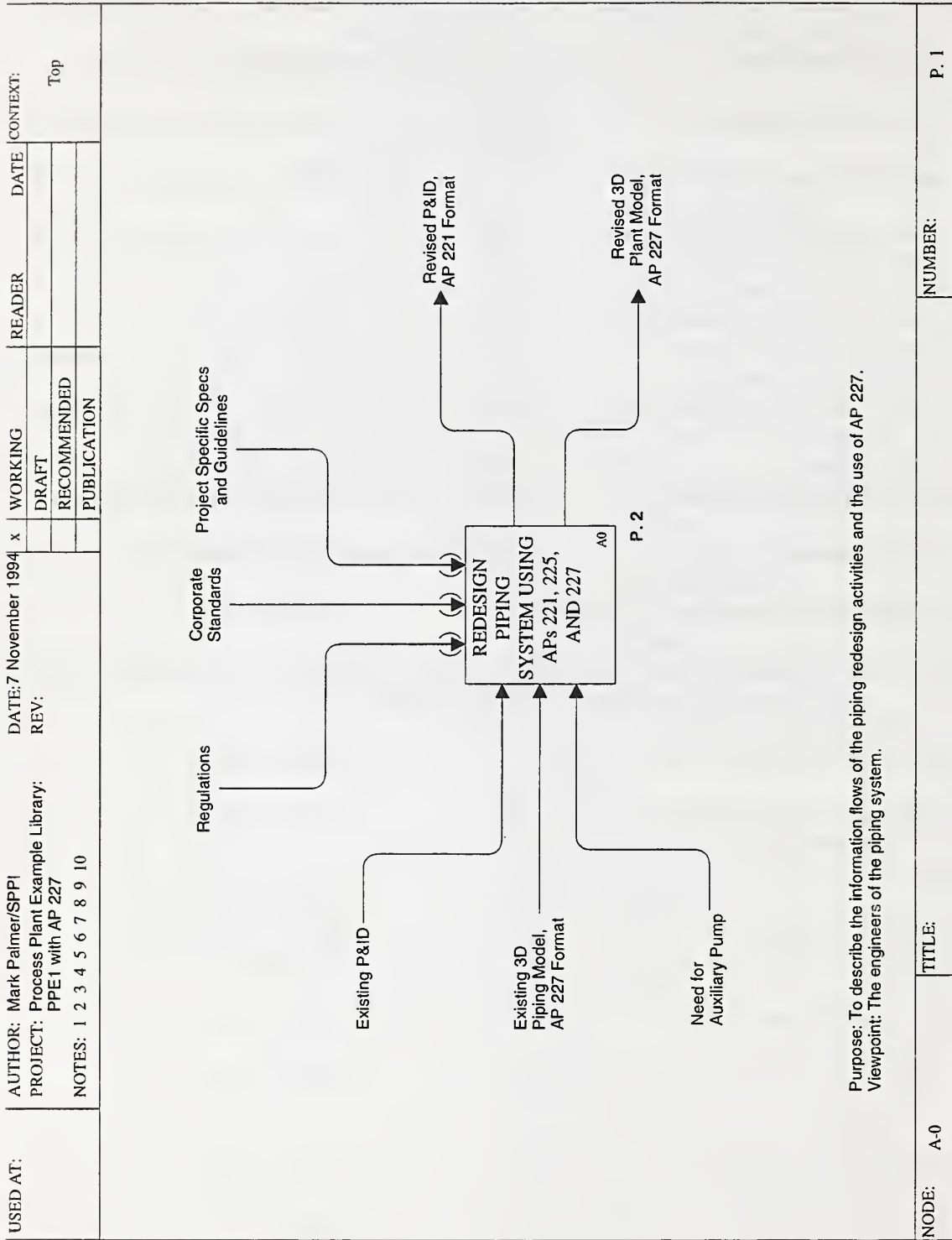
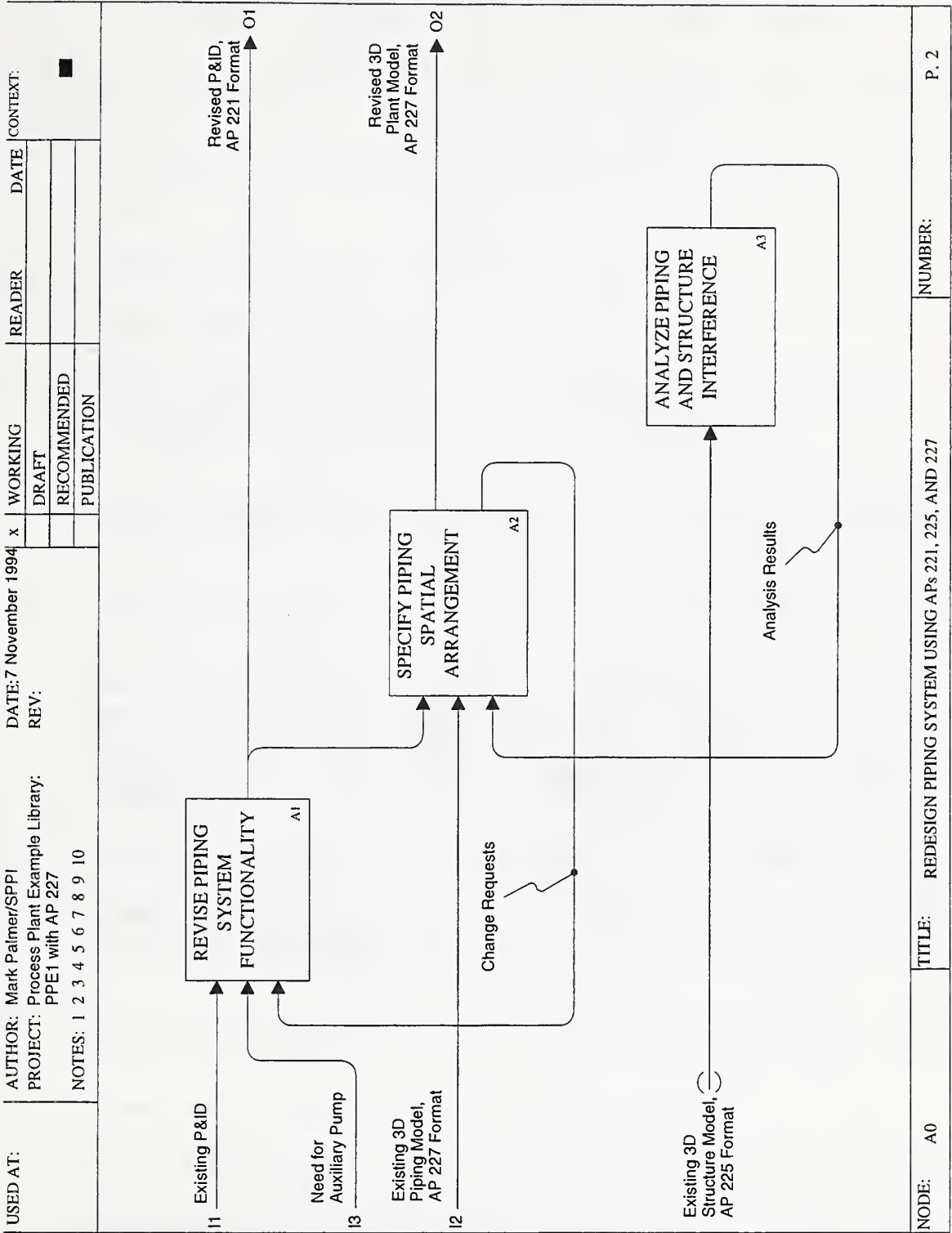

Figure B.3.2-1 - A-0: Redesign of Piping System in IDEF0



NODE: A0      TITLE: REDESIGN PIPING SYSTEM USING APs 221, 225, AND 227      NUMBER: P. 2

**Figure B.3.2-2 - A0: Redesign Piping System Using AP 221/AP 225/AP 227 in IDEF0**



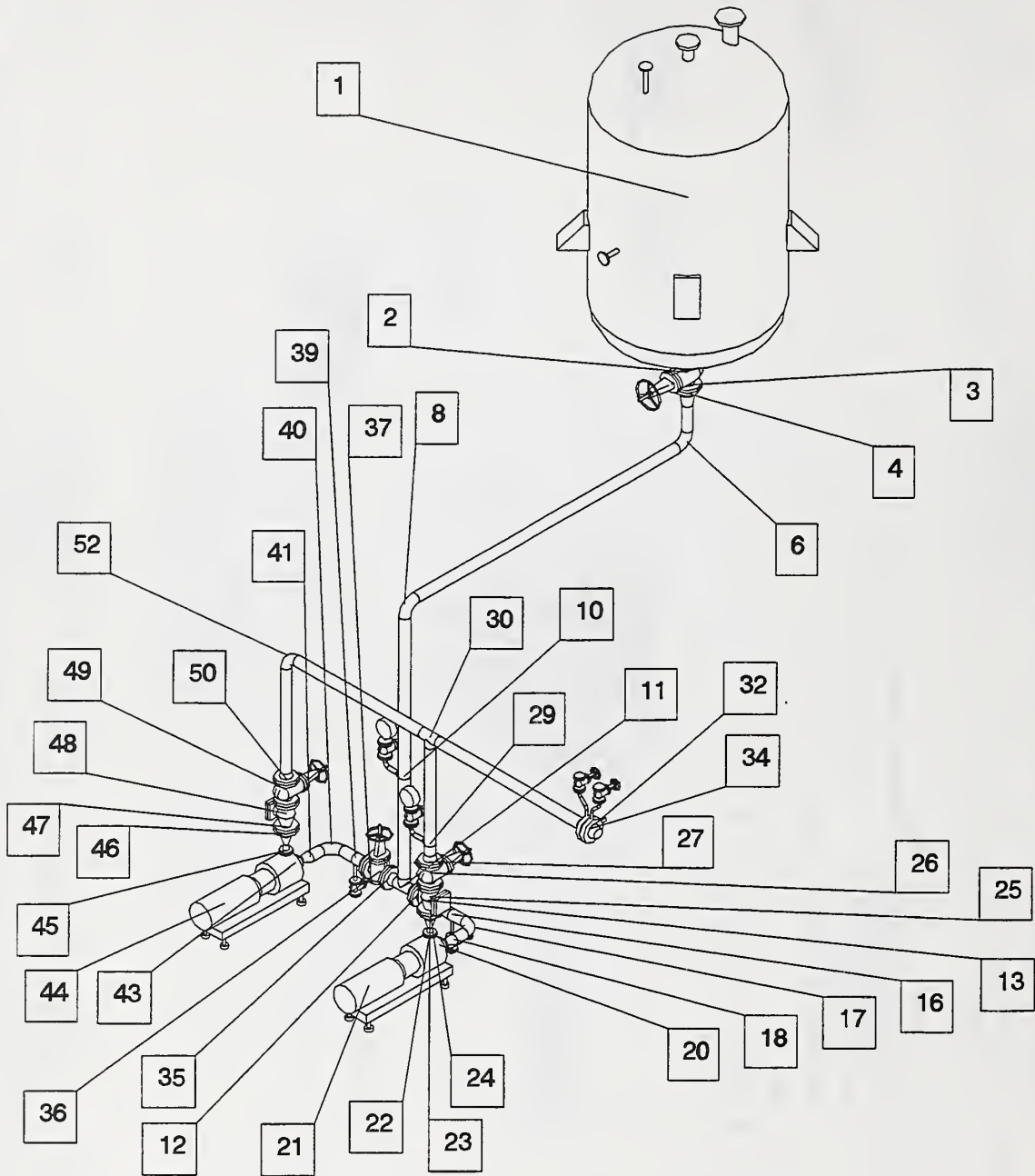

Figure B.3.2-3 - Modified Piping Arrangement - Perspective View

## Annex C

### Summary of Original Twenty Three Usage Scenarios

The following is the list of data exchange scenarios identified by the PlantSTEP project team on 13 April 1994.

- S1 Technical Specification (detailed) interchange between owner and designer in timely manner.
- S2 Interdepartmental or interdisciplinary information exchange.
- S3 Engineer transfer pipe design data to pipe fabricator.
- L4 Owner revamps portion of existing process with new process; puts together initial conceptual engineering package; needs input from existing site personnel, internal engineering resources and resources from external engineering firm.
- S5 Locate foundations. Foundation design is performed by Structural Group using a dedicated software system. Structural Engineering Group provides foundation configuration and design data to Plant Layout Group. Plant Layout Group places foundations in plant model.
- L6 Ongoing exchange between design and construction or fabricators. Purposes: plan rigging, modifications/changes.
- L7 Owner engineering staff doing conceptual design work for project in China; local law requires that AE firm is agency of Chinese government. Problem flow: language difficulties, ignorance of local codes/customs by owners/engineers (AE firm wanted to know what a purchase order was), lack of understanding of quality of locally supplied components.
- L8 Retrofit an old plant with a new process; fitting new process within an old building.
- S9 Procurement cycle; specification and acquisition, bidding, revisions to expected weights, characteristics, materials. Interchange between engineering, procurement, and vendors; for all products, e.g., control valves, pumps; almost standard, but not quite!
- S10 Exchange from construction firm back to engineering (AE); recommendations to modify structures for constructability.
- L11 Exchange/review or change of vendor drawings/data internally between disciplines.
- L12 Intercompany exchange, e.g., exchanging site information, joint decision about how plant is to be laid out/coordination. Identification of interface points, merging the design activity.
- S13 Engineering firm exchanges hazards and safety data with boiler and machinery insurance firm.

## Validation Report for ISO/CD 10303-227

- L14 Owners using outside (prime) engineering firm to put in new plant; decide on design system; later, bring in new company with different system brought in for major part of the plant. Plant site wish to take ownership of database after construction. Need to import/incorporate third party data.
- L15 Design and place Mechanical Equipment. Mechanical equipment (rotating and fixed) is specified and designed by multiple internal and external groups. A model of the equipment (detailed or outline) is either developed by or provided to the Plant Layout Group for inclusion in the plant model. The equipment model data may be either functional or physical or both.
- S16 Delivery of design data to regulatory authorities for approval or certification (permitting).
- S17 AE firm relies on vendor for pressure vessel design. Information arrives too late to support piping and structural design.
- L18 Exchange of information between construction management (CM), AE, and owner.
- S19 CM re-engineers things that don't work. Needs to provide feedback to AE/owner. Erectors request for redesign. As-built.
- S20 Assessment of compliance for new environmental and safety requirements for existing plant between owner and regulatory authority.
- L21 Layout Plant Piping Systems. P&ID and related data and system functional definitions are used to define and develop the physical piping system designs. Specific physical and functional data for parts (pipe, fittings, valves, instruments, etc.) are provided by multiple parties to assemble the physical piping designs.
- S22 Fabricate Structural Steel. Structural design is provided to fabricator. Fabricator performs detailed design for connections and provides fabricated steel and erection drawings to constructor.
- L23 Multi-party consortium, performing different functions, e.g., structural design, nuclear steam supply system (NSSS) design, and balance-of-plant (BOP) design. Exchange of information in support of an efficient work process.

### Legend:

S = specialized, narrow-focus scenario

L = large, general-purpose scenario

## Annex D

### Bibliography

- [1] ISO TC184/SC4/WG3 N442, *Part 227: Application Protocol: Plant Spatial Configuration*, 16 October 1995.
- [2] ISO 10303-1:1994, *Industrial automation systems and integration - Product data representation and exchange - Part 1: Overview and fundamental principles*.
- [3] *Federal Information Processing Standards Publication 183, Integration Definition for Function Modeling (IDEF0)*, FIPS PUB 183, National Institute of Standards and Technology, December 1993.
- [4] ISO 10303-11:1994, *Industrial automation systems and integration - Product data representation and exchange - Part 11: Description methods: The EXPRESS language reference manual*.
- [5] *Federal Information Processing Standards Publication 184, Integration Definition for Information Modeling (IDEFIX)*, FIPS PUB 184, National Institute of Standards and Technology, December 1993.
- [6] Nijssen, G. M. and Halpin, T. A.; *Conceptual Schema and Relational Database Design: A Fact Oriented Approach*, Prentice Hall, 1989.
- [7] ISO 10303-41:1994, *Industrial automation systems and integration - Product data representation and exchange - Part 41: Integrated generic resources: Fundamentals of product description and support*.







