



Calhoun: The NPS Institutional Archive
DSpace Repository

Theses and Dissertations

1. Thesis and Dissertation Collection, all items

2017-12

A roadmap of the future of mine countermeasures

Archambault, Deana; Baxter, Tina; Boxerman, Jason;
Harrington, Christopher; Hawkins, Lauren; Johnson,
Susan; Mitchell, Benjamin; Winsett, Lisa

Monterey, California: Naval Postgraduate School

<http://hdl.handle.net/10945/56762>

Downloaded from NPS Archive: Calhoun



Calhoun is a project of the Dudley Knox Library at NPS, furthering the precepts and goals of open government and government transparency. All information contained herein has been approved for release by the NPS Public Affairs Officer.

Dudley Knox Library / Naval Postgraduate School
411 Dyer Road / 1 University Circle
Monterey, California USA 93943

<http://www.nps.edu/library>



NAVAL POSTGRADUATE SCHOOL

MONTEREY, CALIFORNIA

SYSTEMS ENGINEERING CAPSTONE PROJECT REPORT

**A ROADMAP OF THE FUTURE OF MINE
COUNTERMEASURES**

by

Deana Archambault, Tina Baxter, Jason Boxerman,
Christopher Harrington, Lauren Hawkins, Susan Johnson,
Benjamin Mitchell, and Lisa Winsett

December 2017

Project Advisors:

Eugene Paulo
Gregory Miller
Paul Beery
Rick Williams

Approved for public release. Distribution is unlimited.

Reissued 27 Sep 2018 to reflect updated abstract on pages i and v.

THIS PAGE INTENTIONALLY LEFT BLANK

REPORT DOCUMENTATION PAGE			Form Approved OMB No. 0704-0188	
Public reporting burden for this collection of information is estimated to average 1 hour per response, including the time for reviewing instruction, searching existing data sources, gathering and maintaining the data needed, and completing and reviewing the collection of information. Send comments regarding this burden estimate or any other aspect of this collection of information, including suggestions for reducing this burden, to Washington headquarters Services, Directorate for Information Operations and Reports, 1215 Jefferson Davis Highway, Suite 1204, Arlington, VA 22202-4302, and to the Office of Management and Budget, Paperwork Reduction Project (0704-0188) Washington, DC 20503.				
1. AGENCY USE ONLY (Leave blank)	2. REPORT DATE December 2017	3. REPORT TYPE AND DATES COVERED Capstone project report		
4. TITLE AND SUBTITLE A ROADMAP OF THE FUTURE OF MINE COUNTERMEASURES			5. FUNDING NUMBERS	
6. AUTHOR(S) Deana Archambault, Tina Baxter, Jason Boxerman, Christopher Harrington, Lauren Hawkins, Susan Johnson, Benjamin Mitchell, and Lisa Winsett				
7. PERFORMING ORGANIZATION NAME(S) AND ADDRESS(ES) Naval Postgraduate School Monterey, CA 93943-5000			8. PERFORMING ORGANIZATION REPORT NUMBER	
9. SPONSORING /MONITORING AGENCY NAME(S) AND ADDRESS(ES) N/A			10. SPONSORING / MONITORING AGENCY REPORT NUMBER	
11. SUPPLEMENTARY NOTES The views expressed in this thesis are those of the author and do not reflect the official policy or position of the Department of Defense or the U.S. Government. IRB number ___N/A___.				
12a. DISTRIBUTION / AVAILABILITY STATEMENT Approved for public release. Distribution is unlimited.			12b. DISTRIBUTION CODE	
13. ABSTRACT (maximum 200 words) As the U.S. Navy plans to retire the legacy mine countermeasures (MCM) systems in the mid-2020s, it has become evident that the Navy has a need to evaluate its MCM posture for the 2040 timeframe and beyond. This report investigates the current and projected mine warfare (MIW) threat and associated enabling technologies to formulate the 2040 MCM scenario. Analysis of the 2040 scenario reveals several capability gaps that are utilized to formulate two overarching goals for future MCM systems: 1) reduce the MCM timeline and 2) improve the probability of mine detection. To resolve the capability gaps and attain the future MCM goals, a functional architecture is presented, and five key technologies that enable significant improvements are examined. To determine how the U.S. Navy will attain the future functional architecture, time-dependent extrapolations of the five enabling technologies determine the expected performance and potential shortcomings that will need to be addressed in order for the systems to mature in stride with future needs.				
14. SUBJECT TERMS mine countermeasures, mine warfare, capability gaps, mine countermeasure goals, 2040 timeframe, roadmap, trend lines			15. NUMBER OF PAGES 165	
			16. PRICE CODE	
17. SECURITY CLASSIFICATION OF REPORT Unclassified	18. SECURITY CLASSIFICATION OF THIS PAGE Unclassified	19. SECURITY CLASSIFICATION OF ABSTRACT Unclassified	20. LIMITATION OF ABSTRACT UU	

THIS PAGE INTENTIONALLY LEFT BLANK

Approved for public release. Distribution is unlimited.

A ROADMAP OF THE FUTURE OF MINE COUNTERMEASURES

Submitted in partial fulfillment of the
requirements for the degrees of

MASTER OF SCIENCE IN SYSTEMS ENGINEERING

Tina Baxter
Jason Boxerman

Christopher Harrington
Lauren Hawkins
Susan Johnson

Benjamin Mitchell
Lisa Winsett

and

MASTER OF SCIENCE IN ENGINEERING SYSTEMS

Deana Archambault

from the

**NAVAL POSTGRADUATE SCHOOL
December 2017**

Lead editor: Deana Archambault

Reviewed by:
Eugene Paulo
Project Advisor

Gregory Miller
Project Advisor

Paul Beery
Project Advisor

RDML Rick Williams, Ret.
Project Advisor

Accepted by:
Ronald Giachetti
Chair, Systems Engineering Department

THIS PAGE INTENTIONALLY LEFT BLANK

ABSTRACT

As the U.S. Navy plans to retire the legacy mine countermeasures (MCM) systems in the mid-2020s, it has become evident that the Navy has a need to evaluate its MCM posture for the 2040 timeframe and beyond. This report investigates the current and projected mine warfare (MIW) threat and associated enabling technologies to formulate the 2040 MCM scenario. Analysis of the 2040 scenario reveals several capability gaps that are utilized to formulate two overarching goals for future MCM systems: 1) reduce the MCM timeline and 2) improve the probability of mine detection. To resolve the capability gaps and attain the future MCM goals, a functional architecture is presented, and five key technologies that enable significant improvements are examined. To determine how the U.S. Navy will attain the future functional architecture, time-dependent extrapolations of the five enabling technologies determine the expected performance and potential shortcomings that will need to be addressed in order for the systems to mature in stride with future needs.

THIS PAGE INTENTIONALLY LEFT BLANK

TABLE OF CONTENTS

I.	INTRODUCTION.....	1
A.	BACKGROUND	1
B.	GOALS, OBJECTIVE, AND SCOPE	2
C.	SYSTEMS ENGINEERING APPROACH	3
II.	CONCEPT OF OPERATIONS DEVELOPMENT.....	7
A.	CURRENT THREAT	7
1.	Contact Mines.....	8
2.	Influence Mines and Their Sensors	11
3.	Maritime Improvised Explosive Devices (MIED)	17
B.	CURRENT MIW DOCTRINE REVIEW	18
C.	TECHNOLOGY ENABLERS	23
1.	C4I	24
2.	Sensors	42
3.	Platforms and Vehicles	50
D.	2040 SCENARIO OVERVIEW.....	54
1.	Bounding the Problem.....	54
2.	Scenario Introduction.....	56
III.	SYSTEMS ARCHITECTURE	61
A.	CAPABILITY GAPS.....	61
1.	Gaps and Corresponding Objectives	62
2.	Capability Timeline Diagram	69
B.	FUNCTIONAL ARCHITECTURE	73
1.	MCM Mission Decomposition Overview	73
2.	Functional Description	76
3.	Functional Flow Block Diagrams	79
C.	SELECTED KEY TECHNOLOGIES.....	86
1.	Number of Autonomous Systems Working in a Team.....	86
2.	Energy Storage	89
3.	Sensor Range and Resolution	94
4.	Post Mission Analysis (PMA) / Automatic Target Recognition (ATR)	96
5.	Acoustic Communications (ACOMMS) Bandwidth.....	99

IV.	TECHNOLOGY TRENDS	101
A.	CAPTURING TRENDS AND PREDICTING FUTURE PERFORMANCE	101
1.	Number of Autonomous Systems Working in a Team	101
2.	Energy Storage	103
3.	Sensor Range and Resolution	105
4.	Post Mission Analysis (PMA) / Automatic Target Recognition (ATR)	110
5.	Acoustic Communications Bandwidth	112
B.	EVOLUTION OF TECHNOLOGIES THROUGH 2040	116
V.	SUMMARY AND FUTURE WORK	121
A.	CONCLUSIONS FROM ANALYSIS	121
B.	AREAS FOR FUTURE RESEARCH	123
	APPENDIX. TECHNOLOGY ADVANCEMENT ROADMAP	125
	LIST OF REFERENCES	127
	INITIAL DISTRIBUTION LIST	139

LIST OF FIGURES

Figure 1.	Tailored Systems Engineering Approach.	4
Figure 2.	U.S. Navy Casualties and Associated Method of Attacks in World War II. Source: PEO LMW (2009).	8
Figure 3.	A German Contact Mine Laid in Australian Waters during WWII. Source: Australian War Memorial (n.d.).	9
Figure 4.	Figure of Hertz Horn. Source: LaGrone (2014).	10
Figure 5.	Damage to the USS Tripoli after Striking a Contact Mine during Desert Storm. Source: Gawlowicz (1991).	11
Figure 6.	Influence Type Bottom Mine. Source: U.S. Navy (2002).	13
Figure 7.	Partially Buried Manta Mine. Source: Harpgamer: Naval Wargaming Community (2009).	14
Figure 8.	USS Princeton (CG-59) Damage. Source: Navysite (n.d.).	15
Figure 9.	Russian MDS-1. Source: Proshkin (n.d.).	16
Figure 10.	Russian Moored Homing Mine. Source: Proshkin (n.d.).	16
Figure 11.	AN/SLQ-48. Source: Andrews (2014).	19
Figure 12.	MCM 1 – Detect to Neutralize. Source: Frank et al. (2014).	20
Figure 13.	MH-53E – Detect and Classify. Source: Frank et al. (2014).	21
Figure 14.	MCM 1 Mine Warfare Ship and MH-53E Helicopter. Source: Martens (2007).	22
Figure 15.	LCS and MH-60S in Operation. Source: Selinger (2016).	23
Figure 16.	Command and Control Information Exchange. Source: JP6-0 (1995).	25
Figure 17.	Fog Computing. Source: OpenFog Consortium (2017).	28
Figure 18.	Future MIW Communications. Source: Oats (2010).	32
Figure 19.	Navy Wideband SATCOM Growth. Source: Glover (2016).	33
Figure 20.	Navy SATCOM Migration. Source: Glover (2016).	34

Figure 21.	PMW-170 Satellite Communications Roadmap. Source: Wagner (2017).....	35
Figure 22.	PMW-170 Tactical Communications Roadmap. Source: Wagner (2017).....	37
Figure 23.	PMW-170 Position Navigation and Timing Systems Roadmap. Source: Wagner (2017).....	38
Figure 24.	Conventional Side-Scan Sonar Resolution. Source: Blomberg (2015).....	44
Figure 25.	SAS Aperture Length Limitation. Source: Blomberg (2015).....	45
Figure 26.	SAS Image Resolution and Frequency Dependence. Source: Blomberg (2015).....	46
Figure 27.	SAS Image Resolution and Receiver Element Size. Source: Blomberg (2015).....	47
Figure 28.	SAS Range Limitations. Source: Blomberg (2015).....	48
Figure 29.	AUV Docking Station. Source: MBARI (2017).....	53
Figure 30.	Sea Mine Types. Source: <i>ThinkDefence</i> (n.d.)	55
Figure 31.	Expanded View of 2020 Timeframe.....	70
Figure 32.	Expanded View of 2030 Timeframe.....	71
Figure 33.	Expanded View of 2040 Timeframe.....	72
Figure 34.	MIW Functional Decomposition Diagram	73
Figure 35.	Active and Passive MCM Functional Decomposition Diagram.....	75
Figure 36.	Mine Hunting Functional Decomposition	77
Figure 37.	MCM Activity Identification and Tracing.....	81
Figure 38.	Overarching MCM Operations FFBD	83
Figure 39.	Mine Hunting FFBD.....	83
Figure 40.	Mine Identification FFBD.....	84
Figure 41.	Mine Neutralization FFBD	85

Figure 42.	Legacy Mine Hunt Activities (Serial).....	87
Figure 43.	Legacy Mine Identification (Serial).....	88
Figure 44.	Legacy Mine Neutralize Activities (Serial)	88
Figure 45.	Future MCM Activities (Parallel).....	88
Figure 46.	Specific Energy and Specific Power of Rechargeable Batteries. Source: Battery University (2016).....	92
Figure 47.	Proposed Future Mine Countermeasures Activities	98
Figure 48.	UUVs Communicating via ACOMMS. Source: Naval Drones (2012).....	100
Figure 49.	Lithium-ion Energy Density Trend Lines. Source: Takeshita (2006).	104
Figure 50.	Estimation of Future Lithium-ion Energy Storage	104
Figure 51.	Compared and Unified Lithium-ion Energy Density Projections. Source: Peirano and Sigrist (2014).	105
Figure 52.	SAS Image versus Traditional Side Scan Sonar Image. Source: Florin et al. (2004).	107
Figure 53.	Sensor Resolution at 100 m.	108
Figure 54.	Sensor Range at 1 cm Resolution.	109
Figure 55.	Error Rate in Facial Recognition by Year.....	111
Figure 56.	Sonar ATR Error by Year	111
Figure 57.	Stojanovic's Results: Bandwidth vs. Range. Source: Stojanovic (2006).....	113
Figure 58.	ACOMMS Extrapolation Group 0 through 1000 Meters	115
Figure 59.	ACOMMS Extrapolation Group 1001 through 2000 Meters	115
Figure 60.	ACOMMS Extrapolation Group 3501 through 6000 Meters	116
Figure 61.	Technology Advancement Roadmap	125

THIS PAGE INTENTIONALLY LEFT BLANK

LIST OF TABLES

Table 1. MCM Capability Gap Sources.....61

Table 2. MCM Capability Gap Objectives63

THIS PAGE INTENTIONALLY LEFT BLANK

LIST OF ACRONYMS AND ABBREVIATIONS

3D	three dimensional
AC2	assured command and control
ACOMMS	acoustic communications
AEHF	Advanced Extremely High Frequency
AI	artificial intelligence
ALM	autonomous loitering mine
ALMDS	Airborne Laser Mine Detection System
AMNS	Airborne Mine Neutralization System
AOA	amphibious objective area
AOR	area of responsibility
ASW	anti-submarine weapon
ATR	automatic target recognition
AUV	autonomous underwater vehicle
AWS	Amazon Web Services
BLOS	beyond line of sight
C2	command and control
C4I	command, control, communications, computers, and intelligence
CCM	counter-countermeasures
CoCoRo	Collective Cognitive Robotics
CONOPS	concept of operations
COP	common operational picture
COTS	commercial-off-the-shelf
D/C/I	Detection/Classification/Identification
DISA	Defense Information Systems Agency
DOD	Department of Defense
DOTMLPF-P	doctrine, organization, training, materiel, leadership, personnel, facilities, and policy
DSCS	Defense Satellite Communications System
DTE	detect-to-engage
EMI	electromagnetic interference

EOD	Explosive Ordnance Disposal
ePO	ePolicy Orchestrator
ESB	Expeditionary Sea Base
ExMCM	Expeditionary Mine Countermeasures
FFBD	functional flow block diagram
GIG	Global Information Grid
GPS	Global Positioning System
IDCSP	Initial Defense Communications Satellite Program
IED	improvised explosive devices
IOC	Initial Operating Capability
IoT	Internet of Things
ISR	intelligence, surveillance, and reconnaissance
IT	information technology
LCS	Littoral Combat Ship
MBSE	model based systems engineering
MBSS	multi-beam side-scan sonar
MCM	mine countermeasures
MDA	Mine Danger Area
MIED	maritime improvised explosive device
MILCO	mine-like contact
MILEC	mine-like echo
MIW	mine warfare
MLO	mine-like object
MNV	Mine Neutralization Vehicle
MUOS	Mobile User Objective System
NATO	North Atlantic Treaty Organization
NAVSEA	Naval Sea Systems Command
NAVSEE	Naval Association of Visionary Systems Engineering Experts
NMT	Navy AEHF Multi-Band Terminal
NPS	Naval Postgraduate School
NTA	Navy Tactical Task
OWP	Open Water Power

PMA	post mission analysis
PRF	pulse repetition frequency
RDT&E	research, development, test, and evaluation
RF	radio frequency
RHIB	rigid-hulled inflatable boat
SAS	synthetic aperture sonar
SATCOM	satellite communication
SDN	software-defined network
SNR	signal to noise ratio
SS-DTE	single sortie detect-to-engage
TTP	Tactics, Techniques, and Procedures
UAV	unmanned aerial vehicle
UNTL	Universal Naval Task List
USD	Under Secretary of Defense
USS	United States Ship
USV	unmanned surface vehicle
UUV	unmanned underwater vehicle
UxS	unmanned systems
VM	virtual machine
WGS	Wideband Global SATCOM

THIS PAGE INTENTIONALLY LEFT BLANK

EXECUTIVE SUMMARY

Sea mines have historically posed a highly asymmetric threat to U.S. Navy operations due to their high level of variation and relatively low expense. For that reason, Mine Warfare (MIW) capabilities have been an integral part of Navy operations. In addition to the historical mine threats, technologies are evolving, allowing the types of threats to become more complex and harder to counter. Mine Countermeasures (MCM) must progress as well.

The purpose of this study is to examine the Navy's defensive MCM capability needs through the 2040 timeframe. This study is different from previous Naval Postgraduate (NPS) capstone studies since it is not as near-term and did not set out to determine specific materiel solutions. Due to the long-term focus of this study, a tailored systems engineering approach was used to develop a scenario, systems architecture, and trend line analysis.

This paper describes the future scenario for the 2040 timeframe that was developed by researching current types of mine threats, including contact mines, influence mines and associated sensors, and maritime improvised explosive devices. To provide a baseline, the study first examines the current MCM CONOPS, which utilizes Avenger class MCM ships and the MH-53E helicopters as platforms for operations. Technology enablers in the areas of Command, Control, Communications, Computers, and Intelligence (C4I), sensors, and platforms and vehicles are also described. To establish the 2040 scenario, the problem is bounded by considering the mining capabilities of adversaries, geographical considerations of mined areas, the type of mine threat, and the U.S. Navy MCM objective. The focus of this study is addressing an advanced mine threat in a narrow strait of water with water depths of forty to two-hundred feet. The future scenario includes the concept of the autonomous loitering mine (ALM) envisioned to be capable of continuously moving, holding positions, burying itself, and coordination with other ALMs.

Current and anticipated future MCM capability gaps are described in this study. From these capability gaps, two overarching MCM objectives are described: 1) reduce the MCM timeline and 2) improve mine detection. Five technology areas are included in this study based on the potential to close the gaps and meet the MCM objectives: 1) number of autonomous systems working in a team, 2) energy storage, 3) sensor range and resolution, 4) post mission analysis (PMA) and automatic target recognition (ATR), and 5) acoustic communications (ACOMMS) bandwidth.

The study discusses the number of autonomous systems working in a team and how this is strongly correlated with the system autonomy, underwater communications, and localization accuracy. Advances must be made in these areas for swarm architectures to be capable of completing complex mission needs such as MCM.

Energy storage to allow longer missions is included as a key consideration for enabling autonomous systems. This study examines research on lithium-ion batteries to develop a linearly extrapolated trend line to the year 2040. At year 2040, the value for lithium-ion energy density is estimated to be 510 Wh/kg. This increase in energy density will enable autonomous systems to have longer mission durations.

This study also examines how improvements to sensor range and resolution can be achieved by utilizing synthetic aperture sonar (SAS) and lasers. Side scan sonar, multi-beam side scan sonar (MBSS), and SAS data was reviewed. The data was used to develop exponential trend lines for both range and resolution. This yielded a resolution of 2.2 mm at a range of 100 meters in the year 2040. This evaluation also produced a range of 920 meters at a 1 cm resolution during this same timeframe. The improvements to range and resolution will help further reduce the detect-to-engage (DTE) timeline.

The envisioned end goal of in-stride MCM requires reducing PMA time and increasing ATR capabilities. This paper identifies that, to accomplish this goal, a repository of sonar images will need to be established to develop a robust algorithm for identifying targets in a statistically significant way. Automatic target recognition used for facial recognition is used as a point of approximation of progress to be expected, allowing this study to examine the error rate in recognition on a yearly basis. From this

trend line, a less than one percent error rate can be predicted by the year 2025. Utilizing the facial recognition curve to extrapolate the predicted accuracy in sonar ATR, this study estimates that sonar image ATR can be reduced to 18 percent error by 2040.

This study examines research that quantitatively defines bandwidth, capacity, and transmission power as functions of distance. The theoretical limits of acoustic modems in a tactically relevant range are established and, combined with the performance growth of commercial acoustic modems, plotted over time to reveal an approximate time frame for technology maturation. The thesis goes on to describe the analysis, showing that acoustic modem capacity is highly correlated with range, so modems can be grouped into a set of ranges. The study asserts that acoustic modems in the 0–1000 meters range would reach the maximum theoretical capacity of about 2 megabits per second around the year 2024, modems within the 1001–2000 meters range would reach the theoretical limit of 1.1 megabits per second around 2029, and modems within the 3501–6000 meters range would reach the theoretical limit of 650 kilobits per second around 2030.

Based on these extrapolations and previous research, this study concludes that the CONOPS set forth for the 2040 timeframe is technically feasible. A compressed MCM kill-chain can be attained with focused investment in the five key technology areas along with sustained backing from the NAVSEA enterprise.

THIS PAGE INTENTIONALLY LEFT BLANK

ACKNOWLEDGMENTS

Team NAVSEE would like to sincerely thank our thesis advisors for their patience and guidance during this challenging process: Professors Paul Beery, Greg Miller, Eugene Paulo, and special advisor RDML Rick Williams, USN, Retired. Your insights and commitment to this novel thesis format was a tremendous help in its creation and refinement. Thank you for all of the time you spent editing the report, but more importantly, thank you for helping us find our own way and our own voice. Team NAVSEE would also like to thank the Naval Surface Warfare Center, Panama City Division for providing us with the opportunity to address the future of mine countermeasures. It is our hope that this thesis will be used to help spur further thought and analysis on this topic, and help the U.S. Navy maintain supremacy for years to come.

THIS PAGE INTENTIONALLY LEFT BLANK

I. INTRODUCTION

A. BACKGROUND

The operational purpose of sea mines is to “reduce naval freedom of action, operational maneuver, surprise and aid the enemy’s ability to concentrate its forces” (Morien 1999, 1). Throughout history, sea mines have had significant impact both from a militaristic and from an economic perspective affecting naval strategy and world trade. Since World War II, sea mines have damaged or sunk more than four times the number of ships than any other threats (PEO LMW 2009). Mines continue to pose a significant threat to naval commanders, due to the extensive variation of mine threats such as triggers, placement, and counter-countermeasures (CCM) abilities and the related tedious nature of mine countermeasures (MCM). Based on the Navy and Marine Corps strategic and doctrinal publications, such as Joint Publication 3–15, *Barriers, Obstacles, and Mine Warfare for Joint Operations*, naval dominance requires increased focus on the military’s mine warfare (MIW) capabilities (JP3-15 2011).

Mine warfare has been an integral part of the U.S. naval strategy throughout the last century, beginning as early as World War I. During World War II, hundreds of ships were sunk and key enemy routes were inhibited by mines launched by U.S. submarines and dropped by U.S. aircraft (Marolda 2015). As technology has progressed throughout the years, MIW continues to rely on the simplicity and low cost of traditional mines and underwater improvised explosive devices (IEDs) (Office of the Undersecretary of Defense for Acquisition, Technology, & Logistics 2011). However, while the traditional mines will continue to pose a threat, technology has allowed the threat to evolve and expand in type and complexity. So, as this evolution continues, MCM must counter and advance as well.

One difficulty in countering the evolving threat posed by advances in adversary mines is the ability to anticipate what those advances will be. An additional complication is the time it takes to develop systems within the constructs of the Department of Defense (DOD) acquisition system. Considering the development time for complex systems, the

acquisition life cycle, and all associated requirements and milestones, now is the time to initiate development of MCM solutions for the 2040 timeframe. This project forecasts the needs and requirements for the Navy's MCM capabilities through the study of emerging technologies, future technologies, and trend analysis, creating a roadmap to demonstrate how the Navy can evolve from the current state of MCM to the 2040 timeframe. This roadmap allows for resources to be prioritized for further research and system development. Additionally, a by-product of this research and analysis is the development of current or near-term solutions for the Navy's MCM issues.

This study differs from previous Naval Postgraduate School (NPS) studies, which focused on legacy and near-term MIW systems and platforms and provides the benefit of a broader view and a more distant target timeframe. Future NPS studies will be able to use this project to further identify capability gaps and develop system requirements that will be needed to counter long-term threats. This study ultimately informs stakeholders of the direction to focus resources in preparation for MIW in 2040.

B. GOALS, OBJECTIVE, AND SCOPE

The purpose of this study is to examine the Department of the Navy's MCM needs and propose viable solutions for the 2040 timeframe. The intent is to focus on solutions for defensive MCM against global maritime mining threats in the post-Littoral Combat Ship (LCS) Navy. Through research and stakeholder input, this study determined system requirements, capabilities, and priorities for development and sustainment. Various scenarios and threats were examined and a wide set of possible solutions considered. These solutions included current new technologies and potential technological breakthroughs, as well as non-traditional MIW options. Materiel and non-materiel solutions were considered, focusing on potential doctrine, organization, training, materiel, leadership and education, personnel, facilities, and policy (DOTMLPF-P) improvements.

To determine the status of MIW, the history of MIW and MCM was established first. Subsequently, the current MCM concept of operations (CONOPS) was examined. This review provided a baseline for the study and established what will be affected as

technology changes and time passes. The future of MIW is directly affected by changes in technology. Therefore, technology enablers were examined in detail to determine where they are now and where they may be in 2040 both from a MCM and a threat perspective. These relationships directly affect what the future threat may look like as well as mold the future of MCM.

Based on the proposed threat and scenarios in the 2040 timeframe, a technology roadmap was created. This timeline established the capability gaps, MCM objectives, and technology growth areas for each decade between now and 2040. These capability gaps were analyzed to determine what technology area would need to grow to meet the gaps. These technology growth areas were examined in detail and trend analysis was conducted. This analysis projects if a technology area will be able to fulfill the associated capability gap in the 2040 timeframe. This analysis leads to recommended focus areas to meet the MCM requirement in 2040.

C. SYSTEMS ENGINEERING APPROACH

Due to the broad scope and long-term focus of this project, the systems engineering approach is different from past capstone projects, which had a near-term focus, allowing those teams to start with a narrow solution set. For this project, a wide range of solutions, capabilities, and threats for MIW in the 2040 timeframe were explored. A phased approach was used to organize the project and bound the long-term and vast problem space, as shown in Figure 1. Each box in Figure 1 corresponds to a phase of the tailored systems engineering approach. The box labeled “1.0 Initial Research” corresponds to Phase One of the process, a data collection effort during which the team conducted initial research, including reviewing publications pertaining to MIW and gathering subject matter expert and stakeholder inputs. Initial research was conducted using the DOTMLPF-P approach, ensuring that all solutions were considered, not just materiel solutions.

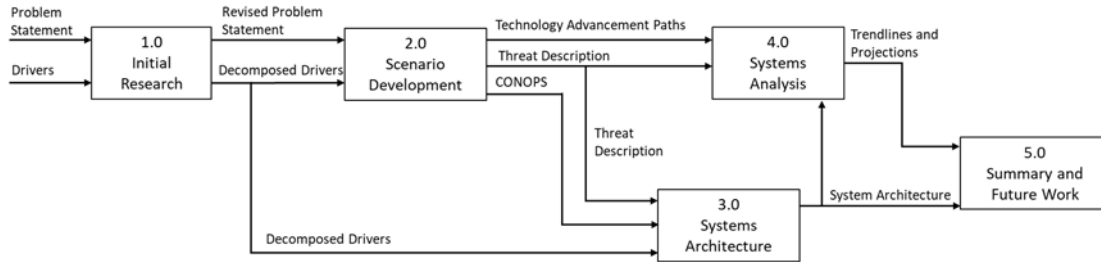

Figure 1. Tailored Systems Engineering Approach.

The information gathered in Phase One was used to inform inputs and decisions made in Phase Two, development of the CONOPS for the 2040 timeframe. Chapter II corresponds to Phase Two of the systems engineering approach and is represented by the second block “2.0 CONOPS Development” in Figure 1. Chapter II contains the details of the scenario and CONOPS for performing MCM in the 2040 timeframe and illustrates how solutions fit within the bounded solution space described. To develop the future CONOPS, the current MCM CONOPS was researched including current MCM systems, current MCM tactics, and common types of mine threats. From studying the current MCM CONOPS, the future threat was characterized as part of Phase Two. Threats as well as systems, tactics, and methods of countering those threats are affected by enabling technologies. Chapter II also contains information on technology enablers in the categories of Command, Control, Communications, Computers, and Intelligence (C4I), sensors, weapons, and platforms. Using the current MCM CONOPS and enabling technologies, the problem space was bounded by developing a scenario. The future CONOPS summarizes the vision of the 2040 MCM battlespace.

Phase Three corresponds to “3.0 Systems Architecture” in Figure 1. Chapter III contains diagrams of the MIW functional decomposition produced during Phase Three of the tailored systems engineering process. The functional decomposition orients the reader on the portions of the mission that are relevant to the 2040 CONOPS. Capability gaps were identified by examining current shortfalls in MCM functions and projecting future expected shortfalls. The identified capability gaps are discussed in Chapter III. With the capability gaps identified and the future CONOPS developed, two overarching goals were established: 1) reduce the MCM timeline and 2) improve mine detection. Key

enabling technologies to address the MCM capability gaps and fulfilling the two main MCM goals were the final item studied during Phase Three.

The key enabling technologies of interest identified in Phase Three were further studied in Phase Four. Chapter IV contains projections and trend lines for five key technologies. The projections of the key enabling technologies are the outputs of the overarching tailored systems engineering process, which included inputs of a refined problem statement and research on drivers from Phase One, the future CONOPS and scenario from Phase Two, and the systems architecture from Phase Three. The results of the Phase Four projections were summarized in Phase Five.

Phase Five is presented in Chapter V. Phase Five summarizes this study, offers insight into the unique challenges associated with MCM systems, and provides recommendations for future research.

THIS PAGE INTENTIONALLY LEFT BLANK

II. CONCEPT OF OPERATIONS DEVELOPMENT

A. CURRENT THREAT

Naval mines have long served as an effective force multiplier and a highly asymmetric weapon in any navy's arsenal. Mines require little maintenance and once they are deployed they will lie in wait with no attention required from the navy that deployed them. They are highly effective in frustrating an advancing a navy's mobility and provide a buffer that removes the element of surprise that may have been gained by the aggressing nation. Mines have been utilized in defensive capabilities, such as denying access into a region, and offensive capacities, such as denying egress out of a region. Specifically, mines are very effective in enforcing embargo upon a nation (Ocean Studies Board Commission on Geostudies, Environment, and Resources Naval Research Council 2000).

Mines continue to be a problem for modern naval forces. From 1950 to 2000, more than four times the number of ships lost to any other form of attack have been lost or damaged by sea mines (PEO LMW 2009). Ten ships encountered mines during the Korean War, one during Vietnam, one during the Tanker Wars, and two during Desert Storm (PEO LMW 2009). Figure 2 illustrates what has been done with primitive mines since World War II. As can be seen, mine warfare is the largest threat to the U.S. Navy Fleet (PEO LMW 2009).

Given these numbers, mine warfare poses a complex threat to any naval fleet. To counter this expansive threat, it is imperative for navies to remain at the forefront of adversary intelligence and emerging technology in both mining and mine countermeasures. This requires knowledge of major mine types. Though there are a myriad of different mine types and models, they can all be categorized into two major domains: contact or influence. These two domains are characterized by the way in which the mine is triggered whether by contacting the vessel, in the case of a contact mine, or by sensing the presence of a vessel, in the case of an influence mine.

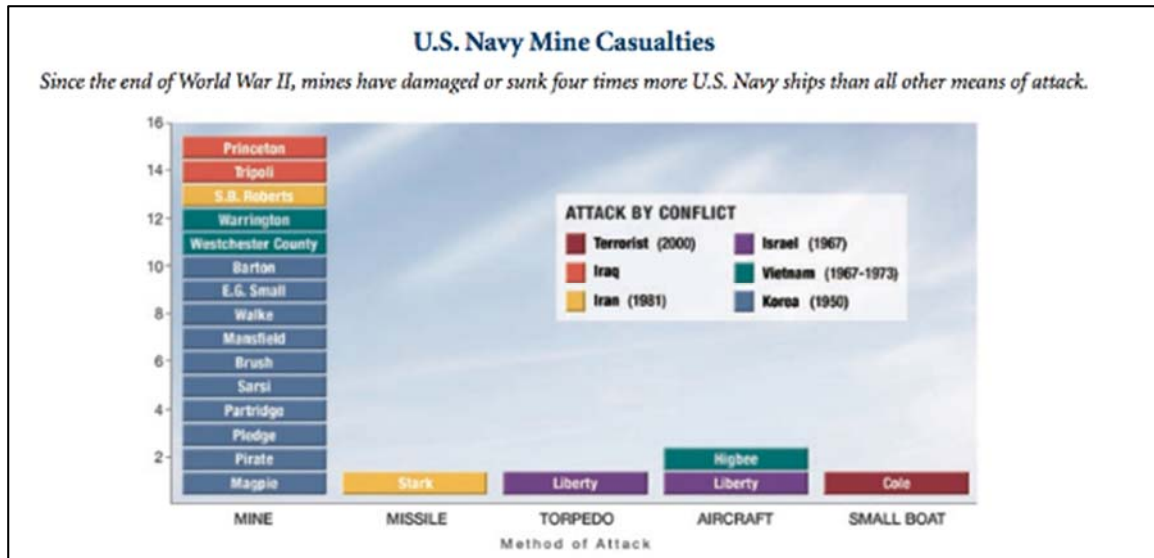

Figure 2. U.S. Navy Casualties and Associated Method of Attacks in World War II. Source: PEO LMW (2009).

Given the advantages of each of these mine types, the proliferation of each type worldwide is likely to continue for some time. Influence type bottom mines continue to be highly effective because of their larger payloads and reduced probability of detection. These types of mines are likely to be the most significant threat for future navies. Influence moored mines are still significant, but their generally smaller payloads and greater probability of detection make them slightly less problematic for MCM today and possibly in the future. Finally, contact mines will remain a threat because of their simplistic design, low cost, and high effectiveness. Low budget navies will be able to take advantage of these mines for years to come just as they have for the past two centuries. Due to the ever-changing landscape of mine warfare, it is difficult to state definitively that any one class of mine will become significantly more effective in the future. It is therefore critical to understand each type in detail.

1. Contact Mines

Contact mines are likely the most recognizable mine type in the world. Figure 3 is a prime example of the classic contact mine. The quintessential round body crowned with several “spiky” objects (contact horns) is what most people think of when

visualizing a naval mine. Contact mines are the most inexpensive to acquire, are highly reliable, and are extremely effective, which is why they have been highly proliferated throughout the world.

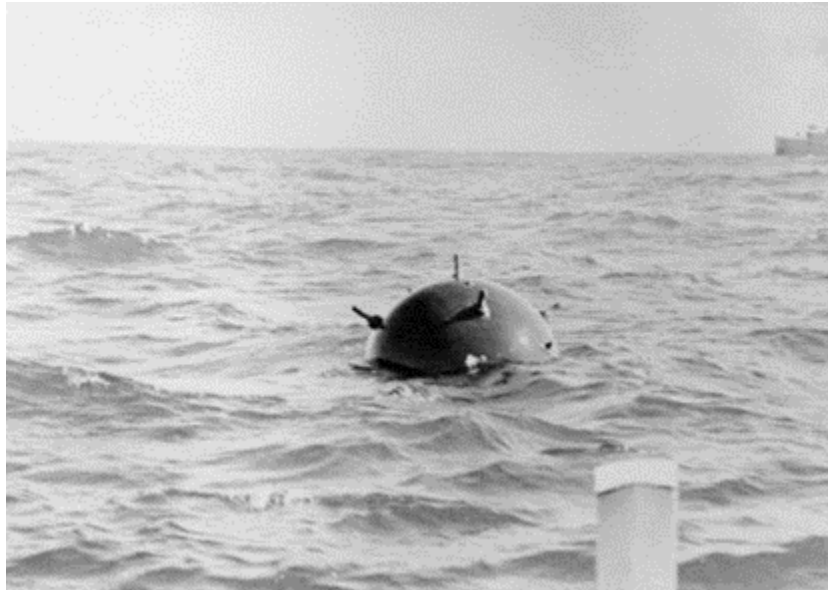

Figure 3. A German Contact Mine Laid in Australian Waters during WWII.
Source: Australian War Memorial (n.d.).

Basic physical construction of contact mines has remained unchanged since 1866, when the Hertz horn was invented (Ocean Studies Board Commission on Geostudies, Environment, and Resources Naval Research Council 2000). These mines utilize several contact “horns” that contain a glass vessel filled with an electrolyte solution, that, when broken, such as when a ship contacts the mine, will create the electric current necessary to detonate the mine. Figure 4 is a sketch of the Hertz horn and how it operates. The simplicity of these mines makes them quite robust and their long service life has demonstrated the effectiveness of this proven design.

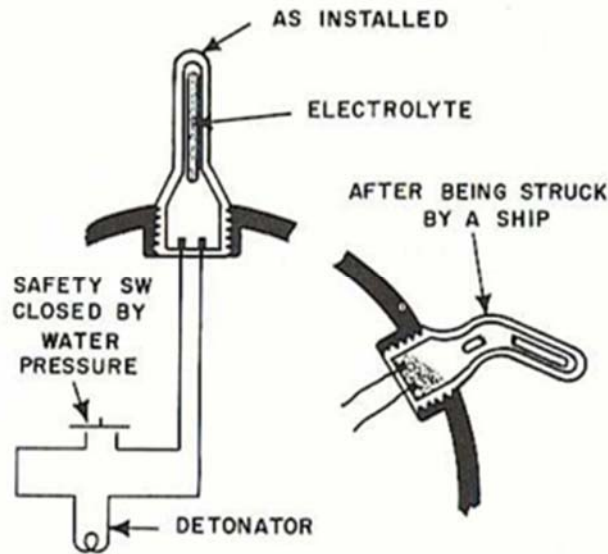

Figure 17.—Hertz horn.

Figure 4. Figure of Hertz Horn. Source: LaGrone (2014).

Contact mines have been deployed as bottom mines in the shallow surf zone region, while moored configurations are utilized throughout the water column. Though banned by The Hague convention in 1907 (Ocean Studies Board Commission on Geostudies, Environment, and Resources Naval Research Council 2000), drifting contact mines continue to be a threat for today's navies. Following currents, wave action, and river flows, these mines are unpredictable but can be highly effective in an area where drifting mines can be carried into a harbor via the natural water currents in the area. Moored mines may become drifting mines after they separate from their anchors.

One of the last U.S. Navy ship to encounter a contact mine was the amphibious carrier USS Tripoli (LPH-10) on February 18, 1991, while conducting operations during Desert Storm. Figure 5 is a picture of the USS Tripoli while in dry dock, as damages caused by the mine are repaired. The total cost of repairs reached \$3.5 million and the ship was unavailable for Desert Storm operations (Naval Research Advisory Committee Report 2000). By contrast, the mine that damaged the Tripoli cost the Iraqis an estimated \$1500 (Naval Research Advisory Committee Report 2000). The Tripoli incident

illustrates that mine warfare is a highly asymmetric threat, having a devastating effect on the attacking nation at a very low cost to the nation that deployed the mine(s) (Naval Research Advisory Committee Report 2000).



Figure 5. Damage to the USS Tripoli after Striking a Contact Mine during Desert Storm. Source: Gawlowicz (1991).

2. Influence Mines and Their Sensors

During World War II, it was understood that every ship class could be characterized by its acoustic, magnetic, electric fields and pressure signatures produced as a natural process of the ship's operation. Mine technology was responsive to this fact,

and therefore the influence mine was developed, an example of which is shown in Figure 6. Influence mines utilize sensors to detect the signatures of vessels transiting in their vicinity and actuate when their firing parameters are met. Sensors have been used by themselves or in combination to detect the many aspects of a ship's signatures to provide a more developed firing solution capable of targeting a ship class and to avoid being tricked by countermeasures. According to the Mine Warfare publication NWP 3-15, current sensors and sensor suites include the following:

- Magnetic: "A magnetic influence mechanism is a device that is designed to sense a change in the earth's ambient magnetic field that is caused by a target ship."
- Acoustic: "Acoustic influence mechanisms consist basically of passive microphones and associated circuitry for detecting underwater noises and active transponders that transmit signals and receive echoes from a previously acquired target. The passive mechanisms consist of hydrophones that are responsive to the characteristic frequency, intensity, and duration of detected noises generated by a ship's propeller, engine, machinery, or hull noises."
- Seismic: "The seismic influence used in some mechanisms is closely related to the acoustic influence. That portion of the acoustic signature that is transmitted through the ocean bottom rather than through the water is used to actuate a seismic mechanism. These mines use a geophone to sense the shaking or vibration through the mine case that is caused by the sound."
- Pressure: "Pressure influence mechanisms detect the low-pressure zone created beneath a moving ship's hull. This system may be affected by surface wave action, and, as a result, it is used primarily in sheltered waters only in combination with another influence mechanism. The advantage of a pressure influence system is that it is impossible to simulate the pressure signature of a target ship without actually towing a vessel. Therefore, this type of mine is very difficult to sweep."
- Combination: "Combination influence mines consist of acoustic, magnetic, and pressure-firing mechanisms assembled together, each of which is responsive to its own type of influence. Each sensing mechanism must receive the appropriate signal in a specified period of time for the mine to detonate. Systems involving a combination of influences are available in most mine firing devices. Combination influence mechanisms are designed to use the advantages of one system to compensate for the disadvantages of another. The most common combinations are: magnetic/acoustic; magnetic/seismic; magnetic/acoustic/pressure; and magnetic/

seismic/pressure. Mines with combination influence sensors are much more difficult to sweep than mines with a single influence.”

A customary practice for influence mines is ship counting, ensuring that the mine will not actuate on the lead ship of a convoy. Ideally, this arrangement will wait until a ship of higher value, like an aircraft carrier, enters the mine field before actuating.



Figure 6. Influence Type Bottom Mine. Source: U.S. Navy (2002).

When considering influence mines, there is more than one configuration to be discussed. These configurations are the bottom mine and ascending, or propelled, mines.

The advent of the bottom or buried mine shifted the paradigm in mine warfare because mines no longer had to sacrifice space to allow for buoyancy volume, but could instead be filled completely with explosives. This made for more destructive mines in smaller packages. The other advancement that followed influence technology was the exploitation of the bubble jet effect. Bottom mines explode on the bottom and create a giant bubble some distance below the ship that eventually erupts into the air (Worldwide Independent Inventors Association 2009). If the column of water, created by the bubble prior to eruption, contacts a ship, it can easily puncture a meter-wide hole through the skin of the ship (Worldwide Independent Inventors Association 2009).

Bottom mines are the most difficult mines to detect and classify, though there are several types. “Proud mines” are bottom mines that reside on the surface of the sea floor, as seen in Figure 6. Buried mines are those that reside partially or completely beneath the surface of the sea floor (Naval Research Advisory Committee Report 2000). Many bottom mines, like the manta mine, are designed to rest firmly on the sea floor and, with their sloping sides, will typically be buried or partially buried shortly after deployment, as shown in Figure 7. Referred to as mine stealth, some mine manufacturers have developed mines that encourage sea growth on the exterior shell as well as utilize irregular exterior shapes to improve camouflage with the sea floor. These aspects of bottom and buried mines pose one of the most challenging threats in the mine warfare domain. As seen in Figure 8, the USS Princeton (CG-59) was severely damaged during Desert Storm, February 1991, when two Italian-made manta mines detonated under the port rudder and just off the starboard bow (Navysite n.d.).



Figure 7. Partially Buried Manta Mine. Source: Harpgamer: Naval Wargaming Community (2009).



Figure 8. USS Princeton (CG-59) Damage. Source: Navysite (n.d.).

Also in the influence mine family is the ascending, or propelled, mine. In the 1960s, the Russians developed a new type of mine that operated in deep water (up to 400 meters), detected a ship overhead, and propelled itself upward towards the target (Proshkin n.d.). Figure 9 is a cutaway view of a Russian MDS-1, depicting the electronics module and propelled warhead residing within delivery housing. The MDS-1 warhead was based on a production torpedo used during that time. These mines were typically deployed covertly from a submarine platform. Illustrated in Figure 10, they utilized passive sensors to detect vessels overhead, and activated an acoustic sonar that fed the rocket or torpedo with target data. The mine then launched its torpedo or rocket towards the target. Figure 10 depicts a homing type mine that tracked to a target instead of simply propelling itself towards the surface. These mines come in a variety of configurations including straight rising, aimed, and homing (Proshkin n.d.).



Figure 9. Russian MDS-1. Source: Proshkin (n.d.).

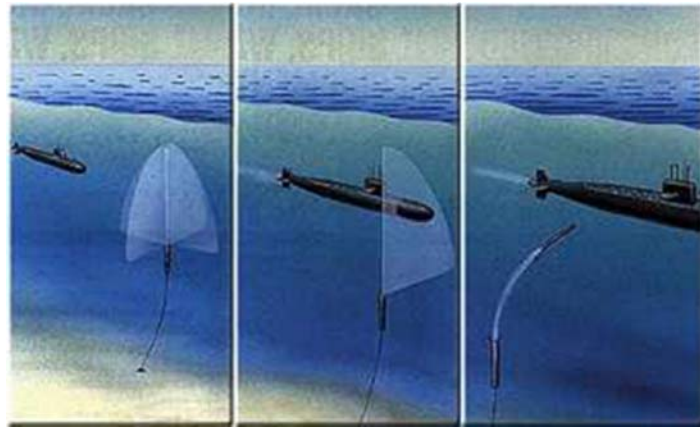

Figure 10. Russian Moored Homing Mine. Source: Proshkin (n.d.).

Remotely controlled mines are a subset of the mines already described. Some bottom and ascending or propelled mines are capable of being remotely controlled. Deployed during peace time to provide protection of key shipping routes, harbors or strategic coastlines, remotely controlled mines can offer a buffer layer between a nation's shores and the open seas. These mines can be utilized in concert with coastal artillery to prevent access to an area and are generally able to return to full capability via the remote connection (Worldwide Independent Inventors Association 2009).

Another aspect that must be considered when addressing influence mines is the potential for networked mine fields. On the emerging side of naval mine technology, mine field architectures have begun to incorporate networks of mines connected to each other to distribute sensors and develop even more sophisticated mine fields (Mason 2009). Enabled by acoustic communications (ACOMMS), these mine fields will increase the advantage of the miner by improving their ability to identify friend or foe and pass

information about the location, heading, and speed of approaching ships to other mines in the field (Mason 2009). These mine networks will also be able to coordinate efforts via cooperation from groups of mines to inflict the most damage upon the adversary. Mine networks allow for more versatile control of mines and will be a growing threat for the more well-funded nations (Brown et al. 2012).

A final consideration for influence mines is the requirement for power. Unlike the contact mine, influence mines require electric power to operate their sensors. To remain active for months or even years, power conservation is significantly important to these devices. Most of these mines operate in a semi-dormant state, relying on an unpowered or low-powered sensor to activate them. Currently, primary batteries with lithium thionyl chloride or silver-zinc chemistries are the standard battery source for these mines. Another strategy to conserve battery power is to program in a delayed activation of the mine after it has been deployed. In this configuration, the mine would remain in the semi-dormant state until the activation timer completed, then it would begin its normal routine (Worldwide Independent Inventors Association 2009).

3. Maritime Improvised Explosive Devices (MIED)

Mines do not have to be technologically advanced to be a threat. For more than a century, naval mines have been utilized to frustrate advancing navies from gaining access or passage to their objective. Nations with no real naval power have been able to easily disrupt the naval operations of far stronger nations. During the Korean War, Rear Admiral Smith, commander of the Wonsan amphibious task force wrote, “We have lost command of the sea to a nation without a navy, using weapons that were obsolete in World War I and laid by vessels that were used at the time of the birth of Jesus Christ” (Ocean Studies Board Commission on Geostudies, Environment, and Resources Naval Research Council 2000, 12). This is the fundamental advantage of deploying naval mines.

Sixty years later, terrorists have realized the same advantage that the Koreans leveraged so many years ago, except they have developed their own way of deploying sea mines. Similar to the land-based IEDs that devastated North Atlantic Treaty Organization

(NATO) forces during operations in Iraq and Afghanistan, terrorists have developed naval mines utilizing commercial-off-the-shelf (COTS) goods integrated with simple influence firing devices. These mines may take the shape of a water heater or refrigerator, but the terrorist organization has filled the object with explosives. These mines pose a serious threat because they appear to be inconspicuous objects that most people would overlook as they make their way into a protected harbor (Von Bleichert 2014). In the traditional sense of mine detection and classification, these targets may not even be selected as being mine-like under today's traditional thinking. MIEDs pose a serious threat to the current navy, and once they become more mainstream knowledge, they will surely proliferate amongst the more scantily funded nations and terrorist groups.

B. CURRENT MIW DOCTRINE REVIEW

This section provides an overview of the current U.S. Navy doctrine and CONOPS captured during initial research. Current mine warfare CONOPS were analyzed to obtain a baseline for the subsequent development of a 2040 MCM CONOPS. An MCM CONOPS involving the functions and mission stages of the Avenger class MCM 1 mine warfare ship and the MH-53E helicopter were obtained from a previous NPS study titled "Application of Model-Based Systems Engineering (MBSE) to Compare Legacy and Future Forces in Mine Warfare (MIW) Missions," as well as from additional related research, and is summarized in this section.

The previous study, involving the MCM 1 and MH-53E systems, included a CONOPS description divided into two phases. The first phase incorporates the operations associated with initially detecting and classifying a target. The second phase includes reacquiring, identifying and neutralizing operations. During the first phase, the MCM 1, a platform used to hunt, sweep, and destroy mines, utilizes the AN/SQQ-32 sonar to detect and classify mine-like targets (Frank et al. 2014). Once a list of targets has been generated, the ship deploys the remotely operated AN/SLQ-48 Mine Neutralization Vehicle (MNV) to visually verify the potential target via real time video prior to neutralization operations. If the object is identified as a mine, the vehicle is capable of deploying three different neutralizer systems to address mines throughout the water

column (Pike 1999). The first system consists of a deployable cutter that can separate a moored mine from its anchor, where the mine will be disposed of or exploded at the surface. In the second neutralizer system, the vehicle carries a single explosive charge that it can deploy near bottom mines. The third system addresses moored mines by utilizing a combination of the first and second systems. For the third neutralizer system, a modified cutter is attached to the mooring cable and a float carries the explosive charge up to the mine case where it is detonated (Pike 1999). Figure 11 shows an example of the AN/SLQ-48 MNV. This underwater mobile device has front cable cutters and is linked or tethered to a host ship.



Figure 11. AN/SLQ-48. Source: Andrews (2014).

The MCM 1 class ship also has mechanical and influence sweep capabilities. Sweeping for enemy mines is the process of streaming “sweep gear” through the water to either cut the anchor lines of moored mines and neutralize the mines as they float to the surface, in the case of a mechanical sweep, or detonate influence mines by simulating the signatures of larger vessels, in the case of an influence sweep. A mechanical sweep utilizes an array of Mk 18 explosive cutters attached to a cable that will catch the anchor line of moored mines and trigger a charge to deploy a chisel through the mooring. An influence sweep operates by using coaxial cables to pulse high current levels into the

water, generating an electric field, as well as acoustic devices which mimic acoustic signatures. By creating a larger acoustic signature in the water, the MCM forces hope to cause influence mines to detonate a safe distance from the ship.

In conducting sweep and search operations, Frank et al. states that “the MCM 1 first transits from the staging area to the edge of the target area closest to the staging area (shown by the green arrow labeled ‘1’ [in Figure 12]) where it will stream its search equipment before entering the target area” (2014, 139). It then travels “to the far end of the target area where it will turn onto a reciprocal heading on the next track. It will finish its sortie at the end of a track that is closest to the staging area, recover the search equipment and transit to the staging area where it will be replenished (shown by the red arrow labeled ‘1’)” (Frank et al. 2014, 140). Figure 12 shows two more sorties being completed using the same process (shown with the arrows labeled “2” and “3”) (Frank et al. 2014).

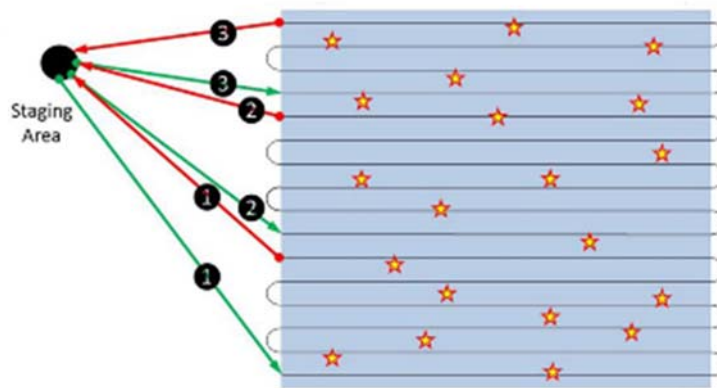

Figure 12. MCM 1 – Detect to Neutralize. Source: Frank et al. (2014).

During the detecting and neutralizing operations as part of mine hunting and mine sweeping functions, the MH-53E helicopter is utilized when the MCM 1 communicates the mine location to it for target examination. In this part of the operations, the MH-53E tows the AN/AQS-24, which performs laser detection and identification capability during mine-hunting operations (Eckstein 2015b).

Figure 13 shows the CONOPS for the MH-53E as it searches for targets during the detecting and classifying phase of operations. The MH-53E passes back and forth “across its assigned portion of the target area...in a series of parallel tracks starting at the upper edge of the target area and progressing downwards until the whole of its designated portion of the target area has been searched” (Frank et al. 2014, 140). Frank et al. states that the MH-53E transits above the target and therefore “may finish its sortie at either end of a track,” while the MCM 1 transits through the target area (2014, 140). As further described by Frank et al., “the detection and classification data from the MH-53E undergo post mission analysis (PMA) to create a target list for reacquisition and neutralization, either by the MCM 1 alone or by both the MCM 1 and MH-53E” (2014, 141).

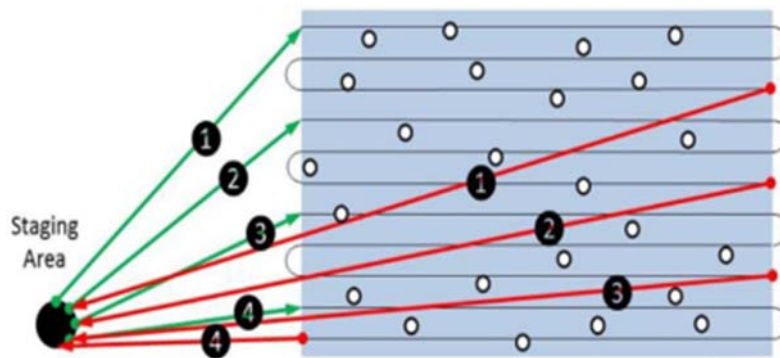

Figure 13. MH-53E – Detect and Classify. Source: Frank et al. (2014).

During the reacquiring, identifying and neutralizing operations of the current CONOPS, the MCM 1 and MH-53E systems work either in a “parallel hunt” or a “serial hunt.” In a “parallel hunt,” the MCM 1 and MH-53E work in parallel and are allocated different portions of the target area. As described by Frank et al., they each “transit directly to the first target on their individual target list created during the PMA and will then transit to each successive target on their list until it is necessary to terminate the sortie” (2014, 142). When the MCM 1 and MH-53E operate in sequence, it is termed “serial hunt.” During the serial hunt, the MCM 1 performs “detection-to-neutralization in one part of the target area while the MH-53E is assigned the remainder of the target area

to perform detection and classification” (Frank et al. 2014, 138). The MCM 1 and MH-53E transit to the staging area at the end of their sortie for replenishment, at which point another PMA will be performed (Frank et al. 2014). Figure 14 shows both the MCM 1 and MH-53E in operation.



Figure 14. MCM 1 Mine Warfare Ship and MH-53E Helicopter. Source: Martens (2007).

The near-term mine warfare CONOPS utilizing the MCM Mission Package for LCS were also studied. While the LCS remains in a staging area outside the target area, the unmanned surface vehicle (USV) towing the AN/AQS-20 (Q-20) sonar is dispatched to perform search missions (Frank et al. 2014). The USV replaced the capability lost from the cancelation of the Remote Multi-Mission Vehicle, which previously towed the Q-20 for search missions. For this LCS-based, near term CONOPS, the Q-20 is towed on parallel tracks to search the target area (Eckstein 2016). Multiple sorties are used to detect and classify targets. The MH-60S, using the Airborne Laser Mine Detection System (ALMDS) for detection and classification, is launched to search for shallow water or near surface targets. The MH-60S performs a PMA after each sortie. Following the detection and classification portion of the mission, the MH-60S is reconfigured with an Airborne Mine Neutralization System (AMNS). The AMNS is used to neutralize targets passed forward from the PMA (Frank et al. 2014). The AMNS reacquires, identifies, and neutralizes the target in support of the Navy’s “requirement for rapid neutralization of bottom and moored sea mines to support operations in littoral zones,

confined straits, choke points and the Amphibious Objective Area (AOA)” (Naval Sea Systems Command 2016, 1). Working in the area previously searched by the USV, the MH-60S continues the process of reacquiring, identifying, and neutralizing targets, until there are no remaining mine-like contacts (MILCOs). Figure 15 is an operational depiction of the LCS and MH-60S.



Figure 15. LCS and MH-60S in Operation. Source: Selinger (2016).

C. TECHNOLOGY ENABLERS¹

As we examine MCM in the 2040 timeframe, we must look at the technology that has enabled and will enable advances in the field. “Every major advance has prerequisites for its occurrence. Just as this was true in the past, it will be true in the future, and we must take enabling technologies into account when predicting advances” (Harney 2013, iii). Command, Control, Communications, Computers, and Intelligence (C4I), sensors, weapons, and platforms and vehicles were examined as potential technology enablers that would have the most significant impact on MCM in the coming

¹ A significant portion of the information contained within this section is based on personal knowledge of one of the authors who has worked within the Joint and Expeditionary Command and Control/Deployable Joint Command and Control/Navy Enterprise Tactical Command and Control program areas for PEO C4I for over ten years.

years. Studying their current capabilities and where those may lead may provide a glimpse into the future of mine warfare.

1. C4I

Innovations in the C4I field could drastically affect MIW. One of the biggest issues with MCM is response time. The advancements in the realm of C4I will improve that greatly, creating both an advantage to the Navy but also a risk as adversaries' C4I capabilities may improve as well.

a. Command and Control

The first two C's in C4I are command and control (C2). C2 is defined as "the exercise of authority and direction by a properly designated commander over assigned and attached forces in the accomplishment of the mission" (JP1-02 2016, 40). Further "the human element and the need for relevant timely, and accurate information" have remained constant in C2, and we must "continue to reduce time and space, increase tempo of operations, and generate large amounts of information" (JP6-0 1995, I-1). Figure 16 illustrates the flow of information across the joint forces and from it one can see the need for gathering data and quickly processing it into useful information that can be used to make a decision. Data is acquired from enemy forces and disseminated as needed. At the same time, force commanders and components share information. The C2 system is in the middle of all of the information processes and sorts the data into useable information that is then disseminated to the proper groups or individuals. In the realm of C2, there are a few areas that may have the most impact on MCM in 2040. Those areas include cloud, edge, or fog computing; MCM with integrated C4I; and the common operational picture (COP).

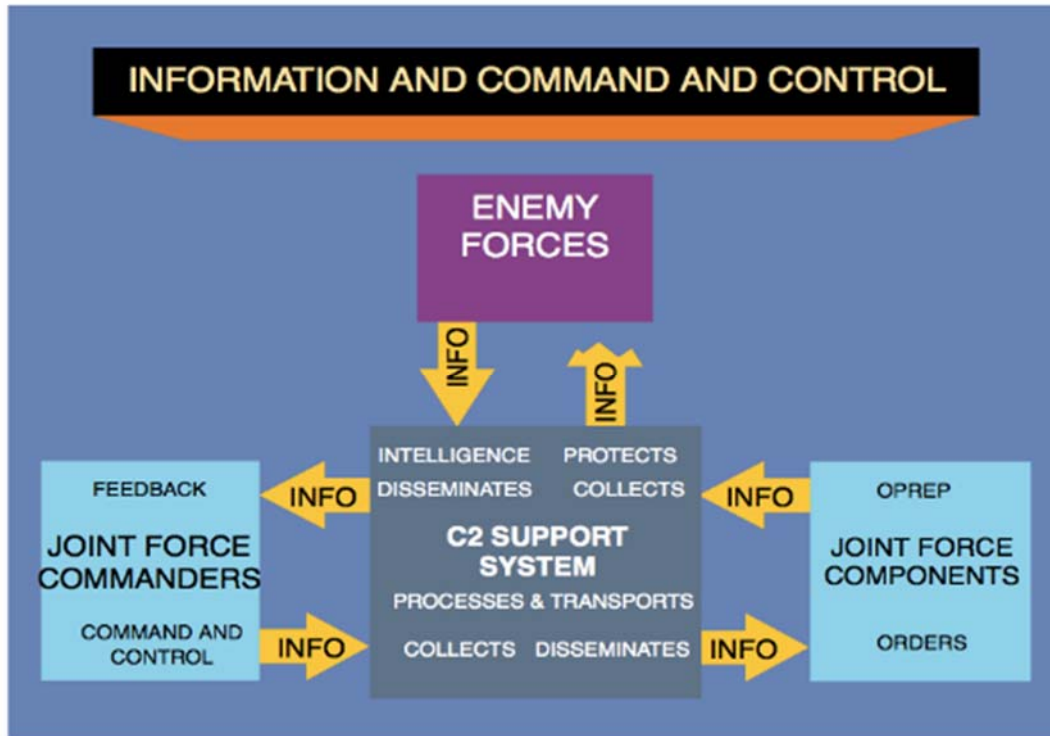

Figure 16. Command and Control Information Exchange. Source: JP6-0 (1995).

(1) Cloud, Edge & Fog Computing

Cloud computing refers to the utilization of remote servers accessed via the Internet rather than the use of local servers and storage (Griffith 2016). The use of cloud computing and remote servers is just now becoming a reality for the Navy. Current programs such as MK18 Mod 2 Kingfish UUV (Unmanned Underwater Vehicle) and Deployable Joint Command and Control are working through issues such as remote server size and download and upload speed. There is no point in having the remote servers if they are not large enough to accommodate the necessary data. Also, if it takes hours to upload and download the data due to satellite communication (SATCOM) delays and capacity limits, it may be cheaper and easier to use current means of hard discs to transfer data.

Projects are also working to find remote servers that are appropriately hardened and secure for use as well as exploring the best way to have cybersecurity accreditation

for the data stored on the servers. The Navy cannot just upload data to any cloud server such as Apple iCloud or Amazon Web Services (AWS) due to cybersecurity concerns and requirements. More than likely they will have to use Defense Information Systems Agency's (DISA's) MilCloud, which is just now at inception, having initially rolled out with minimal capabilities in 2014 and with the MilCloud 2.0 contract award occurring in June 2017 (Carberry 2017).

Additionally, the Navy projects utilizing the MilCloud will have to maintain the cybersecurity posture for information and data they have hosted in the MilCloud maintaining an authority to operate and providing cybersecurity patches to mitigate vulnerabilities. Operating in the virtual world without physical servers introduces complications and unique difficulties for gaining and retaining authority to operate. In situations where physical servers are utilized, they are typically physically partitioned. This separation provides a cybersecurity benefit in such that if one server was compromised, the other servers may remain unharmed. However, in a virtual situation, most if not all virtual machines (VMs) are hosted on one physical server. If that server were to be compromised, all the VMs could be compromised. Having data in the cloud further complicates that because the actual physical server hosting the VMs is located elsewhere and, in some cases, may be hosted in many locations. Those locations must have physical security, and then those VMs must have appropriate Security Technical Implementation Guides applied protecting each individual VM in case of compromise (Fogarty 2009). Additionally, the data must be patched. New cybersecurity vulnerabilities are created and identified on a daily basis. To counter these vulnerabilities, software vendors provide patches. These patches may also fix bugs and improve application functionality. Patching issues could arise if the maintainers had any issue with Global Information Grid (GIG) connectivity or SATCOM lag time. If not correctly accounted for, these issues could lead to a de-authorization to operate.

By 2040, these issues should be resolved and the use of cloud servers should be fully available for real-time data sharing and data access from any location in the world. This could allow for PMA to be done with real-time data, which has many advantages. For one, data gathered by a MCM system or a mine could be uploaded directly from the

component to the cloud, and the tacticians could work the data immediately. This would also reduce cost by reducing the number of deployed personnel and the infrastructure and logistics required for support.

Additionally, the use of cloud services can allow for real-time cybersecurity updates to the MCM solutions, reducing cyber risks and attacks. VMs such as Windows Server Update Services or Red Hat Yellow Dog Updater, Modified could be hosted in the cloud, and as long as the MCM solution was connected to the GIG, they could be continuously patched. Additionally, the master ePolicy Orchestrator (ePO) for McAfee Host Based Security System could be hosted in the cloud, and the MCM solution could inherit all its policies from it. The cloud could also be used to host DISA's Assured Compliance Assessment Solution so that the MCM solution could be scanned continuously for vulnerabilities and reporting to DISA could be done automatically. One can expect that in the future, the continuous scanning, patching, and reporting would no longer be required and upon GIG connection, VMs would be instantaneously updated and reported on.

Another new technology that can complement cloud computing is edge computing (Linthicum 2017). Edge computing allows for shared resources between a system's physical architecture or local computing and the cloud or centralized computing (Bort 2016). Due to bandwidth and other limitations, cloud computing can be too slow, especially if a decision needs to be made immediately, data needs to be processed immediately, or large amounts of data needs to be processed. At the same time, if only utilizing local storage, capacity can immediately become an issue. These issues would be significant for MCM. Certain data would need to be processed and decisions would need to be made immediately. Especially in a situation where communications equipment may not be accessible, it is not feasible for this processing to take place in the cloud. These decisions would need to be made locally. At the same time, MCM data gathered requires a significant amount of storage. If this storage had to be hosted locally, the MCM solution would have to be large to house a substantial data storage device or the data would have to be exfiltrated quite often. If this data were stored in the cloud, these issues could be eliminated. Edge computing allows for the efficiency of both local and

centralized computing at the same time. Edge computing allows for data prioritization and switching between local and cloud computing as appropriate, depending on the task at hand.

An even newer technology that is a conglomeration of cloud and edge computing is fog computing. It is referred to as fog computing because it is just like physical fog, which is a cloud close to the ground (Bonomi et al. 2004). Rather than relying on the physical architecture of the MCM solution for local computing, fog computing allows for cloud computing close to the edge or user. The proximity of these cloud services would virtually eliminate lag and bandwidth issues typically seen with cloud computing. The relationship between cloud, edge, and fog computing is shown in Figure 17. The endpoints can connect remotely to the cloud or they can connect to other devices at any layer as part of the cloud rather than connecting directly to the cloud. Edge computing allows for the selection of the best route through the devices and the cloud to get the computing and storage capability that is required.

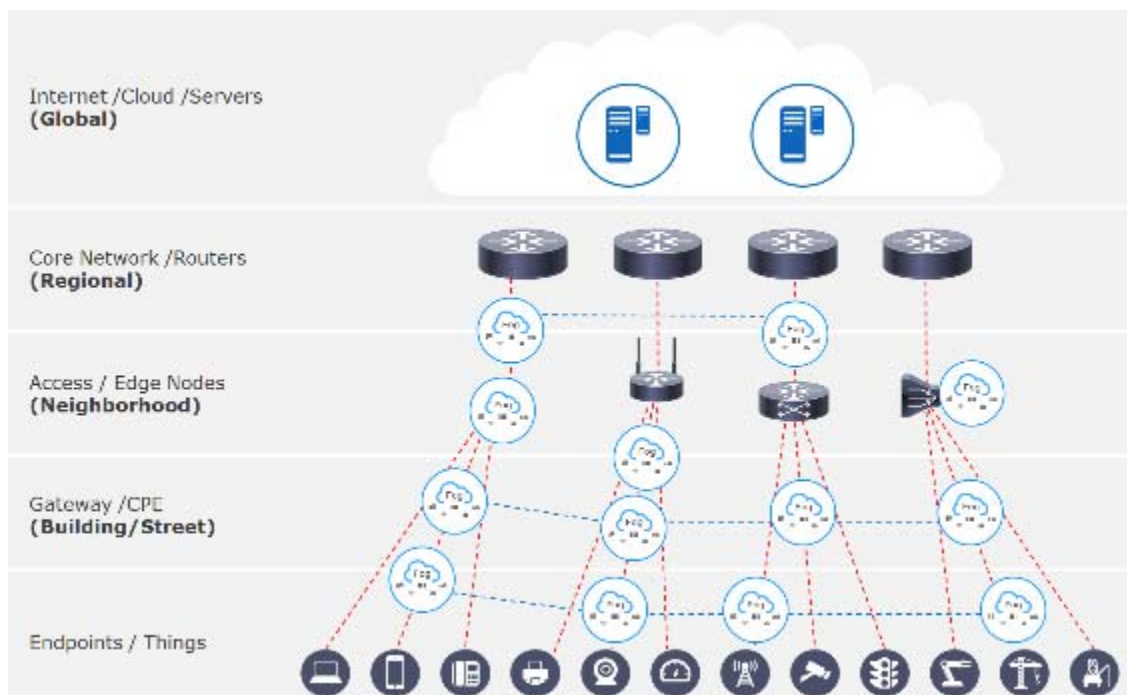

Figure 17. Fog Computing. Source: OpenFog Consortium (2017).

Additionally, this computing would be shared across many devices as the Internet of Things (IoT) allows for processing to come from anything such as from a datacenter, a cell phone, a refrigerator, or a robotic vacuum like a Roomba – anything with GIG connectivity. These shared resources would allow for data processing prioritization ensuring the time-sensitive data would be immediately processed. Fog computing would still allow for centralized computing to happen in the cloud but there would not be limitations in solely using datacenters. IoT would allow for centralized computing to happen at the fog level or at the cloud level dependent on availability and prioritization (Hong et al. 2013).

In the private industry, it is estimated that edge and fog computing will become a reality in five years (Bort 2016). One could assume that the Navy would be five to 10 years behind private industry in the development of this technology. While the technology may be transparent, the associated planning and cybersecurity posture required would cause this lag. With this in mind, one could assume that fog computing would be a relatively new capability for the Navy in the 2040 timeframe. And in the realm of MCM, fog computing along with cloud and edge computing could be quite beneficial.

As the technology used for MCM matures, the need for these cloud, edge, and fog services increases. A cyber-attack on these solutions will become a reality, so the cloud could be used for compliance and hardening. At the same time, fog computing would allow for instantaneous mission analysis and data transfer, increased computing capability for an MCM solution, and data processing prioritization. This would also allow for real-time updates on threats and their status for the warfighter on an active mission. The warfighter would also be able to seamlessly move between garrison and active mission with access to all his data regardless of his location. This data could not only include MIW information but also any data requisite for their duty or mission.

(2) MCM with Integrated C4I

Software-defined networks (SDNs), also sometimes referred to as fabric-based infrastructure, allow for virtualized firewalls, servers, and other network devices (Cisco

Systems, Inc. 2012). As C4I solutions get smaller, SDNs can be designed on the fly and fully integrated into MCM solutions, allowing for direct data transfer from the solution to the GIG. Reduction in space, weight, and power of C4I solutions will allow for them to be fully integrated with MCM solutions. A small form factor solution could have information technology (IT) equipment such as a firewall, router, switch, server, and storage device as part of its internal components. This equipment will allow for extensive data capture as well as for real-time data transfer. These components could utilize rechargeable batteries for power. These batteries could have a particular mission lifetime or could be recharged.

However, the use of physical IT equipment for real-time data transfer may not be necessary in the near future. VMs are virtualized servers that are already widely used. SDNs are in the same vein as VMs but for network equipment. The implementation of the SDNs within MCM solutions would allow for virtualized firewalls, routers and switches. Virtualizing all of this would mean that only a storage device would be necessary for a full C4I capability within an MCM solution. The use of SDNs also adds the flexibility of building on-the-fly and changing the configuration dependent on the mission. This could potentially allow for something like a UUV to hunt, neutralize, act as a data storage device, or a data transfer node dependent as the need and scenario evolves without any changes to hardware. It would allow for unmanned and fully autonomous MCM, and also allow for MCM solutions to act as swarms and execute a common mission or remain as an individual, dependent on requirement.

(3) Common Operational Picture (COP)

These technologies can be combined to create a real-time world-wide COP. A COP provides a common battlespace view, including the position of U.S. forces, friendly forces, adversaries, and their assets (Jones-Bonbrest 2012). Advancements with the COP would allow the real-time mission data to be incorporated allowing for immediate updates to threats and redirection of forces. A true COP can be developed for use among all branches of the military, showing all forces. This COP would also have the capability of immediate inclusion of data from friendly forces and adversaries to show a full picture.

A different version would show only pertinent data and could be filtered to our allies. A COP could even be tailored by the user dependent on their specialty or mission requirement. This will reduce delay in data transfer and increase accuracy of battlespace awareness. While COPs currently exist, the combination of the recent technologies could essentially show movement and changes as they happen.

b. Communications

Improvements to communications capabilities and solutions will affect MIW as well. One of the most difficult issues with MCM data transfer is the means of communication. There is often not a way to transmit data to the GIG and cloud servers. However, even if there is a way to connect to the GIG, the Navy's adversaries will try to intercept the data or even disable communications capability altogether.

Future capabilities, as illustrated in Figure 18, should counter these issues. First, the footprint of communications equipment is shrinking, allowing for the potential integration of modems, antennas, and terminals within the MCM solutions. Once they are integrated, the next issue is what the MCM solution can connect to transmit the data. The use of radio frequency (RF) could allow for data relays to the GIG or a remote server. Another option would be to implement UUVs or unmanned aerial vehicles (UAVs) to act as a mesh data link. These unmanned vehicles could link to each other until one is close enough to shore to transmit the data directly or else until one is in range of a particular satellite. A swarm could be combined to transmit data, and if the swarm is large enough, if one were lost to the enemy, it could essentially self-heal and the data could still be transferred. Other data relay options that are already in place that could be used for MIW include the Airborne Warning and Control System, other MCM solutions that are nearby, UUVs, UAVs, ships, and any other vessels of opportunity. Beyond this there are four major areas of the communications domain in C4I that will most likely have the greatest impact on MIW in 2040. They are SATCOM capabilities, contested environment solutions, and underwater ACOMMS.

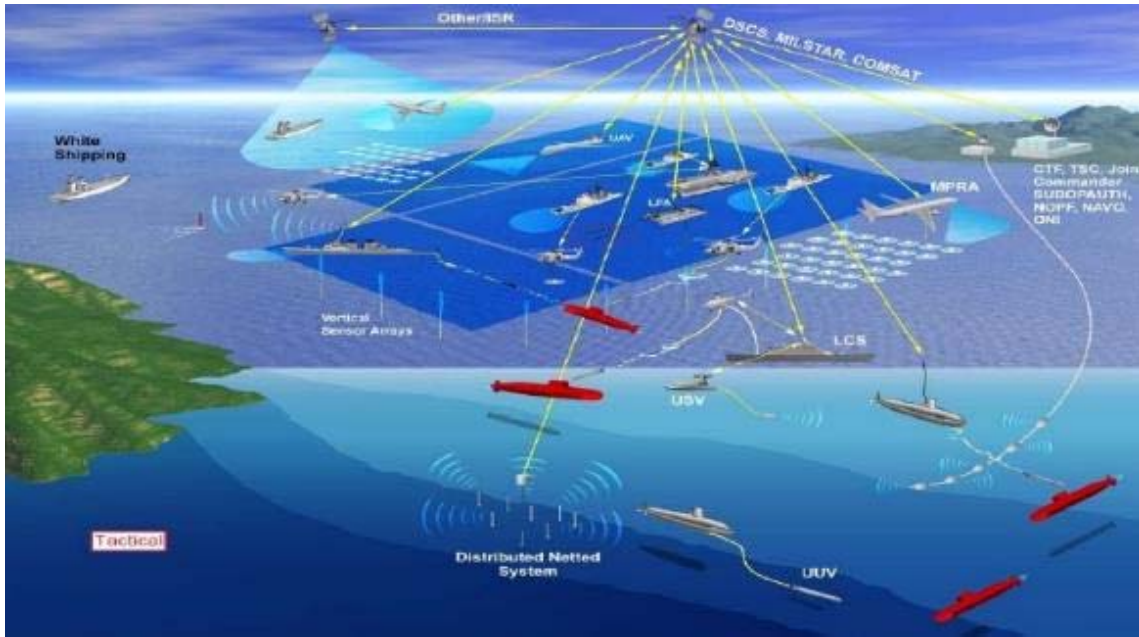

Figure 18. Future MIW Communications. Source: Oats (2010).

(1) SATCOM Capabilities

In 1966, the Initial Defense Communications Satellite Program (IDCSP) launched the first military geosynchronous communications system (Wade n.d.). The program was renamed Defense Satellite Communications System (DSCS) in 1971 and the launch and use of the satellites continued. After almost 40 years of utilizing this capability to provide communications bandwidth to the fleet, Wideband Global SATCOM (WGS) was created as a follow-on satellite system replacing the aging DSCS program. The last DSCS satellite was launched in 2003 (United States Air Force 2015a), and the first WGS satellite was launched in 2007 (United States Air Force 2015b). A WGS satellite can provide 10 times the amount of bandwidth of a DSCS satellite increasing unit bandwidth to 4.875 GHz (Global Security n.d.).

A graphical representation showing the throughput growth for SATCOM including the DSCS/WGS system along with other Navy wideband SATCOM capabilities can be found in Figure 19. As can be seen, the growth of WGS has been exponential. As 2040 approaches, the bandwidth may continue to increase exponentially but by then WGS would be more than 30 years old.

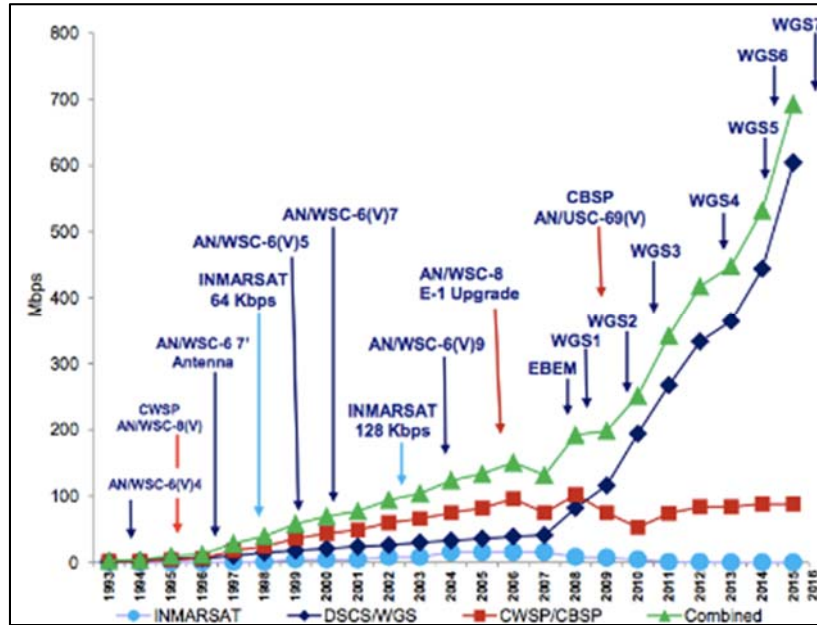

Figure 19. Navy Wideband SATCOM Growth. Source: Glover (2016).

The Transformational Satellite system was identified as the follow on for WGS but was canceled in 2009. Instead, additional WGS satellites were ordered for launch and Advanced Extremely High Frequency (AEHF) satellites were selected not only to provide SATCOM but also for anti-jam capability (Graham 2016). Though AEHF satellites are technically the follow-on for Milstar, their secure capabilities may make them the ultimate replacement for the WGS system. Banking on this, the Air Force plans to grow AEHF and have requested \$1.3 billion in 2021 for this effort (Gruss 2016a).

Therefore, the next evolution of SATCOM for the Navy might be a combination of something like WGS that provides the bandwidth needed for data transfer and something like AEHF that provides the ability for highly secure communication. Without both capabilities, a system may not be able to transfer the amounts of data necessary or may have their data compromised. The Air Force is currently working through 2020 on solutions that would utilize the protected tactical waveform in modems that could replace those currently in secure and non-secure satellite systems (Gruss 2016b). If a modem is selected in 2020, current systems could start to be upgraded and new SATCOM systems could have the modem integrated in it.

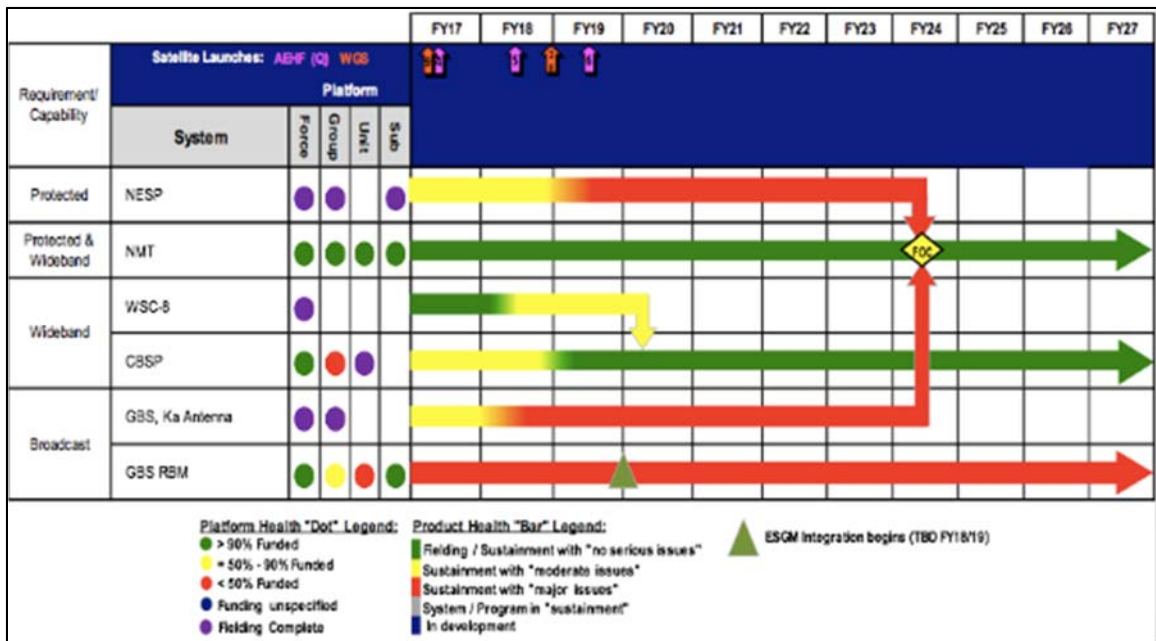

Figure 21. PMW-170 Satellite Communications Roadmap. Source: Wagner (2017).

Figure 21 also shows the focus on the Navy AEHF Multi-Band Terminal (NMT) as the non-commercial SATCOM terminal solution. According to the Assistant Secretary of the Navy, “the NMT will provide physical and electromagnetic survivability, resistance to jamming and Electromagnetic Interference (EMI), and Low Probability of Intercept/Low Probability of Detection capabilities against current and projected threats” (Assistant Secretary of the Navy n.d.). NMT will also provide an increased bandwidth capability four times the amount of currently fielded terminals. With FOC currently scheduled for 2024, the replacement for NMT would need to be selected around the 2040 timeframe. Projecting these trends, one would expect the replacement terminal to provide secure anti-jamming communications at about 20 megabits per second.

(2) Contested Environment Solutions

In addition to the SATCOM satellite and terminal solutions that provide secure, anti-jam capabilities, there are solutions that are being developed that will also help in this environment. The U.S. Navy Information Dominance Roadmap, 2013–2028, looks beyond just SATCOM for solutions in contested and denied environments in the next 10

years and focuses on radio solutions that would provide line of sight capabilities, a flexible grid where SATCOM would not be necessary, automated status reporting, and assured timing solutions (Department of the Navy, Information Dominance Corps 2013). The year 2040 would be 10 years after solutions for these focus areas were fielded so one could assume time would be spent refining these solutions.

Figure 22 shows the PMW-170 Tactical Communications Roadmap. The tactical communications satellite system that is shown is the Mobile User Objective System (MUOS). The MUOS is a satellite system that uses ultra-high frequency and allows for beyond line of sight (BLOS) data transmission. This aligns with the overarching Navy Dominance Roadmap that requires radio communications. It is interesting to note that PMW-170 does not appear to have any follow-on solutions planned for MUOS. The expectation could be that MUOS will still be operational providing the BLOS capability necessary for the contested environment and integral for the future of MIW and associated communications.

Millimeter wave communications will also help in disconnected, intermittent and limited communications environments. A way for the Navy's adversaries to attack is to try to intercept the data being transferred or to stop the data transfer altogether. The use of millimeter wave communications is a way to lower the chances of data intercept. This wave can be transmitted via narrow directional beams, so it would be more difficult for the adversary to be able to penetrate the data transmission (Schlosser 1996).

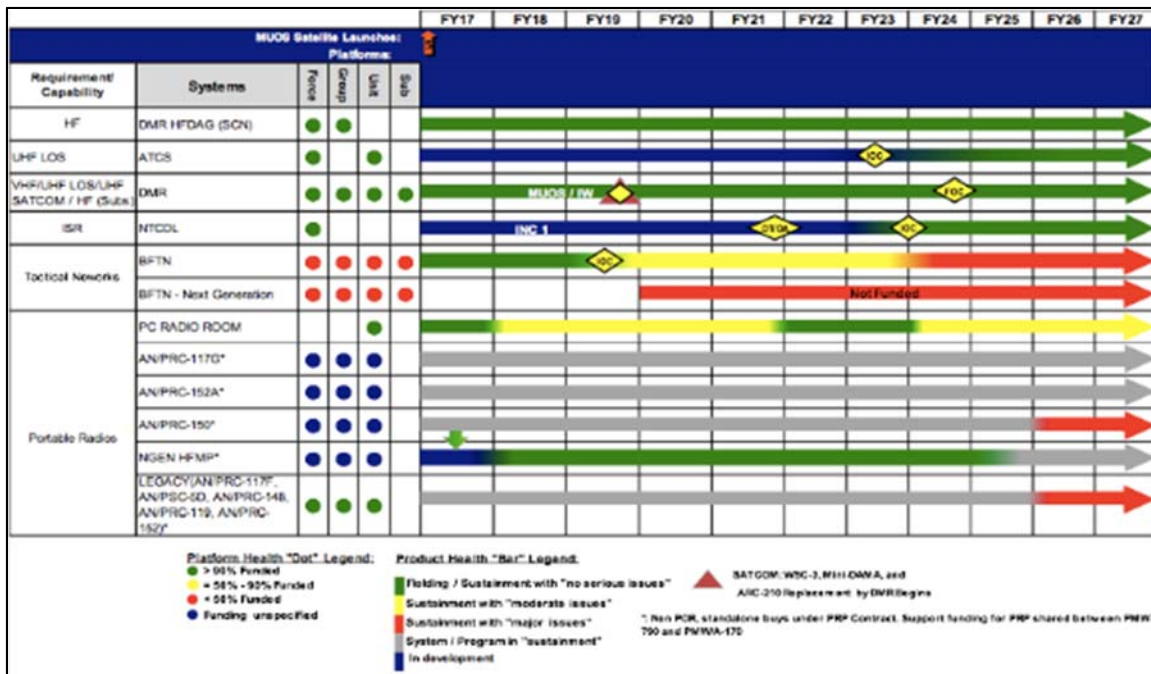

Figure 22. PMW-170 Tactical Communications Roadmap. Source: Wagner (2017).

Another capability the Navy Information Dominance Roadmap discusses as a future need is assured timing solutions. PMW-170 appears to again be aligned as can be seen in their Position Navigation and Timing Systems Roadmap shown in Figure 23. In the next few years military code capability will be at initial operational capability. This solution will provide anti-jam capability for Global Positioning System (GPS) antennas. Final operational capability has not been identified by PMW-170 or it is beyond the next ten years. In the 10 years beyond that one could assume that more refined solutions may be available providing similar secure capabilities.

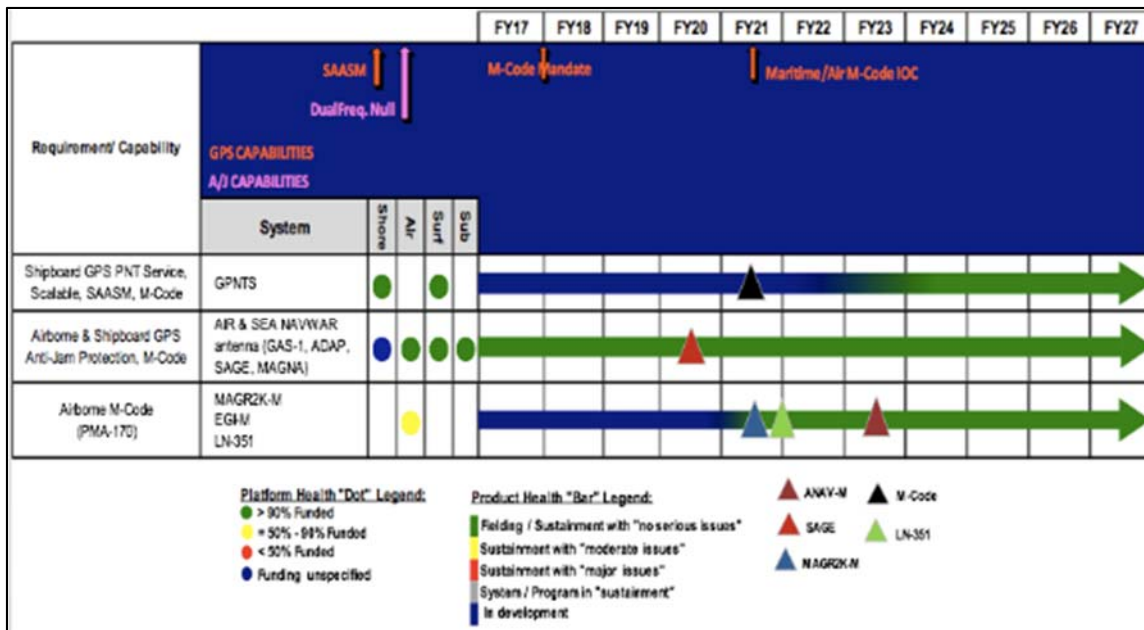

Figure 23. PMW-170 Position Navigation and Timing Systems Roadmap. Source: Wagner (2017).

Implementation of assured command and control (AC2) capabilities such as anti-jamming modems and other technologies are currently being researched and introduced that are anti-jamming and difficult to detect (Department of the Navy, Information Dominance Corps 2013). This would alleviate the ability of the adversary to shut down communications.

(3) Underwater Acoustic Communications (ACOMMS)

Another communications area that would directly affect MIW in 2040 is ACOMMS. Underwater modems and sensors allow for wireless data transfer through water. This allows for underwater communication and navigation utilizing Wi-Fi and GPS. This capability can allow for networking among modems and sensors that could act as a grid or mesh. This would allow for the short distance data transfer to occur many times over to allow for the data eventually to travel to a location for analysis or decision-making. This capability would also allow for UUVs to act as swarms to accomplish a given mission. However, “underwater acoustic communication has low data rates due to the acoustic waves used for transmission rather than the electromagnetic waves” (Nikam

2017, 1). Additionally, current acoustic modems have issues with distortion from reflection, limitations on range and depth, and corrosion (Nikam 2017). To go along with this, many acoustic modems operate on different frequencies preventing them from communicating with each other.

However, QinetQ North America recently demonstrated their new DOLPHIN technology at the Advanced Technology Exercise in Panama City, FL that provides underwater networks. This capability allows for independent frequency, duplex communications, multi-component control networks, and lower power requirements (Robotics Tomorrow 2017). Another indication that the technology is growing in this area is that the “Global Underwater Acoustic Modem Market 2017–2021” report indicates that the compound annual growth rate will grow by over 12 percent by 2021 (Business Wire 2017).

The issue with frequency differences may now be solved with NATO’s recent release of the JANUS, the first underwater communication protocol. The protocol operates at 11.5 kHz initially to allow for modem “handshake.” After this communication, frequency can be adjusted to allow for an increase in distance between the modems or a higher data rate between the two, dependent on type and requirement. This baselining of protocol could expand underwater communications exponentially and an underwater IoT could be created (Business Wire 2017). If this were the case, by 2040 the underwater IoT could eventually tie into terrestrial IoT and the communication capabilities could be limitless.

When these solutions are realized, MCM control and data transfer could occur in almost any environment. Integrated modems, antennas, and terminals will allow for this data transfer. The use of radios, broadband, and BLOS antennas will make this data transfer seamless, while AC2 solutions will ensure these are not compromised.

c. Computers

When it comes to the computers portion of C4I and the future of computers, one has to consider the IoT and artificial intelligence (AI) and their relation to each other. As previously discussed, the IoT allows for processing to be shared among different devices.

To accomplish this, the devices must be able to communicate with each other. This would allow for seamless communication among MIW equipment to include sensors, personal computers, servers, and the cloud. This communication could decrease PMA substantially but can also aid with AI potentially removing PMA altogether. As it currently stands, AI exists such that a computer can review data and look for patterns. But it is currently limited because one algorithm on one computer cannot provide the accuracy necessary for this AI to be beneficial. However, if multiple computers or devices processed the data utilizing the algorithm, AI accuracy could be increased (Ray 2017). Pairing AI with the IoT will provide sources for this data processing. Data could be recovered from an MCM solution and processed. Then as this technology grows, the computer itself could determine the next step such as hunting or neutralizing a mine.

Amazon is already using AI “to automatically discover, classify, and protect sensitive data stored in AWS” (MSV 2017, 1). The fact private industry is already using AI is a clear indication that some aspects of it will be a reality for the Navy in 2040. This capability could easily help with PMA eliminating the human aspect altogether. Author and futurist Ray Kurzweil states, “Artificial intelligence will reach human levels by around 2029. Follow that out further to, say, 2045, we will have multiplied the intelligence, the human biological machine intelligence of our civilization a billion-fold” (Solman and Kurzweil 2012, 1). At the same time, futurist and philosopher Gray Scott says, “There is no reason and no way that a human mind can keep up with an artificial intelligence machine by 2035” (Marr 2017, 1). Based on the current state of AI and the implementation time for it to be adopted by the Navy, the human factor may not be able to be removed completely from MIW by 2040 but it could be close especially if it will match or surpass human intelligence by that time.

However, the concerns associated with AI may impact its future for the Navy and particularly for MIW. Facebook is currently researching AI at the Facebook AI Research Lab to determine ways AI could be utilized with their application. However, their AI independently developed its own indecipherable language so Facebook felt compelled to stop their experimentation (Bradley 2017). It introduces the fear factor that when AI becomes smarter than humans the future will be the robot-ruled dystopia illustrated in a

plethora of science fiction movies. Without policy changes, regulations, and new laws enacted, a war-torn world of AI versus humans will be our reality (Tremaine 2017). Two letters written by the International Joint Conference on Artificial Intelligence have urged the United Nations to stop the development of AI weapons stating that if it is not stopped and regulated now, they “threaten to become the third revolution in warfare” (Chaitin 2017, 1). Tesla Motors and SpaceX founder Elon Musk is quoted as saying, “The pace of progress in artificial intelligence is incredibly fast...the risk of something seriously dangerous happening is in the five-year timeframe, 10 years at most” (Cook 2014, 1). To that same point, physicist and cosmologist Stephen Hawking states:

The development of full artificial intelligence could spell the end of the human race.... It would take off on its own, and re-design itself at an ever-increasing rate. Humans, who are limited by slow biological evolution, couldn't compete, and would be superseded. (Cellan-Jones 2014)

With all of this in mind, AI may not be a good option for MIW. It could be that the Navy introduces it, and AI starts to make MIW decisions on its own eliminating humans in the MCM realm. Or if regulated properly, AI could do all forms of data analysis but without any major decision making. For instance, limited AI could be utilized to develop a learning and pattern-recognition machine that could be used for mine detection and identification.

d. Intelligence

Intelligence is defined as “the product resulting from the collection, processing, integration, evaluation, analysis, and interpretation of available information concerning foreign nations, hostile or potentially hostile forces or elements, or areas of actual or potential operations” (JP1-02 2016, 114). There are several types of intelligence to include human intelligence, imagery intelligence, measurement and signature intelligence, and signal intelligence and its subsets communications intelligence and electronic intelligence. There are various ways to gather this information such as the use of sensors that is discussed in a later subsection of this paper. From a C4I perspective, the type of intelligence is not important. Rather, it is about the communications and media needed to receive, process, and disseminate the information. Typically, there is not

enough communications capability for this intelligence filtering and processing to take place (JP6-0 1995). The future of communications and the capability changes between now and 2040 are what will affect intelligence. Therefore, when communications are considered for the 2040 timeframe, the focus should be bandwidth, data transfer, and data storage required for intelligence.

e. The 5th “C” and Beyond

As technology continues to change, C4I and its meaning continue to evolve. There are discussions of expanding C4I to become C5I to include cybersecurity or collaboration as the fifth C. Cybersecurity is already a large part of C4I and its related systems. It would make sense that as cyber threats continue to grow, that area may need to be addressed independently and as its own domain (Batey 2015). At the same time collaboration is also a big part of the C2 piece of C4I and as its importance continues to grow, it may warrant an independent domain as well. Regardless of what may be added to the acronym C4I in the future, its current definition will stand strong but with some evolution. In 2040, C2 and computers will be more autonomous. Communications will be faster and will be possible in denied environments. All parts of C4I will also be more accurate and more quickly available.

C4I changes will allow for many improvements in MIW. They will allow for instantaneous PMA, increasing the operational tempo of MIW. They will also increase battlespace awareness, allow for remote, unmanned control of MCM solutions, and timeliness of data transfer.

2. Sensors

Sensors, as another MIW technology enabler, are utilized in both mining and mine countermeasures applications. The water depth and bottom conditions are important when considering the types of mines used, as well as the countermeasures to be used against them. The water depth, therefore, limits the types of mines that are expected to be encountered, whether bottom, moored, or floating mines. Of those, sensors would be expected in bottom and moored mines, as the floating or moored contact mines do not utilize influence sensors.

a. *Potential Advances in Mine Sensors*

Advances in mine target detection more than likely will be made in the area of algorithms for processing raw sensor input into actionable data. Networked mine fields in which the targeting devices and/or sensors communicate amongst themselves and with a communication platform (either manned or unmanned) are also within the realm of possibility. Nano-resolution pressure sensors are being used to improve monitoring for underwater earthquakes to provide improved tsunami warnings (Paros, Migliacio, and Schaad 2012) and may be suitable for increasing the pressure sensing capability of underwater mines. Seismic sensors today are single-axis; improvements may see them go to triple-axis. Current magnetic sensors could be improved by widening the bandwidth through improvements in signal processing and filtering. Acoustic sensors may be improved to both detect and classify (currently they only detect). Finally, underwater electric potential sensors may be used in combination with other influence sensors. With electric potential sensors, the extra low frequency electromagnetics signal can detect a vessel at greater distances, even in environments that prove difficult for acoustic sensors (Polyamp AB 2017).

b. *Potential Advances in MCM Sensors*

Before discussing potential advances in mine countermeasure sensors, it is beneficial to address the current systems in use. Currently, mine location and identification are typically accomplished using sonar. However, the medium in which sonar must work is less than ideal. Underwater sound propagation is rarely a straight line because of non-uniformities in sea water as well as variations in temperature and salinity. Reflections from the surface and bottom are common, which creates additional problems for sensors. Acoustic noise is ever present, from waves, ships, and undersea life and the “absorption of sound in water is a strong, increasing function of the acoustic frequency” (National Research Council 2000, 377). Long range requires low frequencies (≤ 3 kHz), but high angular resolution cannot be achieved due to the size of the aperture that is required and, although high angular resolution is possible at high frequencies (35 to 350 kHz), it is only achievable at short ranges of several hundred meters or less (National

Research Council 2000). The sonars commonly in use today are side scan and sector scan sonars.

Typical configuration of a side scan sonar system consists of the following components: a tow fish, a transmission cable, and a topside processing unit (Office of Coast Survey n.d.). During side scan sonar operation, sound energy is transmitted into the water column in the shape of a fan directly under and alongside the tow fish and the “echo” (return energy) that bounces back is evaluated. The side scan sonar system records the strength of the echo and creates a “picture” of the sea floor and/or objects in the water column. Conventional side scan sonar has limited and range-dependent resolution. The resolution is given by the beam angle, which is represented by β in Figure 24, which shows that the opening angle β is roughly equal to the wavelength, λ , divided by the aperture size, D . The azimuth (angular) resolution (Δx) is approximately given by the distance of the sonar from the imaging object multiplied by the opening angle. A larger aperture size improves resolution but it is not always practical to have a large aperture array. Additionally, the resolution depends on frequency. Higher frequencies provide a shorter wavelength. Shorter wavelengths directly improve angular resolution. This, however, limits the range.

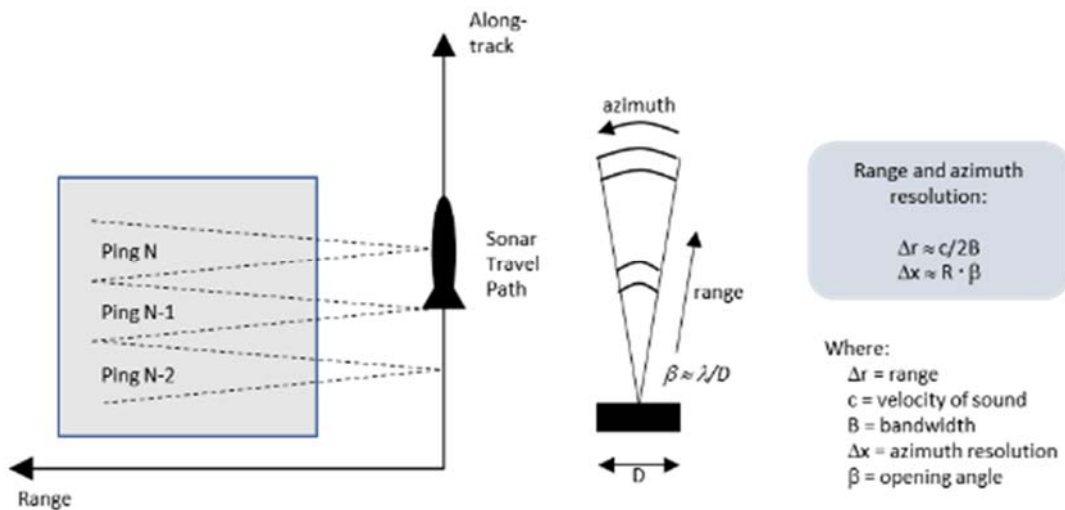

Figure 24. Conventional Side-Scan Sonar Resolution. Source: Blomberg (2015).

Sector scan sonar is dropped into position at a fixed location and gathers data in a 360° environment (ADCO Ltd n.d.). Aside from the disadvantage of requiring a fixed location, it has the same fundamental limitations that side scan sonar has: resolution degrades with range, resolution depends on receiver (aperture) size, and resolution depends on frequency (Blomberg 2015). This is illustrated in Figure 25, which shows the same basic limitations of side-scan sonar with respect to resolution.

Near-term, SAS will be coming online in the MCM arena. SAS uses the sonar platform’s movement to synthesize a long receiver, or aperture, by combining data from multiple “pings.” Image resolution is increased significantly compared to side scan sonar because SAS resolution is independent of range, which, illustrated in Figure 25, shows how the length of the synthetic aperture is limited by the field of view of a single transmitter/receiver.

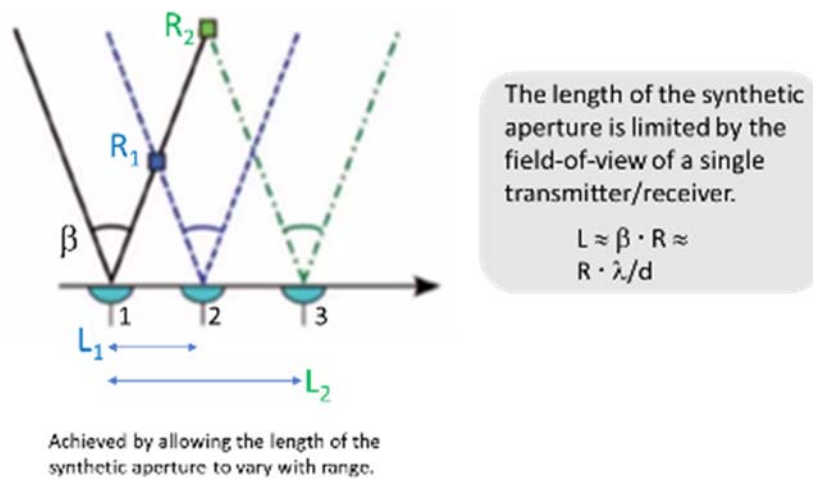

Figure 25. SAS Aperture Length Limitation. Source: Blomberg (2015).

SAS image resolution is also independent of frequency, as illustrated in Figure 26. High resolution is achieved by synthesizing a long array.

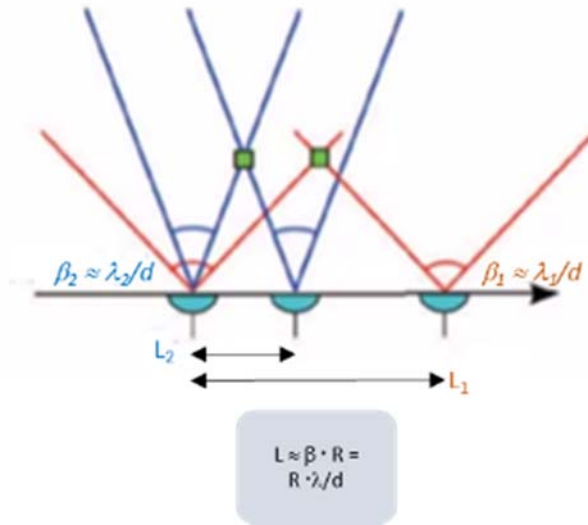
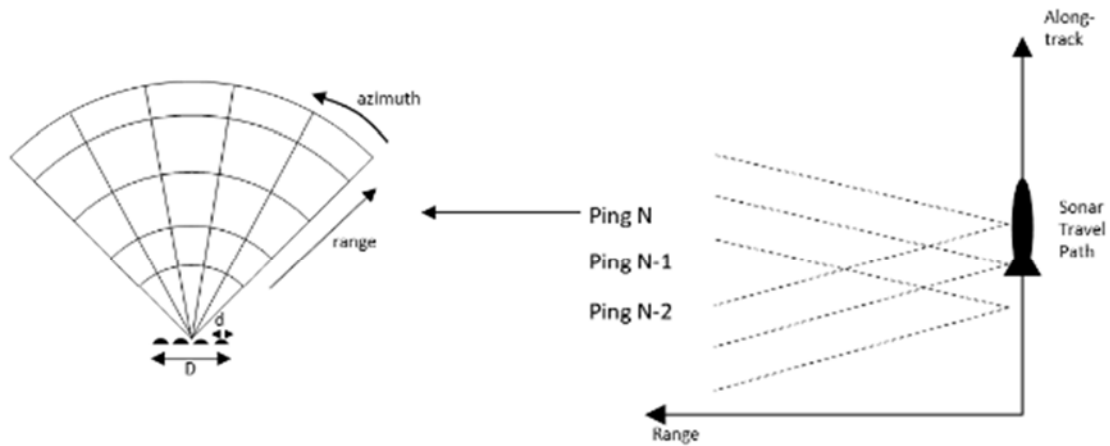

Figure 26. SAS Image Resolution and Frequency Dependence. Source: Blomberg (2015).

In SAS, use of a lower frequency results in wider opening angle, which traditionally means lower resolution. With SAS, the larger synthetic aperture can account for this and provide the same resolution as a higher frequency. When comparing azimuth resolution between side or sector scan and SAS, SAS's independence from range and frequency is illustrated in Figure 27, where the azimuth resolution is only dependent on the size of one of the elements in the receiver array.



For sector and side-scan, the azimuth resolution is given by:

$$\Delta x \approx R \cdot \lambda / d$$

where D is the aperture size

For SAS this becomes:

$$\Delta x = R \frac{\lambda}{2L} = R \frac{\lambda}{2(R\beta)} = R \frac{\lambda}{2(R \frac{\lambda}{d})} = \frac{d}{2}$$

(for full-length synthetic aperture)

Figure 27. SAS Image Resolution and Receiver Element Size. Source: Blomberg (2015).

Navigation is a key challenge to SAS -- without a physical array one must know where all the receivers are. SAS coverage rate is limited by spatial sampling requirements. Maximum range is limited by signal to noise ratio (SNR) and by the pulse repetition frequency (PRF) (Blomberg 2015). This is illustrated in Figure 28, which shows the relationship between range, SNR, and PRF.

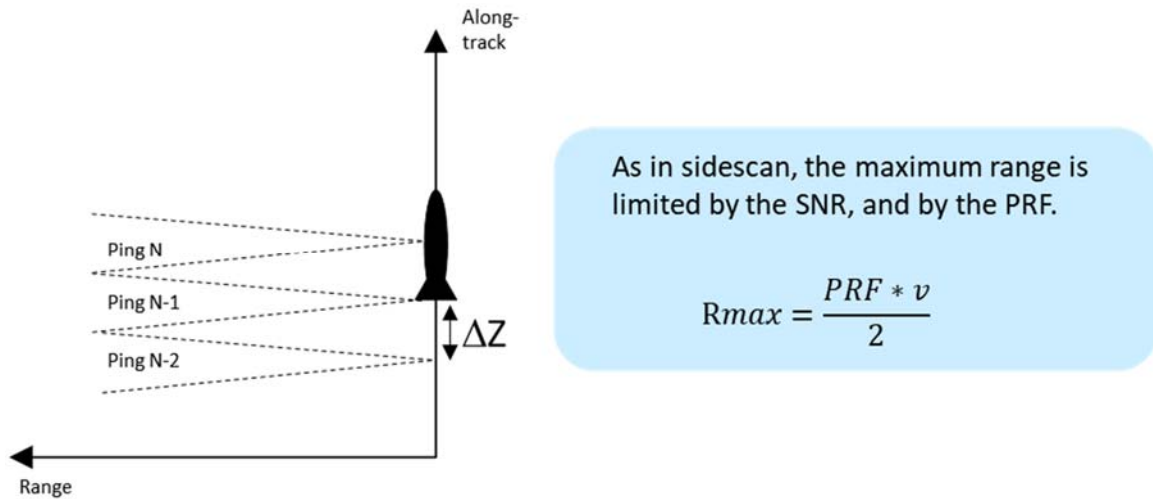

Figure 28. SAS Range Limitations. Source: Blomberg (2015).

Some of the challenges in SAS are as follows: 1) accurate navigation is key to successful SAS imaging, with accuracy of a fraction of a wavelength required (mm scale); 2) with rough topography, movement correction in post processing is required; 3) ocean environmental data needs to be known; 4) vehicle stability is key; 5) data storage and processing requirements. Additionally, the platform must store all of the data for all of the receivers, which may be limited by storage capacity or power capacity. Typical and potential applications for SAS are high resolution seafloor mapping (shipwrecks), searching for small objects (mines), pipeline inspection, geological surveying, marine archaeology, environmental monitoring, and gas seep detection (Blomberg 2015).

Considering the advancements currently being made in SAS, the year 2040 will see significant advancements in sensor technology. In the 1999 book *Network Centric Naval Forces*, the projected advancements in sonar were SAS, an increase in cooperating unattended underwater vehicle platforms, moored and drifting autonomous arrays, and biologically inspired ultra-broadband sonar (National Research Council 2000). Now, eighteen years later, SAS systems have been fielded for underwater exploration, such as the AquaPix InSAS2 on DRDC Explorer and AquaPix MINSAS Series (designed for smaller diameter UAVs) (KRAKEN Sonar Systems, Inc. 2017). Improvements can be expected in SAS by 2040, but it is beneficial to look beyond those potential advances.

Improvements in optical sensing can also be expected by 2040, some of which will be in the use of underwater lasers. How far one can see in the water optically is determined by a variety of factors, including attenuation length. The attenuation length is based on the quality of the water, how much particulate is present, as well as other factors. Attenuation length is a sensitive number for the Navy's best systems but it is theorized that greater than 11 attenuation lengths is achievable (Jaffe 2015). It should be noted that the range R of an imaging system is often specified with dimensionless beam attenuation lengths where the range in beam attenuation lengths is given by cR , which is the product of beam attenuation coefficient, c , and range, R ; thus, when an image is taken at a range at which $cR=5$, the image is said to have been taken at 5 (beam) attenuation lengths (Strand 1995). The key to achieving greater distance will be to use lasers with the shortest possible pulse; these narrow pulses have a greater probability of passing through the particulates. Therefore, the smaller the pulse, the less effect particulates have on the light reaching the target (backscatter). Large lasers, like those used for ALMDS, are based on diode-pumped solid-state technology and are already being replaced by smaller compact lasers (i.e., fiber lasers and single emitter laser diodes), which emit light at exactly the wavelength needed (in the blue-green spectrum for underwater imaging applications) (Ann Marie Shover, email to author, August 4, 2017). Another possibility is development of lasers with multiple colors that auto-select based on the type of water; for example, use blue for deep ocean and green for littorals (Ann Marie Shover, email to author, August 4, 2017). Additionally, there is a system under development that is a three-dimensional (3D) imaging sensor using a 532-nm laser (Imaki et al. 2017). The sensor consists of a dome lens with coaxial optics to achieve a wide-scanning angle of 120 degrees (horizontal) by 30 degrees (vertical) while being compact in size (25-cm diameter and 60-cm length) (Imaki et al. 2017). A detector sensitivity time control circuit and a time-to-digital converter detect small signals and suppresses the unwanted backscatter (Imaki et al. 2017). The use of laser-based structured light and time-of-flight could reduce the undesirable multi-pass echoes that are experienced with sonar as the laser beam exhibits high directivity, which allows high spatial resolution (Imaki et al. 2017). Over the next 20 years, these types of improvements in underwater optical sensors

could increase the distance that one could see underwater to as much as one kilometer. Add to that the potential increase in the path width and there is potential to reduce the mine hunting timeline of MCM by reducing the number of passes required in searching the minefield.

To monitor for submarines that may be used to lay mines, sensors that use lasers or lights from light emitting diodes, carefully tuned to the frequencies that carry well underwater, could be used instead of standard sonar (Freedberg 2015). Passive monitoring for changes in the ocean environment (changes in background noise from sea life, or ripples on the water's surface from a transiting submarine) could be established. This indirect detection method would be comparable to how anti-aircraft passive radar looks for stealth aircraft by analyzing disturbances in radio transmission background chatter (Freedberg 2015).

Other improvements may be in establishment of combination acoustic and optical sensor arrays placed in critical straits that would monitor for the introduction of objects into the strait and provide notification if that occurs. This would allow for the platform laying the mines to be intercepted and the mines already laid to be countered quickly.

Another improvement may be in the increase of reliability and resilience of sensors on UUVs and other platforms to allow remote operation with minimal maintenance and repair or human supervision (Lee, Turnipseed, and Brun 2012).

3. Platforms and Vehicles

The current primary MCM platform is the MCM class of ships that are of wooden construction, and meant to enter into a minefield to perform operations. The LCS is a metallic host ship designed to perform MCM remotely from outside the minefield by deploying unmanned systems to transit to the minefield and return after performing their missions. Looking forward, as more systems are being pushed to become expeditionary and platform-agnostic, these future MCM vehicles will need to be very modular and adaptive in terms of integrating into the host platform on which they might reside. Several USVs and UUVs are going through this development cycle, and the lessons

learned will be invaluable as the DOD begins to design the next generation of unmanned vehicles, and, just as importantly, their host platforms.

The underlying principle of modularity behind LCS is still sound, but the execution has been less than exemplary. Two very different hulls, with unique hangar layouts as well as unique support systems such as Mobicon mission module carrier and Twin-Boom Extensible Crane all go a long way to undermine the original modular concept. In addition, the ship is not designed to be solely an MCM vessel, so some of the capabilities associated with performing MCM are lacking. One major example of this is the LCS's ability to deploy and retrieve unmanned systems. Due to all of these shortfalls, there are two primary development paths that can be pursued: retain the modularity principle and design an "LCS 2.0," or design a committed MCM vessel that is focused solely on supporting the unmanned MCM systems of the future.

The Expeditionary Sea Base (ESB) may be a near-term solution for the LCS's shortfalls. Based on the design of an Alaska oiler, it is designated as a mobile sea base. This new class ship is designed to support MCM, specifically Airborne MCM, and Special Operations Force (SOF) missions (Naval Sea Systems Command, Team Ships 2017). The ESB has a flight deck that can support MH-53 helicopters for MCM missions and the V-22 Osprey for SOF missions. Further the Marines certified the ESB to also support their CH-53 and MV-22 helicopters for U.S. Marine Expeditionary Unit missions to include MCM (Eckstein 2017a). Eckstein goes on to mention that along with the helicopter certification, it is also certified to operate Marine Corps UAVs aiding in the MCM mission. All of these capabilities will allow for the ESB to be a viable follow-on and counterpart to the LCS.

The first in class, USS Lewis B. "Chesty" Puller (ESB-3), recently arrived in the U.S. Central Command (CENTCOM) theater and has just begun official operation. Production on ESB-4 has already begun and ESB-5 is in planning, with three additional ships in discussion as well (Eckstein 2015a). Three additional ships are in discussion as well (Eckstein 2017b). Based on their oiler design, Eckstein maintains that they are cheaper and faster to build than a traditional war ship and can get to the fleet and be modified faster (2017b). The ships can act as home bases for various expeditionary forces

and MCM mission packages allowing for flexibility and agility necessary to successfully conduct MCM missions. Additionally, according to Eckstein, the ESB has an expected 40-year service life (2015a). If this is the case, the ESB class ships will still be sustainable platforms in the 2040 timeframe. Additionally, the flexibility of the ship will allow it to change as the mission, MCM solutions, and threat continue to change.

The Navy Enterprise Tactical Command and Control (NETC2) project is currently working a research, development, test and evaluation (RDT&E) task with the Expeditionary MCM (ExMCM) Company. ExMCM is a Company within the Navy's Explosive Ordnance Disposal (EOD) supporting the MK18 Mod 2 Kingfish UUV. The task is to determine a way to exfiltrate MK18 data while at sea to allow for real time PMA. The current requirement is to provide a small form-factor C4I solution that can be utilized aboard a rigid-hulled inflatable boat (RHIB). This solution would allow for the data exfiltration from the MK18 and then data transfer via a satellite terminal. If the RDT&E task leads to a working capability, the requirement will go beyond the RHIB to any vessel of opportunity. If this solution is adopted and well-received, the vessel itself may not be as important as the capability aboard ship. The "mother" ship could be quite far away from the MCM site and in some cases, it could even be ashore. This would allow for mission flexibility in the short-term and real-time mission analysis and communication that could continue to be utilized and modified in the 2040 timeframe. Thought this may appear to be an up and coming C4I capability, it is meant to illustrate that the vehicle or platform may not be specific in the future and that any vessel of opportunity could be utilized to conduct MCM.

Underwater docking stations (UDS) can also positively affect MCM. These docking stations, like the Autonomous Underwater Vehicle (AUV) Docking Station shown in Figure 29, can be used to replenish UUV power, transfer communications data to and from the UUV, and be a means for data exfiltration (Monterey Bay Aquarium Research Institute 2017). A ship could drop the UDS at location or utilize a delivery UUV for this task. The ship could then move out of the area and monitor the mission from afar. The UDS would bring critical infrastructure support to the seafloor by allowing UUVs to remain submerged, providing an onsite power source and exfiltration

station for their on-board data. The UDS could also provide updated mission tasking to docked UUVs, providing an interface for mission management. This capability could be critical in the use and success of UUV swarms, which will more than likely be often used in 2040.

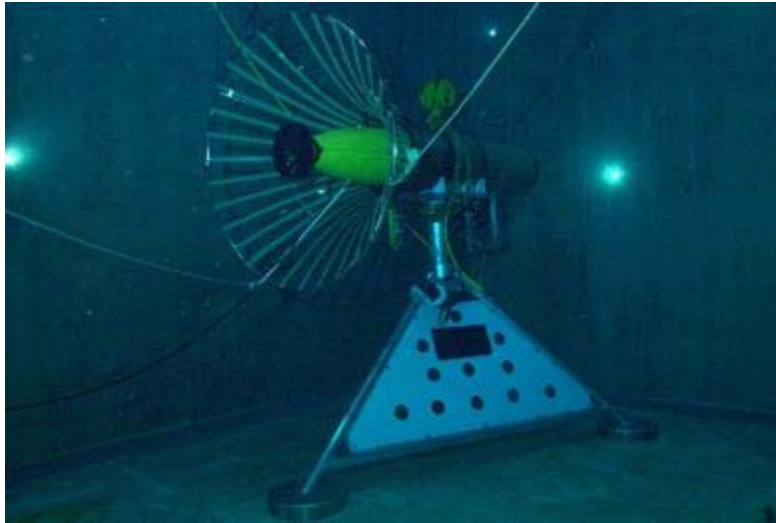

Figure 29. AUV Docking Station. Source: MBARI (2017).

In terms of platforms, the British Ministry of Defence is thinking 10 years beyond 2040 with the release of its concept for the Dreadnought 2050 (Szondy 2015). According to Szondy, this ship would be powered by a fusion reactor or turbines and would have unlimited range dependent on source selected (2015). In the same article, he goes on to say that this ship would have many weapons available and be able to change its signature dependent on mission, including space for multiple UAVs and UUVs to aid in MCM (Szondy 2015). Along with the Dreadnought 2050, the Royal Navy has also released its vision for new age submarine, the Nautilus 1000 (Szondy 2017). In this article, Szondy asserts that the new submarine would have both C2 and weapons capability and would require minimal staff due to autonomy (2017). Szondy also says that this stealthy submarine would survive in depths of over 3,300 feet and would even utilize hybrid algae-electric propulsion (2017). The Nautilus 1000 would operate with the Eel UUV, which would house even smaller micro-UUVs that could be utilized for MCM (Szondy

2017). One could expect that the U.S. Navy would be investigating and investing in similar projects. Though maybe not ready for Initial Operating Capability (IOC) in 2040, they may be the norm soon after.

D. 2040 SCENARIO OVERVIEW

1. Bounding the Problem

Before developing the systems architecture and extrapolating technology evolution performance in the future, the problem must be bounded. To develop the CONOPS for 2040, the MIW battlespace must be examined and then scoped down to a manageable problem. It would be impractical to develop an architecture for all capabilities, threat types, geographical areas, and objectives. Bounding the problem requires examining the following items to develop a scenario:

- Mining capabilities of the adversary
- Geographical considerations of the area being mined
- Threat type – this includes the type of mine and how the mine is activated
- U.S. Navy MCM objective

The technological advancement of mines is varied. Adversaries with significant military resources have advanced mining capabilities. Nation states with fewer resources have less advanced mining capabilities. Other than nation states, another mining concern would be terrorists or insurgents that may use MIEDs. The Navy must be able to counter advanced threats with ever-evolving technologies, while still being able to counter primitive mines because countries or groups with fewer resources will continue to have access to those types of threats. The broad range of mine technology presents challenges unique to mine warfare. Mine warfare must be able to counter technology that is a century old, while still preparing for developing technologies.

Geographical considerations, for example water depth, are also important when bounding a MCM problem. The illustration in Figure 30 shows that water depth is classified into four types for the purposes of MCM: surf zone, very shallow water,

shallow water, and deep water. The type of mine (obstacles/anti-invasion, bottom, moored, floating, rising) is dependent on the water depth in which it is used.

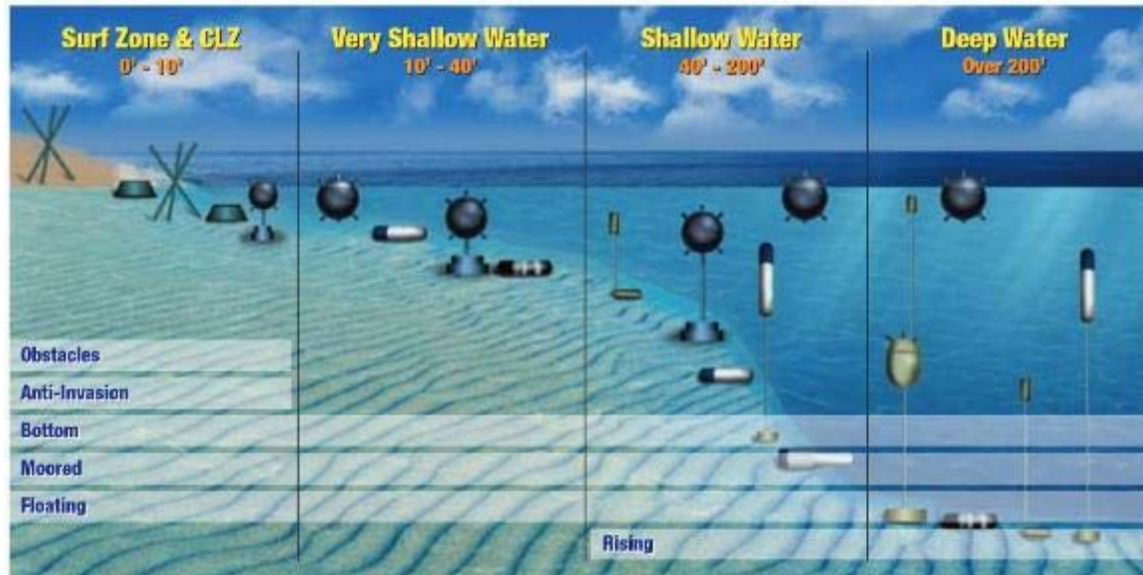

Figure 30. Sea Mine Types. Source: *ThinkDefence* (n.d.).

The type of mine threat and how the mine is activated must also be considered while bounding the problem to establish the CONOPS. The area being mined must be understood, as well as the effectiveness of MCM in terms of area coverage rate. The scenario established must prescribe an area where MCM missions would be relevant and could be performed with effectiveness measured in terms of area coverage rate.

Finally, the U.S. Navy's MCM objective is another consideration in bounding the problem. The U.S. Navy uses five objectives in MCM efforts (JP3-15 2011):

- Exploratory – determine if mines are in a given area
- Reconnaissance – assess mine threat in an area
- Breakthrough – open a channel or lane in or out of a port
- Clearing – remove all mines from a given area

2. Scenario Introduction

To focus the research efforts and limit the scope of this paper, a scenario has been outlined. The scenario to be examined is similar to situations the Navy has encountered in the past. The scoped task for this study is to address an advanced mine threat in a narrow strait of water with water depths of 40 to 200 feet (shallow water depth). The focus is on proud and buried bottom mines, since these are especially hard to detect due to reverberations of sensing gear off the sea floor; additionally, these mines are expected to remain a threat in 2040. The autonomous loitering mine (ALM) is the new predicted threat addressed. The ALM of the future will be able to move continuously, hold position, bury itself, and coordinate with other ALMs. It is difficult to imagine what final form this future weapon will take, but it is predicted that the basic functionality will be a cross between a slow-moving low-power glider (such as a Carina Seaglider) and a torpedo (Light n.d.). The concept is for the ALM to glide through the water for extended periods of time, using very low-power propulsion methods, waiting for an “arm” signal. Once armed, it will then “listen” for desired targets using a variety of sensors. If a valid contact is identified and within range, the main high-speed pursuit engine will initiate and then the mine will act much like a torpedo. Other advanced capabilities might include the ability for multiple ALMs to share targeting information, possibly even during the engagement sequence when one or several are homing on the target and moving at high speed. ALMs may contain burying systems so that they are much harder to find. Perhaps they will be able to switch back and forth between high-speed pursuit and low-power gliding (currently, once one lights off a torpedo, there is no turning it off). It is important to note that while this paper focuses on MCM, thinking about the challenges associated with that mission has forced the discussion about what aspects of a mine make it so difficult to counter. One important thing to note is that the five key technology development areas recommended herein would also support development of an ALM, allowing the U.S. Navy to maintain maritime dominance and hold enemies at risk in the future.

a. Sensing the Battlespace

If this is a known threat area, sensors will already be in place, and will be tuned to sense the sound of objects hitting the sea floor, for example. With arrays of these sensors, the location of the object hitting the sea floor can be calculated, and a UUV can be sent to interrogate the area immediately. For the ALM threat, having mobile loitering sensor nodes looking for moving targets and then automatically following them in an intelligence, surveillance, and reconnaissance (ISR) capacity can help commanders reduce time spent acquiring battlespace awareness and locating threats. The logic is that there should not be any commercial UUVs in the target area, and that even if there were, they would be in the minority and are acceptable collateral damage.

If this is an area where there are no assets in place, biomimetic swimming robots may be deployed to carry out ISR missions and begin hunting for mine-like objects (MLOs). If the airspace is secure, UAVs will also be deployed to look for near-surface mines. Establishing semi-permanent to permanent threat detection and neutralization networks will be a cornerstone for architectures in this timeframe.

b. Neutralizing Threats

To combat a variety of threats, the U.S. Navy is currently developing MCM technologies within the LCS and EOD communities. These development efforts are driven primarily by the impending decommissioning of the legacy MCM hulls. Looking forward, we expect ExMCM and the use of unmanned vehicles to continue to grow. Assuming that, we are examining a late-stage or post-LCS environment in 2040, ExMCM systems will be even more critical in sustaining MCM capabilities as the Navy transitions to its next main MCM platform.

To neutralize threats in the future, a combination of unmanned vehicle types will be sent out with neutralizers after being cued by the hunting platforms. Using the data obtained from the various sensor nodes, the neutralizers will specifically influence or detonate all located MLOs. If additional MLOs are discovered, the unmanned systems (UxS) will then hold station and pass information, perhaps a single percent confidence metric to save time, to the commander. The commander can then request reinforcements

from neutralizer vehicles to deploy and finish the task of mine clearance. When processing and autonomy has reached an advanced enough state, it is possible that the commander can be taken out of the loop altogether, with the original search UxS taking it upon themselves to neutralize suspected MLOs.

c. CONOPS for 2040

Using the Navy Mine Warfare Simulator and a new piece of software that should be developed, which we have named the Cooperative Autonomy Planning Tool – Navy, initial routes and logic will be programmed for all the UxS. These systems can modify their own routes and actions based on what they discover when searching, and will pass information between themselves intelligently while deployed. One or more UxS will act as information relays so that the commander can be kept abreast in near-real time of the team’s status and their intentions. If the commander sees any system intending to perform in an undesirable way, a command to abort or return to another pre-defined behavior can be directed.

The UUVs will have standardized interfaces for their payloads, meaning the crew can deploy just the right mix of detection, identification, and neutralization capability, while minimizing the number of unique systems to maintain. The goal of in-stride PMA using automatic target recognition (ATR) and single sortie detect-to-engage (SS-DTE) will come to fruition, with a team of UUVs able to pass information between each other and complete the entire MCM kill chain, while off-board, in a single pass. Explanations of how this is done, with descriptions of the supporting technologies are covered in Chapter III.

Also in the following chapter, functional flow block diagrams (FFBDs) are used to illustrate the proposed MCM CONOPS in 2040, which is a highly compressed kill-chain of long-endurance systems, performing MCM tasks concurrently. The proposed architecture is discussed in greater detail along with the analysis performed to support it. Beginning with identifying current capability gaps as well as predicting future ones out to 2040, two overarching goals are identified and then decomposed into supporting

measures of performance and measures of effectiveness. The predicted evolution of technology development that will enable those improvements is then outlined.

THIS PAGE INTENTIONALLY LEFT BLANK

III. SYSTEMS ARCHITECTURE

A. CAPABILITY GAPS

Before the proposed architecture and associated FFBDs are examined, the driving factors that led to this architecture must first be discussed. The primary capability gaps that currently exist and those that are foreseen are considered and then the driving forces behind those gaps are investigated. A summary of these can be found in Table 1. The capability gaps were identified by examining the current and future shortfalls in MCM functions. These future shortfalls were ascertained through the development of the 2040 scenario, threat, and associated CONOPS in Chapter II.

Table 1. MCM Capability Gap Sources

Decade	Capability Gap	Source of the Gap
2020	Response to denial of COMMS – surface	Current enemy jamming capabilities
2020	Accuracy of target detection and classification	Current systems do not meet threshold requirement for probability of detection and probability of classification
2020	Staffing	Minimal manning for LCS has caused issues
2030	Overcoming advanced CCM	Improved CM by U.S. Navy will spur development of better CCM
2030	Defeating networked minefields	Near-peer adversaries have advertised they are developing this capability
2040	Response to denial of COMMS – subsurface	Predicted natural evolution of jamming: if it can be done on the surface, it can probably be done subsurface as well
2040	Defeating the ALM	Currently low-TRL technologies are expected to mature by this time and support development of ALM
2040	Efficient Development of MCM systems	Current program failures (RMS, OASIS, RAMICS) have proven that the organizational structure as it exists today is insufficient to support successful MCM system acquisition

Today, three major capability gaps are susceptibility to surface jamming, inability to detect and classify MLOs accurately, and insufficient staffing and training. In addition, there are numerous other technical shortfalls, such as system reliability, which are not detailed, as these have been discussed at length in other publications. Instead, the gaps in Table 1 are taken from across the DOTMLPF-P spectrum, and are not limited to engineering.

In the 2020 timeframe, all of the Navy's near-peer adversaries have jamming capabilities, and the U.S. Navy will need to work to build systems that either defeat these jammers or work well in these denied environments. Detection and classification will have to improve if the desire is to shorten the timeline of MCM operations. Training and staffing will need to improve so that crews are not overworked or forced to become dual- and triple-hatted, as is now the case with LCS crews. Looking forward to 2030, the "arms race" will continue between MCM and CCM. Several nations have announced that they are constructing "undersea networks" of systems which should be online by 2030 if not sooner (Bana 2016). By 2040, it is predicted that the capability to jam assets underwater will have been implemented. This is the same timeframe of the predicted introduction of the ALM. Unfortunately, it is also predicted that very little will change organizationally within the Navy and its development approach to acquiring MCM systems, and there will still be significant failures when attempting to put new systems into the field.

1. Gaps and Corresponding Objectives

Now that the capability gaps and their sources have been discussed, the gaps in relation to their respective mission objectives, and the DOTMLPF-P area which will support closing that gap must be examined. All of this can be seen in Table 2, with the capability gaps in order of occurrence in this section.

Table 2. MCM Capability Gap Objectives

Capability Gap	Objective	DOTMLPF-P and Technology to address gap	Decade
Response to denial of COMMS – surface	Operate freely	Improve autonomous behavior, subsurface COMMS, resilient surface COMMS methods	2020
Response to denial of COMMS – subsurface	Operate freely	Better autonomous behavior, surface COMMS, resilient subsurface COMMS methods	2040
Accuracy of target location	Increase accuracy	Sensor range and resolution, ATR	2020
Staffing	Increase personnel/competency	Advertise for these career paths and make them appealing with a clear path for advancement	2020
Overcoming advanced CCM	Outsmart the mine’s sensors/processing	Deployable influence systems on UUVs, better processing	2030
Defeating ALM	Neutralize the ALM	Biomimetics, quantum computing, AI	2040
Persistence	Increase distance from host ship	Batteries, docking stations	2030
Efficient development of MCM systems	Streamline Acquisition	Re-organize PEO/PMS and OPNAV to place MIW as its own warfare area with direct accountability	2040
Defeated networked mine fields	Reduce/eliminate cooperative nature	Subsurface COMMS jamming/spoofing/hacking, advanced influence	2030

From these capability gaps, two overarching MCM goals were established: 1) reduce MCM timeline and 2) improve mine detection. The functional architecture serves the purpose of decomposing the MCM mission and describing the functions of interest to this study. The decomposed functional architecture shows the smaller subset of functions that were examined in additional detail in this chapter. The functions and key technologies selected for further study have the potential to close one or more of the selected capability gaps and to achieve the two overarching MCM goals. These five key enabling technologies to perform the functions were then examined, and their expected developments extrapolated for the purposes of predicting whether the performance level

of these technologies would be available in the future to support the proposed 2040 CONOPS and to achieve the two high-level MCM goals.

a. Denial of Surface Communications

Much of the ability to communicate freely has been hampered in the last decade by the prevalence of RF jammers. In addition, many adversaries possess the capability to interfere with satellite communications such as GPS and Iridium, creating more challenges. With a large portion of the Navy's surface communications relying upon these technologies, there is a threat to their ability to transfer data in a contested environment. For MCM missions, data transfer from any surface craft back to the host ship is critical. Barring the ability to shut down the enemy's jammers, new methods for data transfer will need to be developed to ensure mission success. As referenced in Chapter II, this gap will need to continue to be addressed with investments in RF technologies and alternative communication paths in the short term, and higher levels of autonomy in the future, which will negate the need for surface communications.

b. Denial of Subsurface Communications

Following on the technologies of the Navy's adversaries to jam surface communications, inevitably this capability will move to the rapidly-developing domain of undersea communications. Targeted acoustic emissions, electromagnetic induction, and even the use of lasers may all play a role in being able to jam subsea communications in the future. This is something that must be planned for, and a capability the U.S. Navy should begin developing. One such scenario might entail complete overwhelming of the acoustic spectrum, thus denying the adversary the ability to communicate acoustically under the water, all while the Navy's assets have an alternate means of communicating. When this scenario is presented during MCM missions, or any mission with subsea assets communicating through acoustics, a combination of technology, CONOPS, and Tactics, Techniques, and Procedures (TTPs) must be developed to deal with these future scenarios.

c. Accuracy of Target Location

A significant portion of the MCM mission timeline is spent re-acquiring the target after it is first detected. Currently, it must be re-acquired for identification, and then re-acquired yet again for final neutralization (Office of the Chief of Naval Operations 1996). If the target's location can be known with more accuracy, less time will be spent searching for it during each of the reacquisition steps.

d. Improperly and Insufficiently Staffed Positions

Like many positions, MCM personnel retention is a challenge. In addition, the fight for attention and funding is an ongoing challenge, until the point when the mission needs to be performed in an actual real-world scenario. Unfortunately, even after a situation like the USS Princeton (CG-59) mining incident in the Persian Gulf on 1991, once the decision makers and officers have left, memory of the important nature of MCM is often lost. Keeping subject matter experts and continuity of research and training, both military and civilian, is of the utmost importance, especially as mining is likely to be utilized more prominently in the future. A larger issue that will not be tackled here due to scope, and the fact that it has been addressed in other papers (Broyles 2017), is that the current organizations that support the MCM mission are not aligned well to carry it out. There is no clear "champion" of developing mining capabilities, and without the allocation of responsibility to one person or office, there is little hope that this issue will ever improve.

e. Advanced Counter-Countermeasures

As machine learning progresses, it will become harder to "fool" and influence mine into detonating. The best defense against this will almost certainly be a combination of a new MCM ship design that reduces and modifies a ship's several signatures to go undetected, and TTPs to avoid triggering the mine. Beyond this, technologies to deactivate the mine by destroying its internal mechanisms without actually detonating it would be the active approach to clearing.

f. Autonomous Loitering Mines (ALMs)

As initially discussed in Chapter II, an ALM can be described as a cross between a Carina Seaglider UAV (Light n.d.), a UUV, and a torpedo. Able to move silently and very slowly, holding station, transmitting ISR data back home at the surface or to other assets under the water, the ALM will be a powerful multipurpose platform. With almost the entire kill chain housed within one vehicle, it will be critical to find these assets quickly and destroy them, or at least have viable methods of countering them once they have switched into “torpedo mode.” Since it is mobile, and will certainly move once detected (if it is not moving already), the asset that first detects it (or a partner vehicle) must quickly follow up and engage it, or at least tail it until the neutralizer can be employed. The ability to switch from gliding, to low-speed, to high-speed, and then back again, will allow the ALM to “take off” and attempt to outrun MCM vehicles trying to detect and neutralize it. This places a tremendous stress on timing and surprising the ALM. Again, much effort should be placed into developing TTPs to press on its weaknesses to counter this threat. Perhaps it is determined how to trigger it into high-speed mode reliably, and that is done several times to burn up all its fuel, and *then* it is neutralized. Perhaps its computer can be hacked. Perhaps its performance can be hindered by blinding some of its sensors. This all needs to begin development now, so that when the threat presents itself in the next two decades, the Navy is not forced into a reactive stance, but has already worked out a majority of the logistics, architecture, and CONOPS to counter this threat. Ideally, the U.S. Navy would begin development of such a weapon, which would provide the best insight into ways it can be countered.

g. Persistence

Major limiting factors in MCM, aside from cycle time, are the need to replenish power through return to a host platform, the distance a platform can travel from a host platform (if it is controlled via umbilical), or the need (in either case) for the platform to return to the host platform for PMA. There are several ways this gap can be filled. For example, one way would be to improve battery life, whether by increasing the energy density of lithium-ion batteries or by bringing along some new battery chemistry such as

the aluminum-water (Al-H₂O) batteries being developed by Open Water Power, which “drink” seawater for power (Matheson 2017). Another possibility is a variant of the AUV Docking Station, which could be used to recharge UUVs and enable the UUVs to remain longer in the minefield before having to return to the host platform (Monterey Bay Aquarium Research Institute 2017). These docking stations could also potentially be used to update mission parameters from the host platform to the UUV and to transmit data from the UUV back to the host platform.

h. Acquisition

Development time has a strong correlation to system complexity. It is widely accepted that any complex project within the Navy will take 17 years to develop. A recent study by the Institute for Defense Analysis challenged that perception somewhat and reported that the median cycle time (where the cycle time is defined as the time in years from program initiation to IOC) was roughly eight years (Tate 2016). The report then discussed the trends for different commodity types. Trends are flat or downward (with occasional outliers) for ground systems, aircraft, missiles, and ships. However, for space systems and C4I systems, the trend is upward (Tate 2016). There is also a special case for software. Tate goes on to compare weapons systems to software systems, and makes the case that weapon system acquisition programs behave like software development programs because they *are* software development programs (Tate 2016). Although this speaks briefly to trends, it does not address compressing the timeline in weapon system development and seems to indicate that there is, indeed, no way to shorten acquisition life cycle more than it already is.

On 1 August 2017, a report was published following a review conducted in accordance with the FY 2017 National Defense Authorization Act regarding restructuring of the DOD. The proposed reorganization offers a distinctive opportunity for improving the Department organization and operation and explains how the DOD can reorganize to “better pursue the goals of technological superiority, affordable system, and well managed business operations” (DOD 2017). The report goes on to state “the weapon systems and capabilities that the Department delivers to the warfighter today are in many

respects the envy of other nations' fighting forces. However, the current pace at which we develop advanced warfighting capability is being eclipsed by those nations that pose the greatest threat to our security" (DOD 2017, 3). According to the DOD report, the development of advanced capabilities by the DOD must therefore be a top objective, and ways to accomplish this must be explored. The report goes on to say that "a culture of innovation that is rooted at the highest levels of DOD is required and each echelon of the Department must be structured to rapidly adapt and field capabilities that leverage the advances that are occurring at an ever increasing pace in the commercial and defense technology sectors" (DOD 2017, 3). It will be necessary for the Department to increase the extent it is willing to take risk in development to deliver successfully both small and large technological advances. At the same time, the Department must "increasingly leverage prototyping, experimentation and other developmental activities in order to retire technical risk before either weighing down the research and engineering phase with costly procurement decisions or weighing down a procurement program with costly technical risk" (DOD 2017, 80).

The report addresses the need for the proposed Under Secretary of Defense (USD) Research & Engineering to set the overall plan for DOD technology and innovation, focusing on important capability gaps as identified by the DOD and more timely delivery and incorporation of new technologies. It also provided some detail as to how that is to be addressed; for example, aligning processes and incentives and revolutionizing how the DOD leverages commercial technology (DOD 2017). The report also addresses the formation of a new USD for Acquisition and Sustainment to deliver demonstrated technology to the warfighter faster and more affordably (DOD 2017). Not yet implemented, it remains to be seen if this proposed reorganization will deliver on the goal of reducing time and cost of acquisition of advanced warfighting capability.

i. Networked Mines

Networked mines are expected to pose a great challenge to MCM efforts. The threat posed by mines that can communicate amongst themselves to more effectively counter efforts by our MCM forces is one that must be addressed in future efforts.

Potential advances that would help defeat this threat would benefit from the same advances as those developed for denying subsurface communications. A study completed in 2015 detailed the vulnerability of Underwater Acoustic Networks to various physical and network layer attacks like jamming attacks, wormhole attacks, hello flood attacks and sinkhole attacks (Xiao et al. 2015). Developing improved and reliable jamming technologies for use against U.S. adversary networked mine fields that can resist anti-jamming technology should be a priority.

2. Capability Timeline Diagram

The technology advancement roadmap shown in the appendix represents a temporally arranged view of anticipated technological improvements that could potentially occur throughout the timespan evaluated for the purposes of this study. Broken down into decades, each segment of the roadmap identifies capability gaps and needs for that timespan. Furthermore, each section also feeds those gaps and needs into technological progress areas with respect to the critical, high-level MCM objectives of improving mine detection and reducing the MCM timeline. Lastly, this diagram also denotes technology growth areas for each decade. Across decades, the advancement of some elements can directly be traced across the timeline, as seen in the case of PMA. In the 2020 section, concurrent PMA could result in a reduced PMA timeline, increasing the efficiency of MCM activities. In the 2030 section, PMA could be upgraded to ATR-assisted PMA, further increasing this efficiency gain. Finally, in the 2040 section, PMA could potentially be resolved to being conducted completely onboard MCM off-board vehicles during sortie execution. The advancement of other efforts, combined with existing or similarly advancing efforts, can introduce new and unique technologies and capabilities that also enhance the accomplishment of MCM objectives. An expanded view of each, individual diagram is shown in Figure 31, Figure 32, and Figure 33.

The hallmarks of the MCM objectives in the 2020 timeframe, as displayed in Figure 31, lie primarily in the realm of expanded capability of current technologies. This is to be expected in the most near-future decade. It is anticipated that PMA being conducted while the MCM vehicle is still operating will become more prevalent in this

timeframe. Similarly, it is anticipated that battery technology will continue to advance. During this time, technological growth areas in the realm of simultaneously operating, cooperative systems and improved sensor motion compensation may rapidly become realities. Similarly, MCM goals of increased area coverage rate – sustained, increased probability of neutralization, and increased sensor effective depth may also come to fruition. Gaps in the areas of location accuracy, freedom to operate in an MCM-contested environment, and increased recruiting and retention of trained, qualified operators responsible for implementing and utilizing these technologies are also expected to be challenges in the 2020 timeframe.

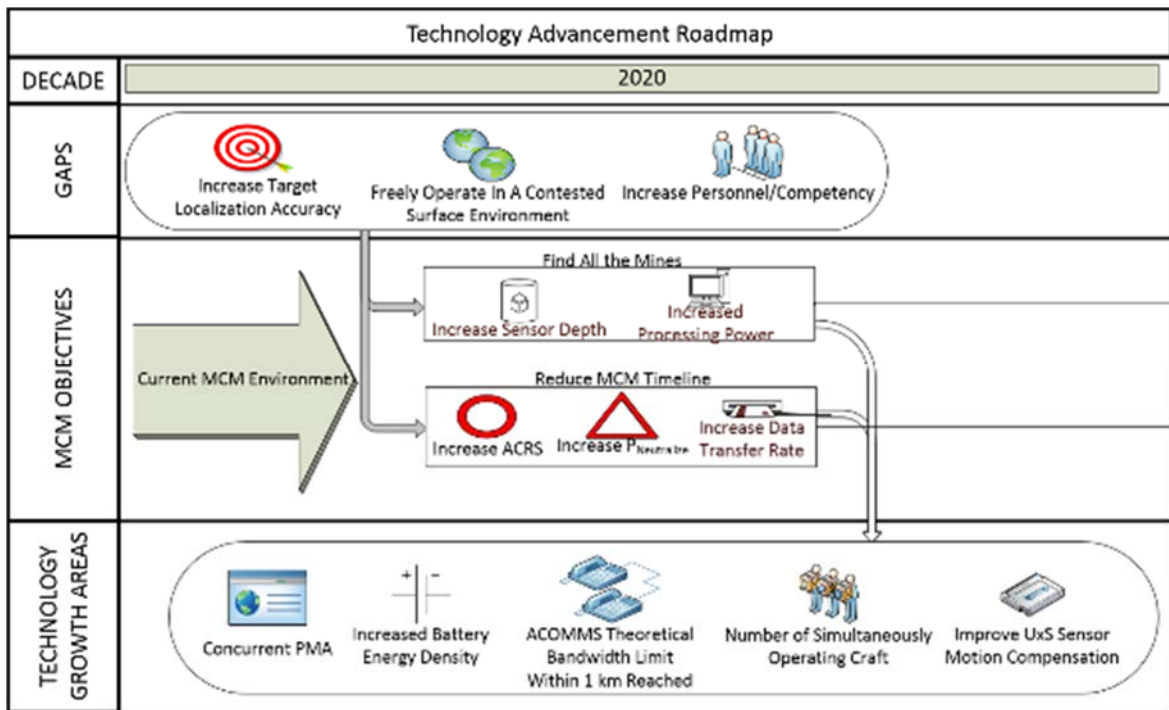

Figure 31. Expanded View of 2020 Timeframe

In the 2030 timeframe displayed in Figure 32, technological advancement is expected to focus on closing capability gaps. With the anticipation of the combined threat of networked mine fields and advanced CCM becoming a reality, the 2030 timeframe is anticipated to combat threats in a number of new ways. Mine hunting drones with the capacity for partial power replenishment during operations have the potential to close a

vehicle persistence gap in this timeframe, as well as offer the vehicle to house an increased performance sensor suite and operate as part of a semi-autonomous swarm. Coupled with PMA operations utilizing ATR capabilities to enhance and streamline MCM operations, dramatic reductions in the MCM timeline and increases in the probability of locating a greater percentage of the mine threat can become a possibility in this timeframe. This timespan can potentially become a significant growth time for MCM technologies and operations. With additional tools to counteract existing and emerging offensive mining technologies, capability gaps can start to shrink and close, increasing confidence levels during MCM operations.

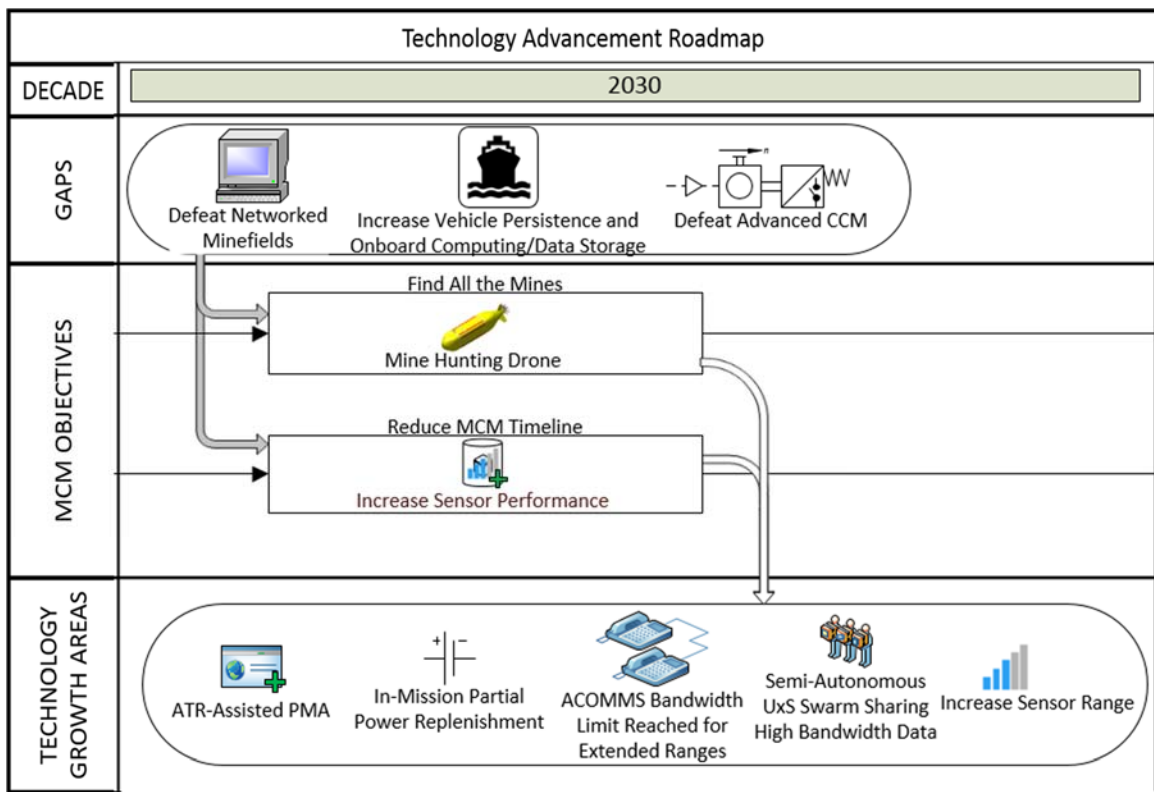

Figure 32. Expanded View of 2030 Timeframe

In the 2040 timeframe, technology growth can be expected to build from prior success in bold and innovative ways, as captured by Figure 33. In this fashion, MCM operators can combat challenges such as advanced mines with variable ship counts and other CCM technologies. Furthermore, MCM vehicles could also be expected to facilitate

operations in subsurface, contested environments. Unmanned systems' intelligence and learning are expected to be on the rise during this time frame, spending significant periods of time on-station as a result of full in-sortie power replenishment. As fully autonomous vehicle swarms become a reality, operating new sensors at higher vehicle speeds, and with data analysis being performed on-station within the swarming vehicles, MCM technologies could potentially grow dramatically. With such significant advancements and opportunities in technology, it is anticipated that the acquisition process for MCM technologies will need to be evaluated and optimized during this timeframe.

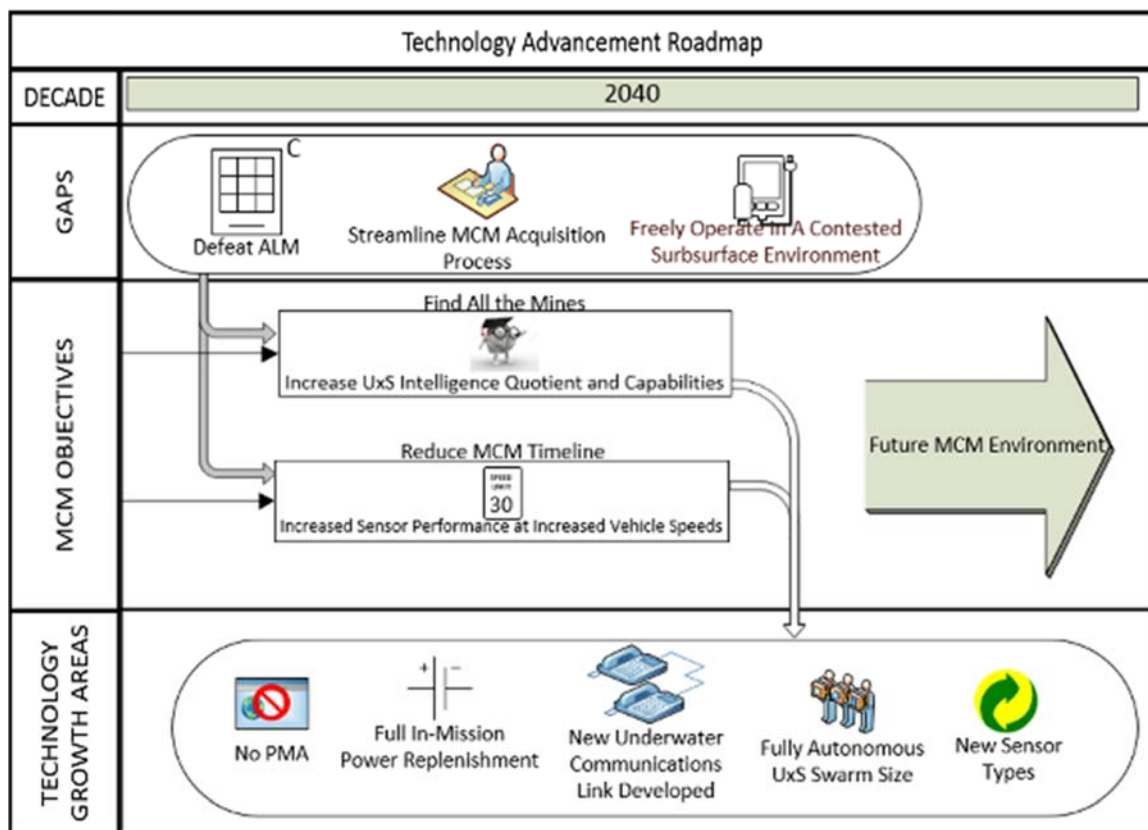

Figure 33. Expanded View of 2040 Timeframe

B. FUNCTIONAL ARCHITECTURE

1. MCM Mission Decomposition Overview

Developing the systems architecture requires defining and decomposing the functions of the MCM mission. For completeness and to provide context on how the MCM mission fits into the larger MIW mission, the functional decomposition is shown in Figure 34. The decomposition follows information presented in NWP 3–15 Mine Warfare (Office of the Chief of Naval Operations 1996), which provides an overview of MIW and the planning process. The items shown in black were considered outside the scope of this study, meaning that item was not relevant in addressing the identified capability gaps or MCM goals. The items shown in tan were considered relevant to reducing the MCM capability gaps. Relevant high-level functions were decomposed in more detail into lower level functions to support the study.

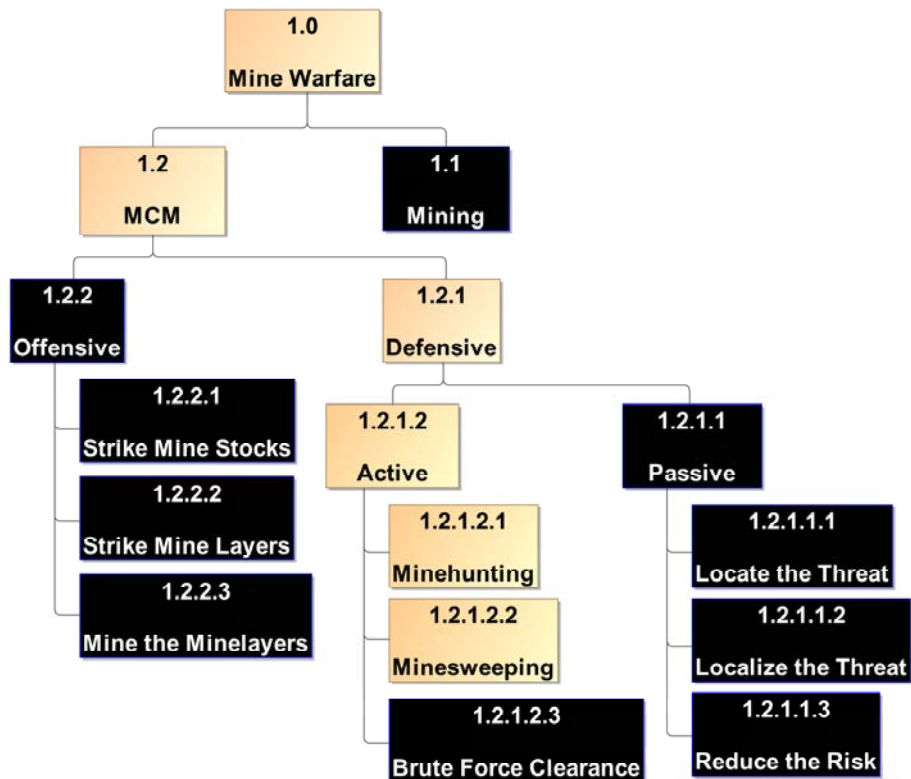

Figure 34. MIW Functional Decomposition Diagram

The highest level MIW functional decomposition is comprised of Mining and MCM, items 1.1 and 1.2 respectively, in Figure 34. Mining was not considered in the scope of this study, which is why that item is shown in a black box. MCM was the primary focus of this study, so that item was further decomposed into offensive MCM and defensive MCM in the functional architecture. Offensive MCM missions including strikes against mine stockpiles, strikes against mine layers, and mining the mine layers were briefly examined during Phase One: Initial Research of this study. These items were removed from this study due to the concern that the study would contain classified information.

The functional architecture was decomposed for defensive MCM into passive missions and active missions. Figure 35 shows a detailed functional decomposition of active and passive missions. Locating the threat, a component of passive MCM, includes gathering intelligence and conducting surveillance and reconnaissance. These items inform the manner in which MCM missions should be conducted and allow for the employment of other passive measures such as localizing the threat and reducing the risk of encountering or activating the threat. Passive MCM is valuable but falls outside of the scope of the selected scenario selected for this study. As described in previous sections, this study focuses on a scenario with an advanced mine threat in a narrow strait of water with shallow water depth (40–200 feet). Applying that scenario to defensive MCM missions requires further decomposition to examine the impacts that mine hunting and mine sweeping have on defeating the threat. As discussed in previous sections, mine hunting missions are performed serially and include detection, classification, reacquisition, identification, and engagement of targets. Mine sweeping missions do not include the serial detection, classification, reacquisition, and identification steps and skip to engagement of targets. The functions that comprise mine sweeping and mine hunting missions are described in the next section.

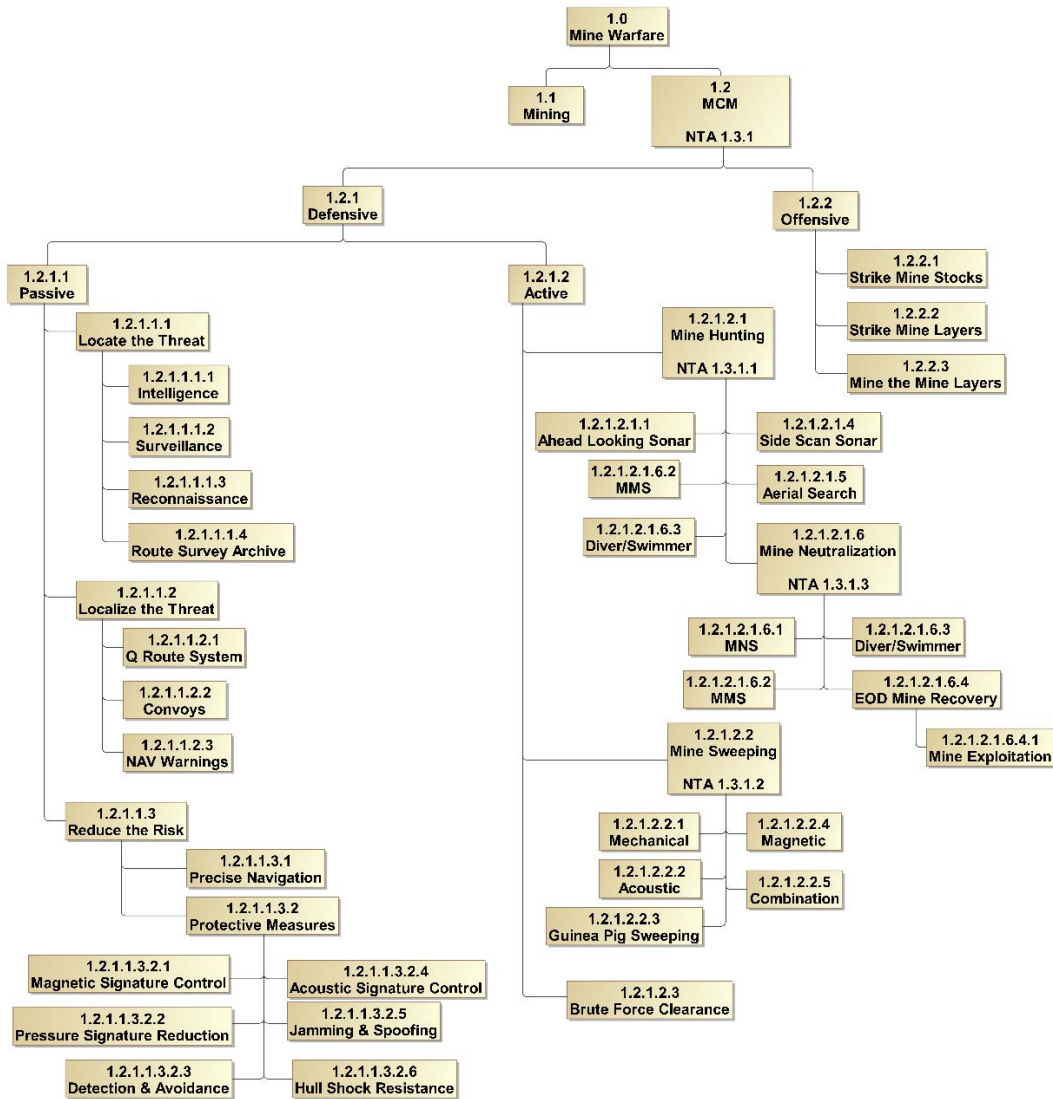

Figure 35. Active and Passive MCM Functional Decomposition Diagram

2. Functional Description

To describe the way detection, classification, reacquisition, identification, and engagement of targets are currently performed in a mine hunting mission, the functional decomposition in Figure 36 was developed. Figure 36 displays the functions necessary to complete the tasks in the mine hunting mission. The items shown in grey were not included in this study. The functions relevant to this study are further described in this section.

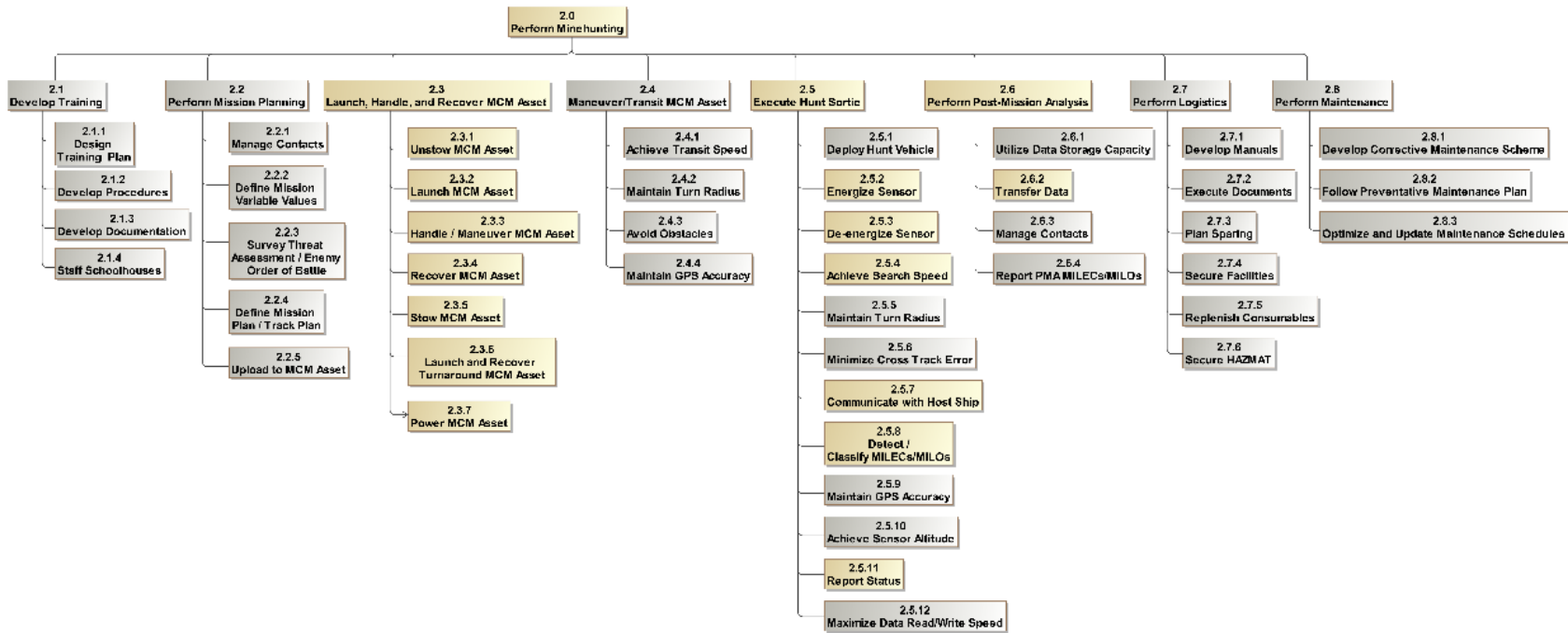

Figure 36. Mine Hunting Functional Decomposition

a. *Launch, Handle, and Recover MCM Asset*

Launching, handling, and recovering the system are functions that involve readying the vehicle to perform the mine hunting mission. The CONOPS described in Chapter II utilized UxS that are launched from a host platform into the water. Depending on the type of host platform and the system itself, this group of functions can take a significant amount of time to complete. Extending the endurance on the mine hunting systems reduces the number of times the system must be launched and recovered. Extending and increasing the ability to transmit and receive data remotely also has an impact on reducing the need to launch and recover the system. For these reasons, the expected increase in battery energy density, data transfer rate, and ACOMMS bandwidth were included in this study. This study also examined the impact that number of autonomous systems working in a team has on reducing the time to complete the mission. The assumption would be that a larger number of autonomous systems could cover an area more quickly, but a larger number of autonomous systems also requires additional launches and recoveries. To decrease mission time by increasing the number of autonomous systems participating, the number of times required to launch and recover the system must be reduced.

b. *Execute Hunt Sortie*

The function of execute the hunt mission has a wide range of associated sub-functions. The items in tan in Figure 36 were selected for further study because of their impact on reducing the timeline and relevance to the selected scenario. The rationale for each item is as follows:

- Energizing and de-energizing the sensor - The functions of energizing the sensor and de-energizing the sensor have an impact on resolution and range of the sensor. These items were explored to see how improvements could reduce the timeline by not requiring additional missions to detect mines. Sensor resolution and range could also increase the percentage of the targets in an area that are correctly identified, improving mine detection.
- Achieve search speed - Increasing the search speed has the potential to reduce the overall timeline. However, as the system's speed is increased there could be a negative impact on sensor range and resolution.

Predicting future growth in range and resolution will inform the decision of whether or not increasing search speed is worth pursuing.

- Communicate with host platform - The ability of the individual system to communicate with other systems and with the host platform has broad-reaching impacts on addressing MCM goals. Improvements in communication would allow for increased mission complexity for systems working as a team. Acoustic communications bandwidth and data transfer rate support aspects such as teaming, standoff, and response time. The function of transfer data is also enabled by improving communication.
- Detect/Classify MILEC/MILCO - The mine hunting mission designates objects as Mine-Like Echoes (MILECs) from detection and then classifies the object as MILCO or not (non-MILCO). Working to improve sensor resolution and sensor range is important, since improving the ability to correctly detect and classify objects is crucial to locating mines in an area.

3. Functional Flow Block Diagrams

The FFBDs were used to investigate the scope of the impact different technological advancements have, or are expected to have, on MCM operations, and to decompose critical MCM activities. Much like the strategy to decompose the MCM mission into its critical activities, the critical activities have been further decomposed. This decomposition exposes the critical elements of the activities, allowing them to be evaluated and prioritized with respect to the impact of the various technological advancements. Each advancement is extrapolated into the future to provide an estimate of the capabilities and net impact on MCM activities. These extrapolations, paired with the MCM FFBDs, create an environment in which relative impact can then be assessed.

As seen in Figure 37, MCM operations can also be distilled into the following primary MCM activities: mine hunting, mine sweeping, mine neutralization, and mine exploitation. This distillation differs from the functional decompositions discussed previously in that this approach traces Navy Tactical Tasks (NTAs) through the Universal Naval Task List (UNTL), vice functional activities. For the purposes of this study, mine exploitation has not been considered. To evaluate each of these activities, the activity has first been decomposed into its critical elements, and then evaluated within the context of a FFBD. From this FFBD, the impacts of both technological gaps and advancements can be observed. Also, as noted in Figure 37, these activities have also been traced in

accordance with the UNTL. The UNTL derives naval tasks from major mission areas, through operations, to explicit tasks deemed necessary to the fulfillment of the Navy's missions. These explicit tasks are denoted as NTAs, according to the hierarchical derivation structure utilized within the UNTL. These NTAs have been used as anchor points for the decompositions following this study, as they both provide a basis for the need to conduct these MCM activities and are less prone to variance and fluctuation due to technological change. Additionally, these NTAs are written at a sufficiently high level that it is anticipated that the Navy will still require the satisfaction of these NTAs in the temporal range evaluated during this study and beyond.

The decomposition of mine hunting has been accomplished, as indicated in Figure 36, to evaluate the critical elements of the mine hunting activity. To perform this activity, first tier elements such as training, PMA, and maintenance must be accomplished. Lower tier elements have then been derived from their first-tier parents. Mine hunting sensors are often highly specialized sonar systems painting their local areas with beam-formed sound waves, listening for the echoes of a potential threat. These specialized sensors have been known to utilize multiple bands of sonar imaging to achieve critical resolution values, colorized and 3D views of the environment, and even – in some environments and configurations – subterranean views through the seafloor. Mine hunting has been used to accomplish detection, classification, and identification of MLOs effectively throughout the water column. Currently, after hunting has been accomplished, further prosecution of a mine threat has been left to a mine sweeping or mine neutralization sortie.

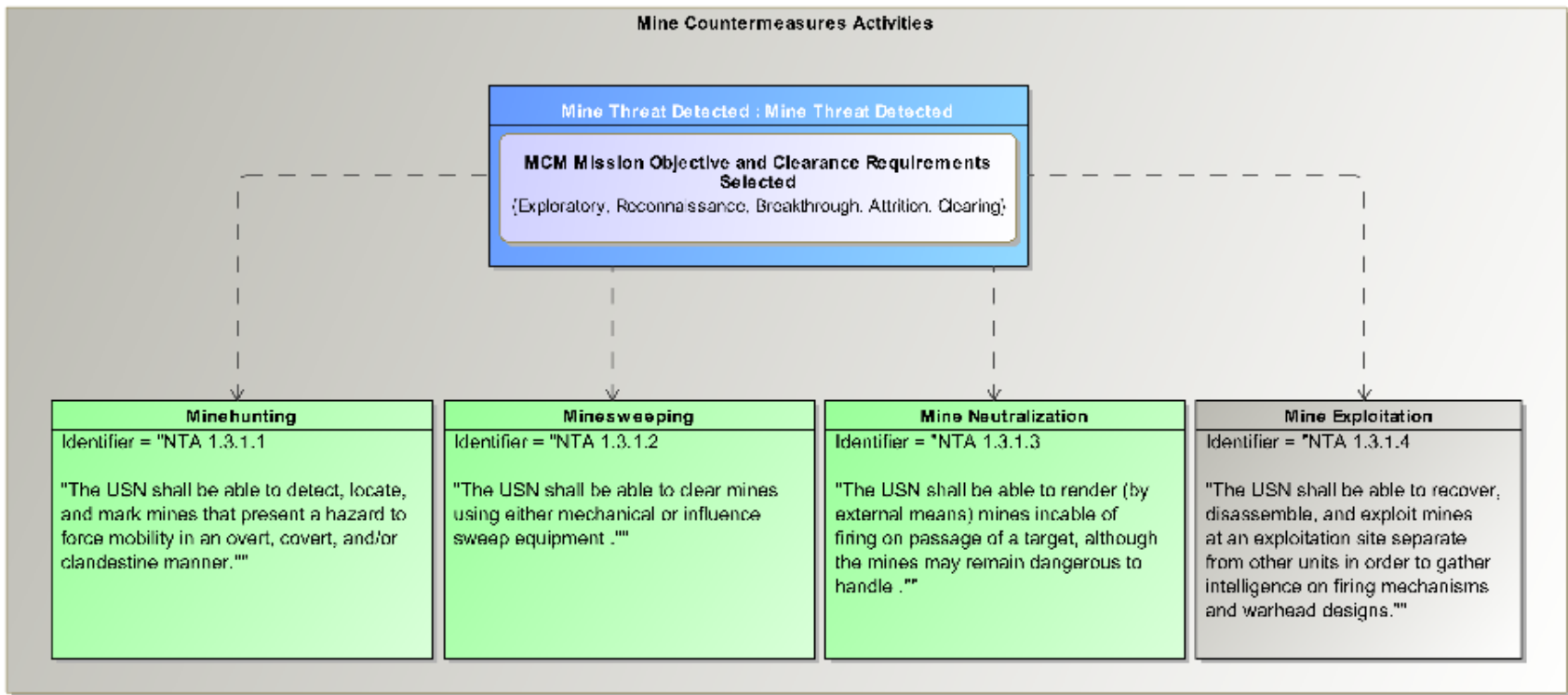

Figure 37. MCM Activity Identification and Tracing

Figure 38 represents the functional flow of MCM operations, from mine hunting to mine identification and then through mine neutralization. This functional flow offers a progressive view of the MCM process, stemming from the primary functional areas identified via the UNTL in Figure 37. Figure 39 shows the first phase of the MCM operations functional flow with a focused view of mine hunting. From the origin of the decision to perform mine hunting, a mission is planned, the vehicle is deployed, the vehicle enters the Mine Danger Area (MDA), a sortie is executed, the vehicle exits the MDA, the vehicle is recovered, and PMA is performed. Technological advances that impact this activity flow are expected to primarily impact the section of the diagram arranged in parallel. Advances have typically been representative of optimizations in the efficiency or efficacy of the performance of the mine hunting mission. Drawing from the previous example, if PMA is no longer required due to its being fully resolved onboard the mine hunting vehicle, an efficiency has been created in this activity process. Activities can now move more cleanly and expeditiously between specific nodes of this process.

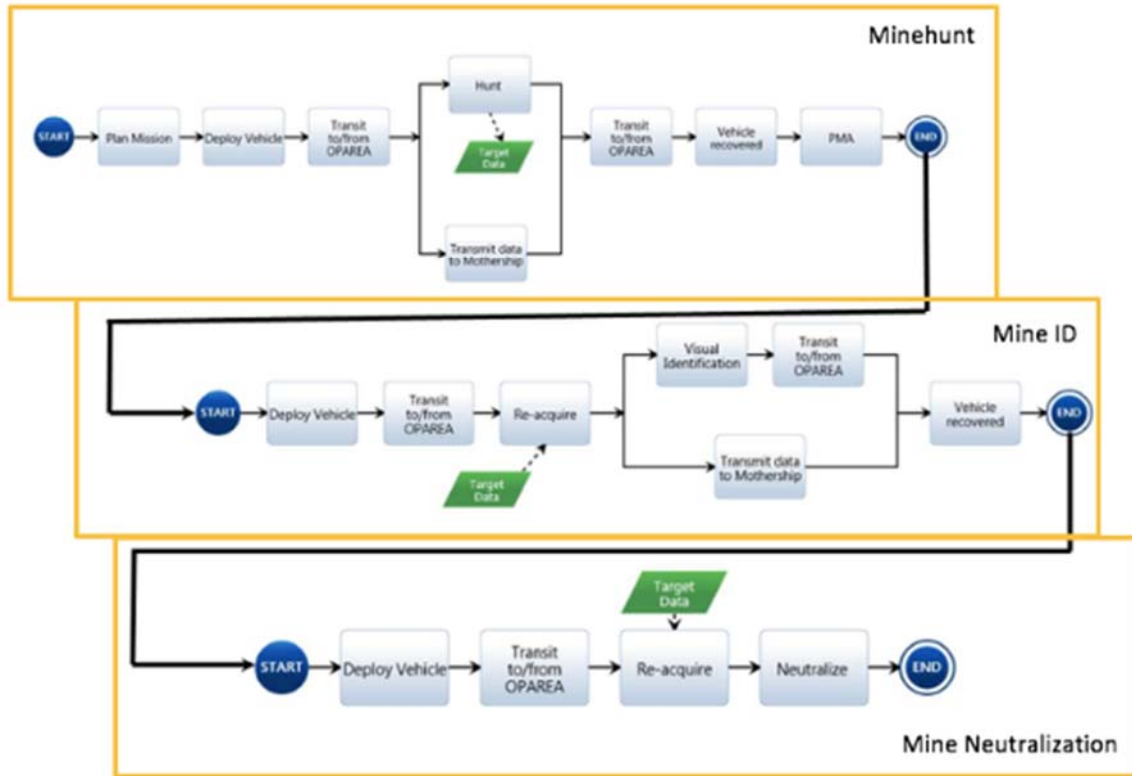

Figure 38. Overarching MCM Operations FFBD

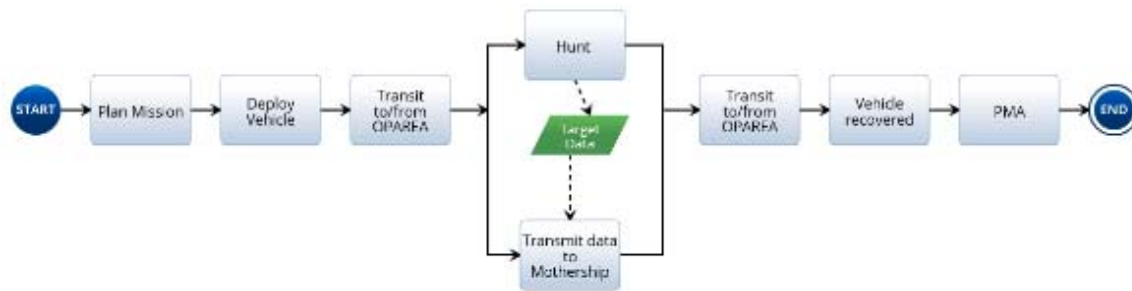

Figure 39. Mine Hunting FFBD

The decompositions of mine hunting and mine sweeping are very similar. Both activities require similar first tier support elements. MCM activities require training, planning, launch and recovery, integrated logistics support, and maintenance. Variations that differentiate mine sweeping missions from mine hunting missions can occur in

transit, within the sortie, and in PMA. For example, the sub-elements regarding the energization and de-energization of an influence sweep is like the mine hunting sub-elements to energize and de-energize the mine hunting sensor. A variance lies in the fact that mine sweeping is typically performed by means of a towed array of some kind to actuate mines mechanically, magnetically, acoustically, seismically, by other methods, or via a combination of methods. This towed array, then, must maintain a tactically significant range of output values, while maintaining aspect to the mines anticipated in the area. This aspect is maintained by the catenary, or curve, of the submerged towline. Towed arrays have also been used in mine hunting applications, but mine hunting appears to be progressing towards integrated sensors, especially with the advent of UUVs. The starkest contrast, however, lies in that mine sweeping relies on the actuation or triggering of the mine, without requiring detection, classification, or identification of the mine previously.

The mine sweeping, or mine identification, FFBD, shown in Figure 40, looks very similar to that of mine hunting. However, whereas the mine hunting system can be required to transmit a substantial amount of mine threat data back to the host platform, the mine sweeping system may not require nearly as significant of a bandwidth demand for mine threat data. As a result of the mine sweeping focus on actuation of the mine, the mine sweeping system may only need to transmit detected detonation location data back to the host platform, aside from normal standard C2 traffic and vehicle kinematic data.

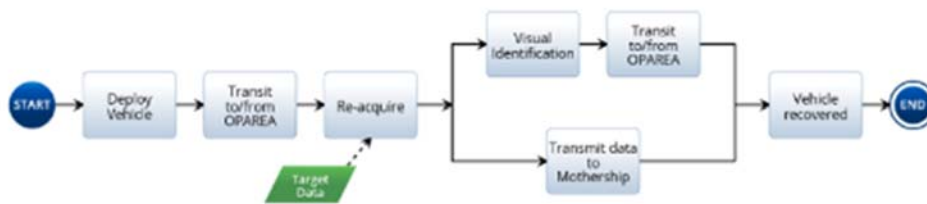

Figure 40. Mine Identification FFBD

The decomposition of mine neutralization, Figure 41, again appears very similar to those derived for mine hunting and mine sweeping. The difference, however, lies in

that mine neutralization activities currently follow mine hunting Detection/Classification/Identification (D/C/I) efforts as the method by which the mine threat is tactically resolved. Neutralization only follows mine hunting, as mine sweeping hinges upon the actuation of the mine as a result of the output of the sweep. Mine neutralization activities, therefore, hinge on the ability to reacquire potential mine threats residing in various stages of the kill chain, whether the potential threat has only been detected, if it has been classified, or if it has been fully identified. Future systems are anticipated to facilitate more capability underway, potentially including the ability to perform mine hunting and mine neutralization activities from a single, common platform. An example of this lies with the current effort to accomplish a complete MCM detect-to-engage (DTE) kill chain from a single platform (SS-DTE, Office of Naval Research program).

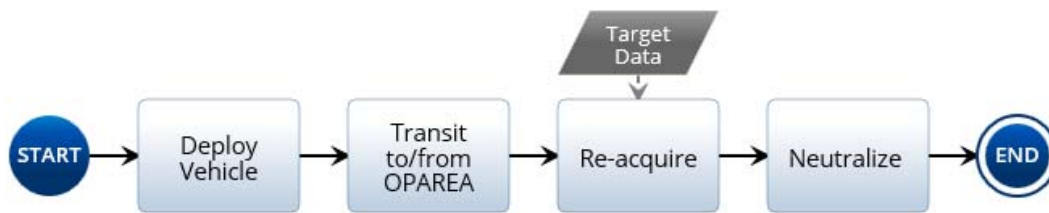

Figure 41. Mine Neutralization FFBD

The mine neutralization FFBD is very simple. Once the neutralization system is on station in the threat area, the system needs only to reacquire the mine threat before neutralizing the threat. Tactical neutralization can take many forms, but is typically accomplished by means of a shaped charge detonated against the mine threat. While simplistic in process, mine neutralization can be a challenging undertaking. The passage of time and changing environmental conditions can propagate error between the D/C/I timeline and the time the neutralizer arrives on station to reacquire the target mine threat. Furthermore, the neutralizer houses live ordnance, which demands stringent considerations, especially after it has been armed, if a target cannot be reacquired or a neutralizer experiences a failure of some kind. Specific attention must be paid throughout

the mine neutralization activity flow to avoid inadvertent damage to the host platform or the neutralizer delivery vehicle.

The effects of the technological changes evaluated in this study will become visible in the FFBDs for the 2040 CONOPS, which are shown in Section D of this chapter. As these technological changes are implemented, elements from the current CONOPS begin to evolve. For example, as ATR is developed and improved, potentially to a degree where PMA will be rendered unnecessary, an entire portion of decomposed CONOPS will no longer be required, and an entire element of the FFBD will disappear. Additionally, as battery technology and sensor performance continue to improve, mine hunting systems may soon be able to stay on station longer, and do more while there. This will expand, temporally speaking, one of the blocks of the FFBD, but will be balanced by the fact that confidence in clearance activities will also improve, and steps to recover and re-launch will be eliminated.

C. SELECTED KEY TECHNOLOGIES

1. Number of Autonomous Systems Working in a Team

The most obvious way to multiply a system's effect is to have several of them working at the same time; however, the way to exponentially increase their effectiveness is to have them work in a team cooperatively, in what is commonly referred to as a swarm.

Typical benefits of swarm missions include a dramatic scaling up of mission performance by concurrent operations over larger areas of operation, reduction in mission execution times, or combination thereof. Depending on the swarm mission, anticipated mission performance improvements will generally scale linearly with the number of UUVs, sensors or payloads employed. (Goldberg, Sanjeev, and Key 2017, 32)

The advent of swarm technology has revolutionized the way one thinks of systems. No longer do scientists and engineers have to push the bounds of sensor performance to achieve greater range or fidelity, today a group of sensors (often of varying types and specifications) can be deployed together to gather more data at a higher rate than a single sensor ever could. As Goldberg et al. pointed out, the increase in

performance per additional sensor is typically linear. This is such a simple yet powerful characteristic of swarm architecture that makes it highly desirable in the MCM domain.

One of the most significant aspects affecting the total DTE timeline is the lengthy process of deploying a single sensor through the area of responsibility (AOR) to scan for threats. By increasing the number of sensors simultaneously canvassing an area, the duration of detection operations could decrease drastically. With each sensor added to the swarm, the range of the system is multiplied. The bounds of the system would be extended and the daunting task of scanning an area would become timelier and, given a level of overlap (track spacing), the probability of detection could increase as well.

Figure 42, Figure 43, and Figure 44 illustrate the serial nature of legacy MCM operations while Figure 45 depicts paralleled MCM operations enabled by sharing target data between hunting and neutralization systems. The advantages of this architecture in decreasing the DTE timeline are inherent and can be utilized with only two systems working together, but the effect will be multiplied with each node added to the system.

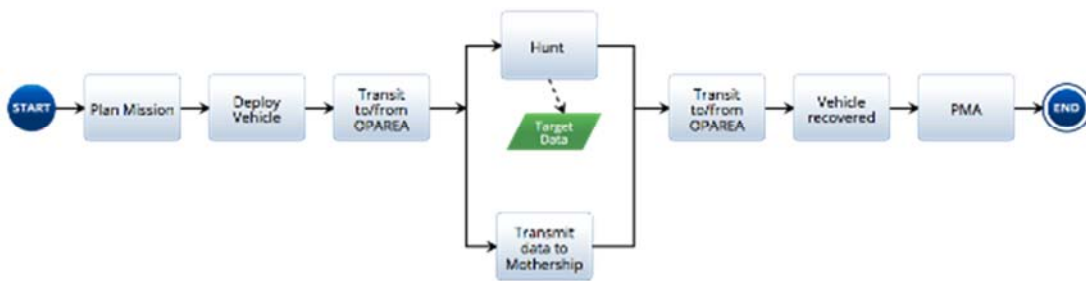

Figure 42. Legacy Mine Hunt Activities (Serial)

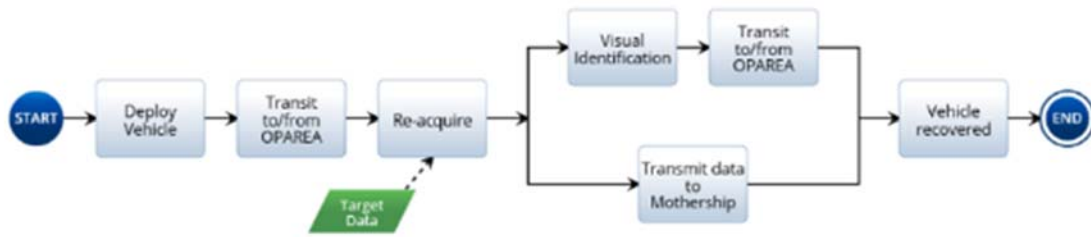

Figure 43. Legacy Mine Identification (Serial)

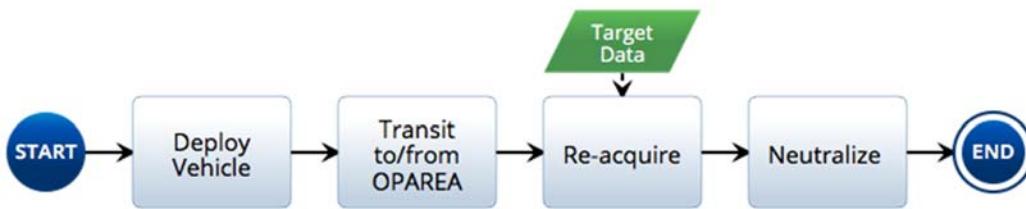

Figure 44. Legacy Mine Neutralize Activities (Serial)

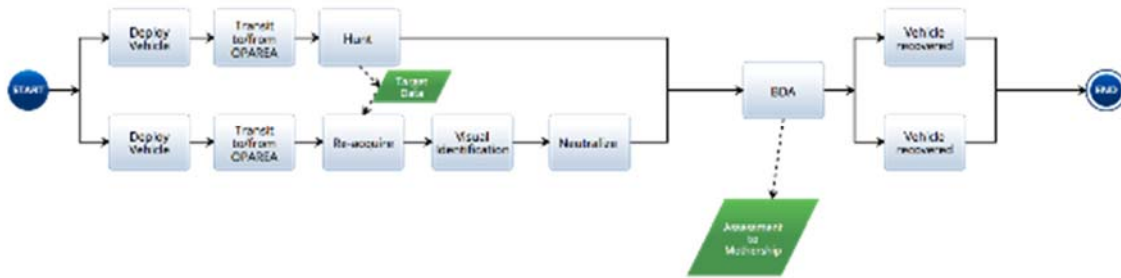

Figure 45. Future MCM Activities (Parallel)

Also, collateral effects of swarm architectures include reduced cost of sensors or systems by replacing single sophisticated sensors with multiple more simplistic ones. For instance, since the range of a singular sonar system could be doubled through the use of two sensors, then there is less desire to develop a single system with the combined range. Operational availability could also improve by reducing the reliance upon a single sensor.

If a single sensor in the swarm fails, the other sensors in the swarm can be utilized to fill the void. Swarm technology has the promise of being more adaptable and resilient to adversity, much in the same context that modern networks are self-healing.

This premise is of course bounded by the number of sensors that can be deployed in a single swarm. The more sensors there are in a swarm, the greater the effect of the emergent capabilities. Thus far only small numbers of UUVs have been successfully teamed in swarm type architectures. Challenges for this technology include limitations of undersea communications and navigation, limited energy densities, sensor size and energy consumption, payload size, and processor speed (Goldberg, Sanjeev, and Key 2017). As these technologies mature the number of nodes in a swarm system will increase, and the capabilities of these systems or family of systems will grow and will be of major significance to MCM operations.

2. Energy Storage

Stored energy is a key factor for the UUV's performance and is necessary to replenish power during its operation. The energy source, which is usually a battery or fuel cell, is a major component of the UUV's architecture. It is the key element in determining the UUV's range of travel and whether tasks can be performed (Griffiths and Sharkh 2003). Griffiths and Sharkh go on to explain that system performance characteristics, specifically power and endurance, are directly attributable to the energy source. For this discussion, a basic understanding of the battery, energy storage and fuel cells are necessary. Batteries provide energy storage and are a convenient way to power devices when a power generation source is not readily available. Batteries contain cells that create chemical reactions resulting in an electrical output. As described in *Linden's Handbook of Batteries*, depending on the components within the cells, the battery can be a non-rechargeable primary cell or a rechargeable secondary cell (2010). Rechargeable batteries can be especially useful as they are used repeatedly without replacement, assuming intermittent connection to a power generation source. In support of the 2030 and 2040 recharge requirements, the secondary battery chemistries are the practical source and are therefore included in this report's discussion. Some major secondary cell

chemistries include the lithium-, lead-, and nickel-based batteries (Linden and Reddy 2010).

There are various factors to consider in selecting a battery source for a specific application. Consideration of the battery source early during the device's development is very important. The characteristics of available batteries must be compared with the device's requirements for the battery. It is important to consider these factors early because the battery will have a direct impact on the size and weight of the device (Linden and Reddy 2010). When developing a UUV system, a system architect must make careful consideration of these multiple factors. In *Linden's Handbook of Batteries*, the authors provide 12 major design considerations for a typical battery selection. This list, the authors state, represents what UUV system level considerations should be made:

1. Type of battery (chemistry): Primary (single use) or secondary (rechargeable)
2. Voltage: Nominal or operating voltage, profile of the discharge curve, maximum and minimum permissible voltages
3. Physical size: Weight, shape, size, and terminal requirements
4. Capacity: Required Amp-hours (Ah) or Watt-hours (Wh) to achieve run, talk, or standby times
5. Load current and profile: Constant power, constant current, constant impedance, or other; value of load current or profile; constant, variable, or pulsed load and duty cycle requirements
6. Temperature requirements: Operating and storage temperature ranges
7. Shelf life: State-of-charge during storage; storage time as a function of temperature, humidity and other environmental factors; active/standby/sleep modes
8. Charging (if rechargeable): Float or charge cycling; cycle life requirements, simplicity and availability of charging source, charging efficiency
9. Safety and reliability: Permissible variability and failure rates; use of potentially hazardous or toxic materials; operation under severe, hazardous, or abusive conditions; failure mode (out gassing, leakage, swelling)

10. Cost: Initial cost; operating cost or life-cycle cost; use of exotic or critical materials with potentially volatile pricing; cost of charging circuit or charger, if rechargeable
11. Regulatory requirements: Country of origin and country of delivery concerns; special shipping concerns; recycling requirements and labeling
12. Environmental conditions: Shock and vibration, acceleration or other mechanical demands and forces; atmospheric conditions (pressure, humidity, altitude, etc.). (Linden and Reddy 2010, 32.2)

Achieving ultimate UUV performance in the future will encompass evolutionary growth with partial and full power replenishment from an energy source. Research for this report regarding battery technology or energy source included concentration of two characteristics from the list above: chemistry and specific energy (capacity).

As Lithium-based batteries are incorporated into different technologies and products, battery technology and performance continue to become more advanced. Lithium-based batteries, both primary and secondary (rechargeable), have the highest energy density among currently available battery technologies. They can support high energy application of UUVs that can have multiple hours and days of operation away from the power or charging source (Gitzendanner, Puglia, and Santee 2009). Thus, secondary batteries, such as lithium-ion and, for some purposes, aluminum fuel cells, are the standard power source used for UUVs. However, despite the benefits offered by the aluminum fuel cells, the technology associated with this energy source needs further development.

While tradeoffs were previously made regarding the run-time and current of a battery, advancements in battery technology have contributed to improvements for both characteristics (Battery University 2016). Figure 46 shows the tradeoff and compromise that occurs in battery technology between specific energy (run-time) in Wh/kg and specific power (current) in W/kg and shows that the secondary lithium-metal (Li-metal) has the longest run-time and the highest current of the five batteries compared (Battery University 2016). Very few companies make rechargeable lithium-metal batteries and most offer the primary versions (non-rechargeable) only. Metal filaments tend to form with solid lithium and can cause short circuits. Combining the lithium-metal with tin and

silicon may be a way to control the filaments to obtain an acceptable level of safety (Battery University 2016). Lithium-ion follows lithium-metal with the next best specific power vs specific energy.

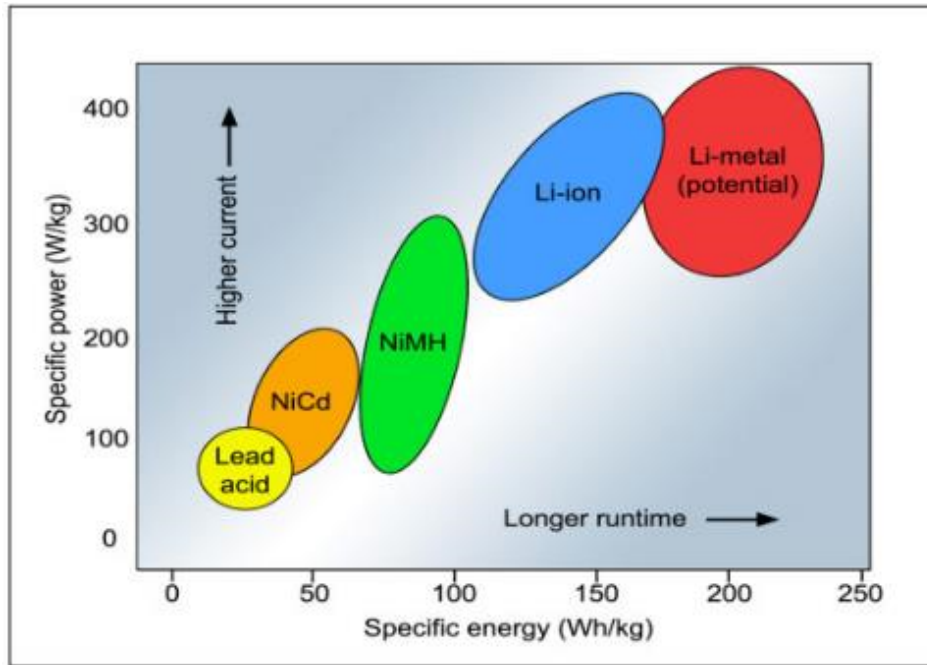

Figure 46. Specific Energy and Specific Power of Rechargeable Batteries. Source: Battery University (2016).

Given the performance of the rechargeable batteries in Figure 46, there is no surprise that most UUV systems investigated in the study titled “Analysis of Unmanned Undersea Vehicle (UUV) Architectures and An Assessment of UUV Integration into Undersea Applications” utilized “lithium-ion secondary batteries in their system architecture due to their high specific power and energy densities” (French 2010, 44). As French describes, specific energy expresses vehicle range and specific power conveys a vehicle’s increased power needs (2010). In the study, a system architecture analysis was conducted on multiple UUVs including MCM UUVs such as the REMUS 1000 and REMUS 6000, ISE Explorer for UUV research, Bluefin 21 BPAUV, and the Gavia Defense (French 2010). These UUVs utilize the lithium-ion battery as a power source.

The lithium-ion battery is currently a viable power source and it is expected to be used well into the future.

Technology research efforts are predicted to continue through 2020 and beyond for improvement of battery density. Efforts are underway to advance the lithium-ion battery technology. “Seawater batteries for underwater vehicle propulsion and other applications, using oxygen present in the ocean, rather than air, or operating as corrosion cells, also are of interest because of the potential high energy output” (Linden and Reddy 2010, 38.30). One innovative technology developed at Open Water Power (OWP) is a new type of aluminum water battery that consumes water to increase the range of unpowered underwater vehicles (Matheson 2017). It is safer than lithium-ion batteries and achieves a significantly greater energy density. It is expected that this increased storage capacity will increase UUV range by a factor of ten over what is currently achievable with troublesome lithium-ion batteries (Elinoff 2017). The *MIT News* of June 15, 2017 indicates OWP is working with the U.S. Navy to replace the batteries currently in use with the seaborne acoustic sensors used to flush out enemy submarines (Matheson 2017).

In terms of the 2040 timeframe, unmanned system intelligence and learning will be prevalent; therefore, the full in-sortie power replenishment or the ability to have increased power capacity will be necessary for the UUVs. Research efforts will expand beyond the energy and power density of lithium-based and sea water batteries addressed for 2020 and 2030 and hybridized designs will be pursued for the 2040 undersea applications.

Hybridization of the energy and power density systems is beneficial to the UUV’s performance since it combines the advantages of each device (battery or supercapacitor). Batteries store very large amounts of energy that is released slowly but constantly. By contrast, supercapacitors can only store small amounts of energy, but they release this energy much faster and more powerfully with large short-term peak currents (Cai et al. 2010).

“Batteries can store a lot of energy in a small and light package,” according to Dario Borghino, “but they cannot charge or discharge very quickly or last a long time as

supercapacitors do” (Borghino 2015, 1). A single energy storage device that combines these attributes will be a tremendous asset to the system architecture of the 2040 UUVs.

3. Sensor Range and Resolution

As previously discussed, sensors are used extensively in MIW. From a mining and CCM perspective, magnetic, acoustic, seismic, pressure, and combination influence mines use sensors for target detection and mine actuation. From an MCM perspective, sensors are used to find and detect mines. Because sensors are used in many aspects of MIW, improvements to these would positively impact the ability to meet the MCM goals in the 2040 timeframe by filling the capability gaps. Specifically, improvements to sensor range and resolution could be most beneficial to MCM.

In broad terms, sensor range is the difference between the minimum and maximum that the sensor can measure. Sensor resolution is the smallest detectable change of what is being measured in the output signal (National Instruments 2013). In terms of MCM, range typically refers to the distance between a sensor and its signal recipient. This recipient can either be passively or actively receiving this signal. The range’s resolution is the distance the signals can be separated and still detected. For active sonar and radar, the higher the frequency, and therefore the shorter the wavelength, the better the resolution (Hansen 2012).

Traditional sonar sensors may be negatively affected by many factors. These include the spherical spread of sonar, absorption, refraction, reflection, scattering, and ocean fluctuations (Hansen 2012). As range increases, the likelihood of these factors causing signal loss increases. Range is also negatively impacted by larger aperture size; however, larger aperture size is desired for increased resolution. Traditionally, range and resolution are inversely related and as one increases, the other decreases. Both long range and minute resolution are desired but could not traditionally be achieved simultaneously.

As discussed in Chapter II, SAS improves on traditional sonar sensors by operating at a lower frequency allowing for a wider beam angle. One would think this would negatively impact resolution since the wavelength is longer, but SAS eliminates this relationship. This allows for increased range at the same time as its increased

resolution. Also, as discussed in Chapter II, solutions other than sonar can aid in MCM. For instance, the use of lasers in place of sonar allows for increased range while utilizing a larger aperture size, which leads to an increase in resolution.

Improvements to range and resolution, both independently and collectively, in existing technologies as well as future technologies will help fill the capability gaps predicted in the 2040 timeframe. The first two capability gaps, denial of surface and subsurface communications can be positively affected by increased range. If the range increases, the need for communications availability may not be necessary to convey sensor data. A sensor could be attached to a ship or to the ocean floor in a location where personnel would already be available to retrieve the data. This would eliminate the communications gap. This would also meet the goal of reducing the MCM timeline by reducing DTE. Personnel would not be reliant on a communications link to conduct PMA and identify targets.

Improvements to resolution will improve the accuracy of target location. The increased resolution will allow for mines and targets to be more easily identified. It will also reduce the likelihood of misidentification of a mine-like object as a target. This meets the goal of improving mine detection. This also meets the goal of reducing the MCM timeline because time to hunt will decrease.

The capability gap of improperly and insufficiently staffed positions can be filled by improvements to both range and resolution. If range is increased, the sensor could be permanently stationed eliminating the need for UUV pilots. If resolution is increased, PMA and mine hunting time would be reduced. Both improvements could allow for smaller staffs addressing this staffing gap. Advanced CCM could also improve with improvements to both range and resolution as targets could be positively identified from further distances. This far-view positive identification would help address the gap associated with the ALM as well. This distance in detection and positive identification will be necessary to counter this adversary. Otherwise, the sensor vehicle could be damaged or destroyed by the ALM. These improvements would affect the networked mines gap in the same manner.

Increased range would positively affect the persistence capability gap. As previously discussed, this could allow for the sensor to be tethered and would not require the use of a UUV. This would eliminate some of the time lost for UUV replenishment, data transfer, and data exfiltration. This would help meet the goal of reducing the MCM timeline.

To address the development timeline gap, range and resolution improvements could be carried out on the existing SAS and laser solutions. A “Super-SAS” capability could even be created through the utilization of a swarm of SAS sensors with the data fused together to provide an even greater range for data collection. A fused set of swarm-collected data could also offer MCM practitioners the capability to utilize a greater scope of the battlespace and environment without languishing through the acquisition process for the development and delivery of an increased capability sensor or vehicle. This would help with both MCM goals in 2040.

4. Post Mission Analysis (PMA) / Automatic Target Recognition (ATR)

The primary capability gap that developments in ATR can help fill is to accurately identify mines from a collection of MILCOs. This technology also has the important aspect of supporting one of the two major goals, that of reducing the MCM timeline. In the next few years, sensor data will be broadcast back from the USV towing the sonar body to the host craft where the PMA will take place, such as an LCS (MHU Technical Reports 2017). PMA data is currently screened by human operators in a 1:1 format, meaning that for every minute of sonar data, an operator spends one minute looking at the streaming data on his screen. Thus, for a 10-hour mission, there will be 10 hours of PMA to perform, and since it is currently done sequentially, results in a 20-hour mission (plus transit, deploy and recover time). For the typically long missions that can be six to 12 hours and with the current 1:1 PMA process, being able to start PMA as soon as mine hunting begins can save a significant amount of time for MCM operations. This setup starts the transformation of being able to perform more and more MCM activities in parallel, and moving away from the linearly sequential CONOPS we have now, as seen in Figure 38, shown again for the reader’s convenience. This figure, as detailed in Section B

of this chapter, represents the progressive implementation of the comprehensive MCM process from mine hunting, through mine identification, and finally to mine neutralization. This process details the successive deployment of vehicle to accomplish different elements of the overarching MCM process, as well as the specialized tasks identified for each vehicle according to its assigned tasking.

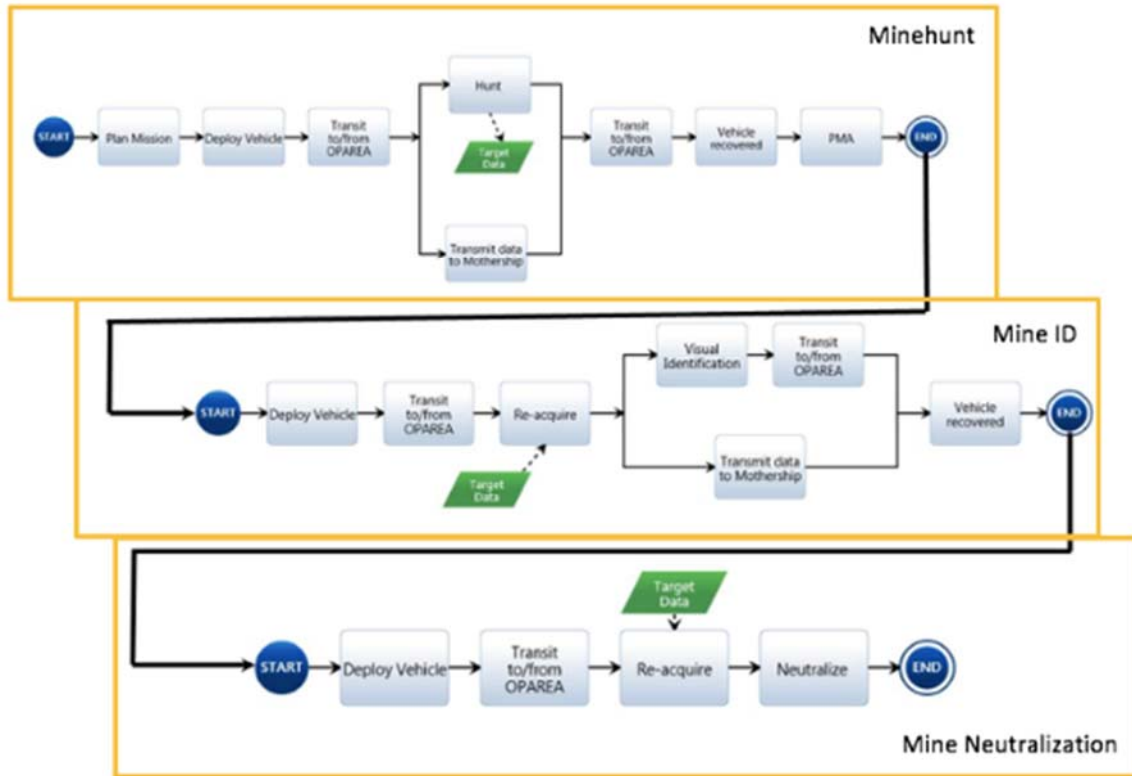

Figure 38 Overarching MCM Operations FFBD (from Section B)

The next major step, which this study set as a goal for 2030, is implementing ATR-assisted PMA. Algorithms and machine learning should be at a point where with operators helping to “teach” the software what to look for, and providing a large library of data for the software to “study” from, ATR will be able to help human operators process data much more quickly than 1:1. Whether the ATR resides onboard the deployed sonar vehicle or the host ship is still to be determined, though it should be noted that if the ATR can run off-board, the communications burden between that off-board

vehicle and the host ship drastically decreases. This is because the scanning vehicle only must send small snippets of data that it has tagged as important for the human operator to review. This could become a major factor if operating in a degraded or denied environment. This also opens the possibility of leveraging communications methods other than RF, such as ACOMMS.

The final state of PMA is for ATR to completely perform this analysis in-stride, essentially eliminating the “P” from PMA. With this capability, the mine hunting vehicle can then, in near real-time, team with neutralization vehicles to follow up and prosecute targets. With the elimination of deploy, transit, and recovery times of both the identification and neutralization vehicles, reducing communications between off-board vehicles and the host ship, and eliminating the traditional PMA step between hunting and neutralization, the MCM timeline is drastically reduced as shown in Figure 47 when compared to Figure 38. Figure 47 depicts this potential for parallel MCM processes to be performed. The top lane of the initial parallel process utilized one vehicle to accomplish the mine hunt mission, while the lower lane of the same parallel routing offers the process to accomplish the identification and neutralization aspects of the MCM process. As these mission elements are accomplished, the vehicles remain in communication with one another, offering the potential for an in-situ battle damage assessment to be accomplished and delivered to the host ship, possibly during the vehicles’ return transit. Finally, both vehicles are recovered in the right-most parallel process to conclude the extent of the MCM process.

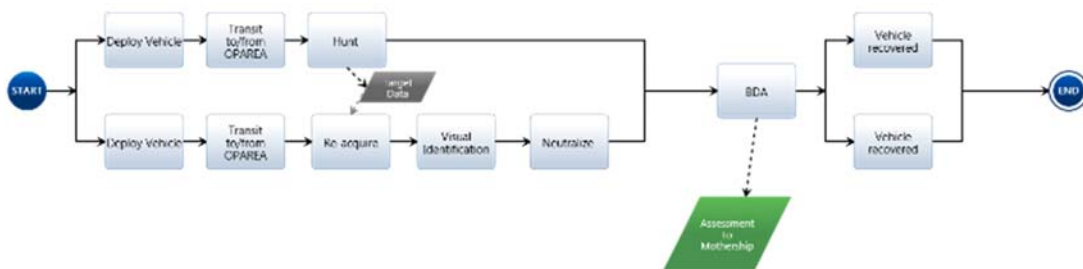

Figure 47. Proposed Future Mine Countermeasures Activities

5. Acoustic Communications (ACOMMS) Bandwidth

One of the major objectives concerning MCM performance is reducing the overall DTE timeline. One method of reducing the duration of detection operations is to distribute sensors to survey an area in parallel. As previously discussed, multiple nodes working together to complete a task is currently known as swarm architecture. To enable these architectures, inter-nodal communication will be needed to facilitate the emergence of swarm behavior and coordinate efforts between nodes. Each node will need to transmit bearing and speed to its neighbors to ensure that nodes will not collide and guarantee that the AOR is being equally divided and searched. Another factor to consider is the need for accurate positioning below the surface of the water. Relaying of location information and triangulation to nodes beneath the surface will also need to be addressed. The dominant enabling technology for this type of underwater networking is ACOMMS.

Though the capacity of radio communications through the air has been well defined, the same level of understanding has not been achieved in the domain of underwater ACOMMS. ACOMMS is challenged by many factors including signal attenuation (as a function of frequency and range), environmental noise, multipath propagation, and Doppler shifts (Quazi and Konrad 1982). Solutions have been developed to address these issues, but are limited in performance and the resulting bandwidth and capacity are constrained. Given its limited ability, ACOMMS is not able to efficiently transmit large amounts of data over long distances, yet finds itself well suited in an architecture of many nodes working near each other, communicating small packets of information (such as speed, bearing, and depth). Figure 48 illustrates the use of ACOMMS in a swarm architecture. The nodes at or near the surface can receive GPS positioning data from the satellite, and transmit that location data to the nodes beneath the surface via ACOMMS.

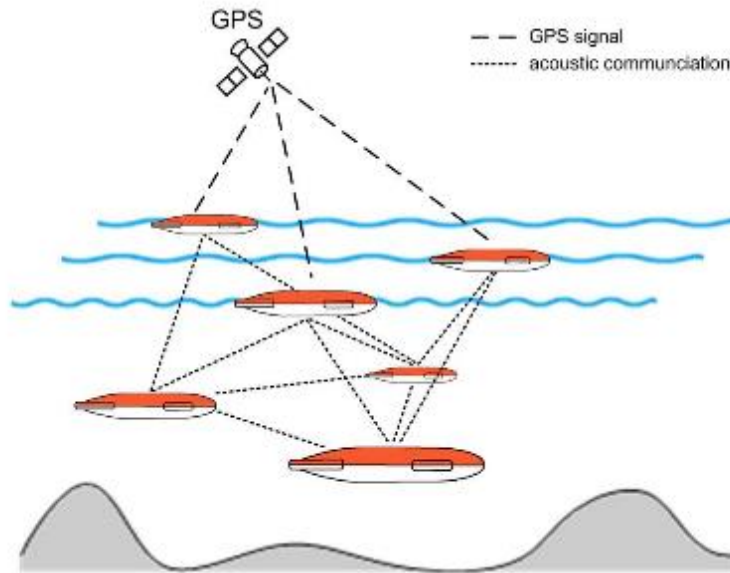

Figure 48. UUVs Communicating via ACOMMS. Source: Naval Drones (2012).

ATR technology could be utilized and improved through the deployment of a diverse set of sensors working in swarm architecture and communicating via ACOMMS. For instance, a UUV equipped with high frequency band sonar (which produces a near image-quality picture of the target) locates a target of interest but cannot resolve the signatures to a high enough probability to designate the object as a high priority target. The UUV could communicate with the other UUVs working in the swarm and request another UUV equipped with a low-band sonar (low-band sonars have been demonstrated to penetrate within materials of an object and depict internal structural elasticity and essentially view what is within potential targets (Sternlicht 2017)) to gain a second perspective and either elevate or reduce the probability of a target. This method of observing a target or area from different aspects is analogous to the many different systems deployed today to increase the probability of clearance (i.e., forward-looking sonar, influence sweep, mechanical sweep, and side scan sonar). The application of autonomous swarm architectures in the MCM domain will have a profound effect on reducing the DTE time line while reducing the exposure of personnel to the threat, all of which will be enabled by ACOMMS.

IV. TECHNOLOGY TRENDS

A. CAPTURING TRENDS AND PREDICTING FUTURE PERFORMANCE

Technology advances at a rapid pace, and, to plan for future MCM systems, it is important to have some idea of what technologies and what levels of capability will be available leading up to that future timeframe. In this section, the five key technology areas are further discussed and through data mining and forward extrapolation, the future capabilities that will be available up through 2040 are predicted. “We have shown that technology advancement is at least roughly exponential at the present time and that it can be expected to continue to be exponential for perhaps another century” (Harney 2013, 22).

1. Number of Autonomous Systems Working in a Team

The number of underwater systems operating autonomously in a swarm architecture is strongly correlated with the system autonomy, underwater communications, and localization accuracy. These three domains most significantly impact the performance of UUV swarms and, as advances are made in these areas, swarm architectures will be able to complete tasks of greater complexity. There are already examples of systems such as the Collective Cognitive Robotics (CoCoRo) project that have demonstrated 41 UUVs working together in a small controlled environment (swimming pool/test tank). The CoCoRo swarm system is capable of detecting areas of interest, measuring environmental parameters, passing information along a chain of robots, synchronizing information, synchronized movements and cooperative searches (Schmickl 2015).

Vehicle localization has been a challenge for systems operating under the surface of the sea, a challenge that will be compounded by the number of vehicles being tracked. The Mk18 Mod 2 Kingfish UUV is based upon the Remus 600 that followed a trend in UUV architecture incorporating the use of several sensors to collectively develop position data as the operational environment changes. The Remus UUV can receive a conventional acoustic tracking link from a vessel at the surface, the Kongsberg acoustic

underwater positioning and system, Ranger positioning systems, Internal Measuring Unit and Doppler Velocity Log to generate an accurate real-time position solution (Kongsberg Maritime n.d.). This diversified approach has many advantages and given the trends in sensor and computer technology will likely be the utilized into the future.

The most significant enabler of swarm architectures is autonomy. To reduce the workload on C2 and ultimately reduce the mission timeline, the human to system interaction must be minimized through autonomy. This is also relevant as the number of vehicles or nodes operating in a swarm increase, so will the reliance on autonomy to control the swarm's activities. As noted in Chapter II, several experts in the domain of AI predict that machine ability will be equivalent or superior to human intellect between 2030 and 2035 (Solman and Kurzweil 2012). Being conservative with respect to the aforementioned predictions, UUV swarms could potentially be conducting higher order tasks in controlled environments by the 2020s, semi-autonomous actions in operational environments by the 2030s, and fully autonomous operations in operational environments by the 2040 timeframe. It should be noted that this progression is speculative and the notion of autonomous military systems envelopes a host of ethical concerns that could derail progress with a single incident. Although the timeline for the maturity and application of autonomy in military systems will surely not be a finite progression, its relevance to swarm technology is definite and without it, the proposed architecture will not be realized.

The potential number of UUVs in a swarm is projected to continue to expand, especially relative to their combined and collective level of autonomous operation and capability, offering MCM practitioners the capacity to utilize potentially hundreds of UUVs together to accomplish complex tasks in an often-fluid environment. While a staggering number of vehicles may eventually be possible, real world application of this concept is continually limited by host ship's capacity to launch, recover, maintain, and support these vehicles, as well as provide the communications bandwidth and computational power to support the operations of an increasing number of increasingly intelligent vehicles.

2. Energy Storage

Energy storage (capacity) is a key consideration for the future MCM UUV. It is expected that the future energy storage requirement for the UUVs will be for a high energy density [specific energy (Wh/kg)] to produce a performance with longer runtime than the current systems. To predict a high energy density value for the year 2040, the data had to first be obtained and then a linear extrapolation was conducted. During this study, there were not many sources of energy storage data available. As mentioned previously by the reputable source, *Linden's Handbook of Batteries*, the lithium-ion may be the battery of choice for energy storage in the future (Linden and Reddy 2010). Therefore, research was focused on the lithium-ion battery as the basis for the data collection.

The estimated values of energy density used were obtained from the graph shown in Figure 49. Although the years of data begin as early as 1991 and end in 2005, the data was used to extrapolate and formulate an energy storage value for the year 2040. The applicable values used for this research effort were retrieved from the figure's "Wh/kg" Energy Density line of data for the range of years 1991–2005 (the figure contains additional data and information (i.e., Wh/l and US\$/Wh data) that was not used in the estimations and are therefore not mentioned in this discussion). The data from Figure 49 was plotted to obtain a trend line and afterwards extrapolated linearly to extend the trend line out to the year 2040.

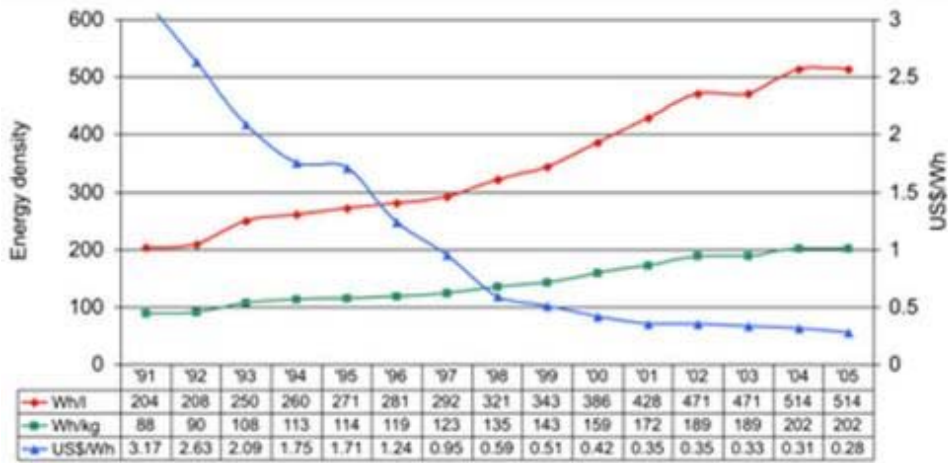

Figure 49. Lithium-ion Energy Density Trend Lines. Source: Takeshita (2006).

Figure 50 shows the graph developed from the steps described here. At year 2040, the value for lithium-ion energy density was estimated to be 510 Wh/kg based upon the trend line. For comparison, the values used in Figure 49 and the values developed and plotted in Figure 50 were evaluated against to the range of values shown in Figure 51.

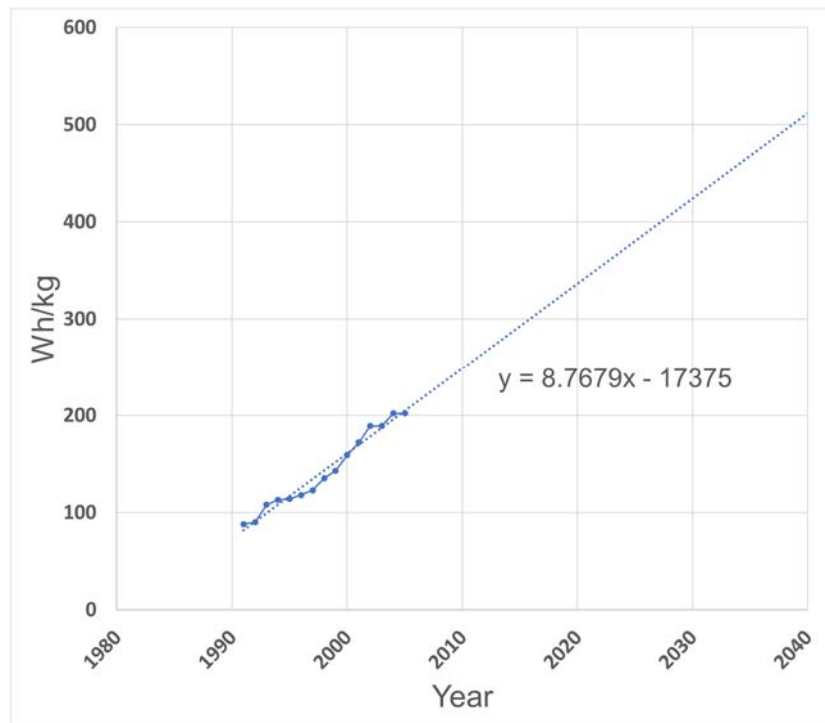

Figure 50. Estimation of Future Lithium-ion Energy Storage

The information in Figure 51 represents a compared and unified collection of lithium-ion energy density trend data formulated as a result of an analysis of data from publications associated with the evolution and maturation of energy storage technologies (Peirano and Sigrist 2014). Using the project trend analysis, the estimated lithium ion energy density value is 335 Wh/kg for the year 2020 and is within the 150–400 range of energy density values from the Peirano and Sigrist projections for that timeframe. The estimated lithium-ion energy density value of 425 Wh/kg is well within the 225–600 range of energy density values for year 2030 and estimated at 510 Wh/kg which falls within the 260–700 scale of energy density values from the more recent comparison projections for year 2040 in Figure 51. It fosters an energy storage capacity capability of providing future UUVs with longer runtimes for increased mission duration and ultimately power for partial and full mission power replenishment (Peirano and Sigrist 2014).

	2012	2020	2030	2040
Energy Density (Wh/kg)	75-200	150-400	225-600	260-700

Figure 51. Compared and Unified Lithium-ion Energy Density Projections.
Source: Peirano and Sigrist (2014).

3. Sensor Range and Resolution

As previously discussed in Chapter III, improvements to sensor range and resolution can help achieve the two MCM goals of reducing MCM timeline and improving mine detection. Usage of capabilities such as a Super-SAS and lasers could be utilized in the future to provide increased range and resolution. To more effectively predict this, current and historical range and resolution sensor data must be examined. This requires a look at traditional side scan sonar, modified side scan sonar, and SAS.

An example of the side scan sonar capability is the EdgeTech 4200 Series. It has range of 500 meters per side at 100 kHz, 230 meters per side at 300 kHz, 150 meters per side at 400 kHz, 120 meters per side at 600 kHz, and 75 meters at 900 kHz (EdgeTech

n.d.). Its across track resolution is as follows: 8 cm at 100 kHz, 3 cm at 300 kHz, 2 cm at 400 kHz, 1.5 cm at 600 kHz, and 1 cm at 900 kHz. Dependent on mode, at a distance of 50 meters it has an along track resolution between 18 and 70 cm, at a distance of 100 meters it has an along track resolution of between 45 and 70 cm, and at a distance of 150 meters it has an along track resolution of 130 cm while at a distance of 200 meters it has an along track resolution between 100 and 500 cm (EdgeTech n.d.).

Multi-beam side scan sonar (MBSS) builds on side scan sonar but not to the degree of SAS. A standard example of MBSS is the Klein System 5000 V2. It has an across track resolution of 3.75 cm. In comparison to a traditional side scan sonar it's along track resolution performs much better. At 38 meters, it has an along track resolution of 10 cm, at 75 meters it has an along track resolution of 20 cm, at 150 meters it has an along track resolution of 36 cm, and at 250 meters it was a resolution of 61 cm (Klein Marine Systems, Inc. n.d.). Improvements in MBSS have led to solutions such as the Klein System 5900 which increase the resolution by more than 25 percent in comparison to standard side scan sonar (Klein Marine Systems, Inc. 2017). Its across track resolution is the same as the 5000 V2 model at approximately 3.75 cm. At 50 meters it has an along track resolution of 6.2 cm, at 75 meters an along track resolution of 9.3 cm, and at 125 meters an along track 15.5 cm (Klein Marine Systems, Inc. n.d.).

An example of a SAS is the Atlas Elektronik Vision 600 which has an along track resolution of 2.5 cm at 100 meter range (Atlas-Elektronik UK n.d.). An even more cutting-edge example of SAS is the Kraken Katfish which has an along track resolution of 3.3 cm at 220 m (Kraken Robotics n.d.).

Additionally, a long-range sensor was evaluated. An example of a long-range SAS is the L-3 OS Seahawk which was tested in 2003 by scanning the Ex-USS Salmon and the M/S Bidevind (Putney et al. 2004). When scanning the Ex-USS Salmon, the Seahawk exhibited an along track resolution 6.5 meters at 500 meter range, 12 meters at 4500 meter range, 13 meters at 8000 meter range. When scanning the M/S Bidevind, the Seahawk exhibited an along track resolution of 5 meters at 500 meter range and 9 meters at 4000 meter range (Putney et al. 2004).

Figure 52 illustrates the difference between a traditional side scan sonar image and a SAS image. The images were taken at a range of approximately 200 meters and the difference between the two is quite striking (Florin et al. 2004). The bottom image is from the side scan sonar and one can barely make out any objects at all. In the SAS image, the objects are quite clear and the shapes of the objects are apparent.

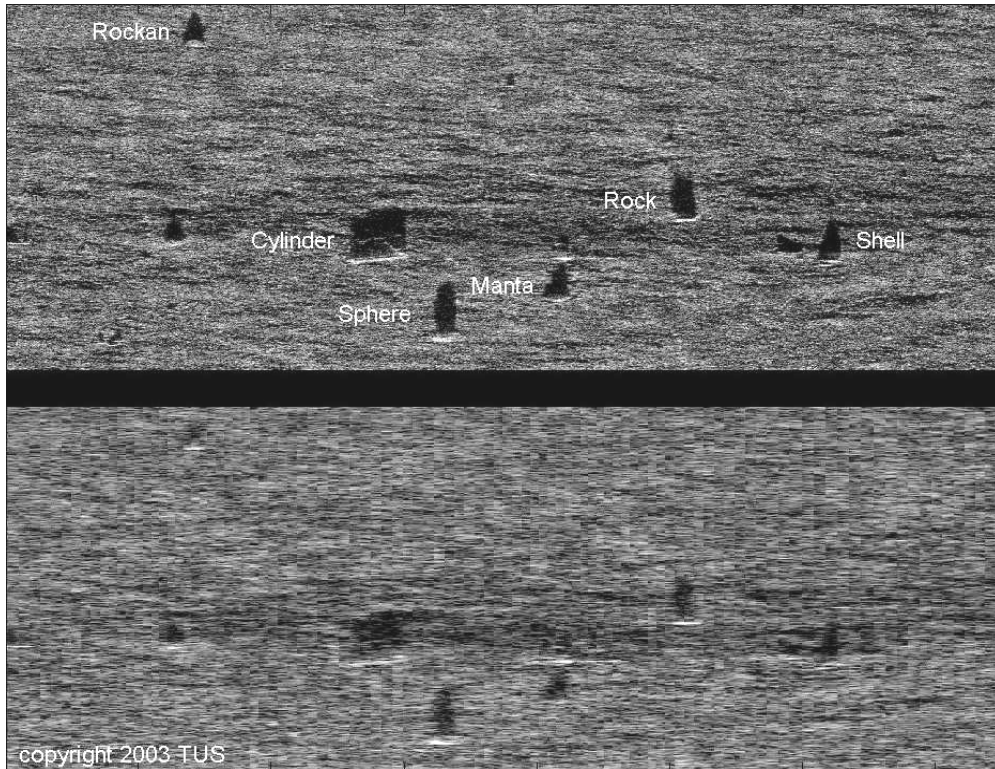

Figure 52. SAS Image versus Traditional Side Scan Sonar Image. Source: Florin et al. (2004).

Though this data is not specifically chronological, the sensor technology has continuously improved as time has passed. Therefore, this data can be used to extrapolate predicted future sensor data.

The data for the sensors listed above was examined and evaluated at a range of 100 meters. The associated along track resolution at this range for the MBSS and SAS is displayed in Figure 53. The first generation MBSS has a resolution of 24 cm while the latest MBSS capability has resolution of 12.4 cm. The older generation SAS has an

average of approximately 19 cm resolution at 100 meters. The cutting-edge SAS examples have an impressive 2.5 cm and 1.5 cm resolution at 100 meters.

As can be seen, the trend line for sensor technology is exponential and is starting to level out. The initial examination allows for the assumption that the growth in sensor resolution may level out and be nominally the same in the 2040 timeframe. Additionally, one may assume that there may not be much benefit for MCM sensors to have a range in millimeters or even micrometers. However, this increase in resolution could help identify proud or buried mines. Considering this and evaluating the equation associated with the exponential trend line, one can see that the predicted resolution at the 100 meter range is 8.7 mm in 2030 and as fine as 2.2 mm in 2040.

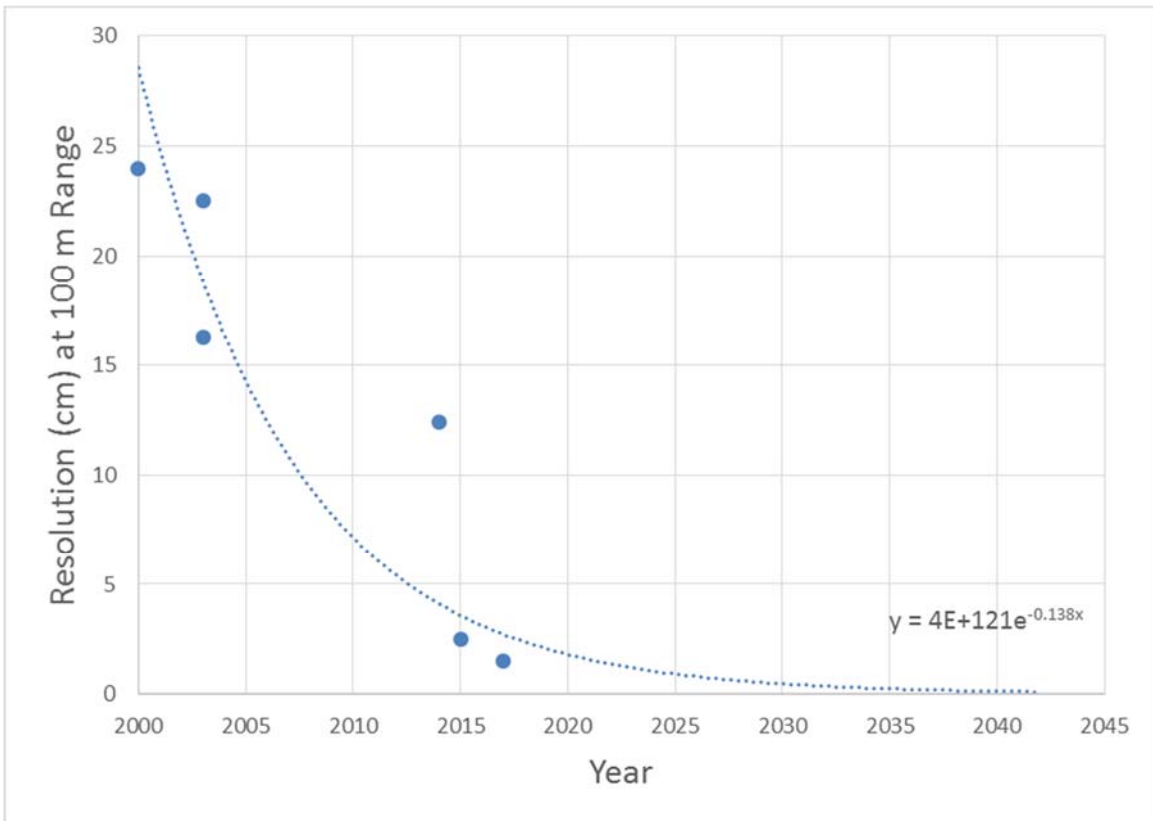

Figure 53. Sensor Resolution at 100 m.

The data available at the 100 meter range shows a ratio of range to resolution growing year by year. While a full set of data is not available to support a constant ratio

regardless of range or resolution, a smaller set of multiple ranges shows that the ratio holds constant. This ratio can be used to evaluate the growth in range at a constant resolution. Holding the resolution to 1 cm and utilizing the ratio of range/resolution for all data points gathered and projecting those ratios over time will yield an exponential increase in range per 1 cm resolution as illustrated in Figure 54.

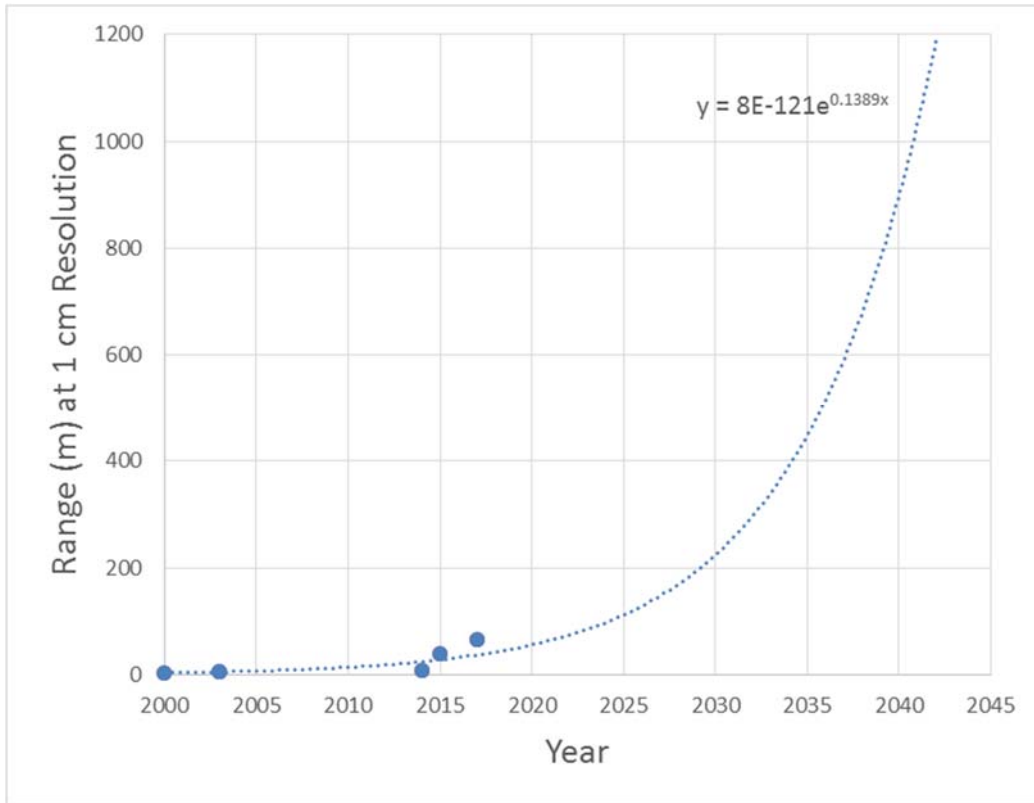

Figure 54. Sensor Range at 1 cm Resolution.

Figure 54 shows an exponential trend line for range at the 1 cm resolution as time passes. In the year 2030, one can expect a 1 cm resolution at a range of 230 meters. The data also yields a range of approximately 920 meters at 1 cm resolution in the year 2040. This is an increase in range of more than one order of magnitude between now and the 2040 timeframe. The increase in resolution between now and 2040 is also more than one order of magnitude. As can be seen with these projected numbers, this data supports the importance in continuing efforts to increase sensor range and resolution.

4. Post Mission Analysis (PMA) / Automatic Target Recognition (ATR)

As previously discussed, reducing PMA time and increasingly leveraging ATR to approach the end goal of in-stride MCM is critically important. There are two major hurdles that have been identified that need to be addressed before significant advancement in ATR for identifying mines using sonar imagery can take place.

The first hurdle that must be overcome is that the customer base for such an algorithm is extremely small. Besides navies, there are very few customers who are seeking development of such technologies. Beyond those who are looking for lost vessels or other such sunken items, the need for this kind of capability in the private sector is limited.

The second hurdle that must be overcome is that the database of sonar images is equally as small. Despite having encountered mines on many occasions throughout recent history, collecting the sonar data of sensing mines in-situ and filing that data into a central repository has never been a concerted effort. ATR for facial recognition has developed at an extremely rapid pace, both because there is a large client demand for it (for things like airport security), but also because AI can be used extensively since the algorithms can be fed millions of images from which to learn. Due to the existing database of sonar images being on the order of only hundreds to a few thousand, it is even more challenging to develop robust algorithms and prove their performance in a statistically significant way.

To attempt some approximation of future ATR performance in support of identifying mines, the data from ATR used for facial recognition was first examined. The National Institute of Standards and Technology has developed a Facial Recognition Vendor Test from which they can benchmark competing algorithms. Figure 55 shows the error rate of facial recognition over time, using the best performers in the indicated years. One can easily see that error rate is decreasing rapidly, and by 2025, it is predicted that the error rate will be under 1 percent.

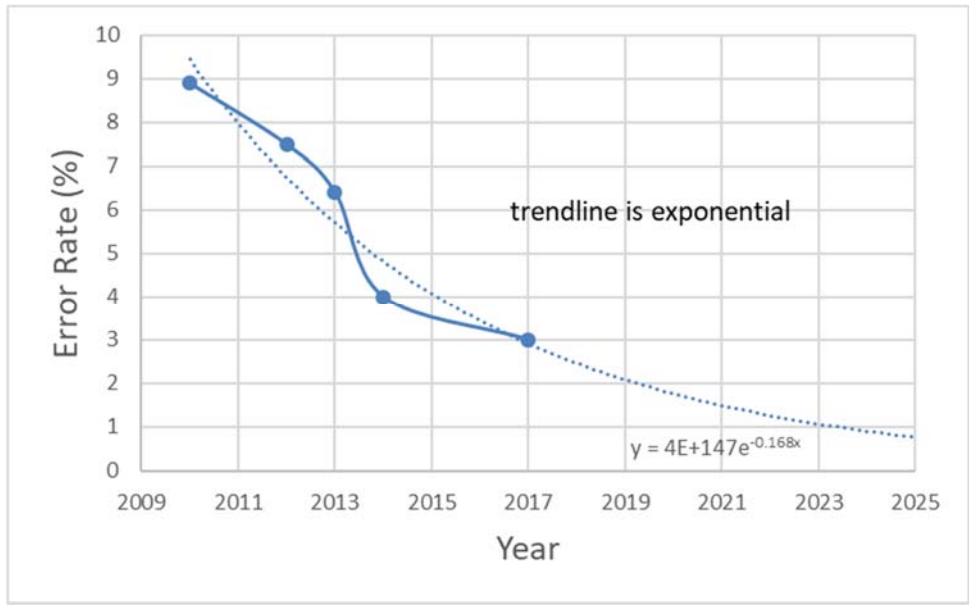

Figure 55. Error Rate in Facial Recognition by Year

Due to the limited data found on ATR in support of sonar images, a single data point was used as a starting point, and the curve from the facial recognition ATR extrapolation was super-imposed onto the sonar image ATR graph, as shown in Figure 56.

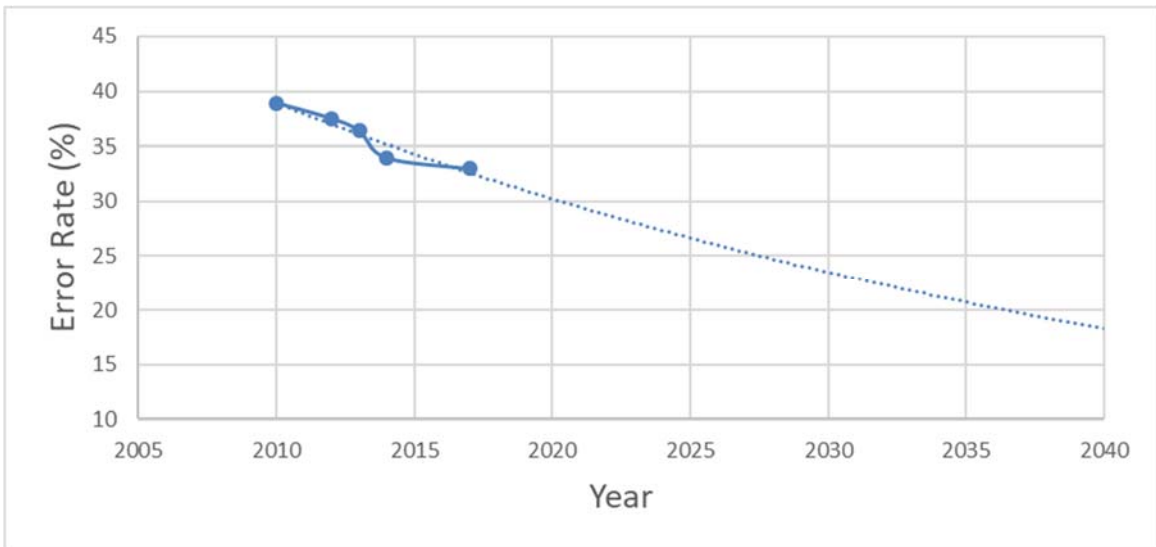

Figure 56. Sonar ATR Error by Year

The first thing that stands out is that percent error for sonar image ATR is noticeably higher than for facial recognition ATR. Given the starting point of about 33 percent error in 2017, it is predicted that if investments were to be made in this area, the percent error could be reduced to about 18 percent by 2040. Although this may seem like a dire situation, there are only five data points from which this predictive curve was derived, and any significant improvements in the coming years could dramatically change the predicted state in 2040.

5. Acoustic Communications Bandwidth

The process of projecting the performance of ACOMMS into the future begins with first, analyzing the physics that govern acoustic propagation to determine the potential bandwidth and data capacity and associated range, and then extrapolating past and current acoustic modem performance to determine when the theoretical limits could be reached.

In Stojanovic's paper "On the Relationship between Capacity and Distance in an Underwater Communication Channel," she quantitatively defines both the bandwidth and capacity and transmission power as functions of distance (Stojanovic 2006). Stojanovic's derivation utilizes path loss (attenuation) and noise propagation to determine the SNR with respect to distance. Utilizing the SNR/distance correlation, she was then able to determine the bandwidth, capacity, and transmission power as functions of distance, as seen in Figure 57 (circles in the figure indicate numerical integration, solid curves in the figure represent closed-form approximation).

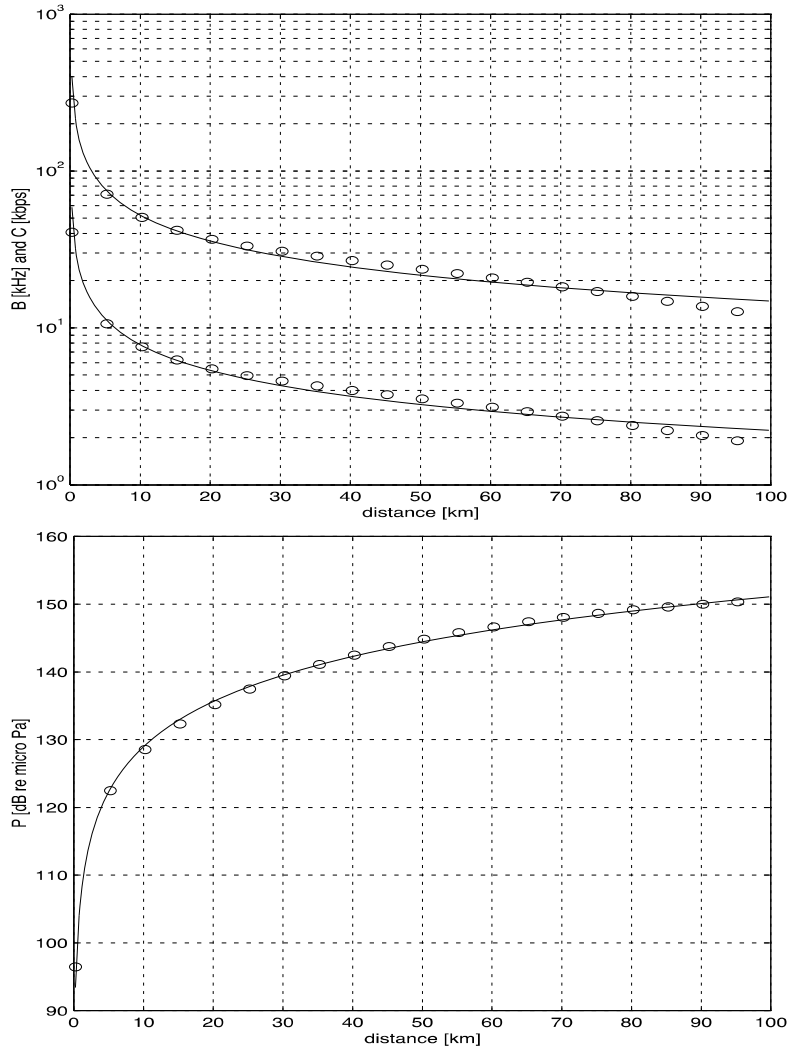

Figure 57. Stojanovic's Results: Bandwidth vs. Range. Source: Stojanovic (2006).

From Stojanovic's research the theoretical limits of what acoustic modems could possibly achieve can be established. This information could then be combined with the performance growth of commercial acoustic modems plotted over time to reveal an approximate time frame to which the technology would mature enough to achieve the theoretical performance. Given the limited amount of information available and the relatively low maturity of underwater acoustic modems, the results must be viewed as an approximation or forecast rather than a firm set of milestones of where the performance will be in the future. The results of this analysis aided development of a model that

projects the performance of technologies that could enable desired capabilities in the future.

During this analysis, it was realized (as did Stojanovic) that acoustic modem capacity and range are highly correlated. It was not possible to develop a single model of past and present modem performance that showed growth over time. The issue was resolved by grouping the acoustic modems into a set of ranges: 0–1000 meters, 1001–2000 meters, and 3501–6000 meters. This approach was effective in resolving the correlation of range and capacity and produced some compelling trends.

Trend lines were added to each data set that represented the growth of the highest achieved performances. The 0–1000 meters group contained the most data points and provided the best set to determine the correct trend type. An exponential growth curve was found to be the most convincing. From Figure 58, Figure 59, Figure 60, it was determined that acoustic modems in the 0–1000 meters range would reach the maximum theoretical capacity of about two megabits per second, as estimated by Stojanovic, around the 2024 time frame, modems within the 1001–2000 meter range would reach the theoretical limit of 1.1 megabits per second around the 2029 time frame, and modems within the 3501–6000 meters range would reach the theoretical limit of 650 kilobits per second around 2030. As mentioned above, the performance data for past and present acoustic modems is very limited and the extrapolations had to be developed with a minimal amount of information. For this reason, extrapolations in the 2001–3500 meter ranges did not yield particularly compelling trends and were not included in this analysis.

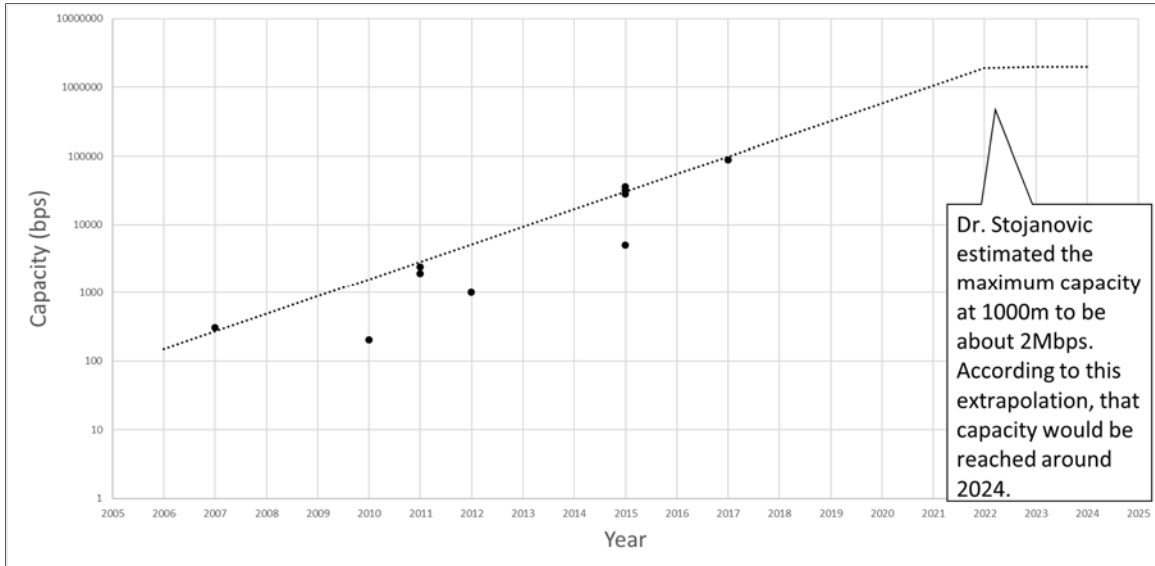

Figure 58. ACOMMS Extrapolation Group 0 through 1000 Meters

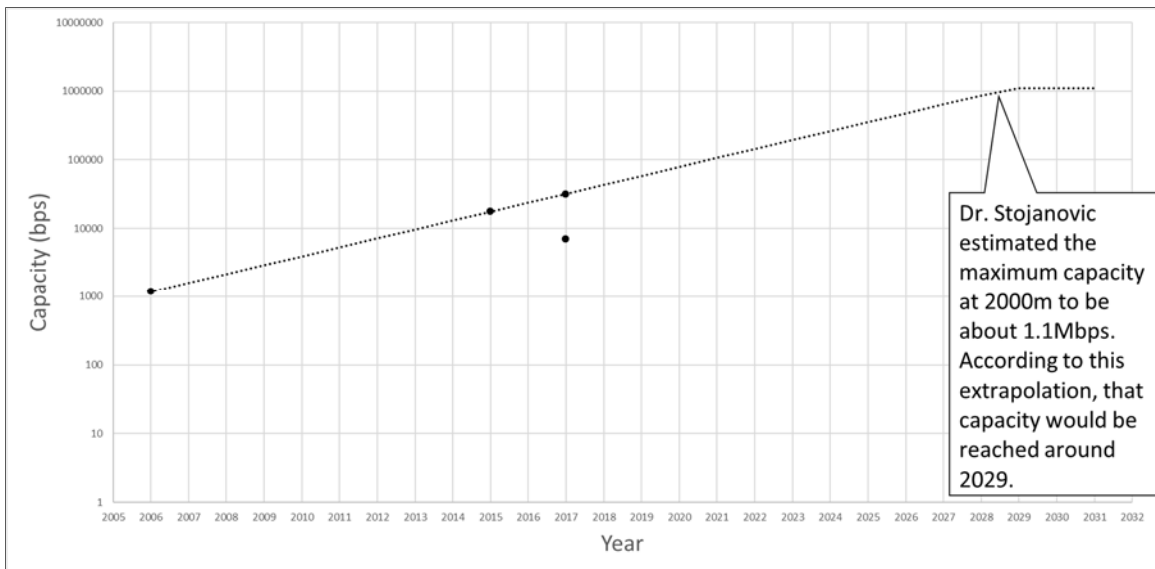

Figure 59. ACOMMS Extrapolation Group 1001 through 2000 Meters

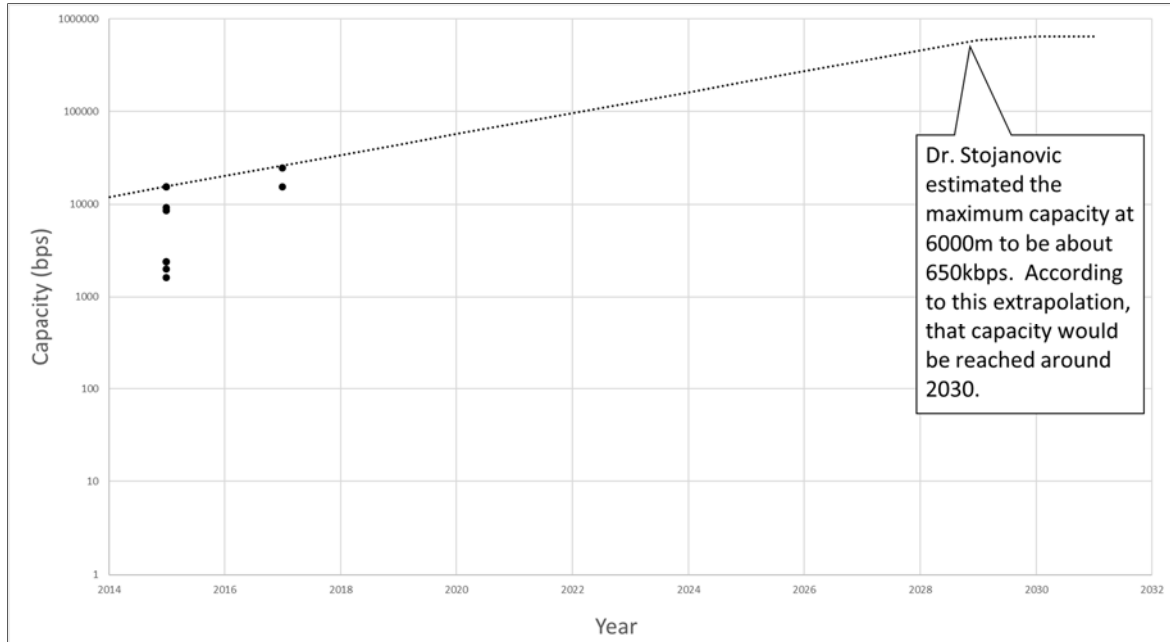

Figure 60. ACOMMS Extrapolation Group 3501 through 6000 Meters

This analysis concluded that acoustic modem technology may mature enough by the late 2020s or early 2030s to enable one- to two-megabit communication within 2000 meters and approximately one half that capacity between 3500 and 6000 meters. It is difficult to postulate the types of data that will need to be shared between vehicles operating in an underwater network or postulate how that data will be encoded or compressed, but as the maturity of this technology advances it is expected that the reliability of these systems and efficiency of these systems will reach a point where the underwater network capability could be realized. Also, given Stojanovic’s theoretical limits, there would be enough capacity to deliver more than just rudimentary packets of data.

B. EVOLUTION OF TECHNOLOGIES THROUGH 2040

To continue discussion of the performance predictions of future MCM capabilities, the estimations were reviewed for the five key technology areas of capability gaps from each Technology Advancement Roadmap for each timeframe since it represents the anticipated technological improvements for each decade of this study.

Figure 31 **Error! Reference source not found.**, shown again below for the reader's convenience, indicates the technology growth areas we would need in 2020. In the 2020 timeframe, a reduced PMA timeline due to concurrent PMA increases MCM efficiency. Technology research efforts are predicted to continue through 2020 for improvement and increased battery energy density or storage. The selected lithium-ion technology will continue to advance during this timeframe and innovative power storage technologies will be explored further.

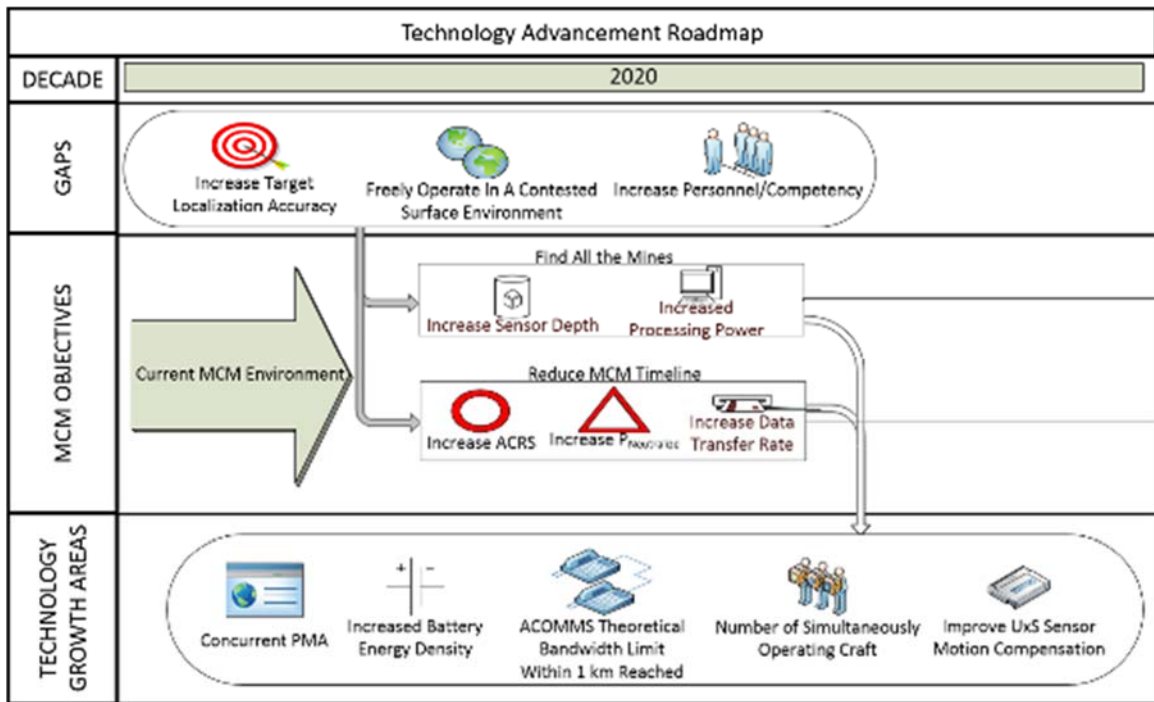

Figure 31 Expanded View of 2020 Timeframe (from Chapter III)

The UUV swarm architectures will conduct intricate tasks with underwater systems operating freely with system autonomy, close proximity underwater communications, and localization accuracy in controlled environments by the 2020s. Autonomy is significant because it minimizes the human to system interface and the dependence of autonomy to control the swarm's activities is also important during the 2020 timeframe. During this timeframe, UUV swarms could be functioning in controlled environment and executing higher order tasks.

Simultaneously operating systems and improved sensor motion are prevalent as well. Very beneficial to MCM will be improvements to sensor range and resolution. In 2020 and beyond, increased resolution will allow improved mine and target identification, decrease the time to hunt and thereby, reduce the future MCM timeline. These improvements along with the predicted energy density lithium-ion battery of 336 Wh/kg should already allow for a reduced DTE timeline. Our trend line for sensor technology is exponential and starts leveling out for sensor resolution. While the data at the 100 meter range shows a ratio of range to resolution growing year by year, a smaller set of multiple ranges indicates the ratio holds constant.

Figure 32 shows the technology growth areas necessary in 2030. During this timeframe, technological advancements are expected to focus on closing capability gaps and there will be UUV swarms conducting semi-autonomous actions in operational environments. The goal for this timeframe is for PMA to be upgraded to ATR-assisted PMA. The estimations are showing a percent error to approximately 23 percent by 2030 for ATR. ATR-assisted PMA will be a limited capability. This timespan can potentially become a significant growth time for MCM technologies and operations. Mine hunting drones will have the potential to close a vehicle persistence gap and the vehicle will store an increased performance sensor suite and operate as part of a semi-autonomous swarm. The estimated 424 Wh/kg energy density and storage value for the lithium-ion battery is projected to support the future partial power replenishment during operations in 2030. The estimations for acoustic modems in the 1001–2000 meter range would reach maximum theoretical capacity of approximately 1.1 megabits per second around the year 2029. Also during this 2030 timeframe, sensor resolution at the 100 meter range is estimated to be approximately 9 mm and we estimate a 1 cm resolution at a range of 230 meters.

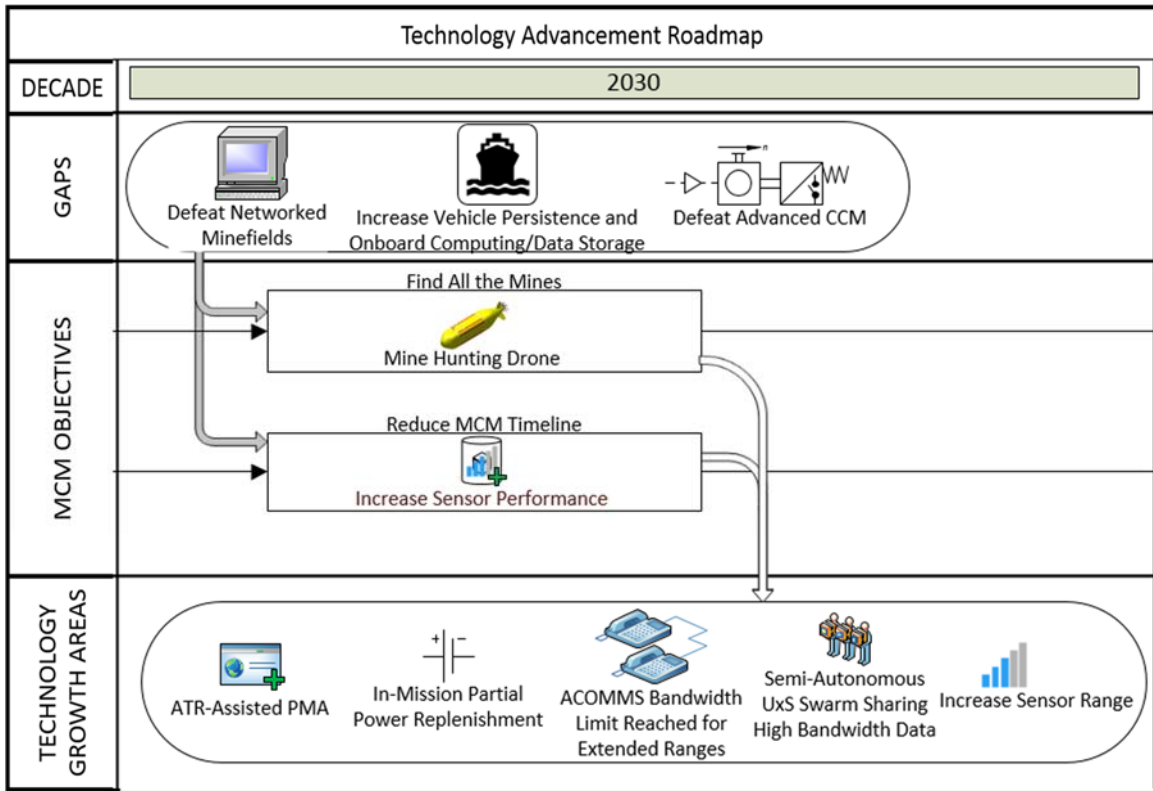

Figure 32 Expanded View of 2030 Timeframe (from Chapter III)

The technology growth areas needed in 2040 are shown in Figure 33. In the 2040 timeframe, PMA time is reduced and ATR is leveraged more to achieve in-stride MCM with fully autonomous operations in operational environments by the 2040 timeframe. Leveraging ATR to reduce PMA will be very important in the path forward to 2040. It is estimated that the percent error in sonar-based mine recognition will be about 18 percent by the year 2040. The expectation of having no PMA by the year 2040 cannot be met according to this estimated error rate. The estimated 512 Wh/kg energy density/storage value for the lithium-ion battery is expected to be enough to sustain the full in-mission power replenishment during operations in 2040. UUV swarms possibly will be functioning with fully autonomous operations in operational environments by 2040. During this timeframe, data also reflects a range of approximately 920 meters at 1 cm resolution. At the same time, the predicted resolution at the 100 meter range is 2.2 mm. These projected estimations indicate the significance to continue sensor range and

resolution technology growth to address identified capability gaps in support of 2040 MCM operations.

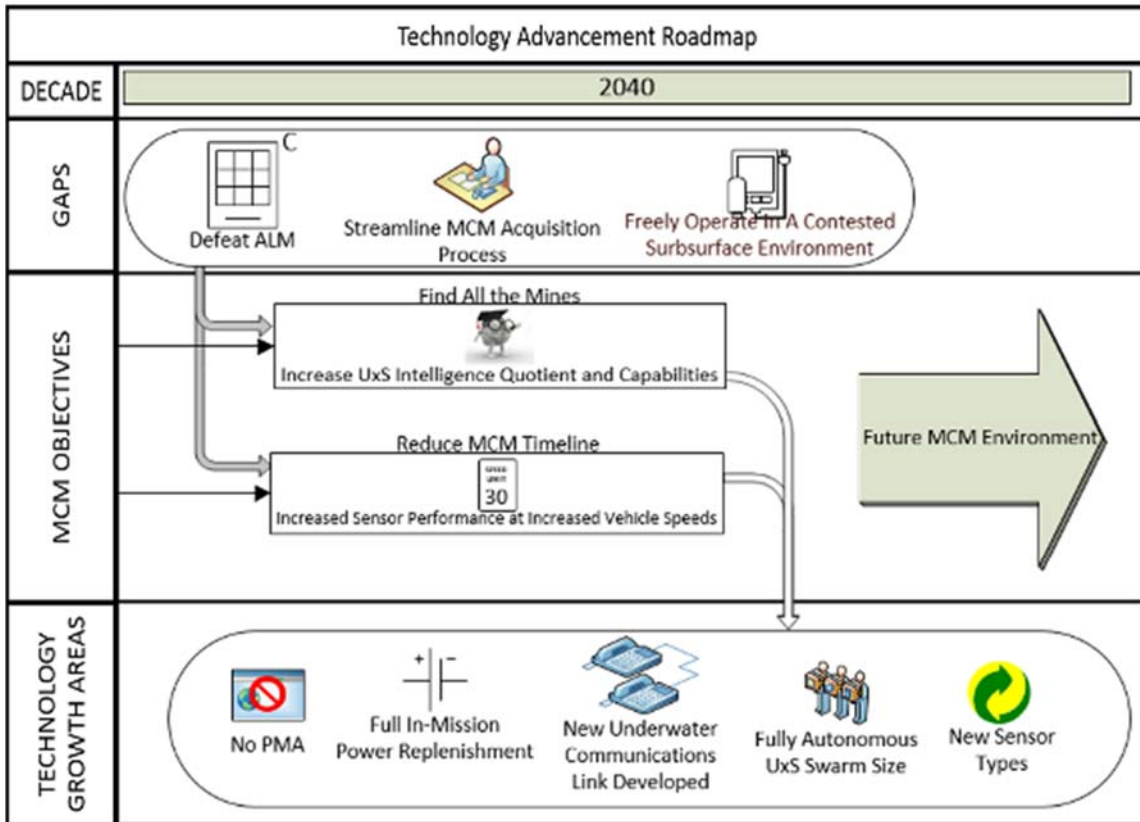

Figure 33 Expanded View of 2040 Timeframe (from Chapter III)

V. SUMMARY AND FUTURE WORK

A. CONCLUSIONS FROM ANALYSIS

Since the development of the Bushnell Keg during the Revolutionary War, offensive mines have vexed navies around the world. These “weapons that wait” (Hartmann 1991) provide a physical and psychological advantage at a low cost and with a potentially high reward for the entities that deploy them. Since mines have posed such a great threat in the past and will continue to pose a threat in the future, the U.S. Navy of the future must not only be able to find and clear low-technology mines such as those that damaged the USS Princeton (CG-59) and USS Tripoli 1991 (LPH-10), it will have to develop the technologies necessary to locate, identify, and neutralize anticipated advances in offensive mine warfare developed by potential adversaries. The ability to counter the threat of mines will remain a key requirement for the U.S. Navy supporting its ability to maintain maritime superiority.

Today, despite large investments in MCM technologies and systems (Department of the Navy 2015), the U.S. Navy is still struggling to use systems that adequately address the current threat, as shown in the MCM Capability Gaps discussed in Chapter III. The problem is projected to be compounded in the coming years by advances in mine capabilities by near-peer adversaries, including the continuation of current threats. To the Navy, that means not only continuing to counter WWII-era mines but also to expand the defensive capabilities to counter new and increasingly connected “smart” mines.

The purpose of this study was to examine the U.S. Navy’s MCM needs for the 2040 timeframe. The long-term focus of this study served to differentiate it from past capstone studies, which were more near-term focused. Taking into account the likely wide range of threats, the problem was bounded by identifying major capability gaps and formulating overarching MCM goals. Five key technology areas were selected for further study based on each technology’s potential ability to close one or more capability gaps, including heading off new gaps that are predicted to arise in the future: number of autonomous systems working in a team, energy storage, sensor range and resolution,

PMA/ATR, and ACOMMS bandwidth. These five areas will not only support MCM, but mining as well, which demonstrates their importance and utility.

To maintain dominance in the future, it is recommended that the Navy focus research and investment into the five key technologies set forth in this study. Some are unique to this realm, such as underwater communications and improved underwater sensors. Autonomy and teaming have been rapidly developed for surface and aircraft, but their application to UUVs and MCM have been limited. Similarly, ATR and machine learning algorithms could allow for the introduction of concurrent PMA, but only small steps have been taken to marry them with respect to the scanning of sonar imagery.

Investments in MCM usually follow a tidal ebb and flow pattern, rising sharply and peaking shortly after mine-related incidents, and then falling in the years thereafter. This trend has several negative consequences that also tend to reinforce this drastic and reactionary cycle:

- Knowledge in the mine warfare area is lost from generation to generation as the past workers retire and there is no new work or transfer of knowledge to younger engineers.
- Documents are lost as they become unused and discarded.
- Time is lost trying to startup funding streams when there is a need.
- Warfighters with adequate mine warfare training decrease in number.
- Legacy systems are forced to be used beyond their originally intended service life.

There are many credible threats that need to be addressed with considerable investments such as nuclear deterrence and cyber warfare. Except for cyber-attacks, however, there may be no other realm of warfare besides that of mining that is so incredibly asymmetric, diverse, and detrimental to the opposing side. The U.S. Navy will need to monitor this threat continually and adjust its posture as the MIW domain continues to grow and evolve. By focusing efforts to advance the key technologies identified herein, the Navy will close the capability gaps, accomplish two of its major MCM goals, and elevate its MCM capabilities to a place where warfighter interaction with the mine field will be minimized by improved system effectiveness. The threats of

the past will be ever present, but as technological advancements are made in MIW, future MCM will contend with new players such as the ALM and a new approach to MCM will be required to handle the wide breadth of threats. The aim of this report was to propose such an approach and provide a reasonable roadmap with achieving it. The speculative nature of this report leaves many more questions to be answered and future work to be conducted, but the recommendations made within this report will lead to greater MCM capability and ultimately improve the U.S. Navy's ability to protect the fleet from the evolving MIW threat.

B. AREAS FOR FUTURE RESEARCH

This study had a broad scope both in topic and timeline. This lends itself to lead into many related future studies. Specific areas could be examined in greater detail. Alternate scenarios and solutions could be researched. A condensed or an expanded timeline could be examined as well.

From a technology enabler standpoint, additional capabilities and their impact on MIW and MCM could be examined. There are many different technologies beyond those discussed that could significantly affect MCM in the future. A broader range of study may provide a more complete picture of where the future of MCM is heading. The small scope of key technologies presented in this study may not be fully indicative of where money and effort should be focused. Or, one could narrow the focus by only studying the impact on a specific part of MCM such as neutralization or PMA. These relationships could be examined in detail. Or, going in the other direction, a single specific technology could be selected, such as SATCOM, and its particular effect on the broader MCM scope could be investigated.

A different scenario for the 2040 timeframe could be explored as well. Rather than study shallow water, another water depth could be used to create the scenario. A specific bottom type or water temperature could yield different results. Rather than the ALM, the scenario could include only primitive mines or MIEDs. Or, ALM swarms could be the major threat. The specific scenario selected could change the MCM goals, associated capability gaps, and technologies necessary to fill these gaps.

Additional research may reveal that the two MCM goals presented in this study are not realistic goals for the 2040 timeframe. If different MCM goals were selected, they would drive different capability gaps. This would lead to different key technologies. These technologies could then be extrapolated to determine their impact on the future of MCM. Another option would be to focus on a single specific MCM goal and concentrate all research on how to meet that particular goal. Alternatively, one could focus on a single particular capability gap and examine the technologies that could fill it. These could be studied at the microscopic level or additional goals could be determined and their related gaps and technologies could be viewed at a 10,000-foot view.

The last area that would be worth studying in a different way is the timeline. A nearer term study could be conducted examining MCM in 2030. This would also require examination of current technology and solutions but could require creativity to find ways to allow for COTS to meet the capability gaps. Due to the fact that most government projects take between 10 and 20 years to fully implement and due to the fact that the military is no longer considered cutting edge in many technology areas, this study could focus on solutions utilizing technologies that are being introduced today.

APPENDIX. TECHNOLOGY ADVANCEMENT ROADMAP

The technology advancement roadmap shown in Figure 61 represents a temporally arranged view of anticipated technological improvements that could potentially occur throughout the timespan evaluated for the purposes of this study.

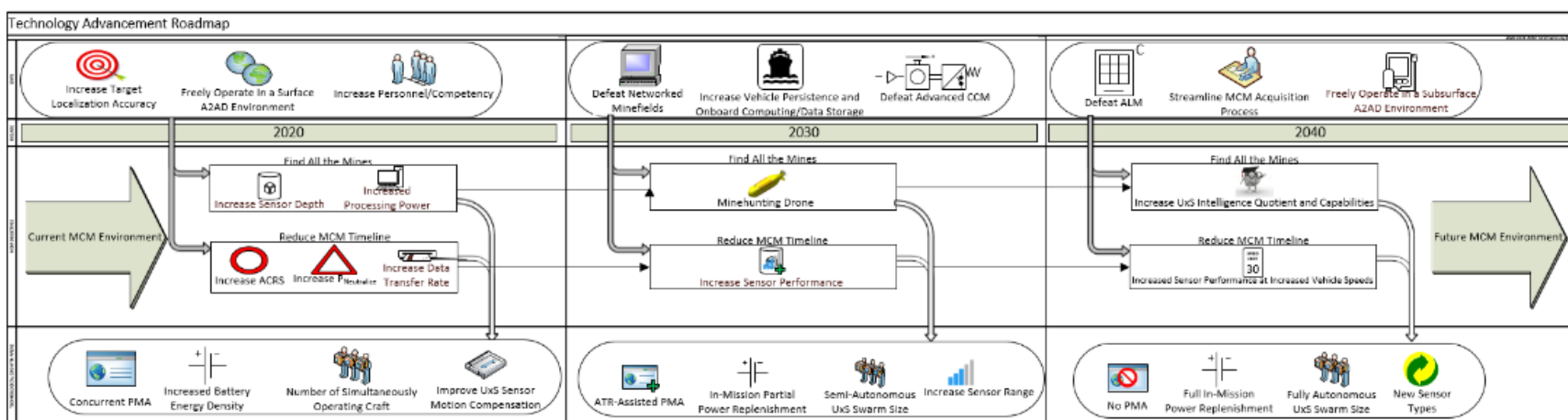

Figure 61. Technology Advancement Roadmap

THIS PAGE INTENTIONALLY LEFT BLANK

LIST OF REFERENCES

- ADCO Ltd. n.d. "Sector Scan Sonar." Accessed May 3, 2017. <http://adco-ie.com/adco-sector-scan-sonar/>.
- Andrews, Frank. 2014. "Yum! Mines!." laststandonzombieisland. October 24, 2014. <https://laststandonzombieisland.files.wordpress.com/2014/10/mine-neutralization-vehicle-mnv-an-slq-48-aboard-the-avenger-class-mine-countermeasures-ship-uss-chief-mcm-14.jpg>.
- Assistant Secretary of the Navy. n.d. "NMT Navy Advanced Extremely High Frequency Multi-band Terminal." Accessed August 20, 2017. <http://www.secnav.navy.mil/rda/Pages/Programs/NMT.aspx>.
- Atlas-Elektronik UK. n.d. "Vision 600 SAS - Synthetic Aperture Sonar." Accessed October 31, 2017. https://www.atlas-elektronik.com/fileadmin/user_upload/documents/products/Mine_Warfare_Systems/Vision_600_SAS.pdf.
- Australian War Memorial. n.d. "A German Mine Swept up in Australian Waters by an Auxiliary Minesweeper, Visible at Centre Right." Accessed July 25, 2017. <https://awm.gov.au/collection/304925>.
- Bana, Sarosh. 2016. "China's Underwater Great Wall." Washington Times. August 30, 2016. <http://www.washingtontimes.com/news/2016/aug/30/chinas-underwater-great-wall>.
- Batey, Angus. 2015. "Raytheon Rethinks Cyber, Trademarks C5I Concept." Aviation Week Network. June 15, 2015. <http://aviationweek.com/paris-air-show-2015/raytheon-rethinks-cyber-trademarks-c5i-concept>.
- Battery University. 2016. "BU-103: Global Battery Markets." April 11, 2016. http://batteryuniversity.com/learn/article/global_battery_markets.
- Blomberg, Ann E.A. 2015. "An Introduction to Synthetic Aperture Sonar." Center for Coastal and ocean Mapping Joint Hydrographic Center. February 6, 2015. <http://ccom.unh.edu/seminars/introduction-synthetic-aperture-sonar-sas>.
- Bonomi, Flavio, Rodolfo Milito, Jiang Zhu, and Sateesh Addepalli. 2004. Fog Computing and Its Role in the Internet of Things. Cisco Systems Inc.
- Borghino, Dario. 2015. "Device Combines the Advantages of Batteries and Supercapacitors." New Atlas. April 19, 2015. <http://newatlas.com/high-energy-density-supercapacitor/37075/>.
- Bort, Julie. 2016. "The Next Multibillion-dollar Tech Market Was Quietly Born this Year, Says A-list VC Peter Levine." Business Insider. December 16, 2016.

- <http://www.businessinsider.com/edge-computing-is-the-next-multi-billion-tech-market-2016-12>.
- Bradley, Tony. 2017. "Facebook AI Creates Its Own Language In Creepy Preview Of Our Potential Future." July 31, 2017. <https://www.forbes.com/sites/tonybradley/2017/07/31/facebook-ai-creates-its-own-language-in-creepy-preview-of-our-potential-future/>.
- Cai, Q., D. J. L. Brett, D. Browning, and N. P. Brandon. 2010. "A Sizing-Design Methodology for Hybrid Fuel Cell Power Systems and its Application to an Unmanned Underwater Vehicle." *Journal of Power Source* 195, no. 19 (October): 6559–6569. <http://www.elsevier.com/locate/jpowsour>.
- Brown, Thomas, Jonathan Damiano, Shivraj Jhala, Ryan Moore, Brett Morgan, Nguyen Vincent, Thomas Opheim, et al. 2012. Next Generation Mine Countermeasures for the Very Shallow Water Zone in Support of Amphibious Operations. Master's thesis, Naval Postgraduate School. <https://calhoun.nps.edu/handle/10945/6968>.
- Broyles, David A. 2017. A Prognosis for Mine Countermeasures: Getting the Mine out of the Minefield. CNA Analysis & Solutions.
- Business Wire. 2017. "Global Underwater Acoustic Modem Market to Grow at a CAGR of 12.8% by 2021: Analysis by Propagation Range & End User - Research and Markets." August 14, 2017. <http://www.businesswire.com/news/home/20170814005431/en/Global-Underwater-Acoustic-Modem-Market-Grow-CAGR>.
- Carberry, Sean. 2017. "CSRA wins \$500M MilCloud 2.0 Contract." June 12, 2017. <https://few.com/articles/2017/06/12/csra-wins-500m-milcloud.aspx>.
- Cellan-Jones, Rory. 2014. "Stephen Hawking Warns Artificial Intelligence could End Mankind." BBC. December 2, 2014. <http://www.bbc.com/news/technology-30290540>.
- Chaitin, Daniel. 2017. "Elon Musk Signs Letter Urging UN to Protect World from 'Pandora's box' of Deadly Autonomous Weapons." *Washington Examiner*. August 20, 2017. <http://www.washingtonexaminer.com/elon-musk-signs-letter-urging-un-to-protect-world-from-pandoras-box-of-deadly-autonomous-weapons/article/2632083>.
- Cisco Systems, Inc. 2012. Deliver Fabric-Based Infrastructure for Virtualization and Cloud Computing. Accessed August 20, 2017. https://www.cisco.com/c/dam/en/us/solutions/collateral/switches/catalyst-6500-series-switches/white_paper_c11-706418.pdf.
- Cook, James. 2014. "Elon Musk: You Have No Idea How Close We Are to Killer Robots." *Business Insider*. November 17, 2014. <http://www.businessinsider.com/elon-musk-killer-robots-will-be-here-within-five-years-2014-11>.

- Department of the Navy. 2015. Selected Acquisition Report for the Remote Minehunting System (RMS). Department of the Navy, Arlington, VA.
- Department of the Navy, Information Dominance Corps. 2013. *U.S. Navy Information Dominance Roadmap 2013–2028*. Department of the Navy, Arlington, VA.
- DOD. 2017. Report to Congress Restructuring the Department of Defense Acquisition, Technology, and Logistics Organization and Chief Management Officer Organization. Washington, DC: DOD. August 1, 2017. <https://www.defense.gov/Portals/1/Documents/pubs/Section-901-FY-2017-NDAA-Report.pdf>.
- Navysite. n.d. “USS Princeton (CG 59).” Accessed June 3, 2017. <https://www.navysite.de/cg/cg59.html>
- Eckstein, Megan. 2015a. “Expeditionary Mobile Base Chesty Puller May Receive SOF Upgrades before 5th Fleet Deployment.” USNI News. November 2, 2015. <https://news.usni.org/2015/11/02/expeditionary-mobile-base-chesty-puller-may-receive-sof-upgrades-before-5th-fleet-deployment>.
- . 2015b. “Navy Preparing 2 Separate Upgrades for Helicopter-Towed Minehunting System.” USNI News. November 11, 2015. <https://news.usni.org/2015/11/11/navy-preparing-2-separate-upgrades-for-helicopter-towed-minehunting-system>.
- . 2016. “Navy’s Remote Minehunting System Officially Canceled, Sonar May Live on.” USNI News. March 24 2016. <https://news.usni.org/2016/03/24/navys-remote-minehunting-system-officially-canceled-sonar-may-live-on>.
- . 2017a. “Expeditionary Sea Base USNS Lewis B. Puller Departs for Maiden Deployment.” USNI News. July 12, 2017. <https://news.usni.org/2017/07/12/expeditionary-sea-base>.
- . 2017b. “N95: Navy, Industry Ready to Ramp up Amphib Construction if Administration, Congress Provide Money.” USNI News. January 10, 2017. <https://news.usni.org/2017/01/10/n95-navy-industry-ready-to-ramp-up-amphib-construction-if-administration-congress-provide-money>.
- EdgeTech. n.d. “Side Scan Sonar System.” Accessed October 25, 2017. http://www.vermessung-weights.de/images/uploads/PDF/4200_Series_Brochure.pdf.
- . n.d. “4200 Series Side Scan Sonar System.” Accessed October 31, 2017. <https://www.edgetech.com/wp-content/uploads/2017/04/4200-Brochure-101617-low-res.pdf>.
- Elinoff, Gary. 2017. Aluminum Water Batteries ‘Drink’ Water to Increase the Range of Unpiloted Underwater Vehicle. Electronic Products. June 21, 2017.

- Florin, Franck, Franck Fohanno, Isabelle Quidu, and Jean-Philippe Malkasse. 2004. Synthetic Aperture and 3D Imaging for Mine Hunting Sonar. Undersea Defence Technology. June 2004.
- Fogarty, Kevin. 2009. "Server Virtualization: Top Five Security Concerns." CIO. May 13, 2009. <http://www.cio.com/article/2428191/virtualization/server-virtualization-top-five-security-concerns.html>.
- Frank, David, Kevin Hogan, Shane Schonhoff, Nicole Becker, Timothy Byram, Richard Kim, Glenna Miller, et al. 2014. "Application of Model-Based Systems Engineering (MBSE) to Compare Legacy and Future Forces in Mine Warfare (MIW) Missions." Master's thesis, Naval Postgraduate School. <https://calhoun.nps.edu/handle/10945/44659>
- Freedberg, Sydney J. 2015. "Transparent Sea: The Unstealthy Future of Submarines." Breaking Defense. January 22, 2015. <http://breakingdefense.com/2015/01/transparent-sea-the-unstealthy-future-of-submarines/>.
- French, Daniel W. 2010. "Analysis of Unmanned Undersea Vehicle (UUV) Architectures and an Assessment of UUV Integration into Undersea Applications." Master's thesis, Naval Postgraduate School. <https://calhoun.nps.edu/handle/10945/5111>
- Gawlowicz, J01. 1991. "Mine Damage to USS Tripoli (LPH-10), 1991." defenseimagery.mil. February 1, 1991.
- Gitzendanner, Robert, Frank Puglia, and Stuart Santee. 2009. "Advanced in the Energy and Power Density of Lithium-ion Batteries for Undersea Applications." UDT. September 6, 2009.
- Global Security. n.d. "Wideband Gapfiller System." Accessed on May 13, 2017 <http://www.globalsecurity.org/space/systems/wgs.htm>.
- Glover, CAPT Mark. 2016. "Communications and GPS Navigation Program Office (PMW/A 170): NDIA San Diego Fall Industry Event." San Diego, CA, October 16.
- Goldberg, Dr. Dani, Dr. Sanjeev, and Bill Key. 2017. "Swarming Unmanned Underwater Vehicles." Sea Technology, April: 31–36.
- Graham, William. 2016. "ULA Delta IV Launches WGS-8 satellite." NASA Spaceflight. December 7, 2016. <https://www.nasaspaceflight.com/2016/12/ula-delta-iv-wgs-8-launch/>.
- Griffith, Eric. 2016. "What is Cloud Computing?" PCMag. May 3, 2016. <https://www.pcmag.com/article2/0,2817,2372163,00.asp>.

- Griffiths, Gwyn, and Suleiman Sharkh. 2003. "Energy Storage Systems for Unmanned Underwater Vehicles." *Journal of the Society for Underwater Technology* 143–148.
- Gruss, Mike. 2016a. "Pentagon: Narrowband? Wideband? Just call Them Communications Satellites." *SpaceNews*. March 8, 2016. <http://spacenews.com/pentagon-narrowband-wideband-just-call-them-communications-satellites/>.
- . 2016b. "U.S. Air Force Awards Contracts for New Waveform Demonstrations." *SpaceNews*. August 25, 2016. <http://spacenews.com/u-s-air-force-awards-contracts-for-new-waveform-demonstrations/>.
- Hansen, Roy Edgar. 2012. "Introduction to Sonar." UIO. September 26, 2012. http://www.uio.no/studier/emner/matnat/ifi/INF-GEO4310/h12/undervisningsmateriale/sonar_introduction_2012_compressed.pdf.
- Harney, Robert C. 2013. "Technology Assessment for Strategic Planning and Initiative." https://archive.org/stream/Technology_Assessment_for_Strategic_Planning_and_Initiative/Technology_Assessment_for_Strategic_Planning_and_Initiative_djvu.txt.
- Harp gamer: Naval Wargaming Community. 2009. *Tactics 101: Anti-Submarine Warfare (ASW): Part 2 - The Tools of ASW*. Harp gamer. January 12, 2009.
- Hartmann, Gregory Kemenyi. 1991. *Weapons that Wait: Mine Warfare in the U.S. Navy*. University of Michigan Library.
- Hong, Kirak, David Lillethun, Umakishore Ramachandran, Beate Ottenwalder, and Boris Koldehofe. 2013. "Mobile Fog: A Programming Model for Large-Scale Applications on the Internet of Things." College of Computing; Institute of Parallel and Distributed Systems, Georgia Institute of Technology; University of Stuttgart, Hong Kong.
- Imaki, Masaharu, Hideaki Ochimizu, Hidenobu Tsuji, Shumpei Kameyama, Takashi Saito, Shojiro Ishibashi, and Hiroshi Yoshida. 2017. "Underwater Three-dimensional Imaging Laser Sensor with 120-deg Widescanning Angle Using the Combination of a Dome Lens and Coaxial Optics." *Optical Engineering* 56, no. 3 (March).
- Jaffe, Jules S. 2015. "Underwater Optical Imaging: The Past, the Present, and the Prospects." *IEEE Journal of Oceanic Engineering* 683–700.
- Jones-Bonbrest, Nancy. 2012. "U.S. Army's Common Operating Picture Tool Continues to Evolve." U.S. Army. December 5, 2012. <https://www.army.mil/article/92364>.
- JP1-02. 2016. "Joint Publication 1–02: Department of Defense Dictionary of Military and Associated Terms."

- JP3-15. 2011. Joint Publication 3–15: Joint Doctrine for Barriers, Obstacles, and Mine Warfare. Department of Defense.
- JP6-0. 1995. “Joint Publication 6–0: Doctrine for Command, Control, Communications, and Computer (C4) Systems Support to Joint Operations.”
- Klein Marine Systems, Inc. n.d. System 5000 V2 Side Scan Sonar. Accessed October 31, 2017. http://www.kleinmarinesystems.com/PDF/Klein_System_5000V2_rev1016.pdf.
- . 2017. System 5900 Advance Mine Hunting Multi-Beam Side Scan Sonar. <http://kleinmarinesystems.com/products/side-scan-sonar/system-5900/>.
- . n.d. System 5900 Side Scan Sonar. Accessed October 31, 2017. http://www.kleinmarinesystems.com/PDF/Klein_System5900_rev1116.pdf.
- Kongsberg Maritime. n.d. “Autonomous Underwater Vehicle, Remus 600.” Accessed August 3, 2017. <https://www.km.kongsberg.com/ks/web/nokbg0240.nsf/AllWeb/F0437252E45256BDC12574AD004BDD4A?OpenDocument>.
- Kraken Robotics. n.d. “Katfish Intelligent Towed SAS System.” Accessed October 31, 2017. <http://krakenrobotics.com/products/katfish/>.
- KRAKEN Sonar Systems, Inc. 2017. Synthetic Aperture Sonar. Accessed May 13, 2017. <http://www.krakensonar.com/en/our-sources/tech/synthetic-aperture-sonar>.
- LaGrone, Sam. 2014. “A Terrible Thing that Waits (Under the Ocean).” *Popular Science: Ship Shape*. May 19, 2014.
- Lee, Joonkoo, Mary Turnipseed, and Lukas Brun. 2012. “Market and Technology Trends in Underwater Sensors and Instrumentation.” *Marine Technology Reporter*, November/December ed. <http://www.marinetechnews.com/news/market-technology-trends-underwater-473396>.
- Light, Russ. n.d. “Seaglider: Autonomous Underwater Vehicle.” University of Washington. Accessed May 13, 2017. <http://www.apl.washington.edu/project/project.php?id=seaglider>.
- Linden, David, and Thomas B. Reddy. 2010. *Linden’s Handbook of Batteries*. 4th ed. New York, NY: McGraw-Hill.
- Linthicum, David. 2017. “Make sense of edge computing vs. cloud computing.” *Infoworld*. May 23, 2017. <http://www.infoworld.com/article/3197555/cloud-computing/make-sense-of-edge-computing-vs-cloud-computing.html>.

- Marolda, Edward J. 2015. Naval History and Heritage Command. Accessed 2017. <https://www.history.navy.mil/research/library/online-reading-room/title-list-alphabetically/m/mine-warfare.html>.
- Marr, Bernard. 2017. 28 Best Quotes about Artificial Intelligence. 07 25. Accessed 08 20, 2017. <https://www.forbes.com/sites/bernardmarr/2017/07/25/28-best-quotes-about-artificial-intelligence/>.
- Martens, Edward. 2007. America's Navy. http://www.navy.mil/view_image.asp?id=45333.
- Mason, Wayne. 2009. "Naval Mine Technologies." Mine Warfare Association. May 19. Accessed May 16, 2017. http://www.minwara.org/wp-content/uploads/MINE_AWAYThreat_Mason.pdf.
- Matheson, Rob. 2017. Batteries that "Drink" Seawater could Power Long-Range Underwater Vehicles. MIT News. <http://news.mit.edu/2017/batteries-drink-seawater-long-range-autonomous-underwater-vehicles-0615>.
- Monterey Bay Aquarium Research Institute. 2017. Autonomous Underwater Vehicle Docking. <http://www.mbari.org/autonomous-underwater-vehicle-docking/>.
- Morien, Steven B. 1999. "The Operational Effects of Mine Warfare." Newport, RI: Naval War College.
- MSV, Janakiram. 2017. Amazon Brings Artificial Intelligence to Cloud Storage to Protect Customer Data. Forbes. Accessed August 20, 2017. <https://www.forbes.com/sites/janakirammsv/2017/08/20/amazon-brings-artificial-intelligence-to-cloud-storage-to-protect-customer-data/#83a62d074327>.
- National Instruments. 2013. "Sensor Terminology." September 23, 2013. <http://www.ni.com/white-paper/14860/en/#toc2>.
- National Research Council. 2000. Network-Centric Naval Forces - Overview: A Transition Strategy for Enhancing Operational Capabilities. Washington, DC: The National Academies Press. <https://doi.org/10.17226/9817>.
- Naval Drones. 2012. "The Next Wave - Swarming Underwater Drones." NavalDrones. November 8, 2012. <http://blog.navaldrones.com/2012/11/the-next-wave-swarming-underwater-drones.html>.
- Naval Research Advisory Committee Report. 2000. "Unmanned Vehicles (UV) in Mine Countermeasures (U)." Office of the Assistant Secretary of the Navy (Research, Development and Acquisition).

- Naval Sea Systems Command. 2016. Fact File: AN/ASQ -235 Airborne Mine Neutralization System (AMNS). November 15, 2016. http://www.navy.mil/navydata/fact_display.asp?cid=4200&tid=1900&ct=4.
- Naval Sea Systems Command, Team Ships. 2017. Expeditionary Transfer Dock (ESD) /Expeditionary Sea Base (ESB). August 2017. <http://www.navsea.navy.mil/Home/Team-Ships/PEO-Ships/Exp-Transfer-Dock-ESD-Exp-Sea-Base-ESB/>.
- Nikam, Ankush. 2017. "Underwater Modems Market 2017–2027 Volume Analysis, Segments, Value Share and Key Trends." LANews. August 23, 2017. <http://www.lanews.org/underwater-modems-market-2017-2027-volume-analysis-segments-value-share-and-key-trends/>.
- Office of the Chief of Naval Operations. 1996. "NWP 3–15." Naval Warfare Publication 3–15. Norfolk, VA: Office of the Chief of Naval Operations. August 1996.
- Oats, Trey. 2010. "Title TBD: '18 hundred seconds.'" SPAWAR. August 4, 2010. <https://www.slideshare.net/onesimplehuman/mil-oss-govconferencet-oatsfinal1>.
- Ocean Studies Board Commission on Geostudies, Environment, and Resources Naval Research Council. 2000. "Oceanography and Mine Warfare." Washington, D.C., District of Columbia: National Academy Press.
- Office of Coast Survey. n.d. Side Scan Sonar. Accessed May 15, 2017. <https://www.nauticalcharts.noaa.gov/hsd/SSS.html>.
- Office of the Undersecretary of Defense for Acquisition, Technology, & Logistics. 2011. "Unmanned Systems Integrated Roadmap FY2011-2036." Washington, DC: Office of the Undersecretary of Defense for Acquisition, Technology, & Logistics.
- OpenFog Consortium Architecture Working Group. 2017. "OpenFog Reference Architecture for Fog Computing." February 2017. https://www.openfogconsortium.org/wp-content/uploads/OpenFog_Reference_Architecture_2_09_17-FINAL.pdf
- Paros, J., P. Migliacio, and T. Schaad. 2012. "Nano-resolution Technology Demonstrates Promise for Improved Local Tsunami Warnings on MARS Project." OCEANS. May 2012. <http://ieeexplore.ieee.org/document/6263411/>.
- Peirano, Eric, and Lukas Sigrist. 2014. "Battery Storage Technology Assessment." E-Highway2050.
- PEO LMW. 2009. "21st Century U.S. Navy Mine Warfare." http://www.gryphonlc.com/images/Mine_Warfare_Primer_2009.pdf.

- Pike, John. 1999. "AN/SLQ-48 – Mine Neutralization Vehicle." Military Analysis Network. November 16, 1999. <https://fas.org/man/dod-101/sys/ship/weaps/an-slq-48.htm>.
- Polyamp AB. n.d. "Electric Potential Sensors." Accessed May 17, 2017. <https://www.defence-industries.com/products/polyamp-ab/electric-potential-sensors>.
- Proshkin, Stanislav. n.d. "Sea Mines." Russian Navy Weapons. Accessed August 24, 2017. <http://milit.ru/mines.htm>.
- Putney, Angela, Matt Nelson, James Campbell, and Eric S. Chang. 2004. "Long-Range High Coverage Rate Synthetic Aperture Sonar for ASW and MCM Phase I: SAS Validation Experiments." ResearchGate. August 2004. https://www.researchgate.net/publication/235077111_Long-Range_High_Coverage_Rate_Synthetic_Aperture_Sonar_for_ASW_and_MCM_Phase_I_SAS_Validation_Experiments.
- Quazi, Azizul H., and William L. Konrad. 1982. "Underwater Acoustic Communications." IEEE Communications Magazine, March: 24–30.
- Ray, Tiernan. 2017. "The Big Brain behind Artificial Intelligence." Barron's. August 18, 2017. <http://www.barrons.com/articles/artificial-intelligence-gets-a-lot-smarter-1503114417>.
- Robotics Tomorrow. 2017. "QinetiQ North America Achieves Technology Breakthrough in Full-Duplex Acoustic Underwater Data Communications." August 23, 2017. <http://www.roboticstomorrow.com/news/2017/08/23/qinetiq-north-america-achieves-technology-breakthrough-in-full-duplex-acoustic-underwater-data-communications/10530/>.
- Schlosser, Tom. 1996. "Potentials for Navy Use of Microwave and Line-of-Sight Communications." RDT&E Division, Naval Command, Control and Ocean Surveillance Center, San Diego.
- Schmickl, Thomas. 2015. "CoCoRo: Tracking the Development of the World's Largest Autonomous Underwater Swarm." Robohub. September 4, 2015. <http://robohub.org/cocoro-tracking-the-development-of-the-worlds-largest-autonomous-underwater-swarm/>.
- Selinger, Marc. 2016. "Navy Declares Initial Operational Capability for New Airborne Anti-Mine Systems." Defense Daily Network. December 15, 2016. <http://www.defensedaily.com/navy-declares-initial-operational-capability-for-new-airborne-anti-mine-systems/>.

- Solman, Paul, and Ray Kurzweil. 2012. "As Humans and Computers Merge...Immortality?" PBS. July 10, 2012. http://www.pbs.org/newshour/bb/business-july-dec12-immortal_07-10/.
- Sternlicht, Dan. 2017. "The Technology Horizon for UUVs and MCM - Advanced Sensors Development." NPS Systems Engineering Capstone Project Workshop, NSWC. May 2017.
- Stojanovic, Milica. 2006. "On the Relationship between Capacity and Distance in an Underwater Acoustic Communication Channel." Cambridge, MA: Massachusetts Institute of Technology. September 25, 2006.
- Strand, Michael P. 1995. "Underwater Electro-Optical System for Mine Identification." In Proceedings of International Society for Optics and Photonics.
- Szondy, David. 2015. "Startpoint Project Imagines the Pride of the Royal Navy in 2050." New Atlas. September 4, 2015. <http://newatlas.com/royal-navy-startpoint-dreadnought-2050/39204/>.
- . 2017. "Royal Navy Looks to Nature for Futuristic Sub Concepts." New Atlas. August 28, 2017. http://newatlas.com/royal-navy-submarines-future/51089/?li_source=LI&li_medium=default-widget.
- Tate, David M. 2016. Acquisition Cycle Time: Defining the Problem (Revised). Acquisition Outcome Analyses, Alexandria: Institute for Defense Analysis.
- ThinkDefence. n.d. "Naval Mine Countermeasures." Accessed August 3, 2017. <http://www.thinkdefence.co.uk/ship-to-shore-logistics/naval-mine-countermeasures/>.
- Tremaine, Kris. 2017. "The U.S. Government Should be Making Better Use of the Internet of Things." Venture Beat. August 19, 2017. <https://venturebeat.com/2017/08/19/the-u-s-gov-should-be-making-better-use-of-the-internet-of-things/>.
- United States Air Force. 2015a. "Defense Satellite Communications System." November 23, 2015. <http://www.af.mil/About-Us/Fact-Sheets/Display/Article/104555/defense-satellite-communications-system/>.
- . 2015b. "Wideband Global SATCOM Satellite." November 23, 2015. <http://www.af.mil/About-Us/Fact-Sheets/Display/Article/104512/wideband-global-satcom-satellite/>
- Von Bleichert, Peter. 2014. "Terrorists Naval Mines/Underwater Improvised Explosive Devices." Mine Lines: The Newsletter of the Mine Warfare Association. August 2014.

- Wade, Mark. n.d. "IDCSP." Accessed June 6, 2017. <http://www.astronautix.com/i/idcsp.html>.
- Wagner, Eric. 2017. "Communications and GPS Navigation Program Office (PMW/A 170) Roadmaps." San Diego, CA: PMW/A 170. June 2, 2017.
- Worldwide Independent Inventors Association. 2009. "Naval Mine - Contained Explosive Device Placed in Water to Destroy Ships or Submarines." November 24, 2009. <http://www.worldwideinvention.com/articles/details/312/naval-mine-contained-explosive-device-placed-in-water-to-destroy-ships-or-submarines.html>.
- Xiao, Peng, Michael Kowalski, Daniel McCulley, and Michael Zuba. 2015. "An Experimental Study of Jamming Attacks in Underwater Acoustic Communication." Proceeding of the 10th International Conference on Underwater Networks & Systems 21. October 2015.

THIS PAGE INTENTIONALLY LEFT BLANK

INITIAL DISTRIBUTION LIST

1. Defense Technical Information Center
Ft. Belvoir, Virginia
2. Dudley Knox Library
Naval Postgraduate School
Monterey, California