

STEAM HEATING FOR BUILDINGS;

HINTS TO STEAM FITTERS.

BEING

DESCRIPTION OF STEAM HEATING APPARATUS FOR WARMING AND VENTILATING PRIVATE HOUSES AND LARGE BUILDINGS, WITH REMARKS ON STEAM, WATER, AND AIR, IN THEIR RELATION TO HEATING; TO WHICH ARE ADDED USEFUL MISCELLANEOUS TABLES.

BY

WILLIAM J. BALDWIN,

Member American Society of Mechanical Engineers.

WITH MANY ILLUSTRATIONS.

THIRTEENTH EDITION.

SEVENTH THOUSAND.

NEW YORK:
JOHN WILEY AND SONS,
53 EAST TENTH STREET,

1893.

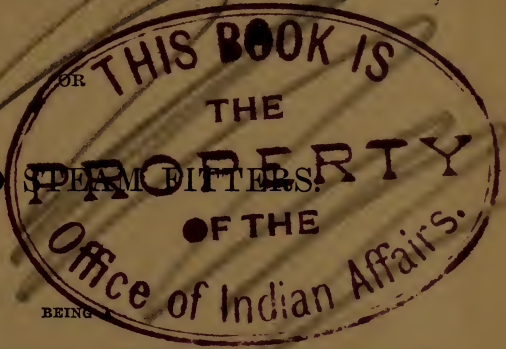

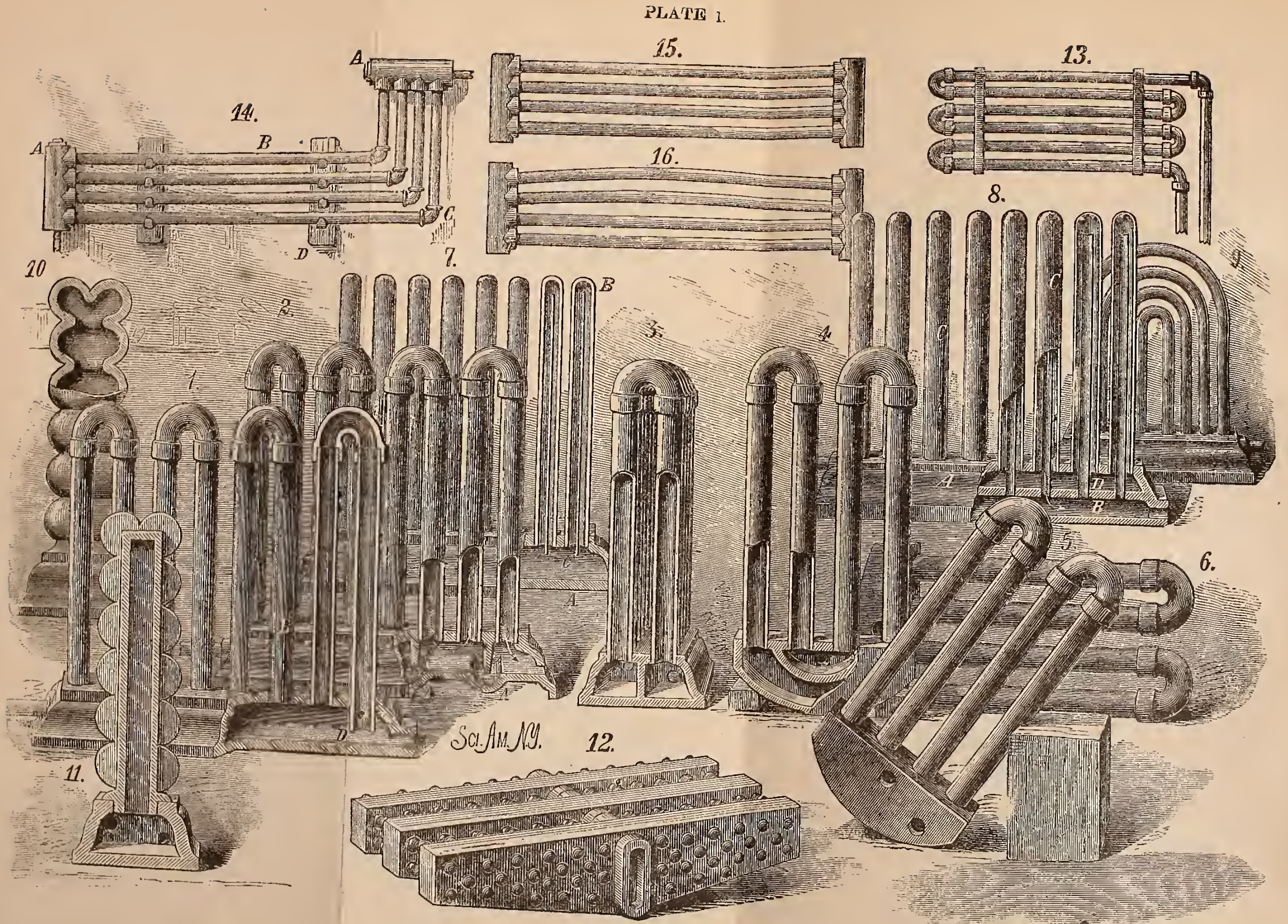

Sci. Am. N.Y.

12.

TH 7561
B23
1893

COPYRIGHT,

1881,

By JOHN WILEY & SONS.

By Transfer
Reclamation Bureau

JUN 4 - 1930

PRESS OF J. J. LITTLE & CO.,
NOS. 10 TO 20 ASTOR PLACE, NEW YORK.

30-32483

P R E F A C E .

THE dearth of practical information on steam heating, and the want felt by the young steam-fitter, in almost all branches of his trade, has suggested to me the necessity of explaining, so far as lies in my power, some of the many questions which often arise.

This volume has no scientific pretensions beyond what are actually necessary to explain a few laws, which affect the action of steam, water, and air, within pipes; and is simply a *Vade Mecum* of practical results to the fitter which the trade has tacitly adopted, and from repeated failures at first it has come to practical success eventually. These results I call "Hints," since I make many assertions I do not explain, which are known to be facts, and which will be of more *real* value to a beginner, than a long-drawn exhortation of both sides of the question, defeating its own object by leaving the student undecided.

CONTENTS

CHAPTER I.

GRAVITY CIRCULATING APPARATUS.

	PAGE
1 Gravity Systems of Piping.....	1
2 Nomenclature.....	3
3 Water-line.....	5
4 How a Building is Piped.....	6
5 Two Heaters from the same Connection.....	6
6 Outlets of the Risers.....	7
7 Risers.....	7
8 Radiator Connections.....	8
9 Steam-mains (see Chapter XV.).....	9
10 Return of the Water under all Conditions of Pressure.....	10
11 The Size of Mains.....	10
12 How Steam-pipes should leave the Boiler.....	11
13 Relief Pipes.....	11
14 Pitch of the Main.....	12
15 Tees in a Main.....	12
16 Stop-valves in Risers.....	12
17 Stop-valves in Mains.....	13
18 Main Return-pipes.....	14
19 Dry Return-pipes.....	15
20 Check-valves in Returns.....	15

CHAPTER II.

RADIATORS AND HEATING SURFACES.

21 Vertical Tube Radiators.....	17
22 Steam Entering a Radiator (circulation).....	18
23 Cast-iron and Secondary Surface Radiators	20
24 Sheet-iron Radiators.....	21
25 Coils	24
26 To Estimate Heating Surfaces for Direct Radiation	25
27 Isolated Buildings.....	27

CHAPTER III.

CLASSES OF RADIATION.

28 How Direct Radiating Surfaces should be Placed.....	29
29 Indirect Radiators.....	30
30 Indirect Radiator Boxes.....	31
31 Air-flues.....	31
32 Change of Air in Rooms.....	33
33 Direct-indirect Radiation.....	33
34 Position for Indirect Heaters with the Action of Air in Rooms, etc., and the Cause of Cold Feet.....	35
35 Cold-Air Inlet-ducts.....	38

CHAPTER IV.

HEATING SURFACES OF BOILERS.

36 Fire-box and Flues.....	40
37 Crowding the Fire-box with Hanging Surfaces.....	42
38 Corrugated Fire Surfaces.....	43
39 Boilers which have Given the Best Results.....	43
40 Proportioning Boilers.....	44
41 Can a Boiler be Robbed of its Heat by the Gases of Combustion ?.....	44
42 Reverberatory or Drop Flue Boilers.....	45
43 Will the Quantity of Water within a Boiler Effect Evaporation ?.....	45

CONTENTS.

vii

CHAPTER V.

BOILERS FOR HEATING, ETC.

	PAGE
44 Simplicity of Parts.....	47
45 Requirements for House Boilers.....	47
46 Construction of Upright Boilers.....	49
47 Construction of Horizontal Boilers.....	50
48 Contracted Passages under Boilers.....	50
49 Technical Names of Parts of Boilers, and their Setting.....	51

CHAPTER VI.

FORMS OF BOILERS USED IN HEATING.

50 A Source of Danger to the Fitter.....	53
51 Upright Boiler without Tubes.....	53
52 Upright Multi-tubular Boiler.....	54
53 Upright with Steam-dome.....	55
54 Upright Drop-tube Boiler.....	56
55 Base-burning Boiler.....	60
56 Horizontal Tubular Boilers.....	61
56½ Horizontal Multi-tubular Boilers.....	64

CHAPTER VII.

REMARKS ON BOILER SETTING.

57 Thickness of Walls.....	67
58 Marshy or Sandy Ground.....	67
59 Why Boiler Walls Crack.....	67
60 Fire-bricks in a Furnace.....	69
61 Front-connection Division.....	69
62 Dead Plates.....	71
63 Bridge-walls.....	71
64 Ash-pits.....	71
65 Lugs on Boilers.....	71

CHAPTER VIII.

PROPORTION OF THE HEATING SURFACES OF BOILERS TO THE HEATING SURFACES OF BUILDINGS.

	PAGE
66 Relation of Boiler to Heaters.....	73

CHAPTER IX.

RELATION OF GRATES AND CHIMNEYS TO BOILERS.

67 Grate of a House Boiler.....	78
68 Size of Grate to Boiler.....	79
69 Size of Chimneys.....	79
70 Examples of Grates and Chimneys.....	80
71 Table of Grates and Chimneys.....	82
72 Conclusions Drawn.....	82
73 Why Grates Break?.....	84

CHAPTER X.

SAFETY VALVES.

74 Boilers Bursting when Working at Ordinary Pressures.....	87
75 The Office of the Safety-valve.....	87
76 Decrease of Pressure under the Valve.....	88
77 Table of Lift of a 4-inch Valve at various Pressures.....	88
78 Graphic Illustration of the Size of the Opening of a 4-inch Valve when Blowing off at various Pressures.....	89
79 Formulæ for Calculating the Size of Safety-valves.....	90
80 Construction and Operation of Safety-valves.....	91

CHAPTER XI.

DRAFT REGULATORS.

81 Diaphragms.....	95
82 Construction of Regulators.....	96
83 Connecting Regulators.....	98

CONTENTS.

ix

	PAGE
84 Doors to be Regulated.....	98
85 Construction of Doors for Regulator.....	99

CHAPTER XII.

AUTOMATIC WATER-FEEDERS.

86 Construction.....	100
87 When a Water-feeder should be used.....	103
88 Connections to Water-feeders.....	103
89 Draught in Pipes.....	104

CHAPTER XIII.

AIR-VALVES ON RADIATORS.

90 Where they should be Placed	105
91 Drawing Air from Coils, etc.....	105
92 Air-valves, Construction and Design.....	107
93 Waste of Water from Air-valves at High Pressure.....	110

CHAPTER XIV.

WROUGHT-IRON PIPE.

94 Description of Pipe.....	111
95 Nominal Size of Pipe.....	111
96 Table of Standard Dimensions of Pipes.....	112
97 How to Calculate the Relative Areas of Pipes.....	113
98 Table of Relative Areas of Pipes.....	115
99 Diagram of Relative Areas of Pipes.....	117
100 Expansion of Pipes and its Relation to Steam-mains	118
101 Expansion of Return-pipes	119
102 Effect of Lime and Moisture on Pipes.....	120
103 Expansion of Pipes Buried in the Ground.....	120
104 Expansion-joints and how to Compensate without them.....	120
105 Connecting Boiler, Domes, etc.....	121

	PAGE
106 Expansion of Cast-iron	123
107 Expansion of Wrought-iron	123
108 A Table of Linear Expansion of Wrought and Cast Iron Pipes	124

CHAPTER XV.

MAIN-PIPES.

109 Size of Mains.....	125
110 Loss of Heat from Imperfect Apparatus.....	125
111 Heat or Power Necessary to put Water into Boilers	127
112 Poor Economy to Use Small Piping.....	127
113 Necessity for Providing for a Direct Return.....	128
114 How to Determine the Size of the Main.....	128
115 The <i>Unit</i> of Size in Pipes.....	129
116 Relation between Heating Surface and Diameter of Pipe.....	129
117 Diagram of the Size of Main-pipes for Gravity Apparatus	130

CHAPTER XVI.

STEAM.

118 Temperature of Steam.....	133
119 Technical Terms.....	133
120 Table of Elastic Force, Temperature, and Volume of Steam..	135
121 Calculations on Steam, Water, etc.....	136
122 Diagram of Rankine's Formula.....	138

CHAPTER XVII.

HEAT OF STEAM.

123 The Unit of Heat.....	140
124 Sensible and Latent Heat of Steam.....	140
125 A Diagram of Sensible and Latent Heat of Steam and Water.	143
126 Equivalent of Heat.....	144

CONTENTS.

xi

CHAPTER XVIII.

AIR.

	PAGE
127 What Air Is.....	146
128 Air Necessary for an Adult.....	147
129 Specific Weight and Volume.....	149
130 Expansion of Air.....	149
131 Watery Vapor in the Atmosphere.....	151
132 Quantity of Moisture Air is Capable of Taking Up.....	152
133 Drying Power of Air.....	152
134 A Table of the Watery Vapor Air is Capable of Taking Up...	153
135 Saving in Time by High Temperatures in the Drying Room..	153
136 What Does Ventilation Cost ?.....	154

CHAPTER XIX.

HIGH-PRESSURE STEAM USED EXPANSIVELY FOR HEATING.

137 Systems.....	158
138 The Holly System.....	159

CHAPTER XX.

EXHAUST STEAM AND ITS VALUE.

139 Thermal Value.....	167
140 How Hot can Feed-water be Made.....	168
What Percentage of the Coal Heap does the Heating of the Feed-water Represent.....	168
How much of the Exhaust Steam can be used in Warming the Feed-water.....	169
141 Warming Buildings with Exhaust Steam.....	170
142 Loss from Back Pressure.....	170
143 Exhaust and Live Steam in the same Coils.....	171

CHAPTER XXI.

BOILING AND COOKING BY STEAM, AND HINTS AS TO HOW THE APPARATUS
SHOULD BE PIPED.

	PAGE
144 Steaming and Vegetable Steamers.....	173
145 Steam-kettles.....	178
146 Warming Water in Tanks.....	184
147 Warming Water at the Nozzle or Cock	185
148 Warming Water for Baths, etc., when there is no Steam- boiler... ..	186

CHAPTER XXII.

DRY BY STEAM.

149 Description.....	189
150 Laundry-drying.....	191
151 Dry Kilns and Other Modes of Drying.....	195

CHAPTER XXIII.

STEAM-TRAPS.

152 How Used.....	198
153 Construction and Operation of the Direct-Return Steam Trap.	199
154 Atmospheric Traps.....	204

CHAPTER XXIV.

VALVES FOR RADIATORS.

155 Corner-Valve for Radiators.....	209
156 Automatic Electro-Pneumatic Valve.....	211

CHAPTER XXV.

BOILER CONNECTIONS AND ATTACHMENTS.

157 Feed-pipes, Blow-off Cocks, Valves, Gauges, etc.....	212
--	-----

CONTENTS.

xiii

CHAPTER XXVI.

MISCELLANEOUS ARTICLES.

	PAGE
158 Cutting Walls and Covering Risers.....	218
159 Turning Exhaust Steam into Chimneys.....	219
160 Soldering of Pipes and Brass Fittings.....	221
161 Painting Pipes.....	222

CHAPTER XXVII.

Miscellaneous Notes and Tables of Service in Estimating....	223
Dimensions of Standard Radiators.....	234
Dimensions of Standard Registers and Ventilators.....	240

APPENDIX A.

SPECIFICATION FOR A STEAM-HEATING APPARATUS, INCLUDING COOK- ING, WASHING, AND DRYING.....	243
---	-----

APPENDIX B.

PLURAL BOILER SPECIFICATIONS.....	255
-----------------------------------	-----

INTRODUCTION.

WITHIN twenty years, the warming of buildings with steam carried through pipes became a science; previously, it was a chaotic mass of pipes, and principles.

A low-pressure gravity apparatus is the most healthful, economical, and perfect heating appliance known, and may be constructed to heat a single room, or the largest building, with a uniformity which cannot be attained by any other means.*

By a gravity apparatus is meant, one without an outlet, whose circulation is perfect, wasting no water, and requiring no *mechanical means* to return the water to the boiler. It may be likened to the circulation of the blood—the *boiler* being the heart; the *steam-pipes*, the arteries; and the *return-pipes*, the veins: thus carrying heat and life into every part of a building.

When reference is made to steam-pressure in this volume, it is understood to mean *pressure above the atmosphere*. Nearly all tables of reference on steam are given in *absolute* pressures—namely, pressures including the pressure of the atmosphere—which *unapparent* pressure has to be overcome before it is appreciable on a steam-gauge; and, as the steam-fitter has little, if anything, to do with pressures below atmosphere, the tables, etc., herein used will be modified, to commence

* Low-pressure hot water ranks equal to it in point of healthfulness.—*Au.*

at atmospheric pressure ($14\frac{7}{10}$ pounds of the absolute scale), thus conveying comparison in the *ordinary terms* to which the steam-fitter is accustomed; and preventing the necessity of a mental calculation, which always involves fractions, and enjoins a task which should not be thrown on a beginner. Therefore, all pressures mentioned will be *apparent pressures*—namely, pressures that would be indicated by a *properly regulated steam-gauge*.



BALDWIN'S

STEAM HEATING FOR BUILDINGS.

CHAPTER I.

GRAVITY CIRCULATING APPARATUS.

1. THE *low-pressure gravity circulation* is at present very much used in the steam heating of private houses, churches, and schools. Its principal merits, when well done, are : It is safe ; noiseless ; the temperature of the heating surface is low and uniform ; all the water of condensation is returned into the boiler, except a very small loss from the air-valves ; it is easy to keep the stuffing-boxes of the heater-valves tight ; and it is no more trouble to manage than a hot-water apparatus.

There are four systems of low-pressure steam-piping, whose principal features are :

1st. Main distributing pipes and distributing risers, with corresponding return mains and risers (see Fig. 1, at A).

2d. Main distributing pipes and distributing risers, with a corresponding return main, and a *separate return riser for every coil or heater* ; the return risers not con-

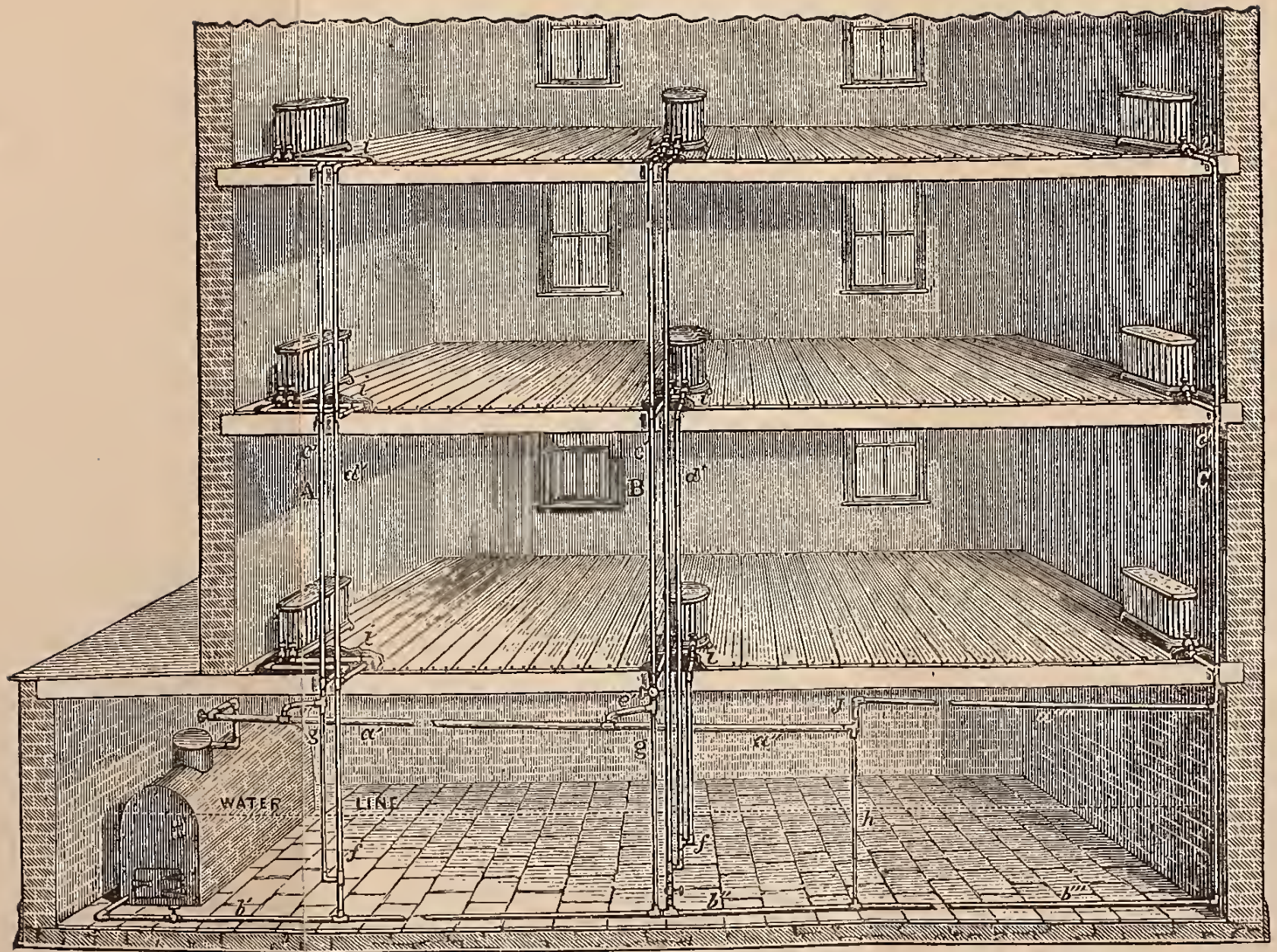

SYSTEMS OF PIPING.

Fig. 1

necting with each other until they are below the water-line (see Fig. 1, at B).

3d. Main distributing pipes and distributing risers, with corresponding return mains and *no* return risers, the distributing riser carrying the water of condensation back, through a relief, to the main return pipe on the floor of basement (see Fig. 1, at C).

4th. (The single-pipe job, always a small one.) A single pipe for every heater, run directly from the top of the boiler to the heater, rising all the time in the direction of the heater, and of size sufficiently large that the steam passing to the heater, to supply the loss from condensation, will not interfere with the condensed water *returning* along the bottom of the pipe.

System No. 1 can be run at *any* pressure, provided the pipes are sufficiently large in diameter and properly put up, and is the system commonly used in large buildings; not because it gives the very best results when the pressure is low, but because it gives ordinarily good results and saves much pipe and labor.

System No. 2 *should always be used in private houses*, and in buildings where extremely low pressure is employed, as with this system a job can be made perfectly noiseless, when done with care, and there is *never* any difficulty in expelling the air.

Systems 3 and 4 are only employed in low-pressure heating, and when very large horizontal mains are used they give good results; but are not to be recommended for large or complex jobs.

For those not acquainted with the technical names of the different parts of the systems, and to prevent misconception of terms used, the following explanation is given :

NOMENCLATURE.

2. The same names always apply to the same part of the circulation, no matter what the system. The word *circulation* here means the whole distribution of pipe in any one job or apparatus.

The Main Steam or Distributing Pipe.—The nearly horizontal live-steam main, generally near the cellar ceiling (*a' a'' a'''*).

The Main Return Pipe.—The nearly horizontal pipe on the floor, or thereabouts, of the cellar, for carrying the condensed water back to the boiler (*b' b'' b'''*).

The Steam Riser.—The pipe that carries the steam from the main distributing pipe to the radiators (*c' c'' c'''*).

The Return Riser.—The pipe that carries the condensed water from the radiators to the main return (*d' d'*).

The Steam-Riser Connection.—The pipe that joins the main distributing pipe and steam riser (*e' e'*).

The Return-Riser Connection.—The pipe that connects the return riser with the main return pipe on the floor, and which has one or more T's in it, below the water-line,—to receive the steam-riser relief (*f f*).

The Steam-Riser Relief.—The pipe that connects the bottom of the steam riser with a T, in the bottom of the return-riser connection, or main return pipe, below the water-line; to carry the water that runs down the steam riser into the return-riser connection or main return pipe (*g g*).

Main Relief Pipes.—Connections between the main steam and return pipes, to throw the water carried from the boiler, and that condensed in the main steam-pipe,

into the return main, also employed as an equalizer of pressure in the system (*h*).

Radiator Connections.—The pipes which run from the risers to the radiators, both steam and return, usually no longer than is necessary to get spring enough for the expansion of the risers (*i i i*).

A Relay.—The jumping up of a main steam-pipe, with a main relief at the lower corner. This is to admit of keeping the main steam-pipe near the line of the risers and the ceiling, and above the water-line, when the main lines are long (*j*).

Pitch—Is the inclination given to any pipe, and in

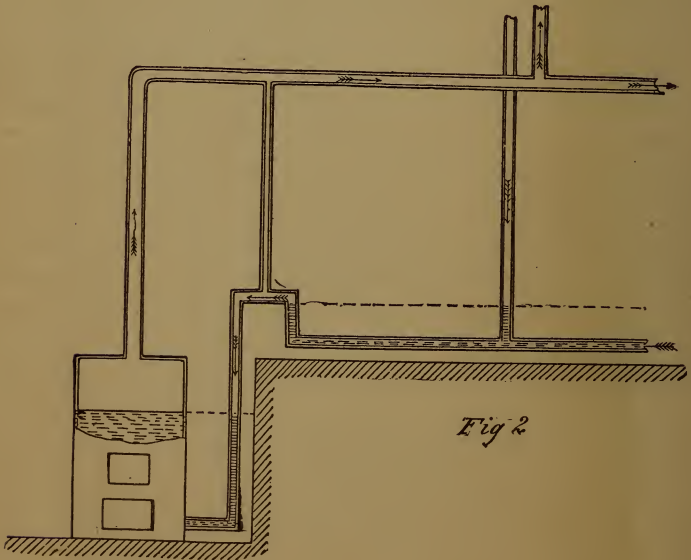

the steam mains of a low-pressure or gravity apparatus, it should be down and away from the boiler (except in

System No. 4), and, if possible, toward the boiler in the main return. (When the water and the steam run in the same direction through pipes, one source of noise is prevented.)

3. *Water-Line*.—The general level of the water in the boiler and throughout the apparatus. In some cases, where the boilers are at a distance, or in a subcellar, and the fitter wishes to gain the advantages of having returns and reliefs coming together *below water*, he makes an *artificial water-line* by raising the main return pipes higher than his connections before he drops to the boiler. It is also necessary to bring a relief from the main steam-pipe to this *raised* part of the return to prevent siphoning into the boiler. Fig. 2 shows how this should be done.

It frequently happens in buildings where the line of the floor is below the water-line, that there are good reasons for not running the return pipe on the floor, when a modification of what is shown in Fig. 2 may be used; the return pipe being hung from the same hangers as the steam-main, and immediately below it, but raised about as shown before being dropped to the floor at the first favorable position. Still another modification is to *trap* each return riser with an inverted water siphon by running the return riser five or six inches below the main return pipe, then rising and connecting with it. When any of these means have to be resorted to, it would be well to have a pet-cock at their lowest points to draw the water from them in cold weather should they not be in constant use, as these water-traps might freeze.

HOW A BUILDING IS PIPED.

4. The steam-fitter should commence his work in a new building at an early period of its construction ; and architects and parties paying for the work should see that the contract for steam heating be let when the mason and carpenter work is let.

The *risers* are the first work done in a new building constructed in the ordinary way. If the builder and steam-fitter have an understanding at the commencement of the work, the former can leave the proper recesses in the walls exactly where the steam-fitter wants them. This will save much work to the fitter, and prevent the mutilation of the walls, and be no expense to the mason.

When the walls are up, the joists in their places, and the roof-boards or roof on, the steam-fitter should then put up his risers.

If the building has not more than three floors to be heated, it will answer to rest the risers on a support at the bottom of the recess ; but in higher buildings the risers should be suspended by the *middle*, so that the expansion may be divided. By allowing the riser to go both up and down from the middle, the steam-fitter will be able to get along with shorter radiator connections, and will avoid the deep cutting of the floor joists.

5. The steam-fitter should avoid, as much as possible, taking *two* heaters from the same steam connection on a floor, and if it be unavoidable, he should drop his returns down, and bring them into the return riser some distance apart ; or, better still, he should run them *separately* down below the water-line (System No. 2), as it will prevent one heater from taking the air from the others.

6. If the risers are on the side of the room, so that their outlets come between the joists, *it is best to keep the T's about half-way between the laths and the flooring*, as this admits of *nippling up*, and leaves room for *crossing* the pipes, if required, below the floor. But if the outlets come at the *side* of the joists, care must be taken that the T's come *in the exact place*. In a building with the risers resting on the bottom, and *all the expansion upward*, the top outlet must be the greatest distance below the top of the joist, but it must never come within $\frac{3}{4}$ of an inch of the floor when expanded to the utmost; so also with the rest of the T's, according to their distance from the bottom of the riser.

7. With low-pressure steam, the steam risers should be large. The general practice with steam-heaters is to reduce one size of pipe for each floor. This rule is not arbitrary; but as architects' specifications usually call for it, there are no objections, provided the pipe *is large enough*.

In System No. 1 the return riser is generally one size smaller than the steam riser, but it should never be smaller than $\frac{3}{4}$ of an inch pipe.

In System No. 2, where many return risers are brought down in the same place, a 1-inch pipe for large heaters, and a $\frac{3}{4}$ -inch pipe for small ones, are the usual sizes.

When the risers are in, the outlets should be plugged up with *pieces of pipe* a foot or so in length, instead of the ordinary plug, as the latter is often *difficult* to get out when the plastering is done.

The risers should then be tested with cold water to from 100 to 200 pounds per square inch; this will show if there are any cracked fittings or split pipe, and will

save much time and annoyance when steam is gotten up.

When *automatic air-valves* are to be used on the steam-heaters, a $\frac{3}{8}$ -inch pipe should be run in the *riser recess*, with an outlet at each floor to receive the air-valve connection. The lower end of this air and vapor pipe should be taken to the nearest sewer, *outside of the sewer traps*.

8. At this stage of the work, and before the floors are laid, the radiator connections should be run, and firmly fastened in their places, making due allowance for the thickness of the furring on the walls, for the plastering, and for the baseboard. The radiator connections are usually run 1 inch or $1\frac{1}{4}$ -inch for the steam connection, with a corresponding $\frac{3}{4}$ or 1 inch pipe for the return, according to the size of the heater; $1\frac{1}{2}$ -inch steam-pipe being enough for a direct radiator of 150 square feet of heating surface, at low pressure, *with a main of sufficient size*.

When the radiator valves are threaded right-handed, the elbows on the ends of the connections may be left-handed, to admit of connecting, by a *right-and-left-hand nipple* below the valve, and between the valve and elbow, or *vice versa*.

When both valves are at the same end of the radiator, it is better to have the right and left nipples between the valves and the radiator. With this arrangement both valves of the radiator can be connected simultaneously, and the movement of the radiator will be in the direction of the valves. It also admits of the disconnection of a heater after simply closing the radiator valves.

When the radiators are to be connected by any of the

foregoing plans, the connections can be firmly fastened (but not confined at their ends), so they may come in their exact places through the floors. The *free* ends of the connections should be closed with pieces of pipe long enough to come above the floors when laid. The air-pipe should also be run at the same time, and brought through the floor in close proximity to the position the air-valve will occupy on the heater.

At this stage of the work the steam-heater usually waits until the floors are laid, plastering done, partitions set, and the basement graded.

9. *Steam Mains.*—Nearly all the success of the apparatus depends on its steam mains, *their sizes*, and *how they are run*.

A job has never yet been spoiled by having its steam mains large; still, there should be a limit to their size, to prevent unnecessary expense, and to keep the condensation and radiation of the distributing pipes at a minimum consistent with the actual requirements of the heating surfaces.

The size of steam mains depends on the pressure of steam to be used, the distance it is to be carried, the temperature of the exposure of the heating surfaces, and their extent. But as it is not my intention here to speak of steam used expansively, I shall endeavor to give sizes only for *direct return*, or gravity-circulation apparatus.

Gravity-circulation apparatus are of two kinds, low and high pressure. The low-pressure apparatus depends for a circulation on the difference of level of water in the return risers and the boiler, irrespective of the steam pressure at any part of the distributing pipes; but the maximum pressure of steam to be car-

ried must never exceed the equivalent of a difference in level of water between the water-line of the boiler and the lowest part of the distributing main.

There is another condition under which this system will work, and that is, an *increase* of pressure sufficient to nearly establish an initial pressure throughout the apparatus; but the *difference* in pressure at any part of the apparatus must not exceed the equivalent of a head of water between the water-line in the boiler and the lower part of the steam main. It is then a high-pressure gravity circulation.

A well-arranged gravity circulation should be made to work at *any pressure*; for with its heating surface properly proportioned it can be made to meet the exigencies of fall, winter, or spring weather, by simply carrying a pressure suitable to the occasion.

10. To have the water of condensation return directly into the boiler, under all conditions of pressure, the main pipes *must be large enough to maintain the pressure of the boiler, to within one pound, in every part of the apparatus*, and the water-line of the boiler should be not less than 4 feet from the bottom of the horizontal distributing mains at their lowest part; and that distance will only answer in short mains, such as those used in the generality of city business buildings and blocks. In large public buildings and others, having their boilers in out-houses, the difference between the boiler line and the mains should be all it is possible to get.

11. A main should not decrease in size according to the area of its branches, but very much slower, and should be rated by the heating surface and the distance it is to be carried. Neither should the main at the

boiler be equal to the aggregate size of all its branches—an expression very much in vogue in specifications for steam heating.

Mains which have given the best results leave the boiler of sufficient size (calculated from practical results), and are reduced very slowly, if at all, until very near the end.

The area of the cross section of a 1-inch steam-pipe is taken as unity, for the sake of easy calculation, in the rating of steam-pipes, and *the area of a 1-inch pipe in the main, at the boiler, to each 100 square feet of heating surface, mains included*, is deduced, from the size of the mains and heating surfaces of some of the best heated buildings in the United States, and has been the writer's rule for some years.

12. When the main steam-pipe leaves the boiler, it should, if possible, be carried high at once, and have the stop-valve at the highest part in the pipe, so that condensed water cannot lodge at either side of it when shut. This will prevent cracking at this part of the pipes when the valve is opened. If this arrangement cannot be carried out, and the valve has to be nipped on the dome of the boiler, or if there are several boilers, and they have to be made interchangeable with regard to their use, there should be a *relief* of large size in the main, just outside the valves.

13. It is well to mention here that a relief which leaves the steam-pipe must be brought into the return pipe in a position corresponding exactly to where it leaves the main; that is, when it comes from the outside of the main stop-valve, it should be taken to the outside of the main return valve. Otherwise, if an attempt is made to shut off, and both valves are closed,

the water will *back up* and fill the apparatus. So, also, with all branches, risers or connections; if there is a valve in the steam part, *there must also* be one in the return, and reliefs must leave the steam-pipe and enter the return on corresponding sides of the respective valves.

14. From the highest point the main steam-pipe should drop slowly, as it recedes from the boiler ($\frac{1}{2}$ inch to 10 feet being a fair pitch), that the course of the steam and the water may be in the same direction.

A main steam-pipe should not run very close to the wall up which the risers go. There should be room enough for a riser connection (2 or 3 feet), and when the mains are long, and the expansion great, the distance should be increased.

15. The T's in the main, for the riser connections, are better turned *up* than sidewise, as by nipping an elbow to them you can get any desired angle, and should the measurement for the main be a little incorrect, it will make no difference. This arrangement also makes a good expansion joint, if the mains have much travel.

Where the pipe reduces in size, it is well to put a relief in the lower side of the reducing fitting, as the water that is pocketed there, by the large pipe pitching in the direction of the smaller one, may be the cause of cracking and noise in the pipe. Some steam-heaters use an eccentric fitting in reducing, which brings the bottom of the pipes on the same line and makes nice work.

16. When it is necessary to have stop-valves to the risers, the steam-fitter often places them in the riser connections, with a valve also in the riser relief. This arrangement requires three valves, and also stops the local circulation and equalization of pressure when they are closed.

It is better to use only two valves, one to the steam and one to the return riser, and place them a few inches up the riser, above the riser connection, which brings them also above the steam-riser relief, saving a valve and lessening the chances for noise in the pipes.

In System No. 2, where the returns are carried down separately, and collected together below the water-line, the return valve should be below all such connections, and the *steam-riser relief* should have a separate connection with the *main return*, and have no valve. Straightway valves are best for risers.

The extreme end of a steam main should be connected by a *relief* with the main return, being in fact, a continuation of the main down and into the return.

17. Stop-valves in main steam-pipes are either globe,

Fig. 3.



Fig. 4

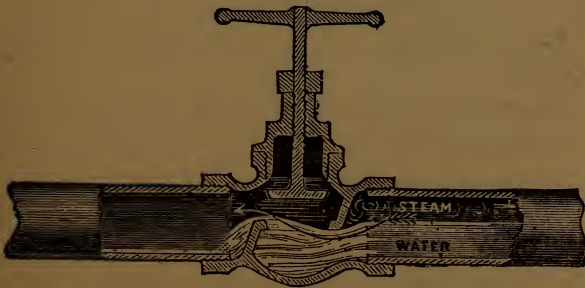

angle, or straightway. When a globe valve is used, it should be turned with its stem nearly horizontal, as

shown in Fig. 3. The reason for this is obvious, when we consider that the water of condensation in any pipe runs along the bottom of it. When a globe valve is turned up, as in Fig. 4, the water in the pipe has to half fill it, before it flows over the valve seat, to pass along in the pipe. But, when the valve is on its side, it is different, for then *the side of the opening of the valve seat is as low as the bottom of the pipe.*

Neither should the stem of any valve be quite horizontal when it can be avoided. It should be raised enough (10 degrees) to prevent water from collecting in the threads of the nut and stem, and being forced out, by the pressure of the steam, through the stuffing-box; which makes a constant dropping of water, that it is almost impossible to hold with ordinary packing. But with dry steam it can be held.

Globe or angle valves should be so turned in a heating apparatus that by simply closing the valve *to be packed*, and its *corresponding valve* in the return, or *vice versa*, and waiting for the steam to cool down, the stuffing-box or gland can be removed without the escape of steam. To do this it is necessary to have the *pressure side* of every pair of valves turned toward the boiler. By the pressure side of a valve is meant the under side of the disk.

18. *Main Return Pipes.*—In small apparatus (up to 3-inch steam-pipe) they are usually run one or two sizes smaller than the corresponding steam-pipe.

In returns which are below the water-line, or are trapped to give them an artificial water-line, and consequently always full of water, there are no *currents* but the flow of the water toward the boiler. This style of return admits of the smallest piping, but good practice

has placed it at one quarter of the area of the steam-pipe, for all conditions, for apparatus with larger than a 3-inch steam-pipe.

In apparatus with less than 3-inch pipe, the return is usually only one size smaller than the steam-pipe, that it may have a practical magnitude, and thus avoid the possibility of getting it stopped with the dirt or sediment carried to an elbow with the current of the water.

19. In dry returns—*i. e.*, which have no water-line—there are local currents, often going in contrary directions, the water gravitating toward the boiler, the steam flowing to the heaters, and the air—the greatest source of annoyance to the steam-heater—going any place except out of the air-valve. This style of return is not much used, but in cases where there is no basement it cannot always be avoided.

One-half the area of the steam-pipe has been found, in practice, to give good results in dry return pipes.

20. Check-valves are generally used in return pipes where they enter the boiler. Some steam-heaters leave them out on account of the back pressure they cause to the return water; but the practice is very much to be condemned when two or more boilers are connected, as an inequality in draught, or the cleaning of a fire, will make a small difference of pressure between boilers, causing the water to run from one boiler to another through the return pipes.

Check-valves of large area in the opening, with a small bearing on the seat, can be made that will not give more than one eighth of a pound back pressure. If the valve is not ground, and cleaned frequently, when the job is new, there will be nothing but the actual weight of the disk to overcome.*

* Swinging check-valves are now in use that practically cause no resistance to the flow of water.

It is sometimes convenient to reduce a return pipe where it enters the boiler for a short distance. This may be done to a limited extent, bearing in mind the actual quantity of water to be admitted to the boiler in a given time.*

Extra strong pipe and fittings should be used in all returns and feed-pipes, from where they are tapped into the boiler, to outside the brickwork; and when they are exposed to the action of the fire it is well to cover them with a "slip tube" made of a larger size, ordinary steam pipe.

* I have frequently been asked what the limit of reduction should be in a return pipe entering boilers. As an answer to this, I must refer the reader to Thomas Box's Practical Hydraulics, wherein will be found the velocity of flow of water through pipes for different conditions, from which deductions can be formed. Or the reader may with safety be guided by the tables of G. A. Ellis, C.E., on the friction of water in pipes for one hundred feet in length, by increasing the diameter one size for a practical magnitude, and to overcome loss by rough ends, fittings, etc.

CHAPTER II.

RADIATORS AND HEATING SURFACES.

21. ALL radiators—box coils, flat coils, plate or pipe surfaces, arranged to warm the air of buildings—are *heating surfaces*.

The vertical tube radiator is now the accepted type of a first-class heater, and nearly all manufacturers have their own peculiar style, with varying results as to efficiency. The steam-fitter or purchaser should use *great caution* in the selection of radiators.

The common return-bend radiator, Plate I., Fig. 1, is the most widely manufactured ; it is not patented, and is second to no other vertical tube-heater.

The construction is simple ; a base of cast-iron, A, being simply a box, without diaphragms, with the upper side full of holes, about $2\frac{1}{4}$ inches from center to center, tapped right-handed ; a pipe, B, for every hole, 2 feet 6 inches or 3 feet long, threaded right and left handed, and half as many return bends, C, as there are pipes tapped left-handed.

The manner of putting these heaters together is to catch the right-handed thread of two pipes one turn in the base, then apply the bend to the upper and left threads of the same two pipes, and screw them up simul-

taneously with a pair of tongs on each pipe, while a second person holds the bend with a wrench made for the purpose.

Steam-fitters who buy bases, and make only a few radiators, to keep the boys at work when in the shop, should count each set of threads in ; but they who make for the trade gauge their threads and pipes, so as to always enter the base first. If the pair of pipes in any one bend are not plumb, screw the pipe at the side from which they lean a little tighter, which will shorten that side and draw the bend over.

22. I will here explain the action of steam entering a radiator, as nearly all the patents on the so-called positive circulating radiators are to facilitate the expulsion of the air and the admission of steam.

The general impression among steam-fitters is, that when steam enters a radiator the air is backed up and confined in the top of the pipe ; and it will be, when the pipe is single and closed at the top, without any of the usual means to get it down, although steam is but slightly over one-half the weight of air ; which may seem an anomaly to the scientific engineer.

When two pipes are connected at the top with a bend, or when there is an inside circulating pipe, or diaphragm of sheet-iron slipped into it, the air immediately gives way and falls in the pipes nearest the inlet first ; but should there be no air-valve on the radiator, the air will be crowded at first to the further end of the radiator, and should the system be a gravity circulation, without an outlet to the atmosphere, it will remain in the radiator, impairing its efficiency and often deceiving the novice, as it in time heats by contact with the steam ; but when there is a thumb-cock or air-valve on the radia-

tor, usually on the furthest pipe from the inlet, the result is quite different. In the common return-bend radiator and others of good construction the action is direct, and the pipes heat consecutively, excepting, perhaps, the pipe the air-valve is on, and a few near it, which sometimes heat ahead of their order, on account of the draught of the air-valve.

Thus, when the steam enters a well-constructed radiator, the air falls to the base, and is driven out at the air-valve, the pipe of which may be run down inside the base (as is seen at D, Fig. 1), which will bring it into the lower stratum, drawing it off to the last.

This is the most simple test for a good heater. Any kind of radiator that nearly always has a few cold pipes, sometimes in one part of the heater, and sometimes in another, should be avoided.

Fig. 2 shows a device (patented) for making a return-bend radiator positive. The pockets A A, filling with condensed water, makes a seal which at times prevents the flow of steam along the base and forces it in a continuous stream through the pipes (see arrows in cut).

Figs. 3 and 4 show cross section of modifications of positive return-bend radiators. Fig. 3 can be used as a vertical radiator only, but Fig. 4 can be used in any position from perpendicular to horizontal, as seen at Figs. 5 and 6, and is peculiarly adapted to indirect heating.

Single-tube radiators, welded or closed at the top with a cap, with an inside circulating device, are also much used; some of them compare favorably with the return-bend radiator, but are slower in heating.

Fig. 7 shows the first of this class put on the market. A is the cast-iron base, B the welded tube, and C the

septum of wrought iron slipped inside the tube and projecting an inch into the base. This heater depends on the gravity of the air for a circulation.*

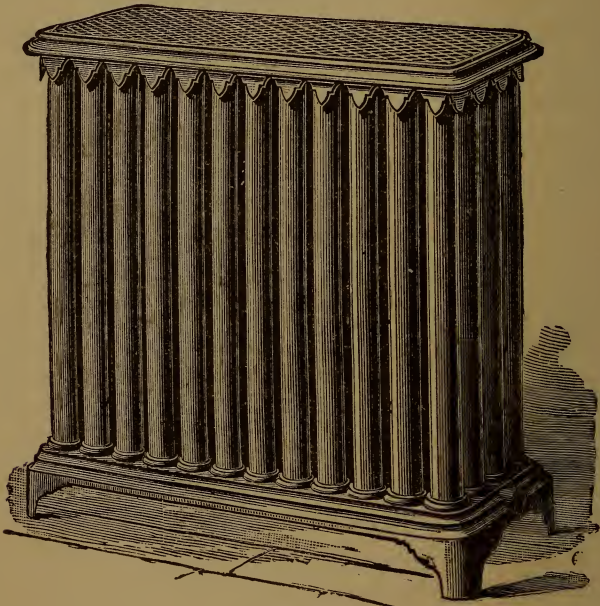

Fig. 7a.

Fig. 8 shows another heater of this class which is positive in its action. A, cast-iron base ; B, diaphragm cast in base ; C, welded tube ; D, inside tube, open top and bottom, and screwed into the diaphragm. The action of the steam can be seen by the arrows.

Fig. 9 shows a fire-bent tube radiator very positive in its action.

* This was the original "Nason" radiator. An improved form of this radiator (Fig. 7a) is now on the market, in which the bases of the double rows and all wider are perforated at the lower end of every tube, to provide for a more free circulation of the air.

23. Cast-iron radiators are of two kinds, *plane* and *extended* surfaces.

Plane surfaces, as the trade understands them, may be either flat, round, or corrugated, provided the coring, or inside surface of the iron, corresponds and follows the indentations of the outside, as in Fig. 10, and in all wrought-iron heaters. Extended surface is understood when the outside surface of the heater is finned, corrugated, or serrated, with the inside straight, as in Fig. 11.

For direct radiation, where the heater is placed in the room, there is little or nothing gained by having the surface of the heater extended, and a steam-fitter, in calculating the extent of his heating surfaces, should not take into consideration the whole outside surface of such a heater, unless he gives it some value less than unity, the *unit* being a square foot of plane surface.

For indirect heating (the coil being under the floor or in a flue) the result is a little different as compared with *shallow* plane surface coils, where the air cannot stay long enough in contact with them to get thoroughly warmed, but presses into the room without hindrance. In this case the extended surface gives a better result, not because a square foot of the surface can transmit as much heat in the same time, but because it hinders the direct passage of the air, holding it longer in contact and preventing stratification.

The cast-iron vertical tube radiator is a quick heater, the large size of the tubes causing chambers large in size and few in number, thus expediting the expulsion of the air.

Fig. 11a shows the "Bundy" cast-iron *loop* radiator. It is a cast-iron base with air apertures through its

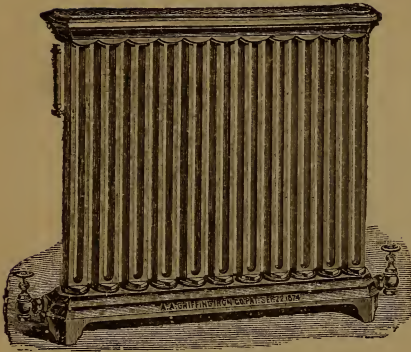

Fig. 11a.

bottom, and the loops are double tubes cast in one, and joined to the base by a single thread.

Fig. 11b is the "Reed" cast-iron loop radiator. The bases are apertured for the passage of the air, and the loops are Ω -shaped tubes fastened at each

extremity to the base by the assistance of copper ferrules, into which the loop is forced by pressure. The bends of the loops, at the top, interlock and are confined by a rod to prevent disturbance in the handling.

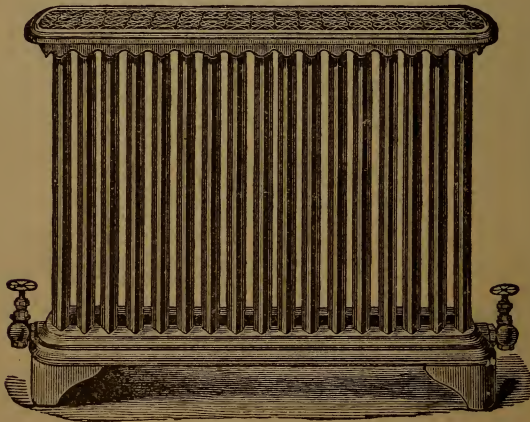

Fig. 11b.

Fig. 12 shows a stack of cast-iron extended-surface radiators for indirect heating.

Fig. 12a shows a coil of *secondary* surface, known as "Gold's" compound coil surface, and which is prin-

cipally used for indirect heating, either as a steam coil or as a hot-water coil. It is also made into direct heaters in the form of one-inch vertical pipe radiators



Fig. 12a.

covered with the *secondary* surface, and inclosed within a sheet-iron case, with a register in the top to control the heat.



Fig. 12b.

Fig. 12*b* shows an inch pipe covered with this surface, which is No. 14 square wire in the helical form,

one pound being wrapped on each lineal foot of pipe. It increases the efficiency of the one-inch horizontal pipe in condensing power full *three* times when made into indirect coils and properly boxed, and in vertical radiators of moderate height the efficiency is about double what it would be for plain pipe.

24. Sheet-iron radiators are used in very low-pressure heating, the commonest form of which is the flat Russia-iron heater, seamed at the edges and studded or stayed in the middle, with a space of about $\frac{3}{8}$ of an inch between the sides. They are used in a one-pipe apparatus.

COILS.

25. Coils are always made of wrought-iron steam-pipe and fittings, and though not considered an ornament are first-class and cheap heaters.

Fig. 13 shows a *flat coil*, which is a continuous pipe, connected with return bends at the ends, and strapped with flat iron, and is a very positive heater.

Fig. 14 shows a miter or wall coil. It is composed of headers or manifolds, A A; steam-pipes, B; elbows, C; and hook plates, D.

There are many modifications of this coil, but one indispensable point in the making of it is, it must *turn a corner* of the room, or miter up on the wall. The pieces from the elbows to the upper header are called *spring pieces*; they are screwed in right and left, and are the last of the coil to be put together.

If a coil is put together, straight between two headers, as seen at Fig. 15, it will be like Fig. 16 when heated, and cannot be kept tight for a single day; the expansion of the first pipe to heat, being a powerful purchase to

force the headers asunder, and when it cannot do so it will spring them sidewise.

TO ESTIMATE THE AMOUNT OF HEATING SURFACE NECESSARY TO MAINTAIN THE HEAT OF THE AIR OF INCLOSED SPACE IN BUILDINGS TO THE DESIRED TEMPERATURE.

26. The ordinary rule-of-thumb way, of the average pipe fitter, is, *to multiply the length by the breadth of a room, and the result by the height, then cut off two figures, from the right hand side, and call the remainder, square feet of heating surface, with an addition of from 15 to 30 per cent. for exposed or corner rooms. This is for high pressure steam, but for low pressure—2 to 5 lbs.—as much as 100 per cent. is sometimes added, according to the size of rooms and the purpose they are intended for.*

In computing heating surfaces, however, there is more to be considered, as it is evident, the amount of surface necessary for a good and well constructed building, will not be enough for a cheap and poorly put up one.

The cubical contents of a room, occupy only an inferior place, when estimating for large rooms and halls, and little or no place, in figuring for small or ordinary office rooms or residences, which are heated from day to day throughout the winter.

If in a small room, on the second floor of a three story building, with only one outside wall, no windows, and the whole furred, lathed, and plastered, while all the other rooms of the building are heated, and maintained to 70° Fahr., we place a portable heater, and keep it there, until the room is heated to 70° also, then remove it. How long will it take to cool 10°? Answer, perhaps one hour. Now make a window without blinds, and you find it cools 10° in less than half the time.

Why? Because the glass of the window, being a good transmitter of heat, it is able to cool more air than the whole outside wall. You may now say: What about the inside walls and floors? Why, they actually help to maintain the heat in the room by conduction, etc., from the other rooms.

Thus, the windows are the *first and most considerable item*. Secondly, consider the outside walls and how they are plastered—whether on the hard walls, or on lath and furring. Thirdly, the prospect—whether exposed or sheltered. Fourthly, whether the whole house is to be heated, or only part of it; and, lastly, what the building is to be used for.

TABLE OF APPROXIMATE POWER FOR TRANSMITTING HEAT, OF VARIOUS BUILDING SUBSTANCES, COMPARED WITH EACH OTHER.

Window glass	1,000
Oak and walnut sheathing on walls	66 to 100
White pine and pitch pine	80 to 100
Lath and plaster, walls good	75 to 100
“ “ common	100 to 150
Common brick (rough)	150
“ “ (hard finish).....	200
“ “ (hollow walls, hard finish).....	150
Sheet iron	1,100 to 1,200

In figuring wall surface, etc., multiply the superficial area of the wall in square feet, by the number opposite the substance in the table, and divide by 1,000 (the value of glass), the product is the equivalent of so many square feet of glass in cooling power, and may be added to the window surface and treated in the same way.

The following method has given good results, and is not wholly empirical. The writer has used it for many years in preference to any other :

Divide the difference in temperature, between that at which the room is to be kept and the coldest outside atmosphere, by the difference, between the temperature of the steam pipes, and that at which you wish to keep the room, and the product will be the square feet, or fraction thereof, of plate or pipe surface to each square foot of glass, or its equivalent in wall surface.

Thus : Temperature of room, 70° ; less temperature outside, 0° ; difference 70° . Again : Temperature of steam pipe, 212° ; less temperature of room, 70° ; difference, 142° . Thus : $142 \div 70 = 0.493$, or about one half a square foot of heating surface, to each square foot of glass, or its equivalent.

It must be distinctly understood that the extent of heating surface found in this way, offsets only the windows and other cooling surfaces *it is figured against* ; and does not provide for cold air admitted around loose windows, or between the boarding of poorly constructed wooden houses. These latter conditions, when they exist, must be provided for separately, and usually require as much as 50 per cent. additional ; a good common rule for ordinary purposes being three-fourths of a square foot of heating surface to each square foot of glass, or its equivalent in wall surface.

27. In isolated buildings, exposed to prevailing north or west winds, there should be a generous addition of the heating surfaces of the rooms on the exposed sides, and it would be well to have an *auxiliary heater*, to prevent over-heating in moderate weather.

In windy weather it is well known to the observant, that the air presses in through every crack and crevice on the windward side of the house ; and should they take a candle, and go to the other side of the house,

they will find that the flame of the candle will press out through some of the openings. Thus the air in a house blows in the same general direction as the wind outside, and forces the warmed air to the leeward side of the house; this is why the sheltered side of a house is often warmer in windy weather than in ordinary cold weather.

Simple conditions, which tend to the warmth of a house, in windy and cold weather, *without* stopping the leakage of air, under doors or around windows are: 1st, blinds on the windows inside; 2d, blinds on the windows outside; 3d, window shades and curtains; and papered walls. The leakages are really blessings in disguise, in houses which are not systematically ventilated.

In buildings where the heating surfaces have proved slightly insufficient, double sashes in the windows have served to raise the heat to the required standard.

In green-houses the saving of heat, when double glass sashes are used, is very apparent; and in buildings warmed altogether with direct radiation (where no air is changed by flues, etc.), $\frac{1}{4}$ to $\frac{1}{5}$ less surface will do. But when the system is indirect, the saving is not so great, as the heat lost by ventilating will be the same; the saving being proportional to the amount of air only, which would be cooled through the single glass.

CHAPTER III.

CLASSES OF RADIATION.

HEATING surfaces are divided into three classes : 1st, direct radiation ; 2d, indirect radiation ; and 3d, direct-indirect radiation.

28. *Direct radiating surfaces* embrace all heaters placed within a room or building to warm the air, *and are not directly connected with a system of ventilation.*

The best place in a room to put a radiator, is where the moist air is cooled—namely, *before or under the windows, or on the outside walls.* When the heater is a vertical tube radiator, or a short coil, which can occupy only the space of one window, and when, as often occurs in corner rooms, there are three windows, the riser should be so placed as to bring the line of radiators in front of, and under the windows where they will do the most good—as the middle window. It is better still, when a small extra cost is not considered, to use two heaters, and place one in front of each extreme window.

When the room is large, and has many windows, the heating surface should be divided into as many parts as there are windows ; or, if the occupants object to so many windows being partly obstructed, divide into half as many parts, and distribute accordingly.

In schools or buildings with many windows, where children or persons *cannot change their positions*, but have to remain seated for several hours at a time, care must be taken that the heating surface is very evenly distributed. A coil run the whole length of the outside wall is best, but if any kind of short heaters are used, every window should have its quota. Should a single window be left unprovided for, it will be found by experiment that a cold current of air will fall down in front of such window, and flow along the floor, in the direction of the nearest heaters, and cause cold feet to any who are in the line of its passage.

The natural currents in a room with the outside atmosphere the coldest, are *down* the windows and outside walls, and *up* at the center or rear walls. This downward and cold current, should be met by the heated and upward current from the radiator, and reversed and broken up, as much as possible.

29. Indirect radiation embraces all heating surfaces placed outside the rooms to be heated, *and can only be used in connection with some system of ventilation.*

There are two distinct modifications of indirect radiation. One, where all the heating surface is placed in a chamber, and the warmed air distributed through air ducts, and impelled by a fan in the inlet or cold air duct. The other, where the heating surface is divided into many parts, and placed near the *lower ends* of vertical flues, leading to the rooms to be heated.

The first of this class—namely, *chamber-heat*—has not proved a great success, and architects and steam heating engineers are likely to have very little to do with it, unless the air is impelled with a fan, as it has been found, that in windy weather it is almost impossible to

force air to the side of a building against which the wind blows, with natural currents alone. The second of this class does better than the first without a fan, as it admits of taking advantage of the force of the wind, to aid in bringing the warmed air into the rooms, and does very well for private houses.

In estimating the heating surface for low-pressure indirect radiation, it is well to nearly *double* what would be used for direct radiation. This great increase is not necessary where the air is forced, but with natural currents it is hazardous to do with less, with ordinary indirect coils.

30. The indirect heater is usually boxed, either in wood lined with tin, or in sheet metal. The former is best when the cellar is to be kept cool, as there is a greater loss by radiation and conduction through metal cases; otherwise metal is best, as it will not crack, and when put together with small bolts can be removed to make repairs, without damage.

31. The vertical air ducts are usually rectangular tin flues built into the wall when the building is going up; sometimes they are only plastered; but round, smooth metal linings with close joints give much the best results. The cross section of an air duct should be comparatively large, as a large volume of warmed air, with a slow velocity, gives the best result.

A 12-inch flue in a wall will deliver about 10,000 cubic feet of air in an hour to a room on the second floor of an ordinary house, if it is not too much obstructed by the radiator or register, and about one-half that amount will be delivered under similar conditions to the first floor. A good common rule is to make the first floor flue twice the area of the second floor flue.

There should be a separate vertical air duct for every outlet or register. In branched vertical air ducts, one is generally a failure.

The heated air from one heater, may be taken to two or more vertical air ducts, when they start directly over it; but one should not be taken from the top, and the other from the side; or the latter will be a total failure, unless the room to which the flue runs is exhausted; *i. e.*, the cold or vitiated air of the room is drawn out by a heated flue or otherwise.

Inlet or cold air ducts are best, when there is one for every coil or heater; and its mouth, or outer end, should face the same way as the room to be heated. By this means, when the wind blows against that side of the house, the pressure is into the cold air duct, and materially assists the rarefied column of air, in the vertical duct, to force its way into the room.

Often the steam-heater uses only one large branched cold air duct; but this system may give trouble unless all the rooms are exhausted, or unless it has two connections with the outer air, arranged with swinging doors, so the prevailing wind may always blow into it.

The steam-heater should not take a job of indirect heating unless the building has been arranged especially for it, with some efficient system of flues, sufficient to change the entire air at least once in an hour.

Frequently, architects make no provision for drawing out the cold or depreciated air, other than an open fire-place, and often they make *no* outlet. Such a room as the latter cannot be warmed by indirect heating at all. But when there is a chimney, or an unwarmed outlet or foul air flue, the heated column of air in the vertical hot air flue is generally sufficient to force its way through.

Very large rooms, with high ceilings, are difficult to warm by indirect heating alone.

A cheap and good way to draw, or exhaust, outlet or foul air flues, is to connect them all to one large annular flue, around the boiler chimney flue.

Warmed fresh air flues should be in or near the outside walls, and should discharge near the windows; and foul air flues should be in the inner walls, and have an opening near the floor and ceiling, with register valves, to allow the occupant to use either, or both, as he thinks proper.

32. *To find the time in minutes*, it will take for a room of known cubical contents, to change its air through a flue of one square foot cross section: Multiply the velocity of the air through the flue in feet per second, by 60, and divide the cubical contents of the room in feet by the result. Thus: Velocity of air 5 feet \times 60 = 300 \div into cubical contents, say, 4,000 = 13.3 minutes.

To find the time for *other sized flues*, multiply this result by the cross section of flues, in square feet, or fractions thereof.

The velocity of the air in heating flues with only a natural draught, rarely reaches 8 feet per second, no matter what the conditions; and 2 feet, 4 feet, and 5 feet respectively, are fair averages of velocities for first, second, and third floors of a house.

33. Direct-indirect radiation embraces all heating surfaces placed within, or partly within, the room to be warmed, *in direct connection with some system of ventilation*.

Heaters of this class are usually placed on the outside walls or under windows, following the same general rules as direct radiation, excepting the clusters are deeper, so as to prevent the cold air from rushing through without being warmed.

Fig. 5 is a favorite modification of this style of heating. It is a section of a room, showing the action of the currents of air. *A A*, outside wall; *B*, partition wall; *C*, radiator; *D*, inlet flue; *E*, damper or valve; *F*, ven-

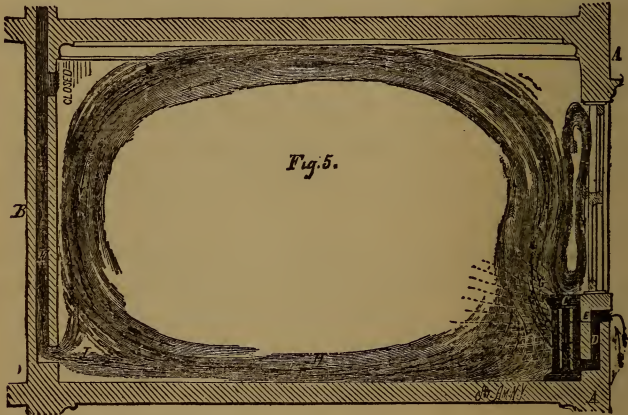

tilating flue or foul air outlet; *G*, fresh air mixing with the air of the room; *H*, air of the room passing along the floor to the heater; *I*, a percentage of the air in the room passing off by the ventilator.

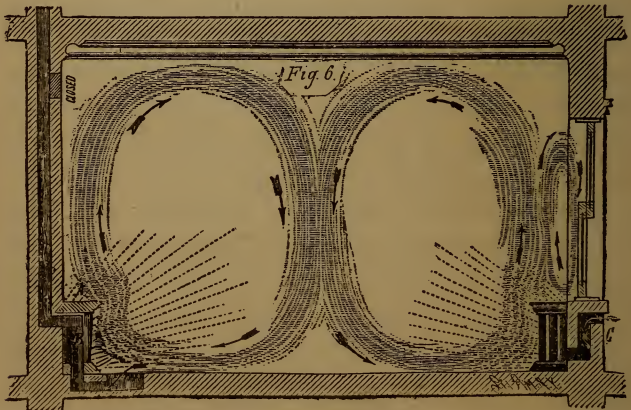

Fig. 6 is another modification of direct-indirect radia-

tion, where some of the *local heat* is employed to exhaust or draw out the vitiated air of the room. The arrows show the action of the air currents. *A* is a section of a radiator built with a sheet-iron flue, *B*, between the tubes, and passing through a hole, cored in the base, which connects with the register in the floor, and a foul air flue in the wall.

Some of the radiant heat, etc., from the radiator, *A*, warms the sheet-iron flue, *B*, which in turn warms the air within it, causing an acceleration of the current in the foul air flue, and consequently drawing an equal amount of fresh air in at the opening, *C*.

In estimating heating surfaces, for direct-indirect heating, it is well to use *once and a half* as much as would be used for direct radiation alone.

There is this further distinction between the three systems of radiation: Direct radiation warms only the air of the room and maintains the heat. Indirect heating warms only the air that passes in, and cannot warm the same air twice, and consequently has to raise the temperature of all the air that passes, from the outside temperature, to that necessary to maintain the temperature of the room, and make up for the loss by ventilation. Direct-indirect radiation warms part of the air over again, and warms all the air admitted for ventilation, which latter can be varied to suit the occupants.

POSITION FOR INDIRECT HEATERS.

34. With indirect radiation, the heating apparatus being steam, a building may ordinarily be sufficiently ventilated; but it frequently happens in large rooms, with very high ceilings, or large auditoriums, as churches, schools, theaters, or assembly rooms of any

kind, that they are not always satisfactorily heated ; for it is difficult to warm them by indirect radiation alone, unless there is a heater to each register, and many registers placed before the windows, supplemented by direct radiators, placed near doors or passages, through which there will be strong local currents.

Heated air from a few large registers in a very large room, goes directly to the ceiling, and fills the room from above, expelling the same amount of air through the ventilators ; if the building had no windows, this would answer ; but as buildings have windows—which cool the air rapidly, there will be a falling of air, in front of the windows, which has not been pressed down, by the warm air above ; but has fallen of its own gravity, by losing its heat, from contact with the *cooling surfaces* of the building ; and these downward currents, having nothing to neutralize them, pass cold along the floor, in their passage to the ventilator, or to an ascending current of warm air—caused by the heat given off from the bodies and lungs of the audience.

This is why people in churches and theaters suffer from cold legs and feet, and sometimes have a cold current on their heads, which makes the occupant certain—the window *is open a little* ; though a thermometer near by marks 70°, for the thermometer is not in the cold current.

If a building must be heated entirely by indirect radiation (except where the occupants can change their position and draw down curtains, or close inside blinds), use as many heat registers as possible, and place them in front of the windows, or where a cold current is likely to come down.

Usually in office rooms, and ordinary rooms in resi-

dences, *one* register in the coldest part of the room can be made to answer; but if the room is large, with many windows, more should be used.

Figs. 7 and 8 are perspective elevation and section, respectively, of one of the indirect radiators in the Cambridge Hospital, and show the arrangement of the air-inlet pipes *A*, mixing-valve *D*, hot-air pipe *H*, and register-box *R*, within the wards, as well as a section of the vent-ducts, *V A*, with the vent-outlet under each bed (*V*).

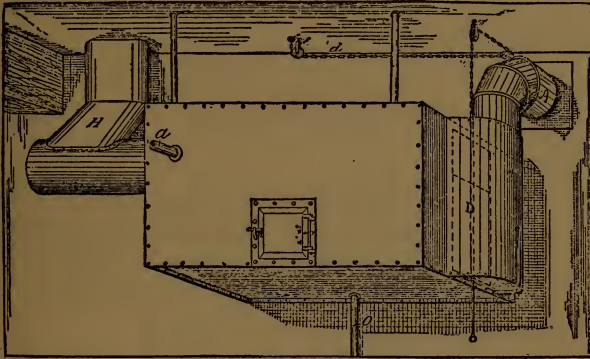

Fig. 7.

The coil casings or air boxes are made of No. 22 galvanized iron, with flanged corners, and the steam-radiator is suspended midway in the case, as seen in Fig. 8. The indirect heaters are "pin" sections, centre connection, eight sections being used to each hot-air box. The cold air enters through the 10-inch round pipe *A*, Fig. 7, and shown separated on cellar plan by the arrows, the mouth of which is protected by a register-face and frame. As the air enters through *A* it can be made to pass either under and through or above the heating-surfaces of the radiator by means of a sliding damper, *D*, or the air-current may be divided by placing the

damper in a nearly central position, allowing some of the air to pass each way, thereby regulating its temperature without reducing its volume. The upper end of this damper is connected by a chain with a pull-and-stop mechanism within the ward, so that the attendant can regulate the heat of the air without leaving the room. The registers are in every case underneath the windows between the piers.

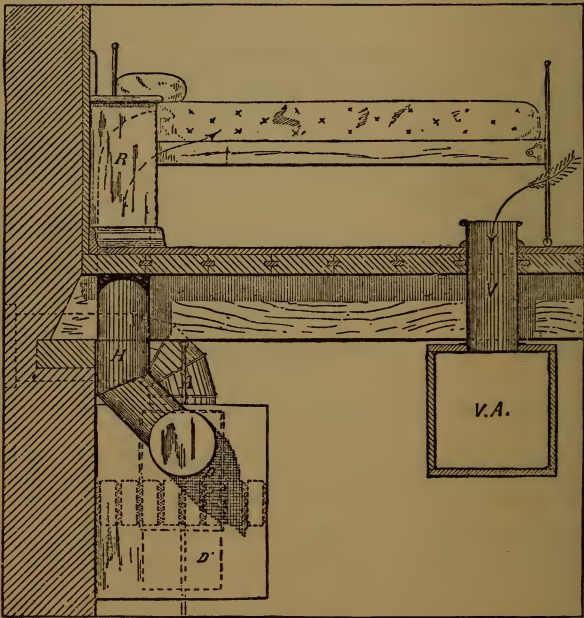

Fig. 8.

35. It will be seen that the dampers in the cold air inlets are not automatically regulated. They are sometimes so regulated, to prevent the freezing of the coils; but when the steam and return pipes are sufficiently large, coils are seldom frozen; for when steam is up,

they cannot freeze, and when steam is not up, there is no water in the coils to freeze, for it has subsided to the water line.

Only an apparatus with *scant pipes and parts* will freeze, unless the coil is too close to the water line, or partly below it.

Indirect coils, if they have valves, should never be shut off in very cold weather. If the room is not to be heated, close the registers and inlet ducts. The closing, or partly closing of a valve, may freeze a coil, by interrupting the circulation. The closing of one valve, and the leaving open of the other, is sure to freeze a coil, if exposed to sufficient cold; as in either case, it will fill with water. *This applies to all radiators.*

Fig. 8 *a*, shows the Nason Indirect Radiator arranged for hospitals, asylums, etc. It has a metal case and can be shut off in sections.

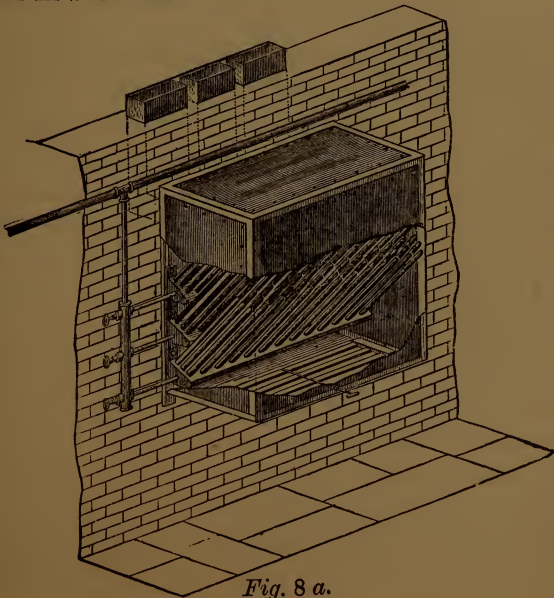

Fig. 8 *a*.

CHAPTER IV.

HEATING SURFACES OF BOILERS.

36. THE direct heating surface of a boiler (fire-box), has a value, several times greater than the indirect surface (flues and tubes) ; but the shape of the furnace, its size, and the angle of the heating surface, as well as the length, size, and position of the flues, give a greater or less value to the indirect surface ; but these values are only *comparative*.

In constructing boilers for heating apparatus, an effort should be made to have the greatest amount of direct surface, with a minimum of indirect surface ; for it is desirable to have slow combustion, with thick fires, and thus reduce the attendance to a minimum.

When furnaces are comparatively small, with a high rate of combustion, flue surfaces may be lengthened with beneficial results ; but in a private house, with a self-feeding boiler (base-burner), or one which has a deep furnace, constructed to put in six to eight hours' coal, and keep steam uninterruptedly for that time, a great part of the heating surface should be in the fire-box ; the heat from the gases being comparatively low tempered, and the amount passed in a given time small.

It would be well to say, that most writers on boilers,

put too high a value on what is termed *direct heating surface*, in contradistinction to *indirect* or flue surface. Not that the value of a square foot of surface in a fire-box of ordinary construction has not $2\frac{1}{2}$ to 4 times the value, for the same size of average tube surface, but they convey the idea, that by increasing surface, near, or in the fire-box, and decreasing the tube surface, near, or in the direction of the chimney in a threefold proportion, to the increase in the fire-box—they can evaporate as much water with the decreased surfaces. Below certain sizes and proportions (which have already been attained in boilers of ordinary good construction), this may be so, but when a fire-box or furnace is large enough for proper combustion, the surface of it is then receiving all the radiant heat *there is*, and by increasing the surface directly exposed to the action of the fire (beyond the required chamber for combustion), it will be necessary to have the surface of the fire-box as a whole, more remote from the fire; as radiant heat from any source has its effect decreased, *directly as the surface which absorbs it*.

From a central point of heat, the rays diverge on all sides, and the intensity diminishes *inversely as the square of the distance*, which will be found to be *directly as the surfaces of different sized spheres, which might surround it*; the value of the heating surface (for radiant heat), decreasing for each unit of distance, in a geometrical progression, whose ratio is 4. The above can be likened to the fire in an upright boiler; assuming it has no downward radiation.

In horizontal boilers, or boiler with long fire-boxes, or fired within horizontal cylindrical furnaces, the fire can be likened to a long column of heat, from which the

rays go off parallel to each other in the line of its length, but diverge in a line of its cross section; which will give an inverse geometrical progression whose ratio is 2, as the decreased value of the surface, for each unit of distance it is removed from the fire; but in any case, the assertion, that the intensity of radiant heat decreases directly as the surface which absorbs it, will hold good for any shape of fire, or any shape of furnace; and that hanging tubes, projections, or corrugations in a fire-box, receive nothing from the radiant heat that would not be received by the plain surface; so, although a person may take 4 foot of tube surface away, and add one foot to the fire-box, without perceiving they lost anything, yet they cannot, in a boiler that is already $\frac{1}{2}$ furnace, and $\frac{1}{3}$ flue, whose gases of combustion escape at a sufficiently low temperature, take away all the flues, or a large percentage of them, and by adding $\frac{1}{4}$ of their surface to the fire-box, makes as much steam.

37. All that can be gained by *crowding* the fire-box with surfaces, hanging or otherwise (which must not interfere with combustion), is, to reduce the bulk of the boiler; the surfaces will be the same still, for the same work. It is therefore poor economy to reduce the size, when nothing else is gained, and make surfaces which will fill up on the inside with sediment, choke up in the tubes, or between them with soot and ash, and wear out in one-third of the ordinary time.

It is an incontrovertible fact, that boilers with very small parts, require more surface for the same work done, than with large and plain parts; because of the impossibility to thoroughly clean them, and the rapidity with which they choke; the nearness of the tubes allowing the dirt to *bridge* between them.

A maximum of fire-box, with a minimum of flues, is proper, and should be the *rule in house heating*, where there is generally plenty of room in the cellar.

38. If the surface of the fire-box be increased by projections or corrugations, for the purpose of an increase of surface in contact with the highly heated gases of the furnace, the folds should be large and in vertical rows, so nothing can find a lodgment on them.

39. The boilers which have given the best evaporative results, as well as the least trouble, and lasted the longest, have been the simplest, and the evaporative results of a boiler depend more on the care with which they are kept clean, and the unimpeded circulation of the water within them, than on any *peculiar disposition* of the heating surface.

Large boilers, compared to the work, are most economical; but the limit is hard to fix, there are so many conditions to be taken into consideration, as well as styles of boilers; and as it is really the size of the grate, and the velocity of the draft, compared to the work to be done (after the boiler is large enough), which regulate the economy—hence a sufficiency of boiler, with the *right grate surface*, to burn the fuel, accomplish the most satisfactory results.

A boiler that may do very well for the first year, may not give satisfaction the second year. Such will be the case with boilers barely sufficient for the work, which, while they are clean, and the person in charge of them has a pride in doing well, will pass muster; but the second year, when the novelty has passed off, it will be quite different, then complaints will be heard, and one investigating steam apparatus with a view to putting it in his house, will be apt to reject it should he inquire

no farther. Then it is too late to assert—the trouble is known and can be easily remedied.

40. In proportioning the size of boilers, all calculations must be based on the supposition that the boiler will be neglected to a certain extent, and that there are parts of the best boilers which cannot be properly cleaned, and that all boilers deteriorate in transmissive power (the gravity return least of all, as the return water is *pure*) more rapidly at first, until a point is reached, where external deposits fall off, after which the impairment is slow, and caused only by slight deposits on the inside, chiefly oxides, which have a high transmissive power themselves.

41. Can a boiler, it may be asked, be robbed of its heat, by the gases of combustion, by retaining them too long in contact, in passing through long flues? Not if they are internal tubes or flues; but there is a *point* beyond which there is no gain,—namely, where the temperature of the gas and the steam becomes the same. Up to that point, the gases of combustion being the hotter, impart heat to the flue, but beyond it, neither the flue can impart heat to the gas, nor the gas to the flue, as they are of the same temperature. Boilers, when they are new, should have some such point, which simply moves nearer the chimney, as they become old and dirty.

The rate of combustion will also give this point a variable position, for the time being.

Some engineers think it preferable to let the gases of combustion escape at a higher temperature than the steam. In that case, the point can be assumed to represent any *constant* difference of temperature of the gas, above the steam.

42. Reverberatory, or drop flues, in upright boilers, save much heat. A cause of loss of heat, in upright boilers (and possibly in many other boilers), which have a great many tubes, many more than the aggregate area of the chimney, is, the heated gases find the tubes directly over the fire and pass out rapidly at a high heat, of their own gravity, leaving the gas in the outer rings of tubes inert, as may be seen in almost any upright boiler, where the tubes of the outer circles are clogged with dirt; the velocity of the draft in the middle tubes keeping them comparatively clean. But when there is a row of drop tubes, as shown in Fig. 14, or a flue built around the outside of the shell of the boiler, with brickwork, with the chimney flue leading from the bottom, as shown in Fig. 13, the gases are then *drawn out*, or "exhausted" by the heat in the chimney; and the gases around the upper part of the boiler, become uniform in temperature, and stratify, the lowest being drawn off first, and the others following according to their temperature.

When combustion is good, and the gases as they leave the boiler and enter the chimney flue, have not too high a temperature, *the water within such a boiler has absorbed all the available heat*; hence, to increase the surface of such a boiler, will not do much good, unless the grate surface is also increased; since *all* the heat evolved has been absorbed.

43. Will the quantity of water within a boiler effect evaporation?

Many steam heaters and others use boilers composed of very small parts, so as to have the greatest surface with the least water, with a view to evaporate more water in a given time, and cite the time *between*

starting the fire and the time *steam is up*, as a proof of it. This is a mistake! The reason why steam is gotten up quicker, is because there is less water to heat to 212° before steam begins to make, but beyond that, the result, with regard to steam making is the same, for the same surface, other things being equal.

What is gained in *first time*, with sensitive boilers, is more than compensated for, in house heating, by having boilers which contain a large quantity of water, by keeping steam where a new fire is put in; as boilers which contain small quantities of water are rapidly chilled, as well as rapidly heated, and must be fired often, and regularly.

Fire engine boilers, require to be sensitive, and when much power, with small weight is a desideratum, they are all right.

CHAPTER V.

BOILERS FOR HOUSE HEATING.

44. BOILERS for heating apparatus should have very few parts, and be as simple as it is possible to make them; every part of them being constructed with a view to permanency; and parts that wear out more rapidly, such as grates, should be so arranged that they can be renewed by the most inexperienced person.

45. Requirements for house heating boilers are:

1st. They should contain a quantity of water, sufficiently large to fill the pipes, and radiators, with steam, to any required pressure, *without lowering the water enough in the boiler to require an addition*, when steam is up; for should the steam go down suddenly, there will be too much water in the boiler. This occurs in boilers made with very small parts or pipes, which have a small capacity, at the water line, and require great care; for should the boiler have an automatic water feeder, set for the *true* water line, it will fill up, but cannot discharge again, when the steam goes down; while, if it has *no* feeder, there is danger of spoiling the boiler, as too great a proportion of the water is in the pipes *in the form of steam*.

For the quantity of water necessary to fill the pipes,

with steam at any pressure, at a maximum density, see Table 13.

2d. The fire-box should be of iron, with a water space around it, as in upright, or locomotive boilers; to prevent clinkering on the sides, and the necessity of repairs to brickwork, which are *unavoidable* in brick furnaces.

3d. The fire-box should be deep, below the fire door; to admit of a thick fire, to last all night, and thus keep up steam.

4th. The fire-box should be spacious, for the sake of good combustion.

5th. The flues and tubes should be large, and in a vertical position, so they will not foul easily, and that any deposit may fall to the bottom.

6th. The heating surface should be great in diameter, instead of in the direction of the chimney, and the last turn be a drop.

7th. They should, if possible, be constructed of such shape and design, that they will require no sweeping, or cleaning, other than removing the ashes; but when it is unavoidable, every facility should be made for easy access to such parts; because they are often operated by inexperienced persons (house servants), who will condemn anything which gives trouble to them.

8th. The fire-grate must be easy to clean (anti-clinker), and so designed, it will not crack or break when heated (see Grates, page 80).

9th. The grate and ash-door must be so constructed, that a new grate can be put in quickly by any one.

10th. There should be no tight dampers in the chimney flue, and when the flue goes out near the bottom

(drop flue), it may be dispensed with altogether; but the fire and draft-doors should be made to close airtight (planed), so as to be capable of entirely damping the fire. This will prevent the possibility of coal gas escaping into the house; the damping of a fire, by shutting off its supply of air, is the proper way; for the draft of the chimney being unimpaired, draws all the harder on any crack, or crevice, in the brickwork, causing an inward current, which entirely precludes the escape of gas.

11th. The perpendicular height of the boiler should not be too great for the cellar, so the water line will not be too near the level of the main pipes.

12th. It should be so inclosed in brickwork as not to perceptibly raise the temperature of the cellar, in which it is, and have the whole outside of the boiler, heating surface, if required, by having either an upward or downward flue.*

When upright boilers are constructed with drop tubes, as shown at *a'*, Fig. 14, or with drop flues, as shown in Fig. 13, it is generally necessary to use a direct smoke pipe, as well as a bottom pipe, as shown, in which case an upper damper is required, and possibly it is better to have a lower damper also; the two dampers should be connected at right angles to each other by a rod, as shown at *i*, Fig. 14, which prevents the possibility of having both dampers closed together.

46. In upright boilers, for house heating, the proportion of fire-box to the flue surface admits of almost any modification, as the boiler can be made of large diameter, with short tubes and high fire-box drawn in at the bottom with dead plates, for the desired size of grate, or drawn in as shown in Fig. 12.

* Asbestos-lined jackets of iron, or other suitable jackets of refractory materials, may take the place of the brickwork.

47. Horizontal multi-tubular boilers admit of very little modification; an increase of diameter, with short shell and large tubes being best, for slow combustion, with a great distance between the grate and boiler, and no bridge-wall, other than enough to keep the fire on the grate.

A chamber behind the bridge-wall is not of any particular service, when the bridge-wall is low; but making *contracted* throats, at the bridge-wall, or behind it, to make the heat "hug" the boiler, is a mistake. What is wanted in the furnace, and under the whole length of the boiler, is *space* sufficient for complete combustion. Below a certain size of cross section combustion is interfered with, and the oxygen which passes through the fire will not combine with the unconsumed carbon, which has been decomposed by the heat at the grate; but with ample space this ignition will be continuous, until complete with a sufficiency of oxygen, where the temperature is not below (800°) eight hundred degrees Fahr.

For a high rate of combustion the boiler may be longer, with tubes of small diameter and with great space under the boiler.

48. A contracted passage, or having only the area of the chimney at the bridge-wall, may impinge more heat on that particular part of the boiler, but it will not cause the evolution of more heat; and the sum total remaining the same, it will do the same duty, whether absorbed by a small part of the boiler, to which it may do injury, or by the whole surface at a more general temperature.

The extent of the sides of the furnace, when made of brick, may be used as an argument against a large

chamber; but the loss through a well-made brick wall is so little that it will not offset the benefit.

Figs. 18, 19, and 20 show a horizontal multi-tubular boiler, as ordinarily set; 18 being longitudinal section, 19 half front and half cross section, and 20 floor plan.*

49. The different parts of boilers, and their settings, have technical names, applying to the corresponding parts of all boilers, as far as the construction will permit; the shape, sometimes, modifying the name, and increasing or lessening the parts. As an example, a *return-flue boiler*, and a *drop-return-flue boiler* are shown (Figs. 9 and 10).

The return-flue boiler can be used as a stationary or marine boiler with or without a water-bottom; the drop-return being constructed for stationary boilers, as it has no steam chimney, and the smoke connection is a sheet iron breeching.

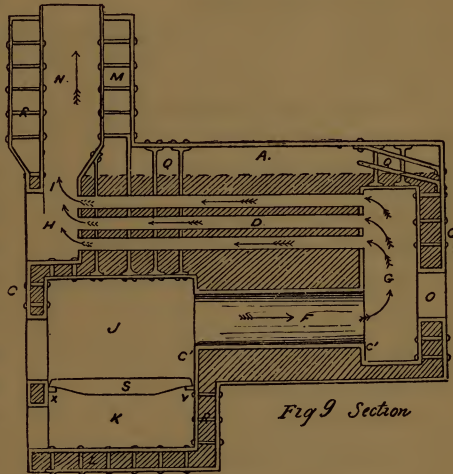
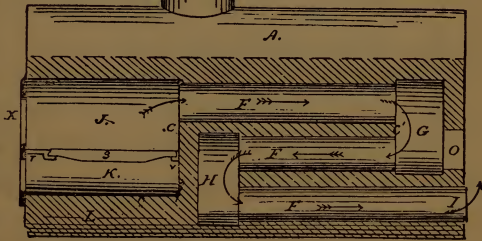

Fig. 9 Section



Fig. 10



* The proportions for boiler and setting, shown in Plate 2, are better than those just mentioned.

- A.* Boiler-shell.
- B.* Steam-dome.
- C.* Boiler heads.
- C'*. Flue sheets.
- D.* Tube.
- F.* Flues.
- G.* Back connection.
- H.* Front “ or smoke connection.
- I.* Smoke “
- J.* Furnace, or fire-box.
- K.* Ash-pit.
- L.* Water-bottom.
- M.* Steam chimney (marine).
- N.* Smoke chimney (marine).
- O.* Man-hole, to back connection.
- P.* Bridge-wall.
- Q.* Braces.
- R.* Stay, or socket bolts.
- S.* Grate bars.
- T.* Coking, or dead-plates.
- U.* Front-bearer.
- V.* Back-bearer.
- W.* Division, between front connection and fire-box.
- X.* Boiler-fronts, cast iron.
- Y.* Side walls.
- Z.* Lugs.

The division between furnaces, and the sides of furnaces, are called “Legs” in fire-box boilers.

The same letters apply to the corresponding parts of the horizontal boilers, Figs. 18 and 21.

CHAPTER VI.

FORMS OF BOILERS USED IN HEATING.

THE conditions required for heating boilers, which are of such proportions they may be fitted up to work automatically, are simplicity of construction, durability of parts, and ordinary economy in firing.

50. A source of danger to the success of the young steam-fitter and to many inexperienced in steam-fitting—is their endeavor to construct ideal boilers, which usually prove to be failures. It is far better to use boilers proved successful by others, and improve their weak points, after your own experience with them. Success lies in that which will give *least trouble*, and will not wear out rapidly—the burning of a few tons of coal more or less in a year, is not a proper test; as the conditions of management, the size of the house, the amount of ventilation, the number of hours the apparatus is operated in the year, and last, though not least, the comfort and satisfaction—all must be taken into consideration to prove economy.

51. Fig. 11 shows the simplest form of upright boiler, used for heating, excepting, perhaps, one with a flat crown sheet. The grate is drawn in at the bottom, by a slanting annular dead plate, as shown; the center

part of the grate only has openings. The brick-work is very simple, and is built around the boiler, leaving

about a three-inch space for a flue, and the smoke pipe is taken out at the bottom. It does not rate very high in point of economy of fuel; but it is very easily kept clean, and lasts a long time.

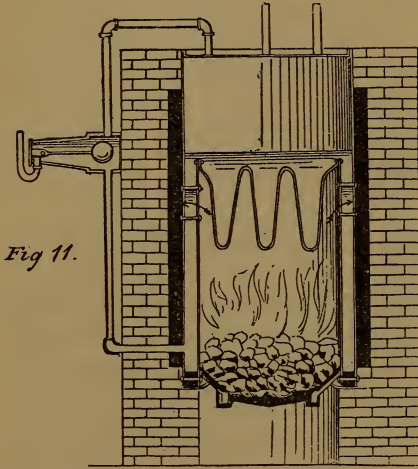

Fig 11.

52. Fig. 12 shows an upright boiler (multi-tubular), which is drawn in at the fire-box, to the size for

the grate. This dispenses with the annular dead plate, and makes a very permanent piece of work. This boiler is set to carry the heat, when it leaves the tubes down one side of the boiler, and up the other, passing under a septum of iron, or a division wall, which may be run very near the boiler, but so as not to press against it. When the tubes of this boiler are not smaller than two and a half inches, or longer than three feet, and nothing but hard coal is used, it will require cleaning but once a year, provided there is no leak in the fire-box, or about the ends of the tubes.* To clean them,—remove the cover *a'*, and use a steel wire tube brush. The cover *a'* is covered with sand, or fine ashes, on the top,

* Much moisture causes the fine white ash which comes from hard coal to bake on the heating surfaces, and should be prevented.

and in the space *c*, around the top, to prevent radiation, or danger from fire. It will be noticed, this boiler is set on a cast iron plate, to give it stability. This plate is more satisfactorily made in *two* parts, and bolted together, which will prevent the heat of the fire from cracking it, after it is set. The grate is here

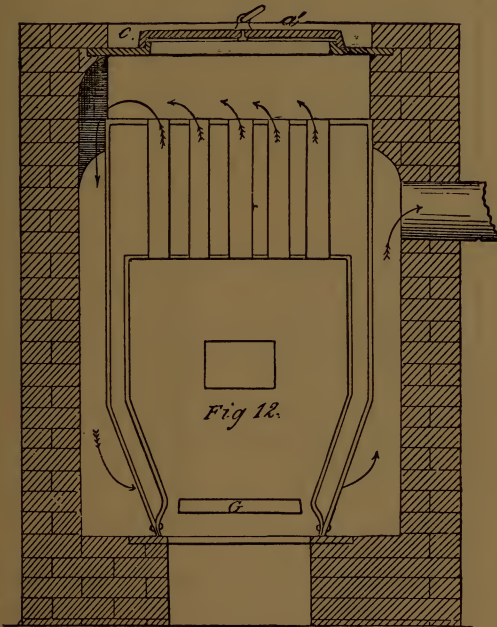

shown, a little higher than it is usually set; but it would be well to keep it as high as the rivets.

53. Fig. 13 shows the ordinary upright boiler, set for heating. It has a peculiar steam dome, as shown (patented), which prevents an excessive heat on top, and it is claimed slightly superheats the steam. It also has an ash-sifting grate, which saves much dust, in the

manipulating of the ashes, and prevents the grate proper from burning out rapidly.

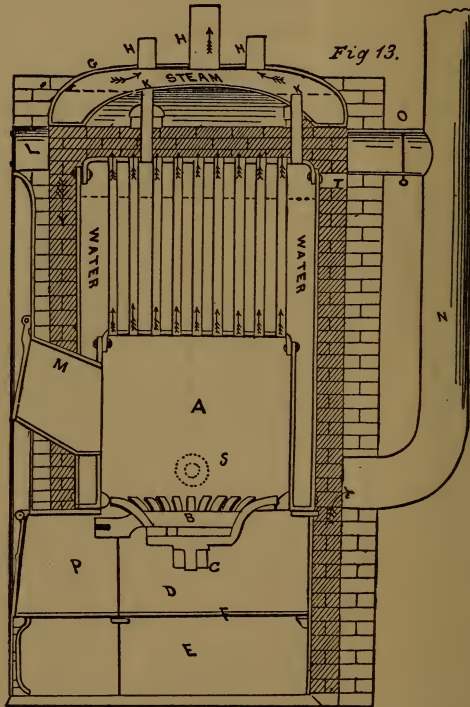

54. Figs. 14 and 15 show an *upright multi-tubular drop tube boiler*. Fig. 14 is a vertical section, on a center line, and Fig. 15, a half cross section, to show the walls and tubes. In Fig. 14, *FP* is the fire-pot, or dead plate; *F*, the fire-box, or furnace; *G*, the grate; *H*, a bar set in the brickwork of the ash-pit, in such a way, it may be removed to put in a new grate, and into which the grate is pivoted, a certain distance below the edge of the fire-pot, to admit of shaking and cleaning from the bottom; the amount of opening is

regulated by washers, on the pivot of the grate, to suit the size of coal used; *O*, the direct tubes; *a'*, the drop

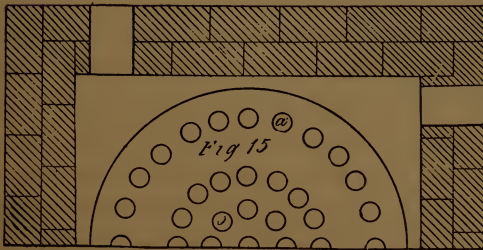
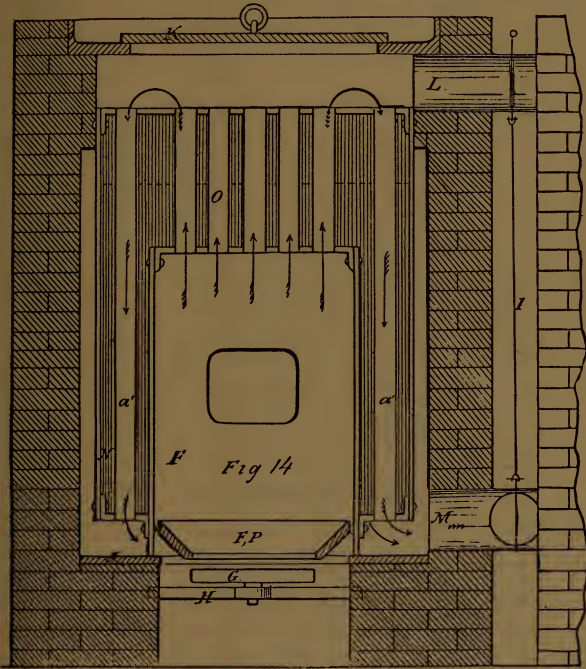

tubes; *J*, the bottom plate; *K*, the cover; *L*, the direct chimney flue; *M*, the bottom or drop chimney flue.

In point of economy of fuel, probably there is no

house-heating boiler stands higher than this; and in permanency, it is fully equal to any used; besides, it is not difficult to clean. It will be seen that all the flues are internal, and if the gases of combustion cannot impart any heat, to the boiler, after cooling to a certain degree, they cannot abstract any *from* it; as happens in external flues, when the gases cool to the temperature of the steam, before reaching the chimney.

It is also an excellent boiler where light power is desired, in which case the tubes may be of smaller diameter than would be used for heating, and longer, to suit a higher rate of combustion.

When upright boilers are inclosed in brickwork, the outside is usually built square, to suit the door castings, and for appearance; but the inside is generally built *round*, three or four inches from the boiler, to make a flue or an air space, which will be the same distance from the boiler, at every part. If it is necessary to have a flue so constructed, with the outside still square, build two walls; a round one and a square one; but the inner one must not touch the outer, or the latter will *crack*; otherwise build the wall square inside and outside, as shown.

When boilers are constructed for low-pressure heating, have them built just the same as if they were intended to carry high steam, taking care the leg (the part formed by the side of the fire-box, and the shell marked *N*, in Fig. 14) is properly stayed with socket-bolts, or stay-bolts; for boiler-makers often show a disposition to leave the legs unstayed, when they know the boiler is for very low pressure.

Fig. 16 represents this boiler when set, and fully fitted with the necessary self-acting appurtenances. *A*,

is the main steam pipe, which must be run for no other purpose, but to distribute steam to the heaters; *B*, the safety valve, with its auxiliary diaphragm; *C*, the draft-door regulator (the pipe carried up inside the

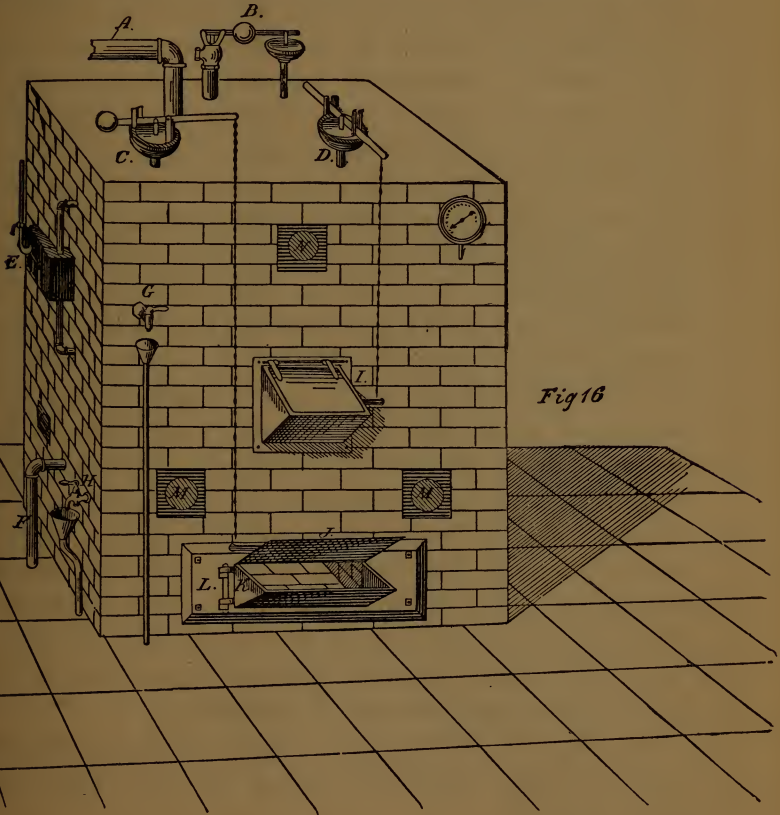

Fig 16

brickwork); *D*, the fire-door regulator, which is not absolutely necessary; but it is well to have, in case anything should prevent the draft-door from closing; *E*, the automatic water regulator, whose connections should not be a branch, from any other pipe—nor

should *they* be branched for any purpose; *F*, the main return pipe, which should have no valves in it, unless there are valves in the main steam pipe to correspond. But when there is but one boiler, it is generally better to dispense with valves in the mains at the boiler. *G*, the gauge cock, which for cleanliness may have a drip-pan under it, connected with the ash-pan; *H*, the blow-off cock, which in a heating apparatus *should never be connected directly with the sewer or drain*, but should be a lever handle cock, over a funnel, as shown, to prevent the *possibility* of water passing out of the boiler, without the knowledge of the person in charge. The funnel can be removed when not in use. *I*, the fire-door, on a good slant, so as to form a shute for the coal, and to close without a latch; *J*, the draft-door, an attachment to the ash-door; *K*, the ash-door, which is hinged to the frame *L*, and will open without interfering with the draft-door; the chain and the bolt having nearly the same *common axis*; *L*, the ash-door frame, which is bolted to a skeleton frame, built into the brick work, and can be removed, to put in a new grate; *M M*, are hand holes, to clean the space at the bottom of the drop tubes; *N*, a hand hole, to clean the upper tube sheet through, and through which a steam tube cleaner may be used, if desired.

55. Fig. 17 represents a boiler, which came into public notice within five years, and has given good satisfaction.*

It is a *drop tube* boiler, with a *coal magazine*, similar to the base burning stoves, and is entirely constructed of wrought iron, except the cast-iron magazine. When set, according to the manufacturer's instructions, every

* It is the patent of Wm. B. Dunning.

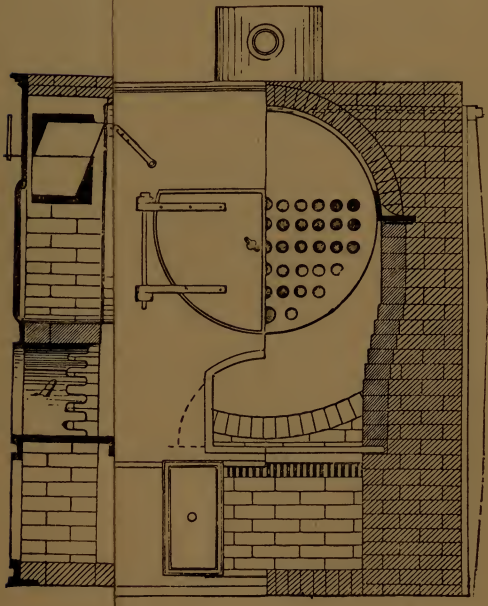
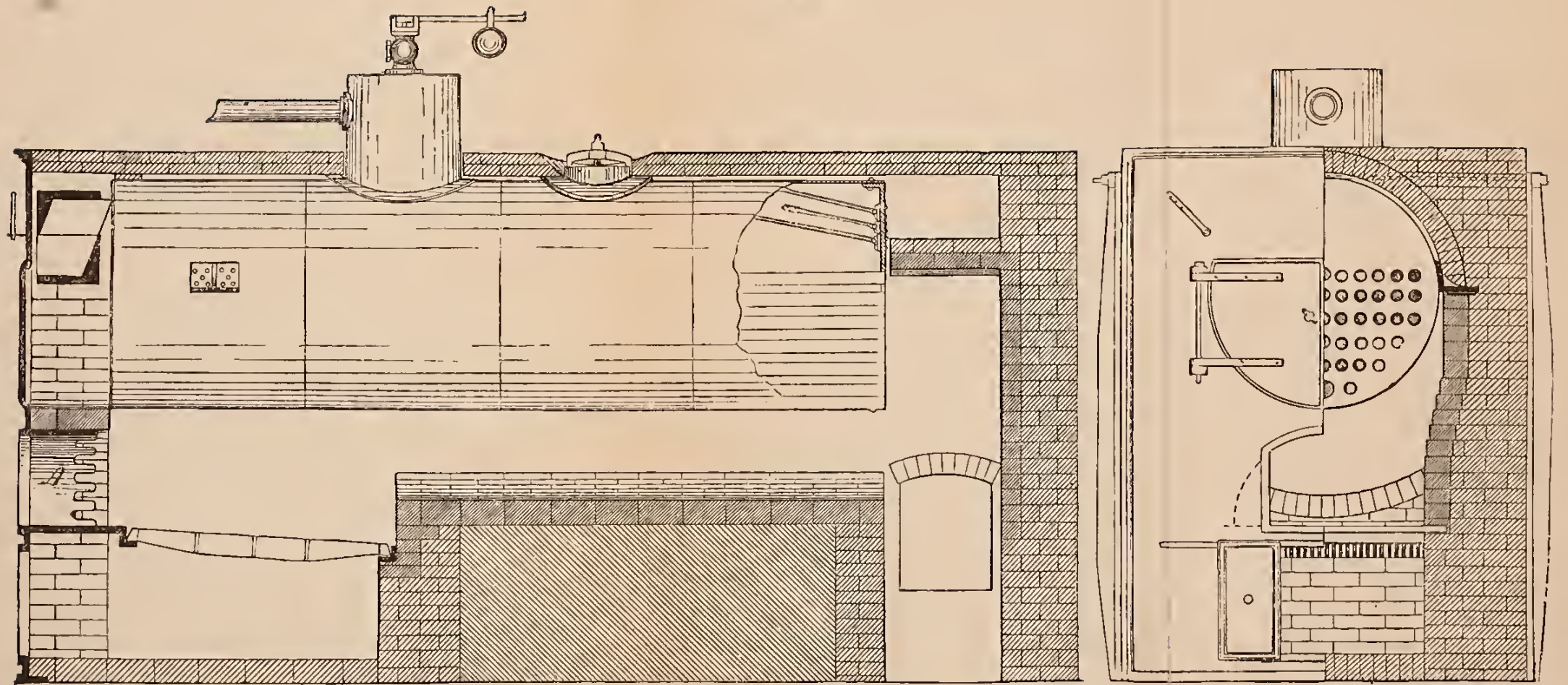
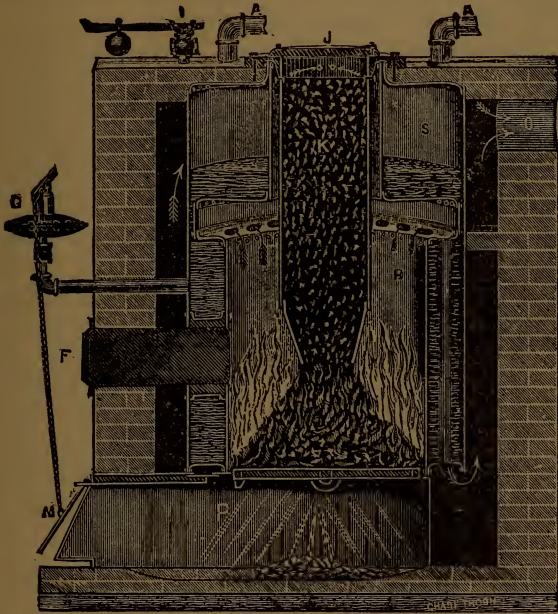

PLATE 2.



HORIZONTAL-MULTI-TUBULAR-BOILER.

part of the boiler is exposed as heating surface; the heat passes between the magazine and the fire-box, and thence down the drop tubes, *D*, and up and around the



shell. The magazine is made to pull out, and care should be taken when setting them, to have sufficient room overhead to accomplish this.

It is claimed this boiler will run twelve hours, and keep steam without requiring attention during that time. They are manufactured for the trade, and parts of them likely to wear out (magazine, muzzle, grate, etc.) are made in duplicate.

56. Figs. 18, 19, and 20 show longitudinal section, half front elevation, and half-cross section; and plan, of an ordinary horizontal boiler, set for heating or for power.

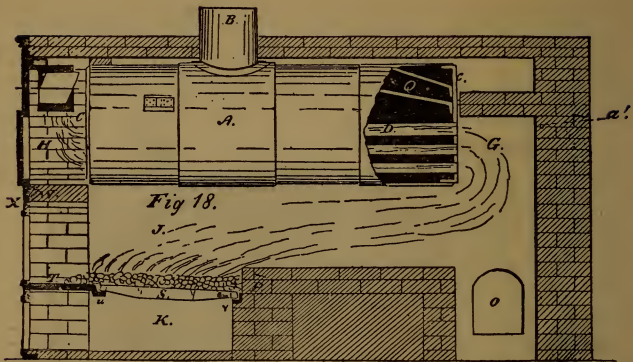

This is the style of boiler most in use in the United States, when the building is of such proportions, an upright boiler is not deemed sufficient, as there is a prejudice against very large upright boilers. They are sometimes fitted with automatic appurtenances, but where two or more of them are in a building, automatic draft regulators are all that should be used; and a careful engineer or

fireman should do the rest.*

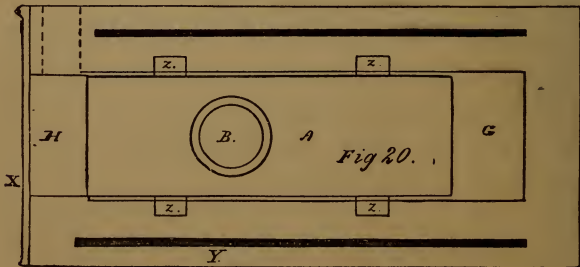
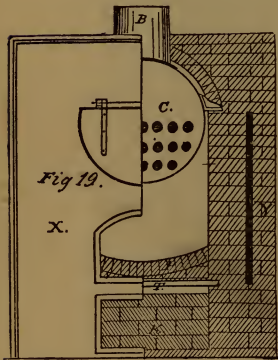

* Apparatus fitted up automatically, and left for long periods, never should have more than one boiler.

When used for power where the water contains mud, they should be fitted with a mud pipe, as shown in Fig. 21, or if used for heating, when the water is *not* returned by some means; but this is scarcely necessary in a gravity apparatus.

Fig. 21 shows a horizontal boiler, where the front end of the shell is supported by resting in the cast iron front; with the front connection formed, by what is known as *breeching*; this is sometimes made of light iron and bolted on; but it is better to form it by an extension of the boiler shell, as shown. This dispenses with the division *W*, as shown in Fig. 18.

There seems to be a dislike to this front, for no better reason, than because it is not considered ornamental. It is certainly a more substantial front, and if set as shown, with deep dead

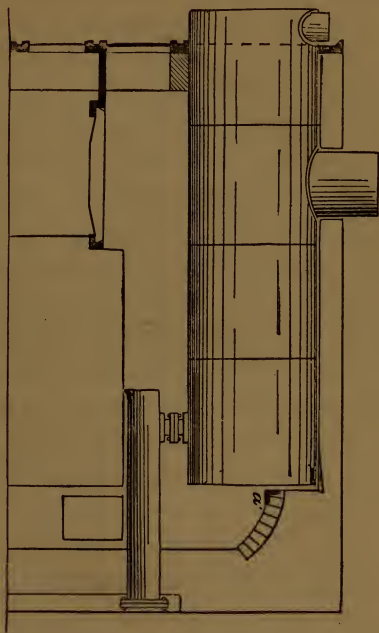
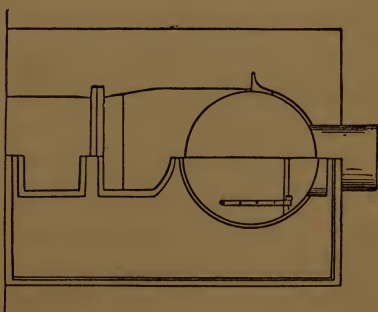

Fig 21



plate, and two courses of fire-

brick lining, it will seldom require repairs; but if the front bearer is bolted to the cast front, and the front, lined with a single course of fire-bricks, held in their place around the door, by a cast iron frame, the frame will burn off, the lining fall down, and the front become heated and cracked. With a straight front, a dead plate is *always* used, to carry the fire away from *W*, Fig. 18. The thickness of the wall necessary to form *W*, forms a lining for the front, which *must* be kept in repair, or *W* will fall, and as *W* cannot be dispensed with in a boiler, set as in Fig. 18, the front is thus preserved. If the dead plate is used, and made sufficiently deep, whether *W* is used or not, the front will last!

This front and setting also obviates the necessity for the projection, shown in Fig. 22, which is spoken of elsewhere.

56½. Plate 2 shows a horizontal multi-tubular boiler, similar to the boiler shown in Fig. 18, but with the *improved cast-iron fire door arch, A*; with the man-hole on the shell and sliding ash-pit doors.

As there are more of these boilers used in New York, and other large cities, for heating and supplying power for elevators than any other type, it would be well to give them more than a passing notice.

It is usual to make their shells of No. 1 charcoal hammered iron,—though many are now made of a certain grade of boiler steel. When iron is used, shells up to 36 inches should be made of $\frac{1}{4}$ inch plate; from 36' to 48" of $\frac{5}{16}$ thick plate, and from 48" to 60" of $\frac{3}{8}$ thick plate; with head sheets of $\frac{3}{8}$ to $\frac{7}{16}$ and $\frac{1}{2}$ respectively, constructed of best flange iron.

The domes of these boilers are usually made one-half the diameter of the shells, and about the same height;

but the limited height of cellars often reduces the height of the dome, and in some cases renders it necessary to dispense with them altogether.

The height for the setting of a 48-inch shell, should not be less than 10 feet, and as much more as can be conveniently had. This will allow 2 feet from the paving of the ash-pit to the grate, and 2 feet more from the grate to the boiler; and though it is a little more than can be obtained with ordinary fronts now in use, it is not more than would be best to employ; this is especially true in respect to the distance between the grate and the boiler.

Low cellars are a detriment to a heating apparatus in another and very important respect—they bring the main steam pipe too near the water line of the boiler, and frequently cause the contractor to use a *return trap* on a job which otherwise could be made more perfect by a gravity apparatus.

When the man-hole of a boiler is in the top of the dome, a hole in the shell underneath the dome, large enough to easily admit a man from the dome into the shell, is required. This is bad practice, as this large hole weakens the boiler materially: which fact engineers generally pay no attention to. The shell of a boiler underneath the dome should not be cut out; but should be perforated with a number of small holes—say 2 inches in diameter, until their aggregate is three or four times that of the steam pipes.

When the man-hole is in the top of the boiler an extra heavy man-hole frame should be riveted to the shell; its longest diameter being *across* the shell.

The tubes in horizontal boilers give the best results when not “staggered” but placed in vertical rows, and should have at least *one* inch between the tubes at their

nearest parts, and should be not nearer the shell than 3 inches.

These boilers should be tested to 150 lbs. per square inch by hydraulic pressure. This is absolutely necessary to test the bracing and other parts, such as heads and man-hole frames.

There is a prevalent idea that testing a boiler with cold water may injure it. If a boiler will not stand twice the ordinary pressure it is made to carry, without injury under a hydrostatic test, with water at 40 degrees Fahrenheit, *it should not be put into a building.*

Plate 3 shows a water-tube boiler. It is of a class that may be used for either heating or power. The height of these boilers usually prevented their use in basements or cellars with a gravity apparatus. Now modified forms are being made, called "architects' boilers," which are lower, that are intended to overcome this difficulty.

A point in their favor is their greater safety when compared with the shell boiler. Eleven feet in these boilers is rated as a horse-power, while fifteen is the usual rate in the multi-tubular shell.

PLATE 3.

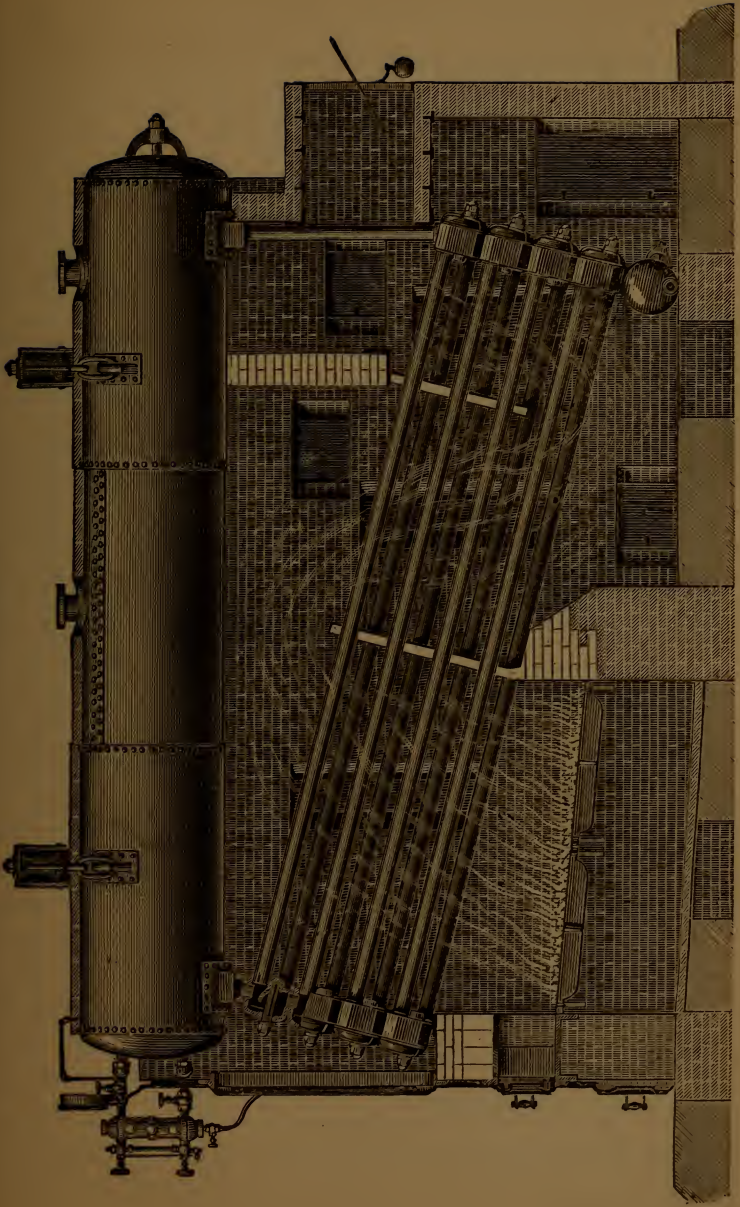

CHAPTER VII.

REMARKS ON BOILER SETTING.

57. THE best materials should be used in the settings of boilers, and less than a 12-inch wall should not be allowed even in the setting of the *smallest class* of *horizontal boilers*. Large boilers should have 12-inch walls additional to the thickness of the fire-brick lining of the furnace, and 20, and 24-inch walls are not uncommon.

It is not desirable to put a number of masons on boiler walls, and hurry them; for neatness and deliberation are required with every brick, and *makeshifts* should never be allowed.

58. On marshy, or sandy ground, it is well to excavate for the whole size of the apparatus, and put in a thick concrete foundation, which will keep the work substantial, and helps to cut off moisture from the earth.

59. It is generally assumed, that the greater expansion of the bricks, on the inside of the furnace, is the cause of boiler walls cracking; and it is, to some extent true, but cracks from this cause are generally distributed all over the walls, and are not so great that more than a few coats of whitewash are sufficient to fill them.

The large fissures, which often appear in walls of boilers, are usually caused by an insufficient foundation; the walls resting on or against the boiler; or by unequal or abrupt changes of thickness.

The arch, over the back-connection of a boiler (see Fig. 18), should not be turned *against* the boiler, as is often the case, but should be sprung from the side walls; with a rod to form the cord of the arch, the rod to be just covered from the heat, in the back wall (see Fig. 18, at α'), and with the necessary flanges, or buck staves on its ends.

If it is desirable to turn the arch from the back wall to the back head of the boiler (since some think this shape more desirable), use a heavy angle iron, to turn it against, and keep the angle iron half an inch from the boiler, taking care no mortar or bits of brick lodge between them (see Fig. 21, at α').

When the lugs of a boiler are firmly built into the brickwork, without iron plates in the wall, for the lugs to "give and take" on, the walls will crack, because the iron of the boiler contracts and expands more than the wall does.

The arch, turned over a boiler, should not touch it, but there should be one or two inches of space between them; the arch should spring from the side walls, and be self-supporting, and not turned *on* the boiler.

A good way to build these arches, is to lay inch strips of wood lengthwise on the boiler, and draw them out, as the work progresses.

When boilers are not arched over but the side walls are run straight up, and the space, over the boiler, filled with sand, the walls are very apt to crack and shove them out of plumb. Every time the boiler cools, sand

will pass down between the boiler and the wall, and the whole mass of sand will settle down; when the boiler becomes heated again, and expands, the sand will not go up again, hence the wall is shoved out. This often occurs, and it is blamed *directly* to the action of the heat as something unavoidable.

When boilers are set on sandy ground, the foundation should be deep, and good, or the heat of the furnace will drive out the moisture from the sand, and leave it a *quick-sand*, which will allow the walls to settle.

An air space within a boiler wall is not of any service, the same thickness of brick would prove more serviceable and will not weaken the wall.*

60. The fire-brick, in a furnace, should have the smallest possible quantity of fire-clay between them, barely sufficient to level the work; and it should be laid with a couple of courses of headers at the top, so the side linings could be removed, without effecting the stability of the wall. The other courses should *not* have headers, as the breaking out of a row of headers will injure the wall.

61. The division (*W*, Fig. 18) between the furnace and the front-connection, is another source of annoyance; when constructed of iron, it burns out rapidly, and when made of fire-brick, in the shape of an arch, it falls out; or may often be broken in using the fire tools.

Hollow castings, with air and water circulations in them, have been tried; but do not last. The shell of the boiler is sometimes allowed to project, and cover

* I do not wish to convey the idea that a space in the walls of a building is not valuable; since it interrupts the passage of moisture, the evaporation of which, from the walls, will require more heat than would be lost otherwise.

the space; but as it has heat on both sides of it, it *buckles* and burns out, in a year or so.

Sometimes the shell is extended with a water space, formed on it by a projection of the head sheet and shell, which forms a *permanent* fixture; and, if the part is well studded with stay-bolts, there can be no objection to it; but care must be taken, when great pressure of steam is to be used, as this "shovel nose" will form the weakest part of the boiler (see Fig. 22).

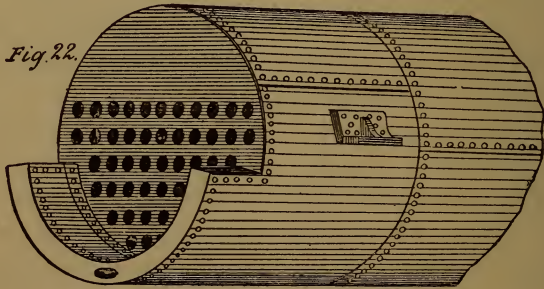

If an iron arch is used underneath a brick arch to support it, and keep it from being knocked out, it will last longer; but the inner edge of the casting will bulge down, and get out of shape, long before the iron will be burned away, which suggested to the writer, that if the cast arch (which should spring from the dead plate, and form the doorway to the furnace) flared inward, and was cut into, for about one third its depth, making large and course prongs (about 2" wide, with one inch of a slot), to support and guard the bricks, it would stand for a long time. This method has been used for 10 years, and the prongs have not bent down, while they burn off very slowly from their points, not being shortened even 1 inch; but only rounded on their ends.

62. A deep dead-plate saves the *front* linings, as it keeps a body of comparatively dead coals, between the front and the fire.

63. Bridge walls are often built straight across, but an inverted arch is better; not on account of combustion, but in an arch, the bricks are *keyed* in, and are not as likely to be poked out by the fire tools.

64. Deep ash-pits are the best, and a second or ash-grate, will help preserve the grate-proper; as there is less reflection of heat from it, than there would be from a hard brick bottom.

65. Lugs on boilers.

The brackets riveted to the sides of boilers to support them in the brickwork, are commonly called "lugs," and many engineers, in the construction of what they consider long boilers, put *three* on a side, fearing the weight will be too great for two only. This is evidently a mistake, and frustrates the object for which the third is put on. The settling of the brickwork at one end, will then throw the whole weight of the boiler on the *middle pair*, and even if the walls should not settle, the heating of the under side of the boiler more rapidly than the top (which may often take place, for instance, upon starting a fire, before steam is up), will, in a measure, force up the ends, leaving the whole weight on the middle lugs.

Four lugs properly put on, are found to be the best number.

Lugs are sometimes left off, until a boiler is in the basement, for the purpose of getting it through doorways. This is not wise, as the rivets should be driven on the inside of the shell, before the tubes are put in. Putting them on with tap bolts is not good, as two or

three bolts may have to carry the whole end of the boiler ; and should they leak, the side wall would have to be torn down.

A good plan when the lugs must be left off, is to have a shoe riveted to the boiler at the proper time, into which they will slip, similarly to a stove leg ; which must be sufficiently strong for the work.

CHAPTER VIII.

PROPORTIONS OF THE HEATING SURFACES OF BOILERS TO THE RADIATING SURFACES OF BUILDINGS.

66. THERE is no simple relation, between the heating surfaces of boilers, and the radiating surfaces of the buildings they have to supply the steam to, for the following considerations apply to every type of boiler: the method of setting, what the grate surface is, the character of the work they are designed for, and whether the air is simply to be maintained at a certain temperature, as in direct radiation, or whether every cubic foot of air which comes in contact with the radiator must be warmed from the outside temperature, as in indirect radiation, or whether the apparatus is *direct-indirect* or composite, all these would have to be considered, and the results would then be only *approximate*; for even then, neglect of cleaning, a certain amount of neglect of management, and the state of the fire—whether on the first hour of the new fire, or the last hour of the dirty fire, for the time they are to run, must enter into this calculation.

If the effect of the cooling, produced by loss, through the glass and walls of a building can be estimated, and added to the amount of heat lost in warming the air ad-

mitted for ventilation, a close estimate can be made of the *smallest* grate, which would burn fuel enough to evaporate the amount of water in a boiler *sufficiently* large; but the following points the constructor must never lose sight of in estimating for an automatically fitted boiler,—namely, that it is the amount of opening of the draft door, which regulates the fuel burned; next, the fuel burned regulates the water evaporated; and, finally, the water evaporated regulates the heat—both the heat of the room (by having a sufficiently large heater) and the heat (or pressure) necessary to move the diaphragm, which regulates the draft, so that really what is required are *certain limits, within which he knows he is safe, and to exceed which would be an unnecessary expense.*

Boilers for very large buildings, which have an engineer in charge, may be figured pretty closely; as he is supposed to be constantly at his post, and to clean his boiler fires regularly, and to fire often, and in small quantities; keeping his fire door open the shortest time possible, and further, to clean the tubes or flues whenever required. But this is not the case in house boilers, they must run for long periods without cleaning or interruption, and be adequate to every contingency of change within their limit of time to keep steam.

It has been found by experiment in a general way, and from practice, that for ordinary buildings, with average window surface, and for the greatest range of temperature in our northern states, when nothing but direct radiation with no ventilation is used, one square foot of boiler to every ten square feet of the radiating surface *will answer*; assuming the radiating surface is *ample.*

For indirect radiation, if the heating or radiating sur-

face of the coils are figured *double* what they would be for direct radiation without ventilation, the *same* proportion of boiler to coil will suffice; but, if instead of doubling, the same surface be used or a slight increase as $\frac{1}{4}$ or $\frac{1}{3}$, and the building be kept warm by moving the air faster, through a small coil—we must proportion the boiler the same as if we did double—that is, allow one square foot of boiler surface to 5 square feet of coil surface, the same as figured for direct radiation; bearing in mind, a boiler is proportioned to the cooling which goes on—heating, ventilating, etc., and *not* to the coil surface, unless the coil surface is known to be ample for the conditions of temperature, etc.*

When air is forced (as with a fan), more heat can be taken from a coil in the same time, than when the air moves naturally, from a difference in temperature; but as the heat necessary for the building remains the same, the boiler must be proportioned to the building, and when the proper coil surface has been found—sufficient to maintain the heat, for the range in temperature incidental to the climate and local conditions—it establishes the *simplest data* from which to calculate the boiler.

For direct-indirect radiation, proportion the boiler $1\frac{1}{2}$ times greater than it would be for direct radiation.

These estimates are for boilers with ordinary high combustion, such as horizontal boilers which are kept clean without interruption; but for house boilers (wrought-iron shell) with slower combustion, an addition of from $\frac{1}{8}$ to $\frac{1}{4}$ may be used, and in small water tube boilers (pipe boilers) $\frac{1}{4}$ to $\frac{1}{2}$ may be added, in the judgment of the fitter.

The manufacturers of the boiler, shown in Fig. 11, make 3 sizes, of 45, 60, and 75 square feet of heating

* This is a common and approximate rule only, and represents about the maximum condition required for boilers.

surface, and say they will furnish steam for 300, 500, and 700 square feet of direct radiation coils.

The manufacturer of the boiler, shown in Fig. 13,* publishes a list of 24 sizes of boilers, from 54 square feet of surface to 400 square feet, in which he gives the maximum and minimum number of cubic feet of air in ordinary buildings, each boiler will carry radiation for; his apparatus being *all indirect*.

The following is a condensed table of this list:

No. of Boiler.	Feet of Surface of Boiler.	Maximum and Minimum of Cubic Feet of Air in Building.
1	54	18 to 25 thousand.
6	107	40 " 54 "
9	151	55 " 75 "
12	202	72 " 100 "
18	302	116 " 152 "
24	403	164 " 215 "

There is no doubt this list is ample when upright multi-tubular boilers are used, or any kind of *shell* boilers, with simple parts.

It will be seen that by figuring the radiating surface of a building, by the old rule of allowing ten square feet of pipe or plate surface to each one thousand cubic feet of air (minimum) for direct radiation alone, and then doubling it, as mentioned for indirect above—the result agrees very nearly with the maximum number of cubic feet in the list; the difference between maximum and minimum forming a factor for safety, when the difference in construction of buildings and in neglect of management is considered.

* Major Light. A steam-heating engineer of many years' experience.

Morris, Tasker and Co. give a list which rates are nearly the same, the variation for circumstances being greater. It is as follows :

Feet of Surface of Boiler.	Contents of the Building in Cubic Feet.
115	18 to 30 thousand.
125	26 " 43 "
133	37 " 62 "
148	55 " 92 "

In the Nason Manufacturing Company's circular is to be found the following list—in which the grate to the heating surface of the boiler is about as 1 to 27, and the heating surface of the boiler to the radiating surface of the building 1 to 6½.

Square feet of Grate Surface	2	2½	3	3½	4	4½	5	6	7
Square feet of Boiler Surface exposed to the fire	55	65	78	83	105	116	131	158	182
Square feet of Radiating Surface which it will heat	350	440	525	600	700	775	900	1050	1225

CHAPTER IX.

GRATES AND CHIMNEYS.

67. FOR a house heating apparatus, the grate and fire-pot should be so constructed, that as the fire burns, the body of fuel will move together, centrally as well as downwards, and thus keep a compact body of ignited coal for a long time on the grate. When a grate is broad, with a thin fire on it, the fire burns out at certain parts of the grate faster than at others, and a fireman has to build his fire accordingly, giving it constant attention to keep up steam and not waste coal; but in a private house, all parts of the apparatus, including the grate and fire-box, must be constructed so that the fire can be left unattended for a comparatively long time; and engineers unacquainted with this class of work, will be surprised at what has been done in this respect; six hours' duration being common for a fire to keep steam, and make a better showing, for the same weight of coal per radiating surface, than large boilers with flat rectangular grates, fired regularly and often, with a high rate of combustion.

When a grate is surrounded with a fire-pot, or when the fire-box is drawn in, to any angle not greater than

30° from the perpendicular, the coal as it burns will press to the center and slip down, keeping a deep fire in a good condition longest. This is necessary in an apparatus constructed to run all night without attention, unless it is constructed with a magazine, as in a base burning stove. It can be understood by reference to Figs. 12 and 14 of upright boilers.*

68. Grates should be proportioned to the heating surface in the building, radiating surface, and the water to be evaporated, assuming the boiler to be sufficiently large.

69. The chimney must be capable of passing sufficient air, for the greatest consumption of fuel likely to be used. Less air will not do! More than is needed does no harm; for it is within the power of the operator, or the automatic draft regulator, to diminish it.

Again, the *openings* in the grate must be large enough to pass sufficient air, when the fire is *packed with ashes, in the last hour it is supposed to run, without attendance*. Smaller ones will not answer, and much larger are unnecessary; although there is considerable scope in this latter respect, as it is the constant opening or closing of the draft-door, which really regulates the proper quantity of air supplied. As theoretical values and sizes in grates and chimneys are of very little use to the artizan,—the *formulæ* being all founded on conditions, which give them only relative values and estab-

* The writer thinks this same principle has been applied to locomotive boilers in England. The drawing in of the lower part of the fire-box, at a steep angle, all round the grate, allows the fire to shake down and together, by the motion passing over the rails, while the wedge shape keeps the fuel at the same density for the whole time, between the firings.

lish laws, that even in the hands of an educated engineer, leave too much to be assumed—the writer believes it would be better to tell from practical results and experience what *has been found sufficient*, and what *has not*, rather than copy some formula from a text book.

70. The following four examples have been selected, from actual experience, as they represent, very nearly, a *minimum*.

1st. A chimney, 130 ft. high (built in the walls of a building), 16" by 32" (512 square inches), with two horizontal multi-tubular boilers attached; each grate $17\frac{1}{2}$ square feet (35 in all), burning $9\frac{1}{2}$ lbs. of coal per hour for each square foot of grate, and evaporating 11 lbs. of water from the temperature of the *return*. The grates having a *whole* area of 5,040 square inches and 2,016 square inches of *openings*, compared with 512 square inches of cross section, in chimney 130 ft. high, giving a rate of combustion of $9\frac{1}{2}$ lbs. coal per square foot of grate, $23\frac{3}{4}$ lbs. per square foot of openings in grate, and $93\frac{6}{10}$ lbs. per square foot of cross section in chimney, *per hour*; which, by allowing 200 cubic feet of air, at the temperature of 100° Fahr., necessary for the combustion of one pound of anthracite coal, which will be, at the least, increased to 300 cubic feet, by expansion, by passing through the fire, will give a velocity of the gases in the chimney of very nearly 8 ft. per second, and should the gases be increased to double their bulk, by discharging them at a higher terminal, the velocity will be very nearly 10.5 ft. per second; giving about one third the *theoretical* velocity.

The above chimney proved just sufficient for the work; but if the engineer who proportioned the boilers,

and set them, had the construction of the chimney also, he would have made it more equilateral and increased the cross section one half.

In the same building there were three such boilers (reserve), connected to the very same size and height of a chimney, but when the three were run together, there was so little gained, if any, the fireman preferred to run but two.

2d example was, where a horizontal boiler with $4 \times 4 = 16$ ft. grate was attached to a 16-inch circular, cast iron chimney 75 ft. high, built within a ventilating flue. The whole area of the grate was 2,304 square inches, and the spaces 920 square inches, the cross section of chimney being 201 square inches, and rate of combustion 6 lbs. per hour per square foot of grate (Pittsburgh coal), automatically regulated at the chimney.

3d example was a chimney 80 ft. high, 20 by 20 inches (400 sq. inches), two boilers, each 4 by 4 ft. grates, in all 4,608 sq. inches of grates, with 1,840 sq. inches of space, burning 4,000 lbs. of coal in 14 hours, nearly 9 lbs. per hour per sq. foot of grate, although it was thought desirable to burn more. Still it will be seen it burned 100.14 lbs. of coal for each sq. foot of cross section of chimney per hour, which was better than the chimney 130 ft. high, with the oblong cross section. The velocity of the gases, allowing 400 cubic feet for each pound of coal after combustion, was 11.1 ft. per second, which would tend to prove that the square chimney, 80 ft. high, would pass more gas per sq. foot of cross section than the flat chimney 130 ft. high, other things being equal.

4th example was a horizontal boiler with $5 \times 5 = 25$

sq. ft. of grate, one third openings, the chimney 16×16 inches (256 sq. inches), and 60 ft. of its length was in the walls of building, with 15 ft. of iron stack, 18" in diameter, 254.5 sq. inches on top of it; the latter was put on with a view to improve the draft, but all proved insufficient for the work to be done.

A new chimney, 18 by 24 inches, was built 75 ft. high, all of brick, which proved a success, and burned 273 lbs. of coal in an hour, giving a chimney velocity of 10 ft. per second, and burning 10.9 lbs. of coal per sq. foot of grate (the new grate had $\frac{2}{3}$ ths openings), and burning 90.1 lbs. coal per sq. foot of cross section of chimney per hour.

71. The following table is a digest of the above, showing the relative values :

Example No.	Height of chimney in feet.	Cross section of chimney in square inches.	Cross section of chimney in square feet.	Square feet of grate.	Square feet of opening in grate.	Square inches of grate.	Square inches of openings in grate.	Water evaporated from temperature of return in lbs.	Lbs. of coal consumed per sq. foot of grate per hour.	Lbs. of coal consumed per square foot of opening in grate per hour.	Lbs. of coal consumed per sq. foot of cross section of chimney per hour.	Calculated velocity in chimney if the bulk of the gases for 1 lb. coal is 300 cubic feet.	Ibid. for 400 cubic feet.	Dimensions and shape of chimneys in inches.
1.	130	512	3.56	37.5	14.0	5,040	2,016	11	9.5	23.75	93.6	8.0	10.5	16x32
2.	75	201	1.4	16.0	6.39	2,304	920	..	6.0	16" diam.
3.	80	400	2.78	32.0	12.78	4,608	1,840	..	9.0	22.54	100.14	..	11.1	20x20
Old 4.	60 + 15	256	1.78	25.0	83.3	3,420	1,324	16x16 18" diam.
New	75	432	3.0	25.0	10.0	3,420	1,440	..	10.9	27.25	90.1	..	10.0	18x24

72. From the above table, the following conclusions

may be drawn—viz., that for rectangular chimneys, between 50 and 100 ft. high, with not less than 16 inches on the shortest side, one square foot of cross section of chimney, to each 75 lbs. of coal to be burned per hour, would be safe ; and that for rectangular chimneys, 30 to 50 ft. high, with not less than 16 inches on the side, one square foot of cross section, to 50 lbs. of coal burned per hour will be sufficient.

An 8×12 inch chimney is the smallest that should be built in a house for a heating apparatus ; not because it will require that size chimney for the combustion of the coal, but to give a practical magnitude for roughness and want of cleaning, etc., and no other pipe should be taken into it.

For apparatus, such as are put into large mansions, which burn 40 to 50 tons of coal in 180 days, a 12×16 inch flue is little enough for the above reasons.

Care in building a chimney is necessary, a smoothly plastered chimney giving a better draft and keeping clean longer than any other. Offsets in chimneys should be avoided, and parallel insides are best.

It will also be noticed that the low pressure automatically regulated boiler, had one square foot of grate to each six pounds of coal burned per hour, and that the high pressures, with quick combustion, had one square foot of grate to each ten pounds of coal, or even a little more. The latter agreeing very nearly with arbitrary rules laid down in hand-books.

Thus for large boilers, fired regularly with ordinary good draft, one square foot of average grate (nearly $\frac{1}{2}$ openings) to each 10 pounds of coal, forms an *average* ; but for conditions such as are found in private houses, or where the apparatus is governed automatically, and

expected to run comparatively dirty (with an accumulation of ashes on the grate, as happens with thick fires attended to at long intervals), one square foot to each five pounds of coal burned in the hour is not too much, and may be used with safety.*

The following table gives the number of inches in diameter for circular grates, from one square foot to six, inclusive; advancing by $\frac{1}{4}$ of a square foot.

Diameter of Round Grates in Inches.	Square Feet of Surface in Grate.
13 $\frac{1}{2}$ inches.	1 feet.
15 "	1 $\frac{1}{4}$ "
16 $\frac{1}{2}$ "	1 $\frac{1}{2}$ "
18 "	1 $\frac{3}{4}$ "
19 $\frac{2}{10}$ "	2 "
20 $\frac{1}{8}$ "	2 $\frac{1}{4}$ "
21 $\frac{1}{2}$ "	2 $\frac{1}{2}$ "
22 $\frac{1}{2}$ "	2 $\frac{3}{4}$ "
23 $\frac{1}{2}$ "	3 "
24 $\frac{1}{2}$ "	3 $\frac{1}{4}$ "
25 $\frac{1}{8}$ "	3 $\frac{1}{2}$ "
26 $\frac{1}{8}$ "	3 $\frac{3}{4}$ "
27 $\frac{1}{10}$ "	4 "
28 "	4 $\frac{1}{4}$ "
28 $\frac{3}{4}$ "	4 $\frac{1}{2}$ "
29 $\frac{1}{2}$ "	4 $\frac{3}{4}$ "
30 $\frac{1}{8}$ "	5 "
31 "	5 $\frac{1}{4}$ "
31 $\frac{3}{4}$ "	5 $\frac{1}{2}$ "
32 $\frac{1}{2}$ "	5 $\frac{3}{4}$ "
33 $\frac{2}{10}$ "	6 "

73. Why grates break ?

Round grates made of concentric rings, and straight

* It is supposed the grate is half bar, and half opening. If the openings are less than half, increase the grate in diameter until there is a rate of one square foot of opening to each 10 lb. of coal burned in the hour.

radial arms, always break and fall to pieces, never wearing out in the ordinary way. There is usually the same result with parallel bars, confined with a ring,

Fig.23*Fig.24.**Fig.25.**Fig.26.*

and they are the two forms most likely to be made by any one who is required to get up patterns and has not had experience in the matter ; since the pattern for the straight-barred grate is so much easier to make. The

reason of breaking is, because the thrust of the straight parts of the grate is not compensated for when expansion takes place, and a rupturing of the rings is the result.

In this matter, it would be well for the engineer to take pattern from the stove manufacturer, and follow him in this respect. No straight bars are here used in circular grates, as a rule; or, if he has to use straight bars, they are short and unconfined at one end, radiating in or out.

The same principle applies to *all* grates; the old-fashioned *three-barred grate* fails by reason of the ends dropping off, and that, when it is least expected, caused by the unequal thrust of the bars against their ends, and quietly cracking them in the angles, where they are the weakest. Figs. 23 and 24 show grates that will crack; Figs. 25 and 26 show grates which will not crack, if very sharp corner angles are avoided by rounding them a little.

CHAPTER X.

SAFETY VALVES.

74. Every boiler, for the generation of steam, for power or heating, *must* have a safety valve.

A perfect safety valve is a desideratum, for with a valve of sufficient area that would respond to the desired pressure of steam, an explosion from *over-pressure* would be an impossibility.

Many boilers burst when working at their *ordinary pressure*, and mysterious unavoidable causes are often assigned as the reason; but there is only one reason—*insufficient strength*; either from a defect of construction, or by deterioration of the material, or neglect; and in a case of this kind no safety valve can respond, the valve being set for a higher pressure than that at which the boiler explodes.*

75. The office of the safety valve, being to relieve the boiler of pressure, above its ordinary working pressure, it must be large enough to let the greatest quantity of steam, ever likely to be made, escape freely.

* The writer has entered boilers where pins were out of braces, and braces broken: and one case where the mud deposit in a horizontal boiler covered four rows of tubes at the back end, cracking and bulging the shell; the bank of mud, apparently, holding the boiler together.

In proportioning safety valves for small boilers, and in fact for most boilers, *the size is simply guessed at*; the engineer or fitter puts on a certain size valve, because he is in the habit of doing so, or because some former employer did it; having in mind the while, an idea, that if a certain sized pipe, carried all the steam the boiler could make to the engine, a safety valve very much smaller in area would answer, since it escaped into the atmosphere *only*—not knowing that a two-inch safety valve blowing off at 60 lbs., had an opening so small that if it was round *he could not put his pencil through it*.

76. When a valve begins to blow off, the pressure underneath the disk decreases, out of all conceptional proportions; the decrease not being due to a diminution of the pressure in the boiler (as the steam may actually be increasing), but to the *draft* caused by the escape, the laws of which are imperfectly understood, but the results being conclusively proven, by Prof. Throwbridge and others; the proportional difference being greater for greater pressures.

77. Professor Burg, of Vienna, found by measurements, made by actual experiments, with an apparatus constructed for the purpose, that a valve of 4 inches diameter, raised from its seat, when blowing off, according to the *two* first columns of the following table. The last two columns are calculated, that the fitter may form an *actual conception* of the openings, by comparing them to something he is perfectly acquainted with.

The first column is, lbs. per square inch; 2nd, actual lift in fractions of an inch; 3d, actual size of openings in decimals of a square inch, when the bevel of the valve seat is 45 degrees; and the 4th, the internal *nominal* size of gas pipe, nearest the actual opening.

TABLE No. 2.

1. Press.	2. Lift.	3. Area.	4. Pipe.
12	$\frac{1}{36}$.25	$\frac{1}{2}$
20	$\frac{1}{48}$.187	$\frac{3}{8}$
35	$\frac{1}{54}$.166	
45	$\frac{1}{63}$.137	
50	$\frac{1}{86}$.1043	$\frac{1}{4}$
90	$\frac{1}{168}$.0534	$\frac{1}{8}$

78. The following graphic illustration has been made to show at a glance the size of the openings :

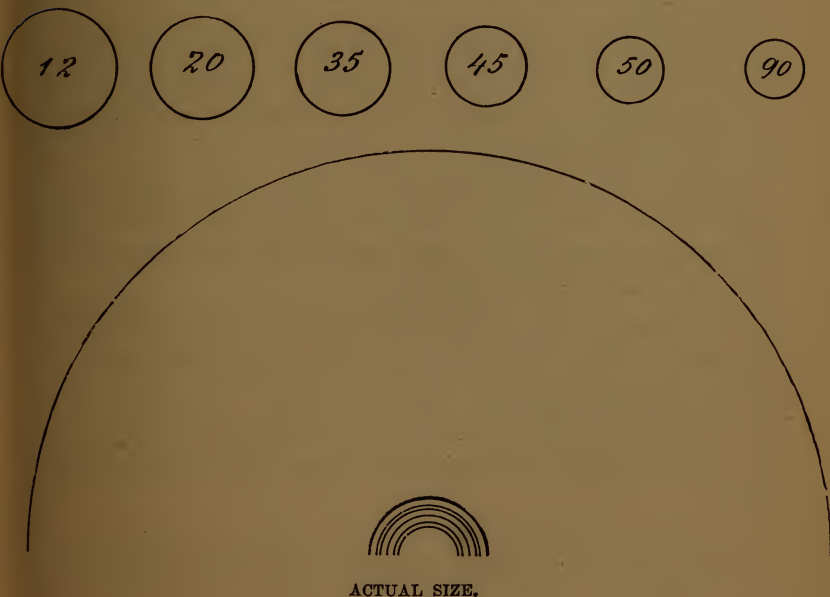

ACTUAL SIZE.

the large rim, inclosing the area of a 4-inch disk (12.56 square inches), and the smaller ones, the areas of the openings at the different pressures.

It can be seen from the foregoing, that an increase of pressure lessens the size of the opening; nor do the increased pressure, and flow of the steam, compensate for the decrease in the size of the opening, and what is required is a valve of very great diameter, or one that will open its FULL AREA. In this latter respect the steam-heater has done much, as will be shown hereafter.

79. There are many formulæ for calculating the size of safety valves, all based on the size of the disk; and, though arbitrary, may be useful, as they give sizes, about *four* times, the area of ordinary practice.

Fairbairn allows 29 square inches for a 50 horse-power boiler.

Rankine says: "Divide the number of lbs. of water which enters the boiler in an hour (to supply the loss by evaporation), by 150, and the product is the area of the valve in inches."

Bourne says: "Multiply the area of the piston in inches by its velocity in feet per minute, and divide by 300 times the pressure of the steam, and the product is the area of the valve in inches."

According to the *relative volume* of steam, at *half its theoretical velocity* when flowing into the air, two square inches of actual opening of valve should be ample for the number of cubic feet of water evaporated per minute, at the different pressures given in the following table:

Pressure in boiler above atmosphere.	Cubic feet water evaporated per minute.	Actual size of opening in valve.
1	.25	2 square inches.
25	.80	2 " "
50	1.25	2 " "
100	2.13	2 " "

By a study of the above, it will be seen that if a boiler is of such construction, that 25 lbs. of steam is the maximum, it will require a larger valve for the same amount of water evaporated than a high pressure boiler, and that indiscriminate rules are not to be used.

80. There has been much effort to obtain a safety valve which will give a large opening, and in some instances, valves thus made, have proved practically a success, though not in general use, since the necessity for them is not recognized by the public, who content themselves with a *danger signal*, where the noise it makes when blowing off, is all that can entitle it to the name of safety valve.

Fig. 27 shows a common safety valve, with an auxiliary attachment, which is capable of pulling the valve open to its full extent. *A* is an ordinary safety valve, put on in the regular way; *B*, a common low-pressure diaphragm or regulator (see draft regulator for construction), attached to the end of the lever, and suitably fastened to the boiler; with the pipe connection *C*, to the under side of the diaphragm, and taken from the water space of the boiler, for two reasons,—namely, that the water in the pipe may be cold, so as not to affect the rubber of the diaphragm, and the water, being steady and solid, prevents vibrations, and gives the

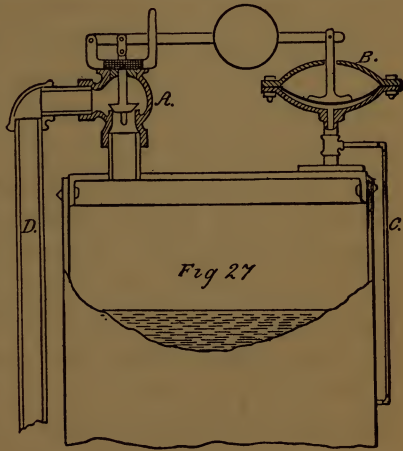

initial pressure unaffected. Fig. 28 shows the same in a position to blow off, the pressure under the rubber overcoming the weight.

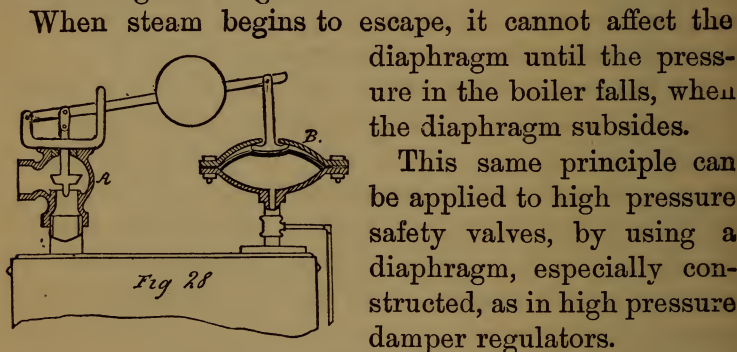

When steam begins to escape, it cannot affect the diaphragm until the pressure in the boiler falls, when the diaphragm subsides.

This same principle can be applied to high pressure safety valves, by using a diaphragm, especially constructed, as in high pressure damper regulators.

The escape pipe (*D*, Fig. 27) is sometimes carried down, and under the grate, by steam-fitters, that the escaping steam may damp the fire, and check it; by interfering with combustion: a point worthy of consideration by all engineers.

Another arrangement for very low pressure is a water column, connected as in Fig. 29. A connection, *A*, is taken from the steam space, and carried down and up, forming an inverted siphon filled with water.

When the pressure in the boiler exceeds the weight of the column of water in the pipe, it blows it out, letting the steam escape, which will blow until the steam is all gone, or the pipe again filled with water.

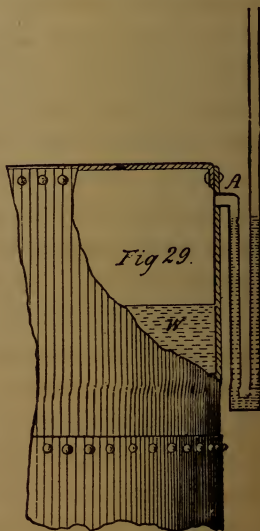

A modification of this principle has been constructed, by which steam can be carried to about 12 lbs. per square

inch, in buildings of ordinary height. A cylinder of any suitable construction is connected to the boiler, as shown in Fig. 30, and filled with water; the pressure of the steam through the pipe (*a*) on the surface of the water in the cylinder, presses it up in the pipe (*b*); but when the pressure is great enough to send the water over into the pipe (*c*), the steam escapes at (*d*). This arrangement, like the one before, will not stop blowing without manipulation; it being necessary to close the valve (*e*) and open the valve (*f*), to let the water again into the cylinder.

A boiler with this arrangement on it, should also have a common safety valve set at a lower pressure, to give warning, for should this start to blow off, and be neglected, it will waste water and steam from the boiler. The pipe (*a*) may be long, so as to have the

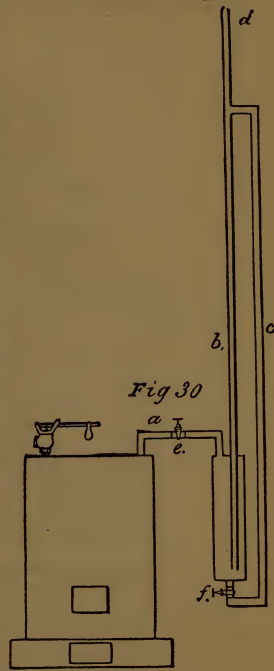

cylinder a considerable distance from the boiler: in one case where it was set against it, the heat evaporated the water from the cylinder.

A boiler with a water column on it, as described, should have a vacuum valve also, to prevent the water from being drawn into the boiler, when steam goes down.

Another arrangement, which has been tried with some success, is an ordinary safety valve of large size, with a pipe (*a*) carried from the under side of the disk,

down into the water in the boiler, as shown in Fig. 31 ; the orifice of the valve forming an annular space around the pipe.

The philosophy of this valve is—that the pipe being

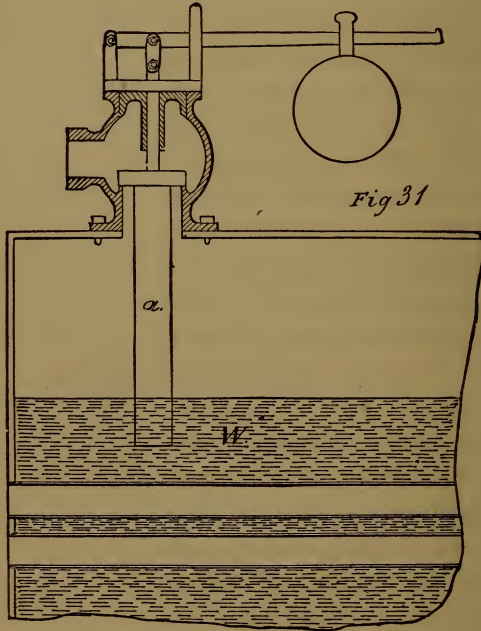

carried down into the water, represents a certain area of the disk, which would be of scarcely any value when blowing off, but by being in the water, the pressure underneath it is not relieved.

Pop-safety valves with differential disks and seats are also used for high pressures, by which very much larger steam passages can be secured than with ordinary valves of the same diameter.

CHAPTER XI.

DRAFT REGULATORS.

81. WHEN the steam-heater wishes to govern anything automatically, his first thought is, whether a diaphragm answers, and if he can regulate what he wants with a rubber diaphragm, he will never resort to a moveable piston: knowing the diaphragm will work until it wears out, without getting out of order, and that a piston must be kept in the nicest of order to be depended on, since it is affected by corrosion and dust, while the diaphragm, being simple and cheap in construction, and having no delicate parts, will respond to the smallest difference of pressure, and will run for many years, when constructed and put on by one who understands it.

The steam-fitter uses it to regulate the ash-pit door, for the admission of the proper quantity of air to the fire, to govern the steam pressure; to open the fire-door, to admit cold air through the furnace, in case the draft-door is neglected, by leaving a clinker or lump of coal underneath the edge; to open the safety valve, and sometimes to open a "break draft," an opening in the chimney. He also uses it for regulating the air supply to indirect radiators; to govern the pressure of

steam, when expanding from high to low pressures. in different systems, and to regulate water pressures with.

82. Fig. 32 shows a regulator of ordinary construction, with a *bowl* at the top and bottom of the diaphragm, in which *A* is the bottom bowl, to which the support and pipe are attached; *B*, the upper bowl, to which the fulcrum and lever are attached; *C*, dia-

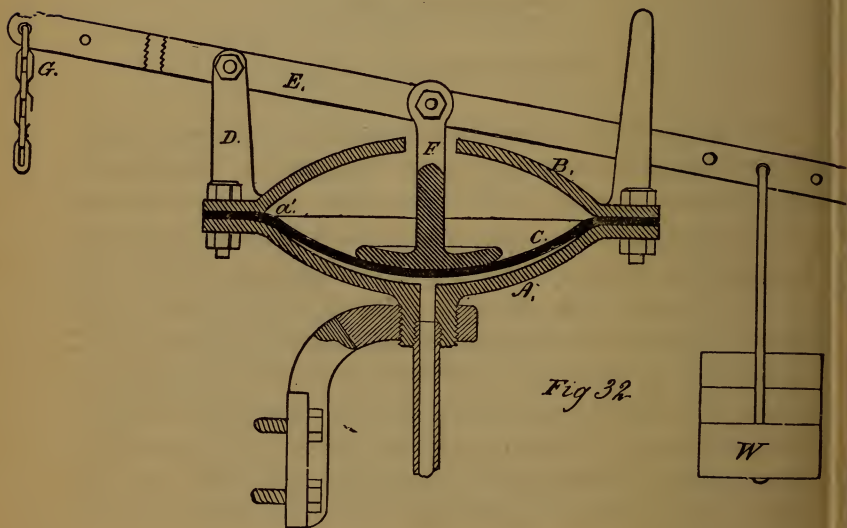

phragm; *D*, fulcrum; *E*, lever, and *W*, the weight; the pressure under the diaphragm being the power.

In constructing regulators, *sharp edges* of the metal should not be left to cut the rubber; the corners of the bowls at *a'* should be nicely rounded, and the flanges around the edge deep, to give room for the holes, so that they would not be too near the inner edge. The standard *F* should not be riveted to the rubber, but only rounded on the bottom to lay on it; nor should

there be holes made in the rubber for any purpose inside of the holes in the flanges.

Common flat rubber does not make a good diaphragm; it should be of extra good quality, and thick, and *dished* to fit the bowls; so that when inflated, there will be no tension on the rubber.

Some makers leave off the upper bowl, using only a flange; but better practice uses one, for it is impossible then for over-pressure to burst it, when supported by the iron over its whole extent.

In the construction of a diaphragm for high pressure, which will not burst, it is necessary that a very small portion of the surface of the rubber should be unsupported at any time; and that the movement should be small, to admit of using a compound lever with an ordinary weight.

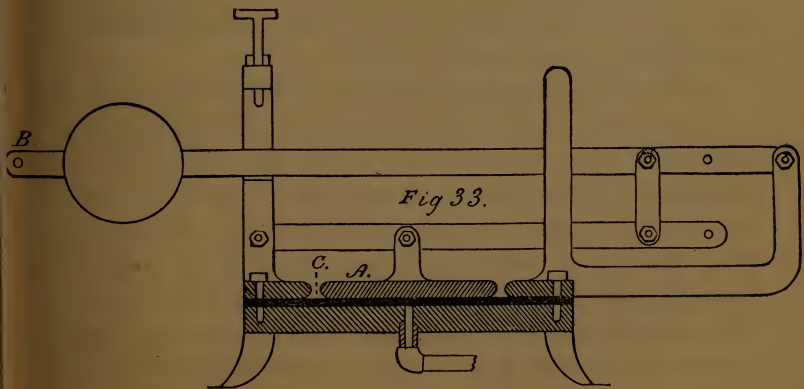

Fig. 33 shows a *high pressure draft regulator*, with a compound lever, in which a very small movement of the disk, *A*, will give 6 inches or so at the end of the lever, at *B*, without straining the rubber in the least;

the slackness at *C* forming a concentric corrugation, which admits of all the movement necessary.

83. In connecting diaphragms with the boiler, it is best to take the pipe from the water space, as shown in Fig. 27, at *C*; but when that cannot be done, it may be taken from the boiler dome, or any other convenient place, *except tapping a pipe*, which already has a "draft" on it (rapid passage of steam through it); for in order to prevent irregularities of pressure, it is necessary to have the initial pressure constantly under the rubber.

When it is necessary to take a steam pipe to a diaphragm, instead of a water pipe, the pipe must be *trapped* in such a manner that it will fill with water, and the capacity of the trap must be greater than the bowls of the diaphragm; so the water that has filled the trap and cooled therein, when it is pressed forward, will be sufficient to more than fill the bowls, thus always insuring cold water on the rubber.

Some will not put a valve in a diaphragm pipe in a private house, fearing it may be shut off by some meddler; but this is a matter which must be left to the judgment of the fitter. A very good way is to use not less than a $\frac{3}{8}$ pipe, and immediately under the regulator plug the pipe with iron, and bore a $\frac{3}{16}$ inch hole through the plug. This hole will pass the water rapidly enough for the regulator, and in case the rubber should burst, the flow of hot water would not be large.

When the rubber is fitted in the bowls without tension, it very seldom gets holes in it, and will give warning by leaking first, but should it be tight it will give way suddenly.

84. When regulators are attached to ash-pit doors, or

to *extra* draft-doors, set in one side of the ash-pit (leaving the door-proper for the removal of the ashes only), the chain is fastened to the end of the lever marked *G*, and to the door ; care being taken in placing the regulator so that the chain will have a direct pull, and not interfere with the opening of other doors. When a regulator is attached to the fire-door, the other end of the lever should be used, and *this* regulator is set a pound or so stronger than the draft-door regulator.

It is not a good plan to make one regulator do both duties, by using each end of the lever, as the doors work too close together, and a waste of fuel is the result, by letting cold air through the furnace frequently ; the intention being not to open the fire door, unless as a last resort.

85. Doors for regulators should be set at an angle of about 45 deg. When a door hangs perpendicularly (with the hinges on the top, usual in such doors), the leverage changes, as the door swings from the perpendicular, throwing a rapidly increasing weight on the diaphragm ; but when the door is on a good angle, the increase is not so rapid (the ball being set to partly balance the weight of the door, if necessary), and the door is positive in its action when closing, being hung on an axis further from its center of gravity.

Doors should be *planed* to fit perfectly, and hinges and edges should be so constructed, that ashes will not lodge on or under them, so as to clog them.

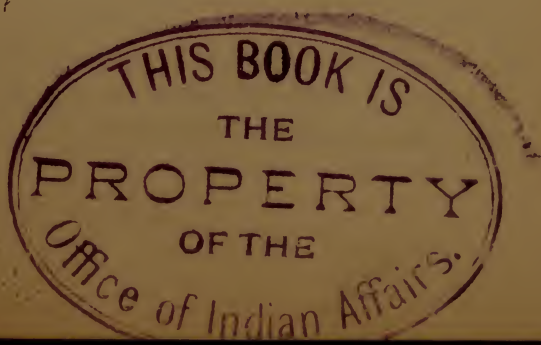

CHAPTER XII.

AUTOMATIC WATER FEEDERS.

86. THE water feeders that are attached to low-pressure heating boilers, are simply regulators,—they have no power in themselves to force water into a boiler, and must be used in connection with waterworks, or a tank near the top of the house ; the head of water supplying the requisite power.

So far, there has been but one description of automa-

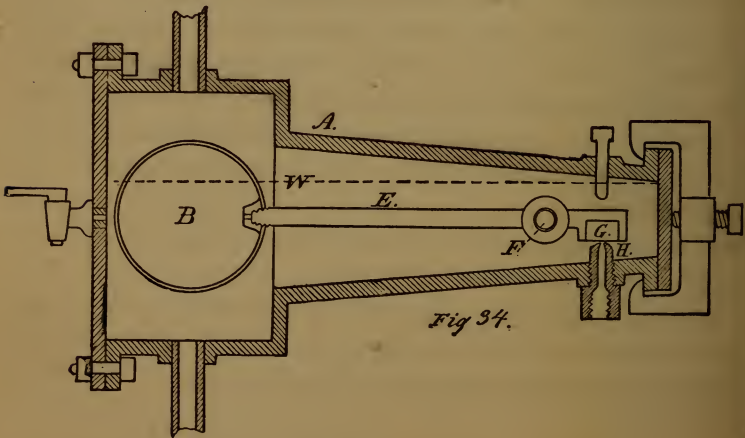

tic water feeder, used in connection with steam-heating, and though different makers modify the shape and the valve, the principle is the same. Fig 34. is a very good

representation, in which *A* is a cast iron case of suitable design; *B*, a copper float, with buoyancy enough for the work, and sufficiently thick, so it will not collapse with the pressure; *E*, a lever, made of brass, to admit of bending; *F*, a fulcrum, and *G*, a valve, formed with a piece of hard rubber, inserted in the end of the lever, in connection with the nozzle *H*, which is usually of brass.

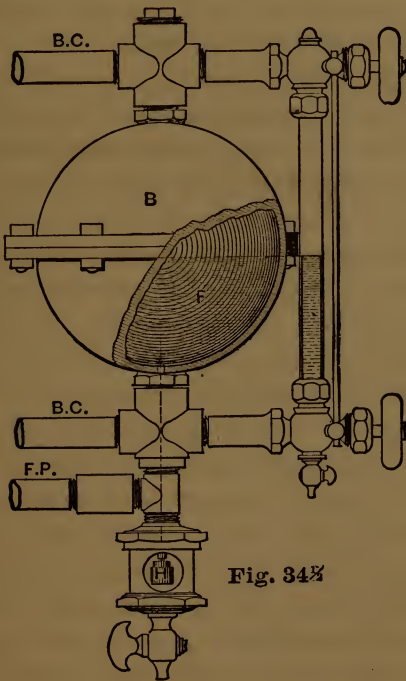

Fig. 34½

Fig. 34½ shows a modified form of water feeder lately brought into use, in which the float acts directly on the valve, and in which the valve is visible through the glass *H*. This is very desirable, as it allows the operator to observe the valve and feed water when it enters,

and enables him to detect either a leakage or a stoppage. With this valve the pressure of the water has a tendency to close the valve, whereas, with Fig. 34 the tendency of the pressure is to open it and cause leakage. The pipes *BC* are the boiler connections, and *FP* is the feed pipe.

Copper floats in boilers under high pressure, nearly always collapse; but for low pressure, they have been constructed to stand very well, though occasionally they fill with water, when not well made.

Hollow copper ball floats are usually made of two pieces of copper hammered into hemispheres, and brazed together. If they could be hammered after brazing, they could be made very strong; but as the reverse is the case, and the heating to redness makes them very soft, there is nothing for the artificer to do but make them as thick as he can, without impairing their floating power. In the brazing of a ball together, it is necessary to leave a vent hole in one hemisphere, until the joint is thoroughly brazed, and then plug it up. A very good way to make floats for regulators, since they require some kind of a boss to fasten the lever to, is to put a boss on the inside of the hemisphere, as shown at *a'*, and bore a small hole through it, having the thread for the lever tapped tapering; this hole will answer for a vent while brazing, and when ready to be fastened to the lever, the thread in the boss and the thread on the end of the lever can be tinned with soft solder, and screwed together cold, which will make a perfectly water-tight joint, and not leave a partial vacuum in the ball, as would happen if the ball was closed in the fire, and this vacuum would form a factor, not generally taken into consideration,

which will materially add to the pressure it is subject to in a low pressure boiler.

There is one point in the construction of water feeders which requires particular attention,—namely, the size of the hole in the nozzle *H*, which forms the valve. This hole should be small, and the higher the pressure of the water works, the smaller should be the hole. It will be seen by looking at the figure, that the float is the *power* and the force of water the *weight*, and by increasing the area of the hole in *H*, the weight can be made to overcome the power. A $\frac{1}{8}$ of an inch hole is usually sufficient to admit all the water required; but if a larger hole is wanted, care should be taken that the ball has a preponderance; otherwise the valve will not set firmly to its seat, and the leakage will fill the boiler and prove a source of annoyance. This should be guarded against, for though it is not dangerous, it is disagreeable, and many fitters prefer to leave the feeder off on that account, since a straw, or the least dirt, will make it inoperative, and flood the boiler in consequence.

87. When there are steam-traps to any part of the apparatus, which do not return *all* the water directly into the boiler, the water-feeder should be put on, unless there is some one constantly in attendance. With a return gravity apparatus it may, however, be dispensed with, for the operator, by looking at the water once a day, and letting in a supply when necessary, is a better reliance. A positive open and shut feeder, under all circumstances, has yet to be invented.

88. When a water feeder is used, the upper or steam pipe *must not* be taken as a branch from another pipe; it must be taken from the top of the boiler, or dome, and away from other large pipes.

Special attention should be paid to the foregoing. A case which came under the writer's notice, was of a large horizontal boiler, with a water feeder connected to the dome, the water pipe entering the regular feed pipe; the feeder had a glass on it, similar to the water glass on the front of boilers, and this boiler was furnished with an extra water glass, connected with the front tube sheet, in the ordinary way; the upper pipe being taken from very near the flange. It was noticed that the water in the feeder glass, always stood about five inches higher than the water in the boiler glass, which led to an investigation, and it appeared that the water in the front glass was the true level. The upper pipe of the feeder was then taken from the dome, and tapped into the boiler shell, when both glasses showed the same level of water.

89. This question of draft in pipes is of *vast importance*, and should receive more consideration than is usually paid to it, *in connection with boiler appurtenances however.*

CHAPTER XIII.

AIR VALVES ON RADIATORS.

90. THE usual position for an air valve on a radiator, is near the return pipe.

With high pressure steam the position of the air valve is not of as much importance as with low pressure, and one that will work with low pressure, will *always* work with high.

In vertical tube radiators, the valve is generally placed high up on one of the pipes, the lower end of which is sometimes run down within the base of the heater, to very near the bottom, this is done on the assumption that the air being heavier than steam, will be the first to go out by the air-vent.

In single chamber heaters, and heaters made of pipes, having free passage top and bottom, the air valve is often put near the top, the gravity of the air apparently not affecting its egress.

91. The greatest difficulty exists in drawing the air from a *flat coil*, when the return pipe does not run below the water lines, but permits of *live* steam entering the coil from the lower end, and forcing the air toward the middle of the coil. Some steam-fitters put an air valve on a return-bend, at a point about $\frac{1}{3}$ the length of

the coil from the lower end, but the result is often a disappointment. The best way in case of box coils and flat coils, is to carry their return pipes *below the water line* and any work so piped will never prove troublesome in this respect; for the current of the live steam is always from the steam to the return valve.

The idea of the air *always* gravitating through the steam, and finding the lowest part of a heater composed of small pipes, is erroneous, *unless* the steam is let in one top.

In what is called the atmospheric radiator, the steam enters on top, with a hole near the bottom to let the air out, and a drain to carry off the condensation in the bottom. Steam enters this radiator through a very small pipe, with a nicely graduated valve, which admits any desired quantity of steam, and which fills *downward*, and permits a part, or the whole of the heating surface of the radiator to be used. It may be likened to a balloon partially filled with gas, the gas always remaining in the top.*

With system "No. 2," low pressure steam piping, there is never any trouble to discharge the air, and for extremely low pressure (private house heating) it should be used.

Air and steam mix within a heater, to a certain extent and at certain pressures; this mixture being of unknown gravity, but always of greater weight than steam of the same density.

Steam at the pressure of the atmosphere, and a temperature of 212° Fahr., has a gravity about one half that of air at the pressure of the atmosphere, and a temperature of 34° ; but when the air is increased in

* These heaters cannot be used in a gravity return apparatus.

temperature about 160° the steam is then about two-thirds the gravity of the air.

92. Air valves are various in design, but may be separated into three kinds : the old-fashioned pet-cock, a compression thumb-screw valve, and the automatic air valve.

The first needs no explanation, and may be used on rough work, but should not be used on fine work, for a plug cock will not stay tight on steam work, and will leak on the floors, and wet the ceilings.

The second is much used, and is simply a small angle valve, with or without a stuffing-box, as shown in Fig. 35.

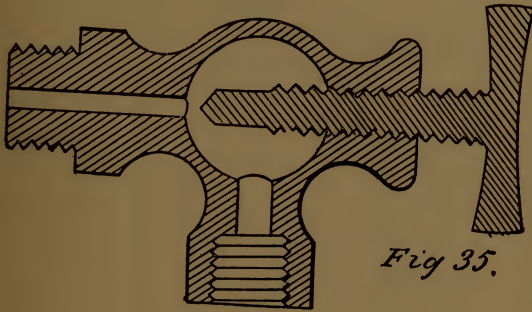
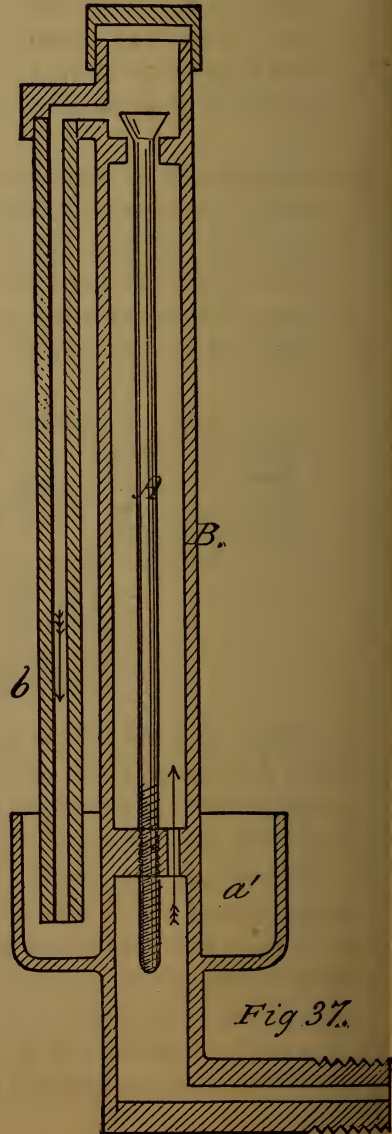
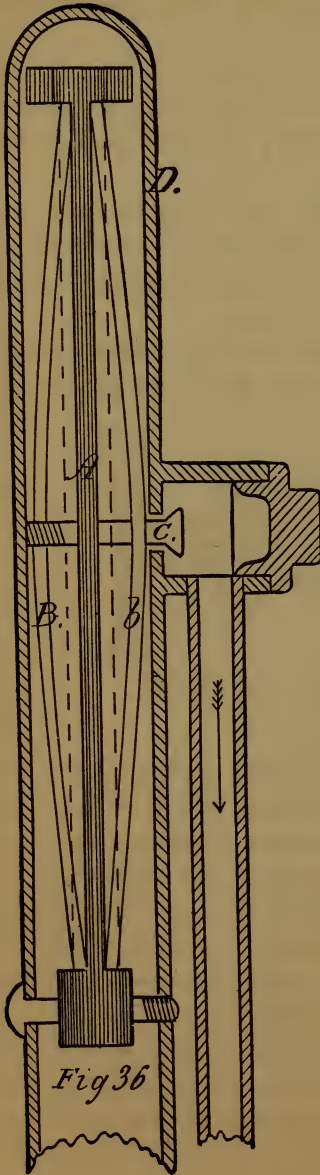

Fig 35.

The third (the automatic air valve), embraces nearly as many designs as there are manufacturers of heating apparatus ; but the principle used is the same in each instance, *viz.*, the taking advantage of the difference of expansion of any two metals that will stand the action of steam, one of which has a greater coefficient of expansion than the other ; and in reality becomes a metallic thermostat, which operates a little valve.

Fig. 36 shows a simple form of this arrangement ; *A*, being a strip of cast iron ; *B*, and *b*, strips of brass, set against shoulders on the cast iron, and *C*, the valve and



stem, passing through holes in the bar *b*, and the cast iron *A*, and screwing into the other brass (*B*).

When heated above the temperature at which they are fitted, the brass expands more than the iron and forms a bow shape, as shown, and draws the valve to its seat; the dotted lines show its normal position. The stem, where it screws through the brass *B*, forms a regulator, which can be adjusted with a screw driver, applied to a slot in the valve. The outside *D* may be a piece of pipe, or a casting, with a boss on the side of it, to tap a small pipe into, so as to carry the vapor away, if required.

Fig. 37 is another modification of the same principle, but has a point of excellence worth mentioning, to wit — a vapor cup, as seen at *a'*. The center stem *A* has less expansion for the same increase of heat than the case *B*, and when it expands, closes the valve; but, as stated, the point most worthy of note is the vapor cup. Any condensed steam which escapes through the valve runs down the small pipe *b*, and drops in the evaporating cup *a'*, which forms an annular chamber around the case, which is always hot when steam is on the radiator. For private houses, and offices, this is an advantage, as the escape from the valve can be regulated so as to give any desired moisture to the air in a room.

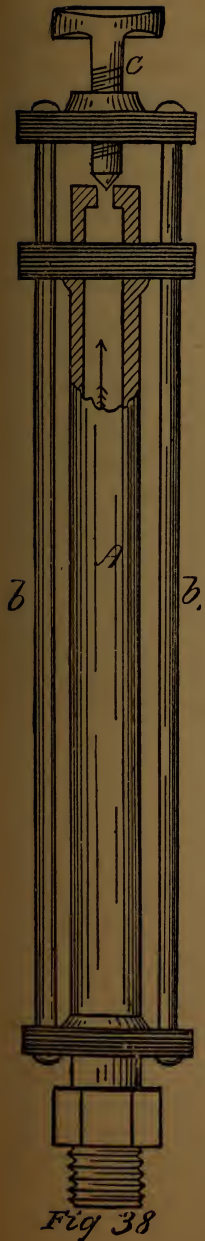

Fig 38

Fig. 38 shows a form in which one metal only (brass) can be used, the rods *bb* not being expanded as much as the case *A*, for the reason they are outside, and not in direct contact with the steam. When the case *A* expands, it presses on the thumb-screw *C*, forming a valve.

93. There is still another kind of air-vent used which is simply a small-chambered fitting, with a very small hole bored in it, which always remains open and is attached to a radiator in the ordinary way. Where the pressure does not exceed 1 lb. above atmosphere it may be used ; but for high pressure it will not answer, for the waste may be very great, since a hole $\frac{1}{32}$ of an inch in diameter is capable of passing about 1 lb. of steam in 33 minutes at 50 lbs. pressure ; which from 100 vents in 24 hours would be more than two tons of water.*

* The above is a theoretical computation based on the flow of steam through a theoretical orifice, when no allowance is made for friction in so many little holes, which might reduce it one half, but even then it is so considerable that attention must be drawn to it.

CHAPTER XIV.

PIPE.

94. THERE are two kinds of wrought iron, steam and gas pipe—namely, lap-welded and butt-welded.

There is no lap-welded pipe smaller than $1\frac{1}{4}$ inch, though butt-welded pipe is made of all sizes, excepting extremely large sizes.

Lap-welded pipe is considered the best, although for sizes smaller than two inches it makes little difference which is used, if the butt-welded pipes are properly made.

The butt-welded pipe is the most uniform in size, and generally works easier, as it is softer.

All the pipe and all fittings made in the United States and Canada are supposed to be of *standard* dimensions; so the whole is interchangeable.*

Occasionally in old buildings pipe is found, which is known as "old gauge," which is somewhat larger than the pipe now in use.

95. The size of pipe is *standard*, but the standard is *arbitrary*; the inside diameter being nearest the nominal size of the pipe, which it always somewhat exceeds; small sizes are most disproportioned (as can be seen by reference to the table of "Standard Dimensions of Wrought-iron Pipe," or to the diagram of sizes of pipe).

The threads on the ends of pipes should taper $\frac{1}{16}$ of an inch for an inch in length of thread.

* This is not absolutely so, but they are near enough for common work, and with adjustable dies the fitter finds little trouble in getting along. A committee of the Society of Mechanical Engineers have secured the adoption of the Biggs Standard for pipe and fitting threads since the above was written, and it is hoped that hereafter the threads furnished by the trade will be absolutely interchangeable; the Pratt & Whitney Co., of Hartford, having already commenced the preparation of the standard gauges.

96.—TABLE NO. 3.

TABLE OF STANDARD DIMENSIONS OF WROUGHT IRON WELDED PIPE FOR STEAM, GAS, OR WATER.

Inside Diameter.	Actual Outside Diameter.	Thickness.	Actual Inside Diameter.	Internal Circumference.	External Circumference.	Length of Pipe per square foot of inside surface.	Length of Pipe per square foot of outside surface.	Internal Area.	External Area.	Length of Pipe containing one cubic foot.	Weight per foot of length.	Number of threads per inch of screw.
Inches.	Inches.	Inches.	Inches.	Inches.	Inches.	Feet.	Feet.	Inches.	Inches.	Feet.	lbs.	
1	0.405	0.068	0.270	0.848	1.272	14.15	9.44	0.0572	0.129	2500.0	0.243	27
1½	0.51	0.088	0.364	1.144	1.696	10.50	7.075	0.1041	0.229	1385.0	0.422	18
2	0.675	0.091	0.494	1.552	2.121	7.67	5.657	0.1916	0.358	751.5	0.561	18
2½	0.84	0.109	0.623	1.957	2.652	6.13	4.502	0.3048	0.554	472.4	0.845	14
3	1.05	0.113	0.824	2.589	3.299	4.635	3.637	0.5333	0.866	270.0	1.126	14
3½	1.315	0.134	1.048	3.292	4.134	3.679	2.903	0.8627	1.357	166.9	1.670	11½
4	1.66	0.140	1.380	4.335	5.215	2.768	2.301	1.496	2.164	96.25	2.258	11¼
4½	1.9	0.145	1.611	5.061	5.969	2.371	2.01	2.038	2.835	70.65	2.694	11¼
5	2.375	0.154	2.067	6.494	7.461	1.848	1.611	3.355	4.430	42.36	3.667	11¼
5½	2.875	0.201	2.468	7.754	9.032	1.547	1.328	4.788	6.491	30.11	5.773	8
6	3.5	0.217	3.067	9.636	10.996	1.245	1.091	7.388	9.621	19.49	7.547	8
6½	4.0	0.226	3.543	11.146	12.566	1.077	0.955	9.887	12.566	14.56	9.055	8
7	4.5	0.237	4.026	12.618	14.137	0.949	0.849	12.730	15.904	11.31	10.728	8
7½	5.0	0.247	4.503	14.153	15.708	0.848	0.765	15.939	19.635	9.03	12.492	8
8	5.563	0.259	5.045	15.849	17.475	0.757	0.629	19.990	24.299	7.20	14.564	8
8½	6.625	0.280	6.065	19.054	20.813	0.63	0.577	28.889	34.471	4.98	18.767	8
9	7.625	0.301	7.023	22.063	23.954	0.544	0.505	38.737	45.663	3.72	23.410	8
9½	8.625	0.322	7.982	25.076	27.096	0.478	0.444	50.039	58.426	2.88	28.348	8
10	9.688	0.344	9.001	28.277	30.433	0.425	0.394	63.633	73.715	2.26	34.077	8
10½	10.75	0.366	10.019	31.475	33.772	0.381	0.355	78.838	90.762	1.80	40.641	8

DIAGRAM OF CROSS-SECTION OF WROUGHT IRON PIPE.

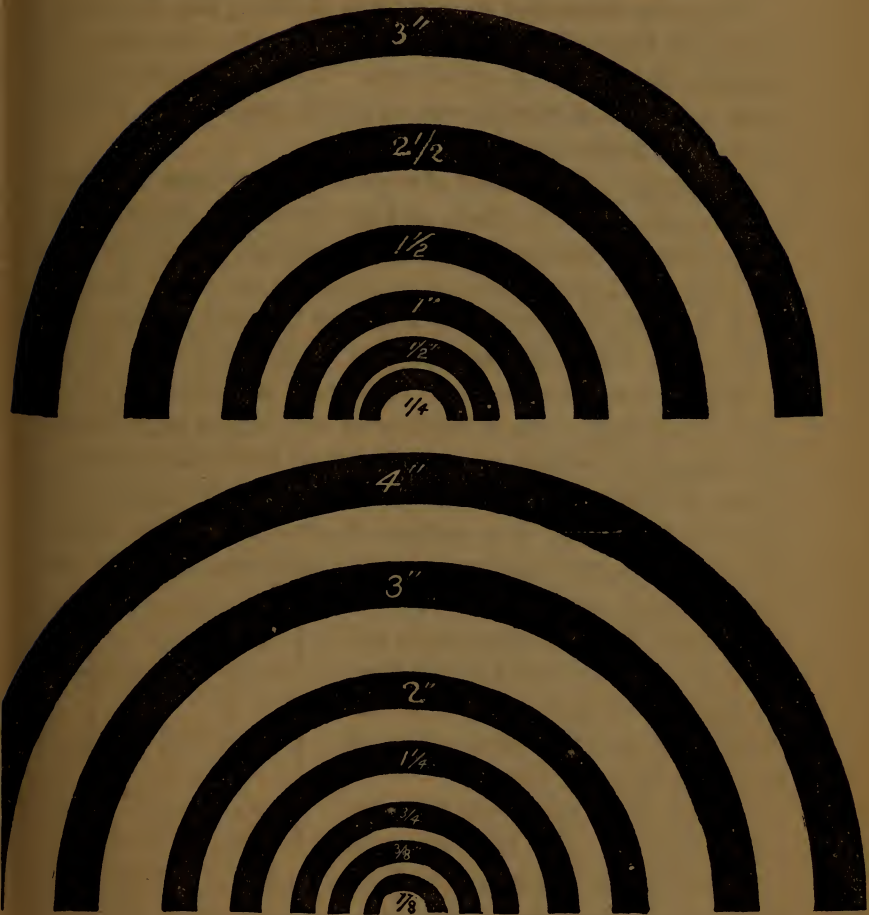

ACTUAL SIZE.

RELATIVE AREAS OF PIPES.

97. The young steam-fitter has not always a just conception of how the size of one pipe compares with

that of another ; not knowing how rapidly the area of a pipe increases with an increase of diameter.

When the diameter of a pipe is *doubled*, the area has increased fourfold, and if one having $\frac{1}{4}$ the diameter of another, it has but $\frac{1}{16}$ of its area. Thus, the area of the cross sections of circular pipes are to each other, as the squares of their diameters.

As circles and squares always bear the same relative proportions to each other, and as either can be likened to the cross section of a pipe, the *beginner* can always find the number of times, the area one pipe will divide that of another, by making a square (a') and calling the side of it the diameter of the smallest pipe ; then around the smaller square construct a larger one, the side of it being the diameter of the larger pipe, with the corner b forming a *common corner* for both squares. Thus, if the square a' represents a 1-inch pipe, and you draw around it a square $3\frac{1}{2}$ inches on the side, and lay the larger square off into squares, the size of the smaller one, as shown, the number of the whole squares and the sum of the parts of the squares within the larger square, is the number of times a 1-inch pipe will go into a $3\frac{1}{2}$ -inch pipe.

It will be seen, there are nine *whole* squares, six *half* squares, and one *quarter* square, which equals $12\frac{1}{4}$ squares : the number of times a 1-inch pipe will go into a $3\frac{1}{2}$ -inch pipe.

To prove the above according to the rule—"Pipes are to each other as the squares of their diameters," square the smaller pipe for a *divisor*, and the larger

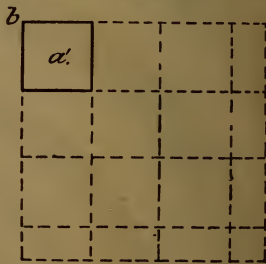

pipe for a *dividend*, and the quotient will be the number of *times*.

Example :

$$1 \times 1 = 1.$$

$$\begin{array}{r} 3.5 \times \\ 3.5 \\ \hline 175 \\ 105 \\ 1.)12.25(12.25\text{—Ans.} \end{array}$$

Ex.—To find how many times a $\frac{3}{4}$ -inch pipe will go into a 2-inch pipe.

$$\begin{array}{r} .75 \times \\ .75 \\ \hline 375 \\ 525 \\ \hline .5625 \end{array}$$

$$\begin{array}{r} 2 \times \\ 2. \\ \hline .5625)4.0000(7.11\text{—Ans.} \\ 3.9375 \\ \hline 6250 \\ 5625 \\ \hline 6250 \\ 5625 \\ \hline 625+ \end{array}$$

98. The following table, has been calculated for the use of the steam and gas-fitter, and shows how many times the area of one pipe will go into another.

In practice, however, with pipes of constant lengths, more branches may be taken from a pipe than are here shown.

To use the table.—Find the size of the smaller pipe, in the left-hand column, and follow it to the right, until it is under the size of the larger pipe, or *vice versa*; the number thus found is the *times* the small pipe will go into the large one.

99. The following diagram also illustrates, almost at a glance, the relative proportions of pipes, from one inch to twelve inches in diameter: the column of figures being the diameters of the pipes in inches.

A DIAGRAM OF RELATIVE AREAS OF PIPES, FROM 1 TO 12 INCHES, SHOWING THE INCREASED AREA FOR *each* INCH OF INCREASE OF DIAMETER.

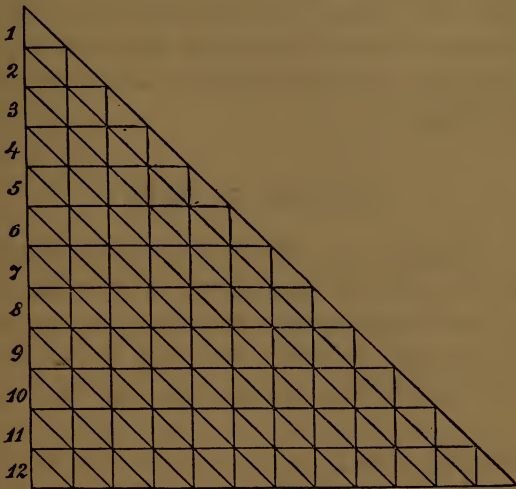

The 1-inch pipe is represented by *one triangle*; the triangle immediately opposite the figure.

The 2-inch pipe is represented by four triangles; the three immediately opposite the figure and the *one* above it.

The 3-inch pipe is represented by nine triangles;

the five immediately opposite, and *all* above it: and so on to the end.

The *sum* of the triangles immediately opposite the size of a pipe, and *all* the triangles above it, gives the square of the diameter in inches.

The number of triangles, immediately opposite the size of a pipe, gives the increase in *units* of size (the unit being the area of a 1-inch pipe) over the pipe next smaller than it; and the number of triangles, opposite the size of a pipe, with *all* above it, as far as the size of any other pipe, gives the increase in *units* for the difference between the two sizes.

It will also be seen, that the increase of the area of pipes, for each inch of increase of diameter, is an arithmetical progression, whose common difference is *two*, the first term being *one*.

EXPANSION OF PIPES.

100. In running pipe, for any purpose, special attention must be given to its expansion or contraction, for nearly all leaks which occur after work is completed and tight, if not due to defective material, are caused by expansion or contraction, which has not been provided for.

When a main pipe is run close to a wall, and branches taken through holes in the wall, the holes being just sufficient for the branches to pass, the latter break off, when heated; but if branches are taken the other way across the room, the branches being unconfined, near the main, even though confined near their farther ends, the *spring* of the pipe, especially if it is of small diameter, will admit of the expansion or contraction of the main

in the direction of its own length. But the branches should not be confined in the direction of their length, or they will shove the main out of line, and should a branch start, directly opposite to a branch so confined, it will either be pushed out of position, or broken.

Main pipes, to look well, must be straight; and should be hung so it will expand, in the direction of its length, avoiding all the side motion possible, and throwing the expansion of the branches in the direction of their own lengths.

Long mains should never be run very close to a wall up which risers go; for the risers admit of very little lateral movement, and all the linear expansion of the main will be thrown on the *riser-connection* in the form of torsion.

When a main is turned with its branch Tees looking up, a nipple and elbow can be screwed in to the Tee, so as to get any desired angle in running to the wall or elsewhere, and this nipple and elbow, with the pipe from the elbow, will admit of more *torsion* than a straight pipe; and in extreme cases the threads of the nipple will turn a little, and prevent anything from breaking.

Special attention should be given to pipes laid between floors, or when they have to cut into floor joists or beams. They must not be confined at their ends and their branches for 3 or 4 feet from where they leave a Tee, and should have room enough to allow for the greatest difference of length possible.

101. It is common for steam-fitters to run their return pipes around cellars and basements before the concreting is done, and to allow them to be buried and cemented into this mass, which becomes as one stone, and for a time (when they do not give out upon the

first warming up) must actually overcome the elasticity of the iron; but it more frequently breaks or leaks, either by shoving through the threads of the fittings, or else pulling them apart; or the branches break off, by having a large pipe, which may not be confined at one end, forced past them.

102. There is another reason, why pipes should not be buried in floors,—namely, *lime with moisture destroys them rapidly*. Work so hid from observation, is the first to give out. If connections around boilers, pump connections, and the like, were kept above the floor, they would wear the boiler out.

103. When hot water or steam has to be carried under ground, it must be conveyed in wrought-iron pipe, with screwed joints, or cast-iron pipe, with flanged joints; hub and spigot pipes with leaded joints are not suitable, for it is impossible to keep them tight when subjected to much difference of temperature, as the lead expands in a different ratio from the iron, and takes a permanent set with comparatively little pressure.

Cast-iron gas or water pipes, put down in the streets, with leaded joints, will compensate in the joints, by slipping; the difference on a twelve-foot length being about the $\frac{1}{50}$ th of an inch for a difference in temperature of 20 degrees.

104. The steam-fitter should avoid using expansion joints (slip joints) when it is possible to compensate in any other way. In private houses and single city buildings it can always be avoided by taking advantage of right angle turns; but frequently in long runs of pipe, in narrow passages and with pipe of large diameter, they must be used, as spring bends cannot be used unless they have considerable length, and a four

or five-foot turn, on a 6-inch pipe, if the expansion was one inch, would be very liable to make mischief. An eight-foot turn, on a 2-inch pipe 100 feet long, will compensate for any difference of temperature that may take place, with ordinary ranges of pressure; but on a 3-inch pipe it would in all probability break, assuming that the long run of pipe is prevented from springing sidewise.

Sometimes in running pipe through long, straight passages, if the passages have a width of about 6 feet, by frequently crossing from side to side, we obtain a beneficial result; especially if it is a return pipe. The objection to this method for a steam pipe is the great number of turns which would be required for a pipe larger than 2 inches; but when passages make one or two *right angle turns*, nothing can be better where the pipe is hung, and has not to pull or push its own weight over rough surfaces; the length of pipe each way from the elbow not being sensible of any torsion.

105. When several boilers are connected together between their domes or ends, the connections should not be run "short across" from dome to dome. The

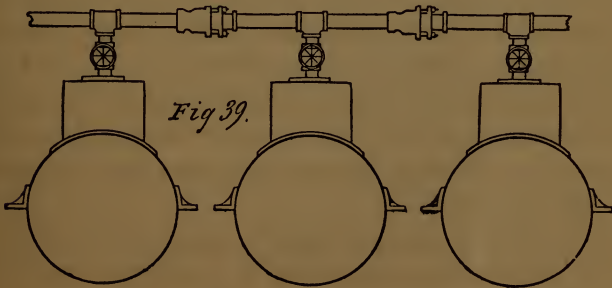

pipes should be run back, or forward, from the domes, 3 to 6 feet, and then, connected across.

The reason of this is plain, when we consider that settling of brickwork, or the expansion of the pipes, will suffice to throw the weight of the boilers on *rigid connections*. For the same reasons, pipes passing through the brickwork of boilers should not rest in the walls, but have large holes, covered with loose flanges, around the pipes.

Figs. 39 and 40 show plans of boiler connections, when using expansion joints, and when the expansion

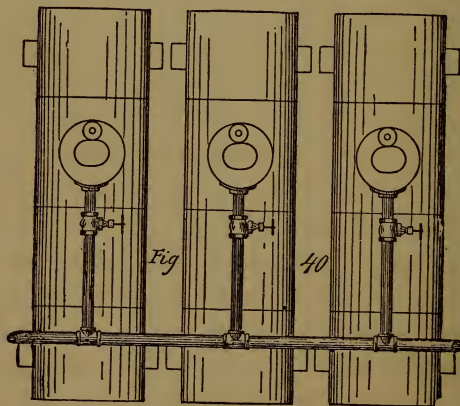

is provided for by *spring*, the latter being the most permanent way, when properly done.

By reference to the figures it will also be seen, that a *slip joint* only provides for a linear contraction or expansion, or a twisting motion, and does not compensate for a *difference in level*.

Fig. 41 shows distant rigid objects connected by a pipe, in which the expansion is provided for by the use of *spring bends*.

The expanding power of a 2-inch pipe, when heated

to the temperature of 100 pounds of steam, exerts a force sufficient to move 25 tons.

106. Cast iron expands one one hundred and sixty-two thousandths ($\frac{1}{162000}$) of its length for each degree Fahrenheit it is subjected to within ordinary limits,

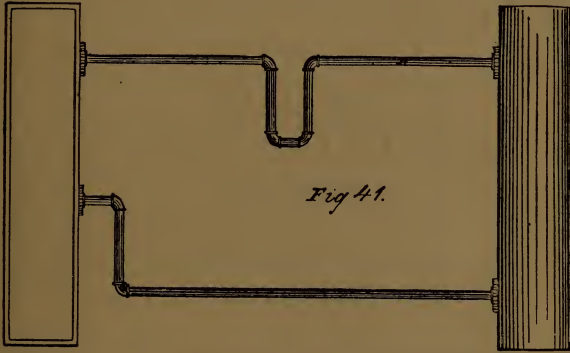

Fig 41.

while in the solid state. Its expansion is less than wrought iron.

107. Wrought-iron pipe expands the one one hundred and fifty thousandths ($\frac{1}{150000}$) of its length, for each degree Fahr. it is subjected to within any limits it can be used by the steam-fitter; and the length of the pipe in inches, multiplied by the number of degrees it is heated, and divided by 150,000, will give the expansion for that difference in temperature *in inches*, or fractions of an inch.

Example.—Find what the length of a one hundred feet of pipe will be, when heated to the temperature of 100 pounds of steam, its initial temperature being zero.

Thus, $100 \times 12 = 1200 \times 338^\circ = 405600 \div 150000 = 2.70$
 inches. (See table.)

108.*—A TABLE OF LINEAR EXPANSION, OF WROUGHT AND CAST IRON PIPES (TO WITHIN THE $\frac{1}{100}$ OF AN INCH), FOR EACH 100 FEET IN LENGTH, AT TEMPERATURES AND PRESSURES MOST FREQUENTLY REQUIRED BY THE STEAM-FITTER.

WROUGHT IRON.

Temperature of the Air, when the pipe is fitted.	Length of pipe when fitted.	Length of pipe when heated to							
		215° or 1 lb. of steam.		265° or 25 lbs. of steam.		297° or 50 lbs. of steam.		338° or 100 lbs. of steam.	
Degrees, Fahr.	Feet.	Feet.	Ins.	Feet.	Ins.	Feet.	Ins.	Feet.	Ins.
0	100	100	1.72	100	2.12	100	2.31	100	2.50
32	100	100	1.47	100	1.78	100	2.12	100	2.45
64	100	100	1.21	100	1.61	100	1.86	100	2.19

CAST IRON.

0	100	100	1.59	100	1.96	100	2.20	100	2.50
32	100	100	1.36	100	1.65	100	1.96	100	2.27
64	100	100	1.12	100	1.43	100	1.73	100	2.00

* Calculated for Regnault's temperatures and Lavoissier and Laplace's difference of expansion.

CHAPTER XV.

SIZE OF MAIN PIPES.

109. No gravity heating apparatus is perfect, unless it *heats thoroughly* at all pressures; unless the water of condensation runs back and into the boiler at *all pressures*; unless it is noiseless under all ordinary conditions, so the duty of the person in charge is simply to take care of the fires, and see there is always sufficient water in the boilers.

The fitter, in all probability, knows that a gravity apparatus requires the largest pipes, and thus he can take it for granted, the size sufficient for such will be enough for any other description of work.

As this book is principally devoted to the heating of buildings and blocks, which have their own boilers, situated either in the buildings or near to them, the rule mentioned hereafter is intended for determining the size of main pipes for gravity apparatus for all ranges of pressure or where an early *initial* pressure is required, as with an automatic direct return steam-trap.

110. With high pressure steam, which is allowed to expand through a building, and eventually escape through atmospheric traps, a very much smaller piping will do; but the waste of heat is sometimes enormous

with traps which discharge into an open tank, or to atmosphere. The difference in favor of a gravity apparatus, or apparatus working properly, with direct return traps, can always be estimated at 15 per cent. over apparatus which permits the water to escape, and thus either loses it, or obtains it by pumping it back: and when traps are neglected (which is the rule), it may reach 30 per cent. of all the heat.

This is not an assertion in the interest of direct return, or one which cannot be verified, as the following will show.

When water is returned to the boiler, at a temperature of 180° (the ordinary temperature of water from gravity apparatus), it requires 1,000 heat units to make one pound of it a pound of steam, and in condensation to water again, and returning it to the boiler at 180° , it loses just 1,000 *heat units*: which have all been utilized within the building. Thus every unit of heat, added to the water, has been realized, and it represents *the maximum economy possible in steam heating*; the power required to put the water back being at a minimum—*i. e.*, gravity. In the case of an apparatus that *wastes* its return water, and has to pump water from the waterworks at a temperature of 40° , it has to add to every pound of water converted to steam, 1,140 *units*, and gets only 1,000 from it, when the water is cooled to 180° (a very *low* temperature by the way for ordinary traps to expel water at). Thus, for every 1,140 units added to the water, 140 are lost, or over $12\frac{1}{4}$ per cent. When the pressure in the radiator is 40 pounds, and the water, passing the trap at a temperature corresponding to that pressure (285° Fahr.), is allowed to waste—there are 1,140 units required to raise fresh water at a mean

temperature to steam: and only 902, utilized in cooling to 285° , the temperature of water at 40 lbs., which leaves 245 units unaccounted for,—or a loss of more than $21\frac{1}{4}$ per cent.: and this does not take into consideration the heat lost in pumping water into the boiler.

111. The power necessary to put a pound of water into a boiler against 70 lbs. pressure, is greater than 160 *foot pounds*, and requires one-third of a horse power for a cubic foot. As a cubic foot of water evaporated in a boiler, and used in a common engine at medium high pressure, does work equal to 1,980,000 foot pounds, it is evident it requires $\frac{1}{180}$ of a pound of steam to put one pound of water into a boiler, the equivalent of a loss of about 5.5 *heat units* to every pound of water returned mechanically—assuming the condensation, is pumped into the boiler without loss of heat, other than its latent heat—but which in practice reaches about 1 per cent.

112. If the water from traps, discharging at 40 pounds pressure, is saved in a tank, and pumped into the boiler again, then the condensed water, after being received into the tank, will have a temperature of about 200° . But it will be said the water escaping from a trap at 40 pounds pressure had a temperature of 285° , hence the water should be received at that temperature. Since it is necessary to have a tank open to the atmosphere (with either an overflow pipe or a vapor pipe), to receive the water; and water at a pressure of the atmosphere cannot have a temperature above 212° , the difference escaping in vapor, or low pressure steam, through the vapor pipe; and if you have a *tight tank* without traps, you must have *as large pipes* very nearly, to get water to gravitate to the tank, as are required for the boiler, so that when the difference of level will permit, it is

better to put it direct into the boiler. But to return : the temperature of the water in the open tank we will take at 200, and to raise a pound of it to steam, will require 979 units, and 894 units of it will be realized in cooling if it passes the trap at a temperature corresponding to 40 pounds, the difference being lost into the atmosphere by getting into a condition fit to remain in the tank—this is over $8\frac{1}{2}$ per cent., to which add 1 per cent. for pumping the water back, which will equal $9\frac{1}{2}$ per cent.; but should the water be lost each time and fresh cold water be supplied it will equal $21\frac{3}{4}$ per cent.

113. Thus it will be seen, it is poor economy to use small pipes, and resort to tanks, traps, pumps and other contrivances, to get water back, when the *price of a steam pump* expended on larger pipe is frequently sufficient to get the water back, and obtain an effect, which so far as the heating surface is concerned, will give the *maximum duty*, and do away with one source of continual expense, as well as the loss of heat occasioned by such irregular means. Twenty-five years ago it was excusable, because it was not then generally known that water could be returned *at all pressures*; but now it is unpardonable, when the circumstances of the case, position of building, etc., will admit of doing better. Furthermore, it should be the duty of the architect to provide, if possible, for *direct return*, in the general planning of buildings, at least for direct heating.

114. There is no definite rule amongst those who attempt steam heating, by which they may determine the correct size of pipes; hence much confusion and many failures occur, to the general injury of the trade. Those who make a specialty of heating, soon find they must use large pipes, and they generally adopt some arbitrary unit, such as to allow the size of a $\frac{3}{4}$ -inch pipe to each radiator: a half a square inch in the cross

section of the main to each 100 square feet of heating surface, or to each radiator; and the area of a *one-inch pipe* to each 100 square feet of heating surface. The latter the writer has adopted as the only one that is ample.

This latter rule also compares very nearly with deductions made from the steam pipes of certain buildings throughout the country, which are considered representative pieces of work, and have proved themselves ample, when the greatest cold prevailed.

115. Thus, the area of a *one-inch steam pipe*, .7854 of a square inch, may be taken as the *unit*; and it serves very well, as by simply squaring the diameter of a pipe *in inches*, you have the number of 1-inch pipes, or *units*, or hundreds of square feet, of pipe or plate surface, the main pipe will supply steam for. Thus a 3-inch pipe will supply steam for 900 square feet of heating surface, when subjected to the greatest condensation possible within buildings, and still not raise the water line in the pipes to any appreciable extent.

116. There is another reason why the area of a one-inch pipe (.7854 of a square inch), as the arbitrary unit, is more satisfactory than a square inch; namely, *the increase of the diameter of a steam pipe is directly as the square root of the heating surface*; and according to the arbitrary unit here adopted, *the diameter of the pipe in inches*, is exactly *one-tenth* of the square root of the heating surface in feet. Thus, when you find your heating surface, extract its square root, in feet, and call one-tenth of it *the diameter of the main, in inches*.

117. This is on the assumption that the mains increase in length in a certain proportion to their diam-

eters. For instance, assuming the 2-inch pipe to be about 50 feet in length; the 2½, about 75 feet long; 3-inch, 100 feet, and each successive size about 100 feet longer than the one that preceded it.

This is about the conditions of long, low buildings, such as insane asylums, hospitals, depots, etc., and the

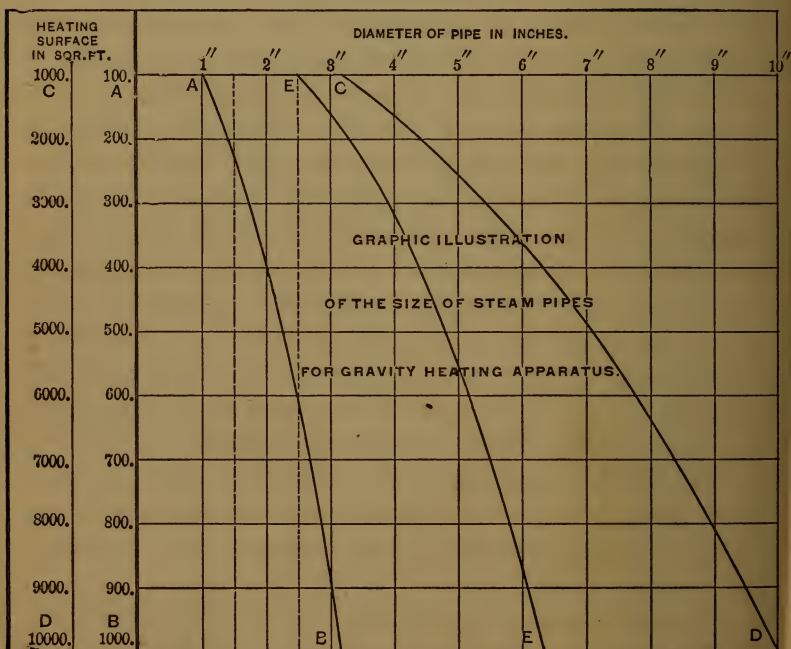

EXPLANATION OF DIAGRAM.

above diagram may be used without much error for such buildings, and illustrates at a glance, and gives the size of main pipes for surfaces, from 100 to 10,000 square feet.

The ordinates of the curve, *A B*, correspond to the

square feet of heating surface in the column marked AB ; and the perpendicular dotted lines, which express the size of the pipe, in inches, correspond with the curve opposite the numbers in the column, which express square feet of heating surface.

The ordinates of the curve CD bear the same relation to the column CD as the curve AB bears to the column AB , and shows the size of pipe for heating surfaces from 1,000 to 10,000 square feet.

It will be seen that, 1,000 at the head of the column AB corresponds to 1,000 at the bottom of the column CD , and the ordinates of both curves agree near the 3-inch pipe line.

Example.—Required the size pipe, for 600 square feet of heating surface. Find 600 in the column, and follow the horizontal line to where it crosses the curve AB ; then follow the nearest perpendicular line to the nearest size of standard pipe *above* the line, in case it should not come exactly on a standard size; in this case it is a little below $2\frac{1}{2}$ -inch pipe, which size should be taken.

Less than a $1\frac{1}{2}$ -inch pipe should not be used horizontally in a main, unless for a single radiator connection.

If this rule is used to determine the size of the steam pipe in radiator connections, *increase the pipe one size*, to give them a practical magnitude, to overcome loss by short turns, etc. Main pipes should not decrease in size, according to the area of their branches, but should be proportioned by the same rule as for determining the size of the main the first time. The same is true of the large branches. Find what they have to supply steam for, and proportion them as you

would a main, figuring their own surface as radiating surface unless they are to be covered. When the distributing pipes are to be covered with some good nonconducting material, the surface of them may not be figured as against their size, but when they are excessively long, or exposed in their *own* surface, it should be considered.

Of course it is not necessary to use main pipes of as great a diameter as given above, if the mains and coils are very much above the boiler, but for cellars or basements 10 feet or under, it will not be found too large, unless the mains are very short. Discretion, also can be used in the use of this rule, when pipes run 4 inches or over. For the size mentioned, 2,000 to 2,500 feet of heating surface may be taken from it under favorable circumstances, provided its branches follow this rule. A 6-inch pipe will be ample for 5,000 feet of surface under good conditions also, and 10-inch for from 15,000 to 20,000, if not too long.

For pipes of equal short lengths the increase of diameters would be in the ratios of the fifth root of the square of the radiating surface, which would call for about a 2½-inch pipe for 1,000 feet of surface; a 4-inch pipe for 3,000 square feet; a 5-inch pipe for 5,500 square feet; and a 6-inch pipe for 8,700 square feet, and this will be ample for lengths of 50 feet or thereabouts of straight pipe for direct radiation. The line *E* shows diameters for constant lengths. This forms minimum conditions for high buildings, such as are to be found in New York and other large cities, and with the selection of a pipe one size larger in diameter, will be ample to provide for the resistance and loss of pressure caused by the valves and elbows and greater ordinary lengths to be found in high building practice for gravity apparatus.

CHAPTER XVI.

STEAM.

118. TEMPERATURES of steam according to the different formulæ, all agree at the atmospheric pressure, but as the pressures become high, they vary slightly: Regnault and Rankine are nearly alike, while the experiments of the Franklin Institute are about five degrees higher for 75 lbs. apparent pressure.

119. The *technical terms*, used about steam by writers, and the expressions in vogue amongst steam-fitters, want some explanation to make them clear, as many of them are synonymous and the fitter does not always know what is meant.

Pressure—Is the force of steam, usually expressed in pounds per square inch, and “elastic force”; “expansive force”; “tension,” and “elasticity,” are synonyms.

Temperature.—The heat of steam, usually expressed in English and American books in degrees of *Fahrenheit's scale*.*

Density.—The weight of a cubic foot of steam, compared to a cubic foot of water. Syn.—Weight of water in steam.

* The use of Centigrade and Réaumur scales and foreign weights and measures, are very much to be condemned in English reading books or papers for practical men, the reduction to familiar terms often requiring more mental effort than the problem to be solved.

Maximum density of steam.—The proper quantity of water in the steam, suitable to the pressure, *i.e.* when the steam is neither superheated nor laden with particles of water mechanically. Syns.—Dry saturated steam; dry steam.

Superheated steam.—Expanded by heat, or an increase of pressure by heat, without the addition of water.

Wet steam.—Water carried up into the steam by force of ebullition, and held in the steam by the rapidity of evolution, when the steam space of a boiler is not large enough. Syn.—Saturated steam.

Foaming.—A condition differing from wet or saturated steam, by having an excess of some foreign substance in the water, causing it to seem lathery and which appears to give the water in the boiler a temperature above what would be due to the pressure, by retarding the separation of the steam, and raising the whole mass of water into a froth. Syns.—Priming; drawing water.

Priming in a boiler is effected by two causes—*viz.*: Taking away the steam in intermittent puffs, faster than it is made and foaming. Priming in boilers is generally an *effect*: foaming a *cause*.

Volume.—The space occupied by a given quantity of water, should the water be converted into steam. The *relative volume* decreases as the pressure increases. Syns.—Relative volume; bulk for bulk.

Specific gravity of steam.—The *weight* of its *bulk*, compared to the same *bulk* of water, air, or any other substance it is contrasted with. Syn.—Density.

Specific heat of steam.—The *heat* of a given *weight*, compared to a given *weight* of air, iron, or any other substance it is contrasted with.

120. The annexed table gives the *apparent* pressure of steam from atmosphere to 100 lbs. in *pounds* per square inch; *absolute* pressures in *inches* of mercury, and *temperatures* in degrees Fahrenheit (to within one half degree), according to Regnault, the *volume* being calculated.

TABLE NO. 5.

ELASTIC FORCE, TEMPERATURE AND VOLUME OF STEAM.

ELASTIC FORCE.		Temperature of Steam corresponding to its Pressure.	RELATIVE VOLUME	Average Rise of Temperature for one lb. Pressure for each 10 lbs.
<i>Apparent</i> Pressure of Steam in lbs. per Square Inch.	<i>Absolute</i> Pressure in Inches of Mercury.		Bulk of Steam compared to Bulk of Water.	
0	30.0	212.0	1710.0	} 2.8
1	32.03	215.5	1612.0	
2	34.07	219.0	1523.0	
3	36.11	222.0	1442.0	
4	38.15	225.0	1372.0	
5	40.18	227.5	1312.0	
6	42.22	230.0	1248.0	
7	44.27	232.5	1194.0	
8	46.30	235.0	1168.0	
9	48.33	237.5	1103.0	
10	50.37	240.0	1061.0	} 1.75
11	...	242.0	
12	244.0	
13	246.0	
14	248.0	
15	60.56	250.0	895.0	
16	252.0	
17	253.5	
18	254.5	
19	256.0	
20	70.75	257.5	718.0	} 1.5
21	259.0	
22	260.5	
23	262.0	
24	263.5	700.0	
25	80.91	265.0	684.0	
26	..	266.5	
27	268.0	
28	269.5	
29	271.0	
30	91.12	272.5	614.0	

TABLE No. 5—Continued.

ELASTIC FORCE.		Temperature of Steam corresponding to its Pressure.	RELATIVE VOLUME	Average Rise of Temperature for one lb. Pressure for each 10 lbs.
<i>Apparent</i> Pressure of Steam in lbs. per Square Inch.	<i>Absolute</i> Pressure in Inches of Mercury.		Bulk of Steam compared to Bulk of Water.	
31	274.0	} 1.3
32	275.5	
33	277.0	
34	278.5	
35	101.31	279.5	558.	
36	280.0	
37	282.0	
38	283.0	
39	284.5	
40	111.5	285.5	510	
41	286.5	} 1.15
42	288.0	
43	289.0	
44	290.0	
45	121.7	291.0	470.	
50	131.88	297.0	435.	
55	302.0	
60	152.25	307.0	390.	
65	311.0	
70	172.43	315.0	343.	
75	320.0	} 0.8
80	193.0	323.0	305.	
85	327.0	
90	213.38	331.0	283.	} 0.7
95	334.0	
100	233.76	337.5	260.	} 0.65

121. When the pressure in inches of mercury is not given, multiply the *apparent* pressure in pounds per square inch by 2.0376, and the answer will be the *inches of mercury above atmosphere*; or that which an old fashioned mercury column would show.

Example.—10lbs. \times 2.0376 = 20.376 inches of mercury.

If the *absolute* pressure is required, add 30 to the above. (20.37 + 30 = 50.37. See table.)

When the *volume* of steam is not given, add 459 to the temperature of the steam; multiply the product by 76.5, and divide by the absolute pressure in inches of mercury; the answer is the *volume*, or number of cubic feet, a cubic foot of water will occupy when made into steam at the pressure required.

Example.—Required the *volume* for 10 pounds pressure, temperature 240° Fahr. — $240 + 59 = 699 \times 76.5 = 53473.50 \div 50.37 = 1061.9$ (see table).

To find what a cubic foot of steam will weigh at different pressures, divide 1000 by the *volume*, corresponding to the required pressure, and the answer will be the weight in *ounces*.

Example.—What will a cubic foot of steam at maximum density weigh, at 40 lbs. per square inch.—Volume $510 \div 1000 = 1.96$ oz.

To find the number of cubic feet of steam a pound of water will make at the different pressures.—Divide the weight of a cubic foot in ounces (as above) into 16, and the answer will be the volume in *cubic feet to the pound*.

Example.—How many cubic feet of steam, at 20 lbs. pressure, will one pound of water make.—Volume $718 \div 1000 = 1.39 \div 16.0 = 11.5$ cubic feet to the pound of water. (See Diagram of dry saturated steam.)

To find the weight of steam necessary to raise a given quantity of water a certain number of degrees.—Subtract the lowest temperature of the water from that to which it is to be heated for a dividend,—subtract the highest temperature of the water, from 1147 for a divisor, and the quotient from these will be the weight of the steam compared to the weight of water.

Example.—Find the weight of steam necessary to raise water from 75° to 190° .—Thus $190^{\circ} - 75^{\circ} = 115$, for a dividend $0.1147 - 190 = 957$, divisor $0.957 \div 115 = 12$ or $\frac{12}{100}$ the weight of the water.

To find the weight of water, a given weight of steam will heat.—Proceed as above, only *transpose* the divisor and dividend.

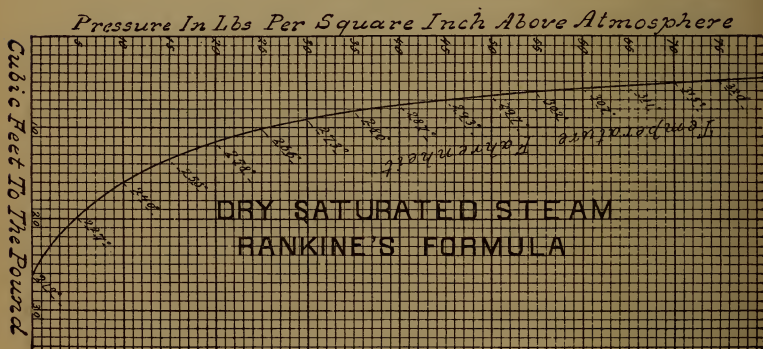

Example.— $115 \div 957 = 8.32$ times the weight of the steam.

122. The above diagram of Rankine's formula has

been modified to commence at the atmospheric pressure —15.7 of the absolute scale being one pound here, and shows at a glance the cubic feet of steam to the pound weight of water, at the different pressures, as well as the temperatures, corresponding to the pressure.

CHAPTER XVII.

HEAT OF STEAM.

123. THE UNIT of heat is the raising the temperature of *one pound* (16 oz.) of water *one degree Fahrenheit*, and is the *standard measure of values* used in all calculations pertaining to heat.

The equivalent in *force* of the unit of heat, is the raising of 772 pounds avoirdupois, one foot high, and is called the *mechanical equivalent of heat*.

The equivalent of the unit of heat in the warming of air, is 52.5 cubic feet of dry air at a temperature of 32° Fahr., raised one degree in temperature.*

124. Sensible and latent heat.—Steam has a temperature corresponding to its pressure, as given in the table, and that *apparent temperature* is known as the *sensible heat of steam* ; but it is found that steam contains *more* heat than a thermometer will show ; heat that can be made manifest in the warming of air, water, etc., warming a very much larger quantity than would appear by a comparison of the temperature of the steam, with the

* In calculations made on the air of drying rooms, etc., the weight of water vaporized must be provided for, as so much water converted into steam.

ordinary temperatures of water, and this *extra* heat, which is not sensible to the thermometer, is called *latent heat of steam*.

When a solid becomes a liquid, or a liquid becomes a vapor, heat is absorbed, more than was necessary to raise it to the temperature of conversion, and this *latent heat* does work in the destruction of the force of cohesion and other occult changes which take place, and must be absorbed *from some other substance*. In the case of steam in a boiler, it comes from the fuel during combustion, and when a pool of water is vaporized in the street, it comes from the sun directly, and from the earth, air, etc., indirectly. When steam or vapor is condensed, this same quantity of heat that was received—no matter where, is again given off to any substance within its influence, air, water, etc., colder than itself, and it is this property, to convey *more* heat within ordinary controllable temperatures, than any other substance which makes water and its vapor so valuable.*

It takes as much heat to melt a pound of snow from a temperature of 32° , to water at 32° , as would warm a pound of water from 70° to 212° . This heat is absorbed by the water in changing from a solid to a liquid, and must be given off again before the water could be frozen.

From the temperature of ice, to 212° under the pressure of the atmosphere, there is no heat made latent in confinement, the water receiving only 180° of heat; but in the conversion of one pound of water at 212° , to steam at 212° , it receives 966 more units of heat: enough to warm $5\frac{1}{3}$ pounds of water from 32° to 212° , or to cool

* Water has the greatest specific heat of any known substance, with two unimportant exceptions: one of them being the principal component of water.

9 pounds of iron from redness to zero. And this heat is the *latent heat*, and the real *thermal* value of the steam.

The *sum* of the sensible and latent heat of steam, is nearly the same for all pressures. At atmosphere, the sensible heat is 212° , and the latent $966^{\circ}.6=1178^{\circ}.6$ as the total heat; at 100 pounds the sensible heat is 337.5, and the latent 874.8, equalling 1212.3 as the total heat; the difference being 33.7, but this *difference* is not manifest in the heating of water when the steam is allowed to expand to atmospheric pressure in cooling, for it expends itself in force, which would be manifest in an engine, and account for the "startling discovery" of Mr. Holly, when he asserts "The power is taken out, and the heat left in the steam; and that every unit of heat that left the boiler, remained in it (the steam) as long as it was steam at any pressure." (Pages 25 and 26, circular of 1880.) This is a mistake. Steam allowed to expand to its full volume against atmosphere, exerts nearly the same force as if expanded against the piston of an engine—plus the loss by radiation, etc.

Actually, the heat is carried out of the boiler; being another form of heat *made latent*, the *extra* units remaining in the steam in the form of *force*, which a little calculation will show, though it falls short of the actual theoretical duty, being 26,000 foot pounds, when the difference is 33.7 units.

Hence the assertion—the *total heat of steam is the same for all pressures*, is correct in making calculations on warming, as it is presumed the steam is expanded to atmosphere in using; the total heat, however, according to the experiments of Regnault, increases as the pressure advances.

The annexed diagram has been constructed from the

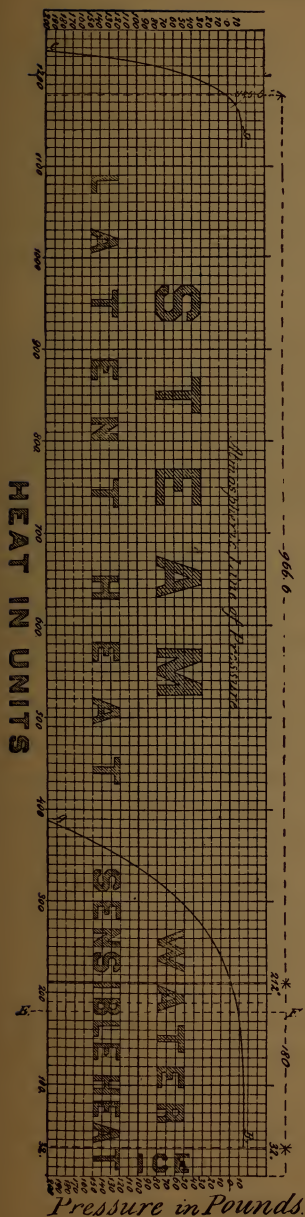

tables of Regnault, to show the increase of heat, above the *constant* 1146.6, which is usually taken as the *sum* of the heat of steam—from 32° upwards.

It also shows the number of *units* in latent and sensible heat of steam, compared with each other; the ordinates of the curve *AB* showing the sensible heat, from one pound pressure to 200, counting from the *line* marked zero, or counting from any other imaginary line, as 32° (ice), or from the line *EF*, which may be taken as the temperature of return water. The difference between ordinates of the curve *AB*, and the curve *CD*, gives the *latent* heat of steam for the different pressures noted. The difference between the ordinates of the curve *CD*, and the *constant* line 1146.6, shows the increase of the *sum* of the heat, above the constant 1146.6.

125. A pound of water converted to vapor in the open air, or a pound of water vaporized from clothing in the drying room, requires very nearly the same heat as would be required to evaporate one pound of water to steam, in a boiler; and for

all practical calculations it can be taken as the same. Thus, the weight of steam necessary to dry clothing, or to evaporate water, in any kind of cooking apparatus, etc., can never be *less* than the weight of the water *driven off*; and of necessity, it will be greater to supply the loss by radiation, or in warming the fresh air of a drying room (which must be changed as often as it becomes saturated), and from other causes.

126. Equivalentents of heat.

The heat necessary to warm a pound of water at *mean temperature* (39° Fahr.) one degree (*the heat unit*), will warm very nearly four (3.94) pounds of air, one degree; $2\frac{1}{10}$ pounds of vapor of water, one degree; 9 pounds of iron, one degree, and very nearly 2 pounds of ice, one degree.*

The heat necessary to convert one pound of water from the temperature of feed water, or return water, at 178° , to steam at one pound pressure (or to any pressure not noting the slight increase for high pressures), is 1,000 *heat units*, and will heat 52,500 cubic feet of dry air one degree; or 5,250 cubic feet of air 10 degrees; or 525 cubic feet of air 100 degrees, making no allowance for the expansion of the air, which will increase the bulk $\frac{1}{5}$ for a difference of 100 degrees; in other words, the 525 cubic feet will be increased to 630 when heated 100 degrees, and the 5,250 will be increased to 5,360 or $\frac{1}{8}$ of its bulk for a rise of temperature of 10 degrees.

The heat necessary to warm one cubic foot of water, from the temperature of the return water to steam, is

* It must not be confounded with melting the ice, but refers to changing the temperature of ice below 32° .

capable of warming 45,572 cubic feet of dry air from zero to 72°, but if the air absorbs 5 grains of vapor of water for each cubic foot—as from clothes in a drying room, it will be equivalent to the fall of the temperature of the air to 34.5, but if the moisture is already in the air, and has only to be warmed (superheated), it will not be equal to the cooling of it, one and a half degree.

One *grain* of water vaporized is equivalent to cooling from 7.5 to 8.6 cubic feet of air one degree according to the initial temperature, and is a *constant*; but 1,000 grains of vapor *already* in the air, warmed *any* number of degrees, cools $3\frac{1}{2}$ to 4 cubic feet of the air the same number of degrees.

When water is evaporated at the expense of the heat of the air, it makes a large factor, which cannot be overlooked; but vapor already in the air, when warmed along with the air, forms a small factor and is not of much practical consequence.

CHAPTER XVIII.

A I R .

127. AIR is a *mixture* whose parts are not chemically combined : consisting of 77 per cent. of *nitrogen*, and 23 per cent. of *oxygen*, by weight, when considered *pure*, *i. e.* when it is in the condition best suited to support animal life. It also contains about $\frac{1}{2000}$ of its volume of carbonic acid gas and some watery vapor, and is capable of absorbing any other gas, or vapor, to a certain extent, distributing them throughout the whole atmosphere, by what is called *the law of gaseous diffusion*—a property which gases have of mixing and diluting, which prevents gases of the most opposite specific gravities from stratifying for any considerable time. Prof. Youmans says, —This effect will be produced even through a membrane of india-rubber; carbonic acid gas rising and mixing with hydrogen, though twenty times heavier. Thus exhaled air, and air contaminated in any other way, is perpetually made respirable by diffusion.

This property is of the utmost importance to air, for if its elements were to become separated, or the addition of a noxious gas to remain separated from the mass, death would be the result in all unventilated

houses in a very few hours. It frequently happens in mines and wells, where the entrance is small, and there are not sufficient disturbing influences, that poisonous gases become abundant, the diffusion being too slow for the generation of the deleterious gas.

In confinement, air may have its oxygen increased or diminished ; an increase of 2 or 3 per cent. causing fever, and a diminution of 3 per cent. causing death, if the carbonic acid gas from the lungs is exhaled into such air and the air inhaled afterward.

128. The amount of *fresh* air necessary for respiration for an adult, is often stated to be about 300 cubic feet in 24 hours, meaning fresh air which had no specific contamination. This general statement, however, is misleading, and the idea that is intended to be conveyed is, that an average individual requires about 300 cubic feet of air in each 24 hours to inflate his or her lungs. If no more air than 300 cubic feet per 24 hours was provided, it would be necessary to have a man's nostrils furnished with an induction and eduction pipe, with check valves connecting with the atmosphere outside the house, the lungs acting as a pump, taking air through the one pipe and discharging it through the other, to keep him in any kind of fair health on such a limited supply. But as air in rooms is likely to be breathed again, in a more or less degree, and as it is vitiated by moisture from the skin and lungs, and by other means well known to people of ordinary intelligence, 300 cubic feet *per hour* should be little enough to provide for in ordinary ventilating ; not with the expectation of keeping the air absolutely pure, but to keep it in a state of dilution which will not be injurious, if it receives no other contamination than that from the body in health.

Hospitals should be supplied with ventilating apparatus capable of supplying 3,000 cubic feet of air per hour to each patient; with means to double or quadruple the quantity by forcing it (as with a fan) in times of contagious disease, or in very warm weather.

School and class-rooms should have at least from 1,000 cubic feet of fresh air per hour per child for large children or the higher classes, to 500 cubic feet for small children, ranging between as the classes advance. This is considered a fair allowance under the practical difficulty of admitting so much air in the aggregate without making draughts.

A theatre, or other auditorium, should have at least 1,000 cubic feet of fresh air per hour *per capita*.

Chambers in dwelling-houses should have 1,000 cubic feet per hour per sleeper.

Even with these amounts of air moved, a room may be poorly ventilated and poorly warmed also, if proper mixing of the air is not produced within the room. This is accomplished by the positions of registers, both inlets and outlets, but it principally depends on the outlets.

The size of a room has no particular bearing on the amount of air to be admitted, if it is to be occupied continuously. Four workers or four sleepers will be as well off, in this respect, in a room of 1,000 cubic feet as they would be in one of 4,000 cubic feet, provided the fresh air is admitted to both alike. If there is little or no ventilation (air admitted systematically), then the large room is the better, as the air already in may be assumed to be pure, and it will take four times as long to vitiate it to a given standard as it will the small one.

An ordinary kerosene lamp requires the oxygen of about 40 cubic feet of air in an hour, and possibly vitiates the air as much as two persons in the same time.

129. Air, assumed as *unity*, is taken as the standard of weight of gases, when its temperature is 60° Fahr., and the barometer 30 inches.

Air for the same weight, at a temperature of 32°, occupies 775 times the space water does; a cubic foot weighing 565 troy grains.

At the temperature of 32°, $12\frac{1}{3}$ cubic feet of air weighs (very nearly) one pound avoirdupois, which increases to $13\frac{9}{10}$, $14\frac{1}{10}$, and 15, for 60, 70 and 100 degrees respectively.*

130. The expansion of air is nearly uniform at all temperatures, expanding about $\frac{1}{490}$ of its bulk at 32°, and for each increase of *one degree* in temperature. Regnault putting it a little less, while Dr. Dalton puts it as high as $\frac{1}{83}$, and other authorities have put it at $\frac{1}{80}$: any of these formulæ being near enough for small differences of temperature.

The following table will show the increase or decrease, of one thousand cubic feet of air at a temperature of 32°, when the expansion is $\frac{1}{90}$.

TABLE NO. 6.

Temperature ...	20°—,	10°—,	Zero. 0,	10°+,	20°+,
Volume.....	895,	914,	935,	953,	975,
Temperature ...	32°+,	40°+,	50°+,	60°+,	
Volume.....	1000,	1017,	1036,	1057,	
Temperature ...	70°+,	80°+,	90°+,	100°+,	
Volume.....	1077.5,	1098,	1128,	1139.	

* One pound of air at 32° Fahr., under the pressure of the atmosphere (29.9 inches of mercury) will occupy a space of 12.387 cubic feet, and its specific heat is .2379, water being unity at the same temperature.

To compute the volume for other temperatures, its volume at 32° being unity, use the following—

Rule.—Divide the difference between 32° and the required temperature by 490; to the answer add *one* (whole number), if the required temperature is above 32° , but if it is below, subtract it from *one* and multiply the volume of air at 32, by it.

Example.—Find the volume a thousand cubic feet of air at 32° will be at 212° .—Thus, $212^{\circ} - 32^{\circ} = 180^{\circ} \div 490 = 0.367 + 1.0 = 1.367 \times 1000 + 1367.0$ cubic feet.

To find what a volume of air at 70 will be at 40.—Multiply the volume by the number corresponding to 40, and divide by the number corresponding to 70.

To find what a volume at 40 will be at 70.—Multiply by the number corresponding to 70, and divide by the number corresponding to 40.

Example.—Required what a volume of 3417.0 cubic feet of air at 100° will be at 50° .—Thus, $3417 \times 1036 = 3539988.0 \div 1139.0 = 3108.0$ cubic feet.

The following table is copied from a text-book, and given as Dr. Daltons'; though it does not agree with that which is given as his difference of expansion; it agrees very nearly with other tables which are given as his. It shows the increase of bulk from 75° to 680° when the volume at 32° is 1,000.

TABLE NO. 7.

Fahr.	Bulk.	Fahr.	Bulk.
Temp. 75.....	1099	Temp. 97.....	1146
“ 76 Summer heat.....	1101	“ 98.....	1148
“ 77.....	1104	“ 99.....	1150
“ 78.....	1106	“ 100.....	1152
“ 79.....	1108	“ 110.....	1173
“ 80.....	1110	“ 120.....	1194
“ 81.....	1112	“ 130.....	1215
“ 82.....	1114	“ 140.....	1233
“ 83.....	1116	“ 150.....	1255
“ 84.....	1118	“ 160.....	1275
“ 85.....	1121	“ 170.....	1295
“ 86.....	1123	“ 180.....	1315
“ 87.....	1125	“ 190.....	1334
“ 88.....	1128	“ 200.....	1364
“ 89.....	1130	“ 210.....	1372
“ 90.....	1132	“ 212 Water boils.....	1375
“ 91.....	1134	“ 302.....	1558
“ 92.....	1136	“ 392.....	1739
“ 93.....	1138	“ 482.....	1919
“ 94.....	1140	“ 572.....	2098
“ 95.....	1142	“ 680.....	2312
“ 96.....	1144		

WATERY VAPOR IN THE ATMOSPHERE.

131. Air is capable of holding a certain quantity of vapor of water, or any other condensable vapor, in solution, so to speak—the proportion depending on the temperature of the air. The warmer it is, the larger quantity it will hold, and as it becomes cool again, it deposits it, or forms clouds or fog, which condense on anything colder than the air; leaving the air upon raising its temperature, capable of taking up more moisture, to be again deposited in dew or rain. It is this property of air which gives it its drying qualities.

The atmosphere is seldom laden with moisture to its

utmost, and is still capable of taking up more moisture ; this difference being its *drying power*, which is going on, in a more or less degree, *at all temperatures*.

132. An absolutely dry atmosphere is an almost impossibility. The coldest air contains some moisture, but it is not always possible to tell how much, as air is seldom saturated to its maximum ; so to find the quantity of water, air at a certain temperature is capable of taking up, a quantity of the air must be cooled until the moisture becomes apparent—forming a *dew point*—when a knowledge of the quantity of moisture already in the air can be had from tables (the result of experiments of Dr. Dalton and others, who have made a study of the hygrometric state of the atmosphere) which give the greatest quantity of vapor the air is capable of containing, for the different temperatures. Thus, if air is cooled from 70 to 50, and shows condensation at the latter point, all the moisture the air is capable of taking up for 70 is the difference between the quantities of vapor at those temperatures in the table.

133. The drying power of air, which enters a drying-room, is therefore, *the difference between the maximum saturation for the highest temperature of the air, and its dew-point before its enters*.

The object in introducing this subject, and giving the following table of the quantities of vapor, air is capable of taking up, is to show the great economy there is in time, and some saving in heat, by having the highest possible heat in a drying room, that will not injure the goods or materials to be dried.

TABLE NO. 8.

134.—A TABLE OF THE QUANTITY OF VAPOR OF WATER WHICH AIR IS CAPABLE OF ABSORBING TO THE POINT OF MAXIMUM SATURATION, IN *grains* PER CUBIC FOOT FOR VARIOUS TEMPERATURES.

Degrees Fahr.	Grains in a cubic foot.	Degrees Fahr.	Grains in a cubic foot.
10	1·1	85	12·43
15	1·31	90	14·33
20	1·56	95	16·60
25	1·85	100*	19·12
30	2·19	105	22·0
32	2·35	110	25·5
35	2·59	115	30·0
40	3·06	130	42·5
45	3·61	141	58·0
50	4·24	157	85·0
55	4·97	170	112·5
60	5·82	179	138·0
65	6·81	188	166·0
70	7·94	195	194·0
75	9·24	212	265·0
80	10·73		

135. It will be seen by a study of the table, that the quantity of vapor, per cubic foot of air, increases very rapidly as the temperature advances—a *common difference* of about 25 degrees in the rise in temperature of the air, doubling the quantity of moisture it is able to take up. Hence, all other things being equal, an increase in temperature of 25 degrees in a drying-room will reduce the time for drying one half, and an increase of 50 degrees will reduce the time to one-fourth, and so on in that geometrical ratio.

* Up to 100 degrees the table has been copied from the *Encyclopædia Britannica*, where the full table to 100, advancing by degrees, can be found. Beyond 100 degrees the table has been calculated from the elastic force of vapors according to Regnault, and are approximately correct.

The saving in heat is not so apparent, as it takes just so much heat to vaporize a certain quantity of water, and the quantity of heat is a *constant*. But there is a saving, in not having to heat the air, and the moisture it contains from its initial temperature, so many times as compared to the amount of moisture carried off; in other words, the amount of heat necessary to evaporate the moisture will be the same for all temperatures, but the quantity of heat lost in the application is less, for the air can be moved more slowly and kept in contact with the materials longer, or until it is fully saturated, and its desiccating power is apparent to the last. This is especially true in drying woods, *as the high heat will penetrate wood and expel moisture, even when the air is not capable of holding any more moisture in suspension.*

THE COST OF VENTILATION.

136. A house 40×40 ft. is warmed and ventilated in two stories. Each story is 11 feet in the clear, making 33,600 cubic feet, and it is desirable to change the air in the house *once in each hour*, which is ample to maintain a very pure atmosphere. In order to know its cost, a business man would proceed to figure in the following way: The steam-heater has told him the apparatus put in, would convert between 10 to 12 pounds of the return water to steam, at an expenditure of one pound of coal (a pretty high average); consequently, the next thing to know is, *what is the equivalent of 1 lb. of coal in the warming of air.* Now it is admitted that a cubic foot of water, losing *one degree* of its heat, will warm 3,000 cubic feet of air *one degree*, and that one pound of it, will warm 48 cubic feet of air one degree; but in con-

verting the pound of water to steam, it absorbs heat, equivalent to warming it 1,000 degrees, which, of course, is equivalent to warming 48 cubic feet of air 1,000 degrees, or 480 cubic feet 100 degrees, or 4,800 cubic feet 10 degrees.* Thus the fact is established, that a pound of steam returned to water, will warm 4,800 cubic feet of air 10 degrees; but it is not so well established that the coal evaporates 10 to 12 times its *own weight of water* from the temperature of the return. If the water was returned at 180° Fahr. and the coal *the best*, 14 pounds of the water, converted to steam, would be the *greatest possible theoretical quantity*; but 11 to 12 has been attained in practice, though it is not common, 8 to 10 being ordinary for house boilers. So, for the sake of safety, and to get the price as *high* as the poorest practice would make it, he takes only one-half the theoretical quantity and figure it at 7 pounds of water to the pound of coal. Thus we have $4800 \times 7 = 33600$ cubic feet of air, which can be warmed 10 degrees by one pound of coal. But it appears that 10 pounds of coal have been burned per hour, a quantity sufficient to warm 33,600 cubic feet of air 100 degrees. Whence, then, is this apparent discrepancy? Assume air outside to be 20° Fahr., and as it passes the heat registers it has a temperature of 120 degrees, having

* The quantity of air, water or steam will warm, is figured according to the *specific heat of each, for the same weight*. Approximately, water requires 4.2 times as much heat to warm a given weight of it, any number of degrees, than the same weight of air; but as air occupies 775 times the space water does, for the same weight, it will have to be multiplied by this factor (relative volumes), and by the heat.—Thus, $1 \times 775 \times 4.2 = 3255$. As air contains a little moisture, which must be warmed also, the odd 255 may be dropped, and is usually figured at 3,000.

been warmed, just 100 degrees, in passing through the indirect radiator; but an examination of the air, as it goes out at the ventilating register, shows its temperature to be 70, which would suggest 50 degrees of the heat had been utilized in the rooms, in maintaining the temperature, and the other 50 had escaped through the ventilator, and been lost as heat; but it has produced *ventilation*, and the movement of the air. Now, the ventilating flues aggregate 2 square feet of cross section, and the air, as it escapes, has a velocity of 5 feet per second in the middle of the flues, and which, if it were not for the friction of the sides, would pass 36,000 cubic feet in an hour. Making some allowance for friction, we will say 33,600 cubic feet of air passes in an hour, exactly the cubic contents of the part of the house, ventilated; taking one half of all the heat with it, or what represents 5 lbs. of the coal burned in the hour.

Thus the ventilation of a good home can be fairly done for $1\frac{1}{4}$ cents per hour, when coal costs 5 dollars per ton, less than $3\frac{1}{2}$ cents per 100 M. cubic feet of air moved under conditions, which *all* preponderate against the price; the difference of temperature between the inside and outside being 50 degrees, which is a high average.

There seems to be a *simple relation*, between the amount of heat necessary to maintain the temperature in a room, and the amount passed off in ventilation, no matter at what temperature the air passes the register entering the room, in indirect heating.

For instance, let air enter at 20, and instead of raising its temperature to 120, it is raised to 95 as it passes into the room. The difference between the temperature of the room (70°) and 95 and 120, is as 1 and 2. Thus, if the windows, etc., cool a certain quantity of the air,

from 120 to 70, they will cool *twice* that quantity from 95 to 70, to maintain the same heat, and *twice* the quantity of air will have to pass out through the ventilator at *half* the greater difference, to make room for the fresh supply necessary to keep up the heat. So, the temperature at which air passes through the heat registers (of the same building) only affects the quantity of air moved and not the heat.

This also points to another result—namely, the less the difference between the temperature the air leaves the heat register at, and the temperature the room is to be maintained at (so long as it proves sufficient), the *more air* there must be passed in a given time to keep the required warmth : which will of necessity make the air purer.

A private house heated altogether and kept properly warm by indirect radiation, with air entering the rooms at about 100° Fahr., cannot be other than sufficiently ventilated for the number of persons who would ordinarily occupy it.

CHAPTER XIX.

HIGH PRESSURE STEAM USED EXPANSIVELY IN PIPES FOR HEATING.

137. It has been customary, when speaking of steam-heating apparatus, to divide them into two kinds—called respectively *high* and *low* pressure; but these names cannot now be accepted in their literal meaning, any more than high and low pressure would express the difference between non-condensing and condensing engines.

Very high pressure steam is now used in the *gravity apparatus*, which some years ago was only constructed for low pressure steam. At that time, the terms low pressure apparatus and gravity apparatus were synonymous; but since the gravity apparatus has been made to run at *any* pressure, the terms *gravity system* and *expansive system* have become common—to distinguish the two principal systems.

When steam has been let into pipes at any pressure, and run arbitrarily, to suit the convenience of one, who wants steam at a distance, under the supposition steam will run to any place where pipes can be put (as it will when certain conditions are complied with), such piping

amongst steam-fitters used to be called *high pressure*, and is now synonymous with "expansive system," or steam used expansively for heating.

The conditions alluded to are: the steam must be allowed to expand,—to blow through in fact; if the pipes are not run on some system, that provides for the taking away of the water, at every low point in the piping; and *the quantity of steam used in a given time, must be sufficient to carry along the water of condensation which forms in the pipe during transmission.*

Scattered buildings, heated from *one* source, must be heated expansively, if they have no basements, and are on different levels, and the condensed water must be taken care of by steam traps.

It is usually attended with considerable waste of heat from imperfect steam-traps, etc., and requires the constant vigilance of the engineer, and should not be used in single buildings, when it is possible to make a gravity apparatus.

138. Lately, Mr. Holly has brought this system before the public on a large scale—the heating of towns and cities; but it is only *the old system* on a larger and grander scale. Instead of heating three or four buildings from one source, he heats hundreds.

The magnitude of the apparatus prevents any attempt to take back the condensed water, which of necessity is wasted after it is cooled to its utmost practical limit; and as the water becomes the property of the consumer it can be used in the house for culinary purposes, and in the laundry, *if the rust from wrought iron pipe*, carried along with the water, will not discolor clothes.*

The following quotation is from the Holly circular and explains the system in their own words:

* Mr. Charles Emery now successfully returns the water of condensation in the plant of the New York Steam Co.

“ THE MECHANICAL DETAILS

of this system we will present briefly, by detailing the course of the steam from the boilers through the various devices to control and regulate its use until it is finally condensed into pure distilled

WATER FOR DOMESTIC PURPOSES.

“ In this system of heating it is desirable to have as few plants as possible placed at central points, as convenient as may be, to coal and water. As the profit to those who supply the steam will depend upon its economical production, it will become of the first importance to admit nothing known to modern engineering art that will secure the largest amount of evaporation of water, at a minimum cost for coal, as steam is used merely as

A CARRIER OF HEAT.

“ It is of course unnecessary to say, that the best and most economical boilers should be selected, and the most careful and competent engineers and assistants obtained. It is by no means an unimportant fact to be considered by cities with reference to this system, that the dangers and annoyances of boilers will be confined to a few localities, and their objectionable features obviated in cities like New York, St. Louis and Cincinnati, where thousands of boilers are distributed through the city.

“ From the boilers the steam passes into

THE MAINS AND LATERALS.

The material used after experiments with cast iron and other substances, is the ordinary *lap-welded, wrought iron*

steam-pipe. These are always tested by the manufacturers to a tension far above any possible use, for example : a 12-inch pipe of this kind $\frac{1}{4}$ -inch thick, has a tensile strength of 60,000 lbs., and would bear a pressure of 2,500 lbs. to the square inch, as no pressure exceeding 100 lbs. will ever be required in this system.

“DANGER FROM EXPLOSION

of pipes can never become a subject for discussion, but *condensation is*. For unless steam can be transmitted to considerable distances without too great loss by condensation, all devices to use it in buildings, however ingenious, would of course be useless. Condensation being caused by the radiation of heat from the pipes, the

SUGGESTION OF COMMON SENSE

would be to arrest the radiation, that is, *keep in* the heat by inclosing the pipes in the best non-conducting material that is attainable, and cheap enough. There is nothing new about it. Wool, hair, charcoal, brickdust, ashes, plaster, cotton, sawdust, gypsum, etc., have been used in various ways ever since metal pipes were used to convey steam.

“The pipe is placed in a lathe and wound about, first, with asbestos, followed by hair felting, porous paper, manilla paper, finally thin strips of wood laid on lengthwise and the whole fastened together by a copper wire wound spirally over all. This is thrust into a wooden log, bored to leave an intervening air-chamber between the pipe and wood, and of sufficient size to leave from three to five inches of wood covering. The elasticity of the wrappings permits the free expansion and contraction of the pipe irrespective of the wood log which is securely anchored and made immovable. The whole is placed in a trench a short distance below the

surface without regard to frost. At the bottom of the trench is laid an earthen tile drain to carry off any earth moisture, and in order further to insure the continuous dryness of the wood log inclosing the pipe, if desired, one and one-half inch plank are fastened around the log leaving an air space, and the whole daubed with coal tar and covered with earth never again within the experience of this generation to be disturbed.

“WE SAY NEVER,

because the mains are never tapped for the attachment of service pipes, as in the case of gas and water mains, and because the precautions taken to secure the wood against alternations of dryness and moisture will, according to experience, preserve it indefinitely.

“Pipes prepared in the manner described have been thoroughly tested, and it is proven beyond doubt that condensation can be reduced to a point that renders the general transmission of steam not only practical, but profitable. At the risk of being tedious, we will quote, for the benefit of the curious, a well-attested experiment of Mr. Holly. In 1,600 feet of three-inch pipe, laid on a descending grade of 20 feet, the lower end trapped for water, steam pressure constant at 20 pounds at both ends, during 12 hours, water of condensation carefully weighed, amounted to 82 pounds per hour. The Holly boilers, accurately tested, evaporated 9 pounds of water per pound of coal. 82 pounds of water therefore represented 9 pounds of coal, or $2\frac{1}{4}$ per cent. More clearly thus: Each pound of steam above 212° contains 960 units of heat; the heat units lost in the condensation of 82 pounds of water were 78.7-20, or at the rate of 1.312 units per minute. Now the capacity of a 3-inch pipe at 20 pounds pressure is 765 cubic feet per minute, containing 27.044 units of heat, of which only 1.312 were

lost, viz., $2\frac{1}{4}$ per cent. Experiment and practice, since verified in 15 cities, show that the most economical pressure to be maintained in the mains is from 40 to 60 pounds, although in some cities 70 pounds has been used. Experience with large mains is yet limited, 8-inch being the largest in use. By calculation, the condensation at 60 pounds pressure is, in 3-inch pipes, per mile, 2.6; in 6-inch pipes, per mile, 2.0; in 12-inch pipes, per mile, 0.7. The condensation in large pipes is greater, but the relative percentage less.

“The experience of Detroit demonstrates the fact that 60 pounds pressure could be maintained in four miles of 10-inch and 6-inch pipes, against the drafts for power and heat along the line. The capacity of a 6-inch pipe at 60 pounds pressure may be estimated thus: a 6-inch pipe at 60 pounds pressure will discharge 102 cubic feet per second. A horse-power is one cubic foot of water, or 1712 cubic feet of steam, or 427 cubic feet of steam per second. Therefore a 6-inch pipe at 60 pounds pressure will supply 216 horse-power per mile, and the same amount of steam will supply

3,000 CONSUMERS PER MILE,

averaging 12,000 cubic feet of air space to be heated.

“The next serious obstacle was found in the

EXPANSION AND CONTRACTION

of metallic pipes between the extremes of temperature, say 32° , and the heat of steam at 60 lbs. pressure 307° . The expansion of wrought iron is $\frac{1}{542}$ of its length, about $2\frac{1}{4}$ inches in 100 feet. It was the inability to obviate this, that defeated the effort to inaugurate a general system of steam-heating in European cities. This difficulty was completely overcome by

THE JUNCTION AND SERVICE-BOX.

These are placed at convenient intervals along the line of 100 to 200 feet. The arriving-pipe from boilers is inserted by a nickle-plated extension or telescopic joint, made steam-tight by passing through a stuffing-box. The departing pipe is immovably attached to the box, so that one end of each 100 feet of pipe is fast and the other movable, affording free-play to the expansion and contraction.

“ All service-pipes are taken from the junction-box, which is securely bolted to the masonry, and anchored to the pipes. The bottom of the box being placed lower than the pipes, all water of condensation is carried forward and deposited in it, to be taken up subsequently as

ENTRAINED WATER,

and reconverted into steam, at lower pressure, as the steam passes through the reduction valve.* The adjustable hoods are for the purpose of regulating the passage of dry or moist steam. The junction-box provides for the expansion of mains, the attachment of service-pipes and reception of water, no water is ever found therefore in the mains, and no provisions for trapping off water are required. The boxes are accessible by man-holes in the street; from the junction-box, the steam passes to

* From the above, one is likely to be led to believe—all the so-called entrained water flies into steam; but this is not so! Only that quantity of it is converted into steam at a low pressure, which can be evaporated, by the difference of the units of sensible heat of steam for the different pressures, which for the difference between 50 pounds and 2 pounds is equivalent to the re-evaporating of less than $\frac{1}{10}$ of the water condensed under the high pressure; the rest has to be forced through the pipes by the passage of the steam.—REMARK BY THE AUTHOR.

THE REGULATOR

by means of which the pressure of steam is reduced, and the supply to the building regulated automatically. This is accomplished by two diaphragms of rubber packing, acted upon by weighted levers, and moving two slide-valves. The first valve is weighted to 10 lbs., and the second to 5 lbs., or 2 lbs. if required. When the steam arrives at the first valve of the regulator, it contains, suspended in minute particles, all the water which has been condensed in the mains, and brought forward to the junction-boxes. This is known as entrained water, which, under 60 lbs. pressure, cannot become steam, but does so at lower pressure of 10 lbs., and any further moisture remaining is further converted into steam, at a still lower pressure of 3 lbs., thence it passes at a uniform pressure through

THE METER,

placed, as seen in the plate, above the regulator. It resembles, and in fact is, the movements of a 55-day Yankee clock; as the steam passes, the movements are made to rotate a screw, upon which hangs a pointer moving along a dial, each revolution registers an arbitrary unit, the value of which has been previously ascertained by weighing the water. The clock marks the time and registers the quantity." *

When one building furnishes steam to several adjacent buildings, or when a cluster of buildings have a boiler house, it is not necessary to use junction boxes, or even common expansion joints; the expansion may be provided for with right angle turns, or by throwing the expansion *within* the walls of the different buildings.

* This meter proved unreliable for many reasons, and the New York Steam Co. is now trying one on a different principle.

Comparatively small piping can be used in an expansion system, and when there is no provision for draining the condensed water from the pipes, a size barely sufficient to carry the required steam along is preferable ; as in that case, the draft will carry the water out of the pipes ; whereas, if the pipes were larger, the draft of the steam would be so slow, the pipes would fill until the contracted passage increased the velocity of the steam to such a degree it forced itself through in irregular pulsations, and caused pounding.

CHAPTER XX.

EXHAUST STEAM AND ITS VALUE.

139. Among the many who own steam engines and the engineers who run them, there are few who have a just appreciation of the *thermal* value of the clouds of exhaust steam continually blown to the winds from the apparently numberless exhaust pipes, which can be seen from the top of a high building in any of our large cities.

When I say that three-quarters of the *practical* thermal value of every pound of coal burned in the boiler furnace, is lost past recovery to the consumer, I am putting it at less than the actual loss ; and could this heat be converted into available motion, suitable for power purposes, it would be a boon indeed, and a fortune to the one who could do it. Perhaps there is a chance for the electrician to convert it into energy ; but as yet engineers can use it for heating purposes only, where its full value can be shown in the heating of water, air, or any tangible substance.

The first purpose for which the exhaust steam is generally employed is to warm the feed water, the object being to raise its temperature as high as possible, before it enters the boiler, thereby to save fuel.

140. The first question which nearly always suggests itself to the engineer is, How hot can feed water be made? The second which he sometimes considers, but seldom arrives at a satisfactory conclusion about, is, What percentage of the coal does the heating of the feed water represent? and the following, which rarely come under his notice, is, How much of the exhaust steam from an engine can be used in heating all the feed water necessary to supply the loss caused in the boiler by supplying steam to the same engine? and how much of it is left for use elsewhere, partly or wholly, to heat the *factory* in winter or for drying purposes?

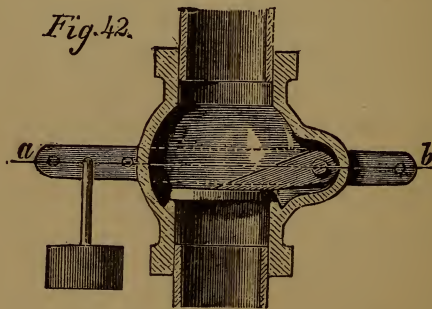

The answer to the first question is: Water under the pressure of the atmosphere cannot be heated above 212° Fahr., and when the feed water passes the check valve at a temperature of 200° it should be considered satisfactory, although it is possible to do better.

Where water is *forced through* a heater, the temperature can be raised higher than when drawn by a pump, *from* the heater, as the lessening of the pressure also lessens the capacity of the water for *sensible* heat.

Some makers of feed water heaters claim they can heat the water above 212° , because it is under pressure;

but it is evidently a mistake to attempt it, as both the water to be heated, and the *steam necessary to heat it*, should have a pressure above atmosphere, and any attempt to keep a back pressure in the exhaust pipe for the *simple purpose only* of warming the feed water above 212° is attended with a loss instead of a gain.

The attempt to heat the feed water 5° above 212° by a back pressure of 2 pounds, the mean pressure in the cylinder being 50 pounds, is attended with a loss in energy, greater by more than five times the gain to the feed water.

The answer to the second question is : That when the feed water is raised from *mean temperature* 39° to 212° by the use of the exhaust steam at atmospheric pressure, it is equivalent to very nearly two-thirteenths of the weight of the fuel necessary to convert water, at *mean temperature*, to steam at *any pressure*, and 15·18 per cent. of the coal is the greatest possible saving that can be made for this difference of temperature.

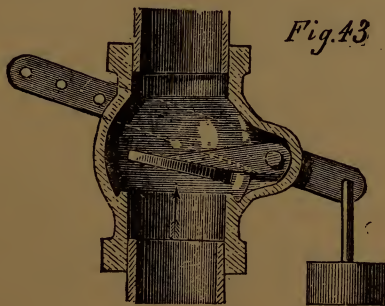

To find the saving of other differences of temperature in the feed water, divide the difference between the temperature of the cold water as it enters the heater and that at which it enters the boiler into 1,146, less the

difference between the cold water and 32, and the product is the fraction of the coal heap.

141. The answer to the third question is : That two-elevenths of the exhaust steam is the greatest quantity that can be utilized in the warming of the feed water, and making a generous allowance for loss by radiation, etc., there will still be three-fourths of all the exhaust steam for other purposes.

The next general purpose for which the exhaust steam from an engine can be used is in the warming of the air of a building, to which purpose it is often applied, *though not as much as it should be*, as there appears to be an idea among many users of steam, *that it is just as well to take live steam from the boiler* as to cause one or two pounds back pressure on the engine for the purpose of getting a circulation, and driving the air from all parts of the coils.

142. The loss in power to an engine from back pressure is very nearly directly as the difference between back pressure and mean pressure. Thus, in an engine of 50 pounds mean pressure, with a back pressure of 2 pounds, there is a loss of 4 per cent., and as the available energy of an engine cannot represent one-quarter of the *practical thermal* value of the coal, the loss caused by 2 pounds back pressure cannot represent more than 1 per cent of the coal, and as it is an incontrovertible fact that the exhaust steam contains more than three-fourths, or 75 per cent. of the *practical thermal* value of the coal, the balance is largely in favor of *using the exhaust steam*. The steam-

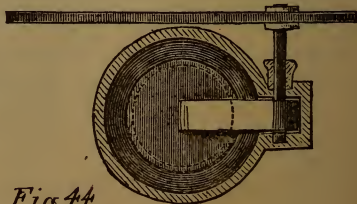

Fig. 44

fitter when preparing to use the exhaust, usually places a *back pressure valve* in the exhaust pipe, of such construction, that it can be loaded to suit, so as to reduce the back pressure to a minimum, when in use, and to hold it open when not required.

Fig. 42 shows a section of a back pressure valve, with the weight hanging on the *positive* end of the lever, showing the position of the valve when the steam is turned into the coils. Fig. 43 shows the weight on the negative end of the lever, the position usually used in summer. Fig. 44 shows cross section on line *a b*, and stuffing-box and spindle.

143. Exhaust, and live steam, should never be used in the same coil at the same time. It is often attempted, but is very difficult to regulate, and the better way is to make the exhaust coils no larger than the steam will fill, and should this not prove sufficient for the space to be heated, add live steam coils, with entirely independent connections.

Sometimes coils are furnished with two sets of connections, live and exhaust; but this requires constant attention to prevent workmen, etc., from crossing the steams, thereby causing a waste.

Another objection to having live and exhaust steam connections on the same coil, is the style of trapping used, for one is not fit for the other.

A very good way to *trap*, and provide for the con-

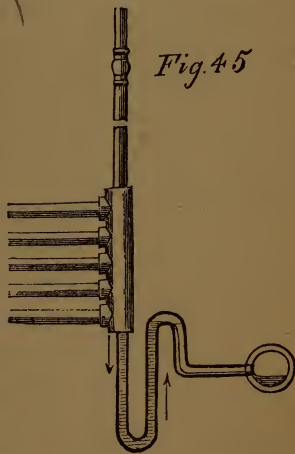

condensed water from an exhaust steam coil, is to have an inverted water siphon to the sewer or tank, as shown in Fig. 45, with a vapor pipe to the roof, to remove an excess of pressure and the air. This pipe should have a check valve on it, to prevent the return of the air, between the strokes of the engine, and the water trap should be as deep as possible.

Buildings are now very successfully warmed by low-pressure steam expanded through a regulating valve near the boiler. Into this *low* system the engines and pumps are allowed to exhaust through a check valve. Should the quantity of steam from the engines, etc., be greater than the coils can condense and raise the pressure slightly, the regulating valve at the boiler will close, and admit no more live steam, and should the pressure still continue to increase by the addition of exhaust steam, a back-pressure valve at the engine will open and let the excess escape to the roof through the summer exhaust pipe.

CHAPTER XXI.

BOILING AND COOKING BY STEAM, AND HINTS AS TO HOW THE APPARATUS SHOULD BE CONNECTED.

144. LARGE institutions with many inmates, find it almost impossible to cook without the aid of steam; and manufacturers have long since abandoned all externally fired kettles for this purpose.

Of the superiority of steam, as a means of drying and cooking, there is no question, and the occasional failures which occur, should not be attributed to steam, but to errors in the construction of apparatus, and an ignorance of their *use*. Satisfactory appliances are within the reach of the steam-fitter, though frequently the ruinous competition in *small things*, which compels the lowest bidder to neglect and omit everything possible, or in other words, "*to do the least for the least money*," ruins the effect of otherwise successful machines.

The first and commonest kind of cooking by steam, is "steaming," which is again divided into steaming in the atmosphere (or at atmospheric pressure), and *steaming under pressure*, in closed tanks or boilers. Steaming can be used in the preparation of anything into which water cannot enter, or become part of, as oils; or of substances which want an addition of water, but are capable of

taking up only sufficient water to properly prepare them; as vegetables, or substances which want to be bleached or disintegrated, as rags.

The simplest form of *steamer* is the ordinary kitchen steamer; a wire basket or tin pot with holes in the bottom of it, suspended in a larger pot with water in the bottom of the latter, the water not reaching the bottom of the basket, but the steam, rising and mixing with the air in the basket, gives a uniform heat, when the water in the lower pot is boiling.

It is well known to the intelligent cook, that vegetables cooked this way can be done *through* without break-

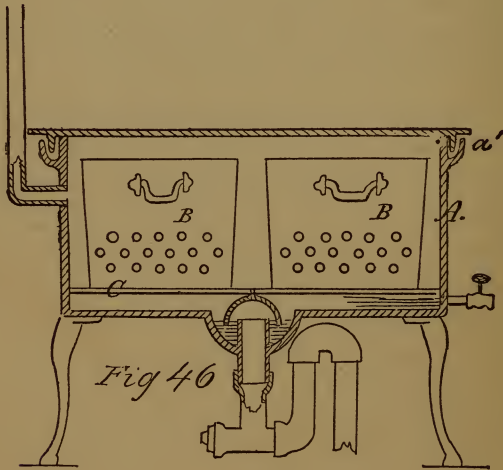

ing, or without losing any of their starch. This cannot be done in boiling water, as the mechanical action of the water during ebullition breaks and washes out part of the substances, etc., before they can be sufficiently cooked in the center.

The modification of this simplest kitchen steamer,

used in large buildings, such as hotels and public institutions, is shown in Fig. 46.

The outside case, *A*, may be of cast iron, or sheet iron riveted and soldered with a cover of sheet iron. The *baskets*, *B B*, rest inside the outer case, on a perforated shelf, *C*, and are usually made of heavy tin plate, with holes in the bottom for the condensed steam to run off.

The connections to these steamers require particular attention, far more than would appear from a superficial examination.

The condensed water which gathers in the bottom of the outside case should be carried to the sewer or drain, and must be connected in such a way, that the foul air of the sewer cannot return into the steamer and contaminate the food. And as much—and more—attention must be paid to the waste connection from a vegetable steamer, than is paid to the connections from a wash basin, even in a sleeping room. It is not only essential *how* the connections are run, but from *what* material they are composed, and further, how the joints are made, and from what material.

As the steam and hot water are capable of destroying lead pipes and traps, or working the lead joints out of cast iron pipes, it is best to use either wrought iron screwed pipe, or cast iron pipe with rust joints; using a very deep S-trap, constructed of fittings, with plugs at every corner, so as to get straight openings at every part of the pipe, by simply removing the plugs. This is necessary to remove grease, or any obstruction that may pass into the pipe. The pipes should be of large diameter (about 3") with the trap sufficiently deep to prevent the pressure of steam within the steamer, from blowing it out, and connected with some contrivance, vacuum

valve, or vent pipe, run on approved sanitary principles, to prevent its siphoning out, as is common to all soil pipes.

There is another source of contamination or poison, in the connections of vegetable steamers, or any other steam boiler, which must have a vapor pipe; these pipes should not be constructed of galvanized iron or copper, or any other substance whose salts are poisonous, as the condensation which takes place within this vapor pipe, falls back into the kettle, continually washing down carbonate or sulphate, or whatever may be formed that yields easily to the action of pure water. These pipes should be constructed of iron gas pipe, with screwed joints, or cast iron pipes, with *rust* joints.

The live steam connection to an *open* steam box, or steamer, should be very small. Usually a $\frac{3}{4}$ or $\frac{1}{2}$ -inch pipe is used, and there is no discretion exercised in the manipulation, but an endeavor made to cook as rapidly as possible, regardless of steam. Beyond a certain quantity of steam admitted, nothing is gained in time, as just steam enough to expel the air is all that can be used; a greater supply is only wasted through the vapor pipe, or escapes into the kitchen, under the edge of the cover.

There is another point in the construction of open steamers worth considering—namely, a water seal around the edge of the cover.

The seal consists of a groove or channel around the top edge of the case, into which a rib around the under side of the cover fits, as can be seen at *a'*, Fig. 46.

This seal should be as deep as possible, and to be effective should run around the whole cover, and not be dispensed with on the side of the hinges, as is frequently done.

The object of this water trap, or seal, is to prevent steam from escaping into the kitchen and to force any excess of pressure out through the vapor pipe.

To get the greatest economy, the water seal should be two inches or more deep, with a small sized vapor pipe with a valve in it, so it can be *choked down*, to hold a pressure in the steamer, but not enough to force the water seal.

Steaming under pressure must be done in a closed boiler or tight tank, capable of resisting high pressure steam.

A common form of this class of steamers is the rag boiler in the paper mill. It is a horizontal cylinder,

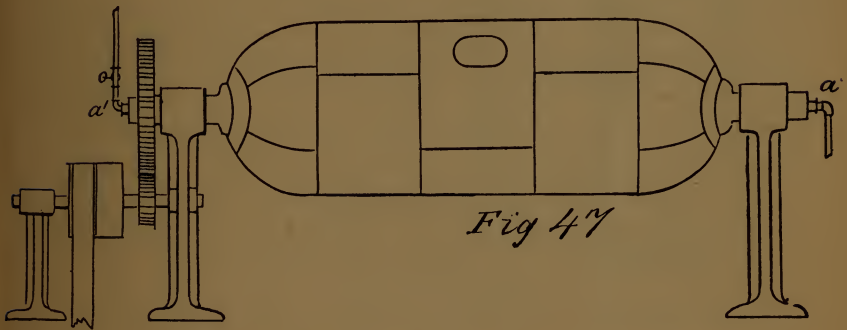

with conical ends, supported on trunions, and made to revolve by machinery, so as to use the mechanical motion in assisting the disintegration of the rags. This boiler is shown in Fig. 47, and should be constructed of exceedingly heavy iron, or it may explode, and do much injury. The pipe connections are made at the ends of the trunions (*a'*), which are provided with stuffing-boxes revolving around the pipe, thus leaving *it* stationary.

Another form of high pressure steamer is an upright

tank of strong construction, in which fats are rendered and separated by the action of high pressure steam. This tank is shown at Fig. 48, and is often 20 to 30 feet long.

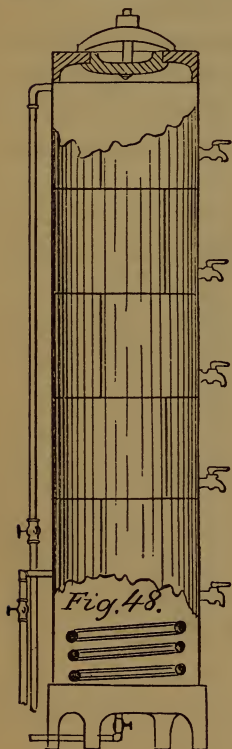

The fats and oils stratify, according to their gravity, with the water of condensation underneath, and are drawn off at the numerous cocks, according to their quality.

145. The steam connections on these tanks are made top and bottom, and they are sometimes constructed with a spiral coil near the bottom.

Cooking and manufacturing, by the *transmission of steam heat through metal surfaces*, and not by direct contact, as in steaming, includes apparatus of varied designs, often the result of years of experimenting, the following modifications being the most common.

Figs. 49 and 50 show sections of two of the ordinary forms of double-bottomed steam cooking kettles.

The various uses to which these kettles are applied are wonderful. Differing very little in shape, the size alone adapts them to the special use. Small sizes, 20 to 40 gallons, can be used for glue melting, etc.; sizes running from 60 to 100 gallons are mostly used in hotels and institutions for cooking meats and farinaceous foods, and larger ones, up to 500 gallons, are used in sugar-houses and soap boiling establishments.

Sizes to 200 gallons are usually cast iron, but larger ones are often made of wrought iron, riveted and calked.

The connections to these kettles are plain, but the steam pipe should be large, and the return water pipe *should not* be put back into a return gravity circulation apparatus, but *should be* carried away by a good steam trap of approved pattern.

Vapor pipes from these kettles should be of iron, for the same reason mentioned in connection with "steamers."

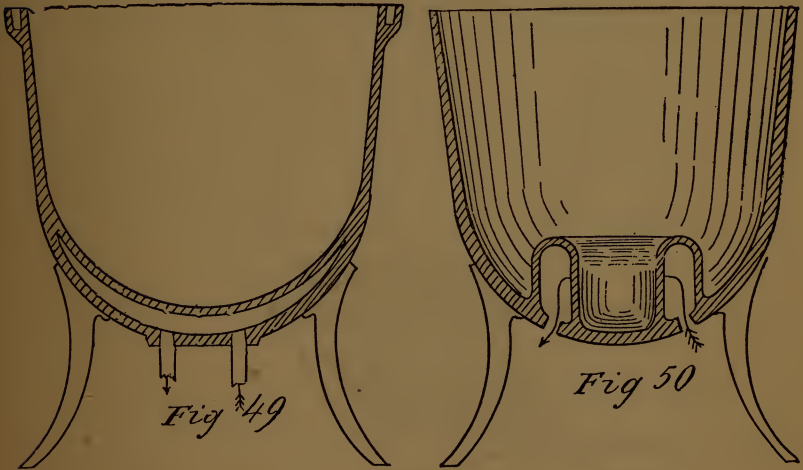

The pipe from the inside of the kettle, which carries the contents to a receptacle, or sewer, should be large, with tees and plugs at every right angle, instead of elbows, to permit of easy and rapid cleaning, should it get stopped with grease, or any other substance which hardens on cooling.

In these kettles *steam cannot be wasted* unless it is

passed through a defective steam trap, the consumption of steam depending on the amount of work to be done, and the radiation from its sides.

This radiation is often partly prevented by an outside *loose jacket*, and if the space between the jacket

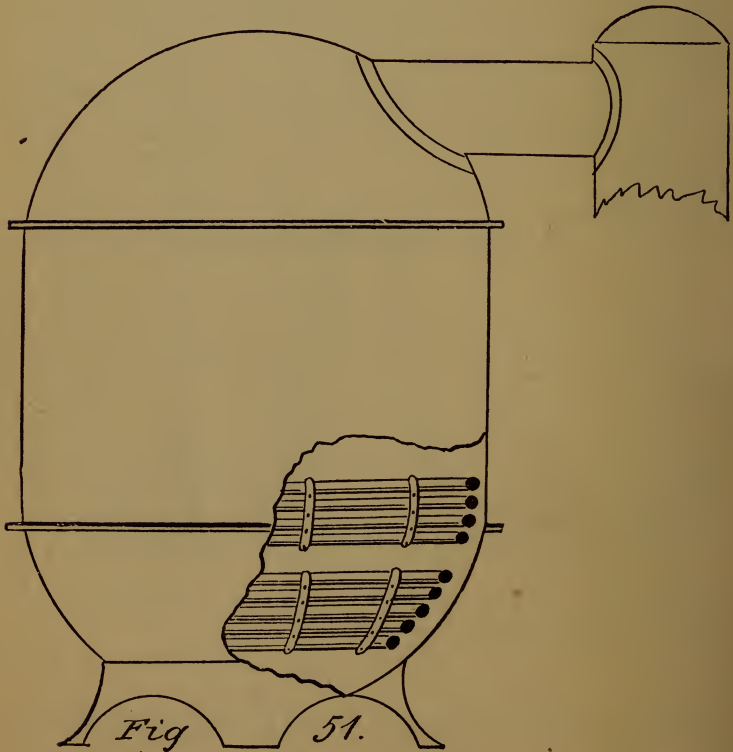

and the kettle is filled with some non-conducting material, the loss of heat from the outside of the kettle will be reduced to a minimum.

There is another class of kettles or pans which are not double-bottomed, but boil and cook by steam heat

transmitted through spiral coils, passed around the inside of the bottom, the pan itself being partially exhausted of atmosphere; that the contents may boil at a temperature much below 212° Fahr.

These kettles or pans are usually very large, and are principally used in sugar-houses and condensed milk establishments, or any place where boiling or evaporating, at very low temperatures, is a desideratum.

Fig. 51 shows a section of one of these pans, the principal points of importance to the steam-fitter, or coppersmith, are the sizes of the pipes, and the manner in which they should be run.

When a quantity of water is to be raised from ordinary temperatures (35° to 55° Fahr.) to boiling, it must be borne in mind by the fitter, or constructor, that it will take, *in steam*, at least $\frac{1}{3}$ of the weight of the water in the pan, to raise it to the boiling point, and that when steam is first turned into the space, between the bottoms of jacketed kettles, or into the spiral coils of tanks, or vacuum pans, the *shrinkage*—i. e., condensation of the steam, for the greatest difference of temperature, is something enormous; and unless the supply of steam is continuous, and the pipe which conveys it ample for the greatest amount of work that can be put on it at any time, the result will be the filling up of the space or coil with water. This is caused by the absence of pressure of steam through the pipe, coming on the surface of the condensed water, to keep it down, and under some conditions the vacuum produced actually drawing water into the coil, from some other coil or the branch return pipes.

To get a proper result, and economize in *time*, the pipe from the boiler must be sufficiently large, and all

the connections and valves have area enough, to supply the greatest quantity of steam required for the greatest work. Some have an idea they can waste steam, by giving a *heating* or boiling apparatus a full head of steam, but this is a mistake if they have proper steam traps, or return into, or are part of a return gravity apparatus. For the boiling of water, or the heating of air, can only use *the steam it can condense*, and the amount of steam used from first to last, is the same in any case, plus the loss by radiation for the time.

It is not long coils of small diameter that are required, but short coils of large diameter, with large piping throughout.

With small long coils the apparatus, at first, takes a considerable time to heat up; but when it is in "train," it seems to do very well. The reason of this being plain, when we consider that all the steam required to *keep a kettle boiling* is exactly equal to what is given off in steam, from the surface of the water in the kettle.

At first, while the *great* difference of temperature between the water and the steam lasts, the coil is warmed a comparatively short distance of its length, because all the steam that can pass in a given time, is condensed in this first part of the coil, consequently the *whole* coil is not doing duty, when it should be most efficient.

Many have found that by turning on the steam first, and then letting in the water slowly, the kettle was boiling by the time it was full, and if they filled it with cold water first, it would not boil in an hour.

Some might reason from this, if their pipe and coil

were large enough to pass sufficient steam to boil the water in 15 minutes, by passing it in slowly, it should boil the whole in the same time, since it takes the same quantity of steam to boil a cubic foot of water, no matter how it is applied ; that this is not correct, as far as the size of the pipe is concerned, the following will show :

In the first case, where the water is let in slowly, the coil or space is hot, and the quantity of water not being enough at any one time to condense the steam faster than it can pass, the whole coil is doing duty during the whole time. But when the large body of water is acted on by the steam, the latter rushes into the coil and is immediately condensed, *filling the coil with water*, the greatest part of its length, and leaving the first *short* heated part of the coil, to boil the water in the kettle, before the pressure of steam will pass through, to keep down the water of condensation.

Many again think, this condensed water will run off by its own gravity ; but this is not so, as it cannot run off unless there is a pressure on its surface equal to the pressure of the atmosphere, if it connects with a trap, and equal to the pressure in the return pipe, if it connects with a gravity apparatus.

The steam which can be passed through a 2-inch pipe in an hour is capable of boiling about 4 tons of water, making allowance for loss of heat and friction, at a pressure of about 40 lbs.

When a pan has two or more coils in it, they may take their steam from the same source, provided it is sufficient, but the *returns* from these coils should be separate ; with a separate trap to each return, and the discharge from these traps should not be put into the

same pipe, or into any confined space, where the discharging of one of the traps may cause pressure in the others, and cause them to discharge in advance of the proper moment.

Long, flat wooden vats, with any convenient-shaped coil in the bottom, are often used for the evaporation of the water from brine by the salt manufacturer. Exhaust steam from neighboring engines can be used here to advantage, thus utilizing heat that would otherwise be lost.

146. Another common way of warming or boiling water, when the object is not evaporation, but the warming of a tank of water for laundry purposes, or when the addition of the condensed steam is a benefit (provided it is not greasy), is to put the steam-pipe directly into the water, in the form of an *open butt*, or a perforated coil.

This mode is usually attended with noise, but it is *quick and effective*.

When a perforated coil is used, it is usual for the fitter to have as many small holes in the coil as will aggregate equal to the area of cross-section of the pipe in the coil; but in practice this is not nearly sufficient, if he wants to pass out all, or nearly all, of the steam and water which the supply-pipe is capable of passing.

Within an empty pipe, steam has a very high velocity, but striking the water, as it passes the holes, retards it so much that 5 to 10 times the area of the pipe in small holes has not been found too great in practice, the time of boiling lessening rapidly up to 10 times with shallow water and 40 lbs. of steam.

The pressure of the steam and the depth of the water affects the time of heating; high pressure accelerates and deep water retards.

The lower the pressure of the steam that will pass out, as it strikes the water, the less the noise will be; and a good way to avoid noise is to have a large diameter coil or pipe in the water, with a great many small holes in it, letting the high pressure steam expand into this perforated pipe through a "throttled" valve, until the desired low pressure is attained.

Another way to prevent noise, is, to place a tin cylinder, with wire-cloth ends, filled with shot, over the end of the steam-pipe, the pipe turned up into the cylinder, and the cylinder in a vertical position. (See Fig. 52.)

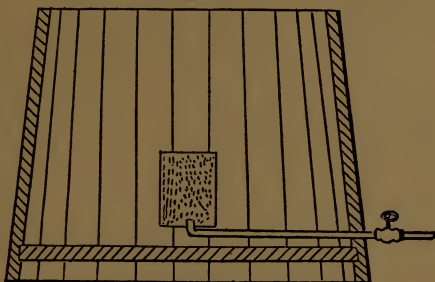
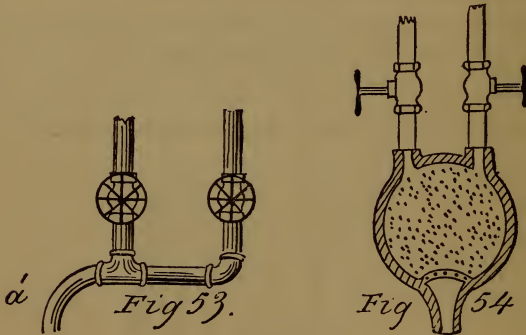

Fig 52

147. Another way to warm water with steam is at the nozzle or cock where it is drawn. A very simple method is by mingling the steam and the water *after they pass their respective cocks or valves* (as shown at Fig. 53). There should be no cock or valve put in the bib, *a'*, for closing it will either force the water or steam (which ever has the greatest pressure) into the other. Therefore it is necessary to have little resistance in the pipe after passing the valves.

A very simple noiseless nozzle is shown in Fig. 54. It consists of an enlargement after passing the valves filled

with shot, with a strainer to prevent the shot from passing out; or it may be filled with clean gravel, or anything the steam and water will have the least action on. By the regulation of the valves, a steady stream of water of almost any temperature between 212° and the temperature of the cold water can be had.



148. Often the pipe-fitter is called upon to construct means to warm water for bath-houses, laundries, or any place where they have no steam, and require no power, hence do not wish to have a steam boiler; nevertheless use more water than can be warmed by the ordinary water back in the stove. The problem is, then, to warm the largest amount of water with the smallest expenditure of fuel. Fig. 55 shows an apparatus that for permanency and cost of maintenance is very satisfactory. *A*, is a tank of any convenient shape; *B*, a cast or wrought iron boiler, similar to that used for green-house heating; *C*, connection from top of boiler to the side of the tank, *not very high up*, as all the water below the point it enters the tank cannot be estimated as part of the working capacity of the tank, for it is necessary to always keep this pipe covered with the water; *D*, the return-pipe

from the tank to the boiler, its inner end being carried a few inches above the bottom of the tank, to prevent sediment from being carried into the boiler, and *E*, the pipe leading from the tank, for the distribution of the hot water, the position it occupies being important, as it must always be above the pipe *C*, to

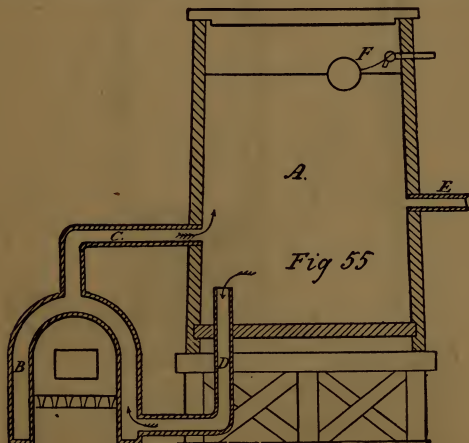

prevent the possibility of drawing the water in the tank entirely down to that point.

The tank may be furnished with a ball-cock, to the cold-water pipe, as shown at *F*, to keep a constant level of water.

By feeding the water into the tank, instead of the boiler, impurities are deposited in the bottom of it, instead of being carried into the boiler. *The same is true of all hot-water apparatus*, if the bottom of the tank is below the return-pipe, with capacity enough in the tank to prevent rapid currents.

A coil of pipe is sometimes used in a stove instead of a boiler, but it soon fills with mud or lime, and burns out.

Fig. 55½ shows steam roasting ovens. They are cast-iron, with double bottoms and double sides for about two-thirds of their heights; the double side forming a terrace or step on the inside of the oven. It is within this space the steam circulates. Tight-fitting heavy

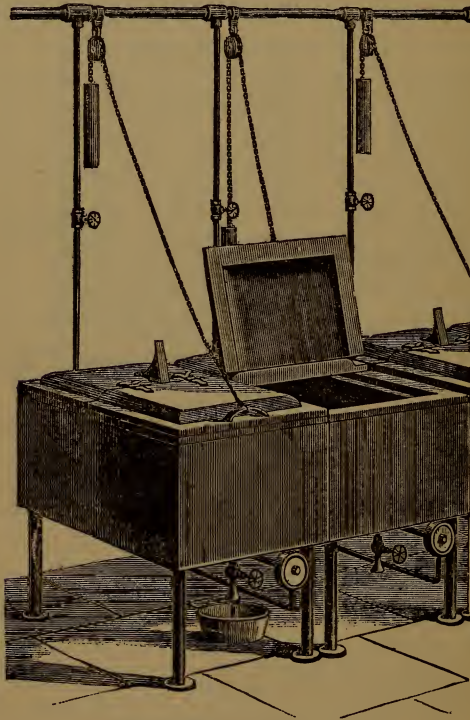

Fig. 55½.

covers fit over one-half the top to retain the hot vapors given off by the meats.

They are connected similar to an ordinary radiator, and are getting to be much liked in public institutions, an oven being capable of holding 60 to 70 lbs. of meats, and cooking it in an hour and one half with 40 pounds pressure of steam.

CHAPTER XXII.

DRYING BY STEAM.

149. THREE-FOURTHS of all the manufacturers outside of the metal trades, and even many of them, use heat for drying purposes ; and various as are the manufacturers, so various are the modes of drying, in many instances satisfactory results being attained only by years of experience.

No manufacturer of wooden articles can get along without a *drying kiln*. The laundry man or woman, the dyer, the hatter, the tobacconist, the piano and organ maker, the dried-fruit manufacturer, the japanner, the tanner, all must have a means of drying faster and more conveniently than can be had by exposure out-of-doors.

Usually steam is used in drying rooms and drying kilns because of its cleanliness, its even distribution, its safety from fire, its easy and quick management, and the cheapness of its maintenance.

The higher the temperature of a drying room, the cheaper can the articles be dried. This may not appear plain at first to those who have studied the laws of equivalents, but nevertheless it is so, being caused by local conditions, which always prevent the utiliza-

tion of all the heat. Thus, the greater the difference in temperature and the slower the movement of the air compatible with the amount of moisture to be carried off, the better the result in the laundry or dry kiln, or any place where rapid drying only is the object.

In no other place is the power of *radiant heat* (direct radiation) more manifest than in the drying room, and more failures can be traced to placing coils under skeleton floors, or flat on the floor, than any other cause, except, perhaps, an ignorance of the principles of piping, which so many consider can be done by any one who wears a pair of greasy overalls.

Fig. 56.

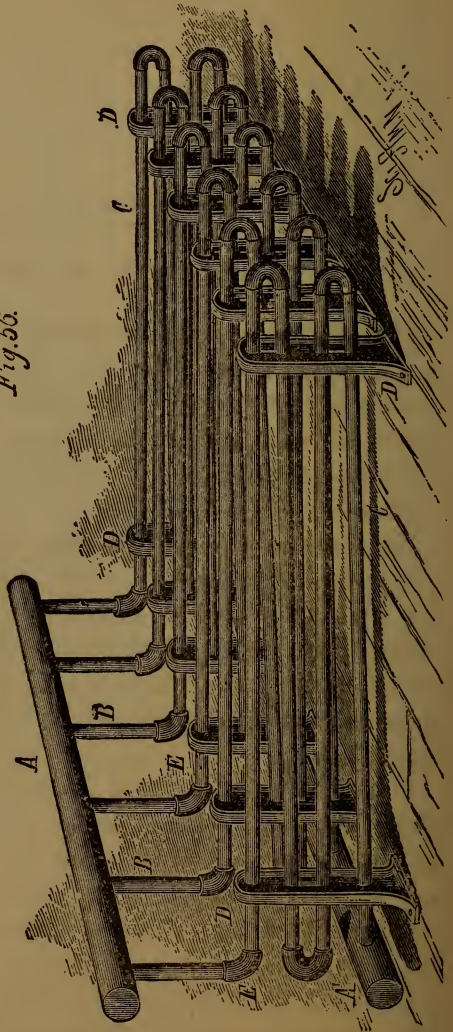

The writer has proved, in many cases, that the same

amount of pipe or plate surface, distributed around and between the materials to be dried, will do the work in half the time it takes the heated air from an indirect coil. This is no mistake; and further, wooden blocks can be dried lighter (proving there is more water driven off) by direct radiation than by indirect radiation, the *times* and *temperatures* being the same.

According to the above it is plain, that in the construction of drying houses, for most purposes, the heating surfaces should be so placed and distributed that the direct *heat rays* from the *iron* could fall uninterrupted, on the greatest surface possible, of the materials to be dried.

150. Fig. 56 shows a perspective of a good arrangement of a *direct radiation laundry drying room coil*,

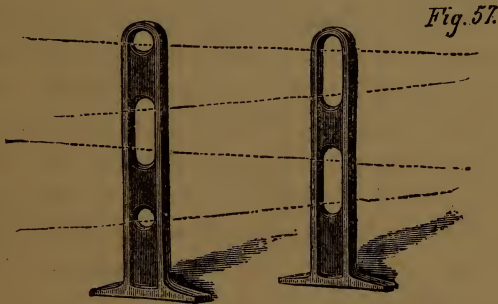

utilizing all the radiant heat that is thrown off, and giving a thoroughly uniform heat throughout the room. *A A'* are *headers* (often called manifolds), usually made of extra heavy pipe, to admit of tapping and threading, instead of using T's, for the cost of the heavy pipe and the drilling and tapping is very much less, as well as better and straighter, than a header composed of many

short pieces of large pipe and the necessary T's. (These remarks apply to all large coils.)

B B are the *spring pieces*, threaded right and left handed; *C C*, the *leaves* or *sections* of the coil; and *D D*, the *coil stands*. The stands are always in pairs, to admit of giving the necessary division and inclination to the pipes, and when viewed through the holes look like Fig. 57. The dotted lines are the centers of imaginary pipes to show the pitch. When coils are very wide in the direction of the length of the headers it is well to keep the coil stand 2 or 3 feet from the header at that end, to prevent the expansion from pulling the screws from the floor.

The distance between the holes in the standing coil header is usually about 12 inches, or as wide as the clothes-horses are from center to center.

The usual way to build these coils is to start at the bottom header, *A'*, Fig. 56, and to put each leaf, *C*, together continuously, working upward until you reach the elbow, *E*; when all the leaves are so far constructed, with all the elbows looking up, with their left-handed thread uppermost, *count in* and *mark* the right and left handed spring-pieces, *B*, then apply the upper header, *A*, and screw the whole up as nearly alike as possible.

Do not be persuaded to do away with the spring-pieces and the elbows through economy, so as to connect the upper headers straight, as in a box coil; if you do you will have trouble should you want to take down a single leaf for repairs.

Fig. 58 shows sectional perspective view through a laundry drying room: *a* being the coil; *b*, the clothes-horse; *c*, the suspended rail, from which the horses

hang ; *d*, fresh-air inlet duct ; *e*, its damper or regulator ;

Fig. 58.

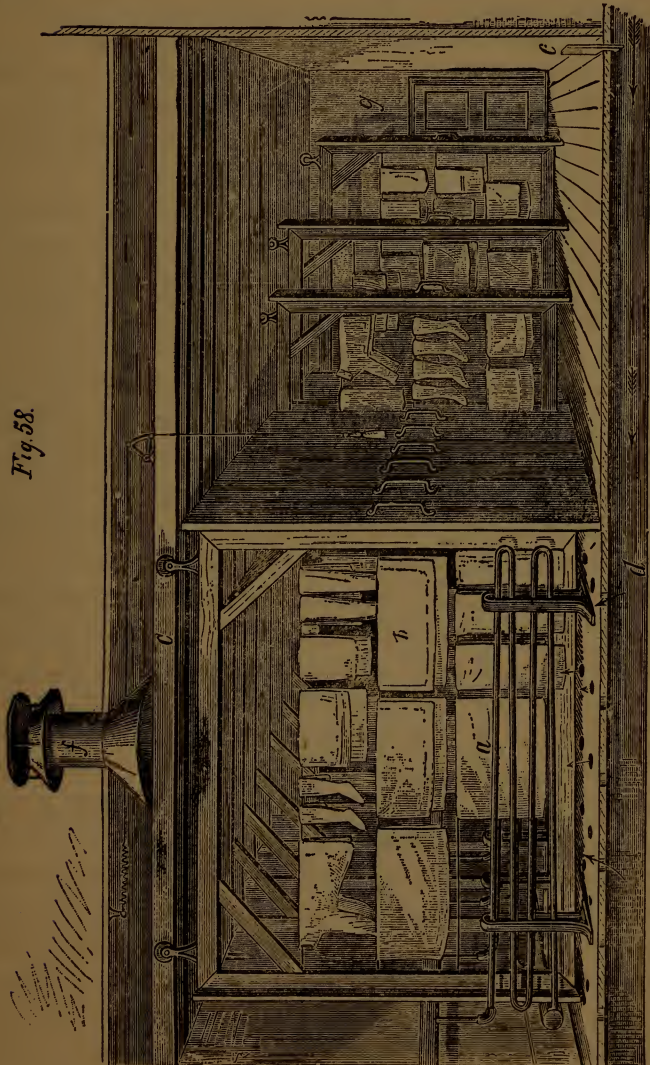

f, ventilator with regulator, usually governed by a cord

and bell crank, and drawn back by a spring; and *g*, the space into which the horses are drawn, which of necessity must be as long as the horses.

This style of drying room gives the direct radiation from both sides of the leaf of the coil to the fabrics to be dried, and also exposes both sides of a fabric to the direct radiation of a section or leaf.

For high pressure steam 1-inch pipe is generally used in the coil; and if exhaust steam is to be used the pipes should be not smaller than one inch, and the total length of any one leaf should not exceed 60 feet under a *back pressure* of 2 pounds at the engine.

For exhaust steam the upper header should be large, 3 inches for 12 leaves of 60 feet each, or about 700 feet in the coil gives satisfactory results; this should be increased in proportion to the increase in leaves, a 4-inch pipe header being enough for a coil of from 1,000 to 1,500 feet, composed of leaves of 60 feet each.

Unless the exhaust steam is carried a long distance horizontally, 50 feet or more, the pipe leading to the header may be one or two sizes smaller than the header, provided it is large enough for the engine.

With steam of high tension, small pipe headers with T fittings may be used; but where the pressure is variable, a large header insures an equal distribution of steam to all the leaves.

Sometimes *gridiron* or *floor* coils are used on account of saving expense, but the same amount of pipe in this form will not dry clothes as fast as the *standing section coil*.

Figs. 59 and 60 show gridiron coils of easy construction, *aa* being the manifolds or headers; *bb*, right and left elbows; *cc*, coil pipes right handed; and *dd*, right and left handed spring-pieces.

In Fig. 59 the pitch of the pipes and headers is in the direction of the arrows.

151. These coils are often used in lumber-drying

Fig. 59.

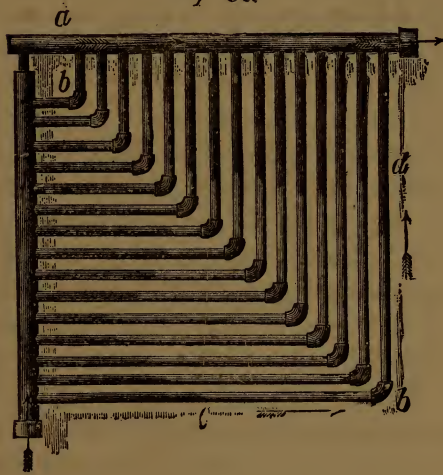
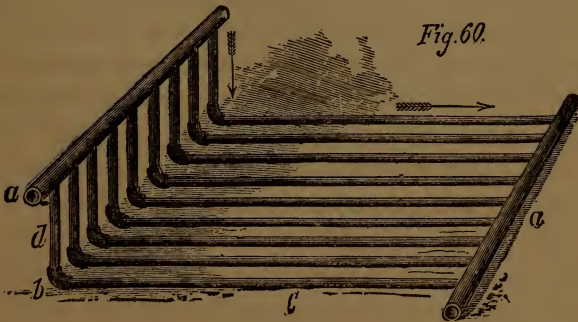

Fig. 60.



kilns, but the same amount of pipe arranged around the walls in miter or wall coils will give a far better result, and will not be a receptacle for dirt, as a floor coil is,

requiring a skeleton floor over it, to walk on and pile the lumber on.

In large drying kilns, on the direct radiation principle, where pipe enough cannot be put on the walls, and for the better distribution of the heat, rows of stanchions should be put up to hang the coils on, in such a manner as not to interfere with the gangways.

The tobacconist prefers to dry without artificial heat, in a temperature of about 60° , with a rapid change of air through the windows. This appears to give dryness without brittleness, but at night and in damp weather they must close the windows, and to get their stock out in time recourse must be had to steam coils.

In experimenting for a well-known tobacco manufacturer in fine cut, it was found that radiators or box coils placed in the middle of the rooms gave the best result. Wall coils under the windows made the room warm, but did not dry quickly, and the tobacco felt wet when brought into a cold room and allowed to remain for a short time. A strong ventilation with a temperature of 80° made it too crisp; but the box coils placed in the middle of the room, with a temperature of 65° , with a small ventilation, and the currents of air in the room, up at the center and down at the windows (contrary to the general principle of warming for comfort), gave a result which was declared satisfactory.

In piano-case manufactories, and where specialties in glued and veneered furniture of the best quality are made, the workmen are generally supplied with a drying cabinet, of a size suitable to the pieces to be dried, in which the work is heated before the glue is applied, and into which it is again placed to dry properly.

These cabinets are usually rectangular boxes, with

holes in the bottom and top, to allow the air from the room to circulate through them so as to carry off the moisture. Their steam coils are usually of the grid-iron pattern, flat on the bottom of the box, and with the valves on the outside. Sometimes they are heated indirectly by the warmed air conveyed in tin pipes from a large coil placed in some favorable position.

Some manufacturers claim the quicker the work can be dried after gluing the better it will be.

It is not profitable to dry by forcing air, as with a fan or blower, in connection with a steam coil, unless the exhaust steam from the engine is condensed in the coils.

A temperature of 130° is considered ample, and can be easily attained in a drying room.

The additional quantity of pipe necessary to raise the temperature of a drying room from 120° to 130° , if again added, will not raise it from 130° to 140° .

With low-pressure steam—2 lbs. per square inch or thereabouts—it is difficult to obtain a temperature above 175° in the drying room, no matter how much surface is used, and with steam at 60 pounds pressure the practicable limit is about 275° Fahr.

CHAPTER XXIII.

STEAM-TRAPS.

152. A STEAM-TRAP is an appliance attached to certain classes of steam apparatus, whose object is to remove the water of condensation without a waste of steam.

A gravity apparatus *does not* require a steam-trap of any kind; and the proof of a perfect gravity circulation is shown by the proper working of the apparatus *without one*.

Traps may be separated into two principal classes—namely, traps which open to the atmosphere, or atmospheric traps, and direct return traps, returning the water to the boiler, without great loss of heat or any loss of water.

Expansion systems of piping and heating require a steam-trap of some kind. When the water is to be saved, and returned to the boiler, the direct return trap is best. When the water is to be wasted, the atmospheric trap, which allows the water to cool to the *lowest* temperature is the best.

Cooking apparatus, such as meat kettles, or kettles or tanks with coils in them, which condense much steam in a short time, should not be connected with a low-pressure gravity apparatus; but should have a separate

pipe from the boiler, and be connected to a trap, in consequence of the great and sudden shrinkage of steam, which takes place when they are quickly filled with cold water. They *may* be connected with a high-pressure gravity apparatus when the supply-pipes are very large.

An *intended* gravity apparatus, which proves too small in the mains, or not properly done, so part of the piping remains full of water, can often be made to answer by the use of a direct return steam-trap; but it should only be used when it is *actually necessary*.

Atmospheric steam-traps should not be attached to a gravity apparatus under any circumstances, as they make an opening which permits the escape of water.

CONSTRUCTION AND OPERATION OF THE DIRECT RETURN STEAM-TRAP.

153. These traps have come into use within ten years, and form a new departure in steam-traps. They must be automatic in action, and of simple construction, and *positive*; for an interruption of an hour or two, will fill the coils and pipes with water, and in very cold weather may be the cause of freezing; so judgment must be exercised in the selection of them. There are now two or three very good modifications of this trap before the public; accomplishing all a steam-pump will do, in the way of returning water to the boiler, and with less loss of heat.

Manufacturers of these traps may claim they should be used on gravity apparatus, for certain purposes—such as to regulate the heat to the weather; but it is evident to a thoughtful man that an apparatus which is perfect,

and that will run for a life-time without interruption (if water is kept in the boiler and fire under it), or assistance from mechanical means, should not be put to the *chance* of an occasional interruption by the use of a *nicely adjusted machine* which wears out.

These traps are excellent in their right place, being capable of returning the condensed water from coils into the boiler, no matter where the coils are placed ; thus doing away with tanks and pumps, in expansion apparatus, and thereby saving heat. Also when a building has no basement, or when the boiler cannot be placed low enough for all the water to return by gravity, they can be used on the low coils ; but in a case where the building is high, it would be best to heat the upper floors by a separate gravity system, and the lower floor or basement by a pipe of its own ; so that if there *was* an interruption, the low coils only would be affected, and thus give less for the trap to do.

The principle involved in these traps is simple, being alternately a vacuum and a pressure ; but, like the single acting reciprocating pump which has no fly-wheel to help it at the end of the stroke, it must have some kind of an auxiliary.

With the aid of the diagram, Fig 61, the action of these traps may be explained. *A* represents the trap proper ; *C*, the receiver, which holds a certain quantity of the return-water ; *D*, a steam-pipe from the boiler to the trap ; *E*, a pipe from the trap to below the water-line in the boiler ; and *F*, a pipe from the receiver to the trap carried up inside the globe. It will also be seen, these pipes are provided with valves ; the steam-pipe has a globe-valve, and the other two pipes, check-valves ; the valve in the pipe *F*, opening toward the

trap, and the valve in the pipe *E*, opening toward the boiler.

Now, if the valve in the steam-pipe is opened and steam admitted to the globe (*B*), until all the air is expelled, and the steam allowed to condense, as it will do in a short time after the valve is closed (by the loss of heat from the steam through the sides of the globe

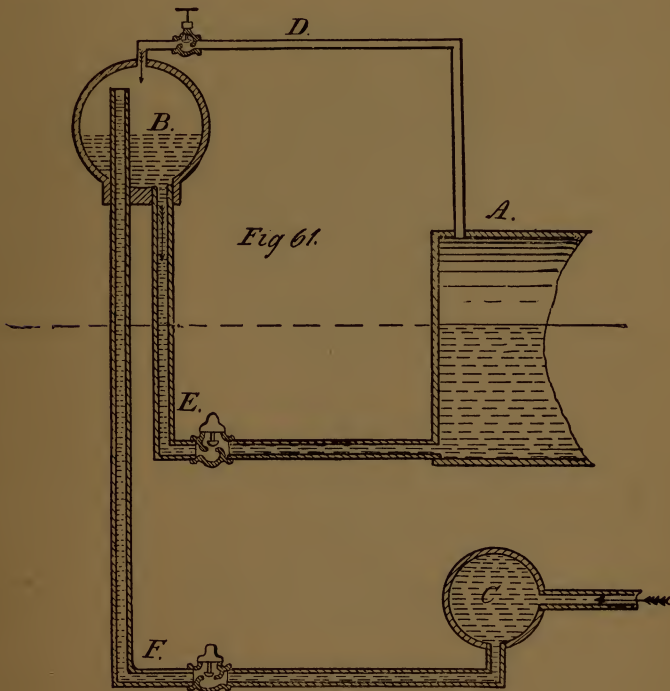

to the outside atmosphere), there will be a vacuum formed in the globe, more or less perfect, which will draw water from the receiver (*C*), when there is a pressure in the pipe which comes from the coils, or else-

where, and this water, passing the check-valve in *F*, will overflow into *B*, and cannot return to *C*, for two reasons — because it *cannot* pass the check-valve backward and cannot get back over the top of the pipe *F*. Now, if the valve in the steam-pipe is opened, and the pressure of the boiler admitted into the top of the globe (*B*), the pressure will become equalized between the boiler and the globe, and allow the water to pass down the pipe (*F*), and into the boiler of its own gravity (precisely as it would if everything was opened to atmosphere), going through the other check-valve, which will not allow it to pass back again, when the valve in the steam-pipe is closed, and condensation will again form a vacuum; which will once more draw the water from the receiver, to flow down into the boiler, when the steam-valve is again opened, and thus the action goes on, being simply that of a *pump without a piston*.

This principle was understood and used, substantially as explained above, before the automatic traps were introduced; but as it was necessary to construct the two globes, or tanks, of large size, to avoid too frequent attendance; and as it required manipulation, at irregular intervals, which, if neglected, would fill the pipes with water, it was not much used. Now, since automatic contrivances have been invented, which takes the place of manipulation, and which can be depended on with some degree of certainty, these traps can be, and are, used on apparatus which otherwise would be almost useless. Thus the difficulty to be overcome in this class of traps as before mentioned, is to construct an automatic contrivance for *opening* and *closing* the steam-valve which can be relied on.

Fig. 62 shows one of these traps, which has been

selected as an example, not because the trap is considered the best—for there are others equally good—but because the action of the auxiliary is so easily explained. It is a view of the trap when set up; *H* is the steam-pipe; *G*, the pipe from the receiver to the trap; and *F*, the pipe from the trap to the boiler. The valve marked *D* is the steam-valve, which is automatically regulated,

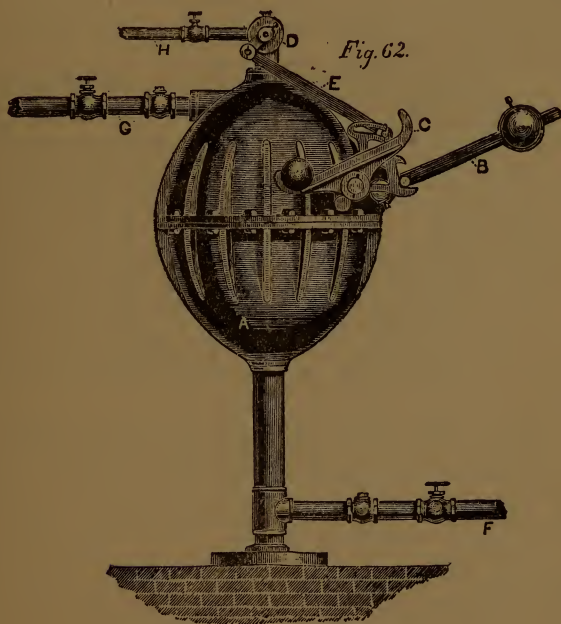

and is a rotary slide-valve; *E*, a connecting rod, between a crank on the valve stem, and an arm, with slack motion, and a part of the casting *C*, which rocks on a stud; *C*, a track, on which rolls a ball, also a part of the casting, which rocks on the stud before mentioned, and which engages another stud, on the lever *B*; the lever

B and its weight are a counterpoise to a float inside the globe. The action is as follows: when there has been a vacuum in the globe, the water will pass through the pipe *G*, and fill the trap, consequently it raises the float and lowers the lever and counterpoise, whose stud engaging *C*, draws it down, until the track passes the horizontal position, without affecting the connecting rod *E*, on account of the lost motion, until the track has *passed* the horizontal position, then the ball will roll along the track, and strike on the opposite end against the hook—a blow sufficient to move the valve on its seat, and open it to its full extent; but not before the globe is full of water. The reverse motion is similar: the float lowering, but not affecting the valve, until the water is nearly all out of the globe; the slack motion allowing the valve to remain open, until the track again passes the horizontal position, when the force exerted by the blow on the hook at the other end of the track closes the valve suddenly.

154. Among the atmospheric traps are found the old expansion traps, now little used; and the open float-traps, which still form a necessary part of certain apparatus.

Fig. 63 shows a well known form of open float-traps, used both in this country and in England, of which there are many modifications of minor importance; the action and principle remaining the same.* *A* is a cast-iron pot, sufficiently strong to withstand high-pressure steam, with an inlet at *F*; *B* is another pot (an open pot), inside the pot *A*, with a spike at the center of the bottom, and a guide to keep the inner pot in a central position. *C* is a brass tube screwed into the cover *D*, and forming a valve with a spike at the inside of the bottom of the

* The "Nason" trap of this type is the best known.

pot *B*; *E* is a valve in the cover of pot *A*, which, when opened, acts as an air-valve, or *blow-through*, to hurry up the circulation when first heating up the coils.

The pot-trap operates thus: the condensed water from the coils, etc., runs in at the pipe *F*, and fills the outer pot *A* with water, until it floats the inner pot *B*, against the stem *C*, closing the valve formed by the

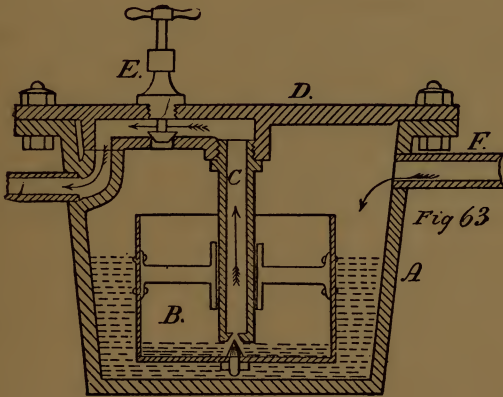

spike and the tube, thus closing the outlet to the tank or sewer. The water, which still continues to flow into the outside pot, rises, and overflows into the inside pot. Then the latter sinks, and opens the valve which the spike forms with the hollow stem, and allows all the water in the inner pot to be forced up through the stem and out by the pressure of the steam in the upper part of the pot acting on the surface of the water. Thus, when the inner pot becomes bouyant again, by the discharge of its water, it closes the valve, and leaves it so, until the increase of the condensed water again overflows it. This action is intermittent, the frequency of it depending on the amount of work to be done.

There is one point in the construction of this trap *on which its working depends*—namely, the area in square inches of the hole in the end of the hollow stem *C* must be no larger than the quotient obtained from dividing the weight in pounds of the inner pot when submerged, by the maximum pressure in pounds per square inch of the steam to be carried.

Thus, if the inner pot weighs $12\frac{1}{2}$ pounds under water, and the greater pressure of the steam is to be 100 pounds per square inch, the hole must be a little smaller than $\frac{1}{8}$ the area of a square inch, say a round hole $\frac{1}{4}$ of an inch in diameter, which leaves a factor of safety of $\frac{1}{5}$ the weight of the pot. The reason for this is plain, when we consider that there is practically no pressure within the stem when the valve is closed; and for the pot to sink, when it is full, it must be heavy enough to pull itself away from the stem, and still be light enough to float $\frac{1}{5}$ of its weight when empty.

This *type* of trap possesses a special point of excellence—it will discharge the water of condensation from coils, or from the cylinder of an engine, into a tank or sewer, at a very much higher level than that which it drains, and it will keep them as dry as if it discharged downward. *It is the only trap opening to atmosphere which will do this*, except by blowing through continuously.

It is peculiarly adapted to elevator engines, which stop and start frequently, and are operated from the car or an upper floor, as it removes the water at a *high* temperature, and will keep a steam-chest *dry* by removing the water which accumulates while the engine is standing with steam turned on; which engines thus used require that they may be always ready for a call.

There is another *open float-trap*, Fig. 64, which contains

a special point of merit, the value of which is not yet generally understood,—namely, a trap capable of taking recognition, so to speak, of temperature, as well as quantity, and which will discharge its water down to

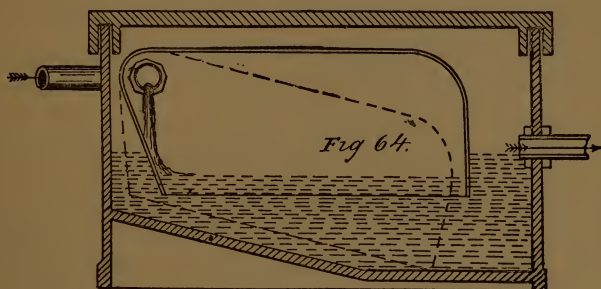

atmospheric *temperature* and *pressure*, no matter what may be the temperature of the water in the coils due to high pressure.

To make this clear, it is necessary to explain, that water which falls to the bottom side of a nearly horizontal pipe, with 50 pounds pressure of steam in it, has not fallen to a temperature of 212° Fahrenheit, as is very generally supposed, but has simply parted with the latent heat of the steam, incidental to the pressure, leaving the temperature of the water (when the flow and pressure of the steam are maintained) a very little less than the temperature of the steam. This water will again give off some of its sensible heat, to be again made latent, making steam of a lower pressure when allowed to expand. But it must not be understood that all the water flies into steam. It does not—the quantity of water converted into steam being represented by the ratio the latent heat of the steam, at the different press-

ures, bears to the sum of the latent heat and the sensible heat of steam.

Thus, when water is drawn directly from a high-pressure coil into the receiver of a trap, and is discharged against atmosphere, before the water has cooled below 212° , it is attended with considerable loss of heat. This can be seen in the blowing of a gauge-cock, for, though the water is solid and dense in the boiler, when it is drawn some of it flies into steam, and makes a cloud which often deludes the novice into the belief that it is all steam, and that possibly he has low water.

The construction of this trap is plain: it consists of an outside case with a loose cover, an open float with the mouth down, and a common plug-cock operated by the float.

When steam or water above 212° in temperature is discharged through the cock, and under the float, the latter is immediately raised by the pressure of the vapor underneath and between the float, and the water which cannot flow over the case. This action closes the cock, which will remain closed until the vapor condenses and allows the float to once more sink, when the cock again discharges the hot water behind it. If this water is below 212° , it will pass rapidly out of the case under the edge of the float; but when it again becomes hot enough to make a little steam, the float raises, and the cock is again shut.

This trap cannot be used on an engine, as it will not discharge any considerable quantity of water until the temperature is below 212° ; but for an expansion system, where the trap has not to discharge against pressure, or for an exhaust system, it is a good one.

CHAPTER XXIV.

VALVES FOR RADIATORS.

155. It is not necessary that I should say much about radiator-valves, as all practical men must be conversant with their application to heaters. Two very important modifications, however, have recently been made, both of which supply a want in steam-fitting. The first, Fig. 65, is a *corner-valve* applicable to all radiators when the connection is to be above the floor. The old and

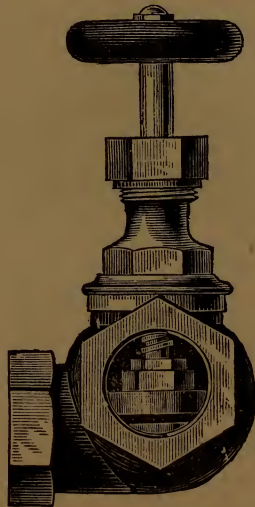

Fig. 65.

usual way was either to raise the radiator on blocks so a nipple and elbow could be used below an ordinary angle valve, or to use gate or globe valve, all of which were very objectionable. To overcome this trouble, Mr. H. M. Smith, of New York, designed the valve shown, which allows the water to drain from the bottom of the radiator; the seat of the valve being on a level with the bottom of the radiator nipple, while the branch to the rising pipe is just one-half the diameter of the pipe lower, allowing all to be above the floor without change to the height of the radiator, or unsightly turns to the pipes or blocks under the legs.

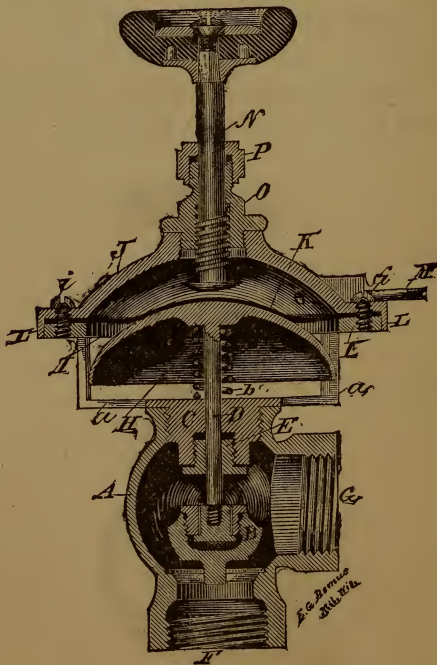

Fig. 66. Sectional View of Diaphragm Valve.

156. Fig. 66 shows the second of these improvements. It is really not a modification of a radiator valve, but is an improvement that may be added to any valve that is to be controlled from a distance.

Its application to a radiator valve is directly for the purpose of controlling the steam in the radiator by the temperature of the room, the medium being a metallic thermostat operating an electric circuit, which, in turn, operates the valve by pneumatic pressure.

It consists of an ordinary valve body, connected with an expansible diaphragm, which serves to close the valve in the valve body. This will be better understood by the following sectional view of the diaphragm valve:

A is the valve body; *B* the valve disc; *C* the packing box through which the stem passes; *H* is a saucer-shaped piece, fastened to the upper end of the stem *D*. The valve is held open by the steel spring *b*, which presses upward on the saucer *H*. Above this saucer *H* is the umbrella-shaped piece *J*, held by the standards *a, a*. Upon the under side of the piece *J*, and fastened firmly to its edges to produce an air-tight joint, is the flexible diaphragm *K*, made of cloth and rubber. There is an opening through the pipe *M* into the chamber formed between the metal piece *J* and the diaphragm *K*. It is easily seen that if air, under pressure, is admitted through the opening *M*, that the valve will be pushed downward to its seat. When the air is allowed to escape from above *K*, the spring *b* will open the valve *B* to its full extent.

It is called the ELECTRO-PNEUMATIC VALVE, and is the result of a series by Prof. W. S. Johnson.

CHAPTER XXV.

BOILER CONNECTIONS AND ATTACHMENTS.

157. *Feed-Pipes.*—The feed-valve should be a globe or angle valve placed near the boiler, with the fewest possible joints in the feed-pipe between it and the boiler. If it is a loose or swivel disk valve, it should be secured with solder (sweated in) in the threads of the double part of the disk, so as to make it almost impossible to loose the disk from the stem; a mark with a center punch or chisel is not enough. The valve should be so turned toward the boiler that the inflowing water will be under and against the disk, so that, in the case of the loss of the disk, it will not act as a check-valve against the influx of the feed-water. This arrangement will bring the pressure of the water in the boiler always against the stuffing-box of the valve; but, all things considered, it is best.

The check-valve should be close to and outside the feed-valve, with only a nipple between them. Always use horizontal check-valves, as they admit of easy cleaning. With the ordinary vertical check it is necessary to take down some part of the feed-pipe to clean it.

When two or more boilers are fed from the same

pump, or when the pump is used for pumping water for some other purpose, it is well to have a stop-valve on each side of the check-valve, as it will enable the engineer to get at his check without stopping the water elsewhere.

In passing through boiler walls or cast-iron fronts, care should be taken that the feed-pipe does not nest, or the settling of the boiler will break it off.

Use a flange union on the feed-pipe instead of the common swivel union; the engineer can take it apart with a monkey wrench, and it makes a more permanent job, and it will not leak.

Never put a T in the feed-pipe inside the feed-valve for the purpose of a blow-off; but make a separate connection to the boiler.

Blow-off Cocks.—Never use anything but a plug cock of the best steam metal throughout. The reasons for using a cock are, that the engineer is always sure when he looks at it whether it is shut or open; it gives a straight opening; if chips, packing, or dirt gets into the cock it will shear them off when closing, or if it does not, the engineer knows it is not shut. Do not use an *iron-body cock with brass plug*, for when the cock is opened to blow down a little, the hot water expands the plug of the cock more than the body, and it is almost impossible to close it. Do not use a globe or angle-valve, as you cannot always tell when it is shut; a chip or dirt getting between the disk and seat will prevent its closing. I have seen two fine boilers destroyed from this cause. Gate or straight-way valves are subject to the same objections as globe or angle.

When it is practicable there should be a T with a plug in it in the blow-off pipe outside the blow-off

cock, the plug arranged so as to be removed when the cock is closed. By this means the engineer can always tell if he is losing water from his boiler.

The blow-off pipe should be large, with few bends in it, and fire bends are better than elbows. It should be attached to the bottom of the shell of a horizontal boiler, and not tapped into the head a few inches up. When there is a mud-pipe, attach it at the opposite end from the feed-pipe.

Safety-Valves.—They are the main-stay of the engineer, acting both as a relief and a warning signal. They should be attached to the steam-dome high up. At the side is better than the top, as they are not so liable to draw water when blowing off in that position. They should be large, and have a large pipe connection all to themselves. The ordinary cross-body safety-valve is very much to be condemned, and I think in some countries there are regulations against their use. They are constructed to save making an extra connection for the main steam-pipe, thereby drawing the largest amount of steam directly from under the disk of the safety-valve. A weighted safety-valve is better than a spring-valve when it can be used, as the lifting of the valve makes practically no difference in the leverage; not so with a spring-valve, for the higher it is lifted the more power it takes to compress the spring.

Gauge or Try Cocks.—Gauge-cocks are various in style, the wood handle compression gauge-cock is a very good kind for all purposes. When setting gauge-cocks care should be taken that they are not too low, and that the drip will not flow over the person who tries them. They should be tapped directly into the

boiler if possible; but when it is necessary to use a piece of pipe to bring them through a boiler front or brick-work, give the pipe an inclination backward, that the condensation may run back and into the boiler. When the pipe inclines outward and down, the condensation remains in it and the cock, and will deceive the unwary, giving the appearance of plenty of water with a short blow.

Glass Water-Gauges. — Water-gauges are best set when attached to a vertical cylinder at the front of the boiler. The cylinder should be connected to the boiler with not less than 1-inch pipe, top and bottom; the top or steam connection should be taken from the boiler shell near the front head, and not from the dome or steam-pipe, as the draught of steam in either will cause the glass to show more water than the boiler contains. The bottom or water connection should be taken from the front head at a point where about two thirds of the water in the boiler will be above it and one third below; this will lessen the chances of the pipe stopping up with mud, etc., and it should also be provided with a half-inch pipe at the lowest point for a blow-out. When gauge glasses are set this way the condensation in the cylinder is downward, and the flow of water being toward the boiler through the bottom pipe, the tendency is to cleanse the glass and cylinder and keep them so.

Steam-Gauges should never be set much above or below the boilers to which they are attached, as each two feet of fall or elevation from the direct connection is nearly equal to a difference of one pound on the steam-gauge; it is always so when the gauge is below, for the condensation in the gauge-pipe fills it with water,

which leaves a pressure on the steam-gauge equal to the hydrostatic head, which is a little over two feet perpendicularly to the pound per steam-gauge, giving the gauge the appearance of being weak. When the gauge is above it is not so always, though generally so even then, for the pipes being long and of small diameter or trapped, which prevents a circulation of steam in them, they fill with water, which acts against the pressure from the boiler and gives a gauge the appearance of being strong. It is a good plan to connect the gauge-pipe to a boiler below the water-line, say 12 or 18 inches, and have the gauge on the boiler about 12 inches above the water-line, using no water-trap or siphon, that the water may run back from the gauge when there is no pressure in the boiler, and thereby prevent the possibility of freezing or of getting steam to the spring of the gauge.

Sometimes a steam-fitter has to run a gauge pipe a long distance to an office or engine room. When such a gauge is far above the boiler he should run a large pipe direct from the steam-dome, and give it sufficient pitch to clear itself of water; it should be covered with some non-conducting material, and be of such size that the flow of steam through the pipe to supply the loss by condensation will be so slow as not to interfere with the flow of water along the bottom of the pipe in a contrary direction, and it should have a siphon immediately under the gauge.

When it is necessary to have a gauge very much lower than a boiler, fill the pipe with water, but before doing so remove the glass and lift the hand or index over the stop-pin and mark where it remains stationary; now fill the pipe to its highest point with water,

then draw the index from its spindle and set it back to the mark where it remained stationary before the pipe was filled, and press it on; then bring it to its normal position on the stop-pin and adjust the glass.

The Main Steam-Pipe for Heating Apparatus should be high up on a boiler, and any pipe larger than 2 inch should not be tapped in, but connected with a flange bolted or riveted to the boiler. Two and a half inch pipe and larger sizes have eight threads to the inch, which forms too coarse a *pitch* to be tapped into one thickness of boiler iron.

Automatic water-feeders, combination water-gauges, or steam-gauges, should not be tapped into the steam-heating or engine pipe, as the draught of the steam through the pipe interferes with their proper working.

Engine or pump pipes should not be taken from the steam-heating pipe, as the draught they cause relieves the pressure in the heating apparatus and spoils the circulation, especially if it is a direct return gravity circulation.

With an automatic return steam-trap, applied to an old job, if the steam-heating pipe is large enough, it will not be necessary to remove the engine pipe, but should the circulation be still defective, remove the engine pipe to the shell of the boiler, and remote from the heating pipe.

All pipes connecting with boilers should be *extra thick* until at least the first cock or valve is reached, as much of the pipe now on the market is below the old Morris Tasker Co. standard, and is too thin; one inch to two inch inclusive being the sizes which give the most trouble.

CHAPTER XXVI.

MISCELLANEOUS ARTICLES.

CUTTING WALLS AND COVERING RISERS.

158. ARCHITECTS often omit to leave a recess where required in the walls of a building, and the fitter has to cut one.

In his anxiety to put up as much pipe as possible, and as he considers the cutting of the wall does not properly belong to him, he cuts it in the quickest and easiest manner he can, regardless of the appearance, and in some loosely put up walls it is a difficult task to make an attractive or even satisfactory piece of work. The proper way would be to have the openings left and cutting avoided; but if it must be done, it should be well done.

Let the fitter provide himself with *sharp* chisels, and a *light* hammer, and he can generally cut a brick, without disturbing it in the wall; but it is also necessary for the master mechanic to consider wall cutting *labor*, and to give the workman to understand he will be credited with cutting walls as well as for putting up pipe.

The fitter should get the architect's permission before he commences to cut, for otherwise there may

be much injury done to a building, by having a recess cut from top to bottom, near a front wall or corner.

The best way to cover a riser recess is with a board. Have the grounds put on before the plastering is done, and have the panel *screwed* on afterward. The panel may be fancy iron-work, with holes in it, which makes a very permanent method. A moveable panel admits of access to the pipes to make repairs without breaking the walls.

Some architects require the recess to be plastered over, using slate, or coarse wire-cloth, to hold the plaster with, so as to entirely hide the appearance of a pipe, but even then they do not entirely succeed, for two or three reasons. When a slate is stuck over the recess with plaster-of-Paris, and plastered over all, the expansion of the slate cracks the plaster; when plastered on wire-cloth, it does very well, and will not crack, but it will turn a dark color in time, as will any thin covering when it becomes warm; and the continuous current of air passing up the wall at that particular spot deposits more dust there than at any other point, and leaves a well-defined mark.

For the same reason, the walls back of radiators get darker more rapidly than the walls of any other part of the room. The same is true of curtains which hang near a register. In parts of the country where soft coal is generally used this is very apparent.

TURNING EXHAUST STEAM OR VAPOR INTO CHIMNEYS.

159. There is a custom among steam-fitters, and others, of turning the exhaust steam from an engine into the boiler chimney in buildings, ostensibly to

make the draft better, but in reality to save running an exhaust pipe to the roof of the building.

Exhaust steam, turned into a long or high brick chimney, will not improve the draft, but impair it.

In locomotives the exhaust steam is turned into the stack to increase the draft, and in *short* iron stacks of portable engines it has the same effect, when properly put in; but it must be borne in mind, that to be effective, it must have such proportions as to make it an *injector*, to increase the velocity of the air by contact with its own high velocity, before it has time to expand and fill the stack.

In long iron stacks, a little steam turned into them may be of some use in warming the stack (which cools rapidly from contact with the wind and air in cold weather), and by assisting the upward current of smoke or air, by mixing with it. Under certain conditions, it makes a mixture of steam and air lighter than the air alone, while, if the increased velocity caused thereby more than compensates for the extra volume which has to pass it, may be an improvement.

But usually the exhaust steam chokes a very long chimney, the latent heat of the steam passing through the sides of the chimney (especially an iron one), and leaving the condensation to run down the insides of the chimney in streams, and to be again partly re-evaporated by absorbing heat from the gases of combustion.

In brick chimneys this is very apparent, condensing and soaking into the brick-work, and absorbing as much heat from the gases of combustion to evaporate and drive off a cubic foot of it as would cool 30,000 cubic feet of air 100 degrees Fahrenheit. It also *destroys* the chimney.

SOLDERING OF PIPES AND BRASS FITTINGS.

160. Often it is necessary to solder or "sweat" pipes into fittings, or male and female threads of brass work. The latter is no trouble, and can be done by tinning the parts to be put together, using only resin for a flux, if done while new, and then screwing them together while hot.

When iron pipe has to be sweated into iron fittings, malleable iron fittings should be used, because they can be tinned by using muriatic acid reduced with zinc; cast iron does not solder well.

When about to sweat a pipe and fitting together, wipe the threads carefully, and run a carefully wiped die over the male thread, to entirely clean it, using a clean tap, to remove any oxide or grease from the female thread in the fitting, then tin cleanly, using muriatic acid for a flux, and screw them together while both are hot.

There is no advantage in soldering a frost burst in an iron pipe, through which steam or very hot water passes, *for it will not last.*

In iron water-pipe, rather than remove the pipe, it may be soldered, but it must be thoroughly cleaned and tinned, and a heavy *wipe* joint made on it; *bolting* is of no avail.

When cracks appear in brass or copper pipes, without any apparent cause, there is very little use in soldering, for they are usually caused by undue expansion or jarring, and are a fault of construction, which soft solder will remedy for a very short time.

Parts of brass goods, such as valves, etc., which are

liable to jar loose, should be sweated together in particular places, such as the disk on a feed-valve, or main stop-valve.

PAINTING PIPES.

161. Distributing pipes may be painted with anything that will arrest oxidation; lead paints are very good, for they are the poorest conductors of heat; but lead paints should not be used on radiating surfaces, as they lessen the radiating and transmitting power, many coats applied, year after year continually, impair their efficiency greatly.

Zinc paint is considered somewhat better, but there is good reason to say it should not be used.

Raw linseed-oil, with ochre of the required color, and turpentine, form a good preparation for radiators, when they are to be bronzed, as it gathers and "fixes" any machine oil or dirt there may be on the pipes, and will make a good *back* for the bronze.

Black baking japan, or black air-drying japan, are very good substances for painting radiators with, as they appear to impair their efficiency but little, and two coats will give a good gloss, which does not require to be renewed; a wipe with a slightly oiled woolen cloth will give them a fresh appearance.

Black paraffine varnish should not be used; it is not permanent; it cokes with heat, and has no body.

Indirect coils, or coils or heaters which cannot be seen, it is best not to paint.

Dust allowed to collect on heaters impairs them very much.

CHAPTER XXVII.

MISCELLANEOUS NOTES AND TABLES.

THESE notes and tables will be found of service in estimating.

The avoirdupois pound is always to be used, unless otherwise specified. It contains 7,000 Troy *grains*; the grain is always Troy.

16 drams	= 1 ounce.	oz.
16 ounces	= 1 pound.	lb.
25 pounds	= 1 quarter.	qr.
4 quarters	= 1 hundred.	cwt.
20 cwt., 2,000 lbs.	= 1 ton.	

The *gross ton* (in which the *quarter* becomes 28 lbs., the hundredweight, 112 lbs., and the *ton*, 2,240 lbs.) is used in estimating English goods at the U. S. Custom-House; in freighting; in the wholesale coal trade; and in the wholesale *iron* and plaster trades, and when *specified*.

$$\begin{aligned}
 1 \text{ lb. avoird.} &= 16 \text{ oz. avoird.} = 7,000 \text{ grs. Troy.} \\
 1 \text{ " " " } &= 437.5 \text{ " " " }
 \end{aligned}$$

$27\frac{7}{10}$ cubic inches of water weigh one pound avoirdupois, at a temperature of 40°.

A cubic foot of water, at a temperature of 60° , weighs 999 ozs., and is taken as 1,000 ounces, or $62\frac{1}{2}$ pounds, for all ordinary calculations. It weighs a little less than 60 pounds when the temperature is 212° .

A cubic foot of water contains very nearly $7\frac{1}{2}$ gallons, and for rough calculations may be taken as such (7.4805 gallons is actual) number.

A cubic inch of water, at its greatest density, weighs 252.725 grains ; a cubic foot, 62.4 pounds.

		1 gal. =	231.0 cubic in.
	1 cub. ft., $7\frac{1}{2}$	" =	1728.0 "
1 bushel, $1\frac{6}{25}$	" $9\frac{3}{10}$	" =	2150.42 "
1 cord, 128.0	"	" =	" "
1 cub. yd., 27.0	"	" =	46656.0 "
1 barrel,* 4.21	" $31\frac{1}{2}$	" =	7276.5 "

* A flour barrel will hold 33.28 gallons, or 4.449 cubic feet, or 2.79 *heaped* bushels (called $2\frac{3}{4}$ bushels).

In estimating quantities of water by barrels, $31\frac{1}{2}$ standard gallons equals the barrel.

TABLE NO. 9.

WEIGHT OF A CUBIC INCH OF VARIOUS METALS.

Iron, cast.....	0.263 of a pound.
“ wrought.....	0.28 “
Lead.....	0.41 “
Copper.....	0.32 “
Nickel.....	0.30 “
Steel.....	0.28 “
Tin.....	0.265 “
Zinc, cast.....	0.24 “
“ rolled.....	0.26 “
Brass, steam metal.....	0.315 “
“ yellow.....	0.282 “

TABLE NO. 10.

WEIGHT OF A CUBIC FOOT OF VARIOUS BUILDING MATERIALS, IN POUNDS
(APPROXIMATE).

Granite.....	168.0 pounds
Marble.....	165.0 “
Sandstone.....	135.0 “
Blue-stone.....	165.0 “
Slate.....	180.0 “
Mortar, dry.....	80.0 to 100 pounds.
Common Brick.....	112.0 pounds.
Dry Sand.....	100.0 “
Fire-brick.....	135.0 “

One *perch* of stone-work, in walls or foundations, measures $24\frac{3}{4}$ cubic feet.

One thousand common bricks, laid in a wall, makes about 50 cubic feet, varying a little for different bricks.

Six fire-bricks to each square foot of lining, one brick thick, is sufficient ; 1,000 bricks will make 170 superficial feet of lining, laid in the ordinary way.

To find the weight of iron castings by computation.— Find its solid contents, in inches, and multiply them by .26, and it will give the weight, in pounds. For rough calculations, it will do to divide the cubic inches by 4, and call the answer pounds.

To find the weight of any other casting, or forging.— Find its solid contents in cubic inches, and multiply by the weight of a cubic inch of the metal, as given in the table, “ Weight of a cubic inch of various metals.”

For irregular castings, which are difficult to measure, and cannot be conveniently weighed, a *rough estimate* of their weight may be taken, provided they are not *cored out*, by weighing the pattern, if it is of soft pine, and allowing 13 times the weight of the pattern, if it

is new, or just out of the sand, and 14 times if it has laid in the pattern loft for some time.

A square foot of cast-iron, one inch thick, weighs $37\frac{1}{2}$ pounds. To find what a square foot of any other thickness will weigh, multiply $37\frac{1}{2}$ by the thickness in inches, or fractions of an inch.

A square foot of rolled wrought-iron, one inch thick, weighs 40 lbs. To find the weight of boiler plates, or sheet-iron, per square foot, multiply 40 by the decimal of an inch in thickness the required plates are to be.

TABLE NO. 11.

THE FOLLOWING TABLE SHOWS THE DIFFERENCE BETWEEN AMERICAN AND ENGLISH WIRE GAUGES, AND THE THICKNESS OF PLATES, IN DECIMALS OF AN INCH FOR EACH.

No. of Gauge.	American. Inches.	English. Inches.
0000	0.46	0.454
000	0.4096	0.425
00	0.3648	0.38
0	0.3248	0.34
1	0.2893	0.3
2	0.2576	0.284
3	0.2294	0.259
4	0.2043	0.238
5	0.1819	0.22
6	0.1620	0.203
7	0.1442	0.18
8	0.1284	0.165
9	0.1144	0.148
10	0.1018	0.134
11	0.0907	0.12
12	0.0808	0.109
13	0.0719	0.095
14	0.0640	0.083
15	0.057	0.072
16	0.05	0.065
17	0.045	0.058
18	0.04	0.049
19	0.035	0.042
20	0.031	0.035

To find the weight of a cast-iron pipe, for one foot or its length.—Multiply the diameter of the pipe in inches by 3.1416, and multiply the answer thus obtained, by the thickness of the pipe in inches, or decimals of an inch, then by 12 and 0.26 respectively ; or instead of the last two, use 3.15.

This will give about the weight of the pipe, including the hubs, as the outside circumference of the pipe is not the *mean* length of the iron, according to its thickness. To be exact. Proceed as above, but take one thickness of the iron from the diameter of the pipe first, and it will give the weight of the pipe without hubs or flanges.

Example.—Required the weight of a 12-inch pipe, $\frac{1}{2}$ inch thick, for one foot of its length. Thus : 12 in. — 0.5 = 11.5 \times 3.1416 = 36.127 \times 0.5 = 18.063 \times 3.15 = 56.89 pounds.

The 3.15 is the *sum* of 12 inches for the length, and 0.263 for the weight.

Definitions and computations in mensuration, required by the steam-fitter.

The *perimeter* of a figure is its outer boundary, without regard to shape.

A *true* circle forms the shortest perimeter for the greatest area inclosed, and is called a *circumference*.

A diameter is a right line, passing through the center of a circle.

A diameter is very nearly $\frac{3.20}{100}$ of the circumference of the same circle, or, *to be exact*, 0.3183 of it. Rule.—Multiply the circumference by 0.3183, and it will give the answer, in the same denomination.

A circumference is $3\frac{14}{100}$ of the diameter of the same circle very nearly, or, *to be exact*, 3.1416.

The *square* of the diameter of a circle is multiplying it once by itself. Thus, if the diameter is 4, the square will be 16. (4 inches \times 4 inches = 16 inches.)

To find the area (the number of square inches) within a circle.—Multiply the square of the diameter by 0.7854, and it will give the answer in the same denomination as it was squared in. Thus, 4'' \times 4'' = 16'' \times 0.7854 = 12.566 square inches, whose diameter is 4 inches.

The *cube* of a number is the number multiplied by itself twice. Thus, 4 \times 4 = 16 \times 4 = 64.

When the *cube* of the diameter of a sphere is multiplied by 0.5236, it gives the solid contents, in numbers of the same denomination as it was cubed in. Thus : 4'' \times 4'' = 16'' \times 4'' = 64'' \times 0.5236 = 33.51 cubic inches, for a ball 4 inches in diameter ; and when multiplied again by 0.263 it gives 8.813, which will be the weight in pounds of a cast-iron ball of the same diameter.

A cylinder of the same length as its diameter has the same surface as a sphere of equal diameter.

To find the surface of a cylinder 4 inches in diameter and 4 inches long.—Multiply the diameter by 3.1416 and the product by the 4 inches in length. Thus, 4 \times 3.1416 = 12.566 \times 4 = 50.2656, the square inches on the outside of a 4 \times 4 cylinder.

To find the surface of a sphere, 4 inches in diameter.—Square the diameter, and multiply by 3.1416. Thus : 4 \times 4 = 16 \times 3.1416 = 50.2656.

To find the outside surface of a pipe.—Multiply the outside diameter by 3.1416, and by the length in inches, and divide by 144, it will give the answer in square feet.

To find the pressure, per square inch, a column of

water of any height will exert.—Multiply the height of the column, in feet, by the weight of a cubic foot of water in pounds at the temperature the water may be, and divide by 144.

Example.—Required the pressure, per square inch, of a head of water of 200 feet, and when the temperature of the water is 40° Fahr. (weight 62½ pounds). Thus, $200 \times 62.5 = 12500 \div 144 = 86.8$ pounds per square inch.

Required the pressure of the water at a temperature of 212°. Thus, $200 \times 59.80 = 11960 \div 144 = 83.05$ pounds per square inch.

TABLE NO 12.

THE FOLLOWING TABLE OF DIAMETERS, CIRCUMFERENCES, AND AREAS IS GIVEN FOR "READY-RECKONING."

Diameter.	Circumference.	Area.	Diameter.	Circumference.	Area.
$\frac{1}{16}$	0.1963	0.0030	$\frac{7}{16}$	4.5160	1.6229
$\frac{1}{8}$	0.3927	0.6122	$\frac{1}{2}$	4.7124	1.7671
$\frac{3}{16}$	0.5890	0.0276	$\frac{5}{8}$	4.9087	1.9175
$\frac{1}{4}$	0.7854	0.0490	$\frac{1}{2}$	5.1051	2.0739
$\frac{5}{16}$	0.9817	0.0767	$\frac{1}{2}$	5.3015	2.2365
$\frac{3}{8}$	1.1781	0.1104	$\frac{3}{4}$	5.4978	2.4052
$\frac{7}{16}$	1.3744	0.1503	$\frac{1}{2}$	5.6941	2.5801
$\frac{1}{2}$	1.5708	0.1963	$\frac{7}{8}$	5.8905	2.7611
$\frac{9}{16}$	1.7671	0.2485	$\frac{1}{2}$	6.0868	2.9483
$\frac{5}{8}$	1.9635	0.3068	2 in.	6.2832	3.1416
$\frac{1}{2}$	2.1598	0.3712	$\frac{1}{16}$	6.4795	3.3411
$\frac{3}{4}$	2.3562	0.4417	$\frac{1}{8}$	6.6759	3.5465
$\frac{13}{16}$	2.5525	0.5185	$\frac{3}{8}$	6.8722	3.7582
$\frac{7}{8}$	2.7489	0.6013	$\frac{1}{2}$	7.0686	3.9760
$\frac{15}{16}$	2.9452	0.6903	$\frac{1}{4}$	7.2649	4.2001
1 in.	3.1416	0.7854	$\frac{1}{8}$	7.4613	4.4302
$\frac{1}{16}$	3.3379	0.8861	$\frac{1}{2}$	7.6576	4.6664
$\frac{1}{8}$	3.5343	0.9940	$\frac{1}{2}$	7.8540	4.9087
$\frac{3}{16}$	3.7306	1.1075	$\frac{5}{8}$	8.0503	5.1573
$\frac{1}{4}$	3.9270	1.2271	$\frac{1}{2}$	8.2467	5.4119
$\frac{5}{16}$	4.1233	1.3529	$\frac{1}{2}$	8.4430	5.6727
$\frac{3}{8}$	4.3197	1.4848	$\frac{3}{4}$	8.6394	5.9395

Diameter.	Circumference.	Area.	Diameter.	Circumference.	Area.
$\frac{13}{16}$	8.8357	6.2126	$\frac{1}{2}$	17.2788	23.7583
$\frac{7}{8}$	9.0321	6.4918	$\frac{9}{16}$	17.4751	24.3014
$\frac{15}{16}$	9.2284	6.7772	$\frac{5}{8}$	17.6715	24.8505
3 in.	9.4248	7.0686	$\frac{11}{16}$	17.8678	25.4058
$\frac{1}{16}$	9.6211	7.3662	$\frac{3}{4}$	18.0642	25.9672
$\frac{1}{8}$	9.8175	7.6699	$\frac{13}{16}$	18.2605	26.5348
$\frac{3}{16}$	10.0138	7.9798	$\frac{7}{8}$	18.4569	27.1085
$\frac{1}{4}$	10.2102	8.2957	$\frac{15}{16}$	18.6532	27.6884
$\frac{5}{16}$	10.4065	8.6179	6 in.	18.8496	28.2744
$\frac{3}{8}$	10.6029	8.9462	$\frac{1}{16}$	19.0459	28.8665
$\frac{7}{16}$	10.7992	9.2806	$\frac{1}{8}$	19.2423	29.4647
$\frac{1}{2}$	10.9956	9.6211	$\frac{3}{16}$	19.4386	30.0798
$\frac{9}{16}$	11.1919	9.9678	$\frac{1}{4}$	19.6350	30.6796
$\frac{5}{8}$	11.3883	10.3206	$\frac{5}{16}$	19.8313	31.2964
$\frac{11}{16}$	11.5846	10.6796	$\frac{3}{8}$	20.0277	31.9192
$\frac{3}{4}$	11.7810	11.0446	$\frac{7}{16}$	20.2240	32.5481
$\frac{13}{16}$	11.9773	11.4159	$\frac{1}{2}$	20.4204	33.1831
$\frac{7}{8}$	12.1737	11.7932	$\frac{9}{16}$	20.6167	33.8244
$\frac{15}{16}$	12.3700	12.1768	$\frac{5}{8}$	20.8131	34.4717
4 in.	12.5664	12.5664	$\frac{11}{16}$	21.0094	35.1252
$\frac{1}{16}$	12.7627	12.9622	$\frac{3}{4}$	21.2058	35.7847
$\frac{1}{8}$	12.9591	13.3640	$\frac{13}{16}$	21.4021	36.4505
$\frac{3}{16}$	13.1554	13.7721	$\frac{7}{8}$	21.5985	37.1224
$\frac{1}{4}$	13.3518	14.1862	$\frac{15}{16}$	21.7948	37.8005
$\frac{5}{16}$	13.5481	14.6066	7 in.	21.9912	38.4846
$\frac{3}{8}$	13.7445	15.0331	$\frac{1}{16}$	22.1875	39.1749
$\frac{7}{16}$	13.9408	15.4657	$\frac{1}{8}$	22.3839	39.8713
$\frac{1}{2}$	14.1372	15.9043	$\frac{3}{16}$	22.5802	40.5469
$\frac{9}{16}$	14.3335	16.3492	$\frac{1}{4}$	22.7766	41.2825
$\frac{5}{8}$	14.5299	16.8001	$\frac{5}{16}$	22.9729	41.9974
$\frac{11}{16}$	14.7262	17.2573	$\frac{3}{8}$	23.1693	42.7184
$\frac{3}{4}$	14.9226	17.7205	$\frac{7}{16}$	23.3656	43.4455
$\frac{13}{16}$	15.1189	18.1900	$\frac{1}{2}$	23.5620	44.1787
$\frac{7}{8}$	15.3153	18.6655	$\frac{9}{16}$	23.7583	44.9181
$\frac{15}{16}$	15.5116	19.1472	$\frac{5}{8}$	23.9547	45.6636
5 in.	15.7080	19.6350	$\frac{11}{16}$	24.1510	46.4153
$\frac{1}{16}$	15.9043	20.1290	$\frac{3}{4}$	24.3474	47.1730
$\frac{1}{8}$	16.1007	20.6290	$\frac{13}{16}$	24.5437	47.9370
$\frac{3}{16}$	16.2970	21.1252	$\frac{7}{8}$	24.7401	48.7070
$\frac{1}{4}$	16.4934	21.6475	$\frac{15}{16}$	24.9354	49.4833
$\frac{5}{16}$	16.6897	22.1661	8 in.	25.1328	50.2656
$\frac{3}{8}$	16.8861	22.6907	$\frac{1}{16}$	25.3291	51.0541
$\frac{7}{16}$	17.0824	23.2215	$\frac{1}{8}$	25.5255	51.8486

Diameter.	Circumference.	Area.	Diameter.	Circumference.	Area.
$\frac{3}{16}$	25.7218	52.8994	$\frac{3}{4}$	36.9138	108.4342
$\frac{1}{4}$	25.9182	53.4562	$\frac{7}{8}$	37.3065	110.7536
$\frac{5}{16}$	26.1145	54.2748	12 in.	37.6992	113.0976
$\frac{3}{8}$	26.3109	55.0885	$\frac{1}{2}$	38.0919	115.4660
$\frac{7}{16}$	26.5072	55.9138	$\frac{1}{4}$	38.4846	117.8590
$\frac{1}{2}$	26.7036	56.7451	$\frac{3}{8}$	38.8773	120.2766
$\frac{9}{16}$	26.8999	57.5887	$\frac{5}{8}$	39.2700	122.7187
$\frac{5}{8}$	27.0963	58.4264	$\frac{1}{2}$	38.6627	125.1854
$\frac{11}{16}$	27.2926	59.2762	$\frac{3}{4}$	40.0554	127.6765
$\frac{3}{4}$	27.4890	60.1321	$\frac{7}{8}$	40.4481	130.1923
$\frac{13}{16}$	27.6853	60.9943	13 in.	40.8408	132.7326
$\frac{7}{8}$	27.8817	61.8625	$\frac{1}{3}$	41.2338	135.2974
$\frac{15}{16}$	28.0780	62.7369	$\frac{1}{4}$	41.6262	137.8867
9 in.	28.2744	63.6174	$\frac{1}{2}$	42.0180	140.5007
$\frac{1}{16}$	28.4707	64.5041	$\frac{3}{8}$	42.4116	143.1391
$\frac{1}{8}$	28.6671	65.3968	$\frac{1}{2}$	42.8044	145.8021
$\frac{3}{16}$	28.8634	66.2957	$\frac{5}{8}$	43.1970	148.4896
$\frac{1}{4}$	29.0598	67.2007	$\frac{7}{8}$	43.5857	151.2017
$\frac{5}{16}$	29.2561	68.1120	14 in.	43.9824	153.9384
$\frac{3}{8}$	29.4525	69.0293	$\frac{1}{3}$	44.3751	156.6995
$\frac{7}{16}$	29.6488	69.9528	$\frac{1}{4}$	44.7676	159.4852
$\frac{1}{2}$	29.8452	70.8833	$\frac{3}{8}$	45.1605	162.2956
$\frac{5}{8}$	30.0415	71.8121	$\frac{1}{2}$	45.5532	165.1303
$\frac{3}{4}$	30.2379	72.7599	$\frac{5}{8}$	45.9459	167.9896
$\frac{7}{8}$	30.4342	73.7079	$\frac{7}{8}$	46.3386	170.8735
$\frac{15}{16}$	30.6306	74.6620	$\frac{1}{2}$	46.7313	173.7820
$\frac{1}{8}$	30.8269	75.6223	15 in.	47.1240	176.7150
$\frac{3}{16}$	31.0233	76.5887	$\frac{1}{3}$	47.5167	179.6725
$\frac{1}{4}$	31.2196	77.5613	$\frac{1}{4}$	47.9094	182.6545
10 in.	31.4160	78.5400	$\frac{3}{8}$	48.3021	185.6612
$\frac{1}{8}$	31.8087	80.5157	$\frac{1}{2}$	48.6948	188.6923
$\frac{1}{4}$	32.2014	82.5160	$\frac{5}{8}$	49.0875	191.7480
$\frac{3}{8}$	32.5941	84.5409	$\frac{3}{4}$	49.4802	194.8282
$\frac{1}{2}$	32.9868	86.5903	$\frac{7}{8}$	49.8729	197.9330
$\frac{3}{4}$	33.3795	88.6643	16 in.	50.2656	201.0624
$\frac{7}{8}$	33.7722	90.7627	$\frac{1}{3}$	50.6583	204.2162
$\frac{15}{16}$	34.1649	92.8858	$\frac{1}{4}$	51.0510	207.3946
11 in.	34.5576	95.0334	$\frac{3}{8}$	51.4447	210.5976
$\frac{1}{8}$	34.9503	97.2053	$\frac{1}{2}$	51.8364	213.8251
$\frac{1}{4}$	35.3430	99.4121	$\frac{3}{4}$	52.2291	217.0772
$\frac{3}{8}$	35.7357	101.6234	$\frac{7}{8}$	52.6218	220.3537
$\frac{1}{2}$	36.1284	103.8691			
$\frac{3}{4}$	36.5211	106.1394			

Diameter.	Circumference.	Area.	Diameter.	Circumference.	Area.
7	53.0145	223.6549	8	67.1517	358.8419
17 in.	53.4072	226.9806	12	67.5444	363.0511
1 1/8	53.7999	230.3308	16	67.9371	367.2849
1 1/4	54.1926	233.7055	20	68.3298	371.5432
1 1/2	54.5853	237.1049	24	68.7225	375.8261
1 3/4	54.9780	240.5287	22 in.	69.1152	380.1336
2	55.3707	243.9771	1 1/8	69.5079	384.4655
2 1/8	55.7634	247.4500	1 1/4	69.9006	388.8220
2 1/4	56.1561	250.9475	1 1/2	70.2933	393.2031
18 in.	56.5488	254.4696	1 3/4	70.6860	397.6087
1 3/8	56.9415	258.0161	2	71.0787	402.0388
1 3/4	57.3342	261.5872	2 1/8	71.4714	406.4935
1 3/2	57.7269	265.1829	2 1/4	71.8641	410.9728
1 3/4	58.1196	268.8031	23 in.	72.2568	415.4766
2	58.5123	272.4479	1 1/8	72.6495	420.0049
2 1/8	58.9056	276.1171	1 1/4	73.0422	424.5577
2 1/4	59.2977	279.8110	1 1/2	73.4349	429.1352
19 in.	59.6904	283.5294	1 3/4	73.8276	433.7371
1 7/8	60.0831	287.2723	2	74.2203	438.3636
1 3/4	60.4758	291.0397	2 1/8	74.6130	443.0146
1 3/2	60.8685	294.8312	2 1/4	75.0057	447.6992
1 3/4	61.2612	298.6483	24 in.	75.3984	452.3904
2	61.6539	302.4894	1 1/8	75.7911	457.1150
2 1/8	62.0466	306.3550	1 1/4	76.1838	461.8642
2 1/4	62.4393	310.2452	1 1/2	76.5765	466.6380
20 in.	62.8320	314.1600	1 3/4	76.9692	471.4363
1 3/8	63.2247	318.0992	2	77.3619	476.2592
1 3/4	63.6174	322.0630	2 1/8	77.7546	481.1065
1 3/2	64.0101	326.0514	2 1/4	78.1473	485.9785
1 3/4	64.4028	330.0643	25 in.	78.5400	490.8750
2	64.7955	334.1018	1 1/8	78.9327	495.7960
2 1/8	65.1882	338.1637	1 1/4	79.3254	500.7415
2 1/4	65.5809	342.2503	1 1/2	79.7181	505.7117
21 in.	65.9736	346.3614	1 3/4	80.1108	510.7063
1 3/8	66.3663	350.4970	2	80.5035	515.7255
1 3/4	66.7590	354.6571	2 1/8	80.8962	520.7692
			2 1/4	81.2889	525.8375

To find the circumferences of *larger* circles, multiply the diameter by 3.1416. For areas, multiply the square of the diameter by 0.7854.

TABLE NO. 13.

SHOWING THE NUMBER OF FEET IN LENGTH OF VARIOUS SIZED PIPES WHICH WILL CONTAIN ONE CUBIC FOOT OF WATER.

Nominal Size of Pipe.	Length in feet which will contain one cubic foot.	Nominal Size of Pipe.	Length in feet which will contain one cubic foot.
$\frac{1}{2}$	470.0	$3\frac{1}{2}$	14.6
$\frac{3}{4}$	270.0	4	11.3
1	167.0	$4\frac{1}{2}$	9.
$1\frac{1}{4}$	96.5	5	7.2
$1\frac{1}{2}$	70.5	6	5.
2	48.9	7	3.54
$2\frac{1}{2}$	30.0	8	2.875
3	19.35	9	2.26

By multiplying the above lengths by the *relative volume** of steam at any required pressure, it will give the length of pipe which will be necessary to contain a cubic foot of water when converted into steam at that pressure.

* See Table No. 5.

DIMENSIONS OF STANDARD RADIATORS.

These tables will be found useful to architects and steam-fitters in determining the size and space occupied by standard radiators.

NASON'S "IMPROVED" VERTICAL TUBE WROUGHT-IRON RADIATORS FOR DIRECT HEATING.

Pattern No. 1.—Single row of Tubes. Outside width, $4\frac{3}{4}$ inches; usual height, 36 inches :

Sizes of Steam Openings.....Inlets, $\frac{3}{4}$ inch. Outlets, 1 inch.

Distances from center of open-

ings to the floor " 4 " " $3\frac{3}{4}$ "

Number of Tubes in length.....	4	6	8	10	12	16	20	24
Total number of Tubes	4	6	8	10	12	16	20	24
Outside length of Radiatorinches	$10\frac{3}{4}$	15	$18\frac{3}{4}$	23	$26\frac{3}{4}$	$34\frac{3}{4}$	$42\frac{3}{4}$	$50\frac{3}{4}$
Square feet of heating surface	4	6	8	10	12	16	20	24

Pattern No. 2.—Two rows of Tubes. Outside width, $6\frac{3}{4}$ inches; usual height, 36 inches :

Sizes of Steam Openings.....Inlets, 1 inch. Outlets, $1\frac{1}{4}$ inch.

Distances from center of open-

ings to the floor..... " 4 " " $3\frac{3}{4}$ "

Number of Tubes in length.....	4	6	8	10	12	16	20	24
Total number of Tubes	8	12	16	20	24	32	40	48
Outside length of Radiatorinches	$10\frac{3}{4}$	$14\frac{3}{4}$	$18\frac{3}{4}$	$22\frac{3}{4}$	$26\frac{3}{4}$	$34\frac{3}{4}$	$42\frac{3}{4}$	$50\frac{3}{4}$
Square feet of heating surface.....	8	12	16	20	24	32	40	48

Pattern No. 3.—Three rows of Tubes. Outside width, $8\frac{3}{4}$ inches; usual height, 36 inches :

Sizes of Steam Openings.....Inlets, 1 inch. Outlets, $1\frac{1}{4}$ inch.

Distances from center of open-

ings to the floor " 4 " " $3\frac{3}{4}$ "

Number of Tubes in length.....	4	8	12	16	20	24	28
Total number of Tubes	12	24	36	48	60	72	84
Outside length of Radiatorinches	$10\frac{3}{4}$	$18\frac{3}{4}$	$26\frac{3}{4}$	$34\frac{3}{4}$	$42\frac{3}{4}$	$50\frac{3}{4}$	$58\frac{3}{4}$
Square feet of heating surface	12	24	36	48	60	72	84

The Nason Radiators—*Continued.*

Pattern No. 4.—Four rows of Tubes. Outside width, $10\frac{3}{4}$ inches; usual height, 36 inches :

Sizes of Steam Openings. . . . Inlets, 1 inch. Outlets, $1\frac{1}{4}$ inch.

Distances from center of openings to the floor. “ 4 “ “ $3\frac{3}{4}$ “

Number of Tubes in length.	4	8	12	16	20	24	28	32
Total number of Tubes	16	32	48	64	80	96	112	128
Outside length of Radiators . . . inches	$10\frac{3}{4}$	$18\frac{3}{4}$	$26\frac{3}{4}$	$34\frac{3}{4}$	$42\frac{3}{4}$	$50\frac{3}{4}$	$58\frac{3}{4}$	$66\frac{3}{4}$
Square feet of heating surface.	16	32	48	64	80	96	112	128

CIRCULAR PATTERN.

USUAL HEIGHT, ABOUT THREE FEET.

Distances from center of openings to the floor—Inlets, $4\frac{1}{2}$ inches. Outlets, 4 inches.

Number.	No. of Tubes.	Square Feet of Radiating Surface.	Outside Diameters. Inches.	Inlets. Inches.	Outlets. Inches.
1	18	18	12	$\frac{3}{4}$	$1\frac{1}{4}$
2	30	30	18	$\frac{3}{4}$	$1\frac{1}{4}$
3	54	54	$20\frac{1}{2}$	$\frac{3}{4}$	$1\frac{1}{4}$
4	72	72	25	1	$1\frac{1}{4}$
5	102	102	$33\frac{1}{2}$	1	$1\frac{1}{4}$
6	130	130	38	$1\frac{1}{4}$	$1\frac{1}{4}$
7	160	160	38	$1\frac{1}{4}$	$1\frac{1}{4}$

COLUMN RADIATORS.

Made in halves to encircle columns. Made in five sizes. Usual height, 3 feet.

Distances from center of openings to the floor—Inlets, $4\frac{1}{2}$ inches. Outlets, 4 inches.

No.	No. of Tubes.	Square Feet of Radiating Surface.	Outside Diameters. Inches.	Inlets.	Outlets.	Diameter of Opening in the Base. Inches.
1	58	58	$26\frac{1}{2}$	$\frac{3}{4}$	$1\frac{1}{4}$	12
2	80	80	$28\frac{1}{2}$	1	$1\frac{1}{4}$	12
3	102	102	$33\frac{1}{2}$	1	$1\frac{1}{4}$	16
4	130	130	38	$1\frac{1}{4}$	$1\frac{1}{4}$	16
5	160	160	38	$1\frac{1}{4}$	$1\frac{1}{4}$	16

GOLD'S "COMPOUND COIL" VERTICAL TUBE DIRECT HEATERS.

OBLONG AND SQUARE HEATERS.

Number of Pipes.	Number of square feet of surface.	Size over all of Casing.			Weight of Heater without Casing. Lbs.	Weight of Heater with Casing. Lbs.	Number of Registers.	Size of each Register. Inches.	Size of Steam Inlet.	Size of Outlet.
		Length. Inches.	Width. Inches.	Height. Inches.						
2 × 4	16	13 $\frac{1}{4}$	8 $\frac{5}{8}$	38	75	98	1	6 × 10	3 in.	3 in.
2 × 6	24	18 $\frac{3}{4}$	8 $\frac{3}{8}$	38	100	131	1	6 × 16	"	"
2 × 8	32	23	8 $\frac{1}{8}$	38	130	166	2	6 × 9	"	"
3 × 6	36	19 $\frac{1}{2}$	13 $\frac{1}{2}$	38	145	186	1	10 × 16	"	"
2 × 10	40	27 $\frac{3}{8}$	8 $\frac{3}{8}$	38	163	207	2	6 × 10	"	"
3 × 8	48	24 $\frac{3}{8}$	12 $\frac{3}{8}$	38	181	239	2	9 × 9	1	"
2 × 13	52	34 $\frac{7}{8}$	8 $\frac{3}{8}$	38	212	269	2	6 × 14	1	"
3 × 10	60	28 $\frac{5}{8}$	13 $\frac{1}{2}$	38	260	320	2	10 × 10	1	"
3 × 11	66	31	12 $\frac{1}{8}$	38	280	349	2	9 × 12	1	"
3 × 13	78	36	12 $\frac{1}{8}$	38	314	386	2	9 × 14	1 $\frac{1}{4}$	1
4 × 12	96	35	16 $\frac{3}{8}$	38	385	477	2	12 × 12	1 $\frac{1}{4}$	1
4 × 13	104	37	16 $\frac{3}{8}$	38	420	522	2	12 × 15	1 $\frac{1}{4}$	1
4 × 15	120	42 $\frac{1}{2}$	16 $\frac{3}{8}$	38	481	598	2	12 × 17	1 $\frac{1}{4}$	1

GOLD'S "COMPOUND COIL" INDIRECT HEATERS.

Width over all, including Casing, ins.	No. of Leaves.	Total Number of 1-inch pipes.	Size of Openings for Steam and Return.	Approximate Weight, lbs.	Heating Surface, Sq. Feet.
11	3	6	1 $\frac{1}{4}$	72	24
13 $\frac{1}{2}$	4	8	1 $\frac{1}{4}$	96	32
16	5	10	1 $\frac{1}{4}$	120	40
18 $\frac{1}{2}$	6	12	1 $\frac{1}{4}$	144	48
21	7	14	1 $\frac{1}{4}$	168	56
23 $\frac{1}{2}$	8	16	1 $\frac{1}{4}$	192	64
26	9	18	1 $\frac{1}{4}$	216	72
28 $\frac{1}{2}$	10	20	1 $\frac{1}{4}$	240	80
31	11	22	1 $\frac{1}{4}$	264	88
33 $\frac{1}{2}$	12	24	1 $\frac{1}{2}$	288	96
36	13	26	1 $\frac{1}{2}$	312	104
38 $\frac{1}{2}$	14	28	1 $\frac{1}{2}$	336	112
41	15	30	1 $\frac{1}{2}$	360	120
43 $\frac{1}{2}$	16	32	1 $\frac{1}{2}$	384	128

All Compound Coils are 26 inches high by 49 inches long, over all.

THE "BUNDY" CAST-IRON RADIATORS FOR DIRECT HEATING.

Single Row of Loops.

Size.	Loops.	Total Length.	Total Width.	Heating Surface.
1 × 3	3	13 inches.	6½ inches.	9 sq. feet.
1 × 4	4	16 "	6½ "	12 "
1 × 6	5	19 "	6½ "	15 "
1 × 6	6	22 "	6½ "	18 "
1 × 7	7	25 "	6½ "	21 "
1 × 8	8	28 "	6½ "	24 "
1 × 9	9	32 "	6½ "	27 "
1 × 10	10	35 "	6½ "	30 "
1 × 11	11	39 "	6½ "	33 "
1 × 13	13	45 "	6½ "	39 "
1 × 15	15	51 "	6½ "	45 "
1 × 20	20	67 "	6½ "	60 "
1 × 26	26	87 "	6½ "	78 "

Two Rows of Loops.

2 × 3	6	14 inches.	10½ inches.	18 sq. feet.
2 × 4	8	17 "	10½ "	24 "
2 × 5	10	20 "	10½ "	30 "
2 × 6	12	23 "	10½ "	36 "
2 × 7	14	26 "	10½ "	42 "
2 × 8	16	29 "	10½ "	48 "
2 × 9	18	32 "	10½ "	54 "
2 × 10	20	35 "	10½ "	60 "
2 × 11	22	38 "	10½ "	66 "
2 × 12	24	42 "	10½ "	72 "
2 × 13	26	45 "	10½ "	78 "
2 × 15	30	51 "	10½ "	90 "
2 × 20	40	67 "	10½ "	120 "
2 × 26	52	83 "	10½ "	156 "

Three Rows of Loops.

3 × 3	9	13 inches.	14 inches.	27 sq. feet.
3 × 5	15	19 "	14 "	45 "
3 × 7	21	26 "	14 "	63 "
3 × 9	27	32 "	14 "	81 "
3 × 11	33	39 "	14 "	99 "
3 × 13	39	46 "	14 "	117 "
3 × 15	45	52 "	14 "	135 "

The "Bundy" Cast-Iron Radiators—*Continued.*

Circular Radiators.

Loops.		
10	17 inches	30 sq. feet.
15	19 " "	45 " "
20	21 " "	60 " "
26	23 " "	78 " "
34	27 " "	102 " "
50	32 " "	150 " "
74	36 " "	222 " "

In Halves to Encircle Columns.

26	23 inches Outside Diameter.	9 Inside Diam.	78 sq. feet.
34	30 " " " "	13 " " "	102 " "
50	36 " " " "	17 " " "	150 " "

We have patterns of Radiators the following heights :

18 inches.	24 inches.	27 $\frac{3}{4}$ inches.	31 $\frac{1}{2}$ inches.
19 $\frac{1}{4}$ " "	24 $\frac{3}{4}$ " "	29 " "	33 $\frac{1}{2}$ " "
19 $\frac{3}{4}$ " "	26 " "	30 " "	34 $\frac{3}{4}$ " "
20 $\frac{1}{2}$ " "	26 $\frac{3}{4}$ " "	31 " "	36 " "
21 $\frac{3}{4}$ " "			

THE GOLD'S "PIN" INDIRECT RADIATOR (CAST IRON).*

Each section is 40 $\frac{1}{4}$ inches long.

" " " 6 $\frac{1}{2}$ " deep at ends.

" " " 10 $\frac{1}{2}$ " " over all at center.

" " " 3 $\frac{1}{4}$ " thick over all at center.

" " should contain 925 pins to be standard.

The outside sections contain the inlets and outlets.

* Made by the A. A. Griffing Iron Co., Jersey City, N. J.; The Kelley & Jones Co., N. Y. City; The H. B. Smith Co., Westfield, Mass., and others.

THE " REED " CAST-IRON RADIATORS FOR DIRECT HEATING.
 Single Row of Columns, 36 Inches High.

Size.	No. of Columns.	Total Width.	Total Length.	Heating Surface.
1 × 4	4	7½ inches.	12½ inches.	8 feet.
1 × 5	5	"	14¾ "	10 "
1 × 6	6	"	17 "	12 "
1 × 7	7	"	19½ "	14 "
1 × 8	8	"	21¾ "	16 "
1 × 9	9	"	23¾ "	18 "
1 × 10	10	"	26 "	20 "
1 × 12	12	"	30½ "	24 "
1 × 14	14	"	35 "	28 "
1 × 16	16	"	39½ "	32 "
1 × 18	18	"	44 "	36 "
1 × 20	20	"	48½ "	40 "
1 × 22	22	"	53 "	44 "
1 × 24	24	"	57½ "	48 "

Double Row of Columns, 36 Inches High.

Size.	No. of Columns.	Total Width.	Total Length.	Heating Surface.
2 × 3	6	12 inches.	11 inches.	12 feet.
2 × 4	8	"	13 "	16 "
2 × 5	10	"	15½ "	20 "
2 × 6	12	"	17¾ "	24 "
2 × 7	14	"	20 "	28 "
2 × 8	16	"	22 "	32 "
2 × 9	18	"	24¼ "	36 "
2 × 10	20	"	26½ "	40 "
2 × 11	22	"	28 "	44 "
2 × 12	24	"	31¼ "	48 "
2 × 13	26	"	33½ "	52 "
2 × 14	28	"	35¾ "	56 "
2 × 15	30	"	37¾ "	60 "
2 × 16	32	"	40 "	64 "
2 × 17	34	"	42 "	68 "
2 × 18	36	"	44½ "	72 "
2 × 20	40	"	49 "	80 "
2 × 22	44	"	53 "	88 "
2 × 25	50	"	59¾ "	100 "
2 × 28	56	"	66½ "	112 "
2 × 31	62	"	73¼ "	124 "

The "Reed" Radiators—*Continued.*

Circular Radiator, 36 Inches High.

No. of Columns.	Outside Diameter.	Sq. Feet Surface.
24	21 inches.	48
36	24 "	72
48	31 "	96
60	36 "	120
68	40 "	136

In Halves to Encircle Columns, 36 Inches High.

No. of Columns.	Outside Diameter.	Sq. Feet Surface.
48	31 inches.	96
60	36 "	120
68	40 "	136

All radiators fifty feet heating surface and smaller, 1 inch feed and $\frac{3}{4}$ inch drip. All radiators larger than fifty feet, $1\frac{1}{4}$ inch feed and 1 inch drip. All right hand tap.

TABLE No. 14.

DIMENSIONS OF REGISTERS AND VENTILATORS.

Nominal Size as given on List.	Opening to admit body of Register. Inches.	Extreme Dimension of Register Face. Inches.	Depth of the Register in inches.	
			Closed.	Open.
$4\frac{1}{2} \times 6\frac{1}{2}$	$4\frac{5}{8} \times 6\frac{5}{8}$	$5\frac{3}{4} \times 7\frac{5}{8}$	$1\frac{1}{4}$	$1\frac{5}{8}$
4×8	4×8	$5\frac{1}{2} \times 9\frac{1}{2}$	$1\frac{3}{4}$	$2\frac{1}{4}$
4×15	4×15	$5\frac{5}{8} \times 16\frac{7}{8}$	$1\frac{5}{8}$	$2\frac{1}{4}$
4×18	$4 \times 17\frac{5}{8}$	$5\frac{5}{8} \times 19\frac{1}{4}$	$1\frac{5}{8}$	$2\frac{1}{4}$
6×8	$6\frac{1}{8} \times 8\frac{1}{8}$	$7\frac{3}{4} \times 9\frac{3}{4}$	$1\frac{7}{8}$	$2\frac{3}{8}$
6×9	$6\frac{1}{4} \times 9$	$7\frac{7}{8} \times 10\frac{3}{4}$	$1\frac{7}{8}$	$2\frac{3}{8}$
6×10	$6\frac{1}{8} \times 10$	$7\frac{7}{8} \times 12$	$1\frac{7}{8}$	$2\frac{1}{4}$
6×16	6×16	$7\frac{3}{4} \times 9\frac{3}{4}$	$1\frac{3}{4}$	$2\frac{1}{3}$
6×18	6×18	8×20	$1\frac{3}{4}$	$2\frac{1}{2}$
7×10	7×10	$8\frac{3}{4} \times 11\frac{3}{4}$	2	$2\frac{3}{4}$
8×8	8×8	$9\frac{1}{8} \times 9\frac{5}{8}$	2	3
8×10	8×10	$9\frac{5}{8} \times 11\frac{5}{8}$	2	3

Nominal Size as given on List.	Opening to admit body of Register. Inches.	Extreme Dimension of Register Face. Inches.	Depth of the Register in inches.	
			Closed.	Cpen.
8 × 12	8 × 12	9 ³ / ₄ × 13 ⁵ / ₈	2	3
8 × 15	8 × 15	9 ³ / ₄ × 16 ⁵ / ₈	2	3
8 × 18	8 × 18	9 ³ / ₄ × 19 ¹ / ₂	2	3
9 × 9	9 ¹ / ₈ × 9 ¹ / ₈	10 ³ / ₄ × 10 ³ / ₄	2 ¹ / ₄	3 ³ / ₈
9 × 12	9 × 12 ¹ / ₈	10 ³ / ₄ × 13 ³ / ₄	2 ¹ / ₄	3 ³ / ₈
9 × 13	9 ¹ / ₄ × 13 ¹ / ₄	11 ¹ / ₂ × 15 ¹ / ₄	2 ¹ / ₄	3 ³ / ₈
9 × 14	9 × 14	11 × 16	2 ¹ / ₄	3 ³ / ₈
10 × 10	10 ¹ / ₄ × 10 ¹ / ₄	12 × 12	2 ³ / ₈	3 ⁵ / ₈
10 × 12	10 × 12	11 ³ / ₄ × 13 ⁷ / ₈	2 ³ / ₈	3 ⁵ / ₈
10 × 14	10 ¹ / ₈ × 14 ¹ / ₈	12 ¹ / ₄ × 16 ¹ / ₈	2 ³ / ₈	3 ⁵ / ₈
10 × 16	10 × 16	12 × 18	2 ³ / ₈	3 ⁵ / ₈
11 × 17	11 ¹ / ₄ × 17 ¹ / ₄	13 ³ / ₄ × 19 ¹ / ₄	2 ¹ / ₂	3 ¹ / ₂
12 × 12	12 × 12	14 × 14	2 ³ / ₄	4 ¹ / ₄
12 × 15	12 ¹ / ₈ × 15 ¹ / ₄	13 ¹ / ₂ × 16 ³ / ₄	2 ³ / ₄	4 ¹ / ₄
12 × 17	12 ¹ / ₄ × 17 ¹ / ₄	14 × 19	2 ³ / ₄	4 ¹ / ₄
12 × 18	12 × 18	14 × 20	2 ⁵ / ₈	4 ¹ / ₄
12 × 19	12 ¹ / ₈ × 19 ¹ / ₄	14 ³ / ₈ × 21	2 ³ / ₄	4 ¹ / ₄
12 × 20	12 ¹ / ₄ × 20 ¹ / ₄	13 ¹ / ₈ × 21 ⁷ / ₈	2 ³ / ₄	3 ³ / ₄
12 × 24	12 × 24	13 ⁷ / ₈ × 25 ³ / ₄	2 ³ / ₄	4 ¹ / ₄
14 × 14	14 ¹ / ₄ × 14 ¹ / ₄	16 ⁵ / ₈ × 16 ⁵ / ₈	2 ⁵ / ₈	3 ⁷ / ₈
14 × 18	14 ¹ / ₄ × 18 ¹ / ₄	16 ¹ / ₂ × 20 ¹ / ₄	2 ⁵ / ₈	3 ⁷ / ₈
14 × 20	14 ¹ / ₄ × 20 ¹ / ₄	16 ¹ / ₈ × 22 ¹ / ₄	3 ¹ / ₈	4 ¹ / ₈
14 × 22	14 ¹ / ₄ × 22	16 ¹ / ₂ × 24 ¹ / ₈	2 ³ / ₄	4
15 × 25	15 ⁵ / ₈ × 25 ¹ / ₂	17 ⁷ / ₈ × 27 ³ / ₄	3 ¹ / ₂	5 ⁵ / ₈
16 × 16	16 × 16	18 ³ / ₈ × 18 ³ / ₈	3	4 ¹ / ₂
16 × 20	16 ¹ / ₈ × 20 ¹ / ₂	17 ⁵ / ₈ × 22 ¹ / ₈	3	4 ¹ / ₂
16 × 24	16 ³ / ₈ × 24 ¹ / ₂	18 ³ / ₈ × 27	3	4 ¹ / ₂
20 × 20	20 ¹ / ₄ × 20 ¹ / ₄	22 ¹ / ₄ × 22 ¹ / ₄	3 ¹ / ₂	5 ¹ / ₂
20 × 24	20 × 24	22 ¹ / ₄ × 26	3 ⁵ / ₈	5 ⁵ / ₈
20 × 26	20 ¹ / ₄ × 26 ¹ / ₄	22 ⁷ / ₈ × 28 ⁷ / ₈	3 ⁵ / ₈	5 ⁵ / ₈
21 × 29	20 ³ / ₄ × 29	23 ⁵ / ₈ × 31 ¹ / ₂	3 ³ / ₄	5 ³ / ₄
24 × 24	24 × 24	26 ¹ / ₄ × 26 ¹ / ₄	3 ³ / ₄	5 ³ / ₄
27 × 38	27 × 38	29 ¹ / ₄ × 40 ¹ / ₄	4 ³ / ₂	6 ¹ / ₂
30 × 30	30 ¹ / ₄ × 30 ¹ / ₄	32 ³ / ₄ × 32 ³ / ₄	4 ³ / ₄	7

APPENDIX A.

The following detailed specification is here introduced to familiarize the reader with an ordinary form for a steam-heating work, and will suggest much useful information to the fitter.

SPECIFICATION

FOR STEAM-HEATING APPARATUS, VENTILATION, COOKING,
WASHING, DRYING, AND PUMPS, FOR A HOTEL OR
PUBLIC BUILDING.

Boilers. THERE will be required for heating and power horizontal multi-tubular boilers, each inches in diameter and feet long, with lap-welded tubes ; inches in diameter, of No. .. wire-gauge iron, no tube to be placed nearer than three (3) inches to shell.

Steam dome. Each boiler will have a steam-dome inches high, and inches in diameter.

Mud-pipes. The mud-pipes for boilers, (if used,) will be inches in diameter by six (6) feet long, with heavy cast-iron connections. The connecting-pipe to be eight (8) inches inside diameter cast metal, not less than one (1) inch in thickness ; the head and flange will also be of cast-iron. The flanges and connections to have turned faces, and to be

fitted with three-fourth ($\frac{3}{4}$) inch bolts, not more than three (3) inches from centers.

Lugs. Each boiler to have four (4) cast-iron lugs or brackets, one and one-fourth ($1\frac{1}{4}$) inch thick, and twelve (12) inches wide, and to project not less than twelve (12) inches from the sides of boilers. The lugs will be fastened to the shell of boilers with not less than ten (10) three-fourths ($\frac{3}{4}$) inch rivets each.

Man-holes. The man-holes of boilers will be twelve (12) by sixteen (16) inches, with heavy plate and guard.

Hand-holes. Each boiler will have two (2) hand-holes, of the ordinary size, provided with heavy plates and guards.

Material. The whole shell, heads, dome, and mud-pipe to be of C. H. No. 1 iron (or boiler steel of the finest quality), each and every sheet used in construction of boilers must be stamped, showing the grade and quality of the iron or steel. The shell of boilers and domes will be..... of an inch thick. Heads, inch thick. Heads of dome, inch. The mud-pipe (if used) will also be of an inch thick.

Stays and braces. Each head of boilers above the tubes to have not less than braces or stays, each brace or stay to have in its smallest diameter one square inch of the best refined iron, and to be fastened to the shell and heads by the best method for equalizing strain. Heads of domes (if made of wrought-iron) to be "crowned" to a radius equal to the diameter of the dome.

Seams. Longitudinal seams to be double riveted. The vertical seams in dome, and flange of dome, to be double riveted. No hole larger than six (6) inches to be made in shell of boiler under the dome, the aggregate area of said holes to be four times that of the steam-pipe.

Rivets. No cupped or button-set rivets are to be allowed—they must be either hand or machine made, the latter

preferred. The use of the drift pin *must be entirely dispensed with*. The splitting or cracking of a hole or sheet will be cause for rejection.

Calking. Where the work is chipped and calked after being fitted and riveted, it must be done in such a manner that the inside sheets will not be *marked* or *seamed* by the chisel or calking-tool; the edges must be driven in straight, and not against, or partly against, the inner sheet, hereby raising a shoulder on it.

Testing. Each of said boilers will be tested to one hundred and fifty (150) pounds cold-water pressure to the square inch before leaving the shops. The Supervising Engineer or Architect to have every facility for examining the work as it progresses.

The boilers to be made in accordance with the drawings, special attention being paid to laying out the tubes.

The non-compliance with any of the above will be cause for the rejection of any or all of the boilers.

Boiler setting. The boiler to be substantially set up in brick-work; walls inches thick, the foundation walls to be of stone, inches thick, laid in cement mortar. All exposed walls will be built of straight well-burned bricks, laid in fresh lime and sand mortar, all brick-work exposed to the fire to be lined with first-class fire-bricks, laid in fire-clay mortar, the floor of fire-pit will be paved with hard burned brick, and well grouted.

Boiler fronts. Each boiler to have a full cast-iron front, the metal to be inch thick. Said fronts will have flue doors, fire doors, and ash doors of sizes drawn, all neatly fitted. The fire doors will be lined with perforated plates to allow free circulation of air between the doors and linings. The boilers to be furnished with cleaning doors, covering-bars, anchors, bolts, tie-rods, buckstaves, and other castings usual and necessary.

Smoke flues. Each furnace to have flues leading from the *front-connection* of boiler, and connecting with a main flue to stack. Said flues to be of wrought-iron of an inch thick, thoroughly riveted and bolted at connections, the flues to be furnished with the required dampers.

Grates. One set of grate bars will be required for each boiler as drawn.

Boiler trim- Each boiler to be provided with a inch
mings safety-valve, a two (2) inch blow-off cock, one eight (8) inch nickel-plated cased steam-gauge of approved construction, one three-fourths ($\frac{3}{4}$) inch water-gauge, three compression gauge-cocks, with wooden handles, a one and one-half ($1\frac{1}{2}$) inch feed-pipe, together with all necessary pipes, valves, fittings, etc., to make the whole complete in all its parts; the boilers to be so connected that they may be separately or together used for heating and all other purposes.

Small pump. Provide and set up where specified or shown, two of Worthington's Duplex boiler feed-pumps, (or any other pump of approved qualities.) Diameter of steam cylinders, inches; diameter of water cylinder, inches; length of stroke, inches.

Pump con- The pumps to be so connected and *cross connect-*
nections. ed, that either can be used for the work of the other.

Steam-pipes. All the pipes used for steam to be of wrought-iron, of standard weight and dimensions. Said pipes to be screwed together with heavy cast-iron fittings, and wrought-iron sockets. Cast-iron flange-unions to be used on all pipes larger than two (2) inches, and *right-and-left* couplings for pipes less than two and a half ($2\frac{1}{2}$) inches.

The main steam-pipes to start from the dome of each boiler with a inch pipe and valve, and run to a cross-main, said cross-main to be inches.

The main distributing-pipe for heating apparatus is to start from cross-main of inches in diameter, and

be run in or about the position shown on plans, and of the sizes there marked, and to be out less than two inches at each of its extremes, and furthermore, no engine-pipe, or elevator-pump pipe, must be taken from the same cross-main ; but must have separate connections to the domes of boilers, when used.

Steam-mains to be supplied with all fittings, valves, etc., usual and necessary for the proper completion of the apparatus. The further distribution of the steam-pipes and returns can be seen by consulting plans.

Expansion joints. The main supply and return pipes, also branch mains and returns, will be supplied with the necessary expansion joints, when the expansion cannot be compensated for by right-angle turns.

Rising mains. Each perpendicular line of coils or radiators will have a separate rising main. Not more than two (2) radiators to be supplied from one rising main on the same floor. The mains to be accompanied by a return-pipe, said return-pipe will be one size smaller than supply-pipe. The rising mains and return-pipes will each have a brass globe or angle-valve same size as pipes, at their lower ends, so that steam may be let on or off one or more sections without interfering with any other.

Relief pipes. The main steam-pipes to be properly drained in suitable places, so that no water of condensation can at any time remain in pipes above the water-line. All pipes to be secured to walls, arches, etc., with expansion hangers and hooks, as may be required.

Return pipes. The main return-pipes for collecting the water of condensation from the coils, radiators, and relief-pipes, must be of sufficient capacity to collect all the water and conduct it back.

All return pipes must be supplied with valves, fittings, etc., to correspond to the main steam-pipe.

Summer supply. Summer supply-pipe will be required for the use of the laundry, kitchen, drying room, ventilating shafts and hot-water tanks, said pipe to be connected to boilers direct, and so arranged that it can be supplied by steam from either boiler, separately and together. This pipe will extend to kitchen etc., inches in diameter, and will have globe-valves same size of pipes on each connection, etc., and the above specified pipe to have branches as drawn, with a brass globe-valve connecting each branch to main.

Summer return pipes. Furnish and fit up return-pipes for collecting the water of condensation from laundry, kitchen, coils in drying room, hot-water tanks, and coils in ventilating shafts, and return the same to boilers (or condensed steam-tank in boiler room,) with all connections, valves, and everything necessary to finish the work. The return-pipes to be one size smaller than supply-pipes, each to be furnished with a brass valve same size of pipe. The whole system of summer supply and return pipes to be entirely independent of the general steam-heating pipes.

Valves. Valves of two (2) inches and under, to be made of the best steam-metal. The bodies of all valves, two and a half ($2\frac{1}{2}$) inches and upward, to be made of the best soft cast-iron, with valves, seats, and stems of steam-metal.

Fittings. The fittings throughout the entire work, unless otherwise specified, must be of the best quality of cast-iron, neatly finished.

Radiators. All radiators used must be *vertical tube radiators*, made of wrought or cast iron with ornamental cast-iron tops and bases.

All rooms in building, with radiators shown on plans, to have one or more of the above style of radiators, situated as near as possible to position marked on plan, and to have not less heating surface in square feet than is marked in figures

on plan of radiator, in each room. Each radiator above, and including eighty (80) square feet of heating surface, to have one and one-fourth ($1\frac{1}{4}$) inch steam-valves and connections, and one (1) inch return-valves and connections. Each radiator less than eighty (80) square feet, and more than forty (40) square feet of heating surface, to have one (1) inch steam-valves and connections, and three-fourths ($\frac{3}{4}$) inch return-valves and connections; all smaller radiators to have three-fourths ($\frac{3}{4}$) inch steam and one-half ($\frac{1}{2}$) inch return valves and connections. Each radiator and coil throughout the work must be provided with an air-valve. Each radiator to be bronzed with the best quality of gold bronze. All radiator-valves to be nickel plated, and have wooden handles.

Coils. The . . . floor will be heated with ornamental coil radiators of size and capacity marked on plan, and will have . . inch steam and . . inch return pipes and valves, the valves to be nickel plated. These coils will be finished with black baking japan, relieved with gold as may be directed.

Horizontal coils. The chapel and dining-rooms will be heated with horizontal coils of one (1) inch pipe, with amount of heating surface marked on plans in square feet, with spring-pieces at inlet ends, all to be provided with the necessary manifolds. The coils to rest on cast-iron ring plates not less than *eight* feet apart, said ring plates to be screwed to neat wooden strips, the strips being well fastened to walls and partitions, the brick walls to be plugged. All coils to be placed on the outside walls under windows.

There will be put up in each ventilating shaft a coil of one (1) inch pipe equal to square feet of heating surface, with supply and return connections, also steam and return valves. The coils will be supported upon the required hook plate. All the coils and pipes, both mains and

returns, will be painted with black baking japan, in best manner.

The maximum pressure of steam is not to exceed
 Heating capacity. fifty (50) pounds to the square inch, and should the amount of heating surface figured on plans be found insufficient in any location of the building, through more than ordinary exposure, the heating surface may be increased to the necessary amount. The extra cost to be governed by prices in schedule.

VENTILATION.

In each of four (4) main ventilating shafts in
 Chapel and wings. rotunda building will be placed square feet of heating surface, in one coil of one (1) inch internal diameter steam-pipe, fastened to the inside of shafts with the necessary hook plates and battens.

Registers. To furnish the necessary registers, of the required size, finished in black japan, and properly set up, and secured in the wall.

Into these shafts the rooms will be ventilated ; as shown on drawings.

All ventilating coils to be united to the summer supply and return pipes.

Drying room. The drying room will be ventilated by a shaft with entrance from ceiling over clothes rack and connected by a lateral duct to boiler smoke stack (or elsewhere).

The supply of fresh air being admitted beneath the floor of drying-room by openings in the wall (between joists), through the floor, by perforations one and one-fourth ($1\frac{1}{4}$) inch in diameter under drying-coils.

KITCHEN.

Meat kettles. To furnish and set up in the kitchen

steam kettles, for cooking meats, etc., each of seventy-five (75) gallons capacity, with all the cocks and valves necessary to complete the same. Make all connections for cold-water, steam, and return pipes of the full size of tapped hole, said pipes to be supplied with brass valves.

Vegetable kettles. To furnish and set up vegetable steamers of thirty-three (33) gallons capacity, with the necessary tin baskets, etc. Make the necessary connections with water, steam, and waste pipe, with valves and cocks of required sizes.

Sinks. To furnish and set up cast iron sinks 3 feet by 3 ft. 6 in., and 10 inches deep, to be set as drawn, with $\frac{3}{4}$ inch hot and cold water connections, provided with compression cocks of brass, and waste connection to sewer, 2 inches internal diameter.

Coffee-urn. To furnish and set up one steam jacket tea and coffee maker or urn, of gallons capacity, with all the necessary steam and water connections, valves, etc.

Hot-water boiler. To furnish and set up one hot-water boiler, . . . feet . . . inches in diameter by . . . feet high, made of one-fourth inch boiler plate, the top end to be riveted in, the bottom to be of cast-iron, bolted to wrought-iron flange. The boiler to be riveted, chipped, and calked, and to be tested to a pressure of one hundred and fifty (150) pounds per square inch. Said boiler to be provided with a coil of lineal feet of one (1) inch internal diameter steam-pipe, for supplying steam heat. Said coil to be connected to the cast-iron bottom of boiler, and to have the necessary supply and return pipes and valves.

Vapor-pipe. Each steam kettle or steamer to have a vapor pipe, three (3) inches in diameter, connected to a six (6) inch main ; said main to be carried to the roof.

LAUNDRY.

Washing-machines. The laundry will be fitted up to run with steam-power. To furnish . . large laundry-size washing-machines with wringer and counter-shaft with the necessary belting, etc., to connect with line-shaft, machines, and wringers; make all water connections (hot and cold), steam and sewer connections.

Soak-tubs. Furnish and set up . . soak-tubs, six (6) feet long by two feet eight inches (2 ft. 8. in.) wide, and two feet four inches (2 ft. 4 in.) deep. Soak-tubs to be made of two inch pine plank matched together, the joints being set in white lead; the angles to be well spiked and secured with wrought-iron straps screwed on in best manner. The tubs to be made water-tight. The wash and soak tubs to be supplied with hot and cold water, and to be provided with a two-inch waste and overflow pipe connected with drain. The hot and cold water supply will be one (1) inch in diameter, with brass compression bibbs. Washing-machines and soak-tubs to have steam connections with at least four (4) feet of one-half ($\frac{1}{2}$) inch perforated brass pipe to each machine and tub, for the purpose of boiling the clothes, with all the necessary valves and fittings to properly finish the same.

Mangle. To furnish and set up one (1) box (or French) mangle securely fastened to the floor of laundry, with the necessary counter-shaft, leather belting, pulleys, etc. Mangle pulley to be . . inches in diameter, by . . inches face, and to have a . . inch leather driving belt. The mangle to be properly loaded and balanced; speed of mangle pulley to be not less than revolutions per minute, nor over

DRYING ROOM.

Steam-pipes. There will be required in the drying room of

laundry coils of one (1) inch pipe ten (10) feet long, and four (4) pipes high, set on hook stands, and each connected into a three (3) inch manifold, to be supplied with a inch steam pipe and valve on feed end, and a inch pipe and valve on return end; said steam-pipes to be connected with summer supply-pipe.

Clothes
racks. Furnish clothes racks, together with rollers, guides, handles, lines, and wrought-iron tracks for the same, to be made of three-sixteenths ($\frac{3}{16}$) inch by three-fourths ($\frac{3}{4}$) inch rolled T-iron, twenty feet long, each, and to be screwed to the floor. All to be finished and set up, in accordance with the drawing, in good working order. The wood-work of clothes racks to be furnished and put up by the joiner, the work being done under the direction of the contractor, who will be held responsible for the proper working of the same.

FINALLY.

Mason and
brick work. The brick and mason work, and all excavations will be done by the builder (excepting the brick and mason work of boilers), and all material belonging to such work will be furnished by the same. The materials for boiler setting will be provided by the contractor.

Carpenter
work. The carpenter work for the entire apparatus will also be done by the joiner, and materials therein used furnished by the same.

The contractor will be held to furnish all of the different kinds of pipe herein stated, and the necessary quantities of each kind; he will furnish all other materials as herein specified; he will do all work which is required of him in these specifications. All materials and all work must be of the best quality and done in the most workmanlike manner. All openings or slats in the walls required to be cut for any pipe, must be done by the contractor, if not otherwise pro-

vided for, and any injury to plastering, or wood-work, in the different buildings, must be borne by him, and made good at his own expense, and in no case shall any cutting be allowed without the permission of the architect.

It is to be distinctly understood, that the true meaning and intent of these specifications are, that the whole work shall be performed in the finest and most secure manner.

All disputes arising from these specifications to be submitted to a board of 3, selected as follows:—The contractor to select one, the owner or architect to select one, and the two thus selected to choose a third—the decision of the majority to be binding on both parties.

APPENDIX B.

PLURAL BOILER SPECIFICATION.

BOILERS FOR HEATING, ETC.

General. To furnish and set up in the Boiler House set apart for that purpose Horizontal multi-tubular Boilers long by inches in diameter, and to contain tubes feet long, with a dome on top of each shell diameter by high, measuring from the top of the shells, and with a man-hole on the top of each shell back of the dome ; the man-holes to be 15 by 11 inches and to be set with their greatest diameters across the shells and a hand-hole $3\frac{1}{2}$ by 5 inches in each head of each boiler.

BOILER SHELLS.

Material. The shells of said boilers to be made of the best steel or any other homogeneous steel acceptable to the ; samples of which when cut at random
Quality. from the edges of the sheets must bear bending cold (completely doubling on themselves and hammered
Thickness. close) without sign of fracture. The said shell
Seams. to be full inch in thickness, and have but *one* longitudinal seam to each course ; the seam to be in the upper side of the shell in each course.

Heads. The head sheets of said boilers to be one-

half inch thick and of the same makers' best flange steel as the shells.

Domes. The domes of said boilers to be made of inch steel, with the heads of inch steel, thoroughly and properly braced, or of cast iron, thickness and weight of metal acceptable to the and approved by

Bracing The heads of said boilers to be braced in the best manner to equalize strain, the number of braces to each head to be not less than nor to be less than one inch in diameter if made of round iron, or its equivalent in cross-sectional area if made of any other shape iron.

These braces and their crow-feet or legs to be made of best Swedish iron, and to be fastened to the heads and shells with not less than two $\frac{3}{8}$ -inch rivets to each end of each brace.

Riveting. All longitudinal seams in the boilers to be double riveted; the rivets not to be staggered, and the seams in the side of the dome, as well as the seams uniting the dome to the shell, to be double riveted, and all other seams to be properly riveted—machine rivets preferred.

Chipping and Calking. All seams of the boilers to be properly chipped and calked (Connelly's calking preferred); a furrow from the chipping chisel or **Injury to plates.** calking tools on any part of a boiler being cause sufficient for its rejection. The breaking or splitting of a hole from drawing with drift pins or otherwise, or a crack or flaw or burn in or from the process of flanging, will be deemed sufficient cause for rejecting the boiler.

Shells under Domes. The shells of the boilers underneath the domes are not to be cut out in *one* large piece,

but to be a number of 2-inch holes aggregating not less than square inches, the bridges between any two holes to be not less than two inches.

Special attention must be paid to this !

Expanding. The boiler tubes to be expanded with a "Dudgeon" expander, with the extension beyond the heads of uniform length, and not broken or ragged by a chipping chisel, but cut with some "cutting-off tool" at the end last expanded.

Lugs. The boilers to be furnished with four cast-iron lugs or brackets for the purpose of supporting the same in brick-work; these lugs to project from the side of the boilers not less than ten inches, and to have a projection below the plane of the brackets with three rivets in this lower projection, and with the usual complement above. If it is necessary to leave the lugs off the boilers until such time as they are in the basement of the building, a shoe must be riveted to the shell in lieu of the brackets, before the tubes are set, into which the lug will slip.

Man-hole. The man-hole casting to be extra heavy, with frame, plate, guard and bolt subject to the approval of the

Hand-holes. The hand-holes to be furnished with plates, bolts and guards; the guard on rear hand-holes to be "turtle-backed," with a projection around the nut to protect them from the flame.

Flanges. The pipe flanges on the domes to be of the sizes marked on drawing and in the positions marked, and to be riveted to the domes and chipped and calked on the inside and set *true* with the axis of the boilers. A . . inch flange to be placed at the rear end of the rear course of the shell, at the bottom side, and to be

set true and riveted and chipped and calked. A 2-inch
 Holes in pipe hole to be drilled and tapped into the
 heads. rear head and $1\frac{1}{2}$ in the front head where shown.

CAST-IRON BOILER FRONTS.

The boilers to be furnished with full cast-iron fronts of good and approved pattern, with planed and properly
 Design. fitted doors. The front connection doors preferably to swing sidewise, but should the design offered, and otherwise approved of, have lifting doors they will be accepted.

Doors. The fire doors to be arched and of the sizes shown, and to have a heavy fire lining of cast iron. The ash pits to be furnished with doors, either sliding or swinging, and about the size as shown.

In addition thereto to furnish the fronts and boilers with grates of size hereafter mentioned, and with all other castings, bolts and anchors necessary and usual for the proper completion of the masonry.

Buckstaves The buckstaves to be feet inches in length, with not less than four-inch face and four-inch ribs and of the number required. The tie rods to be in length and in number. The dead plates to be 15 inches wide from the front to the end of the grate-bar, and to be not less than one inch thick. If the front-bearing bars and dead plates are not combined, the plates must be reinforced on their under side with a rib.

Bearing-bars. The back bearing-bars to be a cast angle-iron one-inch thick, with three-inch flanges, as shown. The cleaning-doors to be heavy, and planed, and furnished with a lining and with latches. Should covering

bars be required for flues or elsewhere in connection with the boiler setting, they are to be furnished.

BOILER SETTING.

Boilers to be set on substantial stone foundation, and at proper level, the side walls of which are to be of the
 Bricks. best common bricks, properly and closely laid in fresh mortar of approved and best quality for this particular construction.

Furnace. The furnace and all the parts acted upon by the flame to be lined throughout, and as per drawing,
 Firebrick. with best quality of firebrick one course thick, laid on their flat and rubbed close together; using only sufficient fire clay mortar to get an even bearing.

Bridge-wall. The bridge-wall to be formed with beveled fire bricks, so as to give the required and necessary inverted arch with close joints. The arch over the back
 Beveled connection to be formed with beveled fire-
 Bricks. bricks suitable to the circle.

In no place must the brickwork rest on the boiler. The boiler to be arched over the top, and the space of one inch maintained between the arch and the boiler.

In the brick walls underneath the boiler
 Lug Rollers. lugs there must be placed bars of iron 14 in. wide and $\frac{1}{2}$ in. thick, to extend the whole distance between the lugs on a side. The six courses of firebricks underneath these irons to be "Headers."

The front lugs to rest directly on these bars, but the rear ones to rest on $1\frac{1}{4}$ -in. rollers placed on the bars to admit of slight lateral motion; care being taken that the brickwork and mortar will not in any manner interfere with the rollers or brackets.

Walls. The walls between the boilers to be in. thick. The boiler walls on the outside to be in. thick, with the bridge-wall in. thick. These thicknesses include the fire-brick linings. These walls to be built solid, and no walls or brick-work of the boilers to have the so-called air space.

Coping. The tops of boiler walls to be furnished with a 12-in. stone coping not less than 3 in. thick. In all cases where this specification on masonry may not be sufficiently explicit, the drawing must be followed.

NOTE.—These specifications were not introduced here to be copied literally and unadvisedly by a novice, with the filling up of the blank spaces to suit his peculiar ideas, but for the purpose of suggesting ideas to him; and they should never be used by any one except intelligently, and when they are capable of selecting such clauses as are particularly applicable to the work in hand.—AUTHOR.

INDEX TO ADVERTISEMENTS.

	PAGE
THE SANITARY ENGINEER AND CONSTRUCTION RECORD,	1
WM. J. BALDWIN, CONSULTING ENGINEER FOR HEATING AND VENTI- LATING,	1
NASON MANUFACTURING CO.,	2
EDWARD E. GOLD & CO.,	3
JOHNSON & MORRIS,	4
JENKINS BROS.' VALVES,	4
WALWORTH MANUFACTURING CO.,	4
KIELEY'S PATENTED STEAM-HEATING SPECIALTIES,	5 and 6
GILLIS & GEOGHEGAN, STEAM-HEATING ENGINEERS,	7
FRED STONE & CO.—VALVES, ETC.,	7
NATIONAL ELECTRIC SERVICE CO.—HEAT-REGULATING APPARATUS,	8
H. R. WORTHINGTON—STEAM PUMPS,	8
THE CONSOLIDATED SAFETY VALVE CO.,	9
THE ASHCROFT MANUFACTURING CO.—STEAM SUPPLIES,	9
THE TUTTLE & BAILEY MANUFACTURING CO.—REGISTERS,	10
THE DUNNING BOILER,	11
GURNEY'S HOT-WATER HEATER,	12
THE "BUNDY RADIATOR" (A. A. GRIFFING IRON COMPANY),	13

THE ENGINEERING AND BUILDING RECORD

AND

THE SANITARY ENGINEER

Is Published Every Saturday at
277 PEARL STREET, NEW YORK.

It maintains a Department of special interest to those interested in Heating by Steam and Hot Water. In fact, more valuable information on this subject has appeared in its columns than in all other publications combined.

"Whatever fault may be found on this side of the Atlantic with the newspaper press of America, it is an undoubted fact that that portion of the periodical literature of the United States which is devoted to science, occupies a most distinguished place amongst the scientific press of the globe. THE SANITARY ENGINEER stands high in this respect. In its pages the various subjects relating to public health—drainage, water supply, ventilation, heating and lighting—are most conscientiously attended to, shortcomings and abuses being fearlessly exposed, and care being taken to have all expressed opinions upon technical matters prepared or revised by specialists."—*Iron, London, Jan. 12.*

Sold by Newsdealers. 10 Cents a Copy.

SUBSCRIPTION, \$4.00 PER ANNUM, POST-PAID.
SAMPLE COPY FREE.

A CARD BY THE AUTHOR.

WM. J. BALDWIN,

Heating and Ventilating Engineer and Contractor.

BUILDINGS WARMED BY

Steam or Hot Water and Ventilated by the most Approved Methods.

Author of "Steam Heating for Buildings," now in 10th Edition,

The "Thermus" Papers, Hot-Water Heating and Fitting, Etc., Etc.

Late Consulting Engineer in Warming and Ventilation.

277 PEARL STREET, NEW YORK.

NASON MANUFACTURING Co.,

71 BEEKMAN STREET,

ESTABLISHED BY JOSEPH NASON IN 1841.

NEW YORK



MANUFACTURERS OF

Nason's Wrought Iron, Welded, Tube Radiators,

VENTILATING FANS,

STEAM TRAPS, GLUE HEATERS, BOILERS, PUMPS, ETC.

WROUGHT-IRON PIPE, VALVES, ❁

❁ FITTINGS, AND GENERAL SUPPLIES.

FULLY ILLUSTRATED CATALOGUE AND LOWEST PRICES
FURNISHED FREE UPON APPLICATION.

EDWARD E. GOLD & CO.,

Bridge Store, No. 6,

N. E. Cor. Frankfort and Cliff Sts., NEW YORK,

MANUFACTURERS OF

HEATING APPARATUS

FOR THE TRADE.

SOLE MANUFACTURERS OF



Gold's Compound Coil Direct Heater, the only one on the market by which temperature of rooms can be regulated.

Gold's Compound Coil Indirect Heaters, which are sent cased ready for connection, weigh less than one-half as much, are 15 per cent. more effective, and 30 per cent. cheaper than any other kind of indirect surface.

Gold's Car-heating Apparatus used

exclusively by Manhattan Elevated Railway Co., Suburban Rapid Transit Railway Co., and Staten Island Rapid Transit Railway Co. These heaters are especially adapted to conservatory heating.

Gold's Automatic "Reliable" Water-feeder, with sight feed. Valve is surrounded by cold water, is self-cleaning, and practically indestructible. Condition of valve can be seen through glass window.

Gold's Automatic Steam Trap, durable, reliable, and cheap.

Gold's Automatic Air Valves, compact, sensitive, and easily adjusted.

Gold's Patent Hose Coupling, steam-tight joint made by one motion of the hands.

Gold's Air Moisteners, for making air in rooms heated by direct radiation more healthful and agreeable.

SEND FOR DESCRIPTIVE CATALOGUE.

JOHNSON & MORRIS,

SUCCESSORS TO

BATES & JOHNSON,

IN NEW YORK AND WASHINGTON.

**Contractors for Steam-Heating Apparatus,
114 LEONARD ST.,
NEW YORK.**

ESTIMATES FURNISHED ON APPLICATION.

JENKINS BROS.' VALVES.

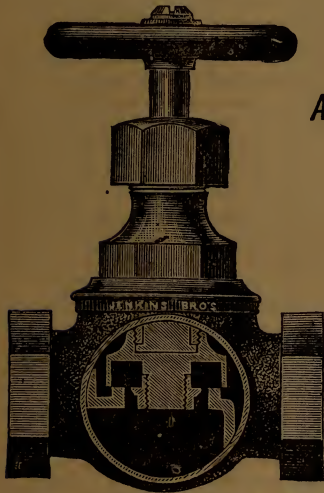

Manufactured of Best Steam Metal.

*ALL PARTS INTERCHANGEABLE.
WARRANTED TIGHT.*

The Jenkins Disc used in these Valves are manufactured under our 1880 Patent, and will stand any and all pressures of steam, oils, or acids.

If you want the best Valves manufactured call for JENKINS BROS.'

71 JOHN ST.,

New York.

105 MILK ST.,

Boston.

WALWORTH MANUFACTURING CO.,

16 Oliver St., Boston, and City Point.

ESTABLISHED 1842.

Steam Heating Engineers, Contractors, and Manufacturers.

PIONEERS in Hot-Water Heating. **ORIGINATORS** of Steam-Heating with Small Pipes.

Plans and Estimates for Warming and Ventilating Hospitals, Schools, and Public Buildings.

**STEAM PIPE, VALVES, FITTINGS, FITTERS' TOOLS AND SUPPLIES, AUTOMATIC
SPRINKLERS AND FIRE APPARATUS, GAS MACHINES,
BOILERS, ENGINES, AND PUMPS.**

KIELEY'S

PATENT STEAM HEATING SPECIALTIES.

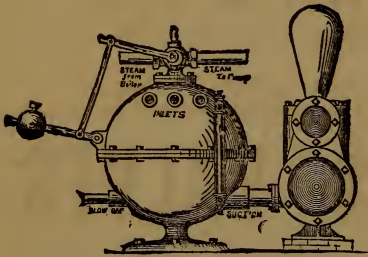

PATENT POSITIVE-ACTING PUMP-GOVERNOR.

For automatically returning condensation to boilers where a very low pressure is carried on the heating apparatus. This Governor will regulate the speed of the pump so as to return the condensation to the boilers as fast as it accumulates. It will also, when connected in a suitable way, hold a water line at any desired height in the return pipes of the heating apparatus, either above or below the water line in boilers, with or without a reduced pressure, and thereby prevent knocking or water-hammering, which causes great annoyance in many buildings which are heated by steam.



PATENT.

IMPROVED EUREKA PRESSURE-REGULATING VALVE.

For reducing pressure on all kinds of heating apparatus and water-mains. Noiseless, most sensitive, durable, and reliable valve in the market.

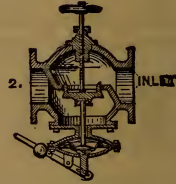

PATENT BACK-PRESSURE VALVE.

Where exhaust steam is mingled with live steam for heating purposes, a SENSITIVE, and at the same time a RELIABLE BACK-PRESSURE VALVE becomes a very important factor, since a leaky and unreliable valve will allow the live steam, with the exhaust, to escape to the roof, instead of being held in the heating apparatus. There being no stuffing-box to produce extra friction, the diaphragm, upon which the released pressure acts, enables this valve to open and close with a variation of not more than one pound pressure, which I claim NO OTHER BACK-PRESSURE VALVE in the market will do.

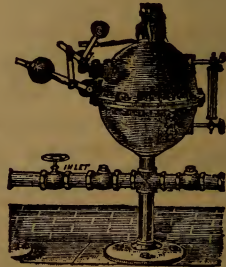

PATENT.

THE CHAMPION RETURN STEAM-TRAP AND BOILER-FEEDER.

For returning condensation to boilers from steam heaters of all kinds, drying cylinders, evaporating pans, brewing kettles, paper dryers, etc., whether above or below the boilers

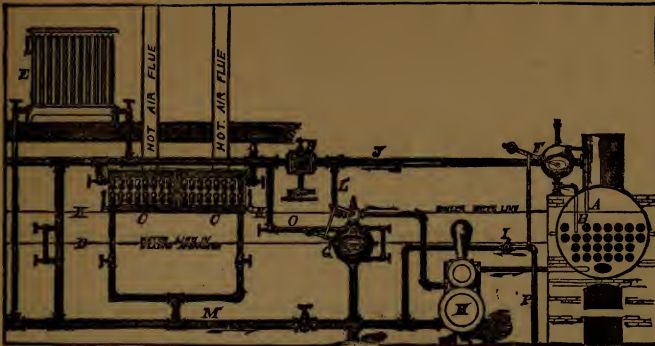

PATENT WATER-LINE SYSTEM.

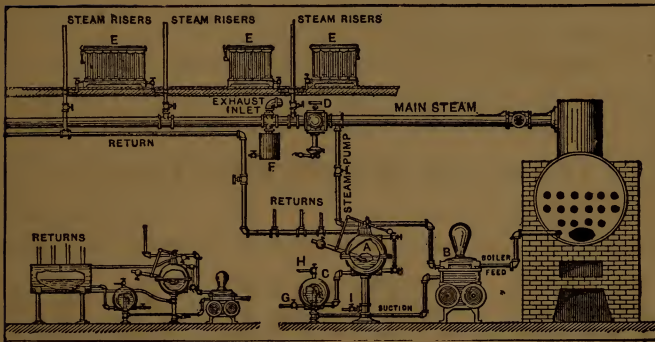

PATENT DRY-RETURN SYSTEM.

The above diagrams illustrate Kieley's systems of returning the water of condensation from a heating apparatus to a boiler. The object of the apparatus illustrated in the first diagram is four-fold: 1st, To be able to carry a lower water-line in the return and relief pipes than in the boiler; 2d, To be able to return the water from a reduced or graduated pressure apparatus; 3d, To be able to use the exhaust steam from engines and pumps for heating the building; and 4th, To be able to force a return of the water of condensation from an imperfectly constructed gravity heating apparatus.

All this applies to the system shown in the second diagram, with the exception of holding a water-line in the return and relief pipes of the heating apparatus. In this system the returns are kept perfectly dry. The chambers marked F and C in this system are oil-traps. They will prevent any oil or sludge from getting into the boiler. They can be applied to and will answer the same purpose in the water-line system. D is the reduced-pressure-regulating valve. The small cut represents this system in connection with a tank.

BY THE USE OF EITHER OF THESE SYSTEMS

A GOOD WORKING JOB AND A SAVING OF FROM 25 TO 50% IS GUARANTEED.

SEND FOR CIRCULARS.

TIMOTHY KIELEY,
7 to 11 West 13th Street, New York.

STEAM HEATING.

LOW OR HIGH PRESSURE.

THIRTY YEARS' EXPERIENCE.

Many hundred examples of our work may be seen in New York and vicinity, including the Stock Exchange Building and Drexel Building, Broad and Wall Sts.; the Catholic Cathedral, 50th St. and 5th Ave.; the Potter and Kelly Buildings, Beekman and Nassau Sts., and the J. J. Astor Block, Broadway and Prince St.; also stores, public buildings, and private houses in Troy, Albany, Washington, Memphis, Tenn., and Galveston, Texas.

GILLIS & GEOGHEGAN,

116 & 118 WOOSTER STREET,

ABOVE SPRING STREET.

NEW YORK.

FRED STONE & CO.,

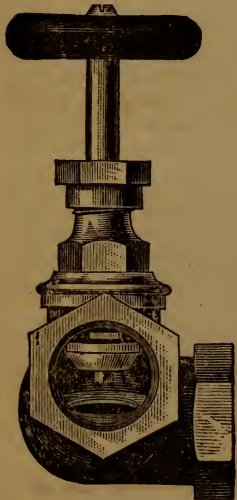

Ludlow Valves
and Hydrants.

MANUFACTURERS OF THE

H.M.S. CORNER VALVE

FOR

RADIATORS.

62 GOLD ST.,

- -

NEW YORK.

Johnson Heat-Regulating Apparatus.



By the use of this invention the heating of buildings to an exact and uniform emperature is accomplished. Rooms and Auditoriums may be kept at any temperature desired, thereby saving fuel, discomfort, il health, the cracking of wood-work, furniture, pictures, etc.

This apparatus applies equally well to **all forms of heating and ventilating** devices, the thermometer in the room **automatically governing** the temperature. It is invaluable in Public Buildings, Private Residences, Churches, Hospitals, Schools, Conservatories, Factories, etc.

Illustrated explanatory catalogue and copies of testimonials will be sent to any address, on application to any of our offices, by mail or otherwise.

NATIONAL ELECTRIC SERVICE Co.,

120 BROADWAY,

NEW YORK.

WORTHINGTON STEAM PUMPS

PATTERNS SPECIALLY ADAPTED TO

House Tank Service

AND

Hydraulic Elevators

ABSOLUTELY NOISELESS



HENRY R. WORTHINGTON

86 and 88 Liberty Street

NEW YORK

Boston

Philadelphia

Chicago

St. Louis

San Francisco

ILLUSTRATED CATALOGUE ON APPLICATION

SAVE YOUR BOILERS FROM DANGER OF OVERPRESSURE.

CHAS. A. MOORE, Pres. MARTIN LUSCOMB, Treas. GEO. W. RICHARDSON, Supt.

THE CONSOLIDATED SAFETY VALVE CO.
CAPITAL, \$100,000.

Manufacturers of the Only **SOLID NICKEL SEATED SAFETY VALVE.**

And Approved by U. S. Board of Super-
vising Inspectors.

Adopted by U. S. Navy on all the
Steel Cruisers.

FOR

STATIONARY, LOCOMOTIVE,
PORTABLE, AND YACHT BOILERS.

This Valve will not corrode or stick. It is always on duty, ready for action. It never fails to open at the pressure to which it is adjusted, and to entirely prevent any accumulation of pressure greater than that which it is set to guard against. **THIS WE GUARANTEE. The only perfect safety valve in the world.** In ordering, state size of boiler and highest working pressure.

Send for Illustrated Catalogue.

SALESROOM,

111 Liberty Street, New York.

FACTORY, BRIDGEPORT, CONN.

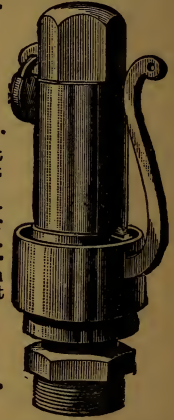
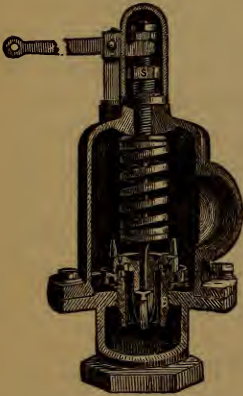

E. L. MAXWELL, Pres. C. A. MOORE, V.-Pres. H. S. MANNING, Treas. M. LUSCOMB, Sec'y.

THE ASHCROFT MFG. CO.
FACTORY, BRIDGEPORT, CONN.

Sole Manufacturers **ROYLE'S PAT. SELF-CLEANSING STEAM TRAP.**

Especially Adapted to High or Low Pressure Steam Heating Work.

ALSO

Steam, Vacuum,
and

Pressure Gauges
Springs made from
Patent Seamless
Drawn Tubes.

TEST GAUGES,
TEST PUMPS,

MARINE
CLOCKS,

ENGINE
REVOLUTION
COUNTERS,

SALINOMETERS.

All instruments for
measuring Steam,
Air, Gas, or Water.

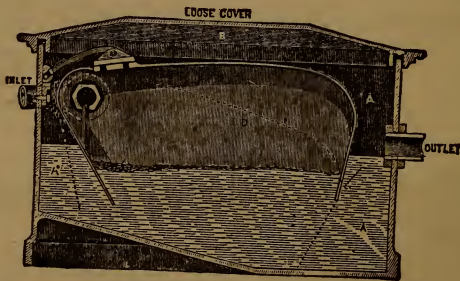

Steam and Gas-
fitters' Tools.

LOW-WATER
DETECTORS,

MAGNETIC
WATER GAUGES,

OIL-TESTING
MACHINES,

SELF-CLEANING
GAUGE-COCKS,

Locomotive
Spring Balances,
Steam Traps,

Steam Whistles,
Packer Ratchet
Drills, etc.

SOLE MANUFACTURERS

THE McCRACKEN PAT. EXPANSION TRAP.

NEAT, SIMPLE, RELIABLE.

ILLUSTRATED CATALOGUES furnished upon application.

OFFICES AND SALESROOM, 111 Liberty St., New York.

The Tuttle & Bailey Manuf'g Co.,
MANUFACTURERS OF
WARM AIR REGISTERS,
Ventilators, Ornamental Screens, etc.

83 BEEKMAN ST., - - NEW YORK.

THE DUNNING BOILER,

PATENT, WROUGHT IRON OR STEEL.

OVER 5,000 IN USE.

Dampers Regulated and Coal Supplied Automatically.
With Self-feeding Coal Magazine,

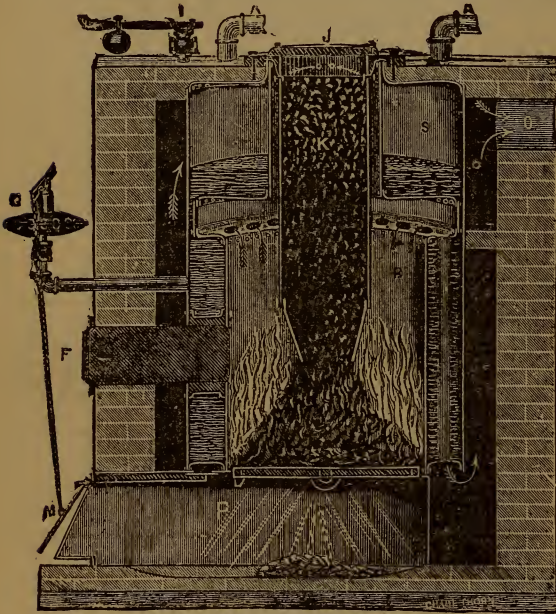

SECTIONAL VIEW.

DESCRIPTION OF CUT—I, Safety Valve; J, Magazine Cover;
K, Coal Magazine, showing gas-holes at top; M, Damper
Door; O, Smoke-exit; P, Ash Pit; R, Fire Box;
S, Steam Space.

IS THE OLDEST AND BEST
FOR

**Low Pressure
Steam Heating,**

And Insures a Warm House,
Day and Night.

MADE AS FOLLOWS:

As a **MAGAZINE BOILER**,
which requires attention
but once in 24 hours.

As a **SURFACE BURNER**, to
burn hard or soft coal,
wood or coke.

As a **HOT WATER BOILER**,
for greenhouse and hot
water heating.

As a **PORTABLE BOILER**, to
be set without brick work.

Also in **TWO SECTIONS**, to
pass through any door where
a larger one cannot be used.
And, in addition to the
above, we have under way
an entirely new **CONSTRUCTION**
OF BOILER, which will
excel anything yet upon the
market.

Send for Illustrated Cata-
logue with full description
and Price List.

Agents Wanted.

N. B. — Correspondence
solicited from Architects
and persons building.

Unexcelled for Heating Private Residences.

MANUFACTURED AT

**NEW YORK CENTRAL IRON WORKS,
GENEVA, NEW YORK.**

WM. B. DUNNING, - - Proprietor.

Send for Illustrated Catalogue with full description and Price List.

N. B.—Correspondence solicited from Architects and persons building.

Also Steam Engines and Boilers of all kinds and Machinery Generally.

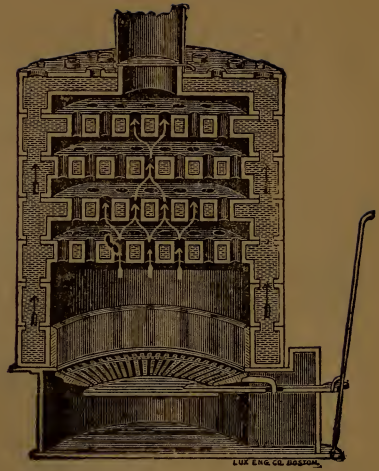
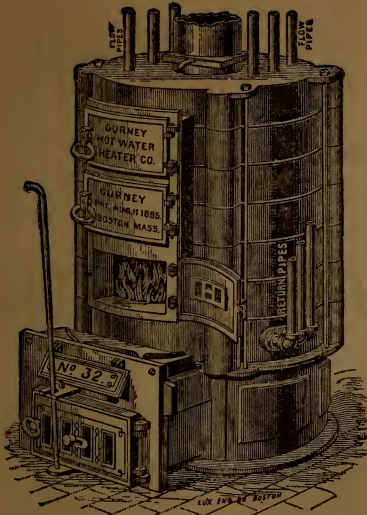

GURNEY'S HOT-WATER HEATER,

(Patented August 11, 1885.)

FOR WARMING

Private Dwellings, Offices, Public Buildings, AND Conservatories

—BY—

HOT WATER CIRCULATION.

Absolutely safe, as the system is open to the atmosphere. The cheapest in the market. An entire new principle. The greatest heating surface. The most efficient fire chamber. Ironstone lining to fire pot, whereby fire is easily and steadily maintained.

Does not corrode or rust out. Flues are easily and quickly cleaned. Noiseless in operation. The best and most perfect working Heater made. Specially designed for Hot-Water Heating purposes. Over 2500 now in use and giving good satisfaction.

AWARDED 1887.

GOLD MEDAL,
MASS. CHARITABLE MECHANIC ASS'N,
BOSTON, MASS.

HIGHEST AWARD,
AMERICAN INSTITUTE, N. Y.

MANUFACTURED BY THE

GURNEY HOT-WATER HEATER CO.,

Works at East Boston.

237 Franklin St., Boston, Mass.

FULL INFORMATION GIVEN TO FITTERS UPON APPLICATION.

SELLING AGENCIES.

Middle States . . . M. H. JOHNSON, 140 Centre Street, New York, N. Y.
West and Southwest,
Mich. and Ohio . . . RICE & WHITACRE MFG. CO., 42 and 44 W. Monroe St., Chicago, Ill.
Pacific Coast . . . T. R. CHASE, 31 Edmund Place, Detroit, Mich.
Tenn. and Ky. . . . WM. GARDINER & CO., Portland, Oregon.
N. and S. Carolina. . . . JOHN L. FRISBEE, 526 Philadelphia Street, Covington, Ky.
Georgia and Florida. . . . VALK & MURDOCH, Charleston, S. C.

A. A. GRIFFING IRON COMPANY,

450 to 460 Communipaw Ave., Jersey City,

And 42 and 44 West Monroe St., Chicago,

PROPRIETORS AND MANUFACTURERS OF

THE BUNDY HOT WATER RADIATOR,



So extensively
used in Canada,
England, and the
United States.

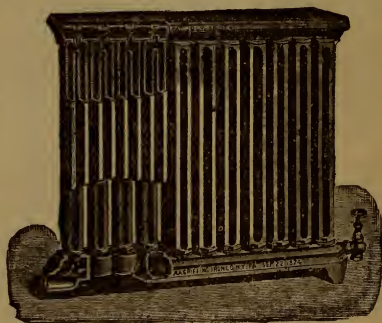

Circulation is
quick and positive
with a uniformity
of temperature in
small or large
Radiators.



SECTION OF

THE CLIMAX INDIRECT RADIATOR.



For Indirect Steam or Hot Water Heating.

Positive Circulation—Simple—Convenient—Efficient.

THE BUNDY DIRECT STEAM RADIATOR.

THE BUNDY INDIRECT STEAM RADIATOR.

THE TRIUMPH STEAM RADIATOR.

GOLD'S PIN INDIRECT RADIATOR.

Send for Descriptive Catalogue which fully explains points of excellence and merit.

STEAM-ENGINES, BOILERS, ETC.

THEORY OF STEAM-ENGINE. Translated from the fourth edition of Weisbach's Mechanics, by A. Jay Du Bois. Containing notes giving practical examples of Stationary, Marine, and Locomotive Engines, showing American practice, by R. H. Buel. Numerous illustrations. Second edition. 8vo, cloth. \$5 00

A MANUAL OF THE STEAM-ENGINE. By Prof. Robert H. Thurston. Part I.—Structure and Theory. History of the Steam-Engine, Structure of Modern Engines, Philosophy of the Steam-Engine, Thermo-dynamics of Gases and Vapors, Theory of the Steam-Engine, Compounding, Jacketing, Superheating, Efficiencies of the Steam-Engine. Part II.—Design, Construction, Operation. Design of the Steam-Engine, Valves and Valve Motions, Regulation, Governors, Fly-Wheels, Inertia Effects, Construction and Erection, Operation, Care and Management, Engine and Boiler Trials, Specifications and Contracts, Finance, Costs and Estimates. Each part 8vo, 900 pages. \$7.50, or two parts at once, \$12 00

REFLECTIONS ON THE MOTIVE POWER OF HEAT, and on Machines Fitted to Develop that Power. From the original French of N. L. S. Carnot. By Prof. R. H. Thurston. 12mo, cloth. \$2 00

THE PRINCIPLES OF THERMO-DYNAMICS. With Special Applications to Hot-Air, Gas and Steam-Engines. By Robert Röntgen. With additions from Profs. Verdet, Zeuner, and Pernolet. Translated, newly and thoroughly revised, and enlarged, by Prof. A. Jay Du Bois, of Sheffield Scientific School. 1888. 732 pages. Third edition. 8vo, cloth. \$5 00

THERMO-DYNAMICS OF THE STEAM-ENGINE AND OTHER HEAT ENGINES. By Prof. C. H. Peabody, Massachusetts Institute of Technology. Third edition. 8vo. \$5 00

- THERMO - DYNAMICS, HEAT MOTORS,
AND REFRIGERATING MACHINES.** By
Prof. De Volson Wood. Sixth edition, revised
and enlarged. 8vo, cloth..... \$4 00
- ENGINE RUNNERS' CATECHISM.** By
Robert Grimshaw. Telling how to Erect, Adjust,
and Run the Principal Steam-Engines in use in
the United States, being a sequel to the author's
Steam-Engine Catechism. 18mo.....\$2 00
- THE PRACTICAL CATECHISM.** A Series
of Direct Practical Questions and Answers on
Subjects Connected with Engineering. By
Robert Grimshaw. 18mo, cloth..... \$1 25
- STATIONARY STEAM - ENGINES.** Espe-
cially adapted to Electric Lighting Purposes.
Treating of the Development of Steam-Engines
—the principles of Construction and Economy,
with description of Moderate Speed and High
Speed Engines. By Prof. R. H. Thurston. Fifth
edition. 1892. 12mo, cloth.....\$1 50
- A HAND-BOOK OF ENGINE AND BOILER
TRIALS, AND THE USE OF THE INDI-
CATOR AND THE BRAKE.** By R. H.
Thurston, Director of Sibley College, Cornell
University. Second edition, revised. 8vo.... \$5 00
- DEVELOPMENT OF THE PHILOSOPHY
OF THE STEAM-ENGINE.** By Prof. R. H.
Thurston. 18mo, cloth.....\$0 75
- STEAM-ENGINE DESIGN.** For the use of
Mechanical Engineers, Students, and Draughts-
men. By Prof. J. M. Whitham. Numerous illus-
trations. Full-page and folding plates. Second
edition, revised. 8vo, cloth.....\$6 00
- CONSTRUCTIVE STEAM-ENGINEERING.**
A Descriptive Treatise on Constructive Steam-
Engineering, embracing Engines, Pumps and
Boilers, and their Accessories and Appendages.
By Jay M. Whitham, M.E., C.E. Thoroughly
illustrated with 795 illustrations, many full-page
and twenty-two folding plates. 908 pages. 8vo,
cloth.....\$10 00

INDICATOR PRACTICE AND STEAM-ENGINE ECONOMY. With Plain Directions for Attaching the Indicator, Taking Diagrams, Computing the Horse-Power, Drawing the Theoretical Curve, Calculating Steam Consumption, Determining Economy, Locating Derangement of Valves, and making all desired deductions; also, Tables required in making the necessary computations, and an Outline of Current Practice in Testing Steam-Engines and Boilers. By Frank F. Hemenway, Associate Editor "American Machinist," Member American Society Mechanical Engineers, etc. Adopted as a Text-Book in Stevens Institute of Technology. Fifth edition. 12mo, cloth.....\$2 00

TWENTY YEARS WITH THE INDICATOR. Being a Practical Text-Book for the Engineer or the Student, with no complex formulæ, and with many Rules as to the best way to run any Steam-Engine to get the Most Economic Results—How to Adjust Valves and Valve Motions, with Directions for Working up Horse-Power—Amount of Steam or Water per Horse-Power—Economy of Fuel—Directions for Attaching the Indicator—Motions to Use and Not to Use—How to Compute by Planimeter or without, etc., etc. By Thomas Pray, Jr., Consulting and Constructing and Civil and Mechanical Engineer, etc., etc. Tenth thousand (1892). Newly arranged and complete in one volume. Royal 8vo, cloth..... \$2 50

TABLES OF THE PROPERTIES OF SATURATED STEAM AND OTHER VAPORS. By Cecil H. Peabody, Assistant Professor of Steam-Engineering in the Mass. Institute of Technology. Sixth edition, revised. 8vo, cloth.....\$1 00

VALVE-GEARS. By H. W. Spangler, U.S.N., and Professor of Mechanical Engineering, University of Pennsylvania. Second edition. To the second edition a chapter on the mathematical demonstration of the Hamilton-Corliss Valve-Gear has been added. 8vo, cloth.....\$2 50

VALVE-GEARS FOR THE STEAM-ENGINE. By Prof. C. H. Peabody, Institute of Technology, Boston, Mass. Analysis by the Zeuner-Valve Diagram. 33 folding plates. 8vo, cloth.....\$2 50

MARINE ENGINES AND DREDGING MACHINERY. Showing the latest and best English and American Practice. By Wm. H. Maw. Illustrated by over 150 fine steel plates (mostly two-page illustrations) of the engines of the leading screw steamships of England and other nations, and 295 fine wood engravings in text. Folio, half morocco. \$18 00

TABLES, WITH EXPLANATIONS, RELATING TO THE NON-CONDENSING STATIONARY STEAM-ENGINE, AND OF HIGH-PRESSURE STEAM-BOILERS. By W. P. Trowbridge. Plates. 4to, paper boards.....\$2 50

A MANUAL OF STEAM-BOILERS, THEIR DESIGNS, CONSTRUCTION, AND OPERATION. For Technical Schools and Engineers. By Prof. R. H. Thurston. 183 engravings in text. Fourth edition. 8vo, cloth.....\$5 00

STEAM-BOILER EXPLOSIONS IN THEORY AND IN PRACTICE. By R. H. Thurston, M.A., Doc. Eng., Director of Sibley College, Cornell University. Containing Causes of—Preventives—Emergencies—Low Water—Consequences—Management—Safety—Incrustation—Experimental Investigations, etc., etc., etc. With many illustrations. Second edition. 12mo, cloth.\$1 50

BOILER MAKING FOR BOILER MAKERS. A Practical Treatise on work in the Shop, showing the best Methods of Riveting, Bracing and Staying, Punching, Drilling, Smelting, etc., and the most economical manner of obtaining the best quality of Output at the least expense. By W. H. Ford, M.E. Second edition. 18mo, cloth.....\$1 00

A TREATISE ON STEAM-BOILERS. Their Strength, Construction, and Economical Working. By Robert Wilson, C.E. Enlarged and illustrated from the Fifth English Edition by J. J. Flather, Ph.B., Lehigh University. 108 fine illustrations, Tables, etc. Second edition. 12mo, cloth.....\$2 50

STEAM HEATING FOR BUILDINGS; or, Hints to Steam Fitters. Being a description of Steam Heating Apparatus for Warming and Ventilating Private Houses and Large Buildings, with Remarks on Steam, Water, and Air in their Relations to Heating. To which are added useful miscellaneous Tables. By Wm. J. Baldwin. Thirteenth edition. With many illustrative plates. 12mo, cloth.....\$2 50

REPORT OF A SERIES OF TRIALS OF WARM BLAST APPARATUS FOR TRANSFERRING A PART OF THE HEAT OF ESCAPING FLUE GASES TO THE FURNACE. Second edition. 1 vol., 8vo, cloth.....\$1 50

LOCOMOTIVE-ENGINE RUNNING AND MANAGEMENT. A Practical Treatise on Locomotive Engines, showing their performance in running different kinds of trains with economy and dispatch. Also, directions regarding the care, management, and repairs of Locomotives and all their connections. By Angus Sinclair, M.E. Illustrated by numerous engravings. Twentieth edition, carefully revised and enlarged. 12mo, cloth.....\$2.00

THE GAS-ENGINE. History and Practical Working. By Dugald Clerk. With 100 illustrations. Third edition. 12mo, cloth.....\$2 0¢

MODERN LOCOMOTIVE CONSTRUCTION. With many illustrations. By J. G. A. Meyer, Associate Editor of the "American Machinist." Describing every part, from an oil-cup to a cylinder. 4to, cloth.....\$10 00

LIBRARY OF CONGRESS



0 021 213 052 7