



Calhoun: The NPS Institutional Archive
DSpace Repository

Theses and Dissertations

1. Thesis and Dissertation Collection, all items

2013-06

NROL-41 go for launch

Burniston, Matthew P.

Monterey, California: Naval Postgraduate School

<http://hdl.handle.net/10945/34637>

Downloaded from NPS Archive: Calhoun



Calhoun is a project of the Dudley Knox Library at NPS, furthering the precepts and goals of open government and government transparency. All information contained herein has been approved for release by the NPS Public Affairs Officer.

Dudley Knox Library / Naval Postgraduate School
411 Dyer Road / 1 University Circle
Monterey, California USA 93943

<http://www.nps.edu/library>



**NAVAL
POSTGRADUATE
SCHOOL**

MONTEREY, CALIFORNIA

THESIS

NROL-41 GO FOR LAUNCH

by

Matthew P. Burniston

June 2013

Thesis Advisor:
Second Reader:

Mark Rhoades
Alan Scott

Approved for public release; distribution is unlimited

THIS PAGE INTENTIONALLY LEFT BLANK

REPORT DOCUMENTATION PAGE			<i>Form Approved OMB No. 0704-0188</i>
Public reporting burden for this collection of information is estimated to average 1 hour per response, including the time for reviewing instruction, searching existing data sources, gathering and maintaining the data needed, and completing and reviewing the collection of information. Send comments regarding this burden estimate or any other aspect of this collection of information, including suggestions for reducing this burden, to Washington headquarters Services, Directorate for Information Operations and Reports, 1215 Jefferson Davis Highway, Suite 1204, Arlington, VA 22202-4302, and to the Office of Management and Budget, Paperwork Reduction Project (0704-0188) Washington DC 20503.			
1. AGENCY USE ONLY (Leave blank)	2. REPORT DATE June 2013	3. REPORT TYPE AND DATES COVERED Master's Thesis	
4. TITLE AND SUBTITLE NROL-41 GO FOR LAUNCH		5. FUNDING NUMBERS	
6. AUTHOR(S) Matthew P. Burniston		8. PERFORMING ORGANIZATION REPORT NUMBER	
7. PERFORMING ORGANIZATION NAME(S) AND ADDRESS(ES) Naval Postgraduate School Monterey, CA 93943-5000		10. SPONSORING/MONITORING AGENCY REPORT NUMBER	
9. SPONSORING /MONITORING AGENCY NAME(S) AND ADDRESS(ES) N/A		11. SUPPLEMENTARY NOTES The views expressed in this thesis are those of the author and do not reflect the official policy or position of the Department of Defense or the U.S. Government. IRB Protocol number ___N/A___.	
12a. DISTRIBUTION / AVAILABILITY STATEMENT Approved for public release; distribution is unlimited		12b. DISTRIBUTION CODE A	
13. ABSTRACT (maximum 200 words) The current national economic situation has forced every Department of Defense program to find ways to accomplish more with fewer resources. Spacelift, as one of the most expensive government programs, has continuously been scrutinized and challenged to lower costs and work more efficiently. This thesis reviews a summarized history of events that brought the current launch community to its present state and then details the events of the NROL-41 launch campaign. NROL-41 was the most efficient launch campaign to date and a study of the work completed on the launch shows the depth of effort required to achieve mission success. Spacelift is an expensive and dangerous endeavor, but the risk of launch failures and loss of satellites is worth every penny spent to deliver mission success. This thesis provides the data to justify those costs as well as recommendations of studies that could be performed to define more appropriate places to cut spending without increasing risk.			
14. SUBJECT TERMS Evolved Expendable Launch Vehicle, launch campaign, satellite, space acquisition, Assured Access to Space, risk management, launch manifest			15. NUMBER OF PAGES 87
			16. PRICE CODE
17. SECURITY CLASSIFICATION OF REPORT Unclassified	18. SECURITY CLASSIFICATION OF THIS PAGE Unclassified	19. SECURITY CLASSIFICATION OF ABSTRACT Unclassified	20. LIMITATION OF ABSTRACT UU

THIS PAGE INTENTIONALLY LEFT BLANK

Approved for public release; distribution is unlimited

NROL-41 GO FOR LAUNCH

Matthew P. Burniston
Captain, United States Air Force
B.S., United States Air Force Academy, 2003

Submitted in partial fulfillment of the
requirements for the degree of

MASTER OF SCIENCE IN SPACE SYSTEMS OPERATIONS

from the

**NAVAL POSTGRADUATE SCHOOL
June 2013**

Author: Matthew P. Burniston

Approved by: Mark Rhoades
Thesis Advisor

Alan Scott
Second Reader

Rudolf Panholzer, PhD
Chair, Department of Space Systems Academic Group

THIS PAGE INTENTIONALLY LEFT BLANK

ABSTRACT

The current national economic situation has forced every Department of Defense program to find ways to accomplish more with fewer resources. Spacelift, as one of the most expensive government programs, has continuously been scrutinized and challenged to lower costs and work more efficiently. This thesis reviews a summarized history of events that brought the current launch community to its present state and then details the events of the NROL-41 launch campaign. NROL-41 was the most efficient launch campaign to date and a study of the work completed on the launch shows the depth of effort required to achieve mission success.

Spacelift is an expensive and dangerous endeavor, but the risk of launch failures and loss of satellites is worth every penny spent to deliver mission success. This thesis provides the data to justify those costs as well as recommendations of studies that could be performed to define more appropriate places to cut spending without increasing risk.

THIS PAGE INTENTIONALLY LEFT BLANK

TABLE OF CONTENTS

I.	INTRODUCTION.....	1
	A. BACKGROUND	1
	B. OBJECTIVES AND CORE TENETS	3
	C. RESEARCH QUESTIONS	5
	D. SCOPE	5
	E. METHODOLOGY	6
	F. ORGANIZATION OF THESIS	6
II.	ORIGINS	9
	A. OVERVIEW	9
	B. PAST TO PRESENT	9
	C. UNITED LAUNCH ALLIANCE.....	11
	D. LAUNCH VEHICLES.....	12
	E. ATLAS V 501	15
	F. SUMMARY	17
III.	SCHEDULING.....	19
	A. OVERVIEW	19
	B. NATIONAL LAUNCH FORECAST	19
	C. CURRENT LAUNCH SCHEDULE	21
	D. DIME.....	22
	E. IMPACTS TO INVENTORY	23
	F. SUMMARY	24
IV.	TRAILBLAZER	27
	A. OVERVIEW.....	27
	B. DEFINITIONS	27
	C. LESSONS LEARNED	28
	D. INFRASTRUCTURE	29
	E. TRAILBLAZERS	32
	F. TRANSPORTATION, LIFT, AND MATE REHEARSAL.....	37
	G. SUMMARY	42
V.	LAUNCH CAMPAIGN.....	45
	A. OVERVIEW	45
	B. HARDWARE ARRIVAL.....	45
	C. LAUNCH REHEARSALS.....	48
	D. INTEGRATION AND TEST.....	51
	E. DAY OF LAUNCH.....	56
	F. SUMMARY	59
VI.	CONCLUSIONS AND RECOMMENDATIONS.....	61
	A. OVERVIEW	61
	B. RECOMMENDATIONS.....	61
	C. AREAS FOR FURTHER RESEARCH.....	63

D. CONCLUSION	65
LIST OF REFERENCES.....	67
INITIAL DISTRIBUTION LIST	69

LIST OF FIGURES

Figure 1.	Fiscal Year 11 and 12 Air Force Procurement Budget. From [2].	1
Figure 2.	Fiscal Year 11 and 12 Air Force Procurement Quantities. From [2].	2
Figure 3.	Acquisition Model for Small Quantity Space Programs. From [3].	2
Figure 4.	EELV Manufacturing Plant, Decatur, AL. From [6].	10
Figure 5.	Delta Mariner (Left) and AN-124 Antonov (Right). From [6].	10
Figure 6.	Space Launch Complex 3, Vandenberg AFB, CA	11
Figure 7.	EELV Family of Vehicles. After [6].	14
Figure 8.	Atlas V 501 Configuration. After [6].	16
Figure 9.	5.4-Meter Payload Fairing Comparison. From [6].	16
Figure 10.	NLF and CLS Planning Timing. From [8].	20
Figure 11.	CLSRB Decision Points in the CLS. From [8].	22
Figure 12.	Fixed Umbilical Tower Roof on SLC-3	30
Figure 13.	NROL-41 Electrical Power Configuration	31
Figure 14.	KAMAG with Encapsulated Assembly	32
Figure 15.	Payload Fairing Inside of IPF near SLC-6.	34
Figure 16.	Spacecraft Encapsulation. After [9].	35
Figure 17.	Drive Wheel Unit Incident.	36
Figure 18.	Clean Room to Transfer Tower Clearance	38
Figure 19.	Encapsulated Assembly Inside of IPF and KAMAG Mating	38
Figure 20.	Planning image of L-41 EA over DMSP-18 Booster	40
Figure 21.	Mobile Service Tower Clearance Planning. After [9].	41
Figure 22.	Booster Offload at Vandenberg Air Force Base	46
Figure 23.	Centaur Interstage Adapter Damage	47
Figure 24.	Flight Hardware Arrival and Processing Flow. From [6].	48
Figure 25.	NROL-41 Launch Management Team	50
Figure 26.	Booster Interstage Adapter Mate	51
Figure 27.	Centaur Interstage Adapter Mate	52
Figure 28.	Centaur Mate.	52
Figure 29.	Centaur Forward Load Reactor and Base Module.	53
Figure 30.	Wet Dress Rehearsal at SLC-3	54
Figure 31.	Modified KAMAG Transporter	55
Figure 32.	Encapsulated Assembly Mate	55
Figure 33.	Mobile Service Tower Roll.	57
Figure 34.	Cryogenic Tanking Prior to Launch	58
Figure 35.	NROL-41 Flight Profile. From [10].	59
Figure 36.	NROL-41 Launch Photo	62
Figure 37.	NROL-41 Launch Trail.	65

THIS PAGE INTENTIONALLY LEFT BLANK

LIST OF TABLES

Table 1.	Delta IV Payload Capabilities. From [6].	13
Table 2.	Atlas V Payload Capabilities. From [6].	13

THIS PAGE INTENTIONALLY LEFT BLANK

LIST OF ACRONYMS AND ABBREVIATIONS

AFLD	Air Force Launch Director
AFSPC	Air Force Space Command
AGO	Aerospace Government Organization
BISA	Booster Interstage Adapter
BM	Base Module
CCAFS	Cape Canaveral Air Force Station
CISA	Centaur Interstage Adapter
CFLR	Centaur Forward Load Reactor
CLS	Current Launch Schedule
CLSRB	Current Launch Schedule Review Board
CPM	Common Payload Module
DIME	Diplomatic Information Military Economic
DMD	Deputy Mission Director
DMSP	Defense Meteorological Satellite Program
DoD	Department of Defense
DoL	Day of Launch
DWU	Drive Wheel Unit
EA	Encapsulated Assembly
EELV	Evolved Expendable Launch Vehicle
FC	Flight Commander
FML	Flight Mission Lead
FTL	Flight Technical Lead
FUT	Fixed Umbilical Tower
GEM	Graphite Epoxy Motor
GMIM	Government Mission Integration Manager
HVAC	Heating Ventilation Air Conditioning
ICE	Integrated Crew Exercise
ILC	Initial Launch Capability
IPF	Integrated Payload Facility
IST	Integrated System Test

LCG	Launch Group
LDA	Launch Decision Authority
LISN	Launch Information Support Network
LPM	Lower Payload Module
LRR	Launch Readiness Review
LSIC	Launch Support Integration Contractor
MD	Mission Director
MDR	Mission Dress Rehearsal
MST	Mobile Service Tower
NLF	National Launch Forecast
NOPS	NRO Operations
NRO	National Reconnaissance Office
OD	Operations Director
OSL	Office of Space Launch
PLF	Payload Fairing
RAT	Rehearsal Anomaly Team
RCO	Range Control Officer
ROC	Range Operations Controller
RP-1	Refined Petroleum-1
SE	Safety
SLC	Space Launch Complex
SLS	Space Launch Squadron
SPO	System Program Office
SRB	Solid Rocket Booster
SVPP	South Vandenberg Power Plant
SV	Space Vehicle
ULA	United Launch Alliance
VAFB	Vandenberg Air Force Base
WDR	Wet Dress Rehearsal

ACKNOWLEDGMENTS

The author would like to take this opportunity to thank those who made this thesis possible. First, to the men and women of the 4th Space Launch Squadron, Atlas Flight, whom I had the honor to command during the NROL-41 Launch campaign, your steadfast dedication to the mission enabled success at every turn. Also, the members of United Launch Alliance stationed at SLC-3 deserve every accolade received for this mission's success. Without their expertise, professionalism, and sacrifices the mission never would have left the ground.

I would like thank my thesis advisors for allowing this subject to be studied as well as continuing to push this thesis' completion. Finally, and most importantly, I would like to thank my wife, Amanda, for her unwavering support and for putting up with the time that this research required.



THIS PAGE INTENTIONALLY LEFT BLANK

I. INTRODUCTION

A. BACKGROUND

“The only constant is change, continuing change, inevitable change, that is the dominant factor in society today. No sensible decision can be made any longer without taking into account not only the world as it is, but the world as it will be....” [1] While he was not specifically referring to the United States’ spacelift mission, Mr. Asimov’s words ring true with the evolution of military capabilities and the current economic challenges facing the government on the whole. When looking at the U.S. spacelift capabilities, questions are constantly asked challenging the cost of operations as well as the need for the depth of support we currently utilize. Today, the U.S. is realizing an unprecedented string of launch success without catastrophic failure and while no one wants to see that record change, the question is being asked if equal success can be achieved faster and at a lower cost.

Per program, the largest portion of the United States Air Force budget is dedicated to space assets, specifically on the manufacturing, testing, launch and operation of satellites. The Fiscal Year 2011 and 2012 procurement budget is shown in Figure 1.

Procurement TOA (\$M)	FY 11 PB	FY 12 PB
Aircraft	15,354	14,066
Missiles	4,570	4,915
Ammunition	667	539
Other Procurement	3,587	2,984
Blue Total	24,178	22,504

Figure 1. Fiscal Year 11 and 12 Air Force Procurement Budget. From [2].

It is important to note that the dollars shown in Figure 1 must be compared to the quantities shown in Figure 2 in order to see the per program budget disparity. In Fiscal Year 2012, an average of over one hundred and twenty five million dollars was spent on each aircraft where an average of over three hundred and thirty one million dollars were spent on nine space assets (four launch vehicles and five satellites).

Major Procurement Quantities**					
	FY 11		FY 12		
Aircraft	124	112	Space	5	9
MQ-9A Reaper	36	48	EELV	3	4
F-35A Lightning II	22	19	GPS III	-	2
Light Attack Armed Reconnaissance	-	9	Advanced EHF	-	2
C-27J Spartan	8	9	WGS	1	1
MC-130 Recapitalization	5	6	SBIRS GEO	1	-
CV-22B Osprey	5	5	Weapons	7,540	4,266
HH-60M Operational Loss Replacement	3	3	JDAM	3,500	3,250
RQ-4B Global Hawk	4	3	AGM -114 Hellfire	460	416
C-37A (Lease to Purchase)	2	3	AIM-9X Sidewinder	178	240
HC-130 Recapitalization	4	3	AIM-120D AMRAAM	246	218
Common Vertical Lift Support Platform	-	2	AGM-158 JASSM	171	142
C-130J Super Hercules	8	1	Small Diameter Bomb	2,985	-
AC-130 Recapitalization	-	1			
Light Mobility Aircraft	15	-			
USAFA Flight Program	12	-			

Figure 2. Fiscal Year 11 and 12 Air Force Procurement Quantities. From [2].

In addition to being the most expensive acquisitions in the Air Force, the life of these assets differs from traditional programs. Due to the nature of the environment in which they operate, space assets spend over seventy percent of their budgeted life on the ground before actually operating in their intended field. Figure 3 shows the acquisition model for assets like satellites and launch vehicles and, as shown by the marker labeled “IOC,” illustrates the point that much time and money are invested in these assets before they are able to prove their worth in the field.

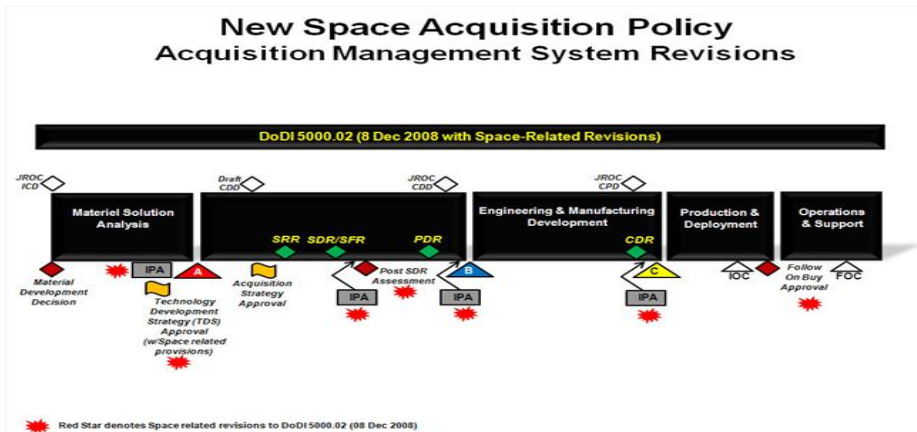

Figure 3. Acquisition Model for Small Quantity Space Programs. From [3].

In the entire life cycle of a satellite there are multitudes of risks which jeopardize mission success and of all those risks, none is more dangerous than launch. Satellites can take between ten and twenty years to design and build and cost billions of dollars. Entire careers have been spent building individual systems and if these systems do not arrive precisely in their intended orbit they are unable to operate as designed. The transition from Earth to space is wrought with perils. The launch vehicles contain tens of thousands of gallons of highly flammable substances and are surrounded by self-destruct and safety devices intended to protect life and property surrounding a launch site. In addition to the volatile risks during launch, the satellite is exposed to tremendous physical and acoustic vibrations as well as temperature changes and debris during ascent and deployment. Each and every one of these risks are documented, researched, simulated, examined, discussed, and eventually accepted by the launch community long before the day of launch. These factors are accounted for in the design of the satellite and the design of the rockets in order to mitigate them in the most advantageous manner possible. In the case of Department of Defense satellites and launches, the designs and efforts are checked and re-checked by active duty military, government civilian, independent, contractor review teams, prime contractor, and sub-contractors throughout the entire life cycle process.

There is no doubt that the process is time consuming and expensive, but the cost of failure is unacceptable to military operations worldwide. Despite the unprecedented string of launch successes we currently enjoy, political pressure is building to reduce the cost of launch. Cost reductions directly reduce the amount of technical reviews and layers of oversight on each launch campaign. The oversight methodology may seem burdensome, but it is the very architecture that allowed the current launch successes. Despite today's budget constrained environment, the United States must continue their concerted effort to keep the spacelift industry alive in order to maintain our nations' assured access to space.

B. OBJECTIVES AND CORE TENETS

The primary objective of this research is to highlight the level of effort required in making a launch successful. Looking through a complete launch campaign for one

mission will allow for an in-depth analysis of each of the precautions taken to arrive at launch day and execute without mission failure. Further discussion will show how the scheduling process is one area that has become a political fighting ground and is hampering the overall program thus leading to a decayed industrial base for spacelift. This research will focus on the necessary steps required to protect our nation's on-orbit capabilities by assuring the successful launch of billion dollar satellites. The bottom line is identifying the level of effort which will provide the level of success demanded by and delivered to the operational forces while meeting key modes of operation presented in the research questions.

As conducting programmatic studies may lead into any number of directions, such a study requires a certain level of focus. Several attributes or tenets are a necessary baseline for discussion and analysis. The attributes, accompanied with the appropriate definition, are as follows:

- Spacelift: The projection of power by delivering satellites, payloads, and materiel into or through space [4]. Spacelift is the physical act of placing an object into orbit around Earth. For this research, the object refers to satellites. Success requires perfect planning, execution and performance from personnel and hardware and may be one of the most complex operations the military conducts. There are only two locations in the world where EELV spacelift operations are executed; Vandenberg Air Force Base, California and Cape Canaveral Air Force Station, Florida.
- Evolved Expendable Launch Vehicle (EELV): The intent of the EELV program was to utilize common components in the design of a new family of launch vehicles in order to reduce cost. The original program goal was to reduce cost by 25%–50% when compared to the preceding vehicles.
- Assured Access to Space: It is the policy of the United States for the President to undertake actions appropriate to ensure, to the maximum extent practicable, that the United States has the capabilities necessary to launch and insert United States national security payloads into space whenever such payloads are needed in space. The appropriate actions shall

include, at a minimum, providing resources and policy guidance to sustain the availability of at least two space launch vehicles (or families of space launch vehicles) capable of delivering into space any payload designated by the Secretary of Defense or the Director of National Intelligence as a national security payload and a robust space launch infrastructure and industrial base [5].

C. RESEARCH QUESTIONS

1. How did the launch community arrive at its current state?
2. What drives the cost and length of a launch campaign?
3. How is a launch campaign planned and executed?
4. What does it take to make a launch a success?

D. SCOPE

The scope of this thesis will include:

- A brief history of the Evolved Expendable Launch Vehicle program and its key members.
- An analysis and information gathering of space launch campaign preparations to include requirements development and refining, rehearsals, and incorporation of lessons learned.
- Information gathering and analysis of key aspects of a launch campaign to include manufacturing, engineering, testing, and operations.
- An analysis of the performance of all the participants within a launch campaign.
- A recommendation for areas of further study and research.

E. METHODOLOGY

1. Research the current prime contractor's history and evolution
2. Research and analyze all aspects of a launch campaign through participation in nominal and anomalous procedure execution.
3. Analyze technical data and procedures of a launch campaign to capture testing, manufacturing, and operational techniques that are used to ensure launch success.
4. Conduct a validation of current processes through execution of a successful launch.

F. ORGANIZATION OF THESIS

CHAPTER I. This chapter discusses the context, background, and justification for further research into how the launch campaign unfolds and the steps taken to assure its success. This background information addresses the reasons for conducting this research, and provides foundation for further research of this topic.

CHAPTER II. This chapter explains the history of the Evolved Expendable Launch Vehicle program, from where the participants originated, and the current structure of the services and products provided. The background of several government and civilian organizations are provided in this chapter. The focus is to discuss details of past and present decisions that have shaped our launch programs and provide a foundation for the study.

CHAPTER III. This chapter will explain the launch scheduling process. Launch scheduling has become a battleground for launch and satellite programs and is critical to the timely execution of missions. Various factors have shaped the scheduling process and the decisions made in this process drive production timelines and delivery decisions. These decisions balance diplomatic, informational, military and economic needs of our nation and can be areas of serious contention for the invested members of the spacelift community.

CHAPTER IV. This chapter will show how the launch community achieved readiness to proceed into the launch campaign. The trailblazer for NROL-41 took three months to execute and guaranteed that all identifiable risks were documented and mitigated prior to delivery and processing of the actual spacecraft. In addition to spacecraft readiness, launch vehicle preparations and base support/infrastructure requirements were also analyzed.

CHAPTER V. This chapter will analyze the launch campaign of the NROL-41 mission from flight hardware arrival through the Day of Launch. Portions of the study will look at planning and manufacturing in the years prior to arrival, the majority of the data focuses on the integration at the launch site in preparation for launch.

CHAPTER VI. This chapter provides a conclusion to the research study as well as recommends areas for further analysis and research.

THIS PAGE INTENTIONALLY LEFT BLANK

II. ORIGINS

A. OVERVIEW

The United States Air Force has always been driven to achieve and maintain air superiority, and over the years that drive has expanded to include outer space. In pursuit of this goal, the United States has been building and improving on the technology necessary to reach the ultimate high ground since the mid-1950's. While the early launch programs were marred by uncertainty and failures, the industry adapted and overcame the unknowns in order to deliver critical capabilities to our nation.

This chapter details the history of a current contractor for Department of Defense spacelift services in order to lay the foundation for the complex work effort required for mission success. The work ethic and historical knowledge that drives launch success today is directly tied to the lessons learned from every previous launch, regardless of its level of success.

B. PAST TO PRESENT

In 1994, the U.S. Air Force officially sought out replacements for their current fleet of space launch vehicles, primarily the Delta II, Atlas II, and Titan IV. The program through which these replacements would be selected is known as the Evolved Expendable Launch Vehicle (EELV) program. The goal was to make launch more affordable and streamline processes to improve space responsiveness. In addition to improving commonality among vehicle components, utilizing multiple contractors would allow for competitiveness and create enough separation between designs that if there were a failure in one system then there would still be another vehicle available to maintain our nation's access to space.

Four contractors initially entered bids but, in the initial launch services contract, only Lockheed Martin and Boeing were awarded launches on their Atlas V and Delta IV vehicles. The two contractors provide similar capabilities, but the means by which they provide those capabilities vary greatly.

Some of the differences can be seen in the manufacturing and assembly processes and other differences can be found in the supply chain methodology chosen by each company. In manufacturing, Lockheed Martin chose a larger, more global approach while Boeing, in general, chose a more domestic approach. Also, Lockheed utilized more existing capabilities and relied more heavily on transporting pieces of their rockets from various locations than Boeing, who chose to build a consolidated manufacturing facility in Decatur, AL, as seen in Figure 4. Even their delivery method of finished rockets differed as Boeing opted to deliver over sea via the Delta Mariner, and Lockheed took to the skies with a Russian AN-124 Antonov, Figure 5.



Figure 4. EELV Manufacturing Plant, Decatur, AL. From [6].



Figure 5. Delta Mariner (Left) and AN-124 Antonov (Right). From [6].

With these and many other differences, the necessary supporting infrastructure also needed to be different. Lockheed chose a vertical integration approach, choosing to use a crane to lift and stack each segment of the rocket onto its launch mount. Figure 6 shows Space Launch Complex 3 at Vandenberg AFB and pictures the facility where the rocket and spacecraft are integrated prior to launch. Boeing opted to assemble the rocket horizontally and transport it to the launch site already assembled where it is then pushed into a vertical position prior to the spacecraft being placed on top in preparation for launch.



Figure 6. Space Launch Complex 3, Vandenberg AFB, CA

Constrained to the current launch facilities which the companies lease, major modifications to the launch sites as well as support facilities were needed. Power, helium, nitrogen, communications, and water commodities were just some of the larger resources that needed to be validated as capable to support the EELV family of vehicles. Almost all of these improvements were made in-between launch campaigns as required for each site.

C. UNITED LAUNCH ALLIANCE

Although the intention to maintain separate contractors to provide launch services was well thought out, there was little that could be done to prevent several issues which threatened both Boeing and Lockheed Martin's space systems divisions.

Due to a coupled decrease in demand from Department of Defense satellites and commercial customers, neither Boeing nor Lockheed were able to independently sustain their space launch service businesses without threatening the quality of the product or the

experienced work force which is critical to mission success. Therefore, in 2008, Boeing and Lockheed space launch services broke off from their parent companies and created a new company, United Launch Alliance.

This new company would spend the next two years consolidating their workforces and optimizing every aspect of their manufacturing, transport, and launch procedures in order to create a long-term, sustainable business model that continues to deliver mission success to every one of their customers. This merger brought ripples throughout the commercial and Department of Defense space agencies. Never before had Boeing and Lockheed attempted to merge products and great care was needed to ensure that only that information pertaining to the launch vehicles was migrated into the new company. Since the Air Force had divided their acquisition and operations forces along the same lines as Boeing and Lockheed, the merger forced a restructuring of military launch operations and acquisition forces as well. The acquisition center for EELV at Los Angeles Air Force Base has undergone several organizational changes and each of the launch bases have seen shifts in the way they operate in order to match the lean practices being adopted by ULA. While all of this effort was slow and, at times, painful, the current operations of each launch vehicle did not stop. Simultaneously with manufacturing and launch efforts, employees from both companies were retrained or terminated and the individual processes of two rival companies were changed or merged into new techniques. A total of nine Atlas V rockets and 6 Delta IV rockets launched successfully over the initial two year merger timeline, all executed without a launch vehicle failure. From [6] ULA, as well as the supporting DoD and civilian agencies, continue to evolve and adjust their force structure to meet the changing face of the industry.

D. LAUNCH VEHICLES

Boeing's Delta IV family of rockets is a two-stage design with the main and upper stage engine coming from an American sub-contractor where Lockheed chose a Russian main engine for the Atlas V family. The prime factor driving the differing performance specifications can be attributed to use of different fuels. The Atlas V operates on RP-1, a form of refined petroleum, and the Delta IV uses liquid hydrogen. Similarly, both

families use liquid oxygen for the oxidizer and liquid hydrogen fuel in their upper stage engines. The upper stage engine is referred to as Centaur in the Atlas family of rockets. The payload capabilities for each Delta and Atlas rocket, by configuration are detailed in Tables 1 and 2.

	GTO Payload* (ETR)	ETR* Reference Orbit	Estimated Launch Price	Configuration	Launch Mass
Delta IV Medium	8,600 lb 3,900 kg	14,900 lb 6,760 kg	U.S. \$70 M	Core + 4m Fairing	349,140 lb 158,340 kg
Delta IVM+ (4,2)	11,700 lb 5,300 kg	20,000 lb 9,070 kg	U.S. \$90 M	Core + 2 GEMS + 4m Fairing	377,990 lb 171,420 kg
Delta IV M+ (5,2)	9,600 lb 4,350 kg	17,300 lb 7,850 kg	U.S. \$80 M	Core + 2 GEMS + 5m Fairing	522,190 lb 231,670 kg
Delta IV M+ (5,4)	13,500 lb 6,120 kg	22,700 lb 10,300 kg	U.S. \$100 M	Core + 4 GEMS + 5m Fairing	522,190 lb 231,670 kg
Delta IV Heavy	27,400 lb 12,400 kg	45,200 lb 20,500 kg	U.S. \$140 M	Core + 2 Core Boosters + 5m Fairing	522,190 lb 231,670 kg

Table 1. Delta IV Payload Capabilities. From [6].

	GTO Payload* (27 degree inclination)	GSO Payload* (0 degree inclination)	Estimated Launch Price	Configuration	Launch Mass
Atlas V 401	11,000 lb 5,000 kg	---	U.S. \$90 M	Common Core + Centaur (1x RL- 10A-4-1)	734,850 lb 334,045 kg
Atlas V 501	9,000 lb 4,100 kg	1,500 lb 3,300 kg	U.S. \$85 M	Common Core + Centaur (1x RL- 10A-4-2)	741,165 lb 336,895 kg
Atlas V 511	10,800 lb 4,900 kg	3,900 lb 1,750 kg	U.S. \$90 M	Common Core + 1 SRB + Centaur (1x RL- 10A-4-2)	831,180 lb 377,805 kg
Atlas V 521	13,200 lb 6,000 kg	4,900 lb 2,200 kg	U.S. \$95 M	Common Core + 2 SRB's + Centaur (1x RL- 10A-4-2)	921,200 lb 418,725 kg
Atlas V 531	15,200 lb 6,900 kg	6,600 lb 3,000 kg	U.S. \$100 M	Common Core + 3 SRB's + Centaur (1x RL- 10A-4-2)	1,011,220 lb 459,545 kg
Atlas V 541	16,700 lb 7,600 kg	7,500 lb 3,400 kg	U.S. \$105 M	Common Core + 4 SRB's + Centaur (1x RL- 10A-4-2)	1,101,230 lb 500,365 kg
Atlas V 551	18,080 lb 8,200 kg	8,200 lb 3,750 kg	U.S. \$110 M	Common Core + 5 SRB's + Centaur (1x RL- 10A-4-2)	1,191,250 lb 541,195 kg
Atlas V Heavy	30,000 lb 13,605 kg	13,000 lb 5,900 kg	U.S. \$130 M	Common Core + 2 Common Core Boosters + Centaur (1x RL- 10A-4-2)	2,120,000 lb 961,451 kg

Table 2. Atlas V Payload Capabilities. From [6].

Both Atlas V and Delta IV utilize a common core methodology, meaning that the main booster for each Atlas and Delta is manufactured identically. Previous approaches in rocket design led to each rocket being specifically built for a given payload. In the EELV concept, boosters can be built without having a specific payload or mission path known at the time of manufacturing. It is still necessary to match specific upper stage sections to specific payloads. The tables above show how the different payload capabilities depend upon the variant of each rocket that is required. For Delta IV rockets, a medium vehicle denotes a 4-meter diameter fairing and zero Graphite-Epoxy Motors (GEMS). Medium-plus vehicles add GEMS in pairs and may increase the size of the payload fairing up to 5-meters. A Delta IV Heavy vehicle is three common booster cores and zero GEMS.

The Atlas V variants are named with a three number indicator. The first number denotes the size of the payload fairing, either 4-meter or 5-meter. The second number calls out the number of Solid Rocket Boosters (SRB) and the third number lists the number of upper stage engines. As an example, an Atlas V 551 is a 5-meter payload fairing with five SRB's and one upper stage engine. Because the main engine, a NPO Energomash RD-180, has twin exhaust, the SRB configuration can be an odd number without jeopardizing flight path. Figure 7 shows the Atlas V and Delta IV family of vehicles.



Figure 7. EELV Family of Vehicles. After [6].

E. ATLAS V 501

The necessary booster configuration for the NROL-41 mission was the Atlas V 501. Historically, the NROL-41 mission was planned for the Delta IV launch vehicle. Prior to the Boeing and Lockheed merger, Boeing was found to be in violation of acquisition policy and misconduct in relation to the initial EELV contract proposal negotiation. As part of the penalty for this violation, Lockheed would be permitted build launch capabilities on Vandenberg AFB and three launches, NROL-41 included, which had previously awarded to Boeing were awarded to Lockheed Martin [7].

The 501 booster has several key design differences from the 400 series rockets. Everything from the RD-180 engine up to the Centaur Interstage Adapter (CISA) is identical to other variants. In the 400 series rockets, the Centaur forms the outermost layer of the rocket and the fairing enclosed payload, also called the Encapsulated Assembly (EA), is attached on top. In the 500 series, the payload fairing extends all the way around the Centaur and requires a Centaur Forward Load Reactor (CFLR). The CFLR minimizes vibrations induced on the Centaur and the larger payload fairing and is critical for stabilizing the rocket throughout ascent. The CFLR, payload fairing, and interstage adapters all separate and clear the vehicle's path prior to spacecraft separation. Figure 8 shows a representative model of the 501 rocket. In the figure, the image of the Orbital Test Vehicle represents the payload and is not representative of the NROL-41 payload.

Because the NROL-41 mission was the first 5-meter Atlas V launch on SLC-3, physical modifications were necessary to the SLC-3 launch tower to be able to accommodate the larger fairing. The size of the payload required more than the sixty-eight feet of payload space depicted in Figure 8. The details of the modifications will be further discussed in the Trailblazer chapter.

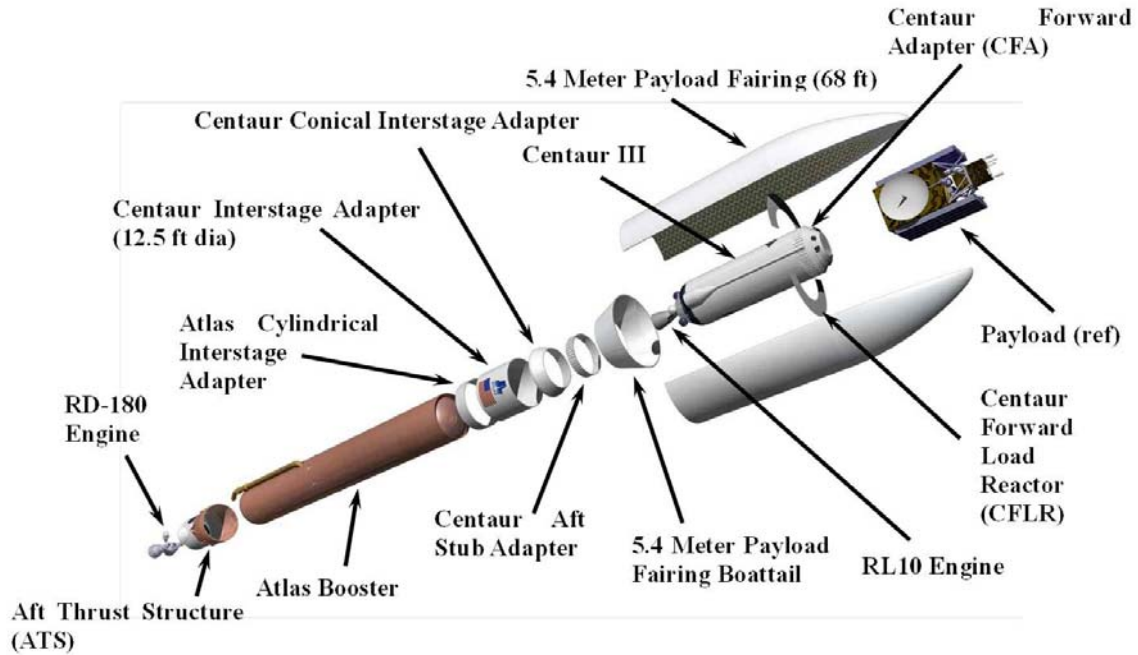

Figure 8. Atlas V 501 Configuration. After [6].

In addition to NROL-41 being the first 5-meter Atlas V to launch from Vandenberg Air Force base, it was also the first 5-meter Atlas V to ever utilize a Lower Payload Module (LPM) to extend the payload fairing. Figure 9 shows the comparison of the 5-meter fairings with and without the LPM.

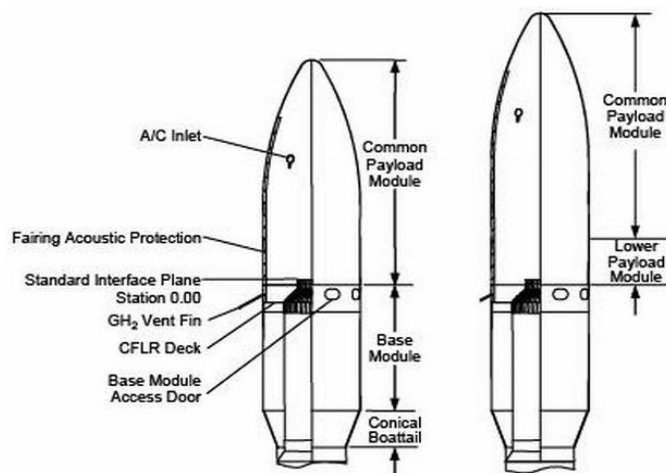

Figure 9. 5.4-Meter Payload Fairing Comparison. From [6].

F. SUMMARY

This section focused on the creation of ULA and how the composition of this company is rooted in the history of space launch. Also included was a very high level overview of the different launch vehicles in the EELV family and a glimpse into how the launch community arrived at its current state. In addition, some differences between the ULA families of rockets were highlighted in order to validate how the single company can meet the legal obligation to maintain assured access to space. Further details of the Atlas V launch vehicle are provided since that was the launch vehicle utilized for the subject mission. The next area of research steps away from the technical aspects of spacelift and looks at the process by which launches are scheduled and the resultant effect on the production and availability of launch vehicles.

THIS PAGE INTENTIONALLY LEFT BLANK

III. SCHEDULING

A. OVERVIEW

Despite the fact that executing EELV launch operations has been contracted out to commercial launch providers, the DoD remains firmly in command throughout the entire process. If there is one place in the EELV launch campaign where government involvement is most evident, it is the scheduling process.

This chapter details the way a launch is forecasted and planned for execution. This portion of the overall launch program has been the slowest to change due to the fact that this is the area where all of the government's competing interests meet and are prioritized. It has also been resistant to change because of the diverse make-up and high level of government and corporate leadership involved in the decision making process. Competing interests often mean that one agency's launches are scheduled while others are delayed temporarily and are put on longer term stand-by status. Depending on the agency, delays can mean the difference between commercial success and failure or, for the government, preventing gaps in national security capabilities.

B. NATIONAL LAUNCH FORECAST

The launch scheduling process can begin up to ten years prior to a desired launch date. The entire process is led by the current 14th Air Force Commander and managed by Air Force Space Command. There are two phases in this process, the forecasting phase and the scheduling phase. The forecasting phase, which is managed using the National Launch Forecast (NLF), is reserved for the planning, programming, and budgeting phases and has no restrictions about how far out missions can be planned. The scheduling phase, also known as the execution phase and managed using the Current Launch Schedule (CLS), looks at missions planning launch in the near term. The separation point is at the two-year mark, as shown in Figure 10.



Figure 10. NLF and CLS Planning Timing. From [8].

The NLF is a projection of national space launches from the Eastern and Western Ranges located in Cape Canaveral Air Force Station and Vandenberg Air Force Base, respectively. The forecasted launches include DoD, National Reconnaissance Office, Civil, other government agencies, and commercial launches. The NLF is kept on the Launch Information Support Network (LISN) which is also managed by Air Force Space Command and is located at <https://lisn.afspc.af.mil> [8].

Missions are added to the NLF in one of two ways. When one of the agencies listed above desires a launch to be added to the NLF, they can contact Air Force Space Command to notify them of their launch requirements. The other method is when Air Force Space Command collects launch data in the form of a data call submitted to each of the stakeholders. These data calls are sent at least once annually, but can be more frequent if emerging requirements necessitate or a particular time looks to be targeted by multiple customers.

Future year fiscal considerations drive the timing of this level of launch planning. Command leaders will gather to further refine and validate their launch requirements in support of the Program Objective Memorandum's five year planning cycle in order to ensure the necessary funding is in place for launch vehicle procurement as well as provide an opportunity to lobby for their program should the fiscal environment threaten to jeopardize launch availability. Once the launch date approaches the two year mark, the mission then begins a review process for consideration to be removed from the NLF and added to the CLS.

C. CURRENT LAUNCH SCHEDULE

Missions moving from the NLF onto the CLS mark a significant step in the launch campaign. It is at this point that launch vehicle manufacturing decisions are finalized and hardware becomes marked for a specific payload and launch date. Addition onto the CLS is not an automatic process; it is closely controlled and managed by the Current Launch Schedule Review Board (CLSRB).

The CLSRB convenes quarterly and is chaired by the current Joint Force Combatant Commander (JFCC)-Space/14th Air Force Commander and is comprised of the Air Force Space Command Planning Directorate Chief, the Space and Missile Systems Center Vice Commander, the National Reconnaissance Office Director, NASA Director, a Federal Aviation Administration representative, facilitators from 14th Air Force staff, and supporting staffs of the board members. The purpose of the board is to assess the readiness of a mission to move into the execution phase and to handle the ramifications of any delays of other missions on the CLS. Emergent issues affecting the launch schedule or a change in national priorities can drive an out-of-cycle CLSRB to be convened if issues are deemed significant enough to require the highest levels of coordination.

Mission readiness is not indicative of a single area of the launch, but is a cumulative assessment of aspects needed for mission success. This includes spacecraft constellation health, spacecraft requirements, assessment of the confidence that the spacecraft will be ready by the desired launch date, spacecraft orbit, ground equipment availability, spacecraft and launch vehicle funding considerations, launch vehicle manufacturing assessments, liens on the launch vehicle fleet, launch pad availability, readiness of the launch vehicle to support the desired launch date, launch range availability, personnel, range maintenance, supporting facilities, and any other limiting factors that could affect the mission flow. Figure 11 shows the CLSRB decision timeline within the CLS.

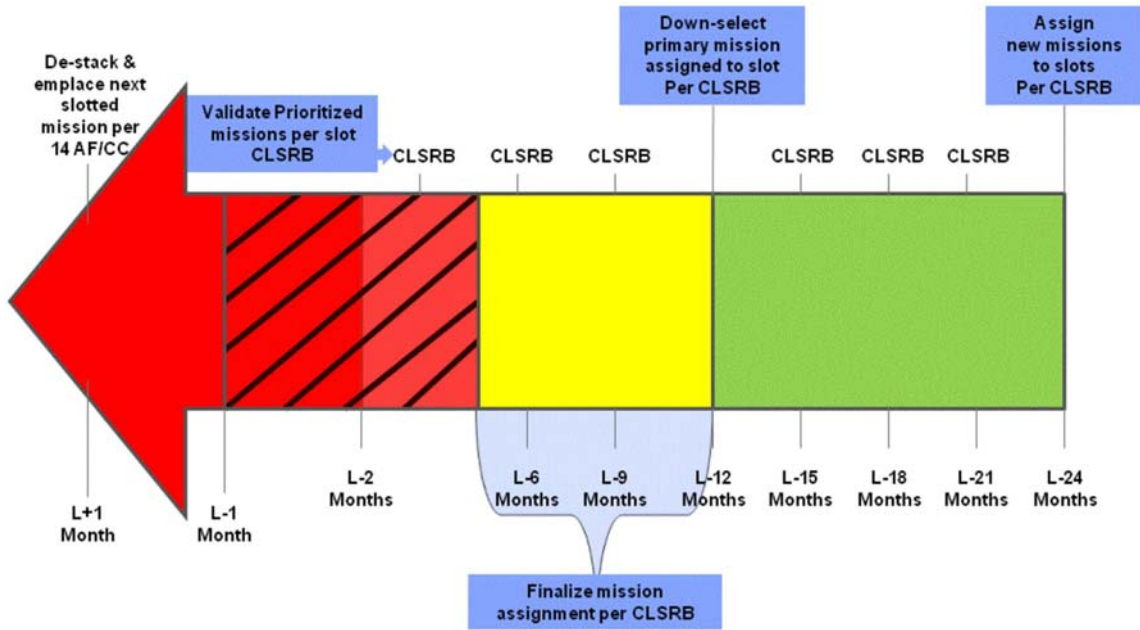

Figure 11. CLSRB Decision Points in the CLS. From [8].

With all of this information provided to the CLSRB, decisions can be made regarding the launch order, assigning launch dates, and optimizing launch opportunities. Those decisions produce the two year CLS and give the stakeholders their necessary timeframes to execute their individual missions against.

D. DIME

In its purest sense, the CLSRB is designed to be a place where the four elements of national power: Diplomatic, Information, Military, and Economic (DIME), compete for available launch opportunities. The CLSRB chairperson, also an active duty three-star Air Force general, listens to all inputs and decides amongst multiple requests for launch priority. No one element is supposed to outweigh another but each facet of DIME has an interest in which satellites launch in a given year. Application of national priorities in this process is meant to protect launch opportunities of smaller stakeholders, but also give the authority to reprioritize the launch schedule at the last minute to support an unplanned national need. A review of the current CLS shows that there are twenty-two EELV launches planned between March of 2012 and February of 2014. Twelve of those launches are DoD, five are National Reconnaissance Office launches, two are

commercial launches and three are NASA launches. Applying the planned launches to the DIME model shows a disparity toward the military element. This is not surprising, since the EELV program is funded by the DoD, National Reconnaissance Office, and NASA in respective percentages, however the intent was to be able to offer launch opportunities to the diplomatic (foreign) and economic (commercial) elements to help keep the launch enterprise stable, cover the cost of the program, and allow companies or countries with less financial flexibility to expand into the space arena.

Past delays to DoD, NRO, and NASA missions have shuffled the CLS so much that the NLF is turning into the equivalent of a five lane expressway merging into two lanes. There is not a fault to be placed on any of the agencies as the delays resulted from issues with the launch vehicles, spacecraft, and launch ranges, but the ramifications of those delays have resulted in a launch manifest that has no openings for the next four to six years. For any competing diplomatic or economic players to utilize EELV would require a planned launch sometime in 2016 at the earliest and would still be subject to prioritization through the CLSRB.

E. IMPACTS TO INVENTORY

Where the CLSRB has lost focus is in its pursuit of maximizing launch opportunities. In the eyes of the CLSRB, a launch opportunity is defined by the number of available launches that ULA can execute in a given twelve month period. This “launch opportunity” nomenclature is derived from AFSPC Instruction 10–1213 and the EELV contract itself where the Air Force has paid ULA for a certain number of launches in a year. That one contract covers all four launch pads at the two different launch bases, so delays in one mission have the potential to cause ripple effects in the manifest and reduce the number of launches realized as compared to the number of launches planned. If ULA launches fewer rockets than was originally planned for the year, the program managers refer to that difference as lost launch opportunities. Speaking strictly financially, this is similar to a cart pulling a horse. EELV rockets cost between \$70M and \$140M depending on the vehicle variant where a single satellite can cost between \$450M and \$2B. Above all, no one in the community is willing to accept a launch failure that results in the

destruction and loss of a launch vehicle and satellite, so if any aspect of the launch is not ready to support, there is no launch attempt. But as long as there are no failures, the CLSRB is left to manage missed launch opportunities as though they are failures, leading to unnecessary flight hardware risk.

As previously discussed, funding and customer need has driven ULA into a force structure that cannot add additional launches into the calendar should a spacecraft problem delay a launch. The CLSRB has attempted to mitigate lost launch slots by stacking multiple satellites on a single launch slot and narrowing down the potential candidates for that slot as the launch date approaches. This poses problems on both sides of the launch hardware and only minimizes schedule risk slightly. For the launch vehicle, it delays integration of the mission specific components of the launch vehicle until the latest possible point in the manufacturing process. This now means that any additional anomalies anywhere else in the manufacturing, shipping, or assembly processes have to be absorbed through overtime work of the technicians or slipping the launch date, furthering the scheduling problem. On the satellite side, not knowing when you will launch keeps calibration of cameras and/or sensors on hold and threatens effectiveness of the satellite once it does reach orbit. In a worst case scenario for large constellation satellites, this could mean that there are multiple satellites aging in warehouses with no launch opportunity or launch vehicle available to augment on-orbit assets.

F. SUMMARY

The EELV launch scheduling system is designed to be very effective, but due to the nature of the launch business it often turns into a battleground. Different agencies budget and plan on different timelines meaning that some agencies get earlier access to contractually entering the launch manifest than others. Some agencies are backed by very powerful political powers and can interrupt a well-planned manifest.

The current structure utilizing a multiple mission stacking approach has only been in place since 2010 and continues to evolve as the community changes to accommodate everyone's launch needs. In order for the process to remain impartial and efficient, the launch community needs to be more open with the information pertaining to the readiness

of their flight hardware. The biggest issues in scheduling arise when someone is not forthcoming about their program issues, hoping that their team can resolve them just in time for launch.

If problems are not known, missions continue to advance to the top of the priority list under the premise of a healthy program and when they attain that top priority, they then hold a launch pad or range hostage with their mission specific hardware, touting that the risk associated in removing their hardware outweighs the cost of additional schedule delays. This is another artifact of a launch manifest that has no availability or flexibility because giving up a launch slot today may mean you may not get another slot for several years.

This chapter showed the key planning requirements and milestones achieved prior to any operations being executed. The planning stages last much longer than the operational stages, but the next chapter will show how the planning and operations merged during trailblazer efforts and allowed the overall campaign to proceed without hindrances.

THIS PAGE INTENTIONALLY LEFT BLANK

IV. TRAILBLAZER

A. OVERVIEW

Preparations for a launch begin years to decades before the actual launch. The entire planning effort starts with the satellite/constellation design. Every nut and bolt selected is in support of meeting the mission of the satellite and the orbit in which the satellite needs to operate. Even the launch vehicle and supporting infrastructure are carefully planned out to achieve a safe launch and delivery into orbit, and to ensure every need of the satellite is accounted for and ready to support the Initial Launch Capability (ILC) date and flight phase of the mission.

The following chapter will break down the three month long trailblazer efforts that preceded the NROL-41 launch campaign. The purpose of the trailblazer was to ensure all processing and transportation preparations were ready for the spacecraft prior to the actual flight hardware showing up to Vandenberg AFB. Since the cost of the satellite alone was over one billion dollars, planning levels and oversight of progress were heavily scrutinized in order to mitigate all anticipated risk at the lowest level possible.

B. DEFINITIONS

A launch campaign trailblazer is a spacecraft driven event. Programmatically speaking, that means the customer must request and plan for any trailblazers at the very beginning of the satellite and launch planning contracts. Financially speaking, that means that any additional campaign costs associated with a trailblazer fall under the umbrella of the customer. Even though the satellite customer is responsible for paying for trailblazers, the trailblazer is not only a satellite focused event. It is vital to incorporate launch vehicle operations into trailblazer operations to ensure as many risks can be mitigated as possible.

As previously mentioned, the goal of trailblazers is to assess supporting spacecraft hardware, spacecraft procedure readiness, and supporting infrastructure preparedness. A

trailblazer also provides a low risk and educational environment to train new personnel in payload operations or to train existing personnel on procedures that they do not normally use.

C. LESSONS LEARNED

The least glamorous and most critical aspect of any launch campaign comes before the first piece of hardware is ever manufactured. Lessons learned provide all of the applicable knowledge from previous, similar operations to the current operations and help the launch team understand all of the documented risks. Lessons learned have been incorporated into campaigns since the first launch campaign and the experience that ULA has built through Atlas and Delta operations over the years gives them a deeper tribal knowledge repository than any other launch contractor.

Experience is priceless in spacelift because there is practically no room for error. Mistakes can cost millions of dollars each day if they result in launch delays and tens of millions of dollars if the flight hardware is damaged. In the case of NROL-41, incorporating lessons learned began with the first successful five meter mission from Cape Canaveral Air Force Station (CCAFS) years prior. Even though the launch sites and processing centers are physically different between the two launch bases, there is always something to be learned from utilizing previously successful techniques. Also, by mitigating the common risks, more attention can be focused on the unique or first-time portions of any procedures.

After the NROL-41 contract was awarded, personnel who would lead operations at Vandenberg began travelling to CCAFS in order to shadow similar operations. Everything from initial hardware offloads to launch operations over several campaigns was witnessed. Existing CCAFS specific handling procedures were modified to fit Vandenberg operations instead of writing them from scratch. When unexpected occurrences arise during procedure execution, the lessons learned are entered into a database which allows the gained experience and knowledge to be incorporated into procedure revisions and to be shared across the launch community.

NROL-41 personnel not only capitalized on past missions to help achieve their goals, but their trailblazer execution helped shape their launch campaign and the campaigns of future missions. Over one hundred and twenty five lessons learned were documented from the trailblazer and addressed prior to the actual campaign operations. They covered topics from hardware to personnel safety and also sequencing of tasks to minimize flight hardware exposure and contamination.

D. INFRASTRUCTURE

The beginning of the trailblazer efforts would also mark the completion of the necessary infrastructure upgrades required to execute the NROL-41 mission. The SLC-3 Mobile Service Tower (MST), encapsulated assembly transporter (KAMAG), and Integrated Payload Facility (IPF) represent the three largest areas of upgrade and/or improvement that were required to support this mission. Other improvements to HVAC, antenna placement, security systems, and other supporting systems were needed but will not be discussed in great detail in this study.

The MST is a 286-foot tall support shelter weighing over two million pounds that surrounds the fixed launch platform where the Atlas V and payload are integrated and prepared for launch on SLC-3. The MST provides the environmental protection, platform access, data throughput, and integration hardware needed for every mission and, when required, moves away from the launch vehicle for fueling and launch operations. When the MST was originally upgraded for the Atlas V vehicle in 2005, 86 additional feet were added in conjunction with a new crane and earthquake resistant commodity systems. For the five meter NROL-41 mission, additional first-time configuration changes were needed. First was the removal of the platforms from the payload access levels of the MST. These platforms were initially designed and installed for the smaller, four meter payloads which preceded the NROL-41 mission. They were re-installed following launch, but required additional attention due to the nature of risk in first-time operations. Also, due to the size difference of the encapsulated assembly, the gaseous hydrogen vent was relocated and additional accesses were added to the environmental doors for HVAC lines to supply clean, forced air into the encapsulated assembly.

The Fixed Umbilical Tower (FUT) is shown in Figure 12 and is adjacent to the MST on SLC-3. As the name suggests, the FUT does not move at any time and houses the conduits for electrical power, fuel, oxidizers, non-transmitting data cables, and associated personnel access. Part of the roof of the FUT was designed and built before the concept of a five meter payload was realized; therefore that section of the roof of the FUT had to be removed in order for the larger encapsulated assembly to safely traverse into the MST for integration. Once the assembly was successfully integrated onto the launch vehicle, the roof could then be reattached as it posed no launch risk.

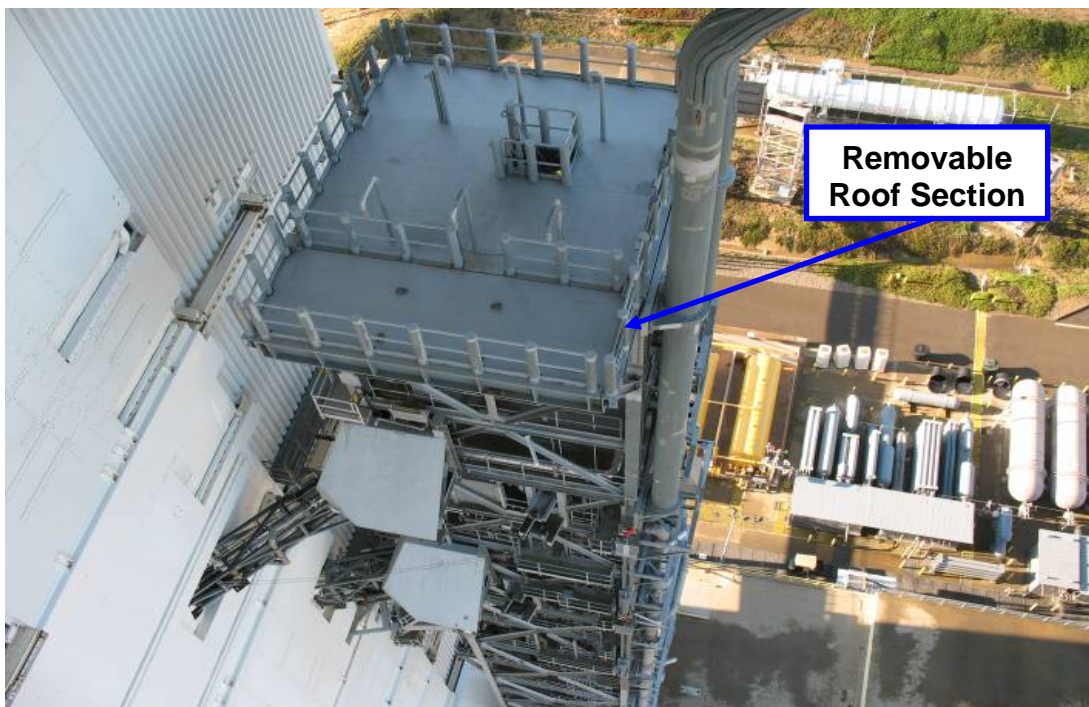

Figure 12. Fixed Umbilical Tower Roof on SLC-3

The next major infrastructure hurdle in the campaign had to do with power. The mission requirement for power is that there must be two, independent sources of power available for the SLC. Vandenberg AFB is capable of meeting this requirement with commercial power and the South Vandenberg Power Plant (SVPP). Every mission needs to validate and test the power configuration prior to launch whether or not they utilize trailblazers during the campaign. Power became a very tumultuous area because Vandenberg AFB experienced a series of failures throughout the time surrounding the

NROL-41 trailblazers and mission. A several thousand acre fire decimated many of the power lines over the entire base and the four power transformers which reside on South Vandenberg all failed within six months of each other. Because these transformers are twelve month lead-time items to replace, spare generators and transformers had to be brought in to support test and launch operations. Figure 13 shows the desired power configuration for launch operations at SLC-3. The figure shows how, nominally, commercial power is supported through a combination of one of four transformers and one of three physical lines. SVPP power is generated through two of five generators alone one of two lines. As a result of the fire and transformer shortages, both commercial and SVPP power were only available through one transformer or generator and one physical line each.

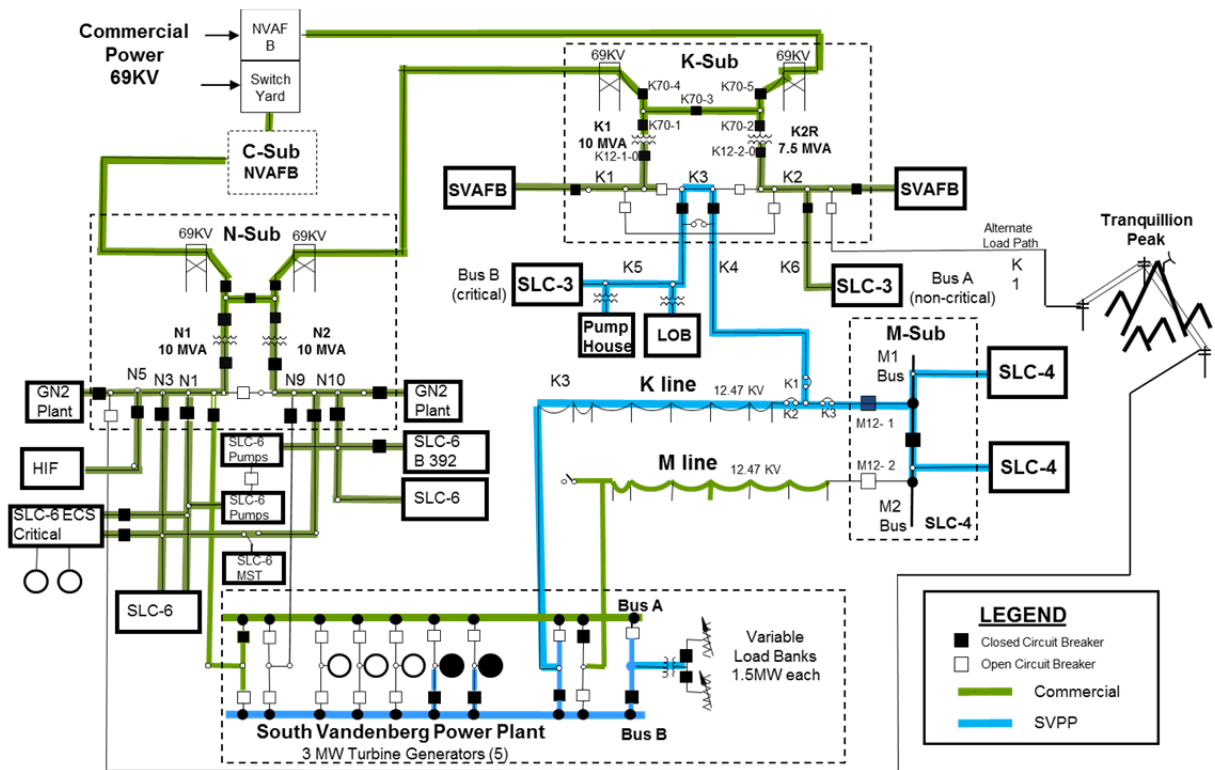

Figure 13. NROL-41 Electrical Power Configuration

The final major support modifications that will be reported were to the KAMAG transporter. This piece of hardware is specifically designed to transport an encapsulated

assembly from a spacecraft processing facility to the launch site. For NROL-41, a secondary environmental control system, back-up generators, and all new hydraulic hoses had to be added to the transporter prior to the trailblazer. Figure 14 shows the trailblazer encapsulated assembly on the KAMAG.



Figure 14. KAMAG with Encapsulated Assembly

E. TRAILBLAZERS

There were two separate trailblazers that were executed in support of NROL-41, an electrical trailblazer and a mechanical trailblazer. The electrical trailblazer's primary purpose was to test the connectivity of several types of lines from the payload back down to the support infrastructure. The secondary objective was to install additional power systems throughout spacecraft support facilities on the launch pad. There was no flight hardware involved, but representative support equipment was brought in to verify configurations and operations. Some of the verifications validated the power connections that are in the support rooms and up on the payload levels while others involved pushing

large amounts of data across the Vandenberg AFB data lines to check data latency from the payload support areas to the launch control centers. Since NROL-41 has a classified mission, the lines being used for data transmission also had to be certified and accredited for the level of classification required of the mission.

An electrical trailblazer is conducted for every mission, regardless of size and typically lasts about two weeks. After the electrical trailblazer, any site modifications or electrical lines are considered locked until after the launch and may not be manipulated or modified without re-accomplishing the electrical trailblazer tests again.

The mechanical trailblazer for NROL-41 had many more goals than the electrical trailblazer and required a great deal more support than any other EELV trailblazer that was ever accomplished at Vandenberg. The overarching goal was to rehearse every step in the launch campaign from spacecraft arrival at Vandenberg until encapsulated assembly mate to the launch vehicle. In addition to these planned campaign operations, the teams would exercise the de-mate procedures and transports back to the satellite processing facility as a precautionary measure should the need arise during the real campaign.

The trailblazer began on March 11, 2009 with preparations at the Integrated Payload Facility (IPF) on south Vandenberg Air Force Base. The IPF at Vandenberg Air Force Base is a remnant from the attempted space shuttle program from the 1980s. The facility was designed with three large bays which, at full capacity, would have been able to simultaneously service three shuttle payloads and then transition them up and out of the facility for loading onto a space shuttle. Because the space shuttle mission was never executed in California, the IPF was converted by an independent contractor for use as a flexible spacecraft processing facility available for any customer. As it stands today, only one bay is utilized for health monitoring and fueling of spacecraft while the other two are able to house other pieces of flight hardware. In the case of NROL-41, those inert bays were used for storing each half of the payload fairing after arrival and assembly on the IPF floor.

Actual flight payload fairings were not used for the trailblazer. Instead, a prototype set of fairings were manufactured to use to validate these critical operations. Although these fairings would never be used for flight, they were identical to the flight units in every aspect relating to the launch vehicle interfaces. Size, shape, assembly hardware, and weight all matched, ensuring the exercise would produce valid results. Figure 15 is a picture of the two segments of one half of the payload fairing inside the cleaning bay of the IPF after arrival to Vandenberg Air Force Base via Antonov AN-124 aircraft, transport from the airfield to the IPF via convoy, and prior to contamination cover removal.



Figure 15. Payload Fairing Inside of IPF near SLC-6

After unwrapping and cleaning of the hardware, the pieces were moved into the clean room portion of the IPF. Mirroring the actual mission flow, each half of the payload fairing was transported and assembled separately then stored vertically before the spacecraft simulator arrived. The left half of Figure 16 is an image capture from the simulation model used to plan out the IPF operations. It shows the point after final fairing erection and spacecraft arrival as the encapsulation is occurring. The right half of Figure 16 shows the most difficult point in the operation where four technicians were staged vertically over each other on each side of the fairing so that all eight turnbuckles (four per side) could be attached and tightened simultaneously ensuring a flush and exact mate.

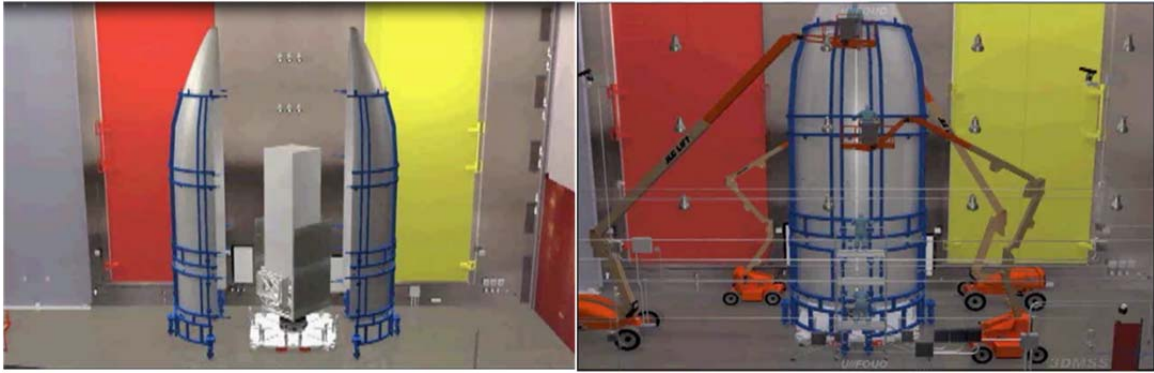

Figure 16. Spacecraft Encapsulation. After [9].

In this simulation, the spacecraft shape is generic and not representative of the actual spacecraft due to security classifications. The technicians worked on scaffolding and man lifts that were positioned around the flight hardware and in close proximity to the facility walls and doors. This procedure alone would have warranted a trailblazer effort due to the scope of resources involved and the precise nature of each step required to execute without damage to the hardware.

All support equipment used was true and actual equipment needed for the actual launch campaign. One particularly valuable lesson learned about the support equipment occurred when handling the drive wheel units (DWU) that allow the fairings to be moved along the floor during assembly and encapsulation. Several DWU's are mounted to the fairing skeleton allowing relatively few operators to lift and move the fairings into their needed position. While preparing to move a DWU from its storage mount, a technician inadvertently caused the DWU to tip and damage the unit and facility. Figure 17 shows the proper use of a DWU on the left as well as two pictures of the fallen unit in the center and right.

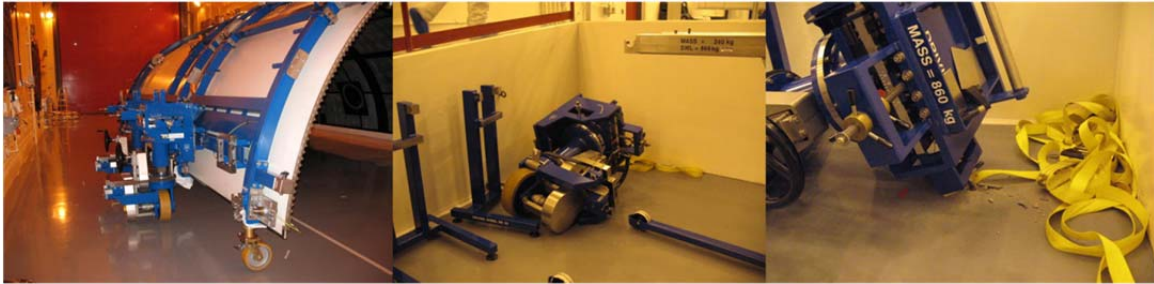

Figure 17. Drive Wheel Unit Incident

This incident necessitated the damaged unit be sent back to the manufacturer for repair and a new DWU be shipped to Vandenberg. Operationally, the incident caused a several day delay to processing. Had the incident occurred during the mission, it would have impacted the launch date while the team waited for a replacement to arrive on location and risked satellite health because every satellite has components which can only be out of a vacuum environment for a limited amount of time before returning to the manufacturer for re-calibration. Delays like these can cost a program tens of thousands of dollars to overcome and validate the requirement for rehearsals.

For the NROL-41 trailblazer, an equivalent sized and shaped simulator was used instead of a real satellite. In terms of security and sensitivity, it was treated exactly as the real hardware, but the use of a simulated spacecraft provided a buffer in case anything anomalous occurred throughout the trailblazer. In addition to security benefits, the trailblazer could be executed in parallel with actual spacecraft manufacturing and testing.

Physical procedures were not the only procedures planned and rehearsed during the trailblazer. The point when the spacecraft transport team delivered the spacecraft simulator to the processing facility marked the official handoff point for leadership of the mission processing from the spacecraft vehicle team to the launch vehicle team. While ownership and overall responsibility never leave the mission payload team, daily operations and handling would transition as the satellite was moved for encapsulation. While seemingly innocuous, practicing handoff of operations benefits the entire team by reducing confusion about who is making final decisions during any anomalous events.

This handoff is standard in any mission and needs to be exercised because the individual satellite manufacturers are not used to handing over control of their hardware. The launch vehicle contractors are experienced in working with their encapsulation hardware and facilities but the satellite contractor have spent years leading the development and manufacturing of the satellite. It is understandable that there could be friction amongst the team during this time, so rehearsing has non-material value in addition to the hardware risk reductions.

F. TRANSPORTATION, LIFT, AND MATE REHEARSAL

The complete set of encapsulation procedures concluded successfully on April 28, 2009 with the assembly being removed from the IPF for transport to the launch site. As was described above, each individual piece of the encapsulated assembly was transported horizontally and arrived in stages through the front door of the facility. Once assembled, the assembly stood sixty five feet tall vertically and could not be transported out the front of the IPF. The IPF was designed this way and includes a separate crane and transfer tower that lift the EA out of the clean room and then out the back of the IPF where the transporter was stationed.

The procedure is simple to conceptualize, but significantly more complex to execute. This was the largest encapsulated assembly ever processed at the IPF and custom lifting slings and rigging were required to articulate the assembly out of the building. The sensitivity of any satellite means very little room for errors of any kind, but the size of this assembly meant that room for error was minimal during transfers. There were less than three inches of clearance as the assembly transitioned from the clean room up into the transfer tower and less than twelve inches of clearance on each side of the assembly when moving out of the transfer tower door to the outside of the facility. Figure 18 shows the limited clearance during the clean room to transfer tower transition.



Figure 18. Clean Room to Transfer Tower Clearance

Figure 18 also shows technicians holding guide ropes to eliminate swing in the assembly during lifting. The guide ropes made the transition out of the facility possible because of swirling Pacific Ocean winds trying to swing the assembly into the facility walls. Figure 19 shows the encapsulated assembly just prior to lifting (left) and just prior to mating to the KAMAG transporter (right).



Figure 19. Encapsulated Assembly Inside of IPF and KAMAG Mating

Preparation for any flight hardware transport is substantial and began a month prior to first movement for every transport on/across Vandenberg. Some of the

preparations include procedure reviews, route surveys, weather analysis, security, convoy escort planning, road closures, contingency planning and individual transport personnel training. The preparation only guaranteed the ability to attempt to move the encapsulated assembly. There were also wind, humidity, and temperature restrictions that had to be met at the IPF, along the transport route, and at the launch site. Primary and secondary portable environmental systems had to operate as needed and base power systems had to operate in non-standard configurations to provide redundant power strings to the lifting cranes.

After overcoming the clearance and weather issues, the convoy was able to proceed to the launch site. The convoy was composed of eleven vehicles which moved at three miles per hour and took three hours to complete. Two scheduled satellite and KAMAG systems health checks were executed along the route to ensure the environment inside of the encapsulated assembly remained inside of limits and also to validate that the transport itself was not damaging the sensitive systems.

Planning and performing every step correctly and efficiently was paramount to risk mitigation as well as success because there was a finite amount of time the encapsulated assembly was allowed to be on the KAMAG transporter. The environment needed to keep the satellite healthy is best achieved in a clean room and creating that environment while moving down a road required portable nitrogen, helium, and oxygen systems in addition to sustainable vehicle power. The sensitivity of this operation shows another critical reason the trailblazer was needed. By using a spacecraft simulator and actual mission support equipment, any catastrophic event could be analyzed and corrected without jeopardizing the mission. Lessons learned from this trailblazer transport showed the mission team that additional portable environmental control systems were needed and that the support team needed to be expanded from the original estimate. Those systems were built and additional personnel were ready in time for NROL-41's actual transport to the launch pad.

The L-41 trailblazer not only mitigated risk against itself during the lifting operation, but also against other mission flight hardware. Because launch operations are year-round, the lifting crane and launch tower at Space Launch Complex - Three were in

use by another mission. The Defense Meteorological Satellite Program (DMSP) was preparing for their eighteenth launch while the L-41 trailblazer was being executed and the launch vehicle for the DMSP-18 mission was in place when the lifting operations occurred. Both the L-41 and DMSP-18 missions had seen lengthy delays in satellite manufacturing and mission execution prior to the L-41 lifting event, so tensions were elevated when the NRO coordinated to lift and hold an encapsulated satellite simulator on a crane over the booster owned by another organization. Figure 20 shows the planned simulation booster combined with actual images of the DMSP-18 booster. To increase assurance that there would be no risk to flight hardware, ULA subcontracted out work to laser image the entire mobile service tower for exact measurements inside the facility. This was extremely beneficial for operations planning and risk mitigation and helped the leadership of all agencies understand the scope of the operation and that everything possible was being done to ensure the safety of personnel and hardware.

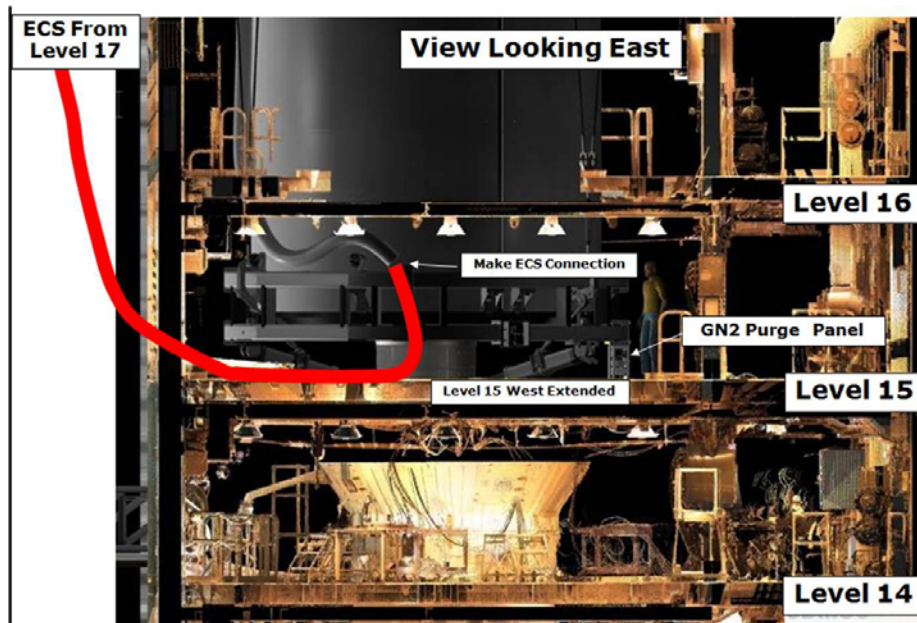

Figure 20. Planning image of L-41 EA over DMSP-18 Booster

Lifting procedures were not as simple as lifting straight up and in to the mobile service tower. A series of precise bridge and trolley maneuvers were necessary to maneuver around permanent structures to successfully navigate into the tower. Spotters

were placed throughout the facility on multiple levels and utilized hand gestures, radio communications, and guide ropes to ensure the encapsulated assembly did not contact any of the facility structures. Given the size, weight, and height above the ground, this was the most risky portion of the operation and planning details literally went down to the inch. When the simulator moved into the tower, the closest clearance to the tower during entry was less than ten inches. There were fewer than twelve inches between the simulator and the DMSP-18 booster when the assembly was in its final position prior to back out. The DMSP-18 booster was a four meter fairing mission, so the mating procedure could not be exercised during the trailblazer. Even though mating was simulated, the team exercised the environmental control system changeover from portable to tower controls. Knowing the sensitivity of any satellite, environmental control can actually be more dangerous than physical mating to the rocket.

A series of planning images from the top and the front used to show clearances of the assembly when entering the tower are shown in Figure 21.

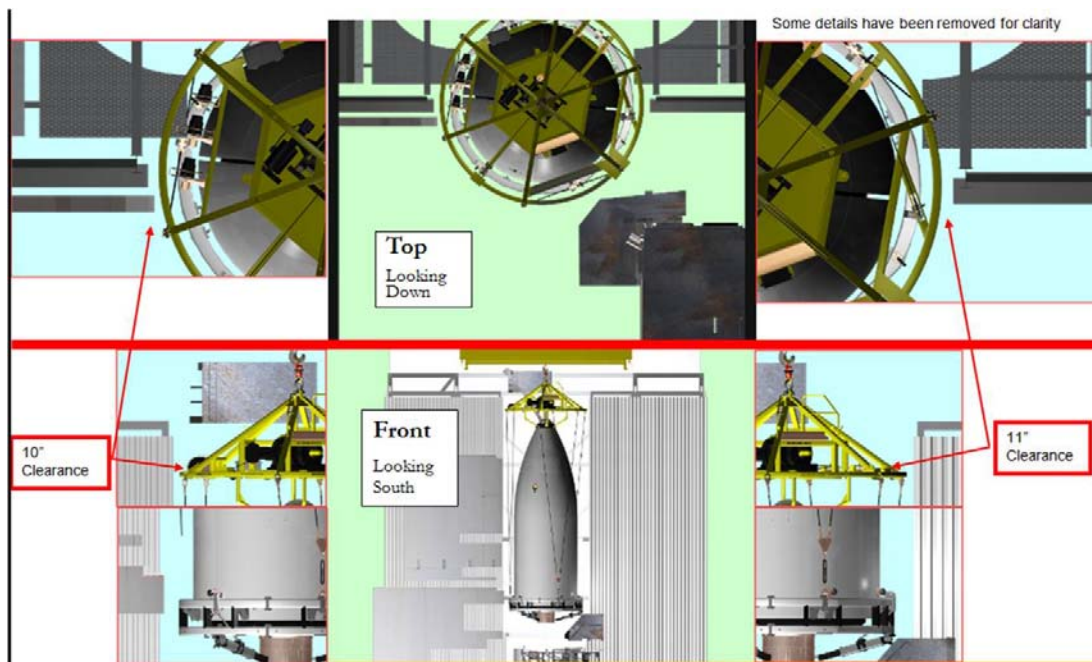

Figure 21. Mobile Service Tower Clearance Planning. After [9].

The reverse procedures closed out the operation on May 2, 2009 and the encapsulated assembly went through equal scrutiny and care on the lift out of the tower, lowering back onto the KAMAG transporter, and transport back to the payload processing facility for de-capsulation rehearsal. De-capsulation is a series of procedures that no one wants to use, but if needed, they would have been the most contentious to get approved if not previously exercised during this trailblazer. Since de-capsulation was not needed for the actual launch campaign it will not be discussed in detail here, but it should be known that the procedures took another twenty days of full team participation to fully vet.

G. SUMMARY

This chapter detailed the efforts of the satellite and launch teams through the completion of prerequisite requirements in support of the NROL-41 launch. Since the mission launched successfully on the first attempt, the team ended up not needing to use the de-capsulation procedures but not having the steps and plans ready if needed would have proved disastrous to the flight hardware and added confusion to a tenuous situation.

The inclusion of trailblazers in the launch campaign are not required or mandated for any mission, but are often opted for when the mission is of high enough importance or if the procedures call for high risk, first time operations. Both high mission importance and first time operations were prevalent in the NROL-41 campaign, thus the mission director wisely included and executed the events. Utilizing the trailblazer on the NROL-41 mission not only reduced hardware risk to the mission equipment, but afforded the different teams an opportunity to develop and optimize communication paths that would minimize unforeseen personality or chain of command issues when the actual flight hardware arrived.

As has been previously discussed, the cost of launch campaigns is high, but it is that way for a reason. Classification and proprietary issues prevent the publication of exact cost breakdowns for the trailblazer, but it is easy to see the magnitude of the cost when you count in trailblazer unique, five-meter payload fairings at over ten million dollars, rental of a commercial spacecraft processing facility and clean room, including

facility operators for three months plus preparation and clean-up time, launch vehicle, satellite vehicle, government mission assurance, and contractor mission assurance teams for three months plus planning and clean-up time, and the multitude of trailblazer specific support pieces required to validate operational techniques. Such costs can be staggering and increasingly difficult to justify as missions continue to succeed. Regardless, the costs are necessary to assure mission success and protection of hardware with unquantifiable amounts of strategic capability.

There is no doubt that the precision at which the NROL-41 campaign operated was a direct result from the time, money, and effort spent in the trailblazer campaign. Without the trailblazer, the launch teams would have been ill-equipped to handle the anomalies of the actual launch campaign while simultaneously mitigating the known risks. This chapter detailed one of the major steps needed to make a launch a success and the next chapter shows that completion of the trailblazer left no doubt or hesitation during the execution of the launch campaign.

THIS PAGE INTENTIONALLY LEFT BLANK

V. LAUNCH CAMPAIGN

A. OVERVIEW

Execution of launch processing and day of launch operations are all preceded by the planning of the mission, building the components, and preparing procedures and personnel. Over a decade of work by hundreds of people from dozens of companies and organizations as well as billions of dollars lead up to the single task of launch.

The following chapter will detail the major milestones of the launch campaign at Vandenberg Air Force Base. The launch base is a significant location not just because it is the launch point, but because the primary launch control centers and hardware processing all occurs close to the launch site. These events began with flight hardware arrival, continued with rehearsals and integration, and eventually led to the successful launch of the NROL-41 rocket.

B. HARDWARE ARRIVAL

As part of the mission assurance program, all flight hardware goes through multiple inspections and acceptance tests even before transport to the launch site. The most scrutinized components of the launch vehicle are the engines. The Energomash RD-180 engine for the booster and the Pratt and Whitney RL-10 engine for the upper stage each are reviewed during and after manufacturing to assure proper operation. The highest standards are adhered to during manufacturing, but even though the contractors have great track records, government civilian aerospace engineers and active duty military engineers and program managers provide additional layers of quality control by performing hardware acceptance reviews before the engines are integrated into the vehicles. These reviews consist primarily of documentation verification of the assembly steps and part manufacturing procedures. Reviews also ensure that the contractor quality assurance processes have been followed and positive control documentation throughout the assembly line is archived in case it is needed at a later date. Prior to the engine being shipped to the launch vehicle manufacturing facility, no fewer than six individual organizations performed tip to tail reviews of each engine.

NROL-41's booster and Centaur assembly were historical due to the fact that they were the final components to be built and delivered from the Lockheed Martin facilities in Denver, Colorado. As part of the United Launch Alliance process improvements, Atlas V manufacturing operations were in the process of being transitioned to the Decatur, Alabama plant where the Delta II and Delta IV rockets are manufactured.

Prior to the establishment of ULA, Lockheed Martin built Atlas V boosters in Denver, Colorado and their Centaur's were built in San Diego, California. After the structures were built, engine integration and test along with final assembly were performed and then the stages were prepared for shipment via Antonov AN-124 from Colorado to whichever launch base the mission required. Today, ULA manufactures all stages of their launch vehicles in Decatur, Alabama and has the option of transporting the stages via air on the Antonov or via water on the Mariner. Payload fairings are built by a subcontractor and, depending on which size is required for the mission, can be transported either by plane or by truck.

The major flight hardware arrivals for NROL-41 consisted of the booster, Centaur, payload fairings, and cylindrical interstage adapters. The booster, Centaur, and payload fairings all arrived on the Antonov AN-124 while the cylindrical adapters arrived at Vandenberg Air Force Base on trucks. In order to offload the hardware from the Antonov, ULA utilizes a mobile track system that attaches to the ramp of the airplane. After the track system is assembled, the hardware can then transition off the plane, Figure 22, and is then transported to the appropriate processing facility.



Figure 22. Booster Offload at Vandenberg Air Force Base

Figure 22 shows two images of the NROL-41 booster being offloaded from the Antonov. Similar operations were executed for the Centaur and payload fairing arrivals. Once at their respective processing facilities, the hardware was inspected and prepared for integration at the launch site.

The NROL-41 hardware arrival was not perfectly smooth. The Centaur Interstage Adapter (CISA) was transported by truck from Harlingen, Texas. Upon receipt and inspection it was found that part of the container structure detached during transport and struck the adapter. Figure 23 shows the CISA with the container contacting the adapter.



Figure 23. Centaur Interstage Adapter Damage

The CISA is a single piece composite which, if not flight worthy, would have delayed launch by four to six months minimum. X-ray's and a full non-destructive inspection were accomplished and engineers from the manufacturer, ULA, the Air Force, and both the satellite and launch vehicle program offices reviewed the damage and inspection findings before determining that the damage was contained to the outer skin only. An issue like this is an example of the immense attention to detail required to assure the safety of the satellite being launched.

Figure 24 shows a graphical representation of the hardware arrival flow all the way from arrival at Vandenberg through acceptance and integration, and concluding with test and assembly at the launch site.

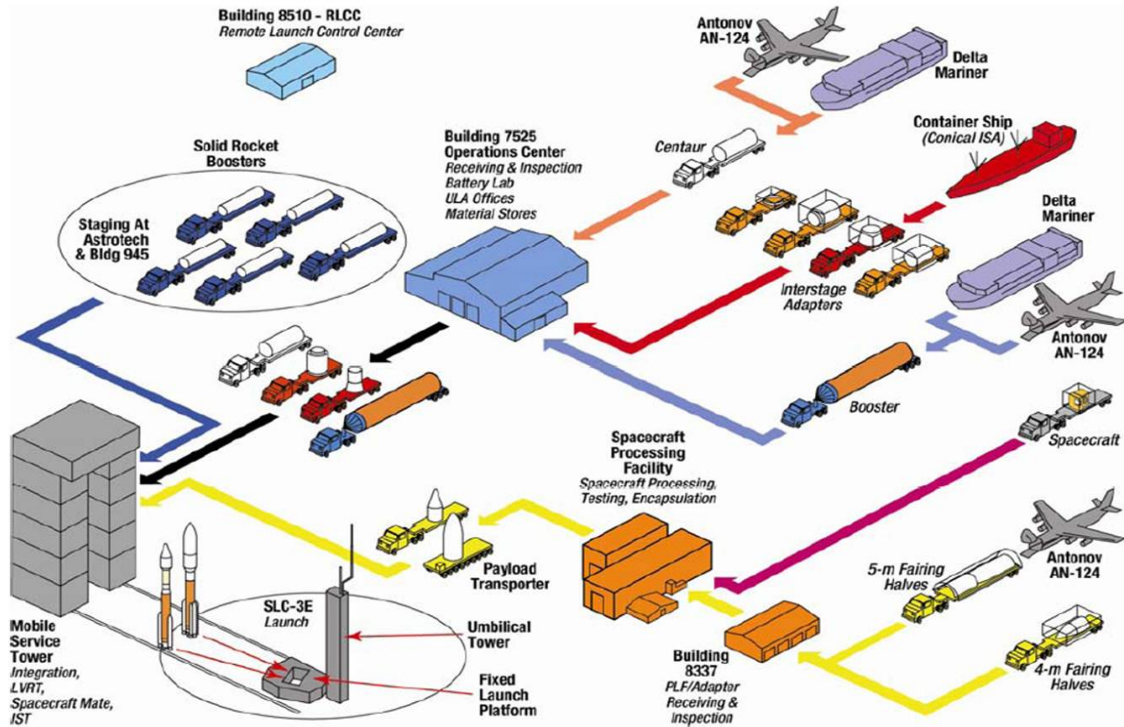

Figure 24. Flight Hardware Arrival and Processing Flow. From[6].

Figure 24 also shows all possible hardware arrival methods for both the Atlas and Delta launch vehicles. For the NROL-41 mission the Delta Mariner was not utilized, there were no Solid Rocket Boosters, and there were also no conical shaped interstage adapters.

C. LAUNCH REHEARSALS

Preparations for the day of launch are not a serial in nature. The actual launch teams who will execute day of launch operations participate in rehearsals in parallel with satellite and launch vehicle transports and deliveries. The primary vehicle for a mission director to gauge the team’s readiness for launch is the Integrated Crew Exercise (ICE). An ICE is best described as practice for launch day. Over the course of fifty years, many

anomalies have been seen while trying to launch a rocket. Since there is no way to be prepared for every contingency and not enough time to practice every anomaly ever experienced, ICE's take the launch procedure and inject the most recent and most common types of anomalies randomly to evaluate how the launch team handles problems. Launches themselves must be initiated at very specific dates and times in order for the satellite to reach its intended orbit. Small anomalies handled poorly can result in the loss of a launch opportunity and add unnecessary risk to mission hardware. The NROL-41 mission programmed two ICE's and one Mission Dress Rehearsal (MDR). The only difference between an ICE and a MDR is that the MDR is executed at the true and actual time that the real launch will begin. This is another key preparation technique since the launch countdown is over six hours long and, in the case of NROL-41, took place through the night.

The anomalies induced in a rehearsal can include problems with the booster, satellite, individual communication methods, building evacuations, natural disasters, support equipment failures, or anything else appropriate to test the resilience of the launch team. Rehearsals are developed by dedicated personnel who work every single launch and leverage that experience to build the most realistic scenarios. These personnel are on the Rehearsal Anomaly Team (RAT) and incorporate lessons learned from past rehearsals and missions to not only have appropriate anomalies, but to time those anomalies so they challenge the launch affectivity as well as crew responsiveness.

Three anomalies may seem redundant, but the team responsible for a launch is made up of many government personnel who rotate in and out of positions so they are not as familiar with the launch procedures as the contractors who have been performing launches for decades. In addition to training new members, rehearsals are an absolute necessity due to the complicated communication structure that is needed to ensure all appropriate agencies can review and concur with any anomaly resolution or major milestone decision. The NROL-41 communication chain is shown in Figure 25.

Launch Management Team

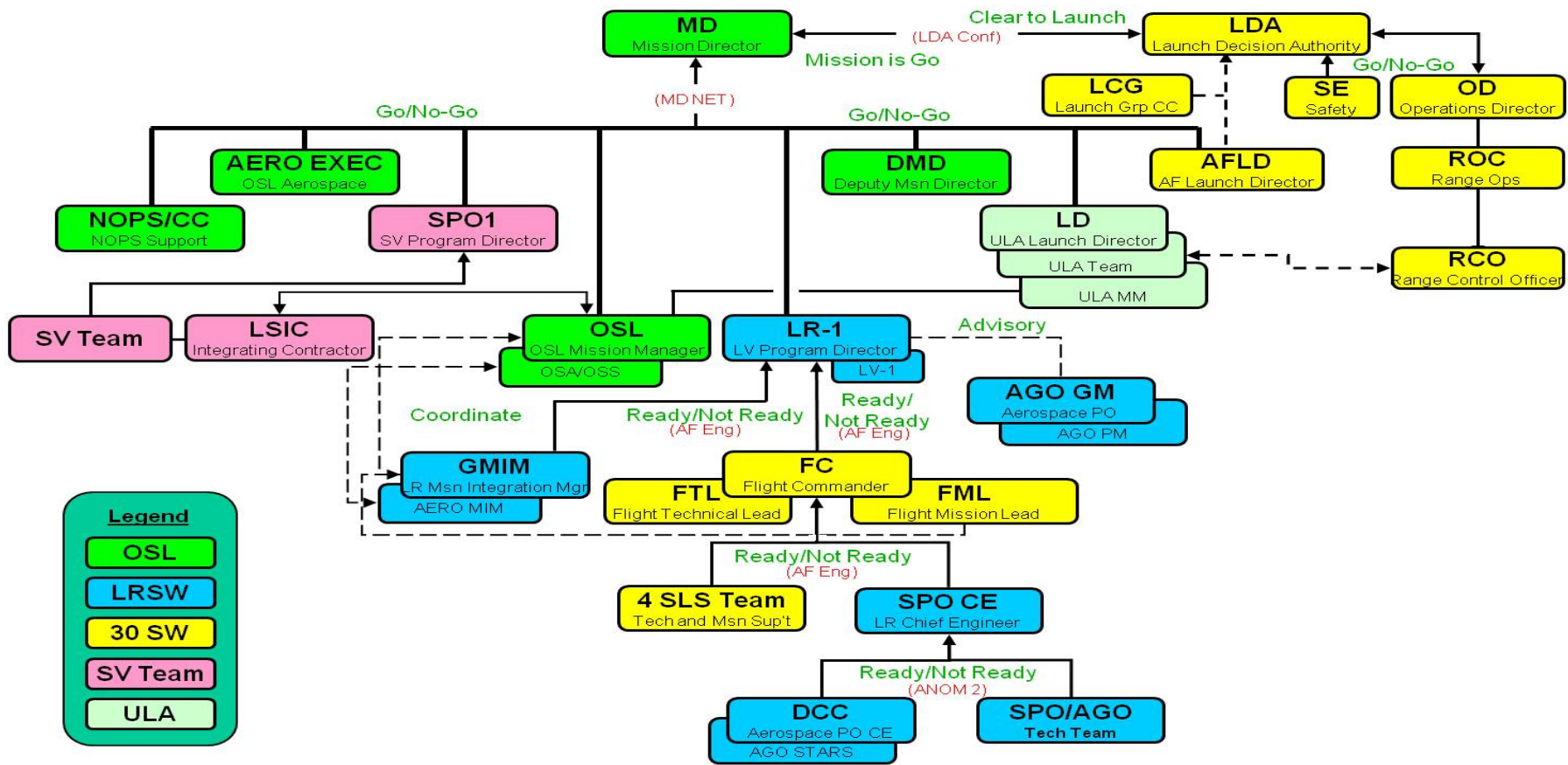

Source: OSL, 4SLS, LLAG
As of: 07/27/09 ICE #1

Figure 25. NROL-41 Launch Management Team

Figure 25 shows the complexity of launch day communication but it only shows part of the situation. Many of the blocks in the diagram above represent one person, but others represent upwards of fifty people all supporting a single function or organization. A specific example is the very bottom blue box on the right labeled SPO/AGO Tech Team which encompasses two separate control rooms and approximately forty personnel.

Launch rehearsals stressed and tested the launch team throughout the launch campaign and increased in complexity each time. The first Integrated Crew Exercise was accomplished on 18 March 2010, prior to the booster being placed on the launch site. The second ICE was completed on 8 June 2010 and the Mission Dress Rehearsal took place on 28 August 2010, less than thirty days before the planned launch date of NROL-41.

D. INTEGRATION AND TEST

After flight hardware receipt and inspection at Vandenberg, the integration of the vehicle at the launch site began in earnest. As previously discussed, the Atlas V is integrated in place at the launch site from the ground up. The booster was the first piece delivered to the launch site and was fixed to the launch mounts after being rotated vertically by the sixty ton crane located on SLC-3. After the booster was in place, the two main interstage adapters were stacked over the booster. Figure 26 shows the Booster Interstage Adapter being lifted and mated onto the booster at SLC-3.



Figure 26. Booster Interstage Adapter Mate

On the following day, the Centaur Interstage Adapter was lifted and mated to the Booster Interstage Adapter. Figure 27 shows the lift and mate of the CISA to the BISA.



Figure 27. Centaur Interstage Adapter Mate

The milestone of “Booster on Stand” is used to delineate when every major component except for the payload has been integrated at the launch site. This is attained after the Centaur mate (shown in Figure 28) and boattail and was accomplished on 14 May 2010.



Figure 28. Centaur Mate

On a four meter booster, the encapsulated spacecraft is mated directly to the top of the Centaur. For a five meter fairing, a base module surrounds the Centaur and a CFLR is installed to partially distribute the weight of the spacecraft and fairings and to eliminate shifting loads during flight. Figure 29 shows the CFLR prior to mate and the base module being lowered over the CFLR and onto the Centaur.



Figure 29. Centaur Forward Load Reactor and Base Module

Once the booster was integrated at the launch site, the final major test prior to permitting the spacecraft to be encapsulated and transported to the launch site is executed. The Wet Dress Rehearsal (WDR) is the operation used to validate that all integration has been done correctly and the vehicle is prepared to move into the final launch procedures. In the WDR, the booster is fueled exactly as it will be for launch and held at maximum fueling for a predetermined amount of time while communications between the booster and the launch range are tested. By holding the vehicle at maximum fuel levels for longer than planned the vehicle is showing it can withstand any minor delays on the true day of launch and the communication checks verify that the launch range can maintain control of the vehicle during the most volatile period of the countdown. Figure 30 shows the NROL-41 booster after the Mobile Service Tower has transitioned away from the vehicle and just before cryogenic fueling began on 24 August 2010.



Figure 30. Wet Dress Rehearsal at SLC-3

After successfully completing the Wet Dress Rehearsal, final spacecraft encapsulation procedures were allowed to proceed as planned. The encapsulation of the spacecraft occurred exactly as it did during the trailblazer and the booster was prepared to receive the satellite which was completed six days after the completion of WDR. Spacecraft transport and mate were twenty-four hour straight operations and took place on 3 September 2010. As described in the Trailblazer chapter, the transport and mate was an orchestrated operation spanning multiple government agencies and a tremendous amount of oversight as the satellite moved from its processing facility onto the launch vehicle. The additional environmental control systems required to be added to the KAMAG for transport can be seen in Figure 31.



Figure 31. Modified KAMAG Transporter

The transport from the spacecraft processing facility was uneventful and so was the lift and mate onto the launch vehicle. Figure 32 shows the encapsulated assembly being lifted (left) and the lowering of the encapsulated assembly just prior to mating to the base module (right).



Figure 32. Encapsulated Assembly Mate

The encapsulated assembly mate marked the final major mechanical test. The final system test that is needed prior to launch is called the Integrated System Test (IST). IST is a complete communications health check for both the launch vehicle and the satellite. This is the first chance that the satellite team has to interact with the launch range systems and the satellite simultaneously and is also the final milestone prior to launch readiness reviews across every single organization that has a role on the day of launch. Launch Readiness Reviews (LRR) brief the top executives, stakeholders, and commanders that all operational steps prior to launch, all risk mitigation steps, and all procedure reviews are complete and that their areas of responsibility are ready to proceed to launch. All of these industry and government leaders who hold reviews participate in launch day and are the responsible parties who will have to answer if there are any significant problems on the day of launch. The first readiness reviews began two days after IST and the final review took place seven days later on 17 September 2010.

E. DAY OF LAUNCH

On 19 September 2010, the launch team arrived at their respective control centers to prepare the vehicle for launch. Exactly as the rehearsals were executed, the day of launch countdown began seven hours prior to the launch window opening. The procedure itself includes over four hundred individual actions that were completed on the exact minute they were planned in order to support meeting the launch timeline. Multiple vehicle systems execute power-on and other preparation steps in parallel to meet the major polling steps in the launch procedure. There are three critical times during the count when all system operators must be ready to proceed to that major step. They are when the Mobile Service Tower rolls away from the launch vehicle, when cryogenic tanking operations begin, and when the vehicle is about to proceed into the final two minutes of the launch. Figure 33 shows the launch vehicle as the nine million pound MST rolls away from the vehicle.



Figure 33. Mobile Service Tower Roll

As the figure shows, there are many technicians still working near the vehicle up until the vehicle is ready to begin cryogenic tanking. Due to the danger associated with liquid hydrogen and liquid oxygen, no personnel of any kind are on the launch site while cryogenics are flowing to the vehicle. In the event of an anomaly, teams are near the launch site that would enter if needed, but that eventuality is a last resort and was not required for any portion of the NROL-41 countdown. Figure 34 shows the launch vehicle during cryogenic tanking as taken by one of the remote cameras on the launch site.



Figure 34. Cryogenic Tanking Prior to Launch

In the procedure are planned hold periods where paperwork or anomalies could have been completed if necessary. For the NROL-41 countdown, no significant anomalies were encountered and the launch vehicle successfully lifted off from Vandenberg Air Force Base early in the morning of 20 September 2010.

Figure 35 shows the notional flight path that the vehicle took along with the times that the stages of the rocket separated, placing the satellite within meters of its planned insertion point. After spacecraft separation from the upper stage, the Centaur was ignited again for re-entry into the Earth's atmosphere. Not every upper stage re-enters the earth's atmosphere as past missions have sent the Upper stage on a collision orbit with the moon or the sun, but due to the remaining fuel on board and the lack of scientific utility at the time, the upper stage was returned in an effort to minimize space junk in polar orbit inclinations.

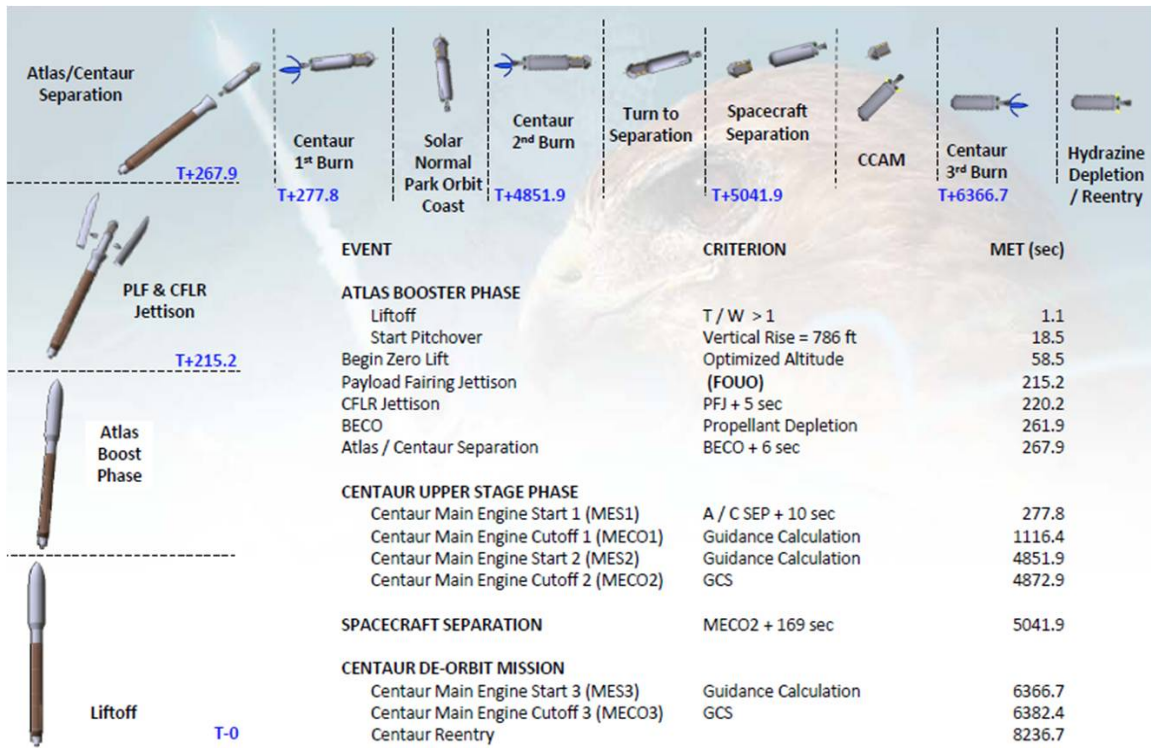

Figure 35. NROL-41 Flight Profile. From [10].

The launch team stands down operations at spacecraft separation and satellite operators then begin their health checks and put the satellite into service. Because of the classified mission of NROL-41, details cannot be discussed here, but the commanders of the satellite reported back to the launch team their sincere thanks that the mission was accomplished with no issues and with no damage to the satellite.

F. SUMMARY

The launch campaign and day of launch act as culminating points for long days and weeks of work by a multitude of organizations. In addition to mission specific issues, the launch team at Vandenberg had to address Atlas V fleet problems as well as juggling opposing missions on Vandenberg for range assets.

The mission detailed in the previous chapter could have been much less successful at numerous points, but thanks to the quality of work performed and the caliber of people responsible for the work required, many issues were handled at a level which did not induce impacts to the launch schedule

THIS PAGE INTENTIONALLY LEFT BLANK

VI. CONCLUSIONS AND RECOMMENDATIONS

A. OVERVIEW

This thesis detailed the steps taken to assure the success of the NROL-41 launch. Research began with a look at how the launch community has evolved from multiple launch contractors and has arrived at its current state of a combination of launch vehicle families.

A review of the launch scheduling process and trailblazer efforts showed how the duration of a launch campaign can span into multiple years. The depth of technical expertise and experience required to execute these operations efficiently are a significant contributor to the high costs of spacelift but are necessary for mission success. Performing launch operations faster and at lower costs only opens the door to riskier execution of procedures and potential damage to valuable flight hardware.

With satellite costs alone of over one billion, two hundred million dollars and over ten years of design and manufacturing, the NROL-41 launch campaign and preparations appropriately protected the investments made and today's national security continues to reap the benefits of the NROL-41 asset.

B. RECOMMENDATIONS

The highest recommendations for maintaining vigilant mission assurance cannot be understated. In this medium, it is not possible to capture every mission assurance aspect of the NROL-41 launch campaign. Critics continue to seek cuts in spending and a mission like NROL-41 can build arguments for both sides of the case. By looking at all of the data from this mission, it is clear that the experience and depth of assurance is why success was all but certain. Maintaining the current levels of mission assurance is the best path forward to help assure future missions are equally successful.



Figure 36. NROL-41 Launch Photo

Another recommendation would be to build a military career field specifically for the launch of satellites. Currently, space launch cadre members are drawn from nuclear missile maintainers, missile operators, and acquisition officers. By the time any of them become adequately proficient in launch operations it is time for them to transition to non-related assignments. There is current Air Force methodology that desires Airmen with breadth across multiple areas rather than depth in a single field. Since the value of space assets are the highest in the Department of Defense, there would be value in cultivating a career field that could be dedicated to the spacelift field in order to help improve operations.

Maintaining mission assurance in the current community is clearly critical to mission success, but the current experience pool cannot provide launch services forever. Launch providers have been tasked with reducing budgets while missions have been reduced or cancelled altogether. Educating a new generation of competent spacelift operators is a task that must begin today. The current operators gained their experience by performing launch operations and since the launch rate is less than a tenth what it was at the beginning of the spacelift era, we must leverage that experience before it is lost. Increasing personnel for training may seem redundant and an unnecessary cost, but there

is only a small window to train alongside the most successful generation of launch operators and today's train-as-you-go methods look good for the budget, but place one of a kind hardware at unacceptable levels of risk.

C. AREAS FOR FURTHER RESEARCH

A recommended approach to study this topic further would be to analyze a competitor launch campaign and compare track records and costs to see if equal certainty can be attained at a lower cost. The down side is that there are not a lot of commercial launch agencies with government contracts, but similar studies could be extrapolated against a civilian payload. Again, it would not be an equal comparison because the physical size, capabilities, and cost of civilian satellites do not come close to the satellites built under Department of Defense contracts. The newest competitor for government contracts is SpaceX, so if research was done on one of their launches it would also be appropriate to explore where the expertise in that company originated as many employees transitioned during the initial creation of ULA when the company eliminated redundant positions.

Another area to research would be the different contracting vehicles used in the overall launch process. The largest area of concern in the NROL-41 launch campaign was work that was deferred from the manufacturing plant and completed at the launch site in order to save schedule. The work performed at the launch site is compensated under different methods than the contract which purchased the flight hardware. Studies could be done on the performance of the manufacturing contracts against the launch services contracts.

EELV contracts are expensive for many reasons; one reason is because of the heavy government involvement combined with constant personnel changes. A ten year satellite manufacturing period equates to at least four different program manager rotations. This means redundant training and opportunities for poor continuity. Launch squadrons swap personnel on average every two years. For Vandenberg personnel, that averages two launches executed before changing roles. It would be beneficial to study the entire military turnover in the life of a satellite and determine how much additional work

is placed on satellite and launch vehicle contractors to contend with those changing government positions. Additional personnel research could be done to see if building a cadre of launch professionals would be better for the launch community than moving Airmen in between nuclear missile maintenance and spacelift communities.

If lowering costs is a high priority then the unfortunate truth is large, sweeping changes would be required. Economics proves that to lower costs either purchased volume would need to increase or infrastructure needs to be reduced. Since today's economic situations do not lend themselves to purchasing more launch vehicles or building more launch facilities, that leaves reductions. In the spacelift world, reductions would have to come from rehearsals and layers of government involvement. In the launch campaign chapter, the readiness review process shows that a large amount of time and resources are spent explaining anomalies or basic operations to agencies that are not familiar with the mission, but have a responsibility tied to them in some indirect way.

The current ULA structure of launch vehicles is built upon the foundation of two separate companies and their historical launch facilities. In order to get past the current limitations of launch scheduling, the community could benefit from a study into a new launch facility that is capable of launching both the Atlas V and Delta IV rockets. New facilities mean high costs up front and long design and building periods, but in order to be truly flexible with the current launch vehicles, a different launch site that is not bound to a single vehicle type is one of the only ways to eliminate congestion in an already crowded launch manifest.

A final area of further research would be to examine redundant military organizations inside of launch operations. At each launch base there are launch squadrons who have the responsibility to receive, integrate, test, and launch the mission hardware. There are other organizations above these launch squadrons who travel to the launch bases to augment the launch team. The travelling organizations are made up of identical career fields as those who reside at the launch sites. The additional studies could focus on adding personnel and responsibilities to the launch bases to focus on the launch services contracts and operations while reducing the travelling personnel and allowing the remaining support to focus on the manufacturing contracts and operations.

D. CONCLUSION

The success of the NROL-41 mission was a complete team effort. This mission specifically highlighted the benefits of the mission assurance process and resulted in being acclaimed as the most efficient execution of an Atlas V mission to date.

As long as the current process is in place, execution costs will continue to be high and the value of the process will vary by the importance and cost of each individual mission. The government should continue taking advantage of the broad spectrum of commercial experience that has delivered consistent mission success over the entire Atlas V, Delta II, and Delta IV launch history. The lessons learned from past experiences will help to improve the process as long as we cultivate that experience by continuing to infuse youth into the system. Without a proactive approach to the mission assurance process and support of the operators, a root cause to a launch failure would be very difficult to pinpoint and the blame would be placed on others rather than accepted by responsible parties.

Launch will always be the riskiest operation to expensive hardware that the government actively operates, but continued diligence to the process will allow the unparalleled string of successes with these operations to continue.



Figure 37. NROL-41 Launch Trail

THIS PAGE INTENTIONALLY LEFT BLANK

LIST OF REFERENCES

- [1] I. Asimov, *Asimov on Science Fiction*. Hammersmith: HarperCollins Publishers Ltd, 1983.
- [2] *United States Air Force FY 2012 Budget Overview*, Secretary of the Air Force/FMB., Washington, DC, 2011, pp. 5–17.
- [3] *National Security Space Acquisition Policy*, DTM 09–025, January 11, 2013.
- [4] *Air Force Doctrine Document*, AFDD 2–1, 2000.
- [5] *Space Programs*, Title 10, USC, Subtitle A, Part IV, Ch 135, 2273, 2012.
- [6] United Launch Alliance. (2010, March). *Atlas V Launch Services Guide* [Online]. Available:
http://www.ulalaunch.com/site/docs/product_cards/guides/AtlasVUsersGuide2010.pdf
- [7] K. A. Finn. (2005, March). *Air Force Lifts Boeing Suspension* [Online]. Available:
<http://www.contractormisconduct.org/ass/contractors/13/cases/32/2565/air-force-pr.pdf>
- [8] *Launch Scheduling and Forecast Procedures*, A.F. Space Command Instruction 10–1213, Peterson Air Force Base, CO, 2012, pp. 15–18.
- [9] United Launch Alliance, NROL-41 Trailblazer Simulation Data, 2010, unpublished.
- [10] United Launch Alliance, NROL-41 Mission Profile, 2010, unpublished.

THIS PAGE LEFT INTENTIONALLY BLANK

INITIAL DISTRIBUTION LIST

1. Defense Technical Information Center
Ft. Belvoir, Virginia
2. Dudley Knox Library
Naval Postgraduate School
Monterey, California