



Class QA37

Book .K4

Copyright N^o 1907

COPYRIGHT DEPOSIT.

The D. Van Nostrand Company

intend this book to be sold to the Public
at the advertised price, and supply it to
the Trade on terms which will not allow
of discount.



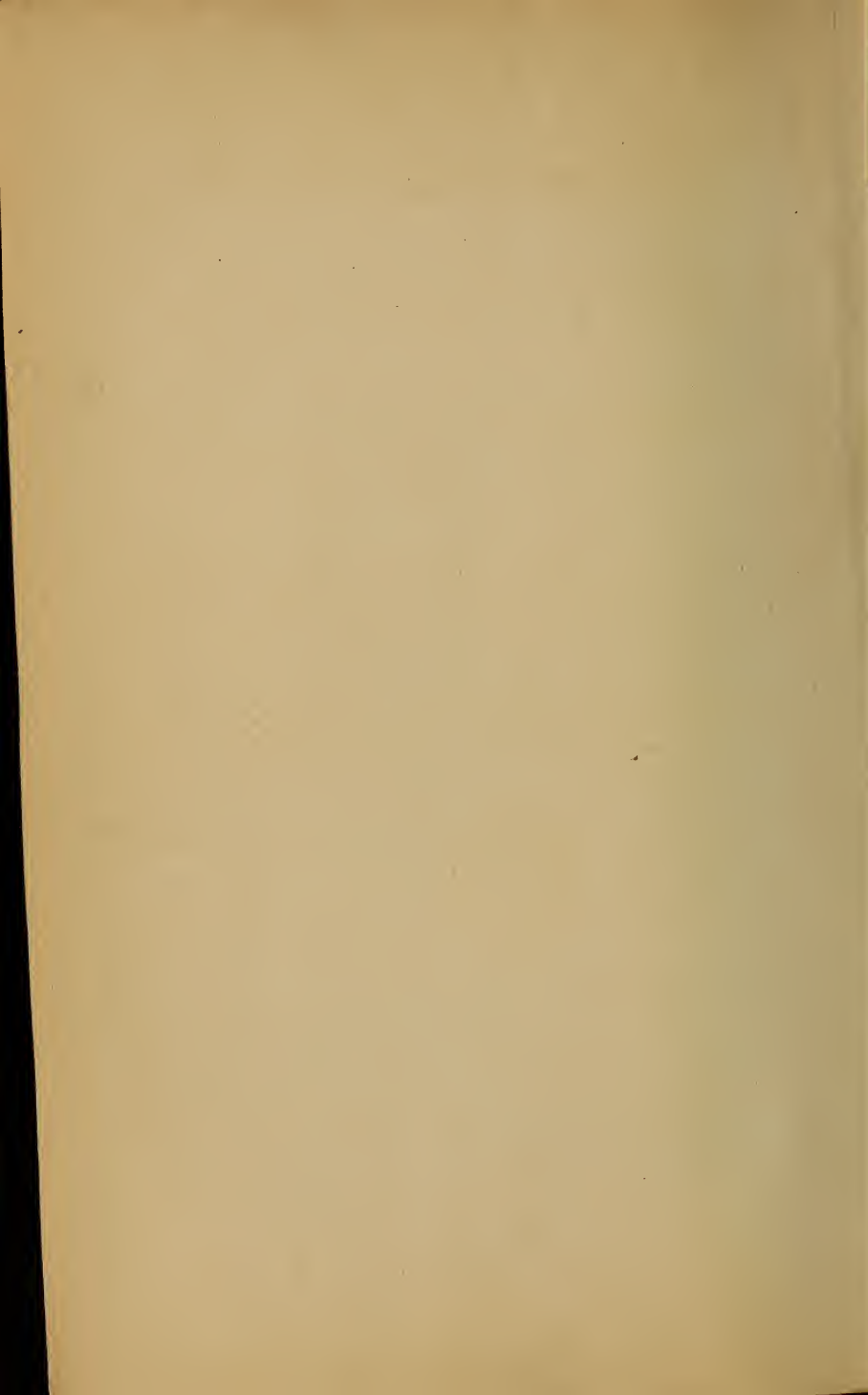

Carnegie Technical Schools Text Books

MATHEMATICS

FOR
ENGINEERING STUDENTS

BY
S. S. KELLER AND W. F. KNOX
CARNEGIE TECHNICAL SCHOOLS

ANALYTICAL GEOMETRY AND CALCULUS



NEW YORK:
D. VAN NOSTRAND COMPANY
23 MURRAY AND 27 WARREN STS.

1907

LIBRARY of CONGRESS
Two Copies Received
NOV 21 1907
Copyright Entry
Nov 21, 1907
CLASS *a* XXc. No.
192603
COPY B.

QA37
.K4
1907

COPYRIGHT, 1907, BY
D. VAN NOSTRAND COMPANY.

C
C
C
C
C
C
C

Stanbope Press
F. H. GILSON COMPANY
BOSTON, U. S. A.

P R E F A C E.

MUCH that is ordinarily included in treatises on Analytics and Calculus, has been omitted from this book, not because it was regarded as worthless, but because it was considered quite unnecessary for the student of engineering.

In Analytics the attention is called, at the beginning, to the fact that the commonest experiences of life lie at the basis of the subject, and at all stages of its development the student is encouraged to consider the matters presented in the most informal and untechnical way.

In the Calculus a somewhat radical departure has been attempted, in order to avoid the difficult and somewhat mystifying subject of limits, or rather to approach similar ends by less technical paths.

The average engineer will assert that he never uses the Calculus in his practical experience, and it is the author's ambition to make it effective as a tool, believing, as they do, that it is not used because it has never been presented in sufficiently simple and familiar terms.

S. S. K.

*Carnegie Technical Schools,
Pittsburg, Pa.*

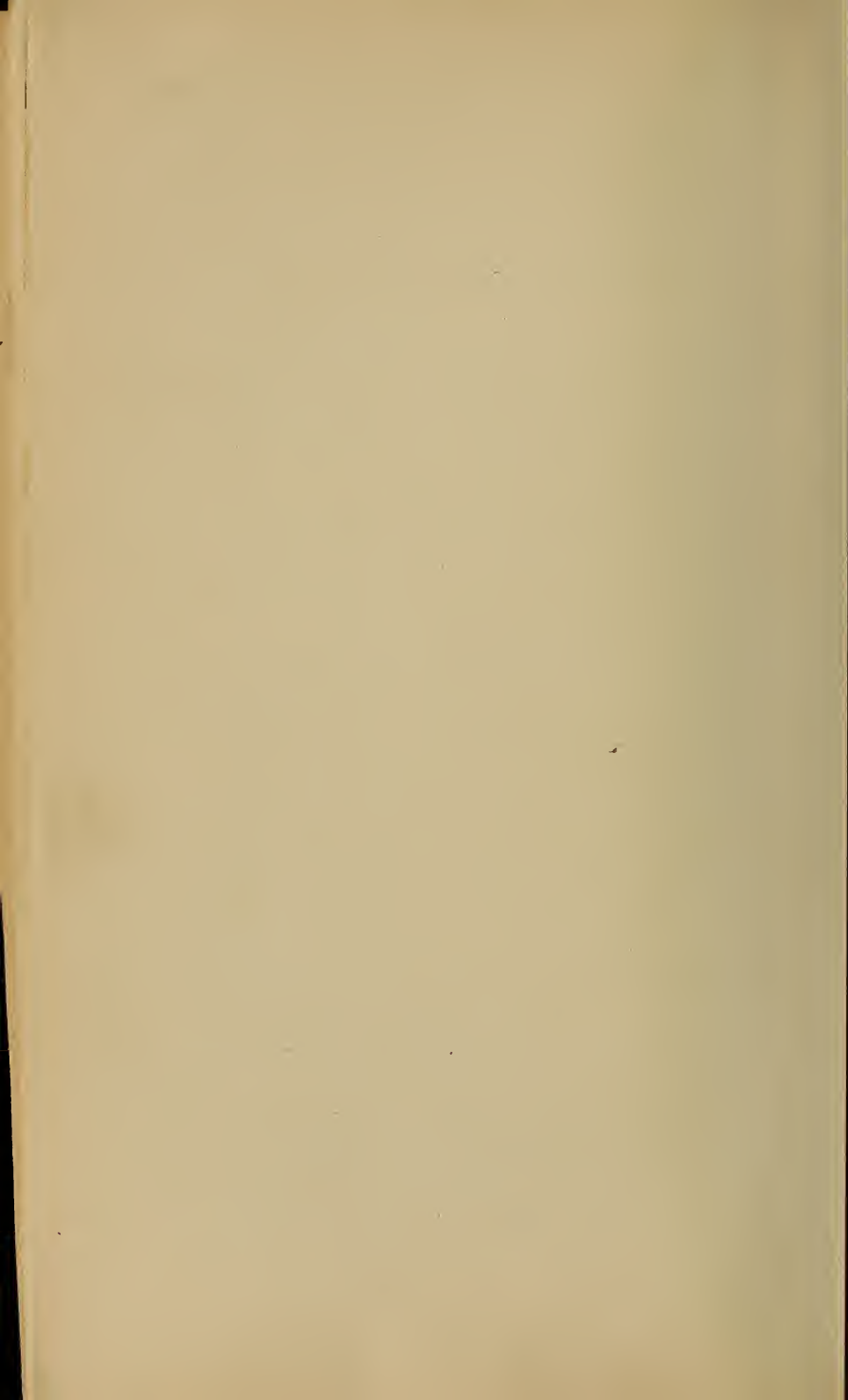

ANALYTICAL GEOMETRY.

CHAPTER I.

ARTICLE 1. Analytical Geometry may be called the science of *relative position*. The principles upon which the results of Analytical Geometry are based, are drawn directly from daily experience.

When we measure or estimate distance, it is always from some definite starting point previously fixed.

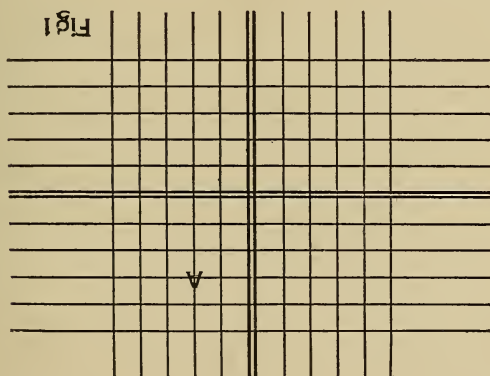

Fig. 1.

For instance, most of our cities are laid out with reference to two streets intersecting each other at right angles.

If it is desired to indicate the position of a certain building in such city, it is customary to say, "it is located so many squares north or south and so many squares east or west." Let the double lines in Fig. 1 represent the reference streets, and the lines parallel to them, the streets running in the same direction, then the point A would be accurately located, by saying it lies two squares east and three squares north.

The government lays out the public lands upon the same system; locating two lines intersecting at right angles (called the Principal Meridian and the Base Line, respectively) as reference lines. Then lines run parallel to these at intervals of six miles, divide the territory into squares each containing 36 square miles. In this region any piece of land is easily located by indicating its distances by squares from these two reference lines. In short, since our knowledge is practically all relative, the principles of Analytical Geometry lie at the foundation of all our accurate thinking.

ART. 2. The two intersecting lines are called *Co-ordinate Axes*, and their point of intersection is called the *Origin*.

In the system most frequently used, the axes meet at right angles, and hence it is known as the *rectangular system*. In comparatively rare instances it is desirable to have the lines oblique to each other, when the system is known as *oblique*.

ART. 3. The vertical axis is called the *axis of ordinates* and the horizontal axis, the *axis of abscissas*.

ART. 4. Distances are always measured from either axis, parallel to the other; hence when the system is rectangular, the distances mean always perpendicular distances. The distance of any point from the axis of ordinates (right or left), measured parallel to the axis of abscissas, is called the *abscissa* of the point, usually represented by x . The

distance from the axis of abscissas (up or down), measured parallel to the axis of ordinates, is called the *ordinate* of the point, usually represented by y .

ART. 5. Clearly if we would be accurate we must distinguish between distance to the right and to the left, and upward and downward. For instance, suppose it is required to locate a point whose abscissa, $x = 5$ and ordinate, $y = 2$; it is plain that the point might be located in any one of four positions: to the right 5 units and up 2 units; to the left 5 and up 2; to the right 5 and down 2; or to the left 5 and down 2.

If, however, it is agreed that abscissas measured to the right from the axis of ordinates shall be called plus, and those to the left, minus; and that ordinates measured upward from the axis of abscissas shall be called plus, and those downward, minus, there need be no confusion.

$x = + 5, y = + 2$ will then indicate definitely the first position referred to above; $x = - 5, y = + 2$, the second; $x = + 5, y = - 2$ the third, and $x = - 5, y = - 2$, the fourth.

ART. 6. The intersecting axes evidently divide the sur-

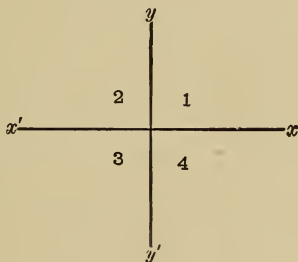

Fig. 2.

rounding space into four parts called quadrants, numbered 1, 2, 3, 4, from the axis of abscissas (usually called the X-axis)

around to the left back to the X-axis again. Thus XOY is quadrant 1; X'OY is quadrant 2; X'OY' is quadrant 3 (Fig. 2).

ART. 7. To locate a point let it be required to locate the point $x = -5$, $y = +3\frac{1}{2}$ [written for brevity $(-5, 3\frac{1}{2})$]. Let the axes be XOY and YOY' as in Fig. 3.

By what has been said the point is located 5 units to the left of the Y-axis and $3\frac{1}{2}$ units above the X-axis.

Since, it is a matter of *relative* position only, any convenient unit may be used, if it is maintained to the end of the problem; say in this case $\frac{1}{8}$ ".

Then measuring 5 units or $\frac{5}{8}$ " to the left on the X-axis, and from there $3\frac{1}{2}$ units or $\frac{3\frac{1}{2}}{8} = \frac{7}{16}$ " upward parallel to the Y-axis we locate the point P as in Fig. 3.

The point $(0, 2)$ is clearly on the Y-axis, 2 units above the

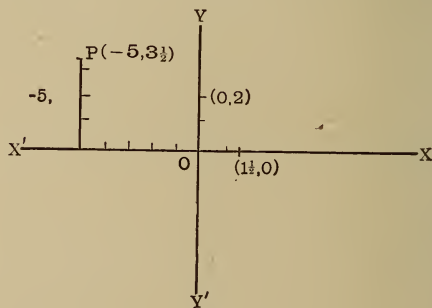

Fig. 3.

origin, because the abscissa is zero, and since the abscissa is the distance from the Y-axis, this point being at no distance, must be on the Y-axis. Likewise, the point $(1\frac{1}{2}, 0)$ is on the X-axis $1\frac{1}{2}$ units to the right.

Locate the following points:

1. $(3, 2)$, $(-2, -1)$, $(\frac{1}{2}, -3\frac{1}{2})$, $(0, 1)$, $(-2, 0)$, $(0, 0)$, $(-6, 5)$, $(\frac{3}{7}, -\frac{5}{8})$.

2. The points $(0, 2\frac{1}{2})$, $(-3, -2)$ and $(1\frac{1}{2}, -2\frac{1}{2})$ are the vertices of a triangle. Construct it.
3. Construct the quadrilateral whose vertices are $(-1, 2)$, $(3, 5)$, $(2, -3)$ and $(-2, -2)$.
4. An equilateral triangle has its vertex at the point $(0, 4)$ and its base coincides with the X-axis. Find the coordinates of its other vertices and the length of its sides.
5. The two extremities of a line are at the points $(-3, 4)$ and $(5, 4)$. What is its position relative to the axes?
6. How far is the point $(-3, 4)$ from the origin?
7. The extremities of a line are at the points $(3, 5)$ and $(-2, 1)$, respectively. Construct it.
8. The extremities of a line are at the points $(-3, -5)$ and $(3, 5)$. Show that it is bisected at the origin.
9. By similar triangles find the point midway between $(-2, 5)$ and $(4, -1)$.
10. A line crosses the axes at the points $(15, 0)$ and $(0, 8)$. What is its length between the axes.

THE POLAR SYSTEM.

ART. 8. Since two dimensions are sufficient to locate a point in a plane, it is readily possible to use an angle and a distance, instead of two distances.

By convention the angle is estimated from a fixed line around counter-clockwise; the revolving line, called the *radius vector*, is pivoted at the left end of the fixed line, which is called the *initial line*, and the pivotal point is known as the *pole*.

The angle is estimated either in degrees, minutes, and seconds or in *radians*.

ART. 9. A *radian* is defined as the central angle which is measured by an arc equal in length to the radius.

Since the circumference of a circle is equal to $2\pi r$ (where r is the radius and $\pi = 3.1416$) and also contains 360° ,

$$2\pi r = 360^\circ$$

and
$$r = \frac{360^\circ}{2\pi} = \frac{180^\circ}{\pi} = 1 \text{ radian.}$$

Hence the number of radians in any angle

$$\theta = \frac{\theta}{180} = \frac{\theta}{180} \pi.$$

That is, the number of radians in an angle is the same fraction of π , that the angle is of 180° .

For example

$$60^\circ = \frac{60}{180} \pi \text{ radians} = \frac{1}{3} \pi \text{ radians.}$$

$$22\frac{1}{2}^\circ = \frac{22\frac{1}{2}}{180} \pi \text{ radians} = \frac{1}{8} \pi \text{ radians.}$$

$$225^\circ = \frac{225}{180} \pi \text{ radians} = \frac{5}{4} \pi \text{ radians, etc.}$$

ART. 10. It is agreed for the sake of uniformity that an angle described by the radius vector from its original position of coincidence with the initial line, counter-clockwise, shall be positive; in the contrary direction, negative.

That when the distance to the point is measured along the radius vector forward, it shall be positive; when measured on the radius vector produced backward through the pole it shall be negative. For example,

the point $\left(3, \frac{\pi}{3}\right)$ would be located thus (Fig. 4):

Draw an indefinite line OB (representing the radius vector) making an angle of $\frac{\pi}{3}$ radians $= \frac{1}{3}$ of $180^\circ = 60^\circ$

with the fixed initial line OA; measure off 3 units on the radius vector from the pole, and the point P is located (see Fig. 4).

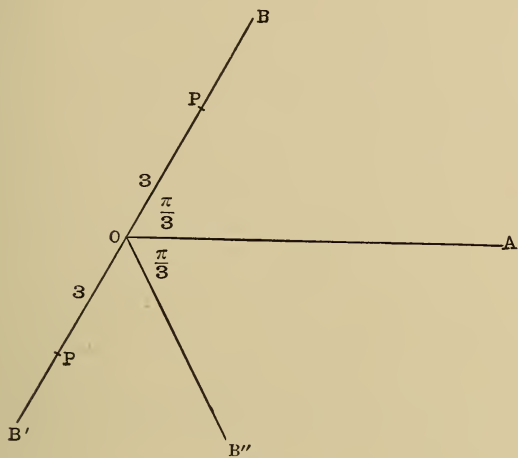

Fig. 4.

If the point had been $(-3, \frac{\pi}{3})$ the 3 units would have been measured back toward B' to P'. If the angle had been $-\frac{\pi}{3}$ the radius vector would have taken the positive direction OB''.

The usual notation for co-ordinates in the polar system is (r, θ) or (ρ, θ) .

EXERCISE II.

1. Locate the points:

$$\left(2, \frac{\pi}{2}\right), \left(-3, \frac{\pi}{4}\right), \left(-1\frac{1}{2}, -\frac{\pi}{6}\right), \left(5, \frac{5\pi}{4}\right), \left(-1, \frac{2\pi}{3}\right),$$

$$\left(3.2, -\frac{3\pi}{2}\right), \left(2\frac{1}{2}, 75^\circ\right), (-4, -30^\circ).$$

2. Express the following radians in degrees:

$$\frac{\pi}{2}, 1.5, \frac{3\pi}{4}, \frac{\pi}{8}, \frac{5\pi}{8}, \frac{7\pi}{16}, 2.4\pi.$$

3. Express in radians:

$$35^\circ, 40^\circ, 45^\circ, 67\frac{1}{2}^\circ, 75^\circ, 150^\circ, 120^\circ, -225^\circ, -195^\circ.$$

4. Construct the triangle whose vertices are,

$$\left(3\frac{1}{2}, \frac{\pi}{3}\right), \left(2, -\frac{\pi}{3}\right), \text{ and } \left(-5, \frac{\pi}{4}\right).$$

5. Construct the quadrilateral whose vertices are,

$$\left(5, \frac{\pi}{6}\right), \left(3, \frac{2\pi}{3}\right), \left(5, -\frac{5\pi}{6}\right), \left(3, -\frac{\pi}{3}\right).$$

What kind of quadrilateral is it?

6. The extremities of a line are the points $\left(6, \frac{\pi}{8}\right)$ and

$\left(-6, -\frac{\pi}{8}\right)$. How is the line situated with reference to the initial line?

7. Construct the equilateral triangle whose base coincides with the initial line and whose vertex is the point

$$\left(4, \frac{\pi}{3}\right).$$

8. The co-ordinates of a point are $\left(5, \frac{\pi}{4}\right)$. Give three other ways of denoting the same point.

AREA OF A TRIANGLE.

ART. II. The system of rectangular co-ordinates affords a ready method of expressing the area of any triangle when the co-ordinates of its vertices are known.

Let ABC (Fig. 5) be any triangle. Draw the perpendiculars AD, BE and CF from the vertices to the x -axis. Then the co-ordinates of A = (OD, AD); of

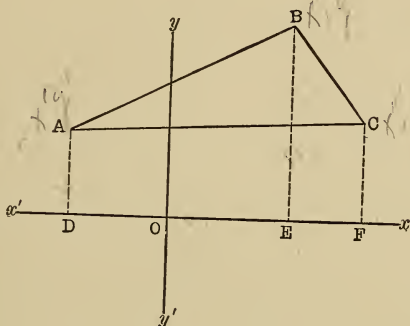

Fig. 5.

B = (OE, BE); of C = (OF, CF); say, $(-x', y')$, (x'', y'') and (x''', y''') .

Now the figure ABCFD is made up of the trapezoids ABED, and BCFE; and if from ABCFD we take ACFD the triangle ABC remains, that is,

$$ABED + BCFE - ACFD = ABC. \quad \dots (a)$$

By geometry, area ABED = $\frac{1}{2} (AD + BE) DE$.

But AD = y' , BE = y'' , and DE = DO + OE = $-x' + x''$.

$$\therefore \text{area ABED} = \frac{1}{2} (y' + y'') (x'' - x').$$

Also area BCFE = $\frac{1}{2} (BE + CF) EF$.

But BE = y'' , CF = y''' and EF = OF - OE = $x''' - x''$.

$$\therefore \text{area BCFE} = \frac{1}{2} (y'' + y''') (x''' - x'').$$

Again; area ACFD = $\frac{1}{2} (AD + CF) DF$.

But AD = y' , CF = y''' and DF = DO + OF = $-x' + x'''$.

$$\therefore \text{area ACFD} = \frac{1}{2} (y' + y''') (x''' - x').$$

Substituting in (a):

$$\begin{aligned} \text{Area } ABC &= \frac{1}{2} (y' + y''') (x'' - x') + \frac{1}{2} (y'' + y''') \\ &\quad (x''' - x'') - \frac{1}{2} (y' + y'') (x''' - x') = \\ &\quad \frac{1}{2} [x''y' - x'y'' + x'''y'' - x''y''' + x'y''' - x'''y']. \end{aligned}$$

The symmetrical arrangement of the accents in this expression is manifest.

Example. Find the area of the triangle whose vertices are $(2, 3)$, $(-1, 4)$ and $(3, -6)$. Let $(2, 3)$ be (x', y') ; $(-1, 4)$ be (x'', y'') , and $(3, -6)$ be (x''', y''') . Then area = $\frac{1}{2} [(-1 \times 3) - (2 \times 4) + (3 \times 4) - (-1 \times -6) + (2 \times -6) - (3 \times 3)] = \frac{1}{2} [-3 - 6 + 12 - 6 - 12 - 9] = -12$.

The minus sign has no significance except to indicate the relation of the trapezoids.

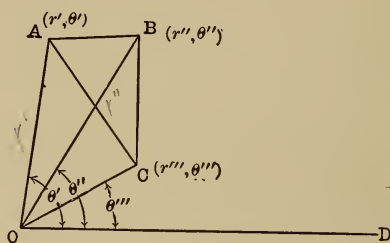

Fig. 6.

Polar System: A reference to Fig. 6 will show that a similar process will give the area of ABC , when its vertices are given in polar co-ordinates.

$$\text{For area } ABC = ABO + OBC - OAC.$$

$$\text{Area } ABO = \frac{1}{2} AO \times OB \sin AOB.$$

$$AO = r', \quad OB = r'' \quad \text{and} \quad AOB = (\theta' - \theta'').$$

A similar treatment of OBC and AOC will give the areas of all the triangles.

CHAPTER II.

LOCI.

ART. 12. Whenever the relation between the abscissa and ordinate of *every* point on a line is the same, the expression of this relation in the form of an equation is said to give the equation of the line. For example, if the ordinate is always 4 times the abscissa for every point on a line, $y = 4x$ is called the equation of the line.

Again, if 3 times the abscissa is equal to 5 times the ordinate plus 2, for every point on a line, then $3x = 5y + 2$ is the line's equation.

ART. 13. Clearly since an equation represents the relation between the abscissa x and the ordinate y for every point on a line, if either co-ordinate is known for any point on the line, the other one may be found by substituting the known one in the equation and solving it for the unknown.

For example, let $2y = 7x - 1$ be the equation for a line, and a point is known to have the abscissa, $x = 2$. To find its ordinate, substitute $x = 2$ in the equation; $2y = 7(2) - 1 = 14 - 1 = 13$; $y = 6\frac{1}{2}$. Therefore the ordinate corresponding to the abscissa, $x = 2$, is $6\frac{1}{2}$.

Further, if the equation is given, the whole line may be reproduced by locating its points. If x for example be given a series of values from 0 to 10 inclusive, by substituting these values in the equation, the corresponding values of y are found, and 11 points are thus located on the desired line. If more points are needed the range of

values for x may be indefinitely extended, and if these points are joined, we have the line. For example, let the equation of a line be $x^2 + y^2 = 9$, to reproduce the curve represented. For convenience in calculating solve for y ;

$$y = \pm\sqrt{9 - x^2}.$$

Then give x a series of values to locate points on this line.

$$\text{If } x = 0 \quad y = \pm\sqrt{9 - x^2} = \pm 3.$$

$$\text{If } x = 1 \quad y = \pm\sqrt{9 - 1} = \pm\sqrt{8} = \pm 2.83.$$

$$\text{If } x = 2 \quad y = \pm\sqrt{9 - 4} = \pm\sqrt{5} = \pm 2.24.$$

$$\text{If } x = 3 \quad y = \pm\sqrt{9 - 9} = \pm\sqrt{0} = 0.$$

$$\text{If } x = 4 \quad y = \pm\sqrt{9 - 16} = \pm\sqrt{-7} = \text{an imaginary.}$$

The last value for y shows that the point whose abscissa is 4 is not on the curve at all; and since any larger values of x would continue to give imaginary values for y , the curve does not extend beyond $x = 3$.

Since we have given x only positive values so far, all our points so determined lie to the right of the Y -axis. To make the examination complete, let x take a series of negative value thus:

$$\text{If } x = -1 \quad y = \pm\sqrt{9 - 1} = \pm\sqrt{8} = \pm 2.83.$$

$$\text{If } x = -2 \quad y = \pm\sqrt{9 - 4} = \pm\sqrt{5} = \pm 2.24.$$

$$\text{If } x = -3 \quad y = \pm\sqrt{9 - 9} = 0 = \sqrt{0}.$$

The similarity of these results shows that the curve is symmetrical with respect to the axes, that is, it is alike on both sides of the axes.

If now these points are located with respect to the axes XX' and YY' and are joined, the result is an approximation to the curve; it is only an approximation because the points are few and not close enough together.

The result is shown in Fig. 7, using $\frac{1}{4}$ inch as a unit for

scale. The points are $(0, +3)$, $(0, -3)$ [being A and A' in the figure], $(1, \sqrt{8})$, $(1, -\sqrt{8})$ [being B and B'], $(2, \sqrt{5})$, $(2, -\sqrt{5})$ [being C and C'], $(3, 0)$ [G], $(-1, \sqrt{8})$, $(-1, -\sqrt{8})$ [D and D'] $(-2, \sqrt{5})$ $(-2, -\sqrt{5})$ [E and E'] and $(-3, 0)$ [F].

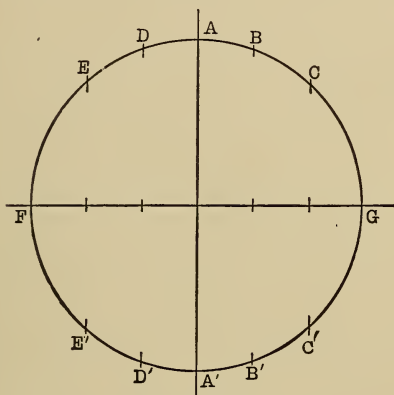

Fig. 7.

Clearly if more points are needed to trace the curve accurately through them (as is the case here), it is necessary to take more values of x between -3 and $+3$, for example:

$$x = 0 \quad y = \pm \sqrt{9} = \pm 3.$$

$$x = .2 \quad y = \pm \sqrt{9 - .04} = \pm \sqrt{8.96} = \pm 2.99.$$

$$x = .4 \quad y = \pm \sqrt{9 - .16} = \pm \sqrt{8.84} = \pm 2.97.$$

$$x = .6 \quad y = \pm \sqrt{9 - .36} = \pm \sqrt{8.64} = \pm 2.94.$$

$$x = .8 \quad y = \pm \sqrt{9 - .64} = \pm \sqrt{8.36} = \pm 2.89.$$

$$x = 1 \quad y = \pm \sqrt{9 - 1} = \pm \sqrt{8} = \pm 2.83, \text{ etc.}$$

Making a similar table for the corresponding negative values of x , the result is three times as many points on the

curve as before, and as they are closer together the curve is much more readily drawn through them, and it will be much more accurate.

Take another example: $9x^2 + 16y^2 = 144$.

Solving for y ; $y = \pm \frac{3}{4} \sqrt{16 - x^2}$.

Then if

$$x = 0 \quad y = \pm \frac{3}{4} \sqrt{16} = \pm 3.$$

$$x = \pm .2 \quad y = \pm \frac{3}{4} \sqrt{16 - .04} = \pm \frac{3}{4} \sqrt{15.96} = \pm 2.99.$$

$$x = \pm .4 \quad y = \pm \frac{3}{4} \sqrt{16 + .16} = \pm \frac{3}{4} \sqrt{15.84} = \pm 2.98 +$$

$$x = \pm .6 \quad y = \pm \frac{3}{4} \sqrt{16 - .36} = \pm \frac{3}{4} \sqrt{15.64} = \pm 2.96.$$

$$x = \pm .8 \quad y = \pm \frac{3}{4} \sqrt{16 - .64} = \pm \frac{3}{4} \sqrt{15.36} = \pm 2.94.$$

$$x = \pm 1 \quad y = \pm \frac{3}{4} \sqrt{16 - 1} = \pm \frac{3}{4} \sqrt{15} = \pm 2.9, \text{etc.}$$

The result is indicated in Fig. 8, same scale as before.

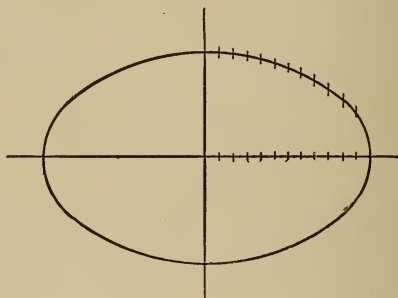

Fig. 8.

ART. 14. Clearly a curve can be traced thus representing almost any form of equation.

Suppose the equation $x^3 - 7x^2 + 7x + 15 = y$ is given. The location of a number of points by giving x a series of values and calculating corresponding values of y from the equation, will enable us to draw through them the curve represented by the equation. In most cases, there will be certain values of x which will make the value of y zero;

such values of x will be roots of the equation $x^3 - 7x^2 + 7x + 15 = 0$, that is, these values of x indentially satisfy this equation.

But if y is zero for a point, the point must be on the X-axis, for by definition the value of y is the distance from the X-axis to the point, hence the curve must cross the X-axis at those points where y is zero. If then none of the values given to x make y exactly zero, but do make y change from a positive value for one value of x to a negative value for the next, or *vice versa*, it must pass through zero to change from one sign to the other, and hence the curve must cross the X-axis.

As an illustration, take the equation $x^3 - 5x^2 + x + 11 = y$. As before make a table of values of x and y , and locate the points as follows:

If	$x = 0$	$y = 11.$
	$x = .5$	$y = 10.375.$
	$x = 1$	$y = 8.$
	$x = 1.5$	$y = 4.625.$
	$x = 2$	$y = 1.$
	$x = 2.5$	$y = - 2.125.$
	$x = 3$	$y = - 4.$
	$x = 3.5$	$y = - 3.875.$
	$x = 4$	$y = - 1.$
	$x = 4.5$	$y = 5.375.$
	$x = - 1$	$y = 4.$
	$x = - 1.5$	$y = - 5.125.$

The curve connecting these points crosses the X-axis at three points; one between 2 and 2.5; one between 4 and 4.5, and one between $- 1$, and $- 1.5$. Hence the three roots of the equation $x^3 - 5x^2 + x + 11 = 0$ are between 2 and 2.5; between 4 and 4.5, and between $- 1$ and $- 1.5.$

If the values of x in the above table had been taken closer together, the points of crossing would have been more accurately known.

INTERSECTIONS.

ART. 15. The point (or points) in which two lines intersect, being common to both lines, its co-ordinates must satisfy both equations, that is, the equations of the two lines are simultaneous for this point (or these points) and hence if the equations be solved as simultaneous by any of the processes explained in algebra, the resulting values of x and y will be the co-ordinates of the point (or points) of intersection. For example :

To find the points of intersection of the circle $x^2 + y^2 = 24$ and the parabola $y^2 = 10x$. By substitution of the value of y^2 from the parabola equation in the circle equation,

$$\begin{aligned} x^2 + 10x &= 24 & x^2 + 10x + 25 &= 49. \\ x + 5 &= \pm 7 & x &= 2, \text{ or } -12 \\ y &= \pm\sqrt{20}, & \text{ or, } & \pm\sqrt{-120}. \end{aligned}$$

The second pair of values for y being imaginary shows there are but two real points of intersection, $(2, +\sqrt{20})$ and $(2, -\sqrt{20})$. Verify by construction.

EXERCISE III.

Loci with Rectangular Co-ordinates.

1. Express the equation of the line for every point of which the ordinate is $\frac{3}{4}$ of its abscissa.
2. Express the equation of the line for every point of which $\frac{2}{3}$ the bascissa equals $\frac{3}{4}$ of the ordinate $+ 1$.

3. Express the equation of the line, for every point of which 9 times the square of its abscissa plus 16 times the square of its ordinate equals 144.

4. Construct the locus of $x^2 = 8y$.
5. Construct the locus of $(x - 2)^2 + y^2 = 36$.
6. Construct the locus of $xy = 16$.
7. Construct the locus of $x^2 + 4y^2 = 4$.
8. Construct the locus of $25x^2 - 36y^2 = 900$.
9. Construct the locus of $3x - 2y = 5$.
10. Construct the locus of $\frac{1}{2}x - \frac{3}{4} = -y$.
11. Construct the locus of $x = 7$.
12. Construct the locus of $y = -5$.

Find the points of intersection of:

13. $(x - 1)^2 + (y - 2)^2 = 16$ and $2y - x = 3$.
14. $2x - 3y = 7$ and $\frac{1}{2}x + y = \frac{2}{3}$.
15. $x^2 + y^2 = 9$ and $x^2 = 8y$.
16. $x^2 + y^2 = 16$ and $2x^2 + 3y^2 = 6$.
17. $x^2 + y^2 = 25$ and $4y = 3x + 25$.
18. Find the vertices of the triangle whose sides are

$$x - y = 1.$$

$$2x + y = 5 \text{ and } 3y - 2x = 7.$$

ART. 16. If the equation of a locus is expressed in polar co-ordinates, the method of procedure is exactly similar to the cases already discussed.

The presence of trigonometric functions introduces no difficulties. For example: To construct the locus of $r = 4(1 - \cos \theta)$. Give θ a series of values, and computing r for each, as follows:

$$\text{If } \theta = 0, \quad r = 0 \text{ since } \cos 0 = 1.$$

$$\text{If } \theta = 5^\circ, \quad r = 4(1 - .996) = .016.$$

$$\text{If } \theta = 10^\circ, \quad r = 4(1 - .98) = .08.$$

$$\text{If } \theta = 15^\circ, \quad r = 4(1 - .97) = .12.$$

$$\text{If } \theta = 20^\circ, \quad r = 4 (1 - .94) = .24.$$

$$\text{If } \theta = 30^\circ, \quad r = 4 (1 - .87) = .52.$$

$$\text{If } \theta = 40^\circ, \quad r = 4 (1 - .77) = .92.$$

$$\text{If } \theta = 50^\circ, \quad r = 4 (1 - .64) = 1.44.$$

$$\text{If } \theta = 60^\circ, \quad r = 4 (1 - .5) = 2. \quad \text{,etc.}$$

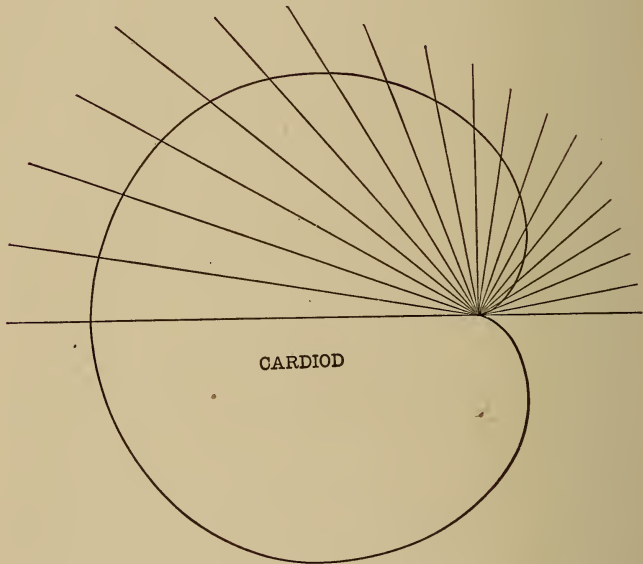

Fig. 9.

Completing the table to $\theta = 360^\circ$ and plotting we get a curve as in Fig. 9.

TRANSCENDENTAL LOCI.

ART. 17. Certain curves have what are known as transcendental equations, that is, equations which cannot be solved alone by the algebraic processes of addition, subtraction, multiplication, and division.

For example, $y = \log x$.

The loci of such equations are found in the usual way, by giving to one of the co-ordinates a series of values and finding corresponding values for the other from tables.

EXERCISE IV.

1. Find the locus of $r^2 = 9 \cos 2 \theta$.
2. Find the locus of $r = 10 \cos \theta$.
3. Find the locus of $r = \frac{4}{1 - \cos \theta}$.
4. Find the locus of $r = \frac{16}{5 + 3 \cos \theta}$.
5. Construct $y = \sin x$.
6. Construct $x = \log y$.

MISCELLANEOUS CURVES.

ART. 18. Curve-plotting is very widely applied in all modern scientific research, to represent graphically the results of observation. This method of presentation has the immense advantage of showing at a glance the complete result of an investigation.

For example, if a test is made of the speed of an engine relative to its steam pressure, the pressures being represented as abscissas (by x) and the corresponding speeds as ordinates (by y), a smooth curve drawn through the points determined by these co-ordinates will reveal at once the behavior of the engine. Especially does this method aid in comparisons of different series of observations of the same kind.

Suppose, for example, it is desired to represent thus graphically the course of a case of fever.

The observations are as follows: —

7 A.M.	temperature	100
8 A.M.	“	$100\frac{3}{8}$
9 A.M.	“	$101\frac{2}{8}$
10 A.M.	“	$102\frac{3}{8}$
11 A.M.	“	103
12 M.	“	$103\frac{2}{8}$
1 P.M.	“	103
2 P.M.	“	$102\frac{3}{8}$
3 P.M.	“	101

Regarding the time of taking observations as abscissas and the temperatures as ordinates, using any desired scale, the result may be represented as follows, in Fig. 10.

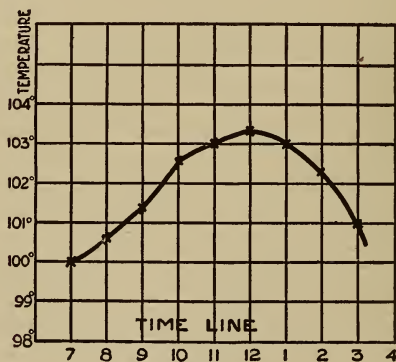

Fig. 10.

Fig. 10.

The figure shows at a glance that the maximum was at noon.

Again; in the test of an I-beam the following observations were taken.

TEST OF CAST-IRON.

<i>Stress Pounds.</i>	<i>Unit Elongation.</i>
○	○
6,950	4.97
12,940	11.44
6,110	6.06
○	1.12 (permanent set)
4,640	4.16
8,780	7.63
12,300	10.78
15,420	15.2
11,900	12.38
8,370	9.42
4,960	6.66
113	2.41

Plot the curve.

CHAPTER III.

THE STRAIGHT LINE.

ART. 19. Since two points determine a straight line and two points imply two conditions, there will be in the equation to a straight line, two fixed quantities (called constants), which must be predetermined for every straight

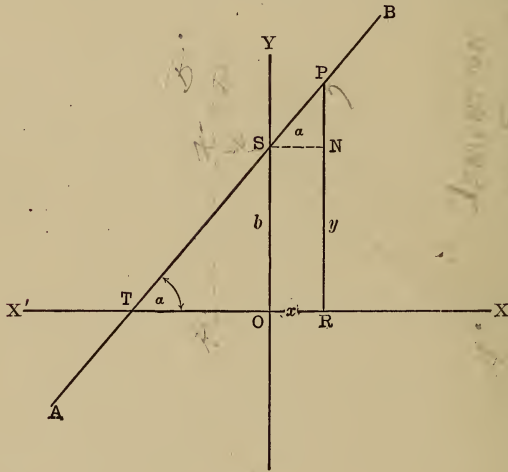

Fig. 11.

line. These constants may be furnished by two fixed points, or by a point and an angle, evidently.

To determine the equation of a given straight line, then, it is necessary to express the relation between the co-ordinates of any (that is, every) point on the line, in terms of the two given constants.

Handwritten notes:
FOR DEFINITION IN 2nd SECTION 30-40
SWING THE WHOLE FIG. THROUGH 90° ABOUT THE Yth

Suppose first we take a point on the y -axis, through which the line must pass, and determine its position by giving its distance from the origin measured on this axis.

Call this distance, b ; and say the line makes an angle α with the x -axis; the angle to be estimated as in trigonometry, positively, that is, counter-clockwise, from the x -axis.*

It is required, then, to determine the relation between the co-ordinates of any point P, selected at random, on the line AB (Fig. 11), using b and any convenient function of α .

Drawing the \perp PR, OR = abscissa of P = x ,

PR = ordinate of P = y , OS = b .

$$\angle BTR = \alpha.$$

The character of the figure would suggest the use of the similar triangles TSO and TPR, but a simple observation shows that only the sides b and y are known; on the other hand we know the angle α , and a line through S \parallel to the x -axis, from S to PR, will be equal in length to OR and will also make the angle α with AB (alternate angles of parallel lines).

Call this line SN. Then in the triangle SPN, $\angle PSN = \alpha$ SN = OR = x , and PN = PR - NR = PR - SO = $y - b$. PN and SN being respectively opposite and adjacent to α in the right triangle SPN, we have,

$$\tan \alpha = \frac{PN}{SN} = \frac{y - b}{x}.$$

* The conventions as to positive and negative direction for lines, and positive and negative revolution for angles, is maintained in Analytical Geometry, as indeed is necessary in order to accomplish consistent results.

Let $\tan \alpha$ be represented by m ;

then

$$m = \frac{y - b}{x},$$

$$mx = y - b$$

$$y = mx + b \quad \dots \dots \dots (A)$$

which expresses the relation between the co-ordinates of of any point, P, and hence of every point on the line in terms of the known constants m and b . $\therefore y = mx + b$

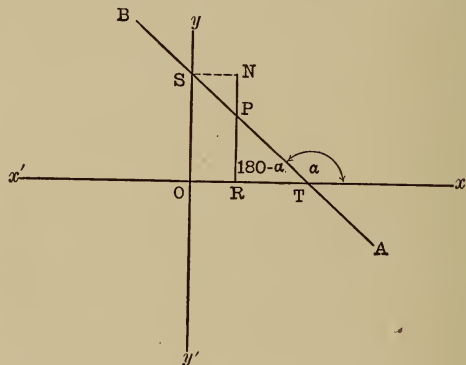

Fig. 12.

is the equation of AB. Had the line crossed the first quadrant the construction would have been as in Fig. 12 and we would have

$$\tan \text{PSN} = \frac{NP}{SN},$$

$$\text{or } \tan (180 - \alpha) = \frac{b - y}{x}$$

$$- \tan \alpha = \frac{b - y}{x}$$

$$- m = \frac{b - y}{x}$$

$$y = mx + b \text{ as before.}$$

See Fig. 11

m is called the *slope* of the line and b its y -intercept. The equation is called the *slope equation* of a line.

If $m = 0$ in the equation to a straight line, then it takes the form $y = b$, which is plainly (since if $m = 0$, $\alpha = 0$) a line \parallel to the x -axis. If $b = 0$, the equation becomes $y = mx$, which is the equation of a line through the origin, making an angle whose tangent is m with the x -axis, etc. Since α may be either acute or obtuse depending upon whether the line crosses the 2d or 4th, or the 1st or 3d quadrants; and b may be either plus or minus depending upon the position of the point of intersection with y -axis, above or below the origin, the form,

- $y = -mx + b$ represents a line crossing quad. I,
- $y = mx + b$ represents a line across quad. II,
- $y = -mx - b$ represents a line across quad. III,
- $y = mx - b$ represents a line across quad. IV.

ART. 20. *If the line be determined by two points (x', y') and (x'', y'') ; to find its equation.*

Let AB (Fig. 13) be the line, P and Q the points (x', y') and (x'', y'') , respectively.

Take any point P' whose co-ordinates are (x, y) . Draw QR, P'S and PT \perp to the x -axis, also PL \perp to QR, as it is clearly here a case for similar triangles.

Then in the similar triangles PLQ and PKP',

$$P'K : KP :: QL : LP, \text{ or } \frac{P'K}{KP} = \frac{QL}{LP}.$$

But $P'K = P'S - KS = P'S - PT = y - y'$
 $KP = HP - HK = x' - x,$
 $QL = QR - LR = QR - PT = y'' - y',$

and $LP = LH + HP = -x'' + x'$.

$$\therefore \frac{y - y'}{x' - x} = \frac{y'' - y'}{-x'' + x'},$$

or symmetrically, $\frac{y - y'}{x - x'} = \frac{y'' - y'}{x'' - x'}$

(changing sign of both) which gives an equation between $x, y, x', y', x'',$ and y'' as required.

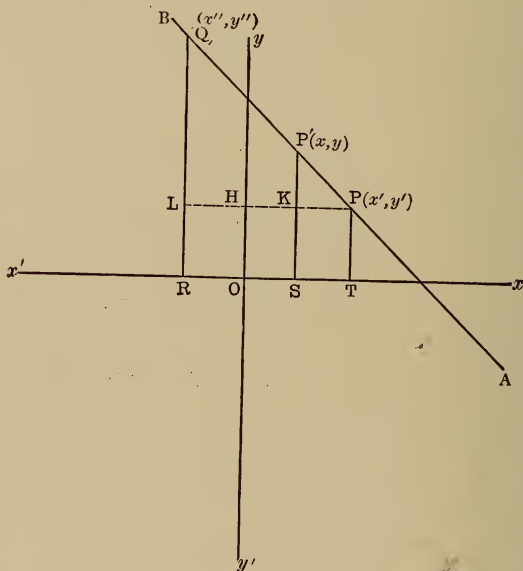

Fig. 13.

The same result might be reached by a purely analytical method having the slope equation of a line given.

Let the slope equation of the line AB be $y = mx + b$.

Since it must pass through the points P, P' and Q, the co-ordinates of these points must satisfy the equation of

the line, since the equation must give the relation between the co-ordinates of *every* point on the line.

Hence, substituting these co-ordinates successively in the equation $y = mx + b$, we know that the three following equations must be true, if P, P' and Q are on the line:

$$y' = mx' + b \quad \dots \dots \dots (1)$$

$$y = mx + b \quad \dots \dots \dots (2)$$

$$y'' = mx'' + b \quad \dots \dots \dots (3)$$

But since the line is to be determined only by the two points P and Q, neither m nor b are known, and hence must be eliminated.

Subtracting (1) from (2) and (1) from (3), we get

$$y - y' = m(x - x') \quad \dots \dots (4)$$

and $y'' - y' = m(x'' - x') \quad \dots \dots (5)$

divide (4) by (5); $\frac{y - y'}{y'' - y'} = \frac{x - x'}{x'' - x'}$,

or $\frac{y - y'}{x - x'} = \frac{y'' - y'}{x'' - x'} \quad \dots \dots \dots (B)$

For example: Find the equation of the line through $(-2, 3)$ and $(-4, -6)$.

Let (x', y') be $(-2, 3)$ and (x'', y'') be $(-4, -6)$ *.

Substituting in (B),

$$\frac{y - 3}{x + 2} = \frac{-6 - 3}{-4 + 2} = -\frac{3}{2}, \text{ or } 2y + 3x = 0.$$

* Since (B) is perfectly symmetrical it is a matter of indifference which point be called (x', y') and which, (x'', y'') . The results are the same. It is to be observed that x and y with accent marks usually mean definite points, while general co-ordinates are represented by unaccented x and y . So that substitutions are always made for the accented variables, when definite points are involved.

ART 21. When the line is determined by an angle and a point situated otherwise than on the y -axis.

Let the tangent of the angle be m and the point be (x', y') . Then $y = mx + b$ (1) can represent the slope equation to the line. This equation satisfies the condition that the line should have the slope m , but it must also pass through the point (x', y') .

Hence, if $y = mx + b$ is to completely represent the line, equation $y' = mx' + b$ (2) must be true.

Since b is a third and unnecessary condition, it must be eliminated between (1) and (2).

$$\begin{array}{r} y = mx + b \\ y' = mx' + b \\ \hline \text{Subtract (2) from (1); } y - y' = mx - mx' = m(x - x') \end{array} \quad (C)^*$$

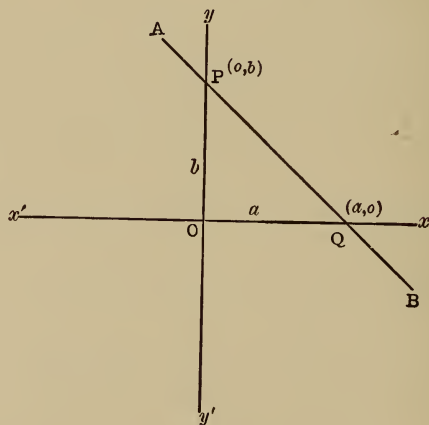

Fig. 14.

ART. 22. When the line is determined by two points, one on each axis.

* It is to be observed that the slope equation is a special form of (C) where (x', y') is $(b, 0)$.

Let the points P and Q, respectively (o, b) and (a, o) , be the determining points (Fig. 14), and let $y = mx + b$ be the slope equation of the line AB; then $b = b$ and $m \tan = PQx = -\tan PQO$. Also

$$\tan PQO = \frac{b}{a}. \quad \therefore m = -\frac{b}{a}.$$

Substituting these values of m and b thus expressed, by a and b in the slope equation,

$$y = -\frac{b}{a}x + b, \quad \text{or} \quad \frac{y}{b} + \frac{x}{a} = 1 \quad \dots (D)^*$$

[dividing by b and transposing].

This form is known as the *intercept equation* of a straight line, since a and b are called the intercepts of the line AB on the co-ordinate axes.

ART. 23. There is still another form of equation to the

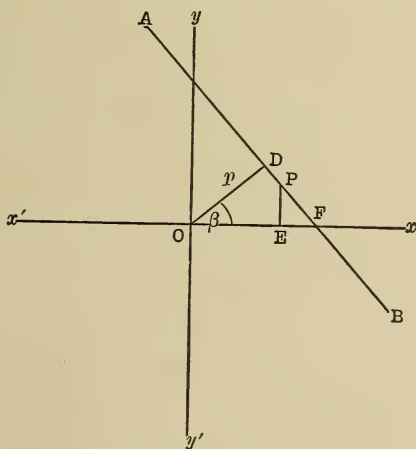

Fig. 15.

straight line determined by a perpendicular to the line

* The same result could be derived from (B) by substituting (a, o) for (x', y') and (b, o) for (x'', y'') .

from the origin, and the angle which this perpendicular makes with the x -axis.

Let OD be a \perp to the line AB from the origin, and β the angle it makes with the x -axis. Let P (x , y) be any point on the line.

Drawing the ordinate (PE) of P, we have two similar right triangles ODF (F being the point where AB crosses the x -axis) and PEF.

Then $PE : OD :: EF : DF$ [homologous sides].

Call OD, p , and OF, a , then above proportion becomes

$$y : p :: (a - x) : DF.$$

But in the right triangle ODF,

$$a = \frac{p}{\cos \beta}, \text{ and } DF = p \tan \beta = \frac{p \sin \beta}{\cos \beta}$$

$$\therefore y : p :: \left(\frac{p}{\cos \beta} - x \right) : \frac{p \sin \beta}{\cos \beta}$$

$$\frac{yp \sin \beta}{\cos \beta} = p \left(\frac{p}{\cos \beta} - x \right) \text{ [extremes and means]}$$

or
$$\frac{y \sin \beta}{\cos \beta} = \frac{p}{\cos \beta} - x \text{ [dividing by } p]$$

that is, $y \sin \beta + x \cos \beta = p$ (E)

This is called the *normal equation*, p being known as a *normal*.

The line AB is plainly a tangent to a circle with O as a centre and p as a radius, hence we are practically determining the line AB as a tangent to a given circle, the position of the radius being fixed by the angle β .

Exercise: By determining the values of a and b from the intercept equation, $\frac{x}{a} + \frac{y}{b} = 1$, in terms of p and β , derive the normal equation from the intercept equation.

ART. 24. Each equation has its characteristic form. For instance, the slope equation $y = mx + b$, has the form of a first degree equation solved for y , hence if any first degree equation be solved for y , it may be compared directly with this slope equation. For example, given the equation $2y - 3x = 8$. Solving for y , $y = \frac{3}{2}x + 4$; comparing this with the typical form; $m = \frac{3}{2}$ and $b = 4$.

Hence the locus of $2y - 3x = 8$ may be constructed as follows, remembering the meaning of m and b , (Fig. 16).

First to construct any line making an angle whose tangent is $\frac{3}{2}$ with the x -axis. By trigonometry if we lay off on the y -axis a distance 3 and on the x -axis a distance 2

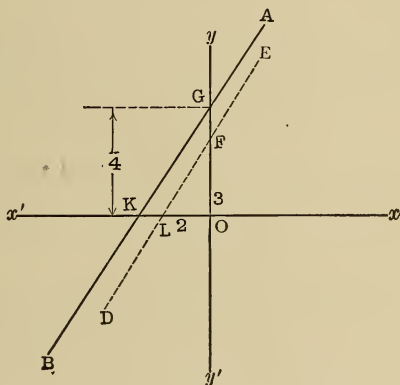

Fig. 16.

(remembering that the angle must be measured from right to left), the line DE , drawn through the points so determined makes an angle whose tangent is $\frac{3}{2}$ with the x -axis,

for $\tan. FLO = \frac{OF}{OL} = \frac{3}{2}$, hence any line drawn \parallel to ED makes the same angle. If this line is drawn through the

point G , 4 units above the origin ($b = 4$), it will be the required line, as AB in the figure.

In this case $m = \frac{3}{2}$ being positive shows that the line crosses either the 2d or 4th quadrants, and $b = 4$ being positive shows it is the 2d, hence the construction.

If m is negative, it crosses either the 1st or 3d quadrants, and the sign of b will determine which one. Hence in every case we know where to make the construction for m .

It is usually easier to make use of two points for the construction of straight lines, and these points are most easily determined on the axes, where the line crosses them.

Since the equation of a line expresses the relation between the co-ordinates of *every* point on the line, it will express the relation for these points on the line where it cuts the axes; but at these points either x or y is 0, depending on whether it is the y or the x -axis. Hence to find the inter-

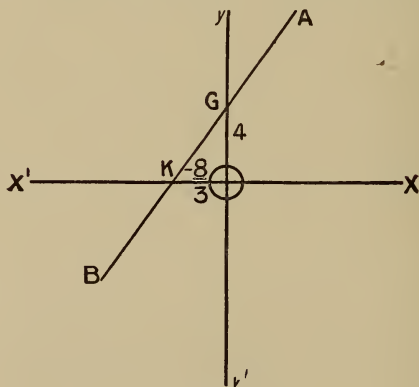

Fig. 17.

cept on the x -axis, set $y = 0$ in the equation (for at the point of crossing $y = 0$); the value of x will then be the x -intercept. Likewise, to find the y -intercept set $x = 0$ in the equation.

In the preceding example,

$$2y - 3x = 8.$$

Set $y = 0$, $0 - 3x = 8$

$$x = -\frac{8}{3} \text{ (} x \text{-intercept).}$$

Set $x = 0$ $2y - 0 = 8.$

$$y = 4 \text{ (} y \text{-intercept).}$$

Hence measuring $-\frac{8}{3}$ to the left on the x -axis and 4 upward on the y -axis, the line passes through these two points.

ART. 25. The characteristic property of the intercept equation is that the right hand member of the equation is 1, and the other member consists of the sum of two fractions whose numerators are respectively x and y . For example, to put the equation $3x - 4y = 7$ into intercept form. To make the right side 1, the equation must be divided by 7.

$$\therefore \frac{3}{7}x - \frac{4}{7}y = 1 \dots \dots \dots (1)$$

To change the left hand side to the sum of two fractions having x and y only for numerators, the equation may be written thus:

$$\frac{x}{\frac{7}{3}} + \frac{y}{-\frac{7}{4}} = 1,$$

comparing this with the type form,

$$\frac{x}{a} + \frac{y}{b} = 1,$$

evidently $a = \frac{7}{3}$ and $b = -\frac{7}{4}$.

These values may be verified by the method indicated in the last article.

Let $y = 0$ in (1), then $\frac{3}{7}x - 0 = 1$ $x = \frac{7}{3} = a.$

Let $x = 0$, then $0 - \frac{4y}{7} = 1,$

$$y = -\frac{7}{4} = b.$$

What is typical of the *normal equation*?

ART. 26. Any equation of the first degree in two variables represents a straight line.

Any equation of the first degree in two variables may be represented by

$$Ax + By = C.$$

This equation may be put in the form

$$y = -\frac{A}{B}x + \frac{C}{B} \dots \dots \dots (A')$$

which is clearly the slope equation of a straight line, whose slope is $-\frac{A}{B}$ and y -intercept, $\frac{C}{B}$; that is, $m = -\frac{A}{B}$ and

$$b = \frac{C}{B}.$$

Again: The equation $Ax + By = C$ may be put in the form $\frac{x}{\frac{C}{A}} + \frac{y}{\frac{C}{B}} = 1$ (D_1) which is the intercept form,

where $\frac{C}{A}$ and $\frac{C}{B}$ are the two intercepts.

Again: To put $Ax + By = C$ in the normal form, $x \cos \beta + y \sin \beta = p$, it is necessary to express $\cos \beta$, $\sin \beta$ and p in terms of A , B and C (Fig. 18). It has been shown above that the intercepts OM and ON (MN being the line) are $\frac{C}{B}$ and $\frac{C}{A}$.

Since $\angle OMN = \angle PON = \beta$, in the right triangle MON ,

$$\sin \beta = \frac{\frac{C}{A}}{\frac{C}{AB}} \frac{1}{\sqrt{A^2 + B^2}} = \frac{B}{\sqrt{A^2 + B^2}},$$

$$\text{and } \cos \beta = \frac{\frac{C}{B}}{\frac{C}{AB} \sqrt{A^2 + B^2}} = \frac{A}{\sqrt{A^2 + B^2}}.$$

In the similar triangles MON and PON, $OM : OP :: MN : ON$,

that is, $\frac{C}{B} : p :: \frac{C}{AB} \sqrt{A^2 + B^2} : \frac{C}{A}.$

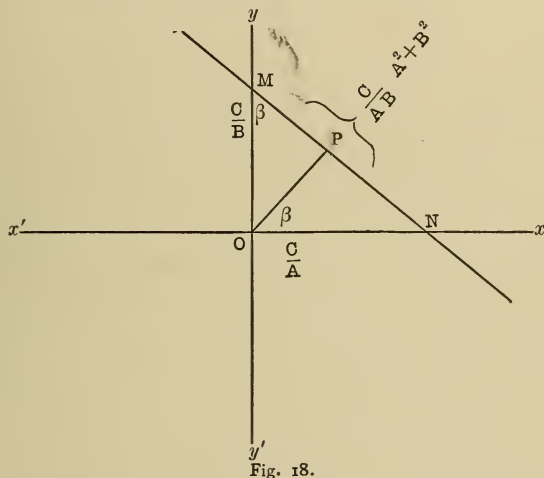

Fig. 18.

Whence $p = \frac{C}{\sqrt{A^2 + B^2}};$

substituting these values in the normal equation,

$$\frac{Ax}{\sqrt{A^2 + B^2}} + \frac{By}{\sqrt{A^2 + B^2}} = \frac{C}{\sqrt{A^2 + B^2}} \quad \therefore (E_1)^*$$

* The sign of $\sqrt{A^2 + B^2}$ is readily determined from the sign of C in $Ax + By = C$, for $p = \frac{C}{\sqrt{A^2 + B^2}}$ and since p is essentially positive, C and $\sqrt{A^2 + B^2}$ must have the same sign that this equation may be true.

which is plainly obtained from $Ax + By = C$, by dividing through by $\sqrt{A^2 + B^2}$, that is, the square root of the sum of the squares of the coefficients of x and y . For example, to put $3x + 4y = 9$ in the normal form:

In this case $\sqrt{A^2 + B^2} = \sqrt{3^2 + 4^2} = \sqrt{25} = 5$.

Dividing then by 5; $3x + 4y = 9$ becomes

$$\frac{3}{5}x + \frac{4}{5}y = \frac{9}{5},$$

where $\frac{3}{5} = \cos \beta$, $\frac{4}{5} = \sin \beta$ and $\frac{9}{5} = p$.

From the above it is seen that a general equation $Ax + By = C$ can assume any of the type forms for a straight line, hence it may always represent a straight line.

ART. 26 (a). Another method of reducing $Ax + By = C$ to the normal form, is easily derived from the following consideration:

If two equations both represent the same straight line, they cannot be independent equations, but one must be obtained from the other, by multiplying it through by some constant factor, like

$$2x - 3y = 1 \text{ and } 8x - 12y = 4.$$

That is, all the coefficients in one are the same number of times the corresponding coefficients in the other, as

$$8 = 4 \times 2, \quad 12 = 4 \times 3 \text{ and } 4 = 4 \times 1.$$

Now if $Ax + By = C$ and $x \cos \beta + y \sin \beta = p$ are to represent the same straight line,

then $\frac{A}{\cos \beta} = \frac{B}{\sin \beta} = \frac{C}{p} = n$, say;

that is, $A = n \cos \beta$ (1)

$B = n \sin \beta$ (2)

$C = np$ (3)

To find n , square (1) and (2) and add;

$$A^2 = n^2 \cos^2 \beta$$

$$B^2 = n^2 \sin^2 \beta$$

$$\frac{A^2 + B^2 = n^2 (\sin^2 \beta + \cos^2 \beta) = n^2}{}$$

[since $\sin^2 \beta + \cos^2 \beta = 1$]

or
$$n = \sqrt{A^2 + B^2}$$

$$\therefore \cos \beta = \frac{A}{\sqrt{A^2 + B^2}} \text{ [from (1)]}$$

$$\sin \beta = \frac{B}{\sqrt{A^2 + B^2}} \text{ [from (2)]}$$

$$\text{and } p = \frac{C}{\sqrt{A^2 + B^2}}.$$

For sign of $\sqrt{A^2 + B^2}$, see note in Art. 26.

ART. 27. From what was said about intersections under loci, it is clear that if two equations representing straight lines are combined as simultaneous, the resulting values of x and y are the co-ordinates of their point of intersection. For example:

Let
$$2x - 3y = 5 \quad (1)$$

$$x + 5y = 17 \quad (2)$$

be the equations of two lines.

Multiplying (2) by 2 and subtracting;

$$2x - 3y = 5$$

$$\underline{2x + 10y = 34}$$

$$13y = 29$$

$$y = \frac{29}{13}, \text{ whence } x = \frac{76}{13}.$$

That is, these two lines intersect at the point $(\frac{76}{13}, \frac{29}{13})$.

Verify by construction.

EXERCISE VI.

Straight Line.

What are the slope and intercepts of the following lines? Construct them.

1. $2y = 3x + 1.$

2. $3y + 2x + 7 = 0.$

3. $5y = -x - 6.$

4. $4y - 7x + 1 = 0.$

5. $\frac{2}{3}x - 1\frac{1}{8}y = 1\frac{1}{3}.$

6. $\frac{1}{2}y - 2x + 3 = y + \frac{1}{2}x.$

7. $x + y = 0.$

8. $y = -3.$

9. A line having the slope $\frac{2}{3}$ cuts the y -axis at the point $(0, -3)$. What is its equation?

10. What are the vertices of the triangle whose sides are $2y - x + 1 = 0$, $5y + x = 2$, $x = -2y + 1$?

11. Find the vertices of the quadrilateral whose sides are $x = y$, $y + x = 2$, $3y - 2x = 5$, $2x + y = -1$.

12. The vertices of a triangle are $(2, 0)$, $(-3, 1)$, $(-5, -4)$. What are the equations of its sides?

13. A line passes through $(-3, 2)$ and makes an angle of 45° with the x -axis. What is its equation?

14. What is the equation to the common chord of the circles $(x - 1)^2 + (y - 3)^2 = 50$ and $x^2 + y^2 = 25$?

15. The points $(6, 8)$ and $(8, 4)$ are on a circle. What is the equation of a chord joining them?

16. Which of the following points are on the line $2y = -3x - 2$; $(2, 1)$, $(-2, \frac{2}{3})$, $(2, -2)$, $(5, 2)$?

17. What is the slope of the line through $(1, -6)$ and $(-3, 5)$?

18. What slope must a line with the y -intercept -3 have that it may pass through $(-3, 2)$?

19. Show that $(1, 5)$ lies on the line joining $(0, 2)$ and $(2, 8)$.

20. Show that the line joining $(-1, \frac{2}{3})$ and $(3, -2)$ passes through the origin.

ART. 28. To find the angle between two intersecting lines from their equations.

Let $y = mx + b$, and $y = m'x + b'$, be the equations of two intersecting lines, AB and CD, in Fig. 19.

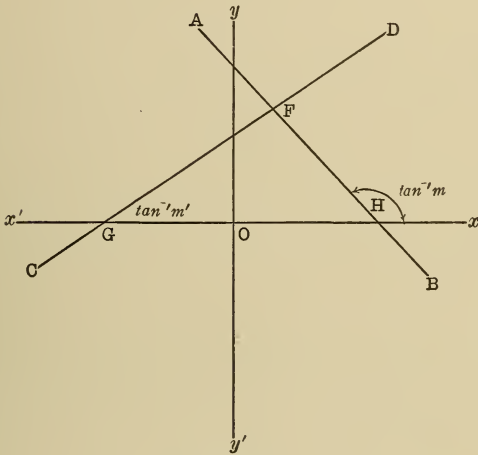

Fig. 19.

Since the slopes are m and m' respectively, $\tan FHx = m$ and $\tan FGx = m'$.

In the triangle GFH, formed by the intersecting lines and the x -axis, the external angle

$$FHx = HGF + GFH$$

or $GFH = FHx - HGF \dots \dots \dots (1)$

Call, for convenience, GFH , θ ; FHx , α ; and HGF , β .

Then by (1) $\theta = \alpha - \beta \dots \dots \dots (1a)$

Since the result must be expressed in m and m' , that is, in the tangents of α and β , the trigonometric formula for

the tangent of the difference of two angles $(\alpha - \beta)$ must be used, that is,

$$\tan(\alpha - \beta) = \frac{\tan \alpha - \tan \beta}{1 + \tan \alpha \tan \beta} = \frac{m - m'}{1 + mm'}$$

But since $\theta = \alpha - \beta$, $\tan \theta = \tan(\alpha - \beta)$.

$$\therefore \tan \theta = \frac{m - m'}{1 + mm'} \dots \dots \dots (F)$$

Which enables us to calculate θ from m and m' . For example, to find the angles between the two lines

$$\frac{2}{3}x - \frac{3}{4}y = 1$$

and

$$\frac{1}{4}x + \frac{1}{3}y = 1\frac{1}{2}$$

Putting these equations in the slope form, they become,

$$y = \frac{8}{9}x - \frac{4}{3}$$

$$y = -\frac{3}{4}x + \frac{9}{2}$$

Since two lines intersecting always form two angles, which are supplementary with each other, and since the only difference that can result in the formula

$$\tan \theta = \frac{m - m'}{1 + mm'}$$

from interchanging m and m' is a reversal of sign, that is, a change from the value of θ to its supplement, unless it is distinctly specified, that the angle of intersection is the acute or obtuse angle, it makes no difference which slope be called m or m' .

Say in above, $m = \frac{8}{9}$ and $m' = -\frac{3}{4}$.

Substituting in formula (F),

$$\tan \theta = \frac{\frac{8}{9} - (-\frac{3}{4})}{1 + (\frac{8}{9})(-\frac{3}{4})} = \frac{\frac{8}{9} + \frac{3}{4}}{1 - \frac{2}{3}} = \frac{\frac{59}{36}}{\frac{1}{3}} = \frac{59}{12} = 4.9167.$$

A table of logarithmic functions will show from this value that $\theta = 78^\circ - 30' - 12'' +$.

Make the construction and test with protractor.

ART. 29. To find condition for perpendicularity or parallelism of lines from their equations.

In formula (F),

$$\tan \theta = \frac{m - m'}{1 + mm'}$$

When the lines are \perp , $\theta = 90^\circ$, and $\therefore \tan \theta = \infty$; that is,

$$\frac{m - m'}{1 + mm'} = \infty$$

Since a fraction whose numerator is finite equals ∞ only when its denominator = 0, \therefore in this case

$$1 + mm' = 0 \text{ or } m' = -\frac{1}{m} \dots \dots (a)$$

That is, two lines are perpendicular to each other when their slopes are negative reciprocals.

For example, $3x - 2y = 5$ and $2x + 3y = 11$ are perpendiculars.

When the lines are parallel, $\theta = 0$ and hence, $\tan \theta = 0$.

That is,
$$\frac{m - m'}{1 + mm'} = 0 \text{ or } m - m' = 0.$$

Whence
$$m = m' \dots \dots \dots (b)$$

That is, their slopes are equal. These conditions enable us to readily draw a perpendicular or a parallel to a given line through a given point.

For we can find the slope of the \perp from the slope of the given line by (a) and of the parallel by (b).

Then the use of the formula for a line through a given point with a given slope will give the required equation.

Example: Find the equation of a \perp to $3x + 2y = 5$

through the point $(-1, 3)$. The slope of $3x + 2y = 5$ is $-\frac{3}{2} [y = -\frac{3}{2}x + \frac{5}{2}]$, hence the slope of the \perp is

$$-\frac{1}{-\frac{3}{2}} = \frac{2}{3}.$$

The type equation for a line with a given slope through a given point is $y - y' = m(x - x')$ (C)

Here $m = \frac{2}{3}, x' = -1$ and $y' = 3$.

Substituting; $y - 3 = \frac{2}{3}(x + 1)$

or $3y - 2x = 11$.*

ART. 30. In Art. 11 it was shown how the area of a triangle may be found when the co-ordinates of its vertices

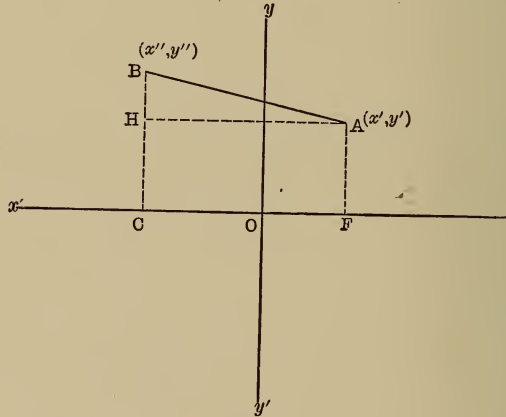

Fig. 20.

are known. By the equation for a line through two given points, the equations of the sides may now be found, and

* Comparing this equation to the \perp with the original equation it will be seen that the coefficients of x and y have simply interchanged, and one of them has changed sign, which suggests a method of writing the \perp to a line. See example at end of chapter.

from them the angles by formula (F). Also we may erect \perp 's to the sides, at any point. It will now be shown in Art. 31 how the lengths of the sides may be easily obtained.

ART. 31. *To find the length of a line between two given points.*

Let the points be (x', y') and (x'', y'') , respectively A and B in Fig. 20.

Draw AF and BC \perp to the x -axis. They are y' and y'' respectively. OF = x' and OC = $-x''$. Draw also AH \parallel to the x -axis.

Then in the right triangle, ABH, $\overline{AB}^2 = \overline{AH}^2 + \overline{BH}^2$. Call AB, L (length of AB). Then $L^2 = (\text{OF} + \text{OC})^2 + (\text{BC} - \text{AF})^2 = (x' - x'')^2 + (y'' - y')^2$ or since $(x' - x'')^2 = (x'' - x')^2$.

$$L = \sqrt{(x'' - x')^2 + (y'' - y')^2} \text{ (written symmetrically).}$$

Example : Find the distance between $(1, -\frac{2}{3})$ and $(\frac{3}{4}, \frac{1}{2})$. Call the first (x', y') and the second (x'', y'') .

$$\begin{aligned} \text{Then } L &= \sqrt{(\frac{3}{4} - 1)^2 + (\frac{1}{2} + \frac{2}{3})^2} = \sqrt{\frac{1}{16} + \frac{49}{36}} \\ &= \sqrt{\frac{205}{144}} = \frac{1}{12} \sqrt{205}. \end{aligned}$$

ART. 32. *To find the co-ordinates of a point which divides a line between two given points into segments having a given ratio.*

Say the ratio is $p : q$, the points are (x', y') and (x'', y'') (A and B in Fig. 21) and the required point P (x, y) . Draw BH, PG and AF \perp to the x -axis, and AK \parallel to the x -axis.

Then AF = y' , PG = y , and BH = y'' . Also OF = x' , OG = x , and OH = x'' . Also AP : PB :: $p : q$.

To find PG and OG in terms of (x', y') and (x'', y'')
 PG = PN + NG = PN + AF. (1)

Since the triangles APN and ABK are similar, $PN : BK :: AP : AB$,
 $AP : AB$,

that is, $PN : (BH - AF) :: AP : AB$,

or $PN : y'' - y' :: p : p + q$.

$$PN = \frac{p(y'' - y')}{p + q}.$$

$$\therefore PG = y = \frac{p(y'' - y')}{p + q} + y' \text{ [from (1)],}$$

or $y = \frac{py'' + qy'}{p + q} \dots \dots \dots (c)$

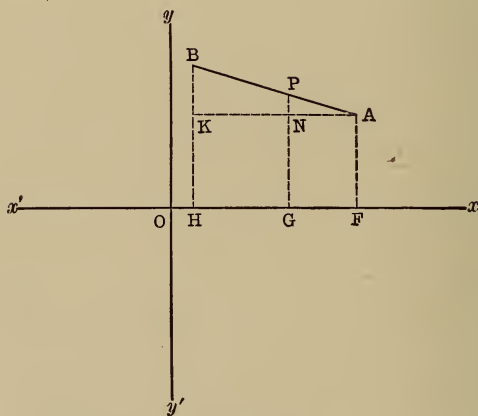

Fig. 21.

Likewise,

$$\begin{aligned} OG = OH + HG &= OH + KN = x'' + \frac{(x' - x'')q}{p + q} \\ &= \frac{px'' + qx'}{p + q} = x. \dots \dots \dots (d) \end{aligned}$$

If the point is to bisect the line then $p = q$, and the formulae become

$$y = \frac{py'' + py'}{2p} = \frac{y'' + y'}{2} \dots\dots (c')$$

and

$$x = \frac{px'' + px'}{2p} = \frac{x'' + x'}{2} \dots\dots (d')$$

ART. 33. *To find the distance from a given point to a given line.*

Since parallel lines are everywhere equally distant, the expedient suggests itself of drawing a line through the given point parallel to the given line, and determining the distance between these two lines at the most convenient point.

Again, since perpendicular distance of course is meant, the normal equation is naturally suggested, because it is determined by a perpendicular from the origin.

Clearly, since these two lines are parallel, the angle β in the equation will be the same for both, and they will differ only in the value of p . Also the difference in the values of p for the two will be their distance apart, that is, will be the distance from the given point to the given line.

Then let $x \cos \beta$ and $y \sin \beta = p$, (E), be the equation to the given line and $x \cos \beta + y \sin \beta = p'$ be the equation of a parallel line.

If this line passes through the given point (x', y') then it must be satisfied by (x', y') .

$$\therefore x' \cos \beta + y' \sin \beta = p' \dots\dots (2)$$

where

$$p' - p = \pm d \dots\dots (3)$$

[d being the required distance]. The $+$ sign will result when the point-line is farther from the origin than the given line; the minus sign, otherwise.

From (3), $p' = p \pm d$.

$$\begin{aligned} \therefore (2) \text{ becomes } x' \cos \beta + y' \sin \beta &= p \pm d. \\ \text{or } \pm d &= x' \cos \beta + y' \sin \beta - p. \quad \dots \dots (G) \end{aligned}$$

Since any equation to a straight line may be put in normal form, the above expression is always applicable. By taking advantage of the general form of normal equation,

$$\frac{Ax}{\sqrt{A^2 + B^2}} + \frac{By}{\sqrt{A^2 + B^2}} = \frac{C}{\sqrt{A^2 + B^2}} \quad \dots (E_1)$$

the formula (G) becomes easier of application. For in above equations we know that

$$\frac{A}{\sqrt{A^2 + B^2}} \text{ corresponds to } \cos \beta,$$

$$\frac{B}{\sqrt{A^2 + B^2}} \text{ corresponds to } \sin \beta,$$

and $\frac{C}{\sqrt{A^2 + B^2}}$ corresponds to p .

$$\begin{aligned} \therefore \pm d &= \frac{Ax'}{\sqrt{A^2 + B^2}} + \frac{By'}{\sqrt{A^2 + B^2}} - \frac{C}{\sqrt{A^2 + B^2}} \\ &= \frac{Ax' + By' - C}{\sqrt{A^2 + B^2}} \quad \dots \dots \dots (G') \end{aligned}$$

This formula (G') may be stated thus:

To find the distance from a given point to a given line, put the equation of the line into the form $Ax + By - C = 0$.

Substitute for x and y the co-ordinates of the given point and divide the left hand member of the equation by the square root of the sum of the squares of the coefficients of x and y . The quotient is the required distance.

Example: Find distance from $(-2, 3)$ to $3x + 4y = -9$.

Comparing $Ax + By = C$,

$$A = 3, B = 4, C = -9, \text{ and } x' = -2, y' = 3.$$

$$\therefore \pm d = \frac{Ax + By - C}{\sqrt{A^2 + B^2}} = \frac{3(-2) + 4(3) - (-9)}{\sqrt{3^2 + 4^2}}$$

$$\frac{-6 + 12 + 9}{\sqrt{25}} = \frac{15}{5} = 3.$$

Since it is merely distance wanted, the sign of d is not important.

SYSTEMS OF LINES.

ART. 34. Since parallel lines have the same slope, but different intercepts, and since the slope is determined entirely by the coefficients of x and y , the equations of parallel lines can differ only in the absolute term.

Thus $Ax + By = K$ is the equation of a line \parallel to $Ax + By = C$. Then two equations that differ only in their absolute terms represent parallel lines.

Again; since the relation between the slopes of perpendicular lines is given by the equation $m' = -\frac{1}{m}$, and m and m' are determined by dividing the coefficient of x by the coefficient of y in the equations of the perpendicular lines, if the coefficients of x and y be interchanged and the sign of one of them reversed, the relation $m' = -\frac{1}{m}$ will be satisfied. The absolute term of course will be different in the two equations.

Thus, $Bx - Ay = L$ is the equation of a line perpendicular to $Ax + By = C$.

Again; $(Ax + By - C) + K(A'x + B'y - C') = 0$ (1)
is the equation of a line through the intersection point of
 $Ax + By = C$ (2) and $A'x + B'y = C'$ (3)

For, transposing C and C' in (2) and (3),

$$Ax + By - C = 0.$$

$$A'x + B'y - C' = 0.$$

Let (x', y') represent their intersection point. Since this point is on both lines, it satisfies both equations; hence,

$$Ax' + By' - C = 0. \quad \dots \quad (4)$$

and
$$A'x' + B'y' - C' = 0 \quad \dots \quad (5)$$

multiply (5) by K and add to (4);

$$(Ax' + By' - C) + K(A'x' + B'y' - C') = 0 \quad (6)$$

If (x', y') be substituted in (1) we get (6), but we know (6) is true.

$\therefore (x', y')$ satisfies (1), and hence (1) is the equation of a line through (x', y') . Since K is an undetermined constant, we can get the equations of any number of lines through (x', y') by giving K different arbitrary values.

Example: To find equation of a line through the intersection of $3x - 5y = 6$ and $2x + y = 9$.

By above formula the equation is,

$$(3x - 5y - 6) + K(2x + y - 9) = 0.$$

If the line must also pass through another point, say $(3, -1)$, K may be determined. For substituting $(3, -1)$ for x and y ,

$$(9 + 5 - 6) + K(6 - 1 - 9) = 0,$$

whence $K = 2$ and above equation becomes

$$(3x - 5y - 6) + 2(2x + y - 9) = 0,$$

or
$$7x - 3y = 24.$$

Example: Find the line \perp to $x - 3y = 5$ through $(2, -1)$. Its equation by Art. 34 is

$$3x + y = k.$$

Since $(2, -1)$ must satisfy it, $6 - 1 = k$, or $k = 5$.

Hence $3x + y = 5$ is the required line.

EXERCISE VII.

1. Find the equation of a line whose intercepts are -3 and -5 .
2. Put the following into symmetrical form and determine their intercepts.

$$\frac{2x - 1}{3} + \frac{y + 2}{2} = -3, \quad 2x - 3y = 5,$$

$$x + y = 1.$$

3. The points $(5, 1)$, $(-2, 3)$ and $(1, -4)$ are the vertices of a triangle. Find the equations of its medians.
4. In Ex. 3, find the equations of the altitude lines.
5. What are the angles of the triangle in Ex. 3?
6. What is the equation of the line \perp to $2x - 3y = 5$ through $(-1, 2)$?
7. What is the equation of line \parallel to $2x - 3y = 5$ through $(-1, 2)$?
8. What is the angle between $y + 2x = 5$ and $3y - x = 2$?
9. The points $(8, 4)$ and $(6, 8)$ are on a circle whose centre is $(1, 3)$. What is the equation of the diameter \perp to the chord joining the two points?
10. What are the co-ordinates of the point dividing the line joining $(-3, -5)$ and $(6, 9)$ in the ratio $1 : 3$?
11. Prove that the diagonals of a parallelogram bisect each other.
12. Show that lines joining $(3, 0)$, $(6, 4)$, $(-1, 3)$ form a right triangle.
13. The vertices of a triangle are $(4, 3)$, $(2, -2)$, $(-3, 5)$. Show that the line joining the mid-points of any two sides is parallel to, and equal to $\frac{1}{2}$ of, the third side.

14. Show that $(-2, 3)$, $(4, 1)$, $(5, 3)$, and $(-1, 5)$ are the vertices of a parallelogram.

15. Show that the line joining $(3, -2)$ with $(5, 1)$ is perpendicular to the line joining $(10, 0)$ and $(13, -2)$.

16. $(2, 1)$, $(-4, -3)$, and $(5, -1)$ are the mid-points of the sides of a triangle. What are its vertices?

17. Three of the vertices of a parallelogram are $(2, 3)$, $(-4, 1)$, $(-5, -2)$. What is the fourth?

18. Find the point of intersection of the medians of the triangle whose vertices are $(1, 2)$, $(-5, -3)$, $(7, -6)$.

19. What is the distance from the point $(-2, 3)$ to the line $5x = 12y - 7$?

20. Find the distance between the sides of the parallelogram in Ex. 14.

21. Change $3x - 4y = 5$ to the normal form.

22. Find the co-ordinates of the points trisecting the line joining $(2, 1)$ and $(-3, -2)$.

23. Find the distance from $(2, 5)$ to $2x - 3y = 6$.

24. Find the altitude and base of the triangle whose vertex is $(3, 1)$ and whose base is the line joining $(\frac{5}{4}, 1)$ and $(4, -\frac{3}{2})$.

25. Find the area of the quadrilateral whose vertices are $(6, 8)$, $(-4, 0)$, $(-2, -6)$, $(4, -4)$.

26. Find the angles of the parallelogram whose vertices are $(1, 2)$, $(-5, -3)$, $(7, -6)$, $(1, -11)$.

27. One side of an equilateral triangle joins the points $(2, \sqrt{3})$ and $(-1, 4\sqrt{3})$. What are the equations of the other sides?

28. What is the equation of a line passing through the intersection of the lines $3x - y = 5$, and $2x + 3y = 7$ and the point $(-3, 5)$?

29. By Art. 34, find the equations to the medians of the triangle whose sides are $y = 2x + 1$, $y + x + 1 = 0$ and $5x = 2y + 2$.

30. Find the co-ordinates of the centre of the circle circumscribing the triangle whose vertices are $(3, 4)$, $(1, -2)$, $(-1, 2)$.

31. The base of a triangle is $2b$ and the difference of the squares of the other two sides is d^2 . Find the locus of the vertex.

CHAPTER IV.

TRANSFORMATION OF CO-ORDINATES.

ART. 35. It sometimes simplifies an equation to change the position of the axes of reference or even to change the inclination of these axes from a right to an oblique angle,

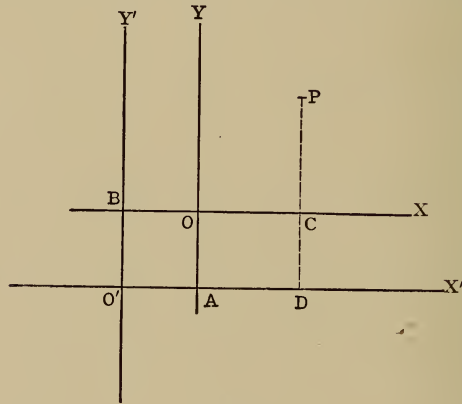

Fig. 22.

or both. To accomplish this it is only necessary to express the original co-ordinates of any point on the line in terms of new co-ordinates determined by the new axes and necessary constants.

ART. 36. *To change the position of the origin without changing the direction of the axes or their inclination.*

Let P be any point on a given line whose equation is to be transformed.

Let its co-ordinates be $x = OC$ and $y = PC$ (Fig. 22),

referred to the axes OX and OY. Let O'X' and O'Y' be new axes, such that the origin O' is at the distance O'A = a, from the axis OY, and at the distance O'B = b, from OX.

Extend PC to D ⊥ to O'X', since the direction of the axes is not changed.

Then the co-ordinates of P with respect to the new axes are x' = O'D and y' = PD.

$$\left. \begin{aligned} \text{Now, } OC = AD = O'D - O'A, \text{ or } x = x' - a \\ \text{PC} = \text{PD} - \text{CD} = \text{PD} - O'B, \text{ or } y = y' - b \end{aligned} \right\} \text{(H)}$$

It will be observed that (-a, -b) are the co-ordinates of the new origin referred to the old axes, hence the old co-ordinates are equal to the new plus the co-ordinates of the new origin, plus being taken in the algebraic sense.

Example: What will the equation $x^2 - 4x + y^2 - 6y = 3$ become, if the origin is moved to the point (2, 3), direction being unchanged?

Here, $x = x' + 2$ and $y = y' + 3$.

Substituting,

$$(x' + 2)^2 - 4(x' + 2) + (y' + 3)^2 - 6(y' + 3) = 3.$$

Expanding and collecting, $x'^2 + y'^2 = 16$ or dropping accents; $x^2 + y^2 = 16$, which indicates how an equation may be simplified by transferring the axes.

ART. 37. *To change the direction of the axes, the angle remaining a right angle.*

Let O'X'' and O'Y'' be the new axes, the axis O'X'' making the angle θ with the old X-axis, and the new origin O' being at the point (a, b).

Let the old co-ordinates of P [OD and PD in the figure] be (x, y) and the new co-ordinates [O'A and PA in the figure] be (x', y'). Draw O'C and BA || to OX and AE ⊥ to OX, then \angle s AO'C and BPA both equal θ .

$$OD = x = OF + O'C - BA \quad . \quad . \quad (1)$$

In the right triangle, $AO'C$, $O'C = O'A \cos AO'C$
 [by Trig.]. That is, $O'C = x' \cos \theta$.

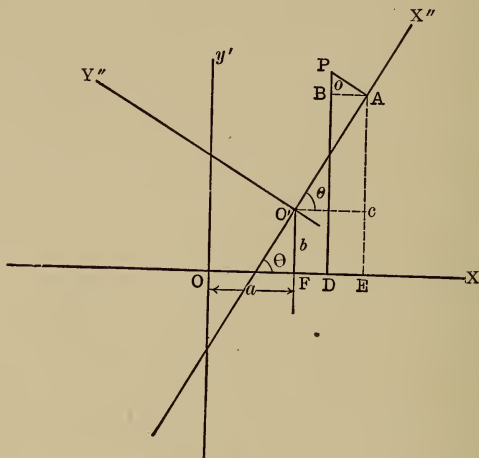

fig. 23.

Also in BPA , $BA = PA \sin BPA$ or $BA = y' \sin \theta$; and
 $OF = a$.

Substituting in (1),

$$x = a + x' \cos \theta - y' \sin \theta.$$

Again: $PD = y = O'F + AC + PB \dots (2)$

$O'F = b$; $AC = O'A \sin AO'C$ or $AC = x' \sin \theta$

and $PB = PA \cos BPA$ or $PB = y' \cos \theta$.

Substituting in (2),

$$\left. \begin{aligned} y &= b + x' \sin \theta + y' \cos \theta \\ x &= a + x' \cos \theta - y' \sin \theta \end{aligned} \right\} \dots (K)$$

If in any equation these values be substituted for x and y , the resulting equation will represent the same locus referred to axes inclined at the angle θ to the old X -axis,

with the origin at (a, b) . As a rule the origin remains the same, hence $a = 0$, $b = 0$, and (K) becomes,

$$\left. \begin{aligned} y &= x' \sin \theta + y' \cos \theta \\ x &= x' \cos \theta - y' \sin \theta \end{aligned} \right\} \dots \dots (K')$$

Example: What does equation $3x - 2y = 5$ become when the inclination of the axes is changed 30° ?

Here $\sin 30 = \frac{1}{2}$; $\cos 30 = \frac{1}{2}\sqrt{3}$

and $y = \frac{1}{2}x' + \frac{1}{2}\sqrt{3}y'$,

$$x = \frac{1}{2}\sqrt{3}x' - \frac{1}{2}y'.$$

Substituting, $3(\frac{1}{2}\sqrt{3}x' - \frac{1}{2}y') - 2(\frac{1}{2}x' + \frac{1}{2}\sqrt{3}y') = 5$

or $(\frac{3}{2}\sqrt{3} - 1)x' - (\frac{3}{2} + \sqrt{3})y' = 5.$

ART. 38. A very similar procedure in the case where the axes are changed from rectangular to oblique, and the origin moved to the point (a, b) , gives rise to the formulae,

$$\left. \begin{aligned} y &= b + x' \sin \theta + y' \sin \phi \\ x &= a + x' \cos \theta + y' \cos \phi \end{aligned} \right\} \dots \dots (J)$$

θ and ϕ being, respectively, the angles made by the new Y-axis and Y-axis with the old X-axis.

When the origin is not changed,

$a = 0$ and $b = 0$, and (J) becomes

$$\left. \begin{aligned} y &= x' \sin \theta + y' \sin \phi \\ x &= x' \cos \theta + y' \cos \phi \end{aligned} \right\} \dots \dots (J')$$

ART. 39. *To change the co-ordinates from rectangular to polar.*

The method is entirely similar to the foregoing; the finding of the simplest equational relation between the old and the new co-ordinates, using necessary constants.

In Fig. 24, let O' be the pole and $O'N$ the initial line, the co-ordinates of O' being (a, b) ; the rectangular co-ordinates of P being (x, y) and the polar, (r, θ) , respec-

tively, OB , PB , $O'P$, and $\angle PO'N$ in the figure. The angle between the initial line and the X-axis is ϕ .

It is then simply a question of expressing x and y in terms of r , θ and ϕ .

The right triangle usually supplies the simplest relations, so we draw $O'A \perp$ to PB , giving us the right triangle $PO'A$ involving r , θ and $O'A = FB$, a part of x .

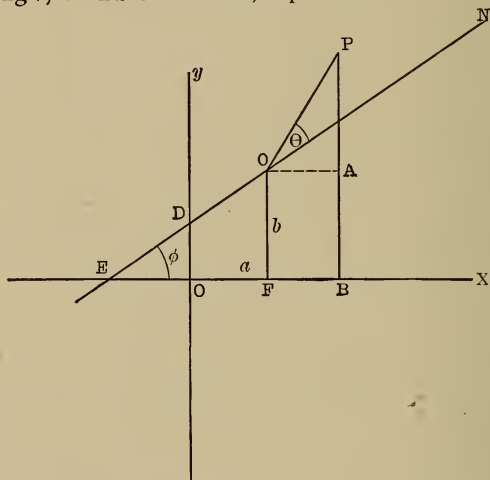

Fig. 24.

Then $OB = x = OF + FB = OF + O'A,$

or $x = a + r \cos (\theta + \phi)$

[since $O'A = O'P \cos PO'A = r \cos (\theta + \phi)$].

Also, $PB = y = AB + PA = O'F + PA,$

$y = b + r \sin (\theta + \phi)$ } (K)

or $x = a + r \cos (\theta + \phi)$ }

If the initial line is \parallel to the X-axis, $\phi = 0$ and (K) becomes

$y = b + r \sin \theta$ } (K')

$x = a + r \cos \theta$ }

If the pole is at the origin, $a = 0$ and $b = 0$

and
$$\left. \begin{aligned} y &= r \sin \theta \\ x &= r \cos \theta \end{aligned} \right\} \dots \dots \dots (K'')$$

ART. 40. To change from polar to rectangular co-ordinates.

It is here necessary only to solve equations (K''), say, for r and θ , as (K'') gives the usual form.

Thus, squaring equations (K''),

$$y^2 = r^2 \sin^2 \theta$$

$$x^2 = r^2 \cos^2 \theta.$$

Add; $x^2 + y^2 = r^2 (\sin^2 \theta + \cos^2 \theta) = r^2$
 [since $\sin^2 \theta + \cos^2 \theta = 1$].

Dividing the first equation in (K'') by the second,

$$\frac{y}{x} = \frac{r \sin \theta}{r \cos \theta} = \tan \theta \text{ or } \theta = \tan^{-1} \frac{y}{x}.$$

Example: Change to rectangular form

$$r^2 \cos 2 \theta = a^2.$$

Substituting in above equation, remembering that $\cos 2 \theta = \cos^2 \theta - \sin^2 \theta = \cos^2 \theta (1 - \tan^2 \theta)$

$$= \frac{1 - \tan^2 \theta}{\sec^2 \theta} = \frac{1 - \tan^2 \theta}{1 + \tan^2 \theta}$$

$$(x^2 + y^2) \frac{\left(1 - \frac{y^2}{x^2}\right)}{\left(1 + \frac{y^2}{x^2}\right)} = a^2,$$

or, $(x^2 + y^2) \frac{(x^2 - y^2)}{(x^2 + y^2)} = a^2,$

or, $x^2 - y^2 = a^2.$

EXERCISE VIII.

Transformation of Co-ordinates.

1. What does $y^2 = 2px$ become when the origin is moved to $\left(-\frac{p}{2}, 0\right)$ without changing the direction of the axes?

2. What does $a^2y^2 + b^2x^2 = a^2b^2$ become when the origin is moved to $\left(-\frac{a}{e}, 0\right)$, axes remaining parallel?

3. What does $y^2 + x^2 + 4y - 4x - 8 = 0$ become when origin is moved to $(2, -2)$?

4. What does $y^2 = 8x$ become when the axes are turned through 60° , origin remaining the same?

5. What does $y^2 = 2px$ become when the origin is moved to the point (m, n) ?

6. What does $a^2y^2 + b^2x^2 = a^2b^2$ become when the origin is moved to (h, k) ?

7. What does $2\sqrt{3}x + 2y = 9$ become when the axes are turned 30° , origin remaining the same?

8. What does $b^2x^2 - a^2y^2 = a^2b^2$ become when the Y-axis is turned to the right, $\cot^{-1} \frac{b}{a}$, and the X-axis to the right, $\tan^{-1} \frac{b}{a}$ [observe negative angle]?

9. Transform the polar equation $\rho = a(1 + 2 \cos \theta)$ to a rectangular equation with the origin at the pole, and the initial line coincident with the X-axis.

10. Change $(x^2 + y^2)^2 = a^2(x^2 - y^2)$ to the polar equation under the conditions of Ex. 9.

11. Change $\rho^2 = \frac{a^2}{\cos 2\theta}$ to rectangular co-ordinates, conditions remaining the same.

12. Change to rectangular co-ordinates, under same conditions,

$$\rho = a \sec^2 \frac{\theta}{2}.$$

13. $\rho = a \sin^2 \theta:$

14. $\rho = \frac{p}{1 - \cos \theta}.$

15. Change to polar co-ordinates, under same conditions,

$$y^2 = \frac{x^3}{2a - x}.$$

16. $4a^2x = 2ay^2 - xy^2.$

17. $x^{\frac{2}{3}} + y^{\frac{2}{3}} = a^{\frac{2}{3}}.$

18. $4x^2 + 9y^2 = 36.$

CHAPTER V.

THE CIRCLE.

ART. 41. *To find the equation to the circle.*

Remembering the definition for the equation of a locus, namely, that it must represent *every* point on that locus, it is only necessary as usual to find the relation between the co-ordinates of *any* point on the circle in terms of the necessary constants, which are plainly in this case, the co-ordinates of the centre and the radius.

Let P be *any* point on the circle A , the co-ordinates of whose centre are (h, k) . The condition determining the

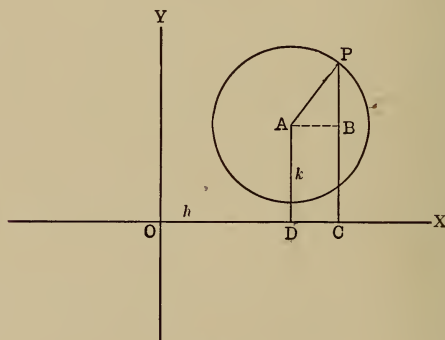

Fig. 25.

curve is that every point on it is equally distant from its centre. Draw the co-ordinates of P [PC, OC] and call them (x, y) , also $AB \perp$ to PC , forming the right triangle APB , involving r and parts of x and y .

Then $\overline{AB}^2 + \overline{PB}^2 = \overline{AP}^2 \dots \dots \dots (1)$

$AB = DC = OC - OD = x - h,$

$PB = PC - BC = PC - AD = y - k.$

Substituting in (1): $(x - h)^2 + (y - k)^2 = r^2 \dots (L)$

Performing indicated operations in (L) and collecting,

$x^2 + y^2 - 2hx - 2ky = r^2 - h^2 - k^2.$

Calling $-2h$, m ; $-2k$, n and $(h^2 + k^2 - r^2)$, R^2 for simplicity, (L) becomes,

$x^2 + y^2 + mx + ny + R^2 = 0 \dots \dots (L')$

It is evident from (L') that any equation of the second degree between two variables in which no term containing the product of the variable occurs, and where the coefficients of the second power terms are either unity or both the same, is the equation of a circle.

Putting (L') in the characteristic form (L) by adding

to both sides $\frac{m^2}{4} + \frac{n^2}{4},$

we have, $x^2 + mx + \frac{m^2}{4} + y^2 + ny + \frac{n^2}{4}$

$= \frac{m^2}{4} + \frac{n^2}{4} - R^2,$

or, $(x + \frac{m}{2})^2 + (y + \frac{n}{2})^2$

$= \frac{m^2}{4} + \frac{n^2}{4} - R^2 = \frac{m^2 + n^2 - 4R^2}{4}.$

Comparing with (L), we find

$h = -\frac{m}{2}; k = -\frac{n}{2}; r^2 = \frac{m^2 + n^2 - 4R^2}{4}.$

That is, the co-ordinates of the centre are $(-\frac{m}{2}, -\frac{n}{2}),$

and the radius is $\frac{1}{2}\sqrt{m^2 + n^2 - 4R^2}.$

Example: Find the co-ordinates of the centre and the radius of $x^2 + y^2 - 2x + 6y - 26 = 0$.

Comparing this with (L'), $x^2 + y^2 + mx + ny + R^2 = 0$, we find, $m = -2$, $n = 6$, $R^2 = -26$; hence the co-ordinates of the centre,

$$\left(-\frac{m}{2}, -\frac{n}{2}\right), \text{ are } \left(-\frac{-2}{2}, -\frac{6}{2}\right) = (1, -3),$$

and the radius

$$\begin{aligned} &= \frac{1}{2} \sqrt{m^2 + n^2 - 4R^2} \\ &= \frac{1}{2} \sqrt{4 + 36 - (-104)} \\ &= \frac{1}{2} \sqrt{144} = 6. \end{aligned}$$

This equation put in form (L) would be,

$$(x - 1) + (y + 3)^2 = 36.$$

ART. 42. As it takes three conditions to determine a circle, and as the above equations contain three arbitrary constants, if three conditions are given that will furnish three simultaneous independent equations between these constants, their values can be found, and hence the equation to the circle.

The three conditions may be, for instance, three given points on the circle, or two given points and the radius, etc.

Example: Find the equation for the circle passing through the points $(3, 3)$, $(1, 7)$, $(2, 6)$.

Taking the general equation,

$$x^2 + y^2 + mx + ny + R^2 = 0 \dots (L')$$

these three points must each satisfy this equation if it is to represent the circle passing through them, since they are on it. Hence, substituting them successively for x and y in (L'), we get three equations between m , n and R^2 as follows:

$$\left. \begin{aligned} 9 + 9 + 3m + 3n + R^2 &= 0 \\ 1 + 49 + m + 7n + R^2 &= 0 \\ 4 + 36 + 2m + 6n + R^2 &= 0 \end{aligned} \right\} \text{ or}$$

$$\begin{aligned} 3m + 3n + R^2 &= -18 \dots \dots \dots (1) \\ m + 7n + R^2 &= -50 \dots \dots \dots (2) \\ 2m + 6n + R^2 &= -40 \dots \dots \dots (3) \end{aligned}$$

Subtract (2) from (1) and (2) from (3).

$$2m - 4n = 32 \text{ or } m - 2n = 16 \dots \dots (4)$$

$$\frac{m - n = 10}{n = -6} \dots \dots (5)$$

Subtract (5) from (4);

whence $m = 4,$
and $R^2 = -12.$

Substituting these values of the constants in (L'),

$$x^2 + y^2 + 4x - 6y - 12 = 0,$$

the required equation.

ART. 43. When the origin is at the centre of the circle, h and k are both zero, and the equation becomes,

$$x^2 + y^2 = r^2 \dots \dots \dots (L'')$$

which is the form usually encountered.

ART. 44. The polar equation is readily derived from (L) by making the substitutions for transformation from rectangular to polar co-ordinates, taking the X-axis as initial line and the pole at the origin.

Then $y = \rho \sin \theta,$
 $x = \rho \cos \theta,$
 $k = \rho' \sin \theta',$
 $h = \rho' \cos \theta',$

where (ρ, θ) are the polar co-ordinates of any point on the circle and (ρ', θ') are the polar co-ordinates of the centre.

Making these substitutions in (L), we get :

$$\begin{aligned} (\rho \cos \theta - \rho' \cos \theta')^2 + (\rho \sin \theta - \rho' \sin \theta')^2 &= r^2, \\ \text{or, } \rho^2 \cos^2 \theta - 2\rho\rho' \cos \theta \cos \theta' + \rho'^2 \cos^2 \theta' + \\ \rho^2 \sin^2 \theta - 2\rho\rho' \sin \theta \sin \theta' + \rho'^2 \sin^2 \theta' &= r^2. \end{aligned}$$

Collecting, $\rho^2(\cos^2 \theta + \sin^2 \theta) + \rho'^2(\cos^2 \theta' + \sin^2 \theta') - 2\rho\rho'(\cos \theta \cos \theta' + \sin \theta \sin \theta') = r^2$.

whence

$$\rho^2 + \rho'^2 - 2\rho\rho' \cos(\theta - \theta') = r^2$$

[since $\cos^2 \theta + \sin^2 \theta = 1$

and $\cos \theta \cos \theta' + \sin \theta \sin \theta' = \cos(\theta - \theta')$].

TANGENTS AND NORMALS.

ART. 45. To find the equation of a tangent to the circle $x^2 + y^2 = r^2$. Since a line may be determined by two conditions, and a tangent must be perpendicular to a radius and touch the circle at one point, the radius being in this case the distance from the origin to the line furnishes one condition and the point of tangency another.

Knowing the equation to a line determined by two points,

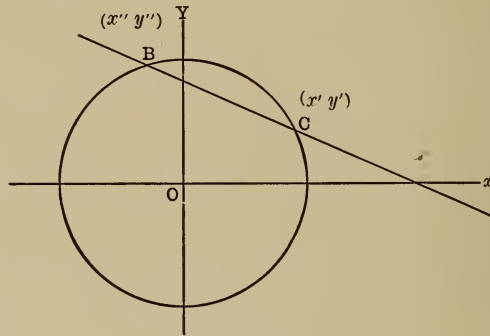

Fig. 26.

and taking these two points on the circle, we are able to convert this condition in the special case of the tangent into the point of tangency and the distance from the origin.

The equation of a line through two points (x', y') and (x'', y'') is,

$$y - y' = \frac{y'' - y'}{x'' - x'}(x - x') \quad \dots \quad (B)$$

Let these two points be B and C on circle O, then (x', y') and (x'', y'') must satisfy the equation to the circle; hence

$$x'^2 + y'^2 = r^2 \quad (2)$$

$$x''^2 + y''^2 = r^2 \quad (3)$$

If these conditions be imposed on (x', y') and (x'', y'') in equation (B), it will become a secant line to the circle.

Subtracting (2) from (3),

$$x''^2 - x'^2 + y''^2 - y'^2 = 0,$$

or, $x''^2 - x'^2 = -(y''^2 - y'^2);$

factoring, $(x'' - x')(x'' + x') = -(y'' - y')(y'' + y'),$

whence $\frac{y'' - y'}{x'' - x'} = -\frac{x'' + x'}{y'' + y'}.$

Comparing (B) with the equation to a straight line having a given slope and passing through a given point,

$$y - y' = \frac{y'' - y'}{x'' - x'} (x - x') \quad (B)$$

$$y - y' = m (x - x') \quad (C)$$

It is evident that $\frac{y'' - y'}{x'' - x'} = m$, so that the slope of a line through two given points (x', y') and (x'', y'') is represented by $\frac{y'' - y'}{x'' - x'}.$

Hence the value of $\frac{y'' - y'}{x'' - x'}, -\frac{x'' + x'}{y'' + y'}$, represents

the slope of a secant line to the circle, and if this value be substituted in (B) the result will be the equation of a secant line through the point (x', y') with the slope

$$-\frac{x'' + x'}{y'' + y'}.$$

Then if (x'', y'') is taken nearer and nearer to (x', y') the secant will approach the position of the tangent at (x', y') , and when (x'', y'') coincides with (x', y') it will be the tangent. Clearly we are at liberty to take (x'', y'') where we please, since it was any point on the circle.

$$\text{Substituting in (B), } y - y' = - \frac{x'' + x'}{y'' + y'} (x - x').$$

$$\text{Making } x'' = x' \text{ and } y'' = y',$$

$$y - y' = - \frac{2x'}{2y'} (x - x') = - \frac{x'}{y'} (x - x');$$

clearing of fractions, $yy' - y'^2 = -xx' + x'^2$;

transposing, $xx' + yy' = x'^2 + y'^2$.

$$\text{But by (2), } x'^2 + y'^2 = r^2.$$

$$\therefore xx' + yy' = r^2 \quad \dots \dots \dots (\text{T}_c)$$

Evidently it would serve as well to make (x', y') approach (x'', y'') , only the line would then be tangent at (x'', y'') . In (T_c) the accented variables always represent the point of tangency.

Example: What is the equation of the tangent to the circle $x^2 + y^2 = 10$ at $(-1, 3)$?

$$\text{Here } r^2 = 10, x' = -1 \text{ and } y' = 3.$$

$$\text{Substituting in } (\text{T}_c), -x + 3y = 10 \text{ or } 3y - x - 10 = 0.$$

Observe that (x', y') is point of tangency, not (x, y) ; never substitute the co-ordinates of point of tangency for the general co-ordinates x and y .

Again: find equation of tangent to the circle $x^2 + y^2 = 9$, from the point $(5, 7\frac{1}{2})$ outside the circle.

The equational form is, $xx' + yy' = 9 \dots \dots (1)$ and it remains to find point of tangency (x', y') . The point $(5, 7\frac{1}{2})$ being on this tangent must satisfy its equation, but it is *not* the point of tangency and must not be substituted for

(x, y) . Hence substituting in (1), $-5x' + \frac{1}{2}y' = 9$. (2)
 Also, since (x', y') is on the circle it must satisfy circle equation; that is,

$$x'^2 + y'^2 = 9 \dots \dots \dots (3)$$

Combining the simultaneous equations (2) and (3), we get,

$$x' = \frac{1.8.9}{8.5} \text{ or } -\frac{1.1.7}{8.5} \text{ y' } = -\frac{4.8}{6.5} \text{ or } \frac{1.5.6}{6.5}.$$

That is, there are two tangents, as we know by Geometry; namely, $63 \times -16y = 195$ and $4y - 3x = 15$. [Gotten by substituting these values of (x', y') in (T_c) .]

CIRCLE.

ART. 46. *To express the equation of a tangent to a circle in terms of its slope.*

Evidently the tangent being a simple straight line may be determined by its slope as well as by the point of tangency, if the slope be such that the line will touch the circle.

Hence it is a question of determining this necessary value of m . If we take the general slope equation to a straight line and find a relation between m, b and r such that the line will touch the circle of radius, r , it is sufficient.

Again, regarding the tangent as the limiting position of the secant line, as its two points of intersection with the circle approach coincidence (as in Art. 45), if we combine the slope equation of a straight line with the equation to a circle, we get in general their two points of intersection expressed in the constants they contain; if then we determine (by Algebra) the conditions these constants must fulfil among themselves that the two points of intersection shall coincide, or become one point, we have the desired result.

Let $y = mx + b$, (1) be the slope equation of a straight line, and $x^2 + y^2 = r^2$, (2) be the equation to a circle.

Regarding (1) and (2) as simultaneous, and substituting the value of y from (1) in (2), we get a quadratic in x , whose two roots are the abscissas respectively of the two points of intersection.

$$\begin{aligned} \text{We get then, } x^2 + (mx + b)^2 &= r^2, \\ x^2 + m^2x^2 + 2mbx + b^2 &= r^2, \\ (1 + m^2)x^2 + 2mbx + (b^2 - r^2) &= 0. \quad (3) \end{aligned}$$

By the theory of quadratics in algebra we know that the two values of x will be the same in (3) if it can be separated into two equal factors, that is, if it is a perfect square.

By the binomial theorem it will be a perfect square if the middle term is twice the product of the square roots of the first and last terms (like $a^2 + 2ab + b^2$).

Hence (3) will have two equal values of x (that is, equal roots) if

$$\begin{aligned} 2mbx &= 2\sqrt{(1+m^2)(b^2-r^2)}x^2, \\ \text{or squaring; if } 4m^2b^2x^2 &= 4(1+m^2)(b^2-r^2)x^2 = \\ &4(b^2x^2 - r^2x^2 + b^2m^2x^2 - r^2m^2x^2), \end{aligned}$$

$$\begin{aligned} \text{dividing by } 4x^2; \quad b^2m^2 &= b^2 - r^2 + b^2m^2 - r^2m^2, \\ b^2 &= r^2 + r^2m^2 = r^2(1+m^2), \end{aligned}$$

$$\text{or} \quad b = \pm r\sqrt{1+m^2}.$$

If this condition be fulfilled, clearly the equation of the secant $y = mx + b$ will become the equation of the tangent

$$y = mx \pm r\sqrt{1+m^2} \quad \dots \quad (T_c, m)$$

The \pm sign indicates that there will be two tangents with the same slope, as should be the case, having y -intercepts numerically equal, but opposite in sign, or vice versa.

Example: Find the value of b in $y = \frac{8}{5}x + b$, that the line may be tangent to the circle $x^2 + y^2 = 25$.

By condition formula, $b = \pm r \sqrt{1 + m^2}$,

we must have, $b = \pm 5 \sqrt{1 + \frac{64}{225}} = \pm 5 \sqrt{\frac{289}{225}} = \pm \frac{17}{3}$.

Hence the equations of the tangents are

$$y = \frac{8}{15}x + \frac{17}{3} \text{ and } y = \frac{8}{15}x - \frac{17}{3},$$

or $15y = 8x + 85$ and $15y = 8x - 85$.

ART. 47. The normal to any curve at a specified point is defined as the line perpendicular to the tangent at that point.

It is evident from geometry that the normal to the circle at any point is the radius drawn to that point.

Since the normal is perpendicular to the tangent, if the slope of the tangent is known the slope of the normal is readily found $\left(m' = -\frac{1}{m}\right)$, and as it must pass through the point of tangency, we have all the conditions necessary to determine its equation.

To find the equation of the normal to the circle $x^2 + y^2 = r^2$. Let the point of tangency be (x', y') . The equation to the tangent at this point is $xx' + yy' = r^2$, or in slope form,

$$y = -\frac{x'}{y'}x + \frac{r^2}{y'} \quad (1), \text{ and its slope is } -\frac{x'}{y'}.$$

Since the normal is perpendicular to it, its slope is

$$m' = -\frac{1}{-\frac{x'}{y'}} = \frac{y'}{x'}.$$

The equation of a line through (x', y') with slope m' is

$$y - y' = m'(x - x') \dots \dots \dots [\text{by (C)}]$$

But, m' is here equal to $\frac{y'}{x'}$,

hence the normal equation is $y - y' = \frac{y'}{x'}(x - x')$,

or $x'y - x'y' = xy' - x'y'$,

whence $y = \frac{y'}{x'}x \dots \dots \dots (N_c)$

This may be written in slope form, using the slope of the tangent, m , by substituting for $\frac{y'}{x'}$, the slope of the normal,

its value $-\frac{1}{m}$.

$$y = -\frac{x}{m},$$

or $my + x = 0$.

ART. 48. To find the length of a tangent from any point to the circle $x^2 + y^2 = r^2$.

By Art. 31, if (x_1, y_1) be the given point and (x', y') the point of tangency, the length (d) of a line between them is, $d^2 = (x_1 - x')^2 + (y_1 - y')^2 = x_1^2 + y_1^2 - 2(x_1x' + y_1y') + x'^2 + y'^2$, but if (x', y') is on the circle and (x_1, y_1) on the tangent, $x'^2 + y'^2 = r^2$ and $x_1x' + y_1y' = r^2$.
 $\therefore d^2 = x_1^2 + y_1^2 - 2r^2 + r^2 = x_1^2 + y_1^2 - r^2 \quad (D_c)$

If the origin is not at the centre of the circle, it is easy to show in exactly the same way from equation (L), that

$$d = \sqrt{(x_1 - h)^2 + (y_1 - k)^2 - r^2}.$$

ART. 49. The locus of points from which equal tangents may be drawn to two given circles is called the *radical axis* of these circles. Having the above expression for the length of a tangent to any circle, it is only necessary to

equate the two values of d for the two given circles, in order to find the equation to the radical axis.

Let the circles be,

$$\left. \begin{aligned} (x - h)^2 + (y - k)^2 &= r^2, (C_1) \\ (x - m)^2 + (y - n)^2 &= R^2, (C_2) \end{aligned} \right\} \text{ and let } (x_1, y_1)$$

be any point on the radical axis to these circles.

If d_1 and d_2 are the tangent lengths from (x_1, y_1) to (C_1) and (C_2) respectively, then,

$$d_1 = \sqrt{(x_1 - h)^2 + (y_1 - k)^2 - r^2}$$

and
$$d_2 = \sqrt{(x_1 - m)^2 + (y_1 - n)^2 - R^2}.$$

But
$$d_1 = d_2 \text{ or } d_1^2 = d_2^2.$$

$$\therefore (x_1 - h)^2 + (y_1 - k)^2 - r^2 = (x_1 - m)^2 + (y_1 - n)^2 - R^2 \quad \dots \dots \dots (3)$$

Since (x_1, y_1) substituted in the equation $(x - h)^2 + (y - k)^2 - r^2 = (x - m)^2 + (y - n)^2 - R^2$ (4) gives (3) which we know to be true, then (x_1, y_1) satisfies (4).

But (x_1, y_1) is any point on the radical axis, hence every point on that axis satisfies (4), and \therefore (4) is the equation of the radical axis to (C_1) and (C_2) .

SUBTANGENT AND SUBNORMAL.

ART. 50. The *Subtangent* for any point on a curve is the distance along the x -axis from the foot of the ordinate of the point of tangency to the intersection of the tangent with that axis.

The *Subnormal* for any point on a curve is the distance measured on the x -axis from the foot of the ordinate of the point of tangency to the intersection of the normal with that axis.

Let O [Fig. 27] be a circle, PT a tangent at P (x', y') , OP a normal at the same point, PA the ordinate (y') of P. Then AT = subtangent and OA = subnormal for P.

To find their values, it is to be observed that the subtangent $AT = OT - OA$. $OT =$ the x -intercept of the tangent, which is found as in any other straight line by setting

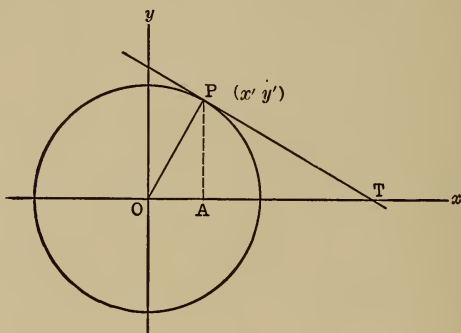

Fig. 27.

$y = 0$ in its equation ($y = 0$ being the ordinate of the point T). Then in equation (T_c) setting $y = 0$, we get $xx' + 0 = r^2$,

$$\text{or} \quad x = OT = \frac{r^2}{x'}.$$

$$\text{Also,} \quad OA = x'.$$

$$\therefore AT = \frac{r^2}{x'} - x' = \frac{r^2 - x'^2}{x'} = \frac{y'^2}{x'}.$$

The subnormal, $OA = x'$ evidently.

Example: The subtangent for the point (3, 4) on a circle is $\frac{16}{3}$. What is the equation of the circle?

$$\text{Here} \quad x' = 3, \quad y' = 4 \quad \text{and} \quad \frac{r^2 - x'^2}{x'} = \frac{16}{3}.$$

$$\text{From this last equation} \quad \frac{r^2 - 9}{3} = \frac{16}{3},$$

$$\text{whence} \quad r^2 = 25; \quad r = 5.$$

Then the equation to the circle is $x^2 + y^2 = 25$.

The origin is taken at the centre of the circle in these discussions because that is the usual form encountered, and the processes are exactly the same wherever the origin may be; the greater simplicity of results recommending this form of equation for explanation.

INTERSECTIONS.

ART. 51. By what has been said in general about the intersections of lines, it follows that if two circles intersect, the points of intersection will be readily found by combining the two equations as simultaneous. If the circles are tangent, the unknowns x and y will have each one value, or rather each will have its values coincident.

Example: Find where

$$\left. \begin{aligned} x^2 + y^2 - 4x + 2y = 0 & \text{ (1) } \\ x^2 + y^2 - 2y = 4 & \text{ (2) } \end{aligned} \right\} \text{ intersect.}$$

Subtracting (1) from (2), $4x - 4y = 4$,

or
$$x - y = 1 \quad (3)$$

Substituting value of x from (3) [$x = y + 1$] in (2),

$$\begin{aligned} y^2 + 2y + 1 + y^2 - 2y &= 4, \\ 2y^2 = 3, \quad y &= \pm \sqrt{\frac{3}{2}}, \end{aligned}$$

whence from (3), $x = 1 \pm \sqrt{\frac{3}{2}}$.

The points of intersection are then $(1 + \sqrt{\frac{3}{2}}, \sqrt{\frac{3}{2}})$ and $(1 - \sqrt{\frac{3}{2}}, -\sqrt{\frac{3}{2}})$.

Plot the figure and verify results.

(3) Is evidently the common chord, for both points satisfy it, and it is the equation of a straight line.

ART. 52. *A circle through the intersections of two given circles.*

If $\left\{ \begin{aligned} x^2 + y^2 + Ax + By + C = 0 & \text{ (1) } \\ x^2 + y^2 + A_1x + B_1y + C_1 = 0 & \text{ (2) } \end{aligned} \right\}$ are any two circles,

then
$$\begin{aligned} (x^2 + y^2 + Ax + By + C) + \\ n(x^2 + y^2 + A_1x + B_1y + C_1) = 0 \quad . . . (3) \end{aligned}$$

is the equation of a circle through the intersections of (1) and (2). For since (3) is a combination of (1) and (2) it must contain the conditions that are common to both, and the only conditions common to both, in general, are their points of intersection. (3) is the equation to a circle, for it can be put in the form,

$$(1+n)x^2 + (1+n)y^2 + (A + A_1n)x + (B + B_1n)y + (C + C_1n) = 0,$$

$$\text{or } x^2 + y^2 + \frac{A + A_1n}{1+n}x + \frac{B + B_1n}{1+n}y + \frac{C + C_1n}{1+n} = 0,$$

which is clearly the equation to a circle of the general form.

Further, (3) is satisfied by any point that satisfies both (1) and (2), for (3) is made up exclusively of (1) and (2). If a third condition be supplied, n can be determined and a definite circle through (1) and (2) results.

EXERCISE.

The Circle.

What are the co-ordinates of the centre and the radii of following circles?

1. $x^2 + y^2 - 2x + 4y = 11.$
2. $x^2 + y^2 - 6y = 0.$
3. $x^2 + y^2 + x - 3y = \frac{1}{4}.$
4. $3x^2 + 3y^2 - 8x - 2y = 102\frac{1}{3}.$
5. $x^2 + y^2 + 8x = 33.$
6. $x^2 + y^2 + 6x + 8y = -9.$
7. $4x^2 + 4y^2 - 2x + y = -\frac{1}{16}.$
8. $8x^2 + 8y^2 - 16x - 16y = 56\frac{1}{2}.$

Write the equations for the following circles, (h , k) being the co-ordinates of the centre, and r the radius.

$$9. \quad h = -2 \quad k = 3 \quad r = 4\frac{1}{2}$$

$$10. \quad h = \frac{1}{2} \quad k = 2\frac{1}{2} \quad r = 4$$

$$11. \quad h = \frac{7}{2} \quad k = -\frac{1}{3} \quad r = \frac{1}{3}^6$$

$$12. \quad h = 0 \quad k = 1 \quad r = 5$$

Find the equations for tangent and normal to following circles:

$$13. \quad x^2 + y^2 = 9 \text{ at } (-1\frac{1}{2}, 3).$$

$$14. \quad x^2 + y^2 = 6 \text{ at } (\frac{1}{3}, \frac{2}{3}).$$

$$15. \quad x^2 + y^2 = 36 \text{ at } (-3, -5).$$

$$16. \quad x^2 + y^2 = 25 \text{ at point whose abscissa is } 3.$$

$$17. \quad x^2 + y^2 = 16 \text{ at point whose ordinate is } -\sqrt{7}.$$

$$18. \quad (x-2)^2 + (y-1)^2 = 100 \text{ at } (6, 7).$$

$$19. \quad x^2 + (y-3)^2 = 25 \text{ at } (3, ?).$$

$$20. \quad x^2 + y^2 = 20 \text{ at } (?, 2).$$

Find the intersection points of the following:

$$21. \quad x^2 + y^2 = 25 \text{ and } x^2 + y^2 + 14x + 13 = 0.$$

$$22. \quad x^2 + y^2 = 6 \text{ and } x^2 + y^2 = 8x - 8.$$

$$23. \quad x^2 + y^2 - 2x - 4y - 1 = 0,$$

$$\text{and } 2x^2 + 2y^2 - 8x - 12y + 10 = 0.$$

$$24. \quad x^2 + y^2 = 4, \text{ and } x^2 + y^2 + 2x - 3 = 0.$$

25. Find the equation of the circle passing through the intersections of $x^2 + y^2 = 9$ and $3x^2 + 3y^2 - 6x + 8y = 1$, which also passes through the point $(4, -5)$.

26. Find the equation of the circle passing through the intersections of $x^2 + y^2 = 16$ and $x^2 + y^2 + 2x = 8$, which also passes through the point $(-1, 2)$.

27. Find the equation of the circle through the three points $(0, 0)$, $(2, 3)$, and $(3, 4)$. What are the co-ordinates of its centre and its radius?

28. Find the equation of the circle through the points $(2, -3)$, $(3, -4)$, and $(-2, -1)$.

29. Find the equation of the circle through the points $(-4, -4)$; $(-4, -2)$; $(-2, +2)$.

30. Find the equation of the circle passing through the origin and having x and y -intercepts respectively 6 and 8.

31. Find the equation of a circle circumscribing the triangle whose sides are $x + 2y = 0$, $3x - 2y = 6$, and $x - y = 5$.

32. Find the equation of a circle passing through $(1, 5)$ and $(4, 6)$ and having its centre on the line $y - x + 4 = 0$.

33. Find the equation of a circle through $(3, 0)$ and $(2, 7)$ whose radius is 5.

34. Find the equation of a circle having the line joining $(\frac{3}{5}, \frac{4}{5})$ to the origin as its diameter.

35. Plot by points the circular curve whose chord is $30'$ and sagitta, $9'$.

CHAPTER VI.

CONIC SECTIONS.

ART. 53. The sections of a right circular cone made by a plane intersecting it at varying angles with its axis, are called *conic sections*.

If the plane is parallel to an element of the cone the intersection is called a *parabola*.

If the plane cuts *all* the elements of one nappe of the cone, the section is called an *ellipse*.

When the plane is parallel to the base of the right cone the ellipse becomes a circle.

If the plane cuts *both* nappes of the cone, the section is called a *hyperbola*.

The hyperbola evidently has two branches (where it intersects the two nappes). All these sections are called collectively *conics*.

ART. 54. *The equation of a conic.*

From the standpoint of analytical geometry, a conic is defined as a curve, the distances of whose points from a fixed straight line, called the *directrix*, and from a fixed point, called the *focus*, bear a constant ratio to each other. This ratio is called the *eccentricity* of the conic. It can be readily proved geometrically that this definition follows from the definitions of Art. 53.

In Fig. 28 let P be any point on a conic, the *y*-axis the directrix, and F the focus. Draw AP perpendicular to the directrix, PB perpendicular to *x*-axis, and join P and F.

Call the constant ratio *e*; then $\frac{PF}{PA} = e$,

or $PF = e \cdot PA \dots \dots \dots (1)$

The co-ordinates of P are $x = OB = AP$, $y = PB$.

Represent the constant distance OF by p , then

$$\overline{PF}^2 = \overline{FB}^2 + \overline{PB}^2 \quad (2) \quad [\text{in the right triangle FPB}].$$

$$FB = OB - OF = x - p. \quad PB = y.$$

$$\text{Substituting in (2); } \overline{PF}^2 = (x - p)^2 + y^2.$$

Hence (1) becomes, $\sqrt{(x - p)^2 + y^2} = ex$.

squaring;

$$(x - p)^2 + y^2 = e^2 x^2,$$

collecting;

$$(1 - e^2)x^2 + y^2 - 2px + p^2 = 0 \quad (\alpha)$$

which is the equation for any conic in rectangular co-ordinates. The polar equation is much simpler. It may be derived by transforming (α) to polar co-ordinates, or thus;

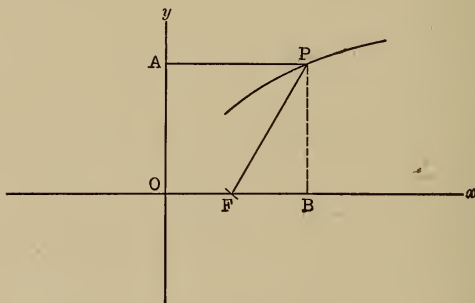

Fig. 28.

in Fig. 28, let the co-ordinates of P be $\rho = PF$, $\theta = \angle PFB$, the pole being at F and the x -axis being the initial line.

$$\text{Then } \cos PFB = \frac{FB}{FP}, \text{ or } FB = FP \cos PFB = \rho \cos \theta.$$

$$\begin{aligned} \text{But } & FB = OB - OF = AP - OF = AP - p, \\ \text{that is, } & \rho \cos \theta = AP - p, \\ \text{whence } & AP = \rho \cos \theta + p. \end{aligned}$$

Substituting in (1); $\rho = e (\rho \cos \theta + p) = e\rho \cos \theta + ep$.
 Transposing and collecting;

$$\rho (1 - e \cos \theta) = ep.$$

$$\rho = \frac{ep}{1 - e \cos \theta}.$$

THE PARABOLA.

ART. 55. The parabola is defined in analytical geometry as a curve, every point of which is equally distant from a fixed point and a fixed straight line. This definition is in entire accord with Art. 53.

Clearly from this definition $e = 1$ in the parabola, hence (α) becomes $y^2 - 2px + p^2 = 0$, or $y^2 = 2px - p^2$ (1). As it is usually convenient to have the origin at the vertex O (in Fig. 29) of the parabola, and as the vertex is midway between

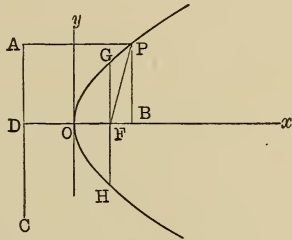

Fig. 29.

the directrix and the focus by definition, the above equation is transformed to new axes having their origin at the vertex by substituting $(x' + \frac{p}{2})$ for x and leaving y unchanged.

The co-ordinates of the new origin are $(\frac{p}{2}, 0)$ with respect to the old, hence the transformation equations are as above,

$$x = x' + \frac{p}{2} \text{ and } y = y';$$

(1) then becomes $y'^2 = 2p(x' + \frac{p}{2}) - p^2 = 2px'$,

or [dropping accents] $y^2 = 2px$ (B)

The equation is derived directly from the definition, thus:

In Fig. 29, let P be any point on the parabola; AC, the directrix, O the vertex and the origin. Draw AP \parallel and PB perpendicular to the x -axis, and let F be the focus. Then if DF be represented by p , OF will equal $\frac{p}{2}$ by definition.

$$PF = PA \dots \dots (a) \text{ [by definition of parabola].}$$

$$\begin{aligned} \text{But } PF &= \sqrt{PB^2 + FB^2} = \sqrt{PB^2 + (OB - OF)^2} \\ &= \sqrt{y^2 + \left(x - \frac{p}{2}\right)^2}, \end{aligned}$$

$$\text{and } PA = OB + DO = x + \frac{p}{2}.$$

$$\text{Substituting in (a); } \sqrt{y^2 + \left(x - \frac{p}{2}\right)^2} = x + \frac{p}{2},$$

$$\text{squaring; } y^2 + \left(x - \frac{p}{2}\right)^2 = \left(x + \frac{p}{2}\right)^2,$$

$$\begin{aligned} y^2 + \cancel{x^2} - px + \frac{p^2}{4} &= \cancel{x^2} + px + \frac{p^2}{4}. \\ y^2 &= 2px, \text{ as before.} \end{aligned}$$

From its equation, the characteristic property of a parabola is, that the ratio of the square of the ordinate of any point on it to the abscissa of that point is a constant, for $\frac{y^2}{x} = 2p$. This relation is used in physics to show that the path of a projectile is a parabola. When the curve is symmetrical to the y -axis as in Fig. 30, the equation takes the form, $x^2 = 2py$.

As an exercise prove this last equation.

ART. 56. If in the equation to the parabola (B), the abscissa of the focus (F), $x = \frac{p}{2}$ be substituted, the

resulting values of y are the ordinates of the points on the parabola immediately over and under the focus;

thus
$$y^2 = 2 p \left(\frac{p}{2} \right) = p^2,$$

whence
$$y = \pm p.$$

These two ordinates together, extending from the point

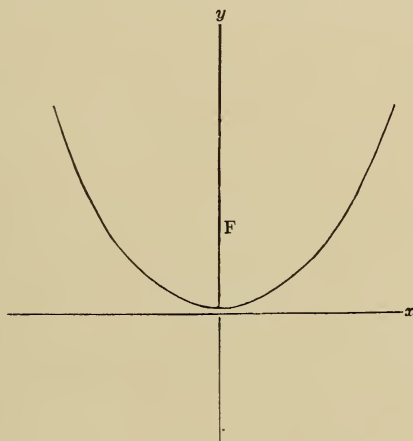

Fig. 30.

above the focus to the point below on the curve, form what is called the *latus rectum*. (GH, Fig. 29.)

The latus rectum evidently equals $2 p$, and is often called the double ordinate through the focus.

ART. 57. *To construct the parabola.*

First Method. The definition suggests a simple mechanical means of constructing the parabola. Let the edge of a T-square (AB, Fig. 31) represent the directrix; adjust a triangle to it, with its other edge on the axis, as DEC. Attach one end of a string whose length is EC, at C and the other end at F. Keeping the string taut against the

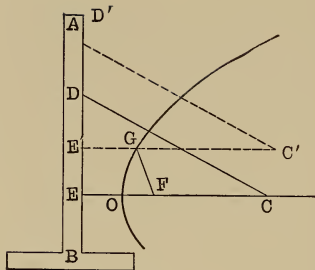

Fig. 31.

base of the triangle with a pencil (as at G) slide the ruler along the T-square and the point of the pencil will describe a parabola, for everywhere it will be equally distant from AB and F, as at G; for $EG = GF$, since $GF = E'C' - GC' = EC - GC' = E'C' - GC' = E'C' - GC'$.

Second Method: For practical purposes it is more convenient to construct by points.

Let AB (Fig. 32) be the directrix; F, the focus, and OX, the axis. Lay off as many points as desired on the axis, as C, D, E, G, H, etc.; then with F as a centre and radii successively equal to OC, OD, OE, OG, OH, etc., draw arcs above and below OX, at C, D, E, G, H, etc.; erect perpendiculars to OX intersecting these arcs at C' and C'', D' and D'', E' and E'', etc.

These points of intersection will be points on the parabola, for they are all equally distant from AB and F by the construction.

By taking these points sufficiently near together,

the parabola can be constructed as accurately as desired.

ART. 58. The polar equation to the parabola is easily derived from the general polar equation to a conic, by remembering that for a parabola, $e = 1$.

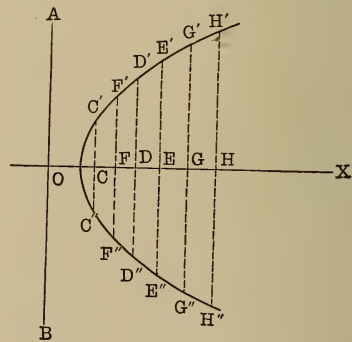

Fig. 32.

Hence
$$\rho = \frac{ep}{1 - e \cos \theta},$$

becomes
$$\rho = \frac{p}{1 - \cos \theta}.$$

ART. 59. It is evident from the form of the parabola equation, $y^2 = 2px$, that x cannot be negative without making y imaginary, hence no point on the parabola $y^2 = 2px$ can lie to the left of the Y-axis; that is, the curve has but one branch lying to the right of the Y-axis. In order to represent a parabola lying to the left of the origin, the equation would have to take the form

$$y^2 = -2px,$$

so that negative values of x would make y^2 positive.

In this latter case no positive value of x would satisfy.

EXERCISE.

What are the equations of the parabolas passing through the following points, and what is the latus rectum in each case?

1. $(1, 4)$; 2. $(2, 3)$; 3. $(\frac{1}{2}, \frac{1}{3})$; 4. $(3, -4)$.

5. The equation of a parabola is $y^2 = 4x$. What abscissa corresponds to the ordinate 7?

6. What is the equation of the chord of the parabola $y^2 = 8x$, which passes through the vertex and the negative end of the latus rectum?

7. In the parabola $y^2 = 9x$, what ordinate corresponds to the abscissa 4? Construct the following parabolas.

8. $y^2 = 6x$.

9. $x^2 = 9y$.

10. $y^2 = -4x$.

11. $x^2 = -8y$.

12. For what points on the parabola $y^2 = 8x$ will ordinate and abscissa be equal?

13. What are the co-ordinates of the points on the

parabola $y^2 = 10x$, if the abscissa equals $\frac{1}{3}$ of the ordinate?

Find intersection points of the following:

14. $y^2 = 4x$ and $y = 2x - 5$.

15. $y^2 = 18x$ and $y = 2x - 5$.

16. $y^2 = 4x$ and $x^2 + y^2 = 12$.

17. $y^2 = 16x$ and $x^2 + y^2 - 8x = 33$.

18. What does the equation $y^2 = 2px$ become when the origin is moved back along the axis to the directrix?

ART. 60. To find the equation of a tangent to the parabola.

The process employed to find the equation of a tangent to the circle is just as effective for the parabola.

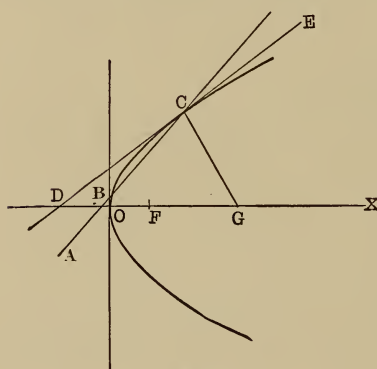

Fig. 33.

If in the equation to a line through two given points, the points be situated on a parabola, and hence are determined by its equation, the equation becomes that of a secant to the parabola. If the two points are then made to approach coincidence, the secant becomes a tangent.

In the equation to a straight line,

$$y - y' = \frac{y'' - y'}{x'' - x'} (x - x') \quad \dots \quad (B)$$

let the points (x', y') and (x'', y'') be on the parabola $y^2 = 2px$; then the two equations of condition

$$y'^2 = 2px' \quad \dots \quad (2)$$

$$y''^2 = 2px'' \quad \dots \quad (3)$$

arise from substituting these values in the parabola equation.

Subtracting (2) from (3);

$$y''^2 - y'^2 = 2px'' - 2px' = 2p(x'' - x').$$

Factoring; $(y'' - y')(y'' + y') = 2p(x'' - x')$.

Dividing through by $(y'' + y')(x'' - x')$,

$$\frac{y'' - y'}{x'' - x'} = \frac{2p}{y'' + y'}.$$

Substituting this value of the slope $\frac{y'' - y'}{x'' - x'}$, in (B);

$$y - y' = \frac{2p}{y'' + y'}(x - x') \quad (4), \text{ which is now the equa-}$$

tion of a secant line to the parabola, say ABC (Fig. 33), the point B being (x'', y'') and C being (x', y') .

If now the point B approach C, (x'', y'') approaches (x', y') and eventually $x'' = x'$ and $y'' = y'$, and the secant ABC becomes the tangent DCE.

Making $x'' = x'$, $y'' = y'$ in (4), it becomes,

$$y - y' = \frac{2p}{y'}(x - x') \quad (T_p),$$

which is the equation to the tangent DCE at the point (x', y') .

Simplifying (T_p) , $yy' - y'^2 = px - px'$

$$yy' - 2px' = px - px' \text{ [since } y'^2 = 2px'];$$

or $yy' = p(x + x')$ (T_p') [transposing, collecting and factoring].

Corollary: The tangent intercept on the X-axis, OD, is found by setting $y = 0$ in (T_p) .

$$\text{Whence} \quad 0 = p(x + x'),$$

$$x = -x'.$$

That is, the intercept is equal to the abscissa of the point of tangency, with opposite sign.

ART. 61. *The equation to the normal.*

Since the normal is perpendicular to the tangent through the same point, it has the same equation except for its slope, which is given by the relation for perpendicular lines,

$$m' = -\frac{1}{m}.$$

In the tangent equation $m = \frac{p}{y'}$.

Hence the normal equation is

$$y - y' = -\frac{y'}{p}(x - x') \quad (N_p).$$

In Fig. 33, CG is the normal at C.

ART. 62. *The equation of the tangent in terms of its slope.*

As in the case of the circle it is only necessary to determine the constants in the slope equation of a straight line, so that it has but one point in common with the parabola.

The equations to parabola and line are,

$$y^2 = 2px \quad \dots \dots \dots (1)$$

and $y = mx + b \quad \dots \dots \dots (2)$

Eliminating y , to find the intersection equation for x ,

$$\begin{aligned} (mx + b)^2 &= 2px, \\ m^2x^2 + 2mbx + b^2 &= 2px, \\ m^2x^2 + (2mb - 2p)x + b^2 &= 0 \quad \dots \quad (3) \end{aligned}$$

The two values of x in equation (3) will be the abscissas of the two points of intersection. These two points will coincide if the two values of x are the same, and this can

only occur if $m^2x^2 + (2mb - 2p)x + b^2$ is a perfect square.

By the binomial theorem this is the case, if

$$x^2 (mb - p)^2 = m^2x^2b^2$$

or $m^2b^2 - 2pmb + p^2 = m^2b^2,$

whence $2pmb = p^2$

$$b = \frac{p}{2m}.$$

Substituting this value of b in (2),

$$y = mx + \frac{p}{2m} \quad (T_{m,p}).$$

which is the equation of the tangent in terms of its slope.

ART. 63. *Equation to the normal in terms of the slope of the tangent.*

Combining $(T_{m,p})$ with the equation to the parabola, we get the co-ordinates of the point of tangency in terms of m and p . Since the normal passes through this point it is necessary to know these co-ordinates.

Combining then, $y'^2 = 2px'$

and $y' = mx' + \frac{p}{2m},$

we get $x' = \frac{p}{2m^2}, y' = \frac{p}{m}$ [x', y' being point of tangency].

The slope of the normal is $m' = -\frac{1}{m}$ [since it is perpendicular to the tangent, whose slope is m].

The equation to a line through a given point with a given slope, m' , is $y - y' = m'(x - x')$ (C)
Substituting in (C) values of x', y' , and m' ,

$$y - \frac{p}{m} = -\frac{1}{m} \left(x - \frac{p}{2m^2} \right),$$

$$m^3y + m^2x = pm^2 + \frac{p}{2} \quad (N_{p,m})$$

This equation being a cubic in m , three values of m will satisfy it, hence through any point on the parabola three normals can be drawn, having the three slopes given by the three values of m .

ART. 64. The following property of a parabola has led to its application for reflectors, making it of peculiar interest in optics.

To show that *the tangent to the parabola makes equal angles with a line from the focus to the point of tangency*

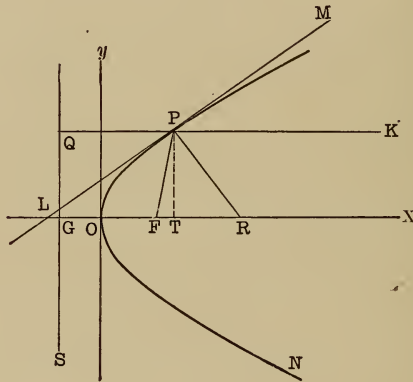

Fig. 34.

(a focal line), and a line drawn through the same point parallel to the axis of the parabola.

LM (Fig. 34) is a tangent to the parabola PON at P, intersecting the axis produced at L.

Draw the focal line FP and PK \parallel to the axis OX. Then $\angle LPM = \angle MPK$.

By Art. 60, Cor., the tangent x -intercept, $OL = -x'$ [(x', y') being point of tangency, P].

Also $OF = \frac{p}{2}$ [by structure of the parabola].

$\therefore LF = x' + \frac{p}{2}$ [the sign of x' is neglected for we want only absolute length].

Let QS be the directrix. Then

$$PF = PQ = GT = GO + OT = \frac{p}{2} + x'. \quad [OT = x']$$

$\therefore LF = PF$, and triangle LPF is isosceles;

hence $\angle LPF = \angle PLF$.

But $\angle PLF = \angle MPK$ [since PK is \parallel to LX].

$$\therefore \angle LPF = \angle MPK.$$

Let PR be the normal; then $\angle FPR = \angle RPK$ [since $\angle LPF = \angle MPK$, and $LPR = MPR$, being right angles].

Since the angles of incidence and reflection are always equal for light reflected from any surface, it follows that light issuing from a source at F would be reflected from the surface of a paraboloid mirror in parallel lines, (as PK).

ART. 65. The *diameter* of any conic may be defined as the locus of the middle points of any series of parallel chords.

A chord is understood to be a straight line joining any two points on the curve. In Fig. 35, AB being the locus of the middle points of the system of parallel chords, of which CD is one, is a diameter of the parabola PON.

ART. 66. To find the equation of a diameter in terms of the slope of its system of parallel chords.

Draw (Fig. 35) a series of chords (like CD) \parallel to each other. To determine the locus of the middle points of these chords, that is, the diameter corresponding to them.

Let the equation of any one of the chords, as CD, be

$$y = mx + b \quad (1),$$

and $y^2 = 2px$ (2) be the parabola equation.

If (1) and (2) be combined as simultaneous, the co-ordinates of C and D, the points of intersection, will be found.

First to find the abscissa, eliminating y by substituting;

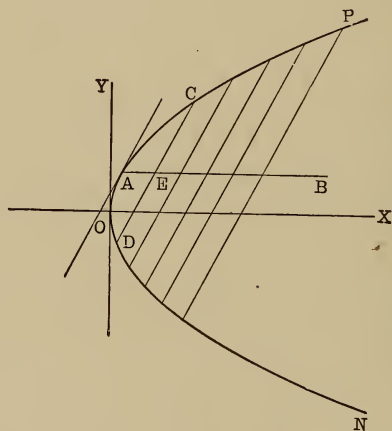

Fig. 35.

$$(mx + b)^2 = 2px,$$

$$m^2x^2 + 2mbx + b^2 = 2px,$$

$$x^2 + \frac{(2mb - 2p)x}{m^2} + \frac{b^2}{m^2} = 0 \quad \dots (3)$$

Now in a quadratic of the form $z^2 + az + b = 0$, the sum

of the two values of the unknown equals the coefficient (a) of the first power of the unknown with its sign changed.*

Hence the two values of x in (3), which are the abscissas respectively of C and D, added together, equal the coefficient of x in (3) with its sign changed.

Call the co-ordinates of C and D respectively (x' , y') and (x'' , y'').

Then
$$x' + x'' = -\frac{2mb - 2p}{m^2}.$$

Eliminating x from (1) and (2), we get from (1)

$$x = \frac{y - b}{m}.$$

Substituting in (2); $y^2 = \frac{2py - 2pb}{m}$

$$y^2 - \frac{2py}{m} + \frac{2pb}{m} = 0 \dots (4)$$

by principle cited above, $y' + y'' = \frac{2p}{m}.$

In Art. 32 it was shown that the co-ordinates of the middle point of a line joining (x' , y') and (x'' , y'') are,

$$\left(\frac{x' + x''}{2}, \frac{y' + y''}{2} \right).$$

* In $z^2 + az + b = 0$, $z = \frac{-a + \sqrt{a^2 - 4b}}{2}$

and $\frac{-a - \sqrt{a^2 - 4b}}{2}$

but $\frac{-a + \sqrt{a^2 - 4b}}{2} + \frac{-a - \sqrt{a^2 - 4b}}{2} = \frac{-2a}{2} = -a =$

coefficient of z with its sign changed.

Calling the co-ordinates of the middle point (E) of CD, (X, Y).

$$\text{Then } X = \frac{x' + x''}{2} = - \frac{mb - p}{m^2} \dots (5)$$

$$\text{and } Y = \frac{y' + y''}{2} = \frac{p}{m} \dots (6)$$

Remembering that an equation to a line must express a constant relation between the co-ordinates of every point on that line, it is clear that b cannot form a part of the equation we are seeking, for b , the y -intercept, of the chords, is different for every chord, but m is constant, since the chords are all parallel. It would ordinarily be necessary then to eliminate b between (5) and (6), but in this case (6) does not contain b and hence it represents the true equation for the diameter. We will designate it thus:

$$y = \frac{p}{m} \dots (D_p)$$

It evidently represents every point on this diameter, for CD was any chord, and hence the expression for its middle point will apply equally well to all the chords.

Cor. I: The form of this equation shows that the diameter is always parallel to the X-axis, that is, to the axis of the parabola.

Cor. II: Combining (D_p) with the parabola equation, we get the co-ordinates of their point of intersection, (A).

$$y^2 = 2px,$$

$$y = \frac{p}{m}$$

$$\text{whence } \frac{p^2}{m^2} = 2px$$

$$x = \frac{p}{2m^2}, y = \frac{p}{m}.$$

By Art. 63 it was found that the tangent whose slope is m touches the parabola at the point $\left(\frac{p}{2m^2}, \frac{p}{m}\right)$, which is A here. Hence in this case the tangent at A has the same slope, m , as the parallel chords, and is, therefore, \parallel to them.

That is, the tangent at the end of a diameter is parallel to its system of parallel chords.

Definition: The chord that passes through the focus is called the parameter of its diameter.

ART. 67. The two following propositions are interesting as applications of the principles already discussed.

To find the equation to the locus of the intersection of tangents perpendicular to each other.

It is plainly necessary to find the concordant equations of any two perpendicular tangents and by combining their equations get their intersection point.

The slope equation for any tangent is

$$y = mx + \frac{p}{2m} \quad \dots \quad (1)$$

then $y = m'x + \frac{p}{2m'}$, (2) will represent any other tangent.

If the two tangents are perpendicular to each other then $m' = -\frac{1}{m}$, and (2) becomes, $y = -\frac{x}{m} - \frac{mp}{2}$. . . (3)

Subtracting (3) from (1),

$$0 = \left(m + \frac{1}{m}\right)x + \frac{p}{2}\left(m + \frac{1}{m}\right); \text{ whence } x = -\frac{p}{2}.$$

This equation being the combination of (1) and (3) represents their intersection, that is, it is the equation of the locus of all intersections. But $x = -\frac{p}{2}$ is the equation of the directrix, hence all tangents to the parabola

that are perpendicular to each other intersect on the directrix.

ART. 68. *To find the locus of the intersection of any tangent, with the perpendicular upon it from the focus.*

The equation of any tangent line is $y = mx + \frac{p}{2m}$, (1).

The equation to a line through the focus having the slope m' is by (C), $y = m' \left(x - \frac{p}{2} \right)$, (2). [The focus being the point $\left(\frac{p}{2}, 0 \right)$]. Since (2) is perpendicular to (1), $m' = -\frac{1}{m}$,

hence (2) becomes $y = -\frac{1}{m} \left(x - \frac{p}{2} \right)$, or $y = -\frac{x}{m} + \frac{p}{2m}$, (3).

Subtracting (3) from (1), $0 = \left(1 + \frac{1}{m} \right) x$.

Whence $x = 0$,

But $x = 0$ is the equation of the Y-axis, \therefore every tangent to the parabola intersects the perpendicular upon it from the focus on the Y-axis.

ART. 69. It is sometimes desirable to express the equation of a parabola with reference to a point of tangency as origin, and with the tangent and a diameter through the point of tangency as axes.

Knowing the co-ordinates of the point of tangency in terms of the tangent slope and knowing that the diameter is \parallel to the axis, it is easy to apply the transformation equations in Art. 38.

Remembering that the new X-axis (a diameter) is parallel to the old, hence $\theta = 0$, and that $\tan \phi = m$, since the new Y-axis is a tangent and ϕ is the angle it makes with the old X-axis.

Also (a, b) the co-ordinates of the new origin become,

$$\left(\frac{p}{2m^2}, \frac{p}{m} \right)$$

Equations. $\begin{cases} x = a + x' \cos \theta + y' \cos \phi, \\ y = b + x' \sin \theta + y' \sin \phi, \end{cases}$

become, $x = \frac{p}{2m^2} + x' + y' \cos \phi$

[since $\cos \theta = \cos 0 = 1$].

$y = \frac{p}{m} + y' \sin \theta$

[since $\sin \theta = \sin \phi = 0$].

Substituting in the parabola equation,

$$y^2 = 2px,$$

we get,

$$\left(\frac{p}{m} + y' \sin \phi \right)^2 = 2p \left(\frac{p}{2m^2} + x' + y' \cos \phi \right),$$

or since $m = \tan \phi = \frac{\sin \phi}{\cos \phi},$

$$\left(\frac{p \cos \phi}{\sin \phi} + y' \sin \phi \right)^2 = 2p \left(\frac{p \cos^2 \phi}{2 \sin^2 \phi} + x' + y' \cos \phi \right),$$

~~$$\frac{p^2 \cos^2 \phi}{\sin^2 \phi} + 2py' \cos \phi + y'^2 \sin^2 \phi =$$~~

~~$$\frac{p^2 \cos^2 \phi}{\sin^2 \phi} + 2px' + 2py' \cos \phi$$~~

$$y'^2 \sin^2 \phi = 2px',$$

$$y'^2 = \left(\frac{2p}{\sin^2 \phi} \right) x' = 2px' \csc^2 \phi.$$

Since $\csc^2 \phi = \cot^2 \phi + 1 = \frac{1}{m^2} + 1,$

this may be written, $y^2 = \frac{2p}{m^2} x + 2px,$

or $y^2 = \frac{2p(1+m^2)}{m^2} x,$

where m is the tangent's slope, or the tangent of the angle it makes with the axis of the parabola.

ART. 70. The parabola is of practical interest also in its application to trajectories.

By the laws of physics a projected body describes a path, determined by the resultant of the forces of projection and of gravity acting together upon the moving body [neglecting air resistance].

In a given time, t , with a velocity, v , a body will move a space, $s = vt$. (1). Meanwhile it falls through a space

$$S = \frac{1}{2} gt^2. \quad (2) \quad [g = \text{acceleration by gravity.}]$$

Square (1) and divide by (2)

$$\frac{s^2}{S} = \frac{2v^2}{g}.$$

It is easy to see that the horizontal distance, s , which the body would move if undiverted by gravity, is like an abscissa, and that the vertical space, S , that the body would fall by action of gravity, is like an ordinate.

Also $\frac{2v^2}{g}$ is clearly a constant, (like $2p$).

Hence $\frac{s^2}{S} = \frac{2v^2}{g}$ or $s^2 = \frac{2v^2}{g} S$ is exactly like $y^2 = 2px$.

That is, the path of a projectile is a parabola, if we neglect the resistance of the air.

EXERCISE.

Find the equations of the tangents to each of the following parabolas:

1. $y^2 = 6x$ at $(\frac{8}{3}, 4)$.

2. $y^2 = 9x$ at $(4, 6)$.

3. $x^2 = 6y$ at $(6, 6)$.

4. $y^2 = -4x$ at $(-1, 2)$
 5. $y^2 = 4ax$ at (x', y') .
 6. $y^2 = 8x$ at $(4 - \frac{1}{2}, ?)$.
 7. $y^2 = -5x$ at $(? - 4)$.
 8. $y^2 = 1\frac{1}{2}x$ at $(6, ?)$.

9. Find the equation of the normal to each of the preceding parabolas.

10. Find the equations of the tangents to the parabola $y^2 = 8x$ from the exterior point $(1, 3)$.

11. Find the equation of the tangent to $y^2 = 9x$ parallel to the line $2y = 3x - 5$.

12. Find the equation of the tangent to the parabola $y^2 = 4x$ perpendicular to the line $y + 3x = 1$.

13. Find the slope equation of the tangent to the parabola $x^2 = 2py$.

14. Find the equation of the tangent to the parabola $y^2 = 8x$ from the point $(1, 4)$.

15. Find the equation to the tangent at the lower end of the latus rectum.

16. The equation to a chord of the parabola $y^2 = 4x$ is $5y - 2x - 12 = 0$. What is the equation of the diameter bisecting it?

17. What is the equation of the parabola referred to this diameter and the tangent at its extremity?

18. In the parabola $y^2 = 8x$, what is the parameter of the diameter whose equation is $y = 16$?

19. What is the equation of the parabola to which $2y = 3x + 8$ is tangent?

20. The equation of a tangent to the parabola $y^2 = 9x$ is $3y - x = 11$. What is the equation of the diameter through the point of tangency?

21. What is the equation to the chord of the parabola $y^2 = 6x$, which is bisected at the point $(3, 4)$?

22. The base of a triangle is 10 and the sum of the tangents of the base angles is 2. Show that the locus of the vertex is a parabola and find its equation.

23. The equation to a diameter of the parabola $y^2 = 9x$, is $y = -3$. Find the equation of its parameter.

24. Find the equation of the diameter to the parabola $x^2 = 2py$.

CHAPTER VII.

THE ELLIPSE.

ART. 71. The *ellipse* is defined, for the purposes of analytics, as a curve every point of which has the sum of its distances from two fixed points, called foci, always the same; that is, constant. It will be seen later that it is a conic in which $e < 1$.

The line AA' (Fig. 36), through the foci, F and F' , ter-

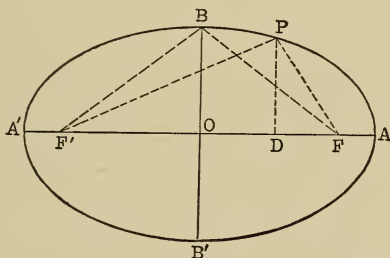

Fig. 36.

minated by the curve is called the *major or transverse axis*: the line BB' perpendicular to AA' at its middle point and terminated by the curve, is called the *minor or conjugate axis*.

ART. 72. To find the equation of the ellipse, taking the centre O (Fig. 36) as origin and the major and minor axes as co-ordinates axes. Draw PF' and PF , lines from any point, P , to the foci (focal lines).

Also PD perpendicular to AA' .

Call the co-ordinates of P , (x, y) [(OD, PD) in Fig. 36]

represent $\frac{1}{2} AA' = OA$, by a ; $\frac{1}{2} BB' = OB$, by b , PF , by r ; PF' , by r' ; $OF = \frac{1}{2} FF'$, by c .

It is required to find the relation between PD and OD , using the constants, a , b , and c . The right triangles PDF and PDF' , immediately suggest the means, as they contain together the co-ordinates (x, y) and part of the constants, and also PF and PF' whose sum is a constant by definition.

In PDF , $\overline{PF}^2 = PD^2 + \overline{DF}^2$,
 or $r^2 = y^2 + (c - x)^2$,
 $r = \sqrt{y^2 + (c - x)^2}$ (1)

In PDF' $\overline{PF'}^2 = \overline{PD}^2 + \overline{DF'}^2$,
 or $r'^2 = y^2 + (c + x)^2$
 or $r' = \sqrt{y^2 + (c + x)^2}$ (2)

By definition $r + r' = a$ constant; let us try to determine this constant. Since the points A and A' are on the ellipse they must obey this definition; hence $FA + F'A =$ this constant.

But $F'A + FA = FF' + 2 FA$.
 Also $F'A + FA = F'A' + FA' = 2 F'A' + F'F$.
 That is, $F'A + 2 FA = 2 F'A' + F'F$,

whence $FA = F'A'$.

$\therefore FA + F'A = F'F' + 2 FA = F'F + FA + F'A' = 2 a$.
 $\therefore r + r' = 2 a$.

Adding (1) and (2);

$\sqrt{y^2 + (c - x)^2} + \sqrt{y^2 + (c + x)^2} = r + r' = 2 a$ (3)

Transposing and squaring;

$y^2 + (c + x)^2 = 4 a^2 - 4 a \sqrt{y^2 + (c - x)^2} + y^2 + (c - x)^2$
 $y^2 + c^2 + 2 cx + x^2 = 4 a^2 - 4 a \sqrt{y^2 + (c - x)^2} + y^2 + c^2 - 2 cx + x^2$

whence $- 4 cx + 4 a^2 = 4 a \sqrt{y^2 + (c - x)^2}$.

Dividing by 4 and squaring again;

$$c^2x^2 - \cancel{2a^2cx} + a^4 = a^2y^2 + a^2c^2 - \cancel{2a^2cx} + a^2x^2$$

$$a^2y^2 + (a^2 - c^2)x^2 = a^2(a^2 - c^2) \dots \dots (4)$$

The form of this equation may be readily changed by expressing c in terms of a and b .

The point B being on the ellipse,

$$BF + BF' = 2a,$$

but $BF = BF'$ (since BB' is perpendicular to AA' at its middle).

$$BF = a.$$

In the right triangle BOF,

$$\overline{BF}^2 = \overline{OB}^2 + \overline{OF}^2 = b^2 + c^2,$$

that is,

$$a^2 = b^2 + c^2$$

or

$$b^2 = a^2 - c^2.$$

Substituting in (4)

$$a^2y^2 + b^2x^2 = a^2b^2 \quad (A_e).$$

The form of this equation shows that the curve is symmetrical with respect to its two axes.

Corollary: The polar equation to the ellipse is that of the conic in general,

$$\rho = \frac{ep}{1 - e \cos \theta},$$

where p = distance from directrix to focus and $e < 1$.

ART. 73. There are, by definition, two latera recta, one through each focus. Since they are ordinates, their values are found by substituting in the equation the abscissas of the foci, that is, $x = \pm c = \pm \sqrt{a^2 - b^2}$.

Substituting this value of x in (A_e) ,

$$a^2y^2 + b^2(a^2 - b^2) = a^2b^2,$$

whence

$$y^2 = \frac{b^4}{a^2} \quad y = \pm \frac{b^2}{a}.$$

That is, $2y = \text{latus rectum} = \frac{2b^2}{a}$.

ART. 74. To find the value of p in the ellipse.

In Fig. 37, $NF' = p$ in general equation to a conic.

Also $\frac{A'F'}{A'N} = e$, since A' is a point on the conic $A'B AB'$

(the ellipse), whence $A'F' = e A'N$ (1)

Also $AF' = e AN$, (2). [Since A is a point on conic.]

Add (1) and (2);

$A'F' + AF' = e (A'N + AN) = e (A'N + A'N + AA')$
 or $AA' = e (2 A'N + 2 A'O) = 2 e (A'N + A'O) = 2 e ON$,

that is, $2 a = 2 e ON$ or $ON = \frac{a}{e}$ (3)

Subtract (1) from (2);

$$AF' - A'F' = e (AN - A'N) = e AA' = 2 ae.$$

But $AF' - A'F' = AF' - FA$

$$[\text{since } FA = A'F', \text{ Art. 82}] = FF' = 2 c.$$

$$\therefore 2 ae = 2 c \text{ [since } FF' = 2 c]$$

$$c = ae \text{ (4)}$$

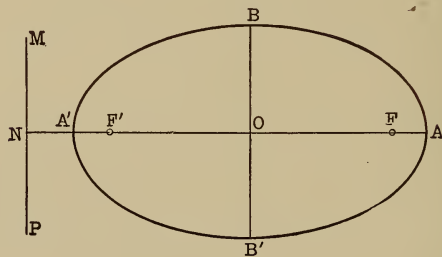

Fig. 37.

Again, $NF' = NO - OF' = \frac{a}{e} - c = \frac{a}{e} - ae$;

that is, $NF' = p = \frac{a - ae^2}{e} = \frac{a(1 - e^2)}{e}$.

Hence the polar equation to the ellipse may be written,

$$\rho = \frac{a(1 - e^2)}{1 - e \cos \theta} = [\text{taking } F' \text{ as pole}].$$

Also from (4) $e = \frac{c}{a} = \frac{\sqrt{a^2 - b^2}}{a}$.

Since $c < a$, e is always less than 1, by above equation.

This is expressed thus; the eccentricity of the ellipse is the ratio between its semi-focal distance and the semi-major axis.

ART. 75. *The sum of the focal distances of any point on the ellipse equals the major axis.*

We know by the definition of the ellipse that this sum is a constant; now we will show that this constant is the major axis from its equation.

Let P be any point on the ellipse ABA'B'. (Fig. 38.)

Draw the focal radii F'P and FP, also PD perpendicular to AA', the major axis.

The co-ordinates of P are (OD, PD), say (x, y) . In

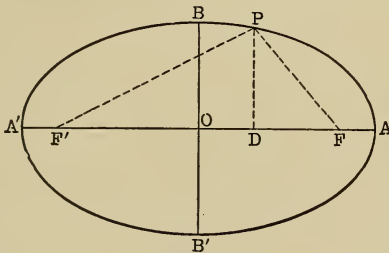

Fig. 38.

the right triangle F'PD,

$$\overline{F'P}^2 = \overline{PD}^2 + \overline{F'D}^2 \dots \dots \dots (1)$$

but $\overline{PD}^2 = y^2 = \frac{b^2}{a^2} (a^2 - x^2)$ [from (A_e)],

and $\overline{F'D} = F'O + OD = ae + x$.

Substituting these values in (1).

$$\overline{F'P^2} = \frac{b^2}{a^2} (a^2 - x^2) + (ae + x)^2 = b^2 - \frac{b^2 x^2}{a^2} + a^2 e^2$$

$$+ 2 aex + x^2 = b^2 - \frac{b^2 x^2}{a^2} + a^2 - b^2 + 2 aex + x^2,$$

$$[\text{since } e^2 = \frac{a^2 - b^2}{a^2}] = a^2 + 2 aex + \frac{(a^2 - b^2) x^2}{a^2}$$

$$[\text{adding } - \frac{b^2 x^2}{a^2} \text{ and } x^2] = a^2 + 2 aex + e^2 x^2$$

$$[\text{for } \frac{a^2 - b^2}{a^2} x^2 = e^2 x^2].$$

$$\therefore F'P = a + ex. \quad \dots \dots \dots (1)$$

By similar process in the right triangle FPD,

$$FP = a - ex \quad \dots \dots \dots (2)$$

Adding (1) and (2). $F'P + FP = 2a$.

Since $F'P$ and FP are any two focal radii, the sum of the focal radii of any point equals $2a$.

To Construct the Ellipse.

ART. 76. The definition of the ellipse, as a curve the sum of the distances of whose points is constant and always equal to the major axis, gives us the method of construction.

First Method: Take a cord the length of the major axis, and attach its extremities at the two foci with a pencil caught in the loop thus formed, and keeping the cord stretched, describe a curve. It will be an ellipse, for the sum of the distances of the pencil point from the two points of attachment (the foci) will always equal the length of the cord, that is, the major axis.

Second Method: Taking one of the foci as centre and any radius less than the major axis, describe two arcs above and below the major axis, then with the other focus as

centre and a radius equal to the difference between the major axis and the first radius, describe intersecting arcs. These points of intersection will be points on the ellipse, for the sums of their distances from the foci will equal the sum of the radii, that is, the major axis. As many points as desired may be located in this way, and the curve joining them will be an ellipse.

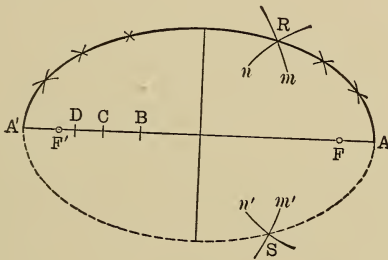

Fig. 39.

As in Fig. 39 let AA' be the major axis, F and F' the foci. Taking, say, AB as radius and F' as centre describe arcs m and m' .

Then taking $A'B$ as radius, and F as centre describe arcs n and n' ; their intersections R and S will be points on the ellipse.

Taking any desired number of points as C , D , etc., perform the same operation, thus determining any desired number of points. A smooth curve through these points will be an approximate ellipse.

ART. 76a. The two following methods of ellipse construction are used by draftsmen. The first based upon the relation between the ordinates of points on the ellipse and those on the auxiliary circles as shown in Art. 97 give a true ellipse; the second gives what is known as a circular-arc-ellipse and is only an approximation.

First Method: Let O be the centre of the ellipse; AA' the major axis; BB' the minor axis; BCB' the minor circle and ADA' the major circle. (Fig. 39a.) Take any number of points on the major circle as R, S, T , etc.

From these points draw radii and ordinates, and through the points of intersection of the radii with the minor circle, draw lines \parallel to the major axis, AA' . Where these parallels

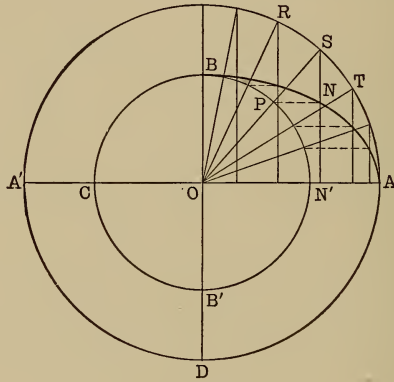

Fig. 39a.

intersect the ordinates will be points on the ellipse. The points may be made as close together as desired by drawing a great number of radii. A smooth curve joining these points will form the ellipse. Take the point S , its radius, OS , and its intersection with BCB' , P . Draw PN .

In the triangle OSN'

$$OP : OS :: N'N : SN',$$

that is, $b : a :: y : y'$, hence N is a point on the ellipse.

Second Method: This is known as the three centre method, or three point method, and is approximate only. Let AA' and BB' be the axes, intersecting at O (Fig. 39b).

Complete the rectangle BOA'D and draw the diagonal A'B. From D draw the line DE perpendicular to A'B and produce it to meet BB' at C; with C as a centre and BC as radius describe arc MN; with E (whose DC cuts AA') as centre and A'E as radius describe arc A'N'.

With O as centre and OB as radius describe arc BF,

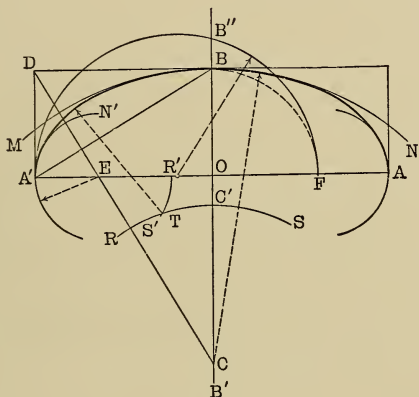

Fig. 39b.

cutting AA' at F. On A'F as diameter construct the semicircumference A'B'F, cutting B'B produced upward at B." Lay off BB'' from O toward B' to C'. With C as centre and CC' as radius describe arc RS.

Lay OB'' from A' on AA' to R'. With E as centre and ER' as radius draw arc R'S', intersecting arc RS at T. With T as a centre and suitable radius, an arc described will touch A'N' and MN, and complete the elliptic quadrant A'B. A similar construction to the right of BB' and also below AA' will complete the ellipse.

EXERCISE.

What are the axes and eccentricities of the following ellipses:

1. $9x^2 + 16y^2 = 144$. 3. $x^2 + 9y^2 = 81$.

2. $2x^2 + 4y^2 = 16$. 4. $\frac{1}{4}x^2 + \frac{4}{9}y^2 = 1$.

5. In an ellipse, half the sum of the focal distances of any point is $4'$, and half the distance between foci is $3'$. What is the ellipse equation?

6. In a given ellipse the sum of the focal radii of any point is $10''$, and the difference of the squares of half this sum and of half the distance between the foci is 16 . What is the equation to the ellipse?

7. The eccentricity of an ellipse is $\frac{4}{5}$ and the distance of the point whose abscissa is $\frac{5}{2}$ from the nearer focus is 3 . What is the equation to the ellipse?

8. The major axis of an ellipse is $34''$, and the distance between foci is $16''$. What is its equation?

9. Find equation of the ellipse, in which the major axis is $14''$ and the distance between foci = $\sqrt{3}$ times the minor axis.

10. In the ellipse $2x^2 + y^2 = 8$, what are the co-ordinates of the point, whose abscissa is twice its ordinate? What are the axes?

11. What are the co-ordinates of the point, on the ellipse $4x^2 + 16y^2 = 64$, whose ordinate is 3 times its abscissa?

12. Find the intersection points of $9x^2 + 16y^2 = 25$ and $2y - x = 3$.

13. Find the intersection points of the ellipse $16y^2 + 9x^2 = 288$, and the circle $x^2 + y^2 = 25$.

14. In Ex. 13, find the equation of the common chord.

15. Find the angle between the tangents to the ellipse

and circle of Ex. 13 at the point of intersection whose co-ordinates are both positive.

16. An arch is an arc of the ellipse whose major axis is $30'$, and its chord, which is parallel to the major axis and is bisected by the minor axis, is $24'$ long. The greatest height of the arc is $8'$. Find the equation of the ellipse and plot the arc.

17. A section of the earth through the poles is approximately an ellipse; a section parallel to the equator is a circle. What is the circumference of the Tropic of Cancer, the angle at the centre of the earth between a line to any point on it and a line to a point on the equator being $23^{\circ}-27'$?

18. If two points on a straight line, distant respectively a and b , from its extremity, be kept on the Y-axis and X-axis, respectively, as the line is moved around, the extremity will describe an ellipse, whose axes are $2a$ and $2b$.

From this, suggest a method of construction for the ellipse.

ART. 77. *Tangent to the Ellipse.*

The method of finding the tangent equation is exactly

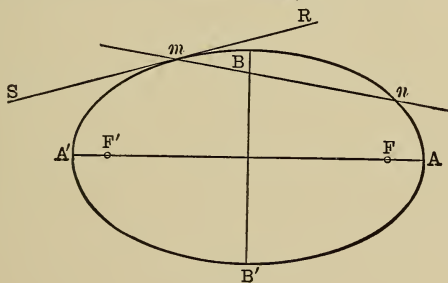

Fig. 40.

similar to that for the circle and for the parabola. Taking equation (B)

$$y - y' = \frac{y'' - y'}{x'' - x'} (x - x').$$

Let the points (x', y') , (x'', y'') be on the ellipse, $ABA'B'$, say m and n , then they must satisfy the equation

$$a^2 y'^2 + b^2 x'^2 = a^2 b^2.$$

That is, $a^2 y'^2 + b^2 x'^2 = a^2 b^2$ (1)

and $a^2 y''^2 + b^2 x''^2 = a^2 b^2$ (2)

Subtracting (2) from (1);

$$a^2 (y''^2 - y'^2) + b^2 (x''^2 - x'^2) = 0.$$

Factoring and transposing,

$$a^2 (y'' - y') (y'' + y') = -b^2 (x'' - x') (x'' + x'),$$

whence $\frac{y'' - y'}{x'' - x'} = -\frac{b^2}{a^2} \cdot \frac{(x'' + x')}{(y'' + y')}$. . . (3)

Substituting this value of $\frac{y'' - y'}{x'' - x'}$ in (B);

$$y - y' = -\frac{b^2 (x'' + x')}{a^2 (y'' + y')} (x - x') \quad . . . (4)$$

which is the equation of the secant mn (Fig. 40). If now the point n (x'', y'') is made to approach m (x', y') , when coincidence takes place, mn becomes the tangent SR , and (4) becomes the equation of the tangent, namely,

$$y - y' = -\frac{b^2 x'}{a^2 y'} (x - x'),$$

or $a^2 yy' - a^2 y'^2 = -b^2 xx' + b^2 x'^2.$

$$a^2 yy' + b^2 xx' = a^2 y'^2 + b^2 x'^2 = a^2 b^2 \text{ [by (1)]} . \quad (T_e)$$

Cor. Letting $y = 0$ in (T_e) we get the x -intercept, [OM, Fig. 41].

The subtangent, $RM = OM - OR = OM - x'.$ *

Letting $y = 0$ in (T_e)

$$a^2 yy' + b^2 xx' = a^2 b^2,$$

$$x = \frac{a^2}{x'} = OM.$$

* It is to be observed that only length is considered in estimating the subtangent and subnormal, hence it is unnecessary to regard the sign of x' .

$$\begin{aligned} \text{Then subtangent} = RM &= \frac{a^2}{x'} - x' \\ &= \frac{a^2 - x'^2}{x'} = \frac{a^2 y'^2}{b^2 x'}. \end{aligned}$$

ART. 78. *Equation of the normal.*

Since the normal is perpendicular to the tangent its slope is the negative reciprocal of the tangent slope, by the relation

$$m' = -\frac{1}{m}.$$

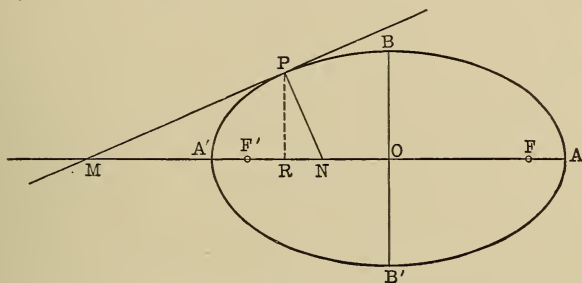

Fig. 41.

The tangent slope is $-\frac{b^2 x'}{a^2 y'}$,

hence the normal slope is $\frac{a^2 y'}{b^2 x'}$ and its equation will be

$$y - y' = \frac{a^2 y'}{b^2 x'} (x - x') \dots \dots (N_e)$$

Cor. Letting $y = 0$ in (N_e) we get the x -intercept of the normal, ON , and the subnormal,

$$RN = OR - ON = x' - ON.$$

Letting $y = 0$ in (N_e) , $y - y' = \frac{a^2 y'}{b^2 x'} (x - x')$,
 $- y' = \frac{a^2 y'}{b^2 x'} (x - x')$,
 $- b^2 x' = a^2 x - a^2 x'$,
 $x = \frac{a^2 - b^2}{a^2} x' = ON.$

Then $RN = x' - \frac{a^2 - b^2}{a^2} x' = \frac{b^2 x'}{a^2}.$

ART. 79. *Slope equation of tangent.*

Let $y = mx + c. (1)$

be a secant line to the ellipse $a^2 y^2 + b^2 x^2 = a^2 b^2 . . . (2)$

Combining (1) and (2) to find points of intersection,

$$a^2 (mx + c)^2 + b^2 x^2 = a^2 b^2.$$

$$a^2 m^2 x^2 + 2 a^2 mcx + a^2 c^2 + b^2 x^2 = a^2 b^2.$$

$$x^2 (a^2 m^2 + b^2) + 2 a^2 mcx + (a^2 c^2 - a^2 b^2) = 0.$$

Now if this secant becomes a tangent the two points of intersection, whose abscissas are given by this equation, become one point, the point of tangency. As we know the condition that this equation should have equal roots is

$$(a^2 m^2 + b^2) (a^2 c^2 - a^2 b^2) = (a^2 mc)^2,$$

or, $\cancel{a^4 m^2 c^2} - a^4 m^2 b^2 + a^2 b^2 c^2 - a^2 b^4 = \cancel{a^4 m^2 c^2}$

or $c^2 = a^2 m^2 + b^2,$
 $c = \pm \sqrt{a^2 m^2 + b^2}.$

Substituting this value of c in (1) it becomes the equation of the tangent in terms of m, a and b , that is, the slope equation of the tangent,

$$y = mx \pm \sqrt{a^2 m^2 + b^2} (T_{e, m})$$

ART. 80. *To draw a tangent to the ellipse.*

It will be observed that the tangent to the ellipse has the

same x -intercept as the tangent to a circle having the major axis for a diameter; hence to draw a tangent to an ellipse on the major axis as a diameter, construct a circle and produce the ordinate of the point of tangency to meet the circle. This point on the circle and the point of tan-

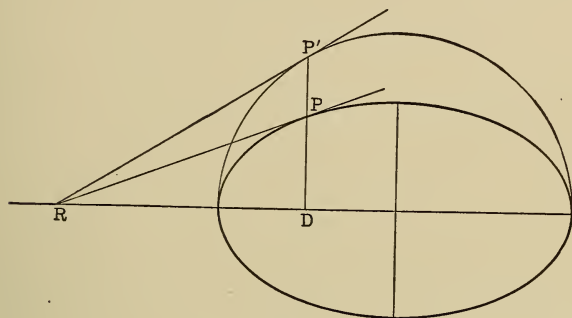

Fig. 42.

gency on the ellipse will have the same abscissa, and hence the x -intercept of the tangents to the circle at this point and to the ellipse will cut the X -axis in the same point.

Draw a tangent to the circle at this point and join the point of intersection with X -axis with the point of tangency on the ellipse. The last line will be a tangent to the ellipse at the required point. (Fig. 42.)

P = point of tangency; P' = the point in which the ordinate of P cuts the circle; R = intersection of circle-tangent, RP' , with the axis.

Then RP is the tangent to the ellipse.

Supplemental Chords.

ART. 81. The chords drawn from any point on an ellipse to the extremities of the major axis are called *supplemental chords*.

Let AP and A'P be supplemental chords of the ellipse ABA'B' for the point P. (Fig. 43.)

The equation of AP through the point A [whose co-ordinates are (a, 0)], and having say the slope m, is [by (C)]

$$y = m(x - a) \dots \dots \dots (1)$$

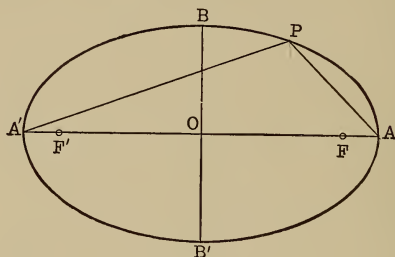

Fig. 43.

The equation of A'P, through the point A' [whose co-ordinates are (0, -a)], and having slope m', is [by (C)]

$$y = m'(x + a) \dots \dots \dots (2)$$

multiplying (1) and (2) together,

$$y^2 = mm'(x^2 - a^2) \dots \dots \dots (3)$$

which expresses the relation between the co-ordinates of P, their intersection. But P (x, y) is on the ellipse, hence

$$a^2 y^2 + b^2 x^2 = a^2 b^2,$$

or

$$y^2 = \frac{b^2}{a^2} (a^2 - x^2) \dots \dots \dots (4)$$

Since (3) and (4) express the relation between the co-ordinates of the same point, they must be the same equation; hence comparing; $mm' = -\frac{b^2}{a^2}$, which gives the relation between the slopes of supplemental chords.

ART. 82. *The equation to a diameter of the ellipse.*

The diameter it will be remembered, is the locus of the middle points of a system of parallel chords.

Let RS be any one of a system of parallel chords of the ellipse ABA'B' (Fig. 44), and T its middle point.

Let $y = mx + c$ (1) be the equation of RS, and $a^2 y^2 + b^2 x^2 = a^2 b^2$ (2) be the ellipse equation. Combining (1)

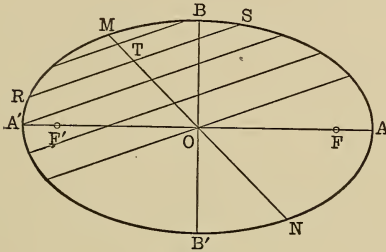

Fig. 44.

and (2), we get an equation whose roots are the abscissas of R and S, respectively, if y be eliminated; an equation whose roots are the ordinates of R and S, if x be eliminated.

$$\begin{aligned} \text{Eliminating } y; \quad & a^2 (mx + c)^2 + b^2 x^2 = a^2 b^2, \\ & a^2 m^2 x^2 + 2 a^2 mxc + a^2 c^2 + b^2 x^2 = a^2 b^2, \\ & x^2 + \frac{2 a^2 mc}{a^2 m^2 + b^2} x + a^2 c^2 - a^2 b^2 = 0 \quad \dots (3) \end{aligned}$$

Let the two roots of (3) be represented by x' and x'' .

Then by the structure of a quadratic,

$$x' + x'' = - \frac{2 a^2 mc}{a^2 m^2 + b^2}.$$

Calling the ordinates of T, (X, Y),

then $X = \frac{x' + x''}{2} = - \frac{a^2 mc}{a^2 m^2 + b^2}$. (4) [by Art. 32]

Eliminating x from (1) and (2)

$$\begin{aligned} & a^2 y^2 + b^2 \left(\frac{y - c}{m} \right)^2 = a^2 b^2, \\ & a^2 y^2 + \frac{b^2 y^2 - 2 b^2 yc + b^2 c^2}{m^2} = a^2 b^2, \end{aligned}$$

$$a^2 m^2 y^2 + b^2 y^2 - 2 b^2 y c + b^2 c^2 = a^2 b^2 m^2,$$

$$y^2 - \frac{2 b^2 c}{a^2 m^2 + b^2} y + b^2 c^2 - a^2 b^2 m^2 = 0 \dots (5)$$

Calling the two roots of (5), y' and y'' ,

$$\therefore y' + y'' = + \frac{2 b^2 c}{a^2 m^2 + b^2},$$

and $Y = \frac{y' + y''}{2} = \frac{+ b^2 c}{a^2 m^2 + b^2} \dots (6)$

Since c is a variable it must be eliminated between (4) and (6), for we must express the relations between the co-ordinates of these mid-points of the chords in terms of constants to get the true equation of their locus.

Divide (6 by (4)

$$\frac{Y}{X} = \frac{\frac{+ b^2 c}{a^2 m^2 + b^2}}{\frac{- a^2 m c}{a^2 m^2 + b^2}} = \frac{- b^2}{a^2 m}.$$

That is, $y = - \frac{b^2}{a^2 m} x \dots (D_e)$

is the equation of the diameter, since it expresses a constant relation between the co-ordinates of the mid-point of RS, and RS stands for any one of the parallel chords. m is a constant because the chords being parallel, all have the same slope. The form of this equation shows that the diameters pass through the centre, since the constant or intercept term is missing.

Since this equation represents any diameter whatever, it follows that any chord passing through the centre of the ellipse is a diameter, and hence bisects a system of parallel chords.

Conjugate Diameters.

ART. 83. It will be observed in the equation

$$y = -\frac{b^2}{a^2 m} x, \text{ the slope is } -\frac{b^2}{a^2 m}; \text{ that is, it is } -\frac{b^2}{a^2}$$

divided by m , the slope of the chords.

If a system of chords be drawn parallel to this first diameter, their slope will be that of this diameter, namely,

$$-\frac{b^2}{a^2 m}.$$

The slope of the diameter corresponding to this system of chords, by above principle, will be

$$-\frac{b^2}{a^2} \div -\frac{b^2}{a^2 m} = m.$$

Hence the equation of this second diameter is $y = mx$.

The slope of this diameter is the same as that of the chords of the first; hence each is parallel to the chords of the system determining the other.

Such diameters are called *conjugate diameters* and are determined by the condition that the product of their slopes is,

$$-\frac{b^2}{a^2}, \text{ for } (m) \times -\left(\frac{b^2}{a^2 m}\right) = -\frac{b^2}{a^2}.$$

ART. 84. *Tangents at the extremities of conjugate diameters.*

The farther a chord is from the centre the nearer together are its intersection points with the ellipse, evidently. Since the mid-point must always lie between these intersection points, in any system of parallel chords, as the chords are drawn farther and farther from the centre, their points of intersection and their mid-points approach coincidence, and eventually the chord becomes a tangent at the end of the diameter, when the three points coincide.

Hence the tangent at the extremity of a diameter is parallel to its system of chords.*

This fact, combined with the relation between conjugate diameters, defined in Art. 83, enables us to readily draw any pair of conjugate diameters. Thus: at the extremity of any diameter draw a tangent to the ellipse; the diameter drawn parallel to this tangent will be the conjugate to the given diameter.

ART. 85. *The co-ordinates of extremities of a diameter in terms of the co-ordinates of the extremity of its conjugate.*

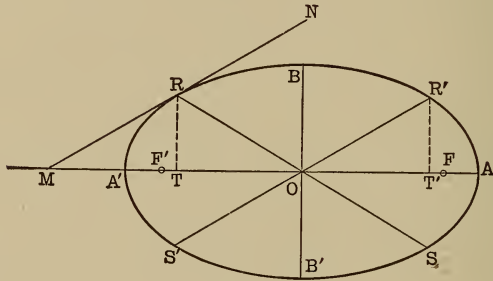

Fig. 45.

Let the co-ordinates of R, the extremity of the diameter RS, be (x', y') , to find the co-ordinates of R'.

* This may be shown analytically thus: The intersection point of the diameter $y = -\frac{b^2}{a^2 m} x$ with the ellipse $a^2 y^2 + b^2 x^2 = a^2 b^2$, is (by combining equations) $x' = \frac{a^2 m}{\sqrt{a^2 m^2 + b^2}}$ and $y' = \frac{b^2}{\sqrt{a^2 m^2 + b^2}}$. Taking the tangent equation (T*), and substituting these points for points of tangency, we find the slope of the tangent at x', y' , to be m , but this is the slope of the chords. Hence tangent is parallel to chords.

Draw the tangent (Fig. 45) MN at R. By (T_e) its equation is $a^2 yy' + b^2 xx' = a^2 b^2$.

Then the equation to R'S' is $a^2 yy' + b^2 xx' = 0$. . (1) since it is parallel to MN, but is drawn through the origin, hence the absolute term is 0.

Let the ellipse equation be as usual, $a^2 y + b^2 x^2 = a^2 b^2$.

Since (x', y') is on the ellipse;

$$a^2 y'^2 + b^2 x'^2 = a^2 b^2 \quad (2)$$

If (1) and the ellipse equation be combined, the resulting values of x and y will be the co-ordinates of the points of intersection, R' and S'.

Substituting the value of y from (1) in the ellipse equation,

$$a^2 \left(\frac{-b^2 xx'}{a^2 y'} \right)^2 + b^2 x^2 = a^2 b^2,$$

$$\frac{b^4 x^2 x'^2}{a^2 y'^2} + b^2 x^2 = a^2 b^2,$$

$$\frac{b^2 x^2 (b^2 x'^2 + a^2 y'^2)}{a^2 y'^2} = a^2 b^2,$$

$$\frac{b^2 x^2 (a^2 b^2)}{a^2 y'^2} = a^2 b^2.$$

[Since $b^2 x'^2 + a^2 y'^2 = a^2 b^2$,
point (x', y') being on the ellipse.]

Whence $x^2 = \frac{a^2 y'^2}{b^2},$

$$x = \pm \frac{ay'}{b},$$

and hence $y = \mp \frac{bx'}{a}$

ART. 86. *The length of conjugate diameters.* Draw the co-ordinates RT and R'T' of R and R' respectively, R and

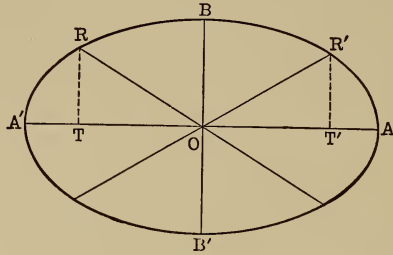

Fig. 46.

R' being the extremities of conjugate diameters. (Fig. 46.)

Then if (OT, RT) are $(-x', y')$, $(OT', R'T')$ are

$$\left(+\frac{ay'}{b}, +\frac{bx'}{a} \right) \text{ [by Art. 85].}$$

In the right triangles ORT and $OR'T'$

$$\overline{OR}^2 = \overline{OT}^2 + \overline{RT}^2 = x'^2 + y'^2,$$

$$\text{and } \overline{OR'}^2 = \overline{OT'}^2 + \overline{R'T'}^2 = \frac{a^2 y'^2}{b^2} + \frac{b^2 x'^2}{a^2}.$$

$$\begin{aligned} \text{Then } \overline{OR}^2 + \overline{OR'}^2 &= x'^2 + \frac{a^2 y'^2}{b^2} + y'^2 + \frac{b^2 x'^2}{a^2} \\ &= \frac{b^2 x'^2 + a^2 y'^2}{b^2} + \frac{a^2 y'^2 + b^2 x'^2}{a^2} \\ &= \frac{a^2 b^2}{b^2} + \frac{a^2 b^2}{a^2} = a^2 + b^2, \end{aligned}$$

for since (x', y') is on the ellipse,

$$b^2 x'^2 + a^2 y'^2 = a^2 b^2.$$

That is, the sum of the squares of any pair of conjugate diameters equals the sum of the squares of the axes.

Conjugate diameters are usually represented by a' and b' , hence

$$a'^2 + b'^2 = a^2 + b^2.$$

ART. 87. *Major and Minor auxiliary circles.*

The circle drawn with the major axis as diameter is called the *major auxiliary circle*.

The circle drawn with the minor axis as diameter is called the *minor auxiliary circle*.

Fig. 47, the angle AOP' , is called the *eccentric angle* of the point P on the ellipse.

The eccentric angle of any point is determined, thus:

Produce the ordinate of the given point to meet the

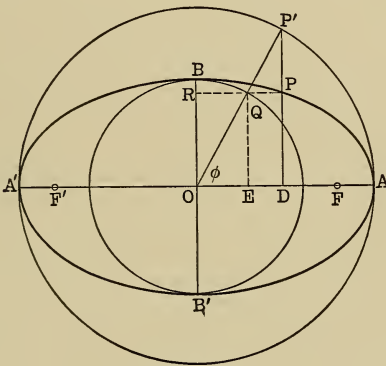

Fig. 47.

major auxiliary circle, and join this point of meeting on the circle with the centre. The angle between this joining line and the axis, measured positively, is the eccentric angle of the point on the ellipse.

ART. 88. *Relation between the ordinates of a point on the ellipse and of the corresponding point on the major circle.*

The equation of the major circle, whose radius is a , is,

$$x^2 + y^2 = a^2 \text{ or } y^2 = a^2 - x^2 \quad \dots (1)$$

Call the Point P' (Fig. 47), (x', y'') and P , (x', y') .
(Observe P' and P have the same abscissa.)

Then from (1), $y''^2 = a^2 - x'^2$ (2)

Also, $y'^2 = \frac{b^2}{a^2} (a^2 - x'^2)$ (3) (from ellipse equation).

Dividing (3) by (2)

$$\frac{y'^2}{y''^2} = \frac{b^2}{a^2},$$

or $\frac{y'}{y''} = \frac{b}{a}$, whence $y' : y'' :: b : a$.

That is, *the ordinate of any point on the ellipse is to the ordinate of the corresponding point on the major circle as the semi-minor axis is to the semi-major axis.*

Corollary: Let Q be the intersection of OP' with the minor circle. (Fig. 47.)

Join Q with P .

Then since $OQ = b$ and $OP' = a$,

and $y' : y'' :: b : a$, $y' : y'' :: OQ : OP'$,

or $PD : P'D :: OQ : OP'$.

That is, QP is parallel to OD ; that is, parallel to the axis.

Hence RP , the prolongation of QP , to BB' , equals $OD =$ the abscissa of P and P' . This furnishes another method of drawing an ellipse. Thus:

Draw two concentric circles with the given major and minor axes as diameters, respectively, in their normal positions.

Make any angle with the major axis, as AOP' in Fig. 47, and let the terminal line of this angle intersect the two circles in Q and P' respectively. Then the intersection of the abscissa, RQ , of Q , with the ordinate, $P'D$, of P' , will be a point on the ellipse.

This may be shown by analytical means, purely, for (Fig. 47) in the right triangle $OP'D$, $OD (= RP) = OP' \cos P'OD = a \cos \phi$, say, and drawing QE perpendicular to OA ,

$PD = QE = OQ \sin QOD = b \sin \phi$, but the values $a \cos \phi$ for x , and $b \sin \phi$ for y , satisfy the ellipse equation.

$$a^2 y^2 + b^2 x^2 = a^2 b^2,$$

thus,
$$a^2 b^2 \sin^2 \phi + a^2 b^2 \cos^2 \phi = a^2 b^2,$$

$$\sin^2 \phi + \cos^2 \phi = 1,$$

hence since OD and PD are the co-ordinates of P , P is on the ellipse.

ART. 89. *The eccentric angle between two conjugate diameters.*

Let the eccentric angle of R' (x', y'), the extremity of $R'S'$ be θ , and that of R ($-\frac{ay'}{b}, +\frac{bx'}{a}$), the extremity of

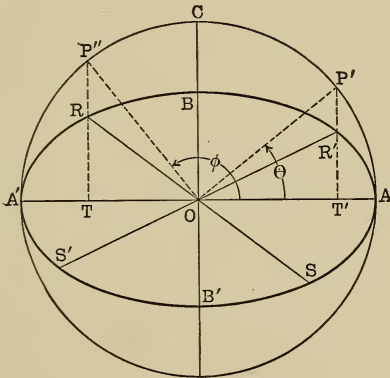

Fig. 48.

the conjugate diameter RS be ϕ . (Fig. 48.)

Then in the right triangle $OP'T'$,

$$\cos P'OT' = \frac{OT'}{OP'} \quad \text{or} \quad \cos \theta = \frac{x'}{a} \quad \dots (1)$$

In the right triangle $OP''T$,

$$\sin P''OT = \frac{P''T}{OP''} = \frac{\frac{a}{b}(RT)}{OP''} \quad \dots [\text{Art. 88}]$$

$$\text{That is, } \sin (180 - \phi) = \sin \phi = \frac{\frac{a}{b} \left(\frac{bx'}{a} \right)}{a} = \frac{x'}{a} \quad \dots (2)$$

$\therefore \sin \phi = \cos \theta$ from (1) and (2),

whence by trigonometry,

$$\phi = 90 + \theta \quad \text{or} \quad \phi - \theta = 90^\circ.$$

That is, the difference between the eccentric angles of the extremities of conjugate diameters is a right angle.

ART. 90. By combining the slope equations of two perpendicular diameters, both expressed in terms of the slope of one, it is readily proved, as was done under the parabola, *that the locus of their intersections is a circle, whose equation is*

$$x^2 + y^2 = a^2 + b^2.$$

This circle is called the *director circle*. Also by a similar process it can be shown that the *major auxiliary circle is the locus of the intersection of a tangent with the perpendicular to it from a focus*.

ART. 91. The ellipse possesses a physical property, somewhat similar to that possessed by the parabola, namely:

The angle formed by the focal radii to any point on the ellipse is bisected by the normal at that point.

Geometry tells us that the bisector of an angle of a triangle divides the opposite side into segments proportional

to the other sides, hence, if we can prove (Fig. 49) that $F'N : FN :: F'P : FP$ our proposition is established. It is necessary then to find values for these four lines in the same terms. ON the x -intercept of the normal was found in Art. 78, Cor. to be

$$\frac{a^2 - b^2}{a^2} x' = e^2 x',$$

where x' is the point of tangency.

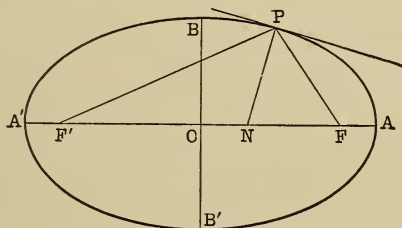

Fig. 49.

Let P (Fig. 49) be (x', y') .

Then $F'N = F'O + ON = c + e^2x' = ae + e^2x'$,

(since $\frac{c}{a} = e$, hence $c = ae$),

$$FN = FO - ON = ae - e^2x'.$$

$$F'P = a + ex' \text{ and } FP = a - ex' \quad \dots \text{ (Art. 75)}$$

But
$$\frac{ae + e^2x'}{ae - e^2x'} = \frac{e(a + ex')}{e(a - ex')} = \frac{a + ex'}{a - ex'}.$$

$$\therefore \frac{F'N}{FN} = \frac{F'P}{FP} \text{ or } F'N : FN :: F'P : FP.$$

It follows from the law of reflection for vibrations, that if light or sound issue from one focus of an ellipse it will be reflected to the other focus.

ART. 92. *The area of an ellipse.*

Draw the major auxiliary circle to the ellipse $ABA'B'$, and construct rectangles as indicated in Fig. 50.

Then the area of one of these rectangles in the ellipse as $mnpo$ is

$$\text{Area } mnpo = mn \times pn.$$

Let the points on the ellipse beginning with p be (x', y') , (x'', y'') , (x''', y''') , etc., and the corresponding points on the circle beginning with R , be (x', y_1) , (x'', y_2) , (x''', y_3) etc.

Then $\text{Area } mnpo = (x' - x'') y'$.

The corresponding rectangle in the circle

$$mnRS = (x' - x'') y_1,$$

$$\therefore \frac{mnRS}{mnpo} = \frac{(x' - x'') y_1}{(x' - x'') y'} = \frac{y_1}{y'} = \frac{a}{b}.$$

As this is a typical rectangle each circle rectangle is to each ellipse rectangle as a is to b , hence by the law of continued proportion, the sum of all the circle rectangles is to the sum of all the ellipse rectangles as a is to b .

As the above expression is independent of the size or

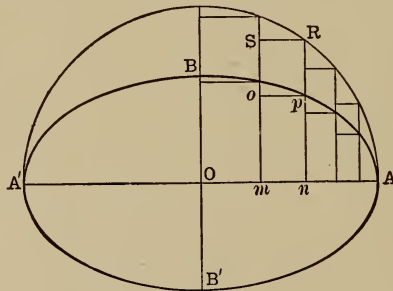

Fig. 50.

number of the individual rectangles the relation is the same when the number of rectangles becomes infinite. But

in this latter case the sum of the areas approach, respectively, the area of the circle and that of the ellipse; hence, finally,

$$\frac{\text{Area of the circle}}{\text{Area of the ellipse}} = \frac{a}{b}.$$

That is, area of the ellipse = $\frac{b}{a}$ times the area of the circle, but area of the circle = πa^2 .

$$\therefore \text{area of the ellipse} = \frac{b}{a} \cdot \pi a^2 = \pi ab.$$

EXERCISE.

What are the equations of the tangents to the following ellipses?

1. $x^2 + 4y^2 = 4$ at the point $(\frac{3}{2}, \frac{4}{5})$.
2. $4x^2 + 9y^2 = 36$ at the point $(1, \frac{4}{3}\sqrt{2})$.
3. $x^2 + 3y^2 = 3$ at the point $(\frac{3}{2}, \frac{1}{2})$.
4. $9x^2 + 25y^2 = 225$ at the point $(4, ?)$.
5. $25x^2 + 100y^2 = 25$ at the point $(?, 2)$.
6. $x^2 + 2y^2 = 18$ at the point $(?, 1)$.
7. Find the normal equation to the above ellipses.
8. What are the equations of the tangents to the ellipse $16y^2 + 9x^2 = 144$ from the point $(-3, 2)$?
9. What is the equation of the tangent to the ellipse $9x^2 + 25y^2 = 225$, that is parallel to the line $10y - 8x = 5$.
10. What is the equation of the tangent to the ellipse $x^2 + 4y^2 = 4$, that is parallel to the line $\frac{y}{2} - \sqrt{3x} = 1$?
11. What is the equation of the tangent to the ellipse $4x^2 + 9y^2 = 36$, which is perpendicular to the line $y - 3x = 5$?

12. The subtangent to an ellipse, whose eccentricity is $\frac{2}{3}$, is $\frac{5}{3}$. What is the ellipse equation?

13. Find the equation of the tangent to the ellipse in terms of the eccentric angle of the point of tangency.

14. What are the equations of the tangents to the ellipse $\frac{x^2}{9} + \frac{y^2}{4} = 1$, which form an equilateral triangle with the axis?

15. What is the equation of the diameter conjugate to $4y + 9x = 0$?

16. $2y + x = 12$ and $2y = \frac{1}{4}x + 3$ are supplementary chords of an ellipse. What is its equation?

17. The middle point of a chord of the ellipse $25y^2 + 9x^2 = 225$ is $(-5, 1)$. What is the equation of the chord?

18. The equation of a diameter to the ellipse $4x^2 + 16y = 64$ is $4y = x$. What is the equation of a tangent to the ellipse at the end of its conjugate diameter?

19. Find the equation of the tangents to the ellipse $\frac{9y^2}{16} + \frac{x^2}{9} = 1$, which makes an angle whose tangent is 3 with the line $2y = x - 1$.

20. Find the equation of the normal to the ellipse $x^2 + 4y^2 = 4$, which is parallel to the line $4x - 3y = 7$.

21. Show that the product of the perpendiculars from the two foci upon any tangent is equal to the semi-minor axis.

22. Find the equation to a diameter of the ellipse $\frac{x^2}{16} + \frac{y^2}{9} = 1$, which bisects the chords parallel to

$3x - 5 = 9$.

23. Find the locus of the centres of circles which pass through $(1, 3)$ and are tangent internally to $x^2 + y^2 = 25$.

24. The equation of an ellipse is $\frac{x^2}{169} + \frac{y^2}{144} = 1$.

What is the eccentric angle of the point whose abscissa is 5?

25. Find the equation of the chord joining the points of contact [called the chord of contact] of two tangents to the ellipse $9x^2 + 16y^2 = 144$, drawn from (4, 3) outside the ellipse.

26. Find the locus of the vertices of triangles having the base $2a$, and the product of the tangents of their base angles $\frac{b^2}{c^2}$.

27. The minor axis of an ellipse is 18, and its area is equal to that of a circle whose diameter is 24. What is the equation to the ellipse?

28. The axes of an ellipse are 40 and 50. Find the areas of the two parts into which it is divided by the latus rectum.

CHAPTER VII.

THE HYPERBOLA.

ART. 93. The characteristic of the hyperbola is that the difference of the distances of any point on it, from two fixed points, is constant.

With this understanding of the locus,

To find the equation of the hyperbola.

In Fig. 51, let P be any point on the hyperbola, whose foci are F and F' , and whose vertices are A and A' . Draw the ordinate PD and the focal radii PF , PF' .

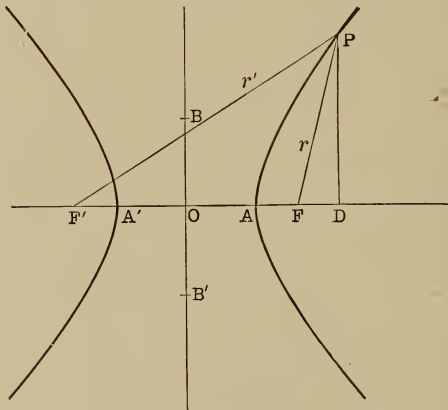

Fig. 51.

The co-ordinates of P are (OD, PD) , say (x, y) , O being the origin, OX and OY the axes. It is our problem then

to find a relation between OD and PD, and the right triangle PFD suggests itself.

In the right triangle PFD, $\overline{PF}^2 = \overline{PD}^2 + \overline{FD}^2$ (1). Call the focal distance OF, c . Then (1) becomes,

$$\overline{PF}^2 = r^2 = y^2 + (x - c)^2 \text{ [since } \overline{FD} = \overline{OD} - \overline{AF} = x - c]$$

$$r = \sqrt{y^2 + (x - c)^2} \dots \dots \dots (2)$$

In the right triangle F'PD,

$$\overline{PF'}^2 = \overline{PD}^2 + \overline{F'D}^2. \text{ That is, } r'^2 = y^2 + (x + c)^2 \text{ [since } \overline{F'D} = \overline{OD} + \overline{OF'} = x + c]$$

or $r' = \sqrt{y^2 + (x + c)^2}$ (3)

By definition, $r' - r = \text{constant} = 2m$, say.

Subtract (2) from (3);

$$\sqrt{y^2 + (x + c)^2} - \sqrt{y^2 + (x - c)^2} = r' - r = 2m.$$

Transpose and square;

$$y^2 + x^2 + 2cx + c^2 = 4m^2 + 4m\sqrt{y^2 + (x - c)^2}$$

$$+ y^2 + x^2 - 2cx + c^2$$

Transpose, collect, and divide by 4;

$$m\sqrt{y^2 + (x - c)^2} = cx - m^2.$$

Square again;

$$m^2 y^2 + m^2 x^2 - 2m^2 cx + m^2 c^2 = c^2 x^2 - 2m^2 cx + m^4.$$

Collect; $m^2 y^2 + (m^2 - c^2) x^2 = m^2 (m^2 - c^2) \dots \dots (4)$

To determine m it is only necessary to give x and y suitable values, or rather to give y the particular value 0, since the above equation is true for every point on the hyperbola. We then get the value of x for the vertex, since the ordinates of A and A' are 0.

Letting $y = 0$ in $\dots \dots \dots (4)$

$$(m^2 - c^2) x^2 = m^2 (m^2 - c^2),$$

whence $x^2 = m^2$; $x = \pm m$,

but x here equals OA or OA' ,

hence $m = OA$ or OA' ;

that is, $2m =$ the major axis AA' . As in the ellipse

call AA' , $2a$; then $m = a$, and (4) becomes,

$$a^2 y^2 + (a^2 - c^2) x^2 = a^2 (a^2 - c^2) \dots (5)$$

Let $c^2 - a^2 = b^2$,

which by analogy with the ellipse we may call the minor axis. We shall see that this is justified. Then (5) becomes,

$$a^2 y^2 - b^2 x^2 = -a^2 b^2,$$

or $b^2 x^2 - a^2 y^2 = a^2 b^2 \dots (A_h)$

ART. 94. A glance at the figure will show that c is greater than a , hence the eccentricity,

$$e = \frac{c}{a} \text{ is } > 1.$$

Then in the polar equation for conics

$$\rho = \frac{ep}{1 - e \cos \theta} \quad (e > 1),$$

and by a process exactly like that in Art. 84, this becomes for the hyperbola,

$$\rho = \frac{a(e^2 - 1)}{1 - e \cos \theta}.$$

ART. 95. To determine b in the figure of a hyperbola.

The relation $c^2 - a^2 = b^2$, immediately suggests a right triangle with c as hypotenuse. Hence with c as radius and A or A' as centre, describe arcs cutting the y -axis at B and B' , OB will equal

b , or $BB' = 2b$; for $\overline{OB}^2 = \overline{AB}^2 - \overline{OA}^2 = c^2 - a^2$.

It is plain that the curve does not cut this minor axis, for, setting $x = 0$ [the abscissa of any point on $BB' = 0$] in (A_4) ,

$$-a^2 y^2 = a^2 b^2$$

$$y = \pm \sqrt{-b^2} = \pm b \sqrt{-1}, \text{ an imaginary value.}$$

ART. 96. To find the length of the focal radii for any point, r and r' .

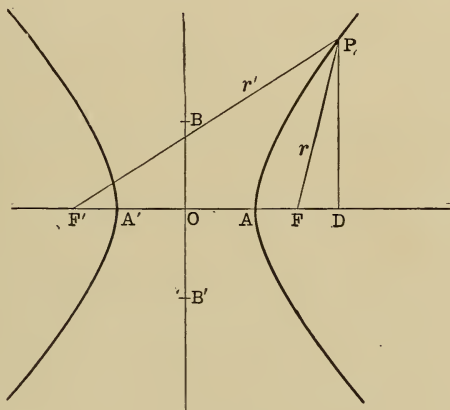

Fig. 51a.

In Fig. 51a, $\overline{PF}^2 = r^2 = \overline{PD}^2 + \overline{FD}^2$,

or
$$r^2 = y^2 + (x - c)^2 \dots \dots \dots (1)$$

Since
$$e = \frac{c}{a}, \quad c = ae,$$

and (1) becomes,

$$r^2 = y^2 + (x - ae)^2,$$

or
$$r^2 = y^2 + x^2 - 2aex + a^2 e^2.$$

By (A_h), $y^2 = \frac{b^2}{a^2} (x^2 - a^2)$.

$$\begin{aligned} \therefore r^2 &= \frac{b^2 x^2}{a^2} - b^2 + x^2 - 2 a e x + a^2 e^2 \\ &= \frac{b^2 x^2 + a^2 x^2}{a^2} - b^2 - 2 a e x + a^2 e^2 \\ &= \frac{(a^2 + b^2) x^2}{a^2} - b^2 - 2 a e x + a^2 e^2. \quad [\text{But } a^2 + b^2 \\ &= c^2] = \frac{c^2 x^2}{a^2} - b^2 - 2 a e x + a^2 e^2 = e^2 x^2 - 2 a e x \\ &+ a^2 e^2 - b^2 = e^2 x^2 - 2 a e x + a^2 \quad [\text{since } a^2 e^2 - b^2 \\ &= \frac{a^2 c^2}{a^2} - b^2 = c^2 - b^2 = a^2] \end{aligned}$$

$$\therefore r = e x - a \quad (3)$$

By exactly similar treatment of (3) Art. 93, we get,

$$r' = e x + a \quad (4)$$

Subtract (3) from (4), $r' - r = 2 a$, which shows that the constant difference $r' - r$ is always equal to the major axis.

ART. 97. A comparison of the ellipse and hyperbola equations shows that if in the ellipse equation $-b^2$ is substituted for $+b^2$, the hyperbola equation results; hence since the fundamental processes in deriving tangent, normal, and diameter equations are the same for all curves, the equations for these lines in relation to the hyperbola can be derived from the corresponding equations in the ellipse by substituting $-b^2$ for b^2 .

For example:

(a) The ellipse tangent has the equation,

$$a^2 yy' + b^2 xx' = a^2 b^2,$$

hence the *hyperbola tangent* is,

$$a^2 yy' - b^2 xx' = -a^2 b^2$$

or

$$b^2 xx' - a^2 yy' = a^2 b^2 (T_h)$$

The slope form is,

$$y = mx \pm \sqrt{a^2 m^2 - b^2} (T_{hm})$$

(b) The normal equation for the ellipse is,

$$y - y' = \frac{a^2 y'}{b^2 x'} (x - x'),$$

hence the *normal equation* for the hyperbola is,

$$y - y' = -\frac{a^2 y'}{b^2 x'} (x - x') (N_h)$$

(c) The *subtangent* then is $\frac{x'^2 - a^2}{x'}$, and the subnormal is $\frac{b^2 x'}{a^2}$, the same as for the ellipse.

(d) The equation for a diameter of the ellipse is,

$$y = -\frac{b^2}{a^2 m} x,$$

hence a diameter to the hyperbola is,

$$y = \frac{b^2}{a^2 m} x.$$

Conjugate diameters are defined in the same way, hence the product of their slopes, m and m' , say, is

$$mm' = \frac{b^2}{a^2} [-b^2 \text{ replaces } b^2].$$

ART. 98. As the ellipse becomes a circle when its axes become equal, for when $b = a$,

$$a^2 y^2 + b^2 x^2 = a^2 b^2 \text{ becomes } y^2 + x^2 = a^2,$$

so if the axes of a hyperbola become equal, we call it an *equilateral hyperbola*, which is the hyperbola-analogue of the circle.

In $b^2 x^2 - a^2 y^2 = a^2 b^2$, let $b = a$; then $x^2 - y^2 = a^2$ is the equation of an equilateral hyperbola.

ART. 99. The latus rectum of the hyperbola is readily found from its equation by setting

$$x = \pm c = \pm \sqrt{a^2 + b^2}.$$

Whence

$$b^2(a^2 + b^2) - a^2 y^2 = a^2 b^2$$

$$y^2 = \frac{b^4}{a^2}, \quad y = \pm \frac{b^2}{a}$$

$$2y = \frac{2b^2}{a} = \text{latus rectum, since it is the}$$

double ordinate through the focus.

EXERCISE.

What are the axis and eccentricities of the following hyperbolas:

1. $2x^2 - 3y^2 = 9.$

2. $x^2 - 4y^2 = 4.$

3. $16y^2 - 9x^2 = 144.$

4. $5x^2 - 8y^2 = 15.$

5. $9y^2 - 4x^2 = -36.$

6. $4y^2 - 3x^2 = 12.$

7. $x^2 - 16y^2 = 16.$

8. $4x^2 - 16y^2 = -64.$

9. What is the equation of a hyperbola, if half the difference of the focal radii for any point is 7, and half the distance between foci is 9?

10. What is the equation of the hyperbola, whose conjugate axis is 6 and eccentricity, $1\frac{1}{4}$?

11. The co-ordinates of a certain point on a hyperbola, whose major axis is 20, are $x = 6$, $y = 4$. Find its equation.

12. The eccentricity of a hyperbola is $1\frac{2}{3}$, and the longer focal radius of the point $x = 5$, is 32. Find hyperbola equation.

13. In a hyperbola $2a = 20$, and the latus rectum = 5. Find its equation.

14. The conjugate axis = 10, and the transverse axis is twice the conjugate. Find the equation.

15. The conjugate axis = 16 and the transverse axis = $\frac{5}{3}$ of the distance between foci. Find the equation.

16. In the hyperbola $25x^2 - 4y^2 = 100$, find the co-ordinates of the point whose ordinate is $2\frac{2}{3}$ times its abscissa.

17. In the hyperbola $25x^2 - 169y^2 = 4225$, find the focal radii of the point whose ordinate is $10\sqrt{2}$.

Find the intersection points of the following :

18. $16y^2 - 4x^2 = 16$ and $2x - y = 3$.

19. $\frac{x^2}{4} - \frac{4y^2}{9} = \frac{1}{9}$ and $3y - 2x + 8 = 0$.

20. $9y^2 - 16x^2 = 144$ and $x^2 + y^2 = 36$.

21. $9y^2 - 6x^2 = 36$ and $4x^2 + 9y^2 = 36$.

22. $16x^2 - 25y^2 = 400$ and $4x^2 + 16y^2 = 16$.

23. $x^2 - y^2 = -50$ and $x^2 + y^2 = 100$.

24. Find the equation of the tangent to the hyperbola $16y^2 - 9x^2 = 144$ at the point $(\frac{1}{3}, 5)$.

25. At what angle do the curves in Ex. 22 intersect?

CONSTRUCTION OF THE HYPERBOLA.

ART. 100. The definition of the hyperbola suggests a method of mechanical construction similar to that for the ellipse.

Since the difference between the focal radii is constant, if a fixed length of string be taken, attached at the two foci, and the same amount subtracted from each of two branches, continually, the hyperbola results.

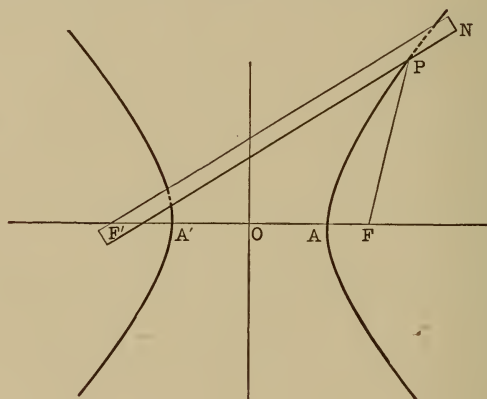

Fig. 52.

In Fig. 52, let a straight edge of length $l + 2a$, be pivoted at F' , and one end of a string of length l be fastened to its free end, N , and attached to the focus F , at its other end.

A pencil pressed against the straight edge, keeping the string stretched (as at P), will describe the right branch of the hyperbola. For at any point as at P ,

$$\begin{aligned} PF' - PF &= (F'N - PN) - (NPF - PN) = \\ F'N - NPF &= l + 2a - l = 2a. \end{aligned}$$

The other branch may be described similarly by pivoting at F , and attaching the string at F' .

Second Method : The hyperbola may also be constructed by points, making use of the definition. Let AA' [Fig. 52 (a)] be the major axis, F and F' the foci and O the centre.

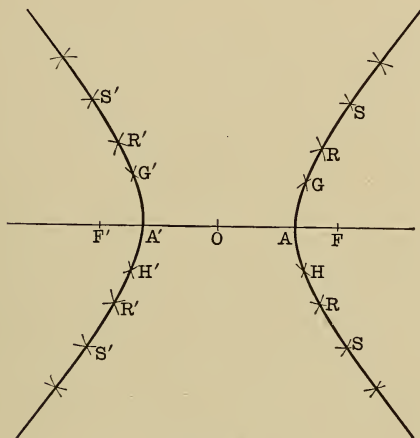

Fig. 52a.

Let LK [Fig. 52 (b)] = AA' . Extend LK and take any number of points on LK produced as P, R, S, T , etc. With

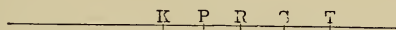

Fig. 52b.

$LP > LK$ as radius and F and F' , successively, as centres describe arcs as at G, H, G' and H' ; with the same centres and KP as radius, describe intersecting arcs at G, H, G' and H' . The intersections will be points on the ellipse for the radii $LP - KP = LK = AA'$. The same process with points R, S, T , etc., will give as many points as desired. A smooth curve through these points will be the hyperbola.

CONJUGATE HYPERBOLA.

ART. 101. The hyperbola whose axis coincides with the axis of ordinates is called the *conjugate hyperbola* to the one whose axis is the x -axis. MBN — RB'S (Fig. 53).

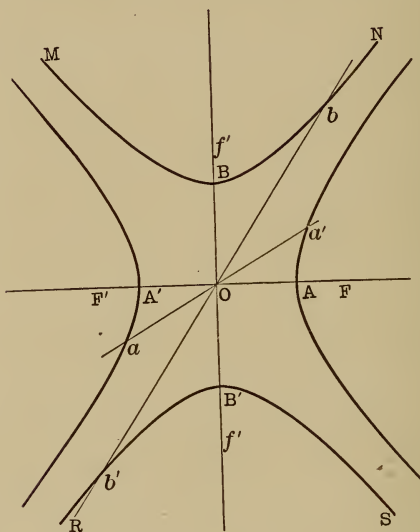

Fig. 53.

Its equation is readily found to be

$$a^2y^2 - b^2x^2 = a^2b^2.$$

ART. 102. If the equations of two conjugate diameters be combined with the equation to the original hyperbola, it will be found that the results will be imaginary for one of the diameters, showing that both diameters do not touch the original hyperbola. Thus:

Let $y = mx \dots \dots \dots (1)$

and
$$y = \frac{b^2x}{a^2m} \dots \dots \dots (2)$$

be conjugate diameters.

Combining these with

$$b^2x^2 - a^2y^2 = a^2b^2 \dots \dots \dots (3)$$

we get from (1) and (3),

$$x^2 = \frac{a^2b^2}{b^2 - a^2m^2};$$

from (2) and (3),

$$x^2 = \frac{a^2}{a^2m^2 - b^2}$$

If $b^2 - a^2m^2$ is plus, $a^2m^2 - b^2$ must be minus, hence if the first x^2 is plus, and hence x , real, the second x^2 is minus, and hence x , imaginary, or vice versa.

But if (2) be combined with the conjugate hyperbola,

$$a^2y^2 - b^2x^2 = a^2b^2,$$

$$x^2 = \frac{a^2}{b^2 - a^2m^2}, \quad \text{which is real,}$$

if
$$\frac{a^2b^2}{b^2 - a^2m^2} \quad \text{is real.}$$

Hence conjugate diameters intersect, one, the original hyperbola, the other, its conjugate, as aa' and bb' (Fig. 53).

ASYMPTOTES.

ART. 103. An asymptote of the hyperbola may be defined as a tangent at a point whose co-ordinates are infinite, which, nevertheless, intersects at least one of the co-ordinates, axes at a finite distance from the origin.

To find the equation of the asymptotes then, it is neces-

sary to determine a line that will touch the hyperbola at infinity (Fig. 54).

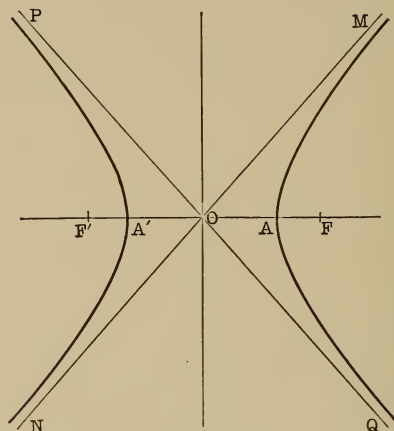

Fig. 54.

Let the equation of a line be

$$y = mx + c \quad \dots \dots \dots (1)$$

and the equation to the hyperbola be

$$b^2x^2 - a^2y^2 = a^2b^2 \quad \dots \dots \dots (2)$$

Combining (1) and (2),

$$b^2x^2 - a^2m^2x^2 - 2a^2mcx - a^2c^2 = a^2b^2,$$

$$\text{or } x^2(b^2 - a^2m^2) - 2a^2mcx - (a^2c^2 + a^2b^2) = 0$$

wherein the values of x are the abscissas of the point of intersection. By the theory of equations, these values will be infinite if the coefficient of

$$x^2 = 0,$$

$$\text{that is, if } b^2 - a^2m^2 = 0$$

$$\text{or } m = \pm \frac{b}{a}.$$

For in the typical quadratic, $ax^2 + bx + c = 0$

$$x = \frac{-b + \sqrt{b^2 - 4ac}}{2a} \quad \text{or} \quad \frac{-b - \sqrt{b^2 - 4ac}}{2a}.$$

In either case if the denominator $2a = 0$ or $a = 0$ the values of x will be infinite, having a denominator 0; but a is the coefficient of x^2 ; hence the rule.

\therefore if $m = \pm \frac{b}{a}$ the line $y = mx + c$ meets the hyperbola $b^2x^2 - a^2y^2 = a^2b^2$ at infinity.

We found, however, in Art. 107, that the slope equation, of the tangent to the hyperbola is,

$$y = mx \pm \sqrt{a^2m^2 - b^2};$$

that is, in $y = mx + c$, if $c = \pm \sqrt{a^2m^2 - b^2}$, $y = mx + c$ becomes a tangent.

If $m = \pm \frac{b}{a}$, however,

$$a^2m^2 - b^2 = \frac{a^2b^2}{a^2} - b^2 = b^2 - b^2 = 0.$$

\therefore at infinity $y = mx + c$ becomes a tangent if $c = 0$ and $m = \pm \frac{b}{a}$. Hence the equation to an asymptote is

$$y = \frac{b}{a}x \quad \text{or} \quad y = -\frac{b}{a}x.$$

The form of these equations shows that the asymptotes pass through the origin.

ART. 104. *Relation between the equations of the asymptotes and that of the hyperbola.*

Clearing the two above equations of fractions, transposing and multiplying together,

$$(ay - bx)(ay + bx) = 0,$$

or $a^2y^2 - b^2x^2 = 0$ or $b^2x^2 - a^2y^2 = 0.$

Comparing this with $b^2x^2 - a^2y^2 = a^2b^2$, it is observed that they are the same except for the constant term a^2b^2 , hence given its two asymptotes it is easy to write the equation of the hyperbola, or vice versa.

If $y = \frac{b}{a}x$ and $y = -\frac{b}{a}x$ are the equations of the asymptotes to a hyperbola, its equation may be written,

$$b^2x^2 - a^2y^2 \pm C = 0 \dots \dots (n)$$

the minus sign of C indicating the primary hyperbola; the plus sign, its conjugate. If in addition a point is given through which the hyperbola must pass, C can be determined.

For example: The asymptotes of a hyperbola are $y = \frac{1}{2}x$ and $y = -\frac{1}{2}x$. If the hyperbola passes through the point $(6, 2\sqrt{2})$, to find its equation. The equation will be

$$(2y - x)(2y + x) \pm C = 0$$

or $4y^2 - x^2 \pm C = 0.$

Substituting;

$$4(2\sqrt{2})^2 - (6)^2 \pm C = 0,$$

whence $C = \pm 4$, whence $4y^2 - x^2 \pm 4 = 0$ are the equations to primary and conjugate hyperbola.

Corollary: The same principle will clearly apply no matter where the origin is taken, since both hyperbola and asymptotes are referred to the same point as origin, and hence the relation between their equations remains the same. For example, if $2y - 3x - 1 = 0$ and $y + 2x + 3 = 0$, are the asymptotes of a hyperbola, its equation is,

$$(y + 2x + 3)(2y - 3x - 1) \pm C = 0.$$

ART. 105. It is often desirable to refer the equation of a hyperbola to its asymptotes as axes.

By determining the angles made by the new axes (the asymptotes) and the old, and using the transformation equations (J'), Art. 38, the result is most readily achieved.

These equations are

$$\left. \begin{aligned} y &= x' \sin \theta + y' \sin \phi \\ x &= x' \cos \theta + y' \cos \phi \end{aligned} \right\} \dots (J')$$

$\theta = \text{reflex } \angle xON = \angle -xON, \phi = MOx$ (Fig. 55).

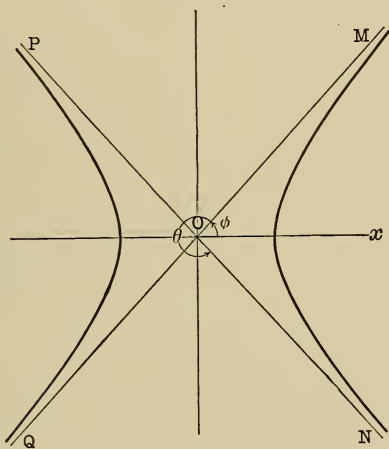

Fig. 55.

Since the new axes are asymptotes, their slopes are $+\frac{b}{a}$ and $-\frac{b}{a}$ from their equations, that is,

$$\tan \theta = -\frac{b}{a}; \quad \tan \phi = \frac{b}{a}$$

whence by Goniometry,

$$\sin \theta = -\frac{b}{\sqrt{a^2 + b^2}}, \quad \cos \theta = \frac{a}{\sqrt{a^2 + b^2}},$$

$$\sin \phi = \frac{b}{\sqrt{a^2 + b^2}}, \quad \cos \phi = \frac{a}{\sqrt{a^2 + b^2}}.$$

Substituting these values in (J'),

$$y = \frac{b}{\sqrt{a^2 + b^2}}(y' - x') \quad \dots \quad (1)$$

$$x = \frac{a}{\sqrt{a^2 + b^2}}(y' + x') \quad \dots \quad (2)$$

Substituting (1) and (2) in the hyperbola equation,

$$b^2x^2 - a^2y^2 = a^2b^2,$$

$$\frac{a^2b^2}{a^2 + b^2}(y' + x')^2 - \frac{a^2b^2}{a^2 + b^2}(y' - x')^2 = a^2b^2,$$

or $(y' + x')^2 - (y' - x')^2 = a^2 + b^2,$

whence $4x'y' = a^2 + b^2.$

Dropping accents,

$$4xy = a^2 + b^2 = c^2 \quad \dots \quad (A_{a, h})$$

which is the equation of a hyperbola referred to its asymptotes.

It shows that the co-ordinates of a hyperbola referred to its asymptotes vary inversely as one another.

ART. 106. *Equation of the tangent to the hyperbola referred to its asymptotes.*

Pursuing exactly the same method as before, we determine the equation of a secant line and revolve this line to a tangent position.

The equations of any line through (x', y') and (x'', y'') is

$$y - y' = \frac{y'' - y'}{x'' - x'} (x - x') \quad \dots \quad (B)$$

If the points (x', y') and (x'', y'') are on the hyperbola, they must satisfy $4xy = c^2$.

$$\therefore 4x'y' = c^2 \quad \dots \quad (1)$$

$$4x''y'' = c^2 \quad \dots \quad (2)$$

Subtracting (1) from (2) and simplifying;

$$x''y'' - x'y' = 0 \quad \text{or} \quad x''y'' = x'y' \quad \dots \quad (3)$$

Subtracting $x''y'$ from both sides to get the value of $\frac{y'' - y'}{x'' - x'}$;

$$x''y'' - x''y' = x'y' - x''y'$$

Factoring; $x''(y'' - y') = -y'(x'' - x')$

or
$$\frac{y'' - y'}{x'' - x'} = -\frac{y'}{x''}$$

Substituting in B,

$$y - y' = -\frac{y'}{x''} (x - x') \quad (4). \quad [\text{The equation of a secant.}]$$

As the points approach coincidence x'' approaches x' and y'' approaches y' , and eventually $x'' = x'$, $y'' = y'$.

Substituting in (4);

$$y - y' = -\frac{y'}{x'} (x - x')$$

whence
$$x'y - x'y' = -xy' + x'y'$$

$$x'y + xy' = 2x'y'$$

or
$$\frac{y}{y'} + \frac{x}{x'} = 2 \quad \dots \quad (T_h a)$$

EXERCISE.**Tangents and Asymptotes.**

Find the equation of a tangent to the following hyperbolas:

1. $2x^2 - 3y^2 = 12$, at $(12, 2)$.
2. $16y^2 - 9x^2 = 144$, at $(4\sqrt{3}, 6)$.
3. $x^2 - 4y^2 = 4$ at $(?, \frac{3}{2})$.
4. $16x^2 - 9y^2 = 144$ at $(?, 3)$.
5. $25y^2 - 16x^2 = 400$ at $(3\frac{3}{4}, ?)$.
6. $36y^2 - 25x^2 = 900$ at $(3\frac{1}{5}, ?)$.
7. Find the normal to each of the above.
8. What points on a hyperbola have equal subtangent and subnormal?
9. What are the equations of the tangents to the hyperbola $16x^2 - 9y^2 = 144$, parallel to the line $3y - 5x + 3 = 0$?
10. What are the equations of the tangents to the hyperbola $x^2 - 4y^2 = 4$, perpendicular to the line $y = -2x + 3$?
11. What is the equation of the normal to the hyperbola $x^2 - 4y^2 = 4$, perpendicular to the line $y = -2x + 3$?
12. Find the equations of the common tangents to $16x^2 - 25y^2 = 400$ and $x^2 + y^2 = 9$.
13. Find the slope equation of a tangent $a^2y^2 - b^2x^2 = a^2b^2$.
14. Find the equations of tangents to the hyperbola $2x^2 - y^2 = 3$, drawn through the point $(3, 5)$.
15. Find the equations of tangents drawn from $(2, 5)$ to the hyperbola $16x^2 - 25y^2 = 400$.
16. Find the equations of the tangents to the hyperbola $16y^2 - 9x^2 = -144$, which with the tangent at the vertex form an equilateral triangle.
17. Find the angle between the asymptotes of the hyperbola $16x^2 - 25y^2 = 400$.

18. What is the equation of the hyperbola having $y - 2x + 7 = 0$ and $3x + 3y - 5 = 0$ for its asymptotes, if it passes through $(0, 7)$?

19. Show that the perpendicular from the focus of a hyperbola to its asymptote equals the semi-conjugate axis.

20. Find the equations of the tangents to the hyperbola $9y^2 - 4x^2 = 56$ at the points where $y - x = 0$ intersects it.

21. A tangent to the hyperbola $9x^2 - 25y^2 = 225$ has the x -intercept $= -3$. Find its equation.

22. Two tangents are drawn to $9x^2 - 4y^2 = 36$ from $(1, 2)$. Find the equation of the chord joining the points of contact.

23. The product of the distances from any point on a hyperbola to its asymptotes is constant. What is the constant?

24. Show that the sum of the squares of the reciprocals of the eccentricities of conjugate hyperbolas equals unity.

25. The equation of a directrix of the hyperbola $b^2x^2 - a^2y^2 = a^2b^2$, being

$$x = \frac{a^2}{c} \quad [c = \sqrt{a^2 + b^2}],$$

show that the major auxiliary circle passes through the points of intersection of the directrix with the asymptotes.

ART. 107. *Supplemental chords.*

Supplemental chords in the hyperbola are defined as they were in the circle and ellipse, hence from the relation between ellipse and hyperbola the relation between the slopes of supplemental chords in the hyperbola is,

$$mm' = \frac{b^2}{a^2} \quad [\text{putting } -b^2 \text{ for } b^2 \text{ in ellipse condition}].$$

Since this is also the relation between the slopes of conjugate

diameters, it follows that there is a pair of diameters parallel to every pair of supplemental chords, which suggests an easy method of drawing conjugate diameters.

ART. 108. *The eccentric angle.*

Since the ordinates of the hyperbola do not cut the auxiliary circles, the eccentric angle of a point is not so

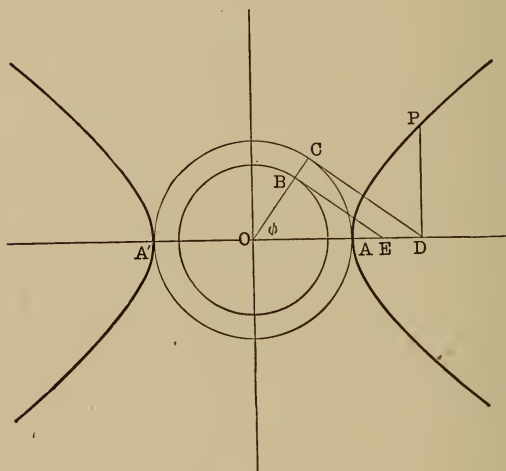

Fig. 56.

readily determined as in the ellipse and a more arbitrary definition is necessary. The angle ϕ so determined that

$$x = a \sec \phi \text{ and } y = b \tan \phi,$$

is called the eccentric angle for the point (x, y) . These values will satisfy the equation

$$b^2 x^2 - a^2 y^2 = a^2 b^2;$$

for substituting;

$$a^2 b^2 \sec^2 \phi - a^2 b^2 \tan^2 \phi = a^2 b^2,$$

or $\sec^2 \phi - \tan^2 \phi = 1.$

which is true by goniometry.

To construct this angle for a given point, the auxiliary circles [with radii a and b] are drawn. (Fig. 56.)

Let P be any point on the hyperbola. Draw its ordinate PD and from the foot of PD draw a tangent to the major auxiliary circle touching it at C , then $\angle COD = \phi$ for point $P, (x, y).$

For, draw BE a parallel tangent to the minor circle, then in the right triangle $OCD,$

$$\cos \text{COD} = \frac{OC}{OD} = \frac{a}{x} \text{ [OD = abscissa of P]}$$

or $x = a \sec \text{COD}. \dots (1)$

Again in the right triangle OBE

$$\tan \text{BOE} = \tan \text{COD} = \frac{BE}{OB} \dots (2)$$

The triangles COD and BOE are similar.

$$\therefore OB : OC :: BE : CD,$$

whence

$$BE = \frac{OB \times CD}{OC} = \frac{OB \sqrt{OD^2 - OC^2}}{OC} = \frac{b \sqrt{x^2 - a^2}}{a}$$

or $\overline{BE}^2 = \frac{b^2}{a^2} (x^2 - a^2).$

But $y^2 = \frac{b^2}{a^2} (x^2 - a^2)$ from $(A_h).$ $\therefore BE = y.$

Hence from (2) $\tan \text{COD} = \frac{y}{b}$

or $y = b \tan \text{COD} \dots (3)$

Comparing (1) and (3) with the condition equations for $\phi,$ we see that $\text{COD} = \phi.$

Hence the eccentric angle is found by drawing from

the foot of the ordinate of a point, a tangent to the major auxiliary circle. Then the angle formed with the axis by the radius drawn to the point of tangency is the eccentric angle for that point. The eccentric angle is used to best advantage in the calculus.

ART. 109. There are two interesting geometrical properties of the hyperbola when referred to its asymptotes.

(a) *The product of the intercepts of any tangent on the asymptotes is the same.*

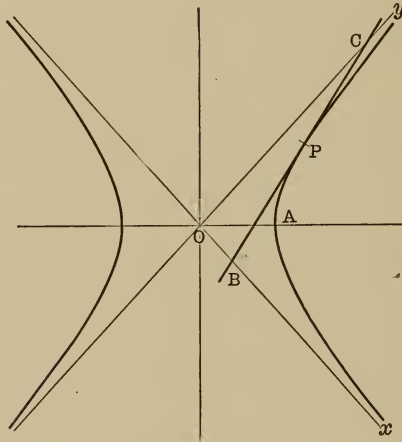

Fig. 57.

Let BPC (Fig. 57) be a tangent at P, then its intercepts on Ox and Oy (OB and OC), respectively, will be found by setting successively $y = 0$ and $x = 0$ in its equation,

$$\frac{y}{y'} + \frac{x}{x'} = 2,$$

whence

$$\left. \begin{aligned} x &= OB = 2x' \\ y &= OC = 2y' \end{aligned} \right\} (x', y' \text{ being point P}),$$

and

multiplying; $OB \cdot OC = 4 x' y' = a^2 + b^2$ (a constant).

Since $x'y'$ is on the hyperbola $4 x'y' = a^2 + b^2$.

(b) The area of the triangle formed by a tangent and the asymptotes is constant. The area of the triangle BOC (Fig. 57), by trigonometry, is

$$\text{Area BOC} = \frac{OB \cdot OC}{2} \sin \angle BOC = \frac{OB \cdot OC}{2} \sin 2\phi$$

$$[\text{COA} = \text{BOA} = \phi, \text{ Art. 105}] = OB \cdot OC \sin \phi \cos \phi$$

$$[\text{since } \sin 2\phi = 2 \sin \phi \cos \phi] =$$

$$OB \cdot OC \cdot \frac{b}{\sqrt{a^2 + b^2}} \cdot \frac{a}{\sqrt{a^2 + b^2}} = OB \cdot OC \cdot \frac{ab}{a^2 + b^2}.$$

But

$$OB \cdot OC = a^2 + b^2.$$

$$\therefore \text{area BOC} = (a^2 + b^2) \frac{ab}{a^2 + b^2} = ab.$$

That is, the area of this triangle always equals the product of the semi-axes.

EXERCISE.

General Examples.

1. If $y = 3x + 15$ is a chord of the hyperbola $36x^2 - 16y^2 = 576$, what is the equation of the supplementary chord?

2. The point $(5, \frac{8}{3})$ lies on the hyperbola $4x^2 - 9y^2 = 36$. Find the equations of the diameter through this point and of its conjugate.

3. Find the equation of the line passing through a focus of a hyperbola and a focus of its conjugate hyperbola.

4. Find the angle between a pair of conjugate diameters of the hyperbola, $b^2x^2 - a^2y^2 = a^2b^2$.

5. Find the equation of the chord of the hyperbola $9x^2 - 16y^2 = 144$, which is bisected by the point $(2, 3)$.

6. Show that the locus of the vertex of a triangle, whose base is constant, and the product of the tangents of its base angles is a negative constant, is a hyperbola.

7. Show that the eccentric angles of the extremities of a pair of conjugate diameters are complementary.

8. What is the equation of the focal chord which is bisected by the line $y = 6x$?

9. In the hyperbola $9x^2 - 16y^2 = 144$, what is the equation of the diameter conjugate to $y - 3x = 0$?

10. Show that tangents at the ends of conjugate diameters intersect on the asymptotes.

11. The base of a triangle is $2b$ and the difference of the other sides is $2a$. Show that the locus of the vertex is a hyperbola. [Take the middle of the base as origin.]

12. For what point of the hyperbola $xy = 12$ is the subtangent $= 4$?

13. Show that an ellipse and hyperbola which have the same foci intersect at right angles.

14. What are the equations of the tangents to the hyperbola $x^2 - 4y^2 = 4$, which are perpendicular to the asymptotes?

15. In the hyperbola $25x^2 - 16y^2 = 400$, find the equations of conjugate diameters that cut at an angle of 45° .

16. In the hyperbola $16x^2 - 25y^2 = 400$, what are the co-ordinates of the extremity of the diameter conjugate to $25y + 16x = 0$?

17. In the hyperbola $4x^2 - 9y^2 = 36$, the equation of a diameter is $3y - 2x = 0$. What is the equation of any one of its system of chords?

CHAPTER VIII.

HIGHER PLANE CURVES.

ART. 101. There are several other curves known as Higher Plane Curves because their equations are more complex, that are used extensively in engineering. These we will consider briefly.

THE CYCLOID.

The cycloid, much used in gear teeth, is the curve generated by a point on the circumference of a circle of given radius, as the circle rolls along a straight line. The circle may be called the *generator circle*, and the straight line the *directrix*.

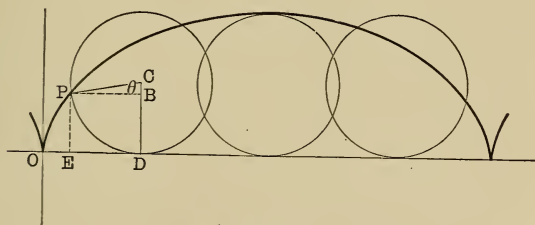

Fig. 58.

To find its equation. Let P (Fig. 58) be the generating point, r the radius CP, $OE = x$ and $PE = y$ for P, and call $\angle PCB$, θ .

Then $PE = CD - CB = r - r \cos \theta$.

That is, $y = r - r \cos \theta$ (1)

Also $x = OE = OD - ED = OD - PB = r\theta - r \sin \theta$ (2)

Since θ is an extra variable, its elimination is necessary.

From (1) $\cos \theta = \frac{r - y}{r} = 1 - \frac{y}{r}$,

whence

$$1 - \cos \theta = \text{vers } \theta = \frac{y}{r} \quad \text{or} \quad \theta = \text{vers}^{-1} \frac{y}{r}.$$

Substituting this value of θ in (2),

$$x = r \text{vers}^{-1} \frac{y}{r} - r \sin \left(\text{vers}^{-1} \frac{y}{r} \right)$$

or $x = r \text{vers}^{-1} \frac{y}{r} - \sqrt{2ry - y^2}$.

For $\text{vers}^{-1} \frac{y}{r} = \theta$,

$$\frac{y}{r} = \text{vers } \theta = 1 - \cos \theta,$$

$$1 - \frac{y}{r} = \cos \theta, \quad \left(\frac{r - y^2}{r} \right) = \cos^2 \theta.$$

$$1 - \left(\frac{r - y^2}{r} \right) = \frac{2ry - y^2}{r^2} = 1 - \cos^2 \theta = \sin^2 \theta.$$

Whence $\sin \theta = \frac{\sqrt{2ry - y^2}}{r}$,

and $r \sin \theta = r \sin \left(\text{vers}^{-1} \frac{y}{r} \right) = \sqrt{2ry - y^2}$.

CONSTRUCTION OF THE CYCLOID.

ART. III. From the nature of the development of the cycloid, it is readily constructed by points. The first method to be shown produces an accurate cycloid if sufficient points be taken.

The second method, which is employed in mechanical drawing, gives a cycloid of sufficient approximation.

First Method: Let M be the generator circle in its middle position, and XX' the directrix. Make OV equal $\frac{1}{2}$ the circumference of M . Divide the semi-circumference OCN into 6 equal parts, also OV into 6 equal parts. Then

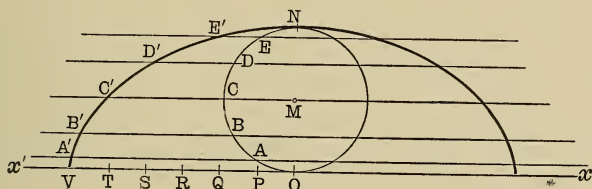

Fig. 59.

clearly the 6 points on OCN would exactly coincide with the 6 points on OV if the circle were rolled back toward V .

Through the division points on OCN : A, B, C, D, E , draw lines parallel to the directrix. Now if the circle were revolved toward V until A and P coincided, then N would be on the level now occupied by E , that is, it would be somewhere on the parallel through E ; N would still be the same distance from A that it now is; hence if we take a radius AN , with P as a centre, we will cut the parallel through E in the place where N was when A was at P . Likewise with Q as a centre and radius BN , cut the parallel through D , and we have the position of N when B was at Q . The same process continued will give all the succes-

sive positions of N , and if these be joined by a smooth curve, we have the cycloid described by N .

ART. 112. *Second Method*: This approximate construction used in mechanical drawing is based on the fact that for very small arcs the arc does not sensibly differ from its chord, so the divisions are "stepped off" with the compasses, thus really getting chords not arcs, but by taking the distances small enough, any degree of approximation may be attained.

Draftsmen use this slightly modified method, which gives a sufficient approximation, as follows:

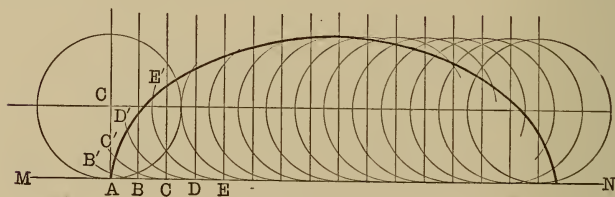

Fig. 60.

Fig. 60. Let MN be the directrix and C the generator circle. Lay off any small distance on MN a sufficient number of times choosing the distance small enough so that as a chord it would not sensibly differ from its arc, as AB . Then AB, BC, CD , etc., will practically equal corresponding arcs on C . Draw a series of circles (or parts of them) having the radius of C . These represent the generator circle in its successive positions.

From B, C, D , etc., successively "step off" with compasses on the arc passing through them, 1, 2, 3, etc., units (as AB). These will give points on the cycloid as A', B', C', D' , etc. The curve drawn through these points will be a very good approximation.

ROULETTES.

The *hypocycloid* is described by a point on the circumference of a circle, which rolls on the inner side of the circumference of a second circle.

If the generator circle rolls on the outside of the circumference of the directrix, the resulting curve is called an *epicycloid*.

The two circles may have any relative radii, and if the ratio between them is commensurable, the cycloids will be closed curves, consisting of as many arches as the ratio contains units. The common ratio is 4. If the ratio is 1, the *epicycloid* resulting is called a *cardioid* (see Art. 16).

Curves described by rolling one figure upon another are known collectively as *roulettes*.

ART. 114. To find the equation of the *hypocycloid*.

Let circle C be the directrix and circle C' the generator circle (Fig. 61). Let P be the generating point, starting

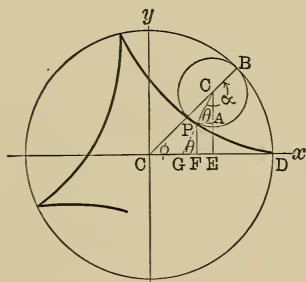

Fig. 61.

from coincidence with D. Draw the co-ordinates of P, CF and PF (x, y); C' E perpendicular to CD and PA \parallel to CD, and let CD and CY (\perp to CD through C) be the axes. Let $\angle BCD = \phi$, $\angle BC'P = \alpha$; $\angle C'PA = \theta$; $CB = r$ and $C'B = r'$.

Then $CF = CE - FE = CE - PA = CC' \cos \phi - C'P \cos \theta$ or $x = (r - r') \cos \phi - r' \cos \theta$.

Extend $C'P$ to meet CD at G ; $\angle C'GD = \theta$, and $\alpha = \phi + C'GC = \phi + (180 - \theta)$

[α is exterior angle of triangle $C'GC$].

Hence $\alpha - \phi = 180 - \theta$.

$\cos(\alpha - \phi) = \cos(180 - \theta) = -\cos \theta$ [Goniometry].

Substituting in (1);

$$x = (r - r') \cos \phi + r' \cos(\alpha - \phi) \dots (2)$$

Likewise, $y = (r - r') \sin \phi - r' \sin(\alpha - \phi) \dots (3)$

But since arc $BD =$ arc BP by method of description of the hypocycloid $r\phi = r' \alpha$, or $\alpha = \frac{r\phi}{r'}$.

Substituting in (2) and (3);

$$x = (r - r') \cos \phi + r' \cos \frac{(r - r')\phi}{r'} \dots (a)$$

$$y = (r - r') \sin \phi - r' \sin \frac{(r - r')\phi}{r'} \dots (b)$$

If ϕ be eliminated between (a) and (b) the rectangular equation for the hypocycloid results, but in this general form the equation would be exceedingly complicated.

But if $r = 4r'$, as is customary, the result is comparatively simple, thus:

(a) becomes; $x = \frac{3}{4}r \cos \phi + \frac{1}{4}r \cos 3\phi$.

(b) becomes; $y = \frac{3}{4}r \sin \phi - \frac{1}{4}r \sin 3\phi$,

or $x = \frac{r}{4}(3 \cos \phi + \cos 3\phi) \dots (a')$

and $y = \frac{r}{4}(3 \sin \phi - \sin 3\phi) \dots (b')$

By Trigonometry $\left\{ \begin{array}{l} 3 \cos \phi + \cos 3\phi = 4 \cos^3 \phi \\ 3 \sin \phi - \sin 3\phi = 4 \sin^3 \phi \end{array} \right.$

Hence (a') becomes $x = r \cos^3 \phi$. (a'')
 and (b') becomes $y = r \sin^3 \phi$. (b'')
 Combining (a'') and (b'') ; $x^{\frac{2}{3}} = r^{\frac{2}{3}} \cos^2 \phi$,
 $y^{\frac{2}{3}} = r^{\frac{2}{3}} \sin^2 \phi$.
 Add; $x^{\frac{2}{3}} + y^{\frac{2}{3}} = r^{\frac{2}{3}} [\text{since } \cos^2 \phi + \sin^2 \phi = 1]$.

ART. 115. *To construct the hypocycloid.*

Let C be the directrix; (Fig. 62) C' the generator circle; P the generating point. Divide the quadrant P'K into 8 equal parts and the semicircle PE' into 4 equal parts. Let P start at P', then when A' and A coincide as the circle C'

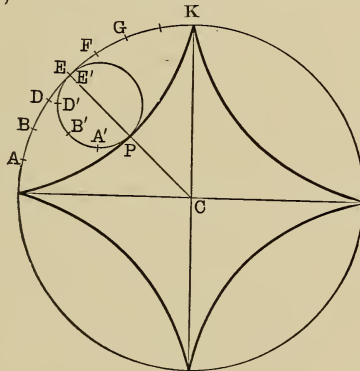

Fig. 62.

rolls, P will be at the distance DD' from P' and at the distance A'P from A. Hence with P' as a centre and DD' as radius describe an arc intersecting another described with A as centre and A'P as radius. This intersection point will be a point on the hypocycloid.

When B' is at B, P will be at the distance BB' from P' and at the distance B'P from B. The intersection of arcs described with centres P' and B and radii BB' and B'P, respectively, will be a second point on the hypocycloid, and so on.

Evidently the greater the number of equal parts into which the quadrant and the generator circle are divided the more accurate will be the hypocycloid.

If the ratio of the radii of the two circles is 3, the entire directrix will be divided into 3 times as many parts as the circumference of the generator circle and similarly for any ratio. In the figure 62 the ratio is 4.

ART. 116. *Draftsman's method of constructing the hypocycloid.*

This method is almost exactly similar to that described for the cycloid, using, however, angular division of the directrix, which is now a circumference.

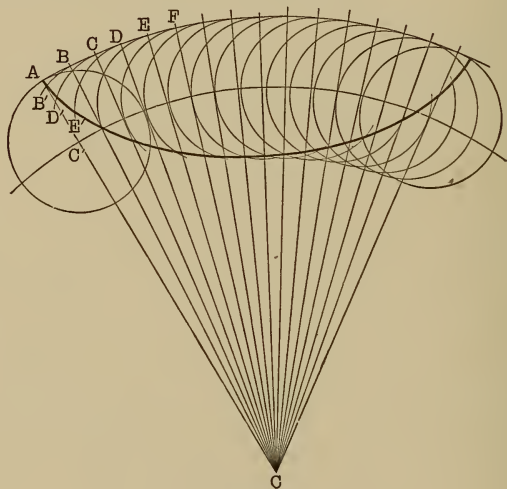

Fig. 63.

Fig. 63. Let C be the centre of the directrix and C' the generator circle. "Step off" on the circumference of C any small equal arcs as AB, BC, CD, DE , etc.; at A, B, C, D, E , etc., draw tangent circles equal to C' . From A, B, C, D, E , etc.,

successively "step off" 1, 2, 3, 4, etc., times the distance AB, the resulting points will determine the hypocycloid. An exactly similar process will produce the epicycloid, if the generator circle be rolled on the outside.

ART. 117. Another form of roulette is the *involute*, which is described by a fixed point on a straight line, that rolls as a tangent on a fixed circle. Let C (Fig. 64) be the directrix circle and MN the initial position of the line.

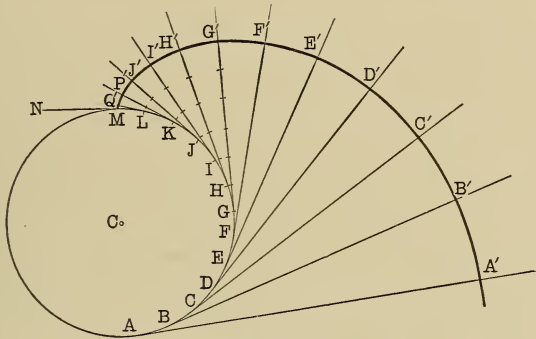

Fig. 64.

"Step off" any small equal arcs on the circumference of C as AB, BD, DE, etc. Draw tangents at the points of division and beginning with A stepoff, successively 1, 2, 3, 4, etc., times the distance AB on the tangent lines. The resulting points will determine an involute. Any curve whatever will produce an involute in this way, but the circle is most commonly used. A gear tooth is made up of cycloid, evolute, and circular arc in varying proportions.

SPIRALS.

ART. 118. A spiral is described by a point receding, according to some fixed law, along a straight line that revolves about one of its points. There are a number of

spirals, one of which will illustrate this type of curve. The revolving line is called the *radius vector* and the angle it makes, in any position, with the initial line, is called the *vectorial angle*.

The *hyperbolic spiral* is the curve generated by a point, which moves so that the product of radius vector and vectorial angle is constant.

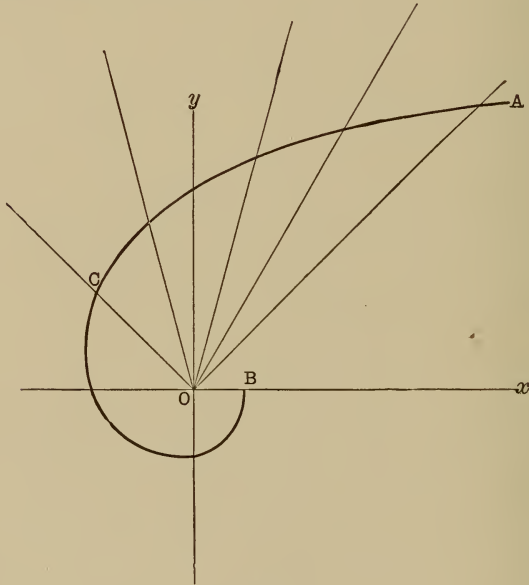

Fig. 65.

Calling the radius vector, r ; the vectorial angle θ and the constant C , we have by definition,

$$r \theta = C.$$

To construct it when $C = 11$, then $r = \frac{11}{\theta}$.

Make a table of values for r , as follows;

When $\theta = 0$, $r = \infty$, $\pi = 3\frac{1}{2}$.

$$\theta = \frac{\pi}{4}, \quad (45^\circ), \quad r = 14.$$

$$\theta = \frac{\pi}{3}, \quad (60^\circ), \quad r = 10.5.$$

$$\theta = \frac{5\pi}{12}, \quad (75^\circ), \quad r = 8.4.$$

$$\theta = \frac{\pi}{2}, \quad (90^\circ), \quad r = 7.$$

$$\theta = \frac{7\pi}{12}, \quad (105^\circ), \quad r = 6.$$

$$\theta = \frac{3\pi}{12}, \quad (135^\circ), \quad r = 4\frac{2}{3}, \text{ etc.}$$

One complete revolution of the radius vector from 0° to 360° describes a *spire*, as from ∞ to B [Fig. 65], and the circle described with the final radius vector of the first spire, as radius, is called the *measuring circle*.

ELEMENTARY CALCULUS.

ELEMENTARY CALCULUS.

CHAPTER I.

FUNDAMENTAL PRINCIPLES.

ART. 1. *Variables and constants.* Suppose we wish to plot a curve, corresponding to the relation $y = x^3 + 2x^2 - 5x - 6$; and for this purpose assign to x certain arbitrary values, calculating from these the corresponding and *dependent* values of y . Now in such a case both x and y are variable quantities, x being called an independent, and y a dependent variable.

In general: *A Variable* is a quantity which is subject to continual change of value, while an *Independent Variable* is supposed to assume any arbitrary value, and a *Dependent Variable*, is determined when the value of the Independent Variable is known.

Examples: $y = x^4$, $y = \tan x$, $y = \log x$.

In the above examples x is the independent, and y the dependent variable.

When a quantity does not change or alter its value such as $\pi = 3.14159 \dots$, it is called a *Constant Quantity*, or simply a *Constant*.

ART. 2. *Functions.* Let us again take the equation $y = x^3 + 2x^2 - 5x - 6$; we know that for every value of x there is a corresponding value of y ; not necessarily different, for if $x = 3$, $y = 0$, and if $x = 2$, $y = 0$, but

nevertheless to each value of x there corresponds a certain definite value of y . When two quantities, x and y , are related in this manner we say that y is a *function of* x .

In the examples given above, namely, $y = \tan x$, $y = x^4$, $y = \log x$, we see that in each case if we assign a value to x there corresponds a definite y value; we therefore call y a function of x .

Again, if we note the barometer readings corresponding to each hour of the day, we can involve the observations in a curve, and we say that the height of the barometer is a function of the time, because to each change in the time there corresponds a certain definite barometric height. It is equally true that the barometer readings are a function of the time.

In general, *A quantity P is a function of a quantity Q, when to every value which Q can assume there corresponds a certain definite value of P.*

It is customary to express the term "function of" by the symbols F , f , ϕ (Phi); thus we write $\sin x = F(x)$, $\sin x = f(x)$ or, $\sin x = \phi(x)$, meaning that the sine of an angle is a quantity which assumes certain definite values dependent upon the size of the angle x . Again, if $y = \cos x$, then $y = f(x)$ or in the case of an equation such as $y = x^3 + 2x^2 - 5x - 6$ we may also write $y = f(x)$.

This latter mode of expressing an equation briefly by the symbol $y = F(x)$ or $y = f(x)$ is in very general use.

From the definition of a function, given above, we see that if an expression involves any quantity, it is itself a function of that quantity; for example, $\frac{3x^2}{5}$ is a function of x , since this fraction has a definite value corresponding to each change in the value of x , likewise $3 \cos \alpha + 5 \tan \alpha$ is a function of α .

Further, the area of a triangle is a function of its base and also of its altitude. Such a double relation is indicated thus: area $\Delta = f(b, h)$, while the area of a square is a function of its side. If x is a side and y the area, then $y = x^2$; we may write this equation in the general form $y = f(x)$. Again, the volume of a sphere is a function of its radius, or $V = \phi(r)$.

ART. 3. *Object of the Differential Calculus.* In algebra, geometry, and trigonometry, the quantities which enter into the calculations are fixed; they have absolute unchanging values.

Now, suppose we wish to find the greatest value that y can assume, between $x = 3$ and $x = 2$ when $y = x^3 + 2x^2 - 5x - 6$. Here we have two variables, x and y , entering into the calculation, each of which may have an infinite number of values and from which one special value of x is sought, which is defined by the condition imposed.

A problem, such as the above, involving the relation of two or more variable quantities, comes within the province of the differential calculus. In general the differential calculus supplies us with a means of obtaining information regarding the properties of quantities, the number of whose values are infinite, and which vary according to some known law.

One of the chief advantages of the calculus lies in the comparative simplicity with which complex problems involving variable quantities are solved, problems, which if attacked by other methods, would require long and tedious operations and sometimes be impossible of solution.

ART. 4. *The Differential Coefficient.* Suppose an observer to take notice of a passing bicyclist, and to estimate his speed at 10 miles an hour; now, a statement to this

effect would imply that the bicycle *at the moment of observation* was travelling with a velocity, which *if maintained for the next hour*, would cause the rider to cover 10 miles. It does not follow, however, that this will be the case, for 5 seconds later the speed of the bicyclist might be either reduced or accelerated; further, the above statement in no way refers to the velocity of the bicycle prior to the time of observation, having reference to the speed only, at the *exact moment when the bicyclist passed the observer*.

Should it be desired to make an accurate determination of the speed of the machine, we might place two electrical contacts in its path, which on closing would cause the time taken in traversing the space between them to be automatically registered. Then if v = velocity, s = space, t = time, we have $v = \frac{s}{t}$ as a measure of the velocity.

In choosing a position for the second contact, we would undoubtedly select a point near to the first; because the speed of the machine at the moment of passing the first contact would be unlikely to remain constant for a space say of 100 yards, but would be less liable to change in 10 yards, less in 1 yard, still less in 1 foot, and so on.

Hence it is, that if we wish to obtain an accurate result, giving the velocity of a body *at the moment of passing a certain point*, we measure as *short* a portion of its path as is practicable, and divide by the correspondingly small time interval.

Let us now examine a case of uniform motion; suppose a point to travel a distance of 30 miles in 6 hours with uniform velocity. Now, *uniform velocity* implies that equal lengths of path are traversed in equal times, *no matter how small* are the time intervals considered. Hence a point travelling 30 miles in 6 hours, at uniform speed, travels

5 miles in 1 hour, 1 mile in one-fifth of an hour, and so on, as indicated in the following table:

Space described (in miles).	Time (in hours).	Velocity (in miles per hour).
30	6	$v = \frac{30}{6} = 5$
5	1	$v = \frac{5}{1} = 5$
1	$\frac{1}{5}$	$v = \frac{1}{.2} = 5$
$\frac{1}{10}$	$\frac{1}{50}$	$v = \frac{.1}{.02} = 5$
$\frac{1}{100}$	$\frac{1}{500}$	$v = \frac{.01}{.002} = 5$
.		
.		
$\frac{1}{1000000}$	$\frac{1}{5000000}$	$v = \frac{.000001}{.0000002} = 5$
$\frac{1}{10000000000}$	$\frac{1}{50000000000}$	$v = \frac{.00000000001}{.00000000002} = 5$

Now it is most important to note, that no matter how small the space traversed may be, even if beyond all possibility of measurement and conception, the *ratio* of any such exceedingly small space to the minute time interval taken in traversing it, invariably gives as a quotient 5, in the example cited. The last space taken, which is .00000000001 miles is equivalent to about one-six hundred millionth of an inch, while the corresponding time interval is .00000000002 hours, which is approximately three billionths of a second; the ratio $\frac{s}{t}$ is nevertheless equal to 5, giving a velocity of five miles an hour.

In general we may state that the ratio of two quantities, each of which is so small as to be entirely beyond our comprehension, *may*, nevertheless, result in an appreciable and practically useful quotient, a fact which should be most carefully noted.

When we wish in general to indicate that we are considering a small finite space, we employ the symbol Δs , while Δt is used to express a short time interval. Thus $\frac{\Delta s}{\Delta t}$ means that we are comparing a small space with a correspondingly small time interval.

In the example above, we have:

$$\frac{\Delta s}{\Delta t} = 5 \quad \text{or} \quad \Delta s = 5 \cdot \Delta t.$$

Carrying this conception still further we may consider Δs to become smaller than any imaginable quantity; in other words, that the space taken is infinitely small. This we indicate by ds , and call ds a differential of space.

The same process of reasoning applied to Δt gives dt as representing an infinitely small time interval or a differential of time. We often refer to ds and dt simply as differentials. The infinite reduction of the space and time will not affect the value of their *ratio*. We will still have

$$\frac{ds}{dt} = 5 \quad \text{and} \quad ds = 5 \cdot dt.$$

The value of the ratio of two differentials such as ds and dt , is referred to by German mathematicians as a *differential quotient*; hence 5, in our case, is called a *differential quotient*.

Again, if we write the expression, $\frac{ds}{dt} = 5$ in the form $ds = 5 \cdot dt$, then 5 becomes a coefficient, for it multiplies

the differential of the dependent variable dt and is therefore called a *differential coefficient*.

For the present the student might consider a *differential quotient*, in general, as the value of the ratio of two differentials; while the term *differential coefficient* implies the same quantity regarded as that factor of the differential of the independent variable which makes it equal to the differential of the dependent variable.

It will be found later that these conceptions are susceptible of a deeper meaning and lead to results of great practical value.

Progress in the study of the calculus, primarily depends upon the thorough understanding of the meaning of the differential quotient or coefficient. Much misunderstanding has arisen from the fact, that when we have such expressions as above, viz. $\frac{ds}{dt} = 5$ and also $ds = 5 \cdot dt$, it is customary to speak of the 5 in *either case* as a differential coefficient; in the former case it is strictly a quotient, which quotient becomes a coefficient when we write $ds = 5 \cdot dt$.

ART. 5. Rates of Increase.

Suppose we have a square A_1 (see Fig. 1), a side of which

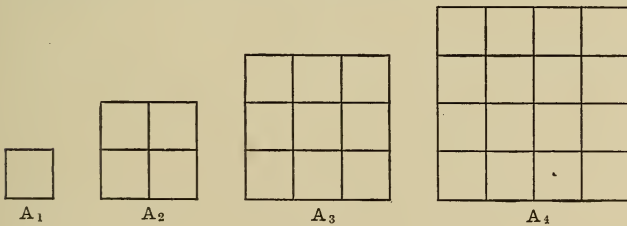

Fig. 1.

is of unit length; further imagine that while the left lower corner remains fixed, the sides are capable of continuous

uniform extension, so that the square A_1 assumes larger and larger proportions, thus passing, during this continuous expansion, through the dimensions shown by A_2, A_3, A_4 , in which the side of each new square is one unit greater than that of the preceding. Now by an inspection of A_1, A_2, A_3, A_4 , we see that

Square.	Side in Linear Units.	Area in Square Units.	Area Increase in Square Units.
A_1	1	1	
A_2	2	4	3
A_3	3	9	5
A_4	4	16	7

Note that if the side of each square is increased by additions of *one linear unit*, the area increases by 3, 5, and 7 square units, and as the side lengthens, *the greater is the proportionate increase of area*, in fact the square might be considered as growing with an accelerated increase of area. As before said we are considering that the square *continuously* expands; now in order to compare the increase in area with the increasing length of the side, we find it convenient to assume an arbitrary unit of time. Hence we say *the rate of increase of the square* is greater than *the rate of increase of its side*.

This assumption, which is very general, enables us to compare the relative *rate* of increase or decrease of any two mutually dependent quantities. Thus we say the rate of increase of the volume of a sphere, in units of volume, is greater than the rate of increase of its diameter, in linear units, and so on.

Let us return to the case of the bicycle and the observer (Art. 4); we found, that if we wished to calculate the actual

speed of the bicycle at the *moment* of passing the point of observation, then the smaller the space measured, the more accurate would be our results; this would clearly hold if the bicyclist passed the observer with an *accelerated velocity*.

Now this case is similar to that of the square above mentioned, for suppose the side of the square, which is continuously lengthening, pass through the point at which $x = 3$ linear units, we might ask ourselves, what is the relation of the rate of increase of area of the square, *at the moment when $x = 3$* to the rate of linear increase of its side.

Let the side $x = 3$ centimetres, and let y be the area of the square on x ; we thus get $y = x^2 = 9$. Now let the side x receive a small increase, called an *increment*, which we will represent by Δx (read, delta x), let $\Delta x = 0.1$ centimeters; thus x becomes $x + \Delta x = 3 + 0.1 = 3.1$. Upon the increased side describe a second square; we now have two squares (see Fig. 2), and the increase in area of y , due to the increment Δx , is represented by the shaded strip; this increment, which we will call Δy , is obviously an *increment of area*. We thus have:

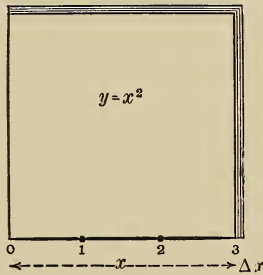

Fig. 2.

$$\text{Area of square on } (x + \Delta x) = (x + \Delta x)^2 = (3.1)^2 = 9.61.$$

$$\text{Area of square on } x = x^2 = (3)^2 = 9.$$

$$\text{Difference} \quad (x + \Delta x)^2 - x^2 = \Delta y = 0.61.$$

Now the difference $\Delta y = 0.61$, is the increase in area of the square y , in square centimetres, during the time that x increased from $x = 3$ to $x = 3.1$ centimetres; intro-

ducing the arbitrary unit of time before alluded to, we say:

$$\frac{\text{Rate of increase of square } y}{\text{Rate of increase of side } x} = \frac{0.61}{.1} = \frac{\Delta y}{\Delta x} = 6.1.$$

We will now tabulate a number of values, calculated exactly as above, for $\frac{\Delta y}{\Delta x}$, for $x = 3$ centimetres:

$$\text{If } \Delta x = 0.1 \text{ then } \frac{\Delta y}{\Delta x} = \frac{.61}{.1} = 6.1$$

$$\Delta x = .01 \quad \frac{\Delta y}{\Delta x} = \frac{.0601}{.01} = 6.01.$$

$$\Delta x = .001 \quad \frac{\Delta y}{\Delta x} = \frac{.006001}{.001} = 6.001.$$

$$\Delta x = .000001 \quad \frac{\Delta y}{\Delta x} = \frac{.000006000001}{.000001} = 6.000001.$$

We thus see that $\frac{\Delta y}{\Delta x}$ approaches the value 6 more and more nearly, *the less the increment* Δx .

If Δx is infinitely small, in other words becomes the differential dx , then the number of zeroes to the right hand of the decimal point before the one would be infinite, and the value of the quotient would be truly 6. If Δx becomes a differential of length, dx , then Δy , becomes a differential of area, dy ; and as the quotient 6 is the result of the comparison of these two differentials, it is, therefore, a differential quotient; thus we write:

$$\frac{dy}{dx} = 6.$$

Hence we say $\frac{\text{the rate of increase of the square}}{\text{the rate of increase of the side}} = 6$ at moment when the side is 3 units in length. As before

mentioned we sometimes write $dy = 6 dx$; here, *six* figures as the coefficient of the differential dx of the independent variable, and is therefore called a differential coefficient. We might calculate this differential quotient in another manner, which would lead us to a more general result; thus, taking $x = 3$, and $\therefore y = x^2 = 9$ and $\Delta x = .001$, the side x becomes $x + \Delta x$. Now area of square,

$$\left\{ \begin{array}{l} (x + \Delta x)^2 = (3 + .001)^2 = 9 + 2(3)(.001) + .000001 \\ x^2 = 3^2 = 9 \end{array} \right.$$

By subtraction; $\Delta y = 2(3)(.001) + .000001$
 $2(x)(\Delta x) + \overline{\Delta x^2}$

Dividing by $\Delta x = .001$, we get $\frac{\Delta y}{\Delta x} = 2(3) + .001$.

Now if Δx becomes dx , then the number of zeroes before the 1 in the last term would be infinite and we would have $\frac{dy}{dx} = 2(3) = 6$.

Now 3 is the length of the side x , which is as we see introduced into the calculation in a perfectly general way, as is also the factor 2. Thus if $x = 8$ and $\Delta x = .00001$ then

$$\frac{\Delta y}{\Delta x} = 2(8) + .00001$$

$$2(x) + \Delta x$$

and similarly for any other values of x and Δx . Hence it would seem that we might write for the differential quotient the general value $\frac{dy}{dx} = 2x$, where x represents the length of a side at any moment. If $x = 7$ then $2x = 14$, and since $dy = 2x dx$, we find that the rate of increase of the square in square units = 14 times the rate of increase of the side in linear units at the moment when the side is 7 units in length. We will now approach

this matter more generally and see if the result above indicated is a rigid truth.

ART. 6. *Geometrical view of the differential coefficient of $y = x^2$.*

Suppose we have a square the side of which is x (see Fig. 3). The area x^2 , we call y , thus we have $y = x^2$.

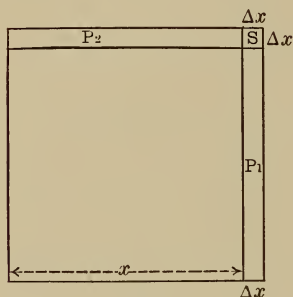

Fig. 3.

Now let x receive an increment Δx , then $x + \Delta x$ can be considered as the side of a larger square $(x + \Delta x)^2$. Completing the construction shown in Fig. 3, we notice that the difference between the squares $(x + \Delta x)^2$ and x^2 , which is $(x + \Delta x)^2 - x^2$, is made up of two rectangles P_1 and P_2 together with the small square S . The rectangles have each an area of $x \cdot \Delta x$ and the square S of $\Delta x \cdot \Delta x = \Delta x^2$. These parts taken together represent the increase Δy of the square y when x changes to $x + \Delta x$, in virtue of its increment Δx . We thus get :

$$\Delta y = 2 \cdot x \cdot \Delta x + \Delta x^2$$

$$\text{(Increase of square } y) = \text{(Two rectangles } P_1 P_2) + \text{(Square } S).$$

We further notice that the square S is much less in area than the two rectangles P_1 and P_2 . Now the smaller the increment Δx , the narrower become the rectangles and the less the relative area of S . This is easily seen, for suppose Δx is exceedingly small, then the rectangles P_1 and P_2 may be represented by long thin lines (see black line Fig. 4), while S is reduced to their intersection.

If now we consider the lines representing these rectangles to be infinitely thin, then the sides of the squares become infinitely short, while the lines representing the rectangles remain of finite length, hence it would take an infinite number of such squares to make one of the rectangles. Clearly the square S tends to vanish if the rectangles become infinitely narrow, that is if Δx changes to dx then $(dx)^2$ is evanescent, that is, *tends to vanish*.

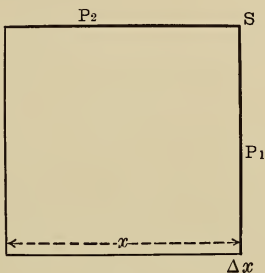

Fig. 4.

We had above, $\Delta y = 2x\Delta x + (\Delta x)^2$.

If Δx becomes dx then $dy = 2x dx$

and $\frac{dy}{dx} = 2x$.

We thus find that if $y = x^2$, then $\frac{dy}{dx} = 2x$. In other words we have found that if a quantity y (in our case the area of a square) is dependent upon another x (here the side of a square), in such a manner that $y = x^2$, then *the rate of increase of y at any moment, compared to the rate of increase of x at the same moment, is $= 2x$* , which latter quantity is called the differential quotient of the expression $y = x^2$, or more generally, the differential coefficient of x^2 with respect to x .

ART. 7. *Differential coefficient of $y = x^2$. Analytical method.*

We will now examine a general analytical method of obtaining the differential coefficient of x^2 with respect to x in the case of the function $y = x^2$.

$$\begin{array}{l} \text{Given} \qquad \qquad \qquad y = x^2, \\ \text{then } y + \Delta y = (x + \Delta x)^2 = x^2 + 2x\Delta x + \Delta x^2, \\ \text{now} \qquad \qquad \qquad y + \Delta y = x^2 + 2x\Delta x + \Delta x^2, \\ \text{and} \qquad \qquad \qquad y = x^2. \end{array}$$

$$\text{Subtracting;} \qquad \qquad \qquad \frac{\Delta y = 2x\Delta x + \Delta x^2.}{\hline}$$

$$\therefore \frac{\Delta y}{\Delta x} = 2x + \Delta x.$$

If Δx becomes dx then the value of Δx alone tends to vanish or is evanescent.

$$\therefore \frac{dy}{dx} = 2x.$$

Hence again we find if $y = x^2$, then the differential quotient of the expression $y = x^2$ is $2x$; which is also the differential coefficient of x^2 with respect to x , for $2x$ is the multiplier of the differential dx of the independent variable x when we write $\frac{dy}{dx} = 2x$ in the form of $dy = 2x \cdot dx$.

ART. 8. *Differential coefficient of $y = x^3$.*

We will now take another case; if $y = f(x)$ and the function be such that $y = x^3$, what is the relation of dy to dx ?

Suppose x to be a straight line, then x^3 will represent the volume of a cube = y .

Now let x increase by Δx , then $x + \Delta x$ will form the side of a second larger cube whose volume is $y + \Delta y$.

Now if we examine Fig. 5, we see that Δy which is the difference in volume of the two cubes, $(x + \Delta x)^3$ and x^3 , is made up of three slabs each of dimensions $x \cdot x \cdot \Delta x = x^2 \Delta x$ together with three parallelipipidons of dimensions $x \cdot \Delta x \cdot \Delta x = x \cdot \Delta x^2$ and of one cube of volume $\Delta x \cdot \Delta x \cdot \Delta x = \Delta x^3$.

Hence we have $\Delta y = 3 x^2 \Delta x + 3 x \Delta x^2 + \Delta x^3,$

and $\frac{\Delta y}{\Delta x} = 3 x^2 + 3 x \Delta x + \Delta x^2.$

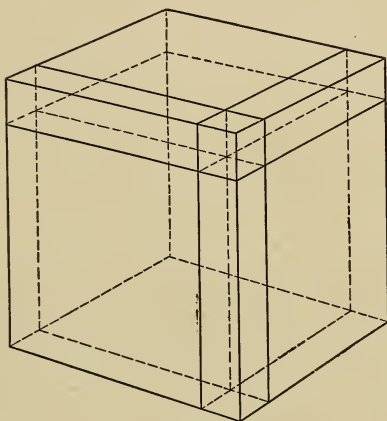

Fig. 5.

If Δx becomes dx then,

$$\frac{dy}{dx} = 3 x^2 + 3 x \cdot dx + (dx)^2.$$

Now both $3 x \cdot dx$ and $(dx)^2$ are evanescent, but remembering the *ratio* of the infinitely small quantities dy , dx , is finite, it is in fact the quotient $3 x^2$.

Hence if $y = x^3$ then $\frac{dy}{dx} = 3 x^2,$

or

$$dy = 3 x^2 dx.$$

Therefore the differential coefficient of $y = x^3$, with regard to x , is $3 x^2$ and the expression $dy = 3 x^2 dx$ means that at *any moment* the rate of increase of the volume in

units of volume is $3x^2$ times the rate of increase of the side in linear units.

If the sides be 2 inches and the increment Δx is .001 then $\frac{\Delta y}{\Delta x} = 3x^2 + 3x\Delta x + \Delta x^2$.

$$\begin{aligned}\therefore \frac{\Delta y}{\Delta x} &= 3(4) + 3(2)(.001) + (.001)^2 \\ &= 12 + .006 + .000001.\end{aligned}$$

Obviously if Δx becomes evanescent, the value of the right hand member becomes = 12.

$$\therefore \text{when } \frac{\Delta y}{\Delta x} \text{ becomes } \frac{dy}{dx}, \text{ then } \frac{dy}{dx} = 12.$$

This result we could obtain at once from the previous expression $\frac{dy}{dx} = 3x^2$; for putting $x = 2$,

$$\text{we get } \frac{dy}{dx} = 3(4) = 12.$$

Meaning, that *at the moment* when the side x is two units in length, the volume of the cube increases 12 times as fast in units of volume as the side in linear units.

ART. 9. *d.c. of $y = x^3$, analytically.* Orders of Infinitesimals.

$$\begin{aligned}\text{If } & y = x^3, \\ \text{then } & y + \Delta y = (x + \Delta x)^3 \\ & \therefore y + \Delta y = x^3 + 3x^2\Delta x + 3x\overline{\Delta x^2} + \overline{\Delta x^3}, \\ & y = x^3.\end{aligned}$$

$$\text{Subtracting; } \Delta y = 3x^2\Delta x + 3x\overline{\Delta x^2} + \overline{\Delta x^3}.$$

And if Δx becomes dx ,

$$\text{then } dy = 3x^2 dx + 3x(dx)^2 + (dx)^3.$$

Now dx is an infinitesimal, and when it occurs in the first power, is said to be of the *first order*; similarly $(dx)^2$ and $(dx)^3$ are of the *second* and *third orders* respectively.

Obviously the same reasoning that causes us to consider an infinitesimal of the first order as unimportant when compared to a finite quantity, leads us to regard an infinitesimal of any higher order as evanescent when compared with one of lower order. Then the quantities $3x(dx)^2$ and $(dx)^3$ are unimportant terms in the expression

$$dy = 3x^2dx + 3x(dx)^2 + (dx)^3.$$

Hence
$$dy = 3x^2dx$$

and
$$\frac{dy}{dx} = 3x^2$$

ART. 10. *The d.c. and the gradient.*

In engineering work grades are often described by referring the rise in level of a point to its corresponding horizontal distance from some fixed position. We thus speak of a grade of 20 ft. in 100 ft., meaning the slope resulting from a rise of 20 ft. in 100 ft., or 1 ft. in 5 ft., as indicated in Fig. 6, and measured by the tangent $\angle BAC$. The

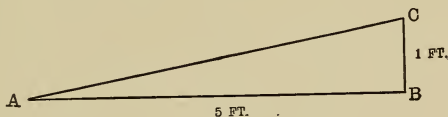

Fig. 6.

term "gradient" is applied to the numerical value of the ratio,

$$\frac{\text{vertical rise}}{\text{horizontal distance}} = \frac{BC}{AB}. \quad (\text{See Fig. 6.})$$

Now $\text{tangent } BAC = \frac{BC}{AB} = \frac{1}{5} = 0.2$, and since the natural tangent of $(11^\circ 19') = 0.2$ unit, therefore, the

gradient of the slope AC is 0.2, and the angle BAC is approximately $11^{\circ} 19'$.

Suppose a straight line AB to make an angle DCB with the x -axis. (See Fig. 7.)

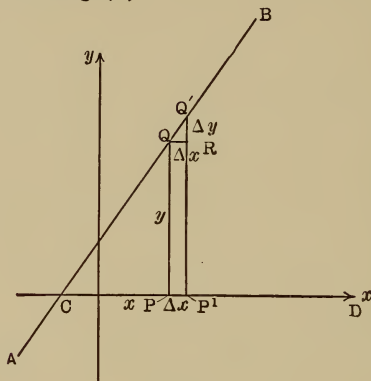

Fig. 7.

Let the co-ordinates of any point Q on AB be x and y . Let x be increased by Δx , and y by Δy .

Completing the construction shown in Fig. 7, we have

$$\tan \angle DCB = \frac{PQ}{CP} = \frac{RQ'}{QR} \quad (\text{by similar triangles}),$$

$$\text{and} \quad \frac{RQ'}{QR} = \frac{\Delta y}{\Delta x};$$

$$\text{Hence} \quad \frac{\Delta y}{\Delta x} = \text{tangent } \angle DCB.$$

If the increment Δx becomes infinitely small, then

$$\frac{dy}{dx} = \text{tangent } \angle DCB.$$

This means that in the case of a linear function, that is, a function whose graph is a straight line, the ratio of an infinitely small increment of the y -ordinate to dx gives the

tangent of the angle which the straight line makes with the x -axis, and therefore its gradient.

We will now test this numerically by the following example.

Given the linear function, $y = 0.7x + 2$, to find the differential coefficient with respect to x , namely, the value of $\frac{dy}{dx}$, and hence the gradient of the line.

We have $y = 0.7x + 2$,

then $y + \Delta y = 0.7(x + \Delta x) + 2$.

Hence $y + \Delta y = 0.7x + 0.7\Delta x + 2$.

But $y = 0.7x + 2$.

Subtracting; $\Delta y = 0.7\Delta x$.

$$\therefore \frac{\Delta y}{\Delta x} = 0.7,$$

and $\frac{dy}{dx} = 0.7$.

Now 0.7 is the approximate natural tangent of 35° . Hence by differentiating the function $y = 0.7x + 2$ we have not only found the ratio of the increase of the ordinate to the abscissa at any moment, but also *the gradient of the line* and hence the angle it makes with the x -axis.

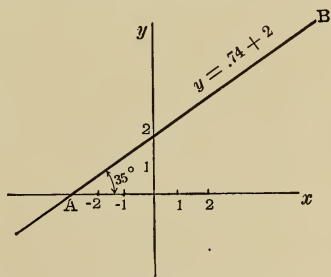

Fig. 8.

The line AB, Fig. 8, was plotted from the equation $y = 0.7x + 2$, and the angle BAx will be found, upon measurement with a protractor, to be approximately 35° .

ART. 11. *The gradient of a curve.*

Suppose we have two bodies, B_1 and B_2 , travelling in parallel paths, the former with an *accelerated* velocity of 2 ft. per second per second and the latter with a *uniform* velocity of 2 ft. per second. Further, imagine that B_1 starts upon a line A_1A_2 (see Fig. 9), while B_2 starts one foot to the left of it but at *the same moment*.

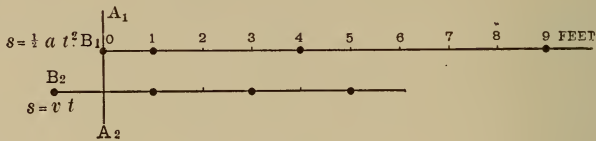

Fig. 9.

In the first case, that of B_1 , where the velocity is accelerated, we have $s = \frac{1}{2} a t^2$, where $a = 2$ is the acceleration, hence $s = \frac{1}{2}(2) t^2$, and therefore, $s = t^2$.

In the second case, the velocity is constant, and we have the space traversed by B_2 expressed by the equation $s = vt$, and since $v = 2$, we have $s = 2t$.

The following table gives the spaces traversed by B_1 and B_2 at the conclusion of different time intervals.

B_1 .	B_2 .
Space traversed from rest at the end of	Space traversed from rest at the end of
$\frac{1}{2}$ second = $\frac{1}{4}$ ft.	$\frac{1}{2}$ second = 1 ft.
1 second = 1 ft.	1 second = 2 ft.
2 seconds = 4 ft.	2 seconds = 4 ft.
3 seconds = 9 ft.	3 seconds = 6 ft.

In Fig. 9, we have depicted the relative positions of the two bodies B_1 and B_2 graphically, showing a portion of their paths, and using the data given in the above table. Notice

that *during* the first second, B_1 travels *slower* than B_2 , and that B_2 has caught up with B_1 at the end of the first second, and for *one instant of time* the two are *abreast*, and *travelling with the same velocity*, after which the speed of B_1 is *greater* than that of B_2 and is constantly growing, as shown by the increasing distance covered in each ensuing second.

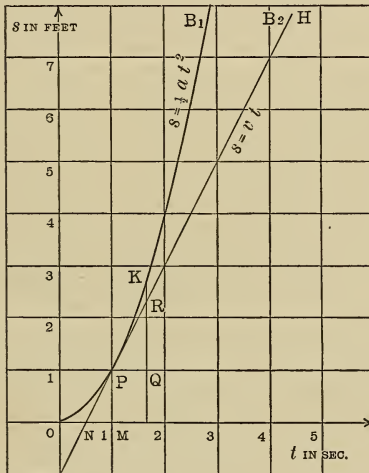

Fig. 10.

Plotting the values given for s and t in the above table we obtain in the case of B_1 a curve (see Fig. 10), and in that of B_2 a straight line; this latter, it will be noticed, touches the curve at the point P ; which point corresponds to the positions of the two bodies when they are, *for an instant of time*, one foot from the line A_1A_2 and traveling with the same velocity.

We have already said (Art. 10) that the gradient of a line is measured by the tangent of the angle that the line makes with the abscissa; but if a line is a geometrical tangent to a curve, then at the point of tangency the two have the same direction. Hence the slope of the geometrical tangent to a curve, at a point, shows the steepness of the curve at that point, but the gradient of the line is measured by the tangent of its abscissa angle. We thus have the following definition: *The gradient of a curve at any point is measured by the tangent of the angle which the geometrical tangent, at that point, makes with the abscissa.*

Now the gradient of the line NH is measured by $\tan \text{MNP} = \frac{\text{MP}}{\text{NM}} = \frac{1}{\frac{1}{2}} = 2$, and this quantity is also a measure of the gradient of the curve at the point P, from the above definition.

Let us now take increments to the ordinates of P; let the time increment of t be $\Delta t = \text{PQ}$, in both the case of the curve, and that of the line; for the space increment we have, for the line, $\Delta s = \text{QR}$, and for the curve, $\Delta s = \text{QK}$.

$$\text{Hence for the line, } \frac{\Delta s}{\Delta t} = \frac{\text{QR}}{\text{PQ}},$$

$$\text{for the curve, } \frac{\Delta s}{\Delta t} = \frac{\text{QK}}{\text{PQ}} = \frac{\text{QR} + \text{RK}}{\text{PQ}}.$$

Now clearly in this case if Δt is infinitely small, then the latter expression becomes $\frac{ds}{dt}$, as can be inferred from the figure.

Hence $\frac{ds}{dt}$ at the point P has the same value for both the line and curve, namely $\frac{ds}{dt} = 2$.

That is, the value of the differential quotient of the function $s = t^2$, for the point P (1, 1), namely $\frac{ds}{dt} = 2$, is the tangent of the angle the geometric tangent makes at P.

We will now see if this statement is susceptible to a general application.

Let $y = f(x)$ be any curve of which a portion of the

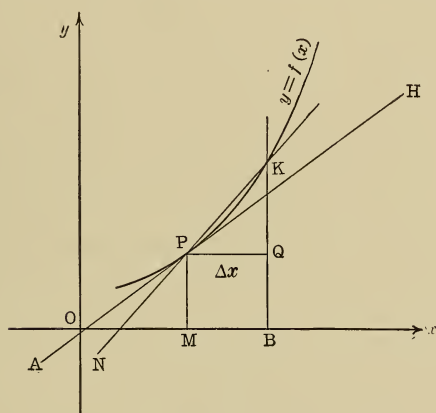

Fig. 11.

graph is shown in Fig. 11. Suppose the point P upon $y = f(x)$ has the co-ordinates $OM = x$ and $MP = y$.

If $MB = \Delta x$ then $QK = \Delta y$, and the ratio of the rate of increase of the function y to the rate of increase of the independent variable x , will be expressed by $\frac{\Delta y}{\Delta x}$. Now

$\frac{\Delta y}{\Delta x} = \tan KNB$; which latter is the tangent of the angle that the geometrical secant NK makes with the x -axis.

The value of $\frac{\Delta y}{\Delta x}$ will depend upon the size of the increment Δx , as we have already seen, except in the case of a straight line when the function is linear. Further the value of $\frac{\Delta y}{\Delta x}$ is dependent upon the position of the point P, as can be readily inferred from the figure, for if P were moved to the right, then an increment Δx would bring about an immensely increased corresponding increment, Δy , because of the steeper slope of the curve, and therefore $\frac{\Delta y}{\Delta x}$ would assume a greater value.

If, however, Δx is gradually decreased, then the point K will continually approach the point P, while the secant NK will cut the abscissa at a more and more acute angle, until finally, when $\Delta x = dx$, the secant will take its limiting position AH, which is the geometric tangent to the curve $y = f(x)$ at the point P, and we have $\frac{dy}{dx} = \tan \text{HOM}$.

It is important to notice that the value of $\frac{dy}{dx}$ depends wholly on the direction of the curve at the point P, and, therefore, expresses its gradient at this point.

Hence, if $y = f(x)$, then the differential coefficient of this function is equal to the tangent of the angle which the geometric tangent to the curve at any point upon it makes with the x -axis, while, at the same time it expresses the gradient of the curve at that point.

From Art. 9, we know that if $y = x^3$ then $\frac{dy}{dx} = 3x^2$; putting $x = 1.1$ we find $3x^2 = 3(1.1)^2 = 3.63$, therefore

$\frac{dy}{dx} = 3.63$; which on referring to a table is found to be the natural tangent of $74^\circ 36'$.

We thus have found that given $y = x^3$, the ratio of the rate of increase of the ordinate to that of the abscissa at a point where abscissa is 1.1, is 3.63. This latter is the gradient of the curve at that point, while the geometrical tangent makes an angle of $74^\circ 36'$ with the x -axis.

Let us test the above calculation by actually plotting the curve and drawing the tangent. Fig. 12 shows a part of

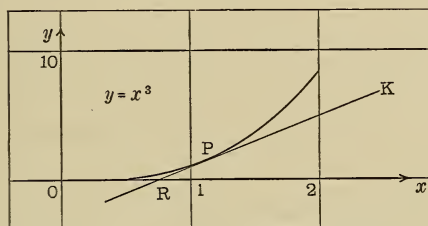

Fig. 12.

the curve, while P is that point whose abscissa is 1.1. If the angle KRx be measured, it will be found to be about 20° , but the angle which the tangent to the curve at P makes with the x -axis, is, according to our previous calculation, $74^\circ 36'$; the discrepancy is due to the fact that the unit of measurement used on the x -axis is 10 times that used on the y -axis.

In order that the tangent should represent the true gradient of the curve at P, we must refer the ordinates and abscissas to the *same scale*, or we will not obtain the true comparative rate of increase of y to x . $\tan 20^\circ = 0.363$ (nearly), or $\frac{1}{10}$ of the true value.

In order to make this important point quite clear, we have plotted the curve $y = x^3$ a second time (see Fig. 13),

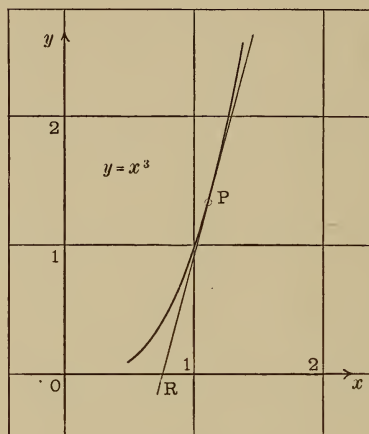

Fig. 13.

and have used the same scale for both ordinates and abscissas. Upon measuring the angle PRx with a protractor it will be found to be $74^{\circ} 36'$ approximately, which corresponds with the result $\frac{dy}{dx} = 3.63$.

ILLUSTRATIVE EXAMPLES.

I. Derive the differential coefficient of the function

$$y = 2x^2 - 3x + 1.$$

Now, $y + \Delta y = 2(x + \Delta x)^2 - 3(x + \Delta x) + 1.$

$$\begin{array}{l} \therefore y + \Delta y = 2x^2 + 4x\Delta x + 2\overline{\Delta x^2} - 3x - 3\Delta x + 1 \\ \text{but, } y = 2x^2 \qquad \qquad \qquad - 3x \qquad \qquad + 1 \end{array} \left. \vphantom{\begin{array}{l} \therefore y + \Delta y = 2x^2 + 4x\Delta x + 2\overline{\Delta x^2} - 3x - 3\Delta x + 1 \\ \text{but, } y = 2x^2 \qquad \qquad \qquad - 3x \qquad \qquad + 1 \end{array}} \right\}$$

Subtracting; $\Delta y = 4x \Delta x - 3 \Delta x + 2 \overline{\Delta x^2}$.

$$\therefore \frac{\Delta y}{\Delta x} = 4x - 3 + 2 \Delta x.$$

If Δx becomes dx , then $2 dx$ is evanescent.

Hence $\frac{dy}{dx} = 4x - 3$.

II. Find the gradient of the curve $x^2 - x + 2 = y$ at the point where $x = 1.15$, and the angle the geometrical tangent at this point makes with the x -axis.

$$y = x^2 - x + 2,$$

$$y + \Delta y = (x + \Delta x)^2 - (x + \Delta x) + 2,$$

$$y + \Delta y = x^2 + 2x \Delta x + \overline{\Delta x^2} - x - \Delta x + 2,$$

$$y = \frac{x^2 - x + 2}{}$$

$$\therefore \Delta y = 2x \Delta x - \Delta x + \overline{\Delta x^2}.$$

$$\frac{\Delta y}{\Delta x} = 2x - 1 + \Delta x. \quad \text{Hence } \frac{dy}{dx} = 2x - 1.$$

To find the gradient of the curve at the point where $x = 1.15$ we substitute as follows:

$$\frac{dy}{dx} = 2x - 1 = 2(1.15) - 1 = 1.30.$$

Hence 1.30 is the gradient required, and since $\tan 52^\circ 26' = 1.30$, we find, therefore, that the geometrical tangent at the point where $x = 1.15$ makes an angle of $52^\circ 26'$ with the x -axis.

III. Find the rate at which the area of a square is increasing at the instant when the side is 6 feet long, supposing the latter to be subject to uniform increase of length at the rate of 4.5 feet per second.

Let x = length of side,

$$y = x^2 = \text{area.}$$

By Art. 7, $dy = 2x dx$,

that is, the rate of variation of area = $2x$ times the rate of variation of the side.

Substituting the given values, we get

$$dy = 2(6)(4.5) = 54 \text{ sq. ft. per second.}$$

EXERCISE I.

Find the differential coefficient of the following five functions by the method of Art. 7.

1. $y = 2x^2 - 3.$

2. $y = (x - 2)(x + 3).$

3. $w = \frac{2}{x^2}.$

4. $y = x^4.$

5. $y = \frac{x - 1}{x + 1}.$

6. Plot the graph of $x^2 + 3x - 2 = y.$

(a) What can you tell about the roots of the equation from the appearance of the graph?

(b) Find the general expression for the gradient of the curve at any point.

(c) Find the angle which the geometrical tangent makes with the curve at those points on it where $x = 0$, $x = -\frac{3}{4}$, $x = -\frac{3}{2}$, $x = -2.$

(d) Draw tangents at the points where $x = -\frac{3}{4}$ and $x = -2$, and test your answers to question *c* by actual measurement.

(e) What effect would it have upon the gradient of the graph at any point, if the scale for the y -axis was made 10 times as large as that of the x -axis?

(j) If $y = f(x)$ and $\frac{dy}{dx} = \alpha$ for a certain x value, what does this imply?

7. Differentiate the function $s = \frac{1}{2} \alpha t^2$ with respect to t . What does the result mean?

8. A man cuts a circular plate of brass the diameter of which is 4 inches; after heating he finds the diameter to have increased by .006 of an inch. What is the increase of area?

9. If x be the side of a cube which is increasing uniformly at the rate of 0.5 inch per second per second, at what rate is the volume increasing at that instant when the side is exactly 2 inches in length?

10. If a body travels with an accelerated velocity of 2 ft. per second per second, and we call the space traversed at the end of the first second s , show by arithmetical computation that if Δs is any positive increase of s , then $\frac{\Delta s}{\Delta t}$ approaches more nearly the actual momentary velocity of the body at the end of the first second, the smaller Δs is taken.

CHAPTER II.

DIFFERENTIATION.

I. Algebraic and Transcendental Functions.

ART. 12. An *Algebraic Function* is one in which the only operations indicated are, addition, subtraction, multiplication, division, involution, and evolution; further, such a function must be expressed by a finite number of terms, and any exponents involved must be constant. Examples of algebraic functions are,

$$x^2 + 2x, (x - m)^{\frac{1}{2}}, (x - n)^{\frac{1}{3}}, \frac{\sqrt[3]{x^2 + 3x - 1}}{(x - 4)}.$$

In distinction to the above we have the so-called *Transcendental Functions*, which cannot be expressed algebraically in a finite number of terms; examples of which are as follows:

$$\sin x, \tan x, \text{vers } x, \log_e x, e^x.$$

The Binomial Theorem.

In works on algebra a general proof of the following expansion may be found:

$$\begin{aligned} (a + b)^n &= a^n + na^{n-1}b + \frac{n(n-1)}{1 \cdot 2} a^{n-2}b^2 \\ &+ \frac{n(n-1)(n-2)(n-3)}{1 \cdot 2 \cdot 3} a^{n-3}b^3 + \dots \end{aligned}$$

For convenience we will put $n = C_1, \frac{n(n-1)}{1 \cdot 2} = C_2$, etc.;

we thus get,

$$(a + b)^n = a^n + C_1 a^{n-1}b + C_2 a^{n-2}b^2 + C_3 a^{n-3}b^3 + \dots$$

ART. 13. *Differentiation of ax^n and x^n .*

If $y = ax^n,$

then $y + \Delta y = a(x + \Delta x)^n.$

Expanding the right-hand member, as explained in the previous paragraph, and multiplying through by a , we get

$$y + \Delta y = ax^n + a C_1 x^{n-1} \Delta x + a C_2 x^{n-2} (\Delta x)^2 + a C_3 x^{n-3} (\Delta x)^3 + \dots$$

But, $y = ax^n.$

$$\therefore \Delta y = \frac{a C_1 x^{n-1} \Delta x + a C_2 x^{n-2} (\Delta x)^2 + a C_3 x^{n-3} (\Delta x)^3 + \dots}{}$$

and $\frac{\Delta y}{\Delta x} = a C_1 x^{n-1} + a C_2 x^{n-2} \Delta x + a C_3 x^{n-3} (\Delta x)^2 + \dots$

If Δx becomes dx , then all the terms of the right-hand member after the first are evanescent (Art. 6); and remembering $C_1 = n$ (see Art. 12), we get

$$\frac{dy}{dx} = anx^{n-1}.$$

Now if in the function $y = ax^n$, $a = 1,$

we get $y = x^n,$

and $\frac{dy}{dx} = nx^{n-1}.$

To differentiate $y = x^n$ with respect to x . *First, multiply x by the index and then obtain the new power by diminishing the index by unity.*

Example: $y = x^4$; $\frac{dy}{dx} = 4x^{4-1} = 4x^3.$

To differentiate $y = ax^n$; *differentiate the function x^n and multiply the result by the constant.*

Example: $y = 5x^3$; $\frac{dy}{dx} = 5(3)x^{3-1} = 15x^2.$

The results above obtained are true for all values of n , whether positive, negative, or fractional; the proof of the latter two cases is simple, and is left as an exercise for the student.

$$\text{Examples: } y = \frac{1}{2} x^{-3}; \frac{dy}{dx} = -\frac{3}{2} x^{-3-1} = -\frac{3}{2} x^{-4},$$

$$y = \frac{2}{3} x^{\frac{2}{5}} \frac{dy}{dx} = \frac{2}{5} \cdot \frac{2}{3} x^{\frac{2}{5}-1} = \frac{6}{5} x^{-\frac{3}{5}}.$$

$$\begin{aligned} \text{Example: } * y = 2 \sqrt[3]{x^2} \therefore y = 2 x^{\frac{2}{3}}; \frac{dy}{dx} &= \frac{4}{3} x^{-\frac{1}{3}} \\ &= \frac{4}{3 \sqrt[3]{x}}. \end{aligned}$$

ART. 14. *Differentiation of a constant.*

We have defined a constant as a quantity which does not change or alter its value. Hence if k is a constant, $\Delta k = 0$ and $\frac{\Delta k}{\Delta x} = 0$, therefore $\frac{dk}{dx} = 0$.

ART. 15. *Differentiation of a sum.*

Suppose $y = u + v$, when both u and v are functions of x . Now if x becomes $x + \Delta x$, then u and v become $u + \Delta u$ and $v + \Delta v$, respectively, and we get,

$$y + \Delta y = u + \Delta u + v + \Delta v.$$

But

$$\begin{aligned} y &= u + v. \\ \therefore \Delta y &= \Delta u + \Delta v. \end{aligned}$$

$$\text{Divide by } \Delta x; \therefore \frac{\Delta y}{\Delta x} = \frac{\Delta u}{\Delta x} + \frac{\Delta v}{\Delta x}.$$

* If the function involves a radical which can be reduced to the form $x^{\frac{n}{v}}$, then express the radical as a fractional power and proceed as above.

If Δx becomes dx ,
 then
$$\frac{dy}{dx} = \frac{du}{dx} + \frac{dv}{dx}.$$

In a similar manner we can show that if

$$y = u \pm v \pm w \pm \dots$$

then
$$\frac{dy}{dx} = \frac{du}{dx} \pm \frac{dv}{dx} \pm \frac{dw}{dx} \pm \dots$$

Hence, the differential coefficient of the sum of several functions is the sum of the differential coefficients of the several parts, due regard being given to the signs.

Example:
$$y = 3x^3 - 5x^2 + 2x + 3.$$

By Art. 14,
$$\frac{d(3)}{dx} = 0.$$

$$\therefore \frac{dy}{dx} = 9x^2 - 10x + 2.$$

ART. 16. *Differentiation of a product.*

If $y = u \cdot v$ where u and v are each functions of x , required the value of $\frac{dy}{dx}$.

In order to obtain a clear idea of the meaning of the above function, suppose $u = 5x$ and $v = 3x$. Then

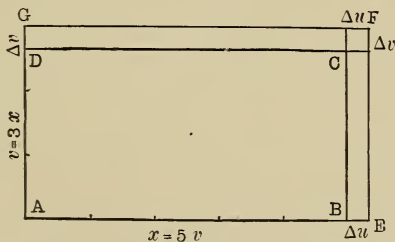

Fig. 14.

$u \cdot v$ can be geometrically represented by a rectangle ABCD (see Fig. 14), two of whose opposite sides are each of

length $u = 5x$, while those adjacent are represented by $v = 3x$.

If x is increased by Δx then,

$$u + \Delta u = 5(x + \Delta x) = 5x + 5\Delta x = AE,$$

and
$$v + \Delta v = 3(x + \Delta x) = 3x + 3\Delta x = AG.$$

Hence
$$\Delta u = 5\Delta x \text{ and } \Delta v = 3\Delta x.$$

Completing the figure as shown, we see that Δy , which is the difference in area between the rectangles AEFB and ABCD, is made up of three small rectangles whose areas are obviously $3x(5\Delta x)$, $5x(3\Delta x)$, and $(5\Delta x)(3\Delta x)$, respectively.

Hence
$$\Delta y = 3x(5\Delta x) + 5x(3\Delta x) + (5\Delta x)(3\Delta x).$$

$$\therefore \frac{\Delta y}{\Delta x} = 3x(5) + 5x(3) + 5(3\Delta x).$$

Now if Δx is a small decimal say 0.0000001, clearly the last term, which represents the least of the rectangles, will tend to vanish; therefore, if Δx becomes dx , we have

$$\frac{dy}{dx} = 3x(5) + 5x(3) \quad \dots \quad (1)$$

But
$$u = 5x \text{ and } v = 3x,$$

and the differential of the first function is $\frac{dx}{du} = 5$ and that

of the second is $\frac{dv}{dx} = 3$.

Hence substituting in (1);

$$\frac{dy}{dx} = v \cdot \frac{du}{dx} + u \cdot \frac{dv}{dx}.$$

In general if $y = u \cdot v$;

$$y + \Delta y = (u + \Delta u)(v + \Delta v).$$

$$\therefore y + \Delta y = uv + v\Delta u + u\Delta v + \Delta u \cdot \Delta v,$$

but $y = uv.$

$$\text{Hence } \Delta y = v\Delta u + u\Delta v + \Delta u \cdot \Delta v.$$

Dividing by Δx ;

$$\frac{\Delta y}{\Delta x} = v \frac{\Delta u}{\Delta x} + u \frac{\Delta v}{\Delta x} + \frac{\Delta u}{\Delta x} \Delta v.$$

If Δx becomes dx then $\frac{\Delta u}{\Delta x} \Delta v = \frac{du}{dx} dv$ which is evanescent, for although the quotient $\frac{du}{dx}$ is finite, it is multiplied by the differential dv , and therefore tends to vanish.

$$\text{Hence } \frac{dy}{dx} = v \frac{dx}{du} + u \frac{dv}{dx}.$$

$$\text{Again if } y = u \cdot v \cdot w;$$

$$\text{then putting } u \cdot v = z$$

$$\text{we get } y = z \cdot w,$$

$$\text{and } \frac{dy}{dx} = w \frac{dz}{dx} + z \frac{dw}{dx} \dots \dots \dots (a)$$

$$\text{But since } z = u \cdot v,$$

$$\therefore \frac{dz}{dx} = v \frac{du}{dx} + u \frac{dv}{dx}.$$

Substituting this value of $\frac{dz}{dx}$ in (a)

$$\text{we get, } \frac{dy}{dx} = vw \frac{du}{dx} + uw \frac{dv}{dx} + uv \frac{dw}{dx}.$$

A like form can be found for the differential coefficient of any number of variables.

Hence, *the Differential Coefficient of a Product of several variables, is the sum of the products of the differential coefficients of each variable multiplied by all the others.*

Example: $y = (3x + 2)(5x - 6)$

$$\begin{aligned} \frac{dy}{dx} &= (5x - 6) \frac{d(3x + 2)}{dx} + (3x + 2) \frac{d(5x - 6)}{dx} \\ &= (5x - 6)(3) + (3x + 2)(5). \\ \therefore \frac{dy}{dx} &= 30x - 8. \end{aligned}$$

ART. 17. *Differentiation of a quotient.*

Let $y = \frac{u}{v}$,

when u and v are functions of x .

We have, $u = vy$,

$$\frac{du}{dx} = y \cdot \frac{dv}{dx} + v \cdot \frac{dy}{dx}.$$

$$\therefore v \cdot \frac{dy}{dx} = \frac{du}{dx} - y \cdot \frac{dv}{dx};$$

but $y = \frac{u}{v}$, $\therefore v \cdot \frac{dy}{dx} = \frac{du}{dx} - \frac{u}{v} \cdot \frac{dv}{dx}$,

and $\frac{dy}{dx} = \frac{\frac{du}{dx} - \frac{u}{v} \frac{dv}{dx}}{v}$.

Multiplying numerator and denominator by v we get

$$\frac{dy}{dx} = \frac{v \frac{du}{dx} - u \frac{dv}{dx}}{v^2},$$

Hence, the *Differential Coefficient* of a fraction whose numerator and denominator are variables, is equal to the product of the denominator and the differential coefficient of the numerator minus the numerator times the differential coefficient of the denominator, the whole divided by the square of the denominator.

If $y = \frac{c}{v}$ where c is a constant, then, since the differential of a constant is zero, we get,

$$\frac{dy}{dx} = \frac{0 - c \frac{dv}{dx}}{v^2} = -\frac{c}{v^2} \frac{dv}{dx}.$$

Example: $y = \frac{1-x}{1+x^2},$

$$\begin{aligned} \frac{dy}{dx} &= \frac{(1+x^2) \frac{d(1-x)}{dx} - (1-x) \frac{d(1+x^2)}{dx}}{(1+x^2)^2} \\ &= \frac{(1+x^2)(-1) - (1-x)(2x)}{(1+x^2)^2}, \\ \therefore \frac{dy}{dx} &= \frac{x^2 - 2x - 1}{(1+x^2)^2}. \end{aligned}$$

ART. 18. *Differentiation of a function of a function.*

Suppose we wish to evaluate $\sqrt[3]{x^2 + 3x + 2}$, when $x = 1, 2$, etc. Putting

$$\sqrt[3]{x^2 + 3x + 2} = y \text{ and } x^2 + 3x + 2 = z,$$

then $y = \sqrt[3]{z}$

if $x = 1, z = 6$ and $y = \sqrt[3]{6} = 1.817$

$x = 2, z = 12$ and $y = \sqrt[3]{12} = 2.289.$

Clearly z is a function of x , and further the value of y depends upon that of z , hence y is also a function of z . We thus see that y is a function of z which in turn is a function of x , and we therefore say that y is a *function of a function*.

This latter term is sometimes puzzling at first, and care

should be taken that it is thoroughly understood. Let us take the general case

$$y = F(z)$$

and

$$z = f(x).$$

Now if x undergoes a small change in value then z will change likewise.

If x becomes $x + \Delta x$,

z becomes $z + \Delta z$,

but
$$\frac{\Delta y}{\Delta x} = \frac{\Delta y}{\Delta z} \cdot \frac{\Delta z}{\Delta x},$$
 [An identity, found by multiplying and dividing $\frac{\Delta y}{\Delta x}$ by Δz .]

and if Δx becomes dx ,

then
$$\frac{dy}{dx} = \frac{dy}{dz} \cdot \frac{dz}{dx}.$$

Hence, if $y = F(z)$ and $z = f(x)$, the differential coefficient of y , with respect to x , is equal to the product of the differential coefficient of y with respect to z , times the differential coefficient of z with respect to x .

Example I: $y = \sqrt{u}$, to find $\frac{dy}{dx}$,

where $x^2 + 3 = u$.

Since $y = \sqrt{u}$,

we have, $y = F(u)$ and $u = f(x)$.

From the above,
$$\frac{dy}{dx} = \frac{dy}{du} \cdot \frac{du}{dx},$$

but $y = u^{\frac{1}{2}}$.

$$\therefore \frac{dy}{du} = \frac{1}{2} u^{\frac{1}{2}-1} = \frac{1}{2} u^{-\frac{1}{2}} = \frac{1}{2} (x^2 + 3)^{-\frac{1}{2}};$$

and since

$$\begin{aligned}
 u &= x^2 + 3, \\
 \therefore \frac{du}{dx} &= 2x, \\
 \therefore \frac{dy}{dx} &= \frac{1}{2} (x^2 + 3)^{-\frac{1}{2}} (2x), \\
 \therefore \frac{dy}{dx} &= \frac{x}{\sqrt{x^2 + 3}}.
 \end{aligned}$$

In general we would proceed thus:

Given, $y = \sqrt{x^2 + 3},$
 $\therefore y = (x^2 + 3)^{\frac{1}{2}},$
 $\frac{dy}{dx} = \frac{1}{2} (x^2 + 3)^{-\frac{1}{2}} \cdot 2x = \frac{x}{\sqrt{x^2 + 3}}.$

Example II: $y = (x^3 + 2)(x + 3)^3.$

Here we have a product, hence by Art. 16 we get,

$$\begin{aligned}
 \frac{dy}{dx} &= (x + 3)^3 \cdot \frac{d(x^3 + 2)}{dx} + \\
 &\quad (x^3 + 2) \frac{d(x + 3)^3}{dx}. \dots \dots (1)
 \end{aligned}$$

As the expression $(x + 3)^3$ is a function of a function,

we have, $\frac{d(x^3 + 2)}{dx} = 3x^2 \dots \dots (2)$

and $\frac{d(x+3)^3}{dx} = 3(x+3)^2 \cdot \frac{d(x+3)}{dx} = 3(x+3)^2 \cdot 1 \dots (3)$

Substituting (2) and (3) in (1) we find,

$$\begin{aligned}
 \frac{dy}{dx} &= (x + 3)^3 \cdot 3x^2 + (x^3 + 2) \cdot 3(x + 3)^2, \\
 \text{and } \frac{dy}{dx} &= 6x^5 + 45x^4 + 54x^3 + 6x^2 + 36x + 135.
 \end{aligned}$$

EXERCISE II.

1. $y = 5x^3 + 3x^2 - x + 2.$ 2. $y = ax^2 + bx + c.$

3. $y = \frac{7x^2}{a}.$ 4. $y = \frac{a}{7x^2} = \frac{a}{7}x^{-2}.$

5. $y = 3x^{\frac{3}{2}} - 5x^{\frac{1}{2}} + 7 - 8x^{\frac{3}{2}} + 2x^{-\frac{3}{2}}.$

6. $y = \sqrt[3]{x}.$ 7. $y = \sqrt[5]{x^4}.$

8. $y = x^2 \sqrt[4]{x}.$

9. $y = \frac{1}{\sqrt[3]{x}}.$

10. $y = \frac{b}{x^2 \sqrt{x^3}}.$

11. $y = \sqrt{x} \sqrt{x^3}.$

12. $y = \sqrt[p]{x^q}.$

13. $y = (x^2 + 2)^2.$

14. $y = a(3x^2 - 2x + 1)^2.$

15. $y = \left(\frac{1}{x} - b\right)^3.$

16. $y = (ax^2 + bx + c)^n.$

17. $y = (3x^2 - 2)^{-2}.$

18. $y = \sqrt{2x^3 + 3x}.$

19. $y = \frac{1}{\sqrt{x^2 - 3ax}}.$

20. $y = \sqrt{x + b} + \sqrt{x - b}.$

21. $y = -\frac{2}{\sqrt[4]{(1 - x^3)^2}}.$

22. $y = (2x + 1)(3x - 2).$

23. $y = x^2(2x^3 + 1).$

24. $y = (x + 1)(x^2 - x + 1).$

25. $y = x\sqrt{1 - x^2}.$

$$26. y = x^2 \sqrt{2x^2 - 1}.$$

$$27. y = \frac{2b}{x^2} \sqrt{b^2 - x}.$$

$$28. y = \frac{x^2 - 3x + 1}{x^2 - 1}.$$

$$29. y = \frac{b - x}{b + x}.$$

$$30. y = \sqrt{\frac{b - x}{b + x}}.$$

$$31. y = \frac{(x^2 - b)^2}{(x^3 - b)^3}.$$

$$32. y = \frac{\sqrt{x + 1}}{x^2}.$$

$$33. y = \frac{\sqrt{x - 1}}{\sqrt{x + 1}}.$$

$$34. y = \frac{x}{\sqrt{b^2 - x^2}}.$$

$$35. y = \frac{x}{\sqrt{a^2 - x^2 - x}}.$$

$$36. y = \sqrt{\frac{1 - \sqrt{x}}{1 + \sqrt{x}}}.$$

$$37. y = \frac{\sqrt{1 + x} - \sqrt{1 - x}}{\sqrt{1 + x} + \sqrt{1 - x}}.$$

$$38. y = \sqrt{\left\{ \frac{1 - x^2}{(1 + x^2)^3} \right\}}.$$

$$39. y = \frac{x^n}{(1 + x)^n}.$$

$$40. y = \frac{\sqrt{1 - x^2} + x\sqrt{2}}{\sqrt{1 - x^2}}.$$

II. Differentiation of Transcendental Functions.

ART. 19. The value of $\frac{\sin \alpha}{\alpha}$ and $\frac{\tan \alpha}{\alpha}$ when α becomes infinitely small. In higher mathematics, angular measurement is always expressed in radians. The choice of the radian as a unit possesses many advantages. It enables us, for example, to compare *directly* the rate of change of a sine with the rate of change of its corresponding angle.

It is important that the student should now examine the values of the two expressions $\frac{\sin \alpha}{\alpha}$ and $\frac{\tan \alpha}{\alpha}$ as α diminishes.

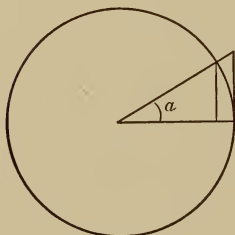

Fig. 15.

A glance at Fig. 15 will show that for any angle α ,

$$\sin \alpha < \alpha < \tan \alpha.$$

Dividing by $\sin \alpha$, we get

$$\frac{\sin \alpha}{\sin \alpha} < \frac{\sin \alpha}{\alpha} < \frac{\sin \alpha}{\cos \alpha} \frac{1}{\sin \alpha}.$$

$$\therefore 1 < \frac{\sin \alpha}{\alpha} < \frac{1}{\cos \alpha}.$$

But $\cos 0 = 1$, hence $\frac{1}{\cos 0} = 1$; and as α diminishes, the

more nearly does $\frac{1}{\cos \alpha}$ approach the value 1, and when

α is infinitely reduced, $\frac{1}{\cos \alpha} = 1$; therefore; we may put

the expression $\frac{\alpha}{\sin \alpha}$ or $\frac{\sin \alpha}{\alpha} = 1$ when the angle α is infi-

nitely small, for $\frac{\alpha}{\sin \alpha}$ stands constantly between 1 and a

quantity, $\frac{1}{(\cos \alpha)}$, which continually approaches 1, as shown by the inequality, hence $\frac{\alpha}{\sin \alpha}$ must itself approach 1 in advance of $\frac{1}{\cos \alpha}$, and will reach it when $\frac{1}{\cos \alpha}$ arrives at that value.

Again, $\frac{\tan \alpha}{\alpha} = \frac{\sin \alpha}{\alpha} \cdot \frac{1}{\cos \alpha}$, but we have seen that each of the expressions $\frac{\sin \alpha}{\alpha}$ and $\frac{1}{\cos \alpha}$ tends to approach the value unity as the angle diminishes; hence we may put $\frac{\tan \alpha}{\alpha} = 1$ when α is infinitely small.

ART. 20. *Differentiation of $y = \sin x$ and $y = \cos x$.*

If $y = \sin x$,

then $y + \Delta y = \sin (x + \Delta x)$.

$$\therefore y + \Delta y = \sin x \cos \Delta x + \cos x \sin \Delta x.$$

And $y = \sin x$.

$$\therefore \Delta y = \sin x \cos \Delta x - \sin x + \cos x \sin \Delta x.$$

$$\therefore \Delta y = \sin x (\cos \Delta x - 1) + \cos x \sin \Delta x.$$

Hence $\frac{\Delta y}{\Delta x} = \frac{\sin x}{\Delta x} (\cos \Delta x - 1) + \cos x \frac{\sin \Delta x}{\Delta x}$,

but when Δx is infinitely small,

$$\cos \Delta x = 1 \text{ and } \frac{\sin \Delta x}{\Delta x} = 1.$$

\therefore when Δx becomes dx , then

$$\frac{dy}{dx} = 1(0) + \cos x \dots \dots \dots (1)$$

$$\therefore \frac{dy}{dx} = \cos x.$$

In an exactly similar manner to the above we may show that if

$$y = \cos x, \quad \frac{dy}{dx} = -\sin x.$$

ART. 21. *Differentiation of $y = \tan x$ and $y = \cot x$.*

If $y = \tan x$,

then $y = \frac{\sin x}{\cos x}$.

By Art. 17, $\frac{dy}{dx} = \frac{\cos x \cdot d(\sin x) - \sin x d(\cos x)}{\cos^2 x}$,

$$\frac{dy}{dx} = \frac{\cos x \cdot \cos x - \sin x (-\sin x)}{\cos^2 x},$$

$$\frac{dy}{dx} = \frac{\cos^2 x + \sin^2 x}{\cos^2 x}.$$

$$\therefore \frac{dy}{dx} = \frac{d(\tan x)}{dx} = \frac{1}{\cos^2 x} = \sec^2 x.$$

In like manner, if $y = \cot x$, we may show that

$$\frac{dy}{dx} = -\frac{1}{\sin^2 x} = -\csc^2 x.$$

ART. 22. *Differentiation of $y = \sec x$ and $y = \operatorname{cosec} x$.*

If $y = \sec x$, then $y = \frac{1}{\cos x}$.

Differentiating, we find

$$\frac{dy}{dx} = \frac{\sin x}{\cos^2 x} = \tan x \sec x.$$

[Since $\frac{\sin x}{\cos x} = \frac{\sin x}{\cos^2 x} \cdot \frac{1}{\cos x} = \tan x \sec x$.]

Similarly, when $y = \operatorname{cosec} x$, then $y = \frac{1}{\sin x}$,

and
$$\frac{dy}{dx} = -\frac{\cos x}{\sin^2 x} = -\cot x \operatorname{csc} x.$$

The following convenient table should be committed to memory : *

$$y = \sin x; \frac{dy}{dx} = \cos x \quad y = \cos x; \frac{dy}{dx} = -\sin x$$

$$y = \tan x; \frac{dy}{dx} = \sec^2 x \quad y = \cot x; \frac{dy}{dx} = -\operatorname{csc}^2 x$$

$$y = \sec x; \frac{dy}{dx} = \tan x \sec x$$

$$y = \operatorname{cosec} x; \frac{dy}{dx} = -\cot x \operatorname{csc} x.$$

Since $\operatorname{vers} x = 1 - \cos x$, if $y = \operatorname{vers} x$,
we have $y = 1 - \cos x$, and, therefore, $\frac{dy}{dx} = \sin x$;

also if $y = \operatorname{covers} x = 1 - \sin x$, $\frac{dy}{dx} = -\cos x$.

EXERCISE III.

1. $y = \tan (bx).$
2. $y = \cos \frac{a}{x}.$
3. $y = \sin (3x^2).$
4. $y = \tan \sqrt{nx}.$
5. $y = 3 \cos (x^n).$
6. $y = b \sin \frac{2}{x}.$
7. $y = \sin (1 + ax^2).$
8. $y = \cos \sqrt{\frac{1}{x}}.$
9. $y = \sin^5 x.$
10. $y = \cos^4 ax \cdot x^2.$

* Note that the differential coefficients of all the co-functions have a negative sign. The significance of this will be seen later.

$$11. y = \frac{1}{n} \tan (nx). \quad 12. y = -\frac{1}{15} \cos^5 (3x).$$

$$13. y = \cos^n x \sin^n x.$$

$$14. y = \cot x + \frac{1}{3} \cot^3 x.$$

$$15. y = x - \tan x + \frac{\tan^3 x}{3}.$$

$$16. y = \frac{\sin x + \cos x}{\sin x \cos x}.$$

$$17. y = \tan x (\sin x).$$

$$18. y = \frac{\sin^n x}{\cos^m x}.$$

$$19. y = \sqrt{a \cos^2 x + b \sin^2 x}.$$

$$20. y = \sin ax (\sin x)^a.$$

Of what functions are the following the differential coefficients:

$$21. \frac{dy}{dx} = 5 \sin^4 x \cos x.$$

$$22. \frac{dy}{dx} = a [\cos (b + ax) + \sin (b - ax)].$$

$$23. \frac{dy}{dx} = 3 \tan 3x \sec 3x.$$

$$24. \frac{dy}{dx} = -20x \cos^4 2x^2 \sin 2x^2.$$

$$25. 2m \cot mx \operatorname{cosec} mx.$$

**DIFFERENTIATION OF LOGARITHMIC AND
EXPONENTIAL FUNCTIONS.**

The series $y = A + Bx + Cx^2 + Dx^3 + \dots$

ART. 23. Consider the geometric series,

$$1 + \frac{1}{2} + \left(\frac{1}{2}\right)^2 + \left(\frac{1}{2}\right)^3 + \dots$$

the value of which when the number of terms is infinite is

2. We can approach this value to any required degree of accuracy by taking a sufficient number of terms.

The general notation for such a series is as follows:

$$y = A + Bx + Cx^2 + Dx^3 + \dots$$

when A, B, C, etc., are constants. The calculation of numerical quantities and of experimental results is often referred to a series of this form.

In order to calculate the logarithms of numbers, we make use of a series in which x either is equal to or involves the quantity whose logarithm is sought, and hence the latter can be calculated to any required degree of accuracy.

Such a series to be of practical value should possess the following properties: it must converge rapidly, so that it will not require a large number of terms to be taken before the necessary accuracy is reached, and it must be convenient of computation.

The binomial theorem supplies us with an expression of the form $y = A + Bx + Cx^2 + Dx^3 \dots$; and it has been found that the determination of the value of $\left(1 + \frac{x}{n}\right)^n$, when n becomes infinite, forms a suitable starting-point from which to begin investigations with a view of obtaining a practical logarithmic series. This will be discussed in its proper place.

ART. 24. The value of $\left(1 + \frac{1}{n}\right)^n$ when n becomes infinite.

Suppose in the expression $\left(1 + \frac{1}{n}\right)^n$ we put $n = \infty$, we get $\left(1 + \frac{1}{\infty}\right)^\infty = (1 + 0)^\infty = 1^\infty$; now 1^∞ is indeterminate, for infinity has no *definite value*; we regard the symbol ∞ as referring to a magnitude which is greater than any we can conceive.

We shall refer to the matter of indeterminate forms in a subsequent article. In the mean time we shall show that by approaching the calculation in another manner we can obtain a more definite result for the evaluation of $\left(1 + \frac{1}{n}\right)^n$ when $n = \infty$.

By the Binomial Theorem, we have

$$\begin{aligned} \left(1 + \frac{1}{n}\right)^n &= 1 + n \cdot \frac{1}{n} + \frac{n(n-1)}{1 \cdot 2} \left(\frac{1}{n}\right)^2 \\ &\quad + \frac{n(n-1)(n-2)}{1 \cdot 2 \cdot 3} \left(\frac{1}{n}\right)^3 + \dots \\ &= 1 + 1 + \frac{\left(\frac{n-1}{n}\right)}{1 \cdot 2} + \frac{\left(\frac{n-1}{n}\right)\left(\frac{n-2}{n}\right)}{1 \cdot 2 \cdot 3} + \dots \\ &= 1 + 1 + \frac{\left(1 - \frac{1}{n}\right)}{1 \cdot 2} + \frac{\left(1 - \frac{1}{n}\right)\left(1 - \frac{2}{n}\right)}{1 \cdot 2 \cdot 3} + \dots \end{aligned}$$

If $n = \infty$, then terms such as $\frac{1}{n}$, $\frac{2}{n}$, etc., vanish;

$$\begin{aligned} \left(1 + \frac{1}{n}\right)^n &= 2 + \frac{1}{1 \cdot 2} + \frac{1}{1 \cdot 2 \cdot 3} + \dots \\ &= 2.71828 \dots \end{aligned}$$

We will put $e = 2.71828$.

The evaluation of e to any required degree of accuracy can be conveniently performed as follows :

	1.000000
2	1.000000
3	0.500000
4	0.166667
5	0.041667
6	0.008333
7	0.001389
8	0.000198
9	0.000025
	0.000003

adding; $2.718281 = e.$

Now if $a^x = N$ then $\log_a N = x$. If then we can obtain a convenient series for e^x we shall be able to calculate the logarithms of numbers to the base e ; for if $e^x = N_1$, then $\log_e N_1 = x$. Let us, therefore, endeavor to develop a series for e^x .

ART. 25. *The expansion of e^x and the logarithmic series.*

If $n = \infty$ then, $\left(1 + \frac{1}{n}\right)^{nx} = e^x.$

But $\left(1 + \frac{1}{n}\right)^{nx}$

$$= 1 + nx \cdot \frac{1}{n} + \frac{nx(nx-1)}{1 \cdot 2} \left(\frac{1}{n}\right)^2$$

$$+ \frac{nx(nx-1)(nx-2)}{1 \cdot 2 \cdot 3} \left(\frac{1}{n}\right)^3 +$$

$$= 1 + x + \frac{1}{2} x \frac{(nx-1)}{n} +$$

$$\frac{1}{6} x \frac{(nx-1)(nx-2)}{n^2} + \dots$$

$$\begin{aligned}
&= 1 + x + \frac{1}{\angle 2} \frac{x^2 \left(n - \frac{1}{x} \right)}{n} + \\
&\frac{1}{\angle 3} \frac{x^2 \left(n - \frac{1}{x} \right) x \left(n - \frac{2}{x} \right)}{n \cdot n} + \dots \\
&= 1 + x + \frac{x^2 \left(1 - \frac{1}{nx} \right)}{\angle 2} \\
&+ \frac{x^3 \left(1 - \frac{1}{nx} \right) \left(1 - \frac{2}{nx} \right)}{\angle 3} + \dots
\end{aligned}$$

Now if $n = \infty$ then the terms $\frac{1}{nx}$, $\frac{2}{nx}$, etc., vanish.

Hence we have

$$e^x = 1 + x + \frac{x^2}{\angle 2} + \frac{x^3}{\angle 3} + \frac{x^4}{\angle 4} + \dots$$

Now put $x = 2$ then

$$\begin{aligned}
e^2 &= 1 + 2 + \frac{4}{1 \cdot 2} + \frac{8}{1 \cdot 2 \cdot 3} + \frac{16}{1 \cdot 2 \cdot 3 \cdot 4} \\
&\quad + \frac{32}{2 \cdot 3 \cdot 4 \cdot 5} + \dots \\
&= 1 + 2 + 2 + 1.333 + 0.667 + 0.267 + \dots \\
&= 7.266.
\end{aligned}$$

Hence we have $\log_e 7.266 = 2$ nearly.

It is obvious that the above series would be far from practical, since it converges slowly and it would be difficult to obtain the logarithms of consecutive integers. It is, however, easily possible to obtain either by elementary mathematics, or by an application of the calculus (see Art. 54) the following series,

$$\log_e (1 + x) = x - \frac{x^2}{2} + \frac{x^3}{3} - \frac{x^4}{4} + \dots$$

This is known as the *Logarithmic Series*, and by its means we could calculate many logarithms, but since it also converges slowly and only between the values $x = +1$ and $x = -1$, it is not suitable for general logarithmic computation. From this latter series we can, however, obtain the following:

$$\begin{aligned} & \text{Log}_e (Z + 1) \\ &= \log_e Z + 2 \left[\frac{1}{2Z + 1} + \frac{1}{3(2Z + 1)^3} + \frac{1}{5(2Z + 1)^5} \right. \\ & \quad \left. + \frac{1}{7(2Z + 1)^7} \dots \right]. \end{aligned}$$

This series is most convenient for our purpose, for instance if $Z = 1$, then

$$\begin{aligned} \log_e 2 &= \log_e 1 + 2 \left[\frac{1}{3} + \frac{1}{3(3)^3} + \frac{1}{5(5)^5} + \dots \right]. \\ \therefore \text{Log}_e 2 &= 0.6931. \end{aligned}$$

And in a similar manner the logarithms of other quantities could be calculated.

ART. 26. *The logarithmic modulus.* Logarithms calculated to the base e are known as Napierian logarithms, because of their introduction by Napier; they are also called Natural Logarithms. This latter term was applied because they appeared first in the investigation conducted for the purpose of discovering a method for calculating logarithms. The base e is used exclusively in higher mathematics, but this system is not suitable for practical computation; the student will be aware that for the latter purpose the base 10 is chosen.

We will now show how logarithms to the base e can be transformed to the base 10 and vice versa.

$$\begin{aligned} \text{Let} \quad & y = \log_e x \text{ and } z = \log_{10} x, \\ \text{then} \quad & e^y = x \text{ and } 10^z = x. \\ & \therefore e^y = 10^z. \end{aligned}$$

I. To transform $\log_{10} x$ to $\log_e x$, we had

$$e^y = 10^z.$$

$$\therefore y \log_e e = z \log_e 10.$$

But $\log_e e = 1$ and $\log_e 10 = 2.30258$, and since $y = \log_e x$ and $z = \log_{10} x$,

$$\therefore \log_e x = 2.30258 \log_{10} x.$$

The quantity 2.30258 is called the Modulus of the Napierian logarithms and is often denoted by M . In this notation we have

$$\log_e x = M \log_{10} x.$$

II. To transform $\log_e x$ to $\log_{10} x$, we had

$$e^y = 10^z.$$

$$\therefore y \log_{10} e = z \log_{10} 10.$$

Now $y = \log_e x$ and $\log_{10} e = 0.43429$, while $\log_{10} 10 = 1$ and $z = \log_{10} x$.

$$\text{Hence} \quad \log_{10} x = 0.43429 \log_e x.$$

The quantity 0.43429 is called the Modulus of the Briggs System and is denoted by m . We therefore have,

$$\log_{10} x = m \log_e x.$$

ART. 27. *The relation between M and m .*

We have $\log_{10} x = m \log_e x$ and $\log_e x = M \log_{10} x$.

$$\text{Now} \quad \log_e x = \frac{\log_{10} x}{m}.$$

Substituting in the second equation above we get

$$\frac{\log_{10} x}{m} = M \cdot \log_{10} x.$$

$$\therefore M = \frac{1}{m} \quad \text{and} \quad m = \frac{1}{M}$$

or $M \cdot m = 1$.

Hence to transform logarithms from the base a to the base b multiply by $\frac{1}{\log_a b}$. Note $\log_e a = \frac{1}{\log_a e}$.

ART. 28. *The d. c. of $y = \log_e x$.* We will now write $\ln x$ for $\log_e x$.

We have $y = \ln x$.

$$\begin{aligned} \therefore y + \Delta y &= \ln(x + \Delta x) \\ \Delta y &= \ln(x + \Delta x) - \ln x = \ln\left(\frac{x + \Delta x}{x}\right). \end{aligned}$$

Multiplying by $\frac{x}{\Delta x}$ we get,

$$x \cdot \frac{\Delta y}{\Delta x} = \frac{x}{\Delta x} \ln\left(1 + \frac{\Delta x}{x}\right) = \ln\left(1 + \frac{\Delta x}{x}\right)^{\frac{x}{\Delta x}}.$$

$$\text{Hence } \frac{\Delta y}{\Delta x} = \frac{1}{x} \ln\left(1 + \frac{\Delta x}{x}\right)^{\frac{x}{\Delta x}}.$$

If Δx becomes dx then $\frac{\Delta x}{x} = 0$, while $\frac{x}{\Delta x} = \infty$.

Putting $\frac{x}{\Delta x} = n$ then $\frac{\Delta x}{x} = \frac{1}{n}$, and

$$\left(1 + \frac{\Delta x}{x}\right)^{\frac{x}{\Delta x}} = \left(1 + \frac{1}{n}\right)^n,$$

which for $n = \infty$ is equal to e (Art. 24).

Hence we get $\frac{dy}{dx} = \frac{1}{x} \ln e$,

but $\ln e = 1$,

$$\frac{dy}{dx} = \frac{1}{x}.$$

ART. 29. *The d. c. of $y = \log_a x$,*

$$y = \log_a x,$$

$$\therefore a^y = x.$$

$$y \ln a = \ln x,$$

$$\therefore y = \ln x \cdot \frac{1}{\ln a}.$$

But by Art. 26, $\frac{1}{\log_a a} = \log_a e$.

$$\therefore y = \ln x \cdot \log_a e,$$

and

$$\frac{dy}{dx} = \frac{1}{x} \log_a e.$$

Note $\log_a e$ is a constant, $\therefore \frac{d \log_a e}{dx} = 0$, hence the second term in the differentiation of the product is zero.

ART. 30. $\frac{\text{The d. c. of } y = a^x}{y = a^x}$.

$$\therefore \ln y = x \ln a,$$

$$\therefore \frac{1}{y} \cdot \frac{dy}{dx} = \ln a.$$

$$\therefore \frac{dy}{dx} = a^x \ln a.$$

ART. 31. $\frac{\text{The d. c. of } y = e^x \text{ and } y = e^{ax}}{y = e^x}$.

$$\therefore y = 1 + x + \frac{x^2}{1 \cdot 2} + \frac{x^3}{1 \cdot 2 \cdot 3} + \frac{x^4}{1 \cdot 2 \cdot 3 \cdot 4} + \dots$$

Differentiating each term we get,

$$\frac{dy}{dx} = 0 + 1 + x + \frac{x^2}{1 \cdot 2} + \frac{x^3}{1 \cdot 2 \cdot 3} + \dots$$

$$\therefore \frac{dy}{dx} = 1 + x + \frac{x^2}{1 \cdot 2} + \frac{x^3}{1 \cdot 2 \cdot 3} + \dots$$

Hence $\frac{dy}{dx} = e^x.$

This is a function of great importance, and is the only one known whose differential coefficient is equal to the function itself. The appearance of e^x and e^{ax} in many

physical formulæ makes these quantities of particular interest to the student, who will have no difficulty in showing that when $y = e^{ax}$ then $\frac{dy}{dx} = ae^{ax}$ by a process similar to the above.

ART. 32. *The d. c. of $y = u^v$.* Let $y = u^v$ when both u and v are functions of x .

$$\ln y = v \ln u.$$

$$\therefore \frac{1}{y} \cdot \frac{dy}{dx} = v \cdot \frac{1}{u} \frac{du}{dx} + \ln u \frac{dv}{dx}.$$

If we now multiply by u^v we get,

$$\frac{dy}{dx} = vu^{v-1} \frac{du}{dx} + u^v \ln u \frac{dv}{dx}.$$

Hence, to differentiate a function of the form $y = u^v$; first, differentiate as though u were variable and v constant,

(as when $y = x^n$, $\frac{dy}{dx} = nx^{n-1}$); second, as though v were

variable and u constant (as when $y = a^x$, $\frac{dy}{dx} = a^x \ln a$) and take the sum of the results.

The following table gives the differential coefficients thus found:

$$y = \log_e x; \quad \frac{dy}{dx} = \frac{1}{x}.$$

$$y = \log_a x; \quad \frac{dy}{dx} = \frac{1}{x} \log_a e.$$

$$y = a^x; \quad \frac{dy}{dx} = a^x \log_e a.$$

$$y = e^x; \quad \frac{dy}{dx} = e^x.$$

$$y = e^{ax}; \quad \frac{dy}{dx} = ae^{ax}.$$

EXERCISE IV.

1. $y = \ln (2x^2 - 1)$.
2. $y = 3x^3 \ln (5x^2 + x)$.
3. $y = e^x \cdot x^a$.
4. $y = x^x$.
5. $y = e^x \sin x$.
6. $y = a \ln (\sqrt{x+a})$.
7. $y = a^{\ln x}$.
8. $y = \cos (\ln x)$.
9. $y = \ln (\ln x)$.
10. $y = (e^x)^x$.
11. $y = (x^x)^x$.
12. $y = \frac{x}{1 + e^x}$.
13. $y = e^{ax} \sin nx$.
14. $y = \ln \left(\frac{1+x}{1-x} \right)^{\frac{1}{2}}$.
15. $y = x^{\frac{1}{x}}$.
16. $y = \frac{e^x - e^{-x}}{e^x + e^{-x}}$.
17. $y = \log \cot e^x$.
18. $y = a \sqrt{\frac{1}{a^2 - x^2}}$.
19. $y = \ln x - \ln (a - \sqrt{a^2 - x^2})$.
20. $y = \ln \frac{1 - \cos x}{1 + \cos x}$.
21. $y = \ln \left(\frac{b}{2} + x + \sqrt{x^2 + bx + a} \right)$.
22. $y = a^{\sin x}$.
23. $y = e^{\frac{x}{2}}$.
24. $y = x^{uvw}$ (u, v and w are functions of x).
25. $y = e^{at} (\cos ux)^k$.

III. Differentiation of the Inverse Trigonometrical Functions.

ART. 33. When we wish to express in symbols that y is an angle whose sine is x , we write $y = \sin^{-1} x$, and similarly if we write $y = \cos^{-1} x$, $y = \tan^{-1} x$, we mean that y is an angle whose cosine or tangent is x . Now $\sin^{-1} \frac{1}{2} = 30^\circ$, from which we at once obtain the inverse expression $\sin 30^\circ = \frac{1}{2}$; clearly, if $y = \sin^{-1} x$ then $x = \sin y$.

The German mathematicians write $y = \text{arc sin } x$ instead of $y = \sin^{-1} x$. The former expression may be read y is an arc whose sine is x . A similar interpretation is given to $y = \text{arc tan } x$ and $y = \text{arc sec } x$, and so on.

The inverse trigonometrical functions $y = \sin^{-1} x$, $y = \cos^{-1} x$, etc., are of great importance in the Integral Calculus.

ART. 34. *The d. c. of $y = \sin^{-1} x$ and $y = \cos^{-1} x$.*

If $y = \sin^{-1} x$,

then $x = \sin y$,

and $dx = \cos y \cdot dy = \sqrt{1 - \sin^2 y} dy$.

$$\frac{dy}{dx} = \frac{1}{\sqrt{1 - \sin^2 y}}.$$

Hence $\frac{dy}{dx} = \frac{1}{\sqrt{1 - x^2}}$.

The sign of the root depends upon that of $\cos y$ in the expression $dx = \cos y dy$. For angles in the first quadrant this is clearly positive.

By a similar process the student will find that if

$$y = \cos^{-1} x,$$

then $\frac{dy}{dx} = -\frac{1}{\sqrt{1 - x^2}}$.

ART. 35. *The d. c. of $y = \tan^{-1} x$ and $\cot^{-1} x$.*

If $y = \tan^{-1} x$,

then $x = \tan y$,

and $dx = \sec^2 y dy = (1 + \tan^2 y) dy$.

$$\therefore \frac{dy}{dx} = \frac{1}{1 + \tan^2 y}.$$

Hence $\frac{dy}{dx} = \frac{1}{1 + x^2}$.

Similarly, if $y = \cot^{-1} x$, $\frac{dy}{dx} = -\frac{1}{1 + x^2}$.

ART. 36. The d.c. of $y = \sec^{-1} x$ and $y = \operatorname{cosec}^{-1} x$.

If $y = \sec^{-1} x,$

then $x = \sec y,$

$$dx = \sec y \tan y dy = \sec y \sqrt{\sec^2 y - 1} dy,$$

$$\frac{dy}{dx} = \frac{1}{\sec y \sqrt{\sec^2 y - 1}}.$$

Hence $\frac{dy}{dx} = \frac{1}{x \sqrt{x^2 - 1}}.$

In like manner, if $y = \operatorname{cosec}^{-1} x,$

then $\frac{dy}{dx} = -\frac{1}{x \sqrt{x^2 - 1}}.$

ART. 37. The d.c. of $y = \operatorname{vers}^{-1} x$ and $\operatorname{covers}^{-1} x$.

If $y = \operatorname{vers}^{-1} x,$

then $x = \operatorname{vers} y = 1 - \cos y,$

$$dx = \sin y dy = \sqrt{1 - \cos^2 y} dy,$$

$$dx = \sqrt{1 - (1 - \operatorname{vers} y)^2} dy$$

$$= \sqrt{2 \operatorname{vers} y - \operatorname{vers}^2 y} dy$$

$$= \sqrt{2x - x^2} dy.$$

$$\therefore \frac{dy}{dx} = \frac{1}{\sqrt{2x - x^2}}.$$

Similarly, if $y = \operatorname{covers}^{-1} x,$ then $\frac{dy}{dx} = -\frac{1}{\sqrt{2x - x^2}}.$

Note that the differential coefficients of all the co-inverse functions have a *negative sign*, and that in each case where a root occurs any ambiguity of sign may be disposed of by referring to some previous function of y .

The following table gives the above results in concise form:

$$y = \sin^{-1} x; \quad \frac{dy}{dx} = \frac{1}{\sqrt{1-x^2}}.$$

$$y = \cos^{-1} x; \quad \frac{dy}{dx} = -\frac{1}{\sqrt{1-x^2}}.$$

$$y = \tan^{-1} x; \quad \frac{dy}{dx} = \frac{1}{1+x^2}.$$

$$y = \cot^{-1} x; \quad \frac{dy}{dx} = -\frac{1}{1+x^2}.$$

$$y = \sec^{-1} x; \quad \frac{dy}{dx} = \frac{1}{x\sqrt{x^2-1}}.$$

$$y = \operatorname{cosec}^{-1} x; \quad \frac{dy}{dx} = -\frac{1}{x\sqrt{x^2-1}}.$$

$$y = \operatorname{vers}^{-1} x; \quad \frac{dy}{dx} = \frac{1}{\sqrt{2x-x^2}}.$$

$$y = \operatorname{covers}^{-1} x; \quad \frac{dy}{dx} = -\frac{1}{\sqrt{2x-x^2}}.$$

EXERCISE V.

1. $y = \sin^{-1} (2x).$

2. $y = \tan^{-1} 3x^2.$

3. $y = \cos^{-1} \frac{1}{x}.$

4. $y = \sin^{-1} \left(\frac{a-x}{x} \right).$

5. $y = \cos^{-1} \sqrt{ax}.$

6. $y = \sin^{-1} \sqrt{1+x^2}.$

7. $y = \tan^{-1} \frac{1}{\sqrt{x}}.$

8. $y = \tan^{-1} \sqrt{\frac{1-x}{1-x^2}}.$

9. $y = \operatorname{arc} \sin 2ax^3.$

10. $y = \operatorname{arc} \tan \frac{a}{\sqrt{1-x^2}}.$

$$11. y = b \operatorname{arc} \cot \frac{1}{\sqrt{x}}. \quad 12. y = a \cdot \sin^{-1} \left(\frac{x}{a-x} \right).$$

$$13. y = b \sin^{-1} \frac{n + m \cos x}{m + n \cos x}.$$

$$14. y = \cot^{-1} x \sqrt{1-x^2}. \quad 15. y = \cot^{-1} \sqrt{\frac{1-x}{1+x}}.$$

$$16. y = \sec^{-1} ax^3. \quad 17. y = x \cdot e^{\tan^{-1} x}.$$

$$18. y = e^{\ln x}. \quad 19. y = e^x \sin^{-1} 2x.$$

$$20. y = \operatorname{covers}^{-1} \frac{x}{a}. \quad 21. y = \operatorname{vers}^{-1} \frac{a}{x}.$$

$$22. y = \cot^{-1} \frac{2x}{1+x^2}. \quad 23. y = \operatorname{arc} \cos \sqrt{\cos x}.$$

$$24. y = \operatorname{arc} \cos \frac{x^{2n} - 1}{x^{2n} + 1}.$$

$$25. y = \frac{1}{3} \cot^{-1} \frac{x}{\sqrt{1-x^2}} + \frac{1}{3} \sec^{-1} \frac{1}{2x^2 - 1}.$$

CHAPTER III.

INTEGRATION.

ART. 38. In Chapter I we found that if $y = f(x)$ be the equation to a curve, then the Differential Coefficient $\frac{dy}{dx}$ expresses:

(1) *The rate of change of the function as compared with the rate of change of the independent variable.*

(2) *The gradient of the curve at any point.*

Now suppose the differential coefficient of a certain function $y = f(x)$ be given; would it be possible to obtain a law which would enable us to find the original function from which the given differential coefficient has been derived? For example, if $\frac{dy}{dx} = 3ax^2$ or $dy = 3ax^2 \cdot dx$,

of what function is $3ax^2$ the differential coefficient?

Let us examine the following table:

If $y = ax$, $y = ax^2$, $y = ax^3$, $y = ax^4$. . .
then

$$dy = a \, dx, \quad dy = 2ax \cdot dx, \quad dy = 3ax^2 \, dx, \quad dy = 4ax^3 \, dx.$$

If $y = \frac{a}{2} x^2$, $y = \frac{a}{3} x^3$, $y = \frac{a}{4} x^4$

$$dy = ax \cdot dx, \quad dy = ax^2 \, dx, \quad dy = ax^3 \, dx \quad \dots \dots$$

(I) Notice, that in each case, if we multiply the differential coefficient by x , or, what is the same, *raise* the power of x in the differential coefficient by unity, we obtain the

index of x in the original function. (In differentiating we diminished the power of x by unity.)

(II) Again, if we divide by the increased power we obtain the numerical factor of the original function in each case.

(III) The constant factor a remains unaltered.

(IV) The differential disappears.

Take the general case, $\frac{dy}{dx} = ax^n$ or $dy = ax^n dx$. Applying the above rules we obtain the original function,

$$y = a \frac{x^{n+1}}{n+1}.$$

Note if we differentiated this latter expression, we would

have
$$\frac{dy}{dx} = \frac{a}{n+1} (n+1) x^{n+1-1},$$

and hence,
$$dy = ax^n \cdot dx.$$

The process of finding a function when its differential coefficient is given, is called Integration, and we would say in the above case we had integrated the expression $ax^n \cdot dx$.

We have now the following rule:

To integrate a differential of the form $ax^n dx$, first raise the power of x by unity, then divide by the raised power; omit the differential of the variable.

Example: Suppose $dy = 3x^{15} dx$.

Integrating, we find
$$y = 3 \frac{x^{16}}{16} = \frac{3}{16} x^{16}.$$

ART. 39. It was supposed by Leibnitz, that a function was made up of an infinite number of infinitely small differences (differentials), and that their sum made up the func-

tion. Hence, to show that the sum was to be taken, the letter S was used. We might thus write $S \, dy = S (3 x^2 \, dx)$, and, therefore,

$$y = x^3.$$

Later, for convenience, instead of the letter S the symbol \int was employed. This symbol, it will be noticed, is simply an elongated S. It is called the Integral sign, and the process which it represents, Integration. The word "Integrate" means "to form into one whole, or to give the sum total of."

In modern mathematics we would write:

Given $dy = 3 x^2 \, dx.$

$$\int dy = \int 3 x^2 \, dx,$$

read, (The integral of dy) = (the integral of $3 x^2 \, dx$).

$$\therefore y = x^3.$$

Notice that the integral sign, \int , is only a *symbol*, which can be looked upon as meaning that we are to find the function whose derivative with respect to x is a certain given quantity. Thus $\int 3 x^2 \, dx = x^3$, can be read, the function whose derivative with respect to x is $3 x^2 \, dx$, is x^3 .

We see from the above discussion that *Integration* may be looked upon as the inverse of *Differentiation*. In fact, problems of Integral Calculus are dependent upon an inverse operation to those of Differential Calculus.

ART. 40. *The constant of integration.* Let us now take the equation $y = x^2$. If we plot the corresponding graph we shall obtain a curve, known as a parabola, which

will cut the y -axis at $y = 0$; from the equations, $y = x^2 + 1$, $y = x^2 + 2$, $y = x^2 + 3$, etc., and again $y = x^2 - 1$, $y = x^2 - 2$, $y = x^2 - 3$, etc., we obtain a series of similar curves, with coincident axes, which will cut the y -axis at points $y = 1$, $y = 2$, $y = 3$, etc., and also at $y = -1$, $y = -2$, $y = -3$, etc.

A general expression for all such curves would be $y = x^2 + C$, where C is a constant. When the value of C is known, then a particular curve is indicated.

Let us take the differential coefficient $\frac{dy}{dx} = 2x$, or $dy = 2x dx$. By integration we have from

$$dy = 2x dx,$$

$$y = x^2.$$

But $\frac{dy}{dx} = 2x$ would be obtained by differentiating an infinite number of expressions of the form $y = x^2 + C$. There is nothing to tell us definitely from which special function the $2x$ has been obtained, hence we see that we must write:

Given
$$\frac{dy}{dx} = 2x,$$

or
$$dy = 2x dx,$$

then
$$\int dy = \int 2x dx,$$

and
$$y = x^2 + C.$$

C is called a *constant of Integration*, and must always be added when integrating an expression about which nothing more is known than that it is the differential coefficient of a certain function. An expression such as $\int 2x dx = x^2 + C$

is called an Indefinite Integral, because, from the given data, the function cannot be definitely determined. In practical problems we can generally obtain one or more conditions which will indicate the required functions.

Suppose, for instance, we had given $dy = 2x dx$ and the condition that the curve pass through the point $x = 2$, $y = 5$.

We have by integration, $y = x^2 + C$.

\therefore substituting, $5 = 4 + C$,

and

$C = 1$.

Hence the function is definitely found to be $y = x^2 + 1$. This expression obtained from the Indefinite Integral is called a *Definite Integral*.

Take $dv = a dt$.

Here $\int dv = \int a dt$.

$\therefore v = at + C$

where a is the original acceleration, due to gravity, and C the constant of integration. Now if the condition is imposed that the body starts from rest, when $t = 0$, $v = 0$, and $\therefore C = 0$, and we get the definite integral $v = at$, where C stands for the initial velocity, which is zero in this case.

From the above we see that strictly,

$$ax^n dx = a \frac{x^{n+1}}{n+1} + C,$$

and therefore, $\int 3x^4 dx = \frac{3}{5}x^5 + C$.

In practice, however, the constant of integration is often understood. We shall refer again to the integration constant in a later article.

ART. 41. A constant factor may be placed outside the integration sign. The differential of ax is a dx ,

$$\text{hence,} \quad a \cdot dx = ax = a \int dx.$$

Rule. If an expression to be integrated has a constant factor, this factor may be placed without the integration sign.

ART. 42. The integration of a sum or difference. In the Differential Calculus, we found

$$\frac{d(u \pm v \pm w)}{dx} = \frac{du}{dx} \pm \frac{dv}{dx} \pm \frac{dw}{dx},$$

$$\text{or} \quad d(u \pm v \pm w) = du \pm dv \pm dw,$$

$$\text{hence} \quad \int (du \pm dv \pm dw) = \int du \pm \int dv \pm \int dw.$$

Rule. The integral of an algebraic sum is equal to the algebraic sum of the integrals of the various terms.

ART. 42a. A problem of integral calculus geometrically considered. Mechanics supplies us with the following relation:

$$v = at$$

where v = velocity, a = acceleration, and t = time. In Chapter I we realized that $v = \frac{ds}{dt}$ where s = space traversed in the time t .

$$\text{Hence} \quad \frac{ds}{dt} = at,$$

$$\text{and} \quad ds = at dt.$$

$$\therefore \int ds = \int at dt.$$

$$\therefore s = \frac{1}{2} at^2.$$

We have thus found that the differential coefficient $\frac{ds}{dt} = at$ results from the differentiation of the function $s = \frac{1}{2} at^2$.

We will now investigate this matter geometrically and the student will at once be convinced that the Integral Calculus has a much wider scope than has been thus far indicated.

The graph of $v = at$ is a straight line, and since we will assume that there is no initial velocity, and, therefore, no added constant, this straight line passes through the origin.

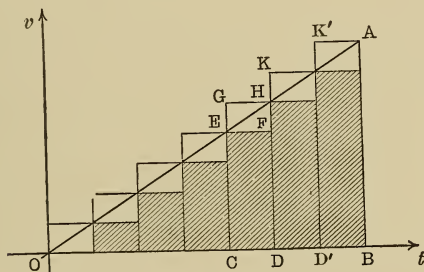

Fig. 16.

In Fig. 16 let OA represent the graph of $v = at$, while the units of time and velocity are referred to the co-ordinates as shown.

Suppose the time represented by OB , which is the abscissa of any point A , to be divided into a number of equal parts, and the construction of the figure completed as shown. In the case of *uniform velocity* $s = vt$.

Take any small time interval CD and suppose the velocity of the moving body *constant for this short period*. The velocity of the body at the *beginning* of this time interval would be represented by CE and at the *end* by DH .

Since $s = vt$ is the *space* traversed by the body during the time represented by CD, then, under the supposition, that throughout this short time interval a constant velocity equal to CE is maintained, $CE \times CD$ or the area of the rectangle CDFE would geometrically represent the *space traversed*.

Again, since DH represents the final velocity at the end of the time interval CD, then the area of the rectangle CDHG would represent the space traversed, under the supposition that throughout the time CD this latter velocity be constantly maintained. The actual space traversed would be more than the first result would indicate, and less than the latter.

Now the complete space traversed would be clearly *more* than that represented by the shaded rectangles and *less* than that indicated by the larger rectangles, of which CDHG is a representative. The difference or error would be given by the sum of the small rectangles, one of which is EFHG.

Now the sum of these latter is equal to the rectangle D'BAK'. But the area of D'BAK' can be infinitely reduced by making the time interval small, and when the latter is dt or infinitely small, the area of D'BAK' is evanescent. In this case the error or difference disappears and the whole space traversed during the time OB is represented by the area of the triangle OAB.

Now the area of the triangle $OAB = \frac{1}{2} \cdot OB \times BA$.

But $OB = t$ and $BA = v$.

Hence $OAB = \frac{1}{2} t \cdot v = \frac{1}{2} t \cdot at$,

or area of $OAB = \frac{1}{2} at^2$.

But the area of OAB represents s ,

$$\therefore s = \frac{1}{2} at^2.$$

Hence we find that when we integrate thus, $\int ds = \int at \cdot dt$, and find $s = \frac{1}{2} at^2$, we have really obtained the sum of an infinite number of elementary areas, each $v \cdot dt$ or $at \cdot dt$, the total of which gives the space traversed by the body during the time t , and moving in accordance with the law $v = at$.

The summation of elementary areas with a view of obtaining a result indicated by their total is a marked feature of the Integral Calculus.

ART. 43. *The definite integral.* Should it be required to determine the space traversed by a moving body under

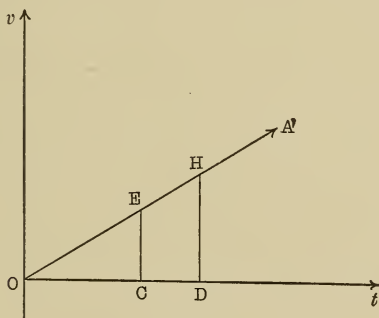

Fig. 17.

the law $v = at$ during a *finite time* interval CD we might proceed thus: putting $OD = t_2$ and $OC = t_1$ (Fig. 17), and integrating $ds = \int at \cdot dt$, we get $s = \frac{1}{2} at^2 + C$, as we have already seen, and if the initial velocity is zero we have $s = \frac{1}{2} at^2$.

The space traversed from zero to t_2 is represented by the

area of the triangle $ODH = \frac{1}{2} at_2^2$, and that from zero to t_1 , by the area of $OCE = \frac{1}{2} at_1^2$.

Subtracting, we have $\frac{1}{2} at_2^2 - \frac{1}{2} at_1^2 = \text{area CDHE}$, which gives the required space traversed. In the language of the Integral Calculus we express the above as follows :

$$\int_{t_2}^{t_1} atdt = \int at_2 dt - \int at_1 dt = \frac{1}{2} at_2^2 - \frac{1}{2} at_1^2,$$

or thus,

$$\int_{t_1}^{t_2} atdt = \left[\frac{1}{2} at^2 \right]_{t_1}^{t_2} = \frac{1}{2} at_2^2 - \frac{1}{2} at_1^2.$$

The integral $\int_{t_1}^{t_2} atdt$ is called a Definite Integral; t_2 and t_1 are referred to as the superior or upper, and inferior or lower limit, respectively. We read the expression thus: the integral from t_1 to t_2 of $at \cdot dt$.

It will be noticed that the quantity enclosed in brackets is the solution of the general or indefinite integral, and that the solution of the definite integral is obtained by substituting first the upper limit, then the lower, and taking the difference.

The constant is clearly made to disappear by taking the difference between the integrals formed by giving two successive values to the independent variable.

To find the value of a definite integral solve the general integral, then substitute first the upper, then the lower limit, and take the difference. This process will be made clear by the following simple example:

Required the space traversed between 5th and 7th seconds, given the acceleration equal to 4 feet per second per second.

$$s = \int_5^7 at \cdot dt = \left[\frac{1}{2} at^2 \right]_5^7.$$

$$\therefore s = \frac{1}{2} \cdot 4 \cdot (7)^2 - \frac{1}{2} \cdot 4 \cdot (5)^2 = 48 \text{ sq. ft.}$$

INTEGRATION OF GENERAL FORMS.

ART. 44. It is to be observed that in the formula,

$$\int ax^n dx = a \frac{x^{n+1}}{n+1} \dots \dots \dots (A)$$

x stands for any expression whatever. Hence, whenever we have a quantity, monomial or polynomial, raised to any power and the differential of this quantity (without its exponent), formula (A) applies.

Example. $\int (2x^3 - 3x^2 + 5)^{\frac{2}{3}} (x^2 - x) dx = \text{what?}$

Since a constant does not affect differentiation, it does not affect integration, so that we are always at liberty to introduce a constant factor behind the integral, if at the same time we divide the integral by the same factor, in order that the value be not altered. *But no expression containing the variable can be removed from behind the integral or introduced in any way.*

In the example above,

$$d(2x^3 - 3x^2 + 5) = (6x^2 - 6x) dx = 6(x^2 - x) dx.$$

Hence if the expression $(x^2 - x) dx$ be multiplied by 6, it becomes the differential of $2x^3 - 3x^2 + 5$ and we get form (A); thus,

$$\begin{aligned} & \int (2x^3 - 3x^2 + 5)^{\frac{2}{3}} (x^2 - x) dx = \\ & \frac{1}{6} \int (2x^3 - 3x^2 + 5)^{\frac{2}{3}} (6x^2 - 6x) dx = \\ & \frac{1}{6} \int z^{\frac{2}{3}} dz \text{ [Like (A)], [where } z = 2x^3 - 3x^2 + 5\text{]}. \\ \therefore & \int (2x^3 - 3x^2 + 5)^{\frac{2}{3}} (x^2 - x) dx \\ & = \frac{\frac{1}{6} (2x^3 - 3x^2 + 5)^{\frac{5}{3}}}{\frac{5}{3}} = \frac{(2x^3 - 3x^2 + 5)^{\frac{5}{3}}}{15}. \end{aligned}$$

Again $\int \frac{x dx}{\sqrt{r^2 - x^2}} = \text{what?}$

$$\int \frac{x dx}{\sqrt{r^2 - x^2}} =$$

$$- \frac{1}{2} \int (r^2 - x^2)^{-\frac{1}{2}} (-2x dx) = - (r^2 - x^2)$$

since $-2x dx = d(r^2 - x^2)$.

TRIGONOMETRIC INTEGRALS AND LOG INTEGRALS.

ART. 45. Since integration is the reverse of differentiation, we easily derive the following, by reversing the formulæ for differentiation:

$$\int \cos x dx = \sin x + c.$$

$$\int \sin x dx = -\cos x + c.$$

$$\int \sec^2 x dx = \tan x + c.$$

$$\int \csc^2 x dx = -\cot x + c.$$

$$\int \sec x \tan x dx = \sec x + c.$$

$$\int \csc x \cot x dx = -\csc x + c.$$

$$\int \frac{dx}{\sqrt{1 - x^2}} = \sin^{-1} x + c, \text{ or } -\cos^{-1} x + c.$$

$$\int \frac{dx}{1+x^2} = \tan^{-1} x + c.$$

$$\int \frac{dx}{\sqrt{a^2-x^2}} = \sin^{-1} \frac{x}{a} + c \text{ or } -\cos^{-1} \frac{x}{a} + c.$$

$$\int \frac{dx}{a^2+x^2} = \frac{1}{a} \tan^{-1} \frac{x}{a} + c \text{ or } -\frac{1}{a} \cot^{-1} \frac{x}{a} + c.$$

$$\int \frac{dx}{x} = \log x + c, \text{ etc.}$$

Put these all into rules.

EXERCISE VI.

Integrate:

1. $\int x^{\frac{3}{2}} dx.$ 2. $\int (x-2)^2 dx.$

3. $\int (3x+5)^{\frac{3}{2}} dx.$

4. $\int (2x^2-4x+5)^{\frac{1}{2}} (x-1) dx.$

5. $\int (x^2-1)^{\frac{3}{2}} x dx.$ 6. $\int (x^2+3x)^2 dx.$

7. $\int (5x^{\frac{3}{2}}-3x^{\frac{1}{2}}+1) dx.$ 8. $\int \frac{x^5-1}{x-1} dx.$

9. $\int \frac{xdx}{(x^2+1)^{\frac{1}{2}}}.$ 10. $\int \frac{x^3-2x^2+1}{x^2} dx.$

11. $\int (1-x)^3 \sqrt{x} dx.$ 12. $\int (\sqrt{n}-\sqrt{x})^2 dx.$

13. $\int (3x^2-x^3)^{\frac{1}{2}} (2x-x^2) dx.$

- | | | | |
|-----|------------------------------------------|-----|-------------------------------------------|
| 14. | $\int \frac{dx}{\sqrt[3]{x^2}}.$ | 15. | $\int (1 - \sqrt[3]{x})^3 dx.$ |
| 16. | $\int \cos^3 x \sin x dx.$ | 17. | $\int (1 - \cos x)^2 \sin x dx.$ |
| 18. | $\int \tan^{\frac{3}{2}} x \sec^2 x dx.$ | 19. | $\int \cot^3 x \csc^2 x dx.$ |
| 20. | $\int \sec^2 x \tan x dx.$ | 21. | $\int \csc^3 x \cot x dx.$ |
| 22. | $\int \sin^{\frac{3}{2}} x \cos x dx.$ | 23. | $\int e^{x^2} x dx.$ |
| 24. | $\int \tan x dx.$ | 25. | $\int \frac{dx}{\sin x \cos x}.$ |
| 26. | $\int \cos x^2 x dx.$ | 27. | $\int e^{3x} dx.$ |
| 28. | $\int \frac{x dx}{x^2 + 1}.$ | 29. | $\int \frac{(x^2 + 1) dx}{x^3 + 3x - 2}.$ |
| 30. | $\int \frac{x^3 dx}{x + 1}.$ | 31. | $\int \frac{(x^2 - 3)^3}{x^4} dx.$ |
| 32. | $\int \frac{2x - 3}{2x + 3} dx.$ | 33. | $\int 3 \frac{\sec^2 x dx}{\tan x}.$ |
| 34. | $\int \frac{\sin x dx}{1 + \cos x}.$ | | |

ART. 46. *The sine curve; harmonic motion.* Suppose P_1 (Fig. 18) is a body moving in a circle with uniform velocity, the centre of the circle being O ; let P_2 be a second body moving in the fixed diameter AB , but in such a manner that P_2 always maintains a position at the foot of the

perpendicular from P_1 upon AB . Now the body P_2 travels backwards and forwards upon the diameter and its velocity

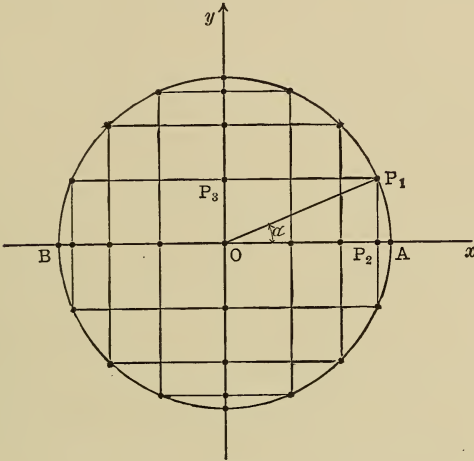

Fig. 18.

will be at a *maximum* as it passes O and diminishes as it approaches B and A ; such motion executed by P_2 is called *Simple Harmonic Motion*.

The distance from O to A or B is called the *Amplitude*. If we fix upon any point in AB , then, once at each complete revolution of P_1 , the body P_2 will pass this fixed point, travelling in *the same direction*. The time thus occupied by P_2 in completing such a cycle of motion is called a *Period*. The motion of a tuning fork, an oscillating pendulum and an alternating current, are good examples of periodic motion. The change of position or motion of the particle P_2 is clearly a function of the time, and further since each cycle of motion recurs periodically, we say that the Simple

Harmonic Motion of a point is a periodic function of time.

In general a *Periodic Function* is one, the value of which recurs at fixed intervals, while the variable increases uniformly.

In Fig. 18, suppose OP is a revolving radius, and tracing a constantly increasing angle, α .

Putting the radius of the circle equal to unity

$$\text{then} \qquad \sin \alpha = P_2P_1,$$

$$\text{or in general} \qquad y = \sin \alpha.$$

$$\therefore y = \sin (\alpha + 2\pi).$$

Evidently, then, $y = \sin \alpha$ is a periodic function, and the period is the time taken to complete one revolution. This is equal to 2π divided by the angular velocity, which we will call θ . We thus have the Period $T = \frac{2\pi}{\theta}$.

The *Frequency*, or the number of periods in a second, is

$$f = \frac{1}{T}.$$

$$\text{Note that } \theta = 2\pi \cdot \frac{1}{T}, \text{ and } \therefore \theta = 2\pi f.$$

In electrical work the number of alternations per minute is often used instead of the frequency. From the annexed diagram it will be seen that the motion of the Point P_3 is exactly similar to that of P_2 , excepting that when P_2 is at the extremity of its path, where the instantaneous velocity is zero, the point P_3 is passing through the O with its maximum velocity and so on.

Calling the radius of the circle a (the Amplitude), we have,

$$\cos (90^\circ - \alpha) = \frac{OP_3}{OP_1} = \frac{y}{a},$$

but $\cos (90^\circ - \alpha) = \sin \alpha,$
 $y = a \cos (90 - \alpha).$

$$\therefore y = a \sin \alpha,$$

or $y = a \sin (\alpha + 2\pi).$

Hence we see that $y = a \sin \alpha$ represents the Simple Harmonic Motion of the point P_3 ; where a is the Amplitude and α the angle described from a fixed starting point, and is the product of the angular velocity and time, $\alpha = \theta t$, we generally write $y = a \sin \theta t$.

Note that since the sine can never be greater than $+1$ or less than -1 , hence the maximum and minimum values of $\sin \theta t$ are $+1$ and -1 , respectively.

We will now draw a graph of the Simple Harmonic Function $y = \sin \alpha$:

If $\alpha = 0 \quad y = 0 \quad \alpha = \frac{3\pi}{4} \quad y = 0.707$

$\alpha = \frac{\pi}{4} \quad y = 0.707 \quad \alpha = \pi \quad y = 0$

$\alpha = \frac{\pi}{2} \quad y = 1 \quad \alpha = \frac{5\pi}{4} \quad y = -.707$

$\alpha = \frac{3\pi}{2} \quad y = -1$

$\alpha = \frac{7\pi}{4} \quad y = -.707$

$\alpha = 2\pi \quad y = 0.$

Referring α , expressed in radians to the x -axis, and using the same scale as the ordinate, we obtain a sinuous or wavy curve, known as the *Curve of Sines* or the *Harmonic Curve*. If the motion of the point giving rise to this graph be made quicker or slower, the undulations of the curve will be more widely spread or brought nearer together.

Increase in Amplitude gives increased rise to the undulations and vice versa.

Fig. (18a) shows the same curve plotted by another

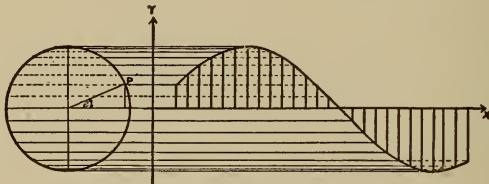

Fig. 18a.

method; the student should have no difficulty in understanding the principle after an inspection of the figure. It will be noticed that the curve does not begin upon the x -axis, but that the periodic time is counted from the instant that the point P_1 has passed through the angle e . This angle e is called by electrical engineers the *lead*; when negative it is known as the *lag*.

The term *Phase* is used to denote the interval of time that has elapsed since the point P passed through its initial position at A , and hence e is often called the *Phase Constant*.

ART. 47. *Plane areas.* Let $y = f(x)$ be a curve, and AB a fixed ordinate. Now suppose CD = y be a second ordinate corresponding to the value $x = OC$ (Fig. 19).

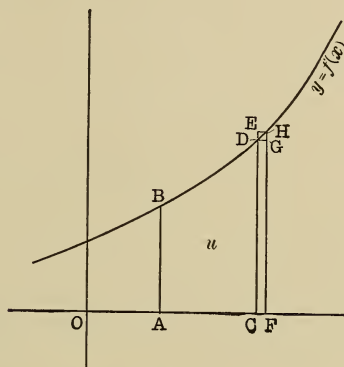

Fig. 19.

Consider the area ABDC, call this area u , let $CF = \Delta x$, then $\Delta u = CFHD$, and $\Delta y = GH$.

Now $CDGF < \Delta u < CEHF$; but $CDGF = y \cdot \Delta x$, and $CEHF = FH \cdot \Delta x$.

Hence $y \cdot \Delta x < \Delta u < FH \Delta x$.

$$\therefore y < \frac{\Delta u}{\Delta x} < FH.$$

Now the smaller Δx becomes, the more nearly will y and FH approach $\frac{\Delta u}{\Delta x}$ in value; hence when Δx becomes dx , then $FH = y = \frac{du}{dx}$ and $du = y \cdot dx$.

Hence if any area is bounded by a curve ($y = f(x)$), a portion of the abscissa, and two ordinates, then the differen-

tial of such area (du) is equal to the product of the terminating ordinate (y) and dx .

Adopting the notation of the last paragraph we have, for the Definite Integral which expresses the area bounded by the curve, part of the abscissa, and two ordinates, a and b , this expression

$$\int_a^b y \cdot dx.$$

Or since $y = f(x)$ we might write $\int_a^b f(x)dx$.

Note: $y \cdot dx$ gives a numerical measure of an area which may be found as follows:

(I) Integrate the given differential expression, or as we say find the indefinite integral.

(II) Substitute the given limits, first the higher, then the lower; subtract the latter resulting expression from the former.

CHAPTER IV.

TANGENTS, SUBTANGENTS, NORMALS AND SUBNORMALS.

ART. 48. In Analytic Geometry it was found that the form

$$y - y' = m (x - x') \dots \dots \dots (C)$$

expressed the equation of a straight line in terms of its slope (m) and a fixed point (x' , y').

As any curve may be regarded as generated by a point moving according to a definite law, expressed by its equation, the direction of a curve at any point is the direction in which this point (taken as the generating point) is moving at the instant. But the generating point if not constrained to move in the curve, would at any instant move off in a straight line (by the first law of motion) and this straight line would be tangent to the curve at the point of departure; hence:

The slope of a curve at any point is the slope of its tangent at that point, slope meaning as usual the tangent of the angle made with the x -axis.

In equation (C), if (x' , y') is a point on a given curve, and m is the slope of the tangent at that point, then (C) is the equation of the tangent at (x' , y'). But if $y = f(x)$ (where $f(x)$ is any expression containing only x and known quantities) is the equation to a curve it has been shown that $\frac{dy}{dx} =$ the slope of the tangent to the curve, and if the coördinates of a definite point on the curve, like (x' , y'),

be substituted in the value of $\frac{dy}{dx}$, it will then represent the slope of the tangent at that point; say $\left(\frac{dy}{dx}\right)_{x', y'}$ = slope of the tangent at (x', y') .

Then (C) becomes

$$y - y' = \left(\frac{dy}{dx}\right)_{x', y'} (x - x') \quad \dots \quad (T)$$

which is clearly the tangent equation at (x', y') .

ART. 49. From these considerations an expression for the subtangent is readily found, in exactly the same way as described in Analytic Geometry (see Art. 50).

Since the normal is a perpendicular to the tangent at the point of tangency (x', y') , its equation will be,

$$y - y' = - \frac{1}{\left(\frac{dy}{dx}\right)_{x', y'}} (x - x') \quad \dots \quad (N)$$

by the relation between the slopes of \perp lines as developed in Analytic Geometry.

This equation may be written:

$$y - y' = - \left(\frac{dx}{dy}\right)_{x', y'} (x - x'),$$

if we understand $\frac{dx}{dy}$ to represent the reciprocal of $\frac{dy}{dx}$.

As in the case of the subtangent the subnormal is readily found by determining its x -intercept from its equation (N).

Let $y = 0$ in (N),

then $-y' = -\frac{dx}{dy}_{x',y'}(x - x')$,

whence $x = x' + y' \left(\frac{dy}{dx}\right)_{x',y'} = OC$. (Fig. 20)

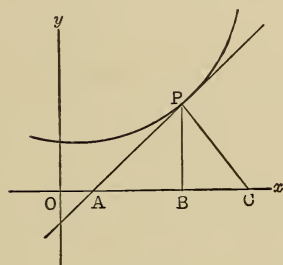

Fig. 20.

But subnormal, $BC = OC - OB$ [$P = (x', y')$]

$$= \left[x' + y' \left(\frac{dy}{dx}\right)_{x',y'} - x' \right] = y' \left(\frac{dy}{dx}\right)_{x',y'}$$

Corollary: The lengths of tangent and normal are readily found, since they are the hypotenuses, respectively, of the triangles APB and BPC.

$$\begin{aligned} \overline{AP}^2 &= \overline{AB}^2 + \overline{PB}^2 = y'^2 \left(\frac{dx}{dy}\right)_{x',y'}^2 + y'^2 \\ &= y'^2 \left[1 + \left(\frac{dx}{dy}\right)_{x',y'}^2 \right], \end{aligned}$$

and $\overline{PC}^2 = \overline{PB}^2 + \overline{BC}^2 = y'^2 \left[1 + \left(\frac{dy}{dx}\right)_{x',y'}^2 \right]$.

Example: Find equation of tangent, subtangent and subnormal to the ellipse $16x^2 + 25y^2 = 400$ at $(3, 3\frac{1}{2})$.

From $16x^2 + 25y^2 = 400$

$$\frac{dy}{dx} = -\frac{16x}{25y}.$$

At the point $(3, 3\frac{1}{5})$ this becomes,

$$\left(\frac{dy}{dx}\right)_{x', y'} = -\frac{16 \times 3}{25 \times \frac{16}{5}} = -\frac{3}{5}.$$

Hence tangent equation is

$$[(x', y') = (3, 3\frac{1}{5})],$$

$$y - \frac{16}{5} = -\frac{3}{5}(x - 5),$$

or $5y + 3x - 25 = 0,$

also $\left(\frac{dx}{dy}\right)_{x', y'} = \frac{1}{-\frac{3}{5}} = -\frac{5}{3}.$

Hence subtangent $= y' \left(\frac{dx}{dy}\right)_{x', y'} = \left(\frac{16}{5}\right) \left(-\frac{5}{3}\right)$
 $= -\frac{16}{3},$

and subnormal $= y' \left(\frac{dy}{dx}\right)_{x', y'} = \frac{16}{5} \left(-\frac{3}{5}\right) = -\frac{48}{25}.$

ART. 50. *Subtangent, subnormal, etc., in polar co-ordinates.*

Using the Polar System, subtangent and subnormal are defined as follows:

The subtangent and subnormal are respectively the distances cut off by tangent and normal from the pole on a line drawn through it \perp to the radius vector of the tangency point, as OT and ON (Fig. 21).

Calling the angle TPO between radius vector and tangent, ψ , we have in the right triangles OPT and OPN,

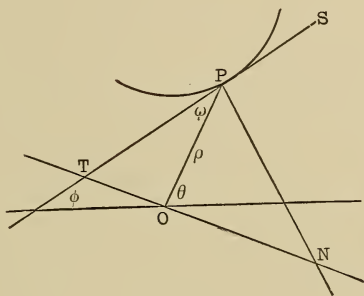

Fig. 21.

subtangent, $OT = OP \tan \text{TPO} = \rho \tan \psi$. Subnormal, $ON = OP \tan \text{OPN} = \rho \cot \psi$ (since $\text{OPN} = 90^\circ - \text{TPO}$)

The angle ψ is determined thus:

Let ACE be any curve (Fig. 22), the co-ordinates of C

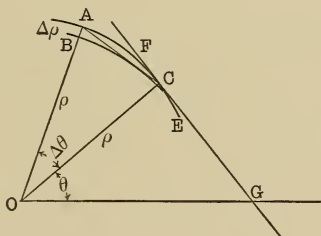

Fig. 22.

being (ρ, θ) , and of A being $(\rho + \Delta\rho, \theta + \Delta\theta)$. Then $AB = \Delta\rho$ and $\text{AOC} = \Delta\theta$. $\tan \text{BAC} = \frac{BC}{AB}$ [since $\Delta\theta$

is a very small angle the arc BC does not differ sensibly from a tangent at B, say]. Whence

$$\tan \text{BAC} = \frac{\rho \Delta \theta}{\Delta \rho}$$

(arc BC = $\rho \Delta \theta$, since an arc = its angle multiplied by the radius). As the point A approaches C, the secant AC approaches the position of a tangent at C (FG) and BAC approaches the value ψ (OCG), hence, finally,

$$\tan \psi = \frac{\rho d\theta}{d\rho}.$$

$$\text{Hence polar subtangent} = \rho \tan \psi = \rho^2 \frac{d\theta}{d\rho},$$

$$\text{and polar subnormal} = \rho \cot \psi = \frac{d\rho}{d\theta}.$$

EXERCISE VII.

1. Find the length of tangent and normal for the parabola $y^2 = 16x$ at $x = 4$.

2. Find the length of subtangent and subnormal to the ellipse $9x^2 + 16y^2 = 144$ at $(6, 6\sqrt{3})$.

3. Find the equations of tangent and normal to $y^2 = 16x^3$ at $(1, 4)$.

4. Find the length of the normal to $x^2(x + y) = 4(x - y)$ at $(0, 0)$.

5. Find where the tangent to $yax = x^3 - a^3$ is parallel to the x -axis.

6. Find where the normal is \perp to the x -axis on the curve, $y^3 = x^2(8 - x)$.

7. Find the angle at which $x^2 = y^2 + 9$ intersects $4x^2 + 9y^2 = 36$.

8. In the equilateral hyperbola $x^2 - y^2 = 16$. The area of the triangle formed by a tangent and the coordinate axes is constant and equal to 16. Prove it.

9. At what angle do $y^2 = 8x$ and $x^2 + y^2 = 20$ intersect?

10. Show that the subtangent to the parabola $y^2 = 2px$ is twice the abscissa of the point of tangency.

11. Show that in a circle the length of the normal is constant.

12. The equation of the tractrix being

$$x = \sqrt{a^2 - y^2} + \frac{a}{2} \log \frac{a - \sqrt{a^2 - y^2}}{a + \sqrt{a^2 - y^2}},$$

show that the length of the tangent is constant.

CHAPTER V.

SUCCESSIVE DIFFERENTIATIONS.

ART. 51. Since $\frac{dy}{dx}$ is, in general, purely a function of x , its differential coefficient may be found as readily as that of the original function. It is usually symbolized thus, $\frac{d^2y}{dx^2}$.

For example, if $y = 3x^3 + 2x^2 - 5x^{\frac{1}{2}}$,

$$\frac{dy}{dx} = 9x^2 + 4x - \frac{5}{2}x^{-\frac{1}{2}},$$

$$\frac{d^2y}{dx^2} = 18x + 4 + \frac{5}{4}x^{-\frac{3}{2}}.$$

Likewise the differential of this second differential may be found in the same way, and is symbolized as $\frac{d^3y}{dx^3}$; the fourth differential coefficient as $\frac{d^4y}{dx^4}$; the n^{th} as $\frac{d^ny}{dx^n}$. It sometimes happens that the successive differential coefficient may be written by analogy after three or four have been found. For example :

$$y = x^m,$$

$$\frac{dy}{dx} = m x^{m-1},$$

$$\frac{d^2y}{dx^2} = m(m-1)x^{m-2},$$

$$\frac{d^3y}{dx^3} = m(m-1)(m-2)x^{m-3},$$

.

$$\frac{d^n y}{dx^n} = m(m-1)(m-2)\dots(m-n+1)x^{m-n}$$

If the function be an implicit function of x and y , it is not necessary to put it in explicit form, as the previously found derivatives may be used to find successively each higher one. For example:

$$x^2 + y^2 = r^2 \dots \dots \dots (1)$$

Take x -derivative: $2x + 2y \frac{dy}{dx} = 0 \dots \dots \dots (2)$

solving for $\frac{dy}{dx}$, $\frac{dy}{dx} = -\frac{x}{y} \dots \dots \dots (3)$

whence $\frac{d^2 y}{dx^2} = -\frac{y - x \frac{dy}{dx}}{y^2} \dots \dots \dots (4)$

substituting value of $\frac{dy}{dx}$ already found from (3) in (4),

$$\frac{d^2 y}{dx^2} = -\frac{y + \frac{x^2}{y}}{y^2} = -\frac{x^2 + y^2}{y^3} = -\frac{r^2}{y^3},$$

$$\frac{d^3 y}{dx^3} = -\frac{3r^2 y^2 \frac{dy}{dx}}{y^6} = -\frac{3r^2 x}{y^5}, \text{ etc.}$$

MACLAURIN'S AND TAYLOR'S FORMULÆ.

ART. 52. It is frequently useful for purposes of calculation to express the value of a function in the form of a series. For example, in algebra, the binomial theorem enables us to develop a binomial raised to any power into a series of powers of the single quantities involved, as,

$$(a + b)^4 = a^4 + 4 a^3 b + 6 a^2 b^2 + 4 a b^3 + b^4, \text{ etc.}$$

Likewise the logarithms of numbers and the trigonometric functions are computed from series.

Hence a general method for the expression of any function of x , say, in series, would prove exceedingly useful.

But such a series has utility only when its sum is a finite quantity. In general, series have an unlimited number of terms, and clearly, unless the sum of these terms is a finite quantity, it is utterly useless. A series whose sum is finite is called a *convergent series*.

It is only with such series that we shall deal here. Let it be required to develop $f(x)$ into a series of powers of $(x - m)$ say. Supposing such a development possible, let

$$f(x) = A + B(x - m) + C(x - m)^2 + D(x - m)^3,$$

etc. (a)

Differentiate (a) successively:

$$f'(x) = B + 2C(x - m) + 3D(x - m)^2 + 4E(x - m)^3 + \dots \text{ etc.}$$

$$f''(x) = 2C + 6D(x - m) + 12E(x - m)^2 + \dots$$

$$f'''(x) = 6D + 24E(x - m) + \dots$$

$$f^{iv}(x) = 24E + \dots$$

Since x is assumed to have any value, let

$$x = m.$$

Then $f(m) = A$	or	$A = f(m);$
$f'(m) = B,$		$B = f'(m);$
$f''(m) = 2C,$		$C = \frac{f''(m)}{2};$
$f'''(m) = 3 \cdot 2D,$		$D = \frac{f'''(m)}{3};$
$f^{iv}(m) = 4 \cdot 3 \cdot 2E,$		$E = \frac{f^{iv}(m)}{4}, \text{ etc.}$

Substituting in (a)

$$f(x) = f(m) + f'(m)(x-m) + \frac{f''(m)}{\angle 2}(x-m)^2 \\ + \frac{f'''(m)}{\angle 3}(x-m)^3 + \frac{f^{iv}(m)}{\angle 4}(x-m)^4 + \dots \quad (b)$$

Example: Develop $\log x$ in powers of $(x-2)$.

$$f(x) = \log x, \quad f(2) = \log 2.$$

$$f'(x) = \frac{1}{x}, \quad f'(2) = \frac{1}{2}.$$

$$f''(x) = -\frac{1}{x^2}, \quad f''(2) = -\frac{1}{4}.$$

$$f'''(x) = \frac{2}{x^3}, \quad f'''(2) = \frac{1}{4}.$$

$$f^{iv}(x) = -\frac{6}{x^4}, \quad f^{iv}(2) = -\frac{3}{8}, \text{ etc.}$$

$$\text{Hence } \log x = \log 2 + \frac{1}{2}(x-2) - \frac{1}{4}(x-2)^2 \\ + \frac{1}{4}(x-2)^3 - \frac{3}{8}(x-2)^4 + \dots$$

ART. 53. If in formula (b), m be made 0, which is clearly permissible, since no restrictions were placed on its value, the formula becomes the development for $f(x)$ in terms of x :

$$f(x) = f(0) + f'(0)x + \frac{f''(0)}{\angle 2}x^2 + \frac{f'''(0)}{\angle 3}x^3 \\ + \frac{f^{iv}(0)}{\angle 4}x^4 + \dots \quad (b)$$

where $f(0)$, $f'(0)$, etc., mean the values of $f(x)$, $f'(x)$, etc., when x is replaced by 0.

Example: Develop $\cos x$ in terms of x .

$$f(x) = \cos x, \quad f(0) = \cos 0 = 1.$$

$$f'(x) = -\sin x, \quad f'(0) = -\sin 0 = 0.$$

$$f''(x) = -\cos x, \quad f''(0) = -\cos 0 = -1.$$

$$\begin{aligned}
 f'''(x) &= \sin x, & f'''(0) &= \sin 0 = 0. \\
 f^{iv}(x) &= \cos x, & f^{iv}(0) &= \cos 0 = 1, \text{ etc.}
 \end{aligned}$$

Substituting in (b):

$$\cos x = 1 - \frac{x^2}{2} + \frac{x^4}{24}, \text{ etc.,}$$

which is the expression from which $\cos x$ is computed.

For example, to find $\cos 30^\circ = \cos \left(\frac{\pi}{6} \text{ rad.} \right)$,

$$\cos 30^\circ = 1 - \frac{\left(\frac{\pi}{6}\right)^2}{2} + \frac{\left(\frac{\pi}{6}\right)^4}{24} - \frac{\left(\frac{\pi}{6}\right)^6}{720} + \text{etc.} \quad (\pi = 3.1416.)$$

$$1 = 1.$$

$$\begin{array}{r}
 \frac{\left(\frac{\pi}{6}\right)^4}{24} = \frac{(.5236)^4}{24} = \frac{.00313}{1.00313} \\
 \frac{\left(\frac{\pi}{6}\right)^2}{2} = -.13708 \\
 \cos 30^\circ = \frac{-.13711}{.86602} \text{ approx.} \quad \frac{-\left(\frac{\pi}{6}\right)^6}{720} = \frac{-.00003}{-} \\
 \phantom{\frac{-.13711}{.86602} \text{ approx.}} \phantom{\frac{-\left(\frac{\pi}{6}\right)^6}{720} = \frac{-.00003}{-}}
 \end{array}$$

The series (b) (and its special form b_1) is known as Maclaurin's Series from its discoverer.

ART. 54. It is frequently necessary to express a function of two quantities in the form of a series of powers of one of them, as for example, $f(h+x)$ in powers of x .

The process is entirely analogous to that employed in the development of Maclaurin's Series, and the result is known as Taylor's formula.

Assuming that $f(h+x)$ can be developed in powers of x , and regarding h as constant:

$$\text{Let } f(h+x) = A + Bx + Cx^2 + Dx^3 + Ex^4 + \quad (c)$$

Taking the derivatives with respect to x ,

$$f'(x + h) = B + 2 Cx + 3 Dx^2 + 4 Ex^3 + \dots$$

$$f''(x + h) = 2 C + 6 Dx + 12 Ex^2 + \dots$$

$$f'''(x + h) = 6 D + 24 Ex + \dots$$

$$f^{IV}(x + h) = 24 E + \dots$$

Since this series must be true for all values of x , being an identity, it is true when $x = 0$; hence setting $x = 0$ in this series of equations we are enabled to determine the constants, thus:

$$A = f(h).$$

$$B = f'(h).$$

$$C = \frac{f''(h)}{2}.$$

$$D = \frac{f'''(h)}{3} \quad (2 = 2 \times 1 = 2).$$

$$E = \frac{f^{IV}(h)}{4} \quad (6 = 3 \times 2 \times 1 = 3).$$

Substituting in (c)

$$\begin{aligned} f(x + h) = f(h) + f'(h) x + \frac{f''(h)}{2} x^2 + \frac{f'''(h)}{3} x^3 \\ + \frac{f^{IV}(h)}{4} x^4 + \dots \end{aligned}$$

Where $f(h)$, $f'(h)$, etc., mean the values of $f(x+h)$, $f'(x+h)$, etc., when $x = 0$.

ART. 55. It will be evident upon consideration, that the binomial theorem as encountered in algebra is a special form of Taylor's formula. The utility of these developments of Maclaurin and Taylor, depends upon the rapidity with which they converge.

As the series developed by these two formulæ is usually infinite, there is always a residual error in taking the sum of a limited number of terms as the value of the function thus expanded. A discussion of this error is unnecessary here; it will be sufficient for us now to observe that a series has satisfactory convergence, if the successive terms decrease rapidly in value, and after a limited number of terms, approach zero.

It is usually an effective test of convergence, when the n^{th} term of a series can be readily expressed, to find the ratio between the $(n + 1)^{\text{th}}$ and n^{th} terms. If this ratio approaches zero as n approaches infinity, the series is convergent, otherwise divergent, and hence, useless for practical purposes.

Example : To test convergency of sine-series.

$$\sin x = x - \frac{x^3}{\angle 3} + \frac{x^5}{\angle 5} - \frac{x^7}{\angle 7} + \dots$$

$$(-1)^{n-1} \frac{x^{2n-1}}{\angle 2n-1}.$$

Inspection of the relation between the coefficients of x , the denominators, and the corresponding term number, gives the n^{th} term as above. The $(n + 1)^{\text{th}}$ term likewise is,

$$(-1)^{n-1} \frac{x^{2n+1}}{\angle 2n+1}.$$

If then the value approached by the ratio,

$$\frac{\frac{x^{2n+1}}{\angle 2n+1}}{\frac{x^{2n-1}}{\angle 2n-1}} \text{ as } n \text{ approaches infinity,}$$

is zero, the series is convergent, otherwise not.

$$\frac{\frac{x^{2n+1}}{\angle 2n+1}}{\frac{x^{2n+1}}{\angle 2n-1}} = \frac{x^2}{(2n+1)2n} = 0 \text{ if } n = \infty.$$

Hence the sine-series is convergent.

It is to be observed that it is only the absolute values of the terms that are considered, as the sign does not affect the ratio. There are numerous more complicated tests for convergency, but they do not come within the scope of this book.

EXERCISE VIII.

1. $y = 4x^3 - 8x^2 + 2x - 1$, find $\frac{d^2y}{dx^2}$.
2. $y = x^3$, find $\frac{d^3y}{dx^3}$.
3. $y = x^n$, find $\frac{d^ny}{dx^n}$.
4. $y = x \log x$, find $\frac{d^2y}{dx^2}$.
5. $y = \log(e^x + e^{-x})$, find $\frac{d^3y}{dx^3}$.
6. $y = e^x(x^2 - 4x + 8)$, find $\frac{d^3y}{dx^3}$.
7. $y = \frac{1}{x}$, find $\frac{d^4y}{dx^4}$.
8. $y = x^4 \log x$, find $\frac{d^3y}{dx^3}$.
9. $y = x^3 - \frac{1}{x^3}$, find $\frac{d^2y}{dx^2}$.
10. $y = \log \sin x$, find $\frac{d^4y}{dx^4}$.

11. $y = \sin 2x$, find $\frac{d^3y}{dx^3}$.
12. $y = \frac{x^2}{1-x}$, find $\frac{d^2y}{dx^2}$.
13. $y = e^{2x}(x^2 - 2x + 1)$, find $\frac{d^3y}{dx^3}$.
14. $y = e^{ax}$, find $\frac{d^n y}{dx^n}$.
15. $y = e^x \sin x$, show $\frac{d^2y}{dx^2} - 2 \frac{dy}{dx} + 2y = 0$.
16. $y = \frac{e^x + e^{-x}}{e^x - e^{-x}}$, express $\frac{d^2y}{dx^2}$ in terms of y .
17. $y = x^2 e^x$, show that $\frac{d^3y}{dx^3} = 6e^x(x+1) + y$.
18. $z = 1 + xe^z$, find $\frac{d^2z}{dx^2}$.
19. $x^3 - 3axy + y^3$, find $\frac{d^2y}{dx^2}$.
20. $b^2x^2 - a^2y^2 = a^2b^2$, find $\frac{d^2y}{dx^2}$.
21. $y^2 = 2px$, find $\frac{d^2y}{dx^2}$.
22. $xy = c^2$, find $\frac{d^3y}{dx^3}$.
23. $e^{x+y} = xy$, find $\frac{d^2y}{dx^2}$.
24. $y = \frac{a}{2} \left(e^{\frac{x}{a}} + e^{-\frac{x}{a}} \right)$, find $\frac{d^2y}{dx^2}$ in terms of y and a .
25. $y^3 = a^2x$, find $\frac{d^2y}{dx^2}$.
26. $x = r \operatorname{vers}^{-1} \frac{y}{r} - \sqrt{2ry - y^2}$, find $\frac{d^2y}{dx^2}$ in terms of y and r .

EXERCISE IX.

Expand by Maclaurin's formula:

1. $\sin x$ (in powers of x).
2. $\tan^{-1}x$.
3. $\log x$ (in powers of $(x - 1)$)
4. $\frac{1}{1 - x}$ (in powers of x).
5. e^x (in powers of $(x - 2)$).
6. $\frac{1}{x}$ (in powers of $(x - h)$).

Expand by Taylor's formula in powers of x :

- | | |
|-----------------------|--------------------------|
| 7. $\sin(n + x)$. | 10. $\log \sin(h + x)$. |
| 8. $\sqrt{1 - x^2}$. | 11. $\sec(a + x)$. |
| 9. e^{a+x} . | 12. $(a - x)^n$. |

CHAPTER VI.

EVOLUTION OF INDETERMINATE FORMS.

ART. 56. Functions of a variable which reduce to such forms as $\frac{0}{0}$, $\frac{\infty}{\infty}$, $0 \cdot \infty$, etc., for certain values of the variable are called *indeterminate*, because we are unable to divide 0 by 0 , or ∞ by ∞ directly, but must approach the quotients by a circuitous path.

The consideration of a definite example may make the idea clearer.

Take for example, $\frac{x^5 - 1}{x - 1}$ when $x = 1$.

Clearly, $\frac{x^5 - 1}{x - 1} = \frac{0}{0}$ when $x = 1$.

But also $\frac{x^3 - 1}{x - 1} = \frac{0}{0}$ when $x = 1$,

and $\frac{x^3 - 8}{x - 2} = \frac{0}{0}$ when $x = 2$,

and $\frac{2x - x^2 - 1}{3x^2 - 2x - 1} = \frac{0}{0}$ when $x = 1$.

Evidently $\frac{0}{0}$ does not mean the same thing in all these cases, nor in the multitude of similar cases that might be cited. Having practically an infinite number of possible values then, the expression $\frac{0}{0}$ is indeterminate. It will be recalled that in discussing the differential quotient, it

was remarked that although two quantities may each be too small (or too large) for individual comprehension, they might yet have a finite, readily expressible ratio, if they belonged to the same order of smallness (or largeness).

To use a somewhat inadequate illustration, two typhoid bacilli, though each hopelessly beyond the reach of our ordinary senses, could be readily compared with one another and their relative size could be expressed by a very simple number. Although a bacillus is not infinitely small, the same illustration may be extended indefinitely. As the chemist has to approach the problem of his inconceivably small atom and the astronomer of his inconceivably vast distances, indirectly, so we will have to deal with our zeroes and infinities.

To return to the expression $\frac{x^5 - 1}{x - 1}$.

Before giving x any definite value, divide the numerator by the denominator, then $\frac{x^5 - 1}{x - 1} = x^4 + x^3 + x^2 + x + 1$.

If in this expression we give x a constantly decreasing value > 1 , the integral function will clearly approach more and more nearly the value 5, while the fraction approaches the value $\frac{0}{0}$. It is easy to infer then that when x is actually 1, the value of $\frac{0}{0}$ becomes exactly 5.

Again the expression

$$\frac{2x - x^2 - 1}{3x^2 - 2x - 1}$$

may be shown to approach $-\frac{1}{3}$ as x approaches ∞ , if we first divide both numerator and denominator by x^2 .

ART. 57. To find a general method for evaluating an indeterminate.

$$\text{Let } \frac{f(x)}{\phi(x)} = \frac{0}{0} \text{ when } x = a.$$

By Maclaurin's formula,

$$f(x) = f(a) + f'(a)(x-a) + \frac{f''(a)}{\angle 2}(x-a)^2 + \frac{f'''(a)}{\angle 3}(x-a)^3 + \dots$$

$$\phi(x) = \phi(a) + \phi'(a)(x-a) + \frac{\phi''(a)}{\angle 2}(x-a)^2 + \frac{\phi'''(a)}{\angle 3}(x-a)^3 + \dots$$

But $f(a) = 0$ and $\phi(a) = 0$ by hypothesis.

$$\therefore \frac{f(x)}{\phi(x)} =$$

$$\frac{f'(a)(x-a) + \frac{f''(a)}{\angle 2}(x-a)^2 + \frac{f'''(a)}{\angle 3}(x-a)^3 + \dots}{\phi(a)(x-a) + \frac{\phi''(a)}{\angle 2}(x-a)^2 + \frac{\phi'''(a)}{\angle 3}(x-a)^3 + \dots}$$

$$= \frac{f'(a) + \frac{f''(a)}{\angle 2}(x-a) + \frac{f'''(a)}{\angle 3}(x-a)^2 + \dots}{\phi'(a) + \frac{\phi''(a)}{\angle 2}(x-a) + \frac{\phi'''(a)}{\angle 3}(x-a)^2 + \dots}$$

(dividing numerator and denominator by $x-a$)

$$= \frac{f'(a)}{\phi'(a)} \quad (\text{since } (x-a), (x-a)^2, \text{ etc.} = 0 \text{ when } x = a).$$

$$\text{If } \frac{f'(x)}{\phi'(x)} \text{ still equals } \frac{0}{0} \text{ for } x = a,$$

it is clear that the expression reduces to $\frac{f''(x)}{\phi''(x)}$; if $f'(x)$

$\phi'(x)$ are replaced by their values, 0, and numerator and denominator be again divided by $x - a$.

$$\text{Hence when } \frac{f(x)}{\phi(x)} = \frac{0}{0} \text{ for } x = a,$$

$$\frac{f(x)}{\phi(x)} = \frac{f'(x)}{\phi'(x)} = \frac{f''(x)}{\phi''(x)}, \text{ etc.}$$

A rule may be stated thus:

Take the successive derivatives of numerator and denominator (as distinct functions) until a derivative is found, say $f^n(x)$, which is not zero for $x = a$. Then,

$$\frac{f^n(x)}{\phi^n(x)} = \frac{f(x)}{\phi(x)} \text{ is the value sought.}$$

$$\text{Example: Evaluate } \frac{\tan x - \sin x \cos x}{x^3} = \frac{0}{0},$$

when $x = 0$.

$$\text{Here } \frac{\tan x - \sin x \cos x}{x^3} = \frac{f(x)}{\phi(x)}.$$

$$\therefore \frac{\tan x - \sin x \cos x}{x^3} = \frac{\sec^2 x - \cos^2 x + \sin^2 x}{3x^2} \quad \text{(taking derivatives).}$$

This expression corresponding to $\frac{f'(x)}{\phi'(x)}$ still equals $\frac{0}{0}$.

Hence taking second derivative,

$$\begin{aligned} \frac{\tan x - \sin x \cos x}{x^3} &= \frac{\sec^2 x - \cos^2 x + \sin^2 x}{3x^2} \\ &= \frac{2 \sec x \tan x + 2 \cos x \sin x + 2 \sin x \cos x}{6x} \\ &= \frac{\sec x \tan x + 2 \sin x \cos x}{3x} \end{aligned}$$

(collecting and dividing by 2).

This is still $\frac{0}{0}$. Taking third derivative $\frac{f'''(x)}{\phi'''(x)}$

$$= \frac{\sec^3 x + \sec x \tan^2 x + 2 \cos^2 x - 2 \sin^2 x}{3} = \frac{3}{3}$$

$$= 1, \text{ when } x = 0.$$

$$\therefore \frac{\tan x - \sin x \cos x}{x^3} = 1, \text{ when } x = 0.$$

ART. 58. If $\frac{f(x)}{\theta(x)} = \frac{\infty}{\infty}$ when $x = a$, a simple transformation reduces the expression to the form $\frac{0}{0}$; for

$$\frac{f(x)}{\phi(x)} = \frac{\frac{1}{\phi(x)}}{\frac{1}{f(x)}} = \frac{0}{0} \text{ for } x = a.$$

If $f(x) = 0$ and $\phi(x) = \infty$ for $x = a$,
 then $f(x) \cdot \phi(x) = 0 \cdot \infty$, an indeterminate,
 but $f(x) \cdot \phi(x) = \frac{f(x)}{\frac{1}{\phi(x)}} = \frac{0}{0}$.

By using the logarithms of the functions as an intermediate step, expressions like 1^∞ , 0^∞ , ∞^0 , etc., may be reduced likewise to $\frac{0}{0}$. For example, let $f(x) = 1$ and

$$\phi(x) = \infty, \text{ when } x = a.$$

Then $f(x)]^{\phi(x)} = 1^\infty$.

$$\text{Let } y = [f(x)]^{\phi(x)}.$$

Taking the log of both sides:

$$\text{Log } y = \phi(x) \log f(x) = \frac{\log f(x)}{\frac{1}{\phi(x)}} = \frac{0}{0} \text{ when } x = a.$$

In these cases we get eventually the logarithm of the function, from which the function itself is readily found.

Example: Evaluate $\left(2 - \frac{x}{a}\right)^{\tan \frac{\pi x}{2a}}$, when $x = a$,

$$\left(2 - \frac{x}{a}\right)^{\tan \frac{\pi x}{2a}} = 1^\infty, \text{ when } x = a.$$

Let $y = \left(2 - \frac{x}{a}\right)^{\tan \frac{\pi x}{2a}}$.

$$\text{Then } \log y = \tan \frac{\pi x}{2a} \log \left(2 - \frac{x}{a}\right) = \frac{\log \left(2 - \frac{x}{a}\right)}{\cot \frac{\pi x}{2a}} = \frac{0}{0}$$

$$\begin{aligned} \therefore \log y &= \frac{\log \left(2 - \frac{x}{a}\right)}{\cot \frac{\pi x}{2a}} = \frac{-1}{a \left(2 - \frac{x}{a}\right)} \\ &= \frac{1}{2a - x} = \frac{1}{a} = \frac{2}{\pi}, \text{ when } x = a. \end{aligned}$$

That is, $\log y = \log \left(2 - \frac{x}{a}\right)^{\tan \frac{\pi x}{2a}} = \frac{2}{\pi}$, when $x = a$.

$$\therefore (2 - a)^{\tan \frac{\pi x}{2a}} = e^{\frac{2}{\pi}}.$$

Example: Evaluate $(a^x - 1)^{\frac{1}{x}}$, when $x = \infty$.

$$(a^x - 1)^{\frac{1}{x}} = (a^\infty - 1)^\infty = (a^0 - 1)^\infty = 0^\infty,$$

when $x = \infty$.

$$\text{But } (a^x - 1)x = \frac{a^x - 1}{\frac{1}{x}} = \frac{0}{0}.$$

$$\therefore \frac{a^x - 1}{\frac{1}{x}} = \frac{-a^x \log a}{-\frac{1}{x^2}} = a^x \log a = \log a,$$

when $x = \infty$.

EXERCISE X.

Evaluate:

1. $\frac{\log y}{y - 1}$, when $y = 1$.
2. $\frac{e^x - e^{-x}}{\tan x}$, when $x = 1$.
3. $\frac{4x \sin x - 2\pi}{\cos x}$, when $x = \frac{\pi}{2}$.
4. $\frac{2}{\cos^2 \theta} - \frac{1}{1 - \sin \theta}$, when $\theta = \frac{\pi}{2}$.
5. $\frac{1}{x^{x-1}}$, when $x = 1$.
6. $(\sin y)^{\tan y}$, when $y = \frac{\pi}{2}$.
7. $\frac{e^z + e^{-z} - 2}{z^2}$, when $z = 0$.
8. $\frac{(1+x)^{\frac{1}{x}} - 1}{x}$, when $x = 0$.
9. $\left(1 + \frac{1}{x}\right)^x$, when $x = \infty$.

10. $\frac{\sin^{-1} x}{\tan^{-1} x}$, when $x = 0$.
11. $\frac{e^y \sin y - y - y^2}{y^2 + y \log(1 - y)}$, when $y = 0$.
12. $\frac{\log \sin 2x}{\log \sin x}$, when $x = 0$.
13. $(m^x - 1)x$, when $x = \infty$.
14. $\frac{e}{e^x - e} - \frac{1}{x - 1}$, when $x = 1$.
15. $\frac{1}{\log x} - \frac{x}{\log x}$, when $x = 1$.
16. $(\cos 2\theta)^{\frac{1}{\theta^2}}$, when $\theta = 0$.
17. $(\log x)^{x-1}$, when $x = 1$.
18. $\frac{\log x}{\csc x}$, when $x = 0$.
19. $(1 - \tan x) \sec 2x$, when $x = \frac{\pi}{4}$.
20. $e^{-x} \log x$, when $x = \infty$.
21. $[\log(e + z)]^{\frac{1}{z}}$, when $z = 0$.
22. $\left(2 - \frac{x}{n}\right) \tan \frac{\pi x}{2n}$, when $x = n$.
23. $\left(\frac{\tan x}{x}\right)^{\frac{1}{x^2}}$, when $x = 0$.
24. $\frac{\sec \frac{\pi x}{2}}{\log(1 - x)}$, when $x = 1$.

25. $\frac{1}{x} - \cot x$, when $x = 0$.
26. $\frac{1 - \cos x}{x^2}$, when $x = 0$.
27. $\frac{x - \sin^{-1} x}{\sin^3 x}$, when $x = 0$.
28. $2^x \sin \frac{a}{2^x}$, when $x = \infty$.
29. $(\sin x)^{\sin x}$, when $x = 0$.
30. $x e^{\frac{1}{x}}$, when $x = 0$.
31. $\frac{x^2 + 2 \cos x - 2}{x^4}$, when $x = 0$.
32. $\frac{1 - \sin x + \cos x}{\sin x + \cos x - 1}$, when $x = \frac{\pi}{2}$.
33. $\frac{x^3 - 5x^2 + 7x - 3}{x^3 - x^2 - 5x - 3}$, when $x = 3$.
34. $\frac{\sqrt{y} \tan y}{(e^y - 1)^{\frac{3}{2}}}$, when $y = 0$.
35. $x \tan x - \frac{\pi}{2} \sec x$, when $x = \frac{\pi}{2}$.
36. $\left(1 + \frac{1}{z^2}\right)^z$, when $z = \infty$.

CHAPTER VII.

MAXIMA AND MINIMA.

ART. 59. When a function has a maximum value it is an increasing function until it reaches the value then a decreasing function just afterward, otherwise this value would not be a maximum. Since the derivative of a function is the ratio between its increase and the increase of its independent variable, if the function is increasing with the variable the derivative will be positive; if it is decreasing as the variable increases the derivative will be negative. Hence when a function passes through a maximum value its derivative changes from positive to negative, and in order to do this it must pass through the value zero, if it is continuous. A similar process of reasoning shows that when a function passes through a minimum value the derivative also passes through zero from negative to positive. It is to be remembered that since a function depends upon its variable for its value, it can be made to take any number of values, as near together as we please, by giving the variable a suitable series of values, that is provided always that the function is continuous.

A graphic illustration may make this plainer.

Since in general any function may be represented graphically by a curve, let the curve AB, Fig. 23, represent $y = f(x)$.

Since the derivative of a function, represented by a curve, is the slope of its tangent at any given point, the change of the derivative and the tangent slope are synony-

mous. Suppose T is a maximum point for the value $x = OD$. A glance at the figure will show that starting, say with the tangent MN at A , the slope of this tangent as the point of tangency moves from A to T will be constantly positive (the inclination being an acute angle, as AMO) but constantly decreasing; at T the slope will be zero, for the tangent, RS , is parallel to the x -axis; beyond the point T , the inclination of the tangent is an obtuse angle as PQx , and hence its tangent is negative, but it will still decrease

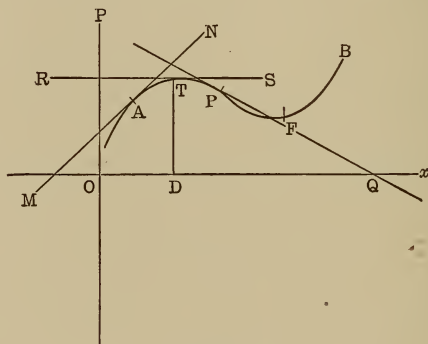

Fig. 23.

in general. Therefore, as indicated, the derivative of the function which is always equal to these slopes, will pass from positive to negative through zero. But a function may pass through zero or infinity without changing its sign, so even when the derivative is zero there may not be a maximum or minimum. Hence it is necessary to determine in a given case whether a maximum or minimum exists.

Recall the fact cited above, that the slope decreases to zero before a maximum and continues to decrease (because it is negative) after a maximum, hence the *derivative* is a

decreasing function at a maximum, hence its derivative, that is, the second derivative of the original function, will be negative from our definition of a derivative.

An examination of the figure around the point F (a minimum) will show that at a minimum the slope, and hence the derivative, passing from negative to positive through zero, is an increasing function, hence its derivative, that is, the second derivative of the function, is positive. This suggests a general method for determining maxima and minima, as follows :

Since the first derivative is always zero at a maximum or minimum point, if the first derivative is found and set equal to zero, the value of the variable found from this equation will, in general, be one of the co-ordinates (usually the abscissa) of the maximum or minimum point on the curve representing the function. To determine whether it is a maximum or minimum, the second derivative is found, and if it is negative in value for this value of the variable, the point is a maximum; if positive, it is a minimum.

ART. 60. It may happen that the second derivative is also zero for this value of the variable, and hence indeterminate as to sign. In this case it is clearly desirable to expand the function in the neighborhood of this value of the variable that its character may be more readily seen.

If $f(x)$ is the function, and $x = a$ be the value found from $f'(x) = 0$, then $f(a - h)$ and $f(a + h)$ will represent the value of the function immediately before and immediately after, respectively, its value for $x = a$, h being a quantity which can be made as small as desired.

By Taylor's formula:

$$f(x + h) = f(x) + f'(x)h + \frac{f''(x)h^2}{\angle 2} + \frac{f'''(x)h^3}{\angle 3} + \dots$$

$$f(x - h) = f(x) - f'(x)h + \frac{f''(x)}{\angle 2} h^2 - \frac{f'''(x)}{\angle 3} h^3 + \dots$$

Replacing x by the value a , and transposing $f(a)$,

$$f(a + h) - f(a) = f'(a)h + \frac{f''(a)}{\angle 2} h^2 + \frac{f'''(a)}{\angle 3} h^3 + \dots$$

$$f(a - h) - f(a) = -f'(a)h + \frac{f''(a)}{\angle 2} h^2 - \frac{f'''(a)}{\angle 3} h^3 + \dots$$

Now since h is to be taken exceedingly small, its square, cube, etc., in the developments will be insignificant, and hence the values of the above expressions will practically equal the first terms of their development. That is, $f(a + h) - f(a)$ will have the same sign as $f'(a)h$, and $f(a - h) - f(a)$ will have the sign of $-f'(a)h$. But if there is a maximum or minimum at a , $f(a + h)$ and $f(a - h)$ must have the same value, because if it increases to a maximum it must decrease beyond the maximum, and hence have the same value just before and just after, as the sun has the same altitude at the same time before noon and after, noon being its maximum elevation.

But the only way $f'(a)h$ and $-f'(a)h$ could both have the same value would be, that both equal zero, that is, that $f'(a) = 0$ [$f'(a)$ being value of $f'(x)$ when $x = a$], which verifies our former conclusion.

If $f'(a) = 0$, then,

$$f(a + h) - f(a) = \frac{f''(a)}{\angle 2} h^2 + \frac{f'''(a)}{\angle 3} h^3 + \dots$$

and

$$f(a - h) - f(a) = \frac{f''(a)}{\angle 2} h^2 - \frac{f'''(a)}{\angle 3} h^3 + \dots$$

Since h is so small, h^2 is much larger than h^3 or any higher power, hence $f(a + h) - f(a)$ and $f(a - h) - f(a)$

are determined by $\frac{f''(a)}{\angle^2} h^2$, and hence are positive if $f''(a)$ is positive, and negative if $f''(a)$ is negative

$$\left[\text{for } f''(a) \text{ determines the sign of the term } \frac{f''(a)}{\angle^2} h^2 \right].$$

But, when $f(a+h) - f(a)$ and $f(a-h) - f(a)$ are both negative, $f(a)$ is a maximum, since it is greater than the values on either side of it [$f(a+h)$ and $f(a-h)$]; likewise, when they are both positive, $f(a)$ is a minimum. But these conditions prevail, respectively, when $f''(a)$ is negative and when $f''(a)$ is positive, which verifies our second conclusion above.

If $f''(a)$ is also zero, then,

$$f(a+h) - f(a) = \frac{f'''(a)}{\angle^3} h^3 + \frac{f^{iv}(a)}{\angle^4} h^4 + \dots$$

and

$$f(a-h) - f(a) = -\frac{f'''(a)}{\angle^3} h^3 + \frac{f^{iv}(a)}{\angle^4} h^4 - \dots$$

A course of reasoning exactly as before, will show that for a turning value (maximum or minimum)

$$\frac{f'''(a)}{\angle^3} h^3 \text{ and } -\frac{f'''(a)}{\angle^3} h^3 \text{ must equal zero,}$$

that is, $f'''(a) = 0$,

and when $f^{iv}(a)$ is positive there is a minimum; when $f^{iv}(a)$ is negative there is a maximum, etc.

Hence the rule:

A function has a maximum or minimum value at $x = a$, if any number of the successive derivatives, beginning with the first, is zero for $x = a$, provided the first that does not equal zero is of even order, being negative for a maximum and positive for a minimum.

The values of the variable which cause the first derivatives of a function to vanish are called *critical values*.

Example: Find turning values of $(x - 1)^3(x - 2)^2$.

$$f(x) = (x - 1)^3(x - 2)^2$$

$$f'(x) = 3(x - 1)^2(x - 2)^2 + 2(x - 1)^3(x - 2)$$

whence $(x - 1)^2(x - 2)(5x - 8) = 0,$

$$x = 1, 1, 2, \frac{8}{5}.$$

$$f''(x) = 2(x - 1)(x - 2)(5x - 8) + (x - 1)^2(5x - 8) + 5(x - 1)^2(x - 2).$$

When $x = 1, f''(x) = 0.$

$$x = 2, f''(x) = 2 \text{ (positive).}$$

$$x = \frac{8}{5}, f''(x) = -\frac{1}{2}\frac{8}{5} \text{ (negative).}$$

Hence for $x = 2$, there is a minimum,

and for $x = \frac{8}{5}$, there is a maximum.

Since $f''(x) = 0$ for $x = 1$, it is necessary to find the third and fourth derivatives.

$$f'''(x) = 2(30x^2 - 84x + 57) = 6 \text{ when } x = 1.$$

Hence there is neither maximum nor minimum at $x = 1$.

Example: What are the dimensions of the cylindrical vessel of largest contents that can be made from 3234 square inches of tin plate, not counting waste?

Since 3234 square inches will constitute the surface of the cylinder (one base) when completed,

$$2\pi rh + \pi r^2 = 3234 \quad \dots \dots \dots (1)$$

$$\text{Volume} = \pi r^2 h \quad \dots \dots \dots (2)$$

which is to be a maximum.

$$\text{From (1) } h = \frac{3234 - \pi r^2}{2\pi r} = \frac{1029 - r^2}{2r} \left[\pi = \frac{22}{7} \right].$$

Substituting in (2)

$$\pi r^2 h = \frac{1029 \pi r - \pi r^3}{2} = \frac{\pi}{2} (1029 r - r^3).$$

Since a constant does not change value it cannot affect a maximum or minimum, hence any constant factor may be ignored, in searching for turning values.

$$\text{Say then, } \quad f(r) = 1029 r - r^3,$$

$$f'(r) = 1029 - 3 r^2 = 0,$$

whence

$$r^2 = 343, r = 7\sqrt{7}.$$

$f''(r) = -6r$ which is negative, hence $r = 7\sqrt{7}$ gives a maximum.

From (1) $h = 7\sqrt{7}$ for $r = 7\sqrt{7}$. Hence the cylinder will have greatest contents when its radius equals its altitude.

EXERCISE XI.

Find maxima or minima:

1. $\frac{y-8}{y^2}$.

2. $\frac{(z+9)(z-2)}{z^2}$.

3. $\frac{4x}{(x-2)^2}$.

4. $\frac{1}{1+x} - \frac{1}{1-x}$.

5. $\frac{y^2 - y + 1}{y^2 + y - 1}$.

6. $\frac{u^2 + 2u + 3}{u^2 + 1}$.

7. Divide a line 1' long into two parts, such that their product will be a maximum.

8. Find the greatest rectangle that can be inscribed in a circle of radius 6".

9. Find the volume of the greatest cylinder inscribed in a sphere of 8" radius.

10. Find the greatest cone in the same sphere.

11. Show that it takes the least amount of sheet iron to make a cylindrical tank closed at both ends, when its diameter equals its height.

12. Find the greatest cylinder that can be inscribed in a right cone of radius, r , and height, h .

13. Calling the E.M.F. of a cell, E ; internal resistance r , external resistance, R , and current, C , $C = \frac{E}{r + R}$ and the power, $P = RC^2$. What value of R will make P a maximum?

14. Find the shortest straight line that can be drawn through a given point (m, n) and limited by the axes.

CHAPTER VIII.

PARTIAL DERIVATIVES.

ART. 61. Up to this time functions of one independent variable only have been considered, but an expression may be a function of two or more independent variables. A function of two variables, x and y say, is symbolized thus:

$$f(x, y), \phi(x, y), F(x, y), \text{ etc.}$$

Continuous functions only give important general results, and a function of two variables is continuous about any specific values of these variables, say $x = h$, $y = k$, when the function runs through an unbroken series of values (as near together as we please) as its variables run through corresponding series of consecutive values, in the vicinity of h and k .

ART. 62. The derivative of a function of two (or more) variables found by considering all the variables except one, as constants, is called its *partial derivative* with respect to the variable that changes. For example, $4xy + 3y^2$ is the partial derivative with respect to x of the function $2x^2y + 3xy^2 + y^3$ (regarding y as a constant) and is represented thus:

$$\frac{\partial}{\partial x} (2x^2y + 3xy^2 + y^3) = 4xy + 3y^2.$$

$$\text{If } z = 2x^2y + 3xy^2 + y^3, \text{ then } \frac{\partial z}{\partial x} = 4xy + 3y^2 \quad . \quad (1)$$

Likewise the partial differential, with respect to x , is represented thus:

$$\partial_x z = 4xy dx + 3y^2 dx \dots \dots \dots (2)$$

Evidently $\partial_x z = \frac{\partial z}{\partial x} dx$, since (2) equals (1) multiplied by dx .

$$\text{Similarly, } \partial_y z = (2x^2 + 6xy + 3y^2) dy \dots \dots \dots (3)$$

By the principles of differentiation already known,

$$dz = 4xy dx + 2x^2 dy + 3y^2 dx + 6xy dy + 3y^2 dy. \quad (4)$$

A comparison of (2), (3) and (4) will show that

$$dz = \partial_x z + \partial_y z = \frac{\partial z}{\partial x} dx + \frac{\partial z}{\partial y} dy.$$

That is, in this case the total differential equals the sum of the partial differentials.

In Art. 4, and succeeding articles, it was explained that a differential quotient (or derivative) was the ratio of the increase of a function to the increase of its variable when these increments were indefinitely small. This may be expressed thus: if $y = f(x)$,

$$\frac{dy}{dx} = \frac{f(x + \Delta x) - f(x)}{\Delta x}, \text{ as } \Delta x \text{ approaches } 0.$$

Likewise in a function of two variables, x and y say, if $z = f(xy)$

$$\frac{\partial z}{\partial x} = \frac{f(x + \Delta x, y) - f(x, y)}{\Delta x} \text{ as } \Delta x \doteq 0.$$

[(\doteq) is a symbol meaning "approaches."]

$$\text{Also } \frac{\partial z}{\partial y} = \frac{f(x, y + \Delta y) - f(x, y)}{\Delta y} \text{ as } \Delta y \doteq 0,$$

in the first case y remaining constant while x changes to $x + \Delta x$, and in the second x remaining constant while y changes to $y + \Delta y$.

Now let these changes take place together in the same function and we have,

$$z + \Delta z = f(x + \Delta x, y + \Delta y) \quad \dots (a)$$

But the result would plainly be the same, if instead of changing simultaneously, x should change while y remained constant and then y would change while $x + \Delta x$ remained constant.

From (a), $\Delta z = f(x + \Delta x, y + \Delta y) - f(x, y)$,
or changing successively,

$$\begin{aligned} \Delta z &= f(x + \Delta x, y) - f(x, y) \\ &\quad + f(x + \Delta x, y + \Delta y) - f(x + \Delta x, y). \\ \frac{\Delta z}{\Delta x} &= \frac{f(x + \Delta x, y) - f(x, y)}{\Delta x} \\ &\quad + \frac{f(x + \Delta x, y + \Delta y) - f(x + \Delta x, y)}{\Delta y} \cdot \frac{\Delta y}{\Delta x}. \end{aligned}$$

(Multiplying and dividing the last two terms by Δy , and dividing through by Δx .) By definition of derivative,

$$\frac{f(x + \Delta x, y) - f(x, y)}{\Delta x} [\text{as } \Delta x \doteq 0] = \frac{\partial z}{\partial x},$$

and

$$\frac{f(x + \Delta x, y + \Delta y) - f(x + \Delta x, y)}{\Delta y} [\text{as } \Delta y \doteq 0] = \frac{\partial z}{\partial y}.$$

That is, $\frac{dz}{dx} = \frac{\partial z}{\partial x} + \frac{\partial z}{\partial y} \frac{dy}{dx}$ or $dz = \frac{\partial z}{\partial x} dx + \frac{\partial z}{\partial y} dy$.

Hence the result found in the specific example above is shown to be general for all continuous functions, namely: *The total differential equals the sum of the partial differentials, each being multiplied by the differential of its independent variable.*

This rule could be easily inferred from the rules already

enunciated for the differentiation of specific forms as, for example, the product of two or more variables, wherein the differential is found by regarding all the variables but one successively as constant, and taking the sum of the results.

ART. 63. In implicit functions, which are presented most frequently for partial differentiation, the form is $f(x, y) = 0$.

An implicit function, it will be remembered, is one in which the variables are thrown together in the various terms, and the function is not solved explicitly for any one, like $3x^2y - xy + 7xy^3$, etc.

From our rule,

$$df(x, y) = \frac{\partial f(x, y)}{\partial x} dx + \frac{\partial f(x, y)}{\partial y} dy = 0,$$

whence

$$\frac{dy}{dx} = - \frac{\frac{\partial f(x, y)}{\partial x}}{\frac{\partial f(x, y)}{\partial y}}, \text{ or shortly, } \frac{dy}{dx} = \frac{\frac{\partial f}{\partial x}}{\frac{\partial f}{\partial y}}.$$

The same process applies to any number of variables, for example, if

$$w = \phi(x, y, z),$$

$$dw = \frac{\partial \phi}{\partial x} dx + \frac{\partial \phi}{\partial y} dy + \frac{\partial \phi}{\partial z} dz, \text{ etc.}$$

ART. 64. If y is itself a function of x , say $y = \phi(x)$, then the form

$$\frac{dz}{dx} = \frac{\partial z}{\partial x} + \frac{\partial z}{\partial y} \frac{dy}{dx}$$

is most effective, for $\frac{dy}{dx}$ can be found from $y = \phi(x)$.

Example: $z = \tan^{-1} \frac{2y}{x}$ and $x^2 + 4y^2 = 1$.

By formula,

$$\begin{aligned} \frac{dz}{dx} &= \frac{\partial \left(\tan^{-1} \frac{2y}{x} \right)}{\partial x} + \frac{\partial \left(\tan^{-1} \frac{2y}{x} \right)}{\partial y} \cdot \frac{dy}{dx} \\ &= \frac{\frac{-2y}{x^2}}{1 + \frac{4y^2}{x^2}} + \frac{\frac{2}{x}}{1 + \frac{4y^2}{x^2}} \cdot \frac{dy}{dx} \dots\dots (a) \end{aligned}$$

From $x^2 + 4y^2 = 1$; $y^2 = \frac{1-x^2}{4}$; $y = \frac{1}{2} \sqrt{1-x^2}$,

whence $\frac{dy}{dx} = -\frac{x}{2\sqrt{1-x^2}} = -\frac{x}{4y}$ [since $y = \frac{\sqrt{1-x^2}}{2}$]

Substituting in (a),

$$\begin{aligned} \frac{dz}{dx} &= -\frac{2y}{x^2 + 4y^2} - \frac{x^2}{2y(x^2 + 4y^2)} = -\left(\frac{x^2}{2y} - 2y \right) \\ &= -\frac{x^2 + 4y^2}{2y} = -\frac{1}{2y} \text{ [since } x^2 + 4y^2 = 1]. \end{aligned}$$

ART. 65. *Successive partial differentiation.*

A function of two or more variables may have successive partial derivatives for the same reason that was given for the successive total differentiation of a function containing but one variable.

The process is indicated thus:

$$\frac{\partial}{\partial x} \left(\frac{\partial f}{\partial y} \right) = \frac{\partial^2 f}{\partial x \partial y}; \quad \frac{\partial}{\partial x} \left(\frac{\partial f}{\partial x} \right) = \frac{\partial^2 f}{\partial x^2}, \text{ etc.}$$

It is readily shown that

$$\frac{\partial^2 f}{\partial x \partial y} = \frac{\partial^2 f}{\partial y \partial x}; \text{ that is, the order is immaterial.}$$

EXERCISE XII.

Find $\frac{dy}{dx}$ by partial derivatives:

1. $a^2 y^2 + b^2 x^2 = a^2 b^2$.

2. $y^2 = \frac{x^3}{2a - x}$.

3. $(x^2 + y^2)^2 = a^2 (x^2 - y^2)$.

4. $9ay^2 = x(x - 3a)^2$.

5. $y = \frac{a}{2} \left(e^{\frac{x}{a}} + e^{-\frac{x}{a}} \right)$.

6. $x^{\frac{1}{2}} + y^{\frac{1}{2}} = a^{\frac{1}{2}}$.

7. $x = r \operatorname{vers}^{-1} \frac{y}{r} - \sqrt{2ry - y^2}$.

8. $z = \tan^{-1} \frac{y}{x}$; show that $x \frac{\partial z}{\partial x} + y \frac{\partial z}{\partial y} = 0$.

9. $z = \log (\tan x + \tan y + \tan u)$; show that

$$\sin 2x \frac{\partial z}{\partial x} + \sin 2y \frac{\partial z}{\partial y} + \sin 2u \frac{\partial z}{\partial u} = 2.$$

10. $x^3 + y^3 + 3axy = 0$; find $\frac{dy}{dx}$.

11. $z = x^2 y + xy^2$; show that $\frac{\partial^2 z}{\partial x \partial y} = \frac{\partial^2 z}{\partial y \partial x}$.

12. $z = \frac{1}{\sqrt{x^2 + y^2 + u^2}}$; show that $\frac{\partial^2 z}{\partial x^2} + \frac{\partial^2 z}{\partial y^2} + \frac{\partial^2 z}{\partial u^2} = 0$.

13. $z = (x^2 + y^2)^{\frac{1}{2}}$, $y = \log x$; find $\frac{dz}{dx}$.

14. $z = \sqrt{r^2 - x^2 - y^2}$, $y^2 = r^2 - x^2$; find $\frac{dz}{dx}$.

CHAPTER IX.

DERIVATIVES OF ARCS, AREAS, VOLUMES, ETC.

ART. 66. The most important applications of the derivative have to do with curves whose equations are known. By the principle of minute increments the characteristics of a curve of irregular curvature are discovered.

In dealing with curves it will be helpful to regard them as described by a point moving according to a fixed law, and at any given instant having the direction of a tangent line to the curve at the position of the point at that instant.

Length of an Arc.

ART. 67. Let AB be an arc of any curve (Fig. 24), P and Q two positions of the describing point, θ and ϕ the

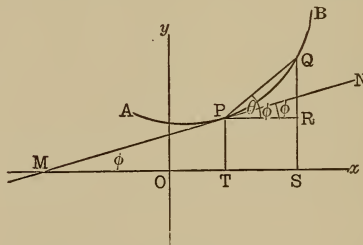

Fig. 24.

angles made respectively by PQ , and the tangent at P , MN , with the x -axis, to find the length of the arc PQ .

Draw the co-ordinates of P and Q , (OT, PT) (OS, QS) .

Then $TS = PR = \Delta x$ and $QR = \Delta y$.

In the right triangle PQR,

chord $\overline{PQ} = \overline{PR}^2 + \overline{QR}^2,$

that is, $\overline{PQ}^2 = \overline{\Delta x}^2 + \overline{\Delta y}^2,$

or $PQ = \sqrt{\overline{\Delta x}^2 + \overline{\Delta y}^2}.$

Dividing by $\Delta x,$

$$\frac{PQ}{\Delta x} = \sqrt{1 + \left(\frac{\Delta y}{\Delta x}\right)^2} \quad (b)$$

But as Δx is taken smaller and smaller, approaching zero, the chord PQ approaches the arc PQ (Q moving down toward P), and eventually $\frac{PQ}{\Delta x}$ becomes $\frac{ds}{dx}$ (where s represents the arc).

$$\therefore \frac{ds}{dx} = \sqrt{1 + \left(\frac{dy}{dx}\right)^2}$$

The same result may be obtained from (b) thus :

$$\frac{\Delta s}{\Delta x} = \frac{\Delta s}{PQ} \cdot \frac{PQ}{\Delta x} \quad \text{[multiplying and dividing by PQ];}$$

whence $\frac{\Delta s}{\Delta x} = \frac{\Delta s}{PQ} \sqrt{1 + \left(\frac{\Delta y}{\Delta x}\right)^2} \quad . . . \text{(from (b))}$

But $\frac{\Delta s}{PQ}$ eventually equals 1, since the chord eventually equals the arc, when,

$$\frac{\Delta s}{\Delta x} = \frac{ds}{dx} .$$

$$\therefore \frac{ds}{dx} = \sqrt{1 + \left(\frac{dy}{dx}\right)^2} \quad (c)$$

Corollary : The tangent MN gives the ultimate direction of the chord PQ, and Δx becomes dx and Δy becomes dy

at the same time. Since by what has been said in Art. 11,

$$\tan \phi = \frac{dy}{dx},$$

from (c)
$$\frac{ds}{dx} = \sqrt{1 + \tan^2 \phi} = \sec \phi,$$

or
$$\frac{dx}{ds} = \cos \phi.$$

Likewise,
$$\frac{dy}{ds} = \sin \phi.$$

Volume of Solid of Revolution.

ART. 68. Let the arc LN revolve about the x -axis, (Fig. 25) to find the volume whose surface is generated by

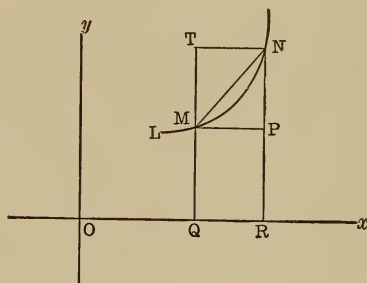

Fig. 25.

$MN = \Delta s$, a portion of LN. This volume plainly lies between the volumes generated by the rectangles TNRQ and MPRQ. Since these will be cylinders, calling the volume generated by MNRQ (MN, the chord), ΔV , we have,

$$\pi (y + \Delta y)^2 \Delta x > \Delta V > \pi y^2 \Delta x$$

$$[x = OQ, y = MQ, \Delta x = QR, \Delta y = NP].$$

Dividing by Δx ,

$$\pi (y + \Delta y)^2 > \frac{\Delta V}{\Delta x} > \pi y^2.$$

As the arc is taken shorter and shorter, N approaching M, R approaches Q, and NR approaches the value MQ; that is,

$$y + \Delta y \text{ approaches } y.$$

But $\frac{\Delta V}{\Delta x}$ always lies between $\pi(y + \Delta y)^2$ and πy^2 , hence it cannot pass πy^2 , but if $\pi(y + \Delta y)^2$ reaches the value of πy^2 , it must also reach it, becoming $\frac{dV}{dx}$ (generated by the arc).

$$\therefore \frac{dV}{dx} = \pi y^2.$$

To Find the Surface Generated.

ART. 69. The surface generated by chord MN will be that of a cone-frustum, hence calling it ΔS (Fig. 25),

$$\Delta S = \pi(2y + \Delta y) MN.$$

As the arc is taken indefinitely small, N approaching M, the chord MN approaches its arc ds , and hence ΔS approaches dS , the surface generated by the arc, as Δx approaches dx , hence finally (dividing through by Δx),

$$\frac{dS}{dx} = 2\pi y \frac{ds}{dx} \text{ [since } \Delta y = 0 \text{ as N approaches M].}$$

$$\text{But } \frac{ds}{dx} = \sqrt{1 + \left(\frac{dy}{dx}\right)^2}.$$

$$\therefore \frac{dS}{dx} = 2\pi y \sqrt{1 + \left(\frac{dy}{dx}\right)^2}.$$

CHAPTER X.

DIRECTION OF BENDING AND CURVATURE.

ART. 70. A curve is said to be *concave upward*, at a given point, when immediately before and after this point it lies above the tangent line at that point.

It is *concave downward* when it lies below the tangent line.

If the curvature changes concavity at a point, that point is called a *point of inflection*.

In Fig. 26 the curve is concave downward at A, concave

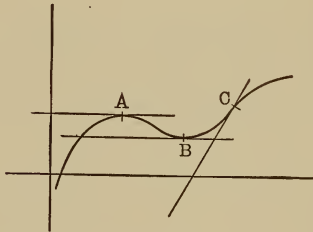

Fig. 26.

upward at B, and has a point of inflection at C. It is evident that at a point of inflection the tangent line crosses the curve.

It is clear also that the conditions for downward concavity are the same as for a maximum, and for upward concavity are the same as for a minimum.

Since the second derivative is negative for a maximum and positive for a minimum, at a point of inflection where

the curve changes from one to the other, the second derivative must change from positive to negative or vice versa, that is, it must pass through zero (or infinity), hence solving the equation,

$$f''(x) = 0,$$

gives the point (or points) of inflexion if such exist. If $f''(x) = 0$ changes sign for this value (or these values), there is a point of inflexion.

Example : Examine $y = \frac{8 a^3}{x^2 + 4 a^2}$ for inflexion.

$$f(x) = \frac{8 a^3}{x^2 + 4 a^2},$$

$$f'(x) = -\frac{16 a^3 x}{(x^2 + 4 a^2)^2},$$

$$f''(x) = \frac{16 a^3 (3 x^2 - 4 a^2)}{(x^2 + 4 a^2)^3};$$

when $f''(x) = \frac{16 a^3 (3 x^2 - 4 a^2)}{(x^2 + 4 a^2)^3} = 0.$

$$x = \pm \frac{2 a}{\sqrt{3}}.$$

Substitute in $f''(x)$, $x = \frac{2 a}{\sqrt{3}} + h$ and $x = \frac{2 a}{\sqrt{3}} - h$

successively, where h is as small as we please.

$$\text{Then } f''(x) = \frac{16 a^3 \left(4 a^2 + \frac{4 ah}{\sqrt{3}} + h^2 - 4 a^2 \right)}{\left(\frac{4 a^2}{3} + \frac{4 ah}{\sqrt{3}} + h^2 + 4 a^2 \right)^3}$$

$$= \frac{16 a^3 \left(\frac{4 ah}{\sqrt{3}} + h^2 \right)}{\left(\frac{4 a^2}{3} + \frac{4 ah}{\sqrt{3}} + h^2 + 4 a^2 \right)^3},$$

and
$$f''(x) = \frac{16 a^3 \left(-\frac{4 ah}{\sqrt{3}} + h^2 \right)}{\left(\frac{4 a^2}{3} - \frac{4 ah}{\sqrt{3}} + h^2 + 4 a^2 \right)}.$$

Since h is so small, the denominator is positive in both cases, but for the same reason $\frac{4 ah}{\sqrt{3}} > h^2$, hence the second value of $f''(x)$ is negative and the first positive, and hence $x = \frac{2 a}{\sqrt{3}} \left[y = \frac{3 a}{2} \right]$ is a point of inflection, as is also $\left(-\frac{2 a}{\sqrt{3}}, \frac{3 a}{2} \right)$, by the same proof.

CURVATURE.

ART. 71. If two curves have the same tangent at a point of intersection they are said to have *contact of the first order*: that is, if $y = f(x)$ and $y = F(x)$ are the equations of the curves, then for a point of intersection the equations are simultaneous and we may combine them any way we please to find p , and

$$f(p) = F(p) \quad (1)$$

Also their tangents being the same,

$$f'(p) = F'(p).$$

[The values of $f'(x)$ and $F'(x)$ when $x = p$] . . . (2)

So these are the conditions for contact of the first order.

If in addition $f''(p) = F''(p)$,

they are said to have contact of the second order, and so on.

In general, a straight line has only contact of the first order with a curve, because the two equations above (1) and (2) (one function representing the straight line, the other the curve), are just sufficient to determine the two arbitrary constants for the equation of a straight line, since two simultaneous equations furnish only enough conditions to determine two unknowns.

Likewise a circle requiring three conditions may have contact of the second order, for three equations will then be required, namely:

$$\begin{aligned} f(p) &= F(p), \\ f'(p) &= F'(p), \\ f''(p) &= F''(p). \end{aligned}$$

Total Curvature.

ART. 72. The *total curvature* of a continuous arc, of which the bending is in the same direction, is measured by the angle that the tangent swings through, as the point of

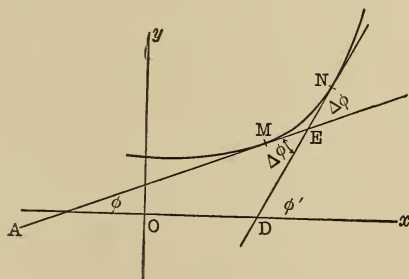

Fig. 27.

tangency moves from one end of the arc to the other; or what is the same thing it is the difference between the slopes at these two points. In Fig. 27 the total curvature of the arc MN is $\phi' - \phi = \Delta\phi$, say. It is evident from geometry

that $\phi' - \phi = \text{AED}$. That is, the total curvature is the angle between the two tangents, measured from the first to the second, hence it may be either positive or negative, according to our conventional rule for positive and negative angle.

The *average curvature* is the ratio between the total curvature and the length of the arc, say $\frac{\Delta\phi}{\Delta s}$, where $\Delta s =$ the arc length.

Measure of Curvature.

ART 73. Following the principle of minute increments, the value of the average curvature, as the arc becomes indefinitely small, is taken as the measure of curvature, usually designated as κ . But as Δs becomes indefinitely small, $\Delta\phi$ likewise becomes indefinitely small, and eventually $\frac{\Delta\phi}{\Delta s}$ becomes $\frac{d\phi}{ds}$ in our notation; that is,

$$\kappa = \frac{d\phi}{ds}.$$

Since $\tan \phi = \frac{dy}{dx},$

$$\phi = \tan^{-1}\left(\frac{dy}{dx}\right), \text{ and } \frac{d\phi}{dx} = \frac{\frac{d^2y}{dx^2}}{1 + \left(\frac{dy}{dx}\right)^2}$$

Also $\frac{ds}{dx} = \sqrt{1 + \left(\frac{dy}{dx}\right)^2}.$

But $\kappa = \frac{d\phi}{ds} = \frac{\frac{d\phi}{dx}}{\frac{ds}{dx}} = \frac{\frac{d^2y}{dx^2}}{\left[1 + \left(\frac{dy}{dx}\right)^2\right]^{\frac{3}{2}}}.$

RADIUS OF CURVATURE.

ART. 74. The circle tangent to a curve (or having contact of the second order) at a given point and having the same curvature as the curve at that point is called the *circle of curvature* for the curve at that point. In a circular arc, the angle made with each other by the tangents at the extremity of the arc is the same as the angle between the radii to these extremities, since a radius is \perp to a tangent at the point of tangency, and a central angle equals (in radians) arc divided by the radius. But the angle between the tangents is the total curvature, $\Delta\phi$.

$$\therefore \Delta\phi = \frac{\text{arc}}{\text{radius}} = \frac{\Delta s}{r} \quad (\text{calling } r \text{ the radius}),$$

dividing by Δs ,

$$\frac{\Delta\phi}{\Delta s} = \frac{1}{r}.$$

And since r is a constant,

$$\frac{d\phi}{ds} = \kappa = \frac{1}{r} \quad \text{or} \quad r = \frac{1}{\kappa} = \frac{\left[1 + \left(\frac{dy}{dx}\right)^2\right]^{\frac{3}{2}}}{\frac{d^2y}{dx^2}}.$$

Since a circle can always be found of such radius that it will have the exact curvature of any curve at a given point, the r as found above is called the *radius of curvature* of a given curve at any point for which $\frac{dy}{dx}$ and $\frac{d^2y}{dx^2}$ are determined.

The radius of curvature is understood to be positive or negative according as the direction of bending is positive or negative; that is, according as $\frac{d^2y}{dx^2}$ is positive or negative.

EVOLUTE AND INVOLUTE.

ART. 75. As every point on a curve in general has a different centre of curvature, that is, the centre of its curvature circle is different, these centres describe a locus as the point on which the curve moves along. This locus is called the *evolute* of the curve. It will be seen later on that this name is peculiarly appropriate.

The curve itself is called the involute of its evolute.

Involute arcs are used extensively in modern gears, where the evolute is usually a circle.

ART. 76. To find the equation of the evolute, let the curve equation be $y = f(x)$ (1)

The equation to a circle is,

$$(x - h)^2 + (y - k)^2 = r^2 \quad \dots \quad (2)$$

If this be the curvature circle at the point (x, y) on $y = f(x)$, then the x and y in (2) have the same value as in (1) for that point, by definition of circle of curvature. Taking derivative of (2) twice with respect to x ,

$$(x - h) + (y - k) \frac{dy}{dx} = 0 \quad \dots \quad (3)$$

$$1 + \left(\frac{dy}{dx}\right)^2 + (y - k) \frac{d^2y}{dx^2} = 0 \quad \dots \quad (4)$$

Eliminating y between (3) and (4),

$$x - h = \frac{\frac{dy}{dx} \left[1 + \left(\frac{dy}{dx}\right)^2 \right]}{\frac{d^2y}{dx^2}}, \text{ or } h = x - \frac{\frac{dy}{dx} \left[1 + \left(\frac{dy}{dx}\right)^2 \right]}{\frac{d^2y}{dx^2}} \quad (5_1)$$

$$y - k = - \frac{1 + \left(\frac{dy}{dx}\right)^2}{\frac{d^2y}{dx^2}}, \text{ or } k = y + \frac{1 + \left(\frac{dy}{dx}\right)^2}{\frac{d^2y}{dx^2}} \quad \dots \quad (5_2)$$

As we know
$$r = \frac{\left[1 + \left(\frac{dy}{dx}\right)^2\right]^{\frac{3}{2}}}{\frac{d^2y}{dx^2}} \dots \dots \dots (6)$$

If no particular point on the curve be taken (5₁), (5₂) and $y = f(x)$ will, by combination, give the equation of the evolute of $y = f(x)$, $\frac{dy}{dx}$ and $\frac{d^2y}{dx^2}$ being found from $y = f(x)$.

Example : Find the evolute of the hyperbola $xy = c^2$.

Here
$$y = \frac{c^2}{x} \dots \dots (1) [y = f(x)],$$

whence
$$\frac{dy}{dx} = -\frac{c^2}{x^2},$$

and
$$\frac{d^2y}{dx^2} = \frac{2c^4}{x^3}.$$

Substituting in (5₁) and (5₂),

$$x - h = -\frac{\frac{c^2}{x^2} \left[1 + \frac{c^4}{x^2}\right]}{\frac{2c^2}{x^3}} = -\frac{c^4 + x^4}{2x^3} \dots \dots (2)$$

$$y - k = -\frac{1 + \frac{c^4}{x^4}}{\frac{2c^2}{x^3}} = -\frac{c^4 + x^4}{2c^2x} \dots \dots (3)$$

From (2),
$$h = \frac{c^4 + x^4}{2x^3} + x = \frac{c^4 + 3x^4}{2x^3} \dots \dots (4)$$

From (3),
$$k = \frac{c^4 + x^4}{2c^2x} + y \text{ (or since } y = \frac{c^2}{x} \text{ from (1))}$$

$$= \frac{c^4 + x^4}{2c^2x} + \frac{c^2}{x} = \frac{3c^4 + x^4}{2c^2x} \dots \dots (5)$$

Adding and subtracting successively (4) and (5),

$$h + k = \frac{c^6 + 3c^4x^2 + 3c^2x^4 + x^6}{2c^2x^3} = \frac{(c^2 + x^2)^3}{2c^2x^3}.$$

$$h - k = \frac{(c^2 - x^2)^3}{2c^2x^3}.$$

Extracting cube root and then squaring,

$$(h + k)^{\frac{2}{3}} = \frac{(c^2 + x^2)^2}{x^2(2c^2)^{\frac{2}{3}}},$$

$$(h - k)^{\frac{2}{3}} = \frac{(c^2 - x^2)^2}{x^2(2c^2)^{\frac{2}{3}}}.$$

Subtract;

$$\begin{aligned} (h + k)^{\frac{2}{3}} - (h - k)^{\frac{2}{3}} &= \frac{4c^2x^2}{x^2(2c^2)^{\frac{2}{3}}} = \frac{4c^2}{(2c^2)^{\frac{2}{3}}} \\ &= \frac{2(2c^2)}{(2c^2)^{\frac{2}{3}}} = 2(2c^2)^{\frac{1}{3}} = (16c^2)^{\frac{1}{3}} = (4c)^{\frac{2}{3}}. \end{aligned}$$

The equation to the evolute is then,

$$(h + k)^{\frac{2}{3}} - (h - k)^{\frac{2}{3}} = (4c)^{\frac{2}{3}},$$

where h and k are the general co-ordinates, like x and y in the usual form.

PROPERTIES OF THE EVOLUTE.

ART. 77. An important relation between evolute and involute is the following: *The difference between any two radii of curvature equals the length of the arc of the evolute between the two centres of curvature from which they are drawn.* This important fact is proved thus:

Let (x', y') be any point on the curve $y = (fx)$; R , the radius of curvature for this point; (h, k) , the corresponding centre of curvature, and α the angle R makes with the

x -axis. Then the equation of R, passing through (x', y') and making angle α with the x -axis, is

$$y - y' = \tan \alpha (x - x') \quad \dots \quad (1)$$

But R also passes through (h, k) , hence (h, k) must satisfy (1).

$$\therefore (k - y') = \tan \alpha (h - x'),$$

whence
$$\frac{k - y'}{h - x'} = \tan \alpha.$$

Squaring and adding 1 to both sides,

$$\frac{(h - x')^2 + (k - y')^2}{(h - x')^2} = 1 + \tan^2 \alpha = \sec^2 \alpha \quad \dots \quad (2)$$

But since R extends from (h, k) to (x', y') its length is given by Analytics as,

$$(h - x')^2 + (k - y')^2 = R^2.$$

Substituting in (2), inverting both sides and extracting square root,

$$\frac{h - x'}{R} = \cos \alpha.$$

whence
$$\left. \begin{aligned} h - x' &= R \cos \alpha, \text{ or } h = x' + R \cos \alpha \\ \text{and } k - y' &= R \sin \alpha, \text{ or } k = y' + R \sin \alpha \end{aligned} \right\} \quad (3)$$

Differentiating (3), $[x', y', R$ and α are all functions of x'].

$$\left. \begin{aligned} dh &= dx' + \cos \alpha dR - R \sin \alpha d\alpha \\ dk &= dy' + \sin \alpha dR + R \cos \alpha d\alpha \end{aligned} \right\} \quad \dots \quad (3d)$$

By Art. 67
$$\left. \begin{aligned} \frac{dx}{ds} &= \cos \phi \text{ or } dx = \cos \phi ds \\ \text{and } \frac{dy}{ds} &= \sin \phi \text{ or } dy = \sin \phi ds \end{aligned} \right\} \quad \dots \quad (4)$$

Since the tangent to $y = f(x)$ is also tangent to the curvature circle at (x', y') , R is \perp to this tangent, hence $\alpha = 90^\circ + \phi$, whence $\cos \phi = \sin \alpha$ and $\sin \phi = -\cos \alpha$.

Also $d\alpha = d\phi$.
 $dx' = \sin \alpha ds$.

Substituting in (4), $dy' = -\cos \alpha ds$.

By Art. 74 $\frac{d\phi}{ds} = \frac{1}{R} = \kappa$,

or since $d\phi = d\alpha$,

$$\frac{d\alpha}{ds} = \frac{1}{R}; \text{ that is, } ds = R d\alpha.$$

and (4) finally becomes,

$$\begin{aligned} dx' &= R \sin \alpha d\alpha, \\ dy' &= -R \cos \alpha d\alpha. \end{aligned}$$

Substituting these values in (3d),

$$dh = \overline{R \sin \alpha d\alpha} + \cos \alpha dR - \overline{R \sin \alpha d\alpha} = \cos \alpha dR.$$

$$dk = -\overline{R \cos \alpha d\alpha} + \sin \alpha dR + \overline{R \cos \alpha d\alpha} = \sin \alpha dR.$$

Squaring and adding,

$$\overline{dh^2} + \overline{dk^2} = (\cos^2 \alpha + \sin^2 \alpha) \overline{dR^2} = \overline{dR^2}$$

[since $\cos^2 \alpha + \sin^2 \alpha = 1$].

But (h, k) being a point on the evolute, letting s be the length of an arc from this point,

$$\frac{ds}{dh} = \sqrt{1 + \left(\frac{dk}{dh}\right)^2} \text{ or } \overline{ds^2} = \overline{dh^2} + \overline{dk^2}. \quad (\text{By Art. 67.})$$

$$\therefore \overline{ds^2} = \overline{dR^2}, \text{ or } ds = \pm dR,$$

which means that R either increases or decreases, but in either case changes just as fast as s .

It follows from this, that the end of a stretched string unwinding from the evolute will describe its involute, or a straight line rolling on the evolute as a tangent, any point on it describes an involute. This latter method is used by draftsmen to draw gear teeth.

ENVELOPES.

ART. 78. The equations of curves, in general, contain one or more constants, and when these constants vary the result is a family of curves, having the same generic qualities, but differing in the constant. For example, in the equation to a straight line,

$$y = mx + b.$$

If m varies, the result is a set of straight lines passing through the same point, $(0, b)$, and making different angles with the x -axis. Again in the ellipse equation,

$$\frac{x^2}{a^2} + \frac{y^2}{b^2} = 1,$$

if a and b both vary, but always obeying the condition,

$$a^2 - b^2 = c^2 \text{ [} c^2 \text{ being a constant],}$$

the result is a family of ellipses with the same foci but different axes.

The locus of the intersections of *consecutive* curves of a family, as the points of intersection approach coincidence, that is, when the constant (or constants) changes by infinitesimal increments, is called the *envelope* of this family.

TO FIND THE EQUATION OF AN ENVELOPE.

ART. 79. Let $f(x, y, m) = 0$, be the equation of a curve, m being originally a constant. Then

$$f(x, y, m + \Delta m) = 0$$

will represent the curve immediately adjacent to

$$f(x, y, m) = 0,$$

Δm being indefinitely small, when m is allowed to vary.

$$\text{From } f(x, y, m) = 0 \quad \dots \dots \dots (1)$$

$$\text{and } f(x, y, m + \Delta m) = 0 \quad \dots \dots \dots (2)$$

we get by subtracting and dividing by Δm ,

$$\frac{f(x, y, m + \Delta m) - f(x, y, m)}{\Delta m} = 0 \quad \dots \dots (3)$$

But by Art. 62 (3) may be represented by

$$\frac{\partial f(x, y, m)}{\partial m} \text{ as } \Delta m \doteq 0,$$

hence

$$\frac{\partial f(x, y, m)}{\partial m} = 0$$

or more simply,

$$\frac{\partial f}{\partial m} = 0 \quad \dots \dots \dots (4)$$

By definition of envelope (4) represents a point on the envelope, since it is the intersection of two consecutive curves $f(x, y, m) = 0$ and $f(x, y, m + \Delta m) = 0$, as they approach coincidence, for in (3) these equations were combined. If now m be eliminated between (4) and (1), we get an equation free from the variable m , but determined by the condition (4), which gives a point in the envelope, hence the result is the equation for this envelope.

The varying constant is called the *variable parameter*.

Example: Find the envelope of the straight line system $y = mx + b$ where b is determined by the relation

$$b = \frac{p}{m} \quad (p \text{ being a constant}).$$

$$\text{Hence } y = mx + \frac{p}{m}; \quad y - mx - \frac{p}{m} = 0;$$

$$\text{whence } \frac{\partial f}{\partial m} = \frac{\partial \left(y - mx - \frac{p}{m} \right)}{\partial m} = -x + \frac{p}{m^2} = 0,$$

combining, $y = mx + \frac{p}{m}$ (1)

and $-x + \frac{p}{m^2} = 0$ (2)

To eliminate m , we get from (2),

$$m^2 = \frac{p}{x}$$
 (3)

squaring (1), $y^2 = m^2x^2 + 2px + \frac{p^2}{m^2}$. . . (4)

substituting value of m^2 from (3) and (4),

$$y^2 = px + 2px + px = 4px,$$

which shows that the envelope is a parabola.

ART. 80. It follows readily from the fact that the evolute of a curve is the locus of its centres of curvature, and that the radii are all normals to the curve (being \perp to the tangents of each point), that *the envelope of the normals to any curve is its evolute*, since these normals (the radii) always pass through the centres of curvature, which all lie on the evolute.

EXERCISE XIII.

1. Find the points of inflection of the curve

$$y = \frac{64}{x^2 + 16}.$$

2. Find the equation of the line through the points of inflection of the curve $y(x^2 + 4) = x$.

3. Find the radius of curvature of the parabola $x^2 = 8y$ at the origin.

4. Find the radius of curvature of

$$y^2 = \frac{x^3}{2a - x} \text{ at } x = a.$$

5. Find the radius of curvature of the hyperbola $4x^2 - 16y^2 = 64$.
6. Find the radius of curvature of the hypocycloid $x^{\frac{2}{3}} + y^{\frac{2}{3}} = a^{\frac{2}{3}}$.
7. Find the evolute of the parabola $y^2 = 2px$.
8. Find the evolute of the hyperbola $xy = c^2$.
9. Find the co-ordinates of the centre of curvature of $4x^2 + 9y^2 = 36$ at $(\sqrt{5}, \frac{4}{3})$.
10. Find the co-ordinates of the centre of curvature of $y^2 = 9x$ at $(3, 3)$.
11. Find the points on the ellipse $a^2y^2 + b^2x^2 = a^2b^2$, where the curvature is a maximum and a minimum respectively.
12. Find the radius of curvature of the cycloid, $x = r \text{ vers}^{-1} \frac{y}{r} - \sqrt{2ry - y^2}$ at the point whose ordinate is $2r$.
13. Find the evolute of the circle, $x^2 + y^2 = r^2$.
14. Find the envelope of $x \cos 3\phi + y \sin 3\phi = a (\cos 2\phi)^{\frac{3}{2}}$, ϕ being the variable parameter.
15. Find the envelope of a straight line in the first quadrant which terminates in the co-ordinate axes, and makes a constant area with the axes.
16. Find the envelope of a variable ellipse with constant area, πab .
17. Find the envelope of $y^2 = m(x - m)$ where m is the variable parameter.

CHAPTER XI.

INTEGRATION AS A SUMMATION.

ART. 81. Integration has been considered, heretofore, merely as the reverse of differentiation. We will now consider its real and much more important meaning.

Let $\phi(x)$ be such a function of x that its first derivative will be a given function, $f(x)$; that is, denoting the first derivative by an accent,

$$f(x) = \phi'(x) = \frac{\phi(x + \Delta x) - \phi(x)}{\Delta x} \text{ as } \Delta x \doteq 0,$$

whence $\phi(x + \Delta x) - \phi(x) = f(x) \Delta x \dots (m)$

In the language of integrals we may write,

$$\int f(x) dx = \phi(x).$$

Suppose in $\phi(x)$, x to start with a value h and change to a value k , $\phi(x)$ would change from $\phi(h)$ to $\phi(k)$, the difference would be expressed by,

$$\phi(h) - \phi(k).$$

Suppose again that instead of one jump from h to k , x changes by minute increments, say making n successive changes of Δx each, then the successive steps would be,

$$\phi(h + \Delta x) - \phi(h) = f(h) \Delta x \quad \text{[by (m)]}$$

$$\phi(h + 2 \Delta x) - \phi(h + \Delta x) = f(h + \Delta x) \Delta x \quad ,,$$

$$\phi(h + 3 \Delta x) - \phi(h + 2 \Delta x) = f(h + 2 \Delta x) \Delta x \quad ,,$$

$$\dots \dots \dots \Delta x$$

$$\phi(h + n \Delta x) - \phi(h + (n-1) \Delta x) = f(h + (n-1) \Delta x) \Delta x$$

adding

$$\phi(h + n\Delta x) - \phi(h) = f(h)\Delta x + f(h + \Delta x)\Delta x + \\ f(h + 2\Delta x)\Delta x + f(h + n\Delta x)\Delta x;$$

or since $h + n\Delta x = k$, by our hypothesis $\phi(k) - \phi(h) = f(h)\Delta x + f(h + \Delta x)\Delta x + f(h + 2\Delta x)\Delta x + \dots$

The left hand side of this equation may evidently be gotten by integrating $f(x)dx$, and then taking the difference between the values of this integral when $x = k$ and when

$x = h$, for by hypothesis $\int f(x)dx = \phi(x)$.

This is usually written

$$\int_h^k f(x)dx = \phi(k) - \phi(h),$$

and is known as a definite integral as was shown in a specific case under Art. 43.

The right hand member is plainly a sum of n terms, as $x \doteq 0$ and hence as $n \doteq \infty$, for there cannot be an infinitely small increment unless there is an infinite number of terms.

For brevity such a sum may be indicated thus:

$$\sum_h^k f(x) \Delta x \left(\sum \text{ being the symbol for summation} \right).$$

When $\Delta x \doteq 0$, this is modified to

$$\int_h^k f(x)dx,$$

which brings us back to our integral symbol, for we have found that this sum is actually equal to the definite integral of $f(x)dx$ (namely, $\phi(k) - \phi(h)$), hence *definite integration is a summation*.

ART. 82. Let us see what is the further significance of this series whose sum we have been finding.

Let uv (Fig. 28) be any curve whose equation is $y = f(x)$. Divide the x -axis from the point A to P into n equal parts,

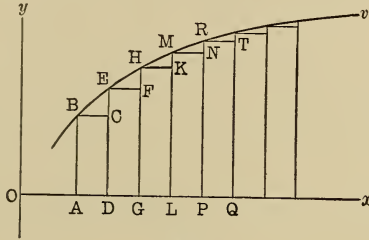

Fig. 28.

calling OA , h , and OP , k , and the equal distances AD , DG , etc., each Δx .

Then

$$AB = f(h)$$

$$DE = f(h + \Delta x)$$

$$GH = f(h + 2 \Delta x)$$

.

$$RP = f(h + n \Delta x).$$

Form rectangles by drawing parallels to the x -axis from B , E , H , etc.

The sum of these rectangles will be less than the area, $ABRP$, but can be made to approach it as nearly as we please by taking Δx indefinitely small, and hence n indefinitely large.

The area of $BCDA = f(h) \Delta x$
 " " " $EFGD = f(h + \Delta x) \Delta x$
 " " " $HKLG = f(h + 2 \Delta x) \Delta x$

 " " " $RTQP = f(h + n \Delta x) \Delta x.$

Adding; Sum of the rectangles = $f(h) \Delta x + f(h + \Delta x) \Delta x + f(h + 2 \Delta x) \Delta x + f(k) \Delta x$ [since $h + n \Delta x = k$].

As $x \doteq 0$ this sum approaches $ABRP$, hence finally, $ABRP = \int f(x) dx + f(h + dx) dx + \dots + \int f(k) dx$. But

the right hand side is the same as obtained in the last article and shown equal to $\int_h^k f(x)dx$, hence

$$\text{area ABRP} = \int_h^k f(x)dx.$$

The area would be given as well by solving the equation for x , say $x = F(y)$ and integrating $\int F(y)dy$, since the rectangles could as easily be formed with respect to the y -axis and summed.

That is, *the definite integral of $f(x)dx$ between fixed limits, where $y = f(x)$ is the equation of the curve, is the area bounded by the curve, the x -axis, and the two ordinates corresponding respectively to these limits, which are the abscissas in this case.*

Example: Find the area of the parabola $y^2 = 8x$, between the origin and the point $(2, 4)$. Here the limits are 0 and 4, the two bounding ordinates, and we have,

$$\int_0^2 \sqrt{8x} dx = \sqrt{8} \int_0^2 x^{\frac{1}{2}} dx = \frac{2}{3} \sqrt{8} \left[(2)^{\frac{3}{2}} - 0^{\frac{3}{2}} \right] = \frac{16}{3}.$$

Corollary: Clearly if we reverse the limits we get the same absolute result, but with contrary sign, that is,

$$\int_h^k f(x)dx = - \int_k^h f(x) dx.$$

It is also evident that we can take the area from $y = h$ to $y = j$ (being between h and k) and then the area from $y = j$ to $y = k$, and if the curve be continuous, the sum of these results will be the same as if we went directly from h to k . That is,

$$\int_h^k f(x)dx = \int_h^j f(x)dx + \int_j^k f(x)dx.$$

Thus a definite integral may be readily expressed as the sum of any number of definite integrals, if the difference between their limits taken together equals the difference between the original limits.

It must be carefully observed that $f'(x)dx$ does not become infinite between the limits. When that occurs the integral must be broken up into parts leading up to the gap on either side.

ART. 83. Remembering that definite integration is a summation between the limits, if the expression for the length of an arc

$$ds = \sqrt{1 + \left(\frac{dy}{dx}\right)^2} dx,$$

which represents any infinitesimal arc whatever of the curve, $y = f(x)$, be integrated between the limits representing the co-ordinates of its extremities, the result will be the sum of all the infinitesimal arcs making up the total arc and hence the length of this arc, that is,

$$\int_h^k \sqrt{1 + \left(\frac{dy}{dx}\right)^2} dx = s,$$

s being the arc from abscissa h to abscissa k .

Example: Find the circumference of the circle,

$$x^2 + y^2 = r^2.$$

Taking derivative; $\frac{dy}{dx} = -\frac{x}{\sqrt{r^2 - x^2}}$,

whence $s = 2 \int_{-r}^{+r} \left(1 + \frac{x^2}{r^2 - x^2}\right)^{\frac{1}{2}} dx = 2r \int_{-r}^{+r} \frac{dx}{\sqrt{r^2 - x^2}}$

$$= 2r \left[\sin^{-1} \frac{x}{r} \right]_{-r}^{+r} = 2r \left[\frac{\pi}{2} - \left(-\frac{\pi}{2}\right) \right] = 2\pi r.$$

It is to be observed that the limits $-r$ and r , which are the extreme values of x , give the length of the semi-circumference only, and hence the factor 2 above.

SURFACE OF REVOLUTION.

ART. 84. It has been shown (Art 69) that the surface of revolution for a variable point, (x, y) on an arc, is given by the formula,

$$dS = 2 \pi y \sqrt{1 + \left(\frac{dy}{dx}\right)^2} dx,$$

where the revolving arc is indefinitely small.

By the same reasoning as before, the surface generated by an arc of any length will be then,

$$S = 2 \pi \int_h^k y \sqrt{1 + \left(\frac{dy}{dx}\right)^2} dx,$$

where h and k represent the abscissas respectively, of the two ends of the arc.

SOLID OF REVOLUTION.

ART. 85. In exactly the same way, using the expression found in Art. 68 for solid of revolution,

$$dv = \pi y^2 dx,$$

which represents an infinitely thin strip,

$$v = \pi \int_h^k y^2 dx,$$

gives us the volume between the limits h and k .

ART. 86. Clearly we are at liberty to divide a given area into strips as we please and to apply the same reasoning to their summation, so that any one of the above for-

mulæ may be expressed in terms of y , if the limits be determined according to y . For example, we may write,

$$S = \int_a^b \sqrt{1 + \left(\frac{dx}{dy}\right)^2} dy,$$

for the length of the arc, if a and b are y -limits, etc.

EXERCISE XIV.

1. Find the length of an arc of the cissoid $y^2 = \frac{x^3}{2a - x}$ from $x = 0$ to $x = a$.

2. Find the total length of the cycloid

$$x = r \operatorname{vers}^{-1} \frac{y}{r} - \sqrt{2ry - y^2}.$$

3. Find the length of the hypocycloid $x^{\frac{3}{2}} + y^{\frac{3}{2}} = r^{\frac{3}{2}}$.

4. Find the length of the catenary $y = \frac{9}{2} \left(e^{\frac{x}{a}} + e^{-\frac{x}{a}} \right)$ from the origin to the point whose abscissa is b .

5. Find the length of $ay^2 = x^3$ from $(0, 0)$ to $(3a, 3\sqrt{3a})$.

6. Find the circumference of the circle,

$$(x - 2)^2 + (y + 1)^2 = 16.$$

7. Find the length of $y = \log x$ from $x = 1$ to $x = 4$.

8. Find the area of the ellipse.

9. Find the area of the circle in Ex. 6.

10. Find the area of the parabola $y^2 = 8x$, between the origin and the double ordinate corresponding to $x = 2$.

11. Find the area of the hypocycloid.

12. Find the area of the circle $x^2 + y^2 + 2rx = 0$.

13. Find the area bounded by $y^2 = \frac{8a^3}{x^2 + 4a^2}$, the ordinate a , and the axes.

14. Find the area bounded by the axes and the line

$$\frac{x}{a} + \frac{y}{b} = 1.$$

15. Find the area between the x -axis and one loop of the sine curve $y = \sin x$.

Find the surface generated by revolving about the x -axis the following curves:

16. The parabola $y^2 = 2px$ from $x = 0$ to $x = p$.

17. The circle $(x - 3)^2 + (y - 4)^2 = 25$ above the x -axis.

18. The ellipse $9x^2 + 16y^2 = 144$.

19. The line $\frac{x}{a} + \frac{y}{b} = 1$ between the axes.

20. The catenary from $x = 0$ to $x = a$.

21. Find the surfaces generated by revolving about the y -axis in Examples 16, 18, and 20.

Find the volumes generated by revolving the following curves about the x -axis:

22. The ellipse $\frac{x^2}{a^2} + \frac{y^2}{b^2} = 1$.

23. The circle $x^2 + y^2 = r^2$.

24. The hypocycloid.

25. The witch $y = \frac{8a^3}{x^2 + 4a^2}$.

26. The line $\frac{x}{a} + \frac{y}{b} = 1$ between the axes.

27. Find the volume generated about the y -axis by the ellipse.

MISCELLANEOUS APPLICATION.

ART. 87. Since our determination of volume depends on our ability to divide our solid into sections, whose areas

can be generally expressed, and then summed, any solid for which this is possible may be estimated.

For example, let it be required to find the volume described by a rectangle moving from a fixed point, its plane remaining parallel to its first position, one side varying as its distance from this point, the other side, as the square of this distance, the rectangle becoming a square 5' on the side, at a distance of 4' from the point.

Take the line \perp to the plane of the rectangle through its middle as the x -axis. Let v be one side and w the other, then by conditions, x being its distance from the point taken as origin at any time,

$$v : x :: 5 : 4, \text{ whence } v = \frac{5x}{4},$$

$$w : x^2 :: 5 : 16, \text{ whence } w = \frac{5x^2}{16}.$$

Hence the area of the rectangle at the distance x (being any point between 0 and 4) is,

$$vw = \frac{25x^3}{64}.$$

This area representing any section of the solid, if multiplied by dx , thus forming an infinitesimal slice, and summed between 0 and 4, will evidently give the total volume; hence volume $= \frac{25}{64} \int_0^4 x^3 dx = \frac{25}{256} [x^4]_0^4 = 25$ cubic feet.

Again: To find the part of the contents of a cylindrical bucket of oil remaining in it, after the oil has been poured out, until half the bottom is exposed (see Figure 29).

Let EGH be any section of the remaining contents, taken parallel to the axes. Take the origin at the centre of the base and the co-ordinate axes as the axis of the cylinder and a diameter of the base.

Then since EGH and DOC are similar,

$$GH = \sqrt{BG \times GA} = \sqrt{r^2 - x^2} \text{ [where OG is } x\text{],}$$

and $EH : CD :: GH : OC,$

or
$$EH = \frac{h \sqrt{r^2 - x^2}}{r}$$

[where h = altitude and r = radius of base].

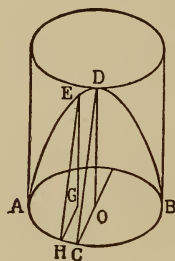

Fig. 29.

$$\text{Hence area EGH} = \frac{1}{2} EH \times GH = \frac{1}{2} \frac{h(r^2 - x^2)}{r}.$$

$$\therefore \frac{1}{2} \int_{-r}^{+r} \frac{h(r^2 - x^2)}{r} dx = \frac{2hr^2}{3} = \text{contents remaining.}$$

EXERCISE XV.

MISCELLANEOUS PROBLEMS.

1. Find the volume generated by an isosceles triangle of altitude, h , moving with its plane always perpendicular to the plane of a circle of radius, r , and having always the ordinates of the circle for bases.
2. What is the volume generated when the circle in Ex. 3, is replaced by an ellipse whose axes are $2a$, and $2b$?
3. Through the diameter of the upper base of a right

cylinder, whose altitude is h and radius, r , two planes are passed, touching the base at the two extremities of a diameter. Find the portion of the cylinder between the planes.

4. Two right cylinders each of radius 3 in., intersect each other at right angles, their axes intersecting. Find common volume.

5. Find the volume of a pyramid whose altitude is h and area of base B .

6. Find volume of a curve whose height is h and radius r .

7. In cutting a notch in a log, the sloping face of the notch makes an angle of 45° with the horizontal face. The log is 3 ft. in diameter; how much wood is cut out?

8. A right circular cone has a small circle of a sphere of radius 6 in. as base, and its vertex is at the surface. If the vertex angle of the cone is 30° , what is the volume of the sphere outside the cone?

9. A square hole is cut through the axis of a grindstone for a bearing. The grindstone is 18 in. in diameter, 2 in. thick at the circumference, and 4 in. at the centre, and has conical faces. If the hole is 3 in. square, how much material is removed?

CHAPTER XII.

INTEGRATION BY PARTS.

ART. 88. It is frequently a great aid in integration to separate the parts of an expression containing two factors, thus producing either a re-arrangement or a change in form of the integral.

This is readily accomplished by using the formula for differentiating the product of two factors,

$$d(uv) = u dv + v du.$$

Transposing, $u dv = d(uv) - v du.$

Taking the integral of both sides,

$$\int u dv = uv - \int v du \quad \dots \dots \quad (\text{B})$$

Example : $\int x^2 \cos x \, dx = \text{what ?}$

Let $x^2 = u$ and $\cos x \, dx = dv$

then $du = 2x \, dx$ and $v = \sin x.$

Substituting in the formula (B),

$$\int u dv = \int x^2 \cos x \, dx = x^2 \sin x - 2 \int x \sin x \, dx.$$

Where the $x^2 \cos x \, dx$ is now made to depend upon the integration of $x \sin x \, dx$, in which the exponent of x is one less than in the original expression. If we treat this integral the same way, using (B) again, letting $x = u$, du will

equal $d(x) = dx$, which eliminates x from the final integral; then

$$\begin{aligned} 2 \int x \sin x \, dx &= -2x \cos x + \\ 2 \int \cos x \, dx &= -2x \cos x + 2 \sin x, \end{aligned}$$

by putting $x = u$ and $\sin x \, dx = dv$,
whence $dx = du$, $-\cos x = v$.

$$\begin{aligned} \therefore \int x^2 \cos x \, dx &= x^2 \sin x - 2 \int x \sin x \, dx = x^2 \sin x - \\ &[-2x \cos x + 2 \sin x] = x^2 \sin x + 2x \cos x - 2 \sin x. \end{aligned}$$

In using the formula (B) no general rule of application can be given for choosing the value for u and for dv , except that they should be so chosen that one factor may be made to disappear eventually or to take such a value that in combination with the other, it may form an integrable part of the original expression. For example, in the expression

$$\int x^2 \tan^{-1} x \, dx,$$

dv can only equal $x^2 dx$ since $x^2 dx$ is the only integrable part; $\tan^{-1} x \, dx$ having no known simple integral, then

$$\begin{aligned} u &= \tan^{-1} x, & dv &= x^2 dx, \\ du &= \frac{dx}{1+x^2}, & v &= \frac{x^3}{3} \end{aligned}$$

and $udv = x^2 \tan^{-1} x \, dx = \frac{x^3 \tan^{-1} x}{3}$

$$- \frac{1}{3} \int \frac{x^3 dx}{1+x^2}; \frac{x^3}{1+x^2} = x - \frac{x}{1+x^2} \text{ [dividing } x^3 \text{ by } x^2 + 1].$$

$$\begin{aligned} \therefore \frac{1}{3} \int \frac{x^3 dx}{1+x^2} &= \frac{1}{3} \int x dx - \frac{1}{6} \int \frac{2x dx}{1+x^2} \\ &= \frac{x^2}{6} - \frac{1}{6} \log(1+x^2). \end{aligned}$$

$$\text{Hence } x^2 \tan^{-1} x dx = \frac{x^3 \tan^{-1} x}{3} + \frac{x^2}{6} - \frac{1}{6} \log(1+x^2).$$

EXERCISE XVI.

Integrate by parts:

- | | |
|-----------------------------------------|---------------------------------------------|
| 1. $\int x \sin 2x dx.$ | 9. $\int \cot^{-1} x dx.$ |
| 2. $\int e^x \cos x dx.$ | 10. $\int x^n \log x dx.$ |
| 3. $\int e^x \sin x dx.$ | 11. $\int ze^{az} dz.$ |
| 4. $\int x \sec^2 x dx.$ | 12. $\int y \tan^2 y dy.$ |
| 5. $\int x^3 \sin x dx.$ | 13. $\int \frac{\log(x+2)}{\sqrt{x+2}} dx.$ |
| 6. $\int x \tan^{-1} x dx.$ | 14. $\int \frac{\log u du}{(u+1)^2}.$ |
| 7. $\int x^2 \cot^{-1} x dx.$ | 15. $\int \frac{(\log x) dx}{x^2}.$ |
| 8. $\int \log \sin x \csc x \cot x dx.$ | 16. $\int x^2 \cos^{-1} x dx.$ |

INTEGRATION BY SUBSTITUTION.

ART. 89. An expression may often be simplified by substituting another variable for a part of the expression to be integrated. No general rule can be given, it being largely a matter for the exercise of originality.

An example or two may aid:

$$\int \frac{dx}{x\sqrt{x^2 - a^2}} = \text{what?}$$

Let $x = \frac{1}{y},$

then $dx = -\frac{dy}{y^2}.$

Substituting,

$$\begin{aligned} \int \frac{dx}{x\sqrt{x^2 - a^2}} &= \int \frac{-\frac{dy}{y^2}}{\frac{1}{y}\sqrt{\frac{1}{y^2} - a^2}} = - \int \frac{dy}{\sqrt{1 - a^2 y^2}} \\ &= -\frac{1}{a} \int \frac{ady}{\sqrt{1 - a^2 y^2}} = \frac{1}{a} \cos^{-1}(ay) \\ &= \frac{1}{a} \cos^{-1} \frac{a}{x} = \frac{1}{a} \sec^{-1} \frac{x}{a}. \end{aligned}$$

Again; $\int \frac{dx}{3x^2 - 2x + \frac{5}{3}} = \text{what?}$

$$\int \frac{dx}{3x^2 - 2x + \frac{5}{3}} = \int \frac{3dx}{9x^2 - 6x + 5}$$

[multiplying and dividing by 3].

Let $(3x - 1) = y,$ then $dy = 3dx$ and

$$\begin{aligned} \int \frac{dx}{3x^2 - 2x + \frac{5}{3}} &= \int \frac{dy}{y^2 + 4} = \frac{1}{2} \tan^{-1} \frac{y}{2} \\ &= \frac{1}{2} \tan^{-1} \frac{3x - 1}{2}. \end{aligned}$$

The suggestion $(3x - 1) = y$ comes from the fact that $9x^2 - 6x + 5$ can be put in the form,

$$9x^2 - 6x + 1 + 4 = (3x - 1)^2 + 4,$$

and the formula

$$\frac{dx}{a^2 + x^2} = \frac{1}{a} \tan^{-1} \frac{x}{a} \text{ is immediately suggested.}$$

ART. 90. Expressions containing the form $\sqrt{x^2 + ax + b}$ can usually be integrated by making the substitution,

$$\sqrt{x^2 + ax + b} = y - x.$$

Example:
$$\int \frac{dx}{\sqrt{x^2 + x - 2}} = ?$$

Let
$$\sqrt{x^2 + x - 2} = y - x.$$

$$x^2 + x - 2 = y^2 - 2yx + x^2;$$

whence
$$x = \frac{y^2 + 2}{1 + 2y}.$$

$$dx = \frac{2y + 4y^2 - 2y^2 - 4}{(1 + 2y)^2} dy = \frac{2(y^2 + y - 2)}{(1 + 2y)^2} dy.$$

$$\begin{aligned} \sqrt{x^2 + x - 2} = y - x &= y - \frac{y^2 + 2}{1 + 2y} \\ &= \frac{y + 2y^2 - y^2 - 2}{1 + 2y} = \frac{y^2 + y - 2}{1 + 2y}. \end{aligned}$$

$$\begin{aligned} \therefore \int \frac{dx}{\sqrt{x^2 + x - 2}} &= 2 \int \frac{\frac{y^2 + y - 2}{(1 + 2y)^2} dy}{\frac{y^2 + y - 2}{1 + 2y}} \\ &= \int \frac{2 dy}{1 + 2y} = \log(1 + 2y) \\ &= \log(1 + 2x + 2\sqrt{x^2 + x - 2}). \end{aligned}$$

ART. 91. Expressions containing the form $\sqrt{-x^2 + ax + b}$, where $-x^2 + ax + b$ can be resolved into two first degree factors, can be integrated by making the substitution,

$$\sqrt{-x^2 + ax + b} = \sqrt{(m - x)(n - x)} = (m - x)y$$

or $(n - x)y$, where $(m - x)$
and $(n - x)$ are the factors of $-x^2 + ax + b$

Example: $\int \frac{x dx}{\sqrt{2 + 3x - 2x^2}} = ?$

$$\sqrt{2 + 3x - 2x^2} = \sqrt{(1 + 2x)(2 - x)} = (2 - x)y,$$

whence $x = \frac{2y^2 - 1}{2 + y^2}$, $dx = \frac{10y dy}{(2 + y^2)^2}$, etc.

EXERCISE XVII.

Integrate by substitution:

1. $\int \frac{x^{\frac{1}{3}} dx}{x^{\frac{2}{3}} + 1}$ [substitute z^3 for x].

2. $\int \frac{dx}{x^{\frac{5}{6}} + x^{\frac{1}{3}}}$ [substitute z^6 for x].

3. $\int \frac{x^{\frac{1}{4}} - 1}{x^{\frac{3}{4}} - x^{\frac{5}{4}}} dx.$

4. $\int \frac{x^{\frac{1}{2}} dx}{x^{\frac{3}{2}} - x^{\frac{5}{2}}}.$

5. $\int \frac{y^3 dy}{\sqrt{y^2 + 1}}$ [substitute $\sqrt{y^2 + 1} = z$].

6. $\int \frac{x dx}{(a^2 - x^2)^{\frac{3}{2}}}$ [substitute $a^2 - x^2 = z^2$].

7. $\int \frac{x dx}{\sqrt[3]{x^2 + 1} - 1}.$

8. $\int \frac{x dx}{1 - x - 2x^2}.$

9. $\int \frac{dz}{z^2 \sqrt{z^2 - 2}}.$

10. $\int \frac{\sqrt{4y - y^2}}{y^2} dy.$

11. $\int \frac{dx}{x\sqrt{5x^2 + 4x - 1}}$.
12. $\int \frac{x dx}{\sqrt{2 + 5x - 3x^2}}$.
13. $\int \frac{dx}{x\sqrt{4 - x^2}}$ [substitute $x = \frac{2}{z}$].
14. $\int \frac{x^2 dx}{(x - 1)^4}$ [substitute $x - 1 = z$].
15. $\int \frac{dx}{e^{2z} - 2e^z}$ [substitute $e^z = x$].
16. $\int \frac{(x^2 - 1) dx}{x\sqrt{x^4 + x^2 + 1}}$ [set $x + \frac{1}{x} = z$].
17. $\int \frac{x dx}{(1 - x)^3}$.
18. $\int \frac{\sqrt{x + 1}}{\sqrt{x - 1}} dx$.
19. $\int \frac{a - x}{\sqrt{2ax - x^2}} dx$.
20. $\int \sqrt{x - x^2} dx$.

REDUCTION FORMULÆ.

ART. 92. Integrals of the general form

$$\int x^m (a + bx^n)^p dx$$

are exceedingly common, as

$$\int x^2 \sqrt{a^2 - x^2} dx, \quad \int \frac{x^3 dx}{(a^2 - x^2)^{\frac{3}{2}}}, \quad \int \frac{dx}{\sqrt{2ax - x^2}}, \text{ etc.}$$

Take for example,

$$\int \frac{x^3 dx}{(a^2 - x^2)^{\frac{3}{2}}}.$$

A careful inspection will show that if $\int \frac{x^3 dx}{(a^2 - x^2)^{\frac{3}{2}}}$, can be made to depend upon $\int \frac{x dx}{(a^2 - x^2)^{\frac{3}{2}}}$, the expression is integrable, for the latter integral is in the form $x^n dx$ or can be readily reduced to it by inserting the factor 2. Again $\int \frac{dx}{(a^2 - x^2)^{\frac{3}{2}}}$ can be found if it can be made to depend upon $\int \frac{dx}{(a^2 - x^2)^{\frac{1}{2}}} = \sin^{-1} \frac{x}{a}$.

In the former case the exponent of x (when the expression is in the form $\int x^m (a + bx^n)^p dx$) is to be decreased, and in the latter the exponent of the parenthesis is to be decreased.

If then a general method can be devised for expressing $\int x^m (a + bx^n)^p dx$ in terms of other integrals where m or p (or both) is increased or decreased as the case may require, many of these forms can be integrated.

The process in one case will suffice to show how these formulæ, four in number, known as *reduction formulæ*, are found. The formula for integration by parts is used, as it is necessary to break up the original expression.

In $\int x^m (a + bx^n)^p dx$, then,

$$\text{let } u = x^{m-n+1} \text{ and } dv = (a + bx^n)^p x^{n-1} dx [x^m dx \\ = (x^{m-n+1})(x^{n-1} dx)]$$

$$\text{Substituting in } \int u dv = uv - \int v du \dots \dots \dots \text{ (B)}$$

$$\int x^m (a + bx^n)^p dx = \frac{x^{m-n+1} (a + bx^n)^{p+1}}{nb(p+1)} -$$

$$\frac{m - n + 1}{nb (p + 1)} \int x^{m-n} (a + bx^n)^{p+1} dx \quad \dots \quad (1)$$

Since $du = (m - n + 1) x^{m-n} dx$ and $v = \frac{(a + bx^n)^{p+1}}{nb (p + 1)}$.

But $\int x^{m-n} (a + bx^n)^{p+1} dx = \int x^{m-n} (a + bx^n) (a + bx^n)^p dx$

[since $z^{p+1} = z \cdot z^p$]

$$= a \int x^{m-n} (a + bx^n)^p dx + b \int x^m (a + bx^n)^p dx$$

[multiplying out].

Substituting in (1) above,

$$\int x^m (a + bx^n)^p dx = \frac{x^{m-n+1} (a + bx^n)^{p+1}}{nb (p + 1)} -$$

$$\frac{a(m-n+1)}{nb (p + 1)} \int x^{m-n} (a + bx^n)^p dx -$$

$$\frac{b(m-n+1)}{nb (p + 1)} \int x^m (a + bx^n)^p dx \quad \dots \quad (2)$$

Transposing the last term of (2) and collecting,

$$\frac{b (np + m + 1)}{nb (p + 1)} \int x^m (a + bx^n)^p dx = \frac{x^{m-n+1} (a + bx^n)^{p+1}}{nb (p + 1)}$$

$$- \frac{a (m - n + 1)}{nb (p + 1)} \int x^{m-n} (a + bx^n)^p dx.$$

Dividing by $\frac{b (np + m + 1)}{nb (p + 1)}$,

$$\int x^m (a + bx^n)^p dx = \frac{x^{m-n+1} (a + bx^n)^{p+1}}{b (np + m + 1)} -$$

$$\frac{a (m - n + 1)}{b (np + m + 1)} \int x^{m-n} (a + bx^n)^p dx \quad \dots \quad (A)$$

Here $x^m (a + bx^n)^p dx$ is plainly made to depend upon the integral $\int x^{m-n} (a + bx^n) dx$, which is exactly like it except that the exponent of x , $[m]$, is reduced by n .

The other three formulæ are as follows:

$$\int x^m (a + bx^n)^p dx = \frac{x^{m+1} (a + bx^n)^p}{np + m + 1} + \frac{anp}{np + m + 1} \int x^m (a + bx^n)^{p-1} dx \quad \dots \quad (B)$$

$$\int x^m (a + bx^n)^p dx = \frac{x^{m+1} (a + bx^n)^{p+1}}{a(m+1)} - b \frac{(np + n + m + 1)}{a(m+1)} \int x^{m+n} (a + bx^n)^p dx \quad \dots \quad (C)$$

$$\int x^m (a + bx^n)^p dx = - \frac{x^{m+1} (a + bx^n)^{p+1}}{an(p+1)} + \frac{np + m + n + 1}{an(p+1)} \int x^m (a + bx^n)^{p+1} dx \quad \dots \quad (D)$$

(A) decreases m by n .

(B) decreases p by unity.

(C) increases m by n .

(D) increases p by unity.

In using these formulæ, the expression to be integrated is carefully inspected, and the known integrable form to which it is to be reduced, is decided upon, then the formula [(A), (B), (C), or (D)] suited to this reduction is applied. Clearly these formulæ may all be applied to one example successively, or any one of them may be used any number of times until the desired form is reached. These formulæ fail when the constants have such a value that the denominators of the fractions reduce to zero. For example, in (A) $b(np + m + 1)$ must *not* reduce to 0, etc.

Example: $\int x^2 \sqrt{a^2 - x^2} dx = ?$

Here the form desired is plainly

$$\frac{dx}{\sqrt{a^2 - x^2}} = \sin^{-1} \frac{x}{a}.$$

To accomplish this, x^2 must reduce to $x^2 = 1$ and $(a^2 - x^2)^{\frac{1}{2}}$ must reduce to $(a^2 - x^2)^{\frac{1}{2}}$. That is, m must be decreased by 2 and p by 1 (why can it not be reduced to the form

$\int \frac{x dx}{\sqrt{a^2 - x^2}}$. To accomplish this, (A) must be used to reduce x^m to x^{m-n} , and (B) to reduce p to $p - 1$.

$$\text{Comparing } \int x^2 \sqrt{a^2 - x^2} dx = \int x^2 (a^2 - x^2)^{\frac{1}{2}} dx$$

with $\int x^m (a + bx^n)^p dx$

$$m = 2, n = 2, p = \frac{1}{2}, a = a^2, b = -1$$

using (A) then,

$$\int x^2 (a^2 - x^2)^{\frac{1}{2}} dx = \frac{x (a^2 - x^2)^{\frac{1}{2}}}{-4} - \frac{a^2}{-4} \int (a^2 - x^2)^{\frac{1}{2}} dx \dots \dots \dots (1)$$

$$[\text{since } x^{m-n} = x^{2-2} = x^0 = 1].$$

Applying (B) to $\int (a^2 - x^2)^{\frac{1}{2}} dx$, where $m = 0$, $n = 2$,

$$p = \frac{1}{2}, a = a^2, b = -1$$

$$\begin{aligned} \int (a^2 - x^2)^{\frac{1}{2}} dx &= \frac{x (a^2 - x^2)^{\frac{1}{2}}}{2} + \\ \frac{a^2}{2} \int (a^2 - x^2)^{-\frac{1}{2}} dx &= \frac{x (a^2 - x^2)^{\frac{1}{2}}}{2} + \\ \frac{a^2}{2} \int \frac{dx}{\sqrt{a^2 - x^2}} &= \frac{x (a^2 - x^2)^{\frac{1}{2}}}{2} + \frac{a^2}{2} \sin^{-1} \frac{x}{a}. \end{aligned}$$

Substituting this value of $\int (a^2 - x^2)^{\frac{1}{2}} dx$ in (1),

$$\int x^2 \sqrt{a^2 - x^2} dx = -\frac{x(a^2 - x^2)^{\frac{3}{2}}}{4} + \frac{a^2 x(a^2 - x^2)^{\frac{1}{2}}}{8} + \frac{a^4}{8} \sin^{-1} \frac{x}{a},$$

where $\int x^2 \sqrt{a^2 - x^2} dx$ is completely integrated. The value of these formulæ lies in the ability to see the integrable form that lies within the original expression, and to select the appropriate reduction formula. It is a matter for observation and ingenuity purely.

Again $\int \sqrt{2ax - x^2} dx =$ what?

Here the required form is $\int \frac{dx}{\sqrt{2ax - x^2}} = \text{vers}^{-1} \frac{x}{a}$.

To put $\int \sqrt{2ax - x^2} dx$ in the form $\int x^m (a + bx^n)^p dx$,

take out x from under the radical, and we have

$$\int x^{\frac{1}{2}} (2a - x)^{\frac{1}{2}} dx.$$

This must be reduced to

$$\int \frac{dx}{2ax - x^2} = \int \frac{dx}{x^{\frac{1}{2}} (2a - x)^{\frac{1}{2}}} = \int x^{-\frac{1}{2}} (2a - x)^{-\frac{1}{2}} dx.$$

Since $n = 1$, here $x^{m-n} = x^{\frac{1}{2}-1} = x^{-\frac{1}{2}}$ the desired form for x , hence (A) is needed. Also p is to be reduced to $p - 1$. [$\frac{1}{2} - 1 = -\frac{1}{2}$] hence (B) is also needed. Applying these successively we get the desired form. Only practice and experience can give facility in the use of these formulæ, and familiarity with the simpler integral forms is desirable, that the inspection of the expression to be integrated should be effective.

EXERCISE XVIII.

Integrate:

- | | |
|------------------------------------------------------|-------------------------------------------------------------------------|
| 1. $\int (x^2 + 6^2)^{\frac{1}{2}} dx.$ | 7. $\int \sqrt{2ry - y^2} dy.$ |
| 2. $\int \sqrt{r^2 - x^2} dx.$ | 8. $\int \frac{x dx}{\sqrt{2ax - x^2}}.$ |
| 3. $\int x^2 (r^2 - x^2)^{\frac{3}{2}} dx.$ | 9. $\int \frac{\sqrt{2ax - x^2}}{x^3} dx.$ |
| 4. $\int \frac{x^2 dx}{\sqrt{x^2 - a^2}}.$ | 10. $\int \frac{dx}{x^2 \sqrt{1 - x^2}}.$ |
| 5. $\int x^3 (m^2 - x^2)^{-\frac{1}{2}} dx.$ | 11. $\int \frac{dz}{(a^2 - z^2)^{\frac{3}{2}}}$ |
| 6. $\int \frac{dz}{(a^2 - z^2)^{\frac{3}{2}}}$ | 12. $\int \frac{dx}{(x^2 - 2x + 5)^2}$ [substitute first $z = x - 1$]. |
| 13. $\int (a^2 + x^2)^{\frac{3}{2}} dx.$ | 17. $\int \frac{x^3 dx}{\sqrt{1 - x^2}}.$ |
| 14. $\int \frac{(x^2 - a^2)^{\frac{3}{2}} dx}{x^4}.$ | 18. $\int \frac{\sqrt{a^2 - x^2} dx}{x}.$ |
| 15. $\int \sqrt{1 - 2z - z^2} dz.$ | 19. $\int \frac{x^3 dx}{\sqrt{2rx - x^2}}.$ |
| 16. $\int \sqrt{y^2 + b} dy.$ | |

RATIONAL FRACTIONS.

ART. 93. If the fractions $\frac{3}{1-x}$ and $\frac{5}{2+3x}$ be added together, we get,

$$\frac{3}{1-x} + \frac{5}{2+3x} = \frac{11+4x}{(1-x)(2+3x)} = \frac{11+4x}{2+x-3x^2}.$$

It will be observed that the numerator of the sum gives no indication of the numerators of the component fractions, but that the denominator does indicate directly the denominators of the components. If the denominator is in the form indicated in the final fraction above, it is easy to factor it.

So that we may regard every rational fraction whose denominator is factorable as made up of simpler fractions having respectively the factors as denominators. If it is required to integrate, for example,

$$\frac{11 + 4x}{2 + x - 3x^2} dx,$$

it is clearly a gain to be able to express this fraction as the sum (algebraic sum of course is meant) of two or more simpler fractions; for when we discover that,

$$\frac{11 + 4x}{2 + x - 3x^2} = \frac{3}{1 - x} + \frac{5}{2 + 3x},$$

we get the integral readily, since

$$\int \frac{3}{1 - x} dx = -3 \log (1 - x) \text{ and } \int \frac{5 dx}{2 + 3x} = \frac{5}{3} \log (2 + 3x).$$

Since we know that this decomposition is possible, for every denominator factor we set a fraction with a letter, or letters, for numerator, which we determine by the principle of identities.

It is necessary to discriminate between first degree and second degree factors, as will appear, hence we have four cases, as follows:

- (a) where the factors are linear only, and not repeated.
- (b) where the factors are linear and repeated.
- (c) where the factors are quadratic and not repeated.
- (d) where the factors are quadratic and repeated.

Case (a).

For every linear factor in the denominator there is a component fraction of the form $\frac{A}{x \pm a}$.

Suppose the fraction is $\frac{f(x)}{F(x)}$; where $F(x) = (x \pm a)(x \pm b)(x \pm c) \dots (x \pm n)$.

Then

$$\frac{f(x)}{F(x)} = \frac{A}{(x \pm a)} + \frac{B}{(x \pm b)} + \frac{C}{(x \pm c)} \dots + \frac{N}{x \pm n}.$$

The original fraction should be a proper fraction, that is, the degree of the numerator should be less than that of the denominator, to avoid complications. If this is not the case in the given fraction, it can be made so, by dividing numerator by denominator until the remainder fraction fulfills this condition. The remainder is then decomposed and the integral quotient added to the result. An example will make the process plainer:

$$\int \frac{(x^2 - 1) dx}{(x^2 - 4)(4x^2 - 1)} = ?$$

$$\frac{x^2 - 1}{(x^2 - 4)(4x^2 - 1)} = \frac{x^2 - 1}{(x - 2)(x + 2)(2x - 1)(2x + 1)}$$

$$= \frac{A}{x - 2} + \frac{B}{x + 2} + \frac{C}{2x - 1} + \frac{D}{2x + 1}.$$

It is to be remembered that this is an identity, not a mere equation, as the two sides must be exactly the same, when cleared of fractions by our hypothesis, A, B, C and D being used because we do not immediately know what their values are.

Clearing; $x^2 - 1 = A(x + 2)(2x - 1)(2x + 1) + B(x - 2)(2x - 1)(2x + 1) + C(x - 2)(x + 2)(2x + 1) + D(x - 2)(x + 2)(2x - 1)$. Since this is an identity it is true for any value of x whatever; hence we can give x such values that the terms will all disappear but one, and thereby find the unknown constant it contains. For example, if we let $x = 2$, all the terms containing $(x - 2)$ will reduce to 0, hence

$$2^2 - 1 = 3 = A(4)(3)(5) + 0 + 0 + 0 = 60A,$$

whence $A = \frac{1}{20}$.

Let $x = -2$, and all terms containing $x + 2$ will reduce to 0; hence $(-2)^2 - 1 = 3 = 0 + B(-4)(-5)(-3) + 0 + 0 = -60B$,

whence $B = -\frac{1}{20}$.

Let $x = \frac{1}{2}$; then

$$\left(\frac{1}{2}\right)^2 - 1 = -\frac{3}{4} = 0 + 0 + C\left(-\frac{3}{2}\right)\left(\frac{5}{2}\right)(2) = -\frac{15}{2}C,$$

whence $C = +\frac{1}{10}$.

Let $x = -\frac{1}{2}$; then

$$-\left(\frac{1}{2}\right)^2 - 1 = -\frac{5}{4} = 0 + 0 + 0 + D\left(-\frac{5}{2}\right)\left(\frac{3}{2}\right)(-2) = \frac{15}{2}D,$$

whence $D = -\frac{1}{10}$.

Then

$$\int \frac{(x^2 - 1) dx}{(x^2 - 4)(4x^2 - 1)} = \frac{1}{20} \int \frac{dx}{x - 2} - \frac{1}{20} \int \frac{dx}{x + 2} + \frac{1}{10} \int \frac{dx}{2x - 1} - \frac{1}{10} \int \frac{dx}{2x + 1}$$

$$= \frac{1}{20} \log(x - 2) - \frac{1}{20} \log(x + 2) + \frac{1}{20} \log(2x - 1) - \frac{1}{20} \log(2x + 1).$$

$$= \frac{1}{20} \log \frac{(x - 2)(2x - 1)}{(x + 2)(2x + 1)} \quad \text{(by the principles of logarithms.)}$$

Case (b).

In using indeterminate coefficients of any sort, it is a cardinal principle that every possible case that may arise must be provided for in the supposition used.

Suppose $\frac{3}{1-x}$, $\frac{5-x}{(1-x)^2}$, and $-\frac{3x^2+1}{(1-x)^3}$ are added.

$$\frac{3}{1-x} + \frac{5-x}{(1-x)^2} - \frac{3x^2+1}{(1-x)^3} = \frac{7-12x+x^2}{(1-x)^3}.$$

Here the $(1-x)^3$ gives no indication directly of the factor $(1-x)^2$, that has disappeared in it. If $(1-x)^3$ is separated into linear factors they would all be alike $(1-x)$, $(1-x)$, $(1-x)$, and there would be no separation at all, neither would the fractions having denominators $(1-x)^2$ and $(1-x)^3$ be provided for. That nothing may be omitted it is necessary then to provide a fraction for each of these, hence for every factor of the form $(x \pm a)^n$ a series of fractions is assumed, thus:

$$\frac{f(x)}{(x \pm a)^n} = \frac{A}{(x \pm a)^n} + \frac{B}{(x \pm a)^{n-1}} + \frac{C}{(x \pm a)^{n-2}} \cdots \frac{N}{(x \pm a)},$$

thus accounting for all the powers.

Example: $\int \frac{x^5 - 5x^2 - 3}{x^2(x+1)^2} dx = ?$

As this is an improper fraction, divide numerator by denominator,

$$\int \frac{x^5 - 5x^2 - 3}{x^2(x+1)^2} dx = \int x dx - 2 \int dx + 3 \int \frac{x^3 - x^2 - 1}{x^2(x+1)^2} dx$$

$$\frac{x^3 - x^2 - 1}{x^2(x+1)^2} = \frac{A}{x^2} + \frac{B}{x} + \frac{C}{(x+1)^2} + \frac{D}{x+1}.$$

[Thus accounting for all the powers of x and of $(x + 1)$.]
Clearing;

$$x^3 - x^2 - 1 = A(x + 1)^2 + Bx(x + 1)^2 + Cx^2 + Dx^2(x + 1).$$

Let $x = -1$; then

$$(-1)^3 - (-1)^2 - 1 = -3 = 0 + 0 + C(-1)^2 + 0 = C,$$

$$C = -3.$$

Let $x = 0$; then

$$0 - 0 - 1 = -1 = A(1)^2 + 0 + 0 + 0 = A$$

$$A = -1.$$

Since no rational value of x will cause the other terms to disappear, we will give x any small values to get two simultaneous equations for the two remaining constants, B and D .

Let $x = 1$; then

$$1^3 - (1)^2 - 1 = -1 = A(2)^2 + B(1)(2)^2 + C(1)^2$$

$$+ D(1)^2(2),$$

or since $A = -1$, and $C = -3$

$$-1 = -4 + 4B - 3 + 2D$$

whence $2B + D = 3$ (1)

Let $x = 2$; whence

$$3B + 2D = 4$$
 (2)

Combining (1) and (2)

$$B = 2 \text{ and } D = -1.$$

Hence,

$$\int \frac{x^3 - x^2 - 1}{x^2(x + 1)^2} = - \int \frac{dx}{x^2} + 2 \int \frac{dx}{x} - 3 \int \frac{dx}{(x + 1)^2} -$$

$$\int \frac{dx}{x + 1} = \frac{1}{x} + 2 \log x + \frac{3}{x + 1} - \log(x + 1)$$

$$= \frac{4x+1}{x(x+1)} + \log \frac{x^2}{x+1} \quad [\text{collecting}].$$

$$\frac{x^5 - 5x^2 - 3}{x^2(x+1)} = \frac{x^2}{2} - 2x + \frac{12x+3}{x(x+1)} + 3 \log \frac{x^2}{x+1}.$$

Case (c).

If for a factor of the second degree we set a fraction of the form $\frac{A}{x^2 + ax + b}$, we overlook the possibility of the form $\frac{Bx}{x^2 + ax + b}$, since this is also a proper fraction, but if both are combined in one thus getting the most general form, all contingencies are provided for. So for factors of the form $x^2 + ax + b$, we have fractions of the form $\frac{Ax + B}{x^2 + ax + b}$.

$$\text{Hence } \frac{f(x)}{\phi_1(x)} = \frac{Ax + B}{x^2 + ax + b} + \frac{Cx + D}{x^2 + cx + d} + \dots$$

$$\text{where } \phi(x) = (x^2 + ax + b)(x^2 + cx + d) \quad (\dots)$$

$$\text{Example: } \int \frac{2x^2 + 1}{(x+1)(x^2+1)} dx = ?$$

$$\frac{2x^2 + 1}{(x+1)(x^2+1)} = \frac{A}{x+1} + \frac{Bx + C}{x^2+1} \quad [(x+1) \text{ is linear}].$$

Clearing;

$$2x^2 + 1 = A(x^2 + 1) + (x+1)(Bx + C) \dots \dots (1)$$

It is plain that no rational value of x will make $x^2 + 1$ equal to zero, and in general with quadratic factors this process is useless. Either x can be given any arbitrary values as in the last case or the following method be fol-

lowed; a method that is entirely general and can be used in every case if preferred.

Multiplying out in (1);

$$2x^2 + 1 = Ax^2 + A + Bx^2 + Cx + Bx + C.$$

Collecting;

$$2x^2 + 1 = (A + B)x^2 + (C + B)x + (A + C).$$

Since this is an identity, the coefficients of like powers of x on the two sides are identical; that is,

$$A + B = 2 \quad \text{coefficients of } x^2.$$

$$C + B = 0 \quad \text{since there is no } x \text{ on the left.}$$

$$A + C = 1 \quad \text{absolute terms.}$$

Combining these as simultaneous:

$$B = \frac{1}{2}, \quad A = \frac{3}{2}, \quad C = -\frac{1}{2}.$$

$$\begin{aligned} \therefore \int \frac{(2x^2 + 1) dx}{(x + 1)(x^2 + 1)} &= \frac{3}{2} \int \frac{dx}{x + 1} + \frac{1}{2} \int \frac{x - 1}{x^2 + 1} dx \\ &= \frac{3}{2} \int \frac{dx}{x + 1} + \frac{1}{2} \int \frac{xdx}{x^2 + 1} - \frac{1}{2} \int \frac{dx}{x^2 + 1} \\ &= \frac{3}{2} \log(x + 1) + \frac{1}{4} \log(x^2 + 1) - \frac{1}{2} \tan^{-1} x. \end{aligned}$$

Case (d)

The same reasoning that was used in case (b), will show that for every factor of the form $(x^2 + ax + b)^n$ there is a series of fractions with numerators of the form $Ax + B$ and denominators successively, $(x^2 + ax + b)^n$, $(x^2 + ax + b)^{n-1}$, $(x^2 + ax + b)^{n-2}$. . . $(x^2 + ax + b)$.

Example:

$$\frac{x^2 - 2x + 3}{x^2(x^2 + 2)^3} = \frac{A}{x^2} + \frac{B}{x} + \frac{Cx + D}{(x^2 + 2)^3} + \frac{Ex + F}{(x^2 + 2)^2} + \frac{Gx + H}{x^2 + 2}.$$

EXERCISE XIX.

Separate into rational fractions and integrate:

1. $\int \frac{2x-3}{x^2+x-6} dx.$
2. $\int \frac{1-2y}{y^3-y} dy.$
3. $\int \frac{5-x+x^2}{(1-x)^2(2-3x)^3} dx.$
4. $\int \frac{3}{x^2(1+x^2)(1-2x)} dx.$
5. $\int \frac{x^3-2x+5}{x^2+2x-3} dx.$
6. $\int \frac{(x-6)dx}{x^3-6x^2+9x}.$
7. $\int \frac{(2x-1)dx}{(x^3+x)^2}.$
8. $\int \frac{z^3-z+1}{(z^2+2)^3} dz.$
9. $\int \frac{dx}{(x-1)(x+1)^2} dx.$
10. $\int \frac{x^2 dx}{(x^2-4)(9x^2-1)} dx.$
11. $\int \frac{x^4-3x^2+2x}{x^3(x-1)} dx.$
12. $\int \frac{x^3 dx}{x^4+x^2-3} dx.$
13. $\int \frac{2x^2-x-1}{(x^2+x+1)(x-1)} dx.$
14. $\int \frac{(2x-1)dx}{x^3+1}.$
15. $\int \frac{4x^4-x^2+4}{(x^3-1)^2} dx.$
16. $\int \frac{(x+6)dx}{5x-4x^2-x^3}.$
17. $\int \frac{(x^2+1)dx}{x^4+x^2+1}.$
18. $\int \frac{y^3+2y-2}{(y-1)(y^3-y^2+y-1)} dy.$
19. $\int \frac{x^2-3x+2}{(x^2+1)(x^2-x+1)} dx.$
20. $\int \frac{x^4-6x^3+4x^2-1}{(x^2+3)^3} dx.$
21. $\int \frac{3x-1}{x^2+x-2} dx.$
22. $\int \frac{6x+1}{(x+2)^3(x-1)} dx.$
23. $\int \frac{z^3-1}{z^3+2z^2} dz.$

24.
$$\int \frac{x^3 - x + 1}{(x^2 + 1)(x^2 - 2x + 3)} dx.$$

25.
$$\int \frac{x^5 - 1}{(x^2 + 2)^2} dx.$$

26.
$$\int \frac{3x^4 - 2x^3 + x^2 - 2x + 1}{x^3(x+1)^2(x^2+1)} dx.$$

CHAPTER XIII.

TRIGONOMETRIC INTEGRALS.

ART. 94. The integration of the more complex trigonometric functions can often be accomplished by substitution, sometimes by breaking up the expression taking advantage of the relations known to exist between the different functions. There are very few general rules and the chief assets are originality and a knowledge of the simpler integrable forms. A few cases may be noted, however.

ART. 95. Integrals of the form $\int \sin^m x \cos^n x dx$ where either m or n is a positive, odd integer.

Say m is odd; then since $\sin^2 x = 1 - \cos^2 x$,

$$\begin{aligned} \int \sin^m x \cos^n x dx &= \int (1 - \cos^2 x)^{\frac{m-1}{2}} \cos^n x \sin x dx \\ &= - \int (1 - \cos^2 x)^{\frac{m-1}{2}} \cos^n x d(\cos x). \end{aligned}$$

$$[\text{For } \sin^m x = \sin^{m-1} x \sin x = (1 - \cos^2 x)^{\frac{m-1}{2}} \sin x.]$$

Since m is odd, $m - 1$ is even and hence $(1 - \cos^2 x)^{\frac{m-1}{2}}$ can be expanded by the binomial theorem; then each term multiplied by $\cos^n x d(\cos x)$ becomes an integral of the form

$\int x^{-n} dx = \frac{x^{-n+1}}{-n+1}$, or $\int \frac{dx}{x} = \log x$, and the result is easily found.

If n is odd, the $\cos x$ is reduced to $\sin x$ and the same process followed.

Example: $\int \frac{\cos^3 x}{\sin x} dx = ?$

$$\int \frac{\cos^3 x}{\sin x} dx = \int \frac{1 - \sin^2 x}{\sin x} \cos x dx = \int \frac{d(\sin x)}{\sin x} - \int \sin x d(\sin x) = \log \sin x - \frac{1}{2} \sin^2 x.$$

If $m + n$ is an even negative whole number,

$\int \sin^m x \cos^n x dx$ may be put in the form

$$\int \frac{\cos^n x}{\sin^n x} \sin^{m+n} x dx = \int \cot^n x \csc^{-(m+n)} x dx, \text{ or,}$$

$$\int \frac{\sin^m x}{\cos^n x} \cos^{m+n} x dx = \int \tan^m x \sec^{-(m+n)} x dx.$$

Since $m + n$ is an even negative integer, $-(m + n)$ will be a positive even integer, hence leaving $\sec^2 x dx$ as the $d(\tan x)$, $\sec^{-(m+n)-2} x$ can be expressed entirely in terms of the tangent by the relation $\sec^2 x = 1 + \tan^2 x$.

Example: $\int \frac{\cos^2 x}{\sin^6 x} dx = ?$ Here $m + n = -6 + 2 = -4$.

Hence

$$\int \frac{\cos^2 x}{\sin^6 x} dx = \int \frac{\cos^2 x}{\sin^2 x} \sin^{-4} x dx = \int \cot^2 x \csc^4 x dx.$$

The $\cot^2 x + 1 = \csc^2 x$, hence,

$$\int \cot^2 x \csc^4 x dx = \int \cot^2 x (1 + \cot^2 x) \csc^2 x dx$$

$$= - \int (\cot^4 x + \cot^2 x) d(\cot x) = - \frac{\cot^3 x}{3} - \frac{\cot^5 x}{5}.$$

ART. 96. If the integral is in the form, $\int \sec^{2m} x dx$ or $\int \csc^{2n} x dx$, where n and m are positive integers, the expressions can be readily put in the forms,

$$(\tan^2 x + 1)^{\frac{2m-2}{2}} \sec^2 x dx$$

$$= (\tan^2 x + 1)^{m-1} d(\tan x)$$

and $(\cot^2 x + 1)^{\frac{2n-2}{2}} \csc^2 x dx$

$$= - (\cot^2 x + 1)^{n-1} d(\cot x)$$

which are both readily integrable, since $m - 1$ and $n - 1$ are both integers and the parentheses may be expanded.

Example: $\int \frac{dx}{\cos^6 x} = ?$

$$\begin{aligned} \int \frac{dx}{\cos^6 x} &= \int \sec^6 x dx = \int (\tan^2 x + 1)^2 \sec^2 x dx \\ &= \int (\tan^2 x + 1)^2 d(\tan x) \\ &= \int \tan^4 x d(\tan x) + 2 \int \tan^2 x d(\tan x) + \int \sec^2 x dx \\ &= \frac{\tan^5 x}{5} + \frac{2 \tan^3 x}{3} + \tan x. \end{aligned}$$

ART. 97. If the integral is of the form,

$$\int \sec^m x \tan^n x dx \text{ or } \int \csc^m x \cot^n x dx,$$

where m is anything, and n is a positive odd integer, it may be reduced to

$$\begin{aligned} & \int \sec^{m-1} x \tan^{n-1} x \sec x \tan x \, dx \\ &= \int \sec^{m-1} x \tan^{n-1} x \, d(\sec x), \end{aligned}$$

or

$$\begin{aligned} & \int \csc^{m-1} x \cot^{n-1} x \csc x \cot x \, dx \\ &= - \int \csc^{m-1} x \cot^{n-1} x \, d(\csc x), \end{aligned}$$

and since n is odd, $n - 1$ is even and $\tan x$ and $\cot x$ can be expressed in terms of $\sec x$ and $\csc x$ respectively by the relations, $\tan^2 x = \sec^2 x - 1$ and $\cot^2 x = \csc^2 x - 1$.

ART. 98. If the integrals are in the forms,

$$\int \tan^m x \, dx \text{ or } \int \cot^m x \, dx,$$

they may be put in the forms,

$$\int \tan^{m-2} x \cdot \tan^2 x \, dx = \int \tan^{m-2} x (\sec^2 x - 1) \, dx,$$

$$\text{and } \int \cot^{m-2} x \cdot \cot^2 x \, dx = \int \cot^{m-2} x (\csc^2 x - 1) \, dx.$$

If these are multiplied out, the first term is always integrable and the exponent of $\tan x$ or $\cot x$ is reduced by 2 in the second term; thus each application of the process reduces the exponent m , until an integrable form is reached.

Example: $\int (\tan^4 x) \, dx = ?$

$$\tan^4 x \, dx = \int \tan^2 x (\sec^2 x - 1) \, dx$$

$$\begin{aligned}
 &= \int \tan^2 x d(\tan x) - \int \tan^2 x dx \\
 &= \frac{\tan^3 x}{3} - \int (\sec^2 x - 1) dx \\
 &= \frac{\tan^3 x}{3} - \int \sec^2 x dx + \int dx \\
 &\quad \frac{\tan^3 x}{3} - \tan x + x.
 \end{aligned}$$

ART. 99. When m and n are both positive integers the multiple angle formulæ may be used to simplify, namely,

$$\sin^2 x = \frac{1 - \cos 2x}{2},$$

$$\cos^2 x = \frac{1 + \cos 2x}{2},$$

$$\sin x \cos x = \frac{\sin 2x}{2}.$$

Example : $\int \sin^4 x \cos^2 x dx = ?$

$$\begin{aligned}
 &\int \sin^4 x \cos^2 x dx = \int (\sin x \cos x)^2 \sin^2 x dx \\
 &= \int \left(\frac{\sin^2 2x}{4} \right) \left(\frac{1 - \cos 2x}{2} \right) dx \\
 &= \frac{1}{8} \int \sin^2 2x dx - \frac{1}{8} \int \sin^2 2x \cos 2x dx \\
 &= \frac{1}{16} \int (1 - \cos 4x) dx - \frac{1}{16} \int \sin^2 2x \cos 2x d(2x) \\
 &= \frac{1}{16} \int dx - \frac{1}{64} \int \cos 4x d(4x) - \frac{1}{16} \int \sin^2 2x d(\sin 2x) \\
 &= \frac{1}{16} - \frac{1}{64} \sin 4x - \frac{1}{48} \sin^3 2x.
 \end{aligned}$$

ART. 100. The following formulæ will be useful, but their derivation is not necessary here.

$$\frac{dx}{m+n \cos x} = \frac{2}{\sqrt{m^2 - n^2}} \tan^{-1} \left\{ \frac{\tan \frac{x}{2}}{\frac{m+n}{m-n}} \right\} \text{ where } m > n,$$

$$\text{or } \frac{dx}{m+n \cos x} = -\frac{1}{\sqrt{n^2 - m^2}} \log \frac{\tan \frac{x}{2} - \sqrt{\frac{n+m}{n-m}}}{\tan \frac{x}{2} + \sqrt{\frac{n+m}{n-m}}}$$

where $m < n$.

The integration of $\frac{dx}{m+n \sin x}$ is made to depend upon the same form by first substituting $x = z + 90^\circ$.

$$e^{ax} \sin nx \, dx = \frac{e^{ax} (a \sin nx - n \cos nx)}{a^2 + n^2}$$

$$e^{ax} \cos nx \, dx = \frac{e^{ax} (n \sin nx + a \cos nx)}{a^2 + n^2}.$$

EXERCISE XX.

- | | |
|-------------------------------------------|----------------------------------------|
| 1. $\int \frac{dx}{\cos^4 x}$ | 6. $\int \cot^3 x \csc^3 x \, dx$. |
| 2. $\int \frac{dx}{\sin^6 x \cos^6 x}$ | 7. $\int \tan^3 x \, dx$. |
| 3. $\int \frac{dx}{\sec^2 x \sin^6 x}$ | 8. $\int \cos x \tan^3 x \, dx$. |
| 4. $\int \csc^4 x \, dx$. | 9. $\int \tan^4 x \, dx$. |
| 5. $\int \frac{\tan^3 x \, dx}{\cos^4 x}$ | 10. $\int (\tan x + \cot x)^2 \, dx$. |

11. $\int \cot^6 x \, dx.$
12. $\int \cos^3 x \sin^4 x \, dx.$
13. $\int \frac{\sin^3 x}{\cos^2 x} \, dx.$
14. $\int \frac{\sin^5 x}{\cos x \sqrt{\cos x}} \, dx.$
15. $\int \frac{\sin^3 x \, dx}{\sqrt{1 + \cos x}}.$
21. $\int \sec^3 x \, dx$ [set $\sec x = y$].
22. $\int \frac{dx}{\sin x \cos^2 x}.$
23. $\int \frac{\cos^3 x \, dx}{\sin^5 x}.$
24. $\int \frac{\sec mx}{\cot^3 mx} \, dx.$
25. $\int \frac{dx}{3 - 5 \sin x}.$
26. $\int \frac{dx}{4 + 5 \sin 2x}.$
32. $\int e^{mx} (\sin mx - \cos mx) \, dx.$
33. $\int e^x \cos 3x \, dx.$
34. $\int e^{3x} (\cos 2x + \sin 2x) \, dx.$
16. $\int \frac{\sin^2 x}{\cos^4 x} \, dx.$
17. $\int \frac{\sin x \, dx}{\cos^3 x}.$
18. $\int \frac{dx}{\cos^4 x}.$
19. $\int \frac{dx}{\cos^4 x \sin^2 x}.$
20. $\int \sin^4 x \cos^4 x \, dx.$
27. $\int \frac{dx}{13 - 5 \cos x}.$
28. $\int \frac{dx}{10 + 6 \cos x}.$
29. $\int e^x \sin 2x \, dx.$
30. $\int e^{2x} \sin 4x \, dx.$
31. $\int e^{2x} \cos x \, dx.$

Integrate the following by multiple angle formulæ:

$$35. \int \sin^2 x \cos^4 x \, dx. \quad 37. \int \sin^2 \cos^2 x \, dx.$$

$$36. \int \frac{dx}{\sin^4 x \cos^4 x}. \quad 38. \int \frac{\sin^2 x}{\cos^4 x} \, dx.$$

MULTIPLE INTEGRALS.

ART. 101. As we learned that a given function may have a number of successive derivatives, it immediately follows that a multiple derivative admits of successive integration, thus recovering the lower derivatives and eventually the original function. This process is indicated by repeating the integral sign, thus,

$$\int \int \int \frac{d^3 y}{dx^3}.$$

Suppose we have, for example,

$$\frac{d^3 y}{dx^3} = 2x^2 + 3x.$$

This is what is known as a *differential equation*. To find the relation between y and x it is necessary to integrate three times, since the third derivative is involved. It follows then, that

$$\frac{d^2 y}{dx^2} = 2x^2 dx + 3x dx,$$

$$\text{or } d\left(\frac{d^2 y}{dx^2}\right) = 2x^2 dx + 3x dx.$$

Integrating,

$$\frac{d^2 y}{dx^2} = 2 \int x^2 dx + 3 \int x dx = \frac{2x^3}{3} + \frac{3x^2}{2} + C_1;$$

$$d\left(\frac{dy}{dx}\right) = \frac{2x^3}{3} dx + \frac{3x^2}{2} dx + C_1 dx.$$

Integrating,

$$\begin{aligned}\frac{dy}{dx} &= \frac{2}{3} \int x^3 dx + \frac{3}{2} \int x^2 dx + C_1 \int dx \\ &= \frac{1}{6} x^4 + \frac{1}{2} x^3 + C_1 x + C_2;\end{aligned}$$

$$dy = \frac{x^4}{6} dx + \frac{x^3}{2} dx + C_1 x dx + C_2 dx.$$

Integrating,

$$y = \frac{x^5}{30} + \frac{x^4}{8} + \frac{C_1 x^2}{2} + C_2 x + C_3.$$

C_1 , C_2 , and C_3 are the constants of integration which may be determined in specific cases by the given conditions of the problem. This process is useful in finding the equations of curves, when certain attributes expressed in terms of their derivatives are given, for example, their radii of curvature, although a general application to this end requires a general knowledge of differential equations.

INTEGRATION OF A TOTAL DIFFERENTIAL.

ART. 102. Where several variables are involved it is necessary to reverse the process of partial differentiation, thus integrating for one variable at a time, regarding the others as constant. In the case of a function of two variables say, $z = f(x, y)$, the expression for the total differential is,

$$dz = \frac{\partial z}{\partial x} dx + \frac{\partial z}{\partial y} dy.$$

Say a differential is given in the form $P dx + Q dy$, where P and Q are functions of x and y . If the function is not originally in this form, it may be made to assume it by grouping.

The question arises, is there a function z , of x and y , which will have the expression $P dx + Q dy$ for its differential?

Comparing $P dx + Q dy$ with $\frac{\partial z}{\partial x} dx + \frac{\partial z}{\partial y} dy$, it is apparent that if there is such a function,

$$P = \frac{\partial z}{\partial x} \text{ and } Q = \frac{\partial z}{\partial y} .$$

Differentiating these equations with respect to y and x respectively,

$$\frac{\partial P}{\partial y} = \frac{\partial^2 z}{\partial y \partial x} \text{ and } \frac{\partial Q}{\partial x} = \frac{\partial^2 z}{\partial x \partial y} .$$

But

$$\frac{\partial^2 z}{\partial y \partial x} = \frac{\partial^2 z}{\partial x \partial y} .$$

$$\therefore \frac{\partial P}{\partial y} = \frac{\partial Q}{\partial x} .$$

And when this is true the function z exists, not otherwise.

Example : $3 x^2 dx + 3 y^2 dy - 3 ax dy - 3 ay dx$, to find $f(x, y)$.

Put this in the form $P dx + Q dy$,

$$(3 x^2 - 3 ay) dx + (3 y^2 - 3 ax) dy .$$

Here

$$P = 3 x^2 - 3 ay, \quad Q = 3 y^2 - 3 ax .$$

$$\frac{\partial P}{\partial y} = -3 a; \quad \frac{\partial Q}{\partial x} = -3 a .$$

$$\therefore \frac{\partial P}{\partial y} = \frac{\partial Q}{\partial x} \text{ and } z \text{ exists.}$$

Since

$$P = 3 x^2 - 3 ay .$$

$$\frac{\partial z}{\partial x} = P = 3 x^2 - 3 ay .$$

Integrating this with respect to x , y being constant,

$$z_p = x^3 - 3axy \quad [z_p \text{ means partial value of } z].$$

Since the terms in Q , which contain x , have already been integrated in P , as will be evident if we remember how partial differentiation is effected, it remains only to integrate the terms in Q containing y alone, with respect to y .

Since $Q = 3y^2 - 2ax$, the integration of the term $3y^2$, containing only y , gives y^3 .

Adding this to the partial integral already found in z_p , the total integral becomes,

$$z = x^3 - 3axy + y^3.$$

Hence to integrate an expression of the form $P dx + Q dy$, integrate P with respect to x , then integrate the terms in Q not containing x , and add the results.

DEFINITE MULTIPLE INTEGRALS.

ART. 103. Evidently the conception of multiple integral may include definite integration, where the limits of integration are determined for each variable separately.

$$\text{For example : } \int_0^r \int_0^{\sqrt{r^2-x^2}} (x^2 + y^2) dx dy$$

means that the definite integral of this expression is taken for y (x remaining constant) between the limits 0 and $\sqrt{r^2-x^2}$, then the integral of this result with respect to x , between 0 and r .

We integrate first for the outside differential.

Thus,

$$\int_0^r \int_0^{\sqrt{r^2-x^2}} (x^2 + y^2) dx dy = \int_0^r \left(x^2y + \frac{y^3}{3} \right)_0^{\sqrt{r^2-x^2}} dx$$

$$\begin{aligned}
 &= \int_0^r \sqrt{r^2 - x^2} \left(\frac{r^2 + 2x^2}{3} \right) dx = \frac{r^2}{3} \int_0^r \sqrt{r^2 - x^2} dx + \\
 &\frac{2}{3} \int_0^r x^2 \sqrt{r^2 - x^2} dx \\
 &= \int_0^r \left[\frac{r^2 x}{6} \sqrt{r^2 - x^2} + \frac{r^4}{6} \sin^{-1} \frac{x}{r} + \frac{x}{12} (2x^2 - r^2) \sqrt{r^2 - x^2} \right. \\
 &\quad \left. + \frac{r^4}{12} \sin^{-1} \frac{x}{r} \right] = \frac{\pi r^4}{8}.
 \end{aligned}$$

AREAS AND MOMENTS OF INERTIA.

ART. 104. The determination of areas comes readily under the process of double integration. Take the circle (Fig. 30) for example. Divide the circle up into minute

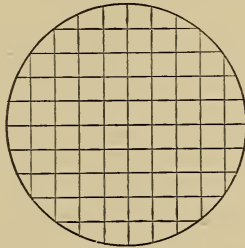

Fig. 30.

squares, by lines drawn parallel respectively to the x -axis and the y -axis, and let those parallel to the y -axis be at a distance Δx apart; those parallel to the x -axis, Δy apart. Then the area of each square is $\Delta x \cdot \Delta y$. The sum of all these squares will be less than the area of the circle by the minute spaces bounded by the sides of the extreme squares and the circumference. But as Δx and Δy approach 0, these spaces also approach 0, and eventually the sum of the squares represents the actual area of the circle, that is,

when $\Delta x \cdot \Delta y$ becomes $dx \cdot dy$. We have learned that definite integration is a summation, hence if we integrate along a line parallel to the x -axis, that is for y , we get a strip parallel to the x -axis, and then integrating parallel to the y -axis, that is for x , we sum these strips and hence we get the circle area. Since we must take limits for y , that will apply to any strip, these limits or rather one of them will be variable, and should be a function of x .

Taking the origin at the centre, the circle equation is

$$y^2 = r^2 - x^2,$$

whence

$$y = \sqrt{r^2 - x^2}.$$

Since the value of y represents any point on the circle, it will represent the distance of any strip from the x -axis, hence starting with the y -axis and integrating to the right along a parallel to the x -axis, the lower limit 0 is the same for all strips (the starting point always being at the y -axis) and the upper limit for any one will then be $\sqrt{r^2 - x^2}$ (the outer end of the strip).

Then these strips are integrated parallel to the y -axis, from the x -axis, to the extreme distance of the last one from the x -axis, that is, r .

We express all this,

$$\begin{aligned} \int_0^r \int_0^{\sqrt{r^2-x^2}} dx dy &= \int_0^r \left[y \right]_0^{\sqrt{r^2-x^2}} dx \\ &= \int_0^r \sqrt{r^2-x^2} dx = \int_0^r \left[\frac{x}{2} \sqrt{r^2-x^2} + \frac{r^2}{2} \sin^{-1} \frac{x}{r} \right] \\ &= \frac{\pi r^2}{4}, \text{ the area of a quadrant.} \\ \frac{\pi r^2}{4} \times 4 &= \pi r^2, \text{ the area of the circle.} \end{aligned}$$

MOMENTS OF INERTIA.

ART. 105. The moment of inertia of a plane area about a given point in its plane is defined in mechanics, as the sum of the products of the area of each infinitesimal portion by the square of its distance from the point.

Taking the point as origin and laying out the strips parallel to the axes, taking the axes in a position most convenient for laying out the strips, we have by Analytic Geometry, that the distance of any point (x, y) from the point (origin) is

$$\sqrt{x^2 + y^2}.$$

Also by the last article the area of any infinitesimal square is $dx dy$.

Since an infinitesimal square is practically a point, we have then the moment of inertia of any square is

$$(x^2 + y^2) dx dy.$$

Integrating this parallel to the x -axis with proper limits, determined as in the last article, and then parallel to the y -axis with limits indicating the extreme of area, we have the required sum. Calling the moment of inertia, I ; the limits for y -integration, $(0, a)$ [where a is a function of x]; those for x -integration, $(0, b)$, the result is expressed,

$$I = \int_0^b \int_0^a (x^2 + y^2) dx dy.$$

This was illustrated in Art. 100. The same process may be used in polar co-ordinates by taking radial strips, instead of rectangular ones.

EXERCISE XXI.

By double integration find the following:

1. The area between $y^3 = x$ and $x^3 = y$.
2. The area between $y^2 = 8x$ and $x^2 = 8y$.
3. The area between $y^2 = 6x$ and $y^2 = 10x - x^2$.
4. Find the segment of the circle $x^2 + y^2 = 16$ cut off by the line $y - x = 4$.
5. Find the area between $y^2 = 2px$ and the line $y = 2x$.
6. Find the moment of inertia about the origin of the circle $(x - 1)^2 + (y - 2)^2 = 9$.
7. Find the moment of inertia of a right triangle, about the origin, legs of length 6 in. and 8 in. respectively forming the axes.
8. Find the moment of inertia of the area in Ex. 5.
9. Find the moment of inertia of the segment in Ex. 4.

The Van Nostrand

Series of

Text Books

12 mo, Half Leather Illustrated

241 Pages Price \$1.25 Net

Schmall & Shack

"Plane Geometry"

330 Pages Price \$1.75 Net

Schmall, C. R.

"FIRST COURSE

IN

Analytical Geometry"

290 Pages Price \$1.75 Net

Cain, Wm. (Prof.)

University of North Carolina

"BRIEF COURSE

IN THE

Calculus"

307 Pages, Price \$1.75

Edward A. Bowser, L.L.D.

Rutgers College

ELEMENTARY TREATISES

ON

"Analytical Geometry"

(Embracing Plane Geometry)

451 Pages

Price \$2.25

**“DIFFERENTIAL AND INTEGRAL
Calculus”**

511 Pages

Price \$3.00

“Analytic Mechanics”

(Seventeenth Edition)

298 Pages

Price \$2.50

“Hydromechanics”

(Fifth Edition)

627 Pages

Price \$2.00

“Practical Mathematics”

Revised by

C. G. Knott, D. Sc., F.R.S.E.

and

J. S. Mackay, M.A., L.L.D.

12mo Cloth, 100 Pages

Price \$1.25 Net

C. G. Gunther, (Prof.)

**“INTEGRATION by TRIGNOMETRIC
and**

Imaginary Substitution”

(Introduction by J. Burkitt Webb, Prof.)

Stevens Institute.

OTHER VOLUMES IN PREPARATION

D. Van Nostrand Company

Publishers and Booksellers

23 Murray and 27 Warren Sts.,

New York

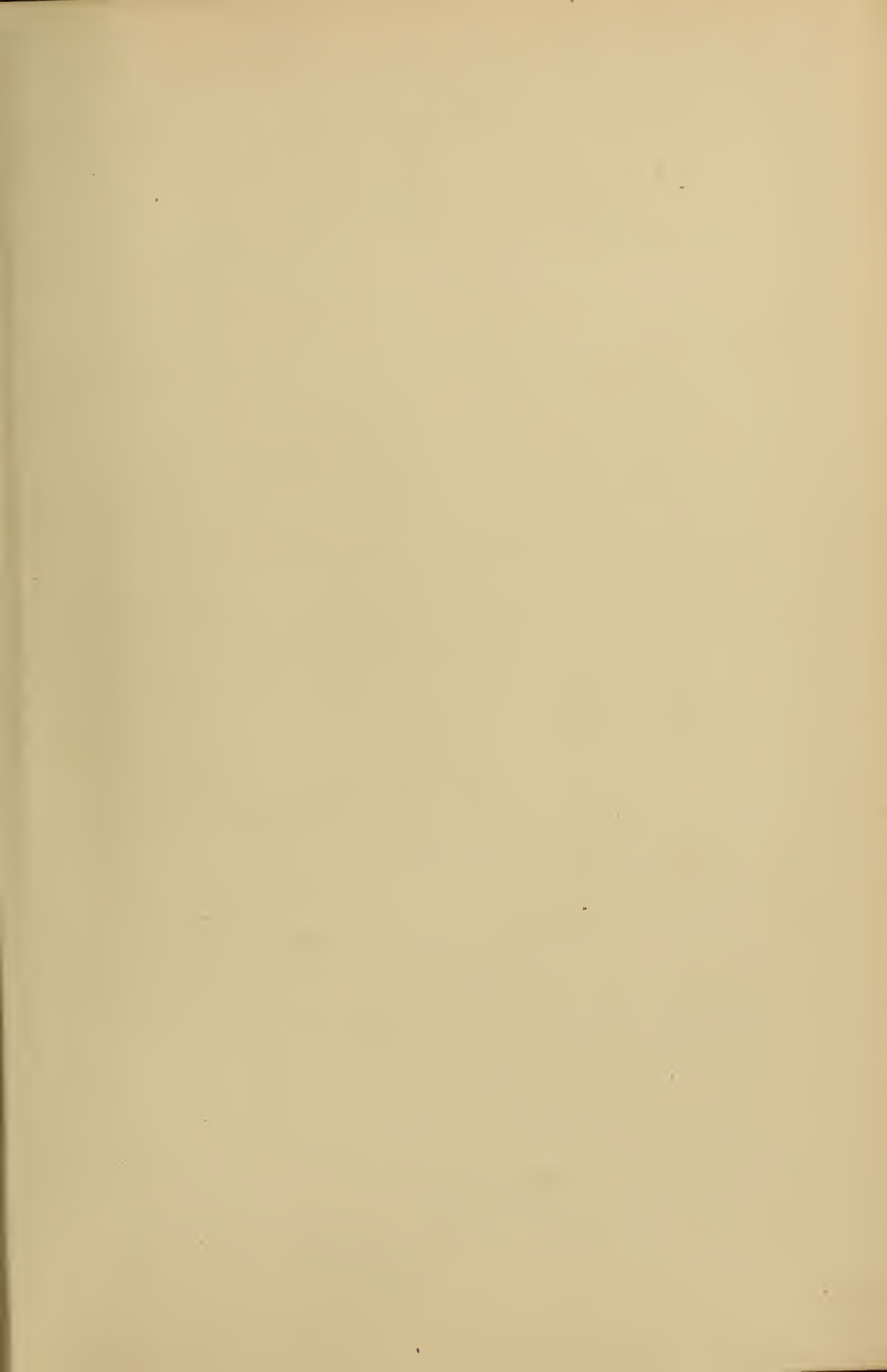

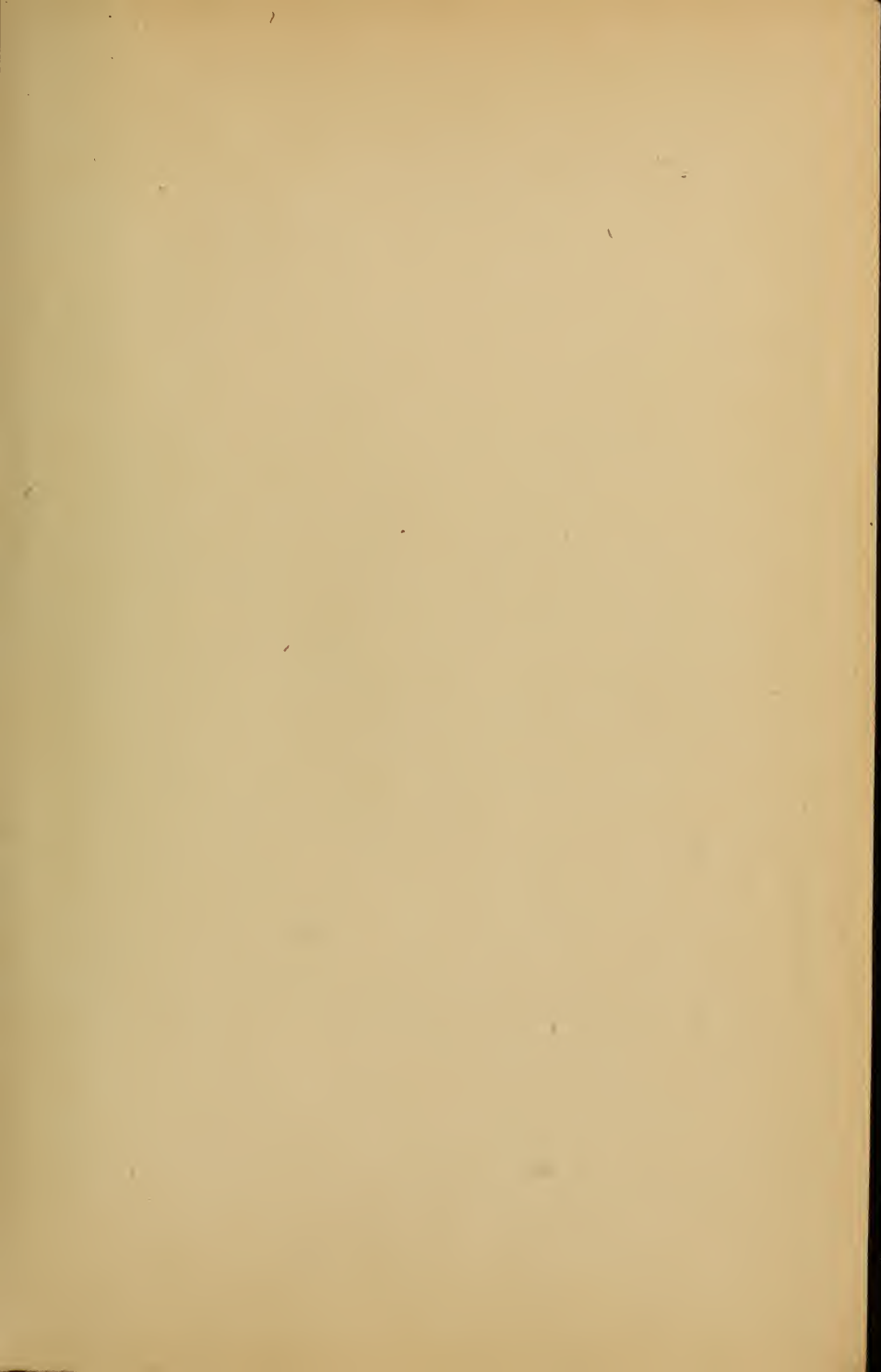

NOV 21 1907

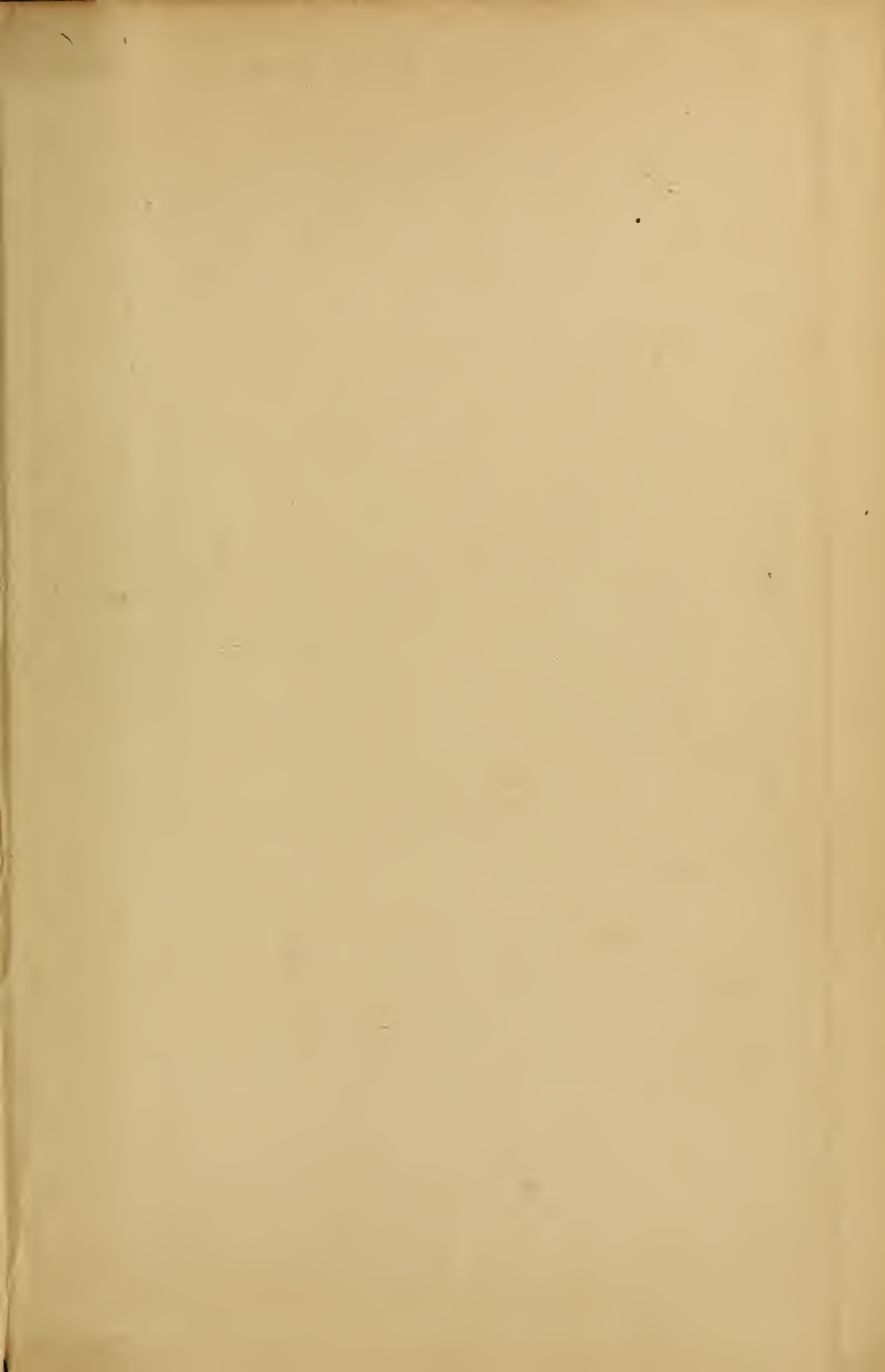

LIBRARY OF CONGRESS



0 005 595 421 5