

FIFTH YEAR

1893.

Academy Architecture.

In Course of Publication. To be Completed in Six Parts.
Parts One to Five Now Ready.

Price of the Complete Work to Subscribers, £6 6 0 nett until July 31,
1893, after which date it will be raised to £7 7 0 nett.

The complete Work will contain One Hundred and Forty-five Plates, of which One Hundred and Seventeen are reproduced from Photographs specially taken for the Work, and Twenty-eight are from Drawings by the Authors. With Letterpress, illustrated by numerous Sketches. The Size of the Plates is 14 in. by 10 in., on Fine Paper, 19 in. by 14 in.

ARCHITECTURE

OF THE

RENAISSANCE

IN ENGLAND:

ILLUSTRATED BY A SERIES OF VIEWS AND DETAILS FROM BUILDINGS ERECTED
BETWEEN THE YEARS 1560—1630, WITH HISTORICAL AND CRITICAL TEXT;

BY

J. ALFRED GOTCH, F.S.A., F.R.I.B.A.,

AUTHOR OF "A COMPLETE ACCOUNT OF THE BUILDINGS OF SIR THOMAS TRESHAM."

ASSISTED BY

W. TALBOT BROWN, A.R.I.B.A.,

"The plates are very attractive, and should be full of instruction for professional students of architecture, as well as for all admirers of an art in which modern England has so much to learn from the past."—*The Times*.

"The reproductions are very good and represent the details of the buildings with great sharpness, as well as the texture of the stores and the incidents of light and shadow."—*The Builder*.

"For the general design and execution of the part before us we have nothing but praise. Within the limits which the authors have assigned to themselves we know of nothing to compare with it."—*The Daily News*.

"The first part well realises the promises with which it was announced. . . . The photographs were all specially taken for this fine work, and the plates in the first part are all well executed."—*The Building News*.

"A book the publication of which will certainly rank as one of the chief events of the architectural year."
—*The Artist*.

"The book is admirably produced, and leaves little to be desired in respect of choice paper, type, and quality of printing, both of plates and letterpress. . . . The photographic work is very good in expressing the detail with clearness and precision."—*The British Architect*.

Full Prospectus and Order Form on applica

B. T. BATSFORD, 94 HIGH HOLBORN



Digitized by the Internet Archive
in 2016



THE J. PAUL GETTY MUSEUM LIBRARY

HEATING APPARATUS

Telegrams—"HEAT, Stourbridge."

MEDALS—1875 and 1881.

SPECIALY ADAPTED FOR
**CHURCHES,
SCHOOLS,
HOSPITALS,
LIBRARIES,
PUBLIC HALLS,**
CATALOGUES FREE.

PATRONISED BY
**H.M. GOVERNMENT,
H.M. COMMISSIONERS OF PRISONS,
H.M. POST OFFICE AUTHORITIES,
LONDON SCHOOL BOARD,** and other Public
Bodies throughout the Country.

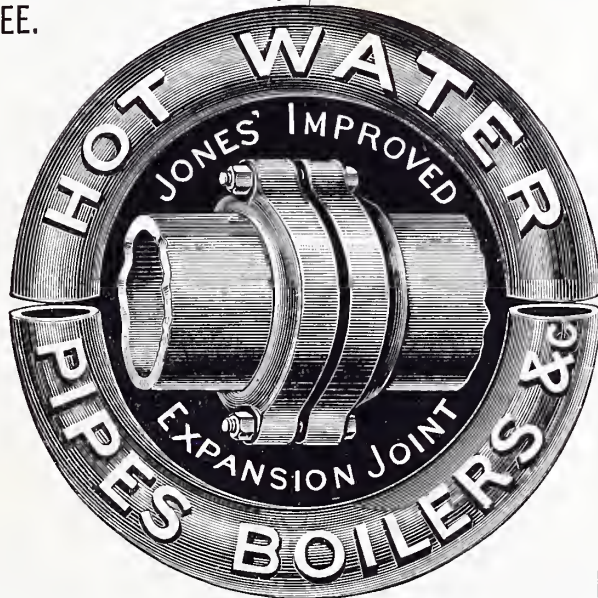

ESTIMATES FREE.

W. JONES' Treatise,
"Heating by Hot Water,"
120 Pages and 50 Engravings.
BOUND IN CLOTH. PRICE 2s.

**MANSIONS,
HOTELS,
BILLIARD ROOMS,
OFFICES,
FACTORIES,**
&c., &c.

Estimates for Warming every description of Building, either by High Pressure, Low Pressure, or Steam. Success guaranteed.

JONES & ATTWOOD.

Engineers and Ironfounders, STOURBRIDGE.

BOYLE'S PATENT Latest Improved Self-acting Air Pump Ventilator.

FIFTY PER CENT. REDUCTION IN PRICE.

THE MOST
POWERFUL EXHAUST
AND
CHEAPEST
VENTILATOR
IN THE MARKET.

**Impervious to wet and
down draught.**

Strongly made
of the Best Steel,
Galvanized, and
Finest Work-
manship.

CAUTION
TO ARCHITECTS.
Fraudulent Substitution.

Having received complaints alleging the failure in certain cases of the Air-Pump Ventilator, upon examination being made it was found in every instance that the contractor had substituted, to secure a greater profit to himself, a cheap and inferior Ventilator resembling, in outward appearance, the Air-Pump Ventilator which had been specified to be used.

It is respectfully requested that, in specifying the Ventilator, the words "BOYLE'S LATEST IMPROVED PATENT AIR PUMP VENTILATOR" be used.

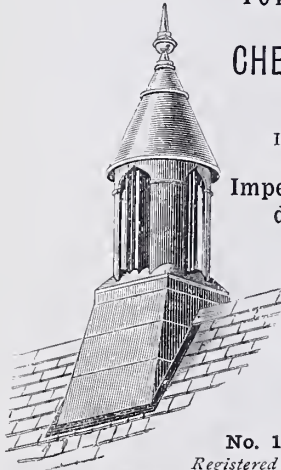

No. 1.
Registered Design.

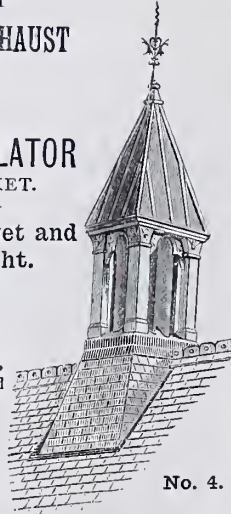

No. 4.

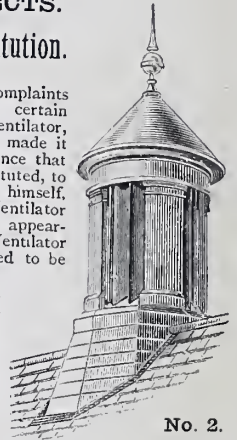

No. 2.

BOYLE'S Latest Improved Air Inlet Brackets and Wall Panels, From 10s. each.

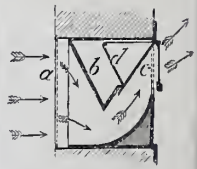
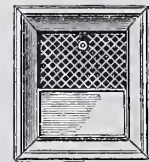
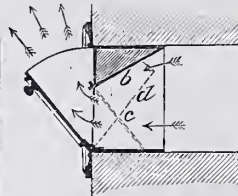
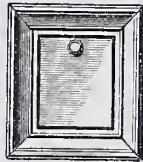
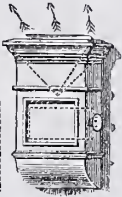
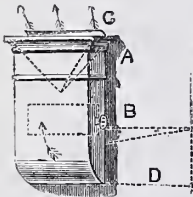

BRACKET. No. 1A. BRACKET. No. 2A. PANEL. No. 2B.

SECTION. No. 2B.

PANEL. No. 2C.

SECTION. No. 2C.

N.B.—All the above Appliances and none are genuine unless they bear our Registered Title and Trade Mark, any Infringement Two Years'



are Manufactured solely by us, bear our Registered Title and of which involves a penalty of Imprisonment.

ROBERT BOYLE & SON, Ltd., Ventilating Engineers,
64 Holborn Viaduct, London, and 110 Bothwell Street, Glasgow.

CATALOGUES, PRICE LISTS, &c., SENT POST FREE ON APPLICATION

ACADEMY ARCHITECTURE

AND

Annual Architectural Review,

1893.

EDITED BY

ALEX. KOCH, Architect,

Membre Honoraire de la Société des Peintres et Sculpteurs Suisse, Expert et Membre du Jury à l'Exposition Nationale Suisse, &c.

CONTAINING

- I.—A Selection of the most prominent Architectural Drawings hung at the Exhibitions of the Royal Academy, London, the Royal Scottish Academy, Edinburgh, and the Glasgow Institute of the Fine Arts, Glasgow.
- II.—A Review of interesting Architectural subjects carried out or designed during the last few years in England and Abroad.

BY SPECIAL PERMISSION.

Copyright in every case strictly reserved.

NA
1
-11
v. 5

PUBLISHED AT "ACADEMY ARCHITECTURE,"

58 THEOBALDS ROAD, LONDON, W.C.

LONDON—SIMPKIN, MARSHALL, HAMILTON, KENT,
AND CO., LIMITED.

LEIPZIG—L. FERNAU.

ZURICH—CAESAR SCHMIDT.

PARIS—ANDRÉ DALY FILS & Cie., 51 Rue des Écoles.

BRUSSELS—E. LYON-CLAESEN, 3 Rue Berckmans.

ROME—MODES & MENDEL, 146 Corso.

MADRID—LIBRERIA NACIONAL Y EXTRANJERA, 59
Jacometrezo.

STOCKHOLM—GUSTAF CHELIUS, Hamngatan, 33.

CHRISTIANIA—CAMMERMEYERS BOGHANDEL, Car
Johansgade, 41 & 43.

ST. PETERSBURG—F. v. SZCZEPANSKI, Kasanskaja,
8-10.

ATHENS—CARL BECK.

CONSTANTINOPLE—OTTO KEIL, 457 Grand' rue de
Péra.

MELBOURNE, SYDNEY & ADELAIDE—GEORGE ROBERTSON & Co.

NEW YORK—CHARLES SCRIBNER'S SONS, 745 Broadway; H. JACOBI, 53 Seventh Street.

THE ART METAL WORKS
 STANHOPE ST
 EVSTON R^D NW

ROGER DAWSON, LIMITED



Electric
 Light
 Installations
 Carried out
 in all parts
 of the world.
 Estimates on
 application

Special
 attention
 given to
 Design
 & Execution
 of Wrought
 Iron ~
 Work.

Neckliers
 Pendants
 Brackets
 & Lantems
 & All fittings
 in Brass
 Silver, Copper
 or Wrought Iron.

Gates Grilles
 Railings
 Stair Panels
 Balconies
 Signs Vanes
 & all kinds of
 outside Wrought
 Iron Work.

SHOWROOM & OFFICES 153 BERNERS ST W

ACADEMY ARCHITECTURE

Will be published annually in May.
Parait toutes les années le mois de Mai.
Erscheint jedes Jahr im Monat Mai.

1893. — LIST OF CONTENTS — 1893.

<p>ADAMS, Maurice B., F.R.I.B.A., Kirkcote, Bedford Park, Chiswick, w. New Pulpit and Choir Stalls, St. Michael's Church, Bedford Park, w. 1539.</p> <p>AITCHISON, Professor George, A.R.A., 150 Harley Street, w. A Smoking Room in a London Mansion. 1648.</p> <p>ANDERSON, R. Rowand, LL.D., 16 Rutland Square, Edinburgh. St. Vitean's Church, Arbroath, Exterior and Interior views. 856</p> <p>ANDERSON, W. J., 136 Wellington Street, Glasgow. Drawing of Chimney-piece. 812</p> <p>ANDRÉ, Gd., Architect, 82 Avenue de Saxe, Lyons. Casino d'Evian, projet</p> <p>BARLOW, J. B., Architect, Lyndhurst Chambers, 84 Elizabeth Street, Sydney, N.S.W. Residence, Elizabeth Bay, Sydney Residence at Pott's Point, Sydney</p> <p>BASILE, Professor Comm. Ernesto, Architect, Palermo. Exhibition Building at Palermo, Principal Entrance</p> <p>BESTON & BURMESTER, 30 Lincoln's Inn Fields, w.c. The Bury, King's Walden, Herts. 1595 King's Walden, Herts, New Stabling. 1596 Hurstbourne, Hants, Principal Entrance. 1597 View from the South-east, 1598.</p> <p>BELCHER, John, F.R.I.B.A., 20 Hanover Square, w. Council Chamber and Library, Institute of Chartered Accountants. 1513</p> <p>BINYON, Brightwen, A.R.I.B.A., Princes St. Chambers, Ipswich. Public Library, Colchester. 1572.</p> <p>BLANC, Hippolyte J., A.R.S.A., 73 George Street, Edinburgh. St. Matthew's Church, Morningside, Edinburgh. 1599.</p> <p>Troon Parish Church. 346 All Souls' Chapel, Invergownie, N.B.</p> <p>New Free Church, Morningside, Edinburgh. 502</p> <p>BOBERG, Ferdinand, Architect, Stockholm. Fire Station, Gefle, Sweden</p> <p>BOESCH, A., Sculptor, Zürich. Brackets, New Public School, Zürich</p> <p>BRIGGS, R. A., F.R.I.B.A., 2 Devonshire Square, Bishopsgate, E.C. House at Northwood</p> <p>BRIOHT, W. Frank, 9 Dartmouth Terrace, Forest Hill, S.E. A Sketch for a Bungalow Sketch for Farm Buildings</p> <p>BROOKE, John, A.R.I.B.A., 18 Exchange Street, Manchester. Edinscourt, Disley, Cheshire. 1592. New Entrance Gateway and Lodge, Welbeck Abbey. 1497.</p> <p>BROWNE, G. Washington, A.R.S.A., 1 Albyn Place, Edinburgh. Royal Hospital for Sick Children, Edinburgh, Design for Billbank Site. 499. New Premises, Prince's Street, Edinburgh, for Messrs. Redfern. 774</p> <p>BURNET, John, Son, & CAMPBELL, 167 St. Vincent Street, Glasgow Glasgow Athenæum, Elevation to Buchanan Street. 1555.</p> <p>BURNIE, David B., 10 North St. David Street, Edinburgh. New Free Church, Moffat. 854.</p> <p>CAMERON, R. Macfarlane, 24 George Street, Edinburgh. Design for New Free Church, Falkirk. 496 First premiated Design, Alloa Public School. 355 First Award and Accepted Design for Kirkecaldy Public School. 497</p> <p>CARÖE, William D., M.A., 35 New Bond Street, w. New Church, Huyton. 1614</p> <p>Interior. Music Room, Highlands, Putney Heath. 1612</p> <p>CAPPER, S. Henbest, M.A., 21 St. Andrew Square, Edinburgh. University Hall Extension, Castle Hill, Edinburgh. 504</p> <p>CHESTON & PERKIN, 5 Union Court, Old Broad Street, E.C. Oxford Municipal Buildings, One of the five premiated designs. 1587 Oxford Municipal Buildings, Drawing submitted in second competition</p> <p>CLARKE & BELL, 212 St. Vincent Street, Glasgow. Sabbath School Home, Orphan Homes of Scotland. 847</p>	<p>CLARKE, John, F.R.I.B.A., 19 Castle Street, Liverpool. A Cheshire House, Side View " " " " Grand Front. 1574</p> <p>CLASON, J. G., Architect, Stockholm. Kronovall, Sweden, for Count C. G. Sparre</p> <p>CLIFFORD, H. E., 193 St. Vincent Street, Glasgow. Redcliff; Troon. 785 Design for School. 792</p> <p>COLCUTT, Thomas E., F.R.I.B.A., 36 Bloomsbury Square, w.o. Staircase, The Imperial Institute. 1586</p> <p>COOPER, C. J. Harold, 58 Theobalds Road, w.c. Soham House, Newmarket, for Wallace M. Johnstone, Esq. COX, Alfred & COOKSEY, 19 Craven Street, Strand, w.c. House at Tonbridge Wells, for Thomas Buss, Esq. 1563</p> <p>D'ARONCO, R., Architect, Messina. Commemorative Monument at Dogali Facade of New Theatre at Tolmezzo, Italy. Competitive Design for New Bridge over the Neva at St. Petersburg. Altar-piece for the Church of St. Joseph, Coni, Italy.</p> <p>D'OENCH & SIMON, Architects, 289 Fourth Avenue, New York. House for Dr. Herman Kuapp.</p> <p>DOUGLAS, CAMPBELL, & MORRISON, 266 St. Vincent Street, Glasgow. The Cowan Institute, Penicuik. 825</p> <p>DOUGLAS & FORDHAM, 6 Abbey Square, Chester. "Glangwina," Carnarvon. 1579. 1580. "Brocksford," near Sudbury, Derbyshire.</p> <p>DZN, J. Verheul, Architect, Rotterdam. Hotel Cafe Restaurant to be built at Rotterdam. Pulpit in Church at Apeldoorn.</p> <p>EDIS, Robert W., F.S.A., 14 Fitzroy Square, w. New Entrance Gates and Lodge, Eaton Hall. 1563</p> <p>EMERSON W., F.R.I.B.A., 8 The Sanctuary, Westminster, s.w. West Front of the Cathedral for the New Lucknow Diocese, India. 1644 Competition Design for South Kensington Museum. 1618</p> <p>EYRE, Wilson Jun., Architect, Philadelphia, U.S.A. House at Pelham Manor, New York.</p> <p>FRENCH, Daniel Chester, Sculptor, 125 West Eleventh Street, New York. The Angel of Death staying the hand of the Sculptor.</p> <p>GEORGE, Ernest, & PRTO, 18 Maddox Street, Regent Street, w. West Dean, Chichester, for W. D. James, Esq., The Staircase. 1545. West Dean, Chichester, for W. D. James Esq., The Hall. 1545.</p> <p>No. 7 Delahay Street, Westminster, S.W. 1544. Villa for His Highness The Gaekwar of Baroda. 1549. Motcombe, for Lord Stalbridge. 1543.</p> <p>GOLDIE, CHILD, & GOLDIE, 10 Kensington Square, w. Church of Our Most Holy Redeemer, Chelsea, Interior.</p> <p>GRIERSON, Robert, A.R.C.A., Bangor, N. Wales. North Wales Training College, Bangor.</p> <p>GROS, Jacques, Architect, Zürich. A Village Church.</p> <p>Haight, C. C., Architect, Trinity Buildings, New York. Design for a City Church.</p> <p>HAPGOOD, Edward T., Architect, 1285 Broadway, New York. House for H. B. Steadman, Esq., Hartford, Conn.</p> <p>HARRISON, William, A.R.I.B.A., 64 Cannon Street, E.C. St. Pancras Municipal Buildings, first premiated design. 1573.</p> <p>HEBLUND & RASMUSSEN, Architects, Gøthenburg. The John Ericsson Memorial, Filipstad, Sweden.</p> <p>HENMAN, W., A.R.I.B.A., 42 Cherry Street, Birmingham. The New General Hospital, Birmingham. 1578.</p> <p>HESKETH & STOKES, 110 Cheapside, E.C. The Hall, Oaklands, Godstone.</p> <p>HOLY, Gustav v., Architect, St. Petersburg. A Village School A Village Church</p> <p>HONEYMAN, John, A.R.S.A., and KEPPIE, 140 Bath Street, Glasgow. Inner Hall, Dunloe, Wemyss Bay.</p>	<p>45 45 133 82 83 77 87 134 112 112 151 42 44 59 58 46 18 23 66 73 74 131 93 61 109 109 19 31 72 76 11 84 67 70 70 22 105 61 67 39 39 78</p>
--	---	---

HUNTLY-GORDON, H., A.R.I.B.A., 123 Cannon Street, E.C. New Banking Premises, Parliament Street, s.w. 1570.....	47	RENWICK, W. W., Architect, 71 Broadway, New York. Doorway, Grace Church, New York.....	128
HUSS, George Martin, Architect, 1285 and 1287 Broadway, New York. House at New Rochelle	117	REUTER & FISCHER, Architects, Dresden. Competitive Design for St. Luke's Church, Dresden.....	142
HUTCHINS, J. Nat, Architect, 14 East 23rd Street, New York. Design for an Artist's House	115	RHIND, W. Bernie, A.R.S.A., Sculptor, St. Helen's, Cambridge Street, Edinburgh. Design for Decoration of Porch of National Portrait Gallery, Edinburgh. 770.....	81
ISRAELS, Charles H., Architect, 90 Nassau Street, New York. A Toll Bridge over a Stream.....	125	RIETH, Otto, Architect, Bulowstrasse 101, Berlin. Sketch.....	141
JONES, Victor T., 12 Albion Road, South Hampstead, N.V. A Summer Cottage for the Undercliff, Niton, Isle of Wight	116	RIMMER, Heber, 6 Abbey Square, Chester. Santiago Cathedral, Spain. West Tower from the Cloisters.....	104
JOSEPH, Delissa, F.R.I.B.A., 17 & 18 Basingball Street, E.C. Chesterfield House, Great Tower Street, E.C.	101	ROBINSON, J. Beverley, Architect, 67 Liberty Street, New York. Sketch for Shooting Box in Delaware County, N.Y.	116
JOSELYN, Edgar A., Architect, 10 Waverley Place, New York, Design for a Country House.....	117	ROWAN, W. G., 234 West George Street, Glasgow. Cathcart U.P. Church. 794	79
KENVON, George, A.R.I.B.A., 35 New Bond Street, W. Small Country House, Yorks. 1519	53	Trinity U.P. Church, Pollokshields, Glasgow.	85
KIRBY, Edmund, F.R.I.B.A., 5 Cook Street, Liverpool. St. John's Church, High Leigh, Cheshire. 1491	62	SALMON, W. Forrest, F.R.I.B.A., 197 St. Vincent Street, Glasgow. Gallowhill Mansion, Screen in Drawing Room. 797	80
KOCH, Alex., 58 Theobalds Road, W.C. Key-stone, principal entrance to New Public Schools, Zürich Design for New Board School, Gais, Switzerland	9 38 143	SCHMIDT, Professor Heinrich Freiherr von, Architect, Munich. Tower added to the Town Hall at Passau.	148
" "	93 144 145	SCHRÖTER, Professor Victor, Architect, St. Petersburg. Design for Sühn-Kirche, St. Petersburg	135
KOSSIAKOFF, W., Architect, St. Petersburg. Chapel at St. Petersburg	136	SCHWEINFURTH, J. A., Architect, Boston, Mass., U.S.A. The Bradley Memorial Chapel and a Gate Lodge Entrance to Fort Hill Cemetery, Auburn, N.Y.	130
LARROUX, Antonin, Sculptor, Paris. Arachné	95	SCOTT, J. Oldrid, F.S.A., 35 Spring Gardens, s.w. Design for Organ Front, St. Mary Abbots's, Kensington, 1505 New Organ for the Church of St. John the Baptist, Croydon	25 97
Return from hunting the Wild Boar	95	SMITH, Bernard, F.R.I.B.A., 8 Gray's Inn Square, W.C. Ingle Nook in New Billiard Room, Bungay. 1625	48
LEADBETTER, Thomas, 122 George Street, Edinburgh. Grantully Castle, Perthshire, as added to	102	SPALDING & CROSS, 15, Queen Street, Cheapside, E.C. Municipal Technical School, Manchester. 1512	43
LEIPER, William, A.R.S.A., 176 Bath Street, Glasgow. The Sun Fire and Life Insurance Offices, Glasgow. 357 ...	68	STARK, MALCOLM & BOWNTREE, 189, St. Vincent Street, Glasgow Competitive Design for Walsall Town Hall. 801	76
LILLJEKVIST, Fredt., Architect, Stockholm. Restoration of the Royal Castle of Gripsholm	132	STEVENS, John Calvin, Architect, Portland, Maine, U.S.A. House at Portland, Maine, The Hall and Dining Room..... " " " " " " View from Pine Street.....	113- 114
LOCKWOOD, T. M. & Sons, 80 Foregate Street, Chester. New Banking Premises, Chester. 1584.....	55	STOKES, Leonard, 3 Princes Street, Westminster, s.w. An Island Home, Lough Allen, Ireland. 1656	56 60
LORD, James Brown, Architect, 160 Fifth Avenue, New York. Competition Design for St. Luke's Hospital, New York ...	118	SUDDEN, W. & Son, Leek, Staffs. Woodcroft, Leek, View showing Extensions. 1483	20
MARSHALL, Henry Rutgers, Architect, 874 Broadway, New York. Residence of Rudyard Kipling, Battleboro, Vt.	124	TALOWSKI, Teodor, Architect, Krakau. A Corner House at Krakau	137
MELENDY, George E., Architect, Bennett Building, New York. House in East Orange, N. J.	120	Private House at Krakau	128
MILLER, James, 223 West George Street, Glasgow. House at Pollokshields 802.....	82	TREADWELL & MARTIN, 2 Waterloo Place, s.w. Scott's Restaurant, Coventry Street, Haymarket, s.w.	98
MITCHELL, Sydney, & WILSON, 13 Young Street, Edinburgh. Woodhall, Kircudbrightshire, for J. W. Hutchinson, Esq. 354.....	71	WARD, F. E., Donegal Place, Belfast. Millburn House, Coleraine. 1576	19
Additions to the Hawes Inn, South Queensferry. 356.....	71	WATERHOUSE, Alfred, R.A., 20 New Cavendish Street, w. New Premises for the National Provincial Bank of England, Piccadilly, W. 1498.....	12
MOUNTFORD, Edward W., F.R.I.B.A., 17 Buckingham Street, Strand, W.C. The Northampton Institute, Clerkenwell. 1524.....	14 18	WATSON, Thomas L., F.R.I.B.A., 108 West Regent Street, Glasgow. Offices of the "Evening Citizen," Glasgow. 345	69
Battersea Town Hall, east side. 1518.....	37	WEARY & KRAMER, and B. Hustace SIMONSON, Architects, Metropolitan Life Building, New York. A Composition	126
" " " " " " Principal Front. 1523.....	36	WILSON, H., 447 Oxford Street, W. Design for the Library, Welbeck Abbey, for His Grace the Duke of Portland. 1623	41
St. Olave's Grammar Schools, Southwark, S.E. 1517.....	37	Design for New Cathedral, Victoria, British Columbia. 1624 " " " " " " Interior	51 110
Sheffield Town Hall, south-west angle. 1516.....	54	" " " " " " West End of Private Chapel, Welbeck Abbey	110
NEVE, W. West, 5 Bloomsbury Square, W.C. Goddington, Chelsfield, Kent. 1536	21	WILSON, J. B., A.R.I.B.A., 112 Bath Street, Glasgow. St. Andrew's Free Church, Ayr. 783.....	75
PATERSON, A. N., M.A., 136 Wellington Street, Glasgow. Competitive Design for Glasgow Art Galleries and Museum. 787.....	86	WITHERS, Creighton, Architect, 21-24 State Street, New York. Stable for Dr. Elias J. Marsb, at Paterson, N.J.	122
PFANN, Paul, Architect, Tech. Hochschule, Munich. Sketch	146	WYLMON & LONG, 16 King William Street, Strand, W.C. Oxford Music Hall, Elevation to Oxford Street, w.	99
PRYNNE, G. H. Fellowes, F.R.I.B.A., 6 Queen Anne's Gate, Westminster, s.w. New Church, Staines, Interior looking East. 1490.	24	" " " " " " Ground Plan and Auditorium.....	100
Design for All Saints' Church, Millbrook, Cornwall.	53	YOUNG & HALL, 17 Southampton Street, Bloomsbury, W.C. New Royal Infirmary, Derby. 1575	57
All Saints' Church, West Dulwich, Interior looking East. " " " " " " East End Grouping.....	96 111	YSENDYCK, J. J. van, Hon. Corr. Member, R.I.B.A., Architect, Brussels. Château "Le Lester," Saint Leonard, Brecht	139
REGL, Professor, Sculptor, Zürich. Key-stone, principal entrance to New Public Schools, Zürich.....	9	RENWICK, ASPINWALL, & RENWICK, Architects, 71 Broadway, New York. Competitive Design for a Church.....	127

MANUFACTURERS' AND TRADES' DIRECTORY.

(Where not otherwise stated, the address is London.)

LONDON ist der adresse beizufügen wo bloss die Buchstaben des Postdistrikts angegeben sind.

LONDRES est à ajouter à l'adresse dans tous les cas où seulement les lettres du district postal sont données.

* Advertiser in this Volume.

ART METAL WORK:—

*Bostwick Gate and Shutter Co., Ltd., Baldwin's Gardens, Gray's Inn Road, E.C.
Brawn & Co., 64 Clement Street, Birmingham.
*Dawson, Roger, Ltd., 53 Berners Street, W.
Evered & Co., Ltd., Drury Lane, London; and Surrey Works, Smethwick.
Hamilton, A. G., Westminster Works, Doris Street, Kennington Road, S.E.
Jones, John, Walker's Croft, Victoria Station, Manchester.
Jones & Willis, 79 Edmund Street, Birmingham; and 43 Great Russell Street, London.
Longden & Co., 447 Oxford Street, W., and Phoenix Foundry, Sheffield.

ASH CLOSETS:—

Parker, W. F., Worcester Place Works, Oxford.

BARROWS (of all kinds):—

Sessions & Sons, Docks, Gloucester.

BLINDS (WINDOW, &c.):—

Haskins, Saml. & Bros., 22 and 24 Old Street, E.C.
Hodkinson & Co., Ltd., Small Heath, Birmingham.
Lowther, R. & Co., 40 South Lambeth Road, Vauxhall, S.W.

BRICKS:—

Aylesford Pottery Co., Aylesford, near Maidstone, Kent; and 150 York Road, Lambeth, S.E.
Barham Brothers, Brick and Tile Works, Bridgewater.
Bracknell Pottery, Brick, and Tile Co., Wick Hill, Bracknell, Berks.
Cliff, J. & Sons, Baltic Wharf, Waterloo Bridge, S.E.; and 2 and 4 Wharfs, G.N. Goods Station, King's Cross, N.
Dunton Green Brick & Tile Works, Limited, Dunton Green, near Sevenoaks.
Eastwood & Co., Ltd., Belvedere Road, Lambeth, S.E.
Ellis, Partridge & Co., Grey Friars, Leicester; and 200 Phoenix Street, St. Pancras, N.W.
Gibbs & Canning, Tamworth.
Hall, John & Co., Fire-clay Works, Stourbridge.
Hamblet, J., West Bromwich, Staffordshire.
Hartshill Brick and Tile Co., Stoke-upon-Trent.
Sessions & Sons, Docks, Gloucester.
Skey, G. & Co., Ltd., Wilnecote Works, near Tamworth.
Stanley Bros., Nuneaton.
Trotter, Haines & Corbett, Stourbridge.

BRICK ORNAMENT:—

*Brown, James, Essex Wharf, Durward Street, Whitechapel, E.
Ellis, Partridge & Co., Grey Friars, Leicester; and 200 Phoenix Street, St. Pancras, N.W.

BUILDERS' IRONMONGERY.

Sessions & Sons, Docks, Gloucester.
Young & Co., Victoria Works, Wolverhampton; and Gray's Inn Chambers, 20 Holborn, W.C.
CARVING, WOOD AND STONE:—
Daymond, John & Son, 7, Edward Street, Vauxhall Bridge Road, S.W.
Farmer & Brindley, 63 Westminster Bridge Road, S.E.
Hitch, N., 60 Harleyford Road, Vauxhall, S.E.
Jones & Willis, 79 Edmund Street, Birmingham; and 43 Great Russell Street, W.C.
Millson, J. J., 24 City Road, Manchester.

Turpin's Parquet Floor, Joinery, and Wood Carving Co., Ltd., 22 Queen's Road, Bayswater, W.

CEMENT:—

Barham Brothers, Bridgewater.
Brotherton & Co., Commercial Buildings, Leeds.
Cliff, J. & Sons, Baltic Wharf, Waterloo Bridge, S.E.; and 2 and 4 Wharfs, G. N. Goods Station, King's Cross, N.
Ellis, J. & Sons, 8 Market Street, Leicester.
Francis & Co., Ltd., Bridge Foot, Vauxhall, S.W.
Greaves, Bull, & Lakin, Warwick.
Nelson, C. & Co., Ltd., 16 South Wharf, Paddington, W.
Peters Bros., 2 Victoria Mansions, Westminster, S.W.
Rugby Portland Cement Co., Rugby, Warwickshire.
Sessions & Sons, Docks, Gloucester.

CHIMNEY COWLS:—

*Barton & Ballard, 151 Oxford Street, W.
*Boyle, R. & Son, Ltd., 64 Holborn Viaduct, E.C.
Fryer, J. D. & W., Brecon, South Wales.
Sutcliffe, Wright, & Son, Globe Sanitary Works, Halifax.

COOKING APPARATUS:—

Killick & Cochran, Seel Street, Liverpool.
Longden & Co., 447 Oxford Street, W., and Phoenix Foundry, Sheffield.
Yates, Haywood & Co., 95 Upper Thames Street, E.C.; and Effingham Works, Rotherham.

DAMP PROOF COURSES:—

Briggs, W., Chemical Manufacturer, Dundee.
Jennings, G., Lambeth Palace Road, S.E.
White, W., Abergavenny.

DECORATING, &c.:—

Cotterell Bros., 11 Clare St., 8 Baldwin St., and 2 and 6 Marsh St., Bristol.
Mellier, Ch. & Co., 48, 49, 50 Margaret Street, Cavendish Square, W.
Pitman & Son, 30 Newgate Street, E.C.

DOOR SPRINGS AND HINGES:—

*Adams, R., 67 Newington Causeway, S.E.
Newman, William & Sons, Hospital Street, Birmingham.
Smith & Stevens, Janus Works, Queen's Road, Battersea, S.W.
*Verity, E. & J. M., Call Lane, Leeds.

DRAIN TESTS:—

Pain, J. & Sons, 9 St. Mary Axe, E.C.

EARTH CLOSETS:—

Parker, W. F., Worcester Place Works, Oxford.

ELECTRICITY:—

Brush Electrical Engineering Co., Ltd., Belvedere Road, Lambeth, S.E.
*Dawson, Roger, Ltd., 53 Berners Street, W.
Drake & Gorham, 66 Victoria Street, Westminster, S.W.
Edison, Swan, Co., Ltd., 14 St. Ann's Square, Manchester.
Henney, Geo. F., 156 Sloane Street, S.W.
Holmes, J. H. & Co., Portland Road, Newcastle-on-Tyne.
Laing, Wharton, & Down, 82a New Bond Street, W.
Lawrence, Scott, & Co., Ltd., Gothic Works, Norwich.
*Middleton, V. G., 3 Princes Mansions, Victoria Street, S.W.

South, Harry, 10 & 12 Garrick Street, Covent Garden, W.C.

ELECTRIC FITTING MANUFACTURERS:—

Brawn & Co., 64 Clement Street, Birmingham.
ENGINES (GAS):—
Manlove, Alliot & Co., Ltd., Blooms Grove Works, Nottingham.
Robey & Co., Globe Works, Lincoln.

FANLIGHT OPENERS:—

*Adams, R., 67, Newington Causeway, S.E.
Hill, J., 100a Queen Victoria Street, E.C.
*Verity, E. & J. M., Call Lane, Leeds.

FIREPROOF FLOORING:—

Dennett & Ingle, 5 Whitehall, S.W.
Fawcett, Mark, & Co., 50 Queen Anne's Gate, Westminster, S.W.
Homan & Rodgers, 17 Gracechurch Street, E.C.
Lindsay, W. & Co., 23 Queen Anne's Gate, Westminster, S.W.

Wilkinson, W. B. & Co., 15 Great George Street, Westminster, S.W.

GAS FITTINGS:—

Brawn & Co., 64 Clement Street, Birmingham.

GAS GOVERNORS:—

Shaw, Joseph, Albert Works, Huddersfield.

GATES, RAILINGS (IRON), &c.:—

Bayliss, Jones & Bayliss, 139 and 141 Cannon Street, E.C., and Victoria Works, Wolverhampton.
*Bostwick Gate and Shutter Co., Ltd., Baldwin's Gardens, Gray's Inn Road, E.C.
Main, A. & J. & Co., 77a Queen Victoria Street, E.C., and Fossilpark, Glasgow.
Wragge, George, 156 Chapel Street, Salford, Manchester.
Wright, G. & Co., 155 Queen Victoria Street, E.C.

Yates, Haywood & Co., 95 Upper Thames Street, E.C., and Effingham Works, Rotherham.

GLASS (STAINED, PAINTED, &c.):—

Egan, James, 38 Broad Street, Golden Square, W.
Farmiloe, G. & Sons, 34 St. John Street, West Smithfield, E.C.
Gibbs, Alexander, 21 Bloomsbury Street, W.C.
Hemming, A. O., 47 Margaret Street, Cavendish Square, W.
Kelley & Co., 45 Tabernacle Street, Finsbury E.C.
Lazenby, Geo. & Co., Stained Glass Works, Leeds Bridge, Leeds.
Lee, John R. & Co., Ltd., Swallow Street, Birmingham.
Nicholls & Clarke, 6 High Street, Shoreditch, E.
Shrigley & Hunt, John-o'-Gaunt's Gate, Lancaster.

GLAZING:—

Braby, F. & Co., Ltd., 352 to 362 Euston Road, N.W.
Grover & Co., Ltd., Britannia Works, Wharf Road, City Road, N.
Helliwell & Co., 9 Victoria Street, S.W., and Patent Glazing Works, Beighouse, Yorks.
Mellows & Co., Corporation Street, Sheffield.
Pennycook Patent Glazing Co., 11 West Regent Street, Glasgow.
Rende, W. E. & Co., Westminster Chambers, 5 Victoria Street, S.W.
Shelly & Co., 55 Lionel St., Birmingham.

GRANITE:—

Penning & Co., 3 Salters' Hall Court, Cannon Street, E.C.
 Freeman, J. & Sons, Penryn, Cornwall.
 Macdonald, A. & Co., Ltd., 373 Euston Road, N.W.
 West of England Granite Co., Penryn, Cornwall.
 Wright, James & Sons, Royal Granite Works, Aberdeen.

HEATING:—

Attwood, J., Stourbridge.
 Boyd, Jas. & Sons, Macdowall Street, Paisley.
 Constantine, J. & Son, The Convuluted Stove Works, Stockton Street, Manchester.
 Cormack, James & Sons, 36 Abercorn Street, Glasgow.
 *De Ridder, R. P., Fairfield Street, Fairfield, Liverpool.
 Gibbs, Renton & Co., Ltd., 259-261 Mill Street, Liverpool, and Ethel Street, Birmingham.
 Haden, G. N. & Sons, Trowbridge, Wilts, and 123 Cromer Street, W.C.
 Hartley & Sugden, Ltd., Halifax.
 *Hope, H., 55 Lionel Street, Birmingham.
 Jennings, G., Lambeth Palace Road, S.E.
 *Jones & Attwood, Stourbridge.
 Killick & Cochran, Seal Street, Liverpool.
 Longden & Co., Phoenix Foundry, Sheffield.
 *Meadow Foundry Co., Ltd., Mansfield.
 Messenger & Co., Loughborough.
 Newsum, Wood & Dyson, Beeston Road, Leeds.
 Saunders, S., 93 and 95, Upper Moss Lane, Hulme, Manchester.
 Shorland, E. H., Manchester Stove Works, Erskine Street, Manchester.
 Venham Co., Ltd., Upper Ogle Street, Fitzroy Square, W.
 Wright, G. & Co., 155 Queen Victoria Street, E.C.

HORTICULTURAL BUILDINGS:—

Boyd, Jas. & Sons, Macdowall Street, Paisley.
 *Hope, H., 55 Lionel Street, Birmingham.
 Messenger & Co., Loughborough.
 Richardson, W. & Co., North of England Horticultural Works, Darlington.

JOINERY:—

Chappell, J. T., 149 Lupus Street, S.W.
 Ebner, Jos. F., 150 Old Street, St. Luke's, E.C.
 *Elliott, S., Albert Moulding Mills & Joinery Works, Newbury.
 Sage, F. & Co., 58 to 62 Gray's Inn Road, W.C.
 Sessions & Sons, Docks, Gloucester.
 Turpin's Parquet Floor, Joinery & Wood Carving Co., Ltd., 22 Queen's Road, Bayswater, W.

KITCHEN RANGES:—

Yates, Haywood & Co., 95 Upper Thames Street, E.C., and Effingham Works, Rotherham.

LAUNDRY APPLIANCES:—

Bradford, Thos. & Co., Crescent Iron Works, Salford, Manchester.
 Manlove, Elliott & Co., Ltd., Bloomsgrove Works, Nottingham.

LIFTS, ELEVATORS, HOISTS, &c.:—

Attwood, A. & Co., Canal Head Foundry & Engineering Works, Ulverston.
 Haskins, Saml. & Bros., 22 and 24 Old Street, E.C.
 Mallinson, William, Blake Street, Stretford Road, Manchester.
 *Otis Elevator Co., Ltd., 4 Queen Victoria Street, E.C.
 Richmond, Joseph & Co., 30, Kirby Street, Hatton Garden, E.C.
 Smith & Stevens, Janus Works, Queen's Road, Battersea, S.W.
 Stones, John, "Rosside," Ulverston.
 Waygood, R. & Co., Falmouth Road, Great Dover Street, S.E.
 Youngs, Ryland Street Works, Birmingham.

LIGHTNING CONDUCTORS:—
 Bailey, W. H. & Co., Albion Works, Salford, Manchester.

Blackburn, J., Gresham Works, Nottingham.
 Bowker, Wm. & Co., Spring Street, Huddersfield.

LIME, SAND, &c.:—

Barham Brothers, Bridgwater.
 Cliff, J. & Sons, Baltic Wharf, Waterloo Bridge, S.E.
 Davies, John & Co., Lliswerry, Newport, Mon.
 Aberthaw Blue Lias, Hydraulic Lime.
 Ellis, J. & Sons, 8 Market Street, Leicester.
 Greaves, Bull, & Lakin, Warwick.
 Parry, H. & Co., Kirton Lindsey, Lincolnshire.
 Peters Bros., 2 Victoria Mansions, Westminster, S.W.
 Rugby Portland Cement Co., Rugby, Warwickshire.
 Sessions & Sons, Docks, Gloucester.

LOCKS AND LATCHES:—

Boobyer, J. H. & Sons, 13 & 14 Stanhope Street, W.C.
 Hill, J., 100a Queen Victoria Street, E.C.
 Hobbs, Hart, & Co. Ltd., 76 Cheapside, E.C.
 Tann, John, 11 Newgate Street, E.C.
 *Verity, E. & J. M., Call Lane, Leeds.
 Young & Co., Victoria Works, Wolverhampton, and Gray's Inn Chambers, 20 Holborn, W.C.

MARBLE:—

Barham Brothers, Marble & Slate Works, Bridgwater.
 De Grelle Houdrett & Co., 130 London Wall, E.C.
 Enley & Sons, Ltd., Newcastle-upon-Tyne.
 Farmer & Brindley, 63 Westminster Bridge Road, S.E.
 Galbraith & Winton, 48 Kelvin Street, Glasgow.
 Goad, J. & E., Phoenix Steam Marble Works, Millbay Road, Plymouth.
 Lomas, R. G., King Street, Derby.
 Odling, Anselm & Sons, Ltd., Marble Wharf, St. Catharine's Docks, E., and Railway Yard, Victoria Road, Battersea Park, S.W.
 Sessions & Sons, Docks, Gloucester.

MARBLE CHIMNEY PIECES:—

Yates, Haywood & Co., 95 Upper Thames Street, E.C., and Effingham Works, Rotherham.

MOSAIC WORK:—

Burke & Co., 17 Newinan Street, Oxford Street, W.
 De Grelle Houdrett & Co., 130 London Wall, E.C.
 Ebner, J. F., 150 Old Street, St. Luke's, E.C.
 Salvati & Co., 213 Regent Street, W.
 Swift, George, 45 The Temple, Dale Street, Liverpool.
 Turpin's Parquet Floor, Joinery, & Wood Carving Co., Ltd., 22 Queen's Road, Bayswater, W.

ORGAN BUILDERS:—

*Gern, A., Boundary Road, Notting Hill, W.

PARQUET FLOORING:—

Arrowsmith, Arthur J. & Co., 80 New Bond Street, W.
 Bassant, H., 87 Charlotte Street, Fitzroy Square, W.
 De Grelle Houdrett & Co., 130 London Wall, E.C.
 Ebner, J. F., 150 Old Street, St. Luke's, E.C.
 Steintz, C. & Co., London Parquetry Works, 45 Grove Lane, Camberwell, S.E., by special appointment to H.R.H. Prince of Wales.
 Turpin's Parquet Floor, Joinery and Wood Carving Co. Ltd., 22 Queen's Road, Bayswater, W.

PAVEMENT LIGHTS:—

*Wilson, H. & Co., 117 Charterhouse Street, E.C.

PIPES:—

Stanley Brothers, Nunceaton.

PLASTERING (ORNAMENTAL &c.):—

Adamant Co. Ltd., 105 Colmore Row, Birmingham.
 *Battiscombe and Harris, 49 and 50 Great Marylebone Street, Portland Place, W.

Jackson, G. & Sons, 49 Rathbone Place, W.
 Plastic Decoration Co., 21 Wellington Street, Strand, W.C.

PLATE GLASS:—

De Grelle Houdrett & Co., 130 London Wall, E.C.

RAIN-WATER PIPES:—

Gregson, J., "Perfectum," Bath Street, Bolton, Lancashire.

ROOFING FELT:—

Engert & Rolfe, Ltd., Felt Works, Barchester Street, Poplar, E.

ROOFS AND BUILDINGS (IRON):—

Humphreys, Ltd., Iron Buildings Works, Knightsbridge, Hyde Park, S.W.
 Leixon, Isaac & Co., Windsor Iron Works, Edge Hill, Liverpool.
 Marshall & Hatch, Bingfield Iron Works, York Road, King's Cross, N.
 Motley & Green, St. George's Works, Great George Street, Leeds.

ROOFS, (ZINC, COPPER, AND LEAD):—

Braby, F. & Co., Ltd., 252-262 Euston Road, N.W.
 Helliwell & Co., Brighouse, Yorkshire, and 9 Victoria Street, S.W.

SAFES AND STRONG-ROOM DOORS:—

Hobbs, Hart, & Co., Ltd., 76 Cheapside, E.C.
 Tann, John, 11 Newgate Street, E.C.
 Taunton, J. & J., Belgrave Works, Sherbourne Road, Birmingham.
 Whitfield, F. & Co., Oxford Street, Birmingham.

SANITARY APPLIANCES:—

*Adams, R., 67 Newington Causeway, S.E.
 Adams & Co., 10 Little Queen Street, Westminster, S.W.
 Andrew & Nanson, Brixton Road, S.W.
 Bowes, Scott, & Western, Broadway Chambers, Westminster, S.W.
 *Boyle, R. & Son, Ltd., 64 Holborn Viaduct, E.C.
 Clark, T. & C. Co., Shakespeare Foundry, Wolverhampton.
 Duckett, J. & Son, Burnley, Lancashire.
 Farniloe, G. & Sons, 34 St. John Street, West Smithfield, E.C.
 Hughes & Lancaster, Acrefair, Ruabon, and 16 Great George Street, Westminster, S.W.
 Jennings, G., Stangate, Lambeth, S.E.
 Jones, Browning, & Co., Farnworth, Widnes, E.C.
 Pontifex & Wood, Ltd., Farringdon Works, E.C.
 Sessions, J. & Sons, Gloucester.
 Shanks & Co., Tubal Works, Barrhead, near Glasgow.
 Stiff, J. & Sons, London Pottery, Lambeth, S.E.
 Twyford, T. W., Cliffe Vale Pottery, Hanley, Staffordshire.
 *Tylor, J. & Sons, Ltd., 2 Newgate Street, E.C., and Belle Isle, York Road, N.
 Woodward & Rowley, Swadlincote, near Burton-on-Trent.
 Yates, Haywood, & Co., 95 Upper Thames Street, E.C., and Effingham Works, Rotherham.

SANITARY WARE:—

Aylesford Pottery Co., Aylesford near Maidstone, and 150 York Road, Lambeth, S.E.
 Burn & Baillie, 14 Newcastle Street, Farringdon Street, E.C.
 Cliff, J. & Sons, Baltic Wharf, Waterloo Bridge, S.E.
 Gibbs & Canning, Tamworth.
 Hartshill Brick & Tile Co., Stoke-upon-Trent.
 Jennings, G., Stangate, Lambeth, S.E.
 Knowles, J. & Co., 38 King's Road, St. Pancras, N.W.
 Sessions, J. & Sons, Gloucester.
 Shanks & Co., Tubal Works, Barrhead, near Glasgow.
 Sharpe Bros. & Co., Swadlincote Potteries, near Burton-on-Trent.
 Skey, G. & Co., Ltd., Wilnecote Works, near Tamworth.

Stanley, Bros., Nuneaton.
 Stiff, J. & Sons, Lambeth, S.E.
 Twyford, T. W., Cliffe Vale Pottery, Hanley, Staffordshire.
 Woodward & Rowley, Swadlincote, near Burton-on-Trent.

SEWAGE AND WATER SYSTEMS:—
 Hughes & Lancaster, 16 Great George Street, Westminster, S.W., and Acrefair, Ruabon.

SLATES:—
 Ashton, Green, Mathews, & Co., 61 St. Mary's Axe, E.C.
 Barham, Bros., Bridgewater.
 Carter, A. & Co., Liverpool.
 Llangollen Slab and Slate Co., Ltd., Llangollen.
 *Roberts, Adlard, & Co., 47 Eastcheap, E.C.
 Sessions, J. & Sons, Gloucester.

STABLE FITTINGS:—
 *Barton & Ballard, 151 Oxford Street, W.
 Bayliss, Jones, & Bayliss, 139 and 141 Cannon Street, E.C., and Victoria Works, Wolverhampton.
 Musgrave & Co., Ltd., Ann Street, Iron Works and Cromac Foundry, Belfast.
 Yates, Haywood & Co., 95 Upper Thames Street, E.C., and Effingham Works, Rotherham.
 Young & Co., 12 Victoria Street, Westminster, S.W.

STABLE PAVING:—
 "Adamantine Clinker," Little Bytham, Grantham.
 Stanley Brothers, Nuneaton.

STACK-PIPES, GUTTERS, &c.:—
 Gregson, J., Perfectum Depot, Bath Street, Bolton, Lancashire.

STAIRCASES, VERANDAHS, &c.:—
 Brawn & Co., 64 Clement Street, Birmingham.
 Marshall & Hatch, Bingfield Iron Works, York Road, King's Cross, N.
 Wright, G. & Co., 155 Queen Victoria Street, E.C.

STONE:—
 Bath Stone Firms, Ltd., Abbey Yard, Bath.
 Crew, J. & A., Cumberland Market, N.W.
 Ham Hill Stone Co., Norton, Stoke-under-Ham, Somerset.
 Lindley Quarries, Mansfield, Notts.
 Sessions & Sons, Docks, Gloucester.
 Thompson's Aneaster Quarries Co., Ltd., 11 Elmer Street, Grantham.
 Trask, Charles & Sons, Douling Stone Quarries, Shepton Mallet.

STONE BREAKERS:—
 Mason, S. & Co., Leicester.

STOVES, RANGES, MANTELS, &c.:—
 Barnard, Bishop, & Barnards, Ltd., Norfolk Iron Works, Norwich.
 Crosthwaite, R. W., Union Foundry, Stockton-on-Tees.
 Falkirk Iron Co., 67 Upper Thames Street, E.C., and Falkirk, N.B.
 Jennings, G., Stangate, Lambeth, S.E.
 Longden & Co., 447 Oxford Street, W., and Phoenix Foundry, Sheffield.
 Musgrave & Co., Ltd., Ann Street Iron Works, and Cromac Foundry, Belfast.
 Sessions, J. & Sons, Gloucester.
 Shorland, E. H., Manchester Stove Works, Erskine Street, Manchester.
 Steel & Garland, 18 Charterhouse Street, Holborn Circus, E.C.
 Teale Fireplace Co. (Teale and Somers), Leeds.
 Walker, W. & Sons, Bunhill Row, E.C.
 Wright, G. & Co., 155 Queen Victoria Street, E.C.
 Yates, Haywood & Co., 95 Upper Thames Street, E.C., and Effingham Works, Rotherham.

STRUCTURAL IRONWORK:—
 Dennett & Ingle, 5 Whitehall, S.W.
 Dorman, Long & Co., Ltd., Middlesbrough.
 Falkirk Iron Co., 67 Upper Thames Street, E.C., and Falkirk, N.B.

Fawcett, Mark & Co., 50 Queen Anne's Gate, Westminster.
 Henderson & Glass, Vulcan Street Iron Warehouses, Liverpool.

Ioman & Rodgers, 17 Gracechurch Street, E.C.
 Moreland, R. & Sons, 3 Old Street, E.C.
 Rowson, Drew & Co., 225 Upper Thames Street, E.C.
 Williamson, J. & Co., Midland Foundry, Wellingborough.

TANKS, CISTERNS, &c.:—
 Braby, F. & Co., Ltd., 352 to 362 Euston Road, N.W.
 London Galvanized Iron Co., 27 Wharf Road, N.
 Motley & Green, St. George's Works, Great George Street, Leeds.
 Williamson, J. & Co., Midland Foundry, Wellingborough.

TERRA-COTTA:—
 *Clark & Rea, Ltd., Wilderness Works, Wrexham.
 Cliff, J. & Sons, Baltic Wharf, Waterloo Bridge, S.E.
 Gibbs & Canning, Tamworth.
 Hamblet, J., West Bromwich, Staffordshire.
 Jennings, G., Stangate, Lambeth, S.E.
 Pulham & Son, Terra Cotta Works, Broxbourne, and 50 Finsbury Square, E.C.
 Skey, G. & Co., Ltd., Wilnecote Works, near Tamworth.
 Stanley, Bros., Nuneaton.
 Stiff, J. & Sons, London Pottery, Lambeth, S.E.

TILES:—
 Aylesford Pottery Co., Aylesford, near Maidstone, and 150 York Road, Lambeth, S.E.
 Barham Bros., Tile and Brick Works, Bridgewater.
 Bracknell Pottery Brick & Tile Co., Wick Hill, Bracknell, Berks.
 Broseley Tile Manufacturers Association, Broseley, Shropshire.
 Caddick, John, Sprucefield Tileries, Stoke-on-Trent.
 Carter & Co., Encaustic Tile Works, Poole, Dorset.

Cliff, Joseph & Sons, Baltic Wharf, Waterloo Bridge, S.E.
 Craven, Dummill & Co., Ltd., Jackfield, Ironbridge, Shropshire, and 37 Maddox St., Regent St., W.
 Dutton Green Brick & Tile Works, Limited, Dutton Green, near Sevenoaks.
 Galbraith & Winton, 48 Kelvin Street, Glasgow.
 Hamblet, J., West Bromwich, Staffordshire.
 Hartshill Brick & Tile Co., Stoke-upon-Trent.
 Major, H. J. & Co., Ltd., Patent Tile Works, Bridgewater.
 Malkin, Edge & Co., Burslem, Staffordshire.
 Maw & Co., Ltd., Benthall Works, Jackfield, Salop.
 Minton, Hollins & Co., Patent Tile Works, Stoke-upon-Trent.
 Prestage & Co., The Milburgh Tileries, Broseley, Salop.

*Roberts, Adlard & Co., 47 Eastcheap, E.C.
 Sessions & Sons, Docks, Gloucester.
 Simpson, W. B. & Sons, 100 St. Martin's Lane, W.C.
 Stanley, Bros., Nuneaton.
 Warne, C. G., Royal Pottery, Weston-Super-Mare.
 Wedgwood, J. & Sons, Etruria, Stoke-on-Trent.

TIMBER:—
 Bloore, W., 60-90 Bond Street, Vauxhall, S.W.
 Rowland, Bros., Steam Saw Mills, & Fencing Works, Fenny Stratford, Bucks.
 Sandell, H. & Sons, Crown Timber Yard, Cornwall Road, Lambeth, S.E.
 Sessions & Sons, Docks, Gloucester.
 Snewin, C. B. N., 7-17 Back Hill, Hatton Garden, and 29 Ray Street, Farringdon Road, E.C.

Stone, Charles, Saw Mills, High Wycombe.
 Tealy & Co., Garrison Side, Hull.

TURRET CLOCKS, BELLS, &c.:—
 Carr, C., Sneathwick.
 Joyce, J. B. & Co., Whitechurch.
 Potts, W. & Sons, Guildford Street, Leeds.
 Smith, John, & Sons, Midland Steam Clock Works, Derby.

VENTILATING:—
 *Adams, R., 67 Newington Causeway, S.E.
 Baxendale & Co., Miller Street, Manchester.
 *Boyle, R. & Son, Ltd., 64 Holborn Viaduct, E.C.
 Constantine, J. & Son, The Convuluted Stove Works, Stockton Street, Manchester.
 Cornack, James & Sons, 36 Abercorn Street, Glasgow.
 *De Ridder, R. P., Fairfield Street, Fairfield, Liverpool.
 Gibbs, Reinton & Co., Ltd., 259-261 Mill Street, Liverpool, and Ethel Street, Birmingham.
 Howorth, James & Co., Victoria Works, Farnworth, near Bolton.
 Kershaw, A. W. & Co., Custom House Buildings, St. George's Quay, Lancaster.
 Kite, C. & Co., Christopher Works, Charlton Street, N.W.
 Shorland, E. H., Manchester Stove Works, Erskine Street, Manchester.
 Sugg, Wm. & Co., Ltd., Vincent Works, Westminster, S.W.

WALL AND CEILING COVERINGS:—
 Anaglypta Co., 92 Great Russell Street, W.C., and Queen's Mill, Lancaster.
 Cotterell, Bros., 11 Clare Street; 2 and Marsh Street, and 8 Baldwin Street, Bristol.

Doveston, Davey, Hull, & Co., Ltd., Albert Square, Manchester.
 *Essex & Co., 116 Victoria Street, Westminster, S.W.
 Jeffrey & Co., 64 Essex Road, Islington, N.
 Lightbown Aspinall & Co., Hayfield Mills, Pendleton, Manchester.
 Pitman & Son, 30 Newgate St., E.C.
 Tynecastle Co., Edinburgh, and 14 Rathbone Place, W.
 *Walton, F. & Co., Ltd., Lincrusta Manufacturers, 2 Newman Street, W.
 *Woollaus, W. & Co., 110 High Street, near Manchester Square, W.

WEATHER BARS:—
 *Elliott, S., Albert Moulding Mills & Joinery Works, Newbury.

WINDOW FRAMES (IRON):—
 *Hope, H., 55 Lionel Street, Birmingham.
 Jones, John, Walker's Croft, Victoria Station, Manchester.
 *Verity, E. & J. M., Call Laue, Leeds.
 Wenham & Waters, Ltd., Paragou Works, Croydon.
 Wragge, George, 156 Chapel Street, Salford, Manchester.

WINDOWS (REVERSIBLE):—
 *Adams, R., 67 Newington Causeway, S.E.

WINE BINS (IRON):—
 Brookes, W. & Co., 1 Victoria Bridge, Salford, Manchester.
 *Farrow & Jackson, 16 Great Tower Street, E.C., and 8 Haymarket, S.W.

WOOD CHIMNEY-PIECES:—
 *Battiscombe and Harris, 49 and 50 Great Marylebone Street, Portland Place, W.
 Walker, W. & Sons, Bunhill Row, E.C.
 Yates, Haywood & Co., 95 Upper Thames Street, E.C., and Effingham Works, Rotherham.

WOOD FLOORING AND PAVING:—
 Acme Wood Flooring Co., Ltd., Glasshouse Street, Vauxhall, S.E.
 Ebner, Jos. F., 150 Old Street, St. Luke's, E.C.
 Lowe, Roger, L., Britannia Works, Farnworth, Bolton, near Manchester.

Perfection in Improved
Patented Specialities of the
Building Trades.



53 Highest Awards at
Competitive Exhibitions.

"Empress Victor"
Patent Pneumatic
Door Spring and
Check.—Strongest
at the closed position,
best and most reli-
able, durable and very

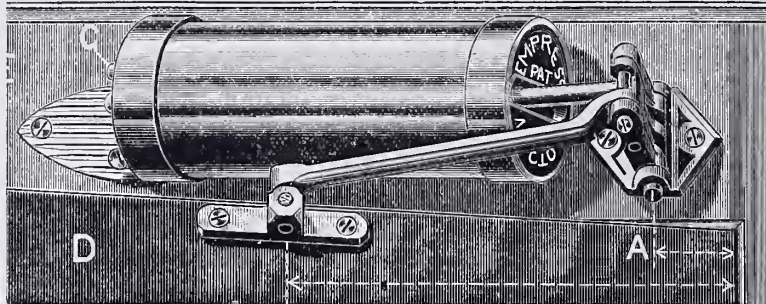

neat, can be fixed on
either side of door or
on right or left hand
side, small space only
required. Various sizes
made.

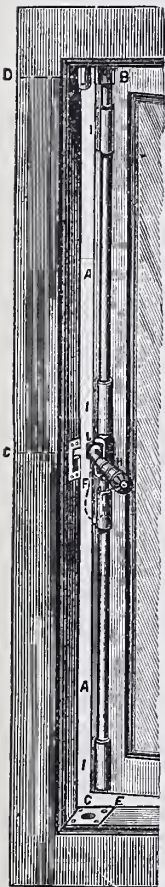

No. 208.

Thrust Motion for very
narrow stiles.



No. 190.

Weather-tight
tongue pattern.



No. 8.

Half-
round pattern.

Special Casement Bolts, triple action for casements
opening in or out, guaranteed reliable and efficient, new
actions.

Write for Lists and Terms for Patent Door Springs,
Fanlight and Lantern Light and Skylight Openers,
Ventilators (Inlets and Outlets) of every descrip-

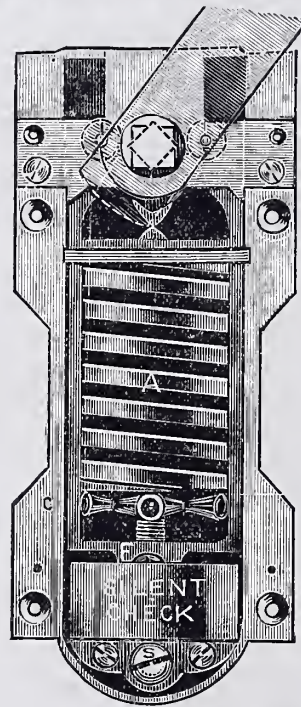

The "Crown" Pattern Floor Hinge for
Swing Doors. Made with the Silent Check
or without; also to suit single action doors
closing one way. These celebrated springs
belong to the "Victor" Class patents, in
which are embodied all recent improvements
not to be found in any other kind.

ROBERT ADAMS,

Telegrams—"Robert Adams, London."
Building Trades' Emporium,
67 Newington Causeway,
London, S. E.

Patent Ventilating Gear for Skylights, Lantern Lights, and other continuous Ranges of Sashes.—
Length no object; efficient and reliable in all cases whatever the weight. Modifications to suit all work.

ROBERT ADAMS' PATENT "UNIVERSAL" FANLIGHT OPENER, with Rod and Handle.

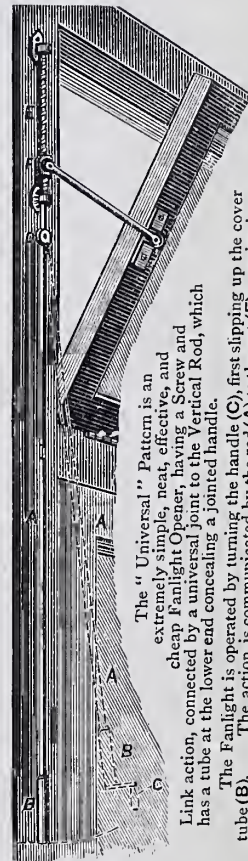

No. 330.

Another favourite pattern is my Link
Motion, No. 114, with Screw at bottom of
Rod, passing through the patent enclosed
gear regulator. This regulator can also be
supplied to revolve the Rod of No. 330.

tion, Gate Hinges and Fittings, Iron
Doors, and Gates, Artistic and other
Metal Work, Metal Casements and
Frames, &c., &c.

The "Universal" Pattern is an
extremely simple, neat, effective, and
cheap Fanlight Opener, having a Screw and
Link action, connected by a universal joint to the Vertical Rod, which
has a tube at the lower end concealing a jointed handle.
The Fanlight is operated by turning the handle (C), first slipping up the cover
tube (B). The action is communicated by the rod (A) to the nut (F), causing it to
traverse the screw (E), thereby acting on the sash by the link. The "Universal
Joint" (D) admits of the rod (A) being angled to any convenient extent for working it
when released from the hand the tube drops over and conceals the handle, and the rod hangs vertically.

ACADEMY ARCHITECTURE,
1893.

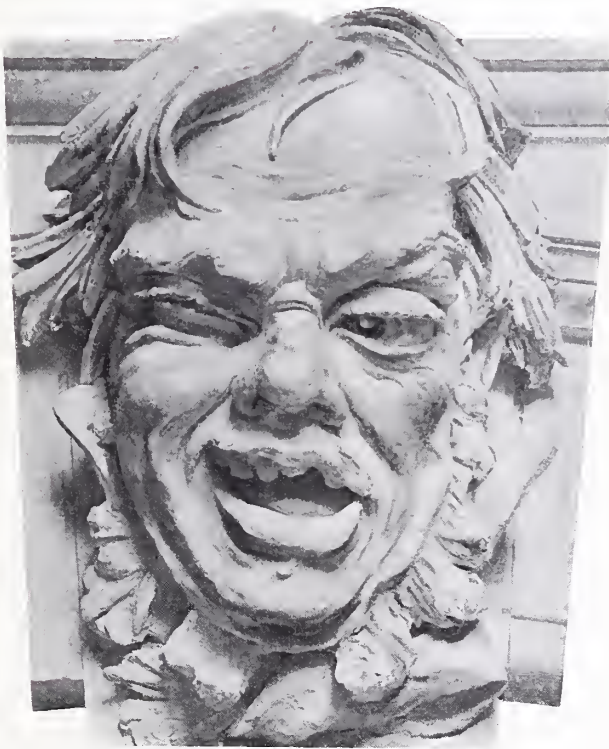

Key-stone, principal entrance to New Public Schools, Zürich. ALEX KOCH, Architect, PROFESSOR REGL, Sculptor, Zürich.

1889 GOLD MEDAL, PARIS, 1889
AND SEVENTEEN OTHER GOLD, SILVER AND BRONZE MEDALS.

W^{M.} WOOLLAMS & CO.,
ORIGINAL MAKERS OF
ARTISTIC
WALL PAPERS



CORRESPONDENCE
INVITED.

GUARANTEED FREE FROM ARSENIC.
W^{M.} WOOLLAMS & CO. are Manufacturers of all kinds of Wall and Ceiling Papers, and have special facilities for printing extra widths and lengths. A large collection of fine old Damask and Chintz Papers. Cheap Papers for Workmen's Cottages. Papers for Country Houses and Town Mansions, Hotels and Club Houses. Sanitary Papers, Bedroom Papers, Staircase Papers.



CORRESPONDENCE
INVITED.

Agents for and printers of Mr. J. ALDAM HEATON'S private designs in Wall and Ceiling Papers.

Estimates for private patterns free.

Specialities—Patent Embossed Flock Papers, Raised Flock Papers, for painting over, and "Chameleon Flocks."

 Sets of patterns in convenient form for the use of Architects gratis on application.

Sole Address :—110 HIGH STREET (NEAR MANCHESTER SQUARE), LONDON, W.
Kindly note "Trade Mark," a bale of "Wool" branded "W," and two "lam(b)s" suspended.

W^{M.} WOOLLAMS & C^{IE.} sont les promoteurs de la fabrication de papiers-peints, imprimés à la planche à colorants exempts d'arsenic. Voir la marque de fabrique ci-dessus. S'adresser à 110 HIGH STREET (NEAR MANCHESTER SQUARE), LONDRES, W. Dix-huit médailles, ci-inclus la médaille d'or Paris, 1889. Spécialité :—Laines à dessins modelés, et laines en relief pour être peintes.

W^{M.} WOOLLAMS & C^{IE.} Tapeten sind mittelst Tafeln gedruckt und durchaus Arsenikfrei. Bitte auf obige Fabrikmarke zu achten. London Adresse: 110 HIGH STREET (NEAR MANCHESTER SQUARE), LONDON, W.

Paris, 1889, Goldmedaille. Ueberdiess siebenzehn andere Gold, Silber, und Bronzemedailen.

ATHENÆUM GLASGOW

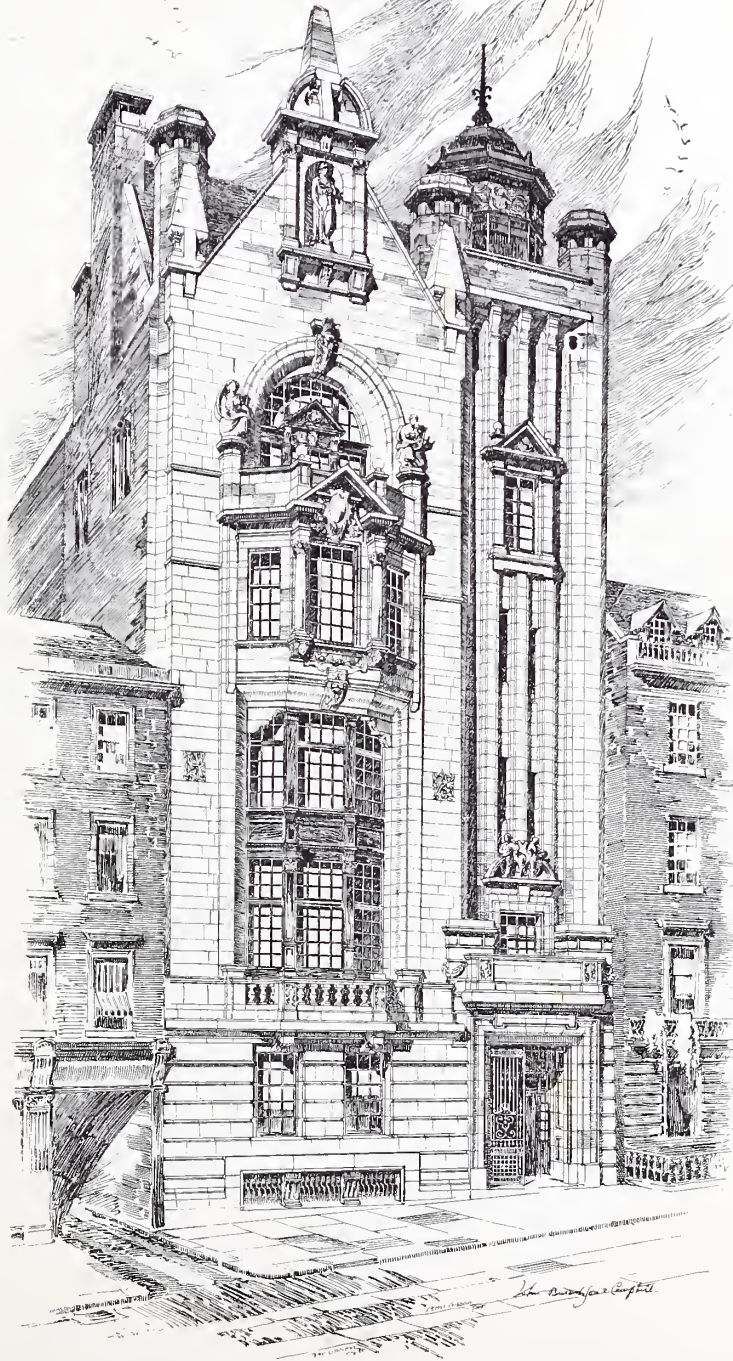

1555. *Glasgow Athenæum, Elevation to Buchanan Street, JOHN BURNET, SON, AND CAMPBELL, Architects.*

Electric Lighting—J. H. Holmes & Co., Portland Road, Newcastle-on-Tyne. Heating and Ventilating—James Cormack & Sons, 36, Abercorn Street, Glasgow. Hydraulic Passenger Lift—The Otis Elevator Company, Ltd., 4, Queen Victoria Street, E. C. The Fireproof Floors on the Fawcett System.



1498. *New Premises for the National Provincial Bank of England, Piccadilly, W., ALFRED WATERHOUSE, R.A..
Architect.*

Hydraulic Passenger and Service Lifts—R. Waygood & Co., Falmouth Road, Great Dover Street. London, S.E.

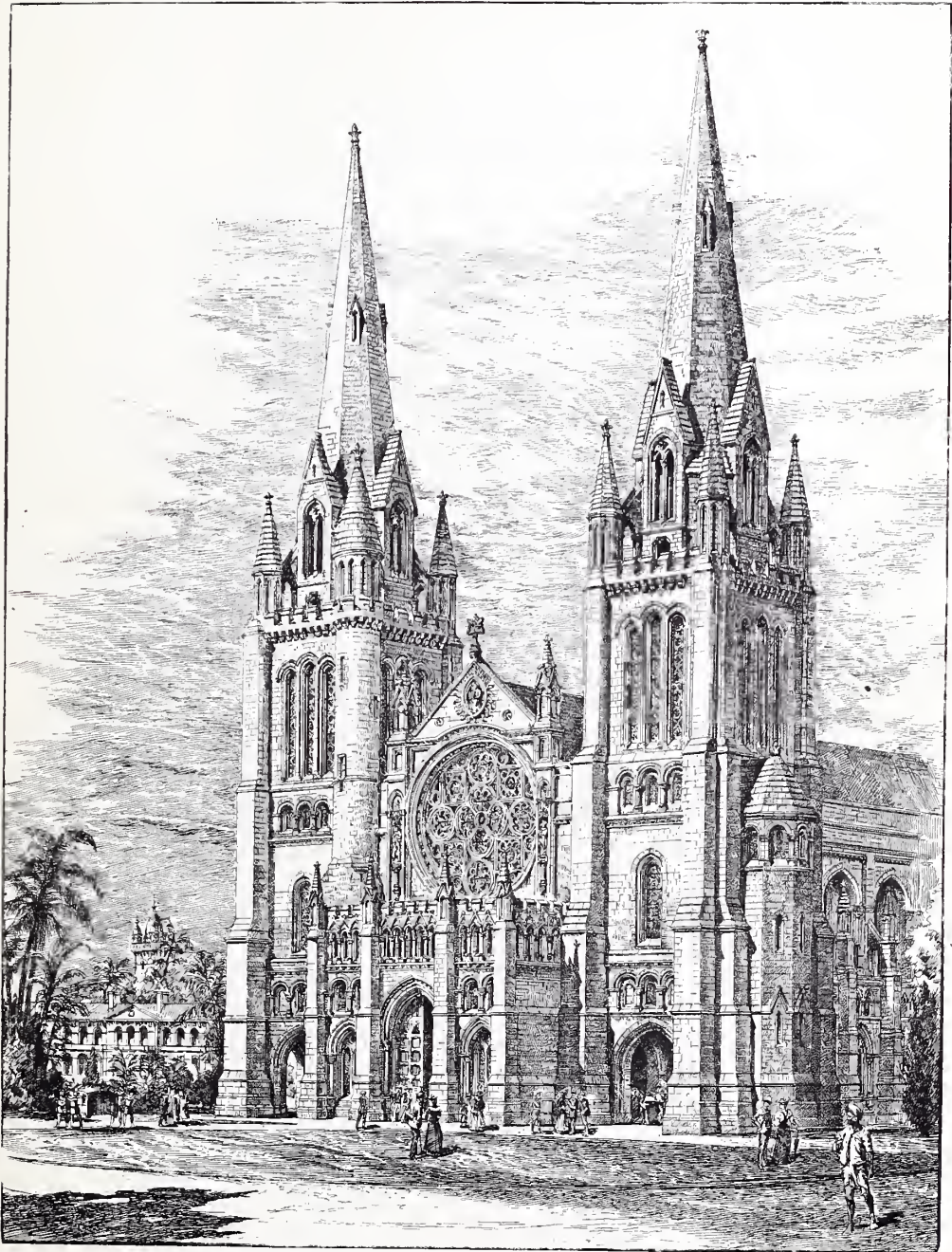

1644. *West Front of the Cathedral for the New Lucknow Diocese, India, WILLIAM EMERSON, F. R. I. B. A., Architect.*



1524. *The Northampton Institute, Clerkenwell, EDWARD W. MOUNTFORD, F.R.I.B.A., Architect.*



1573. St. Pancras Municipal Buildings, first preliminary design, WILLIAM HARRISON, A.R.I.B.A., Architect.

1618. *Competition Design for South Kensington Museum*



WILLIAM EMERSON, F.R.I.B.A., Architect.

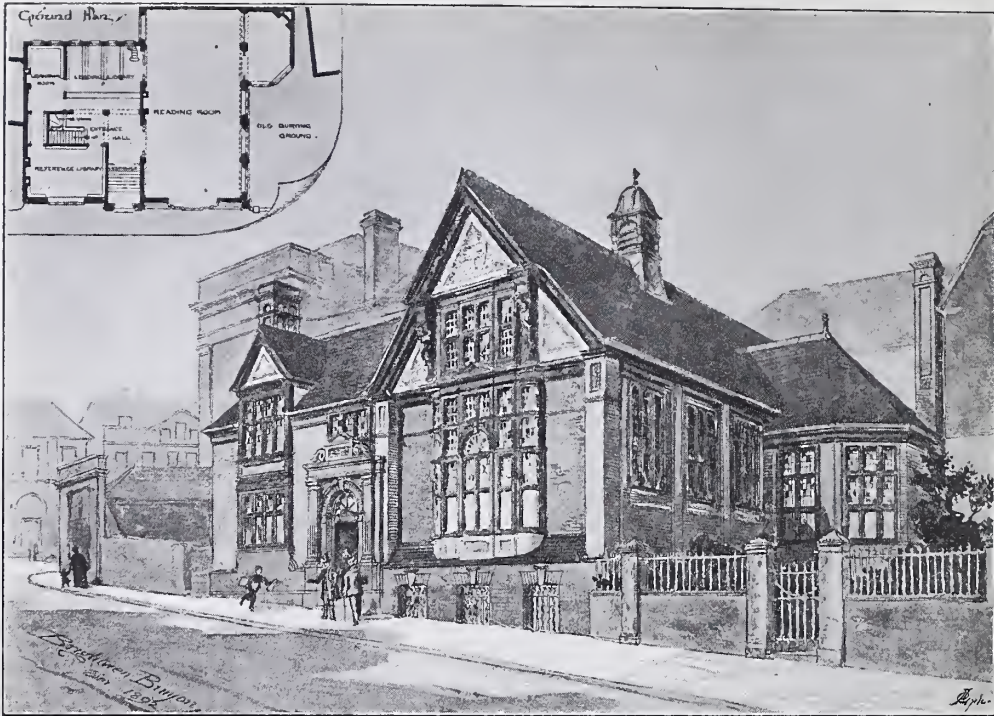

1572. *Public Library, Colchester*, BRIGHTWEN BINYON, A.R.I.B.A., Architect.



1518. *Battersea Town Hall, east side*, EDWARD W. MOUNTFORD, F.R.I.B.A., Architect.

"Edinscourt" Disley, Cheshire.



John Brooke A.R.I.B.A.
Nottingham



1502. Edinscourt, Disley, Cheshire, JOHN BROOKE, A.R.I.B.A., Architect.



"Millburn House"
Colevaine
F. E. Ward, Architect
27, Grosvenor Place, London

1576. Millburn House, Colevaine, F. E. WARD, Architect.



WOODCROFT: LEEK, STAFFS

View showing Extensions

H. DAVENPORT ESQ.

*W. Sugden & Son, Architects,
Leek, July, 1891.*

1483. Woodcroft, Leek, View showing Extensions, W. SUGDEN & SON, Architects.

Heating—G. N. Haden & Sons, Trowbridges, Wilts.

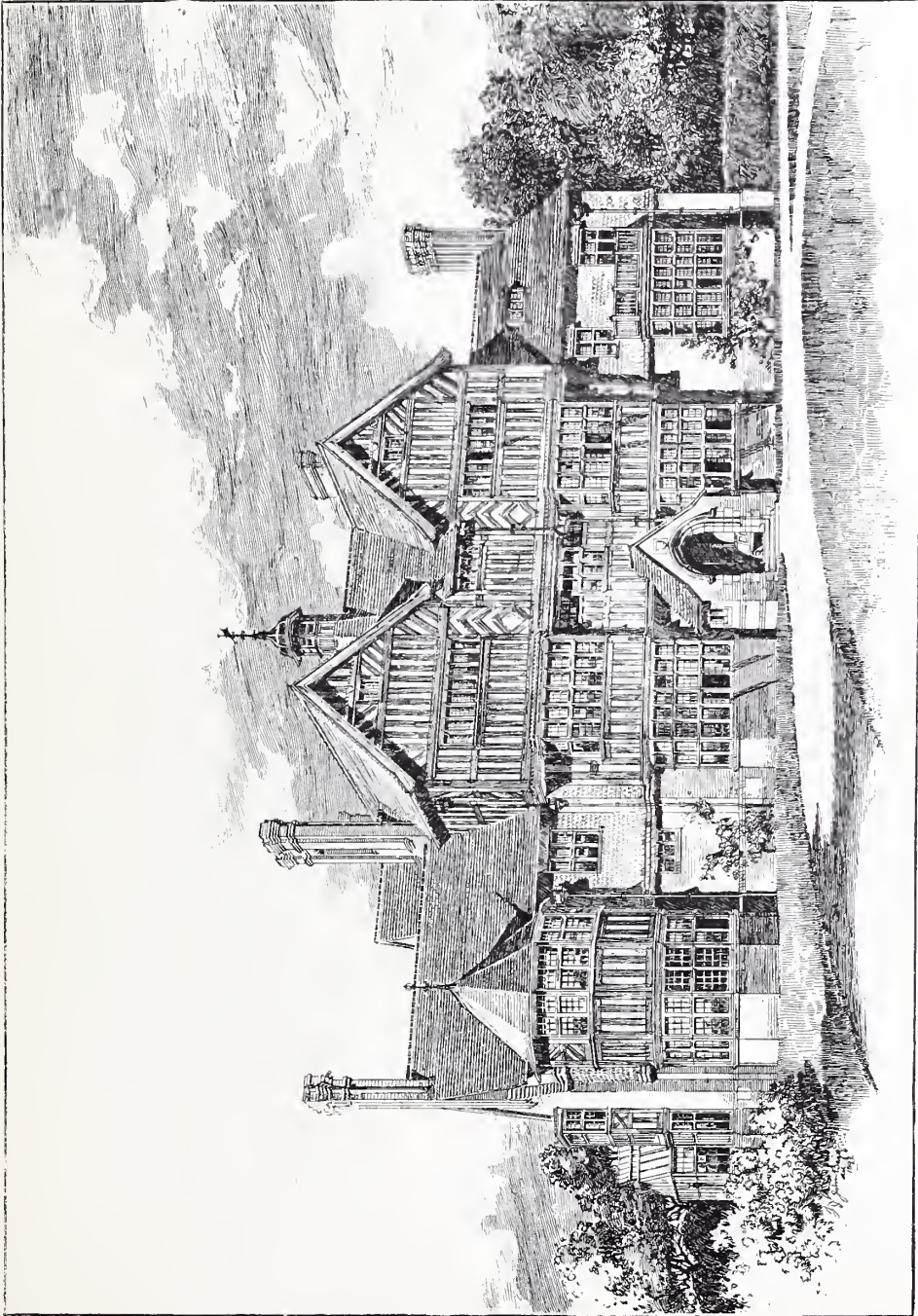

1536. *Goddington, Chelsfield, Kent, for A. Miller, Hallett, Esq., W. WEST NEVE, Architect.*

Electric Lighting—Drake and Corham, 66, Victoria Street, Westminster.
Heating and Conservatory—Messenger & Co., Loughborough.



1614. *New Church, Huyton*, WILLIAM D. CAROÉ, M.A., Architect.

Contractors—Hughes and Stirling, Bootle and Liverpool.
Organ—August Gern, Boundary Road, Notting Hill, W.

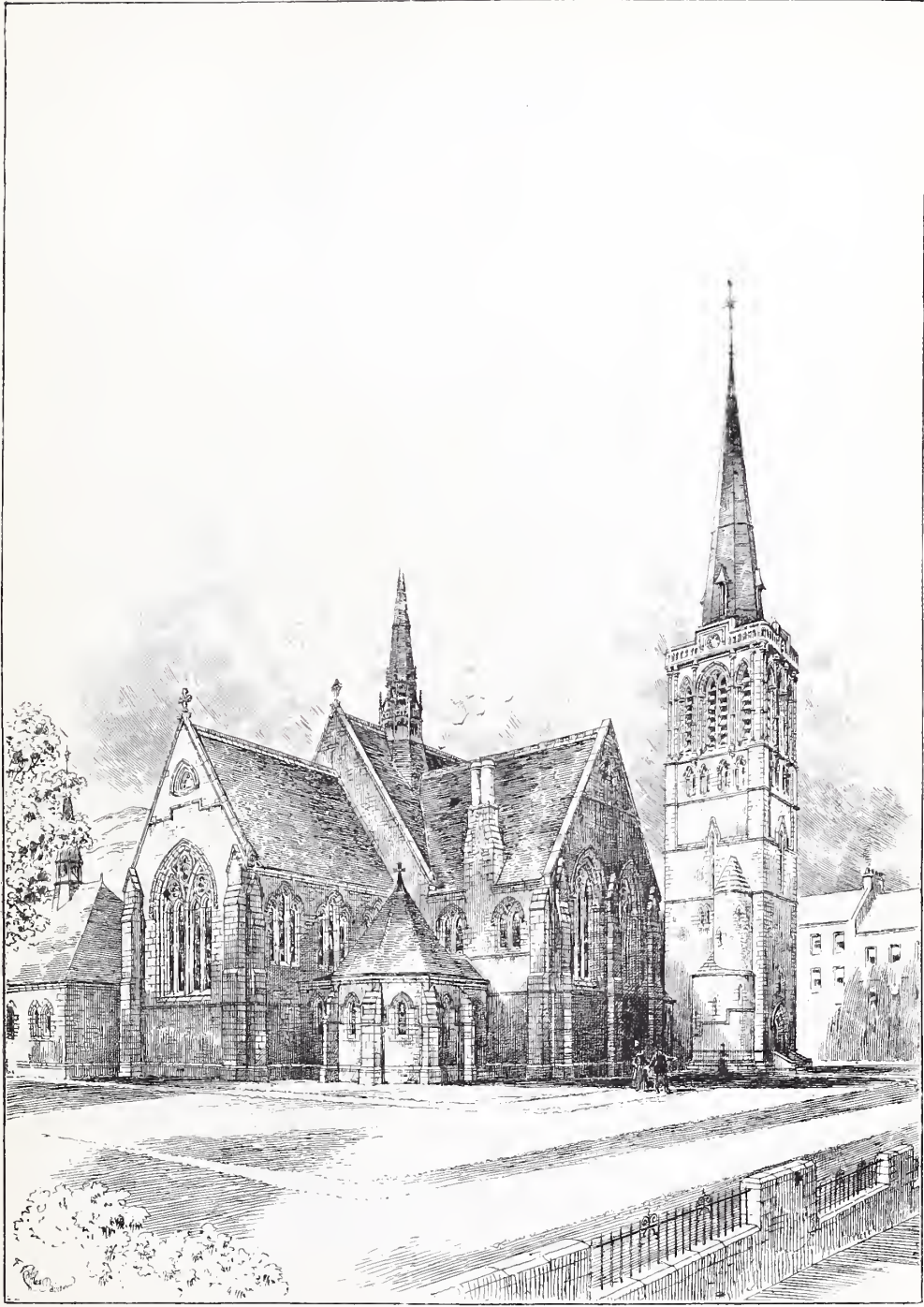

1599. *St. Matthew's Church, Morningside, Edinburgh*, HIPPOLYTE J. BLANC, A.R.S.A., Architect.

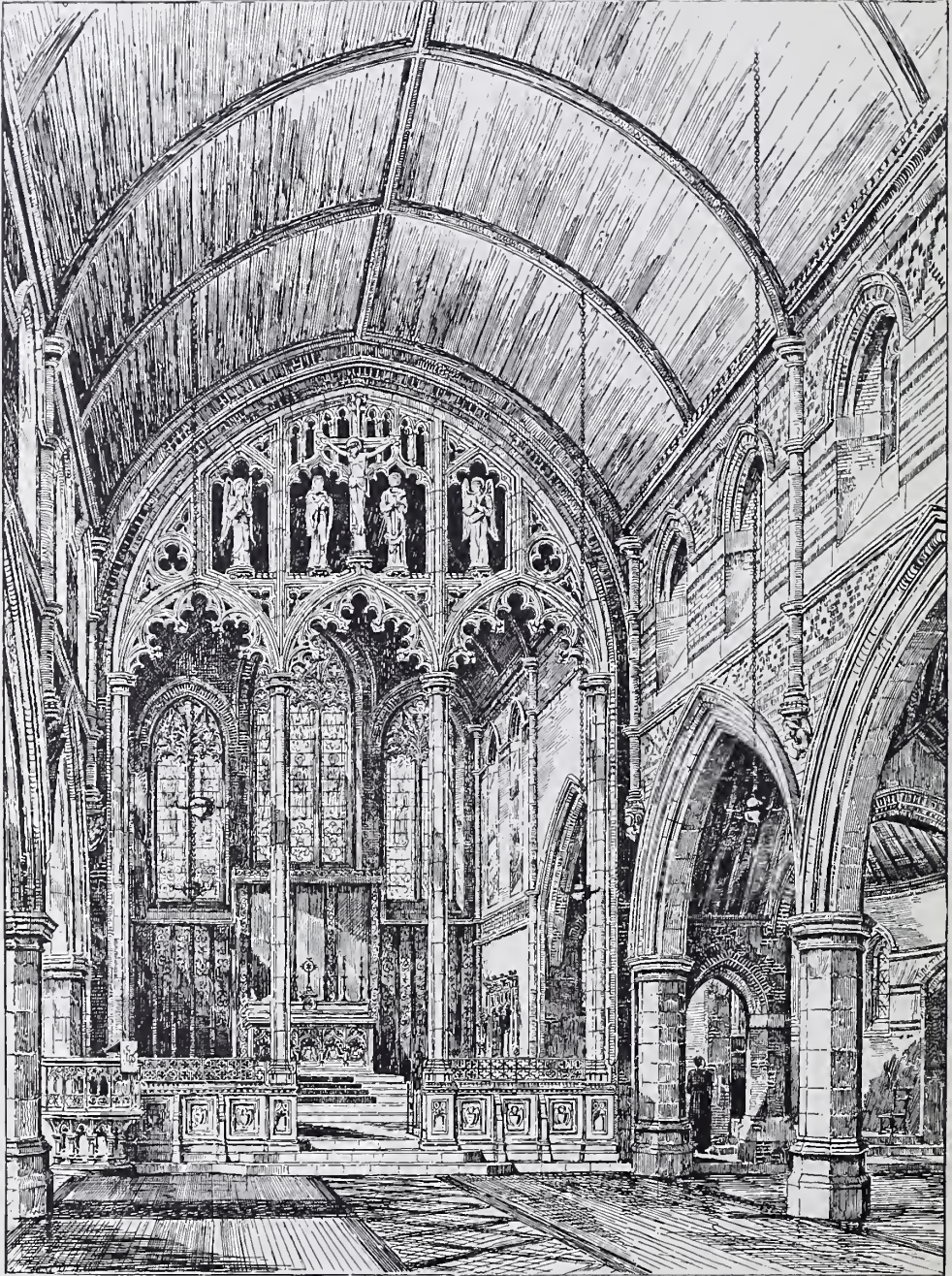

1490. *New Church, Staines, Interior looking East*, G. H. FELLOWES PRYNNE, F.R.I.B.A., Architect.

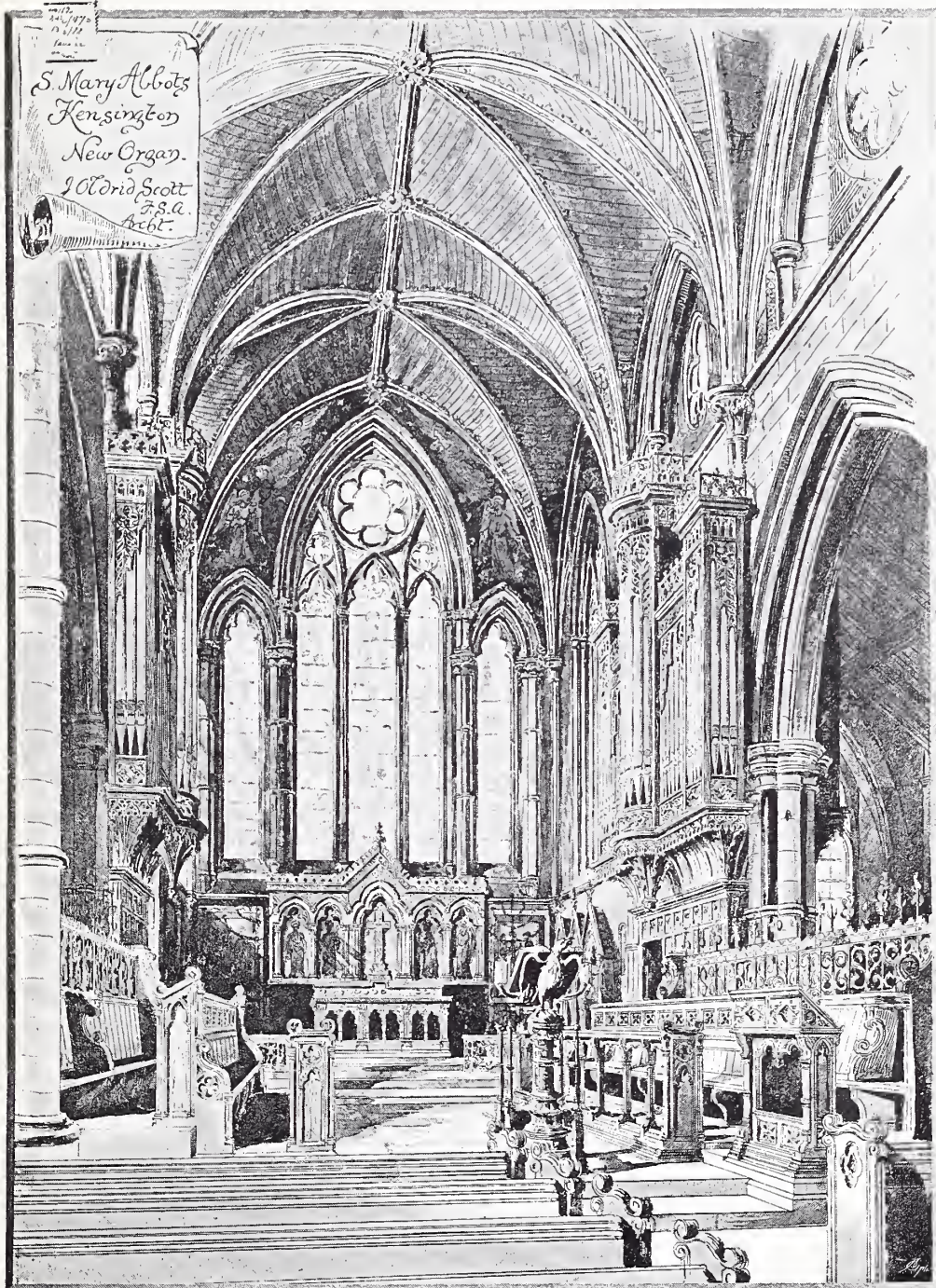

1505. Design for Organ Front, St. Mary Abbots, Kensington, J. OLDRID SCOTT, F.S.A., Architect.

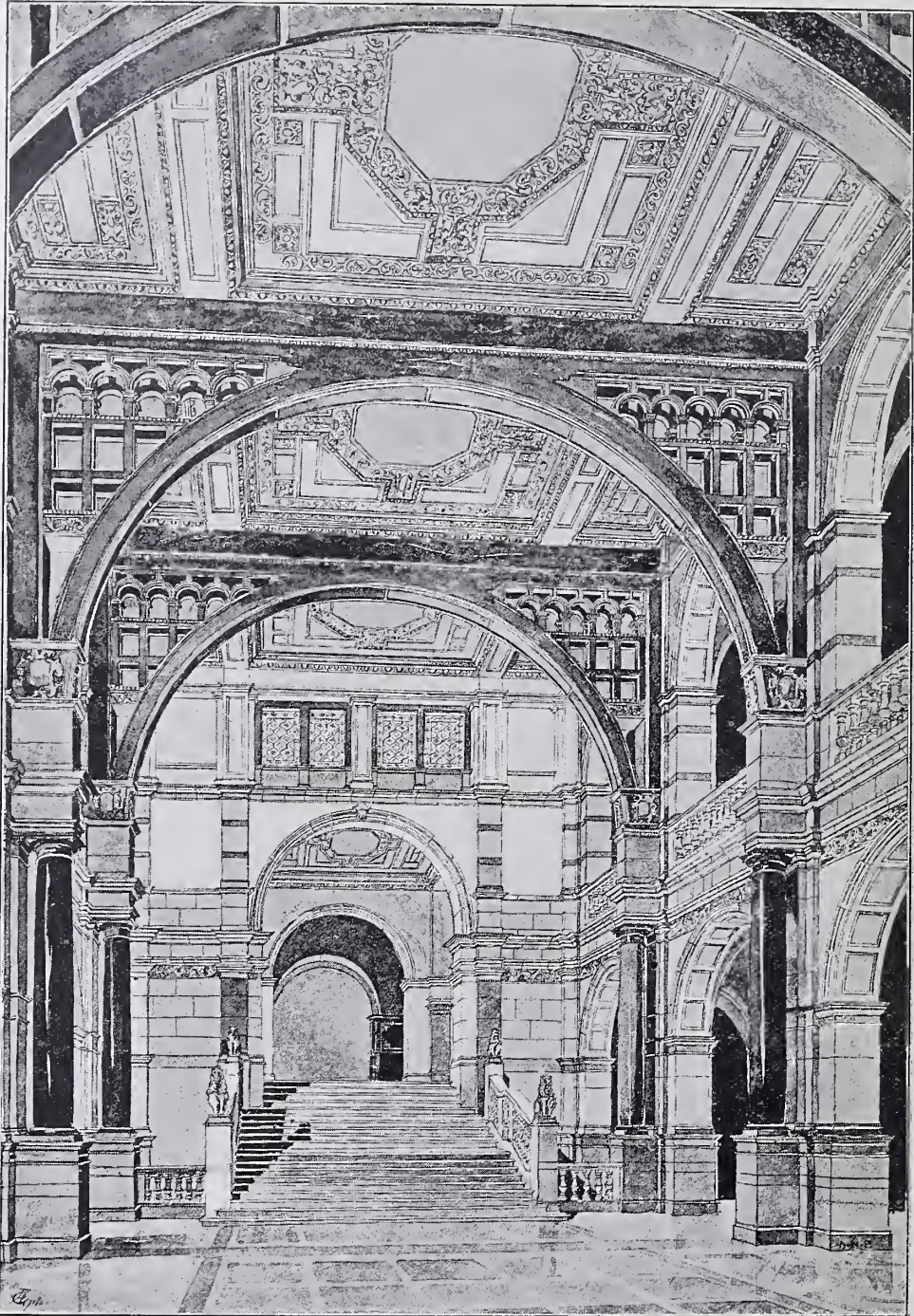

1586. Staircase, *The Imperial Institute*, THOMAS E. COLLCUTT, F.R.I.B.A., Architect.

Contractors—John Mowlem & Co., Grosvenor Wharf, Westminster, S.W.

Hydraulic Machinery and High Pressure Lifts—Archibald Smith and Stevens, Janus Works, Queen's Road, Battersea, S.W.

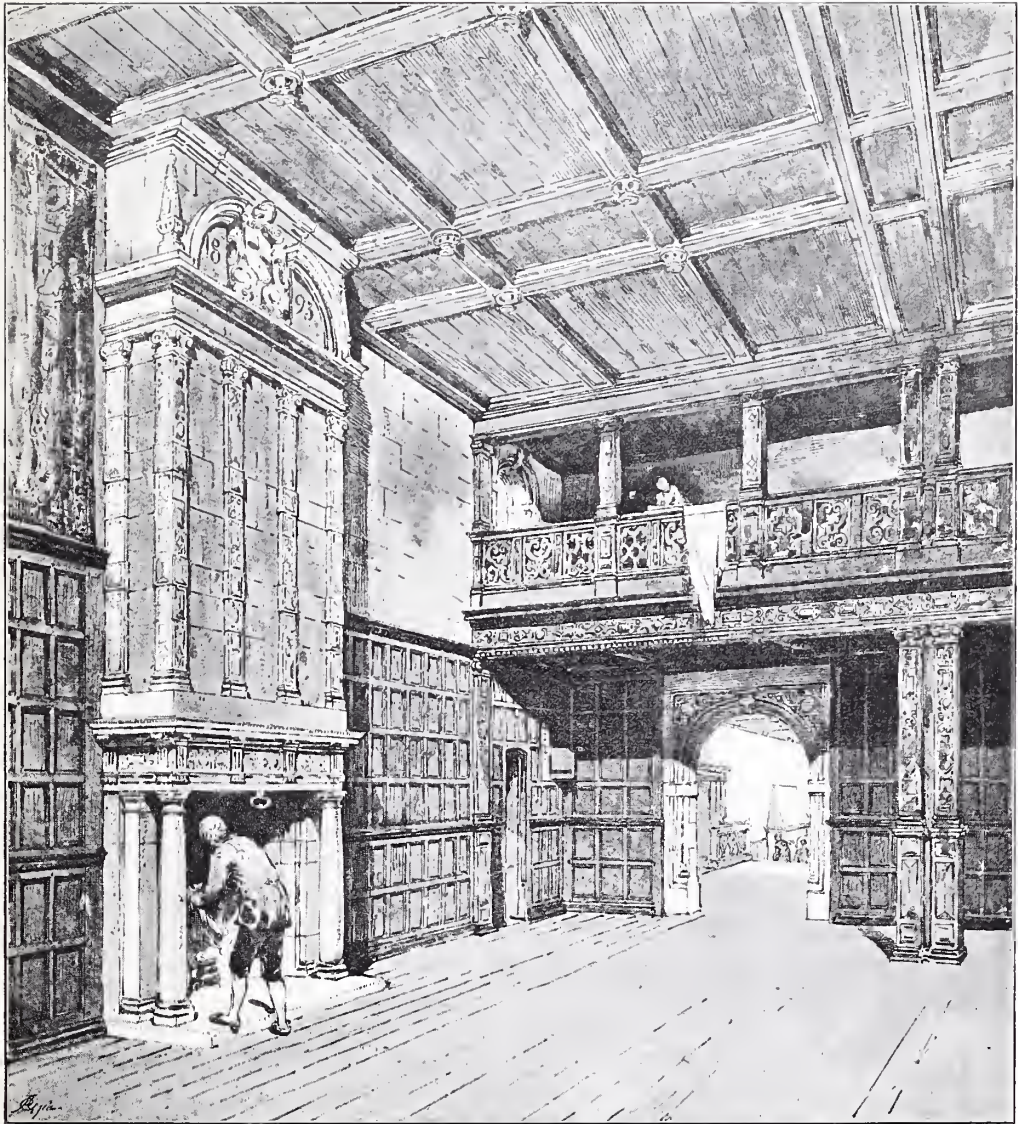

1545. *West Dean, Chichester, for W. D. James, Esq., The Staircase*, ERNEST GEORGE AND PETO, Architects.

Contractors—J. Simpson & Son, 48, Paddington Street, W. Electric Lighting—V. G. Middleton, 3, Princes Mansions, Victoria Street, Westminster, S.W. Decorative Work—Ch. Mellier & Co., 48, 49, and 50, Margaret Street, Cavendish Square, W. Hydraulic Luggage Lift—The Otis Elevator Company, Ltd., 4, Queen Victoria Street, E.C.

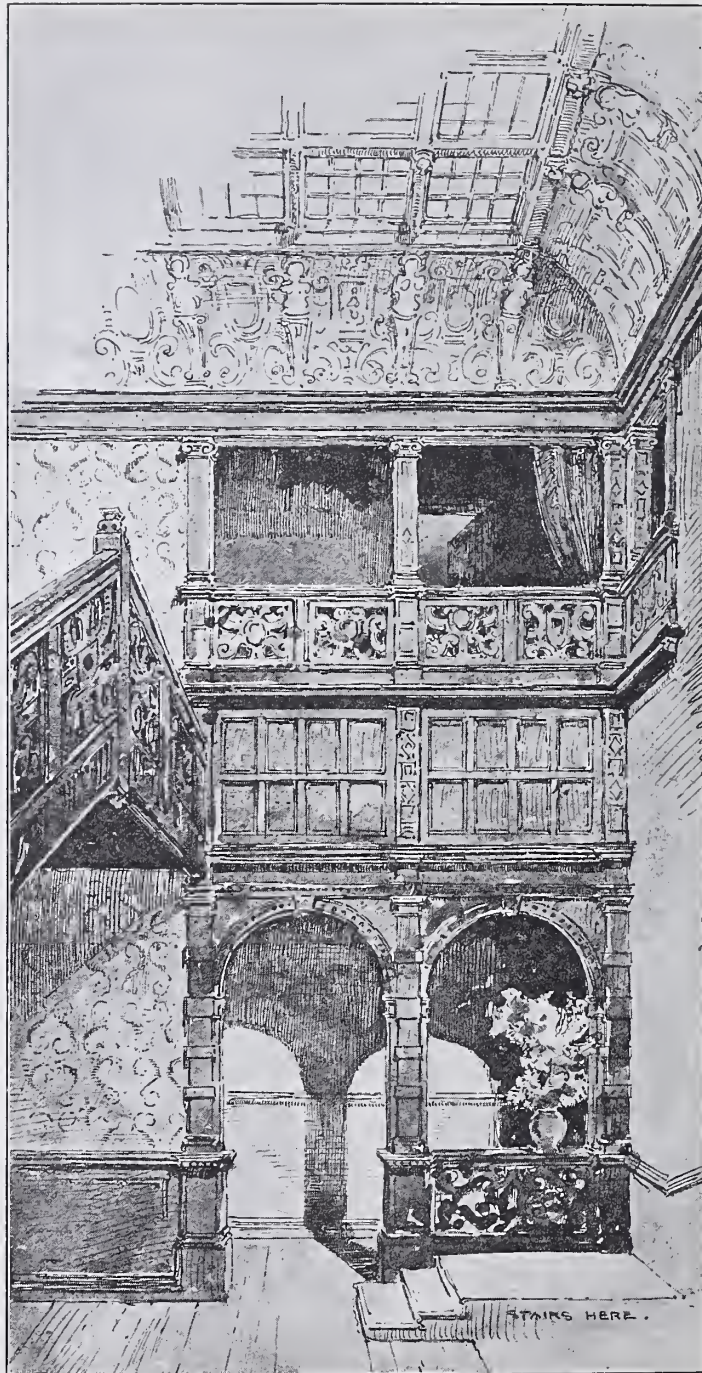

1545. *West Dean, Chichester, for W. D. James, Esq., The Hall, ERNEST GEORGE AND PETO, Architects.*

Contractors—J. Simpson & Son, 48, Paddington Street, W. Electric Lighting—V. G. Middleton, 3, Princes Mansions, Victoria Street, Westminster, S.W. Decorative Work—Ch. Mellier & Co., 48, 49, and 50, Margaret Street, Cavendish Square, W. Hydraulic Luggage Lift—The Otis Elevator Company, Ltd., 4, Queen Victoria Street, E.C.

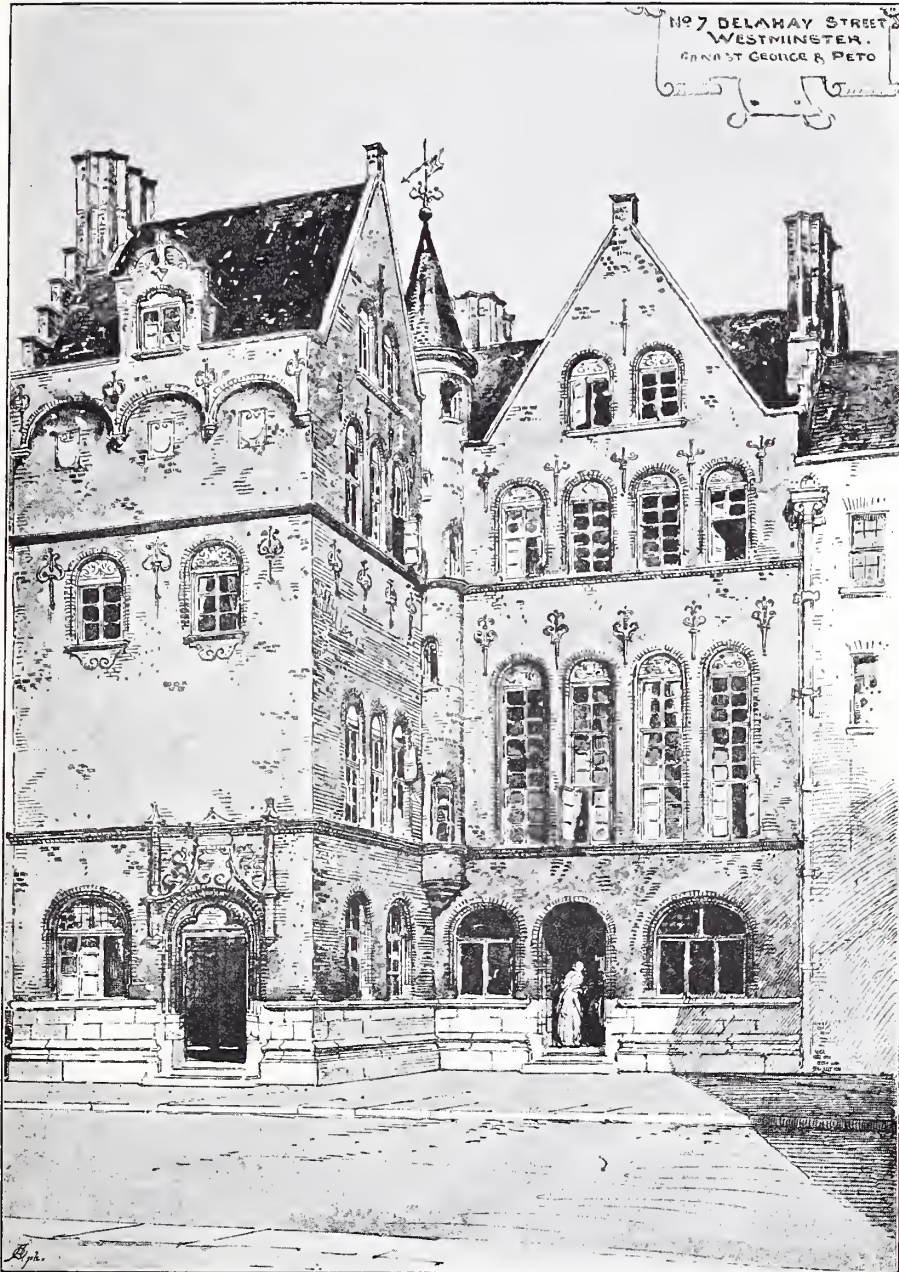

1544. No. 7, Delahay Street, Westminster, S.W., ERNEST GEORGE AND PETO, Architects.

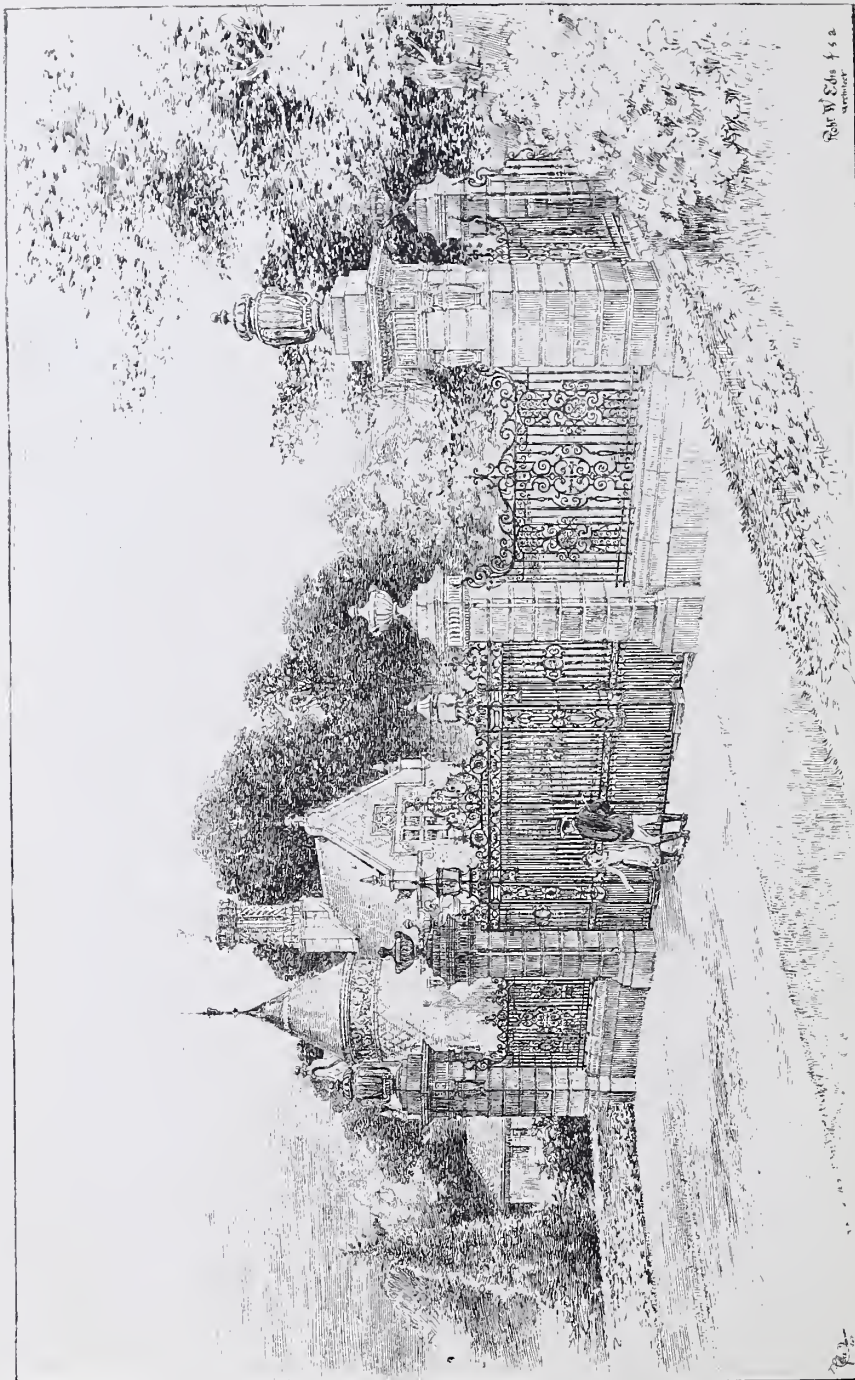

1503. *New Entrance Gates and Lodge, Eaton Hall, Robert W. Edis, F.S.A., Architect.*

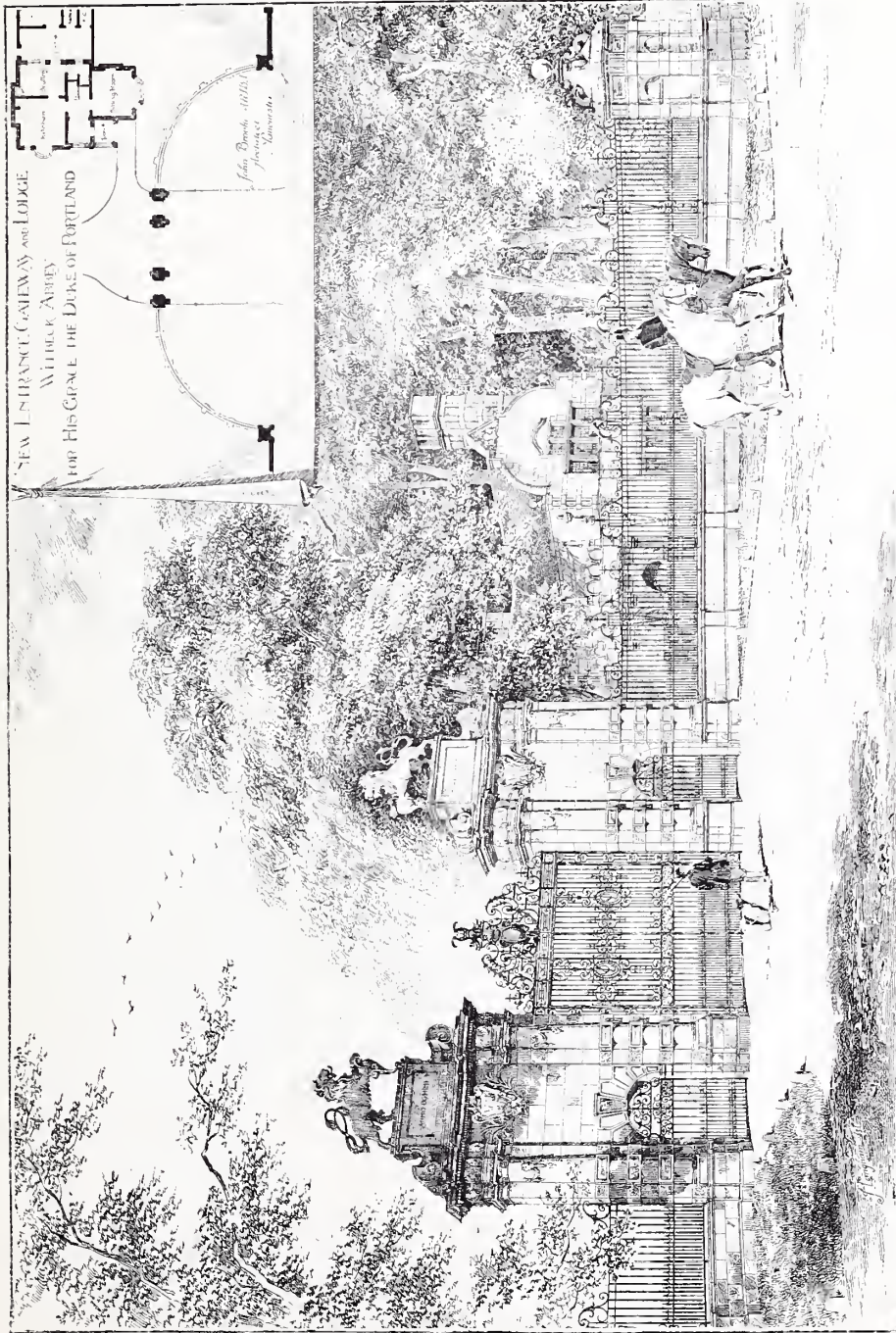

1497. *New Entrance Gateway and Lodge, Welbeck Abbey, for His Grace the Duke of Portland, JOHN BROOKE, A. R. I. B. A., Architect.*

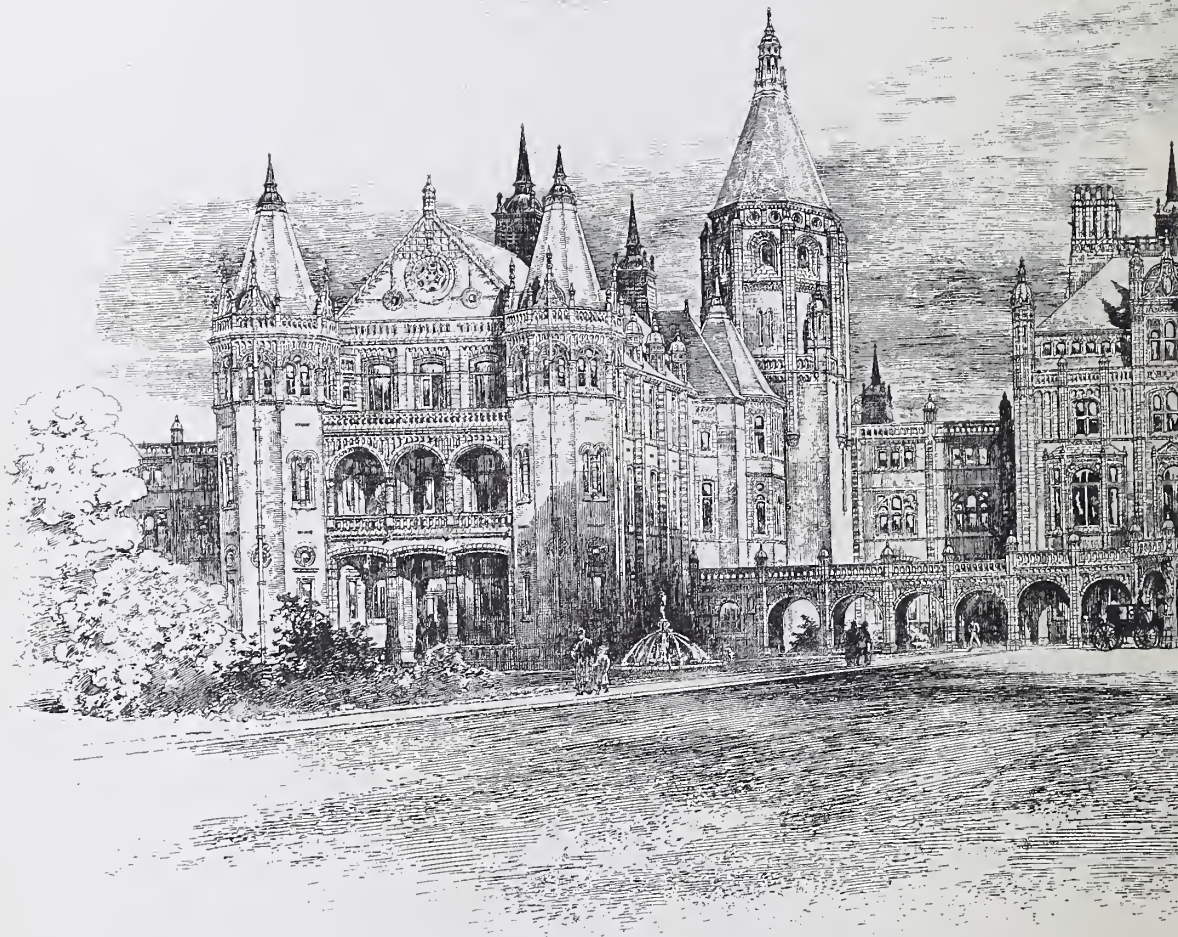

1578. *The New General Hospital, Birmingham*

Contractors for Foundations—John Barnsley & Sons, 102, Ryland Street, Birmingham.

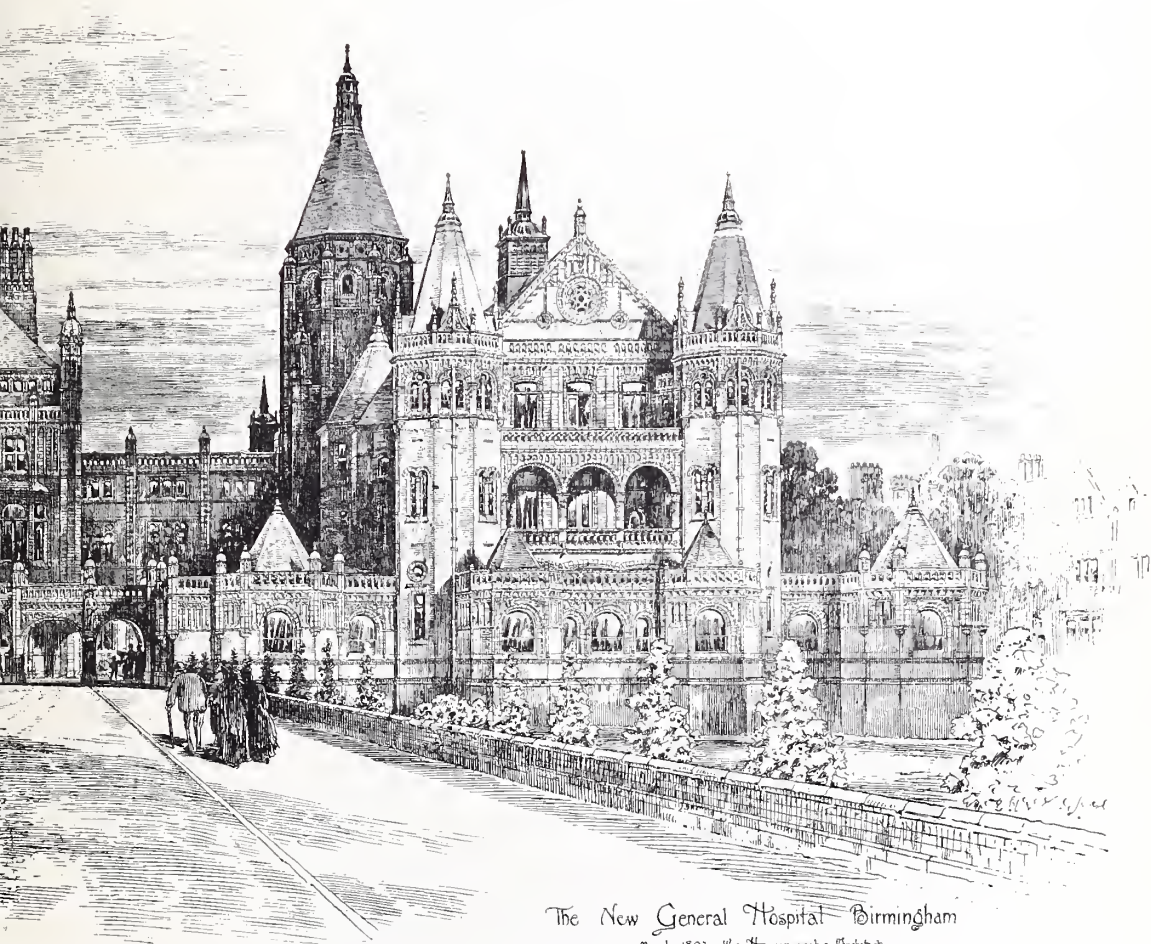

The New General Hospital Birmingham
March 1893 Wm Henman del Architect

TAM HENMAN, A.R.I.B.A., Architect.



1579. "Glangona," Carnarvon, DOUGLAS AND FORDHAM, Architects.

Seasoned Baltic Oak Timber—Tealby & Co., Garrison Side, Hull.



1580. "Glangwena," Carnarvon, DOUGLAS AND FORDHAM, Architects.

Seasoned Baltic Oak Timber—Teebly & Co., Garrison Side, Hull.

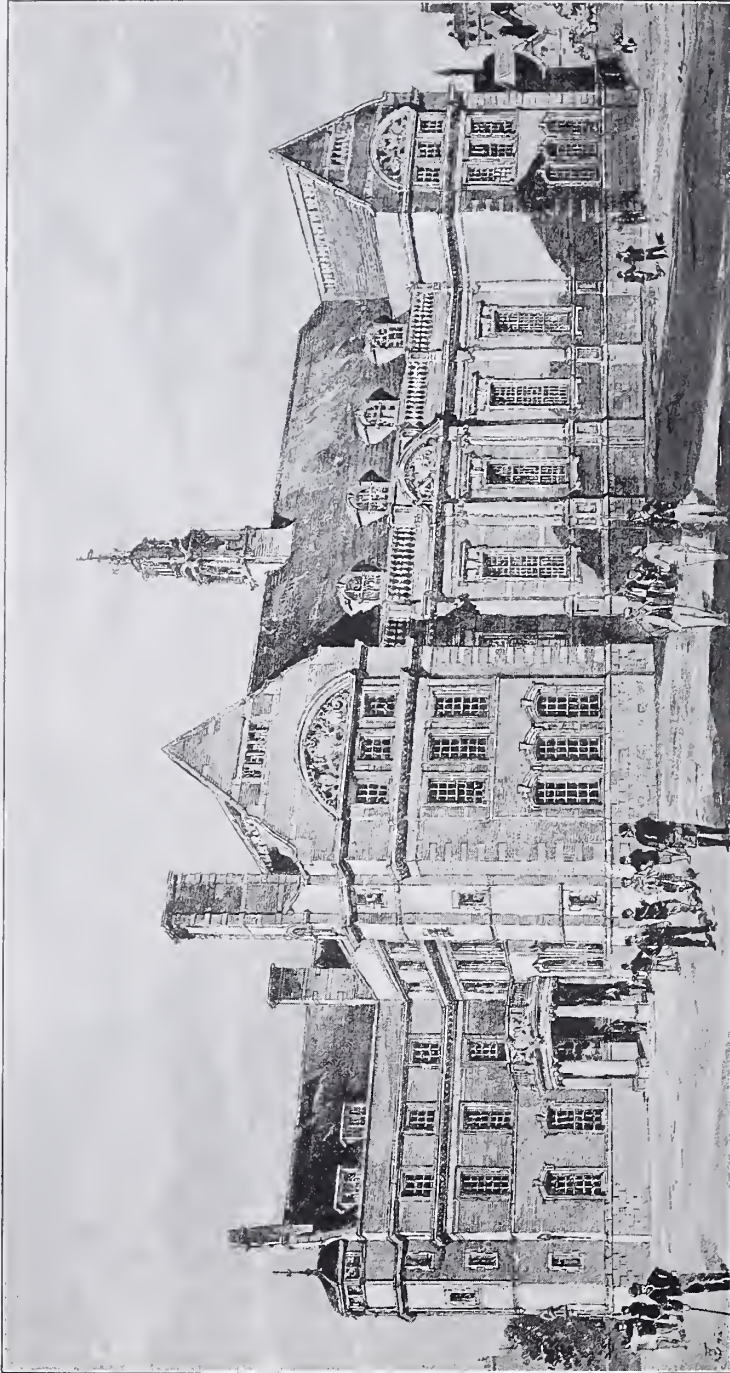

1517. *St. Olave's Grammar Schools, Southwark, S.E., EDWARD W. MOUNTFORD, F.R.I.B.A., Architect.*

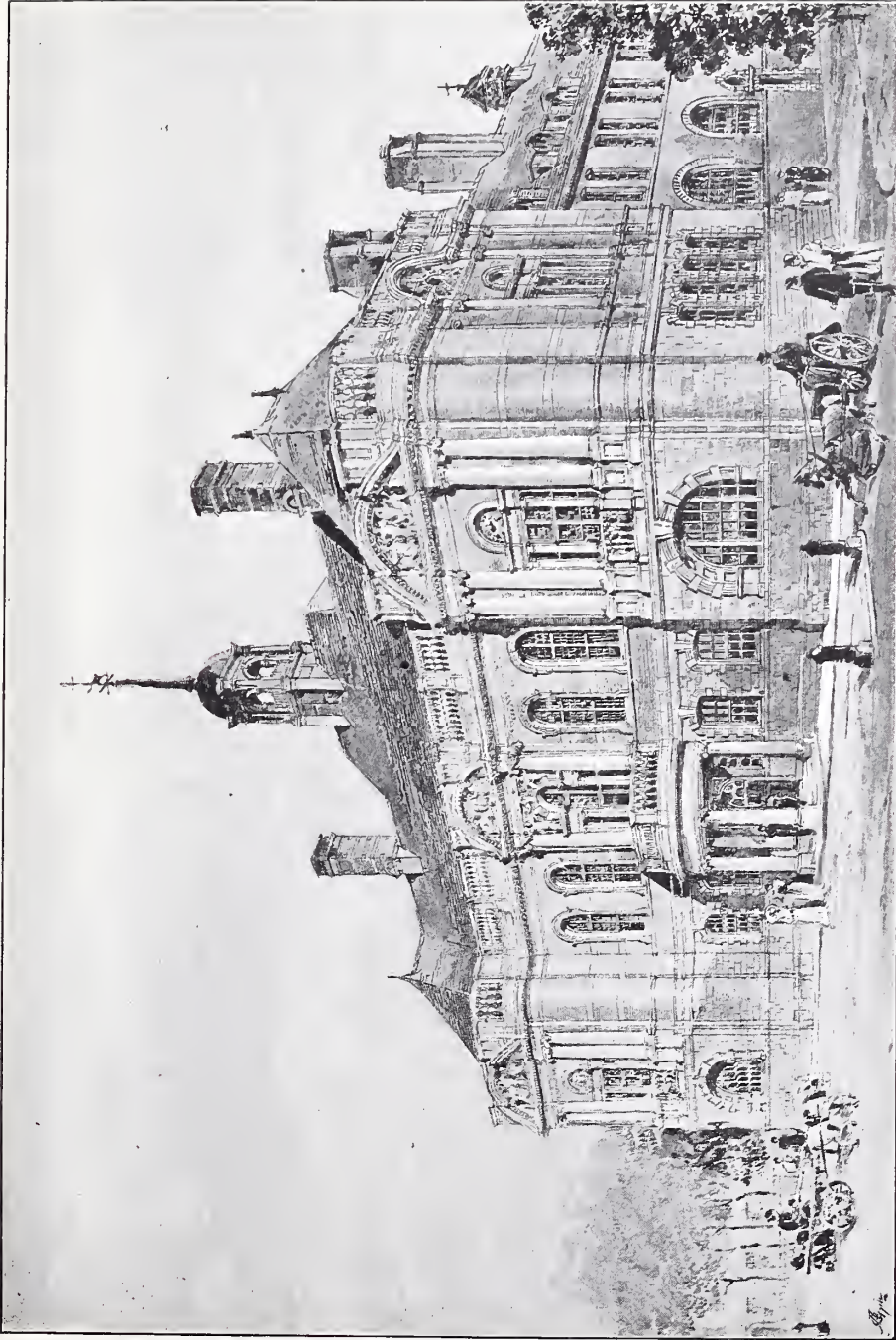

1523. Battersea Town Hall, Principal Front, EDWARD W. MOUNTFORD, F.R.I.B.A., Architect.

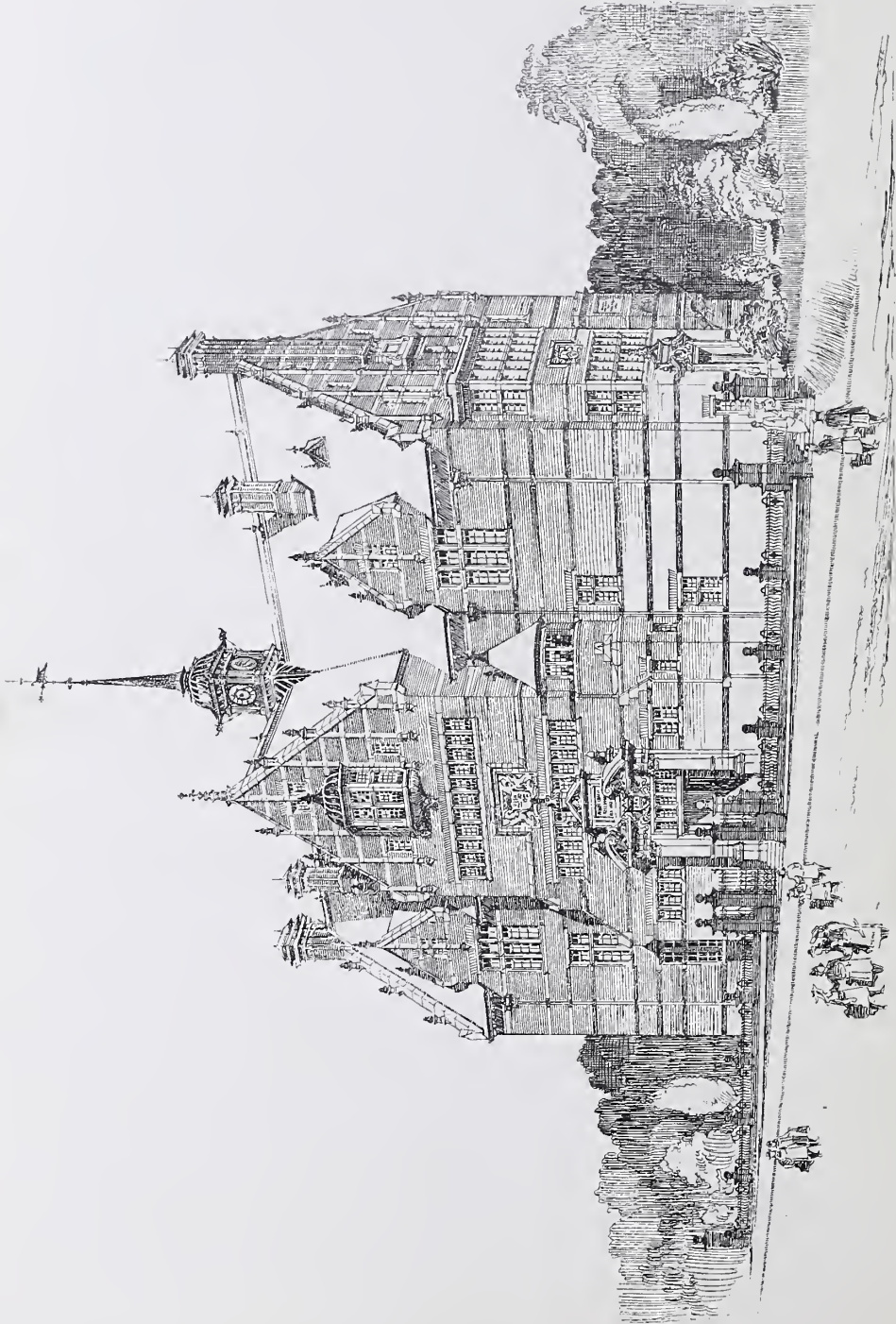

1482. Design for New Board School, Gais, Switzerland, ALEX. KOCH, Architect.

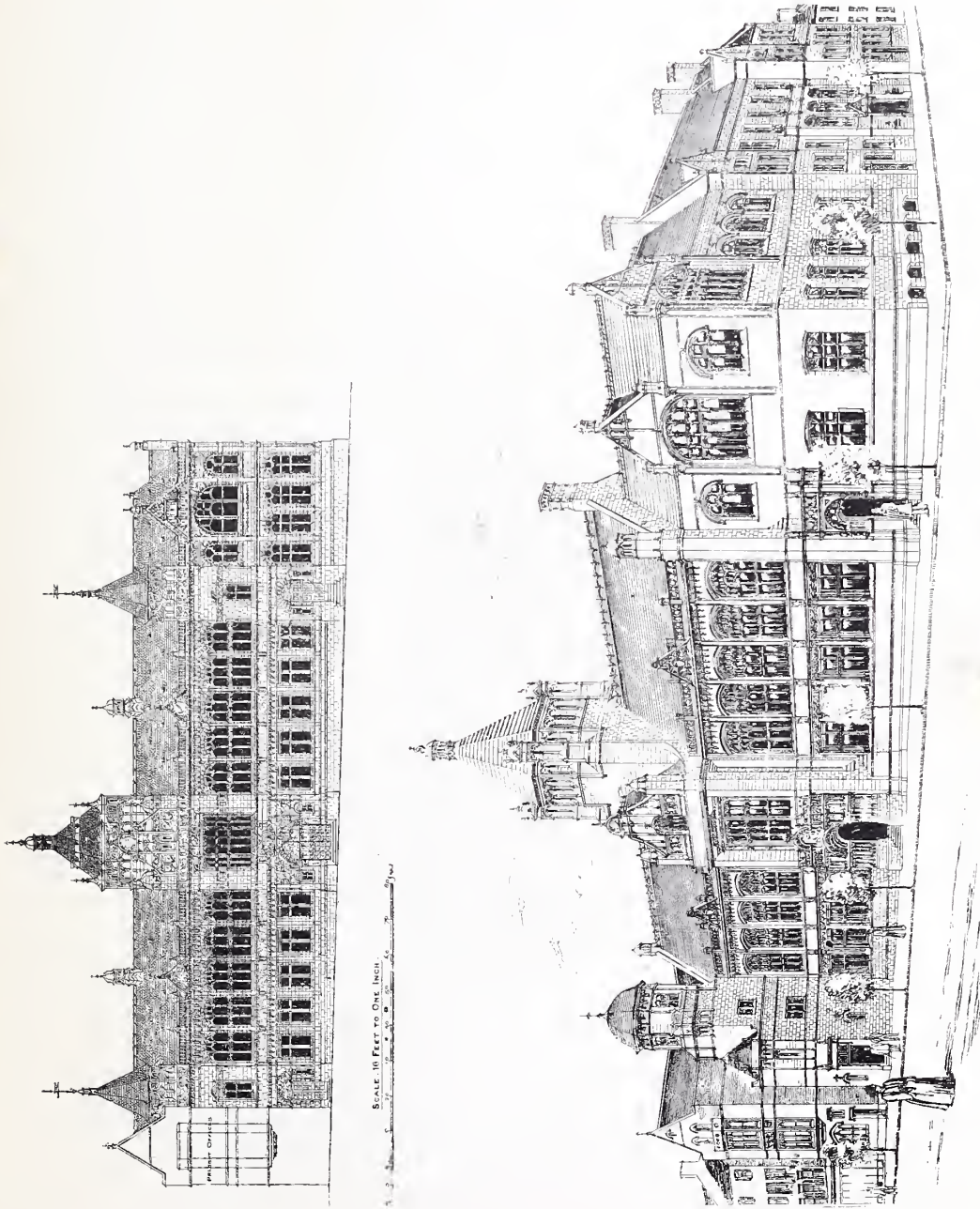

1587. Oxford Municipal Buildings. Top : One of the five premiated designs. Bottom : Drawing submitted in II. Competition, CHESTON AND PERKIN, Architects.

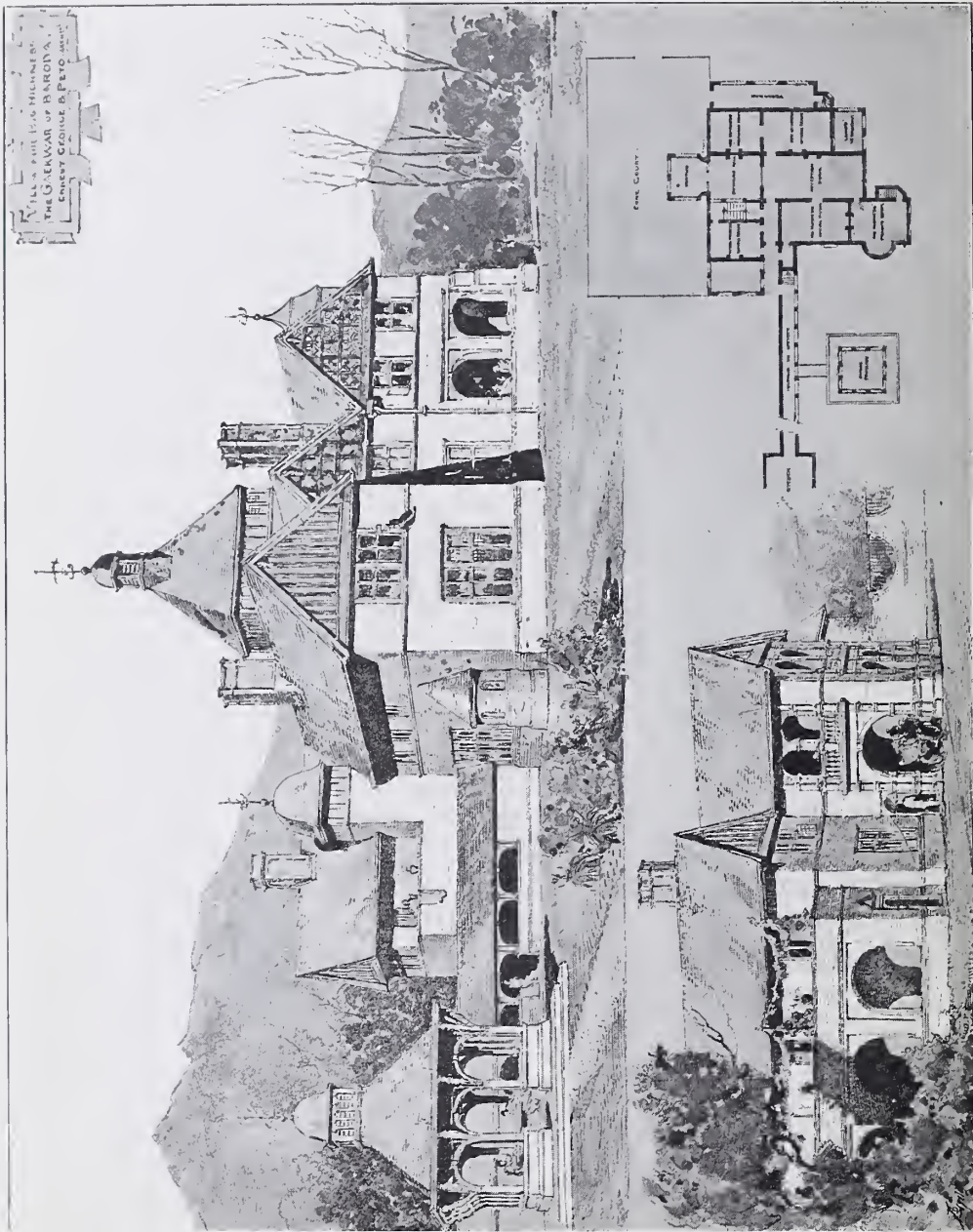

1549. Villa for His Highness The Coakwar of Baroda, ERNEST GEORGE AND PETO, Architects.

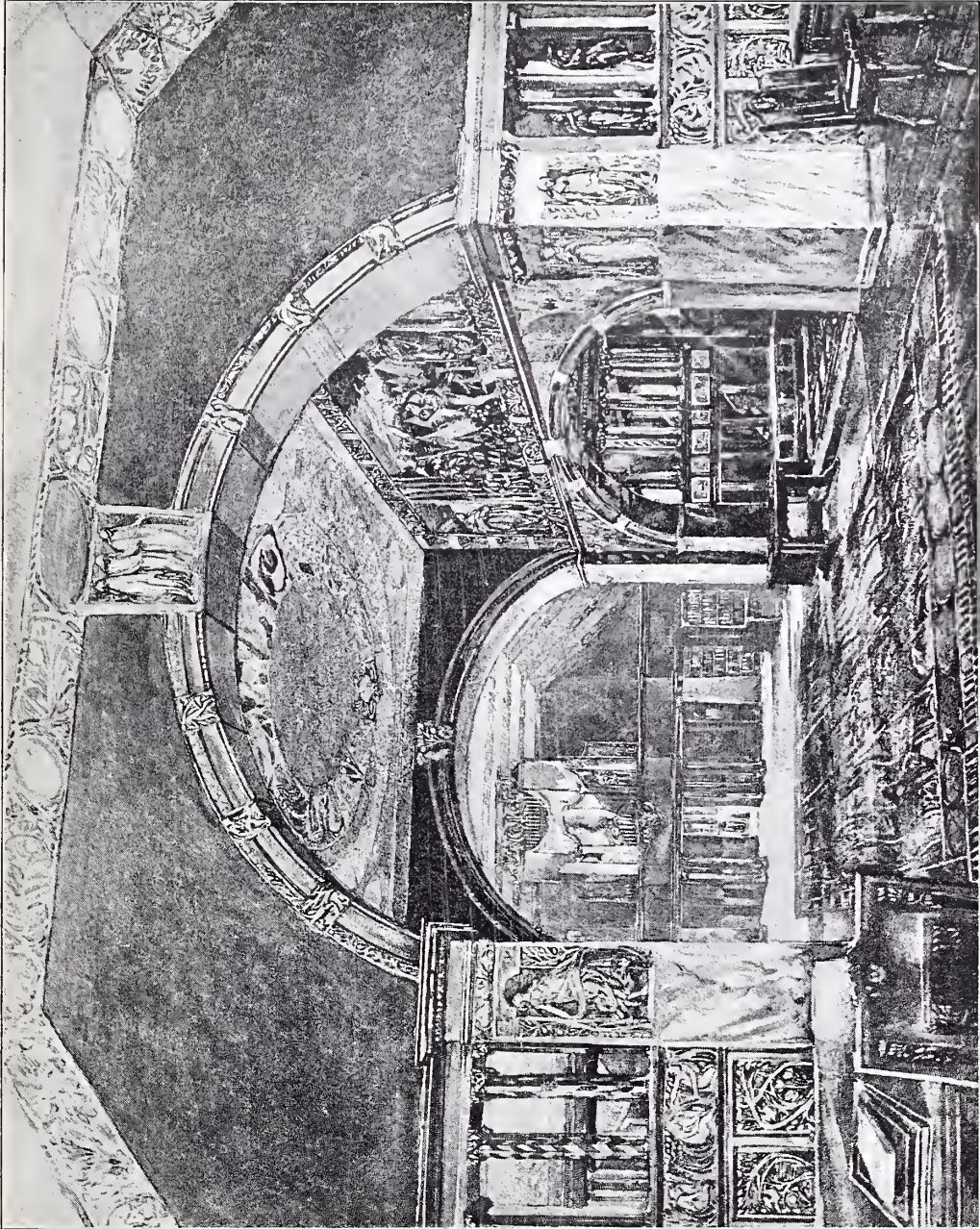

1623. Design for the Library, Welbeck Abbey, for His Grace the Duke of Portland, H. WILSON, Architect.

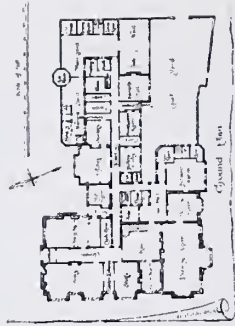

The Bury Lodge, Hertfordshire
 Kings, Woburn, Herts.
 T. F. Harrison, Esq.
 Architects
 J. J. Adcock, Ladywell, Dover.

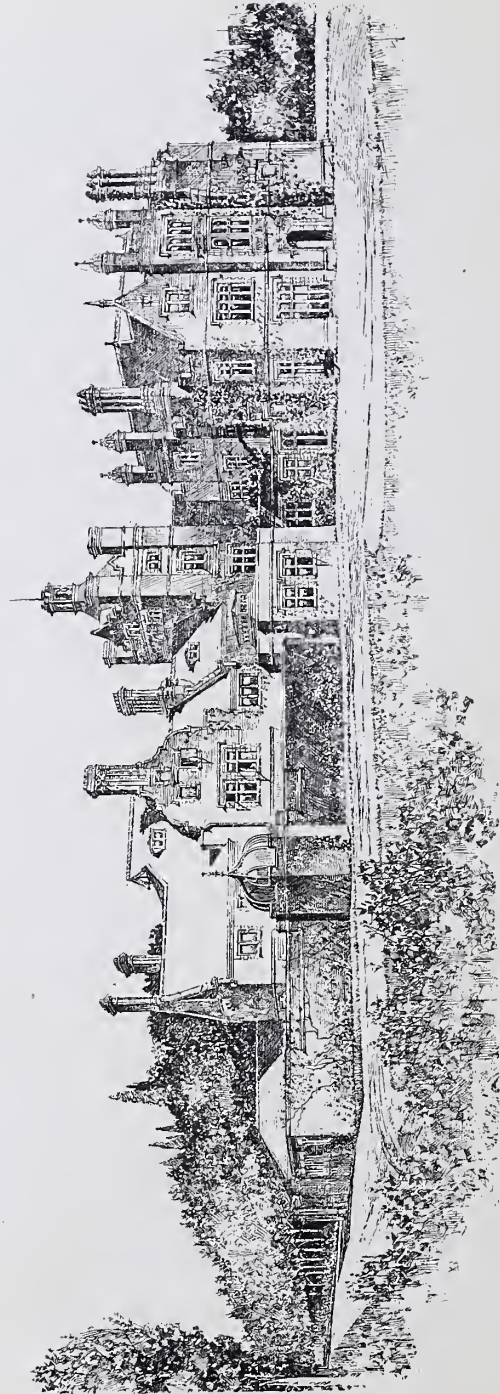

1595. The Bury, King's Walden, Herts, for T. F. Harrison, Esq., BEESTON AND BURMESTER, Architects.

Contractor—W. J. Adcock, Ladywell, Dover.

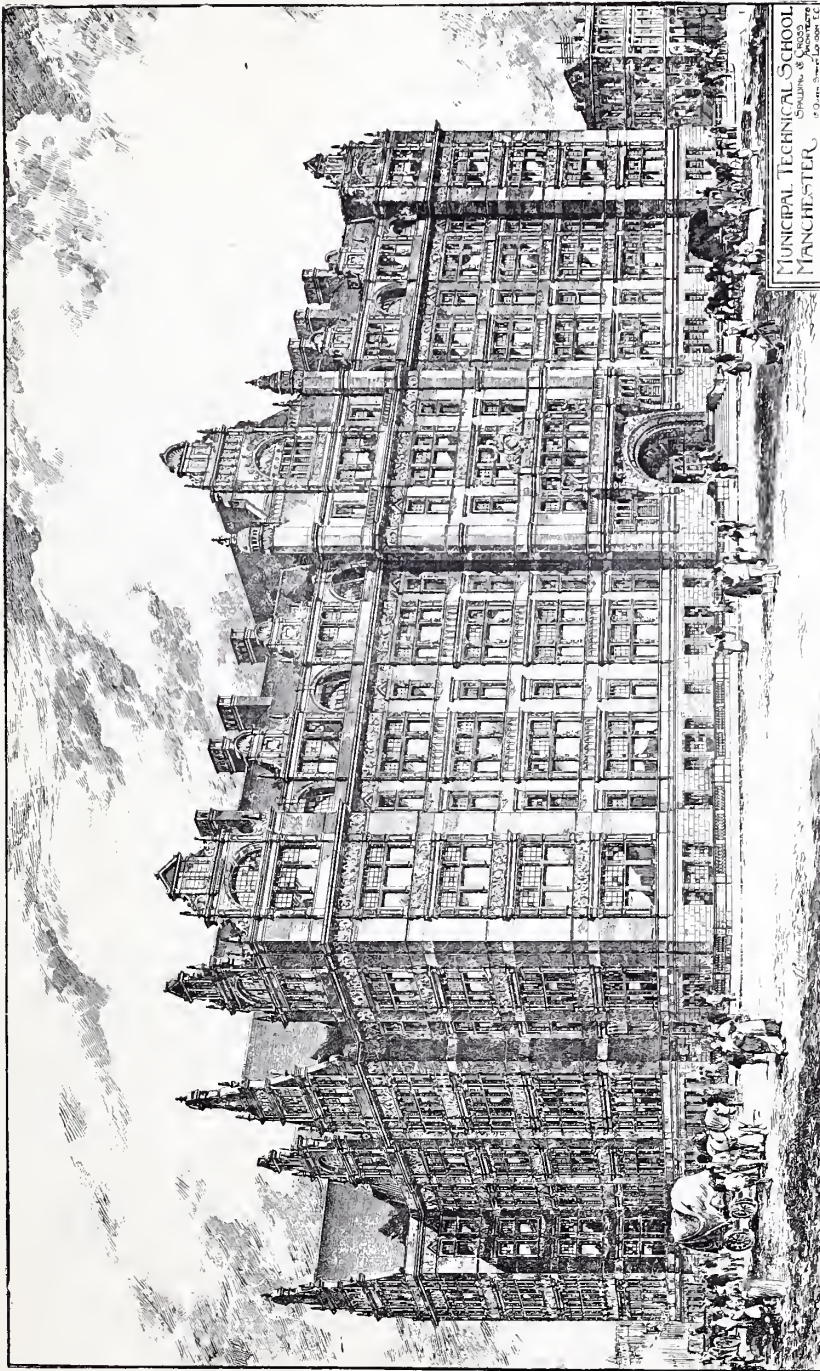

1512. *Municipal Technical School, Manchester, Spalding and Cross, Architects.*

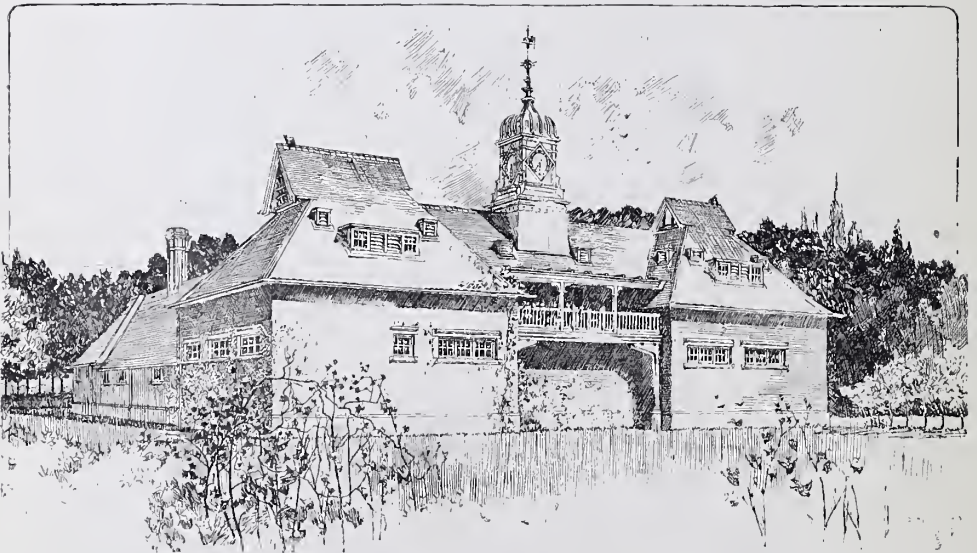
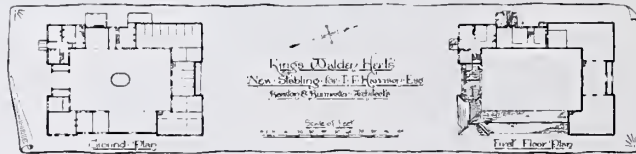

1596. *King's Walden, Herts, New Stabling for T. F. Harrison, Esq.,* BEESTON AND BURMESTER, Architects.

Contractor—W. J. Adcock, Ladywell, Dover.

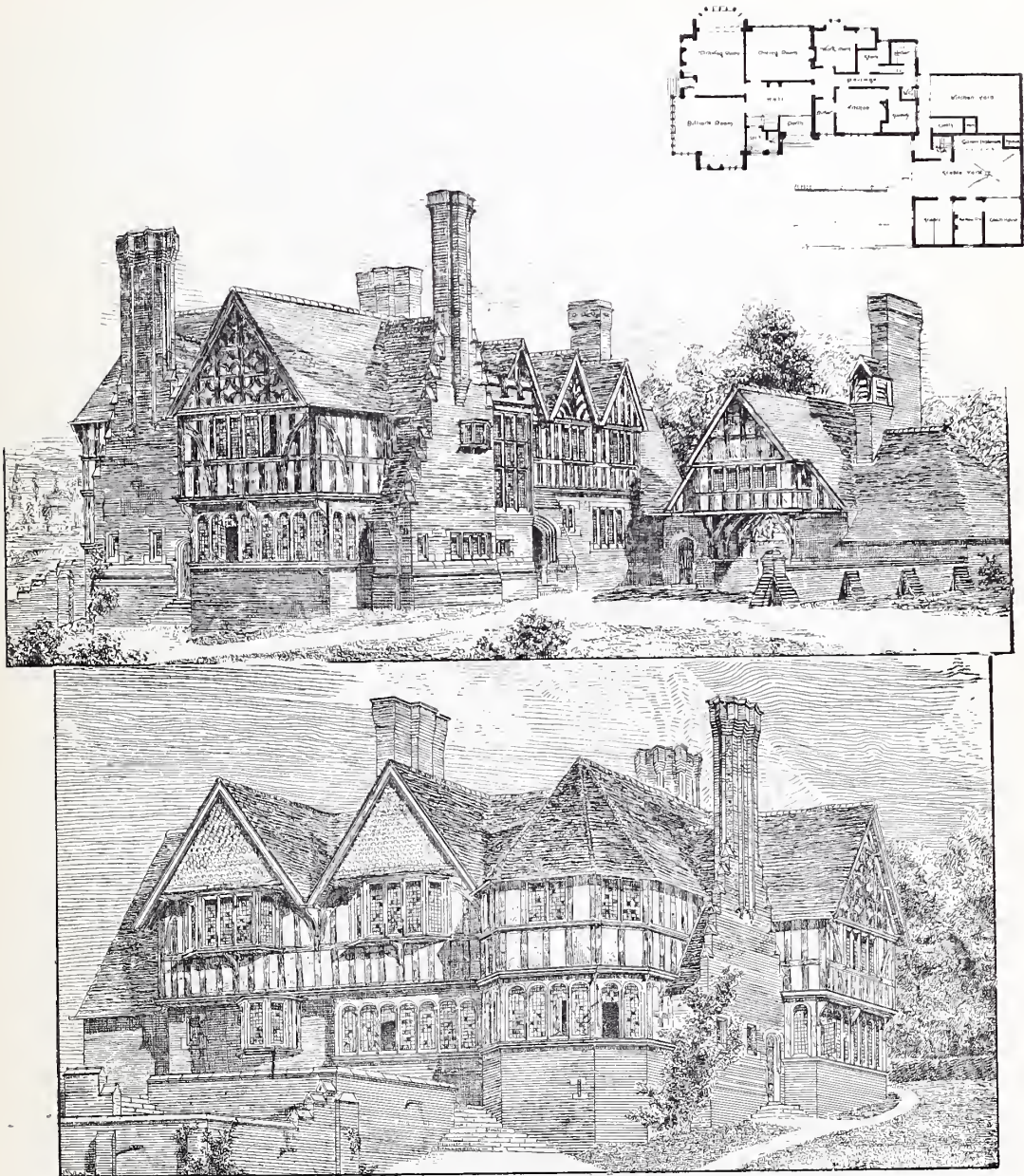

1574. *A Cheshire House, Garden Front*, JOHN CLARKE, F.R.I.B.A., Architect.

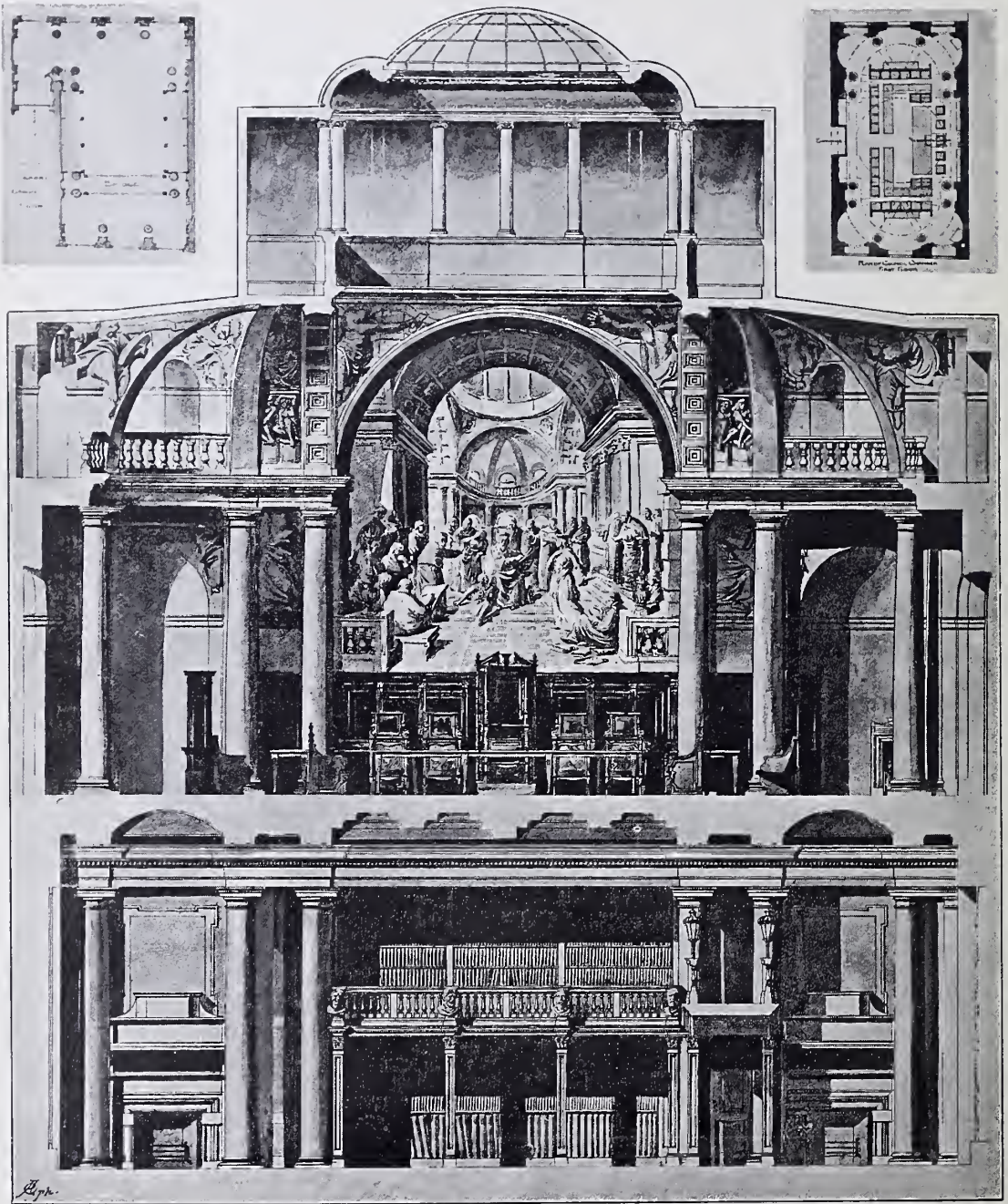

1513. Council Chamber and Library, Institute of Chartered Accountants, JOHN BELCHER, F.R.I.B.A., Architect.



1570. *New Banking Premises, Parliament Street, S.W., H. HUNTLY-GORDON, A.R.I.B.A., Architect.*

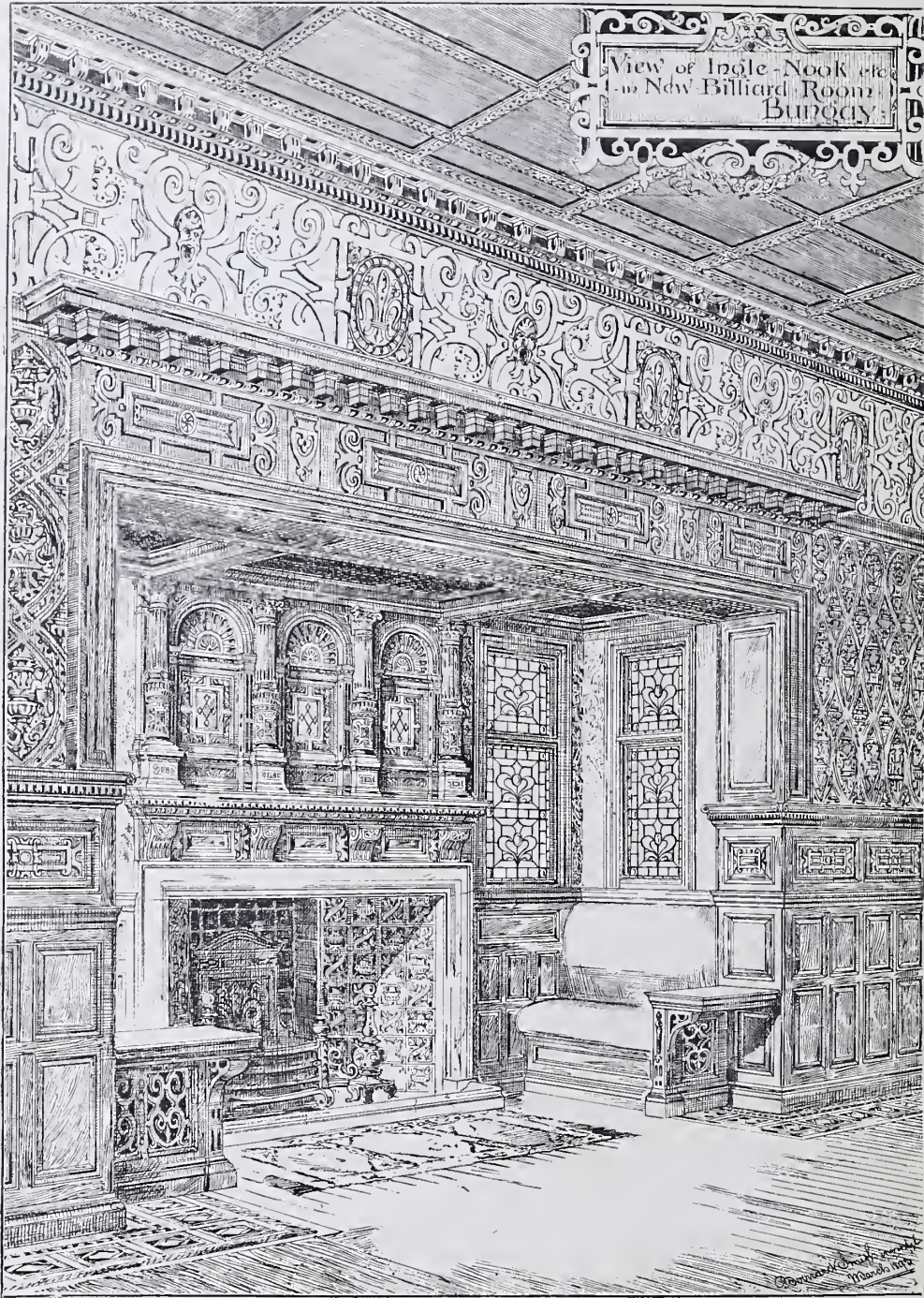

1625. *Ingle-Nook in New Billiard Room, Bungay*, BERNARD SMITH, F.R.I.B.A., Architect.

Ornamental Glazing, Tile Work, and Wall Hanging—W. E. Simpson & Sons, 100, St. Martin's Lane W.C.
Parquetry-Work—Turpin's Company, Ltd., 22, Queen's Road, Bayswater, W.

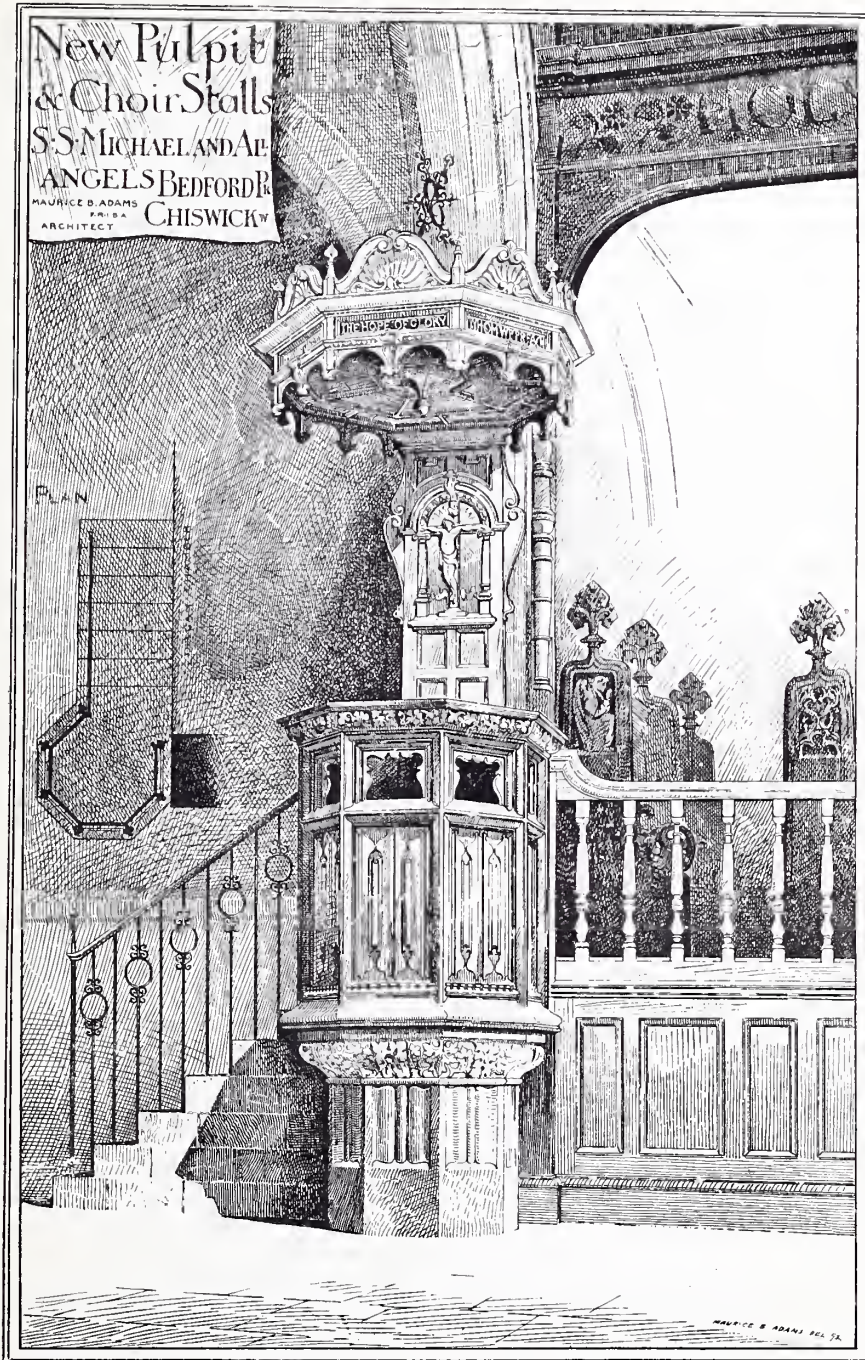

1539. *New Pulpit and Choir Stalls, St. Michael's Church, Bedford Park, W., MAURICE B. ADAMS, F.R.I.B.A., Architect.*

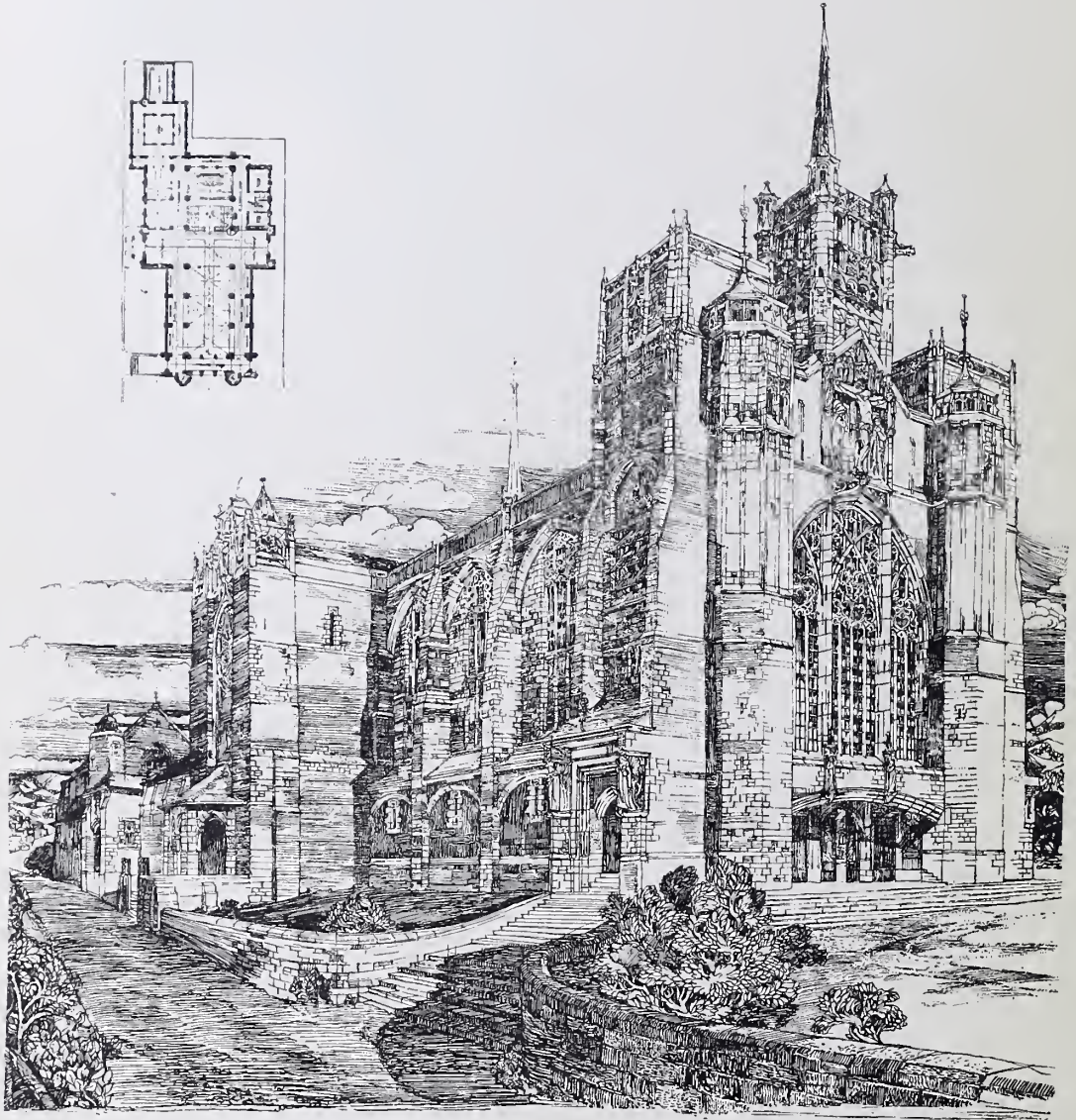

1624. *Design for New Cathedral, Victoria, British Columbia, H. WILSON, Architect.*

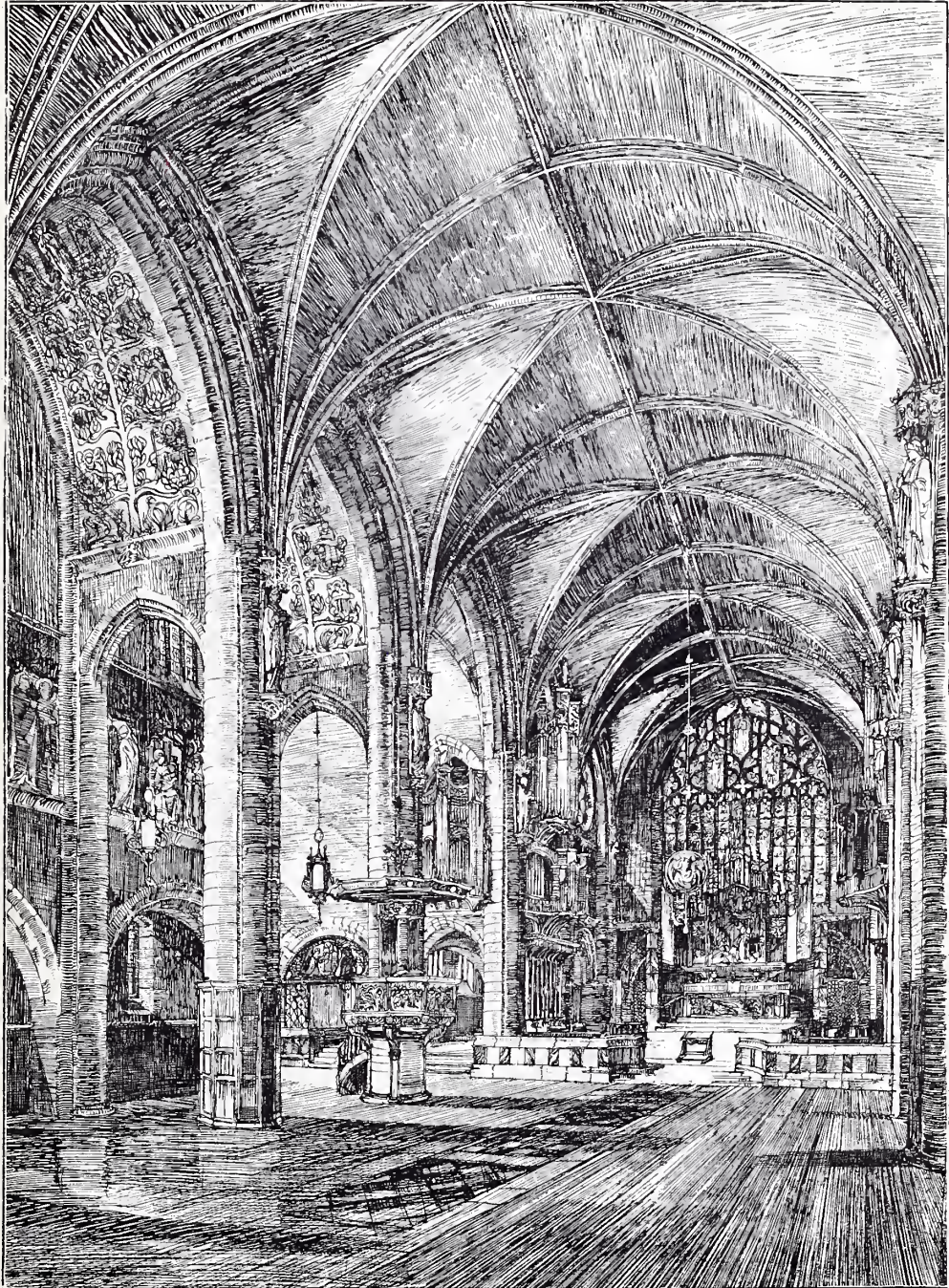

Design for New Cathedral, Victoria, British Columbia, H. WILSON, Architect.

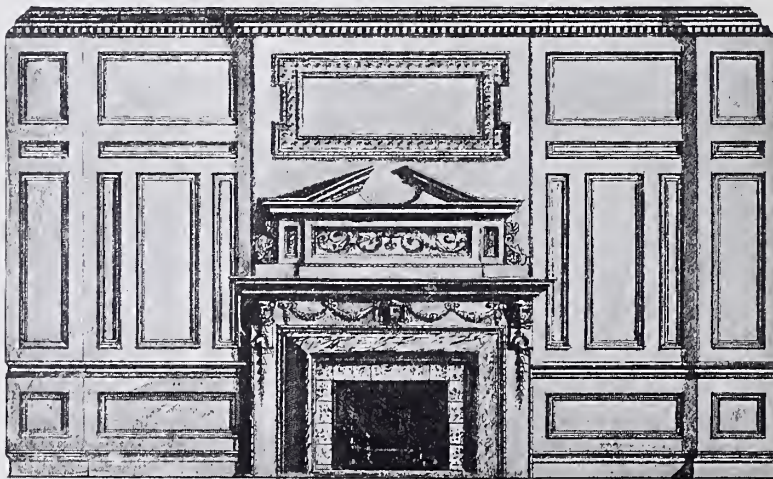
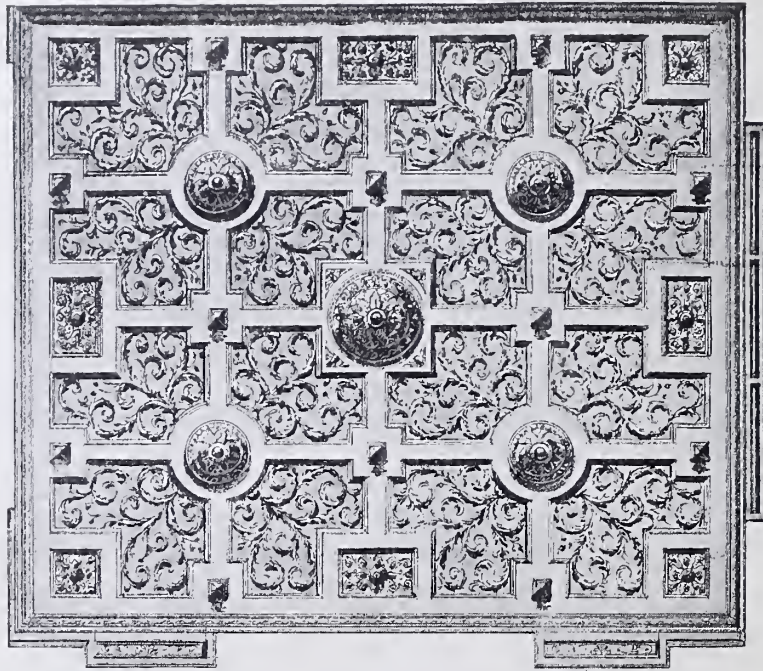

1648. *A Smoking Room in a London Mansion*, PROFESSOR GEORGE AITCHISON, A.R.A., Architect.



Design for All Saints' Church Millbrook, Cornwall, G. H. FELLOWES PRYNNE, F.R.I.B.A., Architect.

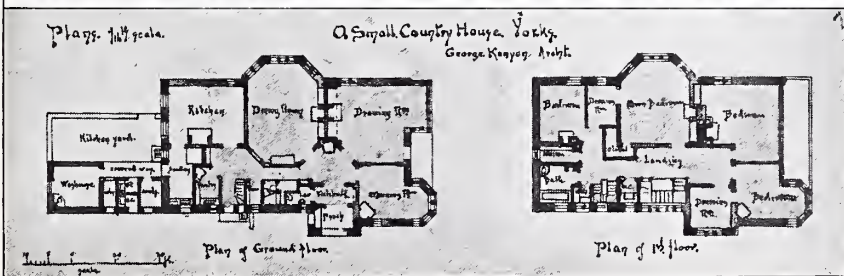

1519. Small Country House, Yorks, GEORGE KENVON, A.R.I.B.A., Architect.

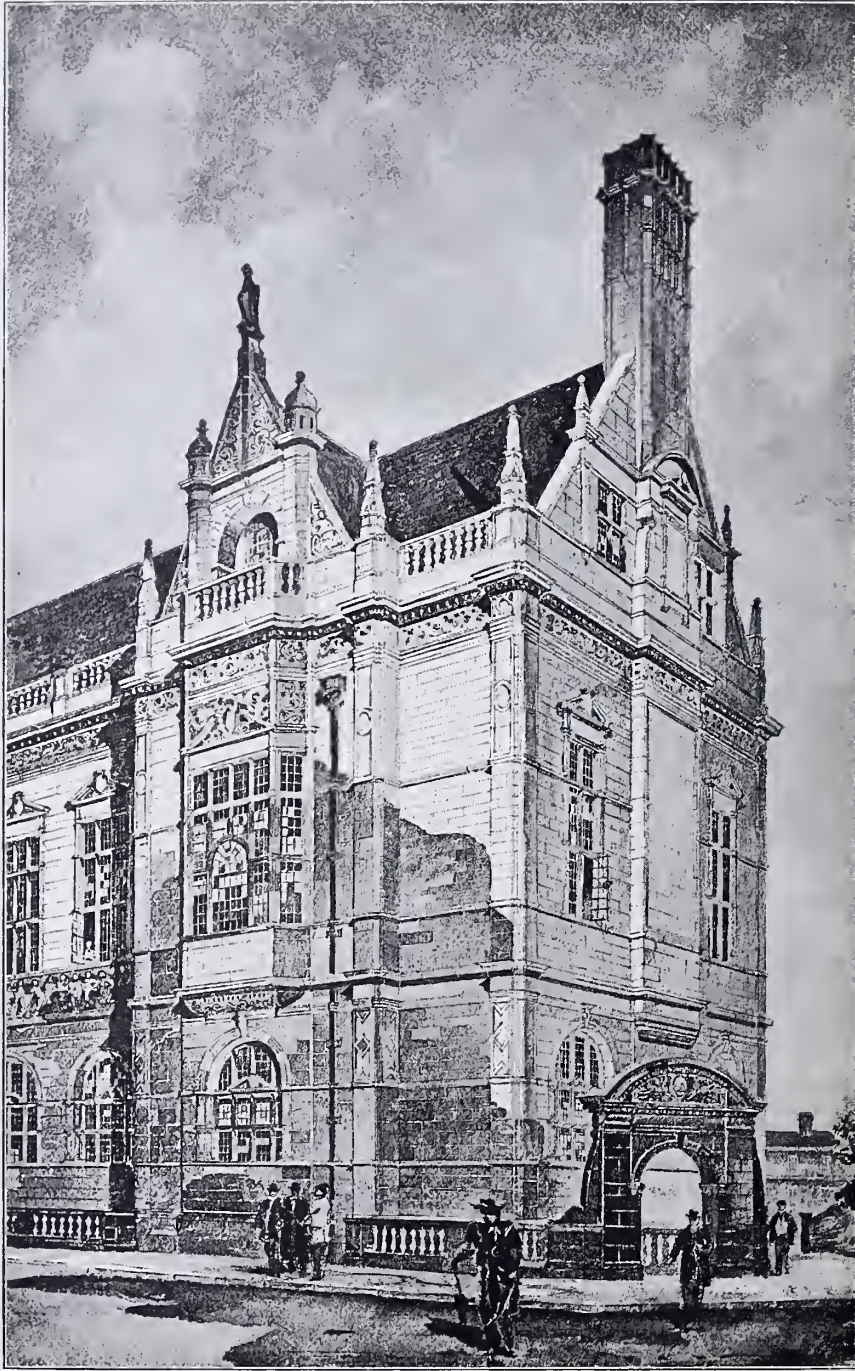

1516. *Sheffield Town Hall, south-west angle*, EDWARD W. MOUNTFORD, F.R.I.B.A., Architect.



1584. *New Banking Premises, Chester*, T. M. LOCKWOOD AND SONS, Architects.

Heating—G. N. Haden & Sons, Trowbridge, Wilts.

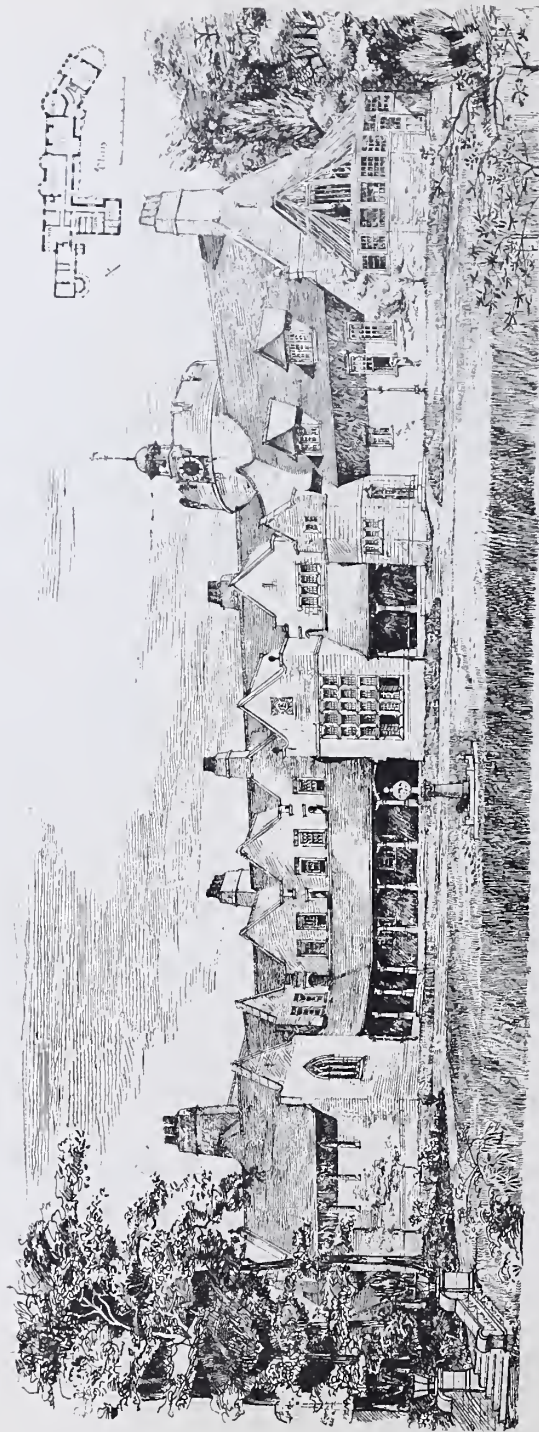

1656. *An Island Home, Lough Allen, Ireland, LEONARD STOKES, Architect.*



1575. *New Royal Infirmary, Derby, YOUNG AND HALL, Architects.*

Contractors—Walker and Slater, Uttoxeter Old Road, Derby.



1598. *Hursbourne, Hants, for the Right Hon. the Earl of Portsmouth, view from the south-east, BEESTON AND BURMESTER, Architects.*

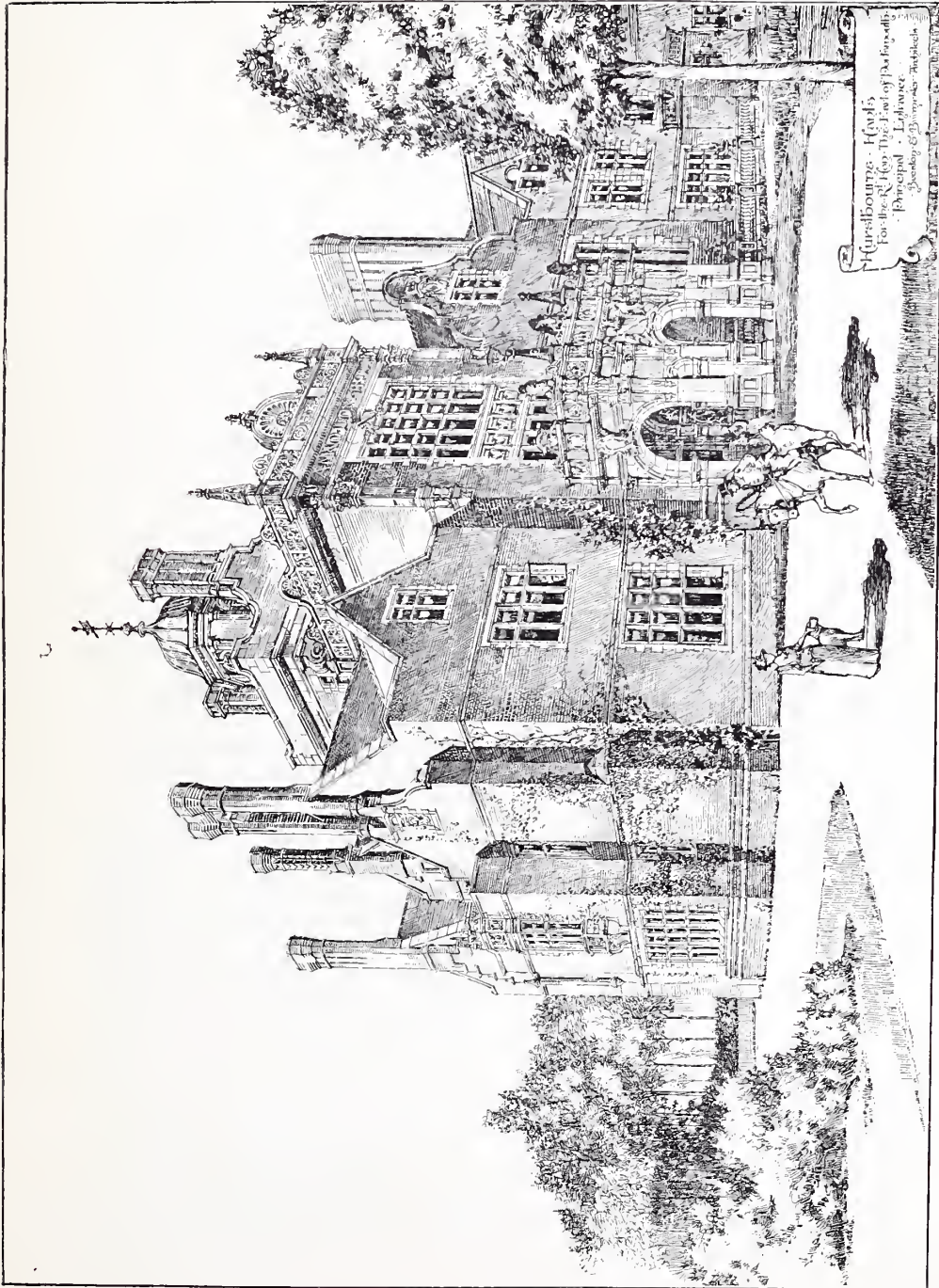

1597. Hurstbourne, Hants, for the Right Hon. the Earl of Portsmouth, Principal Entrance, BEESTON AND BURMESTER, Architects.

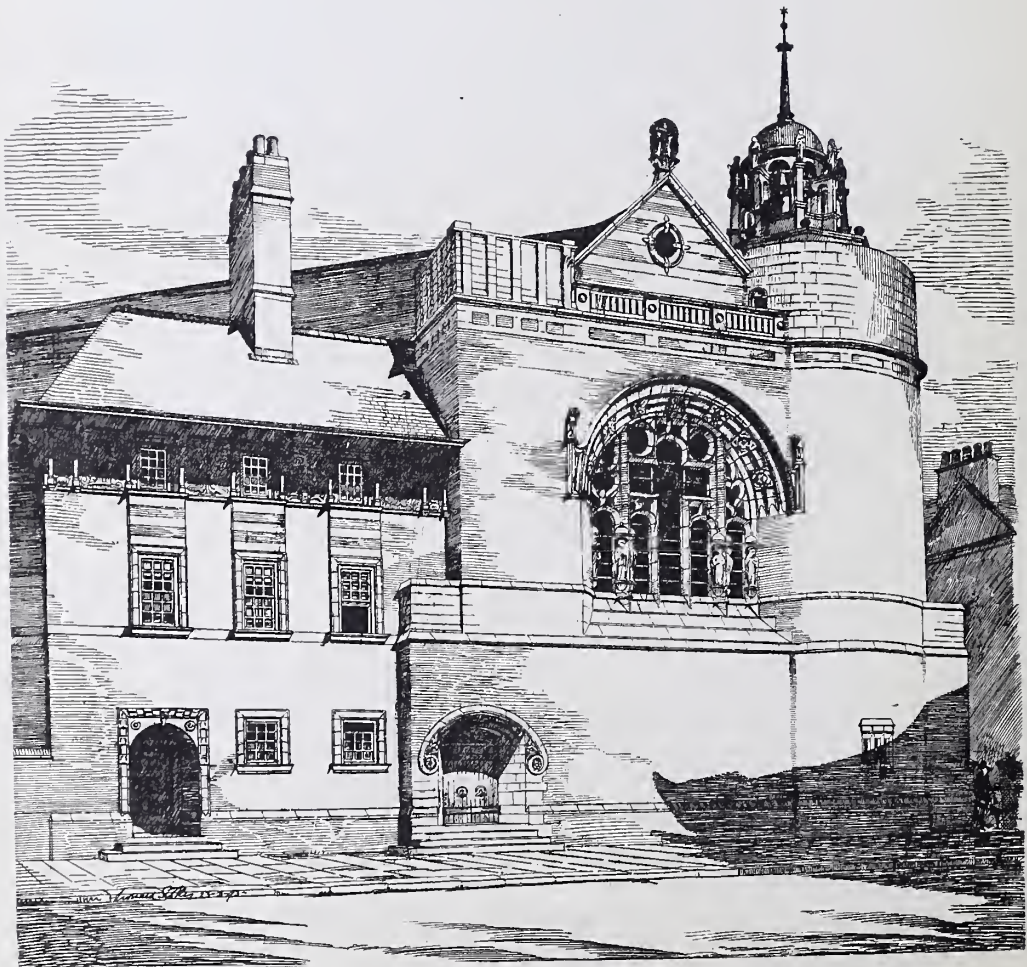
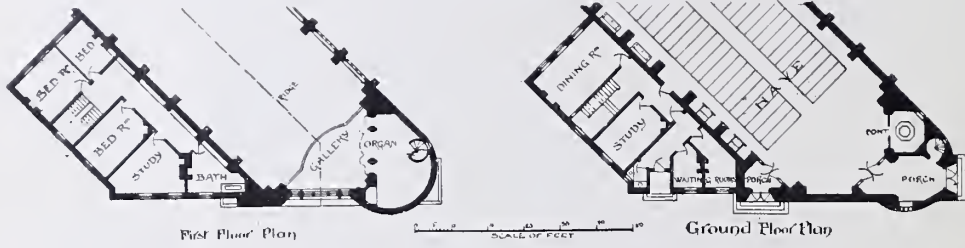

1657. A New Town Church, LEONARD STOKES, Architect.

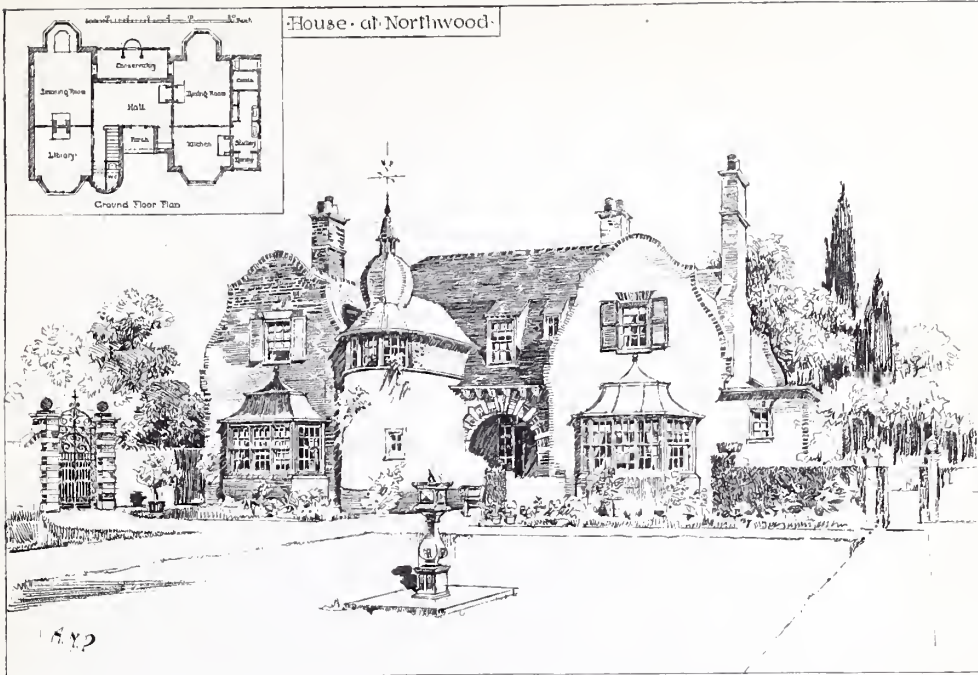

Royal Academy Exhibition 1892.

House at Northwood, R. A. BRIGGS, F.R.I.B.A., Architect.



1612. *Music Room, Highlands, Putney Heath*, WILLIAM D. CAROE, M.A., Architect.

Contractors—Turtle and Appleton, 141, St. John's Hill, Wandsworth, S.W.

Chimney-piece—Nathaniel Hitch, 60, Harleyford Road, Vauxhall, S.E., Sculptor.



1491. *St. John's Church, High Leigh, Cheshire, EDMUND KIRBY, F. R. I. B. A., Architect.*



1543. *Molcombe, for Lord Stalbridge, ERNEST GEORGE AND PETO, Architects.*

ERNEST GEORGE AND PETO,
ARCHITECTS,
15, ABINGDON STREET,
LONDON, E.C. 4.



1563. House at Tonbridge Wells, for Thomas Buss, Esq., ALFRED COX AND COOKSEY, Architects.

THE ROYAL SCOTTISH ACADEMY EXHIBITION.

1893.

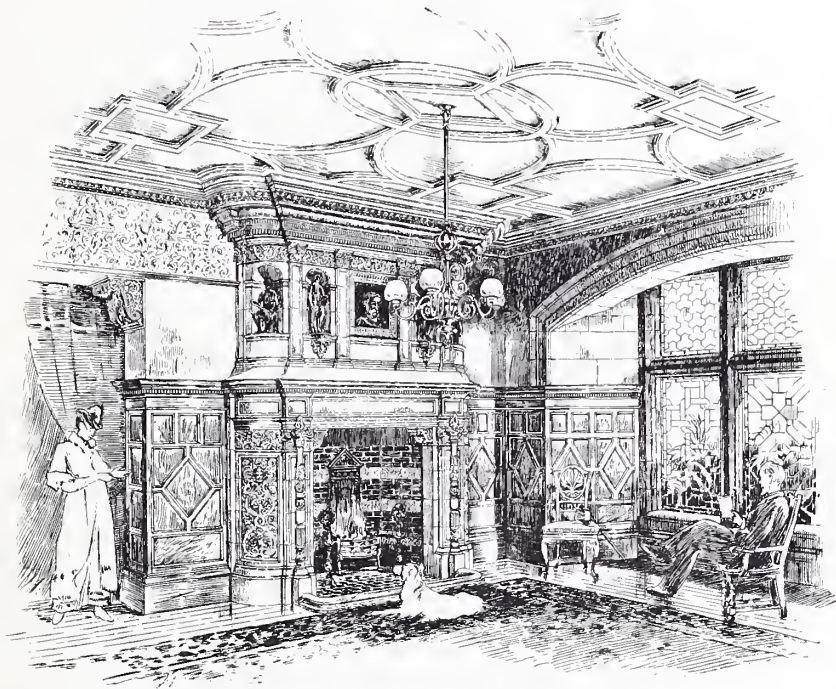

The Inner Hall

347. *Inner Hall, Dunloe, Wemyss Bay*, JOHN HONEYMAN, A.R.S.A., AND KEPPIE, Architects.



Troon Parish Church

346. Troon Parish Church, HIPPOLYTE JEAN BLANC, A.R.S.A., Architect.



496. *Design for New Free Church, Falkirk, R. MACFARLANE CAMERON, Architect.*

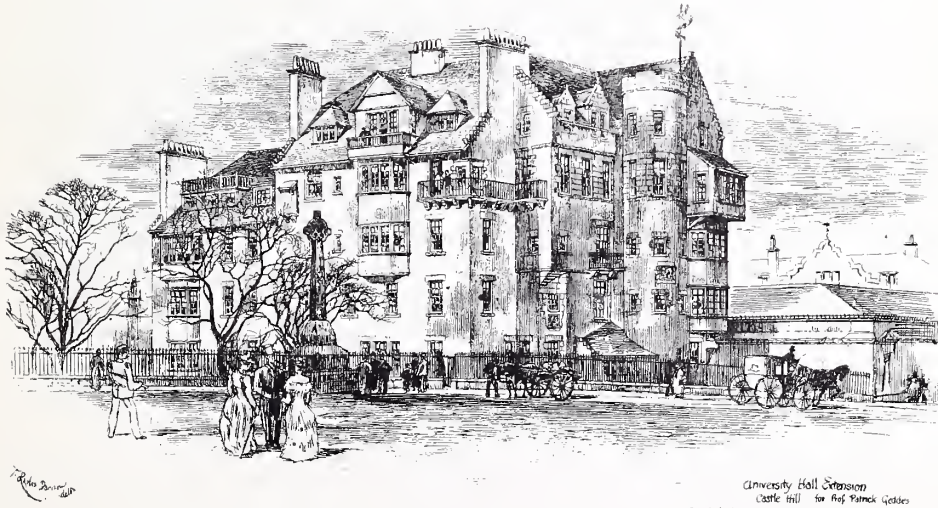

University Hall Extension
Castle Hill for Prof Patrick Geddes
by Henbest (Copper Pl. A. Architect)

504. *University Hall Extension, Castle Hill, Edinburgh, S. HENBEST CAPPER, M.A., Architect.*



357. *The Sun Fire and Life Insurance Offices, Glasgow*, WILLIAM LEIPER, A.R.S.A., Architect.

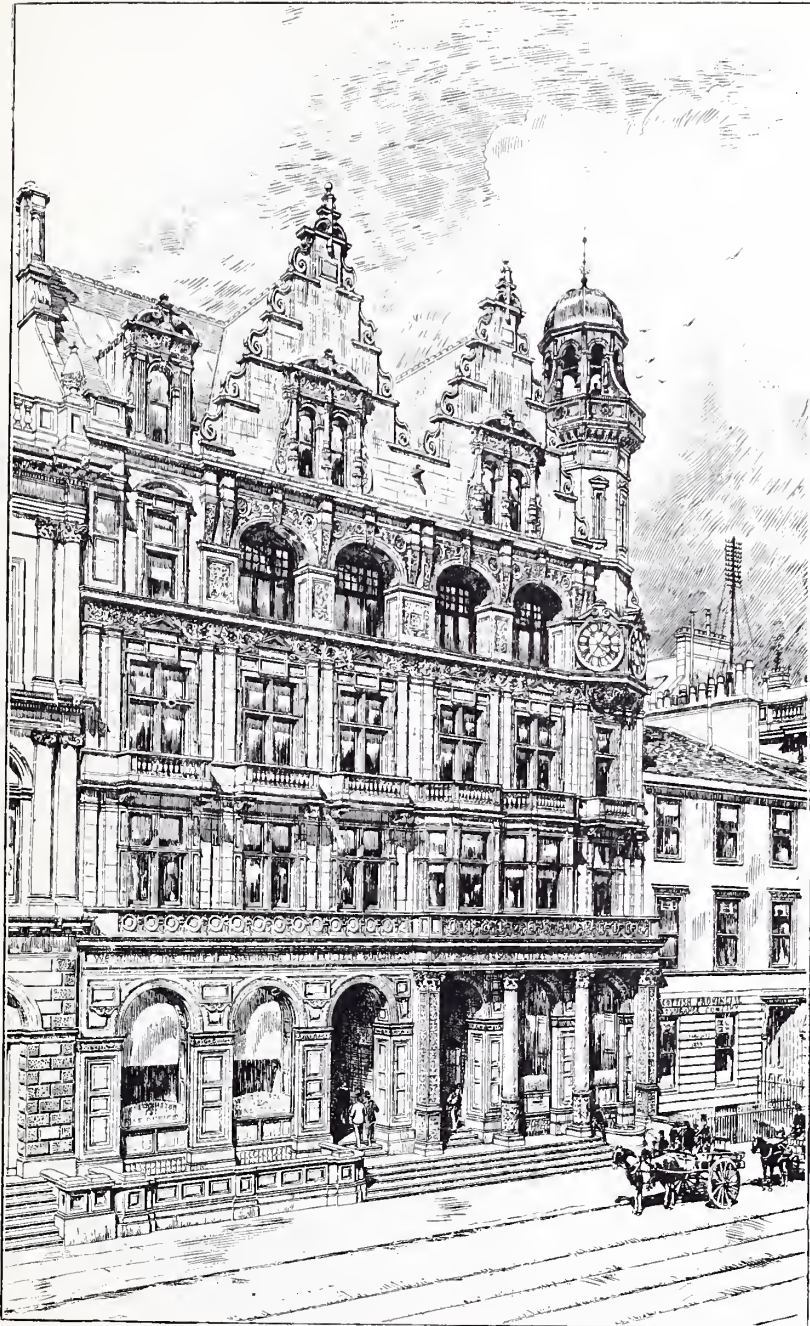

345. *Offices of the "Evening Citizen," Glasgow, THOMAS L. WATSON, F.R.I.B.A., Architect.*

Hydraulic Passenger and Goods Lifts—The Otis Elevator Company, Ltd., 4, Queen Victoria Street, E. C.



355. *First premiated Design, Alloa Public School, R. MACFARLANE CAMERON, Architect.*

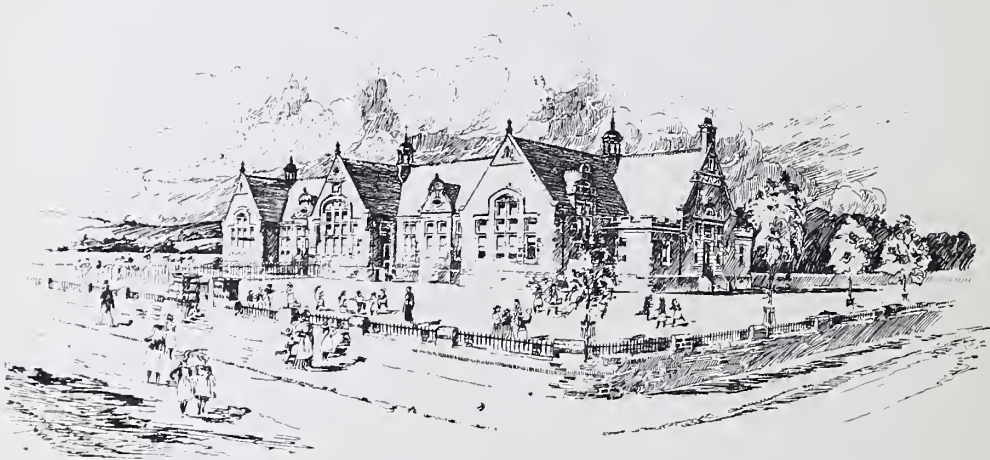

497 *First Award and Accepted Design for Kirkcaldy Public School, R. MACFARLANE CAMERON, Architect.*

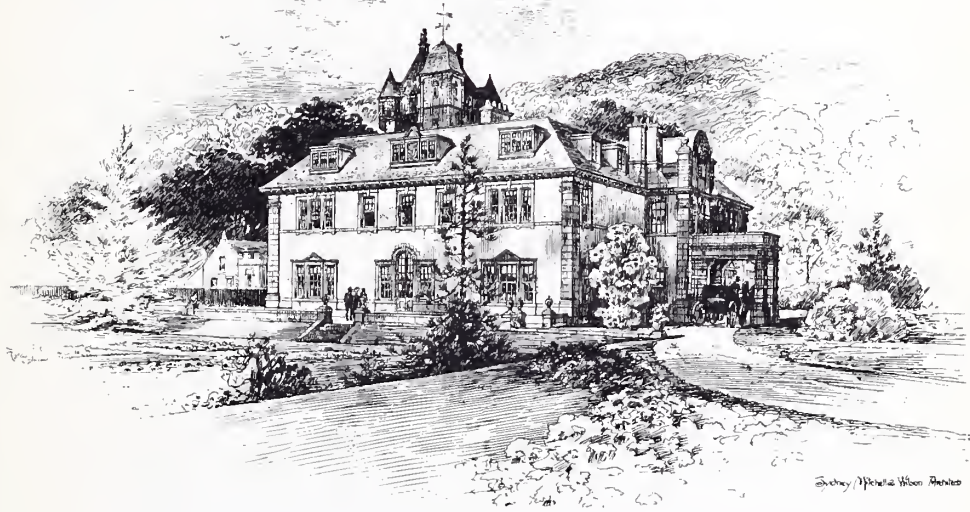

354 *Woodhall, Kircudbrightshire, for J. W. Hutchinson, Esq., SYDNEY MITCHELL AND WILSON, Architects.*

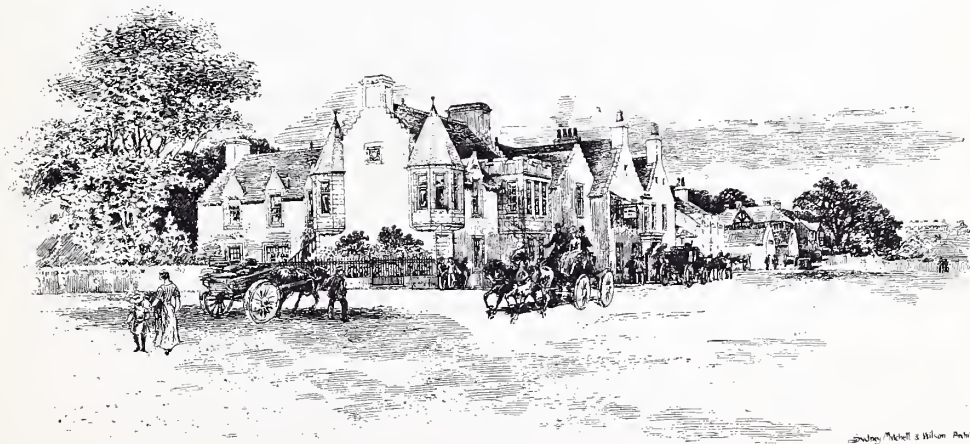

356. *Additions to the Hawes Inn, South Queensferry, SYDNEY MITCHELL AND WILSON, Architects.*

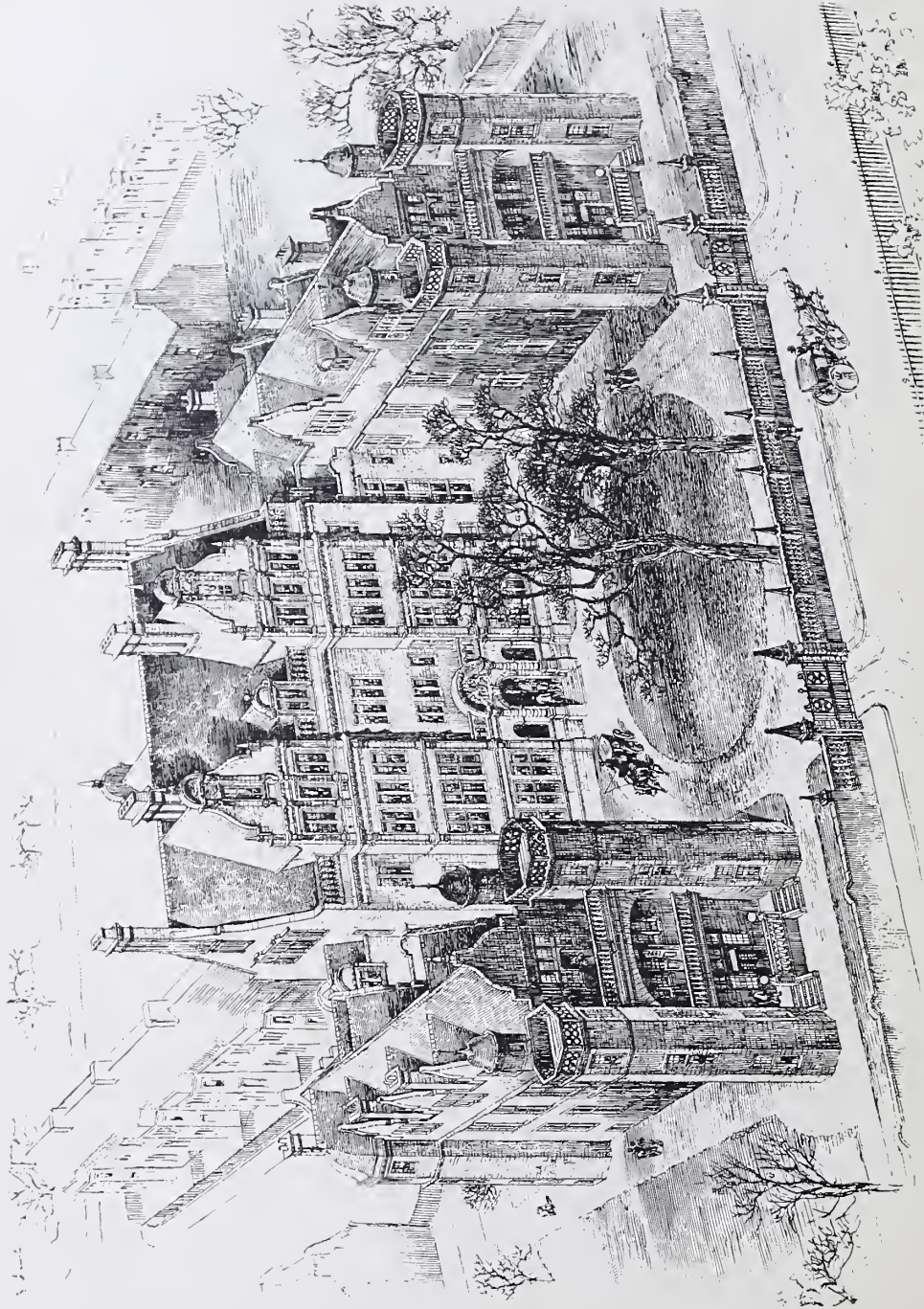

499. Royal Hospital for Sick Children, Edinburgh, Design for Rillbank Site (now in course of erection), G. WASHINGTON BROWNE, A. R. S. A., Architect.



All Souls' Chapel, Invergowrie, N.B., HIPPOLYTE J. BLANC, A.R.S.A., Architect.

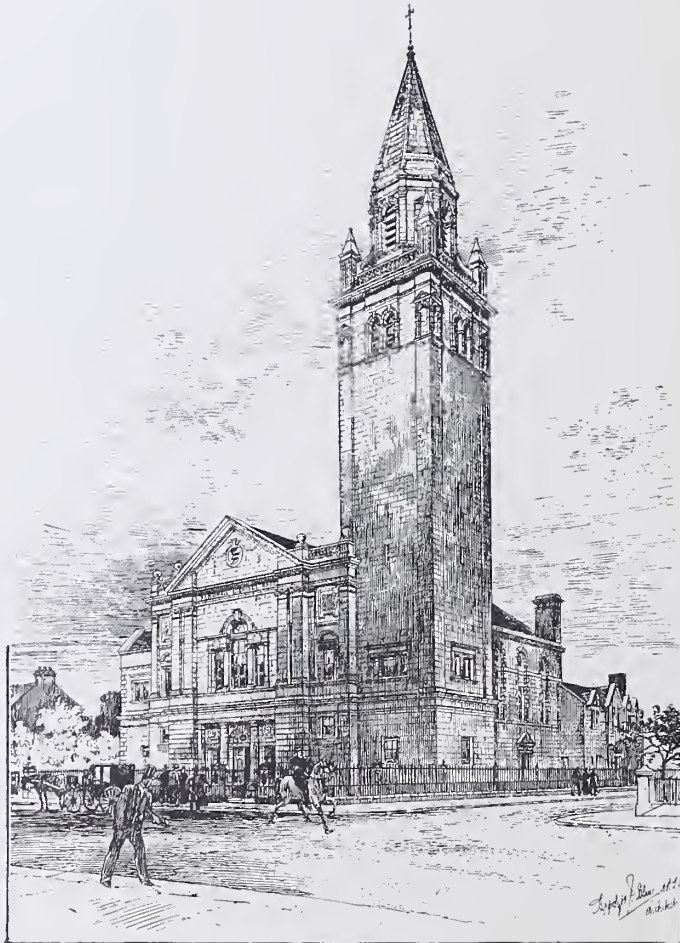

502. *New Free Church, Morningside, Edinburgh*, HIPPOLYTE J. BLANC, A.R.S.A., Architect.

THE GLASGOW INSTITUTE OF THE FINE ARTS
EXHIBITION. 1893.



783. *St. Andrew's Free Church, Ayr*, JOHN B. WILSON, A.R.I.B.A., Architect.

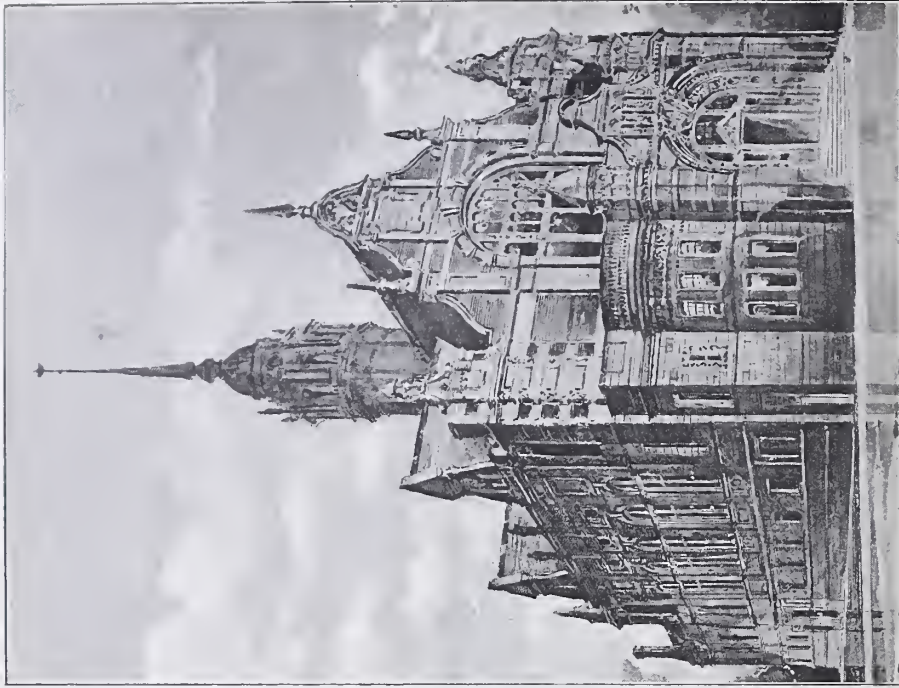

801. *Competitive design for Walsall Town Hall,*
 submitted by MALCOLM STARK AND ROWNTREE, Architects.

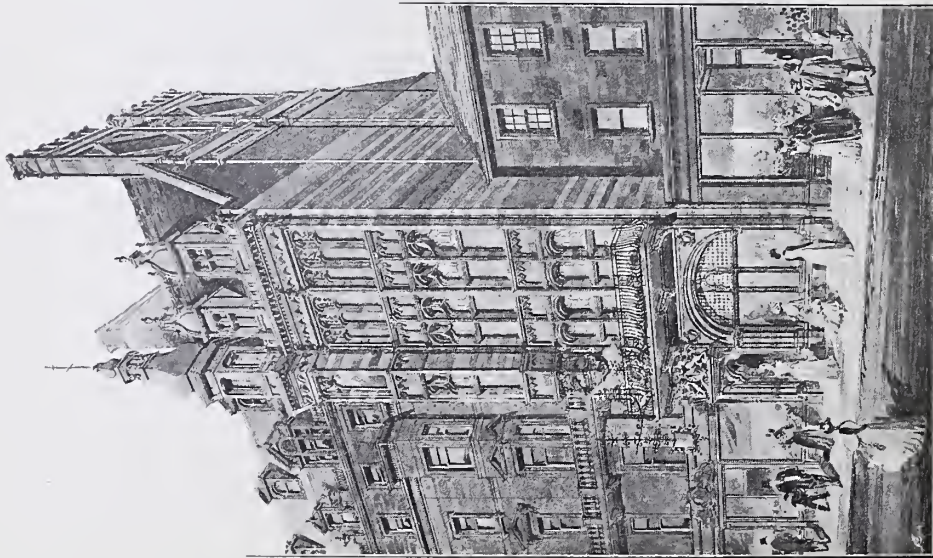

774. *New Premises, Princes Street, Edinburgh, for Messrs. Reidfern,*
 G. WASHINGTON BROWNE, A.R.S.A., Architect.

Hydraulic Passenger Lift—The Otis Elevator Company, Ltd.,
 4, Queen Victoria Street, E.C.

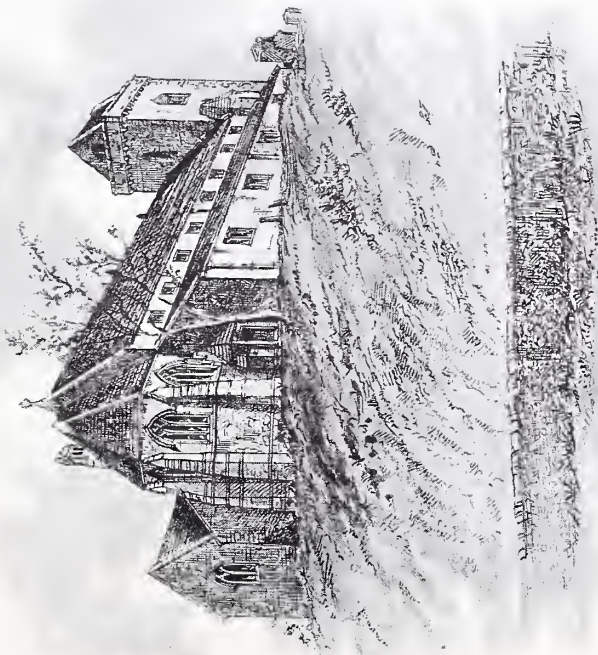
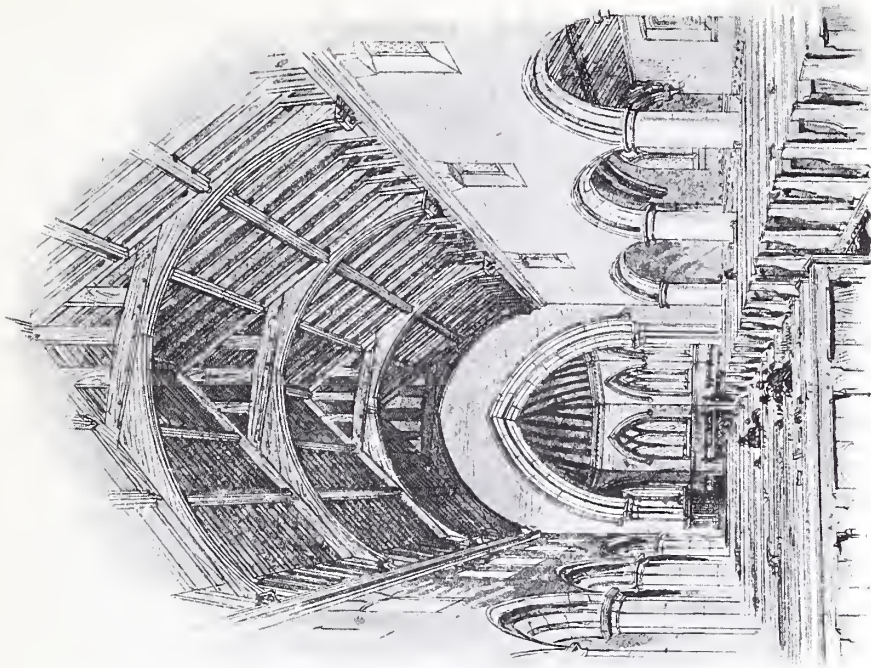

856. *St. Vitae's Church, Arbroath, Exterior and Interior views, K. ROWLAND ANDERSON, LL.D., Architect.*

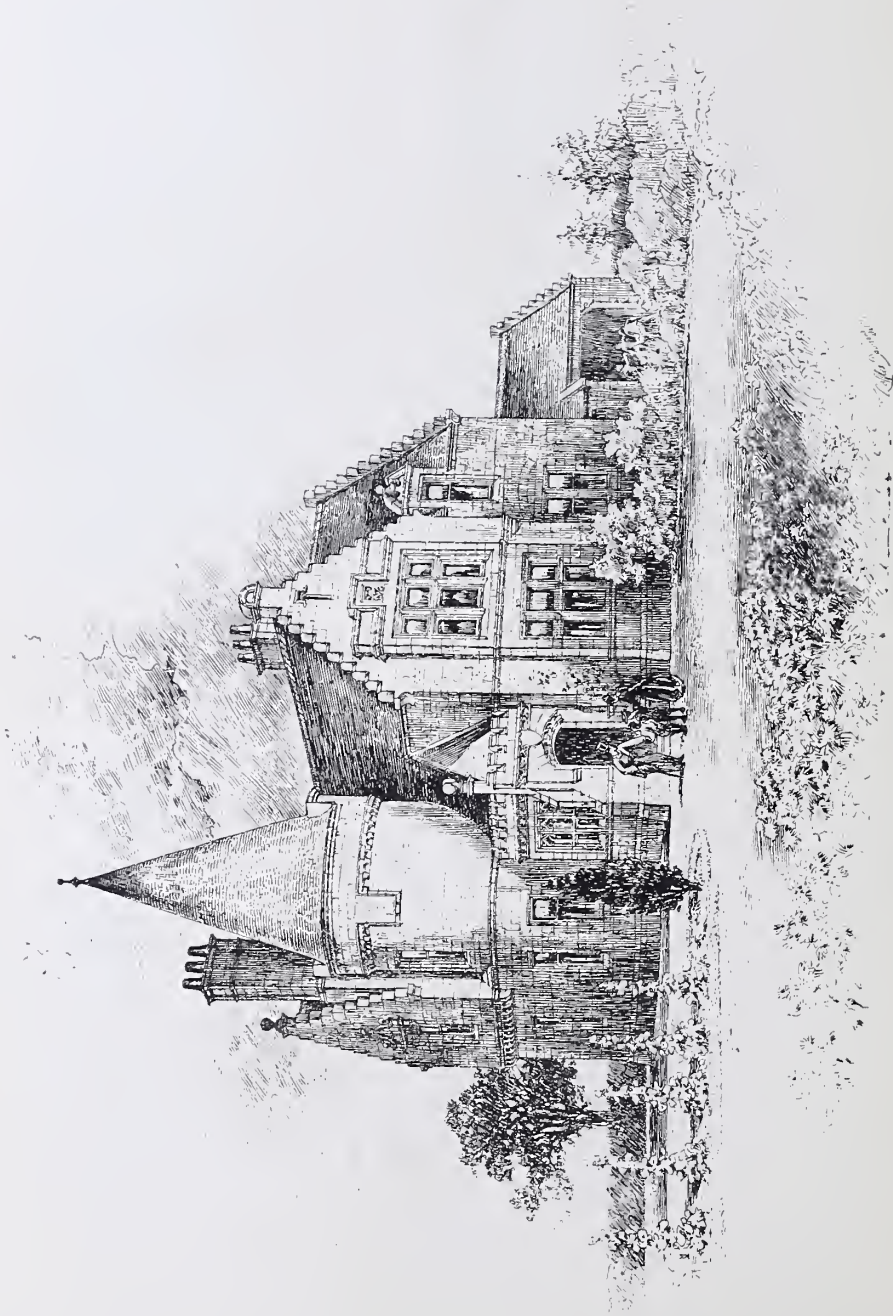

847. *Sabbath School Home, Orphan Homes of Scotland, CLARKE AND BELL, Architects.*

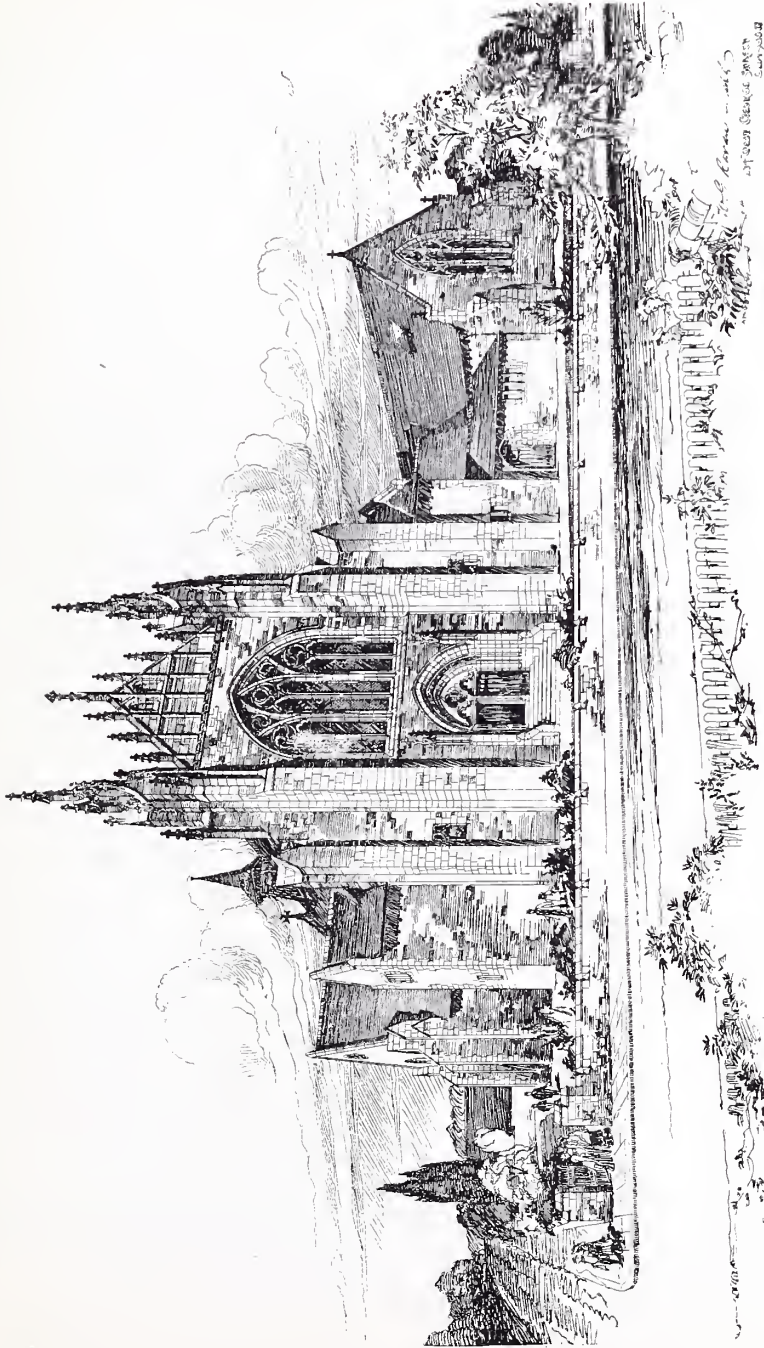

794. *Cathcart U.P. Church*, W. G. ROWAN, Architect.



797. *Gallowhill Mansion, Screen in Drawing Room, W. FORREST SALMON, F.R.I.B.A., Architect.*



770. *Design for Decoration of Porch of National Portrait Gallery, Edinburgh, now being executed,*
W. BERNIE RHIND, A.R.S.A., Sculptor.



GROUND FLOOR PLAN.

785. *Redcliff, Troon*, H. E. CLIFFORD, Architect.802. *House at Pollokshields*, JAMES MILLER, Architect.

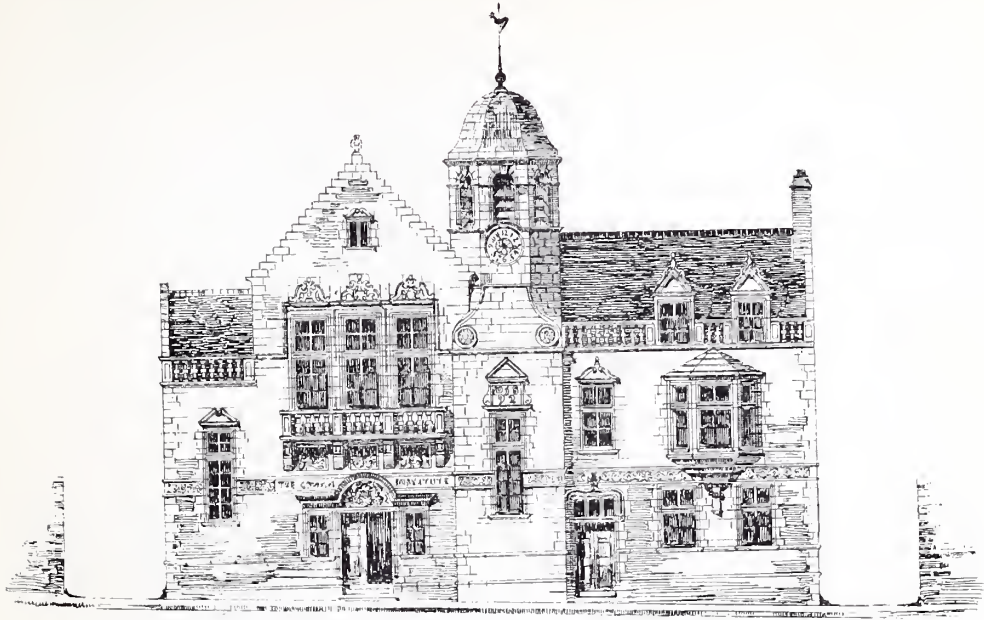

825. *The Cowan Institute, Penicuik*, CAMPBELL DOUGLAS AND MORRISON, Architects.

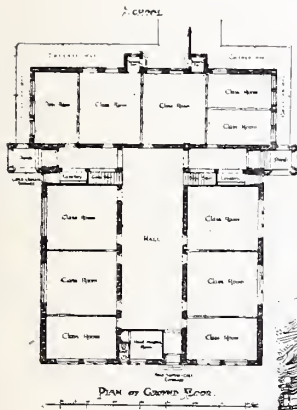

792. *Design for School*, H. E. CLIFFORD, Architect.



854. *New Free Church, Moffat, DAVID B. BURNIE Architect.*

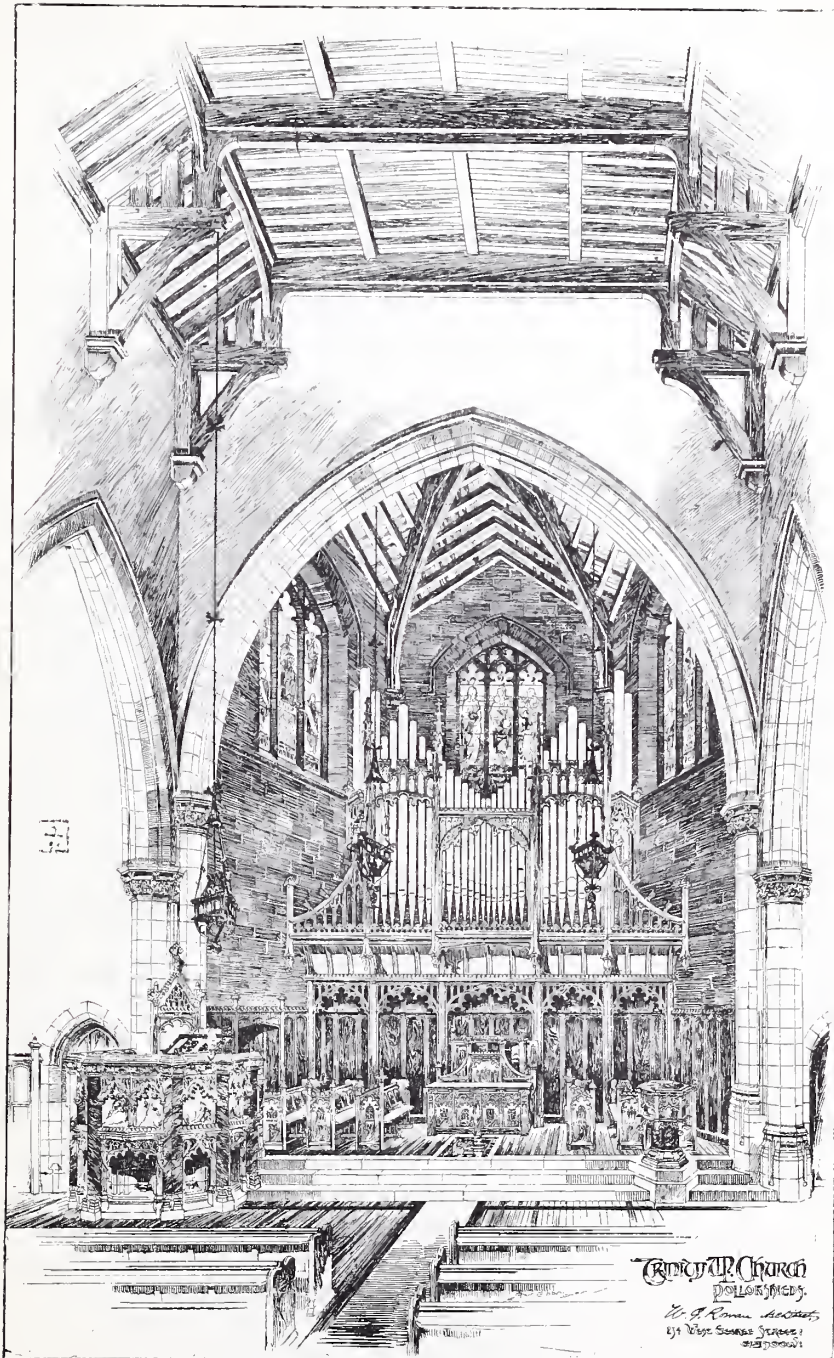

Trinity U.P. Church, Pollokshields, Glasgow, W. G. ROWAN, Architect.

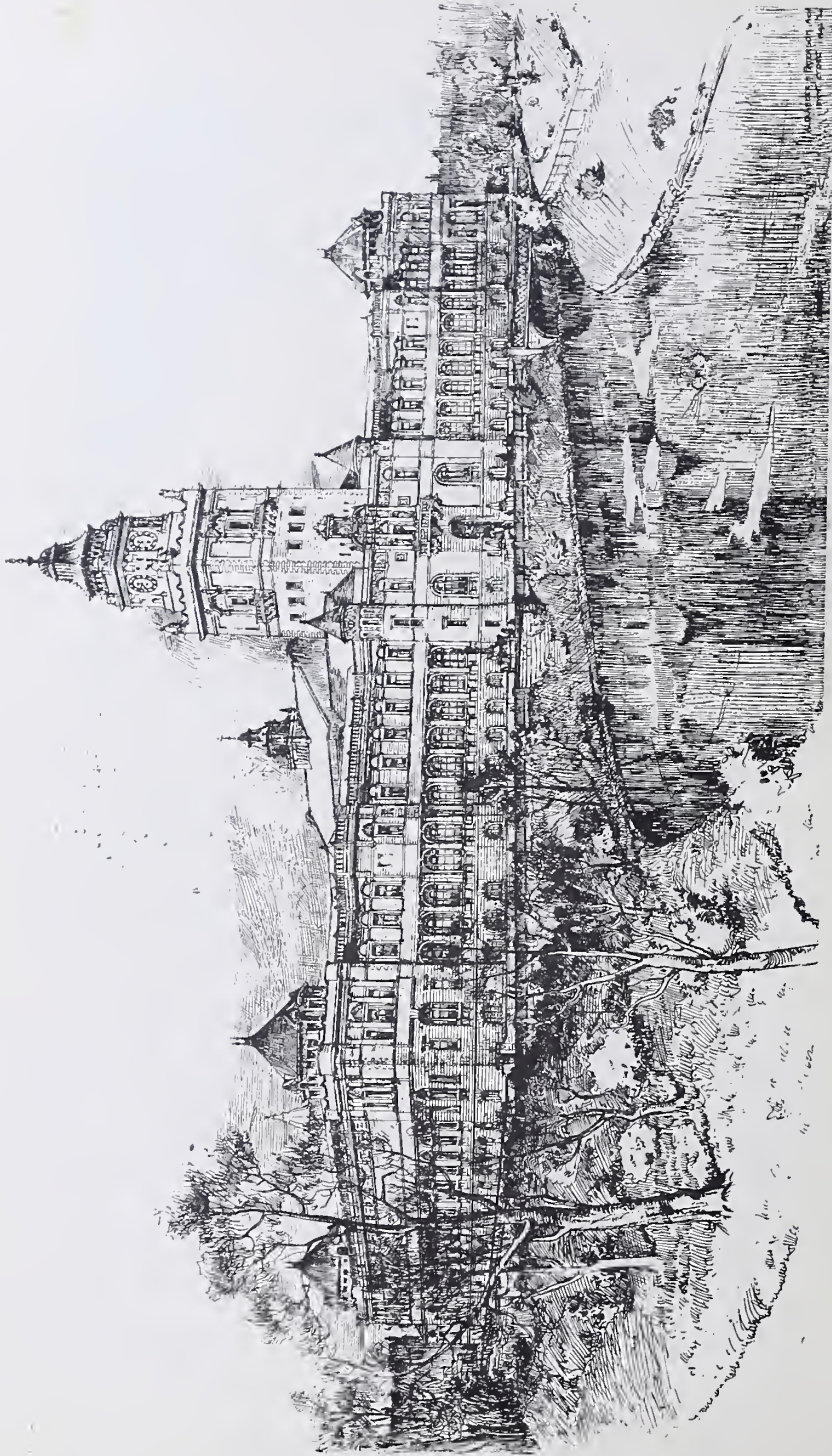

787. *Competitive design for Glasgow Art Galleries and Museum, submitted by ALEX. N. PATERSON, M.A., Architect.*

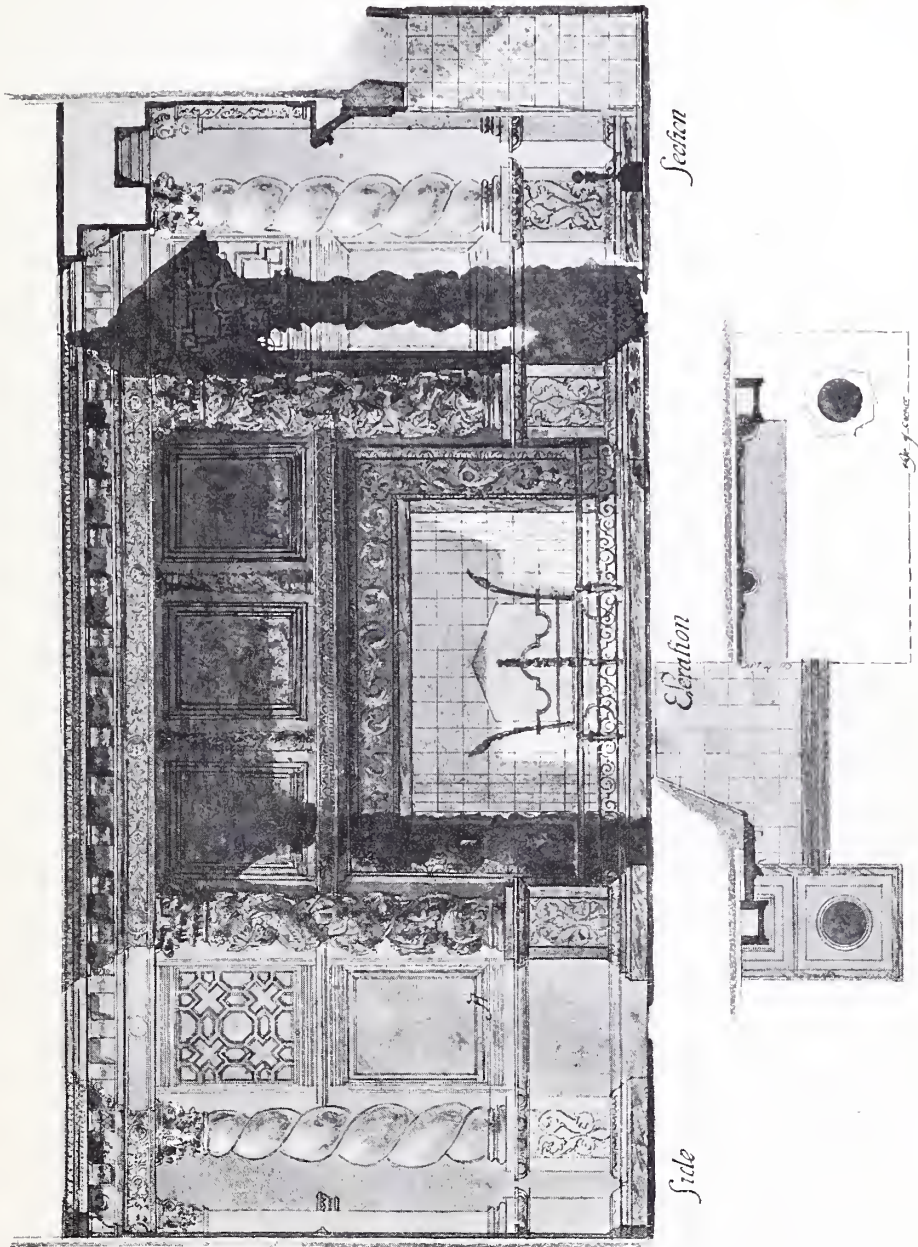

812. Drawing of Chimney-piece for J. N. GRAHAM, Esq., WILLIAM J. ANDERSON, Architect.

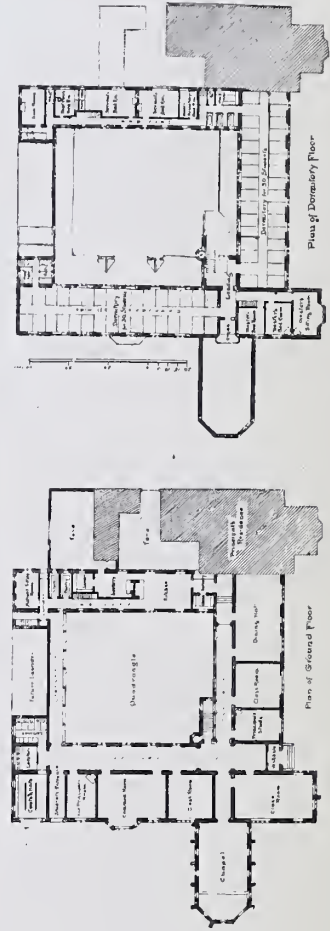

*North Wales Training College, Bangor, ROBERT GRIERSON, A.R.C.A., Architect.
Royal Cambrian Academy Exhibition, 1893.*

OTIS ELEVATOR COMPANY, LIMITED.

Late AMERICAN ELEVATOR COMPANY.

Sole Manufacturers of "Otis" Elevators (or Lifts) for Great Britain, the Continent, and the East.
HYDRAULIC, ELECTRIC, STEAM, & C.

Mansion House Buildings, 4 Queen Victoria Street, London, E.C.

TELEPHONE No. 1710.

Directors.—EDWARD WOODS, M.Inst.C.E., *Chairman*,
HENRY SHERLEY-PRICE, M.Inst.M.E.

Telegraphic Address—"LYNDENTREE, LONDON."

W.M. AUGUSTUS GIBSON, *Managing Director*,
NORMAN SCOTT RUSSELL, M.Inst.C.E.

ROBEKI H. THORPE, Assoc. M.Inst.C.E.

Secretary.—ARTHUR L. GIBSON.

GLASGOW, LIVERPOOL, MANCHESTER, BIRMINGHAM, BERLIN, ROWE, AMSTERDAM, STOCKHOLM, PARIS, BRUSSELS.

All Communications to be addressed to the Company.

THE OTIS STANDARD HYDRAULIC ELEVATOR is in use in the leading Hotels and Office Buildings of the World. List of users will be sent on application.

OTIS ELEVATORS are made to work from all sources of power.

THE OTIS ELECTRIC ELEVATOR represents the best and most modern development of this branch of Engineering.

It is as SAFE and SIMPLE as the Otis Hydraulic Elevator, of which more than 15,000 are in daily use, and in every Country.

We recommend its adoption whenever an electrical current can be employed with more advantage than water power.

Unlike all other Elevators this electrical engine consumes power only in proportion to the load lifted.

The engine is so constructed that it starts and stops with the winding machinery.

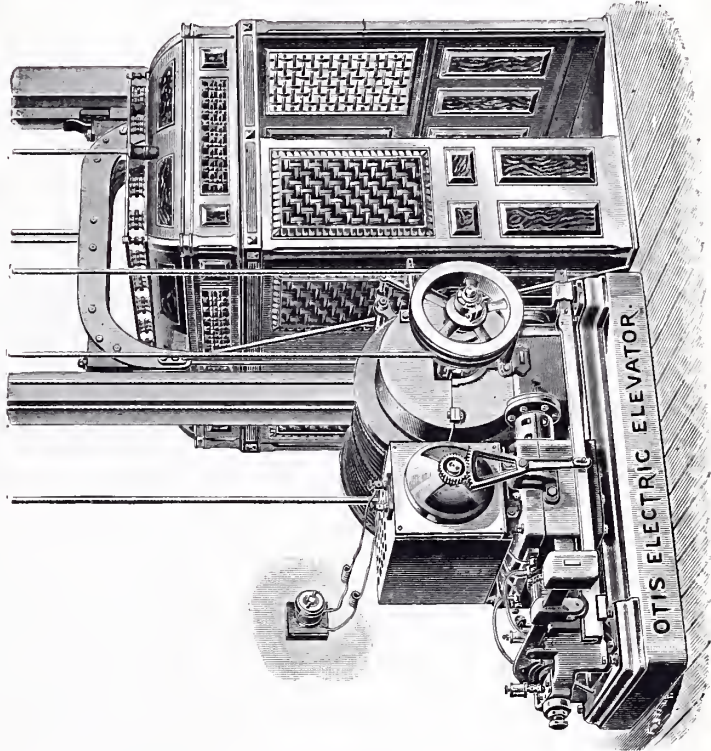

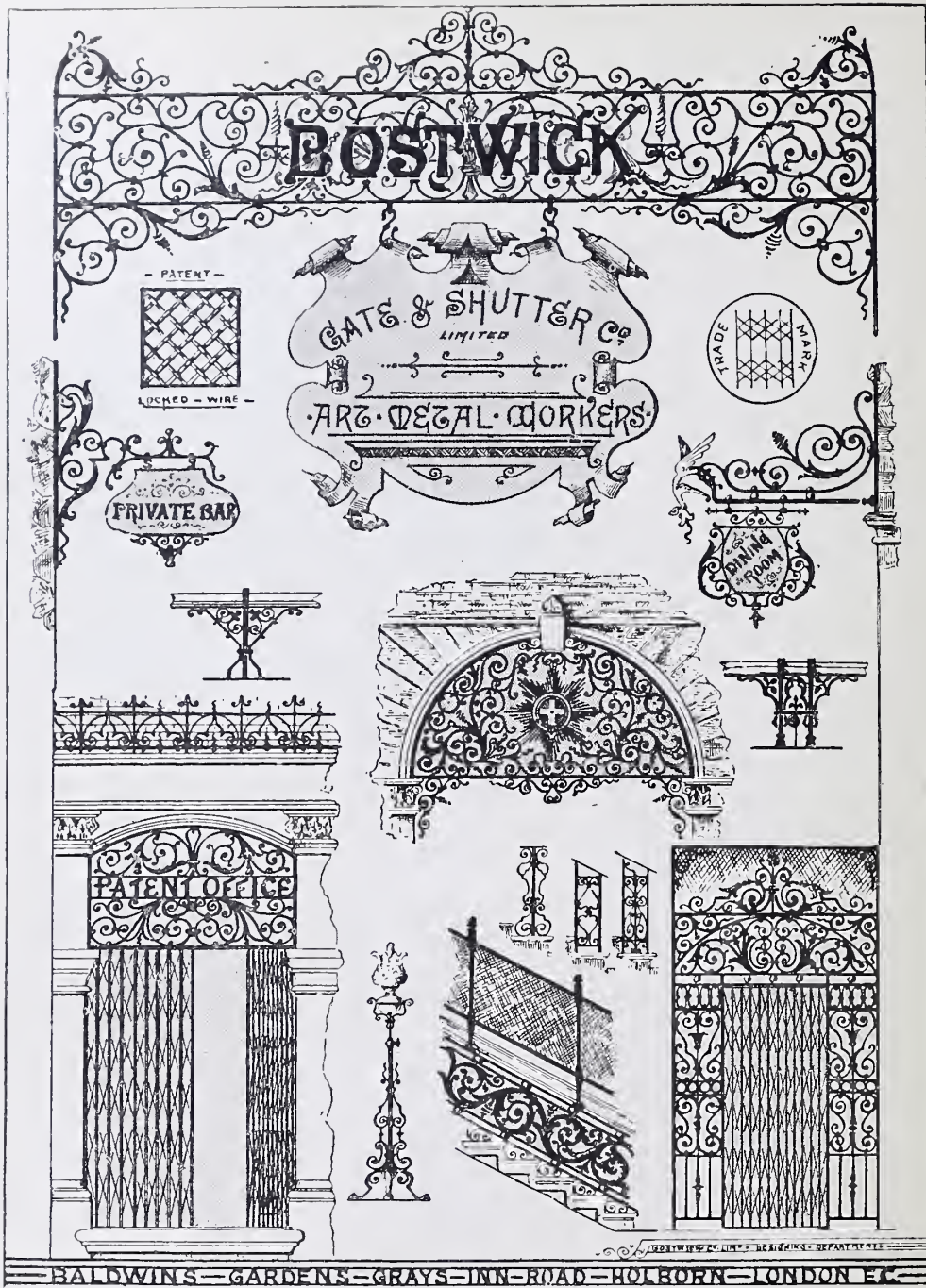

All work made on our own Premises. We invite Architects' inspection during progress. Architects' Designs carefully worked out. Estimates and Designs for all classes of work in any Metal.

THE BOSTWICK GATE AND SHUTTER CO., Limited,
 BALDWIN'S GARDENS, GRAY'S INN ROAD, LONDON, E.C.

ANNUAL ARCHITECTURAL REVIEW, 1893.



The
John Ericsson Memorial
at Filipstad in Sweden.

Hans Hedlund & Niels Rasmussen
Architects
Gothenburg.

The John Ericsson Memorial, Filipstad, Sweden, HEDLUND AND RASMUSSEN, Architects, Gothenburg.

By Her Majesty's



Royal Letters Patent.

ESTABLISHED 1886.

DE RIDDER'S PATENT "SMALL PIPE SAFETY."

NEATNESS.



FULL
SIZE OF
PIPE.

Patronized by

HER MAJESTY'S WAR OFFICE,
THE LONDON SCHOOL BOARD,
THE HANLEY SCHOOL BOARD,
THE MERSEY DOCKS & HARBOUR
BOARD,
THE LEADING LONDON AND PRO-
VINCIAL ARCHITECTS, &c.
APPROVED BY THE PRINCIPAL
INSURANCE COMPANIES.

DURABILITY.



BEST
WROUGHT
IRON.

HOT WATER HEATING APPARATUS FOR WARMING & VENTILATING

Churches, Chapels, Schools, Mansions, Residences, Conservatories, Public Buildings of all kinds; also Turkish and other Baths; Laundries, Drying Rooms, Manufactories and Buildings of every Description.

THIS APPARATUS consists of a continuous tube of only one inch and-a-quarter in diameter, a portion of which forms a Coil, and is placed in a furnace which heats the water in the Coil, causing the Circulation, A Special Expansion Tube with self-acting Valve, &c., which does not seal or bottle up the Apparatus, but provides amply for both the Expansion of Water and Escape of Air, without Loss of Water, a result hitherto thought impossible: thus my Apparatus cannot justly be called High Pressure or Dangerous.

CAUTION.—Attempted Infringement necessitates notifying that "The combination of an Expansion Tube with a Safety Valve" is covered by my Patent, and can only be supplied by me.

SAFETY.—It is perfectly Safe, there being neither Boilers, Steam, Metal Plates, Cisterns to boil over or cause undue strain, nor Hermetical Sealing of the Apparatus. It can also (when desired) be charged with Non-Freezing Liquid, and can be fired any weather, regardless of Frost.

**NO TWO QUALITIES OF PIPING USED. ONLY COMPETENT & STEADY MEN EMPLOYED. NO PIECEWORK ALLOWED.
EVERY APPARATUS IS GRATUITOUSLY GUARANTEED.**

ADVANTAGES.—NO HERMETICAL SEALING—NO CISTERN to boil over or get out of order—NO BOILER—NO STEAM—NO CAST IRON PIPES—NO BURNT AIR OR SULPHUR FUMES—"THE ONLY" SYSTEM PROVIDING FOR SILENT AND SELF-ACTING EXPANSION (without loss) OF WATER AND RELIEF OF AIR.

Plans and Estimates Furnished Free of Charge on Application.

R. P. DE RIDDER, HEATING and VENTILATING
ENGINEER, ETC.,
FAIRFIELD STREET, FAIRFIELD, LIVERPOOL.

(Telegraphic Address—"DERIDDER, LIVERPOOL.")



Brackets, New Public Schools, Zürich, ALEX KOCH, Architect, A. BOESCH, Sculptor, Zürich.



The Angel of Death staying the hand of the Sculptor. From the Monument erected over the grave of the late Martin Milmore, Sculptor, Boston, U.S.A., Composition of DANIEL CHESTER FRENCH, Sculptor, New York.



Return from hunting the Wild Boar (Paris Salon)

ANTONIN LARROUX, Sculptor, Paris.

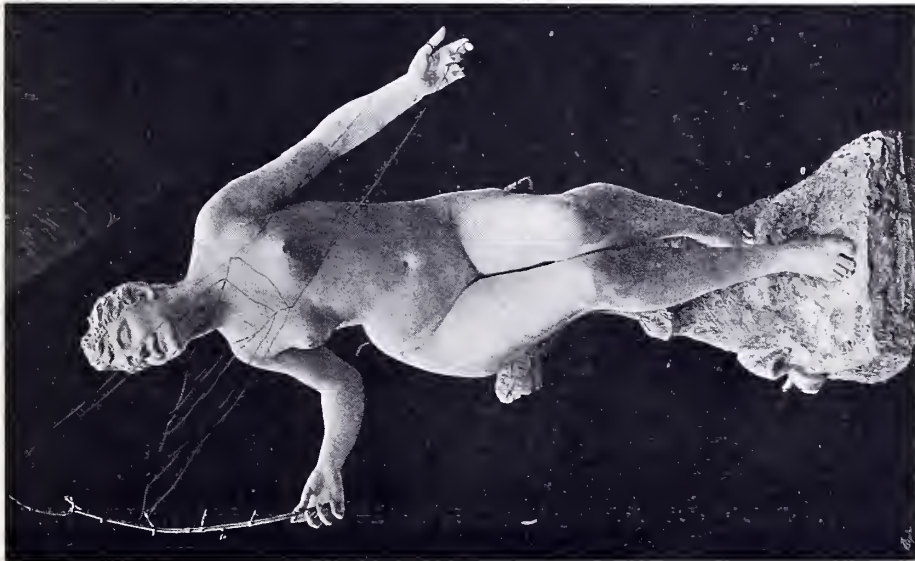

Arachné (Paris Salon)

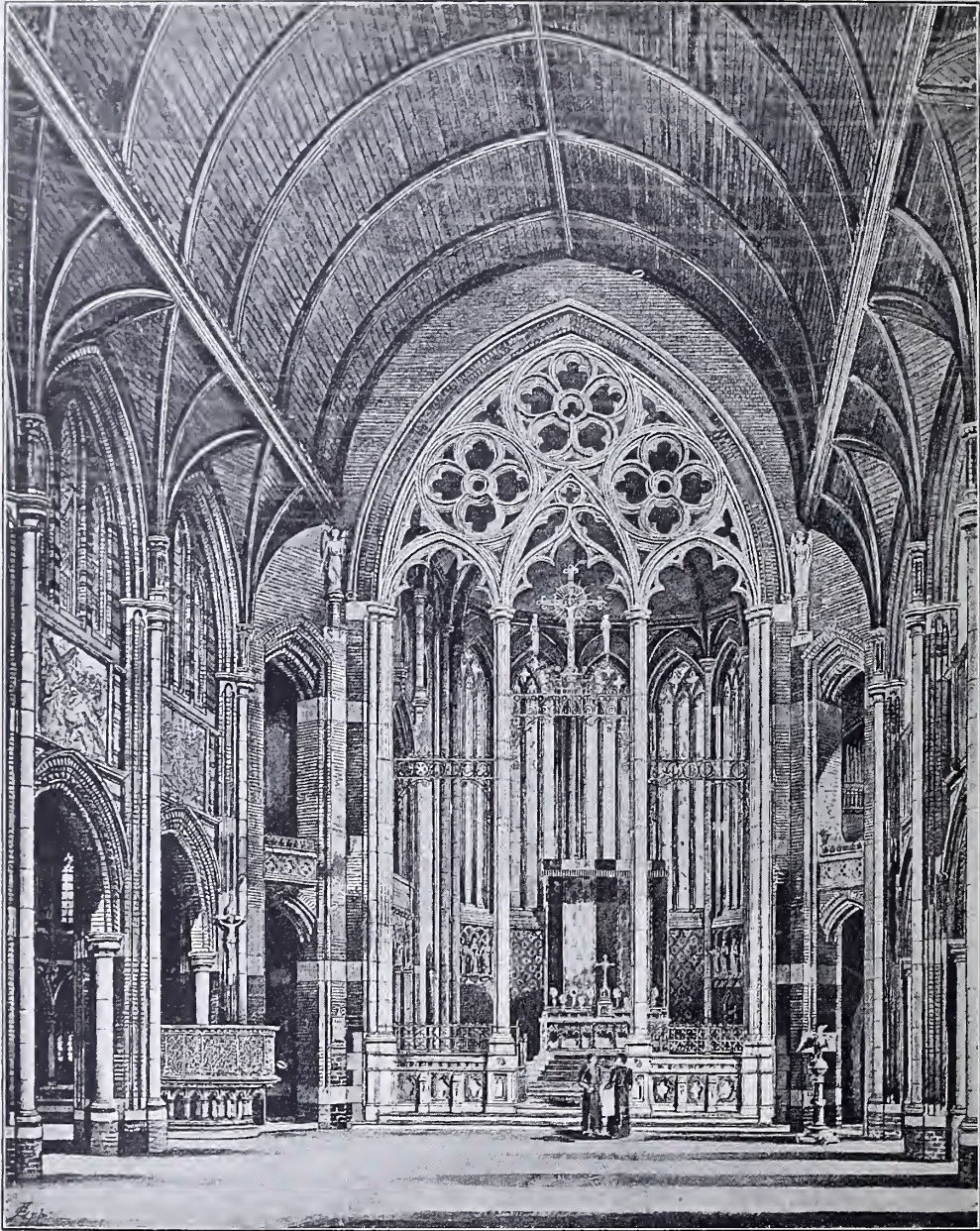

All Saints' Church, West Dulwich, Interior looking East, G. H. FELLOWES PRYNNE, F.R.I.B.A., Architect.

Contractors—J. and C. Bowyer, Westow Road, Upper Norwood, S. E.

Heating—"Patent Small Pipe Safety." R. P. de Ridder, Fairfield Street, Fairfield, Liverpool.

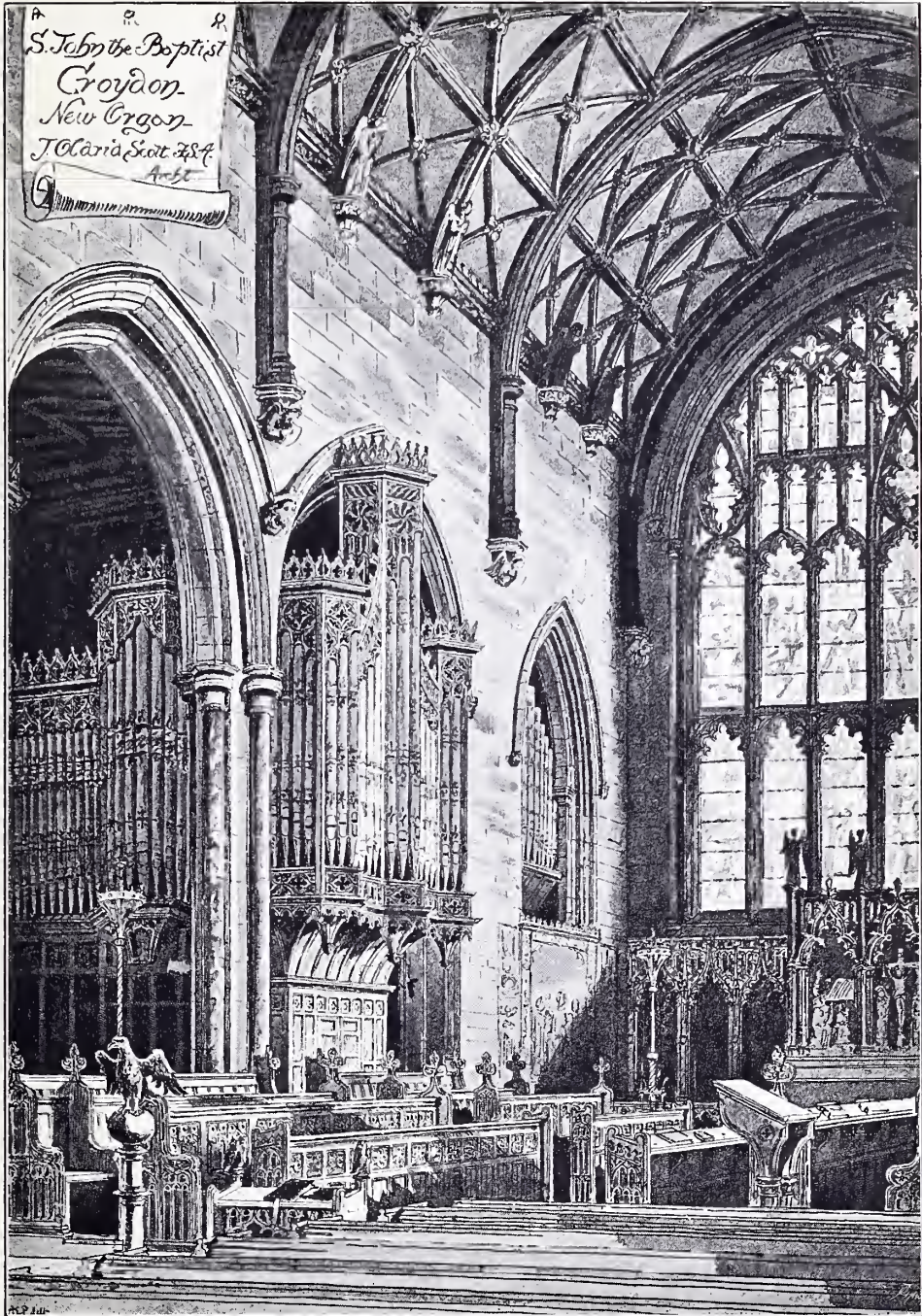

New Organ for the Church of St. John the Baptist, Croydon, J. OLDRID SCOTT, F.S.A., Architect.

Organ Case—J. E. Elwell & Son, North Ear Without, Beverley.



Scott's Restaurant, Coventry Street, Haymarket, S.W., TREADWELL AND MARTIN, Architects.

Marble, Parquetry, Mosaic, and Plate Glass—De Grelle, Hondret & Co., 130, London Wall, E.C. Carving—J. Daymond & Son, Edward Street, Vauxhall Bridge Road, S.W. Fibrous Plaster—Geo. Jackson & Sons, 49, Rathbone Place, W. Patent Entrance Gates—The Bostwick Gate and Shutter Co., Ltd., Baldwin's Gardens, Gray's Inn Road, W.C.



The Oxford Music Hall, Elevation to Oxford Street, W., WYLSON AND LONG, Architects.

Electric Lighting—Harry South, 10, and 12, Garrick Street, Covent Garden, W.C. Constructional Iron Work and Fire Proof Floors—Denmet & Ingle, 5, Whitehall, S.W. Wrought Iron Gates, and Railings, and Bostwick Patent Gates—The Bostwick Gate and Shutter Co., Ltd., Baldwin's Gardens, Gray's Inn Road, W.C.

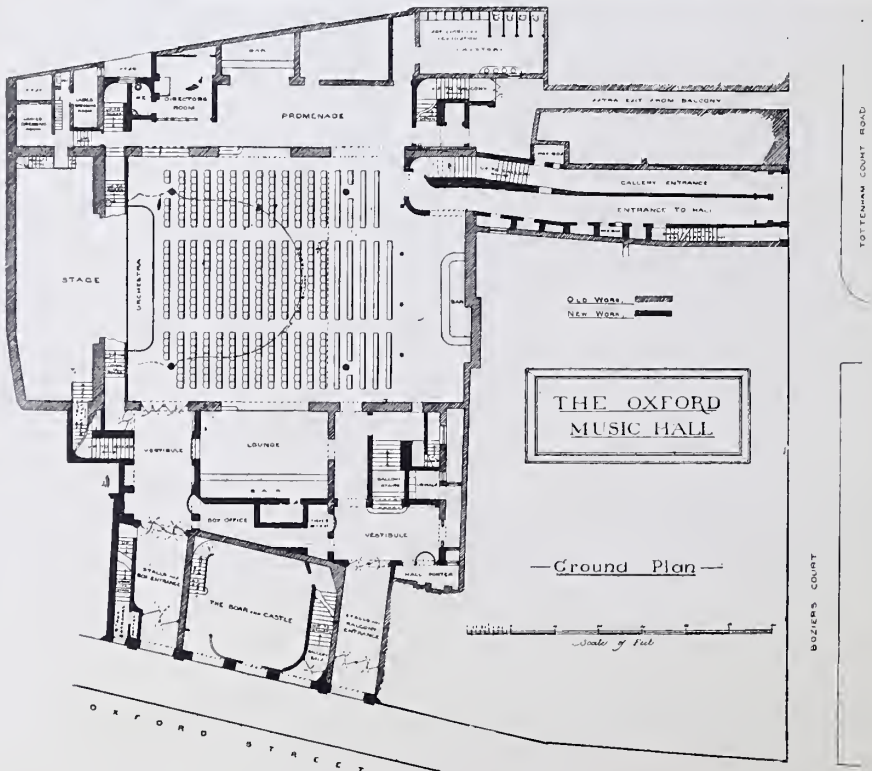
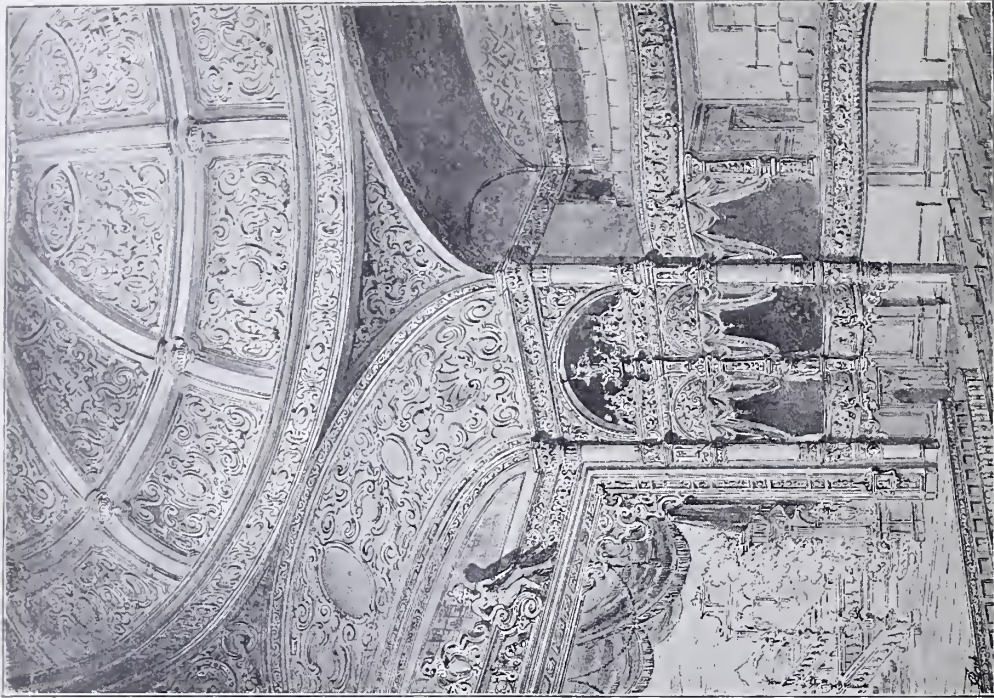

The Oxford Music Hall, Ground Plan and Auditorium, WYLSON AND LONG, Architects.

Interior Ornamentation—Plastic Decoration Co., 21, Wellington Street, Strand, London



Chesterfield House, Great Tower Street, E. C.

DELISSA JOSEPH, F. R. I. B. A., Architect.

Contractors—Perry & Co., Tredegar Works, Bow, E.

Hydraulic Lifts—R. Waygood & Co., Falmouth Road, Great Dover Street, S. E.



Finsbury Circus Buildings, E. C.

DELISSA JOSEPH, F. R. I. B. A., Architect.

Contractors—Perry & Co., Tredegar Works, Bow, E.

Hydraulic Lifts—R. Waygood & Co., Falmouth Road, Great Dover Street, S. E.

GRANTULLY CASTLE, PERKSHIRE. AS ADDED TO
THOMAS LEADBETTER, ARCHITECT EDINBURGH.

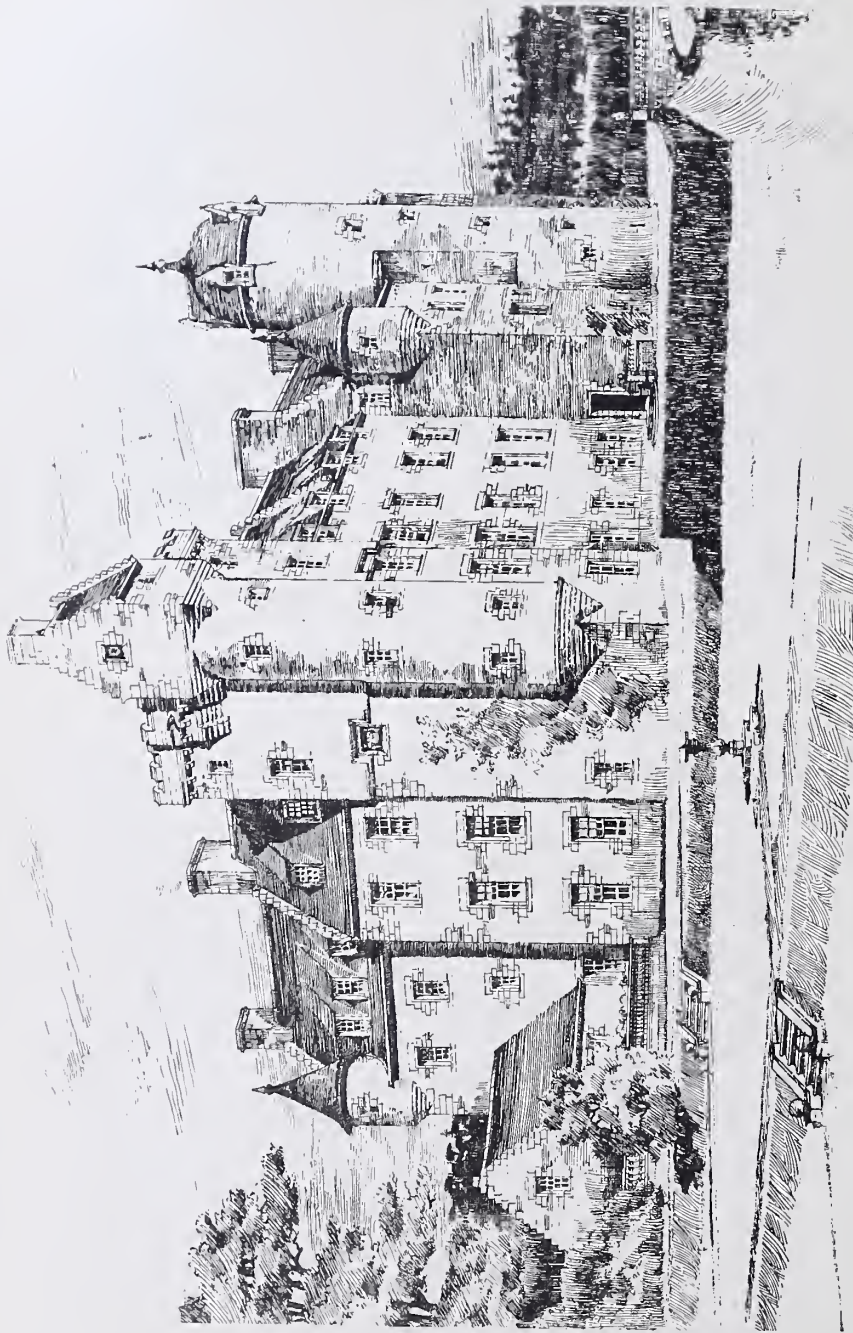

Grantully Castle, Perthshire, as added to, THOMAS LEADBETTER, Architect.

Building Contractors—J. and D. Meikle, Ayr, N.B.



Santiago Cathedral, Spain, West Tower from the Cloisters, Drawn by HEBER RIMMER, Architect.

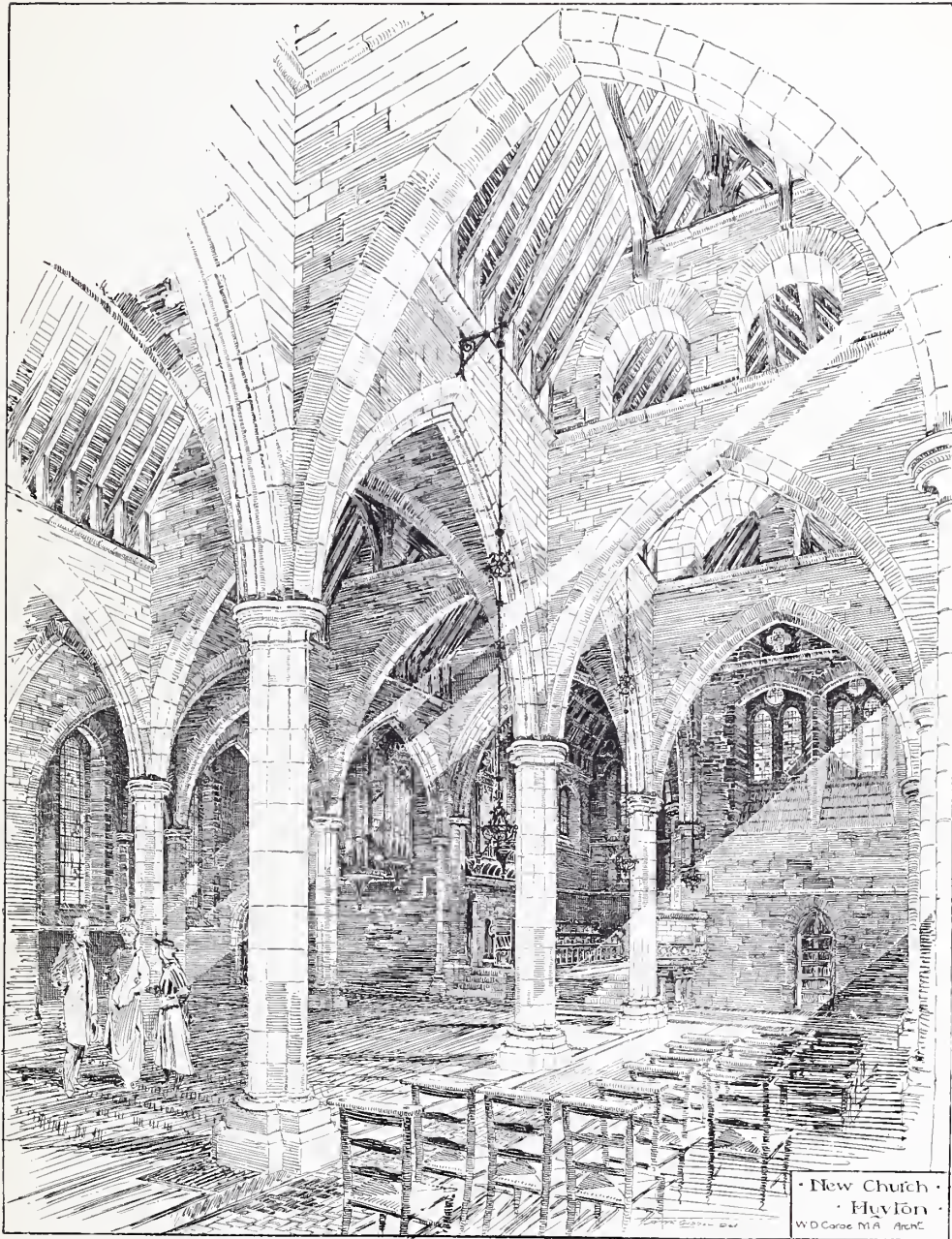

• New Church •
• Huyton •
W.D. Caroe M.A. Archt.

New Church, Huyton, Interior, WILLIAM D. CAROE, M.A., Architect.

Contractors—Hughes and Stirling, Eootle and Liverpool.
Organ—August Gern, Boundary Road, Notting Hill, W.

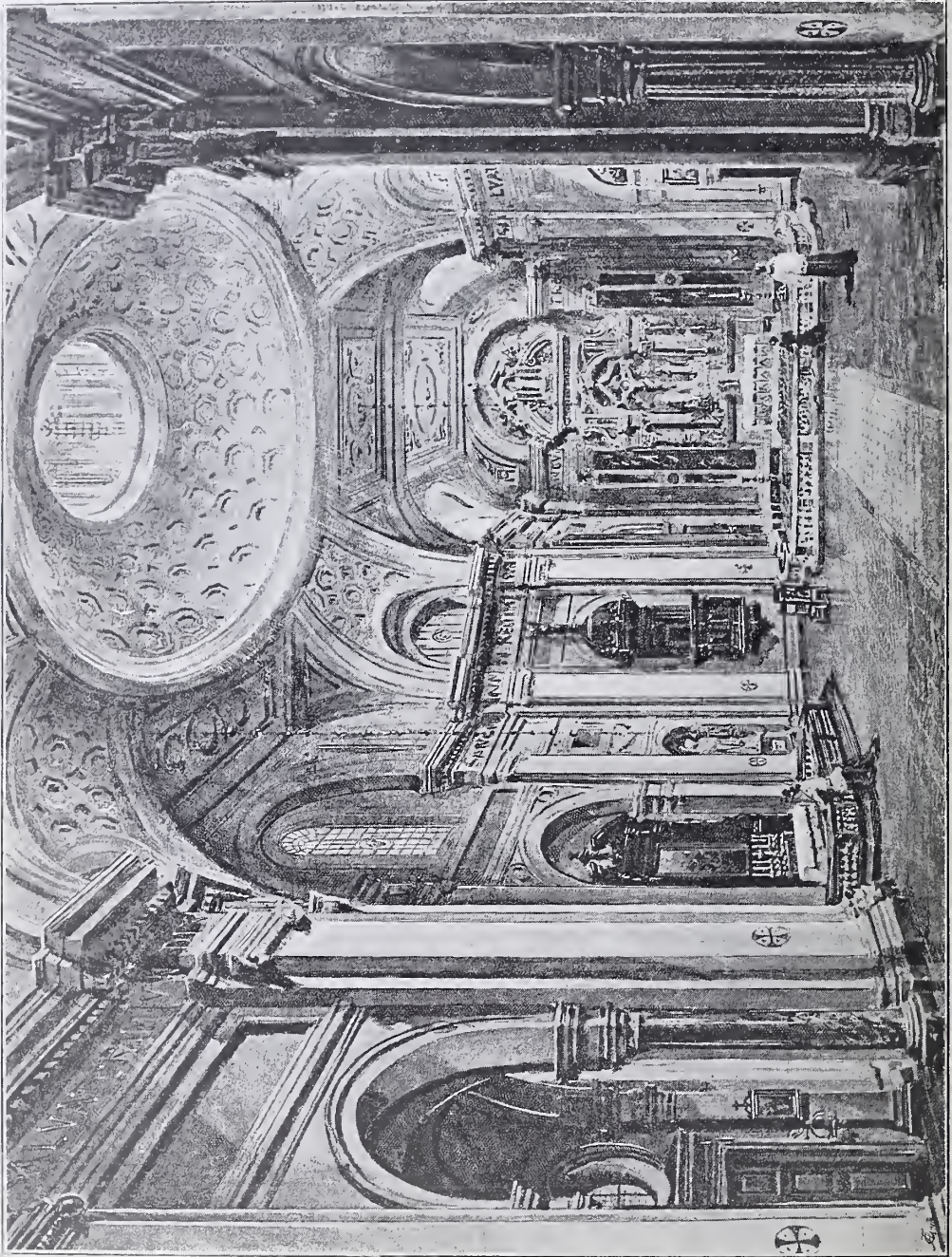

Church of Our Most Holy Redeemer, Chelsea, Interior, Goldie, Child and Goldie, Architects.

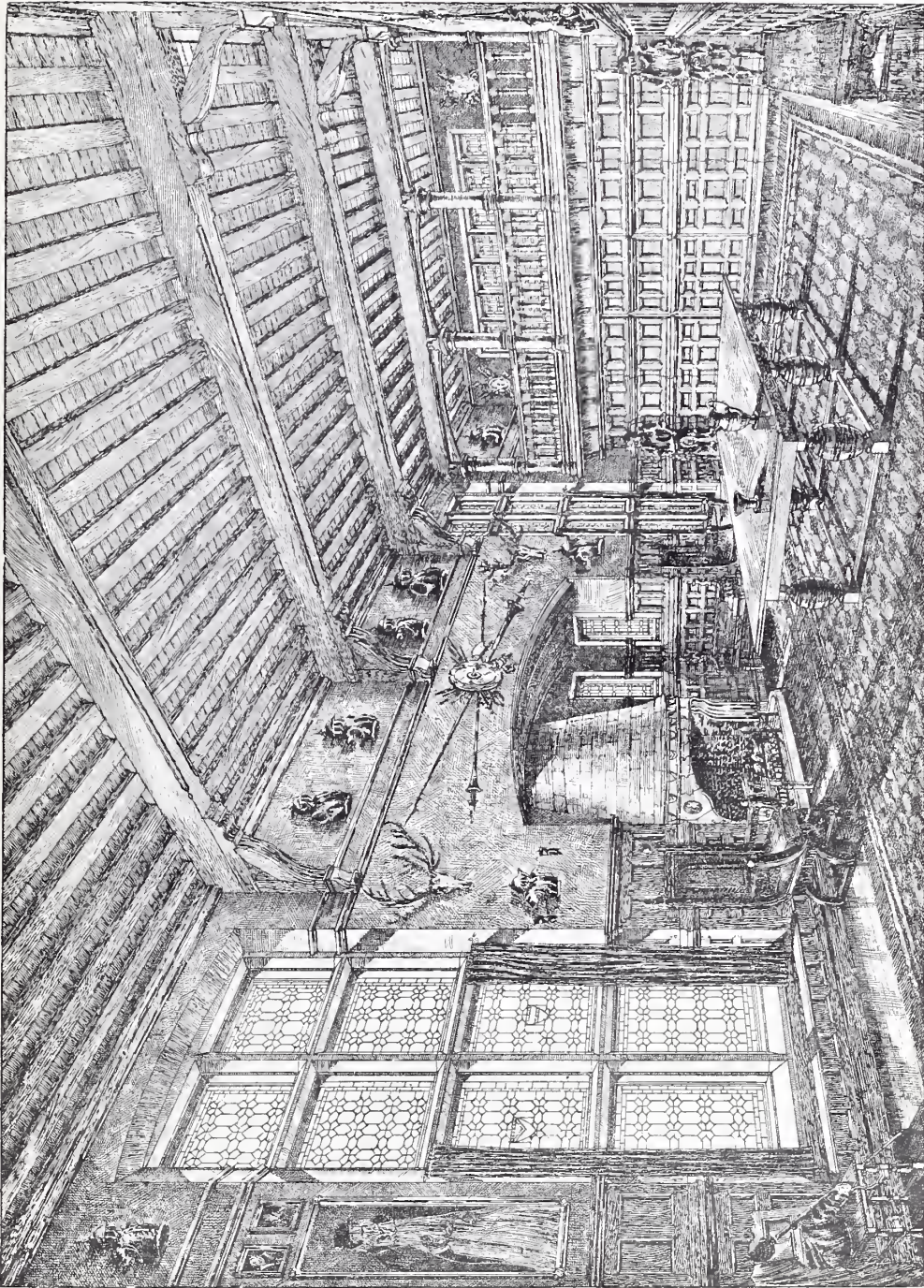

The Hall, Oaklands, Godstone, HESKETH AND STOKES, Architects.



“Brocksford,” near Sudbury, Derbyshire, DOUGLAS AND FORDHAM, Architects.

Contractors—Isaac Ward & Sons, Stone Road, Uttoxeter.



Sketch for Farm Buildings.

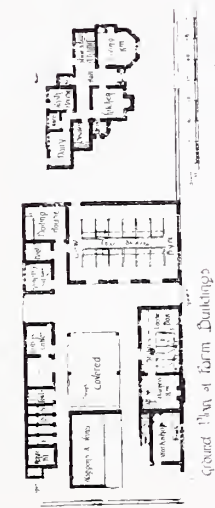

Ground Plan of Farm Buildings



Ground Floor Plan.

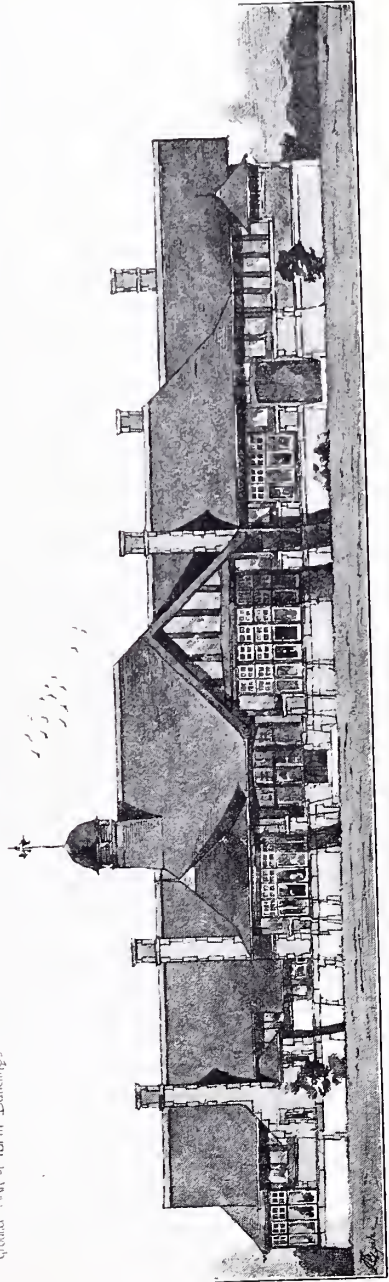

A Sketch for a Bungalow.
W. FRANK BRIGHT, Architect.

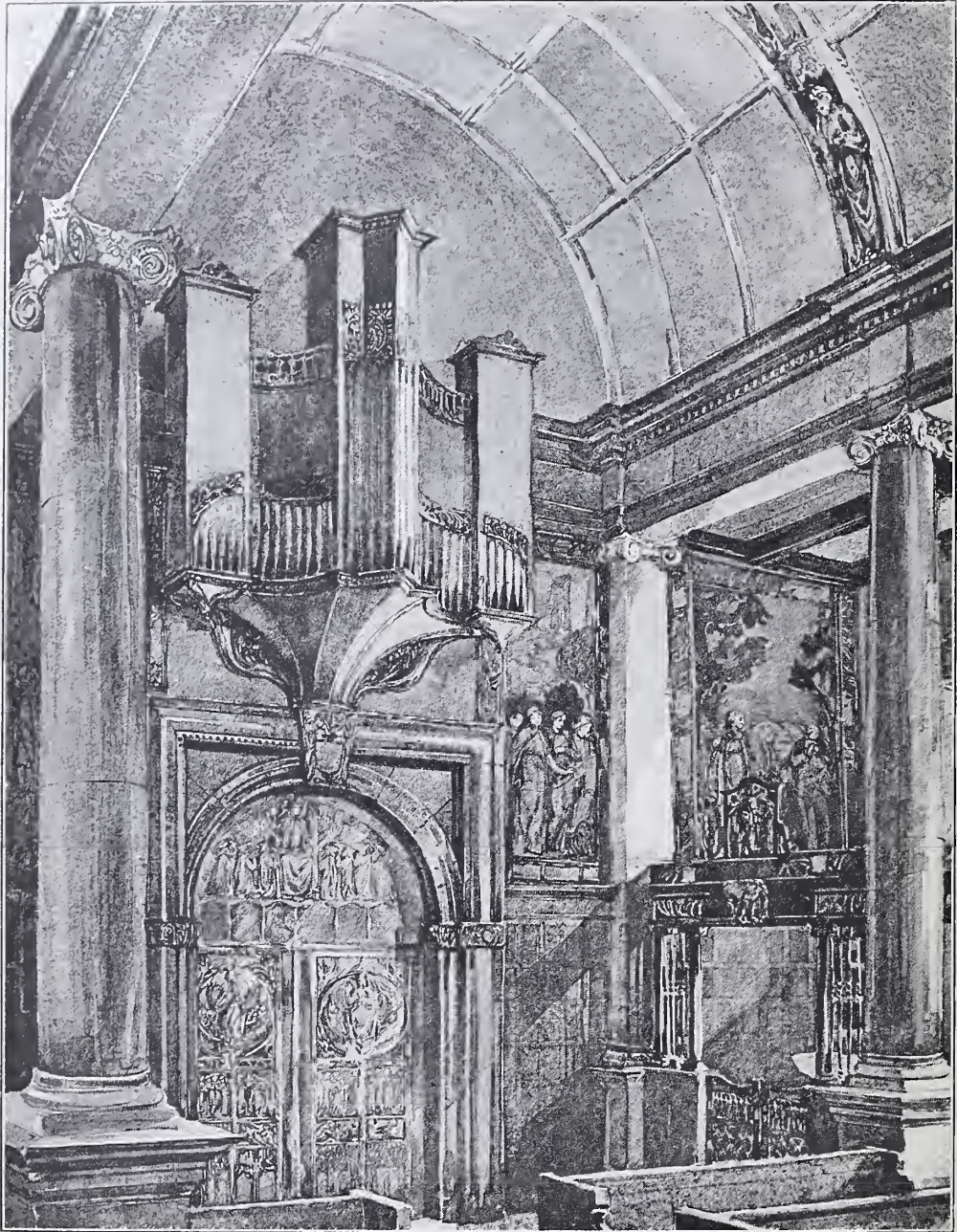

West end of Private Chapel, Welbeck Abbey, H. WILSON, Architect.



All Saints' Church, West Dulwich, East End Grouping, G. H. FELLOWES PRYNNE, F.R.I.B.A., Architect.

Contractors—J. and C. Bowyer, Westow Street, Upper Norwood, S.E.

Heating—"Patent Small Pipe Safety," R. P. de Ridder, Fairfield Street, Fairfield, Liverpool.



Residence at Potts Point, Sydney, J. B. BARLOW, Architect, Sydney.



Residence, Elizabeth Bay, Sydney, J. B. BARLOW, Architect, Sydney.

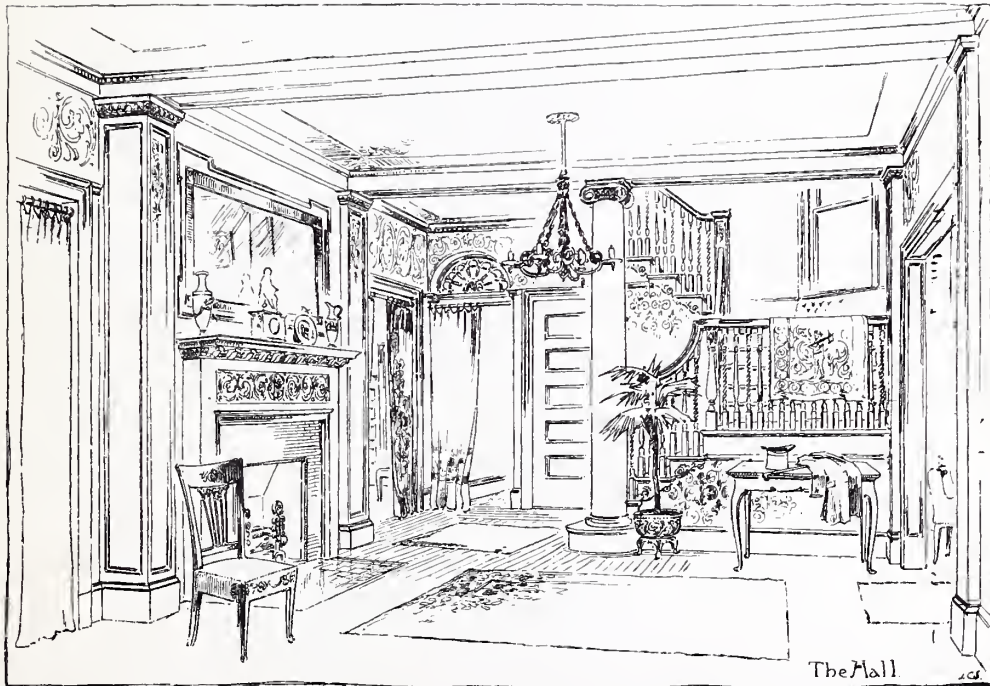
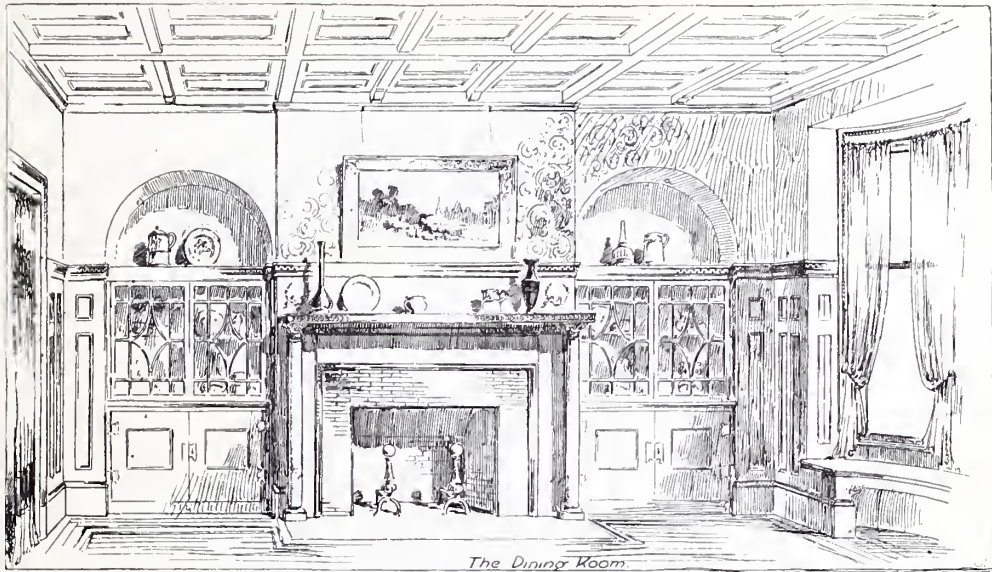

House in Portland, Maine, JOHN CALVIN STEVENS, Architect, Portland, U.S.A.

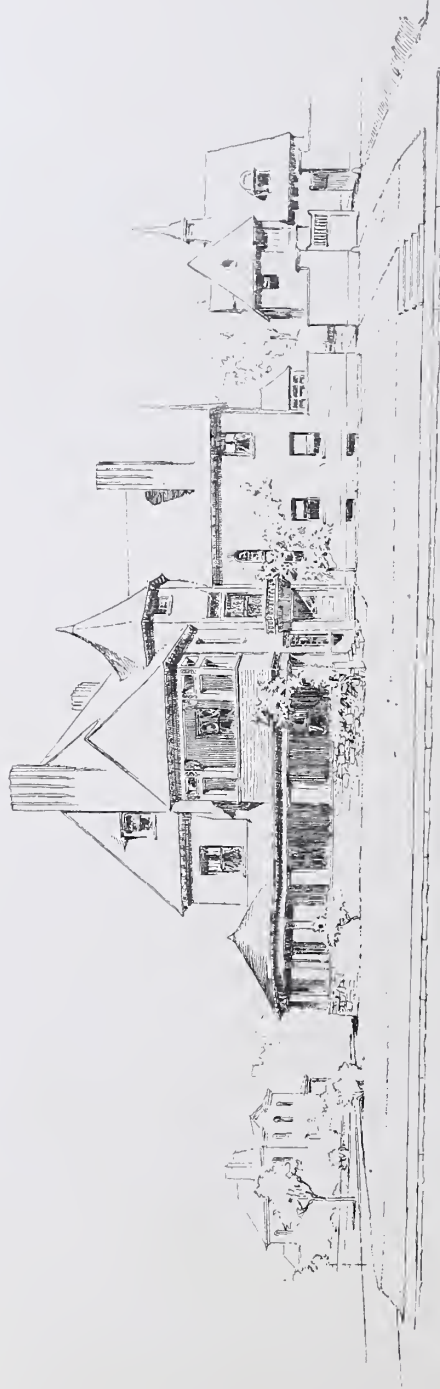

House in Portland, Maine, View from Pine Street, JOHN CALVIN STEVENS, Architect, Portland, U.S.A.

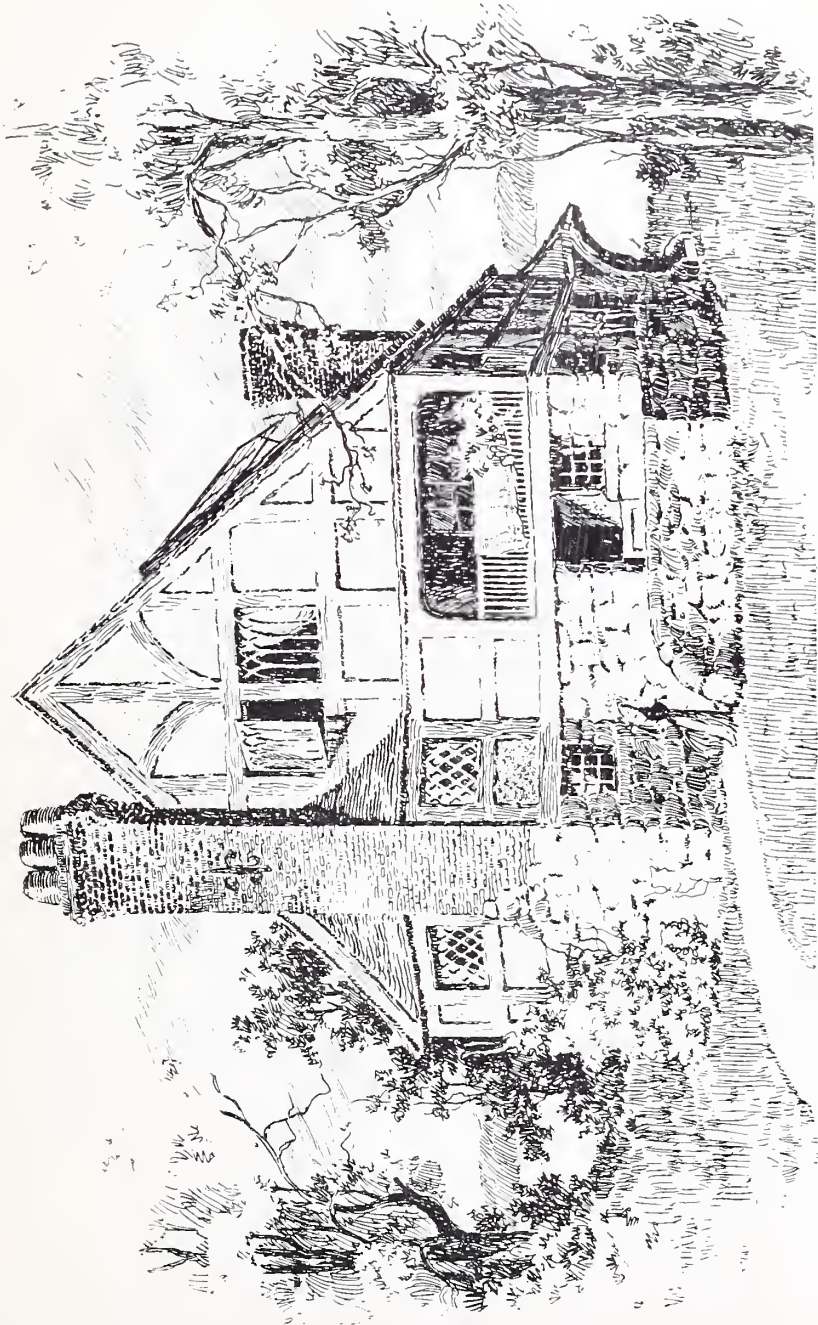

Design of an Artist's House, J. NAT HUTCHINS, Architect, New York, U.S.A.

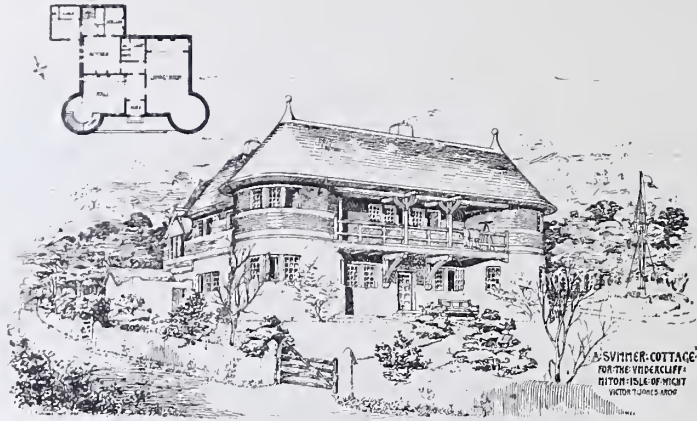

A Summer Cottage for the Undercliff, Niton, Isle of Wight, VICTOR T. JONES, Architect.



Sketch for Shooting Box in Delaware County, N. Y., J. BEVERLEY ROBINSON, Architect, New York, U.S.A.



Design for a Country House, EDGAR A. JOSSELYN, Architect, New York, U.S.A.

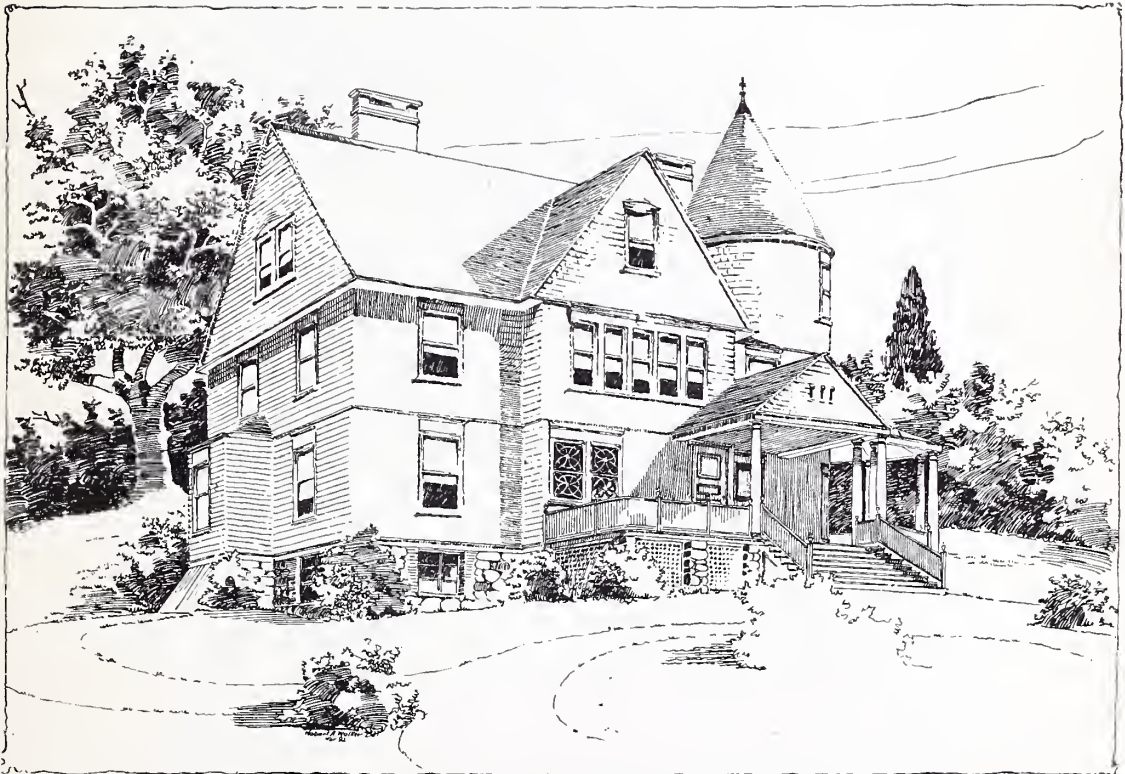

House at New Rochelle, N. Y., GEORGE MARTIN HUSS, Architect, New York, U.S.A.

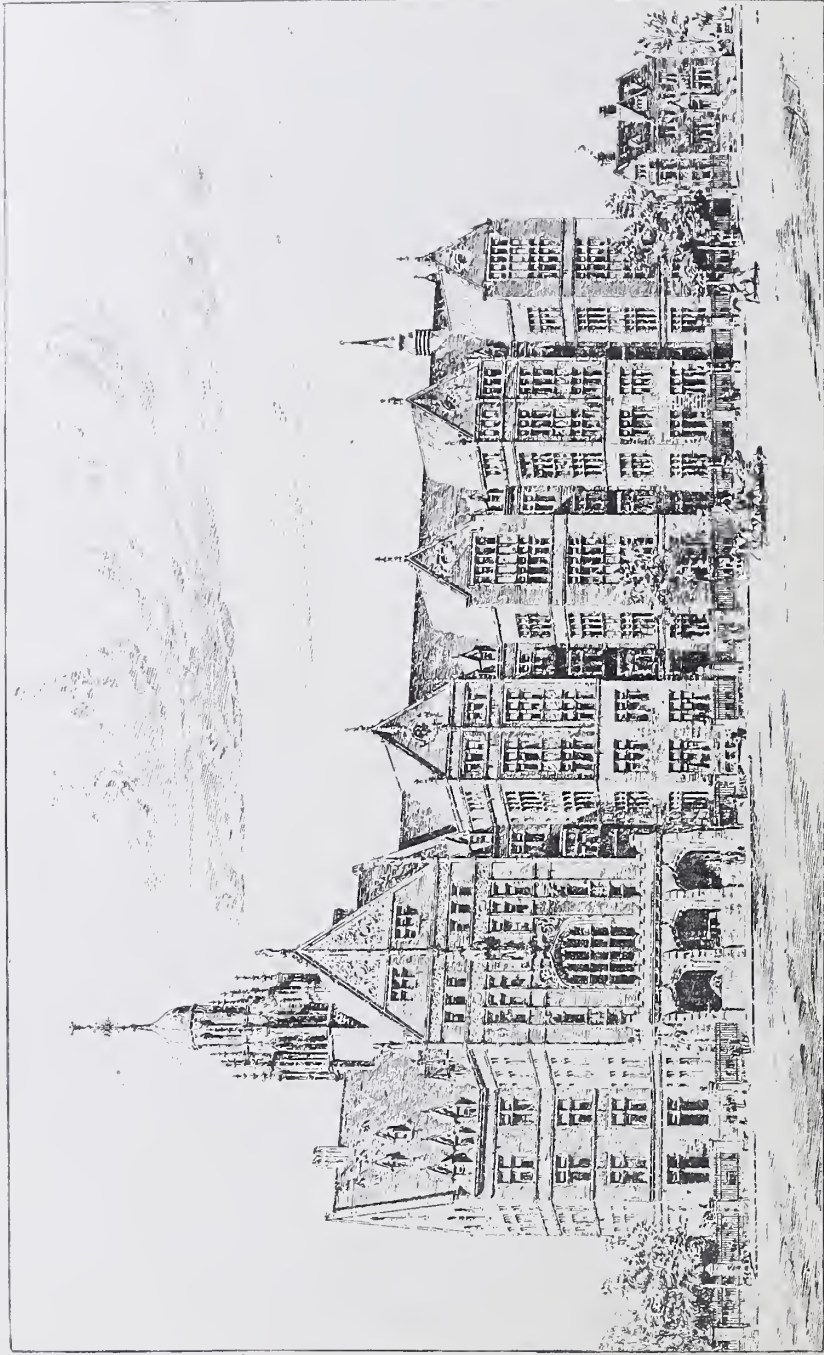

Competition Design for St. Luke's Hospital, New York, James Brown Lord, Architect, New York, U.S.A.



Design for a City Church, C. C. HAIGHT, Architect, New York, U.S.A.

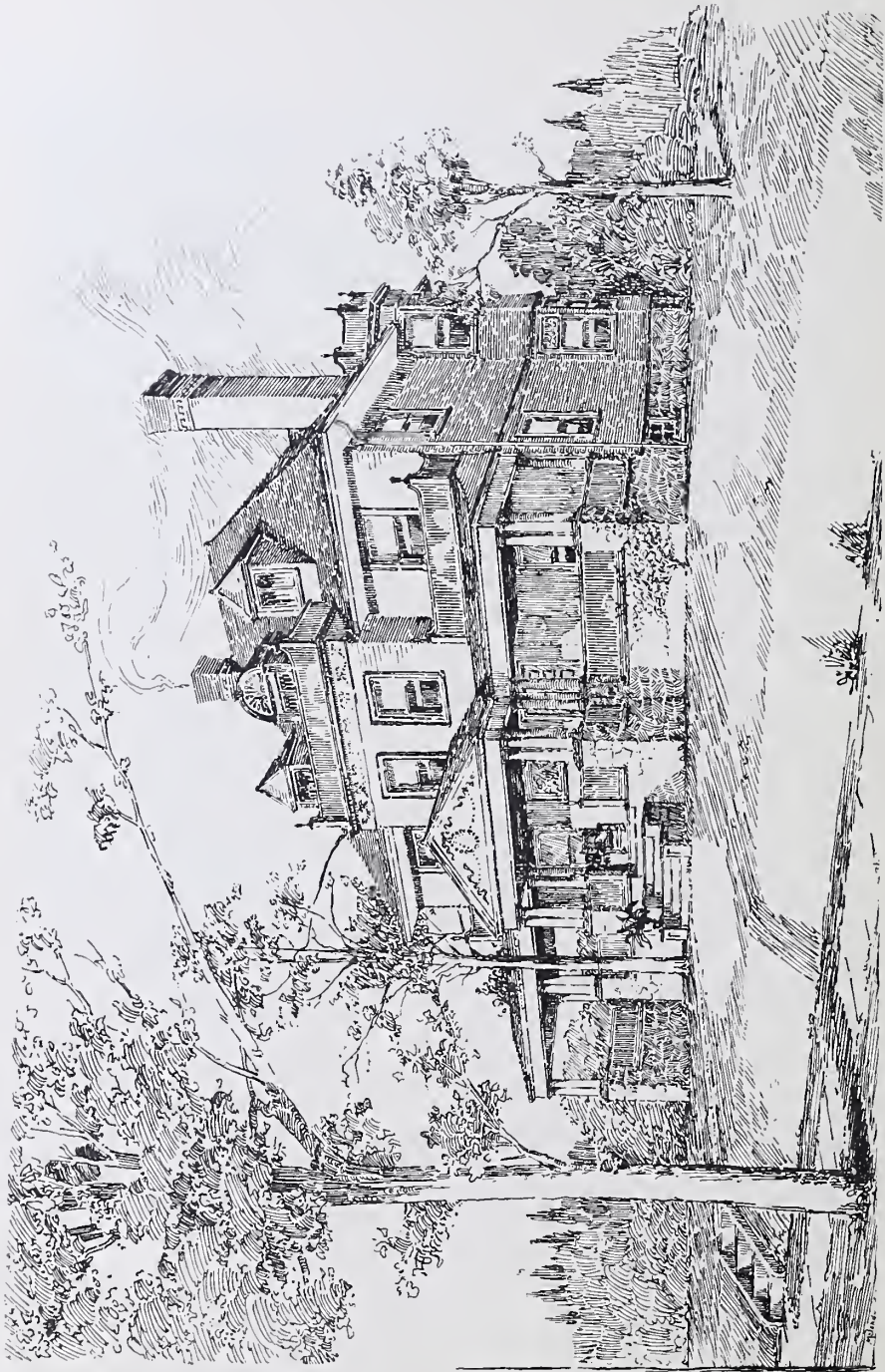

House in East Orange, N. J., GEORGE E. MELENDY, Architect, New York, U. S. A.

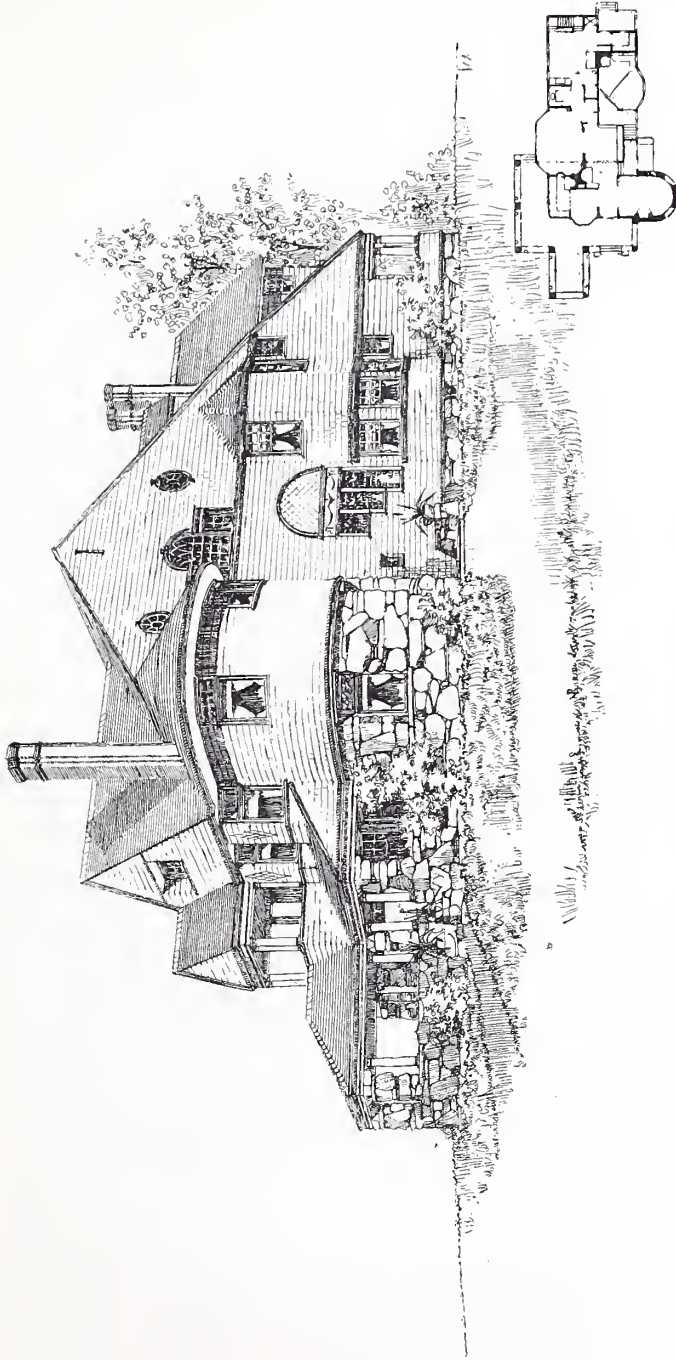

House for H. B. Steadman, Esq., Hartford, Conn., EDWARD T. HAPGOOD, Architect, New York, U.S.A.

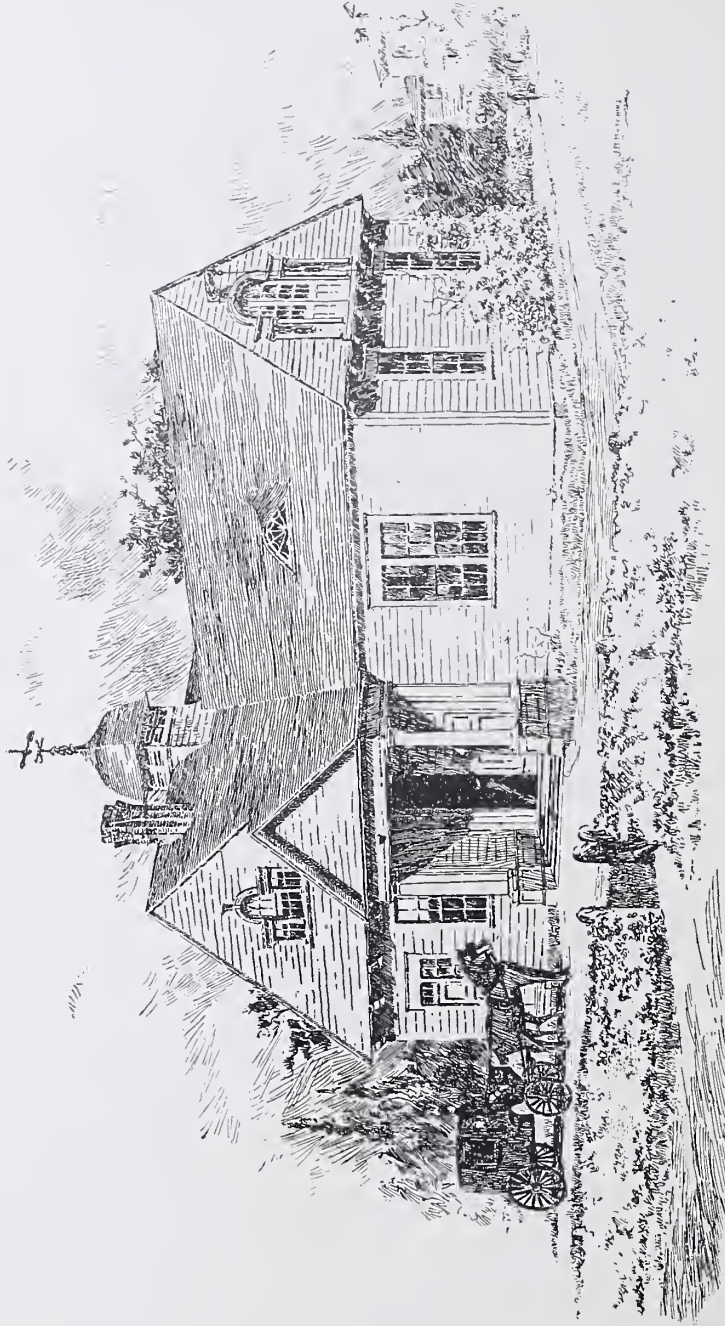

Stable for Dr. Elias J. Marsh, at Paterson, N. J., CREIGHTON WITHERS, Architect, New York, U.S.A.

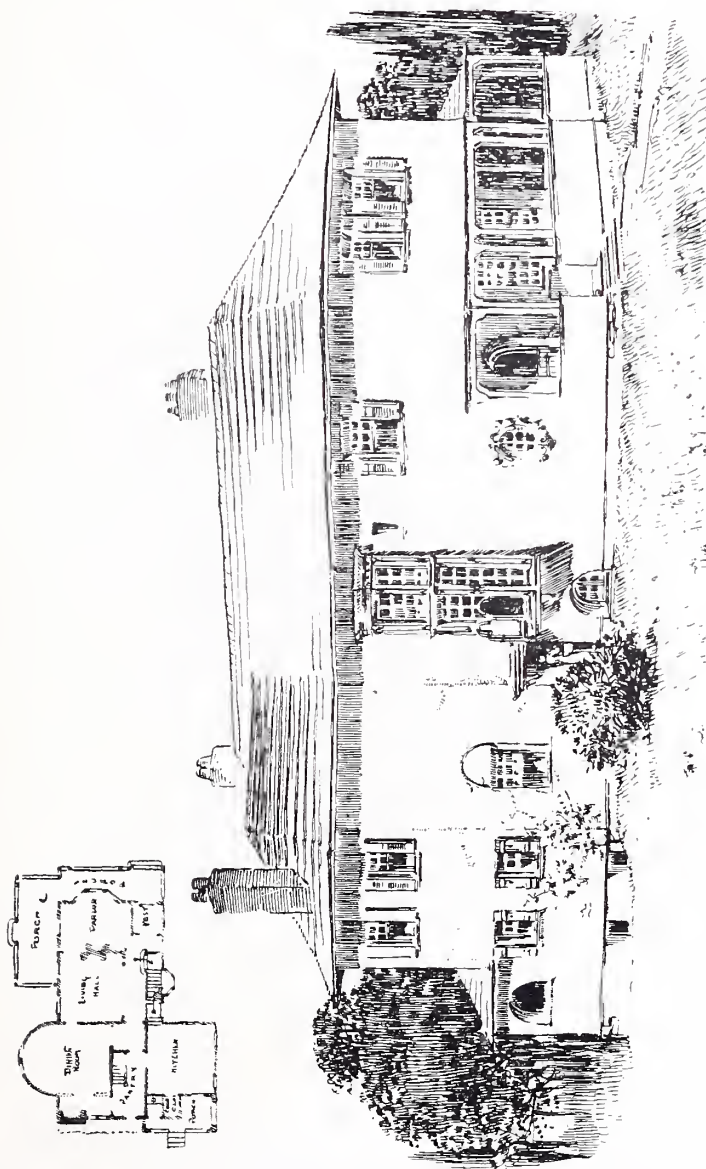

House at Feltham Manor, New York, Wilson Eyre, Jun., Architect, Philadelphia, U.S.A.



Residence of Rudyard Kipling, Battleboro, Vt., HENRY RUTGERS MARSHALL, Architect, New York, U.S.A.

* SKETCH CLUB OF NEW YORK *
" SEPTEMBER COMPETITION "
" A TOLL BRIDGE OVER A STREAM
TWENTY FT. WIDE "

· SUBMITTED BY · CHARLES H. ISRAELS ·
" PLACED THIRD "

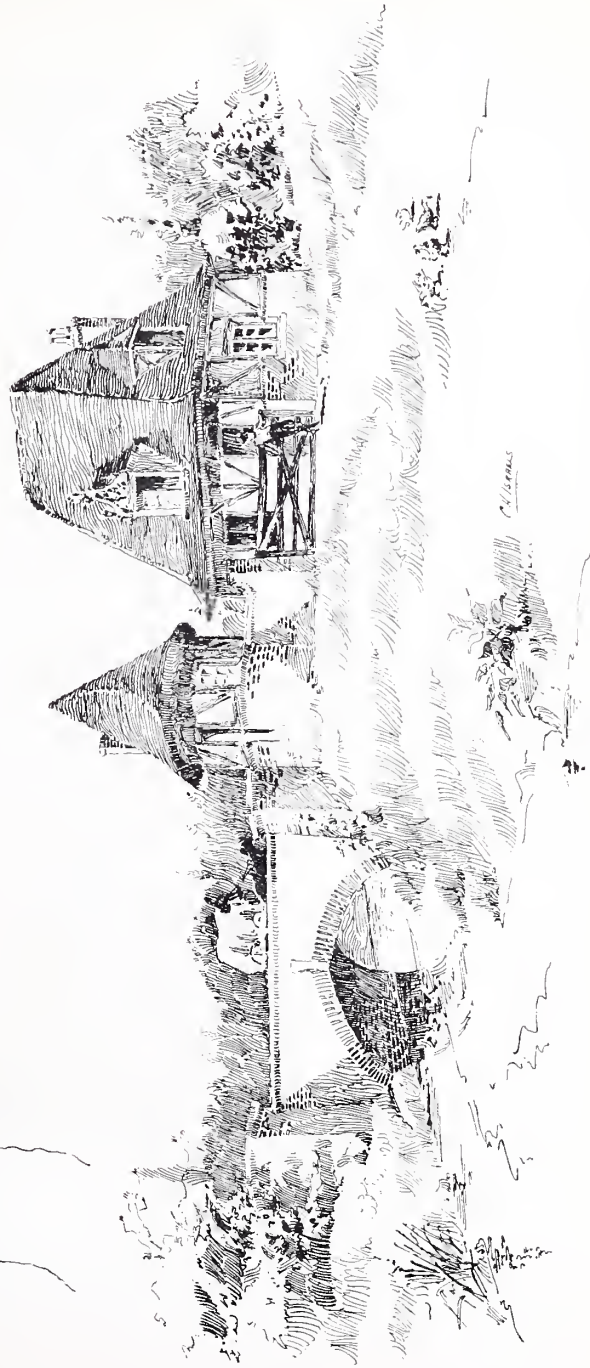
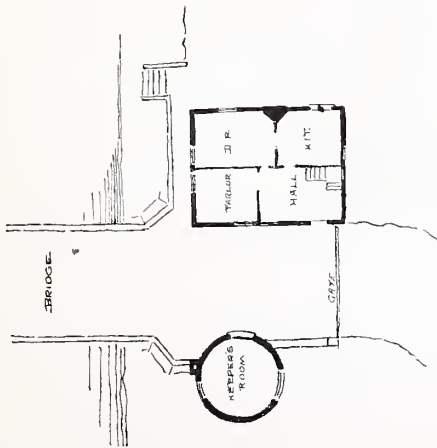

A Toll Bridge over a Stream, Submitted by CHARLES H. ISRAELS, Architect, New York, U.S.A.



WEAVER KRAMER AND B. HUSTACE SIMONSON
 ARCHITECTS
 REFORMERIAN LIFE BUILDING NEW YORK, U.S.A.
 SAVINGS BANK BUILDING AKRON O. U.S.A.

B. HUSTACE SIMONSON 92

A Composite, WEARY AND KRAMER, AND B. HUSTACE SIMONSON, Architects, New York, U.S.A.

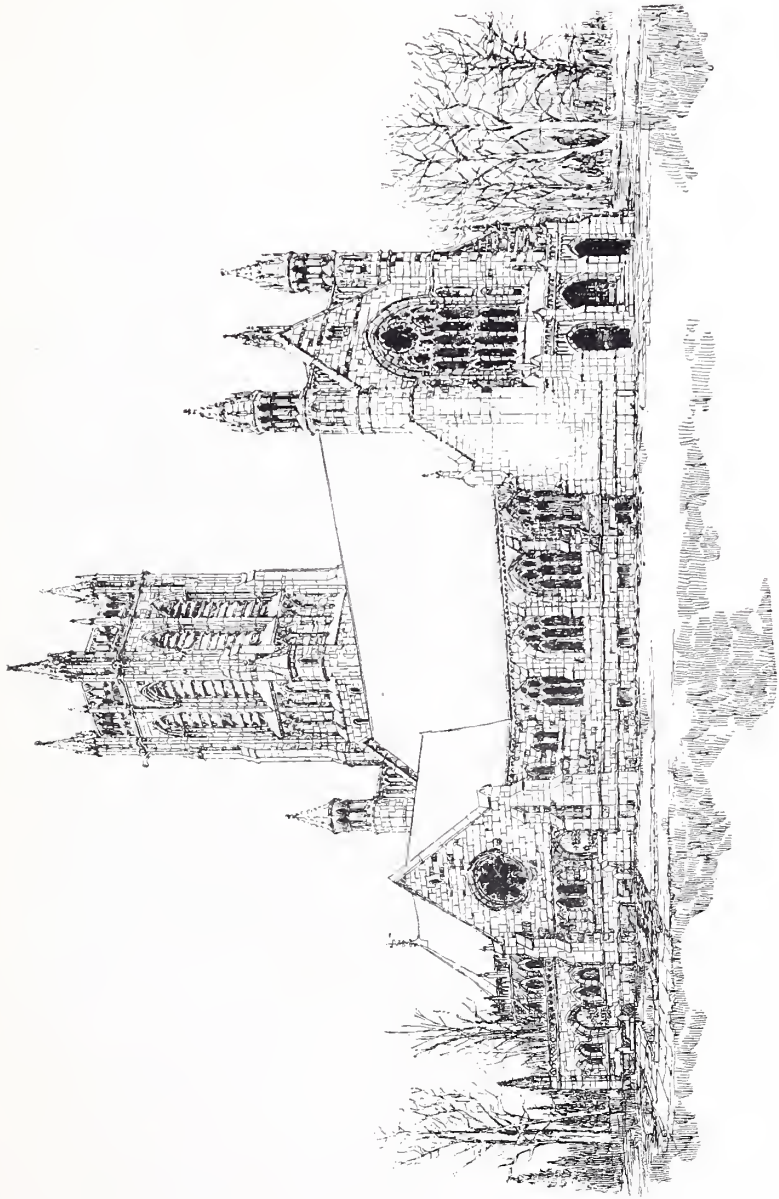

Competitive Design for a Church, RENWICK, ASPINWALL, AND RENWICK, Architects, New York, U.S.A.

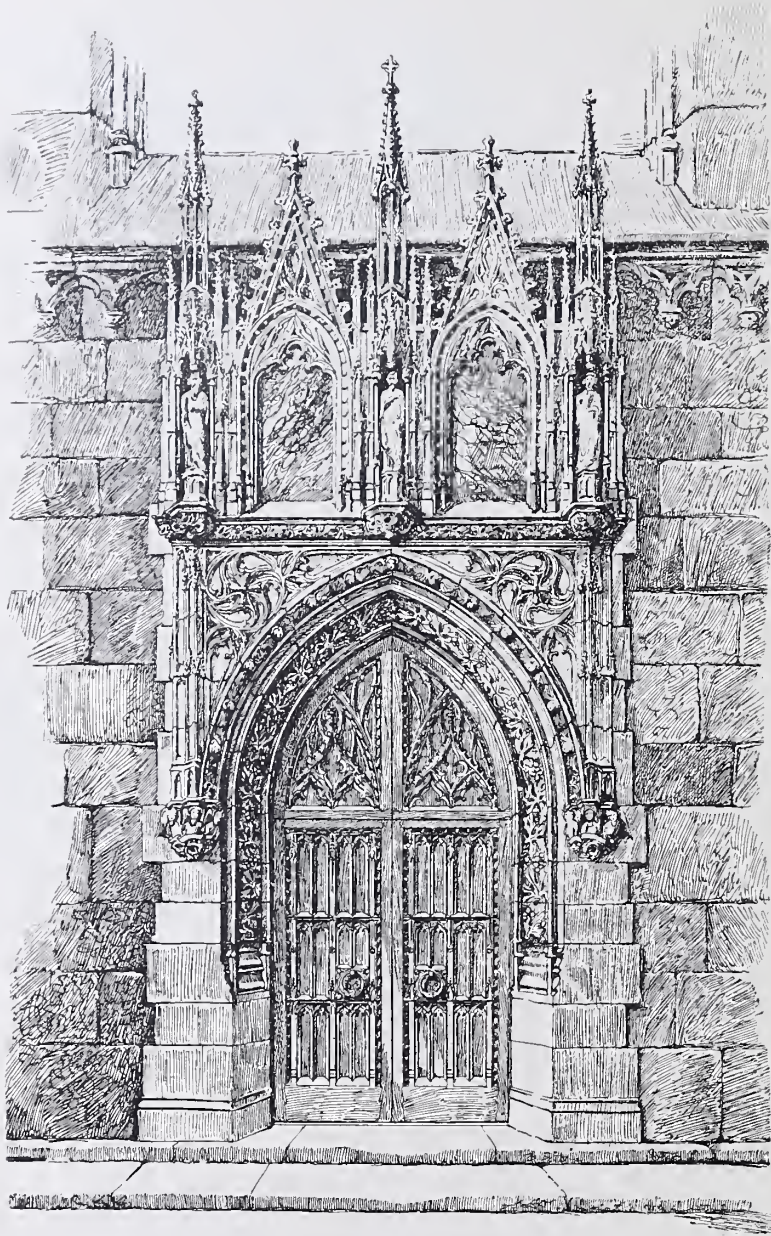

Doorway, Grace Church, New York, W. W. RENWICK, Architect, New York, U. S. A.



House for Dr. Herman Knapp, D'OENCH AND SIMON, Architects, New York, U.S.A.



The Bradley Memorial Chapel and a Gate Lodge Entrance to Fort Hill Cemetery, Auburn, N. Y., J. A. SCHWEINFURTH, Architect, Boston, Mass, U.S.A.



Fire Station, Gefle, Sweden, FERDINAND BOBERG, Architect, Stockholm.

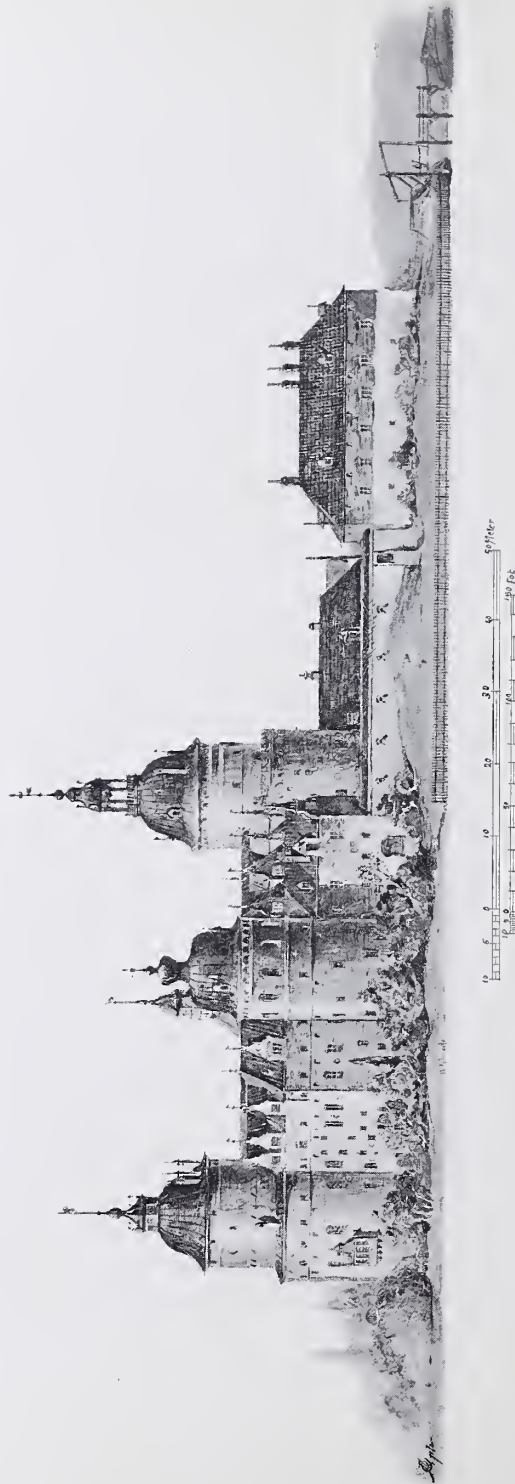

Restoration of the Royal Castle of Gripsholm, FREDR. LILLJEKVIST, Architect, Stockholm.



Kronoberg, Sweden, for Count C. G. Sparre, J. G. CLASON, Architect, Stockholm.



Casino d'Evian, Project, G.D. ANDRÉ, Architect, Lyons.



Design for Sühn Kirche, St. Petersburg, R PROFESSOR VICTOR SCHIROTER, Architect, St. Petersburg.



Chapel at St. Petersburg, W. KOSSIAKOFF, Architect, St. Petersburg.

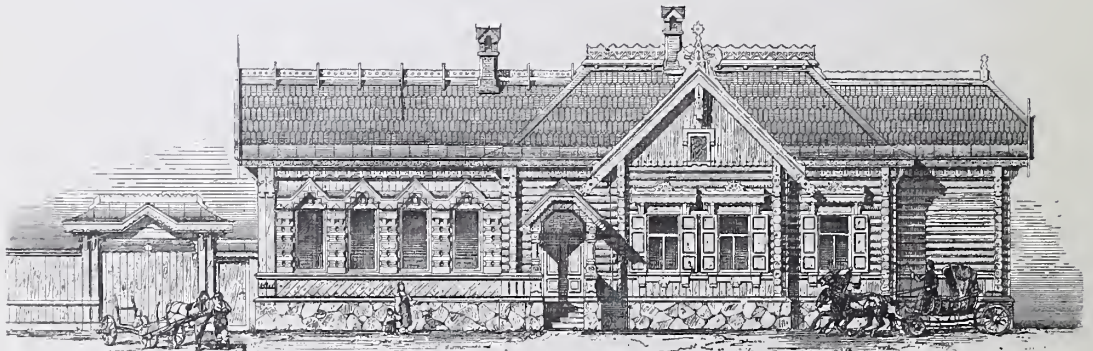

A Village School, GUSTAV v. HOLY, Architect, St. Petersburg.



A Corner House at Krakow, TEODOR TALOWSKI, Architect, Krakow.



Private House at Krakow, TEODOR TALOWSKI, Architect, Krakow.

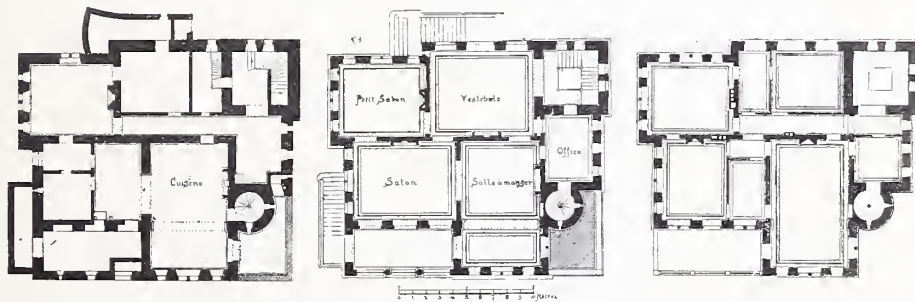

Château "Le Lester," Saint Leonard, Brecht, J. J. VAN YSENDYCK, Hon. Corr. Member, R.I.B.A., Architect, Brussels.



Hotel Café Restaurant to be built at Rotterdam, J. VERHEUL DZN, Architect, Rotterdam.

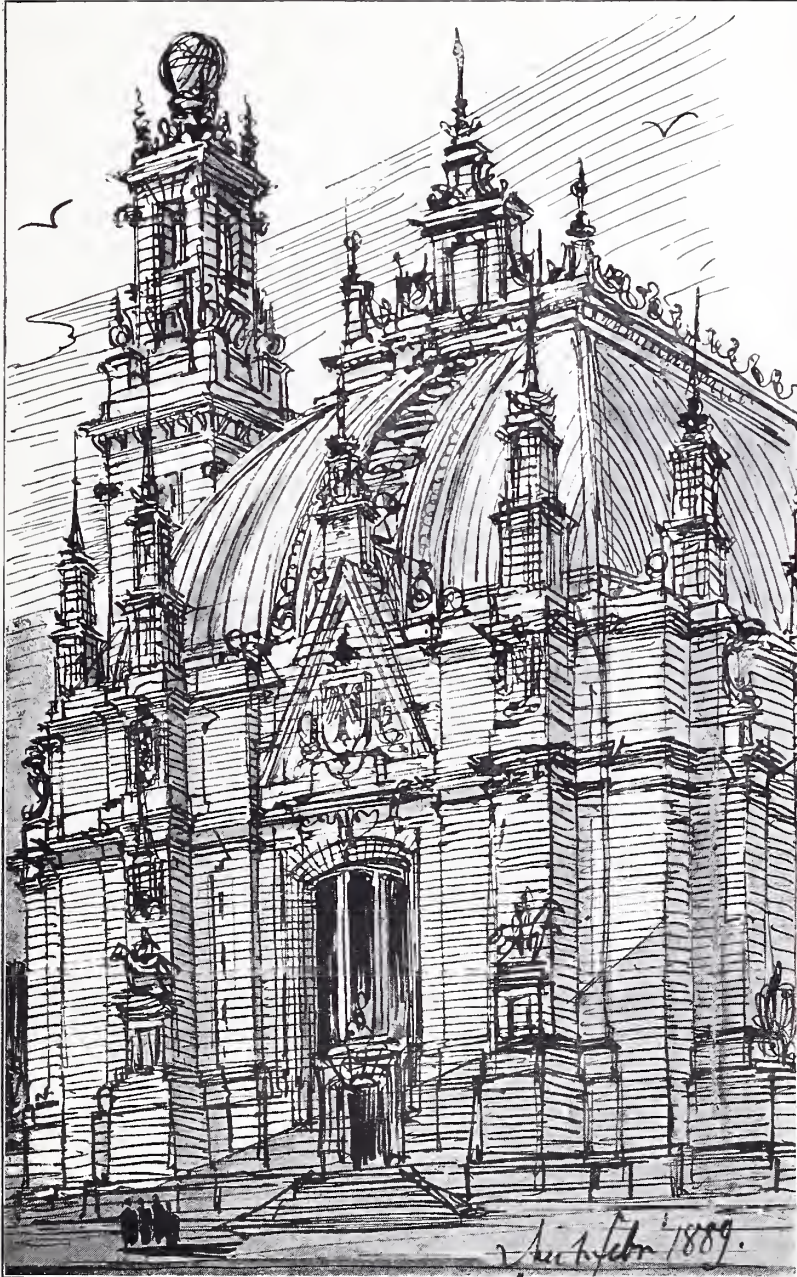

Sketch, OTTO RIETH, Architect, Berlin.



Competitive Design for St. Luke's Church, Dresden, REUTER AND FISCHER, Architects, Dresden.

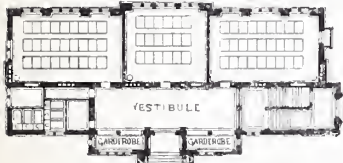
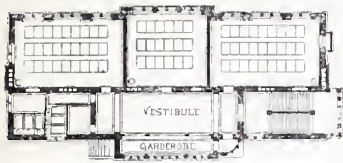

0 1 2 3 4 5 6 7 8 9 10 Meter

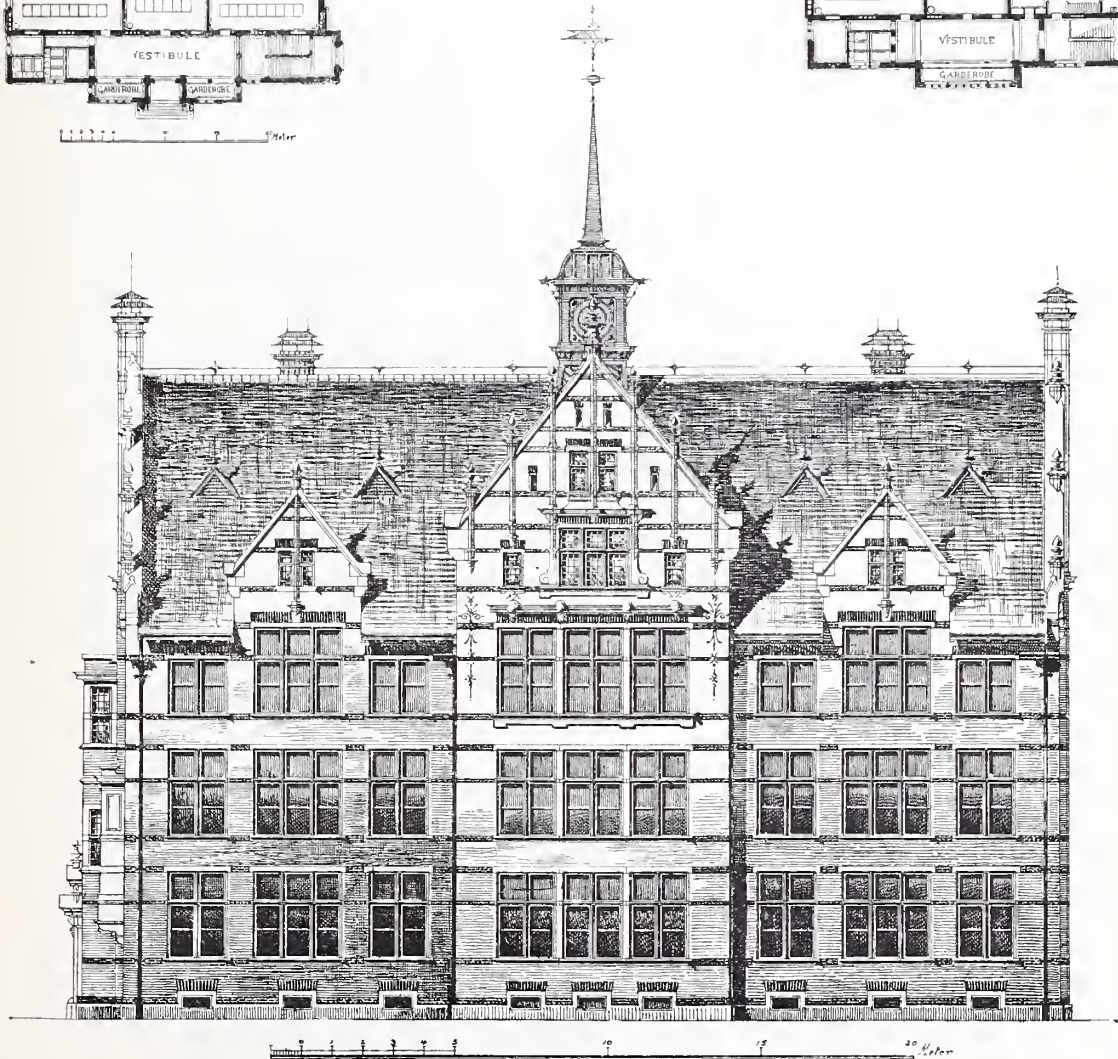
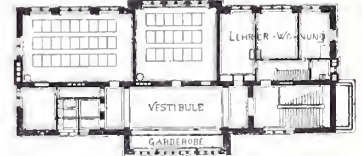
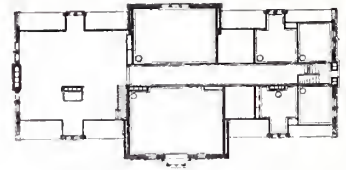

Design for New Board School, Gais, Switzerland, ALEX KOCH, Architect.

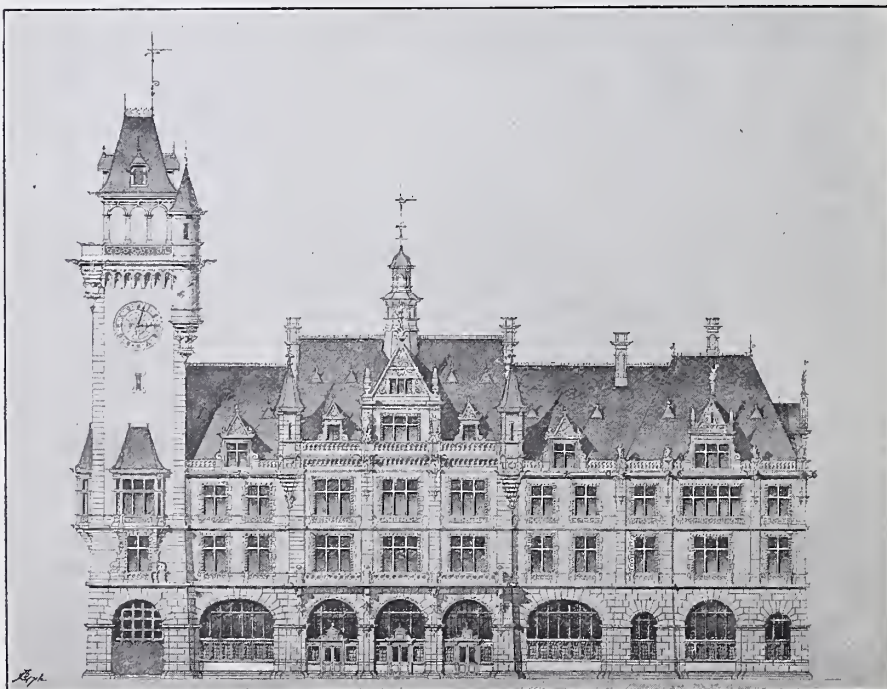
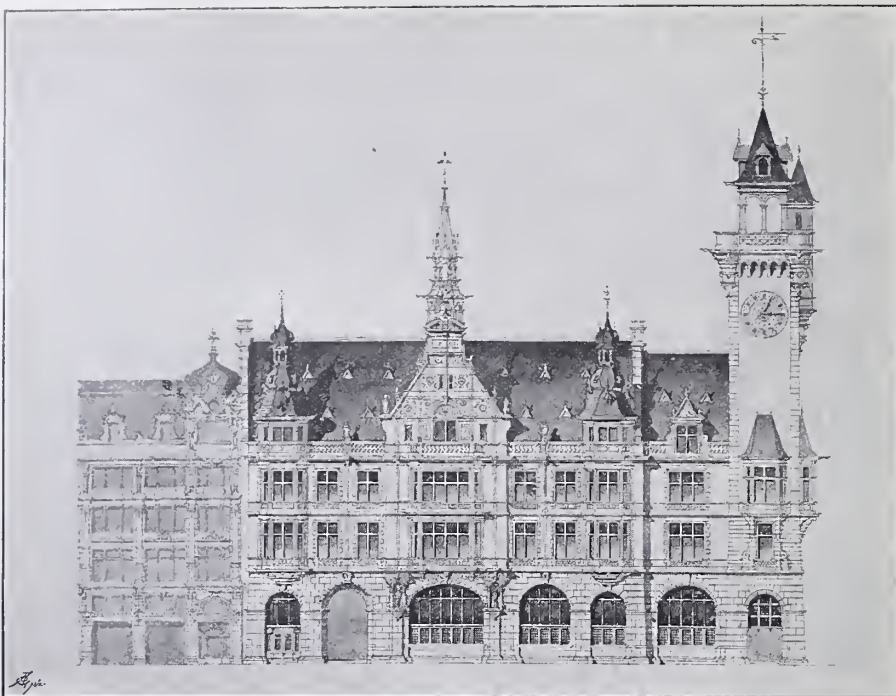

Design for New General Post Office at Zürich, ALEX KOCH, Architect.

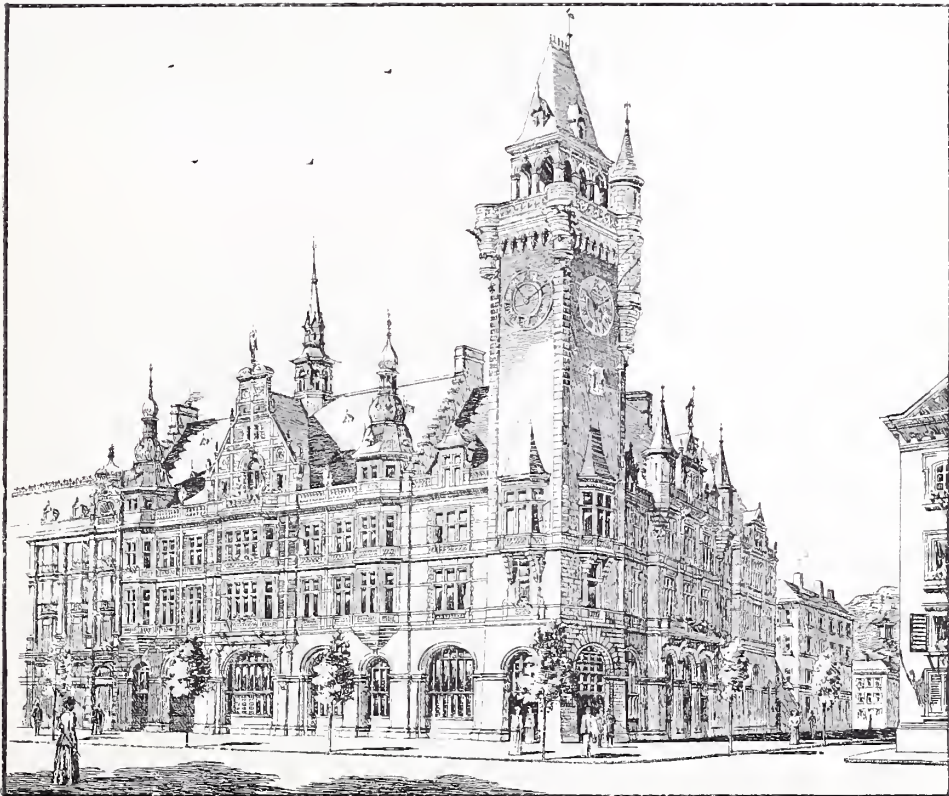

Design for New General Post Office at Zürich, ALEX KOCH, Architect.

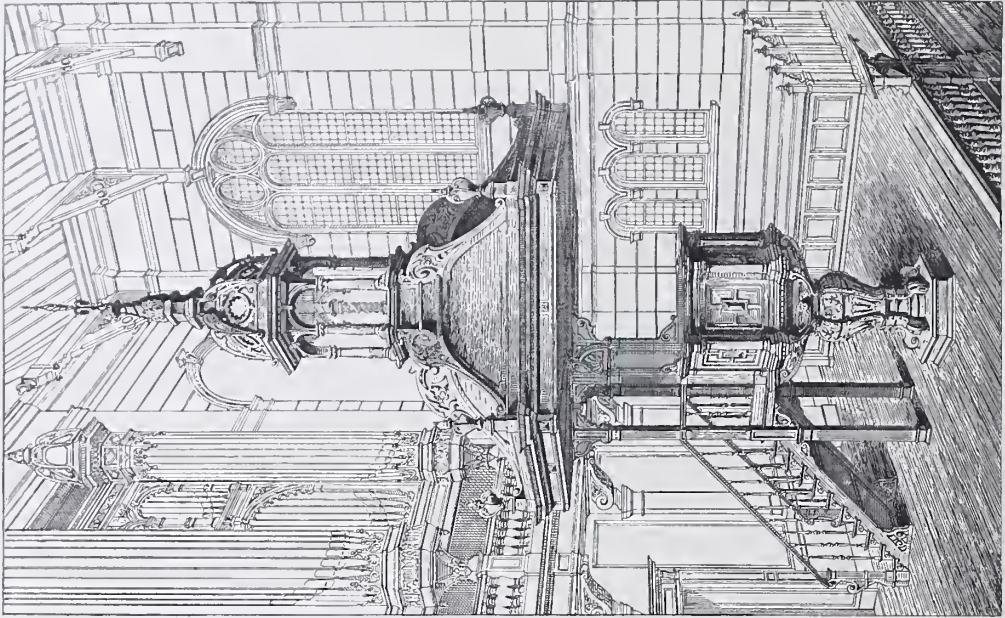

Pulpit in Church at Apeldoorn, J. VERHEUL DZN, Architect, Rotterdam.



Sketch, PAUL PFANN, Architect, Tech. Hochschule, Munich.

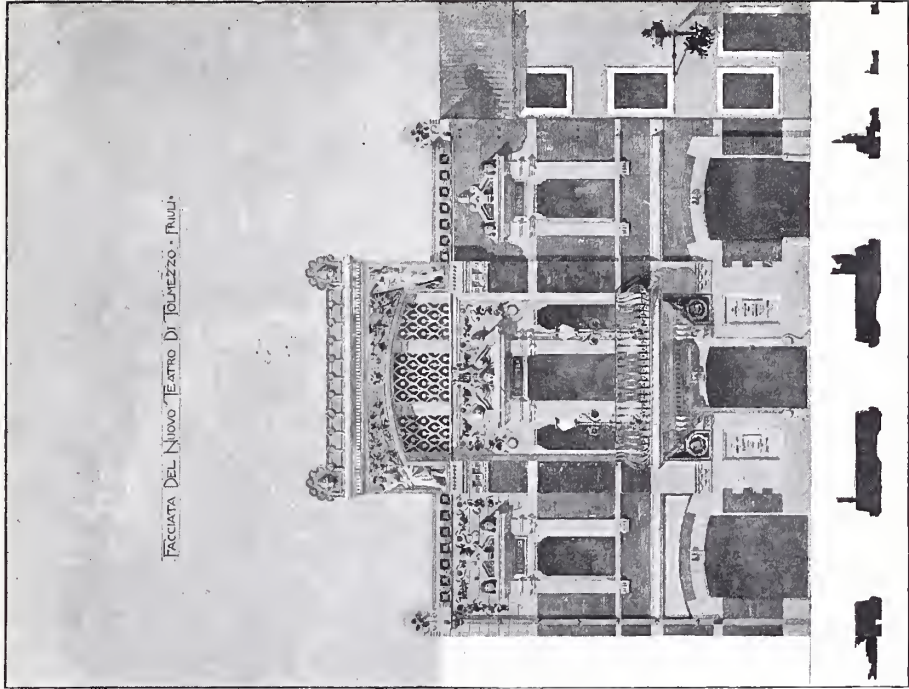

Façade of New Theatre at Tolmezzo, Italy,



Commemorative Monument at Dogali,

R. D'ARONCO, Architect, Messina.

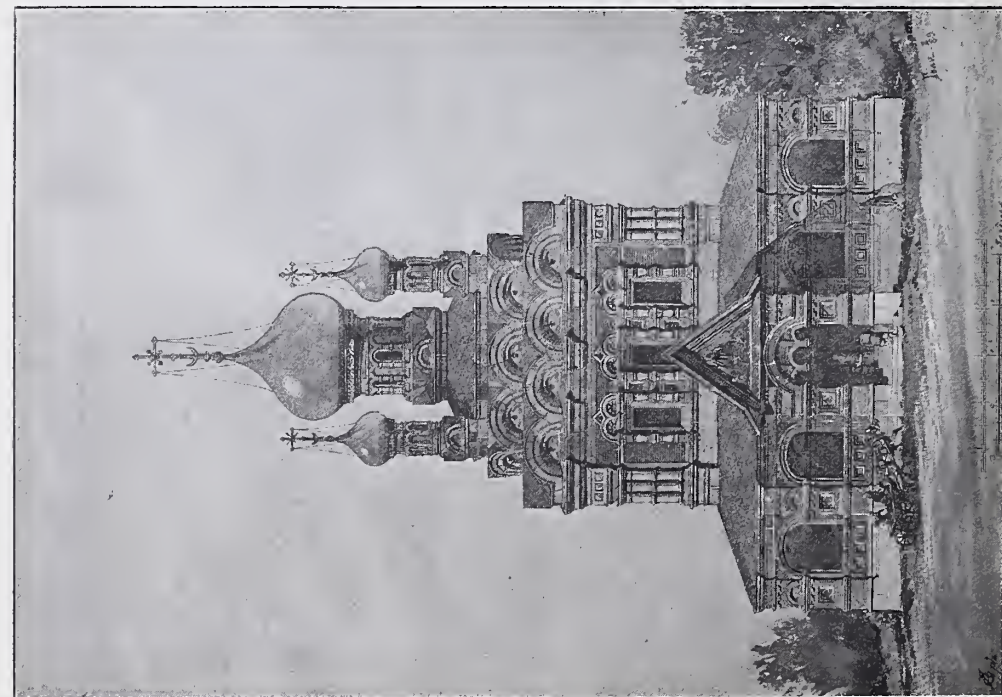

A Village Church, GUSTAV V. HOLY, Architect, St. Petersburg.

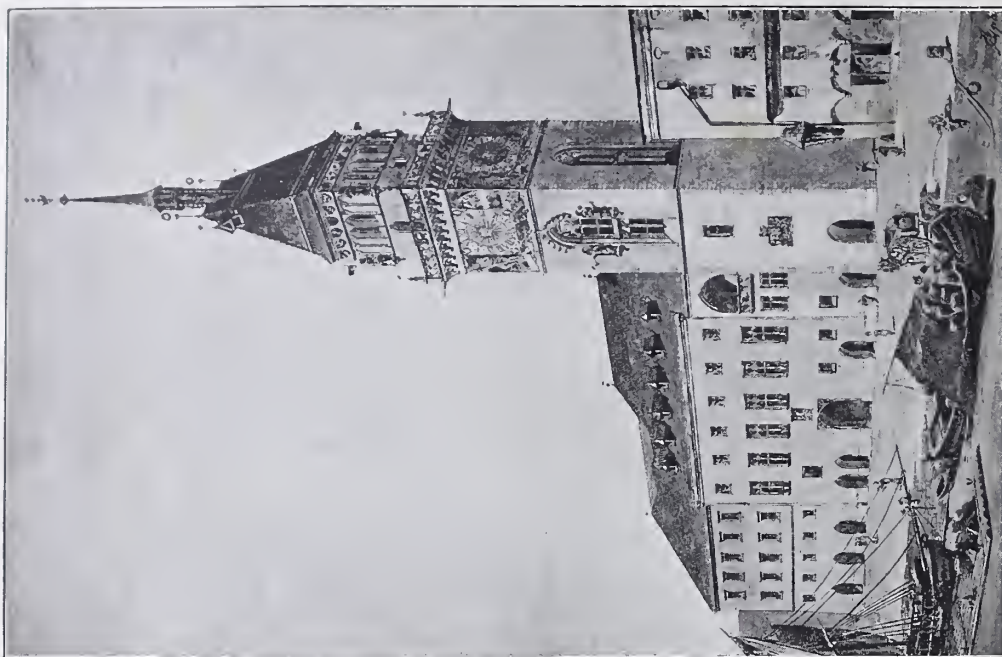

Tower added to the Town Hall, Passau, PROFESSOR HEINRICH FREIHERR VON SCHMIDT, Architect, Munich.

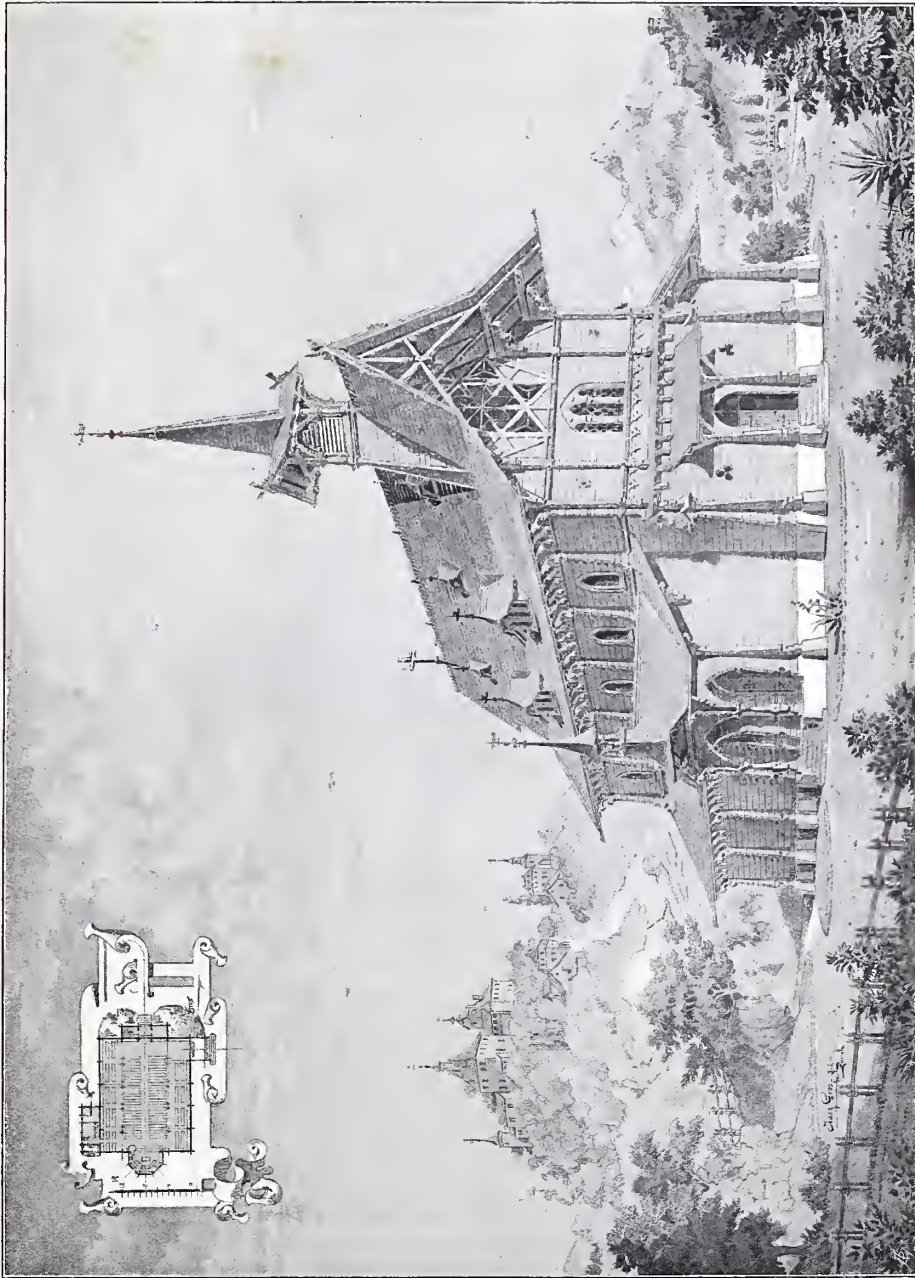

A Village Church, JACQUES GROS, Architect, Zürich.



Competitive Design for New Bridge over the Neva at St. Petersburg, R. D'ARONCO, Architect, Messina.

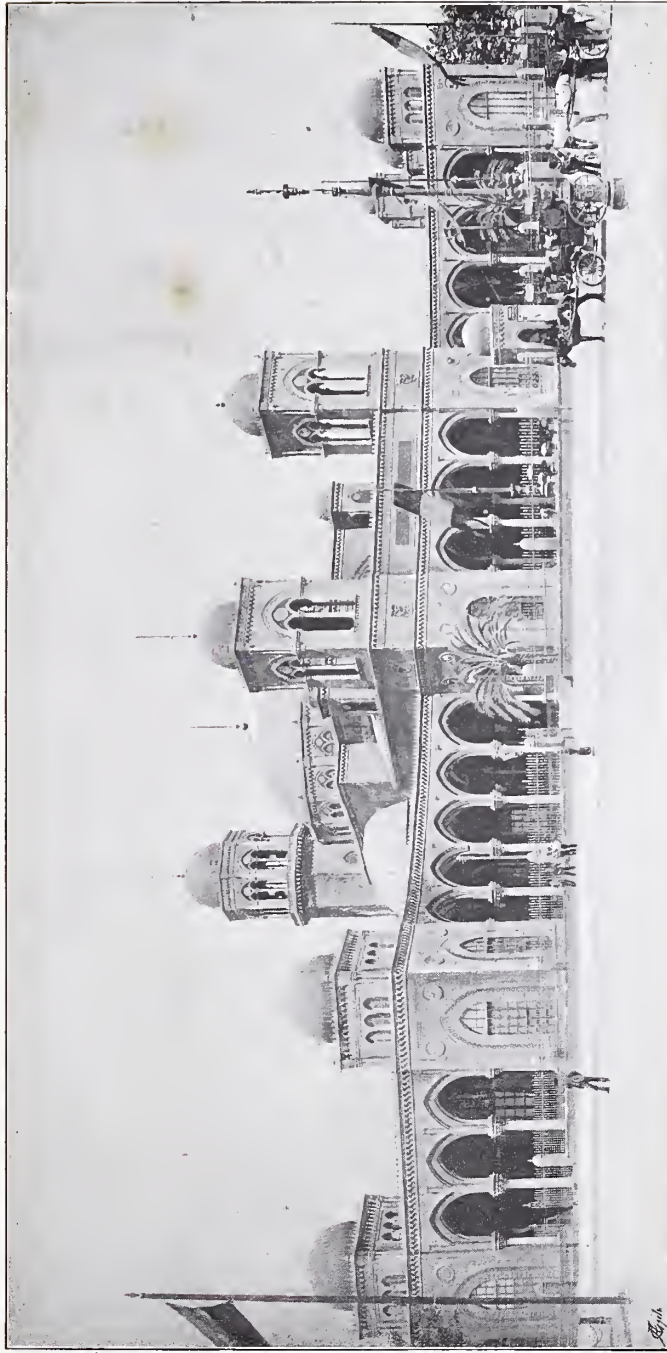

Exhibition Building at Palermo, Principal Entrance, Prof. COMM. ERNESTO BASILE, Architect, Palermo.

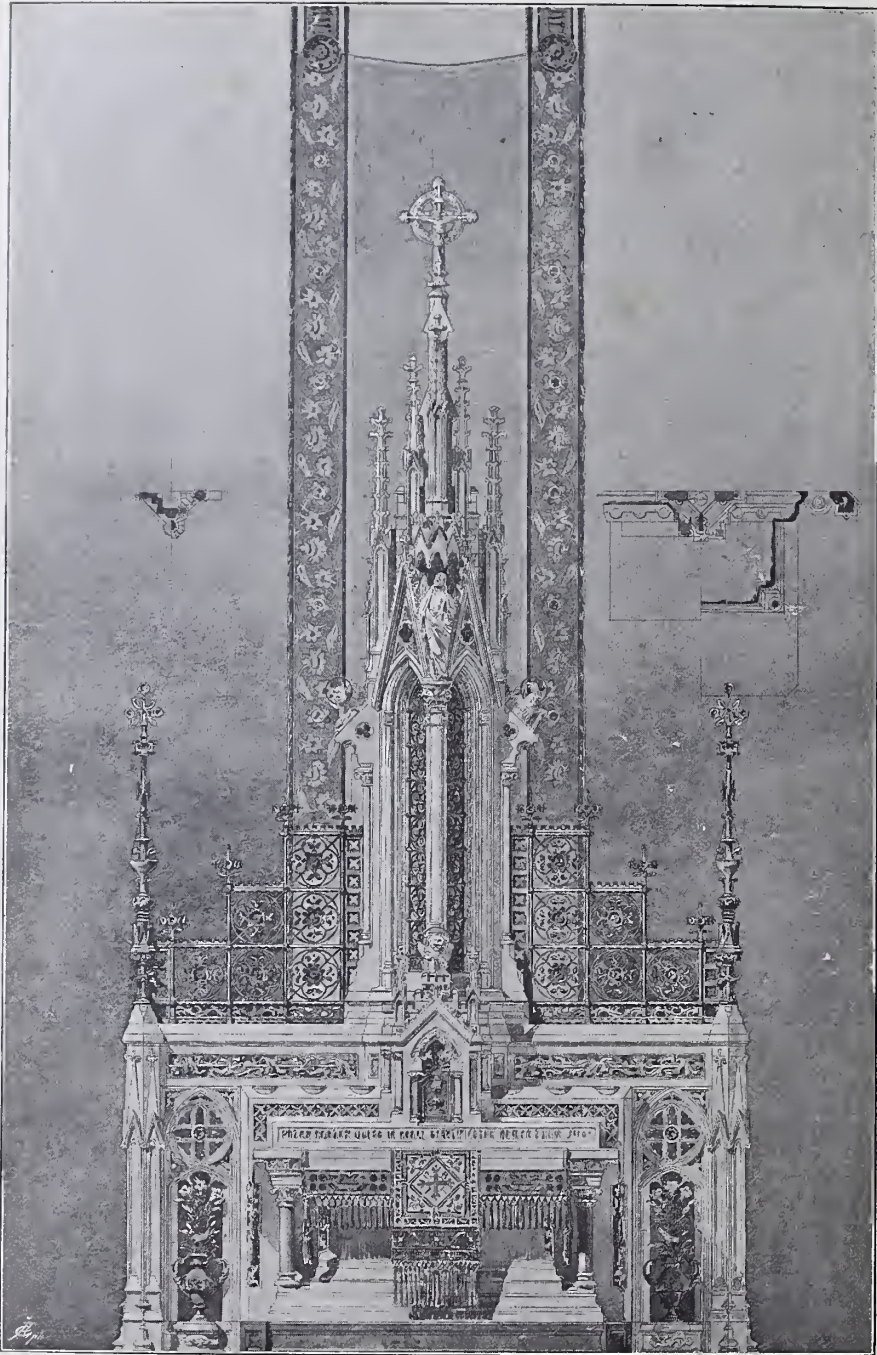

Altar-piece for the Church of St. Joseph, Coni, Italy, R. D'ARONCO, Architect, Messina.

FARROW AND JACKSON.

By Appointment to H.M. THE QUEEN and H.R.H. THE PRINCE OF WALES.

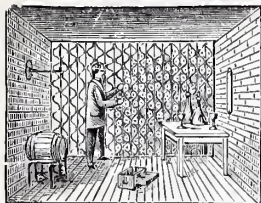

MAKERS OF

WROUGHT IRON WINE BINS

As fitted at the Royal Palaces, and at the principal Hotels and Clubs.

"REGISTERED CELLULAR" BINS

With Separate Rest for each Bottle, Soda Water Racks, &c.

16 GREAT TOWER STREET, E.C., and 8 HAYMARKET, S.W.

ILLUSTRATED CATALOGUES POST FREE.

THE SUNBURY **Lincrusta=Walton.** WALL DECORATION.

DADOES, FILLINGS, FRIEZES, CEILINGS, PLAQUES, PANELS, BORDERS, &c.

SOLID in Colour! SOLID in Relief! SOLID in Value!

Will never Wear out. Indispensable. Inexpensive.

Write for Samples, Illustrations, Price List, and all Particulars to—

FREDERICK WALTON & CO., Ltd., Sole Patentees & Manufacturers,
2 NEWMAN STREET, LONDON, W.

Telegrams—"LINCROSTA-WALTON, LONDON."

Telephone No. 3,760.

ROOFING-SLATES & TILES.

ROBERTS, ADLARD & CO.,

Telegraphic Address—
"Dralda, London." 47 EASTCHEAP, LONDON, E.C.

BANGOR, DINORWIC, PORTMADOC, CARNARVON, AND OTHER WELSH SLATES
Delivered at any Station in England, Scotland or Wales.

WESTMORELAND, EUREKA, & SEDAN (or Permanent) GREEN SLATES always in Stock
SLABWORK of all kinds, plain or enamelled, supplied and fitted for Export or Otherwise.

WHARF AND STEAM SLATE WORKS, BERMONDSEY WALL, LONDON, S.E.

SLATING AND TILING ESTIMATED FOR AND PROMPTLY EXECUTED.

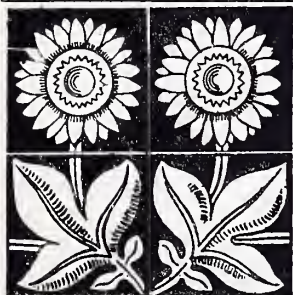

BRICK ORNAMENT

AND ITS APPLICATION.

JAMES BROWN.

LONDON OFFICE AND DEPOT:

Essex Wharf, Durward Street, Whitechapel, E.

(Opposite the London Hospital). TELEPHONE No. 11440.

Catalogue Parts 1, 2, 3 and 4, Now Ready. *Telegraphic Address:* "BRICKS, LONDON."

BARTON AND BALLARD
 STABLE FITTING MANUFACTURERS
 By Special Appointment to H.R.H. the Prince of Wales.

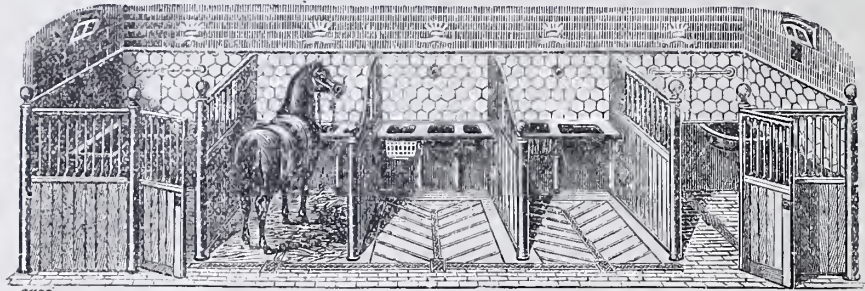

151 OXFORD STREET, LONDON, W.

Estimates free. **SAMUEL ELLIOTT**, Superior Finish.

Albert Moulding Mills and Joinery Works, Newbury.

SPECIALITIES IN HARD AND SOFT JOINERY AND MOULDINGS OF THE HIGHEST CLASS.

(One of the largest Manufacturers in England, with the highest reputation.)

TESTIMONIALS FROM EMINENT ARCHITECTS.

*Interior Fittings to Houses, Public Buildings, and Ecclesiastical Edifices, prepared, fixed, and polished.
 Distance no object.*

Awards at Newbury, London (3), Brussels, Paris (2), York, Edinburgh, Brighton, Cologne, Derby and
 Wolverhampton.

The Moulding Catalogues of Registered Designs (Free on Application) are the most complete ever published.

Manufacturer and Patentee of the **Patent Simplex Weather Bar** for French Casements and Windows.

This Patent has been used throughout at the new New Police Offices, R. NORMAN SHAW, Esq., R.A., Architect; also at the New Imperial
 Institute, T. E. COLLCUTT, Esq., Architect; and is being specified for use to the Principal Public Buildings at home and abroad.

ESTABLISHED 1818.

55, LIONEL STREET,
 BIRMINGHAM.

HENRY HOPE

HORTICULTURAL
 BUILDER & HEATING
 ENGINEER

WROUGHT IRON
 CASEMENTS,

Guaranteed
 Water-Tight.

*Illustrated Catalogue
 Post free on
 application.*

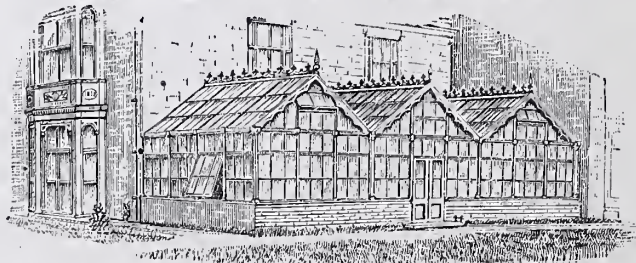

HEATING
 APPARATUS
 For all kinds of
 BUILDINGS,
 on the newest and
 most perfect
 systems.

Architects' designs carried out for Conservatories, Hot Houses, &c., with the most approved forms of Heating and Ventilation.

WILSON'S

DIOPTRIC

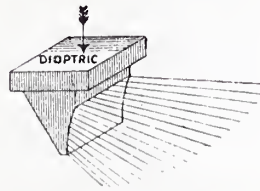

LENSES.

**UTILIZE YOUR BASEMENTS BY ADOPTING
WILSON'S IMPROVED DIOPTRICAL PAVEMENT LIGHTS.**

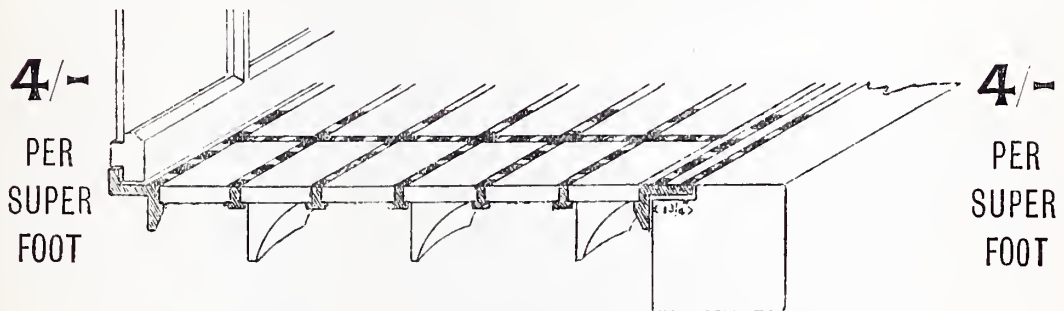

Wilson's Dioptrical Lenses are the only Lenses which properly distribute the Light, and are made of the Best White Flint Glass of High Refractive Power, well annealed so as to stand variations in temperature. Approved by some of the highest Scientific Authorities on Light, and for **UTILITY** and **ECONOMY** are the best in the Market.

Illustrated Catalogues—Plans and Estimates for all Kinds of

PAVEMENT LIGHTS, ORNAMENTAL TILE AND GLASS PAVEMENTS, IMPROVED ILLUMINATING CELLAR FLAPS, ROLLING LIGHTS, AND DAYLIGHT REFLECTORS,

On Application to

H. WILSON & CO.,

Pavement Light Engineers, Ironfounders and Glass Manufacturers,

117 CHARTERHOUSE STREET, LONDON, E.C.

INTERNATIONAL INVENTIONS EXHIBITION, LONDON, 1885.

AWARDED FOR INGENIOUS DEVICES



IN ORGAN MECHANISM



ROYAL LETTERS PATENT.

A. GERN,
Organ Builder,

BOUNDARY ROAD, NOTTING HILL, LONDON.

A. G. begs to inform Architects, that he is prepared to build Organs with either the Tubular Pneumatic or Electro Pneumatic Action, which will allow Organs to be placed in any position most suitable for sound; and to suit Architects' designs. Any information respecting the above may be obtained of A. G., with testimonials. High-class work only.

BATTISCOMBE & HARRIS,

49 and 50 Great Marylebone Street, Portland Place,

LONDON, W.

Manufacturers of Interior Architectural Ornamental Work, in
Wood, Fibrous Plaster, and Carton Pierre.

Carvers and Modellers.

Ceilings—Italian, French, and Flemish Renaissance—Elizabethan, Georgian,
Adams' and other Styles—in Fibrous Plaster.

Chimney Pieces and Overmantels, Carved Wood and in Pine—enriched with Carton
Pierre—for Painting.

ARCHITECTS' DESIGNS CAREFULLY EXECUTED.

ESTIMATES SUPPLIED ON APPLICATION WITH PARTICULARS.

V. G. MIDDLETON, CONSULTING ELECTRICAL ENGINEER.

Plans and Specifications prepared for putting down complete Electric Lighting and Power Plants. Tenders obtained and advised upon, work personally supervised, tested and certified for.

Special experience in the arrangement of Country House Lighting Plants, and in the application of Electric Power to raising water supply, driving laundry machinery, and other domestic uses.

3 PRINCES' MANSIONS, VICTORIA STREET,
WESTMINSTER, S.W.

TELEGRAMS, "BLANCMANCE," LONDON.

TELEPHONE, 3077.



LATEST IMPROVEMENTS-

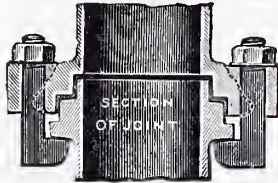

FOR HOT WATER OR STEAM.

Sole Manufacturers—

THE

Meadow Foundry Co., Ltd.,
MANSFIELD, NOTTS.

ADOPTED BY H.M.'S WAR DEPT. HOME OFFICE, LONDON & COUNTRY SCHOOL BOARDS.

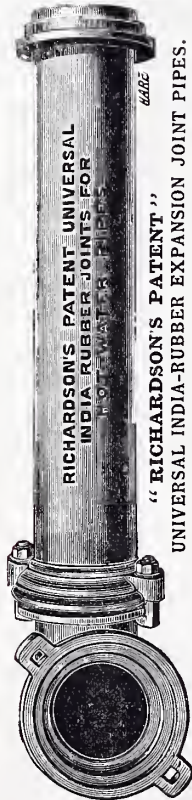

*"RICHARDSON'S PATENT"
UNIVERSAL INDIA-RUBBER EXPANSION JOINT PIPES.
The Only Permanently Sound Joint in the Market.*

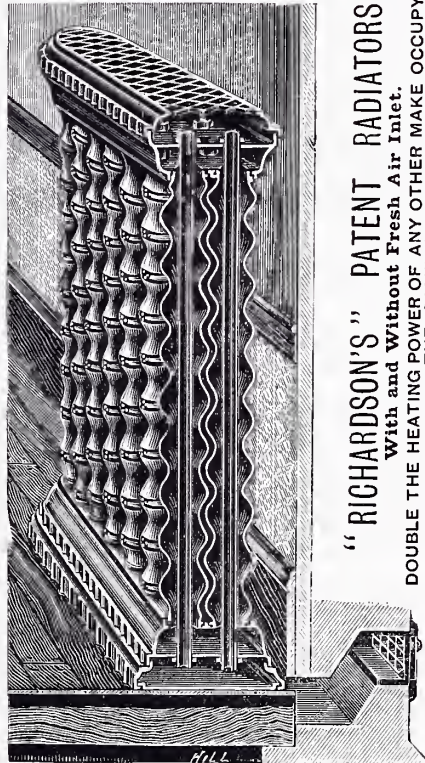

*"RICHARDSON'S" PATENT RADIATORS.
With and Without Fresh Air Inlet.
DOUBLE THE HEATING POWER OF ANY OTHER MAKE OCCUPYING
THE SAME SPACE.*

J. TYLOR & SONS,

LIMITED,

2 Newgate Street, London.

CERTIFICATE
OF
MERIT,

PATENT
"COLUMN"

(Registered No. 151483)

SANITARY
INSTITUTE,
1890.

Pedestal

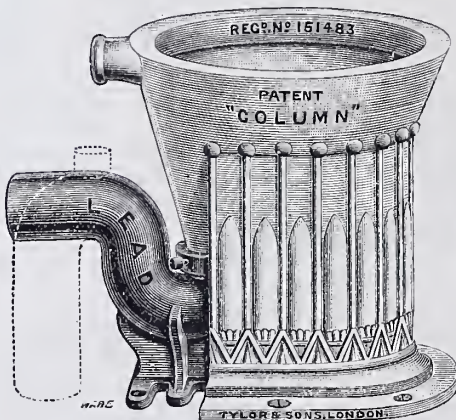

Closet.

This closet is made of best white earthenware, with lead trap to shoot either out or down. The use of a lead trap ensures the joint between the closet and soil-pipe being well made.

The lead trap is joined to the earthenware basin by a simple brass collar, as in the ordinary valve closet.

This joint between earthenware and metal—always a difficult joint to make—being *above the trap*, there is no danger of sewer gas entering the house through careless fixing.

The water stands higher than the joint: careless fixing is therefore instantly detected by the water falling on the floor.

The seat can be fixed to rest upon the earthenware.

A ventilating pipe should be carried from the top of the trap.

PRICES.

	£	s.	d.
Strong earthenware, white inside, yellow outside, with strong hydraulic drawn lead trap	1	19	0
Ornamental ivory china	2	0	0
Ditto, decorated in red or blue	2	12	6
Ditto, "1892 Pattern," with enclosed back in white china	2	7	6

E. & J. M. VERITY,

CALL LANE, LEEDS,

Manufacturers of Machine-made Steel, Wrought Iron, and Gun Metal Casements'

STEEL CASEMENTS and FRAMES, Sections below are half size.
(GUARANTEED WEATHER and WATER-PROOF.)

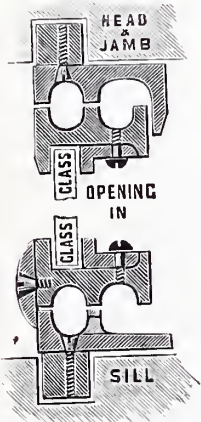

When Sills are Rabbeted,
Fixing Fillet is dispensed
with.

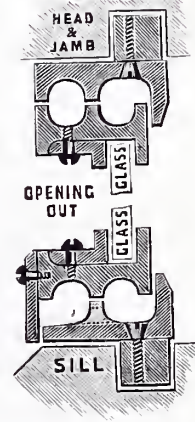

Hinged at side on strong brass butts opening Outwards or Inwards, and prepared to receive glass in one Square each, and with Square Heads.

Quality A are fitted with Gun Metal Lever Handles and patent Casement Stay, Polished or Bronzed; the 4ft. 6in. and upwards have our treble Espagnolette Bolt Fastening with Gun Metal Sockets and Handles.

Quality B have Malleable Lever Handles and any of our patent Casement Stays; the 4ft. 6in. and upwards with Malleable Espagnolette Bolts.

	Quality A.	Quality B.	Fixing Fillets.	Glazing Fillets.
Under 2ft. in height.	38/-	30/-	3/-	3/-
" 3ft. " 	44/-	34/-	3/6	3/6
" 4½ft. " 	56/-	40/-	4/-	4/-
" 6ft. " 	70/-	50/-	4/6	4/6

Semi-Circular or Gothic Heads or the Casement curved to suit Bow or Segment Windows 10/6 each extra, the height of Casements regulate price, the width may be from 2 feet to 6 inches.

Transom Lights to above section hinged at top, bottom, or side, and fitted with any of our patent Regulators, any height to 3 feet, A quality 40/-; B quality 32/-.

Fixed Transom Lights, 25/- each.

WROUGHT IRON CASEMENTS of a cheaper section for Cottages, Schools, &c., hinged at side to open outward or inwards, any width to two feet, and fitted with Malleable and Lever Handles and Stay.

2 feet high, 20/-.

3 feet high, 25/-.

4 feet high, 28/-.

Hopper Ventilators, 1 foot 6 inches high and under, 15/- each.

Do. 2 feet high and under, 18/- each.



ALSO PATENTEES AND MANUFACTURERS OF THE LARGEST ASSORTMENT OF

Special Appliances for Opening Fan, Hopper and Lantern Lights, singly or in Ranges, either Vertical or Horizontal. Iron Skylights from 5/6 each, Casement Weather Bars, Air-Check Door Springs, Security Sash Fasteners, stops rattling in winds, Deadweight, mortice, and Rim Locks, and Lock Furniture.

CATALOGUES FREE.



ESSEX & CO.



THE WESTMINSTER WHIPPERS
LONDON SHOWROOMS & OFFICES
174-116 VICTORIA STREET WESTMINSTER
AND ESSEX MILLS - BATTERSEA

ESSEX AND COMPANY
OF 116 VICTORIA STREET
WESTMINSTER BY VICTORIA
STATION ARE
MANUFACTURERS OF
THE BEST WALLPAPERS
FROM THE DESIGNS OF
THE BEST DESIGNERS

THE COLOGNE
METAL-ORNAMENT WORKS.
MANUFACTURERS IN METAL

FOR
Architectural Structures, Ornaments and Decorations

OF
Every Kind and Modelling,

IN
ZINC, COPPER, BRASS, LEAD, &C.
Art Foundry, Hammering and Stamping
WORKS,

For the Execution of ARTISTICAL COMPOSITIONS as
GROUPS, FIGURES, FOUNTAINS, MONUMENTS, &c.,
TO ANY DESIRED DESIGN OR MODEL.

CATALOGUE WITH 2,000 DRAWINGS.

LARONDELLE, PELZER & CO., COLOGNE (on the RHINE).

MEYER'S STONE-CEMENT

SERVES TO

Imitate and Repair Marble, Granite, Porphyry,

Sandstone, Limestone, Lithographic Stones, &c.,

Also for Mending Broken Edges of Flagstones and Steps,

Repairing the Façades of Churches, Monuments, Statues, &c.

Its principal advantages are—(1) Every kind of Stone (Marble, Granite, Freestone, Sandstone, &c.) can be repaired by it. (2) No head is required in making the mend. (3) It can be coloured in any way required, and the stone may be imitated perfectly. (4) The joins are unaffected by any kind of weather and remain permanently as hard and as durable as the rest of the stone. (5) The cost becomes trifling in comparison with advantages, when it is remembered that one must always use from two to four parts of stone-dust or hard sand to one part of the Cement. (6) The mend is hard and solid in two days, and may be worked, carved, sawn, or polished afterwards in the same way as an ordinary block of stone.

Hundreds of Testimonials from all Parts of the World.

E. FRED. MEYER, STONE MERCHANT, FREIBURG (BADEN).

Verlag von T. O. WEIGEL NACHF. (Chr. Herm. Tauchnitz) Leipzig, Königstr. 7 I.
LEHRBUCH DER GOTISCHEN KONSTRUKTIONEN.

Von G. UNGEWITTER.

Dritte Auflage.

Neu bearbeitet von K. MOHRMANN, Professor am Polytechnikum zu Hannover. Mit über 1500 Abbildungen im Text und auf eingesteppten Tafeln.
2 Bände. Geh. 26 Mk. Elegant in Halbfranz geb. 32 Mk.

LEITFADEN ZUM STUDIUM DER MITTELALTERLICHEN BAUKUNST.

Formenlehre der deutschen und französischen Baukunst, des romanischen und gotischen Stils auf Grundlage ihrer historischen Entwicklung.

Von R. REDTENBACHER.

Mit 544 Figuren und 4 Tafeln Abbildungen. Geh. 5 Mk. Geb. 6 Mk.

GESCHICHTE DER ROMANISCHEN BAUKUNST IN DEUTSCHLAND.

Von D. HEINRICH OTTE.

Mit 4 Tafeln und 309 eingedruckten Holzschnitten. Geheftet 10 Mk.
In Ganzleinen gebunden 12 Mk.

Verlag von GEORG SIEMENS in Berlin W. 30, Nollendorfstr. 42.

G. Ebe: Die Schmuckformen der Denkmalsbauten

aus allen Stilepochen seit der griechischen Antike. In 8 Theilen 4° mit über 300 Abbildungen im Text und auf besonderen Tafeln.

I. u. II. TH. KLASSISCHE ANTIKE UND NORDISCHE KUNSTANFÄNGE.—ALTCHRISTLICHES, BYZANTINISCHES UND KAROLINGISCHES. Mit 33 Textabbildungen, 3 Lichtdruck- u. 1 Farbentafel. Preis 6 M. 40 Pf.

Dieses *Lehrbuch der Decorationskunst* bringt in knapper Form das Beste aller Epochen, was in der Innen- und Aussendecoration der Bauwerke zur Geltung gekommen ist. Das reich illustrierte ca 80 Bogen 4° umfassende Werk wird in seinen weiteren Theilen die *romanische und gothische Epoche, die Früh- und Hochrenaissance, die erste und zweite Barockperiode, Rokoko und Klassicismus* behandeln; jeder der folgenden Theile ist einzeln käuflich.

A. Riegl: Stilfragen. Grundlegungen zu einer

Geschichte der Ornamentik. Mit 197 Textabbildungen. Preis 12 M. Geb. in Hlbfrzbd. 14 M.

Das Werk behandelt zum ersten Mal in zusammenhängender Form und einheitlicher Auffassung die wichtigsten Fragen zur Geschichte des Ornaments in nachfolgenden Capiteln: 1. *Der Geometrische Stil.* 2. *Der Wappenstil.* 3. *Das Pflanzen Ornament.* 4. *Die Arabeske.*

O. Rieth: Architektur-Skizzen. 120 Handzeich-

nungen in Autotypie. Kl. Fol. Geb. Pr. 20 M.

O. Rieth: Skizzen. Eine neue Folge architekton-

ischer und decorativer Studien und Entwürfe. 20 Handzeichnungen in z. Th. farbigem Lichtdruck. Geb. Preis 20 M.

Prospecte nebst Proben auf Verlangen frei vom Verleger.

Innen-Architectur, Interieurs

Meubles u. Kunstgewerbe.



Jährlich über 300 grosse Original-Illustrationen u. Kunstbeilagen!

INHALT.

Innen-Architektur:

Vestibüls, Treppenanlagen, Stukkatur, Vertäfelungen, Kaminparthien, Haus und Zimmerthüren, etc.

Interieurs

einfachem wie reichstem Geschmack, sowie in allen modernen Stilarten, Erkerbildungen, etc.

Dekorative Arrangements

aller Art, Stoff-Draperien, etc.

Möbel

für Wohnräume jeden Stils. Wanddekorationen, Erkerarrangements.

Beleuchtungs-Körper.

Gobelins—Tapeten—Teppiche.

Kunstschmiedearbeiten

Eingangsgitter, Treppengeländer, etc.

Oefen und Kamine, etc.

überhaupt hervorragende Abbildungen von allen modernen kunstgewerblichen Erzeugnissen, welche auf die

Ausschmückung und Einrichtung der Wohnräume

Bezug haben.

Erscheint Anfangs jeden Monats im Format 37x27 ctm. in vorzüglichem Druck. Die Innen-Dekoration ist die beste illustrierte Kunstgewerbliche Zeitschrift in Deutschland, und behandelt die moderne Ausschmückung und Einrichtung der Wohnräume in Wort und Bild.

Price. — 1/2 jährl., 6 reichillustr. Hefte für Deutschland, 8 Mark. Ausland: 9 Shillings, Francs 11.25, Ö fl. 5.30. **Publisher:**—ALEXANDER KOCH, DARMSTADT (Germany) Zu beziehen durch jede Buchhandlung.

**TRAUTE WOHNÄRÄUME
IN WORT UND BILD!**

Mitarbeiter—Contributors.

Arch. *Lothar von Abel*—Arch. Prof. *Rud. Bakalowitz*—Director *Carl Behr*—*H. E. v. Berlepsch*—*Georg Bötticher*—Prof. *F. Brochier*—Arch. *Georg Buss*—Arch. *Rich. Dorschfeldt*—Hofrath Prof. *Jacob v. Falke*—Arch. *Jul. Paulwasser*—Director *Fr. Fischbach*—Arch. *Otto Fritzsche*—Director Prof. *Hermann Götz*—Arch. *Karl Gagel*—Arch. *Ernst Härring*—Arch. Dir. *C. Hammer*—Arch. *Alb. Hofmann*—Berlin—*Eugen Jäck*—Arch. *H. Kirchmayer*—Maler *Carl Hollmann*—Prof. *H. Kolb*—Prof. *Th. v. Kramer*—Prof. *Ferd. Luthmer*—Prof. *Frz. Sales Meyer*—*Rob. Mielke*—Maler *Heinz Muth*—Maler *Pedro Muth*—Prof. *A. Neumeister*—Arch. *Otto Rieth*—Arch. *Ant. v. d. Sandt*—Arch. *B. Schaede*—Prof. *C. Schick*—Reg.-Bmstr. *Hans Schliepman*—Arch. *Otto Schulze*—Köln—Decorateur *Eugen Schwinghammer*—Arch. *Karl Späth*—Arch. *Karl Statsmann*—Director *Dr. Stockbauer*—*Paul Stossek*—*Wilh. F. Toißl*—Director *Aug. Töpfer*—Arch. *Warnemünde*—Prof. *v. Weissenbach*—Maler *Mart. Wiegand*—Arch. *W. Wulff*—*Georg Zimmer*, etc

Probeheft: M2=2sh.

CONTENTS.

Interior Architecture:

Vestibules, staircases, stucco-work, wainscoting, chimney-pieces, room- and street doors.

Interiors

designed in all modern styles—from the plainest to the richest. Bay Windows.

Decorative Arrangements

in every Style. Draperies: Silk and Woollen, etc.

Furniture

of every description, wall-decorations, corner fittings.

Gas and Electric Light Fittings.

Gobelins, wall-papers, carpets.

Wrought Iron-work.

Gateways, Railings, Balustrades.

Stoves and Fire-places.

Designs and Illustrations of all the latest Productions of modern Industrial Art connected with the decoration of sitting- and drawing-rooms.



11/10/11