



**Calhoun: The NPS Institutional Archive**  
**DSpace Repository**

---

Theses and Dissertations

1. Thesis and Dissertation Collection, all items

---

2010-12

**Integrating Defense, Diplomacy, and  
Development (3 D) in the Naval Special  
Warfare operator**

Sulick, Timothy S.

Monterey, California. Naval Postgraduate School

---

<http://hdl.handle.net/10945/5002>

*Downloaded from NPS Archive: Calhoun*



Calhoun is a project of the Dudley Knox Library at NPS, furthering the precepts and goals of open government and government transparency. All information contained herein has been approved for release by the NPS Public Affairs Officer.

**Dudley Knox Library / Naval Postgraduate School**  
**411 Dyer Road / 1 University Circle**  
**Monterey, California USA 93943**

<http://www.nps.edu/library>



# NAVAL POSTGRADUATE SCHOOL

MONTEREY, CALIFORNIA

## THESIS

**INTEGRATING DEFENSE, DIPLOMACY, AND  
DEVELOPMENT (3 D) IN THE NAVAL SPECIAL  
WARFARE OPERATOR**

by

William Fiack  
William Roberts  
Tim Sulick

December 2010

Thesis Advisor:  
Second Reader:

Erik Jansen  
Leo Blanken

**Approved for public release; distribution is unlimited**

THIS PAGE INTENTIONALLY LEFT BLANK

<b>REPORT DOCUMENTATION PAGE</b>			<i>Form Approved OMB No. 0704-0188</i>
Public reporting burden for this collection of information is estimated to average 1 hour per response, including the time for reviewing instruction, searching existing data sources, gathering and maintaining the data needed, and completing and reviewing the collection of information. Send comments regarding this burden estimate or any other aspect of this collection of information, including suggestions for reducing this burden, to Washington headquarters Services, Directorate for Information Operations and Reports, 1215 Jefferson Davis Highway, Suite 1204, Arlington, VA 22202-4302, and to the Office of Management and Budget, Paperwork Reduction Project (0704-0188) Washington DC 20503.			
<b>1. AGENCY USE ONLY (Leave blank)</b>	<b>2. REPORT DATE</b> December 2010	<b>3. REPORT TYPE AND DATES COVERED</b> Master's Thesis	
<b>4. TITLE AND SUBTITLE</b> Integrating Defense, Diplomacy, and Development (3 D) in the Naval Special Warfare Operator		<b>5. FUNDING NUMBERS</b>	
<b>6. AUTHOR(S)</b> William Fiack, William Roberts, Timothy Sulick		<b>8. PERFORMING ORGANIZATION REPORT NUMBER</b>	
<b>7. PERFORMING ORGANIZATION NAME(S) AND ADDRESS(ES)</b> Naval Postgraduate School Monterey, CA 93943-5000		<b>10. SPONSORING/MONITORING AGENCY REPORT NUMBER</b>	
<b>9. SPONSORING /MONITORING AGENCY NAME(S) AND ADDRESS(ES)</b> N/A		<b>11. SUPPLEMENTARY NOTES</b> The views expressed in this thesis are those of the author and do not reflect the official policy or position of the Department of Defense or the U.S. government. IRB Protocol number <u>N/A</u> .	
<b>12a. DISTRIBUTION / AVAILABILITY STATEMENT</b> Approved for public release; distribution is unlimited		<b>12b. DISTRIBUTION CODE</b> A	
<b>13. ABSTRACT (maximum 200 words)</b>  This thesis initiates a conversation focused on enhancing Naval Special Warfare's (NSW) current operational capacity. U.S. Special Operations Command's (USSOCOM) 2010 strategy challenges all special operators to be defter at working within the diplomatic, defense, and development (3-D) construct. The "3-D" operator is USSOCOM's contribution to the whole-of-government approach in the violent struggle against state and non-state actors for legitimacy and influence over the relevant population (irregular warfare/IW). To be effective at the IW mission NSW must select, train, and reward personnel and units to develop and sustain 3-D capabilities. This thesis offers an analysis of the NSW organization and a proposal for developing the NSW 3-D teams and organization for non-traditional roles, such as those on embassy country teams. The research uses organizational contingency theory and case studies as a framework to draw conclusions about cultural differences and training shortfalls and provide recommendations for how NSW can select the right 3-D operators. It argues that the current SEAL team inter-deployment training cycle (IDTC) prepares SEALs to excel in the kinetic, time-sensitive environment (traditional SEAL mission sets) but is inadequate for preparing SEALs for the diplomatic and developmental roles (non-traditional, but essential) with interagency partners in U.S. embassies. This thesis advocates that the NSW anchor detachment operators, rather than the traditional SEAL team operators, are the right personnel postured for roles working within the interagency because their training sets them up for success in the 3-D environment.			
<b>14. SUBJECT TERMS</b> Naval Special Warfare 3-D (Defense, Diplomacy, Development) Operator		<b>15. NUMBER OF PAGES</b> 97	
		<b>16. PRICE CODE</b>	
<b>17. SECURITY CLASSIFICATION OF REPORT</b> Unclassified	<b>18. SECURITY CLASSIFICATION OF THIS PAGE</b> Unclassified	<b>19. SECURITY CLASSIFICATION OF ABSTRACT</b> Unclassified	<b>20. LIMITATION OF ABSTRACT</b> UU

THIS PAGE INTENTIONALLY LEFT BLANK

**Approved for public release; distribution is unlimited**

**INTEGRATING DEFENSE, DIPLOMACY, AND DEVELOPMENT (3 D) IN THE  
NAVAL SPECIAL WARFARE OPERATOR**

William J. Fiack  
Lieutenant, United States Navy  
B.A., University of California Davis, 2001

William J. Roberts  
Lieutenant, United States Navy  
B.S., U.S. Naval Academy, 2001

Timothy S. Sulick  
Lieutenant, United States Navy  
B.A. San Diego State University, 1998

**MASTER OF SCIENCE IN DEFENSE ANALYSIS**

from the

**NAVAL POSTGRADUATE SCHOOL  
December 2010**

Authors : William Fiack  
William Roberts  
Timothy Sulick

Approved by: Dr. Erik Jansen  
Thesis Advisor

Dr. Leo Blanken  
Second Reader

Gordon McCormick, PhD  
Chairman, Department of Defense Analysis

THIS PAGE INTENTIONALLY LEFT BLANK

## **ABSTRACT**

This thesis initiates a conversation focused on enhancing Naval Special Warfare's (NSW) current operational capacity. U.S. Special Operations Command's (USSOCOM) 2010 strategy challenges all special operators to be defter at working within the diplomatic, defense, and development (3-D) construct. The "3-D" operator is USSOCOM's contribution to the whole-of-government approach in the violent struggle against state and non-state actors for legitimacy and influence over the relevant population (irregular warfare/IW). To be effective at the IW mission NSW must select, train, and reward personnel and units to develop and sustain 3-D capabilities. This thesis offers an analysis of the NSW organization and a proposal for developing the NSW 3-D teams and organization for non-traditional roles, such as those on embassy country teams. The research uses organizational contingency theory and case studies as a framework to draw conclusions about cultural differences and training shortfalls and provide recommendations for how NSW can select the right 3-D operators. It argues that the current SEAL team inter-deployment training cycle (IDTC) prepares SEALs to excel in the kinetic, time-sensitive environment (traditional SEAL mission sets) but is inadequate for preparing SEALs for the diplomatic and developmental roles (non-traditional, but essential) with interagency partners in U.S. embassies. This thesis advocates that the NSW anchor detachment operators, rather than the traditional SEAL team operators, are the right personnel postured for roles working within the interagency because their training sets them up for success in the 3-D environment.



THIS PAGE INTENTIONALLY LEFT BLANK

# TABLE OF CONTENTS

<b>I.</b>	<b>INTRODUCTION.....</b>	<b>1</b>
<b>A.</b>	<b>SETTING THE STAGE: A CASE OF A “MISFIT” .....</b>	<b>1</b>
<b>B.</b>	<b>USSOCOM’S 3-D INITIATIVE.....</b>	<b>2</b>
	<b>1. Defense .....</b>	<b>4</b>
	<b>2. Diplomacy .....</b>	<b>4</b>
	<b>3. Development .....</b>	<b>5</b>
<b>C.</b>	<b>TRADEOFFS .....</b>	<b>6</b>
<b>D.</b>	<b>THE NSW ORGANIZATION: OUR APPLIED THEORY.....</b>	<b>7</b>
<b>E.</b>	<b>ROAD MAP.....</b>	<b>7</b>
<b>II.</b>	<b>A DIAGNOSIS OF NSW .....</b>	<b>11</b>
<b>A.</b>	<b>ORGANIZATIONAL CONTINGENCY THEORY: ITS APPLICATION TO NSW .....</b>	<b>11</b>
<b>B.</b>	<b>THE OPEN SYSTEM.....</b>	<b>12</b>
<b>C.</b>	<b>THE NSW ENVIRONMENT .....</b>	<b>13</b>
	<b>1. Geographic Combatant Commands.....</b>	<b>13</b>
	<b>2. USSOCOM .....</b>	<b>15</b>
	<b>3. Training Schedules .....</b>	<b>16</b>
<b>D.</b>	<b>THE LARGER ENVIRONMENT .....</b>	<b>17</b>
	<b>1. Globalization .....</b>	<b>18</b>
	<b>2. Traditional Vs. Irregular Warfare.....</b>	<b>19</b>
	<b>3. Violent Extremism .....</b>	<b>19</b>
	<b>4. Socio-Cultural .....</b>	<b>19</b>
	<b>5. Economic.....</b>	<b>20</b>
	<b>6. International.....</b>	<b>20</b>
	<b>7. Human Resources .....</b>	<b>21</b>
<b>E.</b>	<b>NSW STRUCTURE AND TASKS .....</b>	<b>22</b>
<b>F.</b>	<b>NSW PEOPLE AND CULTURE .....</b>	<b>28</b>
<b>G.</b>	<b>CONCLUSION .....</b>	<b>30</b>
<b>III.</b>	<b>SOCCE NIGERIA .....</b>	<b>33</b>
<b>A.</b>	<b>INTRODUCTION.....</b>	<b>33</b>
<b>B.</b>	<b>SOCCE PROCESSES .....</b>	<b>34</b>
<b>C.</b>	<b>THE ENVIRONMENT OF THE U.S. EMBASSY .....</b>	<b>37</b>
<b>D.</b>	<b>CULTURAL DIFFERENCES.....</b>	<b>41</b>
<b>E.</b>	<b>THE IRREGULAR ENVIRONMENT.....</b>	<b>42</b>
	<b>1. The Operator .....</b>	<b>44</b>
	<b>2. The Misfit.....</b>	<b>45</b>
<b>F.</b>	<b>CONCLUSION .....</b>	<b>46</b>
<b>IV.</b>	<b>NAVAL SPECIAL WARFARE ANCHOR DETACHMENTS .....</b>	<b>49</b>
<b>A.</b>	<b>INTRODUCTION.....</b>	<b>49</b>
<b>B.</b>	<b>A 3-D “FIT” IN THE LONG TERM .....</b>	<b>50</b>
<b>C.</b>	<b>THE NSWAD ORGANIZATION .....</b>	<b>51</b>

D.	ENVIRONMENTAL CONTINGENCIES .....	52
E.	HUMAN RESOURCES.....	55
F.	INTER-DEPLOYMENT TRAINING CYCLE (IDTC).....	56
G.	METRICS OF SUCCESS .....	58
H.	CULTURE.....	58
I.	CONCLUSION .....	59
V.	CONCLUSIONS AND RECOMMENDATIONS.....	61
A.	CONCLUSIONS .....	61
B.	RECOMMENDATIONS.....	62
1.	Manning SOCCEs or Other 3-D Jobs.....	63
a.	Discussion.....	63
b.	Recommendation.....	64
2.	NSWAD Manpower .....	64
a.	Discussion.....	64
b.	Recommendation.....	65
3.	Incentives .....	65
a.	Discussion.....	65
b.	Recommendation.....	65
APPENDIX A.	MAJOR COMPONENTS OF NAVAL SPECIAL WARFARE COMMAND (NAVSPECWARCOM) .....	67
APPENDIX B.	UJTL TASK LINKAGES .....	71
LIST OF REFERENCES.....		73
INITIAL DISTRIBUTION LIST .....		77

## LIST OF FIGURES

Figure 1.	Graphical Portrayal of 3-D Construct .....	3
Figure 2.	Open System Model.....	13
Figure 3.	The NSW Environment and Organization.....	13
Figure 4.	Unified Command Map .....	14
Figure 5.	The Larger Environment and NSW .....	17
Figure 6.	The NSW Task Organization Model .....	22
Figure 7.	SEAL Team Operator Task Organization.....	23
Figure 8.	Mintzberg’s Structural Themes and How NSW Aligns .....	28
Figure 9.	USSOCOM’s 3-D Operator .....	62
Figure 10.	Typical SEAL Operator within 3-D Construct .....	63
Figure 11.	Task Linkages Across the Levels of War .....	71

THIS PAGE INTENTIONALLY LEFT BLANK

## LIST OF TABLES

Table 1.	Sample of Requisite Schools .....	25
Table 2.	Generic ULT Schedule .....	26
Table 3.	NSW Environment and Internal Processes Matrix .....	53
Table 4.	NSWADs Mission Sets.....	55

THIS PAGE INTENTIONALLY LEFT BLANK

## LIST OF ACRONYMS AND ABBREVIATIONS

3-Ds	Diplomacy, Defense, Development
AFRICOM	U.S. Africa Command
AOR	Area of Responsibility
AQIM	al Qaeda in the Islamic Maghreb
BUD/S	Basic Underwater Demolition / SEAL Training
CAP	Country Action Plan (GCC/SOF plan)
CMSE	Civil Military Support Element
COIN	Counterinsurgency
COM	Chief of Mission
CQC	Close Quarters Combat
CRRC	Combat Rubber Raiding Craft
CT	Counterterrorism
DA	Direct Action
DoD	Department of Defense
EOD	Explosive Ordnance Disposal
FID/SFA	Foreign Internal Defense/Security Force Assistance
FMP	Full Mission Profile
GCC	Geographic Combatant Command
GWOT	Global War on Terror
HUMINT	Human Intelligence
IAD	Immediate Action Drill
IDTC	Inter-Deployment Training Cycle
IQT	Initial Qualification Training
ISAF	Commander of International Security Forces-Afghanistan
ISR	Information Surveillance and Reconnaissance
IW	Irregular Warfare
HMMWV	High Mobility Multipurpose Wheeled Vehicle
JPAT	Joint Planning Advisory Team
JCET	Joint Combined Exercise and Training
JSOU	Joint Special Operations University



KPN	Key Partner Nation
MarOps	Maritime Operations
MEND	Movement of Emancipation of the Niger Delta
METL	Mission Essential Task List
MIST	Military Information Support Team
MLE	Military Liaison Element
MSP	Mission Strategic Plan (U.S. Ambassador plan)
NATO	North Atlantic Treaty Organization
NAVSPECWARCOM	Naval Special Warfare Command
NCDU	Naval Combat Demolition Units
NSW	Naval Special Warfare
NSWAD	Naval Special Warfare Anchor Detachment
NSWAT	Naval Special Warfare Anchor Team
NSWCEN	Naval Special Warfare Center
NSWG	Naval Special Warfare Group
ODA	Operational Detachment Alpha/SF Team
OIF	Operation Iraqi Freedom
OPE	Operational Preparation of the Environment
PAO	Public Affairs Officer
PEPFAR	President's Emergency Plan for AIDS Relief
PNG	<i>persona non grata</i>
PRODEV	Professional Development
ROMO	Range Of Military Operations
SA-1/SA-2	Special Activity Teams One/Two
SEALs	Navy Sea, Air, Land Commandos
SIT	Squadron Integration Training
SO	Special Operations
SOCAFRICA	Special Operations Command Africa
SOCCE	Special Operations Command and Control Element
SOCEUR	Special Operations Command Europe
SOF	Special Operations Forces
SOTF	Special Operation Task Force

SOUC	Special Operations Urban Combat
SR	Special Reconnaissance
SWCC	Special Warfare Combatant-craft Crewmen
TASKORD	NSWAD Tasking Order
TSOC	Theater Special Operations Command
UCP	Unified Command Plan
UDT	Underwater Demolition Team
UJTL	Universal Joint Task Lists
ULT	Unit Level Training
USG	United States Government
USSOCOM	United States Special Operations Command
UW	Unconventional Warfare
VBSS	Visit Board Search and Seizure

THIS PAGE INTENTIONALLY LEFT BLANK

## **ACKNOWLEDGMENTS**

We profoundly thank our advisor Dr. Erik Jansen for his commitment to us throughout the thesis process. His guidance, feedback, and advice helped us shape an argument that we hope will be useful to Naval Special Warfare (NSW) and how it trains for irregular warfare. The topic is one that we feel is relevant to the NSW community, particularly as wars mature and our global commitments adjust. Dr. Jansen's dedication in editing multiple revisions significantly enhanced the quality of this product.

We would also like to thank the personnel from Naval Special Warfare Groups One and Two. Without their generous counsel and knowledge, this thesis would not have been possible.

THIS PAGE INTENTIONALLY LEFT BLANK

## I. INTRODUCTION

### A. SETTING THE STAGE: A CASE OF A “MISFIT”

The U.S. Ambassador (Chief of Mission) to Nigeria sat at the head of a long mahogany table. To her left sat the Deputy Chief of Mission—often referred to as “Chargé d’Affaires” or simply *Chargé*. The U.S. Embassy Abuja broadcast a live video feed to telecommunicate with the consulate in Lagos. Around the table sat the lead public affairs, regional affairs, and regional security officers, the general service, financial service, and political-military officers, the defense attaché, a U.S. Agency for International Development representative, the office of security cooperation chief and the special operations command and control element (SOCCE) officer. The individuals around this table were seasoned professionals in their 40s and 50s, each fulfilling a multi-year tour in Nigeria—all except for the SOCCE Commander, who sat at the table for the first time since entering the country. Filling in as the Embassy’s Country Team’s Special Operations representative, the young officer on temporary orders was approximately five pay grades below and 15 years younger than his peers, with limited training and knowledge on the diplomatic processes and interagency environment. This was not a typical SEAL mission.

Prior to his deployment to Nigeria, the SOCCE Commander completed an 18-month work-up cycle, which prepared his SEAL Troop to prosecute missions ranging from combat diving, jungle warfare, long range reconnaissance patrols, ambushing enemy forces, boarding ships seized by pirates in rough seas, and urban combat.<sup>1</sup> Sitting at a table with veteran Foreign Service Officers headed by the U.S. Ambassador—voice of the U.S. President in-country and four star general equivalent—the SEAL lieutenant was far removed from his normal work environment. Language in the teleconference room centered on missions that discussed peaceful engagements rather than the kinetic prosecution of war, such as leading troops in direct action raids with snipers in overwatch

---

<sup>1</sup> Combat diving: placing limpet mines under ships using stealth infiltration. Jungle warfare: surviving in a jungle. Urban combat: managing information surveillance reconnaissance (ISR) and close air support assets while leading troops to an assault at a village compound.

positions and reducing enemy compounds with precision-guided bombs. Prior to the ambassador's meeting, the Deputy Defense Attaché passed the SEAL a note across the table that read, "Whatever you do, DO NOT mention the words 'ODA' (Operational Detachment Alpha/SF Team), I will explain afterward." Folding the paper into a four square and slipping it subtly under his briefing notes, the SEAL officer sat in silence, unassuming yet curious. He speculated how to best craft his narrative in order to avoid upsetting the ambassador his first day on the job.

The conversation went from the ambassador's next ribbon cutting for a newly tapped water well by the civil affairs teams; then it moved to the Public Affairs office's progress on the draft of her address at a new school in a remote village. It segued in to security threats against the embassy, to upcoming congressional delegation visits, to systemic problems with country visa authorizations, and then to the details on the next *President's Emergency Plan for AIDS Relief* (PEPFAR) project. The discussion was out of the normal working context to the SEAL, who had spent his career training for war and had multiple combat tours in Iraq and Afghanistan in recent years. The conversation never diverted to ISR asset allocation windows or a target's "pattern of life."<sup>2</sup> No intelligence officers stood up to give PowerPoint presentations on the location of a high-value terrorist to aid the planning of a capture/kill mission. The SOCCE quickly learned that language discussing kinetic operations was not to be used around the embassy. It had no application and, in fact, it was he, not the discussion, which was out of context.

This case illustrates the disparity in the job a SEAL is trained for and what he is expected to do in irregular warfare (IW).<sup>3</sup> To combat this gap, USSOCOM has published the 3-D Initiative.

## **B. USSOCOM'S 3-D INITIATIVE**

In November 2009, the U.S. Special Operations Command (USSOCOM) released its first ever long-range strategy and implementation plan. Although it does address

---

<sup>2</sup> Information surveillance and reconnaissance (ISR) is commonly used in referencing the assets used for tracking terrorists and understanding their pattern of life (daily routines).

<sup>3</sup> Throughout the duration of this thesis, the term "irregular warfare" is characterized as the violent struggle among state and non-state actors for legitimacy and influence over the relevant population.

resources and the need to continually improve Special Operations Force’s (SOF) fighting position in the war against Al Qaeda and other terrorist networks, the primary focus centers on the *operator*: the human.<sup>4</sup> The USSOCOM 2010 strategy reflects that military theory has shifted from quantity of hardware to the quality of the human. The strategy assumes that the greatest platform for defeating terrorist networks is humans. It requires developing its people—in this case operators—to more effectively leverage defense capabilities through social intercourse (diplomacy) and prepare the strategic environment through development. According to USSOCOM, “This whole-of-government, and potentially whole-of-nation, concept can best be articulated by considering the interrelationship and interaction of Defense, Diplomacy and Development: the ‘3-Ds.’”<sup>5</sup> The concept emphasizes taking a more integrated and collaborative approach to fusing national power elements towards U.S. national security. The strategy characterizes the operator as the three dimensional (3-D) medium who will “fulfill the myriad defense, diplomatic, and development roles required in whole-of-government approaches, while maintaining an unparalleled capability to employ direct action when necessary.”<sup>6</sup>

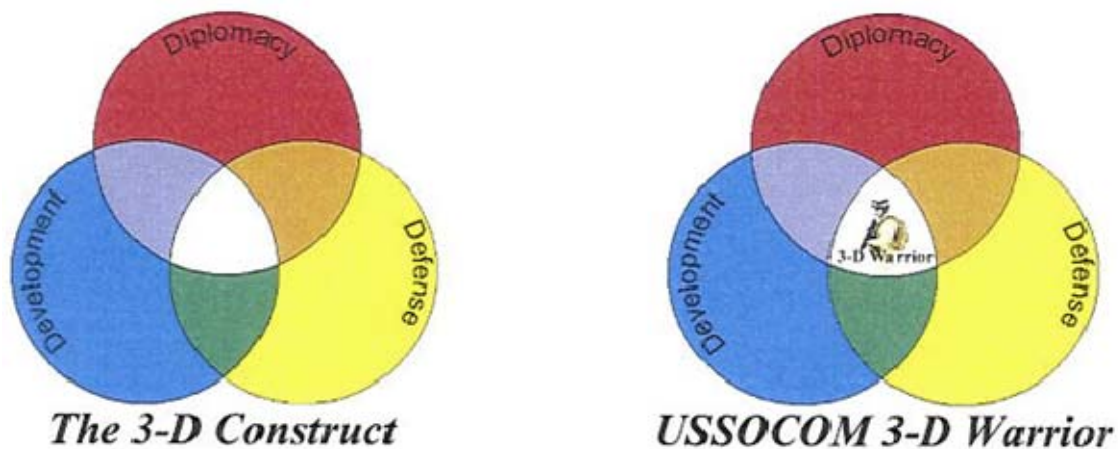

Figure 1. Graphical Portrayal of 3-D Construct

<sup>4</sup> The general term “operator” will be used in this thesis to identify the special operations operator: the individual on the ground executing the mission.

<sup>5</sup> *U.S. Special Operations Command Strategy 2010 (USSOCOM Strategy)* (Tampa, FL: USSOCOM, 2009), 8.

<sup>6</sup> *USSOCOM Strategic Plan*, 5, 8. A “whole-of-government” approach refers to all entities of U.S. national power collaborating to resolve a problem.



The following sections describe how the 2010 USSOCOM strategy defines each “D” and how we associate them to Naval Special Warfare (NSW). Below, we unpack each of the three D concepts to understand them clearly before using them to guide our search for the NSW 3-D operator.

## 1. Defense

“In the realm of Defense, the 3-D operator understands regional and local interests, and builds long term trust in support of diplomatic efforts.”<sup>7</sup> Post 9-11 operations in Afghanistan and Iraq illustrate a robust NSW capacity to perform within the parameters of the “**defense**” dimension of USSOCOM’s 3-D operator concept. For example, missions during Operation Iraqi Freedom (OIF) eventually transitioned from unilateral to bilateral through the inclusion of Iraqi security forces. This transition forced SEAL Special Operation Task Forces (SOTFs) to achieve success “by, with, and through” host nations units, successes largely predicated on NSW’s ability to understand sensitive, non-secular disparities at the regional level as well as political lobbies for power at the local level. Results from NSW “defensive” efforts were largely evident in Al Anbar, Iraq during “The Awakening,” a period from 2006 to 2007 when local citizens and Iraqi Defense Forces collaborated in order to successfully reclaim their neighborhoods from a growing insurgency. Coalition victories during the Awakening showcased NSW’s “defensive” aptitude, but as the conflict seasoned, so did the requirements for victory. “Defensive” efforts alone would not be enough.

## 2. Diplomacy

According to the *USSOCOM Strategic Plan*, “In the realm of Diplomacy, the 3-D Operator integrates assistance activities with broader interagency and international efforts.”<sup>8</sup> As the battlefields in Afghanistan and Iraq matured, NSW units became increasingly interwoven with the interagency and adjacent combat partners to achieve greater efficacy in the full range of military operations (ROMO). This focus centered on

---

<sup>7</sup> *USSOCOM Strategic Plan*, 5.

<sup>8</sup> *Ibid.*

engendering relationships, which is the “**diplomatic**” dimension of the 3-D operator. These operations, which included rebuilding Iraqi security forces (vice unilaterally engaging the enemy), were also conducted successfully. However, unlike defense and diplomacy, “development,” remains an area of expertise that NSW must focus on to build a greater capacity and more completely fulfill all three conditions of the 3-D operator.

### **3. Development**

In the realm of Development, the 3-D operator brings unique skill sets addressing both direct and indirect means. Direct means include those capabilities that aggressively counter adversaries. Indirect means include those capabilities for building partner capacity and establishing long term relationships.<sup>9</sup>

While NSW has shown a healthy capacity for direct means, a delivery mechanism that is properly trained and dedicated solely to capacity building has only recently been established within NSW. The Naval Special Warfare Anchor Detachments (NSWADs) under the Special Activity Teams (SA-1/SA-2) are NSW’s partner capacity builders. Their training provides a force that understands and utilizes the indirect tools necessary to achieve victory in irregular warfare. The NSWADs are discussed at greater length in the fourth chapter of this thesis.

The 3-Ds embody the current way of war for the United States government (USG). The so-called *long war*, also commonly referred to as “Overseas Contingency Operations,” is not like the World Wars on which our military is based, where victory is achieved by subjugating the enemy with overwhelming firepower.<sup>10</sup>

The *Strategic Plan’s Focus Area 1: The Operator, Implementation Task 1.1* is the section that pertains to this thesis. It guides NSW to, “Build mechanisms to effectively mesh DOD irregular warfare activities with the diplomatic and development efforts of interagency partners, especially at country team level.”<sup>11</sup> The adversaries facing the

---

<sup>9</sup> USSOCOM *Strategic Plan*, 5.

<sup>10</sup> The Obama Administration has replaced the “global war on terror” (GWOT) terminology with the term long war, sometimes called “overseas contingency operations,” to describe the ongoing war against Al Qaeda and violent extremist groups.

<sup>11</sup> USSOCOM *Strategic Plan*, 8.

United States and its allies today are predominantly groups or networks of individuals rather than nation states or conventional militaries. Given the irregular nature of this conflict, U.S. and allied forces have to step outside the construct of conventional military wisdom on how to prosecute war. Combined bombing offensives, mechanized infantry battalions, and nuclear powered aircraft carriers that rely on a systematic approach to optimize overwhelming force (i.e., the Napoleonic style of warfare) are not appropriate means in the struggle against Al Qaeda and global extremists. The effort is now focused on the social intercourse of war—the gray area—in which the causal pathway to victory is uncertain.

### **C. TRADEOFFS**

Training a lethal force, such as Navy SEALs (Sea, Air, Land Operators), to be more effective at diplomacy and development will come with a cost: the trade-off between bolstering irregular capability at the expense of surgical lethality. Adjustments in training will need to be made to prepare the operator with, most importantly, the mindset of being able to conduct surgical raids in urban terrain as well as briefing a U.S. ambassador on building a host nation SOF capability while wearing a suit and tie. The Focus Areas of USSOCOM's *Strategic Plan* (separate document implementing the *Strategy*) "outline what SOF needs to do differently, not what it needs to do every day."<sup>12</sup> Our goal is to determine how to improve training to better prepare Naval Special Warfare (NSW) operators for positions that require competence in dealing with the interagency process. The intent of this thesis is to assist NSW leadership in defining what the 3-D team, training, and mission looks like for an operator. In short, how does NSW answer USSOCOM's call to operationalize the "3-D" operator?

---

<sup>12</sup> The plan is separate document and is the "plan" on how to implement the strategy. *USSOCOM Strategic Plan*, 7.

After defining the 3-Ds and the irregular warfare mission, the next section gives the reader the theoretical framework we use to deconstruct NSW as an organization.

#### **D. THE NSW ORGANIZATION: OUR APPLIED THEORY**

NSW has a rich history of adapting to the environment in order to stay relevant. It undoubtedly will have to change again to prepare its operators to stay relevant in the irregular warfare mission of meeting the needs of the 3-D Construct. The idea of an organization that is adapted to its environment in order to survive and accomplish its missions is addressed by organizational contingency theory. We apply it to analyze NSW and discern how it needs to change. “The essence of the contingency theory paradigm is that organizational effectiveness results from fitting characteristics of the organization... to contingencies that reflect the situation of the organization.”<sup>13</sup> This theory provides a framework to show how organizations adapt their internal characteristics (i.e., structure, tasks, people and culture) to meet the challenges posed by their operating environments. When an organization’s internal characteristics are aligned with each other environmental influences (e.g., stakeholders, the market, types of conflict) the organization is said to be in “fit.” If NSW is to fight an irregular enemy and espouse the 3-D operator initiative, contingency theory dictates that it will have to adapt its structure, training, people and culture to fight in an irregular environment.

#### **E. ROAD MAP**

USSOCOM’s 3-D construct calls for an eclectic mix of skills to effectively combat enemies within the irregular warfare arena. Again, the goal of this thesis is to provide NSW leadership with potential solutions to accurately define the team, training and mission of the 3-D operator. In Chapter I, we described the environment of an Embassy Country Team in Nigeria to illustrate why operators from traditional SEAL Troops—who train predominantly for the kinetic mission set—will have a difficult time adapting to the risk averse culture of an Embassy. This sets the stage for why NSW is faced with the tremendous organizational challenge of filling this non-traditional mission

---

<sup>13</sup> Lex Donaldson, *The Contingency Theory of Organizations* (Thousand Oaks, CA: Sage Publications, 2001), 1.

with properly trained personnel. We introduced USSOCOM's 3-D initiative, defined the 3-Ds in how they pertain to NSW, and presented our research question. We then introduced organizational contingency theory as a means to deconstruct NSW and offer solutions to the leadership on how to be better prepared for irregular warfare.

In Chapter II, we diagnose the current state of NSW by using organizational contingency theory to analyze how a SEAL team is organized and designed to combat U.S. adversaries. The larger environment depends on the strategic guidance set forth by national civilian and military leadership and discusses environmental factors that directly or indirectly affect the NSW organization. This section also uses the NSW internal characteristics of structure, tasks, people, and culture to illustrate how a SEAL team, specifically a troop, functions. Here it is important to note that we emphasize human resources processes and structure: the ways and means by which NSW trains people to do the work. Lastly, it describes the SEAL culture and how it can affect the function of an organization. At the conclusion of this chapter, the underlying question in terms of organizational "fit" remains: Is the traditional SEAL Team Inter Deployment Training Cycle (IDTC) adequate for preparing NSW operators for 3-D environments?

In Chapter III, we analyze a former Special Operations Command and Control Element (SOCCE) on the U.S. Embassy Country Team in Nigeria. We use this case to demonstrate the notion of the 3-D Construct, SOF/interagency integration, and how current SEAL team training mentioned in Chapter II is inadequate to prepare operators to take on these types of 3-D roles. The SOCCE is one of the key models for developing and institutionalizing NSW 3-D capabilities in order to be effective in conducting the irregular warfare mission. The chapter illustrates how this small SOF team was an anomaly. Despite being under-prepared for this type of 3-D mission, the team was able to establish a Nigerian counterterrorism unit and overcome significant diplomatic obstacles. The case shows how a small SOF team inserted into a key country embassy can have a positive impact on countering the growing threat of transnational terrorism through host nation capacity building. However, the mission lacks continuity due to the frequent turnover of SOF teams cycling through short duration deployments, and essential relationships with permanent country team members become fragmented. The

U.S. Africa Command (AFRICOM) and the Special Operations Command Africa (SOCAFRICA) strategies place a heavy emphasis on “by, with and through” with interagency and partner nations to promote regional stability, combat terrorism and advance U.S. strategic objectives. A change will need to come in how these missions are resourced with SOF personnel in order to achieve long-term results.

Chapter IV provides an overview and analysis of NSW’s “Anchor Detachments,” or NSWADs, which are regionally-focused SOF units. They are NSW’s solution to operating in the irregular warfare paradigm by integrating with the interagency to meet national objectives. We argue that the NSWAD operators, and not traditional SEAL team operators, are a better fit for staffing missions such as SOCCE Nigeria because they have the appropriate interagency and regional training. Specifically we argue that NSWADs are the long-term solution to USSOCOM’s 3-D operator.

However, short-term success will be difficult given the cultural gap that exists between traditional NSW training focus and that of the new NSWADs. The 2010 USSOCOM Strategy and NSWADs Tasking Order are used to define and review the need for a 3-D operator. Environmental contingencies affecting NSW’s internal processes are addressed in order to demonstrate the need to initiate the NSWADs program as well as indicate how NSW culture will be problematic to overcome. The next section analyzes the NSWADs composition and application in the *long war*. Specifically, training and focus are compared to point out the dramatic differences in the goals of traditional NSW units and those of NSWADs.

Organizational contingency theory is again used to point out that, until recently, NSW generally formulated metrics of success based on kinetic environmental inputs. However, the NSWAD initiative is based on irregular contingencies from the environment and is the reason for one of the shifts in both structure and focus for NSW. Finally, it discusses NSW people and culture, which the SEAL operator embodies. NSW has spent years cultivating a culture steeped in a direct and aggressive mindset in its approach to combating the enemy. Successful implementation of NSWADs indirect culture via NSW will require a severe shift. Over the long term, that shift will require

cultivation time in order to produce the kind of success NSW is used to seeing in its mission sets. In the short term, it will be very difficult to build an indirect culture with operators from the kinetic based culture.

Finally, in Chapter V, we summarize the thesis with the main conclusions of each chapter and offer recommendations to improve NSW training in order to carry out USSOCOM's 3-D vision. We look at implementing 3-D capabilities from a training, organizational and human resources/personnel standpoint. Ultimately, we found that NSWADs were the best fit for the 3-D environment and recommended NSWAD manning and incentives to be improved.

## II. A DIAGNOSIS OF NSW

### A. ORGANIZATIONAL CONTINGENCY THEORY: ITS APPLICATION TO NSW

Organizational contingency theory is a useful tool to diagnose and analyze NSW because the NSW organization has historically exemplified the need to adapt to a changing environment. “Navy special warfare units have a history of boom and bust: rapid buildup during World War II and Vietnam and near elimination following each of these conflicts.”<sup>14</sup> From the Scouts and Raiders, to the Naval Combat Demolition Units (NCDUs), to the Underwater Demolition Teams (UDTs), to what we now call SEAL teams, NSW has battled the military bureaucracy to survive. After WWII, senior conventional navy leaders found little value in the European and Pacific Theater of operations style of UDT tactics.<sup>15</sup> Fortunately for naval special operations, President John F. Kennedy took great interest in unconventional warfare and counterinsurgency capability; naval special warfare revived when he created the first SEAL teams in 1962. Despite the many successes SEALs enjoyed during Vietnam as an inland and riverine guerrilla force, they nearly became extinct as U.S. national security strategy shifted focus to “World War III and the cold war conflict.”<sup>16</sup> Senior SEAL leadership was again forced to prove that SEALs were still a relevant force. NSW officers successfully argued that SEALs were capable of conducting high-impact, kinetic missions that would be necessary in the cold war era.<sup>17</sup> SEAL leadership had survived decades of instability and found job security. In the mid-1980s, USSOCOM was officially established and became the umbrella for all Special Operations Forces.

---

<sup>14</sup> Susan Marquis, *Unconventional Warfare: Rebuilding U.S. Special Operations Forces* (Brookings Institution, Washington, D.C., 1997), 21.

<sup>15</sup> *Ibid.*, 25.

<sup>16</sup> Marquis adds on page 65 from an interview with Captain Ron Yeaw in February of 1994, “...The disorientation and isolation of the SEALs after Vietnam is revealed by the only member of SEAL Team 2 who served three tours in Vietnam, ‘The SEALs were really grasping for something to do....We came back from Vietnam....All of a sudden our reason for being [was gone]....After about six months [in the United States], you were ready to go do something again. And there wasn’t anything available. There was nothing playing. What [were] we going to train for?...The only thinking had been-get ready for Vietnam. [Now] no mission.’”

<sup>17</sup> Marquis, *Unconventional Warfare*, 67.



Organizational contingency theory is used to frame our analysis and show how the NSW organization is currently not designed for the irregular warfare mission because its structures and processes train the operator almost exclusively for the kinetic mission set. By viewing the organization through the lens of “fitness,” NSW can more effectively adjust its internal processes to the security challenges in today’s environment.<sup>18</sup> To better understand the NSW organization, this chapter introduces key concepts of an open system and follows with a discussion relating these concepts to the major components and functions of a SEAL team.

## **B. THE OPEN SYSTEM**

One of the key insights underpinning organizational theory and design is that organizations are open systems. Hannah describes open systems as those that “are dependent on their external environment in order to survive and are, therefore, *open* to influences and transactions with the outside world as long as they exist.”<sup>19</sup> Figure 2 graphically illustrates the open system model that we use to frame our analysis.<sup>20</sup> In short, the environment affects the internal processes of the organization, which then affects the organization’s output. This chapter uses this model as a guide to diagnose and discuss the NSW organization.

---

<sup>18</sup> David P. Hanna, “Understanding how Organizations Function,” in *Designing Organizations for High Performance* (Reading, MA: Addison-Wesley Pub. Co., 1988), 3.

<sup>19</sup> *Ibid.*, 8.

<sup>20</sup> Structure, tasks, and culture are all elements that represent how an organization functions internally.

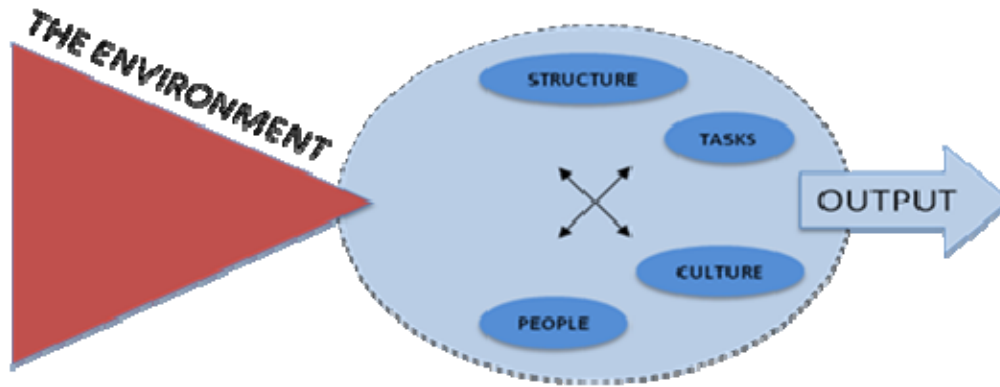

Figure 2. Open System Model<sup>21</sup>

### C. THE NSW ENVIRONMENT

The NSW environment is defined as all elements outside the NSW organizational boundary that affects its ability to function. The major environmental sectors that affect NSW are the stakeholders in superior positions (e.g., chain of command) and the competition with other military units to reserve training sites and attend qualification schools. Figure 3 portrays the influence of NSW environmental sectors on the NSW organization.

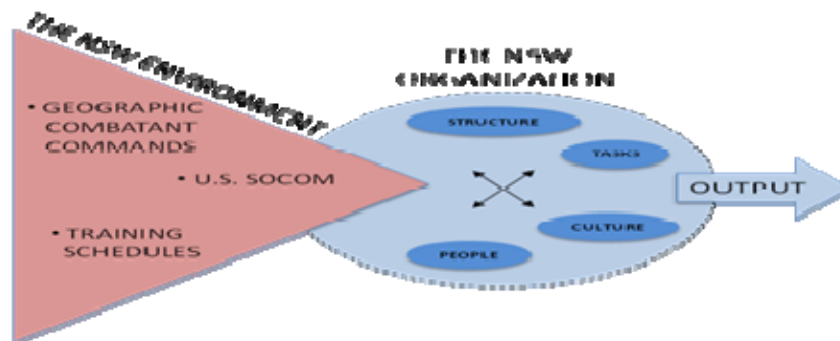

Figure 3. The NSW Environment and Organization

#### 1. Geographic Combatant Commands

The Geographic Combatant Commands (GCCs) are unified commands that have a responsibility to a specific area in the world. The document that explains the GCCs and

<sup>21</sup> Modified framework using the Galbraith, McCaskey, Leavett, and Roberts systems model.

their responsibilities is the unified command plan (UCP). The UCP “establishes the missions and responsibilities for commanders of combatant commands and establishes their general geographic areas of responsibility (AORs) and functions.”<sup>22</sup> Out of the 10 combatant commands delineated by the UCP, the Geographic Combatant Commanders (GCCs) and U.S. Special Operations Command (USSOCOM) exert the greatest amount of influence on NSW.<sup>23</sup> GCCs depend on NSW assets and skill-sets in their respective AORs to conduct a range of military operations in support of regional efforts. These GCCs are able to mandate the receipt of NSW assets via the deployment orders that are directed by the National Command Authority.<sup>24</sup> Figure 4 shows how the world is divided into separate GCC areas of responsibility.



Figure 4. Unified Command Map<sup>25</sup>

---

<sup>22</sup> White House, *The Unified Command Plan (Unclassified)* (Washington, DC: White House, 2006), 1.

<sup>23</sup> Unified commands established by National Security Act of 1947 and Title 10 of the U.S. Code are U.S. Northern Command, U.S. Central Command, U.S. European Command, U.S. Southern Command, U.S. Africa Command, U.S. Pacific Command, U.S. Special Operations Command, U.S. Transportation Command, U.S. Joint Forces Command, and U.S. Strategic Command. GCCs are Combatant Commanders (COCOMs) that have an assigned AOR. COCOMs that have trans-regional responsibilities are functional combatant commanders.

<sup>24</sup> U.S. Department of the Navy, *OPNAV Instruction 1001.24* (Washington, DC: Department of the Navy, 2000), 3.

<sup>25</sup> U.S. Department of Defense, “DefenseLINK-Unified Command Plan,” United States Department of Defense, <http://www.defense.gov/specials/unifiedcommand/> (accessed June 14 2010).

The variance in sources of conflict in these vast regions is high. Currently, the preponderance of NSW forces deploy to Iraq, Afghanistan, and the Philippines. These regions have diverse terrains, cultures, languages, ethnicities, religious affiliations, types of government, security capabilities, and sources of conflict. This presents a highly complex and unstable environment when so many factors persist that have the potential to escalate to violent conflict within a short period. GCCs expect and must rely on NSW units to understand the complexities and historical context within their respective AORs in order to be successful in conducting military operations.

## 2. USSOCOM

USSOCOM is a functional command charged with the responsibility of providing specially trained and equipped Special Operations Forces (SOF) ready to conduct Special Operations (SO) in support of GCC objectives in the region. NSW is the Navy SOF component under USSOCOM's chain of command; it receives all of its funding for training, equipping, and deploying Operators from USSOCOM to support the GCC objectives.

USSOCOM is a force provider, which means it must meet the needs of the environment (requirements of GCCs) by supplying operators who are ready to confront the challenges posed by environments overseas. In order to successfully meet the needs of the environment, USSOCOM publishes a strategy, which is a "plan for interacting with the competitive environment to achieve organizational goals."<sup>26</sup> As introduced in Chapter I, this strategy is to align SOF operators with the "3-D" Construct in order to successfully deter, defeat, or prevent violence in an environment characterized by irregular warfare and asymmetric challenges.<sup>27</sup> Specifically, USSOCOM directs NSW to be able to conduct several missions to achieve these ends. On NSW's unclassified webpage, brief descriptions of missions tasked to SEAL operators are listed:

---

<sup>26</sup> Richard L. Daft, *Essentials of Organization Theory and Design* (Oklahoma City, OK: South-Western Publishing Co, 2003), 20.

<sup>27</sup> *USSOCOM Strategic Plan*.

A tactical force with strategic impact, NSW mission areas include unconventional warfare, direct action, combating terrorism, special reconnaissance, foreign internal defense, information warfare, security assistance, counter-drug operations, personnel recovery and hydrographic reconnaissance. Although NSW personnel comprise less than one percent of U.S. Navy personnel, they offer big dividends on a small investment.<sup>28</sup>

As a result of the environment, NSW has a set of ten disparate missions that the traditional operating unit, a troop, must be prepared to conduct. Becoming competent to perform at a high standard in all of these missions in different environments of the GCCs, is an extremely arduous, time-consuming task.

### **3. Training Schedules**

NSW has a reactive or crisis management style of scheduling training because new commitments around the globe and competition for resources are constantly affecting scheduling efforts. This method of scheduling does not facilitate the training required for kinetic mission sets, let alone irregular missions. NSW attempts to fill a finite amount of time with kinetic training blocks to maintain its core competency, and yet full training cycles are rarely completed. Training cycles are rarely completed because many schools and training sites are outside of NSW control. For example, naval leadership is a required school for promotion by the Navy, which falls outside of NSW's purview. Another example is the NSW requirement to deploy with a certain number of freefall jumpmasters; however, the only school in the military that can qualify a freefall jumpmaster is run by the U.S. Army. NSW troops rarely have the priority at training installations such as Ft. Knox, Kentucky or Ft. Hood, Texas simply because conventional Army units own the training sites. Scheduling conflicts that arise within a replete training cycle cause further problems that often result in cancellations. Adding irregular training to the schedule, which is already at the mercy of other military units, presents a bleak outlook.

These sectors in the NSW environment, however, are only part of the larger environment that affects NSW.

---

<sup>28</sup> Naval Special Warfare Command, "Official U.S. Navy SEAL Home Page," Naval Special Warfare Command, <http://www.navsoc.navy.mil/missions.htm> (accessed June 14, 2010).

#### D. THE LARGER ENVIRONMENT

The larger environment consists of sectors that are outside the control of NSW's chain of command and the U.S. military in general but still affect NSW, often indirectly. Contingency theory describes environments in terms of stability, which is the "rate of change of elements over time," and complexity, which is "the number and dissimilarity of external elements relevant to an organization's operation." We argue that the NSW organization exists within a highly complex and highly unstable environment.<sup>29</sup> The sectors mentioned in this section were taken from the common themes of recent U.S. strategic guidance.<sup>30</sup> These sectors of the environment are not intended to provide a detailed analysis of their individual effect; they are meant to provide a general overview of environmental contingencies relevant to NSW and how they collectively present an unstable and complex environment. Figure 5 shows the larger environment as another layer that influences the NSW environment and ultimately the NSW organization.

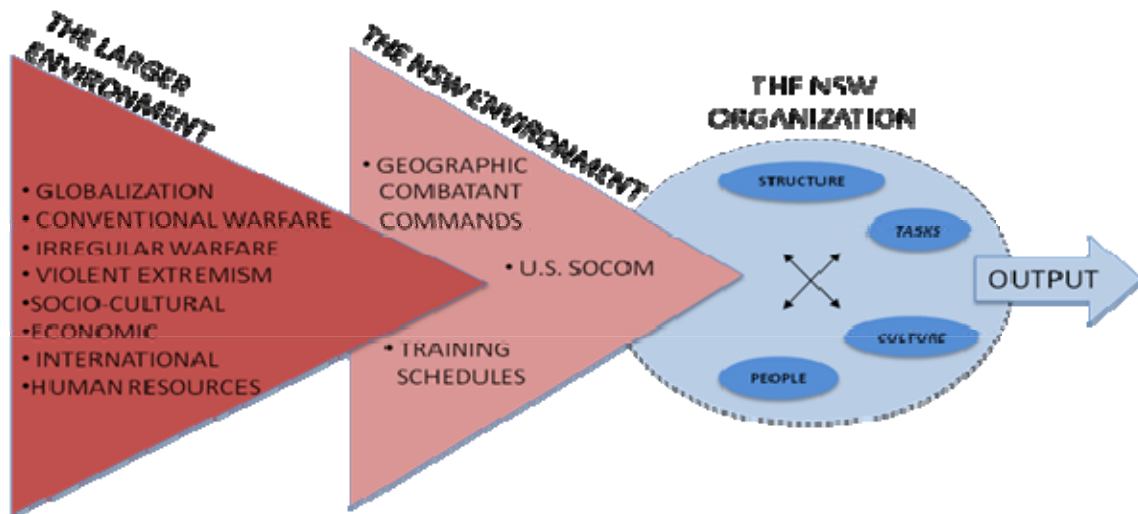

Figure 5. The Larger Environment and NSW

<sup>29</sup> . Naval Special Warfare Command, "Official U.S. Navy SEAL Home Page;" Daft, *Essentials of Organization Theory and Design*, 58.

<sup>30</sup> U.S. strategic guidance is the collection of security strategy publications from the White House, Department of Defense, and the U.S. military. In addition, U.S. maritime strategy and USSOCOM's strategy were used.

## 1. Globalization

Globalization is a vast topic that we can only briefly introduce as it pertains to our topic. Thomas Friedman defines globalization as “connecting all the knowledge centers on the planet into a single global network.”<sup>31</sup> Globalization has both beneficial and damaging effects on the NSW organization. NSW’s ability to exploit technology to improve its global reach in combating irregular enemies is an effect that benefits NSW. However, enemies of the United States are also able to leverage technology as a medium to flatten the playing field. Friedman elaborates on globalization:

...if politics and terrorism do not get in the way—[globalization] could usher in an amazing era of prosperity, innovation, and collaboration, by companies, communities, and individuals. But contemplating the flat world also left me filled with dread, professional and personal. My personal dread derived from the obvious fact that it’s not only the software writers and computer geeks who get empowered to collaborate on work in a flat world. It’s also al-Qaeda and other terrorist networks. The playing field is not being leveled only in ways that draw in and superempower a whole new group of innovators. It’s being leveled in a way that draws in and superempowers a whole new group of angry, frustrated, and humiliated men and women.<sup>32</sup>

The military also recognizes globalization’s potential benefits and pitfalls. According to the *National Defense Strategy*, globalization can “create a web of interrelated vulnerabilities and spread risks even further, increasing sensitivity to crises and shocks around the globe and generating more uncertainty regarding their speed and effect.”<sup>33</sup> The dynamic complexity of globalization illustrated by this quote drives the need for the NSW organization to decentralize in order to combat irregular enemies.

---

<sup>31</sup> Thomas Friedman, *The World is Flat: A Brief History of the Twenty-first Century* (New York: Farrar, Straus, and Giroux, 2006), 8.

<sup>32</sup> Ibid.

<sup>33</sup> U.S. Department of Defense, *National Defense Strategy* (Washington, DC: U.S. Department of Defense, 2008), 4–5, U.S. Department of Defense, [www.defense.gov/news/2008%20national%20defense%20strategy.pdf](http://www.defense.gov/news/2008%20national%20defense%20strategy.pdf) (accessed June 14 2010)

## **2. Traditional vs. Irregular Warfare**

The 2008 *National Defense Strategy* and 2010 USSOCOM strategy reference a capability requirement to combat traditional adversaries in case future security challenges present a conventional warfare environment.<sup>34</sup> While this traditional capability needs to be maintained, it is evident that irregular challenges seen today pose the greatest threat to U.S. national security. Not only is irregular warfare a more accurate description of today's type of conflict, it is an extremely complex style of warfare far removed from waging a war of attrition. IW is a more accurate description of today's conflict because it "manifests itself as one or a combination of several possible forms including insurgency, terrorism, disinformation, propaganda, organized criminal activity (such as drug trafficking)."<sup>35</sup> This style of warfare requires a more comprehensive approach than traditional NSW missions of direct action and special reconnaissance.

## **3. Violent Extremism**

The *National Defense Strategy* notes, "...for the foreseeable future, this environment will be defined by a global struggle against a violent extremist ideology that seeks to overturn the international state system."<sup>36</sup> Specifically, the violent extremist ideologies of non-state actors are a verifiable threat because they are empowered by modern technology to achieve global effects as seen by the World Trade Center attacks on September 11, 2001. The 9/11 attacks initiated one of the greatest struggles against violent extremism, which continues that after ten years.

## **4. Socio-Cultural**

The landscape portraying the types of societies, cultures, demographics, and politics from one area of the world is vastly different from another. This presents a very

---

<sup>34</sup> Fighting traditional adversaries typically involves small-scale to large-scale, force-on-force military operations in which adversaries employ a variety of conventional military capabilities against each other in the air, land, maritime, and space physical domains and the information environment (which includes cyberspace).

<sup>35</sup> Joint Chiefs of Staff, "Strategic Context," in *Joint Operations, Joint Publication 3-0 (Change 2)* 1–6. Washington, DC: Joint Chiefs of Staff, 2001. Joint Electronic Library. <http://www.dtic.mil/doctrine/> (accessed June 14, 2010).

<sup>36</sup> U.S. Department of Defense, *National Defense Strategy*, 2.



difficult problem set for military units because it is difficult to become a regional expert while maintaining core military skill sets. As the White House promulgated, “Profound cultural and demographic tensions, rising demand for resources, and rapid urbanization could reshape single countries and entire regions.”<sup>37</sup> In other words, various regions of the world are increasingly vulnerable to abrupt changes in socio-cultural landscapes. Current U.S. maritime strategy acknowledges the existence of instability; however, it is unclear to what degree the U.S. military, in general, realizes the significant implications in terms of organizational challenges that instability presents.<sup>38</sup>

## **5. Economic**

As world economies develop and populations grow, competition increases for resources. This competition in a world dependent on resources (e.g., fossil fuels) creates a situation ripe with conflict.<sup>39</sup> Increasing resource demand, consumption, and scarcity are premises for conflict, especially when resources are finite (e.g. arable land). The above mentioned factors “coupled with scarcity, may encourage nations to exert wider claims of sovereignty over greater expanses of ocean, waterways, and natural resources—potentially resulting in conflict.”<sup>40</sup>

## **6. International**

The international environment encompasses nation-states, variance in government types, and interaction between governments and non-government entities. The U.S. military will always be concerned with powerful nation-states (e.g., Russia, China, Iran) and their conventional military might, but now various types of governments and non-government organizations must be given equal consideration. As stated in the current U.S. maritime strategy titled, *A Cooperative Strategy for 21<sup>st</sup> Century Seapower*, “Increasingly, governments, non-governmental organizations, international organizations,

---

<sup>37</sup> White House, *National Security Strategy* (Washington, DC: White House, 2010), 8.

<sup>38</sup> U.S. Marine Corps, U.S. Department of the Navy, U.S. Coast Guard, *A Cooperative Strategy for 21st Century Seapower* (Washington, DC: U.S. Marine Corps, U.S. Department of the Navy, U.S. Coast Guard, 2007), U. S. Navy, [www.navy.mil/maritime/maritimestrategy.pdf](http://www.navy.mil/maritime/maritimestrategy.pdf) (accessed June 14, 2010).

<sup>39</sup> White House, *National Security Strategy*, 8.

<sup>40</sup> U.S. Marine Corps, U.S. Department of the Navy, U.S. Coast Guard, *A Cooperative Strategy*.

and the private sector will form partnerships of common interest to counter these emerging threats.”<sup>41</sup> The international sector of the larger environment is important to understand because the methods used by different governments and their stakeholders to meet the needs and expectations of their populations differ. If the stakeholder needs are not being met, conditions may exist for a society to replace a government with one that is more capable.<sup>42</sup>

## **7. Human Resources**

Human resources, as they pertain to NSW, are the inputs it receives from the larger environment. Specifically, these inputs are individual human beings. Civilians enlisting to pursue careers as SEALs have a direct effect on the health of the NSW organization. NSW dependence on people raises two significant issues. The first issue is recruiting and selecting the appropriate people. The second issue is the number of people needed to become SEALs and populate the force.

These issues have become problematic because NSW forces are feeling the effects of difficult training, deployments, and continuous combat operations since the GWOT began in 2001. Numerous SEALs have died, been wounded, and generally feel exhausted. The annual number of SEALs retiring or separating from the service compounds the problem of replenishing the increased demand. In order to re-populate SEAL manpower, the NSW community must pull from the larger environment to replenish its forces.

The influences of the larger NSW environments pose a great challenge to the NSW organization and its ability to successfully operate in a highly unstable and complex environment. The next step is to take a look at how NSW is organized to interact within such an environment. The structure, tasks, people, and culture of the SEAL teams is an important part of the open system framework that will further understanding of NSW.

---

<sup>41</sup> U.S. Marine Corps, U.S. Department of the Navy, U.S. Coast Guard, *A Cooperative Strategy*.

<sup>42</sup> *USSOCOM Strategic Plan*, 3.

## E. NSW STRUCTURE AND TASKS

A basic description that states how Naval Special Warfare Command (NAVSPECWARCOM) is generally organized and structured is provided by the NSW homepage:

The major operational components of Naval Special Warfare Command include Naval Special Warfare Groups ONE and THREE in San Diego, CA, and Naval Special Warfare Groups TWO and FOUR in Norfolk, VA. These components deploy SEAL Teams, SEAL Delivery Vehicle Teams, and Special Boat Teams worldwide to meet the training, exercise, contingency and wartime requirements of theater commanders.

With approximately 5,400 total active-duty personnel--including 2,450 SEALs and 600 Special Warfare Combatant-craft Crewmen (SWCC)--NSW forces are busier than ever answering “911 calls” from around the globe. NSW also calls on a 1,200-person reserve of approximately 325 SEALs, 125 SWCC and 775 support personnel.<sup>43</sup>

Figure 6 illustrates a more detailed task organization model of NSW:

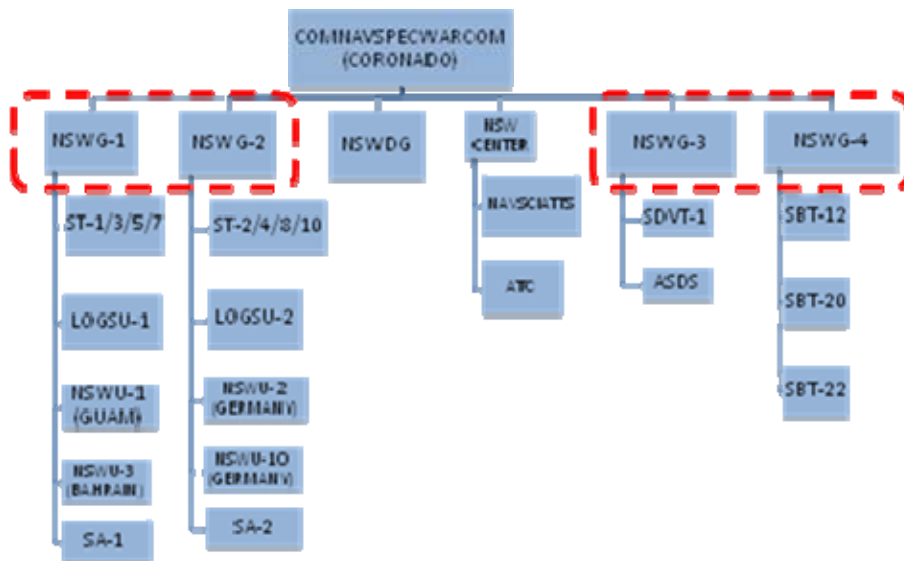

Figure 6. The NSW Task Organization Model

<sup>43</sup> Naval Special Warfare Command, “Naval Special Warfare Small Investment, Big Real-World Dividends. Committed to Combating Global Terrorist Threats,” Naval Special Warfare Command, <http://www.navsoc.navy.mil/default.htm> (accessed June 14, 2010).

The major components highlighted in Figure 6 are the four NSW groups (NSWG-1/2/3/4). These are major commands responsible for training, equipping, and funding SEALs and Special Warfare Combatant Crewmen (SWCC); these functions provide GCCs the maritime arm of SOF. A brief description of all components of NSW can be found in Appendix A, but NSWG-1 and NSWG-2 have the preponderance of the SEAL force and will be the focus of this thesis from this point forward.

Within each NSWG, four SEAL teams exist that consist of three SEAL troops.

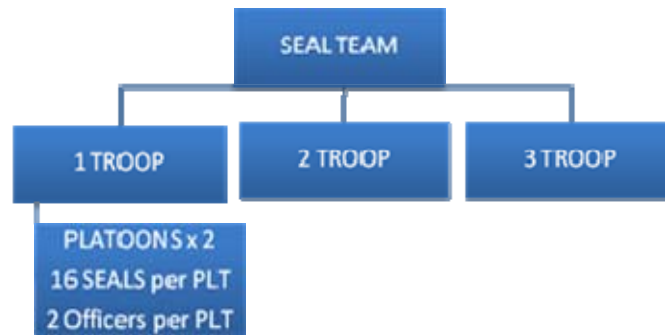

Figure 7. SEAL Team Operator Task Organization

At any given time, approximately 100 SEAL Operators exist within the SEAL Team. The difference between SEAL Operators and the senior leadership, usually filling the executive positions, is equivalent to different roles of the players of a sports team and their coaches. The operators are the practitioners of their leadership’s strategy. The SEAL operator is the backbone of the NSW force responsible for executing the tactical aspect of special operations overseas, meeting the capricious challenges of the environment.

To prepare for combat deployment, a SEAL troop is formed at the beginning of what is called the Inter-Deployment Training Cycle (IDTC). This IDTC is broken up into three, six-month phases designed to complete several tasks that ultimately deem a troop ready to deploy. The military refers to these tasks as mission essential task lists (METLs) and describes them as “an action or activity (derived from an analysis of the mission and concept of operations) assigned to an individual or organization to provide a

capability.”<sup>44</sup> NSW METLs fall within a broader military system of universal joint task lists (UJTLs) designed to drive the way in which forces train to accomplish a given mission.<sup>45</sup> NSW METLs accomplished during IDTC, such as long-range vehicle navigation, fast roping from helicopters, and close quarters combat, largely support special reconnaissance and direct action missions. These METLs are the heart of SEAL combat readiness, and they are essential to developing the troop’s ability to succeed in kinetic mission sets while on deployment.

The first phase of IDTC, professional development (PRODEV), is the time and funding allotted for individual SEALs to attend a variety of qualification courses or schools. This phase is first because the troop depends on individual specialties as it progresses toward the next phase. This high degree of specialization serves the troop’s best interest as individuals can focus on single skill sets and become the platoon’s subject matter expert in a given field (e.g., radio communication or sniper operations). This portion of training is the genesis for standardization of skills and the decentralization that the SEAL community prides itself on.<sup>46</sup> A sample of schools is listed in Table 1.

---

<sup>44</sup> Joint Chiefs of Staff, *Universal Joint Task Manual, CJCSM 3500.04e* (Washington, DC: Joint Chiefs of Staff, 2008), A-4, DTIC online, [www.dtic.mil/doctrine/training/cjcsm3500\\_04e.pdf](http://www.dtic.mil/doctrine/training/cjcsm3500_04e.pdf) (accessed June 14, 2010).

<sup>45</sup> See Appendix B of this thesis for more detail.

<sup>46</sup> Hanna, *Understanding how Organizations Function*, 198.

Table 1. Sample of Requisite Schools

<ul style="list-style-type: none"> <li>• <b>Sniper School:</b> Thirteen week course designed to teach long range photography, digital manipulation of photographs (Adobe Photoshop), transmit photos via satellite with field radio; how to stalk a target (Urban, Mountain/Desert, Jungle), isolate and contain, send back reports to Command and Control element; and become an expert in long-range target interdiction—500meters and beyond with high powered, multi-caliber rifles.</li> </ul>
<ul style="list-style-type: none"> <li>• <b>Breacher:</b> Operators becomes experts in demolition with plastic explosives, chainsaws, “quickie-saws,” opening tools.</li> </ul>
<ul style="list-style-type: none"> <li>• <b>Advanced Special Operations:</b> Preparation of the environment.</li> </ul>
<ul style="list-style-type: none"> <li>• <b>Languages:</b> Operators go through language immersion programs. They are provided all the material to maintain proficiency when deployed.</li> </ul>
<ul style="list-style-type: none"> <li>• <b>Outboard Motors (OBM):</b> Learn how to fix outboard motors that power small rubber boats, or Combat Rubber Raiding Craft, used as an infiltration platform.</li> </ul>
<ul style="list-style-type: none"> <li>• <b>Hazardous Material (HAZMAT):</b> Transport all hazard material (demo, ordnance, fluids) over land/air.</li> </ul>
<ul style="list-style-type: none"> <li>• <b>Static Line Jump Master/Free Fall Jump Master:</b> Army schools that qualify personnel to be in charge of static or free fall jump evolutions.</li> </ul>
<ul style="list-style-type: none"> <li>• <b>Load Master:</b> Learn rules/regulations to package all cargo/equipment on military aircraft.</li> </ul>
<ul style="list-style-type: none"> <li>• <b>High Speed and Off Road 4x4 Driving:</b> Specialized training designed to give driving experience in hazardous terrain and 4x4 vehicle capability.</li> </ul>

In the second phase, unit level training, the entire troop physically works and trains together. This phase gives troops the opportunity to train as a unit in various kinetically focused mission profiles in both land and water environments. This is also the first time troop leaders are able to evaluate personnel and assess any equipment shortfalls that need to be addressed prior to deployment. A brief outline of a generic ULT schedule is in Table 2.

Table 2. Generic ULT Schedule

<ul style="list-style-type: none"> <li>• <b>Rifle/Marksmanship:</b> One week of troop sighting in weapons at ranges</li> </ul>
<ul style="list-style-type: none"> <li>• <b>Close Quarters Combat (CQC):</b> Advanced weapons tactics—two weeks in Mississippi</li> </ul>
<ul style="list-style-type: none"> <li>• <b>Special Operations Urban Combat (SOUC):</b> Three weeks of mission planning and execution of direct action missions (squad, platoon, troop size) on urban structures in Indiana; follow-on training from CQC.</li> </ul>
<ul style="list-style-type: none"> <li>• <b>Land Warfare:</b> Five weeks of two man-squad-platoon-troop size Immediate Action Drills (IADs)—breaking contact or assaulting the enemy in a firefight, Land Navigation, Ambush training (Demo intensive), and finishing with full mission profiles using rotary wing and close air support.</li> </ul>
<ul style="list-style-type: none"> <li>• <b>Combat Diving:</b> Three weeks of two-man, four-man, eight-man dive profiles: penetrating harbors undetected and planting inert mines/charges underneath ships to disable/sink them; three days of troop full mission profiles (FMPs) on the last week.</li> </ul>
<ul style="list-style-type: none"> <li>• <b>Maritime Operations (MarOps):</b> Two weeks of navigating inter-coastal waterways and seas with Combat Raiding Rubber Craft (CRRC).</li> </ul>
<ul style="list-style-type: none"> <li>• <b>Visit Board Search and Seizure (VBSS):</b> Two weeks of interdicting ships with high speed assault crafts in different sea states (calm/high), and gaining control of their movement. FMPs are the last few days and usually consist of “terrorists” or “pirate” scenarios getting control of a ship and our mission is to neutralize the threat and/or rescue the hostages.</li> </ul>
<ul style="list-style-type: none"> <li>• <b>Mobility in Desert Warfare:</b> Two weeks at Hawthorne, Nevada conducting long-range patrols in off-road vehicles (HMMWVs) and executing vehicle IADs to assault or break enemy contact.</li> </ul>
<ul style="list-style-type: none"> <li>• <b>Admin Weeks:</b> Three to four weeks mixed in the training cycle one week at a time that give operators the chance to take care of personal business (pay bills, see family, decompress) after being on the road for months at a time.</li> </ul>

The third and final phase, Squadron Integration Training (SIT), is designed to make final preparations for the upcoming deployment. Additional personnel and specialties, such as explosive ordnance disposal (EOD) technicians, logisticians, and administrative support are attached to the troop. This phase is also designed to refine and tailor combat skills by introducing maritime and air assets. Rather than operating solely as operators on the ground, SEALs are given the chance to incorporate the dynamics of maneuver assets. Full mission profiles (FMPs) are conducted by the troop and graded by

senior enlisted and officers from the SEAL team chain of command. This exercise forces the troop to perform as it would when faced with the greater complexity and realities of combat. Lastly, this phase is designed to allow for SEALs and their families to spend ample time together prior to a six-month deployment.

Given the framework of the IDTC, its tasks, and the troop structure, NSW as an organization resembles a hybrid form of a professional-machine bureaucracy.<sup>47</sup> Machine-like organizations rely on standardized rules and operating procedures and have large, elaborate administrative support staffs. NSW is influenced by these characteristics because it is part of the larger military environment that seeks efficiency and reliability. Standardized means of execution, uniforms, a focus on how one executes work processes through standard training cycles, forms, and templates are all mechanistic parts of the NSW organization. However, NSW is not an archetypal mechanistic organization, especially at the operating core. The extensive training that SEALs endure also includes education to make complex judgments. SEALs are trained to be “thinking shooters,” to use judgment that is more akin to the judgments required of operators in professional bureaucracies. An NSW troop is a hybrid between a mechanistic and professional organization, both of which flourish in stable environments or environments where SEALs know generally what to expect.<sup>48</sup> Figure 8 shows where this hybrid professional-machine falls in accordance with Mintzberg’s structural configurations.

---

<sup>47</sup> Henry Mintzberg, “Organization Design: Fashion or Fit?,” *Boston Harvard Business Review* 59, no. 1, (1981): 103.

<sup>48</sup> *Ibid.*, 108–110.





Figure 8. Mintzberg’s Structural Themes and How NSW Aligns

The current NSW IDTC is structured to prepare SEAL troops for conducting direct action missions in a kinetic environment. NSW structure and tasks are not the only internal processes of the NSW organization that promote a kinetically oriented force. The most significant internal processes of the NSW organization are its people and culture. The next section gives an overview NSW people and culture in order to give a human resources perspective.

## F. NSW PEOPLE AND CULTURE

Marcoulides and Heck define organizational culture as “patterns of shared values and beliefs over time which produce behavioral norms that are adopted in solving problems.”<sup>49</sup> The distinctive point in time that begins to establish the shared values and beliefs for NSW is when recruits arrive at Basic Underwater Demolition/SEAL (BUD/S) training in Coronado, California. Marquis notes that students, at the onset of this training, quickly realize their elite status and attribute these differences to SOF values of independence and unconventional thinking that goes against the usual military characteristics of conformity, hierarchy and direct thinking.<sup>50</sup>

<sup>49</sup> George A. Marcoulides and Ronald H. Heck, “Organizational Culture and Performance: Proposing and Testing a Model,” *Organization Science* 4, no. 2 (1993): 211.

<sup>50</sup> Marquis, *Unconventional Warfare: Rebuilding U.S. Special Operations Forces*, 8.

The SEAL culture is one that is lethally focused. BUD/S training and all subsequent training consist of mission profiles that are aimed primarily at killing or capturing enemy personnel (e.g., direct action and special reconnaissance). As one Commanding Officer of Naval Special Warfare Center stated to students the night before a HELL week, “this community is about killing people and breaking things.”<sup>51</sup>

The focused lethal mindset is a constant throughout the organization. It personifies the operators’ commitment and their ability to perform a diverse set of missions over hours of arduous training in different environments (e.g., sea, mountain, jungle, riverine, desert). This is why SEALs are considered among the most diverse and competent SOF operators of the U.S. military.

Military organizations or other organizations that exhibit “strong cultures,” such as NSW, typically publish some form of a statement to encapsulate shared norms and beliefs. NSW calls this the SEAL creed.<sup>52</sup>

#### United States Navy SEALs

In times of war or uncertainty there is a special breed of warrior ready to answer our Nation’s call. A common man with uncommon desire to succeed. Forged by adversity, he stands alongside America’s finest special operations forces to serve his country, the American people, and protect their way of life. I am that man.

My Trident is a symbol of honor and heritage. Bestowed upon me by the heroes that have gone before, it embodies the trust of those I have sworn to protect. By wearing the Trident, I accept the responsibility of my chosen profession and way of life. It is a privilege that I must earn every day.

My loyalty to Country and Team is beyond reproach. I humbly serve as a guardian to my fellow Americans always ready to defend those who are unable to defend themselves. I do not advertise the nature of my work, nor seek recognition for my actions. I voluntarily accept the inherent hazards of my profession, placing the welfare and security of others before my own.

---

<sup>51</sup> Anonymous SEAL during the week long evolution where BUD/S candidates go through endless training exercises/physical evolutions and receive little to no sleep.

<sup>52</sup> Marcoulides and Heck, “Organizational Culture and Performance,” 209.

I serve with honor on and off the battlefield. The ability to control my emotions and my actions, regardless of circumstance, sets me apart from other men. Uncompromising integrity is my standard. My character and honor are steadfast. My word is my bond.

We expect to lead and be led. In the absence of orders I will take charge, lead my teammates and accomplish the mission. I lead by example in all situations.

I will never quit. I persevere and thrive on adversity. My Nation expects me to be physically harder and mentally stronger than my enemies. If knocked down, I will get back up, every time. I will draw on every remaining ounce of strength to protect my teammates and to accomplish our mission. I am never out of the fight.

We demand discipline. We expect innovation. The lives of my teammates and the success of our mission depend on me - my technical skill, tactical proficiency, and attention to detail. My training is never complete.

We train for war and fight to win. I stand ready to bring the full spectrum of combat power to bear in order to achieve my mission and the goals established by my country. The execution of my duties will be swift and violent when required yet guided by the very principles that I serve to defend.

Brave men have fought and died building the proud tradition and feared reputation that I am bound to uphold. In the worst of conditions, the legacy of my teammates steadies my resolve and silently guides my every deed. I will not fail.”<sup>53</sup>

Former SEAL Dick Couch attempted to characterize the culture when he stated, “Navy SEALs are intelligent, proud, determined, resourceful, aggressive, persistent—and the list goes on.”<sup>54</sup>

## **G. CONCLUSION**

To reiterate, organizational contingency theory states that organizational effectiveness is a result of an organization’s ability to match internal processes with the

---

<sup>53</sup> “The SEAL Creed,” Naval Special Warfare, <http://www.seal.navy.mil/seal/PDF/Seal.Creed.pdf> (accessed June 14, 2010).

<sup>54</sup> Dick Couch, *The Finishing School: Earning the Navy SEAL Trident*, 1st ed. (New York: Crown Publishers, 2004), 173.

environmental contingencies and factors influencing the organization.<sup>55</sup> In translation, the idea that an organization with a human resources structure designed to work well within kinetic environments, such as NSW, that realistically operates within irregular environments is a misfit. This chapter presents this misfit by first providing an analysis of the larger and NSW environments based on U.S. strategic guidance and indicates why the environment can be classified as being unstable and complex. Second, it describes the blend of mechanistic and professional bureaucratic characteristics that enable NSW to manage and coordinate direct action and special reconnaissance centric tasks in a kinetic and complex environment. Third, it discusses NSW people, their strong organizational culture and how it has a clear sense of its identity and purpose to serve with honor by meeting the nation's most lethal threats.

SEALs are professionals who want to be effective. NSW is effective in conducting direct action and special reconnaissance missions overseas because the NSW culture and people are a fit to meet these kinetically focused mission sets. However, do the internal processes of the traditional NSW Troop meet an environment shaped by irregular warfare? We argue that the NSW Troop does not effectively meet the needs of today's irregular environment. The next chapter uses the SOCCE on the Embassy Country Team in Nigeria to analyze a how a traditionally trained NSW unit is not adequately prepared to operate within the context of irregular warfare.

---

<sup>55</sup> Donaldson, *The Contingency Theory of Organizations*, 1.

THIS PAGE INTENTIONALLY LEFT BLANK

### III. SOCCE NIGERIA

#### A. INTRODUCTION

We promote the SOCCE as one organizational model for NSW to develop and institutionalize its 3-D capabilities to fashion its effectiveness in the long term, irregular warfare mission. The current Special Operations Command Africa's (SOCAFRICA) strategy places a heavy emphasis on “by, with and through” to collaborate with the interagency and partner nations in order to promote regional stability, combat terrorism and advance U.S. strategic objectives. This chapter examines our personal experience on a previous SOCCE attached to the U.S. Embassy Country Team in Abuja, Nigeria. Nigeria is one of SOCAFRICA's identified key partner nations (KPNs) where NSW has current strategic interests.<sup>56</sup> The chapter first describes the 3-D environment—“Operators executing missions across the construct of Defense, Diplomacy, and Development”—and how it pertains to SOF in countries like Nigeria.<sup>57</sup> It analyzes SOF/interagency integration on the country team to demonstrate the notion the 3-D Construct with civil affairs, information operations and building a counterterrorism capacity. It highlights the KPN's growing radical Islamic movement to set the stage for how NSW is a primary agent in the current effort to counter violent extremism.

Second, it describes the embassy environment and its challenges through a NSW lens with insight into the field of low intensity missions—the SOF and interagency differences in ways of doing business. Third, it describes the importance of the irregular warfare mission and the challenges for NSW to bring continuity to the mission. A frequent turnover of NSW personnel with temporary duty assignments fragments critical relationships with country team members, which are imperative for success in the long-term mission. The chapter illustrates how a small SOF team was an anomaly. Despite being under prepared for this type of 3-D mission, the team was able to establish a Nigerian counterterrorism unit and overcome significant diplomatic obstacles. However,

---

<sup>56</sup> SOF-Theater Strategic Objectives (S-TSOs) and Key Partner Nations (KPNs) are terms derived from SOCAFRICA's Country Action Plan (CAP).

<sup>57</sup> *USSOCOM Strategic Plan*.

even though the SOCCE was successful in the end, the mission lacked continuity due to the frequent turnover of SOF teams cycling through short duration deployments. The purpose of this chapter is to show how current SEAL team training discussed in Chapter II is inadequate to prepare operators to take on these types of 3-D roles. To achieve greater long-term results, proper resourcing of regionally focused SOF personnel will be needed to have a greater impact on countering the growing threat of transnational terrorism with host nation capacity building.

## **B. SOCCE PROCESSES**

*It is also necessary to remember that the DoS serves as the lead USG department for combating terrorism overseas, which brings the interagency process immediately into play. It is not a DoD 'show' alone.*<sup>58</sup> JSOU CT Reference Manual.

A primary role for the SOCCE in Nigeria was to establish rapport and integrate with all personnel in the embassy country team. Success in the embassy mission can be distilled into one ingredient: relationships. Once again, this emphasizes the critical importance of human resources to the NSW organization. The SOCCE Commander routinely met with country team department heads and Nigerian executive service officials to develop relationships in order to set up special operations training and exercises. This was the diplomacy dimension of the job, which Hocevar, Thomas, and Jansen refer to as using social capital as a lateral mechanism and establishing a network. They write, "Collaboration is attained through a personal touch, a handshake and a smile."<sup>59</sup> Once the training received approval, the SOCCE's Joint Planning Advisory Team (JPAT) established a program of instruction to train and select the right personnel to fulfill the first Nigerian Counterterrorism (CT) Battalion and build up the host nation's

---

<sup>58</sup> Joint Special Operations University, *Special Operations Forces Interagency Counterterrorism Reference Manual* (Hurlburt Field, FL: JSOU Press, 2009), 2.

<sup>59</sup> Susan Hocevar, Gail Thomas and Erik Jansen, *Innovation through Collaboration: Building Collaborative Capacity: An Innovative Strategy for Homeland Security Preparedness* (Oxford: Elsevier Ltd., 2006), 267.

counterterrorism capability. In addition, the SOCCE Commander managed the other special operations assets, which focused mostly on the development dimension of the SOF mission: Army and Navy Civil Affairs and Information Operations.

The civil military support element (CMSE), which conducted the majority of SOCCE missions, dug wells to provide clean water to remote villages and refurbished schools to improve education for children. The military information support team (MIST) worked with local media organizations to distribute messages with American democratic values. Both teams provided unprecedented access and placement for the SOCCE in often politically sensitive parts of the country because they engendered the trust of the local people. Their combined efforts developed the country's economic infrastructure and empowered Nigerians by working with local contracting businesses and bringing capital to austere locations. The focus of the CMSE and MIST was population centric, not threat or enemy centric. Altogether, the SOCCE was a team of regional experts who leveraged the resources and assets of the country team to synthesize the TSOC's country action plan (CAP), which was the general's published goals for the SOF team in country, with the *Ambassador's Mission Strategic Plan* (MSP), which was the document that guided the country team towards national objectives. This was no easy task because the CAP and the MSP were two separate strategic plans that often had conflicting interests; this meant the SOCCE members had to please two different bosses with two separate agendas. This is one of the challenges of the 3-D operator: adeptly navigating through the matrices of military and diplomatic bureaucracies.<sup>60</sup> These are skills that are not imparted in traditional NSW training.

Within the ambassador's MSP for the U.S. campaign in Nigeria, the SOCCE was responsible for building the infrastructure to assist the Nigerian government with developing a counterterrorism capacity. In October 2008, the Nigerian Ministry of Defense officially requested that the U.S. Embassy assist them with developing a national joint counterterrorism force. The SOCCE Commander was tasked with establishing this unit from the ground up, because nothing existed in the way of Nigerian Special

---

<sup>60</sup> Matrix bureaucracies are structures where two or more bosses exist. These structures rely heavily on the judgment and interpersonal skills of the employee, which in this case is the SOCCE.



Operations. Ultimately, he provided the framework for doctrine, task organization and force disposition for the strategic CT unit. However, because the SOCCE was not a large enough unit to independently accomplish this task, it had to use USSOCOM's episodic Joint Combined Exercise and Training (JCET) events with SEAL/Special Forces teams. The JCETs would conduct a Special Operations Program of Instruction to screen personnel from the Nigerian joint services for the national CT force. The U.S. Department of Defense allocated \$7.9 million in 1206 CT funding to train and equip the Nigerian CT force to execute unilateral special operations in the desert, jungle, mountain, and riverine environments.

The Ministry of Defense requested a U.S. Special Operations unit because counterterrorism is a high priority for the Nigerian government, and it wanted expert instruction. U.S. Embassy Political/Military Officers helped draft CT legislation to request government funding and expedite approval in the Nigerian Senate. This was because Nigeria remains a strategically important country for the United States with its growing terrorist threat and its abundance of crude oil. According to the U.S. Energy Information Administration, as of September 2010, Nigeria was the third largest exporter of oil to the United States behind Mexico and Canada.<sup>61</sup> Reliant on oil to keep its economic engine running, the United States is often at the mercy of militant groups like the Movement of Emancipation of the Niger Delta (MEND), which formed in January 2006 and routinely abducts Western oil workers, sabotages pipelines and engages in armed conflicts with government forces.<sup>62</sup> The group is small, but their efforts have proven effective at disrupting Nigeria's production and export of oil, which threatens to politically and economically destabilize the West African state even more.

---

<sup>61</sup> U.S. Energy Information Administration, "U.S. Imports by Country of Origin," U.S. Energy Information Administration [http://www.eia.gov/dnav/pet/pet\\_move\\_impcus\\_a2\\_nus\\_ep00\\_im0\\_mbb1\\_m.htm](http://www.eia.gov/dnav/pet/pet_move_impcus_a2_nus_ep00_im0_mbb1_m.htm), (accessed June 14, 2010).

<sup>62</sup> The United States consumes 27 percent of global oil each year, according to the International Energy Agency (IEA). Wang Yuheng, "China's Pipelineistan 'War,'" October 12, 2010, Mother Jones, <http://motherjones.com/politics/2010/10/china-natural-gas-pipeline-central-asia> (accessed June 14, 2010).

The northern part of Nigeria has seen a growing number of radical Islamic groups. In October 2010, the online website Jihad and Terrorism Threat Monitor reported that Al Qaeda in the Islamic Maghreb (AQIM) has Nigerian representation in its ranks and is increasing its outreach in support of the Nigerian jihadist group known as Boko Haram, or the Nigerian Taliban. After the sectarian violence in the northern city of Jos in July 2010, AQIM urged Nigerian Muslims to wage war against the Christian minority, stating, “We are prepared to provide weapons training to your sons along with men, arms, ammunition and supplies.”<sup>63</sup> This message supplemented Ansar-al-Mujahideen’s (jihadist web forum) online video in support of jihad in Nigeria, which encouraged Boko Haram, whose goal is to overthrow the state government in Nigeria and to implement strict Islamic law and abolish what it calls “Western-style education.”<sup>64</sup> AQIM’s efforts to align extremist groups in Nigeria is another reason why the country remains a key partner nation with SOCAFRICA and is central to the USG in preventing extremist proliferation in the Trans-Sahara. The small NSW teams charged with helping Nigeria build a CT force have the ability to enhance host nation and interagency capabilities with the right pre-deployment training and long-term commitment of selected personnel. In the long term they can dramatically change Nigeria’s geostrategic landscape by training organically grown security forces.

### **C. THE ENVIRONMENT OF THE U.S. EMBASSY**

One of the daily challenges for the SOCCE was staying above the always-present DoS-DoD working rivalries and not committing any blunders that would adversely affect

---

<sup>63</sup> “The Tightening Ties between Nigerian Boko Haram and Al Qaeda,” *The Jihad and Terrorism Threat Monitor*, posted October 3, 2010, [http://www.memrijttm.org/content/en/blog\\_personal.htm?id=3866&param=IDTA](http://www.memrijttm.org/content/en/blog_personal.htm?id=3866&param=IDTA) (accessed June 14, 2010).

<sup>64</sup> Joe Boyle, “Nigeria’s ‘Taliban’ Enigma,” *BBC News*, July 31 2009, <http://news.bbc.co.uk/2/hi/8172270.stm> (accessed June 24, 2010); Evan Kohlmann. “A Beacon for Extremists: The Ansar al-Mujahideen Web Forum,” *CTC Sentinel* 3, no. 2 (February 2010): 1.

According to the February 2010 edition of the *CTC Sentinel* published by West Point, Evan Kohlmann Ansar-al-Mujahideen’s is a “contemporary jihadist discussion forum website. The website began in 2008 as a rather low-frills, Arabic-language clone forum with questionable credibility, and a membership of mostly silent observers. Today, however, the Ansar al-Mujahideen forum has blossomed into a prolific, multi-language enterprise with an enviable following of skilled and highly-motivated English-speaking members.” Kohlmann. “A Beacon for Extremists.”

subsequent SOCCEs. SOF personnel rotating every few months made it difficult to maintain trust with the country team, which takes many years to establish. The calculated risk-taking and assertive personalities that are common with SOF personnel often clash with the cautious personalities of individuals comfortable in professional bureaucracies, such as Foreign Service Officers. This personality conflict is exacerbated when a liberty incident occurs and military personnel are at fault.

One SOCCE in particular ran into this problem. The blunder involved SOCCE personnel driving under the influence of alcohol in a rental vehicle with unauthorized diplomatic plates; they crashed through the compound wall of the Belgium Embassy. Although no personnel were seriously hurt and the wall was immediately fixed (official apologies followed promptly), the incident caused public embarrassment for the embassy on a multi-nation front and was out of line with the low profile and good order and discipline that SOF holds itself to. Prior to the accident the ambassador had learned about the rental vehicle with diplomatic plates and admonished the SOCCE Commander to remove them. He failed to carry out her order and was declared *persona non grata* (PNG)—officially banned from country—by the ambassador after the accident for demonstrating leadership incompetence and not enforcing proper liberty discipline among his troops. The ambassador subsequently shut down all SOCCE operations for six months, extinguishing all momentum in advancing SOCCE capital in country. Follow on SOCCEs had to start at ground zero to re-establish trust with the front office and make reparations to the SOF’s professional reputation.<sup>65</sup> The setback broke the trust between the SOCCE and ambassador, damaging the precious personal relationships needed for success in the long-term mission.<sup>66</sup>

Understanding the different dynamics within country team meetings and the accepted language took time. Following his first country team meeting experience, the SOCCE Commander learned from the Deputy Defense Attaché that the acronym “ODA,” or Special Forces Operational Detachment Alpha, could easily be misconstrued by state

---

<sup>65</sup> Front Office refers to the ambassador, her deputy, and staff.

<sup>66</sup> This story is based on the after action report of the SOCCE team associated with this incident and the personal experience of one of the authors that filled the SOCCE role many months after it occurred.

officials in the embassy. It carried the connotation of a Special Forces detachment coming to participate with host nation forces to conduct capture/kill operations in Nigeria. Nigerians, along with State Department personnel, often fear that USSOF or other military forces will further destabilize a country with kinetic missions. This is a result of the ample TV coverage on Iraq and Afghanistan, where bombings routinely rock urban cities and cause pandemonium among the local populace. The wrong choice of words in an embassy meeting has vast repercussions because of how negatively the public can react to a news release, regardless of whether they are true or not. Any public acknowledgement of U.S. Special Operations involvement in anything other than training Nigerian troops could potentially cause a media firestorm that the ambassador would have had to answer for. The *right* choice of words, which are soft in overtones and do not leave room for interpretation, was paramount when briefing both Nigerian and American officials on non-kinetic missions because they help to dispel preconceived notions that Special Operations Forces are only in country to capture/kill terrorists.

At the time, the U.S. Chief of Mission for Nigeria was not comfortable with the SOCCE pursuing low visibility operations. A lack of trust still remained with the ambassador over the SOCCE team. She was reluctant to reinstate its full operational status because of the incident that happened many months prior and resulted in the PNG of the SOCCE Commander. Other than digging wells, refurbishing schools, supporting local media distribution and helping the Nigerians create a CT capability through JCETs, the SOCCE was restricted in fulfilling its operational outreach potential.

Missions involving operational preparation of the environment (OPE) or human intelligence (HUMINT) collection—usually executed by the Military Liaison Element (MLE)—were out of the question.<sup>67</sup> HUMINT missions were for the CIA, as far as the

---

<sup>67</sup> Joint Publication 3-13 defines OPE as “non-intelligence activities conducted to plan and prepare for potential follow-on military operations” conducted under Title 10 authority. Joint Chiefs of Staff, *Joint Publication 3-13: Joint Doctrine for Information Operations* (Washington, DC: Joint Chiefs of Staff, 1998), [www.c4i.org/jp3\\_13.pdf](http://www.c4i.org/jp3_13.pdf) (accessed June 14, 2010). Michael T. Kenney, “Leveraging Operational Preparation of the Environment in the GWOT,” *A Monograph. School of Advanced Military Studies* (Fort Leavenworth, KA: United States Army Command and General Staff College, 2005–2006). Kenney adds, “Through predictive analysis and preemptive action, the United States can identify potential terrorist support areas, enhance situational understanding of these regions, and set the conditions to find, fix, and finish terrorists in these locations as or even before they take root.”

ambassador was concerned, and the Theater Special Operation Command (TSOC) could not adequately convince her how their missions differed. Regardless of the fact that the Special Operations Forces fell under the command and control of the TSOC (by regulation in the National Security Decision Directive-38) all SOCCE missions still had to be passed up in a memorandum through the front office and receive signature approval by the COM.<sup>68</sup> Technically, she did not have this authority because, at the time, the Joint Special Operations Task Force under SOCEUR made the go, no-go decision on SOCCE missions. However, it was tacitly understood by the TSOC that the ambassador's trust with the SOCCE would suffer if she did not have signature approval. In the end, she ultimately wielded the ability to impede the TSOC's progress by reducing the SOCCE's access by denying their embassy and country clearances if she was kept out of the decision process. Again, working for two bosses created a constant friction for the SOCCE because it often added additional layers of bureaucracy.

The TSOC did not want to relinquish control of its forces by permanently assigning them to the embassy, because if the mission in Nigeria went away the forces would have to be reassigned to another country. However, the ambassador did not like having a unit that she could not control or ensure would work toward her strategic plan on her country team. From her perspective this made sense. As it is stated in the *SOF/Interagency CT Reference Manual* produced by JSOU: "The Chief of Mission is head of the country team and must translate the interagency policies, strategies and plans into productive action on the ground. The COM has the discretionary authority to organize their country team in whatever fashion they see fit."<sup>69</sup> If the SOCCE had made the decision to conduct its operations without the COM's approval, she could have

---

<sup>68</sup> U.S. Department of State, "NSDD-38: Staffing at Diplomatic Missions and Their Overseas Constituent Posts," April 26, 2002, U.S. Department of State, <http://www.state.gov/m/pri/nsdd/45148.htm> (accessed June 14, 2010). The National Security Decision Directive dated June 2, 1982, gives the Chief of Mission (COM) control of the size, composition, and mandate of overseas full-time mission staffing for all U.S. government agencies. However, military forces temporary active duty or not permanently assigned (PCS) to the embassy, fall under the operational control of the commanding general of that theater. This is to ensure that special operations troops can easily be reassigned to another area if the mission in that country goes away. U.S. Department of State, "NSDD-38."

<sup>69</sup> Joint Special Operations University, *Special Operations Forces*, Chapter 2-1.

countered by eliminating the unit's position on the country team. Each department in the embassy lived by the rule of "choosing battles" with the ambassador.

A lack of discretion can instantly dissolve key relationships with the country team and front office despite the years it took to develop them—as the SOCCE liberty incident illustrated. If the ambassador deems that unit is no longer an asset to the country team, she may terminate its embassy access at her discretion. Truncated embassy access is potentially devastating to any Department of Defense entity in a country where no U.S. military bases are present because, in a failing state such as Nigeria, force protection measures dramatically increase for a unit operating without the infrastructure support of the State Department. Most countries in Africa are not like Afghanistan or Iraq, where massive DoD forward operating bases—serviced by Kellogg, Brown, and Root—exist. Without an embassy's protection and resources a small group of special operations personnel cannot be expected to accomplish its goals.

#### **D. CULTURAL DIFFERENCES**

The open format in which a U.S. embassy operates is another unfamiliar environment for NSW operators. In the world of special operations, which relies heavily on secrecy, transparency is not intuitive; the operator is accustomed to compartmentalization and special access programs and usually lives in the shadows during overseas operations. Being forthcoming about the intricacies of a mission to multiple individuals on the country team—even though those with comparable security clearances—carries a risk to the operator because of the open embassy culture about day-to-day operations. From the embassy's perspective, openness facilitated dialogue, which allowed department heads to synthesize efforts in favor of their common mission. From the SOCCE's perspective, compartmentalization and limited visibility protected the mission by minimizing exposure. While the SOCCE believed not everyone on the country team had a "need to know" about their missions, the ambassador ultimately mandated that most of the department heads did, noting that what the SOCCE did in the field had the potential to affect the missions of other country team departments. Synthesizing all efforts would contribute to the overarching mission strategic plan.

A department on the country team that was outside the normal inclusion scope of SOCCE operations sometimes needed access to that information in order to provide the Special Operations team with adequate support for its mission. For example, the Public Affairs Officer (PAO) did not usually have a need to know about SOCCE missions. However, a major combined joint training exercise between U.S. and Nigerian troops warranted the PAO's knowledge to prepare public release statements—approved by the ambassador—in case a Nigerian news story was leaked about the event. One of the constant challenges for the embassy's PAO was to prevent misleading stories in the Nigerian media that would undermine U.S. credibility. Other countries that have a presence in most African countries and compete for natural resources (e.g., Russia and China)) often engage in political subterfuge by manipulating the local media into spinning fraudulent stories and disparaging the United States. The PAO described a hypothetical example in which a Nigerian newspaper might print something like “U.S. Special Forces secretly train Nigerian troops as a cover to conduct capture/kill missions against radical Islamists in the North.”<sup>70</sup> Conspiracy stories are a common tactic by other countries to undermine U.S. credibility in the host nation. The ambassador was always adamant about transparency, believing strong inter-communication among departments would stave off disinformation and contribute to the country team mission as a whole. As sensible as it may sound, this model was not typically how special operations personnel conducted business, and it was often a point of friction between the SOCCE and the front office.

## **E. THE IRREGULAR ENVIRONMENT**

As mentioned earlier in this chapter, a typical tour for a SEAL is spent either with his troop prosecuting terrorist capture/kill missions in a combat theater or executing joint combined exercise and training (JCETs) events in non-combat theaters. However, the job profile of a SEAL today is more comprehensive than it was in the past because of increased deployments, with higher operational tempo, to different theaters of operations performing a multitude of roles. The role and task complexity is especially increasing as

---

<sup>70</sup> This was a discussion between the SOCCE and Embassy Public Affairs Office on the importance of staying on ahead of news releases to report accuracy and limit potentially damaging stories.

NSW and the interagency are becoming more interwoven in order to meet today's complex challenges. The transnational nature of radical Islamic organizations and their proliferation in countries with weakened or failing states—such as Nigeria, which lists as number fourteen on the 2010 failed states index—requires SOF personnel to have a position on embassy teams in countries where there is no dominant U.S. military presence and where the host nation lacks the resources to effectively counter radical groups.<sup>71</sup> In October 2010, militants from the Movement for the Emancipation of the Niger Delta (MEND) detonated two car bombs in Abuja, killing eight people during a public ceremony celebrating Nigeria's fiftieth anniversary of independence.<sup>72</sup> The 2009 Christmas “underwear bomber” was also a Nigerian who received training in Yemen, although he failed in his attempt to detonate his explosive briefs on an airline inbound for Detroit. These examples illustrate the importance and immediacy of the issue, which necessitates enhancing information sharing between all SOF and interagency assets and to take alternative measures to interdict AQIM lines of communication and outreach programs where direct military action is not an option. In Afghanistan and Iraq, CT forces would target these threats through direct action, but that option does not exist in Nigeria, which is not a declared war zone where U.S. forces can prosecute kinetic capture/kill operations. The political environment requires an indirect approach by SOF and the interagency in order to get to the root of the problem.

Nigeria is just one example of an African country with a growing domestic and international terrorist threat that needs USG support to reinforce its CT apparatus. In his article in the 2010 May/June edition of *Foreign Affairs*, Defense Secretary Robert Gates comments:

In the decades to come, the most lethal threats to the United States' safety and security—a city poisoned or reduced to rubble by a terrorist attack—are likely to emanate from states that cannot adequately govern themselves

---

<sup>71</sup> Foreign Policy, “Failed States Index 2010,” *Foreign Policy* (June–July 2010), Foreign Policy, [http://www.foreignpolicy.com/articles/2010/06/21/2010\\_failed\\_states\\_index\\_interactive\\_map\\_and\\_rankings](http://www.foreignpolicy.com/articles/2010/06/21/2010_failed_states_index_interactive_map_and_rankings) (accessed June 14, 2010).

<sup>72</sup> “Deadly Blasts near Parade in Nigeria,” *New York Times*, October 1, 2010, *New York Times*, [http://www.nytimes.com/reuters/2010/10/01/world/africa/international-us-nigeria.html?\\_r=2&hp](http://www.nytimes.com/reuters/2010/10/01/world/africa/international-us-nigeria.html?_r=2&hp) (accessed June 14, 2010).



or secure their own territory. Dealing with such fractured or failing states is, in many ways, the main security challenge of our time.<sup>73</sup>

The challenge the United States government (USG) faces is synthesizing all of the components of national power—the whole-of-government approach—and empowering failed or weakened states with the resources necessary to counter the global extremist threat. As it states in the *SOF Interagency Counterterrorism Reference Manual* of the Joint Special Operations University: “No single department, agency, or organization of the U.S. Government (USG) can, by itself, effectively locate and defeat terrorist networks, groups and individuals.”<sup>74</sup> NSW’s role in collaborative CT efforts is critical because its operators are gaining more of a presence in these types of 3-D roles. State Department officials often have limited knowledge of SOF capabilities and the responsibility is on the operator to educate them on what SOF resources can be provided to a country team’s counterterrorism campaign plan.

## **1. The Operator**

With Al Qaeda developing franchise networks and affiliates around the world (e.g., Arabian Peninsula, AQIM—Trans-Sahara) the battlefield is becoming more complex for SOF, which has a heightened role in irregular warfare across a wide spectrum of different cultures. The overarching theme in USSOCOM’s *Strategic Plan’s* “Implementation Tasks of Focus Area 1: The Operator” is developing SOF to understand the differences in cultures—traditional languages and customs of a people—of a country and operate more effectively in the disparate working environments where they are deployed. Implementation Tasks 1.2 to 1.5 have overtones of the actions of T.E. Lawrence (“Lawrence of Arabia”), the British liaison officer who played an influential role in orchestrating the Arab Revolt of 1916–18. The *Tasks* state, “Build long-term trust with populations, local/regional officials, and foreign security forces; understand how to create local development programs and integrate them with broader interagency efforts;

---

<sup>73</sup> Robert M. Gates, Defense Secretary, *Foreign Affairs*, May/June 2010.

<sup>74</sup> Joint Special Operations University, *Special Operations Forces*, 1–1.

and develop regional/local expertise and diplomacy skills.”<sup>75</sup> USSOCOM’s viewpoint is that the geostrategic perspective is not about the specific nature of the threat so much as it is about the people and their environment.

USSOCOM’s strategy recognizes that today’s challenges are much more complex and entrenched than can be addressed through pure direct action, and, as such, success “requires an understanding of the root causes of global problems as well as the systemic relationships that connect these issues across regions.”<sup>76</sup> USSOCOM argues that shifting the focus from the *threat* to the *population* is the key to this approach; however, the majority of NSW training does not prepare an operator with this type of mindset.

## **2. The Misfit**

The traditional six-month SEAL team and Special Activity Team deployments do not lend continuity to the long-term mission that is required for an operator to gain regional expertise and develop relationships with the host nation. It also is difficult for new Special Operations teams to establish credibility and trust with the permanent embassy country team members because of their frequent turnover. SEAL teams typically rotate their personnel in and out of the AFRICOM Theater every six months, as was the case for SOCCE Nigeria; the individuals are there to execute a specific mission, and they usually never see the country again. By the time the team gets the mission off the ground and makes a few tangible strides, they are ready to redeploy; continuity becomes an issue because the new team has to establish a new relationship with the country team. Foreign Service Officers who deploy to an embassy for three years regarded the SOCCE’s high turnover rate as damaging to the overall mission because relationships become fragmented and only a few tangible results are achieved. As Hocevar, Thomas, and Jansen argue, continuity at the mid-management level is a key ingredient for success in building collaborative capacity. It is the difference of being forced to do something (external incentive) and wanting to do something (internal incentive). They hypothesize that “interagency interactions that are based solely on

---

<sup>75</sup> USSOCOM Strategic Plan, 8.

<sup>76</sup> Ibid., 6.

external [rather than internal] incentives will not develop a sustainable collaborative orientation or necessary collaborative capacity unless participating organizations are able to successfully develop social networks.”<sup>77</sup> The Naval Special Warfare Anchor Detachments—regionally focused teams with a more permanent presence—discussed in the subsequent chapter are potentially a solution to this problem.

## F. CONCLUSION

The SOCCE Nigeria was filled with traditional SEAL team members who were not adequately trained for the mission; however, 180 days after the official Nigerian request, the SOCCE initiated the largest Special Operations Joint Combined Exercise and Training of record between the United States and Nigeria in March 2009. One hundred forty-three candidates from the Nigerian Army, Air Force and Navy started the CT selection course. This achievement was an anomaly for the SOCCE Nigeria. A Nigerian counterterrorism battalion continues to grow to this day as SEAL platoons cycle in and out of the country to train the host nation soldiers in special operations tactics. However, the battalion’s success did not come without the SOCCE overcoming significant structural, cultural and diplomatic hurdles—people overcoming a misfit—on the Nigerian side, which threatened to cancel the entire program before it even started. The lack of organization and continuity in the Nigerian government and their defense services made it difficult for USSOF to support the Nigerians in establishing a robust counterterrorism campaign strategy. Fortunately, with the arduous efforts by all members inside the U.S. embassy country team—knowing the right people in the right places within the Nigerian government—the Nigerian national CT program was saved prior to Special Operations Command Europe cancelling the exercise. The relationships between the SOCCE and country team were the key to success in establishing the CT unit, which was deemed a strategic success by the U.S. Embassy.

This chapter uses the Special Operations Command and Control Element on the U.S. embassy country team in Abuja, Nigeria as an example of the diplomatic, development and defense roles special operations personnel are routinely tasked with in

---

<sup>77</sup> Hocevar, Thomas, and Jansen, *Innovation through Collaboration*.

the current irregular warfare paradigm. The intent is to convey to the reader how the current NSW inter-deployment training cycle of preparing SEALs for war (threat focused) is not adequate for preparing them with the necessary skills to excel in an embassy working environment (population focused). The chapter then gives an overview of the SOCCE and the disparate types of missions they carried out in country and segued into the cultural differences, command and control issues over mission approval authority that stem from NSDD-38, and how Nigeria is part of the epidemic of transnational terrorism influencing weakened or failed states. To achieve greater continuity with the country team and success in the long-term mission, NSW will have to dedicate regionally focused operators to resource this type of 3-D mission.

THIS PAGE INTENTIONALLY LEFT BLANK

## IV. NAVAL SPECIAL WARFARE ANCHOR DETACHMENTS

The environment in which we find ourselves has changed. Instead of traditional nation-state conflict, both USSOCOM's and USSOF's assigned missions are predominantly focused on addressing non-state or transnational violent extremist threats. Future threats are emerging more from the complex convergence of crime, migration, and extremism and less from traditional nation-state adversaries.<sup>78</sup>

Admiral Olson, USSOCOM Commander

### A. INTRODUCTION

During the summer of 2009, the commanding officer of Naval Special Warfare Command, Admiral Winters, initiated a program designated Naval Special Warfare Anchor Detachments (NSWADs). This was in response to the needs of the *long war*, or what USSOCOM refers to as the need for, "...regionally oriented, long term engagement in key countries/regions in order to enable foreign internal defense/security force assistance (FID/SFA) in those areas and provide embedded advise/assist functions."<sup>79</sup> This chapter gives an introduction to NSWADs within NSW Special Activity (SA) Teams' chain of command and proposes how they are one solution to the irregular warfare problem. It argues that the NSWAD operators, not traditional SEAL team operators, are a better fit for 3-D missions, such as SOCCE Nigeria, because they have the appropriate interagency and regional training. Second, it demonstrates that NSWADs is a 3-D operator "fit" over the long term because, as an open system, NSWADs will adjust to the contingencies presented by the environment and embrace what USSOCOM refers to as "indirect" means.<sup>80</sup> Third, it shows how it is problematic for the NSW community to rapidly overcome its traditional culture of "direct" means in order to

---

<sup>78</sup> Eric T. Olson, "Commanders Intro," 2010 (U. S. Special Operations Command, posture statement).

<sup>79</sup> Anonymous SEALs, Special Activities Team 1, interview with author, August 2010.

<sup>80</sup> Indirect means include those capabilities for building partner capacity and establishing long-term relationships.

embrace a new culture.<sup>81</sup> Finally, this chapter examines the environmental contingencies that influence the NSWAD organization, its internal processes, and how this organization aligns with the needs of the 3-D operator.

## **B. A 3-D “FIT” IN THE LONG TERM**

In August of 2010, the Commander of International Security Forces-Afghanistan (ISAF), General David Petraeus, released his first edition of COIN guidance to the soldiers, sailors, airmen, marines, and civilians of NATO ISAF and U.S. Forces-Afghanistan. Listed in his guidance are 24 tasks. Not until the fifth task does the phrase, “Pursue the enemy relentlessly” appear. The first four tasks are as follows: “Secure and serve the population;” “Live among the people;” “Help confront the culture of impunity;” and, finally, “Help Afghans win accountable governance.”<sup>82</sup> This is significant because we believe that, from a NSW perspective, the last 30 years of NSW IDTC and ten years of conflict have been largely focused on directly combating the enemy with U.S. forces rather than empowering other nations through capacity building to engage their own populations and fight an irregular enemy. “Diplomacy” and “development” themes are emphasized throughout ISAF’s guidance. Based on successful COIN decisions in Iraq, General Petraeus states that indirect rather than direct means should be the preponderance of U.S. and NATO efforts in Afghanistan. Further justification for capacity building comes from Admiral James Stavridis, NATO’s Supreme Allied Commander, who believes, “Foreign military training is the most important long-term activity our military undertakes in terms of delivering security in this century. It is the way forward—so long as the wars go as planned.”<sup>83</sup> Enhancing regional security in this century is a task the NSWAD organization is postured to accomplish.

---

<sup>81</sup> Direct means includes those capabilities that aggressively counter adversaries.

<sup>82</sup> Commander International Security Assistance Force/U.S. Forces-Afghanistan, *COMISAF’s Counterinsurgency Guidance* (Kabul, Afghanistan, 2010).

<sup>83</sup> Kevin Baren, “Pentagon Sees Training Allies as its Greatest Hope,” *Stars and Stripes* (July 30 2010): 1.

### C. THE NSWAD ORGANIZATION

According to the NSWAD tasking order (TASKORD),<sup>84</sup> the long-term strategy for NSWADs is as follows: "...persistent presence and focus will have the effect of convincing counterparts that NSW is partnered for 'the long haul' while also reducing knowledge disconnects that occur as main force units deploy into and out of respective areas of responsibility (AOR)."<sup>85</sup>

The NSWADS comprise operators with regional expertise who have the proper training and skills to conduct irregular warfare missions. They encompass the "development" and "diplomatic" dimensions of the 3-D operator, allowing NSW to embody all dimensions of USSOCOMs 3-D construct. The following are vision-driving declarations for NSWADs as stated by its TASKORD as well as tactical leadership figures:

Ideally, as we begin to have personnel go out on successful deployments to the same locations, refine their language and cultural skills, and fully understand the problem sets particular to their country, the NSWADs will create a pool of regional experts embedded with partner units in key locations. They will provide persistent capacity building and situational awareness and over time will be able to share information and influence host nation operations in favor of U.S. objectives. NSWADs will also serve as early warning for potential crisis and will provide continuous situational awareness to the Theater Special Operation Commands (TSOCs).<sup>86</sup>

These assertions combine to illustrate NSWAD's broad-spectrum plan for dealing with the environmental influences or contingencies that require an indirect approach. The next section outlines the strategic, operational, and tactical environmental contingencies that NSW must address in order to remain relevant.

---

<sup>84</sup> Edward G. Winters, III. "TASKORD for NSW Anchor Team Realignment," December 1, 2009 (Coronado, CA). The Tasking Order is from an official message promulgated to the NSW force by the Commander NAVSPECWARCOM initiating NSWADs.

<sup>85</sup> Winters, III, "TASKORD for NSW Anchor Team Realignment."

<sup>86</sup> Anonymous SEAL Special Activities Team 1, interview with author, August 2010.



#### D. ENVIRONMENTAL CONTINGENCIES

USSOCOM Commander, Admiral Eric Olson, wrote the following regarding the new environment within which NSW must operate successfully: “The complexity of the current strategic environment requires that SOF Operators maintain not only the highest levels of warfighting expertise but also regional knowledge and diplomacy skills.”<sup>87</sup> The current environment facing NSW with the *long war* has produced contingencies that USSOF, specifically NSW, must address in order to remain relevant. These contingencies influence NSW across the strategic, operational, and tactical levels of conflict and directly affect NSW structure, task, and culture by forcing change in order to remain effective.

Environmental contingencies and their affects on NSW are presented in Table 3. Column 1 represents NSW structure at the strategic, operational, and tactical levels of the larger environment. At the strategic level, globalization has created a super-empowered individual. That super-empowered individual affects NSW by forcing its leadership to reconfigure the force structurally as well as alter NSW areas of operation (AORs) to consider the irregular threat. At the operational level, structure is altered by USSOCOM’s call for NSW to align with the 3-D operator concept. At the tactical level, NSW structure is affected because a larger force required to lethally combat an enemy is no longer prudent. The 3-D environment requires smaller units focused on the indirect approach and garnering interagency assets through collaboration.

Column two represents NSW tasks at the strategic, operational, and tactical levels of the larger environment. At the strategic level NSW tasking is altered to reflect the COCOM’s request for smaller DoD footprints overseas as larger footprints are ill advised in IW. At the operational level, language, culture, and regional knowledge become a higher priority of focus for the TSOCS translating to a new focus for NSW. At the tactical level, NSW deploys to new AORs requiring indirect assistance.

---

<sup>87</sup> *U.S. Special Operations Command Strategy 2010*, 1.

Column three represents NSW culture at the strategic, operational, and tactical levels of the larger environment. At the strategic level, NSW operational units must move away from a culture that deploys large numbers of personnel to a single AOR. A more self-reliant unit that does not require administration/logistics personnel for example must be adopted to alleviate the need for a larger U.S. military footprint. At the operational level, the NSW operator must adopt a new mindset embracing the METLs associated with the new IW mission. At the tactical level the individual NSW operator needs to adopt a new mindset in order to be competent and safe at the new METLs commensurate with IW mission sets.

Table 3. NSW Environment and Internal Processes Matrix<sup>88</sup>

		Levels of the Environment		
		1. STRATEGIC	2. OPERATIONAL	3. TACTICAL
Internal NSW Organization	STRUCTURE	Globalization: "Super-empowered Competition/Enemy" -Robb	COCOMS request smaller forces as large military footprint ill advised	Small units must be self-reliant -Forces personnel to be mature and understanding
	TASKS	USSOCOM creates 3- D Warrior - 3Ds become new strategic tasks	Language, Culture, and Regional Knowledge are New Focus for T-SOCS	NSW operators must embrace new mission sets associated with IW
	CULTURE	Less of a lethal approach required -More collaboration vs. competition	COCOMS/T-SOCS alter operational focus to reflect NSW deployments to new regions requiring "indirect" assistance	Forces NSW individual to be competent in various METLs commensurate w/ IW mission

<sup>88</sup> John Robb, *Brave New War: The Next Stage of Terrorism and the End of Globalization* (Hoboken, N.J.: John Wiley & Sons, 2007), 3.

Table 3 shows the affects at the strategic level on structure, task, and culture and how they have a top-down effect on the operational and tactical levels of the environment. The decisions made by the strategic echelons of the NSW organization only take effect if they are embraced by the operator at the tactical level. NSW prides itself on being a bottom-up organization, where much of the change in how it fights comes from the operators pushing new ideas to the top after recent combat experiences. If the operator does not contribute input to alterations in task, structure, or culture to embrace the 3-D Construct, then NSWADs chances for success will be limited.

NSW has reprioritized its mission sets in order to achieve a more appropriate balance between direct and indirect means. The result is a NSWADs mission list that seeks to accomplish different goals than those traditionally affiliated with NSW troops tasked with utilizing direct methods. The following concept from NAVSPECWARCOM drives the task list that follows. The last sentence explains NAVSPECWARCOM's intention.

The ability to conduct direct action operations of operational and strategic importance has and will continue to remain a core NSW capability. However, being the best at direct action (DA) does not and will not come at the expense of also being exceptional at irregular warfare (IW). NAVSPECWARCOM is directing the reinvestment and expansion of NSW indirect capabilities that have always been part of our primary mission.<sup>89</sup>

The NSWAD task list yields two takeaways. The first is that NSW needs to revitalize its irregular warfare capability. Second, IW will not be diminished or overshadowed by any other mission set, including "direct missions." This is NSW's commitment to IW. NSWADs' missions lean heavily toward establishing trust through capacity building with host nation partners, rather than conducting DA style missions against the enemy: NSW's focus since Vietnam. Based on the new NSWAD mission list, NSW culture and mind set must be radically altered. Immediate attempts to form

---

<sup>89</sup> Winters, III, TASKORD for NSW Anchor Team Realignment," 2.

and deploy NSWADs are accompanied by the difficult task of altering internal processes, specifically culture. A look at NSWADs human resources will reveal the personnel, configuration, and training associated with this new unit.

Table 4. NSWADs Mission Sets

Conduct Foreign Internal Defense (FID)
Conduct Unconventional Warfare (UW)
Perform Tactical Surveillance and Reconnaissance (SR)
Conduct Information Warfare (IW)

#### E. HUMAN RESOURCES

From a human resources perspective, the larger environment introduced three key issues. The first issue for NSW is recruiting and selecting individuals who fit the 3-D environment. The second is introducing enough individuals to qualify as SEALs in order to populate NSW and maintain its health as a force. A third issue is developing an indirect mindset within the NSW community. According to Commander Havloc of NSW, “We are looking for a guy who has deployed to that area. They have to be adaptable, mature and professionally seasoned with an affinity for this kind of work...”<sup>90</sup> All selectees, regardless of their military specialty, experience level, or level of affinity for the work, come from the same NSW community. Below is an excerpt from the TASKORD that discusses this further:

Each NSWAD shall initially consist of approximately six personnel comprised of [NSW workforce] from the rank of E-5 to O-5, and qualified civilians with previous military experience. Each NSWAT (smaller team with the NSWAD that deploys to partner nation) will typically consist of one officer and two enlisted personnel. Manning for NSWADs was pulled

<sup>90</sup> Scott Williams, “A Long-Term Human Investment,” *Navy SEAL ETHOS Magazine*, no. 8 (2010):6, SEALSWCC. (2010), 6, <http://www.sealswcc.com/navy-seal-ethos-magazine/issue/8/navy-seal-ethos-magazine-issue-8.aspx> (accessed October 19, 2010).

from across NSW to include SEAL Teams, Naval Special Warfare Center (NSWCEN), Special Boat Teams, and Naval Special Warfare Groups. Several nomination boards were conducted which identified personnel who fit the requirements and eventually earmarked over 30 personnel ranging in rank from lieutenant to E-5 to fill the initial four deployment phases. Members will possess a minimum experience of one (6 month) deployment to the region to which the NSWAD will be assigned.<sup>91</sup>

While the excerpt annotates how NSWADs plan to man its force, it does not address the time needed to depart from NSW's traditional and direct approach to conducting special operations. Adapting to the NSWAD requisite mindset will be difficult in the short term.

NSWADs will accomplish mission sets by "forming teams to embed with select partner nations forces and deploy for an initial twelve months. Follow-on deployments will occur to the same specific location until a four year tour of duty is complete."<sup>92</sup> Even for an individual who embraces the NSWAD initiative, the deployment cycle that includes an entire year with host nation units is a significant leap from traditional six-month NSW deployments. This, once again, illustrates the need to build a bridge between culture and task.

#### **F. INTER-DEPLOYMENT TRAINING CYCLE (IDTC)**

The time allotted for IDTC schedules of traditional NSW troops and NSWADs are similar; however, the training focus is different between the two.

NSWAD IDTC will be 10–12 months long just prior to deployment. Members must complete initial qualification training (IQT) to include, but not limited to language, instructor, SFA, regional and cultural familiarizations, and interagency training. An individual's initial deployment will be followed by a training cycle consisting of professional development, and assignment as a trainer for relevant positions or short augments overseas.<sup>93</sup>

---

<sup>91</sup> Commander Naval Special Warfare Command, *Tasking Order for Naval Special Warfare Anchor Detachments*, 4.

<sup>92</sup> *Ibid.*, 2.

<sup>93</sup> *Ibid.*, 6.

NSWAD personnel are asked to complete all of the normal baseline schools of their designator (SEAL/SWCC) in addition to completing the above-mentioned training. Additional training foci are primarily language capabilities, instructor qualifications, and understanding different regional sensitivities. The indirect training pipeline is in stark contrast to the direct style of traditional training. It creates a potential rift within the operator core. This is because the difference between what is considered normal training for a SEAL and what is required for NSWADs is so great. There are often no obvious incentives for a SEAL operator to become a champion of the indirect approach.

According to the NSWADs TASKORD, “Small teams of regionally oriented SEALs operating with foreign and interagency partners predate all current task organization models.”<sup>94</sup> While NSW historically produced structures based on environmental contingencies yielding small teams with regional foci, post Vietnam contingencies produced a vastly different structure. During Vietnam, NSW deploying units ranged from four to eight members who focused largely on advisory roles. Post-Vietnam platoon structures focusing on “direct measures” have traditionally been characterized by a minimum of 16 members continuously training together over 18 months towards direct style mission sets such as DA, SR, and maritime operations. The METLS of these mission sets, such as land warfare and weapons handling skills, specifically emphasized unilateral action and not instruction or capacity building with host nation or other agencies. According to one anonymous SEAL, “Only within the last few years has any NSW training been dedicated to host nation capacity building, and the majority of it still involved an entire [traditional] SEAL platoon or larger unit.” He added, “All of my past work-ups [training] were geared toward three things... aggressively finding, fixing, and finishing the enemy. Very little time, if any, has been devoted to training host nation defense forces.”<sup>95</sup> A departure from these NSW structures and tasks focusing on direct means is a considerable undertaking considering the three and one half decades devoted to excellence through direct means.

---

<sup>94</sup> Commander Naval Special Warfare Command, *Tasking Order for Naval Special Warfare Anchor Detachments*, 4.

<sup>95</sup> Anonymous SEAL, Special Activities Team 1, interview with author, August 2010.

## **G. METRICS OF SUCCESS**

We feel that the following sentiment from an individual within the NSW community indicates NSW's past metrics of success were based on targeted killing. "...I joined the SEAL Teams to kill terrorists."<sup>96</sup> These metrics of success were based on tangible items such as the number of enemy targets prosecuted or the number of enemy personnel neutralized. Perhaps even the number of DA operations conducted might be added to this list. These refer to "feedback."<sup>97</sup> Until recently, NSW has been using what cybernetics and systems theorists call negative or corrective feedback. That is, feedback that assesses whether or not the output fits the purpose and goals of the organization. NSW was producing an effective product via training commensurate with DA style outputs. However, when USSOCOM began to ask the question of whether it was meeting the environmental needs, NSW began to utilize "positive feedback" which, "...measures whether or not the purpose and goals align with environmental needs."<sup>98</sup> This shift to indirect missions represents NSW's transition to a less tangible but more appropriate metric based on the environment. As a tactical leader involved with the NSWADs program suggested, "[NSWADs metrics of success] will be very hard to quantify...and may come in the form of evaluations and observations during bilateral training events."<sup>99</sup> This shift in metrics further demonstrates the key differences that will prove difficult for NSW personnel involved in NSWADs to culturally embrace. Metrics can be viewed as one component on a list of many that combine to fashion culture. Just as the metrics have changed, so must the culture of NSW.

## **H. CULTURE**

NSW culture, until now, used direct means as the preferable way to operate. As previously stated, NSW culture begins at BUD/S and is reinforced everyday an individual remains within NSW. Regardless of the tasks for which NSW has claimed responsibility,

---

<sup>96</sup> Anonymous SEAL, Special Activities Team 1, interview with author, August 2010.

<sup>97</sup> Hanna, "Understanding how Organizations Function," 14.

<sup>98</sup> Ibid., 15.

<sup>99</sup> Anonymous SEAL, Special Activities Team 1, interview with author, August 2010.

the focus or daily effort since Vietnam has been direct means. Drawing on personal experience as SEALs, we make the case that little time has been devoted to indirect means in training. This has resulted in a lack of understanding of the term “indirect.” Three inferences can be drawn from this common lack of understanding within NSW. The first is that NSW has created and devoted itself to a single-mindset culture that required a significant number of years and effort to establish. The second is that when culture is instilled with institutions such as BUD/S, developed over time, and enabled further by combat experience, it facilitates a high degree of operational success: in this case, direct action mission successes as seen in Iraq and Afghanistan. The final inference is that culture is cyclical, and its perpetuation hinges on the individual operator. If the operator does not internalize an indirect culture, he can never mentor or hope to instill an indirect culture. Therefore, it is incumbent on NSW to “instill,” “develop,” and “enable” an indirect culture that co-exists with the traditional direct culture, and thereby achieves relevance in the *long war*.

Based on these inferences, USSOCOM states accurately that the “Operator is the central focus of its efforts...” It understands that without the operator, changes within USSOF cannot take place. As a result, NSWAD personnel are left with an immense charge, which is to embrace a new culture based on instruction and not destruction, on regional familiarization and not unilateral missions. Consequently, we feel that ordering the operator’s acceptance of a new culture without the “instilling,” “developing,” and “enabling” is, at best, difficult in the long term and virtually impossible in the short. As NSWADs are new and virtually untested, the culture they require has been mapped out by a TASKORD but time will uncover NSWADs acceptance or deviation from that path as evident by its successes or failures.

## **I. CONCLUSION**

First, this chapter introduces NSWADs as a long-term solution to the irregular warfare problem. Second, it justifies the creation of NSWADs by emphasizing the importance of capacity building and regional security. Third, it illustrates how current environmental contingencies affect NSWAD’s internal processes: structure, task, and



culture. Fourth, it diagnoses NSWADs through the lens of human resources to distinguish the disparity between what training is currently providing to the operator vice what it needs to provide: an IW focus. We then looked at metrics of success and the IDTC to highlight, once again, the gap between a traditional and irregular focus. Finally, this chapter discussed culture and established that ample time is necessary to effectively change an organizational culture from one that is focused on the “direct” approach to the “indirect” approach because the operator, as the embodiment of NSW culture, cannot change over night. This reinforces the key takeaway from this chapter: NSWADs is a 3-D operator “fit” over the long term because as an open system NSW reacts to environmental contingencies and embraces indirect means. It will be problematic however for this community to overcome the traditional culture of direct means, and this will ultimately make it extremely difficult for NSW to rapidly embrace a new culture.

## **V. CONCLUSIONS AND RECOMMENDATIONS**

### **A. CONCLUSIONS**

NSW will need to adapt in order to practice the 3-D operator initiative and effectively combat an irregular enemy. Our thesis emerged from discussions concerning the frustration of NSW operators continually tasked to conduct recurring missions that they are ill prepared to execute. Our intent was to start a conversation to entice and perhaps provoke NSW leadership to consider who it recruits and how it trains those recruits to conduct a range of military operations in a 3-D environment.

Chapter I began with an anecdote to develop a vivid context for the reader and to illustrate the immediate sense of misfit where the SEAL operator was not prepared for the 3-D environment because his training did not match the mission. Next, this chapter defined USSOCOM's 3-D construct. Finally, it introduced organizational contingency theory to illustrate the importance of fit between an organization and its environment. To accomplish our research goals, we took a systematic approach.

Chapter II gave an organizational overview of NSW. This chapter described the relevant factors of the NSW, its structure, tasks, people and culture and its larger environments; this allowed us to analyze the misfit between the current system and the challenges posed by a highly complex and unstable environment. From a human resources point of view, the majority of the NSW force is considered to be a fit for operating in kinetic environments; however, it is a misfit for today's non-kinetic environments.

In Chapter III, we analyze a former Special Operations Command and Control Element (SOCCE) on the U.S. Embassy Country Team in Nigeria. The SOCCE is one of the key models for developing and institutionalizing NSW 3-D capabilities to effectively conduct irregular warfare missions. The disparity between the NSW operator's direct focused approach and the embassy's indirect focused approach highlight the organizational challenge NSW must contend with in order to become more relevant toward fighting an irregular natured conflict. Additionally, the mission lacks continuity

due to the frequent turnover of SOF teams cycling through short duration deployments. A change will need to come in how these missions are resourced with SOF personnel in order to achieve long-term results.

Chapter IV provides an overview and analysis of NSWADs as the solution to operating in the irregular warfare paradigm by integrating with the interagency to meet national objectives. We specifically argue that NSWADs offer a long-term solution to USSOCOM's 3-D operator. Environmental contingencies affecting NSW's internal processes are addressed in order to demonstrate the difficulty of overcoming barriers currently embedded in the NSW culture; training and focus are compared to point out the dramatic differences in the goals of traditional NSW units and those of NSWADs. Modifying the lethally focused, assertive, and strong culture of SEAL operators cannot happen overnight; cultural change takes time. Despite this nebulous forecast, once the storm of cultural change passes, operational successes of an irregular nature will occur.

## B. RECOMMENDATIONS

This research has argued—we hope convincingly—that NSW is not currently training or preparing its operators to comprehensively embrace the defense, development, and diplomacy vision put forth by USSOCOM in 2010. Whereas USSOCOM envisions a 3-D operator to appear skilled in all three dimensions, similar to Figure 9.

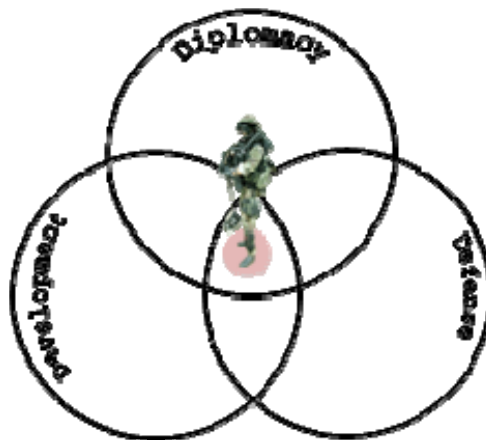

Figure 9. USSOCOM's 3-D Operator

Currently the SEAL team operator is not equipped with the skill sets required to be adept in the diplomacy and development dimensions of the 3-D construct. Figure 10 illustrates where we feel the current SEAL team operator lies.



Figure 10. Typical SEAL Operator within 3-D Construct

So how do we get from NSW's current 3-D depiction to one that more fully represents what the USSOCOM strategy intended?

Training for kinetic operations is still the dominant focus in the SEAL teams because it underscores the core capability of the community, which must never be compromised. As Admiral Olson says, "The complexity of the present strategic environment requires that SOF operators maintain not only the highest levels of war fighting expertise but also regional knowledge and diplomacy skills."<sup>100</sup> Kinetic skill sets remain an important part of counterinsurgency. Keeping this in mind, we offer the following recommendations.

## 1. Manning SOCCEs or Other 3-D Jobs

### *a. Discussion*

Chapter III describes how the interagency mission for NSW (SOCCE, which is now called Special Operations Forces Liaison Element [SOFLE]) is being filled with operators who are inadequately prepared for the 3-D mission. The interagency

---

<sup>100</sup> Eric T. Olson in *USSOCOM Strategy*, 2010, 2.

mission is about engendering long-term relationships and maintaining continuity to establish effective host nation programs of instruction to build CT/COIN capacity. Unfortunately, in the case of the Nigeria SOCCE, the lack of 3-D centric training coupled with the high frequency turnover with SEALs every six months (now every three months due to an increased SEAL team rotational cycle) is compromising the overall mission and sacrificing credibility with the country team.

***b. Recommendation***

NSWAD operators, not SEAL team operators, are fit to fulfill SOFLE/SOCCE jobs because the training meets the needs of the environment and the extended deployments facilitate building rapport. The episodic JCETs in each country should still be executed by SEAL platoons cycling in and out of country to conduct the exercise. However, the billet on the Embassy Country Teams should be filled by SEALs who have regional expertise, have diplomatic and development training, and execute multiple extended tours to that embassy in the Key Partner Nation—becoming the “Lawrence of Arabia’s” within NSW.

**2. NSWAD Manpower**

***a. Discussion***

NSW has a limited number of regionally trained operators with diplomatic and development skill sets. Currently NSW does not have the 3-D depth to fill every SOFLE or other 3-D mission with an operator who fits that environment. Rather, these positions are filled with kinetically trained SEAL team operators. USSOCOM emphasizes core capability; thus, it is important for SEAL team operators to train to the kinetic missions and not be forced to compromise kinetic skill sets.

***b. Recommendation***

NSW should bolster its IW capacity by growing NSWAD operators. NSWAD operators need to grow in numbers because staffing 3-D positions with SEAL team operators degrades core capability and damages diplomatic and development efforts.

**3. Incentives**

***a. Discussion***

In order to grow the NSWAD force an incentive structure needs to be in place that effectively encourages SEALs to break away from the traditional mission set. Current incentives fail to bridge the cultural gap created by the NSWADs initiative. In other words, what can NSWADs offer the SEAL team operator that entices him to depart from a kinetic mindset? For example, the first incentive listed in the NSWADs TASKORD is that the individual assigned to NSWADs will receive extensive language and cultural training. We feel it is fair to assume that most SEAL operators did not join to become language or cultural experts. Therefore, this really is not an incentive and, in some cases, may be perceived as a punishment. The second incentive listed in the NSWAD TASKORD is that the service member will be allowed to maintain the same home duty station for four years.<sup>101</sup> While this may give the NSWAD operator's family a greater degree of continuity, that NSWAD operator is likely to be away from home and family for training and deployments for at least two out of those four years. Therefore, there is no significant difference between time away from home at an NSWAD and a SEAL team. In order for people to sustain high levels of performance over the long-term in jobs atypical to traditional SEAL missions, effective incentives must be evident.

***b. Recommendation***

Make NSWADs a more attractive billet. For example, diminish the hardship of a full year away from family by allowing NSWAD operator's family

---

<sup>101</sup> Winters, III, Commander Naval Special Warfare Command, *Tasking Order for Naval Special Warfare Anchor Detachments*, Coronado, CA, December 2009.

accompanied tours to embassy country teams where possible. Prove to NSWAD operators that they are valued members of the NSW organization by offering choice sets of orders after NSWAD commitment. These are two incentives we feel would be effective; a financial incentive would also increase NSWAD attractiveness. Regardless, NSW should make a greater investment of NSWADs incentives to benefit the community and produce greater dividends in the long term.

USSOCOM has made tremendous strides in moving towards embracing the softer side of special operations by emphasizing diplomacy and development skill sets to get to the root of global extremism. The greatest challenge currently with the 3-D operator concept is NSW finding the right balance between training for diplomacy and development missions versus defense—specifically the legacy SEAL team kinetic training cycle. If NSW can work toward implementing these recommendations we feel that it will be better prepared to combat our nation’s adversaries in the 3-D environment.

## **APPENDIX A. MAJOR COMPONENTS OF NAVAL SPECIAL WARFARE COMMAND (NAVSPECWARCOM)**

### **NAVAL SPECIAL WARFARE CENTER (NSWC)**

The NSWC is based at Naval Amphibious Base (NAB) Coronado, CA.

- Commanded by a Navy captain (O-6).
- Schoolhouse for NSW training.
- 26-week BUD/S course.
- Nine-week Special Warfare Combat Crewman (SWCC) course.
- Advanced maritime special operations training.
- Maintains a detachment at the NAB, Little Creek, VA for training of East Coast personnel.

### **NAVAL SPECIAL WARFARE DEVELOPMENT GROUP (NSWDG)**

The NSWDG is located in Dam Neck Naval Base, VA.

- Commanded by a Navy captain (O-6).
- Conducts tests, evaluations, and development of current and emerging technology.
- Develops maritime ground and airborne tactics.

### **NAVAL SPECIAL WARFARE GROUP ONE (NSWG-1)**

NSWG-1 is located in Coronado, CA at NAB.

- Commanded by a Navy captain (O-6).
- Operational and administrative control, of ST-1, ST-3, ST-5, ST-7, LOGSU-1, and SA-1.
- Administrative control of NSWU-1 (Guam) and NSWU-3 (Bahrain).
- NSWG-1 concentrates on the Pacific and Central Areas of Responsibility (AOR).

### **SEAL TEAMS ONE, THREE, FIVE, SEVEN (ST-1/3/5/7)**

ST-1/3/5/7 are located in Coronado, CA at NAB

- Commanded by a Navy commander (O-5).
- Comprise of one headquarters (HQ) unit and three NSW troops that have two 16-man SEAL platoons each.
- Provide administrative and tactical support to three troops/six operational platoons charged with conducting Special Operations in the Pacific and Central AORs.



#### NAVAL SPECIAL WARFARE GROUP TWO (NSWG-2)

NSWG-2 is located in Virginia Beach, VA at NAB Little Creek.

- Commanded by a Navy captain (O-6).
- Operational and administrative control, of ST-2, ST-4, ST-8, ST-10, LOGSU-2, and SA-2.
- Administrative control of NSWU-2 (Germany) and NSWU-10 (Germany).
- NSWG-2 concentrates on the Southern, European, African and Central AORs.

#### SEAL TEAMS TWO, FOUR, EIGHT, TEN (ST-2/4/8/10)

ST-2/4/8/10 are located in Virginia Beach, VA at NAB Little Creek.

- Commanded by a Navy commander (O-5).
- Comprise of one HQ unit and three NSW troops that have two 16-man SEAL platoons each.
- Provide administrative and tactical support to three troops/six operational platoons charged with conducting Special Operations in the Southern, European, African, and Central AORs.

#### SPECIAL ACTIVITY TEAMS ONE, TWO (SA-1/2)

NSWG-2 is located in Virginia Beach, VA at NAB Little Creek.

- Commanded by a Navy commander (O-5).
- Comprised of one HQ unit, Cross Functional Troops, NSWADs, and one Cultural Engagement Team.
- The Special Activity Team mission is to man, train, equip, organize, and deploy forces to conduct Preparation of the Environment (PE); Intelligence, Surveillance, Reconnaissance (ISR); Special Operations (SO); and Combat Support (CS) for Commanders, Interagency, and Host Nation Partners.

#### NAVAL SPECIAL WARFARE GROUP THREE (NSWG-3)

NSWG-3 is located in Coronado, CA at NAB.

- Commanded by a Navy captain (O-6).
- Operational and administrative control of all undersea NSW programs and commands to include SDVT-1 (Hawaii) and SDV Det-2 (Little Creek, VA).

#### NAVAL SPECIAL WARFARE GROUP FOUR (NSWG-4)

NSWG-4 is located in Virginia Beach, VA at NAB Little Creek.

- Commanded by a Navy captain (O-6).
- Operational and Administrative Control of SBT-12, SBT-20, SBT-22.
- Mission is to organize, train, equip and deploy NSW personnel and maritime mobility systems.

#### NAVAL SPECIAL WARFARE UNIT ONE (NSWU-1)

NSWU-1 is located in Guam at the Naval Base.

- Commanded by a Navy captain (O-6).
- A small command charged with logistical support for SEALs conducting Special Operations and building partnerships via the Theater Security Cooperation Plan (TSCP) in the Pacific AOR.

#### NAVAL SPECIAL WARFARE UNIT THREE (NSWU-3)

NSWU-3 is located in Bahrain at the Naval Base.

- Commanded by a Navy captain (O-6).
- A small command charged with logistical support for SEALs conducting Special Operations, planning for exercises and contingencies, and building partnerships via the Theater Security Cooperation Plan (TSCP) in the Central AOR.

#### NAVAL SPECIAL WARFARE UNIT TWO (NSWU-2)

NSWU-2 is located in Stuttgart, Germany at the Patch Barracks.

- Commanded by a Navy captain (O-6).
- A small command charged with logistical support for SEALs conducting Special Operations, planning for exercises and contingencies, and building partnerships via the Theater Security Cooperation Plan (TSCP) in the European AOR.

#### NAVAL SPECIAL WARFARE UNIT TEN (NSWU-10)

- NSWU-10 is located in Stuttgart, Germany at the Patch Barracks.
- Commanded by a Navy commander (O-5).
- A small command charged with logistical support for SEALs conducting Special Operations, planning for exercises and contingencies, and building partnerships via the Theater Security Cooperation Plan (TSCP) in the African AOR.

#### SEAL DELIVERY VEHICLE TEAM ONE (SDVT-1)

SDVT-1 is based in Pearl Harbor, HI.

- Commanded by a Navy commander (O-5).
- SDVT-1 conducts undersea special operations throughout the globe.
- Has three SDV, Dry Deck Shelter (DDS) troops and a headquarters element.
- Each SDV/DDS Troops can deploy independently of submarines, but can deploy on board a submarine, using it as a host for SDV operations.

#### SPECIAL BOAT TEAM TWELVE (SBT-12)

SBT-12 is based in Coronado, CA at NAB.

- SBT-12 is comprised of Rigid Hull Inflatable Boat (RHIB) Detachments and Mk V Special Operations Craft (SOC) detachments. Each detachment is comprised of two boats.
- SBT-12 supports open-water special operations in the Pacific and Central AORs as well as training for Coronado based SEAL Teams.

#### SPECIAL BOAT TEAM TWENTY (SBT-20)

SBT-20 is based in Virginia Beach, VA at NAB Little Creek.

- SBT-20 is comprised of Rigid Hull Inflatable Boat (RHIB) Detachments and Mk V Special Operations Craft (SOC) detachments. Each detachment is comprised of two boats.
- SBT-20 supports open-water special operations in the European, Southern, African and Central AORs as well as training for Little Creek based SEAL Teams.

#### SPECIAL BOAT TEAM TWENTY-TWO (SBT-22)

SBT-22 is based in Stennis, MS.

- Commanded by a Navy commander (O-5)
- Consists of a HQ element and four Special Operations Craft—Riverine (SOCR) Troops. Each troop consists of two SOCR detachments and each detachment consists of two SOCRs.
- SBT-22 focuses on providing insert, extraction, and Quick Reaction Force support for SEALs conducting Special Operations in riverine environments throughout the globe.

## APPENDIX B. UJTL TASK LINKAGES

Taken from the Universal Joint Task Manual CJCSM 3500.04E, Appendix A Enclosure B (B-A-7-8): An example of vertical linkages in the UJTL is illustrated in Figure 11 with maneuver tasks. This illustrates the stakeholders at strategic and operational levels and the design used to influence the task lists required by an NSW troop or other tactical unit.

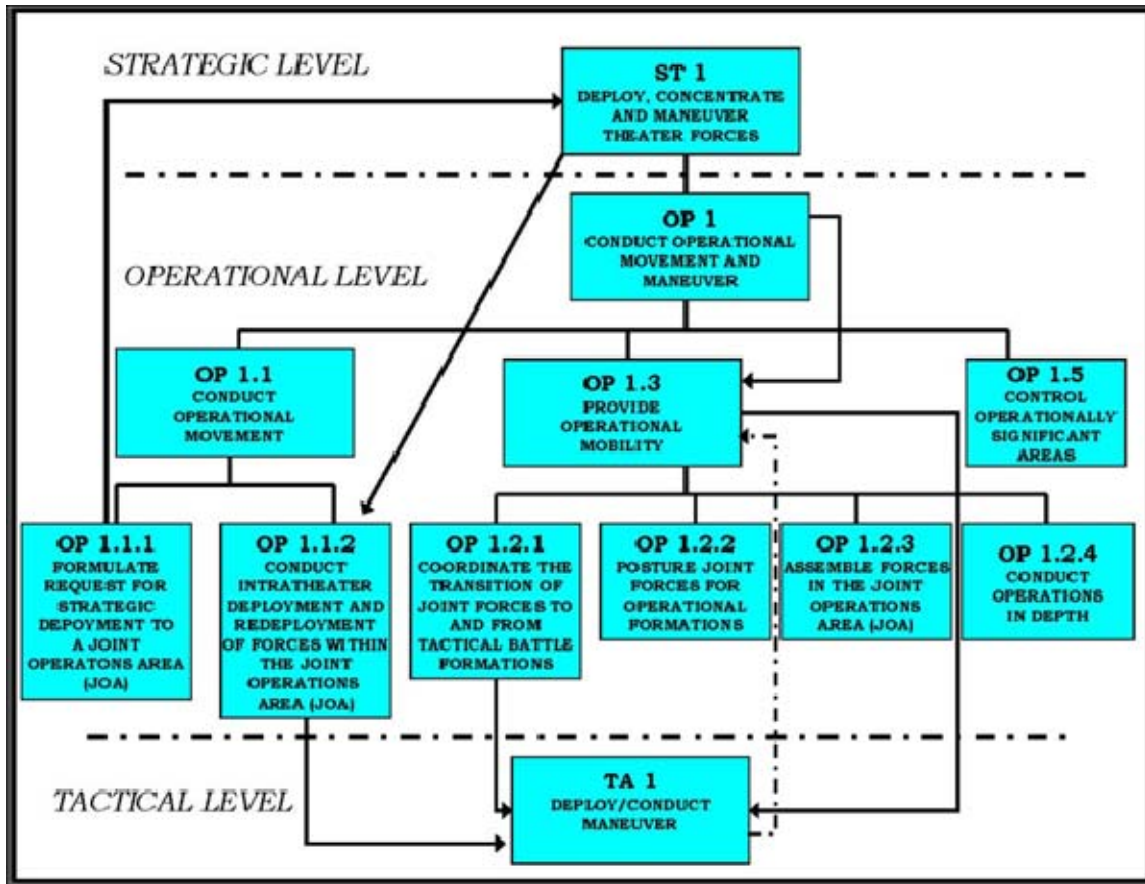

**Figure B-2. Task Linkages Across the Levels of War**

Figure 11. Task Linkages Across the Levels of War

(1) Figure B-2 [Figure 11] displays the tasks involved in bringing forces to bear on an enemy. In one of the first actions, forces might have to conduct a theater strategic movement and maneuver (ST 1, “Deploy, Concentrate, and Maneuver Theater Forces”) based on a request from a JFC. Once in the theater of operations, or joint operations area, it may be necessary to further deploy these forces (OP 1.1.2, “Conduct Intratheater Deployment and Redeployment of Forces within the Joint Operations Area”) into positions that will respond to enemy force movements. The movement will give them a relative advantage over enemy forces and support the JFC's intent for his subordinate campaign plan. At the same time, joint forces in the joint operations area could be maneuvering (OP 1, “Conduct Operational Movement and Maneuver,” and OP 1.2 “Conduct Operational Maneuver and Force Positioning”) to put forces into a position from which they can deploy and conduct tactical maneuver (TA 1, “Deploy/Conduct Maneuver”) and employ direct and indirect fires. Included in this is the transitioning of forces to battle formation (OP 1.2.1, “Coordinate the Transition of Joint Forces to and from Tactical Battle Formations”). At the tactical LOW, maneuver deals with achieving positional advantage over an enemy force in conjunction with fire support.

(2) Figure B-2 [Figure 11] can also be viewed from a bottom-up perspective as shown by the dotted line from the tactical level to the operational level. In this case, the results of a tactical-level maneuver (TA 1, “Deploy/Conduct Maneuver”) could achieve an advantageous position over the enemy. At the tactical level, a penetration, or flanking maneuver might achieve tactical success and permit maneuver to operational depths (exploitation and pursuit), helping to achieve operational and theater strategic objectives (OP 1, “Conduct Operational Movement and Maneuver”). (3) The vertical linking of the tasks across levels of the UJTL can be used to make connections between related capabilities at the tactical, operational, and strategic LOWs and illustrate how an inadequate capability at any LOW can impact the ability of a joint force to integrate that capability across the three LOWs. Such linkages exist in all general task areas of the UJTL, to include movement and maneuver, intelligence, firepower, sustainment, command and control, and protection.

## LIST OF REFERENCES

- Baren, Kevin. "Pentagon Sees Training Allies as its Greatest Hope." *Stars and Stripes*. July 30 2010: 1.
- Boyle, Joe. "Nigeria's 'Taliban' Enigma." *BBC News*. July 31 2009.  
<http://news.bbc.co.uk/2/hi/8172270.stm>.
- Commander International Security Assistance Force/U.S. Forces-Afghanistan.  
*COMISAF's Counterinsurgency Guidance*. Kabul, Afghanistan, 2010.
- Couch, Dick. *The Finishing School: Earning the Navy SEAL Trident*. 1st ed. New York: Crown Publishers, 2004.
- Daft, Richard L. *Essentials of Organization Theory and Design*. Oklahoma City, OK: South-Western Publishing Co, 2003.
- "Deadly Blasts near Parade In Nigeria." *New York Times*. October 1, 2010. New York Times. [http://www.nytimes.com/reuters/2010/10/01/world/africa/international-us-nigeria.html?\\_r=2&hp](http://www.nytimes.com/reuters/2010/10/01/world/africa/international-us-nigeria.html?_r=2&hp). Accessed June 14, 2010.
- Department of the Navy. *OPNAV Instruction 1001.24*. Washington, DC: Department of the Navy, 2000.
- Donaldson, Lex. *The Contingency Theory of Organizations*. Thousand Oaks, CA: Sage Publications, 2001.
- Foreign Policy. "Failed States Index 2010." *Foreign Policy* (June–July 2010). Foreign Policy.  
[http://www.foreignpolicy.com/articles/2010/06/21/2010\\_failed\\_states\\_index\\_interactive\\_map\\_and\\_rankings](http://www.foreignpolicy.com/articles/2010/06/21/2010_failed_states_index_interactive_map_and_rankings). Accessed June 14, 2010.
- Friedman, Thomas. *The World is Flat: A Brief History of the Twenty-first Century*. New York: Farrar, Straus, and Giroux, 2006.
- Hanna, David P. "Understanding How Organizations Function." In *Designing Organizations for High Performance*. Reading, MA: Addison-Wesley Pub. Co., 1988.
- Hocevar, Susan, Gail Thomas and Erik Jansen. *Innovation through Collaboration: Building Collaborative Capacity: An Innovative Strategy for Homeland Security Preparedness*. Oxford: Elsevier Ltd., 2006.

- Joint Chiefs of Staff. *Joint Publication 3-13: Joint Doctrine for Information Operations*. Washington, DC: Joint Chiefs of Staff, 1998. [www.c4i.org/jp3\\_13.pdf](http://www.c4i.org/jp3_13.pdf). Accessed June 14, 2010.
- . “Strategic Context.” In *Joint Operations, Joint Publication 3-0 (Change 2)* 1–6. Washington, DC: Joint Chiefs of Staff. Joint Electronic Library, <http://www.dtic.mil/doctrine/>. Accessed June 14 2010.
- . *Universal Joint Task Manual, CJCSM 3500.04e*. Washington, DC: Joint Chiefs of Staff, 2008. DTIC online. [www.dtic.mil/doctrine/training/cjcsm3500\\_04e.pdf](http://www.dtic.mil/doctrine/training/cjcsm3500_04e.pdf). Accessed June 14, 2010.
- Joint Special Operations University. *Special Operations Forces Interagency Counterterrorism Reference Manual*. Hurlburt Field, FL: Joint Special Operations University Press, 2009.
- Kenney, Michael T. “Leveraging Operational Preparation of the Environment in the GWOT.” *A Monograph. School of Advanced Military Studies*. Fort Leavenworth, KA: United States Army Command and General Staff College, 2005–2006.
- Kohlmann, Evan. “A Beacon for Extremists: The Ansar al-Mujahideen Web Forum.” *CTC Sentinel* 3, no. 2 (February 2010): 1.
- Marcoulides, George A. and Ronald H. Heck. “Organizational Culture and Performance: Proposing and Testing a Model.” *Organization Science* 4, no. 2 (1993): 211.
- Marquis, Susan. *Unconventional Warfare: Rebuilding U.S. Special Operations Forces*. Brookings Institution, Washington, DC, 1997.
- Mintzberg, Henry. “Organization Design: Fashion or Fit?” *Boston Harvard Business Review*, 59, no 1, (1981): 103–106.
- Naval Special Warfare Command. “Naval Special Warfare Small Investment, Big Real-World Dividends. Committed to Combating Global Terrorist Threats.” Naval Special Warfare Command. <http://www.navsoc.navy.mil/default.htm>. Accessed June 14, 2010.
- Naval Special Warfare Command. “Official U.S. Navy SEAL Home Page.” Naval Special Warfare Command. <http://www.navsoc.navy.mil/missions.htm>. Accessed June 14, 2010.
- Olson, Eric T. “Commanders Intro.” 2010. U. S. Special Operations Command (posture statement).

- Robb, John. *Brave New War: The Next Stage of Terrorism and the End of Globalization*. Hoboken, N.J: John Wiley & Sons, 2007.
- Robert M. Gates, Defense Secretary, *Foreign Affairs*, May/June 2010.
- “The SEAL Creed.” Naval Special Warfare.  
<http://www.seal.navy.mil/seal/PDF/Seal.Creed.pdf>. Accessed June 14, 2010.
- “The Tightening Ties between Nigerian Boko Haram and Al Qaeda.” *The Jihad and Terrorism Threat Monitor*. Posted October 3, 2010.  
[http://www.memrijttm.org/content/en/blog\\_personal.htm?id=3866&param=IDTA](http://www.memrijttm.org/content/en/blog_personal.htm?id=3866&param=IDTA)  
Accessed June 14, 2010.
- U.S. Department of Defense. “DefenseLINK-Unified Command Plan.” United States Department of Defense. 2010. <http://www.defense.gov/specials/unifiedcommand/>. Accessed June 14 2010.
- . *National Defense Strategy*. Washington, DC: U.S. Department of Defense, 2008. U.S. Department of Defense.  
[www.defense.gov/news/2008%20national%20defense%20strategy.pdf](http://www.defense.gov/news/2008%20national%20defense%20strategy.pdf). Accessed June 14 2010.
- U.S. Energy Information Administration. “U.S. Imports by Country of Origin.” U.S. Energy Information Administration.  
[http://www.eia.gov/dnav/pet/pet\\_move\\_impcus\\_a2\\_nus\\_ep00\\_im0\\_mbb1\\_m.htm](http://www.eia.gov/dnav/pet/pet_move_impcus_a2_nus_ep00_im0_mbb1_m.htm). Accessed June 14, 2010.
- U.S. Marine Corps, U.S. Department of the Navy, U.S. Coast Guard. *A Cooperative Strategy for 21st Century Seapower*. Washington, DC: U.S. Marine Corps, U.S. Department of the Navy, U.S. Coast Guard, 2007. U. S. Navy.  
[www.navy.mil/maritime/maritimestrategy.pdf](http://www.navy.mil/maritime/maritimestrategy.pdf). Accessed June 14, 2010).
- U.S. Special Operations Command Strategy 2010*. Tampa, FL: USSOCOM, 2009.
- U.S. Department of State. “NSDD-38: Staffing at Diplomatic Missions and Their Overseas Constituent Posts.” April 26, 2002. U.S. Department of State.  
<http://www.state.gov/m/pri/nsdd/45148.htm>. Accessed June 14, 2010.
- White House. *National Security Strategy*. Washington, DC: White House, 2010.
- . *The Unified Command Plan (Unclassified)*. Washington, DC: White House, 2006.



Williams, Scott. "A Long-Term Human Investment." *Navy SEAL ETHOS Magazine*, no. 8 (2010):6. SEALSWCC. <http://www.sealswcc.com/navy-seal-ethos-magazine/issue/8/navy-seal-ethos-magazine-issue-8.aspx>. Accessed October 19, 2010.

Winters, III, Edward G. "TASKORD for NSW Anchor Team Realignment." December 1, 2009. Coronado, CA. Tasking order is from an official message promulgated to the NSW force by the Commander NAVSPECWARCOM initiating NSWADs.

Yuheng, Wang. "China's Pipelineistan 'War.'" October 12, 2010. Mother Jones. <http://motherjones.com/politics/2010/10/china-natural-gas-pipeline-central-asia>. Accessed June 14, 2010.

## INITIAL DISTRIBUTION LIST

1. Defense Technical Information Center  
Ft. Belvoir, Virginia
2. Dudley Knox Library  
Naval Postgraduate School  
Monterey, California
3. SOCOM J-7  
MacDill AFB, Florida
4. Naval Special Warfare Command  
Coronado, California
5. Patrick P. Pihana, Col, USAF, National Defense University  
Fort Lesely J. McNair, Washington, D.C.
6. JSOU  
Hurlburt Fld, Florida
7. Department of the Air Force, Institute for National Security Studies  
U.S. Air Force Academy, Colorado
8. HQ USSOCOM Library  
Hurlburt Field, Florida
9. Bradley Voigt, USSOCOM NSWCEN  
Coronado, California
10. ASD/SOLIC  
Washington, D.C.
11. CDR Leif Mollo, SEAL Team 8  
Virginia Beach, Virginia