





Digitized by the Internet Archive
in 2015

<https://archive.org/details/britishcarpenter00pric>

complete

307
H
year

6 Circles

1



$$\begin{array}{r}
 50 \\
 52 \\
 37 \\
 \hline
 146
 \end{array}$$

$$\begin{array}{r}
 171 \\
 157 \\
 \hline
 328
 \end{array}$$

2019



37

146

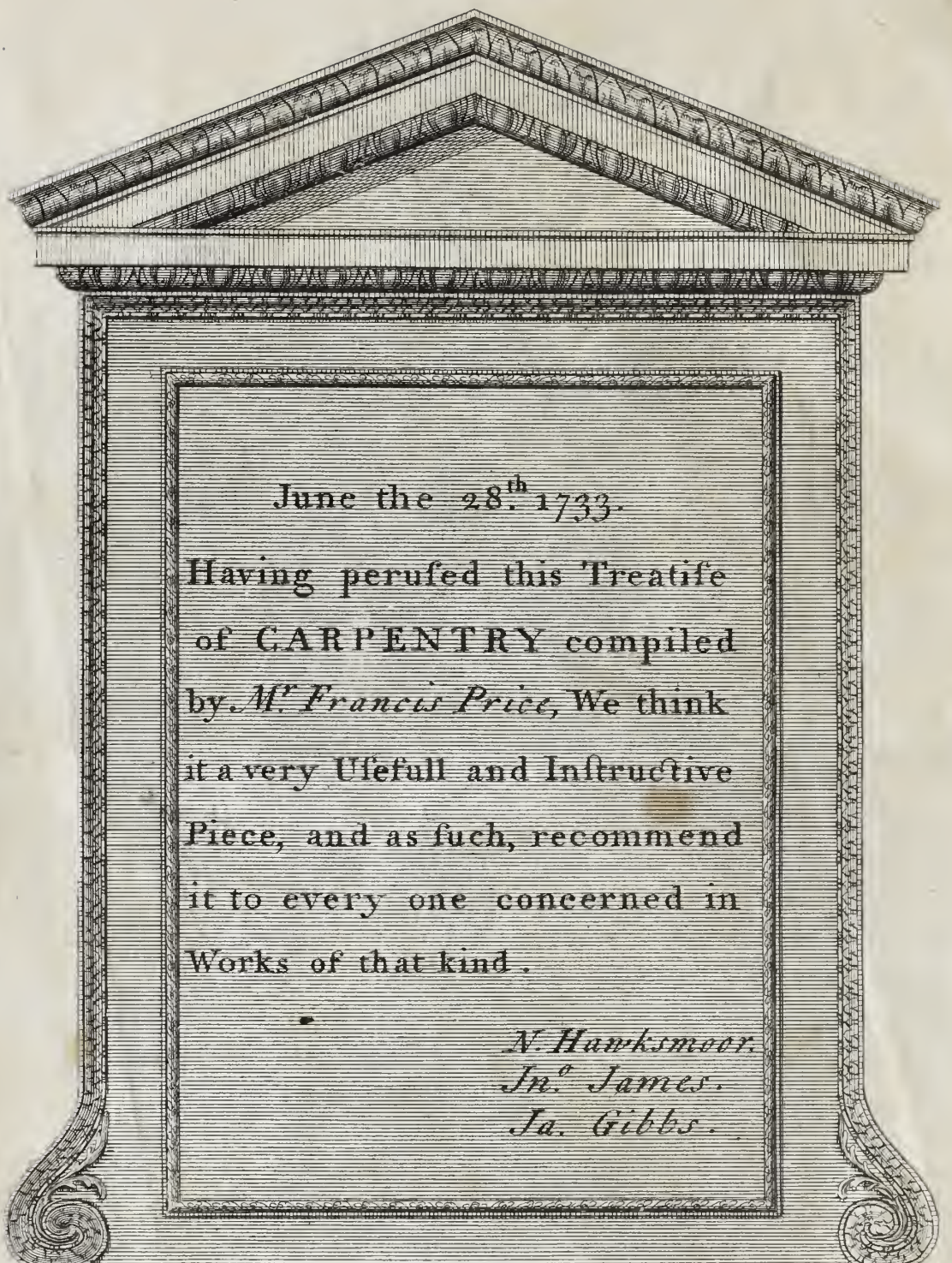

June the 28.th 1733.

Having perused this Treatise
of **CARPENTRY** compiled
by *M^r Francis Price*, We think
it a very Usefull and Instructive
Piece, and as such, recommend
it to every one concerned in
Works of that kind.

*N. Hawksmoor.
Jn.^o James.
Ja. Gibbs.*

BRITISH CARPENTER:

OR, A

TREATISE

ON

CARPENTRY.

Containing the most concise and authentick

RULES of that ART,

In a more

Useful and Extensive METHOD, than has been
made Publick.

The SECOND EDITION *enlarged, with an Addition of*
Sixteen COPPER-PLATES.

By *FRANCIS PRICE.*

LONDON: Printed by C. ACKERS in *St. John's-Street*;

And Sold by the AUTHOR, in *Mount-Street*, near *Grosvenor-Square*; also
by A. BETTESWORTH and C. HITCH at the *Red-Lion* in *Pater-*
Noster-Row; and T. ASTLEY at the *Rose* in *St. Paul's Church-Yard.*

MDCCLXXXV.





TO THE
RIGHT HONOURABLE
ALGERNON,
Earl of *Hertford*, Baron *Percy*, &c.

My LORD,



OUR natural Inclination to encourage Arts, makes me presume to lay this Treatise of CARPENTRY, at your Lordship's Feet; hoping it not unworthy your Patronage, since it's a Part belonging to Architecture. As this Branch of Building has never been usefully treated of, I have endeavour'd to explain

D E D I C A T I O N.

explain it so as to render it useful : Therefore nothing more is wanting to recommend it to the World, and secure it from Malice and Envy, but the Protection of so Noble and Worthy a Patron. I am, with the greatest Respect,

My LORD,

Your Lordship's

Most Obedient,

And Dutiful Servant,

FRANCIS PRICE.



T O T H E

R E A D E R .



THE Recommendation which I obtain'd to my first Labours, and the kind Reception it thereby met with from the Publick, caused me to go through this Subject again.

Having been importuned by many to add somewhat more thereto, whenever a Second Edition should be required, therefore to oblige such, as well as the Publick in general, I have seriously perused the first Impression, to which are herein added many Things particularly useful; and that the whole might be made worthy its Recommendation, no Pains has been spared.

Note,

Note, *As great Care has been taken to insert such Things only as have been experienced; therefore it may be presumed I shall give no Offence, by calling this Second Edition, The BRITISH CARPENTER.*

N. B. *I have so compiled the Additions, that whoever purchased the first Impression, may joyn them thereto without Injury.*





INTRODUCTION.



All Buildings are composed of three principal Parts, viz. Strength, Use, and Beauty, therefore CARPENTRY naturally comes in among the Essential Heads of Architecture. It is an Art that has been taken Notice of, by all the most famous Architects; therefore these and the like Circumstances, prompted me to compile the most approv'd Methods of connecting Timber together, for most of the various Uses in Buildings, with the Rules necessary to be observed therein; but when I considered such a Treatise might not give a sufficient Variety, therefore it appeared necessary to add several other Things appertaining to the Art, in order to make the whole particularly useful.

I have used my utmost Endeavours to render this Treatise not only intelligible to Carpenters, but at the same Time to be of Use to the ingenious Theorist in Building; and have digested it in such a Manner as to need little or no Explanation, otherways than carefully inspecting the PLATES.

*Nevertheless it may not be improper, in this Place, to mention some general Observations. There is a Moisture in all Timber; therefore all Bearing-Timber ought to have a moderate Camber, or Roundness: For 'till that Moisture is in some sort dry'd out, the said Timber will sag with its own Weight; and that chiefly is the Reason, Girders are trussed and used, as in its Place will be shewn. But here observe that Girders are best trussed when they are first sawn out, for by their Drying and Shrink-
ing, it tightens the Trusses in them yet more.*

*Observe also, that all Beams, or Ties, be cut, or forced in Framing, to a Camber, or Roundness, such as an Inch in the Length of
eighteen*

INTRODUCTION.

eighteen Feet; and that principal Rafters be also cut, or forced up to a Camber, or Roundness, as before: The Reason of this is, all Trusses, though ever so well framed, by the Shrinking of the Timber, and Weight of the Covering, will sag, and sometimes so much as to offend the Eye of the Beholder; so that by this Preparation your Truss will ever appear well.

Also observe, that all Case-Bays, either in Floors or Roofs, do not exceed twelve Feet if possible; that is, do not let your Joists in Floors, your Purloins in Roofs, &c. exceed twelve Feet in their Length, or Bearing; but rather let the Bearing be eight, nine, or ten Feet; which should be observ'd in forming a Plan.

Also in Bridging-Floors, do not place your Binding or Strong-Joists above three, four or five Feet a-part; and that your Bridgings or Common-Joists are not above ten or twelve Inches a-part, that is, between one Joist and the other.

Here also observe, never to make double Tenants or Tenons for Bearing Uses, such as Binding-Joists, Common-Joists or Purloins; for, in the first place, it weakens very much whatever you frame it into; and, in the second place, it is a Rarity to have a Draught in both Tenons, that is, to draw your Joint close by the Pin; for the said Pin, by passing through both Tenons, (if there is a Draught to each,) must bend so much, that without the Pin be as tough as Wire, it must needs break in driving, and consequently do more hurt than good.

I hope these Observations will not be ill taken, my Meaning being to make such only as are of general Use.

N. B. All the PLATES mark'd thus *, are to shew, that at my first compiling this Treatise, I intended no more than those without the said Mark; but since, receiving better Encouragement than I could at first expect, I conceived it necessary to joyn those PLATES to render the Whole complete.



T H E

C O N T E N T S.

PLATE	PAGE
A , Useful Propositions in Geometry	1, 2, 3, 4, 5
B , Scarfing or Tabling of Timber together, with the Manner of trussing Girders	6
C , Joggles or Butments for Trusses, with a Method for the Bigness of Mortices or Tenons, for different Uses	7
C* D* , Necessary Cautions in framing Floors, with the different Methods to be used therein	8
D , Pope's Method to form Hipt Roofs	9
E , A Rule whereby to reduce Bevel Roofs to square Workmanship	10
E* F* , Rules to find the Back of any Hip, or Rafter, &c. whatever, so the Plan, and Roof be composed of straight Lines	11
F , To lay a square Roof in Ledgment as framed	12
F* G* , To lay a Bevel Roof in Ledgment as framed	13
F* G* G* , The Manner of preparing the Ceiling Floor of a Building, in such a Manner as to embrace every Part with the Roof	14
G , Sections or Profiles of Roofs, whose Height or Pitch, is made agreeable to the Covering proposed to be used	15
H , Other Sections, whose Pitch or Slope varies by another Method	16
I , Trusses for Roofs suited to many Uses, but chiefly for Theaters	17
I* K* , Trusses for Roofs whose Tye may be interrupted	18
K , Trusses, whose Tyes are interrupted, and are applicable for Saloons, Chapels, &c.	19
L , The Sections of Roofs, whose Rafters are interrupted, (i. e. M. Roofs,) also an Example of a Truss extending beyond the Walls	20
M , Trusses of Roofs suitable to Churches, Chapels, &c.	21

The CONTENTS.

PLATE

PAGE

M* N*, Trusses of a great Extent, compared with some that were taken from noted Buildings	22
N, Various Trusses fitted for Partitions, with the Manner of Timber Fronts	23
N* O*, The Plan, Elevation or Truss, and Section of a flat Timber Bridge	24
N* O**, Trusses of Timber Bridges, in form of an Arch	25
N* O***, The Trusses of a moveable Timber Bridge, in form of an Arch	26
N* O****, The Particulars of a Timber Bridge performed with Piles	27
O, Rules to frame a Neich or Dome, or such Roofs as are Circular	28
O* P*, The Section or Profile, with part of the Plan of a large Dome	29
O* P**, The Section of the Dome of St. Paul's, with part of its Plan	30
P, Particular Observations in Curvilinear Roofs, with the Method of backing their Hips, &c.	31
P* Q*, Trusses of Curvilinear Roofs of a great Extent	32
P* Q**, The Formation of Spires or Steeples, with useful Remarks	33
P* Q***, The total Form of Spires, with their particular Dependants	34
Q, The Method and Rule of centering for Vaults, with Groins	35
R, Other Methods, with a Rule to find the Curvilinear Face or Form thereof	36
R* S*, The Construction and Force of Arches, with Variety of Plans and Sections of Groins	37
S, Examples for finding the Curvilinear Face of any Cove, Sphere, &c. with the Manner of Feneering a Neich, or ribing it for Plaistering	38
S* T*, Rules of Tracery, with select Examples in many Cases	39, 40, 41
T, The Plan of a Dogleg, and Open Newel Stair-case, with Observations con- cerning the Formation thereof	42
T* U*, Variety of Plans of Stair-cases, with Remarks	43
V, The Rule to be observed, in forming a proper Ramp, and kneeling to the Hand-rail of Stair-cases, &c.	44
U* W*, Sections, or Profiles of some of the foregoing Plans, shewing the Use and Necessity of their being described	45
W, A Rule for forming a Scrole, proper for the Plan of a twisted Rail	46
X, An infallible Rule for accounting for, and squaring any twisted Rail what- ever	47
X* Y*, A Rule for humouring the Grain of the Wood, in a twisted Rail, with other Methods for squaring the twisted Part	48
Y, A Rule to find the Length of the Newel and Ballusters that stand under the Twist, without putting the Rail in its Position	49
Z, A Rule for squaring a Rail that Ramps on a circular Plan, also a Method for making the Newel that stands under the Twist, of the same Length with the rest	50
A Table of the Scantlings of Timber, proper to be used in any Fabrick, great or small, in all the Variety of Cases	51
Remarks on the said Table, shewing its Use, &c.	52

PLATE

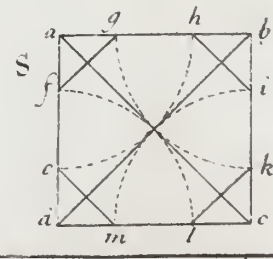
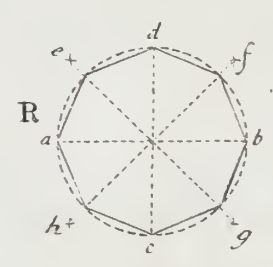
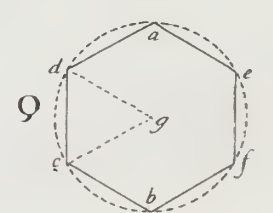
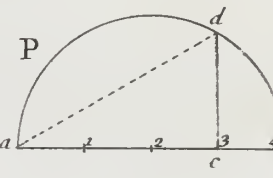
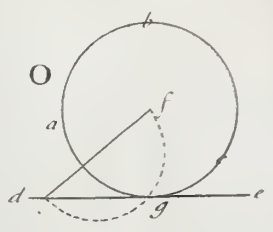
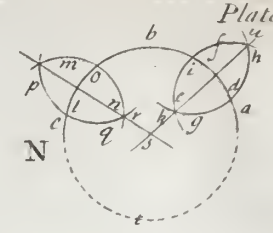
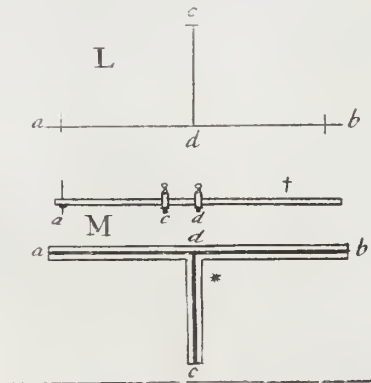
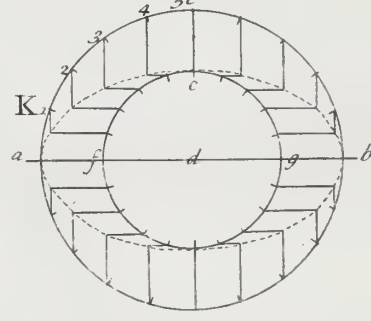
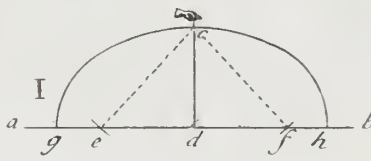
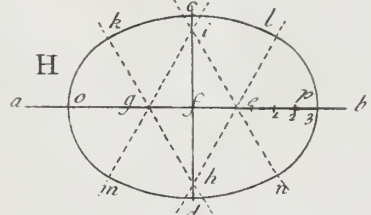
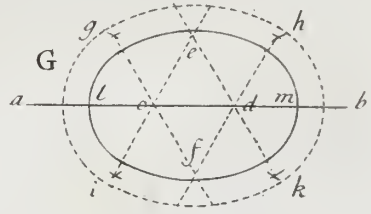
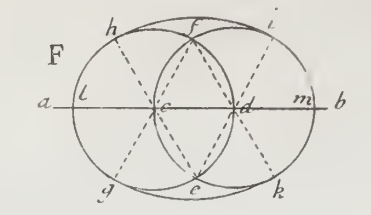
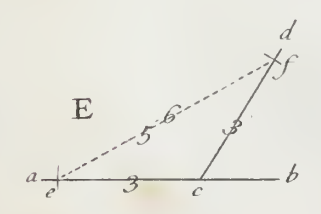
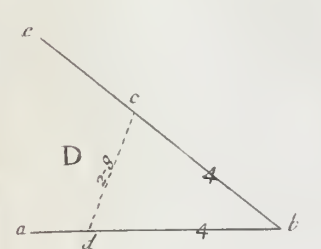
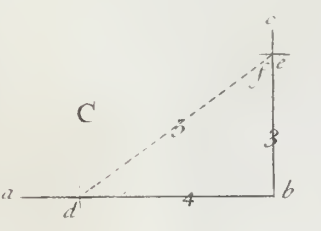
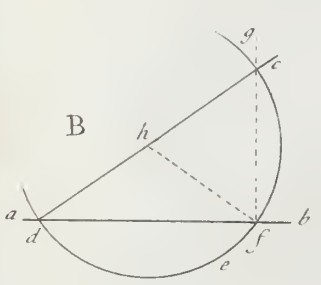
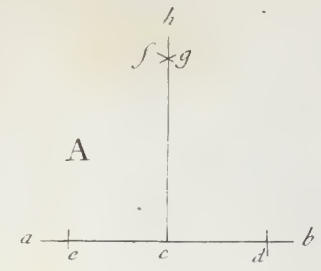



S none of the following Branches of Carpentry can be truly performed without some Knowledge of Geometry, I therefore begin with a few useful Propositions, and such only as seem necessary to render the understanding of this Treatise more familiar.

PROP. A. *To erect a Perpendicular on a Right Line given.*

Let a, b , be the Line. At the Point c , place one Foot of your Compasses, with which, being opened at Pleasure, make the two Touches e , and d . Open your Compasses yet wider; set one Foot in d , make the Section g ; place one Foot in e , make the Section f . Lastly, from the Point c , and through the Intersection of f , and g , draw the Line c, h ; which is perpendicular to the Line a, b , that was given.

PROP. B. *To erect a Perpendicular at the End of a Line.*

Let a, b , be the Line, and f , a Point given; take your Compasses, place one Foot in f , the other at Pleasure, as in h . Remove that Foot from f , to a Part of the Base it cuts, as in d . Draw a Line through those two Points d , and h , long enough. Lastly, with your Compasses describe the Arch d, e, g , from the Point h ; observe where it cuts the slope Line, as at c , and draw the Line from the Point f , and through the Intersection, as at c ; which is perpendicular to the Base given.

PROP. C. *To erect a Perpendicular at the End of a Line, another Way.*

Let a, b , be the Line, and b , its Point given, or End. With a five-foot Rod set off from b , to d , four Feet, and from b , to e , three Feet. Lastly, from d , to e , set off five Feet. At the Intersection of e , and f , and to the Point b , draw the Line b, c ; which is perpendicular to the Line given. This is useful to every one concern'd in Building; and may be done by eight Feet, six Feet, and ten Feet; or by sixteen Feet, twelve Feet, and twenty Feet, each being proved by what Geometricians call the Powers

of Numbers; and is thus: Four Times four is sixteen, and three Times three is nine, which added together makes twenty five; and so is five Times five, twenty five; that is, the Squares of the Base and Perpendicular, of all Right-angled Triangles, added together, are equal to the Square of the Hypotheneuse.

PROP. D. *An acute Angle being given, to take the same.*

Let a, b, be a Line given, and b, e, the Line that makes the Angle. Then take from your Scale the Length of four Feet, and place it on the Line a, b, at d, and on b, e, at c. Then take the Distance between those two Points d, c, which here suppose two Feet eight Inches. This Method will take the Angle.

PROP. E. *An obtuse Angle being given, to take it.*

Let a, b, be some Line, and c, d, the Line making the Angle. From c, place three Feet, as at e; also from c, place three Feet, as at f. Lastly, from e, to f, take the Distance, which here is five Feet six Inches.

PROP. F. *To describe an Oval to a Length given.*

On a Line, as a, b, place the Length l, m; divide it into three equal Parts; with one, as c, d, make the two Circles; their Intersections give the Place of the Curves Meeting, and also the Centers, by which describe the Oval g, h, i, k.

PROP. G. *To describe an Oval to a Length or Width given.*

On a Line, as a, b, make two Equilateral Triangles, not exceeding the Width of the Oval, as c, d, e, and c, d, f, whose Sides continued give the Centers and Places of the Sections Meeting, so that you may describe an Oval to either the Length or Width, as g, h, i, k.

PROP. H. *To describe an Oval to any Length or Width given.*

On a Line, as a, b, limit your Length, as o, p; also your Width, as c, d. Take the Width c, d, in your Compasses; place one Foot in o, observe how far it cuts on the Base, as at e; divide the Distance from e, to p, into three equal Parts; with two of them, placed on each Side the Center f, make two Equilateral Triangles, as g, e, i, and g, e, h; whose Sides being continued,
give

give the Centers and Places of the Sections Meeting, by which you describe the Oval *k, l, m, n*. This is of general Use; but more particularly to Masons, and Bricklayers, for in Arches thus describ'd they have Occasion but for two Moulds.

PROP. I. *To describe an Oval to any Length and Width, by another Method.*

On some Line, as *a, b*, limit the Length of your Oval, as *g, h*; also limit your half Width (or Height) *d, c*. Take half the Length, as *g, d*; in *c*, place one End of your Length; observe where that Length *g, d*, cuts the Base, as in *e*, or *f*; drive a Nail in each Point: Then with a String you may describe the Oval desired.

PROP. K. *To describe an Oval by the Meeting of Lines.*

On some Line, as *a, b*, make a Circle the Length of your Oval, as *a, e, b*; also make a Circle the Width of your Oval, as *f, c, g*; divide either into a Number of equal Parts, as here into twenty; lay a streight Rule from the Center to each of these Parts; let it touch the Periphery of the other Circle, by which it is divided into twenty Parts also. Draw Lines parallel to the Base, from the Circle for the Width; and also, Perpendiculars from those Divisions on the Circle for the Length. The Meeting of them forms a compleat Oval, as *a, c, b*.

PROP. L. *To describe an Oval more particularly useful than any of the foregoing Methods, with a Trammel.*

Let *a, b*, represent the Length of an Ellipsis or Oval, and *d, c*, half the Width or Height of the same Ellipsis or Oval.

Let the Form of the Trammel be Fig. M.

Let † be the Rod of a Trammel, and * the Groove or Stock of the same: Take the Groove *, and fix the Middle thereof, as *a, b*, on the Base Line given in *L*; also observe that the Groove *d, c*, in *, be over the Line *d, c*, in *L*. Lastly, having two Pieces like the Head of a Gage to slip on †, and fasten at Pleasure, the Bottom of which is made a Pin, the exact Bigness of the Groove in *, on †, let *a*, be a Pencil fix'd; take

the Half Width of your Oval in L, as c, d, and place the moving Head c, †, to the same Distance, as a, c; take also your Half Length from L, as a, d; which place from a, the Pencil in †, to d, the other moving Head, as a, d; each being fix'd, move the Rod †, in the Groove*: So will the Pencil a, form the true Curve desired. An Ellipsis so form'd, is agreeable to a Circle in any Position: Such as Groins, or Angle Brackets, without Tracing.

PROP. N. *Part of a Circle being given, to form the Whole.*

Let a, b, c, be Part of the Circle given. With your Compasses opened at Pleasure, place one Foot on the Curve given in d; describe the Section e, f. Place one Foot, as in i; describe the Section g, h. Remove your Compasses, place one Foot in l, describe the Section m, n; place one Foot in o, describe the Section p, q. Lastly, through the Intersections draw the Lines k, u, and r, p, that meet in s; it is the Center by which you may describe the Circle. This seldom falls out to be used, but is in Fact the same as bringing three Points given, which are not in a right Line, into a Circle.

PROP. O. *A Circle and Tangent Line given, to know its Point of Contact or Touch.*

Let a, b, c, be the Circle given, and d, e, the said Tangent Line. From the Center f, to any Part of the Tangent Line, draw a Line at Pleasure; on which Line form a Semi-Circle to its Extent, and observe where it passes through both, as at g; for that is the Point of Contact or Touch.

PROP. P. *Shewing how to increase or decrease a Scale to any Proportion desired.*

Let a, b, represent one Foot or ten Feet of a Scale by which a Drawing has been perform'd: Let the same Drawing be demanded to be contracted, so as to contain one Fourth, or one Half, or three Fourths of the same Bigness in its Superficies. If three Fourths, divide the Line a, b, into four equal Parts, and at 3 raise the Perpendicular c, d; observe where it passes through the Circle first made on the Line: So from a, to d, is a Scale of
one

one Foot, or ten Feet, which will be in the Proportion desired; and from d, to b, will be a Scale one fourth as big; that is, your Drawing, when perform'd by either of these Scales, will be in the Proportion propos'd.

PROP. Q. *To divide a Circle into six equal Parts, or any Number in Progression generated by six.*

Let a, f, c, be the Circle given; its Radius, or Semi-Diameter, g c, or g d, will divide it into six equal Parts, as d, a, e, f, b, c; by subdividing each into two, you have it in twelve; if into three, eighteen; if into four, then your Circle will be in twenty four; and so on.

PROP. R. *To divide a Circle into eight Parts, or any Number in Progression generated by eight.*

Let a, b, c, d, be a Circle given to be divided into eight equal Parts. First draw the Diameter through the Center, as a, b; at Right Angles draw the Diameter c, d, also through the Center; that divides the Circle into four equal Parts; then by subdividing each into two, your Circle is divided into eight equal Parts, a, e, d, f, b, g, c, h; by subdividing each again into two, you divide the Circle into sixteen equal Parts; and if again into two, then your Circle will be in thirty two equal Parts; and so on.

PROP. S. *To form an Octagon within a Geometrical Square.*

Let a, b, c, d, be the Square given. Draw the diagonal Line a, c, also the Diagonal b, d; place one Foot of your Compasses, or, if required, one End of a Rod, in a; make the Section e, h, with half the Diagonal, and remove to b; make the Section g, k; then remove to c; make the Section m, i; remove to d; make the Section f, l. Lastly, draw Lines from f, to g; and from h, to i; and from k, to l; and from m, to e; so is e, f, g, h, i, k, l, m, the Octagon required. And this is so useful, that every Artificer in Building ought to be acquainted with it.



BECAUSE it is useful, I have shewn the Manner of Scarfing, or Piercing of Timber together.

In a, and b, are shewn Joynts for Plates, Lintels, or Timber for Tyes; and if for Beams, add the Bolts, as represented in the Figures.

Where more Strength is required, see c, d, e, f; which last may be done without wasting any of the Length of your Timber; that of d, is suited for an extraordinary Use; for by its being in two Thicknesses, it may be made as strong in a Manner as tho' in one Piece. I do not propose to limit the Length of these Joynts, but only to shew their Form of being framed or fabled together.

In g, h, i, is shewn the Manner of Trussing Girders that are to bear above twenty four Feet.

First, cut out two Pieces of Timber, which together make the Scantling proposed, with some good, dry, and strait-grain'd *English* Oak, of four Inches by three, or six Inches by four, as the Nature of the Thing shall require. Let half into one Piece, as in g, at l, m, n, as tight End-ways as it's possible to drive them in; then cut a Vacancy in the other Half, as h, which shall also drive on that of h, as tight End-ways at l, and m, as it's possible; lastly, bolt them together, as is shewn above, and they are fit for Use.

In i, is yet a stronger Method, because it divides the Bearing into three equal Parts.

As before, let in the Pieces o, p, q, r; and at the Foot of o, and r, you may mortice through both Fitches, by which you may with a Wedge, tighten the said Girders, when the Building is cover'd in, which Conveniency is worthy of the strictest Regard, and requires to be well perform'd.

In k, is the Way proposed or taught by *Leon Baptist Alberti*. Take two Pieces or Fitches, being well dried, and turn the But-End of the one, to the Top-End of the other without Trussing at all, and bolt, or screw them together; the short Lines, at the Ends of the Truss, represent the Walls to bear them when done.

In the lower Part of the Plate, is shewn how Timber may be used, that is not long enough, and must be camber'd at w, x, y; that is, each of the Pieces t, u, and s, as is shewn by z, z.

Plate B.

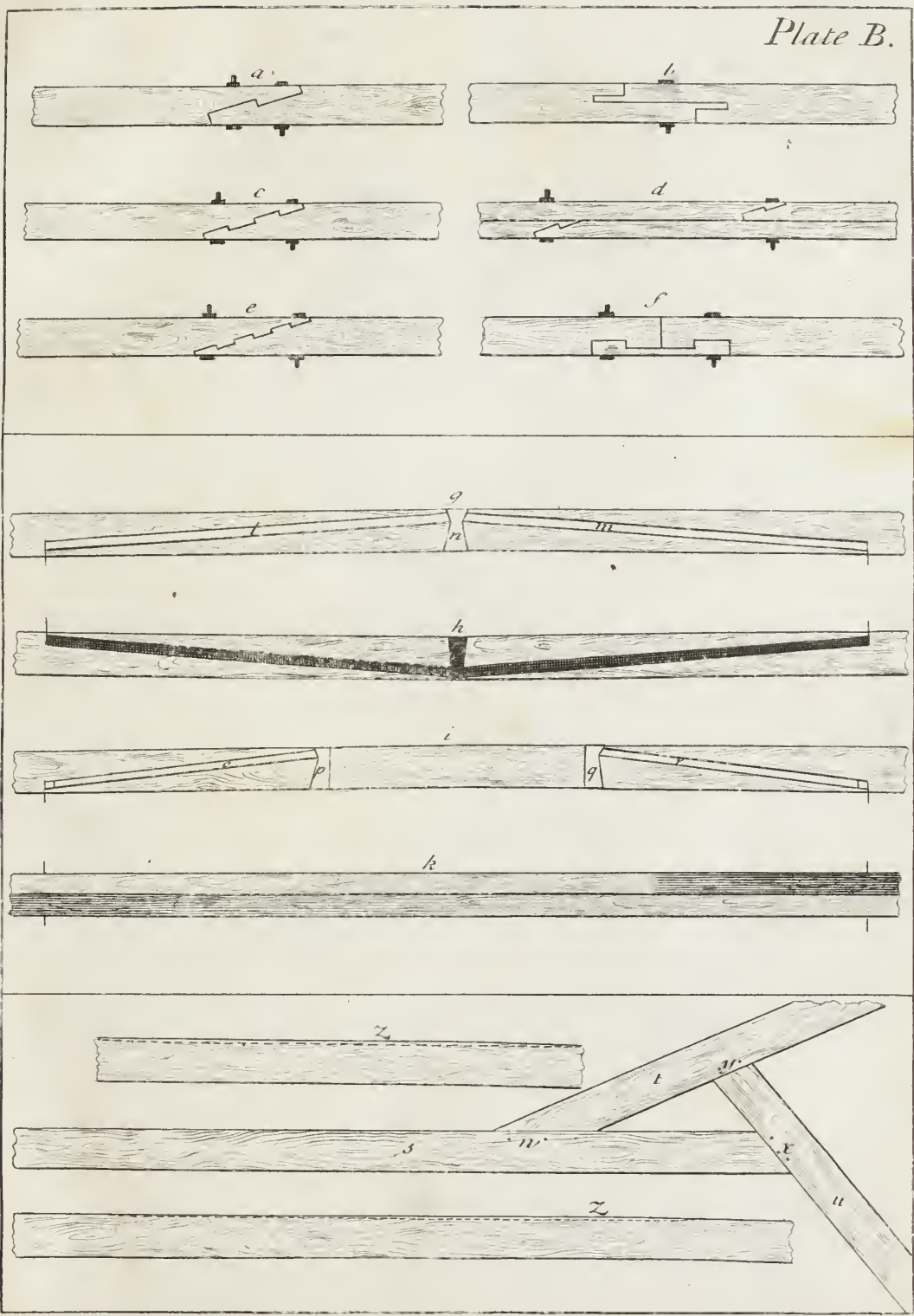

Toms sculp.

Plate C.

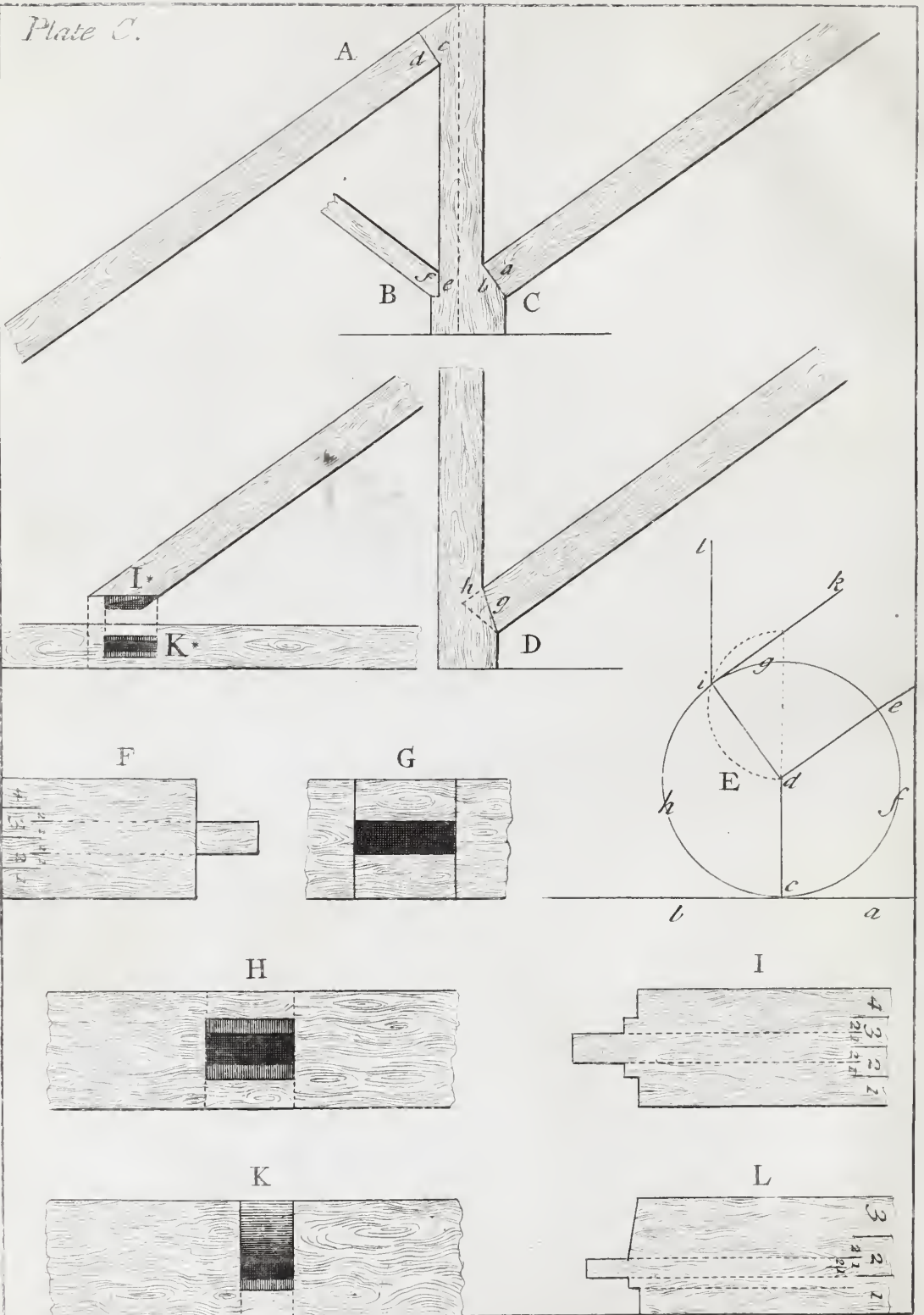



CONSIDERING how useful the Way of framing Timber together may be, to some of my Readers, I hope this Plate may not be unseasonably applyed, since none of the following Parts can be perform'd without a just Knowledge of it.

At A, is the Joynt of a principal Rafter, as d ; fram'd into the Top of a King Post, as c ; and is generally framed as F, G.

At B, is the Joynt of a Strut or Brace, as f, fram'd into the Bottom of a King Post, as e ; and may be framed as F, G: This is when Timber is scanty ; or else the best Way is at C, because a square Joynt takes the full Force of the Weight ; let b, be the King Post, and a, the Strut or Brace, and framed as F, G.

In D, is shewn a different Manner, for Variety, and may be framed as H, I ; because then the Butment on the Side of the Tenon may be cut, as the prick'd Line h ; tho' the Joynt next the Eye, be as appears at g.

In E, is shewn a true Way to make a proper Joggle on a King Post, &c. Let a, b, represent the Top of a Beam, and c, d, the Bigness of a Brace, to be used ; with c, d, form a Circle as h, g, f ; from the Point d, set the Slope of the Brace, as d, e ; also its Bigness, as from i, to d, and from k, to e ; by PROPOSITION O, find the Point of Touch, i ; so is i, l, the Side of the King Post.

Let K *, represent a Beam, and I *, a principal Rafter : It is to be framed as H I ; for then the Butments give it a greater Strength.

In F, and G, is shewn the Proportion a Tenon or Mortice ought to bear to the Stuff to be made use of, for the aforesaid Uses, or for Partitions.

In H, and I, is the Proportion for the Tenon or Mortice for the Use observ'd above.

In K, and L, is shewn the Proportion the Tenons and Mortices of Floors ought to bear to the Depth of the Stuff to be used ; and here it may not be amiss to observe, that I do not insist it ought to be exactly so, but at the same Time, the nearer the better.



CONSIDERING Difficulties often arise, from placing Timber different Ways, it is necessary to observe how they are to lie, and also how they shall be framed.

Therefore, here is the Plan of a House; in which is shewn, by the pricked Lines, the best Way of placing your principal Timbers, so as to lie firm, that is, not to lay them over Doors or Windows, nor too near Chimneys, and at the same Time to have the Boards lie all one Way, which is generally the Way that you have the best Vistoe; as M*, N*, O*.

Because I would not confuse the Plan, by shewing the Manner in which the Floors are to be framed, therefore observe the Floors of three Rooms; as P*, Q*, R*.

That of Q*, is call'd Bridging Floors, as being framed with a Binding, or strong Joist, in every three or four Feet Distance, and flush to the Bottom of the Girder; so that when the House is cover'd in, you pin down your Bridgings thereon, and flush with the Top of your Girder: And this is the best Way of Carcase Flooring.

That of P*, and R*, may as well be framed flush to the Top of the Girders in each, and have every third or fourth Joist the Depth of the Girder, and those between more shallow.

In T*, is shewn the Manner of Bridging Floors; a, and b, representing the Ends of two binding Joists, on which is the Bridging, d, c; and into these Binding Joists, are fram'd the Cieling Joists, e, f, g.

In V*, is shewn two deep Joists of the other Floors, or common Way, as l, m; and also three shallow ones, as n, o, p; and also the Cieling Joist, q. And because these deep Joists, as well as Binding Joists, are so prepared as to put in the Cieling Joists, when the House is cover'd in, observe in S*, the supposed Side of either, with the Mortices for the said Cieling Joists; as h, a single Mortice, and i, k, double, or Pully Mortices, (as they are call'd.)

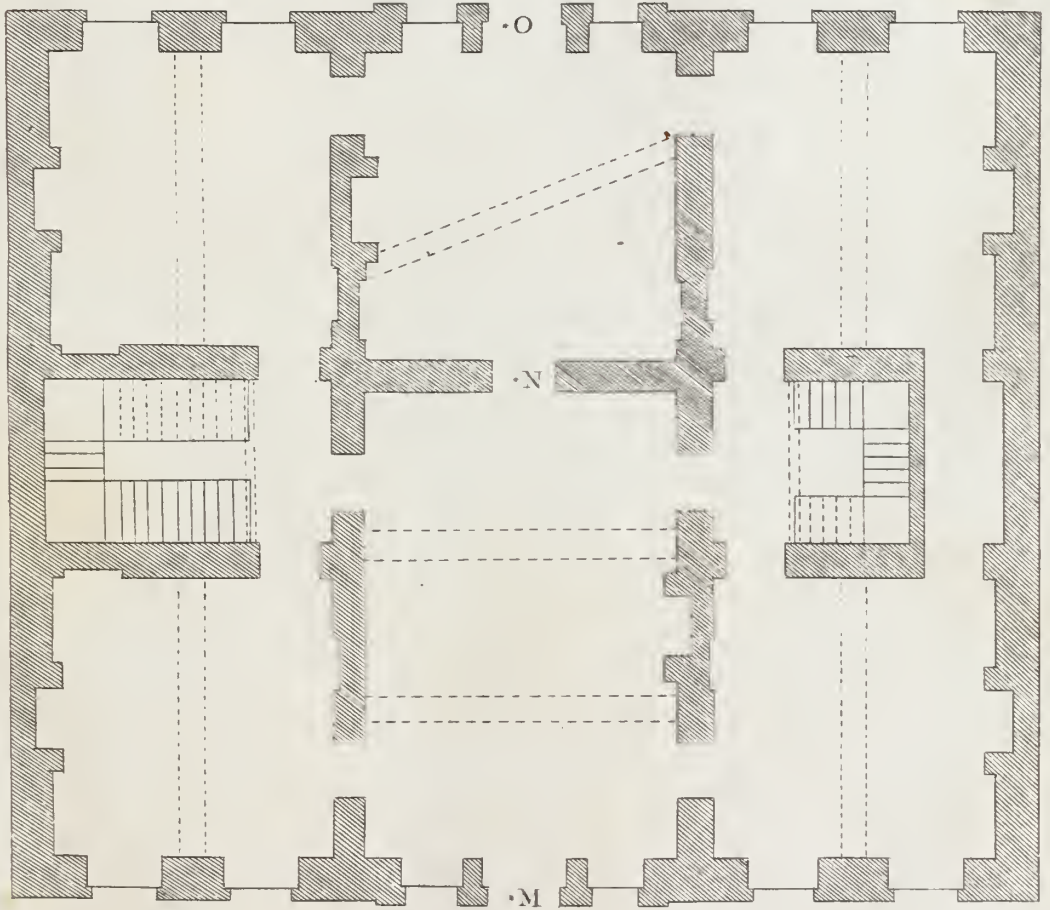
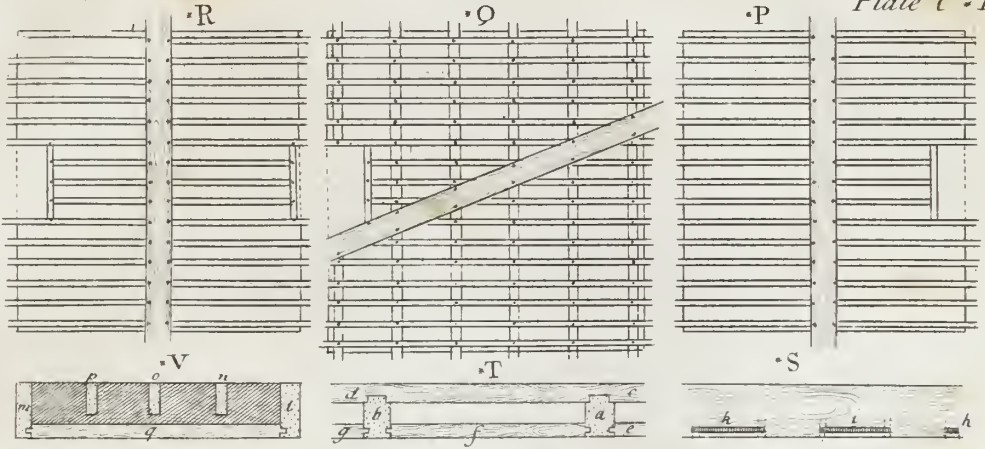



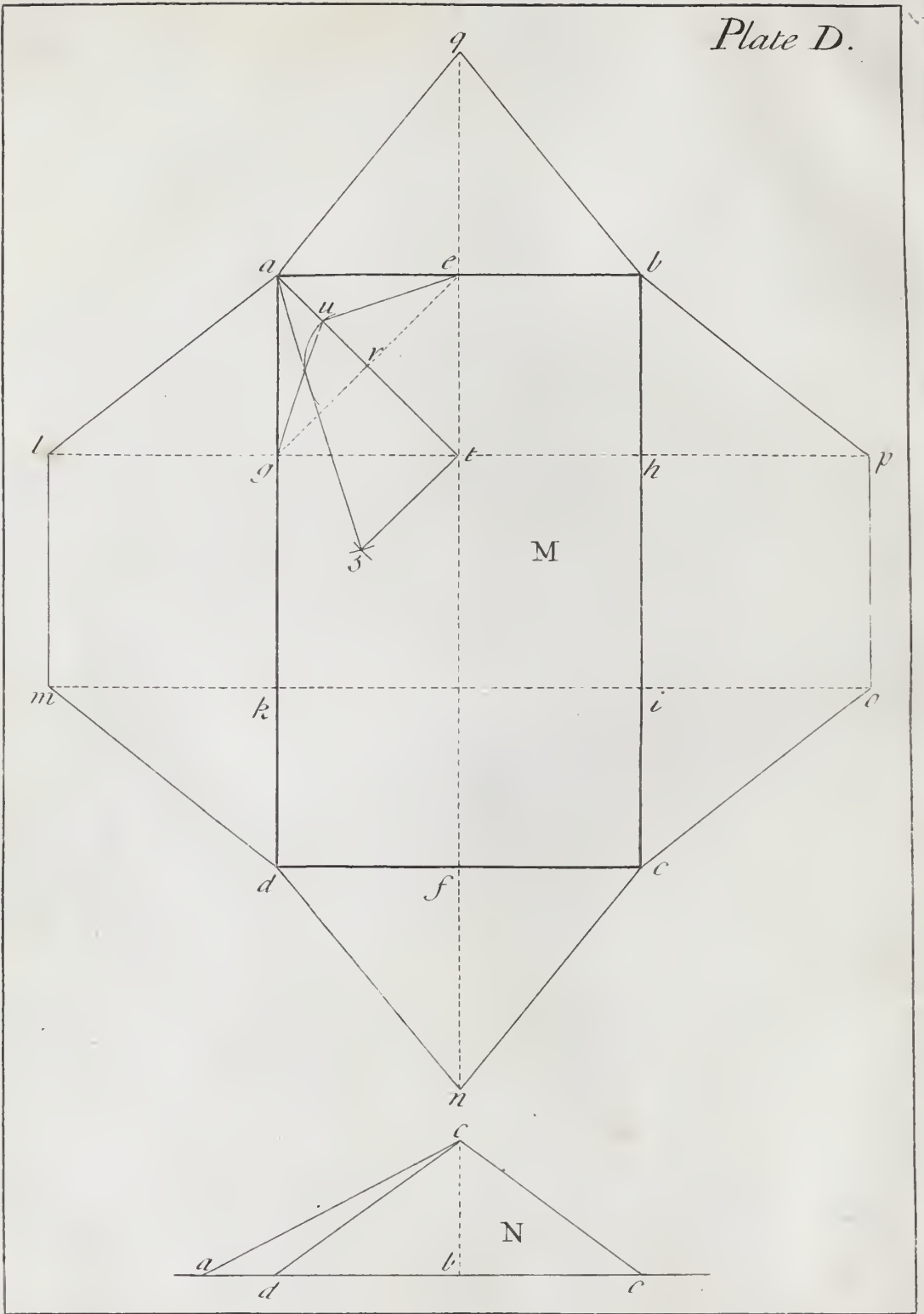



DIRECTLY after having shewn how Timber is to be framed together, it appear'd necessary to observe how Roofs are to be form'd, and in which I have us'd, with a little Variation, what is said to be Mr. *Pope's* Method.

Let M, be a Plan to be inclosed with a Hipp'd Roof. To find its Skirts; first, form some Slope, or Pitch, as at N, *which shall be better clear'd in the following Plates.*

Let a, b, c, d, be the Plan, which divide in two equal Parts, as e, f; draw that Line at pleasure, long enough; set the Distance of that middle Line, as from a, b, to g, h, which also draw long enough, at pleasure; again, set the same Distance off, as from c, d, to i, k, and draw that Line also at pleasure; this done, apply to N, where d, c, or c, c, each alike are the Length of the Rafter, which set off, as from e, to q; and from h, to p; and from i, to o; and from f, to n; and from k, to m; and from g, to l.

Apply to N, take the Length of the Hip a, c; which is found by taking the Base of the Hip in M, as a, t; and set it off in N, as from a, to b; which Length is the same as was given by limiting the Length of your Rafter on each prick'd Line; so that, your Skirt is a, q, b; and b, p, o, c; and c, n, d; and d, m, l, a.

To find the Back of the Hip. Make the Angle a, t, s, in M, from a, b, c, in N; draw the Line g, e; place one Foot of your Compasses in r; extend the other to the nearest Distance, it will touch the Hip a, s; with that Distance make a Section; observe where it cuts the Base, as in u; so that g, u, e, is the Back of that Hip.

This is the Method given by Mr. *Pope*, for either Square or Bevel Roofs, either above Pitch or under.



VERY Man may judge that Bevel Buildings ought to be avoided if possible; but as it frequently happens otherways, see the Plan O, whose Angles are unequal.

Let a, b, c, d , be the Angles of the Plan. First, take the Middle of it, as e, f ; with that Distance, draw from r , to e and square to the End a, b , draw through the Line g, h ; also place that Distance, from s , to f , and square from one End, as before, draw through, at pleasure, the Line i, k . This being done, shew some Pitch, or Slope, as in P, at h, r, g , which is the Pitch, or Slope; h, r , or g, r , being the Length of the Rafter terminate the same, as before.

Draw the Base of each Hip in the Plan O; as e, a , and e, b also f, c , and f, d ; which, being applyed to the Section P, shew the Length of each Hip: So that by this, or the foregoing Plate describe the Skirts, a, l, b ; and b, m, n, d ; and d, o, c ; and c, p, q, a . By Proposition B, draw the Line l, r, e , being the Rafter and Beam, each being square; as also that of o, s, f .

Thus by laying your Beams square, you have little Trouble more, than if your Building was square; otherways than having the Trouble to back each Hip separately; although here is only one shewn, the Rule being said to be general.

The Lines n, t , and t, f, u , and u, p , are only to shew the Trouble that attends laying the Beams bevel; the large Circles are only to shew the Hips equal in Length, one to its opposite.

To back the Hips, observe in the Plan O, a, e, q , is the Hip taken from P, as before; draw the Line r, g , place one Foot of the Compasses in u , extend the other Foot to the nearest Distance it touches the Hip a, q , which set on the Base, as at w ; so that r, w, g , is the Back of that Hip; and so of the rest, respectively

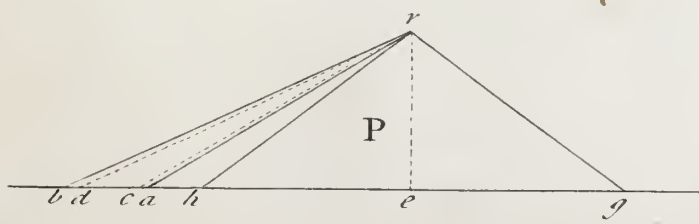
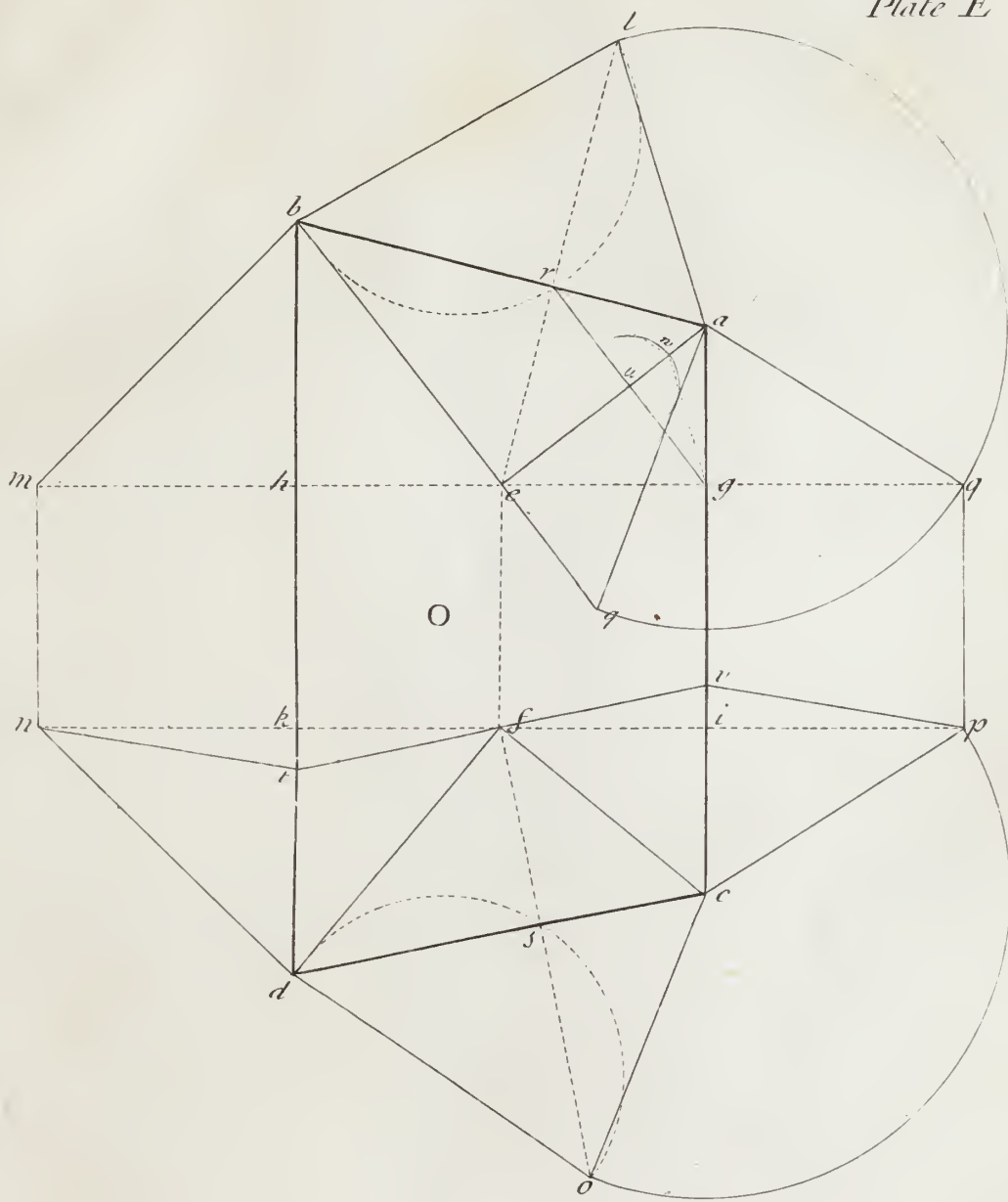

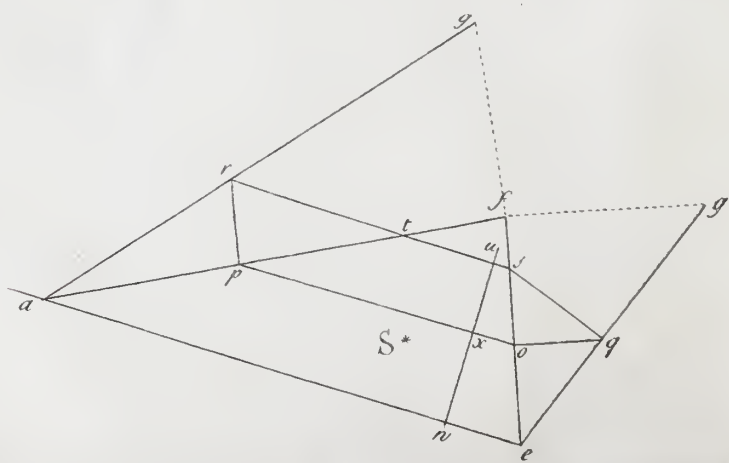
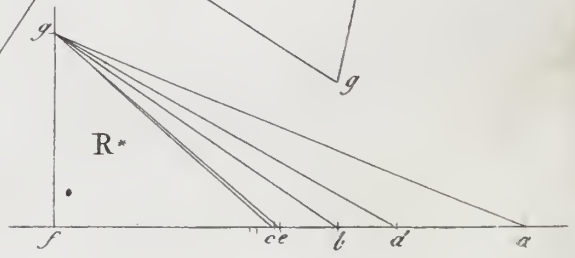
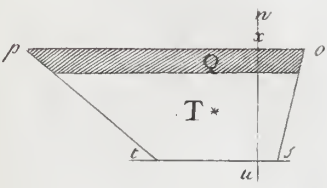
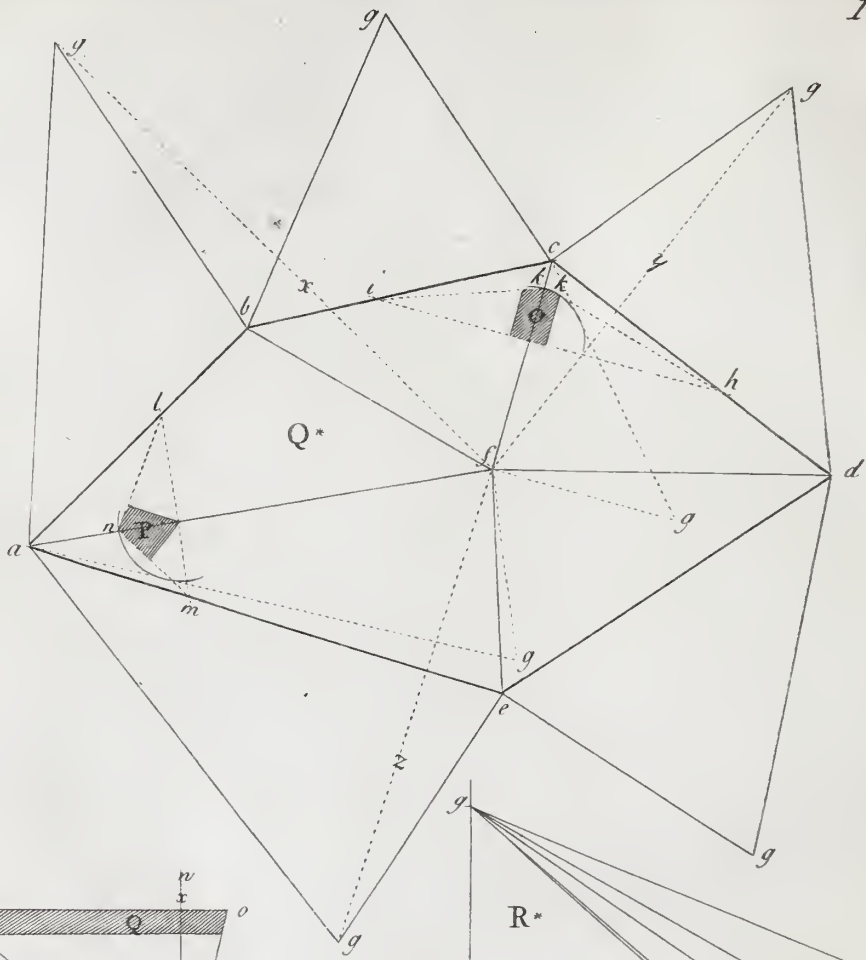



VERY Form of Bevel Roofs, may easily be conceived by this Plate, and left any Objections should be made to what I have hitherto said on this Head, I have therefore strictly considered the Nature of Hipt Roofs and their Dependents, and make no doubt of its meeting with a kind Reception.

Admit the Plan Q*, was required to be enclosed with a Hipt Roof; first find the Middle of it, as f; then draw the Bases of your several Hips, as a, f; b, f; c, f; d, f; and e, f, resolve on some Pitch or Height, as in R*, at f, g; to this Section bring all the Bases of your respective Hips, as the Letters of Reference shew; this gives you the Length of each respective Hip; therefore from this Section R*, you describe the Skirts round the Plan Q*, as a, b, g; and b, c, g; and c, d, g; and d, e, g; and e, a, g; which form the Roof required.

To find the Back of any Hip, do thus, draw a Line at pleasure, crossing the Base of the Hip at right Angles; as the Line h, i, which crosses the Base of the Hip c, f; observe where it passes through the Sides of the Plan; on the base Line of this Hip raise its Section, from R*, as c, g, f; Lastly, place one Foot of your Compasses in the Interfection, as at y; open the other Foot, till it touch the Hip c, g; at its nearest Distance, draw a small Section till it cross the Base as at k; so is h, k, k, i, the Back of that Hip; *and is the most exact, and easiest Method, that ever was delivered for this Purpose*; the shadowed Part O, is the Section of the supposed Timber the Hip is shaped out of, being cut off at right Angles with its Side and Back. What is said of this, explains the Hip a, f; whose Back is l, m, n; and its Section P, is shaped so as to have the Purlin come square against it; the Letters of Reference shew the rest.

To find the Side Joint of a Purlin, (in case the Hip be not shaped as above) so as to cut it by a Templet, supposing there be not room, or Occasion, to frame it into the Hip; for Example, take any two of the Hips from the Plan Q*, as e, f; and a, f; which to keep from Confusion is transfer'd as to S*, and admit the Plan of the Purlin to be o, p; first raise the Sections of the Hips from R*, as e, f, g; and a, f, g; as the Letters shew; then raise Perpendiculars at o, and p, to the Back of the Hips, as o, q, and p, r; Lastly, draw a Line from the Point q; and at right Angles from the Back of the Hip e, g; (as it is so near a Square; or else it should be drawn from the Back of a Rafter standing at right Angles with the Sides of the Plan;) observe where it cuts the Base as at s; draw also the Line s, t, parallel to the Purlin; Lastly, draw the Line t, r; from all which you take the Templet Q, in T*, in the following Manner. Draw the Line u, w, in S*, at right Angles from the Side a, e, which transfer to T*, as u, w; take from S* the Distances, u, s, and u, t, and transfer them to T*; take also the Distances x, o, and x, p, in S, and transfer them to T*; take also the Distances s, g; in S*, and transfer to T*, as s, o; Lastly, take from S*, the Distances, t, r; and transfer to T*, as t, p; so that Q, is the Templet to cut the Side, and the Skirt e, a, g, is the Templet to cut the Back. I think any farther Explanation needless, because by a little serious Inspection, the Reader may see that all the Lines necessary to be understood in a Roof, are contained in this Plate.

That is, all the Parts of a Roof, may be cut by Templets, as these Lines and the Explanation of them does direct; and although I have shewn but one Example for the cutting of any Purlin that comes against a Hip, as explained in h, k, i, I hope it will be sufficient, because the Method in l, m, n, cuts off all such Difficulties, *and is equally as strong*.

The Lines f, x, g, and f, y, g, and f, z, g, are only to shew the Position of the small Rafters, *viz.* to lie square from each respective Side, by which means one may cut the Stuff out square, and avoid the difficulty of cutting them bevel; which Caution may serve as a Rule, in case the principal Timbers be confined to lie bevel, or not at a right Angle from the Side.



OR Variety sake here is represented a Floor, and Roof, lying in Ledge-ment.

Every Man who frames Roofs, does first piece his Plates, cock or dovetail down his Beams on the said Plates, and prepare Pieces on which his Hips are to stand; as appears in this Plan Q, as at Y, Z.

Then he frames his Principals, as R; and likewise his Hips, as S, into the Pieces prepared for them to stand on: And although all these respectively are framed, for the generality, on the Floor, and which in Practice is the best Way, they are here placed by themselves, to avoid Confusion.

I hope the prick'd Lines are enough to shew that the Skirts, T, V, W, X, are laid out agreeable to the Plan Q; and in which are shewn that one Purlin lies above the Strut, and the other below it; for if all were to lie in a right Line, in the first Place, it cuts the Stuff to Pieces, so as to weaken it still more, and at the same Time, you loose your Pinning.

Here is shewn a Method to turn up your Hip most exactly true without Backing at all; and is thus: Your Hips being first framed into the Pieces they are to stand on, take a broad Board, or small Pannel; lay it on the Place where your respective Hip stands, and there mortise it as if it was your Beam; cut off the Corners of it; so as to make its Angles agreeable to your Plan, whether square or bevel; Lastly, when you come to turn up your Hip in framing the Skirts, slip this Mould, as Y, upon the Tenon at the Foot of your Hip, and there give it a Tack with a Nail; the Angles of that Board will turn up a Hip, as desired, and is far preferable to any other Method whatever.

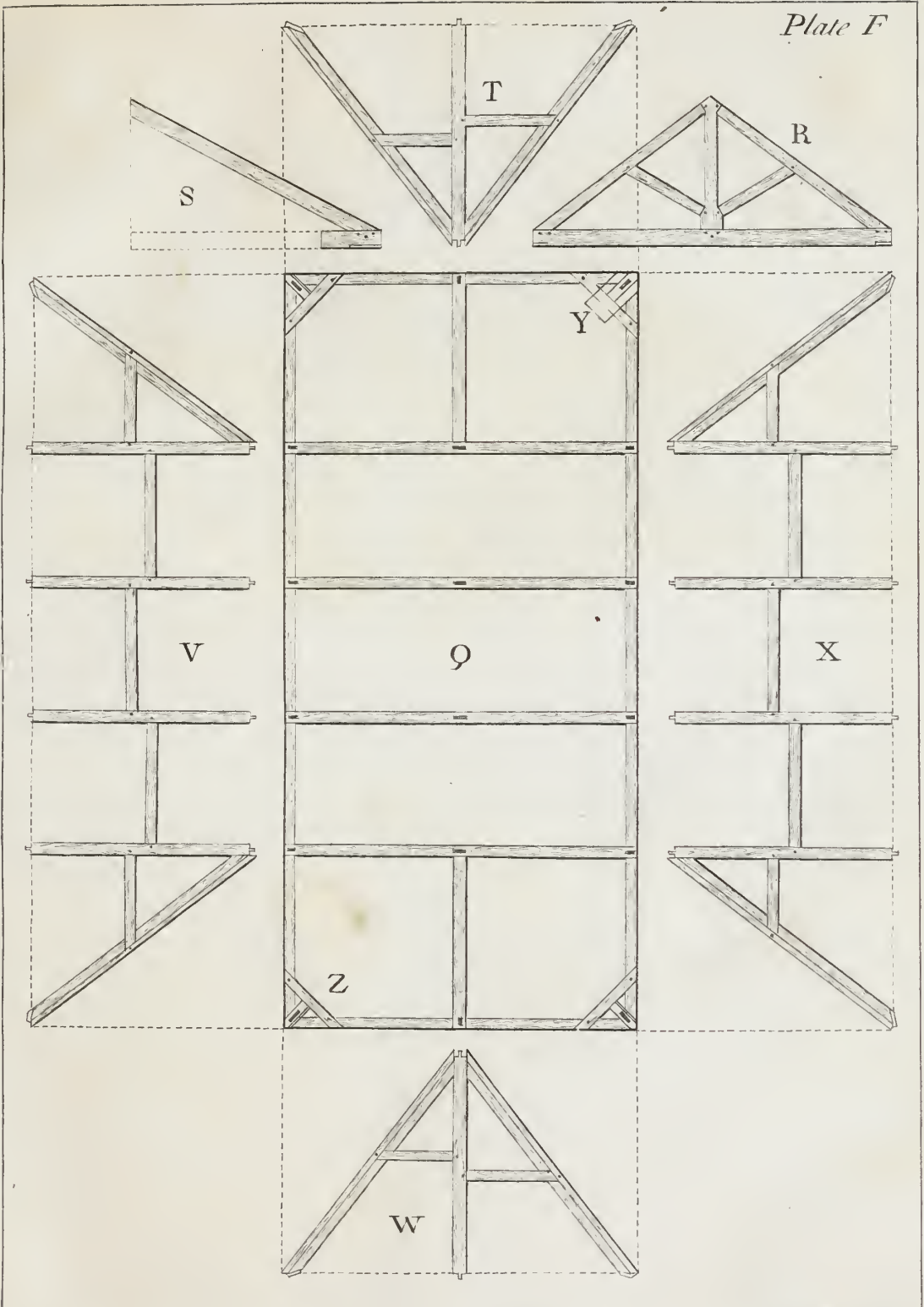



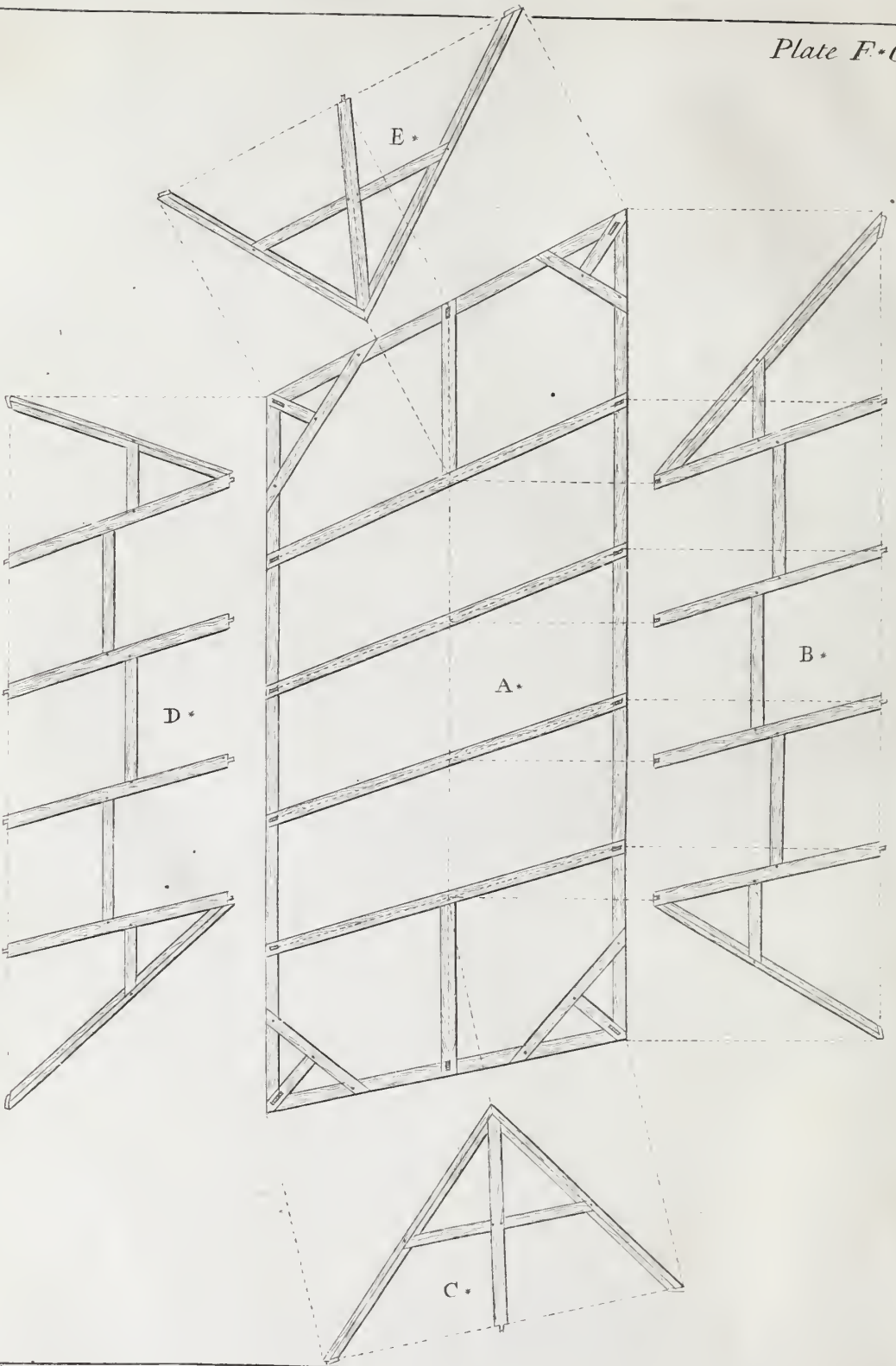



OR general Use, I did make myself intelligible in P L A T E E: My Meaning there being to shew how to avoid abundance of Trouble if possible: But because sometimes Buildings must be bevel, and Necessity requires the Beams to be laid so, to miss some Chimney or Window; therefore let A*, represent a bevel Plan, and whose Beams also lie bevel; I doubt not but the pricked Lines will shew how much each principal Rafter must lie bevel, at the Time of Framing; and that is, just as much as Half the Beam does, that the Rafter stands on; the Skirts B*, C*, D*, E*, are the same Way shewn, as before.

The Method described in P L A T E F, with being separately applied, will turn up each Hip, and also each principal Rafter.

I hope it will not be taken ill, my saying that a Man must be deprived of Sense, who would run into this almost endless Trouble, of cutting his Timbers all bevel, unless some unavoidable Necessity require it, such as above is observed, but rather use the Method, I proposed in P L A T E E.

The Sides with each principal Rafter, &c. and the pricked Line at the Foot thereof, is the Bevel of each Skirt respectively, as by the Skirts lying in Ledge may appear, if compared to the Bevel of the Plan.

In this, and all other such Difficulties that must be well understood before executed, I advise that a Model be cut out of a Piece of Wood, by a large Scale; or with slit Deal, form the Skirts, as has been shewn, and by putting them together, so as to form the Roof proposed, all Difficulties of this Nature may be solv'd: And which indeed is the plainest Way of Demonstration. I shall insert one Plate more, concerning the Form and Manner of Roofs, and then proceed to their proper Declivities and Sections.



FOR general Rules, whereby to form and frame a Roof, there seems sufficient Variety already in the foregoing Plates; but as the general Plan of a Building must be managed after another Manner, than has been mentioned, this Plate may not be deem'd unnecessary.

Admit the Plan F*, were to be prepared for a Roof, either with Hips, and Vallies; or Hips only: The said Plan is the same as in PLATE C*, D*; those Openings of G, and H, are over the Staircases; (in case they cannot be lighted from the Sides,) they may be left to be finish'd at Discretion.

Let the first Observation be the Chimney Funnels, as I, K, L, M, N, O; then describe the Windows, and Doors; observing to place your Timbers so, that they lie on the Piers; (and not too near the said Funnels,) and at the same Time, observe to connect them so together, as that they embrace every Part of the said Plan; and not be liable to be separated by the Force and Weight of the Roof. I have represented the said Timbers so, that the foregoing Paragraphs will explain the Particulars of them. That of P, is a Partition of Timber, to discharge the Weight of the Roof over the Salon.

Admit Q, the upper Part of the Front, and R, a Pedement over the small Break, whose Height gives that of the blank Pedestal, or Parapet S*; and suppose T, represented half the Roof, as coming to a Point or Ridge, so as to span the whole at once; which was the good old Way, as we are shewn by *Serlio*, *Palladio*, &c. or admit V, to represent the Roof, so as to have a Flat, or Skyelight over the Lobby F*, its Ballustrade being W; or we may suppose X, to represent the Roof, as spanning the whole at three Times, and which may please some, better than either of the others.

Admit either of these were used; if that of X, then the Vally and Hip should be framed as Y, the Vally being supported; if as T, then the principal Rafter should be framed as Z, in order to bring part of the Weight of the Roof, and Covering, on the partition Walls; a farther Explanation seems needless.

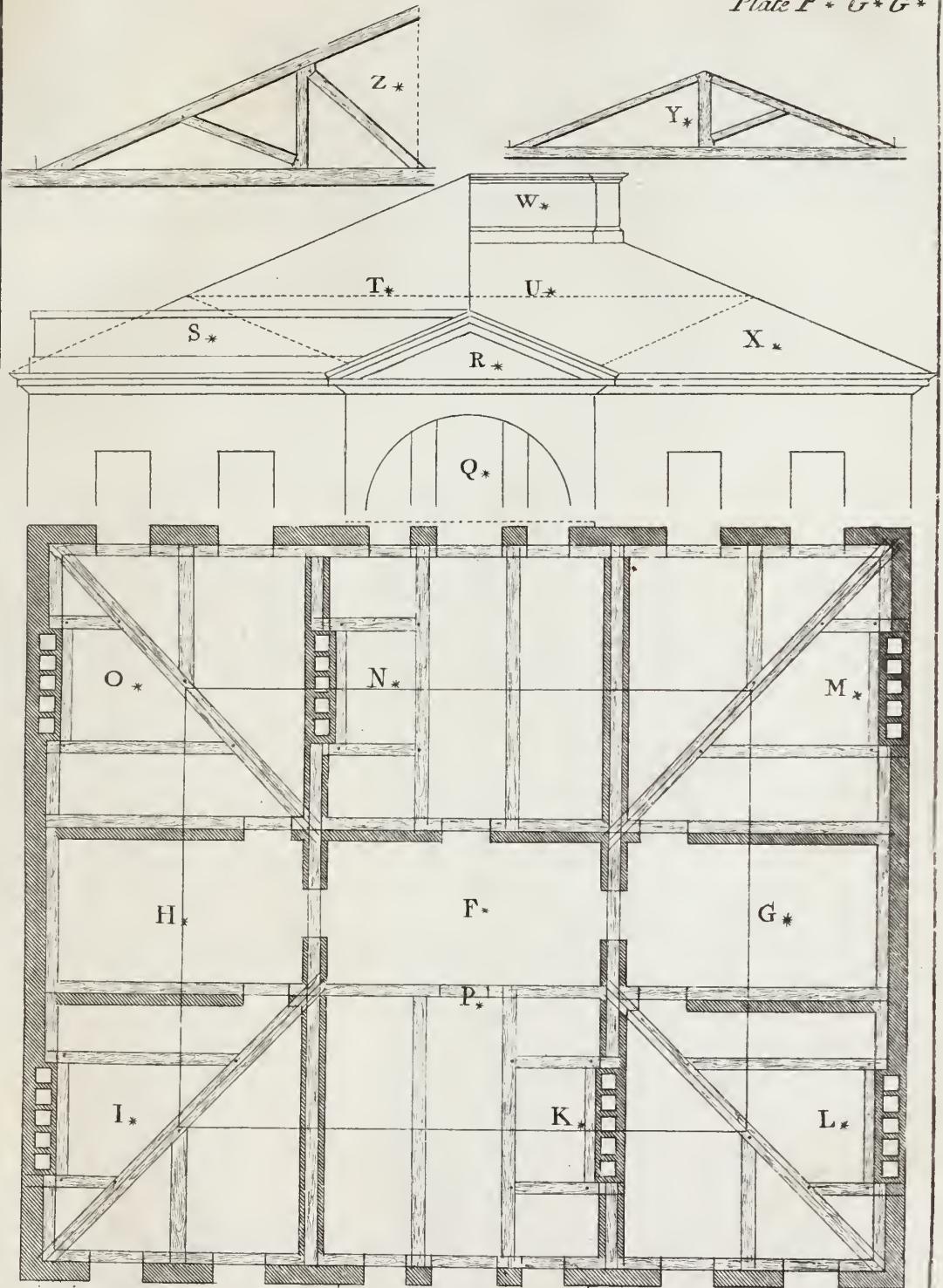

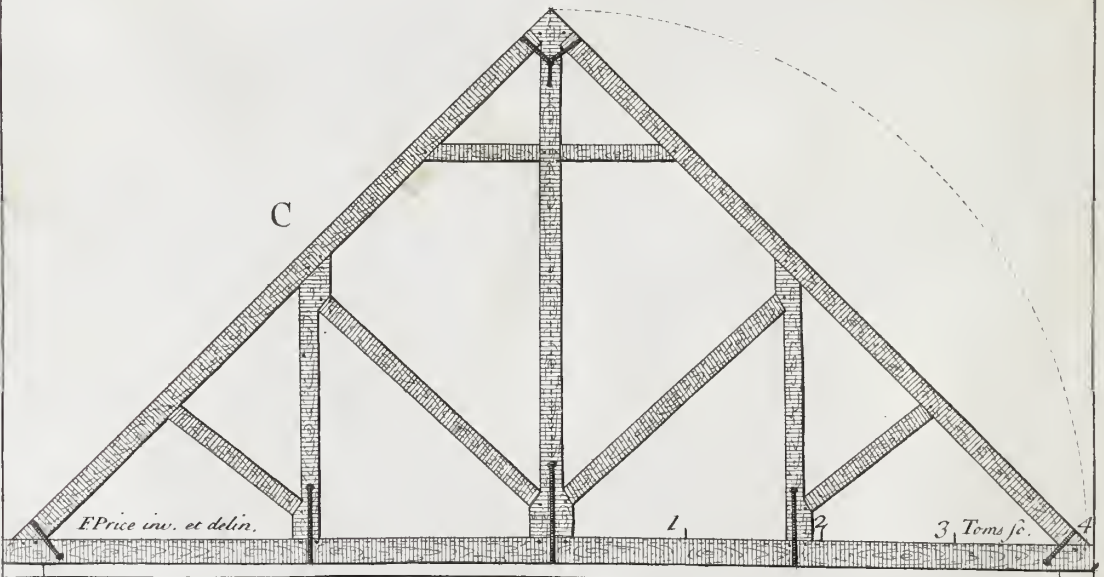
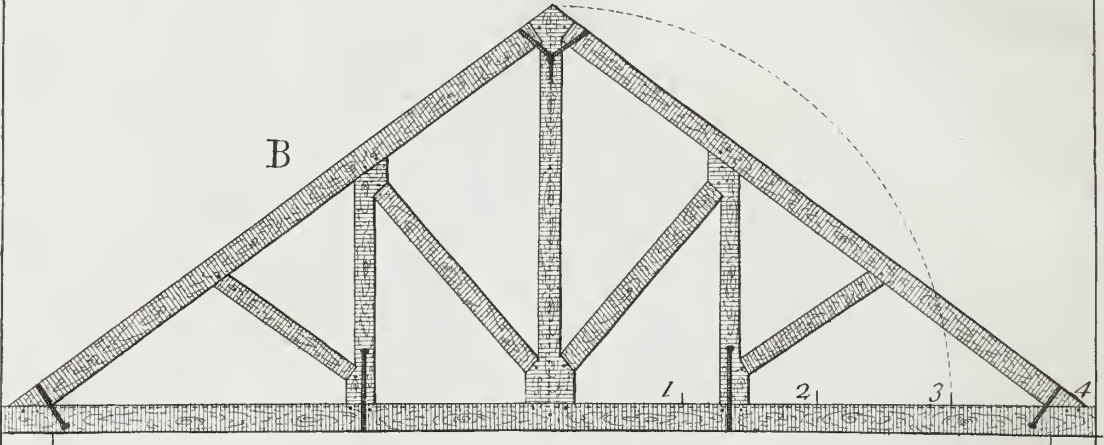
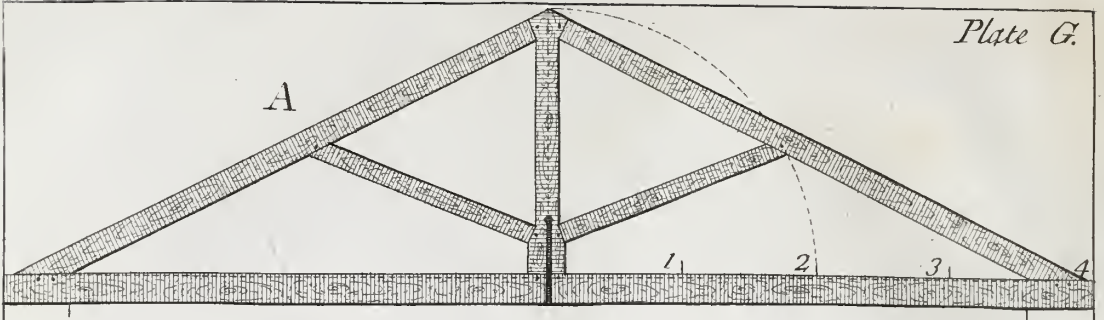



R A N T I N G that I have explain'd the Manner of laying of Roofs in Ledgement, as far as may be shewn by mere Inspection, I propose therefore to shew the Manner of making different Pitches or Slopes, agreeable to each Kind of Covering in Use, as Lead, Pantiles, and Plaintiles.

Take any Width, as in A, and to be covered with Lead; divide the Width, first into two Parts; and one of them, again, into four, as 1, 2, 3, 4; at 2, and with two of these Parts, describe the Quarter-Circle, which gives a proper Pitch, or Slope to be cover'd with Lead: And is call'd Pedement Pitch.

Again, take any Width, as in B, and to be covered with Pantiles; divide it, as before, into two Parts, and again one of them into four, as 1, 2, 3, 4; with three Parts, as at 3, describe the Quarter-Circle: Which gives a proper Pitch for the Use.

Also take any Width, as in C, and to be covered with Plaintiles; divide it into two Parts; with one make the Quarter-Circle, as the prick'd Line shews: Which gives a Pitch, or Slope proper for the Use.

These Trusses have been practis'd with Success; and therefore better to begin with.

The short Lines under each Beam, represent the In-Side of the Wall, so that the Weight of the Truss relies wholly thereon.





OW necessary these Sections of Roofs may be thought, I cannot say; but they were introduced, lest the Methods made use of before, should not give Variety enough.

And although it should be argued, there is not a Necessity for either, yet the Trusses in each may be acceptable: And, I think, they need no Apology.

Take any Width, as D, which is to be covered with Pantiles; divide it into six Parts, as appears by the Draught; take four of these Parts, and with them make two Sections, as the prick'd Lines shew; the Interfection of these Lines gives the Height, or Pitch of the Roof.

Take also any Width, as E, which is to be covered with Slates; divide it into seven Parts; take five of them, make the two Sections; their Meeting forms a complete Pitch, or Slope for Slates, as appears by the Draught.

Take any Width, as in F, and to be covered with Plaintiles; divide it into eight equal Parts; with six of those Parts, make the two Sections; their Meeting forms a Slope proper for Plaintiles, called true Pitch. And whereas the most eminent Writers, both Ancient and Modern, have taken notice of the Sections of the Roofs of those Buildings they represented, therefore I chose to give a great Variety of Trusses, not only to gratify every one's Humor, but because it demonstrates the Laws of Strength and Weakness, and therefore necessary to be known by every one, and which chiefly prompted me to compile this Treatise.



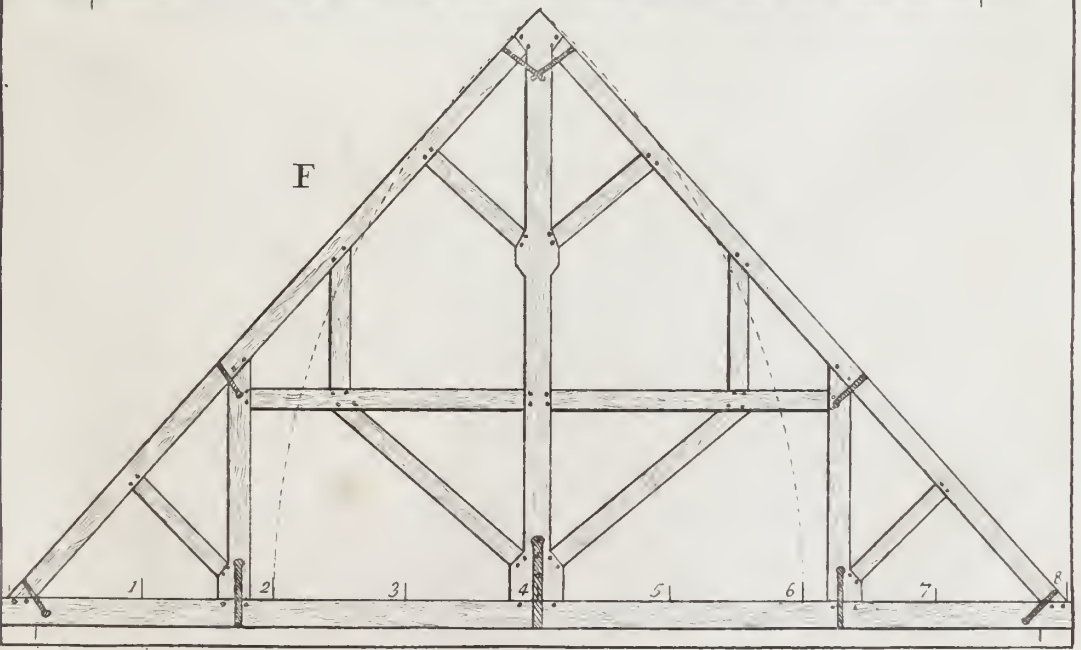
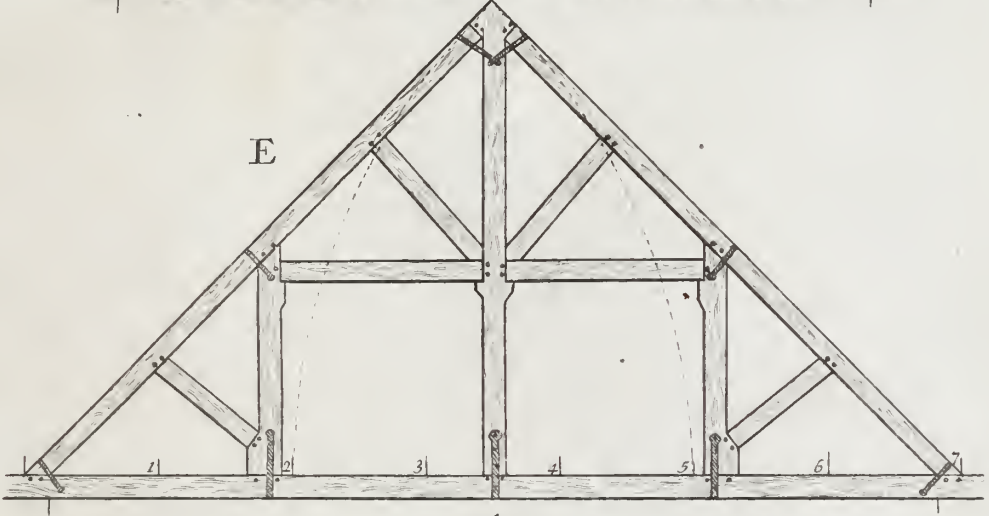
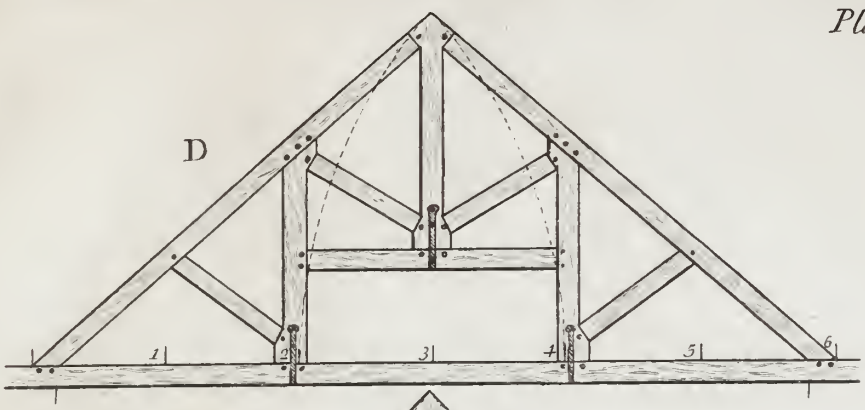

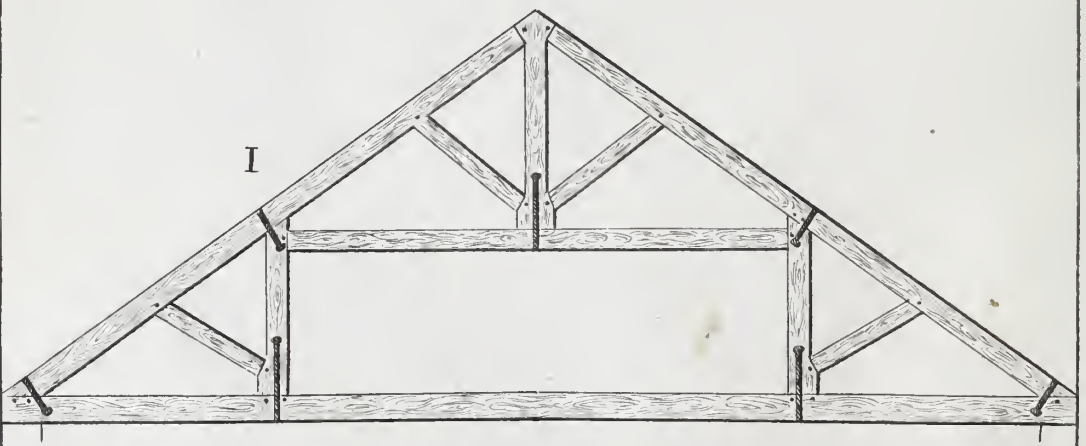
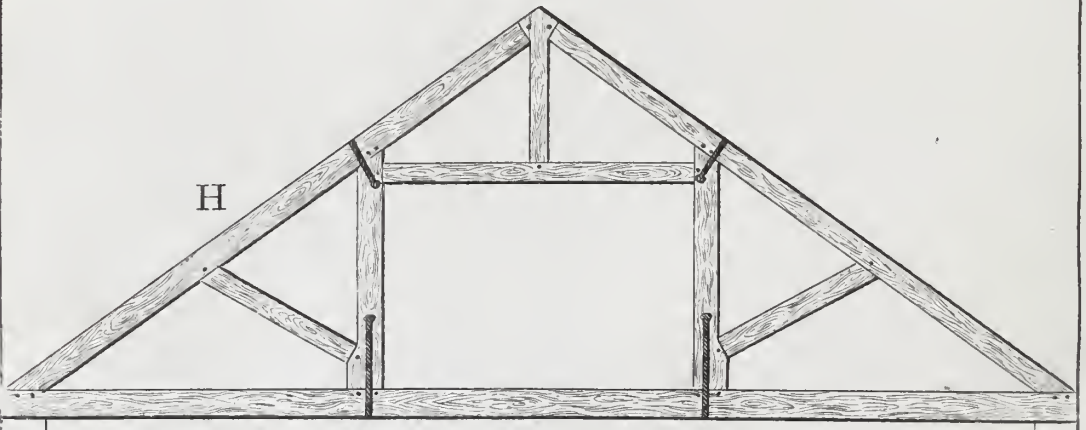
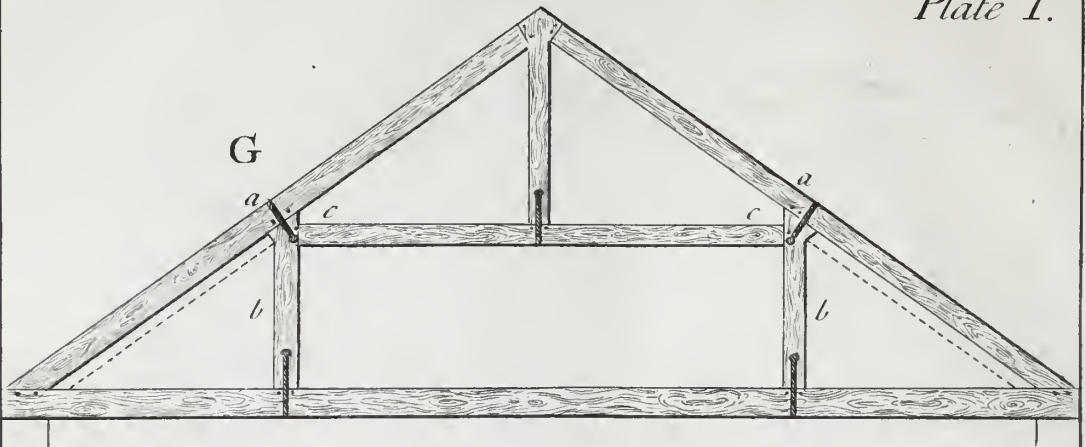



BELIEVE these Trusses may be acceptable, although they differ so very little from those in the last, P L A T E H. The Strength of this or any other Truss may thus appear.

In G, the prick'd Posts b, b, (or King-Posts b, b,) being tyed to the Back of the Rafter, as at a, a, with iron Straps, as appears in the Draught, so firm that it cannot yield; if the Strutting-Beam c, c, be drove in very tight, it takes all the Weight off from the Rafters, as at a, a; and if some extraordinary Weight be to hang thereon, as the Machinery of a Theater, then it would be well to cut the said King-Posts with a Joggle, by which means you might put Braces, as represented by prick'd Lines, under each Rafter, so as to make this Truss able to carry any Burthen whatever, at the Extent of sixty Feet, &c. allowing the Truss G, to be sufficiently strong: I say, this of H may be well adapted to many Uses; as dividing the Floor, and Rafter, each into three equal Bearings. If Occasion require it, you may cut the King-Posts with a Joggle, and make use of Braces underneath the Rafters, as before.

Also this of I, by what was before said, may be rendered a complete good Truss for almost any Use, there being so large an Opening, as indeed is requisite in what was before observed, altho' this allows of good Garrets, if used in a Dwelling-House.

What is shewn, and mentioned, in these three P L A T E S, of Roofs whose Ties remain entire, may be sufficient.

All that I conceive necessary to be said further, is, that the less in Number the Divisions or Pieces are, which compose each Truss, the stronger it is; for even the Shrinking of the Wood will let a well-framed Truss sag, or droop, in Process of Time; for which Reason I cannot help recommending *English* Oak, particularly for King-Posts.



Know there are several Sections of Roofs already given by others; but as no other Book yet published gives any tolerable Account of them, I make no doubt of these giving Satisfaction to the Curious.

These three Trusses may be useful where Lodging-Rooms are wanted in the Roofs, if used in Dwelling-Houses. And as their Ties may be interrupted, or not, as Occasion shall require, they are therefore applicable to other Uses, and seem to want no Explanation otherways than this; that of A, is well adapted to such a Situation as would command a fine Prospect, from the Flat on Top of it; or might please such as don't love to see a high Roof; that of B, is called a Kirb Roof, and is much in Use, on account of its giving so much Room withinside; that of C, is an exceeding good Truss for a Roof, if applied on a Dwelling-House where Garrets are wanting; or is fit to place on a large *Salon, Chapel, &c.* It may with much safety be converted into a good Truss for a Bridge, or a Roof with a Flat on Top of it, if the prick'd Lines be observed duly.

N. B. There is one Particular, that had like to have escaped my Notice, concerning the placing of iron Straps on any Truss, thereby meaning to help its Strength, which is by turning the End square, as those of d, f, and a; which may appear more apparently in D; this Method embraces the Timber in such a Manner, as to make it like a Dovetail, *which cannot draw from its Place*; another Observation is, to bolt on your Straps with square Bolts; for this Reason, if you use a round Bolt, it must follow the Auger, and cannot be helped; by this Helping the Auger Hole, that is, taking off the Corners of the Wood, you may draw a Strap exceeding close, and at the same Time it embraces the Grain of the Wood, in a much firmer Manner than a round Pin can possibly do.

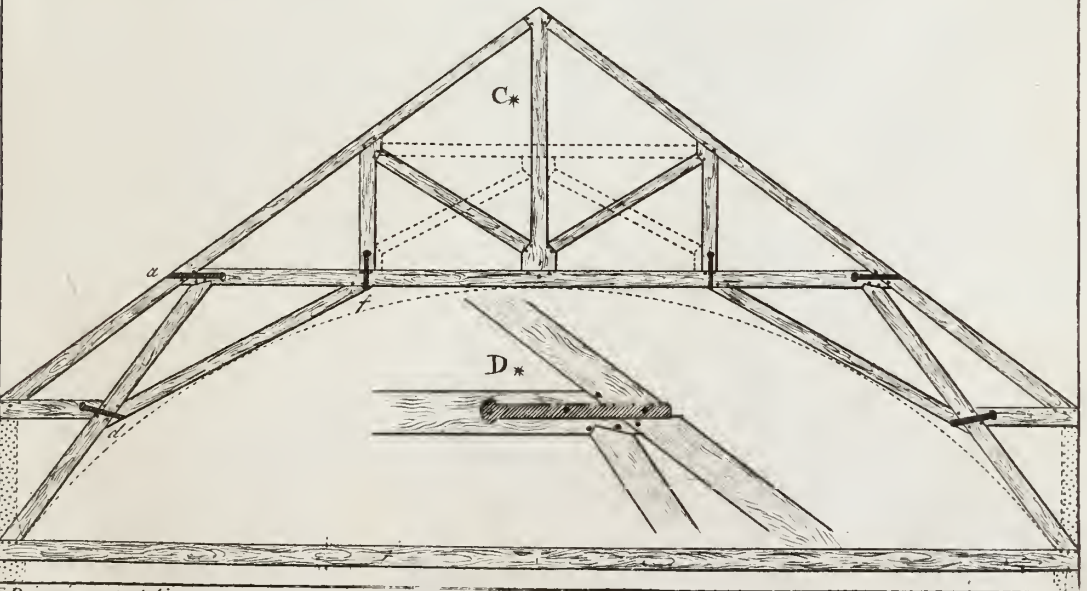
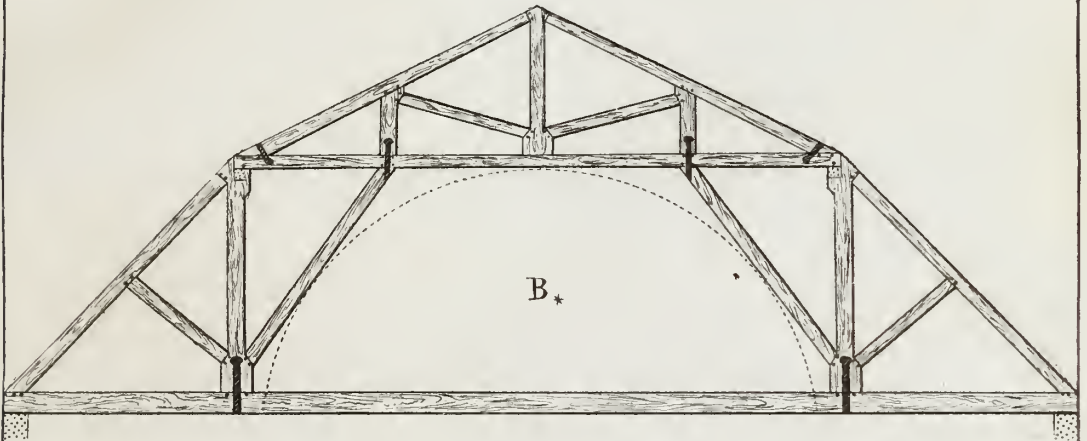
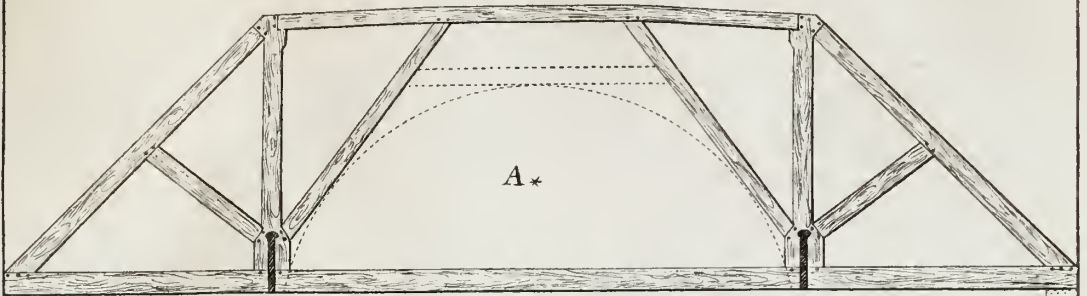



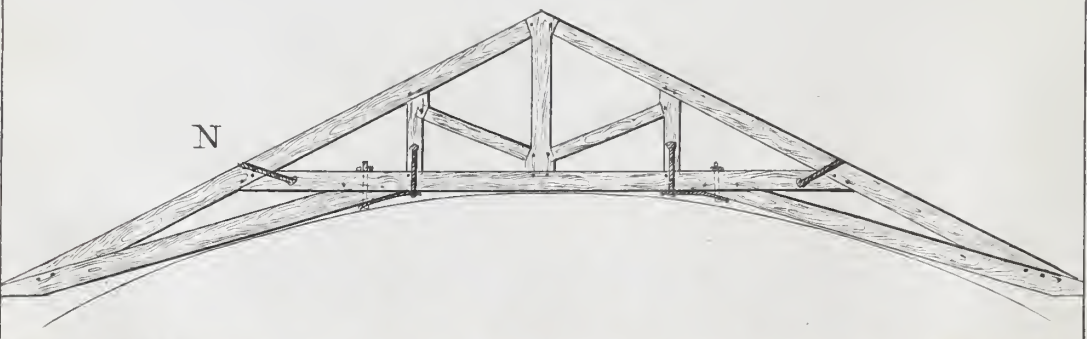
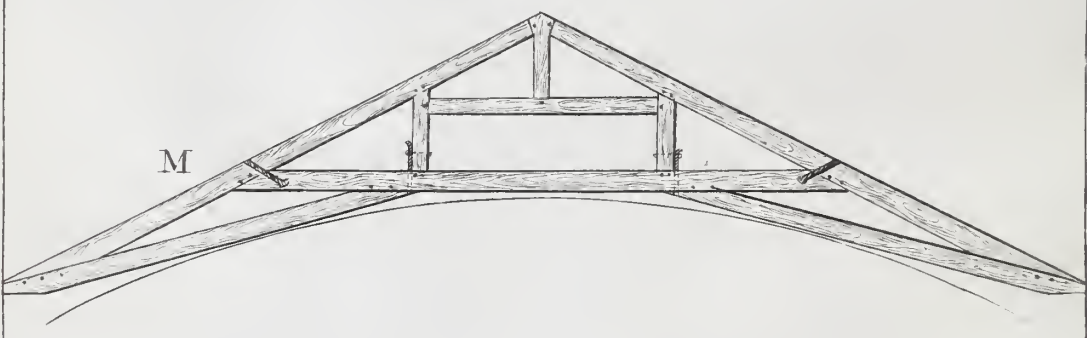
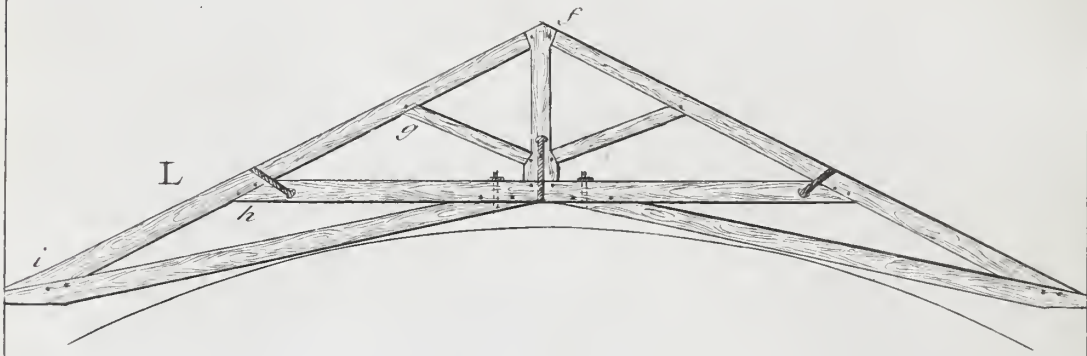
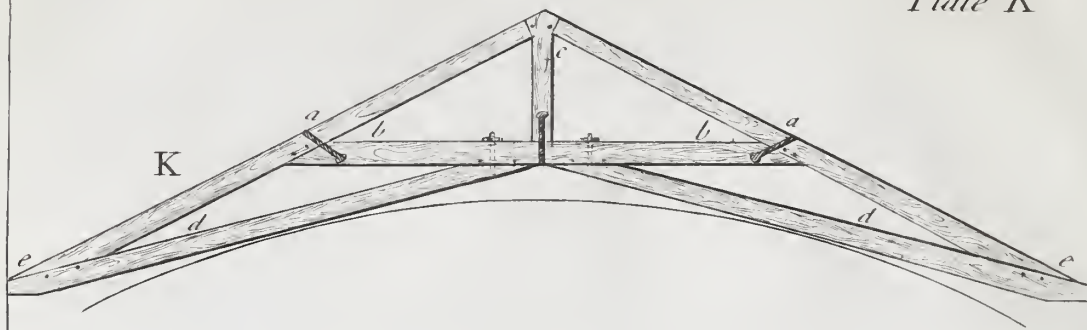



NOWING Variety to be most Entertaining, I have introduced four Trusses, whose Tie or Beam is interrupted, and may be suited to some Places, where the others might not be so well adapted.

Here also, as in *Fig. K*, it is proposed to demonstrate the Strength of a Truss, lest the Mention before should not be sufficient to make it evident they are really strong; and tho' this should seem Tautology to some of my Readers, it will not, I am persuaded, appear so to all.

First, then, the Beam *b, b*, being tyed to the Back of each Rafter, as at *a, a*, with an Iron Strap, in a firm Manner; also the King-Post *c*, tyed to the Beam *b, b*, I doubt not but the upper Part will be allowed strong, or firm; if so, let the Hammer-Beams *d, d*, be well bolted to the Beam *b, b*, and the Bottom *e, e*, be framed as other principal Rafters generally are; I say, if it be objected that there is too much Trust reposed on the Iron-Work, may it not be asked, if any common Strap, at the Bottom of a King-Post, was ever known to break by continual Pressure? Witness the Straps in a Theater, to which is fix'd a prodigious Weight.

If that be granted, another Objection may arise, in putting them together, and which I shall endeavour to answer.

Let the Truss *L*, be required to be put together. First, enter your King-Post into the Beam; put in your Braces; then enter the Top of your principal Rafters into the King-Post, as at *f*; so by bringing down its Bottom, you enter the Brace *g*, and Beam *h*; then enter your Hammer-Beam as at *i*; pin all together, and put on your Straps, and your Bolts through both Beams in a good Manner. Then let one think what Force can part them.

What is said of this, may be said of *M*, and *N*: Not that I would propose that either of these should be used, without mature Advice.



EST it should be thought a Neglect, I have here shewn in two Examples; how to contract the Height of Roofs, which are call'd M Roofs, and frequently made use of.

Let O, be a Truss for a Roof. By the Figures it appears that one third Part of its Height is taken off, and yet the Truss is made firm with very little Stuff and Labour. On the Head of the Middle King-Post is let in a Gutter-Plate, which bears the Inside-Rafters, and is so adapted to Use, that you may support it at pleasure, between one Truss and the other.

In P, is shewn another Truss for M Roofs; and by Inspection may appear to be but three fourths of the Height, it would be, if the Rafters were continued. In this, the Gutter-Plate lies on the Strutting-Beam, and over the Head of the King-Post; by having those Braces under the principal Rafters, I cannot say you need the Braces shewn by the prick'd Lines.

In Q, is shewn a Roof whose Span is beyond the Walls; such as *Covent-Garden*, and *Horsley-Down* Churches, and which gives a Kind of Shelter, therefore may not be misapplied to other Uses.

At the Foot of each Rafter is supposed an Iron Strap, that not only fastens the Rafter and Beam together, but at the same Time passes through a Binding-Beam, whose Office is to bear the small Rafters between one Truss and the other; under which, and a-cross the Main Beam of the Truss, suppose a flat Bar of Iron, so that the Ends of the Straps have a Screw made on each; then consequently two Iron Nuts being screw'd on at the Bottom make each Truss exceedingly firm. I imagine there is no Difficulty in the Execution.

I do not mean to give Offence, by describing this Truss different to either of those before mentioned, each doing its Office excellently well.

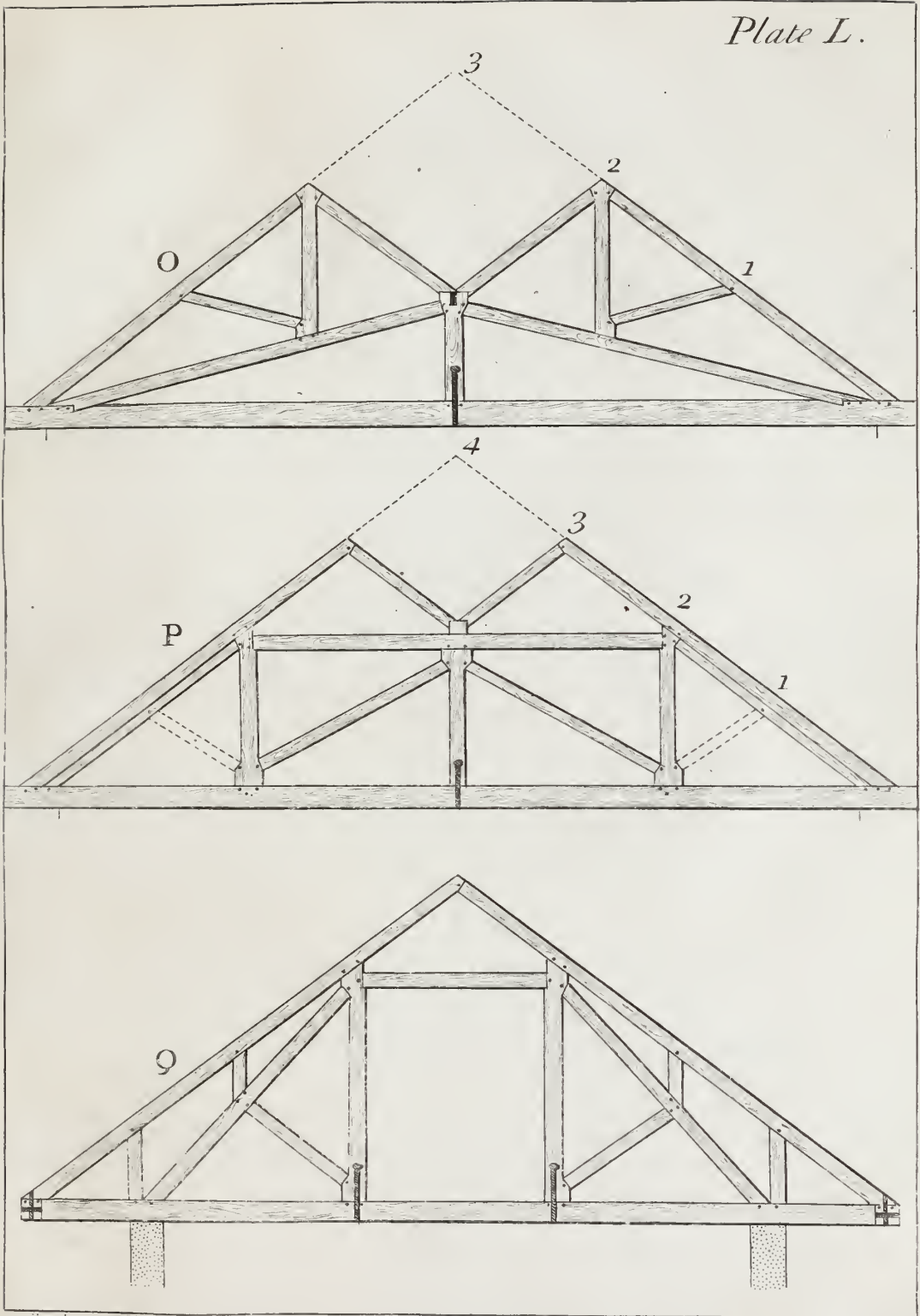

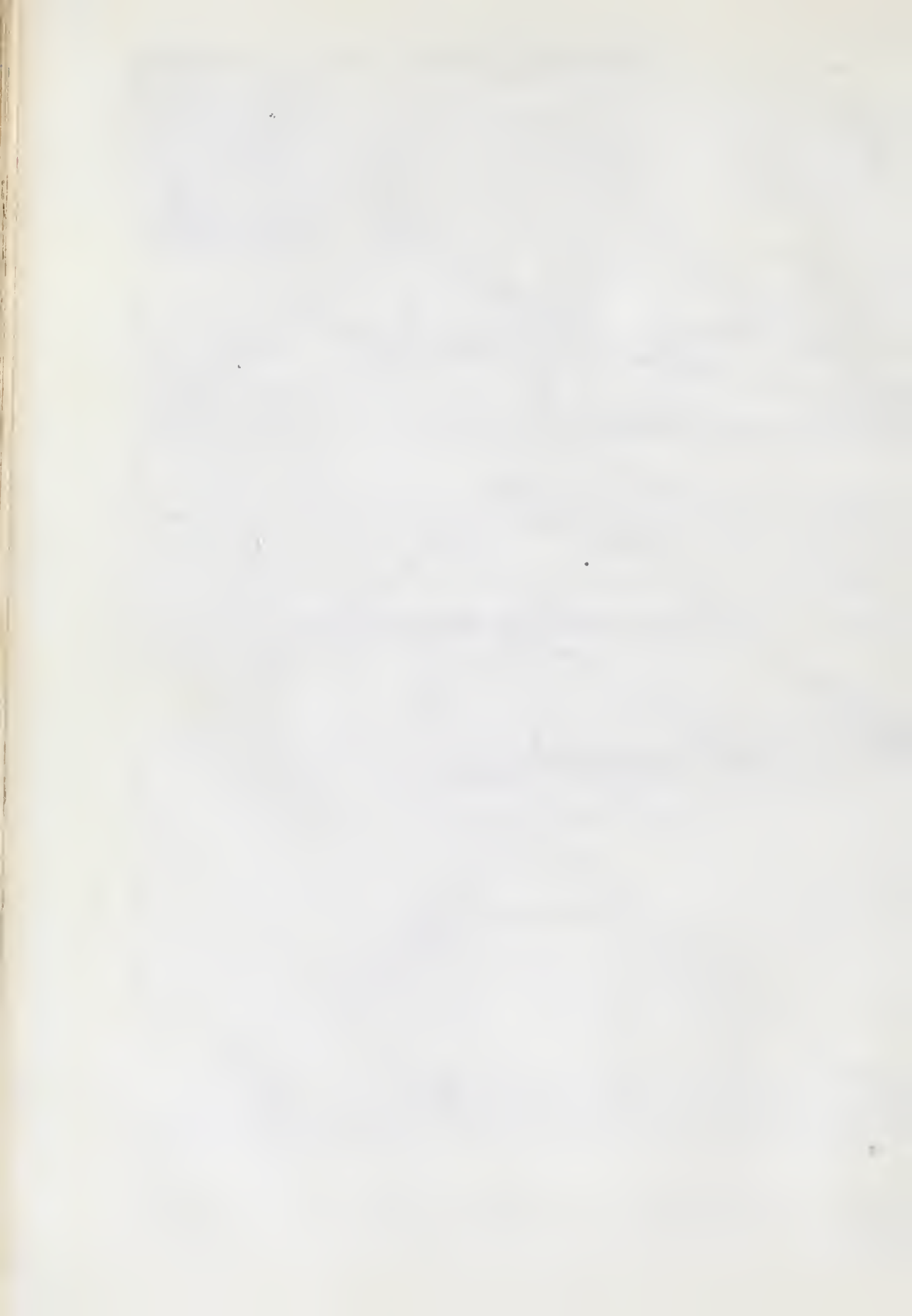



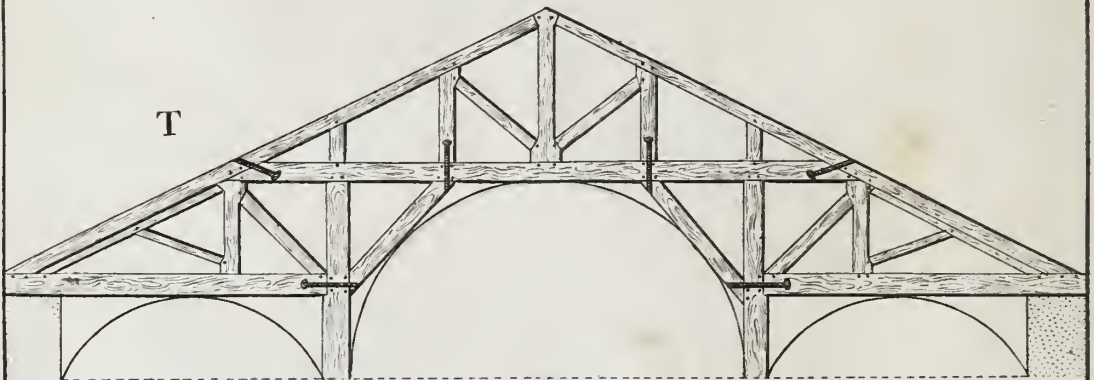
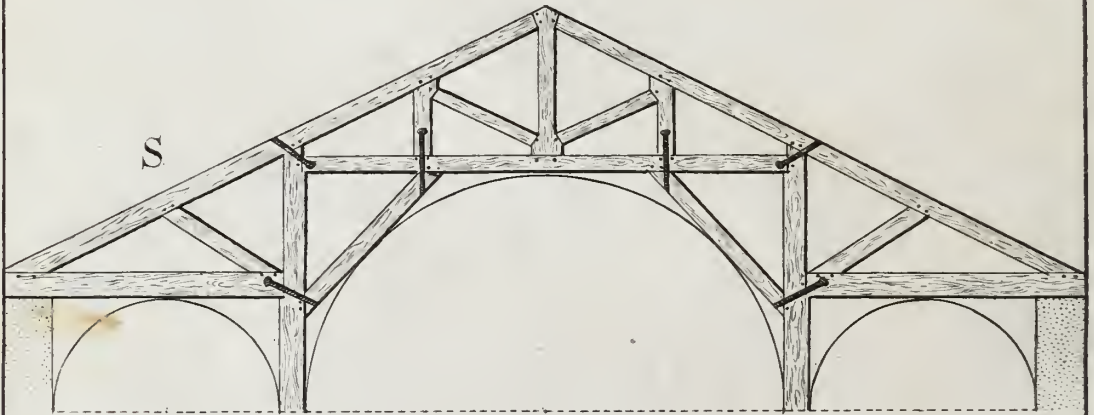
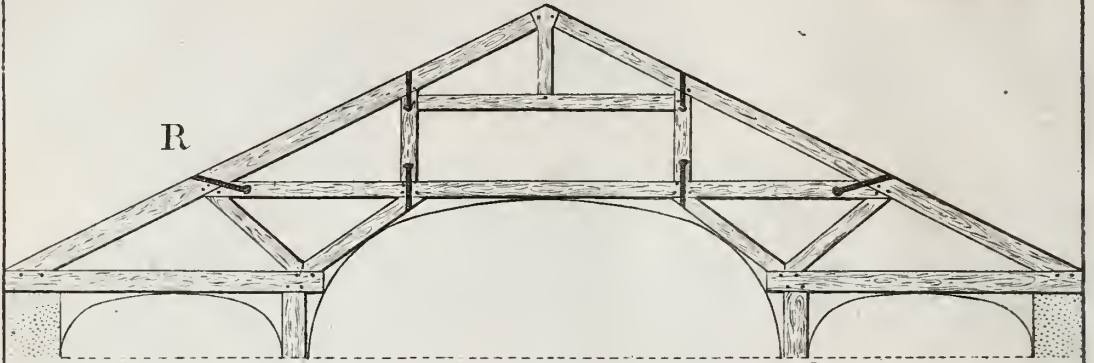



ANY, perhaps, may be offended, to see that I should describe Roofs suited to Churches, seeing that so many have been done of late Years.

However, as these differ in some Respects from what has been done, I hope they will be acceptable to some of my Readers.

In that of R, each Opening is an Ellipsis or Oval, which has been approved on, by competent Judges of the Art, to be best adapted to such Uses; and for its Strength, there seems to want little or no Apology.

In that of S, each Opening is an exact Semi-Circle, as it may best fall out to suit the Windows; and, to my thinking, has not so great a Bearing on the Columns that support it, as some that have been executed have had. These may be adapted well to span seventy or eighty Foot without any Difficulty.

In that of T, the Middle Part is a Semi-Circle, and the Sides are a Segment, or Part of a Circle; but these may be varied at pleasure. This Truss seems suited to span a greater Width than either of the others.

It may be said of these and the foregoing, without Ostentation, that they have each a very just Bearing, and are done with little Stuff and Labour. And as Purlins, or Bridgings, do not concern the Strength of the Trusses, therefore I have omitted them, with this Caution: If Purlins are used, they ought to be agreeable in Number to their Supports; thus the Truss R, requires to have two Tiers of Purlins, S, three, and T, four, which if bridged needs not be regarded.

As to the Scantlings of Timber, I shall refer you to the Inspectional Table, at the End of this Treatise, both for these and the foregoing Trusses, as well as those in the P L A T E S that follow.



ANY do not conceive what I mean, by inserting this Plate in the first Impression with so little Explanation, which was done that I might not give Offence; therefore whoever takes amiss my inserting it, and making Remarks on the Strength of the Trusses, will, I am persuaded, pardon me, on account of the Necessity that appeared for my so doing; having always had recourse to Experience, without which no Perfection can be attained to. As to my representing but the Half of each Truss, 'twill make them the more handy to compare to one another.

That of U, was composed from inspecting duly the Roof W; which was first placed on the Building without the Parts thus* marked, they having been since put there to render the Truss capable of supporting the Weight of the Covering.

That of X, was composed from inspecting the Roof Y; whose Braces a, b, are placed the wrong Way; therefore c, does the intended Office of both; tho', I confess, the Roof could not have sagged so much as it does, were it not for the Shrinking of the Timber, which is already sufficiently mentioned in the foregoing Paragraphs.

That of Z, was composed from inspecting the Roof &, whose Timbers are so ill placed, as to require almost as many Pieces of Iron marked thus*, as there are Pieces of Timber, or it would scarce stand; indeed as it is, there lies a prodigious Weight on the Columns, as at d; and yet this Truss has abundance of Timber in it, which plainly shews that it is not the abundance of Timber, that makes a Truss strong; therefore the Art lies in connecting it together.

That of Z*, was composed from inspecting the Roof &*, which has no material Fault, otherways than a Misapplication of the Braces e, f; especially the latter, as may be seen by the Iron*.

N.B. The Posts g, g, have something very particular in their Use, which perchance Inspection of &c, may make clear.

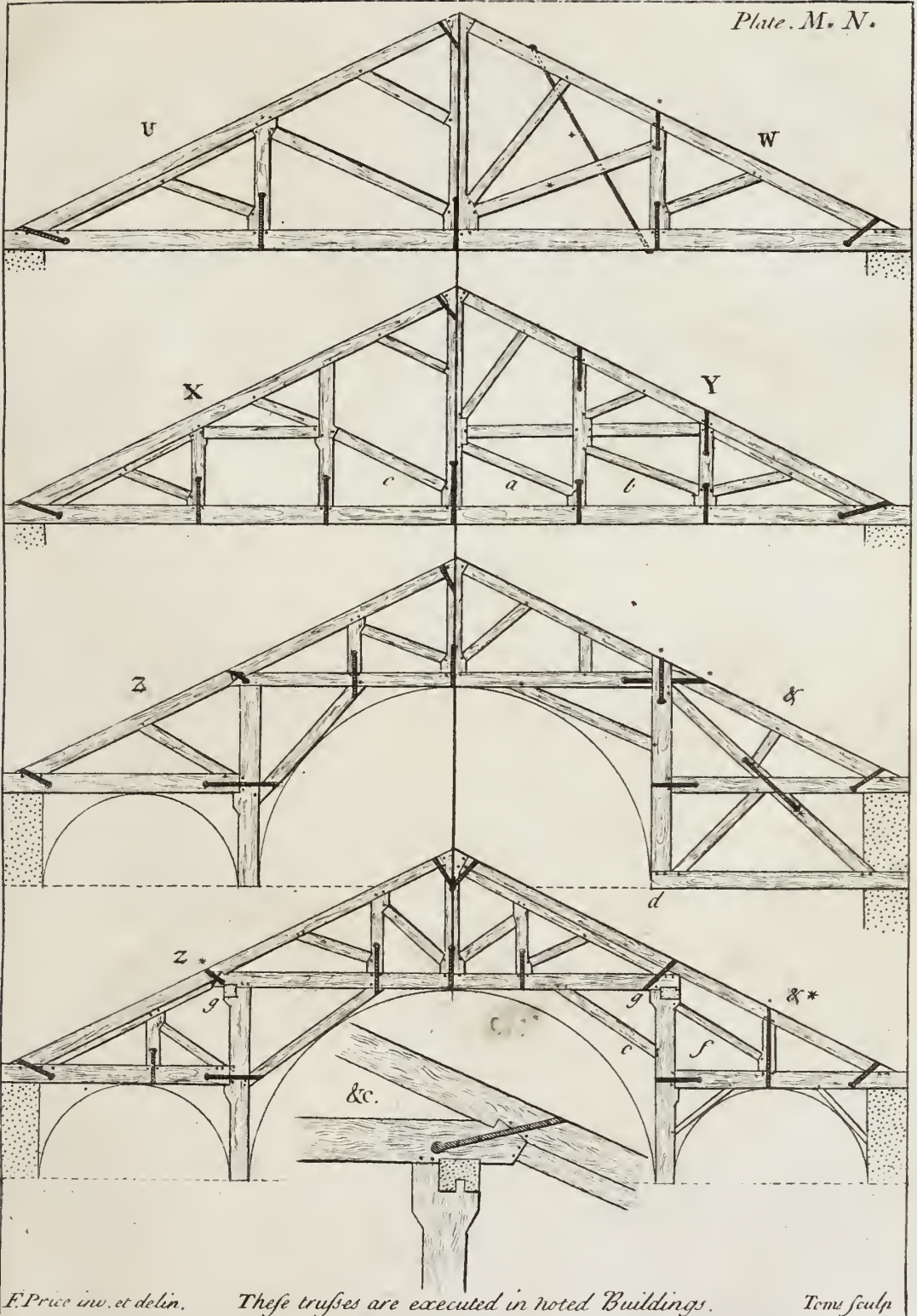

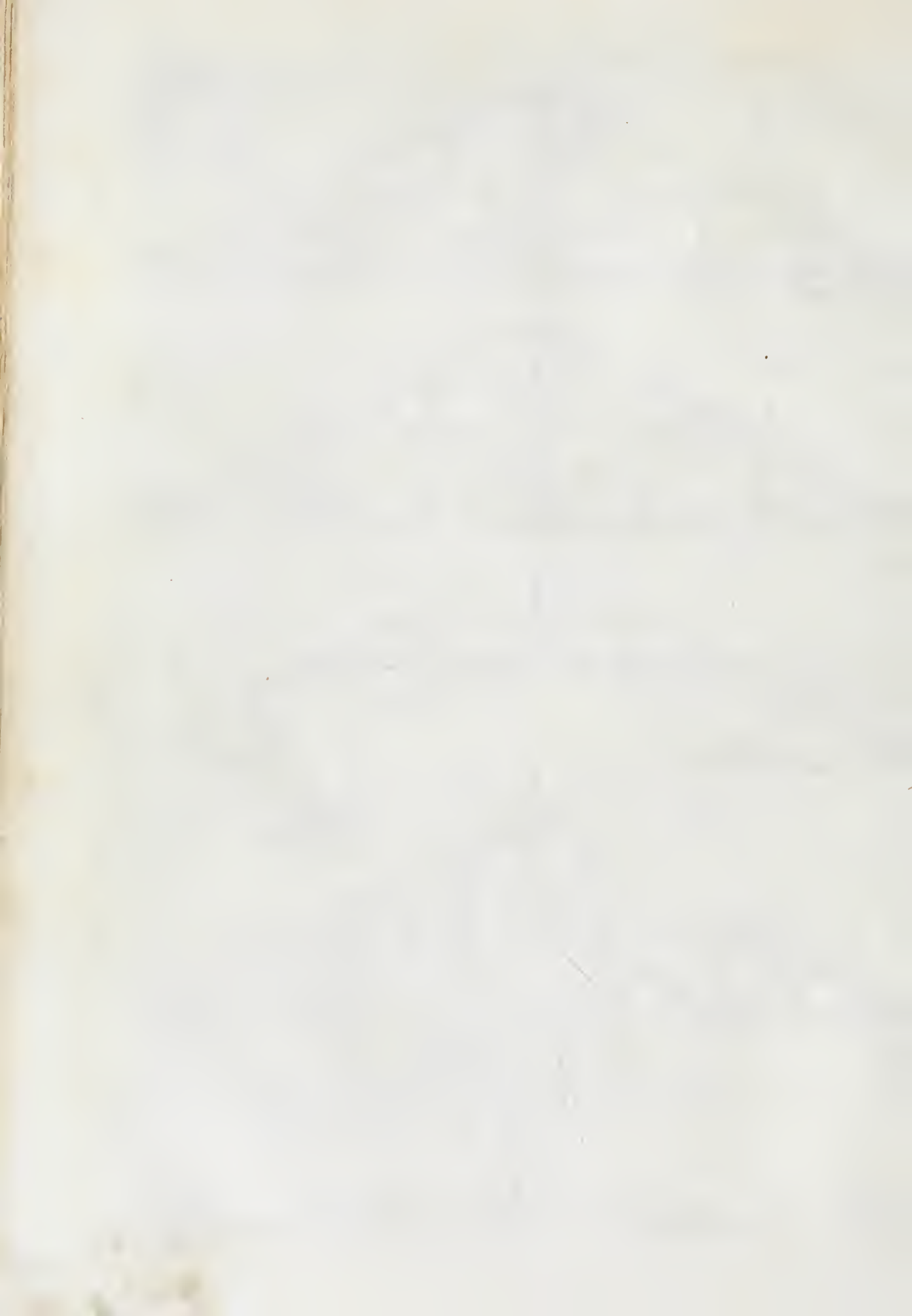

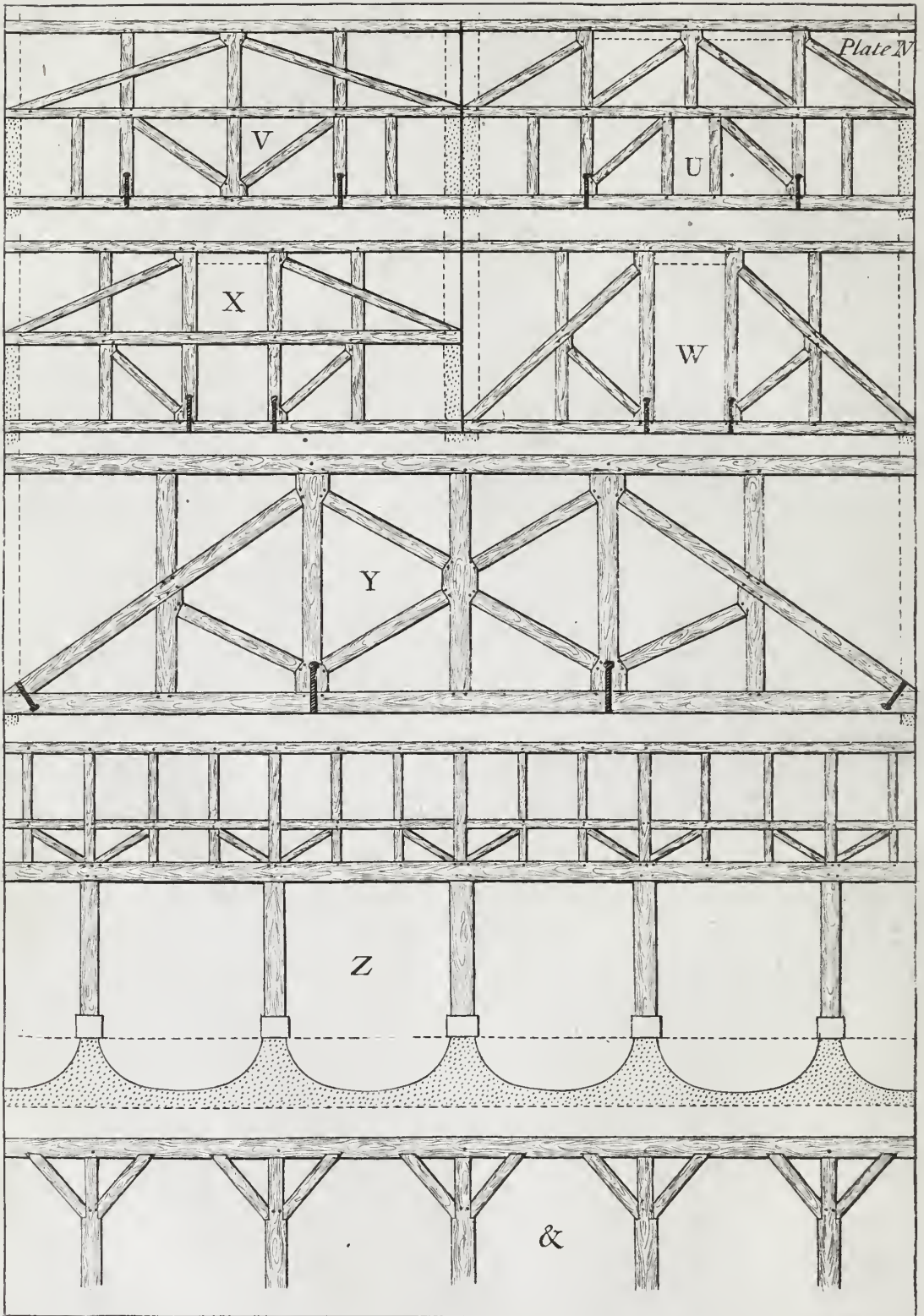

Plate IV



NOTWITHSTANDING what has been said of Trusses in Roofs, those of Partitions vary from them in some Parts, on account of their having Door-ways, which interrupt their Tye or Support, as here in Halving some Timbers together, that is, Letting one into the other, half the Thickness of each, so that both the Sides are Even or Flush; and which I would never advise, without Necessity require it; because this Method weakens the Timber, and renders it less capable of Support; although if used as a Tye, 'tis weaken'd but little.

In V, is shewn a Partition, supposed to be between Rooms, in which Door-ways are wanted, as towards each Wall. And here the Inter-Ties, and King-Post, and prick'd Posts, must be Halved together, but not the Braces, on no Terms, they being the chief Support.

In U, is also a Partition between Rooms, having three Door-ways, one in the Middle, and one to each Wall. This also must be Halved together; that is, the two King-Posts and Inter-Ties, but the Braces are whole.

In W, and X, are shewn two more Partitions, with Door-ways in them. And this Method I approve; because if Necessity require it, when the Building is settled, you may raise the Partition in the Middle with Shores, and by driving in fresh Struts yet longer, as the prick'd Lines shew, you may keep it to its proper Height.

In Y, is a Partition supposed to bear a Gutter, (or Girders, on each Post;) or may bear a Wall, by having Timber in Proportion to its Use.

In Z, is shewn the Manner of a Timber Front, supposed to be open underneath in Form of an Arcade. And for such Open Fronts, the Foundation should be laid in Reversed Arches, which will strengthen it very much; by this means, the Ground bears between one Post or Pillar, and the other, as well as under the same.

If on it you would have Brick-work, or even Stone, then support the Brest-Summer, as is shewn in &: Which manner of Framing renders it as strong between the Posts, or Pillars, as it is directly on the same. And this seems sufficient to explain proper Bearings for Partitions.



OT Only Partitions, but Bridges, require Timber to be Halved together; more especially such as extend a considerable Length. And because these Timber-Bridges have never been intelligibly explain'd, as to the Connection of their Timbers, therefore, I hope, the following will be kindly received.

Let A*, be the Plan, supposed to extend any Length not exceeding one hundred Feet, nor twenty four Feet in Width; also let B*, be the Side, or Upright of the same; and let C*, be the Section of the same by a larger Scale.

Left every one should not conceive the Particulars by Inspection, observe in A*, that a, a, a, a, are the Butment, or Support to each Shore; and let b, b, be the Tying-Beams, which are Halved into the Posts; also let c, c, be the Bearing-Beams; and let d, d, d, d, be the Binding-Joints, which are let into the Bearing-Beams, (*as shewn in PLATE C*, D*, at T**); also let e, e, e, be the Plan of the several King-Posts.

And in B*, observe that f, f, is the Top of the Water, at its common Level, and let g, g, be the Butments, or Support to each Shore; also let h, h, be the Tying-Beam, as Halved into the Posts; let i, i, be the Plate for the Braces, l, l, to rest on, which support the Posts k, k; so do the Braces m, m, discharge the whole Weight; also let n, n, be Struts to help the Strength, as by butting against each Brace; let o, o, o, be the Top-Plate, or Rail, and p, p, a Plank Weathered to throw the Water off.

N. B. *The additional Beams, &c. &c. do add prodigiously to its Strength.*

And in C*, which is the Section by a larger Scale, let q, q, be the Posts, and r, r, the Bearing-Beam, framed therein, and let s, s, be the Binding-Joints; also let t, t, be the Top-Rail, being wider than the rest to preserve the Joints the better; and let u, u, be the said Plank Weathered to throw the Water off yet better, as at w, w. It is necessary to let the Tying-Beam into the Posts, a small Matter, because the Plank x, x, bears on it, as well as on the Binding-Joints; let y, y, be Straps of Iron bolted thro' the Posts, in order to strengthen the same; the lower Bolt goes thro' the said Strap, and comes under the Bearing-Beam, and which with the Joggle z, z, preserves a good Bearing for the Beam, which ought to be truss'd, as shewn in PLATE B; and &, &, is the Gravel, and Paving.

To preserve the Timber the better, let the Truss B*, be boarded on each Side.

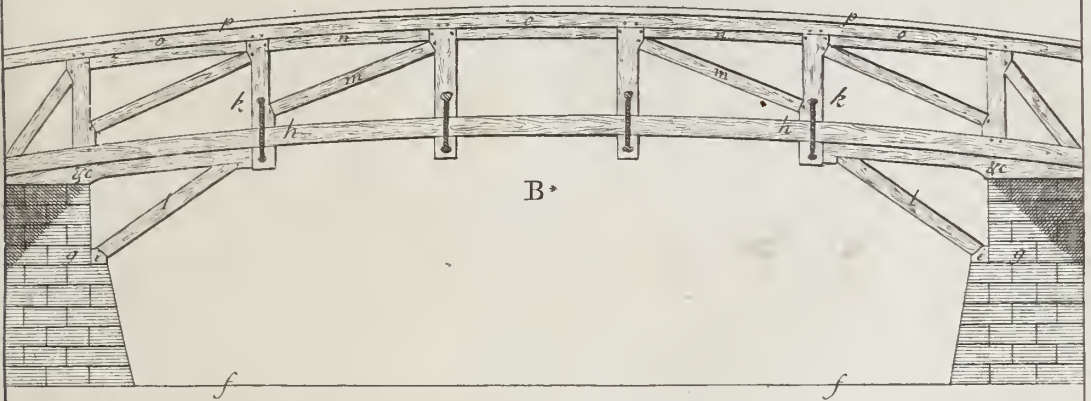
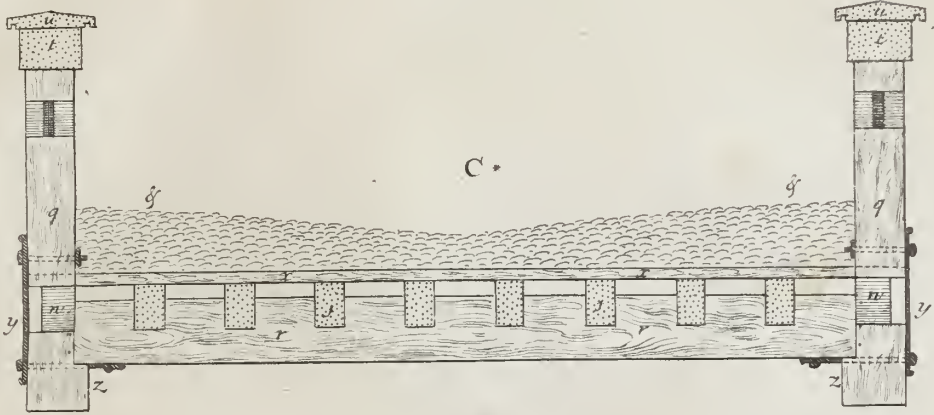

D*

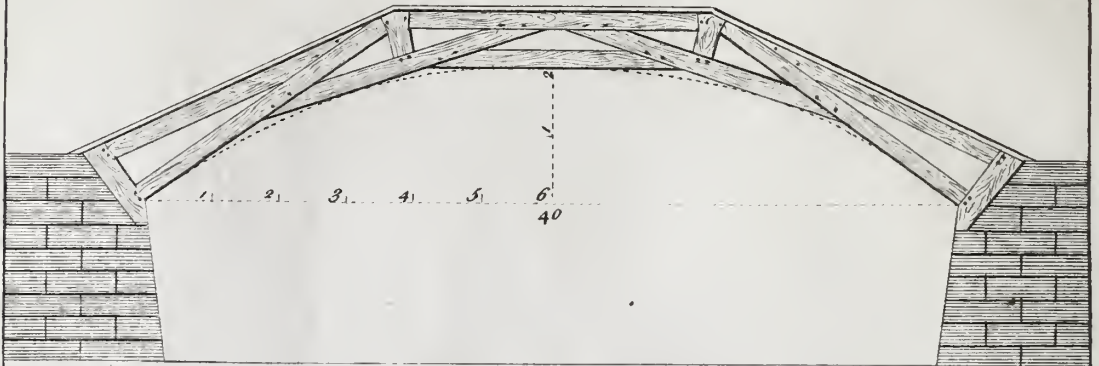

E

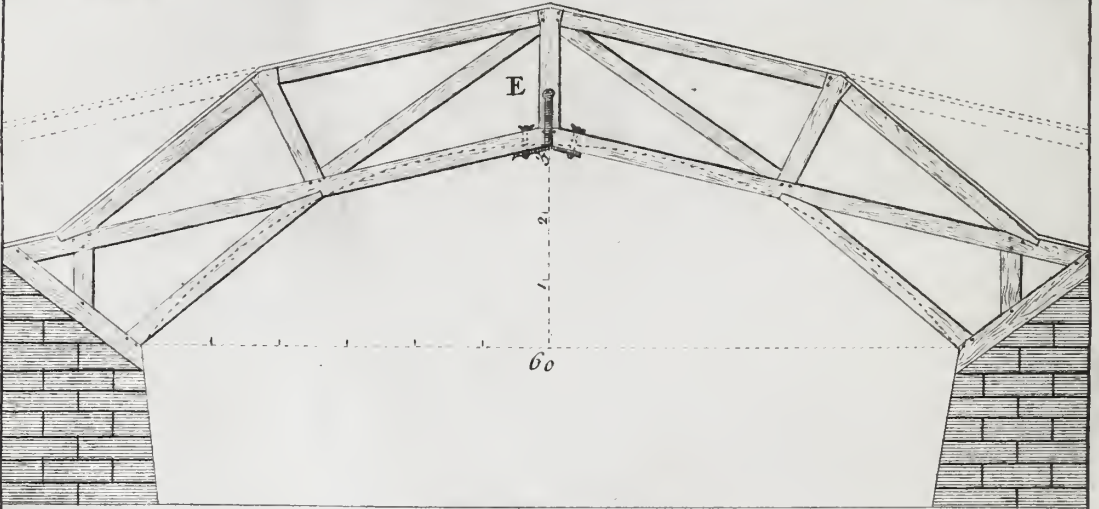

F

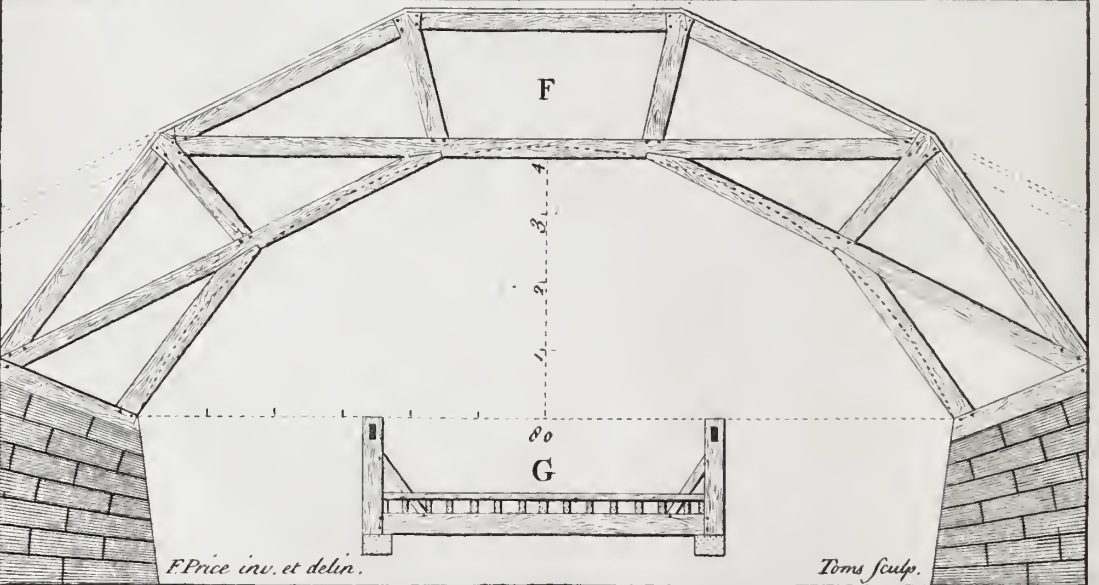

F. Price inv. et delin.

Toms sculp.



NOT Only over Rivers, but also over hollow Roads, these Timber Bridges, in form of an Arch, may be extremely useful; and tho' they may be said to rise too high for the Passage of Carriages, &c. these are so made as to suit with the various Uses they may be applicable to; the upper Part not requiring so quick an Ascent; as the lower Part has, which affords the greater Strength; the upper Part may be made as the prick'd Lines shew, and become a Help to the Passage, so that Cattle may the easier draw a heavy Load over.

There be many Parts of *England*, as well as other Places, that abound with hollow Roads, which interrupt Gentlemen from going with Pleasure to transact their Affairs, &c. or even to do what is necessary to their respective Estates, or their Pleasures, which might at a small Expence be accommodated by one of these Timber Bridges; especially that of D*. And as these Bridges are so adapted, as to serve either for Land or Water, their Use becomes the more extensive.

As to what relates to the Soundness of their Foundation, or Springing, no Rule can be fixed, one being obliged to vary that Part, as Occasion or Conveniency require; such as sometimes to have Stone Butments; at other times to have Piles drove down, and assisted with brick or stone Piers; always observing the Circumstances that naturally occur, from a serious Survey of the Place they are to be executed in.

That of D is suited to a hollow Way, or River of thirty, or forty Feet wide, and rises one sixth of its Width. That of E is suited to a Place of fifty, or sixty Feet extent; and rises one fourth of the Width of the Place; that of F* is prepared to extend yet farther, and rises one third of the Width of the Place; which Width I suppose to be seventy, or eighty Feet, and may be executed without the least Difficulty; that of G* is the Section of either; thus I think to have adapted them to all manner of Places that may happen.

N. B. The foregoing Plate being so fully explained, I think these can want no more than what has been said.



O Other Person having taken Notice of these Particulars, therefore I have inserted a Bridge that may be more acceptable than the foregoing ones, because it is adapted to publick and private Uses, by being so formed of small Parts, that it may be carried to any assign'd Place, and there put together at a short Notice.

This Bridge H, I suppose to consist of two principal Ribs, as i, k, made thus, the Width of the Place is span'd at once by an Arch rising one sixth Part of its Extent; its Curve is divided into five Parts, which I purpose to be of good seasoned *English* Oak Plank, of three Inches thick, and twelve Broad, their Joynt or Meeting tends to the Center of the Arch; within this Rib is another, cut out of Plank as before, of three Inches thick, and nine broad; in such sort as to break the Joynts of the other. In each of these Ribs, are made four Mortices, of four Inches broad, and three high, and in the Middle of the said nine Inch Plank, (these Mortices are best set out with a Templet, on which the said Mortices have been truly divided and adjusted;) Lastly, Put each principal Rib up in its Place, driving loose Keys into some of the Mortices, to hold the said two Thicknesses together; while other Help is ready to drive in the Joists, which have a Shoulder Inward, and a Mortice in them Outward; through which, Keys being drove, keeps the whole together; on these Joists, lay your Planks, Gravel, &c. so is your Bridge compleat, and suitable to a River, &c. of thirty six Feet wide.

In case the River, &c. be forty or fifty Feet wide, the Stuff should be larger, and more particularly framed; as is shewn in part of the Plan enlarged as I; these Planks ought to be four Inches thick, and sixteen wide; and the inner ones that break the Joynts, four Inches thick, and twelve broad; in each of these are six Mortices, four of which are four Inches wide, and two high; through these are drove Keys, which keep the Ribs the better together; the other two Mortices are six Inches wide, and four high; into these are framed the Joists, of six Inches, by twelve; the Tennonns of these Joists are morticed to receive the Posts, which serve as Keys; as is shewn in the Section K, and the small Keys are shewn as in L; all which Inspection will explain. That of M, is a Method whereby to make a good Butment in case the Ground be not solid; and is by driving two Piles perpendicularly, and two sloping; the Heads of both being cut off so as to be embraced by the Cill, or Resting-Plate; which will appear by the prick'd Lines drawn from the Plan I, and the Letters of Reference.

All that I conceive necessary to be said farther is, that the Whole being performed without Iron, it is therefore capable of being painted on every Part, by which means the Timber may be preserved; for though in some respects Iron is indispensably necessary, yet if in such Cases where Things are, or may be often moved, the Iron will rust and scale, so as that the Parts will become loose, in process of Time; which, as I said before, if made of sound Timber will always keep tight and firm together. It may not be amiss to observe, that whereas some may imagine this Arch of Timber is liable to give way, when a Weight comes on any particular Part, and rise where there is no Weight, such Objectors may be satisfied that no Part can yield, or give way, till the said six Keys are broke short off at once, which no Weight can possibly do.

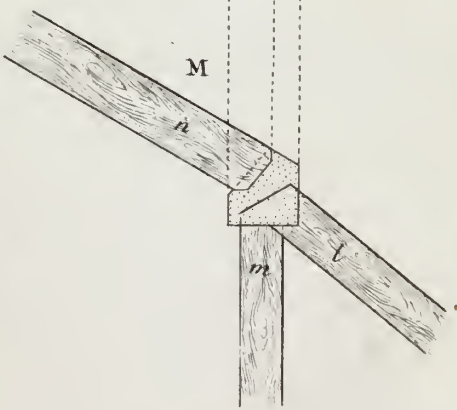
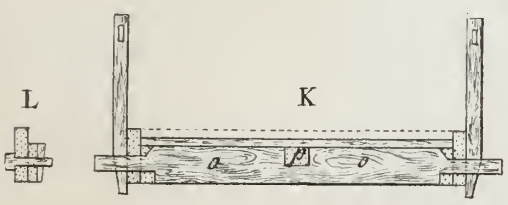
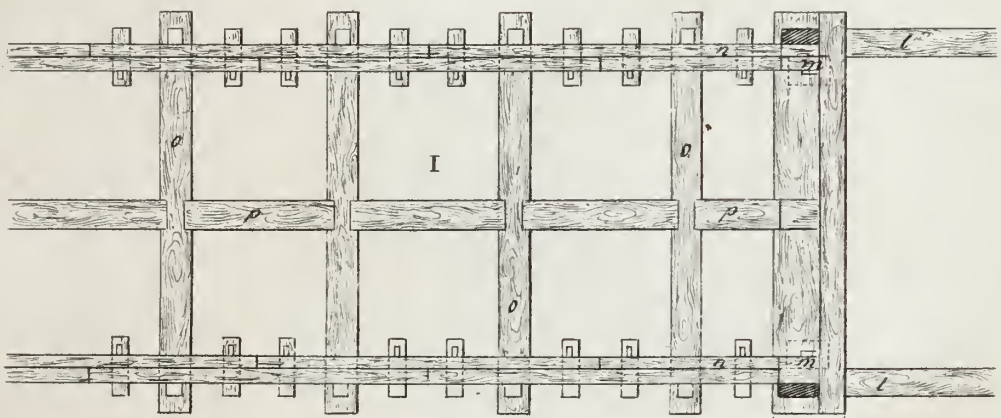
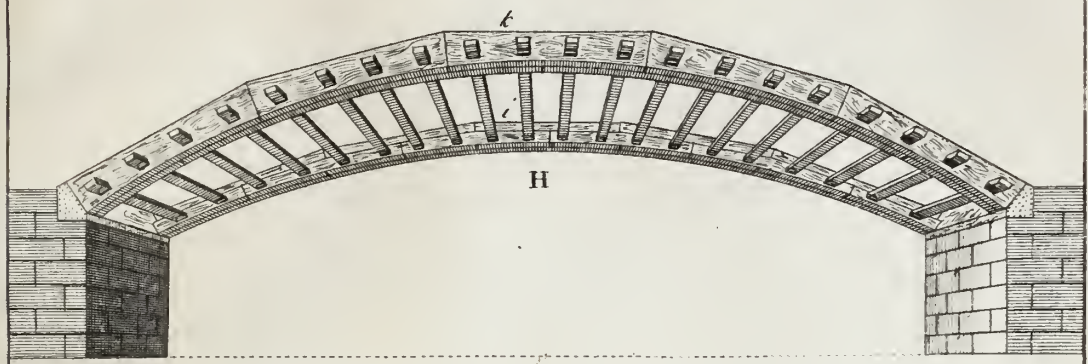

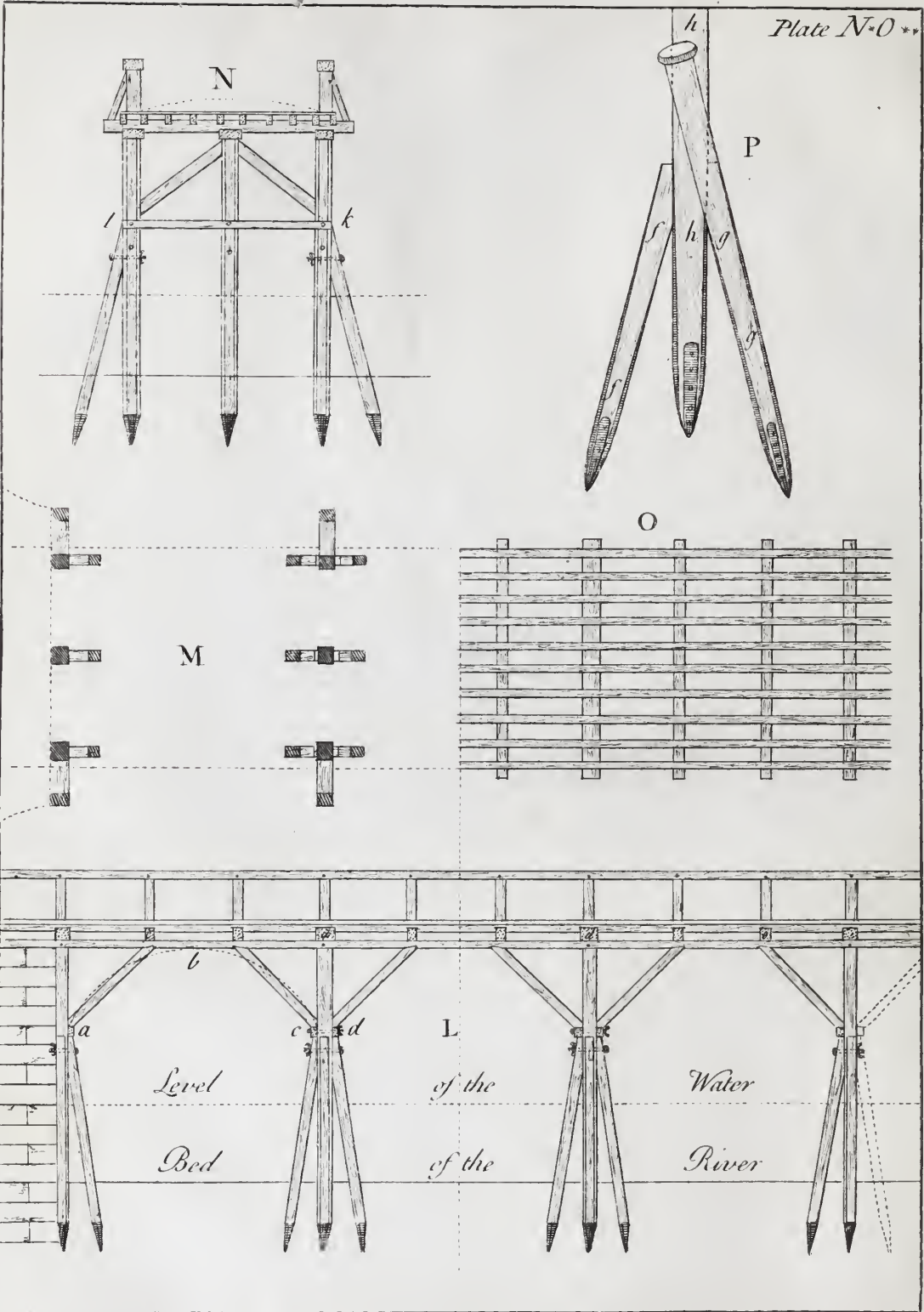



NOTWITHSTANDING the Pains I have taken to describe Trusses proper for Timber Bridges, the Method of driving down Piles, gives so general a Satisfaction, and is indeed esteem'd the safest Kind of Bridge; therefore I have drawn an Example of one, not that it is less subject to Casualties, or less expensive than those whose Dependence lies on a Truss; but because Rivers of a large Extent may be accommodated with one of these Bridges. At the same Time it may be observed, that there is generally a Fear possesses the Spirits of some, who pass over a truss'd Bridge, because they cannot comprehend its Streugth.

This Bridge consists of three Arches, each rising one third of its Width, as a, b, c; the Piles betwixt the Arches are together one twelfth Part of the Opening, as c, d; the Bridge L, may extend one hundred Feet in Length, and in Breadth twenty; and in Consideration that Piles are most subject to decay, at the Top, or common Level of the Water, therefore the outer Piles have four Feet, or Supports, and those of the middle ones have three Feet, or Supports, as may appear by inspecting the Elevation L; the half of the Plan, as M; and the Section N; from all which it appears that the Piles betwixt each Arch, are in Number eleven; of which five support the great Beams d, d, &c. and three of them support each of the small Beams e, e, &c. by which Means the whole is divided into nine equal Barings; that of O is half the Plan of the Beams, and the Joists laid on them, as was particularly clear'd in PLATE N*, O*; these small Piles, or Braces, are drove down first, and cut off so as to receive the great ones; which when drove down, there is an Iron Bolt drove through them all, and is key'd, or screw'd, by which means they are firmly connected together.

On the Top of the three small Piles, or Braces, that stand within the Arch, is laid a Beam, whose End is represented as at a, c, d; and which is also bolted thro' the large Piles, as appears by the Section; on this Beam i, k, in the Section, stands the Braces that support the Beams e, e, &c. Any farther Explanation seems needless, without it be the driving down the Bracing Piles, as in P; first drive down the Pile, or Brace f, f, which being cut so as to come close to the great Pile, and which gives an Opportunity to drive down that of g, g, which is also cut off as the prick'd Line shews; Lastly, The Pile h, h, is drove down betwixt both, and these should be bolted or screw'd together, as before was observed; and this Method admits of no Objection, otherways than being liable to be injur'd by a great Frost, if executed where the Tide has an Influence; and even that may be remedied by breaking the Ice, round about the Piles.



Of what has hitherto been described, nothing appears so beautiful when done, as Domes, or Circular Roofs; and, as far as I can perceive, Nothing has appear'd so difficult in doing. Therefore it will be proper to speak something of them.

Let B, represent a Plan: In which let b, b, b, be the Plate on the supposed Wall; and let c, c, c, be the Kirb, on which stands a Lanthorn, or Cupola; also let a, a, a, represent the principal Ribbs.

From the Plan B, make the Section A; in which the Kirb, or Plate b, should be in two Thicknesses; as also that of c; by which it is made stronger: And indeed the principal Ribbs would be much better to be in two Thicknesses. The best Timber for this Use is *English Oak*, because abundance of that naturally grows crooked. As to the Curve or Sweep of this Dome A, it is a Semi-Circle; altho' in that Point, every one may use his pleasure. And in it are described the Purlins d, e, from which Perpendiculars are drop'd to the Plan B; so that f, is the Mould the lower Purlins are to be cut out by, before they are shaped or squared for Use; and that of g, is the Mould for the upper Purlins. I rather shew it with Purlins, because under this Head may be shewn the Manner of framing Circular Roofs in Form of a Cone.

To shape or square these Purlins, observe in A, as at d, and e, they are so squared, that the Joyns of the supposed small Ribbs are equal. Observe, as at e, the Corners of the Purlin, from which the Perpendiculars are let fall to the Plan B. So that your Purlin being first cut out to the Thickness required, as appears in e; and also to the Sweep f; so that k, is the Mould for the Bottom, and l, the Mould for the Top; by which, and the Lines from the Corners of the said Purlin e, the same may be truly shaped or squared.

N. B. This particular ought to be well digested, it being a principal Observation in a Circular Roof.

And from the Purlin d, in the Section A, Perpendiculars are drop'd to the Plan B. And in which it appears that h, is the Mould for the Top, and i, the Mould for the Bottom; so may this also be squared, which completes the Performance. As to other Particulars, due Inspection will explain them. If any should say, a Dome cannot be done, so safe without a Cavity as usual, let them view *St. Stephen's Walbrook, Stocks-Market*, built by that Great Architect Sir *Christopher Wren*.

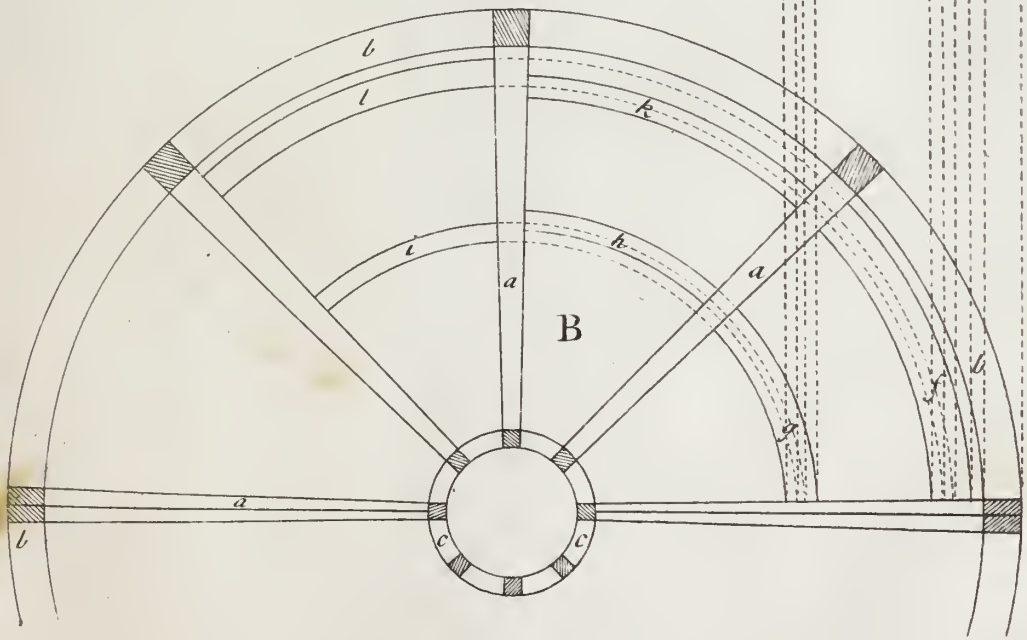
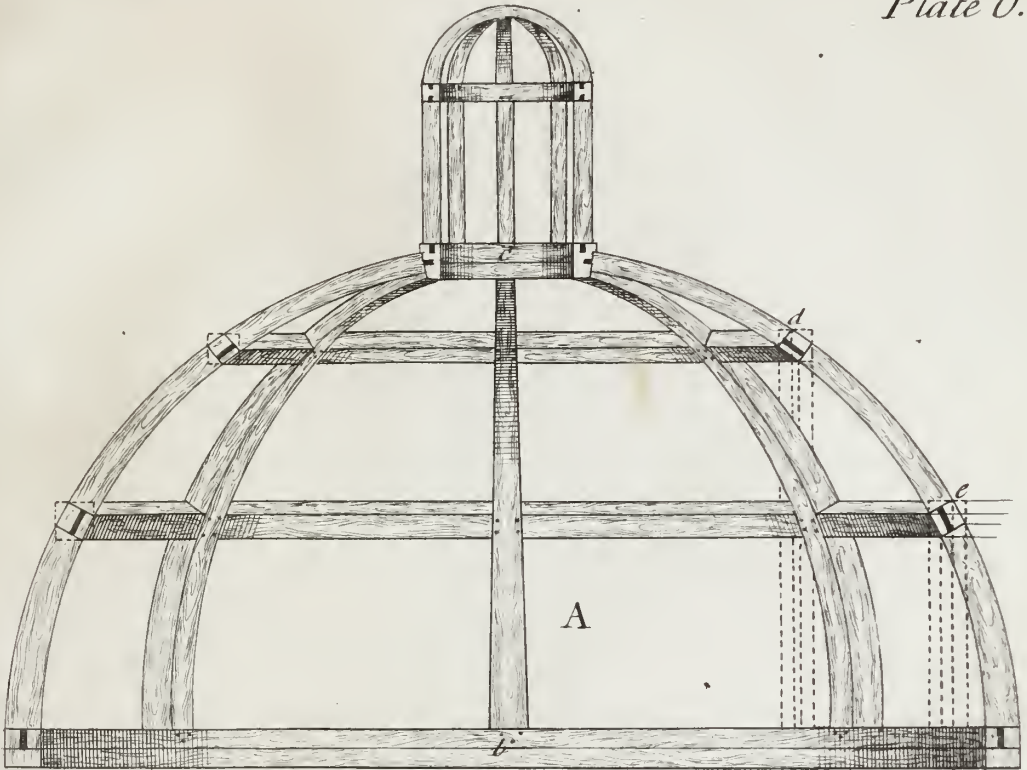





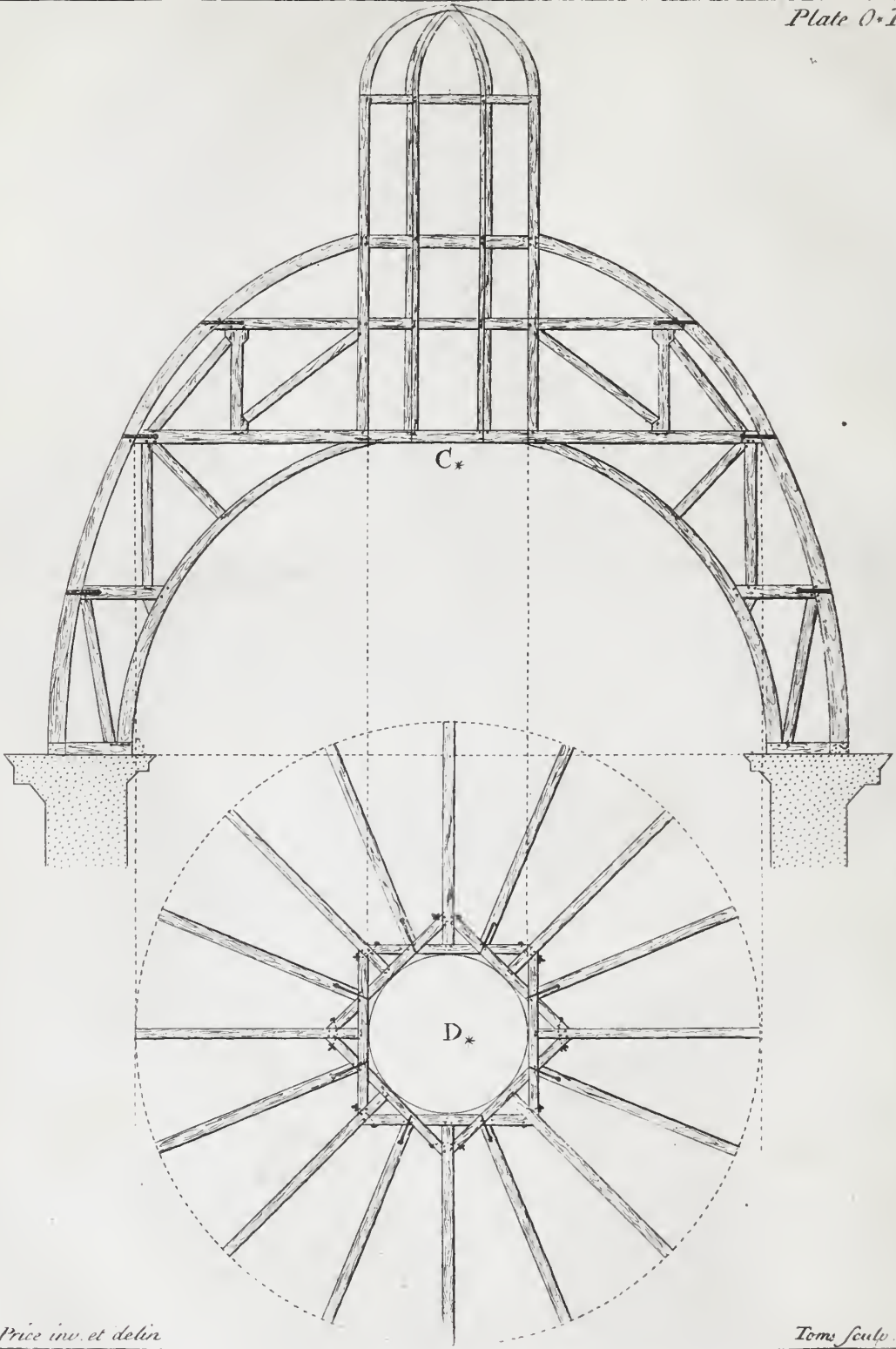



IN Perusing the foregoing Dome, which has no Vacancy, and that of *St. Paul's* Dome, that has so great a one, I thought necessary to represent one at a Medium, and which seems very concisely adapted to a Temple, of eighty Feet Diameter, in the Clear; the Walls I have represented one eighth Part of the Opening.

I suppose this a Temple standing clear from other Buildings, so that one may have a beautiful View of it; as to its Performance, 'twas sufficiently explained in the foregoing Plate; the Vacancy gives a great Strength to it, and renders it more capable of bearing the Cupola; for by framing that Part of the Section C*, as at a, a, in the Manner represented in D*, it not only gives an Opening for the Light to illuminate the In-side, but gives a great Strength to the Whole.

N. B. In all Roofs of a great Extent, the Wind is to be prepared against, as strictly as the Weight of the Materials which cover it, because it has so great a Force in Storms of Wind, and Rain; that is, it acts with more Violence than the Materials do, they being, (what we may call) a steady Pressure.

The Plan D* may be observed to consist of two square Frames of Timber, crossing each other, and halved together, the Corners of which, and the Intersections prove a very good Tye, and at the same Time is of a resisting Nature; so that it becomes the chief Connection in the Dome.

I suppose this Dome, to consist of sixteen principal Ribs; which is a Mean betwixt the foregoing one, which has but eight, and that of *St. Paul's*, that has thirty-two; this also may be framed with Purlins, or may have Ribs let into these principal ones, horizontally; so that the Boards that cover it, may stand upright as it were; altho' I don't think that a material Point. If the Plan were to be prepared for twelve principal Ribs, then two equilateral Triangles, crossing each other, might better suit than to half two Squares together.



N *St. Paul's Church* stands this Dome, a lasting Monument of the extensive Knowledge of Sir *Christopher Wren*.

As the Section of the Timber-work relates chiefly to this Treatise, and which by mature Consideration I find artfully contrived, therefore it might seem Negligence not to oblige the Publick with it; I shall not mention the Strength, &c. of the Brick, and Stone, that form the other Parts of it, because it would fill a small Essay to give a particular Account thereof. I shall therefore give some Explanation of these Parts, as described on the Plate.

That of E, is a Dome turned over with Bricks; which were made on purpose, of two Feet in Length, which is Plaistered and Painted in a most beautiful Manner, by the late Sir *James Thornhill*.

That of F, is a Cone of Bricks, being one Foot six Inches in Thickness, and is also Plaistered, and Painted, and is seen through the Opening e, e.

That of G, is part of the Cupola, which is of *Portland Stone*, and is twenty one Feet Diameter, and near sixty four Feet high; and chiefly supported by the said Cone F; though it is mutually assisted by the Timber-work H, H, both which are curiously tyed together with Iron Cramps, that are run with Lead into the Stones c, c, c, &c. and then bolted through the Hammer Beams e, e, &c. so that by the Stone being work'd into, and with the Brick-work, it becomes like a Dovetail. Through this Section, (that is, between the Timbers) a Pair of Stairs leads to the Top of the Dome, on a Balcony as d, d, from whence you have a most beautiful Prospect.

That of I, is half the Plan of the Ribs H, which are interrupted as at a, a, a, &c. to give Light to the Windows in the Cone F, as at b, b, b; there are thirty two single Trusses as at H, which form the Dome.

That of K, is half the Plan of the said Cupola.

By this time I think nothing material has been neglected to be mentioned, except it be that this Dome has not Purlins in it, but is prepared with small Ribs that lie horizontally; so that the Boards that are nailed thereon, stand as it were upright. In so large a Work, these said Ribs have no occasion to be shaped as shewn in Plate O, but are placed so as that their Sides tend to the Center of the Dome, and which gives the Center for their proper Sweep, or Curve.

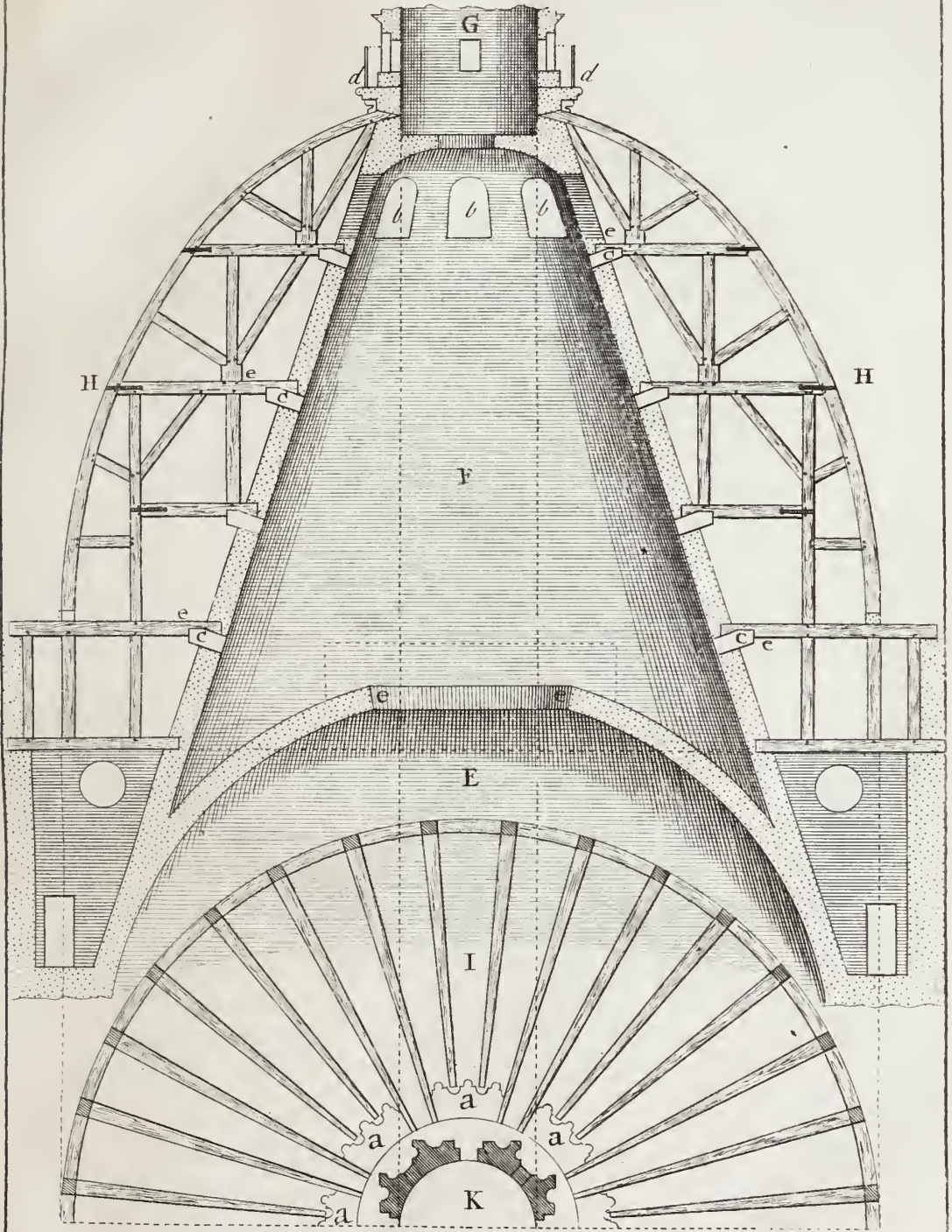

F. Price delin.

taken in the Year 1753

Tom's fecit

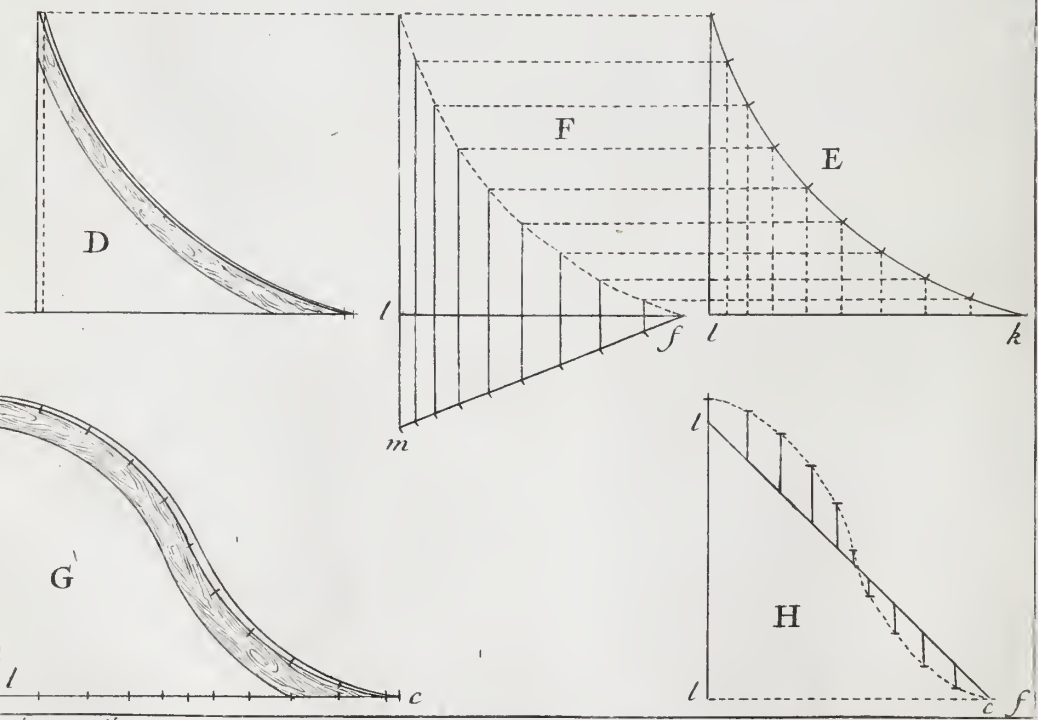
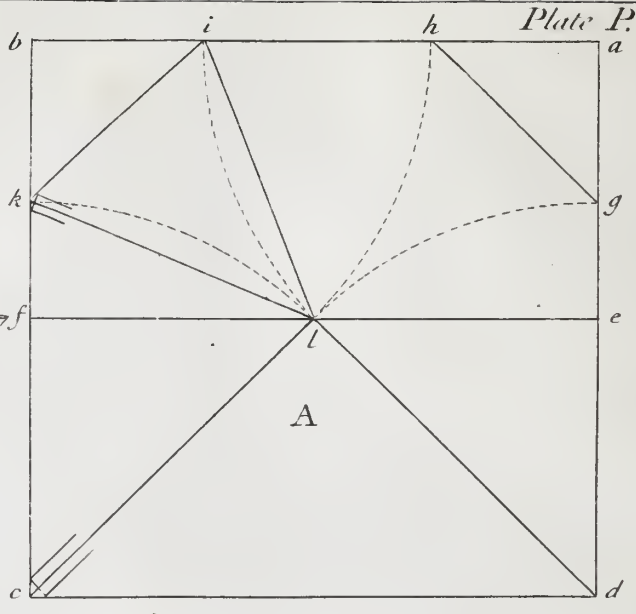
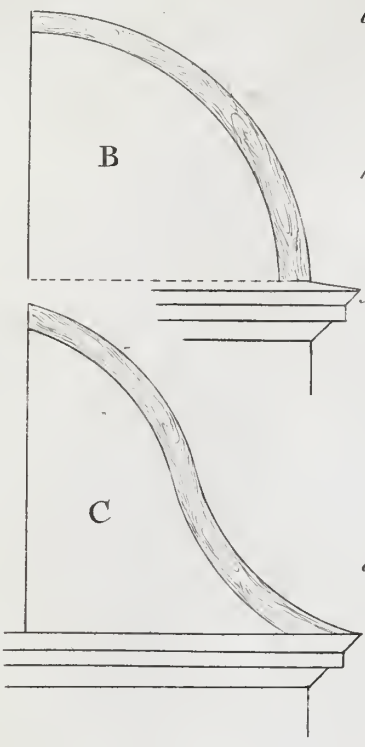



ARTICULAR Observations on the Manner of Covering Lanthorns, or Cupolas.

Let A, be a Plan, the upper Part of which is made Half an Octagon, by PROPOSITION S.

It is observable, that a Circular Roof, as B, should extend no farther than the Upright of its Support, and there made so as to carry off the Water; whereas an OG, Roof, as C, may extend to the Extremity of the Cornice, without Injury to its Strength, or Offence to the Eye of the most Curious. Also a hollow Roof, as D, may extend to the Extremity of the Cornice.

It appears to me, that the many Angles of a Cupola give it Beauty; therefore the Sweep E, is a regular Curve, the Base Line l, k, being taken from the Angle of the Octagon in the Plan A, as at l, k. This Curve E, is divided into a Number of equal Parts. In order to trace the common Rib F, from the said angular Rib E, observe in A, the Base of the common Rib f, l, which is placed in F, as from l, to f; continue the Perpendicular l, at pleasure; take the Base l, k, in E, on which are the Perpendiculars drop'd from the Curve, and observe to place that Distance k, l, in E, from f, in F, to any Part where it cuts the Perpendicular l, in F, as at m; from those Divisions raise Perpendiculars. So by continuing Base Lines, from the Divisions in E, to these Perpendiculars in F, their Intersection, or Meeting, is a Curve or Sweep exactly agreeable; and which indeed may serve as a Standard Rule to trace any Moulding whatever.

To Back the said angular Bracket D, observe to describe the Thickness of it on your Plan, as in A, at k; which shews how much your Mould must be shifted, as may appear in D. This also may be observed to be a general Rule for the Backing of any Bracket.

In G, is the angular Bracket of an OG, Roof, taken from the Plan A; as at l, c. And H, is the common Rib, or Bracket l, f, traced from G, as above is shewn. As also the Manner of Backing the Hip G, which must of course appear by Inspection.



ERCHANCE I may be accused with Neglect, if I don't give some Account of curvilinear Roofs of a great Extent, having given some general Hints of small ones in the foregoing Plate, therefore I have inserted these three Sections of them, to shew how firm they may be made. The chief Difficulty to struggle with, is the Plan of the Roof; which ought to be so contriv'd, that the Pressure of the Trusses may not thrust out the Plates; in order to which, the best way is, by halving two Triangles of Timber together, crossing each other; or two Squares, and by bolting the Points of each, through the Plate, or Kirb; the Plan being a Circle. Indeed Dovetailing them down, may be sufficient to prevent its flying out by the Pressure.

N. B. This may be better conceived by inspecting the Plates O* P*, and P* Q**.

That of I*, is prepared to bear a Ballustrade, such as may suit the middle Part of a Building; if it rise above the rest, so as to command a Prospect.

That of K* is suited to a round Temple, &c. and in Execution will have the Appearance of a Dome; because the hollow Part at Bottom will not be perceiv'd, it being so small; at least if it be, 'twill be no Defect; the Cupola on it may serve for a Clock to stand in, as having the Advantage of being seen at a Distance, or it may serve to illuminate the Inside; each of these are prepared to be supported by Columns, as at a, a.

That of L* may serve also to cover a round Temple, and by its being hollow in itself, may give the more Variety, if it stand disengaged; each of these, if used on a circular Plan, must be performed by the Rules laid down in Plate C; but if they were to stand on an Octagon, or any regular Polygon, then all Difficulties of that kind would be avoided; and to my thinking have full as pleasing an Effect.

I think, by this time, enough has been said of all Roofs whatever, and hope to give no Offence by so great a Variety.

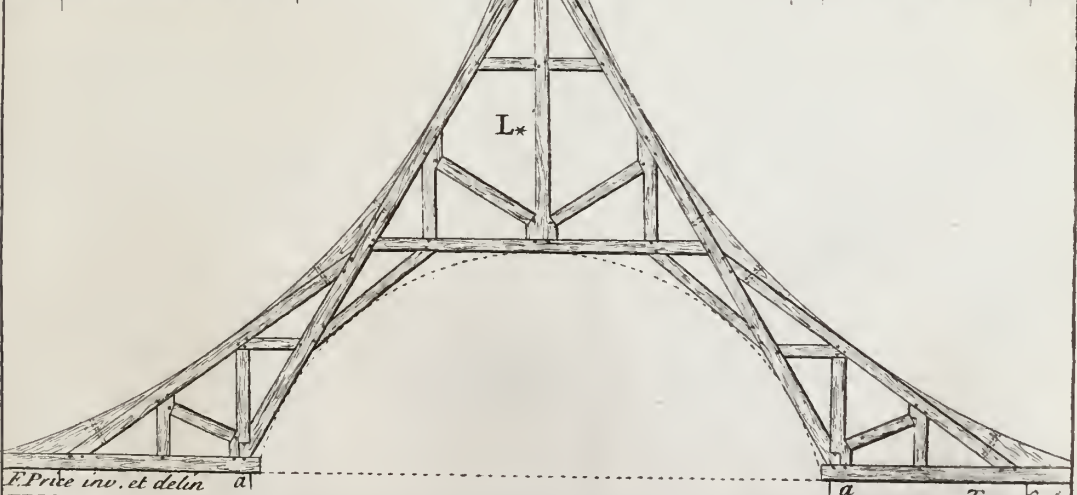
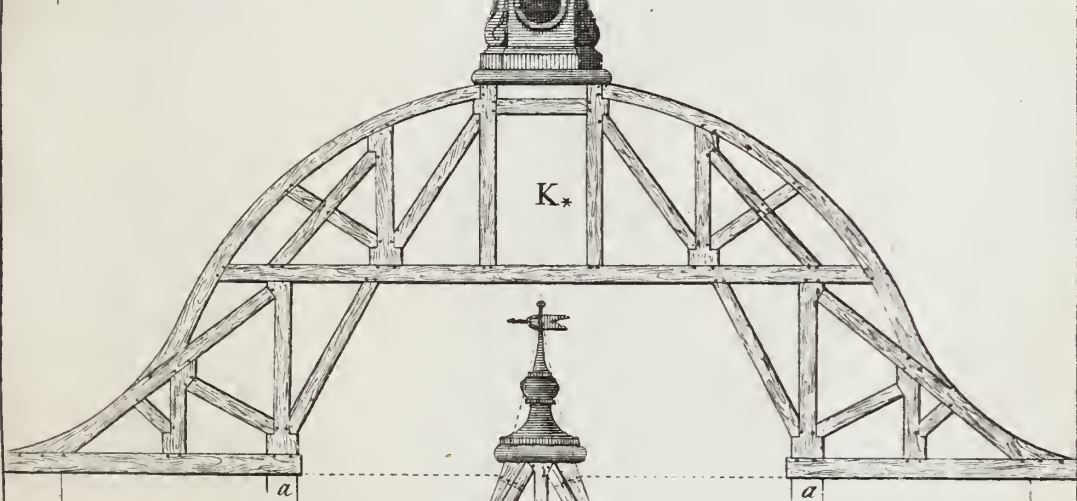
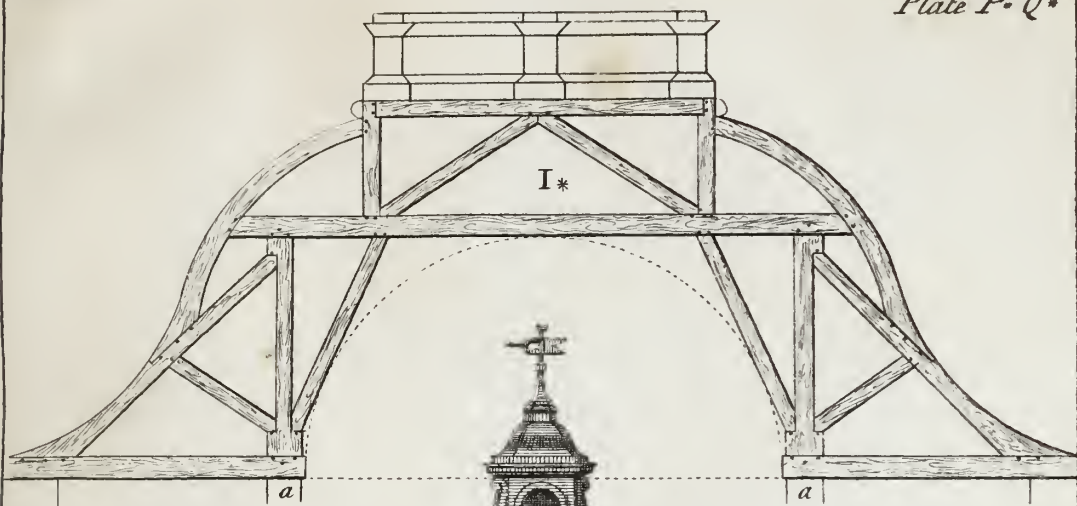

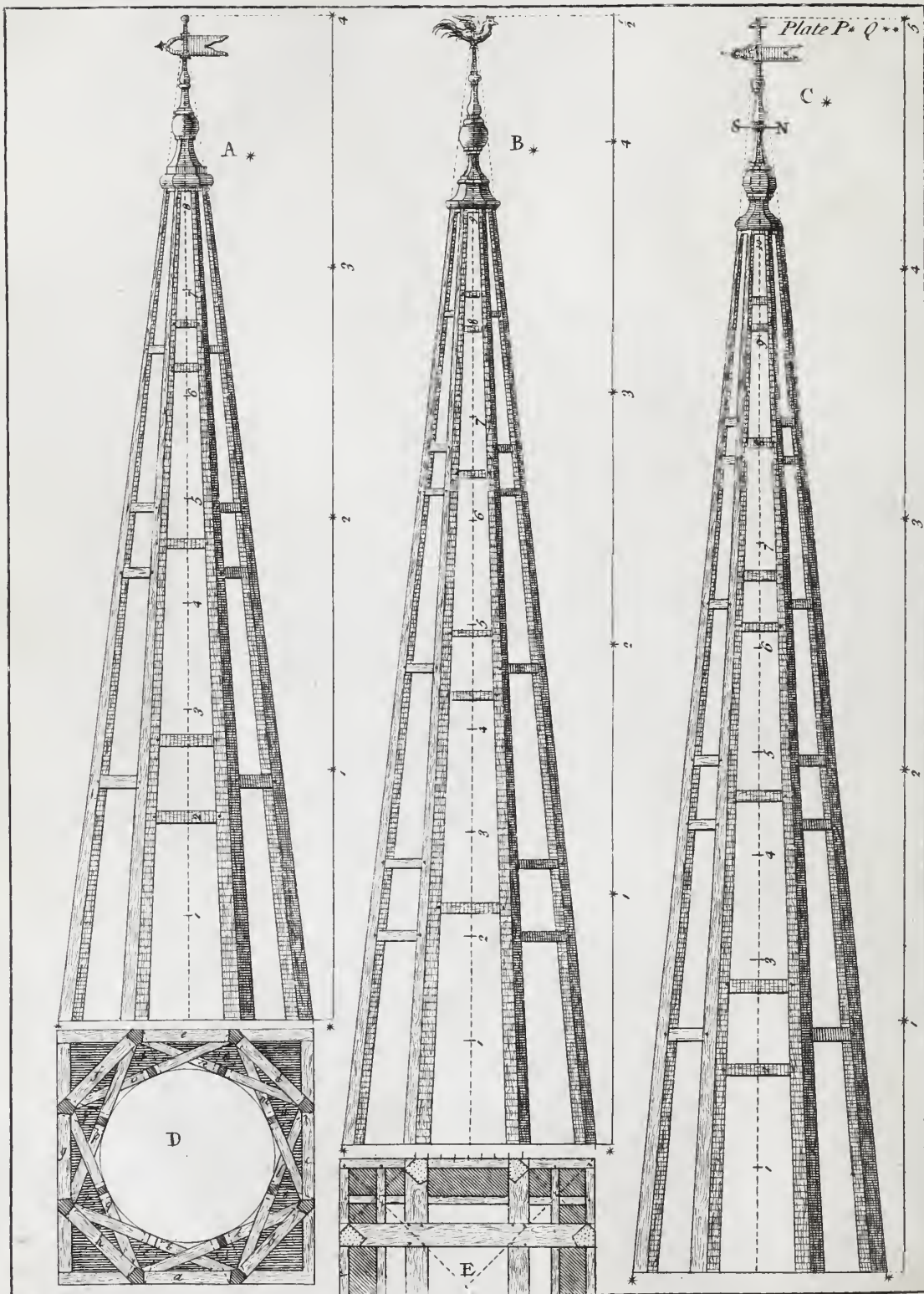



PERUSING the many Examples I have given for the Trusses of Roofs, (or Coverings in general,) I hope 'twill not be displeasing to say somewhat of Timber Spires; and as they have a pleasing Effect, I have presumed to lay down Rules whereby to shape them; which were founded on a serious Perusal of some of the most celebrated ones about *London*.

The first Proposition, as A*, is thus: Take the Width, or Diameter, of the intended Base of the Spire; the whole Height is equal to four Diameters; an Octagon is the best Plan for a Timber Spire, for many Reasons; and since none of them are executed without Weather-cocks, or Vanes, (*and which I am led to think was the Cause of erecting them*) to find their proper Height, with their Ornaments, do thus; take one Side of an Octagon, that may be described on the Plan; and make each Side equal in Height to eight times that Breadth, as does appear in the Draught, by the Scale. The remaining is for the Height of the Vane, or *Weather-cock*, with its Ornaments. The Length of the said Vane, is equal to two thirds of one Side of the Octagon at Bottom, being divided into three Parts, one for its Point, or *Dart*, and two for its Tail.

N. B. What is said of this, explains those of B, and C, with a little due Inspection; these Spires answer the three finest proportion'd Columns, *viz.* that of A, has each Side equal in Height, to eight times the Side of an Octagon, that may be described on its Plan. That of B, is equal in Height to nine. And that of C, is equal to ten. Which appears by the Draughts of each.

The Timbers of the Plan D, are thus connected together; first frame an Octagon, with Timber, as a, b, c, d, e, f, g, h; then halve two Squares together, as i, k, l, m, n, o, p, q; and frame them into the said Octagon. Lastly, (Cock or) Dovetail down the Beams, r, s, t, u, w, x, y, z, on which your Hips or corner Posts stand, and are framed into. So that by bolting these Frames together, and working up betwixt them, with such Materials as the Tower it stands on is built with, it takes off the Objection, that may be made, concerning its Rocking, Shaking, or Heaving, as it may be term'd.

Note, As to the Framing of the Sides, it admits of no great Variety; each Side becoming a Truss, by its being a Triangle; the other Parts that occur, have been explain'd in the foregoing Plates.



ERCHANCE Quotations from other Books, or Remarks on Fabricks already erected, might have given Satisfaction to some of my Readers; however, as this Subject has been drawn from Experience, I hope it will be acceptable, and more to the Purpose, than such a Production would have been; and as Spires are a material Part of Carpentry, I am therefore induced to describe somewhat more Variety of them, (as to the Tower that a Spire stands on, I cannot conceive it to be any other, than a kind of Pedestal,) therefore the Particulars of the Total Form, I shall leave to Inspection.

Lanterns, or large Openings, render a Spire weak, unless care be taken in the Performance; therefore I choose to explain that Particular, as usual. The Plan H, embraces the upper Part of the Tower F, as at a, b; not but on Occasion the upright Part, whereon generally the Dial is placed, may be of Timber. (And therefore capable of any Form, if done with Brackets, which may be fix'd on the principal Timbers); the Ogee Roof, by its Spreading, helps to embrace and strengthen the whole the better. The Plan I, embraces the upper Part of the Tower G, as at c, d; and as I said before, all Openings require Care, more particularly a Lantern; therefore I have drawn the Parts at large; K being the Plan on Top of the Lantern, as at e, f; and as so much was said of the Connection of the Timbers, &c. in the foregoing Plate, it needs not be repeated here; that of L, is the Lantern enlarged, and in which is shewn, how the diagonal Pieces, on which the Hips stand, are embraced by the Frame g, h, &c. being underneath the said diagonal Pieces, and the Pieces i, k, &c. lying on the said diagonal Pieces, which being bolted or screw'd together, prevent the Weight of the Materials, or the Force of the Wind, from separating them.

I make no doubt but due Inspection will explain the Particulars; and thus, I think to have compleatly furnished the Students in Architecture, with many Examples of the most firm Methods, of connecting Timbers together, in all the Variety of Cases that may probably happen.

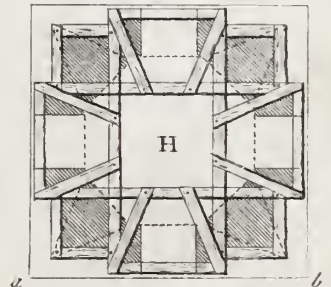
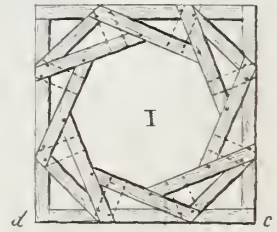
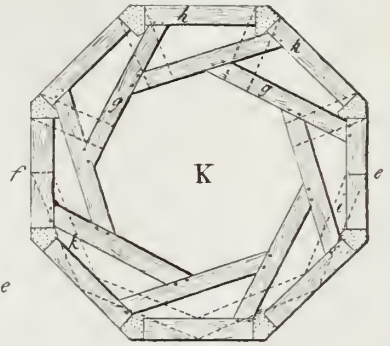
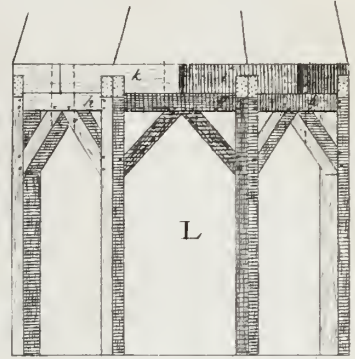
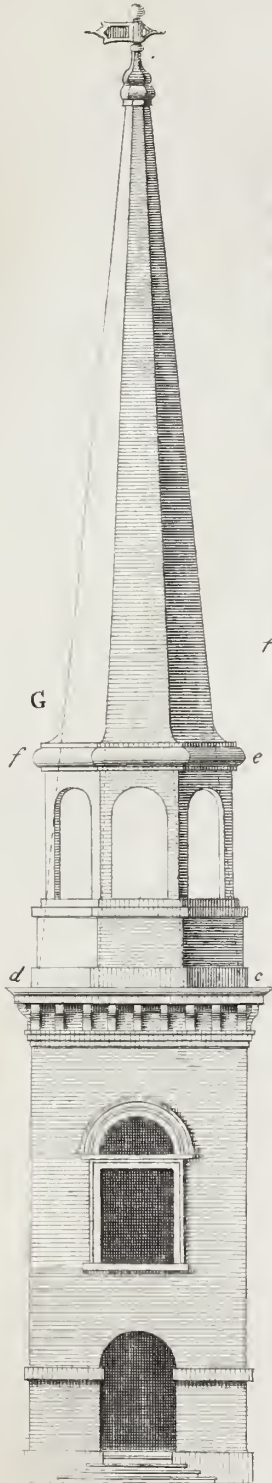
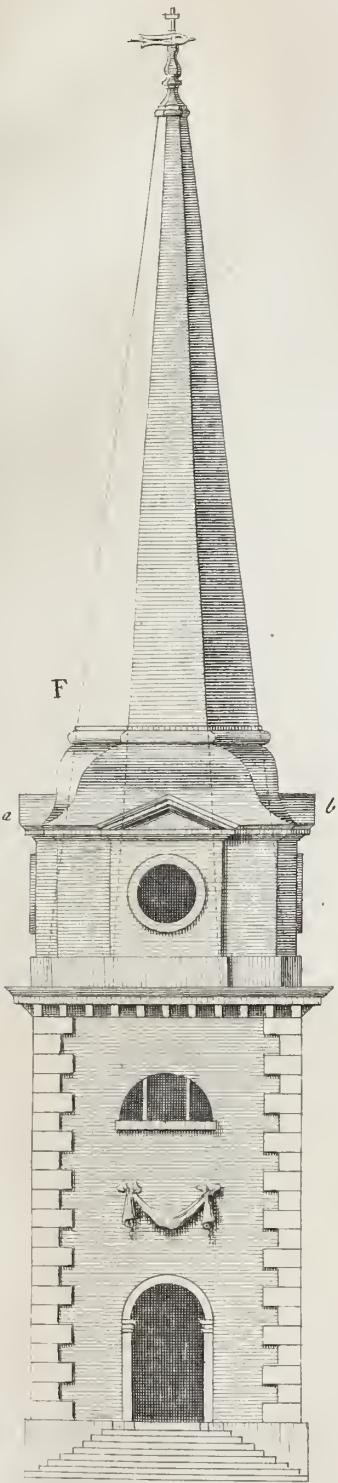

B

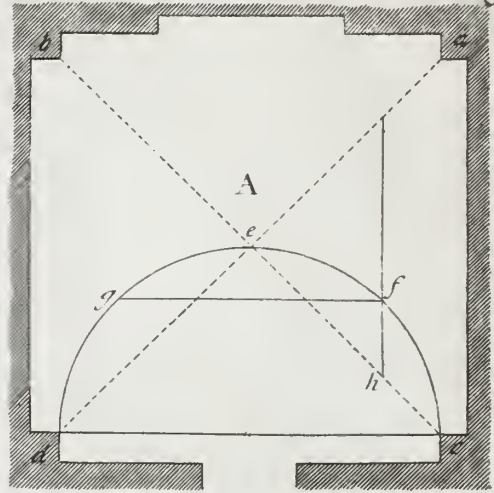
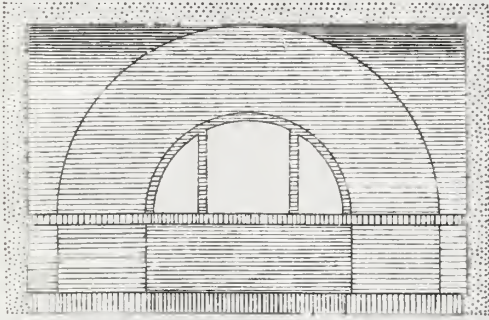

F

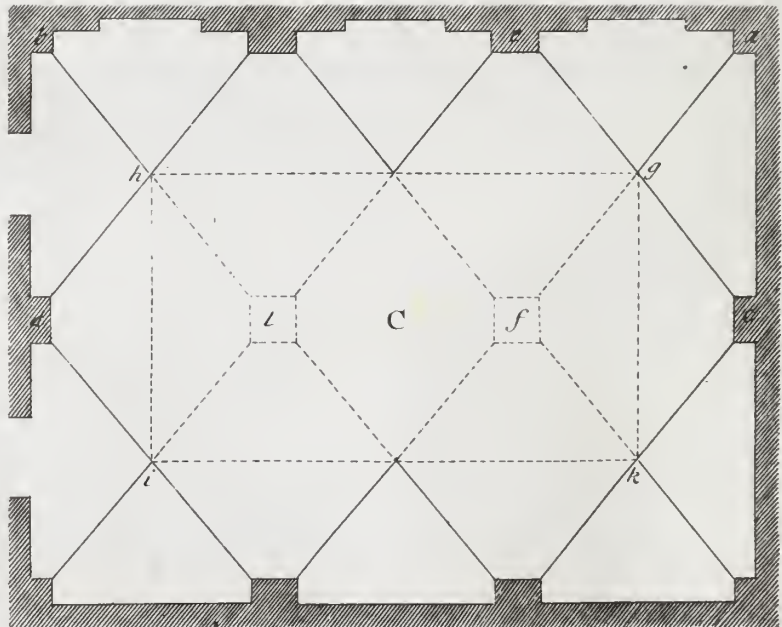
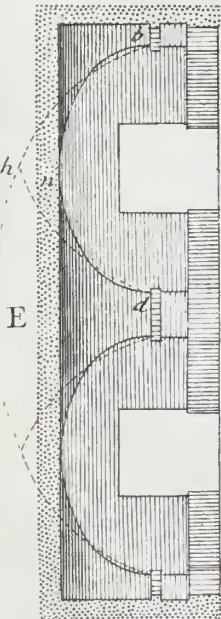
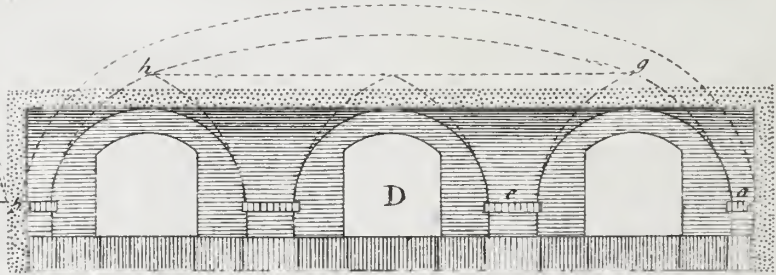
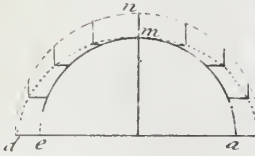



QUITE satisfied with what has been treated of, as to the Roof or Cover; I think it proper to shew the Nature of Centering for Vaults.

Let A, be a Plan of a Vault to be centered for Groins. At a, b, c, d, are Piers, generally prepared in and with the Foundation, which bear the Weight of the Brick-work. First resolve on the Curve you would have; as d, e, c, being a Semi-Circle, which is shewn by the Section B. Begin in A, at d, e, c; Center it through, as if it were a Common-Vault, and Board it; which being done, to make your Groin, set Centers, as from a, to c, and from b, to d; divide the Curve d, e, c, into four equal Parts, as at g, and f; so is g, e, f, small Centers you will want to nail on the Centers first boarded, whose Place or Plan is at h; these small Centers may be put in at pleasure, according to the Bearing of your Boards, that is, as to the Distance between each Center. To make your Groin streight on its Base, at some little Height over the Centers, strain a Line from b, to c, or d, to a; from which drop Perpendiculars on your Boarding, first fix'd at as many Places as you please, there drive in Nails, and bend a streight Rod 'till it touch them all; and then with a Pencil, or Chalk, describe the Curve so form'd, to which bring the Boards to be nailed on these little Centers, and their Joints will form a streight Groin. If this should be disapproved, in the next PLATE is a more accurate Method.

Let C, be a Plan of greater Extent, and which suppose to be supported by two Piers, as f, l. The Section D, is composed of entire Semi-Circles; then consequently your Curves in the Section E, will be Elliptical, as b, m, d, and may be described with a Trammel, or traced (by PROPOSITION K) as in F, may appear. What was said of A, explains this at one View.

If these Pillars should be in the Way, view the Plan and Sections again. First, form some principal Curve, as in D, at a, g, h, b; being an Ellipsis, so that the Centers will be a Gothick Sweep; against the Windows, as e, g, a, trace the Curve d, h, b, in E, agreeable to e, g, a, in D, with which Center it, as shewn in A, and make good your Groins to the Sides: Lastly, Make a flat Center, as at g, h, i, k, which Flatness is shewn in either of the Profiles or Sections D, or E, and fix it on your Centers before compleated, which, doubtless, due Inspection will make plain; and hereby you avoid the Pillars, and are equally as firm.

N. B. The Cause of those Centers against the Windows being a kind of Gothick Arch, proceeds from their making Part of the whole Sweep, or Arch, which though it does not add to its Beauty, it does to its Strength in a particular Manner. PLATE



REGARDING Variety, I have given here another Method for Vaults, and which indeed may give more pleasure to the Reader, as being a Curiosity never before publish'd, and may appear more intelligible than that in the foregoing P L A T E.

View the Plan G, and its Section H, which is compos'd of entire Semi-Circles, as b, f, e. See also the Section I, which is an Ellipsis traced from b, f, e, in H: But for Use, nothing is more true than the Trammel, as shewn in PROPOSITIONS L, M. This, I suppose, is so plain as to need no Explanation, otherways than what was said in the foregoing P L A T E, as on *Fig. A.*

See this Plan again, and also its Section I, from which is describ'd the Curvi-lineal Face K, and also the Face of the Semi-circular Arches, as L; all being alike. And this is what I call a more accurate Method for finding the Groin, so as to be streight over its Base, and at the same Time gives a standard Rule, whereby to account for any Curve, or Face of a Cieling whatever. The Curve in I, is divided regularly, tho' seemingly into unequal Parts, which being drawn to the Groin in the Plan G; as appears by the Figures 1, 2, 3, 4, 5, 6, 7, 8, 9; and which are transferr'd into L, at 1, 2, 3, &c. Also the Circle b, f, e, in H, is divided into eighteen equal Parts; the Half, consequently, into 9; which appears from b, to e, in L. This Method doubtless will be plain, and therefore needs no farther Explanation.

That of K, belongs to the Section I, extended as it were; and that of L, belongs to one of the small Arches of H, also stretch'd out, they being all alike.

N. B. To find the Groin by a more common Method, do thus: Erect a streight Piece of a Board, or the like, on the Corner of the Pier the Groin springs from; and drive a Nail in the Point of the Groin's meeting, on which fasten one End of a Chalk-Line, straining it tight, slide it down the Side of the said streight Piece, and it will form the Groin, so as to stand Perpendicularly over its Base.

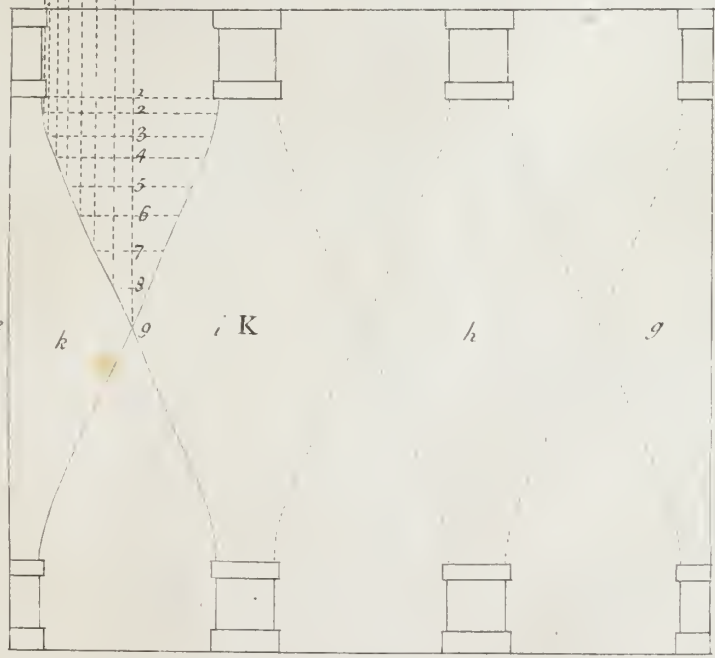
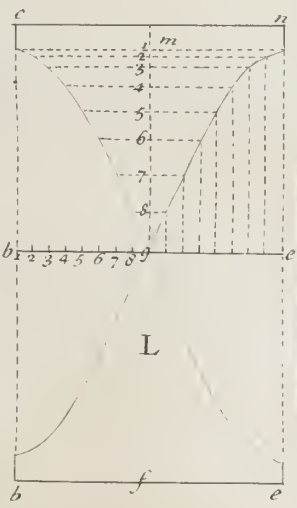
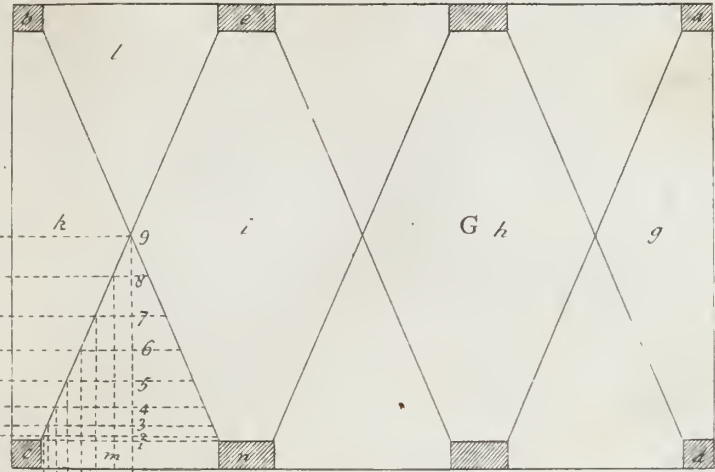
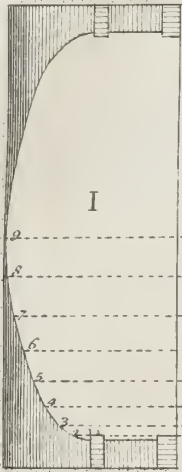
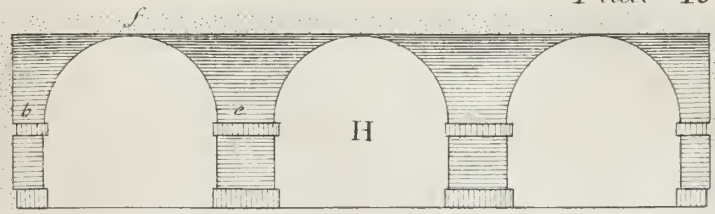

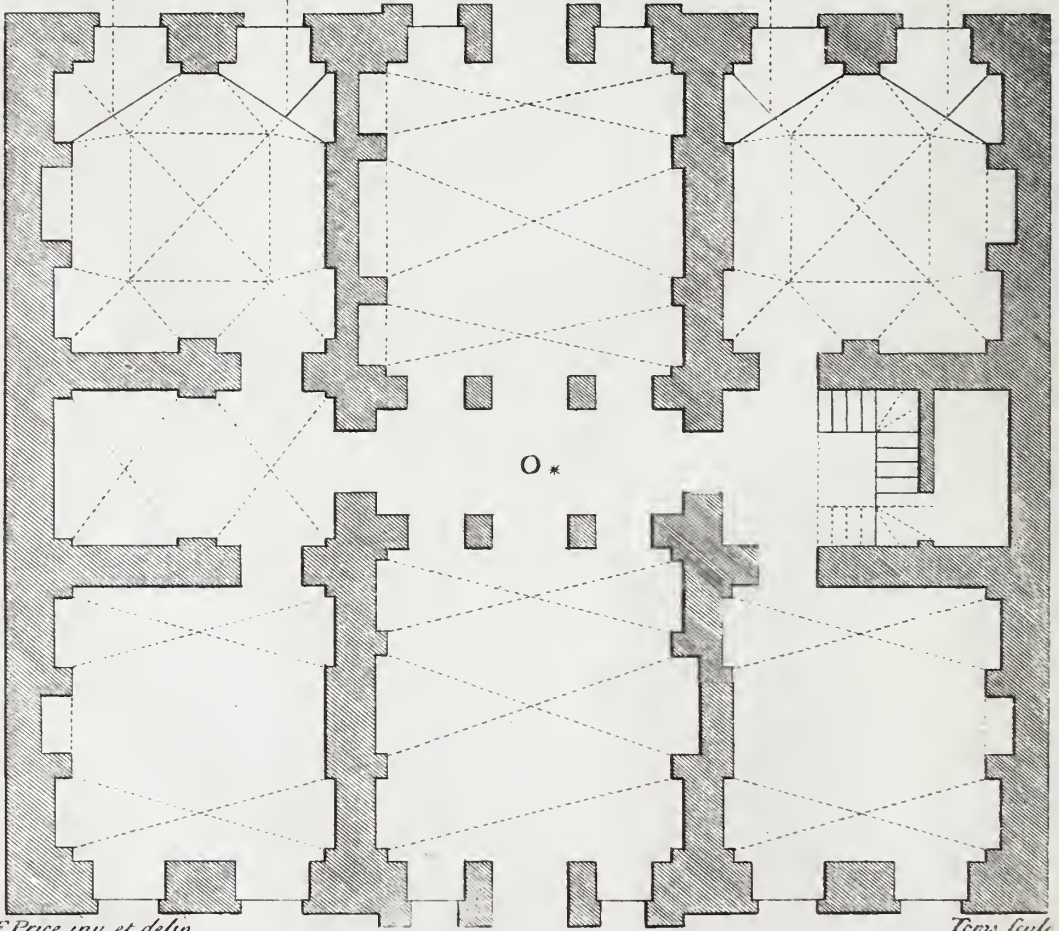
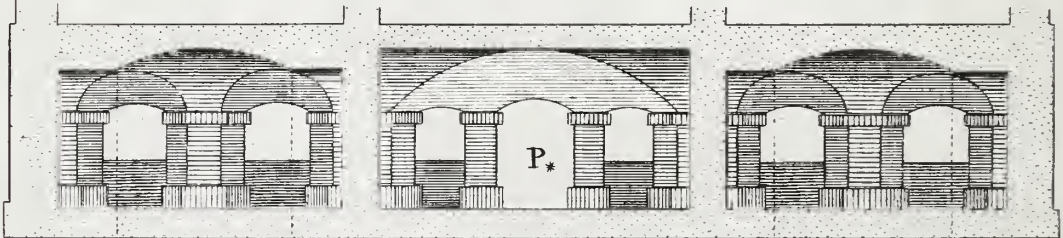
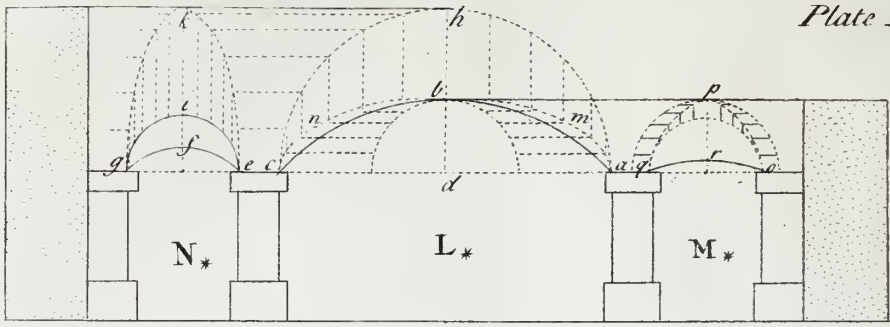



REVIEWING Seriously some Remarks, which I had made, concerning the Force of Arches; they seem'd worthy of Observation, and will, I hope, be acceptable to the Publick.

Admit the Opening L*, to be a Segment, or Part of a Circle of a great Extent, as a, b, c; and Necessity should require the small Opening M*, or N*, to be joined thereto, and arched over for a particular Use; such as a Bridge, or Portal, &c. the proper Sweep, or Curve for them, (according to the Laws of Strength,) will be thus: Take the Height of the large one, as d, b; observe how many times it may be contained in the Base a, c, as here four times and an half; therefore divide the Opening e, g, in N*, into nine Parts, two of which is the due Height; as e, f, g; (*it may be done by the arithmetical Rule of Proportion.*) This small Arch will be more capable of resisting the Force of the great one, if it be part of the same Curve, as in M*, at o, r, q.

Observe the same Figure again; and admit the Opening L*, to be a Semi-Circle, as a, h, c; then the Side Arch as N*, may be a Semi-circle also, as e, i, g; observing to place it on the same Base or Level.

There is abundance of Difference between what is above observed, and centering for Brick-work, or ribbing for Plastering; for in Brick-work especially, the Groin's embracing several Parts of the Plan, gives it Strength; and its rising to an equal Height, gives it Beauty; a Specimen of which, we may see in the aforesaid Figure, *viz.* admit the Opening L*, to be a Semi-Circle, as a, h, c; and the lesser Opening N*, to be an Ellipsis, agreeing with it, as e, k, g; or again, admit the large Opening L*, to be an Ellipsis, as a, m, b, n, c; and the lesser Opening M*, to be an Ellipsis, agreeing with it, as o, p, q; these will necessarily prove both Assertions.

I have describ'd the Cellar Plan of a Dwelling-House, as O, to shew the Variety of Groins, that may be required; which I have done with intent to make the Knowledge thereof more plain.

The Plan of each Groin, is represented by prick'd Lines, whose Section is P*; the rest seems plain by Inspection.



SUPPOSE *M*, to be the Plan of a Cieling, as *a, b, c, d*; and in it, it is required to have a large Frame, Gulochi, or Pannel, as *g, h, i, k*.

First, produce some one Side or End of the Room, as *N*. Let it be required to describe the curvilinear Face of the Cove. The Extent of the End of the said Room, is *a, b, f, e*; and it is Coved one fourth of its Height, as *m, b*. The said Frame or Pannel being *g, h*; the Quarter-Circle *m, g*, is divided into eight equal Parts, which are transferred to *P*; so that *m, g, h, l*, is the Face of *O*, as stretch'd, or extended out, on which any thing propos'd to be describ'd therein, may be truly perform'd.

In *Q*, is shewn the Plan of a Nich, or Dome. If a Nich, let it be demanded to be finere'd with Walnut-tree, &c. If a Dome, let it be required to be cover'd with Boards or Lead. Divide it into any Number of Parts, as here into nine; which transfer to *S*, as appears from *k*, to *l*. Describe the Section also, as *R*, being a Quarter-Circle, which divide into any Number of Parts, as here into five, as is shewn in the Figure from *h*, to *i*; which transfer in the Plan *Q*, from *a*, to *f*; Middle some one Division, as from *4*, to *5*; then take those Distances from *R*, and transfer them to *S*, as from *f*, to *5*; so that each Division is Halved, or Middled, as *f, a; f, a; &c.* on these Lines place the Distances from *Q*, as at *e, d, c, b*, to *1, 2, 3, 4*, in *S*; and these will form such Curves as shall meet.

N. B. The more Parts it is divided into, the better and truer it will be perform'd.

In *T*, is shewn the Plan of an Elliptical Nich; its Section is the same. In the Plan *T*, is shewn the Thickness of the Ribs (supposing it to be prepared for Plaistering) as *i, k, l, m, n*. The Manner of forming their several Curves, as *U, W, X, Y, Z*, is best done with a TRAMMEL. Some of these Ribs must be sloping, so as to require the Mould to be shifted, as has been before shewn, in PLATE P.

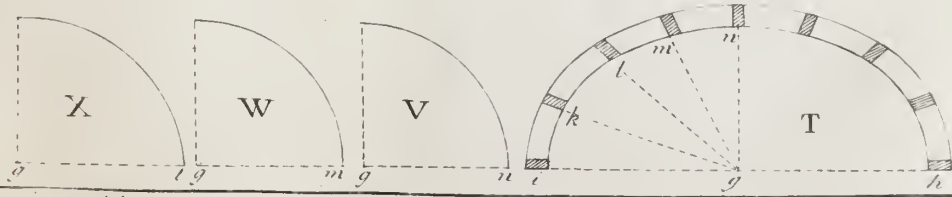
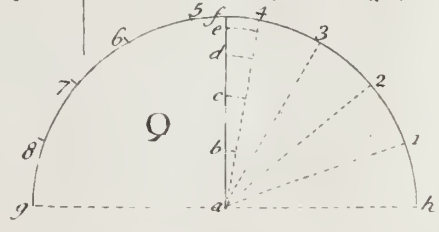
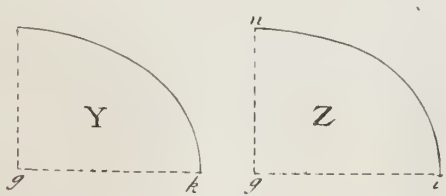
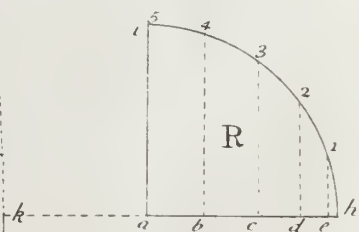
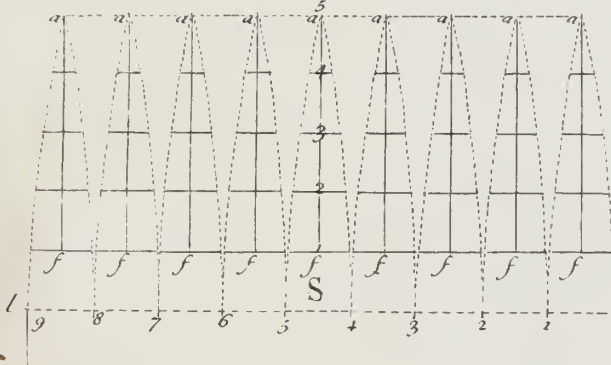
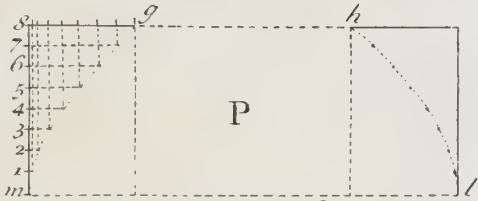
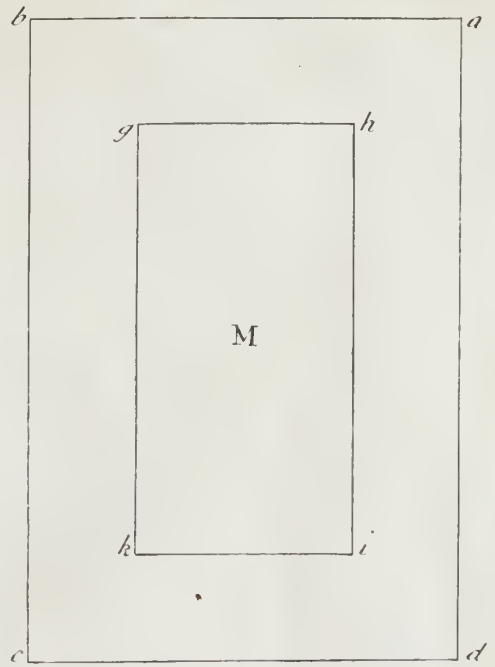
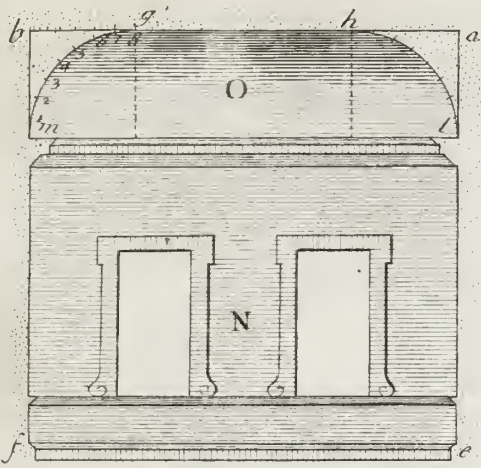

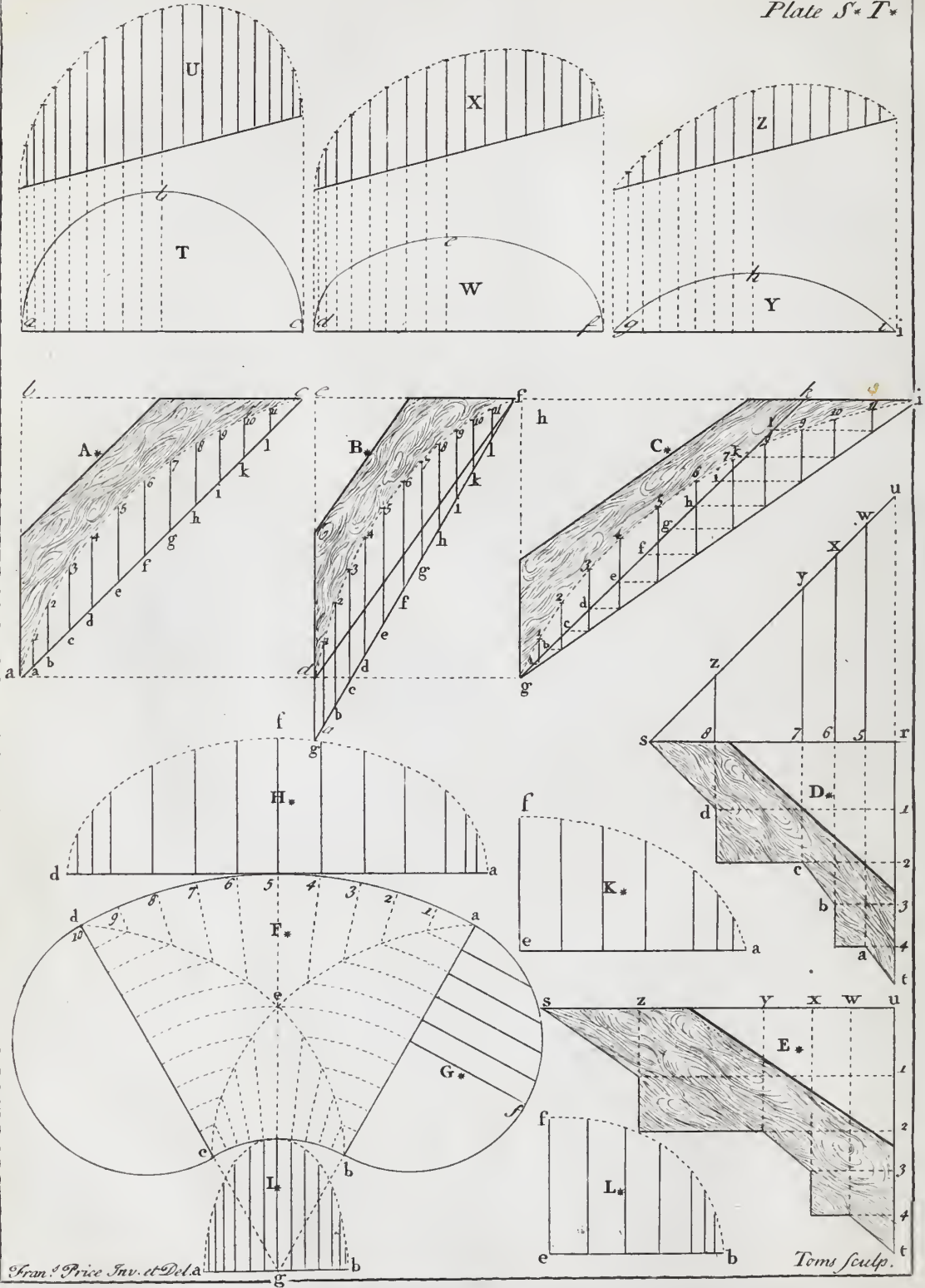



MUCH Things, as the Construction and Use of Lines, are not conceiv'd by every one; therefore because I would omit nothing that, I think, would prove useful, I have inserted several more Examples of Tracery, the Knowledge of which seems indispensably necessary.

That of T, is a regular Semi-Circle, as a, b, c; from which is traced the Raking (or Rampant) one U; that of W, is a regular Ellipsis, as d, e, f; from which is traced the Raking one X; that of Y, is a regular Segment (or Part of a Circle,) as g, h, i; from which is traced the Raking one Z; the Manner whereof being so plain, a farther Explanation seems needless.

As to the particular Use of these kind of Arches, I must leave to the Determination of the Curious, and have nothing farther to say on that Head, than that if Occasion require either of them to be executed, there is no other true Way to describe them.

That of A*, is supposed to be the Mitre Bracket of a Cove, whose Projection is b, c; and the Height thereof is a, b; the Curve being a Segment, or Part of a Circle, let it be demanded to trace a Curve from it, as B*, which shall be agreeable thereto, if applyed as a common Bracket, e, d, being its Height, as before, and e, f, its Projection, first, divide the given Curve, being A*, into a Number of Parts, or if you make Points thereon promiscuously, 'tis equal. From these Divisions, or Points, drop Perpendiculars to some streight Line, as that of a, c, observing their Meeting with the said Line a, c; and for Practice, take off all these Distances on a Lath, (or Rod), applying the proper End thereof to the Projection of the common Bracket B*, being f; observing where the other End passes through the Perpendicular Line e, d, as at g; there raise Perpendiculars (long enough) from the said Points, then draw the Line d, f. Lastly, Transfer the Distances, as from the streight Line a, c, in A*, to the Figures, to that of d, f, in B*; which no doubt Inspection will explain, more especially if the Letters and Figures be duly observed.

And for Variety, view the Figure A*, again; and admit it were the Curve of a common Bracket, let it be demanded to trace a Mitre, or Angle Bracket from it, as C*; g, h, being its Height as before, and h, i, its Projection, (as to the Method of finding the Projecture of either, no doubt but every one knows it) take the Line, as a, c, in A*, which in Practice (as was before observed,) I suppose to be on a Rod or Lath, with its Divisions, or Points on it; and which transfer to C*, as g, k; then draw the Line g, i; Lastly, from the said Points on the Line g, k, draw Base Lines, observing their meeting the Line g, i; at which respective Places raise Perpendiculars, and transfer your several Heights from A*, as before, observing to place each in its due Position. And although the Abundance of Points should render this Method somewhat confused, it may be evaded by making but few Points, and driving Nails therein, round which a straight Lath being bent till it touch them all, the Curve may be described with a Pencil, &c.

N. B. This may serve as a general Rule, for all such Curves as are not regular, or cannot be formed with a Trammel, supposing either to be the given Curve.

That of D*, represents a common Bracket for a plaister'd Cornice, *whose Shape, the Plaisterer ought always to be consulted for,* let it be required to trace a Corner, or Angle Bracket from it, as E*; first, draw base Lines from the respective Angles, a, b, c, d, to the Line t, r, as 1, 2, 3, 4; and also Perpendiculars to the Line r, s, as 5, 6, 7, 8; and (because an Example for finding the Projecture of the Angle or Mitre Bracket, may be required) observe to make r, u, equal to r, s; so is u, s, the Projecture of the said Angle or Mitre Bracket; and the Points will be w, x, y, z; so that by transferring this said Line with its Points, as before, to E*, as also those of the Height, as before, draw Perpendicular and Base Lines; as no doubt Inspection shews. Their Meeting gives the Shape of the Bracket as desired, and this also may serve as a standard Rule, in any such Case. As to shifting this Mould (in Practice) so as to give the said Angle Bracket its true Back, there seems to have been enough said in Plate P.

Note, The principal Curve being formed on any plain Superficies, it may be taken off on a Lath, as before was observed; and by it the required Curve may be described on a Piece of Slit-Deal, &c. of a Width equal to what the Arch rises from a straight Line, with an Allowance of Wood capable of holding it together.

That of F*, is a Plan, or Specimen of circular Groins, whose Extent is a, b, c, d; an Example of which may be seen in *St. Clements Danes*, in the *Strand*, and in several other circular Buildings, and in my Opinion it is a Curiosity worthy of Regard. To find the Plan of these Groins do thus: Divide from a, to d; and from a, to b; into a like Number of Parts, as into ten; the Lines a, b, and d, c, being continued, meet in a Point as g; being the Center of the Curves, a, d, and b, c, divide also from a, to d, into ten Parts; which being drawn to the Center g, divides the Line b, c, into the same Number of Parts equally, so that the Meeting of these Lines, is the Plan of the Groins, as a, e, c, and b, e, d; and their Upright is H*, I*, K*, L*, each being traced from the Semi-Circle, a, b, f, in G*, (being the principal Curve;) as to the Method whereby it is done, enough seems to have been said of the foregoing Examples to explain it; the Letters of Reference shews plainly what Part of the Plan each Curve belongs to, which being bent agreeable thereto, will strictly correspond with each other.

N. B. If the principal Curve had been a Segment, (or Part of a Circle,) or an Ellipsis, the Method of Performing would have been the same.

This Plan would be difficult in Performance, if required to be ribbed with *Timber* for *Plastering*; but if to be centered for *Brick-work*, it would be much easier; because the Centers might be placed as from the Line a, b, to that of c, d; as in a common Vault. The Curves of each Center would be different on account of its being Taper, but the Height is equal; these Centers should be boarded as others are, the Boards requiring to be taper only.

To make the Groins so as to hang over the Plan, the Sides a, b, e, and c, d, e, must not be centered as usual; but have Ribs agreeable to the Plan, and placed horizontally, so that the Boards would stand as it were upright; as in Domes, which was explained in the foregoing Plates, which shews the Method for finding the curvilinear Form of any Ceiling.

N. B. The foregoing PLATES must be well understood, in order to describe on the Centers first boarded, the accurate Curve of the Groat; which can be done by no other Method, than is there shewn.

If this Plan were to be executed with Ribs of *Timber* for *Plastering*, then the Groins must be performed by the Methods as will be hereafter inserted, for the twisted Rails of Staircases, on account of their Plan, not being a regular Curve.



THINKING it may be agreeable to my Reader, I have chose to explain some principal Matters in Stairs, such as their Form, the Kneeling, and Ramp of their Rails, with a new and exact Method to square a twisted Rail, either for Stairs or other Uses; which Point having never yet been fully clear'd, I hope it will be found useful.

Let A, be a Plan, or Opening for a Stair-case; and b, c, d, be Door-Ways, and e, a Window to light the same. The first Thing to be considered, is the Height of the whole Story, or Floor; then form some Plan for the Landing the Steps, and the Half-pace; observing that the Rise of each Step be not less than five Inches, nor more than seven: And that the Tread, or Breadth of the Step, be not less than nine Inches, nor more than fourteen: These are best done on a Rod, dividing them exactly. This Height or Rise, and the Tread or Breadth of each Step, is called a Pitch-Board; which shall be hereafter shewn, with its Use: The Length of each Step may be any thing above three Feet, as the Place will allow. (These are called Dog-leg'd-Stairs.)

In B, is shewn an Open Newel Stair-case; g, h, i, being a *Venetian* Window to light the same, and k, l, m, n, f, Door-Ways leading to, or from the said Stairs. These open newell'd Stairs may be lighted from above, supposing there is not a Conveniency for the Window, g, h, i.

It may be observed, that Stairs ought to be described, and accounted for justly, at the same Time a Plan of a Building is made, for want of which sometimes unpardonable Errors have been committed: Such as having a little, blind Stair-case to a large House, or, on the other Hand, to have a large spacious Stair-case to a little one.

PALADIO says, in placing of Stair-cases, the utmost Care ought to be taken; it being a Difficulty to find a Place convenient for them, that will not at the same time prejudice the rest of the Building.

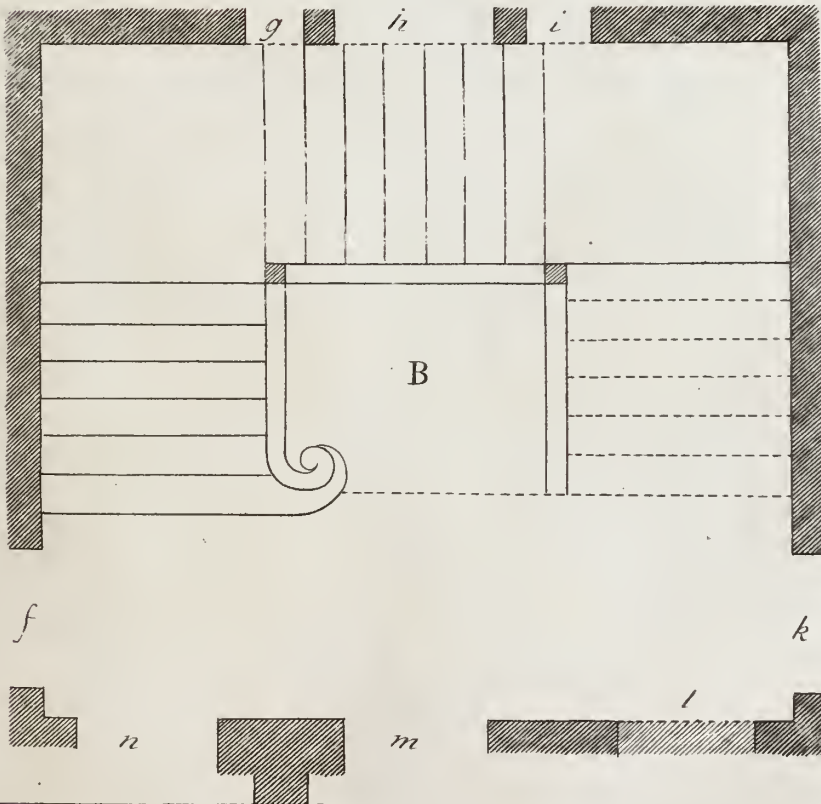
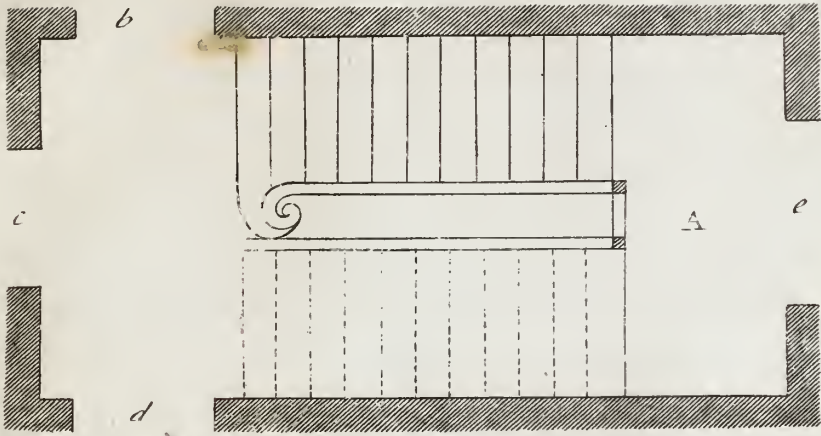



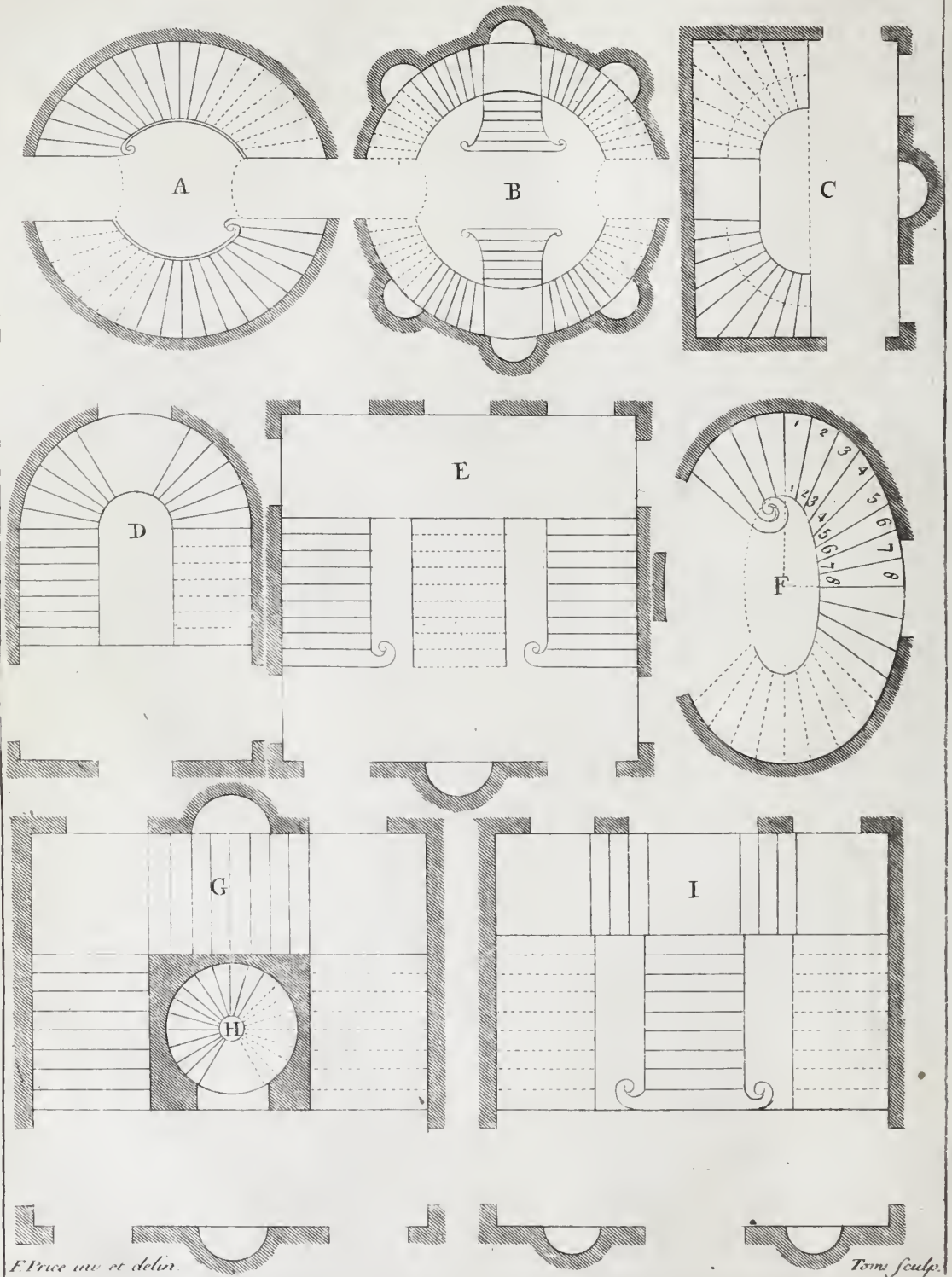



HAT Practice has been my Guide, may easily appear by this Variety of Plans of Stairs, conformable to what was observed before.

Circular Stairs are never used for Beauty, but chiefly for Conveniency of going up in a little Room; they admit of being better lighted from above, in case they are placed in the Middle of a Building; and in their Formation should have this strict Observation, *viz.* to be equal in their Tread, or Breadth to the other Steps, at the Distance of two Feet from the Middle of the Rail, or nearly so; the Reason is, in going up, or down, your Hand is generally on the Rail, (which is made for that Purpose,) so that betwixt both your Feet, will generally be this Distance of two Foot, as was before observed, so that the Stairs are thereby render'd easy; the Feet feeling no Difference, for what is contracted on one Side, is seldom trod on, and very seldom on that Part that is extended, unless two Persons go up or down together, or pass each other.

This Method is observed in the Plans A, B, C, D, H; but is varied a little in the Plan F, on account of its being Oval, or Elliptical; on which Curves the Steps are equally divided, on account of the Rail, and String-board, &c. as will be more plainly shewn in PLATE U, W, by Sections of each. Those of A, and B, may be lighted from above. Those of C, D, F, may be lighted by a Side Light, or as Occasion or Convenience require.

Those Plans of E, G, I, are proper where Midzanino's are made use of, especially that of E, on account of its coming up half the Height of the Story, at the Half-pace; as to that of G, I cannot highly commend, but that indeed is not material, my Meaning being to give Variety only.

I beg leave to make one Observation, concerning the placing of *Busto's*, or *Vases*, in Niches by the Sides of Stairs, *viz.* by having so many different Views of them, in ascending, and descending, no Part of their Beauty is lost. I therefore conclude, they must necessarily prove very entertaining, and answer the End of their being so placed.



NT O some, this Method may be known though not practised. To find the proper Kneeling and Ramp of Rails.

In C, is represented a short Flight of four Steps, and Part of a Half-Pace, on which are shewn two Ballusters on a Step; a, b, is the Rise or Height of one Step, and b, c, is the Newel, generally two Feet four Inches and a half high, and sometimes two Feet six Inches high, c° and c, d, is the Thickness of the Rail, the Kneeling o, is in the Middle of the first Balluster; from e, to f, is also the Height of the first Step on the Half-Pace; and f, g, the Height of the Newel, agreeable to that of b, c, and g, h, is the Thickness of the Rail; from h, to i, is generally the same as from o, to c, which Line h, i, continue at pleasure; for on it is the Center for the Ramp. With your Compasses find the Center k, which touches the Back of the Rail n, and the Point of the Ramp i; by PROPOSITION O, find the Point of Touch n; draw the Line k, n; describe the Ramp, and also the turned Part of the Ballusters, as may be seen by the prick'd Line.

Over this, is represented the Alteration that ought to be made, if you place three Ballusters on a Step; that is, that the Kneeling ought to come to the Back-side of the first and last Ballusters, as at p, and q. If it be said, the Method in Figure C, is not fully express'd; to find the Height of the Ramp agreeable to the Kneeling, let Z, be the Rail, the Bottom is continued as by the prick'd Line appears at u, and w; take the Distance u, t, and set from w, to x; from x, set one Rise, or the Height of one Step, as at y; and that gives the Height of the Ramp, and is the same as the Method in Figure C, notwithstanding they differ in Appearance.

In D, is shewn the Manner of Fluting Newels for Stairs, as *; and also Ballusters, as †; the Newel having twelve Flutes, and the Ballusters eight. If the Stuff be large, the Flutes may vary; thus the Newels to have sixteen Flutes, the Ballusters twelve; and in this Case, PROPOSITIONS Q, and R, may be useful.

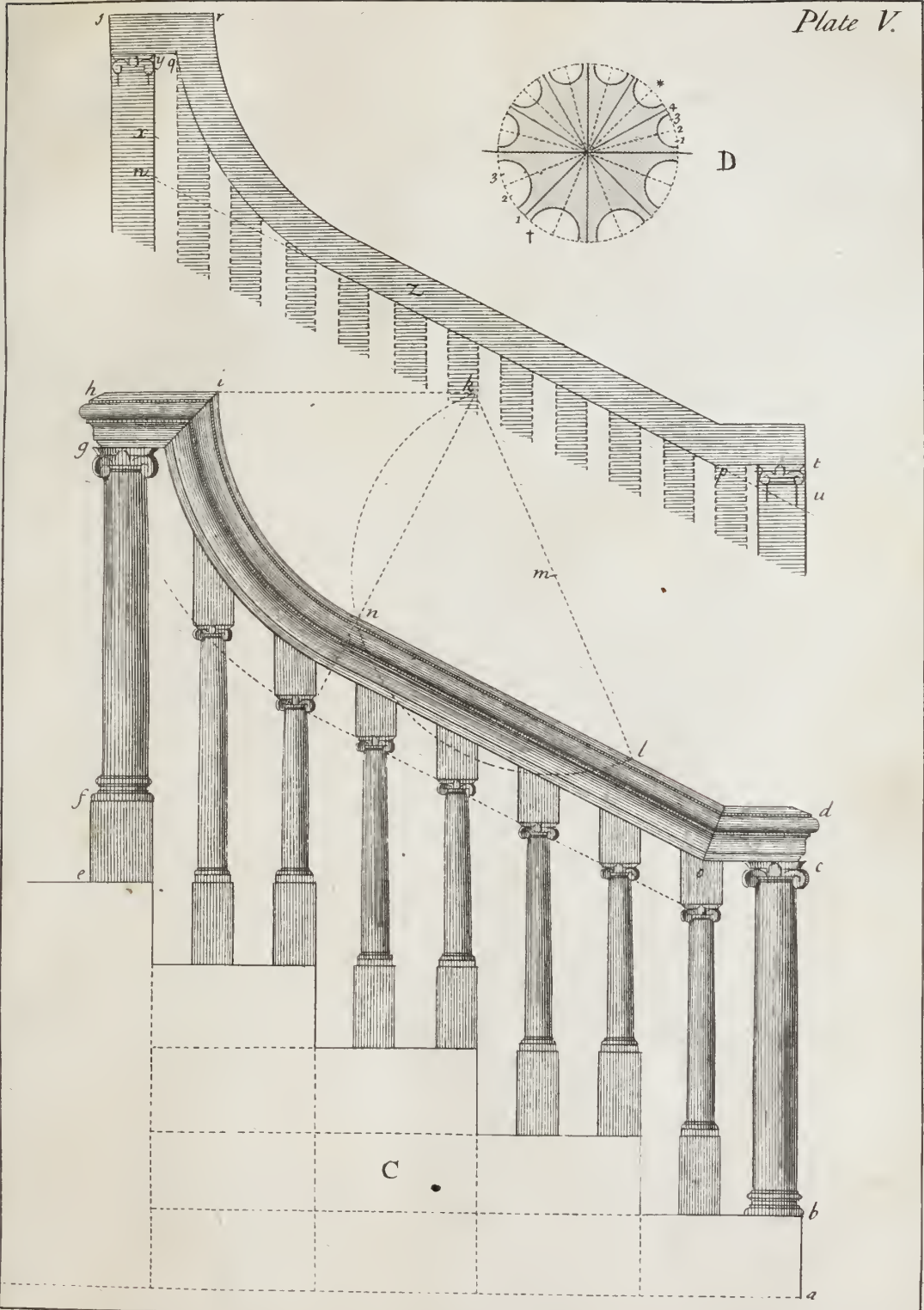

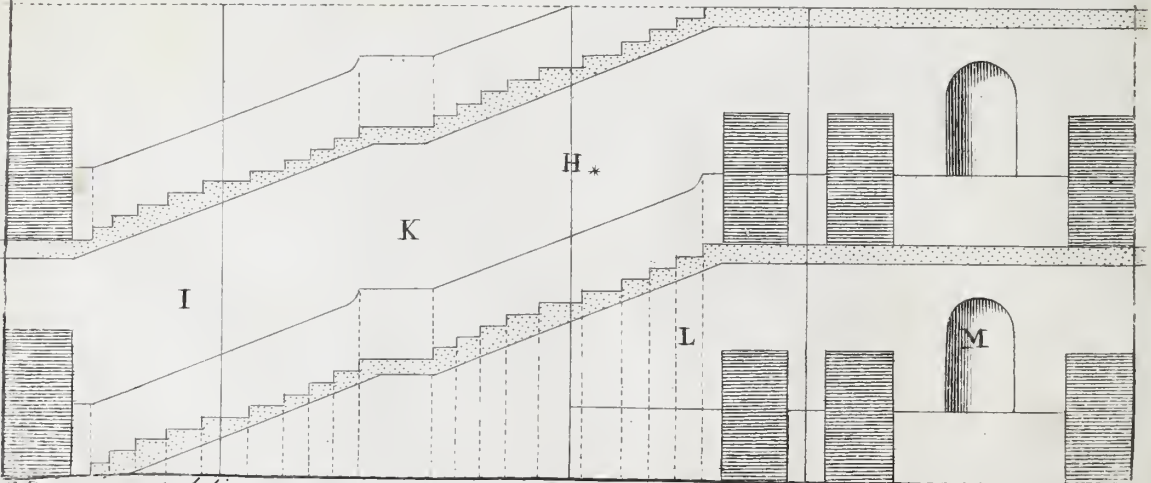
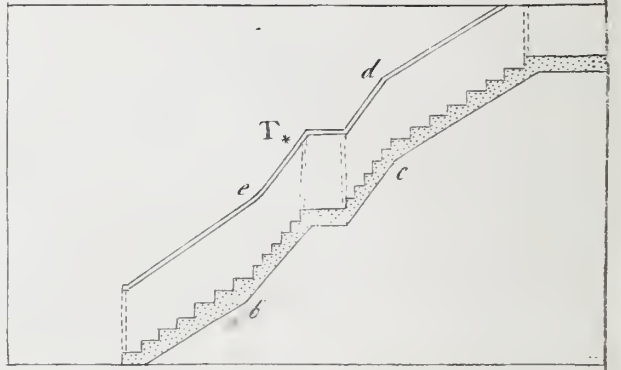
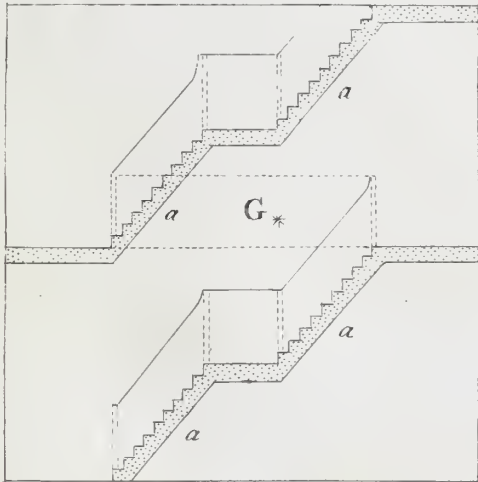
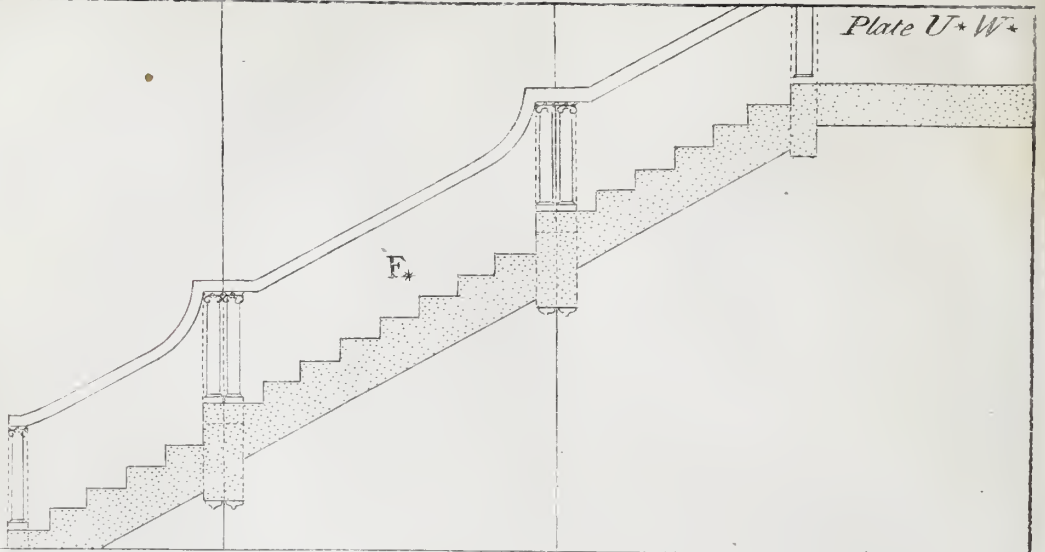



UNTO Workmen that have not had Experience, these Profiles, or Sections of Stairs, are more immediately necessary to be known, and described, before executed; for there are many Difficulties which naturally occur, if these Sections be neglected, therefore I hope they'll not be useless.

The Section F*, is taken from the Plan B, in P L A T E T, and is the Meeting of the Steps and Risers; with that of the String-boards. Which not only shews the Use of the Pitch-board, in striking out the String-board, the Newels, and Rails; but at the same Time, may be of Use in other Respects; 'till Practice has made Things of this Nature more familiar.

The Section T*, is taken from the Plan D*, in P L A T E T*, U*, and as before is the Meeting of the Steps and String-board. In this Figure, as at b, c, d, e, is shewn the ill Appearance, created by placing circular taper Steps, among streight, or parallel ones; the Defect consists in the sudden Turn, at the Meeting of the said mix'd Steps, which causes a very ill Appearance in the String-board, and Rail; notwithstanding they may be humour'd a small Matter. There also appears a Defect in its Strength, if executed with Wood, though indeed if executed in Stone, 'tis not so.

That of G*, is taken from the Plan C*, in P L A T E T*, U*, and as the Plan consists of two Quarter-circles, on which the Steps are equally divided, the Section as at a, a, a, a, is a streight Line; which, when bent agreeable to the Plan, becomes twisted, and circular every way.

And as the Form of the twisted Part of the Rails, will be shewn in the following Plates; there seems no Occasion to take Notice of them here, therefore in Lieu, I will endeavour to shew a farther Use these Sections may be of, *viz.* the Section H*, is taken from the foregoing Plan C*, in Plate T*, U*, and as I, K, L, M, represents the Walls thereof, in which are the Doors, and the Profile of the Steps, &c. by describing two Stories of any odd Plan, in this Manner, you not only discover whether you can accommodate your Doors, Windows, &c. but are always sure to be satisfied concerning the Head-way; which is a material Point; all which, as I said before, will be greatly assistant to such as have not had Experience.



W HATEVER may appear Difficult in this Method of forming Scroles proper for the Plans of twisted Rails, due Application will make easy and expeditious.

First, Form a Scrole with Chalk, or a Pencil, agreeable to the Bigness of the Place in which it is to stand; next resolve on the Bigness of your Stuff to be used for your Rails, and also your Mouldings on the Side thereof as in C. Let d, be the Center of your chalked Scrole in D; on which describe, with the Projection of your Mouldings from C, the small Circle d; take from C, half the Bigness of the Stuff, as e, g, or e, f, which add to the small Circle, and form the Circle h, i, t; which is the Bigness of the Eye of the Scrole: This done, take the Distance from i, to the In-side of the Rail, as the supposed chalked Scrole, which suppose k; with it, make a diminishing Scale, by setting that Distance up, from t, to l; draw the Line k, l; place one Foot of your Compasses in k, describe the Part of a Circle t, 8; which divide into eight equal Parts, because here your supposed chalk'd Scrole was to come into its Eye, or Block, at one Revolution of a Circle. (Scroles may be made to any Number of Revolutions desired, by the same Rule) *Witness that above in Figure E.*

Place one Foot of your Compasses in d, describe the large Circle w, l, l, u; which always divide into eight Parts, because you strike one eighth Part of a Circle every Time, till you come into the Eye, or Block i, t, h; from the said Divisions on the large Circle, draw Lines through, for on them your Sections meet, which form the Scrole. It is observable in drawing your Sections, that they don't end in the Line drawn through the great Circle, only the Out-side Scrole; for those of the In-side Scrole end on a Line drawn to each respective Center. I suppose A, and B, to be two Steps; the rest I think cannot fail of being understood, by observing the Letters and Figures, which shew each Part distinctly.

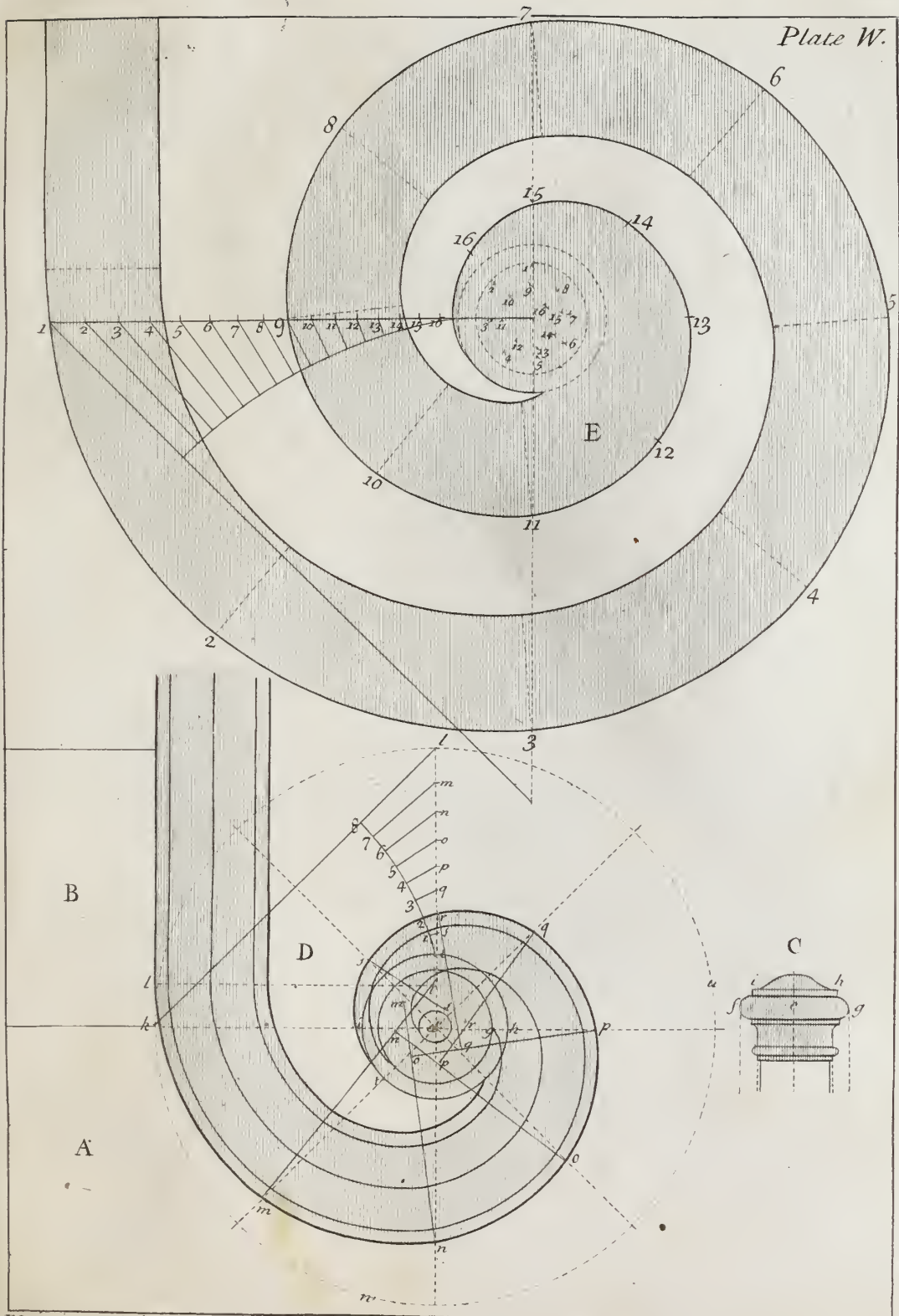



— I N order to make the Squaring of a Twisted-Rail easy, see the Plan F, which is the same as that in the foregoing PLATE W, and by PROPOSITION O, find the Point of Touch b. From these Curves a Mould must be traced out, in order to form a Sweep, which when applied on the Rake, is agreeable to this of a, b, c, d, as that of K. (It is first to be observed that you will want Wood extraordinary, both on the Top of the Rail, as in L, at e, a; and also under the same, as g, h.) To find which observe where your Sweep begins, in the Plan F, as at a, c; also observe that o, and n, is the End of the twisted Part. Therefore from a, to n, divide into a Number of equal Parts, so as to transfer them on some Line, as in M, from a, to n; also divide the In-side of F, as from c, to o, into equal Parts, so as to transfer them on some Line, as in N, from c, to o; take the Distance e, a, in F; apply it to the Pitch-board, as from g, to e; take the Pitch-board I, with it place e, to c, in N; draw the Line d, q, and make the Point s; divide from d, to s, into eight equal Parts, also from d, to o, into the same Number; draw the Lines which forms a Sweep, whose Use shall be hereafter shewn.

Likewise take the Pitch-board I, and apply e, to a, in M; draw the Line e, p, and make the Point r; from e, to r, divide into eight equal Parts; also from e, to n, do likewise; draw straight Lines from each Division: That Curve shews how much Wood is wanting on the Back of the Rail, as b, t, which describe in L, from e, to a; and there describe the Bigness of the Rail; which shews how much Wood is wanting, as may be observed by what was said above. The other Part of the Twist is cut out of a parallel Piece, as O. Which Thickness extraordinary is shewn in L, at e, a.

To square the twisted Part of the Rail, having so much Wood extraordinary on the Top and Bottom, observe in F, from a, to e, and from c, to f, must be traced, as was above mentioned. Take a, e, in F, apply it to the Pitch-board I, it shews g, i, which Length place in K, from k, to i; also take from F, the Distance b, d, apply it to the Pitch-board I, it shews g, m, which Length place in K, from l, to m. This done, trace out the raking Mould K, agreeable to the Plan F, by the Method before shewn, in PLATE P, which by Inspection, and a little Practice will become easy, and without which nothing is known truly. I say the Wood extraordinary being accounted for in L, both on the Top and the Bottom of the Rail, observe to place your Stroke f, in its true Place, that is, at the Beginning of the twisted Part; take the raking Mould K, set i, to f, in L; there strike it by; with the Angle of your Pitch-board describe the prick'd Line f; by the Side of the Rail, then apply the Mould K, to the Bottom; set i, to this prick'd Line, and there describe by it, with your Pencil; Lastly, Cut that Wood away; also cut the remaining Part of the Scrole out of the Block, as O; then glue these together, and bend both Moulds M, and N, round the Rail; strike them by that, and cut the Wood away; so will the Back of your Rail be exactly square, and fit to work.



----- You are always to observe this general Rule, *viz.* to conceive each respective Paragraph as it occurs, before you begin another; the Neglect of which, appears by some who cannot conceive the Particulars of the foregoing Plate, although I had put it in so clear a Light.

I have here described three distinct Methods of squaring the twisted Part of a Rail, which may be known, and the Rail squared, with more ease than in the foregoing Plate. But when done, they will not have that agreeable Turn, in their twisted Part, as they would have, if done by the foregoing unerring Rule, as may more clearly appear, by the following Explanation.

That of P*, is the raking Mould, taken from K, in P L A T E X; (*whose Use and Application was therein clearly shewn;*) that of Q*, is the Pitch-board, taken from I, in P L A T E X; which gives the Rake, or Declivity of the Rail.

In R*, is shewn how to square a Rail, without bending a Templet round the twisted Part thereof; and which is by being guided by the Back; first describe the Bigness of the Stuff to be used, as a, b, h, i; which shews how much Wood will be wanted at Bottom; supposing S*, to be the Side of the Rail. And because the Grain of the Wood should be agreeable to the falling of the Twist, therefore consider how many Thicknesses of Stuff will make the Wood required to cut the Twist out of; as here three. Therefore as in S*, continue the Line a, b; place one Foot of your Compasses in a, make the Section, or Part of a Circle c, d; divide it into four Parts, as 1, 2, 3, 4, because the Rail S*, must be always reckoned as one; this by Inspection shews how the Grain of the Wood is to be managed, as appears by the Shape of the several Pieces, T*, U*, W*, which are better if cut so by the Pitch-board, before glew'd together.

In X*, is shewn how to square the twisted Part, making the Bottom your Guide; the Section shews how much Wood is wanted on the Back.

In Y*, is shewn how to square the twisted Part, making a Middle Line on the Back your Guide; the Section shews the Wood wanting on the Back, and at the Bottom.

That of Z*, may be cut out of a parallel Piece, of the Thickness of the intended Rail, which when it is glewed to the twisted Part, will want little or no humouring.

N. B. There is a Nicety in working the Mitre thereof, as k, l, m.

P L A T E

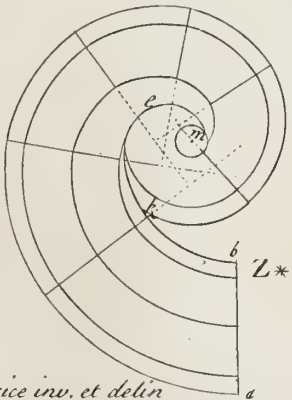
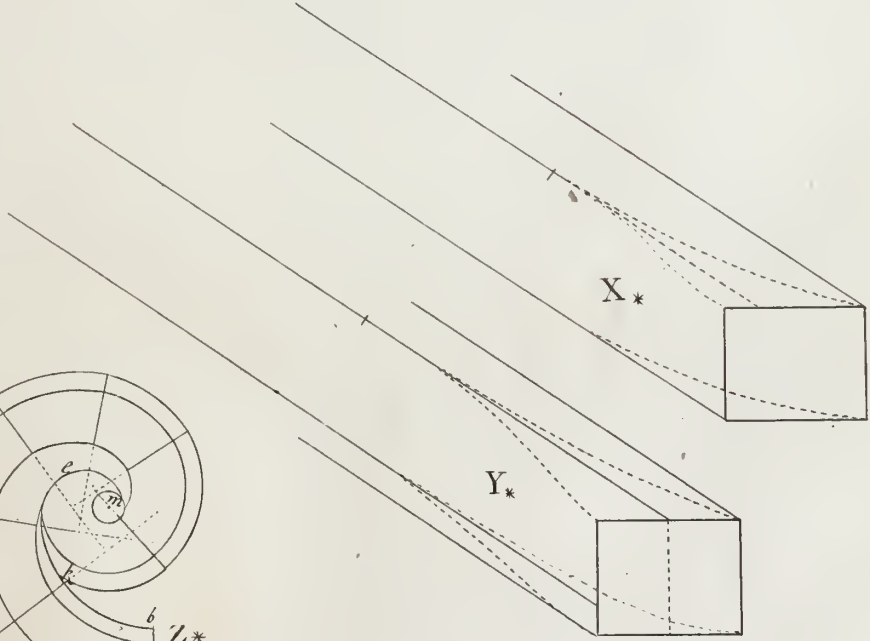
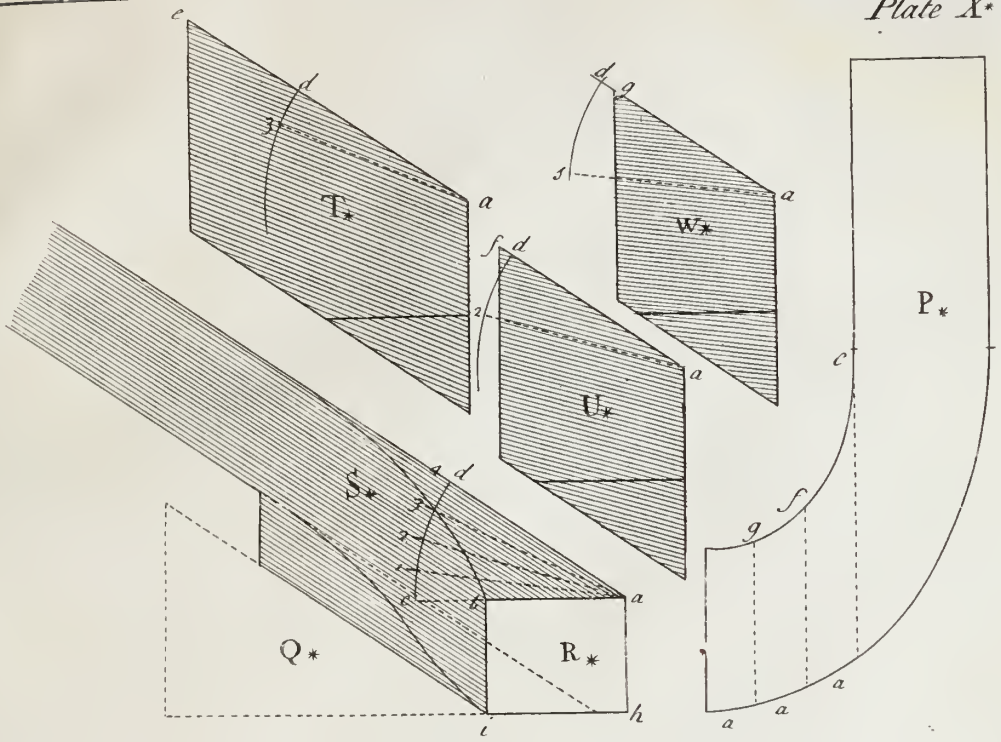



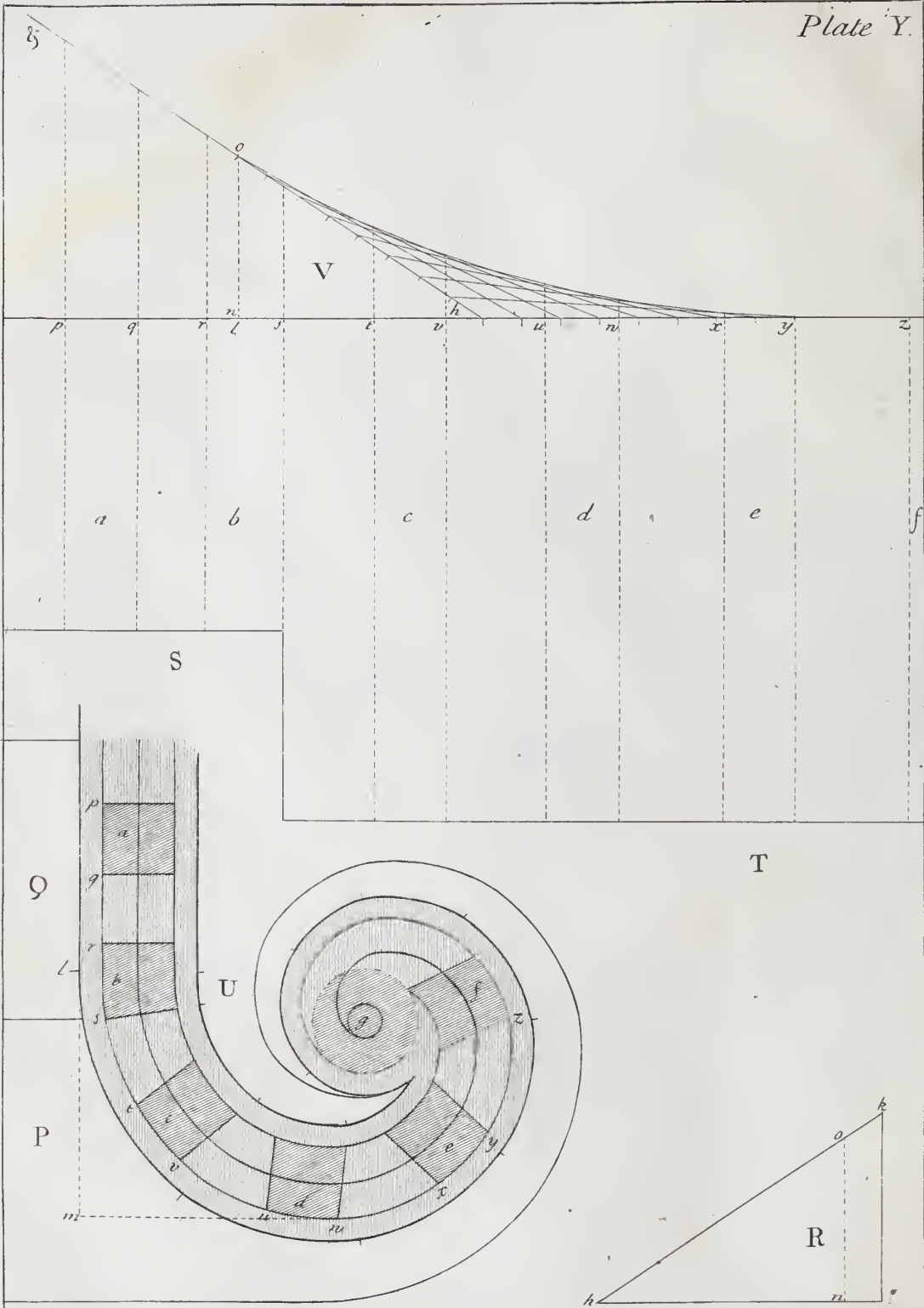



YOU are to observe, the foregoing PLATES must be well understood, and then, in this PLATE, the Lengths of the Newel, and Ballusters that stand under the Twist or Scrole are truly described; that is, their Length and Bevels may be known before the Rail be put up in its Place; and that it may prove easy, observe, the Plan of the Twist or Scrole is the same as before, and so are the two Steps P, and Q, and the Pitch-board R.

First, resolve on the Bigness of your Ballusters, as a, b, c, d, e, f; and also the Newel. Divide the said Ballusters truly on a Line drawn in the Middle of the Rail; for then what is wide on one Side, is narrower on the other. It is for that Reason I chuse to divide them on a middle Line. Describe the Plan of the Ballusters, as p, q; r, s; t, u; u, w; x, y; and z; for there your twisted Part ends; from thence to the Eye is level.

Observe where your Scrole begins, as at l; and on some Line, as above, in V; First, Make a Point at l; then from your Plan take the Distances p, q; r, s; t, v; u, w; x, y; and z: Which transfer, as above, observing to have regard to place truly each Distance from l, both Ways, as p, q; r, s; t, v; u, w; x, y; and z. ---- Observe also, to take from the Plan the Distance from l, to m, which apply to the Pitch-board R, as from h, to n, which gives the Length h, o; take this Pitch-board, and apply it on the Line above, which by Inspection the Letters will shew; this gives the Slope of the Rail, as h, o, &. From o, to h, and from h, to y, form the Curve by equal Divisions, and drawing streight Lines, as was before shewn.

Lastly, Having the Lengths of your fix'd Ballusters, as a, b, describe the Steps S, and T, with the Pitch-board. So that by continuing perpendicular Lines, from the Points on the Line first terminated, to the said Curve, and to the Steps, you have the accurate Lengths of the Ballusters, as a, b, c, d, e, f, the Newel g, being the same Length as f, because at f, or z, the twisted Part ends.

The Curve of the first, or Curtail-Step P, is form'd by the same Rule as deliver'd for the Plan of the Rail.

It may not be amiss to observe, particularly the Point of the Sweep, or Curve's Beginning, and being particular also in its Application, by which this, and the foregoing, tho' represented with but two Steps, is the same in Fact, as tho' I had described a whole Flight, to shew its Use.



EALOUS to promote what may be useful, in this PLATE I have made easy the Difficulty of Squaring a Rail that ramps on a Circular Base.

Observe, W, is the Plan of a Stair-case; and at the Landing is a Quarter-Circle: To make this easy; in X, is three Steps, described by a larger Scale, and the same Method as shewn in PLATE V. Likewise in Y, is the Plan of the Rail. It was shewn in PLATE X, how to trace out a Mould on the Rake, agreeable to this Plan, or indeed any other. A considerable Thickness of Wood more than usual is required on the Back of this Rail, as in &, at p, b; which will appear more plain by inspecting PLATE X: As also the Method to trace your Moulds that shall bend round the said Rail. Let the Sides be squared as was shewn in PLATE X. Observe here in Figure X, the Line k, p, o; take the Distance k, p, and place it on some Line, at pleasure, as in Z; then divide the outer Circle in Y, into a Number of equal Parts, as into six, as from g, to h, which transfer to Z, as g, 1, 2, 3, 4, 5, 6, h. The Point of the Ramp may be observed to fall within the fifth Division, as at s, so that by the Intersection of streight Lines, and equal Divisions, you describe the Sweep for the Ramp g, b, which makes Z, the Mould to bend round the Out-side of the said Rail.

Observe also in Y, from b, to f, divide it into six equal Parts, which transfer to &, as from e, to f; (and observe again) the Ramp falls within the fifth Division, as at r. So divide the Distance from e, to g, and from g, to b, into equal Parts, and by drawing streight Lines, you have the Sweep b, e. From the Point b, to p, is the Thickness you want to be added extraordinary on the Back of the Rail &, and which is the Inner-Mould; so that by bending both these Moulds round the Rail, and by drawing them with a Pencil, and cutting away the superfluous Wood you have an exact square Back. There seems no Difficulty now left, unmentioned, to square twisted Rails in any Form whatever.

Because I have all along strove to give Variety, observe M*; in which is shewn a Method to have your Newel under the Twist, the same Length as the rest; by which means also the Rail twists no farther than the first Quarter, and consequently the remaining Part may be cut out of a Plank, of the Thickness of your Rail, without twisting at all. There seems no Explanation wanting to clear this Point, but Inspection, and a good Conception of PLATE X: In this of M*, l, f, is the Thickness of Wood extraordinary wanting on the Back of the Rail.

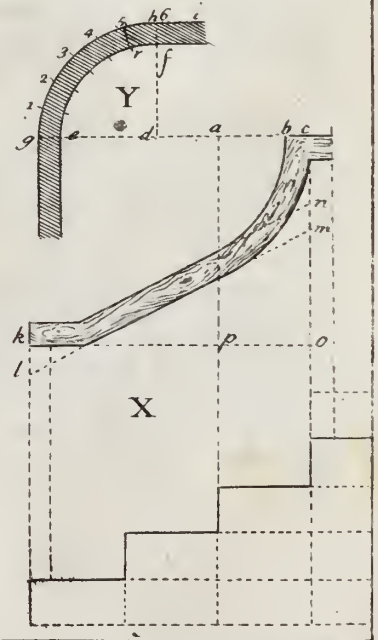
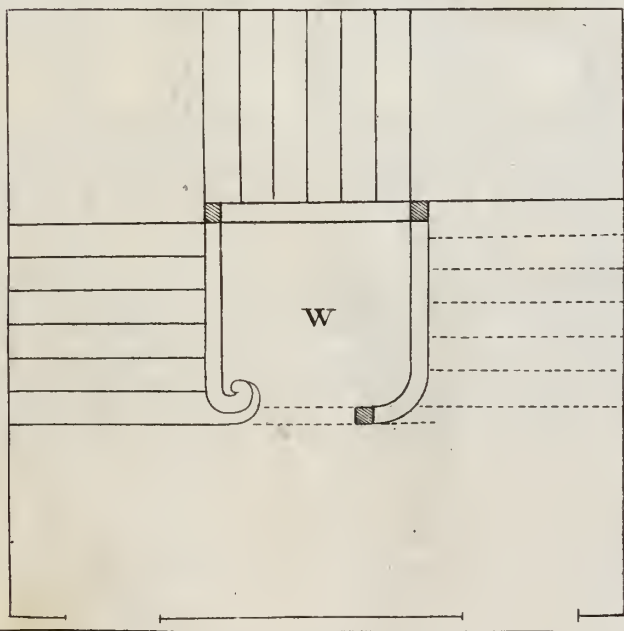
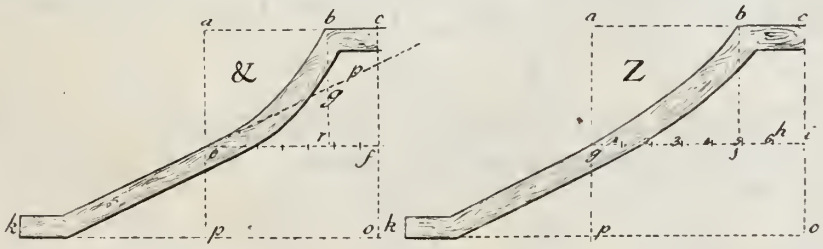
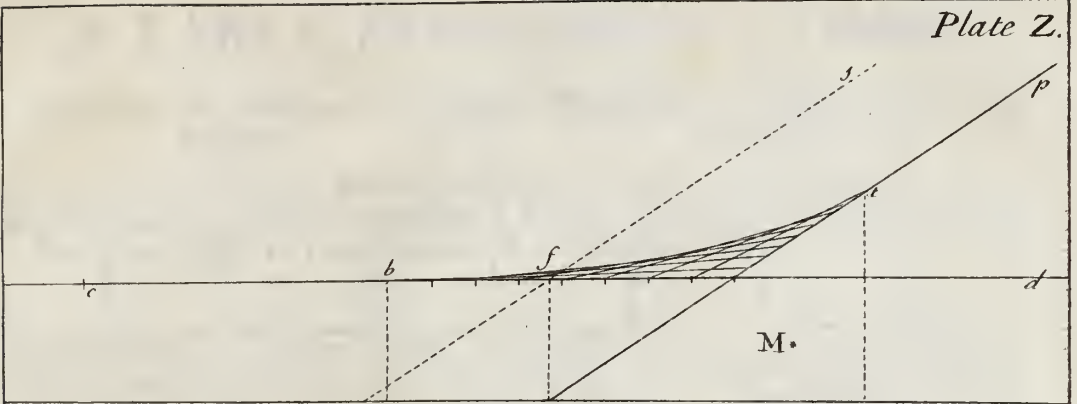



ALTHO' this Table seems so plain as to need no Explanation, it may not be amiss to observe some Particulars, such as that all Binding or Strong-Joists ought to be half as thick again as Common-Joists; that is, if a Common-Joist be given three Inches thick, a Binding-Joist should be four Inches and a half thick, altho' the same Depth.

Observe also, that if Conveniency do not allow of Posts in Partitions being square, in such Cases, multiply the Square of the Side of the Posts, as here given, by itself: For Instance, if it be six Inches square, then as six Times six is thirty six, consequently to keep this Post nearly to the same Strength, find some Number that shall agree thereto; as suppose the Partition to be four Inches thick, then let your Post be nine Inches the other Way, so that nine Times four is thirty six, being the same as six Times six; so that the Strength is nearly the same, altho' being equal in its Squares is best for the Strength.

Posts that go the Height of two or three Stories, need not hold this Proportion, because at every Floor it will meet with a Tye; admit a Post was required of thirty Feet High, and in this Height was three Stories; two of ten Feet, and one of eight. Look for Post of Fir of ten Feet High, their scantling is 5 Inches square, *i. e.* 25 square Inches; which double for the two Stories.

And take also that of 8 Feet High, being 4 Inches square, *i. e.* 16 square Inches, all which being added together make 64 square Inches; so that such a Post would be 8 Inches square. On Occasion it may be lessen'd in each Story at it rises.

I do not insist that the Scantlings of Timber ought to be exactly as by this Table is express'd, but may be varied in some Respects, as the Workmen shall see fit; the Reason of its being inserted is in consideration of the Scantlings of Timber, as formally settled by Act of Parliament, and which if compared will prove the Necessity, and Use of this Table.

As to Plates on Walls, or Brest-Summers to support Walls, I do not find they can come into any regular Proportion, as the rest do, therefore must be left to Discretion.

And as I have herein described a great Variety of the principal Things requisite to be known by every Carpenter, I shall conclude this Part with my Wishes that it may prove as useful as my earnest Endeavours have been to make it so.



PALLADIO

PALLADIO's
orders of
ARCHITECTURE
with the Ornaments
of
DOORS WINDOWS
&c.

J. Price inv.

M. J. Jones sculp.

A
S U P P L E M E N T

T O T H E

British Carpenter:

C O N T A I N I N G

P A L L A D I O's

O R D E R S o f A R C H I T E C T U R E,

W I T H T H E

Ornaments of D O O R S and W I N D O W S,

Proportion'd and adjust'd by D I V I S I O N S o n S C A L E S; together
with the accurate C U R V E S o f t h e i r M O U L D I N G S, and t h e i r
Application to U S E.

Described on Sixteen COPPER-PLATES.

By *FRANCIS PRICE.*

L O N D O N: Printed by C. A C K E R S in St. John's-Street;

And Sold by the A U T H O R, in Mount-Street, near Grosvenor-Square; also
by A. B E T T E S W O R T H and C. H I T C H at the Red-Lion in Pater-
Noster-Row; and T. A S T L E Y at the Rose in St. Paul's Church-Yard.

M D C C X X X V.



TO THE
R E A D E R.



HAVE herein presented the Publick with the five Orders of ARCHITECTURE, according to that most judicious Master ANDREA PALLADIO, together with the Ornaments of DOORS, WINDOWS, &c. and their Application to Use, after a Method much easier in Practice than any Thing of the Kind; which I have by many Persons been importuned to do, that thereby the Whole might be render'd of general Use to the several Artificers in Building. Altho' it may not appear to every one, that these are the Proportions of PALLADIO, I am fully convinc'd every competent Judge will soon discern it, (and every other Person that would be satisfy'd, may, by Observation and Compare, find it to be so;) therefore I shall not trouble the Reader with Quotations, to prove the Veracity thereof.

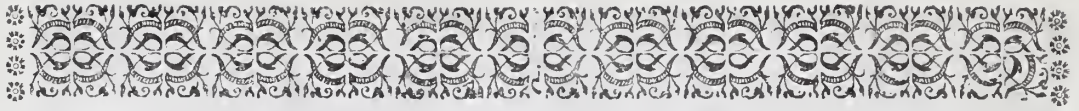

T H E

C O N T E N T S.

PLATE	PAGE
A, <i>The Proportions of the Tuscan Order explain'd</i>	1
B, <i>The Proportions of the Dorick Order, &c.</i>	2
C, <i>The Proportions of the Ionick Order, &c.</i>	3
D, <i>The Proportions of the ancient and modern Ionick Capital</i>	4
E, <i>The Proportions of the Corinthian Order, &c.</i>	5
F, <i>The Proportions of the Corinthian Capital</i>	6
G, <i>The Proportions of the Composite Order, &c.</i>	7
H, <i>The Composite Capital, with the Intercolumniations of each Order</i>	8
I, <i>The Proportions of the Ornaments of Doors, Windows, &c.</i>	9
K, <i>The proper Declivity or Pitch of Pediments, with their Dependants</i>	10
L, <i>The foregoing Proportions applyed to Practice in the Dress of Doors, Windows, and Chimney-pieces</i>	11
M, <i>The several Pedestals of the foregoing Orders, regulated, &c.</i>	12
N, <i>The several Columns, and Capitals, of the foregoing Orders regulated</i>	13
O, <i>The several Entablatures regulated, with the Construction of the Orders entire</i>	14
P, <i>The Application of the foregoing Proportions to Use, in the Dress of Doors, &c.</i>	15
Q, <i>The Application of the aforesaid Orders to Practice, in adorning Arches</i>	16

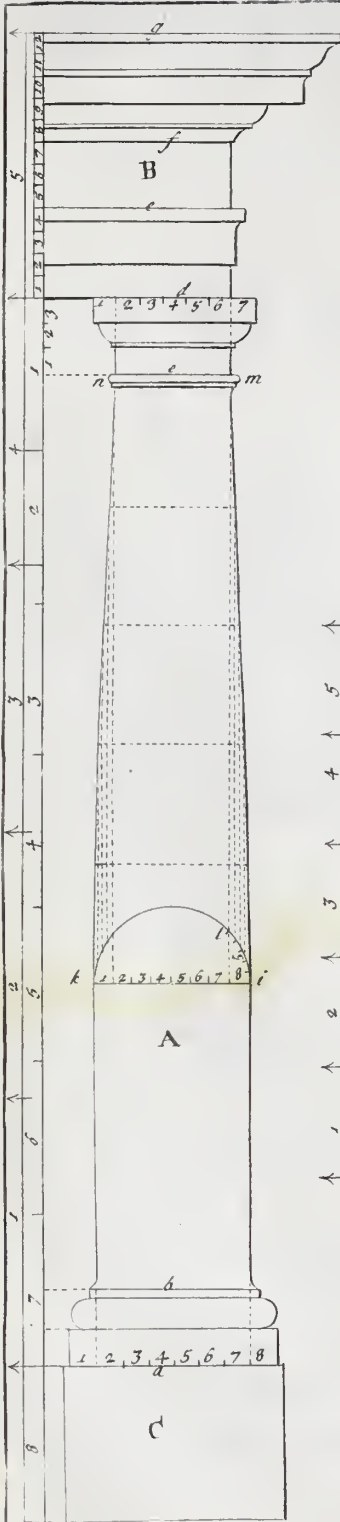

F. Prus delin.

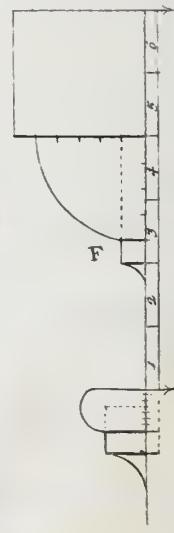
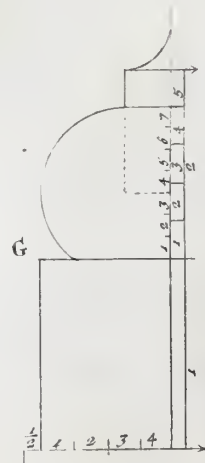
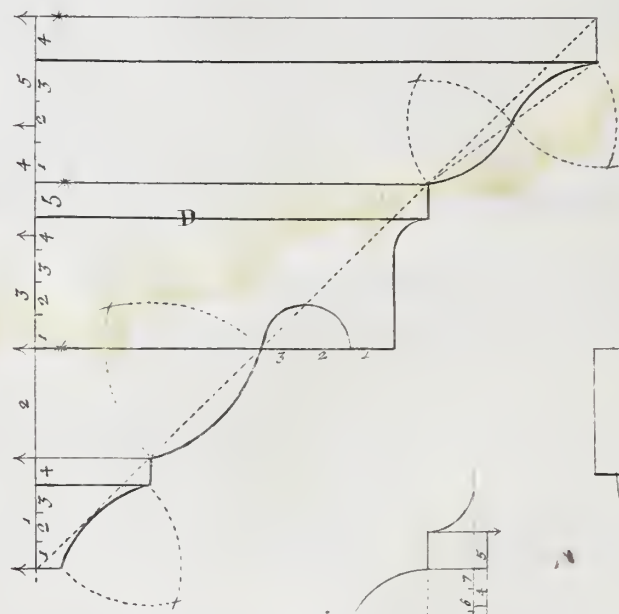
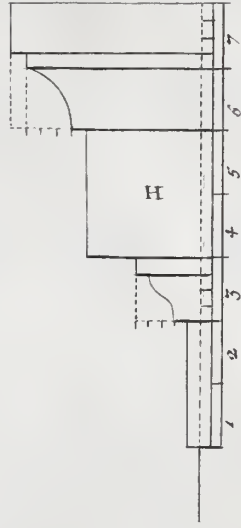

Toms sculp.

The Proportions of the TUSCAN ORDER.

THE Column A, is seven of its Diameters in Height including its Base a, b, and Capital c, d; each having half the Diameter of the Column. The Entablature B, is one fourth of the Length of the said Column; which being divided into twelve Parts, four is for the Architrave d, e, three for the Freeze e, f, and five for the Cornice f, g. The Plinth C, is one Diameter of the Column, as appears by the Scale. So that a Height being given for this Order, divide it into thirty-nine equal Parts; four will be the Diameter of the Column; by which the other Parts are proportion'd.

The Base a, b, projects one sixth Part of the Diameter of the Column on each Side. The Shaft diminishes one fourth Part of the Diameter below; for which diminishing, divide the Length of the Shaft b, c, into three Parts, leaving the lower Part perpendicular. On the said third Part, i, k, describe a Semi-Circle observing where the Diminution passes through it as at l; from i, to l, divide into Parts at Pleasure, as here, into five; observing to divide the upper two thirds of the Shaft, into the same Number; drawing Base Lines from the one, and Perpendiculars from the other, their Meeting gives an agreeable Curve for the Swelling of the Column.

Note, The Astragal m, n, is reckon'd a Part of the Column.

The Projecture of the Capital e, d, is found by dividing the diminished Part of the Shaft into five equal Parts, one of which is for the said Projecture, the Architrave d, e, projects one seventh of its Height, and the Cornice f, g, projects equal to its Height. And that the particular Parts may appear the better, each is enlarged: D, being the Cornice, whose Particulars appear by Inspection. E, is the Architrave, enlarged agreeable to that of the Cornice, as also the Capital F, and the Base G, whose Projecture is divided into four Parts, which shews the Projection of the Plinth. That of H, is the Impost of the Arch, whose Height is found by dividing the Diameter of the Column into twelve Parts; seven of which is the Height thereof, and three is its Projecture.

By observing the several Scales duly, there needs no farther Explanation.

The Proportions of the DORICK ORDER.

THE Column I, is eight Diameters high, including its Base, o, p, and Capital q, r, each having half the Diameter of the Column. The Entablature K, is two such Parts as the Length of the Column contains nine; which is divided into fifteen Parts, four for the Architrave r, s, six for the Freeze s, t, and five for the Cornice t, u. The Pedestal L, contains two such Parts as the Length of the Column does seven; which being divided into seven Parts, one is for the capping o, w; four for the Die w, x, and two for the Base, and Plinth x, z, z; which being divided into three Parts, one is for the Base x, y, and two for the Plinth y, z, as appears by the Scale. So that a Height being given for this Order, divide it into one hundred and forty-five Parts, twelve will be the Diameter of the Column; (by which the other Parts are proportion'd.)

The Base o, p, projects one sixth Part of the Diameter of the Column, on each Side, which gives the Breadth of the Die of the Pedestal; and the Breadth of the Die, or Trunk of the Pedestal, being divided into five Parts, one is for the Projecture of the Capping o, w, and Base x, y. The said Column diminishes one sixth Part of its Diameter at Bottom, the Capital q, r, projects one fourth Part of the said Diameter. The Architrave r, s, projects one seventh of its Height, the Freeze s, t, is adorned with Triglyphs, and Metops; the Triglyphs being in Breadth, equal to two thirds of their Height. And the Metops, or Space between is perfect square. The Cornice t, u, projects four such Parts as its Height contains three.

And that the particular Parts may appear plain, they are enlarged. M, being the Cornice, and N, part of its Soffit, that of O, being the Freeze, and P, the Architrave, also Q, is the Capital, and R, the Impost of the Arch; its height being two thirds of the Diameter of the Column, including its Astragal, and its Projecture is one fourth. S, is the Base of the Column, T, the Capping of the Pedestal, and U, the Base, or Mouldings thereof.

By observing the several Scales duly, a farther Explanation is needless; without it be the Projecture of the several Mouldings, most of which come under one Rule, *viz.* all Ogees, Quarter-rounds, and Hollows project with their Lifts, equal to their naked Height; the said Lifts projecting one sixth Part of that naked Height, as may appear. The Cymas project equal to their Height, and the Curves of each Member are thus; all Hollows and Rounds are described by placing one Foot of the Compasses on the Line that separates the Member from its Lift, and the Cymas and Ogees are form'd by the Point of an equilateral Triangle, as may appear by Inspection.

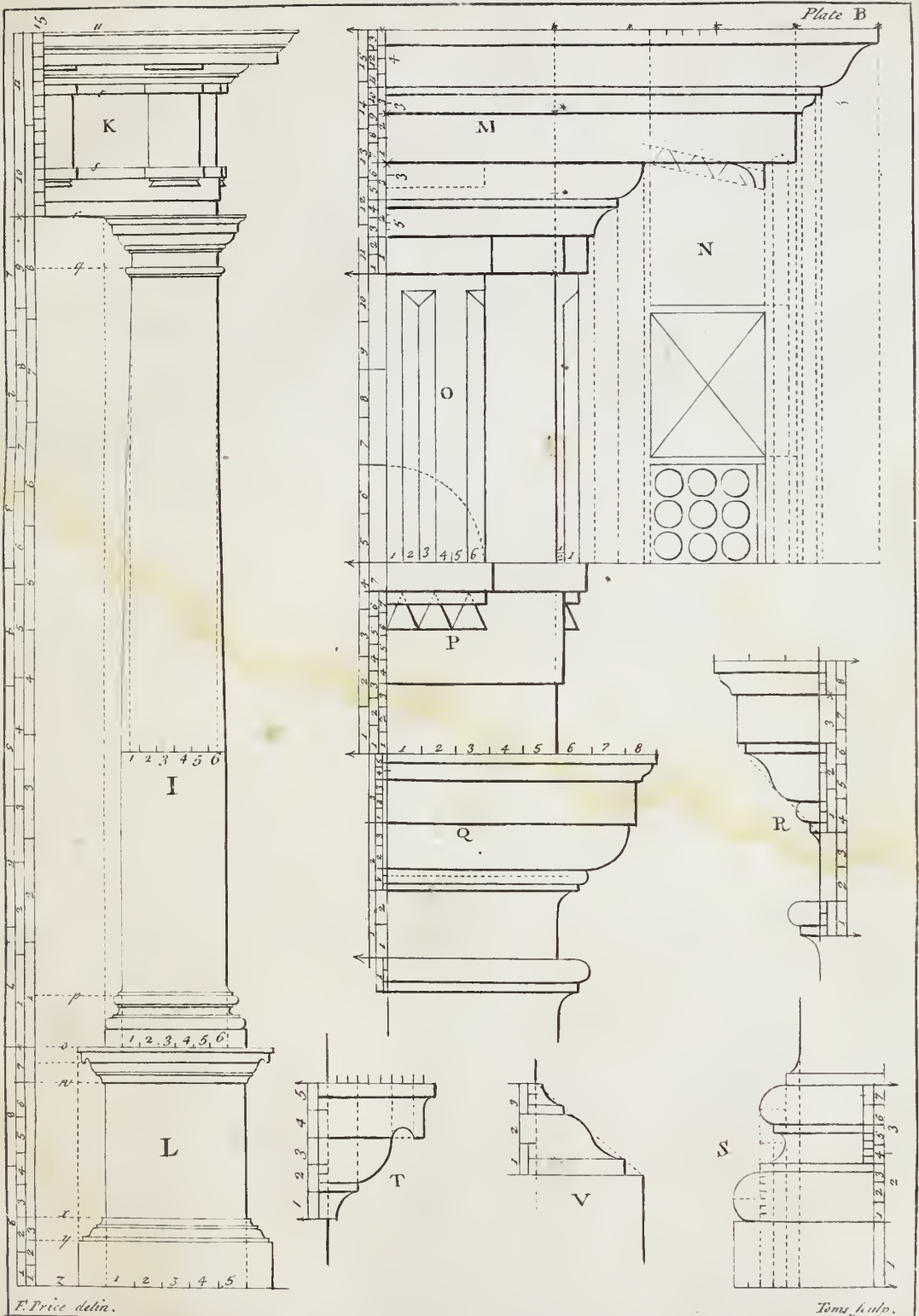

F. Price delin.

Tom. I. h. 10.

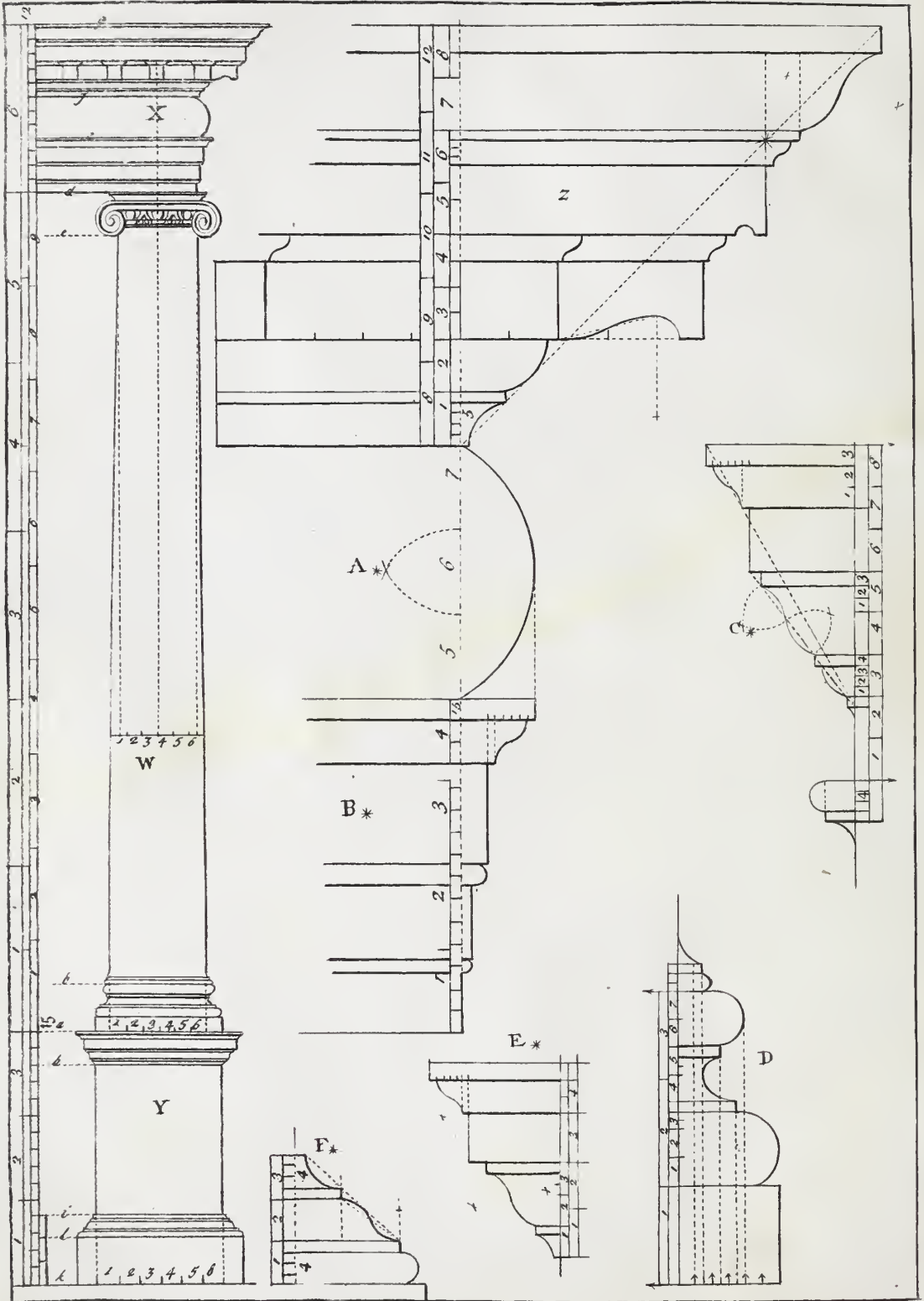

The Proportions of the IONICK ORDER.

THE Column W, is nine Diameters in height including its Base a, b, and Capital c, d; each being half the Diameter of the Column, the Entablature X, is one fifth of the Height of the Column, (as may appear by the Scale,) which Height is divided into twelve Parts; of which, four is for the Architrave d, e, three for the Freeze e, f, and five for the Cornice f, g; the Pedestal Y, has three such Parts, as the Entablature has two; *i. e. three tenths of the Height of the Column.* Which being divided into fifteen Parts, two is for the Caping a, h, nine for the Die, or Trunk h, i, and four for the Base, and Plinth i, k, which being again divided into three; one is for the Base i, l, and two for the Plinth l, k; so that a Height being given for this Order, divide it into twenty-seven Parts; two is for the Diameter of the Column, by which the other Parts are proportion'd.

The Base of the Column a, b, projects one sixth Part of the Diameter on each Side, which gives the Breadth of the Pedestal; which being divided into six Parts, one is for the Projecture of the Caping a, h, and Base i, l. This Column also diminishes one sixth Part of its Diameter. The Capital e, d, being somewhat more difficult to conceive, than the former; therefore I reserve it for the next Plate. The Architrave d, e, projects equal to that of the Freeze e, f, which is found by making an equilateral Triangle, of the Middle third Part; so that its Point is the Center for the Curve, which gives the said Projecture of the Architrave. The Cornice f, g, projects equal to its Height. To find the Modilion, divide the diminished Part of the Column into ten Parts; two such Parts, are for the Breadth of each Modilion; three for its Length, and four for the Space betwixt them.

And that the particular Parts may appear plain, I have enlarged them; as in Z, A*, B*, D*, E*, F*, so that Inspection will explain the Particulars. That of C*, is the Impost of the Arch, whose Height (exclusive of the Astragal,) is found, by dividing the Diameter of the Column into three Parts; two of which is its Height, and one fourth of the said Diameter is its Projecture.

The Proportions of the IONICK CAPITAL.

THE Height m, n , (being half the Diameter of the Column,) is divided into nineteen equal Parts; of which, three is for the Ogee, with its Lift; one for the Lift or Rim of the Scrole; three for the Recess; four for the Ovola; and two for the Astragal, which is the Eye or Volute; on which are described the thirteen Centers, by which the said Scrole is formed.

The Projection of the said Capital G , as n, o , is equal to the Diameter of the Column below; by limiting the Projecture of the Ogee, drop a Perpendicular from the Foot thereof; observing where it passes through the said Astragal, for that is the Center of the Volute; which is enlarged as in H ; so that the particular Centers, for forming the spiral Line or Scrole, may appear by Inspection. And because the said Scrole is spiral, therefore betwixt the Centers that are marked $1, 2, 3, 4, \&c.$ divide each, into four equal Parts, so that the Part next to the said marked Centers, is the Centers for forming the said Spiral, or diminishing of the Scrole. The other Parts Inspection will explain. From this Elevation G , the Plan I , is made, as the Letters and prick'd Lines shew.

If this Column, or the following ones, be fluted, it has twenty-four Flutes, which are thus made; the two Diameters crossing each other at right Angles, and the diagonal Lines, being drawn, divides the Plan into eight equal Parts. So that by dividing each again into three, gives the Centers for describing each Flute; the Lift betwixt each being one third of the said Flute. If the said Column be fluted, then all the proper Parts should be carved, and the Pedestal should be opened with a Pannel, whose extent is equal to the Diameter of the Column above; not but on Occasion, there may be Ornaments left swelling beyond the Die of the Pedestal, equal to the Bigness of the Column as before.

Note, *In this Case the adjoining Parts should be enriched in Proportion, which is esteemed an essential Part of Symmetry.*

And in Consideration, that this ancient Capital, is not so frequently used, as the Modern one; therefore I have inserted it as on the other half of the said Plan, as K , and in the other half of the Elevation, as L , which is thus. Make a geometrical Square, equal to one Diameter, and one third of the Column; as r, s, t, u ; *Lastly*, Divide the Diameter of the Column into eight Parts; take seven thereof, and place on the diagonal Lines, as from the Center u , to w, x, y, z , which being drawn Parallel to the Diagonals, observe where it crosses the said Square r, s, t, u , for that terminates the Horns of the Abacus, whose Curvature is formed by the Point of an equilateral Triangle, being equal to the Points marked on the Sides of the said Square. The Flower in the Middle of each Face, is one fourth Part of the Diameter of the Column.

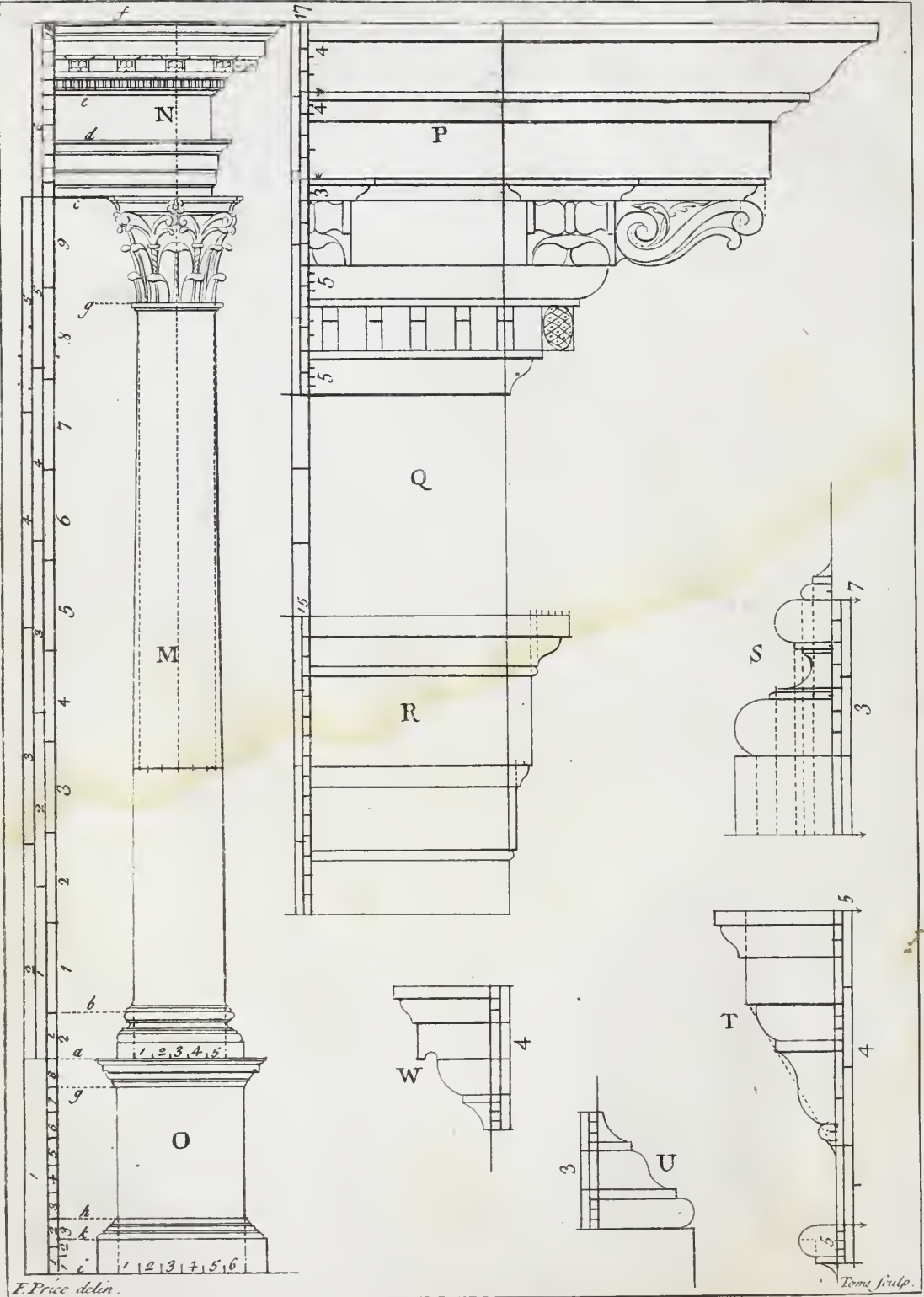

F. Price delin.

Tome sculp.

The Proportions of the CORINTHIAN ORDER.

THE Column M, including its Base a, b, and Capital c, g, is nine Diameters and an half high; of which the said Capital has one Diameter, and one sixth Part for its Height; the Base being half a Diameter as before. The Entablature N, is one fifth Part of the Height of the Column. Which being divided into twelve Parts, four is for the Architrave c, d, three for the Freeze d, e, and five for the Cornice e, f. The Pedestal O, is one fourth Part of the Height of the Column, and is divided into eight equal Parts; of which, one is for the Capping a, g, five for the Die, or Trunk g, h, and two for the Base and Plinth h, i, which is again divided into three; one is for the Base h, k, and two for the Plinth k, i. So that a Height being given for this Order, divide it into sixty-nine equal Parts; five is the Diameter of the Column, which proportions the rest as before.

The Base a, b, projects one fifth of the Diameter of the said Column, which gives the Breadth of the Die, of the Pedestal; which being divided into six Parts, one is for the Projecture of the Capping a, g, and Base h, k. This Capital g, c, requires to be explained by itself, therefore will be inserted on the next Plate. The Architrave c, d, projects one fifth Part of its Height, the Freeze d, e, is Perpendicular to the diminished Part of the Column, (which is one sixth as before,) the Cornice e, f, projects equal to its Height, which being divided into seventeen Parts, five is for the Projecture of the Bed-moulding; seven for the Length of the Modilion; and the other five for that of the Cornice; the Breadth of each Modilion is four such Parts; and the Space betwixt is eight. And to adjust the Dentils, divide their Height into three Parts, two of which is their Projecture, and Width, and one is for the Space between each.

And that the particular Parts may appear plain, observe, as in P, Q, R, S, U, W, each Part is enlarged. And if the Divisions or Scales, be duly observed, there needs no farther Explanation, otherways than that T, is the Impost of the Arch, whose Height is two thirds of the Diameter of the Column; exclusive of its Astragal, the Projecture of the said Impost, is one fourth of the Diameter of the Column.

The Proportions of the CORINTHIAN CAPITAL.



TO form this Capital, a geometrical Square must be made equal to one Diameter and an half of the Column, as *l, m, n, o*; draw the diagonal Lines *m, o, l, n*, and from the Center *p*, mark one Diameter of the Column on the said Diagonals, observing where it passes through the Sides of the said Square, which terminates the Horns of the Abacus, so that by making an equilateral Triangle with the Part remaining, between the Points so terminated, as *p, q, r*; its Point will be the Center for describing the Curvature of the Abacus. So that from the half of the Plan as *X*, is made the Elevation *Y*; whose Height is one Diameter, and one sixth of the Column, and is divided into seven Parts; of one is made the Abacus *s, t*, and of the other, is made the Head of the Scroles, *s, u*: So that the remaining five, is for the Leaves, as Inspection shews. To find the Projecture of the said Leaves, draw a Line from the Extremity of the Abacus, to that of the Astragal of the Column, to which the Tip or Head of the Leaves come.

As to the Position of the Leaves, Perpendiculars are let fall from the Elevation *Y*, to the Plan *X*; as the prick'd Lines shew. There are eight Leaves in each of the first and second Tire; and between the latter are Stalks, as is shewn in the other Part of the Plan, as *Z*; from whence spring the upper Tire of Leaves, as also the Scroles, each of which are in Number sixteen, from the said Plan *X, Z*; the Particulars of the Elevation *Y*, are shaped, as Inspection will make appear; the Flower in the Middle of the Abacus, is in Breadth and in Height, one fourth Part of the Diameter of the Column; its Plan being a Portion of a Circle. As to the other Particulars, due Inspection and Practice only will make them intelligible. The Astragal is reckoned as a Part of the Column, and is one twelfth of the Diameter thereof in Height, its Projection being the same.

The cutting in of the Leaves, should be no deeper than the Bottom of the Flutes, so that the Bell of the Capital, is equal to the solid Part of the Column; the Lifts between the Flutes give the Bigness of the Stalks of the Leaves, by which a kind of suppositional Strength is preserved. These Leaves are cut variously, as sometimes with Olive, Parsley, or Acanthus; but that the *Carvers* are most expert at.

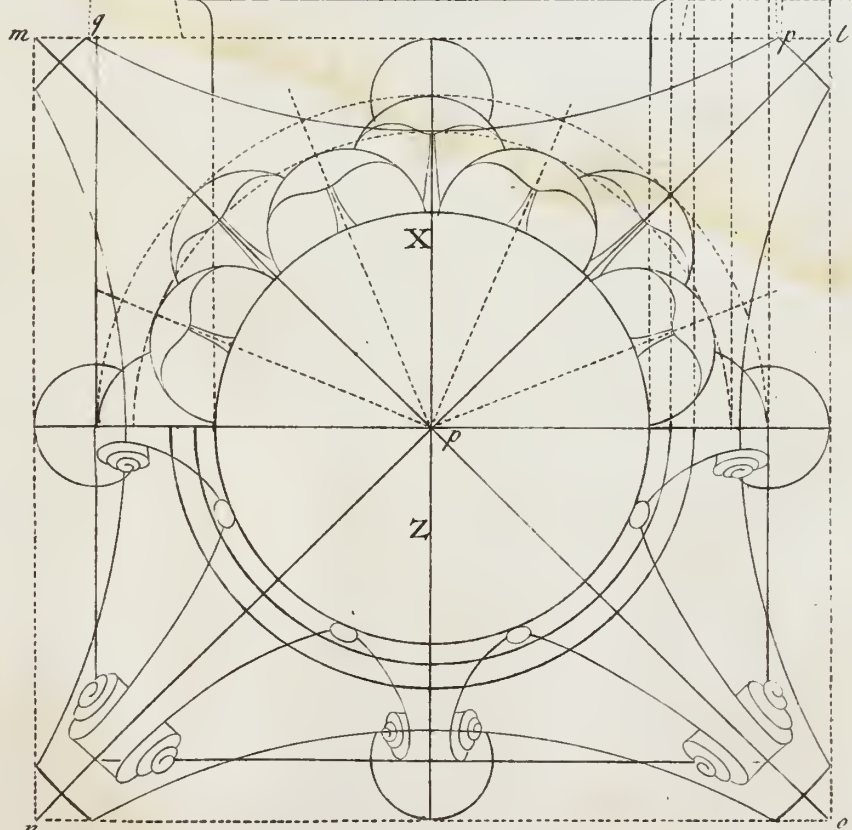
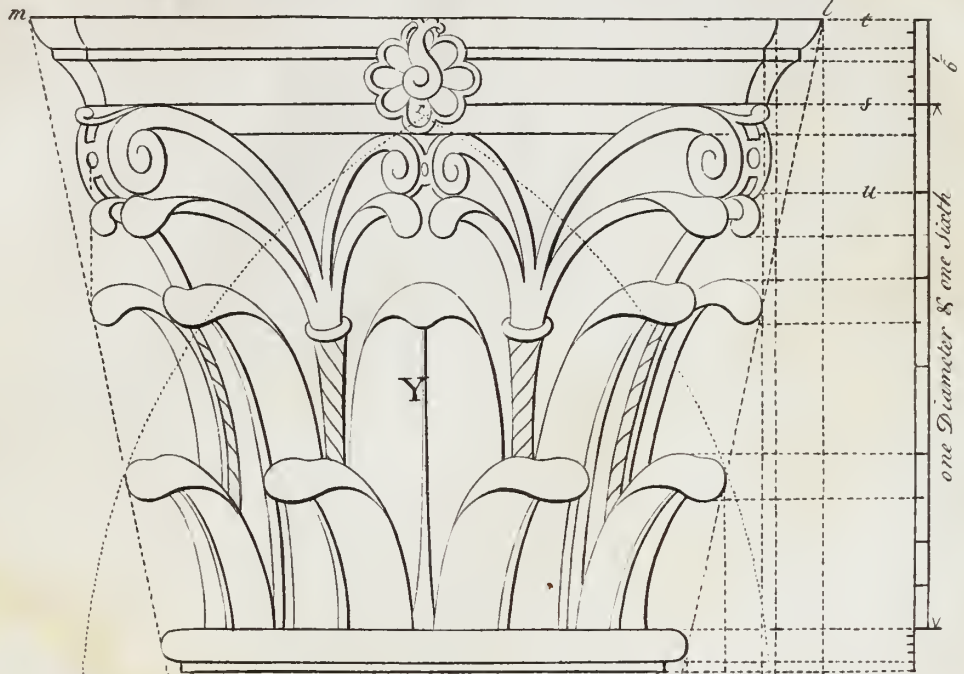

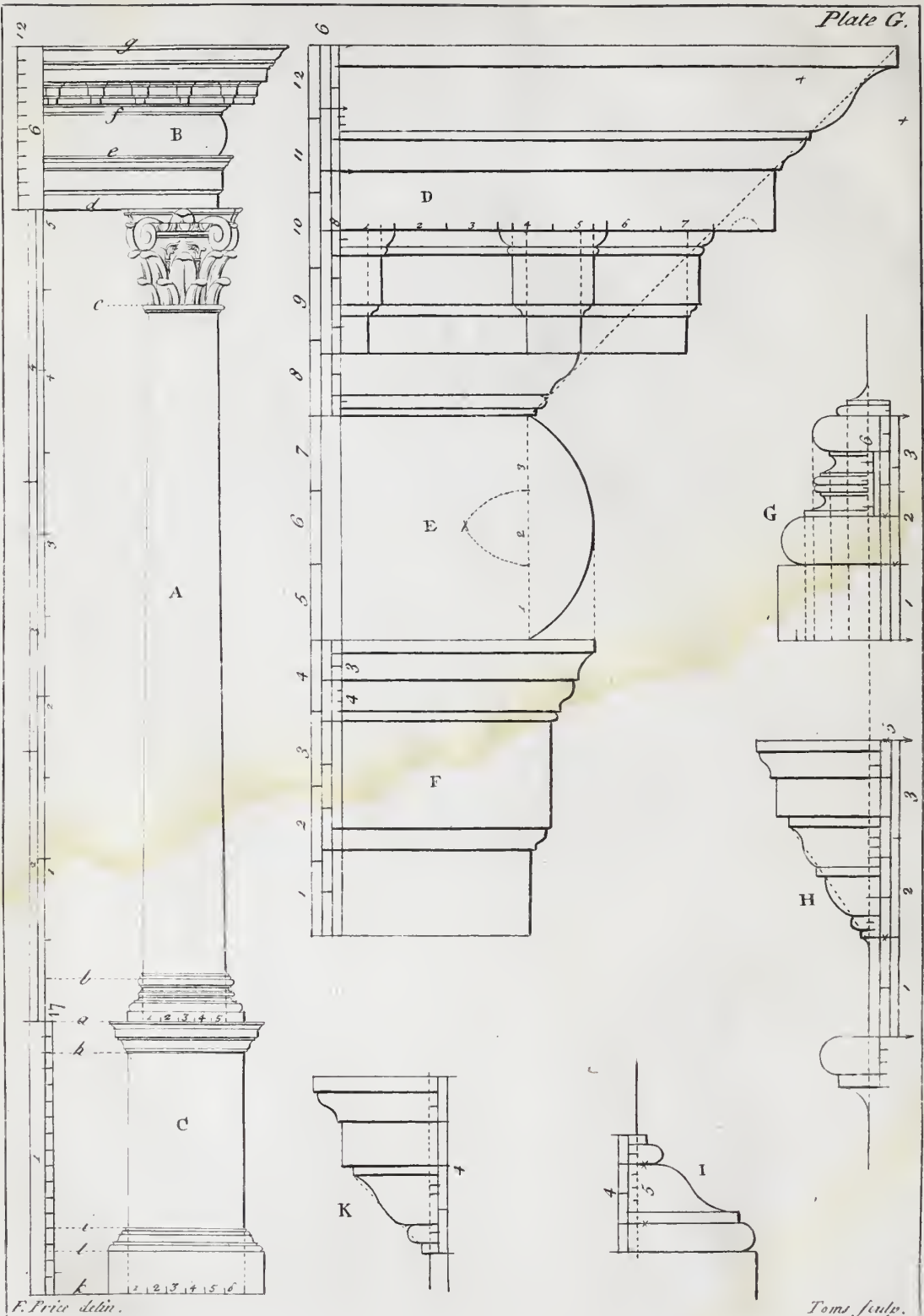

The Proportions of the COMPOSITE ORDER.



THE Column A, is ten Diameters high, including the Base a, b, and Capital c, d, each being as in the *Corinthian Order*. The Entablature B, is one fifth Part of the Height of the Column, as may appear by the Scale; this Height is divided into twelve Parts, giving four to the Architrave d, e, three to the Freeze e, f, and five to the Cornice f, g. The Pedestal C, is one third of the Height of the Column, which being divided into seventeen Parts, two is for the Caping a, h, eleven for the Die or naked h, i, and four for the Base and Plinth i, k, which being again divided into three Parts, one is for the Base i, l, and two for the Plinth l, k; so that any Height being given for this Order, divide it into forty-six equal Parts; three of which is the Diameter of the Column: From whence the other Parts are proportioned.

The Diameter of the Column being divided into five Parts, one is for the Projecture of the Base on each Side; and which gives the Breadth of the Die, or Trunk. The Breadth of the Pedestal being divided into six Parts, one is for the Projecture of the Caping a, k, and Base i, l. The Capital c, d, is one Diameter and one sixth in Height; and projects three-fourths of a Diameter, from the central Line; but as this Capital requires an Explanation by itself, as the foregoing *Ionick* and *Corinthian* Capitals, therefore I shall pass over it, to the Architrave d, e, which projects equal to that of the Freeze e, f, which is found as the *Ionick* Freeze was, *viz.* by making an Equilateral Triangle of the middle Part, its Point being the Center thereof. The Cornice f, g, projects equal to its Height.

The particular Parts are enlarged, as in D, E, F, G, H, I, K, each of which I make no doubt but Inspection will explain; except it be the Cornice, in which by drawing a Line from the extream Projection thereof, to the Foot most of the Projections are shewn. From the central Line of the Column, to the Projecture of the Modilion, as limited by the said Line, divide into seven Parts, two of which are for the Length of the Modilion, two for the Space betwixt each, and two for the largest Projection, so that this Modilion being a kind of Architrave, the first *Facia* has one of these Parts, and the second *Facia* has one and an half.

The Proportions of the COMPOSITE CAPITAL, together with the Intercoluniation proper to each Order.



HIS Capital is in Height, one Diameter and one sixth, or it is equal to the Height of the Architrave and Freeze together, the Plan is the same as that of the *Corinthian*; the Scale shews the Height of each distinct Part. This Capital is composed of the *Ionick*, and *Corinthian* Caps, as appears by the Elevation L; the whole Height being divided into seven Parts, the upper three are the *Ionick* Capital, differing in nothing but its Plan, as will appear by Compare. The lower four Parts are for the two Tire of Leaves, taken from the *Corinthian* Cap; for which Reason 'tis call'd the *Composite Order*. As to the Particulars, it comes so nearly alike to that of the *Corinthian*, that a farther Explanation would be little else but Repetition. Therefore in Lieu, I shall mention the Intercoluniation proper to each Order. (That is, the Space betwixt one Column and another if used in Colonades.)

Paladio says, we must keep a due Proportion and Harmony between the Intercoluniation, or Spaces, and the Columns. Because if small Columns be made with large Intercoluniations, it will very much lessen their Gracefulness. And on the contrary, if large Columns have small Intercoluniations, the too little Vacuity, will make them look without the least Grace. Therefore if the Spaces be three Diameters, the Thickness of the Column must be a seventh Part of its Altitude, as in the *Tuscan Order*; which manner of placing Columns is called *Areostylos*, as in M. But if the Space be two Diameters, and two thirds, the Length of the Column should be eight Diameters, as in the *Dorick Order*; and this manner of placing Columns, is called *Dyastylos*, as in N. If two and a Quarter, the Column must be nine Diameters in Length, as in the *Ionick Order*; and this manner is called *Eustylos*, as in O. And if no more than two, the Columns must be nine Diameters and an half high, as in the *Corinthian Order*; which manner is called *Systylos*, as in P. And, *lastly*, If of one Diameter and an half, the Length of the Column should be ten Diameters, as in the *Composite Order*; and this manner of placing Columns is called *Pycnostylos*, as in Q. I have been thus free, *says He*, in making my Observations, to the End that they may serve as Examples.

One Diameter and an half

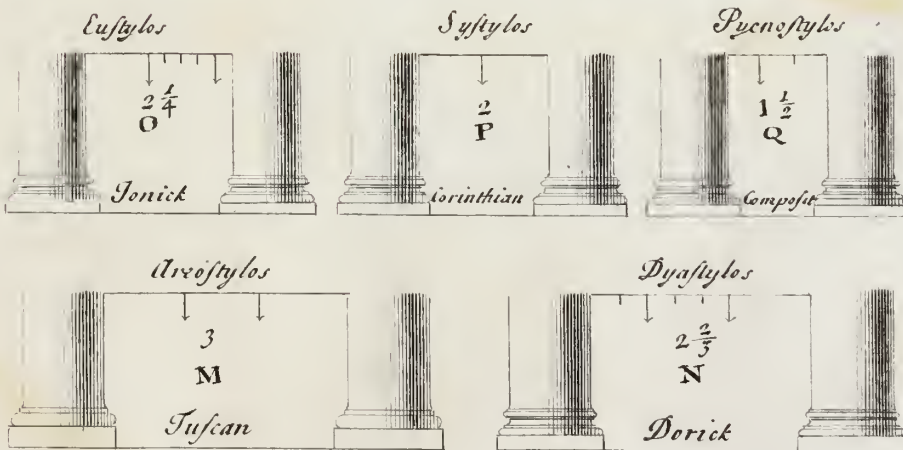
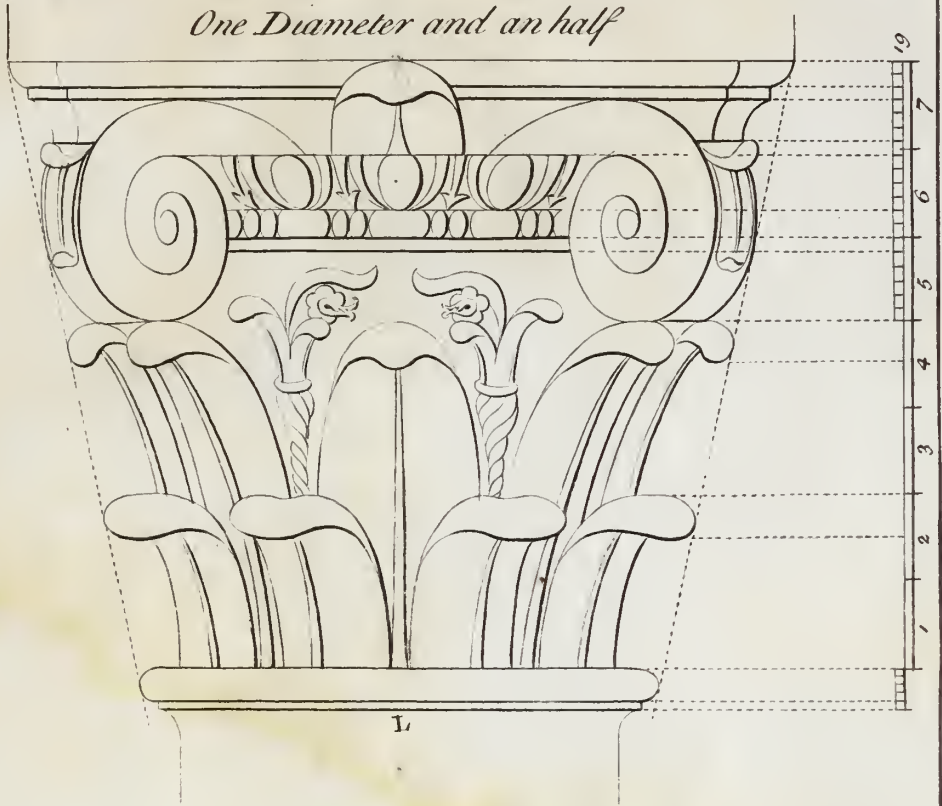

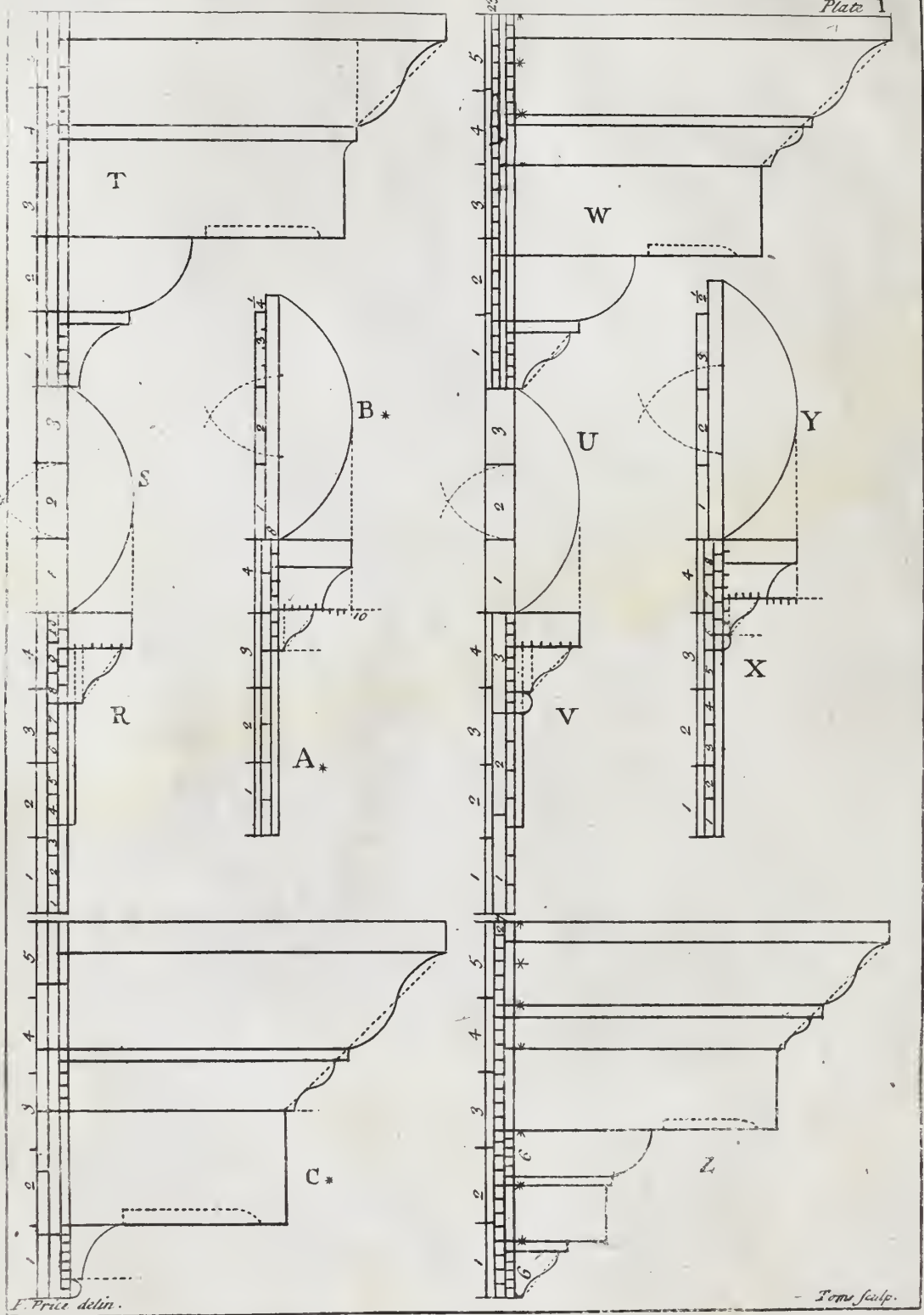

*The Proportions of the Ornaments of DOORS,
WINDOWS, &c.*



THE Width of either being given, make its Height equal to two Diameters; or two Diameters and a sixth Part: Which, is esteemed as the best Proportion. The said Width being made as the Use and Conveniency of the Place allows, (of which more will be observed in its due Place,) divide it into six equal Parts, one of which is for the Architrave as in R; which being divided into four equal Parts, three give the Height of the Freeze S; and five such Parts give the Height of the Cornice T; all which is easily conceived by the Scale, therefore to my thinking can want no Explanation, otherways than due Inspection.

Again, admit that of V, was an Architrave proportioned as before. U, being the Freeze, and W, the Cornice, the Method is as before, (the Ornaments only varying;) these Members will be easily conceived, by duly inspecting the Scales; and as to the Curves of each Moulding, enough seems to have been shewn in the foregoing Plates.

N. B. *The first Face of the Architrave should be as far from the Frame of the Door, or Window, as the Breadth of the whole Architrave; observe also that this Proportion is taken from the Width between one Architrave and the other, as will be shewn in its due Place.*

Admit the Architrave X, were one sixth Part of the Opening; which being divided into four Parts, as before, the Freeze Y, has three such Parts, and an half, as appears by the Scale; and the Cornice Z, has five Parts as in the other Examples. Each of these Cornices projects equal to their Height; and the Freeze in all being formed by an equilateral Triangle, made with one third Part thereof, gives the Projection of the Architrave; whose Parts are shewn distinctly, by the Scales.

The Architrave A*, being one sixth Part of the Opening, is divided into four Parts; of which, the Freeze B*, has three and one fourth; and Cornice C*, has five such Parts. So that here are four Manners, of forming the Ornaments of *Doors* and *Windows* according to PALLADIO.

*The Proportions of P E D I M E N T S, and their De-
pendants.*



O raise the Pitch, or Slope, of a Pediment, with Grace and Beauty, *says* PALLADIO, divide the Width given into nine equal Parts, two of which will be its perpendicular Height, as in D; for, *says He*, if it rise one fourth of its Width, it will be too High; and if one fifth, it will be too Low. Therefore the most comely Proportion, will be two ninths as before.

And in Consideration that no Pediment can be perform'd without two kinds of Cornice, (except it be knee'd at its Bottom or Springing, which is reckoned a kind of Defect,) therefore to give each of the Cymas such a Shape, or Curve, as shall strictly agree in their Miter, do thus. Describe the Curve of the level Cornice F, as a, b, c, by two such Portions of Circles, as that the Centers for forming each, may be on an Horizontal, or level Line, drawn through the Middle of the said Cyma; as * * c, d; being the Projecture thereof. Draw Lines from the Points of the said Cyma, agreeable to the Slope of the Pediment, which gives or terminates the Bigness of the raking Cornice or Cyma G; so that by drawing a Line through the Middle of the said Member, on it are the Centers * *, by which the Curves e, f, g, are described; the Projecture g, h, being as before. In Case a Break or Return be made in the Pediment, then another kind of Cyma must be formed, which shall agree with the two former, as H; the Centers for forming each Curve, being on an horizontal Line drawn through the Middle of the Cyma, as before; i, k, l, is the Curve whose Projecture as before is l, m; these three Kinds of Cornice being thus formed, will agree with each other, without the Trouble of Tracing. *But if the given Curve, be not described as before, then observe the Method proposed in I; by which the Curve of any raking Moulding whatever, may be truly described.* Admit the Cornice given were K; n, o, p, being its Curve, and p, q, its Projecture; by making Points on the said Curve, draw Lines from them, agreeable to the Slope of the Pediment, on which place each respective Projecture from K, to L, so is r, s, t, its Curve, the Projecture being t, u, as before. And if a Break or Return be made as M, then transfer the several Projectures from K, observing that the Points be on the Lines drawn agreeable to the Rake of the Pediment, so will w, x, y, be the Curve, and y, z, the Projecture as before; which no doubt but Inspection explains.

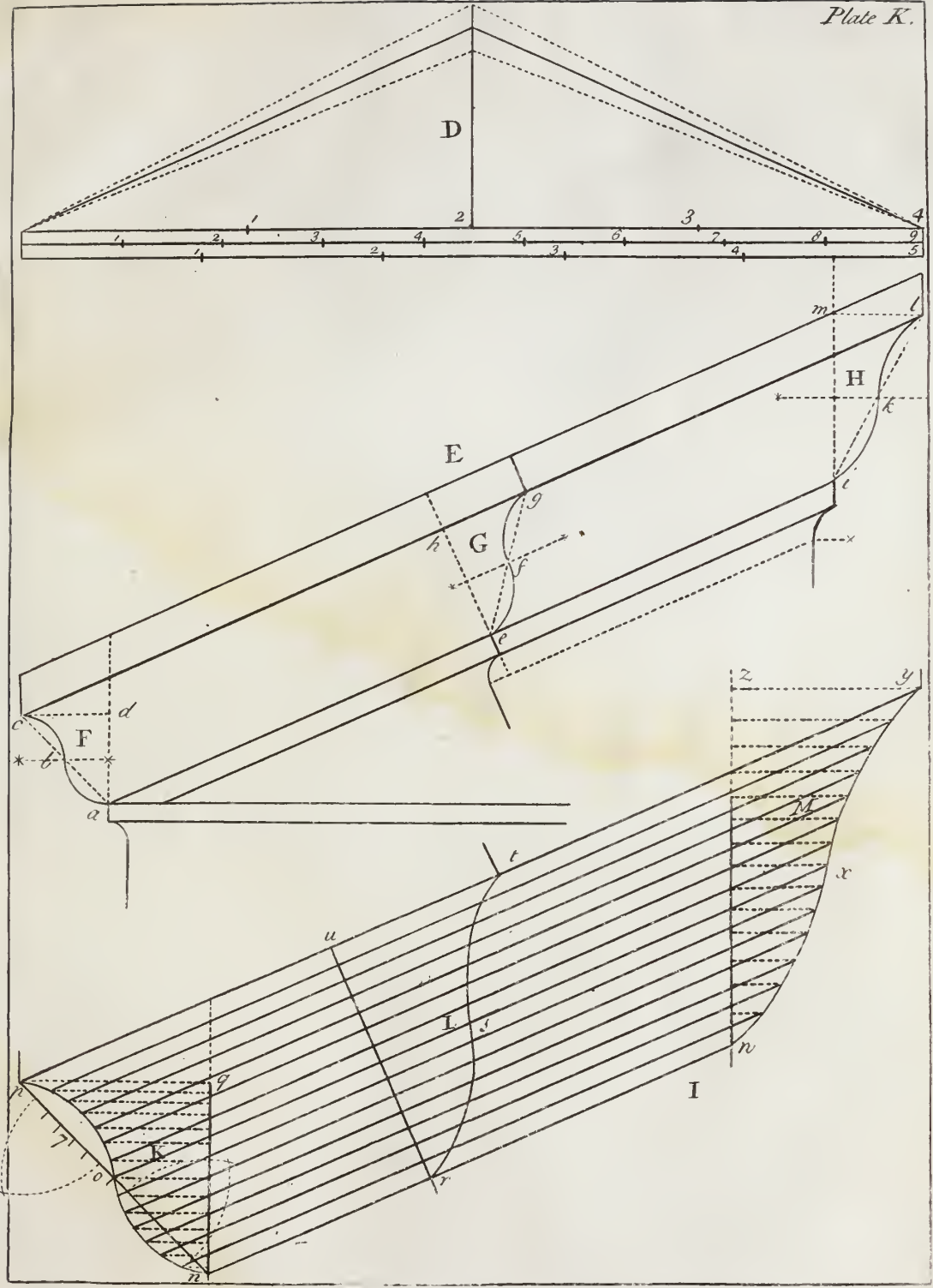



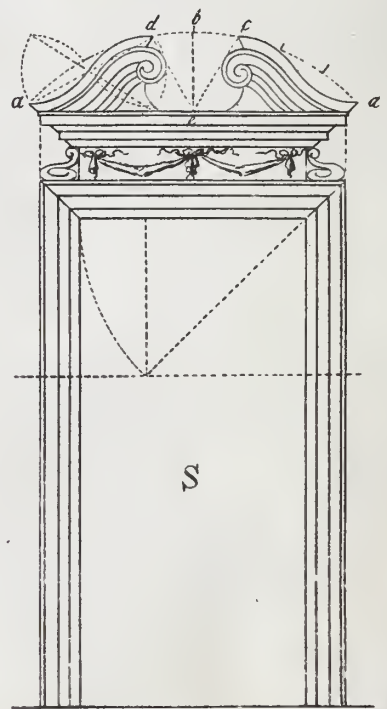
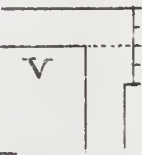
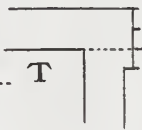
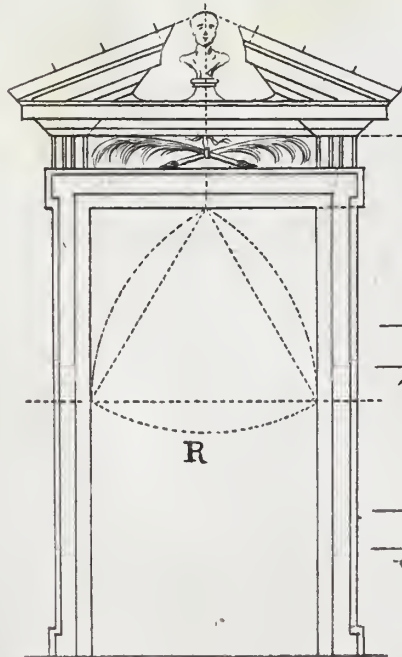
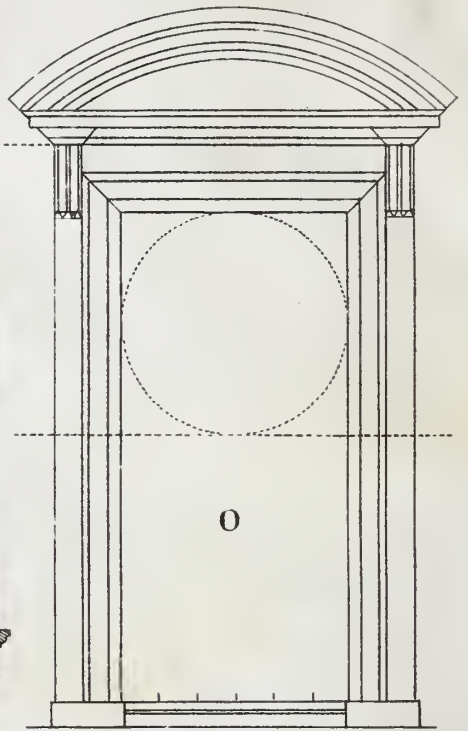
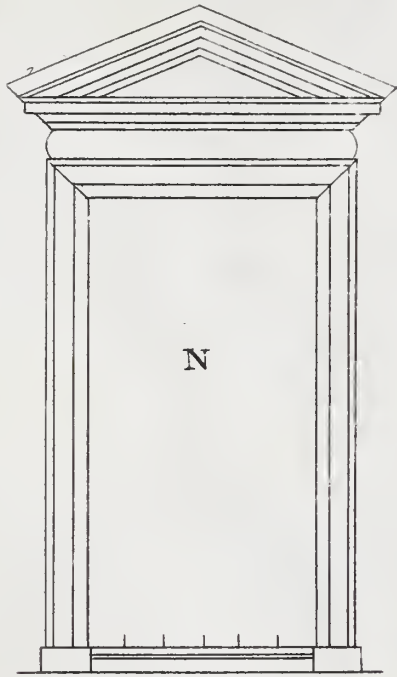

The foregoing Proportions apply'd to PRACTICE.



HAVING mentioned the various Ornaments proper to adorn *Doors* and *Windows* in the foregoing PLATE, viz. the Architrave, Freeze and Cornice; as also the Pitch of Pediments, &c. it remains to apply the same to Practice.

That of N, is a *Door* or *Window* of two Diameters high; and that of O, two Diameters and one sixth Part: The Architrave being divided into three Parts, two is for the Breadth of the Pilaster, as in P; on these Pilasters are placed the Trusses, Scroles, or Corbels, as in Q; whose Shape is almost at Pleasure; if either of these are used as Frontispieces of external Doors, the Pediment ought not to be broken, or opened, and the Architrave should stand on a Plinth, equal to two thirds thereof, or to the Height of the Step, by which one ascends into the House, &c. but if used in the internal Part, the Architrave may come down to the Floor or Pavement, and the Pediment may be opened as in R; the Knee, or Break of the Architrave is one fourth of the Width thereof, its Length being equal to the whole Breadth of the Architrave, as in R, or to one Diameter and an half as in T, or two Diameters as in V; at Pleasure. In this Freeze, are placed Trusses, whose form is U, which brings the Pediment forward to receive the Busto; as to the opening Inspection will explain it. This Door is two Diameters high, and that of S, is two Diameters and one sixth, and has its Freeze contracted. The Pediment is opened to receive a Shield, &c. and as to the other Particulars, (that is, the distinct Members,) enough has been shewn in the foregoing PLATE.

Either of these may serve as a Chimney-Piece, by changing the Proportion of their Height only; for instance, admit the Height were equal to its Width, as in O; or by describing an equilateral Triangle, whose Sides are equal to the Width, as in R; or, *lastly*, By the Diagonal of a Square, as in S; all which have a pleasing Effect. The Pediment is proportion'd by making a Quarter-Circle, as a, b, a, which being divided into eight Parts, three are for the Parts of the Pediment on each Side, and two for the Opening c, d, f that by drawing the Line c, e, or d, e, the Projecture of the Scroles are terminated, the rest may appear by Inspection.

A Regular Proportion for the several PEDESTALS.



HAVING delivered the Proportions of the five Orders, together with the Ornaments of Doors, Windows, &c. according to PALLADIO; I hope 'twill not displease any, that I take the Liberty to insert such Observations as naturally occur'd from going through such a Task.

PALLADIO proportions the *Dorick* Pedestal, by making its Die a perfect Square, as W, equal to the Breadth of the Plinth of the Column, which Bigness is found by dividing the Body, or Diameter of the Column, into six Parts, of which one is for the Projecture of the said Plinth on each Side, and by being divided into four equal Parts, one is for the Caping, and two for the Base and Plinth, which being divided into three, one is for the Base, and two for the Plinth, as appears by the Scale.

N. B. *This is the same Proportion as was before delivered.*

The *Ionick* Pedestal, is proportion'd by making its Die a Square and one sixth, as X, which being divided into four Parts and an half, i, e, nine Parts; two is for the Caping, and four for the Base and Plinth, as before.

The *Composite* Pedestal, is proportion'd by making its Die, a Square and two sixths, as Z, which being divided into ten Parts, two is for its Caping, and four for the Base and Plinth, as before.

The *Corinthian* Pedestal, is proportion'd by making its Die, a Square and three sixths, as Y, i, e, a Square and an half; (the Bigness of which is found, by dividing the Diameter of the Column into five Parts, one is for the Projecture of the said Plinth on each Side,) which being divided into eleven Parts, two is for the Caping, and four for the Base and Plinth.

N. B. *This is also the same Proportion as was before deliver'd.*

By this Method, the Pedestals rise one above the other by a regular Proportion, *viz.* The *Dorick* is two Diameters, and one third of the Column, the *Ionick* is two Diameters and two thirds, the *Composite* is three Diameters, and the *Corinthian* is three Diameters and one third. As to the Proportion of the small Members, 'twas sufficiently explained before, therefore needs not be repeated.

Note, The *Ionick* and *Composite* Plinths, are found by dividing the Difference between that of the *Dorick*, and that of the *Corinthian*, into three Parts, giving one to the Augmentation of each Plinth.

Doric

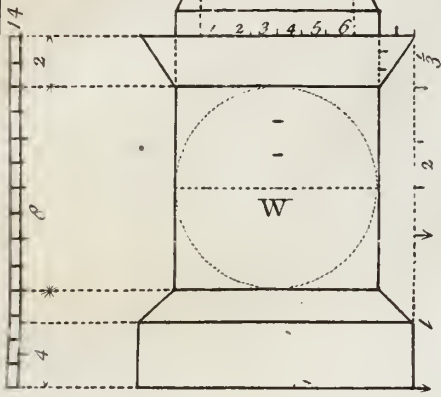

Corinthian

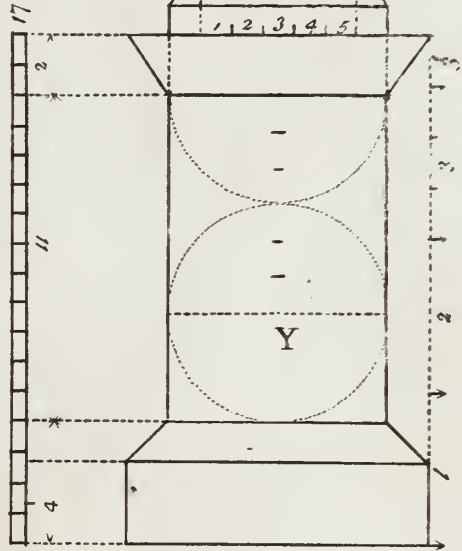

Tonick

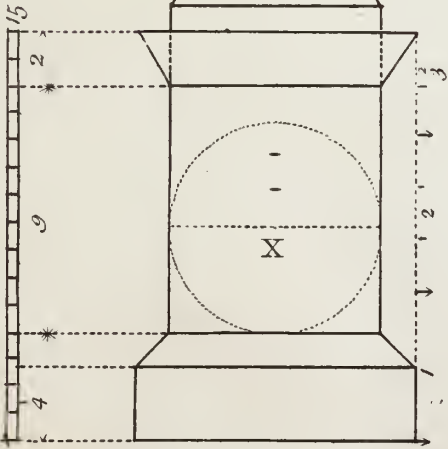

Composite

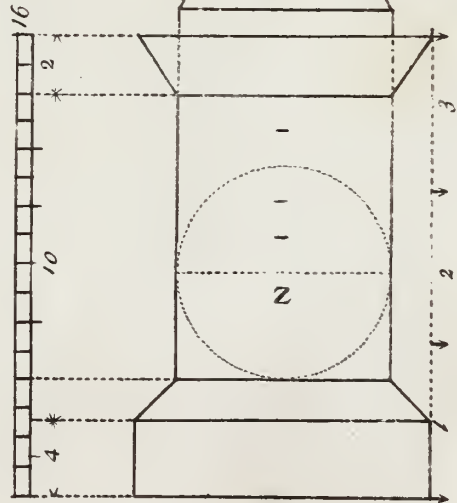

Plate N

Corinthian

$\frac{1}{2}$ a Diam.
 Dor. Cap.
 Ion. Cap.
 Comp. Cap.
 Corin. Cap.
 1. Diam. of 6.

Composite.

Ionick.

Doric.

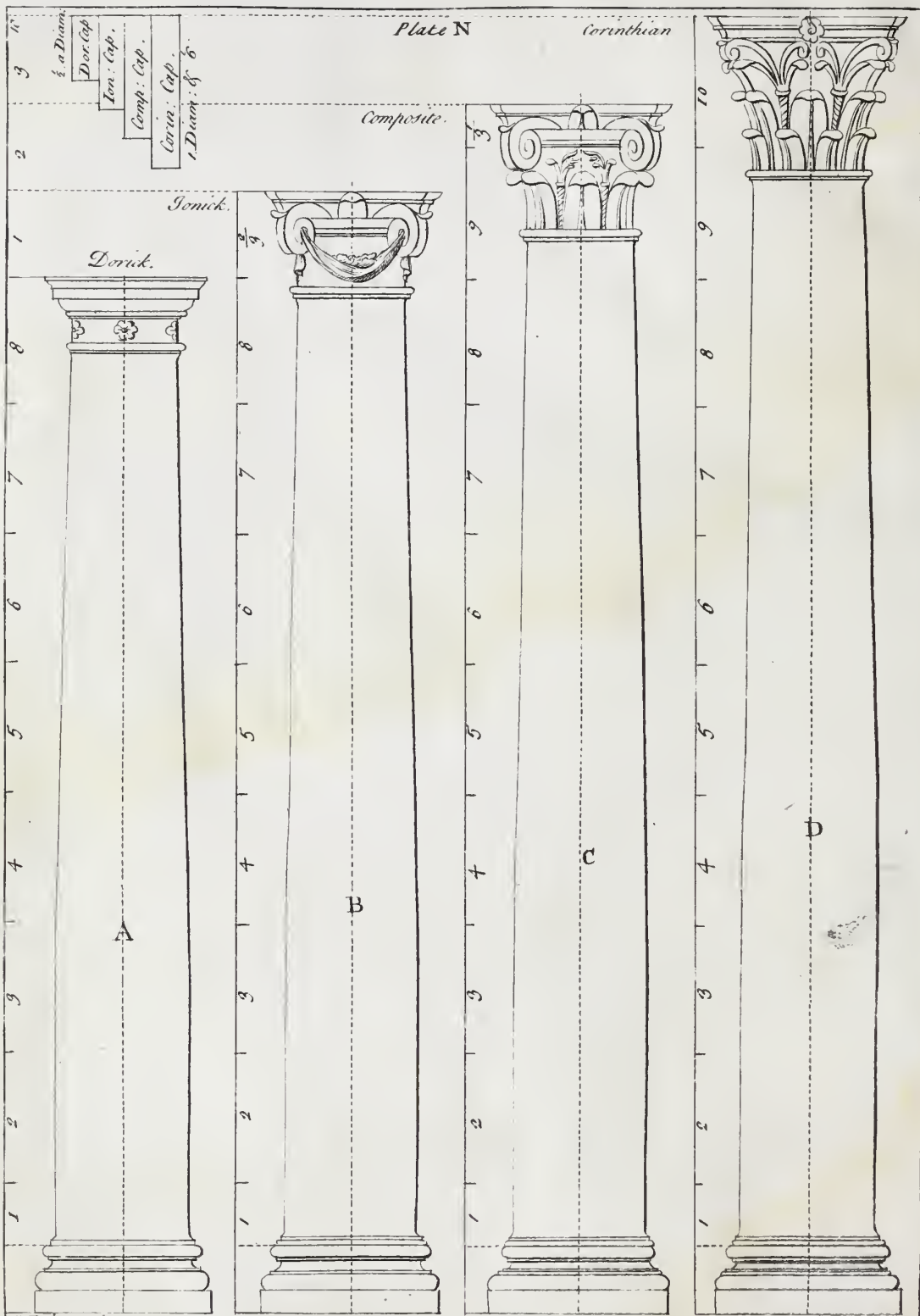

*A Regular Proportion for the several COLUMNS
and CAPITALS.*



MAKE the *Dorick* and *Corinthian* my Standards, as before. The *Dorick* Column A, together with its Base and Capital; (each being half the Diameter of the Column,) is eight Diameters high. And the *Corinthian* Column D, together with its Base and Capital, is ten Diameters high. The Base being half a Diameter in Height, and the Capital one Diameter and one sixth; so that by dividing the Difference betwixt the Height of these Columns (being two Diameters,) into three equal Parts, one is given to the Augmentation of each Column: By which Means the *Ionick* Column B, together with its Base and Capital, is eight Diameters and two thirds high. And the *Composite* Column C, including its Base and Capital is nine Diameters and one third in Height: So that the Columns rise in Height, proportionable to one another.

Note, The *Dorick* Capital is half a Diameter high, and the *Corinthian* Capital is one Diameter and one sixth. Therefore I divide the Difference into three equal Parts, as above; giving one Part to the additional Height of each Capital; all which the Scales so plainly shew, that a farther Explanation is needless. The *Ionick* Capital is diverted by Festoons of Drapery, which go through its Volutes, and which, as Occasion shall direct, may be of Fruit, Flowers, &c. There are abundance of Examples of this kind of *Ionick* Capital, to be found in the Productions of the Ancients, and also in the Works of Sir *Christopher Wren*; particularly in the Front of *St. Magnus's Church*, at the Foot of *London Bridge*. The *Composite* Capital, is diverted by the Volutes of the *Ionick*, and Leaves of the *Corinthian*. And of this kind of Capital, also abundance of Examples might be produced in the Works of Sir *Christopher Wren*. At the same Time it is so agreeable to the Words of most able Writers on this Subject, that it will need no enforcing.

N.B. By making the Capitals in this Proportion, the Shafts of the Columns will be agreeable in Height to one another, so that the whole rises progressively, which Point has not been regarded hitherto, although a very material one.

A Regular Proportion for the several Entablatures, together with the Construction of the Orders.



HAVING adjusted the several Pedestals, Columns, and Capitals, it remains that something should be said of the Entablatures, which will be thus, *viz.* PALLADIO observes in Words, that the *Dorick* Entablature E, should be one fourth of the Height of the Column, (but does not verify the same by Example,) and the *Corinthian* O, one fifth; which I shall otherways call $\frac{3}{12}$ ths and $\frac{3}{1}$ ths, so that the *Ionick* Entablature H, is $\frac{1}{3}$ ths, and the *Composite* L, $\frac{3}{4}$ ths, which may better appear by inspecting the PLATE; at which time may be observed, that each Entablature is two Diameters of the Column; and for the particular Proportion of the several Members, enough seems to have been shewn in the foregoing Examples; except it be in the *Dorick* Entablature E, (which was there shewn, at the Proportion of two ninths of the Height of the Column,) which was divided into fifteen Parts; therefore as this is one fourth of the Height of the Column, it must be divided into sixteen Parts, of which six is for the Cornice, the other Parts are as before, except its Projecture.

That these Proportions are applicable to Use, may thus appear; any Height being given for an entire *Dorick* Order, divide it into thirty-seven Parts; of which, seven is for the Pedestal G, twenty-four for the Column F, and six for the Entablature E; so that the Confinement being for any Part, the same Scale gives the Proportions.

Note, Three such Parts is the Diameter of the Column.

Admit a given Height was for the *Ionick* Order entire, divide it into forty equal Parts; of which eight is for the Pedestal K, twenty-six for the Column I, and six for the Entablature H.

Again, Let any Height be given for the *Composite* Order, divide it into forty-three equal Parts; of which nine is for the Pedestal N, twenty-eight for the Column M, and six for the Entablature L.

Lastly, Admit a Height were given for the *Corinthian* Order, divide it into forty-six equal Parts, ten are for the Height of the Pedestal Q, thirty for the Height of the Column P, and six for the Entablature O; so that if the foregoing Method be thought tedious, this may supply its Place, by being more expeditious, as well as easier to be conceived.

Note, The Particulars may be easily conceived, by perusing the foregoing PLATES, and Paragraphs.

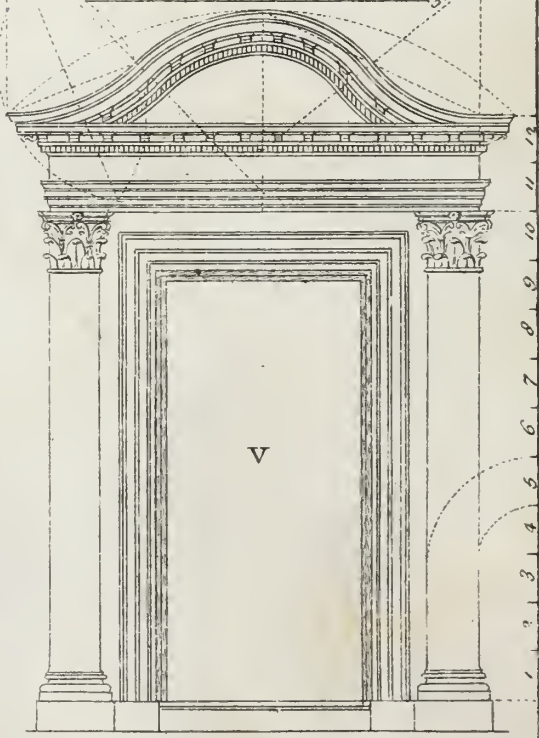
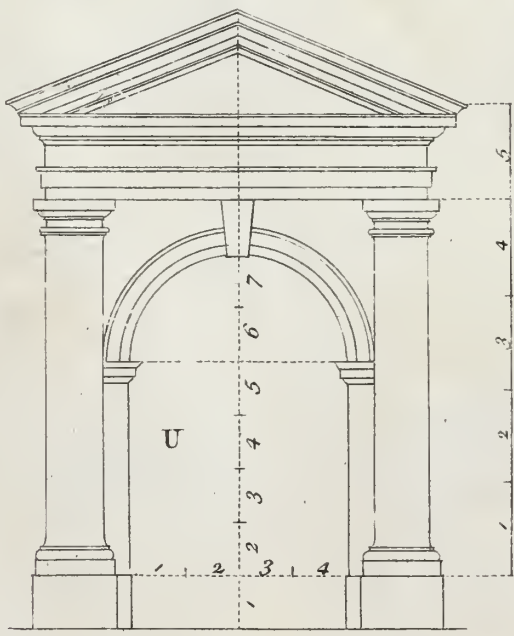
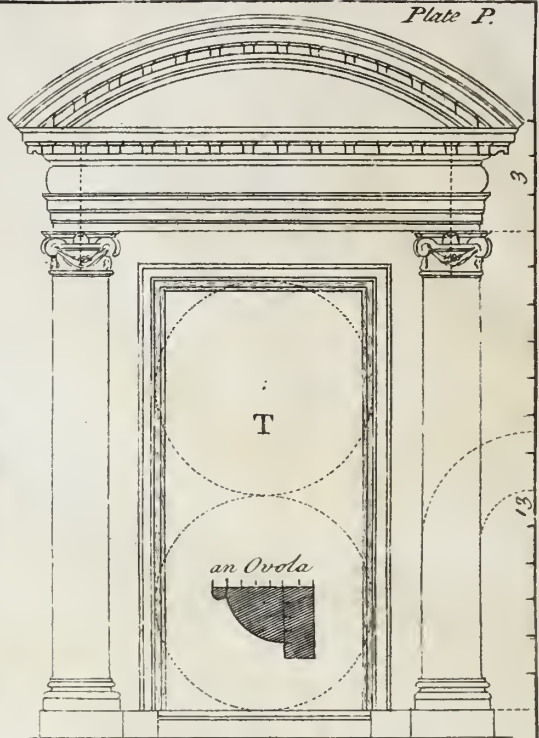
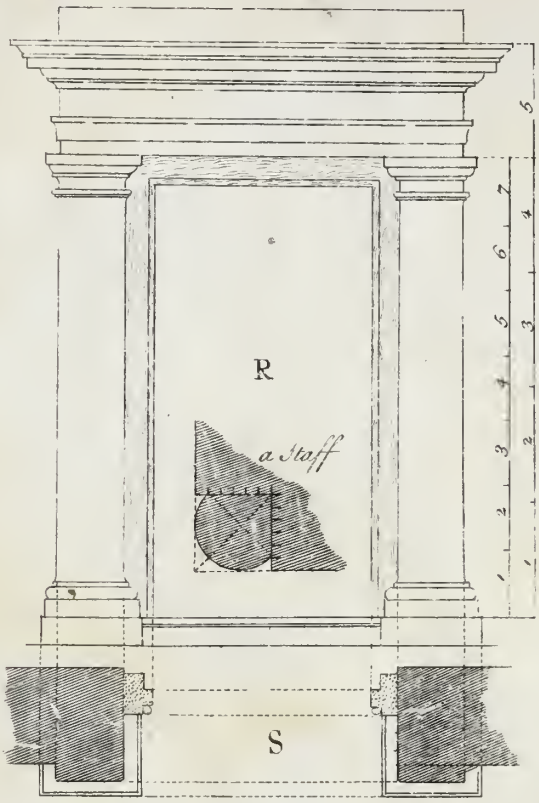

The foregoing Proportions apply'd to Practice in the
 Decoration of Doors, &c.



THE Door R, is adorned in a plain Manner, with *Tuscan* Pilasters, which stand on a Plinth, equal in Height to the Step by which one ascends into the Building. The Opening of the Door Frame is of two Diameters in Height, so that by determining how much of the said Frame shall be seen, (*viz.* as much as will take the Projecture of the Base, and Capital of the Pilasters;) which shews the Height of the Pilasters, as appears by Inspection; these Pilasters shew one fourth Part of their Diameter Outwards, and their whole Breadth Inwards, as appears by the Plan S.

Note, By placing the Door Frame so far within the Face of the Wall, the Door is the better sheltered.

The Door T, is adorned in a more beautiful Manner, with *Ionick* Pilasters, &c. The Opening between the Ovola's is of two Diameters, which being divided into twenty Parts, one is for the Part of the Door-case in Sight, which leaves the Opening of the Door two Diameters and one sixth; the Ovola being one twelfth of the aforesaid Opening, and the Margent round it one sixth, which terminates the Height of the Pilasters.

The Door V, is yet richer, being adorned with an Architrave, and *Corinthian* Pilasters; the Opening is as before, the Architrave being one sixth thereof, and the Margent one twelfth, which terminates the Height of the Pilasters, whose Proportions have been shewn before; on the Entablature, is raised a Pediment in two Manners, as is easily seen by Inspection. The Cyma is of the same Bigness in either of these Pediments, as at its Ends.

N. B. Pilasters ought never to be diminished in their Shafts as Columns are, unless they stand immediately behind Columns; and then if fluted, they have an ill Appearance, on account of the Flutes not being Perpendicular, as in Columns.

The Arch U, is adorn'd with *Tuscan* Pilasters, the Height of the Opening is one Diameter and three Quarters as appears; the Width being divided into four Parts, one is the Diameter of the Pilaster, by which the other Parts are proportion'd, as Inspection shews.

The foregoing Proportions apply'd to Practice in
ARCHES, adorn'd with COLUMNS or PILASTERS.



THESE four Arches come under one Rule, if duly observed. The Height only varying according to each Order; for Instance, the *Dorick* Arch W, is of two Diameters high, which if adorn'd with Columns, or Pilasters standing on a Plinth, the Width of the Opening must be divided into four Parts, (as in the *Tuscan* in the foregoing P L A T E;) one is for the Height of the Plinth, and is also the Diameter of the Column, and Length of the Key-stone, the Width being half its Height, if the Column stand on a Pedestal, the Opening must be divided into fourteen Parts, and three such Parts will be the Diameter of the Column; the other Parts were sufficiently explain'd in P L A T E O. The Pilaster that supports the Arch, is half the Diameter of the Column in each, as is also the Architrave, whose Mouldings may be somewhat plainer, than those of the Architrave of the Entablature.

The *Ionick* Arch X, is two Diameters and one sixth in Height, the other Parts being proportion'd by dividing as before.

The *Composite* Arch Y, is two Diameters and two sixths in Height, the other Parts being proportion'd as before.

The *Corinthian* Arch Z; is two Diameters and three sixths, *i. e.* two Diameters and an half in Height, the other Parts being as before.

Note, If Pilasters are used in either of these Cases, they must project forward one fourth Part of their Diameter, (or more at Pleasure,) on account of the Impost of their Arch finishing against them. And if Columns be used, they must project forward three fourths of their Diameter, (or three fourths of their Circumference,) on account of the Projecture of the Impost. By this Means the Column will appear free, and not encumbered or divided by the Impost of the Arch, as no doubt any Person may conceive.

N. B. I have endeavoured to compleat the Whole, in such a Manner, as to make it of general Use to the several Artificers in Building, having all along used my utmost Care to keep up to the general Rules of PALLADIO.

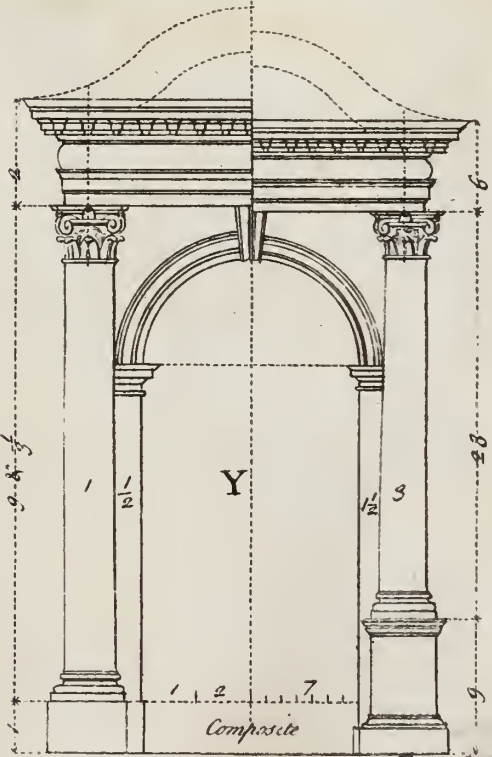
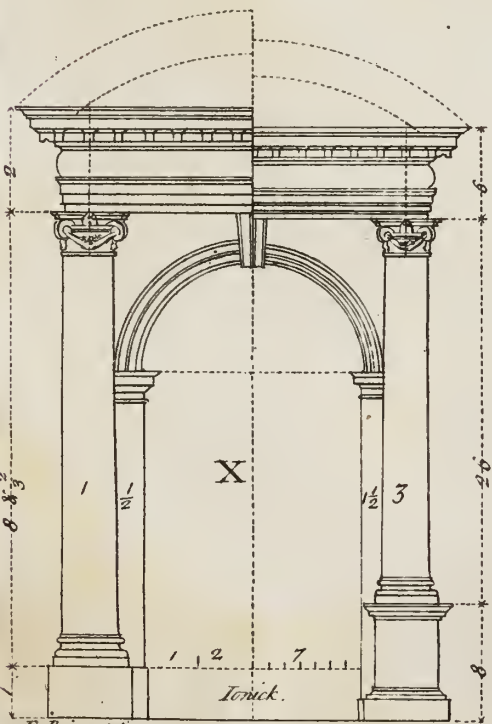
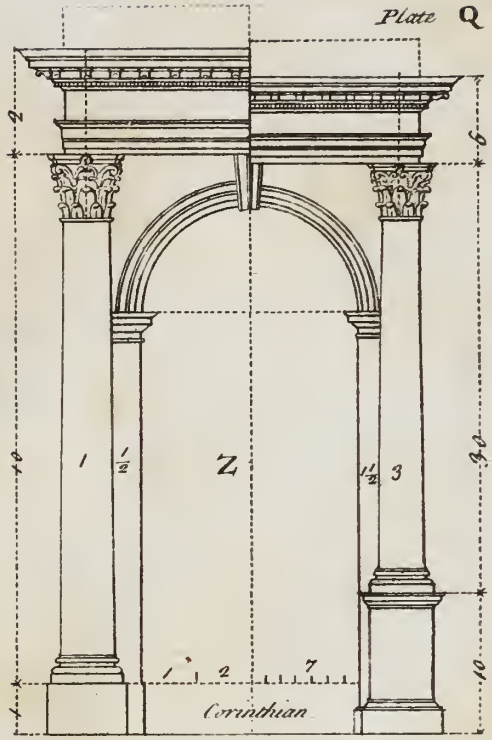
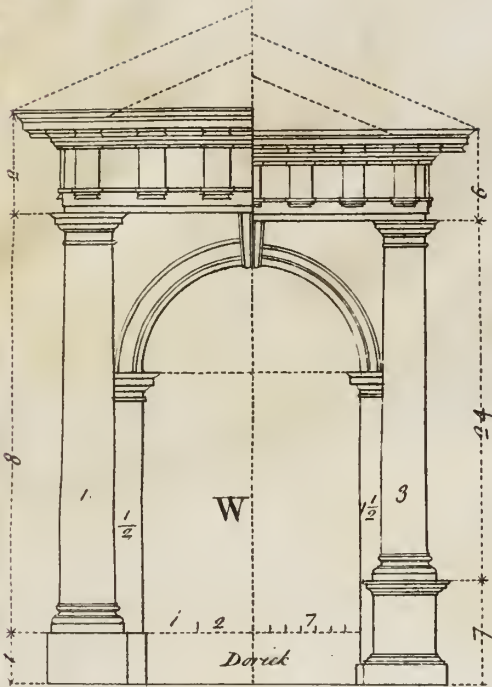

F. Price delin

Tombs sculp



SPECIAL 74-B
1874/3

