



*Experiment Station*

LIBRARY

Main Lib.

Agric. Dept.

OF THE

UNIVERSITY OF CALIFORNIA.

Received *June* , 189*8*

Accessions No. *71763*. Class No.

BIOLOGY  
LIBRARY.  
G



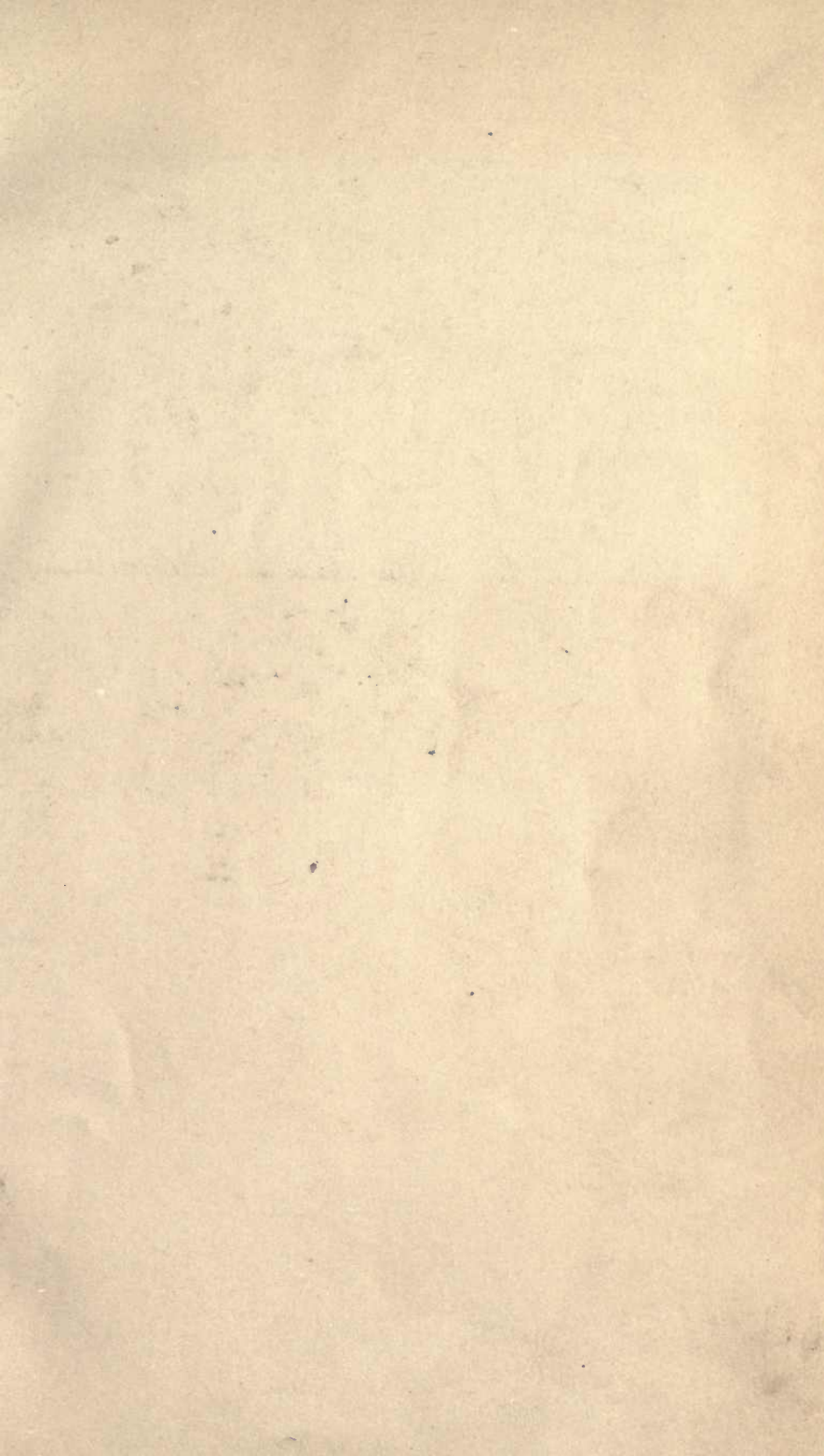



BACTERIOLOGY  
AND  
INFECTIVE DISEASES





A TEXT-BOOK  
OF  
BACTERIOLOGY

INCLUDING THE  
*ETIOLOGY AND PREVENTION*  
OF  
INFECTIVE DISEASES

AND A SHORT ACCOUNT OF  
YEASTS AND MOULDS, HÆMATOZOA, AND  
PSOROSPERMS



BY  
EDGAR M. CROOKSHANK, M.B.

PROFESSOR OF COMPARATIVE PATHOLOGY AND BACTERIOLOGY, AND FELLOW OF KING'S  
COLLEGE, LONDON.

*FOURTH EDITION*  
RECONSTRUCTED, REVISED AND GREATLY ENLARGED

PHILADELPHIA  
W. B. SAUNDERS  
925 WALNUT STREET  
1897

QR41

C8

1897

BIOLOGY  
LIBRARY  
6

Main Lib  
Agric. Dept

71763

W. B. STUBBS





To

SIR JOSEPH LISTER, BART., M.B., P.R.S.,

WHO HAS CREATED A NEW EPOCH IN

MEDICINE AND SURGERY,

BY APPLYING A KNOWLEDGE OF MICRO-ORGANISMS

TO THE TREATMENT OF DISEASE,

This Work is, with permission, Dedicated

BY THE AUTHOR

AS A

TOKEN OF ADMIRATION AND RESPECT



# PREFACE

TO THE

## FOURTH EDITION.

---

THIS book, though nominally a fourth edition, is practically speaking a new work. The progress of Bacteriology has been very rapid, and many new investigations have been made in connection with the etiology, prevention and treatment of communicable diseases. It has been necessary to reconstruct, enlarge and thoroughly revise the text of the third edition, and I have added twenty-six chapters.

The most important researches conducted in bacteriological laboratories are those relating to the *contagia*. In many diseases of man and animals it has not been possible to identify the contagium with a bacterium, or indeed with any micro-organism; but when the virus is chemically examined, or investigated with a view to protective inoculation, or utilised for experiments in serum-therapeutics, such researches are within the province of the bacteriologist.

The recognition of the fact that in so many diseases the nature of the contagium has not yet been determined will have the effect of encouraging continued activity in this important field of scientific investigation.

I hope that this work will continue to be of use as a text-book for the bacteriological laboratory, and that the chapters on the etiology and prevention of the communicable diseases



of man and animals will be not only of scientific interest, but of practical value to Medical Officers of Health and Veterinary Inspectors.

I have divided the book into three parts. Part I. is mainly technical, and includes the most recent methods employed in studying bacteria and investigating the etiology of disease. Part II. deals with infective diseases and the bacteria associated with them. Any clinical or pathological evidence which may help to throw light on the nature and origin of the contagia is taken into account. The most effectual measures for *stamping out* these diseases are referred to, as they are intimately connected with a knowledge of the life-history of micro-organisms. Part III. contains descriptions of about five hundred bacteria. Many are of no practical importance and of very little scientific interest, but a text-book for the laboratory cannot be considered complete unless an account is given of all bacteria which have been more or less completely investigated. I have endeavoured to refer to the original descriptions and to verify them by comparison with actual cultivations, but in a very great number of instances this has been quite impossible, and I desire to acknowledge the assistance I have received from the works of several authors, especially those of Flügge, Fränkel, Eisenberg, Baumgarten, Frankland, Sternberg, Lehmann and Neumann.

I have rearranged the bibliography according to the chapters, and the names of authors are given in alphabetical order. With the aid of the current numbers of the *Annales de l'Institut Pasteur*, the *Zeitschrift für Hygiene*, the *Centralblatt für Bakteriologie und Parasitenkunde*, and the *Journal of Comparative Pathology and Bacteriology*, it is possible to become acquainted with the most recent literature of the subject.

Many of the coloured plates illustrating the last edition have not been reproduced. Those substituted for them have been drawn from my own preparations, and most of them

have already appeared in my Reports to the Board of Agriculture and in other publications.

One hundred and thirty-three woodcuts and photographs have been added in the text, and I have reverted to the plan which I adopted in the second edition, of having many of them printed in colours.

I take this opportunity of thanking Professor Fränkel for kindly permitting me to reproduce some of the photographs in his excellent Atlas.

I am particularly indebted to Professor Hamilton for the use of *clichés* of figures in his classical treatise on Pathology, and to the New Sydenham Society for several from the English translation of Professor Flügge's well-known work on micro-organisms.

To my Demonstrator, Dr. George Newman, D.P.H., I am indebted for much assistance in correcting the proof-sheets, and for the preparation of an index.

EDGAR M. CROOKSHANK.

SAINT HILL, EAST GRINSTEAD, SUSSEX,  
*August 1st, 1896.*

P.S.—Since this work was finally passed for press the conclusions of the Royal Vaccination Commissioners have been published. I have at the last moment added extracts in the form of a supplementary Appendix.

E. M. C.

*September 18th, 1896.*





# CONTENTS.

---

## PART I.

### *THEORETICAL AND TECHNICAL.*

#### CHAPTER I.

PAGE

✓ HISTORICAL INTRODUCTION . . . . . 1 ✓

#### CHAPTER II.

✓ MORPHOLOGY AND PHYSIOLOGY OF BACTERIA . . . . . 11 ✓

#### CHAPTER III.

EFFECT OF ANTISEPTICS AND DISINFECTANTS ON BACTERIA . 30

#### CHAPTER IV.

CHEMICAL PRODUCTS OF BACTERIA . . . . . 39

#### CHAPTER V.

IMMUNITY . . . . . 49

#### CHAPTER VI.

ANTITOXINS AND SERUM THERAPY . . . . . 56

#### CHAPTER VII.

THE BACTERIOLOGICAL MICROSCOPE . . . . . 65

#### CHAPTER VIII.

MICROSCOPICAL EXAMINATION OF BACTERIA . . . . . 83

#### CHAPTER IX.

PREPARATION OF NUTRIENT MEDIA AND METHODS OF CULTIVATION . . . . . 99 ✓

	PAGE
CHAPTER X.	
EXPERIMENTS UPON THE LIVING ANIMAL . . . . .	134
CHAPTER XI.	
EXAMINATION OF AIR, SOIL, AND WATER . . . . .	140 ✓
CHAPTER XII.	
PHOTOGRAPHY OF BACTERIA . . . . .	150

## PART II.

### *ETIOLOGY AND PREVENTION OF INFECTIVE DISEASES.*

CHAPTER XIII.	
SUPPURATION, PYÆMIA, SEPTICÆMIA, ERYSIPELAS . . . . .	173
CHAPTER XIV.	
ANTHRAX . . . . .	191
CHAPTER XV.	
QUARTER-EVIL.—MALIGNANT ŒDEMA.—RAG-PICKERS' SEPTICÆMIA.—SEPTICÆMIA OF GUINEA-PIGS.—SEPTICÆMIA OF MICE . . . . .	217
CHAPTER XVI.	
SEPTICÆMIA OF BUFFALOES.—SEPTIC PLEURO-PNEUMONIA OF CALVES.—SWINE FEVER.—SEPTICÆMIA OF DEER.—SEPTICÆMIA OF RABBITS.—FOWL CHOLERA.—FOWL ENTERITIS.—DUCK CHOLERA.—GROUSE DISEASE . . . . .	226
CHAPTER XVII.	
PNEUMONIA.—INFECTIOUS PLEURO-PNEUMONIA OF CATTLE.—INFLUENZA . . . . .	233
CHAPTER XVIII.	
ORIENTAL PLAGUE.—RELAPSING FEVER.—TYPHUS FEVER.—YELLOW FEVER . . . . .	250

## CONTENTS.

xiii

PAGE

## CHAPTER XIX.

SCARLET FEVER.—MEASLES . . . . . 261

## CHAPTER XX.

SMALL-POX.—CATTLE PLAGUE . . . . . 284

## CHAPTER XXI.

SHEEP-POX.—FOOT-AND-MOUTH DISEASE . . . . . 297

## CHAPTER XXII.

HORSE-POX.—COW-POX . . . . . 303

## CHAPTER XXIII.

DIPHTHERIA . . . . . 330

## CHAPTER XXIV.

TYPHOID FEVER . . . . . 340

## CHAPTER XXV.

SWINE FEVER . . . . . 347

## CHAPTER XXVI.

SWINE MEASLES.—DISTEMPER IN DOGS.—EPIDEMIC DISEASE OF  
FERRETS.—EPIDEMIC DISEASE OF MICE . . . . . 355

## CHAPTER XXVII.

ASIATIC CHOLERA.—CHOLERA NOSTRAS.—CHOLERAIC DIARRHŒA  
FROM MEAT POISONING.—DYSENTERY.—CHOLERAIC DIAR-  
RHŒA IN FOWLS . . . . . 360

## CHAPTER XXVIII.

TUBERCULOSIS . . . . . 375

## CHAPTER XXIX.

LEPROSY.—SYPHILIS.—RHINOSCLEROMA.—TRACHOMA . . . . . 406

## CHAPTER XXX.

ACTINOMYCOSIS.—MADURA DISEASE . . . . . 413

## CHAPTER XXXI.

GLANDERS . . . . . 451



	PAGE
CHAPTER XXXII.	
TETANUS.—RABIES.—LOUPING-ILL . . . . .	457
CHAPTER XXXIII.	
FOOT-ROT . . . . .	464
CHAPTER XXXIV.	
FOUL-BROOD.—INFECTIOUS DISEASE OF BEES IN ITALY.— PÉBRINE.—FLACHERIE.—INFECTIOUS DISEASE OF CATER- PILLARS . . . . .	469

---

## PART III.

### *SYSTEMATIC AND DESCRIPTIVE.*

CHAPTER XXXV.	
CLASSIFICATION AND DESCRIPTION OF SPECIES . . . . .	475

---

## APPENDICES.

APPENDIX I.	
YEASTS AND MOULDS . . . . .	577
APPENDIX II.	
HÆMATOZOA IN MAN, BIRDS, AND TURTLES.—HÆMATOZOA IN EQUINES, CAMELS AND FISH.—HÆMATOZOA IN FROGS . . . . .	589
APPENDIX III.	
PSOROSPERMS OR COCCIDIA.—AMCEBA COLI . . . . .	609
APPENDIX IV.	
APPARATUS, MATERIAL AND REAGENTS EMPLOYED IN A BAC- TERIOLOGICAL LABORATORY . . . . .	612
APPENDIX V.	
BIBLIOGRAPHY . . . . .	639
SUPPLEMENTARY APPENDIX.	
EXTRACTS FROM THE FINAL REPORT OF THE ROYAL VACCINA- TION COMMISSION . . . . .	667



## LIST OF ILLUSTRATIONS.

### WOOD ENGRAVINGS AND PHOTOGRAPHS.

FIG.	PAGE
1. Ascococcus Billrothii, × 65 (Cohn) . . . . .	14
2. Spirochæta from Sewage Water, × 1200 (E.M.C.) . . . . .	15
3. Flagella (Koch, Brefeld, Warming, Zopf) . . . . .	16
4. Bacillus Megatherium (De Bary) . . . . .	17
5. Clostridium Butyricum, × 1020 (Prazmowski) . . . . .	18
6. Leuconostoc Mesenteroides; Cocci-chains with Arthrospores (Van Tieghem and Cienkowski) . . . . .	19
7. Spore-bearing Threads of Bacillus Anthracis, double-stained with Fuchsine and Methylene Blue, × 1200 (E.M.C.) . . . . .	20
8. Bacilli of Tubercle in Sputum, × 2500 (E.M.C.) . . . . .	21
9. Comma Bacilli in Sewage Water, stained with Gentian Violet, × 1200 (E.M.C.) . . . . .	22
10. Vibrios in Water contaminated with Sewage, × 1200 (E.M.C.) . . . . .	22
11. Refraction of Light (Carpenter) . . . . .	66
12. Spherical Aberration (Carpenter) . . . . .	67
13. Combination of Lenses in Abbé's Homogeneous Immersion (Carpenter) . . . . .	67
14. Chromatic Aberration (Carpenter) . . . . .	68
15. Objective with Collar Correction (Zeiss) . . . . .	69
16. Microscope—English Model (Swift) . . . . .	71
17. Removable Mechanical Stage (Swift) . . . . .	72
18. Microscope—Continental Model (Zeiss) . . . . .	73
19. Iris Diaphragm (Zeiss) . . . . .	74
20. Abbé's Condenser (Zeiss) . . . . .	75
21. Microscope Lamp (Baker) . . . . .	6
22. Large Microscope Lamp (Swift) . . . . .	77
23. Arrangement of Powell and Lealand's Microscope in working directly on the Edge of the Flame, with Stand for Micrometer Eye-piece to secure Steadiness and Accuracy of Measurement (Carpenter after Nelson) . . . . .	79
24. Ramsden Micrometer Eye-piece (Swift) . . . . .	80
25. Micrometer Eye-piece (Zeiss) . . . . .	81
26. Inoculating Needles (E.M.C.) . . . . .	84
27. Freezing Microtome (Swift) . . . . .	94
28. Microtome (Jung) . . . . .	95
29. Wire-cage for Test-tubes (Muencke) . . . . .	100
30. Hot-air Steriliser (E.M.C.) . . . . .	101

FIG.	PAGE
31. Hot-water Filtering Apparatus (Muencke)	102
32. Method of making a Folded Filter (E.M.C.)	103
33. Steam Steriliser (Baird and Tatlock)	103
34. Incubator (Muencke)	104
35. Method of Inoculating a Test-tube containing Sterile Nutrient Jelly (E.M.C.)	105
36. Levelling Apparatus (E.M.C)	107
37. Iron box for Glass Plates (Muencke)	108
38. Method of Inoculating Test-tubes in the Preparation of Plate-cultivations (E.M.C.)	108
39. Damp-chamber containing Plate-cultivations (E.M.C)	110
40. Pasteur's Large Incubator (Becker)	111
41. Petri's Dish (Becker)	112
42. Glass Benches and Slides (Becker)	112
43. Koch's Serum Steriliser (Muencke)	114
44. Hueppe's Serum Inspissator (Baird and Tatlock)	115
45. Box for Sterilising Instruments (Becker)	116
46. Damp Chamber for Potato-cultivations (E.M.C.)	117
47. Apparatus for Sterilisation by Steam under pressure (Baird and Tatlock)	119
48. Drop Cultivation (Flügge)	121
49. Simple Method of forming a Moist Cell (Schäfer)	122
50. Warm Stage (Schäfer)	123
51. Warm Stage shown in Operation (Schäfer)	123
52. Warming Apparatus in Operation (Israel)	124
53. Section of Warming Apparatus and Drop-culture Slide (Israel)	125
54. Israel's Warming Apparatus	125
55. Gas Chamber in use with Apparatus for generating Carbonic Acid (Schäfer)	126
56. Gas Chamber (Schäfer)	126
57. Moist Cell adapted for Transmission of Electricity (Schäfer)	127
58. Apparatus arranged for Transmitting Electricity (Schäfer)	127
59. Slide with Gold-leaf Electrodes (Schäfer)	128
60. Lister's Flask (Becker)	128
61. Sternberg's Bulb (Becker)	128
62. Aitken's Tube (Becker)	129
63. Miquel's Bulb (Becker)	129
64. Pasteur's Flask (Baird and Tatlock)	130
65. Pasteur's Double Tube (Baird and Tatlock)	130
66. Fränkel's Anaerobic Tube-culture (Frankland)	131
67. Anaerobic Culture Tube (Liborius)	132
68. Apparatus for Anaerobic Cultures (Roscoe and Lunt)	133
69. Koch's Syringe (Baird and Tatlock)	135
70. Syringe with Asbestos Plug (Baird and Tatlock)	135
71. Hesse's Apparatus (Muencke)	142
72. Sedgwick and Tucker's Tube (Baird and Tatlock)	143
73. Pouchet's Aeroscope (Hamilton)	143
74. Apparatus for Estimating the number of Colonies in a Plate-cultivation (Muencke)	146
75. Esmarch's Roll-culture (Frankland)	147
76. Apparatus for Counting Colonies in a Roll-culture (Becker)	148
77. Horizontal Micro-photographic Apparatus (Swift)	156



FIG.	PAGE
78. Reversible Micro-photographic Apparatus (E.M.C.) . . . . .	157
79. Reversible Micro-photographic Apparatus arranged in the Vertical Position (E.M.C.) . . . . .	158
80. Large Micro-photographic Apparatus (Swift) . . . . .	160
81. Photograph of an Impression Preparation (E.M.C.) . . . . .	162
82. Photograph of a Cultivation of <i>Bacillus anthracis</i> (E.M.C.) . . . . .	168
83. Suppuration of Subcutaneous Tissue (Cornil and Ranvier) . . . . .	174
84. Pus with Staphylococci, × 800 (Flügge) . . . . .	177
85. Subcutaneous Tissue of a Rabbit forty-eight hours after an Injection of Staphylococci, × 950 (Baumgarten) . . . . .	177
86. Ulcerative Endocarditis: Section of Cardiac Muscle, × 700 (Koch) . . . . .	183
87. Pure-cultures of Streptococcus Pyogenes (E.M.C.) . . . . .	184
88. Section of Skin in Erysipelas (Cornil and Ranvier) . . . . .	185
89. Streptococcus Pyogenes Hominis; Pure-cultures on Nutrient Gelatine (E.M.C.) . . . . .	187
90. Streptococcus Pyogenes Bovis; Pure-cultures on Nutrient Gelatine, (E.M.C.) . . . . .	188
91. Gonococcus, × 800 (Bumm) . . . . .	190
92. Bacillus Anthracis, × 1200. Blood Corpuscles and Bacilli unstained; from an Inoculated Mouse (Fränkel and Pfeiffer) . . . . .	192
93. Pure-cultivation of <i>Bacillus anthracis</i> in Nutrient Gelatine (E.M.C.) . . . . .	193
94. Colonies of <i>Bacillus anthracis</i> , × 86 (Flügge) . . . . .	194
95. Impression-preparation of a Colony, × 70 (E.M.C.) . . . . .	194
96. Margin of a Colony, × 250 (E.M.C.) . . . . .	195
97. Filaments with Oval and Irregular Elements, × 800 (E.M.C.) . . . . .	195
98. Spores of <i>Bacillus anthracis</i> stained with Gentian Violet, × 1500 (E.M.C.) . . . . .	197
99. Anthrax in Swine (E.M.C.) . . . . .	203
100. Anthrax in Swine (E.M.C.) . . . . .	205
101. Bacilli of Quarter-evil, × 1000 (Fränkel and Pfeiffer) . . . . .	218
102. Pure-culture of Bacilli of Quarter-evil in Grape-sugar Gelatine (Fränkel and Pfeiffer) . . . . .	218
103. Bacilli of Malignant Œdema, × 950 (Baumgarten) . . . . .	221
104. Pure-culture of Bacillus of Malignant Œdema in Grape-Sugar Gelatine (Fränkel and Pfeiffer) . . . . .	222
105. Bacilli of Malignant Œdema, × 1000 (Fränkel and Pfeiffer) . . . . .	223
106. Pure-cultivation of the Bacillus of Septicæmia of Mice in Nutrient Gelatine (E.M.C.) . . . . .	225
107. Bacterium of Rabbit Septicæmia; Blood of Sparrow, × 700 (Koch) . . . . .	228
108. Bacterium of Fowl-cholera, × 1200 (E.M.C.) . . . . .	228
109. Bacterium of Fowl-cholera, × 2500 (E.M.C.) . . . . .	228
110. Bacterium of Fowl-cholera; Section from Liver of Fowl, × 700 (Flügge) . . . . .	229
111. Bacillus of Hæmorrhagic Septicæmia, × 950 (Baumgarten) . . . . .	231
112. Bacillus of Hæmorrhagic Septicæmia: Pure-culture in Gelatine (Baumgarten) . . . . .	231
113. Bacterium Pneumoniæ Crouposæ from Pleural Cavity of a Mouse, × 1500 (Zopf) . . . . .	234
114. Friedländer's Pneumococcus; Pure-culture in Nutrient Gelatine (Baumgarten) . . . . .	234
115. Capsule Cocci from Pneumonia, × 1500 (Baumgarten) . . . . .	235
116. Micrococcus of Sputum Septicæmia, × 1000 (Fränkel and Pfeiffer) . . . . .	236

FIG.	PAGE
117. Colonies of Sternberg's Micrococcus, × 100 (Fränkel and Pfeiffer) .	237
118. Acute Catarrhal Pneumonia, × 480 (Hamilton) . . . . .	239
119. Infectious Pleuro-pneumonia of Cattle (Hamilton) . . . . .	240
120. Infectious Pleuro-pneumonia of Cattle (Hamilton) . . . . .	241
121. Bacillus of Influenza, × 1000 (Itzerott and Niemann) . . . . .	248
122. Bacillus of Influenza, × 1200 (E.M.C) . . . . .	249
123. Bacilli of Plague and Phagocytes, × 800 (Aoyama) . . . . .	253
124. Spirillum Obermeieri in Blood of Monkey inoculated with Spirilla after Removal of the Spleen (Soudakewitch) . . . . .	258
125. Pure-cultivations of Streptococcus Pyogenes (E.M.C.) . . . . .	263
126. Free Surface of Diphtheritic Larynx, × 350 (Hamilton) . . . . .	331
127. Bacillus of Diphtheria; from a Cultivation on Blood Serum, × 1000 (Fränkel and Pfeiffer) . . . . .	332
128. Pure-cultures of Bacillus Diphtheriæ on Glycerine-Gelatine (E.M.C.)	333
129. Typhoid Fever. Ileum of Adult, showing Sloughy and Infiltrated Patches (Hamilton) . . . . .	341
130. Typhoid Bacilli from a Colony on Nutrient Gelatine, × 1000 (Fränkel and Pfeiffer) . . . . .	342
131. Typhoid Bacilli, × 950 (Baumgarten) . . . . .	342
132. Flagella of Typhoid Bacilli, × 1000 (Fränkel and Pfeiffer) . . . . .	343
133. Colonies of the Typhoid Bacillus (Fränkel and Pfeiffer) . . . . .	344
134. Pure-culture of Typhoid Bacilli inoculated in the Depth of Nutrient Gelatine (Baumgarten) . . . . .	344
135. Typhoid Bacilli in a Section of Spleen, × 800 (Flügge) . . . . .	345
136. Typhoid Bacilli in a Section of Intestine invading the Submucous and Muscular Layers, × 950 (Baumgarten) . . . . .	346
137. Ulceration of the Intestine in a Typical Case of Swine-fever (E.M.C.)	348
138. Klein's Bacillus of Swine-fever (No. 1) . . . . .	349
139. From a Preparation of Bronchial Mucus of Klein's Swine-fever Bacillus (No. 2) . . . . .	349
140. Bacilli from an Artificial Culture with Spores, Bacillus No. 2 (Klein)	349
141. Blood of Fresh Spleen of a Mouse after Inoculation with Swine-fever Bacillus No. 2 (Klein) . . . . .	350
142. Bacilli of Swine Erysipelas (Baumgarten) . . . . .	356
143. Blood of Pigeon inoculated with Bacilli of Swine Erysipelas, × 600 (Schütz) . . . . .	356
144. Pure-culture in Nutrient Gelatine of Bacilli from Swine Erysipelas (Baumgarten) . . . . .	357
145. Cover-glass Preparation of a Drop of Meat Infusion containing a Pure-cultivation of Comma-bacilli (Koch) . . . . .	361
146. Arthrospores of Comma-bacilli (Hueppe) . . . . .	361
147. Flagella of Comma-bacilli; stained by Löffler's Method (Fränkel and Pfeiffer) . . . . .	362
148. Involution Forms of Comma-bacilli, × 700 (Van Ermengem) . . . . .	362
149. Colonies of Comma-bacilli on Nutrient Gelatine; natural size (Koch)	362
150. Colonies of Koch's Comma-bacilli, × 60 (E.M.C.) . . . . .	363
151. Cover-glass Preparation from the Contents of a Cholera Intestine, × 600 (Koch) . . . . .	363
152. Cover-glass Preparation of Cholera Dejecta on Damp Linen, × 600 (Koch) . . . . .	363
153. Section of the Mucous Membrane of a Cholera Intestine, × 600 (Koch) . . . . .	364



FIG.	PAGE
154. Pure-cultivations in Nutrient Gelatine of Koch's and of Finkler's Comma-bacilli (E.M.C.) . . . . .	365
155. Comma-shaped Organisms with other Bacteria in Sewage-contaminated Water, × 1200 . . . . .	366
156. Comma-bacilli of the Mouth, × 700 (Van Ermengem) . . . . .	367
157. Finkler's Comma-bacilli, from Cholera nostras, × 700 (Flügge) . . . . .	367
158. Deneke's Comma-bacilli, from Cheese, × 700 (Flügge) . . . . .	367
159. Pure-cultivation of the Spirillum Finkler-Prior, in Nutrient Gelatine (E.M.C.) . . . . .	370
160. Tropical Dysentery; Mucous Membrane of Large Intestine (Hamilton) . . . . .	372
161. Tubercle of the Lung in a very Early Stage, × 400 (Hamilton) . . . . .	376
162. Primary Tubercle of Lung two to three weeks old, × 50 (Hamilton) . . . . .	377
163. Large Oval Giant Cell from Tubercle of Lung, × 300 (Hamilton) . . . . .	377
164. Bacillus Tuberculosis, from Tubercular Sputum, × 2500 (E.M.C.) . . . . .	379
165. Pure-cultivation of the Tubercle Bacillus on Glycerine Agar-agar (E.M.C.) . . . . .	380
166. Pure-cultivation in Glycerine Agar-agar after ten months' growth (E.M.C.) . . . . .	381
167. Pure-cultivations of Tubercle Bacillus in Glycerine Agar-agar; a sub-culture from a Pure-culture in Glycerine Milk (E.M.C.) . . . . .	381
168. Section through a Lupus Nodule of the Nose (Hamilton) . . . . .	387
169. Tubercular Ulceration of Mucosa of Ileum (Hamilton) . . . . .	388
170. Section of Lupus of the Skin; Giant Cell containing Tubercle Bacillus (Flügge) . . . . .	389
171. Tuberculosis of Pleura; "Grape-disease" (E.M.C.) . . . . .	390
172. Tubercular Ulceration of the Intestine of a Cow (E.M.C.) . . . . .	393
173. Tubercular Ulceration of the Intestine of a Rabbit (E.M.C.) . . . . .	395
174. Tubercular Lungs of Rabbit (E.M.C.) . . . . .	396
175. Cover-glass Preparation of Pus from a Chancre, × 1050 (Lustgarten) . . . . .	410
176. Wandering Cell containing Bacilli (Lustgarten) . . . . .	410
177. Section of Liver from a Case of Actinomycosis in Man (E.M.C.) . . . . .	417
178. Actinomycotic Tumour in the Throat of a Steer (E.M.C.) . . . . .	424
179. Actinomycotic Tumour of the Cheek (E.M.C.) . . . . .	424
180. Steer with Emaciation the Result of Actinomycosis (E.M.C.) . . . . .	425
181. Actinomycotic Growths from the Pleura resembling "Grape-Disease" (E.M.C.) . . . . .	425
182. Actinomycosis of the Skin (E.M.C.) . . . . .	430
183. Part of Human Foot with Madura Disease (E.M.C.) . . . . .	448
184. Bacilli of Glanders, × 700 (Flügge) . . . . .	452
185. Section of a Branch of the Pulmonary Artery showing Glanders Bacilli penetrating the Wall (Hamilton) . . . . .	453
186. Pure-culture of the Tetanus Bacillus in Grape-sugar Gelatine (Fränkel and Pfeiffer) . . . . .	458
187. Foot of Sheep showing Disease of Horn (Brown) . . . . .	465
188. Section through the Foot showing a Crack extending through the Wall . . . . .	465
189. Secreting Membrane covered with Fungoid Growths (Brown) . . . . .	466
190. Advanced Form of Disease of Skin between the Claws (Brown) . . . . .	466
191. Distortion of Hoof in an Advanced Form of Foot-rot (Brown) . . . . .	467
192. Diseased Comb (Cowan) . . . . .	469
193. Spores of Bacillus Alvei (E.M.C.) . . . . .	470
191. Pure-culture in Nutrient Gelatine (Cheshire and Cheyne) . . . . .	470

F.G.	PAGE
195. Cultivation on the Surface of Gelatine (Cheshire and Cheyne)	471
196. Cladothrix Dichotoma (Zopf)	479
197. Friedlander's Pneumococcus, × 1500 (Zopf)	483
198. Ascococcus Billrothii (Cohn)	498
199. Clostridium Butyricum (Prazmowski)	503
200. Bacillus Cyanogenus, × 650 (Neelsen)	507
201. Pure-cultivation of Bacillus figurans on the Surface of Nutrient Agar-agar (E.M.C.)	509
202. Photograph of Part of an Impression Preparation of Bacillus figurans on Nutrient Gelatine, × 50 (E.M.C.)	510
203. Part of the same Specimen, × 200	510
204. Bacillus Indicus : Colonies in Agar, × 60	518
205. Bacillus Neapolitanus, × 700 (Emmerich)	522
206. Bacillus Megatherium (De Bary)	524
207. Pure-culture of Bacillus Megatherium in Gelatine (E.M.C.)	524
208. Bacillus Putrificus Coli, × 1000 (Bienstock)	529
209. Bacillus Pyogenes Foetidus, × 790 (Passet)	530
210. Bacillus Saprogenes, No. 1 (Rosenbach)	531
211. Bacillus Subtilis with Spores (Baumgarten)	535
212. Pure-culture of Bacillus Subtilis in Nutrient Gelatine (Baumgarten)	535
213. Pure-culture of Bacillus Subtilis on the Surface of Nutrient Agar (E.M.C.)	536
214. Bacterium Zopfii (Kurth)	542
215. Beggiatoa Alba (Zopf)	543
216. Phase-forms of Beggiatoa Persicina (Warming)	544
217. Cladothrix Dichotoma (Zopf)	545
218. Crenothrix Kühniana (Zopf)	546
219. Leuconostoc Mesenteroides (Van Tieghem and Cienkowski)	550
220. Micrococcus in Pyæmia in Rabbits (Koch)	556
221. Proteus Mirabilis ; Swarming Islands on the Surface of Gelatine, × 285 (Hauser)	561
222. Proteus Mirabilis ; Involution Forms, × 524 (Hauser)	561
223. Proteus Vulgaris, × 285 (Hauser)	562
224. Sarcina, × 600 (Flügge)	563
225. Spirochæta Plicatilis (E.M.C.)	566
226. Comma-bacilli in Water contaminated with Sewage	567
227. Comma-bacilli of the Mouth, × 700 (Van Ermengem)	568
228. Deneke's Comma-bacilli, from Cheese, × 700 (Flügge)	568
229. Streptococcus in Progressive Tissue Necrosis in Mice (Koch)	571
230. Vibrio Rugula, × 1020 (Prazmowski)	574
231. Black Torula ; Pure-cultivation on Potato (E.M.C.)	581
232. Head and Neck of Calf with Advanced Ringworm (Brown)	585
233. Non-pigmented Amœboid Forms (Marchiafava and Celli)	590
234. Pigmented Amœboid Forms (Golgi)	590
235. Semi-lunar Bodies of Laveran (Golgi)	590
236. Rosette Forms with Segmentation (Golgi)	591
237. Flagellated Forms (Vandyke Carter)	591
238. " Surra " Parasites, occurring Singly and Fused, × 1200	598
239. Parasites in the Blood of Rats (Lewis)	599
240. A Monad in Rat's Blood, × 3000 (E.M.C.)	601
241. Monads in Rat's Blood, × 1200 (E.M.C.)	602
242. Monads in Rat's Blood stained with Methyl Violet, × 1200 (E.M.C.)	603



## LIST OF ILLUSTRATIONS.

xxi

FIG.	PAGE
243. Organisms in the Blood of Mud-fish (Mitrophanow) . . . . .	604
244. Organisms in the Blood of the Carp (Mitrophanow) . . . . .	605
245. Amœba cola in Intestinal Mucus (Lösch) . . . . .	611
246. Warm Stage (Schäfer) . . . . .	613
247. Warm Stage (Stricker) . . . . .	614
248. Combined Gas Chamber and Warm Stage (Stricker) . . . . .	614
249. Vertical Micro-photographic Apparatus (Leitz) . . . . .	622
250. Koch's Steam Steriliser (Muencke) . . . . .	623
251. Hot-air Steriliser (Muencke) . . . . .	623
252. Section of Hot-air Steriliser (Muencke) . . . . .	623
253. Hot-water Filtering Apparatus with Ring Burner (Rohrbeck) . . . . .	624
254. Wire-cage for Test-tubes (Muencke) . . . . .	626
255. Platinum-needles (E.M.C.) . . . . .	626
256. Damp Chamber for Plate-cultivations (E.M.C.) . . . . .	626
257. Apparatus for Plate-cultivations (E.M.C.) . . . . .	627
253. Box for Glass-plates (Muencke) . . . . .	627
259. Glass Benches for Glass-plates (Becker) . . . . .	627
260. Israel's Case (Becker) . . . . .	628
261. Damp Chamber for Potato Cultivations (E.M.C.) . . . . .	628
262. Koch's Serum Steriliser (Muencke) . . . . .	629
263. Serum Inspissator (Muencke) . . . . .	629
264. D'Arsonval's Incubator (Muencke) . . . . .	631
265. Schlosing's Membrane Regulator (Muencke) . . . . .	632
266. Gas Burner protected with Mica Cylinder (Muencke) . . . . .	633
267. Koch's Safety Burner (Muencke) . . . . .	633
268. Babès' Incubator (Muencke) . . . . .	634
269. Moitessier's Gas-pressure Regulator (Muencke) . . . . .	634
270. Reichert's Thermo-regulator (Muencke) . . . . .	635
271. Meyer's Thermo-regulator (Muencke) . . . . .	636
272. Siphon Bottle with Flexible Tube, Glass Nozzle, and a Mohr's Pinch- cock (E.M.C.) . . . . .	637
273. Desiccator (E.M.C.) . . . . .	638



## DESCRIPTION OF PLATES.

### DESCRIPTION OF PLATE I.

#### Bacteria, Schizomycetes, or Fission Fungi.

Following p. 14.

1. Cocci singly and varying in size. 2. Cocci in chains or rosaries (streptococcus). 3. Cocci in a mass (staphylococcus). 4 and 5. Cocci in pairs (diplococcus). 6. Cocci in groups of four (merismopedia). 7. Cocci in packets (sarcina). 8. *Bacterium termo*. 9. *Bacterium termo* × 4000 (Dallinger and Drysdale). 10. *Bacterium septicæmiæ hæmorrhagicæ*. 11. *Bacterium pneumoniæ crouposæ*. 12. *Bacillus subtilis*. 13. *Bacillus murisepticus*. 14. *Bacillus diphtheriæ*. 15. *Bacillus typhosus* (Eberth). 16. *Spirillum undula* (Cohn). 17. *Spirillum volutans* (Cohn). 18. *Spirillum cholerae Asiaticæ*. 19. *Spirillum Obermeieri* (Koch). 20. *Spirochæta plicatilis* (Flügge). 21. *Vibrio rugula* (Prazmowski). 22. *Cladothrix Försteri* (Cohn). 23. *Cladothrix dichotoma* (Cohn). 24. *Monas Okenii* (Cohn). 25. *Monas Warmingii* (Cohn). 26. *Rhabdomonas rosea* (Cohn). 27. Spore-formation (*Bacillus alvei*). 28. Spore-formation (*Bacillus anthracis*). 29. Spore-formation in bacilli cultivated from a rotten melon (Fränkel and Pfeiffer). 30. Spore-formation in bacilli cultivated from earth (Fränkel and Pfeiffer). 31. Involution-form of *Crenothrix* (Zopf). 32. Involution-forms of *Vibrio serpens* (Warming). 33. Involution-forms of *Vibrio rugula* (Warming). 34. Involution-forms of *Clostridium polymyza* (after Prazmowski). 35. Involution-forms of *Spirillum cholerae Asiaticæ*. 36. Involution-forms of *Bacterium aceti* (Zopf and Hansen). 37. Spirulina-form of *Beggiatoa alba* (Zopf). 38. Various thread-forms of *Bacterium merismopedioides* (Zopf). 39. False-branching of *Cladothrix* (Zopf).

### DESCRIPTION OF PLATE II.

#### Pure-cultivations of Bacteria.

Following p. 100.

FIG. 1.—In the depth of Nutrient Gelatine. A pure-cultivation of Koch's comma-bacillus (*Spirillum cholerae Asiaticæ*) showing in the track of the needle a funnel-shaped area of liquefaction enclosing an air-bubble, and a white thread. Similar appearances are produced in cultivations of the comma-bacillus of Metchnikoff.

FIG. 2.—On the surface of Nutrient Gelatine. A pure-cultivation of *Bacillus typhosus* on the surface of obliquely solidified nutrient gelatine.

FIG. 3.—*On the surface of Nutrient Agar-agar.* Pure-cultivation of *Bacillus indicus* on the surface of obliquely solidified nutrient agar-agar. The growth has the colour of red sealing-wax, and a peculiar crinkled appearance. After some days it loses its bright colour and becomes purplish, like an old cultivation of *Micrococcus prodigiosus*.

FIG. 4.—*On the surface of Nutrient Agar-agar.* A pure-cultivation obtained from an abscess (*Staphylococcus pyogenes aureus*).

FIG. 5.—*On the surface of Nutrient Agar-agar.* A pure-cultivation obtained from green pus (*Bacillus pyocyaneus*). The growth forms a whitish, transparent layer, composed of slender bacilli, and the green pigment is diffused throughout the nutrient jelly. The growth appears green by transmitted light, owing to the colour of the jelly behind it.

FIG. 6.—*On the surface of Potato.* A pure-cultivation of the bacillus of glanders on the surface of sterilised potato.

#### DESCRIPTION OF PLATE III.

##### Plate-cultivation.

*Following p. 108.*

This represents the appearance of a plate-cultivation of the comma-bacillus of Cholera nostras, when it is examined over a slab of blackened plate-glass. The drawing was made from a typical result of thinning out the colonies by the process of plate-cultivation. At this stage they were completely isolated one from the other; but later they became confluent, and produced complete liquefaction of the gelatine.

#### DESCRIPTION OF PLATE IV.

##### *Streptococcus Pyogenes.*

*Following p. 178.*

FIG. 1.—From a cover-glass preparation of pus from a pyæmic abscess. Stained with gentian-violet by the method of Gram, and contrast-stained with eosin.  $\times 1200$ . Powell and Lealand's apochromatic  $\frac{1}{2}$  Hom. imm. E. P. 10.

FIG. 2.—From cover-glass preparations of artificial cultivations of the streptococcus in broth and in milk at different stages of growth.  $\times 1200$ . Powell and Lealand's apochromatic  $\frac{1}{2}$  Hom. imm. E. P. 10.

In these preparations there is a great diversity in size and form of the chains and their component elements. In the drawing examples are figured of the following:

- (a) Branched chains.
- (b) Simple chains composed of elements much smaller than the average size.
- (c) Chains with spherical and spindle-shaped elements at irregular intervals. These are conspicuous by their size, and are sometimes terminal.
- (d e) Chains in which the elements are more or less uniform in size.
- (f) Complex chains with elements dividing both longitudinally and transversely, and varying considerably in size in different lengths of the same chain.



## DESCRIPTION OF PLATE V.

**Bacillus Anthracis.***Following p. 192.*

- FIG. 1.—From a cover-glass preparation of blood from the spleen of a guinea-pig inoculated with blood from a sow.  $\times 1200$ . Powell and Lealand's apochromatic  $\frac{1}{2}$  Hom. imm. E. P. 10.
- FIG. 2.—From a section of a kidney of a mouse. Under a low power the preparation has exactly the appearance of an injected specimen. Under higher amplification the bacilli are seen to have threaded their way along the capillaries between the tubules, and to have collected in masses in the glomeruli. Stained with Gram's method (gentian-violet), and eosin.  $\times 500$ .
- FIG. 3.—*Bacillus anthracis* and *Micrococcus tetragenus*. From a section from the lungs of a mouse which had been inoculated with anthrax three days after inoculation with *Micrococcus tetragenus*. A double or mixed infection resulted. Anthrax-bacilli occurred in vast numbers, completely filling the small vessels and capillaries, and in addition there were great numbers of tetrads. Stained by Gram's method (gentian-violet), and with eosin.  $\times 500$ .

## DESCRIPTION OF PLATE VI.

**Bacillus Murisepticus.***Following p. 224.*

- FIG. 1.—From a section of a kidney of a mouse which had died after inoculation with a pure-cultivation of the bacillus. With moderate amplification, the white blood-corpuscles have a granular appearance, and irregular granular masses are scattered between the kidney tubules. Stained by Gram's method with eosin.  $\times 200$ .
- FIG. 2.—Part of the same preparation with high amplification. The granular appearances are found to be due to the presence of great numbers of extremely minute bacilli.  $\times 1500$ .

## DESCRIPTION OF PLATE VII.

**Casual Cow-pox.***Following p. 278.*

- FIG. 1.—Case of W. P.—, a milker, infected from the teats of a cow with natural cow-pox. There was a large depressed vesicle with a small central crust and a tumid margin, the whole being surrounded by a well-marked areola and considerable surrounding induration.
- FIG. 2.—The same case a week later, showing a reddish-brown crust on a reddened elevated and indurated base.



## DESCRIPTION OF PLATE VIII.

**Bacillus diphtheriæ and Bacillus typhosus.***Following p. 332.*

- FIG. 1.—Cover-glass preparation from a pure-cultivation of *Bacillus diphtheriæ* on blood serum; obtained from the throat in a typical case of diphtheria. Stained with gentian-violet.  $\times 1200$ .
- FIG. 2.—Cover-glass preparation from a pure-cultivation of *Bacillus typhosus* on nutrient-agar; from the spleen in a case of typhoid fever. Stained with gentian-violet.  $\times 1200$ .

## DESCRIPTION OF PLATES IX. AND X.

**Swine Fever.***Following p. 348.*

- PLATE IX.—Part of intestine from a typical case of swine fever, showing scattered ulcers and ulceration of the ileo-cæcal valve.
- PLATE X.—From the same case of swine fever. The lungs were extensively inflamed and partly consolidated, and the lymphatic glands were enlarged and of a deep red or reddish-purple colour.

## DESCRIPTION OF PLATE XI.

**Bacillus tuberculosis.***Following p. 378.*

The figures in this plate represent the bacilli of tuberculosis in different animals, examined under the same conditions of amplification and illumination.  $\times 1200$ . Lamp-light illumination.

- FIG. 1.—Bacilli in pus from the wall of a human tubercular cavity. In this specimen the bacilli are shorter than those in tubercular sputum, and are very markedly beaded.
- FIG. 2.—Bacilli in pus from a tubercular cavity from another case in man. They are present in the preparation in enormous numbers. The protoplasm occupies almost the whole of the sheath, and the bacilli are strikingly thin and long.
- FIG. 3.—Bacilli in sputum from an advanced case of phthisis, showing the ordinary appearance of bacilli in sputum; some beaded, others stained in their entirety; occurring both singly and in pairs, and in groups resembling Chinese letters.
- FIG. 4.—Bacilli in a section from the lung in a case of tuberculosis in man. The bacilli in human tuberculosis are found in, and between, the tissue cells; and sometimes, as in equine and bovine tuberculosis, in the interior of giant cells, but not so commonly.
- FIG. 5.—From a cover-glass preparation of the deposit in a sample of milk from a tubercular cow. The bacilli were longer than the average length of bacilli in bovine tissue sections, and many were markedly beaded.

- FIG. 6.—From a section of the brain in a case of tubercular meningitis in a calf, showing a giant cell containing bacilli with the characters usually found in sections of bovine tuberculosis.
- FIG. 7.—From a section of the liver of a pig with tubercle bacilli at the margin of a caseous nodule.
- FIG. 8.—From a cover-glass preparation of a crushed caseous mesenteric gland from a rabbit infected by ingestion of milk from a cow with tuberculosis of the udder.
- FIG. 9.—From a section of lung in a case of equine tuberculosis, showing a giant cell crowded with tubercle bacilli.
- FIG. 10.—From a section of lung from a case of tuberculosis in the cat, with very numerous tubercle bacilli.
- FIG. 11.—From a cover-glass preparation of a crushed caseous nodule from the liver of a fowl, with masses of bacilli. These are for the most part short, straight rods; but other forms, varying from long rods to mere granules, are also found.
- FIG. 12.—From sections of the liver and of the lung in a case of tuberculosis of a Rhea. Isolated bacilli are found, as well as bacilli packed in large cells, colonies of sinuous bacilli, and very long forms with terminal spore-like bodies and free oval grains.

The preparations from which these figures were drawn were all stained by the Ziehl-Neelsen method, with the exception of the first, which was stained by Ehrlich's method.

#### DESCRIPTION OF PLATE XII.

##### **Tubercular Mammitis.**

*Following p. 394.*

- FIG. 1.—From a section of the udder of a milch cow. The tubercular deposit is seen to invade the lobules of the gland. Lobules comparatively healthy are marked off, more or less sharply, from the diseased ones in which the new growth in its progress compresses and obliterates the alveoli. Stained by the Ziehl-Neelsen method and with methylene-blue.  $\times 50$ .
- FIG. 2.—Part of the same preparation. On the right of the section part of a healthy lobule is seen. On the left a lobule is invaded by tubercular new growth composed of round cells, epithelioid cells and typical giant cells. Tubercle bacilli can be seen both singly and collected in groups. They are found in and between the cells, and in the interior of giant cells. Bacilli may be seen between the cells lining an alveolus and projecting into its lumen.  $\times 800$ .

#### DESCRIPTION OF PLATE XIII.

##### **Tuberculosis in Swine.**

*Following p. 400.*

Section of liver of a pig with scattered tubercular nodules. Microscopical sections of the liver showed tubercle bacilli in very small numbers.



## DESCRIPTION OF PLATE XIV.

**Bacillus Lepræ.***Following p. 408.*

FIG. 1.—From a section of the skin of a leper. The section is, almost in its entirety, stained red, and, with moderate amplification, has a finely granular appearance. Stained by the Ziehl-Neelsen method (carbolised fuchsine and methylene-blue).  $\times 200$ .

FIG. 2.—Part of the same preparation with high amplification, showing that the appearances described above are due entirely to an invasion of the tissue by the bacilli of leprosy.  $\times 1500$ .

## DESCRIPTION OF PLATES XV. AND XVI.

**Actinomyces.***Following p. 432.*

## PLATE XV.

FIG. 1.—From a preparation of the grains from an actinomycotic abscess in a boy; examined in glycerine. The drawing has been made of a complete rosette examined by focussing successively the central and peripheral portions. Towards the centre the extremities of the clubs are alone visible; they vary in size, and if pressed upon by the cover-glass give the appearance of an irregular mosaic. Towards the periphery the clubs are seen in profile, and their characteristic form recognised. At one part there are several elongated elements, composed of separate links.  $\times 1200$ .

FIG. 2.—Different forms of clubs from preparations in which the rosettes have been flattened out by gentle pressure on the cover-glass.  $\times 2500$ .

- (a) Single club. (b) Bifid club. (c) Club giving rise to four secondary clubs. (d) Four clubs connected together, recalling the form of a bunch of bananas. (e) Mature club with a lateral bud. (f) Apparently a further development of the condition represented at (e). (g) Club with a lateral bud and transverse segmentation. (h) Single club with double transverse segmentation. (i) Club with oblique segmentation. (j) Collection of four clubs, one with lateral gemmation, another with oblique segmentation. (k) Club with lateral buds on both sides, and cut off square at the extremity. (l) Club with a daughter club which bears at its extremity two still smaller clubs. (m) Club divided by transverse segmentation into four distinct elements. (n) Elongated club composed of several distinct elements. (o) and (p) Clubs with terminal gemmation. (q) Palmate group of clubs. (r) Trilobed club. (s) Club with apparently a central channel. (t) Filament bearing terminally a highly refractive oval body.

## PLATE XVI.

FIG. 1.—From a section of a portion of the growth removed from a boy during life. The tissue was hardened in alcohol, and cut in celloidin. The section was stained by Gram's method and with orange-rubin.  $\times 50$ .

FIG. 2.—From the same section. A mass of extremely fine filaments occupies the central part of the rosette. Many of the filaments have a terminal enlargement. The marginal part shows a palisade of clubs stained by the orange-rubin.  $\times 500$ .



FIGS. 3 and 4.—From cover-glass preparations of the fungus teased out of the new growths produced by inoculation of a calf with pus from a boy suffering from pulmonary actinomycosis. Stained by Gram's method and orange-rubin. The threads are stained blue and the clubs crimson (*a*). In the younger clubs the thread can be traced into the interior of the club (*b*). In some of the older clubs the central portion takes a yellowish stain, and in others the protoplasm is not continued as a thread, but is collected into a spherical or ovoid or pear-shaped mass. In others, again, irregular grains stained blue are scattered throughout the central portion (Fig. 4).  $\times 1200$ .

FIG. 5.—From a pure-culture on glycerine-agar. (*a*) branching filaments, (*b*) a mass of entangled filaments. Gram's method.  $\times 1200$ .

FIG. 6.—From a similar but older cultivation. (*a*) a filament with spores, (*b*) chains of spores simulating streptococci. Gram's method.  $\times 1200$ .

## DESCRIPTION OF PLATES XVII. AND XVIII.

### Actinomycosis Bovis.

*Following p. 434.*

#### PLATE XVII.

Section of an actinomycotic tongue stained by the method of Gram and with eosin.

FIG. 1.—This illustrates the appearance which is usually seen under a low power, when a section is stained by Gram's method and with eosin. The central portion of a mass of the fungus is either unstained or tinged with eosin, while the marginal portion is stained blue. The reverse is seen, as a rule, in sections from man; although under a low power the general appearance of sections from these two sources is somewhat similar.  $\times 50$ .

FIG. 2.—*a, b, c, d,* represent the earliest recognisable forms of the ray fungus in the interior of leucocytes. In *e* the club-forms can be recognised. In *f* and *g* there are small stellate groups of clubs.  $\times 500$ .

FIG. 3.—A part of the section represented in Fig. 1, under a high power. The marginal line of blue observed under a low power is now recognised as the result of the stain being limited to the peripherally arranged clubs. At (*a*) part of a rosette has undergone calcification; the clubs are granular, and have not retained the stain. At (*b*) and close to it there are the remains of rosettes in which the process of calcification is almost complete.  $\times 500$ .

#### PLATE XVIII.

The figures in this plate are taken from sections of a case of so-called "osteosarcoma," in which the growth of the fungus was remarkably luxuriant. The specimens were stained by Plauts' method.

FIG. 1.—Different forms of clubs in different specimens:  $\times 1200$ .

(*a*) Very small club-shaped elements.

(*b*) A club with transverse segmentation.

(*c*) A club with lateral daughter clubs.

(*d* and *e*) Clubs with terminal offshoots resembling teleutospores.

(*f*) A club with developing daughter clubs on the left, and on the right a mature secondary club.

(*g*) A segmental club with lateral offshoots.

(*h*) Two clubs undergoing calcification.

FIG. 2.—A very remarkable stellate growth comprised of nine wedge-shaped collections of clubs radiating from a mass of finely granular material.  $\times 500$ .

FIG. 3.—A rosette undergoing central calcification, and consisting in part of extremely elongated clubs resembling paraphyses. Calcareous matter is also being deposited in the club-shaped structures.  $\times 500$ .

FIG. 4.—Part of a rosette with continuation of the club-shaped bodies into transversely segmented branching cells apparently representing short hyphæ.  $\times 500$ .

FIG. 5.—A rosette from another section in which similar appearances are observed as in Fig. 4.  $\times 500$ .

#### DESCRIPTION OF PLATE XIX.

##### Pure-cultivations of Actinomyces.

*Following p. 488.*

These tubes were selected from a great number of cultivations in which there were different appearances. In some instances the growths had a faint tinge of pink.

FIG. 1.—Pure-cultivation on the surface of potato, showing a luxuriant sulphur-yellow growth entirely composed of entangled masses of filaments. After three months' growth.

FIG. 2.—Pure-culture from the same series, on glycerine-agar. In this case the culture remained perfectly white. The jelly was coloured reddish-brown. After fifteen months' growth.

FIG. 3.—Pure-culture on glycerine-agar in which the growth was dark-brown, in parts black, and the jelly stained dark-brown. After nearly two years' growth.

#### DESCRIPTION OF PLATES XX. AND XXI.

##### Actinomycosis Bovis.

*Following p. 447.*

##### PLATE XX.

FIG. 1.—From a section of an actinomycotic tongue stained by the triple method (Ziehl-Neelsen, logwood and orange-rubin). In this section the separate centres of growth are clearly shown. Each neoplasm consists of a fungus system, in which the masses of the fungus, situated more or less centrally, are surrounded with round cells, epithelioid cells, sometimes giant cells, and lastly fibrous tissue forming a more or less distinct capsule. In parts the fungi have fallen out of the section.  $\times 50$ .

FIG. 2.—From a section of a "tubercular" nodule from the lungs of a Norfolk heifer with pulmonary actinomycosis. The nodule is a multiple growth surrounding a bronchus, and is enclosed by a capsule, in the



vicinity of which the pulmonary alveoli are compressed. It is composed of a number of separate neoplasms, and each of the latter is composed of secondary centres of growth resembling the giant-cell systems of bacillary tuberculosis. The new growth is composed of ray-fungi, large multinucleated cells, sometimes distinct giant cells, round cells, epithelioid cells, and, surrounding them, fibrous tissue. On examination of the same specimen with a higher power the typical rosettes of clubs are sometimes surrounded by multinucleated cells, and sometimes small rosettes are found like tubercle bacilli, in the interior of giant cells. From a preparation stained by Ziehl-Neelsen, logwood, and orange-rubin.  $\times 50$ .

#### PLATE XXI.

FIG. 1.—(a) A leucocyte containing the fungus in its earliest recognisable form. (b) A large multinucleated cell containing the fungus in an early stage with the club-form already visible. (c) A leucocyte containing a small stellate fungus. (d) A large cell containing clubs arranged in a small rosette. (e) A multinucleated cell with clubs arranged in a palmate form. All the above are drawn from sections of actinomycotic tongues stained by the triple method.  $\times 500$ .

FIG. 2.—A giant cell with large vesicular nuclei at the periphery, and in the centre a fully formed rosette of actinomycetes with a smaller growth within a "daughter" cell. From a section of the tongue of an ox stained by the triple method.  $\times 500$ .

FIG. 3.—A very large circular giant cell, with its ring of nuclei at the periphery, enclosing several isolated tufts of actinomycetes. From a section of a nodule in the lung. Stained by the triple method.  $\times 500$ .

FIG. 4.—Three rosettes of actinomycetes surrounded by a row of large, somewhat angular multinucleated cells. From a section of the tongue of an ox stained by the triple method.  $\times 430$ .

#### DESCRIPTION OF PLATE XXII.

##### **Bacillus tetani.**

*Following p. 458.*

FIG. 1.—From a cover-glass preparation of a pure-cultivation of the tetanus bacillus in broth; stained with Neelsen's carbolised fuchsine.  $\times 1200$ . Lamplight illumination.

FIG. 2.—From a cover-glass preparation from the same source; stained with Neelsen's solution and methylene blue.  $\times 1200$ . Lamplight illumination.



PART I.

*THEORETICAL AND TECHNICAL.*







# BACTERIOLOGY

AND

## INFECTIVE DISEASES.

---

---

### CHAPTER I.

#### HISTORICAL INTRODUCTION.

THE researches of Pasteur into the rôle played by bacteria in the processes of fermentation and putrefaction, and the investigations of the practical mind of Lister, with the resulting evolution of antiseptic surgery, demonstrated the necessity for a more intimate acquaintance with the life-history of these micro-organisms. Further researches in diseases such as anthrax, the silkworm malady, pyæmia, septicæmia, and fowl-cholera, invested the science of Bacteriology with universal interest and vast importance; while the investigations which established an intimate connection between bacteria and other infective diseases, and more especially the discovery by Koch of bacteria in tuberculosis and in Asiatic cholera, claimed the attention of the whole thinking world.

Those bacteria which are connected with disease, and more especially those which have been proved to be the *causa causans*, are of predominant interest and importance.

The first attempt to demonstrate the existence of a *contagium vivum* dates back almost to the discovery of the microscope. Athanasius Kircher, nearly two and a half centuries ago, expressed his belief that there were definite micro-organisms to which diseases were attributable. The microscope had revealed that all decomposing substances swarmed with countless micro-organisms which were invisible to the naked eye, and Kircher sought for similar organisms in diseases which he considered might be due to their agency. The microscope which he described obviously could not



admit of the possibility of studying, or even detecting, the micro-organisms which are now known to be associated with certain diseases ; and it is not surprising that his teachings did not at the time gain much attention. They were destined, however, to receive a great impetus from the discoveries which emanated from "the father of microscopy."

Antony van Leeuwenhoek had learned as a youth to grind and polish lenses, and later in life employed his spare time in constructing microscopes, and in conducting those researches which have made for him a name which is familiar to all microscopists. His researches were published in a series of letters to the Royal Society. In 1675 he described extremely minute organisms in rain-water, well-water, infusions of pepper, hay, and other vegetable and animal substances, in saliva, and in scrapings from the teeth ; and, further, he was able to differentiate these minute living things by their size, their form, and the character of their movements. In 1683 these discoveries were illustrated by means of woodcuts, and there can be little doubt, from the drawings of these micro-organisms, that they are intended to represent leptothrix filaments, vibrios, and spirilla. Indeed, we can almost recognise these micro-organisms as bacteria from Leeuwenhoek's graphic descriptions, apart from his figures. They were described as moving in the most characteristic manner, progressing with great rapidity, or spinning round like a top, and so excessively minute that they were only perceived with great difficulty. The smallest forms could hardly be examined individually ; but, viewed *en masse*, they closely resembled a swarm of gnats or flies. In another communication, published in 1692, he gives some idea of the size of these animalcules by stating that they were a thousand times smaller than a grain of sand. Others which were, comparatively speaking, of considerable length, were characterised by their peculiar mode of progression, bending and rolling on themselves—movements which, he adds, created both delight and astonishment in the mind of the observer. Leeuwenhoek himself was not disposed to believe in the possibility of such organisms being found in the blood in disease ; but as soon as he had proved the actual existence of such minute creatures, theoretical physicians were not wanting who at once attributed various maladies to their agency. Among these, Nicholas Andry is made conspicuous by his work published in 1701. Andry classed the minute organisms discovered by Leeuwenhoek as worms.

In 1718 Lancisi believed that the deleterious effect of the air of malarial districts depended upon animalcules, and others considered

that the plague in Toulon and Marseilles in 1721 arose from a similar cause. In fact, by some, all diseases were attributed to vermicules, and this led to the theory being ridiculed and discredited.

In spite of adverse criticism, the theory of *contagium vivum* survived, and Linnæus acknowledged it by placing the micro-organisms discovered by Leeuwenhoek, the contagia of specific fevers, and the causes of putrefaction and fermentation, into one class—"chaos." The theory was further supported by the writings of Plenciz, who, in 1762, very ably discussed the nature of contagium, as well as the relation of animalcules to putrefaction and disease. However, no proofs in support of these theories were forthcoming, and gradually the idea of *contagium vivum* fell into obscurity, and indeed came to be regarded by some as an absurd hypothesis.

Though a causal relation of animalcules to diseases was for a time discredited, the natural history of these micro-organisms was studied with increasing interest. In 1778 Baron Gleichen described and figured a great number of micro-organisms which he had discovered in various vegetable infusions. Joblot, Lesser, Réaumur, Hill, and many others worked at the same subject. Hill remarked that there was hardly the least portion of matter or the least drop of fluid of any kind naturally found in the earth, which was not inhabited by multitudes of animalcules. But these observers inclined rather to searching for new forms than to studying more thoroughly those which had been already discovered; and, as a result, but little scientific progress was made until the time of Müller, of Copenhagen. Müller, in 1786, criticised the work of previous writers, and pointed out that they had been too much occupied with merely finding new micro-organisms. Müller took into account the form of the micro-organism, its mode of progression, and other biological characters, and on such data based a classification. Thus the scientific knowledge of these minute beings was considerably advanced by his writings and illustrations.

The subject which now eclipsed all others in interest was the origin of these micro-organisms. Two rival theories were widely discussed—spontaneous generation, and development from pre-existing germs; and the researches that were made in the course of this discussion, and the discoveries which resulted, indirectly yet materially advanced the germ theory of disease, and explain many of the phenomena in the life-history of the pathogenic microbes which have been brought to light in recent years.

Spontaneous development of micro-organisms in putrescible infusions was believed in by many, but was supported by no one



with greater persistency than Needham. Needham found that animalcules readily developed when meat infusion was boiled and transferred to a well-stoppered flask, and he could only explain this by supposing that they originated spontaneously from the material of the infusion. In 1768 Bonnet strenuously opposed these conclusions on purely theoretical grounds, and maintained that it was far more probable that the ova of the animalcules were present in the infusions or were suspended in the air enclosed in the flask.

Spallanzani was the first to demonstrate by experiment the correctness of Bonnet's arguments. It occurred to him to boil the infusion in flasks, and *to seal the vessels during the process of boiling*. As a result the flasks remained free from putrefaction, and animalcules only developed when the infusion was exposed to the air by making a hole in the flask. That Spallanzani's experiments were reliable, and his conclusions correct, was evidenced by the fact that his simple precaution led to great practical results, as François Appert introduced, on this principle, the method of preserving meats, vegetables, and other provisions.

The disciples of Needham nevertheless brought forward counter objections. Treviranus urged that a certain *quantity* and *quality* of air was necessary for the spontaneous development of these infusoria, and that by sealing the flasks, too small a quantity of air was in contact with the infusion, and, further, that this air had become changed in quality by the process of boiling.

Spallanzani argued against these objections, but did not support his opinions by further experiments, so that the question remained for a time undecided.

In 1836 Francis Schulze devised an experiment which brought still further evidence against Needham's theory. Schulze filled a glass vessel half full with distilled water and different animal and vegetable substances. This was plugged with a doubly-bored cork, and through each perforation a glass tube was introduced, bent at a right angle. On boiling the flask, steam issued freely from each tube, and all parts were thoroughly sterilised. Each tube was then connected with a bulbed tube, one bulb containing concentrated sulphuric acid and the other a solution of potash. Fresh air was drawn into the flask by aspiration, and this was deprived of any germs which might be present by its passage through the sulphuric acid. The result was that the infusion remained without any development of micro-organisms. When, on the other hand, air was admitted without first being drawn through the sulphuric acid, the infusion in a short time teemed with animalcules. In other words,



Schulze demonstrated that in spite of free access to air, *which had not been heated*, the infusions remained free from germs.

Schwann, in 1837, arrived at similar results. He found that putrescible substances remained sterile if exposed to an abundant supply of air which was heated by being passed through a melted mixture of metals. This convinced him that the cause of the decomposition which would otherwise have occurred must exist in the air.

The objection remained that in the experiments of Schulze and Schwann, the air which was admitted to the flasks had undergone either a *chemical* or a *thermal* change, and therefore the theory of Needham was not yet entirely disposed of.

In 1854 the final blow was dealt by Schröder and Van Dusch. These investigators demonstrated that decomposition could be obviated without resorting either to thermal or chemical treatment of the air, as simple filtration of the air through cotton-wool was shown to be efficacious in excluding germs. Finally, Hoffman in 1860, and independently, Chevreuil and Pasteur in 1861, showed that even cotton-wool could be dispensed with, as a sterile solution would remain sterile when the neck of the vessel was bent into an S-shaped curve. Micro-organisms in the air entering the flask were deposited by gravitation in the bend of the tube.

The advocates of spontaneous generation were ready with fresh objections. They now urged that the medium lost its power of undergoing decomposition by being boiled. This objection was at once set aside by the fact that when unfiltered air was admitted to the infusion, decomposition set in. Additional evidence was brought against spontaneous generation by the experiments of Pasteur, Burdon Sanderson, Lister, and others, in which it was shown that blood, urine, and milk would remain without decomposition, when all precautions were adopted to avoid contamination in filling the sterilised flasks.

Even at this stage of this great scientific controversy fresh difficulties arose, for it was found that in certain solutions which had been boiled and hermetically sealed in flasks micro-organisms made their appearance. In 1872 Charlton Bastian published a research which was to prove that spontaneous generation actually took place. Decoctions of turnip and cheese which had been filtered, neutralised, and boiled for ten minutes, and hermetically sealed during the boiling, were found after a time to contain micro-organisms. These results, however, were before long explained by the fact that in milk, infusions of hay, and certain other decoctions, the spores of bacilli are present, which are much more resistant

than the bacilli themselves. In such cases mere scalding or boiling for a few minutes will not sterilise the solution. The bacilli are destroyed, but not their spores; and if the latter remain unhurt, they will germinate, and rapidly multiply. But if, as Tyndall found, the boiling be repeated a second and a third time, all the spores will be destroyed; for in the intervals between the boilings the spores sprout into bacilli, and the bacilli at the next boiling perish; so that after three or four repeated boilings the infusion is rendered perfectly free from germs.

While this discussion was occupying the attention of the whole scientific world, some investigators had been again following up the theory of a connection between micro-organisms and disease.

In 1837 Cagniard Latour and Schwann independently made the discovery that the yeast plant was a living organism, and the true cause of yeast fermentation. The close analogy between the processes of fermentation and of certain diseases had long been held; and, therefore, when it was proved that fermentation was due to a micro-organism, fresh advocates appeared in support of the theory that diseases were produced by similar agencies. Boehm, in 1838, described certain organisms in cholera, which was at that time raging in Europe; but the researches of Bassi, who a year previously had discovered the cause of a disease of silkworms, attracted much greater attention.

Bassi discovered that in this disease extremely minute spores existed on the bodies of the worms, which were conveyed from the sick to the healthy. They destroyed the healthy worms by germinating in their skins and growing into their bodies. These discoveries may be said to have brought the theory of *contagium vivum* to life again; and Henle, in reviewing the facts of the case in 1840, came to the conclusion that the cause of all contagious diseases must be of a living nature, and this he maintained, although he had searched in vaccine and small-pox lymph, in the desquamation of scarlet fever, and in other diseases without success.

Bassi's discovery and Henle's doctrine encouraged a number of investigators, and remarkable results followed. In favus, in herpes tonsurans, in pityriasis versicolor, fungus threads and spores were found, and were regarded as being of etiological importance, inasmuch as the morbid lesions corresponded with the growth of the particular fungus.

Cholera became especially a subject for research. Swaine, Brittan, and Budd found micro-organisms in choleraic dejecta. Davaine described certain monads in the intestinal contents, but no



causal connection was established between these organisms and the disease ; and when the cholera disappeared the interest in *contagium vivum* waned, and was eclipsed by the question of fermentation. The discoveries which followed in this subject had a very important bearing on the micro-parasitic origin of communicable diseases.

Pasteur, following up the researches of Cagniard Latour and Schwann, demonstrated in 1857 that the lactic, acetic, and butyric fermentations were produced by micro-organisms.

Previously to this, in 1850, Davaine and Rayer had noted the existence of little rod-like or filamentous bodies about the size of a blood corpuscle in the blood of a sheep that had died of splenic fever. Pollender had seen similar bodies in the blood of cows. Davaine did not at first pay much heed to this discovery ; but in 1863 he thoroughly reinvestigated the subject, and conducted a series of experiments which led him to the conclusion that the actual cause of splenic fever was an organised being whose presence and multiplication in the blood produced changes in that fluid of the nature of fermentation, resulting in the death of the animal.

These conclusions were not accepted by all, and indeed, the evidence was so far incomplete that sceptics were justified in considering that these experiments afforded only a working hypothesis. But Davaine's comparison between this disease and fermentation attracted the attention of Pasteur, whose mind had been fully trained for entering upon this investigation by the researches which he had been carrying on in the interval between Davaine's publications of 1857 and 1863.

Pasteur, as already mentioned, had been working at fermentation, and his attention was next directed to studying the so-called diseases of wines, and subsequently to a contagious disease which committed ravages among silkworms. By laborious researches Pasteur was able to confirm the belief that this disease of silkworms was due to the presence of micro-organisms discernible with the aid of the microscope. These oval shining bodies in the moth, worm, and eggs had been previously observed by Cornalia, and described by Nägeli as *Nosema bombycis*, and by Lebert as *Panhistophyton*. But it was reserved for Pasteur to introduce a means of combating the disease. Pasteur showed that when a silkworm, whose body contained these micro-organisms, was pounded up with water in a mortar, and the mixture painted with a brush on the leaves on which healthy worms were fed, they would all without fail succumb to the disease.

As the contagious particles were transmitted to the eggs, a method for preventing the spread of the disease suggested itself.



Each female moth was kept separate from the others, and allowed to deposit her eggs on a small linen cloth. The moth was then pinned to the corner of the cloth, and left for future examination. When the time for this arrived, the moth was crushed up with water in a mortar, and a drop examined under the microscope. When any trace of corpuscular matter was found to be present, the cloth with its collection of eggs was burnt; and if not, the eggs were set aside for use.

Complete as this appears to be as a demonstration of a causal connection between the micro-organisms and the disease, it could obviously be objected that there was no distinct proof that the corpuscular bodies constituted the actual contagium. There was no isolation of the organisms, no artificial cultivation of them apart from the diseased moth or worm, and subsequent production of the disease by means of the isolated organisms. The same objection was applicable to Davaine's investigations. Davaine found rods in association with anthrax, and maintained that they were causally related; but others stated that it was possible to inoculate animals with anthrax blood containing rods, and to produce the disease without being able to detect the rods again in the blood of the animal experimented upon. It was also urged that it was possible to infect with anthrax blood after the rods had disappeared, and to find a reappearance of the bacilli in the blood of the inoculated animal.

The well-known fact that anthrax was especially prevalent in certain seasons and certain localities appeared to lend great support to these objections. The disease, in fact, was regarded by some as originating from peculiar conditions of climate and soil. The fallacies in these objections were, however, rapidly dispelled. Bollinger, in 1872, pointed out that the blood, from which the rods had disappeared, was still virulent owing to the presence of the *spores* of the bacillus, and that it was owing to the soil being impregnated with these spores that the disease broke out in certain localities. Yet there still remained many who refused to regard these particles as living bodies, some looking upon them simply as crystals; and the question of their importance remained undecided for several years.

In 1877 Robert Koch published a memoir in which he fully described the life-history of the anthrax or splenic fever bacillus, and gave a complete demonstration of the life-history of the micro-organism, and the definite proofs of its pathogenic properties. He pointed out how the rods grew in the blood and tissues by lengthen-

ing and by cross division. Further, that in the blood or in serum or in aqueous humour they not only grew into long leptothrix filaments, but they produced enormous numbers of seeds or spores. He traced, by continuous observation on the warm stage, the whole life cycle, from the fission of the rods to the formation of spores and the sprouting of the spores into fresh rods. Further, he carried on the disease by inoculating from mouse to mouse for several generations, and observed that in the blood of the animal and in the swollen spleen the glass-like rods were always to be found.

Pasteur also studied the microbe of splenic fever, and amply confirmed and extended the observations of Koch by his researches on the attenuation of the anthrax virus.

Pasteur also met with adverse criticism. Paul Bert argued that the bacilli were of no importance, because he could destroy them by exposing material containing them to great pressure, and yet the material produced the disease on inoculation. But such measures did not destroy the *spores*; and finally, Paul Bert was convinced of his error when Pasteur demonstrated cultures of the anthrax bacillus in urine, from which successive generations were started, and that with such cultivations the disease could always be produced.

It was, however, principally the researches of Koch which placed the doctrine of *contagium vivum* on a scientific basis.

Koch's improvements in the methods of cultivation, his recommendation of the necessary microscopical apparatus, his histological methods for examining these minute organisms, and his famous postulates for proving beyond controversy the existence of specific pathogenic micro-organisms, elevated the theory of *contagium vivum* to a demonstrated and established fact. The chain of evidence regarded by Koch as essential for proving the existence of a pathogenic organism was as follows:—

1. The micro-organism must be found in the blood, lymph, or diseased tissue of man or animal suffering from or dead of the disease.

2. The micro-organisms must be isolated from the blood, lymph, or tissues, and cultivated in suitable media—*i.e.*, outside the animal body. These pure cultivations must be carried on through successive generations of the organism.

3. A pure cultivation thus obtained must, when introduced into the body of a healthy animal, produce the disease in question.

4. In the inoculated animal the same micro-organism must again be found.



The chain of evidence is still more complete if we can from artificial cultures obtain a chemical substance which is capable of producing the disease independently of living micro-organisms.

It is of very little value merely to detect or artificially to cultivate a bacterium associated with disease. We must endeavour to establish the exact relationship of the bacteria to disease processes, and the determination of the true pathogenic microbe is beset with fallacies. In many diseases bacteria have been regarded as the actual contagia, until a searching inquiry by other investigators has shown that the evidence was most unsatisfactory or entirely misleading. For example, in diseases with lesions of the external or internal linings of the body, extraneous micro-organisms may get into the circulation and be swept into the internal organs, where they either perish in the battle with the healthy tissues which are opposed to their existence, or they may gain the upper hand, and set up destructive processes. Such organisms, when found in association with these diseases, may be discovered in the blood and internal organs; and though only accidental epiphytes, often associated with septic complication, they may too readily be accepted by the enthusiast as the actual contagium of the disease in question.

It is only when such fallacies are exposed that we are brought once more face to face with the fact that the nature of the contagium in hydrophobia, variola, vaccinia, scarlet fever, measles, and many other diseases, is still undetermined.



## CHAPTER II.

### MORPHOLOGY AND PHYSIOLOGY OF BACTERIA.

BACTERIA may be considered as minute vegetable cells destitute of nuclei. They are distinguished from animal cells by being able to derive their nitrogen from ammonia compounds, and they differ from the higher vegetable cells in being unable to split up carbonic acid into its elements, owing to the absence of chlorophyll. Von Engelmann and Van Tieghem include among the bacteria certain organisms, named by them *Bacterium chlorinum*, *Bacterium viride*, and *Bacillus virens*, which are coloured green by this substance, but it is quite possible that they may be Algæ, and further researches are required before any conclusions are definitely arrived at as to the exact place these particular organisms occupy in the vegetable kingdom.

**Composition.**—For our knowledge of the chemical composition of bacteria we are chiefly indebted to Nencki. Their constituents are found on analysis to vary slightly, according to whether the bacteria are in zoologæa or in the active state. In the latter condition they are said to consist of 83·42 per cent. of water. In one hundred parts of the dried constituents there are the following :—

A nitrogenous body . . . . .	84·20
Fat . . . . .	6·04
Ash . . . . .	4·72
Undetermined substances . . . . .	5·04

This nitrogenous body is called myco-protein, and consists of

Carbon . . . . .	52·32
Hydrogen . . . . .	7·55
Nitrogen . . . . .	14·75

but no sulphur or phosphorus.

The nitrogenous body appears to vary in different species, for in *Bacillus anthracis* a substance has been obtained which does not

give the reactions of myco-protein, and, therefore, is distinguished as anthrax-protein.

Considering bacteria as cells, we may speak of the cell-wall and the cell-contents. The cell-wall consists of cellulose, or, according to Nencki, in the putrefactive bacteria of myco-protein. It may be demonstrated by the action of iodine, which contracts the protoplasmic contents, and renders the cell-wall visible. By staining cover-glass preparations of the anthrax bacillus by the method of Gram, the rods are at first uniformly stained, by subjecting them to iodine solution the protoplasmic contents are contracted, and alcohol decolorises the sheath, which may be then stained in contrast, with eosin.

The cell-wall may be either pliable or rigid. Pliability is observed in the long filaments, which are endowed with a slow vermicular movement, while rigidity accounts for the maintenance of the characteristic form of several species, such as spirilla.

The cell-protoplasm yields myco-protein. In some it is homogeneous, and in others granular. The action of the aniline dyes indicates a close relation to nuclear protoplasm, though all nuclear stains are not suitable for bacteria. In some cases also the bacteria remain stained under the influence of a reagent, which removes the colour from nuclei. The power of fixing the stain is not always present, and indicates a difference in the protoplasm of different species. Thus in staining phthisical sputum, the nitric acid removes the stain from all bacteria and bacilli present, with the exception of the tubercle bacillus. This difference in the protoplasm of different species is also illustrated by the necessity, in many cases, of using special processes, owing to the ordinary methods being unsatisfactory or not producing any result.

The protoplasm of some bacteria contains starch granules; thus *Clostridium butyricum* gives the starch reaction with iodine. Sulphur granules are present in some species of *Beggiatoa* which thrive in sulphur springs. The colouring-matter of the pigmented bacteria is probably external to the cell as a rule: for example, in *Micrococcus prodigiosus* the pigment granules are distinctly between the cells; on the other hand, in *Beggiatoa roseo-persicina*, or the peach-coloured bacterium, the special pigment *bacterio-purpurin* appears to be dissolved in the cell protoplasm. In *Bacillus pyocyaneus* the pigment is certainly not localised entirely in the cell, for it becomes rapidly diffused in the surrounding medium, considerably beyond the confines of the growth itself.

In several species, either as a result of a secretion from the cell or



of the absorption of moisture and consequent swelling of the outer layer of the cell-wall, a mucinous or gelatinous envelope develops around them. This envelope may form a capsule, such as we meet with in certain bacteria found in the rusty sputum of pneumonia, and in *Micrococcus tetragenus*; or it may occur as a continuous sheath around a chain of bacteria, which by its disappearance sets free the individual links. The capsule is soluble in water, and under some circumstances is difficult to demonstrate. In the pneumococcus of Friedländer the capsule disappears on cultivation, but reappears in preparations made from an inoculated animal. In the pleuritic fluid of a mouse these cocci are often found with a particularly well-marked capsule, and in other encapsuled cocci the extent of the envelope has been observed to vary considerably in the same species of bacterium.

When this gelatinous material forms a matrix, in which numbers of bacteria are congregated in an irregular mass, we have what is termed a *zooglœa*. The zooglœan stage is a resting stage, often preceded or followed by a motile stage. Thus bacteria may be present in a solution in an active state, and after a time a scum or pellicle forms on the surface of the liquid, which consists of zooglœa. At the edges of the zooglœa, individuals may be seen to again become motile, and after detaching themselves to swim off in the surrounding fluid.

The zooglœan stage may be observed sometimes in cultivations in broth, and also in nutrient gelatine which has become liquefied. The inoculated bacteria grow and multiply, and after a time a film appears on the surface of the liquefied layer. In cultivations on potato the appearances in this stage are varied, and sometimes extremely characteristic. In the case of a bacillus which readily develops on unsterilised potatoes, the zooglœa may spread over the cut surface, forming a pellicle which can be raised *en masse* like a delicate veil. Another bacillus forms a zooglœa, consisting of a tenacious layer which can be drawn out in long stringy threads. In *Ascococcus Billrothii* the gelatinous envelope develops to such an enormous extent that it forms the characteristic feature of the species. (Fig. 1.)

**Form.**—The individual cells vary in form, and may either remain isolated or attached to each other. Round cells and egg-shaped cells are called *cocci*. The spherical form is the most common, but cocci are occasionally exclusively ovoid, as in *Streptococcus bombycis*. The giant cocci of some species are spoken of as *megacocci*, to distinguish them from the ordinary cocci, or *micrococci*.





The fission by which the cocci increase may take place in one direction only, and if the two resulting cells remain attached to each other they form a *diplococcus*. If these two cells again divide, and the resulting cells remain linked together, we get a chain or rosary, termed *streptococcus*. These chains may consist of a few individuals linked together, or of several hundreds, in which case the chains are generally curved or twisted. When the division occurs in two directions, so that four cocci result, a tetrad or *merismopedia* is formed; when in three directions, one coccus divides into eight, and the result is a packet form or *sarcinacoccus*. Immediately after division, the daughter cells are not perfectly circular, but are flattened or faceted where they are opposite to

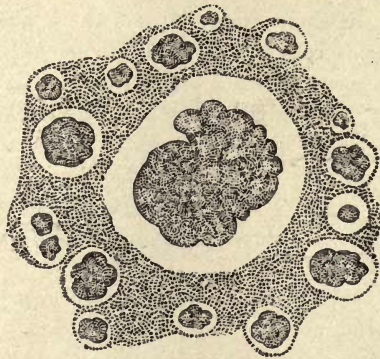

FIG. 1.—ASCOCOCCUS BILLROTHII,  $\times 65$ . [After Cohn.]

each other. They gradually become rounded off, and each daughter cell is then ready to divide in its turn. In other cases the cocci after division only form irregular heaps or collections like bunches of grapes. This form is sometimes distinguished as *staphylococcus*, but it cannot be considered an important feature. When we find irregular masses of cocci united by intercellular substance and embedded in a tough gelatinous matrix, the form is described as *ascococcus*.

Another type is the rod, characteristic of *bacterium* and *bacillus*. The rods may vary considerably in length. The very short rods with rounded ends are difficult to distinguish from the oval cocci, but differ in that a rod, however short it may be, must have two sides parallel. The *vibrio* or bent rod may be considered as the connecting link between the rods and the corkscrew forms or



## DESCRIPTION OF PLATE I.

### Bacteria, Schizomycetes, or Fission Fungi.

1. Cocci singly and varying in size. 2. Cocci in chains or rosaries (streptococcus). 3. Cocci in a mass (staphylococcus). 4 and 5. Cocci in pairs (diplococcus). 6. Cocci in groups of four (merismopedia). 7. Cocci in packets (sarcina). 8. *Bacterium termo*. 9. *Bacterium termo*  $\times$  4000 (Dallinger and Drysdale). 10. *Bacterium septicæmiæ hæmorrhagicæ*. 11. *Bacterium pneumoniae crouposæ*. 12. *Bacillus subtilis*. 13. *Bacillus murisepticus*. 14. *Bacillus diphtheriæ*. 15. *Bacillus typhosus* (Eberth). 16. *Spirillum undula* (Cohn). 17. *Spirillum volutans* (Cohn). 18. *Spirillum cholerae Asiaticæ*. 19. *Spirillum Obermeieri* (Koch). 20. *Spirochæta plicatilis* (Flügge). 21. *Vibrio rugula* (Prazmowski). 22. *Cladothrix Försteri* (Cohn). 23. *Cladothrix dichotoma* (Cohn). 24. *Monas Okenii* (Cohn). 25. *Monas Warmingii* (Cohn). 26. *Rhabdomonas rosea* (Cohn). 27. Spore-formation (*Bacillus alvei*). 28. Spore-formation (*Bacillus anthracis*). 29. Spore-formation in bacilli cultivated from a rotten melon (Fränkel and Pfeiffer). 30. Spore-formation in bacilli cultivated from earth (Fränkel and Pfeiffer). 31. Involution-form of *Crenothrix* (Zopf). 32. Involution-forms of *Vibrio serpens* (Warming). 33. Involution-forms of *Vibrio rugula* (Warming). 34. Involution-forms of *Clostridium polymyxa* (after Prazmowski). 35. Involution-forms of *Spirillum cholerae Asiaticæ*. 36. Involution-forms of *Bacterium aceti* (Zopf and Hansen). 37. Spirulina-form of *Beggiatoa alba* (Zopf). 38. Various thread-forms of *Bacterium merismopedioides* (Zopf). 39. False-branching of *Cladothrix* (Zopf).



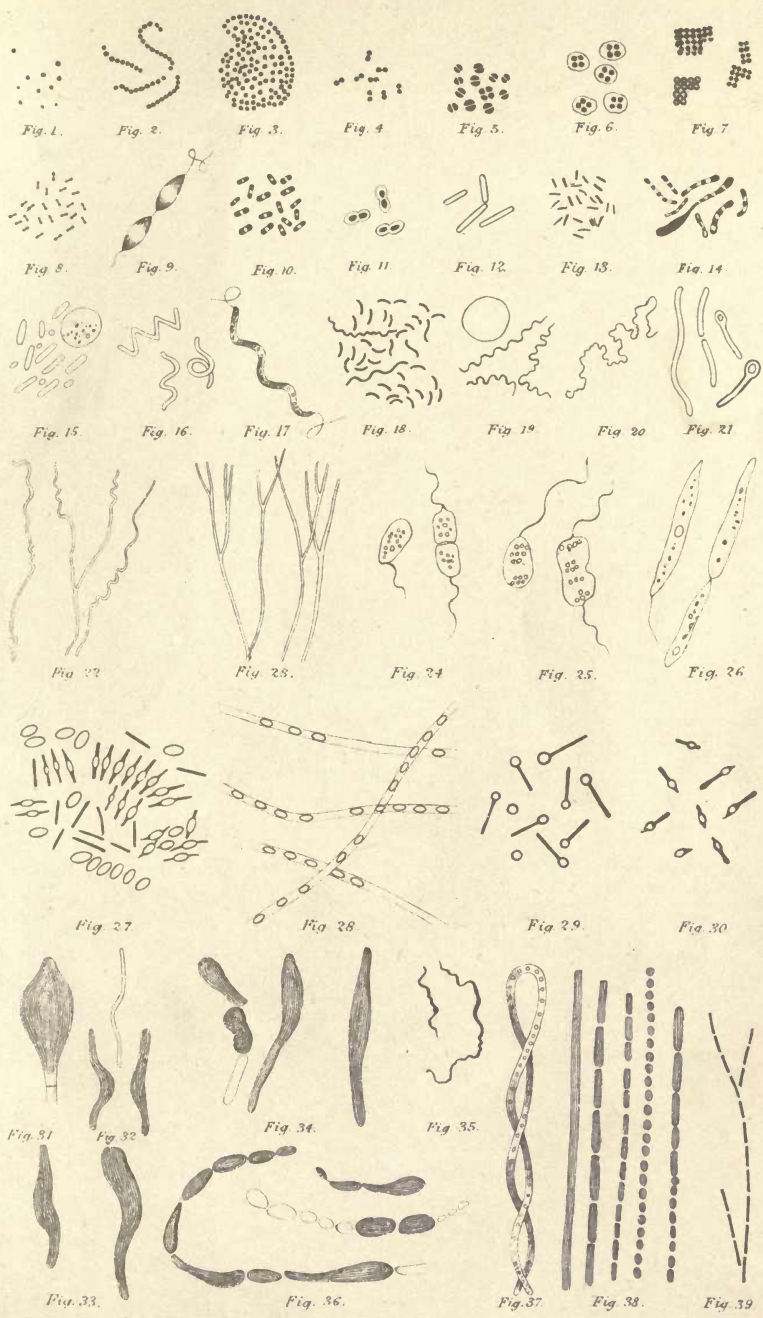

BACTERIA, SCHIZOMYCETES, OR FISSION FUNGI.





*spirilla*. Lastly, we have the filamentous forms, which may be straight, *leptothrix*, or wavy, *spirochæta*, or the wavy thread may be looped and entwined on itself, *spirulina*.

The term *involution form* is applied to certain peculiar shapes, which result more especially in bacteria grown under abnormal conditions. They are round, oval, pear-shaped, or club-formed enlargements.

**Movement.**—Many bacteria are devoid of movement throughout the whole of their life history. Others, during certain stages of their life cycle, and possibly some forms always, are endowed with locomotive power. The character of the movement is very varied, and ranges from a slow undulatory motion to one of extreme rapidity. Many appear to progress in a definite direction. Others move continuously, first in one direction and then in another, and others again seem to hesitate before altering their course. They may either glide along smoothly or progress with a tremulous motion.



FIG. 2.—SPIROCHÆTA FROM SEWAGE WATER,  $\times 1200$ .

They appear to be able to avoid obstacles, and to set themselves free from objects with which they have accidentally come into contact. Vibrios have a peculiar serpentine movement, but other forms, such as the commonly known *Bacterium termo* and segments of spirilla, such as comma-bacilli, revolve around their long axis as well as make distinct progression. The complete spirilla are characterised by the familiar corkscrew movement. With regard to cocci there is some doubt as to whether they are endowed with independent movement, any quivering or oscillation being generally regarded as only Brownian or molecular. In some straight thread-forms, which are motile, the movement is very slow and vermicular in character, but in wavy threads, such as the *Spirochæta plicatilis*, there is not only an undulatory motion, with rapid progression across the field of the microscope, but if they are confined by more or less *débris*, they give very peculiar and characteristic spasmodic movements. (Fig. 2.)

The rod-forms of *Proteus vulgaris* exhibit very extraordinary



movements on the surface of solid nutrient gelatine. Groups of rods may be observed to pass each other in opposite directions. Single individuals meet and progress side by side, or one or more individuals may part from a group and glide away independently. Occasionally a number of rods progress in single file. It is, however, difficult to believe that these movements can occur on a solid surface.

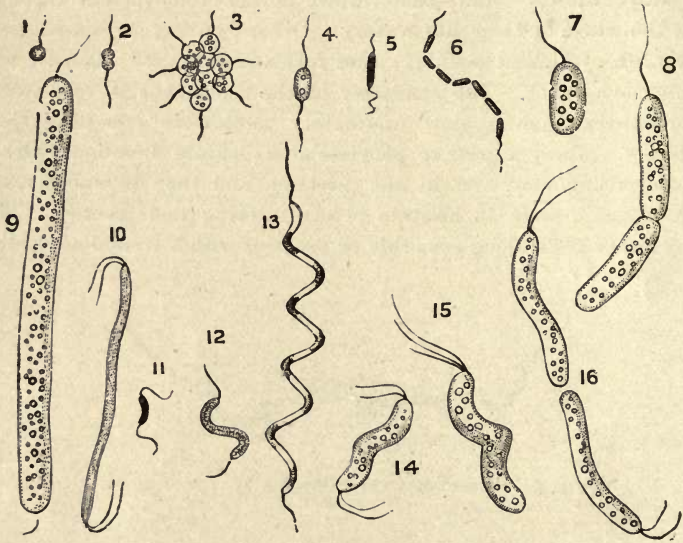

FIG. 3.—FLAGELLA.

1. Coccus with flagellum. 2. Similar coccus dividing, with two flagella. 3. Colony of flagellated macrococci of *Beggiatoa roseo-persicina*. 4. Short rod from the same *Beggiatoa* with flagella [all after Zopf]. 5. Bacillus with flagella [from a photograph by Koch]. 6. *Bacillus subtilis* [after Brefeld]. 7, 8. Short rod-forms of *Beggiatoa roseo-persicina* with one flagellum [after Zopf]. 9. Very long rod of the same, with flagellum at both ends [after Warming]. 10. Vibrio, with double flagellum at each end [after Warming]. 11. Vibrio, with flagella [from a photograph by the author]. 12. Spirillum with flagella [from a photograph by Koch]. 13. Spirillum with flagella [after Zopf]. 14. Spirillum with double flagella [after Zopf]. 15. *Beggiatoa roseo-persicina*, with a triple flagellum at one end; and 16, with a double flagellum at both ends [after Warming].

The author is inclined to believe that there is an almost inappreciable layer of liquid on the surface of the gelatine, which is expressed after the gelatine sets. In tubes of nutrient agar-agar gelatinised obliquely and then kept upright the liquid so expressed collects at the bottom of the sloping surface.

The means by which bacteria are endowed with the power of spontaneous movement and of progression may still be said, in some cases, to be unsettled. The author has watched the movement of long slender threads in sewage-contaminated water, which could only be explained by the inherent contractility of the protoplasmic contents; for if any drawing or propelling organ existed in proportion to the length of the organism, it would probably have been visible. But in many cases the organism is provided with a vibratile lash or *flagellum* at one end, or with one or more at both ends, or with numerous lateral and terminal flagella.

Some observers believe that the movement of cocci is due to the

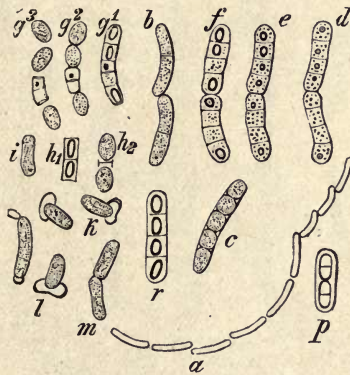

FIG. 4.—BACILLUS MEGATHERIUM.

a. A chain of rods,  $\times 250$ . The rest  $\times 600$ .

b. Two active rods.

d to f. Successive stages of spore-formation.

h to m. Successive stages of germination.

[After De Bary.]

existence of a flagellum. In *Bacterium termo* the existence of a lash at either end was first determined by the researches of Dallinger and Drysdale. In motile bacilli, such as the hay bacillus and *Bacillus ulna*, and in vibrios and spirilla, the flagella can be readily recognised by expert microscopists with the employment of the best lenses, and, what is of equal importance, proper illumination. They are objects of extreme delicacy and tenuity, and in stained preparations may be absent from retraction or injury. Koch succeeded in photographing them after staining with logwood, which turned them a brown colour. The author has observed them in vibrios in preparations stained with gentian violet, from which also they have been photographed, in spite of the violet colour, by the use of



isochromatic dry plates, and more recently special methods have been introduced, by Löffler and others, by which they can be stained and photographed with comparative facility.

It is not certain whether the flagella are extensions of the cell-wall, or derived from the internal protoplasm. Van Tieghem holds the first view, and does not regard them as motile organs at all. Zopf, on the other hand, adheres to the second view, and moreover believes that they can be retracted within the cell-wall.

**Reproduction.**—Bacteria multiply by fission and by processes which may be considered as representing fructification. The

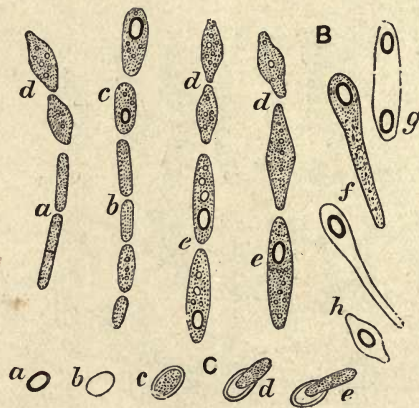

FIG. 5.—*CLOSTRIDIUM BUTYRICUM*,  $\times 1020$ .

B. Stages of spore-formation.

C. Stages of germination.

[After Prazmowski.]

bacteria exhibiting the latter processes have been divided into two groups, distinguished by the formation of *endospores* in the one and of *arthrospores* in the other. In the process of fission the cell first increases in size, and a transverse septum forms from the cell-wall, dividing the internal protoplasm into two equal parts; these may separate and lead an independent existence, or remain linked together. In chains of cocci the individual cells are easily visible and distinct, but in the thread-forms resulting from the linking together of rods, as in the anthrax bacillus, the composition of the thread is only demonstrated by the action of reagents.

Endospore formation may be conveniently studied in *Bacillus anthracis*, *Bacillus megatherium*, or *Bacillus subtilis*. The proto-



plasm becomes granular, and at certain points in the thread a speck appears, which gradually enlarges and develops into a circular or egg-shaped, sharply defined, highly refractive body. The spore grows at the expense of the protoplasm of the cell, which in time, together with the cell-wall, entirely disappears, and the spore is set free. These phenomena are best seen in an immotile bacillus in a drop-cultivation on a warm stage; the whole process may then be observed continuously from beginning to end. Spores may form in each link of the thread, so that a regular row results, or they may occur at irregular intervals. Spore-formation also occurs in bacilli which do not develop into leptothrix filaments. The spores may develop in the centre or at one end of the rod. In the tetanus bacillus a spore develops at the extreme end, producing the appearance of a drum-stick. The spore may be considerably wider, but is never longer than the parent cell.

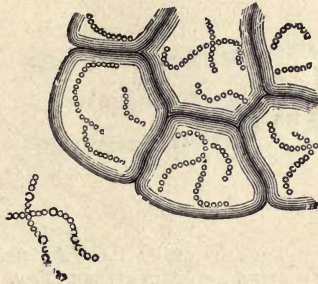

FIG. 6.—*LEUCONOSTOC MESENTEROIDES*; COCCI-CHAINS WITH ARTHROSPORES  
(after Van Tieghem and Cienkowski).

Arthrospore formation is illustrated in *Leuconostoc mesenteroides*. Certain elements in the chain of cocci, apparently not differing from the rest, become larger, with tougher walls, and more refractive. The remaining cells die, and these cells having acquired the properties of spores are set free, and can reproduce a new growth in any fresh nourishing soil. That this occurs in all species which do not form endospores is at present only a supposition.

Spores are invested by a thick membrane, which is believed to consist of two layers. To this they probably owe the property they possess of retaining vitality when desiccated, and of offering a greater resistance to the action of chemical reagents and heat than the parent cells.

Spore-formation has been regarded by some as occurring when the nourishing soil is exhausted, thus providing for the perpetuation

of the species. In anthrax the bacilli do not form spores in the living body, but when the animal dies the development of spores takes place, and hence the danger of contaminating the soil if the body is disposed of by burial. Klein, however, has pointed out that if mice and guinea-pigs which have died of anthrax are kept unopened, the bacilli simply degenerate and ultimately disappear. Thus there is good reason for believing that spore-formation is not due to exhaustion of the pabulum, but probably free access to oxygen constitutes an important factor in inducing this condition. If we inoculate a potato with anthrax, copious spore-formation occurs, though we cannot consider that the nourishing soil has been exhausted. But we have in this case the surface of the potato freely exposed to the air in the damp chamber. In the same way, in cultivations on agar-agar solidified obliquely (so as to get a large surface), spore-formation readily takes place. Contamination of

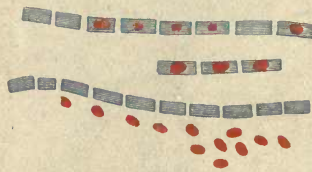

FIG. 7.—SPORE-BEARING THREADS OF *BACILLUS ANTHRACIS*, DOUBLE-STAINED WITH FUCHSINE AND METHYLENE BLUE,  $\times 1200$ .

the ground results, therefore, from animals in which a post-mortem examination has been made and the blood and organs freely exposed to the air; or from carcasses the hides of which have been soiled with excretions, and with blood which issues from the mouth and nostrils before death.

When spores are introduced into a suitable medium at a favourable temperature they develop again into rods. The spore loses its sharp contour, and, at one pole or on one side, a pale process bursts through the membrane, gradually growing into a rod from which the empty capsule is thrown off.

Spores differ from the parent cells in their behaviour to staining reagents. Like them, they can be stained with aniline dyes, but not by the ordinary processes. They require to be specially treated. This is probably due to the tough capsule, which must be altered or softened by heat or strong acid, until it allows the stain to penetrate.



Once stained, they again differ from the parent cells in resisting decolorisation ; this fact is taken advantage of to double-stain spore-bearing bacilli (Fig. 7).

In staining micro-organisms, the protoplasm is sometimes broken up into irregular segments or granules, as in many spirilla, and we may add the bacilli of tuberculosis and leprosy. The beaded appearance of the tubercle bacillus is well known. Some observers have regarded the beads, others the bright spaces between them, as spores. But spores in unstained preparations appear as glistening bodies with sharp contour. They do not stain at all, or very little, by the ordinary processes. These considerations led the author to stain and examine tubercular sputum and pure-cultures under careful illumination, and with such lenses as Powell and Lealand's  $\frac{1}{25}$  in. hom. imm. The tubercle bacillus in sputum (Fig. 8), as a rule,

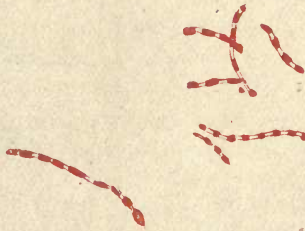

FIG. 8.—BACILLI OF TUBERCLE IN SPUTUM,  $\times 2500$  (from photographs).

consists of a very delicate sheath, holding together a number of deeply stained granules, for the most part round or cylindrical, with irregular contour, and differing considerably in size, while the light interspaces are seen to vary in form according to the shape of the granules. On the other hand, particularly in old cultures, more or less spherical, sharply defined bodies are observed in the bacilli, and also set free. These are the true spores of the tubercle bacillus, and are quite distinct from the irregular granules. There can be no doubt that a tubercle bacillus consists of a very delicate sheath, with protoplasmic contents which have a great tendency to break up or coagulate into little segments or roundish granules, partly owing to their age and the conditions under which they are grown, and partly to the treatment they are subjected to in making a microscopical preparation. This does not always occur, for the bacilli at times are not beaded, but are stained in their entirety.

In the leprosy bacilli a similar appearance occurs. In stained



sections the rods have a beaded appearance, but the intervals between the granules are sometimes very long, and occasionally the protoplasm appears to have collected only at the extreme ends of the rod.

The appearances in the case of the bacillus of glanders and the bacillus of hæmorrhagic septicæmia may be similarly explained.

The fact that tubercular sputum preserves its virulence for several months, even after desiccation, is to be attributed to the formation of spores. Babès claims to have succeeded in differentiating them by double staining.

In his definition of spirilla, Zopf gives the spore-formation as absent or unknown. In comma-bacilli in sewage water the author has often noted appearances suggestive of refractive spores; and the same also may be observed in vibrios, differing by their regular contour from the irregular spaces occasionally observed in stained preparations; but they are only vacuoles.



FIG. 9.—COMMA-BACILLI IN SEWAGE WATER, STAINED WITH GENTIAN VIOLET,  $\times$  1200.



FIG. 10. VIBRIOS IN WATER CONTAMINATED WITH SEWAGE,  $\times$  1200.

**Respiration and Nutrition.**—Like all a-chlorophyllous vegetables, bacteria require for their nutrition oxygen, nitrogen, carbon, water, and certain mineral salts. Many require free access to oxygen, others can derive it from the oxidised compounds in the medium in which they grow. Pasteur divided bacteria into two great classes—the aerobic and anaerobic, and considered that the latter not only had no need of oxygen, but that its presence was actually deleterious. Though this view must be considerably modified, the terms are convenient, and are still retained. They are well illustrated by the bacillus of anthrax, and the bacillus of malignant œdema; and a simple plan of demonstration has been employed by the author. A fragment of tissue from the spleen, for example, known to contain anthrax bacilli, is deposited with a sterilised inoculating needle, with the necessary precautions, on the surface of nutrient agar-agar in a test-tube; another tube of nutrient agar-agar is liquefied, and when cooled down almost to the point of

gelatinisation, a part is poured into the first tube, so that when it sets the piece of tissue is completely embedded. A piece of tissue from an animal suffering from malignant œdema is treated in the same way, and the tubes are placed in the incubator. If we examine them after two or three days, we shall find no change in the anthrax tube; the bacillus being eminently aerobic, no growth whatever has occurred. In the tube containing the bacilli of malignant œdema there will be a more or less characteristic cultivation.

The nitrogen which is essential for building up their protoplasm can be obtained either from albumins, or from ammonia and its derivatives. That the albumins can be dispensed with was shown by Pasteur, who employed an artificial nourishing solution constituted upon a formula representing the essential food constituents.

Carbon is derived from such substances as cane sugar, milk sugar, and glycerine, and, in some cases, by the splitting up of complex proteid bodies.

Water is essential for their growth, but deprivation of water does not kill all bacteria. Desiccation on potato is employed for preserving some micro-organisms, as a new growth can be started, when required, by transferring some of the dried potato to fresh nourishing ground. Comma-bacilli, on the other hand, are destroyed by drying. Sugar is used in making preserves, because by abstracting water it prevents the development of micro-organisms.

Mineral or inorganic substances, such as compounds of sodium and potassium, and different phosphates and sulphates, are necessary in small proportions.

#### CIRCUMSTANCES AFFECTING THE GROWTH OF BACTERIA.

*Nature of the Soil.*—Though we know the elements necessary, we are, nevertheless, as yet unable to provide a pabulum suitable for all kinds of bacteria. Thus we are quite unable to cultivate some species artificially. Others will only grow upon special media. Many grow upon nutrient gelatine; but some species only if it be acid or alkaline respectively. Whether in the latter case this is due purely to the reaction or to the presence of the particular ingredients is an unsettled point. Though the comma-bacillus of Koch, like the majority of organisms, grows best on an alkaline medium, yet it is well known to flourish at the temperature of the blood on the surface of potato, which is acid.





*Temperature.*—The influence of temperature on bacteria will be found to vary according to the species, but still for the majority we may distinguish a *maximum*, *optimum*, and *minimum* temperature.

Many grow best at the temperature of the blood, and hence the value of nutrient agar-agar, which is not liquefied at 37° C. The tubercle bacillus will only grow satisfactorily at a temperature varying between 30° C. and 41° C. On the other hand, many forms grow between the limits of 5° C. and 45° C. At these temperatures their functional activity is paralysed, but they are not destroyed, for by removal to favourable conditions they spring again into life. Bacteria seem to have a special power of resisting the effects of cold. It has been stated that comma-bacilli exposed to a temperature of -10° C. for an hour, and bacilli of anthrax after exposure to a temperature of -110° C., still retained their vitality. Temperatures over 50° to 60° C. destroy most bacteria, but not their spores; spores of anthrax retain their vitality after immersion in boiling water, but are destroyed by prolonged boiling. Roughly speaking, all pathogenic bacteria grow best at the temperature of the blood, and non-pathogenic bacteria at the ordinary temperature of the room.

*Movement.*—Bacteria probably grow best when left undisturbed. Violent agitation of a vessel in which they are growing certainly retards their growth, but a steady movement is stated not to affect it; at any rate, anthrax bacilli grow with enormous rapidity in the blood-vessels, in spite of the circulation.

*Compressed Air.*—Paul Bert maintained that a pressure of twenty-three to twenty-four atmospheres stopped all development of putrefactive bacteria. Oxygen, under a pressure of five or six atmospheres, is stated to stop their growth. Other observers have, however, obtained different results.

*Gases.*—Hydrogen and carbonic acid are stated to stop the movements of the motile bacteria. Chloroform is believed to arrest the changes brought about by the zymogenic species.

*Electricity.*—Cohn and Mendelssohn found that a constant galvanic current produced a deleterious effect owing to electrolysis. At the positive pole the liquid became distinctly acid, and at the negative pole distinctly alkaline. With a weak current there appeared to be no effect, two powerful cells at the very least being necessary.

*Light.*—Downes has shown that sunlight is fatal to putrefactive bacteria. This is believed to be due to a process of induced hyper-oxidation, from which living organisms ordinarily are shielded by protective developments of the cell-wall, or of colouring-matter,



which cut off injurious rays. Duclaux has investigated the same subject, and observed that micrococci were more sensitive to sunlight than the spore-bearing bacilli. Engelmann has described a bacterium whose movements cease in the dark, and Zopf states that in his cultures of *Beggiatoa roseo-persicina* the growth was much more strongly developed on the side of the vessel facing the light. Arloing, Marshall Ward, and Dieudonné have studied the effect of the sun's rays on anthrax spores, and on chromogenic and other bacteria, and maintain that they are bactericidal. The effect is due chiefly, if not entirely, to the blue rays.

*Chemical Reagents.*—Many substances, such as carbolic acid, corrosive sublimate, chlorine, bromine, have a marked effect upon the growth of bacteria. This will be more fully described in another chapter. In several cases the bacteria themselves secrete a substance which is injurious to their future development.

#### PRODUCTS OF GROWTH.

Bacteria may be grouped together according to the changes produced in the media in which they grow. Thus we have pigment-forming, phosphorescent, fermentative, putrefactive, nitrifying, and disease-producing bacteria.

*Chromogenic* or pigment-forming bacteria elaborate during their growth definite colour stuffs. Such species are exemplified by *Bacillus violaceus*, which produces a striking purple growth; *Bacillus pyocyaneus*, which secretes pyocyanin, a substance which has been isolated and obtained in a crystalline form; *Micrococcus prodigiosus*, which produces a pigment allied to fuchsine; *Beggiatoa roseo-persicina*, which is characterised by the presence of bacterio-purpurin; *Sarcina lutea*, *Bacillus cyanogenus*, and many others.

*Photogenic*, or light-producing, bacteria are found more especially in sea-water. There are several species of phosphorescent bacilli, and according to Beyrinck the best medium for their cultivation is fish-broth made with sea-water. Photographs can be obtained of cultures by their own light.

*Zymogenic* or ferment bacteria produce their changes in non-nitrogenised media. *Bacterium aceti*, by its growth produces the acetic fermentation in wine by which alcohol taking up atmospheric oxygen is converted into vinegar:—

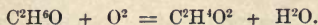

The fermentation of urine, by which urea is converted into carbonate of ammonia, can be brought about by several micro-organisms, but

notably by the *Bacterium ureæ*. The change produced is represented by the following formula :—

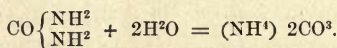

*Clostridium butyricum* converts the salts of lactic acid into butyric acid, producing the butyric fermentation in solutions of starch, dextrine, and sugar. These bacteria are agents in the ripening of cheese, and the production of sauerkraut. Thus, in a solution neutralised with calcium carbonate :—

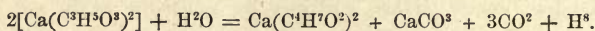

In the so-called viscous fermentation of wines, *Streptococcus viscosus* produces a gummy substance. According to Pasteur, the change may be thus represented :—

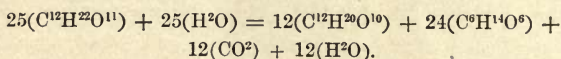

And as another example, the *Bacillus acidi lactici* may be mentioned, through the agency of which sugar of milk is converted into lactic acid :—

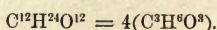

*Saprogenic* or putrefactive bacteria play a most important part in the economy of nature. They produce changes allied to fermentation in complex organic substances. Their action on proteids, according to Hoppe-Seyler, may be compared to digestion; bodies like peptones are first produced, then leucin, tyrosin, and fatty acids; lastly indol, phenol, sulphuretted hydrogen, ammonia, carbonic acid, and water. They abstract the elements they require, and the remainder enter into new combinations. Associated with the formation of these substances are certain bodies which have a poisonous effect when introduced into animals. These poisonous alkaloids, *ptomaines*, produce a septic poisoning, which must be distinguished from septic infection. The effects of septic poisoning depend on the dose, whereas the effects of septic infection are, to a certain extent, independent of the dose. A small quantity of a septic poison may produce only transient effects, and a relatively large quantity may be necessary to produce vomiting, rigors, and death. Septic infection, on the other hand, may result equally from a small dose, because the poison introduced is a living organism which is capable of propagation and multiplication. Our knowledge of these alkaloids is largely attributable to the researches of Selmi, Gautier, and Brieger, and the result of their work will be referred to again.



*Nitrifying* bacteria play a very important part by providing plant life with a most necessary food. They occur in the soil, and two kinds have been described—the one kind converting ammonia into nitrous acid, and the other changing nitrous into nitric acid. To Winogradsky and Frankland we are principally indebted for our knowledge of these bacteria.

*Pathogenic* bacteria are those which are genetically related to disease. Many organisms have been supposed to be pathogenic, or have been described in connection with diseases, which are only saprophytic associates. By *saprophytic* we mean organisms which feed upon dead organic matter. They include many forms which are found on the skin, in the intestinal canal, and sometimes in the internal organs, especially the liver and kidneys; the tissues have lost their vitality, and the organisms, through some lesion, have been carried into the circulation.

That many organisms are causally related to disease, there is strong evidence in proof. No organism can be considered to be productive of disease unless it fulfils the conditions which have been laid down by Koch. Great stress must be laid upon the importance of successive cultivation through many generations, as the objection that a chemical virus may be carried over from the original source is thus overcome. Any hypothetical chemical poison carried over from one tube to another would, after a great number of such cultivations, be diluted to such an extent as to be inappreciable and absolutely inert.

Though we may accept as a fact the existence of pathogenic organisms, we are not in all cases in a position to assert the means by which they produce their deleterious or fatal effects. Many theories have been propounded. It has been suggested that the pathogenic organisms may be compared to an invading army. The cells or *phagocytes* arrayed against them endeavour to assimilate and destroy them, but perish themselves in the attempt. This might explain the breaking down of tissue, and the formation of local lesions, but does not assist us in understanding the fatal result in thirty-six to forty-eight hours produced by the inoculation of the bacilli of anthrax. Another view is that the invading army seizes upon the commissariat, appropriating the general pabulum, which is so essential to the life of the tissues. This would hardly account for so acute and fatal a result as in anthrax, but would lead one to expect symptoms of inanition and gradual exhaustion. Moreover, against this theory we have the fact that death may result, in some cases, with the presence



of comparatively few bacilli in the blood; and, again, the blood may teem with parasites such as the flagellated monads in well-nourished, healthy-looking rats, without apparently causing any symptoms whatever. In the same category may be placed the theory that eminently aerobic organisms seize upon the oxygen of the blood and produce death by asphyxia. Another explanation is afforded by the suggestion of interference with the functions of the lung and kidney by mechanical blocking of the capillaries. Here the same objection is met with in the case of anthrax, the same fatal result may occur with only a few bacilli, while other cases yield very beautiful sections, looking like injected preparations from the mapping out of the capillaries with the countless crowds of bacilli.

Putrefactive bacteria derive their necessary elements from complex organic substances, and accompanying the residue we find the presence of poisonous substances. Pathogenic bacteria, in a similar way, give rise to virulent poisons. Anthrax bacilli produce poisonous principles in the blood which cause death, independently of the number of bacilli, provided there are sufficient present to develop a fatal dose.

It has been also suggested that possibly a special ferment is secreted by some organisms, and that by the changes ultimately wrought by the action of this ferment the symptoms and phenomena of disease arise. We have an analogy with this theory in the alkaline fermentation of urine by means of the *torula ureæ*. By the researches of Musculus, and later of Sheridan Lea, it has been shown that a ferment is secreted by the cells which can be isolated in aqueous solution, and is capable of rapidly inducing an active fermentation of urea.

We can now understand how it is that in anthrax or in tuberculosis we may find the presence of only a few bacilli, or that in tetanus we can have such a violent disturbance of the system produced by the presence of very few micro-organisms. We may conceive that different species of bacilli may vary greatly in their power of producing a *toxin* or secreting a ferment, just as the elaboration of pigment is much more marked in some species than in others; thus it need not follow that the number of micro-organisms bears any relation to the virulence or activity of the substance they produce. There is, however, yet another factor in the production of disease. We know that in health we are proof against most of these micro-organisms; if it were not so, we should all rapidly fall victims to the tubercle bacillus or others, which in

health we inhale with impunity. We know that a microbe may only cause a local lesion in one animal, but death in another. It is still more striking that the same micro-organism, as is the case with anthrax, may have no effect whatever upon certain species of animals, though it is deadly to others. Again, an animal naturally susceptible to the effect of a pathogenic organism may be rendered proof against it. These matters will be discussed in a future chapter.

#### DISTRIBUTION OF BACTERIA.

Bacteria are commonly described as ubiquitous. They are ever present in the air, though not in such exaggerated numbers as is commonly supposed. In nutrient media exposed to the air one is often astonished at times at the comparatively few bacteria which develop in comparison to the amount of floating matter, such as mineral particles, scales, spores of fungi and *débris* known to be present. In water they are also present in considerable numbers, though of course varying according to the character of the water. Wherever there is putrefaction, they are present in vast numbers. In the soil, in sewage, in the intestines and, in uncleanly persons especially, on the skin and between the teeth, various species may always be found, but in the healthy blood and healthy tissues bacteria are never present. In a previous chapter the method of examining the blood of living persons has been described, and there is, by this means, ample opportunity for satisfying oneself that bacteria are never to be found in the blood in health. The organs removed from a perfectly healthy animal, with the necessary precautions, and placed in sterilised media, can be kept indefinitely without undergoing putrefaction, or giving any development of bacteria. This has been established by many observers, notably Cheyne and Hauser; and the results of former observers to the contrary must be attributed to imperfect methods admitting of accidental contamination.



## CHAPTER III.

### EFFECT OF ANTISEPTICS AND DISINFECTANTS ON BACTERIA.

IN the previous chapter several conditions were alluded to which affected the growth of bacteria, such as the nature of the nutrient soil, temperature, light, and electricity. The effect of certain chemical substances, and of excessive heat and cold, was also mentioned; but this constitutes a subject of such practical importance that it must be considered more fully.

Agents which retard the growth of bacteria are generally spoken of as *antiseptics*, as distinguished from *disinfectants* which altogether destroy their vitality.

Though chemical disinfectants, or germicides, when diluted, act as efficient antiseptics, the converse, that an antiseptic in a sufficiently concentrated form will act as a disinfectant, is not the case. The term "antiseptic," indeed, should be restricted to those substances or agents which arrest the changes bacteria produce, but which do not prevent their springing into activity when removed to favourable conditions. Thus excessive heat, which destroys bacteria and their spores, is a true disinfectant; and excessive cold, which only benumbs them, retarding their development without killing them, is an antiseptic.

Spores have a greater power of resisting the action of these various agents than the parent cells, and many species of micro-organisms differ from each other in their resisting power. An exact knowledge of the subject can, therefore, only be based upon investigations which will determine the effect of these agents upon pure cultivations of the different micro-organisms causally related to putrefaction and disease. In the latter case, especially, this is not possible in the present state of our knowledge. In some cases of communicable disease there is considerable doubt as to the etiological importance of the organisms which have been described; in other cases no organisms have as yet been discovered, or the organisms



cannot be artificially cultivated, or the disease is not reproduced by inoculation, so that there is no means of testing whether the agents have had any effect. One can, therefore, only draw general conclusions by selecting some well-known pathogenic and non-pathogenic micro-organisms, and considering the influence of chemicals, of hot air and of steam upon them, as representing the effect upon the various contagia of disease and the causes of putrefaction.

Such knowledge must necessarily prove of the greatest importance: to the sanitarian, who is concerned in preventing the spreading of disease and in the disposal of putrefactive matter; to the surgeon, who is anxious to exclude micro-organisms during surgical operations, and to arrest the development of bacteria which have already gained an entrance in wounds; to the physician, in the treatment of micro-parasitic diseases.

The sanitarian and the surgeon must profit directly by such experiments, for in the disinfection of clothes and the sick-room by the one, and in the application of antiseptic dressings and lotions by the other, the micro-organisms are encountered, as in the experiments, outside the living body.

The physician, on the other hand, is principally concerned in dealing with micro-parasites when circulating in the blood, or carrying on their destructive processes in the internal tissues. So far as our knowledge at present goes, the physician can avail himself but little of the effect of the direct application of the substances which have been found to retard or destroy the growth of the organisms in artificial cultivations, for the concentrated form in which they would have to be administered would prove as deleterious or as fatal to the host as to the parasites. Thus Koch has stated that to check the growth of the anthrax bacillus in man it would be necessary that there should be twelve grammes of iodine constantly in circulation, and that the dose of quinine necessary to destroy the spirilla of relapsing fever would be from twelve to sixteen grammes. The retarding influence, however, of certain substances when diluted, and the fact that disinfectants are sometimes equally efficacious in a diluted form when their application is prolonged, seem to indicate measures which may be adopted, in some cases, with chances of success, such as the inhalation of antiseptic vapours in phthisis. For the most part the physician must look rather to combating the effects of micro-organisms by restoring to its normal standard the lowered vitality which enabled the bacteria to get a footing.

There is no wider field for research than the determination of the real effect of disinfectants and antiseptics. Painstaking and laborious as the researches are which have been hitherto made, the subject is so beset with fallacies, leading, in some cases, to totally erroneous conclusions, that it is not surprising that one meets on all sides with conflicting statements. The author has no intention of analysing these results, but a general idea will be given of the methods which have been employed, and for further details reference must be made to the original papers mentioned in the bibliography.

*Chemical Substances.*—It was customary to judge of the power of a disinfectant or antiseptic by adding it to some putrescent liquid. A small portion of the latter was, after a time, transferred to some suitable nourishing medium, and the efficacy of the substance estimated by the absence of cloudiness, odour, or other sign of development of bacteria in the inoculated fluid. Koch pointed out the errors that might arise in these experiments from accidental contamination, or from there being no evidence of the destruction of spores, and we are indebted to him for a complete and careful series of observations with more exact methods.

Instead of employing a mixture of bacteria, Koch's plan was to subject a pure cultivation of some well-known species with marked characteristics to the reagent to be tested. A small quantity was then transferred to fresh nourishing soil, under favourable conditions, side by side with nutrient material inoculated from a cultivation without treatment with the disinfectant. The latter constituted a control test, which is most essential in all such experiments. To test the resistant power of bacteria which are easily destroyed, two species were selected, *Micrococcus prodigiosus*, and the bacillus of blue pus. These were cultivated on potatoes, the surfaces of which were sliced off and dried. A fragment transferred to freshly prepared potato gave rise to a growth of the particular micro-organism; but if after treatment with some reagent no growth occurred, the conclusion was drawn that the reagent was efficacious in destroying the vitality of the bacteria.

Anthrax bacilli in blood, withdrawn from an animal just killed, were taken to represent sporeless bacteria, while silk threads steeped in an artificial cultivation of the bacilli and dried, afforded a means of testing the vitality of spores.

Even by employing pure cultivations on solid media, great precautions were necessary to avoid mistakes. When, for instance, a large quantity of the growth which had been subjected to some chemical solution was carried over to the fresh tube containing



the nutrient medium, or when a silk thread, which had been dipped in a solution, was directly transferred to the new soil, enough of the supposed disinfectant might be mechanically carried over to retard the development of the bacteria, though it was ineffectual in destroying them. From a growth not appearing, it was concluded that the spores or the bacteria had been affected, and so a mistake occurred. To avoid this, Koch made a point of transferring a minimum of the disinfected growth to as large a cultivation area as possible, so that any chemical substance mechanically carried over would be so diluted as to be inert. For the same reason, threads, after withdrawal from the disinfecting solution, were rinsed in sterilised water, or weak alcohol, and then transplanted; or, instead of judging from the development on nutrient gelatine, the effect of inoculation in a healthy animal was made the test.

A few examples may be quoted in illustration. Silk threads, impregnated with anthrax spores, were placed in bottles containing carbolic acid of various strengths. A thread was removed from each on successive days, and transferred to nutrient gelatine, and the result noted. It was found that immersion of the thread in a 5 per cent. solution of carbolic acid was sufficient in two days to effect complete sterilisation, and seven days in a 3 per cent. solution was equally efficacious. Since for practical purposes a strength should be selected which would be effectual in twenty-four hours, Koch recommended that for general use, allowing for deterioration by keeping, a solution containing not less than 5 per cent. should be employed, and for complex fluids probably a still higher percentage would be necessary. In the case of sporeless bacilli the results were very different. Blood containing the bacilli, from an animal just killed, was dried on threads, and after exposure for two minutes to a 1 per cent. solution, was completely sterilised; and fresh blood mixed with a 1 per cent. carbolic solution produced no effect when inoculated. On the other hand, when the blood was mixed with a .5 per cent. solution, the virulence was not destroyed. The facility with which the bacilli are destroyed, compared with their spores, illustrates how easily errors may occur, when mere arrest of growth or loss of motility is regarded as a sign of the efficacy of disinfection.

To test vapours, Koch exposed anthrax spores or the spores which occur in garden earth by suspending them over solutions, such as bromine or chlorine, in a closed vessel. After a time they were transferred to a nutrient medium to test their vitality. To test the power of sulphurous acid gas, the spores were spread about

in a room in which the gas was generated by burning sulphur in the ordinary way for disinfecting a room. To test chemicals which might be recommended for disinfecting vans and railway carriages, spores were laid on boards, which were then washed or sprayed, and the spores then transferred to the nutrient gelatine.

Sternberg has also made an elaborate series of experiments with regard to the action of germicides. In this case cultivations of well-known pathogenic organisms in liquid media were employed. The supposed germicide was added to the liquid cultivation, and after two hours a fresh flask of sterilised culture was inoculated from the disinfected cultivation, and placed in the incubator. In twenty-four to forty-eight hours, if the chemical proved inefficient, there was evidence of a growth of bacteria. Blyth has investigated the disinfection of cultivations of *Bacterium termo*, of sewage, and typhoid excreta, and, in conjunction with Klein, the effect of well-known disinfectant materials on anthrax spores. Miquel, Laws, and others have also contributed to our knowledge of the effect of antiseptics and disinfectants upon micro-organisms. In spite of all that has been done there is room for many workers; a great deal of ground must be gone over again to rectify discrepancies, examine conflicting results, and thus determine what observations may be relied upon for practical application.

This may be illustrated by referring in detail to some experiments made with corrosive sublimate. Koch investigated a long list of chemical reagents, and according to these experiments the salts of mercury, and the chloride especially, proved most valuable. Where heat is not admissible, these compounds were therefore highly recommended, though their poisonous nature is a drawback to their indiscriminate use. Koch stated that for disinfecting a ship's bilge, where a 5 per cent. solution of carbolic acid must be left forty-eight hours, a 1 in 1000 solution of mercuric chloride would only require a few minutes.

But there was good reason for doubting the efficacy of very dilute solutions; for, though according to Koch's experiments anthrax spores subjected to a 1 in 20,000 solution of mercuric chloride for ten minutes, and then *washed in alcohol*, gave no growth in nutrient gelatine, silk threads exposed for ten minutes to a 1 in 20,000 solution, or even 1 in 10,000, still proved fatal to mice.

Herroun cultivated ordinary septic bacteria in albuminous filtrates, containing 1 in 2000, and concluded that the value of mercuric chloride as an antiseptic was much over-rated. It is precipitated by albumins though, as Lister has shown, the precipitate



of albuminate of mercury is redissolved when there is an excess of albumin present.

Geppert, and later Behring, recognised that the methods employed for testing the efficacy of corrosive sublimate were unreliable. They found, for example, that corrosive sublimate could not be removed from silk threads by washing; and therefore to study the effect of this antiseptic acting for a given time, it was necessary to dip the threads in ammonium sulphide solution after the treatment with corrosive sublimate.

The author confirmed the results of Geppert and Behring, and made a series of experiments to test the value respectively of carbolic acid and corrosive sublimate in antiseptic surgery. The method of dipping an infected thread into an antiseptic solution for a few minutes, and then transferring it to the surface of a nutrient medium to test its efficacy in a given time, was discarded as fallacious; the thread being still wet with the solution when transferred to the medium, it was obvious that the action of the antiseptic continued for many days. To wash infected silk threads with alcohol after exposure to the antiseptic to stop its further action, also proved to be a fallacious method, for the author found in control experiments that absolute alcohol will destroy *Streptococcus pyogenes*, *erysipelatis*, and *Staphylococcus pyogenes aureus*, acting for only one minute. Other methods were therefore resorted to, and cultures on the sloping surface of nutrient agar were at first used. The antiseptic was poured into the culture tube until the growth was covered, and when it had acted for a definite time (one minute, five minutes, or fifteen minutes) a solution was added which immediately stopped further action. In the case of corrosive sublimate, ammonium sulphide was employed, which is quite inert as an antiseptic. The liquid contents of the test tube were carefully poured off, and an inoculation was made into a fresh tube of broth or agar from the culture still adhering to the surface of the nutrient medium. As the results disproved the efficacy of corrosive sublimate, it was thought possible that the solution had not been able in the time to penetrate the film of growth. Another plan was accordingly adopted. Cultures were made in broth, and when fully developed the supernatant liquid was carefully poured off. Corrosive sublimate solution was added to the test tube, and agitated until any flocculent masses were disintegrated and the whole of the liquid became uniformly turbid. Ammonium sulphide was added when the time had expired, and tubes of fresh broth were inoculated with the mixture. In the case of carbolic acid the cultures, after its action, were thoroughly washed

with water, and its efficacy tested by making inoculations from the cultures in fresh media. The results were entirely in favour of carbolic acid. *Staphylococcus pyogenes aureus* and *Streptococcus pyogenes* were not destroyed, even when corrosive sublimate solution of 1 in 1000 was allowed to act for an hour. In the case of the cultures of streptococcus of erysipelas the results were different. A solution of 1 in 10,000 had no effect, but 1 in 4,000, acting for one minute, destroyed the culture. With carbolic acid the results were very striking. Cultures were exposed to solutions of 1 in 20, 1 in 30, 1 in 40, 1 in 50, for one minute, five minutes, fifteen minutes. The attempts to make subcultures in every case failed. Carbolic acid 1 in 40, acting for only one minute, was sufficient to destroy *Streptococcus pyogenes* and *Streptococcus erysipelatis* and *Staphylococcus pyogenes aureus*. Further experiments were made with tubercular sputum, the test being subsequent inoculation of guinea-pigs. Corrosive sublimate solution as strong as 1 in 500 had no effect, but 1 in 20 carbolic acid, shaken up with the sputum for one minute, completely neutralised it.

Koch's statements with reference to the germicidal power of corrosive sublimate in extremely weak solutions had led Lister to substitute it for carbolic acid as a detergent in surgery. The author's experiments, which were undertaken in 1892, encouraged Lister to revert to the use of carbolic acid, which, indeed, had always proved efficacious in surgical practice. Lister pointed out that carbolic acid has also the great advantage of combining eagerly with fats and epidermis, so that the seat of operation can be effectually cleansed.

These experiments also point to the conclusion that carbolic acid should be used in hospital wards for the disinfection of tubercular sputum instead of mercuric chloride and other less efficacious disinfectants commonly in use.

*Hot Air and Steam.*—Koch, in conjunction with Wolfhügel, also made exhaustive experiments to test the value of hot air. A similar plan was adopted to that employed in disinfection with chemicals. Bacteria and spores were subjected for a certain time to a known temperature in the hot-air chamber, and then were transferred to a nourishing soil or inoculated in animals.

Paper parcels, blankets, bags, and pillows, containing samples of micro-organisms wrapped up inside, were also placed in the hot-air chamber, to test the power of penetration of heat.

The conclusions from these experiments were as follows:—

Sporeless micro-organisms at a little over 100° C. are destroyed in one hour and a half.



Spores of bacilli require three hours at 140° C.

If enclosed in pillows and blankets, exposure from three to four hours to 140° C. is necessary.

Spores of fungi require one and a half hours at 110° C. to 115° C.

Further experiments showed that at the temperature necessary for the destruction of spores of bacilli almost all fabrics are more or less injured.

Koch, in conjunction with Gaffky and Löffler, also investigated the effect of steam under pressure and at the atmospheric pressure.

Rolls of flannel with anthrax spores or earth spores, and a thermometer wrapped up inside, were subjected to steam, and the results compared with the effect obtained with hot air.

Thus in hot air four hours' exposure to a temperature of 130° C. to 140° C. brought the temperature inside the roll to 85° C., and the spores were not injured; on the other hand, exposure to steam under pressure at 120° C. for one and a half hours, raised the internal temperature to 117° C. and killed the spores.

By such experiments the superior penetrative power of steam-heat was established.

To test steam-heat at the atmospheric pressure, water was boiled in a glass flask with its neck prolonged by means of a glass tube, the temperature in which was found to be uniform throughout. Anthrax and earth spores placed in the tube were found to be unable to withstand steam at 100° C. even for a few minutes. It was, therefore, concluded that disinfection by steam at atmospheric pressure was superior to hot air from its greater efficiency, and to steam under pressure from the simplicity of the necessary apparatus.

Parsons and Klein made some experiments which were more in favour of dry heat than the above. These observers state that anthrax bacilli are destroyed by an exposure of five minutes at from 100° C. to 103° C. and that anthrax spores are destroyed in four hours at 104° C., or in one hour at 118° C. Guinea-pigs inoculated with tuberculous pus which had been exposed for five minutes to 104° C., remained unaffected. They concluded that as none of the infectious diseases, for which disinfecting measures are in practice commonly applied, are known to depend upon the presence of bacilli in a spore-bearing condition, their contagia are not likely to retain their activity after being heated for an hour to 105° C. (220° Fahr.)

In experiments with steam the results were in accordance with those already given, and complete penetration of an object

by steam-heat for more than five minutes was deemed sufficient. They also arrived at the same result as in Koch's experiments, viz., that steam-chambers are preferable to those in which dry heat is employed, though it must be borne in mind that some articles, such as leather, are injured by exposure to steam.

#### PRACTICAL APPLICATION.

Nurses and others attending infectious cases should freely use 1 in 40 carbolic for the hands and a weaker solution for the body generally. The skin of patients after recovery should be sponged with 1 in 40 carbolic. The dead should be wrapped up in a sheet soaked in 1 in 20 carbolic acid or a strong solution of chloride of lime. Infected clothing and bedding should be burnt unless in exceptional cases, when they may be disinfected by boiling, or by exposure to dry heat at 105° C. to 110° C. for three hours, or by steaming at 100° C. for fifteen minutes. Leather and other articles which would be destroyed by any of these processes should be sponged with 1 in 40 carbolic. The walls of the sick-room and furniture should be exposed to the fumes of burning sulphur, and next day washed down with 1 in 40 carbolic, and the room freely ventilated by opening all windows and doors. Rags should be burnt, or disinfected by boiling or exposure to steam when supplied to manufacturers. The importation of rags from places where there are cases of cholera or small-pox should be prohibited. Infected ships must be fumigated with sulphur, and the bilge disinfected with carbolic acid. Infected railway carriages should be disinfected in the same way as a sick-room.

Tubercular sputum, cholera and typhoid evacuations and other excreta should be disinfected by 1 in 20 carbolic acid, or by a strong solution of chloride of lime.



## CHAPTER IV.

### CHEMICAL PRODUCTS OF BACTERIA.

THE products of the metabolism induced by bacteria may be divided into three classes: (1) ptomaines or alkaloids; (2) albumoses or tox-albumins; and (3) enzymes. Alkaloids and albumoses are directly poisonous; enzymes or ferments are harmless except in the presence of proteids, which they are capable of transforming into poisonous albumoses.

#### PTOMAINES AND TOX-ALBUMINS.

The study of these products may be said to date back to 1822, when Gaspard and Stick found an intensely poisonous principle in cadaverous extracts. In 1856 Panum discovered a poisonous substance in putrid flesh; and in 1863 Bergmann and Smiedeberg found a nitrogenous crystallisable substance in putrid beer which they named *sepsin*. In 1872 Gautier found that the decomposition of fibrine led to the formation of various complex alkaloidal substances, and in 1875 Richardson obtained in pyæmia an alkaloid, *septin*. This subject, however, received most attention from the classical researches of Selmi, the Italian toxicologist. Selmi, in a celebrated poisoning case, demonstrated the presence of an alkaloid as the result of post-mortem changes. Similar substances were found in alcohol in which morbid specimens had been preserved. Thus the researches of Gautier and Selmi established the fact that albuminoid material undergoing decomposition leads to the formation of cadaveric alkaloids. These animal alkaloids Selmi named *ptomaines*. Brieger, finding the bases derived from the products of putrefaction less poisonous than those obtained from the pathogenic bacteria, suggested the term *toxins* for the latter. Ptomaines have been divided into two classes—those which are non-oxygenous, liquid, and volatile, and those which are oxygenous, solid, and crystallisable. They are, for the most part, precipitated by the ordinary reagents

for alkaloids, such as chloride of gold, double iodide of mercury and potassium, picric acid, and tannin. Phospho-molybdic acid precipitates them without exception. They are powerful reducing agents. Ferro-cyanide of potassium is converted into ferri-cyanide in their presence, and the addition of ferric chloride gives the Prussian blue test. Selmi discovered this test, and Brouardel and Boutmy regarded it as absolutely characteristic of ptomaines; but this is not the case; some vegetable alkaloids, for example, behave in the same way.

As examples of the non-oxygenous ptomaines there are:—

*Parvolin* ( $C^9H^{13}N$ ) an oily base of an amber colour prepared from putrid mackerel and horse-flesh.

*Hydrocollidin* ( $C^8H^{13}N$ ), from the same source. It is highly toxic, being compared by Gautier to the venom of the cobra di capello.

*Collidin* ( $C^8H^{11}N$ ), from putrid gelatine and the pancreas of a bullock, also highly toxic.

*Neuridin* ( $C^6H^{14}N^2$ ), from fish, flesh, and decaying cheese.

*Saprin* ( $C^5H^{14}N^2$ ), isomeric with *neuridin*.

*Cadaverin* ( $C^5H^{14}N^2$ ), a third isomeride, from ordinary putrefaction and herring brine.

*Putrescin* ( $C^4H^{12}N^2$ ) from putrefaction.

The oxygenous ptomaines are in some instances found also in healthy tissues. They include the following:—

*Neurin* ( $C^5H^{13}NO$ ), found in cadaveric putrefaction.

*Cholin* ( $C^5H^5NO^2$ ), in bile.

*Muscarin* ( $C^5H^{13}NO^2$ ), in a poisonous mushroom, *Agaricus muscarius*, and in putrid fish. These are all highly poisonous.

*Gadinin* ( $C^7H^{16}NO^2$ ), in putrefying codfish.

*Mytilotoxin* ( $C^6H^{15}NO^2$ ), in poisonous mussels.

Poisonous alkaloids are of great importance in connection with those cases of meat poisoning produced by sausages, hams, poultry, and cheese. Tyrotoxin is a poisonous alkaloid obtained from cheese.

The toxic substances of most interest to the bacteriologist are those isolated from pure cultivations of pathogenic bacteria, such as *typhotoxin*, isolated by Brieger from cultivations of the bacillus of typhoid fever, and *tetanin*, from cultivations of the tetanus bacillus; and the poisons known as albumoses or tox-albumins, which are allied to the albumose of snake poison.

Pasteur, in 1885, suggested that in anti-rabic inoculations the immunity resulted from the action of a substance secreted by a microbe, though the microbe has not as yet been discovered in rabies. Salmon produced immunity from hog cholera by the injec-



tion of the toxic products in filtered culture fluids. Wooldridge, Hankin, and Martin studied the products of *Bacillus anthracis*. Charrin, and later Woodhead, Wood, and Blagovestchensky, investigated on these lines *Bacillus pyocyaneus*. Roux and Chamberland experimented with the bacillus of malignant œdema; Roux with symptomatic anthrax; Chantemesse and Widal with the typhoid bacillus. Roux, Yersin, Brieger, Fränkel, Martin, and Behring worked on the same lines with diphtheria. Koch introduced tuberculin, Kalning mallein, while others have utilised the products of streptococci and pneumococci. Anrep found an albumose in the medulla of rabid animals, and Babès claims to have found an albumose in both rabies and glanders.

**Cholera.**—Brieger found several ptomaines, including putrescin and cadaverin, in pure cultures of the spirillum of Asiatic cholera, and Petri found in addition to poisonous bases a proteid body which produces in guinea-pigs muscular tremors, paralysis, and a rapidly fatal result. Roux and Yersin obtained from cultures a tox-albumin insoluble in water, which kills guinea-pigs in two or three days, but has no effect on rabbits. Pfeiffer also investigated the toxic substances in cultures. Chloroform, thymol, and drying destroyed comma-bacilli, leaving their toxic products unaffected. Concentrated solutions of neutral salts and boiling produced secondary toxic substances, but the original toxic substances were ten or twenty times more virulent.

**Typhoid Fever.**—Typhotoxin ( $C^7H^{17}NO^2$ ), the alkaloid obtained by Brieger from cultures of the typhoid fever bacillus, produces in mice and guinea-pigs salivation, rapid breathing, dilatation of the pupil, diarrhœa, and death in twenty-four to forty-eight hours. At the post-mortem examination the heart is found in a state of systolic contraction, and the condition of the heart after death and the absence of convulsions during life serve to distinguish typhotoxin from an isomeric base obtained by Brieger from putrid horse-flesh. Roux and Yersin have obtained a tox-albumin. It is soluble with difficulty in water, and more toxic to rabbits than guinea-pigs.

**Tetanus.**—Brieger obtained the alkaloid *tetanin* from impure cultures of the tetanus bacillus. It is a base having the formula  $C^{13}H^{22}N^2O^4$ . The hydrochloride is a very deliquescent salt, and soluble in alcohol. Tetanin injected into guinea-pigs produces rapid breathing, followed by tetanic convulsions. Another toxic product, *tetanotoxin* ( $C^5H^{11}N$ ), produces the same effects as tetanin. The formula of a third base, *spasmotoxin*, has not been determined. Cadaverin and putrescin are also present in cultures. Kitasato and

Weyl analysed the products of pure-cultures, and obtained the same substances, tetanin and tetanotoxin; and subsequently Brieger and Fränkel found that in pure-cultures a tox-albumin could be obtained which is soluble in water, and infinitely more active than the toxic ptomaines.

**Anthrax.**—In 1887 Wooldridge succeeded in protecting rabbits from anthrax by a new method. A proteid body obtained from the testis and from the thymus gland was used as the culture fluid. This proteid substance was dissolved in dilute alkali, and the solution sterilised by repeated boiling. This was inoculated with the anthrax bacillus, and kept at 37° C. for two or three days. A small quantity of the filtered culture fluid injected into the circulation in rabbits produced immunity from anthrax. Subcutaneous inoculation of extremely virulent anthrax blood, made simultaneously with the injection of the protecting fluid, produced no effect. Wooldridge showed that the growth of the anthrax bacillus in special culture fluids gave rise to a substance which, when injected into the organism, protected not only against an immediate but also subsequent attacks.

In 1889 Hankin worked under the guidance of Koch in the Hygienic Institute of Berlin. The acquired tolerance of the effect of ordinary albumoses, and the experiments of Sewall, who produced immunity against lethal doses of the albumose of snake poison by the injection of minute doses, led Hankin to expect that an albumose developed in anthrax cultures, and that the anthrax albumose would probably confer immunity from the disease. Hankin succeeded in isolating it from culture fluids. It was precipitated by excess of absolute alcohol, well washed in alcohol to free it from addition of ptomaines, filtered, dried, then redissolved and filtered through a Chamberland filter. With this substance Hankin succeeded in producing immunity in mice and rabbits.

Sidney Martin, working quite independently, grew anthrax bacilli in a solution of pure alkali albumin made from serum proteids. After ten or fifteen days the organisms were removed by filtration through a Chamberland filter. The filtrate contained *proto-albumose* and *deutero-albumose*, a trace of *peptone*, an *alkaloid*, and small quantities of *leucin* and *tyrosin*. The mixture of albumoses proved poisonous to mice. The anthrax alkaloid produced symptoms and lesions similar to the albumoses, but much more rapidly and severely. It is an amorphous yellow body, soluble in alcohol and alkaline in reaction. Martin concluded that the anthrax bacillus formed the albumoses and the alkaloid by digesting the alkali albumin; and suggested that the alkalinity of the albumoses explained their toxic



properties, the alkaloid probably being in a nascent condition in the albumose molecule.

**Tuberculosis.**—Koch prepared a glycerine extract of the product of the tubercle bacillus in pure cultivations, and found that the injection of small doses produced a remarkable reaction, both local and general, in tubercular cases, and especially lupus. This extract, called *tuberculin*, came to be extensively used as a therapeutic agent, but with disappointing results. Very shortly after the first announcement of Koch's discovery, the author, in conjunction with Herroun, investigated the chemical properties and physiological effects of the products of the tubercle bacillus. Cultures in glycerine-broth were filtered through porcelain, and a clear amber-coloured liquid was obtained, which gave important and suggestive chemical reactions. As this filtrate contained the products of the growth of the bacillus most probably in minute quantities, it was evaporated at a low temperature over sulphuric acid. The viscous residue was dissolved in distilled water and tested on the healthy guinea-pig. The result was a marked fall of temperature, staring coat, extreme irregularity of the heart's action, muscular spasms, loss of control over the extremities, and death.

A preliminary examination of glycerine-broth cultivations having shown the presence of non-coagulable proteid bodies of the nature of albumose and peptone, and a crystallisable precipitate of a remarkable character resulting on the addition of iodine, the idea naturally suggested itself that the tubercle bacillus might form albumoses and an alkaloid or ptomaine similar to the substances isolated by Martin from pure cultivations of the *Bacillus anthracis*.

Koch pointed out that the effective substance in his extract could be precipitated by absolute alcohol; the author and Herroun determined to investigate the properties and physiological effects of the separated products. They accordingly set to work to isolate the ptomaine, of the existence of which they had some qualitative indication, and at the same time to examine the properties of the albuminous bodies.

In this endeavour the general method they found satisfactory was as follows. The clear filtrate from the culture was evaporated at 40° C. to a very small bulk, and the residue thus obtained was mixed with an excess of absolute alcohol, which precipitated the albumoses and peptone. It was found that by adding the alcohol by degrees a partial separation of the albumose from the peptone could be effected, the latter being only precipitated when the alcohol was nearly absolute. The precipitated albumose was collected on

a filter and redissolved in distilled water. In another experiment the albumose underwent a second precipitation, and after washing was again dissolved.

The alcoholic filtrate from the precipitated albuminous bodies was then concentrated at a very gentle heat until a viscous residue was left containing the glycerine originally present in the cultivating medium and the extractives and products of the bacillus soluble in alcohol. With this residue definite reactions of an alkaloidal substance or ptomaine were obtained.

Careful experiments, however, led to the belief that the whole of the ptomaine was not separated from the albuminous precipitate by simple addition of alcohol, and the above method was therefore slightly modified.

The ptomaine is soluble in water and alcohol, and sparingly soluble in amyl-alcohol, but insoluble in benzine, ether, or chloroform, which liquids therefore fail to extract it from aqueous solutions. In its aqueous solutions it is distinctly but not strongly alkaline to test-paper. Phospho-tungstic acid gives with it a white flocculent precipitate. Phospho-molybdic acid gives a pale yellow precipitate, soluble in ammonia to a blue solution which becomes colourless on boiling. In this respect it resembles the vegetable alkaloids, aconitin and atropin. It must be remembered, however, that albuminous bodies are precipitated by both this and the preceding reagents, and in the case of the former a reduction of the phosphomolybdate giving the blue solution with ammonia is obtained.

The reducing power of the ptomaine is shown by the conversion after a short time of ferri-cyanide of potassium to ferro-cyanide, giving the Prussian blue test with ferric chloride, to which much undue importance was attached by Brouardel and Boutmy. The solution of albumose and solution of peptone are both capable of giving this reaction as well as many vegetable alkaloids. A solution of the ptomaine is not precipitated by ferro-cyanide of potassium or potassic bichromate.

In strong solutions it yields precipitates with platinic chloride (yellow), gold chloride (pale yellow), and mercuric chloride (white). That yielded by the first of these reagents is granular in character, and quite insoluble in alcohol, though apparently soluble in water. The precipitation by gold chloride excludes amides and ammonium salts.

With iodine in hydriodic acid or potassic iodide a precipitate is obtained which is occasionally crystalline, more often granular or amorphous.



This precipitate is soluble in alcohol, and is redeposited when the alcohol is evaporated. On heating it is redissolved into oily drops of a dark colour. With picric acid a granular precipitate is obtained, which under the microscope is seen to consist of minute crystals. This precipitate, on standing, is converted into rounded crystalline masses with numerous small crystals admixed.

The ptomaine appears to be easily broken up by heating, especially in the presence of mineral acids or of baryta. The actual quantity obtained from a considerable amount of culture fluid was very small, and as it was possible that when the bacilli were grown in a medium richer in albumin, such as the animal body, more of these products might be formed, the liquid obtained by extracting large masses of tubercular growths from cattle was examined in a similar manner. In this extract, after filtration through porcelain, an albumose, and minute quantities of a ptomaine were obtained which in reactions was identical with that obtained from the artificial cultivation of the bacillus, but present in even smaller amount. The probable explanation of this is, that in the living animal the ptomaine is constantly being removed; or it may indicate that it is only formed in minute quantity under those conditions.

Having succeeded in obtaining the albumose and the ptomaine in separate solutions, we next proceeded to ascertain the effects of these substances upon healthy and tubercular guinea-pigs.

The effect of the ptomaine isolated from different series of cultures was as follows. A rise of temperature occurred in tubercular animals, and distinct enlargement of tubercular glands. There was a slight indication of a depression of temperature or hypothermic effect on healthy animals. The albumose, whether obtained from pure cultivations of the bacillus or from tubercular tissue, produced a marked rise of temperature in tubercular guinea-pigs. On the other hand, in a control experiment on a healthy guinea-pig there was an equally well-marked fall of temperature. The effect upon the tubercular glands in the cases associated with marked rise of temperature was to render them well-defined, indurated, and painful, rather than any considerable increase in volume.

Hunter made a chemical examination of Koch's crude extract, and confirmed the presence of albumoses and alkaloidal substances. The albumoses consisted chiefly of proto-albumose and deuterio-albumose with hetero-albumose, and occasionally a trace of dys-albumose. Two alkaloidal substances were obtained in the form of platinum compounds of their hydrochlorate salts. In addition there were extractives, mucin, inorganic salts, glycerine, and colouring-matter.



**Swine Fever.**—Schweinitz applied Brieger's methods in the investigation of the products of the swine fever, or hog cholera bacillus. Broth-cultures were neutralised with dilute hydrochloric acid, and evaporated in the water bath. The residue was treated with 96 per cent. alcohol, and the filtered solution with mercuric chloride. A heavy crystalline precipitate was separated by filtration, treated with water, and decomposed with sulphuretted hydrogen, and cadaverin and methylamine were isolated. The filtrate from the mercuric chloride precipitate was freed from excess of mercury by sulphuretted hydrogen, and the mercury sulphide filtered off. The residue, after concentration of the filtrate, was extracted with absolute alcohol, and the solution showed the presence of an alkaloidal salt. The double salt obtained with platinum chloride was submitted, after crystallisation, to an analysis, and the results gave the formula ( $C^{14}H^{34}N^2PtCl^6$ ). The hydro-chloride is soluble in absolute alcohol as well as in water, and produces needle-like crystals.

On treating the culture fluids with excess of absolute alcohol a white flocculent precipitate was obtained partly soluble in water, and re-precipitated by alcohol. It was obtained in the form of white crystalline plates. A watery solution gives almost insoluble needle-crystals on the addition of platinum chloride. These products were respectively termed sucholo-toxin and sucholo-albumin. Small doses of these substances produce in guinea-pigs a slight rise in temperature, and ulceration at the seat of injection. Large doses produce a fatal result in six to twenty-four hours. Schweinitz asserts that he has produced immunity in guinea-pigs. An attempt to produce immunity in swine by injection of the albumose gave unsatisfactory results.

**Diphtheria.**—Roux and Yersin finding that filtered cultures of the diphtheria bacillus produced paralysis, affecting chiefly the hind legs, and a fatal result in rabbits and guinea-pigs, proceeded to investigate the chemical products. They succeeded in obtaining a white amorphous substance which was extremely active when injected into guinea-pigs. It was precipitated by alcohol from an aqueous solution, and it was calculated that .0004 gram would destroy eight guinea-pigs of 400 grams, or two rabbits of 3 kilos. each. They concluded that the poison was an enzyme or ferment, as it not only acted in extremely small doses, but it was attenuated by heat and destroyed by boiling.

Brieger and Fränkel confirmed these experiments, and asserted that the poison was a tox-albumin; but according to Martin their chemical analysis and reactions were vitiated by the fact that they



had peptone in their cultivating medium. Martin examined the products by using as a culture medium a 1 to 2 per cent. solution of alkali-albumin in broth made from beef, omitting the peptone. After about thirty days the bacillus had converted the alkali-albumin into albumoses, which gave the reactions of proto- and deuterio-albumose, with small quantities of an organic acid. A single dose of these albumoses produced weakness of the hind limbs, which after a time passed off. The animal was killed, and the nerves which were examined showed degeneration. Repeated intravenous injection on successive days, amounting in all to a dose of 1.69 grams per kilo. of body weight, produced high fever, followed by depression of temperature, severe watery diarrhœa, and emaciation. The tendon reflexes began to diminish after the ninth day, on the eleventh or twelfth day there was definite paralysis of the hind legs, and on the seventeenth day reflexes could scarcely be obtained.

Martin thus gives his method of abstracting the poisonous products either from cultures or from diphtheritic tissues. In dealing with tissues, the spleen and other organs are first finely minced and placed in rectified spirit, and the blood is also placed in spirit, and allowed to stand till the proteids are coagulated; they are then filtered, and the residue extracted with cold water, all the extracts are mixed together, and evaporated at 35° C. to a small bulk, and thrown into absolute alcohol. Most of the albumoses are precipitated, the alcohol is poured off, evaporated to dryness at a low temperature, and extracted by absolute alcohol until nothing more dissolves. The residue is deuterio-albumose and mineral salts. All the proteid is mixed together, dissolved in water, and precipitated by alcohol, the process being repeated to remove any traces of bodies soluble in alcohol and the excess of mineral salts. At the last precipitation the precipitate is allowed to stand under alcohol for about two months. The alcohol is then poured off, and the precipitate dried *in vacuo*.

The resulting product is a light yellowish-brown powder soluble in water, cold or boiling, giving a yellowish and faintly acid or nearly neutral reaction. It is composed of deuterio-albumose with a slight amount of proto-albumose but no peptone. It gives the ordinary actions of proteids and a well-marked biuret reaction. It is precipitated from solution by ammonium sulphate, and slightly by nitric acid. The reactions are similar to those of peptic deuterio-albumose. The alcoholic extract of the tissues is strongly acid, and contains free fatty acid and an organic acid insoluble in chloroform. The organic acid is readily soluble in water and absolute alcohol,

and insoluble in ether, chloroform, and benzine. It is a yellowish amorphous body, becoming a deep brown when made alkaline.

Martin concludes that whereas the *Bacillus anthracis* produces albumoses and an organic base, in diphtheria we find albumoses and an organic acid.

**Glanders.**—Kalming has obtained from cultures of the glanders bacillus an extract similar to tuberculin. This crude extract is known as *mallein*, and is extensively used for the diagnosis of glanders. In a glandered horse it causes a rise of temperature and swelling at the seat of the injection, and the glandered nodules become swollen and painful. Finger claims to have produced immunity from glanders by inoculation of the products contained in sterilised cultures. Schweinitz extracted from cultures a non-poisonous albumose, and obtained only traces of a ptomaine.

**Suppuration and Pneumonia.**—Brieger obtained a ptomaine from cultures of *Staphylococcus pyogenes aureus*, and Roux and Yersin a tox-albumin fatal to rabbits and guinea-pigs in a few days. There was pus-formation at the seat of inoculation, with redness and swelling of the surrounding parts.

From pure-cultures of the micrococcus of pneumonia Klemperer obtained a tox-albumin, for which the name pneumo-toxin has been suggested.

#### ENZYMES OR FERMENTS.

Many bacteria liquefy the nutrient gelatine in which they are cultivated. This is due to the development of a ferment or enzyme, which dissolves the albumin and gelatine.

Enzymes are products of the vital activity of living bacteria. Bitter, and independently Sternberg, showed that when a liquefying bacterium is removed by filtration or destroyed by heat, the culture fluid retains the power of liquefying gelatine. As this occurs usually when the reaction is alkaline, bacterial enzymes resemble trypsin and papain rather than pepsin. They can be extracted with glycerine, and are quite harmless. If injected into animals no effect is produced, and after a few hours no trace of them can be found. According to Fermi, the influence of temperature on the enzymes produced by different bacteria will be found to vary very considerably. The enzyme of *Staphylococcus pyogenes aureus* is destroyed at 55° C., while the enzyme of *Bacillus anthracis* succumbs at a temperature of 65° C. to 70° C.

Some bacteria produce both enzymes and toxins, but many produce enzymes and not toxins, and others toxins but not enzymes.



## CHAPTER V.

### IMMUNITY.

THE condition of being insusceptible to an infective disease may be either natural or acquired. In studying the pathogenic organisms several examples of natural immunity will be encountered. The bacillus of septicæmia, so fatal to house mice, has been shown to have no effect upon field mice. The bacillus of anthrax is innocuous to cats and white rats. The bacterium of rabbit septicæmia is equally inert in dogs, rats, and guinea-pigs. The immunity may be as in these cases complete, or only partial. Ordinary sheep are very easily affected with anthrax, but Algerian sheep succumb only to large doses of the virus. Natural immunity may not only be characteristic of certain species, but it may occur in certain individuals of a susceptible species. The same immunity occurs in man, for certain individuals, though equally exposed during an epidemic of small-pox, may escape, whereas others readily fall victims to the disease.

Acquired immunity is illustrated by the protection afforded by one attack of the exanthemata against subsequent attacks. Thus one attack of measles or small-pox, as a rule, affords complete protection. A knowledge of the immunity resulting in the latter case led to the introduction of inoculation of small-pox as a protection against natural small-pox.

Immunity may be acquired by acclimatization, for the inhabitants of tropical climates are less susceptible to the diseases of the country, malarial fevers, for instance, than strangers.

In civilised communities also, there appears to be a degree of acquired immunity, for infectious diseases like measles introduced among savages or isolated communities have assumed the most malignant type.

The immunity acquired by protective inoculation constitutes, in connection with the study of pathogenic micro-organisms, a subject of pre-eminent interest and importance. Pasteur, in his researches

upon fowl-cholera, observed that after non-fatal cases the disease either did not recur, or the severity of a subsequent attack was in inverse proportion to the severity of the first attack. It occurred to him to endeavour to obtain the virus of this disease in a form which would provoke a mild attack of the disease, and thus give protection against the virulent form. This attenuation or mitigation of the virus was successfully attained by allowing cultivations of the microbe in chicken-broth to remain with a lapse of several months between the carrying on of successive cultivations in fresh media. The new generations which were then obtained were found to have diminished in virulence, and ultimately a virus was obtained which produced only a slight disorder; on recovery the animal was found to be proof against inoculation with virulent matter. The explanation given by Pasteur of this change was, that prolonged contact with the oxygen of the air was the influence which diminished the virulence, and he endeavoured to prove this by showing that when broth was inoculated in tubes which could be sealed up, so that only a small quantity of air was accessible to the microbe, the virulence of the cultures was retained.

Toussaint investigated the possibility of attenuating the virus of anthrax. Sheep injected with 3 cc. of defibrinated blood, containing anthrax bacilli, which had been exposed to 55° C. for ten minutes, recovered, and were afterwards insusceptible. Pasteur subsequently argued that this method did not admit of practical application, because difficulties would arise in dealing with infective blood in quantity, and artificial cultivations started from this blood could not be relied upon, as they proved sometimes as virulent as ever.

Pasteur endeavoured to apply the same method for obtaining an attenuated virus of anthrax, as he had successfully employed in fowl-cholera. A difficulty was soon encountered, for in cultivations of this bacillus, with free access of air, spore-formation readily takes place, and the spores are well known to have an extraordinary power of retaining their virulence. Pasteur found that the bacilli ceased to develop at 45° C., and he believed that spore-formation ceased at 42° to 43° C., the bacilli continuing to develop by fission only. The cultivations were, therefore, kept at this temperature, and at the end of eight days the bacilli were found to have lost their virulence, and were quite inert when inoculated in guinea-pigs, sheep, or rabbits. This total destruction was, however, preceded by a gradual mitigation, so that a virus



could be obtained, by taking it at the right time, which gave only a mild disease, and afforded subsequent protection.

At Melun, in 1881, the protective inoculation against anthrax was put to a practical test. Sheep and oxen were inoculated with the mitigated virus, and then with a virulent form; at the same time other sheep and oxen were inoculated with the virulent form without previous vaccination, as a control experiment. The unprotected sheep died without exception; the unprotected oxen suffered from œdematous swellings at the seat of inoculation, and a rise of temperature; but all the protected animals remained healthy.

As a result of these experiments an idea arose that by preventive inoculation with attenuated virus all communicable diseases would in time be eradicated; but this does not follow, for all communicable diseases do not confer immunity after a first attack; in influenza the very reverse is believed to occur, and erysipelas of the face leads to an increased liability to subsequent attacks. Even with regard to the prevention of anthrax, Pasteur's researches were opposed and criticised. Koch investigated the subject, and came to the conclusion that the process did not admit of practical application, chiefly on the ground that as immunity lasted only a year, the losses from the vaccination process would be as great or even greater than from the spontaneous disease; further, there was danger in disseminating a vaccine of the strength required to be effectual.

Chauveau proved that the attenuation was due to the temperature, and not to the prolonged effect of oxygen. By keeping cultivations at  $42^{\circ}$  to  $43^{\circ}$  C. *in vacuo*, the virulence was found to disappear in twenty-four hours, and by keeping cultivations at a low temperature with free access of air, the virulence was retained. Chauveau considered, therefore, not only that oxygen was not the agent, but that the mitigation was much more easily effected in its absence. In spite of these adverse criticisms, these researches nevertheless confirmed the principle of Pasteur's conclusion, that immunity could be induced by experimental measures, and further showed that he had considerably advanced the methods by which this could be effected.

Chauveau succeeded also in attenuating the virus by a modification of Toussaint's method. Sterilised broth was inoculated with the bacilli, and placed in the incubator at  $42^{\circ}$  to  $43^{\circ}$  C. After the lapse of twenty hours it was removed to another incubator at  $47^{\circ}$  C. According to the time of exposure to this increased temperature, the mitigation varied in degree. Thus inoculation with the virus, before

it was exposed to 47° C., was fatal to guinea-pigs; but after one hour at 47° C. the virulence was diminished, and, though ultimately fatal, life was prolonged; after two hours' exposure at 47° C. only half the animals died; and after three hours' exposure they recovered, and were rendered refractory to subsequent inoculation.

Attenuation of the virus of anthrax has also been induced by chemical means. Chamberland and Roux stated that a fresh growth started from a cultivation of bacilli which had been subjected for twenty-nine days to  $\frac{1}{800}$  of carbolic acid was found to be inert in guinea-pigs and rabbits. Bichromate of potash added to a cultivation in the proportion of  $\frac{1}{12000}$  to  $\frac{1}{5000}$  gave, after three days, a new growth, which killed rabbits, guinea-pigs, and half the sheep inoculated; after ten days, rabbits and guinea-pigs, but not sheep; and after a longer time even guinea-pigs were unaffected.

In other diseases similar results have been obtained. Arloing, Cornevin, and Thomas found that by inoculating a small quantity of the virus of symptomatic anthrax anywhere in the subcutaneous connective tissue, or a moderate quantity at the root of the tail, and even by intravenous injection, immunity was obtained from a virulent dose.

In swine-erysipelas, Pasteur and Thuillier obtained attenuated virus upon quite another principle. They discovered that by passing the virus through pigeons the virulence was increased, but by passing it through rabbits it was progressively diminished. Thus a virus was obtained from the rabbit, which produced only a mild disease in pigs, and after recovery complete immunity. Similarly in rabies, Pasteur found that passage of the virus through various animals considerably modified its properties. By inoculating a monkey from a rabid dog, and then passing the virus through other monkeys, the virulence was diminished; but by inoculating a rabbit from the dog, and passing the virus from rabbit to rabbit, the virulence increased.

In rabies, Pasteur has employed another method of attenuating the virus. The spinal cord of inoculated rabbits is removed with all possible precautions, and portions a few centimetres in length are suspended in flasks in which the air is dried by fragments of potash. By this process the virulence is found to gradually diminish and finally disappear. Animals inoculated with portions of these cords, after suspension for a certain time, are rendered refractory to inoculation with virulent cords. Having rendered dogs, which had been previously bitten, free from the supervention of symptoms of hydrophobia by means of protective inoculation, Pasteur proceeded



to apply the same treatment to persons bitten by rabid animals, with results which tend to the belief that a real prophylactic for rabies has been discovered.

Immunity may also be produced by injecting the toxic products existing in pure cultivations after removal of the bacilli. Salmon was the first to produce immunity in this way, by utilising the toxic products of the bacterium of hog-cholera, which were separated by filtration from the living micro-organisms; and shortly afterwards Wooldridge demonstrated that filtered anthrax cultures contained a substance which conferred immunity. Behring and Kitasato produced immunity by mixing cultures with terchloride of iodine. Vaillard filtered the cultures through porcelain, and attenuated the products by heating at different temperatures.

Lastly, in the course of Behring's and Kitasato's experiments, it was found that the blood serum of animals rendered immune was capable of conferring immunity on other animals. The injection of the toxic products of pathogenic bacteria leads to the development of substances in the blood to which the term "antitoxin" has been applied. These protective substances neutralise or destroy the injected poison, and blood serum which has thus been rendered antitoxic can be utilised to confer immunity on other animals.

Haffkine's system of vaccination as a protection against Asiatic cholera is supposed to be based upon the principle of inducing the formation of antitoxins or defensive proteids.

#### MECHANISM OF IMMUNITY.

Raulin has shown that *Aspergillus niger* develops a substance which is prejudicial to its own growth, in the absence of iron salts in the nutrient soil, and Pasteur suggested that in rabies, side by side with a living microbe, there is possibly some chemical product or anti-microbe which has, as in Raulin's experiment, the power of arresting the growth of the microbe. If we accept the theory of arrest by some chemical product, we must suppose that in the acquired immunity afforded by one attack of an infectious disease this chemical substance is secreted, and, remaining in the system, opposes the onset of the micro-organism at a future time. In the natural immunity of certain species and individuals we must suppose that this chemical substance is normally present.

Another theory is, that the micro-organisms assimilate the elements which they require for their nutrition from the blood and tissues, and render the soil impoverished or otherwise unsuitable for

the development of the same species of micro-organisms hereafter ; this condition may be permanent, or the chemical constitution of the tissues may be restored to normal, when immunity ceases. If, however, we explain acquired immunity by the result of the growth of a previous invasion of micro-organisms, we are still confronted with the difficulty of explaining natural immunity.

A third theory is that the tissues are endowed with some power of vital resistance to the development of micro-organisms, similar to the vital resistance to coagulation of the blood, which is supposed to exist in the lining membrane of the healthy blood-vessel ; that in some species and individuals this exists to a high degree, and hence their natural immunity. But this does not explain how one attack confers immunity from a subsequent one. One would expect that the vital resistance would invariably be lowered by a previous attack, and increased liability be the constant result.

A fourth theory was propounded by Metchnikoff, who maintains that immunity depends upon *phagocytosis*. If anthrax bacilli are inoculated in the frog, white blood-cells, or phagocytes, are observed to incorporate and destroy them until they entirely disappear, and the animal is not affected. But if the animal, after inoculation, is kept at a high temperature, the bacilli increase so rapidly that they gain the upper hand over the phagocytes, and the animal succumbs.

It has also been suggested that bacteria may attract or repel the phagocytes, exercising either a positive or a negative *chemio-taxis*. This power is supposed to depend upon some special product of the bacteria or possibly upon their toxins, as suggested by Roux. We must suppose that the negative chemio-taxis has become changed to a positive chemio-taxis in an immunised animal, so that the phagocytes, instead of withdrawing and leaving the bacteria to multiply, are readily drawn into the contest and destroy the invaders.

In septicæmia of mice, the white blood-cells are attacked and disintegrated by the bacilli in a remarkable way. It is difficult, however, to accept these observations as affording a complete explanation of immunity. It is difficult to conceive that the leucocytes in the blood and tissues in the field mouse are differently constituted from those in the house mouse, so that they form an effectual barrier to the onset of bacteria in the one case, though so readily destroyed in the other, or that in acquired immunity the result is due to educating the phagocytes to respond to a positive chemio-taxis.



Phagocytosis cannot explain the immunity which results from the injection of filtered cultures, or of antitoxins, but when blood serum of immunised animals was shown to possess antitoxic properties, a new explanation of immunity was at once forthcoming. In the light of these discoveries immunity, whether natural or acquired, was regarded as due to the accumulation in the blood and tissues of substances which have the property of counteracting partially or entirely the products by which pathogenic bacteria produce their poisonous effects. These antitoxins, or protecting proteids, can be obtained not only from the blood but also from the spleen and the lymphatic and other glands. They result from the metabolism of the cells of the tissues of the body. Phagocytes in their conflict with bacteria may play a small part, but it is more than probable that immunity is altogether independent of phagocytosis.

## CHAPTER VI.

### ANTITOXINS AND SERUM THERAPY.

It has been clearly shown by the experiments of Fodor and Nuttall that some species of bacteria are killed by a mixture with fresh blood. Fodor pointed this out in the case of the anthrax bacillus, and Nuttall confirmed the experiments, and repeated them with a number of different species of bacteria.

Behring and Nissen followed up this line of inquiry, and found that there was a great difference in the behaviour of freshly drawn blood to different bacteria. In some cases the bacteria were destroyed, in others their growth was only retarded, and in others again they were not affected at all. Boucharde pointed out that although the normal blood serum of a rabbit may be used for the cultivation of *Bacillus pyocyaneus*, the blood serum of a rabbit, which has been rendered immune, will attenuate or entirely nullify the pathogenic properties of the bacillus.

Ogata and Jasuhara obtained similar results by cultivating anthrax bacilli in the blood of immune animals. Buchner demonstrated that this property of fresh blood belonged to the serum and not to the cellular elements, and strongly advocated the theory that the force opposed to invading bacteria was to be found in the serum rather than in phagocytes.

Similar experiments were made with the bacteria of swine-fever, and Emmerich and Mastbaum discovered that the blood serum of immune rabbits could be used as a therapeutic agent to prevent the progress of the disease in animals already showing symptoms of infection.

A new light was thrown upon this question by the experiments of Behring, Kitasato, Tizzoni and Cattani, and others in connection with tetanus and diphtheria. In these diseases the bacteria do not invade the body, but the poisonous principles elaborated at the seat of inoculation are absorbed into the system and produce deleterious effects. It was obvious that attention must be turned towards counteracting or destroying these poisonous products.



It was in this direction that the experiments of Behring and Kitasato, in 1890, proved to be of profound importance. It was shown that the blood serum of a rabbit rendered immune against tetanus or diphtheria had no destructive or retarding effect on the growth of the bacilli, but it possessed the power of neutralising the poison developed by the agency of the bacilli. In short, the serum was shown to possess an antitoxic instead of a bactericidal power.

Hankin conceived the idea that this property is due to substances of the nature of *defensive proteids*, and the blood serum of the naturally immune rat was found to contain a proteid body with well-marked alkaline reaction, possessing the power of destroying anthrax bacilli. Injection of this proteid into mice, together with fully virulent anthrax spores, prevented the development of the disease. Young rats are susceptible to anthrax, and, according to Hankin, they can be protected from anthrax by injection of the blood serum of the parent. Tizzoni and Cattani expressed the opinion that the antitoxic substance in the blood serum of animals rendered immune against tetanus is a globulin to which they gave the name tetanus antitoxin. Buchner proposed the term *alexins* ( $\alpha\lambda\epsilon\xi\omega$ , I defend), to signify these substances. Hankin subdivided them into *sozins* and *phylaxins*. Sozins are defensive proteids occurring in normal animals; phylaxins are only found in animals artificially immune; and each of these are sub-classed by Hankin according to their power of attacking the bacteria themselves or the products they generate.

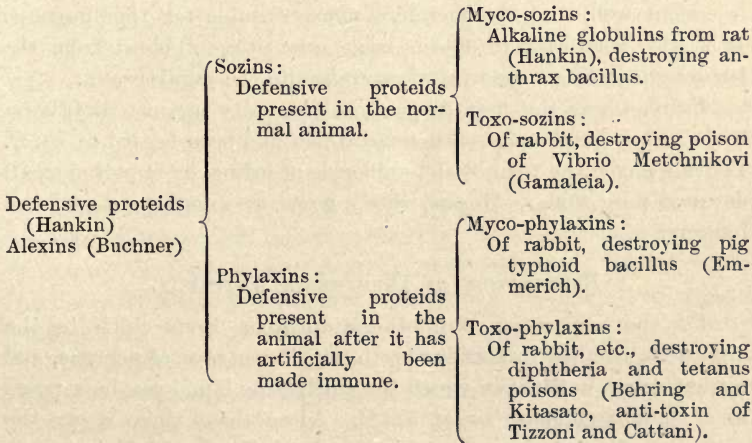

Tizzoni and Cattani immunised dogs and other animals against tetanus, and employed the antitoxin as a therapeutic agent. Its

active substance was precipitated by alcohol. Behring, Kitasato, and Schütz experimented with a view to conferring immunity upon horses. The cultures were mixed with terechloride of iodine, and injected at intervals of eight days, and the antitoxic power tested on mice. By using increasingly virulent cultures, the blood became increasingly antitoxic.

Vaillard filtered tetanus cultures through porcelain, and heated the filtrate at gradually diminishing temperatures. The first injections were made with 10 cc., which had been raised to 60° C. for an hour, then a filtrate was used which had been heated to 55° C., and lastly, a filtrate which had been heated to 50° C. The blood became antitoxic, and by injecting increasing quantities of virulent filtrates the antitoxic power was rapidly intensified, and animals which were injected with antitoxin of full strength possessed immunity many months afterwards.

Roux and Vaillard introduced another method. Virulent cultures were filtered through porcelain, and the filtrate mixed with Gram's solution of iodine in iodide of potassium. To give immunity to a rabbit, 3 cc. of toxin with 1 cc. of Gram's solution were injected on the first day, and increasing doses of toxin mixed with increasing doses of Gram's solution on the following days. The same method was applied to horses, sheep, and cattle. The antitoxin was found not only in the blood, but in the urine and saliva, and in the milk in cows. With cows and goats it is necessary to proceed with the utmost care; while horses, on the other hand, bear the injections well, and are therefore more suitable for this purpose. It is also very easy to obtain large quantities of blood from the horse by inserting a trocar and cannula into the jugular vein.

Fränkel was the first to produce immunity against diphtheria by injecting guinea-pigs with toxin which had been heated to 70° C. Behring mixed the toxin with terechloride of iodine, or employed small doses of pure toxin. Horses, sheep, goats, and dogs were rendered immune.

#### PREPARATION OF DIPHTHERIA ANTITOXIN.

For the preparation of diphtheria antitoxin Roux cultivates the diphtheria bacillus in alkaline broth with 2 per cent. of peptone, and by preference, in flasks in which the cultivating liquid can be exposed to a current of moist air at 37° C. After about three weeks the culture is filtered through a Chamberland filter, and if tested on a guinea-pig it will be found that  $\frac{1}{10}$  of a cc. will kill an animal weighing five hundred grammes in forty-eight hours. The diphtheria



toxin immediately before the injection is mixed with  $\frac{1}{3}$  of its volume of Gram's solution. This is used for several weeks, and afterwards only pure toxin is injected.

The horses employed for this purpose are animals no longer fit for work, and it is necessary to inject them first of all with *mallein* to be sure that they are not suffering from glanders.

In a horse inoculated by Roux, the injection began with  $\frac{1}{4}$  cc. of iodised toxin, increased to 1 cc. by the thirteenth day, and the injection continued daily. On the seventeenth day  $\frac{1}{4}$  cc. of pure toxin was injected, and this was increased by the forty-first day to 10 cc.; and on the forty-third day 30 cc. of pure toxin were injected, causing pronounced œdema. The doses were still further increased, until on the eightieth day 250 cc. were injected. In two months and twenty days the horse had received 800 cc. of toxin.

On the eighty-seventh day the serum obtained had an immunising power of over 50,000. By this is meant that a guinea-pig resisted inoculation of  $\frac{1}{2}$  cc. of virulent diphtheria culture when injected twelve hours beforehand with serum in quantity equal to the  $\frac{1}{50000}$  part of its body weight.

There are two tests which can be applied to the serum. First, the antitoxic serum added to diphtheria toxin renders it inert; and, secondly, if serum is injected into a guinea-pig and toxin injected several hours afterwards, no result follows.

Several ways have been suggested for estimating the immunising power of the serum.

In Ehrlich's system, the unit is represented by .1 cc. of anti-toxic serum, which, added to .8 cc. toxin, will neutralise it so that the whole may be injected subcutaneously in a guinea-pig without producing œdema. The standard toxin is a toxin of which .3 cc. is fatal to 1 kilo. of guinea-pig.

But the preventive power of the serum is best expressed by the result of a subsequent injection of toxin. The immunising power is estimated by the number of grammes of guinea-pig which can be protected against the minimum fatal dose of toxin by 1 cc. of anti-toxic serum.

The antitoxic serum can be kept in sterilised flasks in the dark, with the addition of a small piece of camphor, or it may be dried *in vacuo*, powdered, and thus supplied in a convenient form for transport. It has merely to be dissolved in water before use.

Klein employed a modified plan by which he claimed to have obtained antitoxin in a far shorter time than is possible by Roux's

method. Unfiltered attenuated cultures were injected into the horse. Later, large quantities of living diphtheria bacilli from the surface of solid cultures, of gradually increasing virulence, were repeatedly injected so as to allow the bacilli to grow and multiply. In twenty-three days an antitoxic serum was obtained, one part of which was found capable of protecting 20,000 to 40,000 grammes of guinea-pig against more than a fatal dose of both living bacilli and the resulting toxin.

**Serum Treatment of Diphtheria.**—The results obtained by Behring, Ehrlich, Kossel, and Wasserman, in the treatment of diphtheria in children in Germany by means of the curative serum, and by Roux and others in France, led to the adoption of the treatment in this country. It is best to use an especially constructed hypodermic syringe, which can be easily taken to pieces, and placed in boiling water to sterilise it. The skin surface of the flank is washed, and disinfected with 1 in 20 carbolic, and the antitoxin is then injected. The syringe is taken to pieces, placed again in boiling water, and thoroughly cleaned.

The dose will depend upon the age of the patient and the strength of the serum. From 10 cc. to 20 cc. are injected in children under fifteen, and 30 cc. to 40 cc. in older patients, and the injection may be repeated in 12 hours. The best results are said to be obtained by injecting every 12 hours, for the first 12, 36 or 48 hours, according to the nature of the case, 1,000 Behring's units, this being the dose calculated according to the immunising power of the serum. The result of the injection is to lower the temperature and pulse, but frequently the reverse occurs, and in about half the cases an urticarial and sometimes a scarlatiniform rash is produced. Pains in the joints, in rare cases effusion, may also result from the injection.

The beneficial results of the treatment are, according to the Report of the Medical Superintendents of the hospitals of the Metropolitan Asylums Board, as follows:—

- (1) Diminution of the faucial swelling and of the consequent distress;
- (2) Lessening or entire cessation of the irritating and offensive discharge from the nose;
- (3) Limitation of the extension of membrane;
- (4) Earlier separation of the exudation;
- (5) Limitation and earlier separation of membrane in laryngeal cases;
- (6) Improvement in general condition and aspect of patients;



(7) Prolongation of life, in cases which terminate fatally, to an extent not obtained with former methods of treatment.

Statistics have also been brought forward which show, assuming them to be reliable, a great reduction in the mortality after the antitoxin treatment. A few instances may be quoted to illustrate the statistical evidence.

According to Behring, in the four years prior to the employment of antitoxin, there were in Berlin 15,958 cases of diphtheria, with a mortality of 35·2 per cent. In 1894-5 there was an epidemic of 5,578 cases. Behring asserts that if the mortality had not been reduced by the antitoxin treatment 1,963 would have died instead of 1,056. Behring also states that in the Charité Hospital there were 299 patients, with 53 deaths, or 16·7 per cent. In the Bethania Hospital, where antitoxin was not employed, there were 249 patients, with 112 deaths, or 43 per cent.

At Vienna, at the Anna Hospital for children, the mortality in 760 cases was 50·65 per cent., but after the introduction of antitoxin there were 40 deaths in 159 cases, giving a mortality of 25·5 per cent.

In New York, it is said that before the introduction of antitoxin the mortality ranged from 30·67 to 37·34, while in 1895, under treatment with antitoxin, the mortality fell to 19·43; but it was also pointed out that since the introduction of antitoxin many children with trifling attacks had been treated, and reported as suffering from actual diphtheria, and that they would have recovered without antitoxin, and therefore these cases have given the remedy some credit which it does not deserve.

In London, according to the Report of the Medical Superintendents of the hospitals of the Metropolitan Asylums Board there were in 1894, before antitoxin was employed, 3,042 cases of diphtheria with 902 deaths or 29·6 per cent., and in 1895, when antitoxin was used, 3,529 cases with 796 deaths or 22·5 per cent. : a reduction of 7·1 per cent. below that of 1894. The conclusions drawn from the statistical and clinical observations are summed up in the Report thus :—

The improved results in the diphtheria cases treated during the year 1895, are :—

(I.) A great reduction in the mortality of cases brought under treatment on the first and second day of illness.

(II.) The lowering of the combined general mortality to a point below that of any former year.

(III.) The still more remarkable reduction in the mortality of the laryngeal cases.

(IV.) The uniform improvement in the results of tracheotomy at each separate hospital.

(V.) The beneficial effect produced on the clinical course of the disease.

A consideration of the statistical tables and clinical observations, covering a period of 12 months and embracing a large number of cases, in our opinion sufficiently demonstrates the value of antitoxin in the treatment of diphtheria.

It must be clearly understood, however, that to obtain the largest measure of success with antitoxin it is essential that the patient be brought under its influence at a comparatively early date—if possible not later than the second day of disease. From this time onwards the chance of a successful issue will diminish in proportion to the length of time which has elapsed before treatment is commenced. This, though doubtless true of other methods, is of still greater moment in the case of treatment by antitoxin.

Certain secondary effects not infrequently arise as a direct result of the injection of antitoxin in the form in which it has at present to be administered, and, even assuming that the incidence of the normal complications of diphtheria is greater than can be accounted for by the increased number of recoveries, we have no hesitation in expressing the opinion that these drawbacks are insignificant when taken in conjunction with the lessened fatality which has been associated with the use of this remedy.

We are further of the opinion that in antitoxin serum we possess a remedy of distinctly greater value in the treatment of diphtheria than any other with which we are acquainted.

On the other hand it has been urged that the decline in the mortality in 1895 in London, which has been attributed entirely to the antitoxin treatment, may possibly be partly due to the prevalence of a mild type of the disease, and that the fall in the mortality during the seven previous years from 59 per cent. in 1888 to 29 per cent. in 1894, continued in 1895.

It is obvious that the whole subject requires to be very carefully considered, and before any final conclusion can be arrived at as to the therapeutic value of antitoxin, the evidence of others who have had great experience in the treatment of diphtheria by the old and the new methods must be taken into account, and reliable statistics allowed to speak for themselves.

#### PREPARATION OF TETANUS ANTITOXIN.

Antitoxin for use in the serum treatment of tetanus is obtained from the horse. The tetanus bacillus is cultivated in an atmosphere of hydrogen, in flasks specially constructed for the purpose. In



about a fortnight the cultures are extremely toxic. The toxin is obtained free from bacilli by filtration through porcelain. Injections may be given daily, subcutaneously or intravenously, beginning with 1 cc. of iodised toxin, and gradually increasing the dose until the pure toxin may be injected without danger.

Roux and Vaillard produced immunity in about three months. When a few days have elapsed after the last injection, the blood is drawn, by means of a trocar and cannula, from the jugular vein into a sterilised glass vessel, and set aside to coagulate; next day the serum is drawn off with a pipette, and used in the liquid state, or dried in a vacuum over sulphuric acid, and subsequently powdered. When required for use the powder is dissolved in cold water. About 5 grammes are used for a dose.

**Serum Treatment of Tetanus.**—The result, so far, of the employment of tetanus antitoxin in animals suffering from tetanus is disappointing, and the serum treatment is not likely to be of much value in veterinary practice. Nocard infected sheep with tetanus by inserting splinters of wood infected with spores into the muscles of the leg. Tetanus supervened in eleven days, and the splinters were removed, the tissues excised, and the wounds dressed with iodoform. About twelve hours after the symptoms had shown themselves, the sheep were inoculated with antitoxic serum at intervals of one hour, but they all succumbed to tetanus. In one case the total amount injected was 160 cc. of highly antitoxic serum.

The antitoxin has been employed in tetanus in man. Kanthack has collected the history of a number of cases, and they indicate that the treatment is useless in acute cases in man with a short incubation period, while chronic cases with a long incubation period often recover after the treatment. At the same time it must be remembered that recovery often took place in chronic cases before the introduction of the antitoxin treatment.

The question must still be considered to be *sub judice*, and a trustworthy conclusion can only be based upon a more extended use of the antitoxin and impartial reports of every individual case.

#### ANTITOXIN OF SEPTIC INFECTIONS.

An anti-streptococcic serum has been prepared by Marmorek. A culture of streptococcus was intensified in virulence by inoculation from rabbit to rabbit, and highly virulent cultures gave rise to a powerful toxin. Roget and Charrin also, found that the serum of immunised rabbits and of a horse conferred immunity. A patient



with puerperal fever was injected with 8 cc., on the following day with 16 cc., and on the third day with 25 cc. On the fourth day the temperature had fallen, and the patient recovered. Favourable results are said to have followed the use of the serum in 46 cases of erysipelas.

Bokenham, working independently, cultivated the streptococcus in a mixture of broth and serum. Horses and asses were inoculated, and a considerable degree of immunity established. The serum of an inoculated ass possessed antitoxic power.

Ruffer and Bullock succeeded in immunising four horses against the toxin of *Streptococcus pyogenes*; two had been previously immunised against the toxin of the diphtheria bacillus. The streptococcus was cultivated by Marmorek's methods in a mixture of two parts of blood-serum and one part of peptonised broth, and the virulence of cultures maintained by inoculation of rabbits. On testing the immunising power of the antitoxic serum on rabbits, the effect appeared to be slight in comparison with the antitoxins of the bacilli of diphtheria and tetanus. In treating cases of septic infection in the human subject, it has been recommended to commence with two injections of 10 cc., and it is said that no unfavourable results have been met with which could be attributed to the effect of the serum.

#### ANTITOXIN OF TYPHOID FEVER AND OTHER DISEASES.

An antitoxic serum has been obtained by Chantemesse for use in cases of typhoid fever, and it is probable that attempts will be made to extend the principle of the antitoxic treatment to other infective diseases.



## CHAPTER VII.

### THE BACTERIOLOGICAL MICROSCOPE.

THE instruments sometimes in use in biological and pathological laboratories are not sufficient for the study of bacteria. It is absolutely essential for the examination of such minute objects that the microscope should be equipped with an objective of sufficiently high magnifying power and with a special illuminating apparatus, while the mechanical arrangements of the stage must admit of the examination of plate-cultivations. It would not be within the scope of this work to give a detailed account of the mechanical arrangements and optical principles of the microscope. These matters are fully dealt with in special works on the subject,\* but sufficient will be said to afford assistance in the selection of a suitable instrument, and to explain the improvements in the microscope which have been such an aid in bacteriological investigations.

A magnified image of an object is the result of the change produced in the direction of rays of light which are made to pass through lenses. This alteration in the course of the rays is known as *refraction*. A ray of light passing from a rarer into a denser medium is refracted towards a line drawn perpendicularly to the surface of the latter. A ray of light passing through air and impinging on water will not pass on in the same direction, but will be refracted towards a line drawn perpendicularly towards the surface of the water. If the ray pass into glass instead of water a greater refraction will take place, and if it pass into diamond the bending in its course will be still greater (Fig. 11).

The sines of the angle of incidence and refraction of different substances have a constant ratio to each other, which is known as the *index of refraction*, and this is determined for different substances by the refraction produced by the passage of rays from a vacuum. Thus the index of refraction for flint glass is about 1.6,

\* Carpenter: *The Microscope*. Nägeli and Schwenderer: *The Microscope in Theory and Practice*.

the sine of the angle of incidence of a ray passing from a vacuum into glass being to the sine of the index of refraction as 1.6 to 1.

If we study the course of a *pencil* of rays we find that some of the rays are *reflected* instead of entering the medium and being refracted. When, for example, a pencil of rays falls upon water or glass, after passing through air, some of the rays are lost by reflection, and the proportion of the lost rays will increase with their obliquity. The diminution of the brightness of the image when pencils of rays have to pass through lenses is thus accounted for, and this loss of light increases when the number of surfaces

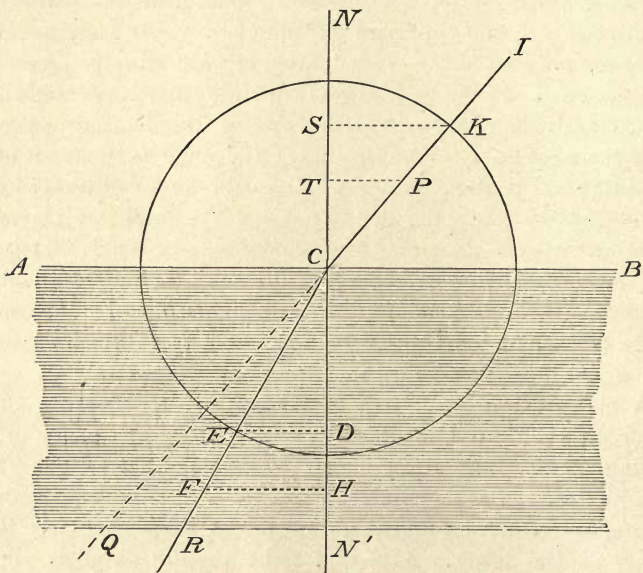

FIG. 11.—THE REFRACTION OF LIGHT.

through which the rays pass are, as in high-power objectives, increased. There is an additional loss when there is an increase in the difference between the refractive power of the different media through which light passes. When pencils of rays pass from glass into air, and then into glass again, the loss is much greater than when the air is replaced by a medium with a refractive index more nearly approaching that of glass. This explains the value of the immersion system, which will be referred to more fully later on; and also the advantage of cementing pairs of lenses with Canada balsam or glass paste. The lenses used in the optical arrangements



of a microscope are principally convex, and the imperfections which result must, if possible, be entirely overcome. These imperfections are spherical and chromatic aberration.

**Spherical aberration** results from the unequal refraction of rays passing through lenses with equal curvatures. The rays passing through an ordinary convex lens do not all come to the same focus. The rays passing through the marginal portion come to a focus at a

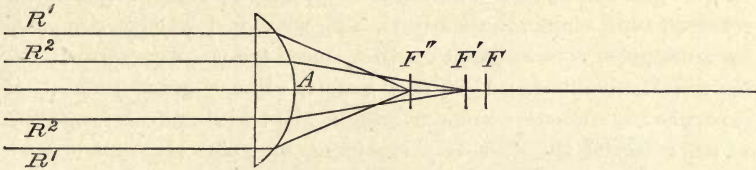

FIG. 12.—SPHERICAL ABERRATION.

point much nearer to the lens than the focus of the rays passing through the more central portion of the lens (Fig. 12). If the whole aperture of the lens is used there must of necessity be blurring, for at the point at which the marginal rays form a distinct image the central rays will be out of focus, and at the point at which the central rays form a distinct image the marginal rays will have diverged, causing indistinctness.

This is partially remedied by using a diaphragm and shutting out the marginal rays; but this is at the cost of loss of light and diminution of the angle of aperture. The difficulty is approximately overcome in practice by using a combination of lenses. The aberration of a convex lens is the opposite of that of a concave lens (Fig. 13). The makers of the best lenses endeavour to obtain this correction as perfect as possible to get the sharpness of the image, so essential in studying the morphology of bacteria.

**Chromatic aberration** is the result of the unequal refrangibility of the coloured rays which compose white light. If parallel rays of light pass through a convex lens the violet rays, which are the most refrangible, will come to a focus at a point much nearer to the lens than the focus of the red rays, which are the least refrangible; and the intermediate rays of the spectrum will be focussed at points between the red and the violet. A screen held at either of these foci will show an image with prismatic fringes (Fig. 14).

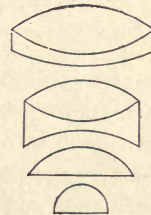

FIG. 13.—COMBINATION OF LENSES IN ABBÉ'S HOMOGENEOUS IMMERSION.

The chromatic aberration may be reduced by stopping out the marginal rays; but as it is necessary to get the most perfect correction possible, advantage is taken of the different relations which the refractive and dispersive powers bear to each other in different glasses. By combining a double convex lens of crown glass with a plano-convex lens of flint glass, correction is obtained for the violet and red rays. An *achromatic objective* is constructed on this principle, but the result is not perfect, as the intermediate coloured rays remain uncorrected, and what is termed a *secondary spectrum* gives rise to images with coloured fringes, especially at the margin of the field. Abbé and Schott, after a great number of experiments, succeeded in discovering a glass with optical properties which removed the secondary spectrum, and objectives made with the new glass are termed *apo-chromatic*. There is much more

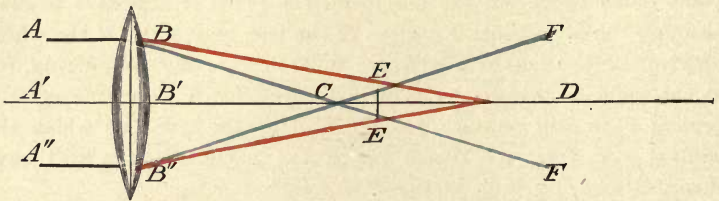

FIG. 14.—CHROMATIC ABERRATION.

perfect concentration of the component rays than in the ordinary achromatic objectives, and the advantages thus obtained are very great. The objectives can be made of higher angle and admit of higher eye-pieces being used without materially diminishing the brilliancy and definition of the image. There is a complete absence of coloured fringes, and the perfect definition is invaluable in micro-photography.

Another fault which has to be corrected is the aberration caused by covering a microscopical preparation with a cover-glass. Ross was the first to point out the difference in the image when the object was examined under a cover-glass, and that by altering the position of the front pair of lenses, in an objective corrected for an uncovered object, the objective could be corrected for the covered object (Fig. 15).

Objectives are generally corrected for a standard thickness of cover-glass, but H. Lister devised a screw-collar adjustment by which the position of the front pair of lenses could be altered at will; and as it is almost impossible to obtain cover-glasses which



do not vary slightly in thickness, the most perfect definition can only be obtained by adjusting for each separate cover-glass preparation.

**Immersion system.**—All objectives were formerly used *dry*—that is to say, with an air space between the objective and the specimen to be examined—but high-power objectives are now almost entirely made on the *immersion* system, a drop of liquid being interposed between the objective and the cover-glass.

About fifty years ago Amici observed that if a drop of water intervened between the cover-glass or an uncovered object and the lens the image was more brilliant. The passage of rays from the object or the cover-glass into air, and again from air into glass, caused considerable loss of light. With objectives of wide angle of aperture the advantages were counteracted by the reflection of rays falling obliquely upon the lens. By interposing water more rays are bent in or refracted, and enter the lens instead of being reflected and lost.

Hartnack, Nacet, and others adopted the immersion system, and high-power *water immersion* lenses were constructed with high angle of aperture.\* It was found that there was less necessity for correcting for covers of different thickness, as the aberration from this cause was diminished. The lenses were corrected for an average thickness of cover, and slight deviations produced hardly any appreciable effect.

Wenham, Stephenson, Abbé, and Zeiss carried the system to perfection. They argued that the advantages obtained by water immersion would be intensified if a liquid could be found of the same refractive and dispersive power as crown glass. The media would be optically uniform, and the result a *homogeneous immersion* system.

\* *The angle of aperture* is “the angle made by the most diverging of the rays of the pencil issuing from any point of an object that can enter the lens, and take part in the formation of an image of it.”

The numerical aperture is defined by Abbé as equal to “the sine of the angle of aperture multiplied by the refractive index of the medium between the object and the objective.”

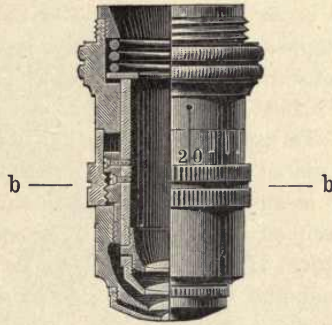

FIG. 15.—OBJECTIVE WITH COLLAR CORRECTION (b).

After experimenting with different liquids—solutions of salts, and various essential oils—Abbé recommended cedar oil as most suitable for the purpose. In its optical properties it very closely resembles crown glass, and it is far more convenient for use than any watery solutions of salts, especially when it is necessary to make a more or less prolonged examination of an object.

The difference between the dry, water, and oil immersion systems may be illustrated, as Fränkel has pointed out, by a very simple experiment. If a glass rod is inserted into an empty test-tube, it is easily visible owing to the difference in refraction between the glass and the surrounding air. If the tube is filled up with water the rod is seen with difficulty, and if, instead of water, cedar oil is used, the part of the rod immersed in the oil will entirely disappear from view. The rays of light pass through an optically uniform medium in the experiment with cedar oil, and no refraction or reflection of rays of light can occur.

To use an oil immersion objective, a minute drop of cedar oil is placed on the centre of the cover-glass, and the lens lowered by means of the coarse adjustment until it touches the oil. The specimen is then carefully brought into focus with the fine adjustment. If the slide is held between the finger and thumb of one hand, and moved from side to side while the other hand is working the fine adjustment, there can be no danger of injuring either the objective or the specimen.

Microscopes are made upon either the Ross or the Jackson model. In the Ross model the body of the microscope is fixed at its base to a transverse arm, which is raised or lowered with it by the rack and pinion. In the Jackson model the body is supported for a great part of its length on a solid "limb."

In the Ross model, unless the body and transverse arm are very solid as in Powell and Lealand's microscopes (Fig. 23), there will be vibration at the ocular end; but in the Jackson model vibration is practically prevented, and this is most essential, especially in working with very high powers.

The steadiness of the microscope also largely depends upon the form of stand. There are four different types of stands. The tripod (Fig. 23); the plate, with double columns; the single column, ending in a plate or a bent claw; and the horse-shoe (Fig. 18).

The tripod stand with cork feet is the steadiest form of stand, but it is cumbrous and expensive, and these objections also apply to the model made by Ross.

The single upright should be unquestionably condemned, as it



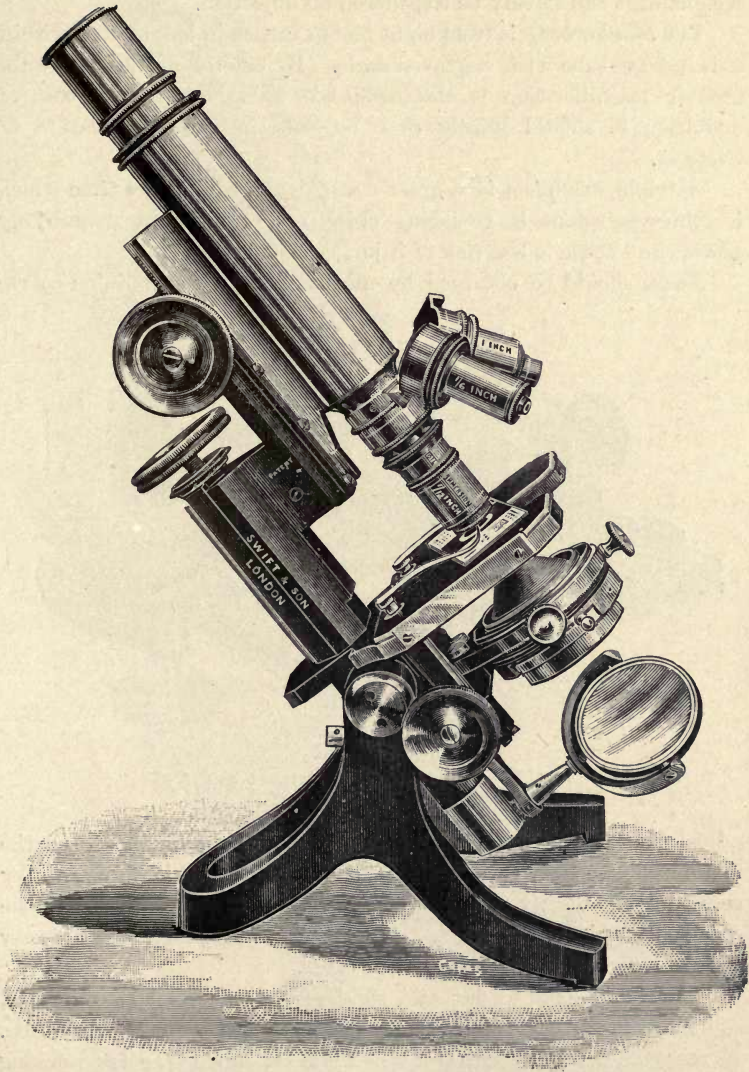

FIG. 16.—ENGLISH MODEL.

freely admits of vibration, and is most inconvenient for laboratory work. The heavy horse-shoe form is compact and firm, and the weight of it can hardly be considered an objection.

The *tubular body* is from eight to ten inches in length, and within it is a draw-tube with engraved scale. By extending the draw-tube greater magnification is obtained; but as this is at the cost of definition it should hardly ever be used in the examination of bacteria.

A triple *nose-piece* is a great convenience, saving the time which is otherwise spent in replacing objectives of different magnifying power, and there is less risk of injuring them.

*Focus* should be obtained by means of a rack and pinion coarse

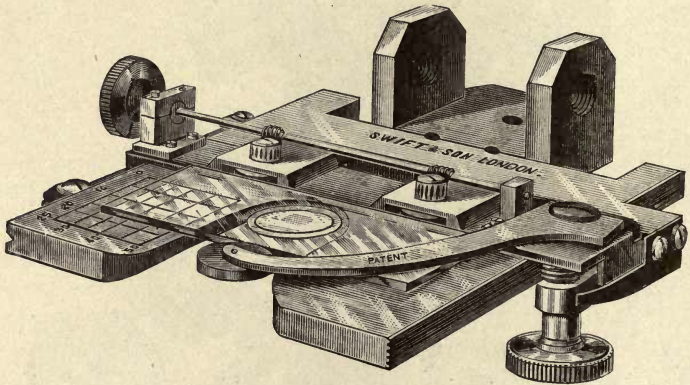

FIG. 17.—REMOVABLE MECHANICAL STAGE.

adjustment. The sliding tube is not to be recommended, as the motion may be stiff, encouraging the use of force, which in turn may result in the objective being brought violently into contact with the specimen, injuring the lens or damaging the preparation; or it may get too loose and readily slip out of focus.

The *stage* should be flat and rigid, either rectangular or circular, so long as it is sufficiently large to accommodate a plate-cultivation. A removable mechanical stage is of great advantage for working with high powers, as a motile bacterium can be constantly kept in view while one hand is engaged in working the fine adjustment (Fig. 17). It may also be employed as a finder if it is engraved with a longitudinal and vertical scale, and provided with a stop. The mechanical stage must be removable, so that the stage proper



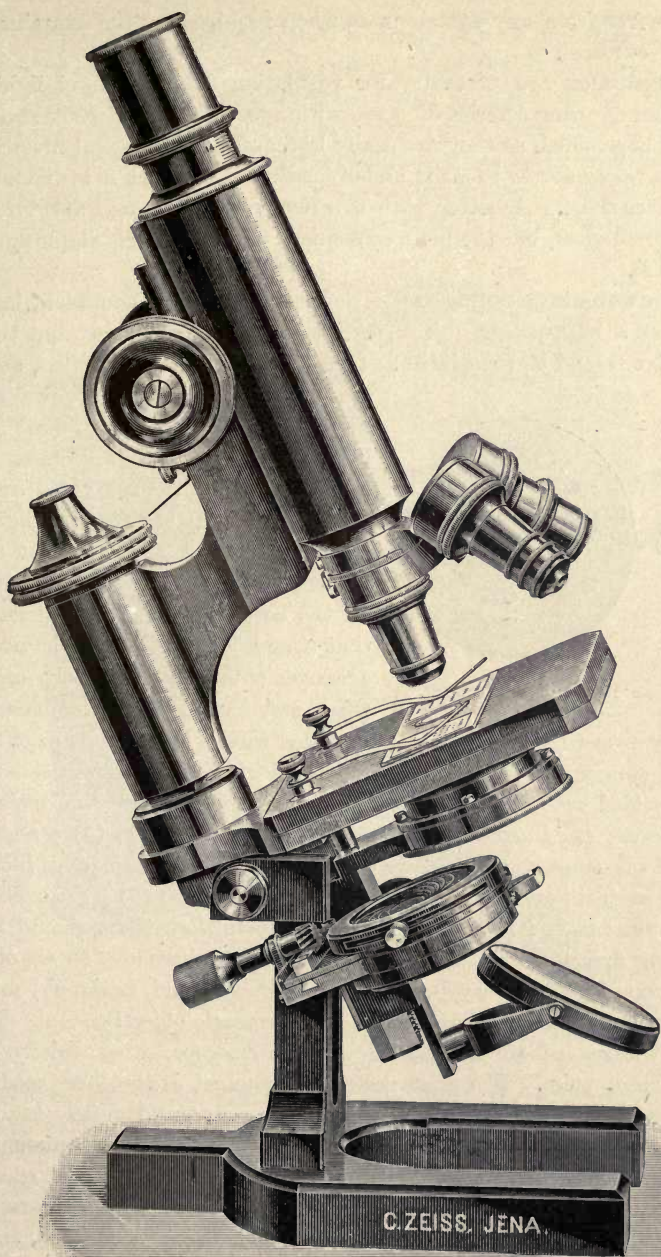

FIG. 18.—CONTINENTAL MODEL.

may be free from any attachments when required for the examination of cultures.

*Diaphragms* are necessary for regulating the amount of light. The plan of using a series of discs, with apertures of different sizes, should be avoided, as they are easily lost, and bacteriological investigations may have to be made under conditions in which it is difficult to replace them. A better plan is a revolving plate with apertures of different sizes, but the most convenient form is the iris diaphragm (Fig. 19).

The sub-stage condenser is quite as necessary in bacteriological work as a high-power objective. In fact, the condenser and the objective should be considered as forming one optical apparatus, and the microscope regarded quite as incomplete without a condenser as it would be without an objective.

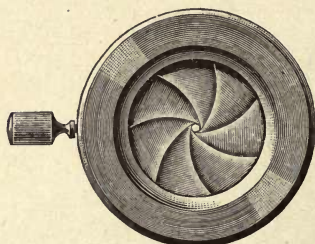

FIG. 19.—IRIS DIAPHRAGM.

By means of the sub-stage condenser (Fig. 20) the rays of light are concentrated at one point or on one particular bacterium; and for the best definition it is essential that there should be mechanical arrangements for accurately centring and focussing the condenser.

It may even with advantage be provided with a fine adjustment.

To sum up, a microscope for bacteriological investigation should be provided with (1) a steady stand of either the tripod or horse-shoe form; (2) a tubular body on the Jackson model; (3) a wide-angled sub-stage condenser, such as Abbé's; (4) objectives of an inch,  $\frac{1}{8}$ th of an inch, and a  $\frac{1}{12}$ th homogeneous immersion; (5) a removable mechanical stage; and for the most accurate work there should be centring arrangements and a coarse and fine adjustment to an oil-immersion sub-stage condenser such as Powell and Lealand's, and a  $\frac{1}{12}$ th homogeneous oil-immersion apo-chromatic objective.

With regard to the choice of a microscope, it is chiefly a question of price. The most perfect instrument is the large model by Powell and Lealand, but it is most expensive, and quite unsuitable for laboratory work. For general use excellent instruments are made by Zeiss, Leitz, Reichert, or Swift. The bacteriological microscopes of these makers are in the necessary equipment practically identical. The Zeiss microscope is the most finished, and costs about twenty pounds. A similar microscope by Leitz and by Swift costs about eighteen, and both make an excellent students'



bacteriological microscope, with a cheap form of adjustment to the sub-stage condenser, at a total cost of about fifteen pounds.

**Method of Illumination.**—Good daylight is the best for general work. The microscope should be placed near a window with a northern aspect. Direct sunlight should never be utilised, and the best light is that reflected from a white cloud. When daylight is not available good results can be obtained with either gas or a

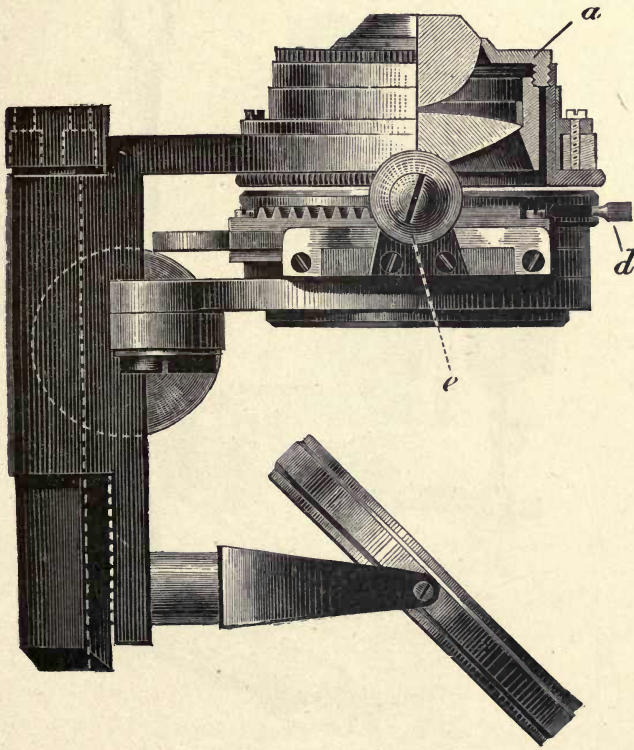

FIG. 20.—ABBÉ'S CONDENSER CONSTRUCTED BY ZEISS.

paraffin lamp. In the author's laboratory the microscope lamps are fitted with Welsbach incandescent mantles. These have many advantages over an Argand burner or a paraffin lamp. A steady and beautifully white light is obtained, and the lamps are quickly lit, and require comparatively little attention. In using high powers and carefully focussing the sub-stage condenser, the image of the fabric of the mantle is embarrassing, and is an objection to this light for the most accurate observations, but in other respects, and

for general use, it is the best form of artificial illumination for the microscope.

An ordinary paraffin lamp of the cheapest form may be used, but there are many objections to it, such as the shape of the chimney, and the striæ and defects in the glass. The best form of paraffin lamp is constructed by Baker and by Swift from sug-

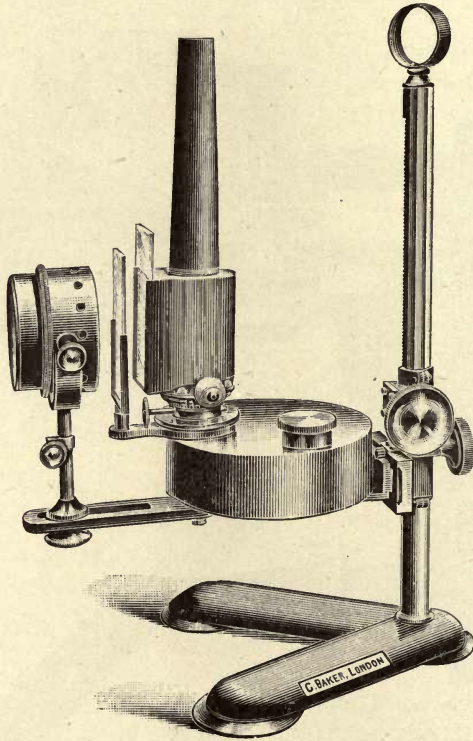

FIG. 21.—MICROSCOPE LAMP.

gestions by Nelson and Dallinger (Fig. 21); there is also a similar but much larger pattern which is made by Swift (Fig. 22). This form of lamp has a large flat bowl for the oil. It is attached to a standard, and can be raised or lowered to the desired position. The chimney is of metal and blackened, so that there is no reflected light, and it may also with advantage be provided with a shade, so that no light reaches the eye except through the microscope.

The burner may be made to revolve, so that either the edge or



the flat of the flame may be utilised. Great care should be taken to have the wick evenly trimmed. The best paraffin oil should be burnt, and it is as well to add a small lump of camphor. The metal chimney has an aperture in front, giving exit to the rays of light, which is closed in by a slip of glass. The glass is very liable to crack when exposed to the full force of the flame, and it is as well, therefore, to be provided with a stock of glass slips, which have

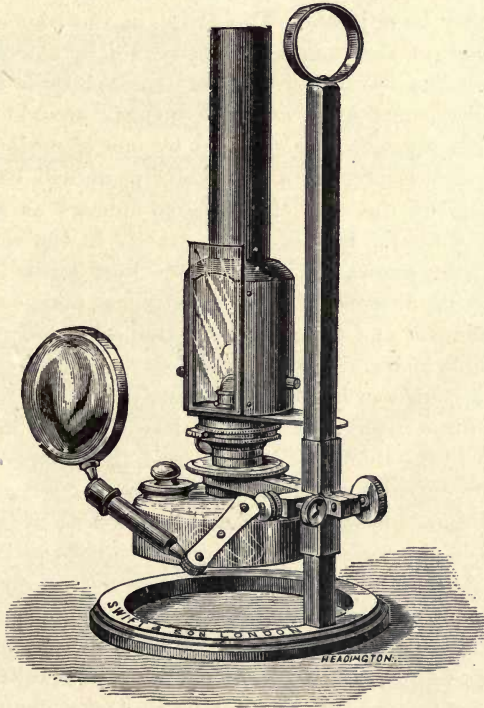

FIG. 22.—LARGE MICROSCOPE LAMP.

been annealed by being enveloped in a cloth and boiled for two or three hours.

The flat of the flame is used with low powers. The image of the flame is reflected by a plane mirror, and a bull's-eye condenser interposed between the lamp and the mirror to give an equal illumination of the whole field. In working with high powers the lamp is turned with the flame edgewise, and the mirror is dispensed with. By working, as it is termed, directly on the edge of the flame, the illumination is greatly increased, and a band of light can

be concentrated on that part of the microscopical preparation which requires most careful study (Fig. 23).

To obtain the best definition considerable time must be spent in the arrangement of the illumination. The lamp and microscope having been placed in position, a low power is first used and the smallest diaphragm. On looking through the microscope it will probably be observed that the image of the diaphragm is not in the centre of the field. By moving the centring screw of the condenser this may be adjusted. The image of the edge of the flame may not be central, and this must be adjusted by moving the lamp into position. The low power is then replaced by a high power, the largest diaphragm used, and the bacteria brought into focus. The diaphragm must now be replaced by one of medium size, and by racking the condenser up and down, a point will be arrived at when the image of the edge of the flame appears as an intensely bright band of light. If this is not exactly in the centre of the field the centring screws of the condenser must again be adjusted. Lastly, by trying different sizes of diaphragms, and focussing with the fine adjustment, and using the correction collar, we arrive at the sharpest possible image of the bacteria.

When the condenser has been accurately centred, it will still be necessary to focus it for each individual specimen, so as to correct for difference in the thickness of slides and the layers of mounting medium. Correction for different thickness of cover-glasses must in each case be made by means of the collar adjustment in the following way. A high-power eye-piece is substituted for the ordinary eye-piece, and the fault in the image will thereby be intensified. By moving the collar completely round, first in one direction and then the other, while carefully observing the effect on the image, it will be seen to become obviously worse whichever way the collar is turned. The collar must then be turned through gradually diminishing distances until an intermediate point is reached at which the best image results with the high-power eye-piece, and on replacing this by the low-power eye-piece the sharpest possible image will be obtained.

**Effect of the sub-stage condenser.**—The sub-stage condenser gives the most powerful illumination when it has been racked up until it almost touches the specimen. It produces a cone of rays of very short focus, and the apex of the cone should correspond with the particular bacterium or group of bacteria under observation. The effect of the condenser without a diaphragm is to obliterate what Koch has termed the *structure picture*. If the component parts of a tissue section were colourless and of the same refractive power as



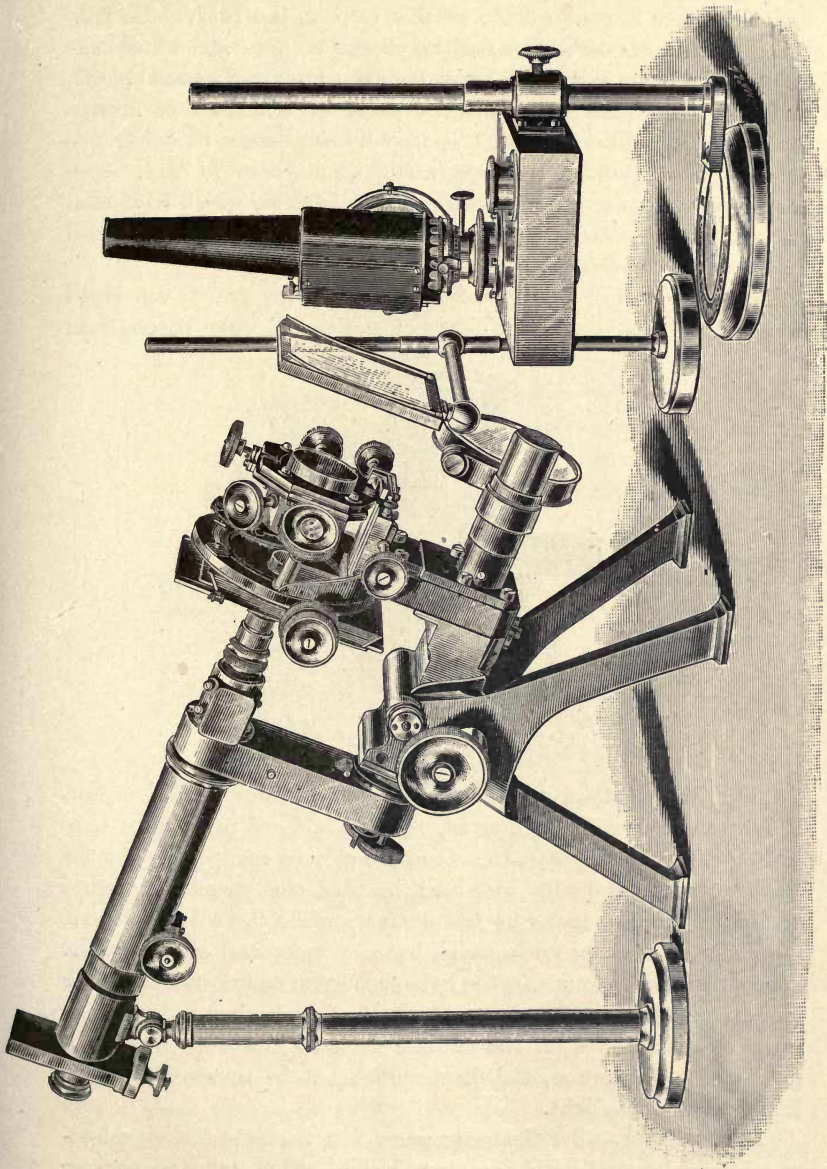

FIG. 23.—ARRANGEMENT OF POWELL AND LEALD'S MICROSCOPE IN WORKING DIRECTLY ON THE EDGE OF THE FLAME, WITH STAND FOR MICROMETER EYE-PIECE TO SECURE STEADINESS AND ACCURACY IN MEASUREMENT. (NELSON.)

the medium in which the section is mounted, nothing would be visible under the microscope. As, however, the cells and their nuclei, and the tissue fibres do differ in this respect, the rays which pass through them are diffracted, and an image of lines and shadows is developed. If in such a tissue there were minute coloured objects, and if it were possible to mount the tissue in a medium of exactly the same refractive power, the tissue being then invisible, the detection of the coloured objects would be much more easy. This is exactly what is required in dealing with bacteria which have been stained with aniline dyes, and the desired result can be obtained by the use of the sub-stage condenser.

If we use the full aperture of the condenser the greatly converged rays play on the component parts of the tissue, light enters from

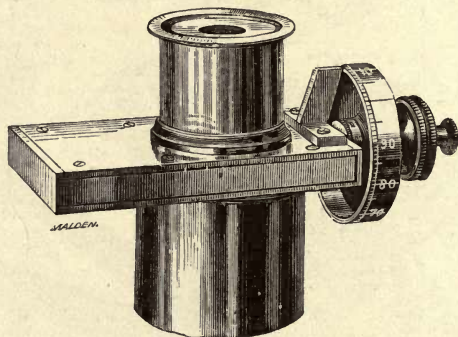

FIG. 24.—RAMSDEN MICROMETER EYE-PIECE.

all sides, the shadows disappear, and the structure picture is lost. If now a diaphragm is inserted, so that we are practically only dealing with parallel rays, the structure picture reappears. As the diaphragm is gradually increased in size the structure picture gradually becomes less and less distinct, while the colour picture, the image of the stained bacteria, becomes more and more intense. When, therefore, bacteria in the living condition and unstained tissues are examined a diaphragm must be used, and when attention is to be concentrated upon the stained bacteria in a section or in a cover-glass preparation, the diaphragm must be removed and the field flooded with light.

**Micrometer.**—For the measurement of bacteria a stage micrometer may be used with a camera lucida. The stage micrometer consists of a slip of thin glass ruled with a scale consisting of tenths and hundredths of a millimetre. The image of this can be projected



on a piece of paper, and a drawing made, and the object to be measured can then be projected on the paper and compared with the scale.

In the Ramsden micrometer eye-piece (Fig. 24) two fine wires are stretched across the field of an eye-piece, one of which can be moved by a micrometer screw. In the field there is also a scale with teeth, and the interval between them corresponds to that of the threads of the screw. The circumference of the brass head is usually divided into one hundred parts, and a screw with one hundred threads to the inch is used. The bacterium to be measured is brought into a

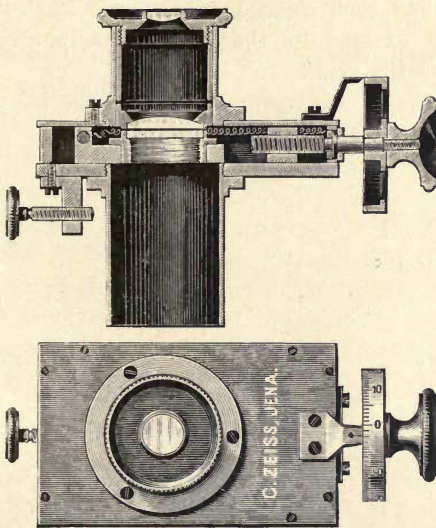

FIG. 25.—MICROMETER EYE-PIECE BY ZEISS.

position in which one edge appears to be in contact with the fixed wire, and the micrometer screw is turned until the travelling wire appears to be in contact with the other edge. The scale in the field and the scale on the milled head together give the number of complete turns of the screw and the value of a fraction of a turn in separating the wires.

In the micrometer eye-piece constructed by Zeiss, the eye-piece with a glass plate with crossed lines is carried across the field by means of a micrometer screw (Fig. 25). Each division on the edge of the drum corresponds to  $\cdot 01$  mm. Complete revolutions of the drum are counted by means of a figured scale in the visual field. Another method of measuring bacteria will be referred to in the

chapter on micro-photography. The unit of measurement is one thousandth of a millimetre or a *micro-millimetre* or micron, and is expressed by the Greek letter  $\mu$ .

#### CARE OF THE MICROSCOPE.

After use the objectives, sub-stage condenser, and eye-piece should be carefully wiped with soft linen, an old silk handkerchief, or chamois leather, and the microscope covered with a bell-glass to protect it from dust. If a lens comes into contact with Canada balsam it must be very carefully wiped with a soft rag moistened with alcohol, and then cleaned with a soft leather. Microscopes should not be exposed to the fumes of sulphuretted hydrogen, chlorine, or volatile acids.



## CHAPTER VIII.

### MICROSCOPICAL EXAMINATION OF BACTERIA.

#### (A) BACTERIA IN LIQUIDS, CULTURES, AND FRESH TISSUES.

IN conducting bacteriological researches the importance of absolute cleanliness cannot be too strongly insisted upon. All instruments, glass vessels, slides, and cover-glasses should be thoroughly cleansed before use. A wide-mouthed glass jar should always be close at hand, containing refuse alcohol for the reception of rejected slide preparations or dirty cover-glasses. When required again for use, slides can be easily wiped clean with a soft rag. Cover-glasses require further treatment, for, unless they are perfectly clean, it is difficult to avoid the presence of air bubbles when mounting specimens. They should be left in strong acid (hydrochloric, sulphuric, or nitric) for some hours; they are then washed, first with water and then with alcohol, and carefully wiped with a soft rag. The same principle applies in the preparation and employment of culture media; any laxity in the processes of sterilisation, or insufficient attention to minute technical details, will surely be followed with disappointing results by contamination of the cultures, resulting in the loss of much time.

For the preparation of microscopical specimens it will be found convenient to use a platinum inoculating needle. This consists of two or three inches of platinum wire fused into the end of a glass rod about eight inches in length. Platinum is employed as it rapidly cools after being raised to a white heat in the flame of a Bunsen burner. It is thus completely sterilised, and in a few moments is cool enough not to destroy the bacteria with which it is brought into contact.

When using platinum needles, either for inoculating fresh tubes in carrying on a series of pure cultures, or in transferring a small portion of a cultivation to a cover-glass for examination under the microscope, the careful sterilisation of the needle by heating the

platinum wire till it is white hot in every part, and heating also as much of the glass rod as is made to enter the test-tube, must be carried out with scrupulous care. Indeed it is a good plan to

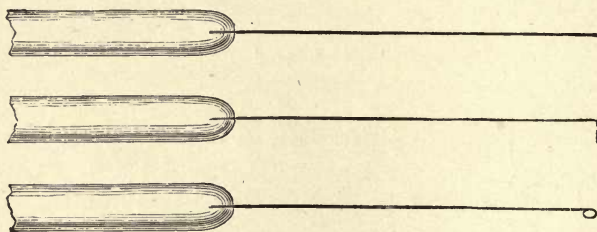

FIG. 26.—INOCULATING NEEDLES.

let it become a *force of habit* to sterilise the needle before and after use on every occasion, whatever may be the purposes for which it is employed.

#### UNSTAINED BACTERIA.

The bacteria in liquids, such as pus, blood, and culture-fluids, can be investigated in the unstained condition by transferring a drop with a looped platinum needle or a capillary pipette to a slide, covering it with a clean cover-glass, and examining without further treatment. If it is desirable to keep the specimen under prolonged observation, a drop of sterilised water or salt solution must be run in at the margin of the cover-glass to counteract the tendency to dry.

Cultures on solid media can be examined by transferring a small portion with a sterilised needle to a drop of sterilised water on a slide, thinning it out, and covering with a cover-glass as already described.

Tissues in the fresh state may be teased out with needles in sterilised salt solution, and pressed out into a sufficiently thin layer between the slide and cover-glass. Glycerine may in many cases be substituted for salt solution, especially for the examination of micro-organisms such as *Actinomyces* and mould fungi.

There is, as a rule, no difficulty in recognising the larger micro-organisms such as those just mentioned; but when we have to deal with very small bacilli and micrococci, they may possibly be mistaken for granular detritus or fat-crystals, or *vice versa*. They are distinguished by the fact that fatty and albuminous granules are altered or dispersed by acetic acid, and changed by solution of potash; alcohol, chloroform, and ether dissolve out fat-crystals



or fatty particles; on the other hand, micro-organisms remain unaffected by these reagents. Baumgarten demonstrated tubercle bacilli in sections by treating them with potash, which clarified the tissues and brought the bacilli clearly into view. Actinomyces and other vegetable structures will not disappear when sections are immersed in weak hydrochloric acid and mounted in glycerine.

In examining unstained bacteria, it is necessary, in order to obtain the structure picture, that the light entering the microscope should be reduced by employing a small diaphragm, and the sub-stage condenser carefully centred and focussed. To focus an unstained specimen in which only bacteria are present, is often difficult. The slide may be gently raised towards the objective, and the stage may be constructed to enable this to be done with the index finger (Fig. 16). If on tilting the slide the organisms come into focus it will serve as a guide in working the fine adjustment. Another plan when bacteria are examined in water, is to look for an air-bubble, and then to focus its edge until the bacteria appear in view.

The simple method of covering the liquid with a cover-glass will not answer for a prolonged examination, as the liquid evaporates and the specimen dries up. To keep living bacteria under observation for any length of time, in order to study their movements or spore-formation, a special slide must be employed (p. 120).

#### STAINED BACTERIA.

Weigert first pointed out the value of the aniline dyes for staining bacteria, and we are principally indebted to Koch, Ehrlich, Gram, and Löffler for many valuable processes.

The staining of fresh preparations, especially those with no coagulable albumen to fix them, may be carried out by the method of His. A slide is prepared as already described for the examination of micro-organisms in the fresh state. The reagents are then applied by placing them with a pipette drop by drop at one margin of the cover-glass, and causing them to flow through the preparation by means of a strip of filter-paper placed at the opposite margin.

Babès recommends another rapid means of examining cultivations. A little of the growth, removed by means of a sterilised platinum hook or small loop, is spread out on a cover-glass into as thin a film as possible: when almost dry, a drop or two of a weak aqueous solution of methyl violet is allowed to fall from a pipette upon the film. The cover-glass with the drop of stain is, after a minute,

carefully turned over on to a slide, and the excess of stain gently and gradually removed by pressure with a strip of filter-paper. This affords a rapid means of demonstration—for example, of a cultivation of Koch's comma bacilli in nutrient gelatine—enabling the microbes to be seen in some parts of the preparation both stained and in active movement.

#### COVER-GLASS PREPARATIONS.

Bacteria may be spread out into a thin layer on a cover-glass, and then treated with a dye, or sections of tissues containing bacteria can be stained and then mounted in the usual way.

The method of making a cover-glass preparation is one which is very commonly employed. In addition to its value as a means of examining bacteria in liquids and solid culture media, it affords the additional advantage of enabling, if necessary, a large number of preparations to be made, which, when dried, can be preserved, stained or unstained, in ordinary cover-glass boxes; they are then in a convenient form for transport, and can be mounted permanently at leisure.

The method is as follows: A cover-glass is smeared with the cut surface of an organ or pathological growth, or with sputum; or a drop of blood, pus, or culture-fluid is conveyed to it with a looped platinum needle. It is absolutely necessary to spread out the micro-organisms into a sufficiently thin layer, so that the individual bacteria may be as much as possible in the same plane, otherwise some in the field will be in focus and others out of focus, and it would be impossible to obtain a satisfactory photograph of such a specimen. To overcome this it will be necessary, in the case of cultures on solid media, to diffuse the bacteria in a little sterilised water; and even cultures in liquids may sometimes with advantage be diluted in the same way. By means of another cover-glass the juice or fluid is squeezed out between them into a thin layer, and on sliding them apart each cover-glass bears on one side a thin film of the material to be examined; or a culture is spread out into a thin film by means of a hooked platinum needle. The cover-glass is then placed with the prepared side upwards, and allowed to dry. After a few minutes, it is taken up with a pair of flat-bladed or spring forceps, with the prepared side uppermost, and passed rapidly from above downwards three times through the flame of a spirit lamp or Bunsen burner. Two or three drops of an aqueous solution of fuchsine or methyl violet will be sufficient to cover the film, and after a minute or two the surplus stain is washed



off with distilled water by means of a siphon apparatus or a wash-bottle. The cover-glass may be allowed to dry, and then mounted in Canada balsam, or it may, while still wet, be turned over on to a slide, the excess of water removed with filter-paper, and the exposed surface wiped dry. It may first be examined with a power of about 250 diams.; and if a high magnification is required, which is usually the case, a droplet of cedar oil is placed on the cover-glass, and the specimen examined with an immersion lens.

If the specimen is to be made permanent, fix the cover-glass at one corner with the thumb, and with a soft rag carefully wipe off the cedar oil; then float off the cover-glass by running in distilled water at its margin, and having made a little ledge with a strip of filter-paper, place the cover-glass up against it upon one of its edges and leave it to dry. When perfectly dry mount in Canada balsam, or put it away in a cover-glass box provided with a label of contents.

In many cases it is necessary or preferable to apply the stain for a much longer period. This may best be effected by pouring some of the staining solution into a watch-glass, and allowing the cover-glasses to swim on the surface, with their prepared side, of course, downwards. Throughout all these manipulations it is necessary to bear in mind which is the prepared surface of the cover-glass.

Instead of using the watery solutions of the aniline dyes the author prefers in many cases to use stronger solutions, and to reduce the staining by a momentary immersion in alcohol. Very beautiful preparations of streptococci, sarcinæ and other bacteria can be obtained by this method, which is as follows: Cover-glass preparations are stained with carbolised fuchsine (Neelsen's solution) for about two minutes, rinsed in alcohol for a few seconds, quickly washed in water, and either examined in water or dried and mounted in the usual way. The extent of decolorisation is a matter of practice: a momentary immersion in alcohol is sometimes sufficient; too long immersion will remove too much of the colour; too short immersion will leave the delicate outlines indistinct. This method is especially valuable for sarcinæ and streptococci, the divisions between the elements being sharply defined, and as any albuminous particles or *débris* in the preparation are decolorised, much cleaner and sharper preparations are obtained than with the watery solutions. Löffler's and other concentrated solutions may also be used, but Neelsen's solution may be regarded as the standard one for this method.

Aniline oil, carbolic acid, and some other chemicals, when added to the aniline dyes, have the property of acting in the manner of mordants, in some way fixing the colour in the bacteria, so that they are not so readily acted upon by decolorising agents.

*Löffler's Solution.*—Potash intensifies the staining power, and Koch and Löffler have both used it with methylene blue. Löffler's solution consists of 30 grammes of methylene blue in 100 grammes of 1 in 10,000 solution of potash. It may be used with advantage for almost all kinds of bacteria.

**Gram's Method.**—With a solution of gentian-violet the whole film on the cover-glass is at first stained violet. By immersing the cover-glass in a solution of iodine in iodide of potassium the stain is fixed in the bacilli, but not in any *débris*, pus cells, or tissue elements present in the film. Consequently by transferring the cover-glass to alcohol the bacilli alone remain stained, the violet colour being merely changed to blue. By employing a contrast colour, such as eosin, a double staining is obtained. In some bacteria the sheath is by this method differentiated from the protoplasmic contents.

The stock solution of gentian-violet is prepared by shaking up 1 cc. of pure aniline with twenty parts of distilled water, and filtering the emulsion. Half a gramme of the best finely powdered gentian-violet is dissolved in the clear filtrate, and the solution filtered before use.

The details of the method will now be described. In the first place, it is much better to employ the aniline-gentian-violet solution quite freshly prepared, and the following useful method is invariably used by the author: Place four or five drops of pure aniline in a test-tube, fill it three-quarters full with distilled water, close the mouth of the tube with the thumb, and shake it up thoroughly. Filter the emulsion twice, and pour the filtrate into a watch-glass or glass capsule. To the perfectly clear aniline-water thus obtained add drop by drop a concentrated alcoholic solution of gentian-violet till precipitation commences. Cover-glasses must be left in this solution about ten minutes, transferred to iodine-potassic-iodide solution until in two or three minutes the film becomes uniformly brown, and then rinsed in alcohol. The process of decolorisation may be hastened by dipping the cover-glass in clove-oil and returning it again to alcohol. The cover-glass is once more immersed in clove-oil, then dried by gently pressing between two layers of filter-paper, and finally mounted in Canada balsam.



## DOUBLE STAINING OF COVER-GLASS PREPARATIONS.

To double stain cover-glass preparations they can be treated by Ehrlich's method for staining tubercular sputum, or by Neelsen's modification, or by staining with eosin after treatment by the method of Gram.

**Ehrlich's method** is as follows: Five parts of aniline oil are shaken up with one hundred parts of distilled water, and the emulsion filtered through moistened filter-paper. A saturated alcoholic solution of fuchsine, methyl-violet, or gentian-violet, is added to the filtrate in a watch-glass, drop by drop, until precipitation commences. Weigert recommended that exactly eleven parts of the dye should be used to one hundred parts of the aniline solution.

Cover-glass preparations are floated in this mixture for fifteen minutes to half an hour, then washed for a few seconds in dilute nitric acid (one part nitric acid to two of water), and then rinsed in distilled water. The stain is removed from everything except the bacilli; but the ground substance can be after-stained brown if the bacilli are violet, or blue if they have been stained red.

*Neelsen's Solution and Methylene Blue.*—Ziehl suggested the use of carbolic acid as a substitute for aniline oil, and Neelsen recommended a solution composed of 100 cc. of a 5 per cent. watery solution of carbolic acid, 10 cc. of absolute alcohol, and 1 gramme of fuchsine. This stain is commonly known as the Neelsen or Ziehl-Neelsen solution. Cover-glass preparations are floated on the hot dye for two minutes, they are then rinsed in dilute sulphuric acid 25 per cent., washed in water, immersed in watery solution of methylene blue for three minutes, again washed in water, dried, and mounted in balsam.

*Gram's Solution and Eosin.*—Double staining of cover-glasses can be obtained by combining Gram's method with eosin. The method is very useful for differentiating the sheath of *Streptococcus pyogenes* and *Bacillus anthracis*, from the protoplasmic contents, and for staining preparations of pneumonic sputum, or of micrococci and other micro-organisms in pus. After decolorising the preparation in alcohol, the cover-glass is transferred to a weak solution of eosin for two or three minutes, then washed again in alcohol, immersed in clove-oil, dried between filter-paper, and mounted in balsam.

## STAINING OF SPORES.

A slight modification of the ordinary process employed in making cover-glass preparations has to be adopted to stain the spores of

bacilli. Under ordinary circumstances the stain will not penetrate the sheath, but if it can be made to penetrate, it is not readily removed. The cover-glass preparation must be heated to a temperature of  $210^{\circ}$  C., for half an hour, or passed as many as twelve times through the flame of a Bunsen burner, or exposed to the action of strong sulphuric acid for several seconds, and then a few drops of a watery solution, of an aniline dye may be applied in the usual way.

To double stain spore-bearing bacilli the cover-glass preparations may be floated, for from twenty minutes to an hour, on Ehrlich's fuchsine-aniline-water, or on the Ziehl-Neelsen solution. The stain must be heated—by preference in a capsule placed in a sand-bath—until steam rises. The fuchsine is removed from the bacilli by rinsing in water and washing in weak hydrochloric acid, and then the preparations are washed again in water, and floated for a few minutes on a watery solution of methylene blue. They are again rinsed in water, dried, and mounted. Neisser's decolorising solution consists of 25 parts of hydrochloric acid to 75 parts of alcohol.

#### STAINING OF FLAGELLA.

Koch first stained flagella by floating the cover-glasses on a watery solution of hæmatoxylin. From this they were transferred to a 5 per cent. solution of chromic acid, or to Müller's fluid, by which the flagella obtain a brownish-black coloration. The author succeeded in demonstrating and photographing flagella in preparations stained with a saturated solution of gentian violet in absolute alcohol; but these methods are now superseded owing to the much more satisfactory method introduced by Löffler.

**Löffler's method** depends upon the employment of a mordant. Löffler tried tannate of iron, and after a number of experiments the following method was introduced. An aqueous solution of ferrous sulphate is added to an aqueous solution of tannin (20 per cent.), until the mixture turns a violet-black colour, then 3 or 4 cc. of a 1 in 8 aqueous solution of logwood are added. This constitutes the mordant, and a few drops of carbolic acid may be added, and the solution kept in well-stoppered bottles. The dye consists of 1 cc. of a 1 per cent. solution of caustic-soda, added to 100 cc. of aniline water, in which 4 or 5 grammes of either methyl violet, methylene blue, or fuchsine, are dissolved. A cover-glass preparation is made in the ordinary way, the bacteria being diffused in water, and then spread out in a very thin film. After drying and very carefully fixing, the film is covered with the mordant, and the cover-glass



held over the flame until steam rises. The mordant is then washed off with distilled water, and all traces removed from the edge of the cover-glass with alcohol. The stain is filtered, and a few drops allowed to fall on the film, and after a few minutes the cover-glass is again very carefully warmed until steam rises. The stain is then washed off with distilled water, and is ready to be examined and subsequently mounted. For some bacteria it is necessary to modify the solutions, either by the addition of acetic or sulphuric acid, or by varying the quantity of soda solution.

Trenkmann introduced a modification of Löffler's system. Cover-glasses are floated for from two to twelve hours on a solution consisting of 1 per cent. tannin and  $\frac{1}{2}$  per cent. hydrochloric acid. After washing in water the preparation is stained with a saturated alcoholic solution of any of the aniline dyes diluted in the proportion of 2 drops of the dye to 20 of water. The cover-glasses which remain in the solution for from two to four hours are then washed in water, and examined. The best results are obtained with carbolised fuchsin, diluted in the proportion of 2 drops to 20 drops of 1 per cent. carbolic. Trenkmann also recommended the use of catechu and logwood as mordants, with the addition of very dilute acid, and subsequent staining with fuchsin.

Lutesch suggested the use of ferric acetate. To avoid any deposit on the surface of the preparation, freshly prepared saturated ferric acetate is used, and 5 to 10 drops of acetic acid are added to 16 cc. of the mordant. After warming the solution the preparation is washed in water, followed by 20 per cent. acetic acid, again thoroughly washed, and then stained with hot solution of fuchsin or gentian-violet in aniline water.

Van Ermengem used a mordant composed of 1 part of 2 per cent. solution of osmic acid, 2 parts of 10 to 25 per cent. solution of tannin, with to every 100 cc. of this mixture 4 or 5 drops of acetic acid. A black ink is thus formed, and the solution is applied for from five to thirty minutes. After washing in water and alcohol the cover-glasses are placed in a solution of nitrate of silver and transferred to another solution composed of 5 grammes of gallic acid, 3 grammes of tannin, 10 grammes of acetate of soda, and 330 grammes of distilled water. In a few moments they are again placed in nitrate of silver, and then washed and mounted in balsam.

Sclavo's method answers well for certain micro-organisms. The preparations are left for one minute in solution of tannin, washed in distilled water, transferred for a minute to 50 per cent. phosphomolybdic acid, again washed and stained from three to five minutes

in hot saturated solution of fuchsine in aniline water, washed in water, dried on filter paper, and mounted in balsam. The tannin solution consists of 1 part of tannin to 100 cc. of 50 per cent. alcohol.

Nicolle and Morax also, have modified Löffler's method. Perfectly clean cover-glasses are used, and the film is dried without fixing in the flame. Cover-glasses are covered with the mordant, and heated for about ten seconds, and when steam rises the mordant is shaken off and the film rinsed with water. The same process is repeated three or four times, and finally the cover-glass is stained with Neelsen's solution, holding it over the flame once or twice for a quarter of a minute; it is then washed and examined.

Bunge prefers as a mordant a mixture of aqueous solution of tannin with 1 in 20 aqueous solution of sesquichloride of iron in the proportion of 3 parts of the tannin solution, 1 part of the iron solution, with the addition of 1 cc. of a saturated watery solution of fuchsine added to 10 cc. of the mixture. The mordant is kept before use, and applied for five minutes. The preparation is then washed and stained with Neelsen's solution. In another plan the cover-glasses are immersed for one half to one minute in 5 per cent. solution of acetic acid, washed and dried. The mordant is then applied three or four times, and the cover-glasses washed, dried, and then stained with gentian-violet, dipped in 1 per cent. acetic acid, washed, dried, and mounted. Peroxide of hydrogen may be added to the mordant, drop by drop; it becomes reddish-brown in colour, and must be shaken up and filtered before use. Cover-glasses are exposed to its action for about a minute, and Neelsen's solution is used for staining.

Hessert dispenses with the mordant. The film is fixed by treating cover-glasses with a saturated alcoholic solution of corrosive sublimate. After washing, the cover-glass is stained for thirty to forty minutes in a hot dye, by preference a 10 per cent. watery solution of saturated alcoholic solution of fuchsine.

#### COVER-GLASS IMPRESSIONS.

One of the most instructive methods for examining micro-organisms is to make an *impression-preparation*. This enables us, in many cases, to study the relative position of individual micro-organisms one to another in their growth on solid cultivating media, and in some cases produces the most exquisite preparations for the microscope. A perfectly clean, usually small-sized, cover-glass is carefully deposited on a plate-cultivation, and gently and evenly pressed down. One edge is then carefully levered up, with a needle,



and the cover-glass lifted off by means of forceps. It is then allowed to dry, passed through the flame three times, and stained as already described. In some cases of plate-cultures, especially where no liquefaction has taken place, the growth is bodily transferred to the cover-glass, and a vacant area left on the gelatine or agar-agar, corresponding exactly with the form and size of the cover-glass employed.

#### PRESERVATION OF PREPARATIONS.

After examining a cover-glass preparation with an oil immersion objective the cedar oil must be carefully wiped off, and the slide set aside for the Canada balsam to set. At a convenient time all preparations should be sealed with a ring of Hollis' glue; the cedar oil used at subsequent examinations of the specimen will not be able to work its way under the cover-glass, and prevent the balsam from hardening. When it is ringed cedar oil can be readily wiped off, and the specimen cleaned without danger of moving the cover-glass and injuring the preparation.

#### (B) BACTERIA IN SECTIONS OF TISSUES.

*Methods of Hardening and Decalcifying Tissues.*—To harden small organs, such as the viscera of a mouse, they should be placed on a piece of filter-paper at the bottom of a small wide-mouthed glass jar, and covered with about twenty times their volume of absolute alcohol. Larger organs, pathological growths, etc., are treated in the same way, but must first be cut into small pieces, or cubes, varying from a quarter of an inch to an inch in size. Müller's fluid may also be employed, and methylated spirit may be substituted for alcohol, from motives of economy. Tissues hardened in absolute alcohol are ready for cutting in two or three days, and those hardened in Müller's fluid in as many weeks.

Teeth, or osseous structures, must first be placed in a decalcifying solution, such as Kleinenberg's. When sufficiently softened, they are allowed to soak in water, to wash out the picric acid, and then transferred through weak spirit to absolute alcohol. Ebner's solution also gives excellent results, especially when the structures to be decalcified are placed in fresh solution from time to time.

*Methods of Embedding, Fixing, and Cutting.*—The author finds that freezing with ether combined with the method of embedding in celloidin gives excellent results. The pieces of tissue to be embedded are placed, after the process of hardening is com-

pleted, in a mixture of ether and alcohol for an hour or more. They are then transferred to a solution of celloidin in equal parts of ether and alcohol, and left there, usually for several hours.

The piece of tissue is then placed in a glass capsule, and some of the celloidin solution poured over it. The capsule can be placed

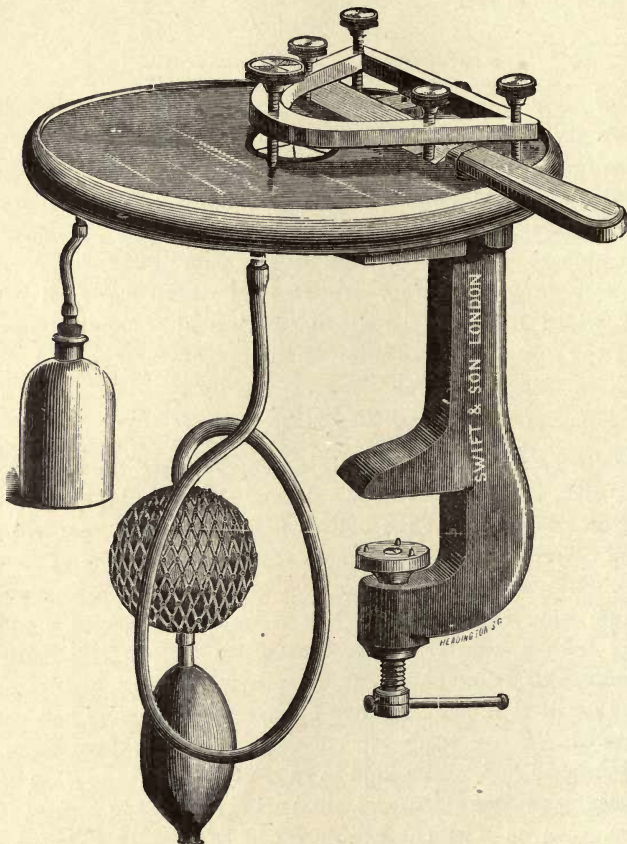

FIG. 27.—SWIFT'S FREEZING MICROTOME.

bodily in 60 to 80 per cent. alcohol, and left until the following morning. The celloidin will then be of the consistency of wax. The piece of tissue is next cut out, and after trimming off superfluous celloidin is put in water until it sinks. It is then transferred to gum, and frozen and cut with a freezing microtome.

For cutting with Jung's microtome, the tissues are embedded



in paraffine or celloidin, and mounted on cork; or, if firm enough, they may be fixed upon cork without any embedding material at all. Paraffine, dissolved in chloroform, will be found very serviceable as an embedding material.

Corks ready cut for the clamp of the microtome are smeared over with the solution of celloidin. This can be applied with a glass rod to the surface which is to receive the piece of tissue. The corks are then set aside for the film of celloidin to harden. In the case of lung, or degenerated broken-down tissue, the specimen should be left for a much longer time than is found to be sufficient for firmer structures. When ready, it is removed from the celloidin solution with forceps and placed upon the pre-

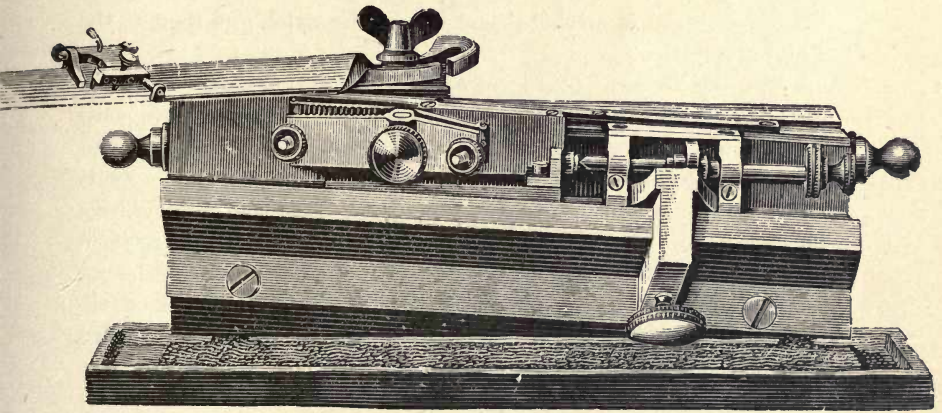

FIG. 28.—JUNG'S MICROTOME.

pared cork. Enough of the solution, which is of syrupy consistence, is allowed to fall on the piece of tissue to cover it completely, and the mounted specimen is placed in the alcohol to harden. The specimen will be ready for cutting next day.

The specimen may be more neatly embedded by fixing it with a pin in a small paper tray, pouring the celloidin solution over it, and then placing the tray in alcohol to harden the celloidin. The embedded specimen is then fixed on a cork, which has been cut for the clamp of the microtome. The celloidin in the section disappears in the process of clearing with clove-oil.

In the case of specimens embedded in celloidin, or mounted directly on a cork, the tissue, as well as the blade of the knife, should be kept constantly bathed with alcohol, and the sections transferred from the blade with a camel's-hair brush, and floated in alcohol.

For fixing directly on cork, small organs and pieces of firm tissue such as the kidneys of a mouse, or liver, we may employ gelatine or glycerine gelatine, liquefied over a Bunsen burner in a porcelain capsule. Glycerine gelatine may be used with advantage for fixing irregular pieces of tissue, as it does not become of a consistency that would injure the edge of the knife. The cork, with specimen affixed, is placed in alcohol, and is ready for cutting sections next day.

Material infiltrated with paraffine must be cut perfectly dry, and the sections prevented from rolling up by gentle manipulation with a camel's-hair brush. They must then be picked off the blade of the knife with a clean needle, and dropped into a watch-glass containing xylol. This dissolves out the paraffine. The sections are then transferred to alcohol to get rid of the xylol, and then to the staining solution.

*Staining Bacteria in Tissue Sections.*—Sections of fresh tissues made with the freezing microtome are to be floated in .8 per cent. salt solution, and then carefully transferred, well spread out on a platinum lifter, to a watch-glass containing absolute alcohol. Similarly, sections selected from those cut with Jung's microtome may be transferred from the spirit to absolute alcohol. The sections may be then stained by any of the methods to be described.

It is often advisable to employ some method which will enable one to study the structure of the tissue itself; and sections, however stained, should always be first examined with low powers, to enable one to recognise the tissue under examination, and to examine in many cases the topographical distribution of masses of bacteria. With a power of about 250 diams. (one-sixth), very many bacteria can be distinguished; and with the oil immersion lenses the minutest bacilli and micrococci can be recognised, and the exact form of individual bacteria accurately determined. As most good modern instruments are provided with a triple nose-piece, there is no loss of time in examining a preparation successively with these different powers.

**Weigert's Method.**—A very useful method for staining both the tissue and the bacteria is as follows: Place the sections for from six to eighteen hours in a 1 per cent. watery solution of any of the basic aniline dyes (methyl violet, gentian violet, fuchsine, Bismarck brown). To hasten the process, place the capsule containing the solution in the incubator, or heat it to 45° C. A stronger solution may also be employed, in which case the sections are far more rapidly stained, and are easily over-stained. In the latter case



they must be treated with a half-saturated solution of carbonate of potash. In either case the sections are next washed with distilled water, and passed through 60 per cent. alcohol into absolute alcohol. When almost decolorised, spread out the section carefully on a platinum lifter and transfer it to clove-oil, or stain with picro-carmin solution (Weigert's) for half an hour, wash in water, alcohol, and then treat with clove-oil. After the final treatment with clove-oil, transfer with the platinum lifter to a clean glass slide. Dry the preparation by pressure with a piece of filter-paper folded several times, and preserve in Canada balsam, dissolved in xylol.

**Gram's Method.**—In the method of Gram sections are stained for ten minutes in a capsule containing aniline-gentian-violet solution. Great care must be taken not to injure the sections. If there is any difficulty in finding them, it is best to carefully pour off the stain and fill up the capsule with water. The sections are then readily visible, and can be taken up on the end of a glass rod and placed in the iodine and iodide of potassium solution, where they remain for two or three minutes, until stained uniformly brown and resembling in appearance a boiled tea-leaf. They are then placed in absolute alcohol, and washed by carefully moving the sections in the liquid with a glass rod. When completely decolorised they are spread out on a lifter, and transferred to clove-oil until completely clarified. Each is transferred with a lifter to a slide, and the clove-oil is run off and then completely removed by gently pressing two or three layers of filter-paper upon the section. Finally, the section is mounted in Canada balsam.

The process of decolorisation may be hastened by transferring the section from alcohol to clove-oil, and back again to alcohol, repeating this two or three times.

On examination the tissue appears colourless, or slightly tinged yellow from too long immersion in the iodine solution, while the micro-organisms are stained blue or blue-black.

Double staining is obtained by transferring the sections after decolorisation to eosin, Bismarck brown, or vesuvin. They are left in a watery solution for two or three minutes, then again washed in alcohol, before clarifying in clove-oil and mounting in balsam.

Another instructive method is to place the decolorised sections in picro-carminate of ammonia for three or four minutes, and then treat with alcohol and clove-oil.

A similar result is obtained by placing the sections in Orth's solution (picro-lithium carmine), transferring to acidulated alcohol, and then passing through clove-oil and mounting in balsam.



In Ehrlich's method delicate sections are liable to be injured by immersion in the nitric acid, and therefore Watson-Cheyne suggested the use of formic acid.

The Ziehl-Neelsen method, in which sulphuric acid is used instead of nitric acid, is much to be preferred to Ehrlich's method.

**Ziehl-Neelsen Method.**—The solution is warmed, and sections left in it for ten minutes. The red colour, which disappears when the section is placed in weak sulphuric acid (25 per cent.), may partly return when the section is placed in water. In this case the section must be again immersed in acid and passed backwards and forwards from acid to water until the red colour has completely, or almost completely, disappeared. It must be thoroughly washed in water to remove all traces of the acid, and then placed in a watery solution of methylene blue for two or three minutes, washed again in water, immersed in alcohol, clarified in clove-oil, and mounted in the usual way. Sections are brilliantly stained, and the results are very permanent.

Many special methods of staining have been introduced, and will be given in subsequent chapters with the description of the bacteria to which they apply. The methods already described are those which are more or less in constant use in studying bacteria and in conducting original researches.



## CHAPTER IX.

### PREPARATION OF NUTRIENT MEDIA AND METHODS OF CULTIVATION.

To cultivate micro-organisms artificially, and, in the case of the pathogenic bacteria, to fulfil the second of Koch's postulates, they must be supplied with nutrient material free from pre-existing micro-organisms. Hitherto various kinds of nutrient liquids have been employed, and in many cases they still continue to be used with advantage, but for general use they have been, in a great measure, supplanted by the methods of cultivation on sterile solid media about to be described. The advantages of the latter methods are numerous. In the first place, in the case of liquid media, in spite of elaborate precautions and the expenditure of much labour and time, it was almost impossible or extremely difficult to obtain a pure culture. When a drop of liquid containing several kinds of bacteria is introduced into a liquid medium, we have a mixed cultivation from the very first. If in the struggle for existence some bacteria were unable to develop in the presence of others, or a change of temperature and soil allowed one form to predominate over another, then we might be led to the conclusion that many bacteria were but developmental forms of one and the same micro-organism; while possibly the contamination of such cultures might lead to the belief in the transformation of a harmless into a pathogenic bacterium. The secret of the success of Koch's methods greatly depends upon the possibility, in the case of starting with a mixture of micro-organisms, of being able to isolate them completely one from another, and to obtain an absolutely pure growth of each cultivable species. When sterile nutrient gelatine has been liquefied in a tube and inoculated with a mixture of bacteria in such a way that the individual micro-organisms are distributed throughout it, and the liquid is poured out on a plate of glass and allowed to solidify, the individual bacteria, instead of moving about freely as in a liquid medium, are fixed in one spot, where they develop individuals of

## DESCRIPTION OF PLATE II.

### Pure-cultivations of Bacteria.

- FIG. 1.—*In the depth of Nutrient Gelatine.* A pure-cultivation of Koch's comma-bacillus (*Spirillum cholerae Asiaticæ*) showing in the track of the needle a funnel-shaped area of liquefaction enclosing an air-bubble, and a white thread. Similar appearances are produced in cultivations of the comma-bacillus of Metchnikoff.
- FIG. 2.—*On the surface of Nutrient Gelatine.* A pure-cultivation of *Bacillus typhosus* on the surface of obliquely solidified nutrient gelatine.
- FIG. 3.—*On the surface of Nutrient Agar-agar.* Pure-cultivation of *Bacillus indicus* on the surface of obliquely solidified nutrient agar-agar. The growth has the colour of red sealing-wax, and a peculiar crinkled appearance. After some days it loses its bright colour and becomes purplish, like an old cultivation of *Micrococcus prodigiosus*.
- FIG. 4.—*On the surface of Nutrient Agar-agar.* A pure-cultivation obtained from an abscess (*Staphylococcus pyogenes aureus*).
- FIG. 5.—*On the surface of Nutrient Agar-agar.* A pure-cultivation obtained from green pus (*Bacillus pyocyaneus*). The growth forms a whitish, transparent layer, composed of slender bacilli, and the green pigment is diffused throughout the nutrient jelly. The growth appears green by transmitted light, owing to the colour of the jelly behind it.
- FIG. 6.—*On the surface of Potato.* A pure-cultivation of the bacillus of glanders on the surface of sterilised potato.



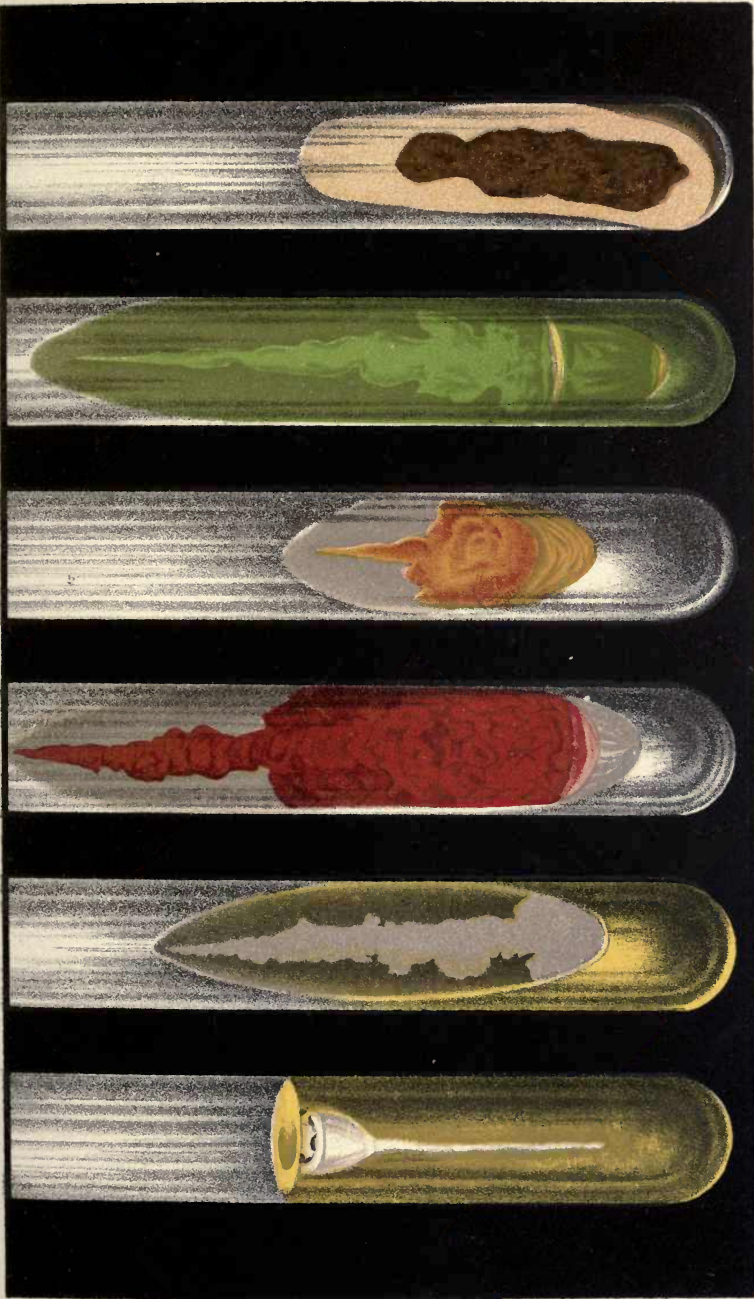

Fig. 6.

Fig. 5.

Fig. 4.

Fig. 3.

Fig. 2.

Fig. 1.

PURE-CULTIVATIONS.





squeezing through a linen cloth or a meat press. The red juice thus obtained must be brought up to a litre by transferring it to a large measuring glass and adding distilled water. It is then poured into a sufficiently large and strong beaker, and set aside after the addition of 10 grammes of peptone, 5 grammes of common salt and 100 grammes of best gelatine.

In about half an hour the gelatine is sufficiently softened, and subsequent heating in a water-bath causes it to be completely



FIG. 30.—HOT AIR STERILISER.

dissolved. The danger of breaking the beaker may be avoided by placing a cloth, several times folded, at the bottom of the water-bath.

The next process requires the greatest care and attention. Some micro-organisms grow best in a slightly acid, others in a neutral or slightly alkaline, medium. For example, for the growth and characteristic appearances of the comma bacillus of Asiatic cholera a faintly alkaline soil is absolutely essential. This slightly alkaline medium will be found to answer best for most micro-organisms, and may be obtained as follows :—

With a clean glass rod dipped in the mixture, the reaction upon litmus-paper may be ascertained, and a concentrated solution of carbonate of soda must be added drop by drop, until red litmus-

paper becomes faintly blue. If it has been made too alkaline, it can be neutralised by the addition of lactic acid.

Finally, the mixture is heated for an hour in the water-bath. Ten minutes before the boiling is completed, the white of an egg beaten up with the shell is added, and the liquid is then filtered while hot. For the filtration, the hot-water apparatus (Fig. 31) can be used with advantage, furnished with a filter of Swedish

paper, which may be conveniently made in the following way:—

About eighteen inches square of the best and stoutest filter paper is first folded in the middle, and then creased into sixteen folds. The filter is made to fit the glass funnel by gathering up the folds like a fan, and cutting off the superfluous part. The creasing of each fold should be made firmly to within half an inch of the apex of the filter, which part is to be gently inserted into the tube of the funnel. To avoid bursting the filter at the point, the broth, when poured out from the flask, should be directed against the side of the filter with a glass rod. During filtration the funnel should be covered over with a circular plate of glass, and the process of filtration must be repeated, if necessary, until a pale, straw-coloured, perfectly transparent filtrate results.

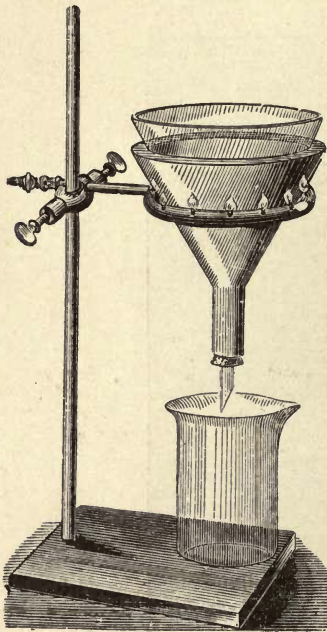

FIG. 31.—HOT-WATER FILTERING APPARATUS.

The sterilised test-tubes are filled to about a third of their depth by pouring in the gelatine carefully and steadily, or by employing a small sterilised glass funnel. The object of this care is to prevent the mixture touching the part of the tube with which the plug comes into contact; otherwise, when the gelatine sets, the cotton-wool adheres to the tube and becomes a source of embarrassment in subsequent procedures. As the tubes are filled they are placed in the test-tube basket, and must then be sterilised. They are either lowered into the steam steriliser, when the thermometer indicates  $100^{\circ}\text{C}$ ., for twelve minutes for four or five successive days, or they



may be transferred to the test-tube water-bath, and heated for an hour a day for three successive days.

If the gelatine shows any turbidity after these processes it must

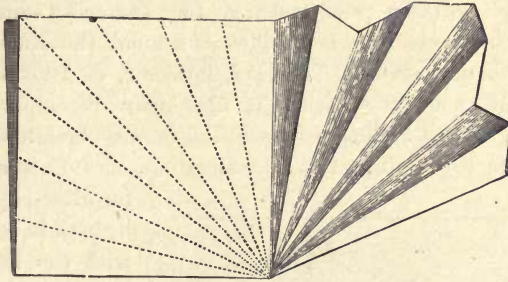

FIG. 32.—METHOD OF MAKING A FOLDED FILTER.

be poured back from the test-tubes into a flask, boiled up for ten minutes, and filtered once more, and the processes of sterilisation just described must be repeated.

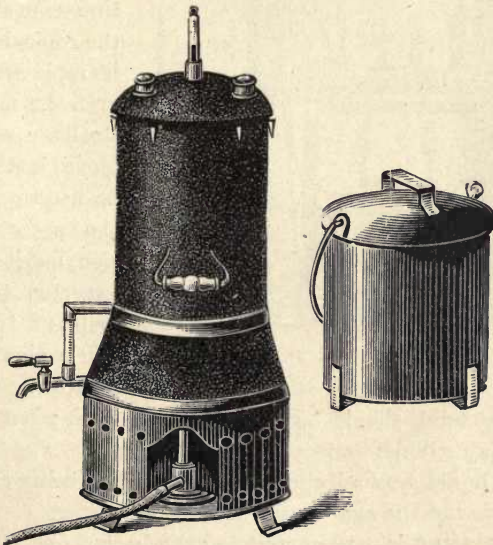

FIG. 33.—STEAM STERILISER.

**Nutrient Agar-agar.**—Agar-agar is a substance prepared from seaweed which grows on the coasts of Japan and India, and is supplied in long crinkled strips. It boils at 90° C., and

remains solid up to a temperature of about  $45^{\circ}$  C. It is therefore substituted for gelatine in the preparation of a jelly for the cultivation of those bacteria which will only grow, or grow best, in the incubator at the temperature of the blood. It may also be employed at ordinary temperatures for bacteria which liquefy gelatine. The preparation is conducted on much the same principles as those already described. Instead, however, of 100 grammes of gelatine, only about 20 grammes of agar-agar are employed (1.5 to 2 per cent.), and to facilitate its solution it must be allowed to soak in salt water overnight. For the filtration, flannel is substituted



FIG. 34.—INCUBATOR.

for filter-paper, or may be used in combination with the latter. The hot-water apparatus is invariably employed, unless, to accelerate the process, the glass funnel and receiver are bodily transferred to the steam steriliser. If the conical cap cannot be replaced, cloths laid over the mouth of the steriliser must be employed instead. It may be necessary to repeat the process of filtration, but it must not be expected that such a brilliant transparency can be obtained as with gelatine. The final

result, when solid, should be colourless and clear; but if slightly milky, it may still be employed.

A little liquid gradually collects in the tubes, being expressed by the contraction of the agar-agar.

**Wort-gelatine** is used in studying the bacteria of fermentation. It is made by adding from 5 to 10 per cent. of gelatine to beer-wort.

**Glycerine Agar-agar.**—This is prepared by adding 5 per cent. of glycerine to nutrient agar-agar, after the boiling and before the filtration, and other modifications can be made for special purposes by the addition of grape-sugar or of gelatine.



After the final treatment in the steam steriliser some of the tubes of gelatine and agar-agar are placed upright and allowed to set, and others are placed on an inclined plane or in the blood-serum inspissator, and left to gelatinise with an oblique surface.

(B) METHODS OF EMPLOYING NUTRIENT JELLY IN TEST-TUBES  
AND ON GLASS PLATES.

**Test-tube-cultivations.**—To inoculate test-tubes containing nutrient jelly, the cotton-wool plug is first twisted round in case there are any adhesions between the plug and the test-tube. It is then removed with the thumb and index finger of the right hand, and placed between the fourth and fifth fingers of the left hand, instead of being put down on the laboratory table and thereby probably contaminated with bacteria or the spores of mould fungi. A sterilised needle charged, for example, with blood or pus containing bacteria, or with a colony from a plate-culture, is thrust once in the middle line into the nutrient jelly, and steadily withdrawn. The tube should be held horizontally or with its mouth downward, to avoid, as far as possible, accidental contamination from the gravitation of germs in the air; and the plug replaced as quickly as possible. The cotton-wool projecting beyond the mouth of the tube is then thoroughly burnt in the flame of a Bunsen burner or blow-pipe, and an india-rubber cap fitted over the mouth of the tube

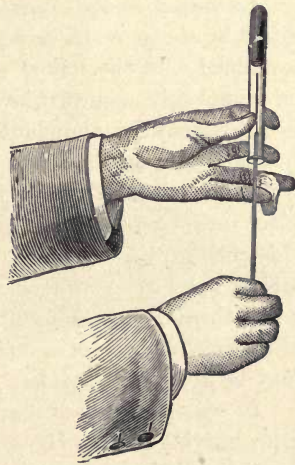

FIG. 35.—METHOD OF INOCULATING A TEST-TUBE CONTAINING STERILE NUTRIENT JELLY.

The chances of error arising from contamination of the cultivations are reduced by avoiding draughts at the time of inoculation, and it is best that these manipulations should be carried on in a quiet room in which the tables and floor are wiped with damp cloths, rather than in a laboratory in which the air becomes charged with germs through constant sweeping and dusting, and the entrance and exit of classes of students. In conducting any investigation a dozen or more tubes should be inoculated, and if by chance an adventitious germ, in spite of all precautions, gains an entrance,

the contaminated tube can be rejected, and the experiments continued with the remaining pure cultivations.

When, however, one tube containing a liquid medium is inoculated from another, as in the process of preparing plate-cultures, or when a culture is made from a tube in which the growth has liquefied the gelatine, it is obvious that the tubes cannot be inverted or held horizontally, and they must then be held and inoculated as in Fig. 38. To inoculate those tubes of nutrient media which have been solidified obliquely, the point of a straight sterilised needle charged with the material to be cultivated is traced over the surface of the jelly from below upwards, or the inoculated material may be spread out with a hooked or looped needle.

*Examination of Test-tube-cultivations.*—The appearances produced by the growths in test-tubes can be in most cases sufficiently examined with the naked eye. In some cases the jelly is partially or completely liquefied, while in others it remains solid. The growths may be abundant or scanty, coloured or colourless. The nutrient jelly may itself be tinged or stained with products resulting from the growth of the organisms. When liquefaction slowly takes place in the needle track, or the organism grows without producing this change, the appearances which result are often very delicate, and in some cases very characteristic. The appearance of a simple white thread, of a central thread with branching lateral filaments, of a cloudiness, or of a string of beads in the track of the needle, may be given as examples.

In some cases much may be learnt by examining the growth with a magnifying glass. Here, however, a difficulty may be encountered, for the cylindrical form of the tube so distorts the appearance of its contents, that the examination is rendered somewhat difficult. To obviate this, a very simple contrivance may be employed with advantage. This consists of a rectangular vessel, about four inches in height and two inches in width, which may be easily constructed by cementing together two slips of glass to form the back and front, with three slips of stout glass with ground edges forming the sides and base (Cheshire). The front may be constructed of thin glass, and the base of the vessel made to slope so that the test-tube when placed in the vessel has a tendency to be near the front. The vessel is filled with a mixture of the same refractive index as the nutrient gelatine. The latter has a refractive index rather higher than water, which is about 1.333; alcohol has a refractive index of 1.374. The vessel is filled with water, and alcohol is then added until the proper density is reached. The test-tube is placed in the



vessel, and held in position by means of a clip. The vessel can be fixed on the inclined stage of the microscope, and the contents of the tube conveniently examined with low-power objectives.

**Plate-cultivations.**—By this method, as already mentioned, a mixture of bacteria, whether in fluids, excreta, or in cultivations on solid media, can be so treated that the different species are isolated one from the other, and perfectly pure cultivations of each of the cultivable bacteria in the original mixture established in various nutrient media. We are enabled also to examine under a low power of the microscope the individual colonies of bacteria, and to distinguish by their characteristic appearances, micro-organisms which, in their individual form, closely resemble one another, or are even identical. The same process, with slight modification, is also employed in the examination of air, soil, and water, which will be referred to later.

The preparation of plate-cultivations, therefore, must be described in every detail; and to take an example, we will suppose that a series of plates is to be prepared from a test-cube-cultivation.

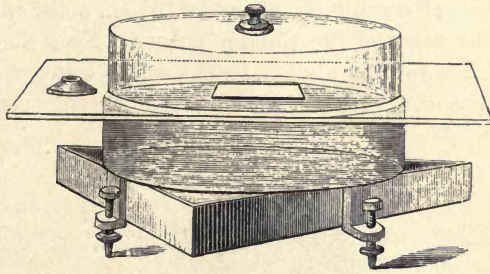

FIG. 36.—LEVELLING APPARATUS.

*Arrangement of Levelling Apparatus.*—In order to spread out the liquid jelly evenly on the surface of a glass plate, and hasten its solidification, it is necessary to place the glass plate upon a level and cool surface. This is obtained in the following manner: Place a large shallow glass dish upon a tripod stand, and fill it to the brim with cold water; carefully cover the dish with a slab of plate-glass, or a pane of window-glass, and level it by placing the spirit-level in the centre and adjusting the screws of the tripod. Substitute for the spirit-level a piece of filter-paper the size of the glass plates to be employed, and cover it with a shallow bell-glass.

*Sterilisation of Glass Plates.*—The glass plates are sterilised in an iron box placed in the hot-air steriliser, at 150° C., from one to two hours. As these plates are used also for other purposes, a quantity ready sterilised should always be kept in the box.

*Preparation of Damp Chambers.*—The damp chambers for the reception of the inoculated plates are prepared thus: Thoroughly

cleanse and wash out with 1 in 20 carbolic acid a shallow glass dish and bell. Cut a piece of filter-paper to line the bottom of the glass dish, and moisten it with the same solution.

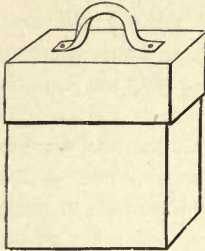

FIG. 37.—IRON BOX FOR GLASS PLATES.

*Method of Inoculating the Test-tubes.*—In a glass beaker or an ordinary glass tumbler, with a pad of cotton-wool at the bottom, place the tube containing the cultivation, the three tubes to be inoculated, three glass rods which have been sterilised by heating in the flame of a Bunsen burner, and a thermometer. Provide a strip of paper, a large label, a pencil, a pair of forceps, and inoculating needles. All is now ready at hand to commence the inoculation of the tubes.

Liquefy the gelatine in the three tubes by placing them in a beaker containing water at 30° C., or by gently warming them in the flame of the Bunsen burner. Keep the tubes, both before and after the inoculation, in the warm water, to maintain the gelatine in a state of liquefaction. Hold the tube containing the cultivation

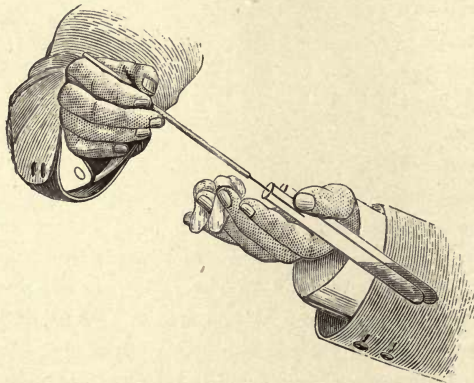

FIG. 38.—METHOD OF INOCULATING TEST-TUBES IN THE PREPARATION OF PLATE-CULTIVATIONS.

and a tube of the liquefied gelatine as nearly horizontal as possible between the thumb and index finger of the left hand. With the index finger and thumb of the right hand loosen the plugs of the tubes. Take the looped platinum needle in the right hand and hold it like a pen. Remove the plug from the culture-tube by using the fourth and fifth fingers of the right hand as forceps, and place it between





## DESCRIPTION OF PLATE III.

### **Plate-cultivation.**

This represents the appearance of a plate-cultivation of the comma-bacillus of Cholera nostras, when it is examined over a slab of blackened plate-glass. The drawing was made from a typical result of thinning out the colonies by the process of plate-cultivation. At this stage they were completely isolated one from the other; but later they became confluent, and produced complete liquefaction of the gelatine.



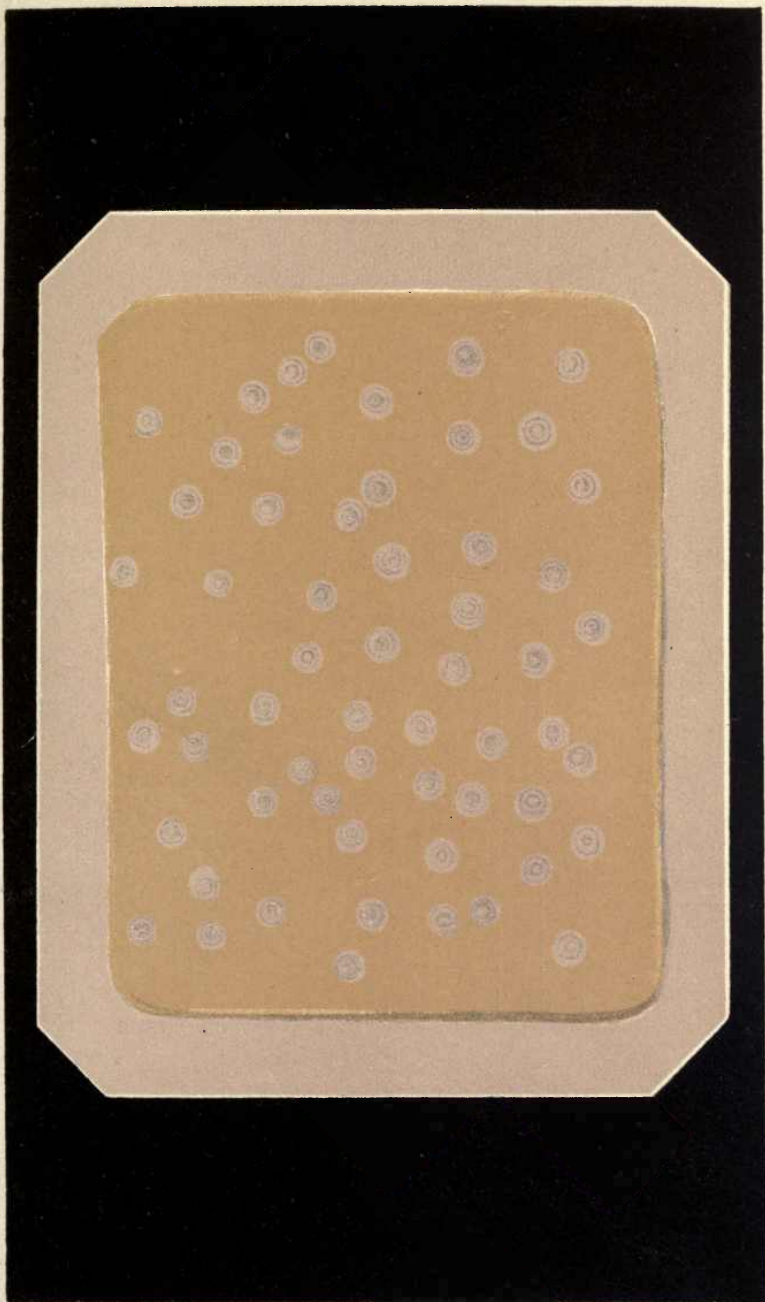

PLATE - CULTIVATION.





the fourth and fifth fingers of the left. Remove the plug of the other tube in the same way, placing it between the third and fourth fingers of the left hand. With the needle take up a droplet of the cultivation and stir it round in the liquefied jelly. Replace the plugs, and set aside the cultivation. Hold the freshly inoculated tube between the index finger and thumb of either hand, almost horizontally, then raise it to the vertical, so that the liquid gelatine gently flows back. By repeating this motion and rolling the tube between the fingers and thumbs the micro-organisms which have been introduced are distributed throughout the gelatine. Any violent shaking, and consequent formation of bubbles, must be carefully avoided. From the inoculated tube, in the same manner inoculate a fresh tube of liquefied gelatine, introducing into it three droplets with a sterilised needle. After tilting and rolling this tube, as in the previous case, the same process is repeated with a third tube, which is inoculated from the second tube. This last tube must be inoculated in different ways, according to experience, for different micro-organisms. Sometimes a sufficient separation of the micro-organisms is attained by inoculating the last tube with a straight, instead of a looped, needle, dipping it from the one into the other from three to five times.

The next process consists in pouring out the gelatine on glass plates and allowing it to solidify.

*Preparation of the Gelatine-Plates.*—The directions to be observed in pouring out the gelatine are as follows :—

Place the box containing sterilised plates horizontally, and so that the cover projects beyond the edge of the table; remove the cover, and withdraw a plate with sterilised forceps; hold it between the finger and thumb by opposite margins, rapidly transfer it to the filter-paper under the bell-glass, and quickly replace the cover of the box. On removing the plug from the tube which was first inoculated, an assistant raises the bell-glass, and the contents of the tube are poured on to the plate; with a glass rod the gelatine must be then rapidly spread out in an even layer within about half an inch of the margin of the plate. The assistant replaces the bell-glass, and the gelatine is left to set. Meanwhile a glass bench or metallic shelf is placed in the damp chamber, ready for the reception of the plate-cultivation, and when the gelatine is quite solid the plate is quickly transferred from under the bell-glass to the damp chamber; precisely the same process is repeated with the other tubes, and the damp chamber, labelled with the details of the experiment, is set aside for the colonies to develop. Not only plate-cultures should be carefully labelled with date and description, but

the same remark applies equally to all preparations—tube-cultures, potato-cultures, drop-cultures, etc.

Corresponding with the fractional cultivation of the micro-organisms obtained in this manner, the colonies will be found to develop in the course of a day or two, the time varying with the temperature of the room. The lower plate will contain a countless number of colonies which, if the micro-organism liquefies gelatine, speedily commingle, and produce, in a very short time, a complete liquefaction of the whole of the gelatine. On the middle plate the colonies will also be very numerous, but retain their isolated position for a longer time; while on the uppermost plate the colonies are completely isolated from one another, with an appreciable surface of gelatine intervening.

*Examination of Plate-cultivations.*—The macroscopical appearances of the colonies are best studied by placing the plate on a

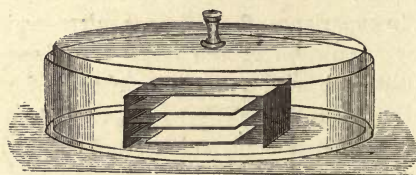

FIG. 39.—DAMP CHAMBER CONTAINING PLATE-CULTIVATIONS.

slab of blackened glass, or on a porcelain slab if the colonies are coloured.

To examine the microscopical appearances, a selected plate is placed upon the stage of the microscope. The smallest diaphragm is employed, and the appearances studied principally with a low power. These appearances should be carefully noted, and a sketch or photograph of the colony made. The morphological characteristics of the micro-organisms of which the colony is formed can be examined in the following way: A small looped or hooked platinum needle is held like a pen, and the hand steadied by resting the little finger on the stage of the microscope. The extremity of the needle is steadily directed to the space between the lens and the gelatine without touching the latter, until, on looking through the microscope, it can be seen in the field, above or by the side of the colony under examination. The needle is then dipped into the colony, steadily raised, and withdrawn. Without removing the eye from the microscope this manipulation can be seen to be successful by the colony being disorganised or



completely removed from the gelatine. It is, however, not easy to be successful at first, but with practice this can be accomplished with rapidity and precision. A preparation is then made by rubbing

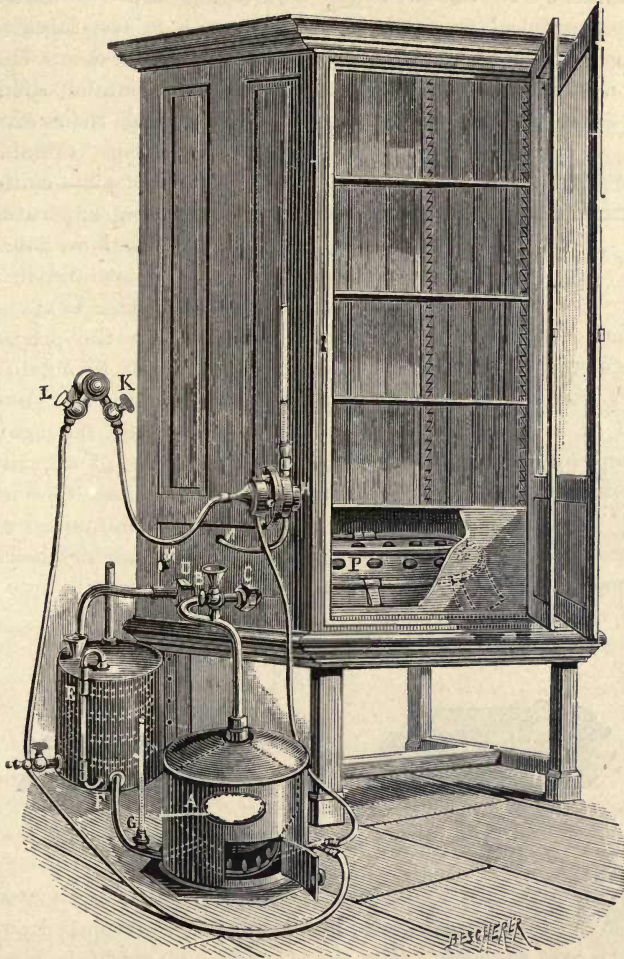

FIG. 40.—PASTEUR'S LARGE INCUBATOR.

the extremity of the needle in a droplet of water on a slide, covering with a cover-glass, and examining in the fresh state, or by spreading out the droplet on a cover-glass, drying, passing three times through the flame, and staining with a drop of fuchsine or gentian violet.

Inoculations should be made in test-tubes of nutrient gelatine



and agar-agar, from the micro-organisms transferred to the cover-glass before it is dried and stained, from any remnants of the colony which was examined, or from other colonies bearing exactly similar appearances. In this way pure cultivations are established, and the macroscopical appearances of the growth in test-tubes can be obtained. The plates should be replaced in the damp chamber as soon as possible; drying of the gelatine, or contamination with micro-organisms gravitating from the air during their exposure, may spoil them for subsequent examination.



FIG. 41.—PETRI'S DISH.

A much simpler method of plate-cultivation is to dispense with the levelling apparatus, and pour the liquefied jelly into shallow, flat dishes. They take up much less room, and in many ways are more convenient (Fig. 41).

Nutrient agar-agar can also be employed for the preparation of plate-cultivations, but it is much more difficult to obtain satisfactory results. The test-tubes of nutrient agar-agar must be placed in a beaker with water and heated until the agar-agar is completely liquefied. The gas is then turned down, and the temperature of the water allowed to fall until the thermometer stands just above  $50^{\circ}$  C. The water must be maintained at this temperature, and the test-tubes must be in turn rapidly inoculated and poured out upon the glass plates, or better still, into glass dishes, as already described.

A very much simpler plan is to liquefy the agar, pour it into



FIG. 42.—GLASS BENCHES AND SLIDES.

a shallow dish, and allow it to solidify. The culture material is thinned out in sterilised broth, and a few drops are spread out over the surface of the agar. The dishes are then placed in the incubator at  $37^{\circ}$  C.

Glass plates may also be employed in a much simpler way. The nutrient jelly is liquefied, poured out, and allowed to set. A needle charged with the material to be inoculated is then drawn in lines over the surface of the jelly. This method is of use for inoculating different organisms side by side, and watching the effect of one upon the other, or a micro-organism in this way may be



sown upon the gelatine which has been already altered by the growth of another micro-organism; the change produced in the gelatine, as in the case of the *Bacillus pyocyaneus*, extending far beyond the limits of the growth itself.

Nutrient jelly may also be spread out on sterilised glass slides, which after inoculation are placed in damp chambers for the growths to develop.

**Esmarch's Roll-cultures.**—Esmarch introduced a modification of the method of plate-cultivation which may sometimes be used with advantage. The ordinary test-tubes may be employed, or tubes considerably larger in size.

After the liquid jelly has been inoculated in the tube, instead of pouring it out on to a glass plate or into a dish, the cotton-wool plug is replaced, and an india-rubber cap fitted over the mouth of the tube.

The tube is then placed horizontally on a block of ice or in a vessel containing iced water. The neck of the tube is steadied with the left hand, and the tube turned round and round with the right hand. In a very short time the gelatine sets, and the tube is lined inside with a thin coating. There is far less danger of contamination, and the cultures are in a much more convenient form when circumstances render it necessary to move them.

#### (c) PREPARATION AND EMPLOYMENT OF SOLIDIFIED BLOOD SERUM.

**Solid Blood Serum.**—The tubercle-bacillus, the bacilli of glanders and of diphtheria, and many other micro-organisms, thrive well when cultivated on solid blood serum. This medium has the additional advantage of remaining solid at all temperatures. The technique required for its preparation and sterilisation is as follows: Several cylindrical vessels, about 20 cm. high, are thoroughly washed with carbolic acid (1 in 20), and then with alcohol, and finally rinsed out with ether. The ether is allowed to evaporate, and the vessels are then ready for use. The skin of the animal selected—calf, sheep, or horse—is washed with carbolic at the seat of operation, and the bleeding performed with a sterilised knife or a trocar and cannula. The first jet of blood from the vein is rejected, and that which follows is allowed to flow into the vessels until they are almost full. The ground-glass stoppers, greased with vaseline, are replaced, and the vessels set aside in ice, as quickly as possible, for from twenty-four to thirty hours. By that time the separation of the clot is completed, and the clear serum can then be transferred to

plugged sterilised test-tubes. These should be filled, with a sterilised pipette, to about one-third of their capacity.

Formerly the tubes were sterilised by Tyndall's process of discontinuous sterilisation. The tubes were placed in Koch's serum steriliser, with the temperature maintained for an hour or more at  $56^{\circ}$  C., and this was repeated for six successive days, the temperature on the last day being gradually raised to  $60^{\circ}$  C. This completed the sterilisation, and to solidify the serum the tubes were arranged in the inspissator at the angle required, and the temperature was kept between  $65^{\circ}$  C. and  $68^{\circ}$  C. Directly solidification took place the tubes were removed.

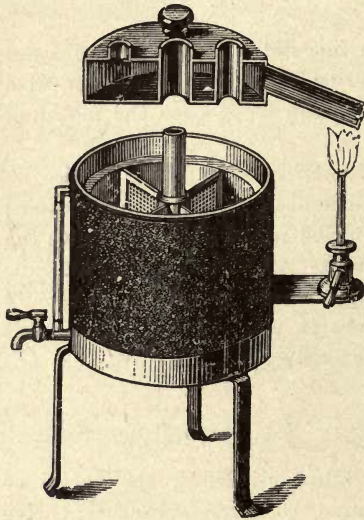

FIG. 43.—Koch's Serum Steriliser.

The new process is much less tedious, and consists in taking every possible precaution to obtain the blood without contamination by bacteria in the air or in the vessels employed. There is then no need to sterilise the serum, and it can be coagulated immediately. The tubes are tested by placing them in an incubator at  $37^{\circ}$  C. for a week, and if any show signs of contamination they are discarded, and the rest can be used or kept in stock.

The serum should then present the character of being hard, solid, of a pale straw colour, and transparent. A little liquid collects at the lowest point, and the serum is sometimes milky in appearance at its thickest part.

*Löffler's Blood Serum* is prepared by mixing two-thirds of fresh serum with one-third of broth, prepared in the usual way but with the addition of 1 per cent. grape-sugar. The mixture is decanted into test-tubes, avoiding the formation of air-bubbles, and it is then coagulated in the usual way. The serum may be employed not only in test-tubes, but also in small flasks, glass capsules, or other vessels, all of which must be cleansed and sterilised.

Hydrocele fluid and other serous effusions may be prepared in the same manner. Gelatine may be added to the serum in the proportion of 5 per cent.



*Inoculation of the Tubes.*—A small portion of a culture or of the material to be inoculated is taken up with a sterilised platinum needle, and traced over the sloping surface of the serum; or a fragment of tissue, such as diphtheritic membrane or tubercle, may be introduced into the tube and rubbed gently over the serum so as not to break the surface.

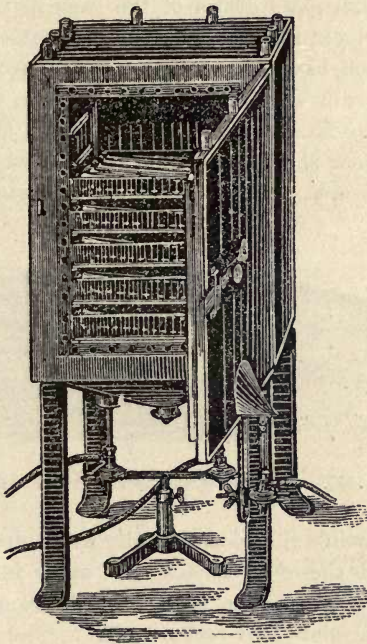

FIG. 44.—HUEPPE'S SERUM INSPISSATOR.

#### (D) PREPARATION AND EMPLOYMENT OF STERILISED POTATO.

**Potato-cultivations.**—Sterilised potatoes form an excellent medium for the cultivation of many micro-organisms, more especially the chromogenic species. Potato-cultivations also give in some cases very characteristic appearances, which are of value in distinguishing bacteria which possess morphological resemblances.

*Preparation of Sterilised Potatoes.*—Potatoes, preferably smooth-skinned, which are free from "eyes" and rotten spots, should be selected. If they cannot be obtained without eyes and spots, these must be carefully picked out with the point of a knife. The potatoes are well scrubbed with a stiff brush, and allowed to soak in 1 in 20 carbolic for a few minutes. They are then transferred to the potato-

receiver, and steamed in the steam steriliser for twenty minutes to half an hour, the time varying according to the size of the potatoes. When cooked, the potato-receiver is withdrawn and left to cool, the potatoes being retained in it until required for use.

Damp chambers are prepared ready for the potatoes, the vessels being cleansed and washed with carbolic as described for plate-cultivations. Small glass dishes of the same pattern as the large ones may be employed for single halves of potatoes. Potato-knives and scalpels, which have been sterilised in an iron box by heating them in the hot-air steriliser at  $151^{\circ}$  C. for one hour, should be ready to hand. Knives sterilised by heating them in the flame of a Bunsen burner should afterwards be placed upon a sterilised glass plate and covered with a bell-glass. It must not be forgotten,

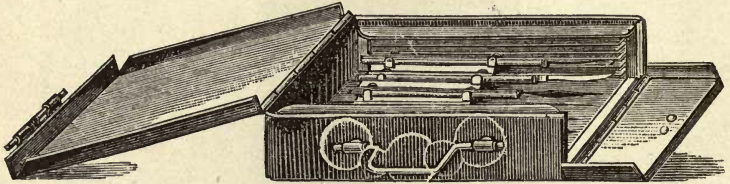

FIG. 45.—BOX FOR STERILISING INSTRUMENTS.

however, that heating the blades in the flame destroys the temper of the steel, and therefore knives and other instruments should preferably be sterilised in the hot-air steriliser, enclosed in an iron box, or simply enveloped in cotton-wool.

*Inoculation of Potatoes.*—The coat-sleeves should be turned back, and the hands, after thorough washing with good lathering soap, be dipped in 1 in 40 carbolic. An assistant opens the potato-receiver, and a potato is selected and held between the thumb and index finger of the left hand. With the knife held in the right hand, the potato is almost completely divided in the direction which will give the largest surface. The assistant raises the cover of the damp chamber, and the potato is introduced, and while the knife is withdrawn, allowed to fall apart. The cover is quickly replaced, and another potato treated in the same way, is placed in the same damp chamber. The four halves are then quite ready for inoculation. As an extra precaution, the left hand is again dipped in carbolic, and one half of a potato is taken up between the tips of the thumb and index finger, care being taken to avoid touching the cut surface. Holding it with its cut surface vertical,



a small portion of the substance to be inoculated is placed on the centre with a sterilised platinum needle. With a sterilised scalpel the inoculated substance is rapidly spread over the surface of the potato with the flat of the blade, to within a quarter of an inch of the margin, and the potato is then as quickly as possible replaced in the damp chamber. With another sterilised scalpel a small portion of the potato from the inoculated surface of the first half is in the same way spread over the surface of the second half, thus thinning out the bacteria as in plate-cultivations. Exactly the same is repeated with a third potato, and even a fourth, so that a still further thinning out or fractional cultivation of the micro-organisms may be obtained. In some cases it is necessary to place the cultures in an incubator (Fig. 40); others grow very well at the

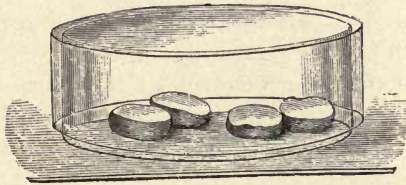

FIG. 46.—DAMP CHAMBER FOR POTATO-CULTIVATIONS.

temperature of the room. As in plate-cultivations, the potato may also be inoculated by simply streaking it in lines with a needle charged with the material to be cultivated.

*Potato in Test-tubes.*—Large surfaces of potato are employed when we wish to obtain cultures of micro-organisms in considerable quantities, as in the examination of the products of chromogenic bacteria; but under ordinary circumstances potato is employed in test-tubes. The central portions of raw potatoes are cut out in cylindrical pieces with a cork-borer. These are divided obliquely in their whole length, and each half is placed in a test-tube. The test-tubes are plugged with cotton-wool, and then steam in the steam-steriliser for twenty minutes. The sloping surface is inoculated in the same way as obliquely solidified jelly, and the advantages are great. The cultures are obtained in a more convenient form, and there is less danger of contamination.

*Potato-paste* may be employed when it is desirable to obtain an extensive growth of certain bacteria. The potatoes are boiled for an hour, and the floury centre squeezed out of the skins. This is then mashed up with sufficient sterilised water to produce a thick

paste, and is heated in the steam steriliser for half an hour for three successive days.

(E) PREPARATION AND EMPLOYMENT OF BREAD-PASTE, VEGETABLES, FRUIT, WHITE OF EGG.

Some micro-organisms, more especially mould fungi, grow very well on *bread-paste*. This is prepared by removing the crust from slices of bread and drying them in the oven. They are then broken up, and reduced to a fine powder with a pestle and mortar. Small, carefully cleansed, conical, or globe-shaped flasks are plugged with cotton-wool and sterilised in the oven. When cool, a small quantity of the powder is placed in them, and sterilised water added in the proportion of one part to every four of the powder. The paste is sterilised by steaming in the steriliser at 100° C. for half an hour for three successive days. The flasks can be reversed, and may be inoculated with a platinum needle.

Boiled carrots and other vegetables, and various kinds of stewed fruit, are also occasionally employed for the cultivation of bacteria. The sterilisation of these media must be carried out on the principles already explained.

White of egg may be solidified in shallow glass dishes, in the steam steriliser. After inoculation the dishes should be placed in a damp chamber.

LIQUID MEDIA.

(F) PREPARATION OF STERILISED BROTH, LIQUID BLOOD SERUM, URINE, MILK, VEGETABLE INFUSIONS, AND ARTIFICIAL NOURISHING LIQUIDS.

Nutrient liquids are still largely employed. For inoculation experiments when the presence of gelatine is undesirable, for studying the physiology and chemistry of bacteria, and when for any object a rapid growth of micro-organisms is necessary, the employment of liquid media is not only advisable, but absolutely necessary. Liquid media comprise two distinct groups—*natural* and *artificial*. Natural media include meat broth, blood, urine, milk, and vegetable infusions; artificial media are solutions composed from a chemical formula representing essential food constituents.

**Broth** may be made from beef, pork, chicken, or fish in the manner which has been described for the preparation of nutrient gelatine, simply with omission of the gelatine. After the process



of neutralisation with carbonate of soda solution, the flask of broth is placed in the steam steriliser for half an hour at  $100^{\circ}$  C. A clear liquid results on filtration which is transferred to plugged sterilised flasks or test-tubes, and sterilisation effected by exposing them in the steam steriliser for half an hour at  $100^{\circ}$  C. for two

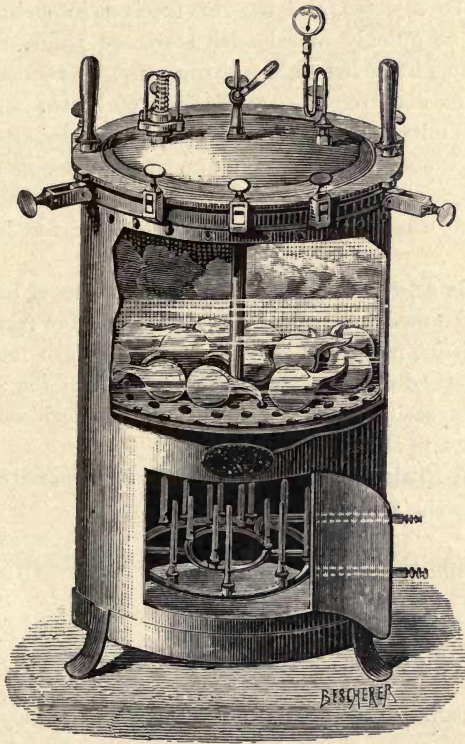

FIG. 47.—APPARATUS FOR STERILISATION BY STEAM UNDER PRESSURE.

or three successive days, or by using the apparatus for sterilising by steam under pressure. For some bacteria a more suitable cultivating medium is obtained by the addition of glycerine or grape-sugar.

**Liquid Blood Serum.**—The preparation of blood serum has already been described. It may be required for cultivations before the final treatment by which it is solidified, for example, in the method of drop-cultivation, and may be used with the addition of glycerine or grape-sugar. Hydrocele fluid, peritonitic and pleuritic

effusions, can also be employed after sterilisation in the steam steriliser. The fluid should be withdrawn with a sterilised trocar and cannula, and received into plugged sterilised flasks.

**Urine.**—In order to obtain urine free from micro-organisms the following precautions must be observed: The orifice of the urethra must be thoroughly cleansed with weak carbolic. The first jet of urine should be rejected, and the rest received into sterilised vessels, which must be quickly closed with sterilised plugs. If these precautions be not attended to, the urine must be rendered sterile by the means described for the sterilisation of broth.

**Milk.**—If milk has been drawn into sterile flasks, after thoroughly cleansing and disinfecting the teats and hands, it may be kept without change. If procured without these precautions, it must be steamed in the steriliser for half an hour for five successive days.

**Vegetable and other Infusions.**—Infusions of hay, cucumber, and turnip are used for special purposes, and more rarely decoctions of plums, raisins, malt, and horse-dung. They are mostly prepared by boiling with distilled water, after maceration for several hours. The filtrate is received into sterile flasks and sterilised in the usual way in the steam steriliser.

**Artificial Fluids.**—Pasteur's solution is prepared by mixing the ingredients in the following proportions:—

Distilled water . . . . .	100
Pure cane-sugar . . . . .	10
Ammonium tartrate . . . . .	1
Ash of yeast . . . . .	·075

Mayer's modification of the nourishing fluid employed by Cohn is as follows:—

Distilled water . . . . .	20
Ammonium tartrate . . . . .	·2
Phosphate of potassium . . . . .	·1
Sulphate of magnesium . . . . .	·1
Tribasic calcium phosphate . . . . .	·01

**Drop-cultures.**—This method of cultivation is a particularly instructive one. It enables us to study many of the changes which take place during the life history of micro-organisms. This is illustrated, for example, in a drop-culture of the anthrax bacillus, in which we can watch the gradual growth of a single bacillus into



a long filament, and the subsequent development of bright oval spores. It is necessary carefully to observe the minutest details in order to maintain the cultivation pure. An excavated slide is thoroughly cleaned, and then sterilised by being held with the cupped side downwards in the flame of the Bunsen burner. A ring of vaseline is painted round the excavation, and the slide is then placed under a glass bell. Meanwhile a carefully cleansed cover-glass is also sterilised by passing it through the flame, and should be deposited on a sterilised glass plate. With a sterilised looped needle, a drop of sterile broth is transferred to the cover-glass, and this is inoculated by touching it with another sterilised needle charged with the material to be examined, without disturbing the form of the drop. It is quite sufficient just to touch the drop

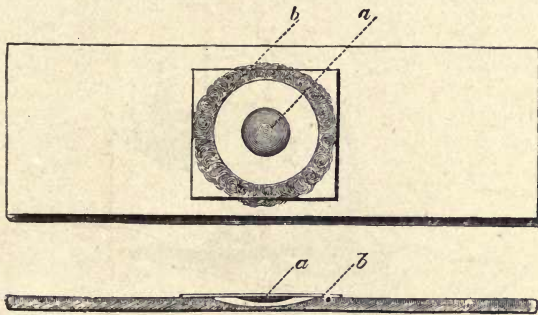

FIG. 48.—DROP CULTIVATION.  
(a) Drop of broth; (b) layer of vaseline.

instead of transferring a visible quantity of blood, juice, or growth, as the case may be. The slide is then inverted and placed over the cover-glass, so that the drop will come exactly in the centre of the excavation, and is gently pressed down. On turning the slide over again the cover-glass adheres, and an additional layer of vaseline is painted round the edges of the cover-glass itself. The slide must be labelled, and if necessary, placed in the incubator, and the results watched from time to time. Instead of broth, liquid blood serum may be employed in this form of cultivation. If it is required to preserve the drop-cultivation as a microscopic preparation, the cover-glass is gently lifted off and allowed to dry. Any vaseline adhering to the cover-glass should be wiped off, and the cover-glass can then be passed through the flame and stained in the usual manner.

*Moist Cells.*—Unless drop-cultures are very carefully prepared

they are liable to dry up, if kept for examination for several days. Many therefore prefer employing a moist cell, of which there are several different forms in use.

The drop-culture slide may be converted into a moist cell by having a deep groove cut round the circumference of the concavity. This groove is filled with sterilised water by means of a pipette. A ring of vaseline is painted with the camel's-hair brush outside the groove, and the cover-glass, with the drop-cultivation, is inverted and placed over the concavity. This form is very useful, as the slide can be easily cleansed and effectually sterilised by holding it in the flame of the Bunsen burner.

A very simple form of moist cell recommended by Schäfer

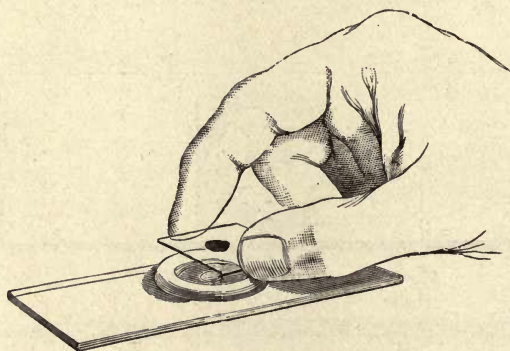

FIG. 49.—SIMPLE METHOD OF FORMING A MOIST CELL.

may be used in some cases, but possesses the disadvantage of not admitting of sterilisation by heat. A small piece of putty or modelling wax is rolled into a cord about two inches long and  $\frac{1}{8}$  inch thick. By uniting the ends a ring is formed, which is placed on the middle of a clean glass slide. A drop of water is placed in the centre of the ring, and the cell roofed in by applying a cover-glass.

A cell somewhat similar in form, which has the advantage of permitting of thorough cleansing, may be constructed by cementing a glass ring with flat surfaces to an ordinary slide. Vaseline is applied with a camel's-hair brush to the upper surface of the ring, and one or two drops of water placed with a pipette at the bottom of the cell. The cover-glass, with the preparation, is then inverted over the cell and gently pressed down upon the glass ring. The vaseline renders the cell air-tight, and, to a certain extent, fixes the cover-glass to the ring.



*Warm Stages.*—To apply warmth while a preparation is under continuous observation, we must either place the microscope bodily

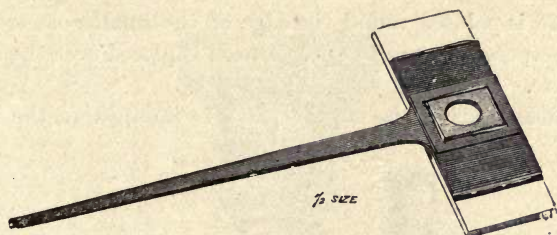

FIG. 50.—WARM STAGE.

within a special incubator, with the eye-piece protruding through an opening, or we must employ some means of applying heat directly to the preparation.

A simple warm stage may be made of an oblong copper plate,

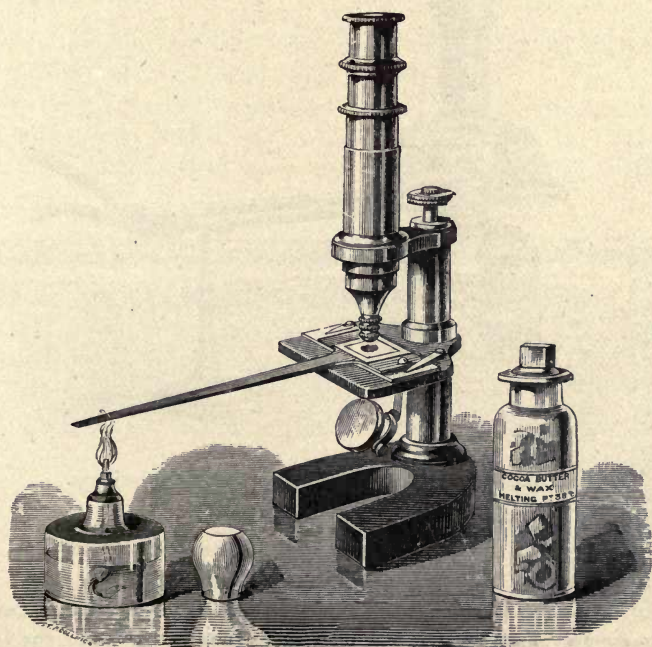

FIG. 51.—WARM STAGE SHOWN IN OPERATION.

two inches long by one inch wide, from one side of which a rod of the same material projects. The plate has a round aperture in the

middle, half an inch in diameter, and is fastened to an ordinary slide with sealing-wax. The drop to be examined is placed on a large-sized cover-glass and covered with a smaller one. Olive oil or vaseline is painted round the edge of the smaller cover-glass to prevent evaporation, and the preparation is placed over the aperture in the plate.

The slide bearing the copper plate is clamped to the stage of

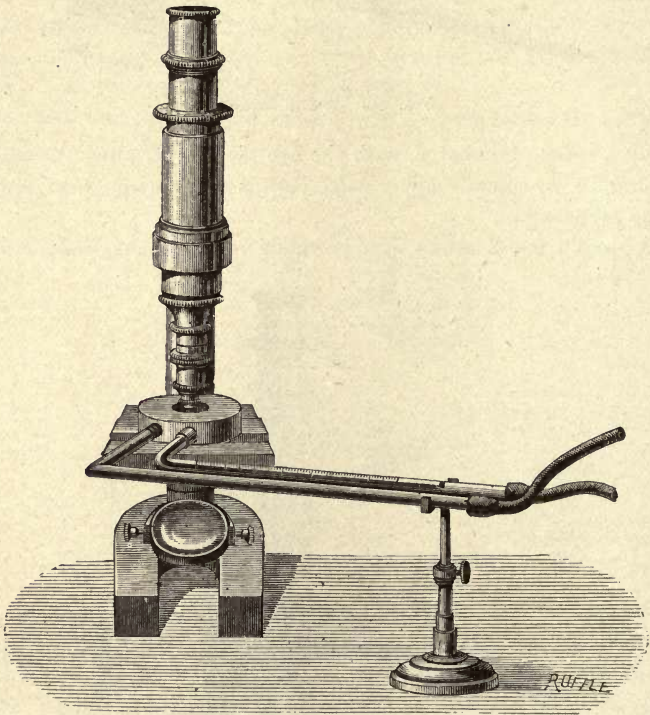

FIG. 52.—ISRAEL'S WARMING APPARATUS IN OPERATION.

the microscope. The flame of a spirit-lamp is applied to the extremity of the rod, and the heat is conducted to the plate and thence transmitted to the specimen. In order that the temperature of the copper plate may be approximately that of the body, the lamp is so adjusted that a fragment of cacao butter and wax, placed close to the preparation, is melted.

*Israel's Warming Apparatus.*—It is obvious that in employing very high powers a difficulty will be presented by the warm stages



commonly used for accurate observations, such as Schäfer's or Stricker's, owing to their interference with the illumination. To

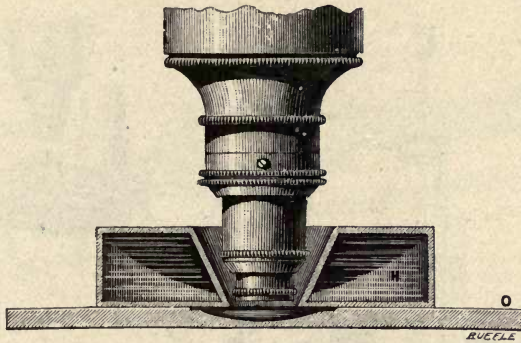

FIG. 53.—SECTION OF ISRAEL'S WARMING APPARATUS AND DROP-CULTURE SLIDE,

overcome this an apparatus has been constructed by which the slide is warmed from above (Figs. 52, 53).

The drop-culture slides are provided with a shallow groove, .1 mm. deep and 1 mm. broad, cut round the concavity. Into this the cover-glass fits, so that its upper surface is level with that of

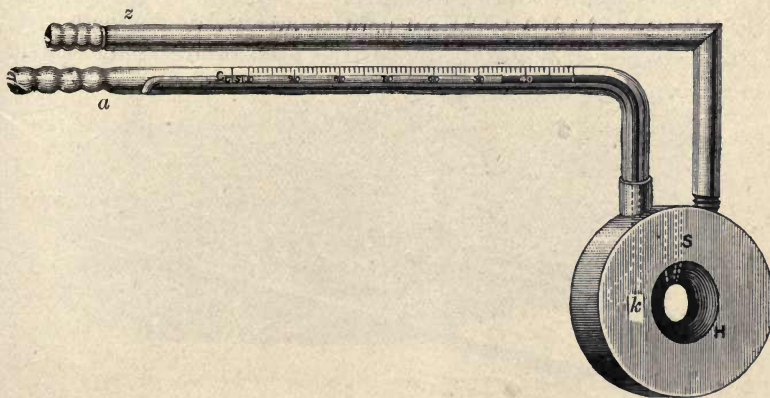

FIG. 54.—ISRAEL'S WARMING APPARATUS.

the slide. The heating apparatus consists of a flat disk-shaped box with a central conical aperture.

The entrance and exit pipes are fixed on at a right angle to the

side (Fig. 54). The former, *z*, is of metal, and the latter, *a*, of glass fitted with a thermometer, the bulb of which, *k*, is contained within the box. A partition, *s*, keeps up a current between the openings

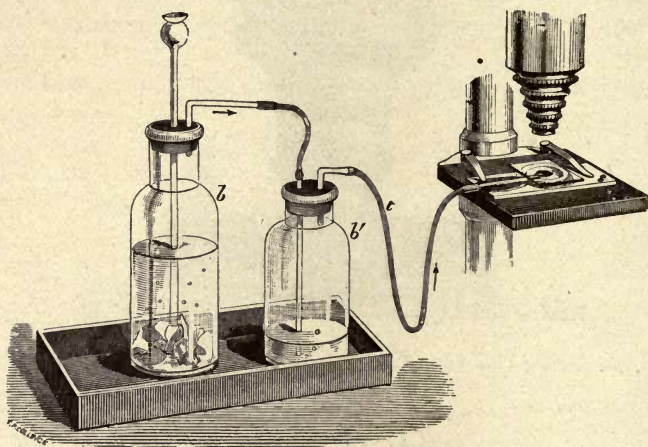

FIG. 55.—GAS CHAMBER IN USE WITH APPARATUS FOR GENERATING CARBONIC ACID.

of the pipes, which are supported on a stand and connected by tubing with the hot-water supply.

A mixture of paraffine and vaseline is recommended for indicating the temperature of the chamber, and experience has shown that if a temperature of  $37^{\circ}$  C. is required the temperature of the water in the box must range between  $42^{\circ}$  and  $47^{\circ}$  C.

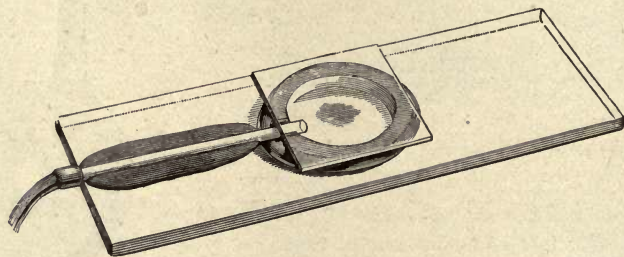

FIG. 56.—GAS CHAMBER.

*Gas Chambers.*—To investigate the action of gases or vapours upon micro-organisms, a modification of the moist cell may be employed.

A piece of glass tubing is first fixed to the slide by means of



sealing-wax, and the ring of putty is so placed as to include one end of it, leaving a small interval at the side, or a little notch is made in the putty opposite, so as to afford an exit for the gas or vapour.

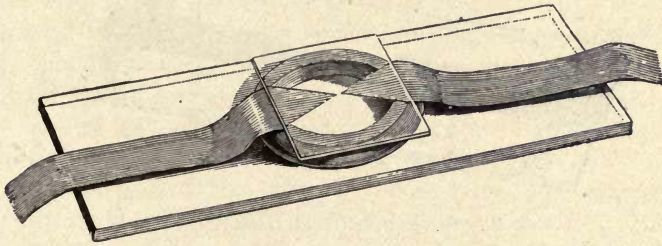

FIG. 57.—MOIST CELL ADAPTED FOR TRANSMISSION OF ELECTRICITY.

*Application of Electricity.*—To study the effect of electricity we may prepare a drop-culture in the moist cell. The cover-glass to be used is provided with two strips of tinfoil, which are

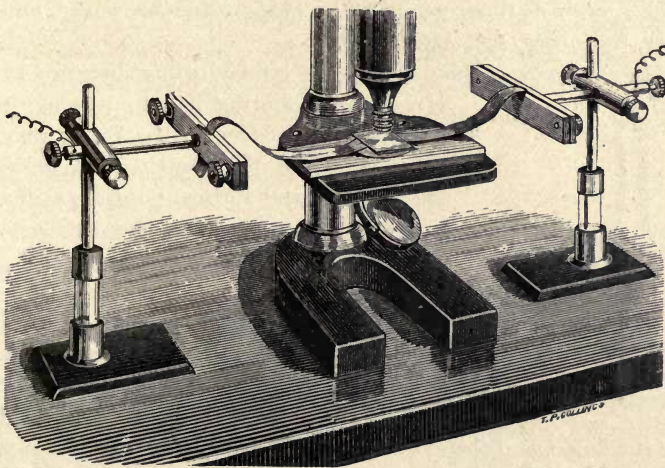

FIG. 58.—APPARATUS ARRANGED FOR TRANSMITTING ELECTRICITY.

isolated from the brass of the microscope, and so arranged that a current of electricity may be passed through them.

A much simpler plan, which may also be employed, is to take an ordinary glass slide and coat the surface with gold-size. The

slide is then pressed firmly down on gold-leaf or tinfoil and allowed to dry. When dry, the metal is scraped away, leaving two triangles with a small interval between them.

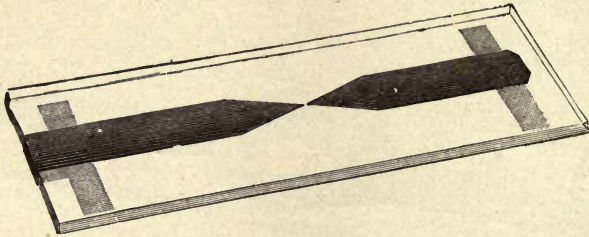

FIG. 59.—SLIDE WITH GOLD-LEAF ELECTRODES.

The liquid containing the micro-organisms is placed between the electrodes, covered with a cover-glass, and then subjected to the electric current.

(G) METHODS OF EMPLOYING AND STORING LIQUID MEDIA.

Cultivations in liquid media can be carried on in test-tubes, but it is more satisfactory to employ special forms of flasks, bulbs, and U tubes, such as those employed by Pasteur and his school, and by Lister, Sternberg, and Aitken.

*Lister's Flasks.*—These flasks were especially introduced by Lister as a means of storing liquid nutrient media. They are so constructed that after removal of a portion of the contents, on restoring the vessel to the vertical position, a drop of liquid always remains in the extremity of the nozzle, which prevents regurgitation of unfiltered air.

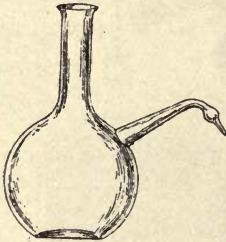

FIG. 60.—LISTER'S FLASK.

*Sternberg's Bulbs.*—The method of introducing liquid into the bulb employed by Sternberg, and of sterilising and inoculating it, is as follows: The bulb is heated slightly

over the flame, and the extremity of the neck, after the sealed point has been broken off, is plunged beneath the surface of the liquid. As the air cools the liquid is drawn into the bulb, usually filling it to about one-third of its capacity. The neck of the flask is again sealed up, and the liquid which has been introduced is sterilised by repeatedly boiling the flasks in the water-bath.



FIG. 61.—STERNBERG'S BULB.

They should then be placed in the incubator for two or three days;



and if the contents remain transparent and free from film, they may be set aside as stock-bulbs, to be used when required.

To inoculate the liquid in the bulb the end of the neck is heated to sterilise the exterior, the bulb is gently warmed, and the extremity of the neck nipped off with a pair of sterilised forceps. The open extremity is plunged into the liquid containing the micro-organisms, and a minute quantity enters the tube and mingles with the fluid in the bulb without fear of contamination by atmospheric germs. The extremity of the neck is once more sealed up in the flame of a Bunsen burner.

*Aitken's Tubes.*—These tubes are plugged and sterilised, and the nutrient medium introduced as into ordinary test-tubes. Instead of withdrawing the cotton-wool plug, they are inoculated through a lateral arm. The sealed extremity of the arm is nipped off with sterilised forceps, and the inoculating needle is carefully introduced through the opening thus made. It is directed along the arm until it touches the opposite side of the test-tube, where it deposits the material with which it was charged. The needle is withdrawn, and the end of the lateral arm again sealed up in the flame; the test-tube is then tilted until the liquid touches the deposited material; on restoring the tube to the vertical, the material is washed down with the nutrient liquid.



FIG. 62.—AITKEN'S TUBE.

*Miquel's Bulbs.*—The *tube à boule* of Miquel is also a very useful form. It consists of a bulb of 50 cc. capacity, blown in the middle of a glass tube. The part of the tube above the bulb is contracted in two places, and can either be left quite straight or made to curve slightly. Between the contractions the tube is plugged with asbestos. The portion of the tube below the bulb is S shaped, and drawn out at its extremity into a fine point. The bulb is charged with nutrient liquid and inoculated by aspiration, and the point of the S tube sealed in the flame of a Bunsen burner.

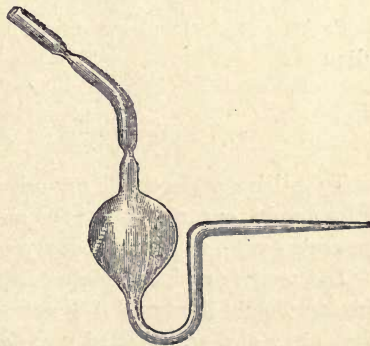

FIG. 63.—MIQUEL'S BULB.

*Pasteur's Apparatus.*—Special forms of tubes, bulbs, and pipettes are employed by the school of Pasteur. The tubes are provided

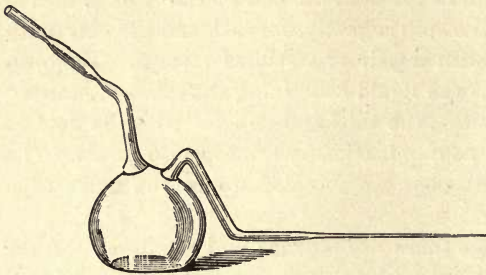

FIG. 64.—PASTEUR'S FLASK.

with lateral or with curved arms drawn out to a fine point, and with slender necks plugged with cotton-wool. A double form (Fig. 65) shaped like a tuning-fork, each limb with a bent arm, is convenient for storing sterilised broth. The

sealed end of an arm is nipped off with sterilised forceps, the sterile broth aspirated into each limb, and the arm again sealed in the flame; a series of such tubes can be arranged upon a rack on the working table.

Bulbs with a vertical neck drawn out to a fine point, others with a neck bent at an obtuse angle, plugged with cotton-wool, and a lateral curved arm drawn out to a fine point, are also employed. For a description of these various vessels and their special advantages, the works of Pasteur and Duclaux must be consulted.



FIG. 65.—PASTEUR'S DOUBLE TUBE.

#### (H) CULTIVATION OF ANAEROBIC BACTERIA.

To cultivate anaerobic organisms the same media are employed as for aerobic organisms, but the methods must be modified, or special apparatus used, so that the oxygen in the air may be excluded.

In the preparation of plate-cultivations, before the film of gelatine has completely hardened it is covered with a sheet of mica, and the edges are sealed with melted paraffine. By this process the air is not completely excluded, so that only those organisms which are not strictly anaerobic can be grown by this method. Liborius recommends boiling a considerable volume of gelatine in a tube, cooling it, and after thoroughly distributing the organisms in the still liquid jelly, rapidly solidifying it by placing the tube in iced water. By this



process very little air re-enters the jelly, and colonies of even strictly anaerobic bacteria will develop in the lower part of the tube. The drawback is the difficulty encountered in examining the colonies, and in preparing sub-cultures. For this purpose the tube must be broken, or carefully warmed until the jelly can be shaken out.

Esmarch first prepares a roll culture, and when the gelatine film has set, the tube is completely filled with liquefied gelatine which has been cooled down almost to the temperature at which it solidifies. The same difficulty arises as in the previous method, in the examination of the colonies.

Buchner places the culture tube inside a much larger tube containing a small quantity of pyrogallic acid and closed with a gutta-percha cap. The pyrogallic acid absorbs the oxygen, but the method is not altogether successful.

The most satisfactory plan is to exhaust the air with an air pump, or to substitute an atmosphere of hydrogen which does not affect the growth of the bacteria.

Various forms of flasks and tubes for cultivating bacteria have been devised, which can be easily connected with an exhausting apparatus, and readily sealed by the flame of the blowpipe when the air has been removed.

If hydrogen is employed the most convenient plan is to use a Kipp's apparatus, from which the hydrogen is passed through two bottles, one containing a solution of lead, to remove any sulphuretted hydrogen, and the other pyrogallic acid, to intercept any oxygen.

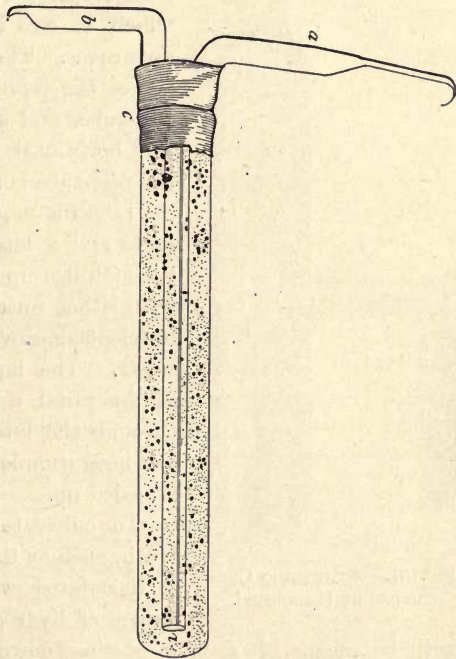

FIG. 66.—FRÄNKEL'S ANAEROBIC TUBE-CULTURE  
*a, a*, Glass tube through which hydrogen is passed; *b*, exit tube; *c*, india-rubber stopper coated externally with paraffin (FRANKLAND).

In the method recommended by Fränkel a tube of gelatine is liquefied, and inoculated. A gutta-percha stopper is substituted for the cotton-wool plug (Fig. 66). It is perforated by two holes, through which two tubes pass which are bent at a right angle. One tube only just passes through the stopper, the other reaches

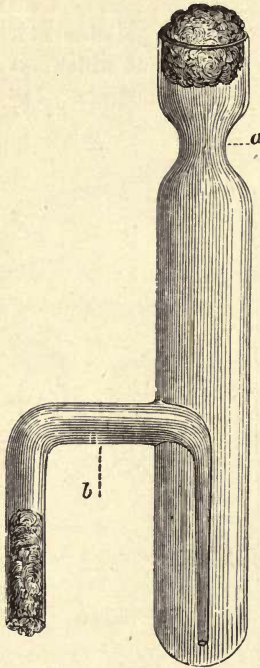

FIG. 67.—ANAEROBIC CULTURE-TUBE (LIBORIUS).

down to the bottom of the test-tube. The horizontal part of each tube has a narrow neck. The long tube has a plug of sterilised cotton-wool, and is connected, with a short piece of india-rubber tubing by which it can be connected with Kipp's apparatus. The hydrogen drives the air out of the liquefied jelly and out of the test-tube, and after about half an hour the horizontal tubes are sealed up, and the test-tube is made into a roll culture.

Liborius employs a tube with a narrow neck and a lateral arm (Fig. 67). The tube is filled up to the height of the arm with either nutrient agar or a mixture of nutrient agar with 2 per cent. of grape-sugar. The liquefied jelly is inoculated in the usual way, and hydrogen passed through the lateral arm. When the air has been completely driven out, the tube is sealed up.

To cultivate anaerobic organisms in broth, such as the tetanus bacillus, a flask is inoculated with the bacillus, and a stream of hydrogen is passed through the

broth by means of a tube passing down to the bottom of the flask. The air in the flask escapes by a lateral arm which is bent down at a right angle, and immersed in a capsule of mercury. When the air has been completely expelled the entrance tube is hermetically sealed, and the mercury in the capsule prevents any air from re-entering the flask by the lateral arm (Fig. 68).

#### METHOD OF FIXING CULTURES.

The colonies in plate-cultivations and the growths of bacteria in test-tubes may be stopped at any stage of their growth, and permanently fixed by exposing the culture to the fumes of formic



aldehyde. The test-tubes, dishes, or capsules are placed in a cylindrical glass vessel containing a pledget of cotton-wool moistened with

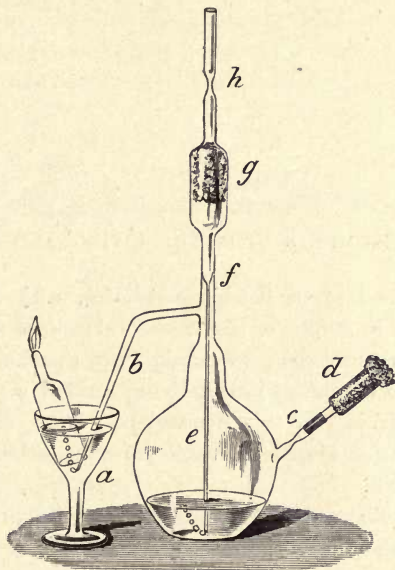

FIG. 68.—APPARATUS FOR ANAEROBIC CULTURES.  
(ROSCOE AND LUNT.)

formic aldehyde. The vessel is fitted with a ground glass stopper and set aside. The growth almost immediately ceases. Any liquefied gelatine is hardened, so that the exact appearances of cultures are obtained in a permanent form.

## CHAPTER X.

### EXPERIMENTS UPON THE LIVING ANIMAL.

To carry out the last of Koch's postulates, and so complete the chain of evidence in favour of the causal relation of micro-organisms to disease, and to study the mode of action of a pathogenic bacterium, it is necessary to introduce into a living animal a pure cultivation of the micro-organism or its chemical products. For this purpose various animals are employed, such as mice, rabbits, guinea-pigs, pigeons, and fowls.

*Inhalation.*—The animals may be made to inhale an atmosphere impregnated with micro-organisms by means of a spray. In this way Friedländer succeeded in administering the bacteria of pneumonia to mice; and the production of tuberculosis by experimental inhalation has thrown light upon the clinical records of cases reported as instances of the infectiousness of phthisis.

*Ingestion.*—A sheep fed upon potatoes which have been the medium for the cultivation of the anthrax bacillus dies in a few days. Rabbits fed on cabbage sprinkled with a culture of the bacillus of fowl cholera, rapidly succumb to the disease. Animals fed upon the nodules of bovine tuberculosis or upon tubercular flesh and milk will be readily infected.

Milk, or bread soaked in milk, is a very convenient medium, and from a public health point of view, a most instructive way of administering and testing the effect of pathogenic bacteria.

*Vaccination and Subcutaneous Inoculation.*—Vaccination may be performed by making a few superficial scratches and inoculating the wound with a sterilised platinum needle charged with the micro-organisms. Another simple method is to take a sterilised scalpel, infect the point with the material to be inoculated, and then make a minute puncture or incision. In either case a situation should be selected, such as the root of the ear, which cannot be licked by the animal after the operation.



Subcutaneous inoculation is very simple and effectual, and consequently the method most frequently employed. The animal selected—for example, a guinea-pig—is held by an assistant, who covers it with a towel, leaving only the hind extremities exposed. By so doing, and gently laying it upon its back, with its head low, a guinea-pig passes apparently into a state of hypnotism, and the

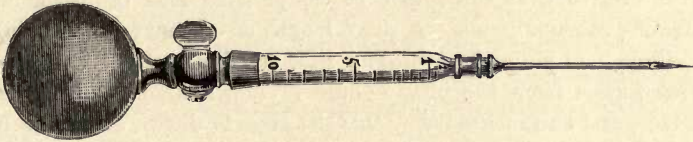

FIG. 69.—Koch's SYRINGE.

trivial operation can be performed with little or no movement on the part of the animal. From a spot on the inner side of the thigh the hair is cut close with a small pair of scissors curved on the flat, and the skin must be thoroughly purified with 1 in 20 carbolic acid. A small fold of skin is then pinched up with a pair of sterilised forceps, and with a pair of sharp sterilised scissors, or with a tenotomy knife, a minute incision is made. A sterilised platinum loop is charged with the material to be inoculated, and the loop is gently inserted under the skin, forming a small pocket in the subcutaneous tissue. The needle is then withdrawn, and the sides of the wound gently pressed into apposition and painted over with collodion.

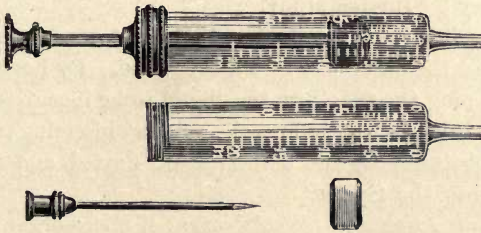

FIG. 70.—SYRINGE WITH ASBESTOS PLUG.

In inoculating a mouse the same process is adopted, with the exception that the root of the tail is the usual site of the operation.

In some cases it may be necessary to inoculate cultures diffused in sterilised salt solution, or blood or lymph containing bacteria, or a culture in broth, or a filtrate containing the toxic products,

and then a hypodermic syringe may be required. One of the ordinary pattern may be used, but it is very much better to employ a syringe which has been especially constructed to admit of thorough disinfection. Koch's syringe is a convenient form, the liquid being expressed by pressure on a rubber ball.

The author has generally preferred to improvise a substitute for the hypodermic syringe which can be quickly made, and is destroyed after use, so that there can be no possible risk of accidentally infecting other animals. A short length of ordinary glass-tubing is sterilised, and plugged at one end with sterilised cotton-wool; about three inches from the plug a bulb is blown about the size of a marble, and two inches below this the glass is drawn out into a long capillary tube. A sufficient quantity of the liquid to be injected rises up into the tube by capillary attraction, or can be drawn up by means of an india-rubber ball, until the bulb is full. The point of the capillary tube is inserted through the opening in the skin, and gently pushed into the subcutaneous tissue, and then withdrawn for a short distance. By pressure on the bulb the contents of the tube are injected. In dealing with chemical products there is no risk in applying the lips and blowing out the contents of the tube, or indeed of filling it by suction, for if too much force were applied the liquid which might enter the mouth would be stopped by the cotton-wool plug.

A number of these capillary tubes can be placed in a small case, and when it is necessary to go to a distance to investigate an outbreak, they will be found most convenient to bring back lymph or blood to the laboratory for further study.

Sternberg takes a piece of glass-tubing, blows a bulb at one end, and draws out the other end into a thin tube. By heating the bulb and then dipping the tube into the liquid to be inoculated the latter rises in the tube as the bulb cools. After inserting the point of the tube subcutaneously the bulb is again heated, and the liquid is forced out into the tissues.

*Intravenous Injection.*—A cultivation of micro-organisms may be mixed with sterilised water, and then injected with a syringe directly into the circulation. This may be performed without much difficulty by injecting, with a hypodermic syringe, the large vein at the base of the ear in rabbits, or the jugular vein in large animals.

*Special Operations.*—In many cases it is absolutely necessary to perform an operation of greater severity. After the administration of an anæsthetic, infective material may be inserted, or injected, into the peritoneal cavity, or injected into the duodenum in the manner



employed in the case of Koch's comma bacilli by Nicati and Rietsch. In such cases antiseptic precautions must be rigidly followed, and use made of iodoform and other antiseptic dressings. The disinfection of the skin of the animal, of the instruments employed, and of the hands of the operator, are details essential to secure success.

To inoculate tubercular matter, sputum may be rubbed up with distilled water, and some of the mixture injected into a tracheal fistula; or the first steps of the operation of iridectomy may be performed and tubercular material inserted into the anterior chamber of the eye, but this method is only justifiable when it is absolutely necessary for the results and changes to be observed from day to day.

To inoculate rabbits or other animals with the virus of rabies, the skull is trephined, and an emulsion prepared from the spinal cord of a rabid animal is injected beneath the dura mater.

Before every inoculation the instruments must be sterilised in a hot-air steriliser or by immersion in boiling water in a flat dish or enamel tray heated by a spirit-lamp, and after each operation all instruments should be placed in carbolic acid (1 in 20) or in boiling water, wiped dry, and again sterilised in the hot-air steriliser, before they are put away. If these precautions are not observed, instances of accidental infection are sure to occur.

After the inoculation is completed a careful record must be made of the date and details of the experiment. The form in which the virus was used, the quantity employed, and the seat of inoculation, must be taken into account. The animals must be kept under close observation, the temperature taken, and any signs of illness, such as ceasing to feed, difficulty in breathing, staring coat, and any local signs, such as the development of a tumour or an enlargement of the lymphatic glands, must be carefully noted.

It is perhaps hardly necessary to add that in this country no experiments of any kind may be performed on living animals without a license.

#### METHOD OF DISSECTION AND EXAMINATION.

All animals that die after an experimental inoculation should be examined immediately after death. Every precaution must be taken in conducting the dissection, to exclude extraneous micro-organisms, and all instruments employed must have been sterilised in the hot-air steriliser, or by immersion in boiling water. If a mouse, for example, has died after inoculation with anthrax, it should be at

once pinned out by its feet on a slab of wood or in a gutta-percha tray, and bathed with 1 in 40 carbolic. In the same way, before examining a dead rabbit, a stream of carbolic should be directed over it to lay the fur, which otherwise interferes with the dissection. The hair should be cut away with sterilised scissors from the seat of inoculation, which is the first part to be examined, and any suppuration, hæmorrhage, œdema, or other pathological change should be carefully noted. From any pus or exudation that may be present, material for inoculations should at once be taken, and cover-glass-preparations made for microscopical examination.

To examine the internal organs and to make inoculations from the blood of the heart or spleen, the skin is cut through from below upwards in the median line of the abdominal and thoracic regions. The abdominal cavity is then opened, and the walls pinned back on either side of the animal. Any abnormal appearances in the peritoneum should be noted, and the state of the spleen should be carefully examined by turning the intestines aside. After noting its appearances, it should be removed with sterilised forceps and scissors, and deposited upon a sterilised glass slide, and incised with sterilised scissors. The cut surface is then touched with the point of a sterilised inoculating needle, and cultures are made in test-tubes of nutrient gelatine and agar-agar, and also on potato, and in broth in the form of drop-cultivations. Precisely the same care must be taken in examining lymphatic glands, tubercles, or pathological nodules; any chance putrefactive micro-organisms on the surface should be destroyed by carbolic acid or the actual cautery; an incision is then made, and a minute fragment snipped out of the centre of the nodule, which can be inoculated in the living animal or transferred to a cultivating medium.

The examination of the thorax is made by cutting through the ribs on either side of the sternum with sterilised scissors, and turning the sternum up where it will be out of the way. The pericardium is then opened, and the right auricle or ventricle pierced with the point of a sterilised scalpel, and inoculations and cover-glass-preparations are made from the blood which escapes.

The lungs also require to be especially studied. They should be incised with a sterilised scalpel, and inoculations and cover-glass-preparations made from the cut surface. It may be necessary to embed a piece of lung or fragment of spleen, so that it shall be free from air. This may be done by isolating a fragment with the precautions just described, and depositing it upon the surface of a test-tube of nutrient agar-agar. The contents of another tube,



which have been liquefied, and allowed to cool almost to the point of gelatinisation, must then be poured over it. From a potato a little cube must be cut, the tissue deposited in the trough thus formed, and the cube replaced, or cultures may be prepared by any of the methods which have been described for dealing with anaerobic bacteria. Blood may also be taken directly from a vein by laying it bare by dissection, making a small opening with sterilised scissors, and inserting a looped platinum needle, the needle of a hypodermic syringe, a capillary tube, or the extremity of the capillary neck of a Sternberg's bulb. If the cultivation, in spite of these precautions, is contaminated, or if there was more than one organism present in the blood or tissues under examination, it will be necessary to separate the different kinds by plate-cultivation.

Having completed the dissection, the organs of such a small animal as a mouse may be removed *en masse*, and transferred to absolute alcohol for subsequent examination. In other cases it may be only necessary to reserve portions of each organ. In experimenting with a virulent micro-organism like anthrax, any remaining part of the animal should be cremated, and the hands and all instruments should be thoroughly disinfected.

*Isolation of Micro-organisms during Life.*—Micro-organisms in the living subject may be isolated from the pus of abscesses, or other discharges, and from the blood and tissues. Abscesses should be opened, and other operations performed, when practicable, with Listerian precautions, and a drop of the discharge taken up with a looped needle or capillary pipette, as already explained.

To make a cultivation from the blood of a living person, the tip of a finger must be well washed with soap and water and sponged with 1 in 20 carbolic. Venous congestion is produced by applying an elastic band or ligature to the finger, which is pricked with a sterilised sewing needle. From the drop of blood which exudes the necessary inoculations and examinations can be made. Another way of extracting blood from the living patient is to apply a leech. This method has been found of considerable value in experimenting upon the blood of patients suffering from malaria, and may be useful in other diseases, if the blood is required for further examination, or in quantity.

## CHAPTER XI.

### EXAMINATION OF AIR, SOIL, AND WATER.

#### AIR.

THE air, as is well known, contains in suspension, mineral, animal, and vegetable substances. The mineral world is represented by such substances as silica, silicate of aluminium, carbonate and phosphate of calcium, which may be raised from the soil by the wind, and particles of carbon, etc., which gain access from accidental sources. Belonging to the animal kingdom we find the *débris* of perished creatures, as well as, sometimes, living animals. The vegetable world supplies micrococci, bacilli, and other forms of the great family of bacteria, spores of other fungi, pollen seeds, parts of flowers, and so forth. The air of hospitals and sick rooms has been found to be especially rich in vegetable forms; fungi and spores have been stated to be present in particularly large numbers in cholera wards; spores of trichophyton have been discovered in the air of hospitals for diseases of the skin, and of achorion in wards with cases of favus. The tubercle bacillus is said to have been detected in the breath of patients suffering from phthisis.

These points indicate that, in addition to the interest for the micro-biologist, considerable importance, from a hygienic point of view, must be attached to the systematic examination of the air. A knowledge of the microbes which are found in the air of marshy and other unhealthy districts, and in the air of towns, dwellings, hospitals, workshops, factories, and mines, will be of practical value.

Miquel, who has particularly studied the bacteria in the air, has found that their number varies considerably. The average number per cubic metre of air for the autumn quarter at Montsouris is given as 142, winter quarter 49, spring quarter 85, and summer quarter 105. In air collected 2,000 to 4,000 metres above the sea-level, not a single bacterium or fungus spore was found, while in 10 cubic metres of air from the Rue de Rivoli (Paris) the number was computed at 55,000.



The simplest method for examining the organisms in air consists in exposing plates of glass or microscopic slides coated with glycerine, or with a mixture of glycerine and grape sugar, which is stable, colourless, and transparent. Nutrient gelatine spread out on glass plates may be exposed to the air for a certain time, and then put aside in damp chambers for the colonies to develop. Sterilised potatoes, prepared in the usual way, may be similarly exposed. In both the last-mentioned methods separate colonies develop, which may be isolated, and pure cultivations carried on in various other nutrient media. Nutrient gelatine has also been employed in the special methods of Koch and Hesse.

*Koch's Apparatus.*—This consists of a glass jar, about six inches high, the neck of which is plugged with cotton-wool. In the interior is a shallow glass capsule, which can be removed by means of a brass lifter. The whole is sterilised by exposure to 150° C. for an hour in the hot-air steriliser. The nutrient gelatine in a stock-tube is liquefied, and the contents emptied into the glass capsule. The jar is exposed to the air to be examined for a definite time, the cotton-wool plug replaced, and the apparatus set aside for the colonies to develop.

*Hesse's Apparatus.*—The advantage of this apparatus is that it enables the experimenter to examine a known volume of air. A glass cylinder, 70 cm. long and 3·5 cm. in diameter, is closed at one end by an india-rubber cap, perforated in the centre. Over this fits another cap, which is not perforated. The opposite end of the cylinder is closed with a caoutchouc stopper, perforated to admit a glass tube plugged with cotton-wool. The tube can be connected by means of india-rubber tubing with an aspirating apparatus, which consists of a couple of litre-flasks, suspended by hooks from the tripod-stand which supports the whole apparatus. The cylinder, caps, and plug are washed with solution of carbolic acid, and then with alcohol. After being thus cleansed, 50 cc. of nutrient gelatine are introduced, and the whole sterilised by steaming for half an hour for three successive days. After the final sterilisation, the cylinder is rotated on its long axis, so that the nutrient medium solidifies in the form of a coating over the whole of the interior. When required for use, the cotton-wool plug is removed from the small glass tube, and the latter connected with the upper flask by means of the india-rubber tubing.

The apparatus is placed in the air which is to be examined, the outer india-rubber cap removed from the glass cylinder, and the upper flask tilted until the water begins to flow into the lower one.

The emptying continues by siphon action, and air is drawn in along the cylinder to replace the water. When the upper flask is empty, the position of the two is reversed, and the flow again started. When a sufficient volume has been drawn through the cylinder, the outer cap and the cotton-wool plug are replaced, and it is set aside for the colonies to develop. As an example, twenty-five litres of air from an open square in Berlin gave rise to three colonies of bacteria and sixteen moulds; on the other hand, two litres from a school-

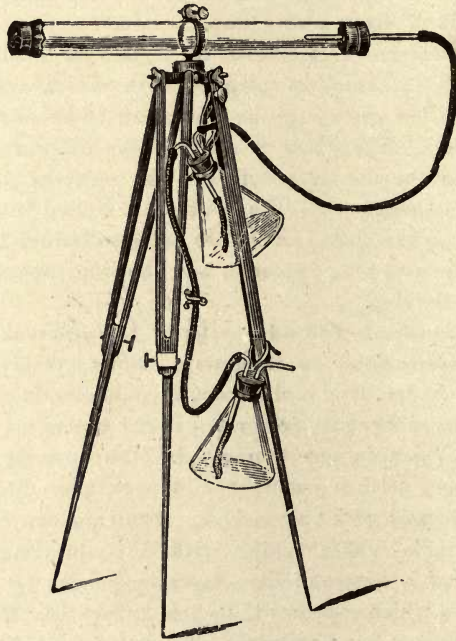

FIG. 71.—HESSE'S APPARATUS.

room just vacated by the scholars gave thirty-seven colonies of bacteria and thirty-three moulds.

Porous substances, such as sand, powdered glass, or sugar, may be used for the filtration of samples of air; and an apparatus is employed in a convenient form to be conveyed to the laboratory for the subsequent examination.

*Petri's Apparatus* consists of a glass-tube 9 cm. long, containing two sand-filters separated from each other. A known volume of air is aspirated through the tube. The bacteria are arrested and can



be examined by spreading the sand out in a dish and covering it with nutrient gelatine; or it may be shaken up with sterilised water and plate-cultivations prepared. The sand-filter nearest to the aspirator should remain free from bacteria.

*Sedgwick and Tucker* employ a glass cylinder which is drawn out at one end into a narrow tube to contain sterilised powdered cane sugar. Both ends of the apparatus are plugged with sterilised cotton-wool. By means of an exhausting apparatus a known volume of air is drawn through the tube. The cotton-wool plug is re-

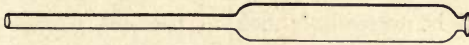

FIG. 72.—SEDGWICK AND TUCKER'S TUBE.

moved, and liquid gelatine is introduced into the cylinder, the plug is replaced, and the sugar is shaken into and quickly dissolves in the jelly. The cylinder is then treated in the same way as a roll-culture, and set aside for the colonies to develop (Fig. 72).

Various forms of "aeroscopes" and "aeroniscopes" have from

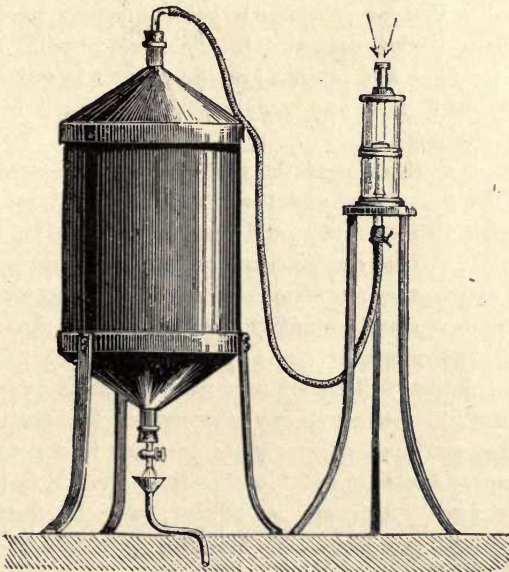

FIG. 73.—POUCHET'S AEROSCOPE.

time to time been employed. Pouchet's aeroscope consists of a small funnel, drawn out to a point below which is a glass slip coated with

glycerine. The end of the funnel and the glass slip are enclosed in an air-tight chamber, from which a small glass tube passes out and is connected by india-rubber tubing with an aspirator (Fig. 73). The air passing down the funnel strikes upon the glycerine, which arrests any solid particles. For a full description of the apparatus employed by Maddox, Cunningham, and Miquel, reference should be made to the writings of these authors, and particularly to the treatise published by the last-named.

#### SOIL.

Surface soil is exceedingly rich in bacteria. Miquel has computed that there exists in a gramme of soil an average of 750,000 germs at Montsouris, 1,300,000 in the Rue de Rennes, and 2,100,000 in the Rue de Monge. As agents in putrefaction and fermentation they play a very important *rôle* in the economy of nature; but there exist in addition, bacteria in the soil which are pathogenic in character. Pasteur has succeeded in isolating the bacillus of anthrax from the earth. Sheep, sojourning upon a plot of ground where animals with anthrax have been buried, may succumb to the disease. Pasteur considered that the spores were conveyed by worms from buried carcasses to the surface soil. The bacilli of malignant œdema and tetanus are also present in soil. Nicolaier produced tetanus in mice and rabbits by inoculating a little garden earth under the skin.

To obtain a cultivation of the microbes in soil a sample of the latter must be first dried and then triturated. It may then be shaken up with distilled water, and from this a drop transferred to sterilised broth. The employment of solid media is, however, much more satisfactory: a sample of earth is collected, dried, and triturated, and a small quantity sprinkled over the surface of nutrient gelatine prepared for a plate-cultivation. In another method the gelatine is liquefied in a test-tube, the powder added, and distributed, in the usual way, throughout the medium, which is then poured out upon a glass plate or made into a roll-culture. In the same way the dust which settles from the air in houses and hospitals, or food substances in powder, may be distributed in nutrient gelatine, and examined both for aerobic and anaerobic bacteria. The different kinds which develop, must be thoroughly investigated as regards their morphological and biological characters, and pathogenic properties.



## WATER.

In the case of water, as in that of air, a knowledge of the micro-organisms which may be present is not only of interest to the bacteriologist, but of the greatest importance in practical hygiene. Common putrefactive bacteria and vibrios may not be hurtful in themselves, but they indicate the probability of the presence of organic matter in which there may be danger. The detection of *Bacillus coli communis* may be taken to indicate a probable contamination with human excreta.

The Microzyme Test which was introduced for the detection of putrefactive bacteria, consisted in adding three or four drops of the sample of water to 1 or 2 cc. of Pasteur's fluid, the nourishing fluid having been previously boiled in a sterilised test-tube. If the microzymes or their germs existed in the water, the liquid in a few days became turbid from the presence of countless bacteria. This test is of no real value, for it does little more than indicate that bacteria are present, which we know to be the case in all ordinary water, and even in ice. On the other hand, the bacteriological test of Koch is a most valuable addition to the usual methods of water analysis. It enables us not only to detect the presence of bacteria, but to ascertain approximately their number, and to study very minutely their morphological and biological characteristics. The importance of a thorough acquaintance with the life-history of the individual micro-organisms cannot be too strongly insisted upon. For example, by such means the spirillum of Asiatic cholera can be distinguished from most other comma-shaped organisms, and inasmuch as its presence may be an indication of contamination with choleraic discharges, such water should be condemned for drinking purposes, even though we are not yet in a position to affirm that the microbe is the cause of the disease. The detection of the bacillus of typhoid fever or of the *Bacillus coli communis* in suspected water or milk would be evidence of considerable importance.

Koch's test, in short, consists in making plate-cultivations of a known volume of water, counting the colonies which develop, isolating the micro-organisms, and studying the characters of each individual form.

*Collection and Transport of Water Samples.*—Sternberg's bulbs, or Erlenmeyer's conical flasks of about 100 cc. capacity, may be employed with advantage for collecting the samples of water. The latter are cleansed, plugged, and sterilised in the hot-air steriliser.



When required for use, the plug is removed and held between the fingers, which must not touch the part which enters the neck of the flask. About 30 cc. of the water to be examined are introduced into the flask, and the plug must be quickly replaced and covered with a caoutchouc cap. If collected from a tap, the water should first be allowed to run for a few minutes, and the sample should be received into the flask without the neck coming into contact with the tap. From a reservoir or stream, the flasks may be filled by employing a sterilised pipette. During transport contact between the water and cotton-wool plug must be avoided, and if likely to occur the sample must be collected and forwarded in a Sternberg's bulb.

*Examination by Plate-cultivation.*—The apparatus for plate-cultivation should be arranged as already described. Crushed ice

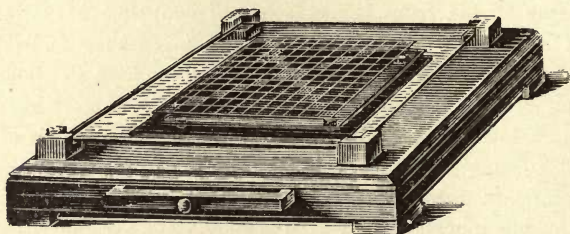

FIG. 74.—APPARATUS FOR ESTIMATING THE NUMBER OF COLONIES IN A PLATE-CULTIVATION.

may be added to the water in the glass dish to expedite the setting of the gelatine, so that the plate may be transferred as quickly as possible to the damp chamber. The caoutchouc cap is removed from the flask, and the cotton-wool plug singed in the flame to prevent contamination from adventitious germs on the outside of the plug. The flask is then held slantingly in the hand, and the plug twisted out and retained between the fingers. With a graduated pipette a measured quantity ( $\frac{1}{10}$  or  $\frac{1}{20}$  cc.) of the sample is transferred to a tube of liquefied nutrient gelatine, and the plugs of the flask and of the tube quickly replaced. If the water is very impure, it may be necessary to first dilute the sample with sterilised water. The inoculated tube must be gently inclined backwards and forwards, and rolled as already explained, to distribute the germs throughout the gelatine, and the gelatine finally poured on a plate. When the gelatine has set, the plate is transferred to a damp chamber, which should be carefully labelled and set aside in a place



of moderate temperature. In about two or three days the cultivation may be examined. In some cases the colonies may be counted at once; more frequently they are so numerous that the plate must be placed on a dark background, and a special process resorted to. A glass plate, ruled by horizontal and vertical lines into centimetre squares, some of which are again subdivided into ninths, is so arranged on a wooden frame that it can cover the nutrient-gelatine plate without touching it (Fig. 74). A lens is used to assist in discovering minute colonies. If then the colonies are very numerous, the number in some small division is counted, if less in some large one, and an average is obtained from which the number of colonies on the entire surface is calculated. A separate calculation of the *liquefied* colonies should be also made, and their number, as well as the total number of colonies present in 1 cc. of the sample, recorded. Any peculiar macroscopical appearances, colours, etc., should be noted, and then the microscopical appearances of the colonies studied. Lastly, examination of the individual organisms should be made by cover-glass preparations, and by inoculation of nutrient gelatine, potatoes, and other media.

Instead of plates, Petri's dishes may be used both for gelatine and agar-agar cultivations.



FIG. 75.—ESMARCH'S ROLL-CULTURE.

*a*, India-rubber caps; *b b b*, longitudinal line drawn on the tube; *c, c, c*, transverse lines for counting colonies (FRANKLAND).

Another plan is to take a measured quantity of the sample of water and prepare a roll-culture, using a large-sized test-tube (Fig. 75). The colonies can be counted with the aid of a lens (Fig. 76). Microscopical preparations and sub-cultures can be made from the colonies, and the anaerobic bacteria can be examined by Fränkel's modification of this method (p. 131).

A drop of the sample of water may also be added to liquefied nutrient gelatine in a test-tube, the organisms distributed, and the gelatine allowed to solidify in the tube. A rough comparison of water samples may be made in this way.

*Microscopic Examination.*—A drop of the water may be mounted and examined without staining; or allowed to evaporate on a cover-

glass, which is then passed through the flame, and stained in the usual manner.

**Parietti's Method.**—As typhoid fever bacilli are apt to be crowded out by more rapidly growing micro-organisms, some method had to be devised for restraining the growth of the latter, and Chantemesse and Widal suggested the use of carbolic acid. Parietti put this into practice by the method he introduced. This consists in adding to tubes of broth about five drops of a mixture composed of sterilised water (100 parts), hydrochloric acid (4 parts), and carbolic acid (5 parts). The tubes are first tested by incubation, and are then ready for use. A few drops of the suspected water are added

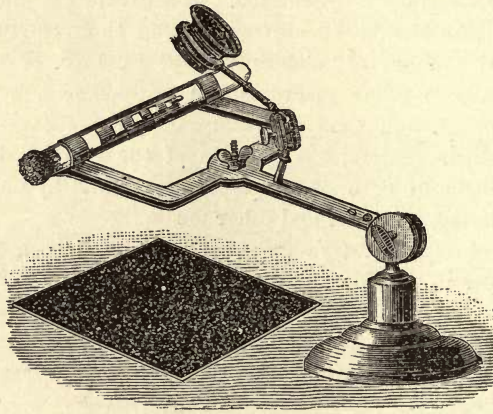

FIG. 76.—APPARATUS FOR COUNTING COLONIES IN A ROLL CULTURE.

to the broth, and if it becomes turbid in a day or two the typhoid fever bacillus is present in the form of a pure-culture.

An excess of bacteria in a fresh sample indicates an excess of organic matter, and points to possible contamination with sewage. Where there is such contamination we are very likely to find pathogenic bacteria; and moreover impure water is a constant source of danger, for if the contagia of infectious diseases are introduced they will retain their vitality in such water for a long period, and will in some cases even multiply, whereas the same organisms introduced into pure water would in a short time perish.

The actual number of bacteria in water is not of very great importance, and it must be remembered that if a sample is set aside for a few days there will be an enormous increase in the number of bacteria present; but in dealing with perfectly fresh samples it



may be said that water containing less than 100 bacteria to the cubic centimetre is very pure water. Water containing 1,000 or more should be filtered. Water containing 100,000 to 1,000,000 is contaminated with surface water or sewage. It is necessary to bear in mind that in typhoid fever and Asiatic cholera the excreta contain the bacteria in great numbers, and wells and streams receiving surface water may be contaminated in various ways. The cholera bacillus dies as a rule quickly in distilled water, while it preserves its vitality for a long time in water of a bad quality.

It is necessary to lay stress upon the fact that a bacteriological analysis may show the presence of pathogenic bacteria when their detection is not possible by any other means. They may be present in water in such small numbers that no chemical analysis would detect any contamination, but as they are living organisms capable of increasing in a suitable environment, they can readily be discovered by bacteriological methods.

The examination of rain water, drinking water, tap water, sea water, various liquids and infusions, by these methods, opens up a wide field for research. Pettenkofer has shown that impregnation of water containing many bacteria with carbonic acid diminishes the number of the latter. The examination of waters before and after filtration, or after addition of chemical substances, are matters which require further investigation, though a great deal of work has already been accomplished. The reader will find in *Micro-organisms in Water* by P. and G. Frankland, a very complete account of this subject with valuable analytical tables.

## CHAPTER XII.

### PHOTOGRAPHY OF BACTERIA.

THE production of pictures of microscopic objects by photographic means was attempted at an early date. Some authorities regard the very earliest recorded experiments as being the first experiments alike in photography and micro-photography. The experiments of Wedgwood and Sir Humphry Davy were embodied in a paper read before the Royal Institution in 1802. They obtained with the solar microscope impressions upon paper, and with greater success upon white leather, though the results were transitory when exposed to daylight.

In 1816 Nicéphore Niepce described his experiments in connection with fixing the image obtained by the camera. He was at first only able to obtain negatives, and these were transitory. But, after joining with Daguerre, who had been experimenting in the same direction, a process was invented which was published in 1839 under the name of daguerreotype.

This invention, and the rapid improvements which followed, were taken advantage of by Reade, Donné, Hodgson, Kingsley, and Talbot, who were early workers in the field of micro-photography.

So early as 1845 it is stated that Donné produced a work illustrated with engravings copied from daguerreotypes.

Subsequently this interesting branch of photography was taken up by many in France and Germany, in America, and in England. Of those to whom we are indebted for the literature of the subject, and for many improvements, the names of Wenham, Dancer, Draper, Maddox, Shadbolt, Redmayne, Woodward, Highley, Deecke, Moitessier, Gerlach, Koch, Sternberg, Fränkel, Pfeiffer, and Pringle may especially be mentioned.

Of these workers the name of Woodward stands pre-eminently foremost. His skill in microscopical manipulations, combined with access to the very best apparatus and objectives, placed at



his disposal in the Museum at Washington, enabled him to obtain photographs of diatoms which probably have never been surpassed.

To Koch belongs the credit of being the first to extend the application of micro-photography to the delineation of bacteria. A series of instructive photographs was first published by him in 1877. These were photographs of cover-glass preparations, and all admirably illustrated the subjects from which they were taken; while two, showing the flagella of bacilli and spirilla, were triumphs in this new departure.

Lewis, in India, was one of the first to illustrate his writings on the subject of micro-organisms by means of photographs.

About the same time Sternberg, in America, took some excellent photographs of bacteria. Heliotypæ reproductions of these were published in 1884.

Hauser and Van Ermengem and many other bacteriologists successfully resorted to photography for illustrating their researches, and Fränkel and Pfeiffer's, and Itzerott and Niemann's atlases of photographs of bacteria, in microscopical specimens and cultivations, are especially worthy of mention.

Opinions have differed widely as to the merits of photographic illustrations. Many, taking the standpoint solely of a comparison with drawings, have decried their use. By judging from such a comparison alone the real value of photographs may be lost sight of. On the other hand, many who have looked at the question from all sides, have been led to value even a defective photograph more than an ordinary drawing.

In his first publication on this subject, Koch strongly advocated photography on the ground that illustrations would then be as true to nature as possible. The photographs which accompanied his paper were all taken from preparations of bacteria which had been made from blood, cultivations, or infusions, by drying a thin layer on a cover-glass and staining, or from specimens prepared in the same way but left unstained. But when, having committed himself to this opinion, Koch attempted, later, to photograph the bacteria in animal tissues, he was led to modify his previous conclusion. For though no trouble was spared, yet disappointing results were met with. This was owing, he explains, to the fact that the smallest and most interesting bacteria can only be made visible in animal tissues by staining them, and thus obtaining the advantage of colour.

This introduced the same difficulties which are met with in photographing coloured objects, such as tapestry and oil paintings.

As these difficulties had been to a certain extent obviated by the use of eosin-collodion, Koch adopted the same method for photographing stained bacteria. By the use of eosin-collodion, and by shutting off portions of the spectrum by coloured glasses, he succeeded in obtaining photographs of bacteria which had been stained with blue and red aniline dyes. But, owing to the long exposure which was necessary, and the unavoidable vibrations of the apparatus, the results were so wanting in definition that they not only proved unsatisfactory as substitutes for drawings, but did not in some cases give any evidence of what was to be seen in the preparations.

Koch, in consequence, stated that he would abstain from publishing photographic illustrations until he had the advantage of improved methods.

We find, however, in spite of this, that in 1881 Koch published a series of reproductions from his negatives in illustration of what could be accomplished by photography.

Here again we find that many of the photographs of cover-glass preparations were admirable, but those of tissue-sections gave evidence of the difficulties Koch encountered, and were undoubtedly unsatisfactory from the want of flatness of field, some of the illustrations recalling rather a map of a mountainous country than a microscopical preparation.

In consequence of the difficulties met with in attempting to photograph bacteria stained with the aniline dyes most commonly used, Koch recommended that the preparations should be stained brown, pointing out as his reason that, though the bright and concentrated colour of the red and blue aniline dyes catches the eye far more readily than the somewhat sombre brown colours, yet no one up to the time of his publication had succeeded in obtaining good photographs of bacteria which had been stained either blue or red, and mounted in Canada balsam, while there was no difficulty in obtaining photographic representations of preparations stained yellow or brown.

Though this stain could be easily employed in most cover-glass preparations, it was by no means easy to obtain a good differential stain of bacteria in the tissues by employing Bismarck brown. An attempt was, therefore, made to photograph preparations stained blue and red by the aid of the dry-plate process, and by interposing glasses of suitable tints. After many fruitless experiments this method had to be abandoned, and the method of staining the object brown was adopted. In many cases this gave excellent



results; in others again, compared with the results of staining with blue or red stains, there was much to be desired, and further improvement was needed.

That a stain, such as yellow or brown, must be employed which absorbs the blue rays, and acts on the sensitive plate like black, which absorbs all the light, constituted the first condition laid down by Koch as an essential for success. It was further pointed out that the suitability of the stain could be ascertained by first passing the light, to illuminate the preparation, through a solution of ammonio-sulphate of copper, under which condition the bacteria would appear black on a blue ground.

The second condition was, that sunlight must be employed, but that direct projection upon the object was disadvantageous, and it must, therefore, be diffused by the interposition of one or more plates of ground glass.

Lastly, an illuminating condenser was recommended, of such construction that the diffused sunlight brightly illuminates the object from all sides.

Sternberg encountered the same difficulty in photographing red, blue or violet preparations, while he produced excellent pictures of preparations stained with aniline brown, or a weak solution of iodine (iodine grs. iiij, potassic iodide grs. v, distilled water grs. 200). Thus the results of a large number of attempts to photograph the tubercle bacillus in sputum, only ended in producing such extremely faint impressions, that any one unacquainted with the object as seen under the microscope could form scarcely any idea of its form or minute structure with even an accompanying explanation and the closest inspection of the photograph.

Dufrenne, in attempting to photograph the same object by the ordinary method, found the plates were uniformly acted on, or the image was so faint, or so lacking in contrast, that they were useless for obtaining proofs on paper or glass. By interposing green glass between the objective and the sensitive plate, so that the red rays were absorbed, while the green rays passed through and acted on the plate, he states that better results were obtained.

The work of Hauser illustrated the great value of photography in the production of pictures of impression-preparations and colonies in nutrient gelatine. To give the general effect, as well as faithfully reproduce the minute details in these difficult subjects would in most cases create insurmountable difficulties, except to the most accomplished draughtsman.

Hauser employed Gerlach's apparatus and Schleussner's dry

plates, and obtained the illumination by means of a small incandescent lamp, which gave a strong, white light, with three or four Bunsen elements. In another respect Hauser's results were of practical value. The preparations to be photographed were stained brown as recommended by Koch, but they were mounted in the ordinary way in Canada balsam. The objection to the mounting medium most commonly employed was thus set aside. The prevalent idea, however, that the preparations must be stained brown was still a formidable obstacle, and the way out of this difficulty was clearly shown by Van Ermengem's photographs. These were pictures of comma-bacilli which had been stained with fuchsine and methyl violet. These photographs afforded the first practical illustration of the value of isochromatic plates in micro-photography which had been previously noted by Van Ermengem in 1884, and their introduction marks a distinct era in the progress of micro-photography.

A short explanation may be given of what is meant by isochromatic, or what have been more properly termed *orthochromatic* dry plates. The difficulties encountered in photographing certain stained preparations have been mentioned. It is a familiar fact that in portraits, blue or violet comes out almost or quite white, while other colours, such as yellow, are represented by a sombre shade or perhaps black. This failure in correctly translating colours is explained by the want of equality between the strength of the chemical and luminous rays. If the rays of the spectrum are projected upon a photographically sensitive surface, the greatest effect is found to take place at the violet end. In other words, the violet and blue rays are more actinic or chemically powerful, while the yellow and orange have scarcely any effect. The dyes employed in staining give corresponding results: blue and violet give but a faint impression, yellow and orange a black picture. These results are most clearly demonstrated in a photograph of an oil painting taken in the ordinary way; and they led to experiments being made which have resulted in orthochromatic photography.

The effect of interposing coloured glasses has already been referred to. It was found later that, if plates were coloured yellow, *e.g.*, with turmeric, the blue and violet rays were intercepted, and their actinism reduced. In 1881, Tailfer and Clayton produced the so-called isochromatic plates. The emulsion of bromide of silver and gelatine was stained with eosin, and it was claimed that colours would be represented with their true relative intensity. Chlorophyll and other stains have been tried, and by such methods the ordinary gelatine dry plates can be so treated that they will reproduce



various colours, according to their relative light intensity, and thus be rendered iso- or, what is now more commonly known as, orthochromatic.

#### APPARATUS AND MATERIAL.

*Micro-photographic Apparatus.*—As is well known, various forms of apparatus have from time to time been recommended and employed by different workers.

Many use the microscope in a vertical position, with the camera superposed or fitted to the eye-piece end of the microscope tube; or the microscope tube may be screwed off from the body of the microscope, and a pyramidal camera adjusted in its place, the base of the pyramid being represented by the ground glass screen.

Others again prefer that the microscope and camera should be arranged horizontally.

In another form the ordinary microscope is dispensed with, the objective, stage, and mirror are adapted to the front of the camera, and provided with suitable arrangements for holding the object, supporting the mirror, and adjusting the different parts.

Lastly, the camera may be dispensed with, the operating-room, which must be rendered impervious to light, taking its place, while the image is projected and focussed upon a ground glass screen, which has a separate support.\*

The horizontal position affords greater stability than the vertical, so that the former is to be preferred. The vertical model with the camera fixed to the microscope is particularly to be avoided, as the weight of the camera bears directly upon the microscope, and must affect the fine adjustment, and any vibration in one part of the apparatus is communicated throughout.

The simplest apparatus consists of a camera fixed upon a base-board four or five feet in length, upon which the microscope can be clamped, and which carries also a lamp and a bull's-eye condenser (Fig. 77).

Simplicity and economy must always be borne in mind in recommending any apparatus of this kind, for to insist upon the necessity of a very elaborate apparatus, or a specially fitted-up room, or that a special room should be built with windows facing in a definite direction, will in most cases at once place photography beyond the reach of those who might otherwise employ it. Yet to fulfil

\* For an excellent account of the forms of apparatus which have been employed by different workers the reader is referred to the section on Micro-photography in Beale's *How to work with the Microscope*.

all the purposes for which the apparatus may be required, including the employment of the highest powers, and also that one may be enabled to work for long intervals of time with due comfort, an accurate and complete apparatus will be found to be most desirable.

Though most preparations will admit of being photographed when the stage of the microscope is vertical, yet if we require to photograph micro-organisms in liquids, or colonies upon partially liquefied gelatine, the apparatus must admit of being placed so that the stage of the microscope becomes horizontal. In addition, the apparatus is rendered somewhat complex if we employ powerful

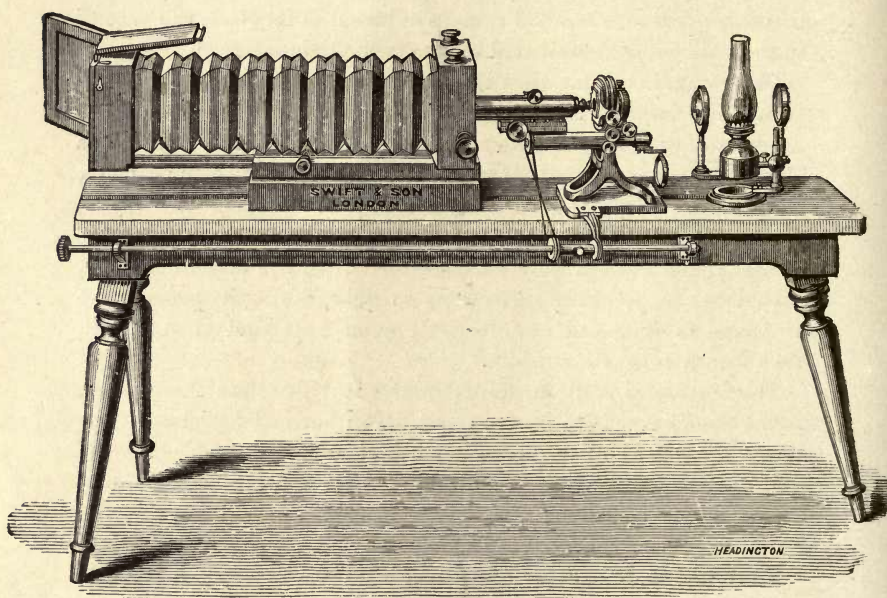

FIG. 77.—HORIZONTAL MICRO-PHOTOGRAPHIC APPARATUS.

artificial light. Sunlight, no doubt, is the best and cheapest, but it is not always available, especially in a city like London; and, moreover, evenings and dull days will probably be the very time which can be best spared for this work. We must, therefore, fall back upon the paraffine lamp, or the magnesium, oxyhydrogen, or electric light.

To fulfil all these conditions Swift has constructed an apparatus under the author's directions (Fig. 78). It is merely a modification of the ordinary horizontal model, which admits of being readily placed



in the vertical position, while the illumination is supplied from an oxyhydrogen lantern.

To place the apparatus in the vertical position two small hinged

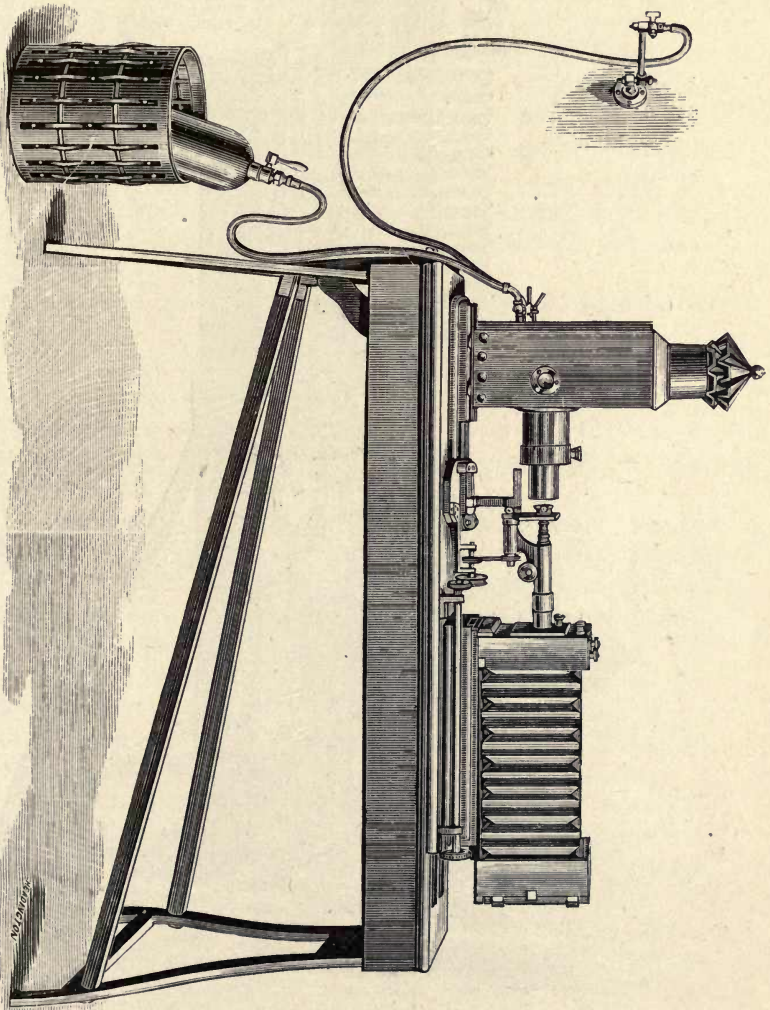

FIG. 78.—REVERSIBLE MICRO-PHOTOGRAPHIC APPARATUS.

brackets, at the end distant from the camera, are forced up with a smart blow of the hand. The corresponding ends of the stretcher bars are dislodged from their fittings, and allowed to descend; when

horizontal, the opposite extremities of the bars are easily released from their sockets. The leg or support at this end can then be

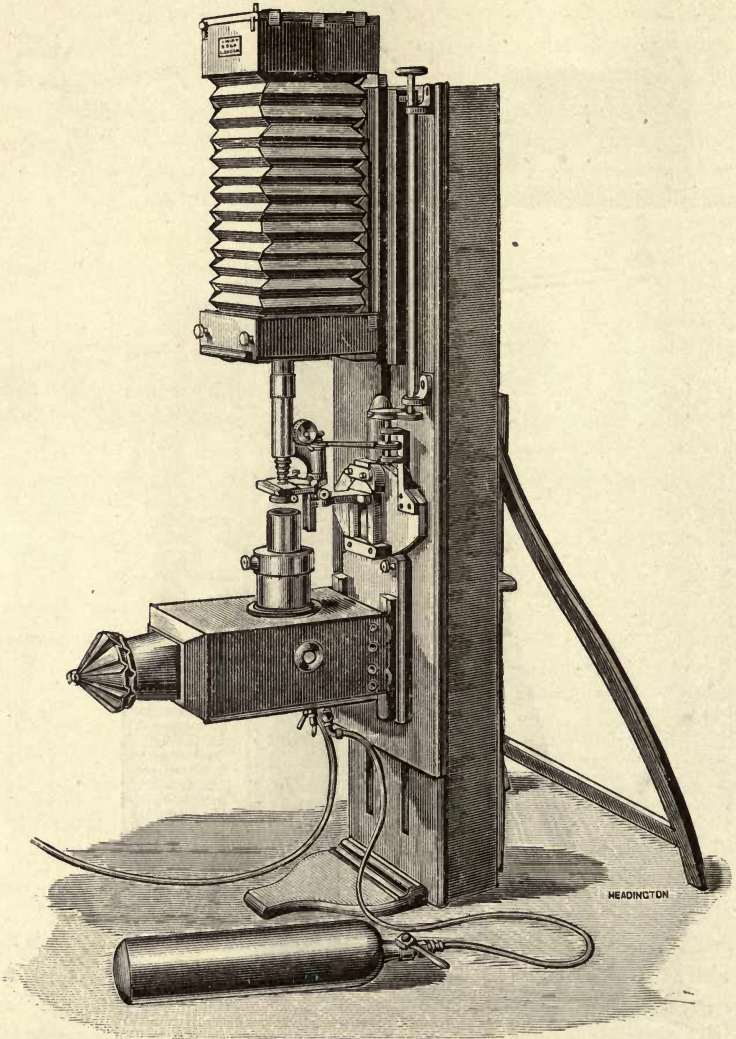

FIG. 79.—REVERSIBLE MICRO-PHOTOGRAPHIC APPARATUS ARRANGED IN THE VERTICAL POSITION.

turned up and fixed underneath the apparatus by a button, and the end of the apparatus itself gently lowered to the ground.



A hinged end-piece is also to be turned out to increase the base upon which the whole apparatus will stand when raised to the vertical. The two-legged support at the opposite end of the apparatus is next worked down by a quick thread screw, and on raising the apparatus to the vertical, the two-legged support drops to the ground, and assists in maintaining the stability of the whole. If it is thought necessary, a simple means can be readily devised for clamping the apparatus, in either position, to the wall of the room, so as to eliminate as much as possible all chances of vibration. A second quick thread screw moves the base-board upon which the camera and central sliding-board are mounted, so that the camera, microscope and lantern can be raised to a convenient height from the ground.

The various parts of this apparatus may be described in detail.

*The Microscope and its Attachments.*—It is most essential that the microscope should be perfectly steady. The microscope was made by Zeiss, and to ensure steadiness, the horse-shoe footpiece fits under a projecting ledge, and is then clamped by a cross-piece, so that it is firmly fixed.

The microscope with the means for clamping it and the oxy-hydrogen lantern are carried upon an independent sliding-board, which admits of movement to or from the camera. The sliding-board also moves upon a centre, which enables the microscope to be turned out from the median line; in fact, to be turned at a right angle to the position it occupies when ready for the exposure. The object of this contrivance is to enable the operator to sit down by the side of the apparatus, and with comfort to arrange the object in the field of the microscope. On turning the microscope back into the median line, it is fixed in the optical axis of the apparatus by means of a suitable stop. The sliding-board is provided with a small grooved wheel receiving an endless cord, made of silk or fishing-line, which passes round the grooved, milled head of the fine adjustment of the microscope. When the sliding-board is returned to the median line of the apparatus, the milled wheel connected with the fine adjustment impinges upon the wheel of the long focussing rod. The latter is provided with an india-rubber tire, which grips the teeth of the milled wheel, and thus the long focussing rod is placed in connection with the fine adjustment of the microscope.

*Illumination.*—The oxy-hydrogen lamp has been more frequently employed by the author than the paraffine lamp, partly on account of the diminished time in exposure, especially when employing very



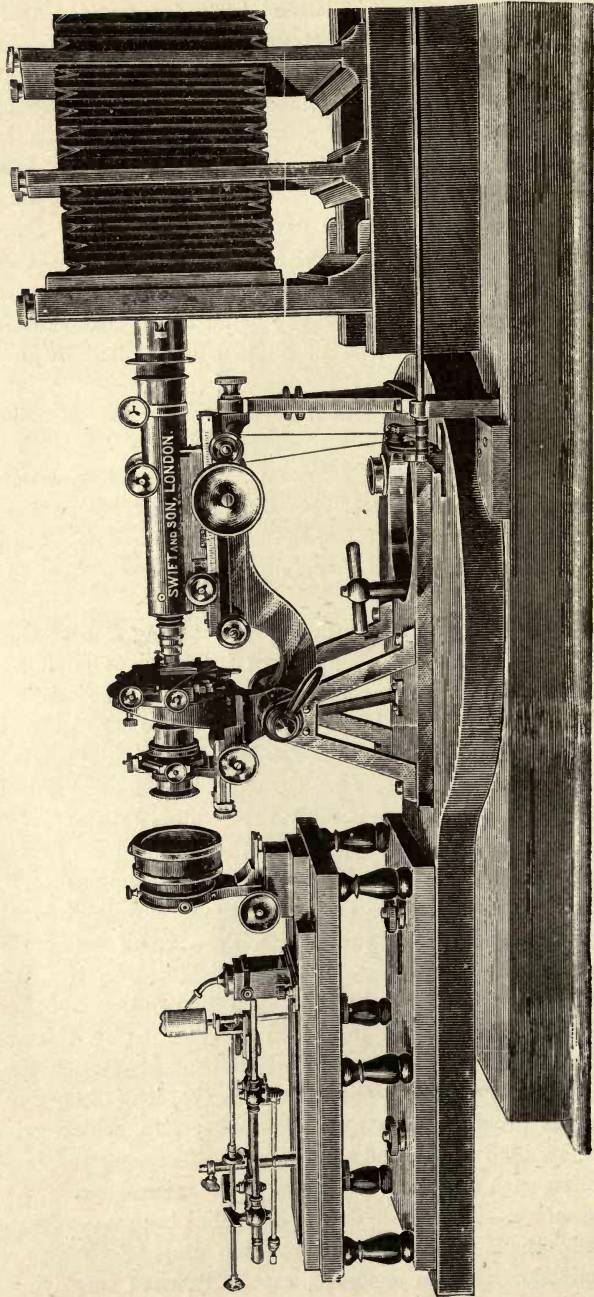

FIG. 80.—SWIFT'S LARGE MICRO-PHOTOGRAPHIC APPARATUS.



high powers; this is of great importance where there is likely to be vibration from passing traffic. With rapid plates and the highest powers, the exposure has only been two or three seconds, whereas with the paraffine lamp it may vary from three to ten minutes, or even longer.

Walmsley gives the following table for exposures with the paraffine lamp:—

$1\frac{1}{2}$ inch objective	. . . . .	3 to 45 seconds.
$\frac{2}{3}$ " "	. . . . .	7 " 90 "
$\frac{4}{10}$ " "	. . . . .	$\frac{1}{2}$ " 3 minutes.
$\frac{1}{5}$ " "	. . . . .	2 " 7 "
$\frac{1}{10}$ " "	. . . . .	4 " 10 "

The illuminating apparatus represented in the accompanying engraving (Fig. 78) consists of a lantern which not only moves together with the microscope on the central sliding-board, but can be moved independently to or from the microscope, and be clamped with screws at the requisite distance for obtaining the best illumination. It is provided with two 3-inch condensing lenses of long focus, constructed of optical glass, which is much whiter than that used for ordinary lantern condensers. The lime-cylinders should be of the hardest and best quality, as they give a more actinic light than those made of soft lime. The "Excelsior" lime-cylinders are strongly recommended. They are supplied in hermetically sealed tins which can be easily opened and re-sealed, so that a cylinder can be taken out and used, and the rest preserved for a future occasion. The hydrogen can be obtained by using the coal-gas supplied to the house, and the oxygen should be supplied preferably in a compressed state in iron bottles. Not only are the bottles much less cumbrous than the bags, but a small quantity of gas can be used, and the residue left for an indefinite time; moreover, the gas is always at hand to be turned on when required. On the other hand, the retention of unused gas in bags is liable to cause their corrosion, owing, it is believed, to impurities which are carried over in the manufacture of the oxygen. If gas is not laid on in the house, then it also must be procured in a compressed state in bottles. As the blow-over jet is recommended on account of its safety, the bottles should be supplied in this case with a supplementary valve. It is then just as easy and free from danger to employ the compressed gas as it is to make use of the house-supply.

*The Camera.*—A long-focus, half-plate camera is mounted upon a sliding platform. This admits of the camera being pushed up to

the microscope when it is in the long axis of the apparatus, so as to make a light-tight combination. The opening which is filled in an ordinary camera by the lens can be shut off by means of an internal shutter, which is opened and closed by turning a screw at the side of the camera. The dark-back is provided with plate-carriers, so that either half, quarter, or lantern-size plates can be employed. It will be found convenient to have two or more dark-backs, so that several plates may be exposed without rearranging the light for each exposure.

Much more elaborate and expensive micro-photographic cameras have been constructed by Zeiss, and also by Swift. The latter has



FIG. 81.—PHOTOGRAPH OF AN IMPRESSION PREPARATION.

carried out a suggestion made by Pringle for a support at the ocular end (Fig. 80).

*The Dark-room.*—In every bacteriological laboratory there should be a developing room provided with shelves, gas, water-tap, and sink, but these arrangements are not absolutely indispensable. All that is essential is a room impervious to light; and a closet or cupboard, if it can be ventilated, will answer perfectly well, with a jug and basin instead of the tap and sink. The steam-steriliser employed in the preparation of nutrient media for cultivating bacteria, if not required at the time for such purposes, may be filled to the brim with water, and will form an excellent cistern and tap, while a pail, or small sanitary bin, may be utilised as a sink.

Various kinds of lamps are made for the dark-room, burning



either candles, oil, or gas. In any case, the light must pass through two thicknesses of ruby glass.

*Dry Plates.*—A small supply of any of the ordinary plates in the market may be procured for preliminary trials in acquiring a knowledge of the processes; but to overcome the difficulties of certain stained preparations, the isochromatic or orthochromatic plates should be used. The  $\frac{1}{4}$  plate will be found to be the most suitable size.

There are numerous formulæ for the requisite solutions for developing and fixing the negatives, and instructions are usually enclosed in the boxes of dry plates, but it is best to abstain from trying a number of different formulæ, as it leads to a great expenditure of time. There is a temptation to do this, it being supposed that there is probably some great advantage in one formula over another. It is much better to get accustomed to the behaviour under different exposures of one, or perhaps two methods.

In France the iron developer is much in vogue, and is recommended by Tailfer and Clayton for use with their isochromatic plates. It has the advantage of great simplicity in the mode of employment, and, therefore, is very suitable for a beginner. In England, on the other hand, the alkaline developer is very much used, as it gives more command over the plate, enabling the photographer more fully to compensate for incorrect exposure.

It is very desirable before attempting to take photographs with the microscope to learn how to take photographs with an ordinary landscape camera, and to get thoroughly accustomed to the use of some good developer, so that mistakes may be corrected and the clearest and sharpest negatives obtained.

#### PRACTICAL MANIPULATION.

*Arrangement of Apparatus.*—For working with the paraffine lamp, the mode of procedure is, as regards the illumination, briefly as follows. The sub-stage condenser is dispensed with when a low power is employed, as well as the mirror, and the lamp is so placed that the image of the flat of the flame appears accurately in the centre of the field of the microscope. A bull's-eye condenser is then interposed, so that the image of the flame disappears, and the whole field is equally illuminated. With high powers the sub-stage achromatic condenser is necessary, and a more intense illumination is obtained by using the flame edgewise. In using a low power with the oxyhydrogen light, the lantern is withdrawn some little distance from the microscope, and the top combination of the achromatic condenser removed.

It is best to begin with the use of a low power, and a trial object, such as the blow-fly's tongue, spine of Echinus, or trachea of silkworm.

In order to explain the management of the apparatus (as represented in Fig. 78) the steps in the arrangement of the apparatus and exposure of the plate will be described in detail for the employment of a high power and the oxyhydrogen light. The solutions being ready for use, it is proposed to take a photograph of tubercle bacilli in sputum, with a  $\frac{1}{12}$  apochromatic oil-immersion objective. The first point to claim attention is the arrangement of the light. Having lighted the gas at the hydrogen jet, the lime-cylinder should be revolved until heated equally all round. The oxygen is then carefully turned on until only a small spot of incandescence is produced. The central sliding-board is turned out, a low power screwed on to the microscope, and the image of the bright spot focussed and accurately centered. To protect the sight, an eye-piece provided with a smoked glass shade is used. The immersion objective is then substituted for the low power, and the oxygen turned on until the right admixture of gas is obtained to produce a brilliant illumination. It is well at this stage to sit down to focus the selected object, and to spend some little time in searching for the most characteristic part of the specimen to be photographed. This being decided upon, the eye-piece is carefully withdrawn, and the central sliding-board rotated back into the median line. To make a light-tight connection between the camera and the microscope, the camera is pushed up until a velvet-lined tube, which occupies the position of the lenses of an ordinary camera, is enclosed within a short wide tube which is adapted to the eye-piece end of the microscope.

On opening the camera-shutter the image will be projected upon the ground glass screen of the camera. It is necessary, however, to obtain the exact focus, and to effect this the ground-glass screen is turned away, and the dark-back with a piece of plain glass is substituted. Here again time may be well spent in getting the sharpest image, with the aid of a focussing glass of proper focal length.

The greatest delicacy in manipulation is necessary, as in working with such high powers a turn too much of the fine adjustment will cause the image to vanish. Having determined the best visual focus, which will be found with the high-power objectives of most makers to correspond with the chemical focus, the dark-back must be cautiously removed, to prevent any vibration, and the plain



glass replaced by a sensitive plate. To effect this change, the operator retires to the dark-room, and opens a box of plates with as little exposure to the red light as possible. Having removed a plate, it is necessary to ascertain which is the sensitive side. This may be done by momentarily exposing it to the red light, and seeing which is the sensitive side by the dull appearance of the film. A less satisfactory way is to moisten the tip of a finger, and press it at one corner of the plate. The film side will be recognised by imparting a sticky sensation. The film must be dusted with a camel's-hair brush, as well as the dark-back, and the plate is placed film-side downwards in the dark-back, which is then securely closed.

Care should be taken that the plates then remaining in the box are packed away before light is admitted to the dark-room.

*Exposure of the Plate.*—On returning to the apparatus, the camera-shutter is closed. Then the dark-back is gently slid into its place, and its slide withdrawn. A few moments are allowed to elapse, so that the least possible vibration, which might be caused by inserting the dark-back, has had time to cease, and all is ready for the exposure.

In the case of the object we have selected, three seconds will probably be the exposure required. This is done by opening and closing the camera-shutter with one hand, while a watch can be held in the other. The slide of the dark-back is then carefully closed, and the plate is ready to be carried off to the developing room.

As the light will not be again required until the next exposure, the oxygen must be turned off, while the coal-gas may be allowed to play over the lime.

*Development and Fixation of the Image.*—It is well to be systematic, and therefore, before the plate is taken out of the dark-back, light is admitted to the dark-room, and everything arranged so that the position of the trays and bottles may be remembered in the dark. First, let the ruby lamp be lit, place two dishes or trays close by, and a row of four dishes within easy reach. Pour out some fixing solution in the first porcelain dish, alum in No. 2, and water in Nos. 3 and 4. Put the necessary quantity of "pyro" solution into the glass measure, and place it with the ammonia drop-bottle in front of the ruby light. Then, when all light except that from the ruby lantern has been excluded, everything is ready to commence the development of the plate.

Opening the dark-back, the plate may be turned out on to the palm of the hand. The film side is then uppermost, and the plate is to be transferred in the same position to a tray, and covered with water. This is to soak the film and obtain an equal action of the developer; or the solution of fresh pyro may be poured on to the plate without previous soaking, if the flow is uniform, and the formation of bubbles avoided. In the first case the water is run off and the pyro allowed to flow evenly over the plate. To protect the plate from prolonged exposure to the ruby light, a second tray may be inverted over it, or the developing tray covered with a piece of card-board. Gently rock the tray for a minute or so, then to a few drops of ammonia in a measuring glass add the pyro from the developing tray, and pour the mixture back again over the plate. After again gently rocking the tray for a few minutes, more ammonia is added by drops in the same way. If the exposure has been properly timed,—and the time necessary must be ascertained by trial for each preparation,—the image will gradually begin to appear, and the action must be allowed to continue until sufficient density has been obtained. To determine this requires some experience. It is generally recommended to take the plate out of the tray and hold it for a moment, film-side towards the operator, in front of the ruby light. Though the plate is not nearly so sensitive when the image has commenced to develop, and there is, therefore, not the same danger of fogging, a safer plan is to occasionally turn the plate film downwards in the tray, and when the image appears on the back the development will be found to be completed.

With such a preparation as tubercle bacilli in sputum it is not easy to trace the gradual formation of the image, and hence the advantage of commencing with a well-marked object such as the blow-fly's tongue. It is then easy to watch the gradual progress of the image. The bright parts or high-lights appear first, then gradually the half-tones, or less brightly-lighted parts, and lastly every shade except the deepest shadows is represented. When, however, all action seems to have ceased, we must still wait until we have judged, in the manner already described, that the density is sufficient. This being determined, we pour off the developing solution and thoroughly wash the plate with water. It is then ready to be placed in dish No. 1, containing "hypo," and here it must be left for some minutes after all appearance of creaminess has disappeared from the back. White light may now be admitted, the plate removed from the hypo and thoroughly washed under the tap,



and then placed in dish No. 2. When another plate is ready to take its place, transfer it to dish No. 3, and then to No. 4, and, after a good final washing under the tap, place it upon a rack to dry. If there is any tendency for the film to detach itself from the plate, "to frill," the alum bath must be used before fixing, as well as after.

*Frilling* or *blistering* may be due to an error in manufacture, and is liable to occur in hot weather, or when using a developer too strong in ammonia. If it occurs during washing or fixing, the alum bath must be employed before the hypo. *Fogging*, or the appearance of a veil over the plate, may arise from error in the manufacture, from admission of extraneous light, from over-exposure, or from prolonged exposure to the ruby light during development. Care must be taken that the camera and dark-room are light-tight. *Crystallisation*, or powdery deposit, upon the negative when dry, is due to insufficient washing out of the hyposulphite of soda. *Thinness of the image*, or *want of density*, may be due to insufficient development, too weak a developer, or too short or too long an exposure. *Too great density* results from too long immersion in the developer.

*Spots* may sometimes occur upon the negatives. They may be caused by dust upon the plate or by air bubbles in the developer.

In the text-books of photography full accounts of failures will be found, their causes and prevention; but it will be advantageous when these difficulties are encountered to take the negatives to a skilled photographer and get advice upon them. It is necessary to persevere, and not be disheartened if several negatives have to be made of a preparation before a successful result is obtained.

It may here be remarked that the beginner will far more rapidly learn the *technique* if he avail himself of a practical demonstration from a photographer. When he has learnt to obtain successful negatives, if he prefer silver prints, and time is an object, it will be found to be true economy to get the printing and mounting done by a professional photographer. The credit of a successful photograph of bacteria is due to the bacteriologist who prepares the microscopical specimen and obtains the negative.

*Determination of the Amplification.*—The amplification varies not only with the objective employed, but with the distance of the focussing screen from the object. In order to ascertain the amplification afforded by a certain objective at a certain distance, a photograph should be taken, under the same conditions, of the lines of a micrometer slide. It is easy then to calculate the amplification

obtained in the micro-photograph; supposing, for example, in the micro-photograph the lines which are  $\frac{1}{1000}$  inch apart are delineated 1 inch apart, the magnifying power must be 1,000 diameters. Moreover, having thus ascertained the amplification, we can accurately compute from the photograph the size of the objects taken.

*Value of Photographs.*—It is not necessary to compare the relative merits of diagrams and photographs. Diagrams which do not purport to be accurate representations, but are intentionally the means for simplifying instruction, will always be valuable, even if we have the original preparations under the microscope before us. We must consider the relative merits of photographs and of drawings which purport to be exact representations of what is seen under the microscope. Thus in the case of micro-organisms, when their biological characters are studied under low powers of the microscope, photographs are preferable because they give a more faithful representation. At the same time, apart from this comparative value, we must not lose sight of the actual value of photography in placing within the reach of the student or investigator, who may not be a draughtsman, a most valuable means for illustrating all kinds of preparations.



FIG. 82. — PHOTOGRAPH OF A CULTIVATION OF BACILLUS ANTHRACIS.

For double-stained or triple-stained tissue preparations an accurately coloured drawing leaves little to be desired; but if we reproduce the same by a wood engraving, and so lose the advantage of the coloured picture, which is instructive in indicating the method of staining, a photograph will, in many cases, be far more satisfactory.

When we have to deal with the growth of bacteria *en masse*, as in test-tube and plate-cultivations, with colonies as seen under a low power of the microscope, and with impression-preparations both under low and high powers, unless the bacteriologist is a most accomplished draughtsman as well as an accurate and reliable observer, photography undoubtedly affords the best mode of illustration. The apparatus being ready and at hand, a negative can be produced in a few minutes of a preparation which, from the amount of detail it contains, would take perhaps several hours to draw and colour. From that negative any number of facsimiles can



be obtained, whereas an original drawing, even in the best hands, if cut on wood or lithographed, is almost certain to fall short of being an exact copy.

With regard to individual bacteria, the result is more satisfactory in many cases than a drawing; for there is the advantage of being absolutely certain that any particular structure, form, or shape which may be represented is actually what exists, and not what may have been evolved by unconscious bias in the mind of the observer. Many illustrations might be given of this. Thus Lewis, who was a most conscientious observer, published an account of organisms in the blood of rats in India, and illustrated it with a wood engraving and with micro-photographs. The identity of the organisms which were found in the common brown rat of this country was established much more readily from these photographs than from the wood engraving or the description in the letterpress.

A micro-organism, even under the highest powers, appears as so minute an object that to represent it in a drawing requires a very delicate touch, and it is only too easy to make a picture which gives an erroneous impression to those who have not seen the original. If, on the other hand, to represent the object more clearly we draw an enlarged picture, we can only do so by representing what we *think* the object would be like if it could be amplified to the size represented. In such cases a photographic enlargement is certainly more valuable.

Photography enables us also to record rapid changes, and it is possible that as the art advances we may find that the film is more sensitive than the human retina, and brings out details in bacteria which would be otherwise unseen.

Photographs can be readily transmitted by post, and when we can neither make a great number of preparations to illustrate some object, nor perhaps be able to go to the expense of having a drawing reproduced, this method will be of value in enabling others to benefit by our observations.

The author is convinced that if the employment of photography is encouraged in bacteriological and other research laboratories for depicting microscopical preparations and cultivations of bacteria, the results of increasing experience and practice will lead to its being made more general use of as a faithful and graphic method, valuable alike for class demonstrations and for illustrating publications.





PART II.

*ETIOLOGY AND PREVENTION OF INFECTIVE  
DISEASES.*





## CHAPTER XIII.

### SUPPURATION, PYÆMIA, SEPTICÆMIA, ERYSIPELAS.

#### ABSCESS.

WHEN inflammation is followed by an accumulation of leucocytes and of plasma which does not coagulate, the result is a white or creamy liquid called pus, and when the surrounding tissues are involved so that a cavity develops containing pus, we have what is termed an abscess. The almost constant association of bacteria with the production of pus has created a belief that they are the direct cause of suppuration. Ogston found micrococci present in all acute abscesses, and concluded that acute inflammation was invariably due to their presence. The fact that inflammation occurs more frequently in the external tissues of the body is accordingly explained by the ready entrance of bacteria which are in the air; and suppuration following pericarditis, pleurisy, and other conditions in which air is excluded is attributed to the presence of pyogenic cocci, which have gained access by the blood stream. There is no pyogenic organism constantly present, but several different species of bacteria have been isolated from pus and carefully studied, and the antiseptic treatment is based upon the principle of excluding bacteria in surgical operations, and destroying any which may have previously obtained access to wounds and broken surfaces. Inflamed tissue and pus form a most suitable medium for the growth of bacteria, which in some cases are unquestionably only accidental epiphytes.

In tuberculosis, actinomycosis, and glanders, pus formation may take place without the presence of pyogenic cocci; and it is generally believed that chemical irritants, such as croton oil, turpentine, iodine, cadaverin, and tuberculin, will excite the formation of pus in the absence of bacteria, although Klemperer, after a number of very careful experiments, maintains that no genuine pus will be produced if the chemical irritants are first carefully sterilised.

The bacteria which have been isolated from pus include:—*Staphylococcus pyogenes aureus*, *albus*, and *citreus*, *Staphylococcus cereus flavus* and *albus*, *Streptococcus pyogenes*, *Micrococcus pyogenes tenuis*, *Micrococcus pneumoniae crouposa*, *Bacillus pyocyaneus*, *Bacillus pyogenes foetidus*, *Micrococcus tetragenus*, *Bacillus intracellularis meningitidis*, *Gonococcus*, *Bacillus septicus vesicae*, *Urobacillus liquefaciens septicus*, *Bacillus typhosus*, *Bacillus coli communis*, *Bacillus anthracis*, *Bacillus tuberculosis*, *Bacillus mallei*, and *Actinomyces*.



FIG. 83.—SUPPURATION OF SUBCUTANEOUS TISSUE.

*d*, Leucocyte containing micrococci ; *d'*, leucocyte with pale nucleus showing necrosis ; *c*, fixed connective tissue cells, much enlarged, containing several nuclei, of which some (*n'*) are pale and necrotic ; numerous cocci, diplococci, and short chains. (CORNIL and RANVIER.)

Some idea of the distribution of the bacteria most commonly occurring in pus may be gathered from the records made by Passet and by Karlinski.

Passet examined acute abscesses, and found *Staphylococcus pyogenes aureus* and *albus* in 11 cases, *Staphylococcus pyogenes albus* alone in 4, *Staphylococcus pyogenes albus* and *citreus* in 2, *Streptococcus pyogenes* alone in 8, *Staphylococcus pyogenes albus* and *Streptococcus pyogenes* in 1, and *Staphylococcus pyogenes albus* and *citreus*, and *Streptococcus pyogenes* in 1.



Karlinski tabulated his cases thus :—

DISEASE.	Cases.								
	Staphylococcus Pyogenes Aureus.	Staphylococcus Pyogenes Citreus.	Staphylococcus Pyogenes Albus.	Streptococcus Pyogenes.	Micrococcus Tetragonus.	Bacillus Pyogenes Fœtidus.	Pneumobacillus (Friedländer).	Bacillus Anthracis.	
Mastitis . . . . .	36	22	4	4	6	—	—	—	
Subcutaneous Abscess . . . . .	30	10	2	8	6	2	2	—	
Phlegmon . . . . .	24	—	—	—	24	—	—	—	
Furuncle . . . . .	20	9	—	10	—	1	—	—	
Bubo . . . . .	17	8	1	1	7	—	—	—	
Subperiosteal Abscess . . . . .	16	6	—	10	—	—	—	—	
Panaritium Cutaneum . . . . .	16	7	—	9	—	—	—	—	
Panaritium Osseum . . . . .	10	7	—	3	—	—	—	—	
Dental Abscess . . . . .	10	1	—	4	1	3	1	—	
Hordeolum . . . . .	10	6	—	4	—	—	—	—	
Abscess of the Middle Ear . . . . .	4	2	—	—	—	—	—	2	
Carbuncle . . . . .	4	2	—	1	1	—	—	4	
Osteomyelitis . . . . .	3	2	—	1	—	—	—	—	
Total . . . . .	200	82	7	55	45	6	3	2	4

#### PYÆMIA AND SEPTICÆMIA.

When pyogenic micrococci get access to the blood stream they may be carried into distant parts, and by multiplying produce metastatic abscesses in the lymphatic glands, bones, joints, and internal organs, a condition which is recognised as pyæmia.

If there is a general invasion of the blood stream by micrococci, and absorption of their poisonous products, septicæmia results, and death may occur before the development of any secondary lesions. When septic micro-organisms multiply locally, and their chemical products are absorbed, or their products are separated from putrid material and injected into the circulation, the result may be called *sapræmia*. The blood in septicæmia contains living organisms, and is infective. The blood in *sapræmia* contains only the toxic chemical products, and is not infective. The one is septic infection and the other septic intoxication. Pyæmia may follow accidental wounds, surgical operations, parturition, acute suppuration of bones, scarlet fever, typhoid fever, and other diseases.

To avoid pyæmia in surgery and midwifery, the greatest care must be taken to prevent micro-organisms from being conveyed by instruments, sponges, bandages, and by the hands of the surgeon or the obstetric physician. By the use of antiseptics and absolute cleanliness the chances of infection are reduced to a minimum.



Rosenbach examined six cases of metastatic pyæmia: *Streptococcus pyogenes* was found five times, partly in the blood and partly in the metastatic deposits, and twice in company with *Staphylococcus pyogenes aureus*.

Baumgarten, also, found *Streptococcus pyogenes* in the internal organs in pyæmic cases, and Eiselsberg found *Streptococcus pyogenes* in company with *Staphylococcus pyogenes aureus* in the blood of cases of septicæmia.

Fränkel isolated a streptococcus from puerperal fever, which he at first called *Streptococcus puerperalis*, but subsequently identified with *Streptococcus pyogenes*. These researches have been confirmed by others. Winkel obtained a pure cultivation of a streptococcus from the blood of the heart in a case of puerperal peritonitis. It produced erysipelatous redness when inoculated in the rabbit's ear, and in form and in cultivation was similar to the streptococcus in erysipelas. Cushing also found *Streptococcus pyogenes* associated with puerperal infection. The cocci were found in endometritis diphtheritica as well as in secondary puerperal inflammation. These observations were still further confirmed by Baumgarten, and Bumm isolated the same organism in puerperal mastitis.

#### DESCRIPTION OF BACTERIA IN PUS.

A description may now be given of the cocci most frequently found. *Staphylococcus pyogenes aureus* and *albus* and *Streptococcus pyogenes* and *Gonococcus* are the most important of these. *Staphylococcus pyogenes citreus*, *cereus albus* and *flavus*, are probably merely epiphytic. *Micrococcus tetragenus*, *Micrococcus pyogenes tenuis*, *Bacillus pyogenes fœtidus*, *Bacillus pyocyaneus*, *Bacillus coli communis*, *Bacillus septicus vesicæ*, *Urobacillus liquefaciens septicus*, and *Bacillus intracellularis meningitidis* will be described fully in Part III. The description of *Actinomyces*, of *Micrococcus pneumoniae crouposæ* and of the bacilli of anthrax, tuberculosis, glanders, and typhoid fever, will be found in other chapters in Part II.

***Staphylococcus pyogenes aureus*** (Rosenbach).—Yellow coccus in pus (Ogston). Cocci singly, in pairs, very short chains, and irregular masses. Cultivated on nutrient agar-agar, an orange-yellow culture develops, looking like a streak made with oil paint. One variety grows on nutrient gelatine without liquefying it; another produces rapid liquefaction, and the growth subsides as



an orange-yellow sediment. On potatoes and blood serum a similar orange-yellow culture grows luxuriantly. They may also form colourless growths in sub-cultures, and are then indistinguishable from *Staphylococcus pyogenes albus*. The cocci do not cause any septic odour in pus, nor does any gas develop. Albumin is converted by their action into peptones. They produce rapid ammoniacal fermentation in urine (Shattock).

The micro-organisms injected into the pleura or knee of a rabbit produce, as a rule, a fatal result on the following day; but if it survives longer, it eventually dies of severe phlegmon. If injected into the knee of a dog, suppuration occurs, followed by disintegration of the joint. Injected into the peritoneal cavity of animals, they set up peritonitis, and introduced into the jugular vein they produce septicæmia and death. When a small quantity of a cultivation is introduced into the jugular vein after previous fracture or contusion of the bones of the leg, the animal dies in about ten days, and abscesses are found in and around the bones, and in some cases in

the lungs and kidneys, and the cocci are found in the blood and pus.

Garré caused suppuration by inoculating a pure culture in a wound near his finger nail. Bockhart suffered from several pustules after vaccinating his arm with a pure culture suspended in salt solution, and Bunm gave himself a hypodermic injection of a pure culture and produced an abscess. This micro-



FIG. 84.—PUS WITH STAPHYLOCOCCI,  $\times 800$  (FLÜGGE).



FIG. 85.—SUBCUTANEOUS TISSUE OF A RABBIT 48 HOURS AFTER AN INJECTION OF STAPHYLOCOCCI,  $\times 950$  (BAUMGARTEN).

organism is practically ubiquitous. It has been cultivated from the skin and mucous membranes and secretions of healthy persons, and it occurs in the air, in soil, in dust, and in water, and in

association with suppuration, pyæmia, puerperal fever, and acute osteomyelitis.

**Staphylococcus pyogenes albus** (Rosenbach).—Cocci microscopically indistinguishable from the above. In cultivations also they resemble *Staphylococcus pyogenes aureus*, but the growth consists of opaque white masses. They, as a rule, liquefy nutrient gelatine very rapidly, and subside to the bottom as a white sediment; more rarely they liquefy very slowly; and a variety has also been described which does not produce any liquefaction. They are similar to the above-mentioned in their pathogenic action. Pure-cultivations of the organism were obtained from a case of acute suppuration of the knee-joint.

**Staphylococcus pyogenes citreus** (Passet).—Cocci singly, in pairs, very short chains, and irregular masses. If cultivated on nutrient gelatine or nutrient agar-agar, a sulphur or lemon-yellow growth develops. When inoculated under the skin of mice, guinea-pigs, or rabbits, an abscess forms after a few days, from which a fresh cultivation of the micro-organism can be obtained.

**Staphylococcus cereus albus** (Passet).—Cocci, morphologically similar to the above, but distinguished by forming on nutrient gelatine a white, slightly shining layer, like drops of stearine or wax, with somewhat thickened, irregular edges. In the depth of gelatine they form a greyish-white, granular thread. In plate-cultivations, on the first day, white points are observed, which spread themselves out on the surface to spots of 1 to 2 mm. When cultivated on blood serum a greyish-white, slightly shining streak develops, and on potatoes the cocci form a layer which is similarly coloured.

**Staphylococcus cereus flavus** (Passet).—Cocci which produce in nutrient jelly a growth which, at first white, becomes lemon-yellow, somewhat darker in colour than *Staphylococcus pyogenes citreus*. Microscopically *Staphylococcus cereus flavus* corresponds with *Staphylococcus cereus albus*. Inoculation experiments with both kinds give negative results.

**Streptococcus pyogenes** (Rosenbach).—Cocci occurring singly, in masses, and in chains. The individual cocci are small spherical cells, with a special tendency after fission for the resulting elements to remain attached to each other, forming chains or rosaries. In cultures on solid media they often occur in the form of staphylococci, but in liquid cultures there may be a few, three or more elements, linked together; or a great number, forming long chains which may be straight, serpentine, or twisted.





## DESCRIPTION OF PLATE IV.

### **Streptococcus Pyogenes.**

FIG. 1.—From a cover-glass preparation of pus from a pyæmic abscess. Stained with gentian-violet by the method of Gram, and contrast-stained with eosin.  $\times 1200$ . Powell and Lealand's apochromatic  $\frac{1}{1\frac{1}{2}}$  Hom. imm. E. P. 10.

FIG. 2.—From cover-glass preparations of artificial cultivations of the streptococcus in broth and in milk at different stages of growth.  $\times 1200$ . Powell and Lealand's apochromatic  $\frac{1}{1\frac{1}{2}}$  Hom. imm. E. P. 10.

In these preparations there is a great diversity in size and form of the chains and their component elements. In the drawing examples are figured of the following:

- (a) Branched chains.
- (b) Simple chains composed of elements much smaller than the average size.
- (c) Chains with spherical and spindle-shaped elements at irregular intervals. These are conspicuous by their size, and are sometimes terminal.
- (d e) Chains in which the elements are more or less uniform in size.
- (f) Complex chains with elements dividing both longitudinally and transversely, and varying considerably in size in different lengths of the same chain.



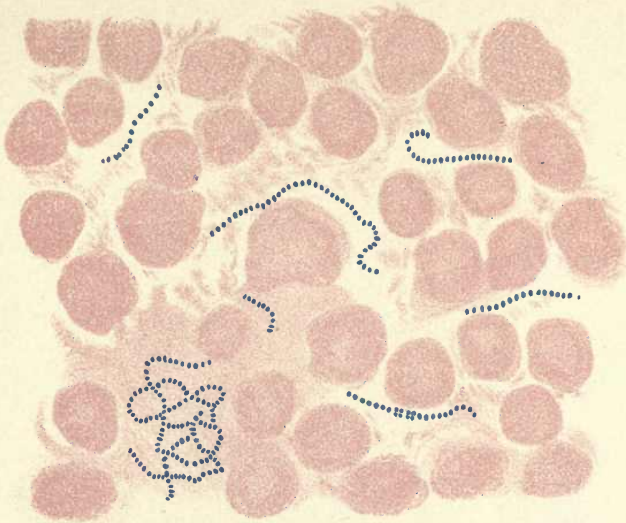

Fig 1.

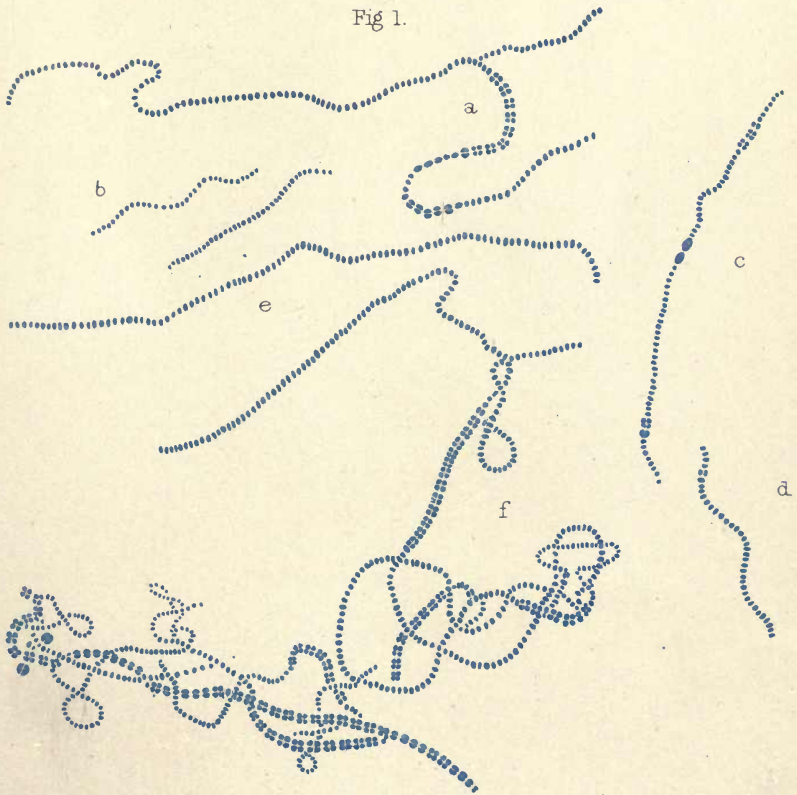

Fig 2.

STREPTOCOCCUS PYOGENES





The individual elements composing the chains will be found to vary considerably in size: here and there in a preparation will be found a chain composed of excessively small cocci, in another part the elements will be all on a larger scale, and again in another part they will be peculiarly conspicuous on account of their size. So great is the diversity in the size of the cocci in some of the chains, that one might imagine that there was more than one kind of streptococcus present in a preparation, until on examining some of the longest chains it is observed that various sizes are represented in different lengths of the same chain. Very characteristic appearances result from the fact that the cocci enlarge and divide both longitudinally and transversely; and, indeed, the largest, for the most part, clearly show a division in two directions, resulting in the formation of tetrads. In addition to the forms resulting from the fission of the cocci, there are here and there in a chain, and sometimes terminally, larger elements, which are spherical, spindle-shaped, or in the form of a lemon. In the length of the chains, as in the size of the individual cocci, there is usually great diversity. In some cases they are composed of only a few, three or four cocci; in others eight, ten, or twenty. Here and there an exquisite rosary will extend in a straight line across the field of the microscope, or be twisted, curved, or serpentine; in some preparations twisted or entangled strands are observed which are composed of several hundred elements. Such chains will be found to be much thicker in one part than another. Another characteristic appearance is produced by separation of the elements resulting from fission in the long direction of the chain, by which lateral twigs or branches are formed. Another character, which is very striking, may be seen when the individuals in a chain have become separated; an unstained or faintly stained membrane may be found bridging across the interval. This will become still more visible in preparations contrast-stained with eosin.

In plate-cultivations the appearances of the colonies are not very striking. They appear to the naked eye after three or four days as extremely minute, greyish-white, translucent dots, which under the microscope have a slightly yellowish-brown colour. They are finely granular and well defined. They do not liquefy the gelatine, and after several weeks may not exceed the size of a pin's head.

If the surface of nutrient gelatine solidified obliquely be traced over once or twice with a platinum needle bent at the extremity into a little hook charged with the cocci, a ribbon-shaped film develops in two or three days. This film is composed of minute,

greyish-white, translucent dots or droplets, which can be more easily recognised with the aid of a pocket lens (Fig. 87). According to the number of organisms sown on the jelly, the dots or colonies may be completely isolated, or form a more or less continuous film. The film by reflected light has an iridescent appearance like mother-of-pearl, but has a bluish or bluish-grey tint by transmitted light, and with a pocket lens appears distinctly brownish. The gelatine is not liquefied, and even after several weeks the cultivation is limited to the inoculated area, and the individual colonies are, as a rule, not larger than pins' heads. In gelatine-cultivations of the same age, but kept in the incubator at 18° C., the colonies get irregular in form, especially at the margin of the film, and give the growth an arborescent, fringed, or serrated appearance. Cultivated on the oblique surface of nutrient agar-agar at 37° C. the growth is very similar, forming a film composed of minute white colonies like grains of sand; but the film appears less transparent, is whiter, and the colonies have a greater tendency to get irregular in form. If inoculated with one tracing of the needle the growth is scanty, but tends to get thicker in the centre than towards the margins, which may have a terraced appearance. Inoculated in the depth of gelatine, there appears after a day or two at 18° C. a thread-like growth along the track of the inoculating needle. This delicate growth is found on examination with a pocket lens to consist of a linear series of extremely minute granules. In a few days more, the beads or granules become more marked, but even after weeks, the cultivation only appears like a string of minute, white, compact, globular masses or grains. In broth at 37° C. the cocci in twenty-four hours create a turbidity, and gradually develop beautiful chains varying in length according to the age of the cultivations. Even in forty-eight hours there may be chains of eight, ten, twenty, or a hundred elements. After a few days the growth settles down at the bottom of the tube in the form of a white deposit, while the supernatant liquid becomes again clear.

Inoculated subcutaneously in the ear of rabbits, they produce in two days an inflammatory thickening with erysipelatous redness, or sometimes suppuration.

They may occur in vaccine lymph, as the result of contamination, and Pfeiffer suggested that before calf lymph is employed for vaccination it should be tested on a rabbit's ear. If in two days no rash has been produced, the possibility of the presence in the lymph of *Streptococcus pyogenes* or *erysipelatis* is excluded.



According to Flügge and others, after subcutaneous inoculation of mice with a small quantity of a cultivation, there is no result in 80 per cent. of the animals experimented upon. Sometimes there is limited pus formation at the seat of inoculation, sometimes the animals die without any very striking pathological appearances.

They occur in abscesses, pyæmia, and septicæmia, and are often found in diseases such as scarlet fever and typhoid, associated with septic complications. They have been isolated from air, soil, and water.

The streptococcus found in erysipelas agrees in description, and is merely a variety of *Streptococcus pyogenes*. It has been definitely established by the researches of Fränkel and Freudenberg, and later by those of the author, Raskin, Prudden, and Bayard Holmes, that *Streptococcus pyogenes* is frequently found in scarlet fever and diphtheria, and in other diseases associated with septic complications. The author has isolated *Streptococcus pyogenes* from acute abscesses, from suppuration after surgical operations, from pyæmia, from pyæmia after scarlet fever, and from purulent peritonitis. Some of these cultures have been kept up for very long periods, extending over some years, so that opportunities occurred for a complete investigation into the life history of this micro-organism. Variations in the appearances of cultures have been observed when obtained from the same source. A number of cultures from pus were prepared on gelatine and agar, made according to the usual formula, but at different dates, and, therefore, varying slightly in composition and quality. Sub-cultures were also started in nutrient gelatine of precisely the same composition, but from primary cultures of the same micro-organism in different media—agar-agar, milk, and broth. The descriptions of the streptococcus hitherto published were then found to be inadequate. The different cultures and sub-cultures presented striking variations in the microscopical and macroscopical appearances. Some sub-cultures on gelatine, for example, exhibited a finely dotted appearance, others showed every variety in the size, and degree of opacity of the colonies (Fig. 89). Cultures in broth also, varied in appearance, owing to slight variation in the composition of the medium, to slight differences of temperature, and other conditions difficult to determine. The addition of glycerine to broth materially alters the appearance of the culture. It was conclusively proved that minute differences arise from different conditions of the cultivating media. The author was led to study exhaustively the streptococcus of acute suppuration in bovines. Primary cultures of *Streptococcus pyogenes* from man, and primary cultures from

a case of purulent peritonitis in a cow, were carried through sub-cultures under exactly similar conditions. Cultivations of the *Streptococcus pyogenes bovis* exhibited variations in microscopical and cultural characters which were even more marked than in the case of the *Streptococcus pyogenes hominis*. By selecting certain cultures from both sources there was a striking similarity if not identity between them, but, when compared under exactly identical conditions, there was more difference in cultural characters between the *Streptococcus pyogenes bovis* and the *Streptococcus pyogenes hominis* than between the *Streptococcus pyogenes hominis* and the *Streptococcus erysipelatis*, and they may therefore be regarded as distinct varieties (Figs. 89, 90).

Some of the diseases and conditions in which *Streptococcus pyogenes* has been found may be alluded to more in detail.

*Spreading Gangrene.*—From a case of spreading gangrene, which was identical with Ogston's erysipelatoïd wound gangrene, and regarded by him as the most intense and dangerous form of erysipelas, Rosenbach obtained pure-cultivations of a streptococcus by incising the skin of the limb, and inoculating tubes from the turbid reddish fluid which escaped. That the streptococcus was identical with *Streptococcus pyogenes* was ascertained by comparison with a cultivation derived from pus, of the mode of growth, and of the effect on animals.

*Surgical Fever.*—Eiselsberg proved the presence of a streptococcus in the blood of several cases of surgical fever in Billroth's clinic. The organism was identified by cultivation with *Streptococcus pyogenes*.

*Diphtheria.*—In three cases of typical diphtheria, Löffler found a streptococcus. He isolated it by cultivation, found that it was similar in form, characters on cultivation, and effects after inoculation, to Fehleisen's streptococcus of erysipelas. Löffler was not inclined to regard them as identical, because Fehleisen never found his cocci in the blood-vessels. Flügge named the organism *Streptococcus articulorum*, and states, that after subcutaneous inoculation or injection of a cultivation in mice, a large proportion of the animals die, and in the sections of the spleen and other organs the streptococci are again seen. Baumgarten investigated the same subject, and decided that the streptococcus was identical with *Streptococcus pyogenes*.

*Small-pox.*—Hlava has established the presence of *Streptococcus pyogenes* in the pustules of variola, and Garré found streptococci in the internal organs in a case of variola hæmorrhagica. In a fatal case of variola complicated with pemphigus, Garré found a streptococcus in the pemphigus vesicles. Whether it was identical with *Streptococcus erysipelatis* Garré left an open question.

*Yellow Fever.*—Babès observed the presence of streptococci in the vessels of the kidney and liver in yellow fever. Cultivation experiments are wanting. It was probably a case of secondary infection with *Streptococcus pyogenes*.



*Bilious Fever.*—Babès, in a case of fièvre bilieuse typhoïde, found masses of streptococci filling the vessels of the liver, kidney, and spleen. This was probably another instance of secondary infection with *Streptococcus pyogenes*.

*Measles.*—From the blood and inflammatory post-products in measles, Babès isolated a streptococcus, which he describes as closely resembling the *Streptococcus pyogenes*.

*Ulcerative Endocarditis.*—Wyssokowitsch found cocci in the internal organs in ulcerative endocarditis, and produced the disease in animals, after injury to the valves, by injection of *Streptococcus pyogenes* and other organisms. Weichselbaum, by microscopical research and by cultivation experiments, proved the presence of *Streptococcus pyogenes* in acute verrucous endocarditis. Baumgarten confirmed this. He found



FIG. 86.—ULCERATIVE ENDOCARDITIS : SECTION OF CARDIAC MUSCLE,  $\times 700$  (KOCH).

*Streptococcus pyogenes* alone in one case and accompanied by *Staphylococcus aureus* in another.

*Broncho-pneumonia.*—Thaon found a streptococcus in the lungs of children in fatal cases of broncho-pneumonia, complicating measles, diphtheria, and whooping cough. It was regarded as identical with the streptococcus isolated by Löffler from diphtheria. Fränkel discovered a streptococcus in the lungs of a case of true croup complicated with broncho-pneumonia, and by cultivation established its identity with *Streptococcus pyogenes*.

*Anthrax.*—Charrin found cocci in rabbits, examined some hours after death from anthrax. These, when isolated, produced death in rabbits from septicæmia, without suppuration. Chains composed of from fifteen to twenty elements were found in all the organs. This was probably another instance of *Streptococcus pyogenes*.

*Syphilis.*—Kassowitz and Hochsinger found the presence of a strepto-

coccus in the tissues and internal organs, and especially in the blood-vessels, in fatal cases of congenital syphilis. These observers regarded their discovery as having an important bearing on the etiology of syphilis, but Kolisko pointed out that it was only the result of septic infection with presence of *Streptococcus pyogenes*, as had already been established in scarlet fever.

*Cerebro-spinal Meningitis.*—From the meningeal exudation of a case of apparently idiopathic cerebro-meningitis, Banti found *Streptococcus pyogenes* and *Staphylococcus aureus* and *albus*. The cocci probably entered through an abscess of the jejunum.

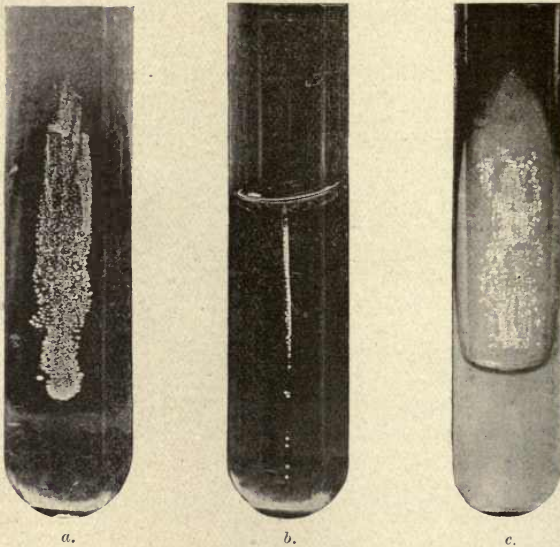

FIG. 87.—PURE-CULTURES OF *STREPTOCOCCUS PYOGENES*.

a, On the surface of nutrient gelatine ; b, in the depth of nutrient gelatine ;  
c, on the surface of nutrient agar.

*Blepharadenitis and Dacryocystis.*—Widmark isolated by cultivations *Streptococcus pyogenes* and other organisms from cases of blepharadenitis and phlegmonous dacryocystis. In phlegmonous dacryocystis Widmark found *Streptococcus pyogenes* almost exclusively.

*Leukæmia.*—Flügge cultivated a streptococcus from necrotic patches in the spleen of a fatal case of leukæmia. Cultures corresponded very closely with *Streptococcus pyogenes*. Inoculation in the ears of rabbits produced similar results to *Streptococcus pyogenes* or erysipelatis. Flügge calls it *Streptococcus pyogenes malignus*, but concludes that it is probably identical with the streptococcus from pus.



## ERYSIPELAS.

Erysipelas is an acute inflammation of the skin, occurring in connection with wounds, when it is traumatic, and on surfaces apparently sound, when it is idiopathic, as in erysipelas of the face. It is highly contagious in surgical wards, and it gives rise to rapidly fatal puerperal fever in lying-in hospitals. In such cases the virus is obviously conveyed from sick to healthy persons by direct contact, or by instruments and sponges, or by the hand of the surgeon, physician, or nurse, and possibly by the air.

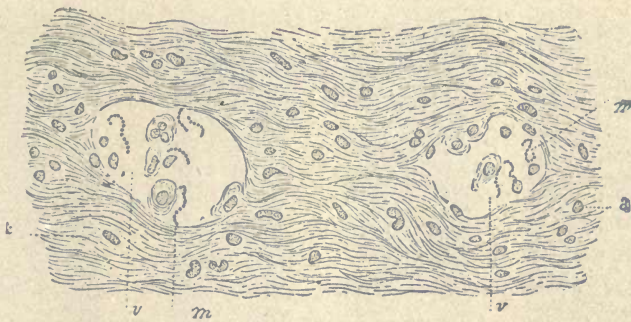

FIG. 88.—SECTION OF SKIN IN ERYSIPELAS.

*v, v*, two lymphatic vessels containing leucocytes and *m, m*, streptococci; *t*, connective tissue; *a*, connective tissue and wandering cells.  $\times 600$  (CORNIL and RANVIER).

**Streptococcus of Erysipelas.**—In 1882, Fehleisen isolated a streptococcus in erysipelas, described the appearances on cultivation, and maintained that it could be distinguished from the streptococcus of suppuration. Rosenbach agreed that the two micro-organisms could be distinguished by parallel experiments, and named the one *Streptococcus pyogenes* and the other *Streptococcus erysipelatis*. (Fehleisen). Rosenbach asserted that the colonies of the latter were more opaque and whiter than those of *Streptococcus pyogenes* and the growth more marked in the depth of nutrient gelatine, while microscopically the chains were better marked and larger, and the individual cocci larger than in *Streptococcus pyogenes*. Others who investigated this subject could not distinguish them with certainty, either by their morphological or cultural characters or effects on inoculation. Passet found that inoculation of *Streptococcus pyogenes* induced a condition very similar to that produced by inoculation of *Streptococcus erysipelatis*. Hoffa and Hajek described minute differences, but Biondi and Eiselsberg failed to confirm these.

Baumgarten failed to prove any essential difference. Mitchell Prudden found that *Streptococcus pyogenes* injected into the subcutaneous tissue of the ears of rabbits, produced in one no effect; in four, slight transient redness; in five, local redness followed by abscess; in twelve, well-marked erysipelatos redness, followed by complete resolution in seven, abscess in three, and death in two. Passet, Biondi, Eiselsberg, Baumgarten, and Mitchell Prudden concluded that, in their morphological, biological, and pathogenic characters, so far as animals are concerned, the two organisms are practically identical.

The author investigated the morphology and cultural characters of the *Streptococcus erysipelatis*, which he had isolated from a typical case. This result cleared up the conflicting statements which had been made by different observers. By carrying out absolutely parallel experiments, the *Streptococcus pyogenes* and *Streptococcus erysipelatis* were unquestionably distinguishable, as Fehleisen and Rosenbach had asserted. In both cases, however, inoculation of a trace of a culture from a solid medium produced only transient redness. Injection hypodermically of a broth-culture produced in both cases a spreading erysipelatos redness, followed by suppuration. It was found that primary cultures of the two micro-organisms, cultivated under precisely the same conditions, differed in the size and character of their chains, in the size of the individual elements, in the greater opacity of the colonies of *Streptococcus erysipelatis*, in a greater tendency to confluence, and in a more rapid growth. The author found that the difference was most marked in broth-cultures. Abundant flocculi were formed by *Streptococcus pyogenes*; a powdery deposit with special tendency to form a granular adhesive film at the bottom of the culture flask, in the case of the streptococcus of erysipelas. Lastly, they differed in their power of resisting germicides.

Fehleisen inoculated patients in hospital suffering with malignant growths, and produced a typical erysipelas with sub-cultures after an incubation of from sixteen to twenty hours. The disease was marked by rigors, fever, and general disturbance. Patients who had recently suffered from erysipelas had an immunity.

Emmerich succeeded in proving the presence of streptococci in the air of a hospital where erysipelas had broken out. These cocci in their form, their characters on cultivation, and their inoculation results, were identified with the *Streptococcus erysipelatis*. It is not therefore exclusively parasitic.

*Streptococci* identical or agreeing very closely in their description



with *Streptococcus pyogenes*, have been found in cattle plague, foot and mouth disease, strangles, contagious mammitis in cows, and progressive tissue necrosis in mice, and they will be referred to fully in subsequent chapters.

#### EXAMINATION AND CULTIVATION OF STREPTOCOCCI.

Cover-glass preparations can be stained with the watery solutions of the aniline dyes. In some cases very beautiful preparations can be obtained by using Neelsen's solution, and removing excess of

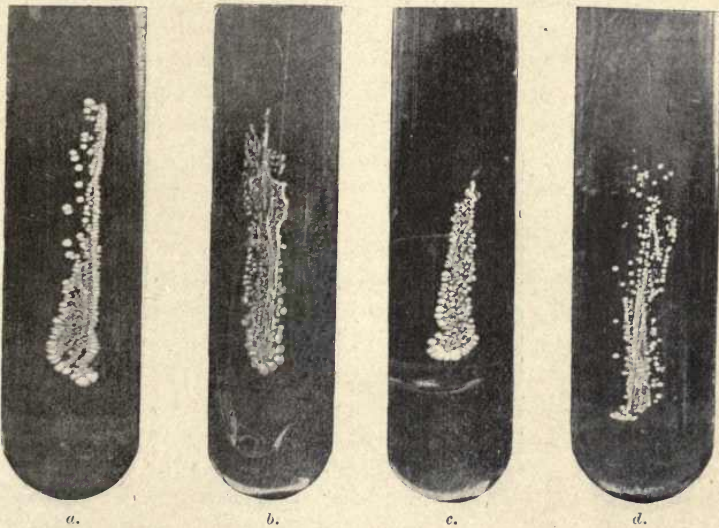

FIG. 89.—*STREPTOCOCCUS PYOGENES HOMINIS*. Pure-cultures on nutrient gelatine.

*a*, Sub-culture from agar.  
*c*, Sub-culture from milk.

*b*, Sub-culture from broth.  
*d*, Sub-culture from milk.

stain by rinsing in alcohol. To examine pus, milk, or broth, take an ordinary platinum needle bent at the extremity into a hooklet. Dip it into the liquid to be examined, and spread it on a cover-glass into as thin a film as possible; the preparation is treated in the ordinary way, that is to say, the film is allowed to dry, and the cover is taken up with forceps, and passed three times through the flame with its prepared side uppermost.

*Gram's Method with Eosin*.—In this way the streptococci are stained blue, and stand out in marked contrast to the rest of the preparation. Use freshly prepared solution. Float the cover-glasses

on the solution for ten minutes to half an hour, then transfer them to iodine-potassic-iodide solution, until they assume the colour of a tea leaf; then immerse them in alcohol until they are decolorised; dip them in an alcoholic solution of eosin for a few moments, and then transfer them to clove oil to clarify the film; to remove the clove oil gently press the cover between two layers of clean filter paper, then mount in xylol balsam.

A good method for cultivating streptococci is to employ a sterilised looped platinum wire, and to spread a droplet, for example, of pus or blood, over the surface of nutrient agar-agar solidified obliquely.

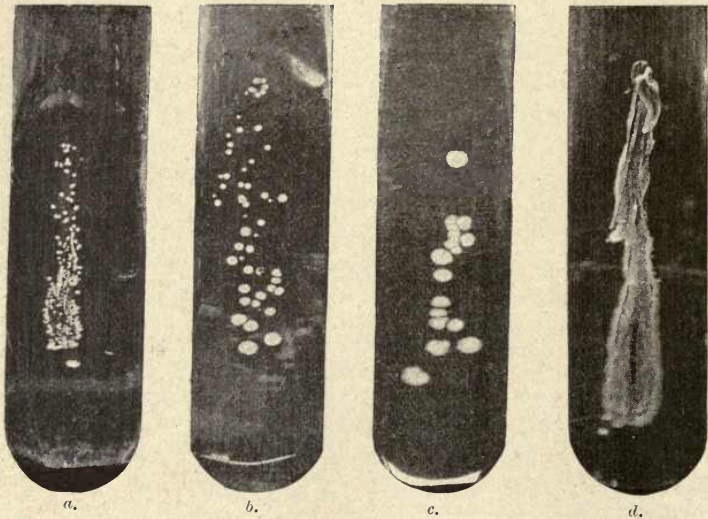

FIG. 90.—STREPTOCOCCUS PYOGENES BOVIS. Pure-cultures on nutrient gelatine.

*a*, Sub-culture from agar.

*c*, Sub-culture from milk.

*b*, Sub-culture from broth.

*d*, Sub-culture from milk.

The tubes are then placed in the incubator at 37° C.; the streptococci will appear in the course of two or three days in the form of minute dotted colonies. If present alone, and in considerable quantities, the inoculated surface will exhibit a pure cultivation consisting of a number of such colonies, whilst a flocculent mass is observed in the liquid which collects at the bottom of agar-agar tubes; this flocculent mass will be found to be composed of chains. From such a tube inoculate a number of the small flasks employed in Pasteur's laboratory for cultivations in liquids. In this way a number of pure-cultivations in milk and broth are established, which can be readily examined from time to time. From a pure-



cultivation in broth or agar-agar tubes of nutrient gelatine can be inoculated. Cover-glass-preparations from the growths on solid media can be made in the usual way, and stained with either a watery solution of fuchsin or gentian violet: but to stain preparations made from milk or broth, or from the liquid in agar-agar tubes, use the method of Gram; the stain will then be removed, except from the streptococci, and very beautiful preparations result.

#### GONORRHOEA.

Gonorrhœa is the result of a catarrhal inflammation of the mucous membrane of the urethra, vagina, or conjunctiva caused by a characteristic pyogenic organism discovered by Neisser in 1879.

**Gonococcus of Neisser.**—Cocci, usually in pairs  $1.6 \mu$  in length,  $.8 \mu$  in width, and tetrads, with those surfaces of the component elements which are in contact, flattened. The elements are more or less kidney-shaped, and are separated by a clear unstained interval. They are found free in the pus and also in the interior of the pus cells. They stain with the aniline dyes, but are decolorised by Gram's solution. They do not grow on the ordinary media, such as gelatine, agar, and potato, in marked contrast to the common pyogenic cocci; but Bumm succeeded in obtaining a cultivation by using human blood serum, which was procured for the purpose from the placenta. They give rise to a very delicate growth in the form of an almost invisible film, with a moist appearance, which attains its full development in a few days. Steinschneider used human blood serum and agar incubated at  $35^{\circ} \text{C}$ .

Krall recommended either agar with grape-sugar and blood serum, or the same mixture with the addition of 5 per cent. glycerine. Others have employed nutrient agar with the surface moistened with sterilised human blood. More recently Keifer has been successful with a medium which is prepared in the following way: ascitic fluid is filtered and sterilised by Tyndall's process, to this is added an equal quantity of the following mixture, agar 3.5, peptone 5, glycerine 2, salt .5 (per cent.). The ascitic agar is solidified in a Petri's dish, and the culture incubated at  $36^{\circ} \text{C}$ .

They have also been cultivated in albumin from plovers' eggs, and in the fluid obtained from a case of synovitis of the knee joint.

Inoculation of rabbits, dogs, horses, and monkeys, has been invariably unsuccessful, but sub-cultures produce the disease in the healthy urethra.



The cocci are found in pus from the urethra and other mucous membranes affected by the disease. They have also been found in urethral and inguinal abscesses in association with *Staphylococcus pyogenes aureus*.

#### METHOD OF STAINING.

Cover-glass preparations are made in the usual way, and double stained with Löffler's methylene blue, and eosin.

Schütz recommends floating the cover-glasses for five or ten minutes in a saturated solution of methylene blue in 5 per cent. solution of carbolic acid. They are washed in water, rinsed in very weak acetic acid, and again washed in water. Safranin may be used as a contrast stain.



FIG. 91.—GONOCOCCUS  $\times$  800 (BUMM).

*a*, free cocci ; *b*, cocci in pus cells ; *c*, epithelial cell containing cocci.

#### EGYPTIAN OPHTHALMIA.

There are two forms of ophthalmia in Egypt, one associated with *Gonococcus* and the other with a bacillus closely resembling the bacillus of mouse-septicæmia, but there are minute differences.

**Bacillus of Ophthalmia** (Koch and Kartulis). Minute rods which do not grow on gelatine but readily on blood serum and nutrient agar, forming a plainly visible, whitish-grey shining growth. Animals are insusceptible, but cultures produced the disease in the human conjunctiva in two out of six cases.



## CHAPTER XIV.

### ANTHRAX.

ANTHRAX is a very fatal malady, and most irregular in its behaviour. At one time it attacks only one or two animals, and at another time it will destroy nearly all the stock on a farm. Farmers formerly regarded the disease as non-communicable, and possibly the result of excessive or improper feeding, or faulty sanitation, or of climatic conditions over which no control could be exercised. It is obvious that so long as the disease was regarded as the result of unknown conditions, no explanation could be given of its recurrence from time to time, or of certain animals contracting the disease and others not, and no measures of any use could be suggested to cope with an outbreak.

Anthrax has always been more prevalent on the Continent than in England, and this to some extent accounts for the fact that it has received greater attention abroad. In France, Germany, Hungary, Russia, and in India and Persia, anthrax at times produces widespread losses. In Siberia it is still known on this account as the Siberian Plague.

On the Continent there are certain localities known as *anthrax districts* on account of their reputation for anthrax—for example, in the Upper Bavarian Alps in Germany and in Auvergne in France.

In 1849, Pollender happened to examine the blood of a cow after death from anthrax, and discovered peculiar rod-like bodies among the blood cells. The same observation was made independently by Brauell and Davaine about the same time, but the greatest importance must be attached to the publication of Davaine's further researches in 1863. Many ridiculed the discovery of bacilli, and stoutly maintained that they were only blood crystals or accidental structures of no importance.

For many years very little progress was made, and the statements of other observers who were able to verify and add to Pollender's and Davaine's discoveries, were still received with scepticism.

Within the last few years a great change of opinion has taken place. Bacteriologists have investigated the whole subject, so that at the present day we know exactly the cause of anthrax.

**Bacillus anthracis** (*Bactéridie du charbon*, *Bacillus of splenic fever*, *Wool-sorters' disease*, or *malignant pustule*).—Rods 5 to 20  $\mu$  long and 1 to 1.25  $\mu$  broad, and threads; spore-formation present. As a thorough knowledge of the life-history of this bacillus is of the greatest importance, the various steps to be followed in a practical study of it will be successively treated in detail. Its morphological

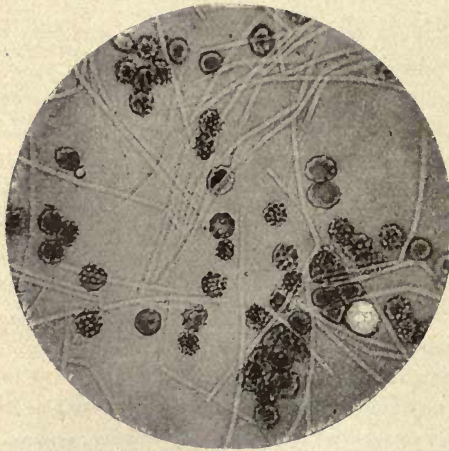

FIG. 92.—BACILLUS ANTHRACIS,  $\times 1200$ . Blood corpuscles and bacilli unstained; from an inoculated mouse (FRÄNKEL and PFEIFFER).

and biological characteristics have been very completely worked out, and it serves as an excellent subject for gaining an acquaintance with most of the methods employed in studying micro-organisms.

A mouse inoculated with the bacillus or its spores will die in from twenty-four to forty-eight hours, or more rarely in from forty-eight to about sixty hours.

*Examination after Death.*—The spleen is found to be considerably enlarged, and may be removed, and examined by making cover-glass preparations, inoculations in nutrient media, and subsequently sections.

*Cover-glass Preparations.*—In cover-glass preparations of the blood of the spleen the bacilli are found in enormous numbers. Preparations should also be made with blood from the heart and with the exudation from the lungs and other organs; it will be





## DESCRIPTION OF PLATE V.

### **Bacillus Anthracis.**

- FIG. 1.—From a cover-glass preparation of blood from the spleen of a guinea-pig inoculated with blood from a sow.  $\times 1200$ . Powell and Lealand's apochromatic  $\frac{1}{4}$  Hom. imm. E. P. 10.
- FIG. 2.—From a section of a kidney of a mouse. Under a low power the preparation has exactly the appearance of an injected specimen. Under higher amplification the bacilli are seen to have threaded their way along the capillaries between the tubules, and to have collected in masses in the glomeruli. Stained with Gram's method (gentian-violet), and eosin.  $\times 500$ .
- FIG. 3.—*Bacillus anthracis* and *Micrococcus tetragenus*. From a section from the lungs of a mouse which had been inoculated with anthrax three days after inoculation with *Micrococcus tetragenus*. A double or mixed infection resulted. Anthrax-bacilli occurred in vast numbers, completely filling the small vessels and capillaries, and in addition there were great numbers of tetrads. Stained by Gram's method (gentian-violet), and with eosin.  $\times 500$ .



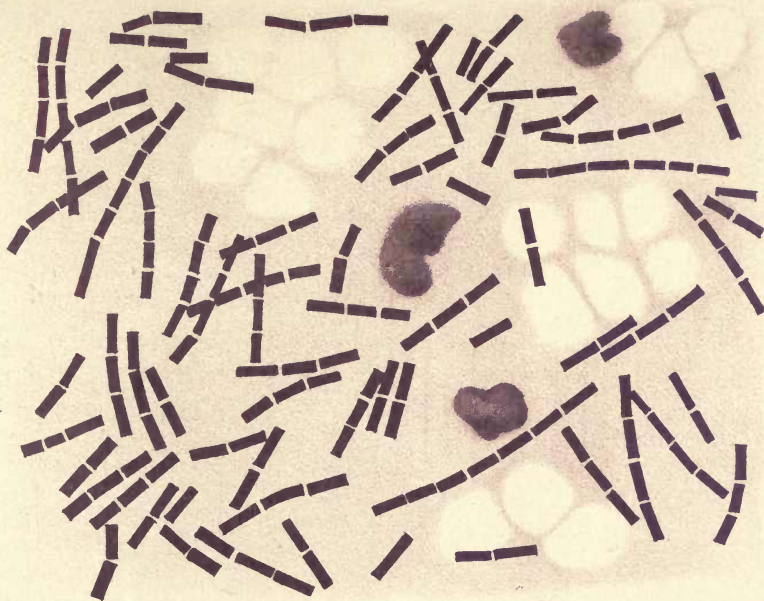

Fig 1.

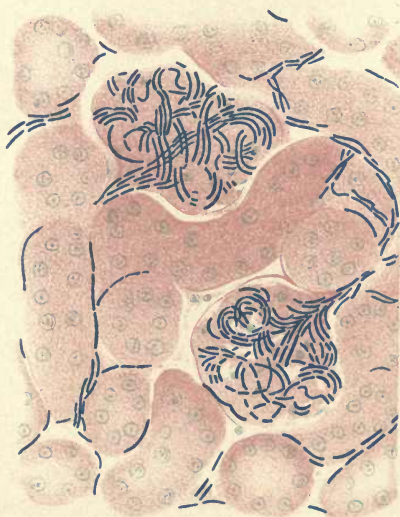

Fig 2.

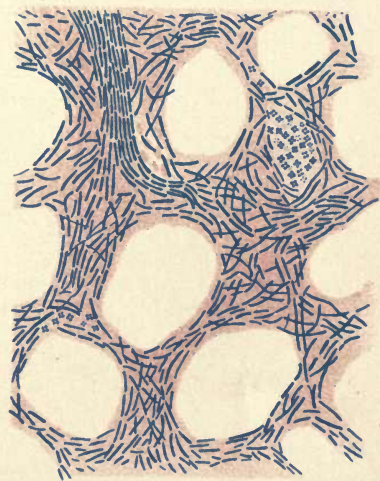

Fig 3.

BACILLUS ANTHRACIS





noted that in these the bacilli are present in very small numbers, or altogether absent. The bacilli should be examined both unstained and stained. The rods are straight or sometimes curved; rigid and motionless. They can be stained with a watery solution of any of the aniline dyes, and are then seen to be composed of segments with their extremities truncated at right angles; between the segments a clear linear space exists, which gives them a characteristic appearance (Plate V., Fig. 1). By double staining, with Gram's method and eosin, the rods are seen to consist of a membrane or hyaline sheath with protoplasmic contents.

*Drop-cultures.*—A little of the blood from the spleen or heart may be employed to inoculate sterilised broth or blood serum. Several of these cultures should be prepared, and some of them placed in the incubator, and examined at intervals of a few hours. It will be observed that the rods grow into long homogeneous filaments, which are twisted up in strands, and partly untwisted in long and graceful curves. The filaments begin to swell, become faintly granular, and bright, oval spores develop (Plate 1). The cultures in the incubator develop rapidly. A temperature of 30° to 37° C. is the most favourable for spore-formation. The spores are eventually set free, and by making a fresh cultivation, or by injecting them into a mouse or guinea-pig, they germinate again into the characteristic bacilli, which in their turn grow into filaments and spores. When the spore germinates it swells, the envelope becomes jelly-like, and gives way at one or other pole, and the contents escape and grow into a rod.

*Test-tube Cultivations in Nutrient Gelatine.*—Typically characteristic appearances are obtained by inoculating a 5 to 8 per cent. nutrient gelatine. A whitish line develops in the track of the inoculating needle, and from it fine filaments spread out in the surrounding medium (Fig. 93). The filaments are more easily observed with a magnifying glass. In a more solid nutrient gelatine the growth appears only as a thick white thread. As liquefaction of the gelatine progresses, these appearances gradually alter, and the growth subsides to the bottom of the tube as a white flocculent mass. In exhausted culture-media, and sometimes in the blood, filaments are seen in a state of degeneration.



FIG. 93.—PURE CULTIVATION OF BACILLUS ANTHRACIS IN NUTRIENT GELATINE.

This has also been observed in sections of the internal organs of a rabbit which had been inoculated with the anthrax bacillus and had died of septicæmia the following morning.

*Test-tube Cultivations in Nutrient Agar-agar.*—Cultivated upon a

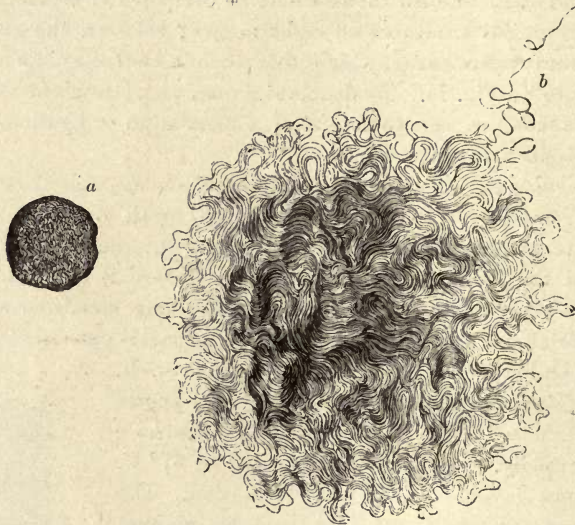

FIG. 94.—COLONIES OF *BACILLUS ANTHRACIS*,  $\times 80$  (FLÜGGE).

*a*, after 24 hours; *b*, after 48 hours.

sloping surface of nutrient agar-agar a viscous snow-white layer is developed, but without access of air no cultivation can be obtained, the bacilli being aerobic. This can be demonstrated by completely embedding a piece of lung or spleen pulp containing bacilli, in nutrient agar-agar (p. 22).



FIG. 95.—IMPRESSION-PREPARATION OF A COLONY,  $\times 70$ .

*Potato-cultivations.*—In about thirty-six to forty-eight hours a creamy-white or very faintly yellowish layer forms over the inoculated surface, usually with a translucent edge, and sometimes a strong, penetrating odour of sour milk.

*Plate-cultivations.*—From the spleen or blood of the heart cultivations may be made in nutrient gelatine on plates.

The colonies develop in about two days, according to the temperature of the room. They appear to the naked eye as little white spots



or specks, which, on examination with a low power of the microscope and small diaphragm, exhibit two distinct forms. One form, on careful focussing, has the appearance of a little compact ball of



FIG. 96.—MARGIN OF A COLONY,  $\times 250$

twisted threads; in the other, liquefaction of the gelatine has commenced, and the threads spread out like locks or plaits of hair in the neighbouring gelatine. These appearances are perfectly characteristic (Figs. 94, 96).

*Cover-glass Impressions.*—The plate-cultivations should be also examined as soon as the colonies appear, by making cover-glass impressions (Fig. 95). The filaments, examined with a high power, will be seen to consist of a number of rods or segments which are perfectly regular in form. On the other hand, filaments from a tube-cultivation in a solid medium will often be found to be composed, not only of rods, but here and there of the so-called involution-forms (Fig. 97). From cultures in gelatine and glycerine agar, very striking preparations are sometimes obtained, with numerous large spherical and lemon-shaped elements. In a



FIG. 97.—FILAMENTS WITH OVAL AND IRREGULAR ELEMENTS,  $\times 800$ .

cover-glass preparation from a potato-culture the individual segments will be found to have a great tendency to be isolated one from the other, and there is copious spore-formation.

*Preservation of Spores.*—Spores may be preserved simply by allowing anthrax blood to dry and then sealing it in a tube. The spores from a potato-cultivation are treated as follows:—The inoculated surface bearing the creamy cultivation is sliced off in a thin layer, and is mashed up with distilled water in a glass capsule. Sterilised silk-thread is cut up into lengths of about a quarter of an inch, and allowed to soak in the paste for some hours, under a bell-glass. The threads are then picked out with a pair of forceps, and laid upon a sterilised glass plate, covered with a bell-glass, and allowed to dry. From the plate, when perfectly dry, they are transferred to a small test-tube, which can be plugged with cotton-wool, or sealed in the Bunsen burner.

*Examination of the Tissues.*—The organs should be hardened in absolute alcohol, and sections prepared and stained by the ordinary methods. The method of Gram is the most instructive, and eosin a very satisfactory contrast stain. The capillaries in the lungs, liver, kidney, spleen, skin, mucous membrane, etc., will be found to contain bacilli. In some cases the bacilli are so numerous that a section under a low power has the appearance of an injected specimen.

*Inoculation of Animals.*—A thread containing spores, a drop of blood from an infected animal, or a minute portion of a cultivation, introduced under the skin of a mouse or guinea-pig, causes a fatal result, as a rule, in from twenty-four to forty-eight hours. Sheep fed upon potatoes which have been the medium for cultivating the bacillus, die in a few days. Goats, hedgehogs, sparrows, cows, horses, swine, and dogs are all susceptible. Rats are infected with difficulty. Frogs and fish have been rendered susceptible by raising the temperature of the water in which they lived. Cats, white rats, and Algerian sheep have an immunity from the disease.

*Attenuation of the Virus.*—Toussaint attenuated cultures by exposing them for ten minutes to 55° C. Pasteur obtained a similar result by resorting to lower degrees of temperature; and Koch, Gaffky, and Löffler concluded from their experiments, that from 42° to 43° C. the bacillus was most easily deprived of its poisonous properties. By cultivating the bacillus in neutralised broth at 42° to 43° C. for about twenty days, the infecting power is weakened, and animals inoculated with it (*premier vaccin*) are protected against the disease. To obtain a still more perfect immunity, they are



inoculated a second time with material (*deuxième vaccin*) which has been less weakened. The animals are then protected against the most virulent anthrax, but only for a time. From a weakened culture, according to Klein, new cultures of virulent bacilli can be started, and a culture that can be used as a vaccine for sheep kills a guinea-pig, and then yields bacilli that are fatal to sheep.

The virulence of the bacillus is also altered by passing the bacillus through different species of animals. The bacillus of sheep or cattle is fatal when re-inoculated into sheep or cattle; but if inoculated in mice, the bacilli then obtained lose their virulence for sheep or cattle, only a transitory illness results, and the animals are protected for a time against virulent anthrax.

Exposure to a temperature of 55° C., or treatment with .5 to 1 per cent. carbolic acid, deprives the bacilli of their virulence.

Chauveau obtained a similar result by cultivating the bacillus at 38° or 39° C. under a pressure of eight atmospheres. The possibility of mitigating the virus depends upon the species of animal; rodents cannot be rendered immune by any known anthrax vaccine. The nature of the toxic products has been described in a previous chapter (p. 42).

#### METHODS OF STAINING THE BACILLUS ANTHRACIS.

Cover-glass preparations of blood, etc., can be stained with a watery solution of any of the aniline dyes, or with Neelsen's solution and subsequent treatment with alcohol (p. 87). The preparations may be dried and mounted permanently in Canada balsam, but the typical appearances are best observed in freshly stained specimens examined in water.

The sheath and protoplasmic contents can be demonstrated in cover-glass preparations from the blood or spleen which have been stained with eosin after the method of Gram.

Spores must be stained by the special methods already described. The most satisfactory preparations are obtained by double-staining with Ziehl-Neelsen solution and methylene blue (Fig. 7).

Tissue sections are best stained by the method of Gram, and *after-stained* with eosin, picrocarminate of ammonia, or picro-lithium-carmin.



FIG. 98.—SPORES OF BACILLUS ANTHRACIS STAINED WITH GENTIAN VIOLET,  $\times 1500$ .

## ORIGIN AND MODE OF SPREAD.

As every outbreak of anthrax is the result of the introduction into the system of the bacilli, the question naturally arises, how are they introduced on the farm? Where do they come from? and what are the channels of infection?

The spores of the bacilli may get into the soil, and may remain there in a dormant state for many years. The spores were believed by Pasteur to be taken up by earth-worms, carried to the surface and deposited in their castings. Animals grazing are thus liable to be infected; but Koch's experiments tended to disprove this theory. Anthrax has been known to break out among cattle grazing on a field where several years previously some Russian hides from infected animals had been buried. By some means or other the spores may contaminate the grass, and hay imported from an anthrax district may start the disease on a farm on which it had never been known to occur. The spores may in a similar way be introduced with blood manure and bone manure, and with refuse used as manure. The skin, hair, wool, hoofs, and horns of infected animals, if soiled with blood, are contaminated by the bacillus.

Another way in which the disease can be communicated may be illustrated by the transmission of the disease to man. Those who handle carcasses, wool or hides of infected animals are liable to contract the disease. Slight scratches, cuts, bites, and pimples, may readily be inoculated with the bacilli or their spores. Veterinary surgeons, butchers, herdsmen, cattle drovers—in fact, all those whose occupation leads them to cut open or skin cattle, sheep, or horses, or to handle hides and wool—are liable to fall victims to this disease.

In one case which was brought to the author's notice, a veterinary surgeon had been called to see a bullock which had died suddenly in a meadow. A post-mortem examination was made, and the veterinary surgeon wiped his hands, which were soiled with blood, on some rough grass, and then washed them in a stream. The sedgy grass made some small cuts on his fingers, and the result was that he was simultaneously inoculated with the blood of the bullock. Local anthrax followed, two of his fingers were amputated, and he fortunately recovered. In another case a butcher dressed the carcass of a beast which had died suddenly, and while doing so scratched a pimple on his neck. An anthrax pustule developed, and after a very serious illness he also recovered; but in many cases the attack is fatal. "Wool-sorters' disease" is



anthrax of the lungs. Bales of foreign wool contain not only wool from living sheep, but wool which has been clipped from skins of dead sheep. If any of the sheep died from anthrax the wool is sure to be contaminated with blood containing the bacilli, and then wool-sorters engaged in picking the wool readily inoculate themselves through a scratch or pimple, or by inhaling the spores. In many cases Wool-sorters' disease is fatal.

A farm may become extensively infected by the *living* animal. Blood containing the bacilli may be discharged from the mouth and nostrils, or be passed with the contents of the intestinal canal and bladder. The droppings contaminate the pasture or byre, and spore formation, especially in warm weather, quickly takes place. From this cause the disease may not only be conveyed to healthy cattle grazing with infected animals, but fresh cases may occur, year after year, on the same farm, and if hay is cut and sold off the farm, other cattle at a distance are similarly infected. If the flooring of cattle sheds is once soiled by infected animals it is easy to account for those otherwise mysterious outbreaks which occur when the cattle are taken in for the winter.

Another source of danger arises when blood from a diseased animal is washed into brooks or streams, for thus the disease may be carried to farms in which it was previously unknown.

#### PREVENTIVE MEASURES.

Early recognition and prompt action are essential to prevent the spread of any communicable disease.

Unfortunately in the case of anthrax only too often the very first indication of the existence of the disease is the sudden death in the pasture or byre of an apparently healthy beast, or possibly of one or more sheep. Nevertheless, the importance of being able to recognise any early indications is very great, because an immediate and careful examination should at once be made of the stock on the farm, and suspicious cases isolated from the rest. The stock-man may notice that one or two animals tend to keep away from the others. They look dull and cease feeding, and possibly shivering may be observed. In horses swelling of the throat may occur, and in some places there is discharge of blood from the orifices. Death follows the appearance of these symptoms in a few hours, and often with startling suddenness. Cattle die rapidly, but sheep, though rapidly contracting the disease, do not as a rule die so suddenly.

The characteristic sign after death is enlargement of the spleen to three or four times its natural size. It is not only enlarged, but extremely soft and dark in colour. Blood spots are visible on the internal organs generally, and the intestine often contains a quantity of blood. The examination of a drop of blood will show under the microscope the characteristic bacilli. It is, however, quite unnecessary to make an elaborate post-mortem examination in order to satisfy oneself whether the disease is really anthrax or not. If an animal has died suddenly and has created a suspicion of anthrax, all that it is necessary to do is to cut off an ear—or a foot in the case of a sheep—and make a cover-glass preparation at the first opportunity.

A farmer with a case of anthrax must be made to realise the fact that an enormous quantity of poisonous material has to be dealt with. In fact, an infected animal is more dangerous when dead than alive. The owner or person in charge must immediately notify to a police constable the existence, or even a suspicion of the existence, of the disease. Prompt measures must be taken to destroy the carcass and all traces of the blood, and thus to reduce to a minimum the chance of the disease spreading to the rest of the stock, and of creating fresh outbreaks in the future. Every possible precaution must be taken to prevent the blood of the dead animal from contaminating the pasture, byre, or water supply. The rest of the stock should be removed from the pasture or cowshed where the disease has broken out. It is desirable to give a complete change of food and water, and the whole of the stock should be examined every day for a week, and any animals showing a rise of temperature should at once be isolated from the rest. Preventive inoculation has been recommended to protect the rest of the stock, but there is not sufficient evidence of the safety of the process to lead to the adoption of this treatment. Animals ready for the butcher may be removed from the risk of infection by immediate slaughter. To disinfect the pasture the best plan is a heavy top-dressing of lime, and after six weeks stock may be readmitted, though not without some risk. If year after year cases of anthrax occur on a particular pasture, the most obvious precaution is to keep stock from it altogether and convert it into arable land. As roots grown on anthrax-infected soil have been known to convey the disease, the wisest course if we have to deal with a small field or comparatively small tract of land is to throw it out of cultivation or to plant it with trees.



## DISPOSAL OF THE CARCASS.

The surest method to render harmless all the bacilli which exist in the carcass is burning, but cremation offers practical difficulties, especially if several carcasses have to be destroyed. In the case of an animal dying in a town, the local conditions may render it best to adopt destruction by burning or by means of chemicals. In such a case the carcass should be covered with quicklime, and then taken, in charge of an officer of the Local Authority, to a horse-slaughterer's or knacker's-yard, and destroyed by exposure to a high temperature, or by chemical agents especially in the vicinity of chemical works. Under the usual circumstances of death occurring on a farm, fortunately the simple plan of *burial*, with the addition of lime or other chemical agents, is perfectly efficacious, and even without the use of chemicals *if the carcass has been left unopened, as the bacilli die rapidly if air is excluded.*

Some experiments carried out by M'Fadyean clearly indicate the importance of leaving the carcass unopened.

On July 16th a sheep was infected with anthrax by feeding it with a virulent culture. Five days later it died, and a microscopic examination of blood from the ear, immediately after death, showed very many anthrax bacilli. The carcass was left unskinned and unopened until July 27th, when the various organs were cut out of the chest and abdomen and placed in a tin box. The box was then buried at a depth of about two feet in garden earth, and left there undisturbed until February 15th, when it was exhumed. The organs had become converted into adipocere, and this was thoroughly mixed up with water and administered to a sheep. The sheep remained perfectly healthy. In another experiment a rabbit was inoculated with anthrax on June 1st. It died on June 3rd, and blood from the ear contained the bacilli. The rabbit was left unopened for three days, and then placed in a flower pot and buried in garden earth at a depth of two feet. It was exhumed on February 15th. The tissues were all destroyed by putrefaction, and the earth in contact with the bones was administered to a sheep without conveying the disease or producing any ill effects.

Thus, in the first experiment, the lungs and the intestines, in which spore formation was most likely to occur, were used as a test, and in the second experiment the entire carcass. In both cases there was destruction or disappearance of the bacilli, and these tests, therefore, confirm in a very marked way the opinion that prompt burial of the unopened carcass is a perfectly safe plan to adopt.

If an animal has died in a meadow, a pit six feet deep should be dug close to the carcass, and if quicklime can be procured without delay the carcass should be buried with a layer about a foot in depth beneath it and with about the same quantity to cover it, and the pit filled up with the excavated soil.

If there are any traces of blood where the animal lay, the contaminated ground should be covered with quicklime or drenched with strong carbolic acid, and the whole of the site of burial fenced off for six months. If an animal dies near a brook or stream then the carcass must be removed for burial to a sufficient distance to prevent any reasonable probability of contamination of the water.

If death has occurred in the byre, the carcass must be removed to the nearest and most convenient spot for burial, any fodder or litter which may have been in contact with the deceased animal must be destroyed, and the shed and cart and any utensils, hurdles, etc., disinfected. For the latter purpose thorough scouring with water and then washing with limewash is recommended. The limewash should be prepared immediately before use, and four ounces of chloride of lime, or half a pint of commercial carbolic acid, be added to each gallon of limewash.

The following is an illustration of the value of preventive measures based upon a knowledge of the exact nature of the disease. A farm on the banks of the Yeo was repeatedly attacked by anthrax. One morning two sheep died, and other cases followed. The farmer learnt that his predecessor had buried cattle which had died of anthrax on the very spot where the sheep were folded. He removed his flock, and had no further losses among the sheep, but he continued to lose cattle grazing in the pastures by the river. These pastures were occasionally flooded by the Yeo. Another farmer in the same locality heavily manured a field, and shortly afterwards anthrax broke out in a most deadly form on his farm.

What was the cause of these mysterious outbreaks? The explanation was forthcoming, and prevention an easy matter. The river Yeo received the washings from the wool factories at Yeovil, and the pastures were contaminated by anthrax spores in the deposit which was left behind when the flood subsided. In the second instance, it was found that the manure used for dressing the pasture consisted of a quantity of refuse from the wool factories.

Infected wool from foreign countries is one of the principal sources of the disease in this country, and the remedy is to insist upon the factories destroying their refuse instead of its being allowed to contaminate the rivers or to be sold as manure.



So long as this source of the disease was unknown anthrax continued to be spread through the agency of the wool factories.

Anthrax spores may also be introduced with foreign oats, hay, and manure, so that it is almost impossible absolutely to prevent the importation of the disease; but the danger of its unlimited extension and disastrous losses can be minimised, and the communication of the disease to man and to swine entirely avoided by simple precautions.

#### ANTHRAX IN SWINE.

The occurrence of anthrax in swine is a subject upon which there has long been considerable diversity of opinion. Some of the

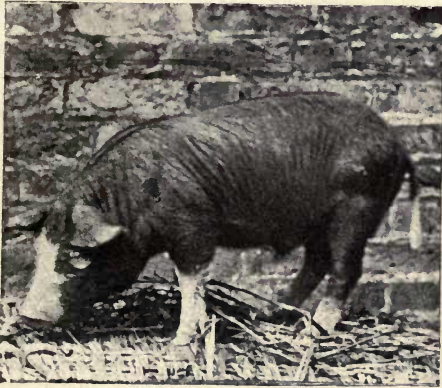

FIG. 99.—ANTHRAX IN SWINE. From a photograph taken during life, showing a swollen condition of the neck and throat six days after ingestion of part of the viscera of a bullock which had died from anthrax.

earliest writers on the diseases of animals speak of outbreaks of anthrax among swine, but whether any or all of these outbreaks were examples of true anthrax has long been a matter of uncertainty; for it is well known that diseases quite distinct were included under the name *anthrax*.

Menschel states that in an outbreak in which twenty-four persons were attacked with malignant pustule, many of them from eating the flesh of beasts suffering from anthrax, pigs which were fed on the same flesh also became affected, and a woman who ate some of the diseased pork was subsequently ill.

Roche-Lubin, while apparently accepting the occurrence of anthrax in swine, taught that the pig resisted inoculation with the blood of a different species.



In this country accounts have been published from time to time of a fatal disease in pigs induced by eating the flesh of animals which had died of what was described as "blood-poisoning."

Some very striking cases occurred in the practice of Mr. Wilson, of Berkhamstead, and were reported in the *Veterinarian*. A farmer consulted Mr. Wilson respecting an illness with which his pigs were affected, stating that two or three were dead and many others seriously ill. They were strong hogs, ranging from six to nine months old. On inquiry it was ascertained that the farmer had lost a beast suddenly about a week previously, that the carcass had been opened in the yard, and the viscera thrown to the pigs. Mr. Wilson expressed the belief that the disease was anthrax, and stated that he found the pigs exhibiting many of the symptoms observable in cattle, with the additional one of enlargement round the throat from infiltration of a yellow fluid causing discoloration of the skin.

Also, in the reports of the Agricultural Department of the Privy Council thirteen pigs were reported as suffering from anthrax in 1886, and one hundred and fifty-nine in 1887.

But the question arose whether the disease in the pigs was genuine anthrax or septic poisoning.

Williams says: "The flesh of animals which have died or have been killed whilst suffering from the disease [anthrax] should not be used as food either for men, pigs, or dogs, as it is apt to cause death by *blood poisoning*"; and Steel writes: "Pigs, dogs, and poultry should not be allowed to feed on blood, flesh, and ejecta of anthrax victims," but no statement is made as to the nature of the illness produced. No doubt these writers have been greatly influenced by the opinion of many bacteriologists, for Toussaint maintained that pigs could not be infected with anthrax, and a similar view was at one time upheld in this country by Klein, who stated that pigs were very insusceptible. In Germany also, pigs have been credited with an immunity from this disease.

In the face of these conflicting statements the author carried out a series of experiments in order to ascertain the nature of the disease in swine resulting from the ingestion of the offal of animals which had died of anthrax; and the result of inoculation with blood of animals which had died of anthrax, and with pure cultivations of the *Bacillus anthracis*.

As a result of these experiments genuine anthrax was produced in swine (*a*) by feeding them with anthrax offal; (*b*) by injection of blood of a bullock which had died of anthrax; (*c*) by passing



bacilli through the guinea-pig, and transmitting them to swine by injection of blood from the spleen; (*d*) by injecting a pure cultivation of the anthrax bacillus; (*e*) and lastly, the anthrax bacillus was isolated from swine in which the disease was accidentally induced on a farm, and the disease reproduced by inoculation of guinea-pigs and mice with blood from the spleen.

*The Author's Conclusions.*—Swine of all ages can be affected with anthrax. If the disease is induced by ingestion of anthrax offal, the tonsils are ulcerated, and constitute the point of access of the bacilli to the blood. In such cases the characteristic symptom is



FIG. 100.—ANTHRAX IN SWINE. From a photograph taken *post-mortem*. Death occurred four days after the ingestion of offal from a bullock which had died of anthrax, and there was well-marked œdema of the throat, cheeks, and eyelids.

enormous swelling around the throat. If the disease is induced by hypodermic injection, the same œdematous infiltration of the tissues occurs at the place selected for inoculation. Death may occur in twenty-four hours, or not until after five or six days. There is a rapid rise of temperature, usually a rash-like discoloration of the skin, sometimes loss of power over the limbs, and general weakness and disinclination to move; the animal may lie helplessly on its belly, and utter plaintive cries when disturbed. At the post-mortem the most characteristic feature is the gelatinous œdema which, in the case of ingestion of offal, is found around the throat. There is usually congestion of all the organs and engorgement of

the heart and large vessels, fluid in the cavities of the chest and abdomen, and enlargement and hæmorrhage into the lymphatic glands. There is in some cases inflammation of the intestines with submucous and subserous hæmorrhages. The spleen may be normal in size, pale and flabby, and the liver only slightly congested and friable; in other cases the condition is characteristic, the spleen is the seat of hæmorrhage, causing more or less local enlargement, which is superficially of a deep purple colour; the liver may also be greatly congested, very friable, and marked with purple patches. The examination of the blood of the heart and spleen for anthrax bacilli must be carried out with great perseverance and discrimination, as they are present only in small numbers, and in some cases have given place entirely to septic organisms. Inoculation with the blood will produce either typical anthrax, or malignant œdema or some other form of septicæmia. Possibly in the cases arising from ingestion of offal the ulcerated condition of the throat affords a nidus and a means of access for septic organisms. It is also well known that blood in a state of putrefaction may contain the bacillus of malignant œdema. In the presence of putrefactive organisms the anthrax bacillus rapidly disappears. If, therefore, inoculation of guinea-pigs or mice is used as a test for ascertaining the nature of an outbreak in swine, it must not be concluded, if Pasteur's or some other form of septicæmia result, that the disease was not anthrax, while, on the other hand, the discovery of the anthrax bacillus in the blood of the pig, or the production of anthrax in guinea-pigs or mice, is positive evidence as to the nature of the original disease.

Peuch, in France, had obtained similar results by injecting pigs with anthrax blood and anthrax cultures. He also carried out some interesting experiments bearing on public health. The leg of a pig which had died of anthrax was covered with pounded sea-salt. Previously to the curing, a slice of the flesh was squeezed in a meat-press, and the liquid thus obtained was employed for inoculation. The animals inoculated died of typical anthrax. In six weeks the curing was considered to be completed, and a slice was cut from the ham and soaked in filtered water. The juice was extracted in the meat-press, and employed for the inoculation of four guinea-pigs and three rabbits. Slight swelling and a certain amount of redness at the seat of inoculation were the only results. A few drops of the muscle-juice were added to sterilised broth, and produced a mixed cultivation of micrococci and motile bacilli. A rabbit and two guinea-pigs inoculated with the cultivation remained quite healthy.



These experiments demonstrated that salting destroys the virulence of the flesh of pigs which have died of anthrax, but in order to obtain this result the salting must be thoroughly carried out. If the process be incomplete the flesh is still virulent. Thus the leg of a pig salted for only fourteen days furnished a juice which possessed a certain amount of virulence. Out of three inoculated rabbits, one died in ninety-seven hours of anthrax, and the others recovered. Three guinea-pigs all succumbed, and a fourth guinea-pig inoculated with a cultivation from the muscle-juice also died. Peuch considers that there is danger in consuming flesh which has not been thoroughly cured.

As it has been clearly shown that pigs may become infected with anthrax, these animals come under the Anthrax Order of 1886. This provides for the disposal of the carcass; and although Peuch has shown that salting destroys the virulence of the flesh of pigs which have died of anthrax, there can be no doubt that it is quite right that such animals should be condemned as unfit for food.

Further, the recognition of the occurrence of true anthrax in swine is an additional reason for condemning the Continental practice of eating hams, sausages, etc., in the raw state. Indeed, the virulence of anthrax flesh suggests one possible explanation of some of those obscure cases of meat poisoning which have occurred in this country. It is possible that the flesh of animals which had died of anthrax was used in the preparation of sausages, pork-pies, etc., and that the cooking was not sufficient to deprive the meat of its poisonous properties.

#### EQUINE ANTHRAX.

Veterinary authorities have described "Anthrax in the Horse," but it remains to be seen whether there are not two or more affections included under this heading. Fleming says: "The most acute form of anthrax, the apoplectic, is somewhat rare in the horse, and has perhaps been most frequently observed on the Continent. Though cases are recorded, but through an error in diagnosis, under other names in the veterinary literature of this country, I have only witnessed two cases in England; though during the intense summer heat in the north of China I had several."

The question to which the author is in a position to give a definite answer is, whether the disease produced by the *Bacillus anthracis* ever occurs in the horse. Whether that has been previously determined, at any rate in this country, it is difficult to say.

Fleming in describing the pathological anatomy of anthrax in the horse, says: "The spleen is double and treble its ordinary volume; its surface is sometimes bosselated by tumours; its texture is softened and transformed into a viscid reddish-brown or violet mass, and the mesenteric glands are infiltrated. The blood in it has been found to contain bacteridia when examined soon after death." Williams, who says that "anthrax in the horse rarely occurs in this country," adds, that it is prevalent in India, and is there termed "Loodiana disease," and in Africa "Horse-sickness." But "Horse-sickness," from recent researches, is certainly not anthrax. Williams described a case which occurred in 1879 as one of anthrax. A carriage-horse died suddenly while in harness; "a large black tumour was found in the lungs, and the pulmonary arteries were engorged with black tarry blood, which, when microscopically examined, was found to contain the bacilli in a most perfect form, and very numerous indeed." In 1884, an outbreak of charbonous fever occurred in Liverpool. Williams proceeded to investigate the outbreak, and found two horses dead on his arrival, one having died only a few hours previously. The bacilli from the blood in this case are figured, and the following statement made: "These bacilli seem to differ from those of splenic fever, being rather smaller in diameter, and so far as my observations go, multiply by fission only, not developing spores."

On the other hand, the author investigated the blood of a mare which was supposed to have died of anthrax, and on examining cover-glass preparations of the blood, it was found to contain large numbers of bacilli with the characteristic microscopical appearances of anthrax bacilli. To place the question beyond any possible doubt a number of tubes of agar-agar were inoculated. These, after three days in the incubator, produced typical cultivations, and on examination by the ordinary methods and by double-staining, yielded very beautiful preparations of filaments and spores.

At the same time that the cultivations were prepared, two mice were inoculated at the root of the tail with a trace of the blood. Two days afterwards they were both found dead, and with the characteristic post-mortem appearances, spleen much enlarged, and anthrax bacilli in enormous numbers.

There can be no doubt that true anthrax occurs in the horse; and the author, in 1887, recommended that it should be scheduled under the Contagious Diseases (Animals) Act, and equine anthrax has been included in the Anthrax Order of 1895.

More recently Pemberthy has described cases of equine anthrax



which he believes to have been the result of infection from feeding on foreign oats or imported hay.

**Preventive Inoculation.**—The prevention of anthrax by means of protective inoculation or vaccination has been attempted on a very large scale in France, and it is claimed that the results have been very beneficial to agriculture in that country :—

Year.	Total No. of Animals Vaccinated.	No. of Veterinary Reports.	Animals Vaccinated after Receipt of Reports.	Mortality.			Total.	Total loss per cent.	Average loss before Vaccination.	
				After 1st Vaccination.	After 2nd Vaccination.	During rest of Year.				
Sheep	1882	270,040	112	243,199	756	847	1,037	2,640	1.08	10%
	1883	268,505	103	193,119	436	272	784	1,492	0.77	
	1884	316,553	109	231,693	770	444	1,033	2,247	0.97	
	1885	342,040	144	280,107	884	735	990	2,609	0.93	
	1886	313,288	88	202,064	652	303	514	1,469	0.72	
	1887	293,572	107	187,811	718	737	968	2,423	1.29	
	1888	269,574	50	101,334	149	181	300	630	0.62	
	1889	239,974	43	88,483	238	285	501	1,024	1.16	
	1890	223,611	69	69,365	331	261	244	836	1.20	
	1891	213,629	65	53,640	181	102	77	360	0.67	
	1892	259,696	70	63,125	319	183	126	628	0.99	
1893	281,333	30	73,939	234	56	224	514	0.69		
Total	3,296,815	990	1,788,677	5,668 (0.32%)	4,406 (0.24%)	6,798 (0.38%)	16,872	0.94		
Oxen or Cows	1882	35,654	127	22,916	22	12	48	82	0.35	5%
	1883	26,453	130	20,501	17	1	46	64	0.31	
	1884	33,900	139	22,616	20	13	52	85	0.37	
	1885	34,000	192	21,073	32	8	67	107	0.50	
	1886	39,154	135	22,113	18	7	39	64	0.29	
	1887	48,484	143	28,083	23	18	68	109	0.39	
	1888	34,464	61	10,920	8	4	35	47	0.43	
	1889	32,251	68	11,610	14	7	31	52	0.45	
	1890	33,965	71	11,057	5	4	14	23	0.21	
	1891	40,736	68	10,476	6	4	4	14	0.13	
	1892	41,609	71	9,757	8	3	15	26	0.26	
1893	38,154	45	9,840	4	1	13	18	0.18		
	438,824	1,255	200,962	177 (0.06%)	82 (0.04%)	432 (0.21%)	691	0.34		

The vaccine is supplied, by a company in Paris, in two strengths. Reports are supplied by veterinary surgeons, and the results have been tabulated by Chamberland and published, and commented upon by Cope in a report to the Board of Agriculture (1894). The column of deaths, in the above table, includes the animals which died from the vaccination, and those which died from natural infection.

It is claimed that the percentage of losses has been reduced from 10 per cent. to '94 per cent. in sheep, and from 5 per cent. to '34 per cent. in cattle. Cope, in the report just referred to, regards these conclusions as somewhat fallacious, because in order to prove that the animals inoculated received immunity, it should be shown that they were subsequently exposed to the risks of natural infection. This was not the case. But a report obtained from the Bureau in Paris gives the actual number of animals on each of the infected farms, and the number which have died of the disease; and when compared with Chamberland's statistics it is evident that nine-tenths were not on farms where the disease appeared—at least, during 1889-92—and that the deaths from anthrax on those farms where it was reported to exist were, if anything, higher than they were supposed to be prior to the introduction of the system of vaccination; and in spite of the immense number of animals vaccinated the official returns obtained from Paris, by Cope, indicate that the mortality from anthrax, calculated in the ordinary way, remains as high as ever.

*Anthrax in France.*

Year.	No. of Outbreaks reported.	No. of Animals in Premises.	No. of which Died.	Percentage of Loss.
1889	618	22,599	1,458	6·5
1890	536	24,073	1,123	4·7
1891	570	21,356	1,444	6·8
1892	607	28,199	1,581	5·6
CATTLE.				
1889	—	6,059	700	11·6
1890	—	5,365	771	14·4
1891	—	7,299	849	11·6
1892	—	5,058	804	15·9
SHEEP.				
1889	—	16,540	755	4·6
1890	—	18,708	352	1·9
1891	—	14,057	545	4·2
1892	—	23,141	777	3·4



In Germany, veterinary and agricultural authorities agree that the results have not met with the success which has been claimed for vaccination in France. Experiments were undertaken for the German Government, and in one set of experiments twenty-five sheep were vaccinated with the first vaccine without an accident, but three died five days after the second vaccine. In another experiment two hundred and fifty-one sheep were vaccinated with only one death, and subsequent inoculation with virulent anthrax proved that they had immunity.

Six head of cattle were vaccinated without any loss, and six more were used for a control experiment. Inoculation with virulent virus proved fatal to the control animals, but the vaccinated were protected. These, with other animals similarly vaccinated, amounting in all to two hundred and sixty-six sheep and eighty-three head of cattle, were then turned out to graze on infected pastures with two hundred and sixteen unvaccinated sheep as a control experiment. Within five months four of the vaccinated and eight of the unvaccinated sheep died of anthrax, and one of the vaccinated and one of the unvaccinated cattle.

The result of these experiments led to the following conclusions :—

- (1) That the first vaccine is mild and harmless.
- (2) That the second vaccine, even in the hands of experts, is dangerous and often fatal.
- (3) That sheep are more affected than cattle by the injections, exhibiting fever and other indications of illness.
- (4) That cattle and sheep which recover from the vaccination have an immunity against anthrax when tested by experimental inoculation.
- (5) That vaccinated cattle and sheep tested by exposure to natural infection by grazing on infected pastures contract the disease in the ordinary way.
- (6) That the time for which immunity is conferred has not been determined.

In England, Klein tested the vaccine, with the result that animals either succumbed to the vaccine, or to virulent anthrax after recovery from the vaccine. Protective inoculation has also been employed in a few instances by leading agriculturists, but with very unsatisfactory results.

**Stamping-out System.**—In Germany the conclusion is that the safest measures are destruction of carcasses and disinfection, and that inoculation will have no effect in lessening the loss caused by this disease.

In England the stamping-out system has been advocated for many years, and is still regarded as the only reliable means for suppressing the disease; and the possible introduction of the disease among healthy stock by vaccination, and especially in localities in which anthrax is unknown, would be contrary to the principles upon which the system is based. These principles are illustrated by the following extracts from the Anthrax Order of 1895:—

#### NOTIFICATION.

2.—(1) Every person having or having had in his possession or under his charge, an animal affected with or suspected of anthrax, shall, with all practicable speed, give notice of the fact of the animal being so affected or suspected, to a constable of the police force for the police area wherein the animal so affected or suspected is or was.

(2) The constable shall forthwith give information of the receipt by him of the notice to an Inspector of the Local Authority, who shall forthwith report the same to the Local Authority.

(3) The Inspector of the Local Authority shall forthwith give information of the receipt by him of the notice to the Medical Officer of Health of the Sanitary District in which the affected or suspected animal is or was.

#### *Duty of Inspector to act immediately.*

3. An Inspector of a Local Authority on receiving in any manner whatsoever information of the supposed existence of anthrax, or having reasonable ground to suspect the existence of anthrax, shall proceed with all practicable speed to the place where such disease, according to the information received by him, exists, or is suspected to exist, and shall there and elsewhere put in force and discharge the powers and duties conferred and imposed on him as Inspector, by or under the Act of 1894 and this Order.

#### *Public Warning as to Existence of Disease.*

4.—(1) The Local Authority may, if they think fit, give public warning by placards, advertisement, or otherwise, of the existence of anthrax in any shed, stable, building, field, or other place, with or without any particular description thereof, as they think fit, and may continue to do so during the existence of the disease, and, in case of a shed, stable, building, or other like place, until the same has been cleansed and disinfected in accordance with this Order.

(2) It shall not be lawful for any person (without authority or excuse) to remove or deface any such placard.

#### *Milk of Diseased or Suspected Cow not to be Removed.*

5. Where anthrax exists or has existed in any shed, stable, building, or other place, it shall not be lawful to remove from such shed, stable,



building, or other place the milk of any cow which is affected with or suspected of anthrax.

*Removal of Dung or other Things.*

6. It shall not be lawful for any person to send or carry, or cause to be sent or carried, on a railway, canal, river, or inland navigation, or in a coasting vessel, or on a highway or thoroughfare, any dung, fodder, or litter that has been in any place in contact with or used about a diseased or suspected animal, except with a Licence of the Local Authority for the District in which such place is situate, on a certificate of an Inspector of the Local Authority certifying that the thing moved has been, so far as practicable, disinfected.

*Disposal of Carcasses.*

7.—(1) The carcass of an animal which at the time of its death was affected with or suspected of anthrax shall be disposed of by the Local Authority as follows:—

- (i.) Either the Local Authority shall cause the carcass to be buried as soon as possible in its skin in some convenient or suitable place removed from any dwelling house and at such a distance from any well or watercourse as will preclude any risk of the contamination of the water therein, and at a depth of not less than six feet below the surface of the earth, having a layer of lime not less than one foot deep beneath, and a similar layer of lime above, the carcass;
- (ii.) Or the Local Authority may, if authorised by Licence of the Board, cause the carcass to be destroyed, under the inspection of the Local Authority, in the mode following: The carcass shall be disinfected, and shall then be taken, in charge of an officer of the Local Authority, to a horse-slaughterer's or knacker's-yard approved for the purpose by the Board, or other place so approved, and shall be there destroyed by exposure to a high temperature, or by chemical agents.

(2) With the view to the execution of the foregoing provisions of this Article the Local Authority may make such Regulations as they think fit for prohibiting or regulating the removal of carcasses, or for securing the burial or destruction of the same.

(3) Before a carcass is removed for burial or destruction under this Article it shall be covered with quicklime. In no case shall the skin of the carcass be cut, nor shall anything be done to cause the effusion of blood.

(4) A Local Authority may cause or allow a carcass to be taken into the District of another Local Authority to be buried or destroyed, with the previous consent of that Local Authority, but not otherwise.

*Digging Up.*

8. It shall not be lawful for any person, except with the Licence of the Board or permission in writing of an Inspector of the Board, to dig

up, or cause to be dug up, the carcass of any animal that has been buried.

*Disinfection in Case of Anthrax.*

9.—(1) The Local Authority shall at their own expense cause to be cleansed and disinfected in the mode provided by this Article—

- (a) All those parts of any shed, stable, building, or other place in which a diseased or suspected animal has been kept or has died or been slaughtered ;
- (b) Every utensil, pen, hurdle, or other thing used for or about any diseased or suspected animal ;
- (c) Every van, cart, or other vehicle used for carrying any diseased or suspected animal on land otherwise than on a railway.

(2) The mode of the cleansing and disinfection of such shed, stable, building, or other place, or the part thereof, shall be as follows :—

- (i.) All those parts aforesaid of the shed, stable, building, or other place shall be swept out, and all litter, dung, or other thing that has been in contact with, or used about, any diseased or suspected animal shall be effectually removed therefrom ; then
- (ii.) The floor and all other parts of the shed, stable, building, or other place with which the diseased or suspected animal or its droppings or any discharge from the mouth or nostrils of the animal has come in contact, shall be, so far as practicable, thoroughly washed or scrubbed or scoured with water ; then
- (iii.) The same parts of the shed, stable, building, or other place shall be washed over with limewash made of freshly burnt lime and water, and containing in each gallon of limewash four ounces of chloride of lime or half a pint of commercial carbolic acid, the limewash being prepared immediately before use ;
- (iv.) Except that where any place as aforesaid is not capable of being so cleansed and disinfected, it shall be sufficient if such place be cleansed and disinfected so far as practicable.

(3) The mode of the cleansing and disinfection of such utensil, pen, hurdle, or other thing, and such van, cart, or other vehicle aforesaid, shall be as follows :—

- (i.) Each utensil, pen, hurdle, or other thing, van, cart, or other vehicle, shall be thoroughly scraped, and all litter, dung, sawdust, or other thing shall be effectually removed therefrom ; then
- (ii.) It shall be thoroughly washed or scrubbed or scoured with water ; then
- (iii.) It shall be washed over with limewash made of freshly burnt lime and water, and containing in each gallon of limewash four ounces of chloride of lime or half a pint of commercial carbolic acid, the limewash being prepared immediately before use.

(4) All litter, dung, or other thing that has been removed from any such shed, stable, building, place, van, cart, or vehicle as aforesaid, shall be forthwith burnt or otherwise destroyed or disinfected to the satisfaction of an Inspector of the Local Authority.



(5) The Local Authority may make such Regulations as they think fit for the purpose of carrying out the provisions of this Article.

*Occupiers to give Facilities for Cleansing.*

10.—(1) Where the power of causing any place, thing, or vehicle to be cleansed and disinfected under this Order is exercised by a Local Authority, the owner and occupier and person in charge of the place, thing, or vehicle shall give all reasonable facilities for that purpose.

(2) Any person failing to comply with the provisions of this Article shall be deemed guilty of an offence against the Act of 1894.

*Regulations of Local Authority as to Movement of Animals,  
Fodder, etc.*

11. A Local Authority may make such Regulations as they think fit for the following purposes, or any of them :—

- (a) For prohibiting or regulating the movement of any diseased or suspected animal into or out of any shed, stable, building, field, or other place, or any part thereof ;
- (b) For prohibiting or regulating the movement of any animal into or out of any shed, stable, building, field, or other place, or any part thereof, in which there is or has been any diseased or suspected animal ; and
- (c) For regulating the removal out of any shed, stable, building, field, or other place of any fodder, litter, or other thing that has been in contact with or used for or about any diseased or suspected animal ;

but nothing in any such Regulation shall authorise movement in contravention of any provision of any Order of the Board for the time being in force ; and a Regulation under paragraph (b) of this Article shall operate so long only as any animal which in the judgment of the Local Authority is diseased or suspected remains in the shed, stable, building, field, or other place to which the Regulation refers, and, in case of a shed, stable, building, or other like place, until the same has been cleansed and disinfected in accordance with this Order.

*Slaughter in Anthrax and Compensation.*

12.—(1) A Local Authority may if they think fit cause to be slaughtered—

- (a) Any animal affected with anthrax or suspected of being so affected ; and
- (b) Any animal being or having been in the same field, shed, or other place, or in the same herd or flock or otherwise in contact with animals affected with anthrax, or being or having been in the opinion of the Local Authority in any way exposed to the infection of anthrax.

(2) The slaughter of animals under this Article shall be conducted in such mode as will so far as possible prevent effusion of blood.



(3) The Local Authority shall out of the local rate pay compensation as follows for animals slaughtered under this Article :—

(a) Where the animal slaughtered was affected with anthrax the compensation shall be one-half of the value of the animal immediately before it became so affected ; and

(b) In every other case the compensation shall be the value of the animal immediately before it was slaughtered.

(4) Provided, that if the owner of the animal gives notice in writing to the Local Authority, or their Inspector or other officer, that he objects to the animal being slaughtered, it shall not be lawful for the Local Authority to cause that animal to be slaughtered except with the further special authority of the Board first obtained.

*Keeping of Swine in Slaughter-houses.*

16. It shall not be lawful for any person, in any case in which the slaughter of any animal is authorised or required by this Order, to use for such slaughter any slaughter-house in which swine are kept.

Whether an anthrax virus can be obtained which is absolutely incapable of creating centres of infection, and can therefore be recommended with safety for vaccination as an auxiliary and voluntary measure, is a matter for further investigation.





## CHAPTER XV.

QUARTER-EVIL.—MALIGNANT ŒDEMA.—RAG-PICKERS' SEPTICÆMIA.—  
SEPTICÆMIA OF GUINEA-PIGS.—SEPTICÆMIA OF MICE.

QUARTER-EVIL in cattle, malignant œdema, and rag-pickers' septicæmia in man, septicæmia in guinea-pigs, and septicæmia in mice, are all varieties of septicæmia produced by bacilli.

An account of quarter-evil, malignant œdema, and rag-pickers' septicæmia may appropriately follow the chapter on anthrax, as they have certain similarities to that disease. They are, however, not only distinct from anthrax, but must be carefully distinguished from each other. In connection with these forms of bacillary septicæmia in man and cattle we may study bacillary septicæmia in small animals.

### QUARTER-EVIL.

The disease known in this country as quarter-evil or black-leg is identical with the French *Charbon symptomatique* and the German *Rauschbrand*. Symptomatic anthrax in a very slight degree resembles anthrax. The disease occurs usually in young cattle from a few weeks to about twelve months old, and attacks sheep and horses, but not swine or poultry. It is characterised by the development of an emphysematous swelling of the subcutaneous tissue and muscles, generally over the hind quarter. Infected animals cease feeding, the temperature rises, lameness supervenes, and death occurs in about forty-eight hours. The tumour on incision is found to contain a quantity of dark sanguineous fluid, with characteristic bacilli.

**Bacillus of Quarter-evil** (*Bacille du charbon symptomatique, Rauschbrand bacillus*).—Motile rods with rounded ends, 3 to 5  $\mu$  in length, .5 to .6  $\mu$  in breadth. Spore-formation present. The spores are oval, generally situated near the extremity of the rods, and when fully developed considerably exceed the rods in diameter.

Involution forms are freely developed in old cultures, and in cultures made in unsuitable media. The bacilli possess numerous

flagella, and their power of movement at once distinguishes them from anthrax bacilli. They can be cultivated in the ordinary media in the absence of oxygen, but more readily with the addition of grape-sugar or glycerine. Radiating filaments grow out from the more or less spherical colonies directly

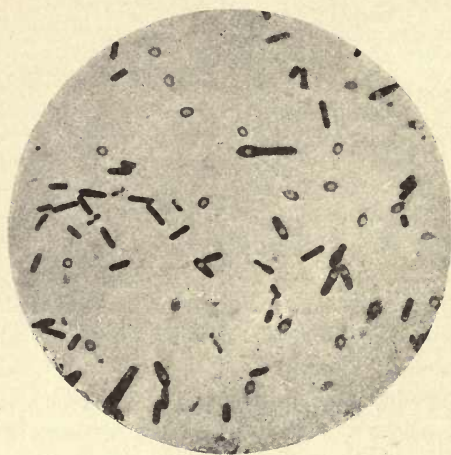

FIG. 101. BACILLI OF QUARTER-EVIL  $\times 1000$ . From an agar culture (FRANKEL and PFEIFFER).

liquefaction commences. In the depth of nutrient gelatine the growth occurs in two or three days at  $20^{\circ}$  to  $25^{\circ}$  C. towards the lower part of the track of the inoculating needle. The gelatine slowly liquefies, and there is considerable formation of gas with the development of a peculiar odour. Spore-formation occurs freely in cultures, but not in the blood of infected animals until after death.

Guinea-pigs inoculated with a pure-culture, or with spore-bearing threads, die in twenty-four to thirty-six hours. An emphysematous infiltration with sanguineous serum is produced at the seat of inoculation, and the surrounding muscles are of a dark colour. The internal organs are more or less congested. The bacilli are found in the local exudation and in the surrounding tissue, and some hours after death in



FIG. 102. PURE-CULTURE OF BACILLI OF QUARTER-EVIL IN GRAPE-SUGAR GELATINE (FRÄNKEL and PFEIFFER).



increasing numbers in the blood of the heart and in the internal organs.

Quarter-evil and malignant œdema, though possessing points of resemblance, are distinct diseases. Not only do the bacilli in the two cases differ in minute morphological and biological details, but Kitasato showed that guinea-pigs rendered immune against virulent quarter-evil had no immunity against malignant œdema.

**Protective Inoculation.**—Arloing, Cornevin and Thomas have produced immunity by inoculating healthy cattle with a small quantity of the fluid from the tumour of an infected animal. Recovery takes place, and subsequent inoculation with a strong dose is without effect. Similar results may be obtained by intravenous injection of a few drops of the exudation. For general application of the system of protective inoculation, the virulent liquid and affected muscles are dried at 32° to 35° C., and the dried mass triturated with water and heated to 100° C. This is used as the first vaccine.

An infusion similarly prepared, but only heated to 80° C., forms the second vaccine. The dry powder is a convenient form for general distribution, and  $\frac{1}{10}$  of a gramme is triturated with 5 cc. of water, and  $\frac{1}{2}$  cc. is injected into each animal. In about ten days the second vaccine is employed, and cattle so treated are said to have a complete immunity from fatal doses.

The place chosen for the injection is the under surface of the tail, a short distance from the extremity. The hair is clipped at this spot, and the point of a syringe is pushed in between the skin and the bone, and the vaccine slowly injected.

Roux and Chamberland produced immunity by inoculation of filtered cultures. Cultures in broth were deprived of bacilli by heating to 115° C., or by filtration through porcelain. Guinea-pigs were inoculated with three doses of 30 cc. at intervals of two days, and subsequently injected with a solution of virulent black-leg powder and lactic acid, which killed control animals in twenty-four hours. Kitt employed cultures on agar a fortnight old, or fresh cultures sterilised by steam for thirty minutes. It was found possible to confer immunity in oxen, sheep, and guinea-pigs against the most virulent extract. Kitt's method has the advantage over others of only necessitating one single injection. Whether these experiments are of scientific interest rather than of practical value may be regarded as an open question.

On the Continent, and especially in France, vaccination against quarter-evil has been carried out extensively; and by comparing the

mortality among the vaccinated and unvaccinated in localities where the disease commonly occurs, it has been said that the results are extremely favourable. The matter was investigated in this country by a committee of the Midland Veterinary Medical Association, and in the course of the experiments some surprising results were obtained. Six calves and four sheep were vaccinated, and five calves and two sheep were left unvaccinated as a control experiment. The seventeen animals were subsequently inoculated with virulent virus in the form of dried and powdered muscle. In forty-eight hours all the sheep died, and all the calves exhibited a swelling at the seat of inoculation. In another set of experiments, healthy calves inoculated with fresh juice from the tumour in a case of quarter-evil were not materially affected. The possibility of those calves which possess a natural immunity being classed as protected by the inoculation must be admitted, and the efficacy and safety of the process is by no means established.

#### MALIGNANT ŒDEMA.

The disease known by surgeons as progressive gangrene, gangrenous emphysema, or surgical gangrene, has been shown by the researches of Chauveau, Arloing, Rosenbach and Babès, to be due to a bacillus identical with the *microbe septique* of Pasteur and the bacillus of malignant œdema of Koch. The bacillus or its spores may be spread by the neglect of antiseptics. The disease occurs especially after compound fractures and gun-shot wounds.

If a guinea-pig is subcutaneously inoculated with earth, putrid fluid, or hay dust, death frequently occurs in from twenty-four to forty-eight hours. At the autopsy the most characteristic symptom is a widespread subcutaneous œdema accompanied by air-bubbles. This originates from the point of inoculation, and contains a clear reddish liquid full of motile and non-motile bacilli. The internal organs are little changed, the spleen is enlarged and of a dark colour, and the lungs are hyperæmic, and have hæmorrhagic spots. Examined immediately after death, few or no bacilli are detected in the blood of the heart, but in that of the spleen, liver, lungs, and other organs, in the peritoneal exudation, and in and upon the serous coating of the abdominal organs, they are present in large numbers. If, on the other hand, the animal is not examined until some time after death, the bacilli are found in the blood of the heart, and distributed all over the body.

**Bacillus Œdematis Maligni**, Koch (Pasteur's Septicæmia).—



Rods from 3 to 3.5  $\mu$  long and 1 to 1.1  $\mu$  wide; they mostly lie in pairs, and then appear to be double this length. The rods are rounded at their ends, and form threads which are sometimes straight, but more commonly curved. In stained preparations they have a somewhat granular appearance. They are motile, possessing flagella, and form spores. The bacilli are distinguished from anthrax bacilli by their being somewhat thinner, by their rounded ends, and by their motility. Moreover, anthrax bacilli never appear as threads in fresh blood, and are differently distributed throughout the body. They are anaerobic, and can be cultivated on blood serum and on neutral solution of Liebig's meat extract in an atmosphere of carbonic acid. By embedding material containing bacilli in nutrient agar-agar

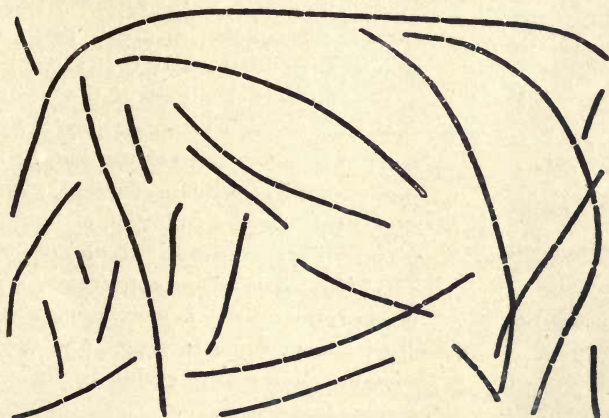

FIG. 103. BACILLI OF MALIGNANT ŒDEMA  $\times$  950. From the subcutaneous tissue of a guinea-pig. (BAUMGARTEN.)

and nutrient gelatine, characteristic cultivations are obtained. The following process may be adopted to obtain a pure cultivation. A mouse inoculated subcutaneously with dust, as a rule, dies in one to two days. It is then pinned out, back uppermost, on a slab of wood, and the hair singed with a Paquelin's cauterly from one hind leg up to the neck, across the latter, and down again to the opposite hind leg. Following the cauterised line, the skin is cut through with sterilised scissors, and the flap turned back and pinned out of the way. With curved scissors little pieces of the subcutaneous œdematous tissue, in the neighbourhood of the inoculated spot, are cut out, and sunk with a platinum needle in a 1 per cent. nutrient agar-agar, or 5 per cent. nutrient gelatine. Fragments of tissue may also be embedded by the method already described for anaerobic bacteria.

The inoculated tubes are placed in the incubator. In a few hours a whitish turbidity spreads out from the piece of tissue, and upwards in the needle track. Examined microscopically, the turbidity is found to be due solely to the development of the bacilli of oedema. The surface exposed to the air exhibits no trace of the bacilli. To investigate the tubes microscopically, a sterilised glass tube with a capillary end may be used, with its neck plugged with sterilised cotton-wool, and provided at the mouth with a suction ball. The capillary end is thrust into the cultivation, and a small fragment removed by aspiration.



FIG. 104. PURE-CULTURE OF BACILLUS OF MALIGNANT OEDEMA IN GRAPE-SUGAR GELATINE (FRÄNKEL and PFEIFFER).

In the course of the first day the bacilli spread throughout a great part of the agar-agar in such a way that a more or less equally diffused cloudiness of the medium ensues, with subsequent appearance of strongly marked clouds or lines of turbidity. At the same time gas-bubbles develop along the needle track, and a collection of liquid takes place, while spore-formation also commences. The following day these appearances are more marked, the opacity is more pronounced, the development of gas increases, and the liquid contains more spore-forming bacilli and numerous free-spores.

The nutrient-gelatine cultures during the first day show no macroscopic change, but after a few days the piece of tissue is surrounded with a white halo. This gradually spreads in all directions, and is apparently beset with hairs. The gelatine liquefies, and the fragment of tissue, degenerated bacilli, and spores, sink to the bottom. The cultivation is also very characteristic in a  $\frac{1}{2}$  per cent. nutrient agar-agar. If placed in the incubator, in a few hours a cloudiness forms around the piece of embedded tissue, which is caused by bacilli gradually spreading in all directions in the nutrient medium. Mice inoculated from these cultivations die more quickly than from the original infection from dust. On potatoes they are cultivated by introducing a piece of liver or other tissue containing the bacilli, into the interior of a sterilised potato, and incubated at 38° C. The bacillus is not deprived of its virulence by cultivation.



The spores of the œdema-bacilli appear to be very widely distributed. They are found in the upper cultivated layers of the soil, in hay dust, in decomposing liquids, and especially in the bodies of suffocated animals, which are left to decompose at a high temperature. From any of these sources animals can be successfully inoculated. The bacillus is not only pathogenic in guinea-pigs, rabbits, and mice, but also in man and in farm animals, including calves but not cattle. Pure-cultures inoculated in animals produce œdema at the

seat of inoculation without appreciable gas formation and without any putrefactive odour. The odour and frothy effusion resulting from the inoculation of earth are due to other bacteria, which are introduced simultaneously with the bacilli of malignant œdema. The spleen is sometimes slightly enlarged. By touching with a cover-

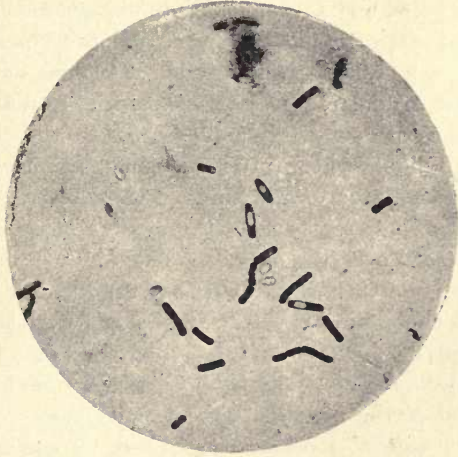

FIG. 105. BACILLI OF MALIGNANT ŒDEMA  $\times 1000$ .  
From an agar culture (FRÄNKEL and PFEIFFER).

glass the capsule of the spleen, or by examining the serous effusion, the bacilli are found in abundance; but if a preparation is made from the interior of the spleen or from the blood of the heart, no bacilli will be found until several hours after death. In this respect there is a marked difference from anthrax. Another difference is shown in spore-formation, which occurs in the living body in malignant œdema, but never in anthrax. Animals which recover from the disease are said to be protected.

**Protective Inoculation.**—Roux and Chamberland produced immunity by injecting the chemical products in the filtrate obtained from cultures in broth. The serum from fatal cases will, it is said, confer immunity on other animals.

There is a variety of this bacillus in soil according to Flügge, agreeing in morphological and cultural but not in pathogenic characters.

## RAG-PICKERS' SEPTICÆMIA.

Rag-pickers' disease has a resemblance to anthrax or wool-sorters' disease. After death the spleen is found to be enlarged, the internal organs are congested, and there are hæmorrhages on the serous membranes. Bordoni-Uffreduzzi isolated bacilli which are quite easily distinguished from anthrax bacilli. They were found in the blood and in sections of the internal organs.

**Proteus hominis capsulatus.**—Rods with rounded ends, singly, in pairs, and in filaments, somewhat smaller than anthrax bacilli, and often irregular in form. Spore-formation not described; they have a well-marked capsule. Colonies are circular, appearing at first granular, and later possessing a filamentous structure. In the depth of gelatine they grow in the shape of a round-headed nail, like a culture of Friedländer's pneumococcus. On the surface of gelatine they form a shining white layer. On agar the growth is somewhat transparent. On potato a moist, glistening film gradually spreads over the surface. They do not liquefy blood serum, and the growth is similar to that obtained on agar. They prove fatal to mice and dogs, but rabbits and guinea-pigs are not very susceptible. Dogs die usually on the second day after intravenous injection, and after death there is congestion of the internal organs and of the intestinal mucous membrane. Œdema is produced at the seat of inoculation in mice. There are hæmorrhages in the lymphatic glands, and congestion of the liver and kidneys. Similar organisms have been described by Kolb and by Babès in purpura hæmorrhagica.

## SEPTICÆMIA OF GUINEA-PIGS.

Guinea-pigs and mice sometimes die of septicæmia, characterised by congestion of the lungs, liver, and kidneys, inflamed peritoneum, pleural and pericardial exudation, congested spleen, and congestion of the mucous and serous coats of the intestine. Klein isolated a bacillus from the blood and the internal organs in these cases.

**Bacillus of Septicæmia in Guinea-pigs.**—Rods with rounded ends, motile, with pleomorphic forms, cocci, short rods and filaments. Colonies appear as small, circular, white dots, which enlarge and become irregular in outline. In the depth of gelatine a white filament develops, and on the surface the growth rapidly spreads with a crenated outline. Broth becomes turbid, and after the second day a copious white sediment is deposited. Spore-formation not observed.





## DESCRIPTION OF PLATE VI.

### **Bacillus Murisepticus.**

- FIG. 1.—From a section of a kidney of a mouse which had died after inoculation with a pure-cultivation of the bacillus. With moderate amplification, the white blood-corpuses have a granular appearance, and irregular granular masses are scattered between the kidney tubules. Stained by Gram's method with eosin.  $\times 200$ .
- FIG. 2.—Part of the same preparation with high amplification. The granular appearances are found to be due to the presence of great numbers of extremely minute bacilli.  $\times 1500$ .



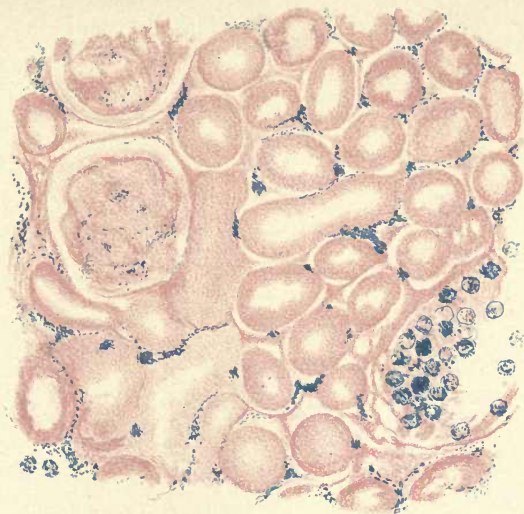

Fig 1

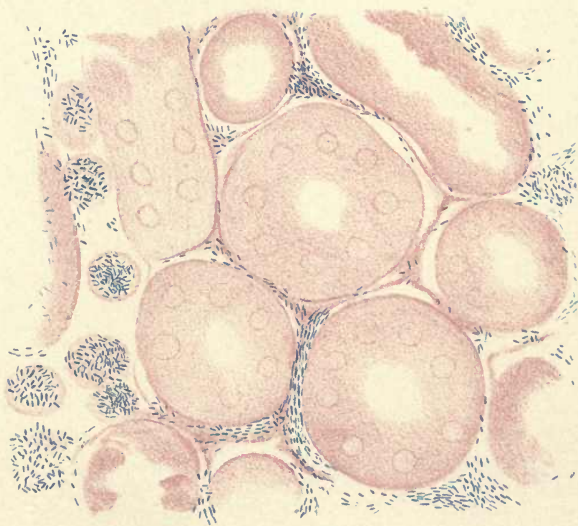

Fig 2.

BACILLUS MURISEPTICUS





According to Wooldridge, the chemical products of this bacillus, separated by filtration, produce on inoculation immunity against virulent bacilli.

## SEPTICÆMIA OF MICE.

Mice inoculated with a minimum quantity of putrid fluid often die of septicæmia. They rapidly sicken, their eyes inflame, their eyelids stick together, they become soporific, and death occurs in forty to sixty hours. There is slight œdema at the seat of inoculation, and enlargement of the spleen; the bacilli are found free and in the interior of white corpuscles, both in the œdematous tissue and in the blood capillaries.

**Bacillus of Septicæmia of Mice (Koch).**

—Extremely minute bacilli,  $\cdot 8$  to  $1 \mu$  long, and  $\cdot 1$  to  $\cdot 2 \mu$  broad, and filaments. In cultivations in gelatine they do not appear to make threads, but the bacilli lie together in masses. Spores have been observed. The bacilli are probably non-motile. They are most commonly in the interior of white blood corpuscles. In these they increase, and in many cases a white blood cell is represented only by a mass of bacilli.

A minimal quantity of blood containing the bacilli produces the disease if inoculated in house-mice or sparrows. Field-mice have an immunity. Rabbits and guinea-pigs inoculated in the ear suffer only from a local erythema, which disappears after five or six days, and renders them for a time immune. Rabbits inoculated in the cornea suffer from an intense inflammation of the eyes. The bacilli form in plate-cultivations scarcely perceptible cloud-like specks, and in a test-tube of nutrient gelatine they form a delicately clouded cultivation along the needle track.

An identical bacillus has been isolated in swine measles.



FIG. 106.—PURE CULTIVATION OF THE BACILLUS OF SEPTICÆMIA OF MICE IN NUTRIENT GELATINE. After two days.

## CHAPTER XVI.

SEPTICÆMIA OF BUFFALOES.—SEPTIC PLEURO-PNEUMONIA OF CALVES.—SWINE FEVER.—SEPTICÆMIA OF DEER.—SEPTICÆMIA OF RABBITS. — FOWL CHOLERA. — FOWL ENTERITIS. — DUCK CHOLERA.—GROUSE DISEASE.

THERE are several varieties of septicæmia occurring naturally in buffaloes, deer, calves, and birds, and artificially induced by inoculation of rabbits with septic material. They are associated with bacteria which agree in their morphological and cultural characters, though in some cases differing in their pathogenic properties. As the differences between the bacteria cultivated from these different sources is not greater than the differences which exist between the morphological, biological, and pathogenic effects of varieties of the tubercle bacillus, it will be convenient and fully justifiable to follow Hueppe and Baumgarten, and regard them as varieties of the bacillus of *hæmorrhagic septicæmia*.

### EPIDEMIC DISEASE OF BUFFALOES.

Oreste and Armanni investigated an epidemic among herds of young buffaloes in Italy (*Büffel-seuche*). The disease was extremely acute, death occurring in from twelve to twenty-four hours. It was probably identical with an epidemic disease described by Bollinger in deer. The symptoms were fever, rapid pulse, discharge of mucus from the nose and mouth, and a local swelling of the head and face leading to suffocation. The only marked feature after death was hæmorrhagic inflammation of the small intestine.

The bacilli were identical with those found by Schütz in swine fever. Cultures inoculated in young buffaloes produced the disease. The bacilli were pathogenic to mice, guinea-pigs, rabbits, pigeons, and fowls, death taking place in from one to three days.



## SEPTIC PLEURO-PNEUMONIA IN CALVES.

Septic pleuro-pneumonia is a disease which attacks young calves within the first two months after their birth. Percussion and auscultation reveal lung mischief. The disease is very rapid and fatal, death occurring on the second or third day. In the less acute cases one or more lobes of the lungs are found after death in a state of lobular and inter-lobular pneumonia. The inter-lobular connective tissue is distended with exudation, giving rise to white or yellowish bands between the inflamed lobules, which produce a marbled appearance, recalling the condition of the lungs in infectious pleuro-pneumonia. The internal organs are congested, and there are very often hæmorrhagic spots on the mucous and serous coats of the small intestine. All the organs contain rods identical with those of septicæmia of rabbits. Rabbits, guinea-pigs, and mice were infected. A calf was injected in the pleural cavity with a broth-culture, and died in twenty hours.

## SWINE FEVER.

This disease will be described in a separate chapter. Several bacteria have been isolated by different investigators. In swine fever in Germany (*Schwein-seuche*) Löffler and Schütz isolated a bacillus which has been identified with the bacillus isolated by Salmon and Smith from hog-cholera in America, and with the bacillus of rabbit septicæmia and of fowl cholera.

## EPIDEMIC DISEASE OF DEER AND BOARS.

A very fatal epizootic (*Wildseuche*) occurred in the royal game preserves near Munich, destroying one hundred and fifty-three deer and two hundred and thirty-four boars (Bollinger). The disease lasted from twelve hours to six days. In the less acute cases pneumonia and pericarditis supervened. In cattle there was also severe hæmorrhagic inflammation of the small intestine. In another form it produced swelling of the head, face, neck, and tongue. The virus proved fatal to rabbits in six to eight hours, and to sheep and goats in about thirty hours. A pig inoculated with a few drops of blood died in twenty-two hours. Kitt also investigated this malady. The bacteria were found to be identical, in their appearance and pathogenic properties, with extremely virulent bacteria from swine fever. Schütz distinguished them from the bacteria obtained from swine fever by their pathogenic effect on pigeons, but cultures obtained from swine fever do not act uniformly in this respect.

## SEPTICÆMIA IN RABBITS.

Koch minutely investigated a disease of rabbits produced by inoculation with impure river water and with putrid meat infusion. Bacteria are found in the blood in abundance, and may be readily cultivated.

The smallest quantity inoculated subcutaneously or in the cornea

of a rabbit produces a rise of temperature and laboured breathing after ten to twelve hours, and death in sixteen to twenty hours. The spleen and lymphatic glands are found to be enlarged, and the lungs congested, but there are no extravasations, and no peritonitis. Mice and birds are very

susceptible; guinea-pigs and white rats have an immunity.



FIG. 107.—BACTERIUM OF RABBIT SEPTICÆMIA; BLOOD OF SPARROW,  $\times 700$  (KOCH).

## DAVAINE'S SEPTICÆMIA.

A disease was produced by Davaine by injecting rabbits with putrid blood. Rabbits, mice, fowls, pigeons, and sparrows are susceptible, and guinea-pigs and rats are insusceptible to the bacteria found in this disease. Rabbits inoculated with a trace of blood containing the bacteria, or with a culture, died in from twenty-four to thirty-six hours. The spleen, liver, lungs, and intestines are highly congested, and sometimes extravasations and peritonitis are found.

## FOWL CHOLERA.

Fowl cholera is an epidemic disease of the poultry-yard much dreaded in France, and well known through the researches of Perroncito, Toussaint, Pasteur, and Kitt.



FIG. 108.—BACTERIUM OF FOWL CHOLERA,  $\times 1200$ . From blood of inoculated Fowl.



FIG. 109.—BACTERIUM OF FOWL CHOLERA,  $\times 2500$ . Muscle juice of Fowl.

Fowls suffering from the disease usually die in from twenty-four to forty-eight hours. The disease shows itself by the fowls becoming



somnolent. They suffer from weakness of the legs, and their wings trail. There is frequently diarrhœa, with slimy greenish evacuations, and death usually ensues after a slight convulsive attack. On making a post-mortem examination the viscera will be found to be congested, and there is intense inflammation of the mucous membrane of the intestine, with hæmorrhages.

The blood from the heart, and the intestinal contents, contain the bacilli which were at one time believed to be peculiar to this disease. Inoculation subcutaneously, or administration with food, of a small quantity of a broth cultivation will produce death in twenty-four to thirty-six hours. Pigeons, pheasants, sparrows,

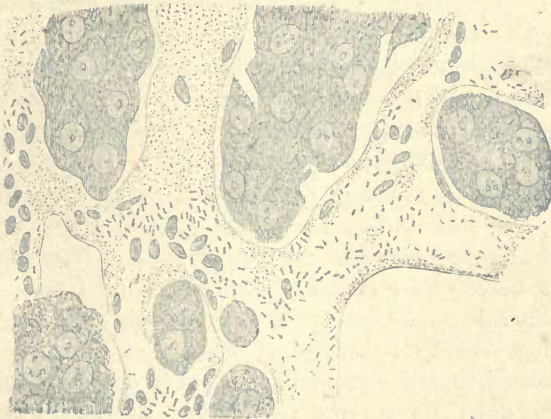

FIG. 110.—BACTERIUM OF FOWL CHOLERA. Section from liver of Fowl  $\times 700$  (FLÜGGE).

rabbits, and mice are susceptible. In guinea-pigs, sheep, and horses, an abscess develops at the seat of inoculation. Rabbits are readily infected by sprinkling a broth-cultivation on cabbage leaves or any suitable food. It was with this microbe that Pasteur proposed to eradicate the plague of rabbits in Australia.

Fowl cholera has an additional interest, as it was with this disease that Pasteur first investigated the attenuation of virus. Broth-cultures which were several months old were found, when injected, to produce apparently only a local effect. This weakening of the virus was attributed by Pasteur to exposure to oxygen. After recovery the fowls were protected against the action of virulent cultures, while fowls not immunised died the following day. Kitt, by working with pure-cultures on solid media, showed that the

weakening was not due to prolonged exposure to oxygen, but that old contaminated broth-cultures after a time completely lost their power, owing to the antagonism of the bacteria accidentally present.

Filtered broth-cultures contain the toxic products of the bacillus, and produce slight illness and subsequent immunity.

#### FOWL ENTERITIS.

Fowl enteritis is an acute infectious disease of fowls, the course and symptoms of which are regarded by Klein as distinct from fowl cholera. The fowls suffer from diarrhœa, with liquid greenish evacuations, but are never somnolent, and death occurs in one or two days. After death the mucous membrane of the intestine is found to be congested, and coated with grey or yellowish mucus; the liver is congested, spleen enlarged, and lungs normal. There are a few bacilli in the blood of the heart, very many in the spleen and liver, and they are in the form of a pure-culture in the mucus of the intestine. Klein says that the bacilli are a little longer and thicker than those found in fowl cholera, which they only slightly resemble, and that the course of the disease, the symptoms and pathological appearances, definitely distinguish it from fowl cholera, but that nevertheless it belongs to the same family of bacilli. Pigeons are said to be insusceptible, rabbits only slightly susceptible. By feeding and by subcutaneous inoculation the disease can be communicated to healthy fowls, but there is no sign of illness until the fourth day. As regards attenuation, the bacilli behave like those from cases of fowl cholera.

#### DUCK CHOLERA.

Duck cholera is an epidemic disease of ducks which was investigated by Cornil. The symptoms are similar to those of fowl cholera. They suffer from diarrhœa and weakness, followed by death in two or three days.

The bacillus cultivated from the blood of ducks is pathogenic in ducks but not in fowls or pigeons, and large doses are required to kill rabbits.

#### GROUSE DISEASE.

Grouse disease is an acute infectious disease of red grouse. According to Klein the chief pathological feature is severe pneumonia; there is also patchy redness of the serous and mucous linings



of the intestine, and the liver is congested and dark, but the spleen is not enlarged. The bacilli are found in the heart, lungs, and liver, and in the extravasated blood. Cultures inoculated in mice and guinea-pigs produce pneumonia and death. Sparrows are susceptible, and other small birds. Fowls, pigeons, and rabbits are insusceptible.

**Bacillus of Hæmorrhagic Septicæmia.**—Very short rods, with rounded ends,  $\cdot 6$  to  $\cdot 7 \mu$  in width and  $1\cdot 4 \mu$  in



FIG. 112. — BACILLUS OF HÆMORRHAGIC SEPTICÆMIA (Rabbit Septicæmia). Pure culture in Gelatine after four days (BAUMGARTEN.)

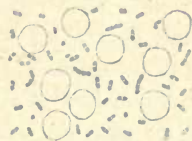

FIG. 111.— BACILLUS OF HÆMORRHAGIC SEPTICÆMIA. Blood of a Rabbit after death from Septicæmia  $\times 950$  (BAUMGARTEN).

length. In stained preparations the rods are observed to be deeply stained at the ends and to have a clear interval in the middle; they were on this account mistaken by earlier observers for dumb-bell micrococci or diplococci. They are non-motile, and spore-formation is unknown. They grow readily in the ordinary media. The colonies in nutrient gelatine appear about the third day. They are circular in form, with a sharp dark outline, and of a yellow colour, lighter at the periphery. Later, the central zone is finely granular, and of a dark yellowish-brown colour, with the lighter peripheral zone more clearly defined. In the depth of gelatine a delicate filament develops in the track of the needle, composed of minute spherical colonies, somewhat transparent, and yellowish-white in colour. At the point of puncture there may be no growth visible, or a flat and very limited growth. Inoculated on the surface of nutrient media a thin layer develops, with an irregular serrated and thickened border. On potato different results have

been obtained by different observers. Some maintain that a greyish-white or yellowish film will develop at the temperature of the blood; but according to Caneva, the bacilli, whatever their source,

will not grow on potato, while Bunzl-Federn maintains that the bacilli from fowl cholera and rabbit septicæmia do grow upon potato, but those from septicæmia in deer, buffaloes, and swine do not. Opinions differ with regard to their action on milk. The reaction for phenol and indol is given in all cases, except with cultures obtained from septicæmia of buffaloes. The virulence of the bacilli may be diminished and attenuated, but it may subsequently be restored by successive inoculation in animals. The pathological lesions vary in different animals. The most common result is congestion of the internal organs and hæmorrhage. The bacilli cultivated from cattle or deer produce fatal results when inoculated in swine. The bacilli from any of these sources inoculated in pigeons will produce fowl cholera, but the bacilli isolated by Schütz from swine, and those from deer, are not fatal to fowls. Further, the bacilli cultivated from swine fever are fatal to guinea-pigs, while the bacilli from rabbit septicæmia have very little effect upon them. The bacilli have been found in association with diseases of cattle, swine, deer, birds, rabbits, and mice, and have been cultivated from healthy mucous membrane. Veranus Moore found the bacilli in the mucus from the upper air passages, of 71 per cent. of cattle, 85 per cent. of cats, and 33 per cent. of dogs. From these sources inoculations were made in rabbits, and rapidly fatal septicæmia was produced, associated in less acute cases with peritonitis, pleurisy, and pericarditis.



## CHAPTER XVII.

### PNEUMONIA.—INFECTIOUS PLEURO-PNEUMONIA OF CATTLE.— INFLUENZA.

#### ACUTE CROUPOUS PNEUMONIA.

PNEUMONIA is an acute inflammation of the lungs with fibrinous infiltration of the air vesicles and interstitial tissue. There are varieties of pneumonia, and one form is commonly believed to be infectious.

The lung passes through three stages—engorgement, red hepatisation, and grey hepatisation. In the first stage the lung is of a deep red colour, but still vesicular; in the second stage the affected part is more or less solid, and has the consistency of liver, owing to the fibrinous lymph which is poured out into the alveolar cavities. In the grey hepatisation, the exudation contains more leucocytes and less fibrin, and this is followed by the stage of suppurative softening and final absorption. The sputum at the commencement of the disease is rusty, from the presence of blood, and later on has the appearance of prune juice. Examination of the sputum by Gram's method will reveal numerous micro-organisms, and two of these are deserving of special study—the pneumococcus of Friedländer, which is present in a considerable proportion of cases, and Sternberg's micrococcus, which was found in sputum by Talamon.

In 1888, there was considerable prevalence of pneumonia in Middlesbrough, with strong tendency to occur in groups of cases; but there was admittedly room for doubt whether the clinical and post-mortem appearances were not identical with ordinary pneumonia. Dr. Ballard maintained that there were facts and considerations which appeared to show that the disease was communicable from the sick to the healthy, and that it was a specific febrile disease, and Klein isolated and described the micrococcus present in these cases.

**Bacterium Pneumoniæ Crouposæ** (Pneumococcus, Fried-

länder).—Cocci ellipsoidal and round, singly, or in pairs (diplococci), rods and thread-forms. The cell-

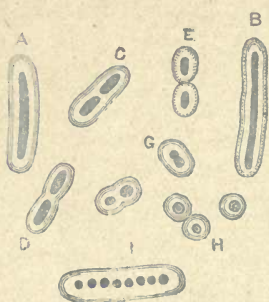

FIG. 113.—BACTERIUM PNEUMONIAE CROUPOSAE, FROM PLEURAL CAVITY OF A MOUSE,  $\times 1500$ . A, B. Thread-forms. C, D, E. Short rod-forms. G. Diplococci. H. Cocci. I. Streptococci. (Zopf.)

membrane thickens, and develops into a gelatinous capsule, which is round if the coccus is single, and ellipsoidal if the cocci occur in pairs or in rod-forms. Cultivated in a test-tube of nutrient gelatine they grow in the form of a round-headed nail, without liquefaction of the gelatine (Fig. 114). The cocci when artificially cultivated have no capsule, but it again appears after their injection into animals. The cocci can also be cultivated on blood serum and on boiled potatoes. They occur in pneumonic exudation. Inoculation of dogs with a cultivation of the cocci occasionally gave positive results; but in rabbits no results followed. Guinea-pigs proved to be susceptible in some cases; but thirty-two mice, after injection of a cultivation diffused in sterilised water, into the lungs, died without exception. The lungs were red and solid, and contained the cocci, which were also present in the blood, and in enormous numbers in the pleural exudation. Inhalation experiments by spraying the cocci diffused in water into mouse cages produced pneumonia and pleurisy in three out of ten mice.

The nail-shaped cultivation is not always produced, nor are these conclusions accepted by all investigators.

#### METHODS OF STAINING FRIEDLÄNDER'S PNEUMOCOCCUS.

Cover-glass preparations of pneumonic sputum or exudation may be treated as follows :—

rods and thread-forms. The cell-

membrane thickens, and develops into a gelatinous capsule, which is round if the coccus is single, and ellipsoidal if the cocci occur in pairs or in rod-forms. Cultivated in a test-tube of nutrient gelatine they grow in the form of a round-headed nail, without liquefaction of the gelatine (Fig. 114). The cocci when artificially cultivated have no capsule, but it again appears after their injection into animals.

The cocci can also be cultivated



FIG. 114.—FRIEDLÄNDER'S PNEUMOCOCCUS. Pure-culture in nutrient-gelatine four days old (BAUMGARTEN).



- (a) Stain by the method of Gram, and after-stain with eosin.
- (b) Treat with acetic acid, then stain with gentian-violet or Bismarck-brown. Examine in distilled water, or dry and preserve in Canada balsam.
- (c) Float them on weak solutions of the aniline dyes twenty-four hours ; differentiation between coccus and capsule is thus obtained.
- (d) Stain with osmic acid ; the contour of the capsules is brought out.

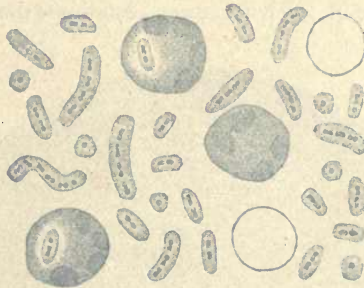

FIG. 115.—CAPSULE-COCCI FROM PNEUMONIA, × 1500 (BAUMGARTEN).

Sections of pneumonic lung should be stained by—

(a) Method of Gram.

(b) Method of Friedländer. This method is employed to demonstrate the capsules in tissue sections. It consists in placing the sections twenty-four hours in the following solution :—

Fuchsine . . . . .	1
Distilled water . . . . .	100
Alcohol . . . . .	5
Glacial acetic acid . . . . .	2

They are then rinsed with alcohol, transferred for a couple of minutes to a 2 per cent. solution of acetic acid, and treated with alcohol and oil of cloves in the usual way, and preserved in Canada balsam.

Sternberg's micrococcus was first found in the blood of rabbits inoculated with saliva. Three months afterwards, Pasteur encountered the same organism in rabbits inoculated with the blood of a child suffering from rabies. The same organism in 1883 was found by Talamon in pneumonic sputum. It was identified by Sternberg. Two years afterwards further observations were made by Fränkel, Gamaleia, and others. It has also been found in purulent meningitis by Netter, and by Monti in cerebro-spinal meningitis, by Wechselbaum in ulcerative endocarditis, and by others in acute abscess of the middle ear, and in purulent inflammation of the joints following pneumonia.

**Sternberg's Micrococcus.** (*Microbe de salive*, Pasteur; *Micrococcus Pasteuri*, Sternberg; *Lancet-shaped micrococcus*, Talamon; *Streptococcus lanceolatus Pasteuri*, Gamaleia; *Diplococcus pneumoniae*, Weichselbaum; *Bacillus septicus sputigenus*, Flügge; *Micrococcus of sputum septicæmia*, Fränkel.) Spherical or oval cocci, singly, in pairs or in chains, often lanceolate and capsuled. Stain readily with the aniline colours and by Gram's method; non-motile. They flourish in alkaline media in the incubator. In broth they produce in twelve hours a cloudiness due to the develop-

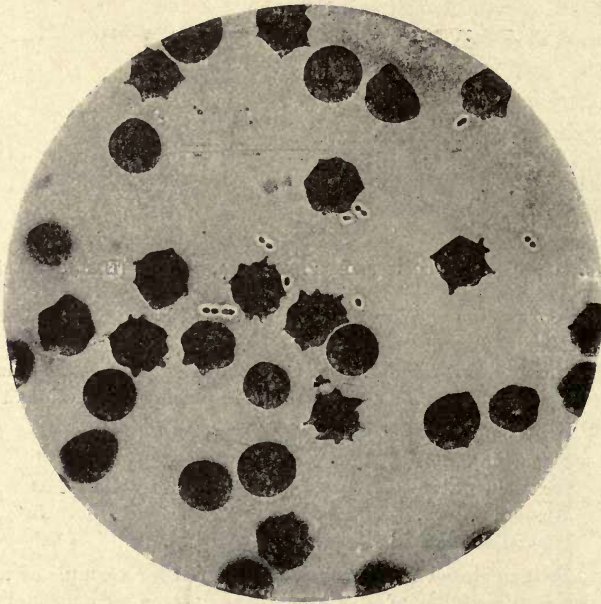

FIG. 116.—MICROCOCCUS OF SPUTUM SEPTICÆMIA. From the blood of a Rabbit.  $\times 1000$  (FRÄNKEL AND PFEIFFER).

ment of cocci and short chains. After a time these subside to the bottom of the tube, and the liquid above becomes clear. In plate-cultivations the colonies are small, circular, white, and granular. In the depth of gelatine, minute white colonies develop along the track of the needle without liquefaction of the gelatine; and on the sloping surface of nutrient agar or blood serum minute transparent drops appear along the line of inoculation. They grow in milk, coagulating casein; but they do not grow on potato. Subcultures quickly lose their virulence, but regain it by inoculation.



The injection of a minute quantity (.2 cc.) of a virulent culture subcutaneously proves fatal to mice and rabbits in from twenty-four to forty-eight hours. Immediately afterwards there is a rise of temperature of 2° or 3° C., later it falls, and just before death it is several degrees below normal. After death, the post-mortem appearances of septicæmia are observed, in addition to diffuse inflammatory œdema extending in all directions from the point of injection. The subcutaneous connective tissue contains sanguineous serum and micrococci in abundance. The liver and spleen are some-

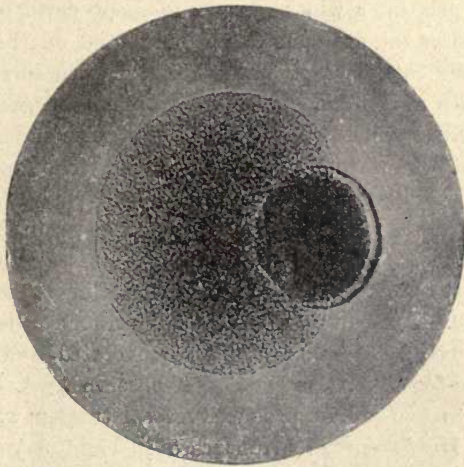

FIG. 117.—COLONIES OF STERNBERG'S MICROCOCCUS. Agar plate-cultivation, after 24 hours.  $\times 100$  (FRÄNKEL AND PFEIFFER).

times dark and engorged, and blood from the heart and internal organs teems with micrococci.

There is no indication of pneumonia after subcutaneous inoculation, but intra-pulmonary injections produce fibrinous pneumonia, often fatal (Talamon, Gamaleia). The result is usually fatal in rabbits and sheep, but dogs, as a rule, recover. Injection of cultures into the trachea of rabbits is said to induce typical pneumonia (Monti).

Sternberg concludes that this micrococcus is the cause of acute infectious pneumonia, but the micrococcus is undoubtedly associated with widely different pathological processes, and the possibility of its being a saprophyte, which finds in pneumonia a suitable soil for its development, must not be overlooked.

**Klein's Micrococcus.**—Klein found in pneumonic sputum a diplococcus which does not appear to differ from Sternberg's micrococcus. In cover-glass preparations the bacilli are surrounded with a halo, but no definite capsule, as in Friedländer's coccus. They appear as short rods constricted in the centre, or dumb-bell forms, and forms intermediate between cocci and bacilli. In gelatine, after two or three days, greyish-white spots appear, which enlarge in the next two or three days into flat, translucent, greyish-white plaques, with irregular serrated outline. Colonies beneath the surface are spherical, and of a brownish-yellow colour. In test-tubes in the depth of the gelatine a whitish-brown filament develops on incubation, composed of minute spherical colonies, and on the surface the growth spreads out into a greyish-white film with serrated margin. On the surface of obliquely solidified gelatine the growth forms a thin whitish film, which enlarges in breadth with irregular outline, reaching its maximum in about a fortnight. The growth on agar is very similar. Broth becomes uniformly turbid in twenty-four hours, then a powdery precipitate makes its appearance. On potato there is a thin, moist, faintly yellowish-brown film. Cultures examined in the fresh state show many rods in a resting stage, and others actively motile. In addition to the dumb-bell forms there are others of greater length, and in old cultures involuted and degenerated forms. Spore-formation has not been observed. A broth-culture inoculated into two rabbits produced a local tumour which subsided in a week. Death ensued in one case in eight days, and in the other in three weeks. There was purulent matter at the seat of inoculation in one; in the other, pericardial exudation and hyperæmia of the lungs. Broth-cultures inoculated intravenously produced no effect. In guinea-pigs there was swelling at the seat of inoculation, or slight indication of disease and recovery. Cultures inoculated in mice produced rapid breathing, drowsiness, and death in from twenty-four to ninety-six hours. The internal organs were congested, the lungs inflamed, and the blood and organs in the inoculated animals contained the diplococci in considerable numbers.

Foa isolated a coccus which he named the *Micrococcus lanceolatus capsulatus*. It produced in small animals either rapid septicæmia and death, or local œdema and death at a later period.

**Protective Inoculation.**—Immunity has been produced in rabbits by the intravenous injection of the virus in a diluted form. Blood obtained from immunised rabbits was kept at 10° C. for twelve hours, and then filtered, and animals injected with it acquired immunity against virulent cultures (Emmerich).



Filtered cultures are said to confer immunity for six months, and raising the temperature of filtered cultures increases the strength of the substance which gives immunity (Klemperer). The blood serum of immune animals can confer immunity on other animals, and, it is said, will arrest the progress of the disease produced by injection of healthy animals with virulent cultures. The cultures contain a proteid body, for which the name pneumo-toxin has been suggested, and anti-pneumo-toxin has been isolated from immunised blood serum.

#### INFECTIOUS PLEURO-PNEUMONIA.

Infectious pleuro-pneumonia is a highly infectious disease peculiar to cattle; it is characterised by rise of temperature and exudation into the lungs. It is often fatal, and sometimes exists in an extremely chronic form. It is believed to have been unknown in England previously to 1840, and is supposed to have been introduced from Holland, where in one year it destroyed seven thousand cattle.

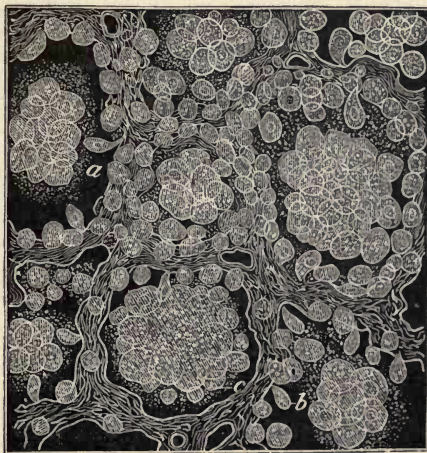

FIG. 118.—ACUTE CATARRHAL PNEUMONIA (Ox).

*a*, Coagulated mucus with catarrhal cells (*c*) embedded in it; *b*, catarrhal cells sprouting from alveolar wall.  $\times 480$ . (Hamilton.)

The disease cannot be conveyed artificially. A living, diseased animal must be the medium of infection. The disease is apparently only communicated by cohabitation. Brown injected large quantities of lymph from diseased lungs into the jugular vein, into the

tissue of the lungs, and into the trachea, without any result except a small abscess at the seat of puncture. Administration of the virus by the mouth gave equally negative results. The lungs from a recently killed animal infected with pleuro-pneumonia were placed in a shed occupied by healthy heifers, and left there for several days. Fodder, litter, and manure were taken from places in which there were diseased cattle, and placed in contact with healthy cattle, and subsequently all the animals used in these experiments were slaughtered and carefully examined, and the results were absolutely negative.

Similarly negative results followed experiments made by Sander-



FIG. 119.—INFECTIOUS PLEURO-PNEUMONIA OF CATTLE,  $\times 480$ .

*a,a,a*, Exudation in air-vesicles, composed of a network of fibrinous lymph with entangled leucocytes; *b,b*, the same caseating; *c*, the air-vesicle filled with leucocytes only. In the centre is a blood-vessel filled with a fibrinous plug. (Hamilton.)

son and Duguid, and thus confirmed the conclusion arrived at by Brown, that the disease could only be communicated by actual contact of a living, diseased animal with a healthy one.

The symptoms of the disease in cattle are a rise of temperature to  $105^{\circ}$  or  $107^{\circ}$ , and a peculiar dry cough, and later the usual indications of pneumonia, difficulty in breathing, and dulness on percussion. As a rule, death follows from exhaustion; but the disease may also assume a chronic form, if the animal escapes slaughter, and the lung may become gangrenous or tubercular. The period of incubation is about thirty days, but it is uncertain. The lesions are



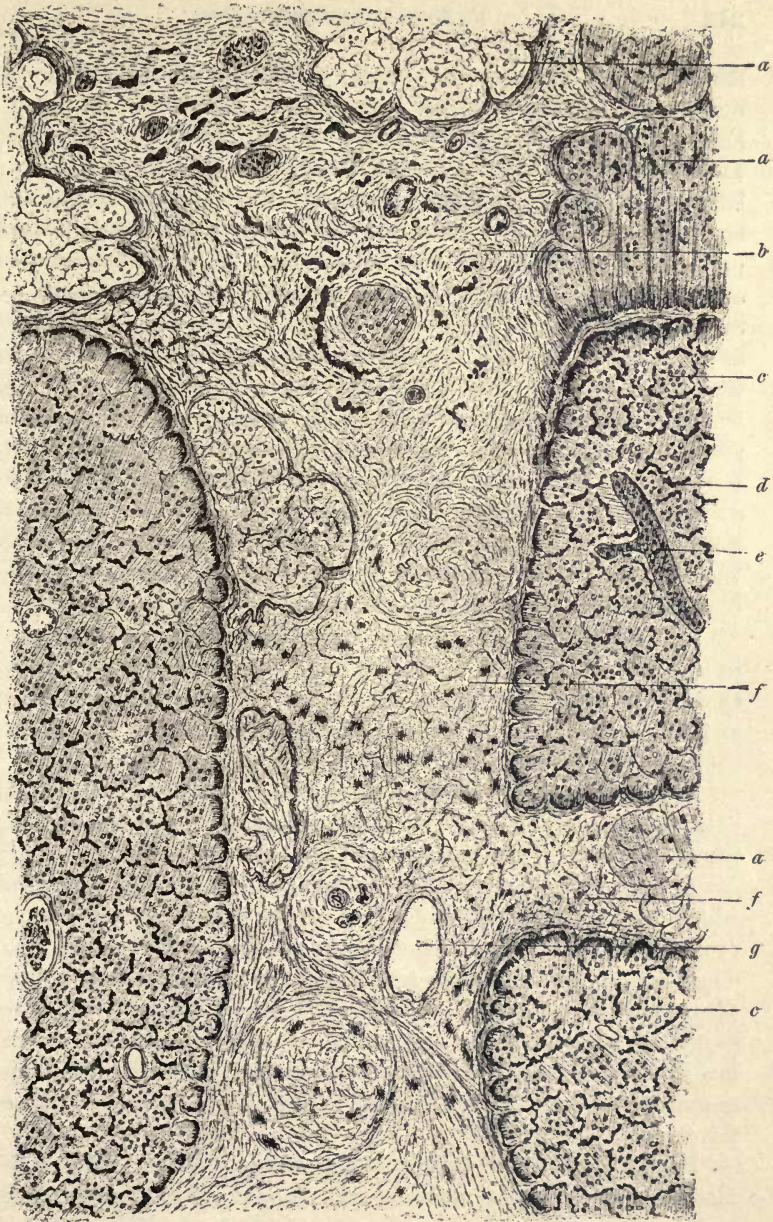

FIG. 120.—INFECTIOUS PLEURO-PNEUMONIA OF CATTLE,  $\times 50$ .

*a, a, a*, Spaces in deep layer of pleura and interlobular septa filled with fibrinous lymph; *b*, deep layer of pleura running down to an interlobular septum; *c, c*, air-vesicles filled with fibrinous lymph; *d*, blood-vessels of alveolar walls, much congested; *e*, large congested blood-vessels; *f, f*, interlobular septa infiltrated with fibrinous lymph; *g*, blood-vessel in interlobular septum (Logwood, Eosin and Farrant's solution).—HAMILTON.

limited almost entirely to the lungs; congestion is quickly followed by inflammation and effusion into the air vesicles and the intra-lobular fibrous tissue which is so well marked in the lungs of cattle. Leucocytes are entangled in the fibrinous lymph, and the intra-lobular septa are enormously enlarged, so that the red lobules are mapped out by the paler septa, and produce on section of the diseased parts a very striking marbled appearance. A somewhat similar appearance is sometimes observed in septic pleuro-pneumonia in calves. The effusion occurs also in the air vesicles. The stages of grey hepatisation and suppurative softening have not, as a rule, time to develop. Hæmorrhagic infarctions are sometimes produced, which in turn become gangrenous or cheesy, and a capsule may form round the diseased part. Roy found micro-organisms in the lymph, but attached no importance to them. Bruylants and Verriet also described a micro-organism in the lymph. Later, Poels and Nolen isolated a micrococcus resembling Friedländer's pneumococcus. Inoculation in the lungs produced a condition in cattle which they considered indicative of pleuro-pneumonia.

Lustig was unable to confirm these observations, but succeeded in isolating from lymph a bacillus and three species of micrococci. One of the micrococci formed an orange growth when cultivated, and was regarded as the specific micro-organism, as it caused subcutaneous tumefaction, and, it is said, some degree of immunity.

Brown cultivated a number of organisms which on inoculation only produced local irritation. Intravenous injection produced death from septicæmia in one case in thirty-six hours.

Arloing isolated four different organisms, including a bacillus which was named *Pneumo-bacillus liquefaciens bovis*. Later, he prepared a fluid from broth-cultures, *pneumo-bacillin*, which produced a more marked rise in temperature in animals suffering from pleuro-pneumonia than in healthy animals, and its use was suggested as an aid in diagnosis. Arloing named the micro-organisms provisionally *Pneumo-bacillus liquefaciens bovis*, *Pneumococcus gutta cerei*, *Pneumococcus lichenoides*, and *Pneumococcus flavescens*.

***Pneumo-bacillus liquefaciens bovis***.—Short rods, non-motile; spore-formation not observed. They rapidly liquefy gelatine, and form on potato a white layer, which becomes brownish and sometimes greenish. According to Arloing pure-cultures produce in the ox, when injected subcutaneously or in the lung, the same lesions which are produced by virulent lymph. Guinea-pigs and rabbits are slightly susceptible, dogs are immune.



Nocard does not accept Arloing's conclusions, and expresses the opinion that the virus is particulate, but is not due to any micro-organism which can be detected or cultivated by the methods at present adopted. In the opinion of the author, who has also examined the micro-organisms in pleuro-pneumonia, it is fully justifiable to regard the nature of the contagium as unknown.

**Preventive Inoculation.**—In 1852 Willems introduced inoculation. The liquid from the lungs of an animal with pleuro-pneumonia, which had recently died, was inoculated in the extremity of the tail by a puncture with a lancet. Swelling occurred at the seat of inoculation, and on recovery the animals were believed to be protected. A Dutch Commission reported that the inoculation gave a temporary protection. A Belgian Commission in the following year reported that the phenomena of inoculation could be produced several times in succession in the same animal, and that it was not a certain preventive. A French Commission in 1854 concluded that a power of resisting infection was given, but the period was undetermined. Protective inoculation continued to be employed, and various modifications of the method were introduced. Threads soaked in lymph were inoculated, or the lymph subcutaneously or intravenously injected.

The usual result of the inoculation is swelling and, in about ten or fourteen days, effusion of straw-coloured fluid, which is occasionally blood-stained. Gangrene may follow, involving amputation of the tail. Germont and Loire in Queensland adopted the method—which was suggested by Pasteur—of inoculating calves in the loose cellular tissue behind the shoulder. This produces intense œdema and a quantity of lymph. There has been much controversy with regard to the value of protective inoculation.

**Stamping-out System.**—Brown maintains that pleuro-pneumonia can be exterminated only by slaughter of the diseased animals, and quotes the results experienced in the Netherlands in support of his views.

In 1871 slaughter for pleuro-pneumonia was commenced in the Netherlands. There were 6,000 cattle attacked by the disease. In 1872 owners were compelled to slaughter not only diseased cattle, but those which had been in contact with them, unless inoculated, and the attacks were, in consequence, reduced to 4,000. In 1873 it was forbidden to move cattle out of infected districts, and the attacks were reduced to 2,479. In 1876 slaughter of the whole herd was decreed, and during the first year of this heroic system the cases fell

from 2,227 in 1875, to 1,723 in 1876, to 951 in 1877, to 698 in 1878, to 157 in 1879, and to 48 in 1880.

In England the Pleuro-pneumonia Act came into force on September 1st, 1890. Notification was to be given by the owner to a police constable of the district, who was required to transmit the information to the Local Authority and also to the Board of Agriculture. An inspector, with the aid of the veterinary surgeon, arranged for the slaughter of the suspected animal, and, if the disease proved to be pleuro-pneumonia, of the rest of the herd. The results are shown in the following table :—

YEARS.	Number of Infected Counties.	Number of Fresh Outbreaks.	Number of Cattle Attacked.	Diseased Cattle.		Healthy Cattle in contact slaughtered.	Cattle slaughtered as suspected, but found free from Pleuro-Pneumonia.
				Killed.	Died.		
1890	36	465	2,057	2,022	37	11,301	
1891	27	192	778	778	—	9,491	232
1892	10	35	134	134	—	3,477	188
1893	4	9	30	30	—	1,157	86
1894	2	2	15	15	—	391	41

Thus the number of cases was reduced from 2,057 in 1890 to 15 in 1894.

A departmental committee appointed in 1892 to inquire into pleuro-pneumonia and tuberculosis, came to the following conclusions with regard to pleuro-pneumonia :—

(1) That the system of compulsory slaughter be applied not only to all diseased cattle, but also to all cattle which have been in association with them, or otherwise in any manner exposed to the infection of the disease.

(2) Compulsory slaughter should be accompanied by supplementary measures, such as restrictions on the movement and sale of cattle within, or coming from, infected districts.

(3) Any exception to, or modification of, the system of compulsory slaughter, as provided in the Slaughter Order, 1888, should only be applicable to cattle in the dairy yards, byres, and cowsheds of large towns, the owners or occupiers of which may claim in writing the privilege of exemption for their cattle from immediate slaughter, on the following conditions :—



- (a) No head of cattle that has been brought into such dairy premises shall be removed therefrom, except for the purpose of immediate slaughter.
- (b) In the event of an outbreak of pleuro-pneumonia, all the diseased cattle shall be slaughtered.
- (c) All the remaining cattle on such premises where an outbreak has occurred shall be branded, and regularly subjected to the thermometer test; and whenever a continuous increase of temperature, rising above 104°, is shown, they shall be slaughtered.
- (d) No fresh cattle shall be admitted into such premises while any of the cattle thus branded remain alive.

(4) Inoculation cannot be recommended as a means of eradicating pleuro-pneumonia, nor as practicable under existing conditions. Although it is open to owners to inoculate their cattle, it should be distinctly understood that that operation shall not give them any immunity from the regulations above suggested.

The order at present in force is the Pleuro-Pneumonia Order of 1895. In addition to regulations for the movement of cattle, for disposal of carcasses, for markets, and for compensation for slaughter, the Order contains the following provisions:—

#### NOTIFICATION.

##### *Notice of Disease.*

(1) Every person having or having had in his possession or under his charge a head of cattle affected with or suspected of pleuro-pneumonia shall with all practicable speed give notice of the fact of the head of cattle being so affected or suspected to a constable of the police force for the police area wherein the head of cattle so affected or suspected is or was.

(2) The constable receiving such notice shall immediately transmit the information by telegraph to the Board of Agriculture.

(3) The constable shall also forthwith give information of the receipt by him of the notice to an Inspector of the Local Authority, who shall forthwith report the same to the Local Authority.

##### *Duty of Inspector to act immediately.*

(1) An Inspector of a Local Authority on receiving in any manner whatsoever information of the supposed existence of pleuro-pneumonia, or having reasonable ground to suspect the existence of pleuro-pneumonia, shall proceed with all practicable speed to the place where such disease, according to the information received by him, exists, or is suspected to exist, and shall there and elsewhere put in force and discharge the powers and duties conferred and imposed on him as Inspector by or under the Act of 1894 and this Order.

(2) The Inspector shall forthwith report to the Board of Agriculture.

*No Movement into or out of Pleuro-pneumonia Infected Place without Licence.*

Cattle shall not be moved into or out of an Infected Place except with a Movement Licence of an Inspector or officer of the Board, and such cattle shall not be moved except in accordance with the conditions contained in such Licence.

*Pleuro-pneumonia found in a Market, Railway Station, Grazing Park, or other like Place, or during Transit.*

The Inspector of the Local Authority shall cause to be seized all the cattle affected with pleuro-pneumonia, and also all cattle being in or on the market, fair, sale-yard, place of exhibition, lair, landing-place, wharf, railway station, common, uninclosed land, farm, field, yard, shed, park, or other such place as aforesaid, and shall forthwith transmit the information by telegraph to the Board of Agriculture.

The Inspector of the Local Authority shall cause all such cattle so seized to be detained at the place where they are seized, or to be moved to some convenient and isolated place and there detained.

*Removal of Dung or other Things.*

It shall not be lawful for any person to send or carry, or cause to be sent or carried, on a railway, canal, river, or inland navigation, or in a coasting vessel, or on a highway or thoroughfare, any dung, fodder, or litter that has been in an Infected Place, or that has been in any place in contact with or used about a diseased or suspected head of cattle, except with a Licence of an Inspector or officer of the Board or of an Inspector of the Local Authority.

*Report to Board of Cattle that have been in Contact with Cattle affected with Pleuro-pneumonia.*

Where it appears to a Local Authority that there is within their District any head of cattle which has been in the same field, shed, or other place, or in the same herd, or otherwise in contact, with any head of cattle affected with pleuro-pneumonia, or otherwise exposed to the infection thereof, the Local Authority shall forthwith report the facts of the case to the Board of Agriculture.

*Disinfection.*

An Inspector or officer of the Board may cause or require any shed or other place which has been used for a head of cattle while affected with or suspected of pleuro-pneumonia, and any utensil, pen, hurdle, or other thing used for or about such head of cattle, to be cleansed and disinfected to his satisfaction.

*Occupiers to give Facilities for Cleansing.*

(1) The owner and occupier and person in charge of any shed or other place which has been used for any head of cattle while affected with or suspected of pleuro-pneumonia shall give all reasonable facilities to an



Inspector or officer of the Board for the cleansing and disinfection of such place, and of any utensils, pens, hurdles, or other things used for or about such cattle.

(2) Any person failing to comply with the provisions of this Article shall be deemed guilty of an offence against the Act of 1894.

*Prohibition to Expose or Move Diseased or Suspected Cattle.*

- (1) It shall not be lawful for any person—
- (a) To expose a diseased or suspected head of cattle in a market or fair, or in a sale-yard, or other public or private place where cattle are commonly exposed for sale ; or
  - (b) To place a diseased or suspected head of cattle in a lair or other place adjacent to or connected with a market or a fair, or where cattle are commonly placed before exposure for sale ; or
  - (c) To send or carry, or cause to be sent or carried, a diseased or suspected head of cattle on a railway, canal, river, or inland navigation, or in a coasting vessel ; or
  - (d) To carry, lead, or drive, or cause to be carried, led, or driven, a diseased or suspected head of cattle on a highway or thoroughfare : or
  - (e) To place or keep a diseased or suspected head of cattle on common or uninclosed land, or in a field or place insufficiently fenced, or in a field adjoining a highway unless that field is so fenced or situate that cattle therein cannot in any manner come in contact with cattle passing along that highway or grazing on the sides thereof ; or
  - (f) To graze a diseased or suspected head of cattle on pasture being on the sides of a highway ; or
  - (g) To allow a diseased or suspected head of cattle to stray on a highway or thoroughfare or on the sides thereof or on common or uninclosed land, or in a field or place insufficiently fenced.

INFLUENZA.

Influenza is an infectious disease characterised by a catarrh of the respiratory or the gastric mucous membrane, accompanied by great prostration and mental depression, and frequently ending fatally by pneumonic complication. One attack is not protective. The disease has occurred in the form of great epidemics, like the pandemic of 1890, which is said to have started from Bokhara, and travelled to St. Petersburg, Berlin, Paris, and London, whence it spread all over this country. The incubation period is extremely short, only a few hours, so that numbers are attacked almost simultaneously. The occurrence of cases in succession in a family, the importation of the disease by an infected person, and the escape of persons in completely isolated localities, point to the existence of a living contagium. Pfeiffer claims to have identified it with a

bacillus which was found by him in the purulent bronchial secretion, and, by Canon, in the blood.

**Bacillus of Influenza.**—Very small rods, singly or in leptothrix filaments. They stain with the aniline dyes, but not by Gram's method. They are non-motile and aerobic; they do not grow in gelatine at the temperature of the room. On glycerine-agar very small transparent drop-like colonies develop in about twenty-four hours. In broth there is only a very scanty growth of whitish particles on the surface, which subside and form a woolly deposit. They are found especially in the bronchial secretion, and only in cases of influenza. Canon obtained them by puncturing the finger,

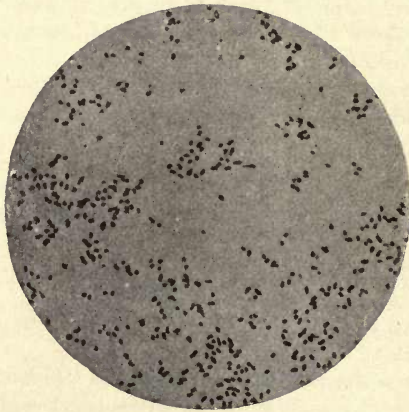

FIG. 121.—BACILLUS OF INFLUENZA.  
From a culture on gelatine,  $\times 1000$ . (ITZEROTT AND NIEMANN.)

and allowing a few drops of the blood to fall upon the surface of glycerine-agar in a Petri's dish. The organism will retain its vitality for fourteen days in sputum, but is quickly destroyed by drying. It is said that by applying the bacillus to the nasal mucous membrane in monkeys, symptoms similar to influenza were produced.

#### METHOD OF STAINING.

To stain the bacilli use Neelsen's solution or Löffler's methylene-blue; or the following method:—

*Canon's method.*—Spread the blood on cover-glasses, allow them to dry, immerse for five minutes in absolute alcohol, and stain in the following solution:—



Aqueous solution of methylene-blue, strong, 40 parts;  $\frac{1}{2}$  per cent. solution of eosin in 70 per cent. alcohol, 20 parts; distilled water, 40 parts.

Float the cover-glasses from three to six hours in a capsule placed in the incubator at 37° C., wash with water, and dry and mount in balsam. The red corpuscles will be stained pink, and the leucocytes, with the bacilli in them, blue.



FIG. 122.—BACILLUS OF INFLUENZA.

From a cultivation showing filaments composed of long and short rods, cocci-forms and irregular elements.  $\times 1200$ .

#### EQUINE INFLUENZA.

Equine influenza, or "pink-eye," has been noticed to be prevalent at the same time as epidemics of influenza in man, but there does not appear to be any evidence of intercommunicability or of any relation between the two diseases.

## CHAPTER XVIII.

ORIENTAL PLAGUE.—RELAPSING FEVER.—TYPHUS FEVER.—YELLOW FEVER.

### THE PLAGUE.

THE plague is a highly infectious disease, having its origin in putrefaction and filth, in tropical climates. The virus in its effects resembles that of typhus. The period of incubation varies from a few hours to a week. The disease produces high temperature and decomposition of the blood, and dark hæmorrhagic patches appear on the skin, but there is no eruption. Lymphatic inflammation and buboes almost invariably occur. The virus is intensified by warmth and overcrowding in houses, and dissipated by exposure to fresh air.

When the plague occurred in this country it was recognised as a foreign pestilence from the East, and once imported it was fostered and intensified in virulence wherever there was filth, putrefaction, and overcrowding. The disease, like the small-pox, was communicated from one person to another. If a case occurred in a house other inmates were liable to suffer from the disease, while visitors to the house ran a similar but less risk. There was a good deal of variation both in the infectivity of the virus and in the susceptibility of individuals, so that one contemporary writer remarked that "no one can account for how it comes to pass that some persons shall receive the infection and others not."

Medical men were credited with enjoying an extraordinary degree of immunity, though there were members of the medical profession who undoubtedly died of the plague. This tradition has been supported, to a certain extent, by the experience of the plague in modern times. In the epidemic in Egypt, in 1835, of the ten French physicians engaged there, only one died; and while those who buried the victims of the plague were liable to suffer from it, and many did so, yet the medical men made more than one hundred post-mortem examinations without any death resulting.



The clothes and coverings of the infected often spread the disease, and yet there are numerous examples of persons who without having adopted any method of protection occupied the beds of plague patients without contracting the malady.

The plague is transmissible from one country to another by sea. An infected ship becomes an infective centre as readily as an infected house. Once imported, whether by land or sea, the virus from infected persons or merchandise spreads wherever the environment is favourable for its development and extension.

Old London afforded in every way a suitable environment for the plague. The situation of the city was unhealthy, and the old town ditch was a receptacle for all kinds of filth. The houses projected over the roadway, and the streets were saturated with constant contributions of slops and of excrement from animals and human beings. The houses were often filthy and unventilated, and the floors strewn with rushes, which were seldom changed. Erasmus goes so far as to say that the rushes were piled the new upon the old for twenty years, and were fouled with spillings of beer, fragments of fish, expectoration, vomit, excrement, and urine. Another very striking insanitary feature of Old London was the overcrowded state of the graveyards, which was well calculated to predispose to pestilence, if not actually to produce it. The burials were so frequent in St. Paul's Churchyard that a new grave could scarcely be dug without bodies being exposed in all stages of putrefaction.

In 1894 the plague broke out in China, with all the symptoms of the fatal bubonic pest of Old London. The disease was confined to the poorest classes and the most overcrowded and most filthy localities. In Canton the deaths exceeded one hundred thousand, and in Hong-Kong numbered about ten thousand. The disease was contagious, and mainly diffused by personal contact. Death occurred, as a rule, in from twenty-four hours to five days. The English and European community escaped, with the exception of a very few out of a large number, mostly soldiers, employed in cleansing the houses. The disease was a specific fever, intensely fatal, accompanied by high temperature, cerebral congestion, delirium, and the formation of buboes. The buboes consisted of exquisitely painful and swollen lymphatic glands. All the glands, in some cases, were affected.

According to Cantlie the glandular swelling when first recognised was almond-shaped in the inguinal region, and globular in other regions, with peri-glandular œdema. The swelling rapidly increased in size, becoming softer, less definite in outline, and less tender, until



by the end of five or six days it consisted of an elevated mass, doughy to the touch, almost circular, with a diameter of six inches. The skin over the swelling was livid and dimpled. The swelling was in some cases due to purulent effusion, but more frequently on incision there was only an escape of sero-sanguineous fluid. The cervical glands in very severe cases sometimes attained an enormous size.

Three out of seven Japanese medical men were attacked and one died, but none out of eleven English doctors, though they were equally exposed to infection. Of eight Englishmen attacked seven were among the soldiers employed, and only two died. No nurses or attendants on the sick were attacked. The virus appeared to be intimately connected with filth in the soil. According to the Chinese, rats, poultry, goats, sheep, cows, and buffaloes are susceptible. In the houses and hotels dead rats were found in great numbers: it was said that they emerged from their haunts in sewers and drains, appeared to be dazed, and limped about, owing to the formation of buboes in their hind legs. Rats, mice, and guinea-pigs inoculated with virus from a human lymphatic gland died with development of buboes. It appears to be clearly proved that rats suffer from the plague in common with man, and it has also been suggested that they may serve to spread the disease. Bacilli were found in human blood and in the swollen lymphatic glands by Kitasato, and independently by Yersin.

**Bacillus of Plague.**—Short rods with rounded ends. They stain with aniline dyes, but not by Gram's method. The stain collects at the ends of the rods, leaving a clear space in the middle. Sometimes the rods are surrounded by a capsule. They are found in abundance in the buboes, and in small numbers in the blood in very serious and rapidly fatal cases.

Material from the buboes inoculated on agar gives rise to white transparent colonies, which have an iridescent edge when examined by reflected light.

The bacilli grow more readily on glycerine-agar and on solidified serum. In broth cultures the liquid remains clear, and a flocculent deposit forms on the sides and at the bottom of the vessel.

An alkaline solution of peptone 2 per cent., with from 1 to 2 per cent. of gelatine, is the best nutrient medium. In cultures the bacilli develop chains of short rods and well-marked involution forms. Swollen and degenerated forms are found most abundantly in old cultures, and stain with difficulty.

Mice, rats, and guinea-pigs, inoculated with bubonic tissue, die in a few days, numerous bacilli being found in the lymphatic glands,



spleen, and blood. Guinea-pigs die in from two to five days, and mice in one to three days.

In guinea-pigs after some hours there is œdema at the seat of inoculation, and the lymphatic glands are swollen. After twenty-four hours the animal refuses to eat, has a staring coat, and after a time suddenly falls on its side, and is attacked by convulsions, which become more and more frequent until death occurs.

After death the seat of inoculation is found to be extensively œdematous, and the neighbouring lymphatic glands enlarged and filled with bacilli. The intestine is often congested, and the liver is

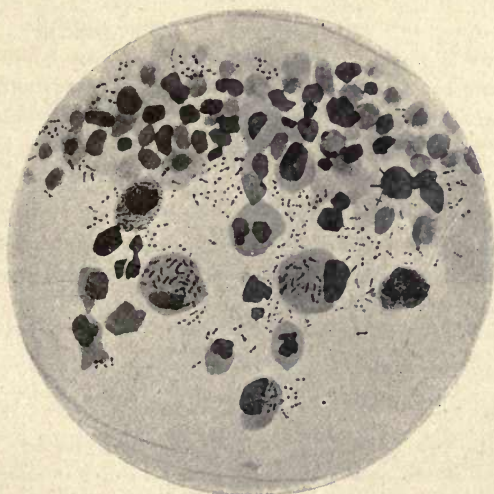

FIG. 123.—BACILLI OF PLAGUE AND PHAGOCYTES.  $\times 800$ .  
From human lymphatic gland. (AOYAMA.)

congested and enlarged. In less acute cases an abscess of the abdominal wall occasionally results.

The bacilli are sometimes found in the pleural and peritoneal exudation. The liver and spleen also contain many bacilli. Those in the blood are a little longer than those in the lymphatic glands.

Inoculations can readily be made from guinea-pig to guinea-pig by using the pulp of the spleen, or the blood. Cultures lose their virulence gradually, but the virus can be intensified by successive inoculations in animals. The disease is infectious to mice as well as inoculable. Pigeons are insusceptible. Rats and flies may convey the bacilli.

According to Aoyama, the bacilli found in the blood of plague

patients and in the buboes are not identical. The bacilli in the buboes are different in form, and they stain by Gram's method.

There is no doubt that the micro-organism which was found in blood is very similar to the bacillus of fowl cholera, and it is quite possible that the so-called plague bacillus is really identical with the bacillus of hæmorrhagic septicæmia, and that the real nature of the contagium in bubonic plague is unknown.

**Protective Inoculation.**—Yersin, Calmette, and Borrell claim not only to have produced immunity, but to have cured animals after infection. Cultures on agar heated to 58° C. for an hour were attenuated, and rabbits after intravenous or subcutaneous inoculation were protected against virulent cultures. The serum of immunised rabbits was capable of protecting from subsequent virulent cultures, and neutralising the effect of a previous inoculation of a virulent culture. A horse was inoculated with cultures which killed mice in two days, and after six weeks a serum was obtained which produced immunity in mice and guinea-pigs.

**Stamping-out System.**—It is not until the sixteenth century that we hear of preventive measures being attempted in England, and then they appear to have been adopted only when an outbreak threatened to be very serious.

Early in the sixteenth century all those who had the plague in their houses were ordered to put up wisps, and to carry white rods in their hands.

In 1543 the Plague Order of Henry VIII. was issued. In place of wisps the sign of the cross was to be made on every infected house, and to remain there for forty days. Persons afflicted with the disease were to refrain, if possible, from going out of doors, or for forty days to carry a white rod in the hand. All straw from the infected houses was to be carried into the fields and burnt. Churchwardens were directed to keep beggars out of churches on holy days, and all streets and lanes were to be cleansed.

In 1547 the means of notification was a blue cross with the addition of the inscription *Lord have mercy upon us*. Later on the colour of the cross was changed to red.

With the outburst of the plague in 1563, came an attempt to enforce a terrible system of compulsorily shutting up infected families. The doors and windows in such houses were to be closed, and no inmates were to leave the premises and no visitors to be allowed for forty days. No better incubator on a large scale could possibly have been devised for both breeding and intensifying the virulence of the plague bacillus, or whatever may be the *contagium vivum* of this disease.

This compulsory shutting up of the sick with the healthy amounted to a compulsory infection of many of the unfortunate inmates who might



otherwise have escaped, and very naturally the order was frequently infringed.

In 1568 the Lord Mayor of London drew up instructions for the Aldermen for dealing with the plague. It was enacted that constables and officers should search out infected houses and report to the authorities. In other words, that there should be *notification by the police*. All infected houses were to be shut up, and no person to be allowed to come out for twenty days. All bedding and clothes used by the victims were to be destroyed.

At Westminster these instructions were to be enforced under a penalty of seven days in the stocks, with imprisonment to follow, making in all a punishment of forty days.

In 1581 the Lord Mayor transferred notification from the constables to searchers. Two honest and discreet matrons in every parish were to search the body of every such person that happened to die in the parish. They were ordered to make a true report to the clerk of the parish, and the said clerk had to report to the wardens of the parish. For failing to notify, the penalty was an exemplary term of imprisonment. The searchers were of course likely to be offered heavy bribes by the people to suppress reports, owing to their anxiety to avoid the shutting up of infected houses.

The continued prevalence of the plague led to the publication, in 1593, of a book by Simon Kellwaye. One chapter "teacheth what orders magistrates and rulers of citties and towns should cause to be observed," which included among other regulations that no dunghills were to be allowed near the city, and the streets were to be watered and cleansed.

No surgeons or barbers who let blood were to cast the same into the streets. All those visiting and attending the sick to carry something in their hand to be known from other people; and if the infection were in few places, all the people were to be kept in their houses during the time of their visitation, and when this was over, all clothes, bedding, and other such things used upon the sick, were to be burnt.

In 1603 Thomas Lodge recommended that discreet and skilful men should be appointed in every parish to notify sickness to the authorities, and so cause them to be visited by expert physicians, and that such as were sick should be separated from the whole, and that isolation hospitals should be built outside the City in separate and unfrequented places.

In 1665 the Great Plague of London occurred, and was attributed by some to the importation of an infected bale of silks from the Levant.

According to Hodges the disease stayed among the common people, and hence was called *The Poor's Plague*. He criticised the system of shutting up infected houses, and strongly recommended that those who were untouched in infected houses should receive "accommodation outside the city." The sick were to be removed to convenient apartments provided on purpose for them. To quote his own words, "Timely separation of the infected from the well is absolutely necessary to be done."

For the purification of houses his directions were to place "a chafing

dish in the middle of the room, where proper things were burnt and exhaled all around." The use of sulphur and quicklime was mentioned.\*

Preventive measures were drawn up and published by the Lord Mayor and Aldermen. Examiners in Health, watchmen, and searchers were appointed. Surgeons were selected to assist the searchers in making their reports, and a fee of twelve pence was allowed for every case. The disease was immediately notified to the Examiner of Health. Rules for disinfection were made, and every infected house was shut up, and no one removed except to a pest-house or tent. Orders were issued for cleaning and sweeping the streets. Hackney coaches were not to be used after conveying patients to the pest-house until they had been well aired. Regulations were also made dealing with loose persons, assemblies, and drinking taverns.

The plague was scarcely over before the whole city was in flames. A new city speedily rose upon the ashes of Old London. A few sporadic cases of plague are given in the London Bills of Mortality down to 1679, when they finally ceased. London was sterilised by the great fire. "Great as this calamity was," wrote Thomas Pennant, "yet it proved the providential cause of putting a stop to one of far more tremendous nature. The plague, which, for a series of ages, had, with very short intervals, visited our capital in its most dreadful forms, never appeared there again after the rebuilding of the city in a more open and airy manner; which removed several nuisances, which if not the origin of a plague, was assuredly one great *pabulum*, when it had seized our streets."

In the years 1720-22 there was a terrible outburst of plague in France. It was attributed at Marseilles to importation by a ship from Syria. This caused a panic in England, and the Lords Justices considered it necessary for the public safety that measures should be taken to defend the country from a fresh invasion of this disease. Dr. Richard Mead was entrusted with drawing up the required recommendations. Mead laid it down as an essential doctrine that the plague was not native to this country, and therefore the first thing was to prevent importation, and if such a misfortune occurred, it was to be prevented from spreading. How was this to be accomplished? Briefly stated, his system was as follows: Lazarettoes were to be provided for the reception of infected men and merchandise. The healthy were to change their clothes and to be kept in quarantine, and the sick were to be kept remote from the healthy and their clothes destroyed.

If, through a miscarriage in the public care, by the neglect of officers or otherwise, the disease was imported, then "the civil magistrates were to make it as much for the interest of the afflicted families to discover

\* During outbreaks of the plague amulets were extremely popular. Walnuts filled with mercury, pieces of cloth coated with arsenic, and arsenical cakes, were very generally worn. The College of Physicians recommended issues on the arms and legs. Dr. Hodges wrote, that the more of the ulcers that were made the better, although their largeness answered as well as more in number. If two issues were preferred, it was recommended to make one on the left arm and the other on the opposite leg. A somewhat similar plan was adopted in Circassia by small-pox inoculators.



their misfortune, as it was when a house was on fire, to call in the assistance of the neighbourhood." The shutting up of infected houses was condemned in the strongest terms, and a system of notification and isolation was proposed on the lines originally suggested by Dr. Hodges.

1. *A Council of Health* was to be established, and entrusted with such powers as might enable them to see all their orders executed with impartial justice.

2. *Notification*.—The ignorant old women employed as searchers were to be replaced by understanding and diligent men, who were to report cases immediately to the Council of Health.

3. *Isolation*.—Physicians were at once to be despatched to visit the suspected cases, and when the suspicion of plague was confirmed, all the families in which the sickness occurred were to be isolated. The sick were to be separated from the sound, and isolation houses to be provided three or four miles out of the town.

The removal of the sick was to be made at night, so as to avoid the danger of spreading infection, and all possible care was to be taken to provide such means of conveyance for the sick that they might receive no injury. The poor were to be isolated in houses provided for the purpose, but the rich were to be allowed to be in their own homes provided that care was taken to separate the healthy from the sick, and no pains were to be spared to provide clean and airy apartments. All expenses were to be paid by the public, and a reward was to be given to the person who made the first discovery of infection in any place.

Mead further pointed out that general sanitation must be carefully attended to. Officers were to see that the streets were washed and kept clean from filth, carrion, and all manner of nuisances. Beggars and idle persons were to be taken up, and such miserable objects as were fit neither for the hospitals nor for the workhouses, were to be provided for in an establishment for incurables. Houses also were to be kept clean, and sulphur was to be used as a disinfectant.

After centuries of experience we have learnt that the necessary conditions for avoiding the plague are more accurate knowledge on the part of the profession and the public of the way in which the disease spreads, and the adoption of sanitary precautions, which must include personal cleanliness, sanitary dwellings, absence of overcrowding, immediate notification, prompt separation of the sick from the healthy, disinfection of infected dwellings, destruction of infected clothing, and extra-mural burial or, better still, cremation. It was because the very reverse of these sanitary conditions existed that the virus of the plague found a suitable environment in Old London and in recent times in Hong-Kong.

#### RELAPSING FEVER.

Relapsing or famine fever is a contagious disease producing a state of high fever lasting about seven days, followed by apparent

recovery, and in about fourteen days by another attack of fever, which may be repeated after another week.

Starvation, in association with overcrowding and filth, is intimately connected with the causation of the disease. The subjects of the disease contaminate the air around them, and the virus is principally conveyed by tramps and dirty people.

Obermeier discovered spirilla in the blood during the paroxysms of fever. The constant occurrence of the spirillum in relapsing fever, and the fact of its not being found in any other conditions, render it very probable that it is the cause of the disease.

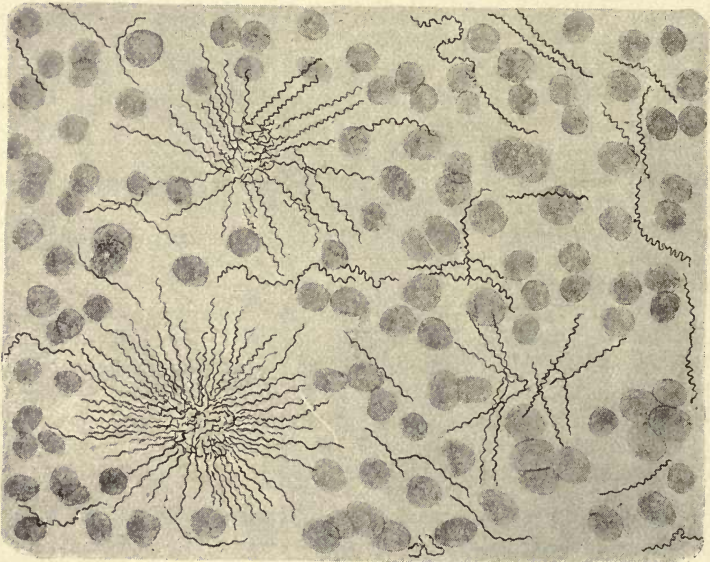

FIG. 124.—SPIRILLUM OBERMEIERI IN BLOOD OF MONKEY INOCULATED WITH SPIRILLA AFTER REMOVAL OF THE SPLEEN (SOUDAKEWITCH).

**Spirillum Obermeieri** (*Spirochaeta Obermeieri*, Cohn).—Threads similar to the *Spirillum plicatile*. In length they are mostly 16 to 40  $\mu$ , with regular screw-curves. They move very rapidly, and exhibit peculiar wave-like undulations. They are absent from the blood during the non-febrile intervals, but are found in the interior of leucocytes in the spleen. In blood serum and 50 per cent. salt solution, they preserve their movements. In cover-glass preparations they are readily stained by any of the aniline dyes, and in sections, by preference, with Bismarck brown. They are not



found in the urine, sweat, or saliva. They have not been cultivated artificially on any nutrient media. Monkeys have been successfully inoculated with blood containing the spirilla by Koch, Carter and Soudakewitch; and Koch found the spirilla in the vessels of the brain, liver, and kidneys, after death. According to Soudakewitch a fatal result is produced in monkeys if the spleen is removed, and the spirilla are found in great numbers in the blood; but if the spleen is not excised the spirilla rapidly disappear, and recovery follows. Münch and Motschutkowsky transferred blood containing the spirilla to healthy persons, and produced typical relapsing fever.

#### TYPHUS FEVER.

Typhus fever is a highly contagious disease, which lasts for two or three weeks, and produces a measly eruption. Like the plague, it is intimately associated with overcrowding and filth, and is liable to occur where these conditions exist in cities, in armies, and in prisons. The virus produces profound changes in the blood, and after death the internal organs are found to be congested, especially the lungs, which are very friable. The spleen is softened and often enlarged, and the blood is dark and imperfectly coagulated.

The virus is dissipated by fresh air. It is given off by the breath of patients, and possibly from the skin. It clings to the clothes of patients, and the disease may be conveyed by their agency. One attack, as a rule, confers immunity. Some persons are naturally insusceptible, failing to contract the disease though daily exposed to it. Hlava has described a bacterium which he believes to be the specific micro-organism. Thoinot and Calmette found the same bacterium with others, but there was no particular micro-organism constantly present. There can be little doubt that the nature of the contagium is unknown.

**Stamping-out System.**—Sanitary precautions, and especially the operation of the Public Health Acts in relation to lodging-houses, prisons, and the better housing of the working classes, have been instrumental in almost completely stamping out the disease in this country.

#### YELLOW FEVER.

Yellow fever is a disease of tropical climates, characterised by abdominal tenderness, hæmorrhagic vomiting (black-vomit), and jaundice. The disease may end fatally, or recovery occur in about two or three weeks. It is especially prevalent in the West Indies and in parts of North and South America.

The virus may be conveyed by infected ships, and has in this way made its appearance at British and French seaport towns. The disease is generally believed to be contagious, but the source of the virus is not known. According to Sternberg the virus is not conveyed by water, but spreads where there is overcrowding and filth.

**Bacteria in Yellow Fever.**—Freire asserts that there is a specific micrococcus in yellow fever which can be grown on all ordinary nutrient media, and that cultures can be used for protective inoculation with satisfactory results. Carmonay Valle also claims to have discovered the contagium; but Sternberg, who has carried on investigations extending over several years, maintains that there is no characteristic micro-organism present in the blood or in the tissues after death. Aerobic and anaerobic cultures were made from the blood, liver, kidney, urine, stomach, and intestines. The liver was found to contain after death a number of bacilli, most frequently *Bacillus coli communis* and *Bacillus cadaveris*. Blood or fresh liver does not produce any disease in rabbits or guinea-pigs, but liver tissue kept for forty-eight hours and inoculated subcutaneously in guinea-pigs is extremely pathogenic. Similar results occur after inoculation of healthy liver which has been kept in the same way. We may conclude from these experiments that the nature of the contagium is unknown.

**Stamping-out System.**—Sternberg states that there are many facts relating to the origin and extension of yellow fever epidemics which support the theory that the virus is present in the evacuations, and that accumulations of faecal matter and of organic material of animal origin furnish in certain climates a suitable soil for the development of the contagium. According to this view the evacuations should be thoroughly disinfected, and with other sanitary precautions and efficient quarantine at seaports, the disease may be stamped out, and the danger of importation from the natural home of the disease reduced to a minimum.



## CHAPTER XIX.

### SCARLET FEVER.—MEASLES.

#### SCARLET FEVER.

SCARLET FEVER is a highly contagious disease peculiar to man. It produces inflammation of the tonsils and adjoining parts, fever, and a general punctiform eruption. The period of incubation is about a week, and the rash usually appears on the second day. In some cases the disease manifests itself in an extremely mild form, known as *latent scarlet fever*, in which there is only a slight febrile attack, or a mild sore throat, with very little or no rash. Many cases would not be recognisable as such if they were not capable of conveying scarlet fever, or unless other cases followed or occurred simultaneously which were undoubtedly typical cases of the disease. The occurrence of such cases in the early history of an epidemic often causes the greatest difficulty in tracing the origin of the outbreak, and indeed in some cases renders it quite impossible to do so.

The virus is given off by the skin, in desquamation, and possibly by the urine. It maintains its vitality in clothing for months, and sometimes longer. It may also be conveyed by the hands of the physician to women during parturition. The disease may be transferred by subcutaneously inoculating persons, who have not previously contracted scarlet fever, with virus obtained by puncturing the eruption on the skin.

After death the internal organs appear to the naked eye more or less healthy. The liver is soft, the kidneys are congested, the ileum is inflamed, and Peyer's patches enlarged and congested; but these conditions are also produced by other causes. There are inflammatory changes in the lymphatic follicles of the tonsils, and the larynx and trachea. Other morbid lesions, especially in the kidneys, are associated with the sequelæ and complications, and though commonly occurring in scarlet fever are also found in other diseases.

These changes appear to be due to the poison which is in the blood, and is excreted by the kidneys. The epithelium is in a state of cloudy swelling, a condition found in other febrile diseases and in septic poisoning.

**Bacteria in Scarlet Fever.**—The occurrence of micro-organisms in cases of scarlet fever has been observed by several investigators—Coze and Feltz, Crooke, Löffler, Babès, Heubner and Bahrtdt, and notably by Fränkel and Freudenberg, and more recently by Klein, the author, Raskin, and others.

Coze and Feltz found cocci in the blood, and Crooke, in cases of scarlet fever with severely affected throat, found bacilli, cocci, and streptococci in the organs of the throat, and cocci in the internal organs. Crooke left it an open question whether these cocci were the specific organisms of scarlet fever, or were to be regarded as diphtheritic or septic associates. He inclined, for clinical reasons, to the latter view.

Löffler, in cases of scarlatinal diphtheria, found the same chain-forming micrococcus which he had found in typical diphtheria.

Babès was able constantly to prove the presence of a streptococcus in inflammatory products secondary to scarlatina.

Heubner and Bahrtdt, in a fatal case of scarlet fever in a boy, complicated with suppuration of the finger and knee-joints, and with pericarditis, found a streptococcus identical in form with *Streptococcus pyogenes*, but cultivations were not made. The secondary infection started from diphtheritically affected tonsils, which were followed by retro-pharyngeal abscesses.

Fränkel and Freudenberg examined, for micro-organisms, three cases of scarlatina with well-marked affection of the throat. In all three cases they obtained cultivations of cocci from the submaxillary lymphatic glands, spleen, liver, and kidney. These cocci could not be distinguished from *Streptococcus pyogenes* derived from pus, nor from the undoubtedly identical streptococcus which one of them (A. Fränkel) had repeatedly cultivated in large numbers from puerperal affections. In two of the cases *Streptococcus pyogenes* was the only organism present, and in all three cases it was far in excess of other colonies which developed. The organisms were also found in sections of the organs by microscopical examination. Fränkel and Freudenberg could in no way distinguish the streptococcus in scarlatina from the streptococcus in pyæmia and septicæmia. The identity of this streptococcus with *Streptococcus pyogenes* and *Streptococcus puerperalis* was established by comparison of their macroscopical and microscopical appearances in cultivations on



nutrient agar-agar, nutrient gelatine, and in broth, both at the ordinary and at higher temperatures, and also by experiments on animals. They concluded that it could be stated with certainty that the organisms in question did not stand in causal relation to scarlet fever. They considered that special methods of microscopical and biological research were apparently needed for demonstrating the true scarlet fever contagium, which probably was especially present in the skin. They considered that the presence of the

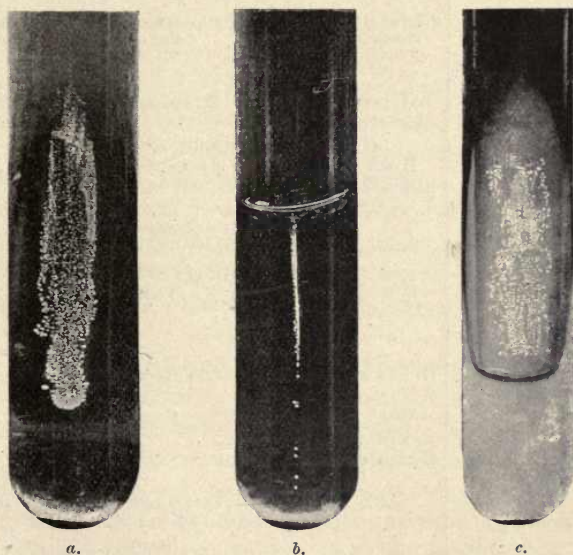

FIG. 125.—PURE-CULTIVATIONS OF STREPTOCOCCUS PYOGENES.

(a) On the surface of nutrient gelatine; (b) In the depth of nutrient gelatine;  
(c) On the surface of nutrient agar.

streptococcus was due to a secondary infection, to which the door was opened by the lesions of the throat—a view which was supported by the fact that the organisms were found in submaxillary lymphatic glands. They preferred to use the term “secondary” to “complicated” or “combined” infection, because this expresses the fact that by the effect of the scarlatinal virus the soil is rendered suitable for this ubiquitous microbe when it has once gained an entrance.

This streptococcus was found by Klein in five out of eleven cases

of scarlet fever in man, twice in association with certain other micro-organisms, and three times alone. The micro-organisms were isolated by inoculating tubes of nutrient gelatine, solidified obliquely, by streaking the surface with blood taken from the finger, the arm, or the heart after death. Those cases from which the organism was obtained were all cases with ulcerated throat, and the culture experiments, from the living patient, were made on or about the day at which the temperature was at its maximum.

	Name of Patient.	Condition of Tonsils.	Source of Blood.	Micro-Organisms Isolated.	Death or Recovery.
1	L— F—, aged 5	Severely ulcerated	Finger	Streptococcus	Ultimately recovered.
2	K— F—, aged 2	Much ulcerated	"	{ Staphylococcus pyogenes aureus Liquefying micro-coccus Streptococcus	} Died of pyæmia.
3	H— L—, aged 8	Ulcerated	"		
4	— (a woman), aged 40	Much ulcerated	Arm	None	[Not stated.]
5	— (a girl), aged 19	"	"	"	"
6	B— M—, aged 15	Ulcerated	Finger	Streptococcus	Recovered.
7	E— W—, aged 22	Much ulcerated	"	None	[Not stated.]
8	R— H—, aged 8	Ulcerated	"	"	"
9	F— G—, aged 2½	"	Heart	Streptococcus	Died.
10	E— F—, aged 3	—	"	None	"
11	R— B—, aged 20 months	Advanced ulceration	"	"	"

Klein regards this streptococcus as the actual cause of scarlet fever in man.

The author, Raskin, Holmes, and others who have investigated this subject agree with the conclusions of Fränkel and Freudenberg. The author is convinced that the streptococci in suppuration, puerperal septicæmia, pyæmia, and septicæmia, and in certain cases of measles, scarlatina, and diphtheria, are identical; and from overwhelming evidence we are justified in concluding that—(1) The nature of the contagium of scarlet fever is unknown. (2) The streptococcus regarded by Klein as the contagium is the *Streptococcus pyogenes*.



(3) This streptococcus is found, sometimes in company with *Staphylococcus pyogenes aureus*, as a secondary result in scarlet fever and many other diseases, and its exact relation to scarlet fever and its identity with the streptococcus from pus and puerperal fever, were definitely established in 1885 by Fränkel and Freudenberg.

#### MILK-SCARLATINA.

It would not be necessary to say anything further on the etiology of scarlet fever if the generally accepted belief, that scarlet fever is a disease peculiar to man, were accepted by the Medical Department of the Local Government Board; but the theory is officially held that scarlet fever is in its origin a disease of cows. Bovine scarlatina is supposed to be an eruptive disease of the teats, and it is maintained that the virus, by contaminating the milk, produces scarlet fever in the human subject. As this theory is very naturally accepted by many medical officers of health, and is mentioned in English medical text-books, it will be necessary to discuss this question in considerable detail, and especially as these opinions were promulgated in this country with official support, and have since been proved to be erroneous.

The theory of the origin of the exanthemata in diseases of the lower animals is a very old one. The Arabians imagined that small-pox arose from the camel. Jenner adopted a similar theory, and expressed his belief that small-pox originated in the horse, being generated by horses suffering with "greasy" hocks. Thus Jenner wrote: "May not accidental circumstances have again and again arisen, still working new changes upon it, until it has acquired the contagious and malignant form under which we now commonly see it, making its devastations among us? and from a consideration of the change which the infectious matter undergoes from producing a disease in the cow, may we not conceive that many contagious diseases now prevalent amongst us may owe their present appearance, not to a simple, but a compound origin? For example, is it difficult to imagine that measles, scarlet fever, ulcerated sore throats, and spotted skin, all spring from the same source, assuming some variety in their forms according to the nature of their new combinations?" Baron informs us that this idea was prevalent in Jenner's mind as early as 1787. It is related that in that year he accompanied his nephew, George Jenner, into a stable to look at a horse with diseased heels, and, pointing to them, he remarked: "There is the source of small-pox. I have much to say

on that subject which I hope in due time to give to the world." And again in 1794, when writing in connection with this subject, he adds: "Domestication of animals has certainly provided a prolific source of diseases among man."

Jenner's views were found to be incorrect, and it was shown by Loy and others that the grease bears no relation to cow-pox, and it is now known that Jenner mistook horse-pox for the disease known as the grease. No one at the present day supports Jenner's theory of small-pox in man arising from any disease of the horse. Indeed, the origin of small-pox from a disease of the horse was not upheld even by Jenner's pupil and nephew, Henry Jenner. The latter promulgated the idea that small-pox originated from the cow. He believed that small-pox, in fact, was cow-pox intensified in its virulence by being passed through man. He thus expressed himself: "Nor may it, perhaps, be too hypothetical to suppose that the cow-pox may possibly be the small-pox in its original unadulterated state, before it became contaminated by passing through the impure and scrofulous habits of human constitutions." The theory of the origin, in animals, of human febrile diseases was, later, advocated by Copland, who stated, firstly, that scarlet fever in man was originally a disease of the horse, and that it formerly occurred, and had recently occurred, epidemically as an epizootic among horses; secondly, that it was communicated in comparatively modern times from horses to man; thirdly, that it might be, and had been, communicated to the dog. But this opinion has not been accepted, for the disease called scarlatina in the horse is a non-infectious disease, generally attacking but one or two horses in a large stud. It neither spreads by contagion nor infection; and Williams states that it is impossible to transmit it from the horse to any other animal, and that many cases of the so-called scarlatina of the horse are in reality identical with purpura.

The theory was again revived, but in another form, and has been adopted by the Medical Department of the Local Government Board. Owing to failure in tracing, in some cases of milk scarlatina, the contamination of the milk from a human source, the theory was started that in such cases the disease is derived from the cow—that, in other words, there is a disease, scarlet fever in the cow, which is responsible for outbreaks of scarlet fever in man.

In 1882 an epidemic of scarlatina in St. Giles and St. Pancras was investigated by Mr. W. H. Power for the Board. The disease was distributed with a milk supply from a Surrey farm. In this case



two facts were ascertained : the one, that a cow recently come into milk had been suffering from some ailment from the time of her parturition, of which loss of hair in patches was the most conspicuous manifestation ; the other, that there existed no discoverable means by which the milk could have received infective quality from the human subject.

In 1885 an outbreak of scarlet fever occurred in Marylebone in connection with milk from a farm at Hendon, and again Power failed to establish infection from any human source in any commonly accepted way—such, for example, as handling of milk, or milk utensils, by persons carrying scarlatina infection. But on examining the cows with a view to ascertain any new condition pertaining to them, it came to light during the inquiry that some of them, which had recently been introduced from Derbyshire, were suffering from a vesicular disease of the teats.

At this stage Klein became associated with Power in the inquiry ; and their belief in the existence of a disease among the cows on the farm capable of producing scarlatina among human consumers of the cow's milk, became unreserved. Klein took away with him samples of milk, contents of vesicles, and discharges from ulcers, and afterwards two of the cows were purchased and kept under observation.

Dr. Cameron of Hendon has given a detailed description of the clinical history of this disease. He expressed his belief that it was a specific disease capable of being communicated to healthy cows by direct inoculation of the teats with virus conveyed by the milker from a diseased animal.

The condition of the teats is described as follows : The teats became enlarged, swollen to nearly twice their natural size, and œdematous. On handling them there was no feeling of induration. Vesicles appeared on the swollen teats and upon the udder between or near the teats. These varied in number from two to four on a teat, and in size from a pea to a horsebean. The vesicle contained a clear fluid. The vesicles were rubbed and broken in milking, and left raw sores, sometimes red, in other cases pale in colour, with raised, ulcerated edges. Sometimes a few accessory vesicles formed around the margin of these ulcerated sores. After the rupture of the vesicle a brown scab formed, which might remain attached for five or six weeks, or fall off in ten days or a fortnight, a smaller one forming afterwards. A thin, watery fluid exuded from under the scab, and the sore ultimately healed.

Cameron examined the teats of several cows five or six weeks

after they were attacked. The scabs then varied in size from a shilling to a florin; they were about one-eighth of an inch thick in the centre, thinning off towards the edges.

Some of the cows were also suffering from an eruption on the rump and hind quarter, consisting of patches of eczematous crusts. When a crust was picked off, the hair came off with it, exposing a raw, moist sore, the crusts and sores looking exactly like eczematous scabs and sores; but this condition corresponds in description with eczema, the result of ringworm which is very common in young stock.

In addition to his own observations, Cameron obtained information from the farmers, and others familiar with cows, who thought they recognised in the disease at the farm one stage of a disease which they were able to describe. Cameron thus gives an account of what he and his informants together would regard as a connected clinical history of the disease.

He did not see the earlier symptoms, and hence these were of necessity learnt from other persons. The account, therefore, of these symptoms was to be held liable to future correction or modification.

Cameron stated that he learnt this disease was capable of being communicated to milkers by inoculation with virus from the vesicles on the teats, though the milkers on the Hendon farm escaped. "A trusty informant received the virus into a recent scratch on the forefinger while milking a diseased cow. General weakness, malaise, and loss of appetite resulted, and after about four or five days a vesicle or small blister appeared on the finger. This broke, and several others formed on the back of the hand. The whole hand and fingers became swollen and inflamed, the inflammation extending in broad lines as far as the elbow. The general disturbance lasted a fortnight."

In the course of the inquiry, Cameron adds that it was strongly asserted by several people, who examined the cows, that they were suffering from cow-pox. He, however, dismissed the diagnosis of cow-pox on the ground that no papule had been observed or subsequent formation of pustule, areola, or pitting, and because the vesicles were not umbilicated. These reasons given for dismissing the diagnosis of cow-pox at Hendon were totally inadequate; a comparison having been made between the characters of the eruption of vaccinia as it appears on an infant's arm, instead of the eruption of the natural or so-called spontaneous disease on the teats of the cow.



Klein stated that on the teats and udders of two cows which he investigated there were several flat irregular ulcers, varying in diameter from one-quarter to three-quarters of an inch. Some ulcers were more or less circular, others extended in a longitudinal direction on the teat. The ulcers were covered with a brownish or reddish-brown scab. The animals looked thin, but not strikingly so. In feeding capacity, milking power, and body temperature there was nothing abnormal.

Four calves were inoculated in the corium of the groin and the inside of the ear, with scrapings from the ulcers after removal of the crusts. In one, which may be taken as an example of the result obtained, there was vesiculation at the margin of the spot inoculated, and in the centre the commencement of the formation of a crust. On the seventh day each sore on the ear had enlarged to about half an inch in breadth, and was covered in its whole extent by a brownish crust. On the eighteenth day they had all healed up and become converted into flat scars.

To search for micro-organisms, Klein removed the crust from an ulcer on the teat, scraped off the most superficial layer, squeezed the ulcer, and made cover-glass preparations. Tubes of nutrient gelatine and nutrient agar-agar were also inoculated, and a streptococcus was isolated which in morphological and cultural characters agreed with those of *Streptococcus pyogenes*.

Two calves were inoculated in the groin with the cultivated micro-organism. One calf died in twenty-seven days. At the necropsy there were found peritonitis, and hæmorrhagic spots on the omentum; the liver, kidneys, and lungs were congested, and there were petechiæ under the pleura, and pericarditis. The second calf was killed, and at the necropsy the lungs and kidneys were congested, and there were hæmorrhagic patches on the spleen.

In these cases, the post-mortem appearances and anatomical features recalled to Klein the lesions of scarlatina. In the kidney, for example, the cortex was congested, and there were hæmorrhages, glomerulo-nephritis, and granular or opaque swelling of the epithelial cells and infiltration with round cells. From the blood of the heart the streptococcus, which had been used in the inoculation, was recovered. In view of this evidence it was concluded that the streptococcus was the virus of the cow disease, and that it produced in calves a disease very closely resembling that of scarlatina in man.

Two of the cows selected from the Hendon farm were killed, and it was observed in one that the lungs were congested, and

that there were numerous adhesions by recent soft lymph between the lower lobes of the lung and the costal pleura. In the liver there were several reddish streaks and patches. The spleen and kidneys, with the exception of slight congestion, appeared normal.

Sections of the kidney showed well-marked glomerulo-nephritis and infiltration of the sheath of the cortical arterioles with numerous round cells. The epithelium of the convoluted tubules was swollen, opaque, and in many places disintegrating.

In the other cow there was great congestion of the lungs and pleural adhesions; the cortex of the kidney was congested, but its medulla was pale.

On microscopic examination there was a good deal of round-celled infiltration in the walls of the infundibula and bronchi in the lung, and round the arterioles in the kidney.

In sections of the ulcers on the teats, the corium was found to be infiltrated throughout the whole extent of the ulcer with round cells. In the superficial layers of the stratum Malpighi, close to the stratum lucidum, as also in the stratum lucidum itself, there were numerous cavities of different sizes. These cavities lay side by side, the most superficial ones being covered by the stratum lucidum, or extending between the layers of this stratum.

At the marginal parts the cavities, although placed side by side, were well separated from one another by thicker or thinner trabeculae, composed of epithelium, while at or near the centre of the ulcer these trabeculae were destroyed, the cavities had become confluent, and the covering layers of the cuticle having here also given way, their contents extended on to the free surface of the ulcer. In short, Klein states that all the anatomical details of the distribution and arrangement of these cavities recalled vividly the conditions observed in the vesicles of cow-pox. Yet as a result of this investigation he concluded that the cow disease at Hendon was bovine scarlatina, and that towards its study and supervision every effort ought to be directed in order to check the spread of scarlet fever in man.

As a result of this conclusion, the Board of Agriculture resolved to have the whole subject fully investigated, and the author was directed to study the bacteriology and micro-pathology of this disease and to report thereon. Professor Axe investigated the origin of the outbreak of the disease in the cows, and Professor M'Fadyean carried out an investigation into the possibility of inoculating cows with the virus from cases of scarlet fever in man.



## THE AUTHOR'S INVESTIGATION.

An outbreak of an eruptive disease of the teats, alleged to be identical with the so-called Hendon cow disease, was raging in some farms in Wiltshire. In this case every facility was given by the owner of the estate for a thorough investigation into the disease. Not only were animals sent from the farm to London, but the author was allowed to visit the farms, to inspect all the infected animals, and to make every investigation, with the hearty co-operation of the bailiff of the farms, and the voluntary assistance of the head cowmen and those under them. Some of these cowmen were unusually intelligent, while two had had experience of cows for more than half a century. Thus, there was not only every opportunity for studying the disease on the lines indicated by Klein, but it was possible by repeated visits to the farms to enter into the clinical history of the disease in the cow, to study very fully the nature of the disease on the hands of the milkers, and to trace the probable mode of its introduction on the estate, and the way in which it spread from one part of the herd to another.

Two cows were sent to London with disease of the teats and of the udder between the teats. On the right teats of one there were numerous sores, covered with crusts varying in size and in thickness, and generally fissured. In some they were flat, in others conical; some were with difficulty removed with forceps, others were readily detached. The crusts varied in colour from reddish-brown to very dark brown or almost black. On detaching or scraping a crust there was a granulating and somewhat indurated base. On the right anterior teat there were several ulcers, from which apparently the thick crusts had been detached, and new scabs were forming. On the left posterior teat there were unusually large, dark brown, or blackish crusts, covering a very extensive area of ulceration, extending over the whole of the lower third of the teat.

In the other cow from Wiltshire there was the same disease on the teats, but not in such a severe form. The sores were covered with thick crusts, but though varying in size they were more regular in form, and more circumscribed.

Having entirely removed the crusts from some of the ulcers, a number of inoculations in nutrient gelatine and nutrient agar-agar were made from the discharge, and cover-glass preparations were made and stained in the ordinary way. Cultures were obtained of the organisms commonly found in pus.

With the discharge and with scrapings from the ulcers two calves were inoculated.

Of the two calves, one was inoculated by scarification in both ears; the other, a small calf, was scarified in the left ear. Scrapings from the ulcers were rubbed into the places thus prepared. In addition, in the small calf an incision was made through the corium in the left groin, scrapings from different ulcers on the teats were well rubbed in with the blade of the scalpel, and a portion of crust inserted into a small pocket in the subcutaneous tissue. In the ears and the groin there were positive results. In the large brown calf one of two places inoculated in the right ear passed through the following changes: On the third day there was apparent vesiculation and commencing formation of crust. From day to day the crust thickened, and on the eighth day the crust was at its height and detached at its edges. By removing the scab an ulcer was exposed; there was slight inflammatory thickening. About the thirteenth day the ulcer had quite healed.

Very similar appearances resulted in the ear of the smaller calf. The result of inoculation in the groin was of a very much severer character. In the course of two or three days the incision had apparently commenced to heal by scabbing, but there was a surrounding area which was inflamed, and painful on manipulation. The inflammatory thickening which resulted continued to increase around the seat of inoculation, and the thickening could be felt to extend deeply into the groin. Suppuration followed, and on firm pressure pus welled up through the wound. The wound then showed very little disposition to heal, and the calf began to exhibit marked constitutional symptoms. During the second week after inoculation the animal became very dull, and was reported by the attendant as refusing to feed. Diarrhœa supervened, and lasted for several days, and bloody urine was passed. The calf was also noticed to cough, and the cough gradually increased in severity. Thirty-six days after the date of inoculation it was decided to kill the calf and examine the condition of the viscera. The appearances which were found at the post-mortem examination were as follows:—

The upper and middle lobes of each lung were adherent to the walls of the chest; there was congestion, especially of the middle lobe, and patches of recent adherent lymph. Posterior parts of the upper lobes of both lungs were completely consolidated, and on section varied in colour from brick-red to greyish-white. The interlobular tissue was infiltrated with inflammatory products, which mapped out the tissue of the lung in small indurated areas, in which the tissue was granular-looking and friable.



These appearances in the upper lobes were due to septic pleuro-pneumonia. They closely resembled, and were supposed to be due to, infectious pleuro-pneumonia. They were, however, found identical with the condition observed in septic pleuro-pneumonia in calves, and the disease was not conveyed by infection to other animals in the same stall. Scattered through the other lobes of both lungs were white, mostly firm, nodules raised above the level of the surface of the lung. They were surrounded by a zone of congestion, and in some cases sections were composed of indurated, in others of friable, lung tissue. In the posterior part of the right upper lobe there was a recent infarct. The bronchial glands at the roots of each lung were enlarged to two or three times their natural size, and were firm and hard on section. The parietal surface of the pericardium was covered with recent adherent lymph. The visceral surface of the pericardium was normal. Along the external surface of the aorta were chains of enlarged lymphatic glands connected by dilated lymphatic vessels. These glands were dark red or purplish in colour, from hæmorrhage into their substance. The heart was normal, and the endocardium not stained. There were chains of red glands on the œsophagus similar to those along the aorta. The appearance of the mesenteric glands was very striking. The mesentery, along the lymphatic vessels, was dotted with glands, varying in size from a large shot to a pea, which were deep red or prune-coloured. In addition, there were here and there enlarged glands without hæmorrhage into their substance, and greyish in colour. There were scattered petechiæ on the spleen. The kidneys were firm on section, and there was marked congestion in both, while it was more pronounced in one kidney than the other. The liver was congested, the congestion being more marked in patches.

Sections from the consolidated upper lobes showed under the microscope thickening of the pleura and infiltration with round cells. The exudation filled the alveoli, and was breaking down in some cases in the centre. The vessels were injected, and there were hæmorrhages into the alveoli. The periphery of the lobules was infiltrated with round cells. In sections of the kidney there was slight infiltration around glomeruli and arterioles with round cells; the epithelium in the convoluted tubules was granular and disintegrating; there was hæmorrhage in the straight tubules, and engorgement of vessels. In sections of liver the inter- and intra-lobular vessels were engorged; there were interlobular collections of round cells displacing the liver cells, and the interlobular connective tissue was infiltrated with round cells; the liver cells were granular and cloudy.

There can be no doubt from the symptoms and post-mortem appearances that this calf had been suffering from septicæmia as the result of introducing the septic virus and crust subcutaneously in the groin.

The two Wiltshire cows were killed, and there was nothing of importance to note in one, but in the other an incision into the udder revealed an enormous abscess.

Though the naked-eye appearances of the kidney in this case were practically healthy, the results of examining sections of the kidney under the microscope were extremely instructive and interesting, as they showed that marked changes had taken place which were indicative of septic complication.

The sections showed glomerulo-nephritis; there was infiltration of the capsule of Bowman with round cells; there was infiltration also of the sheaths of the vessels with round cells, especially in the cortex. The blood-vessels in the boundary zone of the medulla were engorged, the arterioles of the glomeruli were also engorged, and there were slight hæmorrhages into the capsule. The epithelium of the convoluted tubules was granular, opaque, and in some parts breaking down.

Sections of the ulcers of the teats of these cows were also carefully examined, and the appearances corresponded exactly with the description given by Klein.

On visiting the farms it was found that there were altogether about a hundred and sixty cows. Only a few had proved refractory, and had not taken the disease at all. The rest had contracted the disease in varying degrees of severity. About fifty at a time were dry, and they escaped until they were in milk again. The milk was drunk on the farms and in the village, and a quantity was supplied to a large town. Most careful inquiries were instituted to ascertain the existence of scarlatina among consumers of the milk. So far the research was completely analogous to the Hendon investigation; but, in spite of the contamination of the milk, no cases of scarlatina were found either on the farms or in the village, and there was no epidemic in the town in which the milk was distributed.

The disease, in fact, was cow-pox, and in no way connected with scarlet fever; and to assist others who may undertake a similar inquiry the details will now be given of the author's investigation into the nature of the outbreak in Wiltshire.

#### THE DISEASE PROVED TO BE COW-POX.

*Locality of the Wiltshire Outbreak.*—There is considerable interest attached to the fact that the farms were situated a few miles from Cricklade. They are close to the borders of Gloucestershire, and about twenty-five miles from Berkeley. They are, therefore, within that district in which in Jenner's time cow-pox was particularly prevalent.

*Time of Year.*—The outbreak commenced about the end of September 1886, and lasted until about the middle of December. In an outbreak



in 1885, a few miles from these farms, but on a separate estate, the disease appeared in June and July.

*Origin of the Outbreak.*—The author made careful inquiries as to the origin of the outbreak, but beyond ascertaining with certainty that the disease appeared first at one farm, and was conveyed from this to the other farms, all evidence was negative. The milkers were unable to say whether it commenced in one particular cow or whether it broke out in several simultaneously.

The only information which could be obtained, which was very suggestive, was that the milkers were in the habit of receiving their friends from neighbouring farms on Sundays. The friends would assist in the milking, to get the work done as quickly as possible on these occasions. As it was reported that the same disease had occurred that summer on a neighbouring farm, it is quite possible that it was introduced by one of the milkers' friends.

*Mode of Dissemination.*—When the disease made its first appearance, the bailiff, attributing it to the farm being, for some reason, unhealthy, decided to remove the cows to other farms. The herd was therefore divided and sent to two other farms. From these cows the disease was communicated to healthy cows, and, as this interchange was repeated, not only of the cows, but of the milkers, the disease was communicated to four separate farms.

In all cases the disease was limited to the teats, and was conveyed from the teats of a diseased cow to the teats of a healthy cow by the hand of the milker. In no case was there any evidence of the disease being produced in healthy cows by other means than contact.

Bulls and dry cows remained free from the disease, while the cows in milk, numbering about a hundred and twenty, were all attacked, with the exception of about a dozen, which proved to be entirely refractory.

These facts explain how it is that the disease has been known from time immemorial as the "*cow-pox*." We never hear of *cattle-pox* or *bull-pox*. We have not, in other words, to deal with an infectious disease like *cattle-plague* or *pleuro-pneumonia*, but with a disease which is communicated solely by contact.

The disease was only observed in the cows in milk, and was limited to the parts which come in contact with the hand of the milker. The virus was mechanically transferred from diseased to healthy cows, being communicated to all, or nearly all, the animals in the same shed, whether the milker had vesicles on his hand or not.

*Character of the Eruption on the Cow.*—In a recent case which was carefully examined the teats were visibly inflamed, partly red and partly livid in colour. On each teat there were vesicles, some broken, and others which appeared to be just forming. In other cases there was nothing more than the remains of broken and dried vesicles, and more or less characteristic crusts on the teats.

On visiting a byre at the time that the cows were brought in to be milked, it was a striking sight to look along the line and see one animal after another affected with the eruption; and thus one character

of the disease was clearly shown—the tendency to spread through a whole herd.

On examining the eruption carefully, the degree of severity was found to differ very much in different animals. In a few cases the condition was most distressing, both to the cow and to the observer. In such cases the teats were encrusted with huge, dark brown or black crusts, which, when handled in milking, were broken and detached, exposing a bleeding, suppurating, ulcerated base. Such ulcers varied in size from a shilling to a florin, and in form were circular, ovoid, or irregular. Weeks afterwards, when the animals had recovered, the site of these ulcers was marked by irregular scars.

All the milkers agreed as to the general characters of the malady, laying particular stress on the teats being red, swollen, and painful when handled. Vesicles would then appear on the teats—two, three, four, or more on each teat. They were soon broken in milking, and irritated into sores, which became covered with thick crusts. From four to six weeks elapsed before they had entirely healed. Other more observant milkers insisted that before the teats were red and swollen, spots or pimples first appeared which came to a head. This head increased if it was not broken, which might be the case if it was situated between the bases of the teats, until it formed a greyish vesicle of the size of a threepenny-piece or even larger.

*General Symptoms in the Cow.*—As to the general condition of the cows nothing abnormal was observed. They appeared in the best of health, and in only one particular was any difference from their condition in health stated to exist. This was, that in the majority of the cases there could be no doubt that the milk had diminished. This might escape notice by inexperienced milkers in any particular animal, but the total amount of milk supplied by the herd was considerably below the average.

*History of the Eruption communicated to the Milkers.*—The most striking characteristic of this outbreak was the communicability of the disease to the milkers. A milker, with vesicles which presented typically the characters of casual cow-pox, was taken to London and kept under observation. The various cases will be described in the order in which they first presented themselves, their history being given as much as possible in their own words.

CASE I.—J. R., milker, informed the author that he was the first to catch the eruption from the cows. He stated that it came as a hard, painful spot, which formed "matter" and then a "big scab." He had been inoculated about seven weeks previously. He pointed to the scar which remained on his right hand. This scar presented the characters of an irregular cicatrix, indicating considerable loss of substance. He stated that he had also two places on his back, where he supposes he had inoculated himself by scratching. He had continued milking ever since, but had had no fresh places.

CASE II.—W. H., milker. He stated that he was inoculated from the cows about the same time as J. R. They were the two milkers of the herd in which the cow-pox first made its appearance. The eruption



appeared in one place on each hand. He pointed to two irregular scars as the remains of the eruption.

CASE III.—J. L., milker, stated that he also caught the disease from the cows. On his right hand a spot appeared which formed a blister, then discharged matter and produced a bad sore. Lumps formed at the bend of his elbow and in his armpit. He lost his appetite, felt very poorly, and was obliged to leave off work for two or three days.

CASE IV.—W. K., a labourer on the farm, was put on as a milker to take the place of one of the others with bad hands. After his fifth or sixth milking—that is to say, about three days after first milking the cows,—pimples appeared on his hands, which became blistered and then ran on to bad sores. He pointed to three irregular scars on the first and third fingers and palm of the right hand. Lumps appeared in his elbow and in his armpit, but he did not feel very poorly in consequence.

CASE V.—J. F., milker, stated that about a month ago he noticed spots which appeared on both hands. His fingers swelled and were painful. He said it came first like a pimple, and felt hard. Then it “weeped out” water in four or five days. There were red marks creeping up to his arm. There was a sort of throbbing pain, and he could not sleep at night. On the right hand there was a scar, but on the left hand there was an ulcer about the size of a shilling covered with a thick black crust. The crust was partially detached, and exposed a granulating ulcer. It was in this stage the exact counterpart of the ulcers on the cow’s teats.

CASE VI.—W. H., junior, milker, stated that he had both hands bad about a month previously: first on the index finger of the left hand, and then on the right hand on his knuckle and between the first and second fingers. He said that it came up like a hard pimple, and the finger became swollen and red. After a few days it “weeped out” water, and then matter came away. Both his arms were swollen, but his left arm was the worst. About a fortnight after, he noticed kernels in his armpits, which were painful and kept him awake at night. His arms became worse, he could not raise them, and he had to give up milking. He also had had a “bad place” on the lower lip. On examination, I found that the axillary glands were still enlarged and tender. He volunteered the statement that the places were just like the sore teats.

CASE VII.—J. H., the bailiff’s son, also milked the cows. He had a sore on the upper lid of his right eye and on his left hand. In both cases he had been previously scratched by a cat, and the scratches were inoculated from the cow’s teats. The right hand also had been inoculated. The eruption broke out a fortnight previously. His hands were swollen, red, and hot. He felt very poorly and went to bed. Little spots like white blisters appeared on the back of his right hand. His mother remarked that they “rose up exactly as in vaccination.” Thick dark brown scabs formed. He was very ill for two or three days, but did not send for a doctor. He had painful lumps at the bend of his arm and in the armpit. He gave up milking, and had not taken to it since.

On examining him, the thick crusts on his right hand were identical



with the stage of scabbing in vaccinia. The scabs fell off in about three weeks to a month, and left permanent, depressed scars.

CASE VIII.—W. P., milker. This case was pointed out on the occasion of another visit, and is the only one in which the eruption was seen in its earlier stages.

The history of this boy is as follows. He had taken the place of one of the other milkers who had vesicles on his fingers, and had been obliged to give up milking. After the seventh time of milking he noticed a small pimple on his right cheek. This became larger and vesicular. On examination it presented a depressed vesicle with a small central yellowish crust and a tumid margin, the whole being surrounded by a well-marked areola and considerable surrounding induration. On raising the central incrustation a crater-like excavation was seen, in which lymph welled up and trickled down the boy's cheek. On the following day the crust had re-formed, and was studded with coagulated lymph. The areola became more marked, and on pricking the margin of the vesicle, the exuding contents were slightly turbid.

From this day the surrounding infiltration increased enormously, the whole cheek was inflamed, and the eyelids so œdematous that the eye was almost closed. There was enlargement of the neighbouring lymphatic glands. The crust which had re-formed thickened day by day. It retained the character of central depression, and was situated on a reddened, raised, and indurated base (Plate VII.).

From this date the surrounding induration gradually diminished. The crust changed in colour from dark brown to black, and finally fell off, leaving an irregular, depressed scar. This scar, when seen several months afterwards, was found to be a permanent disfigurement. The eruption appeared on the fourth day after exposure to infection, and allowing two days for incubation, the vesicle was at its height on the seventh or eighth day, and a typical tamarind-stone crust fell off on the twenty-first day after infection, leaving a depressed, irregular cicatrix.

A vesicle also formed on the thumb of the left hand. Two days after the pimple appeared on his cheek, the lad said that he first noticed a pimple on his thumb, and this, on examination, presented a greyish flattened vesicle, about the size of a sixpence. Later, its vesicular character was much more marked, and a little central crust had commenced to form. The margins became very tumid, giving it a marked appearance of central depression. The vesicle was punctured at its margin with a clean needle, and from the beads of lymph which exuded a number of capillary tubes were filled.

Two days afterwards suppuration had commenced, the vesicle contained a turbid fluid, and the areola was well marked. Later, the crust had assumed a peculiar slate-coloured hue, and, on pressing it, pus welled up through a central fissure. The areola had increased, and there was considerable inflammatory thickening. The lymphatic glands in the armpit were enlarged and painful. Though there was deep ulceration, which left a permanent scar, the ulceration did not assume





## DESCRIPTION OF PLATE VII.

### Casual Cow-pox.

FIG. 1.—Case of W. P——, a milker, infected from the teats of a cow with natural cow-pox. There was a large depressed vesicle with a small central crust and a tumid margin, the whole being surrounded by a well-marked areola and considerable surrounding induration.

FIG. 2.—The same case a week later, showing a reddish-brown crust on a reddened elevated and indurated base.



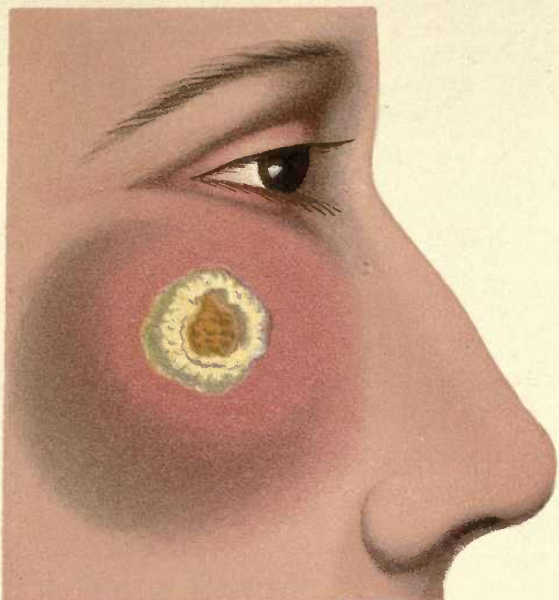

Fig 1.



Fig 2.

CASUAL COW-POX.





quite so severe a character as in some of the other milkers. Possibly this may be accounted for to some extent by the fact that the pock was covered with a simple dressing instead of being subjected to the irritation and injury incidental to working on the farm.

*Revaccination of the Milkers.*—There were in all eight milkers, varying in age from seventeen to fifty-five, who had vesicles on their hands from milking the cows. Seven had been vaccinated in infancy, but not since; one had been revaccinated on entering the navy at fifteen. They were all revaccinated by a public vaccinator after complete recovery from the casual cow-pox (that is to say, from three to four months afterwards), and were all completely protected. On the other hand, two of the three milkers who had escaped infection from the casual cow-pox were also vaccinated, with the result in one of typical revaccination, in the other of very considerable local irritation.

*Retro-vaccination of Calves.*—The result of retro-vaccinating calves with the humanised lymph was strictly in accordance with the experience of Ceely, who has pointed out that in retro-vaccination from the milker's hands the results are doubtful, and depend greatly on the animals selected. "Those of a light colour and with thin skins were generally preferred, but often without avail, scarcely one-half of the operations succeeding." "Vaccine lymph, in passing from the cow to man, undergoes a change which renders it less acceptable and less energetic on being returned to many individuals of the class producing it; some refuse it altogether." Two cases out of four succeeded, and an eruption was produced with all the typical characters of vaccinia, but running rather a rapid course, and the protection passing off after a few weeks, while the result obtained in calves inoculated with pus or scrapers from ulcers was in accordance with what is well known to occur if pus instead of lymph is taken for carrying on calf to calf vaccination.

That the cow-pox in Wiltshire was identical with the so-called Hendon cow-disease there can be little room for doubt, for in both cases we find that—

1. The disease spread through a whole herd of milch cows.
2. The disease was characterised by the appearance of vesicles, which were broken by the hand of the milker, and irritated into deep ulcerations.
3. The disease was conveyed from one cow to another by the hand of the milker.
4. The vesicular eruption was communicable to the hand of the milker.
5. The disease was not fatal, and in cows which were killed and examined the post-mortem appearances could not be distinguished from accidental complications.
6. The naked-eye appearances and the duration of the ulcers of the teats were the same.

7. Sections of the ulcers showed under the microscope identical appearances of a cellular character, and the purulent discharge of the ulcers contained pyogenic cocci.

8. The results produced by inoculation of calves with the septic virus were identical.

If we examine the chain of argument which has been brought forward to maintain the existence of cow-scarlatina at Hendon, we find that it was urged :—

1. That the Hendon cow disease was a disease in which the post-mortem appearances resembled scarlatina.

2. That this disease was associated with a streptococcus, which produced, by inoculation in calves, a disease with post-mortem appearances similar to those of the Hendon cows.

3. That a streptococcus regarded as identical with the one above mentioned was found in certain cases of scarlatina in man, which when inoculated in calves produced post-mortem appearances similar to the post-mortem appearances in the original Hendon cows and in certain cases of scarlatina in man.

But the microscopical appearances of the kidney of a Wiltshire cow were identical with those which were regarded as indicating scarlatina in a Hendon cow; and, indeed, the statements as to the post-mortem appearances in the Hendon cows, when studied, not only do not necessarily indicate scarlatina, but they cannot even be considered of primary importance, or as throwing much light on the question of scarlatina at all. The description of the naked-eye appearances in both cows only suggests coincident pleurisy or pleurisy with pneumonia. The microscopical appearances in both were suggestive of septic complication.

A careful examination of the post-mortem appearances of calves inoculated with scraping of an ulcer of a Hendon cow, or with cultivations of the streptococcus from certain cases of scarlatina, brings to light much more striking changes. These appearances, however, cannot be regarded as indicative of scarlatina. They are in reality the post-mortem appearances of septic poisoning, and occur commonly in many diseases. This is clearly shown by comparing the post-mortem appearances in the calf which was killed while suffering from septicæmia as the result of inoculation from the ulcers of a Wiltshire cow. These visceral changes are not to be distinguished from the post-mortem appearances described in the calves inoculated by Klein. Consequently, that the strepto-



coccus found in certain cases of scarlet fever should produce on inoculation in calves certain post-mortem appearances which are found in many diseases, and should fail to produce fever, ulceration of the tonsils, or scarlatinal rash, or any condition in the least resembling, clinically, the disease in man, and yet that the result should be regarded as scarlatina in the calf, is a conclusion quite untenable.

It is true that visceral lesions similar in character were produced in calves whether inoculated with scrapings or with streptococci from ulcers of the Hendon cows or with streptococci from certain cases of scarlet fever. In both cases the streptococcus is pathogenic, and inoculation of *Streptococcus pyogenes* or the inoculation of septic virus, is liable to produce septicæmia. These facts constitute a mass of evidence which justifies the conviction that the pathological data which appeared to support the theory that the vesicular disease of the teats of cows at Hendon was scarlatina in the cow, admit of an entirely different interpretation, and there can be no longer any doubt that the milk was not infected by the cows but *with the virus of scarlet fever from some human source which Mr. Power failed to discover.*

All the other evidence reported to the Board of Agriculture pointed to the same conclusion. The disease at Hendon was admittedly introduced from Derbyshire; and from Professor Axe's report it appears that only a part of the herd was sold to the farmer at Hendon; other cows with the same eruption were transferred to other dairy farms, and the disease communicated to healthy cows as at Hendon, but in no instance did scarlet fever occur among the consumers of the milk. At the farm of the brother of the dealer the disease was communicated to three of the milkers, and the eruption diagnosed by Dr. Bates as vaccinia.

All this evidence must be regarded as conclusive. The contamination of the milk at Hendon with scarlet fever must necessarily have been a mere coincidence; and the conclusion that the milk could not possibly have become infected from any human source is untenable. Professor Axe even ascertained that scarlet fever existed at Hendon during several months of 1885, and that the dwellings where cases occurred stood within six hundred yards of the cowsheds which contained the incriminated cows, and that out of fourteen men on the farm six lived in a district where cases occurred. Professor Axe has also stated that the father and brother of a girl with scarlet fever, visited the dairy during her illness. Whether any of those engaged on the

farm suffered from latent scarlet fever does not appear to have been ascertained.

There is, it is true, no evidence to show that any one daily carried infection to the milk, but the exact path of infection is not always easy to trace; and because it was not actually traced it was hardly reasonable to assume that the possibility of contamination from a human source could be altogether eliminated.

In attempting to communicate scarlet fever to cows Professor M'Fadyean confirmed the negative results which had been experienced in some earlier experiments by Klein. In 1882 Klein inoculated and fed cows and yearling heifers with diseased products from human patients, using desquamated cuticle and the discharges from the throat; but the experiments all failed. M'Fadyean's failures were still more marked. Cows and calves were inoculated with blood from scarlet fever patients, and they were made to drink water thickened with desquamated cuticle, but all the experiments proved unsuccessful.

The author believes that the outbreak at Hendon was one of cow-pox, which was prevalent in this country in 1886. The outbreak in Wiltshire could not be distinguished bacteriologically or clinically or in its micropathology, from the disease at Hendon, and the Wiltshire outbreak proved on investigation to be true cow-pox. This conclusion was questioned at the time, as cow-pox was generally believed to be extinct in England; but that view is entirely fallacious, and the author's conclusions have since been fully confirmed by independent observers, whose work will be referred to in another chapter (p. 321).

**Stamping-out System.**—The Notification Act of 1890 may be voluntarily adopted in sanitary districts, but it would be a great advantage if notification were carried out uniformly all over the country. Prompt information may lead to detecting the origin of cases of scarlet fever, and isolation and disinfection will assist in preventing its spread. Epidemics have occurred on a large scale owing to scarlet fever existing among those engaged in dairy work, and the precaution not being taken of stopping the milk supplied to the consumers. Scarlet fever cannot be so readily controlled as small-pox, for it may be spread by mild cases before the nature of the disease is suspected, and small-pox cannot be conveyed in milk.



## MEASLES.

Measles is a contagious disease peculiar to man. It lasts for one or two weeks, and produces fever, catarrh of the respiratory mucous membrane, and a characteristic rash. It is highly contagious, especially before the nature of the disease is revealed; there is consequently great difficulty in preventing its spread in schools and households. The contagium appears to be given off from the body, principally if not entirely, by the breath. One attack is protective against future attacks. The whole population of a country may acquire a certain degree of immunity. Measles introduced into countries where it was previously unknown assumes a most malignant form. There are no characteristic post-mortem appearances.

**Bacteria in Measles.**—Micrococci have been found in the blood, catarrhal exudation, and skin, by Keating, Babès, and others, but they are accidental epiphytes of no importance, or associated with secondary complications, as in scarlet fever.

Canon and Pielicke have found in the blood small bacilli varying in form. They do not grow on nutrient agar or blood serum, but cultures were obtained by pricking the finger of a patient suffering from measles, and allowing the blood to drop into sterilised broth. After a few days the broth became cloudy, and later, a flocculent deposit formed. The bacilli were also obtained from the nasal and conjunctival secretions. The nature of the contagium of measles is unknown.

**Stamping-out System.**—Measles is not easily controlled by the stamping-out system; it is, in fact, extremely difficult, almost impossible, to prevent its spread, as it is especially infectious during the period of incubation. Notification, isolation, and disinfection assist in controlling an epidemic, but the value of the system does not apply to the same extent in measles as in other infectious diseases.

## CHAPTER XX.

### SMALL-POX.—CATTLE PLAGUE.

#### SMALL-POX.

SMALL-POX is an infectious and inoculable disease of man, characterised by sudden and severe fever, followed in forty-eight hours by a characteristic papular eruption which gradually becomes vesicular and then pustular. The virus is contained in the vesicles, and in a concentrated form in mature pustules. It also passes into the air from the breath and skin. Infection may occur from the dead body, and clothes and bedding may retain the contagium for months. One attack, as a rule, gives immunity against future attacks.

Small-pox is undoubtedly a disease foreign to this country. Its home is in the East. Some of the old writers held that it spread to Europe from Alexandria about the year 640 A.D., following in the wake of the Arab conquests in Egypt, Palestine, Persia, along the Asiatic coast, through Lycia, Gallicia, along the coast of Africa, and across the Mediterranean to Spain; others maintained that it was not introduced until the end of the eleventh or beginning of the twelfth century, by the returning Crusaders. At any rate, small-pox was imported from the East, and probably from Egypt. Herodotus, who visited Egypt, leads us to infer that epidemics were unknown there during the rule of the Pharaohs; but Egypt undoubtedly became a hotbed of pestilence during the Mohammedan occupation. Prosper Alpinus imagined that both the plague and the small-pox were concocted in the putrid waters of the Nile, but he would probably have been more correct if he had suggested that they arose from the insanitary condition of the Arab conquerors and their filthy camp followers, who did their best to destroy all that remained of that magnificent civilisation which had existed in the days of the ancient Egyptians.

We do not know the exact period at which small-pox was first imported into England, and the records of the disease are very meagre until the sixteenth century.



In 1593 Simon Kellwaye appended to his work on the Plague a short treatise on the small-pox. "Oftentimes," he wrote, "those that are infected with the plague are in the end of the disease sometimes troubled with the small pocks or measels, as also by good observation it hath been seen that they are fore-runners or warnings of the plague to come." According to Kellwaye the disease arose from the "excrements of all the foul humours in our bodies, which striving with the purest doth cause a supernatural heat and ebullition of our blood, always beginning with a fever in the most part."

Small-pox steadily increased in the seventeenth century until it was a formidable scourge, for no advantage was taken of all the experience which had been gained in dealing with the plague. No public measures were adopted to cope with the disease, and the people came to regard the new pestilence as a visitation which was unavoidable. Early in the eighteenth century, small-pox inoculation was introduced, and this was superseded in the nineteenth century by vaccination.

Examination of small-pox cases after death does not reveal any characteristic lesions in the internal organs, but sections of small-pox vesicles show an important structure. A vesicle is formed by the exudation raising up the outer layer of epidermis, and the chief feature is the formation of a vacuolated structure in which, especially in the later stages, bacteria are found in abundance.

**Bacteria in Small-pox.**—Cohn and Weigert found cocci in variolous lymph. Hlava found *Streptococcus pyogenes* in the pustules, and Garré streptococci in the internal organs in a case of variola hæmorrhagica. In a fatal case of variola complicated with pemphigus Garré found a streptococcus in the pemphigus vesicles. Klein and Copeman have found a small bacillus which they regard as characteristic, but its biological characters are unknown, as it will not grow on any nutrient media. The bacteria commonly found in variolous pus are the usual pyogenic organisms. The nature of the contagium of small-pox is unknown.

**Protective Inoculation.**—Experience had taught that a person was not, as a rule, attacked with small-pox a second time; but when and how the method of artificially inducing a mild form of the disease was discovered, or when this preventive treatment was first employed, is unknown. Avicenna of Bokhara was credited with the discovery, and it was supposed that the practice was carried by Tartar and Chinese traders to Surat, Bengal, and China, and by the Mahomedan pilgrims to Mecca. In Constantinople it was supposed by some to have been introduced from the Morea by an old woman, and by others by the women of Circassia. The

Circassian women fastened three needles together, and pricked the skin over the pit of the stomach and heart, the navel, the right wrist, and the left ankle. The variolous matter was applied to the bleeding points, and the eruption came out in five or six days. In Constantinople scarifications were made on the forehead, wrists, and legs, and carefully selected virus applied to the incisions. The needle used was a three-edged surgeon's needle, or the operation was performed with a lancet. The virus was obtained by pricking the vesicles, and pressing out the matter into a clean glass vessel. The Armenians preferred to be inoculated in both thighs. In Barbary a slight wound was made between the thumb and forefinger, and the virus obtained from a mild form of small-pox. In Hindustan the operation was performed at certain seasons of the year, and a preparatory regimen enforced. The inoculators were very careful in the selection of the virus, as they had learnt its varying intensity, and they were credited with being able to control the amount of the eruption. They preferred to inoculate the outside of the arm, midway between the wrist and the elbow in males, and between the elbow and the shoulder in females. The skin over the part to be inoculated was first well rubbed with a piece of cloth; then, with slight touches of a small instrument, little wounds were made over an area which might be covered by a small coin, and sufficient to cause just an appearance of blood. A pledget of cotton-wool charged with the variolous matter, and moistened with water, was applied to the wound. This virus was obtained from inoculated pustules of the preceding year.

In China the contents of the variolous pustules were dried and kept for several years. If the virus was to be used from fresh pustules the "acrimony" of the matter was corrected by steaming. The dried powder was made into a paste, which was wrapped up in cotton-wool and introduced into the nostril.

The Greeks were more cautious in their procedure, and were said to inoculate tens of thousands without an accident. They operated only upon those in perfect health, punctures were made with needles, and the virus was used in the crude state, freshly obtained from the "kindly" pustules of a young child. They were particularly careful in the choice of the "ferment."

Dr. Perrot Williams, in 1722, wrote that the practice of communicating small-pox had long been employed in South Wales. The oldest inhabitants said that it had been a common practice with them "time out of mind," but Lady Mary Wortley Montagu was responsible for the general adoption of small-pox inoculation in



England by persuading physicians in London to employ it. Lady Mary had her child inoculated in Turkey. An old Greek woman inoculated one arm, and Mr. Maitland, surgeon to the Embassy, the other. The disease ensued in due course with an eruption of a hundred pustules. This was the first time that the Byzantine method of inoculation was performed upon an English subject. In 1721 Dr. Harris delivered a lecture before the College of Physicians, and described the successful inoculation of four children of the French consul at Aleppo, by means of a thread imbued with variolous pus. A daughter of Lady Mary was inoculated in England by Maitland in 1721, and subsequently a number of criminals were inoculated by him. Incisions were made through the cutis, and pledgets which had been steeped in variolous pus from ripe pustules, were applied to the wound. This was known as Maitland's or the reformed operation, but it was soon modified, as troublesome ulcers resulted. Shortly afterwards Maitland encountered another obstacle. The child of a Mr. Batt was inoculated, had plenty of pustules, and soon recovered, but six of Mr. Batt's domestic servants, "who all in turn were wont to hug this child while under this operation, and whilst the pustules were out, never suspecting them to be infectious, were all seized at once with the right natural small-pox of several and very different kinds."

Dr. Jurin in 1729 reverted to the Eastern method, and recommended virus from a mild case of small-pox, but the virus was still taken from perfectly matured pustules, and the operation continued to be followed by bad results. In order to diminish the risks, Burgess in 1766 advocated certain improvements. An incision about an inch long was made on each arm through the cuticle, but not so deep as to wound the cellular tissue. A variolous thread was laid along the whole length of the wound and fixed with plaster. Ulcerations and other accidents continued to take place, and a new epoch in the history of inoculation was the introduction of the Suttonian method, in 1764-6.

It was said that Mr. Sutton, with his assistants, inoculated one hundred thousand persons. The method was kept secret at first, but the essential points were all discovered and published by Dr. Dimsdale. Dimsdale recommended a very slight puncture with a lancet wet with variolous matter. Subsequently, Sutton published an account of his method, and the result of his operation may be given in his own words.

"The lancet being charged with the *smallest perceivable quantity* (and the smaller the better) of *unripe, crude, or watery matter*, immediately

introduce it by puncture, obliquely, between the scarf and true skin, barely sufficient to draw blood, and not deeper than the sixteenth part of an inch. Neither patting, nor daubing of the matter, in or over the punctured part, is at all necessary to its efficacy. This practice, indeed, is rather prejudicial than otherwise, as it may affect the form of the incision, and thus be apt to confound our judgment upon it.

*Indications of the Incision.*—In the incipient state of variolous increase in the incision, a small florid spot appears on the part of access, resembling a flea-bite in size; and on passing the finger lightly over it a hardness is felt not larger than a small pin's head. This florid appearance and hardness denote that the variolous principle is effectually imbibed, and their indications point no farther, unless the progress to vesication be very slow, in which case an uncomfortable number of pustules may be expected to follow. The florid spot in most instances of inoculation is somewhat larger, or more extended on the second, than on the third day after the insertion.

“About the fourth day from inoculation, should the incision begin to vesicate, an itching sensation will be complained of on the place of insertion—the occurrence of which symptom is the first indication of a favourable event, yet not of sufficient importance to justify any present relaxation in the preparatory proceedings.

“The vesication of the incision in most instances will begin to be visible on the fourth or fifth day after the insertion of the matter; the sooner it becomes so, the more favourable may be expected to be the event. The extent or diameter of the vesication at this stage does not usually exceed that of a large pin's head, and it has invariably a dint or small depression.”

Adams obtained still more striking results by inoculating with variolous lymph from pearl-pox, a mild variety of small-pox. Starting with lymph obtained from this benign form of small-pox, and selecting the cases, and carrying on arm to arm variolation, the results obtained were practically identical with the phenomena obtained by inoculation of the arm with cow-pox lymph. Similar results were obtained by Guillou, but more rapidly. In 1827 there was an epidemic of variola, and Guillou, having no vaccine virus, took variolous lymph from a girl fifteen years of age on the fifth day of the eruption. The case was one of varioloid or mild small-pox, attributed to previous vaccination. The variolous lymph was inserted in ten places on the arm of a healthy infant still at the breast. This inoculation produced ten beautiful “vaccine” vesicles, from which, on the ninth day, forty-two infants were inoculated under the eyes of two of the local authorities. These furnished virus for the inoculation of one hundred, who were inoculated in the presence of magistrates and many medical men. This experiment was repeated with success. Variolous lymph was taken from two lads at school, and in ten



cases produced appearances with a perfect similarity to ordinary vaccination.

Thiele produced a benign vesicle in the following manner. Variolous lymph was diluted with warm cow's milk, and inoculated like ordinary vaccine lymph. Large vesicles resulted. There were febrile symptoms from the third to the fourth day, and a secondary onset of fever much more pronounced between the eleventh and fourteenth days. The areola was strongly marked, and not confined to the inoculated place, which was occasionally surrounded by minute secondary vesicles. After watching through ten removes, the vesicles finally assumed the characters of an ordinary vaccination with cow-pox lymph. As soon as the secondary fever ceased to occur inoculation was practised from arm to arm without diluting the lymph with cow's milk. The lymph was designated lacto-varioline, and the result was variolation in its mildest form. The result of variolating the cow will be discussed in another chapter.

Small-pox inoculation, or variolation, protected the individual when genuine small-pox was produced, and endangered the community. Persons inoculated became centres of infection, and conveyed the disease to others. Haygarth, although in favour of inoculation, strongly condemned its use without precautions to prevent the spread of the disease. "The most serious and solid objection," he wrote, "that has been advanced against inoculation is deduced from a comparison of the Bills of Mortality for a series of years in various places. They show that a larger proportion of inhabitants have died of the small-pox in towns where it is practised than in the same before it was known, or in others where it is prohibited."

Even Dr. Dimsdale, an ardent inoculator, admitted that more lives were lost in London than before inoculation commenced, and the practice was more detrimental than beneficial to society; and he added: "The disease by general inoculation throughout London spreads by visitors, strangers, servants, washerwomen, doctors, and inoculators, by means of hackney coaches in which the sick are sent out to take the air, or by sound persons approaching them in the streets. The poor in London are miserably lodged; their habitations are in close alleys, courts, lanes, and old dirty houses; they are often in want of necessaries, even of bedding. The fathers and mothers are employed constantly in laborious occupation abroad, and cannot attend the inoculated sick." In 1798 Jenner, who had practised small-pox inoculation, proposed the use of a benign non-infectious lymph obtained from a disease of the cow or horse as a substitute

for variolous lymph, and in 1840 small-pox inoculation was prohibited by Act of Parliament.

**Stamping-out System.**—The disappointing and dangerous results of small-pox inoculation led to a widespread demand for some new method for dealing with small-pox. This induced Haygarth to turn his attention to the subject, and towards the end of the eighteenth century to bring before the medical profession and the public a plan for stamping out the disease. Haygarth, who was a close observer and an able physician, studied the question of the communicability of the disease from one person to another, and its conveyance by infected clothing and other means, and ultimately drew up rules and regulations for its prevention, the importance of which we are only now beginning to fully acknowledge. Haygarth's essential doctrine was "that mankind was not necessarily subject to the small-pox, and that it was always caught by infection from a patient or the poisonous matter," and might be avoided by observing his *Rules of Prevention*.

These rules comprised a regular system of notification and isolation. Inspectors were to be provided to report cases of small-pox, and people were to be rewarded for carrying out the instructions. Several examples were given of the results at Chester, where the plan was adopted.

Haygarth met with considerable encouragement from some of the leaders of the profession. Dr. Fothergill wrote to him in 1778, saying, "I have mentioned the intention of freeing this country from the small-pox to divers of the faculty, and shall continue to do so as it falls in my way. The proposal is variously received, but in exact proportion to their humanity."

In 1793 Haygarth made considerable addition to his rules, and urged that legislation should follow to make them compulsory. Provision was to be made to reward the poor for observing the rules, and public thanks to the wealthy for their support were to be published in the parish church and newspapers. Transgression of the rules was to be punished by a fine of from £10 to £50, one half to go to the informer and the other half to the fund which supplied the expense of rewards to the poor, and all details were to be supplied to the press. It was further suggested that Great Britain should be divided into districts, including a certain number of parishes or townships, and that to each of them a surgeon or apothecary should be appointed as inspector to see that the regulations were exactly observed. In addition, there were to be directors of inspectors, superintended by a commission of Physicians in London and in Edinburgh. All salaries were to be paid by the county rates, and the rewards for observing the rules of prevention were to be guaranteed out of the parish funds. On the requisition of the director and inspector of a circuit, power was to be given to two or more justices of the peace to appoint a separate house for the reception of patients with the small-pox. In conclusion,



Haygarth maintained that the plague had been completely exterminated from this country, for above a century, by civil regulations, and that there seemed to be little doubt that the small-pox was propagated on principles similar to the plague, and that it also might certainly be exterminated from this island.

Haygarth's teachings had a profound influence upon both the profession and the educated public, but his system of compulsory notification was never carried out, for no legislation followed to enforce his recommendations. This is a matter deeply to be regretted, for towards the end of the eighteenth century small-pox was declining in London, general sanitation was making rapid advances, small-pox inoculation, which created fresh centres of infection, was falling into disfavour, small-pox hospitals were built, which served to limit centres of infection, and the profession and the public were influenced by the teaching of Haygarth with regard to the various ways of avoiding the spread of the disease.

It only required the compulsory adoption of Haygarth's system uniformly all over the country to have kept the disease in control, if not to have entirely extirpated it from Great Britain. That a similar conviction existed at the time is evidenced by an article which appeared in 1779 in the *Medical and Chirurgical Review*, in which the following statements were made :—

“Plans for the extirpation of the small-pox have been suggested. . . . To do this, however, the exertions of the physician are incompetent unless they be aided by the powerful hand of Governments, but this has hitherto been withheld. The grand means, however, of extirpating this destructive malady is an early and strict separation of the infected from those that are sound.”

Small-pox in the present century has been largely controlled by legislation, especially in recent years, by the Public Health Acts for England and Wales, for Scotland, and for Ireland; the Epidemic and other Diseases Prevention Act; the Public Health Amendment Act; the Labouring Classes' Dwellings Acts; the Housing of the Working Classes Act; the Public Health (Ships) Act; the Local Government Board Act—and various orders and memoranda of the Local Government Board; the Infectious Diseases Notification Act; the Infectious Diseases Prevention Act; and the Public Health (London) Act.

By the Public Health Act of 1875 England was divided into Urban and Rural Sanitary Districts, and powers were given to enforce regulations of the Local Government Board for guarding against the spreading of infectious diseases; to provide medical aid and accommodation for infected persons, to promote cleansing, ventilation, and disinfection, to provide hospitals, to provide for

destruction or disinfection of infected bedding, clothing, and other articles, and to appoint Medical Officers of Health.

As to the value of notification and isolation in cities such as London we have the evidence of the Metropolitan Asylums Board. In their Report for 1889 we read in reference to the diminution of small-pox: "These very satisfactory results confirm the view taken by the Committee two years ago to the effect that the rapid and systematic removal from crowded districts of infected persons, each of whom might have become a centre of contagion, is an important factor in stamping out small-pox from the metropolitan population. The notification of cases will also greatly facilitate the action of the managers in this direction."

More recently there has been a most striking confirmation of these statements. An outbreak of small-pox occurred in Marylebone, and by the energy of the officials of the Board this outbreak was suppressed in a few days by means of notification and immediate isolation.

The Isolation Hospitals Act of 1893 gives power to County Councils to provide, or cause to be provided, an isolation hospital in any district within their county. An application to a County Council for the establishment of an isolation hospital may be made by any one or more of the authorities defined as local authorities having jurisdiction in the county or any part of the county. Further, the County Council may direct an inquiry to be made by two medical officers of health in the county as to the necessity of an isolation hospital being established for the use of the inhabitants of any particular district in the county, and in the event of such medical officers reporting that such a hospital ought to be established for the use of the inhabitants of a district, may take the same proceedings in all respects for the establishment of such hospital, as if a petition had been presented by a local authority for the establishment of an isolation hospital for the district named in the report of such medical officers of health.

Lastly, the Local Government Act of 1894 provides for the formation of District Councils; and the powers, duties, and liabilities are principally those which were conferred by the Public Health Act of 1875.

In the opinion of the author the Government of this country should enter into friendly negotiations with the Governments of other countries, so that there might be concerted action to prevent an avoidable disease like small-pox. Much good might result from the formation of a permanent International Board of Health. If civilisation is not yet



sufficiently advanced to admit of a system of international notification, our Consular authorities should be instructed to give immediate notification of the existence of small-pox in other countries, and every measure should be enforced to diminish the possibilities of importation. The duties of a Central Health Office, presided over by a Minister of Health, should include the collection of information as to the existence of small-pox in other countries, and details should be published in the Annual Reports of the Department. Regulations, for example, for dealing with the importation of rags from small-pox stricken places should be enforced, as in the case of cholera; and if, in spite of these precautions, isolated cases occurred in this country, they should be dealt with promptly.

Notification should be enforced uniformly all over the country, and there is not the slightest reason why the authorities and the public should not immediately receive information of the existence of small-pox, whilst to procure immediate isolation we have only to imitate the excellent ambulance system of the Metropolitan Asylums Board. To procure prompt notification there must be no loophole for evading the Act, and there should be a heavy penalty for failure to notify not only small-pox, but *any case which may reasonably be supposed to be one of small-pox.*

The police should be required to report any case of small-pox in common lodging-houses or shelters; they should have power to require any tramp suffering from small-pox, or from any disease which may reasonably be supposed to be small-pox, to be examined by the medical officer of the Union, and kept under observation, or transferred at once to the isolation hospital; and inmates of the workhouse should be daily inspected, and no case allowed to leave when there is the least suspicion of small-pox infection.

Objections no doubt will be raised to this proposal, but the frequency with which small-pox is spread by tramps fully justifies these measures. All these measures should be carried out as a matter of routine, and without the semblance of panic.

Isolation should be uniformly enforced all over the country, and vaccination should be relegated to the position of a voluntary auxiliary measure, which should never be allowed to take the place of sanitary regulations to stamp out the disease.

#### CATTLE PLAGUE.

Cattle plague is a highly contagious disease of bovines producing high fever, and characterised by an eruption with a resemblance to human small-pox. The disease is transmissible to other ruminants, and is inoculable in man. One attack gives immunity against future attacks. Cattle plague and small-pox are not intercommunicable, and are specifically distinct diseases, but the resemblance between them was recognised from early times. Ramazzini published an account of the cattle pest in Italy in 1711, and described the pustules which broke out over the body as similar to those of variola in

kind and appearance. Dr. Layard, in 1780, described this disease of horned cattle as an eruptive fever of the variolous kind, with the appearance and stages of small-pox. This resemblance was endorsed by Murchison, one of the Commissioners appointed in 1866 to inquire into the origin and nature of cattle plague.

Murchison pointed out that in both diseases the eruption consisted of pustules and scabs, and that in both it extended from the skin to the interior of the mouth and nostrils; in both, the pustules and scabs were preceded or accompanied by patches of roseola; in both, they were occasionally interspersed with petechiæ; and in both, they sometimes left behind pitted scars and discolorations on the cutis. The other prominent symptoms of rinderpest were also those of small-pox—viz., pyrexia, lumbar pain, salivation, and running from the nostrils, alvine flux, albuminuria, hæmaturia, and “the typhoid state.” The anatomical lesions of the internal organs in rinderpest and unmodified small-pox were identical—viz., congestion or inflammation of the mucous membranes of the air passages and digestive canal, patches of ecchymosis and even gangrene of the stomach and other mucous surfaces, and darkly coloured blood. In both rinderpest and small-pox the duration of the pyrexial stage was on an average about eight days. In both diseases a peculiarly offensive odour was exhaled from the body before and after death. The two diseases resembled one another in their extreme contagiousness, and in the facility with which the poison was transmitted by fomites. Both diseases were easily propagated by inoculation, and in both cases the inoculated disease was milder and less fatal than that resulting from infection. In both diseases there was a period of incubation, which is shorter when the poison has been introduced by inoculation than when it has been received by infection.

Ceely described the result of an accidental inoculation of cattle-plague virus in the human subject. A vesicle was produced which so closely corresponded with the result of inoculated cow-pox that Ceely inclined to the belief that cattle plague was a malignant form of cow-pox. The following is the account of this case as reported by Ceely. Mr. Hancock, a veterinary inspector at Uxbridge, was engaged in superintending the autopsy of a bullock recently dead of cattle plague. His assistant, who was performing the operation, while occupied in removing the skin from the scrotum, accidentally punctured the back of Mr. Hancock’s hand with the point of the knife. The puncture being slight was disregarded at the time, but was washed as soon as practicable, and thought of no more. Five



days afterwards, a small, slightly elevated, hard pimple was felt and seen on the site of the puncture. This gradually advanced till the ninth day of the puncture, the fourth from papulation, when the enlargement became distinctly vesicular. At that time there were but slight constitutional symptoms. On the next day, the tenth from the receipt of the puncture, the fifth from papulation, and the second from vesiculation, Mr. Hancock consulted Mr. Rayner, of Uxbridge, who, on seeing the hand, inquired if the patient had been handling the udder of a cow, as he thought he could recognise a cow-pox vesicle of the ninth day. The vesicle was distended with thin lymph, its margin elevated and slightly brown, its centre depressed and brownish, and the whole surrounded with a large bright red areola. There was then considerable tumefaction extending from the knuckles to above the wrist. The absorbent vessels were considerably inflamed, and, like the axillary glands, were tender and painful; the pulse, naturally slow, was accelerated; there was much pain in the back and limbs, severe distracting headache, etc.; all of which symptoms continued to increase during the two following days. At the end of that time the diffused areola had extended as far as the elbow. Fifteen days after the puncture, and ten days after papulation, the local inflammation and constitutional symptoms had partially subsided. The vesicle contained a rather turbid brownish fluid, and there were present all the indications of a declining vaccine vesicle.

Murchison also saw and described the case, and gave practically the same account of it. He pointed out that the appearances and the entire history were very different from the results of a poisoned wound, but coincided with the appearances seen after vaccination.

In 1832 Macpherson, in Bengal, inoculated eleven native children with cattle-plague crusts. There was no result in six, others suffered from local inflammation, and in one a vesicle formed. With lymph from this vesicle other children were inoculated. The results in all were similar in appearance to those of vaccination. Two children were subsequently inoculated with human variola, and were said to be protected.

In 1834 Macpherson's example was followed by Mr. Furnell in Assam. Furnell inoculated four children with cattle-plague crusts without result, but his assistant succeeded with crusts taken from the back and abdomen of the diseased cattle, and carried on the lymph from child to child. In one case there was a general eruption. Furnell inoculated his own child from one of the native children: a copious eruption followed, and the child died. Furnell

after this misfortune issued a strong warning against taking the virus from the cow. The experiments were made in the belief that cattle plague was really small-pox in cattle, and that the virus would protect against human variola.

Similar results were obtained by Mr. Wood at Gowalpara in 1838.

**Bacteria in Cattle Plague.**—Semner cultivated streptococci from the blood and lymphatic glands of a sheep suffering from cattle plague. A calf inoculated with a cultivation died in seven days. The cocci were stated to lose their virulence by cultivation, and the weakened cultivation to protect against the virulent disease.

The micro-organism was very probably *Streptococcus pyogenes*, and the calf may have died of septic infection. There can be no doubt that the nature of the contagium of cattle plague is unknown.

**Protective Inoculation.**—In the great epidemic of cattle plague in England in 1866, owing to a belief that the analogy between cattle plague and small-pox was closer than it really is, vaccination with cow-pox was attempted as a preventive measure, but was proved to be absolutely useless.

**Stamping-out System.**—When cattle plague was imported in 1865 into London, dairymen and stock-owners made no attempts to prevent the extension of the disease, so that it spread rapidly all over the country through disposal of infected cattle. The losses were enormous, and an Order in Council was passed in July 1865, directing dairymen and others to notify outbreaks of any contagious or infectious disease among the animals under their charge. A Veterinary Department of the State was formed, and inspectors appointed in various parts of the country. A short Act was passed in February 1866. A stamping-out system, consisting of compulsory notification and the slaughter of diseased animals, was soon brought to the notice of the public. There was violent opposition, but nevertheless, after some delay, the system was carried out. The number of cases of cattle plague had reached 18,000 weekly, and on the introduction of the stamping-out system the disease rapidly declined. The disease was again imported into Great Britain in 1872, and there were outbreaks in 1877. In each instance the disease was promptly stamped out, and ever since that year the disease has been kept out of this country.



## CHAPTER XXI.

### SHEEP-POX.—FOOT-AND-MOUTH DISEASE.

#### SHEEP-POX.

SHEEP-POX, or *variola ovina*, is an acute febrile disease accompanied by a general vesiculo-pustular eruption, highly infectious, and capable of being propagated by inoculation or *clavelisation*. It is a common disease in some parts of Europe. In France the disease is called *la clavelée*, and in Italy *vaccuolo*. It has been introduced on several occasions into this country, but has been effectually stamped out. As in human small-pox, there are varieties—the benign and the malignant, the discrete and the confluent; and one attack is protective against the disease in future.

It is very closely analogous to human small-pox. Vaccination with cow-pox lymph has been employed to protect sheep from sheep-pox, but unsuccessfully, and lymph for vaccination has been raised from sheep-pox to protect human beings from small-pox. These experiments were first performed in Italy.

Marchelli, in 1802, took lymph from the vesicles of sheep-pox, and inoculated children. Sacco repeated these experiments, and found there was no appreciable difference from the results obtained with cow-pox lymph. Dr. Legni carried on the inoculations with ovine virus from arm to arm for several years, and when small-pox occurred in Pesaro, it was said that all those who were inoculated with the sheep virus were protected.

Inoculation of children with ovine virus, direct from sheep, was repeated by Sacco and Magnani in 1806.

Marson in England succeeded in producing on the human subject a vesicle with the physical characters of the vaccine vesicle. The vesicle had a bluer tinge, and subsequent inoculation of the patient with human variola was ineffectual. Other experimenters were unsuccessful, but their failures, as in the case of variolation of the cow, do not invalidate the results of those who were successful.

Sheep-pox and cow-pox are quite distinct diseases. Sheep-pox is highly infectious, whereas cow-pox is only conveyed by direct inoculation, and is never infectious, and further, cow-pox inoculated in sheep does not produce sheep-pox.

**Bacteria in Sheep-pox.**—Hallier and Zurn, Klein, and others, have found micrococci and bacteria in the lymph of the vesicles of sheep-pox, but they are only accidental epiphytes. The nature of the contagium is unknown.

**Protective Inoculation.**—Extensive experiments were carried out in England to test the protective power of vaccination against sheep-pox. According to Marson and Simmonds, it was very difficult to get cow-pox to take on sheep, and when an effect was produced, the resulting affection, even when developed to its fullest extent, was very unlike the same disease in the human subject. In the sheep it seldom produced anything more than a small papule, which occasionally resulted in the formation of a minute vesicle, or more commonly, a pustule, which was sometimes, although very rarely, surrounded by a slight areola. Generally, however, neither vesication nor pustulation followed, but a small scab was produced, which soon fell from the site of the puncture, leaving no trace behind. The disease passed quickly and irregularly through its several stages, and terminated by the eighth or ninth day, and not unfrequently even before that time. Lymph was but rarely obtainable, and then only in the smallest quantity, and this on the fifth or sixth day succeeding the vaccination. The effects were only local, and the animal's health was not impaired.

Sheep were found to be just as susceptible of the cow-pox virus on subsequent repetition of the inoculation as they were in the first instance, and hence the conclusion that cow-pox was utterly worthless as a protective against sheep-pox. According to Depaul, however, cow-pox takes characteristically on sheep, and sheep-pox lymph inoculated on cows produces a result indistinguishable from the appearances obtained with the inoculation of cow-pox lymph. It is impossible to say whether these conflicting results depended upon the employment in the experiments of different breeds of sheep or different stocks of vaccine lymph.

The objection to clavelisation or ovination is that the disease may be introduced in localities where it was previously unknown. By ovination, as in the analogous case of variolation, fresh centres of infection are created, whereas every precaution should be taken to prevent the introduction of the disease.

**Stamping-out System.**—Sheep-pox has been imported into this



country on several occasions. It was introduced in 1847, and again in 1862; in 1865 it was introduced again, and active measures of repression were at once taken. The diseased flocks were carefully isolated, and day by day as fresh cases occurred the diseased animals were killed and buried. Owing to the adoption of these precautionary measures, the affection did not extend beyond the flock among which it first appeared. It was introduced again in 1866 at Long Buckby, in Northamptonshire. In this case the disease was exterminated by the slaughter and burial of the whole flock, and immediate application of disinfectants to the hurdles and other things with which the sheep had been in contact. Then it was introduced again in Cheshire, and strict isolation being enforced the infection died out. Since 1866 we have had no outbreak of sheep-pox in this kingdom, but foreign sheep have been landed with sheep-pox in 1868, 1869, 1870, 1871, 1875, 1876, 1878, and 1880, but the disease has been prevented from spreading.

The Sheep-pox Order of 1895 provides for the notification of the disease, for disinfection and for compulsory slaughter of infected sheep, and prohibits the movement of diseased or suspected sheep, and the local authority may, if they think fit, order the slaughter of suspected sheep and of sheep which have been in contact with diseased sheep.

#### FOOT-AND-MOUTH DISEASE.

Foot-and-mouth disease is a highly contagious and infectious febrile disease, characterised by a vesicular eruption affecting the lips, tongue, roof of the mouth, and feet of sheep, cattle, and pigs, and according to some observers it also attacks horses, poultry, hares, and rabbits. Sometimes the mouth only is affected, in other cases the principal seat of the eruption is in the feet. The vesicles soon break and give rise to ulcers. When these occur in the mouth they cause pain and difficulty in taking food. Extensive ulceration may occur on the feet, causing great pain and lameness. In milch cows it sometimes happens that the eruption occurs on the udder and teats, and it is this manifestation of the disease which has received so much attention from Rayer. The milk is contaminated by the discharge of the vesicles, and is unfit for use, either as food for the human being or for the lower animals. It induces a vesicular eruption in the mouth, larynx, pharynx, and intestinal canal. It acts most vigorously when administered warm to young animals, and calves occasionally die quite suddenly after sucking cows



affected with the eruption on the teats. Fatal effects also result when the milk is administered to young pigs.

It has been stated that no injurious consequences arise from the consumption of the milk by human beings, but there is abundant evidence to the contrary, and the conflicting opinions probably arise from the fact that milk is seldom drunk direct from the cow, and rarely in an undiluted form. Hertwig experimented upon himself with milk freshly drawn from a cow with the eruption. He drank a pint, and two days afterwards experienced slight fever, restlessness, and headache. The mouth was dry and hot, and there was tingling in the skin of the hands and fingers. These symptoms continued for seven days after taking the milk. On the ninth day vesicles had formed on the tongue, principally on the edges, and on the mucous membrane of the cheeks and lips (the largest being about the size of a lentil). They were yellowish-white in colour, and contained a whitish turbid liquid, which flowed when the vesicles were pricked with a needle. At the same time a number of vesicles developed on the hands and fingers; and most of them at the time of their first appearance were the size of a millet seed. They were firm to the touch, yellowish-white, and occasioned a slight tingling. The vesicles of the mouth increased in size and eventually broke, and the epithelium detached itself completely from the affected parts, leaving dark red spots, which disappeared gradually. The slight fever present during the first days ceased after the appearance of the eruption; but from this time, until the disappearance of the red spots, Hertwig felt a continual burning pain in the mouth, and speaking and deglutition caused considerable uneasiness. On the lips the vesicles dried up, and were covered with thin brownish crusts, which fell off ten days after the appearance of the first vesicles. The vesicles which developed on the hands ran a slower course. From the tenth to the thirteenth day they filled with a liquid, like turbid lymph. They were large and confluent, and finally broke and dried up.

**Bacteria in Foot-and-mouth Disease.**—Klein in 1885 isolated from the vesicles a streptococcus which in its microscopical and its cultural characters on gelatine, agar and blood serum resembled *Streptococcus pyogenes*. Minute differences in the size of the colonies and in their rate of growth, and in the character of the chains, were observed on making comparative cultures with *Streptococcus pyogenes* from a human source, but no comparison was made with *Streptococcus pyogenes* from acute suppuration in cattle. Baumgarten regarded this micro-organism as *Streptococcus*



pyogenes, and not as the contagium of the disease. The author has pointed out the variation which exists in the size of the chains and of the colonies, and the difference which is found in the rate of growth of cultures of *Streptococcus pyogenes*, and these variations are especially marked in *Streptococcus pyogenes bovis*. Klein believes that the administrations of broth cultures produced the disease in sheep, but the results were very probably due to accidental infection. It is well known how very readily foot-and-mouth disease is spread. The appearance of a case in a flock of sheep or a herd of cattle will be almost certain to be followed by all or nearly all of the other animals being infected with great rapidity. The virus clings to the clothes of shepherds and others who have been in contact with infected sheep, and may be readily conveyed to healthy animals by those who have been visiting infected premises.

Schottelius described chains composed of rounded elements, some of which resembled an amœba or plasmodium. The chains were said to be motile, and delicate growths were obtained in blood serum and agar, and in broth and on potato. Inoculation in sheep and pigs and numerous small animals gave negative results. These organisms were described as streptocytes, to distinguish them from bacteria.

Piani and Fiorentini investigated the contents of the vesicles, and also described corpuscular elements exhibiting amœboid movements. They regarded these bodies as protozoa, and concluded that foot-and-mouth disease is due to their presence.

Until a micro-organism is cultivated which will produce sheep-pox in sheep on a farm or on premises where the disease does not exist, and where there can be no possibility of accidental infection, we are fully justified in concluding that the nature of the contagium of this disease is unknown.

**Stamping-out System.**—Foot-and-mouth disease was imported into this country in 1839. It has been successfully dealt with by the stamping-out system, which in this case is very difficult to apply because of the very short period of incubation, and the value of the stamping-out method very greatly depends upon the length of the incubation period. Foot-and-mouth disease very often, from infection to recovery, does not exceed ten days; yet according to the reports of the Board of Agriculture, when foot-and-mouth disease exists in a manageable state, perfect isolation and effectual disinfection have proved equal to the complete control of the spreading of the infection, and the final extinction of the disease. Nothing more is necessary in any case than to close up all the channels through which infected matter can be conveyed; but in

order that this may be done close supervision by conscientious and responsible officers is required ; without it the case is hopeless.

The Foot-and-mouth Disease Order of 1895 enforces notification, isolation, and disinfection, and the question of slaughter is left to the local authority.

- (1) A local authority may, if they think fit, cause to be slaughtered—
  - (a) Any cattle, sheep, or swine affected with foot-and-mouth disease or suspected of being so affected ; and
  - (b) Any cattle, sheep, or swine being or having been in the same field, shed, or other place, or in the same herd or flock or otherwise in contact with animals affected with foot-and-mouth disease, or being or having been, in the opinion of the local authority, in any way exposed to the infection of foot-and-mouth disease.



## CHAPTER XXII.

### HORSE-POX.—COW-POX.

#### CONSTITUTIONAL GREASE OR HORSE-POX.

HORSE-POX is a vesicular disease of the horse communicable from animal to animal by inoculation, but never infectious. It is communicable by inoculation to man, and the attenuated virus produces phenomena indistinguishable from the results of vaccination with cow-pox lymph.

The existence of this disease of the horse had long been known to farmers and farriers, but Jenner was the first to draw attention to it in writing. "There is a disease to which the horse from his state of domestication is frequently subject. The farriers have termed it *the grease*; it is an inflammation and swelling in the heel accompanied at its commencement with small cracks and fissures, from which issues matter possessing properties of a very peculiar kind." Jenner gave several instances in which this disease was communicated to man and to cows.

Thus, a man named Merret attended to some horses with sore heels and also milked the cows. The cows were infected, and the man had several sores upon his hands.

William Smith, on another farm, attended to horses with sore heels and milked the cows also. The cows were infected, and on one of Smith's hands there were several ulcerated sores.

Simon Nicholls applied dressings to the sore heels of one of his master's horses and at the same time milked the cows, and the cows were infected in consequence.

A mare, the property of a dairy farmer, had sore heels, and was attended to by the men of the farm, Thomas Virgoe, William Wherret, and William Haynes. They contracted "sores on their hands, followed by inflamed lymphatic glands in the arms and axillæ, shiverings succeeded by heat, lassitude, and general pains in the limbs," and the disease was also communicated to the cows.

But Jenner's experience of this disease was not limited to cases in which the eruption occurred in the heel.

He mentions a case in which—

“An extensive inflammation of the erysipelatous kind appeared without any cause upon the upper part of the thigh of a sucking colt. The inflammation continued several weeks, and at length terminated in the formation of three or four small abscesses.” Those who dressed the colt also milked the cows on the farm, and communicated the disease to them.

Subsequently, Jenner gave a more comprehensive description of this disease.

“The skin of the horse is subject to an eruptive disease of a vesicular character, which vesicle contains a limpid fluid, showing itself more commonly in the heels. The legs first become œdematous, and then fissures are observed. The skin contiguous to these fissures, when accurately examined, is seen studded with small vesicles surrounded by an areola. These vesicles contain the specific fluid. It is the ill-management of the horse in the stable that occasions the malady to appear more frequently in the heel than in other parts. I have detected it connected with a sore on the neck of the horse, and on the thigh of a colt.”

Mr. Moore, of Chalford Hill, described a case in 1797, and regarded the disease as *virulent grease*. His horse was attacked with what was supposed to be ordinary “grease.” A cow was subsequently infected, and the disease communicated to the servant, who had “eruptions on his hands, face, and many other parts of the body, the pustules appearing large, and not much unlike the small-pox, for which he had been inoculated a year and a half before, and had then a very heavy burden.”

In 1798, Mr. Fewster, of Thornbury, met with a case of this equine malady, and wrote a very full account to Jenner of its transmission to the human subject.

“William Morris, aged thirty-two, servant to Mr. Cox of Almonsbury in this county, applied to me the 2nd of April, 1798. He told me that four days before he found a stiffness and swelling in both his hands, which were so painful it was with difficulty he continued his work; that he had been seized with pain in his head, small of the back, and limbs, and with frequent chilly fits succeeded by fever. On examination I found him still affected with these symptoms, and there was great prostration of strength. Many parts of his hands on the inside were chapped, and on the middle joint of the thumb of the right hand there was a small phagedænic



ulcer, about the size of a large pea, discharging an ichorous fluid. On the middle finger of the same hand there was another ulcer of a similar kind. These sores were of a circular form, and he described their first appearance as being somewhat like blisters arising from a burn. He complained of excessive pain, which extended up his arm into the axilla. On the 5th of April I again saw him, and found him still complaining of pain in both his hands, nor were his febrile symptoms at all relieved. The ulcers had now spread to the size of a seven-shilling gold coin, and another ulcer, which I had not noticed before, appeared on the first joint of the forefinger of the left hand, equally painful with that on the right. I ordered him to bathe his hands in warm bran and water, apply escharotics to the ulcers, and wrapped his hands up in a soft cataplasm. The next day he was much relieved, and in something more than a fortnight got well. He lost his nails from the thumb and fingers that were ulcerated."

Mr. Tanner, a veterinary surgeon, was the first to succeed in experimentally transmitting horse-pox to the teats of a cow by inoculating some of the liquid matter from the heel of a horse. From handling the cow's teats he became infected himself, and had two pustules on his hand, which brought on inflammation, and made him unwell for several days. The matter from the cow and from his own hand proved efficacious in infecting both human subjects and cattle.

In 1801 Dr. Loy published his experiments. A butcher had painful sores from dressing a horse suffering from 'grease,' and Dr. Loy succeeded in transmitting the disease to the udder of a cow. Matter was taken from the cow and inserted into the arm of a child. Dr. Loy also inoculated a child direct from a horse suffering from 'grease,' and subsequently five other children from this child.

From his experiments and observations Dr. Loy was led to differentiate constitutional grease from the merely local affection commonly known as the grease, and thus he explained the failure on the part of many experimenters to transmit this disease to the cow.

"This fact induces me"—he says—"to suspect that two kinds of grease exist, differing from each other in the power of giving disease to the human or brute animal; and there is another circumstance which renders this supposition probable. The horses that communicated the infection to their dressers were affected with a general as well as a topical disease. The animals at the commencement of their disease were evidently in a feverish state, from which they were relieved as soon as the complaint appeared at their heels,

and an eruption upon the skin. The horse, too, from which the infectious matter was procured for inoculation, had a considerable indisposition, previous to the disease at his heels, which was attended; as in the others, with an eruption over the greatest part of his body; but those that did not communicate the disease at all, had a local affection only. From this perhaps may be explained the want of success attending the experiments of the gentlemen I have mentioned."

Experiments with horse-pox were also made about this time on the Continent. Sacco made some observations upon this disease at Milan. Several horses were suffering from what was called *giardoni*, and Sacco's servant was attacked on both arms, from dressing one of his horses troubled with this disease. Several children and cows were inoculated from the horses, but without success. In another instance, a coachman went to the hospital with the eruption on his hands, and the disease was successfully communicated to three out of nine children.

In 1803 Dr. Marcet described some experiments which had been made at Salonica by M. La Font. The disease was known to the farriers in Macedonia as *javart*. In one case, a horse was attacked with feverish symptoms that ceased as soon as the eruption appeared. The fore legs were much swelled and several ulcers formed. M. La Font took some of the discharge from an ulcer and inoculated a cow and three children, and succeeded in transmitting the disease to two of the latter.

Vaccinogenic grease was observed in Paris in 1812, and Baron cites the case of a coachman who, after dressing a horse with the "grease," had a crop of pustules on his hands, from which the disease was experimentally transmitted by inoculation to two children. A series of inoculations was started from an infant who was infected from one of the scabs taken from the pustules on the hand of the coachman.

In 1813 Mr. Melon, a surgeon at Lichfield, met with vaccinogenic grease in the horse, and some of the virus was sent to Jenner, who carried on a series of arm to arm equinations for some months. And again in 1817, vaccinogenic grease broke out in a farm at Wansell. The farm-servants and the cows were infected, and Jenner employed this equine matter for a series of inoculations for eight months.

In 1817 Baron described a case of a young man who had not less than fifty pustules on his hands and wrists from dressing a horse with this disease, and in the following year Baron obtained some fresh equine virus from the hands of a boy who had been infected directly



from a horse. The disease assumed a pustular form, and extended over both arms.

In 1818 Kahlert met with this equine disease in Bohemia, and confirmed the experiments made by Loy and Sacco. Kahlert noticed that the joint of the foot was swollen, and moisture exuded from it, and that the posterior part of the pastern was slightly red, swollen and hotter than the neighbouring parts, and a clear yellowish fluid with a peculiar odour escaped. At the slightest touch the animal showed signs of pain; the hair was stuck together. The disease was successfully transmitted to cows and from cows to children.

In 1860 the horses at Rieumes, near Toulouse, were attacked by an epizoötic malady; in less than three weeks there were more than one hundred cases. According to the veterinary surgeon, M. Sarrans, the animals suffered from slight fever, rapidly followed by local symptoms, the most marked of which were swelling of the hocks, and an eruption of small pustules on the surface of the swollen parts, which were, at the same time, hot and painful. After three to five days there was a discharge from the pastern which continued for eight to ten days, during which the inflammation gradually diminished. The pustules dried up, and in about a fortnight the crusts with patches of hair fell off, leaving more or less marked scars. The eruption appeared at the same time on different parts of the body, especially on the nostrils, lips, buttocks, and vulva. Sarrans believed that the mares taken to the breeding establishment at Rieumes had been infected from the ropes which had been used in tying up other affected animals, and had become thereby infected with the virus of this disease. One of the mares was taken by the owner, M. Corail, to the veterinary school to be examined by M. Lafosse. About eight days after this visit significant symptoms appeared: loss of appetite, lameness, stiffness of both pastern joints, and a hot, painful swelling of the left pastern joint. The hair was staring, and there were vesicles on the skin, from which a liquid exuded having an ammoniacal odour but less fœtid than the secretion in *eaux aux jambes*.

M. Lafosse successfully transmitted the disease to cows, and from cows to children and to a horse.

In 1863 the subject of vaccinogenic grease or horse-pox again received great attention in France. A student named Amyot was engaged in dressing a horse on which an operation had been performed. The leg which had been operated on became the seat of a very confluent eruption of horse-pox, which was followed by such an abundant flow of serosity that at first the nature of the affection was mistaken, and it was thought to be a complication of *eaux aux*

*jambes*. Amyot had a wound on the dorsal aspect of the first interphalangeal joint of the little finger of his right hand; in spite of this, he continued to dress the horse entrusted to his care. The wound on his finger became accidentally inoculated with the virus, which flowed in great abundance from the horse's leg.

The wound was made on August 3rd, and the next day it was swollen, and rather painful. On the 5th, Amyot suffered from malaise and great weakness; on the 6th, 7th, and 8th, vesicles appeared successively on the fingers of his left hand, and on his forehead between the two eyebrows. On the 9th, these vesicles were fully developed; those of the fingers consisted of very large epidermic bullæ on a bluish-red base. On opening them, a perfectly limpid fluid escaped in such abundance that small test-tubes might have been filled with it. The vesicle on the forehead was surrounded by a bluish-red areola, within which, the epidermis, of a leaden-grey hue, was raised, and had a slight central depression. The liquid which flowed from it when it was opened, and which continued to ooze, was also very abundant and of a deep citrine colour.

The vesicles which had developed on the dorsal side of Amyot's fingers were extremely painful. The incessant shooting pains, of which they were the seat, prevented him from getting any rest for three days. On the 10th, inflammation of the lymphatics followed; both arms were swollen and very painful, with red lines indicating the course of the lymphatic vessels. The glands of the axillæ were also enlarged.

The lymphatic glands behind the jaws were also swollen and painful. Amyot's chief sufferings were occasioned by the intense local pain caused by the vesicles on the fingers, and by the inflammation of the lymphatic vessels and glands, which continued in this state up to the 18th of August. It was only at the end of the month that the vesicles were completely cicatrised.

Bouley felt very great anxiety in the presence of the grave symptoms which accompanied the eruption. The eruption on the forehead was especially a cause of great uneasiness, because glanders manifests itself in a similar way.

With virus from Amyot's vesicles the disease was transmitted to cows and to children.

Further, this outbreak enabled exhaustive experiments to be made, by which it was definitely established that horse-pox is never infectious, but, like cow-pox, is transmitted solely by contact.

In 1880, M. Baillet, Director of the National Veterinary School of Toulouse, was informed that a contagious malady had developed



in the mares, which had been served by the stallions at the breeding establishment at Rieumes, belonging to M. Mazères. M. Peuch was delegated to investigate this outbreak, and he visited for that purpose Bérat, Rieumes, and Labastide-Clermont.

At Bérat three mares were examined. In one, there were scars and crusts, the remains of an eruption on the lips and in the vicinity of the vulva; in another, there were several reddish circular ulcers in the same region; and in a third, there were dried pustules with blackish adherent crusts at the circumference of the vulva and extending over the perinæum. On the lower part of the left flank a vesicle was discovered surmounted by a crust, and when the latter was detached a sero-sanguinolent liquid oozed from the exposed surface. M. Peuch recognised the true nature of this disease, having several times previously had the opportunity of examining mares with a vesicular eruption round the vulva after coition, which eruption he had studied from its first appearance to complete cicatrisation, and had ascertained to be horse-pox.

On proceeding to Rieumes, M. Peuch inspected eleven stallions, six horses, and five asses. In one ass there were several vesicles on the right side of the penis scattered about from the base to the glans. In another ass there was a trace of a vesicle on the penis and a characteristic vesicle on the left nostril.

In an old bay mare there were the remains of an eruption on the circumference of the vulva, and in an old white mare there were not only vesicles on the vulva, but in addition vesicles on the inner side of the lower lip. M. Peuch drew special attention to these cases as likely to be confounded with aphthous stomatitis, but the existence of the same eruption on other parts of the body is an important aid in making a diagnosis of horse-pox.

At Labastide-Clermont one mare was particularly noticed. This mare had been served on the 19th and 21st of April, and on the occasion of the inspection, May 11th, there were the remains of an eruption around the vulva, and lymphangitis existed in the right posterior limb, which was engorged, hot, and painful in its whole extent, so that the animal walked with difficulty. The proprietor had contracted the disease in attending to his mare, and exhibited a vesicle on the thumb of the right hand, excoriated and blackened, but still recognisable.

Some of the crusts collected from the cases at Bérat were used for inoculating a cow. The result was successful, and the disease was transmitted by inoculation to a heifer and several students and children.

M. Peuch ascertained that horse-pox caused considerable alarm from the fact that the breeders regard this eruptive affection as syphilitic, and this alarm consequently brings discredit upon the breeding establishment whence the illness has spread. He was also led to appreciate the great necessity for further study of this disease in relation to *dourine* or *maladie du coit*.

In 1882 M. Peuch had the opportunity of investigating a case of horse-pox in Algeria. The disease occurred in a thoroughbred Arab. There was an eruption of vesicles, and there was also an ulcer the size of a five-franc piece in the nostril. In the mouth and on the lips there were a number of small vesicles about the size of a pea. The sublingual glands were engorged, hot, and painful on pressure. The coat, in patches, on the lateral aspect of the neck, on the shoulders, the flanks, and in the hollow of the heel, was staring, giving the appearance of small paint-brushes. On passing the hand over these, vesicles could be detected partly dry and partly secreting.

The disease was transmitted to cows, and from cows to about one thousand five hundred persons.

Cases similar to the one just described, in which there is more or less marked ulceration of the nostril or nasal septum, must be carefully distinguished from glanders. And again, when the sublingual glands are affected the disease may be mistaken for strangles.

#### NATURE AND AFFINITIES.

Horse-pox and human small-pox are quite distinct diseases, and the theory that horse-pox is derived from grooms or other attendants suffering from small-pox may be dismissed without further comment.

Horse-pox is never infectious, but is communicated solely by contact—either by grooms inoculating the virus with their hands, sponges, or brushes, or by horses coming into contact with each other, and in breeding establishments by coition. Auzias Turenne, who wrote exhaustively on this subject, maintained that horse-pox came into the same category of diseases as syphilis in man.

“A un point de vue, le grease pustuleux inoculé offre la plus parfaite ressemblance avec la verole inoculée, par le produit des accidents secondaires. Des deux côtés nous voyons, absence de contagion par la voie de l'atmosphère, travail local, retentissement lymphatique et ganglionnaire, fermentation universelle de l'organisme, eruption générale et immunité acquise contre de nouvelles atteintes.

“A un autre point de vue, la ressemblance avec la variole est



frappante. Mais il s'en distingue énormément par l'absence de la contagiosité atmosphérique."

Human small-pox belongs to a different group of diseases, and has affinities rather with small-pox of sheep and cattle plague, diseases which are not only inoculable, but highly infectious. Human small-pox is an infectious disease characterised by sudden and severe fever, followed after forty-eight hours by a generalised eruption; horse-pox commences as a local affection, and constitutional symptoms follow. Auzias Turenne, guided by analogy, described the generalised eruptions following "grease" or horse-pox as *greasides* ("comme on dit syphilides").

Horse-pox and human syphilis are absolutely distinct diseases; and there is no more ground for believing that horse-pox originates in human syphilis than there is for accepting the theory that it arises from grooms suffering from small-pox. Syphilis artificially inoculated on the human subject only resembles the casual or intentional inoculation of *virulent* horse-pox. The stages of papulation, vesiculation, ulceration, scabbing, and the formation of a permanent scar, occur in inoculated syphilis, and if we examine Ricord's illustrations and study the experiments of Auzias Turenne, we cannot fail to be struck with the remarkable similarity to the results obtained and depicted by Jenner.

But in order to follow the argument of Auzias Turenne we must study the *natural* and *casual* horse-pox. And if we are not familiar with what has been written on this subject, and if we restrict our knowledge to the artificially cultivated horse-pox, we shall fail to recognise the disease when we meet with it, and we shall be liable to attribute the results of the full effect of the virus to accidental contamination.

Another question of very great interest is the relation of horse-pox to cow-pox. Jenner first of all propounded the theory that all cow-pox arose from horse-pox, or as he termed it "the grease," and thus cow-pox and horse-pox were manifestations of the same disease. But it was established that cow-pox also arose quite independently of horse-pox, and Jenner was led to distinguish between cow-pox, a disease peculiar to the cow, and the eruptive affection transmitted to the cow from the horse, which farmers and others, by a strange perversion of terms, called the cow-pox. Whether the eruption of cow-pox can be distinguished from the eruption of horse-pox communicated to the cow, and whether cow-pox and horse-pox are identical, or only analogous, are questions which call for further investigation.

**Bacteria in Horse-pox.**—Outbreaks of horse-pox have not been investigated from the bacteriological point of view, and the nature of the contagium is unknown.

#### Cow-pox.

Cow-pox is a vesicular disease of the teats of cows. It is never infectious, and only attacks cows in milk, the virus being transferred from cow to cow by the hand of the milker. The disease is communicable to milkers, and the virus artificially inoculated produces what is commonly known as vaccinia. In its clinical history and epidemiology cow-pox is totally distinct from human small-pox, and the hypothetical and entirely erroneous suggestion that the disease arises from milkers suffering from human small-pox is responsible for the belief which prevailed until recently, that cow-pox was an extinct disease in this country; but, by the author's researches, this has been shown to be a mistake.

Cow-pox is not a rare disease, and it has never been found to arise from a milker suffering from small-pox. As this is a matter of great importance in discussing the etiology of the disease, the history of outbreaks and the clinical characters of cow-pox will be given in considerable detail.

According to Jenner, cow-pox had been known among farmers from time immemorial. He refers to cases occurring in 1770, 1780, 1782, 1791, 1794, 1796, and 1798. In 1799 cow-pox was raging in the dairies in London, and outbreaks were investigated by Woodville, Pearson, and Bradley. In the same year cow-pox broke out at Norton Nibley, in Gloucestershire. Pearson and Aikin referred to the prevalence of cow-pox in Wilts, Somerset, Devon, Bucks, Dorset, Norfolk, Suffolk, Leicestershire, and Staffordshire; and Barry mentioned its prevalence in Ireland.

From this time onwards, for a long period, natural cow-pox received little or no attention in this country. Fresh stocks of lymph were raised for the purposes of vaccination, but no further attention was given to studying the disease in the cow. In 1836 Leese described an outbreak of cow-pox, and in 1838 Estlin discovered an outbreak in Gloucestershire. In 1838-39 cow-pox was met with by Mr. Fox, of Cerne Abbas, and again in 1839, in Dorsetshire, by Mr. Sweeting. Ceely frequently met with cow-pox in the Vale of Aylesbury, and particularly refers to outbreaks in 1838, 1840, 1841, and 1845. But after this, outbreaks of this disease in the cow were not recorded, though several medical practitioners met with the disease and raised fresh stocks of vaccine lymph. Thus, when



inquiries were made in 1857, it was found that Mr. Donald Dalrymple, of Norwich (on two occasions), Mr. Beresford, of Narborough, in Leicestershire, Mr. Gorham, of Aldeburgh, Mr. Alison, of Great Retford, Mr. Coles, of Leckhampton, Mr. Rudge, of Leominster, and one or two others, had met with outbreaks of cow-pox.

In 1885 cow-pox was discovered by the author in Wiltshire. The publication of the fact led to the recognition of the disease in the same year in many parts of England, and cases were met with in man in 1888 by Mr. Forty in Gloucestershire, and by Mr. Bucknill near London in 1894.

In Italy, cow-pox was found by Sacco in the plains of Lombardy in 1800, and by other practitioners in 1808-9. In 1812 it was observed at Naples by Miglietta; in 1830 in Piedmont; and in 1832 and 1843 at Rome, by Dr. Maceroni. More recently, several outbreaks of cow-pox have been met with in this country, and the stocks of vaccine lymph renewed.

In France, in 1810, cow-pox was found in the department of La Meurthe, and in 1822 at Clairvaux; at Passy, Amiens, and Rambouillet in 1836; at Rouen in 1839; at St. Illide, at St. Seine, and at Perylhac, in 1841; in 1842 at Pagnac; in 1843 at Deux Jumeaux, where, during the previous thirty years, several fresh stocks of lymph had been raised and circulated. The disease occurred in a cow belonging to M. Majendie in 1844, and it was found at Wasseloune, in the department of Bas Rhin, in 1845; it occurred in three other departments in 1846; at Rheims, and in the department of Eure et Loire, in 1852; in the arrondissement of Sancerre, and at Beziers in 1854; and at Guyonville in 1863. It broke out on farms in three villages near Nogent in 1864 (the disease was introduced by newly purchased cows; milkers were infected, and from one of these milkers a lymph stock was established); it also occurred in 1864, at Petit Quevilly, near Rouen; and in April 1866 at Beaugency; in 1881 at Eysines, near Bordeaux, and again at the same place in 1883; and in 1844 at Cérons.

In Germany, as soon as attention had been drawn to the disease, cow-pox was frequently discovered. There were as many as thirty-eight outbreaks reported in one year in Wurtemberg.

It is hardly necessary, after reciting these instances, to insist that cow-pox is far from being a rare disease, as many have supposed who are unacquainted with the literature of the subject and unfamiliar with the appearances of the natural disease in the cow.

## NATURAL AND CASUAL COW-POX.

To appreciate the characters of the natural disease in the cow, we must dismiss from our minds the artificial disease *vaccinia*, for the ordinary results of vaccination stand in much the same relation to the natural disease cow-pox as the benign vesicle of variolation to natural small-pox.

The description of cow-pox given by Jenner, in 1798, was the first published account. The disease in the cow was described as consisting of irregular pustules on the teats, of a palish blue colour, surrounded by an erysipelatous inflammation, and characterised by a tendency to degenerate into phagedænic ulcers. The animals were indisposed and the secretion of milk lessened.

In referring to an outbreak which occurred epizootically in London in February 1799, Dr. Bradley gave a coloured plate of the disease on the arm and fingers of a milker. The cow-pox, he said, in this instance, "appears to have been very mild, for no loss was experienced by the farmers from the deficiency of milk, as usually happens."

These early descriptions were supplemented by an account of cow-pox by Mr. Lawrence, author of *A Philosophical and Practical Treatise on Horses, and on the Moral Duties of Man toward the Brute Creation*. Lawrence's article on cow-pox not only affords evidence that this disease was known to those who had the care of cattle before Jenner's paper was published, but it shows that it had also been made the subject of practical observation and study by veterinarians. Lawrence concluded by saying: "Whatever may be the fate of cow-pox inoculation, it has and will give further occasion to a pretty large and open discussion, which is always beneficial as having a tendency to produce discovery and promote improvement; and when the public ardour for the present topic shall have become a little cool and satisfied, I hope it will be turned by enlightened men towards another, perhaps of nearly as great consequence—namely, the prevention of the original malady in the animals themselves. Those who have witnessed it and only reflected upon the excessive filth and nastiness which must unavoidably mix with the milk in an infected dairy of cows, and the corrupt and unsalubrious state of their produce in consequence, will surely join me in that sentiment."

Lawrence was almost a century before his time. Cow-pox was not again brought forward in this light until 1887-88, when the author reported the contamination of the milk at the Wiltshire farms, and



advocated the advisability of placing this disease under the Contagious Diseases (Animals) Act.

The numerous pathological details wanting in the early accounts of cow-pox were supplied by the painstaking and laborious researches of Robert Ceely. From his classical papers in the Transactions of the Provincial Medical Association, we can obtain a complete picture of the natural disease in the cow.

In Ceely's experience in the Vale of Aylesbury, outbreaks occurred at irregular intervals, most commonly appearing about the beginning or end of the spring, rarely during the height of summer. There were outbreaks at all periods from August to May and the beginning of June, cases being met with in autumn and the middle of winter, after a dry summer. The disease was occasionally epizootic, or occurring at times at several farms at no great distance from each other, but was more commonly sporadic or nearly solitary. It was to be seen sometimes at several contiguous farms; at other times at one or two farms. Many years might elapse before it recurred at a given farm, although all the animals might have been changed in the meantime. Cow-pox had broken out twice in five years in a particular vicinity at two contiguous farms, while at an adjoining dairy, in all respects similar in local and other circumstances, it had not been known to exist for forty years. It was sometimes introduced into a dairy by recently purchased cows. Twice it had been known to be so introduced by milch heifers. It was considered that the disease was peculiar to the milch cow; it came primarily while the animal was in milk, and it was casually propagated to others by the hands of the milkers. Sturks, dry heifers, dry cows, and milch cows milked by other hands, grazing in the same pastures, feeding in the same sheds, and at contiguous stalls, remained exempt from the disease.

For many years, the "spontaneous" origin of cow-pox had not been doubted in the Vale of Aylesbury. In all the cases that Ceely had noticed he could never discover the probability of any other origin.

*Condition of Animal primarily affected.*—There was much difficulty in determining at all times, with precision, whether this disease arose primarily in one or more individuals in the same dairy. Most commonly, however, it appeared to be solitary. The milkers believed they were able to point out the infecting individual. In two instances, there could be very little doubt on this point. In August 1838, three cows were affected with the disease. The first was attacked two months after calving and seven weeks after

weaning. This animal was considered in good health, but it looked out of condition. Heat and tenderness of the teats and udder were the first noticed signs. The other two were affected in about ten days. In December 1838, in a large dairy, a milch cow slipped her calf, had heat and induration of the udder and teats, with cow-pox eruption, and subsequently leucorrhœa and greatly impaired health; the whole dairy, consisting of forty cows, became subsequently affected, and also some of the milkers. In another dairy, at the same time, it first appeared in a heifer soon after weaning, and in about ten or twelve days extended to five other heifers and one cow, milked in the same shed, affecting the milkers. And in another dairy thirty cows were severely affected, and also one of the milkers. It appeared to originate in a cow two months after calving. The only symptoms noticed were that the udder and teats were tumid, tender, and hot just before the disease appeared.

*Condition of Animals casually affected.*—In some animals, it was less severe than in others, depending on the state and condition of the skin of the parts affected, and the constitution and habit of the animal. It was sometimes observed to diminish the secretion of milk, and in most cases it commonly did actually affect the amount artificially obtained; with this exception, and the temporary trouble, and accidents to the milk and the milkers, little else was observed; the animal continued to feed and graze apparently as well as before. The topical effects varied very much in different individuals; the mildness or severity being greatly influenced by temperament and condition of the animal, and especially by the state of the teats and udder, and the texture and vascularity of the skin of the parts affected. Where the udder was short, compact, and hairy, and the skin of the teats thick, smooth, tense, and entire, or scarcely at all chapped, cracked, or fissured, the animal often escaped with a mild affection, sometimes with only a single vesicle. But where the udder was voluminous, flabby, pendulous, and naked, the teats long and loose, and the skin corrugated, thin, fissured, rough, and unequal, then the animal scarcely ever escaped a copious eruption. Hence, in general, heifers suffered least, and cows most, from the milkers' manipulations.

*Progress of the Disease.*—Cow-pox once arising or introduced, and the necessary precautions not being adopted in time, appeared in ten or twelve days on many more cows in succession, so that among twenty-five cows perhaps by the third week nearly all would be affected; but five or six weeks or more were required before the teats were perfectly free from the disease.



*Propagation by the Hand of the Milker.*—Ceely was able to confirm the way in which the disease was said to spread. In December 1838, on a large dairy farm, where there were three milking-sheds, cow-pox broke out in the home or lower shed. The cows in this shed being troublesome, the milker from the upper shed, after milking his own cows, came to assist in this for several days, morning and evening, when in about a week some of his own cows began to exhibit the disease. It appears that, having chapped hands, he neglected washing them for three or four days at a time, and thus conveyed the disease from one shed to another. During the progress of the disease through this shed, one of the affected cows, which had been attacked by the others, was removed to the middle shed, where all the animals were perfectly well. This cow, being in an advanced stage of the disease, and of course difficult to milk and dangerous to the milk-pail, was milked first in order by the juvenile milker for three or four days only, when, becoming unmanageable by him, its former milker was called in to attend exclusively to it. In less than a week, all the animals of this shed showed symptoms of the disease, though in a much milder degree than it had appeared in the other sheds, fewer manipulations having been performed by an infected hand.

*Topical Symptoms of the Natural Disease.*—For these, Ceely was almost always, in the early stage, compelled to depend on the observations and statements of the milkers. They stated that for three or four days, without any apparent indisposition, they noticed heat and tenderness of the teats and udder, followed by irregularity and pimply hardness of these parts, especially about the bases of the teats and adjoining the vicinity of the udder; these pimples on skins not very dark are of a red colour, and generally as large as a vetch or a pea, and quite hard, though in three or four days many of these increase to the size of a horse-bean. Milking is generally very painful to the animal; the tumours rapidly increase in size, vesicate, and are soon broken by the hands of the milker. Milking now becomes a troublesome and occasionally a dangerous process. Ceely adds: "It is very seldom that any person competent to judge of the nature of the ailment has access to the animal before the appearance of the disease on others of the herd, when the cow first affected presents on the teats acuminated, ovoid, or globular vesications, some entire, others broken, not infrequently two or three interflorent; those broken have evidently a central depression with marginal induration; those entire, being punctured, diffuse a more or less viscid amber-coloured fluid, collapse, and at once indicate the

same kind of central and marginal character. They appear of various sizes, from that of a pin's head, evidently of a later date, either acuminate or depressed, to that of an almond or a filbert, or ever larger. Dark brown, or black, solid, uniform crusts, especially on the udder near the base of the teats, are visible; at the same time, some much larger are observed on the teats; these, however, are less regular in form and less perfect. Some are nearly detached, others quite removed, exhibiting a raw surface with a slight central slough. On the teats, the crusts are circular, oval, oblong, or irregular; some flat, others elevated, some thin and more translucent, being obviously secondary. The appearance of the disease in different stages, or at least the formation of a few vesicles at different periods, seems very evident. The swollen, raw, and encrusted teats seem to produce uneasiness to the animal only while subjected to the tractions of the milkers, which it would appear are often nearly as effectual as usual." Referring again to the character of the vesicle, Ceely says, that "those fortunate enough to have an opportunity of watching the disease in its progress may observe that, when closely examined, they present the following characters: In animals of dark skin, at this period, the finger detects the intumescent indurations often better than the eye, but when closely examined the tumours present at their margins and towards their centres a glistening metallic lustre or leaden hue; but this is not always the case, for occasionally they exhibit a yellowish or yellowish-white appearance."

In describing the crusts in detail, Ceely says that "large black solid crusts, often more than an inch or two in length, are to be seen in different parts of these organs, some firmly adherent to a raw elevated base, others partially detached from a raw, red, and bleeding surface; many denuded, florid, red, ulcerated surfaces, with small central sloughs secreting pus and exuding blood, the teats exceedingly tender, hot, and swollen. . . . In some animals, under some circumstances, this state continues little altered till the third or fourth week, rendering the process of milking painful to the animal, and difficult and dangerous to the milker."

"In many, however, little uneasiness seems to exist. The parts gradually heal; the crusts, although often partially or entirely renewed, ultimately separate, leaving apparently but few deep irregular cicatrices, some communicating with the tubuli lactiferi, the greater part being regular, smoothly depressed, circular, or oval."

Ceely illustrated his classical memoir with a series of valuable coloured drawings. One plate is a faithful picture of the disease on



the teats as it is ordinarily met with ; the other is a composite picture, consisting of the disease as ordinarily observed in the cow, to which is superadded a number of depressed vesicles as they occur in inoculated cow-pox. It is, however, an improvement on a plate published by Sacco. The latter is an elaborate drawing, representing the udder and teats of a cow, with an eruption purporting to be the natural cow-pox. Jenner had described a bluish tint in the vesicles in natural cow-pox, and Sacco deliberately represents the natural disease by a highly coloured diagrammatic illustration in which he depicts clusters of vesicles of *inoculated* cow-pox, coloured blue, and with a silvery lustre.

Hering has given a coloured plate of the natural cow-pox. On the teats are a number of oval and circular *bullous* vesicles and crusts. More recently, Layet has pointed out the same characters in the cow-pox discovered near Bordeaux in 1883 and 1884. The classical characters of the inoculated disease were wanting, particularly the central depression. In Wiltshire, the author could only distinguish, on the cow's teats, globular and broken vesicles and thick prominent crusts and ulcers, appearances which had very little in common with the ordinary results of vaccination.

The early accounts of the severe character of the disease will appear by no means exaggerated to those who have had an opportunity of studying the effects on the hands of the milkers, or indeed to those who have made themselves familiar with the descriptions given by Jenner, in some of his cases :—

“ Joseph Merret had several sores on his hands, swelling and stiffness in each axilla, and much indisposition for several days.

“ Mrs. H. had sores upon her hands which were communicated to her nose, which became inflamed and very much swollen.

“ Sarah Wynne had cow-pox in such a violent degree that she was confined to her bed, and unable to do any work for ten days.

“ William Rodway was so affected by the severity of the disease that he was confined to his bed.

“ William Smith had several ulcerated sores on his hands, and the usual constitutional symptoms, and was affected equally severely a second and a third time.

“ William Stinchcomb had his hand very severely affected with several corroding ulcers, and a considerable tumour in the axilla.

“ Sarah Nelmes had a large pustulous sore on the hand, and the usual symptoms.

“ A girl had an ulceration on the lip from frequently holding her finger to her mouth to cool the raging of a cow-pox sore by blowing upon it.

"A young woman had cow-pox to a great extent, several sores which matured having appeared on the hands and wrists.

"A young woman had several large suppurations from cow-pox on the hands."

Pearson in his investigations encountered, and was informed of, similar experiences.

"Thomas Edinburgh was so lame from the eruption of cow-pox on the palm of the hand as to necessitate his being for some time in hospital. For three days he had suffered from pain in the armpits, which were swollen and sore to the touch. He described the disease as uncommonly painful, and of long continuance.

"A servant at a farm informed Pearson that in Wiltshire and Gloucestershire the milkers were sometimes so ill as to lie in bed for several days.

"Mr. Francis said that cow-pox was very apt to produce painful sores on the hands of milkers.

"A servant of Mr. Francis said that cow-pox affected the hands and arms of the milkers with painful sores as large as a sixpence.

"Mr. Dolling describes the disease as 'a swelling under the arm, chilly fits, etc., not different from the breeding of the small-pox. After the usual time of sickening, namely, two or three days, there is a large ulcer, not unlike a carbuncle, which discharges matter.'

"Dr. Pulteney described the disease as causing 'a soreness and swelling of the axillary glands, as under inoculation for the small-pox, then chilliness and rigors and fevers, as in the small-pox. Two or three days afterwards abscesses, not unlike carbuncles, appear generally on the hands and arms, which ulcerate and discharge much matter.'

"Mr. Bird wrote a short account: 'It appears with red spots on the hands, which enlarge, become roundish, and suppurate, tumours take place in the armpit, the pulse grows quick, the head aches, pains are felt in the back and limbs, with sometimes vomiting and delirium.'

"Annie Francis had pustules on her hands from milking cows. These pustules soon became scabs, which, falling off, discovered ulcerating and very painful sores, which were long in healing. Some milk from one of the diseased cows, having spurted on the cheek of her sister and on the breast of her mistress, produced on these parts of both persons pustules and sores similar to her own on her hands."

In more recent times these descriptions have been confirmed.

In 1836 cow-pox was discovered at Passy, near Paris. A black cow, in very poor condition, had cow-pox six weeks after calving. Bousquet had no opportunity of seeing the eruption in the early stage, but on examination he found reddish-brown crusts on the teats, which later gave place to puckered scars. The milk-woman, Fleury, who had had small-pox, nevertheless contracted the disease from the cow. She had several vesico-pustules on the right hand



and on her lips. A vesico-pustule, when opened with a lancet, discharged like an abscess.

In a letter to Mr. Badcock, dated April 3rd, 1845, Ceely referred to another new stock of lymph raised from a milker's hand. He added:—

“In the enclosed lymph I see nothing unusually severe, except on very thin skins; although the milker's hand exhibits now rough ulcers, one on the hand deep enough to encase a bean.”

*Recent discoveries of cow-pox in England.*—After Ceely's cases in 1840-41, no cases of casual cow-pox on the hands of milkers were recognised as such and recorded in this country for nearly fifty years. In the outbreak of cow-pox discovered by the author in December 1887, in Wiltshire, the disease was communicated to nearly all the milkers. The reader is referred to the account of this outbreak, which has already been given in the chapter on scarlet fever (p. 274).

The author's researches were confirmed by Mr. Forty in 1888, and Mr. Bucknill in 1895.

In June 1888 Mr. Forty, in practice at Wotton-under-Edge, Gloucestershire, reported to the Local Government Board, that at a farm at Alderley, an eruptive disease on the udder and teats was occurring amongst cows, and that the farmer's son, and other persons engaged as milkers, had contracted an eruption like that of the cows. The farmer's son had been under Mr. Forty's care suffering from an eruption, and circum-anal piles. Mr. Forty had watched the course of the eruption from papules to vesicles and scabbing, and concluded that the eruption could not be distinguished from vaccinia. Klein visited the farm, and found a number of cows with sores on the teats and udders. The sores were of various sizes and outline, mostly irregular, and covered with brown or black scabs. Those on the teats were larger and more irregular than those on the udder. Klein was shown several milkers who had had sores on one or more fingers; one had had a bad arm with swollen axillary glands. The farmer had also contracted the eruption; but in these persons only scabs were visible as the remnants of their sores.

A girl of about twenty had taken the place of an incapacitated milker, and noticed a red pimple form on the dorsal surface of her right thumb. Eight days afterwards there was a slightly raised circular vesicle, with dark centre and pale periphery; the centre of the vesicle was slightly depressed. It was just under half an inch in diameter; there was peripheral redness, but no marked areola. The girl had three good vaccination marks.

Klein experimented on calves with lymph from the vesicle and

crusts from the cow's teats, with the result that from both sources an eruption was produced, which in appearance and course was like vaccinia. With lymph from one of the calves, a public vaccinator inoculated a number of infants, and fine vesicles developed, indistinguishable from vaccinia.

In 1894 Mr. Bucknill met with a case in a milkman. He had been milking a cow affected with cow-pox, and on the ninth day after exposure to infection, and the seventh day after the eruption of the first papule, there were three pocks on the fore-arm. The pocks were elevated, circular, and umbilicated, with a dull, creamy-white ring at the circumference, and there was well-marked induration and extensive areola. There were four excellent marks of primary vaccination. The vesicles contained clear lymph, and re-inoculation of the arm failed to take. An attempt to re-vaccinate the man with current calf lymph produced only topical irritation.

#### INOCULATED COW-POX.

*Natural or Virulent Lymph.*—Severe symptoms are not limited to milkers casually infected from the cow. Under certain conditions, artificial inoculation of fresh virus from the cow reproduces the disease without any mitigation. Thus, in Jenner's cases:—

“James Phipps. The incisions assumed at their edges rather a darker hue than in variolous inoculation, and the efflorescence around them took on more of an erysipelatous look. They terminated in scabs and subsequent eschars.

“Susan Phipps was inoculated from the cow by inserting matter into a superficial scratch on December 2nd. The child's arm now showed a disposition to scab, and remained nearly stationary for two or three days, when it began to run into an ulcerous state, and then commenced a febrile indisposition, accompanied with an increase of axillary tumour. The ulcer continued spreading near a week, during which the child continued ill, when it increased to a size nearly as large as a shilling. It began now to discharge pus; granulations sprung up, and it healed.”

Jenner's lymph was employed by Mr. Cline with similar results.

“The child sickened on the seventh day, and the fever, which was moderate, subsided on the eleventh. . . . The ulcer was not large enough to contain a pea.”

Precisely similar experiences have since been encountered, in the early removals of fresh stocks of virulent lymph. Bousquet in France, in his first trials with a new lymph, in 1836, made three punctures, but he had soon to abandon this practice, because the intensity



of the inflammation was sometimes so great that it spread over the entire arm as far as the glands of the axilla. In one case, the vesicles were enormous, and the inflammation so violent, that baths, poultices, fomentations, and antiphlogistic diet scarcely sufficed to reduce it. The crusts when they fell off left ulcerations which were very slow to undergo cicatrisation. In some cases, the vesicles which resulted hollowed out the skin so deeply that they left regular holes.

In the following year Estlin, in England, started a stock of fresh vaccine virus from the cow, and found on inoculating children that the new lymph was extremely active.

- In 52 the disease was regular,  
 ,, 1 severe erysipelas,  
 ,, 4 erythematous eruptions of a violent character,  
 ,, 2 highly inflamed ulcerated arms,  
 ,, 1 no effect after twice vaccinating,  
 ,, 8 result unknown ; supposed to have been favourable.

---

68

---

*Cultivated or Attenuated Lymph.*—When cow-pox lymph has been mitigated by successive transmission through the human subject, or by cultivation on the belly of the calf, with careful selection of vesicles, it will produce effects which are as follows: About the end of the second day after insertion, or early on the third day, a slight papular elevation is noticeable. By the fifth or sixth day, it has become a distinct vesicle, of a bluish-white colour, with raised margin and central cup-like depression. By the eighth day, the vesicle is perfect. It is circular, pearl-coloured, distended with clear lymph, and the central depression is well marked. On the same day, or a little earlier, the areola begins to appear, and gradually extends to a diameter of from one to three inches, accompanied with induration and tumefaction of the subjacent connective tissue. After the tenth day, the areola begins to fade, and the vesicle at the same time begins to dry in the centre; the lymph becomes opaque and gradually concretes, and by the fourteenth or fifteenth day, a hard mahogany-coloured scab is formed which contracts, dries, blackens, and falls off between the twentieth and twenty-fifth days. A circular, depressed, foveated, and sometimes radiated scar remains behind. By selecting characteristic vesicles on the calf or on the human subject, and by collecting the lymph at an early stage on the fifth, sixth, or seventh day, this artificial disease, commonly known as

*vaccinia*, can be kept up in this comparatively mild form. But under certain conditions, such as a peculiarity in the subject inoculated, or if lymph be taken too late, there will be, just as in variolation, tendency to revert to the full intensity of the natural virus.

**Bacteria in Vaccine Lymph.**—Cohn, Sanderson, and Godlee described micrococci in vaccinal vesicles. Quist and Ferré in 1883 investigated the same subject. Voigt in 1885 distinguished three species of micrococcus—a diplococcus, a large coccus, and a third form. Bauer in the same year described the presence of bacilli and sphaerococci. Marotta in 1886 regarded a tetracoccus as the specific micro-organism, and Tenhot in 1887 distinguished a dozen micrococci, two bacilli, and two yeasts. In the same year Garré isolated a micrococcus which appeared to him to be the contagium, but inoculated on a child it neither produced local vesicles nor immunity; while Guttman pointed out three micro-organisms which appeared to be rather more constantly present than others. Pfeiffer much more fully investigated the bacteriology of vaccine lymph, and found *Saccharomyces vaccinae*, which was seldom present in human lymph but constantly found in calf lymph; *sarcinae*, both in human and calf lymph, including *Sarcina lutea*, *Sarcina tetragonus*, *Sarcina aurantiaca*, *Sarcina muscopus*; bacteria and bacilli were found only exceptionally in human lymph, but frequently in calf lymph. These included a bacterium corresponding with *Proteus vulgaris*.

Three mice were inoculated subcutaneously with a drop of the liquefied gelatine, but the result was negative. The injection of a considerable quantity proved fatal to guinea-pigs and rabbits, a result which was probably due to ptomaine poisoning.

There were also several bacilli which did not liquefy gelatine; these were not investigated.

*Staphylococcus cereus albus* was found very frequently, and *Staphylococcus pyogenes aureus* occasionally. Pure-cultivations of these micrococci inoculated on the skin of calves produced a rapid local irritation, followed by vesiculation, but without the classical characters of the vaccine vesicle. The inoculated part was completely healed in three to five days. According to Pfeiffer they explain the so-called false vaccine.

*Micrococcus pyogenes albus* was almost constantly present. Numerous other micrococci were found, but not constantly present; vaccine lymph being a splendid medium for the growth of micrococci. Pfeiffer pointed out that the effects of *Staphylococcus pyogenes aureus*, *albus*, and *citreus*, and of *Streptococcus pyogenes* on rabbits had an important bearing upon the practice of vaccination, and he recom-



mended that calf lymph should be tested before use upon children by inoculation of the ear of a rabbit. If after two days no erysipelas occurs in the inoculated rabbit, the absence of streptococci may be considered as almost proved. Two or three rabbits should be inoculated at the same time.

The author's researches into the bacteriology of vaccine lymph extended over some years. They independently confirmed and extended the results obtained by Pfeiffer. Having on several occasions examined vaccine lymph and vaccine pus, and failed to find a specific bacterium, the author proceeded to make a more systematic examination of the different species of bacteria in samples of current vaccine lymph. Pure-cultivations were obtained by plate-cultivation, and inoculation of the surface of nutrient agar, obliquely solidified in test tubes. Various current stocks of lymph were used in the investigation. Among the specimens of calf lymph, No. 1 yielded a torula, *Bacillus pyocyaneus* and *Bacillus subtilis*; No. 2, a bacterium, a variety of proteus, *Staphylococcus pyogenes aureus*, and yellow bacterium; No. 3, a bacterium, micrococcus, yellow bacterium, and torula; No. 4, yellow micrococcus, white micrococcus, white torula, yellow sarcina, white diplococcus, *Staphylococcus cereus albus*, and a mould fungus; No. 5, yellow sarcina, *Staphylococcus pyogenes aureus*, yellow micrococcus, white bacillus, *Staphylococcus pyogenes albus*, large white micrococcus, yellow bacterium, and a white micrococcus. Among the specimens of human vaccine lymph, No. 1 contained a white micrococcus, proteus, and *Staphylococcus pyogenes aureus*; No. 2, a micrococcus, a tetracoccus, a white liquefying micrococcus, and a yellow bacterium; No. 3, white micrococcus, yellow micrococcus, *Staphylococcus aureus* and *flavus*, a bacterium, a white micrococcus, a bacillus resembling *Bacillus subtilis*, *Staphylococcus pyogenes cereus* and a brown tetracoccus. The author is familiar with these different species of bacteria, and not one of them is peculiar to vaccine lymph; there was no bacterium constantly present in human and calf vaccine, and there was not one which could be regarded as the contagium. To sum up, most of them are well known saprophytic bacteria, and some were identical with bacteria commonly found in suppuration. Vaccine lymph is a most suitable cultivating medium for microorganisms, and bacteria invariably got access to the contents of the vaccine vesicle. There is no evidence to be obtained by the present methods of research as to the bacterial nature of the contagium of vaccine lymph. Copeman obtained similar results, and thus confirmed the author's conclusions.

Klein and Copeman have also observed minute bacilli in calf-

lymph and in variolous lymph. Numerous attempts to cultivate them in nutrient media and in the living animal failed entirely, and the identity of the bacilli could not be determined. Pfeiffer, Guarneri, Monti, Ruffer, and Plimmer have drawn attention to structures in lymph, which they believe to be of the nature of parasitic protozoa. These bodies have been studied, more especially in the tissues. They are four times the size of ordinary micrococci, and are found in the clear vacuole in the protoplasm of epithelial cells. Whether they are really parasites or altered anatomical elements has not been determined. No other conclusion can be drawn from all these observations, except that the nature of the contagium of cow-pox is unknown.

#### ORIGIN OF COW-POX.

Jenner's original theory was that cow-pox was derived from "grease," but subsequently he distinguished between cow-pox, a disease peculiar to the cow, and "grease," a disease transmitted to the cow from the horse, and the mistake of confounding these two diseases was attributed to farmers and farriers. Thus he wrote:—

"From the similarity of symptoms, both constitutional and local, between the cow-pox and the disease received from morbid matter generated by a horse, the common people in this neighbourhood when infected with this disease, through a strange perversion of terms, frequently called it the cow-pox."

Jenner's theory of the origin of cow-pox has been discouraged; so also has the view of its being a "spontaneous" disease in the cow, though Ceely, after many years of research in the Vale of Aylesbury, could never discover the probability of any other origin. Both opinions have given way to the theory that cow-pox is small-pox transmitted to the cow—an opinion advocated by Baron, and supported by an erroneous interpretation of Ceely's and Badcock's variolation experiments. Thus the *cow-pox* and *grease* of farmers and farriers no longer attracted attention in this country, and as natural cow-small-pox has never been discovered, cow-pox has been credited with being extinct.

For a full discussion of this subject the reader is referred to the work by the author on the *History and Pathology of Vaccination*, but the variolation experiments alluded to will be briefly mentioned.

In 1801 Gassner inoculated eleven cows with small-pox lymph, and succeeded in one in producing phenomena indistinguishable from the results of ordinary vaccination with cow-pox, and children were inoculated from the cow.



In 1828 Dr. McMichael reported that several physicians in Egypt had obtained similar results, and children were successfully "vaccinated."

In 1836 Dr. Martin, in America, inoculated the cow's udder with variolous lymph, and by inoculating children produced an epidemic of small-pox with fatal cases. In 1839 Reiter of Munich, after fifty unsuccessful attempts, succeeded in producing a vesicle, and a child inoculated from the vesicle contracted small-pox.

In 1839 Dr. Thiele, after a number of unsuccessful attempts to inoculate cows with variolous virus, succeeded in producing a vesicle with the physical characters of the vaccine vesicle, and from it a stock of lymph was raised from which over three thousand persons were inoculated. Thiele's method was to inoculate the udder with lymph, and to select for the purpose young cows which had recently calved and had delicate skins. In England Ceely succeeded by inoculating the vulva of a heifer. One of the punctures developed into an enormous vesicle, which was undoubtedly variolous. His assistant punctured his hand with the lancet which had been used to open the vesicle, and febrile symptoms appeared, followed by an eruption on the face, neck, trunk, and limbs, at first papular, then vesicular, and finally pustular. The lymph was used in children, and "vaccine" vesicles were produced. One child suffered from vomiting delirium, and extensive roseola, but there was no eruption in any other case.

In 1840 Badcock of Brighton inoculated a cow successfully, and later succeeded in variolating thirty-seven out of two hundred cows upon which he experimented.

In 1847 variolation of the cow was successfully performed at Berlin, but the virus produced variola, and one of the children inoculated died of confluent small-pox.

In 1864 Chauveau inoculated seventeen animals with virulent small-pox lymph. Very small papules resulted, and the virus from the papules produced variola in a child, which was infectious to others. Klein in this country until recently was uniformly unsuccessful. Voigt, Fischer, King, Eternod, Haccius, Hime and Simpson, have all succeeded in inoculating cows and producing variola-vaccine.

The results of these experiments have been very generally misinterpreted, and claimed by some as conclusive evidence of the identity of cow-pox and small-pox. Instead of the vesicle being regarded as the most attenuated form of variola, the experimenters are said to have succeeded in producing *cow-pox*.

It is quite true that they produced phenomena indistinguishable

from the phenomena of an ordinary vaccination, but that does not mean that they produced the disease *cow-pox*. The vesicle which followed the inoculation, whether papular or vesicular, was *small-pox*. Ceely, Badcock, Voigt, and others, succeeded in *ingrafting* the cow with small-pox, and when suitable lymph and suitable subjects were employed, the virus was so attenuated that a benign vesicle resulted. Similar results were obtained by Sutton and Dimsdale, and identical results by Adams, Guillou, and Thiele, by inoculating the human subject with variolous lymph without first ingrafting the disease on the cow.

Vaccination with variola-vaccine is simply a modification of the Suttonian system of small-pox inoculation, only in the first remove the cow is substituted for the human subject. All those who were inoculated with Ceely's, Badcock's, or Simpson's variola-vaccine, were not in the usual meaning of the word vaccinated; they were not inoculated with cow-pox but they were variolated, and in such an extremely attenuated form that the persons so variolated do not convey the infection. By judicious selection it is thus possible to obtain a strain of lymph from variola which, by direct inoculation of the human subject or by first inoculating a cow, is deprived of infectious properties, and produces on the arm the physical characters of an ordinary vaccine vesicle. This has been regarded as a proof of the identity of small-pox and cow-pox, but it is not so. Variola and cow-pox are not the only diseases caused by a virus which can be attenuated until only a vesicle is produced with the characters of an ordinary vaccine vesicle. The results which have been obtained with the virus of cattle plague and of sheep-pox and horse-pox have been given in previous chapters; and no one would urge on this account that human small-pox, cattle plague, cow-pox, sheep-pox, and horse-pox are all manifestations of the same disease. Cow-pox has never been converted into human small-pox, and, in their clinical history and epidemiology, natural cow-pox and human small-pox are so different, that the comparative pathologist is no more prepared to admit their identity than he is prepared to admit the identity of cow-pox and sheep-pox, or small-pox and cattle plague.

**Protective Inoculation.**—Whether vaccination of all heifers on a farm would protect them from cow-pox when they came into milk is not known, the duration of the immunity in calves afforded by vaccination having not been determined. Calves undoubtedly have an immunity after vaccination, lasting for some weeks.

In 1896 Bécèle, Chambon, and Menard experimented upon the immunising power of the serum of vaccinated calves. They



concluded from experiments on animals and children that the serum of a vaccinated calf from ten to fifty days after vaccination will give immunity against inoculated cow-pox. They further stated that, whereas the immunity given by vaccination in the ordinary way is not complete until the eighth day, the immunity obtained by injection of the immunising serum is immediate. The serum has also been credited with therapeutic properties and has, it is said, proved efficacious in cases of small-pox.

Jenner believed that cow-pox did not protect against itself but protected against small-pox, and for a century this has been a subject of much controversy. The reader is referred to the Reports and conclusions of the Royal Vaccination Commission.

**Stamping-out System.**—It would undoubtedly be an advantage if cow-pox were scheduled under the Contagious Diseases Animals Act. Cow-keepers and dairy-men, being anxious that their trade should not be interfered with, very commonly conceal the existence of the disease, and perhaps nothing is known about it, unless a milker infected from the cows seeks for medical advice. The contamination of the milk with lymph, pus, crusts, and sometimes blood, renders it unwholesome, and therefore precautions ought to be taken to prevent its occurrence. If the infected cows in a herd are the last to be milked, and the milker washes his hands after the milking, the disease will not spread.



## CHAPTER XXIII.

### DIPHTHERIA.

DIPHTHERIA is a specific infectious disease, especially of children, characterised most commonly by inflammation, and infiltration with lymph cells and fibrine, of the mucous membrane of the fauces, pharynx, larynx and trachea, followed by necrosis of the mucous membrane and the formation of a greyish-white false membrane, the diphtheritic membrane. In some cases a diphtheritic membrane forms in the stomach, intestine, the urinary organs and in wounds. After the separation of the membrane an ulcer remains, which may gradually heal. In the superficial part of the diphtheritic membrane there are masses of bacteria including cocci, streptococci, and bacilli. The diphtheria bacilli are not found in the blood or in the internal organs. There is no doubt of the fact that diphtheria is a disease which can be communicated from one person to another; but the question of its origin is still a vexed one. There is a close association with insanitary conditions and decaying animal and vegetable refuse, and dampness. Localities with damp houses, defective drainage, and a cold exposure, are favourable to the development of diphtheria; but that does not necessarily indicate that these conditions can originate it. On the other hand, assuming the disease to be due to a living contagium, these insanitary conditions would afford a suitable environment predisposing to the development, and facilitating the spread, of the disease. Scarlet fever and measles predispose to diphtheria; and defective sanitary conditions, causing sore throat, may indirectly act as a predisposing cause. A great many cases have been quoted to illustrate the possibility of the conveyance of diphtheria by milk, and the theory which best harmonises with all these observations is the existence of a specific bacillus, which may be readily transferred from the throat of the diseased to the healthy; which finds also in milk a suitable soil for its growth, and by its agency may be transmitted to the consumer. Such a bacillus was discovered by Löffler,



and may be easily obtained from the throat of diphtheritic patients in the following manner:—

*Culture Outfit.*—

Steel rods like ordinary knitting needles, about six inches in length, are beaten out or roughened at one end, and a pledget of wool is twisted round so as to form a swab. These swabs are placed in clean test-tubes, which are then plugged with cotton-wool. The test-tubes and swabs are sterilised by heating in the hot air steriliser for an hour at 150° C. The so-called culture outfit consists of a small box containing a test-tube of blood serum and a swab. They can be always kept ready for use, and after use should be conveyed by hand for further examination. The danger of transmitting virulent diphtheritic material by post is obvious. When the examination of the tube has been completed, the



FIG. 126.—FREE SURFACE OF DIPHTHERITIC LARYNX  $\times 350$  (HAMILTON).—A, Deposit of diphtheria bacillus on surface of false membrane; B, false membrane; C, mucosa; *l*, lymph-cells and false membrane surrounded by meshes of fibrine; *e*, surface of mucosa deprived of its epithelium; *l,v*, lymph-cells containing shed epithelium.

culture outfit and its contents should be disinfected or destroyed. To inoculate the tubes the patient, if it is possible, should be turned to the light, the mouth well opened, the tongue depressed, and the swab, without touching the teeth or the tongue, should be passed straight to the tonsils or pharynx, and especially to the membranous exudate. The swab is carefully and quickly withdrawn, and at once very gently rubbed over the surface of the blood serum. The culture outfit is then sent to the laboratory with full particulars, and the tubes are placed in the incubator at  $37^{\circ}$  C., and can be examined after twelve hours. If the throat has been disinfected

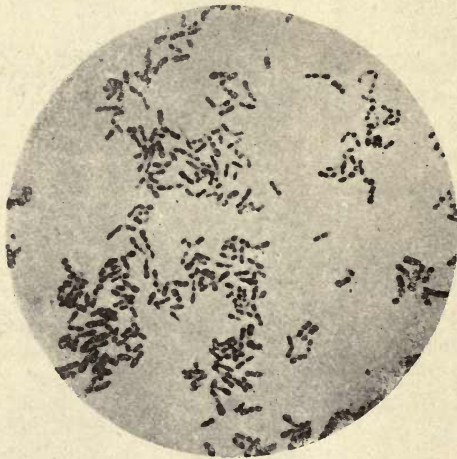

FIG. 127.—BACILLUS OF DIPHTHERIA; FROM A CULTIVATION ON BLOOD SERUM,  $\times 1000$  (FRÄNKEL and PFEIFFER).

before examination, this must be taken into account, as the failure to find bacilli would not then necessarily indicate a wrong diagnosis. In all undoubted cases of diphtheria, growths will be obtained either in the form of a pure-culture of the bacillus, or far more commonly there will also be colonies of various bacteria, especially *Streptococcus pyogenes*.

**Bacillus of Diphtheria.**—Rods, straight or slightly curved,  $\cdot 3$  to  $\cdot 8 \mu$  in breadth, and  $1\cdot 5$  to  $6\cdot 5 \mu$  in length. They occur singly, in pairs, sometimes in chains, and sometimes as short leptothrix forms. In some cultures very irregular forms are observed, the bacilli being swollen at one or both ends or thicker in the middle portion, or the bacillus may contain oval or spherical





DESCRIPTION OF PLATE VIII.

**Bacillus diphtheriæ and Bacillus typhosus.**

FIG. 1.—Cover-glass preparation from a pure-cultivation of *Bacillus diphtheriæ* on blood serum; obtained from the throat in a typical case of diphtheria. Stained with gentian-violet.  $\times 1200$ .

FIG. 2.—Cover-glass preparation from a pure-cultivation of *Bacillus typhosus* on nutrient-agar; from the spleen in a case of typhoid fever. Stained with gentian-violet.  $\times 1200$ .



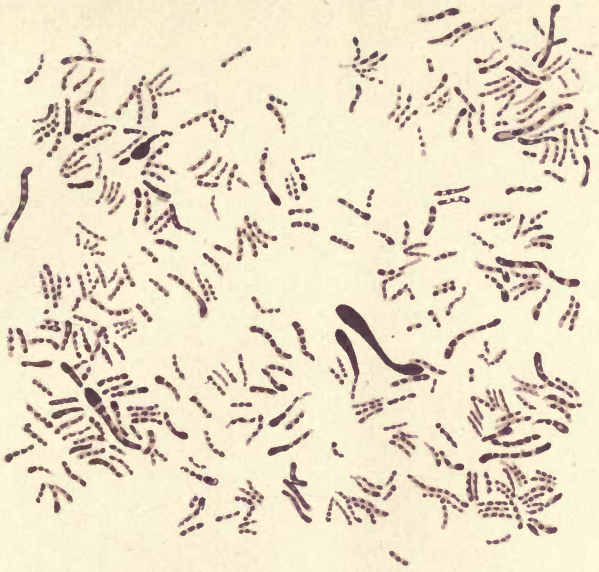

Fig 1. BACILLUS DIPHTHERIÆ



Fig 2. BACILLUS TYPHOSUS





elements. They differ greatly in size and shape, often in the same cultures, and still more in cultures obtained from different sources. Spore formation is unknown. In unstained preparations there are highly refractive elements which correspond with the deeply stained parts of the bacillus. They stain readily with the ordinary aniline dyes. At certain stages of their growth they stain irregularly, the protoplasm of the rod being broken up into irregular segments. The bacillus is non-motile, and does not liquefy gelatine; it grows at 20° C., but much more readily at higher temperatures. Colonies in gelatine plate-cultivations are yellowish-brown, and opaque, granular, and circular, but with more or less irregular margin.

In plate-cultivations on agar and on glycerine agar the same description applies.

On the surface of gelatine the appearances depend greatly on the method of inoculation. The growth may occur in the form of a whitish film, but if a sub-culture has been prepared from broth the growth is often composed of a number of isolated white colonies (Fig. 128, *a*).

On blood serum, after twelve hours the colonies appear in the form of little elevated greyish-white or pearl-grey dots, which coalesce, forming a film if the serum is moist. On the surface of 1 per cent. alkaline glycerine agar, the appearances are found

to vary, and this medium is not so suitable for the cultivation of the bacillus. In slightly alkaline broth, with or without the addition of 1 per cent. grape-sugar, the culture is cloudy, or a fine granular deposit occurs along the sides and bottom of the tube, while the broth remains clear.

On potato the growth is almost invisible, in the form of a dry, thin glaze. Irregular forms are very numerous on microscopical examination, whilst the rods are thicker than usual (Welch and Abbott). In milk the organisms grow readily.

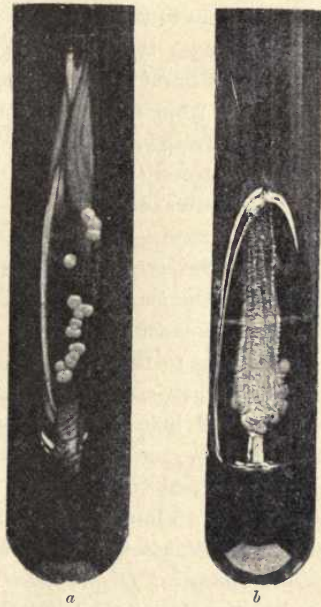

FIG. 128.—PURE-CULTURES OF *BACILLUS DIPHTHERIE* ON GELATINE: *a*, isolated colonies; *b*, filmy growth.

Dried diphtheritic membrane and cultures dried on silk threads retain their vitality for several months.

A broth-culture in forty-eight hours may be used for inoculating guinea-pigs. A few drops will cause death in from three to five days; there is hyperæmia and œdema at the seat of inoculation, the lymphatic glands are enlarged, there is fluid in the peritoneal, pleural and pericardial cavities, and the lungs are congested. The bacillus is found at the seat of inoculation, but not, as a rule, in the blood or internal organs. Inoculation of rabbits produces extensive local œdema, enlargement of the lymphatic glands, and death in from four days to three weeks. Roux and Yersin pointed out that in less acute cases there was paralysis of the hind limbs. Mice and rats have an immunity. Cultures lose their virulence with age, but the filtrate from old cultures contains more toxic substance than that from fresh cultures. The toxin has been described in a previous chapter (p. 46).

Old cultures sterilised by heating for an hour to 60° C. or 70° C. will render guinea-pigs immune in two weeks. The toxic substance is believed to be destroyed by this process, while according to Fränkel the immunity-giving substance which is also present in the culture is not affected.

According to Behring's researches, the blood of immune animals contains diphtheria antitoxin, consequently the blood of an immune animal is capable of neutralising the toxic properties in a filtered culture, not only in the living animal but when added to the culture in a test-tube. These researches led to the employment of the serum of an immune animal as a therapeutic agent in the treatment of diphtheria in man (p. 58).

*Bacteriological Diagnosis.*—The diphtheritic bacilli are not only found in the throat while the lesions exist, but they are found after all sign of the disease has disappeared. In some cases they persist for a few days, in others for three or four weeks, and in rarer cases they have been found several months afterwards. They have also been found in the throats of persons in health, especially of those who have been in contact with cases of diphtheria, such as healthy children in infected families and healthy nurses.

The bacilli which persist in the throat after recovery may be virulent up to the time of their disappearance, or they may gradually become attenuated, and entirely lose their pathogenic properties. The value of a microscopical examination as an aid in the diagnosis of diphtheria has been considerably exaggerated, and unless the



bacillus when isolated is tested by inoculation the test may prove to be entirely fallacious.

Löffler and Von Hoffman both found bacilli in healthy throats, and thus created doubt as to the importance of the Löffler bacillus. Hoffman found this bacillus in the throats of twenty-six out of forty-five individuals, some of them suffering from scarlet fever, measles or some other non-diphtheritic affections, while the rest were healthy. The bacilli from these sources showed slight differences in morphological and cultural characteristics, and Hoffman was unable to decide whether these bacilli were diphtheria bacilli, which had become harmless, or whether they were accidental epiphytes, belonging to a closely allied but different species.

Roux and Yersin confirmed these observations. In a hospital for children in Paris without any question of the existence of diphtheria they found the so-called pseudo-diphtheria bacilli in fifteen cases out of forty-five. In a school, in a seaside place entirely free from diphtheria, the same bacilli were found in twenty-six out of fifty-nine children. They were also found in children with simple sore throats, and in five out of seven cases in measles. Roux and Yersin concluded that these bacilli were not distinct from the Löffler bacillus. There were slight variations, but there was no constant difference except in their pathogenic properties. The appearance of the colonies, the growth in broth, and the peculiar morphological elements showed characters common to both, and there was, in fact, less difference than there is between attenuated anthrax and virulent anthrax in form and in cultures; but inoculations of the bacillus did not cause death, though in some cases in guinea-pigs there was marked œdema at the seat of inoculation. On the other hand, Löffler's bacilli possess different degrees of virulence, some cultures producing only temporary œdema, while others cause death in twenty-four hours.

Virulent diphtheria bacilli subjected to a current of air can in two weeks be deprived of their virulence partially, and in four weeks entirely. Weakened bacilli can be raised in virulence by the simultaneous injection of the streptococcus of erysipelas, but bacilli deprived of their virulence and bacilli originally non-virulent cannot be made to assume virulent properties. Escherich maintained that they could be distinguished by comparative cultures; that the pseudo-diphtheria bacilli made broth alkaline, so that in forty-eight hours litmus was turned red by Löffler's bacilli and blue by the false bacilli. The bacilli themselves, according to Hoffman, are, as a rule, shorter, wider and more uniform in size.

Parke and Beebe, with a view to clearing up this question, made cultures from three hundred and thirty healthy throats. They found bacilli of three varieties: bacilli characteristic in growth producing acid reaction in broth, but having no virulence; bacilli not characteristic in growth producing an alkaline reaction in broth, not virulent; and bacilli producing acid reaction in broth and virulent. The virulent characteristic diphtheria bacilli were found in eight cases, non-virulent diphtheria bacilli in twenty-four, and non-virulent false diphtheria bacilli in twenty-seven. They concluded that the eight cases must have been in contact with diphtheria, although the throats were healthy. With regard to the bacillus in the twenty-four cases they regarded it as the true diphtheria bacillus which had lost its virulence, and the bacillus found in the twenty-seven cases showing differences in size and manner of staining and the reaction produced in broth was properly designated pseudo-diphtheria bacillus.

#### DIPHTHERITIC DISEASES IN ANIMALS.

There are diphtheritic diseases of the lower animals which are in some respects similar to, and, some observers maintain, identical with, human diphtheria.

In pigeons there is a disease accompanied with the formation of false membranes associated with a bacillus described by Löffler.

**Bacterium of Diphtheria of Pigeons** (*Bacillus columbarum*, Löffler).—Short rods with rounded ends, mostly in irregular masses. In plate-cultivations on nutrient gelatine they formed whitish patches on the surface, and compact, ball-like masses when embedded in the gelatine. They were also cultivated on blood serum and potatoes. Subcutaneous inoculation of a pure-cultivation produced in pigeons local inflammation and necrosis; inoculation in the mucous membrane of the mouth gave the appearances of the original disease. Other animals were only locally affected, except mice, in which characteristic symptoms and death resulted. They were isolated from the diphtheritic exudations in pigeons, and in sections were found in the vessels of the lungs and liver.

A similar disease is known to attack fowls, and there are also diseases with development of false membranes of the respiratory passages in horses, cats and swine. Outbreaks of these diseases have been said to occur in times of prevalence of diphtheria in man, and their intercommunicability has been suggested.

Dr. Turner supposes that diphtheria in man originates in diseases



simulating diphtheria in cats, pigs, and horses; and Klein, who accepts this theory, maintains that cats suffer from genuine diphtheria, and that after death the lungs are found full of grey, consolidated lobular patches, and the kidneys are enlarged and white.

Human diphtheritic membrane inoculated subcutaneously in cats produces a painful swelling in the groin, and fever, and a fatal termination in a week. The subcutaneous and muscular tissues at the seat of inoculation are hæmorrhagic and œdematous. The internal organs are congested, and in the kidneys the medulla is congested, while the cortex is fatty.

A recent culture produces illness in twenty-four hours, a painful tumour forms at the seat of inoculation, and death ensues in from two days to a week. Pneumonia and fatty white kidney are found after death, and the tissues at the seat of inoculation are hæmorrhagic, and in parts almost gangrenous.

Klein found that diphtheritic membrane or a pure-culture inoculated into the cornea after removal of the superficial epithelium produced ulceration, and in two cases perforation of the cornea, and purulent panophthalmitis. Bacilli were again recovered from the ulcer similar in cultural characters, but conspicuously shorter and thinner.

An epidemic occurred amongst cats at the Brown Institution. Five out of fourteen died. The symptoms were, running from the eyes, sometimes a muco-purulent discharge, sneezing, coughing, and pulmonary trouble, resulting in emaciation and death in from one to three weeks. After death lobular pneumonia and large white kidney were found; and in one case a diphtheritic condition of the trachea, preparations of which showed diphtheria bacilli in crowds under the microscope.

Klein regarded this disease as an epidemic of cat-diphtheria, and believed that the disease was possibly induced accidentally by the cats drinking milk, which was infected in the course of some other experiments with diphtheria. He states that on account of the very definite results obtained by inoculating diphtheritic membrane and cultures of the bacillus, subcutaneously and on the cornea, and of the condition of the lung and kidney in cats naturally or experimentally infected, the disease must be considered as equivalent to human diphtheria, and the cat capable of communicating the disease to other cats, and also to human beings. These conclusions have not yet met with the acceptance of veterinary authorities. The results of the experimental inoculations

are certainly by no means conclusive. It does not follow from these experiments that the disease diphtheria naturally occurs in the cat or that under ordinary circumstances cats may contract the disease from the human subject; but the experiments show that, like guinea-pigs and rabbits, cats are susceptible to the toxic effects of the extremely poisonous principles developed during the growth of Löffler's bacillus.

#### MILK DIPHTHERIA.

It has been shown that milk infected with diphtheria has been the cause of epidemics among the consumers; there have also been epidemics apparently associated with the milk supply, in which it has not been possible to trace the source from which the milk was infected. A difficulty in tracing the origin in no way excludes the possibility of contamination from a human source. In the light of recent researches we should expect that it would be easy to overlook the source of the virus, if it be true that diphtheria may exist without any symptoms indicating its presence, and be unrecognised until the throat has been examined for diphtheria bacilli. As this fact was unknown until quite recently, the absence of an acknowledged case of diphtheria was taken as evidence that no diphtheria existed, and consequently that the milk must have been infected by a diseased condition of the cow. Mr. Power, whose views upon milk scarlatina have already been referred to, endeavoured to trace the origin of a milk epidemic to the very common disease of "garget," or mammary abscess. This idea may be dismissed without further consideration; but the theory of some disease existing in the cow capable of producing diphtheria in man was resumed by Dr. Cameron, who suggested that there might be an eruptive disease of the teats producing diphtheria, and by Mr. Power, who supported the theory in an investigation of a milk-diphtheria outbreak in 1886 at Camberley. Diphtheria in this case existed in the neighbourhood, but as the source of human infection could not be traced, attention was drawn to two cows in the herd which had recently calved, and especially to one with chapped teats. Following this line of inquiry, Klein investigated the behaviour of milch cows to the diphtheria bacillus. Two cows were injected subcutaneously under the skin of the shoulder with a Pravaz' syringe filled with a sub-culture in broth. There was a rise of temperature, and on the third day a painful tumour, which enlarged to the size of a child's head. In about a fortnight the tumour began to decrease, and ultimately one cow



died and the other was killed. Such results might have been anticipated as the result of injecting a large quantity of the toxic products of the bacillus, but certain other phenomena were observed to which importance was attached. On the fourth day, on one of the cows an eruption on the teat was first noticed, consisting of small vesicles passing into pustules and crusted ulcers. Examination of the contents of the vesicle revealed the bacillus. With matter from the vesicles and pustules two calves were inoculated, and a similar vesiculation produced at the seat of inoculation. The milk of the cows was inoculated on nutrient gelatine, and produced a culture of *Bacillus diphtheriæ*. The question naturally arose whether this eruption had any connection with the original experimental inoculation. No other cows in the locality from which these cows were obtained had a similar eruption, and it was taken for granted that it was the result of the experimental inoculation. By accepting the possibility of this eruption being identical with the chaps on the teats of the Camberley cows, the theory was gradually built up that cows suffer from diphtheria, which manifests itself in the form of an eruptive disease of the teats, and that the disease is conveyed in the milk to the consumers.

In the original experiment the bacilli were found to have multiplied abundantly in the tumour at the seat of inoculation. The eruption might have been, as admitted by Klein, a symptom of the work of the chemical poison, and the elimination of the bacilli by the milk is also possible; but that there is in cows a vesicular disease of the teats which is the origin of human diphtheria is not accepted by veterinarians, and there is not sufficient evidence to justify the conclusion that the infectivity of the milk in epidemics of milk diphtheria has been proved to be due to a morbid condition of the cow.

## CHAPTER XXIV.

### TYPHOID FEVER.

TYPHOID FEVER is a specific febrile disease peculiar to man, with characteristic pathological lesions in the intestine, mesenteric glands, and spleen. The Peyer's glands pass through three stages. They become swollen from *infiltration* of round cells in lymph follicles, due, it is supposed, to the presence of the typhoid fever bacillus. The enlargement of the lymph follicles is followed by *coagulation necrosis* until the entire patch becomes necrosed, and sloughs away, leaving an *ulcer*. The disintegration of the patch may extend in depth, and result in perforation and peritonitis, or the ulcer may heal, and a pigmented scar take the place of the Peyer's patch. The lymphatic glands are found more or less enlarged, and may be easily felt in the groin, axilla, and neck. In some cases there is a tendency to hæmorrhage, followed by infarctions in the spleen and lungs, which may develop into pyæmic abscesses. In the mesenteric glands similar changes take place, but without ulceration. Pneumonia may occur as a pulmonary complication. The bacteria of pneumonia and *Streptococcus pyogenes* may be found in association with the bacillus of typhoid fever. It is now generally accepted that the disease is conveyed by water and food which have become contaminated with the virus contained in typhoid evacuations. This has been practically proved by the number of cases which have been shown to have been intimately connected with contamination of drinking water from wells and other sources, by sewers, cesspools and faulty drains, the sewage presumably having been infected with typhoid excreta; but whether sewage independently of typhoid contamination can originate typhoid is still an open question. Accepting the former theory as a working hypothesis, we must assume that a typhoid fever bacillus exists in the intestinal evacuations, and that it must be able to retain its vitality under very varying conditions until it gains



access by the mouth to a fresh host, and by its development in the intestine, and by the absorption of its toxic products, produces the phenomena which we recognise as typhoid fever.

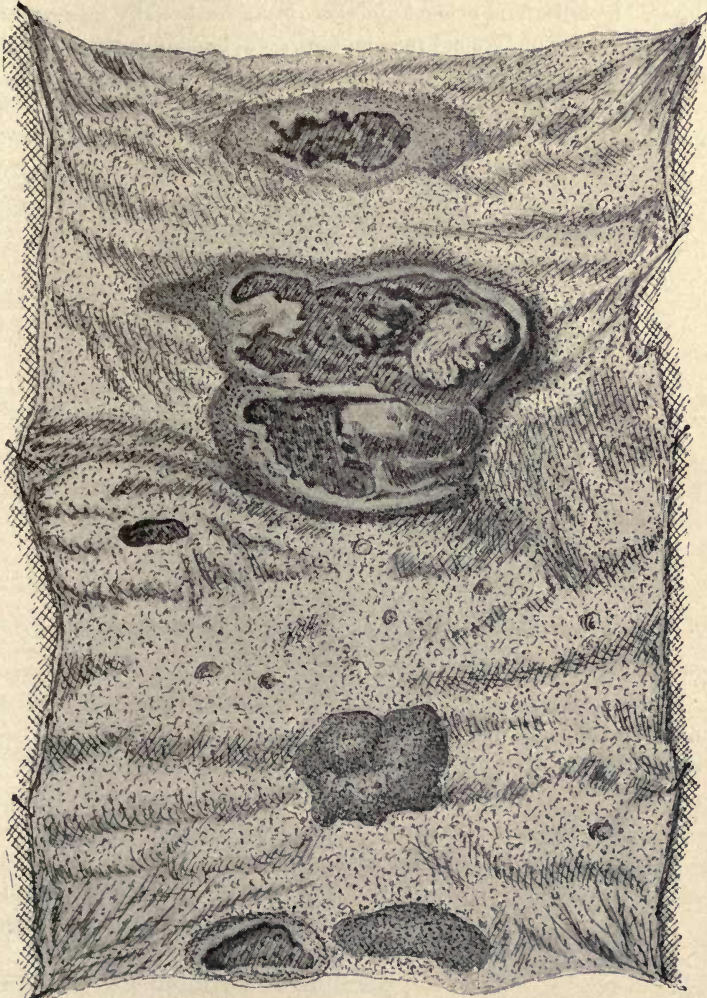

FIG. 129.—TYPHOID FEVER. ILEUM OF ADULT, SHOWING SLOUGHY AND INFILTRATED PATCHES (HAMILTON).

Typhoid fever is also disseminated by milk ; sewage-contaminated water having been added to the milk, or used for washing the milk cans and other vessels.

Typhoid fever cannot be communicated to the lower animals. Numerous experiments have been made by feeding and by injecting typhoid stools, but with absolutely negative results. Murchison gave typhoid fever discharges to pigs, Klein experimented with rabbits, monkeys, and other animals. Motschutkowsky injected the blood from cases of typhoid into monkeys, rabbits, and other animals, but with negative results.

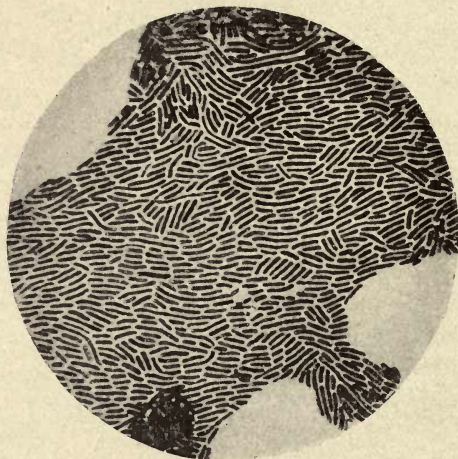

FIG. 130.—TYPHOID BACILLI FROM A COLONY ON NUTRIENT GELATINE,  $\times 1000$  (FRÄNKEL AND PFEIFFER).

Various micro-organisms have been described in typhoid, but the one to which most importance is attached is a bacillus which was first discovered by Eberth, but cultivated and fully described by Gaffky. Gaffky cultivated it from typhoid evacuations, from typhoid ulcers, from the mesenteric glands, and from the spleen. It is found in scattered colonies in the spleen, and is rarely if ever present in the blood.

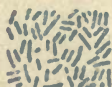

FIG. 131.—TYPHOID BACILLI,  $\times 950$  (BAUMGARTEN).

**Bacillus of Typhoid Fever.**—Rods 1 to 3  $\mu$  in length, and  $\cdot 5$  to  $\cdot 8 \mu$  in breadth, and threads (Plate VIII., Fig. 2). Spore-formation has not been observed, but the protoplasm may be broken up, producing appearances which may be mistaken for spores. They are actively motile, and provided some with a single and others with very numerous flagella, which are from three to five times as long as the bacilli. They stain well with aqueous solutions



of aniline dyes, and grow well at the temperature of the room. In plate-cultivations minute colonies are visible in thirty-six to forty-eight hours; they are circular or oval, with an irregular margin; they appear granular by transmitted light, and are yellowish-brown in colour. Cultivated in the depth of gelatine a well-defined shiny film forms at the point of puncture, and a greyish-white filament, composed of closely packed colonies, develops in the track of the needle (Fig. 134). On the surface of gelatine a greyish-white translucent film forms, with sharply defined margin (Plate II., Fig. 2). On agar there is a whitish transparent layer. They flourish in milk. On potato at the temperature of the blood there is no culture visible, but



FIG. 132.—FLAGELLA OF TYPHOID BACILLI,  $\times 1000$ , STAINED BY LÖFFLER'S METHOD (FRÄNKEL AND PFEIFFER).

the inoculated area appears moist and shining, and cover-glass preparations made from the potato will demonstrate that there is really a copious growth of the bacillus. This almost invisible growth is not peculiar to this micro-organism.

Whether this bacillus is really peculiar to typhoid is much disputed. Bacilli very closely resembling it, if not actually identical, have been found under other conditions. These pseudo-typhoid bacilli are regarded by some bacteriologists as varieties resulting from the different environment afforded by a saprophytic existence. Numerous experiments have been made on animals with pure-cultures of the bacillus, but in the production of typhoid fever they have been no more successful than the experiments with typhoid stools.

Fränkel and Simmonds inoculated a number of rabbits in the vein of the ear, producing death, in some cases in forty-eight hours. Seitz administered broth-cultures by Koch's method of introducing them

into the stomach after the administration of opium in guinea-pigs, and death resulted in several instances. But in all these cases the results depended upon the poisonous products found in the

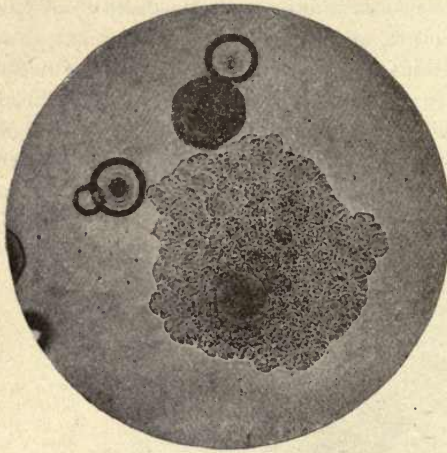

FIG. 133.—COLONIES OF TYPHOID BACILLUS. Three days old.  $\times 100$  (FRÄNKEL AND PFEIFFER).

cultivations, a similar result following the injection of sterilised cultures. An account of the products has already been given (p. 41).

Cassedeat isolated three species of bacilli from water, which could be distinguished with great difficulty, and only after the most careful comparison. The bacillus which most closely resembles it is the *Bacillus coli communis*; in fact, Roux regards it as a non-pathogenic variety of the typhoid bacillus. Others claim to be able to distinguish it by careful comparison and the application of tests. Special importance is attached to potato cultures, the typhoid bacillus forming an invisible film, and *Bacillus coli communis* a well-marked yellowish growth. Terni pointed out that *Bacillus typhosus* retains its motility in media containing hydrochloric acid, while *Bacillus coli communis* and other bacilli resembling those of typhoid lost their motility. Schild maintained that *Bacillus typhosus*

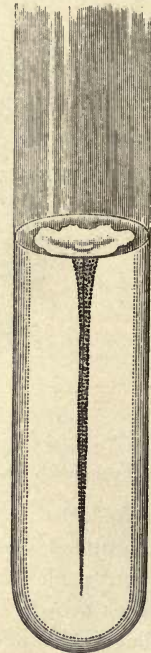

FIG. 134.—PURE CULTURE OF TYPHOID BACILLI INOCULATED IN THE DEPTH OF NUTRIENT GELATINE (BAUMGARTEN).



was destroyed by exposure to the vapour of formalin, while *Bacillus coli communis* and similar bacilli isolated from water gave subcultures after exposure for two hours. Typhoid bacilli do not give the reaction for indol, and there is no development of gas in cultures in the depth of nutrient agar containing 2 per cent. of grape-sugar. According to Müller, sterilised milk is coagulated in twenty-four hours, at 37° C., by *Bacillus coli communis*, but not by the *Bacillus typhosus* until several weeks have elapsed; and, further, cultures on acid potato give different results. The typhoid bacillus on microscopical examination shows marked polar staining, but *Bacillus coli communis* only shows a slight tendency of the protoplasm to break up.

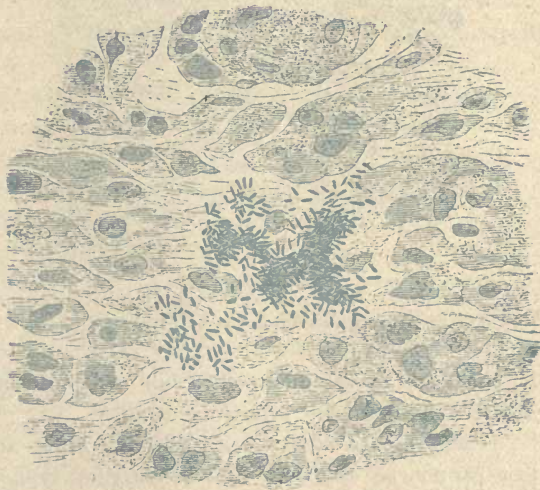

FIG. 135.—TYPHOID BACILLI IN A SECTION OF SPLEEN,  $\times 800$  (FLÜGGE).

Kitasato suggested the negative indol test, and recommended Salkowski's method. Broth-cultivations are treated with a solution of sodium or potassium nitrite: 1 cc. of the nitrite solution (.02 gr. to 100 cc. of water) is added to 10 cc. of a broth-culture after twenty-four hours in the incubator, and on adding a few drops of strong sulphuric acid, the typhoid cultures remain colourless, but cultures of bacilli apparently identical give the red colour. On the other hand, Losener maintains that he has cultivated from earth, water and healthy human evacuations bacilli which could not be distinguished from typhoid bacilli by any of these tests.

The detection of the typhoid bacillus in water has been

described in another chapter (p. 147); but sufficient has been said to show that bacteriological reports in which it is stated that the typhoid fever bacillus has been found in water causing typhoid epidemics must be accepted with great reserve; and further, no one is justified in stating that the typhoid fever bacillus is undoubtedly the cause of typhoid fever. It is not found in every case of typhoid, it is not found in the blood, but it is found in those tissues which are

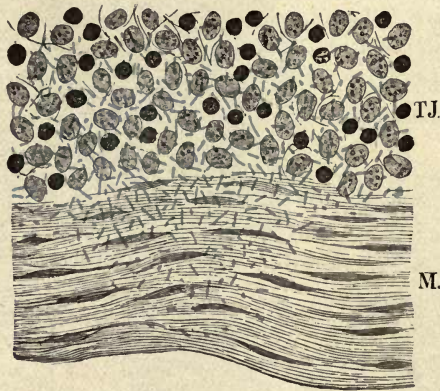

FIG. 136.—TYPHOID BACILLI IN A SECTION OF INTESTINE, INVADING THE SUBMUCOUS (T.J.) AND MUSCULAR LAYERS (M.),  $\times 950$  (BAUMGARTEN).

commonly the seat of secondary invasion of epiphytic bacteria, whose normal habitat is the intestinal canal.

Lastly, as the disease does not exist in the lower animals, the crucial test cannot be applied. The etiology of typhoid fever is still enveloped in doubt, and the nature of the contagium has not yet been determined.



## CHAPTER XXV.

### SWINE FEVER.

PIG TYPHOID, or swine fever, is a highly contagious disease peculiar to swine, causing death in from ten to thirty days, associated with a fibrinous pneumonia, enlargement of, and hæmorrhage into, the lymphatic glands, and characteristic ulcers of the mucous membrane of the stomach and intestines. The lesions may assume the form of extensive croupous or diphtheritic deposit, which may fill the intestinal tube. But the most characteristic appearance results when the lower part of the ileum and commencement of the colon is dotted all over with elevations of the mucous membrane, resembling leather buttons or nux vomica seeds, and sometimes with concentric rings, so that they have been compared to slices of calumba root.

Swine fever is difficult to detect in the early stage, and sometimes symptoms are absent altogether in animals suffering from the disease and quite capable of transmitting it; or nothing may be noted except cough, and possibly enlargement of the inguinal glands. In typical cases the animals are noticed not to feed, to exhibit dulness, and to have occasional rigors. Partial paralysis may follow, producing unsteady gait or loss of power over the hind legs. Diarrhœa sets in, and the evacuations become blood stained. There is occasionally a diffused or patchy reddish or purplish rash on the skin. After death the appearances most commonly found are inflammation of the peritoneum, and redness and enlargement of the mesenteric glands and the lymphatic glands in the lungs. There is generally ulceration, especially of the colon and ileo-cæcal valve, or a diphtheritic exudation, sometimes pale yellow, more commonly greyish or black, similar to the centres of necrosis within the ulcers. The spleen is enlarged and liver congested, and there are hæmorrhages in the kidneys. As the lungs are so commonly affected, Klein proposed the name pneumo-enteritis; but the pulmonary lesions are not constant. Indeed, the cases in which the intestines and

lungs are simultaneously affected are not numerous, and sometimes the lungs may be found to be perfectly healthy in cases with



FIG. 137.—ULCERATION OF THE INTESTINE IN A TYPICAL CASE OF SWINE-FEVER.

long-standing lesion of the intestine. Old pigs may linger on for weeks, and ultimately recover, and in the meantime act as centres for the dissemination of the disease.





DESCRIPTION OF PLATES IX. AND X.

**Swine Fever.**

PLATE IX.—Part of intestine from a typical case of swine fever, showing scattered ulcers and ulceration of the ileo-cæcal valve.

PLATE X.—From the same case of swine fever. The lungs were extensively inflamed and partly consolidated, and the lymphatic glands were enlarged and of a deep red or reddish-purple colour.



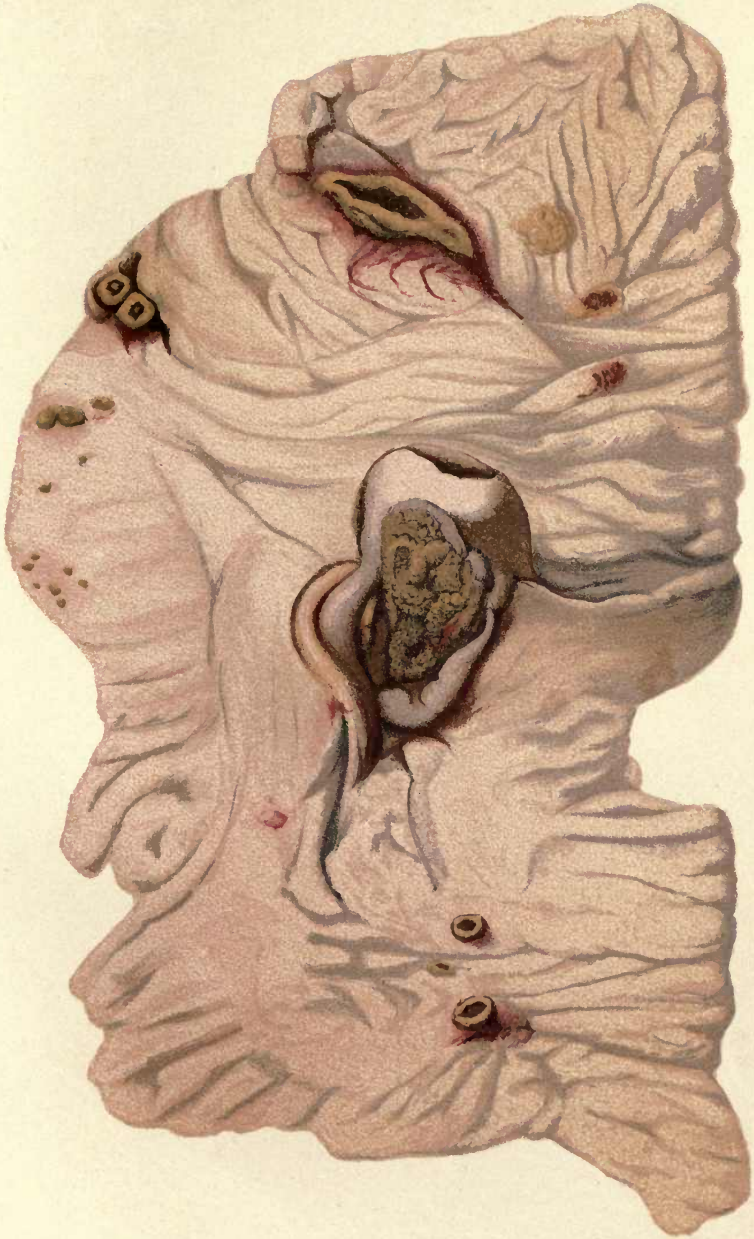

SWINE FEVER.







SWINE FEVER.





Budd first pointed out that this disease might be compared to human typhoid, both diseases being attended by a peculiar ulceration of the intestinal follicles; but the diseases are not to be considered in any sense identical or interchangeable.

**Bacteria in Swine Fever.**

—In 1877 Klein published a research in a Report to the Local Government Board, in which he claimed to have discovered bacilli characteristic of the disease. They were described as similar to *Bacillus subtilis*, or *Bacillus anthracis*, but smaller in size. These bacilli developed

into long leptothrix filaments, and formed spores. It was further asserted that on inoculation, cultures produced lesions indicative of swine fever; the bacilli were also pathogenic in mice and rabbits. Later this bacillus was renounced in favour of another.

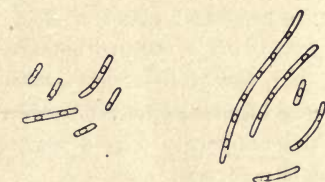

FIG. 138.—BACILLUS OF SWINE-FEVER NO. 1. (KLEIN.)

In the following year Detmers described a bacillus, but subsequently renounced it in favour of a micrococcus.

In 1882 Pasteur maintained that the virus of swine fever in France (*rouget*) was a dumb-bell micrococcus, which produced the same effect in pigeons as the microbe of fowl-cholera. Though



FIG. 139.—BACILLUS NO. 2. FROM A PREPARATION OF BRONCHIAL MUCUS OF A FIG. (KLEIN.)

*rouget* or swine measles is probably a different disease, the occurrence of this micro-organism is of interest in this connection.

In 1883 Klein again investigated swine fever, and discovered *Bacillus* No. 2, and maintained that these bacilli were found in the blood, in the peritoneal and bronchial exudations; and in the air vesicles of the lungs, in the form of leptothrix filaments ten or twenty times the length of single rods. Cultivations were made on solid media. The organisms in these cultures were minute



FIG. 140.—BACILLUS NO. 2. FROM AN ARTIFICIAL CULTURE. (KLEIN.)

rods actively motile, occurring singly or forming chains, two or three

times as long as *Bacterium termo*; and in preparations made from diseased organs they were found to possess a very narrow transparent halo, a sort of hyaline gelatinous capsule. Inoculation of cultures failed to produce the lesions found in animals naturally infected. Two pigs were inoculated, one with a sub-culture from the swollen bronchial gland of a pig that had died of pig-typhoid, and a second with a culture obtained from the spleen of a mouse that had been inoculated from another case of swine fever. After two days the inguinal glands near the seat of inoculation became swollen, and the temperature rose slightly. After three or four weeks the animals recovered.

Mice on the fifth or sixth day after inoculation showed symptoms of illness, then respiration became superficial and slow. Death occurred on the sixth or seventh day.

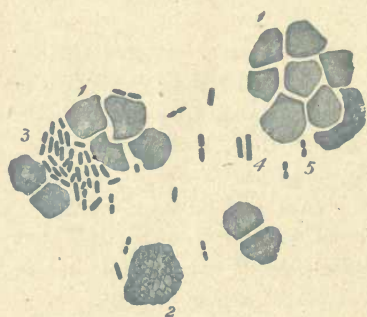

FIG. 141.—BLOOD OF FRESH SPLEEN OF A MOUSE, AFTER INOCULATION WITH BACILLUS NO. 2. (KLEIN.)

Rabbits showed a rise of temperature, and death followed between the fifth and eighth days, the temperature falling before death. At the post-mortem examination there was usually peritonitis, with copious exudation. The kidney, spleen, and liver were enlarged and dark in many cases, there was red hepatisation of the lobes of the lungs,

and generally pericarditis and hæmorrhage under the pericardium.

In 1885 Salmon, in the annual report of the United States Bureau of Animal Industry, published the result of his investigations into American hog cholera, which is identical with English pig typhoid. A motile figure-of-eight bacterium was isolated, each part being about twice as long as broad. The bacterium grew on nutrient gelatine without liquefying it, and on potato produced a brownish growth; broth tubes became turbid on the following day. Colonies in plate-cultivations were oval or circular, and brownish in colour. Six pigs inoculated subcutaneously were all said to have died of hog cholera, and the bacterium was again obtained from the blood of the heart and spleen. The bacteria proved fatal to mice, rabbits, guinea-pigs, and pigeons.

In 1893 Welch and Clement described the hog-cholera bacillus as variable in form, and they further stated that a culture obtained



from Klein, while not possessing the characters originally ascribed to it, could not in its form, biological characters, or pathogenic properties, be distinguished from the American hog-cholera bacillus.

In 1887 pig typhoid was investigated at Marseilles by Rietsch, Jobert, and Martinaud, and a bacillus found. This grew rapidly on all the nutrient media. In gelatine a growth was obtained in twenty-four hours at 18° C.; on blood serum and agar an opaque growth developed; and on potato the growth was yellowish. It was asserted that a young pig was killed by a culture in twenty-two days, and that the characteristic ulcerations were observed in the intestines.

In 1887 pig typhoid was prevalent in Sweden, and Bang and Selander experimented with cultures from a rabbit that died after inoculation with a fragment of spleen from a diseased pig. The bacilli were motile, varying from rods to cocci, without spore-formation and pathogenic in mice, guinea-pigs, and rabbits, but not in pigeons. Pigs fed on broth-cultures were said to have succumbed to genuine pig typhoid. In the blood they were generally found in the form of short oval bacteria, but in the blood of the heart longer rods were sometimes found. Metchnikoff described a bacillus isolated by Chantemesse from an outbreak in France, as highly polymorphic.

Smith identified the hog-cholera bacillus with the bacillus found by Schütz, and this in turn has been identified with the bacillus of hæmorrhagic septicæmia.

From these researches it would appear to be probable that one of the bacteria isolated by Klein, and those found by Salmon, Smith, Bang, Welch and Schütz are identical; and further, that they have been identified with the bacillus of hæmorrhagic septicæmia. We may sum up the characters thus:—

**Bacillus of Klein, Salmon, Smith and Schütz.**—Very small rods, actively motile; spore-formation not observed; colonies circular and brown by transmitted light. Inoculated in the depth of gelatine faintly yellowish-white colonies develop along the track of the needle; on the surface an opalescent film; on potato they produce a straw-coloured layer, changing to brown. There is absence of indol in cultures containing peptone; the bacilli are fatal to mice, guinea-pigs, rabbits, and pigeons. Swine die after intravenous injection, but not, as a rule, after subcutaneous injection.

According to Caneva, the bacillus obtained from the Marseilles epidemic would appear to be closely allied, if not identical, with the bacillus of ferret disease (Eberth and Schimmelbusch), and the bacillus of Texas fever (Billings).

Billings appears to have isolated two bacilli, one identical with the Marseilles bacillus, and the other with the hog-cholera bacillus.

**Bacillus of Rietsch and Jobert.**—Rods about twice as long as broad, rather shorter than the bacillus of typhoid fever, longer and thicker than the American bacillus. They exhibit end-staining. They possess flagella, and are actively motile.

They grow rapidly in nutrient media. They are only feebly pathogenic. They are also said to be distinguished from the bacilli of hog-cholera by producing indol in solutions containing peptone, and by causing an acid reaction in milk.

**Bacillus of M'Fadyean.**—M'Fadyean investigated swine fever in 1895, and found bacilli which he differentiated from hog-cholera bacilli. The method employed was to inoculate the surface of nutrient agar and of potato, with fragments torn out of the centre of a lymphatic gland, with specially constructed forceps. Inoculations were also made from the spleen pulp, and blood, in the usual way. They are from 1 to 2  $\mu$  in length, and  $\cdot 6 \mu$  in breadth. They never grow into filaments, they do not form spores, and they are actively motile. They are readily stained by the watery solutions of the aniline dyes, and are decolorised by Gram's method; with methylene-blue they show end-staining. The bacilli grow on gelatine without liquefaction, forming a thin white line along the needle track. On agar a thin, transparent pellicle forms, which is not easily visible at first, but gradually acquires a faint greyish tint. More characteristic appearances result in plate-cultivations of gelatine-agar, at 37° C. The colonies are distinctly visible in eighteen hours, appearing when viewed by transmitted light as bluish-white, circular specks; each colony has a dark centre and a granular margin. In broth the bacilli produce turbidity after twenty-four hours. On potato there is no visible growth, even when the surface is inoculated with an abundance of material. On solid blood serum the growth is scanty. They grow in milk without producing coagulation. They are harmless to guinea-pigs and feebly pathogenic to rabbits.

Several experiments were carried out upon swine. In the first series the most rigid precautions were taken to prevent accidental infection with swine fever. Four young pigs were inoculated, upon a farm where there was no previous history of the disease. These pigs were killed, and the post-mortem examinations were said to show indications of swine fever, principally patches of diphtheritic material in the colon, and healing ulcers. The next series of pigs was inoculated at the Royal Veterinary College. Cultures were



administered with milk to two pigs. Five days afterwards one pig died; and the mesenteric glands were congested, and the mucous membrane showed spots of necrosis. The other pig was killed, and there were ulcers in the colon. In a third experiment, eight pigs were fed with milk and broth cultures. These pigs were all killed at different dates, and most of them had ulceration of the colon; in control experiments the intestine was normal.

M'Fadyean compared his bacillus with a culture of the hog-cholera bacillus, and found that the American organism grows at a lower temperature in gelatine, and colonies appear in plates much earlier. They produce a less transparent and thicker growth, and much greater turbidity in broth and a more abundant sediment. On potato they form an abundant growth at 37° C., at first yellow, later brown, with considerable resemblance to a glanders culture.

Colonies upon gelatine-agar are distinguished by their opacity and sharp outline. Agar, potato, and broth cultures of the American organism consist of short ovoid forms like the bacilli of fowl cholera, while the bacillus isolated by M'Fadyean has a closer resemblance to the bacillus of glanders. M'Fadyean asserts that the American organism is not pathogenic to the pig. Pigs after feeding on broth cultures remained healthy, and showed no trace of swine fever when killed from one to three weeks afterwards. On the other hand, broth cultures of his bacillus produced the characteristic ulceration of the bowel. M'Fadyean claims, therefore, to have discovered the true pathogenic organism of swine fever. He does not appear to have compared this bacillus with that obtained from the epidemic of swine fever at Marseilles. From the description of the morphological and other details there seems to be a close resemblance between the two.

Not less than three and possibly four species of bacilli have been cultivated from swine fever, two at different times by Klein, one by Reitsch Jobert and Martinaud, and one by M'Fadyean; and cultures of all these bacilli have been credited with producing swine fever in experimental animals, and each one has been pronounced to be the contagium of the disease. We must conclude either that contaminated cultures were inoculated in some cases, or, what is far more probable, the swine fever which resulted in experimental animals was due to accidental infection; and until a bacillus has been cultivated from swine fever from which another investigator can prepare sub-cultures, and with those sub-cultures produce the typical ulcerations of swine fever in pigs on a farm, or on premises

in which swine fever is unknown, we are justified in concluding that the contagium has not yet been discovered.

The mistakes which are likely to occur when the same investigator isolates bacilli from cases of swine fever, and subsequently inoculates or feeds healthy swine, cannot be better illustrated than by quoting from a leaflet issued by the Board of Agriculture, pointing out the great precautions necessary to prevent accidental infection.

“There seems reason to believe that the disease is not infrequently introduced by means of persons who have been in contact with diseased animals. Pig owners, therefore, are advised to prevent strangers from at any time approaching their pigs, and should the admission to the premises of spayers or castrators be necessary, those persons should be required, before approaching the animals, to thoroughly wash their hands with soap and water, and to wash and disinfect their boots with a solution of carbolic acid and water, or some other suitable disinfectant. Such persons might also with advantage be required to wear, while operating, a waterproof apron, which should be washed and disinfected before the wearer is permitted to approach the animals to be operated on.”

**Protective Inoculation.**—The experiments of Salmon and of Schweinitz have been referred to in another chapter (pp. 41, 46). A method of protective inoculation was attempted in America, but the experiments were unsuccessful, and the plan was abandoned.

**Stamping-out System.**—Notification is compulsory, and the order in force is the Swine Fever Order of 1896, but the stamping-out system has not been applied in a thoroughly satisfactory manner, and the disease is still very prevalent.



## CHAPTER XXVI.

SWINE MEASLES.—DISTEMPER IN DOGS.—EPIDEMIC DISEASE OF FERRETS.—EPIDEMIC DISEASE OF MICE.

### SWINE MEASLES.

SWINE MEASLES, or swine erysipelas, is described as an acute, infectious disease of swine which is very prevalent in France and Germany, but is included in this country in the term "swine fever." According to some, it is a distinct disease, and distinguished from pig-typhoid by absence of the ulceration of the intestines which is so characteristic of that disease; while, according to others, ulceration of the intestine and ileo-cæcal valve may be found post-mortem. The onset of the symptoms, as in pig typhoid, is very rapid; the animals cease to feed, and show other general signs of illness; the voice is hoarse, and there is a rapid rise of temperature. On the neck, chest, and abdomen, red patches make their appearance, which extend and coalesce, and change to a dark reddish or brownish colour. These symptoms may be followed by convulsions, and sometimes by paralysis of the hind legs; and death occurs in from one to four days. It is especially a disease of young pigs, and from 50 to 60 per cent. of infected animals die.

On post-mortem examination there is hæmorrhage and œdema in the patches of the skin, the lymphatic glands are swollen and dark red, the peritoneum is ecchymosed, the intestinal mucous membrane is congested and swollen, and the solitary follicles and Peyer's patches are prominent, and in the neighbourhood of the ileo-cæcal valve there are, according to Flügge, ulcers of considerable size. The liver and spleen are congested and enlarged. Pasteur investigated swine measles or *rouget*, and described a figure-of-eight micrococcus, which he believed to be the contagium of this disease. This organism appears to be identical with the bacterium of hæmorrhagic septicæmia, which is also commonly found in pig-typhoid.

In experimenting with the virus obtained from the spleen

Pasteur found that, by successive inoculation of rabbits, the virulence was exalted for rabbits, but attenuated for swine, and the virus which had thus been passed through the rabbit was used as a vaccine for swine, to protect them against virulent erysipelas.

Pasteur found that by passing the virus through pigeons it was made more virulent for swine.

In the blood, and the juice of the internal organs, and of the lymph glands, Schütz found a minute bacillus identical with the bacillus of mouse septicæmia.

**Bacillus of Swine Erysipelas (Schütz).**—Extremely minute rods  $\cdot 6$  to  $1\cdot 8 \mu$  in length, morphologically and in cultural characters identical with the bacillus of mouse septicæmia. Filaments and involution forms. Spore-formation present.

House mice if inoculated with a pure culture die in two to four days. Pigeons are also very susceptible. Fowls and guinea-pigs

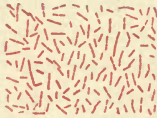

FIG. 142.—BACILLI OF SWINE ERYSIPELAS (BAUMGARTEN).

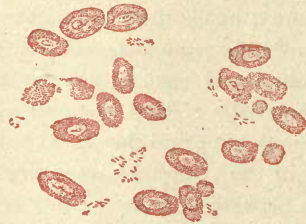

FIG. 143.—BLOOD OF PIGEON INOCULATED WITH BACILLI OF SWINE ERYSIPELAS,  $\times 600$  (SCHÜTZ).

are immune. Rabbits after inoculation of the ear suffer from erysipelatous inflammation, identical with that produced by inoculation of the bacillus of mouse septicæmia. The bacilli are also pathogenic in swine and sheep.

**Protective Inoculation.**—With Pasteur's vaccine immunity is said to be produced which lasts about a year. Schütz and Schottelius found the minute bacilli in Pasteur's vaccine, which they had already found in cases of swine erysipelas in Germany.

The results of vaccination in France are said to be very satisfactory, but in test experiments in Germany they were not so favourable. Out of 119 vaccinated swine 5 per cent. died as the result of the inoculation, while the average loss in the ordinary way is 2 per cent.

Metchnikoff found that the blood of immunised rabbits was antitoxic, and Lorenz maintains that the serum of swine which



have recovered from swine erysipelas is also antitoxic, and will produce immunity in other animals. The treatment introduced by Lorenz is to inject serum in the proportion of 1 cc. to every 10 kilogrammes of the weight of the animal's body. Two days afterwards .5 to 1 cc. of virulent culture is injected, and after twelve days the dose is doubled. Lorenz inoculated 294 pigs; 12 were suffering from swine erysipelas, and of these 6 recovered and 6 died.

In the opinion of the author this disease requires re-investigation, for if it be true that *rouget* or *schweinrothlauf* is associated with ulceration of the intestines, the recognition of it as a disease distinct from our English swine fever apparently rests upon the presence of a bacillus, which cannot be distinguished from the bacillus of mouse septicæmia. The question arises whether this bacillus is really the cause of a distinct disease, swine erysipelas, or, on the other hand, whether the bacillus is really the bacillus of mouse septicæmia which has been isolated from certain cases of swine fever. The bacillus of mouse septicæmia is widely distributed, and it may only be an accidental concomitant in *rouget* or *schweinrothlauf*. The presence of the bacterium of hæmorrhagic septicæmia in both *rouget* and pig typhoid would not prove identity, as this micro-organism is undoubtedly only secondary in both diseases. There is great need, therefore, for further careful investigation. Clinical and pathological observations must be made in this country, to determine whether there are really two diseases included under the name "swine fever." If this prove to be the case, we must ascertain the clinical and pathological differences between *rouget* and pig typhoid. How can *rouget* be distinguished from cases of swine fever in which there is a patchy rash, paralysis of hind legs, but no ulceration of the intestine? Further, how is swine erysipelas with ulceration of the intestine and ileo-cæcal valve to be distinguished from an ordinary case of pig typhoid?



FIG. 144.—PURE-CULTURE  
IN NUTRIENT GELATINE OF BACILLI  
IN SWINE ERYSIPELAS  
(BAUMGARTEN).

## DISTEMPER IN DOGS.

*Distemper* is an infectious febrile disease of dogs, characterised by bronchial catarrh and discharge from the eyes. Bronchitis and pneumonia may supervene, or there may be intestinal catarrh terminating in dysenteric diarrhœa, sometimes complicated by jaundice. The disease may affect the nervous system, and produce convulsive contractions of the muscles of the nose, ears, lips, and limbs. Occasionally there is an eruption, especially in animals which are out of condition. The virus exists in the discharge from the nostrils and eyes, and is given off from the lungs and the skin.

One attack of the disease does not confer entire immunity; and some dogs are completely insusceptible.

**Bacteria in Distemper.**—Millais has isolated a micro-organism resembling the pneumococcus of Friedländer, which he believes to be the cause of the disease. The bacillus occurs with other bacteria and micrococci in the nasal discharge.

**Protective Inoculation.**—Mixed cultures of these bacteria liquefy the gelatine, and the liquid has been used as a vaccine. When applied to the nose, it is said to produce a mild attack of distemper, which protects as much as an attack of the disease contracted naturally. These results require confirmation.

Inoculation of the nasal discharge in healthy dogs has been practised, so that they may have the disease under favourable conditions; but the system should not be encouraged, as dogs need not necessarily contract distemper. Vaccination with cow-pox lymph has been advocated, but it is perfectly useless.

**Stamping-out System.**—Dogs suffering from distemper must be completely isolated. Any straw or litter which has been in contact with a diseased dog should be burnt. Clothing, collars, chains, and the kennel or premises inhabited, must be thoroughly disinfected. The animal after recovery should be washed with carbolic soap.

## EPIDEMIC DISEASE OF FERRETS.

Eberth and Schimmelbusch investigated an epidemic disease of ferrets (*frettchen-seuche*), and isolated a bacillus, which in morphology and cultivation agrees very closely with the bacillus of hæmorrhagic septicæmia.

## EPIDEMIC DISEASE OF MICE.

Löffler investigated an epidemic disease which occurred in mice kept in confinement, and isolated a bacillus resembling *Bacillus typhosus*.



**Bacillus Typhi Murium.**—Rods varying in length; and filaments; motile; flagellated. The colonies are circular, brownish and granular on the surface of obliquely solidified gelatine. The bacteria inoculated on the surface produce a greyish-white semi-transparent growth, and on agar and potato the appearance of the growth is very similar. They can be cultivated readily in milk and in broth. White and field mice are killed in from one to two weeks, when given bread moistened with a culture.

Löffler claims to have used this method with success in Thessaly, where there was a plague of field mice causing great losses to agriculturists.



## CHAPTER XXVII.

ASIATIC CHOLERA. — CHOLERA NOSTRAS. — CHOLERAIC DIARRHŒA  
FROM MEAT-POISONING. — DYSENTERY. — CHOLERAIC DIARRHŒA  
IN FOWLS.

### ASIATIC CHOLERA.

THERE are several diseases in man associated with diarrhœa, which have certain characters in common, but are totally distinct. They include Asiatic cholera, cholera nostras, dysentery, and choleraic diarrhœa. Asiatic cholera is an endemic disease of the Delta of the Ganges, a locality which has become notorious as the home of cholera. Cholera is a filth disease; and the accumulation of filth on the banks of the Ganges, with contamination of the water, and the climate, afford most favourable conditions for the development of the cholera virus.

Four great cholera epidemics have originated in, and spread from, India: in 1817, in 1826, in 1846, and in 1865. Cholera follows the routes of pilgrims and caravans, and now, owing to the rapid means of communication by steamers and railways, it spreads to the most distant parts of the world, covering in a few weeks or days distances which in former times could only be traversed in several months or even years.

In 1892 the epidemic passed from India, through Afghanistan, to Russia in Asia, and quickly spread westwards along the route of the trans-Caspian railway; and all this occurred within the space of a few weeks. By Russian emigrants it was carried to Hamburg and Antwerp; and the virus, finding a suitable environment in the former place, produced a severe epidemic there. Thus, in about three months, it was brought into close proximity with England. Mecca is one of the great infective centres of the world, for there all the conditions are found for the propagation of cholera, including filth, overcrowding, and the water of the famous Holy Well, which is used for ablutions and drinking purposes. The return of



the pilgrims to Egypt, and the proximity of England to Egypt, necessitate the greatest possible precautions to prevent the introduction of the disease into this country.

In 1884 a German Commission was sent out to India, and Koch discovered a micro-organism which he described as a curved or comma-shaped bacillus, and pronounced to be the contagium of this disease.



FIG. 145.—COVER-GLASS PREPARATION OF A DROP OF MEAT INFUSION, containing a pure-cultivation of comma-bacilli, with (a) spirilliform threads,  $\times 600$ . (KOCH.)

**Spirillum cholerae Asiaticae** (*Comma-bacillus*, Koch).—Curved rods, spirilla, and threads. The curved rods or commas are about half the length of a tubercle-bacillus. They occur isolated, or attached to each other forming S-shaped organisms or longer screw-forms, the latter resembling the spirilla of relapsing fever.

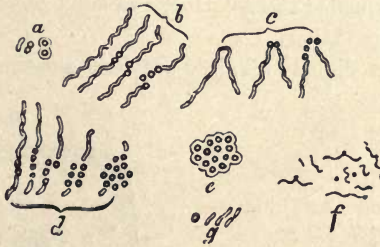

FIG. 146.—ARTHROSPORES; (a) Comma-bacillus breaking up into spheres; (b, c), formation of spheres in spiral forms; (d, e), groups of spheres; (f) spirilla with spheres from an old cultivation; (g) germination of the spheres. (HUEPPE.)

Finally they may develop into spirilliform threads. In old cultivations threads are found with swellings or irregularities (Fig. 148). The commas are actively motile, and possess flagella (Fig. 147). Their movements and development into spirilla may be studied in drop-cultivations. Arthrospore formation has been described by Hueppe (Fig. 146). In plate-cultivations, at a temperature of from

16° to 20° C., the colonies develop as little specks, which begin to be visible after about twenty-four hours. Examined with a low power, and a small diaphragm, these colonies have the following characteristics. They appear as little masses, granular, and

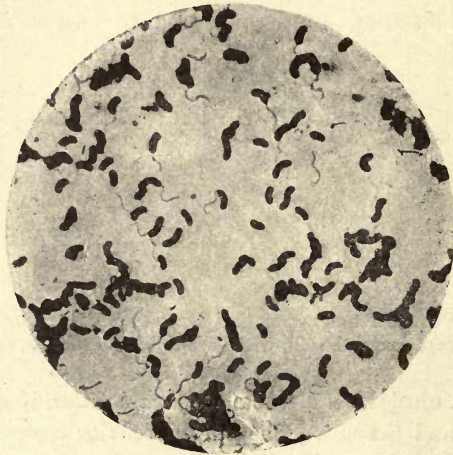

FIG. 147.—FLAGELLA OF COMMA-BACILLI; STAINED BY LÖFFLER'S METHOD (FRÄNKEL AND PFEIFFER).

yellowish-white in colour, and sometimes very faintly tinged with red, which have liquefied the gelatine, and sunk down to the bottom of the resulting excavations.

In test-tubes of slightly alkaline nutrient gelatine (10 per cent.),

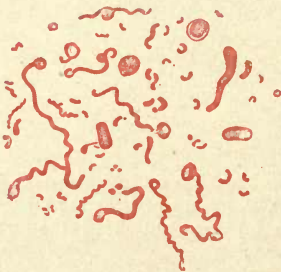

FIG. 148.—INVOLUTION FORMS,  $\times 700$  (VAN ERMENGEM).

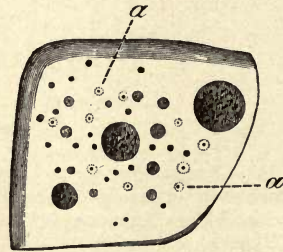

FIG. 149.—COLONIES OF COMMA-BACILLI ON NUTRIENT GELATINE, NATURAL SIZE (KOCH).

the appearance of the growth is very striking. In typical cultures it begins to be visible in about twenty-four hours. Liquefaction sets in very slowly, commencing at the top of the needle track



around an enclosed bubble of air, and forming a funnel continuous with the lower part of the growth; the latter preserves for several days its resemblance to a white thread (Plate II., Fig. 1). In about eight days, however, liquefaction takes place along the whole of the needle track.

On the surface of agar-agar the cultivation develops as a white, semi-transparent layer, with well-defined margin. The

appearance on blood serum is very similar; liquefaction very slowly takes place. In broth they form a wrinkled film on the surface, there is a rapid and abundant growth at the temperature of the



FIG. 150.—COLONIES OF KOCH'S COMMA-BACILLI,  $\times 60$ .

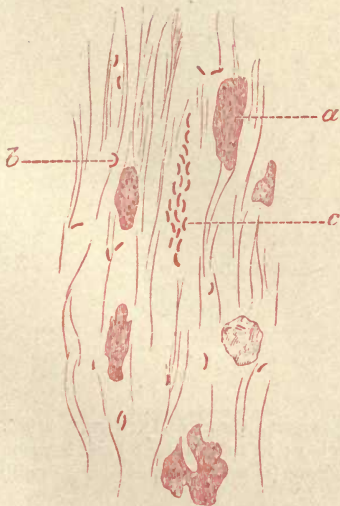

FIG. 151.—COVER-GLASS PREPARATION FROM THE CONTENTS OF A CHOLERA INTESTINE,  $\times 600$ . (a) Remains of the epithelial cells; (b) Comma-bacillus; (c) Group of comma-bacilli (Koch).



FIG. 152.—COVER-GLASS PREPARATION OF CHOLERA DEJECTA ON DAMP LINEN (two days old),  $\times 600$ . Great proliferation of the bacilli with spirilla (a) (Koch).

blood, and the same applies to sterilised milk; and they will even multiply in sterilised water. In potato-cultivations the microbe will only grow at the temperature of the blood ( $37^{\circ}$  C.), forming a slightly brown, transparent layer. Inoculation of a cultivation of the bacillus in the duodenum of guinea-pigs, with and without

ligation of the bile-duct, has given positive results. More recently these results have been confirmed by the following method: Five cc. of a 5 per cent. solution of potash were injected into the stomach of a guinea-pig, and twenty minutes after, 10 cc. of a cultivation of comma-bacilli, diffused in broth, were similarly introduced. Simultaneously with the latter, an injection of tincture of opium was made into the abdominal cavity, in the proportion of 1 cc. for every 200 grammes weight of the animal. Those who have had success with inoculation experiments maintain that choleraic symptoms were produced without any trace of peritonitis or putrid infection, and that the comma-bacilli of Koch were again found in the intestinal contents, and fresh cultivations established.

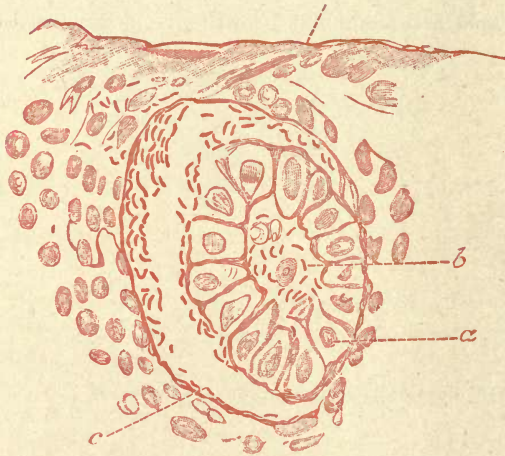

FIG. 153.—SECTION OF THE MUCOUS MEMBRANE OF A CHOLERA INTESTINE,  $\times 600$ .  
A tubular gland (*a*) is divided transversely; in its interior (*b*) and between the epithelium and the basement membrane (*c*) are numerous comma-bacilli (Koch).

On the other hand, these results have been disputed, the fatal effects of the inoculation attributed to septicæmic poisoning, and the proliferation of the bacilli considered to be dependent upon an abnormal condition of the intestines, induced by the injection of tincture of opium. It has, however, been shown that these organisms, like several others which have been isolated from intestinal discharges, produce definite poisonous substances. The comma-bacilli were found in the superficial necrosed layer of the intestine, in the mucous flakes and liquid contents of the intestinal canal of cases of Asiatic cholera. It is stated that they were also detected



in a tank which contained the water supply of a neighbourhood where cholera cases occurred; but comma-shaped organisms are frequently present in sewage-contaminated water. Koch's comma-bacilli are aerobic, and their development is arrested by deprivation of oxygen. They are destroyed by drying on a cover glass, but retain their vitality longer when dried on silk threads. Cultures are sterilised by exposure for fifteen minutes to  $55^{\circ}$  C., and by various antiseptic substances.

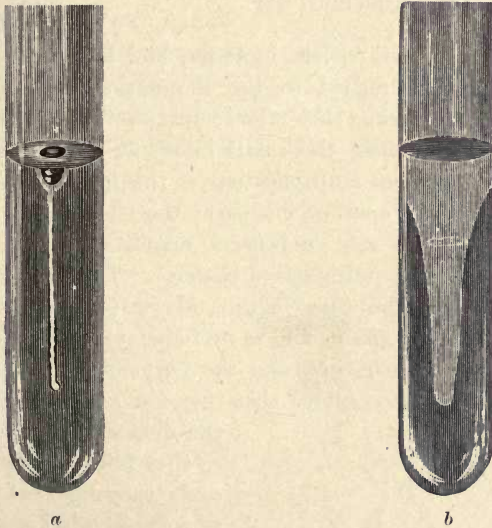

FIG. 154.—PURE-CULTIVATIONS IN NUTRIENT GELATINE. *a*, KOCH'S CHOLERA BACILLUS, twenty-four hours old. *b*, FINKLER'S BACILLUS, twenty-four hours old.

#### METHODS OF STAINING THE COMMA-BACILLI OF KOCH.

In cover-glass preparations they may be well stained in the ordinary way, with an aqueous solution of methyl-violet or fuchsine, or by the rapid method, without passing through the flame (p. 85, Babès' method).

##### *Nicati and Reitsch's method.*

A small quantity of the stools, or of the scraping of the intestinal mucous membrane, is spread out on a glass slide and dried, then steeped during some seconds in sublimate solution, or in osmic acid (1 to 100). It is then stained by immersion in fuchsine-aniline solution (1 or 2 grammes of Bâle fuchsine dissolved in a saturated aqueous solution of aniline), washed, dried, and mounted in Canada balsam.

In sections of the intestine their presence may be demonstrated by:—

(a) *Koch's method.*

Sections of the intestine, which must be well hardened in absolute alcohol, are left for twenty-four hours in a strong, watery solution of methylene-blue, or for a shorter time if the solution is warmed; then treated in the usual way.

(b) *Babès' method.*

Sections, preferably from a recent case of cholera, and made as soon as possible after death, are left for twenty-four hours in an aqueous solution of fuchsine, then washed in distilled water, faintly acidulated with acetic acid, or in sublimate solution 1 in 1000, passed rapidly through alcohol, and finally treated in the usual way.

Klein investigated cholera in India, and does not accept Koch's conclusions. With regard to the inoculation experiments, Klein believes that the living choleraic comma-bacilli, even if introduced in large numbers into the small intestine, are quite innocuous, but capable of great multiplication if the intestine is previously, from some cause or another, diseased; the chemical products of the comma-bacilli then act as poisons analogous to the ptomaines obtained from other putrefactive bacteria. The observations made by Roy, Brown, and Sherrington, in Spain, tended to confirm Koch's views. Comma-bacilli were found to be present, in some cases, in enormous numbers, and the frequency of their occurrence led these observers to believe that they must bear some relation to



FIG. 155.—COMMA-SHAPED ORGANISMS WITH OTHER BACTERIA IN SEWAGE-CONTAMINATED WATER,  $\times 1200$ .

the disease. At the same time, as they failed to find them in all cases, they regarded the existence of a causal relation as not proven. They failed to find the Naples bacterium, or a small, straight bacillus noted by Klein; and they drew attention to certain peculiar mycelium-like threads in the mucous membrane of the intestines; but these cannot be

considered to have any significance. Methylene-blue has been employed by Koch and others, including the author, for staining sections of the intestine from cholera cases, and had they been constantly present, it is hardly possible that such striking objects could have been overlooked. Again, we must bear in mind that hypho-mycetous fungi occasionally have been found to occur saprophytically in the intestinal canal, as well as in the lungs, external auditory meatus, and elsewhere. Cunningham, of Calcutta, maintains



that Koch's comma-bacilli are not constantly found; and that the comma-bacilli obtained from typical cholera cases show a great variation in cultivation, and cannot be distinguished from comma-bacilli from other sources.

Cunningham asserts that comma-bacilli resembling Koch's are found in the intestine in health. Sternberg, on the other hand, made a number of examinations of the evacuations of yellow fever patients and healthy individuals, and failed to find any micro-organism resembling the cholera spirillum.

Various comma-bacilli have been isolated from different sources and compared with Koch's comma-bacillus. Comma-bacilli have been found in the mouth by Lewis; in cholera nostras by Finkler and Prior; in cheese by Deneke; in hay infusion and sewage by Weibel; in the intestines of fowls by Gamaleia, and in water by Sanarelli.

Whether the comma-bacillus is the cause of cholera or not, its detection is an aid in diagnosis. If we are dealing with a case alleged to be one of Asiatic cholera, and a micro-organism is found in the intestinal evacuations, which can be differentiated from the comma-bacillus described by Finkler in cholera nostras, and identified with the comma-bacillus described by Koch, we are justified in regarding the case as one of Asiatic cholera. But we cannot diagnose Koch's comma-bacillus, with certainty, unless we know the source of the culture. The clinical symptoms of cholera in man, and especially the presence of rice-water stools, must be taken into account, together with the biological, morphological, and chemical characteristics of the bacilli which are found to be present. There are several



FIG. 156.—COMMA-BACILLI OF THE MOUTH,  $\times 700$  (VAN ERMENGEM).



FIG. 157.—FINKLER'S COMMA-BACILLI; FROM CHOLERA NOSTRAS,  $\times 700$  (FLÜGGE).

Whether the comma-bacillus is the cause of cholera or not, its detection is an aid in diagnosis. If we are dealing

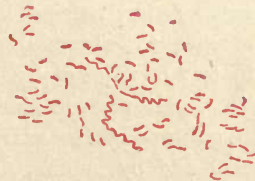

FIG. 158.—DENEKE'S COMMA-BACILLI, FROM CHEESE,  $\times 700$  (FLÜGGE).

chemical tests which can be applied to cultures. According to Fränkel, the Bujwid-Dunham test can be relied upon to distinguish Koch's comma-bacillus from the comma-bacillus of Finkler-Prior (cholera nostras), and from those found by Gamaleia. The comma-bacilli are inoculated in broth containing peptone, and, after twelve hours in the incubator, a drop of strong sulphuric acid added to the culture will produce a red colour, owing to the presence of indol. A test which distinguishes Koch's comma-bacillus from Finkler-Prior's and Deneke's was introduced by Cahen. A solution of litmus is added to the broth, and the culture placed in the incubator, until the following day; in the case of Koch's commas, the colour will have disappeared.

Koch points out that in the bacteriological diagnosis of cholera the first step is to examine the mucus in the evacuations, or in the intestine if the examination is made after death. Cover-glass preparations should be stained with dilute Ziehl-Neelsen solution. Cultures are next made in peptone, and in eight hours will give the indol reaction. In twenty-four hours the colonies may be examined on plate-cultivations. The peptone cultures are prepared by adding a trace of the choleraic evacuations, or of mucus containing the bacilli, to a sterilised 1 per cent. solution of peptone, with .5 to 1 per cent. of common salt. The solution must be alkaline, and the culture is placed in the incubator at 37° C. The pathogenic effects can be ascertained by diffusing the bacilli from an agar-culture in broth, and injecting it into the peritoneal cavity.

*Toxic Products.*—Brieger isolated several toxic products which he had found in association with putrefaction, such as cadaverin and putrescin; but there were also present two new toxic substances, one producing cramps and muscular tremors in inoculated animals, and the other lowering the temperature and depressing the action of the heart. Later, Brieger in conjunction with Fränkel, succeeded in isolating a tox-albumin from pure cultures. Guinea-pigs were killed in two or three days, but rabbits had an immunity. Pfeiffer found that cultures contained a poisonous principle which proved fatal to guinea-pigs in extremely minute doses. It is broken up by alcohol and by boiling, and secondary products formed, of very much mitigated virulence. Similar toxic products were obtained from cultures of both Finkler-Prior's and Metchnikoff's commas.

**Protective Inoculation.**—Haffkine has introduced a system of protective inoculation, which is founded on the principle of inducing the formation of antitoxins, or defensive proteids. Comma-bacilli when first cultivated from a cholera patient are not sufficiently



virulent, and the virulence is increased by cultivation in the peritoneal cavities of a succession of guinea-pigs. This successive cultivation is carried on until a virus is obtained which proves fatal in a few hours when inoculated into the peritoneum. A culture from the peritoneum is obtained on an agar plate-cultivation, and a pure sub-culture on agar is thoroughly shaken up with broth. This constitutes the vaccinating fluid. It may be used as a living vaccine, or the comma-bacilli killed by the addition of carbolic acid.

Haffkine, having studied the pathological and physiological effects on some sixty persons, mostly scientists interested in the subject, and finding the treatment to be harmless, transferred his operations to localities in India affected by cholera. The inhabitants of the northern part of India were the first to come forward and submit themselves to the inoculation. In the course of the first year 22,703 were inoculated in the North-West Provinces and Oudh, and in the Punjab. All classes of the population were included. In the second year operations were carried out in those parts of the country where cholera always prevails, and where, therefore, the method could be more satisfactorily tested.

From March 1894, to July 1895, 19,473 individuals were inoculated in some of the most affected localities.

From observations made at Calcutta by Dr. Simpson, from March 1894 to August 1895, cholera occurred in 36 houses containing inoculated people. There were 521 inhabitants in the infected houses, of whom 181 were inoculated from 1 to 459 days before the occurrence, while 340 remained uninoculated. The uninoculated had 45 cases with 39 deaths from cholera; the inoculated had 4 deaths, 1 occurring 451 days after the first inoculation, and 3 others from 1 to 4 days after the first inoculation. These four cases had not been re-inoculated. If the occurrences in inoculated and non-inoculated during the first 10 days were set aside, and those considered that occurred after the 10 days expired, then, according to Dr. Simpson, the proportion of cases was 19·27 and that of deaths 17·24 times smaller in the inoculated than in the uninoculated.

Cholera broke out in the Gya gaol, and inoculations were made after 6 cases, with 5 deaths, had occurred. During the stay of the prisoners in the gaol, there were 209 uninoculated, with 7 cases and 5 deaths, and 211 inoculated, with 5 cases and 4 deaths.

In July and August in the same year cholera attacked the East Lancashire Regiment. Out of 773 men there were 133 inoculated and 640 uninoculated.

The occurrences of cases and deaths were :—

In 640 uninoculated 120 cases (18·75 %), 79 deaths (12·34 %).

In 133 inoculated 18 cases (13·53 %), 13 deaths (9·77 %).

These results were, it is said, due to the weakness of the vaccines procurable at that period of the work, and to the small doses used.

There were a great many records kept of the results of inoculation of coolies on tea estates in different localities. After a summary of the results Haffkine concludes, in his Report to the Government of India, that, in his opinion, the experimental stage was not yet in so advanced a condition as to be completely closed; but that the observations made and records collected justified steps being taken to give the inoculations a more extended trial.



FIG. 159.—PURE-CULTIVATION OF THE SPIRILLUM FINKLER-PRIOR, IN NUTRIENT GELATINE. In thirty-six hours.

#### CHOLERA NOSTRAS.

Cholera nostras, English cholera, or English dysentery, produces an inflammation of the mucous membrane of the bowels with croupous exudation. The large intestine is commonly affected, and the mucous membrane may be covered with small superficial ulcers. The disease is associated with severe diarrhœa.

Finkler and Prior obtained a comma-bacillus from the evacuations, which they believed to be identical with the comma-bacillus found by Koch in Asiatic cholera. Koch pointed out that there were marked differences in the biological character of the two micro-organisms.

**Spirillum Finkler-Prior** (*Comma-bacillus in Cholera nostras*).—Curved rods, thicker than the comma-bacillus of Koch, and spirilla. The colonies on plate-cultivations are very much larger than those of the comma-bacillus of Koch of the same age. They have a very faint yellowish-brown tinge, a well-defined border, and a distinctly granular appearance. They liquefy nutrient gelatine very rapidly, so that the first plate of a series is, as a rule, completely liquefied on the day following inoculation, and the second plate in two or three days more. In a test-tube cultivation in nutrient gelatine the appearances are especially characteristic: the gelatine is very rapidly



liquefied along the whole track of the needle, so that the cultivation resembles a conical sack, or the finger of a glove turned inside out. On a sloping surface of nutrient agar-agar a white moist layer forms very quickly. On potato they grow at the ordinary temperature of the air, producing a brownish layer and corrosion of the surface of the potato. They have been shown to be pathogenic.

#### CHOLERAIC DIARRHŒA FROM MEAT POISONING.

There are two varieties of choleraic diarrhœa from meat poisoning, and both are associated with vomiting, diarrhœa, pain in the abdomen, in severe cases followed by suppression of urine, collapse, and death. These conditions are brought about by poisonous foods, and include those cases of poisoning by tinned meats, pork pies, hams, cheese, sardines, and other articles of food improperly prepared. In most cases putrefaction has taken place, owing to the action of various bacteria. Associated with their growth we find highly poisonous substances, but no bacteria are found in the body in these cases. They are all due to chemical poisoning; but Klein has also described cases of poisoning due to the growth of bacteria without the presence of putrefaction. The latter were of the nature of an infectious disease. In the Welbeck poisoning cases, described by Ballard, the poisonous hams contained a short bacillus, which was also found in the kidney and spleen in the fatal cases in man. In the Carlisle epidemic, which was due to poisonous pork pies, the pork and gravy stock proved fatal to mice, and from the infected mice a bacillus was cultivated, which, administered to mice by feeding or subcutaneous inoculation, produced enteritis, diarrhœa, and congestion of the lungs.

Gärtner cultivated *Bacillus enteritidis* from the spleen in a fatal case of meat poisoning. Gaffky obtained a similar bacillus in cases of gastro-enteritis, following the consumption of meat and sausages, which had been made of horseflesh.

**Bacillus of Choleraic Diarrhœa from Meat-poisoning** (Klein).—Rods from 3 to 9  $\mu$  in length, 1.3  $\mu$  wide, rounded at their extremities, singly or in chains of two. Spore-formation occurs, the spores being 1  $\mu$  thick, oval, and situated in the centre or at the end of the rod.

Feeding mice with the bacilli and inoculation produced positive results. At the autopsy, pneumonia, peritonitis, pleuritis, enlargement of the liver and spleen, and hæmorrhages were observed, and bacilli were present in the blood and exudations of these animals. They

occurred in the blood and juices, and especially in the glomeruli of the kidneys, of several fatal cases of choleraic diarrhœa.

**Bacillus enteritidis** (Gärtner).—Short rods in pairs, and short chains. They are motile; spore-formation not observed. Colonies are granular, and old colonies at the margin have an appearance of

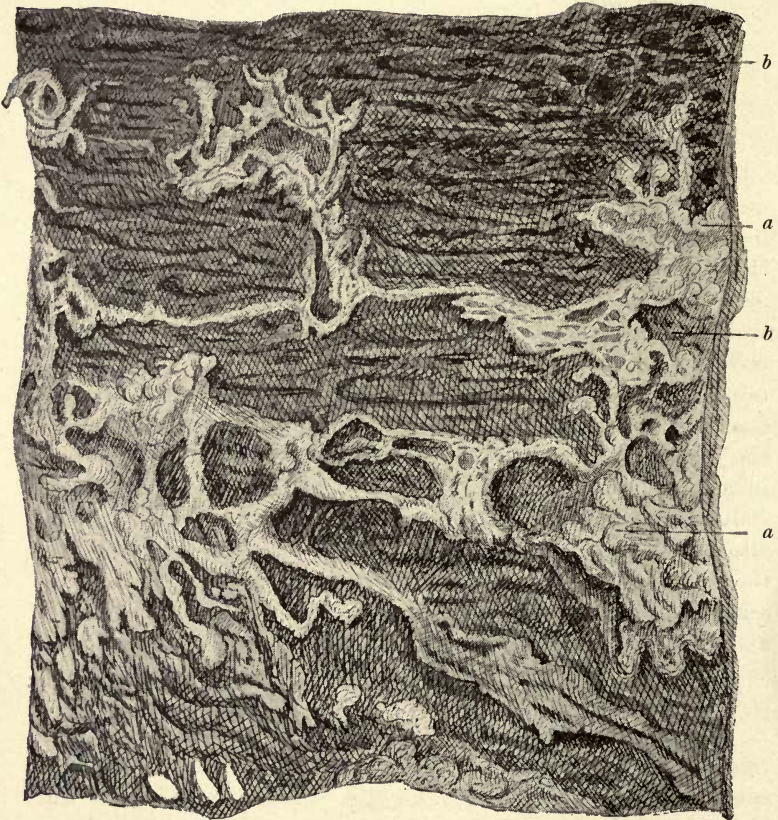

FIG. 160.—TROPICAL DYSENTERY. Mucous membrane of large intestine some months after an acute attack: *a,a*, representing remains of mucosa; *b,b*, intervening parts corresponding to the muscularis (HAMILTON).

powdered glass. On the surface of gelatine a thick greyish-white film develops, which in time becomes wrinkled. In the depth of gelatine a white filament forms. The gelatine is not liquefied. On agar the film is slightly yellowish. On potato it is similar in colour, moist and shining. On blood serum it is very similar. Mice fed



with the bacilli die in one or two days. Subcutaneous injection is fatal in guinea-pigs and rabbits in from two to five days. Dogs, cats, and fowls are immune.

The bacilli were obtained from a cow suffering from a disease associated with diarrhoea, and from the spleen of a man who died twelve hours after partaking of the flesh of this animal.

#### DYSENTERY.

Dysentery is a disease of tropical climates associated with inflammation and ulceration of the large intestine (Fig. 160). At first the discharge from the bowel is a whitish or brownish mucus, which soon becomes blood-stained; later the evacuations become thin and watery, with altered blood clots, fragments of mucous membrane, and pieces of false membrane; and in some cases they become purulent. The virus is believed to be in the intestinal discharges, which by contaminating water or soil may give rise to other cases.

Micrococci have been found in dysentery, but the micro-organism which has received most attention is a protozoon, the *Amœba coli*, which will be described in another chapter.

#### CHOLERAIC DIARRHOEA IN FOWLS.

Choleraic diarrhoea in fowls, or gastro-enteritis cholericæ, is an infectious disease of fowls, occurring in Russia during the summer. The disease is very like fowl-cholera. The birds are sleepy, and suffer from diarrhoea, but the temperature is not raised, as in fowl-cholera. After death there is usually an abundance of greyish liquid in the small intestine, which is stained with blood. It was investigated by Gamaleia, who found a comma-bacillus, to which he gives the name *Vibrio Metchnikovi*.

**Spirillum of Fowl-enteritis** (*Vibrio Metchnikovi*).—Curved rods and spirilla; thicker, shorter, and more curved than Koch's commas. They are motile, and possess a single flagellum at one end. They stain with the usual dyes. Spore-formation doubtful. In plate-cultivations minute white colonies appear in from twelve to sixteen hours, and the gelatine is liquefied. The colonies in about three days resemble those of both Finkler-Prior's and Koch's comma-bacilli, some colonies being more like the one kind, and some like the other. In the depth of gelatine the growth is very much like that of Koch's comma-bacillus, possessing the characteristic air-bubble appearance.

On agar a slightly yellowish growth is obtained, resembling that of Koch's commas; on potato a yellowish-brown or chocolate layer develops after incubation at the temperature of the blood, very similar to cultures from Asiatic cholera. Broth becomes turbid, and a wrinkled film forms on the surface; the addition of sulphuric acid gives the indol test. The spirilla grow in milk, and coagulate it; the milk becoming strongly acid, and the casein being precipitated. They are pathogenic in chickens, pigeons, and guinea-pigs. Pigeons die in about twelve hours after a subcutaneous injection; and the spirilla are found abundantly in blood from the heart. Guinea-pigs die from acute septicæmia in about twenty-four hours. The spirilla are found in the blood and internal organs. Inoculation of pigeons and guinea-pigs with sterilised cultures will produce immunity.



## CHAPTER XXVIII.

### TUBERCULOSIS.

TUBERCULOSIS is a communicable disease of man and animals, characterised by the formation of new growths associated with the presence of the tubercle bacillus. Von Bayle, in 1810, was the first to describe little growths like millet seeds, which were considered to be characteristic of consumption or phthisis. Laennec, in 1834, attached much more importance to the existence of caseous matter and classified miliary tubercle, crude tubercle, granular tubercle, and encysted tubercle, as varieties of tuberculosis. Virchow would not accept all these varieties as tubercular, and only regarded those conditions associated with the presence of miliary tubercles as genuinely tubercular. Laennec's so-called crude tubercle, for example, was simply due to pneumonic caseation. Villemin threw entirely fresh light upon this controversy by proving that tuberculosis was a communicable disease. Rabbits and guinea-pigs, inoculated with tubercular sputum or caseous tubercle, developed miliary tubercle in a few weeks. Sanderson confirmed these experiments, and pointed out that foreign bodies would produce experimental tuberculosis in rabbits. Cohnheim also confirmed the experiments of Villemin, and maintained that tuberculosis was a specific inoculable disease, and, therefore, everything was tubercular which, on inoculation, produced tuberculosis. Koch, in 1882, announced the discovery of the tubercle bacillus, and expressed the opinion that without the tubercle bacillus there could be no tuberculosis. Tubercle was defined as tissue containing the tubercle bacillus, whatever might be the clinical manifestations of the case, or the microscopical and naked-eye appearances of the diseased parts.

A tubercle is a small growth about the size of a millet seed. In the early stage it is circular, hard, grey in colour, and lustrous; but when it undergoes necrosis and caseation it becomes soft and yellowish. In the very early stage it consists of a little collection of round

cells, in which it is possible, though often with extreme difficulty, to demonstrate the tubercle bacillus. The cells originate in the proliferation of endothelial connective tissue and white blood cells. Later on, large oval or circular multi-nucleated cells, or *giant cells*, make their appearance. The tubercle bacilli are only occasionally found in the interior of human giant cells, whereas in the lower animals, in equine and bovine tuberculosis more especially, the bacilli are often present in great numbers, and very commonly in the form of conspicuous rings, visible under a low power of the microscope.



FIG. 161.—TUBERCLE OF THE LUNG IN A VERY EARLY STAGE,  $\times 400$ : *a*, An alveolar wall; *b*, blood-corpuscles in capillaries of the same; *c*, blood-corpuscles extravasated into the alveolar cavities; *d*, alveolar capillaries filled with blood-corpuscles carried forward by the tubercle which is growing into the alveolar cavity; *e*, large endothelium-like cells, of which the tubercle in this stage is mainly composed; *f*, portion of a branch of the pulmonary artery injected (HAMILTON).

Whether the absence of blood-vessels or the action of the bacillus is the main factor in producing caseation, is an open question. When suppuration follows caseation, as commonly happens in tuberculosis of the lungs in man, and in experimental tuberculosis in animals, an abscess forms. In cattle there is a remarkable tendency to the formation of calcareous deposit in the caseous masses.

The tubercle may not degenerate and die, but live and develop.



The giant cells, which are more or less central, have been described as sending off processes, which, by dividing and subdividing, and

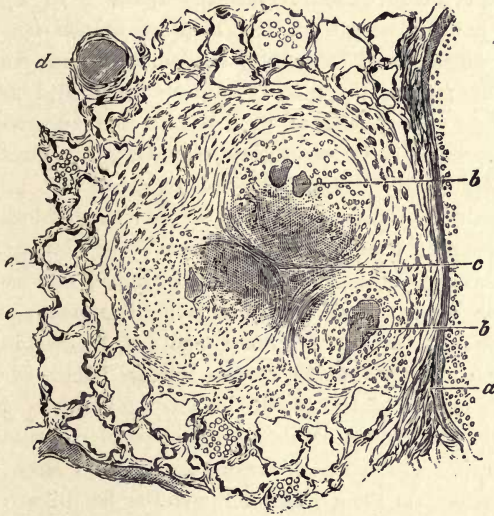

FIG. 162.—PRIMARY TUBERCLE OF LUNG TWO TO THREE WEEKS OLD,  $\times 50$ : *a*, Portion of wall of a branch of the pulmonary artery; *b, b*, giant cells with concentric arrangement of fibrous tissue; *c*, centre of tubercle beginning to caseate; *d*, small branch of pulmonary artery seen on transverse section; *e*, injected capillaries of the alveolar walls (HAMILTON).

interlacing, form a reticulum, or meshwork. Towards the periphery of the tubercle the reticulum may become arranged in the form of a capsule as the age of the tubercle advances, and the reticular giant cell becomes eventually converted into fibrous tissue. The bacillus has disappeared, and the tubercle has healed.

Giant cells cannot be relied upon to indicate tuberculosis. They are not always present in tuberculosis, and they are not peculiar to tubercle, being found, for example, in actinomycosis. The only certain indication of tuberculosis is the presence of the tubercle bacillus, which

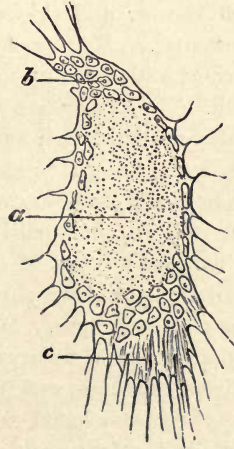

FIG. 163.—LARGE OVAL GIANT CELL FROM TUBERCLE OF LUNG  $\times 300$ : *a*, Granular centre; *b*, nucleated periphery forming a mantle-like sheath; *c*, processes from the same.

can be revealed either by microscopical examination of the suspected tissue, or after inoculation in guinea-pigs.

**Bacillus Tuberculosis** (Koch).—Rods, 2 to 4  $\mu$  and occasionally 8  $\mu$  long, very thin, and rounded at the ends. They are straight or curved, and frequently beaded, and occur singly, in pairs, or in bundles; there are also involution forms and short branched threads. Spore-formation is observed in old cultures. They are non-motile. In the interior of giant cells they are often accompanied by grains which exhibit the same colour reaction.

The bacilli in tissue sections of bovine tuberculosis are shorter and less granular than those in human tubercular sputum, but in milk they are quite as long, and even longer, and very distinctly granular or beaded, and are thus brought much closer, morphologically, to the bacilli in human sputum. Speaking generally, however, the average length of the human bacilli is greater than the average length of the bacilli in cow's milk, but the longest of the bovine bacilli cannot be distinguished in length from the longest human bacilli. There are, however, exceptional cases, for in some preparations of pus from human lungs the bacilli are remarkable, not only for their thinness, and their uniformly beaded character, but more particularly for their extraordinary length. They should be compared with other preparations, in which the bacilli, though in human sputum, are sometimes much more distinctly rod-shaped, much shorter and thicker, with complete absence of any beaded appearance. Neither length nor granularity is a characteristic sufficient to denote any specific difference between human and bovine bacilli. The author has examined minutely the bacilli in tuberculosis of other animals, such as the horse, pig, and cat; and of birds—the fowl, guinea-fowl, pheasant, and ostrich. Here, again, minute morphological differences can be observed. For example, in many cases in fowls the bacilli are conspicuously short and straight. In the liver and lungs of an ostrich, packets of short rod-forms are found, while in other parts of the same sections the bacilli attain a very great length. Many of the long, sinuous forms exhibit a peculiar terminal enlargement. There are also short rods with a similar appearance, and free ovoid bodies, singly and in groups, which, from their connection with the bacilli, and their sharply defined outline in the free state, are similar to spores in old cultures.

Thus, morphological differences are found under different circumstances, and within limits the morphology of the tubercle bacillus varies with its environment.

Koch first succeeded in cultivating the bacillus by employing





## DESCRIPTION OF PLATE XI.

### **Bacillus tuberculosis.**

The figures in this plate represent the bacilli of tuberculosis in different animals, examined under the same conditions of amplification and illumination.  $\times 1200$ . Lamp-light illumination.

- FIG. 1.—Bacilli in pus from the wall of a human tubercular cavity. In this specimen the bacilli are shorter than those in tubercular sputum, and are very markedly beaded.
- FIG. 2.—Bacilli in pus from a tubercular cavity from another case in man. They are present in the preparation in enormous numbers. The protoplasm occupies almost the whole of the sheath, and the bacilli are strikingly thin and long.
- FIG. 3.—Bacilli in sputum from an advanced case of phthisis, showing the ordinary appearance of bacilli in sputum; some beaded, others stained in their entirety; occurring both singly and in pairs, and in groups resembling Chinese letters.
- FIG. 4.—Bacilli in a section from the lung in a case of tuberculosis in man. The bacilli in human tuberculosis are found in, and between, the tissue cells; and sometimes, as in equine and bovine tuberculosis, in the interior of giant cells, but not so commonly.
- FIG. 5.—From a cover-glass preparation of the deposit in a sample of milk from a tubercular cow. The bacilli were longer than the average length of bacilli in bovine tissue sections, and many were markedly beaded.
- FIG. 6.—From a section of the brain in a case of tubercular meningitis in a calf, showing a giant cell containing bacilli with the characters usually found in sections of bovine tuberculosis.
- FIG. 7.—From a section of the liver of a pig with tubercle bacilli at the margin of a caseous nodule.
- FIG. 8.—From a cover-glass preparation of a crushed caseous mesenteric gland from a rabbit infected by ingestion of milk from a cow with tuberculosis of the udder.
- FIG. 9.—From a section of lung in a case of equine tuberculosis, showing a giant cell crowded with tubercle bacilli.
- FIG. 10.—From a section of lung from a case of tuberculosis in the cat, with very numerous tubercle bacilli.
- FIG. 11.—From a cover-glass preparation of a crushed caseous nodule from the liver of a fowl, with masses of bacilli. These are for the most part short, straight rods; but other forms, varying from long rods to mere granules, are also found.
- FIG. 12.—From sections of the liver and of the lung in a case of tuberculosis of a Rhea. Isolated bacilli are found, as well as bacilli packed in large cells, colonies of sinuous bacilli, and very long forms with terminal spore-like bodies and free oval grains.

The preparations from which these figures were drawn were all stained by the Ziehl-Neelsen method, with the exception of the first, which was stained by Ehrlich's method.





Fig 1.

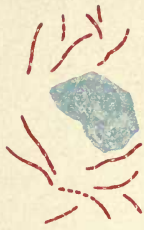

Fig 2

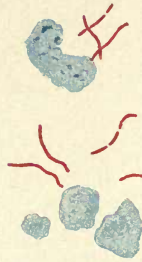

Fig 3

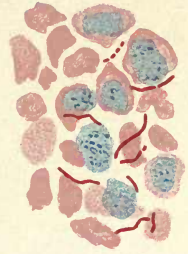

Fig 4.

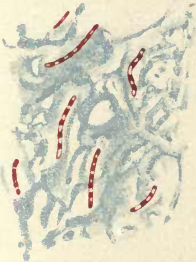

Fig 5



Fig 6

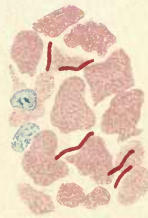

Fig 7.

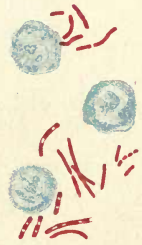

Fig 8.

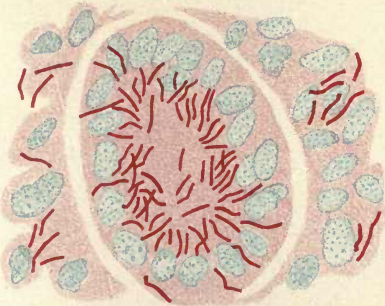

Fig 9.

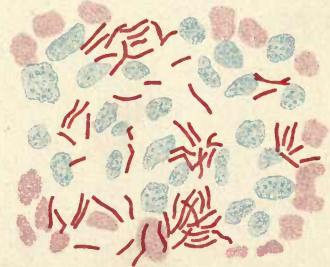

Fig 10.

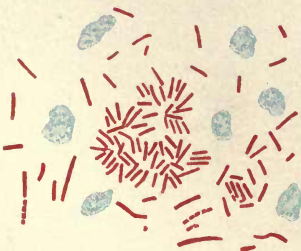

Fig 11.

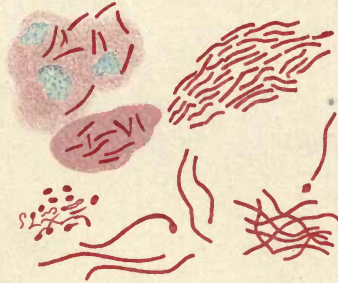

Fig 12.

BACILLUS TUBERCULOSIS.





blood serum. Solid blood serum, with or without the addition of gelatine, was employed, and the cultures incubated at 37° C. The growth takes place very slowly, and only between the temperatures of 30° C. and 41° C. In about eight or ten days the growth appears as little whitish or yellowish scales and grains.

The bacillus can also be cultivated in a glass capsule, on blood serum, and the appearances of the growth studied under the microscope. The scales or pellicles were described by Koch as made up of colonies of a perfectly characteristic appearance, which may be still further studied by making a cover-glass impression. They are then seen to be composed of bacilli, arranged more or less with their long axis corresponding with that of the colony itself, and with an appreciable interval between the individual bacilli. The colonies themselves appear as fine curved lines, the smallest being mostly S-shaped. Longer colonies have serpentine twistings and bendings, which often recall the curves of fancy lettering. The ends of the lines run to sharp points, but the middle of the growth is spindle-shaped. The youngest colonies are extremely delicate and narrow, but the older colonies increase in size, are thicker across, and, blending with each other, gradually obliterate the characteristic appearances;



FIG. 164. — BACILLUS TUBERCULOSIS, FROM TUBERCULAR SPUTUM,  $\times 2500$ . From Photographs.

a lamellated growth results, which increases, and gives the appearance to the naked eye of the scale or pellicle already described. The blood serum is not liquefied unless putrefactive bacteria contaminate the culture. A fresh tube can be inoculated with one of the little scales, and a new generation started. The scales gradually increase in size, and consist entirely of bacilli. In about three to four weeks the cultivation ceases to increase, and it is then necessary to inoculate a fresh tube.

In liquid blood serum a film forms on the surface of the liquid, and is easily broken by agitation. In neutralised broth there is very little indication of success. When a triturated culture is added to the broth, a granular, sandy, whitish deposit collects at the bottom of the vessel, with indications of an increase in amount. Koch also tried nutrient agar-agar, which did not prove to be at

## BACILLUS TUBERCULOSIS.

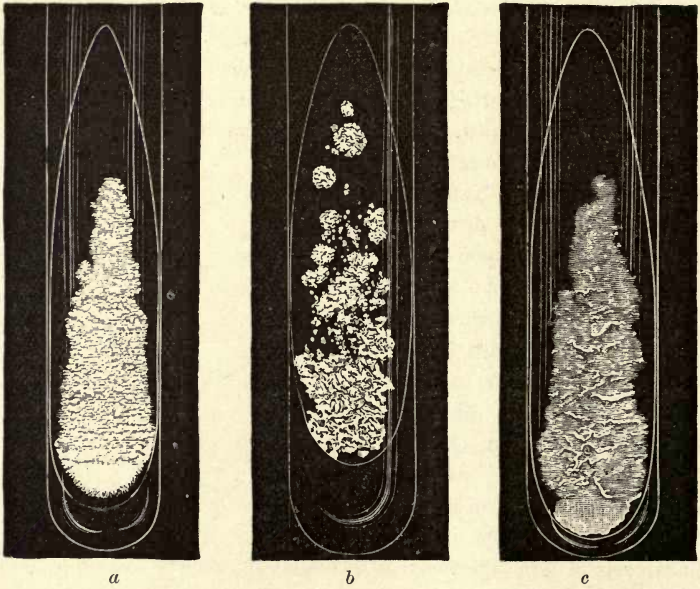

FIG. 165.—PURE-CULTIVATIONS ON GLYCERINE-AGAR FROM HUMAN TUBERCULAR SPUTUM. *a*, After six months' growth. (Fifth sub-culture.) *b* and *c*, After ten months' growth. (Fourth sub-cultures.)



all a favourable medium. Some increase took place, but there was no continuous growth over the inoculated area.

*Glycerine Agar-agar.*—Nocard and Roux were among those who worked at the subject and confirmed Koch's observations. Nocard attempted to get cultures of avian tuberculosis on blood serum to which peptone, salt, and cane sugar had been added. The results were more successful than with ordinary serum. But he encountered a difficulty in the rapid drying of the surface of the medium, which rendered the tubes unfit for use. It occurred to Nocard and Roux to obviate this by the addition of a hygroscopic agent, and accordingly they added sterilised glycerine. The result, which far exceeded their expectation, evidently was not solely attributable to the prevention of desiccation. Following up

their discovery, and being anxious to find a medium more easily prepared than blood serum, they added

6 to 8 per cent. of glycerine to ordinary nutrient agar-agar. The bacillus grew so abundantly in this mixture that a culture in fifteen days equalled in extent a culture on blood serum which was several weeks old. The bacillus was found to grow abundantly in veal broth, to which glycerine had been added in the proportion of 5 per cent., the bottom of the flask being covered in about three weeks with a flocculent deposit, having some resemblance to anthrax cultivations in liquid media. In beef broth, chicken broth, and in Cohn's liquid, cultures were obtained after the addition of glycerine.

*Description of Cultivations on Glycerine Agar-agar.*—The cultivations on the sloping surface of obliquely solidified glycerine agar-

agar begin to appear in from four to six days as very minute white colonies. These steadily increase in size, and either look moist and



FIG. 167.—PURE-CULTIVATION IN GLYCERINE AGAR-AGAR,—A SUB-CULTURE FROM A PURE-CULTURE IN GLYCERINE-MILK. In two months.



FIG. 166.—PURE-CULTIVATION IN GLYCERINE AGAR-AGAR, after ten months' growth.

smooth, or, even at this early stage, appear dry and crinkled. According to the number of bacilli inoculated, the colonies will either remain isolated or coalesce and form a more or less continuous film. If the nutrient agar-agar has only recently been prepared, there is usually a quantity of liquid present, and the bacillus forms a white coating over the inoculated area and beyond it. The appearances are much more characteristic when this medium is, comparatively speaking, dry. A semi-transparent membranous growth develops, thickens, and assumes a characteristic lichenous appearance. Such a culture, examined with a pocket lens, resembles a model in wax in miniature of the folds of the gastric mucous membrane. In about six weeks to two months the culture has fully developed. In old cultures, especially when the individual colonies remain isolated, the appearance is very characteristic. Some cultures in appearance closely resemble cultivations on blood serum. The consistency of the growth depends upon the character of the soil and the age of the culture. When the medium is moist the growth is moist and viscous, but more often it is distinctly tallowy, and in old and dry cultures scaly and friable.

*Cultivations in Glycerine Broth.*—In a few days minute flakes are visible, which steadily increase in size, and subside to the bottom of the flask, forming in time a very copious deposit. On shaking the flask, this deposit, which is extremely tenacious, rises in stringy masses, and gives an appearance which is more or less characteristic. If the flask is left undisturbed, a delicate veil-like film forms over the surface, which can be readily broken up by gentle agitation, forming flakes which gradually sink in the liquid. If undisturbed for several weeks this film increases in thickness, is irregularly fissured, and has more the appearance of masses of tallow floating on the surface. The growth also may be seen to extend up the side of the flask above the liquid. Pasteur or Erlenmeyer flasks can be employed for these cultures. Solidified egg-albumin added to the glycerine broth seems to increase the amount of growth, which clings to the albumin, and waves to and fro in the liquid when the flask is gently shaken. The author has confirmed the observation of Nocard and Roux, that sub-cultures from glycerine agar-agar, or from glycerine broth, will give cultures in ordinary broth without glycerine. Ordinary broth with egg-albumin, and without glycerine, will also give a good growth when inoculated from previous sub-cultures, although the attempt to produce primary cultures in these media has hitherto failed.

*Cultivations in Glycerine-Milk, and other Media.*—In milk the



author found there was only a slight increase in the number of bacilli inoculated, but milk with glycerine in the proportion of 5 per cent. forms a more favourable medium. The author has also cultivated the bacillus on sterilised urine and glycerine, and ordinary nutrient gelatine with 5 per cent. of glycerine. On potato the growth of the bacillus is extremely slow. Beevor succeeded in obtaining cultures at the ordinary temperature of the room.

*Examination of Cultivations.*—To examine the bacilli in these various preparations the author prefers to use Neelsen's method, floating the cover-glasses for from five to ten minutes on warm carbolised fuchsine, and passing them through dilute sulphuric acid. In some cultures the bacilli are shorter and thicker than is commonly observed in human sputum, and they are for the most part without the beaded appearance. In old cultures on glycerine agar-agar the number of granular or beaded bacilli increases, and there are also numerous peculiar forms. There are bacilli, sometimes two or three times the length of an ordinary bacillus, provided with a club-shaped enlargement at one or both extremities, and in rare cases with lateral branches. They are no doubt identical with the bacilli with swollen extremities and the branched forms observed by Nocard and Roux.

In milk the appearance is very striking, many bacilli attaining in old cultures a great length, and all are more uniformly beaded than in any other cultivations. Staining preparations by the method of Gram in all cases exaggerate this appearance.

The important part played by the environment is shown by the morphological differences observed in artificial cultivation under varying conditions, and by the fact that by successive cultivation the bacillus can be educated to grow upon a medium which is unsuitable for obtaining primary cultures.

Impression preparations of the growth of the bacillus on the surface of glycerine agar-agar in capsules show a tendency to the formation of serpentine colonies, composed of bundles of more or less parallel bacilli.

*Spore-formation.*—In old cultivations true spore-formation can readily be observed, both in stained and unstained preparations. In the latter case they are recognised in the form of one or two highly refractive bodies in individual bacilli.

*Toxic Products of Cultures.*—The poisonous substances found in cultures, and the composition and use of tuberculin, have already been described (p. 43).

*Inoculation Experiments.*—A relatively small portion of a culti-



vation inoculated into the subcutaneous tissue, into the peritoneal or pleural cavities, into the anterior chamber of the eye, or directly into the blood stream, produces after three or more weeks artificial tuberculosis in guinea-pigs and rabbits. Dogs and cats can also be infected by experimental inoculation.

When a trace of tubercular virus is inserted subcutaneously in the thigh of a guinea-pig, in about a week or ten days a chain of enlarged glands will be easily felt in the vicinity of the seat of inoculation. This affords an unailing test, which can be applied when there is difficulty in ascertaining by the microscope the presence of the bacilli in the material under examination. It also affords a valuable method for testing the effects of antiseptics on tubercular virus. The appearances observed at the autopsy are swollen lymphatic glands, in the neighbourhood of the inoculation, followed by softening and abscess; enlargement of the spleen and liver, with formation of caseous tubercles; and tubercular deposits in the lungs, bronchial glands, and peritoneum.

After inoculation of the eye, grey tubercles appear on the iris, and undergo enlargement and caseation, followed by tuberculosis of the eyeball and organs generally.

The bacilli appear to be the direct cause of tuberculosis, and the presence of the bacillus in the sputum of patients is a distinctive sign of the existence of this disease. The detection of the bacillus has, consequently, become a test which is constantly applied.

The bacilli are found in all tubercular growths of man, monkeys, cattle (*Perlsucht*), birds, and many other animals, and in cases of artificial tuberculosis, in rabbits, guinea-pigs, cats, etc. In man the bacillus can be detected in the tissues, in the sputum, in the blood, and in the urine.

Tuberculosis may also be produced by inhalation and feeding experiments. The channels of infection in man are also most probably the pulmonary and intestinal mucous membranes. The possibility of inoculation of skin wounds is open to doubt. The bacilli or their spores are inhaled from the air, or taken in with food. Morphologically identical bacilli have also been observed, but very sparsely, in sections of lupus.

#### METHODS OF EXAMINING THE TUBERCLE BACILLUS.

Numerous methods have been recommended for examining the tubercle bacillus. A few of these will be described, as many are only of historical interest.



The Ziehl-Neelsen method is preferred by the author both for sections and cover-glass preparations.

*Koch's original method.*—Cover-glass preparations or sections are laid in Koch's solution (No. 23, c) for twenty-four hours, or for one hour if the solution is warmed to 40° C. Rinse in water; immerse in a watery solution of vesuvin for two minutes; rinse again in water, and examine; or, after rinsing in water, treat with alcohol, clove-oil, and Canada balsam.

*Ehrlich's method.*—Cover-glass preparations are allowed to float in a watch-glass, containing a solution of gentian-violet or fuchsine, added to aniline water. A saturated alcoholic solution of the dye is added till precipitation commences (10 cc. aniline water, and 10 to 20 drops of the colour solution). The cover-glasses are left in the solution for about half an hour; then washed for a few seconds in strong nitric acid (one part commercial nitric acid to two of distilled water), and rinsed in distilled water. After-stain with vesuvin or methylene-blue, rinse in water, dry and preserve in Canada balsam.

*Ehrlich-Koch method.*

Saturated alcoholic solution of methyl-violet or fuchsine	11
Aniline water	100
Absolute alcohol	10

Preparations are left for twelve hours in this solution (colouring of the cover-glass preparations can be expedited by warming the solution).

Treat the preparations with (1 to 3) solution of nitric acid a few seconds.

Wash in alcohol (60 per cent.) for a few minutes (cover-glass preparations need only be rinsed a few times). After-stain with diluted solution of vesuvin or methylene-blue for a few minutes.

Wash again in 60 per cent. alcohol, dehydrate in absolute alcohol. Clear with cedar-oil, mount in Canada balsam.

*Rindfleisch's method.*—Prepare a solution composed of

Saturated alcoholic solution of fuchsine	10 drops
Aniline water	2 drams.

Pour it into a watch-glass, and float the cover-glass; warm the watch-glass over a spirit-lamp until steam rises. Remove it from the flame, and set it aside for five minutes. Take out the cover-glass, and transfer it for a few seconds to acidulated alcohol (two drops of nitric acid in a watch-glass full of alcohol). Wash in distilled water, dry, and preserve in balsam. After-stain, if necessary, with Bismarck-brown, or methylene-blue.

*Gibbes' method.*—Cover-glass preparations are placed in Gibbes' double-staining solution which has been warmed in a test-tube, and, as soon as steam rises, poured into a watch-glass. They are allowed to remain for five minutes, and then are washed in methylated spirit till no more colour comes away, dried in the air or over a spirit-lamp, and mounted in Canada balsam. If the solution is used without warming, the cover-glasses

must be left in it for an hour. Sections are treated on the same principles, but must be left in the solution for several hours. The crumpling of the sections by the action of nitric acid is avoided.

*Baumgarten's method.*—Cover-glass preparations of sputum are made as already described, and immersed in a very dilute solution of potash (1 to 2 drops of a 33 per cent. solution of potash in a watch-glass of distilled water). The cover-glass is pressed down on a slide, and examined with a high power. The bacilli can be thus examined in the unstained condition, and to avoid any mistake from confusion with other species, the cover-glass can be removed, dried, passed through the flame, and stained with a drop of an aqueous solution of fuchsine, or gentian-violet. The putrefactive bacteria are stained, but the tubercle bacilli remain absolutely colourless.

*Baumgarten's new method.*—A solution is prepared as follows: Drop 4 to 5 drops of concentrated alcoholic methyl-violet solution into a small watch-glass full of water. (a) Stain the sections in this solution, wash them in water, and decolorise in absolute alcohol (five to ten minutes); or, before treating with alcohol, immerse the sections for five minutes in a half-saturated solution of carbonate of potash. Pass through clove-oil, and mount in a mixture of Canada balsam, free from chloroform, and clove-oil (equal parts). The object of this process is to differentiate the tubercle bacilli from chance bacteria, inasmuch as the tubercle bacilli are gradually decolorised by the clove-oil. (b) Sections stained in the above solution are placed for five minutes in alcohol, and then in a concentrated solution of Bismarck-brown in 1 per cent. solution of acetic acid. The after-treatment may be conducted as already described.

*Ziehl-Neelsen method.*—Cover-glass preparations may be quickly stained in Neelsen's solution warmed in a watch-glass till steam rises. Sections are left for from five to ten minutes in the solution, and then washed in a watery solution of sulphuric acid (25 per cent.), rinsed in distilled water, and immersed in methylene-blue solution. After two or three minutes they are passed through alcohol and oil of cloves, and mounted in Canada balsam.

*Fränkel's method.*—Sputum preparations are rapidly double-stained by the following method: Prepare a solution by adding concentrated alcoholic methyl-violet or fuchsine solution, drop by drop, till opalescence arises, to 5 ccm. of aniline-water heated to 100° C. Float the prepared cover-glasses two minutes in the warmed solution. The process of after-staining and decolorisation is effected by placing the preparation for one to two minutes in one of the following solutions: for fuchsine-stained preparations, a saturated solution of methylene-blue in a mixture of

Alcohol . . . . .	50
Distilled water . . . . .	30
Nitric acid . . . . .	20

which is filtered before use; for preparations stained in methyl-violet, a saturated solution of vesuvin may be used in

Alcohol . . . . .	70
Nitric acid . . . . .	30



*Ehrlich's Method and Eosin.*—The author has found that after sections have been stained with methyl-violet and Bismarck-brown by Ehrlich's method, as described by Koch, they may with advantage be immersed in a weak alcoholic solution of eosin, then rinsed in clean absolute alcohol, clarified with clove-oil, and mounted in Canada balsam. The giant cells are then stained pink, while their nuclei are brown, and the bacilli blue.

#### TUBERCULOSIS IN MAN.

The disease manifests itself in various forms in man, and most frequently in the lungs, producing phthisis or consumption. The sputum contains the bacilli in large numbers, and is extremely virulent. Scrofula and lupus are forms of tuberculosis; they are



FIG. 168.—SECTION THROUGH A LUPUS NODULE OF THE NOSE.

probably produced by an attenuated variety of the tubercle bacillus. Lupus can be distinguished from tuberculosis of the skin; and scrofulous lymphatic glands are distinguished from tubercular glands by the tendency of the latter to produce generalised tuberculosis. This difference in the intensity of the virus in the two cases, Lingard illustrated by the effect upon inoculated guinea-pigs.

Cavities in the lungs are often thickly lined with bacilli. They are present in great numbers in the caseous matter, though in equine and bovine tuberculosis this is not the case.

Whether the disease in man is contagious is an open question, though numerous cases of supposed communication between husband and wife, brothers and sisters, have been reported, and Ransome

showed that tubercle bacilli were present in the breath in phthisis. On the other hand, the experience in consumption hospitals does not

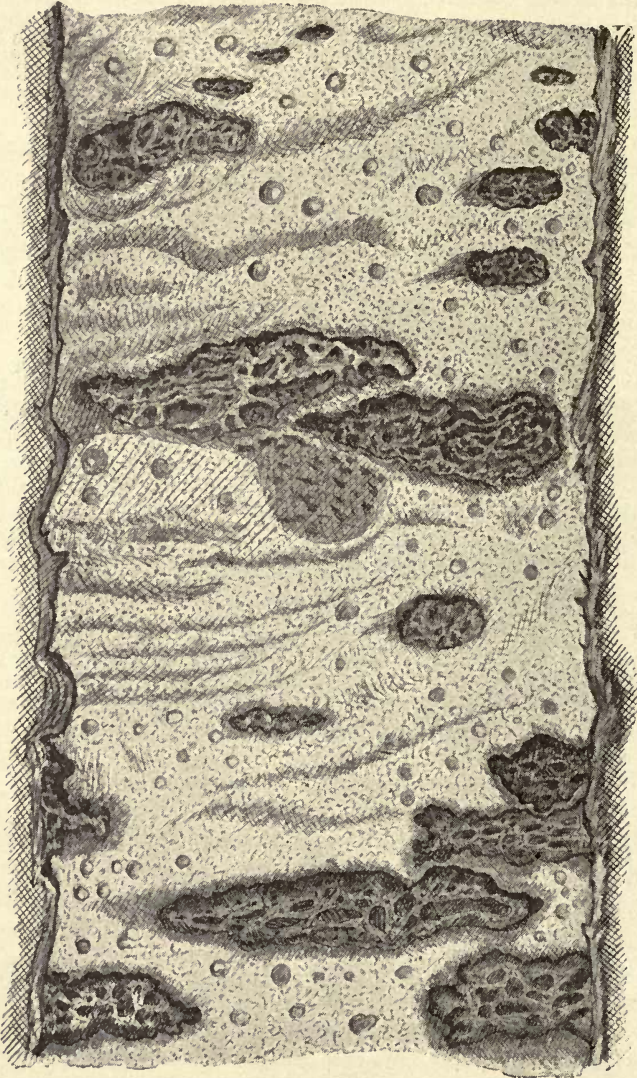

FIG. 169.—TUBERCULAR ULCERATION OF MUCOSA OF HUMAN ILEUM.  
Between the ulcers there are tubercular lymph-follicles (HAMILTON).

support this view, there being no evidence of the communication of the disease to nurses and hospital attendants.



## TUBERCULOSIS OF CATTLE.

In cattle the disease may occur as the result of inhaling bacilli, or of ingestion with food. It is very frequently found in the lungs; and calves may be infected by milk from cows with tubercular udders. Calves may also suffer from congenital tuberculosis, the bacilli having been transmitted from the mother during gestation.

Breeding in-and-in, over-production of milk, and confinement with insanitary surroundings, predispose to tuberculosis. The disease is known in Germany as "Perlsucht"; and in this country the lesions on the pleura are known as "grapes," and the animals themselves are commonly called "wasters."

The disease may also exist in the lungs or in other organs, in a limited form, without any indication of ill health. In such cases the disease can be detected by injection of tuberculin, a marked rise of temperature occurring in tubercular animals.

In advanced cases, the symptoms commonly observed are cough, difficulty in breathing, staring coat, wasting, and diarrhœa; and if the udder is infected, nodules in the gland, and thin bluish milk. In the lungs, after slaughter, a few small cheesy tubercles may be found in animals apparently in perfect health and in prime condition for the market. In advanced cases, the lungs on section show large yellow masses, containing calcified matter, and the bronchi may be full of yellowish pasty contents. The disease will be found to involve the bronchial glands. The serous membrane may be covered with little warts or grape-like masses. The lymphatic glands may be enlarged to an enormous size. Tubercular ulceration of the intestine is sometimes found, but not commonly. In tubercular disease in the udder, a painless swelling is found which may affect one or more quarters of the gland.

**Transmission of Tuberculosis from Man to Cattle.**—It is



FIG. 170.--SECTION OF LUPUS OF THE SKIN,  $\times 700$ . Giant cell containing a tubercle bacillus (FLÜGGE).

for obvious reasons impossible to ascertain by experiment whether tuberculosis can be transmitted from cows to man by milk or otherwise; but some light may be thrown upon this important question by ascertaining the result of inoculating bovines with human tuberculosis. If calves can be infected with tuberculosis from a human source by inoculation or ingestion experiments, and especially if the effect of administering human and bovine tubercle to calves by these means is found to be the same, such experiments will not only serve to dispel any doubt there may be as to the identity of the two affections, but they will strengthen the hands of those

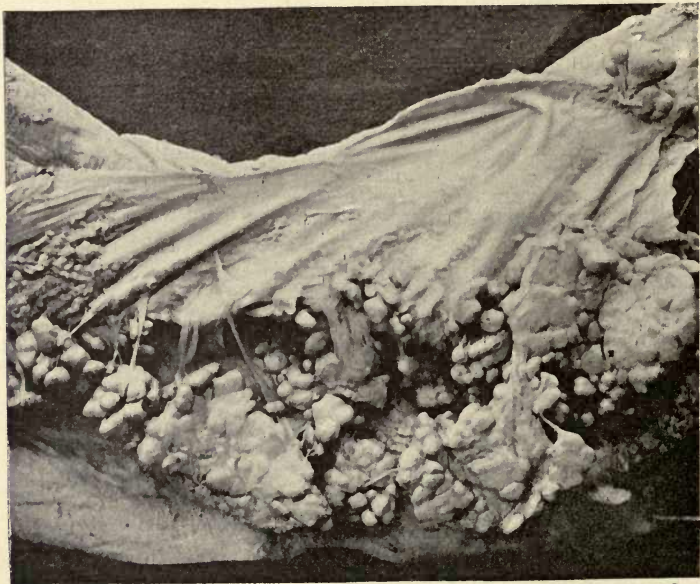

FIG. 171.—TUBERCULOSIS OF PLEURA; "GRAPE-DISEASE."

who insist upon the necessity of more thorough inspection of dairy cows, and of power to deal with tubercular animals.

*Inoculation of a Calf with Human Tubercular Sputum.*—The author obtained sputum containing numerous bacilli from an advanced case of phthisis. The sputum was shaken up with sterilised salt solution and injected into the peritoneal cavity. A few weeks afterwards the calf showed signs of illness. The animal looked dull, did not feed well, had a slight cough, and showed less inclination to move about than usual. These symptoms gradually increased, and death occurred forty-two days after inoculation. Extensive lesions



were discovered at the post-mortem examination. The mesentery was adherent to the abdominal wall, at the seat of the inoculation, and to the rumen; the liver was adherent to the diaphragm. There was extensive tubercular deposit at the seat of inoculation, and an abscess the size of a walnut. Extending over the mesentery from this point there were hundreds of wartlike, fleshy, new growths, some quite irregular in form, others spherical or button-shaped. There were similar deposits on the under surface of the liver, on the spleen, in the gastro-splenic omentum, and on the peritoneal surface of the diaphragm. The spleen was adherent to the rumen, and on dissecting away the adhesions another abscess was opened. The lungs were congested and the pleuræ thickened. On microscopical examination of sections extremely minute tubercles were found to be disseminated throughout the whole of the substance of the lungs and liver, and tubercle bacilli were found in these and in the peritoneal deposits. The abscesses contained *Streptococcus pyogenes*. The calf died of pyæmia, but sufficient time had elapsed for marked local infection leading to generalised miliary tuberculosis.

#### TUBERCULOSIS IN RELATION TO THE PUBLIC MILK SUPPLY.

There is not the slightest doubt that when the udder is involved the milk is highly virulent to the lower animals, and presumably is, therefore, dangerous to man. The virulence of the milk was first insisted upon by Klencke in 1846, and confirmed by Gerlach in 1869, and later, by others.

This subject was again brought forward with the discovery of the tubercle bacillus, and the demonstration of its existence in the milk in certain cases of bovine tuberculosis. Koch pointed out that the milk only contained bacilli, and was only infective, when the udder itself was tubercular. By this he explained the contradictory results obtained by various experimenters with milk from cows undoubtedly suffering from "Perlsucht." Koch considered that positive effects were obtained with milk when it happened to contain tubercle bacilli, and negative with milk from which they were absent. Bang in a number of cases verified the presence of tubercle bacilli in milk, and, owing to the contradictory results of previous investigations, repeated the ingestion experiments. The milk was found to be virulent both to pigs and rabbits.

In this country Woodhead and M'Fadyean tested milk for tubercle bacilli. They examined six hundred cows in the Edinburgh dairies, and found thirty-seven suffering from mammitis, but in only

six were they able to demonstrate the presence of tubercle bacilli in the milk, and then only in small numbers.

Hirschberger found in twenty cases of tuberculosis in cattle that the milk of eleven was virulent to guinea-pigs. Three cows out of nine in which the disease was restricted to the lungs gave infected milk. On the other hand, Nocard inoculated milk from eleven tuberculous cows, of which only one had diseased udder, and only this one gave infective milk. Bang injected rabbits with milk from twenty-one cases of tuberculosis, with the udders apparently normal, and the milk was virulent in two.

The author had two cases of udder tuberculosis under observation, and as no experiments had at the time been made in this country with milk known to contain tubercle bacilli, it was decided to study the effect on rabbits, and test the results obtained by Bang. These cases were both interesting and instructive, and may be referred to in detail.

One was a case of advanced general tuberculosis. There was extreme emaciation, general apathy, and a peculiar dull expression of countenance. The skin was dry and harsh, the coat staring, and there was loss of hair in patches about the face and neck. There was dulness on percussion over a large area of the thorax, and the respirations were increased in rapidity. There was also occasional cough and some diarrhœa. But the most interesting condition was observed on examination of the udder. The gland was swollen, especially posteriorly, and distinct induration could be felt on examination. The deposit appeared to be more or less limited to the posterior quarters. The cow evinced no pain during the examination of the udder, not even on the application of firm pressure.

The author took samples in test-tubes of the milk from all four teats; when freshly drawn, it differed noticeably from the normal secretion. It was a thin, watery, turbid fluid with whitish flakes in suspension, but it was not gelatinous or muco-purulent in character, and was free from any markedly yellow colour. After being set aside in the laboratory for some hours it separated into a layer of cream and a turbid liquid of a yellowish tint, while at the bottom of the test-tube there was a whitish flocculent deposit, especially in the samples from the posterior quarters.

There were tubercle bacilli both in the cream and in the deposit. In the cream they were only present in small numbers, and were detected, therefore, only after careful search. But in the deposit they were readily found, as in a cover-glass preparation there were sometimes four or five in the field of the microscope.

The method adopted for the examination of this deposit was as follows: The whole of the liquid in the test-tube was carefully poured off, and a trace of the sediment spread out on a cover-glass. This was allowed to dry, and passed through the flame, and stained in hot Ziehl-Neelsen solution in the usual manner.



The other cow was also a case of general tuberculosis, and presented somewhat similar lesions of the udder. The induration of the gland was readily detected, and examination of the milk showed, as in the previous case, the presence of tubercle bacilli.

It will be observed that in neither of these cases was the disease limited to the udder; in both the implication of the gland was part of general tuberculosis.



FIG. 172.—TUBERCULAR ULCERATION OF THE INTESTINE OF A COW.

The first cow was killed, and the following lesions were found at the post-mortem examination.

*Thorax.*—The lungs and bronchial glands were extensively invaded with tubercular deposit. The glands were greatly enlarged and densely fibrous, in many cases with central, stone-like masses, grating on section against the edge of the knife. In the lung there was every stage, from the early deposit to purulent cavities, cheesy masses, and calcified *débris*.

*Abdomen.*—There were a few caseous nodules in the liver, but none in the spleen. The mesenteric glands formed an almost continuous chain

of large tumours, mostly with central cretification. Tubercular deposit in the intestines could be recognised from the outside, and on laying them open the mucous membrane was found to be studded with tubercular ulcers. These ulcers were most numerous in the large intestine, and varied in size from a sixpence to a florin. Some were circular, others slightly irregular in form, and others again distinctly oval. In the latter case they were generally situated with their long diameter transversely. The base of the ulcer involved the muscular coat, and was irregularly radiated. The margin was broad, and elevated above the general surface, producing a ring-like appearance.

*Mammary Gland.*—The udder was infiltrated throughout with tubercular new growth, but the invasion was most marked in the posterior quarters. There was apparently very little tendency to caseation.

*Microscopical Examination of the Udder.*—In order to study the histological characters of the gland, and the distribution of the bacilli, sections were stained with logwood and rubin, and others again with fuchsin and methylene-blue. The tubercular new growth consisted of the usual histological elements, round cells, epithelioid cells, and giant cells. Healthy lobules here and there were sharply marked off from those in which the growth was compressing and obliterating the alveoli in its progress. Bacilli were present in the giant cells, and also distributed in vast numbers throughout the tubercular tissue generally. Bacilli were found in epithelioid cells close to the alveolus, and also between the cells lining the alveoli. In parts also the new growth had involved the milk ducts, and therefore it was easy to account for the presence of the bacilli in the milk.

The bacilli were found in considerable numbers also in sections of the intestinal ulcers.

#### EXPERIMENTAL INFECTION OF RABBITS.

**Ingestion.**—A rabbit received the contents of a test-tube which had been filled with milk from one of the posterior teats, mixed with a small quantity of bran. In four weeks there was commencing emaciation; later, diarrhœa set in, and death occurred exactly fifty-eight days after administration of the milk. At the post-mortem examination the mesenteric glands were found to be much enlarged and caseous. A cover-glass preparation from a crushed gland revealed numerous tubercle bacilli. On opening the intestines there was a patch of ulceration, showing the point of access of the bacilli. The intestinal ulceration was a reproduction, to a certain extent, of the condition in the cow which had been the source of the virus.

*Subcutaneous Injection.*—A second rabbit was injected under the skin of the back by means of a capillary pipette with about ten drops of milk, including some of the deposit from the bottom of the test-tube. The sample of milk had in this case also been taken from





## DESCRIPTION OF PLATE XII.

### **Tubercular Mammitis.**

FIG. 1.—From a section of the udder of a milch cow. The tubercular deposit is seen to invade the lobules of the gland. Lobules comparatively healthy are marked off, more or less sharply, from the diseased ones in which the new growth in its progress compresses and obliterates the alveoli. Stained by the Ziehl-Neelsen method and with methylene-blue.  $\times 50$ .

FIG. 2.—Part of the same preparation. On the right of the section part of a healthy lobule is seen. On the left a lobule is invaded by tubercular new growth composed of round cells, epithelioid cells and typical giant cells. Tubercle bacilli can be seen both singly and collected in groups. They are found in and between the cells, and in the interior of giant cells. Bacilli may be seen between the cells lining an alveolus and projecting into its lumen.  $\times 800$ .



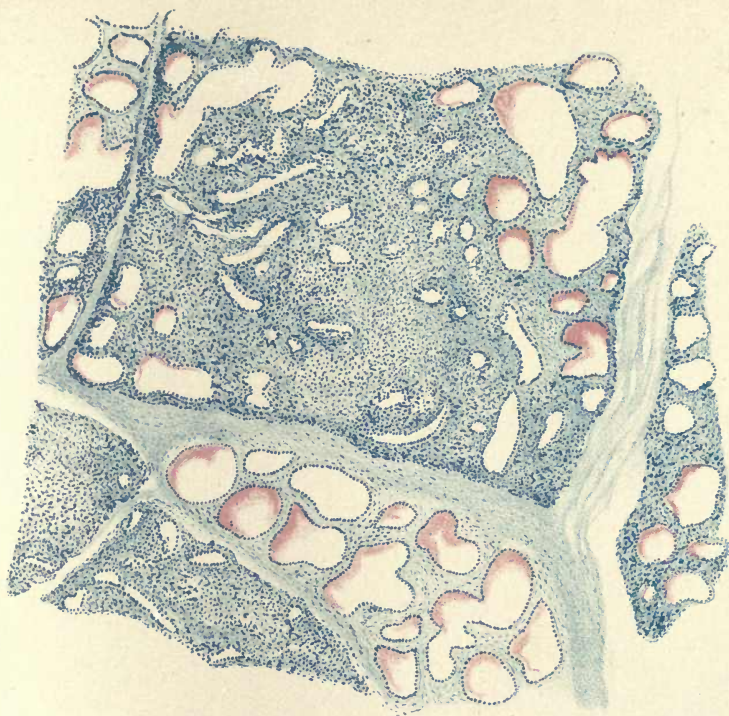

Fig 1.

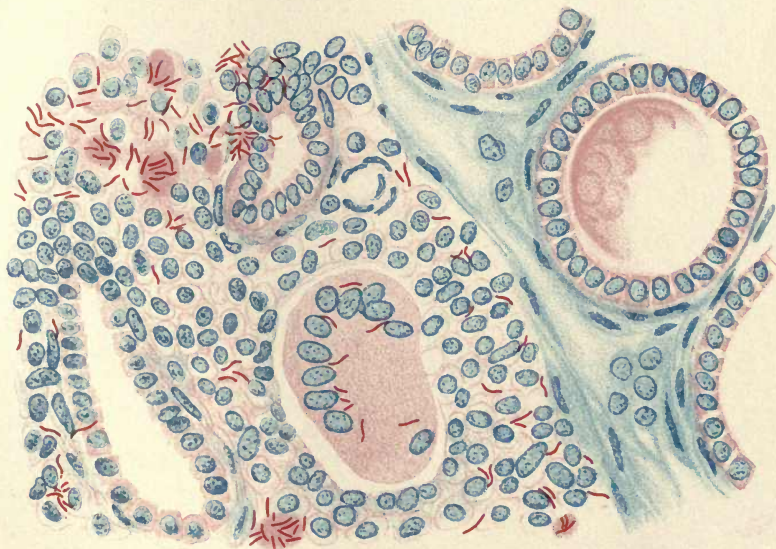

Fig 2.

## TUBERCULAR MAMMITIS





one of the posterior teats. The rabbit was placed in a separate hutch, and death from general tuberculosis occurred ninety-two days after inoculation.

The diaphragm and mesentery were studded with tubercles the size of a pin's head. The kidneys superficially showed whitish rounded nodules projecting above the surface. These were found on section to be continuous, with wedge-shaped deposits in the substance of the kidney. The lungs presented a very striking appearance, being, in short, a mass of tubercular deposit; and the bronchial and tracheal glands were similarly affected. In sections of the kidney and lung the bacilli were present, but they were distributed irregularly; in one part of a section it was difficult to detect a single bacillus, in other parts they were present in large numbers.

The milk from the two cows, previously to their coming under observation, had been mixed with the general supply of a dairy. There is indeed ample evidence that, both in this and in other countries, the milk of tuberculous animals finds its way into the market. The question which naturally arises is the possibility of any manifestation of tuberculosis in man, arising from the consumption of unboiled milk containing tubercle bacilli. We must admit that there is no direct evidence of the transmission of tuberculosis by milk from cow to



FIG. 173.—TUBERCULAR ULCERATION OF THE INTESTINE OF A RABBIT.

man; but this may arise from the difficulty in tracing such a source of infection, owing to the long time which elapses before symptoms manifest themselves in man. Yet, if milk be a source of infection, we should naturally expect that primary tuberculosis of the intestine would be by no means an uncommon manifestation of the disease; and this in the adult is not in accordance with clinical experience. Such an argument would tend to contra-indicate danger to adults; but, on the other hand, the possible danger to children has been rightly insisted upon by the earliest writers on this subject. Woodhead has recently stated that, from his experience in two large hospitals, he has been much struck by the fact that, in children who had died from other diseases during the course of tubercular disease of the abdominal glands, there was frequently

not any trace of tubercular disease in other parts; thus pointing to the intestine as the channel by which the bacillus made its way into the body. Woodhead also remarks that in a large number of cases



FIG. 174.—TUBERCULOSIS OF THE LUNGS.

From a photograph of the lungs of a rabbit which had been injected subcutaneously with about ten drops of milk, including in suspension a small quantity of the deposit at the bottom of a sample of milk from a cow with tuberculosis of the udder. Death occurred from general tuberculosis ninety-two days afterwards. The appearance of the lungs was very striking. They were almost completely composed of tubercular deposit. The bronchial glands, as well as the tracheal, of which one is seen in the photograph, were also enlarged and caseous. There were tubercular deposits in the kidneys and other organs, and also at the seat of inoculation.

of general tuberculosis, where the possibility of infection by the pulmonary passages was evidently excluded, the tubercular process



appeared to have invaded the body by the intestinal canal. These facts, taken in connection with the occasional existence of tubercle bacilli in milk, went far to prove, in his opinion, that milk was a source of tubercular infection, especially to young children.

From his own experiments and observations the author has drawn the following conclusions :—

1. Cows with tuberculosis of the udder are to be found in dairies in this country.
2. The milk of these cows is, as a rule, mixed with the general supply.
3. The milk in cases of udder tuberculosis contains tubercle bacilli.
4. Rabbits inoculated with, or fed upon, milk containing tubercle bacilli contract tuberculosis.
5. Direct evidence of transmission of tuberculosis by milk to man is wanting, but from the effect of such milk on the lower animals it is reasonable to conclude, in the present state of our knowledge, that there may be danger in using the milk of cows with tubercular udders, and therefore strict inspection of dairies should be enforced ; and boiling of milk before use will, as a rule, be a wise, if not absolutely a necessary precaution.

Bollinger has shown that the virulence of cow's milk is reduced by dilution with water in the proportion of 1 in 40 and even of 1 in 100, and that therefore there would be much less danger in consuming tubercular milk which had been mixed with the milk of healthy cows, than there would be in taking it direct from the infected cow. This is a matter of scientific interest ; but it would be no justification for a dairyman to mix the milk of a tubercular cow with milk of cows known to be healthy. The milk of cows suffering from tuberculosis should undoubtedly be rejected.

#### TUBERCULOSIS AND THE PUBLIC MEAT SUPPLY.

The question of the advisability of allowing the flesh of tubercular animals to be sold for food, especially when the disease exists in a very small degree, is a vexed one. Numerous experiments have been made upon the infectivity of the flesh of tubercular animals. Kastner inoculated the juice expressed from the flesh of tubercular cows, Sixteen guinea-pigs were unaffected after injection

of 1 to 2 cc. into the peritoneal cavity. Nocard injected ten to twenty drops of the muscle juice of the hearts of tubercular cattle, in which the disease was well marked, and none of the guinea-pigs were infected. With juice of the muscles of the thigh derived from ten tubercular cows Nocard inoculated forty guinea-pigs, and one only showed signs of tubercle. Nocard concluded that if there was any danger in the flesh of tuberculous animals, it was the exception and not the rule. On the other hand, Chauveau and Arloing produced tuberculosis in two guinea-pigs out of ten inoculated with muscle juice from a tubercular steer.

In 1890 a Royal Commission was appointed to investigate this subject, and the report was issued in 1895. Martin, on behalf of the Commission, tested the flesh of twenty-one tubercular cows. In two cases only was evidence obtained of the presence of the bacillus by inoculation of guinea-pigs. The flesh of eight cows affected with mild tuberculosis produced tubercle in one instance by inoculation, but the ingestion experiments were negative. The flesh of five cows severely affected with tubercle gave the disease in four cases, either by feeding or inoculation, but only one gave the disease both ways. Martin thought that some of the results were due to the butcher infecting the meat in the process of dressing the carcase, either by his hands or knives. Woodhead made a series of experiments to test the effects of roasting and boiling on the tubercular virus in meat. It was found that in boiling and roasting experiments, as ordinarily carried out in the kitchen, the temperature, however high it may be on the surface, seldom reaches  $60^{\circ}$  C. in the centre, except in the case of joints less than about six pounds in weight. Boiling and roasting were found insufficient to destroy tubercular virus enveloped in rolls of meat.

The following were among the conclusions of the Commissioners :—

We have obtained ample evidence that food derived from tuberculous animals can produce tuberculosis in healthy animals. The proportion of animals contracting tuberculosis after experimental use of such food is different in one and another class of animals; both carnivora and herbivora are susceptible, and the proportion is high in pigs. In the absence of direct experiments on human subjects, we infer that man also can acquire tuberculosis, by feeding upon materials derived from tuberculous food-animals.

The actual amount of tuberculous disease among certain classes of food-animals is so large as to afford to man frequent occasions for contracting tuberculous disease through his food. As to the proportion of tuberculosis acquired by man, through his food or through other means, we can form no definite opinion, but we think it probable that an



appreciable part of the tuberculosis that affects man is obtained through his food.

The circumstances and conditions with regard to the tuberculosis in the food-animal which lead to the production of tuberculosis in man are, ultimately, the presence of active tuberculous matter in the food taken from the animal, and consumed by the man in a raw or insufficiently cooked state.

Tuberculous disease is observed most frequently in cattle and in swine. It is found far more frequently in cattle (full grown) than in calves; and with much greater frequency in cows kept in town cow-houses than in cattle bred for the express purpose of slaughter. Tuberculous matter is but seldom found in the meat substance of the carcase; it is principally found in the organs, membranes, and glands. There is reason to believe that tuberculous matter, when present in meat sold to the public, is more commonly due to the contamination of the surface of the meat with material derived from other diseased parts, than to disease of the meat itself. The same matter is found in the milk of cows when the udder has become invaded by tuberculous disease, and seldom or never when the udder is not diseased. Tuberculous matter in milk is exceptionally active in its operation upon animals fed either with the milk or with the dairy produce derived from it. No doubt the largest part of the tuberculosis which man obtains through his food is by means of milk containing tuberculous matter.

Provided every part that is the seat of tuberculous matter can be avoided and destroyed, and provided care be taken to save from contamination by such matter the actual meat substance of a tuberculous animal, a great deal of meat from animals affected by tuberculosis may be eaten without risk to the consumer.

Ordinary processes of cooking applied to meat which has got contaminated on its surface are probably sufficient to destroy the harmful quality. They would not avail to render wholesome any piece of meat that contained tuberculous matter in its deeper parts. In regard to milk we are aware of the preference by English people for drinking cow's milk raw—a practice attended by danger, on account of possible contamination by pathogenic organisms. The boiling of milk, even for a moment, would probably be sufficient to remove the very dangerous quality of tuberculous milk.

#### TUBERCULOSIS IN EQUINES.

Tuberculosis is not very common in the horse, but when it does occur, it is frequently mistaken for glanders. There may be miliary tuberculosis in the lungs, or nodules disseminated throughout the lungs, liver, spleen, and bones. In a number of cases investigated by Nocard, the disease commenced in the abdominal organs, and the affection of the lungs appeared to be secondary. The author has examined several cases of equine tuberculosis. In some cases

the lungs were affected with the disease in a miliary form. The bacilli could not be distinguished from bacilli in sections of the bovine disease. Giant cells were extraordinarily numerous, and in many cases were densely packed with bacilli, so that they could be recognised *en masse* under a low power. The bacilli were also distributed in the tissue generally, but were much more numerous in the giant cells.

#### TUBERCULOSIS IN DOGS.

Peters described a case of tuberculosis in a pet dog, from eating sputum from a tubercular patient. This is said to be a not uncommon cause of canine tuberculosis.

#### TUBERCULOSIS IN CATS.

Nocard reported a case of tuberculosis in a cat from eating tubercular sputum. The abdominal organs were diseased. Bollinger has described two cases of miliary tuberculosis. McFadyean also has described a case. The bacilli are very plentiful in the lung. A minute examination of the individual micro-organisms by the author did not reveal any distinctive character.

#### TUBERCULOSIS IN SWINE.

The author examined the tubercular liver of a pig. The pig was about six months old, and after suffering from cough and emaciation, died.

The liver had caseous nodules scattered throughout its substance, some the size of a pea, and others larger. Tubercle bacilli without distinctive characters were found on examination of sections; but it was in some parts of a preparation difficult to detect any bacilli, and in other parts there were not more than five or six in the field of the microscope. Tuberculosis in swine is said to be very rare in America.

#### TUBERCULOSIS IN BIRDS.

Hens, guinea-fowls, turkeys, pheasants, and partridges, are subject to tuberculosis, and ostriches and other birds kept in confinement may contract the disease.

Tuberculosis in fowls appears to be introduced principally with the food, the disease occurring commonly in the intestines and liver.





DESCRIPTION OF PLATE XIII.

**Tuberculosis in Swine.**

Section of liver of a pig with scattered tubercular nodules. Microscopical sections of the liver showed tubercle bacilli in very small numbers.





TUBERCULAR LIVER OF FIG.





LIBRARY  
OF THE  
UNIVERSITY  
OF CALIFORNIA



The author has examined several cases of so-called spontaneous tuberculosis in fowls. Sections of the liver were in one case remarkable on account of the extraordinary invasion of the caseous deposits with bacilli. Cover-glass preparations had been made from the liver in the following way for diagnostic purposes: A tubercle was readily picked out on the point of a scalpel and crushed between two slides, and the cover-glass preparations stained with the Ziehl-Neelsen solution. The bacilli are for the most part very small. A few attain a considerable length, but the majority are in the form of small, straight rods, with many sizes intervening between these rods and isolated granules.

In July 1888 the author received from Mr. Bland Sutton the liver and lungs of a Rhea, which had died in the Zoological Gardens. The lung was infiltrated with caseous deposits, and there were scattered caseous nodules in the liver varying in size from a pea to a marble. The naked-eye appearance of a section of the liver through these nodules, at once recalled to mind the naked-eye appearance of the deposits in the pig's liver already described. But whereas in microscopical preparations of the pig's liver, bacilli were very scantily present, the sections of the lung and liver of the Rhea contained bacilli in such extraordinary numbers that, under a power of fifty diameters, the collections of bacilli could be recognised as red granular masses. These red masses under a high power were resolved into dense colonies of bacilli. In their number and their distribution in the tissues, in their varying size, and in the extraordinary length of the longest forms, they presented very interesting points for observation. From the naked-eye appearance of the disease and the general microscopical characters, as well as the presence of bacilli agreeing in their staining reactions with the classical tubercle bacilli, the author had no hesitation in pronouncing the disease to be avian tuberculosis.

Klein, who had examined a similar case, alluded to it in a description of leprosy; but this disease is unknown in the lower animals, and all attempts to infect them from man have been almost, if not entirely, negative.

The bacilli in the Rhea are principally collected in the caseous parts, but they are also found in the tissue generally, and often collected in large cells. In size they vary to a marked extent. In the cells they often form compact masses of short bacilli, but in other parts, both in collections and singly, they attain a greater length than is observed in any other form of tuberculosis. Some of the bacilli present a very interesting appearance. They are provided



terminally with a sharply defined ovoid body. There are also collections of short bacilli, many with these spore-like appearances. The author has also seen free ovoid forms, sometimes singly, sometimes in groups. From their connection with the bacilli and their sharply defined outline they are very suggestive of spores.

Johne examined the livers of a number of fowls accidentally infected by phthisical sputum. Nocard reported an outbreak in a poultry-yard where the man in charge had consumption. He also found the disease amongst fowls fed with the infected organs of tubercular cattle. Subcutaneous inoculation, and feeding of fowls with sputum or bovine virus, will produce the disease.

Experimental inoculation of tubercular virus from different sources affords an illustration of the different pathogenic effects obtained by varieties of the same species of bacillus. The bacillus of fowl-tuberculosis is a distinct variety. A very small proportion of guinea-pigs, inoculated in the peritoneal cavity with fowl-tubercle, succumb to the disease, though so susceptible to the effects of human or bovine virus. Maffucci maintains that guinea-pigs have an immunity, and that rabbits rarely develop a generalised tuberculosis. Cultures are not identical in appearance with those obtained from man, and on microscopical examination show many long, thick, and branched forms, which are only rarely found in cultures from a human source.

**Stamping-out System.**—In 1888 a Departmental Committee was appointed to inquire into pleuro-pneumonia and tuberculosis, and they considered that legislation ought to be directed not only to the protection of cattle from tuberculosis, but also to prevent the possibility of the disease being communicated to man.

The following extracts are from the recommendations of the Committee, which were made on the lines of:—

A. PREVENTION.

B. EXTIRPATION.

A.—*Preventive Measures.*

These should include provision for:—

*Improved hygiene of cattle sheds, etc.* (especially in the direction of providing proper ventilation, pure water supply, and adequate disinfection of stalls, etc., wherein tubercular animals have been kept). This has been partly met in the Dairy and Milk Shops Order, but its administration by the local health authorities is at present imperfect; and we would suggest that it should be much more stringently enforced, and that veterinary inspectors should be given more extended powers of entry into all places where animals are kept.



Improvement in the hygienic surroundings of animals should include isolation of all suspected cases, precautions against the flesh or milk of diseased animals being given as food to others—*e.g.*, to pigs, fowls, etc.—and care that fodder, litter, and water should not be taken from one animal or stall and given to another.

Our attention has been drawn to the frequency with which animals, obviously diseased, sometimes even in the last stage of the malady, are sold in open market.

Although in England and Ireland, under the provisions of the Nuisances Removal Act as embodied in the Public Health Act, 1885, the medical officer of health or inspector of nuisances may seize such animals, yet such seizure is rarely performed.

We find the veterinary inspector has no power to prevent such sales, or to seize the beasts for slaughter, since tuberculosis is not included in the Contagious Diseases (Animals) Act of 1878.

We further find that there is actually a regular trade in such stock infected with tuberculosis, and that they go by the name of "wasters" and "mincers," being frequently slaughtered in the neighbourhood of the larger towns, to which such portions of the meat as are likely to escape the observation of the inspector of nuisances are sent, for the purposes of sale among the poorer inhabitants, and especially for the making of sausages.

We are, therefore, very strongly of opinion that power should be given to the veterinary inspector to seize all such animals in fairs, markets, or in transit.

Notwithstanding the uniform prevalence of the disease in Europe and elsewhere, there seems to be no reason to apprehend that, with our present regulations for the slaughter of animals at the port of debarkation, and for quarantine of those imported for breeding, there is any special danger of increasing the infection in England by introduction from abroad. The danger, however, exists in regard to the stock brought from countries, which are exempt from slaughter on landing, and subjected to the ordinary veterinary inspection during the present period of detention of twelve hours.

It is, therefore, evident that the present rules for the prevention of the introduction of disease into the United Kingdom from abroad, are incomplete.

Since all authorities are agreed that the disease is very marked by heredity, we think it highly desirable that breeders should in their own, as well as in the public interest, discontinue breeding from tuberculous stock.

#### B.—*Extirpation.*

In order to insure the gradual extirpation of tuberculosis, we are of opinion that it should be included in the Contagious Diseases (Animals) Acts for the purposes of certain sections of those Acts, so as to provide:—

- (a) For the slaughter of diseased animals, when found diseased on the owner's premises.

- (b) For the payment of compensation for the slaughter of such animals.
- (c) For the seizure and slaughter of diseased animals exposed in fairs, markets, etc., and during transit.
- (d) For the seizure and slaughter of diseased foreign animals at the place of landing in this country.

Notification of this disease should not be compulsory, because it may exist without developing any sufficient outward evidence to enable the owner to detect it, and its growth is so slow, that non-notification of its existence, even in a large number of cases, would do little to nullify the stamping-out effect of the Act of 1878.

The powers and responsibilities of inspectors in ordering the slaughter of diseased animals should be the same for tuberculosis as for pleuropneumonia, according to section 51 (5) of the Act of 1878.

Further, tubercle, though hereditary, is nevertheless much less contagious than the other diseases included under the Act of 1878, and it is clear, therefore, that the immediate slaughter of diseased animals would go far to stamp it out, though, doubtless owing to heredity, this stamping-out process would be gradual in its effect.

A supplementary report was made by Professor Horsley, in which he expressed the opinion that there ought to be legislation to prevent breeding from diseased animals, and compulsory notification:—

#### 1. *Breeding.*

Tuberculosis is notorious, even among the laity, as a disease which is transmitted from parent to offspring. This is a fact with which cattle breeders are specially familiar, and which finds strong expression in the evidence attached to this report. Further, this generally received truth has been completely confirmed by the results of scientific investigation, as is also duly set forth in the report. Considering, therefore, the extreme importance of this point, I think that the act of wittingly breeding from animals so affected should be made an indictable offence. The only objection that can be raised to such legislation, which if effected would prevent the dissemination of the disease among cattle in this country, is that, owing to the present state of want of knowledge among cattle owners, and even veterinary surgeons, of the early symptoms, and physical signs on examination, of this disease, prosecutions would occasionally occur in cases in which no fault could properly be attributed to the owner, and that, therefore, such prosecutions would be needlessly vexatious.

Considering, however, the extreme rarity with which such cases would occur, and that, as in the matter of non-notification, each case would be tried before district magistrates on its own merits, this objection is deprived of the force it might have possessed.



*2. Notification of the Existence of the Disease.*

This point requires no explanation, since it is clear that, unless the veterinary inspectors or authorities receive information of occurrence of diseases, it is impossible to ensure the thorough carrying out of the provisions of the Contagious Diseases (Animals) Act.

That deliberate non-notification should be punished cannot be doubted by any one. Objection, however, to legislation in this direction has been put forward, on the same grounds as those upon which the prevention of breeding from diseased animals was contested. As, however, I consider that these objections have been already shown to have no weight, I recommend that both the forbiddance of breeding from diseased animals, and the notification of the disease, should be included in any legislation for tuberculosis.

The difficulty referred to by the Committee, is presented by cases of the disease which cannot be detected by the ordinary methods of examination, and might possibly be overcome by the use of tuberculin as a diagnostic agent.

## CHAPTER XXIX.

LEPROSY.—SYPHILIS.—RHINOSCLEROMA.—TRACHOMA.

### LEPROSY.

LEPROSY occurs in three forms—tubercular, anæsthetic, and mixed tubercular. It may be classed with the granulomata, as the most common form of the disease is characterised by deposits in the skin, mucous membrane, and internal organs. These deposits are composed of small cells, and large cells resembling giant cells. The cells become deposited in the surrounding tissues, and so the tubercle enlarges, involving the epidermis and developing into an ulcerating sore; or, after a certain stage of development, beginning to decline, and finally leaving a puffy discoloration. In the anæsthetic form the cells invade the connective tissue of nerves. In the mixed form the varieties occur together, but the tubercular character predominates.

Tubercular leprosy commences with the development of an erythematous patch, which becomes infiltrated, and finally tuberculated, the tubercles varying in size from a millet seed to a marble, or even larger. The eruption on the head and face produces a characteristic leonine expression. The progress of the disease is very slow. After death the following changes may be found in the internal organs: Cirrhosis of the liver and spleen, enlargement of the lymphatic glands, and a condition of the lungs corresponding to cheesy bronchial pneumonia.

In the anæsthetic form patches develop on the skin, which become anæsthetic; ulceration follows, and the fingers and toes, or the entire hand and foot, may slough off.

The disease is undoubtedly communicable, but the infectivity is of a very low type.

The infectiousness is illustrated by the well-known case of Father Damien. Arning inoculated a man named Keanu, a condemned criminal, and leprosy developed three years afterwards, but this case



is not regarded as conclusive, as the man had a family history of leprosy. The disease has never been known to spread from patients in this country, who have contracted the disease abroad.

The bacilli of leprosy were first observed by Hansen in 1874, and subsequently fully described by him, and his observations confirmed by Neisser, in 1879.

**Bacillus Lepræ.**—Rods 5 to 6  $\mu$  in length and 1  $\mu$  in breadth. The bacilli are straight or curved, resembling very closely the tubercle bacilli. They are present in the leprosy tubercles of the skin and mucous membrane, in the lymphatic glands, and in the liver, testicles, and kidney; and in the nerves in the anæsthetic variety. They are found between the cells, and in colonies in the cells. They stain readily with the aniline dyes, especially by the Ziehl-Neelsen and Gram's methods. The bacilli are found in extraordinary numbers in the skin, and they are rather straighter than tubercle bacilli, and stain more readily.

Numerous unsuccessful attempts to cultivate the bacillus have been made by many bacteriologists. The author has made repeated inoculations upon glycerine-agar, upon which the tubercle bacillus grew abundantly, but always with disappointing results. On the other hand, Bordoni-Uffreduzzi showed the author a cultivation which he had obtained from the bone marrow of a leper. The cultivation was made on blood serum and glycerine, and cover-glass preparations resisted decolorisation with acid. There were slight morphological differences when compared with the appearance of bacillus lepræ in the tissues, and the results were hardly conclusive.

The English Leprosy Commission also reported successful cultivation of the leprosy bacillus. The author had the opportunity of examining one of the first cultures received in this country, and found that the bacilli stained deeply in ordinary cover-glass preparations, they did not resist decolorisation by the Ziehl-Neelsen method, and they corresponded in culture with one of the varieties of *Bacillus subtilis*, commonly found on the skin.

Inoculation of animals has given equally unsatisfactory results. Numerous experiments have been made by Beaven Rake on small animals and birds, with invariably negative results. The blood of leprosy patients, tubercles from the living subject, fragments of the skin and of the internal organs after death, have been inoculated by different observers without result. Melcher and Ortman alone claim to have produced really definite results. These observers excised leprosy tubercles from the living subject, and inoculated fragments

in the anterior chamber of the eye of rabbits. The animals died after some months with extensive deposits in the cœcum, lymphatic glands, spleen, and lungs.

These tubercles varied in size from a pin's head to a millet seed, and contained bacilli, resembling leprosy bacilli in their staining reactions. The question naturally arises whether the lesions were really indicative of leprosy or tuberculosis. Until the experiments are independently confirmed, and the result of inoculation differentiated from tuberculosis, it would be rash to accept these experiments as conclusive.

It has been suggested that tuberculosis and leprosy are identical. There is a similarity in the bacilli and in the lesions of leprosy and tuberculosis, the injection of tuberculin produces a reaction in leprosy nodules, and many lepers die from tubercular disease of the lung. But while tuberculosis is very readily transmitted to guinea-pigs and rabbits by inoculation of fragments of tubercular tissue, leprosy is inoculable, if at all, in most exceptional instances. The bacilli of tubercle are cultivated with the greatest facility, the bacilli of leprosy, if at all, only with exceptional difficulty; tubercle bacilli are found in giant cells, leprosy bacilli in the so-called leprosy cells. Leprosy bacilli are straighter than human tubercle bacilli, and differ slightly in their behaviour to staining reagents. On the other hand, the morphological differences are not greater than those existing between different forms of tubercle bacilli obtained from tuberculosis in animals and birds. It would be premature to regard leprosy as a variety of tubercle until cultivations of the bacillus have been obtained, and carefully compared with those of the tubercle bacillus. Differences in morphological details and results of inoculation would then carry less weight as a means of differentiation.

The tubercular pneumonia of lepers would be regarded, if the bacilli are identical, as a development of leprosy in the lungs, and not, as at present, a result of double infection with tuberculosis.

#### METHODS OF EXAMINING THE BACILLUS OF LEPROSY.

Cover-glass preparations may be made in the ordinary way, or by a special method, which consists in clamping a nodule with a pile clamp until a state of anæmia of the tissue is produced. On pricking with a needle or sharp knife a drop of clear liquid exudes, from which cover-glass preparations may be made, and stained by Neelsen's method.

For sections the author prefers Neelsen's method and methylene-blue. They can also be stained by Gram's method, which, as a rule, brings out very clearly the beaded appearance of the bacilli.





## DESCRIPTION OF PLATE XIV.

### **Bacillus Lepræ.**

- FIG. 1.—From a section of the skin of a leper. The section is, almost in its entirety, stained red, and, with moderate amplification, has a finely granular appearance. Stained by the Ziehl-Neelsen method (carbolised fuchsine and methylene-blue). × 200.
- FIG. 2.—Part of the same preparation with high amplification, showing that the appearances described above are due entirely to an invasion of the tissue by the bacilli of leprosy. × 1500.



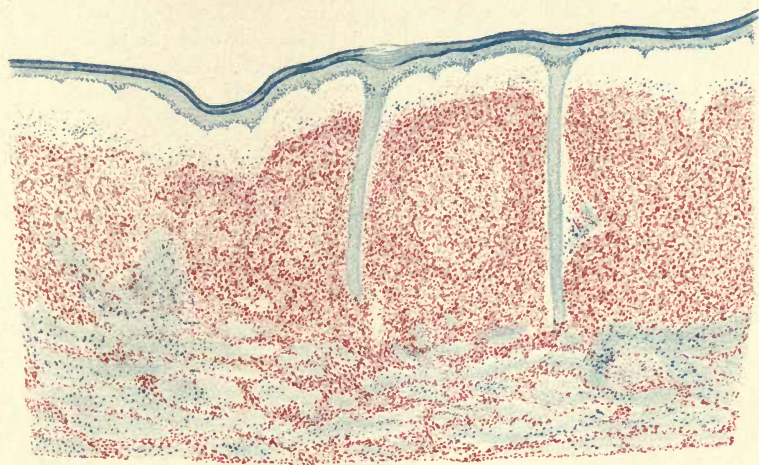

Fig 1.

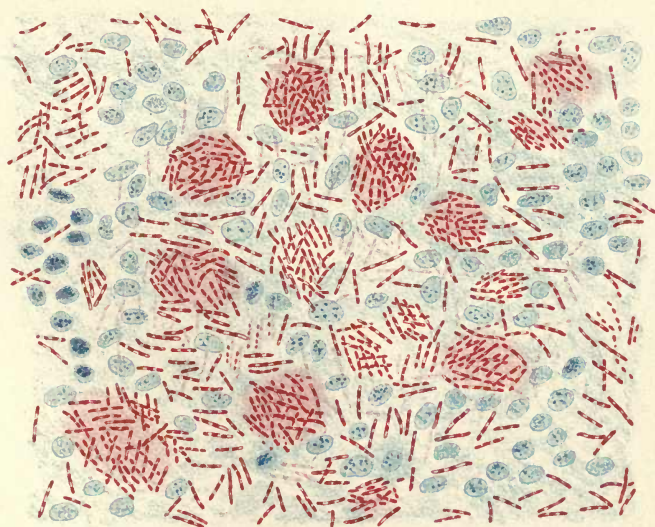

Fig 2.

BACILLUS LEPRÆ





*Method of Babès.*—Preparations are stained in rosaniline hydrochlorate in aniline water, decolorised in 33 per cent. hydrochloric acid, and after-stained with methylene-blue.

**Stamping-out System.**—The history of leprosy in the British Islands during the Middle Ages, and the conditions under which it both increased and declined, have been discussed by several writers. A large number of institutions of a charitable and ecclesiastical character were established in endemic areas and were occupied by the lepers either voluntarily, or compulsorily by means of the Act *De leproso amovendo*. These institutions were to a very small extent a means of segregation. According to Dr. Newman the disease, which had reached its zenith about the twelfth or thirteenth century, began to decline from that time owing to “a general and extensive social improvement in the life of the people, to a complete change in the poor and insufficient diet (which it is evident consisted far too largely of bad meat, salt, putrid and dried fish, and an almost entire lack of vegetables) and to agricultural advancement, improved sanitation and land drainage.” Of all the unfavourable conditions it would appear that food in some way was especially associated with the cause of the disease, either by introducing the bacillus or by rendering the tissues a suitable soil for its reception and development.

In other countries segregation has been attempted voluntarily or compulsorily, but it has never been completely carried out. There can be very little doubt that the presence of a leper in a healthy community is no greater source of danger than the presence of an individual suffering from tuberculosis, but, for other reasons, voluntary isolation should be carried out as completely as local circumstances will permit.

The Leprosy Commission in India recommended—

- (a) That the sale of articles of food and drink by lepers should be prohibited, and that lepers should be prevented from following certain specified occupations.
- (b) That the concentration of lepers in towns should be discouraged.
- (c) That Leper Asylums should be established in which lepers might live voluntarily.
- (d) That Leper Farms scattered over the country should be encouraged.
- (e) That the few children who are born of lepers should be removed to Orphanages.

They concluded that by means of improved sanitation and good dietetic conditions a diminution of leprosy will result.

## SYPHILIS.

Syphilis is a disease peculiar to man, and communicable only by inoculation. The local infection is followed by a period of latency, and by a period during which generalised eruptions appear. One attack confers immunity from future attacks. The virus in its most virulent form is found in the primary seat of inoculation, and in the indurated glands which follow. It is also supposed to be present in the blood and secretions. Lustgarten, Eve and Lingard have found bacteria which they believed to be specific.

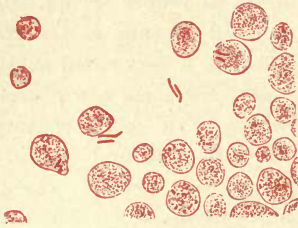

FIG. 175.—COVER-GLASS PREPARATION OF PUS FROM A CHANCRE,  $\times 1050$  (LUSTGARTEN).

power; it is thought that possibly they are spores. The bacilli are always found in the interior of nucleated cells, which are more than double the size of leucocytes. They have been observed in the discharge of the primary lesion, and in tertiary gummata.

Alvarez and Tavel state that an identical bacillus is found in normal secretions (smegma). Eve and Lingard have described a bacillus associated with specific lesions, which differs from the above in its morphology and behaviour towards staining reagents.

**Bacillus in Syphilis** (Lustgarten).—Rods resembling the bacilli of leprosy and tuberculosis, 3 to 4  $\mu$  long, .8  $\mu$  thick. Two or more colourless, ovoid points in the course of the rod are visible with a high

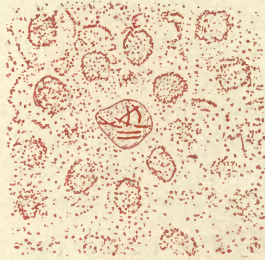

FIG. 176.—WANDERING CELL CONTAINING BACILLI (LUSTGARTEN).

## METHODS OF STAINING THE BACILLUS OF SYPHILIS.

*Method of Lustgarten:—*

Sections are placed for twelve to twenty-four hours in the following solution, at the ordinary temperature of the room, and finally the solution is warmed for two hours at 60° C. :—

Concentrated alcoholic solution of gentian-violet . . . . .	11
Aniline water . . . . .	100



The sections are then placed for a few minutes in absolute alcohol, and from this transferred to a 1.5 per cent. solution of permanganate of potash. After ten minutes they are immersed for a moment in a pure concentrated solution of sulphurous acid. If the section is not completely decolorised, immersion in the alcohol and in the acid bath must be repeated three or four times. The sections are finally dehydrated with absolute alcohol, cleared with clove-oil, and mounted in Canada balsam.

By this method the bacillus is distinguished from many bacteria, but not from the bacilli of tubercle and leprosy which are stained by this process.

*Method of De Giacomi* :—

Cover-glass preparations are stained with hot solution of fuchsin containing a few drops of perchloride of iron. They are then decolorised in strong perchloride of iron, and after-stained with vesuvin or Bismarck-brown.

*Method of Doutrelepont and Schütz* :—

Sections are stained in a weak aqueous solution of gentian-violet and after-stained with safranin.

The nature of the contagium in syphilis is unknown.

**Protective Inoculation.**—Inoculation of the virus, or *syphilisation*, as a protective measure, was at one time practised and strongly advocated; but it is rightly regarded in this country as dangerous and unjustifiable. From the experiments of Ricord it would appear that the local results in the vesicular stage resemble the results of the inoculation of *virulent* vaccinogenic grease or horse-pox. The inoculation goes through the stages of papule, vesicle, ulcer, scab, and scar. The accidental inoculation which occurs in cases of vaccino-syphilis may so closely resemble the results of inoculation with very virulent cow-pox, that it is sometimes difficult to decide as to the exact nature of these cases.

#### RHINOSCLEROMA.

Rhinoscleroma is a rare disease, resembling lupus, and producing in the nostrils and neighbouring parts nodular swellings, composed of granulation-tissue. The disease is met with in America, Egypt, Austria, and Italy. There are no giant cells, but peculiar large cells, which were first described by Mikulicz. Frisch discovered bacteria in sections, and Cornil and Alvarez pointed out the existence of a capsule. In morphology and cultivation they resemble, according to Dittrich, Friedländer's pneumococcus. They are probably identical with this micro-organism, and Paltauf and Eiselsberg, and others, found that they produced septicæmia in rabbits and guinea-pigs.

**Bacterium of Rhinoscleroma** (*Bacillus of Rhinoscleroma*,

Cornil and Alvarez).—Cocci and short rods, 1·5 to 3  $\mu$  in length, ·5 to ·8  $\mu$  thick. Deeply coloured points or granules may occur in the course of the rods when stained, but it is very doubtful whether these can be considered as spores. The bacteria are encapsuled, the capsule being round when enclosing a coccus, and ovoid when enclosing a rod. The capsule is composed of a tough resisting substance; two or more capsules may unite by fusion, enclosing two, three, or a greater number of rods. The bacilli were observed in sections of the tumours, which developed on the lips and in the nasal and pharyngo-laryngeal regions.

#### METHOD OF STAINING THE BACILLUS OF RHINO-SCLEROMA.

##### *Method of Cornil and Alvarez :—*

Sections are immersed in a solution of methyl-violet (B) for twenty-four to forty-eight hours, with or without the addition of aniline-water; and are then decolorised after treatment with the solution of iodine in iodide of potassium. If the sections are left to decolorise in alcohol for forty-eight hours, the capsule is rendered visible.

#### TRACHOMA.

Trachoma is a disease of the conjunctiva, common in Egypt. The new growth is composed of round cells, and may be regarded, according to Kartulis, as the chronic stage of either gonorrhœal or Egyptian ophthalmia. Koch failed to find any micro-organisms in the swollen lymph follicles. Sattler asserted that he had cultivated a micrococcus which produced the disease when inoculated on the conjunctiva. Other observers have found the common pyogenic micrococci in the secretions, especially *Staphylococcus pyogenes aureus* and *albus*.



## CHAPTER XXX.

### ACTINOMYCOSIS.—MADURA DISEASE.

#### ACTINOMYCOSIS.

ACTINOMYCOSIS belongs to the class of infective granulomata. It is a chronic inflammatory affection characterised by the presence of a special microphyte, which by irritation produces a neoplasm, composed of round cells, epithelioid cells, giant cells, and fibrous tissue. These neoplasms form nodular tumours of various sizes. In some cases there is a tendency to develop very large tumours, and in others to break down early and suppurate. In cattle, cretification takes place in the fungus tufts. Actinomycosis closely resembles tuberculosis in its histological characters. The disease attacks man, horses, cattle, and pigs.

Many interesting observations have been made upon the origin of this disease in man. Two cases have been recorded in support of the theory of direct infection from the cow. Stelzner described a case of actinomycosis in a man who had had the care of animals, some of which had suppurating glands. Hacker had a case of actinomycosis of the tongue in a man who had charge of cows, one of which had a tumour of the jaw which he had opened. On the other hand, Moosbrugger found that out of 75 cases, 54 were in men, and 21 in women, including 2 children. In 11 of these men the occupation was not stated. In 33 their occupation did not bring them into contact with diseased animals; they were, for example, millers, glaziers, tailors, shop people, and students. Only 10 cases occurred among farmers, peasants, and farm-labourers, and in only one case out of the 10, had the patient been brought into contact with diseased animals.

Out of the 21 women, there were only 4 peasants, and none of them had been associated with diseased cattle.

Infection by the flesh of diseased animals has also been discussed. But there is no evidence of prevalence of the disease

among slaughterers and butchers, who would be particularly liable to it, if flesh were a source of infection. The chances of infection by ingestion are minimised by the flesh being almost always cooked. Actinomycosis occurs also in pigs, and pork is very often eaten in an uncooked state; but Israël has pointed out that this may probably be excluded, as many of the cases occurred among strict Jews.

The evidence points to the disease originating in man and lower animals from the same source, and there is a very strong suspicion attached to cereals. This view is supported by important observations, with reference to the part played by cereals in inducing the disease in cattle, and it gains additional support from a case described by Soltmann, where the disease resulted from an awn of wall barley. A boy, aged eleven, accidentally swallowed an awn of *Hordeum murinum*. He became very ill, and suffered great pain behind the sternum, extending to the back. An abscess formed, covering an area extending over six intercostal spaces, and when opened, the awn of this grass was found in the evacuated pus. The pain, however, continued, and fresh deposits occurred, and when the boy was taken to the hospital, the ray-fungus was detected. Possibly the spores of the fungus can be conveyed both by air and water.

This disease in cattle has long been known in this country, but its various manifestations were either mistaken for other diseases, or simply received popular names. Indeed, the various forms are still familiar to many as wens, clyers or crewels, scrofulous, tubercular or strumous abscesses, polypus, lymphoma, cancer of the tongue, scirrhus tongue, indurated tongue, ulcerated tongue, cancer of bone, bone tubercle, osteo-sarcoma, fibroplastic degeneration of bone, spina ventosa, and carcinoma.

Bovine actinomycosis is especially prevalent in river valleys, marshes, and on land reclaimed from the sea. The disease occurs at all times of the year, but general experience leads to the belief that it occurs more commonly in the winter.

It is more frequently met with in young animals, and usually occurs between one and three years, but it may be found at almost any age, and probably affects equally both sexes.

There is little if any evidence to show that the disease is hereditary. In numerous cases, the family history has been most carefully inquired into by the author; and in the case of some imported pedigree animals, the disease was quite unknown on the farm where they had been bred.

The tongue is so commonly the seat of the disease, that suspicion



at once falls on food as the means by which the parasite is conveyed. Skin wounds produced by rubbing against the mangers, posts, or wire fencing, may also become infected.

The evidence is very strong in favour of believing that the micro-organism gains access to the system through wounds or lacerations of the mucous membrane and skin, or through carious teeth. It has been pointed out that the common occurrence of the disease at the time of the second dentition may be owing to the wounds produced in the alveolar mucous membrane by the shedding of the teeth. Experience also points to straw being sometimes a factor in the production of the disease, and it is possible that thistles and frozen roots also, by wounding the mucous membrane, may afford a way for the entrance of the micro-organism. The disease in the jaws, both in man and in cattle, is very commonly associated with carious teeth.

The cowsheds, pastures, and drinking tanks may become infected with the discharges from diseased animals. The discharge contaminates the fodder in the sheds, and falls on thistles and siliceous grasses in the pasture, which may first wound, and then introduce the micro-organism. The discharge is also coughed out of the mouth, and expelled from the nose, in cases in which a tumour in the pharynx, or the nasal chambers, has undergone suppuration.

Jensen believed that the disease was produced by different kinds of grain, especially when cultivated on ground reclaimed from the sea. He mentions an instance of a farm, where nearly the whole of the young stock, about thirty in number, had actinomycosis after feeding on mixed forage, grown on a certain field. Two years afterwards the same disease occurred in the same stalls in four animals, after being fed on barley-straw from the same field. According to Jensen, the fungus grows on grain, husks, and straw of different cereals, but most abundantly on barley, which is also the most likely to wound the mucous membrane. John's observations tend to corroborate this view, for in twenty-two out of twenty-four cases in which he found barley sticking in the tonsils of pigs, he found the beard thickly beset with a fungus very similar to, if not identical with, the ray-fungus. These observations are of great interest in connection with Soltmann's case.

Experience points to the belief that the disease is not readily communicable from animal to animal, and it is possible that when it affects a large number of cattle in a herd, the same causes have been acting to produce the disease in a number, which in another instance may only produce it in one. At the same time, isolated

cases are possibly not quite so common as they are reported to be. It is well known that, as a rule, the services of a veterinary surgeon are not called for except in hopeless or very severe cases. The cowmen themselves, in many districts, treat the cows successfully, and then send them into the market, and thus the existence of previous cases may not have come to the knowledge of the veterinary surgeon.

*Historical.*—In 1845 Professor von Langenbeck, of Kiel, made notes of a case of vertebral caries in a man, and prepared drawings of peculiar bodies in the pus from an abscess. The drawings were published together with a reference to the case by Israël in 1878. There can be little doubt that these structures were the fungi of actinomycosis. But the first to publish observations was Lebert in 1848.

Lebert received from M. Louis some pus, of a thick, almost gelatinous consistency, which had been obtained from an abscess of the thoracic wall in a man aged fifty. The patient had been attacked four months previously by a pulmonary affection, which was suspected by M. Louis to be cancerous in nature. The pus contained a very considerable number of little spherical bodies of a slightly greenish-yellow colour, about the size of a pin's head. They could be readily crushed between two strips of glass, and on examination with a power of fifty diameters two elements could be distinguished: a soft connective substance, and many hard, narrow, wedge-shaped corpuscles, arranged in a radiating manner. Under a high power these bodies were observed to be  $\frac{1}{30}$  to  $\frac{1}{40}$  of an inch in length,  $\frac{1}{300}$  in width at the base, and  $\frac{1}{300}$  in width at the apex. Some of these corpuscles were regular, while others showed one or two constrictions, with intermediate flask-shaped swellings. Lebert tested these structures with reagents, with the following results. The bodies were found to remain unaltered by concentrated mineral acids. Acetic acid freed them from foreign elements adhering to their surface. Solution of caustic potash did not affect them if used cold, but a boiling solution reduced the cuneiform structures to a fine greyish powder without dissolving them. Ether, alcohol, and chloroform had no effect upon them when used either hot or cold. Solution of potash, in which these bodies had been heated, mixed with a solution of sulphate of copper and brought to boiling point, did not offer any uniform red colour, which would have been the case if they had contained albumin. Thus, the chief chemical characters of albuminous and fatty substances were wanting, and they resembled chitine in their behaviour to reagents.



Lebert bore in mind the possible existence of some helminthic *débris*, of which these bodies might be hooklets, but he sought in vain for echinococci and cysticerci.

Actinomycotic pus was later described and figured by Robin. In the illustration accompanying the description, the fungi are most

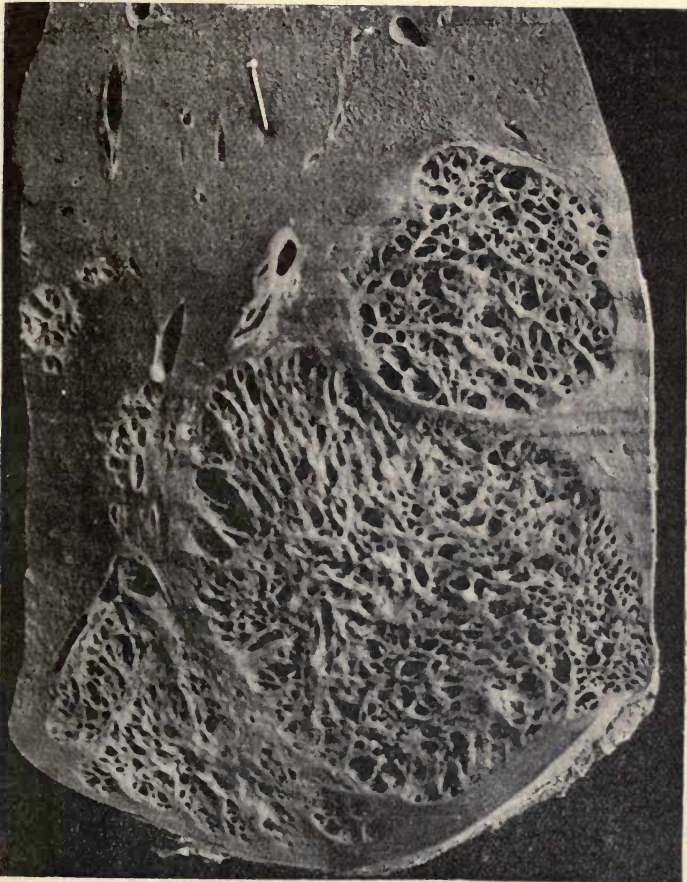

FIG. 177.—SECTION OF LIVER FROM A CASE OF ACTINOMYCOSIS IN MAN.

accurately depicted. Robin states that he had found, in two or three cases in the pus of deep-seated chronic abscesses, yellowish grains attaining a diameter of one-tenth of a mm., surrounded by a sort of halo or thin, viscous, finely granular stratum, containing leucocytes. These grains were composed of elements 2 to 6 mm. in length, swollen

at one end and tapering off at the other, arranged in a regular series, radiating from a common centre which consisted of granular matter. They were highly refractive, possessed a brilliant centre and sharply defined outline; they were dissolved, or at least rendered indistinct, by acetic acid, and proved insoluble in ammonia and ether.

The disease in man was next described by Israël in the paper mentioned above. Ponfick was the first to clearly recognise the identity of the disease in man with the disease in cattle, and he described a number of cases in man. Israël subsequently published a work on the subject. The various cases which had been observed up to that date were described, and the disease classified according to the seat of invasion.

From this time onwards numbers of cases in man have been described, and various important researches published, of which those of Boström and Moosbrugger may be especially mentioned.

In England, Acland recognised a case on examining the liver after death (Fig. 177). H. Taylor was the first, in this country, to detect the fungus during the life of a patient. Shattock found specimens of the disease in museums. Skerrit, Powell and Godlee, Eve, Delepine, Ransome, Poore, Malcolm Morris and others have published cases.

In Italy, Perroncito studied the sarcomata of cattle, and claims to have first observed the micro-organism in 1863. In 1875 he described it in the *Encyclopædia Agraria*, and, from the negative results obtained by inoculation experiments, was led to regard it, not as the cause, but as a result of the disease.

Rivolta of Turin also claims to have been the first to have discovered the fungus in actinomycosis bovis. As early as 1868 he published a paper on a sarcomatous tumour of the jaw of an ox.

Hahn of Munich, in 1870, undoubtedly met with the fungus, for he states that in a case of "wooden-tongue" he found characteristic organised structures, which he provisionally described as a species of mould fungus.

Bollinger was the first to recognise the nature of this disease in cattle. In 1876 he pointed out that new growths occasionally occurred on the upper and lower jaws of cattle, which either started from the alveoli of the back teeth, or from the spongy tissue of the bone, and by increasing in size loosened the teeth. In their progress they destroyed bone, muscles, mucous membrane, and skin. After some time they frequently broke down, forming ulcers, abscesses, and fistulæ; but in some cases tumours were formed, which attained



the size of a child's head. Bollinger stated that this disease had been known by various names,—*Osteosarkome*, *Winddorn* (*Spina ventosa*), *Knochenkrebs*, *Knochenwurm*; in other instances it had been regarded as bone tuberculosis, or mistaken for a simple chronic glossitis. Among breeders of cattle and owners of stock in Germany it had been known under the following names: *Ladendruck*, *Ladengeschwulst*, *dicker Backen*, *Bäckel*, *Kinnbeule*, *Kiefigeschwulst*, etc.

Bollinger pointed out that these swellings consisted of several centres of growth, bound together by connective tissue. They were often as large as a walnut or a hen's egg, and of a pale yellow colour and moist appearance. The cut surface presented yellowish-white, suppurative foci, while in other cases the growths had a spongy texture, owing to the formation of lacunæ or hollow spaces in a fibrous stroma, which contained a turbid, thick, yellow, caseous pulp.

Microscopical examination of the tumour showed that it had a structure like a sarcoma, while the squeezed-out pulp consisted principally of pus cells, granulation cells, fat granules, and granular detritus. In addition, there were numerous opaque, pale-yellow, and coarsely granular bodies of different sizes, which had a mulberry-like appearance, and were sometimes encrusted with chalk. After careful examination Bollinger found that these bodies were true fungi, and he further maintained, from the constancy of their appearance in all parts of the sarcomatous growth, that they were not accidental, but of pathogenic significance. This was found to be the case, not only in fresh preparations, but in old specimens preserved in the museum. This remarkable form of mycosis was observed by Bollinger, not only in the upper and lower jaws, but also in the tongue. It had long been observed that the tongue was sometimes covered with more or less tubercular growths, scattered abundantly over the surface of the mucous membrane, mostly the size of a millet seed or hemp seed, but often reaching the size of a cherry or walnut, or even larger. In the fresh state these nodules were greyish-white, and semi-transparent, but they soon became cloudy or distinctly puriform in the centre; they were surrounded externally with a connective tissue capsule. If the nodules were situated on the surface of the tongue, destruction of the mucous membrane very readily followed, leading to the formation of ulcers. The tongue also might become affected with an interstitial glossitis, which often, in spite of the partial atrophy of the muscular fibres, led to a great enlargement and wood-like hardness of the tongue. On account of this peculiar character, such a tongue was long known in South

Germany as *Holzunge*. In other cases the condition was regarded as "tubercle of the tongue," "chronic sarcoma," "chronic interstitial glossitis," or simply "degeneration of the tongue."

Bollinger described this disease as occurring in cattle of all ages, developing itself gradually, and being always incurable. As a rule, the animals were slaughtered, because the diminished mobility and enlargement of the tongue interfered with feeding. He also pointed out that this disease of the tongue was by no means rare, as he had had no less than six such tongues from different parts of Bavaria in the space of a year, and he also had been able to prove the existence of the disease in museum specimens.

On further continuing his researches, Bollinger found the same fungus in tumours which occurred in the pharynx, larynx, and the mucous membrane of the stomach. These tumours were very common in the throat in some parts of North Germany, where as many as 5 per cent. of the animals had been known to be affected. The disease frequently occurred in the form of subcutaneous neoplasms, called *Lymphome*, *Holzgeschwülste*, *Fibrome*, *Tuberkel*, *Tuberkel-scropheln*.

This disease also appeared in the form of abscesses, which were called, in many districts, *Schlundbeulen*. These growths were found in the neighbourhood of the parotid gland, the larynx, and pharynx, and were similar in every respect to the affection of the jaw. They were described as starting apparently from lymphatic vessels in these parts. Bollinger discovered the fungus in a case of so-called fibroid of the second stomach of a cow, a spongy growth nearly the size of the fist; and he believed that in another case the disease manifested itself in the form of tubercular ulceration of the intestines.

Bollinger submitted the fungus to Dr. Harz, a botanist, who described the fungi as mulberry-like masses from .5 to 1 mm. in diameter. They appeared to the naked-eye as opaque, white grains, and when calcified were difficult to recognise. On slight pressure the tufts of the fungi fell apart into segments of unequal size, each of which appeared to correspond to an individual fungus. The latter was described as beginning at the pointed end of the wedge, with a somewhat cone-shaped basal cell, which, in the absence of a mycelium, perhaps took its place, and bore a great number of short linked hyphæ. At the ends of the hyphæ there were oval, globular, or elongated club-shaped bodies, the reproductive cells or gonidia.

Cultivation experiments, and inoculation of the tongue of a calf with liquid containing the micro-organism, failed. Harz proposed



to call the fungus, from its ray-like appearance, actinomyces; but what the position of the fungus in nature might be, was difficult to determine. It did not, he believed, belong to the yeast fungi, but to the mould fungi, and might be compared to *Botrytis*, *Monosporium*, and *Polyactis*.

Bollinger concluded that there could be no doubt that actinomycosis occupied an important position in the pathology of cattle diseases. As further evidence of the prevalence of the affection, he remarked that Zippelius of Obernburg had observed in the course of about ten years' practice not less than 254 cases of lymphoma, in the neighbourhood of the larynx and pharynx, besides 157 cases of disease of the jaw; and Bollinger says that he had very little doubt that the greater part of the former, and very likely all the cases in the jaw, were due to the fungus which he had discovered. In certain parts of Franconia, according to a communication received from Professor Frank, these tumours of the throat were extremely abundant in cattle.

Bollinger's researches were followed by those of Siedamgrotzky, and later by a communication from Johne. Johne described the various forms of the disease which had up to that date been recognised, including a description of actinomycosis of the bones of the jaws, of the fauces, of the larynx, of the œsophagus, of the stomach and intestinal canal, and of the udder. He carried out a series of experiments, by which it was clearly established that the disease could be communicated from cattle to cattle. Previously Bollinger, Harz, Perroncito, Ponfick, Siedamgrotzky, and Johne had failed, but subsequently by employing fresh material from the living animal, both Johne and Ponfick succeeded.

Siedamgrotzky not only confirmed Bollinger's researches, but he described the presence of the fungus in so-called "multiple sarcomas" of the mucous membrane of the œsophagus. Rabé described the presence of the fungus in tumours known as Winddorn, and pointed out that, in at least one case, he considered that the disease had been carried by the lymphatics. There were eleven subcutaneous tumours in a row on the face, which were connected by swollen, rope-like, lymphatic vessels. They appeared to be secondary to a growth on the nostril, the size of a hen's egg.

Perroncito described a case of "sarcoma" of the intestines and stomach, which proved to be actinomycosis.

Many additional communications were made on the subject of this disease. Ponfick produced it in the lungs by intravenous injection, and subsequently three cases occurring naturally in the

practice of veterinary surgeons were published. They not only deserve especial mention, but as this form of the disease appears to be so seldom recognised, they will be given in detail.

Plug described a case in the lungs. The cow had been out of health for four weeks, did not eat, and had a cough, and two days previous to the visit had become rapidly worse. Schmidt found dyspnoea with abdominal respiration; the nostrils were dilated, the head protruded, and the mouth kept open. There was dulness on percussion, and crepitation. The animal was killed, and the lungs, which alone were diseased, were sent to Plug. The pleura on examination was normal, but beneath it were numbers of miliary tubercles, many equal in size to a pin's head. On section the lung had a granular appearance from the presence of countless numbers of minute deposits, which all had the appearance of grey tubercles; in none was there any central softening. They were present in enormous numbers around the bronchi, and in the vessels of the interlobular tissue. Microscopical examination showed, in the middle of most of these nodules, the presence of greenish-yellow, radiating bodies, which under a high power appeared to be undoubtedly actinomycotic granules. In many there were only rudimentary fungi consisting of four or five clubs; there was only one rosette in each tubercle. The fungus was surrounded by round cells and fibrous tissue. Larger nodules resulted from the agglomeration of several tubercles, or from diffuse infiltration of round cells in the neighbourhood of a tubercle.

Hink met with a somewhat similar case. A ten-year-old cow was slaughtered, and in the middle lobe of the right lung there were yellowish nodules about the size of a pea, scattered over an area the size of the palm of the hand. These nodules were not at first sight distinguishable from ordinary tubercles, but on closer inspection they appeared to be somewhat different, and could be easily shelled out from the thickened lung tissue. On making a section, pus welled up at several points, and contained yellowish, calcareous particles. These particles, on microscopical examination, were found to be strongly calcified tufts of the actinomyces embedded in granulation cells. Addition of hydrochloric acid dissolved the calcareous matter, but had no action on the fungus.

Pusch described a third case. The lungs of a cow, which had been killed on suspicion of having pleuro-pneumonia, were sent for examination. The front lobe of the left lung was collapsed and firm, the pleura was thickened and opaque; the larger bronchi were enlarged, filled with pus, and their walls thickened. In the posterior



lobe of the left lung there was a cavity the size of the fist, which had been opened, and the contents had, for the most part, escaped; what remained was a greyish, purulent liquid, full of yellowish bodies. By the side of this cavity there was another collection of pus, the size of a walnut. In the lower part of the second lobe of the right lung there was a firm, grey tumour, the size of a hen's egg, over which the pleura was much thickened. On section this was cavernous, with similar purulent contents, and yellow grains. These grains under the microscope proved to be ray-fungi. The wall of the cavity consisted of dense connective tissue lined with a soft granulation tissue, bathed in pus. There was no disease of any other parts in this case, so that it corresponded in this respect with the two previous ones. Pusch adds that it was difficult to determine whether the organism had gained access to the lungs by the blood-vessels, or by the inspired air. In his case he inclined to the latter view, and concludes by saying that the organism is probably very common and attached to the most varied objects, from which it may be conveyed by the air.

Pusch refers in the same paper to an interesting case which occurred in the practice of Eggeling. The latter had under his care a cow with extensive paralysis. The spinal cord was compressed by a compact swelling in the neck, consisting of the nodules of actinomycosis. There were no manifestations of disease in any other part of the body.

*Prevalence of the Disease.*—The author found that the disease was not generally recognised as a common affection of cattle in this country, in spite of the interest excited by the work of Fleming, to whom is due the credit of first recognising a case in England. In 1887 there was a disease prevailing in Norfolk, and in the following year outbreaks were investigated by the author in Essex, Hertfordshire, Cambridgeshire, and Middlesex. In the Norfolk outbreak the author found on one farm 8 per cent. of the beasts affected with the so-called "wens" or "sitfasts," which proved on microscopical examination to be cases of actinomycosis. These growths had previously been described in veterinary text-books as the result of strumous or scrofulous inflammation; but in all the specimens of wens received from this country and the colonies, the author has been able to demonstrate the presence of the ray-fungus.

A case of pulmonary actinomycosis, with grape-like growths on the pleura, indicated that wens were not the only manifestation of this disease, which had been lost sight of under the designation of

tuberculosis. Many other cases were examined, and the disease was shown to be prevalent in this country.

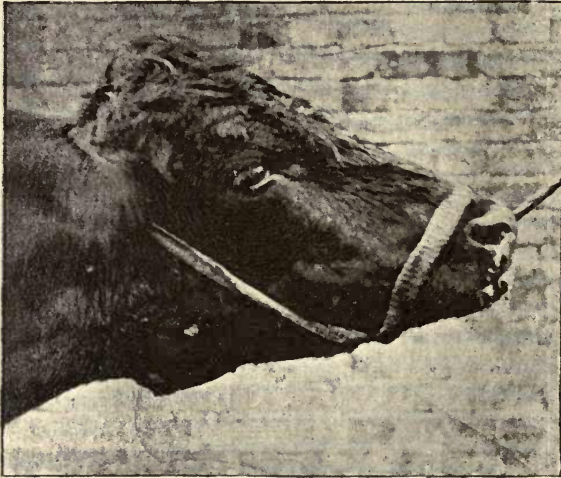

FIG. 178.—From a photograph of a Norfolk steer. There is a growth about the size of an orange in front of the throat, an example of a so-called “scrofulous” or “strumous” tumour. This growth was associated with a large polypoid growth in the pharynx which, by interference with deglutition, produced emaciation (Fig. 180).

In Australia actinomycosis commonly occurs in the form of tumours of the upper and lower jaw, which were attributed to “cancer” or to “scrofulous inflammation.” The disease is still commonly known in Australia as “cancer” and “lumpy jaw.”



FIG. 179.—A NORFOLK HEIFER WITH A LARGE ‘WEN’ IN THE PAROTID REGION.

Reports of the prevalence of actinomycosis in the United States have been published by the Board of Live Stock Commissioners for the State of Illinois. In their Report for 1890 several interesting communications were published. Mr. Casewell, State Veterinarian, investigated an outbreak of this disease, known also in America as “lumpy jaw;”



on a farm in Yates City, where there were 80 head of cattle, and 16 were found to be suffering from actinomycosis. Mr. Casewell

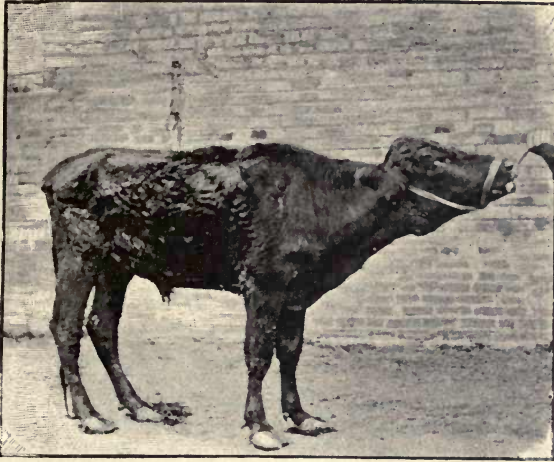

FIG. 180.—Photograph of a steer nearly three years old, but about the size of a yearling. The emaciation and deplorable aspect recall the appearance of “a piner” or “waster” (tuberculosis).

reported that the disease was prevalent in nearly every county in that State, and that in his opinion it was spreading. In one instance 109 cases were slaughtered.

*Actinomycosis in Relation to Tuberculosis.*—When we consider the very high percentage of cases of tuberculosis which has been reported in some localities, the importance of differentiating actinomycosis from tuberculosis cannot be over-estimated. The very great contrast in the appearance of the micro-organisms in the two cases renders this a very easy matter for the pathologist. But practical veterinarians and breeders of cattle are liable to mistake some manifestations of actinomycosis for tuberculosis.

It is of the greatest importance to bear in mind that wens or clyers are really not tubercular, but actinomycotic; and



FIG. 181.—ACTINOMYCOTIC NODULES FROM THE PLEURA.

that a condition of the lungs may occur as the result of actinomycosis, which from the naked-eye appearances may be mistaken for "grapes" or "angleberries." It will be well also to remember in connection with the above remarks, that extreme emaciation may result in actinomycosis, producing a condition which, without a post-mortem examination, would probably be attributed to tuberculosis, the animal being regarded as a "piner" or "waster." If these possible fallacies are taken into account, the excessive percentage of tubercular cases so commonly reported will be very considerably reduced.

There is no evidence to show that the flesh of animals suffering from actinomycotic tumours is unfit for human consumption. In very severe cases it is unwholesome, but there is no evidence that it can produce actinomycosis in man.

#### MANIFESTATIONS OF ACTINOMYCOSIS IN MAN.

(I.) *Invasion by the Mouth and Pharynx.*—The fungus may gain access through carious teeth, or wounds or fistulæ of the jaw, and very possibly by inflammatory processes in the pharynx and tonsils.

The disease attacks the lower jaw most frequently. The tumour is found in close connection with the bone, or in the sub-maxillary or sub-mental regions, and also in the præ-tracheal region. It occurs, though rarely, in the interior of the bone.

In a case described by Israël, which occurred in a woman aged forty-six, there was a small tumour about the size of a cherry attached to the external surface of the lower jaw, with an opening through which a probe could be passed into the bone. The tumour was incised and scraped away, and a cavity discovered in the bone, admitting a small sharp-spoon. Later, a further operation was performed: the periosteum was detached, the cavity of the bone enlarged, and the contents scraped out, consisting of granulation tissue, fragments of bone, and the yellowish fungi. At the bottom of the cavity the fang of the canine tooth was found. No return of the growth occurred.

The first cases of actinomycosis which were observed in America were connected with the jaw. In 1884 Dr. Murphy described two cases at Chicago. The first was that of a woman aged twenty-eight. Two weeks previously she had suffered from severe toothache, with swelling in the throat and great pain in swallowing. It disappeared after poulticing, but she was again attacked with toothache, and a swelling appeared on the angle of the jaw on the left side. The



mouth could not be opened without difficulty; the tonsil was much enlarged, and pus was set free on incision. She still suffered with toothache, and a small swelling now occurred on the left side of the neck below the jaw. She had several carious teeth. The swelling, which was about the size of a walnut, was punctured, and a drainage tube inserted; a creamy-looking discharge containing yellow granules continued to escape, but the swelling and induration increased. A further operation was decided upon. The carious tooth was removed, and a probe passed into the alveolus showed a communication with the external wound; the angle of the jaw was chiselled away, and the alveolus scraped out. Iodoformed gauze was applied, and the case recovered.

The second case was a man aged eighteen, who had also suffered with severe toothache and swelling at the angle of the jaw. On examination a carious tooth was noticed. The swelling was well marked, and there was fluctuation; it was as large as a pigeon's egg, and situated below the jaw. When punctured, thick creamy pus escaped containing the fungi; the sinus was scraped out, and in ten days the wound was healed. Another swelling appeared, and this was treated as before, and the case recovered.

The peculiar feature of these growths is their apparent migration. Israël states that in one case a tumour occurred on the alveolar process, close to carious teeth, and later was close to the edge of the jaw in the sub-maxillary region. From thence it disappeared, and a large swelling formed below the hyoid bone, and after this had been incised and had healed, an abscess formed above the clavicle.

Actinomycotic tumours in this region would sometimes appear to correspond very closely with wens or clyers in cattle; they may discharge through the skin, and the opening close, or a fistula result; but they differ, from their tendency to form burrowing abscesses instead of recognisable tumours. In this respect they recall chronic inflammation rather than the sarcoma-like growths in cattle.

Cases in which the upper jaw is attacked are not so frequent as those in the lower jaw. The progress is usually described as slow, and there is a tendency for the deep-seated soft parts to be involved, while in the lower jaw there is a tendency for the tumour to come to the surface. There may be burrowing suppuration, or small tumours, which, after a time, fluctuate and form distinct abscesses. These may involve the skin, discharge their contents, and leave fistulous openings.

In other cases the disease has been described as extending from the alveolar process to the temporal bone, or the base of the skull,



destroying bones and even reaching the brain; or the growth may descend by the spinal column, implicating the vertebræ, and travelling and pointing in various directions.

(II.) *Invasion by the Respiratory Tract.*—In one recorded case the disease existed for seven years, was localised to the bronchi (*Bronchitis actinomycotica*), and did not extend into the lungs. The sputum was examined, and contained the characteristic fungus.

If the micro-organisms are inhaled they pass into the bronchioles and alveoli, and produce proliferation of round cells, which undergo fatty degeneration. The resulting patches of peri-bronchitis or pneumonia become yellowish-white; suppuration and hæmorrhage from the capillaries follow, and small cavities result, containing pus cells, fat granules, blood, and the fungi. In the neighbourhood of the new growth there is compression of the alveoli, and ultimately the formation of a dense stratum of connective tissue, separated from the cavities by a lining of granulation tissue containing the characteristic fungus. The symptoms are usually obscure; but the sputum may contain the fungi, which are often visible to the naked eye. The apices of the lungs are not, as a rule, affected. There is considerable clinical resemblance to chronic phthisis: cough, night-sweats, pallor, shortness of breath, and hæmoptysis are symptoms common to both. Light may be thrown upon the case by the examination of the sputum. The presence of the actinomyces will be positive evidence as to the nature of the disease. The existence of these symptoms, with absence of tubercle bacilli, would lead to the suspicion of actinomycosis, even failing the discovery of the fungus in the sputum.

In the second stage the symptoms are more characteristic. The disease spreads to neighbouring parts, and pleurisy commonly supervenes. This extension may involve the peri-pleural tissues. Thus the disease may follow the præ-vertebral tissues, descend behind the insertion of the diaphragm, and point as an ordinary psoas or lumbar abscess; it may perforate the diaphragm and reach the abdominal cavity. Peritonitis or sub-phrenic abscess may then result. In some cases adhesions have formed, and the disease has extended to the liver or spleen, or other abdominal organs. The disease may also extend forwards in the direction of the anterior mediastinum and the pericardium.

The primary affection of the lung becomes of secondary importance. Grave symptoms occur, hectic fever, night-sweats, rigors, and marked pallor. In the third stage, the disease comes to the surface, either over the chest, or in the neighbourhood of the dorsal



or lumbar vertebræ; a swelling appears of a livid colour, and if punctured no fluid escapes, but if allowed to make its own way to the surface, the skin gives way, a muco-purulent discharge mixed with pieces of the growth escapes, and the fungi can readily be recognised.

(III.) *Invasion of the Digestive Tract.*—In a case under Chiari, death, with general marasmus, took place at the age of thirty-four, after two years' illness. The mucous membrane of the intestines was almost completely covered with whitish patches, raised in the centre, and covered with yellow and brown granules closely adherent to the adjacent tissues. The teeth were carious.

Small nodules about the size of a pea may be found in the sub-mucous tissue, and in the mucous membrane itself. They soften and form ulcers with undermined edges, the base reaching the muscular layer. They may undergo cicatrisation, but generally the disease extends through the peritoneum to the abdominal cavity, and perforates the bladder or the intestines, or makes its way through the abdominal wall. Symptoms are either absent or not characteristic. The fungus may sometimes be found in the evacuations, or by exploratory puncture.

(IV.) *Undetermined.*—In addition there are a number of recorded cases presenting very varied symptoms and anatomical relations, in which it has not been possible to satisfactorily determine the path of infection. Delépine has described a most interesting case of an actinomycotic tumour of the brain.

#### MANIFESTATIONS OF ACTINOMYCOSIS IN CATTLE.

(I.) In the *Digestive system* we find the disease attacking:—

(a) *The lips, gums, buccal mucous membrane and palate*, and appearing as nodules, wart-like growths, or ulcers. The nodules and ulceration of the palate were well shown in a specimen sent to the author for examination, under suspicion of being the result of severe foot and mouth disease.

(b) *The upper and lower jaw*, where it probably originates in carious teeth, and extending and invading the neighbouring cavities and sinuses destroys the tissues with which it comes in contact, expanding the bones into thin plates or reducing them to the appearance of pumice-stone.

(c) *The tongue*, where we see it most commonly in the form of nodules or wart-like patches under the mucous membrane, with a special tendency to ulcerate, through the irritation of the teeth. These nodules may extend into the deep muscles, and often collect in rows

more or less parallel to the superficial muscular fibres. Complete transverse sections of the tongue, double-stained, readily show this arrangement, even to the naked eye. Induration of the tongue results from secondary interstitial glossitis. The author has seen, in one case only, a tumour embedded in the substance of the tongue about the size of a small Tangierine orange, and more or less isolated from any surrounding growth.

(d) *The pharynx*, where the disease may occur in the form of polypoid growths producing asphyxia.

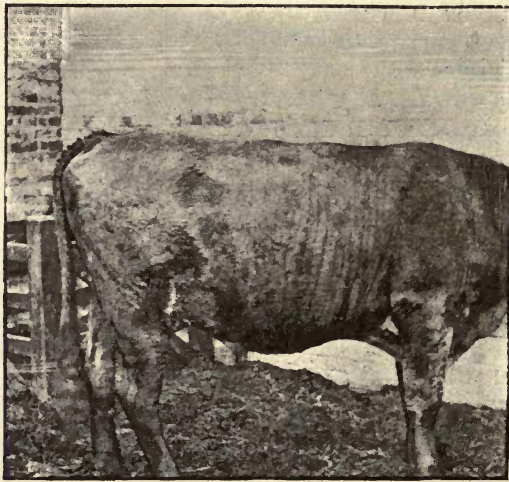

FIG. 182.—A NORFOLK STEER WITH EXTENSIVE ACTINOMYCOTIC ULCERATION OF THE SKIN OF THE FLANK.

(II.) In the *Respiratory system* we may meet with the disease in :—

(a) *The nasal cavities*, originating primarily there or resulting from extension of a growth from the lips, or the pharynx.

(b) *The larynx and trachea*, generally in the form of polypoid growths, sessile or pedunculated, which arise primarily or occur secondarily, by extension from the tissues in the neighbourhood.

(c) *The lungs*, where the differentiation of the disease is most important, as neoplasms in the lungs, especially in the early stages, and nodular growths on the pleura, may be mistaken for tuberculosis.

The disease is very rarely found in connection with the *Nervous system* (III.), but probably does not so rarely attack the *Reproductive system* (IV.).



(V.) The *skin and subcutaneous tissues* are a favourite seat of this disease, producing the so-called wens or clyers so commonly seen in the fen country. A wen is first recognised as a small tumour, the size of a marble or walnut, which increases in size sometimes with great rapidity, and breaks down and discharges its muco-purulent contents through the inflamed and ulcerated skin; or it may go on increasing, and form a large compact growth, the size of a child's head. These growths when excised, hardened, and cut, have a characteristic honeycombed appearance, produced by the interlacing bands of fibrous tissue, which form a spongy structure, from the interstices of which the fungus tufts and thick yellowish pus have for the most part dropped out.

**Actinomyces Hominis.**—Careful examination of pus from a case of actinomycosis in man will reveal to the naked eye little yellowish-white or yellow bodies, which a casual observer might mistake for grains of iodoform. On collecting some of the discharge in a test-tube, and holding it between the light and the eye, the tufts of fungi appeared as brownish or greenish-brown grains, embedded in a muco-purulent matrix.

On spreading some of the discharge on a glass slip, the largest tufts of the fungus are found to be about the size of a pin's head. They have a distinctly sulphur-yellow colour by reflected light, but appear of a yellowish or greenish-brown tint by transmitted light. With a sewing needle, or a platinum wire flattened at the end into a miniature spatula, the grains can be readily picked out of the discharge, or taken off the dressing, transferred to a clean slide, and gently covered with a cover-glass. Examined with an inch objective, they have the appearance of more or less spheroidal masses of a pale greenish-yellow colour. On removing the preparation from the microscope, and gently pressing down the cover-glass with the finger, the grains flatten out like specks of tallow; and on again examining with the same power they are found to have fallen apart into a number of irregular and sometimes wedge-shaped fragments of a faintly brown colour, affording a characteristic appearance. By preparing another specimen, and covering it with a cover-glass without completely flattening out the grains, the spherical, oblong and reniform masses of which the tufts are composed can be recognised with a  $\frac{1}{8}$ -in. objective as rosettes of clubs. By examining the peripheral part of a rosette with a  $\frac{1}{12}$ -in., and especially after pressing the grains into a thin layer, with or without the addition of a drop of glycerine, the characteristic clubs are most readily demonstrated, and the most varied shapes observed by carefully

examining the form of the individual elements. As in the bovine fungus, every variation in form is found, from single clubs to clubs with lateral offshoots, clubs bifid at the extremity, palmate or fan-shaped groups, and banana-like bunches. In many cases the clubs are divided by transverse fission into two, three, or more segments. As a rule, the clubs are irregular in shape, and of about equal size, while a few are conspicuous by their length. In other parts of the preparation the clubs are replaced by long slender forms, which are sometimes transversely divided into a number of short links. With suitable illumination many clubs are seen to taper off into slender filaments. In addition there are free filaments, which are twisted, branched, and sometimes distinctly spirilliform. Many of the clubs are composed of layers differing in their refractive power, and many have the appearance of a central channel. There are also in the preparation small, highly refractive bodies, fat granules, granular detritus, round cells, pus cells, and sometimes blood corpuscles.

The grains differ, as a rule, from those from a bovine source, in the absence of that sensation of grittiness so often transmitted to the finger when pressing the cover-glass upon them, and in the slightly greater tendency of the tufts to retain their compact form. By teasing the grains in a drop of water on a slide, and examining the preparation with a  $\frac{1}{6}$  or a  $\frac{1}{12}$  objective, the explanation of the latter is forthcoming; for by this process the clubs are gradually washed away, and a central core remains, which is composed entirely of a dense network of filaments. This can readily be observed by using a small diaphragm, and it will be found that the rosettes of clubs are now replaced by tangled masses, having some resemblance to miniature tufts of cotton-wool. These filaments constitute the delicate network which is seen in sections stained by the method of Gram. This can be readily verified by making a cover-glass preparation of the grains, and staining by that method. The characters of the fungus can readily be studied by proper illumination, without staining. The clubs have a faintly greenish tint, and in form and arrangement are quite characteristic and easily recognisable. Permanent preparations may be made by mounting the fungus in glycerine.

#### DESCRIPTION OF STAINED SPECIMENS.

The fungus may be stained in alcoholic solution of eosin in the manner to be described for the bovine organism, or in orange-rubin,



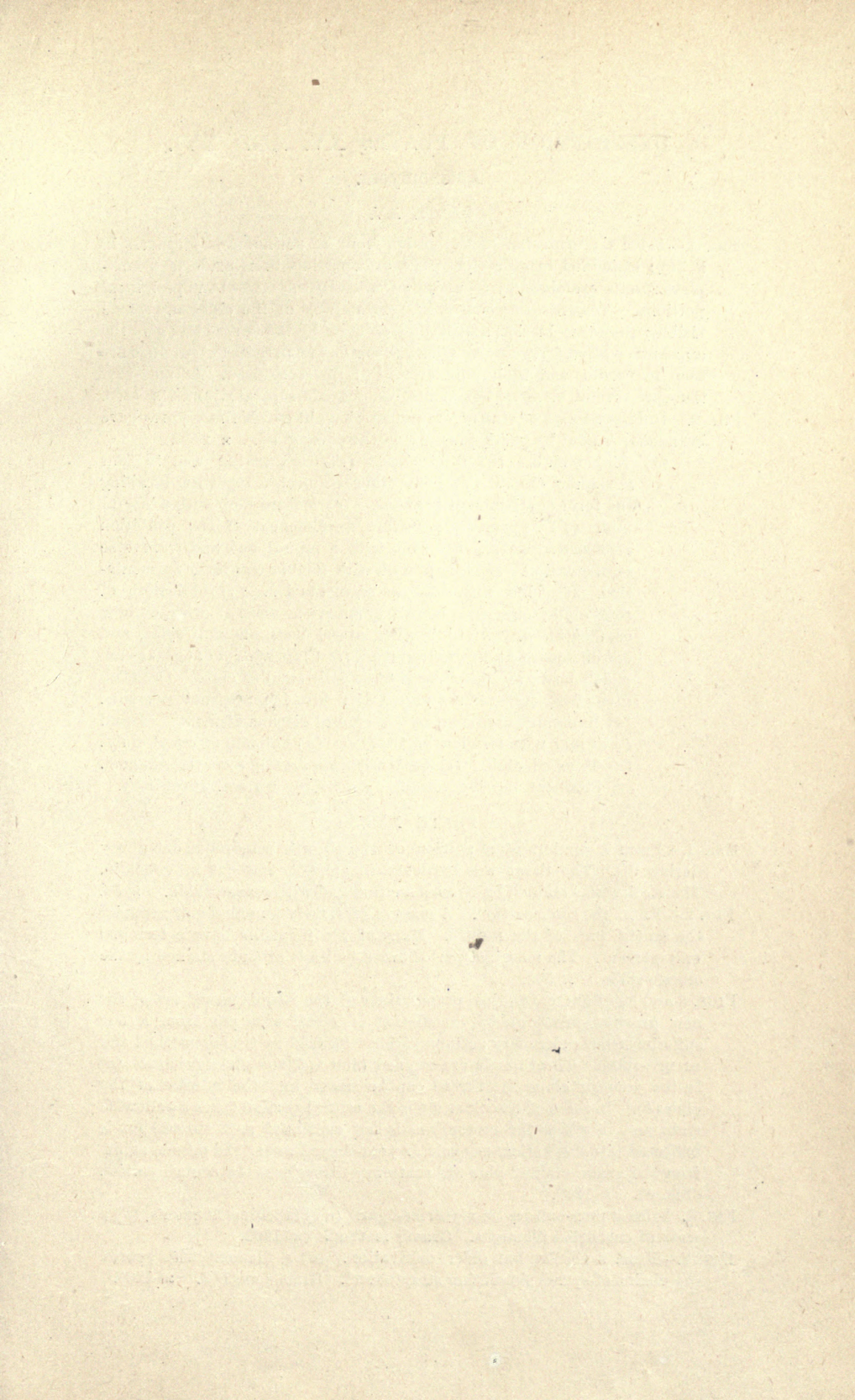

## DESCRIPTION OF PLATES XV. AND XVI.

### Actinomyces.

#### PLATE XV.

- FIG. 1.—From a preparation of the grains from an actinomycotic abscess in a boy; examined in glycerine. The drawing has been made of a complete rosette examined by focussing successively the central and peripheral portions. Towards the centre the extremities of the clubs are alone visible; they vary in size, and if pressed upon by the cover-glass give the appearance of an irregular mosaic. Towards the periphery the clubs are seen in profile, and their characteristic form recognised. At one part there are several elongated elements, composed of separate links.  $\times 1200$ .
- FIG. 2.—Different forms of clubs from preparations in which the rosettes have been flattened out by gentle pressure on the cover-glass.  $\times 2500$ .

(a) Single club. (b) Bifid club. (c) Club giving rise to four secondary clubs. (d) Four clubs connected together, recalling the form of a bunch of bananas. (e) Mature club with a lateral bud. (f) Apparently a further development of the condition represented at (e). (g) Club with a lateral bud and transverse segmentation. (h) Single club with double transverse segmentation. (i) Club with oblique segmentation. (j) Collection of four clubs, one with lateral gemmation, another with oblique segmentation. (k) Club with lateral buds on both sides, and cut off square at the extremity. (l) Club with a daughter club which bears at its extremity two still smaller clubs. (m) Club divided by transverse segmentation into four distinct elements. (n) Elongated club composed of several distinct elements. (o) and (p) Clubs with terminal gemmation. (q) Palmate group of clubs. (r) Trilobed club. (s) Club with apparently a central channel. (t) Filament bearing terminally a highly refractive oval body.

#### PLATE XVI.

- FIG. 1.—From a section of a portion of the growth removed from a boy during life. The tissue was hardened in alcohol, and cut in celloidin. The section was stained by Gram's method and with orange-rubin.  $\times 50$ .
- FIG. 2.—From the same section. A mass of extremely fine filaments occupies the central part of the rosette. Many of the filaments have a terminal enlargement. The marginal part shows a palisade of clubs stained by the orange-rubin.  $\times 500$ .
- FIGS. 3 and 4.—From cover-glass preparations of the fungus teased out of the new growths produced by inoculation of a calf with pus from a boy suffering from pulmonary actinomycosis. Stained by Gram's method and orange-rubin. The threads are stained blue and the clubs crimson (a) In the younger clubs the thread can be traced into the interior of the club (b). In some of the older clubs the central portion takes a yellowish stain, and in others the protoplasm is not continued as a thread, but is collected into a spherical or ovoid or pear-shaped mass. In others, again irregular grains stained blue are scattered throughout the central portion (Fig. 4).  $\times 1200$ .
- FIG. 5. From a pure-culture on glycerine-agar. (a) branching filaments, (b) a mass of entangled filaments. Gram's method.  $\times 1200$ .
- FIG. 6.—From a similar but older cultivation. (a) a filament with spores (b) chains of spores simulating streptococci. Gram's method.  $\times 1200$ .



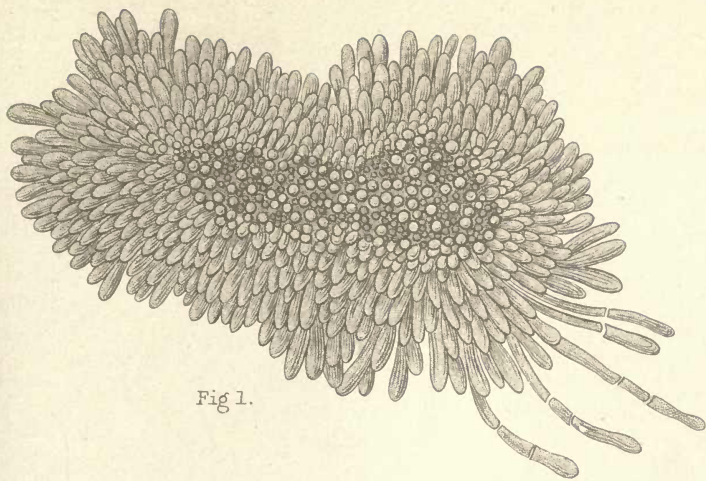

Fig 1.



Fig 2.

ACTINOMYCES







Fig 1.

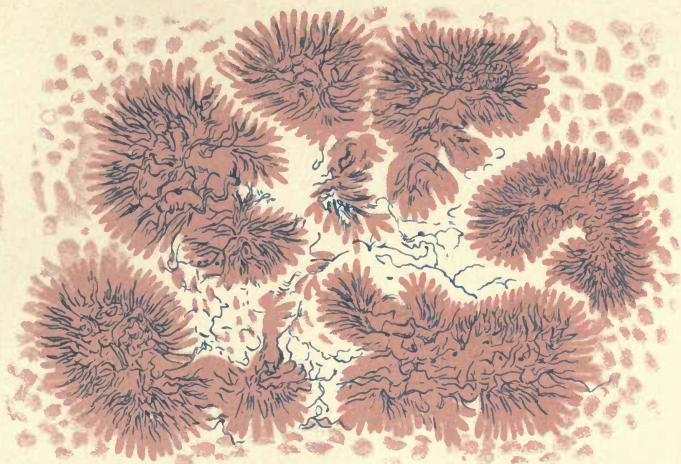

Fig 2.

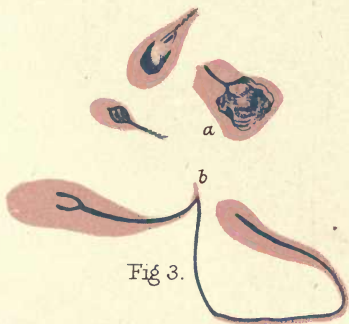

Fig 3.

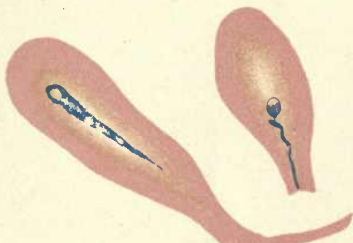

Fig 4.

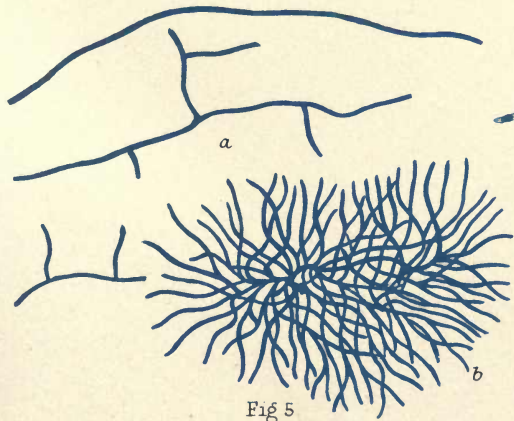

Fig 5.



Fig 6.

ACTINOMYCOSIS HOMINIS.





and in either case mounted in glycerine. But although the fungus can be detected without any staining process, there may sometimes be doubtful appearances, and then cover-glass preparations should be made and stained by the method of Gram with eosin. The filaments can be readily recognised, and this is of great value, as it forms an additional means for the diagnosis of the disease. In combination with orange-rubin we have a test that is as characteristic and useful as staining for tubercle bacilli. The discharge, scraping from a growth, sputum, or the isolated fungus is squeezed between two cover-glasses, which are then slid apart; they are allowed to dry, passed through the flame in the ordinary manner, and then stained. The cover-glasses can be cleared in clove-oil, the excess of clove-oil being removed by gentle pressure between pieces of blotting-paper, and then the preparation can be mounted in balsam and rendered permanent. On examination of these specimens the masses of filaments will be found to be stained blue, and the tissue elements pink. These filaments vary very much in extent and character in different preparations. In some cases there are masses of short threads, which are either straight, sinuous, or twisted, and branched. In other parts the field is occupied by very short, straight, or curved and sometimes spiral fragments; in others, again, there are comparatively long strands. On examination with a high power, and with careful illumination, some filaments will be observed to be moniliform, while others are provided with a terminal oval body. There are also free spherical, and oval, bodies stained blue, which represent the spores of the organism. When orange-rubin is used instead of eosin, the clubs will be stained and easily recognised. This method enables one to determine the exact relation of the threads to the club-shaped bodies; and this is an interesting point, as it has been suggested that the threads are not connected with the clubs, but are merely an adventitious micro-organism growing in the track of the ray-fungus. The threads are stained blue and the clubs crimson. In the younger clubs the protoplasm of the thread can be traced into the interior of the club. In some of the older clubs the central portion takes a yellowish stain, and in others the protoplasm is not continued as a thread, but is collected into a spherical, ovoid, or pear-shaped mass. In others again, irregular grains, stained blue, are scattered throughout the central portion. The sheath of the thread is stained pink; and the protoplasm, stained blue, fills the sheath, or consists of small spherical or irregular grains, giving a distinctly beaded appearance.

The effect of various reagents should be tried upon the isolated

grains. The grains are picked out of the pus and transferred to watch-glasses containing strong potash, xylol, and benzol. If returned to a slide and covered with a cover-glass, the clubs are found unaltered. Water or weak potash washes away the clubs, and the filaments become easily distinguished; ether and strong acids have no effect upon them. Corallin soda, Hanstein's violet, and iodine zinc-chloride fail to give any particular reaction. Hoffman's blue stains the clubs, but without bringing out any structural details which could not be observed in the unstained specimens.

**Actinomyces bovis.**—The fungus in cattle may in the same way be detected with the naked eye in the muco-purulent discharge, or in a scraping from the cut surface of a growth. The tufts of the fungus vary in size under different circumstances, from that of a grain of fine sand to that of a pin's head. If the pus or scraping be spread out on a slide and examined against a dark background, the grains appear to be white or yellowish-white in colour; but if examined by transmitted light, they appear distinctly brownish. On pressing the cover-glass on the slide the grains readily flatten out, being of a soft, tallowy consistency; or in the process of gently pressing the cover-glass on the slide with slight lateral movement, a distinct gritty sensation is transmitted to the finger, owing to the presence of calcareous matter. On examination with a low power the fungus will be recognised in the form of irregular patches scattered over the field, which might readily be regarded as collections of granular *débris* of a brownish or yellowish-brown colour, but on careful examination they are observed to have a more or less characteristic appearance. On examining with a higher power, spherical, ovoid, or reniform bodies are to be seen, which are either typical rosettes of clubs or granular masses, with here and there a club-shaped body at the periphery. Pus cells, round cells, fat granules, and minute spherical bodies may also be distinguished. If the grains consist of typical rosettes, and be merely covered with the cover-glass, and examined without being flattened out between the cover-glass and the slide, they will recall to mind, on focussing alternately the centre and the periphery, the appearance of the capitulum of a composite flower. The central portion appears to consist of spherical forms; these are the extremities of the component elements, and as we focus the edge of the rosette these elements are seen laterally, and their characteristic club-form is readily distinguished. The central portion may be flattened against the cover-glass, and as the individual clubs vary





## DESCRIPTION OF PLATES XVII. AND XVIII.

### Actinomycosis Bovis.

#### PLATE XVII.

Section of an actinomycotic tongue stained by the method of Gram and with eosin.

FIG. 1.—This illustrates the appearance which is usually seen under a low power, when a section is stained by Gram's method and with eosin. The central portion of a mass of the fungus is either unstained or tinged with eosin, while the marginal portion is stained blue. The reverse is seen, as a rule, in sections from man; although under a low power the general appearance of sections from these two sources is somewhat similar.  $\times 50$ .

FIG. 2.—*a, b, c, d*, represent the earliest recognisable forms of the ray fungus in the interior of leucocytes. In *e* the club-forms can be recognised. In *f* and *g* there are small stellate groups of clubs.  $\times 500$ .

FIG. 3.—A part of the section represented in Fig. 1, under a high power. The marginal line of blue observed under a low power is now recognised as the result of the stain being limited to the peripherally arranged clubs. At (*a*) part of a rosette has undergone calcification; the clubs are granular, and have not retained the stain. At (*b*) and close to it there are the remains of rosettes in which the process of calcification is almost complete.  $\times 500$ .

#### PLATE XVIII.

The figures in this plate are taken from sections of a case of so-called "osteosarcoma," in which the growth of the fungus was remarkably luxuriant. The specimens were stained by Plaunt's method.

FIG. 1.—Different forms of clubs in different specimens:  $\times 1200$ .

- (*a*) Very small club-shaped elements.
- (*b*) A club with transverse segmentation.
- (*c*) A club with lateral daughter clubs.
- (*d* and *e*) Clubs with terminal offshoots resembling teleutospores.
- (*f*) A club with developing daughter clubs on the left, and on the right a mature secondary club.
- (*g*) A segmental club with lateral offshoots.
- (*h*) Two clubs undergoing calcification.

FIG. 2.—A very remarkable stellate growth comprised of nine wedge-shaped collections of clubs radiating from a mass of finely granular material.  $\times 500$ .

FIG. 3.—A rosette undergoing central calcification, and consisting in part of extremely elongated clubs resembling paraphyses. Calcareous matter is also being deposited in the club-shaped structures.  $\times 500$ .

FIG. 4.—Part of a rosette with continuation of the club-shaped bodies into transversely segmented branching cells apparently representing short hyphae.  $\times 500$ .

FIG. 5.—A rosette from another section in which similar appearances are observed as in Fig. 4.  $\times 500$ .



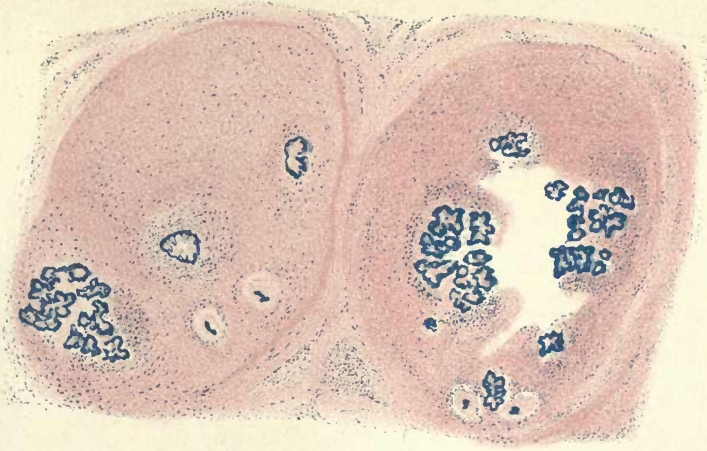

Fig 1.



Fig 2.

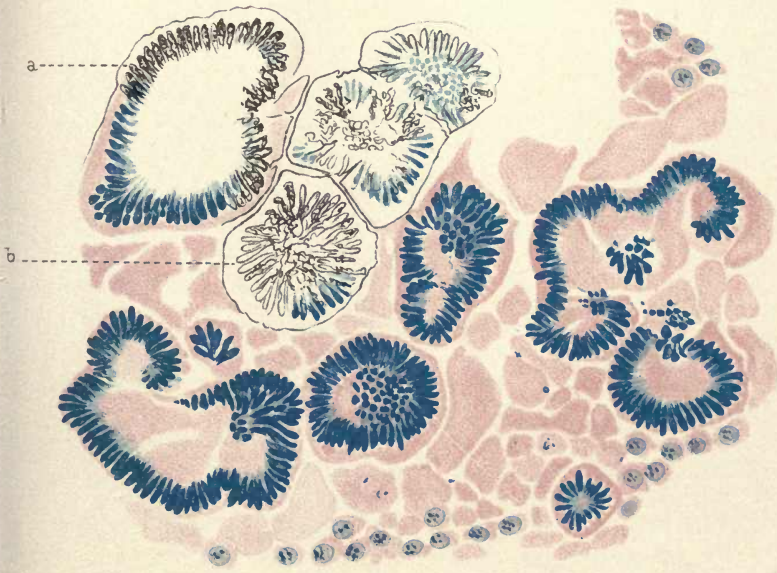

Fig 3.

ACTINOMYCOSIS BOVIS







Fig. 1.



Fig. 2.



Fig. 3.

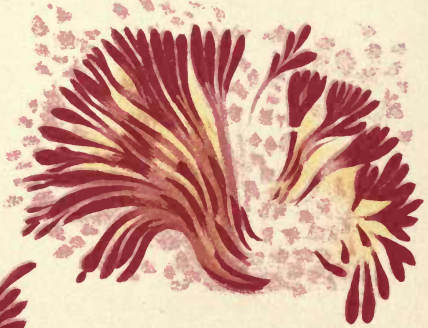

Fig. 4.



Fig. 5.

ACTINOMYCOSIS BOVIS





considerably in size, the appearance of an irregular mosaic is thus produced.

By pressing upon the cover we break up the rosette, and then the clubs are recognised either singly or in pairs, or attached together in the form of wedge or fan-shaped segments. Calcareous material, if present, may readily be demonstrated by the action of acids. It will be found that on the addition of dilute hydrochloric, nitric or acetic acids, the calcareous deposit is dissolved while the clubs are not affected, and even with the addition of the strongest acids the only result will be to dissolve out the calcareous matter and clarify the tufts of the fungus, the form of the clubs being still recognisable. They are not affected by ether or potash, and thus the effects of chemical reagents clearly distinguish them from fat crystals or calcareous particles. By breaking up the growth into small fragments, we may readily study the shape of the individual club-like elements. By using high-power objectives, and properly arranging the illumination, various forms will be clearly delineated. In some cases the club will be found to be bifid at the extremity; in other cases there are lateral offshoots or daughter-clubs. Here and there will be found clubs closely pressed together like a bunch of bananas, and in other cases the broken-off pieces have a palmate form. By teasing out the grains in water, and pressing them apart between the slide and cover-glass, we find that the central portion is composed, as a rule, of a structureless core. More rarely there are the delicate filaments which are found in cultures and in the fungus from man.

If the grains are mounted in glycerine, the appearance of the organism in the fresh state may be preserved.

The granules may be stained by picking them out with needles and transferring them to a watch-glass containing alcohol, to which a few drops of concentrated alcoholic solution of eosin have been added. They remain in the solution until distinctly stained, and they are then placed on a glass slide in a drop of glycerine.

The muco-pus may be spread out into as thin a film as possible on a cover-glass, allowed to dry, fixed by warming slightly over the flame, and stained by the method of Plaut or of Gram. The characters of the fungus can be so readily recognised in the perfectly fresh state, that methods of staining are of secondary importance in diagnosis, though there are certain minute points which can only be satisfactorily determined by means of suitable dyes.

## CULTIVATION OF ACTINOMYCES.

Boström cultivated actinomyces from five cases in animals, and from one case in man. In all cases he obtained a similar result. The fungi were isolated from pus with sterilised needles, and placed in liquefied nutrient gelatine in which they were teased out, and the gelatine then spread on glass plates. The growth is stated to have become visible in a few days. The fungi were isolated from the plates, crushed between sterilised glass slides and inoculated on the surface of nutrient agar-agar and blood serum. In this way pure cultivations were obtained. Nutrient gelatine was not liquefied. The cultures in blood serum and agar-agar grew best at from 33° to 37° C. The track of inoculation gradually spread out during the first two days, having a finely-granular, whitish appearance. During the next few days small yellowish-red spots appeared in the centre of the inoculated area, while the edge was apparently composed of fine processes. The yellowish spots continued to increase for about seven or eight days, and became confluent, and the periphery also was dotted with yellowish-red points. Finally, there were also isolated colonies consisting of a yellowish-red centre with a greyish, downy periphery. The cultivated fungus, if suitably stained, corresponded exactly with that found in human and animal actinomycosis. In the cultures during the first two days threads were found, with true branchings; later the threads were divided into shorter pieces or rods, and when the yellowish centres appeared there were also a number of very short rods and coccilike forms. Boström also described attenuated club-shaped swellings at the end of the threads. He concluded by saying that Actinomyces is not one of the mould fungi, the central threads do not therefore constitute a mycelium; he was inclined to regard it as a branched Cladothrix, and cultivation seemed to prove this. He suggested that it might be the *Streptothrix Försteri* of Cohn. In any case he relegated Actinomyces to the fission fungi or bacteria.

In 1888 the author made cultures on glycerine-agar from a case of human actinomycosis of the thoracic wall. An abscess was opened, the discharge collected in sterilised tubes, and cultivations prepared with as little delay as possible. Some of the discharge was spread out on a sterilised glass slide, and the grains isolated with sterilised needles and quickly transplanted on the surface of the nutrient medium. The tubes were placed in the incubator at 37° C., and the result watched from day to day. For several days there was to the naked eye no promise of success; but gradually the grains began



to change, and by the end of a fortnight there was an appreciable increase in size. Numerous cover-glass preparations were made from what was originally a single grain, and on examination by the method of Gram the appearance was very striking. There could be no doubt as to the increase of the mycelial structure. The dense masses of filaments covered almost the whole area of the preparation. In parts less thickly covered there were very numerous oval bodies, and rod-like segments with terminal enlargements. These "crocus" forms corresponded with the appearances previously described as met with in the interior of certain clubs. From this it would appear that some other condition is necessary for the development of the fully formed club, which is the result of the sheath undergoing some change, possibly mucilaginous, resulting in the formation of a thick investment of the clubbed mass of protoplasm at the end of the thread.

These club-shaped bodies represent organs of fructification, rather than the results of degeneration or death. The difficulty in accepting the view of their being entirely lifeless forms lies in the fact that the author has observed daughter-clubs growing from the mature clubs; and, further, in the bovine fungus the author has been able to trace the stages in the development of a single club to a completely formed rosette.

In the unstained condition, the clubs are found, on the whole, to be very regular in their form and arrangement, and by certain staining methods they can be shown to have a somewhat complex structure. If we take all the characters into account, and particularly the minute structure and the relation to each other of the threads and clubs, we are justified in the opinion that the club in the early stages is an integral part of the living fungus, and that these characters bring the fungus into relation with a higher group of micro-fungi, Basidiomycetes, although the filaments, regarded by themselves, correspond with the characters of *Streptothrix*. The life-history of the micro-organism may be summed up thus:—

The spores sprout into excessively fine, straight, or sinuous, and sometimes distinctly spirilliform threads, which branch irregularly and sometimes dichotomously. The extremities of the branches develop the club-shaped bodies. The clubs are closely packed together, so that a more or less globular body is formed, with a central core composed of a dense mass of threads. The threads can be differentiated by the method of Gram into an external sheath, and protoplasmic contents. The club-shaped body externally appears to be mucilaginous, while internally it is continuous with the protoplasm

of the thread. It is difficult to say what further changes occur in the club-shaped bodies; in all probability they represent organs of fructification. If so, the protoplasm in the interior of the club may possibly undergo changes leading to the development of spores, which are ultimately set free; in some cases the terminal segment of a club is separated by transverse fission in the form of a globular body, a process resembling the formation of spores by abjunction. In others, the forms sprouting from the club are suggestive of teleutospores. There are occasionally long, slender forms, very different from the ordinary clubs; they possibly represent *paraphyses* or abortive elements. In whatever way they may be formed, there can be little doubt that spores are set free in the vicinity of a rosette, and give rise to fresh individuals; the ultimate result recalling, as has been suggested, the appearance of "fairy rings." There can be little doubt that spores and young fungi are taken up by wandering cells, and conveyed to a distance from the parent fungus, and thus fresh centres of growth are established.

*Appearances of cultures.*—Boström, Wolff, Israël, Paltauf, and others have shown that actinomyces can be cultivated in the ordinary nutrient media. More recently the author has carried on a series of cultivations for some years on glycerine agar, gelatine and milk, broth, bread-paste, and potato, in order to observe the changes which take place, and to study the variations which he found in the appearance of sub-cultures. The actinomyces after a few days on glycerine agar at the temperature of the blood forms little, white, shining, moist colonies, which may remain stationary, or increase and coalesce. In a week or ten days, sometimes earlier, and sometimes after several weeks, the cultures turn a bright yellow colour, but some remain, though white; others, again, have a tinge of pink, and others are yellowish-brown (Plate XIX). After a time, a powdery efflorescence makes its appearance on the surface of the culture, which may be either yellow or white in colour. The culture may go on increasing, spreading over the surface of the medium, and retain its yellow colour, or it may turn black in parts or completely so, while the agar is coloured brownish-black. Cultures have a peculiar sour smell; the variations in cultures were all proved, by careful testing by sub-cultures, to be due to the growth of the actinomyces under varying conditions of soil, temperature, and the supply of air. The stage of efflorescence corresponds with the breaking up of the filaments into masses of cocci, and chains often closely resembling streptococci. Gelatine is slowly liquefied.

Wolff and Israël cultivated actinomyces on raw and boiled





## DESCRIPTION OF PLATE XIX.

### Pure-cultivations of Actinomyces.

These tubes were selected from a great number of cultivations in which there were different appearances. In some instances the growths had a faint tinge of pink.

FIG. 1.—Pure-cultivation on the surface of potato, showing a luxuriant sulphur-yellow growth entirely composed of entangled masses of filaments. After three months' growth.

FIG. 2.—Pure-culture from the same series, on glycerine-agar. In this case the culture remained perfectly white. The jelly was coloured reddish-brown. After fifteen months' growth.

FIG. 3.—Pure-culture on glycerine-agar in which the growth was dark-brown, in parts black, and the jelly stained dark-brown. After nearly two years' growth.





Fig 1.

Fig 2.

Fig 3.

PURE-CULTIVATIONS  
OF  
ACTINOMYCES.





eggs, and succeeded, by inoculation in the peritoneal cavity, in producing the disease in rabbits and guinea-pigs, in the form of tumours of the peritoneum. Sauvageau and Radais consider that actinomycetes should not be included with bacteria, and have suggested the name *Oospora bovis*.

#### PREPARATION AND EXAMINATION OF TISSUES.

In order to examine the microscopical appearances, the tissues should be hardened in absolute alcohol and embedded in celloidin. The sections, when stained, are to be dehydrated as a rule in strong spirit instead of absolute alcohol, as the latter dissolves the celloidin. If the sections are very friable, they can be cleared with clove-oil on the slide. By these means the little fungus tufts, which have a great tendency to fall out of the sections, may be preserved *in situ* after passing through the various staining processes. To cut the sections, we can use either Jung's microtome, cutting in alcohol, or the freezing microtome. In the latter case, after the celloidin has hardened, it is necessary to shave off all that surrounds the piece of tissue. It is placed in water until it sinks, and then transferred to gum, and frozen and cut in the ordinary way.

#### *Staining Methods.*

There are several methods by which the organism can be stained in the tissues, but it is best to employ for this purpose Gram's method and modifications of Plaut's method.

*Gram's Method.*—By Gram's method the clubs in the bovine disease are distinctly stained, especially if the sections contain the fungus at a suitable stage. Use freshly prepared staining solution. A few drops of aniline-oil are placed in a test-tube, which is filled up with distilled water, the mouth of the tube closed with the thumb, and the mixture shaken up thoroughly. An emulsion forms, which is then filtered, until a perfectly clear solution of aniline-water is obtained. To this is added, drop by drop, an alcoholic solution of gentian-violet until precipitation commences. About fifteen to twenty drops in a small capsule of aniline-water will be sufficient. Sections are floated in this dye for about ten minutes, then transferred to the iodine-potassic-iodide solution until they turn brown like a tea-leaf. They are then decolorised in alcohol; then stained in a weak alcoholic solution of eosin, dehydrated in strong commercial alcohol, cleared in clove-oil, and mounted in balsam. It will be found that the clubs are stained blue, and that there is a central area, which is, as a rule, tinged by the eosin. There are various modifications of the method, and some of them are extremely successful in affording not only a picture of the fungus, but also the structure of the surrounding tissue. Very instructive results may be obtained by combining the method of Gram with Ehrlich's histological stain. In this case, after the section has been decolorised in alcohol, it is ready to be transferred to logwood and treated as described below.

*Weigert's Method.*—This also gives very beautiful results. The sections

are placed for an hour in Wedl's solution of orseille, which is prepared as follows:—Add liquid extract of orseille to a mixture of absolute alcohol 20 parts, strong acetic acid 5 parts, distilled water 40 parts, until a dark-red liquid results. This must be filtered before use. The sections are left in this solution for an hour, then just rinsed in alcohol, and transferred to a solution of gentian-violet. Such sections show the nuclei of a violet-blue colour, and the peripheral part of the central core in the larger masses of the fungus also takes a blue colour, while the club-shaped structures are stained a striking wine-red colour.

*Plaut's Method and Modifications.*—This is one of the most valuable methods for staining the clubs. The original method was to float sections for ten minutes in magenta solution warmed to 45° C. This solution consisted of magenta two parts, aniline-oil 3 parts, alcohol of specific gravity 0.830, 20 parts, distilled water 20 parts (Gibbes). The sections were then rinsed in water, stained in concentrated alcoholic solution of picric acid for from five to ten minutes, immersed in water five minutes, 50 per cent. alcohol fifteen minutes, passed through absolute alcohol and clove-oil, and preserved in Canada balsam. The clubs are stained a brilliant red and the tissue yellow. Instead of employing the magenta solution, we now use Ziehl-Neelsen's solution.

By removing the picric acid in Plaut's method by prolonged immersion in alcohol, and then staining with gentian-violet or methylene-blue, a very successful contrast can be obtained. The most instructive histological picture can be obtained by first staining with Neelsen's solution, removing the stain from the tissue in the way that has been already described, and then transferring the sections to distilled water, and subsequently staining with Ehrlich's histological stain.

*Ehrlich's New Histological Stain.*—This is a combination of Ehrlich's logwood with orange-rubin. It is of especial value for sections of actinomycosis, and particularly in combination with carbolised fuchsin. It is employed in the following way:—The sections must be placed in alcohol or distilled water, and then in Ehrlich's logwood for about half a minute. From this solution they are transferred to distilled water, washed to remove the excess of stain, and then placed in a large dish of tap-water, where they are left for half an hour or more, until the sections turn blue; if preferred, they may be left overnight. They are then stained for one or two minutes in a solution of rubin, S, and orange, and washed again in distilled water to remove the excess. They must then be dehydrated in alcohol, cleared in clove-oil, and mounted in balsam.

#### *Preparation of Large Sections.*

The method of cutting large sections of organs may be employed in studying actinomycosis. The value of these sections depends not only upon their affording an instructive picture of the naked-eye appearances, but they can also be studied with a pocket lens, or under the microscope with a  $\frac{1}{4}$  or  $\frac{1}{6}$ -in. objective. By staining the sections, the relation of the morbid to the healthy structures is brought out in greater contrast, and thus the topography of the disease can be studied more



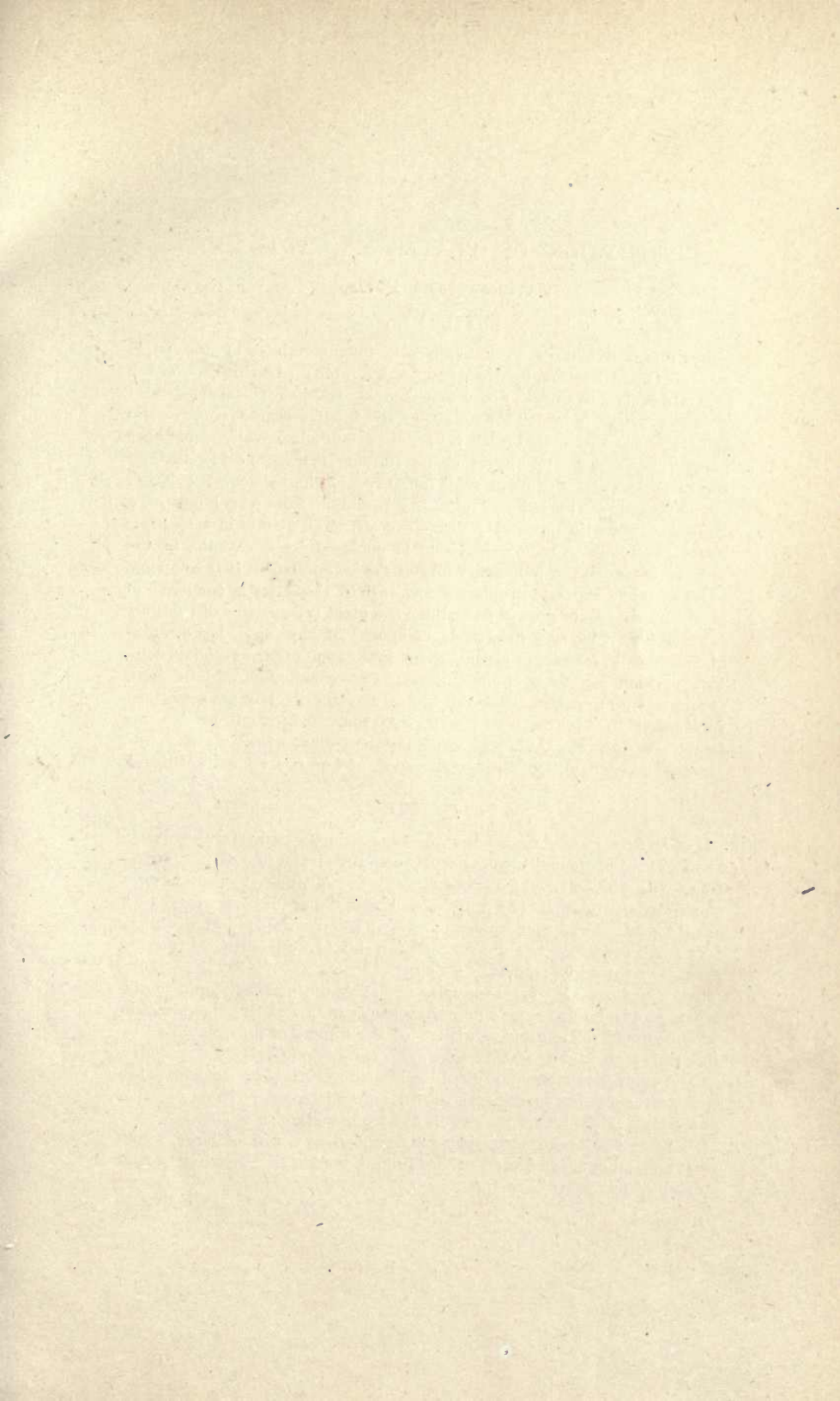

## DESCRIPTION OF PLATES XX. AND XXI.

### Actinomycosis Bovis.

#### PLATE XX.

FIG. 1.—From a section of an actinomycotic tongue stained by the triple method (Ziehl-Neelsen, logwood and orange-rubin). In this section the separate centres of growth are clearly shown. Each neoplasm consists of a fungus system, in which the masses of the fungus, situated more or less centrally, are surrounded with round cells, epithelioid cells, sometimes giant cells, and lastly fibrous tissue forming a more or less distinct capsule. In parts the fungi have fallen out of the section.  $\times 50$ .

FIG. 2.—From a section of a "tubercular" nodule from the lungs of a Norfolk heifer with pulmonary actinomycosis. The nodule is a multiple growth surrounding a bronchus, and is enclosed by a capsule, in the vicinity of which the pulmonary alveoli are compressed. It is composed of a number of separate neoplasms, and each of the latter is composed of secondary centres of growth resembling the giant cell systems of bacillary tuberculosis. The new growth is composed of ray-fungi, large multinucleated cells, sometimes distinct giant cells, round cells, epithelioid cells, and, surrounding them, fibrous tissue. On examination of the same specimen with a higher power the typical rosettes of clubs are sometimes surrounded by multinucleated cells, and sometimes small rosettes are found like tubercle bacilli, in the interior of giant cells. From a preparation stained by Ziehl-Neelsen, logwood, and orange-rubin.  $\times 50$ .

#### PLATE XXI.

FIG. 1.—(a) A leucocyte containing the fungus in its earliest recognisable form. (b) A large multinucleated cell containing the fungus in an early stage with the club-form already visible. (c) A leucocyte containing a small stellate fungus. (d) A large cell containing clubs arranged in a small rosette. (e) A multinucleated cell with clubs arranged in a palmate form. All the above are drawn from sections of actinomycotic tongues stained by the triple method.  $\times 500$ .

FIG. 2.—A giant cell with large vesicular nuclei at the periphery, and in the centre a fully formed rosette of actinomyces with a smaller growth within a "daughter" cell. From a section of the tongue of an ox stained by the triple method.  $\times 500$ .

FIG. 3.—A very large circular giant cell, with its ring of nuclei at the periphery, enclosing several isolated tufts of actinomyces. From a section of a nodule in the lung. Stained by the triple method.  $\times 500$ .

FIG. 4.—Three rosettes of actinomyces surrounded by a row of large, somewhat angular multinucleated cells. From a section of the tongue of an ox stained by the triple method.  $\times 430$ .



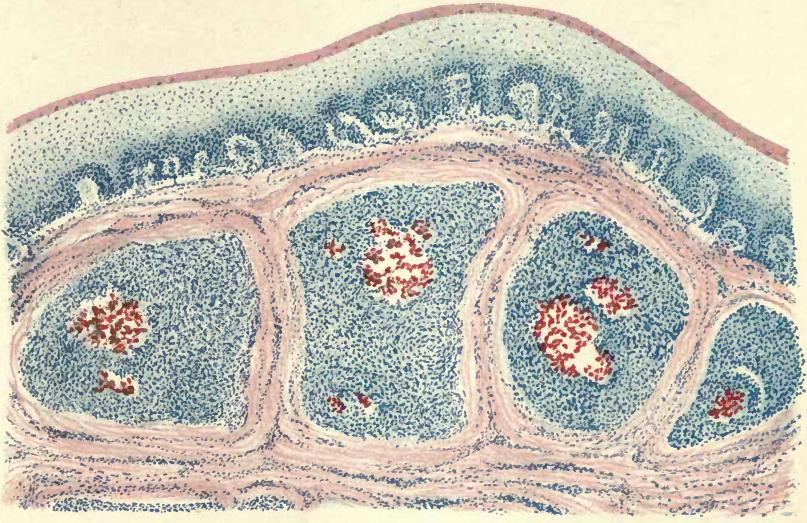

Fig 1.

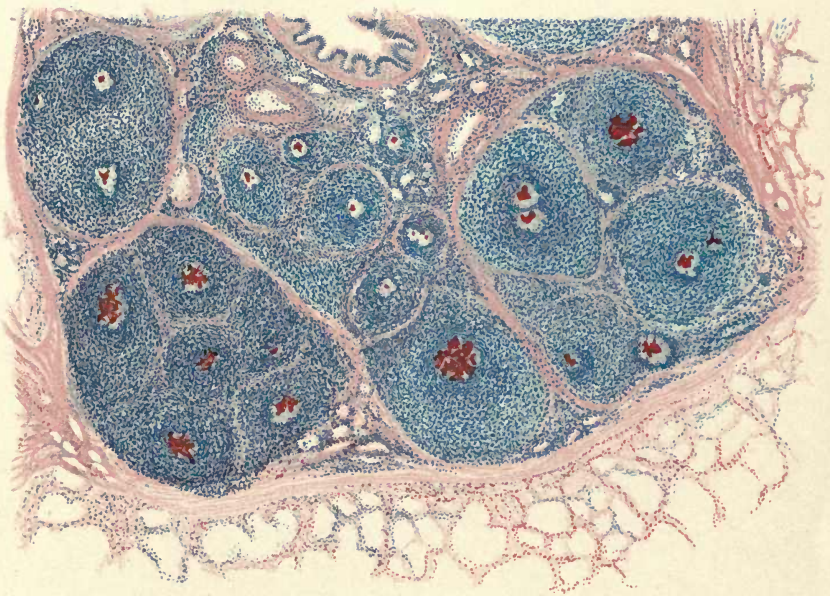

Fig 2.

ACTINOMYCOSIS BOVIS.





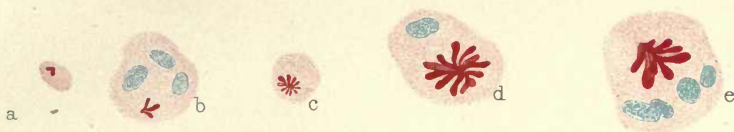

Fig 1.

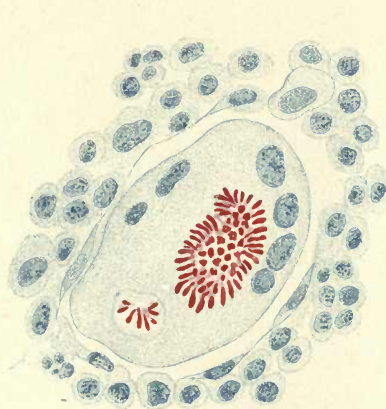

Fig 2.

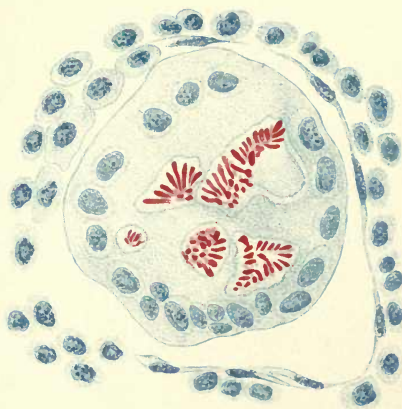

Fig 3.

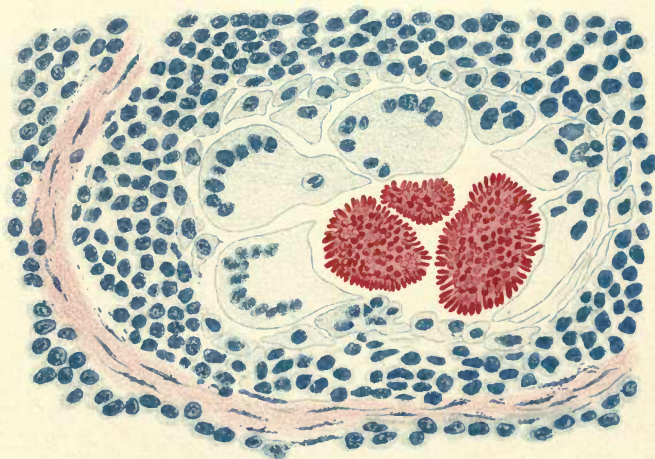

Fig 4

ACTINOMYCOSIS BOVIS





minutely than by simply observing the cut surfaces of organs or growths. And, further, it affords a means of rendering permanent many of the instructive appearances observed at the autopsy, without preserving the whole structure in the form of a museum specimen. Very satisfactory results can be obtained with material hardened either in spirit or Müller's fluid. The fresh material is cut with a large, very sharp knife into slices about a quarter of an inch, or less, in thickness. These slices are placed between filter-paper in large porcelain dishes, such as are employed for photographic purposes, and well covered with the hardening solution, which should be frequently changed. By covering the slice with a small sheet of glass, which is lightly weighted, any curling or turning up of the edges is prevented, and the slice not only kept flat, but hardened with smooth surfaces. Several weeks are required for hardening in Müller's fluid. The slices, after a short time in water, are placed in gum, and then frozen and cut; the slices which are hardened in alcohol are soaked in water until all trace of the spirit has been removed. A large microtome on the Bruce model is used to freeze and cut the sections. But in some cases it will be found better to embed the slices in celloidin, and cut under alcohol with a large microtome of Jung's pattern. The sections are carefully removed from the blade of the knife with a large camel's-hair brush, and in the case of frozen sections floated in water.

The next process is to float a section out in spirit, and with the camel's-hair brush to unfold it and spread it out on a sheet of glass. The glass with the section is lifted out and examined, and if the section is sufficiently thin, transferred to the staining solution. In the same way the section is passed through the various stains, as it should be prevented from rolling up or folding in the dye, or it may not be evenly stained throughout. Modifications of this process will suggest themselves, such as pouring off the dye and leaving the section spread out at the bottom of the dish, and then using the same dish for the next process. The sections are so easily injured, that it is better, as much as possible, to avoid handling them. If the sections are only a few inches in diameter, such as transverse sections of the anterior portion of the tongue of an ox, they can readily be transferred from dish to dish by means of a large spatula, made by soldering a piece of sheet German silver to thick copper wire.

To stain them employ carbolised fuchsine and picric acid, or alum cochineal, or logwood and orange-rubin. The processes of staining are precisely the same as with ordinary sections; but, from their unusual size, experience and practice are required in their manipulation.

When the section is dehydrated, it is ready to be cleared in clove-oil. The glass on which it is to be permanently mounted should be selected without scratches or flaws, and thoroughly cleaned and polished. It is slipped under the section, which is evenly spread out upon it, and then lifted out of the dish. The excess of spirit is drained off, the glass placed on a level surface, and clove-oil poured on the section. It is left until completely clarified; the clove-oil, as much as possible, drained off, and the rest entirely removed by gentle pressure with several thicknesses

of best filter-paper. In this way several large sections can be cleared at the same time. But when only one or two sections are dealt with, they are cleared in clove-oil in a dish, and the mounting glass at this stage passed underneath them as already described. Another plan, which will be found of advantage, is as follows :—A piece of clean, thick, filter-paper rather larger than the section, is slipped underneath it, and then raised with the section upon it. After allowing the excess of clove-oil to drain back into the dish, it is carefully laid on the glass with the section downwards, and gently pressed down. By taking up a corner, the filter-paper is peeled off, and the section left behind on the glass. Any creases or folds are adjusted with needles. After removal of the clove-oil, balsam is run over the section, and a cover-glass gently and dexterously lowered, so as to avoid the presence of air-bubbles. The preparations are set aside to harden in a warm place and on a level surface, and are then ready for fixing in suitable frames.

#### *Naked-eye Appearances of Large Sections.*

In the sections of an actinomycotic tongue it is at once apparent that the new growth is more or less limited to the periphery of the section. In parts there are dense clusters of little nodular neoplasms, *the fungus systems*, each having a rounded form, and averaging in size that of a small pea. In other parts small nodules, varying in size from a millet-seed to a hemp-seed, have a linear arrangement between bundles of muscular fibres. The appearance is suggestive of an invasion of the tongue along the lymphatics.

In many of the nodules the largest tufts of the fungus can be seen, with the naked eye, to occupy a more or less central position. In parts the muscular fibres are replaced by fibrous tissue.

If now these sections be placed under the microscope, the minute structure may be examined; but as it is obvious that still better results may be obtained by small sections, any part which it is necessary to examine with high powers can be selected from a corresponding part of the growth, and prepared in the ordinary way.

In the case of a "wen," the whole growth can be excised with the surrounding tissues, sliced and treated in the way already described, and sections stained by different methods.

The nature of the growth is at once recognisable as actinomycosis, from the characteristic honeycombed appearance produced by the trabeculae of fibrous tissue which form a spongy structure, from the loculi of which the fungus tufts and caseous matter have for the most part dropped out. In other parts this structure is intact, and the tufts of the fungus can be detected with the naked eye, and readily recognised with a pocket lens.

A fungus system may be studied more minutely in ordinary sections of the tongue. Each nodule is composed of the actinomyces surrounded by round cells and epitheloid cells, and fibrous tissue which often forms a distinct capsule. In some specimens the fungus is surrounded by a single row of large multinucleated cells, and in other specimens the fungus is found in the interior of large oval giant-cells.



## TRANSMISSION OF ACTINOMYCOSIS FROM MAN TO THE LOWER ANIMALS.

Inoculation of cultures has already been referred to. The author successfully inoculated a calf with material direct from a living patient.

A calf which had been inoculated in the peritoneal cavity, and killed seventy days afterwards, presented the following lesions. The peritoneum of the rumen, in the vicinity of the seat of inoculation, was studded with hundreds of growths, varying in size from a millet-seed to a pea. The large growths were composed of several small ones collected together. On stripping off the peritoneum, and holding it between the light and the eye, the fungus could be seen with the naked eye in each individual growth. By incising a growth, and examining a scraping under the microscope, the characteristic clubs, and the filaments also, were found to be present. By staining cover-glass preparations with the method of Gram and orange-rubin, the appearances were very striking. The clubs were conspicuous on account of their size, and brilliantly stained. In many, the protoplasm of the thread was demonstrated in the interior of the club. In sections of the peritoneal nodules stained by Gram's method the mycelium was found to be present, and the clubs in part took the stain. With Plaut's method the clubs were most clearly demonstrated.

Israël and Johné failed to infect a calf by intravenous injection, and Ponfick failed to infect dogs, but Israël succeeded with a rabbit. Israël obtained a small piece of actinomycotic granulation tissue from a peri-pleural abscess in a patient with primary disease of the lung, and introduced it into the peritoneal cavity. The rabbit showed no sign of illness, and was killed about ten weeks afterwards. On examination numbers of tumours were found in the abdominal cavity, varying in size from a hemp-seed to a cherry. Larger ones had a somewhat nodular surface with yellowish points; others were found on the abdominal wall on the right side. There was a small growth over the psoas muscle, and one large one attached to an adhesion of the colon. The growths were on the peritoneum, or attached by longer or shorter adhesions. Some of the larger tumours showed on section a hollow space in the centre, which was filled with a pulp, the result of fatty degeneration of the transplanted tissue, which was sharply differentiated in colour and consistency from the new growths. The latter consisted of granulation tissue with abundant formation of fat granules, blood pigment, acicular fat crystals, and actinomycotic



grains. From some of the tumours, radiating processes of a yellowish colour penetrated into the retro-peritoneal tissue.

Rotter inoculated calves, pigs, guinea-pigs, and rabbits. In one case he had a positive result. A piece of actinomycotic growth was introduced into the peritoneal cavity of a rabbit. The animal was killed six months afterwards, and the piece of tissue which had been introduced was found to be encapsuled, and around it were twenty tumours, from the size of a pin's head to that of a hazel-nut, containing the ray-fungus.

The author also succeeded in transmitting the disease to a rabbit. A small quantity of human pus, containing the yellow grains, was diffused in broth, and injected with a hypodermic syringe into the abdominal cavity of a rabbit. This rabbit died seventy-nine days afterwards. On examination several nodules were found, about the size of a millet-seed, on the peritoneum of the stomach, in the gastro-splenic omentum, and on the peritoneum of the diaphragm. There was a rounded nodule, about the size of a pea, attached to the stomach. There were adhesions between the intestines, and a tumour about the size of a marble attached to an adhesion of the cæcum. One of the small nodules was excised and divided, and the scraping from the interior contained typical rosettes of clubs.

The successful transmission of actinomycosis from man to bovines suggests intercommunicability, though the negative evidence as to infection of man from bovines supports the view that the disease is derived from some source which is common to both species.

#### TRANSMISSION OF ACTINOMYCOSIS FROM CATTLE TO CATTLE.

Johne was the first to prove that actinomycosis could be transmitted from cattle to cattle, and his results were confirmed and extended by Ponfick.

A calf was inoculated subcutaneously in the neck and cheek, in the gum, and the abdominal cavity. The animal died in forty days after inoculation with development of actinomycosis.

A calf was inoculated in the cheek and abdominal cavity. Death occurred 114 days after inoculation. In the peritoneal cavity numerous tumours had formed, and the yellowish grains were visible to the naked eye in sections of the new growth.

A cow in calf was inoculated in the left posterior quarter of the udder; phlegmonous mastitis followed, and subsided leaving a small induration, which then increased until the inoculated part of the udder was, in three months, nearly double the normal size, from a



deposit resembling a fibroma. The cow was slaughtered 133 days after inoculation. Typical actinomycosis had been produced.

A colt three and a half years old, was inoculated in the jaw and in the forehead after trephining, and also in the trachea. The animal died without any result.

Ponfick also conducted a series of experiments which amply confirmed the results which had been obtained by Johne.

*Feeding Experiments.*—Repeated experiments, made with masses of the growth chopped up, or with isolated grains of the fungus, gave negative results.

*Inoculation Experiments.*—The growth was inoculated in various regions of the body. Small particles of the growth from quite fresh tumours were introduced into the anterior chamber of the eye in rabbits, with negative results. Rabbits were inoculated in the peritoneal cavity from an animal recently slaughtered, but they died of peritonitis. In dogs also the results were negative.

Seven calves were operated on. In five the abdomen was opened with antiseptic precautions, and in two cases the growth was introduced by injection. In the latter cases the pieces of tumour were suspended in salt solution, but the animals died from peritonitis a few days after the injection. The same result occurred in two out of the five cases in which the abdomen was opened. The three remaining cases gave the following results:—

1.—Pieces of tissue, about 1·5 cm. long, were taken from the lower jaw of a recently killed ox. Twelve of these pieces were introduced into the peritoneal cavity; death occurred after 266 days, from exhaustion and recent lobular pneumonia. At the post-mortem examination several patches of peritonitis were found, with encystment of the remains of fragments of the inoculated tissue, but there was an independent development of several nodules in the neighbourhood of the stomach and urinary bladder. Examination of these new formations showed, even to the naked eye, that they contained yellowish grains, which, on further examination, proved to be the fungi.

2.—Ten pieces of tumour from the jaw of a cow were introduced as before; the calf died suddenly sixty days afterwards, during the injection of fresh pieces of actinomycosis into the jugular vein. At the post mortem it was found that various adhesions had occurred, as the result of peritonitis; and in the false membranes there were sixty-three nodules, varying in size. Microscopical examination showed that all these nodules consisted of typical actinomycotic new formation.

3.—In this case twelve pieces of growth were introduced into the abdomen of a calf eight weeks old. Seven days afterwards fresh pieces were introduced under the skin, in the region of the left lower jaw. A swelling occurred, which was opened. Pus escaped, together with the material which had been used for inoculation, in a state of decomposition. Pieces of tumour were inoculated subcutaneously in the neighbourhood of the right side of the neck, ninety-nine days after the first experiment. The animal was bled to death seven months (210 days) after the first experiment. At the post mortem, peritonitis and adhesions were found, with twenty-one large and several small nodules in the mesentery, in the false membranes between the viscera, and on and in the serous linings of most of the abdominal organs. There were also several large and many small tumours in the subcutaneous and intermuscular tissue, in the region of the lower jaw and neck on the right side, and numerous large and small nodules in both lungs, some undergoing softening in the centre.

Isolated fungi were inoculated in dogs, with negative results, nothing remaining after 45 to 80 days, except a thick emulsion.

Pieces of tumour were introduced in the submucous and subcutaneous tissue of dogs, but no change occurred after 600 days.

In a calf, inoculation under the gum of the upper jaw showed what was possibly only the remains of the growth which had been introduced. At any rate, the experiment was doubtful; but in a second calf there were numbers of nodules developed around the points of inoculation in the subcutaneous and muscular tissue in the neighbourhood of the lower jaw, and in the region of the neck. The results were observed in these regions in 210 and 110 days respectively.

Inoculation of rabbits and dogs, with isolated fungi, produced no results after 156, 165, and 170 days. Experiments on dogs, with grains from a human source, were also unsuccessful. They were examined after 470 days, and there was no sign of any result.

After intravenous injection, positive results were discovered in the only calf which survived this operation, on bleeding the animal to death 110 days afterwards. Numerous nodules (27) were discovered in the parenchyma of both lungs, without suppuration.

Two dogs were injected in the jugular vein with isolated fungi mixed with 60 grammes of salt solution. Examined after 45 and 80 days respectively, the lungs and all the other organs were found to be free from growths.



Ponfick thus summarised these experiments with the bovine fungus :—

1. Rabbits and dogs possess a marked immunity from actinomycosis, whether pieces of tumour or isolated grains are administered by feeding, or by inoculation in the serous cavities, in the subcutaneous or submucous tissue, or by intravenous injection.

2. The most common subject of actinomycosis, the cow, possesses a not less marked susceptibility to the artificial production of the disease. By feeding, an infection was not obtained, probably because the mucous membrane had not been injured; but by inoculation, on the contrary, an independent growth of fresh neoplasms was produced in the subcutaneous and intermuscular tissues, occasionally in the submucous tissue, and in a decided manner in the abdominal cavity. Clear evidence of this growth is obtained in some cases within a month, or after three or four months.

3. By intravenous injection, also, it is possible in a few months to cause typical new growths in the lungs.

#### MADURA DISEASE.

Mycetoma, or Madura foot, is a chronic local disease, attacking chiefly the hands and feet, and having considerable resemblance to actinomycosis. It is a disease of tropical climates, and is commonly known as the "fungus-foot disease" of India. A small tumour forms on the hand or foot, which after a year or two suppurates and bursts, leaving one or more sinuses, from which peculiar black particles, or white or pinkish roe-like bodies, are discharged.

The disease in the foot may commence in the big toe and spread upwards, involving the leg as far as the knee, and even the thigh. In a typical case the foot is enlarged and painful, and later there are several sinuses from which a purulent and blood-stained discharge can be expressed, containing the characteristic particles.

According to Bocarro all early growths are superficial. Dissection of the growths during an operation, or sections made through the diseased tissues after excision or amputation, show that the disease begins generally in the loose cellular tissue, generally the subcutaneous tissue, and thence extends along the sheath of muscles and tendons to other soft tissues, and finally the bones.

There are several facts in connection with the causation of the disease, which are of great interest when it is compared to actinomycosis in cattle. Bocarro states that the disease originates in

wounds, sores and pricks of thorns, and that the points of the thorns of the *Acacia Arabica* have been found embedded in the diseased parts. The disease is common among the agricultural class, and in 90 per cent. of the cases observed in the Hyderabad Civil Hospital it occurred in the hands and feet.

Vandyke Carter was the first to point out the resemblance to actinomycosis, and he believed that the two varieties of the disease, the black and the white, were the result of the growth of a mycelial fungus, *Chionyphe Carteri*.

Kanthack pointed out, that if portions of the growth were placed in ether or chloroform, and afterwards well washed in

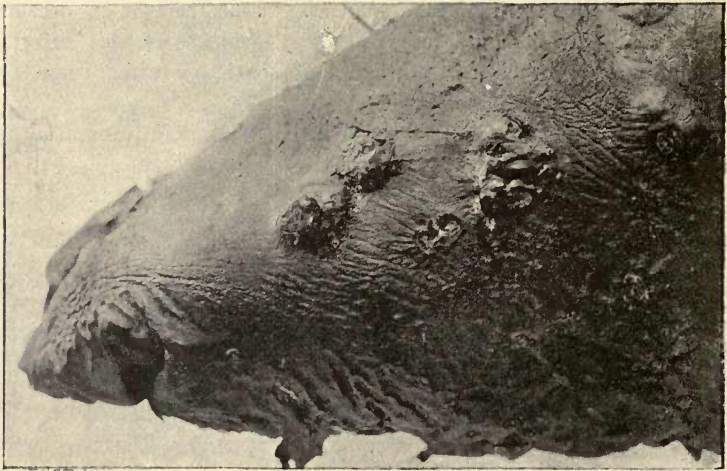

FIG. 183.—PART OF HUMAN FOOT WITH MADURA DISEASE.

caustic potash, small rounded bodies were left, which showed rays under the microscope closely resembling the appearances in actinomycosis, and that the reaction of the fungus to staining reagents was identical with actinomyces. Hewlett examined sections from the disease in the foot, and also found filaments and clubs. Boyce and Surveyor examined a number of cases, and carefully studied the fungus in the black and white varieties of the disease. In the black variety the particles were found to vary greatly in size, from that of a grain of gunpowder to that of a marble. If the particles were boiled for from a few minutes to one hour in concentrated caustic potash, and then transferred to distilled water, the brown colouring matter was removed and a



mycelial fungus could be seen. If tissue, containing particles, was washed for about a minute in *eau de Javel* and then stained, the colouring matter was removed, and the relation of the fungus to the tissue could be observed. This fungus consisted of large radiating and branched hyphæ, like those of a species of *aspergillus*, or *mucor*. Sections of the white, fish-roe bodies showed, usually in the centre, numerous, small, reniform, deeply-stained masses, surrounded by a radiated zone, with the presence of dwarfed club-like elements resembling *actinomyces*.

The author suggested that possibly the presence of the coarser septate mycelium of the black variety might be attributed to a mixed infection.

Vincent in Algiers succeeded in cultivating the micro-organism, and showed that it was a new species of *streptothrix*.

***Streptothrix maduræ***.—Vincent found that the *streptothrix* at first grows scantily in the ordinary culture media, and in such liquids as Cohn's solution. In broth, at the end of about a fortnight, there is a limited growth composed of small, round, greyish masses, and in sub-cultures the growth becomes more abundant.

The little colonies float in the clear liquid when the tube is shaken, and subside to the bottom when the liquid is at rest, while some adhere to the sides of the tube. They may be very small, or attain the size of a pea; after two months they acquire a reddish tinge. Later, on the surface of the liquid, there is a white efflorescence composed of spores.

The *streptothrix* grows well in slightly acid infusions of hay or straw, the proportion of hay to water being 15 grammes to the litre. Vegetable infusions, made with carrots, turnips, and potatoes (20 grammes to 1,000 of water), are suitable media. The *streptothrix* grows at the temperature of the room, but best at 37° C. and with free access to air. Inoculated in the depth of gelatine there is a scanty growth in the track of the needle and on the surface; but it grows best in a nutrient medium, composed of infusion of hay or potato 100 cc., gelatine 9 grammes, glycerine 4 grammes, and grape-sugar 4 grammes. Gelatine is not liquefied.

Ordinary nutrient agar is not a very favourable medium, but on glycerine-agar with grape-sugar there is an abundant growth of circular, projecting, shining colonies, slightly yellowish-white, which later become pink or bright red. When the colonies are numerous they remain small, but isolated colonies increase rapidly; they are depressed in the centre or umbilicated, and the central part remains white while the periphery becomes red. Later, the culture loses its

colour and becomes a dull white. The growth is very adherent to the surface of the jelly, and so tough that it is almost horny. The *Streptothrix* can be cultivated in milk, which it slowly peptonises. It cannot be grown on blood serum or egg. On potato, on the fifth day at 37° C., there are little prominent colonies, which slowly increase. After a month the growth acquires a pale-rose colour, which gradually increases and changes to orange or dark red. The colour is most intense on acid potato, and after a time an efflorescence, or whitish dust, appears on some of the colonies, consisting of spores. The growth is hard and friable.

Rabbits, mice, guinea-pigs, and a cat, were inoculated subcutaneously with particles from the disease, or with cultures; but only a local nodule was produced in each case, which, after a slight increase, subsided. Nocard confirmed these results. Intra-peritoneal and intravenous and subcutaneous inoculations in guinea-pigs, rabbits, pigeons, fowls, dogs, and sheep were negative; and no trace could be found of the cultures in any animal subsequently killed and examined. According to Bocarro, though fresh particles from the disease inoculated in rabbits and dogs gave negative results, inoculation of cultures in guinea-pigs, rabbits, monkeys, and rats, produced a local tumour of slow growth, which, on section, had the character of the inoculated material.

From these experiments we must conclude that the disease has not been shown to be transmissible to the lower animals, by either inoculation of the diseased tissue, or by cultures of the *Streptothrix*; and the exact relation of both the *Streptothrix* and the mycelial fungus to the disease must be considered an open question.



## CHAPTER XXXI.

### GLANDERS.

GLANDERS is a specific inoculable disease of equines, characterised by the formation of nodules and suppurating tumours, with which characteristic bacilli are associated. The disease has been known from very early times. It is described in books of the sixteenth century and in very early treatises on farriery. It attacks horses, asses, and mules. Man and many of the lower animals can be readily inoculated, but cattle and swine have an immunity. The disease is especially prevalent in towns, or wherever horses may be crowded together without those sanitary arrangements which are so much attended to in private stables; and in large establishments fresh horses are being constantly introduced to replace others, and thus the opportunities for the importation of the disease are multiplied. The disease varies in its virulence. It may occur in a form which proves fatal in a few days, or it may exist for months or years without attracting notice, and yet be capable of being transmitted to other animals. The term "farcy" is applied when the disease manifests itself in the form of tumours in the skin.

Glanders in the horse most commonly produces ulceration of the nostrils and enlargement of the glands. It commences in the form of nodules of the mucous membrane resembling miliary tubercles, and, like them, consisting of a collection of round cells. They suppurate and coalesce, forming irregular ulcers and raised, congested nodules. The lymphatic glands become enlarged and suppurate, and the disease extends to the respiratory organs. In the lungs, in the early stage, the disease is readily mistaken for tuberculosis. The nodules suppurate, and cavities are formed, but they do not tend to caseate. A glairy or muco-purulent discharge from the nostrils should lead to very careful inspection, with every possible precaution; and it will probably be easy to detect the ulceration of the nostrils. In other cases there may be slight discharge from the

nostrils and swelling of the glands, and nothing more will be visible until a *post mortem* examination has been made.

Glanders in man is found amongst those whose duties bring them into contact with diseased horses, such as stable-men, cavalry soldiers, and veterinary surgeons; and it is generally the result of accidental inoculation of a wound. An abscess develops, followed by metastatic purulent infiltration of the lungs, liver, spleen, and bones. There may be œdematous swelling of the face and ulcers in the nostrils. The joints may become swollen and painful.

The nodules consist of fibrous tissue and cells, with a tendency to suppuration. In the lungs the disease spreads by the lymphatics.

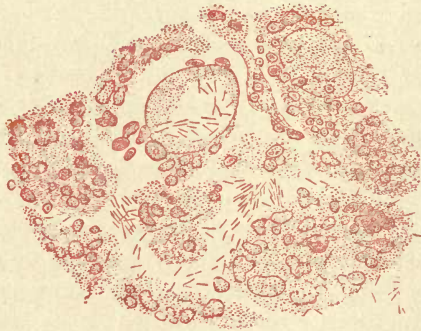

FIG. 184.—BACILLI OF GLANDERS; section of a glanders nodule,  $\times 700$  (FLÜGGE).

The infiltrated patches are necrosed in the centre, which is surrounded by leucocytes and fibrous tissue.

The bacilli were discovered by Löffler and Schütz in 1882. They are found in the discharge from the nostrils, in the pus, and in the nodules of animals artificially infected.

**Bacillus mallei.**—Rods, with rounded ends, shorter and thicker than the tubercle bacillus, occurring singly, or in pairs, and sometimes in filaments. The protoplasm in the rod is broken up in stained preparations, as in the tubercle bacillus. They stain with the watery aniline dyes, and intensely so with alkaline methylene blue or Neelsen's solution; they are non-motile and aerobic; spore formation has been described. They can be cultivated on the usual media, especially on glycerine-agar and on potato; but they will not grow in infusions of hay, straw, or stable manure. On the surface of glycerine-agar a colourless, transparent growth occurs on either



side of the track of the needle; on glycerine-agar with milk a whitish layer develops, which gradually changes in colour from amber yellow to a reddish-brown. On blood serum the growth is transparent and yellowish; on potato it is much more characteristic. After two or three days at the temperature of the blood, a film develops in the vicinity of the inoculated area, which is honey-like, transparent and yellow; the transparency disappears, and in a week the cultures have become reddish-brown. (Plate II., Fig. 6.)

The disease has been communicated to man by accidental inoculation with a hypodermic syringe which had been used for inoculating cultures. Horses, asses, cats, goats, field mice, and



FIG. 185.—SECTION OF A BRANCH OF THE PULMONARY ARTERY SHOWING GLANDERS BACILLI PENETRATING THE WALL (HAMILTON).

guinea-pigs, can all be infected with pure cultures; rabbits, sheep, and dogs are slightly susceptible; cattle, swine, and white mice have an immunity. In the guinea-pig a swelling occurs at the seat of inoculation, followed by the formation of a prominent tumour, developing into an abscess. The skin becomes involved, and an ulcer with indurated margin results. The lymphatic glands also become implicated, and general infection follows, extending frequently to the testicles or ovaries, and death results after several weeks. In rabbits there is generally only a local abscess induced, which terminates in a quickly-healing sore. Mice die in three or four days from general infection; glanders nodules are found in the liver and

spleen, closely resembling miliary tubercles. Löffler recommends inoculation of guinea-pigs as the most reliable method of diagnosis.

Sub-cultures of the bacillus rapidly lose their virulence. The toxic products have been already described (p. 48). Mallein can be prepared from a culture on sterilised potato by extracting with glycerine and water, or from a culture of the bacillus in broth. A virulent culture is obtained from a glandered horse, or from a guinea-pig inoculated with fresh virus. Sub-cultures are prepared in glycerine broth, and incubated at 37° C. for a month or six weeks. If the cultures are found to be pure they are sterilised in the usual way, in the steam steriliser, and by filtering through porcelain a pale, amber-coloured liquid is obtained. To test for glanders, a few drops (2½ cc.) are injected underneath the skin, in the middle of the side of the neck. In healthy horses there is no reaction, or a very slight elevation of temperature. In glandered horses there is marked rise of temperature (101° to 105°), considerable local swelling at the seat of inoculation, and signs of general disturbance, while the glandered tumours become more swollen and painful. The temperature of the horse to be injected should be taken night and morning for two or three days before the operation; and in horses suffering from febrile disturbance the test should be delayed. Thomassen made a number of experiments on horses suffering from pleurisy, bronchial catarrh, strangles, and other diseases, without any reaction, except in a glandered horse, used as a control experiment. Hunting and M'Fadyean, in this country, have made most careful observations and experiments, and there is no doubt that mallein is a very valuable aid in the diagnosis of glanders. In many cases the reaction has been obtained in horses, and the existence of glanders has been discovered only after a most searching post-mortem examination. With this means of diagnosis it is now possible to determine exactly which are the infected animals in a stable where the disease has broken out. The animals can then be slaughtered, and the disease prevented from spreading.

**Stamping-out System.**—Whatever may be the stage of the disease or the extent or variety of it, isolation ought to be carried out in its most complete form—namely, slaughter. The disease might be completely stamped out, if it were not for the difficult question of compensation. It can undoubtedly be checked by the existing laws.

In 1869 glanders was included in the list of contagious diseases, and the provisions with regard to giving notice of the disease, the regulation of movement, or exposure, and disinfection, were applied to



horses suffering from glanders. Under an earlier Act it was made an offence to expose glandered horses in markets or on commons. In 1878 power to slaughter was incorporated in the Animals Order.

(1) Where a person having a horse, ass, or mule in his possession, or under his charge, gives notice to a constable that the horse, ass, or mule is affected with glanders, or any person is convicted of an offence against the Act of 1878 by reason of his having failed to give such a notice, then, if at any time thereafter it appears to the Local Authority, on a special report of a Veterinary Inspector, that the horse, ass, or mule is affected with glanders, and the horse, ass, or mule is alive at the end of fourteen days after the receipt by the Local Authority of that special report, the Local Authority may serve on the owner of the horse, ass, or mule a notice in writing requiring him to slaughter it, or to permit them to slaughter it, within a time specified in the notice.

(2) If in any case the owner fails to comply with the requisition of the notice of the Local Authority, he shall be deemed guilty of an offence against the Act of 1878, unless he shows to the satisfaction of the court of summary jurisdiction before which he is charged that the horse, ass, or mule, is not affected with glanders, or that the slaughter thereof is for any reason unnecessary or inexpedient.

(3) The provisions of this Article may be put in force, from time to time, as often as occasion requires, in relation to the same horse, ass, or mule, on a further special report as aforesaid.

In the order of 1892 it was provided that glanders should include farcy, and power was given to compel slaughter, and to compensate by payment of half the value of a diseased animal, not exceeding £20, and full value in the case of healthy animals. Owing to objections urged against the payment of compensation, another order was passed, which came into operation at the end of 1894; the order to slaughter being amended as under :—

(1) A Local Authority may if they think fit cause to be slaughtered any diseased horse, ass, or mule, provided that if the owner of the horse, ass, or mule gives notice in writing to the Local Authority, or their inspector or other officer, that he objects to the horse, ass, or mule being slaughtered, it shall not be lawful for the Local Authority to cause that horse, ass, or mule to be slaughtered except with the further special authority of the Board of Agriculture first obtained.

(2) A Local Authority may, if they think fit, cause to be slaughtered any suspected horse, ass, or mule, having previously obtained the consent of the owner thereof.

(3) The Local Authority shall out of the local rate pay compensation as follows for any horse, ass, or mule slaughtered under this article :—

(a) Where the horse, ass, or mule was diseased the compensation shall

be such sum as the Local Authority think expedient, being a minimum in the case of a horse of two pounds, and in the case of an ass or mule of ten shillings ; provided that in no case shall the amount of compensation, if above the said minimum, exceed one-fourth of the value of the animal immediately before it became diseased.

- (b) In every other case the compensation shall be the value of the horse, ass, or mule immediately before it was slaughtered.



## CHAPTER XXXII.

### TETANUS, RABIES, AND LOUPING-ILL.

#### TETANUS.

TETANUS is a communicable disease of man and the lower animals, characterised by spasmodic contraction of the muscles. It is commonly the result of an injury, and occurs especially after wounds produced by means of splinters of wood or contaminated with earth or dust, and may follow after surgical operations.

Carle and Rattone first showed, in 1884, that the disease could be communicated from man to other animals. Rabbits inoculated with pus from a case in man developed tetanus, and from these rabbits the disease was conveyed to others. Nicolaier, the following year, found that mice and rabbits inoculated with earth often contracted tetanus, and that the pus which formed at the seat of inoculation contained, amongst other organisms, characteristic bacilli. Pure cultures were first obtained by Kitasato.

**Bacillus of Tetanus.**—Slender, straight rods, and filamentous forms. Spore formation takes place at the end of a bacillus, giving it a drumstick appearance. They stain with aniline dyes, but best with Neelsen's solution, or by Gram's method. By the Ziehl-Neelsen method and methylene-blue, the spores can be stained red, in contrast to the bacilli, which are stained blue. The bacilli are anaerobic, liquefy gelatine, and are slightly motile. They can be grown at the ordinary temperature, but most readily at the temperature of the blood, in an atmosphere of hydrogen, especially after the addition of 1 or 2 per cent. of grape sugar to the nutrient medium. The young colonies on plate-cultivations somewhat resemble those of *Bacillus subtilis*. They have an opaque centre, and are surrounded by fine rays, extending in all directions like thistle-down. In the depth of gelatine a ray-like growth occurs in the lower part of the track of the needle. The gelatine is liquefied very slowly, and gas is given off. The cultures possess a

characteristic odour. In slightly alkaline broth, and peptone with alkaline reaction, in an atmosphere of hydrogen, the gas formed will be sufficient to break the flask if it is sealed up. Kitasato obtained his cultures from pus, by taking advantage of the resistance of the spores to high temperatures. By raising cultures to 80° C. for three-quarters of an hour, the micrococci and bacilli in the mixed culture were destroyed, while the spores of the tetanus bacillus retained their vitality, and then sub-cultures were obtained in a pure state. The spores are said to be killed by



FIG. 186.—PURE-CULTURE OF TETANUS BACILLI IN GRAPE-SUGAR GELATINE. Four days old. (FRÄNKEL AND PFEIFFER.)

exposure to steam for five minutes. A 5 per cent. solution of carbolic acid with .5 per cent. of hydrochloric, will destroy the spores in two hours. Kitasato and Weyl obtained *tetanus* from pure cultures of the bacillus, Brieger having previously obtained it from impure cultures. A tetano-toxin, indol and phenol, and butyric acid are also found. Brieger and Fränkel attribute the pathogenic properties to a tox-albumin. These products have been described more fully in a previous chapter (p. 41). A pure-culture produces tetanus in a mouse in twenty-four hours, and rabbits, guinea-pigs, and rats can also be infected. No pus forms at the seat of inoculation, as after inoculation of earth, but the spasms commence in the muscles nearest to the seat of inoculation. A trace of a broth culture will kill a guinea-pig, the symptoms developing in three days.

Kitasato succeeded in making animals immune to tetanus, and subsequently the discovery was made that the blood in immune animals will produce immunity in other animals, the explanation being that the toxic principle of the tetanus bacillus induces the formation of tetanus antitoxin; and if equal parts of the serum of an immune animal, and a fatal dose of tetano-toxin, are together injected into a healthy guinea-pig, tetanus will not follow, showing that the virus has been neutralised. Tizzoni and Cattani found that blood from an immunised dog was not only capable of completely neutralising the toxic power of filtered cultures, but that the injection of the blood-serum produced immunity in otherwise susceptible animals, except





DESCRIPTION OF PLATE XXII.

**Bacillus tetani.**

FIG. 1.—From a cover-glass preparation of a pure-cultivation of the tetanus bacillus in broth; stained with Neelsen's carbolised fuchsine.  $\times$  1200. Lamplight illumination.

FIG. 2.—From a cover-glass preparation from the same source; stained with Neelsen's solution and methylene blue.  $\times$  1200. Lamplight illumination.



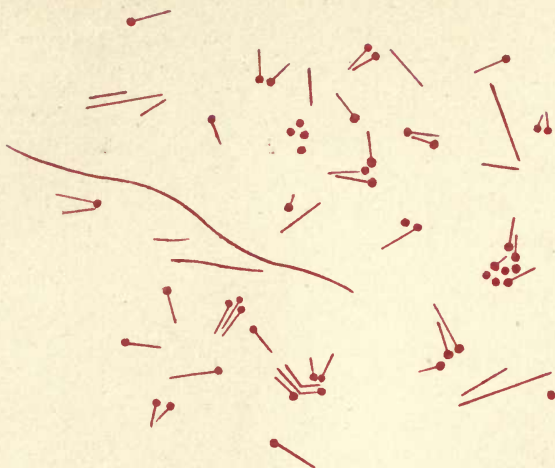

Fig 1.

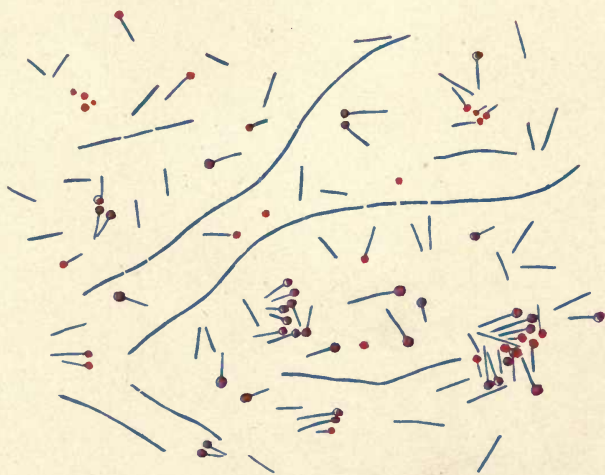

Fig 2.

**BACILLUS TETANI**





guinea-pigs or rabbits. This antitoxin is possibly secreted by special glands, such as the thymus and thyroid; and, according to Brieger and others, extracts of the thymus gland are antitoxic to other toxins, as well as the tetanus toxin.

These experiments have resulted in the employment of tetanus antitoxin as a therapeutic agent (p. 63).

#### RABIES.

Rabies, or hydrophobia, is a disease like tetanus, the symptoms being produced by a virus acting upon the nervous system. The specific virus appears to originate in dogs, wolves, and jackals; and by wounds inflicted by rabid animals, or by inoculation, the disease may be communicated to man, cattle, sheep, deer, cats, rabbits, and swine.

Among the early symptoms observed in the dog are sulkiness and restlessness, depraved appetite, and irritability. A peculiar expression of the countenance may be noticed, with twitchings of the eyes and face, and the animal's attention appears to be fixed upon some imaginary object. A rabid dog is constantly trying to drink, and at times howls or barks in a peculiar tone, whilst the breathing becomes very irregular. On the fourth day, or later, death follows. After death the glands are enlarged and congested, the tonsils are inflamed, and the vessels of the epiglottis injected. In some cases there is inflammation of the lungs, and the stomach may contain a mass of straw, hair, and horse-dung. The membranes of the brain and the spinal cord may be also congested. All these symptoms may be present, or some only, or they may be entirely absent; and it is partly for this reason that Pasteur's researches have been of such enormous value. Very little was known of the experimental production of rabies until Pasteur commenced his investigations; and the test, which can be applied by inoculating rabbits, is invaluable as a means of diagnosing rabies with absolute certainty. Dogs suffer from symptoms simulating those of rabies; and formerly, when human beings were bitten, it was impossible in some cases to determine whether the dog had been suffering from rabies or not. We are indebted to Pasteur for the only reliable test which can be applied; and we are now in a position, when a human being is bitten by a dog supposed to be, but not really, rabid, to remove all cause for the anxiety which would otherwise remain for months and even years.

In man the period of incubation lasts from eight days to

several months, and in rare cases a much longer period. The wound from a bite may have healed, and may again become inflamed, and symptoms follow, owing to the poison affecting the brain, spinal cord, or the peripheral nerves. In the dog the disease appears in two forms—raging madness and dumb madness; and the identity of the virus in the dog and in man is shown by the fact that virus from man can produce both forms of the disease in the dog. The virus may be obtained by inoculation of the saliva of a rabid dog; but this method is uncertain, as other micro-organisms are present. Pasteur endeavoured to obtain it in a pure state, and was able to demonstrate that the spinal cord, the brain, and the nerves contain the virus. It was also found that by direct inoculation of the nervous system the most certain results followed.

**Bacteria in Rabies.**—Cocci have been described in connection with hydrophobia by Fol, Babès, and Dowdeswell. The cocci, it is said, were observed in sections of the spinal cord of rabid dogs. The descriptions given by different observers vary considerably, and there is not any particular coccus constantly associated with the disease. Nor have any of the bacteria been isolated from the diseased animal, which were alleged to be present in stained preparations. By many, hydrophobia is believed to be due to the presence of a micro-organism, but at present the nature of the contagium is unknown.

**Protective Inoculation.**—Pasteur found that a dog inoculated under the dura-mater with virus from the spinal cord of a rabid animal will develop rabies, as a rule, within eighteen days. By trephining rabbits and inoculating the virus, and by, in the same way, transmitting the virus from rabbit to rabbit, the incubation period gradually shortens, until it is reduced to six or seven days. The virus has then reached its maximum virulence in the rabbit, and is "fixed." Pasteur then studied the possibility of producing immunity. The medulla of a rabbit, containing the virulent virus, was suspended in a glass bottle over caustic potash at a temperature of 25° C. If a number of spinal cords were thus treated, and examined from day to day, it was found that they gradually lost their virulence, becoming completely inert in from sixteen to twenty days. A series of cords was thus obtained with diminishing virulence; by injecting subcutaneously an infusion of rabid spinal cord crushed in broth, and beginning with an inert cord on the first day and using the next in the series on the second day, and so on till a fresh spinal cord could be injected, it was found that dogs were rendered insusceptible to the strongest virus, administered by inoculation or by exposing them to the bites of rabid dogs. Dogs have usually



an incubation period of several weeks, and Pasteur conceived that it would be possible to anticipate the symptoms, which would naturally follow in a dog which had been bitten or inoculated, by giving them a mild form of hydrophobia by the injection of attenuated virus of short incubation period. These experiments showed that it was possible to do this, and the outcome was the introduction of a system of protective inoculation in the human subject. Pasteur succeeded in giving immunity from hydrophobia to about fifty dogs of every age and breed.

In 1885 Joseph Meister, a boy nine years of age, bitten badly by a mad dog upon the hands, legs, and thighs, was brought to Pasteur. At a post-mortem examination of the dog, its stomach was found full of bits of hay, straw, and wood, and it had been unquestionably rabid. On July 6th, sixty hours after Meister had been bitten, a syringe full of marrow from a rabbit which had died on June 21st, and therefore fifteen days old, was injected beneath the skin over the right hypochondriac region. The next morning Meister was inoculated with a spinal cord fourteen days old, and so on every day, till on the sixteenth a cord only one day old was used. So many injections, however, need not have been given, as it was subsequently found that the spinal marrows injected during the first five days were inert when tested on rabbits. The marrows of the next five days showed an ascending scale of virulency, until, on the last two days of the treatment, Meister had been inoculated with a virus so virulent that it was capable of causing hydrophobia in dogs after ten days' incubation. Meister remained completely free from hydrophobia. From that time to the present day many thousands of patients have been treated in Paris by slightly modified methods, and it is very generally believed that a real prophylactic agent has been discovered.

Pasteur suggested that the rabic virus might consist of two distinct substances—a living virus capable of developing in the nervous system, and a secondary product which, in sufficient proportions, might have the property of hindering the development of the living virus. The nature of this living virus is quite unknown.

According to a return of the inoculations at the Pasteur Institute, the total number of persons treated in 1895 was 1,523, of whom five died. In three cases the symptoms of hydrophobia occurred within a fortnight of the last inoculation. If these three cases are omitted, the number of persons treated is reduced to 1,520 and the deaths to two. The results are shown in the following table,

for the nine years previous to 1895, during which Pasteur's method has been in operation :—

Year.	Number of persons inoculated.	Number of deaths.	Rate of Mortality.
1886 ... ..	2,671	25	0·94
1887 ... ..	1,770	14	0·79
1888 ... ..	1,622	9	0·55
1889 ... ..	1,830	7	0·38
1890 ... ..	1,540	5	0·32
1891 ... ..	1,559	4	0·25
1892 ... ..	1,790	4	0·22
1893 ... ..	1,648	6	0·36
1894 ... ..	1,387	7	0·50
1895 ... ..	1,520	2	0·13

Of the 1,520 persons treated, 156 were bitten on the head or face, 829 upon the hands, and 535 on other parts of the body ; 122 were bitten by animals experimentally proved to be rabid, 949 by animals declared by veterinary certificate to be rabid, and 449 by animals supposed to be rabid.

Babès at Bucharest inoculated 300 persons in one year, and claimed to have reduced the mortality to ·4 per cent.

**Stamping-out System.**—There is every reason to believe that rabies could be stamped out in England in six months, if a general order for muzzling were enforced, and all ownerless dogs were slaughtered. It is the ownerless cur, the vagrant dog, which is mainly responsible for the spread of rabies ; and if a general muzzling order cannot be put into force, it would undoubtedly check the disease if all dogs were compelled to wear a collar with the name and address of the owner, and all dogs without owners were destroyed.

#### LOUPING-ILL.

Louping-ill is regarded by some as an infective disease. It is a disease of sheep, characterised by symptoms due to an affection of the central nervous system. The symptoms consist in contractions



of the muscles of the head and limbs, loss of co-ordination and finally complete loss of the power of movement. The name is derived from the peculiar jumping movements in the early stage.

Klein and M'Fadyean independently investigated this disease. Klein found bacteria in the cerebral fluid. No micro-organisms were found in the blood. Special attention was drawn to a bacterium which was found by Klein in six out of seventeen cases, and to a micrococcus by M'Fadyean.

**Bacteria in Louping-Ill.**—*Klein's Bacterium*. Oval cocci and rods  $\cdot 6$  to  $1 \mu$  in length,  $\cdot 2$  to  $\cdot 3 \mu$  in breadth. Colonies in gelatine, yellowish by reflected light, are brown by transmitted light. On the surface of gelatine the bacteria form a film, which is crenated at the edge, and thick in the middle, at first grey and later yellowish. In the depth of gelatine a filament forms, composed of closely aggregated minute greyish colonies, and a prominent yellow growth occurs on the free surface. The gelatine is not liquefied. The bacteria grow in milk, and broth becomes turbid in two days, and there is a copious flocculent greyish precipitate.

Injection of broth cultures subcutaneously in rabbits, guinea-pigs, and mice, produced no result, except local swelling at the seat of inoculation, which subsided without causing any constitutional symptoms. The results were equally negative when the cultures were injected subcutaneously in lambs.

*M'Fadyean's Micrococcus*.—Cocci  $\cdot 3 \mu$  in diameter. The colonies are flat, nearly circular, and have a smooth edge. In old colonies the centre appears as a dark spot. Gelatine is rapidly liquefied, and a nearly colourless precipitate forms at the bottom of the tube. Cultures on the surface of agar have a faint yellow tinge. On potato the colour is deeper but the growth not so well marked. Milk is coagulated. In broth there is an abundant growth rendering the liquid turbid and depositing a white precipitate. The micrococci stain by Gram's method. Inoculated in rabbits or guinea-pigs, they produce suppuration; in horses and bovines, an inflammatory swelling results without suppuration. They produce abscesses in sheep and lambs. The cocci were isolated from abscesses in lambs suffering from louping-ill. Though it is admitted that louping-ill belongs to the class of infective diseases, there can be no doubt from these experiments that the nature of the contagium is unknown.

## CHAPTER XXXIII.

### FOOT-ROT.

SHEEP are subject to several diseases which are classed as foot-rot. There is one form, known as contagious foot-rot, which prevails in certain localities, especially on wet land. Brown describes the disease as primarily a disease of the skin, inducing exfoliation of the cuticle, and exudation of fluid containing epithelial scales. The inflammation extends to the membrane of the foot, leading to exfoliation of the hoof, and development of epithelial scales, which form an imperfect horny layer on the diseased membrane. In one outbreak investigated by Brown, the disease in the early stage was confined to the skin between the digits of the fore-feet; the surface was red, tumid and pulpy, and white purulent matter existed on the inflamed parts. Later, the hoof grew to an extraordinary length, fungoid growths made their appearance, developing into foot-rot in an advanced form.

In France, according to Fleming, the contagious character of this disease has long been recognised. So long ago as 1805 Pietet imported 200 half-bred merino sheep, some of which were infected with foot-rot, and placed them with 200 healthy sheep, and in a short time all the sheep were infected. Several years later Favre and Sorillon carried out investigations which conclusively proved the infective nature of the virus. Among other experiments it was found that when healthy sheep were inoculated in the feet with virus from diseased sheep, the disease was communicated.

Contagious foot-rot may be spread by healthy sheep receiving the virus from infected sheep in fairs and markets. Ships, railway-trucks, and carts in which diseased sheep have been conveyed, unless subsequently thoroughly disinfected, may be the means of transmitting the virus to healthy sheep. Healthy sheep turned into pastures quite recently occupied by diseased sheep may be inoculated from the discharges from the feet of the diseased sheep, which contaminate the grass and soil.



Law believed that the disease arose from an undiscovered micro-organism, which was probably present in infected pastures. Others in this country have disputed the contagious character of the disease, and considered that the same conditions of the pasture which produced the disease in a flock would produce it again in imported animals, which would account for the apparent contagiousness.

Brown, in order to test the question of contagion, placed infected sheep in a pen, the bottom of which was covered with straw which was not removed while the experiments were in process. Three healthy sheep, from a locality where foot-rot was unknown, were placed with the infected sheep. At the end of ten days the feet of the sound sheep were still healthy. Subsequently two of the sheep were inoculated, and it was found that the virus introduced

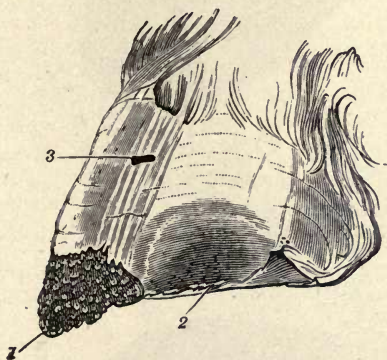

FIG. 187.—FOOT OF SHEEP SHOWING DISEASE OF HORN (BROWN).



FIG. 188.—SECTION THROUGH THE FOOT SHOWING A CRACK EXTENDING THROUGH THE WALL.

subcutaneously in the vicinity of the foot produced the incipient stage of the disease. On making further experiments the contagious nature of one form of foot-rot was established, but it appears that the contagious property is only developed after a long period of exposure, and under certain conditions. On a dry soil the disease will quickly subside, but on moist land the contagious form of foot-rot may be communicated by simple contact, in from six weeks to three months.

From these and other experiments Brown has drawn the following conclusions:—

1. That so far as the evidence goes it justifies the statement that foot-rot is a contagious disease; the infective matter being active when brought into contact with the skin between the claws, or

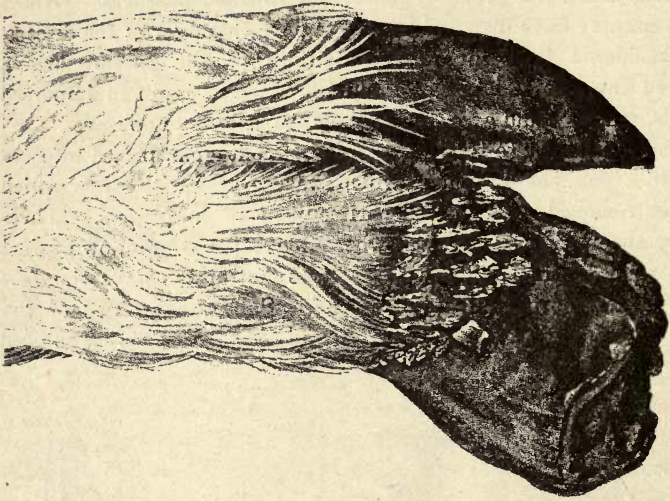

FIG. 190.—ADVANCED FORM OF DISEASE OF SKIN BETWEEN THE CLAWS (BROWN).

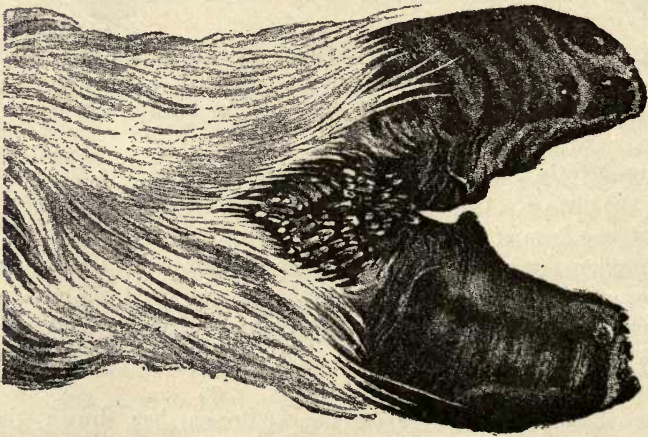

FIG. 189.—SECRETING MEMBRANE COVERED WITH FUNGOID GROWTHS (BROWN).



when introduced into the system by inoculation, and probably when taken in by the mouth from contaminated pastures.

2. That it cannot be produced by long-continued exposure to undrained, moist soils, with an abundant, coarse and wet herbage.

3. That animals exposed to these conditions for many months, and resisting entirely the influences named above, contract foot-rot



FIG. 191.—DISTORTION OF HOOF IN AN ADVANCED FORM OF FOOT-ROT (BROWN).

in from fourteen to twenty-one days on being placed among sheep suffering from the disease.

4. That sheep affected with foot-rot may improve, and from time to time become worse; and finally may recover and present a perfectly healthy condition of foot, notwithstanding that they have been kept the whole period under the conditions which induced the disease.

5. That the contagium of foot-rot remains for some time in the system (ten to twenty days and longer) without any indication of disease appearing in the skin between the claws. An infected sheep may therefore escape detection even by an expert, and may introduce foot-rot into a sound flock.

One attack does not confer immunity. The disease has been known to recur in sheep which have only recently recovered from an outbreak.

The disease is not communicable to other animals, including man. The flesh is harmless, but as in severe cases the sheep are emaciated, the carcass is in consequence of little, if of any, value as food.

The nature of the contagium is unknown.

**Stamping-out System.**—Sheep should not be allowed to be moved from an infected district except for slaughter. When sheep are purchased to add to the stock on a farm, they should be isolated for two or three weeks, and carefully watched before they are allowed to mix with other sheep. If this disease is detected in a flock, every animal should be carefully examined, and any suspicious as well as any diseased sheep should be completely isolated from the rest. Fleming recommends that those which have been in contact, though still apparently quite healthy, should as a precautionary measure, be made to pass through a trough containing a solution of chloride of lime to a depth of about four inches. The solution is made by adding one or two pounds of chloride of lime to two buckets of rain-water. If the trough is placed at the entrance to the sheepfold, the sheep will be compelled to traverse it at least twice a day. It is also recommended, when diseased sheep are treated by this plan, that after recovery, all manure in the fold should be removed and destroyed, and the soil dug up to the depth of six inches, or lime freely spread over the surface. Troughs and hurdles must be thoroughly disinfected, and buildings freely ventilated after similar treatment. No locality can be considered free from suspicion until one or two months have elapsed since the recovery of the last case.



## CHAPTER XXXIV.

FOUL-BROOD—INFECTIOUS DISEASE OF BEES IN ITALY—PÉBRINE—  
FLACHERIE—INFECTIOUS DISEASE OF CATERPILLARS.

### FOUL-BROOD IN BEES.

FOUL-BROOD is a contagious disease attacking bees and especially the larvæ. The larvæ rapidly lose their healthy appearance, die and decompose, turning into a coffee-coloured mass. The cells of the honeycomb are mapped out by the dark-brown cappings of the cells

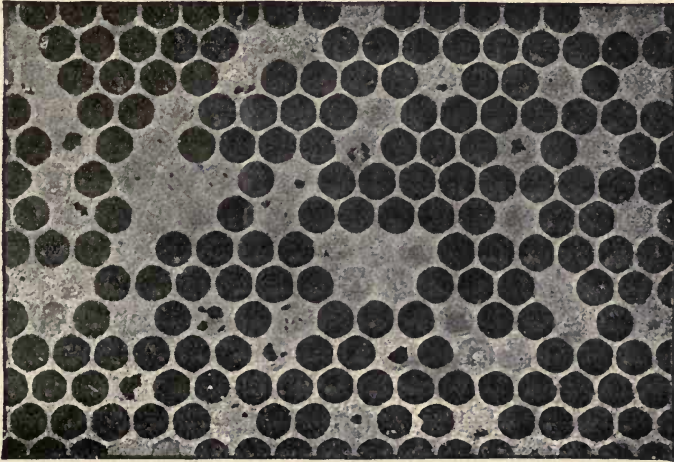

FIG. 192.—DISEASED COMB (COWAN).

containing the diseased larvæ. The decomposition is associated with the production of an unpleasant odour, which can be detected at some distance from an infected hive. The disease has been known from very early times. Preuss investigated it microscopically, and attributed it to "micrococci." These were really the spores of a bacillus, which was first observed by Cohn. Later, Cheshire and

Cheyne investigated fowl-brood, isolated the bacillus, and fully described its morphological and biological characters in nutrient media. By removing the cap of one of the diseased cells, the decomposing larva can be withdrawn, and cover-glass preparations will reveal delicate bacilli and large oval spores. The bacilli can be readily isolated and cultivated in nutrient gelatine.

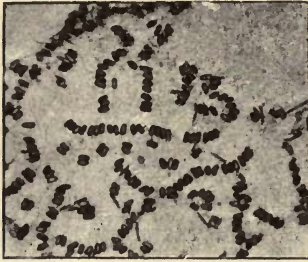

FIG. 193.—SPORES OF BACILLUS ALVEI.

**Bacillus alvei** (Cheshire and Cheyne). Rods varying in size, and forming large oval spores. They are motile and possess flagella. Cultivated in nutrient gelatine in

test-tubes, a delicate ramifying growth appears on the surface, and irregular whitish masses arise along the needle track. Processes shoot out from these masses, and extend through the gelatine for long distances. They are thickened at points in their course, and are clubbed at the ends. The gelatine is gradually liquefied, and the bacilli form a loose, white, flocculent deposit at the bottom of the tube. The liquid in the tube becomes yellowish in colour after a time, and gives off an odour of stale, but not ammoniacal, urine. On the surface of nutrient gelatine the bacilli grow out in chains of rods in single file, or of rows of several side by side. The processes which are formed tend to curve, and at a short distance from the track of the needle form a distinct circle, from which another process grows out, and a fresh circle is developed. The gelatine in the vicinity of the bacilli gradually liquefies, and channels are formed in the gelatine in which the bacilli move backwards and forwards. On nutrient agar-agar a whitish layer develops, consisting of bacilli arranged side by side, which in a few days are replaced by rows of spores similarly arranged. On



FIG 194.—PURE-CULTURE IN NUTRIENT GELATINE,  $\times 4$  (CHESHIRE AND CHEYNE).



potatoes they form a dryish, yellow layer, and in milk a tremulous jelly. A cultivation of the bacillus in milk, sprayed over a honey-comb containing a healthy brood of bee larvæ, produced foul-brood. Adult bees fed on material containing bacilli became infected. Inoculation of mice and rabbits with the bacillus gave doubtful results.

**Stamping-out System.**—The infected bees, combs, frames and quilts must be destroyed, and the hives thoroughly disinfected, as this is the only way in which the resistant spores can be got rid of. Cowan believes that if foul-brood were under Government inspection and infected hives were destroyed, the disease could be stamped out.



FIG. 195.—CULTIVATION ON THE SURFACE OF GELATINE,  $\times 80$   
(CHESHIRE AND CHEYNE).

#### INFECTIOUS DISEASE OF BEES IN ITALY.

In Italy bees are subject to another infectious malady, and Canestrini has found bacilli in the bees and in the larvæ, which are believed to be the cause of the malady.

**Bacillus of Infectious Disease of Bees (Canestrini).**—Rods  $2 \mu$  in width and 4 to  $6 \mu$  in length, occurring singly, in pairs and in chains, sometimes capsulated. They are motile, and spore-formation is present. They liquefy gelatine, colouring the liquid pink and forming a white deposit. On agar they form a white growth, and on potato a claret-coloured layer. Cultures are said to be capable of producing the disease in bees and larvæ.

#### PÉBRINE.

The silkworm disease known in France as *pébrine* is characterised by the appearance of black patches on the skin of the worms. It was investigated by Cornalia, Nägeli, and Pasteur. Pasteur's



prophylactic measures have been described in another chapter (p 7).

**Panhistophyton ovatum.** (Lebert. *Nosema bombycis*, *Micrococcus ovatus*, *Corpuscles du ver-à-soie*).—Shining oval cocci, 2 to 3  $\mu$  long, 2  $\mu$  wide, singly and in pairs, or masses; or rods, 2.5  $\mu$  thick, and twice as long. They multiply by subdivision. They were experimentally proved to be the cause of *pébrine*, *gattine*, *maladie des corpuscles* or *Flecksucht*; and were discovered in the organs of diseased silkworms, as well as in the pupæ, moths, and eggs.

Metchnikoff believes that these micro-organisms are not bacteria, but psorosperms.

#### FLACHERIE.

Silkworms are also subject to a very destructive disease known as *flacherie*, *flaccidezza*, *maladie de morts blancs*. The worms cease feeding, die and become a putrid mass. The disease is dependent upon bad hygienic conditions, and is very infectious. The cause has not been determined with certainty, but it has been attributed to a streptococcus.

**Streptococcus bombycis** (*Mikrozyma bombycis*, Béchamp).—Oval cocci 1.5  $\mu$  diam., singly, in pairs, and in chains. They are said to be present in dust from infected localities.

#### DISEASE OF CATERPILLARS.

Forbes has described an infectious disease of the larvæ of a caterpillar (*Picris rapæ*). Cocci which were found singly and in masses, were regarded as the cause of the malady.



PART III.

*SYSTEMATIC AND DESCRIPTIVE.*





## CHAPTER XXXV.

### CLASSIFICATION AND DESCRIPTION OF SPECIES.

IN reviewing the history of the various classifications which have from time to time been proposed, we shall see that the gradual improvements in the means of studying such minute objects, the methods of cultivating them artificially, and of studying their chemistry and physiology, and the ever-increasing revelations of the microscope, have resulted in establishing these microscopic objects as members of the vegetable kingdom, ranking among the lowest forms of fungi, but with regard to the division into genera and species we are still in a position of doubt and uncertainty.

Müller, in 1773, was the first to suggest a classification. He established two genera, *Monas* and *Vibrio*, and grouped them with the Infusoria. In 1824 Bory de Saint Vincent also attempted a classification; but it was not until Ehrenberg in 1838, and Dujardin in 1841, worked at the subject, that a scientific distinction of species was attempted.

Ehrenberg described four genera :—

- |                       |       |                                 |
|-----------------------|-------|---------------------------------|
| I. <i>Bacterium</i>   | . . . | filaments straight, rigid.      |
| II. <i>Vibrio</i>     | . . . | filaments snake-like, flexible. |
| III. <i>Spirillum</i> | . . . | filaments spiral, rigid.        |
| IV. <i>Spirochæta</i> | . . . | filaments spiral, flexible.     |

Dujardin united *Spirillum* and *Spirochæta*, and classed them thus :—

- |                       |       |                                 |
|-----------------------|-------|---------------------------------|
| I. <i>Bacterium</i>   | . . . | filaments rigid, vacillating.   |
| II. <i>Vibrio</i>     | . . . | filaments flexible, undulatory. |
| III. <i>Spirillum</i> | . . . | filaments spiral, rotatory.     |

Bacteria were still considered as Infusoria, but in 1852 Perty maintained that some of the smallest living organisms belonged to the animal and others to the vegetable kingdom, and that *Vibrios* without question belonged to the latter. In 1853 Robin pointed out

the affinity of the Bacteria and Vibrios to Leptothrix; and Davaine, in 1859, insisted that the Vibrios were vegetables, and were in fact allied to the Algæ.

Since that time a flood of light has poured in upon this subject through the writings of Hoffmann, Pasteur, Cohn, Rabenhorst, Hallier, Billroth, Warming, Nägeli, Magnin, Marchand, Sternberg, Van Tieghem, Koch, Flügge, De Bary, Zopf, Büchner, Hueppe, Marshall Hall, and many others who have studied the morphology, life-history, and classification of bacteria.

Of all these writers we are most indebted to Cohn, not only on account of his researches, which extended over many years, but also for his system of classification, which has since been almost universally adopted.

In his first classification, published in 1872, Cohn considered the Bacteria as a distinct group belonging to the Algæ, and divisible into four tribes, including six genera:—

- |                          |                                      |
|--------------------------|--------------------------------------|
| I. Sphærobacteria . . .  | globules (Micrococcus).              |
| II. Microbacteria . . .  | short rods (Bacterium).              |
| III. Desmobacteria . . . | long rods (Bacillus and Vibrio).     |
| IV. Spirobacteria . . .  | spirals (Sphirochæta and Spirillum). |

Cohn noted, in spite of placing them with the Algæ, that the absence of chlorophyll connected the Bacteria to Fungi, and we find Naegeli subsequently adopting this view, and employing the term Schizomycetes or Fission-fungi.

Billroth, in 1874, disputed the division into species, and considered that all the forms described by Cohn were but developmental forms of one micro-organism, *Coccobacteria septica*. In the following year Cohn answered the criticism of Billroth, and produced a second classification, in which he still maintained that distinct genera and species existed. Cohn considered the genera to be distinguished by definite differences in shape, which were adhered to throughout life, while some special feature, as a difference in size or physiological action, or some minute difference in form, determined the various species.

The second classification of Cohn (1875) only differed from the first in that, instead of keeping the bacteria as a separate group, he placed them, from their close relationship with the Phycochromacæ, under a new group, the Schizophytes, and added the genera Leptothrix, *Beggiatoa*, *Crenothrix*, *Sarcina*, *Ascococcus*, *Streptococcus*, *Myconostoc*, and *Streptothrix*.

Flügge retained the term Schizomycetes, and divided them thus:—



SCHIZOMYCETES (FLÜGGÉ'S ORIGINAL CLASSIFICATION).

{	CELLS ROUND OR OVOID.	Isolated, or in chains, or united in amor- phous gelatinous families . . . . .		<i>Micrococcus.</i>	
		Forming gelatinous families of definite form.	Colonies solid, filled with cells . . . . .	In large numbers, in irregular colonies . . . . .	<i>Ascococcus.</i>
				In small but defi- nite numbers, in regular groups . . . . .	<i>Sarcina.</i>
			Colonies, with simple layer of cells at the periphery . . . . .		<i>Clathrocystis.</i>

{	CELLS CYLINDRICAL.	Short.	Isolated, or in small heaps loosely united, or in irregular gela- tinous families . . . . .		<i>Bacterium.</i>	
			Without ramifica- tions.	Straight filaments.	Short, distinctly jointed . . . . .	<i>Bacillus.</i>
		Long, not dis- tinctly jointed.			Thin . . . . .	<i>Leptothrix.</i>
				Thick . . . . .	<i>Beggiatoa.</i>	
		Long.	Threads isolated, inter- laced, or in bun- dles.	Wavy, or in spirals.	Short rigid . . . . .	<i>Spirochaete (vibrio).</i>
					Long flexile . . . . .	<i>Spirillum.</i>
				Pseudo-ramifications . . . . .		<i>(Streptothrix. Clathrothrix.)</i>
	Threads in roundish gelatinous masses . . . . .		<i>Myconostoc.</i>			

The belief is nevertheless rapidly gaining ground that the lowest forms of vegetable life cannot be divided by a hard-and-fast line into a series with chlorophyll (Algæ), and a series without it (Fungi), and the tendency now is to solve the difference of opinion between Cohn and Nägeli by following the example of Sachs, and amalgamating the two series into one group, the Thallophytes.

Researches by competent observers have more recently clearly demonstrated that several micro-organisms in their life cycle exhibit successively the shapes characteristic of the orders of Cohn.

This doctrine of *pleomorphism*, now widely accepted, was distinctly foreshadowed in a publication by Lister in 1873, though this memoir contained certain conclusions which have since been abandoned. Lister described forms of cocci, bacteria, bacilli, and streptothrix in milk, which he regarded as phases of the same micro-organism, *Bacterium lactis*. As a result of his observations, Lister remarks that "any classification of bacteria hitherto made from that of Ehrenberg to that of Cohn based upon absolute morphological characters is entirely untrustworthy." To Lankester, however, belongs the credit of having definitely and precisely formulated this doctrine. In a paper, also published in 1873, Lankester observed that the series of form-phases which he had discovered in the case of a peach-coloured bacterium led him to suppose that the natural species of these plants were "within the proper limits protean, and that the existence of true species of bacteria must be characterised, not by the simple form-features used by Cohn, but by the *ensemble* of their morphological and physiological properties as exhibited in their complete life-histories." Lankester inferred that these phase-forms were genetically connected, in that they all possessed the common characteristic of a special pigment, bacterio-purpurin. These conclusions were vigorously opposed by Cohn, and doubt still remains in the minds of some as to whether the different forms are really only stages in the life-history of a single species. Nevertheless the theory of pleomorphism has steadily gained ground ever since.

Cienkowski and Neelsen worked out the different forms assumed by the bacillus of blue milk; Zopf has in a similar manner investigated *Cladothrix*, *Beggiatoa*, and *Crenothrix*, and traced out various forms (Fig. 196); Van Tieghem has investigated *Bacillus amylobacter* with a similar result; Hauser has described bacillar, spirillar, spirular, and various other forms in the *Proteus mirabilis* and *Proteus vulgaris*. These facts obviously shake the very foundation of Cohn's classification, and we are left without possessing a sound



basis for classification into genera or species. The mode of reproduction is not sufficiently known to afford a better means for distinction than the other morphological appearances taken alone; nor can we depend upon physiological action, which is held by many to vary with the change of form, according to altered surroundings.

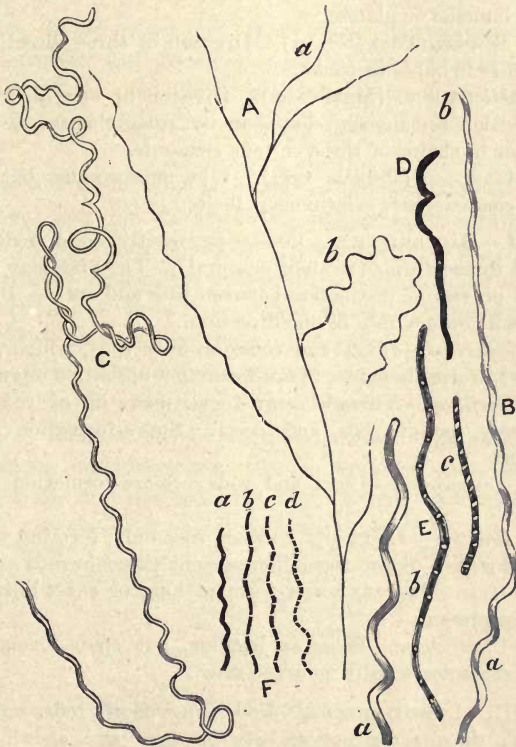

FIG. 196.

CLADOTRICH DICHOTOMA.—A. Branched Schizomycete: (a) Vibrio-form; (b) Spirillum-form [slightly magnified]. B. Screw-form at the ends: (a) Spirillum-form; (b) Vibrio-form. C. Very long Spirochaeta-form. D. Branch fragment, at one end Spirillum-form, at the other Vibrio-form. E. Screw-form: (a) Continuous; (b) Composed of rods; and (c) Cocci. F. Spirochaeta-form: (a) Continuous; (b) Composed of long rods; (c) Short rods; and (d) Cocci (Zopf).

Zopf, who has warmly supported the pleomorphism of bacteria, has suggested as a result of his investigations a division of the Schizomycetes, Spaltpilze, or Fission-fungi, into the following four groups:—

## ZOPF'S CLASSIFICATION.

GROUP I. COCCACEÆ.—Possessing (so far as our knowledge at present reaches) only cocci, and thread-forms resulting from the juxtaposition of cocci. The fission occurs in one or more directions.

Genus I. *Streptococcus* (Chain-cocci).—Division in one or more directions. Individual cocci remain united together to form chains.

Genus II. *Merismopedia* (Plate-cocci).—Divisions in two directions, forming lamellæ or plates.

Genus III. *Sarcina* (Packet-cocci).—Division in three directions, forming colonies in cubes or packets.

Genus IV. *Micrococcus* (Mass-cocci).—Division in one direction, cocci after division remain aggregated in irregular clusters, or singly, or in pairs or in chains of three or four elements.

Genus V. *Ascococcus* (Pellicle-cocci).—Like micrococcus, but the cocci grow in characteristic gelatinous pellicles.

GROUP II. BACTERIACEÆ.—Possessing mostly cocci, rods (straight or bent), and thread-forms (straight or spiral). The first may be absent, and the last possess no distinction between base and apex. Division (as far as is known) occurs only in one direction.

Genus I. *Bacterium*.—Cocci and rods, or only rods, which are joined together to form threads. Spore-formation absent or unknown.

Genus II. *Spirillum*.—Threads screw-form, made up of rods (long or short) only, or of rods and cocci. Spore-formation absent or unknown.

Genus III. *Leuconostoc*.—Cocci and rods. Spore-formation present in cocci.

Genus IV. *Bacillus*.—Cocci and rods, or rods only, forming straight or twisted threads. Spore-formation present either in rods or cocci.

Genus V. *Vibrio*.—Threads screw-form in long or short links. Spore-formation present.

Genus VI. *Clostridium*.—Same as bacillus, but spore-formation takes place in characteristically enlarged rods.

GROUP III. LEPTOTRICHEÆ.—Possessing cocci, rods, and thread-forms (which show a distinction between base and apex). The last straight or spiral.

Genus I. *Crenothrix*.—Threads articulated; cells sulphurless; habitat water.

Genus II. *Beggiatoa*.—Threads unarticulated; cells with sulphur granules; habitat water.

Genus III. *Phragmidiothrix*.—Threads jointless; successive subdivision of cells is continuous; cells sulphurless; habitat water.

Genus IV. *Leptothrix*.—Threads articulated or unarticulated; successive subdivisions of cells not continuous; cells sulphurless.

GROUP IV. CLADOTRICHEÆ.—Possessing cocci, rods, threads, and spirals. Thread-forms provided with false branchings.

Genus :—Cladothrix.



Zopf, however, does not assert that all the fission-fungi exhibit this pleomorphism, nor does he pretend that his classification will include all the micro-organisms described. Cohn, on the other hand, was ready to admit that all the forms described by him were not truly independent species. De Bary, Hueppe, Baumgarten, and Flüge have expressed other views with regard to the classification of bacteria.

De Bary divides them into two great groups—bacteria which form endospores, and bacteria which form arthrospores. This affords but little practical assistance, though regarded by botanists, from a scientific standpoint, as a step in the right direction.

Hueppe, acknowledging that the fructification must eventually be made the basis for classification, suggests an arrangement for provisional use in which this view is introduced (p. 482).

It has already been mentioned that the production of arthrospores is only established in a very few species. Therefore, we are hardly justified in assuming that all bacteria, the spore-formation of which is quite unknown, are to be included with those in which this kind of fructification has been observed, and consequently to distinguish genera on the same grounds may be considered, to say the least, somewhat premature. In Baumgarten's classification the genus bacterium is dispensed with, and the genera divided into two groups, the monomorphic and the pleomorphic.

GROUP I.—MONOMORPHIC.

Genera.—Coccus.  
Bacillus.  
Spirillum.

GROUP II.—PLEOMORPHIC.

Genera.—Spirulina.  
Leptothrix.  
Cladotrix.

Flüge also, in his revised classification, includes the genus bacterium in the genus bacillus. The new classification differs also from the original one in the grouping together of the different species according to the character and behaviour of the colonies in nutrient gelatine. The abolition, in Flüge's and Baumgarten's classification, of the genus bacterium is no doubt owing to confusion having arisen from the distinction, between a bacterium and a bacillus, being made to depend upon length. Observers differed as to whether a rod of a certain length ought to be considered a





bacterium or a bacillus. To meet this difficulty a rough-and-ready rule was suggested—viz., that a rod less than twice its breadth in length should be considered as a bacterium, and otherwise a bacillus. But this purely arbitrary division was inadequate, from the fact that a rod at one stage of its growth or under certain conditions might, as far as length went, truly be a bacterium, and under other circumstances be of such a length as to entitle its being considered a bacillus (Fig. 197). We should avoid such confusion if we followed Zopf, and acknowledged as a difference between a bacterium and a bacillus the presence or absence of that form of spore-formation now distinguished as endogenous spore-formation. We might then conveniently retain this generic term, to include that group of rod-forms in which this spore-formation is as yet

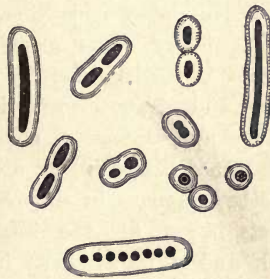

FIG. 197.—FRIEDLANDER'S PNEUMOCOCCUS,  $\times 1500$  (Zopf).

unknown; moreover, we should, by so doing, with one or two exceptions, collect together those short rod-forms which appear to link the simple cocci to the spore-bearing rods or bacilli.

The grouping together of the different species according to the character of the colonies in nutrient gelatine is also of questionable advisability. These characters can hardly be considered to be of sufficient importance, or indeed in many cases to be sufficiently constant, to serve by themselves for this purpose. In many cases a slight variation in the composition of the nutrient medium may considerably affect the appearances of the colonies. At the same time, the appearances are very characteristic of certain species of bacteria, and in some cases the characters of the colonies, together with the characters of the growth in test-tubes, assist us in distinguishing species which are morphologically similar, as in the case of the comma-bacilli of Finkler and of Koch.

The classification of Zopf will lead the investigator to work upon the same lines, and by tracing the life-history of individual forms in pure-cultivations either to extend the work of establishing protean species or to restrict the doctrine of pleomorphism to a few forms. For though the author prefers the classification proposed by Zopf, he is not prepared to accept his views entirely—for instance, to regard the bacterium of rabbit septicæmia as a micrococcus.

Any arrangement at present can only be considered provisional, and therefore the most practical classification must be considered the best. In fact, much more investigation is required before we can arrive at a permanent and thoroughly scientific classification of the known bacteria. Many bacteria have been described by different observers as different species which are really identical. Many micro-organisms have been described and named as new species with very insufficient investigation. The determination of species rests upon the accumulated evidence afforded by a thorough knowledge of their life-history. The morphological appearances under different conditions must be carefully studied, the presence or absence of movement and of spore-formation, and when present the exact character; the appearances of colonies and of test-tube cultivations in different media and under different circumstances; the liquefaction and other changes in nutrient media; the nature of the chemical products, if any, and the effect on the living animal of the bacterium itself and of its products, in varying doses, must all be taken into account. We must also ascertain whether the bacterium is an *aerobe* requiring the presence of oxygen, or an *anaerobe* growing only in the absence of it, or a *facultative anaerobe* growing equally well with or without it; and lastly, we must know whether the bacterium is a *parasite* requiring a living host, or a *saprophyte* existing on dead animal or vegetable matter, or a *facultative parasite* capable both of growing in the living animal and of leading a saprophytic existence. Several writers have classified the bacteria which have been described hitherto by taking some of these characters into account, and so preparing a list which is convenient for the purpose of bacteriological diagnosis. A system of this kind is of value in leading investigators to supply information which is wanting in order to verify and amplify the information upon which the classification is based, and to identify species which have been described under different names.



# CLASSIFICATION OF SPECIES FOR BACTERIOLOGICAL DIAGNOSIS

## COCCI.

### (A) GELATINE NOT LIQUEFIED.

#### (a) Chromogenic.

	COLOUR.	HABITAT.
<i>Micrococcus violaceus</i> . . . . .	Violet . . . . .	Water.
<i>Micrococcus carneus</i> . . . . .	Flesh-red . . . . .	Water.
<i>Micrococcus cerasinus siccus</i> . . . . .	Cherry-red . . . . .	Water.
<i>Micrococcus cinnabareus</i> . . . . .	Cinnabar-red . . . . .	Air ; water.
<i>Micrococcus aurantiacus</i> . . . . .	Orange . . . . .	Water.
<i>Micrococcus versicolor</i> . . . . .	Yellow . . . . .	Water.
<i>Micrococcus luteus</i> . . . . .	Yellow . . . . .	Water.
<i>Micrococcus citreus</i> . . . . .	Yellow . . . . .	Water.
<i>Micrococcus ochroleucus</i> . . . . .	Yellow . . . . .	Water.
<i>Micrococcus cereus flavus</i> . . . . .	Yellow . . . . .	Water.
<i>Micrococcus agilis citreus</i> . . . . .	Yellow . . . . .	Air.
<i>Micrococcus flavus tardigradus</i> . . . . .	Yellow . . . . .	Air ; water.
<i>Staphylococcus viridis flavescens</i> . . . . .	Greenish-yellow . . . . .	Lymph.

#### (b) Non-Chromogenic.

<i>Micrococcus candidans</i> . . . . .	Air ; water.
<i>Micrococcus candidus</i> . . . . .	Water.
<i>Micrococcus concentricus</i> . . . . .	Water.
<i>Micrococcus fervidosus</i> . . . . .	Water.
<i>Micrococcus cereus albus</i> . . . . .	Pus ; water.
<i>Micrococcus aquatilis</i> . . . . .	Water.
<i>Micrococcus aquatilis invisibilis</i> . . . . .	Water.
<i>Micrococcus cumulatus tenuis</i> . . . . .	Nasal mucus.
<i>Micrococcus rosettaceus</i> . . . . .	Water.
<i>Micrococcus viticulosus</i> . . . . .	Air ; water.
<i>Micrococcus plumosus</i> . . . . .	Water.
<i>Micrococcus amyliworus</i> . . . . .	Pear-blight.
<i>Micrococcus acidi lactici</i> . . . . .	Milk.
<i>Micrococcus ureæ</i> . . . . .	Air ; urine.
<i>Micrococcus gingivæ pyogenes</i> . . . . .	Pus.
<i>Micrococcus salivariæ septicus</i> . . . . .	Saliva.
<i>Micrococcus of Manfredi</i> . . . . .	Sputum.
<i>Micrococcus in pleuropneumonia</i> . . . . .	Lymph.
<i>Micrococcus in trachoma</i> . . . . .	Conjunctiva.
<i>Hæmatococcus bovis</i> . . . . .	Urine.
<i>Diplococcus albicans tardissimus</i> . . . . .	Vaginal secretion

	HABITAT.
<i>Diplococcus coryzæ</i> . . . . .	Nasal mucus.
<i>Pseudo-diplococcus pneumoniae</i> . . . . .	Meningitis.
<i>Micrococcus tetragenus</i> . . . . .	Sputum.
<i>Micrococcus tetragenus mobilis ventriculi</i> . . . . .	Stomach.
<i>Pediococcus cerevisiæ</i> . . . . .	Beer ; air.
<i>Pediococcus acidi lactici</i> . . . . .	Malt ; hay-dust.
<i>Streptococcus pyogenes</i> . . . . .	Pus.
<i>Streptococcus brevis</i> . . . . .	Saliva.
<i>Streptococcus septicus</i> . . . . .	Soil.
<i>Streptococcus vermiformis</i> . . . . .	Water.
<i>Streptococcus of mastitis in cows</i> . . . . .	Pus.
<i>Streptococcus in strangles</i> . . . . .	Pus.
<i>Streptococcus acidi lactici</i> . . . . .	Milk.

## (B) GELATINE LIQUEFIED.

## (a) Chromogenic.

	COLOUR.	
<i>Micrococcus agilis</i> . . . . .	Pink . . . . .	Water.
<i>Micrococcus roseus</i> . . . . .	Pink . . . . .	Sputum.
<i>Staphylococcus pyogenes aureus</i> . . . . .	Orange . . . . .	Pus.
<i>Micrococcus in pemphigus</i> . . . . .	Orange . . . . .	Bullæ.
<i>Staphylococcus salivarius pyogenes</i> . . . . .	Orange . . . . .	Saliva.
<i>Micrococcus fuscus</i> . . . . .	Brown . . . . .	Water.
<i>Micrococcus flavus desidens</i> . . . . .	Yellowish-brown . . . . .	Air ; water.
<i>Micrococcus cremoides</i> . . . . .	Yellowish-white . . . . .	Water.
<i>Micrococcus botryogenus</i> . . . . .	Yellowish . . . . .	Equine tumours.
<i>Micrococcus Finlayensis</i> . . . . .	Pale-yellow . . . . .	Yellow fever.
<i>Staphylococcus pyogenes citreus</i> . . . . .	Yellow . . . . .	Pus.
<i>Micrococcus citreus liquefaciens</i> . . . . .	Yellow . . . . .	Eczema.
<i>Micrococcus flavus liquefaciens</i> . . . . .	Yellow . . . . .	Air ; water.
<i>Micrococcus tetragenus versatilis</i> . . . . .	Yellow . . . . .	Blood.
<i>Diplococcus flavus liquefaciens tardus</i> . . . . .	Yellow . . . . .	Eczema.
<i>Diplococcus subflavus</i> . . . . .	Yellow . . . . .	Vaginal mucus.
<i>Diplococcus citreus conglomeratus</i> . . . . .	Yellow . . . . .	Pus ; air.
<i>Diplococcus luteus</i> . . . . .	Yellow . . . . .	Water.
<i>Diplococcus roseus</i> . . . . .	Pink . . . . .	Air.
<i>Diplococcus fluorescens fetidus</i> . . . . .	Green . . . . .	Posterior nares.

## (b) Non-Chromogenic.

<i>Micrococcus albus liquefaciens</i> . . . . .	Nasal mucus.
<i>Micrococcus aerogenes</i> . . . . .	Intestine.
<i>Micrococcus radiatus</i> . . . . .	Air ; water.
<i>Micrococcus fetidus</i> . . . . .	Nasal mucus.
<i>Micrococcus in Biskra-button or Pendjeh sore</i> . . . . .	Pus.
<i>Micrococcus in influenza</i> . . . . .	Blood.
<i>Micrococcus Freudenreichi</i> . . . . .	Milk.
<i>Micrococcus in yellow fever</i> . . . . .	Blood.
<i>Micrococcus lactis viscosus</i> . . . . .	Cream.
<i>Micrococcus acidi lactici liquefaciens</i> . . . . .	Cheesy butter.
<i>Micrococcus ureæ liquefaciens</i> . . . . .	Urine.
<i>Micrococcus in gangrenous mastitis in sheep</i> . . . . .	Milk.
<i>Staphylococcus pyogenes albus</i> . . . . .	Pus.
<i>Staphylococcus pyosepticus</i> . . . . .	Pus.
<i>Diplococcus albicans amplus</i> . . . . .	Vaginal secretion.



	HABITAT.
<i>Pediococcus albus</i> . . . . .	Water.
<i>Streptococcus liquefaciens</i> . . . . .	Blood.
<i>Streptococcus septicus liquefaciens</i> . . . . .	Blood.
<i>Streptococcus albus</i> . . . . .	Water.
<i>Streptococcus of Mannaberg</i> . . . . .	Urine.
<i>Streptococcus coli gracilis</i> . . . . .	Fæces.

## (C) NO GROWTH IN GELATINE.

<i>Micrococcus pneumoniae crouposæ</i> . . . . .	Saliva.
<i>Micrococcus endocarditidis rugatus</i> . . . . .	Heart.
<i>Nitromonas of Winogradsky</i> . . . . .	Soil.
<i>Micrococcus in pemphigus</i> . . . . .	Bullæ
<i>Micrococcus in influenza</i> . . . . .	Sputum.
<i>Micrococcus gonorrhoeæ</i> . . . . .	Pus.
<i>Diplococcus intercellularis meningitidis</i> . . . . .	Meningitis.
<i>Micrococcus tetragenus subflavus</i> . . . . .	Nasal mucus.
<i>Streptococcus giganteus urethræ</i> . . . . .	Urethra.
<i>Streptococcus of Bonome</i> . . . . .	Meningitis.

## (D) GROWTH IN GELATINE UNDETERMINED.

<i>Ascococcus Biirothii</i> . . . . .	Meat infusion.
<i>Leuconostoc mesenteroides</i> . . . . .	Beet juice; molasses.
<i>Streptococcus of progressive tissue necrosis in mice</i> . . . . .	Putrid blood.
<i>Micrococcus pyogenes tenuis</i> . . . . .	Pus.
<i>Micrococcus of pyæmia in rabbits</i> . . . . .	Meat infusion.
<i>Micrococcus of progressive abscess formation in mice</i> . . . . .	Putrid blood.
<i>Micrococcus of Forbes</i> . . . . .	Cabbage caterpillars.
<i>Micrococcus in syphilis</i> . . . . .	Blood
<i>Streptococcus Havaniensis</i> . . . . .	Liver.
<i>Streptococcus perniciosus psittacorum</i> . . . . .	Blood of parrot.
<i>Streptococcus bombycis</i> . . . . .	Diseased silk-worms.

## PACKET COCCI.

## (A) GELATINE NOT LIQUEFIED.

## (a) Non-Chromogenic.

<i>Sarcina pulmonum</i> . . . . .	Phthisical sputum.
<i>Sarcina ventriculi</i> . . . . .	Stomach.

## (B) GELATINE LIQUEFIED.

## (a) Chromogenic.

	COLOUR.	
<i>Sarcina mobilis</i> . . . . .	Red . . . . .	Ascitic fluid.
<i>Sarcina rosea</i> . . . . .	Red . . . . .	Air.
<i>Sarcina flavea</i> . . . . .	Yellow . . . . .	Beer.
<i>Sarcina lutea</i> . . . . .	Yellow . . . . .	Air.
<i>Sarcina aurantiaca</i> . . . . .	Orange-yellow . . . . .	Air; water.

## (b) Non-Chromogenic.

	HABITAT.
<i>Sarcina alba</i> . . . . .	Air ; water.
<i>Sarcina candida</i> . . . . .	Air of breweries.

## RODS.

## (I.) AEROBES OR FACULTATIVE ANAEROBES

## (A) GELATINE NOT LIQUEFIED.

## (a) Chromogenic.

## (A) SPORE-FORMATION PRESENT.

## (a) Motile.

	COLOUR.	
<i>Bacillus cyanogenus</i> . . . . .	Greyish-blue . . . . .	Blue milk.
<i>Bacillus erythrosporus</i> . . . . .	Greenish-yellow . . . . .	Water.
<i>Bacillus</i> in infantile diarrhoea (Lesage)	Green . . . . .	Intestine.

## (b) Non-Motile.

<i>Bacillus brunneus</i> . . . . .	Brown . . . . .	Water.
------------------------------------	-----------------	--------

## (B) SPORE-FORMATION UNKNOWN.

## (a) Motile.

<i>Bacillus rubefaciens</i> . . . . .	Pale-pink . . . . .	Water.
<i>Bacillus rubescens</i> . . . . .	Pale-pink . . . . .	Sewers.
<i>Bacillus fuscus limbatus</i> . . . . .	Brown . . . . .	Rotten eggs.
<i>Bacillus beroliniensis</i> Indicus . . . . .	Indigo-blue . . . . .	Water.
<i>Bacillus cyanogenus</i> Jordaniensis . . . . .	Bluish . . . . .	Sewers.
<i>Bacillus aurantiacus</i> . . . . .	Orange . . . . .	Water.
<i>Bacillus fluorescens aureus</i> . . . . .	Orange . . . . .	Water.
<i>Bacillus fluorescens longus</i> . . . . .	Greyish-yellow . . . . .	Water.
<i>Bacillus fluorescens tenuis</i> . . . . .	Greenish-yellow . . . . .	Water.
<i>Bacillus constrictus</i> . . . . .	Pale-yellow . . . . .	Water.
<i>Bacillus subflavus</i> . . . . .	Pale-yellow . . . . .	Water.
<i>Bacillus aureus</i> . . . . .	Golden-yellow . . . . .	Water ; eczema.
<i>Bacillus flavescens</i> . . . . .	Yellow . . . . .	Swamp-water.
<i>Bacillus heminecrobiophilus</i> . . . . .	Yellowish . . . . .	Caseous glands.
<i>Bacillus canalis parvus</i> . . . . .	Yellowish . . . . .	Sewer-water.
<i>Bacillus fluorescens putidus</i> . . . . .	Greenish . . . . .	Water.
<i>Bacillus dentalis viridans</i> . . . . .	Opalescent-green . . . . .	Carious dentine.
<i>Bacillus virescens</i> . . . . .	Green . . . . .	Sputum.

## (b) Non-Motile.

<i>Bacillus latericeus</i> . . . . .	Brick-red . . . . .	Water.
<i>Bacillus spiniferus</i> . . . . .	Greyish-yellow . . . . .	Eczema.
<i>Bacillus</i> in purpura hæmorrhagica . . . . .	Greyish-yellow . . . . .	Blood.
<i>Bacillus uteus</i> . . . . .	Orange-yellow . . . . .	Water.
<i>Bacillus</i> in cholera in ducks . . . . .	Yellowish . . . . .	Blood.
<i>Bacillus flavo-coriaceus</i> . . . . .	Sulphur-yellow . . . . .	Water.
<i>Bacillus striatus flavus</i> . . . . .	Sulphur-yellow . . . . .	Nasal mucus.
<i>Bacillus fuscus</i> . . . . .	Deep-yellow . . . . .	Water.
<i>Bacillus fluorescens non-liquefaciens</i> . . . . .	Greenish-yellow . . . . .	Water.



**(b) Non-Chromogenic.****(A) SPORE-FORMATION PRESENT.**

	(a) <i>Motile.</i>	HABITAT.
Bacillus putrificus coli . . . . .		Human fæces.
Bacillus septicus vesica . . . . .		Cystitis.
Bacillus in cancer . . . . .		Stomach.

**(b) Non-Motile.**

Bacillus acidi lactici (Hueppe) . . . . .		Sour milk.
Bacillus coprogenes fœtidus . . . . .		Swine measles.
Bacillus subtilis similans . . . . .		Human fæces.
Bacillus epidermidis . . . . .		Skin.
Bacillus of Colomiatti . . . . .		Conjunctiva.

**(B) SPORE-FORMATION UNKNOWN.****(a) *Motile.***

Bacillus œdematis aerobicus . . . . .		Earth.
Bacillus of Fulles (I.) . . . . .		Earth.
Bacillus stolonatus . . . . .		Water.
Bacillus venenosus brevis . . . . .		Water.
Bacillus venenosus . . . . .		Water.
Bacillus gracilis anaerobiescens . . . . .		Water.
Bacillus invisibilis . . . . .		Water.
Bacillus albus . . . . .		Water.
Bacillus venenosus invisibilis . . . . .		Water.
Bacillus aquatilis sulcatus . . . . .		Water.
Bacillus argenteo-phosphorescens . . . . .		Sea-water.
Bacillus gliscrogenus . . . . .		Urine.
Bacillus cystiformis . . . . .		Urine.
Bacillus of Guillebeau . . . . .		Milk.
Bacterium Zopfi . . . . .		Intestine ; air.
Bacillus ventriculi . . . . .		Stomach of dogs.
Bacillus coli communis . . . . .		Intestine.
Bacillus cavicida . . . . .		Intestine.
Bacillus of Utpadel . . . . .		Intestine.
Bacillus aerogenes . . . . .		Intestine.
Helicobacterium aerogenes . . . . .		Intestine.
Bacterium aerogenes . . . . .		Intestine.
Bacillus meningitidis purulentæ . . . . .		Pus.
Bacillus pyogenes fœtidus . . . . .		Pus.
Proteus Zenkeri . . . . .		Putrid substances.
Bacillus enteritidis . . . . .		Poisonous meat.
Bacillus hyacinthi septicus . . . . .		Rotten hyacinths.
Proteus lethalis . . . . .		Septicæmia.
Bacillus endocarditidis griseus . . . . .		Endocarditis.
Bacillus of Roth (I.) . . . . .		Old rags.
Bacillus Schafferi . . . . .		Cheese ; potato.
Bacillus of swine-plague . . . . .		Lymphatic glands.
Bacillus typhi abdominalis . . . . .		Spleen and glands.
Bacillus cavicida Havaniensis . . . . .		Intestine.
Bacillus cuniculicida Havaniensis . . . . .		Intestine.

(b) *Non-Motile.*

	HABITAT.
Bacillus of Okada . . . . .	Dust.
Bacillus pyogenes soli . . . . .	Earth.
Bacillus of Fulles (II.) . . . . .	Soil.
Bacillus candicans . . . . .	Soil.
Bacillus septicus agrigenus . . . . .	Manured soil.
Bacillus scissus . . . . .	Soil.
Bacillus ubiquitous . . . . .	Air; water.
Bacillus multipediculus . . . . .	Air; water.
Bacillus albus anaerobiescens . . . . .	Water.
Bacillus Zurnianus . . . . .	Water.
Bacillus canalis capsulatus . . . . .	Sewer-water.
Bacillus of Roth (II.) . . . . .	Old rags.
Bacillus tenuis sputigenus . . . . .	Sputum.
Bacillus crassus sputigenus . . . . .	Sputum.
Bacillus coprogenes parvus . . . . .	Fæces.
Bacillus of Fiocca . . . . .	Saliva.
Bacillus striatus albus . . . . .	Nasal mucus.
Bacillus capsulatus mucosus . . . . .	Nasal secretion.
Bacillus pseudo-diphtheriticus . . . . .	Healthy throat.
Bacterium ureæ . . . . .	Urine.
Bacillus nodosus parvus . . . . .	Healthy urethra.
Bacillus oxytocus perniciosus . . . . .	Milk.
Bacillus lactis pituitosi . . . . .	Milk.
Bacillus limbatus acidi lactici . . . . .	Milk.
Bacillus ovatus minutissimus . . . . .	Eczema.
Bacillus of Belfanti and Pascarola . . . . .	Pus.
Bacillus of Tommasoli . . . . .	Hair with sycosis.
Bacillus capsulatus . . . . .	Blood.
Bacillus of purpura hæmorrhagica (Babès) . . . . .	Blood.
Bacillus of purpura hæmorrhagica (Kolb) . . . . .	Blood.
Bacillus septicæmiæ hæmorrhagicæ . . . . .	Blood.
Proteus capsulatus septicus . . . . .	Blood.
Bacillus acidiformans . . . . .	Liver.
Bacillus coli similis . . . . .	Liver.
Bacillus hepaticus fortuitus . . . . .	Liver.
Bacillus filiformis Havaniensis . . . . .	Liver.
Bacillus of Martinez . . . . .	Liver.
Bacillus diphtheriæ columbrarum . . . . .	Diphtheritic deposit.
Bacillus diphtheriæ . . . . .	Diphtheritic throat.
Bacillus of Schimmelbusch . . . . .	Cancrum oris.
Bacillus capsulatus Smithii . . . . .	Intestine.
Bacillus erysipelatis suis . . . . .	Blood.
Bacillus in rhinoscleroma . . . . .	Rhinoscleroma.
Bacillus of Friedländer . . . . .	Sputum.
Bacillus pneumosepticus . . . . .	Septic pneumonia.
Bacillus endocarditidis capsulatus . . . . .	Endocarditis.
Bacillus septicus keratomalaciæ . . . . .	Internal organs.
Bacillus of intestinal diphtheria in rabbits . . . . .	Intestine.
Bacillus of acne contagiosa of horses . . . . .	Pus.
Bacillus pseudo-tuberculosis . . . . .	Internal organs.
Bacterium tholeideum . . . . .	Intestine.
Bacillus gallinarum . . . . .	Blood.



	HABITAT.
Bacillus argenteo-phosphorescens . . . . .	Fish.
Bacillus smaragdino-phosphorescens . . . . .	Fish.
Bacillus phosphorescens gelidus . . . . .	Cuttlefish.
Proteus hominis capsulatus . . . . .	Blood.
Bacillus of grouse disease. . . . .	Blood.
Bacillus lactis aerogenes . . . . .	Intestine.

## (A) GELATINE LIQUEFIED.

## (a) Chromogenic.

## (A) SPORE-FORMATION PRESENT.

## (a) Motile.

	COLOUR.	
Bacillus violaceus . . . . .	Deep-violet . . . . .	Water.
Bacillus in disease of bees (Canestrini)	Pink . . . . .	Larvæ of bees.
Bacillus in "red-cod" . . . . .	Red . . . . .	Salted codfish.
Bacillus mesentericus ruber . . . . .	Reddish-yellow . . . . .	Potatoes.
Bacillus fluorescens liquefaciens minutissimus . . . . .	Greenish-yellow . . . . .	Skin.

## (B) SPORE-FORMATION UNKNOWN.

## (a) Motile.

Bacillus ianthinus . . . . .	Bluish-violet . . . . .	Water.
Bacillus violaceus Laurentius . . . . .	Deep-violet . . . . .	Water.
Bacillus lividus . . . . .	Violet-black . . . . .	Water.
Bacillus carnicolor . . . . .	Dark flesh-colour . . . . .	Water.
Bacillus rubidus . . . . .	Brownish-red . . . . .	Water.
Bacillus Indicus . . . . .	Sealingwax-red . . . . .	Intestine.
Bacillus rosaceus metalloides . . . . .	Magenta-red . . . . .	Water.
Bacillus ochraceus . . . . .	Yellow . . . . .	Water.
Bacillus citreus cadaveris . . . . .	Yellow . . . . .	Blood.
Bacillus buccalis minutus . . . . .	Yellow . . . . .	Saliva.
Bacillus arborescens . . . . .	Yellow . . . . .	Water.
Bacillus fulvus . . . . .	Yellow . . . . .	Water.
Bacillus plicatilis . . . . .	Yellowish . . . . .	Water.
Bacillus pyocyaneus . . . . .	Yellowish-green . . . . .	Pus.
Bacillus fluorescens liquefaciens . . . . .	Greenish-yellow . . . . .	Water.
Bacillus cyanofuscus . . . . .	Greenish-brown . . . . .	Cheese ; glue.
Bacillus fluorescens nivalis . . . . .	Bluish-green . . . . .	Water.
Bacillus chromo-aromaticus . . . . .	Green or brown . . . . .	Intestine.
Bacillus viscosus . . . . .	Green . . . . .	Water.
Bacillus pyocyaneus . . . . .	Green . . . . .	Pus.

## (b) Non-Motile.

Bacillus cœruleus . . . . .	Blue . . . . .	Water.
Bacillus glaucus . . . . .	Grey . . . . .	Water.
Bacillus membranaceus amethystinus . . . . .	Violet . . . . .	Water.
Bacillus lactis erythrogenes . . . . .	Red . . . . .	Milk.
Bacillus mycoides roseus . . . . .	Red . . . . .	Soil.

	COLOUR.	HABITAT.
Bacillus prodigiosus . . . . .	Blood-red . . . . .	Air.
Bacillus hydrophilus fuscus . . . . .	Yellow . . . . .	Frog's lymph.
Bacillus cuticularis . . . . .	Yellow . . . . .	Water.
Bacillus helvulus . . . . .	Yellow . . . . .	Water.
Bacillus tremelloides . . . . .	Yellow . . . . .	Water.
Ascobacillus citreus . . . . .	Yellow . . . . .	Skin.
Bacillus argenteo-phosphorescens liquefaciens . . . . .	Yellowish . . . . .	Sea-water.
Bacterium termo (Vignal) . . . . .	Yellowish . . . . .	Saliva.
Bacillus smaragdinus foetidus . . . . .	Green . . . . .	Ozæna.

## (b) Non-Chromogenic.

## (A) SPORE-FORMATION PRESENT.

## (a) Motile.

Bacillus inflatus . . . . .	Air.
Urobacillus Freudenreichi . . . . .	Air ; dust ; sewers.
Bacillus mycoides . . . . .	Soil ; water.
Bacillus ramosus . . . . .	Soil ; water.
Bacillus gracilis . . . . .	Water.
Bacillus circulans . . . . .	Water.
Urobacillus Duclauxi . . . . .	Water.
Urobacillus Maddoxi . . . . .	Water.
Bacillus limosus . . . . .	Sea-dredgings.
Bacillus butyricus . . . . .	Milk.
Bacillus Hessii . . . . .	Milk.
Bacillus lactis albus . . . . .	Milk.
Bacillus liodermos . . . . .	Milk.
Urobacillus Pasteuri . . . . .	Urine.
Bacillus mesentericus fuscus . . . . .	Potato ; dust ; water.
Bacillus mesentericus vulgatus . . . . .	Potato ; water, etc.
Bacillus of potato rot . . . . .	Rotting potatoes.
Bacillus maidis . . . . .	Maize infusion.
Bacillus megatherium . . . . .	Boiled cabbage.
Bacillus tumescens . . . . .	Beet-root.
Bacillus subtilis . . . . .	Dust ; water ; soil.
Bacillus subtilis similis . . . . .	Liver.
Bacillus vacuolosis . . . . .	Liver.
Bacillus of Scheurlen . . . . .	Cancerous tissues.
Bacillus alvei . . . . .	Larvæ of bees.

## (b) Non-Motile.

Bacillus aerophilus . . . . .	Air.
Bacillus implexus . . . . .	Water.
Bacillus filiformis . . . . .	Water.
Bacillus vermicularis . . . . .	Water.
Bacillus incanus . . . . .	Swamp-water.
Bacillus inunctus . . . . .	Swamp-water.
Bacillus granulosis . . . . .	Sea-dredgings.
Bacillus carotarum . . . . .	Boiled carrot.



	HABITAT.
Bacillus brassicæ . . . . .	Cabbage infusion.
Bacillus in gangrene . . . . .	Senile gangrene.
Bacillus of Letzerich . . . . .	Urine.
Bacillus anthracis . . . . .	Blood.

## (B) SPORE-FORMATION UNKNOWN.

(a) *Motile.*

Bacillus pestifer . . . . .	Air.
Bacillus diffusus . . . . .	Soil.
Bacillus gasoformans . . . . .	Water.
Bacillus liquidus . . . . .	Water.
Bacillus guttatus . . . . .	Water.
Bacillus liquefaciens . . . . .	Water.
Bacillus radiatus aquatilis . . . . .	Water.
Bacillus nubilus . . . . .	Water.
Bacillus albus putidus . . . . .	Water.
Bacillus hyalinus . . . . .	Water.
Bacillus vermiculosus . . . . .	Water.
Bacillus delicatulus . . . . .	Water.
Bacillus punctatus . . . . .	Water.
Bacillus reticulans . . . . .	Water.
Bacillus figurans (Vaughan) . . . . .	Water.
Urobacillus Schutzenbergi . . . . .	Water.
Bacillus devorans . . . . .	Water.
Bacillus venosus liquefaciens . . . . .	Water.
Bacillus aquatilis . . . . .	Water.
Proteus sulphureus . . . . .	Water.
Bacillus stoloniferus . . . . .	Swamp-water.
Bacillus phosphorescens Indicus . . . . .	Sea-water.
Bacillus phosphorescens indigenus . . . . .	Sea-water.
Bacillus cyaneo-phosphorescens . . . . .	Sea-water.
Bacillus litoralis . . . . .	Sea-dredgings.
Bacillus halophilus . . . . .	Sea-dredgings.
Bacillus superficialis . . . . .	Sewage.
Bacillus cloacæ . . . . .	Sewage.
Proteus microsepticus . . . . .	Uterine discharges.
Proteus vulgaris . . . . .	Putrid substances.
Proteus mirabilis . . . . .	Putrid substances.
Proteus septicus . . . . .	Septicæmia.
Bacillus foetidus ozænæ . . . . .	Nasal mucus.
Bacillus septicus ulcers gangrænosæ . . . . .	Blood and organs.
Bacillus albus cadaveris . . . . .	Blood.
Bacillus of Guillebeau . . . . .	Milk.
Bacillus Havaniensis liquefaciens . . . . .	Skin.
Bacillus carabiformis . . . . .	Stomach.
Bacillus of Schou . . . . .	Rabbit.
Bacillus leporis lethalis . . . . .	Liver.
Bacillus liquefaciens communis . . . . .	Liver.

(b) *Non-Motile.*

Bacillus buccalis fortuitus . . . . .	Saliva.
---------------------------------------	---------

	HABITAT.
Bacillus ulna (Vignal) . . . . .	Saliva.
Leptothrix buccalis (Vignal) . . . . .	Mouth.
Bacillus varicosus conjunctivæ . . . . .	Conjunctiva.
Bacillus gingivæ pyogenes . . . . .	Alveolar abscess.
Bacillus pulpæ pyogenes . . . . .	Gangrenous tooth-pulp.
Bacillus graveolens . . . . .	Skin of feet.
Pneumo-bacillus liquefaciens bovis . . . . .	Lung.

## (c) NO GROWTH IN GELATINE.

## (A) SPORE-FORMATION PRESENT.

(a) *Motile.*

Bacillus ulna . . . . .	White of egg.
Bacillus in putrid bronchitis . . . . .	Sputum.
Bacillus mallei . . . . .	Glandered tissue.

(b) *Non-Motile.*

Bacillus in erythema nodosum . . . . .	Blood.
Bacillus tuberculosis . . . . .	Tubercular tissue.

## (B) SPORE-FORMATION ABSENT.

Bacillus sanguinis typhi . . . . .	Blood.
Bacillus septicus acuminatus . . . . .	Septic infection.
Bacillus necrophorus . . . . .	Condyloma.

## (c) SPORE-FORMATION NOT STATED.

Bacillus allantoides . . . . .	Air.
Bacillus nitrificans . . . . .	Soil.
Bacillus in measles . . . . .	Blood.
Bacillus in ophthalmia . . . . .	Conjunctiva.

## (D) GROWTH IN GELATINE NOT STATED.

Bacillus senilis . . . . .	Blood.
Bacillus leptosporus . . . . .	Air.
Bacillus allii . . . . .	Putrefying onions.
Bacillus indigogenus . . . . .	Infusion of indigo.

## II. ANAEROBES.

## (A) GELATINE LIQUEFIED.

## (A) SPORE-FORMATION PRESENT.

(a) *Motile.*

Bacillus rubellus . . . . .	Dust.
Bacillus butyricus (Botkin) . . . . .	Milk; water; dust
Clostridium foetidum . . . . .	Earth.



	HABITAT.
Bacillus radiatus . . . . .	Earth.
Bacillus liquefaciens magnus . . . . .	Earth.
Bacillus spinosus . . . . .	Earth.
Bacillus thalassophilus . . . . .	Sea-dredgings.
Bacillus of symptomatic anthrax . . . . .	Tissues (quarter-ill).
Bacillus oedematis maligni . . . . .	Lymph.
Bacillus tetani . . . . .	Wounds; earth.

*(b) Non-Motile.*

Bacillus liquefaciens parvus . . . . .	Earth.
Bacillus anaerobicus liquefaciens . . . . .	Yellow fever.

**(B) GELATINE NOT LIQUEFIED.****(A) SPORE-FORMATION PRESENT.***(a) Motile.*

Bacillus amylozyma . . . . .	Water.
Bacillus solidus . . . . .	Earth.
Bacillus polypiformis . . . . .	Earth.

*(b) Non-Motile.*

Bacillus muscoides . . . . .	Earth.
------------------------------	--------

**(B) SPORE-FORMATION ABSENT.***(b) Non-Motile.*

Bacillus aerogenes capsulatus . . . . .	Blood.
-----------------------------------------	--------

**(C) GROWTH IN GELATINE NOT STATED.****(A) SPORE-FORMATION PRESENT.***(a) Motile.*

Bacillus butyricus . . . . .	Vegetable infusions, etc.
------------------------------	---------------------------

**(B) SPORE-FORMATION UNKNOWN.**

Bacillus cadaveris . . . . .	Liver.
------------------------------	--------

**CURVED RODS.****(A) GELATINE NOT LIQUEFIED.****(a) Chromogenic.***(a) Motile.*

	COLOUR.	
Spirillum rubrum . . . . .	Deep-red . . . . .	Putrid mouse.

**(b) Non-Chromogenic.**

Spirillum suis . . . . .		Intestine of swine.
--------------------------	--	---------------------

	HABITAT.
Spirillum concentricum . . . . .	Putrefying blood.
Spirillum saprophyles . . . . .	Hay-infusion; sewage.

*(b) Non-Motile.***(a) Chromogenic.**

	COLOUR.	
Spirillum flavescens . . . . .	Yellowish-green . . . . .	Sewers.
Spirillum flavum . . . . .	Ochre-yellow . . . . .	Sewers.
Spirillum aureum . . . . .	Orange-yellow . . . . .	Sewers.

**(b) Non-Chromogenic.**

Spirillum linguæ . . . . .	Deposit on tongue.
Spirillum nasale . . . . .	Nasal mucus.

## GELATINE LIQUEFIED.

**(a) Non-Chromogenic.***(a) Motile.*

Spirillum cholerae Asiaticæ . . . . .	Intestine.
Spirillum of Finkler and Prior . . . . .	Intestine.
Spirillum Metchnikovi . . . . .	Intestine of fowls.
Spirillum of Miller . . . . .	Carious teeth.
Spirillum of Sanarelli . . . . .	Water.
Spirillum tyrogenum . . . . .	Old cheese.
Spirillum marinum . . . . .	Sea-dredgings.

## NO GROWTH IN GELATINE, OR UNDETERMINED.

*(a) Motile.*

Spirillum Obermeieri . . . . .	Blood.
Spirillum anserum . . . . .	Blood of geese.
Spirillum undula . . . . .	Putrid infusions.
Spirillum sputigenum . . . . .	Gums.
Spirillum serpens . . . . .	Stagnant water.
Spirillum tenue . . . . .	Putrid infusions.
Spirillum volutans . . . . .	Swamp-water.
Spirillum plicatile . . . . .	Swamp-water.

*(b) Non-Motile.*

Spirillum dentium . . . . .	Gums.
Spirillum sanguineum . . . . .	Brackish water.

## BRANCHING FILAMENTS.

Streptothrix actinomycotica.  
 Streptothrix alba.  
 Streptothrix liquefaciens.  
 Streptothrix musculorum suis.  
 Streptothrix Hofmanni.  
 Streptothrix farcinica.  
 Streptothrix asteroides.  
 Streptothrix carnea.



*Streptothrix aurantiaca.*  
*Streptothrix chromogenes.*  
*Streptothrix odorifera.*  
*Streptothrix violacea.*  
*Streptothrix Försteri.*  
*Streptothrix maduræ.*

## NOT CLASSIFIED.

*Bacillus indigonaceus.*  
*Bacillus proteus fluorescens.*  
*Beggiatoa alba.*  
*Beggiatoa mirabilis.*  
*Beggiatoa roseo-persicina.*  
*Cladothrix dichotoma.*  
*Cladothrix invulnerabilis.*  
*Crenothrix Kuhniana.*  
*Diplococcus citreus liquefaciens.*  
*Leptothrix buccalis.*  
*Leptothrix gigantea.*  
*Micrococcus aquatilis invisibilis.*  
*Micrococcus crepusculum.*  
*Micrococcus fætidus.*  
*Micrococcus Havaniensis.*  
*Micrococcus of septicæmia in rabbits.*  
*Monas Okenii.*  
*Monas vinosa.*  
*Monas Warmingii.*  
*Myconostoc gregarium.*  
*Rhabdomonas rosea.*  
*Sarcina hyalina.*  
*Sarcina intestinalis.*  
*Sarcina litoralis.*  
*Sarcina Reitenbachii.*  
*Sarcina urinæ.*  
*Sphærotilus natans.*  
*Spirillum attenuatum.*  
*Spirillum leucomelaneum.*  
*Spirillum rosaceum.*  
*Spirillum Rosenbergii.*  
*Spirillum rufum.*  
*Spiromonas Cohnii.*  
*Spiromonas volubilis.*  
*Streptococcus cadaveris.*  
*Streptococcus flavus desidens.*  
*Vibrio rugula.*

DESCRIPTION OF SPECIES ARRANGED FOR  
REFERENCE IN ALPHABETICAL ORDER.

**Ascococcus Billrothii.**—Small globular cocci, united into characteristic colonies.

They form on the surface of nourishing fluids a cream-like skin, divisible into an enormous number of globular or oval families. Each family is surrounded by a thick capsule of cartilaginous consistency. In a solution containing acid tartrate of ammonia the fungi generate butyric acid, and change the originally acid fluid into an alkaline one.

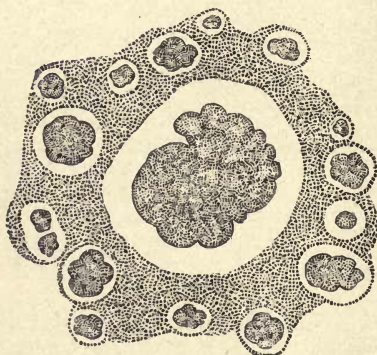

FIG. 198.—ASCOCOCCUS BILLROTHII  
(Cohn).

They were first observed on putrid broth, and later on ordinary nourishing solutions; they also readily develop upon damp slices of boiled roots, carrots, beetroots, etc.

**Ascobacillus citreus** (Unna, Tommasoli).—Rods sometimes curved,  $1.3 \mu$  in length,  $.3 \mu$  in width, singly, in pairs, and masses. The

colonies develop slowly, and are yellowish in colour.

The cocci inoculated in the depth of gelatine form small colonies in the track of the needle, and a slimy pale-yellow growth on the surface; liquefaction sets in slowly.

On agar the growth is gelatinous, and orange in colour, and rapidly extends over the surface.

On potato the growth is abundant, and pale yellow.

They were isolated from the skin in eczema seborrhœicum.

**Bacillus acidiformans** (Sternberg).—Short rods,  $1.5$  to  $3 \mu$  in length,  $1.2 \mu$  in width, and filaments  $5$  to  $10 \mu$ .

Colonies circular; iridescent by reflected light.

Inoculated in the depth of gelatine they grow freely in the track of the needle, and form a hemispherical mass on the surface. They produce gas bubbles.

On agar the growth is milk-white, and the jelly becomes strongly acid.

On potato the growth is abundant. In broth with 5 per cent. glycerine they produce opacity and a copious viscid deposit, and the surface is covered with gas bubbles.

Injected into the peritoneal cavity of rabbits and guinea-pigs, they produce death in twenty-four hours.

They were isolated from the liver in a fatal case of yellow fever.

**Bacillus acidilactici** (Hueppe).—Rods  $1$  to  $2.8 \mu$  long, and  $.3$  to  $.4 \mu$  wide, and thread forms. Spore-formation present. In gelatine



cultures the breadth of the rods is diminished. They grow best between 35° and 42° C., and cease under 10° C. Over 45·5° C. they no longer produce acidity.

Whitish colonies appear on the second day.

In gelatine a delicate growth appears along the whole track of the needle, with spherical forms here and there.

In milk they produce lactic acid and the casein is precipitated.

**Bacillus aerogenes** (Miller).—Small rods varying in length. Colonies white or yellowish-white; concentric.

In the depth of gelatine they produce a yellowish filament, and on the surface a grey patch with dentated periphery; later the filament is brown.

On potato the growth is yellowish and dry.

They were isolated from the intestine in health.

**Bacillus aerogenes capsulatus** (Welch).—Rods straight or slightly curved, 3 to 6  $\mu$ ; threads and chains; capsulated.

Colonies on agar greyish-white, with hairy processes.

They peptonise gelatine and produce gas. Broth becomes turbid, and there is an abundant sediment. Milk is coagulated. Cultures have a faint smell of glue.

Injected into rabbits they produce gas in the blood and internal organs.

They were isolated from a patient after death, with blood-vessels full of gas.

**Bacillus aerophilus** (Liborius).—Rods and filaments.

Colonies punctiform; greyish-yellow.

Inoculated in the depth of gelatine the bacilli produce a funnel of liquefied jelly, with flocculi in the lower part.

On potato they form a smooth yellowish layer.

They were isolated from contaminated cultures.

**Bacillus albus** (Eisenberg).—Rods and chains.

Colonies circular, white.

In gelatine the bacilli grow in the track of the needle, and form a white hemispherical mass on the free surface.

On agar the growth is pure white, and on potato yellowish-white.

They occur in water.

**Bacillus albus anaerobiescens** (Vaughan).—Short rods.

Colonies circular, yellowish-brown.

Inoculated in the depth of gelatine they grow in the track of the needle, and on the free surface.

On agar the growth is pure white, and on potato yellowish-white.

They occur in water.

**Bacillus albus cadaveris** (Straussmann and Stricker).—Rods 2·5  $\mu$  in length, 75  $\mu$  in width, and filaments.

Colonies yellowish; circular, and later radiated.

Inoculated in the depth of gelatine they produce a funnel of liquefied gelatine with a thick deposit.

On agar there is an abundant white growth.

On potato the growth is white or yellowish-white, and colours the potato in the vicinity bluish-brown. The cultures have a putrefactive odour.

Mice inoculated subcutaneously die in six hours, and guinea-pigs in twenty-four.

They were isolated from putrid human blood.

**Bacillus albus putidus** (De Bary).—Rods and filaments.

Colonies circular and brownish.

Inoculated in the depth of gelatine they produce rapid liquefaction.

On agar and potato the growth is slimy. Cultures develop a strong putrefactive odour.

They occur in water.

**Bacillus allantoides** (L. Klein).—Rods 2 to 2·5  $\mu$  in length, 5  $\mu$  in width, and in chains. The rods develop cocci-forms united by a gelatinous substance into zooglæa masses. They were isolated from a contaminated culture.

**Bacillus allii** (Griffiths).—Rods

5 to 7  $\mu$  in length, 2.5  $\mu$  in width, singly, in pairs, and zoogloea.

On agar they produce a bright green film, and cultures are said to emit traces of sulphuretted hydrogen.

They were isolated from putrid onions.

**Bacillus alvei** (p. 470).

**Bacillus amylozyma** (Perdrix).

—Rods 2 to 3  $\mu$  in length and .5  $\mu$  in width, in pairs, and in chains. They are anaerobic.

Colonies white, and producing gas bubbles.

On potato in an atmosphere of hydrogen the bacilli partly liquefy it, and there is abundant formation of gas.

They ferment sugar and starch.

**Bacillus anaerobicus liquefaciens** (Sternberg).—Slender rods, about .6  $\mu$  in diam., in pairs, and in filaments.

Colonies granular and white; surrounded by liquefied gelatine.

They grow along the track of the needle when inoculated in the depth of agar.

They were isolated from the intestine in a fatal case of yellow fever.

**Bacillus anthracis** (p. 192).

**Bacillus aquatilis** (Frankland).

—Rods 2.5  $\mu$  in length, and filaments 17  $\mu$  or longer. They resemble *Bacillus arborescens*.

Colonies after liquefaction of the gelatine have a yellowish-brown nucleus from which proceed twisted strands of filaments.

Inoculated in the depth of gelatine the growth in the track of the needle is at first almost invisible, later liquefaction occurs.

On agar the growth is shining and yellowish.

Broth becomes turbid, and a sediment forms at the bottom of the tube.

On potato there is a slightly yellowish streak.

They occur in water.

**Bacillus aquatilis fluorescens** (Lustig).—Short thin rods with rounded ends. Non-motile.

Colonies fern-like and iridescent.

Compare Eisenberg's *Bacillus fluorescens non-liquefaciens*.

**Bacillus aquatilis graveolens** (Tataroff).—Slender rods 1.3  $\mu$  in length. They rapidly liquefy gelatine and produce an odour like that of perspiration from the feet.

They occur in water.

**Bacillus aquatilis sulcatus** (Weichselbaum), No. I.—Rods morphologically, and in cultures resembling *Bacillus typhosus*.

Colonies in gelatine exhibit lines and furrows.

The growth on the surface of gelatine is said to be greater than in cultures of *Bacillus typhosus* grown for comparison.

They occur in water.

No. II.—Rods also resembling in morphology and cultivation the *Bacillus typhosus*.

Colonies are said to be thicker than those of No. I., and not dentated.

The growth on potatoes is yellowish-brown, and emits a faint odour of urine.

They occur in water.

No. III.—Very short rods.

Colonies show lines and furrows, and are yellowish.

On the surface of gelatine the growth develops as a thin whitish film.

On agar the growth is white and abundant.

On potato the growth is yellow.

They were isolated from water.

No. IV.—Rods and filaments.

Colonies circular and bluish.

On the surface of gelatine the growth is greyish-white, and on agar there is a similar appearance.

They do not grow on potato.

They occur in water.

No. V.—Rods rather thicker than those of *Bacillus typhosus*.

Colonies similar to those of No. I.

The growth on the surface of gelatine is yellow.

On agar the growth is viscid and yellow, and on potato the growth is faintly yellow and the surrounding medium stained bluish-grey.

They occur in water.

**Bacillus arborescens** (Frankland).—Rods 2.5  $\mu$  in length, and



$\cdot 5 \mu$  in width, singly, in pairs, and in short chains, and filaments.

Colonies throw out delicate branches with a highly characteristic appearance; the gelatine slowly liquefies, the nucleus of the colony becomes yellow, and the periphery iridescent.

Inoculated in the depth of gelatine the bacilli form a cloudiness in the track of the needle, and an iridescent layer on the surface with central depression of the gelatine and commencing liquefaction. Later the liquefaction produces a funnel, and there is a yellow deposit.

On the surface of agar the layer is a dirty orange colour.

On potato the growth is orange red with irregular protuberances, and limited in growth.

They occur in water.

**Bacillus argenteo-phosphorescens** (Katz), No. I.—Rods slightly curved with pointed ends,  $2\cdot 5 \mu$  in length, width one-third of their length; singly, in pairs, and long wavy filaments.

Colonies circular; at first transparent droplets, later yellowish in colour.

On the surface of gelatine they form a greenish-yellow film.

In broth they produce turbidity, and later a skin on the surface, and on sterilised fish a pale-yellow sticky growth.

Cultures are photogenic.

They were isolated from the sea at Sydney.

No. II.—Rods with rounded ends  $\cdot 27 \mu$  in length,  $\cdot 67 \mu$  in width, and filaments.

Colonies on gelatine are circular with sharp contours and greyish-yellow in colour; later they are irregular and granular.

Inoculated in gelatine the bacilli form a greyish-white filament in the track of the needle, and a shining patch on the surface.

On the surface of obliquely solidified gelatine they form a bluish-grey film.

In broth they produce only turbidity.

Cultures are photogenic.

They were isolated from phosphorescent fish.

No. III.—Rods not so thick as those of No. II., singly, in pairs, and filaments. They are motile.

Colonies are white, scaly, and wrinkled.

On the surface of gelatine the growth spreads over the medium.

On agar the growth is scanty.

In broth they produce turbidity and a skin floating on the surface.

Cultures are photogenic after a few days' growth.

They were isolated from a piece of cuttle-fish.

**Bacillus argenteo-phosphorescens liquefaciens**.—Rods straight or slightly bent,  $2 \mu$  in length, and in width one-third of their length; filaments.

Colonies circular, pale brown or pale yellow and, after liquefaction, with radiating processes extending into the surrounding gelatine.

Inoculated in the depth of gelatine there is a growth in the track of the needle, and near the surface a cup-shaped area of liquefaction.

In broth they produce turbidity, and form a skin on the surface.

On sterilised fish they form a yellow layer.

They are photogenic but not markedly so.

**Bacillus aurantiacus** (Frankland).—Rods short and thick, singly, in pairs, and in filaments.

Colonies are prominent and pale orange in colour.

Inoculated in the depth of gelatine there is a slight growth in the track of the needle and an orange patch on the free surface.

On agar and potato the growth is also orange.

They occur in water.

**Bacillus aureus** (Adametz).—Slender rods straight or slightly bent,  $1\cdot 5$  to  $4 \mu$  in length, and  $\cdot 5 \mu$  in width; in pairs, filaments, and masses. They are motile.

Colonies circular or oval and yellow in colour.

Inoculated in the depth of gelatine the growth is very limited in

the track of the needle, while small chrome-yellow hemispherical masses develop on the free surface.

On potato they form a chrome-yellow growth.

They occur in water and on the skin.

**Bacillus berolinensis Indicus** (Clässen).—Slender rods, singly, in pairs, and short chains; capsulated.

Colonies at first whitish acquire in a few days an indigo-blue colour.

On the surface of gelatine they form a blue layer, which slowly spreads.

On the surface of agar the indigo-blue colour is very marked.

On potato they grow abundantly, and develop the same colour. The pigment is insoluble in alcohol, chloroform or water, soluble in strong acids, and decolorised by ammonia.

They were isolated from river water at Berlin.

**Bacillus brassicæ** (Pommer).—Rods 1.9 to 5.4  $\mu$  in length, .91 to 1.2  $\mu$  in width, and filaments. They form spores.

Colonies have the appearance of a fine mycelium.

Inoculated in the depth of gelatine the growth in the track of the needle sends off fine filaments, and liquefaction quickly follows.

In the depth of agar white colonies form in the track of the needle, and on the surface the growth is first cloudy and later yellowish.

They were isolated from infusion of cabbage.

**Bacillus brevis** (Mori).—Rods .25  $\mu$  long and .8  $\mu$  broad. Non-motile.

Colonies pale-yellow; non-liquefying.

Inoculated in the depth of gelatine small dots appear along the needle track and a pale yellowish growth on the surface.

On agar at 35° C. a yellowish and on blood serum a greyish growth appears in two or three days. They do not grow on potato. In broth they form a white cloudy deposit.

Mice inoculated subcutaneously die in from sixteen to thirty hours. They are also pathogenic in guinea-pigs and rabbits.

They were found in drain water.

**Bacillus brunneus** (Adametz and Wichman).—Rods small and slender. Spore formation present.

Colonies at first white, later brownish.

Inoculated in the depth of gelatine the growth occurs along the track of the needle and also on the surface, developing a brownish colour in the surrounding gelatine.

They occur in water.

**Bacillus buccalis fortuitus** (Vignal).—Rods 1.4 to 3  $\mu$  in length, singly, and in pairs.

Colonies circular and liquefying.

Inoculated in the depth of gelatine liquefaction occurs slowly, and white flocculi occur in the liquid, and later subside to the bottom.

In broth they produce turbidity and a skin on the surface.

They were isolated from saliva.

**Bacillus buccalis maximus** (Miller).—Rods 2 to 10  $\mu$  in length, 1 to 1.3  $\mu$  in width, and filaments 30 to 150  $\mu$  in length.

They occur in the mouth.

**Bacillus buccalis minutus** (Vignal).—Rods .5 to 1  $\mu$  in length, and slightly less in width.

Colonies circular and faintly yellow.

Inoculated in the depth of gelatine they form a yellowish-white growth in the track of the needle, and a patch of the same colour on the surface; liquefaction commences slowly, and extends downwards until the gelatine is completely liquefied and a yellow mass collects at the bottom of the tube. In broth there is a similar deposit, and an iridescent pellicle on the surface.

On potato they form a yellow film.

They were isolated from saliva.

**Bacillus butyricus**, (Prazmowski. *Bacillus amylobacter*, Van Tieghem; *Bacillus of butyric acid fermentation*).—Rods 3 to 10  $\mu$  long, under 1  $\mu$  wide, often indistinguishable from *Bacillus subtilis*. They



grow out into long, apparently unjointed threads. They are mostly actively motile, but also occur in zoogloea. The rods and threads are sometimes slightly bent, like vibrios. They are anaerobic. The shorter rods as a rule swell in the middle, becoming ellipsoidal, lemon,

best between 35° and 40° C. The spores are widely distributed in nature, and grow readily on fleshy roots, old cheese, etc. They convert the lactic acid in milk into butyric acid, and produce the ripening of cheese.

They occur also in solutions of starch, dextrine, and sugar, and are the active agents in the fermentation of sauerkraut and sour gherkins.

**Bacillus butyricus** (Botkin).—Rods and filaments, spore-formation present. They are anaerobic.

Colonies consist of felt-like masses.

Inoculated in the depth of gelatine with 1.5 per cent. of grape-sugar, the growth commences in the lower part of the needle track with abundant formation of gas bubbles and liquefaction of the jelly.

In milk there is abundant gas formation, which will break the flasks if closed.

They were isolated from milk, earth, and water.

**Bacillus butyricus** (Hueppe).—Rods slightly bent, 2.1  $\mu$  in length, .38  $\mu$  in width, and filaments.

Colonies yellowish; rapidly liquefying.

Inoculated in the depth of gelatine liquefaction occurs along the track of the needle, and later a wrinkled skin floats on the surface.

On agar the growth is yellowish.

On potato the growth is wrinkled and faintly yellow.

They coagulate milk, precipitating and then dissolving the casein.

They occur in milk.

**Bacillus cadaveris** (Sternberg).—Rods 1.5 to 4  $\mu$  in length, and 1.2  $\mu$  in width, singly, in pairs, and in filaments.

They are anaerobic. Colonies in glycerine-agar are irregular, granular, and white.

They produce an acid reaction in cultures.

Subcutaneous injection in guinea-pigs may produce extensive

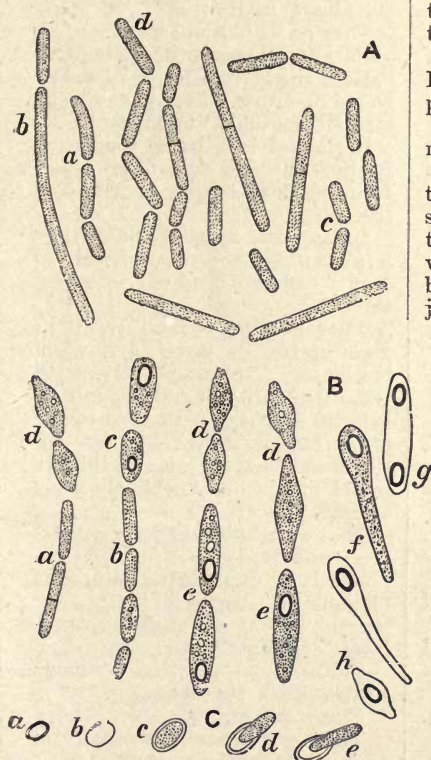

FIG. 199.—CLOSTRIDIUM BUTYRICUM.

A. Active stage. (a, b) Bent rods (vibriiform) and threads. (c) Short rods. (d) Long rods.

B. Spore-formation. C. Spore-germination. (Prazmowski.)

or spindle-shaped; the long rods, and sometimes the short ones, swell at one end; in either case ellipsoidal spores are developed (Fig. 199).

Cultivated in nutrient gelatine, the medium is liquefied, and a scum formed on the surface. They grow

œdema and death in twenty-four hours.

They were obtained from the liver in fatal cases of yellow fever.

**Bacillus cœruleus** (Smith).—Rods 2 to 2.5  $\mu$  in length, and .5  $\mu$  in width, singly and in chains.

Colonies blue.

Inoculated in the depth of gelatine they form a colourless growth in the track of the needle, and a cup-shaped cavity in its upper part, with bluish contents.

On agar they form a blue layer and a deep-blue growth on potato.

They occur in water.

**Bacillus canalis capsulatus** (Mori).—Rods .9 to 1.6  $\mu$  in width, capsulated.

Colonies milk-white.

The growth in the depth of gelatine is similar to Friedländer's pneumococcus.

On agar the growth is viscid, and on potato it is yellowish.

In broth a skin forms on the surface.

They are pathogenic in mice.

They occur in sewage.

**Bacillus canalis parvus** (Mori).—Rods 2 to 5  $\mu$  in length, .8 to 1  $\mu$  in width.

Colonies very minute, pale yellow.

On the surface of gelatine they very slowly form a yellowish film.

On agar the growth is dry and yellow.

They are pathogenic in mice and guinea-pigs.

They occur in sewage.

**Bacillus candicans** (Frankland).—Very short rods and filaments.

Colonies pure white.

Inoculated in the depth of gelatine they form isolated colonies in the track of the needle, and a white button on the free surface.

On agar they form a greyish layer, and flourish on potato.

They occur in soil.

**Bacillus capsulatus** (Mori).—Oval forms and rods, sometimes encapsulated. Non-motile. Colonies white.

Inoculated in the depth of gelatine and agar a nail-shaped growth occurs.

In broth they form a white turbidity, and a white pellicle develops on the surface and on the sides of the vessels.

On potato at 37° C. an abundant moist, yellowish, stringy growth is formed, with production of gas bubbles. They are pathogenic in mice and in rabbits if injected into the pleural cavity.

They occur in drain water.

**Bacillus capsulatus** (Pfeiffer).—Rods singly, in pairs, or in chains and in filaments. They have a well-marked capsule. Colonies white.

Inoculated in gelatine they grow in the track of the needle, and form a white button on the free surface.

On agar and on potato the growth is also white and very viscid, so that it can be drawn out into long threads.

They produce a fatal result in mice in two or three days, when inoculated subcutaneously. A minute quantity of a broth culture injected into the peritoneal cavity of guinea-pigs will prove fatal in thirty-six hours. The bacilli are found in the blood which is made viscid.

They were isolated from a guinea-pig found dead.

**Bacillus capsulatus mucosus** (Fasching).—Rods 3 to 4  $\mu$  in length, .75 to 1  $\mu$  in width; capsulated. Colonies white.

Cultures in gelatine resemble Friedländer's pneumococcus.

They form gas.

They produce a fatal result in mice in thirty-six hours.

They were isolated from nasal mucus in cases of influenza.

**Bacillus capsulatus suis** (Smith).—Rods from 1.2 to 1.8  $\mu$  in length and .8 to .9  $\mu$  in width. There are three varieties of this bacillus having a closer resemblance to the pneumococcus of Friedländer.

They were isolated from the intestines of swine.

**Bacillus carabiformis** (Kaczynsky).—Rods short and slender.

Colonies develop characteristic processes.



Inoculated in the depth of gelatine, the bacilli produce liquefaction and colour the liquid greenish-yellow.

On agar they form a yellowish-white layer.

They were isolated from the stomach of a dog.

**Bacillus carnicolor** (Tils).—Rods 2  $\mu$  long, and .5  $\mu$  broad. Singly actively motile. Spore-formation not observed.

Colonies are in the form of cup-shaped depressions.

Inoculated in the depth of gelatine they grow rapidly along the whole track of the needle, forming a funnel-shaped area of liquefaction at the bottom of which there is a pale pink deposit.

On potato they form slowly a dark flesh-coloured growth.

They occur in water.

**Bacillus carotarum** (A. Koch).—Rods .97 to 1.05  $\mu$  in length and filaments.

Colonies white and circular.

Inoculated in the depth of gelatine the bacilli grow slightly in the track of the needle and abundantly on the surface.

On agar they form a white, and on potato a faintly brown layer.

They occur on boiled carrot and beet.

**Bacillus cavicida** (Brieger).—Rods morphologically and in cultivations similar to *Bacillus coli communis*.

Cultures are said to be pathogenic in guinea-pigs.

They were isolated from fæces.

**Bacillus cavicida Havaniensis** (Sternberg).—Rods 2 to 3  $\mu$  in length, and .7  $\mu$  in width, singly and in pairs.

Colonies are of a pale-straw colour.

Inoculated in the depth of gelatine the bacilli form small translucent pearl-like spherical colonies, and on the free surface the growth is limited.

On potato the growth is at first thin and dirty yellow, and later gamboge yellow.

Guinea-pigs inoculated subcuta-

neously die in ten or twelve hours.

They were isolated from the intestinal contents in a fatal case of yellow fever, by inoculation of guinea-pigs.

**Bacillus chromo-aromaticus**.—Rods which liquefy gelatine and form a yellowish-white scum on the surface.

On potato the growth is iridescent and brownish.

In broth a scum forms on the surface and the broth is coloured greenish-blue. Cultures have an aromatic odour.

They are said to produce pneumonia and pleurisy in rabbits.

They were isolated from a pig with post-mortem appearances of swine-fever.

**Bacillus circulans** (Jordan).—Rods 2 to 5  $\mu$  in length and 1  $\mu$  in width, singly and in short chains.

Colonies are brownish.

Inoculated in the depth of gelatine they liquefy the medium in the track of the needle, forming a conical cavity at its upper part.

On agar they form a translucent film.

Milk is slowly coagulated.

In broth they produce turbidity and a slimy deposit.

They occur in water.

**Bacillus citreus cadaveris** (Strassmann).—Rods .9  $\mu$  in length, .6  $\mu$  in width, singly and in chains.

Colonies pale yellow.

Inoculated in the depth of gelatine the bacilli form minute colonies along the track of the needle, and at its upper part liquefy the gelatine and produce a yellow deposit.

They were found in the blood after death.

**Bacillus cloacæ** (Jordan).—Short rods .8 to 1.9  $\mu$  in length, .7 to 1  $\mu$  in width, singly and in pairs.

Colonies circular, yellowish.

Inoculated in the depth of gelatine liquefaction occurs in the track of the needle, an iridescent scum forms on the surface, and there is an abundant deposit.

On agar the growth is milk-

white, and on potato yellowish-white.

In broth they produce turbidity and a scum on the surface. They reduce nitrates.

They occur in sewage.

**Bacillus coli communis** (Escherich).—See p. 344.

**Bacillus coli similis** (Sternberg).—Rods 1 to 3  $\mu$  in length,  $\cdot 4$  to  $\cdot 5$   $\mu$  in width; singly and in pairs.

Colonies circular and pale brown in colour.

In the depth of gelatine they form a scanty growth in the track of the needle, and on the free surface a translucent film with irregular margins.

On potato the growth is pale brown or dirty white.

They were isolated from human liver after death.

**Bacillus constrictus** (Zimmermann).—Rods from 1.5 to 6.5  $\mu$  in length, and  $\cdot 75$   $\mu$  in width. The rods are segmented.

Colonies are circular, granular, and greyish-yellow.

In the depth of gelatine they form a filament in the track of the needle and irregular yellow heaps on the free surface.

On the surface of agar the growth consists of a yellow shining layer, and on potato the same colour is produced.

They occur in water.

**Bacillus coprogenes foetidus** (Schottelius).—Rods about as large as *Bacillus subtilis*, but shorter. They are non-motile. Spore-formation occurs when the bacilli have access to the air, but not in the animal body.

In the depth of gelatine a filament forms composed of yellowish compact colonies; and on the surface a fine transparent film; cultures emit a strong putrefactive odour.

On potato they form a light grey, dry layer.

Subcutaneous injection of small doses had no effect on mice and rabbits, but very large quantities produced a toxic effect in rabbits. Swine are not affected.

They were found by Schottelius in the intestine in cases of swine erysipelas.

**Bacillus coprogenes parvus** (Bienstock).—Very short rods.

On the surface of gelatine they form a very limited, almost invisible, growth in the track of the needle.

In mice they produce oedema and death in thirty-six hours, and in rabbits a local rash and death in eight days.

They were isolated from human evacuations.

**Bacillus crassus aromaticus** (Taratoff).—Rods 3.5 to 5  $\mu$  long, 1.5  $\mu$  in width; constricted in the centre.

Colonies appear in the form of cup-shaped depressions and produce a fruit-like odour.

In gelatine they grow in the track of the needle, and later produce a funnel-shaped area of liquefaction.

They occur in well water.

**Bacillus crassus sputigenus** (Kreibohm).—Short thick rods, sometimes curved; capsulated. Colonies greyish-white. Cultures in gelatine resemble those of Friedländer's pneumococcus. They are pathogenic in small animals. They were isolated from human sputum.

**Bacillus cuniculicida**, *Bacillus of Rabbit Septicæmia* (see p. 228).

**Bacillus cuticularis** (Tils).—Rods from 2 to 3  $\mu$  in length,  $\cdot 3$  to  $\cdot 5$   $\mu$  in width, and filaments.

Colonies are yellow and the gelatine is liquefied.

In the depth of gelatine they produce liquefaction, and a skin forms on the surface.

On potato the growth is slimy and yellow.

They occur in water.

**Bacillus cuticularis albus** (Taratoff).—Rods 3.2  $\mu$  long, constricted in the middle. Actively motile.

Colonies are opalescent and bluish-white.

Inoculated in the depth of gelatine they form a white rosette-shaped growth on the surface and



a shining white growth along the needle track which sends off long rounded processes.

On agar, glycerine agar and blood serum they produce a luxuriant white shining growth.

Broth becomes turbid with a whitish deposit and pellicle.

On potato there is a thick moist brown growth.

They are found in water.

**Bacillus cyaneo-fuscus** (Beyerinck).—Rods 2 to 6  $\mu$  in length, and half their length in width. Motile.

In the depth of gelatine they produce colonies in the track of the needle, which later develop a black pigment.

In broth with  $\frac{1}{2}$  per cent. of peptone they produce a blue colour, changing to brown and finally black.

They were isolated from cheese, size and glue.

**Bacillus cyaneo-phosphorescens** (Katz).—Rods 2.6  $\mu$  in length, 1  $\mu$  in width, singly, in pairs, and filaments. Colonies circular and brownish or greyish-yellow.

Inoculated in the depth of gelatine they form a grey-white filament in the track of the needle and liquefaction follows at the upper part; later a skin forms on the surface and a yellow deposit occurs at the bottom of the liquefied jelly which has a reddish-brown tinge.

In broth a similar skin floats on the surface and the broth is turbid.

On sterilised fish the growth is viscid and yellow.

Cultures are phosphorescent, especially in media containing excess of common salt.

They were isolated from seawater at Sydney, and are possibly identical with *Bacillus phosphorescens* of Fischer.

**Bacillus cyanogenus** (Hueppe).—*Bacterium syncyanum*. *Bacillus of Blue Milk*.—Motile rods, 2.5 to

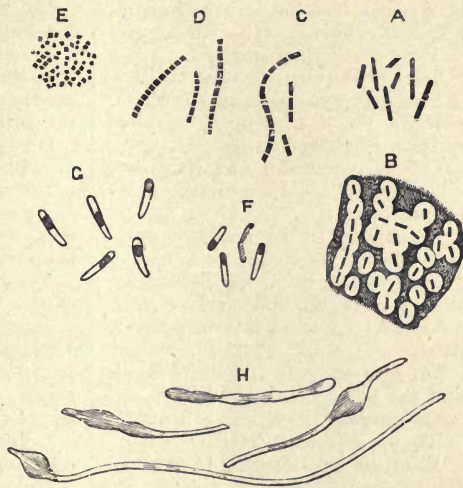

FIG. 200.—*BACILLUS CYANOGENUS*,  $\times 650$ . A. Active rods. B. Rods in zoogloea. C. Chain of short rods. D. Chain of cocci. E. Cocci stage. F, G. Spore-forming rods. H. Involution forms (NEELSEN).

3.5  $\mu$  in length, and .4  $\mu$  wide (Fig. 200). The rods after division may remain linked together, and form chains. Non-motile rods occur enveloped in a gelatinous capsule; and involution forms.

Colonies appear after two days as small greyish-white points which gradually assume a moist appearance. The gelatine becomes steel-grey, throwing the white colonies into strong relief.

In the depth of gelatine a whitish growth appears in the track of the needle near the upper part, and on the free surface, producing also a dark steel-blue discoloration of the jelly which spreads downwards.

On agar a greyish growth appears, and the agar is coloured dark brown.

On potato a yellowish moist growth develops, the potato around it is stained grey-blue. Milk becomes slightly alkaline and of a slate-grey colour, which on the addition of acid changes to an intense blue. Milk in which the

lactic acid bacillus is growing becomes sky-blue from the first.

They are non-pathogenic.

They are present in blue milk.

**Bacillus cyanogenus** (Jordan).—Rods  $1.3\ \mu$  in length,  $.8\ \mu$  in width. Slightly motile.

Colonies granular and irregular. They colour the surrounding gelatine brown.

Inoculated in the depth of gelatine the bacilli produce a scanty growth in the track of the needle, and a film on the surface with coloration of the gelatine beneath it.

On agar they form a white layer, and the jelly is coloured brown.

On potato the growth is brown.

They were isolated from sewage.

**Bacillus cystiformis** (Clado).—Short slender rods. Motile.

Colonies circular, yellowish, granular.

Inoculated in the depth of gelatine there is a scanty growth in the track of the needle, and a white patch on the free surface.

On agar the growth is yellowish-white.

They were isolated from urine.

**Bacillus delicatulus** (Jordan).—Rods  $2\ \mu$  long and  $1\ \mu$  broad, often in pairs or short chains. Actively motile. Spore-formation not observed.

Colonies at first whitish with a radiating edge. Later they liquefy the gelatine and the centres become dark.

Inoculated in the depth of gelatine they rapidly liquefy it and form a whitish pellicle and a brown deposit.

On agar a greyish crinkled growth appears, which gradually becomes white and shining.

On potato there is a grey flat growth.

Milk is coagulated and becomes strongly acid.

Broth is made turbid and a white serum and precipitate formed.

They occur in sewage.

**Bacillus dentalis viridans** (Miller).—Rods slightly bent, singly and in pairs.

Colonies circular, yellowish and concentric.

Inoculated in the depth of gelatine they grow in the track of the needle and on the free surface, and the jelly is coloured green.

On agar the growth is colourless or slightly grey.

Intraperitoneal injections in mice and guinea-pigs produce a fatal result. Subcutaneous injections cause suppuration.

They were isolated from caries of the teeth.

**Bacillus dentriticus** (Bordoni Uffreduzzi and Lustig).—Rods  $.85$  to  $2.8\ \mu$  long, and  $.5$  to  $.85\ \mu$  broad, singly and in zoogloea. Motile. Spore-formation not observed.

Colonies have an arborescent appearance.

Inoculated in the depth of gelatine they form a circular raised growth at the point of puncture, and white colonies along the needle track. The jelly is gradually liquefied.

On agar and blood serum there is a scanty growth on the surface and an abundant growth in the track of the needle. Blood serum is liquefied after some time.

Broth is rendered turbid; a white firm pellicle forms.

On potato there is a thick moist white growth, which later becomes yellow.

Found in water.

**Bacillus devorans** (Zimmermann).—Rods  $.99\ \mu$  to  $1.2\ \mu$  in length,  $.74\ \mu$  in width; singly, in pairs and in chains.

Colonies are circular, granular, and grey, with periphery formed of radiating processes.

In the depth of gelatine they produce a whitish filament and an excavation at the upper part, which may or may not contain liquefied jelly.

On agar a greyish film is found.

They do not grow on potato.

They occur in water.

**Bacillus diffusus** (Frankland).—Rods  $1.7\ \mu$  in length,  $.5\ \mu$  in width; singly, in pairs, and filaments.



Colonies circular, bluish-green, with a granular nucleus and delicate irregular periphery.

In the depth of gelatine there is scarcely any growth in the track of the needle, but a shining greenish-yellow film on the surface, and liquefaction below it.

On agar the growth is faintly yellow.

In broth they produce turbidity and a yellowish deposit.

On potato the growth is yellowish.

They occur in earth.

**Bacillus diphtheriæ** (p. 332).

**Bacillus diphtheriæ columbarum** (p. 336).

**Bacillus dysodes** (Zopf).—Cocci, long and short rods, and spores.

They were observed in bread, making it greasy and unfit for food, and generating a penetrating odour resembling a mixture of peppermint and turpentine. A great loss may result to bakers if the fungus is introduced with the yeast.

**Bacillus endocarditidis capsulatus** (Weichselbaum).—Cocci resembling Friedländer's pneumococci.

Colonies faintly yellow, with dentated contours.

In the depth of gelatine the growth produces a filament in the track of the needle, and a patch like stearin on the free surface.

Large doses injected subcutaneously, or into the peritoneal cavity prove fatal to rabbits.

They were isolated from infarcts in a fatal case of endocarditis.

**Bacillus endocarditidis griseus**.—Rods motile.

Colonies granular and brown or yellowish-brown.

In the depth of gelatine there is a filamentous growth in the track of the needle, and a circular whitish patch on the surface. On agar and potato the growth is greyish-brown.

Cultures cause a fatal result in mice and guinea-pigs.

They were isolated from a case of endocarditis.

**Bacillus enteritidis** (p. 372).

**Bacillus epidermidis** (Bordoni Uffreduzzi).—Rods 2·8 to 3  $\mu$  in length, and 3  $\mu$  in breadth. Spore-formation occurs at 25° C.

They grow very sparingly on gelatine.

On agar there is a surface growth.

On potato at 15° to 20° C. the growth appears first in the form of drops, which gradually extend and coalesce and form a thin layer



FIG. 201.—PURE CULTIVATION OF *BACILLUS FIGURANS* ON THE SURFACE OF NUTRIENT AGAR-AGAR.

over the surface. On blood serum they form a thin film.

Inoculation in rabbits and guinea-pigs and on the human skin produced no result.

They were isolated from flakes of cuticle from between the toes.

**Bacillus erysipelatis suis** (p. 356).

**Bacillus erythrosporus** (Eidam).—Slender rods and

filaments. Motile. Spore-formation present.	Spore-forma-		On potato the growth is brown. They occur in water.
---------------------------------------------	--------------	--	-----------------------------------------------------



FIG. 202.—PHOTOGRAPH OF PART OF AN IMPRESSION PREPARATION OF *BACILLUS FIGURANS* ON NUTRIENT GELATINE,  $\times 50$ .

Colonies circular, with brown nucleus and yellowish-green periphery. In the depth of gelatine they		<b><i>Bacillus figurans</i></b> (Crookshank). —Rods, with rounded ends, varying in length. Spore-formation present.
----------------------------------------------------------------------------------------------------	--	------------------------------------------------------------------------------------------------------------------------

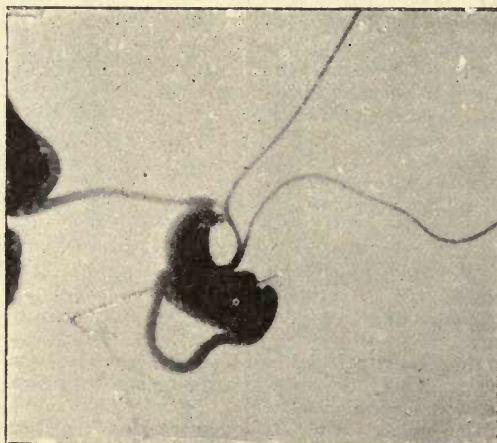

FIG. 203.—PART OF THE SAME SPECIMEN SHOWN IN FIG. 202  $\times 200$ .

grow in the track of the needle and on the free surface, colouring the jelly green by transmitted light, yellow by reflected light.		In plate-cultivations they cause a cloudy growth, spreading from various points; if a cover-glass impression is made, this is found
-------------------------------------------------------------------------------------------------------------------------------------	--	-------------------------------------------------------------------------------------------------------------------------------------



to consist of the regularly-arranged parallel rods. The chains of rods become twisted at intervals into curious convolutions, from which offshoots are continued in various directions. These long shoots or processes are again twisted at intervals into varying shapes and patterns (Figs. 202, 203). Cultivated in nutrient gelatine, the bacilli form on the surface visible windings, from which fine filaments grow down into the gelatine. They spread out also in almost parallel lines transversely from the needle track. The gelatine is not liquefied.

On an oblique surface of nutrient agar-agar the filaments spread downwards into the substance of the jelly, and outwards from the central streak on the surface, forming a feather-like cultivation (Fig. 201).

They were obtained from the air, and later were identified by the author with *Bacterium Zopfii*.

**Bacillus figurans** (Vaughan).—Rods and threads.

Colonies composed of curved and interlacing lines.

In gelatine they grow in the track of the needle, and very slowly liquefy it.

On agar they form a thin white layer.

They were found in water.

**Bacillus filiformis** (Tils).—Rods  $4\ \mu$  in length and  $1\ \mu$  in width, singly and in chains. Spore-formation present.

Colonies are granular, with yellowish nucleus.

Inoculated in the depth of gelatine there is no growth in the track of the needle, but a whitish growth on the surface, liquefying the jelly slowly.

In broth they form a skin on the surface.

On agar the growth is white.

On potato the growth is dry and after a time brownish. They coagulate milk.

They occur in water.

**Bacillus filiformis Havaniensis** (Sternberg).—Long slender rods,  $3\ \mu$  in diam., and filaments.

Colonies circular, irregular; deep

colonies are brownish; superficial colonies thin and translucent.

Inoculated in the depth of gelatine the growth is scanty in the track of the needle.

In the depth of agar an opaque branching growth occurs in the track of the needle, and a scanty milk-white growth on the surface.

In broth they cause opalescence.

They were isolated from the liver in fatal cases of yellow fever.

**Bacillus flavescens** (Pohl).—Rods  $2.1$  to  $2.2\ \mu$  in length,  $.8\ \mu$  in width. Slightly motile.

Colonies yellow and granular.

Inoculated in the depth of gelatine the bacilli produce a filament in the track of the needle, and a growth spreads over the free surface.

On the surface of agar the growth is composed of isolated yellow colonies.

On potato they grow rapidly, forming a shiny yellow layer.

They occur in marsh water.

**Bacillus flavocoriaceus** (Admetz).—Minute rods occurring in zoogloea.

Colonies circular, sulphur-yellow. Under a low power they show a brownish-yellow nucleus and yellow periphery.

Inoculated in the depth of gelatine the growth is granular in the track of the needle and on the free surface.

They occur in water.

**Bacillus fluorescens aureus** (Zimmermann).—Short rods,  $1.9\ \mu$  in length,  $.74\ \mu$  in width.

Singly, in pairs and in masses. Motile; flagellated.

Colonies circular, granular, yellow.

Inoculated in the depth of gelatine they form a filament in the track of the needle and a yellow patch on the surface.

On agar the growth is golden-yellow, and the same on potato.

They occur in water.

**Bacillus fluorescens liquefaciens** (Flügge).—Short rods with rounded ends.

Colonies on plates develop an iridescence around them.

In the depth of gelatine a white filament forms in the track of the needle, with liquefaction in the upper part, and an iridescent sheen is produced in the jelly.

On potato they develop a brownish layer.

They occur in water and in putrid infusions.

**Bacillus fluorescens liquefaciens minutissimus** (Unna and Tommasoli).—Rods 1.5 to 2  $\mu$  in length, .3  $\mu$  in width.

Colonies circular, with brownish nucleus and yellowish marginal zone.

In the depth of gelatine liquefaction forms in the track of the needle. The liquid is turbid and yellowish, and a white sediment forms at the bottom and a fluorescent scum on the surface.

On agar and potato the growth is brownish.

They were isolated from eczematous skin.

**Bacillus fluorescens longus** (Zimmermann).—Rods varying in length, some curved, 1.45 to 1.65  $\mu$  in length, .83  $\mu$  in width, and wavy filaments 14  $\mu$  in length. Motile.

Colonies circular, well-defined, yellowish, with broad twisted markings.

On the surface of gelatine they produce a layer with a bluish-green fluorescent colour.

On agar a thin film forms, and the jelly is coloured greenish-yellow.

On potato the growth is slimy and yellowish.

They occur in water.

**Bacillus fluorescens nivalis** (Schmolek).—Rods and chains. Motile.

Colonies circular, surrounded by liquid fluorescent jelly.

Inoculated in the depth of gelatine they produce liquefaction in the track of the needle, and the jelly is coloured green.

On agar the growth is white and the jelly green.

On potato the growth is brownish.

They are probably identical with *Bacillus fluorescens liquefaciens*.

They were isolated from snow.

**Bacillus fluorescens non-liquefaciens** (Eisenberg).—Short delicate rods. Non-motile.

Colonies have the appearance of fern-leaves, and are opalescent.

Inoculated in the depth of gelatine the growth is very slight in the track of the needle, and on the surface filmy and fluorescent.

On agar they form a greenish layer.

They produce a brownish layer on potato, and bluish-grey discoloration.

They occur in water.

**Bacillus fluorescens putidus** (Flügge).—Short rods with rounded ends. Motile; spore-formation not known.

They form small dark colonies with a greenish sheen, which have a penetrating odour.

Inoculated in the depth of gelatine they produce a pale-grey growth, and after three days colour the medium with a greenish tinge spreading down from above.

On potato they rapidly develop a brownish layer.

They occur on decomposing substances, producing a greenish coloration.

According to Lehmann and Neumann the *Bacillus fluorescens albus* and *Bacillus fluorescens longus* of Zimmermann and *Bacillus fluorescens non-liquefaciens* are merely varieties of *Bacillus fluorescens putidus*; and further, cultures of this bacillus on agar and on potato and in milk and in broth cannot be distinguished from those of *Bacillus fluorescens liquefaciens*.

**Bacillus fluorescens tenuis** (Zimmermann).—Rods 1 to 1.85  $\mu$  in length, .8  $\mu$  in width. Singly, in masses, and filaments. Motile.

Colonies irregular.

Inoculated in the depth of gelatine a delicate filament forms in the track of the needle, and on the surface a greyish-white growth spreads and colours the gelatine yellow.

On agar the growth is shining



and greenish, and on potato yellowish.

They occur in water.

**Bacillus fœtidus** (*Bacterium fœtidum*, Thin).—Cocci, short rods, long rods, and leptothrix. The cocci, 1.25 to 1.4  $\mu$  in diam., occur singly or in pairs. Spore-formation present in the rods.

They were isolated from the exudation in a case of profuse sweating of the feet, and the odour was noticeable in the cultivation (vide *Bacillus saprogenes*).

**Bacillus fœtidus ozænæ** (Hajek).—Short rods, singly, in pairs, and in short chains. Motile.

Colonies irregular and liquefying.

In the depth of gelatine liquefaction occurs along the track of the needle.

On agar the growth is moist and shiny, and on potato yellowish-brown.

Cultures emit a disagreeable odour.

They produce a fatal result in mice and local inflammation in rabbits.

They were isolated from cases of ozæna.

**Bacillus fulvus** (Zimmermann).—Rods .88 to 1.3  $\mu$  in length, .77  $\mu$  in width. Singly, in pairs and in chains.

Colonies vary in form; granular, yellowish-grey.

In the depth of gelatine there is a scanty faintly yellow growth in the track of the needle, and a hemispherical yellow mass on the free surface.

On agar and potato the growth is yellow and shining.

They occur in water.

**Bacillus fuscus** (Zimmermann).—Rods .63  $\mu$  in width, varying in length; sometimes bent and irregular in form.

Colonies irregular, granular, and greyish-yellow.

In the depth of gelatine a hemispherical mass appears on the free surface, which later spreads and forms a yellow wrinkled layer.

On agar and potato the layer is similarly coloured.

They occur in water.

**Bacillus fuscus limbatus** (Scheibenzuber).—Rods and filaments.

Colonies with brown nucleus and light periphery.

Inoculated in the depth of gelatine the growth in the track of the needle is branching and the jelly coloured brown.

On agar and potato the growth is dark brown.

They occur in rotten eggs.

**Bacillus gallinarum** (*Bacillus of Fowl Enteritis*) (see p. 230).

**Bacillus gasoformans** (Eisenberg).—Rods.

The colonies are granular, and liquefy the gelatine.

The bacilli inoculated in the depth of gelatine rapidly produce liquefaction in the track of the needle, and formation of gas bubbles.

They occur in water.

**Bacillus gingivæ pyogenes**: vide *Bacterium gingivæ pyogenes*.

**Bacillus glaucus** (Maschek).—Rods.

The colonies are well-defined, greyish in colour, and after a time liquefy the gelatine.

The bacilli inoculated in the depth of gelatine produce a rapid growth in the track of the needle and on the surface, followed by liquefaction and a sediment at the bottom of the liquid.

On potato and agar they form a greyish layer.

They occur in water.

**Bacillus gliscrogenus** (Malerba).—Rods .57 to 1.14  $\mu$  in length, .41  $\mu$  in width.

Colonies spherical, granular.

The bacilli inoculated in the depth of gelatine give rise to a growth in the track of the needle composed of closely packed disc-shaped colonies.

On agar they produce an opalescent film.

On potato they form a viscid yellowish growth.

They were isolated from viscid urine.

**Bacillus gracilis** (Zimmer-

mann).—Rods sometimes curved, 2.4 to 3.6  $\mu$  in length, .77  $\mu$  in width, and filaments.

The colonies are greyish or yellowish-grey, with concentric markings.

The bacilli inoculated in the depth of gelatine produce isolated colonies in the track of the needle, and a translucent film on the free surface; followed after some time by slight liquefaction.

On agar they produce a bluish-white layer.

There is scarcely any growth on potato.

They occur in water.

**Bacillus gracilis anaerobiescens** (Vaughan).—Rods.

The colonies are brownish.

The bacilli inoculated in the depth of gelatine produce a copious growth in the track of the needle, and gas bubbles, and a film on the surface.

On agar they produce a thin layer, and on potato a yellowish-white mass.

They occur in water.

**Bacillus granulosus** (Russell).—Rods singly, in pairs and in masses, and long filaments. Spore-formation present.

The colonies have concentric linear markings.

The bacilli inoculated in the depth of gelatine cause slow liquefaction spreading downwards in the track of the needle.

On the surface of agar they form more or less isolated whitish or yellowish colonies.

In broth they produce turbidity, and on potato a thick shining layer, which is at first white and later brownish.

They were isolated from deep-sea dredgings.

**Bacillus graveolens** (Bordoni-Uffreduzzi).—Very short rods, .8  $\mu$  in length.

The colonies are greyish-white, and liquefy the gelatine.

The bacilli inoculated in the depth of gelatine produce rapid liquefaction in the track of the needle. They colour the gelatine

greenish-yellow, and produce a foul odour.

On potato the culture is brownish.

They were isolated from skin from between the toes.

**Bacillus guttatus** (Zimmermann).—Rods 1 to 1.13  $\mu$  in length; .93 in width; singly, in pairs, and in chains.

Colonies bluish-grey; granular.

The bacilli inoculated in the depth of gelatine develop colonies in the track of the needle, and a greyish opalescent film on the surface.

On agar the growth is greyish-white. On potato it is yellowish and slimy.

They occur in water.

**Bacillus halophilus** (Russell).—Rods 1.5 to 3.5  $\mu$  in length, .7  $\mu$  in width; singly and in pairs; and toruloid involution forms. Motile.

The colonies liquefy gelatine and become frothy from abundant formation of gas.

The bacilli inoculated in the depth of gelatine grow in the track of the needle, and excavate the jelly at the upper part.

They were isolated from deep-sea dredgings.

**Bacillus Hansenii** (Rasmussen).—Rods 2.8 to 6  $\mu$  long, .6 to .8  $\mu$  wide.

Cultivated on sterilised potato, they form in four days a chrome-yellow layer with an agreeable fruit-like smell. Two or three days later the growth dries, and changes to an orange-yellow colour; later it becomes yellowish or brown, and at the same time spores are formed 1.7  $\mu$  long, 1.1  $\mu$  wide. The colouring matter is insoluble in most reagents.

The bacilli occur as a yellow or whitish skin on nourishing solutions, malt infusion, broth, and wine, which have been kept at 31° to 33° C.

**Bacillus Havaniensis liquefaciens**.—Rods .8  $\mu$  in width, 1.2 to 5  $\mu$  in length, singly, and in pairs; and filaments. Motile.

The colonies are milky, irregular



in outline, and liquefy the gelatine.

The bacilli inoculated in the depth of gelatine cause liquefaction in the track of the needle.

On agar they form a pale-brown layer.

They do not grow on potato.

They were isolated from the skin.

**Bacillus helvolus** (Zimmermann).—Rods 1.5 to 4.5  $\mu$  in length, .5  $\mu$  in width; in pairs, and in chains.

Colonies are pale yellow.

The bacilli form a yellow growth on the surface of gelatine, and produce slow liquefaction.

On agar the growth is yellow.

They occur in water.

**Bacillus heminecrobiophilus** (Arloing).—Rods highly polymorphic, and filaments 1 to 20  $\mu$  in length. Slightly motile.

On the surface of obliquely solidified gelatine they form a yellowish layer.

On potato the growth is yellowish-white.

They produce œdema when subcutaneously inoculated in the vicinity of wounds.

They were isolated from a caseous lymphatic gland in a guinea-pig.

**Bacillus hepaticus fortuitus** (Sternberg).—Rods resembling *Bacillus coli communis*.

The colonies, marked with radiating striæ, are dark brown in colour.

The bacilli inoculated in the depth of gelatine produce a very slight growth at the upper part of the track of the needle, and a hemispherical mass on the free surface.

On potato they form a creamy white growth.

They were isolated from the liver in a fatal case of yellow fever.

**Bacillus Hessii** (Guillebeau).—Rods 3 to 5  $\mu$  in length, 1.2  $\mu$  in width, cocci-forms and filaments.

The colonies are filamentous, and liquefy gelatine.

The bacilli inoculated in the depth of gelatine produce liquefaction, and the liquid jelly is made extremely viscous.

On potato the growth is brownish.

They coagulate milk.

They were isolated from milk.

**Bacillus hyacinthi septicus** (Heinz).—Rods 4 to 6  $\mu$  in length, 1  $\mu$  in width.

The colonies are transparent and bluish-white.

The bacilli inoculated in the depth of gelatine produce a filament in the track of the needle and a layer on the surface.

On potato they produce a slimy, dirty-yellow layer.

They were isolated from diseased hyacinths.

**Bacillus hyalinus** (Jordan).—Rods 3.6 to 4  $\mu$  in length, 1.5  $\mu$  in width, and chains.

The colonies are surrounded by radiating filaments.

The bacilli inoculated in the depth of gelatine produce liquefaction in the track of the needle, a scum on the surface and a deposit at the bottom.

On agar they produce a dry, grey growth.

On potato the growth is greyish-white and tuberculated.

They coagulate milk.

In broth they produce turbidity and a pellicle on the surface; and they are powerful nitrifying agents.

They occur in water.

**Bacillus hydrophilus fuscus** (Sanarelli).—Rods 1 to 3  $\mu$  in length, and filaments 15 to 20  $\mu$  in length.

They rapidly produce a funnel-shaped area of liquefaction when grown in gelatine, followed by complete liquefaction and the formation of a white flocculent deposit.

Inoculated in glycerine agar they grow rapidly and produce gas bubbles. On potato they produce a straw-coloured layer which becomes distinctly yellow and later brown.

They are pathogenic in cold-blooded animals and in small warm-blooded animals. Guinea-pigs succumb in twelve hours; the spleen is enlarged and the bacilli are found

in great numbers in the blood and internal organs.

They were isolated from the lymph of diseased frogs.

**Bacillus ianthinus** (*Bacterium ianthinum* Zopf, *Bacillus violaceus*).

—Slender rods, about four times their width in length, with rounded ends. They also form threads, and are actively motile. Spore-formation present in the rods.

The colonies occur as circumscribed liquefied areas, in the centre of which is a collection of the coloured growth.

The bacilli inoculated in the depth of gelatine produce a funnel-shaped liquefaction, and a granular-looking violet mass subsides to the bottom.

On agar-agar and potato a beautiful violet growth rapidly develops. The colouring matter is soluble in alcohol.

They were observed on pieces of pigs' bladder floating on the surface of water rich in bacteria. They occurred only on the surface of the bladder exposed to the air, and never on the part under water. They occasionally occur in common tap water.

**Bacillus implexus** (Zimmermann). Rods  $2.5 \mu$  in length,  $1.15 \mu$  in width. Non-motile. Spore-formation present.

Colonies white, granular, developing in three days into masses of interlacing white filaments.

Inoculated in the depth of gelatine, a growth develops in the track of the needle and fine filaments penetrate the gelatine. The jelly is liquefied, and a pellicle forms on the surface, and there is a flocculent deposit.

On agar the growth is white, and on potato yellowish-white.

They occur in water.

**Bacillus in acne contagiosa in horses** (Dieckerhoff and Grawitz).—Short rods  $.2 \mu$  in diam.

Inoculated in the depth of nutrient gelatine they form a scanty growth in the track of the needle and a white patch on the free surface. They thrive best on blood serum and on agar.

The bacilli inoculated on the surface of the skin of horses, calves and other animals are said to produce acne pustules. Inoculated subcutaneously in guinea-pigs they produce a fatal result in twenty-four hours.

They were isolated from pus in cases of *acne contagiosa* in horses.

**Bacillus in cancer** (Koubasoff).—Rods; spore-formation present.

Inoculated in the depth of gelatine an irregular filament develops in the track of the needle and a transparent growth with central depression on the surface.

They are said to be pathogenic in small animals, and to produce nodules and ulcers of the mucous membrane of the stomach.

They were isolated from a case of cancer of the stomach.

**Bacillus in cholera in ducks** (Cornil and Toupet), p. 230.

**Bacillus in choleraic diarrhoea** (Bovet).—Rods 2 to  $4 \mu$  in length, 1 to  $1.5 \mu$  in width, singly and in pairs, and filaments.

In the depth of gelatine a filament forms in the track of the needle and a greyish transparent layer on the surface.

On agar a greyish film is formed.

On potato the growth is yellowish and abundant.

Intra-peritoneal injections in guinea-pigs cause peritonitis and death.

They were isolated from a case of choleraic diarrhoea.

**Bacillus in diphtheritic disease of calves** (*Bacillus vitulorum* Löffler).—Rods about five or six times as long as wide, mostly united in long threads.

A piece of membrane from a diphtheritic disease in a calf, placed on blood serum developed a white layer composed of the bacteria. Successive generations were not obtainable.

Mice inoculated directly from the calf died of a characteristic illness, and the same long bacteria were again found in the inoculated animals accompanying widespread infiltration, starting from the point of inoculation. Inoculation of





guinea-pigs and rabbits gave doubtful results. They were found in the deeper stratum of pseudo-diphtheritic patches in calves.

**Bacillus in disease of bees** (p. 471).

**Bacillus in erythema nodosum** (Demme).—Rods 2·2 to 2·5  $\mu$  in length, ·5 to ·7  $\mu$  in width. They can be cultivated at 37°C.

Colonies on agar are white with radiating lines.

The bacilli inoculated in the depth of agar grow in the track of the needle, and produce peculiar offshoots in the surrounding jelly.

They are said to produce an eruption resembling erythema nodosum when inoculated subcutaneously in guinea-pigs.

They were obtained from the eruption and the blood in cases of erythema nodosum.

**Bacillus in fowl enteritis** (Klein), p. 230.

**Bacillus in gangrene** (Tricomi).—Rods 3  $\mu$  in length, 1  $\mu$  in width, singly and in pairs.

Colonies circular, granular, dirty-yellow.

In the depth of gelatine they produce a filament composed of closely aggregated colonies, and at the upper part conical liquefaction of the jelly, beneath a cup-shaped excavation.

On agar and potato the growth is white.

Injected subcutaneously in rabbits and guinea-pigs they produce gangrene and death in a few days.

They were isolated from a case of senile gangrene.

**Bacillus in grouse disease** (Klein), p. 230.

**Bacillus in hog cholera** (p. 351).

**Bacillus in infantile diarrhoea** (Booker).—Rods morphologically identical with *Bacillus coli* communis. There are seven varieties of this bacillus. They were isolated from cases of infantile diarrhoea.

**Bacillus in infantile diarrhoea** (Lesage).—Rods 2·4  $\mu$  in length, ·75  $\mu$  in width, and filaments.

Colonies irregular in contour, colouring the gelatine green.

On the surface of agar they form a greenish growth, and the gelatine is coloured green.

Injected intravenously in a rabbit they produced diarrhoea.

They are said to be identical with *Bacillus fluorescens liquefaciens*.

**Bacillus in intestinal diphtheria in rabbits** (Ribbert).—Rods 3 to 4  $\mu$  in length, 1 to 1·4  $\mu$  in width; singly, in pairs, and in filaments.

Colonies greyish; granular.

They produce in gelatine a delicate growth in the track of the needle. They are pathogenic.

They were isolated from the intestine of rabbits suffering from a diphtheritic inflammation of the mucous membrane.

**Bacillus in jequirity infusion** (see *Bacillus of Sattler*).

**Bacillus in measles** (p. 283).

**Bacillus in noma** (Schimmelbusch).—Rods singly, in pairs, and filaments.

Colonies circular, greyish-white, granular, with irregular margins.

In the depth of gelatine they produce a granular filament and a patch on the surface.

On agar and potato the growth is greyish-white.

They are pyogenic in rabbits.

They were inoculated from a case of noma.

**Bacillus in ophthalmia** (p. 190).

**Bacillus in potato rot**.—Rods 2·5 to 4  $\mu$  in length, ·7 to ·8  $\mu$  in width; singly, in chains, and in filaments. Spore-formation present.

The bacilli inoculated in the depth of gelatine produce a funnel-shaped area of liquefaction.

On agar the growth is composed of greyish-white slimy colonies.

They were isolated from diseased potatoes.

**Bacillus in purpura hæmorrhagica** (Tizzoni and Giovannini).—Rods ·75 to 1·3  $\mu$  in length, ·2 to ·4  $\mu$  in width, singly, in pairs, and in masses.

Colonies have a greyish-yellow nucleus and a marginal zone of fine

filaments both in gelatine and agar. Cultures produce a disagreeable odour.

Subcutaneous injections in guinea-pigs and rabbits produce local œdema and death, with hæmorrhages in the internal organs.

They were isolated from the blood in fatal cases of purpura in children.

**Bacillus in putrid bronchitis** (Lumnitzer).—Rods 1.5 to 2  $\mu$  in length, slightly curved. They can be cultivated at 37° C. The colonies on agar are greyish-white.

The bacilli inoculated on blood serum produce colonies which coalesce and form a greyish-white film. Cultures have a disagreeable odour.

Injected into the lungs of rabbits they produce purulent inflammation.

They were isolated from the sputum in cases of putrid bronchitis.

**Bacillus in "red-cod"** (Dantec).—Rods similar to *Bacillus tetani*, with terminal spore-formation.

Colonies are circular; reddish.

On the surface of obliquely solidified gelatine they form a red growth in the track of the needle slowly followed by liquefaction.

Cultivated on dried cod they produce a red colour.

They were isolated from red-cod.

**Bacillus in rhinoscleroma** (p. 411).

**Bacillus in saliva** (Fiocca).—Very short rods .2 to .33  $\mu$  in width.

Colonies circular, granular, and yellowish.

On the surface of obliquely solidified gelatine they form a growth composed of transparent droplets.

On potato they form a transparent film.

In broth flocculi appear.

They are pathogenic in rabbits and other small animals, and they are probably a variety of the bacillus of hæmorrhagic septicæmia.

They were isolated from saliva of cats and dogs.

**Bacillus in whooping cough** (Afanassiew).—Rods .6 to 2.2  $\mu$  in length, singly, in pairs, and short chains.

Colonies granular, brownish.

Inoculated in the depth of gelatine there is a scanty growth in the track of the needle and a greyish growth on the free surface.

On agar the growth is greyish.

On potato the growth is shining and yellowish or brownish.

They are said to produce symptoms in rabbits and dogs comparable to those of whooping cough.

They were isolated from the throat in cases of whooping cough.

**Bacillus incanus** (Pohl).—Rods 1.2  $\mu$  in length, .8  $\mu$  in width.

They produce rapid liquefaction in the track of the needle when inoculated in the depth of gelatine.

On agar a thick white growth develops.

On potato a whitish growth spreads over the surface.

They were isolated from the water of marshes.

**Bacillus indicus** (Koch).—Very short rods with rounded ends.



FIG. 204.—*BACILLUS INDICUS* COLONIES IN NUTRIENT AGAR,  $\times 60$ .

The colonies have a scarlet tint. They are round, ovoid, or spindle-shaped, and have granular margins.

In the track of the needle beneath the surface no pigment is formed.

Cultivated in nutrient gelatine they liquefy it and colour it crimson, and the growth of a darker crimson hue subsides to the bottom of the tube.

On the surface of nutrient agar the appearances are very characteristic. In a pure cultivation a brilliant vermilion-coloured reticulated pellicle develops on the surface. (Plate II. Fig. 3.)



They form a vermilion layer on potato.

They were isolated by Koch in India from the intestinal contents of an ape.

**Bacillus indigogenes** (Alvarez).—Rods  $3\ \mu$  in length and  $1.5\ \mu$  in width, singly, and in chains; capsulated.

On agar they produce a yellowish-white layer, and are said to develop an indigo-blue colour in infusions of leaves of the indigo plant.

Intravenous injections in guinea-pigs are said to produce death in a few hours.

They were isolated from the leaves of the indigo plant.

**Bacillus indigonaceus** (Cläsen).—Rods  $1.6$  to  $3\ \mu$  long,  $.8$  to  $.9\ \mu$  wide; non-motile.

They form a sky-blue layer on the surface of gelatine.

On potato the growth is dark-blue, and later has a metallic lustre.

**Bacillus indigoferus**, which was found in water at Kiel, is only to be distinguished by its motility.

**Bacillus inflatus** (A. Koch).—Rods  $4.6$  to  $5.5\ \mu$  in length,  $.6$  to  $1.8\ \mu$  in width, and filaments.

The colonies send out delicate processes.

The bacilli inoculated in the depth of gelatine send out fine filaments in the track of the needle followed by slow liquefaction.

On agar they form a shining brownish layer.

In broth a pellicle forms on the surface.

They occur in the air.

**Bacillus inunctus** (Pohl).—Rods  $3.5\ \mu$  in length,  $.8$  to  $.9\ \mu$  in width.

Inoculated in the depth of gelatine they grow both in the track of the needle and on the surface; liquefaction follows in time.

On agar they form a whitish growth.

They were isolated from the water of marshes.

**Bacillus invisibilis** (Vaughan).—Rods; motile.

The colonies are irregular and yellowish.

Inoculated in the depth of gelatine they grow both in the track of the needle and on the surface.

On agar they form a white growth.

On potato they develop an invisible layer.

They occur in water.

**Bacillus iridescens** (Tataroff).—Rods from  $3.5$  to  $5.2\ \mu$  in length and threads. Spore-formation present; slightly motile.

The colonies have a characteristic appearance recalling that of the convolutions of the brain.

Inoculated in the depth of gelatine there is a depression at the point of puncture, and a thread-like growth along the needle track.

On agar they form a thick, uneven, moist, greenish-yellow, iridescent growth, with a pitted surface.

Blood serum is liquefied.

On potato there is a dry, thick, dark yellow growth like honey.

Broth is rendered turbid, and there is a yellow deposit.

They are found in water.

**Bacillus lactis aerogenes** (Escherich).—Rods short and thick,  $.5$  to  $.8\ \mu$  broad, and  $1$  to  $2\ \mu$  long, with rounded ends; usually in pairs side by side and also in irregular heaps. Non-motile; spore-formation not observed. They grow best at  $37^{\circ}\text{C}$ .

Colonies on the surface are raised, moist, shining and porcelain-white. Below the surface they have a yellowish nucleus.

Inoculated in the depth of gelatine the rods form an abundant nail-shaped growth. On potato the culture is composed of white colonies, and bubbles are formed. The colonies may coalesce and produce a creamy layer.

On blood serum there is a raised, moist, shining, white growth.

In milk sugar or grape sugar solutions they produce gas.

Injected subcutaneously in rabbits and guinea-pigs they cause death in from one to three days, and the bacilli are found in the blood and internal organs.

They were found in the intestinal tract of animals fed with milk and of infants at the breast.

**Bacillus lactis albus** (Löffler).—Rods,  $3.4 \mu$  in length,  $.96 \mu$  in width, and filaments. Spore-formation present.

Inoculated in the depth of gelatine they slowly liquefy the upper part, and a white scum forms on the surface.

On agar they form a white layer.

On potato the growth is dry and white. They coagulate milk.

They occur in milk.

**Bacillus lactis erythrogenes** (Hueppe).—Short rods, 1 to  $1.4 \mu$  in length and  $.3$  to  $.5 \mu$  in width, and filaments. Colonies small and circular; greyish-white; later yellow and surrounded by liquefied gelatine with a pink tinge.

In the depth of gelatine the growth in the track of the needle is scanty, but on the surface a whitish patch forms which afterwards turns yellow, and the gelatine is coloured pink. Later liquefaction sets in, and the liquefied gelatine is turbid and pink.

On agar a shining yellow layer develops, and the same on potato.

In broth the bacilli produce turbidity, and they coagulate milk.

They occur in "red milk."

**Bacillus lactis pituitosi** (Löfer).—Rods slightly bent.

Colonies circular, greyish-white.

On agar and potato they produce a greyish-white layer.

They render milk viscid.

They occur in milk.

**Bacillus latericeus** (Adamez and Eisenberg).—Rods and filaments.

Colonies circular, granular, reddish-brown.

In the depth of gelatine there is a scanty growth along the track of the needle and a brick-red growth on the surface.

On potato the growth is also brick-red.

They occur in water.

**Bacillus leporis lethalis** (Gibier and Sternberg).—Rods 1 to  $3 \mu$  in length,  $.5 \mu$  in width.

Colonies transparent and with the appearance of broken glass.

In the depth of gelatine there is a growth along the track of the needle with a conical area of liquefaction at the upper part, and a white sediment.

On agar they form a translucent film. They liquefy blood serum.

On potato the growth is pale-yellow.

Cultures injected into the peritoneal cavity of rabbits are toxic.

They were isolated from the intestinal contents in cases of yellow fever.

**Bacillus lepræ** (p. 407).

**Bacillus leptosporus** (L. Klein).—Rods resembling hay-bacilli, singly, in chains and long twisted filaments.

The spore-membrane is said to form part of the newly grown bacillus, and the filaments are described as possessing peculiar spasmodic movements.

They were isolated from a contaminated culture.

**Bacillus limbatus acidi lactici** (Marpmann).—Rods short, thick; singly, in pairs; capsulated.

Colonies white.

In the depth of gelatine they develop slightly in the track of the needle, and produce a white patch on the free surface.

In milk they produce coagulation and lactic acid.

They occur in milk.

**Bacillus limosus** (Russell).—Rods 3 to  $4 \mu$  in length,  $1.25 \mu$  in width; singly, in pairs and chains; spore-formation present.

Colonies transparent, surrounded by filamentous processes.

In the depth of gelatine prepared with sea-water, liquefaction occurs rapidly in the track of the needle, and a deposit forms at the bottom and a thin skin on the surface.

On agar they form a white layer, and in broth turbidity and a thick scum.

On potato the growth is greyish-white.



They were isolated from deep-sea dredgings.

**Bacillus liodermos** (Flügge).—Small short rods with rounded ends; actively motile.

Colonies with irregular outlines float on liquefied gelatine in the form of small white flakes.

Inoculated in gelatine a greyish growth occurs along the track of the needle, but the medium later becomes liquefied and a greyish-white flocculent deposit settles at the bottom.

On potato a smooth shining yellowish-white layer spreads quickly over the whole surface, and after some days becomes opaque and slightly wrinkled.

They occur on potato.

**Bacillus liquefaciens** (Eisenberg).—Rods short and thick, with rounded ends. Very motile.

Colonies round, with smooth edges and slimy centres. Liquefaction follows, and a putrefactive odour is noticed.

In gelatine they make a funnel-shaped whitish growth along the track of the needle.

On potato the growth is pale yellow.

They occur in water.

**Bacillus liquefaciens communis** (Sternberg).—Rods 1 to 2  $\mu$  in length, and 7  $\mu$  in width; singly and in pairs.

In the depth of gelatine they produce rapid liquefaction in the track of the needle.

On potato a wrinkled pinkish layer is formed.

They were isolated from the evacuations of yellow-fever patients.

**Bacillus liquefaciens magnus** (Lüderitz).—Rods 3 to 6  $\mu$  in length, 8 to 1.1  $\mu$  in width, and filaments. They are anaerobic.

Colonies develop below the surface of the gelatine, and liquefaction extends upwards to the surface.

The bacilli inoculated in the depth of gelatine cause liquefaction in the lower part of the track of the needle.

In the depth of agar the colonies have delicate branches.

They liquefy blood-serum, and produce a putrefactive odour.

They occur in earth.

**Bacillus liquefaciens parvus** (Lüderitz).—Rods 2 to 5  $\mu$  in length, 5 to 7  $\mu$  in width, and filaments. They are anaerobic.

Colonies are white, and liquefy gelatine; but in agar they are spherical or almond-shaped.

In the depth of gelatine isolated colonies appear in the track of the needle, and in the depth of agar there is gas formation.

They occur in earth.

**Bacillus liquidus** (Frankland).—Rods short and flat with rounded ends, usually in pairs, the length of each pair varying from 1.5  $\mu$  to 3.5  $\mu$ . They are very variable in size; highly motile; spore-formation not observed.

Colonies form cup-shaped excavations, with almost clear, colourless contents. The edges are at first smooth and circular, but they become serrated and granular, and soon coalesce.

A broad funnel-shaped depression forms along the whole track of the needle, containing turbid liquid and masses of flocculent material. Later a thin pellicle forms on the surface, which sinks if the tube is shaken.

On agar they grow quickly, forming a smooth shining layer.

On potato a thick flesh-coloured growth appears.

Broth is rendered turbid with an abundant sediment, and after a few days a pellicle forms.

They are common in unfiltered water.

**Bacillus litoralis** (Russell).—Colonies granular, with regular contour; slowly liquefying.

In the depth of gelatine they develop a growth in the track of the needle, and at the upper part produce a cup-shaped cavity lined with the culture. The gelatine is tinged with brown in the vicinity.

On agar they produce a greyish-white film, and in broth turbidity.

Inoculated in the depth of gelatine the bacilli form a funnel-shaped liquefaction along

the track of the needle, and the whole of the gelatine gradually becomes liquid, with a flocculent deposit at the bottom and a greyish wrinkled stain on the surface.

On potato a thick wrinkled whitish skin forms, which rapidly grows over the whole surface. On attempting to raise this skin it will be found to be attached to the potato by a mucous substance which may be drawn out in long threads. According to Hueppe the bacilli cannot form any ropy substances from sugar, but they have an energetic diastatic action. They coagulate the casein in milk in a similar manner to rennet.

The bacilli are ubiquitous.

**Bacillus lividus** (Plage and Proskauer).—Rods.

Colonies blue-black, liquefying.

In the depth of gelatine they produce a colourless thread in the track of the needle and a violet layer on the surface followed by gradual liquefaction.

On agar the growth is blue-black, and on potato violet.

They were isolated from water.

They are probably identical with *Bacillus ianthinus*, or merely a variety.

**Bacillus luteus** (Flügge).—Short immotile rods.

Colonies irregular in form, appear brownish under a low power, and yellow to the naked eye.

In test-tube cultivations they form a yellow growth without liquefying the gelatine.

They occur contaminating plate-cultivations.

**Bacillus maidis** (Cuboni).—Rods 2 to 3  $\mu$  in length, singly, in pairs, and in chains; spore-formation present.

Colonies granular, with wrinkled periphery; later, liquefying.

In the depth of gelatine they produce rapid liquefaction in the track of the needle.

On agar a dry wrinkled white film spreads over the surface.

On potato the growth is wrinkled, and later yellowish-brown. They liquefy blood serum.

They were isolated from human evacuations and infusions of maize.

**Bacillus mallei** (p. 452).

**Bacillus megatherium** (De Bary).—Rods 2.5  $\mu$  wide and four to six times as long, with rounded ends and slightly curved, and in short irregular chains. Transverse division occurs, each segment attaining the length of the original rod. In the fresh state they appear non-articulated, but when treated

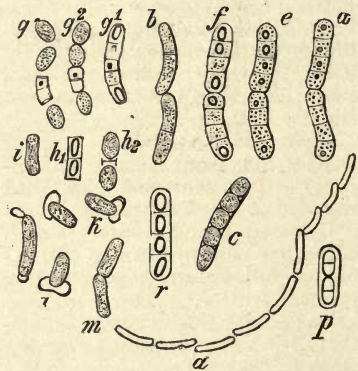

FIG. 205.—*BACILLUS MEGATHERIUM*. (a) A chain of rods  $\times 250$ , the rest  $\times 600$ . (b) Two active rods; d and f, successive stages of germination; h and l, successive stages of germination. (De Bary.)

with a dehydrating agent they are seen to be composed of short segments with granular contents. They are motile.

Colonies are small and circular, and the gelatine is liquefied.

In the depth of gelatine the bacilli grow rapidly, forming a funnel-shaped liquefaction in the upper part.

On agar they form a whitish layer on the surface, and the jelly acquires a dark colour.

On potato yellowish-white cheesy colonies are formed round the point of inoculation. In cultures there is copious spore-formation. They grow best at 20° C.

They were isolated originally from boiled cabbage.





FIG. 206.—PURE-CULTURE OF *BACILLUS MEGATHERIUM* IN GELATINE.

***Bacillus membranaceus amethystinus*** (Eisenberg).—Short rods with rounded ends from 1 to 1.4  $\mu$  long, and .5 to .8  $\mu$  broad. They are grouped together irregularly. Some individual bacilli stain more deeply at the ends than in the middle. Non-motile. They grow only between 15° and 20° C. Spore-formation uncertain.

The colonies gradually assume a violet hue, and after liquefying the gelatine float on the surface as violet pellicles, resembling a membrane stained with gentian violet.

Inoculated in the depth of gelatine a yellowish-white growth appears on the free surface, which after ten days or more becomes violet. Liquefaction takes place gradually, and in about a month a thick violet layer covers the gelatine which lies beneath the liquid part.

On agar the growth, which at first has a yellowish milky appearance, becomes violet after eight or ten days. In three or four weeks it has become very much wrinkled, and has a beautiful deep-violet colour with a metallic lustre. The

jelly is not stained, and the growth can be easily removed from its surface.

On potato they grow slowly, and form a dirty yellow or olive-green colour.

In broth they grow very slowly; after some weeks a violet deposit and pellicle are formed, and the liquid between becomes dark brown.

They were found in well water.

***Bacillus meningitidis purulentae*** (Neumann and Schaffer).—Rods 2  $\mu$  in length, .6 to .7  $\mu$  in width, and filaments.

Colonies granular, greyish.

In the depth of gelatine a greyish-yellow filament develops, composed of closely packed colonies, and on the surface a greyish layer.

On potato the growth is moist and white.

They are pyogenic in small animals and dogs.

They were isolated from a case of purulent meningitis.

***Bacillus mesentericus fuscus*** (Flügge).—Rods small and short, singly, in chains of two and four. Actively motile. Spore-formation present.

Colonies are at first roundish and rather white, with a sharp outline; later delicate brownish-yellow processes appear. Liquefaction occurs rapidly.

Inoculated in the depth of gelatine a whitish growth forms along the track of the needle, the upper portion of which soon liquefies; greyish flakes float in the liquefied portion.

On potato a smooth yellowish growth appears on the first day, but it soon becomes brown and wrinkled. It remains relatively thin and superficial, and quickly spreads over the whole surface.

They are found in hay dust, in the air, on the surface of potatoes, and are very widely distributed.

***Bacillus mesentericus ruber***.—Slender rods, singly, in pairs, and in filaments.

Colonies are circular and yellowish until they come to the surface, when they produce a network and

liquefy the gelatine. The network disappears and a little deposit occurs at the bottom of the liquefied area.

Inoculated in the depth of gelatine a whitish cloudy growth forms along the needle track, liquefaction sets in and extends until the gelatine is completely liquefied.

On potato a thin crinkled film is formed, which is yellowish or reddish-yellow in colour.

They occur on potato.

**Bacillus mesentericus vulgaris** (Flügge).—Rods large and thick, often forming pseudo-threads. They have an oscillating movement. Spore-formation present.

The colonies are bluish-white and almost transparent, though the centres become gradually opaque. They sink in the liquefied gelatine, and are granular with irregular contour.

**Bacillus multipediculus** (Flügge).—Rods long and slender. Non-motile.

The colonies consist of a central oval nucleus, from which numerous tapering processes shoot out mostly towards one pole. This form of growth gives a curious resemblance to an insect with feet and antennæ.

Inoculated in the depth of gelatine a whitish line forms along the track of the needle, from which short processes grow out.

On potato a rather scanty dirty-yellow growth forms, and the surface of the potato becomes discoloured around it.

They are often found as a contamination on potato.

**Bacillus muscoides** (Liborius).—Rods  $1\ \mu$  thick, sometimes forming threads; slightly motile, and with round or oval spores at one end. They are anaerobic.

The colonies ramify and resemble a delicate moss.

They were found in the œdematous fluid of field mice inoculated with garden earth and stale cheese.

**Bacillus mycoides** (Flügge).—Rods rather thick, nearly the size of *Bacillus anthracis*. Motile, often forming long pseudo-threads.

Oval and highly refractive spores both in the rods and threads.

Colonies consist of a whitish turbidity in which colourless branched and interwoven processes are seen; these increase rapidly, and after twelve to twenty hours appear like the mycelium of a fungus.

Inoculated in the depth of gelatine they form very fine and closely set hairs extending from the track of the needle. Later liquefaction occurs.

On potato a whitish layer gradually extends over the surface.

They occur in earth from the surface of cultivated ground.

**Bacillus mycoides roseus** (Scholl).—Rods.

Colonies composed of interlacing filaments.

Inoculated in the depth of gelatine they produce liquefaction in the track of the needle; a reddish scum forms on the surface, and a reddish deposit at the bottom of the liquefied area.

On agar they produce, in the absence of light, a pink growth.

**Bacillus neapolitanus** (Emmerich).—Short rods  $0.9\ \mu$  in width.



a

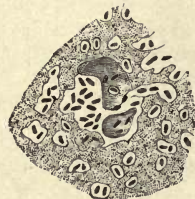

b

FIG. 207.—*BACILLUS NEAPOLITANUS*,  $\times 700$  (EMMERICH). *a*, From intestinal contents in a case of cholera; *b*, From peritoneal fluid of an inoculated guinea-pig.



Colonies circular, later irregular, granular, strongly refractive and yellowish-brown. They are probably identical with *Bacillus coli communis*.

They were isolated from cases of cholera at Naples.

***Bacillus necrophorus* (Löffler).**

—Rods and filaments.

They cannot be cultivated on the ordinary media. In rabbit broth they give rise to fluffy masses of filaments.

Intravenous injection produced in rabbits a pyæmic condition in about a week. The bacilli were found in the pus.

They were isolated from a rabbit which had been inoculated with fragments of a condyloma.

***Bacillus nitrificans* (Winoogradsky).**—Very small rods  $\cdot 5 \mu$  in length, singly and in zoogloea.

Colonies in silica jelly are lenticular, and sub-cultures in liquid media produce a gelatinous deposit. They are powerful oxidising agents.

They were isolated from the soil.

***Bacillus nodosus parvus* (Lustgarten).**—Rods  $1\cdot 2$  to  $2\cdot 4 \mu$  in length,  $\cdot 4 \mu$  in width; singly and in pairs.

Inoculated in the depth of agar they produce a white filament in the track of the needle composed of crowded colonies, and on the surface a hemispherical glistening growth.

They were isolated from the human urethra.

***Bacillus nubilus* (Frankland).**—Slender rods  $3 \mu$  long and  $\cdot 3 \mu$  wide, and threads. Single bacilli have an active rotatory movement, but the long threads in broth cultures are quite motionless. Spore-formation not observed.

The colonies appear as cloudy undefined patches, which rapidly liquefy the gelatine. They consist of a tangled mass of threads.

Inoculated in the depth of gelatine they produce along the track of the needle horizontal circular plates, with a delicate cloud-like appearance, and liquefaction at the

upper part. Later the whole of the gelatine is liquefied.

On agar they form a thin opalescent blue-violet film, the edges of which exhibit later a distinct violet fluorescence.

On potato there is a slightly yellow growth which is scarcely visible.

Broth is rendered turbid with a dirty-white deposit, the surface being covered by a thin pellicle.

They occur in water.

***Bacillus ochraceus* (Zimmermann).**—Rods  $1\cdot 25$  to  $4\cdot 5 \mu$  in length;  $\cdot 65$  to  $\cdot 75 \mu$  in width; singly, in pairs, chains, and filaments; capsulated.

Colonies circular, granular, yellow, liquefying.

Inoculated in the depth of gelatine they produce liquefaction in the track of the needle, and a yellow deposit.

On agar and potato the growth is yellow ochre in colour.

They occur in water.

***Bacillus œdematis aerobicus* (Klein).**—Rods  $\cdot 8$  to  $2\cdot 4 \mu$  in length,  $\cdot 7 \mu$  wide, and long filaments.

Colonies greyish, transparent, with irregular contour.

In the depth of gelatine a filament occurs in the track of the needle, and gas bubbles in isolated colonies in its lower part, and a transparent patch with irregular margin on the free surface.

On the surface of agar they produce a greyish-white layer.

In broth there is turbidity with flocculi.

On potato the growth is yellowish and viscid.

They give rise to extensive œdema in guinea-pigs, and in a less marked form in rabbits.

They occur in earth.

***Bacillus œdematis maligni* (p. 220).**

***Bacillus of Belfanti and Pascarola.***—Very short rods.

Colonies circular, granular, yellowish-grey.

Inoculated in the depth of gelatine they produce a filament composed of closely-packed minute

colonies, and on the surface a greyish film.

On agar they produce a greyish-white growth.

On potato a transparent whitish film.

They are fatal to rabbits, guinea-pigs and small birds.

They are probably identical with *Bacillus septicæmiæ hæmorrhagicæ*.

They were isolated from pus in a case of tetanus.

They were isolated from deep-sea dredgings.

**Bacillus of Colomiatti.**—Minute rods. Spore-formation occurs at the ends of the rods. They can be cultivated at 37° C.

They form a thin film on agar and on blood serum.

They were isolated in cases of conjunctivitis.

**Bacillus of Fulles, No. I.**—Rods 1 to 1.2  $\mu$  in length, .6  $\mu$  in width.

Colonies circular, granular, yellowish-brown.

On the surface of gelatine they produce a thin film, and in broth turbidity and flocculi.

On potato the growth is yellowish.

No. II. Very short rods.

Colonies circular, granular, yellowish.

In the depth of gelatine the growth resembles Friedländer's pneumococcus.

On potato the growth is yellowish.

They were isolated from earth.

**Bacillus of Guillebeau.**—No. I. Short rods 1 to 2  $\mu$  in length, 1  $\mu$  in width.

Colonies spherical, granular.

In gelatine the bacilli produce a growth in the track of the needle and a white patch on the surface.

On agar the growth is white, and on potato yellowish, viscid, and containing gas bubbles.

They coagulate milk.

No. II. Rods resembling the above described but distinguished by the production of viscid colonies and, extremely slowly, of liquefaction in the jelly.

No. III. Rods also resembling the above mentioned, but colonies are

adherent to the jelly and coarsely granular.

Milk and other liquid culture media are rendered extremely viscid.

**Bacillus of Letzerich.**—Rods sometimes bent, and filaments.

They rapidly liquefy gelatine.

They produce purulent peritonitis and death in rabbits.

They were isolated from urine.

**Bacillus of Martinez (Sternberg).**—Short rods 1 to 1.2  $\mu$  in length and .5 to .8  $\mu$  in width; non-motile.

Colonies circular and translucent, with a central, nipple-like projection, and the surface covered with mosaic markings.

In the depth of gelatine the growth consists of large spherical translucent colonies in the track of the needle, and a thin, translucent, scanty growth upon the surface.

They were isolated from the liver in a fatal case of yellow fever.

**Bacillus of Nocard.** (*Vide Streptothrix farcinica.*)

**Bacillus of Okada.**—Short rods rather thicker than the bacilli of mouse-septicæmia, singly, in pairs and in filaments. Spore-formation not observed.

Colonies granular and brownish.

Inoculated in the depth of gelatine they form a white filament, and on the surface a milk-white patch.

Inoculated on agar the growth spreads over the surface forming a milk-white layer.

In broth they produce cloudiness and a layer floating on the surface.

They do not grow on potato.

Cultures produce death in mice, guinea-pigs and rabbits in twenty hours.

They were isolated from dust.

**Bacillus of Roth.**—No. 1 and No. 2. Rods.

Two varieties were isolated from old rags. They appear to be varieties of *Bacillus coli communis*.

**Bacillus of Sattler.**—2 to 4.5  $\mu$  long and .58  $\mu$  thick.

They can be cultivated on nutrient gelatine and blood serum.

Infusion of jequirity containing



the bacilli, inoculated into the conjunctiva of healthy rabbits, produces severe ophthalmia. The poisonous principle is a chemical ferment *abrin*. Boiling, which does not destroy the spores of the bacillus, destroys the ferment, and cultivations started from these spores, though teeming with jequirity bacilli, are quite harmless (Klein).

The bacilli occur in infusions of the beans of *Abrus precatorius* or jequirity.

**Bacillus of Schaffer** (Freudenreich).—Rods 2 to 3  $\mu$  in length, 1  $\mu$  in width, and long filaments.

Colonies circular, granular, yellowish.

In the depth of gelatine a growth develops in the track of the needle and a greyish layer on the surface.

On agar the growth is greyish and sometimes brownish, and on potato yellowish.

In broth with peptone and milk sugar there is copious formation of gas-bubbles.

They closely resemble *Bacillus coli communis*.

They were isolated from cheese and potato.

**Bacillus of Scheurlen**.—Rods 1.5 to 2.5  $\mu$  in length, .5  $\mu$  in width. They were isolated from cancerous growths by Scheurlen, and were later identified with *Bacillus epidermidis*.

**Bacillus of Schou**.—Short rods and cocci-forms.

Colonies are spherical, opaque, and granular.

The bacilli inoculated in gelatine rapidly liquefy it, and a white deposit forms at the bottom of the liquid.

Rabbits inoculated in the trachea, or made to inhale pure-cultures, are said to develop fatal pneumonia. They were isolated from rabbits with pneumonia, following section of the vagi.

**Bacillus of swine plague** (p. 351).

**Bacillus of Tommasoli**.—Short rods from 1 to 1.8  $\mu$  in length, and .25 to .3  $\mu$  in width, singly, and in short chains.

Colonies grey and shiny.

In the depth of gelatine they form a filament composed of closely-packed colonies, and on the surface a shining mass.

On agar the growth consists of greyish patches.

On potato the growth is granular and yellowish-white.

Cultures rubbed into the skin are said to produce a vesicular eruption.

They were isolated from the scalp in a case of sycosis.

**Bacillus of Utpadel**.—Rods 1.25 to 1.5  $\mu$  in length, and .75 to 1  $\mu$  in width, singly, in pairs and short chains.

Colonies milk-white.

On the surface of gelatine the growth is milk-white, and on agar yellowish-white.

Injected subcutaneously in cats, guinea-pigs and mice, they produce extensive œdema, and a fatal termination.

They were isolated from the human intestine.

**Bacillus of Winogradsky**. (See *Bacillus nitrificans*.)

**Bacillus ovatus minutissimus** (Unna).—Short rods with pointed ends .6 to .8  $\mu$  in length, .4  $\mu$  in width, singly, and in masses.

Colonies are minute, granular and yellowish.

The bacilli inoculated in the depth of gelatine form a filament of closely packed greyish-white colonies, and on the free surface there is a shiny, greyish-white layer.

On agar the growth is very similar, and on potato also.

They were isolated from the skin in eczema seborrhœicum.

**Bacillus oxytocus perniciosus** (Wyssokowitch).—Rods short and thick.

Colonies circular, granular, yellowish, or yellowish-brown.

The bacilli inoculated in the depth of gelatine produce a growth resembling Friedländer's pneumococcus.

They coagulate milk.

The products injected intravenously produce death in from three to twenty-four hours.

They occur in sour milk.

**Bacillus pestifer** (Frankland).—Rods  $2.3 \mu$  in length,  $1 \mu$  in width, and filaments. Motile.

Colonies resemble those of *Bacillus vermicularis*.

On agar they produce a dentated transparent layer, and on potato a flesh-coloured growth.

They occur in the air.

**Bacillus phosphorescens gelidus** (Forster).—Very short rods.

Colonies circular, granular, yellowish or greenish.

The bacilli, inoculated in the depth of gelatine, produce very little growth in the track of the needle, and a white film on the surface.

On agar and potato the growth is whitish.

Cultures are photogenic.

They were isolated from phosphorescent fish.

**Bacillus phosphorescens Indicus** (Fischer).—Rods singly and in pairs, and filaments. Motile.

Colonies circular, well-defined, greenish.

The bacilli, inoculated in the depth of gelatine, produce a greyish filament in the track of the needle, and a hemispherical excavation of the jelly at the upper part. Later the jelly is liquefied, and there is a yellowish scum on the surface.

On agar and potato the growth is white.

Cultures are photogenic.

They were isolated from seawater.

**Bacillus phosphorescens indigenus** (Fischer).—Rods  $1.3$  to  $1.2 \mu$  in length,  $.4$  to  $.7 \mu$  in width, singly, in pairs, and filaments.

Colonies circular, greenish, and later yellowish.

The bacilli, inoculated in the depth of gelatine, produce a conical excavation in the upper part of the needle track without liquid contents, but with a dry growth on the sides.

There is no growth on potato.

Cultures are photogenic.

They occur in sea-water and on phosphorescent fish.

**Bacillus plicatus** (Zimmermann).—Minute rods, singly, in pairs, and in short chains.

Colonies yellowish-white.

The bacilli, inoculated in the depth of gelatine, form minute isolated colonies, and on the surface a wrinkled patch with gradual liquefaction.

On potato the growth is dry and yellowish.

They occur in water.

**Bacillus pneumosepticus** (Babès).—Short rods,  $.2 \mu$  in width.

Colonies irregular, semi-transparent.

In gelatine, the bacilli grow in the track of the needle. On agar the growth is whitish and shining.

Rabbits, guinea-pigs and mice die in two or three days of septicaemia when a culture is injected subcutaneously.

They were isolated from a fatal case of septic pneumonia.

**Bacillus polytipiformis** (Liborius).—Slender rods, spore-formation present. They are anaerobic.

Colonies composed of peculiar convoluted processes.

In the depth of blood serum they produce a cloudiness at the lower part of the needle track.

They occur in soil.

**Bacillus prodigiosus** (*Micrococcus prodigiosus*: Cohn.—*Blood rain, Bleeding host*). Very short rods with rounded ends, and thread forms  $.5$  to  $1 \mu$  in width, forming at first rose-red and then blood-red zoogloea.

They liquefy gelatine.

They grow luxuriantly on the sloping surface of nutrient agar-agar, and on sterilised potato, and the colour varies from blood-red to bright-red with sometimes a metallic lustre. The cells themselves are colourless. The colouring-matter resembles fuchsine; it is insoluble in water but soluble in alcohol. The addition of acids changes it to carmine red, and of alkalies to a yellow colour.

They appear occasionally on



bread, boiled rice, and starch paste, and more rarely on boiled white of egg and meat. Milk sometimes becomes coloured blood-red by the growth of this fungus, an appearance formerly attributed to a disease of the cow.

In Paris in 1843 the micro-organism was peculiarly prevalent, attacking especially the bread produced in the military bakehouses.

**Bacillus proteus fluorescens** (Jäger).—Short thick rods and threads. Actively motile.

Colonies resemble minute drops of water.

The rods inoculated in gelatine produce a growth similar to that of Koch's comma-bacilli.

The jelly becomes greenish, and a pellicle forms on the surface.

On agar the growth when fully developed is yellowish-white, with a green fluorescence.

On potato they form a brown layer.

They are pathogenic in mice.

They were isolated from the internal organs of fowls suffering from an epidemic disease.

**Bacillus pseudo-diphtheriticus** (p. 335).

**Bacillus pseudo-tuberculosis** (Pfeiffer).—Rods varying in length.

Colonies circular, with dark nucleus and transparent zone.

In the depth of gelatine they produce a filament composed of small colonies, and on the surface a patch with concentric markings.

They grow on agar, but not readily on potato.

Inoculated in mice, guinea-pigs, rabbits, and hares, they produce a fatal result in from six to twenty days. An abscess forms locally, the lymphatic glands enlarge and caseate, and the internal organs contain nodules resembling tubercle.

They were isolated from the internal organs of a horse supposed to be glandered.

**Bacillus pulpæ pyogenes**.—Rods slightly bent and with pointed ends; singly, in pairs, and in chains.

Colonies circular, yellowish-brown.

Inoculated in the depth of gelatine liquefaction occurs in the upper part of the needle track and extends downwards.

Intraperitoneal injection in mice produces death in from eighteen to thirty-six hours.

They were isolated from putrid dental pulp.

**Bacillus punctatus** (Zimmermann).—Rods 1 to 1.6 in length,  $.77 \mu$  in width, singly, in pairs, and chains.

Colonies composed of stringy masses in liquefied gelatine.

The bacilli inoculated in the depth of gelatine produce rapid liquefaction in the track of the needle, and a white deposit.

On agar the growth is smooth and shining.

On potato the growth is brownish.

They occur in water.

**Bacillus putrificus coli** (Bienstock).—Slender, motile rods,  $3 \mu$  in length, often less, sometimes

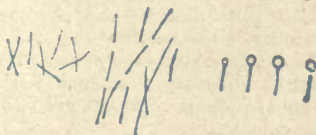

FIG. 208.—**BACILLUS PUTRIFICUS COLI**,  
 $\times 1000$  (BIENSTOCK).

forming long threads. Spore-formation present.

Cultivations in gelatine are iridescent.

They are constantly present in fæces.

**Bacillus pyocyaneus** (Gessard).—Slender rods, singly, in twos and threes, or in irregular masses. Spore-formation present.

White colonies appear in twenty-four hours, which liquefy the gelatine. The whole of the medium acquires a greenish shimmer.

If the bacilli are cultivated in gelatine, the jelly is liquefied, and coloured green by reflected light, and a deep orange by transmitted light.

On agar they form a white layer, and colour the medium a pea-green.

On potato a dry rust-brown growth appears at the seat of inoculation, which becomes green when treated with ammonia.

The pigment formed by the micro-organism is a definite principle—pyocyanin. It can be extracted with chloroform from pus and from washing of bandages; it is soluble in acidulated water, which it colours red. In neutral solution it becomes blue. It crystallises in chloroform in long needles; and forms sometimes lamellæ and prisms.

They cause death in guinea-pigs when injected into the abdominal cavity. Rabbits are not killed by intravenous injection.

The bacilli are antagonistic to anthrax bacilli. Charrin and others have shown that rabbits inoculated with a pure-culture of *Bacillus pyocyaneus* after inoculation with *Bacillus anthracis* will not succumb to anthrax. Woodhead and Wood produced similar results by using sterilised cultures, showing that the results were due to the chemical products of the bacilli.

The rods occur in the pus of those cases in which the wounds and pus-stained bandages exhibit a greenish-blue colour.

***Bacillus pyogenes fœtidus*** (Passet).—Small rods, about  $1.45 \mu$  in length, and  $.58 \mu$  in width;



FIG. 209.—*BACILLUS PYOGENES FŒTIDUS*,  $\times 790$  (PASSET).

often in pairs, or linked together in chains. They are motile, and spore-formation occurs.

Colonies like white points appear after twenty-four hours, and develop into greyish spots, and these enlarging coalesce into a layer.

Cultivated in nutrient gelatine

a greyish, veil-like growth forms on the surface.

In nutrient agar-agar the cultivation resembles the growth in gelatine. On blood serum a moderately thick greyish-white streak develops, and on sterilised potato an abundant, shining, brownish culture.

From all these media a putrid odour emanates, but no smell is detected from a cultivation in milk.

Inoculated into mice and guinea-pigs, abscesses are produced or death from septicæmia results.

They were isolated from putrid pus.

***Bacillus pyogenes soli*** (Bolton).—Rods resembling *Bacillus diphtheriæ*.

Colonies granular, faintly yellow. The bacilli inoculated in the depth of gelatine form colonies in the track of the needle.

They are pyogenic in mice and rabbits.

They are present in earth.

***Bacillus radiatus*** (Luderitz).—Rods 4 to  $7 \mu$  in length,  $.8 \mu$  in width, and filaments. Motile. They are anaerobic. Spore-formation present.

Colonies are composed of delicate interlacing filaments.

In the depth of gelatine a growth occurs at the lower part of the needle track, from which fine filaments are given off in the surrounding gelatine, and liquefaction follows. The growth in the depth of agar is also composed of fine filaments.

In sub-cultures they produce a cloudy liquefaction.

Cultures have a peculiar odour.

They occur in earth.

***Bacillus radiatus aquatilis*** (Zimmermann).—Rods 1 to  $6.5 \mu$  in length,  $.65 \mu$  in width.

Colonies white, with a marginal zone of radiating filaments.

The bacilli inoculated in the depth of gelatine grow in the track of the needle, and excavate and liquefy the surrounding gelatine, and form on the free surface a wrinkled patch, which later subsides



to the bottom of the liquefied area.

On agar a smooth slightly brownish layer is formed, and on potato it is yellowish.

They occur in water.

**Bacillus ramosus** (Eisenberg).—Rods singly, and in chains; filaments. Spore-formation present.

Colonies are composed of curiously twisted filaments.

The bacilli inoculated in the depth of gelatine produce delicate filaments extending in all directions from the track of the needle, followed by liquefaction; later a skin forms on the surface. There is a sediment at the bottom of the tube.

On agar they form a greyish filamentous layer, and on potato a whitish growth.

They occur in earth and water.

**Bacillus reticularis** (Jordan).—Rods  $5\ \mu$  in length,  $1\ \mu$  in width; singly, and in short chains. Motile.

Colonies are composed of radiating filaments, and liquefy the gelatine, forming an excavation with a reticulated lining.

The bacilli inoculated in the depth of gelatine produce filaments extending from the track of the needle, and at the upper part the jelly is excavated in the form of a cup. On agar they form a dry layer, and on potato a white woolly growth.

Broth is made turbid, and milk slowly coagulated.

They occur in water.

**Bacillus rosaceus metalloides** (*Bacterium rosaceum metalloides*, Dowdeswell; *Magenta bacillus*).—Rods  $6$  to  $8\ \mu$  in breadth.

Colonies in the depth of gelatine are colourless, but superficial ones are prominent and magenta in colour.

On the surface of obliquely solidified gelatine they form a beautiful magenta band with a metallic lustre. The gelatine is not liquefied. Similar growths are obtained on agar and potato.

It is one of the most striking of all the chromogenic bacteria. Cultures have the appearance of

having been stained with an alcoholic solution of fuchsine. The colour varies in subcultures from magenta to a sealing-wax-red.

**Bacillus rubefaciens** (Zimmermann).—Rods  $75$  to  $165\ \mu$  in length,  $32\ \mu$  in width, singly, in pairs, and in chains.

Colonies are faintly reddish-yellow.

The bacilli inoculated in the depth of gelatine grow along the track of the needle and form a greyish layer on the surface; later the jelly acquires a reddish tint.

On agar the growth is grey and abundant.

On potato the growth is at first grey, later reddish-brown, and the surface of the potato has a pink discoloration.

They occur in water.

**Bacillus rubellus** (Okada).—Rods resembling those of malignant œdema. They occur singly, in pairs, and filaments; are motile, and possess flagella, and are often capsulated. They are anaerobic.

Colonies are whitish, with offshoots in the surrounding gelatine, which, later, is liquefied, and has a reddish tinge.

The bacilli inoculated in the depth of gelatine produce a growth in the lower part of the needle track composed of isolated colonies with radiating processes. The jelly is liquefied, at first in the part corresponding with the growth, and later completely. The liquefied gelatine is coloured red.

In agar the growth extends from below upwards, and the jelly is coloured red.

In broth they grow rapidly.

They were isolated from dust.

**Bacillus ruber** (Breunig, *Bacille rouge de Kiel*, Laurent).—Rods  $2.5$  to  $5\ \mu$  long, and  $.7$  to  $.8\ \mu$  broad. Slightly motile.

Colonies below the surface of gelatine are pale yellow, and superficial ones are blood-red.

Inoculated in the depth of gelatine they liquefy it and colour it bright red. There is also formation of gas bubbles.

Potato is rapidly covered with a purplish-red growth. Broth becomes turbid, and pink in colour.

Milk is coagulated, and a blood-red colour develops on the surface and gradually extends.

They were found in water.

**Bacillus rubescens** (Jordan).—Rods  $4\ \mu$  in length,  $0.9\ \mu$  in width, singly, in pairs, and short chains.

Colonies pure-white.

Inoculated in the depth of gelatine there is a little growth in the track of the needle, and a pure-white prominent patch on the free surface.

On agar the growth is white and shining, and later has a pink tinge.

On potato the growth is flesh-coloured.

Broth becomes turbid, and a scum forms on the surface.

Milk after a time acquires a pinkish colour.

They occur in sewage.

**Bacillus rubidus** (Eisenberg).—Rods and filaments.

Colonies circular, granular, and slightly red.

The bacilli inoculated in the depth of gelatine produce liquefaction and a brownish-red colour.

On agar and potato they form a brownish-red growth, and liquefy blood serum.

They occur in water.

**Bacillus sanguinis typhi** (Brannan and Cheeseman).—Rods  $1$  to  $2.5\ \mu$  in length,  $.5$  to  $.8\ \mu$  in width; singly, in pairs, and in chains, and involution forms.

Colonies granular, pale-brown.

The bacilli inoculated in the depth of glycerine-agar produce a growth in the track of the needle composed of isolated, minute, white colonies.

Rabbits inoculated die in from two weeks to a month.

They were isolated from the blood of patients suffering from typhus fever.

**Bacillus saprogenes** (Rosenbach).—Three rod-formed organisms have been described by Rosenbach as intimately associated with putrefactive processes.

No. 1.—Large rods (Fig. 210), which form an irregular sinuous streak with a mucilaginous appearance when cultivated on nutrient agar-agar. Spore-formation present. They grow also very readily on blood serum, and all cultivations yield the odour of rotting kitchen refuse. They are not pathogenic.

No. 2.—Rods shorter and thinner than No. 1. They develop very rapidly on agar-agar, forming transparent drops, which become grey. The cultivations yield a characteristic odour similar to the last.

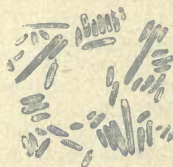

FIG. 210.—**BACILLUS SAPOGENES**, No. 1. (Rosenbach.)

They are pathogenic in rabbits. They appear to be identical with *Bacillus foetidus* (*Bacterium foetidum*, Thin). They were isolated from a patient suffering from profusely-sweating feet.

No. 3.—See *Bacterium saprogenes*.

**Bacillus scissus** (Frankland).—Very short rods,  $1$  to  $2\ \mu$  in length, and  $1\ \mu$  in width.

Colonies yellowish, opaque in the centre, and periphery dentated.

Inoculated in the depth of gelatine there is no growth in the track of the needle, but a shining layer forms on the surface, and the jelly is coloured greenish.

On agar the growth is shining and the jelly coloured green.

On potato the growth is flesh-coloured.

They occur in earth.

**Bacillus septicæmiæ hæmorrhagicæ** (p. 231).

**Bacillus septicus** (Klein).—Rods varying in size. Non-motile. They form threads or leptothrix filaments, and are rounded at the ends. They are anaerobic, and form spores independently of access to air.



In a nourishing fluid they are overcome by the presence of micrococci, *Bacterium termo* or *Bacillus subtilis*.

They occur in the soil, in putrid blood, and many putrid albuminous fluids, and occasionally in the blood-vessels of man and animals after death.

***Bacillus septicus acuminatus*** (Babès).—Rods with lancet-shaped ends, about the size of the bacilli of mouse-septicæmia. They exhibit polar staining. They can be cultivated at 37° C.

On agar and blood serum the colonies are circular, transparent, and later coalesce and form a yellowish layer.

They are fatal to rabbits and guinea-pigs in from two to six days.

They were isolated from an infant after death from septic infection occurring five days after birth.

***Bacillus septicus agrigenus*** (Nicolai).—Rods resembling *Bacillus septicæmiæ hæmorrhagicæ*.

Colonies circular, granular, with concentric zones of varying tints of brown.

Intravenous injections are fatal to rabbits in twenty-four to thirty-six hours, and bacilli abound in the blood.

They occur in recently manured soil.

***Bacillus septicus keratomalaciæ*** (Babès).—Short thick rods singly, and in pairs; often capsulated.

Colonies white, with dentated contours.

The bacilli, inoculated in the depth of gelatine, grow in the track of the needle and on the surface; gas bubbles are developed.

On agar the growth is arborescent and opalescent.

On blood serum they form a shining, somewhat transparent, dentated film. Cultures have an ammoniacal odour.

They produce purulent inflammation of the cornea.

They were isolated from the cornea in a case of septicæmia

following keratomalacia in a child.

***Bacillus septicus ulceris gangranososi*** (Babès).—Short rods  $\cdot 5$  to  $\cdot 6 \mu$  in width.

Inoculated in the depth of gelatine they produce liquefaction and gas in the track of the needle.

On agar greyish-white shining patches are found.

On potato they develop a transparent film.

They are pyogenic in rabbits and mice.

They were isolated from the internal organs and blood in a case of septicæmia following gangrene.

***Bacillus septicus vesicæ*** (Clado).—Rods  $1\cdot 6$  to  $2 \mu$  in length,  $\cdot 5 \mu$  in width.

Colonies circular, transparent, yellowish.

The bacilli inoculated in the depth of gelatine form a delicate filament composed of closely-packed colonies, and on the surface there is a filmy growth.

On agar they form a greyish-white layer, and on potato the growth is dry and brown.

They are poisonous to rabbits, guinea-pigs, and mice.

They were isolated from urine from a case of cystitis.

***Bacillus sessilis*** (L. Klein).—Rods resembling those of the hay bacillus.

They are said to be distinguished by fission commencing in a newly formed rod before it has been set free from the spore.

They were isolated from the blood of a cow.

***Bacillus smaragdino-phosphorescens*** (Katz).—Rods with pointed ends,  $2 \mu$  in length,  $1 \mu$  in width.

Colonies circular, faintly yellow, with concentric rings.

Inoculated in the depth of gelatine a white filament forms in the track of the needle and a greyish-white patch on the free surface; and there is sometimes liquefaction.

In broth they produce turbidity.

On potato they produce a thin brownish-yellow film.

They are photogenic, and the

phosphorescence is most marked in cultures containing an excess of salt.

They were isolated from a phosphorescent herring.

**Bacillus smaragdinus fœtidus** (Reimann).—Slender rods slightly bent.

Colonies on agar irregular, with a yellowish granular nucleus, and transparent marginal zone.

The bacilli inoculated in the depth of gelatine produce a growth in the track of the needle, and liquefaction at its upper part, and a greenish coloration.

In the depth of agar the medium is coloured green.

On potato the growth is brown. Cultures emit a strong odour.

Intravenous injection produces death in rabbits in forty-eight hours.

They were isolated from nasal mucus in oœna.

**Bacillus solidus** (Lüderitz).—Rods 1 to 10  $\mu$  in length,  $\cdot 5 \mu$  in width.

They are anaerobic. Cultivated in grape-sugar gelatine they produce gas bubbles and a penetrating foul odour. The colonies are spherical, and in agar under a low power are seen to be composed of fine filaments like cotton wool.

In broth with exclusion of oxygen they produce a copious growth with abundant formation of fœtid gas.

They were isolated from earth.

**Bacillus spiniferus** (Unna).—Rods sometimes curved, 2  $\mu$  in length,  $\cdot 8$  to 1  $\mu$  in width, singly, in pairs, and masses.

Colonies have peculiar spines, and later a radiated marginal zone.

In the depth of gelatine minute, yellowish, isolated colonies develop in the track of the needle, and a furrowed, yellowish-grey patch on the free surface.

On agar the same yellowish wrinkled growth appears.

On potato they form a shining, faintly-yellow layer.

They were isolated from the skin in eczema.

**Bacillus spinosus** (Lüderitz).—

Rods sometimes bent, 3 to 8  $\mu$  in length,  $\cdot 6 \mu$  in width, and long filaments. Spore-formation present. They are anaerobic.

Colonies are composed of fine radiating filaments, and liquefy the jelly.

In agar the growth is composed of colonies of matted filaments, and there is gas-formation.

They liquefy blood serum.

They occur in earth.

**Bacillus stolonatus** (Adametz).—Rods motile.

Colonies on gelatine, circular, granular, and whitish, or yellowish-brown. Colonies on agar send off peculiar wavy processes.

Inoculated in the depth of gelatine a granular filament develops in the track of the needle, and a white patch on the free surface; later the gelatine is excavated in the upper part, and the culture lines the cavity.

On potato the growth is whitish.

They occur in water.

**Bacillus stoloniferus** (Pohl).—Rods 1·2  $\mu$  in length,  $\cdot 8 \mu$  in width. Motile.

Inoculated in the depth of gelatine they produce rapid liquefaction in the track of the needle.

On the surface of agar they form a white growth.

On potato they grow abundantly, but scarcely at all in milk.

They occur in the water of marshes.

**Bacillus striatus albus** (Bes-ser).—Rods sometimes bent.

Colonies on gelatine appear as minute dry points.

On agar the colonies have a brown nucleus and clear marginal zone.

On the surface of agar the bacilli produce a greyish-white thin layer.

On potato the growth is transparent and slightly gelatinous.

They occur in nasal mucus.

**Bacillus striatus flavus** (Bes-ser).—Short rods, straight or curved; involution forms.

Colonies granular, yellowish.

On the surface of agar they produce a white growth, which later becomes sulphur yellow.



On potato a similar colour is produced.

They were isolated from nasal mucus.

**Bacillus subflavus** (Zimmermann).—Rods  $1.5$  to  $3 \mu$  in length,  $.77 \mu$  in width, and in chains. Motile.

Colonies prominent, yellowish-white.

On the surface of gelatine they form a yellowish-grey layer, and on the surface of agar and potato the growth is yellow.

They occur in water.

**Bacillus subtilis** (Hay bacillus).—Cylindrical rods as much as  $6 \mu$  in length. Single forms grow to double their length, and then undergo division. They also form threads which may be composed of

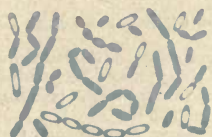

FIG. 211.—*BACILLUS SUBTILIS* WITH SPORES (BAUMGARTEN).

long rods, short rods, and cocci. They are motile, and provided with a flagellum at each end. If the nourishing medium is impoverished, the multiplication of the rods by division gradually ceases, and spore-formation commences. The rods become motionless, and a dark spot is visible, either in the middle or towards one end. This gradually develops into a shining spore with a dark outline. The rods swell slightly during this process; their contour becomes undefined, and soon disappears entirely; spores being set free in about twenty-four hours. The spores are  $1.2 \mu$  long, and  $.6 \mu$  broad. They develop into rods in the following way:—On one side of the spore a swelling appears, at the summit of which an opening in the spore-membrane results, and the germ escapes; this lengthens into a rod, and remains for a time attached to the empty spore-membrane.

The spores are widely distributed, and occur in the air, soil, dust, etc. On the excrement of herbivorous animals the bacilli form a white efflorescence, and a thick crumpled skin on liquid manure.

They flourish equally in liquids and upon damp, solid, nourishing media. They are aerobic; deprivation of oxygen causes the growth of the bacilli to cease, and the rods degenerate.

In plate-cultivations the colonies are white, and, under a low power, granular and irregular in outline and faintly-greenish. Liquefaction sets in, producing depressions like saucers. The centre is opaque, and is surrounded by a network of filaments, which extend into the gelatine surrounding the colony.



FIG. 212.—PURE-CULTURE OF *BACILLUS SUBTILIS* IN NUTRIENT GELATINE (BAUMGARTEN).

Inoculated in the depth of gelatine, liquefaction occurs rapidly in the track of the needle, and a film

floats on the surface. The liquefied gelatine, at first turbid, becomes clear as the bacilli settle at the bottom of the tube.

On agar a wrinkled film develops, and also on serum.



FIG. 213. PURE-CULTURE OF *BACILLUS SUBTILIS* ON THE SURFACE OF NUTRIENT AGAR.

On potato the growth is white, and there is copious spore-formation.

On ordinary nutrient liquids they develop at first a thin, and subsequently a thick, dense, crumpled pellicle, with copious spore-formation.

The simplest way to obtain a culture of the bacillus is to make a decoction of hay. The hay is chopped into small pieces, and boiled with distilled water in a flask for a quarter of an hour. The infusion is then filtered into a beaker, covered with a glass plate, and set aside in a warm place. In two or three days the liquid swarms

with the bacilli, the spores of which exist in great numbers in ordinary hay. A more sure method for obtaining a pure cultivation is as follows:—

(a) Add only a small quantity of water to some finely chopped hay, and set aside for four hours at 36° C.

(b) Pour off the extract, and dilute it to the sp. gr. 1.004.

(c) Boil gently for one hour in a bulb plugged with cotton wool.

(d) Set aside 500 ccm. of the extract at 36° C.

In about twenty-four hours, as a rule, a pellicle has commenced to develop upon the surface of the liquid. If the reaction is definitely acid, carbonate of soda solution must be added to the decoction.

#### METHODS OF STAINING HAY BACILLUS.

To demonstrate the flagella of the bacilli, they may be stained with hæmatoxylin solution (Koch), or by Löffler's method.

The linking together of cocci, long rods and short rods in the threads, is shown by treating with alcoholic solution or fuchsine, or with iodine solution (Zopf).

To stain the spores the cover-glass preparations must be heated to a very high temperature (210° C.), in the hot-air steriliser for half an hour, or they may be exposed for a few seconds to the action of concentrated sulphuric acid (Büchner), or floated for twenty minutes on hot solution of the dye.

**Bacillus subtilis similans.**—There are several bacilli closely resembling *Bacillus subtilis*.

Two have been isolated from human fæces by Bienstock which do not liquefy nutrient gelatine.

No. I. Rods and filaments; spore-formation present.

On agar they produce a delicate wrinkled veil.

No. II. Rods morphologically identical with No. I.

On agar they produce a smooth, shining layer.

**Bacillus superficialis** (Jordan).—Rods 2.2  $\mu$  in length, and .1  $\mu$  in width; singly, and in pairs. Motile.

Colonies have a yellowish-brown



nucleus and transparent marginal zone.

Inoculated in the depth of gelatine there is a slight growth in the track of the needle, and after a time liquefaction at the upper part.

On agar the growth is smooth and shining.

In broth they produce turbidity.

They will not grow on potato.

They occur in sewage.

**Bacillus tenuis sputigenus** (Pansini).—Short rods, singly, and in pairs; capsulated.

They produce a whitish growth on the surface of gelatine.

They coagulate milk.

They are pathogenic in rabbits.

They were isolated from sputum.

**Bacillus termo** (Macé).—Thick rods  $1.4 \mu$  long, and  $.8 \mu$  wide, usually in pairs, sometimes in chains. Actively motile.

Colonies whitish, with a grey edge surrounded by liquefied gelatine.

Inoculated in the depth of gelatine they form a funnel-shaped area of liquefaction, and later the whole of the jelly is liquefied.

Broth is rendered turbid and a thin brittle pellicle is formed.

They are associated with decomposition.

**Bacillus tetani** (p. 457).

**Bacillus thalassophilus** (Russel).—Slender rods varying in length; and filaments. They are anaerobic. Spore-formation present.

Inoculated in the depth of gelatine the growth appears in the lower part of the track of the needle in the form of cloudy colonies, liquefying the jelly and producing gas-bubbles. Cultures emit a penetrating odour.

They were isolated from sea-mud.

**Bacillus thermophilus** (Miquel).—Rods varying in size according to the temperature at which they are cultivated. In broth they grow best between  $65^{\circ}$  and  $70^{\circ}$  C., forming a copious deposit. They occur in air, soil, and water.

**Bacillus tremelloides** (Tils).—Rods  $.75$  to  $1 \mu$  in length,  $.25 \mu$  in width; and in masses.

Colonies circular, yellowish-brown.

The bacilli inoculated in the depth of gelatine produce a growth composed of isolated yellow colonies in the track of the needle, and a yellow mass on the surface. They liquefy the gelatine.

On agar the growth is slimy and golden-yellow.

On potato they form an abundant yellow growth.

They occur in water.

**Bacillus tuberculosis** (p. 378).

**Bacillus tuberculosis gallinarum** (p. 402).

**Bacillus tumescens** (Zopf).—Cocci, long and short rods.

They form a jelly-like disc  $.5$  to  $1$  cm. in diam. on slices of boiled carrot, with the appearance of a rather tough, crumpled skin of a whitish colour. Examination of this pellicle shows that it is formed of rows of rods lying closely together. These rods can be observed to divide into short rods and cocci. Spore-formation occurs in two stages of development—viz., in the cocci and in the short rods. A cultivation is obtained by exposing slices of boiled carrot, slightly moistened, to the air at the temperature of the room.

**Bacillus typhi abdominalis** (p. 342).

**Bacillus ubiquitus** (Jordan).—Rods  $1.1$  to  $2 \mu$  in length,  $.1 \mu$  in width; and filaments.

Colonies granular and well defined.

The bacilli inoculated in the depth of gelatine produce a growth resembling that of Friedländer's pneumococcus.

On agar and potato the growth is greyish-white.

They coagulate milk and reduce nitrates.

They occur in air and water.

Probably a variety of *Bacillus candicans*.

**Bacillus ulna** (Cohn).—Cocci, short rods, long rods, and threads. Diam. of the cocci  $1.5$  to  $2.2 \mu$ . Spore-formation in both short and long rods. No septic odour is pro-

duced by this bacillus in a nourishing liquid. Cloudy masses are found on the surface of the liquid, which later form a thick dry pellicle, consisting of bundles of threads matted together. The formation of ellipsoidal spores occurs in the usual way; they measure 2.5 to 2.8  $\mu$  long, and more than 1  $\mu$  wide. The bacillus is found in rotting eggs, and can be cultivated on boiled white of egg.

**Bacillus ulna** (Vignal).—Rods 2  $\mu$  in length; singly, and in pairs, and in short chains.

Colonies composed of concentric zones varying in granularity.

Inoculated in the depth of gelatine, liquefaction occurs rapidly in the track of the needle; later, there is a deposit at the bottom of the liquefied area and a pellicle on the surface.

On agar they form a white adherent layer, and the jelly is tinged with brown.

In broth a pellicle forms on the surface.

On potato they form a pellicle with characteristic linear markings.

They liquefy serum. Cultures produce a putrefactive odour.

They occur in human saliva.

**Bacillus vacuolosis** (Sternberg).—Rods 1.5 to 5  $\mu$  in length, 1  $\mu$  in width, containing vacuolated protoplasm; filaments, and involution forms. At times slowly motile.

Inoculated in the depth of gelatine, liquefaction occurs slowly at the upper part of the track of the needle, forming a cup-shaped cavity; the liquefied gelatine is viscid, and a cream-white layer forms on the surface.

In agar the development in the track of the needle is scanty; on the surface a cream-white layer is formed, and the bacilli are united in long jointed filaments.

On potato a similar growth is produced.

They were isolated from the intestine in fatal cases of yellow fever.

**Bacillus varicosus conjunctivæ** (Gombert).—Rods 2 to 8  $\mu$  in length, 1  $\mu$  in width.

Inoculated in the depth of gelatine they produce a greyish-white filament in the track of the needle, and a greyish-white patch on the surface; liquefaction follows without turbidity.

On the surface of agar a white, dry, adherent film is formed.

On potato the growth is, at first, white and dry, later, reddish-brown.

They produce hyperæmia when injected into the conjunctiva.

They were isolated from the healthy human conjunctiva.

**Bacillus venenosus** (Vaughan).—Motile rods.

Colonies circular, whitish.

Inoculated in the depth of gelatine there is growth in the track of the needle and on the free surface.

On agar they form a white film, and on potato a moist brownish layer.

They are pathogenic in small animals.

They occur in water.

**Bacillus venenosus brevis** (Vaughan).—Rods short and thick.

Colonies are yellow and composed of concentric rings.

Inoculated in the depth of gelatine they grow in the track of the needle and over the free surface.

On agar they produce a white film.

On potato the growth is brownish.

They are pathogenic in small animals.

They occur in water.

**Bacillus venenosus invisibilis**.—Slender rods.

Colonies irregular, granular.

Inoculated in the depth of gelatine the growth is extremely slow both in the track of the needle and on the surface.

On agar there is a whitish film, and on potatoes a brownish layer.

They are pathogenic in small animals.

They occur in water.

**Bacillus venenosus liquefaciens** (Vaughan).—Rods.

Colonies circular, granular, yellowish.

Inoculated in the depth of gelatine they grow in the track of



the needle and on the surface, and liquefaction occurs after some weeks.

On agar they produce a white growth, and on potato it is brownish or yellowish.

They are pathogenic in small animals.

They occur in water.

**Bacillus ventriculi** (Raczynsky).—Rods 1.5 to 3  $\mu$  in length, 1  $\mu$  in width, singly, in pairs, and in short chains.

Colonies have a dark nucleus and transparent periphery.

On agar they form a white layer.

They were isolated from the digestive tract of dogs.

**Bacillus vermicularis** (Frankland).—Large bacilli 2 to 3  $\mu$  in length, 1  $\mu$  in width, and long threads. Spore-formation present.

Colonies are irregular in contour, the irregularity increasing as the colony comes to the surface. The peripheral part is composed of closely packed, wavy bands of bacilli, and the centre is irregular and wrinkled.

The bacilli inoculated in the depth of gelatine form a flattened band in the track of the needle, and a grey layer on the surface; liquefaction slowly follows.

On agar they produce a smooth, shining, grey layer, and on potato a thick, irregular, flesh-coloured growth.

They reduce nitrates.

They occur in water. Probably identical with *Bacillus vermiculosus*.

**Bacillus vermiculosus** (Zimmermann).—Rods 1.5  $\mu$  in length, .85  $\mu$  in width, singly, in pairs, very short chains and long filaments. They are slowly motile.

Colonies irregular; grey, granular.

Inoculated in the depth of gelatine they produce, after four days, liquefaction in the upper part of the needle track, which spreads downwards, and a reddish-grey sediment collects at the bottom of the liquefied area.

On agar the growth is smooth and

shining, and on potato yellowish-grey.

They occur in water.

**Bacillus violaceus** (*vide Bacillus ianthinus*).

**Bacillus violaceus Laurentius** (Jordan).—Rods 3 to 3.6  $\mu$  in length, .7  $\mu$  in width.

Colonies violet, surrounded by liquefied gelatine.

Inoculated in the depth of gelatine liquefaction occurs in the track of the needle, and a violet sediment collects at the bottom.

On agar the growth is violet, later black.

On potato there is a copious growth, changing in colour from violet to black.

In broth a violet colour is produced in the presence of nitrates.

They coagulate milk, and render it bluish-violet.

They occur in water. Probably identical with *Bacillus ianthinus* (Zopf).

**Bacillus virescens** (Frick).—Rods and filaments.

Colonies irregular, granular, green.

On the surface of gelatine they colour the medium green.

They grow on agar.

On potato they form a brownish growth.

In broth a pellicle is formed on the surface, and beneath it the liquid is coloured green.

They were isolated from green sputum.

**Bacillus viscosus** (Frankland).—Rods 1.5 to 2  $\mu$  in length, singly and in pairs.

Colonies granular, with hairlike processes extending into the gelatine, which is liquefied and has a green colour.

Inoculated in the depth of gelatine they produce liquefaction and a green fluorescence.

On agar they form a greenish-white layer, and colour the jelly green.

On potato the growth is brown.

Probably identical with *Bacillus fluorescens liquefaciens*.

**Bacillus Zurnianus** (List).—

Rods 1·2 to 1·5  $\mu$  in length, ·6 to ·8  $\mu$  in width. Colonies greyish-white, viscid.

The bacilli inoculated in the depth of gelatine develop slightly in the track of the needle, and produce a prominent grape-like growth on the free surface.

On potato the growth is grey or tinged with yellow.

They occur in water.

**Bacterium aerogenes** (Miller).—Short rods, singly and in pairs. Motile.

The colonies are circular, well defined, and yellowish.

Inoculated in the depth of gelatine the growth in the track of the needle is brownish-yellow, and a flat greyish button forms on the free surface.

On agar a pulpy layer develops.

On potato the growth is pulpy and yellowish-white.

The bacteria possess great power of resisting the effect of acids.

They were isolated from the digestive tract.

**Bacterium brunneum** (Schröter).—Motile rods, producing a brown colour.

They were observed on a rotting infusion of maize.

**Bacterium decalvans** (Thin).—Cocci, singly or in pairs, 1·6  $\mu$  in length.

They were observed in the roots of the hair in cases of *Alopecia areata*.

**Bacterium fusiforme** (Warming).—Rods spindle-shaped, with pointed ends, 2·5  $\mu$  long, and ·5 to ·8  $\mu$  thick. They were described as forming a spongy layer on the surface of sea-water.

**Bacterium gingivae pyogenes** (Miller).—Short rods.

The colonies are circular and rapidly liquefy gelatine.

The bacteria inoculated in the depth of gelatine produce rapid liquefaction in the track of the needle and a white sediment.

On agar they produce a moist white growth.

They are pyogenic when inoculated subcutaneously in small ani-

mals, and cause a fatal result when injected to the peritoneal cavity.

They occur in the deposit on the teeth.

**Bacterium hyacinthi** (Wakker).—Cocci resembling *Bacterium termo*.

They were observed in the yellow slime of diseased hyacinth bulbs.

**Bacterium hydrosulfureum ponticum** (Zelinsky).—Long motile rods.

On agar a dark coffee-coloured pigment is produced, which turns black when exposed to air.

Cultures give off sulphuretted hydrogen.

They were isolated from dredgings in the Black Sea.

**Bacterium litoreum** (Warming).—Cocci ellipsoidal, 2 to 6  $\mu$  long, 1·2 to 2·4  $\mu$  wide; singly, never as chains or zoogloea.

They occur in sea-water.

**Bacterium luteum** (List).—Rods from 1·1 to 1·3  $\mu$  long. Non-motile. The colonies are slimy, with orange centres.

Inoculated in the depth of gelatine an orange growth occurs, principally at the point of puncture.

Milk is coagulated.

They occur in water.

**Bacterium merismopedioides** (Zopf).—Threads 1 to 1·5  $\mu$  in thickness; these subdivide into long rods, short rods, and finally into cocci. The cocci divide first in one and subsequently in two directions, forming characteristic groups, which appear like merismopedia. These groups may eventually consist of 64 by 64 cells or more, and ultimately form zoogloea. The cocci develop again into rods and threads.

They were observed in water containing putrefying substances (River Panke, Berlin).

**Bacterium navicula** (Reinke and Berthold).—Cocci spindle-form or ellipsoidal, including motile and non-motile forms. They have one or more dark spots, which may be coloured blue by iodine.

They have been observed in rotting potatoes.



**Bacterium photometricum** (Engelmann).—Rods slightly reddish in colour; motile.

The movements are stated to depend on light.

**Bacterium synxanthum** (Ehrenberg; *Bacterium xanthinum*; *Bacterium of yellow milk*).—Cocci  $\cdot 7$  to  $1 \mu$  in length, and rod-forms. They produce a yellow colour in boiled milk, which at first becomes acid, and then strongly alkaline. They also occur on boiled potatoes, carrots, etc., where they form small lemon-yellow masses.

The colouring-matter is soluble in water, insoluble in ether and alcohol, unchanged by alkalis, decolorised by acids. It is similar to yellow aniline colours, both spectroscopically and in ordinary reactions.

**Bacterium termo** (Vignal).—Rods  $1\cdot 5$  to  $2 \mu$  in length,  $\cdot 5$  to  $\cdot 7 \mu$  in width.

Colonies white, surrounded by liquefied gelatine.

The bacilli inoculated in the depth of gelatine produce a funnel-shaped area of liquefaction; later, the jelly is completely liquefied and coloured green. Cultures have a strong putrefactive odour.

In broth they form a white deposit and colour the medium green.

They were isolated from human saliva.

**Bacterium tholoeideum** (Gessner).—Rods similar to *Bacillus lactis aerogenes*.

Pathogenic in small animals.

They were isolated from healthy human evacuations.

**Bacterium ureæ** (Cohn).—Cocci  $1\cdot 25$  to  $2 \mu$  in diam., singly or in chains, and rods. The rods split up by division into chains of cocci, which after a time are set free. The cocci increase further by subdivision, and a jelly-like membrane develops around them. Masses of cocci exist in the form of irregular or roundish lumps. They are aerobic.

Cultivations, after twenty-four hours, consist exclusively of rods;

after forty-eight hours, of cocci chains; and in fourteen days, of zooglœa; the cocci transplanted into fresh nourishing solution again grow into rods. These observations point to the existence of a pleomorphic species, *Bacterium ureæ*; and the former nomenclature, *Micrococcus ureæ*, must be regarded as untenable.

In urine they set up ammoniacal fermentation, converting urea into carbonate of ammonia. Rods,  $2 \mu$  long and  $1 \mu$  wide, have been isolated from stale urine (*Bacillus ureæ*, Leube), which also most energetically cause the ammoniacal fermentation of urine.

**Bacterium ureæ** (Jaksch).—Rods  $2 \mu$  in length,  $1 \mu$  in width.

Colonies on gelatine semi-transparent.

Inoculated in the depth of gelatine the bacilli form a delicate branching growth in the track of the needle.

They convert urea into carbonate of ammonia, and cultures smell of herring brine.

They occur in ammoniacal urine.

**Bacterium violaceum** (Bergonzi).—Rods similar to *Bacterium termo*,  $\cdot 6$  to  $1 \mu$  thick,  $2$  to  $3 \mu$  long.

They occur on white of egg, forming a violet pigment.

**Bacterium Zopfii** (Kurth).—Cocci,  $1$  to  $1\cdot 25 \mu$  in diam.; rods and threads. Cultivated in a streak on nutrient gelatine spread out on a glass slide, a peculiar development takes place. In twenty-four hours after inoculation threads have developed; in forty-eight hours windings of the threads are observed, and in six days the threads have broken up into cocci. They were observed in the intestine of fowls, especially in the contents of the vermiform appendix. Inoculation of rabbits was followed by negative results. Identical with *Bacillus figurans* (Crookshank).

**Beggiatoa alba** (Vauch).—Cocci, rods, spirals and threads (Fig. 215). The threads are indistinctly articulated, actively oscillating, and colourless; their protoplasm contains

numerous strongly refractive granules consisting of sulphur. They occur as greyish or chalk-white gelatinous threads, 3 to 3.5  $\mu$  thick, in sulphur springs and marshes.

**Beggiatoa mirabilis** (Cohn).—Threads distinguished by their breadth, which may reach 30  $\mu$ . They are motile, bent and curled in various ways, and rounded at the ends. Around the threads, isolated cells have been observed,

families, bound together by gelatinous substance. Later they become larger, globular or ovoid in shape, and hollow, containing watery fluid in their interior. The families reach a diameter of 660  $\mu$ , in which the cocci form simply a peripheral layer. The hollow families or vesicles are often perforated, presenting a delicate reticulated appearance, which finally may become broken up into irregular structures. The red colouring-matter can be

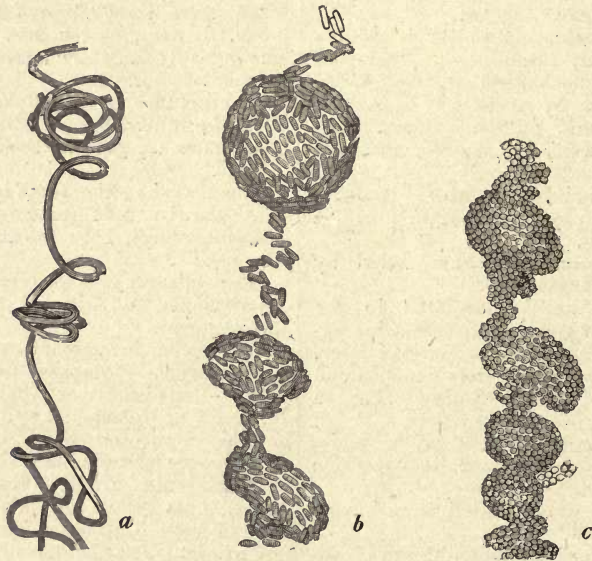

FIG. 214.—BACTERIUM ZOPFII. SUCCESSIVE CHANGES IN THE SAME THREAD,  $\times 740$ . a, A thread form; b, breaking up into rod forms; c, into cocci (Kurth).

*macrococci*, but spiral forms are as yet unknown. The threads are filled with sulphur granules. They occur in sea-water, forming a white gelatinous scum on decomposing algae.

**Beggiatoa roseo-persicina** (*Cohnia roseo-persicina*, *Bacterium rubescens*, or *Peach-coloured bacterium*, Lankester).—Cocci, rods, spirals, and threads (Fig. 216). The cocci, globular or oval, reach 2.5  $\mu$  in diam. They form at first solid

distinguished from other red pigments, and it is designated by the name *bacterio-purpurin*. It is quite distinct from the pigment produced by *Micrococcus prodigiosus*, being peach-blossom red, and insoluble in water, alcohol, etc. Examined spectroscopically, it shows a strong absorption in the yellow, and a weaker band in the green and blue, as well as a darkening in the more refrangible half of the spectrum. In the cocci, especially of the older



vesicles, dark granules are to be seen, which consist of sulphur. The micro-organisms occur on the surface of marshes, or on water in which algae are rotting. They form a rose-red, blood-red, violet-red, or violet-brown scum; and sometimes in such quantity that

**Cladotrix dichotoma** (Cohn). —Threads resembling those of leptothrix; slender, colourless, not articulated, straight or slightly undulated, and in places twisted in irregular spirals with pseudo-branchings. The development can be traced from the cocci to rods and

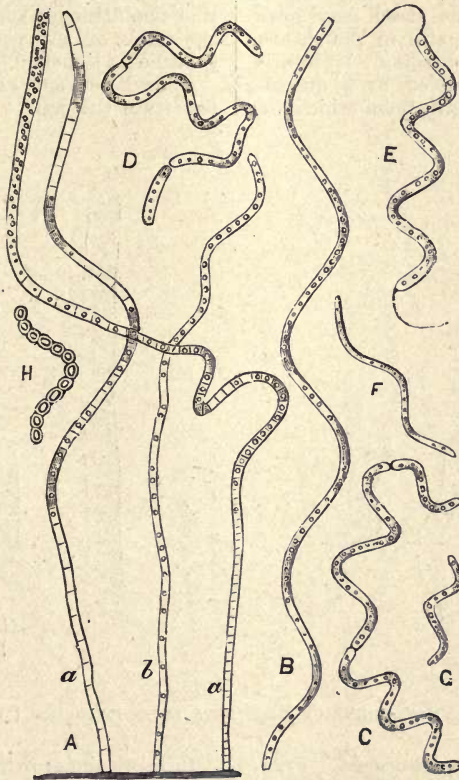

FIG. 215.—*BEGGIATOA ALBA*.

- A. Threads at base distinctly linked, partly spiral. B. A thread, spiral in its whole length. C, D. Fragments detached from threads; immobile. E. Active spirillum-forms, with a flagellum at either end. F, G. Thin and short spiral forms. H. A spiral showing the individual links.  $\times 540$  (Zopf).

whole marshes and ponds may be coloured blood-red by them.

*Spirillum sanguineum*, *rosaceum*, *violaceum*, *monas vinosa* and *Okenii*, and *Rhabdomonas rosea* are possibly phase-forms of *Beggiatoa roseo-persicina*.

threads. The latter are at the beginning simple threads, which were formerly described as *Leptothrix parasitica*, or, if coloured by impregnation with iron, as *Leptothrix ochracea*. Later they form false branches by single rods turning

aside, which by repeated division lengthen into threads. A thread appears to be first composed of long rods, then of short rods, and lastly of cocci. The iodine reaction must be applied to distinguish these forms, especially when the sheath of the threads has a yellow, rust-red, olive-green, or dark brown coloration. The cocci may grow into rods while still in the sheath, and finally become leptothrix threads, surrounded by a delicate gelatinous sheath, from which the

media small tufts, about 1 to 3  $\mu$ , and floating masses.

**Cladothrix Försteri** (*vide Strep-tothrix Försteri*, Cohn).

**Cladothrix intricata** (Russell).—Rods and filaments.

Colonies are composed of a network of twisted threads.

Inoculated in the depth of gelatine fine filaments spread out from the track of the needle, and the gelatine is liquefied.

Grown on agar the filaments penetrate the jelly.



FIG. 216.—PHASE-FORMS OF BEGGIATOA ROSEO-PERSICINA (WARMING).

false branching proceeds. Fragments may break off, which are actively motile, and appear as vibrios, spirilla, and spirochæta-forms. They may also occur in zoogloea (Fig. 217).

They are the commonest of all bacteria in both still and running water, in which organic substances are present. They are observed also in the waste water of certain manufactures, such as sugar. Artificially they can be cultivated on infusions of rotting algæ and animal substances, forming on these

In broth the growth is abundant. They were isolated from sea dredgings.

**Cladothrix invulnerabilis** (Acosta, y Grande Rossi).—Filaments which produce in gelatine a white thread, and liquefy it very slowly.

On potato the growth is abundant and chalky in appearance.

In milk they form a firm yellowish pellicle; and in broth and in water the growth is abundant.

They occur in water.

**Clostridium butyricum** (*vide Bacillus butyricus*).



**Clostridium fœtidum** (Liborius).—Rods  $1\mu$  in width, singly and in filaments. Spore-formation resembles that of *Bacillus butyricus*. They are anaerobic.

Colonies rapidly liquefy gelatine.

gas-formation with unpleasant smell and splitting up of the jelly.

They were isolated from earth.

**Crenothrix Kühniana** (Rabenhorst).—Cocci, rods, and thread-forms. The cocci are globular,



FIG. 217.—CLADOTRICH DICHOTOMA.

- A. Branching schizomycete :—(a) *Vibrio*-form ; (b) *Spirillum*-form [slightly magnified].  
 B. A screw-form with (a) *Spirillum*-form ; (b) *Vibrio*-form.  
 C. Long spirochaeta-form.  
 D. Fragment with *Spirillum*-form at one end, *Vibrio*-form at the other.  
 E. Screw-forms :—(a) continuous ; (b) composed of rods ; (c) composed of cocci.  
 F. Spirochaeta-form :—(a) continuous ; (b) composed of long rods ; (c) short rods ; (d) cocci (Zopf).

On agar the colonies form branching processes resembling colonies of *Bacillus oedematis maligni*.

Inoculated in the depth of gelatine liquefaction spreads from below upwards. There is abundant

1 to  $6\mu$  in diam. The threads are colourless,  $1.5$  to  $5\mu$  thick, and club-shaped at the extremity, reaching a diam. of  $6$  to  $9\mu$ . The threads form colonies with a brick-red, olive-green, or dark-brown to brown-black

coloration, caused by impregnation with oxide of iron. The threads are distinctly articulated, and ensheathed. The segments are

set free when the sheath bursts, and develop into new threads. In other cases the segments remain enclosed, and subdivide into discs,

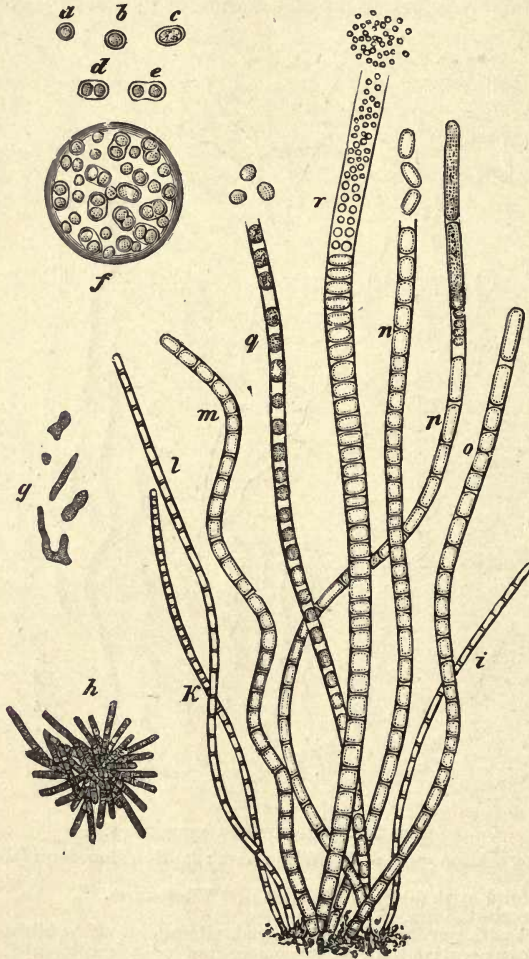

FIG. 218.—CRENOTHRIX KÜHNIANA.

*a, b, c, d, e.* Cocci in various stages of fission,  $\times 600$ .

*f.* Zoogloea of cocci,  $\times 600$ .

*g.* Various forms of zoogloea, natural size.

*h.* Colony of threads composed of rods grown out of a zoogloea of cocci.

*i-r.* Thread-forms; some straight, others spiral, with more or less differentiation between base and apex. (*r*) is composed of short rods at the base, and above these of cylindrical segments, and at the apex these segments have divided into cocci,  $\times 600$  (Zopf).



which, by vertical fission, break up into globular forms (cocci). These again develop into new threads, either within the sheath, eventually penetrating it, or after they are set free.

The micro-organism appears in little whitish or brownish tufts in wells and drain-pipes, and it not only renders drinking-water foul, but may stop up the narrower pipes.

**Diplococcus albicans amplus** (Bumm).—Cocci resembling gonococci but much larger, singly and in tetrads.

Colonies are prominent and greyish-white.

In the depth of gelatine they produce a greyish-white growth in the track of the needle and on the free surface. They slowly liquefy the gelatine.

They were obtained from the vaginal mucous membrane.

**Diplococcus albicans tardissimus** (Bumm).—Cocci morphologically identical with gonococci. They grow extraordinarily slowly on gelatine.

They form very minute colonies, which are opaque and greenish-brown in colour.

Inoculated in the depth of gelatine isolated greyish-white colonies develop in the track of the needle, and on the free surface a thin, white, waxy film with dentated edge.

On agar the growth is very similar.

They were isolated from the vaginal mucous membrane.

**Diplococcus citreus conglomeratus** (Bumm).—Cocci in pairs resembling gonococci,  $1.5\mu$  in diam., in tetrads and in masses.

Colonies lemon-yellow; irregular in form.

Inoculated in the depth of gelatine the cocci develop in the track of the needle, and liquefaction commences at its upper part.

The growth on the free surface is yellow, and floats on the liquefied gelatine or subsides to the bottom of the liquefied area.

They are present in gonorrhoeal pus, in air and in dust.

**Diplococcus citreus liquefaciens** (Unna).—Oval cocci  $.4$  to  $.1\mu$  in diam., in pairs, tetrads, short chains, and masses.

Colonies appear in the form of circular discs, at first greyish-white, later lemon-yellow. They are finely granular, and have sharply defined contours.

Inoculated in the depth of gelatine, at the end of a week the growth is found on the free surface, forming a shining yellow layer; in two weeks liquefaction commences, and the growth floats on the liquefied gelatine which is also yellowish and turbid.

On the surface of agar a yellowish-brown layer is rapidly formed.

The appearance is similar on potato.

They were isolated in cases of eczema seborrhoeicum.

**Diplococcus coryzæ** (Hajek).—Large diplococci.

Colonies are white, prominent.

Inoculated in the depth of gelatine the growth resembles the pneumococcus.

On agar a white layer is formed.

They are probably identical with Friedländer's pneumococci.

They were isolated from the mucus in acute nasal catarrh.

**Diplococcus flavus liquefaciens tardus**.—Cocci resembling gonococci.

Colonies are circular, shining, and chrome-yellow in colour.

Inoculated in the depth of gelatine a yellowish growth occurs along the needle track, and also on the free surface. In a month the surface is depressed, but the gelatine is not liquefied until about two months have elapsed.

On agar a yellowish-white layer is formed, and on potato the colour is more pronounced.

They were isolated from the skin in eczema seborrhoeicum.

**Diplococcus fluorescens fetidus** (Klamann).—Cocci in pairs and chains.

Colonies circular, forming a

brownish deposit surrounded by liquefied gelatine which has a violet or greenish tinge.

Inoculated in the depth of gelatine they produce liquefaction along the track of the needle, with a hemispherical excavation of the gelatine at the upper part. An iridescent film floats on the surface and a greenish sediment forms at the bottom of the liquefied area.

On agar the layer is brownish.

On potato the growth is granular, and the potato in the vicinity has a bluish colour.

They were cultivated from the nasal mucus.

**Diplococcus intercellularis meningitidis** (Weichselbaum).—Cocci singly, in pairs, tetrads and masses. They grow at 37°C.

Colonies on agar are granular and yellowish-brown.

On the surface of agar they form a greyish-white viscid growth. In the depth of agar the growth only occurs in the upper part of the needle track.

On blood serum and broth there is very little growth, and none on potato.

Cultures quickly lose their vitality.

They are pathogenic in mice, guinea-pigs, rabbits, and dogs.

They were isolated from the exudation in cases of cerebro-spinal meningitis, and were observed in the interior of pus cells.

**Diplococcus luteus** (Adamez).—Cocci 1.2 to 1.3  $\mu$  in diam., singly and in chains. Motile.

Colonies are circular and slightly yellow, and granular. Old colonies are bright yellow.

On the surface of gelatine a growth occurs in concentric circles of a lemon-yellow colour, and the gelatine is coloured reddish-brown. After several weeks liquefaction sets in.

On agar a yellow layer forms, and the jelly is coloured reddish-brown.

On potato the growth changes from yellow to brown. Milk is coagulated.

They were obtained from water.

**Diplococcus of pneumonia in horses** (Schutz).—Oval cocci, singly or in pairs, capsulated.

Colonies small and white.

In the depth of gelatine a row of colonies develops in the track of the needle.

On agar the growth is composed of transparent droplets.

Injection into the lung is said to produce pneumonia, ending fatally in eight or nine days.

They are pathogenic in rabbits, guinea-pigs, and mice.

They were isolated from the lungs of a horse suffering from pneumonia.

**Diplococcus roseus** (Bumm).—Cocci identical in description with gonococci.

Colonies are pink, granular, and irregular in form.

Inoculated in the depth of gelatine the cocci grow freely in the track of the needle and on the surface, developing a pink colour and slowly producing liquefaction.

They are present in the air.

**Diplococcus subflavus** (Bumm).—Diplococci similar to gonococci.

Colonies greyish-white, later yellow.

They grow in gelatine and on blood serum, and liquefy broth.

They produce suppuration when injected subcutaneously in man.

They were isolated from lochial discharges, the vesicles of pemphigus, and from the secretion in colitis in children.

They stain by Gram's method.

**Hæmatococcus bovis** (Babès).—Cocci oval, singly, in pairs, and in masses.

Inoculated in the depth of gelatine minute colonies develop in the track of the needle.

On agar the growth is composed of transparent droplets.

On potato a yellowish shining film is formed.

On blood serum the growth is similar to that on agar.

They produce a fatal result in rabbits and guinea-pigs in a week or ten days.

They were isolated from the



blood and organs of cattle which died of an epidemic disease associated with hæmoglobinuria.

**Helicobacterium aerogenes** (Miller).—Bacilli singly, in chains and long wavy filaments. Motile.

Colonies whitish, varying in form.

Inoculated in the depth of gelatine the bacilli give rise to a faintly yellow growth in the track of the needle, and an almost invisible, rapidly growing layer on the surface.

On potato the growth is dry and brownish.

They were isolated from the healthy intestinal tract.

**Leptothrix buccalis** (Robin).—Long, thin threads,  $\cdot 7$  to  $1 \mu$  broad, colourless, often united in thick bundles or felted together. Masses of cocci occur with the threads, and the threads themselves are composed of long rods, short rods, and cocci. The threads may break up into spiral, vibrio, and spirochæta forms. The last-named occur in large numbers in the mouth, and have been named *Spirochæta buccalis*. *Leptothrix buccalis* is found in teeth slime, and is believed to be intimately connected with dental caries. The threads penetrate the tissue of the teeth, after the enamel has been acted upon by acids generated by the fermentation of food. The short rods, long rods, cocci, leptothrix-forms, and screw-forms are found in the dental canals.

The threads of *Leptothrix buccalis* have a special staining reaction (Leber). They become coloured if placed in an acid medium with iodine; if the medium be alkaline, it must first be acidified with very dilute hydrochloric acid or acetic acid. The contents are stained violet, and contrast with the sheath and septa, which remain uncoloured.

**Leptothrix buccalis** (Vignal).—Rods  $1$  to  $1\cdot 5 \mu$  in width,  $1\cdot 6$  to  $30 \mu$  in length.

Colonies greyish-white, prominent and furrowed.

Inoculated in the depth of gelatine a filament forms in the track

of the needle, and a growth occurs on the free surface. Liquefaction sets in at the upper part, forming a cup-shaped cavity, and a bluish skin floats upon the liquid. The liquefaction gradually extends to the side of the tube, and a deposit is formed at the bottom of the liquefied gelatine.

On agar the layer is white, wrinkled and transparent, and later yellowish.

In broth there is turbidity, but no skin on the surface.

On potato the growth is greyish-white.

They are occasionally present in the mouth in health, and are possibly identical with *leptothrix buccalis* (Robin).

**Leptothrix gigantea** (Miller).—Long rods, short rods and cocci can be observed in the same thread. There are also screw-threads, which may take the form of spirals, vibrios, or spirochæta. The threads increase in diameter from base to apex; corresponding with the thickness of the threads, the rods and cocci show different dimensions.

They have been observed in the diseased teeth of dogs, sheep, cats and other animals.

**Leuconostoc mesenteroides**, Cienkowski (*Gomme de sucrerie*, *Froschlauchpilz*, *Frogspawn fungus*).—Cocci and rods singly, in chains, and in zoogloea, surrounded by a thick gelatinous envelope. The life-history has been very thoroughly investigated. The spores,  $1\cdot 8$  to  $2 \mu$  in diam., are of a round or ellipsoidal form, with thick membrane and shining contents. The outer membrane-layer bursts, and a middle lamella oozes out, and forms a thick gelatinous envelope, while the inner layer remains adherent to the plasma. Thus the spore-germination leads to the formation of a coccus with a gelatinous envelope. The coccus then elongates into a short rod-form, and the gelatinous envelope becomes ellipsoidal. The rod divides into two cocci, and each of these lengthens into a rod and divides. By repetition

of this process a chain of cocci results, encased in a cylindrical or ellipsoidal envelope. The chains increase in length, become twisted up, and eventually fall apart into pieces of various lengths.

In nourishing liquids a great number of little masses are formed, which adhere together, and produce pseudo-parenchymatous structures. These latter may join together, forming still larger agglomerations.

This micro-organism occurs occasionally in beet-root juice and the molasses of sugar-makers, forming large gelatinous masses resembling frog-spawn. The vegetation is so rapid that forty-nine hectolitres of molasses, containing 10 per cent. of sugar, were converted within twelve hours into a gelatinous mass; consequently, it is a formidable enemy of the sugar manufacturers.

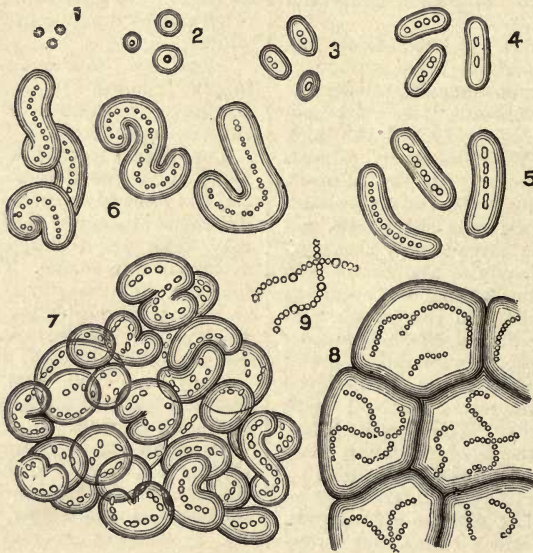

FIG. 219.—LEUCOCOCUS MESENTEROIDES.

1. Spores. 2. Spores after germination, showing gelatinous envelope. 3, 4, 5, 6. Increase by division. 7. Glomerular form of zoogloea. 8. Section of an old mass of zoogloea. 9. Cocci chains with arthrospores (Tieghem and Cienkowski).

The masses of zoogloea are of almost a cartilaginous consistency, and admit of sections being made with a razor. After a long time the envelope liquefies, and the cocci are set free; the latter introduced into fresh nourishing media develop new colonies. In the chains some of the cocci become enlarged without changing their form. These acquire the properties of spores, and are *arthrospores*.

**Micrococcus acidi lactici** (Marpmann).—Large cocci, singly and in pairs.

Colonies yellowish-white.

On the surface of gelatine the cocci produce a yellow layer.

They grow in milk, producing a reddish colour, and coagulation due to the formation of lactic acid.

They were isolated from milk.

**Micrococcus acidi lactici liquefaciens** (Kreuger).—Cocci oval, 1



to  $1.5 \mu$  in diam., in pairs and in tetrads.

Colonies white.

Inoculated in the depth of gelatine the cocci produce a granular filament, changing in two or three days to liquefaction in the form of a funnel; later, a wrinkled membrane floats on the surface of the liquid.

In milk they produce lactic acid.

They were isolated from butter which had turned cheesy.

**Micrococcus aerogenes** (Miller).

—Oval cocci.

Colonies are dark and regular in contour, but have a peculiar spotted appearance.

Inoculated in the depth of gelatine a brownish-yellow growth occurs along the track of the needle, and on the free surface a white button-like elevation. After a time the gelatine is slowly liquefied.

On agar a yellowish-white pulpy layer forms, and a similar growth appears on potato.

They resist the action of acids, so that the presence of gastric juice does not impede their development.

They were obtained from the intestine.

**Micrococcus agilis** (Ali-Cohen).

—Cocci  $1 \mu$  in diam., singly, in pairs, tetrads, and in chains. They are motile, and possess flagella.

Inoculated in the depth of gelatine they grow in the track of the needle, and produce, after two or three weeks, liquefaction or excavation of the jelly.

On agar and potato the growth is pink.

They occur in water.

**Micrococcus agilis citreus**

(Menge).—Cocci in pairs, chains and masses. They are motile, and each coccus possesses a single flagellum.

Colonies appear surrounded by clouded gelatine.

Inoculated in the depth of gelatine there is a scanty growth in the track of the needle, and on the surface a bright yellow patch.

On agar they form a yellow layer,

which is viscid, and may be drawn out in long threads.

In broth they produce cloudiness and a viscous deposit.

The growth on potato is bright yellow.

Milk is not coagulated.

They were isolated from an infusion of peas.

**Micrococcus albus liquefaciens** (Besser).—Large cocci in chains and in masses. They are anaerobic.

Colonies on agar exhibit concentric rings of different shades of brown.

Inoculated in the depth of gelatine they produce liquefaction in the track of the needle.

They occur in mucus from the nose.

**Micrococcus amyliovorans** (Burrill).—Oval cocci, 1 to  $1.4 \mu$  long,  $.7 \mu$  broad, singly, in pairs, and rarely in fours, never in chains, are found embedded in an abundant mucilage which is very soluble in water.

They have been described as producing the so-called "fire blight" of the pear tree and other plants.

**Micrococcus aquatilis** (Bolton).—Small cocci in masses.

Colonies circular, prominent, and pure-white.

Inoculated in the depth of gelatine, there is a white growth in the track of the needle and also on the free surface.

On agar the growth is white.

They occur in water.

**Micrococcus aquatilis invisibilis** (Vaughan).—Cocci oval.

Colonies brown.

In gelatine there is a slight growth in the track of the needle, and a more abundant growth on the free surface.

On agar they form a white film.

On potato the growth is invisible.

They occur in water.

**Micrococcus aurantiacus** (Cohn).—Cocci spherical or oval,  $1.3$  to  $1.5 \mu$  in diam., singly, in pairs, and in groups.

Colonies orange-yellow.

Inoculated in gelatine they form minute colonies in the track of the

needle, and a prominent hemispherical yellow growth on the free surface.

On agar the growth is orange-yellow, and on potato yellow and slimy.

They occur in water.

**Micrococcus botryogenus** (Johne, Rabe).—Cocci 1 to 1.5  $\mu$  in diam., in wavy chains.

Colonies circular, sharply defined. At first silver-grey, later yellowish-grey with metallic lustre, they produce an odour like that of strawberries.

Inoculated in the depth of gelatine a greyish-white filament develops, with slight liquefaction of the gelatine; later, it becomes milk-white, and at its upper part a characteristic bubble appears.

They make hardly any growth on agar.

On potato they grow very abundantly, forming a yellowish layer with the same odour as the colonies on plate cultivations.

Inoculated guinea-pigs die of septicæmia; in sheep and goats severe inflammation spreads from the point of inoculation. Mice are immune. In horses an inflammatory œdema is at first set up, followed in four to six weeks by the formation of new growths, which sometimes suppurate and contain large numbers of micrococci.

They were found in tumours of the spermatic cord and of the connective tissue in other parts in horses.

**Micrococcus candicans** (Flügge).—Cocci which collect in masses.

In plate-cultivations they form in two or three days milk-white colonies; while those below the surface of the gelatine are yellowish. Under a low power the deep colonies are quite circular, with smooth margins, of a blackish-brown colour, and very slightly granular; the superficial colonies are quite irregular in outline, and are finely granular.

Cultivated in test-tubes they form

a white nail-shaped cultivation. They were isolated from contaminated plate-cultivations.

They occur in the air.

**Micrococcus candidus** (Cohn).—Cocci forming snow-white points and spots upon slices of cooked potato.

**Micrococcus carneus** (Zimmermann).—Cocci .8  $\mu$  in diam., occurring in masses.

Colonies circular, greyish-white, with the centre tinged with red.

Inoculated in the depth of gelatine they form a white, granular filament in the track of the needle, and a pale pink layer on the free surface.

On the surface of oblique gelatine a flesh-coloured layer develops, which later assumes a violet colour.

On agar the growth is similar.

On potato the growth is abundant and red in colour.

They were isolated from water.

**Micrococcus cerasinus siccus** (List).—Cocci .25 to .12  $\mu$  in diam., singly and in pairs. They can best be cultivated at 37° C.

On agar they form a cherry-red layer, and a similar growth on potato.

The pigment is insoluble in alcohol, ether, and water, and is not destroyed by acids or alkalis.

They occur in water.

**Micrococcus cereus albus** (p. 178).

**Micrococcus cereus flavus** (p. 178).

**Micrococcus cinnabareus** (Flügge).—Large cocci occurring in twos, threes, and fours.

Colonies develop very slowly, and are punctiform, and bright red at first, and afterwards reddish-brown.

The cocci inoculated on the surface of gelatine form a heaped-up, red-coloured growth.

They were found contaminating old cultivations.

**Micrococcus citreus** (List).—Cocci 1.5 to 2.2  $\mu$  in diam., singly, in pairs and chains.

Colonies are irregular in form, moist and shining, and yellowish in colour.



In the depth of gelatine the growth is very scanty.

On the surface of agar the growth is yellowish.

On potato the growth is similar but more abundant.

**Micrococcus concentricus** (Zimmermann).—Cocci  $\cdot 9 \mu$  in diam., in masses.

Colonies bluish-grey.

Inoculated in the depth of gelatine there is no growth in the track of the needle, but concentric rings form on the free surface.

On agar the growth is greyish-white and smooth.

On potato yellowish and slimy.

They occur in water.

**Micrococcus cremoides** (Zimmermann).—Cocci  $\cdot 8 \mu$  in diam., occurring in masses.

Colonies are spherical, granular and yellowish. The margins are dentated or irregular, and processes extend into the surrounding gelatine.

Inoculated in the depth of gelatine liquefaction occurs in the track of the needle in a few days. A yellow growth floats on the liquefied gelatine, and a yellowish mass subsides to the bottom of the liquid.

On agar a smooth shining layer is formed, and on potato the growth is abundant.

They occur in water.

**Micrococcus crepusculum** (Cohn. *Monas crepusculum*, Ehrenberg. *Mikrokokken in faulenden Substraten*, Flügge).—Round or short oval cells, scarcely  $2 \mu$  in diam.; singly or in zoogloea.

They occur in various infusions and putrefying fluids in company with *Bacterium termo*.

**Micrococcus cumulatus tenuis** (Besser).—Large cocci, oval; in masses.

Colonies on agar have a brown nucleus.

Inoculated in the depth of gelatine they form a white filament, and on the surface a transparent layer.

In broth there is an abundant deposit, and the supernatant liquid is clear.

They occur in mucus from the nose.

**Micrococcus endocarditidis rugatus** (Weichselbaum).—Cocci resembling pyogenic staphylococci.

Colonies have a brown or yellowish-brown nucleus.

In the depth of agar there is a slight growth in the track of the needle, and a wrinkled, waxy layer on the surface.

On potato the growth is dry and brownish.

On blood serum the growth is colourless and adherent.

Injected subcutaneously, they produce, in rabbits, local swelling and redness, and suppuration in guinea-pigs. Injected into the veins after injury to the aortic valves, they produce endocarditis.

They were isolated from a case of ulcerative endocarditis.

**Micrococcus fervidus** (Adametz).—Cocci  $\cdot 6 \mu$  in diam., in pairs and in masses.

The deep colonies are pale-yellow, and look like watery droplets; but superficial colonies are granular and irregular with jagged edges.

Inoculated in the depth of gelatine a granular filament develops in the track of the needle, and on the surface a circular patch with dentated margin.

On agar the growth is white and slimy, and on potato greyish-white.

They occur in water.

**Micrococcus Finlayensis** (Sternberg).—Cocci  $\cdot 5$  to  $\cdot 7 \mu$  in diam., singly, in pairs, tetrads, and in masses.

In the depth of gelatine they produce a growth in the track of the needle, with liquefaction at the upper part with a pale-yellow deposit.

On agar the growth is pale-yellow.

They were isolated from the liver in a fatal case of yellow fever.

**Micrococcus flavus desidens** (Flügge).—Cocci singly, in pairs, or chains of a few elements.

Colonies yellowish-white.

Inoculated in the depth of gelatine they grow along the track of

the needle, and form a yellowish-brown layer at the point of puncture.

Later liquefaction sets in, and a deposit forms at the bottom of the turbid liquid.

They occur in air and in water.

**Micrococcus flavus liquefaciens** (Flügge).—Cocci mostly in twos and threes, also in masses.

Small yellow colonies appear after two or three days, which have a shallow depressed zone surrounding them. Under a low power they are granular and yellowish-brown, with lines radiating from the centre to the circumference. Later they liquefy the gelatine, and coalesce.

Inoculated in the depth of gelatine the cocci produce spherical yellow colonies in two days along the track of the needle. These become confluent, and at the end of eight days the whole of the jelly has become liquid; later the upper part becomes clear, and a yellow mass subsides to the bottom of the tube.

They occur in air and in water.

**Micrococcus flavus tardigradus** (Flügge).—Large cocci showing at times peculiar dark poles; generally arranged in masses.

Colonies develop slowly; the superficial ones have a smooth wax-like surface with projecting centre; those below the surface are of a dark chrome-yellow colour, and are round or oval.

Inoculated in gelatine the cocci develop slowly along the track of the needle, forming small isolated colonies; the gelatine is not liquefied.

They occur in air and in water.

**Micrococcus fœtidus** (Klamann).—Cocci singly, in pairs, and short chains and masses.

Colonies circular or oval, white.

Inoculated in the depth of gelatine a pure white, shining growth forms in concentric circles at the point of puncture, and develops a brownish colour; and liquefaction occurs after a time, and extends along the needle track.

A white layer spreads over the surface of agar.

On potato the growth is slimy and grey in colour, with a red tinge.

Cultures produce an odour like that of ozæna.

They were isolated from the nose.

**Micrococcus fœtidus** (Rosenbach).—Small oval cocci.

Cultivated in agar-agar they develop gas-bubbles and a fœtid odour. They were isolated from carious teeth.

**Micrococcus Freudenreichi** (Guillebeau).—Large cocci, singly and in chains.

Colonies are granular and punctiform.

In broth turbidity is produced, and, later, a flocculent deposit.

On potato a shining film develops, yellowish or brownish-yellow in colour.

In milk the cultures become viscous, and can be drawn out into threads several yards in length.

They were isolated from milk with viscous fermentation.

**Micrococcus fuscus** (Maschek).—Cocci oval.

Colonies pale-brown or black.

Inoculated in the depth of gelatine there is a slight growth along the track of the needle, and a brown layer forms on the surface followed by liquefaction.

On potato the growth is brown or brownish-black and slimy.

Cultures give off an odour of putrefaction.

They occur in water.

**Micrococcus gingivæ pyogenes** (Miller).—Large cocci, singly and in pairs.

Colonies spherical, with sharp contours.

Inoculated in the depth of gelatine there is an abundant growth along the track of the needle and on the free surface.

On agar a thick film develops, with a faint tinge of purple by transmitted light.

Injected into mice subcutaneously they produce local suppuration, and sometimes death. Injected into the peritoneal cavity they produce peritonitis and death.



They were isolated from an abscess of the gums.

**Micrococcus gonorrhœæ** (p. 190).

**Micrococcus havaniensis** (Sternberg).—Cocci  $4.5 \mu$  in diam.

The colonies are circular and of a blood-red colour.

The cocci inoculated in the depth of gelatine produce a colourless growth in the track of the needle and a carmine patch on the surface.

On agar and on potato they form a thick irregular carmine layer.

**Micrococcus in Biskra-button** (Heydenreich).—Cocci in pairs,  $.86$  to  $1 \mu$  in length, occasionally tetrads; capsulated.

Inoculated in the depth of gelatine they form a greyish-white filament composed of closely packed colonies, and a yellowish-white film on the free surface. Liquefaction commences at the upper part of the needle track in a few days, forming a funnel which extends until, in two weeks, the gelatine is completely liquefied.

On the surface of agar a shining white or yellowish-white layer develops in twenty-four hours.

On potato the growth is similar.

Inoculations are said to produce in rabbits, dogs, fowls, sheep and horses a morbid condition of the skin similar to the disease known as Biskra-button or Pendjeh sore. In man they produce suppuration when rubbed on the skin.

They were isolated from the disease known as Pendjeh sore, Biskra-button or *clou de Biskra*.

**Micrococcus in gangrenous mastitis in sheep.**—Cocci singly, in pairs, and in masses.

Colonies are spherical, white, and under a low power have a brown nucleus and transparent margin.

The cocci inoculated in the depth of gelatine produce a conical area of liquefied jelly with a copious white deposit.

On agar they produce a white layer, which later turns yellowish in colour.

On potato they form a greyish growth.

Injected into the mamary gland of sheep they produce inflammatory œdema, and a fatal result in twenty-four to forty-eight hours.

In rabbits they are pyogenic.

They were isolated from the milk in cases of gangrenous mastitis in sheep.

**Micrococcus in infectious pleuro-pneumonia** (Poels and Nolen)—p. 242.

**Micrococcus in influenza** (Fischel).—Cocci from  $1$  to  $1.25 \mu$  in diam., singly, in pairs, and chains.

Extremely minute colonies appear in three days.

Inoculated in the depth of gelatine a milk-white filament forms along the track of the needle. Liquefaction commences in four days at the upper part, and extends slowly.

On agar the colonies are pure-white.

On potato the growth is yellowish-white.

They do not grow on blood serum or in milk.

Intravenous injection in dogs is said to produce symptoms like distemper.

They were obtained from the blood in cases of influenza.

**Micrococcus in influenza** (Kirchner).—Cocci in pairs and chains; capsulated. They grow at  $37^{\circ} \text{C}$ .

The colonies are transparent, whitish.

On the surface of agar there is an abundant growth, but it is limited in the depth of the jelly.

Inoculation experiments were inconclusive.

They were obtained from the sputum in cases of influenza.

**Micrococcus in pemphigus** (Almquist).—Cocci  $.5$  to  $1 \mu$  in diam., singly and in pairs; identical with *Staphylococcus pyogenes aureus*.

The cocci vaccinated on the arm are said to have produced bullæ.

They were isolated from pemphigoid bullæ in children.

**Micrococcus in pemphigus** (Demme).—Cocci  $.8$  to  $1.4 \mu$  in

diam., singly, in pairs, and in masses. They can be cultivated at 37° C.

The colonies on agar are milk-white and prominent. Later, off-shoots occur from the margin, producing a rosetted appearance.

Inoculated in the depth of gelatine the cocci form clubbed or stalactitic out-growths from the filament which develops in the track of the needle.

On the surface of agar a creamy layer is formed with similar off-shoots.

Injected into the lungs of guinea-pigs they are said to produce broncho-pneumonia.

They were obtained from the bullæ in acute pemphigus.

**Micrococcus in pneumonia** (Manfredi).—Oval cocci  $\cdot 6$  to  $1 \mu$  in width,  $1$  to  $1.5 \mu$  in length, singly, in pairs, and short chains.

Colonies on gelatine are circular, whitish, and later spread out and become bluish by transmitted light, and of a pearly lustre by reflected light.

Inoculated in the depth of gelatine there is a limited growth along the track of the needle.

On blood serum they form a shining, granular, faintly greenish-yellow layer.

They also can be cultivated on potato and in broth.

They are pathogenic in dogs, rabbits, guinea-pigs, mice and birds. Birds die in a few days; mammals in from one to three weeks. After death new growths composed of granulation tissue are found in the internal organs, varying in size from a millet seed to a pea. They were obtained from the sputum of pneumonia complicating measles.

**Micrococcus in progressive abscess formation in rabbits** (Koch).—Cocci only about  $\cdot 15 \mu$  in diam., principally in thick zoogloea. The disease was induced by the injection into rabbits of decomposing blood. At the place of injection a spreading abscess formed, which was fatal to the animal in about twelve days. No bacteria were observed

in the blood, but in the walls of the abscess thick masses of cocci were found. The pus is infectious, causing the same disease in healthy rabbits.

**Micrococcus in pyæmia in rabbits** (Koch).—Round cocci and diplococci  $\cdot 25 \mu$  in diam.

The disease was produced by the subcutaneous injection, in a rabbit, of distilled water in which the skin of a mouse had been macerated. At the autopsy there were found great infiltration around the site of injection, peritonitis, and accumulations in the liver and lungs; in short, the appearances of pyæmia.

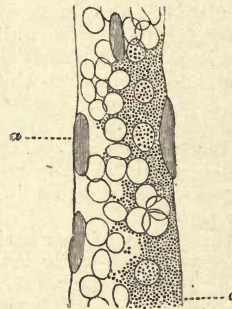

FIG. 220.—MICROCOCUS IN PYÆMIA IN RABBITS: VESSEL FROM THE CORTEX OF THE KIDNEY  $\times 700$ . a, Nuclei of the vascular wall; c, Masses of micrococci adherent to the wall and enclosing blood-corpuses (Koch).

In the capillaries of the organs examined, masses of cocci were observed enclosing blood-corpuses. Fresh inoculations in rabbits with exudation-fluid, or blood from the heart, reproduced the same disease.

**Micrococcus in septicæmia in rabbits**.—Ellipsoidal cocci  $\cdot 8$  to  $1 \mu$  in largest diam. The disease was produced by the injection of putrid meat infusion. After death slight œdema was noted at the site of injection, slight extravasation of blood, and great enlargement of the spleen. No emboli or peritonitis resulted. Masses of cocci were found in the capillaries of



different organs, especially in the glomeruli of the kidneys. Rabbits and mice inoculated with blood from the heart proved susceptible to the disease.

**Micrococcus in syphilis** (Disse and Taguchi).—Cocci and diplococci.

They produce a greyish-white growth in nutrient media.

They are said to produce inflammatory changes in the internal organs and disease of the blood-vessels when inoculated in dogs, rabbits and sheep.

They were obtained from the blood in cases of syphilis.

**Micrococcus in trachoma** (p. 190).

**Micrococcus in yellow fever** (p. 260).

**Micrococcus lactis viscosus** (Conn).—Cocci in pairs and chains.

Colonies circular and granular.

Inoculated in the depth of gelatine liquefaction begins at the upper part of the needle track, and extends until the gelatine is completely liquefied. The liquefied gelatine is viscous, and may be drawn out in long threads.

On the surface of agar they form a white, shining layer.

In broth there is an abundant growth, and a film on the surface.

They coagulate milk, producing butyric acid, and giving it a bitter taste. They were obtained from bitter cream.

**Micrococcus luteus** (Cohn).—Oval cocci 1 to 1.2  $\mu$  in diam.

Colonies yellow, with irregular contours, and granular.

Inoculated in the depth of gelatine a granular filament develops in the track of the needle, and on the free surface a yellow patch.

On agar the growth is slimy and yellow.

On potato the growth is yellow, and after a time wrinkled.

The pigment is insoluble in water, ether and alcohol, and not destroyed by acids or alkalies.

They occur in water.

**Micrococcus luteus** (Schröter).—Cocci similar in size to the above,

elliptical, with highly refractive cell contents.

They form yellow drops of 1 to 3 mm. diam. on boiled potato; and a thick, wrinkled, yellow skin on nutrient liquids.

The colouring-matter is insoluble in water, and unchanged by sulphuric acid or alkalies.

**Micrococcus ochroleucus** (Prove).—Cocci .5 to .8  $\mu$  in diam., singly, in pairs, and short chains.

Colonies minute and colourless, with crenated margin, from which, later, processes extend into the gelatine, while the centre of the colony becomes yellow.

On the surface of gelatine a film develops, which in a few days turns yellow. Old cultures have a peculiar smell.

The yellow pigment can be extracted with alcohol. It is insoluble in water, and decolorised by acids.

They were obtained from human urine.

**Micrococcus of Forbes** (p. 472).

**Micrococcus plumosus** (Brautigam).—Cocci .8  $\mu$  in diam., in masses.

Colonies yellowish-white.

Inoculated in the depth of gelatine long delicate acicular processes shoot out from the needle track and on the free surface.

On potato the growth is similar.

They were isolated from water.

**Micrococcus pneumoniae crouposæ** (p. 236).

**Micrococcus pyogenes tenuis** (Rosenbach).—Cocci irregular, somewhat larger than staphylococci, and with much less tendency to form masses. The ends colour deeply, leaving a clear space in the middle.

Inoculated in the depth of gelatine a slightly opaque growth is formed.

On agar a thin deposit appears along the needle track, which is almost as clear as glass.

They occur in the pus of unopened abscesses, but not often, as they were found by Rosenbach only in three out of thirty-nine cases.

**Micrococcus rosettaceus** (Zimmermann).—Cocci  $\cdot 7$  to  $1 \mu$  in diam., singly, and in masses.

Colonies circular, whitish, or greyish-yellow.

Inoculated in the depth of gelatine the growth is very scanty in the track of the needle, but spreads over the surface as a grey rosette.

On agar a smooth layer with denudated margin is formed.

On potato the growth is faintly yellowish.

They occur in water.

**Micrococcus roseus** (Eisenberg).—Cocci forming pink colonies, and a rose-coloured growth on the surface of nutrient agar-agar.

They were found in sputum in a case of influenza.

**Micrococcus salivarius septicus** (Biondi).—Oval cocci, diplococci, in chains and small masses; capsulated.

They grow best on acid gelatine, or in an atmosphere of carbonic acid.

Colonies are small and circular, with an opalescent centre and a transparent margin, with sharply defined outline. In the interior of the colonies there is an appearance of a network.

Inoculated in the depth of gelatine the cocci form a delicate filament and white dots on the free surface.

On agar the cultures should be made direct from the blood. The growth appears on the surface and resembles dewdrops.

Broth cultures remain clear.

They are fatal to mice in twenty-four to seventy-two hours, and to rabbits in fifteen to thirty days, producing septicæmia. Attenuated cultures are said to give immunity.

They were found in the saliva of healthy and diseased persons.

**Micrococcus stellatus** (Maschek).—Cocci singly.

Colonies stellate.

Inoculated in the depth of gelatine a branching growth appears in the track of the needle. The jelly becomes brownish.

On potato the growth is brownish-yellow and shining.

They occur in water.

**Micrococcus tetragenus** (Gaffkey).—Cocci about  $1 \mu$  in diam., in tetrads, and surrounded by a hyaline capsule.

Colonies form in twenty-four to forty-eight hours as small white dots, which are finely granular, and have a vitreous lustre; when they reach the surface they form thick raised masses.

Inoculated in the depth of gelatine the cocci form an irregular white growth, especially in the upper part of the track of the needle.

On agar the colonies occur along the needle track, and are white, round and circumscribed.

On potato they form a thick, slimy, viscous layer.

White mice inoculated with a minute quantity of a pure-cultivation die in from two to ten days, and the groups of the characteristic tetrads may be found in the capillaries throughout the body, especially in the spleen, lung and kidney.

*Double infection* can be produced by inoculating a mouse with a pure cultivation of *Bacillus anthracis* two or three days after inoculation with *Micrococcus tetragenus*. On examination after death, the capillaries of the lungs, liver and kidney are filled with both anthrax bacilli and masses of tetrads (Plate V., Fig. 3).

**Micrococcus tetragenus mobilis ventriculi** (Mendoza).—Cocci in tetrads; capsulated; motile.

Colonies circular, whitish and granular.

Inoculated in the depth of gelatine they grow on the free surface only, and give off a peculiar odour.

They were isolated from the stomach.

**Micrococcus tetragenus subflavus** (Von Besser).—Cocci singly, and in tetrads.

They do not grow on gelatine.

Colonies on agar are brown and irregular in contour.



On the surface of agar the cocci form a greyish-white band, which turns brown at the periphery, and later is all dark or orange-yellow.

On potato the growth is brown.

They occur in nasal mucus.

**Micrococcus tetragenus versatilis** (Sternberg and Finlay).—Cocci varying in size from  $\cdot 5$  to  $1\cdot 5$   $\mu$ , in tetrads and irregular groups.

Colonies are circular and lemon-yellow in colour.

Inoculated in the depth of gelatine there is very scanty development along the line of puncture, and the gelatine is liquefied in the form of a cup near the surface. At the bottom of the liquefied gelatine a viscid, pale-yellow mass accumulates.

On the surface of agar a thick, viscid, yellow layer is formed along the line of inoculation, which gradually extends over the entire surface. The colour varies from cream-yellow to lemon-yellow, and the surface is moist and shining.

On potato there is a similar growth.

They were isolated from the skin of patients suffering from yellow fever, from mosquitoes after attacking these patients, and from the air.

**Micrococcus ureæ liquefaciens** (Flügge).—Cocci spherical,  $1\cdot 25$  to  $2$   $\mu$  in diam., singly, or in chains of three to ten elements, or in irregular groups.

Colonies appear in two days as small white points. They have sharply defined edges and a granular surface. The gelatine gradually liquefies, and the edges of the colonies become irregular.

The cocci inoculated in the depth of gelatine produce a continuous white line along the track of the needle. Finally, the whole of the gelatine liquefies, and appears as a whitish-turbid fluid with a thick whitish-yellow deposit at the bottom.

They were obtained from urine.

**Micrococcus versicolor** (Flügge).—Small cocci, in pairs and in masses.

White colonies develop in twenty-four hours; after two days they are yellowish, with sharp contours of yellowish-green colour, and finely granular. The superficial colonies form flat deposits,  $2\cdot 6$  mm. in size, increasing to 10 mm. after four or five days.

On the surface of gelatine the cocci form a shining layer with a greenish or bluish shimmer like mother-of-pearl.

Inoculated in the depth of gelatine the growth is composed of spherical yellowish colonies, and on the free surface they form an iridescent film.

They occur in the air.

**Micrococcus violaceus** (Schröter).—Cocci or elliptical cells, described as uniting into violet-blue gelatinous spots, which again unite to form larger patches.

The colonies on gelatine are violet in colour.

Inoculated in the depth of gelatine the growth is scanty in the track of the needle.

On the surface of gelatine they form a bluish-violet layer, and the same on agar and potato.

They were observed on boiled potatoes exposed to the air, and are also found in water.

**Micrococcus viticulosus** (Katz).—Oval cocci  $1$   $\mu$  in width, and  $1\cdot 2$   $\mu$  in length, in masses, but without formation of much gelatinous material.

The superficial colonies are quite different in appearance from the deep colonies. From the deep colonies fine hairlike tendrils are thrown off from a centre, forming a very delicate and extensive network. The threads are found to consist of zoogloea masses, irregular in size, arranged like strings of beads. The colonies which are exposed to the air form a thin layer of muddy-white gelatinous substance, which rapidly spreads, sometimes sending out hairlike processes into the depth of the gelatine.

Inoculated in the depth of gelatine a delicate feather-like growth occurs along the track of the needle,

and on the free surface they produce the appearance which has been described in colonies. This micro-organism is exceedingly rare. It was obtained from a contaminated culture.

**Monas Okenii.**—Short cylindrical cells,  $5\ \mu$  wide,  $8$  to  $15\ \mu$  long, with rounded ends. They exhibit lively movements, each end being provided with a flagellum twice as long as the cell itself. They have pale-red cell-substance, with dark grains.

They occur in stagnant water.

**Monas vinosa.**—Round or oval cells of about  $2.5\ \mu$  in diam., often united in pairs. Their motion is slow and tremulous, and the cell-substance is pale-red with dark grains interspersed. Flagella have not been observed.

They were found in water with decaying vegetable matter.

**Monas Warmingii.**—Cylindrical cells, rounded at the ends,  $15\ \mu$  long,  $5$  to  $8\ \mu$  broad. They are possessed of a flagellum at each end, and exhibit rapid, irregular movements. The cell-substance is pale-red, interspersed at the ends with dark-red grains.

**Myconostoc gregarium** (Cohn).—The threads are very thin, colourless, unarticulated, but fall apart into short cylindrical links when dried.

They form gelatinous masses,  $10$  to  $17\ \mu$  in diam., singly or heaped into slimy drops on water in which algae are decomposing.

**Nitromonas of Winogradsky.**—Very short rods,  $.9$  to  $1\ \mu$  in width,  $1.1$  to  $1.8\ \mu$  in length. Singly, in masses, and in very short chains.

They can be cultivated in silica-jelly.

They are active agents of nitrification.

They were obtained from the soil.  
**Pediococcus acidi lactici** (Lindner).—Cocci  $.6$  to  $1\ \mu$  in diam., singly, in pairs, and tetrads.

Colonies colourless.

On the surface of agar the cocci form a colourless layer.

On potato the growth is almost invisible.

The cocci produce lactic acid in solutions containing sugar.

They occur in hay infusion and malt.

**Pediococcus cerevisiæ** (Balcke).—Cocci singly, in pairs, and tetrads.

Colonies at first colourless, later yellowish-brown.

Inoculated in the depth of gelatine a greyish-white filament occurs in the track of the needle, and a white layer on the free surface.

On agar the growth is transparent and iridescent, and on potato almost invisible.

They were isolated from the air of a brewery.

**Pneumobacillus liquefaciens bovis** (p. 242).

**Proteus capsulatus septicus** (Banti).—Rods isolated from a case of septicæmia, and identical with *Proteus hominis capsulatus*.

**Proteus hominis capsulatus** (p. 224).

**Proteus in gangrene of the lung** (Babès).—Rods  $.8$  to  $1.5\ \mu$  thick, irregular in form, and filaments with irregular enlargements.

Colonies whitish and transparent, with ramifications extending over the gelatine.

In the depth of gelatine a growth occurs along the track of the needle, and a ramifying growth on the free surface.

On agar the growth is slightly yellowish.

On potato the growth is brownish. They are extremely pathogenic in mice and guinea-pigs.

They were isolated from a case of gangrene of the lung.

**Proteus microsepticus** (Karliniski).—Cocci, rods and filaments in morphology, and cultures resembling *Proteus vulgaris*.

Inoculated in the depth of gelatine liquefaction occurs in the track of the needle, forming a funnel with cloudy contents, and in a few days the whole of the gelatine is liquid.

They produce a general infection in mice, and death in twenty-four hours, and occasionally death in





rabbits, and local suppuration in guinea-pigs and white rats.

They were isolated from pus in a fatal case of puerperal pyæmia.

concentric circles, which in time liquefies the medium. Similar movements are observed in capsule-cultivations as in *Proteus vulgaris*.

They were isolated from putrid meat infusion.

***Proteus septicus*** (Babès).—Rods  $4 \mu$  in width, and filamentous forms.

Colonies rapidly liquefy the gelatine.

Inoculated in the depth of gelatine the bacilli form a turbid funnel, or completely liquefy the gelatine in twenty-four hours.

On agar the growth is reticulated.

On potato brownish-white.

Cultures have an unpleasant odour.

They are pathogenic in mice.

They were isolated from the organs in a case of human septicæmia.

***Proteus sulfureus*** (Lindenborn).—Rods  $8 \mu$  in width, varying in length, and long filaments.

They correspond in morphology and cultures with

*Proteus vulgaris*.

They produce sulphuretted hydrogen in cultures.

They were isolated from water.

***Proteus vulgaris*** (Hauser).—



FIG. 221.—*PROTEUS MIRABILIS*: SWARMING ISLANDS ON THE SURFACE OF GELATINE,  $\times 285$  (HAUSER).

***Proteus mirabilis***.—Cocci  $4 \mu$  to  $9 \mu$ . They occur singly and in zoogloea, and sometimes in tetrads, pairs, chains, or as short rods in twos resembling *Bacterium termo*—



FIG. 222.—*PROTEUS MIRABILIS*: INVOLUTION FORMS,  $\times 524$  (HAUSER).

in fact, in all conceivable transition forms.

Cultivated on nutrient gelatine they form a thick whitish layer in

Rods varying in size; some measure  $4 \mu$  in length, and are almost as broad as long, and others vary from  $.94$  to  $1.25 \mu$  long and  $.42$  to

·63  $\mu$  wide. They are actively motile.

Cultivated on nutrient gelatine they convert it into a turbid, greyish-white liquid. If cultivated in a capsule containing 5 per cent. of nutrient gelatine, a few hours after inoculation the most characteristic movements of the individual bacilli

are motile, and the same phenomena are observed on the solid medium as in *Proteus vulgaris*. In cover-glass impressions most varied groupings of the bacilli are seen, and also developmental and involution-forms.

They were isolated from putrid meat infusion.

**Pseudo-diphtheritic bacillus** (p. 335).

**Pseudo-diplococcus pneumoniae** (Bonome).—Oval cocci in pairs and short chains; capsulated.

Inoculated in the depth of gelatine small colonies develop in the track of the needle in twenty-four hours.

On agar there is a scanty, moist growth.

On potato an almost invisible film.

In broth the cocci grow rapidly, and the cultures give off a peculiar odour.

They produce septicaemia in mice, guinea-pigs and rabbits.

This micro-organism is probably a variety of the pneumococcus.

They were isolated from a fatal case of cerebro-spinal meningitis.

**Rhabdomonas rosea**.—Spindle-form rods, 3·8 to 5  $\mu$  broad, 20 to 30  $\mu$  long. They exhibit slow, trembling movements, having at each end of the cell a flagellum. The cell-substance is very pale, with dark grains interspersed.

They occur in brackish water.

**Sarcina alba**.—Small cocci. They form small white colonies on nutrient gelatine.

Inoculated in the depth of gelatine they grow slightly along the needle track, but are heaped up on the surface without liquefying the gelatine.

They are present in the air.

**Sarcina aurantiaca**.—Cocci singly, in pairs, in tetrads, and in packets.

Colonies orange-yellow.

Inoculated in the depth of

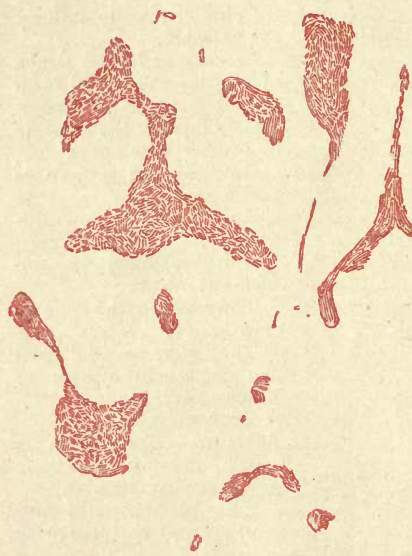

FIG. 223.—*PROTEUS VULGARIS*, FROM THE SURFACE OF NUTRIENT GELATINE,  $\times$  285 (HAUSER).

are observed on the surface of the nutrient gelatine, although at this early stage no superficial liquefaction can be detected. Probably the movements depend upon the existence of a thin liquid layer, as they are not observed if the nutrient medium contains 10 per cent. of gelatine.

They were isolated from putrid meat infusion.

**Proteus Zenkeri**.—Cocci 4  $\mu$ , in twos like *Bacterium termo*, and short rods 1·65  $\mu$  long.

Cultivated on nutrient gelatine no liquefaction results, but a thick whitish-grey layer is formed. The



gelatine they slowly liquefy it along the whole needle track, and form on the surface an orange-yellow growth. On potatoes they slowly develop the same pigment.

**Sarcina candida** (Reinke).—Cocci 1.5 to 1.7  $\mu$  in diam., singly, in pairs, and in tetrads.

Colonies are circular and shining, white, and later yellowish.

Inoculated in the depth of gelatine liquefaction quickly takes place along the track of the needle.

On the surface of agar a white, moist layer develops.

They were found in the air of breweries.

**Sarcina flava** (De Bary).—Small cocci in packets.

Inoculated in the depth of gelatine they produce liquefaction.

On agar they form a yellow layer.

On potato the growth is limited and yellow.

They were isolated from beer.

**Sarcina hyalina** (Kützing).—Cocci round, 2.5  $\mu$  in diam., almost colourless. United in families of 4 to 24 cells, reaching 15  $\mu$  in diam.

They occur in marshes.

**Sarcina intestinalis** (Zopf).—Cocci in groups of four or eight. Very regular in form; never in the large packets which occur in *Sarcina ventriculi*.

They are found in the intestinal canal, especially the cæcum, of poultry, particularly fowls and turkeys.

**Sarcina litoralis** (Oersted).—Cocci 1.2 to 2  $\mu$  in diam., bound together in 4 to 8 families, which, in their turn, may unite and include as many as 64 tetrads. Plasma colourless; in each cell 1 to 4 sulphur granules.

They were found in sea water containing putrefying matter.

**Sarcina lutea** (Schröter).—Cocci singly, in pairs, tetrads and packets. A single individual in a tetrad may be divided into two, or into four, so that a tetrad within a tetrad results.

Colonies are round, slightly granular in appearance, and yellow.

Inoculated in the depth of gelatine they grow rapidly; the gelatine becomes liquefied, and the yellow growth sinks to the bottom of the tube.



FIG. 224.—SARCINA  $\times$  600 (FLÜGGE).

Cultivated in agar they form a colourless growth along the track of the needle, and a bright canary-yellow layer upon the surface.

On potato they form a yellow layer.

They are present in air.

**Sarcina mobilis** (Maurea).—Cocci 1.5  $\mu$  in diam., in pairs, and in tetrads. They are motile.

Colonies, at first white, become brick-red.

Inoculated in the depth of gelatine, there is, after several days, a slight growth along the track of the needle, and a patch of growth on the free surface which gradually turns red. In about two weeks liquefaction produces a funnel-shaped appearance; later the liquefaction extends to the sides of the test-tube.

In broth turbidity is produced, and a yellowish-red deposit.

On agar the growth, at first white, changes to a brick-red colour.

There is no growth on potato, and milk is not coagulated.

They were isolated from ascitic fluid.

**Sarcina pulmonum** (Hauser).—Cocci from 1 to 1.5  $\mu$  in diam., in tetrads and packets.

Colonies white and small. They are coarsely granular.

Inoculated in the depth of gelatine the growth is scanty in the track of the needle, but on the free surface there is a circular, well-defined, translucent patch, which

later becomes greyish-brown, shining, wrinkled and irregular.

On potato the growth is very slight and limited.

They cause ammoniacal decomposition of urine.

They were isolated from phthisical sputum.

**Sarcina Reitenbachii** (Caspary).—Cocci about  $1.5$  to  $2.5 \mu$  in diam., at the time of division lengthened to  $4 \mu$ . Mostly united together from 4 to 8 in number; occasionally 16 or more. Colourless cell-wall, lined with rose-red layer of plasma.

They were found on rotting water-plants.

**Sarcina rosea** (Schröter).—Large cocci, in packets.

Inoculated in the depth of gelatine, liquefaction quickly takes place, and cultures after a time have a reddish colour.

On agar the growth is slow and limited.

On potato the growth is abundant and of a bright-red colour.

In broth they produce turbidity, and a red deposit.

They occur in the air.

**Sarcina urinæ** (Weleker).—Very small cocci,  $1.2 \mu$  in diam., united in families of 8 to 64. They were observed in urine.

**Sarcina ventriculi** (Goodsir).—Cocci reaching  $4 \mu$  in diam., united in groups of four, or multiples of four, producing cubes or packets with rounded-off corners. Contents of the cells are greenish or yellowish-red.

Colonies are round and yellowish.

A yellowish growth forms on the surface of oblique gelatine without liquefaction.

On potato they form a yellow growth, and on serum also.

They grow well in hay-infusion, forming brownish scales and a similarly-coloured deposit.

They occur in the stomach of man and animals in health and disease, and were first detected in vomit.

**Sphærotilus natans**.—Cells 4 to  $9 \mu$  long, and  $3 \mu$  thick, united in a gelatinous sheath to form threads.

The cells comprise rods and cocci-forms; the cocci are set free, and develop into rods, which again form threads. In the last a false branching has been observed. The plasma of the cells break up into minute, strongly-refractive portions, which develop into round spores, at first of a red and afterwards a brown colour.

They occur in stagnant and flowing water contaminated with organic matter, and form floating flakes of a white, yellow, rust-red, or yellow-brown colour.

**Spirillum amyliferum** (Van Tieghem).—Filaments  $6 \mu$  in length and  $1.4$  to  $1.5 \mu$  in width; with from 2 to 4 screw curves.

They act as a strong ferment in the absence of air.

They occur in water.

**Spirillum anserum** (Sakharoff).—Spirilla resembling the *Spirochæta Obermeieri*. Extremely motile.

They have not been cultivated artificially.

Blood from diseased geese, containing the spirilla, produces the disease when inoculated in healthy birds. The geese suffer from diarrhœa, and die in about a week.

They were found in the blood of geese suffering from an epidemic form of septicæmia prevailing at some of the stations on the Transcaucasian Railway.

**Spirillum attenuatum** (Warm-ing).—Threads much attenuated at the ends, which consist usually of three spirals. The middle spiral is about  $11 \mu$  high and  $6 \mu$  in diam., and the end ones  $10 \mu$  high and  $2 \mu$  in diam.

They are found in brackish water.

**Spirillum aureum** (Weibel).—Curved rods with blunt ends, spirilla and spirilliform filaments, and involution forms.

Colonies are circular and golden-yellow.

Inoculated in the depth of gelatine, a finely granular growth forms in the track of the needle, and a yellow-ochre prominent mass on the free surface.



On agar a greyish growth extends over the surface, and later prominent yellowish heaps make their appearance.

On potato there is an abundant growth of a golden-yellow colour.

They were found in sewage mud.

**Spirillum cholerae Asiaticæ** (p. 361).

**Spirillum choleroïdes** (Bujwid).—Curved rods very similar morphologically and in cultures to Koch's comma-bacilli.

They were isolated from river water.

**Spirillum choleroïdes** (Orlowski).—Curved rods very similar to Koch's comma-bacilli.

They were found in well water.

**Spirillum concentricum** (Kitasato).—Short spirilla, and spirilliform filaments.

Colonies are circular, and composed of concentric rings alternately opaque and transparent.

Inoculated in the depth of gelatine there is only a little growth in the track of the needle, and a cloudy growth on the surface extending into the jelly.

On agar the growth is extremely adherent.

In broth they produce turbidity, which disappears after a time; and there is a slimy deposit at the bottom of the tube.

They were found in putrefying blood.

**Spirillum dentium** (Miller).—Spirals 10 to 20  $\mu$  in length, pointed at the ends.

They have not been cultivated.

They occur in the deposit on the teeth, and in company with *Leptothrix buccalis* in carious teeth.

**Spirillum flavescens** (Weibel).—Commas thicker than those found in Asiatic cholera, spirilla, and spirilliform filaments.

Colonies yellowish.

Inoculated in the depth of gelatine a finely granular filament develops in the track of the needle, and on the free surface a pale-yellow patch.

On agar the growth, at first

greyish-white, becomes yellow, and forms a thick layer.

On potato the growth is abundant, and similar in colour.

They were found in sewage mud.

**Spirillum flavum** (Weibel).—Spirilla morphologically identical with spirillum aureum.

Colonies on gelatine are pale-yellow, and later the colour is more intense.

On agar and potato they form a layer the colour of yellow-ochre.

They were isolated from sewage mud.

**Spirillum leucomelaneum** (Koch).—Dark and glass-like spaces alternate in the spirillum, resulting from a regular arrangement of the dark granular contents. A rare form observed in water covering rotting algæ.

**Spirillum linguæ** (Weibel).—Curved rods, spirilla, and spirilliform filaments, and involution forms.

Colonies are composed of interlacing filaments, and offshoots extend into the surrounding gelatine.

Inoculated in the depth of gelatine a delicate growth occurs in the needle track.

On agar the growth is whitish and granular.

In broth a cloudiness is produced, as well as a flocculent deposit.

They are especially distinguished from other spirilla described by Weibel by their staining by Gram's method.

They were isolated from the tongue.

**Spirillum marinum** (Russell).—Curved rods, and spiral filaments.

Colonies circular, granular and striated; later, flocculent masses float in liquefied areas.

Inoculated in the depth of gelatine liquefaction occurs in the track of the needle, and a membrane forms on the surface of the cloudy liquid.

On agar the growth is yellowish and abundant.

On potato a thick, waxy mass

develops, and extends over the surface.

Broth made with sea-water becomes rapidly turbid.

They were obtained from seawater.

**Spirillum Metchnikovi** (p. 373).

**Spirillum nasale** (Weibel).—Large curved rods and spirilliform filaments. Non-motile.

Colonies circular, finely granular, and brownish-yellow.

Inoculated in the depth of gelatine a delicate growth develops in the track of the needle.

On the surface of agar they form a whitish slimy film.

They occur in nasal mucus.

**Spirillum Obermeieri** (p. 258).

**Spirillum of Finkler and Prior** (p. 258).

**Spirillum of Günther** (*Vibrio aquatilis*).—Curved rods, very similar to Koch's comma-bacilli, but there is no growth on potato.

They occur in water.

**Spirillum of Miller**.—Curved rods, singly, in pairs, and spiral filaments.

They liquefy gelatine.

They were isolated from carious teeth.

**Spirillum of Neisser** (*Vibrio berolinensis*).—Similar to Koch's comma-bacillus, but smaller.

Colonies colourless, granular and transparent, liquefying the gelatine much more slowly than Koch's comma-bacillus.

Inoculated in the depth of gelatine they produce a growth similar to that of Koch's comma-bacilli, but much more slowly in milk.

In broth they grow abundantly.

They were found in water.

**Spirillum of Rénon**.—Curved rods longer and broader than the comma-bacilli of Koch.

Colonies yellowish, with dark nucleus.

In gelatine the cultures resemble those of Koch's comma-bacillus.

On agar the growth is white and abundant.

They cause turbidity in broth.

They were isolated from impure water from a well.

**Spirillum of Smith** (*vide Spirillum suis*).

**Spirillum of Weibel**.—Curved rods resembling Koch's comma-bacilli, morphologically, and in cultures on jelly. The gelatine is more quickly liquefied.

There is no growth on potato.

They occur in well water.

**Spirillum plicatile** (Ehrenberg).

—Thin threads  $2.25 \mu$  in breadth, 110 to  $125 \mu$  long, occurring also in spirular forms. The threads have primary and secondary windings; the former are in each example of equal size, but the latter are often



FIG 225.—SPIROCHETA PLICATILE.

irregular. Their ends are cut off bluntly, and they exhibit rapid movement.

They occur abundantly in marsh-water in summer, and can be obtained by allowing algæ to decompose in water. On cultivation the threads break up into long rods, short rods, and, finally, cocci. This change is rendered visible by making cover-glass preparations, and staining with aniline dyes.

**Spirillum rosaceum** (Klein).—Resembles *Spirillum undula*, but is reddish in colour; the colouring-matter is insoluble in water, alcohol or chloroform.

**Spirillum Rosenbergi**.—Threads with 1 to  $1\frac{1}{2}$  windings, 4



to 12  $\mu$  long, 1.5 to 2.6  $\mu$  thick. They are colourless, but the contents include strongly refractive sulphur granules. Also spirals 6 to 7.5  $\mu$  in height, which are actively motile.

They were found in brackish water.

**Spirillum rubrum** (Esmarck).

—Curved rods, spirilla and spirochetæ. They are actively motile.

The growth on artificial media is extremely slow.

Inoculated in the depth of gelatine they grow along the track of the needle, forming a filament of a wine-red colour, without causing liquefaction; and on the free surface the growth is colourless.

In broth long spirillar threads are formed.

They were isolated from the putrid tissues of a mouse.

**Spirillum rufum** (Perty).—

Filaments from 8 to 16  $\mu$  in length, with 1½ to 4 screw curves; non-segmented; chiefly motile; tinged with red.

They form rose or dark red spots on the sides of wells.

**Spirillum sanguineum** (Cohn).

—Threads 3  $\mu$  and more in thickness, with 2 to 2½ spirals, each 9 to 12  $\mu$  high. The ends are provided with flagella. Their colour is due to the presence of reddish granules contained in the cells.

They were observed in brackish water containing putrefying substances. (*Vide* Beggiatoa roseopersicina.)

**Spirillum saprophiles**.—(I.)

Curved rods with pointed ends, .6  $\mu$  in width, 3  $\mu$  in length; spirilla, spirilliform filaments, and involution forms.

Colonies yellowish or greenish-yellow.

Inoculated in the depth of gelatine a white growth forms in the track of the needle, later becoming yellowish; and on the free surface there is a white growth, and beyond this a transparent film spreads over the jelly.

On agar the growth is creamy, and the jelly clouded beneath it.

On potato the growth is slimy and yellowish or dark-brown in colour.

They were obtained from sewage



FIG. 226.—COMMA-BACILLI IN WATER CONTAMINATED WITH SEWAGE.

mud and decomposing hay infusion.

(II.) Curved rods about 2  $\mu$  in length, with blunt ends and in pairs. Extremely motile.

Colonies circular and yellowish-brown.

Inoculated in the depth of gelatine a white growth develops in the track of the needle, and later becomes yellowish-red; on the free surface a white patch forms, surrounded by a transparent film.

In the depth of agar there is no growth in the track of the needle, but a yellowish-white patch on the free surface adherent to the jelly.

On potato the growth is also adherent, and in appearance shining and brownish-green.

They were isolated from decomposing hay infusion.

(III.) Curved rods, spirilla, and spirilliform filaments, and involution forms.

Colonies are circular, granular, and with irregular margin; yellow in the centre, and white at the periphery.

Inoculated in the depth of gelatine a white growth develops in the track of the needle, and on the surface, without producing liquefaction.

On the surface of agar the growth is white.

On potato the growth is distinctly brown.

They were isolated from sewage mud.

**Spirillum serpens** (Müller).—Long spirilliform filaments; often collected in masses.

They were observed in vegetable infusions and stagnant water.

**Spirillum sputigenum** (Lewis).—Curved rods, very similar to the comma-bacilli of Koch; but many observers having failed in repeated



FIG. 227.—COMMA-BACILLI OF THE MOUTH,  $\times 700$  (VAN ERMENGEM).

attempts to cultivate them, maintain that they are biologically distinct from those associated with Asiatic cholera. Klein asserts that they can be cultivated in an acid gelatine, and that they are identical with Koch's comma-bacilli in their mode of growth. They occur with other bacteria in saliva and in scrapings from carious teeth.

**Spirillum suis** (Smith).—Commas and spirilla.

Colonies in gelatine are circular, granular and brownish, and later appear to be composed of concentric rings. The gelatine is not liquefied.

Broth with 1 per cent. of peptone becomes in a few days clouded.

On potato they develop a thin yellowish layer.

The commas are said to be slightly larger than those obtained from Asiatic cholera, and are not pathogenic.

They were obtained from the large intestine in swine.

**Spirillum tenue**.—Very thin threads, with at least  $1\frac{1}{2}$ , usually 2 to 5 spirals. Height of a single screw is 2 to 3  $\mu$ , and the length of spiral therefore 4 to 15  $\mu$ . They are very swiftly motile.

They often occur in dense felted swarms in vegetable infusions.

**Spirillum tyrogenum** (Deneke).—Curved rods, slightly smaller than Koch's comma-bacilli, with a great tendency to form long spirillar threads (Fig. 228).

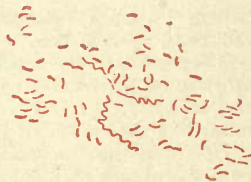

FIG. 228.—DENEKE'S COMMA-BACILLI FROM CHEESE,  $\times 700$  (FLÜGGE).

Colonies on plate-cultivations are sharply defined and of a greenish-brown colour. After a time they liquefy the gelatine, but the liquefaction is much more marked than in colonies of Koch's commas of the same age, though not so rapid as in the case of the commas of cholera nostras.

Inoculated in the depth of nutrient gelatine a turbid liquefaction occurs along the needle track, and on the surface of nutrient agar-agar a yellowish-white layer develops.

Inoculation of potatoes gives no result.

Administration of the bacilli by the mouth, in the manner employed for testing the pathogenic effect of Koch's bacilli, produced a fatal result in a few cases; on the other hand, injection into the duodenum failed entirely. The pathogenic properties may be therefore considered as not yet established.

They were isolated from old cheese.

**Spirillum undula**.—Threads 1.1 to 1.4  $\mu$  thick, 9 to 12  $\mu$  long; spirals 4.5  $\mu$  high; each thread has  $1\frac{1}{2}$  to 3 spirals. They are actively motile, and possess a flagellum at each end.

They occur in various infusions.

**Spirillum volutans** (Ehrenberg).—Threads 1.5 to 2  $\mu$  thick, 25 to 30  $\mu$  long, tapering towards their



extremities, which are rounded off. They possess dark granular contents. Each thread has  $2\frac{1}{2}$  to  $3\frac{1}{2}$  windings or spirals, whose height is 9 to 13  $\mu$ . They have a flagellum at each end, and are sometimes motile, sometimes not.

They are found in the water of marshes and in various infusions.

**Spiromonas Cohnii.**—Colourless cells, consisting of  $1\frac{1}{4}$  spirals, with both ends acutely pointed and provided with a flagellum. Breadth of the cells, 1.2 to 4  $\mu$ .

They occur in water containing decomposing matter.

**Spiromonas volubilis** (Perty).—Colourless, transparent cells, 15 to 18  $\mu$  long. Rapidly motile, and revolving round a longitudinal axis.

They occur in marsh-water and putrefying infusions.

**Staphylococcus pyogenes albus** (p. 178).

**Staphylococcus pyogenes aureus** (p. 176).

**Staphylococcus pyogenes citreus** (p. 178).

**Staphylococcus pyosepticus** (Heucourt and Richet).—Cocci identical with *Staphylococcus pyogenes aureus*.

Subcutaneous injection causes in rabbits intense oedema, and death in twenty-four hours.

They were isolated from pus from an abscess in a dog.

**Staphylococcus salivarius pyogenes** (Biondi).—Cocci .3 to .5  $\mu$  in diam., singly and in masses.

Colonies white and opalescent, producing liquefaction.

Inoculated in the depth of gelatine the growth appears in the track of the needle, and is followed by liquefaction.

On agar the growth is orange-yellow.

The cocci produce local suppuration when inoculated in animals.

They were isolated from an abscess in a guinea-pig following subcutaneous injection of saliva.

This coccus is probably identical with *Staphylococcus pyogenes aureus*.

**Staphylococcus viridis flavescens** (Guttman).—Cocci singly, in pairs and masses; morphologically agreeing with *Staphylococcus pyogenes aureus*.

Colonies are greenish-yellow.

Inoculated in the depth of gelatine a filament forms composed of greyish colonies.

On agar the growth is greenish-yellow.

They grow well on potato.

They were isolated from the vesicles of chicken-pox.

**Streptococcus acidilactici** (Grottenfeld).—Oval cocci .5 to 1  $\mu$  long, .3 to .6  $\mu$  in width, and long chains. They are partially anaerobic.

Colonies are circular and white.

Inoculated in the depth of gelatine a growth occurs only in the track of the needle.

Milk is coagulated.

They were isolated from coagulated milk.

**Streptococcus albus** (Tils).—Cocci forming motile chains.

Colonies are flat and circular, with white periphery and dark nucleus, rapidly liquefying.

Inoculated in the depth of gelatine there is rapid liquefaction in the track of the needle, and a white deposit.

On potato they form a white slimy layer.

They were found in water.

**Streptococcus bombycis** (p. 472).

**Streptococcus brevis** (Lingelheim).—Cocci singly, in pairs and chains, of eight to ten elements.

Colonies on gelatine are circular and very minute.

Inoculated in the depth of gelatine there is a funnel-shaped cavity near the surface, and below this, in the track of the needle, small isolated colonies.

On agar a yellowish-grey film develops along the line of inoculation.

On potato there is a copious white growth in forty-eight hours.

Broth is made turbid.

They were isolated from healthy saliva.

**Streptococcus cadaveris** (Sternberg).—The description corresponds with that of *Streptococcus pyogenes*.

Inoculated in the depth of gelatine the colonies are said to be larger and more opaque.

On the surface of agar they form a thin translucent layer.

In broth little flocculi develop, composed of chains in which in some cases the elements varied considerably in size.

They were obtained from the liver in a fatal case of yellow fever.

**Streptococcus coli gracilis** (Escherich).—Cocci from  $\cdot 2$  to  $\cdot 4 \mu$  in diam., forming chains composed of from six to twenty elements. Some elements in a chain are irregular in form, and show transverse fission.

The colonies are spherical and sink down in the liquefied gelatine.

Inoculated in the depth of gelatine liquefaction occurs in the track of the needle on the second day, and a white deposit forms at the bottom of the liquid. In about a week the gelatine is completely liquefied.

On agar there is a very slight growth.

On blood-serum small scales develop.

On potato the growth is composed of small white prominent colonies.

Milk is coagulated.

They were found in the evacuations of healthy infants.

**Streptococcus conglomeratus** (Kurth).—Cocci and chains, identical with *Streptococcus pyogenes*.

They form an adherent film at the bottom of the tube, which is not broken up by agitation. This is observed in other varieties of *Streptococcus pyogenes*, and is not sufficient to distinguish it.

They are pathogenic in mice.

They were isolated from cases of scarlet fever.

**Streptococcus flavus desidens** (Flügge).—Cocci, diplococci, and short chains. They form yellowish-

white colonies, which gradually sink down in the gelatine.

Inoculated in the depth of gelatine the cocci form china-white, confluent masses in the track of the needle, and on the surface a yellowish-brown slimy layer.

They occur in air and in water, and were originally isolated from contaminated cultures.

**Streptococcus giganteus urethræ** (Lustgarten).—Cocci  $\cdot 8$  to  $1 \mu$  in diam., forming chains composed of several hundred elements. In description they correspond with *Streptococcus pyogenes*.

They do not grow at the temperature of the room.

Colonies on agar are transparent and iridescent.

They were isolated from the healthy urethra.

**Streptococcus Havaniensis** (Sternberg).—Cocci  $\cdot 6$  to  $\cdot 9 \mu$  in diam., forming long chains, composed of cocci, in pairs, and oval elements showing transverse division.

This streptococcus is probably a variety of *Streptococcus pyogenes*.

They were found in the acid vomit of a yellow-fever patient.

**Streptococcus in contagious mammitis in cows** (Nocard and Mollereau).—Cocci spherical or oval, united in long chains.

Colonies are spherical, granular, pale-yellow, or brownish by transmitted light.

The cocci inoculated in the depth of gelatine produce a granular filament in the track of the needle.

On the surface of nutrient gelatine minute spherical colonies are formed, which are bluish by reflected light.

Injected into the mammary gland of cows and goats they produce mastitis.

They were isolated from the milk of cows suffering from contagious mammitis.

From the description this streptococcus appears to be closely related



to, if not identical with, *Streptococcus pyogenes bovis* (Crookshank).

**Streptococcus in progressive tissue necrosis in mice.**—Koch produced a disease in mice by subcutaneous injection of putrid blood. In tissue sections a chain coccus was found which was similar to *Streptococcus pyogenes*.

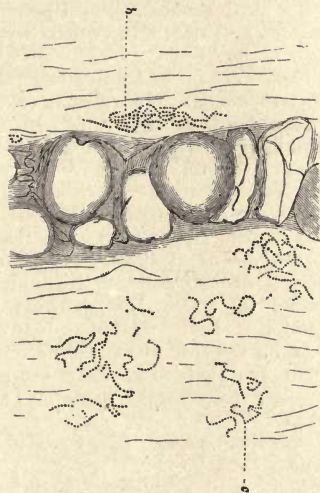

FIG. 229.—STREPTOCOCCUS IN PROGRESSIVE TISSUE NECROSIS IN MICE. a, Necrotic cartilage cells, and (b) chains in masses; c, isolated chains. (Koch.)

**Streptococcus in Strangles** (Schutz).—Cocci forming long chains, which, it is said, do not grow on nutrient gelatine or agar, but form a transparent iridescent culture on blood serum. Cultures in broth produced the disease in horses and mice. Rabbits, guinea-pigs, and pigeons are not affected.

Strangles is a disease of the horse, associated with suppuration of the glands of the head and neck, principally in the sub-maxillary, sub-parotidial, and retro-pharyngeal regions. Schutz found that the pus contains streptococci and produces a fatal disease in mice.

**Streptococcus liquefaciens** (Sternberg).—Spherical and oval

cocci,  $\cdot 4$  to  $\cdot 6 \mu$  in diam., singly, in pairs and short chains.

Inoculated in the depth of gelatine liquefaction occurs rapidly in the track of the needle, and in a week the gelatine is completely liquefied, slightly opalescent, and a scanty deposit forms at the bottom of the tube.

In the depth of agar a filament is formed composed of closely-crowded colonies.

On potato a thin and limited dry white layer is formed along the line of inoculation in four to five days.

They are non-pathogenic.

They were isolated from the liver and intestines of fatal cases of yellow fever.

**Streptococcus mirabilis** (Roscoe and Lunt).—Cocci  $4 \mu$  in diam., singly, and in long chains.

The growth on nutrient media is very scanty.

In broth the growth is composed of a mass of delicate filaments which collect at the bottom of the liquid.

They were isolated from sewage.

**Streptococcus of Bonome.**—Cocci forming chains. They correspond in description with *Streptococcus pyogenes*, but, it is said, they do not grow in gelatine or on blood-serum, and they are said to be distinguished by the characters of the colonies on agar plates.

They are pathogenic.

Inoculated in rabbits and white mice they produce symptoms similar to those produced by inoculations of the pneumococcus. Sub-cultures rapidly lose their virulence.

They were isolated from cases of cerebro-spinal meningitis.

**Streptococcus of Manneberg**—Cocci  $9 \mu$  in diam., singly, in pairs, and in chains.

Inoculated in the depth of gelatine a white filament forms along the track of the needle composed of minute colonies. In about a month the filament is replaced by a funnel of semi-liquefied gelatine.

On the surface of agar the

growth resembles *Streptococcus pyogenes*.

On potato they form a slimy layer.

Milk is rapidly coagulated.

They are pyogenic in dogs and rabbits. Injected into the veins they produce inflammation of the kidneys.

They were isolated from the urine in a case of Bright's disease.

***Streptococcus perniciosus psittacorum*** (*Parrot disease*).—Cocci, singly, in chains, and in zoogloea, have been described in connection with a disease of the grey parrot (*Psittacus erithacus*). This disease is fatal to about 80 per cent. of these parrots imported to Europe. They suffer from diarrhoea and general weakness; their feathers are ruffled; their wings hang loosely, and their eyelids close; convulsions set in, and death follows. At the autopsy greyish nodules are found in the lungs, liver, spleen and kidney. In and around the capillaries of these nodules, and in the blood of the heart, the cocci are found in great numbers in zoogloea, and more rarely in chains. Inflammatory change in the surrounding tissue is absent.

***Streptococcus pyogenes*** (p. 178).

***Streptococcus radiatus*** (Flügge).—Cocci less than  $1\ \mu$  in diam., singly, in small masses, and sometimes in short chains.

Colonies appear in twenty-four hours. They are white, with a yellowish-green sheen; later they liquefy the gelatine and develop a circlet of rays.

Inoculated in gelatine, isolated centres form along the track of the needle which throw out horizontal rays. At the same time a funnel-shaped area of liquefaction forms very slowly in the upper part.

On potato the growth is yellowish-brown.

They occur in air and in water.

***Streptococcus septicus*** (Flügge).—Cocci in chains, indistinguishable microscopically from *Streptococcus pyogenes*.

Colonies on gelatine grow more

slowly than those of most streptococci.

They are pathogenic. Mice die in forty-eight to seventy-two hours after subcutaneous inoculation of a minute quantity of a cultivation. During the last twenty-four hours there is a distinct motor and sensory paralysis of the hind legs. In rabbits inoculation of the ear produces local redness, then a general disease, and death in two or three days.

They were found by Nicolaier, and independently by Guarneri, in earth.

***Streptococcus septicus liquefaciens*** (Babès).—Cocci 3 to  $4\ \mu$ , in pairs, in short chains.

Inoculated in the depth of gelatine a granular filament forms in twenty-four hours along the track of the needle, followed by liquefaction of the gelatine forming a funnel in which the gelatine is clouded; flat, whitish deposits form on the side of the funnel.

On the surface of agar minute shining, transparent colonies are formed.

On blood-serum the growth is almost invisible.

They are pathogenic. Subcutaneous injection in mice and rabbits produces local inflammation and œdema, followed by death in about a week.

They were found in the blood and organs of a child which had died of septicæmia complicating scarlet fever.

***Streptococcus vermiformis*** (Tils).—Cocci forming motile chains.

Colonies are yellowish-white, the central portion finely granular, the periphery radiated.

Inoculated in the depth of gelatine there is rapid liquefaction, and a yellowish deposit at the bottom of the liquid.

On potato the culture forms a dirty-yellow layer.

They were found in water.

***Streptothrix actinomycotica*** (p. 431).

***Streptothrix alba*** (Gasparini).—A variety of *Actinomyces bovis*.



**Streptothrix asteroides** (*Oospora asteroides*, Sauvageau and Radais; *Cladothrix asteroides*, Eppinger).—Branching filaments which form on the surface of grape-sugar-agar a whitish growth, which is later of a brownish-yellow colour.

Broth remains clear, and small pellicles float on the surface resembling drops of stearin.

On potato they form snow-white points, which turn brick-red in colour, and are later covered with a delicate white efflorescence.

The streptothrix is pathogenic in rabbits and guinea-pigs.

It was isolated from pus.

**Streptothrix aurantiaca** (*Oospora aurantiaca*, Sauvageau and Radais, and Doria).—Similar to *Streptothrix asteroides*.

**Streptothrix carnea** (Doria; *Oospora carnea*, Sauvageau and Radais).—Similar to *Streptothrix asteroides*, but the cultures on gelatine are pink.

They are not pathogenic.

**Streptothrix chromogenes** (Gasparini; *Oospora chromogenes*, Lehmann and Neumann).—Cultivated on the surface of gelatine the filaments produce a chalky growth, and the jelly is coloured brown, and is slowly liquefied.

On potato the growth is yellowish or brown, and the potato itself is coloured dark brown or black.

The streptothrix has been isolated from air and water and the contents of the stomach.

**Streptothrix farcinica** (*Bacille du farcin de bœuf*, Nocard; *Oospora farcinica*, Sauvageau and Radais).

Inoculated on the surface of gelatine there is in about two weeks a very scanty granular growth.

In broth greyish pellicles develop with a dusty surface. They are pathogenic in cattle, guinea-pigs, and sheep.

They were isolated from the disease known as *farcin de bœuf*.

**Streptothrix Försteri** (Cohn).—Cocci rods, and leptothrix threads. The threads are twisted in irregular spirals, and branch sparingly and

irregularly. Screw-forms are produced by the threads breaking up into small pieces.

Colonies slowly liquefy gelatine.

On agar they form a whitish growth.

In broth they form shining masses, floating in clear liquid.

They occur in the lachrymal canals of the human eye, in the form of closely felted masses, and in the air, and in fresh- and seawater.

**Streptothrix Hofmanni** (*Micromyces Hoffmanni*, Gruber; *Oospora Hoffmanni*, Sauvageau and Radais).—The filaments flourish in the ordinary culture media with the addition of sugar, but they do not grow on potato.

They produce suppuration in rabbits.

They were isolated from the air.

**Streptothrix liquefaciens** (*Cladothrix liquefaciens*, Garten).—A variety of *Actinomyces bovis*.

**Streptothrix madurae** (p. 449).

**Streptothrix musculorum suis** (*Actinomyces suis*, Dunker).—A variety of actinomyces found in the muscles of swine.

**Streptothrix odorifera** (*Oospora odorifera*, Rullmann). Probably identical with *Oospora chromogenes*.

**Streptothrix violacea** (*Oospora violacea*, Sauvageau and Radais, and Doria).—This streptothrix liquefies gelatine, and gives it a pale wine-red colour.

Agar is coloured a violet tint, and potato becomes a reddish-brown.

**Urobacillus Duclauxi** (Miquel).—Rods  $\cdot 6$  to  $\cdot 8 \mu$  in diam., and filaments 2 to  $10 \mu$  in length. Motile. Spore-formation present.

In gelatine containing ammonia or urea they develop in the track of the needle and cause liquefaction. The liquefied gelatine is viscid.

Broth containing ammonia becomes turbid, a sediment forms, and the liquid gives off an unpleasant odour.

They occur in sewage.

**Urobacillus Freudenreichi** (Miquel).—Rods 1 to 1.3  $\mu$  in width, and filaments 5 to 6  $\mu$  in length.

Colonies circular, white.

Inoculated in the depth of gelatine growth occurs in the track of the needle, and a pure white growth on the surface, followed by slow liquefaction.

In broth they produce turbidity.

They decompose urea.

They occur in air, sewage and dust.

**Urobacillus Maddoxi** (Miquel).—Rods 1  $\mu$  in width, 3 to 6  $\mu$  in length, and involution forms.

Inoculated in the depth of gelatine containing urea they produce white colonies and crystals.

In broth they produce turbidity.

They decompose urea.

They occur in sewage.

**Urobacillus Pasteuri** (Miquel).—Rods attaining 1.2  $\mu$  in width, and 4 to 6  $\mu$  in length, singly and in pairs. Spore-formation present.

They grow in ammoniacal gelatine, slowly liquefying it and forming crystals. The liquefied gelatine is viscid.

They ferment urine, producing a copious deposit of crystals.

They were isolated from decomposing urine.

**Urobacillus Schutzenbergi** (Miquel).—Short rods .5  $\mu$  in width, 1  $\mu$  in length.

They rapidly liquefy gelatine.

On agar they form a white layer.

They grow readily in broth, especially after the addition of urea. The liquid is made cloudy, but after a few days it becomes clear again.

They occur in water.

**Vibrio rugula** (Müller).—Rods and threads, 6 to 16  $\mu$  long, about .5 to 2.5  $\mu$  thick. The rods are either simply bowed, or possessed of one shallow spiral (Fig. 230).

They bear a flagellum at each end. The rods form swarms when causing decomposition, and then, or after, grow out into threads, curved in a screw-like manner. In the

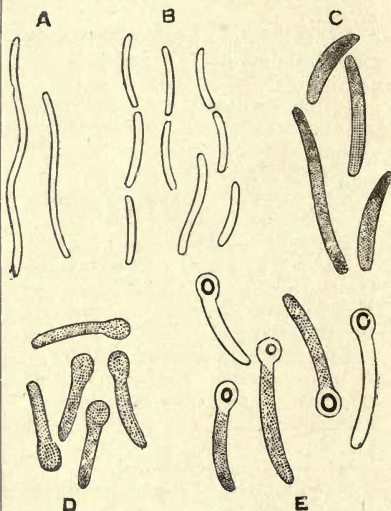

FIG. 230.—*VIBRIO RUGULA*,  $\times 1020$ . A. Bowed threads. B. Slightly-curved rods. C. Rods swollen preparatory to spore-formation. D. Rods swollen at the spore-forming end. E. Various stages of the developing spores. (Prazmowski.)

next stage of development the rods cease to move, and become swollen with granular contents. One extremity develops an enlargement, giving the rod the appearance of a pin. The spore formed by the contraction of the plasma in the swollen end finally becomes globular.

The vibrios appear in vegetable infusions, causing fermentation of cellulose.



APPENDICES.





## APPENDIX I.

### YEASTS AND MOULDS.

*Yeast-fungi* and *mould-fungi*, like *bacteria* or *fission-fungi*, are *achlorophyllous Thallophytes*. They belong to two separate orders—the *Saccharomycetes* and *Hyphomycetes*—which are intimately related to each other, but quite distinct from *bacteria*. Their germs occur widely distributed in air, soil and water, and are constantly encountered in bacteriological investigations. In addition, many species are of hygienic and pathological interest and importance in being either accidentally associated with, or the cause of various morbid processes and fermentations. For a complete account of all the described species and full details of the various forms of development, reference must be made to botanical and other works.\* A description of certain species is appended here, and may afford some useful information to the worker in a bacteriological laboratory.

#### YEAST-FUNGI OR SACCHAROMYCETES.

***Saccharomyces cerevisiæ*** (*Torula cerevisiæ*).—Cells round or oval, 8 to 9  $\mu$  long, singly or united in small chains. Spores occur three or four together in a mother-cell, 4 to 5  $\mu$  in diam. *S. cerevisiæ*, *S. pastorianus* and *S. ellipsoideus* are active alcoholic ferments. According to Jørgensen they will produce in fourteen days in beer-wort from 4 to 6 per cent., by volume, of alcohol.

***Saccharomyces ellipsoideus*** (Hansen). I.—Elliptical cells, mostly 6  $\mu$  long, singly or united in little branching chains. Two to four spores found in a mother-cell, 3 to 3.5  $\mu$  in diam. Cultivated on the surface of wort-gelatine they produce in eleven to fourteen days, at 25° C., a net-like growth by which they can be recognised

\* Sachs, *Text-book of Botany*; Jørgensen, *Micro-organisms and Fermentation*.

with the naked eye. II.—Round, oval, and rarely elongated cells. They produce yeast-turbidity. There are two so-called *disease-yeasts* allied to this species. The colonies of one kind form a network. This yeast causes turbidity in beer, and a bitter after-taste. In the other kind the colonies are sharply defined. It produces a disagreeable aromatic taste to beer, and an astringent after-taste. It is widely distributed, and is the principal agent in accidental fermentation.

**Saccharomyces conglomeratus** (Reess).—Cells round, 5 to 6  $\mu$  in diam., united in clusters, consisting of numerous cells produced by budding from one or a few mother-cells. There are 2 to 4 spores in each mother-cell. They occur on rotting grapes and in wine at the commencement of fermentation.

**Saccharomyces exiguus** (Reess).—Conical or top-shaped cells, 5  $\mu$  long, and reaching 2.5  $\mu$  in thickness, in slightly branching colonies. Spore-forming cells are isolated, each containing 2 or 3 spores in a row. They occur in the after-fermentation of beer; but, according to Hansen, they do not produce *disease* in beer.

**Saccharomyces Jørgensenii** (Lasche).—Cells small, round or oval. On the surface of wort-gelatine the culture is greyish-white, and the gelatine is slowly liquefied. They ferment saccharose and dextrose, but not maltose. When grown in wort with other yeasts they are rapidly crowded out.

**Saccharomyces pastorianus**, I.—Cells oval or club-shaped. Colonies consist of primary club-shaped links, 18 to 22  $\mu$  long, which build lateral, secondary, round or oval daughter-cells, 5 to 6  $\mu$  long. Spores 2 to 4. They occur in the after-fermentation of wine, fruit-wines, or fermenting beer, and in the air of breweries. They produce a bitter taste and unpleasant odour and turbidity in beer. II.—Cells mostly elongated, but also oval or round. Cultivated on the surface of gelatine and yeast-water a growth is produced with smooth edges, by which it can be differentiated from No. III. They occur in the air of breweries, but do not produce disease in beer. III.—They produce yeast-turbidity in beer. On the surface of yeast-water gelatine the cultures, after sixteen days, have hairy edges.

**Saccharomyces apiculatus**.—Cells lemon-shaped, both ends bluntly pointed, 6 to 8  $\mu$  long, 2 to 3  $\mu$  wide. Budding occurs only at the pointed ends. Rarely united in colonies. Spores unknown. They occur with other yeasts in various accidental fermentations and in ripe fruits.



**Saccharomyces sphæricus.**—Cells varying in form; the basal ones of a colony oblong or cylindrical, 10 to 15  $\mu$  long, 5  $\mu$  thick; the others, round, 5 to 6  $\mu$  in diam. United in ramified families. Spores unknown.

**Saccharomyces anomalus** (Hansen).—Cells small, oval, and sometimes elongated. Spores are hemispherical, with projecting rims at the base. They were found in impure brewery yeast.

**Saccharomyces mycoderma** (*Mycoderma cerevisiae et vini*).—Cells oval, elliptical, or cylindrical, 6 to 7  $\mu$  long, 2 to 3  $\mu$  thick, united in richly-branching chains. Spore-forming cells may be 20  $\mu$  long. Spores 1 to 4 in each mother-cell. The colonies in gelatine are greyish and filmy. They form the so-called "mould" on fermented liquids, and develop on the surface without exciting fermentation. When forced to grow submerged, a little alcohol is produced, but the fungus soon dies. They occur on wine, beer, fruit-juices and sauerkraut.

**Saccharomyces albicans** (*Oidium albicans, Fungus of thrush*).—Cells round, oval, or cylindrical, 3.5 to 5  $\mu$  thick; the cylindrical cells 10 to 20 times as long as they are thick. The bud-colonies mostly consist of rows of cylindrical cells, from the ends of which oval or round cells shoot out. Spores form singly in roundish cells. In plate-cultivations the colonies are pure white. In the depth of gelatine a filament is formed composed of white colonies, some with ray-like processes extending into the gelatine. On potato the fungus forms a rapid white growth, and on bread also. They can be easily cultivated in a nutrient solution containing sugar and ammoniac tartrate. The cells germinate according to the richness of the fluid in sugar; they either grow into long threads, or, in a very strongly saccharine solution, many daughter-cells are formed and bud out in various directions. According to Klemperer the thrush-fungus is pathogenic in rabbits, death taking place twenty-four to forty-eight hours after an intravenous injection of a pure-culture. Long mycelial threads are found in the internal organs. They occur on the mucous membrane of the mouth, especially of infants, in greyish-white patches, which consist of epithelium, bacteria, yeasts, and the mycelia of various moulds.

**Saccharomyces pyriformis** (Marshall Ward).—Cells oval. They convert saccharine solutions containing ginger into ginger-beer. They occur with other micro-organisms in the so-called "ginger-beer plant."

**Saccharomyces glutinis.**—Cells round, oval, or short cylinders, 5 to 11  $\mu$  long, 4  $\mu$  wide, isolated, or united in twos.

Cell-membrane and contents are colourless in the fresh state, but when dried and re-moistened possess a pale-reddish nucleus in the middle. Spore-formation unknown. They form rose-coloured, slimy spots on starch paste, and on sterilised potatoes. The colouring matter is not changed by acids or alkalies.

**Saccharomyces ilicis** (Grönlund).—Cells spherical. Spore-formation present without vacuoles. Cultures on the surface of gelatine have a powdery appearance. They produce about 2·8 per cent., by volume, of alcohol in beer-wort, and cause a disagreeable, bitter taste. They were obtained from the fruit of *Ilex aquifolium*.

**Saccharomyces aquifolii** (Grönlund).—Cells large and spherical. Spores contain vacuoles. Cultures on gelatine are variable, smooth and shining, or powdery. They produce about 3·7 per cent. alcohol in beer-wort, and cause a sweet taste with bitter after-taste. They also were obtained from the fruit of *Ilex aquifolium*.

**Saccharomyces Marxianus** (Hansen).—Cells elongated. They develop a mycelial growth on solid nutrient media. They occur on grapes.

**Saccharomyces membranæfaciens** (Hansen).—Cells elongated and vacuolated. Spore-formation abundant. Cultivated on wort-gelatine they produce circular, flattened and wrinkled colonies, greyish, and sometimes with a reddish tinge. The gelatine is slowly liquefied. They occur in the slimy secretion of the roots of the elm, and were also isolated from well-water.

**Saccharomyces Hansenii** (Zopf).—Cells with small spherical spores. They set up alcoholic fermentation in solutions containing sugar. They were found in cotton-seed flour.

**Saccharomyces Ludwigii**.—Cells irregular in form, oval, bottle-shaped, lemon-shaped, and elongated, and mycelial filaments. On wort-gelatine the growth is greyish or yellowish.

**Saccharomyces acidi lactici** (Grottenfelt).—Cells oval, 2 to 4·35  $\mu$  in length, and 1·5 to 2·9  $\mu$  in width. Colonies on nutrient gelatine are porcelain-white. They coagulate milk.

**Saccharomyces minor** (Engel).—Cells spherical. Spore-formation present. They are said to be the most active ferment in the fermentation of bread.

**Saccharomyces rosaceus** (*Pink Torula*).—Cells 9 to 10  $\mu$  in diam. They form a coral-pink growth in nutrient gelatine, nutrient agar-agar, or on sterilised potatoes. They are present in the air.



**Saccharomyces niger** (*Black Torula*).—Cells also present in the air. Cultivated in nutrient gelatine they form a black crust (Fig. 231).

#### MOULD-FUNGI OR HYPHOMYCETES.

The mould-fungi have been divided into five orders: *Hypodermii*, *Phycomycetes*, *Ascomycetes*, *Basidiomycetes* and *Myxomycetes*. The following species, with the orders to which they belong, are of especial interest:—

#### HYPODERMII.

**Ustilago carbo** (*Mildew, Smut*).—Spores brown, circular; episorium smooth; sporidia, ovoid cells. The spores or conidia occur as a black powder in the ears and panicles of wheat, barley and oats.

**Tilletia caries**.—Spores round, pale brown; episorium with reticulated thickenings. In germinating, the sporidia grow out radially from the end of the promycelium; these, at their lower part, conjugate by a cross branch and separate from the promycelium, and at some point of the pair a hypha grows out, on which abundant secondary sporidia develop. The latter are long, oval cells, which can in turn germinate. The fungus occurs in the form of a stinking powder in grains of wheat, which renders the meal impure, and gives it a disagreeable smell.

**Urocystis occulta**.—The spores consist of several cells united together; partly, large dark-brown cells in the interior, and outside, several flat, semicircular, colourless cells. The promycelium germinates as in *Tilletia*, but the cylindrical cells produce a hypha, without, as a rule, previous conjugation. They occur as a black powder in rye-straw in long disintegrated stripes, which are at first greyish. The affected plant produces abortive ears.

**Empusa muscæ**.—A spore or conidium of this fungus alighting upon the white area of the under surface of the body of the house-fly germinates into a hypha. The latter, penetrating the skin, forms toruloid cells, which multiply by germination, and are disseminated in the blood throughout the body of the fly.



FIG. 231.—BLACK TORULA. PURE CULTIVATION ON POTATO.

These cells again grow into hyphæ, which penetrate the skin, each forming a conidium, which is cast off with considerable force. The parasite is fatal to flies, especially in the autumn. They are often observed attached to the walls or window-panes, surrounded by a powdery substance, consisting of the extruded conidia.

**Empusa radicans.**—The spores form long hyphæ, which pierce the transparent skin of the caterpillar of the cabbage white butterfly. The terminal cells ramify, and fill the body of the caterpillar with a network of mycelial filaments. The caterpillars attacked become restless, then motionless, and death ensues.

**Tarichium megaspermum.**—The spores are black in colour, and provided with a thickened episprium. They occur at the sides and ends of mycelial threads, attacking caterpillars (*Agrotis segetum*).

#### PHYCOMYCETES.

**Saprolegnia.**—Colourless threads, forming dense radiating tufts, occur on living and dead animal and vegetable matter in fresh water. The filaments penetrate into the substratum, and branch more or less in the surrounding water. The cylindrical ends of the threads are shut off by a septum—forming *zoosporangia*, or mother-cells, in the interior of which a number of spherical zoospores develop. These are set free through an apical opening in the thread, and after a time coming to rest, give rise to new plants. In the sexual mode of reproduction a spherical bud, the *oogonium*, develops at the end of a mycelial thread; from the thread small processes or *antheridia* sprout out laterally towards the oogonium and blend with its protoplasm. The latter breaks up into a number of *oospores*, which clothe themselves with a membrane while still within the mother-cell, and, eventually being set free, grow into fresh mycelial filaments. The fungus attacks fish and tritons, and produces a diseased condition of the skin, which may be ultimately fatal. In salmon it produces the common “disease of salmon.”

**Peronospora infestans.**—The conidia-bearers of this fungus have as many as five branches, each bearing an egg-shaped conidium. The contents of the conidia falling off and reaching a drop of moisture, break up into a number of swarming zoogonidia, which in turn develop upon plants. Fixing themselves to the cuticle of the host, they throw a germinating filament into an epidermal cell; after piercing first its outer wall, and then its inner



wall, the filament reaches an intercellular space, where the mycelium develops. This continues to grow and spread throughout the plant. In tubers it can hibernate and develop in the young shoots in the following spring. The fungus appears in the form of brown patches on the green parts of the plants, especially the leaves. The attacked parts wither and turn yellow or brown in colour. If the under surface of a diseased leaf is examined, a corresponding dark spot may be observed, accompanied with a faint greyish-white bloom, which covers it. The latter consists of the conidia-bearing branches.

**Pilobolus.**—The fruit-hyphæ possess spherical receptacles containing conidia. When ripe the receptacles with their conidia are detached at their bases, and spring by their elasticity to some distance. The fungus occurs as glassy tufts on the excrement of cows, horses, etc. A cultivation can generally be obtained by keeping fresh horse-dung under a bell-glass.

**Mucor mucedo.**—Hyphæ colourless, simple or branched; sporangia yellowish-brown or black; spores ovoid. They form the familiar white mould on fruits, bread, potatoes and excreta, and penetrate into the interior of nuts and apples. A network of fibrils develops in the substance of nutrient gelatine, with formation of sporangia on the free surface. The germination of the spores and development into hyphæ can be observed in a few hours if the fungus be cultivated in a decoction of horse-dung.

**Mucor racemosus.**—Hyphæ short; sporangia, yellowish to pale-brown; spores round. By continued cultivation in liquids saturated with carbonic acid, the hyphæ become still shorter and exhibit a yeast-like sprouting. These yeast-like or toruloid cells can, when the carbonic acid is withdrawn, germinate into normal mycelium. They occur on bread and decaying vegetable matter.

**Mucor stolonifer** (Lichtheim).—Mycelium grows in the air and then bends down and re-enters the nutrient substratum; sporangia black, and spores globular. The mycelium can penetrate through the shell of eggs, and form conidiophores within them.

**Mucor aspergillus** (Lichtheim).—Fruit-hyphæ thinned at the base, and with many fork-like divisions; dark-brown spores.

**Mucor phycomyces** (Lichtheim).—Mycelium thick-walled; olive-green fruit-hyphæ; black sporangia, and oblong spores.

**Mucor macrocarpus** (Lichtheim).—Spindle-formed, pointed spores.

**Mucor fusiger** (Lichtheim).—Ovoid spores.

**Mucor mellittophorus** (Lichtheim).—Spores elliptical. Found in the stomach of bees.

**Mucor corymbifer** (Lichtheim).—This fungus forms branched fruit-hyphæ. The sporangia have a smooth membrane. It has been found in the external auditory meatus, and on bread it forms a dense snow-white growth. Pathogenic in rabbits.

**Mucor rhizopodiformis** (Lichtheim).—The spores of *Mucor rhizopodiformis* and *Mucor corymbifer*, when introduced into the vascular system of rabbits, can germinate in the tissues, especially in the kidneys, where they set up hæmorrhagic inflammation. Dogs are immune, and only artificial mycosis is known. It occurs on bread.

**Mucor erectus**.—Resembles *Mucor racemosus*. It occurs on rotting potatoes.

**Mucor circinelloides**.—Mycelium much branched, and sporangium carrier is curved.

**Mucor spinosus**.—Sporangia chocolate. Columella has short processes or spines.

#### ASCOMYCETES.

**Oidium Tuckeri**.—Fruit-hyphæ bearing single ovoid conidia. Observed in the form of brown patches, covered with a white mildew-like layer on the leaves, branches and young fruit of the vine, producing "grape disease."

**Oidium lactis**.—Fruit-hyphæ simple, erect and colourless, bearing at their ends a series or chain of conidia. In some cases, the fruit-hypha branches beneath the chain of spores. Spores are short cylinders. The conidia germinate into filaments of varying length, which by subdivision form septate mycelial hyphæ; these and their branches give rise in turn to spores or conidia. The fungus is deeply stained by the ordinary aniline dyes. In a plate-cultivation the colonies appear as white points, and develop into delicate stellate colonies which ultimately coalesce and form a fine mycelial network covering the surface of the gelatine. The gelatine is not liquefied. The growth on the surface of agar is similar to that on gelatine. The fungus occurs in sour milk.

**Achorion Schonleinii** (*Fungus of favus*).—Threads branching at right angles. Favus in man forms yellow crusts on the hairy parts of the body. The crusts are composed of epidermis and mycelial filaments and spores. In plate-cultivations whitish colonies are formed surrounded by liquefied gelatine. Cultivated on the surface



of gelatine the growth resembles that of *Tricophyton tonsurans*, but the liquefaction takes place more slowly, and there is a more distinct yellow colour. On agar the growth is white, dry and firmly adherent.

***Tricophyton tonsurans*** (*Fungus of ringworm*).—Mycelial filaments and spores occur on the crusts and in diseased hairs. In plate-cultivations white colonies are formed, and liquefaction quickly follows. In test-tube cultivations the gelatine is liquefied

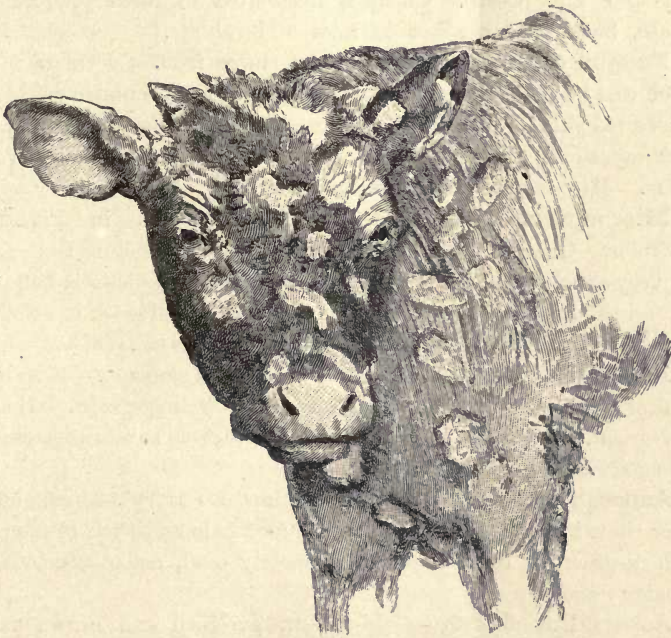

FIG. 232.—HEAD AND NECK OF CALF WITH ADVANCED RINGWORM (*Brown*).

and the fungus forms a membrane on the liquid jelly which is white above and yellow beneath. The surface of the growth is powdery. In man the disease varies in appearance in different parts of the body. Cattle, horses and dogs also suffer from ringworm; but sheep and pigs rarely, if ever. The disease is very common in calves. Sometimes a small portion of the skin is diseased; in other cases, the head, neck, chest and abdomen, or even the whole trunk, may be covered with scabs or crusts. There is often loss of hair in patches, and the skin may be covered with scurf. The disease is transmissible

to the human subject. In one case, according to Brown, seven grooms were infected on the arms from a grey pony which was suffering from the disease in an aggravated form.

**Fungus of fowl-scab.**—Fowls are liable to a disease similar to favus. According to Schütz this disease is characterised by greyish-white patches on the comb and wattles of fowls, which may extend over the neck and body. On nutrient gelatine a white mycelium is formed; and the gelatine is liquefied, and acquires a reddish tint. The fungus can be readily cultivated on bread-paste, agar-agar and potato. Cultures inoculated in fowls produce the disease, but have no effect on mice and rabbits.

**Fungus of mouse-favus.**—Mice suffer from a form of favus which can be communicated to healthy mice by inoculation of scabs or infected skin (Nicolaiër). On nutrient agar the fungus forms a thick mycelium, at first white, and later of a red or reddish-brown colour. Mice can be infected with cultures.

**Microsporon furfur.**—This fungus occurs in Pityriasis versicolor. Grawitz regarded it as identical with *Oidium lactis*, and it is very closely related. Cultivated on gelatine the jelly is hollowed out and the mycelial growth sinks down, and is yellowish in colour.

**Oidium albicans.**—Vide *Saccharomyces albicans*.

**Aspergillus glaucus** (*Eurotium aspergillus glaucus*).—Mycelium at first whitish, becoming grey-green or yellow-green. Spores grey-green, thick-walled. It is found on various substances, chiefly cooked fruit, and is non-pathogenic.

**Aspergillus repens** (*Eurotium repens*, De Bary).—Fruit-heads fewer than in the above, which are at first pale and then blue-green to dark-green in colour. Conidia mostly oval, smooth, colourless or pale to grey-green.

**Aspergillus flavus.**—Gold-yellow, greenish and brown tufts. Fruit-heads round, yellow, olive-green or brown. Conidia round, seldom oval, sulphur-yellow to brown in colour. Saprophytic in man, pathogenic in rabbits.

**Aspergillus fumigatus.**—Greenish, bluish or grey tufts. Fruit-heads long and conical. Conidia round, and rarely oval, smooth, mostly pale and colourless. This fungus occurs on bread, and has been found in the human lungs, external auditory meatus and middle ear, and in the lungs of birds. The spores introduced into the vascular system of rabbits, or into the peritoneal cavity, establish metastatic foci in the kidneys, liver, intestines, lungs, muscles, and sometimes in the spleen, bones, lymphatic glands, nervous system and skin.



**Aspergillus niger** (*Eurotium aspergillus niger*, De Bary).—Dark chocolate-brown tufts. Conidia round, black-brown, or grey-brown when ripe. This mould can be cultivated readily on bread moistened with vinegar, on slices of lemon, and on acid fruits and liquids. It flourishes best of all, according to Raulin, in a liquid of the following composition :—

	Grammes.
Water . . . . .	1500·
Sugar-candy . . . . .	70·
Tartaric acid . . . . .	4·
Nitrate of ammonia . . . . .	4·
Phosphate . . . . .	·6
Carbonate of potassium . . . . .	·6
„ „ magnesium . . . . .	·4
Sulphate of ammonia . . . . .	·25
„ „ zinc . . . . .	·07
„ „ iron . . . . .	·07
Silicate of potassium . . . . .	·07

It was also found that the fungus grew best when the liquid was spread out in a layer 2 or 3 cm. in depth in a shallow dish; and a temperature of 35° C. proved to be the most favourable. The abstraction of zinc from the nutritive liquid reduced the weight of a crop from 25 (the average) to 2 grammes, and the presence of  $\frac{1}{1800000}$  part of nitrate of silver, or  $\frac{1}{500000}$  part of corrosive sublimate, stopped the growth altogether. It is saprophytic in the living body.

#### METHOD OF EXAMINING ASPERGILLUS NIGER.

Species of aspergillus stain intensely with carmine, fuchsine or methyl-violet; but to examine *Aspergillus niger* with a high power a little special technique is employed, as follows :—A drop of glycerine is placed on a clean slide, and a drop of alcohol on a cover-glass. With a fine pair of forceps a few of the fruit-hyphæ with their black heads are immersed in the alcohol. The cover-glass is then turned over on to the drop of glycerine, and the slide held in the flame of a Bunsen burner till the spores or conidia are dispersed. To make a permanent preparation remove the cover-glass, and transfer the fruit-hyphæ so treated to a mixture of glycerine and water (1 to 5); a drop may be conveniently placed ready on a slide provided with a ring of Canada balsam. The specimen is then permanently mounted by employing a circular cover-glass, and surrounding it with a ring of cement in the usual way.

**Aspergillus ochraceus.**—At first flesh-coloured, and then ochre-yellow heads.

**Aspergillus albus.**—Pure-white fruit-heads.

**Aspergillus clavatus.**—Club-shaped fruit-heads on long stems.

**Aspergillus nidulans.**—Bread and potatoes acquire a reddish-brown colour. Pathogenic in rabbits. Occurs on bread.

**Aspergillus subfuscus.**—The growth is olive-yellow in colour. Pathogenic in rabbits. Occurs on bread.

**Aspergillus flavescens.**—The growth is yellowish-green. Pathogenic in dogs and rabbits. Occurs on bread.

**Penicillium glaucum.**—Occurs as a white, and later a blue-green, mould, on which dew-like drops of liquid may appear. Its spores are present in large numbers in the air, and are liable to contaminate cultivations. The fruit-hypha bears terminally a number of branched cylindrical cells, from which chains of greenish conidia are developed. It is the commonest of all moulds.

**Botrytis Bassiana.**—Hyphæ and spores colourless. Hyphæ usually simple, but sometimes united in arborescent stems. It is the cause of *muscardine*, a fatal disease of silkworms, and occurs also in various other caterpillars and insects.

**Chionyphe Carteri.**—Mycelial filaments observed by Carter in Madura disease.



## APPENDIX II.

### HÆMATOZOA.

HÆMATOZOA IN MAN, BIRDS AND TURTLES.—HÆMATOZOA IN EQUINES, CAMELS, RATS AND FISH.—HÆMATOZOA IN FROGS.

#### HÆMATOZOA IN MAN (MALARIA).

IN 1880 Laveran, in Algiers, noticed the existence of peculiar structures in the blood of a patient suffering from malaria, and his researches were communicated to the Academy of Medicine in Paris in 1881 and 1882, and subsequently published *in extenso* in a treatise on the subject.

Laveran described various bodies which he was led to regard as different stages in the life-history of the same micro-parasite. The most striking forms were cylindrical elements with pointed extremities. They were crescent-shaped and pigmented in the middle. There were other forms, more frequently found, which were either free in the serum or in contact with the red blood-corpuscles. They were more or less spherical, pigmented, and endowed with amœboid movement. Other forms, again, were provided with motile filaments three or four times as long as the diameter of a red blood-corpuscle. And, lastly, there were little masses of hyaline material, which Laveran regarded as dead forms.

These observations at first attracted little attention; but they have since been confirmed and extended by Richard, Councilman and Abbot, Marchiafava and Celli, Golgi, Sternberg, Osler, the author, Vandyke Carter, Manson, and others, and their importance fully recognised.

The different forms assumed by the hæmatozoon of malaria may be described in two groups: those within the red blood-corpuscles, and those free in the serum.

**Intra-corpuscular bodies.**—These are of three kinds. *First,*

structureless protoplasmic bodies much smaller than, and within or attached to, the red blood-corpuscles (Fig. 233). These rapidly change their shape, exhibiting amœboid movement. They were first described by Marchiafava and Celli, and possibly represent the first stage in the life-history of the hæmatozoon. Marchiafava and Celli suggested the name *Plasmodium malarix*. *Second*, minute



FIG. 233.—NON-PIGMENTED AMŒBOID FORMS (Marchiafava and Celli).

masses of finely granular or of hyaline protoplasm enclosing granules of pigment (Fig. 234). These forms are sometimes present in large numbers, and at other times can be found only with difficulty. They are more or less spherical, but exhibit amœboid movement, and rapidly change their form. The pigment granules are also in active movement. There may be one or more of these amœboid



FIG. 234.—PIGMENTED AMŒBOID FORMS (Golgi).

bodies to a blood-corpuscle, and they vary in size; one may occupy the whole of the corpuscle. In cases of pernicious malaria, similar bodies may be seen, in tissue sections, in the corpuscles filling the capillaries. *Third*, forms which appear like isolated grains, and larger homogeneous bodies surrounded by clear spaces which change in outline.

**Extra-corpuscular bodies.**—These are the most striking, and



FIG. 235.—SEMI-LUNAR BODIES OF LAVERAN (Golgi).

perhaps the most interesting, forms. *First*, the semi-lunar bodies of Laveran. These are crescent-shaped bodies, sometimes pointed



at the extremities, but more usually rounded off (Fig. 235). They are not always curved; some, indeed, are almost spherical, and others sausage-shaped. They are motionless. In many specimens a delicate line is visible on the concave side of the crescent connecting the extremities. On careful examination this is found to be



FIG. 236.—ROSETTE FORMS WITH SEGMENTATION (Golgi).

the edge of a very delicate membrane. The body is composed of homogeneous protoplasm. Centrally placed is a collection of pigment granules, which on careful examination can be distinctly seen to be in movement. The semi-lunar bodies vary in number in different cases. Sometimes several can be seen in the field at the same time, and in other cases they are only observed after a long and patient search. They are, as a rule, free in the serum; but they have also been seen within the red blood-cells. *Second*, finely granular masses of protoplasm, which arise, according to Golgi, from the intracorpuseular pigmented bodies. The pigment is collected in a rosette, and the protoplasm by segmentation gives rise to a number of small

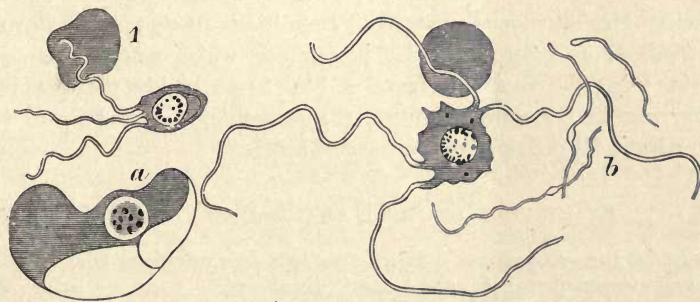

FIG. 237.—FLAGELLATED FORMS (Vandyke Carter).

1. A flagellated spherule; *a*, the same in the interior of a phagocyte; *b*, free motile filaments.

spherical forms, which are ultimately set free (Fig. 236). Golgi believes that these changes occur in definite relation to the development of the paroxysm. *Third*, spherical, pear-shaped, or ovoid bodies, rather smaller than the red blood-corpuseles, and provided with one or more actively motile flagella (Fig. 237). These flagella

are long lash-like filaments, which by their activity set the neighbouring blood-corpuscles in motion. Free filaments in active movement have also been observed. *Fourth*, small spherical pigmented bodies about one-quarter the size of a red blood-corpuscle, which exhibit amœboid movement.

**Inoculation experiments.**—Marchiafava and Celli assert that inoculation of a healthy subject with blood containing the parasites will produce a paroxysm of ague with development of the hæmatozoa. The pathogenic power of these parasites, however, has not been established. There has been no cultivation of the parasite outside the animal body, and reproduction of the disease with a pure cultivation. In favour of its being a pathogenic organism, Laveran points out its invariable presence in some form or other in cases of malaria; the marked changes it effects in the red blood-cells; the increase in the number of the parasites in proportion to the severity of the attack; and, lastly, their disappearance after the administration of quinine. Others, again, have doubted the parasitic nature of these bodies, and have looked upon them as representing pathological changes in the blood-cells.

Laveran first of all suggested the name *Oscillaria malariae*; but subsequently he recognised that these bodies belonged to the animal, not to the vegetable, kingdom. Osler has suggested that, temporarily at any rate, the organism should be placed in the genus *Hæmatomonas* of Mitrophanow, thus: "Genus, *Hæmatomonas*; species, *Hæmatomonas malariae*. Definition—Body plastic; ovoid or globose; no differentiation of protoplasm, which contains pigment grains; flagella variable, from one to four; highly polymorphic, occurring in (1) amœboid form, (2) crescents, encysted form, (3) sporocysts, (4) cellular free pigmented bodies."

#### EXAMINATION OF THE HÆMATOZOA OF LAVERAN.

*In the Living Condition.*—Select a patient by preference who has had several attacks of malaria, and is markedly anæmic. Examine before the invasion of the febrile paroxysm. Take two perfectly clean cover-glasses and two clean slides; wash one of the fingers of the patient with soap and water, and then cleanse with alcohol; apply a ligature, and with a clean needle puncture the thin skin near the root of the nail; touch the drop of blood which collects, with a clean slide; cover quickly with a cover-glass, and gently press it if the layer of blood be too thick. Examine with a  $\frac{1}{2}$  o. i.

*In Stained Preparations.*—Puncture the finger again if necessary; touch the droplet of blood with a clean cover-glass; apply another cover-glass; press them gently together, and then slide them apart; stain with



two or three drops of alcoholic solution of methylene-blue ; wash off excess, and examine in water, or allow the preparation to dry, and mount in balsam.

#### HEMATOZOA OF BIRDS.

According to Danilewsky, birds suffer from malaria in both an acute and a chronic form. The hæmatozoa are very similar to those found in malaria in man, and any slight difference may be attributed to the different character of the blood in birds. Grassi and Feletti have described two kinds of malarial hæmatozoa in birds, one kind belonging to the genus *Hæmamoeba* and the other to the genus *Laverania*.

#### HEMATOZOA OF TURTLES.

Danilewsky has also minutely described and figured hæmatozoa in the blood of turtles, which in some stages of their life history very closely resemble those found by Laveran in man.

#### HEMATOZOA OF EQUINES AND CAMELS (SURRA DISEASE.)

*Surra* is a blood disease occurring in horses, mules, and camels, characterised by fever accompanied by jaundice, petechiæ of mucous membranes, great prostration, and rapid wasting terminating in death. The average duration of the disease is about two months. No organic lesions are found after death, but a parasite exists in the blood during life. By means of subcutaneous inoculation, and by the introduction into the stomach of blood containing the parasite, the disease, according to Evans, can be transmitted to healthy animals. The importance of this disease may be realised from the fact that on one occasion in India the 3rd Punjab Cavalry lost no less than three hundred horses from it.

The disease has not been observed to be contagious or infectious in the ordinary sense, but the possibility of its conveyance by means of large brown flies has been suggested. These flies attack the horses so vehemently that the blood frequently streams from the bites ; and the opinion that they propagate the disease is prevalent among the natives. At the same time it has been particularly noted that where the disease has broken out the water was very impure.

Evans discovered a hæmatozoon, in 1880, in all the diseased horses and mules examined ; in all diseased camels, with one exception ; and in the dogs which had been subjected to experimental inoculations.

Evans stated that when he first discovered the parasite he thought it was a spirillum, but very speedily on closer examination arrived at an opposite opinion.

To him the organism presented the appearance, when fresh and active, of an apparently round body, tapering in front to form a neck and terminating in a blunt head. Posteriorly he described a tapering tail, from which there extended a long slender lash. At the head end there appeared in one or two cases a circlet of pseudopods, and as the body slowly died in serum it gave the appearance of flattening out. After watching very closely all its changes of form and movements, Evans came to the conclusion that there existed on either side of the body two fin-like papillæ, one near where the neck began and the other close to where the tail began. In only very few instances he was able to see the four at once. He suggested that these processes were of the nature of pseudopods.

The parasite he described as extremely active in its movements, with an undulatory, eel-like motion, progressing for the most part head-end foremost, but occasionally moving in the direction of the lash when tugging at a corpuscle. In fresh blood these organisms resembled spermatozoa in colour; but their peculiar characteristic was the power they possessed of attacking and disintegrating the red corpuscles.

Occasionally two were observed to unite and swim off as one body; but the mode of union was a disputed point. Evans thought that they joined with their respective heads and tails in the same direction, overlapping each other; but others to whom they were shown were of opinion that they fastened with their tails in opposite directions.

The parasites were not always present in the blood, but were observed to come and go in successive broods. Evans referred the organism to Lewis for his opinion as to its nature. Lewis arrived at the conclusion that the parasite was "more nearly related to that which he found in the blood of rats than to any other"; but he was of opinion at the time that they did not appear exactly the same.

Five years later Surra broke out in British Burma, and Steel was deputed to investigate the outbreak. Steel confirmed the communicability of the disease to dogs, horses and mules by ingestion and inoculation, but he considerably supplemented Evans' views as to the nature of the disease by careful thermometric observations: these finally led him to regard the disease as a true



relapsing fever, closely resembling relapsing fever in man. At the same time it is worth recording that until Steel observed the presence of the parasite described by Evans he regarded the outbreak as malarious in origin, and provisionally termed it gastric typhoid. In the Burma outbreak, as in the Punjab epidemic, considerable evidence was adduced in favour of regarding the disease as being due to bad water supply.

Steel succeeded in staining the organism with aniline dyes, but his description of the parasite in the fresh state differs very materially from that given by Evans.

Steel failed to recognise the round body tapering in front to a neck. To him the bodies appeared thick in the middle, gradually diminishing in size in either direction, with a blunt and rigid extremity at one end. The opposite end he described as tapering in such a way as to produce a subspiral prolongation, which was uncurled and lashed about freely like a whip. This tail was described as slender in relation to the general size of the parasite; but under the highest power available the presence of a colourless flagellum could not be detected, nor, he adds, did the movements of the blood-constituents indicate its existence.

Steel also failed to see the slightest sign of the two fin-like papillæ on each side as described by Evans—an opinion in which he was supported by Lewis.

These two observers, Evans and Steel, also differed as to whether the movement could be called spiral. Steel felt convinced that their movement was as much of that nature at times as can be expected from organisms with so open a corkscrew shape; while Evans maintained an opposite view. In the dried and stained specimens Steel observed that they retained their subspiral form of body and markedly spiral form of tail.

Steel found that the disease could be communicated to the dog and to the monkey, and then discussed the resemblance of the parasite to the spirillum of relapsing fever in man.

From the different appearances presented by the parasite when in the living state and when dried and stained, Steel thought that there was probably a still closer resemblance to the living spirillum than to the dried and stained one, and argued that the figures of spirilla like corkscrews must be purely imaginary. Steel, it must be observed, founded these remarks upon figures in text-books, and not on photographs or on a practical acquaintance with the spirillum of relapsing fever. One cannot refrain from pointing out the value of photomicrographs, for they cannot be

called into question; and had Steel studied photographs of spirilla he would not have regarded the corkscrew appearance as imaginary.

Steel found the parasite in all cases, and further observed that it appeared as the temperature rose and disappeared during the apyrexial periods.

From all these observations Steel concluded as follows:—That relapsing fever of mules is an invariably fatal disorder, characterised by the periodical occurrence of attacks of high fever, during which a special organism closely resembling the spirillum of relapsing fever in man is found in the blood. This organism is one-sixth the size of a red corpuscle in width and three to six times in length. It is eel-like, and, when dried and stained, presents a thick portion—the body—and a spiral tail. The latter takes less of the dye than the former, and commences as a sudden narrowing of the body, terminating by a fine point. This, he insisted, had nothing of the nature of an infusorian flagellum. The thick portion tapers in either direction from its centre, and terminates in front abruptly in a rigid process, with probably some holdfast organ. The sharpness of the head end varies in different animals. The body portion he described as spiral, and so closely in general appearances to resemble the spirillum of relapsing fever that he concluded that the organism was undoubtedly a spiral bacterium and named it after its discoverer *Spirochaeta Evansi*. This view, however, would not be accepted by Evans, who maintained that, whatever it might be, it was not a member of the family of bacteria.

In the face of these conflicting opinions Evans, in 1885, submitted to the author preparations of the organism in the blood as well as material from the lungs and intestines of a camel that had succumbed to the disease.

On examining a stained preparation the author found that with a power of 200 diameters a number of the parasites could be distinguished in the field of the microscope, and with  $\frac{1}{2}$  and  $\frac{1}{18}$  o. i. objectives the individual characteristics were clearly brought out. These were quite sufficient at once to dispel the idea of its being a spirillum. It was obvious that it was a more highly organized micro-parasite, presenting very peculiar and distinctive structural appearances.

The author came to the following conclusions:—

The somewhat tapering central portion, or body, of the parasite is continuous at one end with a whip-like lash, and at the other end terminates in an acutely-pointed stiff filament or spine-like process.



Here and there, possibly from injury or want of development, the spine-like process appears to be blunted or absent. By very careful focussing on the upper edge of the central portion, the author discovered the existence—much more markedly in some of the parasites than in others—of a longitudinal membrane with either a straight or undulating margin. The membrane is attached along the body, arising from the base of the rigid filament, and becomes directly continuous at the opposite end with the flagellum. In some cases the edge only is deeply stained, giving the appearance of a thread continuous with the flagellum, so that one might be easily led to overlook the membrane, and imagine that the flagellum arose from the opposite end of the body, at the base of the spine-like process.

Close to the base of the spine-like process a clear unstained spot is in many parasites easily distinguished; and at the opposite end there is, in some, the appearance of the deeply-stained protoplasmic contents having contracted within the faintly-stained membranous investment. When the longitudinal membrane has a wavy outline the undulations are much more marked in some cases than in others. Here and there the wavy outline appears first on the one side of the central portion and then on the other; but there never is any waving outline on both sides of the same part of the body, and this was explained by a careful examination, which showed that the somewhat ribbon-like parasite had become doubled on itself. The discovery of this undulating membrane at once suggested to the author an explanation of the lateral pseudopodia described by Evans. If we imagine that we are looking down upon the parasite, with the edge of the membrane towards us, one can conceive that the rapid undulations, first on one side and then on another, might give an image upon the retina which could be construed as due to the protrusion of lateral pseudopodia. In stained preparations no trace of the circlet of pseudopods could be discovered, and the undulating membrane may account for this appearance also.

Owing to the somewhat curved and twisted shape of the parasite and the curling of the flagellum in the stained preparations, it was difficult to make exact measurements; but the average width, according to whether the membrane was visible or not, varied from 1 to 2  $\mu$ , and the length of the body from 20 to 30  $\mu$ . The flagellum was about the same length as the body.

Here and there in a stained preparation there were the forms already described by Evans resulting from the fusion of two para-

sites. But the union obviously took place by the non-flagellated ends, for the two flagella were frequently turned in the same direction, so that the fused parasites resembled, as Evans subsequently suggested, a trophy of buffalo horns. Here and there more than two parasites had united, forming a stellate group; and in one case the author noticed that the individuals had apparently united with their non-flagellated ends just overlapping, so that the unstained spot in one was just situated in a line with the unstained spot of the other.

In Evans's Report, Lewis's opinion is given that these parasites differed slightly, but still were closely allied to certain flagellated organisms which had been observed by him in rats in India. On



FIG. 238.—“SURRA” PARASITES OCCURRING SINGLY AND FUSED.  
(From preparations stained with magenta,  $\times 1200$ . Lent by Dr. Evans.)

referring to his original memoir, it will be found that his description and woodcut differed very materially from the Surra parasite as just described, though a microphotograph which Lewis had appended to the memoir after it was written, indicated a great similarity to this organism. To the author the organisms appeared not only closely allied, but, as far as one can judge from figures and descriptions, morphologically identical with the parasites described by Mitrophanow in the carp, and as a matter of fact, instead of a mere resemblance, the rat and the Surra parasites, when stained, are found to be morphologically identical.



## HEMATOZOA OF RATS.

In describing these organisms, Lewis remarked that it was strange that they had not occupied attention before, and suggested as an explanation that possibly European rats did not harbour these parasites. The author examined a few white rats, but without success, and then proceeded to examine the blood of common brown rats, trapped from the London sewers, and discovered that these organisms are to be found in no less than 25 per cent. of apparently healthy animals. The first question which naturally arose was whether these organisms in European rats were identical with those described by Lewis in Indian rats.

If we refer to the description given by Lewis, we find that he states that when he first noticed them he thought they were vibrios or spirilla. The drop of blood under examination appeared to quiver with life; and on diluting the blood, motile filaments could be seen rushing through the serum and tossing the blood-corpuseles about in all directions.

The filaments were pale and translucent, without any trace of visible structure or granularity, and they were more undulatory in movement than spirilla. A corpusele might be observed to quiver, and this

could be distinctly traced to be due to the existence of a flagellum, *apparently a posterior flagellum*, as the organisms seemed generally to move with the thicker end forward; no flagellum could be detected at the opposite end. The greater number of the figures in the woodcut (Fig. 239) are described as representing these organisms a few hours after the blood had been obtained, when their movements are not so rapid, and the flagellum becomes more easily recognisable.

This observation led Kent, who named the organism *Herpetomonas Lewisi*, to remark that if, as Lewis is inclined to maintain, that organ "propels instead of draws the animalcule through the inhabited serum, we have presented a structural and functional feature without parallel among the other representatives of these *Protozoa flagellata*, the recognition of which would demand the creation of a

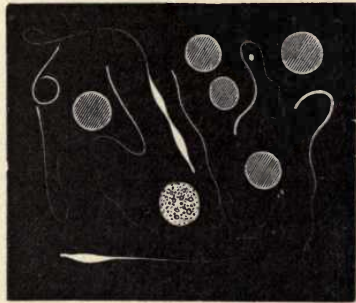

FIG. 239.—PARASITES IN THE BLOOD OF RATS (Lewis).

distinct generic and family group for the reception of these singular organisms." In his later paper, however, Lewis came to the conclusion that, like the generality of flagellated organisms, the rat parasites moved with the lash in front.

On careful examination the plasma which constituted the thicker portion of their substance was observed to suddenly swell out so as to divide the body into two parts, as seen in the centre of the figure; at other times two or three such constrictions or dilatations were detected, and at other times the body assumed an arrow shape, as depicted at the lower part of the figure. When dried, and stained with a little weak solution of aniline-blue, the body presented a very different appearance. It was found to have contracted irregularly, and to manifest a somewhat granular and shreddy appearance, suggestive of a coagulated fibro-albuminous substance. The body portion became flattened towards its middle to double its original width, and both ends almost acutely pointed, while the flagellum was only partly visible. After fixing with osmic acid they measured 0.8 to 1  $\mu$  in width, and 20 to 30  $\mu$  in length; the flagellum was about as long as the body: so that the total length of the organism was about 50  $\mu$ . Lewis detected these parasites in 29 per cent. of the species *Mus decumanus* and *Mus rufescens*, but failed to find them in mice. He considered that they had many features in common with motile organisms of vegetable origin; but they appeared to approach much more closely to the Protozoa, more particularly several of the species of Dujardin's *Cercomonas*. He points out that many, however, believe that these organisms are zoospores and not animalcules. To him they also seemed to be not unlike the flagellated parasite described by Bütschli.

The latter observer detected flagellated organisms (*Leptomonas Bütschlii*) in the intestinal canal of a free nematode (*Trilobus gracilis*). They, too, form stellate colonies, like the *Surra* parasite, owing to their being attached by their non-flagellated ends. When detached from these colonies they presented a somewhat spindle-shaped body about 11  $\mu$  in length, with a somewhat thick flagellum about double this length, so that the total length of the protozoon would be 33  $\mu$ , or, as Lewis states, about half the length of the flagellated organism in the rat's blood. Near the base of the flagellum, Bütschli's protozoon presented a contractile vacuole, but Lewis was unable to detect any such vacuole in the rat hæmatozoa.

In conclusion, Lewis observed that very probably these organisms corresponded with the vermicules observed by Goss in the



blood of a field mouse, and he also mentions that Chaussat found minute "nematodes" in the blood of a black rat.

Wittich discovered in the blood of hamsters whip-like bodies with lively movements. They resembled frog's spermatozoa, possessing a thick portion continued into a long lash-like thread. Wittich considered them identical with the organisms described by Lewis, and they also were observed in apparently healthy animals. Koch later met with the same organisms.

Like Lewis, the author found that the blood of the common brown rat in England appeared to quiver with life, and that the parasites were extremely difficult to examine until their movement was arrested for a moment or they became imprisoned in the serum areas. After examining with various powers, from a  $\frac{1}{5}$  dry to a  $\frac{1}{25}$  o. i. of Powell and Lealand, the author came to the following conclusion:—That they are polymorphic, presenting for



FIG. 240.—A MONAD IN RAT'S BLOOD. The organism is represented at partial rest with its posterior filament impinging on a corpuscle, and showing the undulating longitudinal membrane, the long flagellum, and the refractive spherules in the granular protoplasm ( $\times 3000$ ).

the most part slightly tapering bodies which terminate at one end in a stiff, immotile, acutely-pointed flexible filament or spine-like process, and at the opposite end are provided with a long flagellum, while, longitudinally attached, a delicate undulating fin-like membrane can be traced, which starts from the base of the posterior filament, and becomes directly continuous with the flagellum (Fig. 240).

With careful illumination the body is found to be distinctly granular, with one or more highly-refractive spherules. When the rapid movement is arrested the undulating membrane is distinctly visible. The best opportunity occurs for seeing this when the organism comes to partial rest with its stiff filament against a corpuscle, as if to obtain a *point d'appui*, while lashing its flagellum in all directions (Fig. 241, b). At other times, when the parasite has impinged with its posterior extremity against a corpuscle, or the stiff filament is apparently entangled in *débris*, the movements of the organism give one the idea of its endeavouring to set itself free,

but the author has not been able to persuade himself that they "attack and disintegrate" the red blood-corpuscles.

In the active state the thicker portion, or body, appears to twist and bend from side to side with great activity. The organism can turn completely round with lightning rapidity, so that the flagellum, at one moment lashing in one direction, is suddenly observed working in the opposite direction. Then suddenly the organism makes progression, and it can be distinctly seen to *move in the direction of the flagellum, the flagellum threading its way between the corpuscles and drawing the rest of the organism after it.* Currents set up by evaporation may undoubtedly here and there produce the appearance of the organism "wriggling along" with its flagellum posterior; but the author was convinced, after

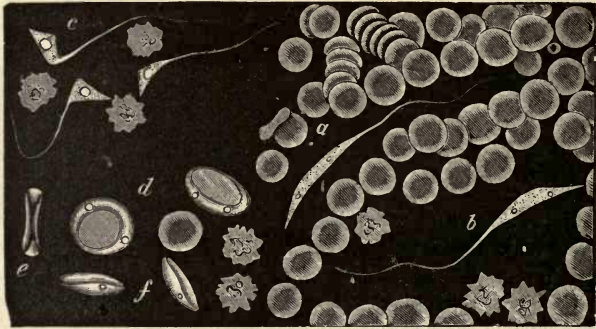

FIG. 241.—MONADS IN RAT'S BLOOD,  $\times 1200$ . *a*, A monad threading its way among the blood-corpuscles; *b*, another with pendulum movement attached to a corpuscle; *c*, angular forms; *d*, encysted forms; *e* and *f*, the same seen edgewise.

hours of patient observation, that in the normal mode of progression the flagellum acts as a tractellum and not as a pulsellum. By treating cover-glass preparations with osmic acid the appearances obtained are very similar to those shown in Lewis's photographs, so that there is no doubt, in spite of the descriptions not completely according, that they are one and the same organism. There was a great likeness to the organisms described by Mitrophanow, and to the Surra parasite; and when the author had stained the rat parasites, the closest examination confirmed his belief that they were morphologically identical with the stained parasites of Surra.

Cover-glasses with a thin layer of blood may be passed three times through the flame of a Bunsen burner in the way commonly employed for examining micro-organisms, and stained with an



aqueous solution of fuchsin, methyl-violet, or Bismarck-brown, or with aurantia, nigrosin, and other aniline dyes. The following method will, however, be found most instructive:—Use freshly prepared saturated solution of fuchsin or methyl-violet in absolute alcohol, and put a drop with a pipette on the centre of the preparation; do not disturb the drop-form for a few moments; then, before the alcohol has evaporated, wash off the excess of stain. It will be found that where the drop rested the organisms will be very deeply stained, while in the surrounding area the colour will vary in intensity. By the effect of the different degrees of staining much

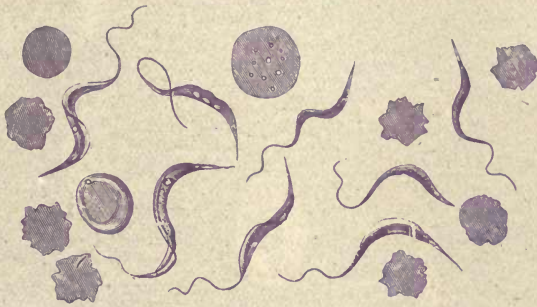

FIG. 242.—MONADS IN RAT'S BLOOD STAINED WITH METHYL VIOLET, SHOWING MEMBRANE UNDER DIFFERENT ASPECTS, BLOOD-CORPUSCLES, SOME CRENATED AND STAINED DISCS ( $\times 1200$ ).

may be learnt (Fig. 242). In one organism the body and entire membrane will be equally stained; in another the margin of the membrane only. In some the posterior stiff filament is stained, and at its base a darkly stained speck is very striking; and in other cases, again, the posterior filament is only faintly tinged, or an unstained spot occurs near its base.

#### HÆMATOZOA OF FISH.

In the year 1883 Mitrophanow published a paper in which he gave an account of organisms in the blood of the mud-fish and the carp.

In the blood of the mud-fish (*Cobitis fossilis*) the organisms at the first glance looked like minute nematodes, but the appearances and changes which took place on further examination showed nothing in common with worms (Fig. 243). As a 1 per cent. salt solution had been added to the blood under examination, it occurred

to Mitrophanow that they were possibly the cytozoa described by Gaule; but this idea was dismissed by the fact that they were found in blood to which no salt solution was added. Their size varied from 30 to 40  $\mu$  in length and 1 to 1½  $\mu$  in width. At first their rapid movements baffled examination, but as the rapidity lessened there was the appearance of a curling movement in the body portion and a swinging movement of the lash. The organism moved in the direction of the lash, the anterior end of the body being more pointed than the posterior, and gradually fining off into the lash. When the body seemed to rest, the lash might be seen to

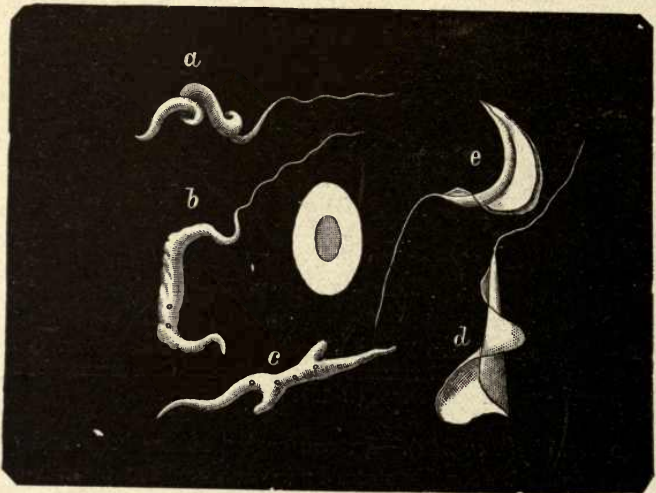

FIG. 243.—ORGANISMS IN THE BLOOD OF MUD-FISH (*Hematomonas cobitis*). *a*, First variety; *b*, second variety; *c*, third variety. *d*, First variety in a state of diminished activity. *e*, The same after treatment with osmic acid. (Mitrophanow.)

whip out in all directions. As the movement of the body gradually diminished, it appeared to have a complicated screw form, the axis of the screw corresponding to the body to which an undulating membrane is fastened spirally. This could be distinguished when the organism was dying, because the body in death contracted, and the membrane then looked like a spiral addition. Thus the organism consisted of a body, a spiral membrane, and a flagellum.

With higher magnification the organism appeared to consist of a refractive, strongly contractile protoplasmic substance, which, when death occurred, formed a shapeless mass. In the same blood two other forms were observed: one without a membrane, but having



two highly refractive spherules in the protoplasm; and another with neither membrane nor flagellum, consisting of very granular protoplasm with several refractive spherules, and capable of protruding processes like pseudopodia.

In the carp (Fig. 244) the parasite is perceptibly larger, and possesses an undulating membrane fastened along the edge of the long body. When the body bent first towards one side and then to the other, a wave-like movement was observable at the free edge of this membrane.

These parasites were found in all the mud-fish examined except

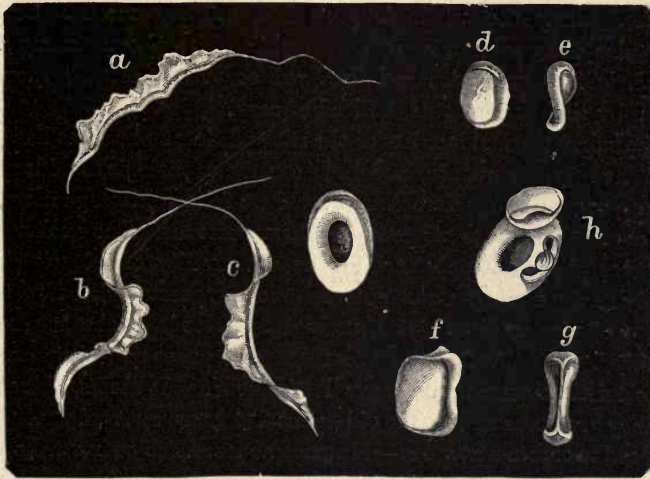

FIG. 244.—ORGANISMS IN THE BLOOD OF THE CARP.

*a, b, c, Hæmatomonas carassii*; *d, e, f, g, h*, other organisms in the same blood (Mitrophanow).

one, and in greater numbers in the hot months. In the carp they were only found occasionally. Mitrophanow described other varieties, which he considered were possibly not complete organisms, but developmental forms. He considered that these organisms were infusoria between the genera *Cercomonas* and *Trichomonas*, with great similarity to the *Trichomonas* described in the Lieberkuhn's glands of fowls and ducks (Eberth).

On account of their special habitat, Mitrophanow suggested a new genus—*Hæmatomonas*, defining this genus as follows:—Parasites of normal fish-blood, worm-like, actively moving organisms, with indistinct differentiation of body parenchyma. Bodies pointed at

both ends, 30 to 40  $\mu$  long and 1 to 1½  $\mu$  wide. May possess in front a flagellum, and on one side an undulating membrane.

Species :—

*Hæmatomonas cobitis*.—Body provided with a spiral membrane and a flagellum at the fore-end. Parenchyma of body homogeneous. Second variety, body and flagellum only. Movement undulatory, body containing highly refractive spherules. Third variety, plasma-like body, without membrane or flagellum; quickly changes form by sending out processes laterally, and contains two to four refractive spherules. Blood of mud-fish.

*Hæmatomonas carassii*.—Long bodies, with narrow membrane attached along the whole length; less actively motile. Several forms also observed strikingly smaller than the above; many disc-shaped. Often seen attached to a red corpuscle, setting them in motion by their movements. Blood of carp.

The morphological identity of the rat and Surra parasites has been established by the author, and both seem morphologically identical with the organism of Mitrophanow. If we follow Mitrophanow, we must obviously enlarge his genus of *Hæmatomonas*. The author does not agree with Mitrophanow in the advisability of adopting this entirely new generic name. Mitrophanow suggested this new term because of the special habitat, normal fish-blood, of the species he discovered. But the characteristic features of these organisms are the characteristic marks of the genus *Trichomonas*. It seems, therefore, that they are embraced by the old genus *Trichomonas*, and that there is no need to create a new one—*Hæmatomonas*. The common habitat of these species may be expressed by grouping them together in one sub-genus—*Trichomonas sanguinis*; but the question arises whether they are distinct species. If it were not for the different description given by Mitrophanow of the organism in the mud-fish, the author would be inclined to say that all these organisms belonged to one and the same species, which might well be named *Trichomonas sanguinis*. The monad in the rat and the Surra parasite are morphologically identical with each other, and both, as far as one can judge from the description, morphologically identical with the monad in the blood of the carp. We have, however, seen that the organism in Surra is believed to be pathogenic, and too much stress must not be laid on morphological identity. There is strong evidence in favour of believing in its pathogenic properties; but at the same time it must be borne in mind that the organism has never been isolated apart from the blood, and the disease then produced by its introduction into healthy animals. It is quite possible that the parasites in



Surra are only associated with the disease, the impoverished blood affording a suitable nidus for their development, while the contaminated water may be the common source of the organism and of the disease. On the other hand, the organism in the rat is found in apparently perfectly healthy, well-nourished animals. The author suggests that the parasites observed in the rat and hamster should be named after Lewis, *Trichomonas Lewisi*; the organism in the mule, camel and horse after its discoverer, *Trichomonas Evansi*; and that the names *Trichomonas cobitis* and *Trichomonas carassii* should be substituted for the names of the species described by Mitrophanow. Thus we should have added provisionally to the

Genus—TRICHOMONAS.

*Sub-genus*—*Trichomonas sanguinis*. Definition: Elongated tapering bodies, provided with a spiral (*T. cobitis*), or longitudinal (*T. carassii*, *Lewisi*, *Evansi*) membrane, terminating in a rigid filament and an anterior flagellum. Highly polymorphic. Habitat, the blood.

*Species*.—*Trichomonas cobitis* (*Hæmatomonas cobitis* Mitrophanow)—Mud-fish.

*Trichomonas carassii* (*Hæmatomonas carassii* Mitrophanow)—Carp.

*Trichomonas Lewisi* (*Herpetomonas Lewisi* Kent)—Rat, hamster.

*Trichomonas Evansi*—(*Spirochaeta Evansi* Steel)—Horse, mule, camel; (pathogenic?).

HÆMATOZOA OF THE FROG.

Lankester described an organism which he had discovered in the blood of the frog (*Rana esculenta*). It consisted of a minute pyriform sac, with the narrower end bent round on itself somewhat spirally, and the broader end spread out into a thin membrane, which exhibited four or five folds and was prolonged on one side into a very long flagellum. The wall of the sac was striated, nucleated and granular; the membrane undulated during life, and the flagellum was also motile. It was named *Undulina ranarum*, but subsequently recognised as identical with *Trypanosoma sanguinis* described by Gruby. In the same blood Lankester also discovered little oblong bodies, in many cases attached to the end of the red corpuscles, and suggested a genetical connection with the *Undulina*.

One or more motionless filaments were occasionally observed attached to these bodies. Gaule subsequently observed the same bodies, and regarded them as resulting from the metamorphosis of the cells of the frog's blood. Gaule's observations were refuted by Lankester in 1882, the parasitic nature insisted upon, and the organism named *Drepanidium ranarum*. Lankester suggested that they were probably the young stage of a sporozoon allied to *Sarcocystis* or to *Coccidium*



## APPENDIX III.

### PSOROSPERMS OR COCCIDIA.—AMCEBA COLI.

#### PSOROSPERMS OR COCCIDIA.

GREYISH-WHITE nodules may occasionally be found in the liver of a rabbit, the result of a disease which may be mistaken for tuberculosis. This disease often proves fatal, and may occur in an epidemic form in rabbit warrens. The nodules have cheesy or purulent contents, which are found, on microscopical examination, to contain great quantities of *Coccidium oviforme*.

The coccidia pass from the intestine into the bile-ducts. The walls of the bile-ducts become dilated and folded; and irregular cavities result from the partial or complete disappearance of the dividing walls of the altered ducts. The folds are composed of connective tissues lined with columnar epithelium, and the coccidia, in different stages of development, are found between the cells, and free in the cavities of the nodules.

The individual coccidia are egg-shaped bodies. They possess a thick smooth shell, with an opening, or *micropyle*, at one end, and protoplasmic contents which may completely fill the capsule or be collected into a spherical mass.

After passing from the liver and intestine, these oval bodies undergo a further development. According to Leuckart, who has very fully described this parasite, the protoplasmic contents divide into four masses, and from each is developed a C-shaped hyaline rod, the cavity of which is occupied by closely packed granules. In this condition they remain until they gain access to a fresh host.

*Coccidium oviforme* has been found in the human liver, and also in sheep, dogs, and cats. Similar, but not identical, bodies occur in mice, and also in fish and other cold-blooded animals.

*Miescher's tubes* are peculiar structures found in swine, cattle, sheep, deer, and mice. They consist of a firm envelope inclosing a number of reniform or bean-shaped bodies.

*Pfeiffer's bodies.*—Pfeiffer has described certain appearances which he attributes to coccidia, in epithelial cells in small-pox, vaccinia, and other vesicular diseases. They are probably only derived from the cell nucleus, and are not parasites.

*Cancer bodies.*—In sections of malignant growths stained by aniline dyes, certain bodies have been found and minutely described and figured by various investigators, and a causal relation suggested. Darier first described bodies like cysts, with spores, in Paget's disease of the nipple. Wickham found similar structures and figured them. Nils Sjöbring described a cancer parasite, and illustrated his researches with plates. Russell drew attention to certain bodies in cancerous tumours, with a great affinity for fuchsin. Soudakewitch, Podwyssozki, Sawtschenko, Ruffer, and Walker have, among others, contributed to the literature of the so-called cancer parasites. These bodies appear in the form of refractile spherical elements, which stain well with reagents, such as the Ehrlich-Biondi stain. Sections are left in this stain for twenty-four hours, washed in alcohol, cleared in xylol, and mounted in xylol balsam. The spherical bodies have sometimes a radiate appearance. These bodies have not been cultivated, and inoculation experiments with cancerous tissue have been negative. The opinion is now very generally held that these bodies are not parasites, but that changes occur in the cells and nuclei, resulting in the formation of peculiar structures, which have been brought to light by the use of aniline dyes and complex staining methods. We are justified in concluding that the cause of cancer is unknown.

Ballance and Shattock have made repeated attempts to cultivate parasitic protozoa from malignant tumours, and they have extended their researches to *vaccinia* and *molluscum contagiosum*, but with negative results. Sand and water were used as the medium for these experiments. Cultivations were made from nine scirrhus carcinomata of the breast, five sarcomata from different sources, two melanotic sarcomata from horses, and a sarcoma from a dog. In every instance the result was negative. No traces of protozoic life could be found, in spite of examinations at regular intervals, and repeated for periods of many months.

#### AMŒBA COLI.

Lösch, Grassi, Kartulis, and others have described an amœba in the intestines of patients suffering from dysentery. Lösch administered the fresh dejecta of a patient containing the amœbæ to dogs,



and in one case a mucous mass was passed containing a number of amœbæ. Eighteen days afterwards the dog was killed, and the mucous membrane of the intestine was reddened, swollen, and



FIG. 245.—AMŒBA COLI IN INTESTINAL MUCUS (LÖSCH).

ulcerated in three places. The mucus in the rectum and in the ulcers contained numerous amœbæ. Cunningham, who has found the amœbæ in choleraic and other cases, and in the intestine of the cow and horse, does not attach any importance to their presence.

## APPENDIX IV.

### APPARATUS, MATERIAL, AND REAGENTS EMPLOYED IN A BACTERIOLOGICAL LABORATORY.

#### (A) HISTOLOGICAL APPARATUS.

**Microscope.**—For the investigation of micro-organisms a good microscope with oil-immersion system and a condenser, such as Abbé's, is essential. Such instruments are supplied by Zeiss, Leitz, Reichert & Hartnack in Germany, and Powell & Lealand, Swift & Baker in England. Zeiss supplies a micrometer eyepiece, with directions for use. Some such arrangement is essential for the measurement of bacteria. Other accessories to the microscope are :

A large bell-glass, for covering the microscope when not in use.

About a foot square of blackened plate-glass.

A white porcelain slab of the same size.

Glass bottles, with ground-glass stoppers, for alcoholic solutions of aniline dyes, etc.

Glass bottles, with funnels, for aqueous solutions of the dyes, and others provided with pipettes.

A small rod-stoppered bottle of cedar oil. This is recommended by Zeiss in preference to other oils for his immersion lenses.

Set of small glass dishes or capsules and watch-glasses, for section-staining, etc.

Stock of best glass slides, in packets of fifty.

Several boxes of round and square thin cover-glasses, in various sizes, of the best quality.

Needle-holders, with a couple of platinum needles, and a packet of ordinary sewing-needles.

Glass rods drawn out to a fine point ; useful for manipulating sections when acids are employed.

Platinum or plated copper section-lifters.

One pair of small brass or spring-steel platinum-pointed forceps, for holding cover-glasses.

One pair of brass tongs.



Collapsible tubes, for containing Canada balsam ; very serviceable for transport and general use.

Turn-table for sealing cover-glass preparations, with rings of cement.

Boxes for preparations, book-form.

Tickets and labels, various sizes.

Soft rags or old pocket-handkerchiefs, for removing cedar oil from immersion lens, cleaning cover-glasses, etc.

Chamois leather for wiping lenses.

**Warm Stages.**—In addition to those already described, Schäfer and Stricker have constructed warm stages for accurate observations. Schäfer's apparatus consists of a vessel (*f*), filled with water which has been boiled to expel the air, and heated by means of a gas-flame at *g*. The warmed water ascends the indiarubber tube (*c*) to the

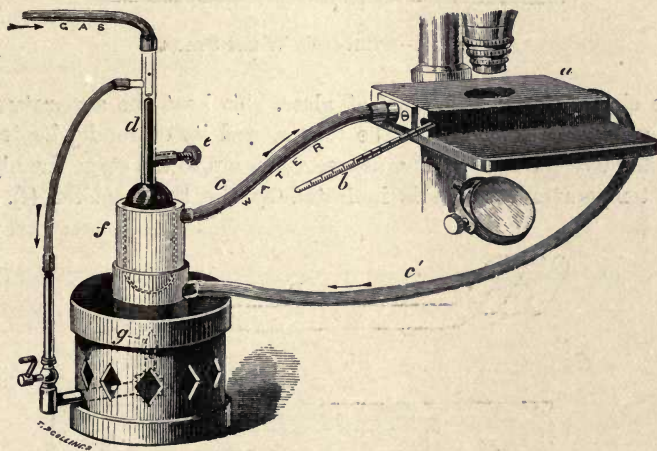

FIG. 246.—SCHÄFER'S WARM STAGE.

brass box (*a*). The box is pierced by a tubular aperture to admit light to the object, and has an exit tube (*c'*), by which the cooled water from the stage returns to be reheated by the flame *g*. At *d* is a gas-regulator, so that a constant temperature at any desired point can be maintained.

Stricker's stage, in which warm water or steam can be used for heating, and by the employment of iced water also used for observing the effects of cold, is shown in Fig. 247. It consists of a hollow rectangular box, with a central opening (*C*) permitting the passage of light. The water makes its exit and entrance at the side tubes (*a, a*), and the temperature is indicated by a thermometer in front.





preferred by many workers. Smaller accessories, which should be within reach, are—

A small can of sewing-machine oil.

A soft rag and chamois leather, for wiping the knives immediately after use.

Stone and leather, for setting and sharpening the same.

Two or three camel's-hair brushes.

A freezing microtome is very useful: such as Swift's, which is used by the author; and the method of embedding in celloidin is combined with the ordinary process of freezing.

(B) REAGENTS AND MATERIAL EMPLOYED IN THE PROCESSES OF HARDENING, DECALCIFYING, EMBEDDING, FIXING AND CUTTING OF TISSUES.

**Alcohol, absolute.**

**Bergamot oil.**

**Celloidin.**

Dissolved in equal parts of ether and alcohol.

**Cork, or stock of ready-cut corks.**

**Ebner's solution.** A mixture in the following proportions:—

Hydrochloric acid . . . . .	.5
Alcohol . . . . .	100
Distilled water . . . . .	20
Chloride of sodium . . . . .	5

**Formalin.**

**Gelatine.**

Melted in a small porcelain capsule, and set aside ready to be re-melted when required for use.

**Glycerine gelatine (Klebs).**

Best well-washed gelatine . . . . . 10

Add distilled water, allow gelatine to swell up, pour off excess of water, melt gelatine with gentle heat, add

Glycerine . . . . . 10

Lastly, a few drops of phenol for preservation.

**Gum.**

**Kleinenberg's solution.**

Saturated watery solution of picric acid . . . . .	100
Strong sulphuric acid . . . . .	2
Filter, and add	
Distilled water . . . . .	300

**Müller's fluid.**

Bichromate of potash . . . . .	2
Sulphate of sodium . . . . .	1
Distilled water . . . . .	100

**Osmic acid.**

Distilled water . . . . .	100
Osmic acid . . . . .	5

**Paper trays** (or small glass capsules).

**Paraffine.**

**Spermaceti.**

**Xylol.**

(C) REAGENTS FOR EXAMINING AND STAINING MICROSCOPICAL PREPARATIONS.

1. **Acetic acid, strong.**

2. **Alcohol, absolute.**

3. **Alcohol, 60 per cent.**

4. **Alcohol, acidulated.**

Alcohol . . . . .	100
Hydrochloric acid . . . . .	1

5. **Alum Carmine (Grenacher).**

Carmine . . . . .	1
Five per cent. solution of alum . . . . .	100

Boil twenty minutes; filter when cold.

6. **Ammonia, strong.**

7. **Aniline.**

8. **Aniline water.**

Distilled water . . . . .	100
Aniline . . . . .	5

Shake well, and filter emulsion.



9. **Bismarck-brown.**

(a) Concentrated solution in equal parts of glycerine and water.

(b) Aqueous solution.

Bismarck-brown . . . . .	2
Alcohol . . . . .	15
Distilled water . . . . .	85

10. **Borax-carmine (Grenacher).**

Borax . . . . .	2
Carmine . . . . .	5
Distilled water . . . . .	100

To the dark purple solution add a 5 per cent. solution of acetic acid until a red colour is produced; set aside twenty-four hours; filter, and add a drop of carbolic acid.

11. **Cedar oil.**

12. **Ehrlich-Biondi solution (Heidenhain).**

To

Saturated aqueous solution of Orange. G. . . . .	100
--------------------------------------------------	-----

Add

Saturated aqueous solution of Rubin. S. . . . .	20
"          "          "          Methyl-green. OO. . . . .	50
To the mixture . . . . .	1
Add water . . . . .	100

13. **Eosin.**

(a) Saturated alcoholic solution.

(b) Aqueous solution.

Distilled water. . . . .	100
Eosin . . . . .	5

14. **Ether.**

15. **Fuchsine.**

(a) Saturated alcoholic solution.

(b) Aqueous solution.

Fuchsine . . . . .	2
Alcohol . . . . .	15
Water . . . . .	85

16. **Gentian-violet.**

(a) Saturated alcoholic solution.

(b) Aqueous solution.

Gentian-violet . . . . .	2.25
Distilled water . . . . .	100



**17. Gibbes' solution, for double staining.**

Take of

Rosaniline hydrochlorate . . . . .	2
Methylene-blue . . . . .	1

Triturate in a glass mortar.

Dissolve aniline oil . . . . .	3
In rectified spirit . . . . .	15

and add slowly to the above.

Lastly, slowly add distilled water . . . . .	15
----------------------------------------------	----

Keep in stoppered bottle.

**18. Glycerine, pure.****19. Hæmatoxylin solution.**

Hæmatoxylin . . . . .	2
Alcohol . . . . .	100
Distilled water . . . . .	100
Glycerine . . . . .	100
Alum . . . . .	2

**20. Iodine solution.**

Iodine, pure . . . . .	1
Iodide of potassium . . . . .	2
Distilled water . . . . .	50

**21. Iodine solution (Gram).**

Iodine . . . . .	1
Iodide of potassium . . . . .	2
Distilled water . . . . .	300

**22. Lithium-carmin solution (Orth).**

Saturated solution of carbonate of lithium . . . . .	100
Carmin . . . . .	2.5

**23. Magenta solution (Gibbes).**

Magenta . . . . .	2
Aniline oil . . . . .	3
Alcohol (sp. gr. .830) . . . . .	20
Distilled water . . . . .	20

**24. Methylene-blue.***(a)* Concentrated alcoholic solution.*(b)* Aqueous solution.

Methylene-blue . . . . .	2
Alcohol . . . . .	15
Water . . . . .	85



(c) Koch's solution.

Concentrated alcoholic solution of methylene-blue	1
Ten per cent. potash solution . . . . .	2
Distilled water . . . . .	200

(d) Löffler's solution.

Concentrated alcoholic solution of methylene-blue	30
Solution of potash, 1 to 10,000 . . . . .	100

25. **Methyl-violet.**

(a) Concentrated alcoholic solution.

(b) Aqueous solution.

Methyl-violet . . . . .	2.25
Distilled water . . . . .	100

(c) Koch's solution.

Aniline water . . . . .	100
Alcoholic solution of methyl-violet . . . . .	11
Absolute alcohol . . . . .	10

26. **Neelsen's solution.**

Dissolve fuchsine . . . . .	1
In alcohol . . . . .	10
Add a 5 per cent. watery solution of carbolic acid	100

27. **Nitric acid, pure.**

28. **Orseille (Wedl).**

Dissolve pure ammonia-free orseille in

Absolute alcohol . . . . .	20
Acetic acid . . . . .	5
Distilled water . . . . .	40

until a dark red liquid results. Filter.

29. **Picric acid.**

(a) Concentrated alcoholic solution.

(b) Saturated aqueous solution.

30. **Picro-carmin (Ranvier).**

Carmin . . . . .	1
Distilled water . . . . .	10
Solution of ammonia . . . . .	3
Triturate; add cold saturated solution of picric acid . . . . .	200

**31. Picro-lithium-carmin** (Orth).

To above-mentioned lithium-carmin solution  
add saturated solution of picric acid . . . . . 2.3

**32. Potash solution.***(a)* 1 to 3 per cent.*(b)* 10 " "*(c)* 33 " "**33. Safranin.***(a)* Concentrated alcoholic solution.*(b)* Watery solution . . . . . 1 per cent.**34. Sulphuric acid, pure.****35. Salt solution** . . . . . 0.8 per cent.**36. Turpentine.****37. Vesuvin.***(a)* Concentrated alcoholic solution.*(b)* Watery solution.**Water, distilled.****Water, sterilised.**

Distilled water can be kept for use in a wash bottle, or far better in a siphon apparatus. Sterilised water is convenient in plugged sterile test-tubes, which may be kept close at hand in a beaker, or tumbler, with a pad of cotton wool at the bottom. The *numbered* reagents can be conveniently arranged on shelves within easy reach. Alcoholic solutions of the aniline dyes and other special preparations should be kept in bottles with ground-glass stoppers. Aqueous solutions of the dyes may be kept in bottles with funnel filters, and the solution filtered before use. To both aqueous and alcoholic solutions a few drops of phenol, or a crystal of thymol, should be added as a preservative. For the rapid staining of cover-glass preparations, it is convenient also to have the most frequently used stains (fuchsine, methyl-violet) in bottles provided with pipette stoppers.

**(D) REAGENTS FOR MOUNTING AND PRESERVING PREPARATIONS.****Acetate of potash.**

Concentrated solution.

**Asphalte lac.**



**Canada balsam.**

Dissolved in xylol.

**Glycerine gum (Farrant's solution).**

Glycerine.

Water.

Saturated solution of arsenious acid.

Equal parts ; mix, and add of picked gum arabic half a part.

**Hollis' glue.****Zinc-white.****(E) DRAWING AND PHOTOGRAPHIC APPARATUS.**

**Camera Lucida.**—The camera lucida of Zeiss is an excellent instrument, though many prefer the pattern made by Nacet of Paris. Combined with the use of a micromillimeter objective, it affords also a simple method for the measurement of bacteria.

For drawing microscopical appearances, and for illustrating microscopical specimens with or without the use of a camera lucida, the following materials should be within reach :—

Pencils.

Etching pens.

Prepared Indian ink.

Water-colour paints and brushes.

Ordinary and tinted drawing paper and other usual accessories.

**Photo-micrographic Apparatus.**—Zeiss of Jena, Seibert & Kraft of Wetzlar, Nacet of Paris, and Swift & Son of London, may all be recommended for constructing an arrangement in which the photographic camera is combined with the microscope.

The best models have been described fully in the chapter on Photography of Bacteria. The accompanying figure (Fig. 249) illustrates a model in which the microscope is used in the vertical position.

For illumination either sunlight or artificial light may be employed. In the case of sunlight a heliostat is necessary to procure the best results ; but as sunlight is not always available by day, and it is also more convenient for many to work at night, it is better to have recourse altogether to artificial light. Excellent results may be obtained with an ordinary paraffine lamp, or with magnesium, oxycalcium, or electric light.

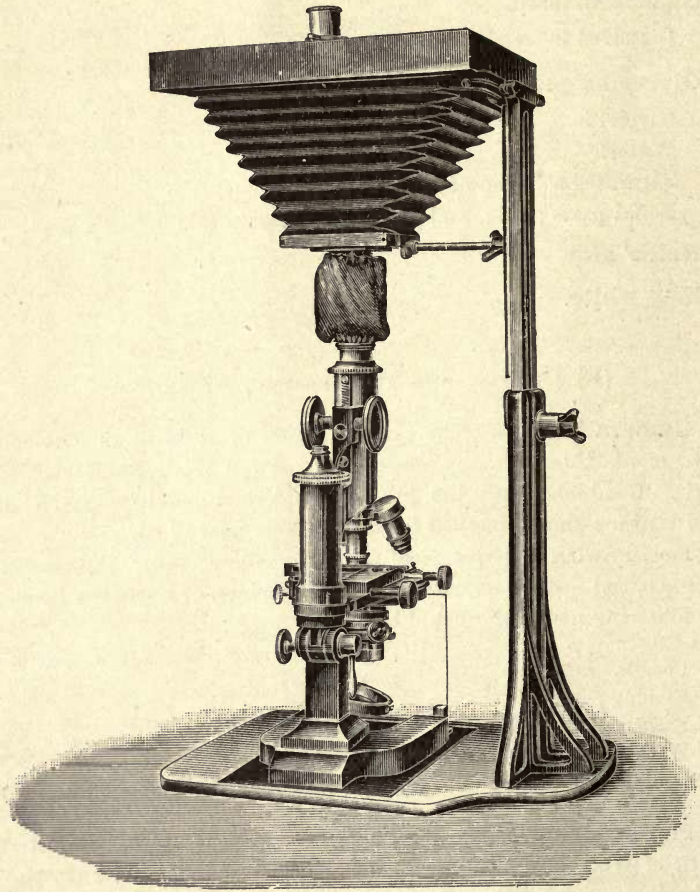

FIG. 249.—VERTICAL MICRO-PHOTOGRAPHIC APPARATUS.

(F) STERILISATION APPARATUS.

**Steam-steriliser.**—A cylindrical vessel of tin about half a metre or more in height, jacketed with thick felt, and provided with a conical cap or lid (Fig. 250). The lid is also covered with felt, has handles on either side, and is perforated at the apex, to receive a thermometer. Inside the vessel is an iron grating or diaphragm about two-thirds the way down, which divides the interior into two chambers—the upper or “steam-chamber,” and the lower or “water-chamber.” A gauge outside marks the level of the water in the lower chamber; this should be kept about two-thirds full.



The apparatus stands upon three legs, and is heated from below with two or three Bunsen burners, or a Fletcher's burner. It is employed for sterilising nutrient media in tubes or flasks, for cooking potatoes, or hastening the filtration of agar-agar. When the thermometer indicates 100° C. the lid is removed, and test-tubes are lowered in a wire basket by means of a hook and string, and the lid quickly replaced. Potatoes or small flasks are lowered into the cylinder in a tin receiver with a perforated bottom, which rests upon the grating and admits of its contents being exposed to the steam. A larger model is shown in Fig. 33.

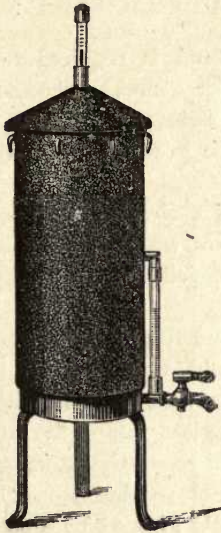

FIG. 250.—Koch's STEAM-STERILISER.

**Hot-air Steriliser.**—A cubical chest of sheet iron with double walls, supported on four legs; it may also be suspended on the wall of the laboratory, with a sheet of asbestos intervening (Figs. 251 and 252).

It is heated with a rose gas-burner from below, and the temperature of the interior indicated by a thermometer inserted through a hole in the roof; in a second opening a gas regulator can be fixed. Test-tubes, flasks, funnels, cotton wool, etc., may be sterilised by exposure to a temperature of 150° C. for an hour or more.

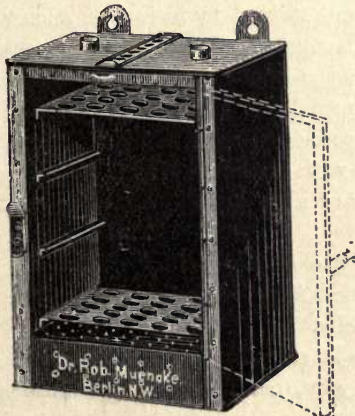

FIG. 251.—HOT-AIR STERILISER.

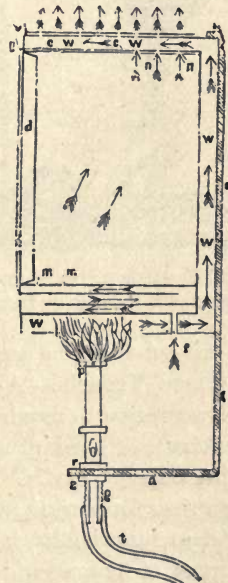

FIG. 252.—SECTION OF HOT-AIR STERILISER.

(G) APPARATUS AND MATERIAL FOR PREPARING AND STORING  
NUTRIENT GELATINE AND NUTRIENT AGAR-AGAR.

**Water-bath.**—A water-bath on tripod stand is required for boiling the ingredients of nutrient jellies and for general purposes. The lid may be conveniently composed of a series of concentric rings, so that the mouth of the vessel may be graduated to any size required.

**Test-tube Water-bath.**—This consists of a circular rack for test-tubes within a water-bath. It is sometimes employed instead of the steam cylinder for sterilising nutrient jelly in tubes, by boiling for an hour for three successive days.

**Hot-water Filter.**—A copper funnel with double walls, the inter-space between which is filled with hot water. A glass funnel fits inside the copper cone, the stem of the glass funnel passing through and being tightly gripped by a perforated caoutchouc plug, which fits in the opening at the apex of the cone. The water in the cone is heated by applying the flame of a burner to a tubular prolongation of the water-chamber. In a more recent model, as represented in Fig. 31, this prolongation is dispensed with, and the temperature is maintained by means of a circular burner which acts at the same time as a funnel ring. In Rohrbeck's model the funnel of the filter is connected with a flask, from which

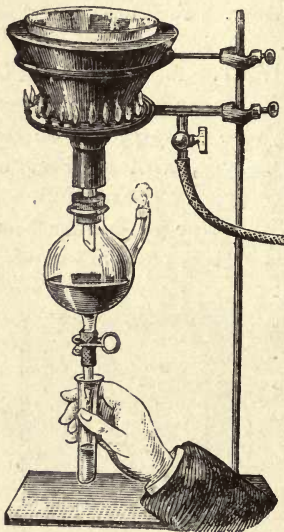

FIG. 253.—HOT-WATER FILTERING  
APPARATUS WITH RING BURNER.

the test-tubes can be easily filled with the liquid jelly (Fig. 253).

**Glass Vessels.**—A number of glass vessels should be kept in stock according to requirements.

Bohemian hard glass flasks are employed in several sizes, for boiling nutrient media. The conical forms are especially used in the larger sizes for storing nutrient jelly.

Glass funnels, large and small, are necessary, not only in the processes of preparing nutrient jelly, but for filtering solutions of aniline dyes and for general purposes.



A liberal supply of test-tubes should always be kept in stock, as they are not only employed for the tube-cultivations, but can be conveniently used for storing bouillon, sterilised water, etc.

Cylindrical glasses graduated in cubic centimetres, 10 ccm., 100 ccm., 500 ccm., are required for measuring the liquid ingredients of nutrient jelly, and also in preparing the various staining solutions.

A large wide-mouthed glass jar, with a glass cover, is extremely useful. It must be padded at the bottom with cotton wool for containing a stock of tubes of sterilised nutrient jelly, and should be placed within reach on the working table.

**Balance and Weights.**—A balance, with large pans and set of gramme weights, is constantly required.

**Cotton Wool.**—The best or “medicated” cotton wool should be procured.

**Gelatine.**—The gelatine for bacteriological purposes must be of the very best quality (gold label).

**Agar-agar.**—This is also called Japanese Isinglass; it consists of the shrivelled filaments of certain Algae (*Gracilaria lichenoides* and *Gigartina speciosa*).

**Peptonum Siccum.**

**Table Salt.**—Prepared table salt can be obtained in tins or packets.

**Litmus Papers.**—Blue or red litmus paper in cheque-books, for testing the gelatine mixture, etc.

**Carbonate of Soda.**—A bottle, containing a saturated solution of carbonate of soda, and provided with a pipette stopper, may be kept, especially for use in the preparation of nutrient jelly.

**Lactic Acid.**

**Filter Paper.**—For filtering gelatine, stout Swedish filter paper of the best quality is recommended.

**Flannel or Frieze.**—This is employed as a substitute for, or combined with, filter paper in the preparation of nutrient agar-agar.

(H) APPARATUS FOR EMPLOYMENT OF NUTRIENT JELLY IN TEST-TUBE AND PLATE-CULTIVATIONS.

**Wire Cages.**—These cages or crates are used for containing test-tubes, especially when they are to be sterilised in the hot-air steriliser; or for lowering tubes of nutrient jelly into the steam-steriliser, etc. (Fig. 254).

**Test-tube Stands.**—The ordinary wooden pattern, or the metallic folding stands, are called into use for holding cultivations. Pegged racks are also recommended for draining test-tubes after washing.

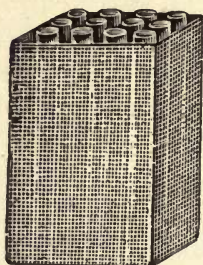

FIG. 254.—WIRE CAGE FOR TEST-TUBES.

**Caoutchouc Caps.**—These are caps for fitting over the cotton-wool plugs, and may be used in different sizes for test-tubes and stock-flasks.

**Platinum Needles.**—A platinum needle for inoculating nutrient media, examining cultivations, etc., consists of two or three inches of platinum wire fixed to the end of a glass rod. Several of these needles should be made with platinum wire of various thicknesses. A piece of glass rod, about seven inches long, is heated at the extreme point in the flame of

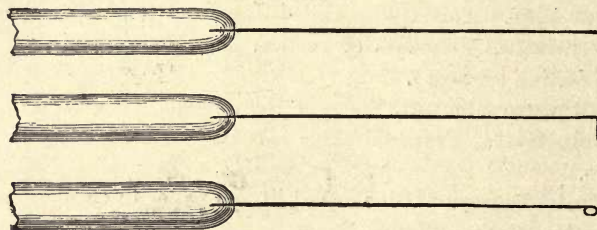

FIG. 255.—PLATINUM NEEDLES; STRAIGHT, HOOKED, LOOPED.

a Bunsen burner, and a piece of platinum wire, held near one extremity with forceps, is then fused into the end of the rod. Some needles should be perfectly straight, and kept especially for

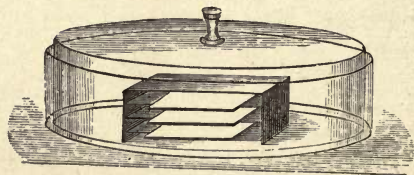

FIG. 256.—DAMP CHAMBER FOR PLATE-CULTIVATIONS.

inoculating test-tubes of nutrient jelly. For other purposes the needles may be bent at the extremity into a small hook, and others provided with a loop (Fig. 255).



**Tripod Levelling-stand.**—A triangular wooden frame supported upon three screw-feet which enable it to be raised or lowered to adjust the level.

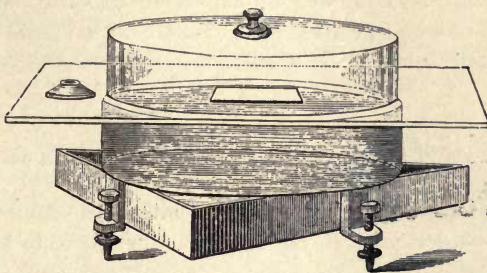

FIG. 257.—APPARATUS EMPLOYED FOR PLATE-CULTIVATIONS.

Tripod Stand; Glass Dish, filled with cold or iced water; Sheet of Plate-glass; Spirit Level, and Glass Bell.

**Large Glass Plate.**—A piece of plate-glass, or a pane of ordinary window-glass, about a foot square.

**Spirit Level.**

**Glass Bells and Dishes.**—Shallow glass bells and dishes, for making a dozen or more damp chambers (Fig. 256), and for completing the apparatus for pouring out liquefied nutrient jelly on glass plates or slides (Fig. 257).

**Iron Box.**—A box of sheet-iron (Fig. 258), for containing glass plates during their sterilisation in the hot-air steriliser, and for storing them until required for use.

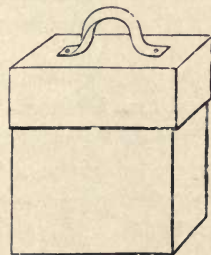

FIG. 258.—BOX FOR GLASS PLATES.

**Glass Plates.**—Small panes of glass, about six inches by four. Not less than three dozen are required for a dozen damp chambers.

**Glass Benches.**—These are necessary for arranging the glass plates or slides in tiers in the damp chambers (Fig. 256). Metal



FIG. 259.—GLASS BENCHES FOR GLASS PLATES OR SLIDES.

shelves may be substituted for them, but the former are to be preferred. They can be easily made, in any number required, by

cementing a little piece of plate-glass at either end of a glass slip (Fig. 259).

**Glass Rods.**—One dozen or more glass rods, twelve to eighteen inches in length. They are employed for smoothly spreading out the liquefied nutrient gelatine or agar-agar on the glass plates, etc.

**Thermometers.**—Two or three centigrade thermometers.

#### (I) APPARATUS FOR PREPARATION OF POTATO-CULTIVATIONS.

**Israel's Case.**—Sterilising instruments in the flame of a Bunsen burner is most destructive. It is better, therefore, to have a sheet-

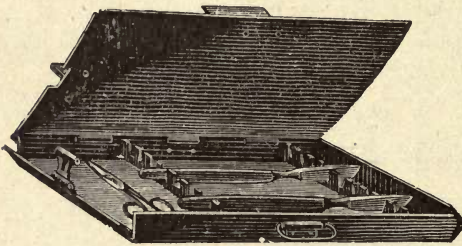

FIG. 260.—ISRAEL'S CASE.

iron case (Fig. 260) to contain potato-knives, scalpels and other instruments, and to sterilise them by placing the case in the hot-air steriliser for an hour at 150° C. The box can be opened at the side, and each instrument withdrawn with

a pair of sterilised forceps when required for use

**Glass Dishes.**—Several shallow glass dishes are required for preparing damp chambers for potato-cultivations (Fig. 261). The upper, being the larger, fits over the lower, and having no handle, admits of these damp chambers being placed, if necessary, in the incubator in tiers. The large size may also be used in the same way for plate-cultivations.

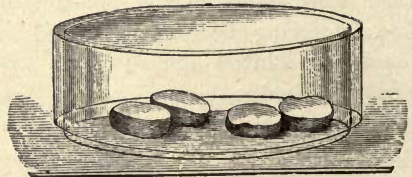

FIG. 261.—DAMP CHAMBER FOR POTATO-CULTIVATION.

**Potato Knives.**—A common broad smooth-bladed knife set in a wooden handle is sold for this purpose.

**Scalpels.**—Half a dozen scalpels, preferably with metal handles, may be kept especially for inoculating sterilised potatoes.

**Brush.**—A common stout nail-brush, or small scrubbing-brush, is essential for cleansing potatoes.



## (J) APPARATUS FOR PREPARATION OF SOLIDIFIED STERILE BLOOD-SERUM.

**Glass Jar.**—A tall cylindrical glass jar, on foot, with a broad ground stopper, for receiving blood.

**Pipette.**—An ordinary or graduated pipette, for transferring the serum from the jars to sterile test-tubes or glass capsules.

**Koch's Serum Steriliser.**—A cylindrical case, with double walls forming an interspace to contain water, closed with a lid, also double-walled and provided with a tubular prolongation of the enclosed water-chamber (Fig. 262). The water in the cylinder is heated from below, and that in the lid by means of the prolongation.

In the centre of the cylinder is a column which communicates with the water-chamber of the cylinder, and from it pass four partitions, which serve to support the test-tubes.

In the lid are three openings, one of which communicates with the water-chamber in the lid by which the latter is filled, and into which a thermometer is then fixed. In the centre an opening admits a thermometer, which passes into the central pipe of the cylinder; through a third opening a thermometer passes to the cavity of the cylinder. The cylinder and cover are jacketed with felt, and the apparatus is supported on iron legs.

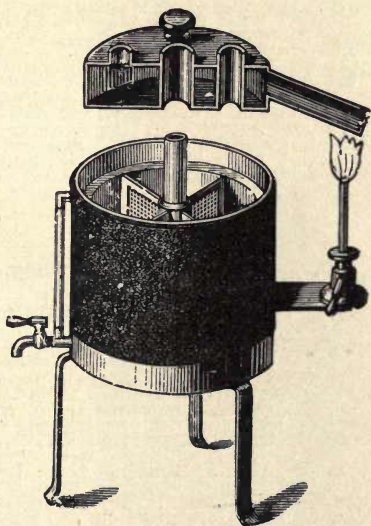

FIG. 262.—Koch's SERUM STERILISER.

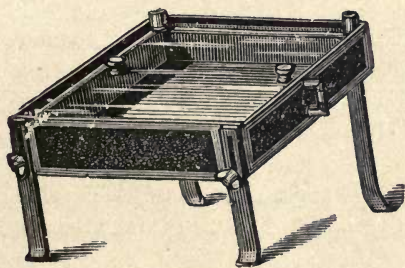

FIG. 263.—SERUM INSPISSATOR.

**Koch's Serum Inspisator.**—A shallow tin case with glass cover, both case and cover jacketed with felt (Fig. 263)

The case is double-walled, and the water contained in the interspace is heated from below. It is supported on four legs, and the two front ones move in grooves in the case, so that the latter can be placed obliquely at the angle required and secured in position by screw-clamps. It is employed for coagulating sterile liquid serum, and for solidifying nutrient agar-agar so as to give them a sloping surface.

**Hueppe's Serum Inspissator.**—By the new process the serum is obtained with every possible precaution, and solidified at once in Hueppe's apparatus (Fig. 44).

**Glass Capsules.**—Small capsules or hollowed-out cubes of crystal glass are employed for cultivation on solid blood-serum, on nutrient gelatine, and on agar-agar. They may be procured of white and blackened glass, and are provided with glass slips as covers.

#### (K) APPARATUS FOR STORING, AND FOR CULTIVATIONS IN, LIQUID MEDIA.

**Lister's Flasks.**—Lister devised a globe-shaped flask with two necks—a vertical and a lateral one. The lateral one is a bent spout, tapering towards its constricted extremity. When the vessel is restored to the erect position after pouring out some of its contents, a drop of liquid remains behind in the end of the nozzle, and prevents the regurgitation of air through the spout. A cap of cotton wool is tied over the orifice, and the residue in the flask kept for future use. The vertical neck of the flask is plugged with sterilised cotton wool in the ordinary way (Fig. 60).

**Sternberg's Bulbs.**—Sternberg advocates the use of a glass bulb, provided with a slender neck drawn out to a fine point and hermetically sealed (Fig. 62).

**Aitken's Test-tube.**—This is an ingenious device for counteracting the danger of entrance of atmospheric germs on removal from the ordinary test-tube of the cotton-wool plug. Each test-tube is provided with a lateral arm tapering to a fine point, which is hermetically sealed (Fig. 62).

**Drop-culture Slides.**—About a dozen or more thick glass slides with a circular excavation in the centre are required for drop-cultures (Fig. 48).

**Vaseline.**—A small pot of vaseline with a camel's-hair brush should be reserved especially for use in the preparation of drop-cultures.



**Bulbed Tubes.**—Glass vessels, such as test-tubes, flasks and pipettes, which are used in dealing with liquid media, have already been mentioned under other headings; but bulbed tubes, Pasteur's bulbs, and various other forms are also required for special experiments.

(L) APPARATUS FOR INCUBATION.

There are several forms of incubator, each of which has its advocates. They are mostly rectangular chests, with glass walls front and back, or in front only. A cylindrical model is preferred by some. Two only will be described here—D'Arsonval's and Babès'. The former admits of very exact regulation of temperature, and the latter is a very practical form for general use.

**D'Arsonval's Incubator.**—The "*Étuve D'Arsonval*" (Fig. 264) is a very efficient apparatus, and is provided with a heat-regulator, which enables the temperature to be maintained with a minimum variation. It consists of a cylindrical copper vessel, with double walls, enclosing a wide interspace for containing a large volume of water. The roof of the water-chamber is oblique, so that the wall

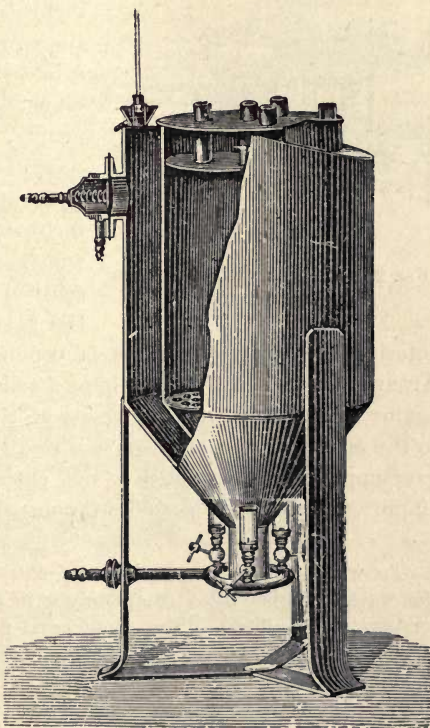

FIG. 264.—D'ARSONVAL'S INCUBATOR.

rises higher on one side than on the other. This admits of the interspace being completely filled with water. At the highest point is an opening fitted with a perforated caoutchouc stopper, through which a glass tube passes. The mouth of the cylinder itself is horizontal, and is closed by a lid, which is also double-walled to contain water. In the lid are four openings: one serves for filling its

water-chamber, and the others for thermometers and for regulating the air supply in the cavity of the cylinder. The cylinder is continued below by a cone, also double-walled, and there is a perforated grating at the line of junction of the cylinder and cone. The cone terminates in a projecting tube provided with an adjustable ventilator. The apparatus is fixed on three supports united to one another below. One of them is utilised for adjusting the height of the heating apparatus. Situated above this leg is the heat-regulating apparatus (Fig. 265), attached to a circular, lipped

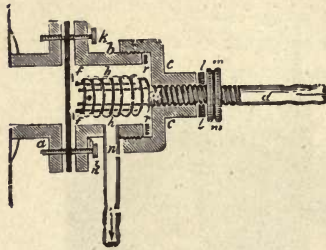

FIG. 265.—SCHLOSING'S MEMBRANE REGULATOR.

aperture in the outer wall of the incubator. To the lip is fixed with six screws the corresponding lip of a brass box, with a tightly-stretched diaphragm of indiarubber intervening. Thus the diaphragm separates the cavity of the box from the water in the interspace of the incubator. The cap of the box, which screws on, is bored in the centre for the screw-pipe, by which the gas is supplied. Another pipe entering the box from below is connected with the gas-burners. Around the end of the screw-pipe a collar loosely fits, and is pressed against the diaphragm by means of a spiral wire spring. Close to the mouth of the screw-pipe a small opening exists, so that the gas supply to the burners is not entirely cut off even when the diaphragm completely occludes the mouth of the screw-pipe.

To work the apparatus the tube and plug must be removed, and the water-chamber filled completely with distilled or rain water at the temperature required. The caoutchouc plug is replaced and the tube placed in position. Gas enters through *d* (Fig. 265), and passes through the opening at its extremity into the chamber of the box. Thence it passes through the vertical exit which is connected with the gas-burners. As the temperature rises the water rises in the tube, and at the same time exercises a pressure on every part of the walls of the incubator, and hence on the diaphragm. In consequence of this, the diaphragm bulging outwards approaches the end of the tube *d*, and gradually diminishes the gas supply. As a result the temperature falls, the water contracts and sinks in the tube, and the diaphragm receding from *d*, the gas supply is again increased. By adjusting the position of the tube *d* to the diaphragm, any required temperature within the limits of the working of the apparatus can be regulated to the tenth of a degree—*provided* (1) that the gas supply is rendered independent of fluctuations of pressure



by means of a gas-pressure regulator; (2) that the height of the water in the tube is controlled daily by the withdrawal or addition of a few drops of distilled water; and (3) that the apparatus is kept in a place with as even a temperature as possible, and sheltered from currents of air.

The burners in Fig. 264 are protected with mica cylinders similar to the burner represented in Fig. 266. The flames of these burners can be turned down to the smallest length without danger of extinction, and the temperature may be regulated very satisfactorily without using the heat-regulator just described, if the gas first passes through a pressure-regulator (Fig. 269). To provide against the danger resulting from accidental extinction of the gas, Koch has devised a self-acting apparatus (Fig. 267), which, simultaneously with the extinction of the flame of the burner, shuts off the supply of gas.

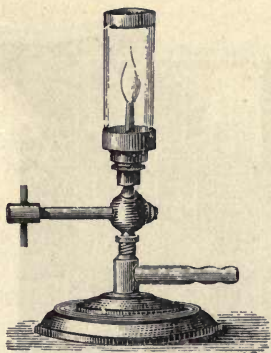

FIG. 266.—GAS-BURNER PROTECTED WITH MICA CYLINDER.

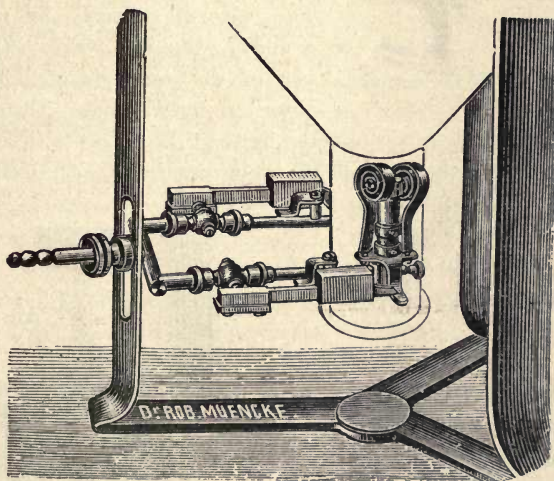

FIG. 267.—KOCH'S SAFETY BURNER.

**Babès' Incubator.**—The pattern used by Babès is a very simple one, and may be recommended for economy and efficiency (Fig. 268).

It consists of a double-walled chest with sides and roof jacketed with felt. Water fills the interspace between the walls, and on the roof are two apertures—one for a gas-regulator and the other

for a thermometer. In front the chest is closed in by a sheet of felt, a glass door, and a sliding glass panel. The apparatus can be suspended on the wall or supported on legs, and is heated from below by means of protected burners.

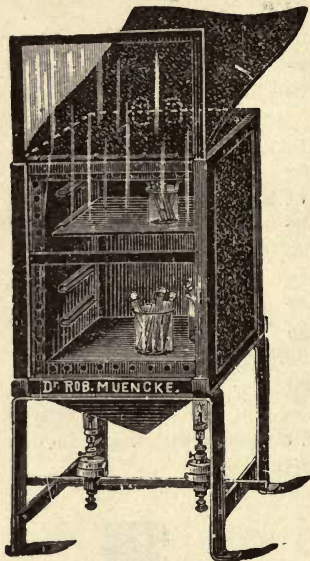

FIG. 268.—BABÈS' INCUBATOR.

valve (*d*), and is thence conducted by the tube *a* to the tube *l*. The bell (*B*) and the weighted dish (*h*) are screwed on to the connecting-rod (*g*). To diminish as much as possible the friction of *g* in *i*, *g* only touches *i* by three projecting ridges. Section of *i* and *g* is shown at *s*. To put the apparatus in use it is first levelled, then *h* is screwed off, and the cover (*n n*) removed. A mixture of two parts of pure acid-free glycerine to one of distilled water is poured into the cylinder until it flows out at *q*, which is then closed, and the cover (*n n*) replaced. The manometers are filled with coloured water, and *k* and *l*

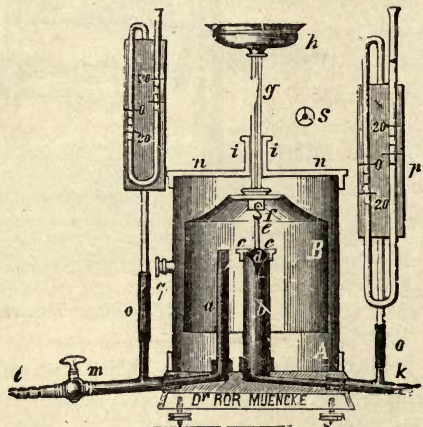

FIG. 269.—MOITESSIER'S GAS-PRESSURE REGULATOR.

The manometers are filled with coloured water, and *k* and *l*



connected with the entrance and exit gas tubing respectively. The pressure of the incoming gas raises the bell (B); and with it the valve (*d*) is raised towards the opening at *c c*. The weight (*h*), which is replaced on *g*, by its downward pressure counteracts this upward pressure of the gas and opens the valve (*c c*). Thus the flame is best regulated in the morning, when the pressure is at a minimum; then supposing an increase of pressure occurs, the weight of *h* is overbalanced, B is raised, and with it *d*, and the gas supply proportionately diminished by the gradual closing of the valved opening.

**Reichert's Thermo-regulator.**—This regulator (Fig. 270) consists of three parts—a hollow T-piece, a stem and a bulb. The T-piece fits like a stopper in the upper widened portion of the stem. One arm of the T is open and connected with the gas supply; the vertical portion terminates in a small orifice, and is also provided with a minute lateral opening. The stem is provided with a lateral arm, and this arm, the stem, and the bulb contain mercury. The regulator is fixed in the roof of the incubator, so that the bulb projects either into the interior of the incubator or into the water-chamber. When the incubator reaches the required temperature, the mercury is forced up by means of the screw in the lateral arm, until it closes the orifice at the extremity of the vertical portion of the T. The gas which passes through the lateral orifice is sufficient to maintain the apparatus at the required temperature. If the temperature of the incubator falls, the mercury contracts, and gas passing through the terminal orifice of the T increases the flame of the burner, and the temperature is restored.

**Page's Thermo-regulator** resembles the above, but instead of the T-piece there are two pieces of glass-tubing. The outer tubing envelops the upper part of the stem of the regulator, and admits of being raised or lowered. The upper end of this tubing is closed by a cork, which is perforated to admit the narrow glass-tubing, which represents the vertical arm of the T, passing within the stem of the regulator. This has a terminal and a lateral opening, and is the means of entrance for the gas. This regulator is adjusted by noting when the thermometer indicates the desired temperature, and then pushing down the outer tube until the terminal opening of the inner tube, which is carried down with it, is obstructed by the mercury.

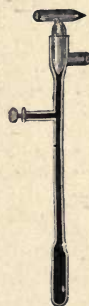

FIG. 270.—  
REICHERT'S  
THERMO-  
REGULATOR.

**Meyer's Thermo-regulator** is represented in Fig. 271. No. I. shows the construction of the regulator: its inner tube terminates in an oblique opening, and is also provided with a minute lateral aperture, which prevents the complete shutting off of the gas supply.

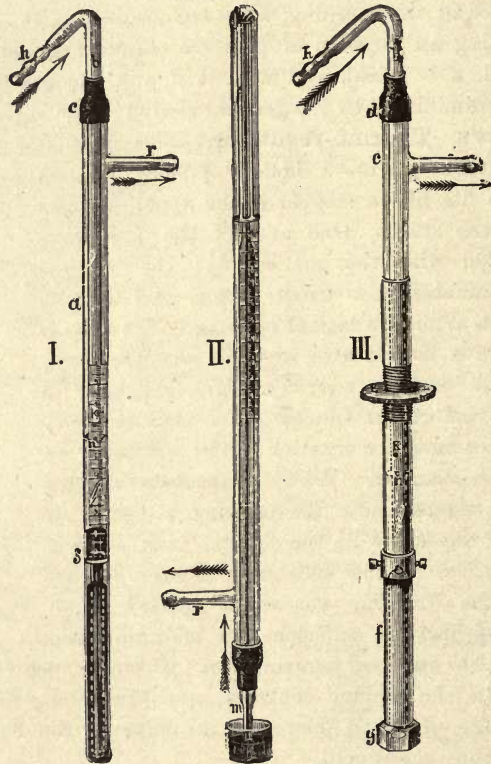

FIG. 271.—MEYER'S THERMO-REGULATOR.

No. II. illustrates the method of introducing the mercury by suction through a filling tube, which is substituted for the inner tube of the regulator. No. III. represents Fränkel's modification of the same instrument.

(M) INOCULATING AND DISSECTING INSTRUMENTS AND APPARATUS  
IN COMMON USE.

**Mouse-cages.**—As mice are the animals most frequently employed for experimental purposes, mouse-cages have been



especially introduced, consisting simply of a cylindrical glass jar with a weighted wire cover.

**Dressing-case.**—A small surgical dressing-case, with its usual accessories—forceps, knives, small, straight and curved scissors, needles, silk, and so forth—will serve for most purposes.

**Pravaz' Syringe.**—Koch's modification of Pravaz' syringe admits of sterilisation by exposure to 150° C. for a couple of hours.

**Special Instruments and Material.**—Instruments required for special operations, and the materials necessary for strict antiseptic precautions, need not be detailed here.\*

**Dissecting-boards.**—Slabs of wood in various sizes, or gutta-percha trays, provided with large-headed pins, are employed for ordinary purposes.

**Dissecting-case.**—A dissecting-case, fitted with scalpels, scissors, hooks, etc., should be reserved entirely for post-mortem examinations.

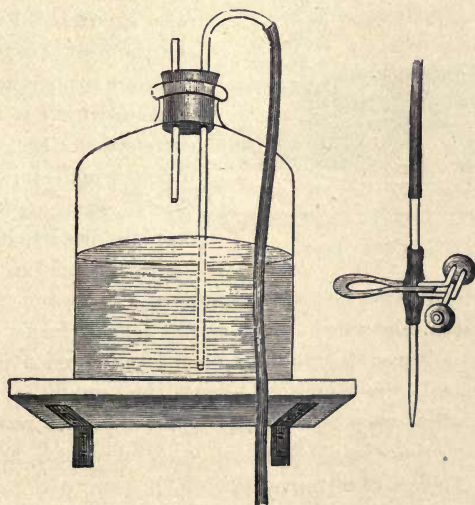

FIG. 272.—SIPHON BOTTLE, WITH FLEXIBLE TUBE, GLASS NOZZLE, AND A MOHR'S PINCHCOCK.

#### (N) GENERAL LABORATORY REQUISITES.

**Siphon Apparatus.**—Two half-gallon or gallon glass bottles, with siphons connected with long flexible tubes provided with glass nozzles and pinchcocks (Fig. 272), should be employed for the

\* *Vide* Cheyne, *Antiseptic Surgery*. 1882.

following purposes:—One is used to contain distilled water, with the nozzle hanging down conveniently within reach of the working table; the other is to contain a solution of carbolic acid (1 in 20), and may be placed so that the nozzle hangs close to the lavatory sink or basin. The former replaces the use of the ordinary wash-bottle, in washing off surplus stain from cover-glasses, etc., and the latter is conveniently placed for disinfection of vessels and hands after cleansing with water. They should be placed on the top of a cupboard or on a high shelf.

**Desiccator.**—The desiccator (Fig. 273) consists of a porcelain

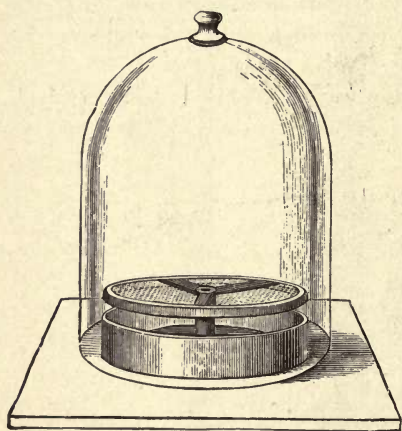

FIG. 273.—DESICCATOR.

pan containing concentrated sulphuric acid and covered over with a bell-glass receiver. The sheet of plate-glass upon which the pan rests is ground upon its upper surface, and the rim of the glass bell is also ground and well greased. In the centre of the pan is a column supporting a circular frame, which is covered with wire gauze. Slices of potatoes, upon which micro-organisms have been cultivated, are rapidly dried by the action of sulphuric acid in confined air.

A detailed description of other kinds of apparatus commonly in use in a research laboratory—such as the various forms of apparatus for filtering cultures in liquids, and the reagents necessary for special chemical investigations—must be sought for elsewhere. Much information may be obtained about the most recent improvements in bacteriological, chemical and physical apparatus by reference to manufacturers' catalogues.\*

\* All bacteriological apparatus may be obtained from Berlin from Dr. Muencke, 58, Louisen Strasse, or Dr. Hermann Rohrbeck, 24, Karlstrasse. Dr. George Grubler, Leipzig, is recommended for special staining reagents. In London, chemicals and bacteriological apparatus can be obtained from Becker & Co., Hatton Wall, or from Baird & Tatlock, 14, Cross Street, Hatton Garden, E.C. Mr. Baker, of High Holborn, W.C., is recommended as the agent for microscopes and objectives by Continental makers, including Zeiss' apochromatic objectives.



# APPENDIX V.

## BIBLIOGRAPHY

### CHAPTER I.

#### HISTORICAL INTRODUCTION.

**Andry**, De la Génération des Vers dans le Corps de l'Homme, 1701. **Charlton Bastian**, Proc. Royal Soc. 1872. **Bonnet**, Considérations sur les Corps organisés, 1768. **Davaine**, Compt. Rend., T. lviii. and lix. **Gleichen**, Dissertation sur la Génération, 1778. **Hill**, Essays in Natural History and Philosophy. **Kircher**, Ars magna lucis et umbræ, 1646. **Koch**, Beiträge zur Biologie der Pflanzen, 1876. **Lister**, Pharmaceut. Journal and Transact., 1877. **Müller**, Animalia infusoria, 1786. **Pasteur**, Compt. Rend., 1859, 1880; Etude sur la Maladie des Vers-à-soie, 1870. **Plenciz**, Opera Medico-Physica, 1762. **Schröder** and **Von Dusch**, Ann. der Chem. und Pharm., vol. lxxxix. **Schültze**, Poggendorff's Ann., vol. xxxix. **Schwann**, Poggendorff's Ann., vol. xli. **Tyndall**, Essays on floating matter of the air, 1881.

### CHAPTER II.

#### MORPHOLOGY AND PHYSIOLOGY OF BACTERIA.

##### MORPHOLOGY.

**Baumgarten**, Lehrbuch der Pathologischen Mykologie, 1890. **Biedert**, Virch. Archiv, Bd. 100, 1885. **Billroth**, Unters. über d. Veg. Form der Coccobacteria septica, 1874. **Brefeld**, Botanische Untersuch. über Schimmelpilze, Heft 1, 1881. **Cohn**, Beiträge zur Biologie der Pflanzen, Bd. I., 1872, 1875. **Cornil** and **Babès**, Les Bactéries, 1885. **Dallinger** and **Drysdale**, Monthly Microscop. Journ., 1875. **De Bary**, Verg. Morph. und Biolog. der Pilze, Mycetozoen, und Bacterien, 1884; Vorlesungen über Bacterien, 1885. **Dujardin**, Histoire Naturelle des Zoophytes, 1841. **Ehrenberg**, Die Infusionsthierchen als Volkcom. Organism, 1838. **Fisch**, Biolog. Centralbl., V., 1885. **Flügge**, Handbuch der Hygiene, 1883; Die Micro-organismen, 2nd Edition, 1886. **Gram**, Fortsch der Med., II., No. 6. **Grove**, Synopsis of the Bacteria and Yeast Fungi, 1884. **Hallier**, Die Pflanzlichen Parasiten, 1866. **Hauser**, Ueber Fäulniss Bacterien, 1885. **Hueppe**, Die Formen der Bakterien, 1885. **Lankester**, Quart. Journ. Microscop. Science, 1873. **Leunis**, Synopsis d. Pflanzenkunde:

Hanover, 1877. **Lister**, Quart. Journ. Microscop. Science, 1873. **Lutz**, Fortschr. d. Med., 1881. **Marpmann**, Die Spaltpilze, 1884. **Miller**, Dent. Med. Woch., 1884. **Nägeli**, Die Niederen Pilze, 1877. **Neelsen**, Biol. Centralbl., III., No. 18, 1883. **Sachs**, Text-book of Botany, 1882. **Van Tieghem**, Compt. Rend., 1879; *Traité de Botanique*, 1883. **Zopf**, Die Spaltpilze, 1885.

## GENERAL BIOLOGY.

**Arloing**, Archiv de Physiol., 1886. **Bordoni-Uffreduzzi**, Fortschr. d. Med., 1886. **Cheyne**, Brit. Med. Journ., 1886. **Cohn** and **Mendelsohn**, Beitr. z. Biol. d. Pflanzen, Bd. III., Heft 1. **Cortes**, Compt. Rend., T. 99, p. 385, 1884. **Downes**, Proc. Roy. Soc., 1886. **Duclaux**, Compt. Rend., 1885. **Engelmann**, Arch. f. d. Ges. Physiologie, Bd. 26, 1881; *Botan. Zeitg.*, 1882. **Fodor**, Archiv f. Hygiene, 1886. **Hausser**, Archiv f. Exper. Patholog. u. Pharmacologie, 1886. **Hofmann**, Allgem. Med. Centralbl., S. 605. **Liborius**, Zeitschrift f. Hygiene, 1886. **Nägeli**, Die Niederen Pilze: München, 1877; *Unters. über Niedere Pilze*: München, 1882. **Nencki**, Virchow's Archiv, 1879; *Beiträge zur Biol. der Spaltpilze*: Leipzig, 1879; *Ber. d. Deutschen Chem. Gesellsch.*, S. 2605, 1884. **Regnard**, Compt. Rend., T. 98, p. 744, 1884. **Tumas**, St. Petersb. Med. Wochenschr., 1879. **Wyssokowitsch**, Zeitschrift f. Hygiene, 1886.

## CHROMOGENIC BACTERIA.

**Babès**, Biolog. Centralbl., Bd. 2, 1882. **Chabert** and **Fromage**, D'une Altération du Lait de Vache, désignée sous le Nom du Lait Bleu, 1880. **Charrin**, Communication faite à la Société Anatomique, 1884. **Cohn** and **Miflet**, Cohn's Beiträge zur Biol. d. Pflanzen, Bd. III., Heft 1, 1879. **Eberth**, Centralbl. f. d. Med. Wissensch., 1863. **Ehrenberg**, Micr. Prodigiosus, Verhandl. d. Berl. Acad., 1839. **Fordos**, Compt. Rend. de l'Acad. de Sc., 1860. **Frank**, Cohn's Beitr. z. Biol. d. Pflanzen, Bd. I., Heft 3, 1875. **Gessard**, De la Pyocyanine et de son Microbe, 1882; *Ann. de l'Institut Pasteur*, T. iv. **Gielen**, Mag. f. Ges. d. Thierheilkunde, 1852. **Girard**, *Unters. über Blauen Eiter*; *Chirurg. Centralbl.*, II., 1875; *Revue des Sc.*, T. 5, 1877. **Hermstädt**, Ueber die Blaue und Rothe Milch, 1833. **Hugues**, *Echo Vétérinaire*, 1884. **Klein**, Quart. Journ. of Micr. Sc., Vol. 15, 1875. **Lankester**, Quart. Journ. of Micr. Sc., Vol. 13, 1873, 1876. **Lücke**, Arch. f. Klin. Chir., 1862. **Mosler**, Virchow's Archiv, Bd. 43, 1868. **Neelsen**, Cohn's Beitr. z. Biologie d. Pflanzen, Bd. III., Heft 2, 1880. **Schröter**, Cohn. Beitr. z. Biol. der Pflanzen, Bd. I., Heft. 2, 1872. **Steinhoff**, *Neue Ann. d. Mecklenb. Landw. Ges.*, 1838. **Wernich**, Cohn's Beiträge zur Biol. d. Pflanzen, Bd. III., Heft 1, 1879. **Van Tieghem**, *Bull. de la Soc. Bot. de France*, 1880.

## ZYMOTIC BACTERIA AND FERMENTATION.

**Béchamp**, Compt. Rend., T. 60, p. 445, 1865; T. 93, 1881. **Boutroux**, Compt. Rend., T. 86, 1878. **Brefeld**, *Landwirthsch. Jahresber.*, Bd. 3, 1874; Bd. 4, 1875; Bd. 5, 1876. **Cienkowski**, *Die Gallertbildungen d. Zuckerrübensaftes*, 1878. **Colin**, *Bull. de l'Acad. de Méd.*, 1875. **Dubrunfaut**, Compt. Rend., T. 73, 1871. **Duclaux**, *Thèses présentées à la Faculté de Paris*, 1865. **Dumas**, Compt. Rend., T. 75. Nr. 6, 1872; *Ann. de Chim. et de Phys.*, 1874. **Eriksson**, *Unters. aus d. Botan.*; *Institut in Tübingen*, Heft 1, 1881. **Feltz** and **Ritter**, *Journ. de l'Anat. et Phys.*, 1874. **Fermi**, *Centralb. f. Bact.*, 1891. **Fitz**, *Berichte d. Chem. Ges.*, Bd. 6, S. 48, 1875; Bd. 10, p. 216, 1878;



Bd. 11, pp. 42 and 498, and Bd. 12, p. 474, 1879; Bd. 13, p. 1309, 1880; Bd. 15, p. 857, 1882; Bd. 16, p. 844, 1883; Bd. 17, p. 1188, 1884. **Fleck**, Ber. d. Chem. Centralst.: Dresden, 1876. **Frankland**, Cantor Lectures, 1892. **Gessard**, De la Pyocyanine et de son Microbe. **Guiard**, Thèse de Paris, 1883. **Hallier**, Gährungserscheinungen, 1867. **Hansen**, Untersuch. aus. d. Prax. der Gährungsindustrie, 1890, 1892. **Harz**, Grundzüge der alkoholischen Gährungslehre, 1877. **Hiller**, Centralbl. f. d. Med. Wiss., S. 53, 1874. **Hofmann**, Aerztl. Verein zu Wien, Mai 1873; Allgem. Med. Centralbl., S. 605, 1873. **Hoppe-Seyler**, Medic.-Chem. Untersuchungen, Heft 4, 1871. **Hueppe**, Mitth. a. d. Ges. Amt, Bd. ii., 1884; Deut. Med. Woch., 1884. **Jacksch**, Zeitschr. f. Physiol. Chemie, Bd. 5, 1881. **Jorgensen**, Microorg. of Ferment Trans., 1893. **Karsten**, Chemismus der Pflanzenzelle, 1869. **Kern**, Bull. de la Soc. Imp. des Naturalistes de Moskau, No. 3, 1881. **Krannhals**, Deut. Arch. f. Klin. Med., Bd. 35, 1884. **Ladureau**, Compt. Rend., T. 99, p. 877, 1884. **Lépine and Roux**, Compt. Rend., T. 101, 1885. **Leube**, Virch. Arch., Bd. 100, S. 540, 1885. **Lex**, Centralbl. f. d. Med. Wiss., S. 291, 1872. **Liebig**, Verhandl. der Münchener Akad. d. Wiss., 1861; 5 Nov. 1869; Ueber Gährung, Quelle der Muskelkraft und Ernährung; Leipzig u. Heidelberg, 1870. **Lister**, The Pharmac. Journ. and Transact., 1877. **Mayer**, Lehrbuch der Gährungschemie; 2 Aufl., 1876. **Mönoyer**, Thèse de Strassburg, 1862. **Müller**, Journ. f. Prakt. Chem., 1860. **Musculus**, Ber. d. Chem. Ges., S. 124, 1874; Compt. Rend., T. 78, 1874. **Nägeli**, Theorie der Gährung: München, 1879. **Pasteur**, Annal. de Chim. et de Phys., III. Sér., T. 58, 1860; Compt. Rend., 1860, 1861, 1863, 1864, 1871, 1872; Bull. de la Soc. Chim., 1861; Ann. de Chim. et de Phys., T. 64, 1862; Etudes sur le Vin, 1866; Bull. de l'Acad. de Méd., No. 27, 1876; Etudes sur la Bière, 1876. **Pasteur and Joubert**, Compt. Rend., T. 83, 1876. **Popoff**, Botan. Jahresber., 1875. **Prazmowski**, Untersuchungen über die Entwicklungsgeschichte und Fermentwirkung einiger Bakterien, 1880. **Richet**, Compt. Rend., T. 88, 1879. **Scheibler**, Zeitschr. f. Rübenzuckerindustrie, 1874. **Schützenberger**, Die Gährungserscheinungen, 1874. **Sheridan Lea**, Journ. of Physiology, 1885. **Trécul**, Compt. Rend., T. 61, 1865; T. 65, 1867; Ann. des Sc., Sér. 7, T. 7, 1867. **Tyndall**, Compt. Rend., T. 58, 1864; Essays on the Floating Matter of the Air, 1881. **Van Tieghem**, Compt. Rend., 1864, 1874, 1879, 1880, 1884.

## PHOTOGENIC BACTERIA.

**Beyerinck**, Archiv Neerland, XXIII. **Fischer**, Zeitschr. f. Hygiene, 1887; Centralbl. f. Bakteriolog., 1888. **Forster**, Centralbl. f. Bakteriolog., 1887. **Girard**, Compt. Rend., 1890. **Girard and Billet**, Compt. Rend., 1889. **Katz**, Centralbl. f. Bakteriolog., 1891. **Lehmann**, Centralbl. f. Bact., 1889. **Ludwig**, Centralbl. f. Bact., 1887.

## CHAPTER III.

## EFFECT OF ANTISEPTICS AND DISINFECTANTS ON BACTERIA.

**Arloing, Cornevin and Thomas**, Lyon Méd., 1883. **Blyth**, Proc. Roy. Soc., 1885. **Buchholz**, Ueber das Verhalten von Bakterien zu einigen Antiseptics, 1876; Arch. f. Exp. Pathol., Bd. 7, 1877. **Chairy**, Compt. Rend., 1884. **Chamberland and Roux**, Compt. Rend., 1883. **Chauveau**, Compt. Rend., 1883, 1884. **Cheyne**, Antiseptic Surgery, 1882. **Colin**, Compt. Rend., T. 99, 1884. **De la**

**Croix**, Arch. f. Exp. Pathol., Bd. 13, 1881. **Dujardin-Beaumetz**, Bull. de l'Acad. de Méd. de Paris, 1884. **Eidam**, Cohn's Beitr. zur Biol., Bd. I., Heft 3, 1875. **Fischer**, Berl. Klin. Woch., 1882. **Fischer and Proskauer**, Mitth. a. d. Kaiserl. Ges. Amt, Bd. II., 1884. **Frank**, Ueber Desinfection von Abtrittsgruben, 1885. **Frisch**, Sitzungsber. d. Wiener Akad., Bd. 75 u. 80, 1877. **Gärtner and Plagge**, Deut. Med. Woch., 1885. **Haberkorn**, Das Verhalten von Harnbakterien gegen einige Antiseptica; Dissert. Dorpat., 1879. **Handford**, Brit. Med. Journ., 1885. **Heydenreich**, Compt. Rend., T. 98, 1884. **Hoffmann**, Experimentelle Untersuchungen über die Wirkung der Ameisensäure Diss. Greifswald, 1884. **Hueppe**, Mittheilg. a. d. Kaiserl. Ges. Amt, Bd. I., S. 341, 1881; Deut. Militärärztl. Zeitschr., 1882. **Koch**, Cohn's Beitr. zur Biol. der Pflanzen, Bd. II., Heft 2, 1876; Mitth. a. d. Ges. Amt, Bd. I., S. 234, 1881. **Koch and Gaffky**, Arbeit. a. d. K. Gesundh. Amt, 1885. **Koch, Gaffky and Löffler**, Mitth. a. d. Kaiserl. Ges. Amt, Bd. I., S. 322, 1881. **Koch and Wolffhügel**, Mitth. a. d. Kaiserl. Ges. Amt, Bd. I., S. 301, 1881. **König**, Chirurg. Centralbl., 1885. **Laillier**, Ann. d'Hygiène, 1883. **Larrivé**, L'Eau Oxygénée: Thèse de Paris, 1883. **Lassar**, Deut. Med. Woch., 1880. **Lebedeff**, Arch. de Physiol. Norm. et Pathol., 1882. **Maly and Emich**, Sitzungsber. d. Kais. Akad. d. Wiss. zu Wien. Jan. 1883. **Marié-Davy**, Revue d'Hygiène, 1884. **Merke**, Virchow's Archiv, Bd. 81, 1880. **Meyer**, Ueb. d. Milchsäureferment u. sein Verhalten gegen Antiseptica, 1880. **Mignet**, Annuaire de l'Observatoire de Montsouris, 1884. **Miquel**, Semaine Médicale, 1883. **Mörschell**, Deut. Med. Woch., 1880. **Nägeli**, Die Niederen Pilze, 1877. **Pasteur**, Ann. d'Hyg., 1880; La Vaccination Charbonneuse, 1883. **Perroncito**, Arch. Ital. de Biol., 1883. **Pictet and Young**, Compt. Rend., T. 98, 1884. **Plaut**, Desinfection der Viehställe, 1884. **Reinl**, Prager Med. Woch., Nr. 10 u. 11, 1885. **Rocheftort, Herscher**, Revue d'Hygiène, 1884. **Rossbach**, Berl. Klin. Woch., 1884. **Schede**, Sammlung Klin. Vorträge, Nr. 25, 1885. **Schill and Fischer**, Mitth. a. d. Kaiserl. Ges. Amt, Bd. II. 1884. **Schnetzler**, Archiv de Gèneve, 1884. **Schröter**, Cohn's Beitr. zur. Biol. der Pflanzen, Bd. I., Heft 3, 1875. **Schultz**, Deut. Med. Woch., Nr. 17, 1883; Nr. 24, 1885. **Schwartz**, Sitzungsber. d. Dorpater Naturf. Ges., 1879. **Soyka**, Ber. d. Bayr. Akad. d. Wissensch., 1879. **Steinmeyer**, Ueber Desinfectionslehre, 1884. **Sternberg**, Amer. Journ. Med. Soc., 1883; Report of Com. on Disinfectants, 1888. **Thol**, Ueber d. Einfluss nicht arom. organ. Säuren. auf Fäulnis u. Gährung: Diss. Greifswald, 1885. **Toussaint**, Bull. de l'Acad., 1880. **Tyndall**, Phil. Trans. of the Roy. Soc., 1877. **Vallin**, Ann. d'Hyg., 1877; Traité des Désinfectants et de la Désinfection, 1883; Les Nouvelles Etuves à Désinfection: Revue d'Hygiène, 1883; Ann. d'Hygiène, 1884. **Wernicke**, Virchow's Archiv, Bd. 78, 1879; Diss. Dorpat., 1879. Grundriss der Desinfectionslehre, 1880. **Wolf**, Centralbl. f. d. Med. Wiss., Nr. 11, 1885. **Wolffhügel**, Mittheilg. a. d. Kais. Ges. Amt., Bd. I., S. 188, 1881. **Wolffhügel and Knorre**, Mitth. a. d. Kaiserl. Ges. Amt, Bd. I., S. 352, 1881.

## CHAPTER IV.

## CHEMICAL PRODUCTS OF BACTERIA.

**Backlisch**, Ber. d. Deutsch. Chem. Gesellsch., Bd. 18, 1880. **Bergmann**, Das Putride Gift., 1866; Deut. Zeitschr. f. Chirurgie, Bd. I., 1872. **Bergmann and Angerer**, Würzburger Jubil. Festschr., 1882. **Bergmann and Schmiedeberg**, Med. Centralbl., 1868. **Blumberg**, Virch. Arch., Bd. 100, S. 377, 1885. **Bocci**,



Centralbl. f. d. Med. Wiss., 1882. **Bouchard**, Compt. Rend. de Biol., 1882. **Brieger**, Zeitschr. f. physiol. Chemie, Bd. 7, 1883; Ber. d. Deutsch. Chem. Ges., Bd. 17, 1884; Berl. Klin. Woch., Nr. 14, 1884; Ueber Ptomaine, 1885; Weitere Untersuchungen über Ptomaine, 1885; Ueber Ptomaine: Berl. Klin. Woch., 1886. **Brouardel** and **Boutmy**, Compt. Rend., T. 92, p. 1056, 1881. **Clementi** and **Thin**, Wien. Med. Jahrb., 1873. **Eber**, Centralbl. f. Bact., 1892. **Etard** and **Olivier**, Compt. Rend., 1882. **Frisch**, Exper. Studien üb. d. Verbreitung d. Fäulnisorganismen, 1874. **Gautier**, Compt. Rend., T. 94, 1882. **Gautier** and **Etard**, Compt. Rend., T. 94, 1882. **Groebner**, Beiträge z. Kenntniss der Ptomaine, 1882. **Guareschi** and **Mosso**, Arch. Ital. de Biolog., 1883. **Hauser**, Ueber Fäulnisbakterien, 1885. **Hemmer**, Exper. Studien über d. Wirkung Faulender Stoffe, 1866. **Hiller**, Centralbl. f. Chirurgie, 1876; Die Lehre von der Fäulnis, 1879. **Husemann**, Arch. d. Pharmac., 1880, 1882, 1883. **Kaufmann**, Journ. f. Prakt. Chemie, Bd. 17, 1878. **Kehrer**, Archiv f. Exper. Pathol., Bd. I., 1874. **König**, Ber. üb. d. Veterinärwesen im Königreich Sachsen, 1881. **Maas**, Fortschr. d. Med., II., 729, 1884. **Martin**, Rep. Med. Off. Local Govt. Board, 1890-91. **Nencki**, Ueber die Zersetzung der Gelatine und des Eiweisses bei der Fäulnis mit Pancreas, 1876; Journ. f. Pract. Chem., Bd. 26, 1882. **Offinger**, Die Ptomaine, 1885. **Otto**, Anleitung zur Ausmittlung der Gifte, 1884. **Panum**, Virchow's Arch., Bd. 60, 1874. **Raison**, Zur Kenntniss der Putriden Intoxication, 1866. **Ravitsch**, Zur Lehre von der Putriden Infection, 1872. **Rosenbach**, Deut. Zeitschrift für Chir., XVI., S. 342, 1882. **Salomonsen**, Die Fäulnis des Blutes, 1877. **Schiffer**, Arch. f. Anat. u. Physiol.: Physiol. Abtheil., 1882. **Schweninger**, Ueber d. Wirkung Faulender Org. Substanzen, 1866. **Selmi**, Chemische Ber., Bd. 6, 7, 12, 1878. **Tanret**, Compt. Rend., T. 92, 1881. **Tappeiner**, Med. Centralbl., 1885. **Vandevelde**, Arch. de Biol. par van Beneden, 1884. **Willgerodt**, Ueber Ptomaine, 1884. **Zülzer** and **Sonnenschein**, Berl. Klin. Woch., 1869.

## CHAPTER V.

## IMMUNITY.

**Arloing**, **Cornevin** and **Thomas**, Du Charbon Bactérien; Pathogénie et Inoculations Préventives, 1883. **Behring**, Deutsche Med. Woch., 1890. **Behring** and **Kitasato**, Deutsche Med. Woch., 1890. **Blazekovic**, Oesterr. Monatschr. f. Thierheilk., 1884. **Bouchard**, Compt. Rend., 1889. **Bouley**, L'Inoculation Préventive de la Fièvre Jaune: Compt. Rend., T. 100, 1885. **Brieger** and **Fränkel**, Berl. Klin. Woch., 1890. **Büchner**, Eine neue Theorie über Erzielung v. Immunität gegen Infectionskrankheiten, 1883. **Chamberland**, Le Charbon et la Vaccination Charbonneuse d'après les Travaux Récents de M. Pasteur, 1883. **Chamberland** and **Roux**, Compt. Rend., T. 96, Nr. 15, 1883. **Chauveau**, Compt. Rend., T. 89, 1879; T. 96, Nr. 9; Nr. 10; Nr. 11, 1883; Gaz. Hebdom. de Méd. et de Chir., 22, 1884. **Feltz**, Compt. Rend., T. 99, p. 246, 1884. **Frank**, Jahresber. d. K. Thierarzneischule in München, 1883. **Gamaleia**, La Semaine Méd., 1890. **Grawitz**, Die Theorie der Schutzimpfung: Virchow's Arch., Bd. 48, 1881. **Hankin**, Brit. Med. Journ., 1889 and 1890; Proc. Roy. Soc., 1890; Centralbl. f. Bacteriolog., Bd. IX., Lancet, 1891. **Hess**, Schweiz. Arch. f. Thierheilk., Bd., 27, 1885. **Kitasato**, Zeitschr. f. Hygiene, Bd. X. **Koch**, Ueber die Milzbrandimpfung, 1882. **Koch**, **Gaffky** and **Löffler**, Mitth. a. d. Ges. Amt, Bd. II., 1884. **Löffler**, Mitth. a. d. Ges. Amt, Bd. I., 1881. **Martin**, Reports

Med. Dept. Loc. Govt. Board, 1890-91; Brit. Med. Journal, 1891. **Massé**, Des Inoculations Préventives dans les Maladies Virulentes, 1883. **Metschnikoff**, Virchow's Archiv XCVI. and XCVII., Ann. de l'Institut Pasteur, 1887, 1889, 1890, 1891, 1895. **Nuttall**, Zeitschr. f. Hygiene, 1888. **Oemler**, Arch. f. Wiss. u. Pract. Thierheilk., 1876, 1881. **Ogata**, Centralb. f. Bacteriolog., 1891. **Ollive**, Compt. Rend., T. 89, 1879. **Pasteur**, Bull. de l'Acad. de Méd. and Gaz. Méd. de Paris, Nr. 18, 1880; Compt. Rend., 1883; La Vaccination Charbonneuse, 1883; Revue Scientifique, 1883; Bull. de l'Acad. de Méd., 1883. **Perroncito**, Atti R. Acc. d. Lincei., 1883. **Pütz**, Vorträge f. Thierärzte, Ser. 7, Heft 1, 1884. **Roux**, Ann. de l'Institut Pasteur, 1888. **Rószahegyí**, Pester Med.-Chir. Presse, 1882. **Salmon and Smith**, Centralb. f. Bacteriolog., 1887. **Semmer**, Virchow's Arch., Bd. 83, 1881. **Semmer and Krajewski**, Centralbl. f. d. Med. Wiss., 1880. **Strebel**, Schweiz. Arch. f. Thierheilk., 1885. **Tizzoni and Cattani**, Centralb. f. Bacteriolog., 1891. **Toussaint**, Bull. de l'Acad. de Méd.; and Compt. Rend., 1880, 1881; Gazette Médicale de Paris, Nr. 32, 1881. **Wooldridge**, Proc. Roy. Soc., 1887; Archiv f. Anat. and Phys., 1888.

## CHAPTER VI.

## ANTITOXINS AND SERUM-THERAPY.

**Béclère, Chambon and Ménard**, Ann. de l'Institut Pasteur, 1896. **Behring** and **Kitasato**, Deutsche Med. Woch., 1890; Trans. Internat. Cong. f. Hygiene, 1891. **Behring and Wernicke**, Zeitschrift f. Hygiene, 1892. **Buchner**, Munich Med. Woch., 1891. **Calmette**, Ann. de l'Institut Pasteur, 1895. **Emmerich and Mastbaum**, Archiv f. Hygiene, 1891. **Fedoroff**, Zeitschr. f. Hygiene, 1893. **Gromakowsky**, Ann. de l'Institut Pasteur, 1895. **Heubner**, Trans. Internat. Med. Congress, 1894. **Hewlett**, Practitioner, 1895. **Kossel**, Zeitschrift f. Hygiene, 1894. **Marchoux**, Ann. de l'Institut Pasteur, 1895. **Marmorek**, Ann. de l'Institut Pasteur, 1895, 1896. **Ogata**, Centralb. f. Bakteriolog., 1891. **Report**, Med. Sup. Metropolitan Asylums Board, 1896. **Roux**, Trans. Internat. Congress of Hygiene, 1894; Ann. de l'Institut Pasteur, 1894. **Roux, Martin, Châillou**, Ann. de l'Inst. Pasteur, 1894. **Tizzoni and Cattani**, Centralb. f. Bakteriolog., 1891. **Welch**, Trans. Assoc. Amer. Physicians, 1895. **Wladmoroff**, Zeitschr. f. Hygiene, 1893.

## CHAPTERS VII., VIII., IX., X.

VII.—THE BACTERIOLOGICAL MICROSCOPE. VIII.—MICROSCOPICAL EXAMINATION OF BACTERIA. IX.—PREPARATION OF NUTRIENT MEDIA AND METHODS OF CULTIVATION. X.—EXPERIMENTS UPON THE LIVING ANIMAL.

**Almquist**, Hygeia, XLV.; Stockholm, 1883. **Banti**, Manuale di Tecnica Batteriologica, 1885. **Baumgarten**, Zeitschr. f. Wissensch. Mikr., 1884. **Behrens**, Hilfsbuch zur Ausführung Mikroskop. Untersuch., 1883. **Bizzozero and Firket**, Manuel de Microscopie Clinique, 1885. **Blanchard**, Rev. Inter. Sci., III., 1879. **Bordoni Uffreduzzi**, Microparasitici, 1885. **Brefeld**, Bot. Untersuch. über Schimmelpilze, Bd. IV., 1881; Botan. Unters. über Hefenpilze, Bd. V., 1883; Verhandl. d. Physik. Med. Ges., in Würzburg, 1875. **Büchner**, In Nägeli's



Untersuch. über Niedere Pilze: Munich, 1882; Aertzl. Intelligenzbl., No. 33, 1884. **Carpenter**, The Microscope and its Revelations (6th Edition), 1881. **Cohn**, Beiträge zur Biologie der Pflanzen, Bd. I., Heft 3, 1875, 1876. **Cornil and Babès**, Les Bactéries, 1886. **Crookshank**, Manuel Pratique de Bactériologie, traduit par Bergeaud; avec 4 Photomicrographies, 1886. **Dolley**, Technology of Bacteria Investigation, 1885. **Duclaux**, Ferments et Maladies, 1881. **Ehrlich**, Deut. Med. Woch., No. 19, 1882; Zeitschr. f. Klin. Med.; Bd. I. 1880. Bd. II., Heft 3, 1881. **Eisenberg**, Bakteriologische Diagnostik, 1886. **Esmarch**, Zeitschrift f. Hygiene, 1886. **Fehleisen**, Ueber Neue Method. der Untersuch. u. Cultur Pathogen. Bakterien; Physik. Med. Ges. zu Würzburg, 1882. **Flügge**, Handbuch der Hygiene und der Gewerbe Krankheiten, 1883. **Friedländer**, Microscopische Technik (1st Edition), 1884. **Gibbes**, Practical Histology and Pathology, 1885. **Gram**, Fortsch. d. Med., II., No. 6, 1884. **Hauser**, Ueber Fäulnisbakterien; mit 15 Tafeln in Lichtdruck, 1885. **Hazlewood**, American Monthly Microscop. Journ., 1883. **Hüber and Breker**, Die Path. Histolog. und Bakteriologischen Untersuch. Methoden, 1886. **Hueppe**, Bakteriologische Apparate: Deut. Med. Woch., 1886; Die Methoden der Bakterien Forschung, 1886; translated by Biggs, 1886. **Johne**, Ueber die Kochschen Reinculturen, 1885. **Klebs**, Archiv f. Exp. Pathol., Bd. I., 1873. **Klein**, Micro-organisms and Disease, 1886. **Koch**, Biol. Klin. Woch., No. 15, 1882; Mitth. a. d. Kais. Ges. Amt, Bd. I., 1881.; Bd. II., 1884; Untersuchungen über Wundinfections Krankheiten, 1878; Beiträge z. Biol. d. Pflanzen; Bd. II., Heft 3, 1877. **Lee**, The Microtometist's Vade Mecum, 1885. **Magnin and Sternberg**, Bacteria, 1884. **Malley**, Photomicrography, 1885. **Orth**, Path. Anat. Diagnostik, 1884. **Pasteur**, Etudes sur la Bière, 1867. **Perty**, Zur Kenntniss Kleinster Lebensform, 1852. **Plant**, Färbungs Methode z. Nachweis. der Micro-organismen, 1885; **Salomonsen**, Bot. Zeit., No. 39, 1879; No. 28, 1880. **Schäfer**, Course of Practical Histology, 1877. **Woodhead and Hare**, Pathological Mycology, 1885.

## CHAPTER XI.

## EXAMINATION OF AIR, SOIL AND WATER.

**Angus Smith**, Rep. to the Loc. Gov. Board, 1884; Sanitary Record, 1883. **Becker**, Reichsmedicinalkalender, 1885. **Beumer**, Deut. Med. Woch., 1886. **Bischof**, Journ. Soc. Chem. Industry, 1886. **Büchner**, Vorträge im Aertzl. Verein zu München, 1881. **Chamberland**, Compt. Rend., T. 99, p. 247, 1886. **Cramer**, Die Wasserversorgung von Zürich, 1885. **Crookshank**, Notes from a Bact. Labor., Lancet, 1885. **Cunningham**, Micr. Exam. of the Air: Calcutta, 1874. **Fodor**, Hygienische Unters. über Luft, Boden u. Wasser., 1882. **C. Frankel**, Zeitschr. f. Hygiene, 1886. **Frankland, P. and G.**, Proc. Roy. Soc., 1885, 1886; Microorganisms in Water, 1894. **Gunning**, Arch. f. Hyg., 3, 1883. **Heræus**, Zeitschr. f. Hygiene, 1886. **Hesse**, Deut. Med. Woch., Nr. 51, 1884; 2, 1884; Mitth. a. d. Ges. Amt, Bd. II., 1884; Ueber Wasserfiltration: Deut. Med. Woch., 1885; Zeitschr. f. Hygiene, 1886. **Klebs and Tommasi-Crudeli**, Archiv f. Exper. Path., Bd. 11, 1879. **Koch**, Mitth. a. d. Ges. Amt, Bd. I., 1881. **Laurent**, Journal de Pharmacie et de Chimie, 1885. **Lemaire**, Compt. Rend., T. 57, 1863. **Letzerich**, Exp. Unters. üb. die Aetiologie des Typhus mit bes. Berücksichtigung der Trink. u. Gebrauchswässer, 1883. **Maddox**, Month. Microscop. Journal, 1870. **Meade Bolton**, Zeitschr. f. Hygiene, 1886. **Miflet**, Cohn's Beitr. z. Biol. d. Pflanzen, Bd. III., 1879. **Miquel**, Annuaire

de l'Observat. de Montsouris, 1877, 1882; Compt. Rend., T. 86, 1878; Bull. de la Soc. Chim., 1878; Ann. d'Hygiene, 1879; Les Organismes Vivants de l'Atmosphère, 1883. **Miquel and Freudenreich**, La Semaine Médicale, 1884. **Moreau and Plantymausion**, La Semaine Médicale, 1884. **Nägeli**, Unters. über Niedere Pilze., 1882. **Olivier**, Les Germes de l'Air, Thèse, Rev. Scientif., 1883. **Pasteur**, Ann. de Chim. et de Phys., T. 64, 1862; Compt. Rend., T. 50, 1860; T. 52, 1861; T. 56, 1863; T. 85, 1877. **Pfeiffer**, Zeitschr. f. Hygiene, 1886. **Pouchet**, Compt. Rend., T. 47, 1858. **Schrakamp**, Archiv f. Hygiene, Bd. II., 1884. **Sehlen**, Fortschr. d. Med., Bd. II., S. 585, 1885. **Smart**, Germs, Dust and Disease, 1883. **Soyka**, Sitz.-Ber. der. K. Bayr. Akad. d. Wiss.: Math. Physik. Classe, 1881; Vorträge im Aerztl. Verein in München, 1881; D. Vierteljsch. f. Oeff. Ges., Bd. 14, 1882; Prager Med. Woch., 1885; Fortschr. d. Med., 1885. **Tissandier**, Compt. Rend., T. 78, 1874. **Torelli**, La Malaria in Italia, 1883. **Tyndall**, Brit. Med. Journ., 1877; Essays on the Floating Matter of the Air, 1881; Med. Tim. and Gaz., 1870. **Wernich**, Cohn's Beiträge z. Biol. d. Pflanzen, Bd. III., S. 105, 1879. **Wolffhügel and Riedel**, Arbeit. a. d. K. Ges. Amt, 1886. **Wollny**, Viert. f. Oeff. Ges., S. 705, 1883. **Zander**, Centralbl. f. Allg. Ges., 1883.

## CHAPTER XII.

## PHOTOGRAPHY OF BACTERIA.

**Crookshank**, Photography of Bacteria, 1887. **Fränkel and Pfeiffer**, Mikrophotog. Atlas, 1889. **Günther**, Photogram. Path. Mikroorg., 1887. **Itzerott and Niemann**, Atlas der Microphotograph, 1895. **Koch**, Cohn's Beiträge zur Biol. der Pflanz., 1877; Mitth. a. d. K. Gesundheitsamte, Bd. I., 1881. **Neuhaus**, Centralbl. f. Bakteriolog., Bd. IV. **Sternberg**, Photomicrographs and How to Make them, 1884. **Woodward**, Rep. to Surg. Gen. U. S. Army, 1870.

## CHAPTER XIII.

## SUPPURATION. PYÆMIA. SEPTICÆMIA. ERYSIPELAS. GONORRHOEA. OPTHALMIA.

**Ainstie**, Lancet, 1870. **Arloing**, Recherches sur les Septicémies, 1884. **Babès**, Compt. Rend., 1883. **Balfour**, Edinb. Med. Journ., 1877. **Barthold**, Pyämisch-Metast. Dissert. Berlin, 1875. **Bastian**, Brit. Med. Journ., 1878. **Béchamp**, Compt. Rend., 1881; Trans. Internat. Med. Cong. London, 1881. **Beck**, Rep. Loc. Govt. Board, 1880. **Birch-Hirschfeld**, Untersuchungen über Pyämie, 1873. **Braidwood and Vacher**, Brit. Med. Journ., 1882. **Burdon-Sanderson**, Trans. Path. Soc., 1872; Brit. Med. Journ., 1875. **Crookshank**, Trans. Internat. Congr. of Hygiene, 1892. **Dowdeswell**, Quart. Journ. Micr. Sc. London, Vol. 18, 1878; Proc. Roy. Soc. London, Vol. 34, 1883. **Dreschfeld**, Brit. Med. Journ., 1883. **Drysdale**, Pyrexia, 1880. **Garré**, Fortschritte d. Med., 165, 1885. **Heiberg**, Die Puerperalen u. Pyämischen Processe, 1873. **Hoffa**, Fortsch. d. Med., 1885. **Horsley**, Rep. Med. Officer Loc. Govt. Board, 1881. **Klemperer**, Zeitschr. f. Klin. Med., 1885. **Koch**, Wundinfectionskrankheiten: Leipzig, 1878; Mittheil. d. Kais. Ges. Amts, Bd. I., 1881. **Lister**, Lancet, 1867; Med. Times and Gazette, 1877; Quart. Journ. Microscop. Science,





1887. **Oertel**, Zur Aetiologie der Infectionskrankheiten, 1881. **Ogston**, Brit. Med. Journ., Vol. I., 1881; Journ. of Anat. and Phys., Vol. 17, 1882. **Passet**, Ueber Mikroorganismen der Eitrigen Zellgewebsentzündung des Menschen; Fortschritte d. Med., Nr. 2, 1885, Bd. 3, 1885. **Perret**, De la Septicémie: Paris, 1880. **Rindfleisch**, Lehrb. der Pathol. Gewebelehre: 1 Aufl., S. 204, 1866. **Rosenbach**, Mikroorganismen bei den Wundinfectionskrankheiten des Menschen: Wiesbaden, 1884. **Sternberg**, Amer. Journ. Med. Sc.; Johns Hopkins Univ. Stud. Biol. Lab., 1882. **Steven**, Glasgow Med. Journal, 1884. **Sutton**, Trans. Path. Soc., 1883. **Tiegel**, Ueber d. Fiebererregenden Eigenschaften des Microsporion Septicum: Bern. Diss., 1871; Virchow's Archiv, Bd. 60, 1874. **Waldeyer**, Virchow's Arch., Bd. 40, 1867; Vortrag. i. d. Med. Ges. zu Breslau, 1871. **Watson-Cheyne**, Trans. Path. Soc., xxxv., 1884.

## OSTEOMYELITIS.

**Becker**, Deut. Med. Woch., and Berl. Klin. Woch., 1883. **Collmann**, Bakterien im Organismus eines an einer Verletzung am Oberschenkel Verstorbenen Mädchens: Göttingen, 1873. **Colzi**, Lo Sperimentale, 1890. **Courmont** and **Jaboulay**, Compt. Rend. Soc. de Biolog., 1890. **Eberth**, Virchow's Arch., Bd. 65, 1875. **Fehleisen**, Phys. Med. Ges. Würzburg, 1882. **Friedmann**, Berl. Klin. Woch., 1876. **Garré**, Fortschr. d. Med., 1885. **Giordano**, Prog. I. Mic. Pyog. infett. u. Eziolog. d. Osteom. Impett. Acuta, 1888. **Krause**, Fortschr. d. Med., Bd. 2, 1884. **Lannelongue** and **Achard**, La Semaine Med., 1890; and Compt. Rend. Soc. de Biolog., 1890. **Peyroud**, Compt. Rend., 1884. **Rodet**, Compt. Rendus, T. 99, 1884. **Rosenbach**, Centralbl. f. Chirurgie, 1884. **Schüller**, Centralbl. f. Chirurgie, Nr. 12, 1876.

## ENDOCARDITIS.

**Birch-Hirschfeld** and **Gerber**, Archiv d. Heilkunde, 1876. **Bramwell**, Diseases of the Heart, 1884. **Bristowe**, Brit. Med. Journ., 1884. **Coupland**, Brit. Med. Journ., 1885. **Gibbes**, Brit. Med. Journ., 1884. **Goodhart**, Trans. Path. Soc., vol. xxxi., 1880. **Hamburg**, Berlin: Inaug.-Diss., 1880. **Klebs**, Archiv f. Exper. Pathol., Bd. 9, 1878. **Koch**, Mittheil. a. d. Kais. Ges. Amt, Bd. I., 1881. **Koester**, Virchow's Arch., Bd. 72, 1875. **Kundrat**, Sitz.-Ber. d. Kais. Acad. d. Wissensch. zu Wien, 1883. **Leyden**, Zeitschr. f. Klin. Med., 1881. **Nocard**, Recueil de Méd. Vét., 1885. **Oberbeck**, Casuistische Beiträge zur Lehre von der Endocarditis Ulcerosa: Inaug.-Diss., 1881. **Orth, J.**, Versammlung Deutscher Naturf. zu Strasburg, 1885. **Osler**, Brit. Med. Journ., 1885; Trans. Int. Med. Congress, 1881. **Ribbert**, Fortsch. d. Med., 1886. **Rosenbach**, Archiv für Exper. Pathol., Bd. 9, 1878. **Wedel**, Berl. Klin. Wochenschr., 1877. **Weichselbaum**, Wien. Med. Woch., 1885. **Weigert**, Virchow's Arch., Bd. 84, 1881. **Wilks**, Brit. Med. Journ., 1882. **Wyssokowitsch**, Centralbl. f. d. Med. Wissensch., Nr. 33, 1885.

## ERYSIPELAS.

**Baader**, Schweiz. Naturf. Gesellsch., 1875. **Denuce**, Etude sur la Pathogénie et l'Anatomie Pathologique de l'Erysipèle, 1885. **Dupeyrat**, Recherches Cliniques et Expérimentales sur la Pathogénie de l'Erysipèle, 1881. **Fehleisen**, Würzburger Phys. Med. Ges., 1881; Deut. Zeitschr. f. Chir., Bd. 16, 1882; Die Aetiologie des Erysipels.: Berlin, 1883. **Hüter**, Med. Centralbl., Nr. 34, 1868.

**Janicke** and **Neisser**, *Centralbl. f. Chir.*, Nr. 25, 1884. **Klebs**, *Archiv f. Exper. Pathol. u. Pharmacol.*, Bd. 4, 1875. **Lukomsky**, *Virchow's Archiv*, Bd. 60, 1874. **Nepven**, *Des Bactéries dans l'Erysipèle*, 1885. **Orth**, *Archiv f. Exper. Pathol. u. Pharmacol.*, Bd. I., 1873. **Raynaud**, *Union Méd.*, 1873, **Recklinghausen** and **Lankowski**, *Virchow's Arch.*, Bd. 60, 1874. **Rheiner**, *Virchow's Arch.*, Bd. 100, Heft 2, 1884. **Tillmanns**, *Verhandl. d. Deutsch. Ges. f. Chirurgie*, 1878; *Archiv f. Klin. Chirurgie*, Bd. 23, 1879. **Trosier**, *Bull. Soc. Anat. de Paris*, 1875. **Wolff**, *Virchow's Arch.*, Bd. 81, 1880.

## PUERPERAL FEVER.

**Aufrecht**, *Naturforsch. Versamml.*, 1881. **Dolérís**, *La Fièvre Puerpérale et les Organismes Infect.*, 1886. **Heiberg**, *Die Puerperalen und Pyämischen Processe*, 1873. **Karewski**, *Zeitschr. f. Geburtsh. u. Gynäkologie*, Bd. 7, 1881. **Laffter**, *Bresl. Aerztl. Ztg.*, 1879. **Mayrhofer**, *Monatsschr. f. Geburtsk. u. Frauenkrankheiten*, Bd. 25, 1865. **Orth**, *Virchow's Arch.*, Bd. 58, 1873. **Pasteur**, *Bull. de l'Acad. de Méd.*, T. 9, 1880. **Recklinghausen** and **Lankowski**, *Virchow's Arch.*, Bd. 60, 1873. **Waldeyer**, *Arch. f. Gynäkologie*, iii., 1872.

## GONORRHOEA.

**Arning**, *Viertelj. f. Dermatol. u. Syph.*, S. 371, 1883. **Aufrecht**, *Pathologische Mittheilungen*, 1881; *Centralbl. f. d. Med. Wiss.*, Nr. 16, 1883. **Bockhart**, *Sitzungsbericht d. Phys. Med. Ges. zu Würzburg*, 1882; *Viertelj. f. Dermatol. und Syph.*, 1883. **Bokai**, *Allgem. Med. Centralzeitung*, Nr. 74, 1880. **Bokai** and **Finkelstein**, *Prager Med. Chir. Presse*, 1880. **Bücker**, *Ueber Polyarthrits Gonorrhoeica*. Diss., 1880. **Bumm**, *Der Mikroorganismus der Gonorrhoeischen Schleimhafterkrankungen*, 1885. **Campona**, *Italia Medica*, 1883. **Chameron**, *Progrès Medical*, 43, 1884. **Eschbaum**, *Deut. Med. Woch.*, S. 187, 1883. **Fränkel**, *Deut. Med. Woch.*, Nr. 2, 1883; S. 22, 1885. **Haab**, *Der Mikrokoccus der Blennorrhœa Neonator*, 1881. **Hirschberg** and **Krause**, *Centralbl. f. Pract. Augenheilk.*, 1881. **Kammerer**, *Centralbl. f. Chirurgie*, Nr. 4, 1884. **Krause**, *Die Mikrokoccken der Blennorrhœa Neonator*, 1882. **Kroner**, *Naturforschervers. in Magdeburg*, *Arch. f. Gyn.*, xxv., S. 109, 1884. **Leistikow**, *Charité-Annalen*, 7 Jahrg., S. 750, 1882. **Lundström**, *Studier öfver Gonokokkus*: Diss. Helsingfors, 1885. **Martin**, *Rech. sur les Inflamm. Métast. à la Suite de la Gonorrhée*, 1882. **Neisser**, *Centralbl. f. d. Med. Wiss.*, Nr. 28, 1879; *Deutsche Med. Woch.*, 1882. **Newberry**, *Maryland Med. Journ.*, 1883. **Petrone**, *Rivista Clin.*, No. 2. **Reter**, *Centralbl. f. d. Med. Wiss.*, 1879. **Sanger**, *Naturforschervers. in Magdeburg*; *Ibid.*, S. 126, 1884. **Schrötter** and **Winkler**, *Centralbl. f. Bact.*, Bd. ix. **Smirnoff**, *Vrach.*, 1886. **Steinschneider**, *Verhandl. der Deutsch. Dermat. Gesellsch.*, 1889; *Berl. Klin. Woch.*, 1890. **Sternberg**, *Med. News*, Vol. 45, Nr. 16, 1884. **Weiss**, *Le Microbe du Pus Blennorrhagique*, 1889. **Welander**, *Gaz. Med. de Paris*, 1884.

## OPHTHALMIC DISEASES.

**Balogh**, *Med. Centralbl.*, xiv., 1879. **Bock**, *Virchow's Arch.*, Bd., 91, 1883. **Cornil** and **Berlioz**, *Compt. Rend. de l'Acad. d. Sc.*, 1883. **Deutschmann**, *v. Graefe's Archiv*, Bd. xxxi., 1885. **Gifford**, *Archiv f. Augenheilkunde*, 1886. **Goldzieher**, *Centralblatt f. Prakt. Augenheilk.*, 1884. **Kahler**, *Prager Zeitschr. f. Prakt. Heilk.*, Bd. I., 1882. **Klein**, *Centralbl. f. d. Med. Wiss.*, Nr. 8, 1884.



**Kroner**, Verh. d. Naturforscher-Vers. Magdeburg, 1884. **Kuschbert**, Deutsch. Med. Woch., Nr. 21, 1884. **Kuschbert** and **Neisser**, Bresl. Aertzl. Zeitschr., Nr. 4, 1883. **Michel**, Graefe's Archiv f. Augenheilkunde, 1882. **Neisser**, Fortschr. d. Med., Bd. 2, S. 73, 1884. **Reuss**, Wien. Med. Presse, 1884. **Röth**, Virchow's Archiv, Bd. 55, 1872. **Salomonsen**, Fortschr. d. Med., Bd. 2, S. 78, 1884. **Sattler**, Ber. üb. d. Ophthalmologen Congress zu Heidelberg, 1882; Zehender's Klin. Monatsblatt, and Wien. Med. Woch., Nr. 17, 1883. **Sattler** and **de Wecker**, L'Ophthalmie Jéquiritique, 1883. **Schleich**, Verh. des Ophthalmologen Congr. zu Heidelberg, 1883. **Vennemann** and **Bruylants**, Le Jéquirity et son Principe Pathogène, 1884. **Vossius**, Berl. Klin. Wochenschr., Nr. 17, 1884. **Widmark**, Hygeia: Stockholm, 1885. **Zehender**, Bowman Lecture: Lancet, 1886.

## CHAPTER XIV.

## ANTHRAX.

**Archangelski**, Centralbl. f. d. Med. Wiss., 1882, 1883. **Bert**, Compt. Rend. Soc. de Biol., T. 4, 1877; T. 5, 1878; T. 6, 1879. **Bleuler**, Correspondenzbl. d. Schweiz Aerzte, 1884. **Bollinger**, Arbeit. a. d. Patholog. Inst. zu München, 1886; Centralbl. f. d. Med. Wiss., Bd. 10, 1872; Sitzungsber. d. Ges. f. Morphol. Physiol. zu München, 1885. **Bouley**, Bull. Acad. de Méd.: Paris, T. 9, 1880; T. 10, 1881; Compt. Rend., T. 92 and 93, 1881. **Branell**, Virchow's Arch., Bd. 11, 1857; Bd. 14, 1858. **Büchner**, Ueber die Exper. Erzeugung des Milzbrandcontagiums aus den Heupilzen, 1880; Sitzungsber. d. K. Bayer. Akad. d. Wissensch., 1880; Vorträge im Aertzl. Verein zu München, 1881; Virchow's Arch., Bd. 91, 1883. **Chauveau**, Compt. Rend., T. 90 and 91, 1880; T. 92, 1881; T. 94, 1882; T. 96, 1883. **Chelchowsky**, Der Thierarzt, 1884. **Colin**, Bull. Acad. de Méd.: Paris, T. 2, 1873; T. 7, 1878; T. 8, 1879; T. 9, 1880; T. 10, 1881. **Crookshank**, Rep. Agric. Dept., 1888. **Davaine**, Compt. Rend.: Paris, T. 77, 1873; T. 57 and 59, 1863; T. 60, 1865; T. 61, 1866, 1877; Rec. de Méd. Vét., T. 4, 1877. **Dowdeswell**, Rep. Med. Off. Local Gov. Board, 1883. **Esser** and **Schütz**, Mitth. a. K. Preuss. Amtl. Vet. Sanitätsbericht, 1882. **Ewart**, Quart. Journ. of Microsc. Sc., 1878. **Feltz**, Compt. Rend., T. 95, 1882. **Fodor**, Deut. Med. Woch., 1886. **Fokker**, Centralbl. f. d. Med. Wissensch., Bd. 18, 1880; Centralbl. f. d. Med. Wiss., 1881; Virchow's Archiv, Bd. 88, 1882. **Frank**, Zeitschr. f. Hygiene, 1886. **Friedrich**, Zur Aetiologie des Milzbrands., 1885. **Greenfield**, Quart. Journ. Micr. Sc. London, 1879; Proc. Roy. Soc. London, 1880. **Hoffa**, Die Natur des Milzbrandgiftes: Wiesbaden, 1886. **Huber**, Deut. Med. Woch., Bd. 7, 1881. **Johne**, Ber. ü. d. Veter. Wesen. i. K. Sachsen, 1886. **Kitt**, Sitzungsber. d. Ges. f. Morphol. u. Physiol. zu München, 1885. **Klein**, Rep. of the Medical Officer of the Local Govt. Board, 1881; Quart. Journ. Micr. Sc., 1883. **Koch**, Beiträge zur Biologie der Pflanzen, Bd. II., Heft 2, 1876; Wundinfectionskrankheiten, 1878; Mitth. aus d. Ges. Amt, Bd. I., 1881; Milzbrand und Rauschbrand: Stuttgart, 1886. **Martin**, Proc. Roy. Soc., 1890; Rep. Med. Off. Local Govt. Board, 1890-91; Brit. Med. Journal, 1891. **Oemler**, Archiv f. Wiss. u. Pract. Thierheilk., Bd. 4, 1878, 1879, 1880. **Osol**, Experiment. Untersuch. ü. das Anthraxgift: Inaug. Diss. Dorpat, 1885. **Pasteur**, Bull. Acad. de Méd., 1877, 1879, 1880; Compt. Rend., Paris, T. 84, 1877; T. 90 and 91, 1880; T. 92, 1881; T. 95, 1882. **Pollender**, Vierteljahrschr. f. Ger. Med., Bd. 8, 1855. **Prazmowski**, Acad. d. Wissensch. in Krakau, 1884;

Biol. Centralbl., Bd. 4, 1884. **Rodet**, Contribution à l'Etude Expérimentelle du Carbon Bactérien, 1881; Compt. Rend., T. 94, 1882. **Roloff**, Archiv f. Wissensch. u. Pract. Thierheilk., Bd. 9, 1883; Der Milzbrand: Berlin, 1883. **Schmidt**, Deut., Zeitschr. f. Thiermed. u. Vergl. Pathol., 1879. **Schrakamp**, Archiv f. Hygiene, Bd. 2, 1884. **Semmer**, Centralbl. f. d. Med. Wissensch., Bd. 18, 1880, 1884; Der Milzbrand und das Milzbrandcontagium, 1882. **Sternberg**, Am. Monthly Micr. Journ., 1881. **Szpilman**, Zeitschr. f. Physiol. Chemie: Strassburg, Bd. 4, 1880. **Toepper**, Die Neueren Erfahrungen über d. Aetiologie d. Milzbrands., 1883. **Toussaint**, Compt. Rend., T. 85, 1877, 1878, 1880; Recherches Expérimentales sur la Maladie Charbonneuse, 1879. **Wachenheim**, Etude Expérimentelle sur la Septicité et la Virulence du Sang Charbonneux, 1880.

## CHAPTER XV.

## QUARTER-EVIL. MALIGNANT OEDEMA. RAG-PICKER'S SEPTICÆMIA OF GUINEA-PIGS. SEPTICÆMIA OF MICE.

## QUARTER-EVIL.

**Arloing**, **Cornevin** and **Thomas**, Compt. Rend., 1880; Bull. de l'Acad. de Méd., and Revue de Méd., 1881; Du Charbon Bactérien, Charbon Symptomatique, etc., 1883; Revue de Méd., 1884; Chabert's Disease: Transl. by Dawson Williams in Micro-parasites and Disease (New Syd. Soc.), 1886. **Babès**, Journ. de l'Anatomie, 1884. **Bollinger** and **Feser**, Wochenschr. f. Thierheilkunde, 1878. **Ehlers**, Unters. üb. d. Rauschbrandpilz: Inaug. Diss. Rostock, 1884. **Hess**, Bericht über die beschädigten Rauschbrand u. Milzbrandfälle im Canton Bern, 1886. **Kitt**, Jahresber. der K. Thierarzneisch. in München, 1884. **Neelsen** and **Ehlers**, Ber. d. Naturforsch. Ges. zu Rostock, 1884. **Strebel**, Schweiz. Archiv f. Thierheilk., 1886.

## MALIGNANT OEDEMA.

**Brieger** and **Ehrlich**, Berl. Klin. Wochenschr., N. 44, 1882. **Chauveau** and **Arloing**, Archiv Vét., 1884; Bull. Acad. de Méd., 1884. **Davaine**, Bull. de l'Acad. de Méd., 1862. **Gaffky**, Mitth. as. d. K. Ges. Amt., 1881. **Hesse**, **W.** and **R.**, Deut. Med. Woch., 1885. **Kitasato** and **Weyl**, Zeitschr. f. Hygiene, Bd. VIII. **Kitt**, Jahresber. der K. Thierarzneischule in München, 1884. **Koch**, Mitth. aus dem Ges. Amt, I, S. 54, 1881. **Lebedeff**, Arch. de Phys. Norm. et Path., 1882. **Lustig**, Jahresber. d. K. Thierarzneischule zu Hannover, 1884. **Pasteur**, Bull. de l'Acad. de Méd., 1877, 1881. **Roger**, Compt. Rend. Soc. de Biol., 1889. **Roux** and **Chamberland**, Ann. de l'Institut Pasteur, 1887. **Trifaud**, Rev. de Chirurg, T. iii. **Van Cott**, Centralb. f. Bact., 1891. **Verneuil**, La Semaine Méd., 1890.

## RAG-PICKER'S SEPTICÆMIA. SEPTICÆMIA OF GUINEA-PIGS. SEPTICÆMIA OF MICE.

**Bordoni-Uffreduzzi**, Zeitsch. f. Hygiene, 1888. **Klein**, Centralbl. f. Bacteriolog., 1890. **Koch**, Wundinfectionskrankheit, Trans. New Syd. Soc., 1880. **Paltauf**, Wiener Klin. Woch., 1888.



## CHAPTER XVI.

## HEMORRHAGIC SEPTICÆMIA.

SEPTICÆMIA OF BUFFALOE. SEPTIC PLEURO-PNEUMONIA OF CALVES.  
 SWINE FEVER. SEPTICÆMIA OF DEER. SEPTICÆMIA OF RABBITS.  
 FOWL CHOLERA. FOWL ENTERITIS. DUCK CHOLERA. GROUSE DISEASE.

**Babès**, Compt. Rend. de l'Acad. d. Sc., 1883; Arch. de Physiol., 1884.  
**Barthélémy**, Compt. Rend., T. 96, No. 18, 1883. **Bunzl-Federn**, Centralbl. f. Bacteriolog., 1891. **Camera**, Centralbl. f. Bacteriolog., 1891. **Cornil**, Arch. de Physiol., Bd. 10, 1882. **Cornil and Chantemesse**, Le Bulletin Méd., 1887. **Cornil and Toupet**, Bull. de la Soc. Nat. d'Acclimation., 1888. **Davaine**, Bull. de l'Acad. de Méd., 1879. **Eberth and Schimmelbusch**, Virchow's Archiv, 1889; Fortschr. d. Med., Bd. VI. **Gaffky**, Mitt. aus dem K. G. Amte, 1881. **Gamaleia**, Centralb. f. Bacteriolog., 1888. **Hueppe**, Berl. Klin. Woch., 1886. **Ioannès and Mégnin**, Journ. d'Acclimatation, 1877. **Kitt**, Allg. Deut. Geflügelzeitung, 1885. **Klein**, Rep. Med. Off. Local Govt. Board, 1877-78; Fortschr. der Med., 1888; Centralb. f. Bakteriolog., 1889. **Koch**, Aetiologie der Wundinfections R., 1878. **Oreste and Armani**, Atti de R. Instit. d'Incorrrag. Alle Sci. Nat., Econ e Tech., 1887. **Pasteur**, Compt. Rend., T. 90, 1886. **Perroncito**, Arch. f. Wiss. u. Prakt. Thierheilk., 1879. **Petri**, Centralbl. f. d. Med. Wiss., 1885. **Rietsch and Jobert**, Compt. Rend., 1888. **Salmon**, Reports Bureau of Animal Industry, 1886, 1887, 1888. **Salmon and Smith**, Amer. Monthly Med. Journ., 1881. **Schütz**, Archiv f. Wiss. und Prakt. Thierheilk., 1888. **Semmer**, Deut. Zeitschr. f. Theirmed. u. Vergl. Path., 1878. **Smith**, Journ. f. Comp. Med. and Surg., 1887; Zeitschr. f. Hygiene, 1891. **Smith and Veranus Moore**, Rep. Bureau of Animal Industry, 1895. **Zürn**, Die Krankheiten des Hausgeflügels, 1882.

## CHAPTER XVII.

PNEUMONIA. INFECTIOUS PLEURO-PNEUMONIA OF CATTLE.

INFLUENZA.

PNEUMONIA.

**Afanassiew**, Compt. Rend. Soc. de Biol. Paris, T. 5, 1884. **De Blasi**, Rivista Internaz. di. Med. e Chir., 1885. **Bruvlant and Verriers**, Bull. de l'Acad. Belge, 1880. **Dreschfeld**, Fortschr. d. Med., Bd. 3, 389, 1885. **Foa and Bordoni-Uffreduzzi**, Deut. Med. Woch., 1886. **Fränkel**, Verhandl. d. Congr. f. Innere Med., Fortschr. d. Med. Nov., 1884; Deut. Med. Woch., 1886; Zeitschr. f. Klin. Med., Bd. x. and xi., 1886. **Friedländer**, Virchow's Arch., Bd. 87, 1882; Fortschr. d. Med., Bd. I., 1883; Bd. II., 1884; Bd. 3, 92, 1885. **Friedländer and Frobenius**, Berl. Klin. Woch., 1883. **Germain-Sée**, Compt. Rend. Acad. de Sc. Paris, 1884; Des Maladies Spécifiques du Poumon, 1885. **Giles**, Brit. Med. J., Vol. II., 1883. **Griffini and Cambria**, Centralbl. f. d. Med. Wiss., 1883. **Jaccoud**, La France Médicale, 1886. **Jürgensen**, Berl. Klin. Woch., Bd. 22, 1884. **Klein**, Centralbl. f. d. Med. Wissensch., 1884. **Korányi and Babès**, Pester Med. Chir. Presse, 1884. **Kühn**, Deutsch. Arch. f. Klin. Med., 1878; Berl. Klin. Woch., Nr. 38, 1881. **Lancereaux and Besançon**,



Archiv Gén. de Méd., 1886. **Maguire**, Brit. Med. Journ., Vol. II., 1884. **Manfredi**, Fortsch. d. Med., 1886. **Matray**, Wien. Med. Presse, Nr. 23, 1883. **Mendelssohn**, Zeitschr. f. Klin. Med., Bd. 7, 1884. **Nauwerck**, Beitr. zur Pathol. Anat. von Ziegler, 1884. **Neumann**, Berl. Klin. Woch., 1885. **Pawlowsky**, Berl. Klin. Woch., 1885. **Peterlein**, Bericht ü. d. Vet.-Wesen. i. K. Sachsen, 1885. **Pipping**, Fortsch. d. Med., Nos. 10 and 14, 1886. **Platanow**, Mitth. a. d. Würzburg. Med. Klinik, 1885; Ueber die Diagnostische Bedeutung d. Pneumoniekokken: Inaug.-Diss. Würzburg, 1884. **Ribbert**, Deut. Med. Woch., Nr. 9, 1885. **Salvioli and Zäslein**, Centralbl. f. d. Med. Wissensch., 1883. Arch. pour les Sc. Méd., T. 8., 1884. **Schou**, Fortsch. der Med., Bd. 3, Nr. 15, 1886. **Sternberg**, Amer. Journ. Med. Sciences, 1885; Journ. Roy. Micr. Soc., 1886. **Talamon**, Progr. Médic., 1883. **Thost**, Deut. Med. Woch., 1886. **Weichselbaum**, Wien. Med. Woch., 1886. **Ziethl**, Centralbl. f. d. Med. Wiss., 1883; Centralbl. f. d. Med. Wiss., 1884.

#### CEREBRO-SPINAL MENINGITIS.

**Bonome**, Centralbl. f. Bact. u. Parasitolog., IV. **Foa**, Zeitschr. f. Hygiene, IV. **Leichtenstern**, Deut. Med. Woch., Nr. 23 u. 31, 1885. **Leyden**, Centralbl. f. Klin. Med., Nr. 10, 1883. **Weichselbaum**, Wien. Klin. Woch., 1888.

#### PLEURO-PNEUMONIA.

**Arloing**, Compt. Rend. cix., 1889. **Bruce and Loir**, Ann. de l'Institut Pasteur, 1891. **Bruylants and Verriers**, Bull. de l'Acad. Belg., 1880. **Cornil and Babès**, Arch. de Physiol. Norm. et Path., T. 2, 1883. **Lustig**, Centralbl. f. die Med. Wiss., 1885. **Mayrwieser**, Woch. f. Thierheilk. u. Viehzucht, 19, 1884. **Pasteur**, Recueil de Méd. Vét., 1882. **Poels**, Fortsch. d. Med., 1886. **Poels and Nolen**, Centralbl. f. d. Med. Wiss., Nr. 9, 1884; Fortsch. d. Med., 1886. **Putz**, Thier. Med. Vorträge, Bd. 1, 1889. **Report on Pleuro-pneumonia and Tuberculosis**, 1888. **Schütz and Steffen**, Archiv f. Wiss. und Prakt. Thierheilk., Bd. xv. **Sussdorff**, Deutsche Zeitschr. f. Thiermed. u. Vergl. Pathol., 1879.

#### INFLUENZA.

**Babès**, Centralbl. f. Bacteriolog., 1890; Deutsche Med. Woch., 1892. **Bein**, Zeitschr. f. Hygiene, 1890. **Bouchard**, La Semaine Méd., 1890. **Canon**, Deutsche Med. Woch., 1892. **Fischel**, Prager Med. Woch., 1890; Zeitschr. f. Heilkunde, 1891. **Jolles**, Wiener Med. Blätt., 1890. **Kirchner**, Centralbl. f. Bacteriolog., 1890; Zeitschr. f. Hygiene, 1890. **Kitasato**, Deutsche Med. Woch., 1892. **Klein**, Brit. Med. Journ., 1892. **Klebs**, Centralbl. f. Bakteriolog., 1890; Deutsche Med. Woch., 1890. **Pfeiffer**, Deutsche Med. Woch., 1892. **Prudden**, New York Med. Rec., 1890.

### CHAPTER XVIII.

ORIENTAL PLAGUE. RELAPSING FEVER. TYPHUS FEVER. YELLOW FEVER.

#### ORIENTAL PLAGUE.

**Aoyama**, Mitth. ü. d. Pest. Epidemie im Jahre 1894; in Hong Kong, 1895. **Yersin**, Ann. de l'Institut Pasteur, 1894. **Yersin, Calmette and Borrel**, Ann. de l'Institut Pasteur, 1895.



## RELAPSING FEVER.

**Albrecht**, St. Petersb. Med. Woch., 1879. **Carter**, Lancet, 1879; Trans. Internat. Med. Congress, 1881. **Cohn**, Deut. Med. Woch., 1879. **Engel**, Berl. Klin. Woch., 1873. **Günther**, Fortschr. d. Med., 1885. **Guttman**, Virchow's Arch., 1880. **Heydenreich**, St. Petersb. Med. Woch., 1876; Der Parasit des Rückfalltyphus, 1877. **Jaksch**, Wien. Med. Woch., Juli, 1880. **Koch**, Deut. Med. Woch., 1879. **Laptschinsky**, Centralbl. f. d. Med. Wiss., Bd. 13, 1875. **Manasse**, St. Petersb. Med. Woch., No. 18, 1876. **Metchnikoff**, Virchow's Archiv, 1877. **Moczutowsky**, Deutsches Archiv für Klin. Med., Bd. xxiv., 1876. **Mühlhäuser**, Virchow's Arch., Bd. 97, 1880. **Obermeier**, Med. Centralbl., 11; Berl. Med. Ges.; Berl. Klin. Wochenschr., 1873. **Soudakewitch**, Ann. de l'Institut Pasteur, 1891. **Weigert**, Deut. Med. Woch., 1876.

## YELLOW FEVER.

**Babès**, Compt. Rend., 17 Sept., 1883. **Bouley**, Compt. Rend., T. 100, p. 1276, 1885. **Carmona y Valle**, Leçons sur l'Étiol. et la Prophylax. de la Fièvre Jaune, 1885. **Cerecedo**, El Siglo Medico, 1886. **Domingos Freire**, Recherches sur la Cause de la Fièvre Jaune, 1884; La Fièvre Jaune et ses Inoculations Préventives, 1896. **Domingos Freire** and **Rebourgeon**, Compt. Rend., T. 99, p. 804, 1884.

## CHAPTER XIX.

## SCARLET FEVER AND MEASLES.

## SCARLET FEVER.

**Coze** and **Feltz**, Les Maladies Infectieuses, 1872. **Crooke**, Lancet, 1883; Fortschr. d. Med., 1885. **Crookshank**, Report Agric. Dept., 1887. **Hahn**, Berl. Klin. Woch., No. 38, 1882. **Heubner** and **Bahrät**, Berl. Klin. Woch., Nr. 44, 1884. **Klein**, Nature, xxxiv., 1886; Report of the Medical Officer of the Privy Council, 1887, 1888, 1889. **Laure**, Lyon Médical, 1886. **McKendrick**, Brit. Med. Journal, 1872. **Pohl-Pincus**, Centralbl. f. d. Med. Wiss., No. 36, 1883. **Roth**, Münch. Aerztl. Intelligenzbl., 1883.

## MEASLES.

**Cornil** and **Babès**, Archiv de Phys., 1883. **Keating**, Phil. Med. Times, 1882.

## CHAPTER XX.

## SMALL-POX. CATTLE PLAGUE.

## SMALL-POX.

**Chauveau**, Compt. Rend., 1868. **Cohn**, Virchow's Archiv, Bd. 55, 1872. **Copeman**, Brit. Med. Journ., 1896; The Practitioner, 1896. **Cornil** and **Babès**, Soc. Méd. des Hôp., 1883. **Crookshank**, History and Path. of Vaccination, 1889. **Haccius**, Variola-vaccine, 1892. **Hamerink**, Ueber die sog. Vac. u. Variola, 1884. **Ischamer**, Aerztl. Verein. Steiermark, 1880. **Klebs**, Arch. f. Exp. Path. u. Pharmakol., Bd. 10, 1874. **Klein**, Rep. Med. Off. Loc. Govt. Board, 1893-4.

**Luginbuhl**, Verhdl. d. Phys. Med. Ges. in Würzburg, 1873. **Marchand**, Revue Mycologique, 1882. **Pfeiffer**, Die Protozoen als Krankheitserreger, 1890; Behndl. und Prophylax. der Blättern, 1893. **Pissin**, Berl. Klin. Woch., 1874. **Plaut**, Das Organis. Contagium der Schafpocken, 1883. **Pohl-Pincus**, Vaccination, 1882. **Quist**, St. Petersburg Med. Woch., Nr. 46, 1883. **Reports**, Royal Vaccination Commission, 1888-96. **Ruffer** and **Plimmer**, Brit. Med. Journ., 1894. **Weigert**, Ueber Bakterien in der Pockenhaut, 1871; Anat. Beitr. z. Lehre v. d. Pocken, 1874. **Wolf**, Berl. Klin. Woch., Nr. 4, 1883. **Zülzer**, Berl. Klin. Woch., 1872.

## CATTLE PLAGUE.

**Crookshank**, History and Pathology of Vaccination, 1889. **Report** of the Cattle Plague Commission, 1865. **Report** on Indian Cattle Plague, 1871. **Semmer** and **Archangelski**, Ueber das Rinderpestcontagium und dessen Mitigation; Centralbl. f. d. Med. Wiss., 1883. **Simpson**, Brit. Med. Journal, 1896. **Smart**, Reports on Cattle Plague, Edinburgh, 1865.

## CHAPTER XXI.

## SHEEP-POX. FOOT AND MOUTH DISEASE.

## SHEEP-POX.

**Crookshank**, History and Path. of Vaccination, 1889.

## FOOT AND MOUTH DISEASE.

**Klein**, Report Med. Off. Local Govt. Board, 1885. **Schottelius**, Centralb. f. Bakteriolog., 1892.

## CHAPTER XXII.

## HORSE-POX. COW-POX.

## HORSE-POX.

**Crookshank**, History and Pathology of Vaccination, 1889.

## COW-POX.

**Bucknill**, Prov. Med. Journ., 1895. **Crookshank**, Brit. Med. Journ., 1888; History and Pathology of Vaccination, 1889 (Vol. II. contains reprints of the works of **Jenner**, **Pearson**, **Woodville**, **Loy**, **Rogers**, **Birch**, **Bousquet**, **Estlin**, **Ceely**, **Badcock**, **Auzias-Turenne**, **Dubreuilh**, **Layet**). **Reports** of the Royal Vaccination Commission.

## CHAPTER XXIII.

## DIPHThERIA.

**Abbot**, Bull. Johns Hopkins Univ., 1891, 1893; Journ. of Path. and Bact., 1893. **Babès**, Virchow's Archiv. 1890. **Behring**, Deutsche Med. Woch. 1890. **Behring** and **Kitasato**, Deutsche Med. Woch., 1890. **Birch-Hirschfeld**, Archiv für Heilk., 1872. **Brieger** and **Fränkel**, Berl. Klin. Woch., 1890.



**Buhl**, Zeitschr. für Biol., 1867. **Cornil**, Arch. de Physiol., 1881. **Eberth**, Med. Centralbl., XI., Nr. 8, 1873. **Emmerich**, Compt. Rendus et Mémoires du V. Congrès Internat. d'Hygiène, 1884; Deut. Med. Woch., 1884. **Everett**, Med. and Surg. Reporter, 1881. **Forster**, Wien. Med. Woch., 1881. **Francotte**, La Diphthérie, 1883. **Freidberger**, Deut. Zeitschr. für Thiermed. u. Vergl. Pathol., 1879. **Fürbringer**, Virch. Arch., Bd. 91, 1883. **Gerhardt and Klebs**, Verhandl. d. Congresses f. Inn. Med., 1882, 1883. **Heubner**, Die Experimentelle Diphtherie, 1883. **Hueter and Tommasi**, Centralbl. f. d. Med. Wiss., 1868. **Klebs**, Arch. f. Exp. Pathol., Bd. 4, 1875. **Klein**, Report Med. Dept. Local Govt. Board, 1889. **Letzerich**, Berl. Klin. Woch., xi., 1874; Virch. Arch., Bd. 55, 1872; Bd. 68, 1876. **Löffler**, Mittheil. a. d. Kais. Ges. Amt, Bd. II., 1884; Microparasites and Disease (New Syd. Soc.), 1886; Centralbl. f. Bacteriolog., 1887, 1890; Deutsche Med. Woch., 1890. **Lumner**, Aerztl. Int. Bl., No. 31, 1881. **Martin**, Rep. Med. Off. Loc. Gov. Board, 1890. **Neumayer**, Neue Thesen zur Diphtheritisfrage, 1880. **Nicati**, Compt. Rend., T. 88, 1879. **Oertel**, Deut. Arch. f. Klin. Med., Bd. 8, 1871; Zur Aetiologie der Infektionskrankheiten, 1881. **Park**, New York Med. Record, 1892, 1893. **Prudden**, Amer. Journal of Med. Sci., 1889; New York Med. Rec., 1891. **Rivolta**, Giornale de Anat. Fisiol. e Patol. delli Anim., 1884. **Roux and Yersin**, Ann. de l'Institut Pasteur, 1888, 1889, 1890. **Salisbury**, Gaillard's Med. Journ.: New York, 1882. **Talamon**, Bull. de la Soc. Anat. de Paris, T. 56, 1881. **Welch**, Amer. Journal of the Med. Sci., 1894. **Welch and Abbott**, Bull. Johns Hopkins Univ., 1891. **Wood and Formad**, Bull. Nat. Board of Health, Wash. and Med. Times and Gazette, 1882. **Zahn**, Beiträge zur Pathol. u. Histol. der Diphtherie, 1878. **Zarniko**, Centralbl. f. Bact., 1889.

## CHAPTER XXIV.

## TYPHOID FEVER.

**Almquist**, Typhöidfeberus-Bakterie, 1882. **Beumer and Peiper**, Zeitschr. f. Hygiene, 1886. **Birch-Hirschfeld**, Zeitschr. f. Epidemiologie, I., 1874. **Boens**, Acad. Roy. de Méd. de Belgique: Bull. 3 Sér., T. 17, 1883. **Brautlecht**, Virchow's Arch., Bd. 84, 1881. **Coats**, Brit. Med. Journ., 1882. **Crooke**, Brit. Med. Journ., 1882. **Eberth**, Arch. f. Pathol. Anat., Bd. 81, 1880; Volkman, Klin. Vorträge, 1883. **Eppinger**, Beitr. zur Pathol. Anatomie aus d. Patholog. Institut, Prag., 1880. **Feltz**, Compt. Rend., T. 85, 1877. **Fischel**, Beitr. zur Pathol. Anat. aus d. Pathol.-Anat. Inst. Prag., 1880. **Fraenkel and Simmonds**, Die Aetiologische Bedeutung des Typhus-Bacillus, 1886. **Gaffky**, Mitth. a. d. Ges. Amt, Bd. II., 1884. **Klebs**, Arch. f. Exper. Pathol. u. Pharmakol., 1880. **Klein**, Med. Centralbl., xii., 1874. **Letzerich**, Virchow's Archiv, Bd. 68, 1876; Archiv f. Exper. Pathol., Bd. 9, 1878; Bd. 10, 1881; Experimentelle Untersuchungen über die Aetiologie des Typhus Abdominalis: Leipzig, 1883. **Luca-tello**, Bollet. d. R. Accad. Med. di Genova, 1886. **Maraghano**, Centralbl. f. d. Med. Wiss., Bd. 15, 1882. **Meisels**, Wien. Med. Woch., 1886. **Meyer**, Unters. über den Bacillus des Abdominaltyphus: Inaug. Diss., 1881. **Michael**, Fortsch. d. Med., 1885. **Neuhauss**, Berl. Klin. Woch., 1886. **Pfeiffer**, Deut. Med. Woch., Nr. 29, 1885. **Rappin**, Contrib. à l'Etude des Bact. de la Bouche, à l'Etat Normal et dans la Fièvre Typhoïde, 1881. **Seitz**, Bakteriolog. Studien z. Typhusätiologie, 1886. **Sirotinin**, Zeitsch. f. Hygiene, 1886. **Tayon**, Compt. Rend., T. 99, p. 331, 1884. **Tizzoni**, Studi. di Pat. Sperim. sulla Gen. d. Tifo.: Milan, 1880. **Wernich**, Zeitschr. f. Klin. Med., Bd. 6, 1882.



## CHAPTER XXV.

## SWINE-TYPHOID.

**Klein**, Rep. of the Med. Offic. of the Privy Council, 1877-78 ; **Virchow's Archiv**, 1884. **M'Fadyean**, Journ. of Comp. Path. and Therapeutics, 1895. **Report of a Conference on Swine-fever**: Board of Agriculture, 1896. **Rietsch**, **Jobert** and **Martinaud**, Compt. Rend., T. 106. **Selander**, Centr. f. Bakt. u. Parasitenk., 1888 ; Ann de l'Institut Pasteur, 1890. **Smith** and **Veranus Moore**, Bull. of Bureau of Animal Industry U.S., 1894. **Welch** and **Clement**, Trans. Internat. Vet. Congress of Amer., 1893.

## CHAPTER XXVI.

## SWINE-MEASLES. DISTEMPER IN DOGS. EPIDEMIC DISEASE OF FERRETS. EPIDEMIC DISEASE OF MICE.

## SWINE-MEASLES.

**Cornil** and **Babès**, Arch. de Physiol., 1883. **Detmers**, Science, 1881. **Eggeling**, Fortschr. d. Med., 1883. **Löffler**, Arbeiten aus dem Kaiserl. Gesundheits Amt, Bd. I., 1885. **Lydtin** and **Schottelius**, Der Rothlauf der Schweine : Wiesbaden, 1885. **Pasteur**, Compt. Rend., T. 95, 1882. **Pasteur** and **Thuillier**, Bull. de l'Acad. de Méd. de Paris : Compt. Rend., T. 97, 1883. **Salmon**, Report Depart. Agricul. Washington, 1881, 1884. **Schütz**, Ueber den Rothlauf der Schweine und die Impfung desselben, 1885.

## CHAPTER XXVII.

## ASIATIC CHOLERA. CHOLERA NOSTRAS. CHOLERAIC DIARRHŒA FROM MEAT-POISONING. DYSENTERY. CHOLERAIC DIARRHŒA OF FOWLS.

## CHOLERA.

**Ali-Cohen**, Fortschr. der Med., 1887, 1888. **Almquist**, Zeitschr. f. Hygiene, 1887. **Babès**, Virchow's Archiv, 1885. **Bianchi**, Lancet., 1884. **Bitter**, Archiv f. Hygiene, 1886. **Bochefontaine**, Expér. pour servir à l'Etude des Phénomènes déterminés chez l'Homme par l'Ingestion Stomacale du Liquide Diarrhéique du Choléra : Compt. Rend., 1884. **Brieger**, Deutsche Med. Woch., 1887 ; Berl. Klin. Woch., 1887 ; Virchow's Archiv, 1887. **Brunetti**, Fatti Considerazioni Conclusioni sul Coléra, 1885. **Büchner**, Archiv f. Hygiene, 1885 ; Münchn. Aerztl. Intelligenzbl., S. 549, 1884. **Büchner** and **Emmerich**, Münch. Med. Woch., 1885. **Bujwid**, Zeitschr. f. Hygiene, Centralbl. f. Bacteriolog., 1888. **Cameron**, Brit. Med. Journ., 1884. **Cattani**, Deut. Med. Woch. 1886. **Carter**, Lancet, 1884. **Cheyne**, Brit. Med. Journ., 1885. **Crookshank**, Lancet, 1885. **Cunningham**, Scientific Memoirs of Med. Off. of Indian Army, 1885, 1891. **Deneke**, Deut. Med. Woch., Nr. 3, 1885. **Doyen**, Soc. de Biol. de Paris, 1884. **Drasche**, Allg. Wien. Med. Zeit., 1885. **Dunham**, Zeitsch. f. Hygiene, 1887. **Emmerich**, Deut. Med. Woch., Nr. 50, 1884. **Ermengem**, Deut. Med. Woch., Nr. 29, 1885 ;



Recherches sur le Microbe du Choléra Asiatique, 1885. **Ferran**, Compt. Rend., T. 100, p. 959, 1885. **Finkler and Prior**, Naturforscherversammlung Magdeburg, 1884; Deut. Med. Woch., Nr. 36, 1884; Ergänzungshefte zum Centralbl. f. Allg. Gesundheitspflege, Bd. I., Heft 5 u. 6, 1885. **Flügge**, Deut. Med. Woch., Nr. 2, 1885. **Gaffky**, Arb., aus d. K. Gesundheitsämte, 1887. **Gamaleia**, Compt. Rend., 1888; Compt. Rend. Soc. de Biolog., 1889. **Gibier and van Ermengem**, Compt. Rend., T. 101, 1885. **Haffkine**, Brit. Med. Journ., 1895. **Héricourt**, Compt. Rend., 1885. **Hueppe**, Berl. Klin. Woch., 1887; Deutsche Med. Woch., 1887; Compt. Rend., 1889; Prag. Med. Woch., 1889. **Hunter**, Brit. Med. Journ., 1884. **Johne**, Deutsche Zeitschr. f. Thiermed., Bd. XI., 1885. **Kitasato**, Zeitschrift f. Hygiene, 1888, 1889. **Klebs**, Ueber Cholera Asiatica, 1885. **Klein**, Brit. Med. Journ. and Proc. Roy. Soc. London, No. 38, 1885; Bacteria of Asiatic Cholera, 1889. **Klein and Gibbes**, An Inquiry into the Etiology of Asiatic Cholera: Bluebook, 1885. **Koch**, Deut. Med. Woch., 1884; Etiology of Cholera: Berlin Cholera Conference: Translated by Laycock, in Microparasites and Disease (New Syd. Soc.), 1885. **Lewis**, Med. Times and Gazette, 1884. **Lustig**, Centralbl. f. die Med. Wiss., 1887; Zeitschrift f. Hygiene, 1887. **Macnamara**, Brit. Med. Journ., 1884. **Miller**, Deut. Med. Woch., Nr. 9, 1885. **Neuhaus**, Centralbl. f. Bacteriolog., 1889. **Nicati and Rietsch**, Arch. de Physiol., 1885; Revue de Médecin, T. 5, 1885; Revue d'Hygiène, 1885. **Petri**, Centralbl. f. Bacteriolog., 1889. **Pettenkofer**, Lancet, 1886. **Pfeiffer**, Corresp.-Bl. des Allgem. Aerztl. Ver. in Thüringen, Nr. 9, 1884; Deut. Med. Woch., 1886-88. **Pfuhl**, Zeitschr. f. Hygiene, 1889. **Roy, Brown and Sherrington**, Proc. Roy. Soc., Vol. xli. **Salkowski**, Virchow's Archiv, 1887. **Schottelius**, Deut. Med. Woch., Nr. 14, 1885. **Strauss, Roux, Thuillier and Nocard**, Compt. Rend. Soc. de Biol., T. 4, 1883. **Tizzoni and Cattani**, Centralbl. f. die Med. Wiss., 1886, 1887. **Vincenzi**, Deutsche Med. Woch., 1887. **Wassiljew**, Zeitschr. f. Hygiene, 1887. **Weisser**, Zeitschrift f. Hygiene, 1886. **Weisser and Frank**, Zeitschr. f. Hygiene, 1886. **Zäselein**, Deutsche Med. Zeitung, 1887-88.

## CHAPTER XXVIII.

## TUBERCULOSIS.

**Albrecht**, Arch. f. Kinderheilk., Bd. 5, 1884. **Andrew**, Lancet, 1884. **Arloing**, Compt. Rend., 1884. **Aufrecht**, Centralbl. für d. Med. Wiss., 1882, 1883. **Babès**, Compt. Rendus, 1883; Centralbl. f. d. Med. Wissenschaft., 1883. **Babès and Cornil**, Journ. de l'Anat. et de la Physiol. Norm. et Pathol., 1884. **Balogh**, Wien. Med. Woch., 1882. **Baumgarten**, Berl. Klin. Woch., Bd. 17, 1879; Centralbl. f. d. Med. Wiss., Bd. 19, 1881; Bd. 20, 1882; Bd. 21, 1883; Bd. 22, 1884; Deut. Med. Woch., Bd. 8, 1882; Zeitschr. f. Klin. Med., Bd. 6, 1883, 1886. **Biedert**, Virchow's Archiv, Bd. 98, 1884; Berl. Klin. Woch., 1885. **Black**, Lancet, 1886. **Bock**, Virchow's Archiv, Bd. 91, 1883. **Bollinger**, Centralbl. f. d. Med. Wiss., Bd. 21, S. 600, 1883; Münch. Aerztl.: Intelligenzbl., Nr. 16, 1883. **Bouley**, La Nature Vivante de la Contagion, Contagiosité de la Tuberculose: Paris, 1884. **Brouilly**, Rev. de Chir., T. 3., 1883. **Celli and Guarneri**, Arch. pour les Sciences Médic., 1883. **Cheyne**, Brit. Med. Journ., Vol. I., 1883; Practitioner, Vol. XXX., 1883. **Chiari**, Wien. Med. Presse, 1883. **Cochet**, Compt. Rend. Soc. de Biol.: Paris, T. 5, 1883. **Cohnheim**, Uebertragbarkeit der Tuberculose: Berlin, 1877. **Cornil and Leloir**, Arch. de Physiol. Norm. et

Pathol., 1884. **Crämer**, Sitzungsber. d. Phys. Med. Soc. zu Erlangen, 1883. **Creighton**, Trans. Path. Soc., 1882; Brit. Med. Journ., 1885; Lancet, 1885. **Crookshank**, Rep. Agric. Dept., 1888; Proc. Phys. Soc., 1890; Trans. Path. Soc., 1891. **Damsch**, Deut. Med. Woch., Nr. 17, 1883. **Déjérine**, Rev. de Méd.: Paris, T. 4, 1884. **Demme**, Jahresber. d. Jennerschen Kinderspitäls: Bern, 1883. **Dettweiler**, Berl. Klin. Woch., Bd. 21, 1880. **Dieulafoy** and **Krishaber**, Arch. de Physiol. Norm. et Path., T. I., 1883. **Doutrelepont**, Vierteljahrsschr. f. Dermatologie u. Syphilis, 1884; Deut. Med. Woch., Nr. 7, 1885. **Ehrlich**, Deut. Med. Woch., 1882, 1883. **Ermengem**, Ann. de la Soc. Belge de Microscopie, 1882. **Ewart**, Lancet, 1882. **Formad**, The Bacillus Tuberculosis: The Philad. Medical Times, 1882. **Fräntzel** and **Palmers**, Berl. Klin. Woch., 1882, 1883. **Fütterer**, Virch. Arch., Bd. 100, Heft 2, 1885. **Gaffky**, Mitth. a. d. Kaiserl. Gesundheitsamte, Bd. II., 1884. **Giacomi**, Fortschr. d. Med., Bd. I., S. 145, 1883. **Gibbes**, Lancet, 1883. **Goldenblum**, Vrach., Nos. I. and XI., 1886. **Green**, Brit. Med. Journ., 1883; Lancet, 1887. **Harries** and **Campbell**, Lupus: London, 1886. **Harris**, St. Barthol. Hosp. Reports, 1885. **Heron**, Lancet, 1883. **Hiller**, Deut. Med. Woch., Bd. 8, 1882. **Johne**, Die Geschichte der Tuberculose, 1883; Ber. üb. d. Veterinärwesen im Königr: Sachsen, 1883; Fortschr. d. Med., Bd. 3, 198, 1885. **Karg**, Centralbl. f. Chir., 1885. **Kirstein**, Deut. Med. Woch., 1886. **Klebs**, Virchow's Arch., Bd. 44, 1868; Arch. f. Exp. Pathol. u. Pharmakol., Bd. I., 1873; Bd. 17, 1883. **Koch**, Die Aetiologie der Tuberculose: Berl. Klin. Woch., 1882; Deut. Med. Woch., Nr. 10, 1883; Mittheilungen aus dem Kais. Ges. Amt, Bd. II., 1884. **Kundrat**, Wien. Med. Presse, 1883. **Küssner**, Deut. Med. Woch., Nr. 36, 1883. **Landouzy** and **Martin**, Rev. de Méd., T. 3, 1883. **Leube**, Sitzungsber. der Phys.-Med. Soc. zu Erlangen, 1883. **Levinsky**, Deut. Med. Woch., Bd. 9., 1883. **Leyden**, Zeitschr. f. Klin. Med., VIII., 1884. **Liechtheim**, Fortschr. d. Med., Bd. I., 1883. **Lustig**, Wien. Med. Woch., Nr. 48, 1884. **Lydtin**, Badische Thierärztl. Mittheil., 1883. **Malassez** and **Vignal**, Compt. Rend., T. 97, 1883; Compt. Rend., T. 99, p. 200, 1884. **Marchand**, Deut. Med. Woch., Nr. 15, 1883. **Max-Bender**, Deut. Med. Woch., 1886. **Meisels**, Wien. Med. Woch., 1883. **Middeldorf**, Fortsch. d. Med., 1886. **Müller**, Centralbl. f. Chir., 3, 1884, 1886. **Nauwerck**, Deut. Med. Woch., 1883. **Obrzut**, Deut. Med. Woch., Nr. 12, 1885. **Pfeiffer**, Berlin. Klin. Woch., Bd. 21, 1883. **Pütz**, Ueber die Beziehungen der Tuberculose des Menschen zu der Thiere, 1883. **Raymond**, Arch. Gén. de Méd., T. 11, 1883. **Ribbert**, Deut. Med. Woch., 1883, 1885. **Rindfleisch**, Phys. Med. Ges. zu Würzburg, Nr. 8, 1882. **Rosenstein**, Centralbl. f. d. Med. Wiss., 1883. **Schill** and **Fischer**, Mitth. a. d. Kaiserl. Ges. Amt, Bd. II., 1884. **Schlegtehdal**, Fortschr. d. Med., Bd. I., 1883. **Schottelius**, Virchow's Archiv. Bd. 91, 1883. **Schuchardt** and **Krause**, Fortschr. d. Med. 1883. **Smith**, Bristol Med. Chir. Journ., 1883. **Somari** and **Brugnatelli**, Redii R. Instit. Lombardo, 1883. **Spina**, Casopsis Lekarů Ceskych, Nr. 4, 1885; Studien über Tuberculose: Wien, 1883. **Sticker**, Centralbl. f. Klin. Med., 1885. **Strassmann**, Virchow's Archiv, Bd. 96, 1884. **Sutton**, Trans. Path. Soc. London, Vol. XXXV., 1884. **Toussaint**, Compt. Rend., T. 93, 1881. **Tscherning**, Fortschr. d. Med., Bd. 3, 65, 1885. **Veraguth**, Arch. f. Exp. Path. u. Pharmakol., Bd. 16, 1883. **Vignal**, Compt. Rend. Soc. de Biol., T. 5, 1883. **Villemin**, Etude sur la Tuberculose, 1868. **Voltolini**, Deut. Med. Woch., Nr. 31. **Wahl**, Deut. Med. Woch., Nr. 46, 1882. **Weichselbaum**, Wien. Med. Jahrb., 1883. **Weigert**, Deut. Med. Woch., Nr. 24f. 1883. **Wesener**, Fütterungstuberculose, 1885. **West**, Lancet, Vol. I., 1883; Trans. Path. Soc., 1883. **Williams**, Lancet, 1883; Journ. Roy. Micr. Soc., 1884. **Ziehl**, Deut. Med. Woch., Nr. 5. 1883.



## CHAPTER XXIX.

## LEPROSY. SYPHILIS. RHINOSCLEROMA. TRACHOMA.

## LEPROSY.

**Arning**, Virchow's Archiv, Bd. 97, 1884. **Babès**, Compt. Rend., 1883. **Babès** and **Kalindero**, La Semaine Med., 1891. **Baumgarten**, Centralbl. f. Bact., 1887; Berl. Klin. Woch., 1889. **Beaven-Rake**, Trans. Path. Soc., 1887; Reports Leper Asylum, Trinidad. **Bordoni-Uffreduzzi**, Zeitschr. f. Hygiene 1887; Berl. Klin. Woch., 1888. **Campava**, La Reforma Med., 1889, 1891. **Cornil** and **Suchard**, Ann. de Dermat. et Syph., 1881. **Creighton**, History of Epidemics in Great Britain, 1894. **Damsch**, Virch. Arch., Bd. 92: Centralbl. f. d. Med. Wissensch., Bd. 21, 1883. **Gaucher** and **Hillairet**, Progrès Méd., 1880. **Guttman**, Berl. Klin. Woch., 1885. **Hansen**, Virchow's Archiv, 1880, 1882, 1886. **Hillis**, Trans. Path. Soc., 1883. **Hills**, On Leprosy in British Guiana, 1881. **Kaposi**, Wiener Med. Woch., 1883. **Köbner**, Virchow's Arch., 1882; **Leloir**, Ann. de Dermat. et de Syph., 1887. **Lubimoff**, Centralbl. f. Bacteriolog., 1888. **Melcher** and **Ortmann**, Berl. Klin. Woch. 1885, 1886. **Moretti**, Il Primo Caso di Lebbra nelle Marcho Confermato dalla Presenza del Bacillus Lepræ, 1883. **Müller**, Deut. Archiv f. Klin. Med., Bd. 34, 1883. **Neisser**, Breslauer Aerzt. Zeitschr., 1879; Jahresber. d. Schles. Ges. für Vaterl. Cultur., 1879; Virchow's Archiv, Bd. 84, 1881, 1886. **Newman**, Leprosy as an Endemic Disease in the British Islands, 1895. **Report**, Leprosy Commission, 1893. **Steven**, Brit. Med. Journ., 1885. **Thin**, Brit. Med. Journ., 1884. **Touton**, Fortsch. d. Med., 1886. **Unna**, Deut. Med. Woch., Nr. 32, 1885, 1886; Virchow's Archiv, 1886. **Unna** and **Lutz**, Dermatologische Studien, Heft I., 1886. **Vidal**, La Lèpre et son Traitement, 1884. **Virchow**, Berl. Klin. Woch., N. 12, 1885. **Vossius**, Ber. über d. Ophthalmologen Congress in Heidelberg, 1881. **Wesener**, Central. f. Bacteriolog., 1887; Munch. Med. Woch., 1887.

## SYPHILIS.

**Alvarez** and **Tavel**, Bull. de l'Acad. de Méd. et Archiv de Phys. Norm. et Path., 1885. **Aufrecht**, Centralbl. f. d. Med. Wissensch., Bd. 19, 1881. **Bienstock**, Fortsch. d. Med., 1886. **Birch-Hirschfeld**, Centralbl. f. d. Med. Wissensch., Nrs. 33, 34, 1882. **Disse** and **Taguchi**, Deut. Med. Woch., 1886. **Doutrelepont** and **Schütz**, Deut. Med. Woch., Nr. 19, 1885. **Eve** and **Lingard**, Brit. Med. Journ., 1886. **De Giacomi**, Correspondenzbl. f. Schweizer Aerzte, Bd. 15, 1885. **Gottstein**, Fortsch. d. Med., Bd. 3, S. 543, 1885. **Heyden**, Préservation de la Syphilis, etc.: Traduit par Roberts, 1883. **Kassowitz** and **Hochsinger**, Wien. Med. Blätter, 1886. **Klebs**, Arch. f. Exp. Pathol., Bd. 10, 1879. **Klemperer**, Deut. Med. Woch., 1885. **Königer**, Deut. Med. Woch., S. 816, 1884. **Letnik**, Wien. Med. Wochenschr., 1883. **Lostorfer**, Arch. f. Dermat. u. Syph., 1872. **Lustgarten**, Wien. Med. Woch., Nr. 47, 1884; Die Syphilisbacillen, 1885. **Martineau** and **Hamonic**, Compt. Rend., p. 443, 1882. **Morison**, Maryland Med. Journ., 1882; Ibid.: Baltimore, 1883; Wiener Med. Wochenschr., 1883. **Peschel**, Centralbl. f. Augenheilk., 1882. **Petrone**, Gaz. Medica Ital., 1884. **Torney** and **Marcus**, Compt. Rend., p. 472, 1884.

## RHINOSCLEROMA.

**Cornil**, B. de la Soc. Anatom., 15 Fev., 1885. **Cornil** and **Alvarez**, Acad. de Méd. et Archiv de Phys. Norm. et Path., 1885. **Davies**, Brit. Med. Journ., 1886. **Paltauf** and **Eiselsberg**, Fortsch. d. Med., 1886.

## CHAPTER XXX.

## ACTINOMYCOSIS AND MADURA DISEASE.

## ACTINOMYCOSIS.

**Acland**, Brit. Med. Journ. and Trans. Path. Soc., 1886; and Allbut's System of Med., 1896. **Bang**, Tidsskrift for Veterinærer, 1883. **Baumgarten**, Berl. Klin. Woch., 1885. **Bollinger**, Centralbl. f. d. Med. Wiss., 1877. **Boström**, Verb. d. Congr. f. Inn. Med. Wiesbaden, 1888. **Chiari**, Prager Med. Woch., Nr. 10, 1884. **Crookshank**, Report of the Agric. Dept. of the Privy Council, 1888; Trans. Roy. Med. and Chirurg. Soc., 1889. **Firket**, Rev. de Méd., 1884. **Fleming**, Actinomycosis, 1883. **Gannet**, Boston Med. and Surg. Journ., 1882. **Hertwig**, Archiv f. Wiss. u. Prakt. Thierheilk., 1886. **Hink**, Centralbl. f. d. Med. Wiss., 1882. **Israël**, Archiv f. Klin. Chir., 1868; Virchow's Arch., Bd. 74, 1878; Bd. 78, 1879; Bd. 96, 1884; Kenntniss der Actinomycose des Menschen: Klinische Beiträge, 1885. **Johne**, Deutsche Zeitschr. f. Thiermed., 1881; Bericht ii. d. Veter.-Wesen i. K. Sachsen, 1885. **Karsten**, Deut. Med. Woch., 1884. **Mag-nussen**, Beiträge zur Diagnostik u. Casuistik der Actinomycose: Diss. Kiel., 1885. **Mitteldorpf**, Deut. Med. Woch., 1884. **Malcolm Morris**, Brit. Med. Journ., 1896. **Murphy**, New York Med. Journ., 1885. **O'Neill**, Lancet, 1886. **Pflug**, Centralbl. f. d. Med. Wiss., 1882. **Penfick**, Breslauer Aerztl. Zeitschr., 1885; Die Actinomycose: Berlin, 1887. **Pusch**, Arch. f. Wiss. u. Pr. Thierheilk., 1883. **Ransome**, Brit. Med. Journ., 1896. **Report of the Board of Live-Stock Com. for the State of Illinois**, 1890. **Roser**, Deut. Med. Woch., 1886. **Soltmann**, Breslauer Aerztl. Zeitschr., 1885. **Treves**, Lancet, 1884. **Zemann**, Wien. Med. Jahrb., S. 477, 1883.

## MADURA DISEASE.

**Boyce and Surveyor**, Proc. Roy. Soc., 1893; Trans. Roy. Soc., 1894; Brit. Med. Journ., 1894. **Hewlett**, Lancet, 1894. **Surveyor**, Brit. Med. Journ., 1892. **Vincent**, Ann. de l'Institut Pasteur, 1894.

## CHAPTER XXXI.

## GLANDERS.

**Babès**, Acad. de Med., 1888. **Baumgarten**, Centralbl. f. Bacteriolog., 1888. **Bouchard**, **Capitan** and **Charrin**, Bull. de l'Acad. d. Sc., Nr. 51, 1882. **Cadeac** and **Malet**, Progrès Méd., 1886, 1887; Rec. de Méd. Vt., 1886; Oester. Monatschr. f. Thierheilk., 1888. **Fröhner**, Rep. d. Thierheilk., 1883. **Grünwald**, Oesterr. Monatsschr. für Thierheilk., Nr. 4, 1884. **Hunting**, Vet. Record., 1896. **Israël**, Berl. Klin. Woch., Nr. 11., 1883. **Kitt**, Jahresber. d. München. Thierarzneisch., 1884. **Kranzfeldt**, Centralbl. f. Bacteriolog., 1887. **Löffler**, Arbeit. a. d. K. Gesundh. Amt., 1886. **Löffler** and **Schütz**, Deut. Med. Woch., Nr. 52, 1882. **Molkentin**, Zur Sicherstellung der Diagnose von Rotz: Inaug.-Diss., 1883. **Raskin**, Zeit. f. Wiss. Mikroskop., 1887. **Salmon**, Reports Bureau of Animal Industry, 1887, 1888. **Smith**, Journal of Comp. Med. and Veterin. Archives, 1890. **Struck**, Deut. Med. Woch., Nos. 51 u. 52, 1883. **Vulpian** and **Bouley**, Bull. de l'Acad. de Méd., 1883. **Wassilieff**, Deut. Med. Woch., Nr. 11., 1883. **Weichselbaum**, Wiener Med. Woch., 21-24, 1884.



## CHAPTER XXXII.

## TETANUS. RABIES. LOUPING-ILL.

## TETANUS.

**Carle** and **Rattone**, Studio Sperimentale sull' Etiologia del Tetano. Giorn. della R. Acad. di Medicina di Torino, 1884. **Hewlett**, Brit. Med. Journ., 1895. **Martin**, Rep. Med. Off. Local Govt. Board 1895. **Nicolaier**, Deut. Med. Woch., Nr. 52, 1884. **Rosenbach**, Archiv f. Klin. Chir., 1886. **Roux** and **Vaillard**, Ann. de l'Institut Pasteur, 1893. **Vogel**, Deut. Med. Woch., Nr. 31, 1884.

## RABIES.

**Babès**, Les Bactéries, 1886. **Bauer**, Münch. Med. Woch., 1886. **Bert**, Compt. Rend., 1882. **Colin**, Bull. Acad. de Méd. Paris, T. 10, 1881. **Dolérís**, Gaz. Méd. de Paris, T. 3: Tribune Méd. Paris, T. 14, 1881. **Dowdeswell**, Journ. Roy. Micro. Soc. and Lancet, 1886. **Fol**, Acad. des Sciences, 1884. **Frisch**, Wien. Med. Woch., 1886. **Gibier**, Compt. Rend., 1883. **Kerr**, Brit. Med. Journ., 1886. **Pasteur**, Compt. Rend., 1881, 1884, 1886; Ann. de Méd. Vétérin, 1884. **Pasteur**, **Chamberland**, **Roux** and **Thuiller**, Compt. Rend., 1882. **Percheron**, La Rage et les Expériences de M. Pasteur, 1884. **Report** of the English Hydrophobia Com. **Vignal**, Brit. Med. Journ., 1886.

## LOUPING-ILL.

**Klein**, Journ. of Royal Agric. Soc., 1895. **M'Fadyean**, Journ. Royal Agric. Soc., 1895, and Journ. of Comp. Path. and Bacteriology, 1895.

## CHAPTER XXXIII.

## FOOT-ROT.

**Brown**, Journ. Royal Agric. Soc., 1892. **Nott**, Journ. Royal Agric. Soc., 1890.

## CHAPTER XXXIV.

FOUL-BROOD. INFECTIOUS DISEASE OF BEES IN ITALY. PÉBRINE.  
FLACHERIE. INFECTIOUS DISEASE OF CATERPILLARS.

**Béchamp**, Compt. Rend., 1867. **Cheshire** and **Cheyne**, Journ. of Roy. Micros. Society. **Cowan**, Journ. Royal Agric. Soc., 1892. **Forbes**, Bull. Illin. State Lab. of Nat. Hist., 1886. **Klamann**, Bienenwirthschaft. Centralbl., 1888. **Pasteur**, Etudes des maladies des ver à soie, 1870.

## CHAPTER XXXV.

## CLASSIFICATION AND DESCRIPTION OF SPECIES.

**Acosta** and **Rossi**, Centralbl. f. Bact., 1893. **Adametz**, Die Bakt. der Nutz. u. Trinkwasser, 1888; Landwirthschaft. Jahrb., 1890. **Afanassiew**, St. Petersburg Med. Wech., 1887. **Ali-Cohen**, Centr. f. Bact., Bd. VI., 1889. **Almquist**,

Zeitschr. f. Hygiene. Bd. X., 1891. **Alvarez**, Compt. Rend., T. cv., 1887. **Arloing**, Compt. Rend., cvi. and cvii. **Arthur**, Proc. Acad. Nat. Sci. Phil., 1886. **Babès**, Bakt. Untersuch. ii. Sept. Proz. des Kindesalters, 1889; Virch. Archiv, Bd. cxv., 1889; Centralb. f. Bacteriolog., Bd. IX., 1891; Progrès Med. Roumain. **Babès** and **Opreșcu**, Ann. de l'Institut Pasteur, Vol. v., 1891. **Baginsky**, Deutsche Med. Woch., 1888. **Banti**, Giornale Medico, 1888. **Beyerinck**, Bot. Zeitung, Vol. xlix., 1891. **Bienstock**, Zeitschr. f. Klin. Med., VIII. **Billet**, Compt. Rend., T. 100., 1885. **Biondi**, Zeitschrift. f. Hygiene, Bd. II., 1887. **Bizzozero**, Virchow's Archiv, xviii. **Bolton**, Amer. Journ. Med. Sci., 1892; Zeitsch. f. Hygiene, Bd. I., 1886. **Bonome**, Archiv per le Sci. Med., Vol. xiii., 1890. **Booker**, Transac. Ninth Internat. Med. Congress, Vol. III. **Bordoni-Uffreduzzi**, Fortsch. der Med., 1886; Zeitschr. f. Hygiene, Bd. III., 1888. **Botkin**, Zeitschr. f. Hygiene, Bd. XI., 1892. **Boucharđ**, Compt. Rend., T. cviii., 1889. **Bovet**, Ann. de Micrographie. Vol. iii., 1891. **Brannan** and **Cheeseman**, New York Medical Record, 1892. **Brefeld**, Ges. Nat. Freunde, 1878. **Breunig**, Bakt. Untersuch. d. Trinkwässers der Stadt Kiel, 1888. **Brieger**, Berl. Klin. Woch., 1884. **Brouardel** and **Boutmy**, Compt. Rend., T. 92, p. 1056. **Bujwid**, Centralb. f. Bacteriolog., 1893. **Bumm**, Der Mikr. der Gon. Schleimk., 1887. **Burri**, U. eim. z. Zuleck. d. Arcthar auz Bact. Untersuch. a. Rhein W. Isol. Bact., 1893. **Burrill**, Proc. Amer. Assoc. Advanc. Sci., 1880. **Caldo**, Bull. de la Soc. d'Anatom. de Paris, 1887. **Canon** and **Pielicke**, Berl. Klin. Woch., 1892. **Caspary**, Schriften der Physik. Oekon. Ges. zu Königsberg, Bd. 15, 1874. **Cazal** and **Vaillard**, Ann. de l'Institut. Pasteur, Vol. v., 1891. **Charrin**, La Maladie Pyocyannique, 1889. **Cheyne**, Brit. Med. Journ., 1886. **Cienkowski**, Die Gallertbild. des Zuckerrubensaftes, 1878; Zur Morphol. des Bakter., 1876. **Clado**, Bull. de la Soc. d'Anat. de Paris, 1887. **Clässen**, Centr. f. Bakt., Bd. VII., 1890. **Cohn**, Max Schultz's Archiv, Bd. III.; Ueber zwei Neue Beggiatoen: Hedwigia, 1865; Beitr. z. Biol. d. Pflanzen. Bd. I., 1872. **Conn**, Centralbl. f. Bakteriolog., Bd. IX., 1891. **Dallinger**, Journ. of the Roy. Micro. Soc. London, 1878. **Dallinger** and **Drysdale**, Monthly Microsc. Journ., 1875. **Dantec**, Ann. de l'Institut Pasteur, 1891. **De Bary**, Vergl. Morph. und Biol. der Pilze, 1884. **Demme**, Fortsch. der Med., 1888; Verhandl. der V. Congress für in Med. in Wiesbaden, 1886. **Deneke**, Deutsch. Med. Woch., 1885. **Dickerhoff** and **Grawitz**, Virchow's Archiv, Bd. cii., 1885. **Dowdeswell**, Ann. de Micrographie, II. **Eberth**, Virchow's Archiv, Bd. 13, 1858. **Ehrenberg**, Verhandl. der Berl. Acad., 1839. **Eidam**, Cohn's Beitr. zur. Biol. d. Pflanzen, 1875. **Eisenberg**, Bacteriolog. Diagnostik, 1891. **Emmerich**, Deutsche Med. Woch., 1884. **Engelmann**, Pflüger's Arch. f. d. Ges. Physiol., Bd. 30, S. 95, 1882. **Engler**, Bericht. d. Kommission z. Erforsch. Deutsch. Meere, 1881. **Ernst**, Zeitschr. f. Hygiene, II. **Escherich**, Die Dankbakterien des Sauglings, 1886. **Esmarch**, Centralb. f. Bact., 1887. **Ewart**, Proceedings of the Roy. Soc., 1874. **Falkenheim**, Arch. f. Exp. Patholog. u. Pharmakol., Bd. 19, 1885. **Fasching**, Centralb. Wiener Akad. Wiss., 1891. **Finkler** and **Prior**, Deutsche Med. Woch. 1884. **Fischel**, Zeitschr. f. Heilkunde, XII., 1891. **Fischer**, Zeitschr. f. Hygiene, 1887, 1888; Centralb. f. Bacter., III. and IV. **Flügge**, Microorganisms and Disease (New Syd. Soc.). **Foutin**, Centralb. f. Bacteriolog., 1890. **Forster**, Centralbl. f. Bacter., II., 1887. **Fränkel** and **Franke**, Knapp. Schweiger's Archiv, XVII. **Frankland**, P. and G., Zeitschr. f. Hygiene, 1889; Proc. Royal Soc., Vol. xlvii., 1890. **Freundenreich**, Ann. de Micrographie, Vol. ii., 1890, and Vol. iii., 1891. **Frick**, Virchow's Archiv, CXVI. **Friedreich**, Virch. Arch., Bd. 30, 1864. **Fulles**, Zeitschr. f. Hygiene. **Gaffky**, Langenbeck's Archiv f. Chir.,





Bd. XXVIII. **Galtier**, Compt. Rend., T. CVI., 1888. **Gamaleia**, Ann. de l'Institut Pasteur, Vol. ii., 1888. **Geddes and Ewart**, Proceed. of the Roy. Soc. of London, 1878. **Gessard**, De la Pyocyanine et de son Microbe, 1882. **Gessner**, Archiv f. Hygiene, Bd. IX., 1889. **Giard**, Compt. Rend., 1882. **Giltay and Aberson**, Arch. Neerland Sci., XXV., 1891. **Globig**, Zeitschr. f. Hygiene, III. **Gombert**, Rech. Exp. sur les Mic. des Conjunctives, 1889. **Goodsir**, Edinb. Med. and Surg. Journ., 1842. **Grotenfelt**, Fortschr. des Med., Bd. VII., 1889. **Guillebeau**, Ann. de Micrographie, Vol. IV., 1892. **Günther**, Deutsche Med. Woch., 1892; Arb. a. d. Kaiserlich. Gesundh., 1893. **Guttman**, Virch. Archiv, Bd. CVII. **Hajek**, Berl. Klin. Woch., 1888. **Hanser**, Deutsch. Archiv. f. Klin. Med., Bd. XLII.; Ueber Fäulnissbakterien, 1885. **Heimer**, Deut. Arch. f. Klin. Med., 1877. **Heinz**, Centralbl. f. Bakt., V. **Heller**, Heller's Arch. f. Chemie, 1847. **Heri-court and Richet**, Compt. Rend., cvii., 1888. **Heim**, Arbeit aus. d. Ges., V. **Heydenreich**, Centralb. für Bact., Bd. V., 1888. **Holschewnikoff**, Fortschr. der Med., VII. **Hueppe**, Mittheil. aus d. Kaiserl. Gesundh., II., 1884. **Itzigsohn**, Virchow's Archiv, Bd. 13, 1858. **Jacksch**, Zeitsch. f. Phys. Chem., Bd. V. **Jaeger**, Zeitschr. f. Hygiene, 1892. **Johne**, Deutsche Zeitschr. f. Thiermed. und Path., Bd. XII., 1886. **Jordan**, Rep. Mass. Board of Health, 1890. **Jordan and Richards**, Report Mass. State Board of Health, Vol. ii., 1890. **Karlinsky**, Centralb. f. Bacteriolog., Bd. V., 1889. **Kartulis**, Zeitschr. f. Hygiene, Bd. VI., 1889. **Katz**, Centralbl. f. Bacter., ix., 1891. **Kirchner**, Zeitschr. f. Hygiene, Bd. IX., 1891. **Kitasato**, Central. f. Bacteriolog., Bd. III., 1888. **Kitt**, Deutsche Zeitschrift. f. Thiermed. und Path., Bd. XVII., 1885. **Klamann**, All. Med. Centralz., 1887. **Klein**, Centralb. f. Bakteriolog., X. **Koch**, A. Habititatus schr. Göttingen, 1888; Mitth. aus dem K. Gesundheitsamte, Bd. II.; Wundinfectionskrankheiten, 1878. **Kolb**, Arbeit. aus dem K. Gesundheitsamte, Bd. VIII., 1891. **Kramer**, Oesterreich Landwirthschaft Centralbl., 1891. **Krüger**, Centr. f. Bacter., Bd. VII. **Kurth**, Botanische Zeitg., 1883; Trans. Ninth Internat. Med. Congress, 1891. **Küschbert and Neisser**, Bresl. Artz. Zeitschr., 1883. **Kützing**, Linnæa, 8, 1833. **Lankester**, Quar. Journ. Mic. Sci., Vol. xiii., 1873, and xvi., 1876. **Laser**, Centralb. f. Bacteriolog., Bd. XI., 1892. **Laurent**, Ann. de l'Institut Pasteur. **Lehmann and Neumann**, Bacteriolog. Diagnostik, 1896. **Lépine and Roux**, Compt. Rend., 1885. **Lesage**, Bull. Méd., 1887. **Letzerich**, Zeitschr. f. Klin. Med., Bd. XIII. **Leube and Grasser**, Virchow's Archiv, Bd. C. **Liborius**, Zeitschr. f. Hygiene, I., 1886. **Lindenborn and Holschewnikoff**, Fort. der Med. **Lindner**, Die Sarcinorg. der Gährungsgeurche, 1888. **Lingelsheim**, Zeitschr. f. Hygiene. **List**, Die Bakt. der Nutz- und Trinkwässer, 1888. **Löffler**, Berl. Klin. Woch., 1887; Mitth. aus d. K. Gesundh., Bd. II. **Loeb**, Centralb. f. Bacteriolog., Bd. X., 1891. **Losdorfer**, Med. Jahrb., Heft 3, 1871. **Lucet**, Ann. de l'Institut Pasteur, Vol. v., 1891. **Lüders**, Ueber Abstammung u. Entwicklung des Bacterium Termo, 1867. **Lumnitzer**, Centralb. f. Bacteriolog., Bd. III. **Lustgarten**, Vierteljah. f. Derm. und Syph., 1887. **Lustgarten and Manneberg**, Vierteljahresber. für Dermat. und Syph., 1887. **Lustig**, Diagnostik der Bakt. d. Wassers. **Macé**, Traité pratique der Bacteriolog., 1892. **Malerba**, Giorn. Intern. d. Sci. Med., 1888. **Manfredi**, Fortschr. der Med., 1886. **Manneberg**, Centralb. f. Klin. Med., 1888. **Marpmann**, Ergänzungshefte des Centr. f. Allgem. Gesund., Bd. II. **Maurea**, Centralbl. f. Bakteriolog., Bd. XI., 1892. **Mendoza**, Centralbl. f. Bakteriolog., Bd. VI. **Menge**, Centralbl. f. Bakteriolog., Bd. VI., 1889; Bd. XII., 1892. **Miller**, Deutsch. Med. Woch., 1884, 1886, 1887; Micro-organisms of the Human Mouth, 1890. **Miquel**, Ann. de Micrographie, 1888-92. **Mori**, Zeitschr. f. Hygiene, Bd. IV., 1888. **Mülhäuser**, Virch. Arch., Bd. 97, 1884.

**Munk**, Virch. Arch., Bd. 22, 1861; Med. Centralbl., 1864. **Muntz**, Compt. Rend., T. cxii. **Neelsen**, Beiträg. z. Biol. der Pflanzen, III. **Neisser**, Archiv f. Hygiene, 1893. **Neumann and Schaeffer**, Virchow's Archiv, Bd. CIX., 1887. **Nocard**, Ann. de l'Institut Pasteur, 1887. **Nocard and Mollereau**, Ann. de l'Institut Pasteur, T. 1, 1887. **Oersted**, Naturhist. Tidsskrift, Bd. III., 1840. **Okada**, Centralbl. f. Bacteriolog., Bd. IX., 1891. **Paltauf and Heider**, Med. Jahrbuch., 1889. **Passet**, Zeitschr. f. Hygiene, Bd. IX.; Untersuch. u. die eitr. Phleg. des Wiensch., 1885; Fortschr. der Med., 1888. **Pasteur**, Ann. de Chim. et de Phys., T. 64, 1862; Compt. Rend., 1876; LII., 1861. **Pansini**, Virch. Archiv, Bd. cxxii., 1890. **Perdrix**, Ann. de l'Institut Pasteur, T. v., 1891. **Perty**, Zur Kenntniss. Kleinst. Lebensform, 1852. **Pfeiffer**, Deutsche Med. Woch., 1888; U. die Bac. Pseudotuberculose bei Nagethiere, 1889; Zeitschr. f. Hygiene, Bd. VI.; Bd. VIII., 1889. **Plagge and Proskauer**, Zeitsch. f. Hygiene, II. **Pohl**, Centralb. f. Bacteriolog., 1892. **Pommer**, Mitth. des Bot. Inst. zu Gratz., I. **Popoff**, Ann. de l'Institut Pasteur, 1890. **Prazmowski**, Untersuch. ü. die Entwick. und Fermentwirkung einer Bakterien, 1880. **Prove**, Beitr. z. Biolog. der Pflanzen, Bd. III. **Raczynsky**, Diss. der Militar. Med. Akad., 1888. **Reimann**, Inaug. Diss. Würzburg, 1887. **Rénon**, Ann. de l'Institut Pasteur, 1892. **Roscoe and Lunt**, Phil. Trans. Roy. Soc., 1892. **Rosenthal**, Zeitschr. f. Hygiene, V. **Roth**, Zeitschr. f. Hygiene, Bd. VIII., 1890. **Russell**, Zeitschr. f. Hygiene, Bd. XI., 1891. **Sakharoff**, Ann. de l'Institut Pasteur, 1891. **Sanarelli**, Centralbl. Bd. IX. 1891. **Scheibenzuber**, Allgem. Wien. Med. Zeit., 1889. **Scheurlen**, Deutsche Med. Woch., 1888. **Schimmelbusch**, Deut. Med. Woch., 1889. **Scholl**, Fortschr. der Med., VII. **Schottelius**, Biol. Untersuch. ü. dem Micrococcus Prodig., 1887; Zeitschr. f. Hygiene, 1890. **Schröter**, Beiträge z. Biol. d. Pflanz., Bd. 1, H. 2. **Schutz**, Archiv f. Wiss. und Prakt. Thierheilk., 1888. **Senger**, Berl. Klin. Woch., 1888. **Smith**, Central. f. Bakteriolog., Bd. X.; Med. News, 1887. **Sternberg**, Report on Etiology and Prev. of Yellow Fever, 1891; Manual of Bacteriology, 1896. **Strassmann and Strecker**, Zeitschr. f. Medicinalbeamte, 1888. **Suringar**, Arch. Neerland, 1866; Bot. Zeit., 1866. **Tappeiner**, Fortschr., der Med., Bd. I. and II. **Tataroff**, Die Dorpater. Wasserbact., 1891. **Tils**, Zeitsch. f. Hygiene, Bd. IX., 1890. **Tizzoni and Giovannini**, Zeigler's Beiträge, Bd. VI., 1889. **Tommasoli**, Giornale d. Mall. Ven. e. d. Pelle., 1889; Monat. f. Prakt. Dermat., Bd. IX. **Trambusti and Galeotti**, Centralb. f. Bacteriolog., 1892. **Trécul**, Compt. Rend., lxi. **Tricomi**, Atti. d. Soc. Ital. de Chir., 1887. **Utpadel**, Archiv f. Hygiene, Bd. VI. **Vandavelde**, Studien zur Chemie des Bacillus Subtilis; Zeitschr. f. Phys. Chemie, Bd. 8, 1884. **Van Ermengem**, Bull. Soc. Belge de Microscop., 1888. **Van Zieghem**, Compt. Rend., lxxxviii. and lxxxix., 1879. **Vaughan**, Amer. Journ. Med. Sci. 1892. **Vignal**, Archiv de Phys., viii., 1886; Le Bacille Mesentericus Vulgatus, 1889; Archiv de Phys., Vol. xxiii. **Von Besser**, Beitr. z. Path. Anat., Bd. VI. **Von Esmarch**, Central. f. Bakteriolog., Bd. I. **Warrington**, Journ. of Chemical Soc., 1890. **Weibel**, Central. f. Bakteriolog., 1887, 1888, 1893. **Weichselbaum**, Fortschr. der Med., Bd. V., 1887; Ziegler's Beiträge, Bd. IV., 1888; Das Osterreich. Samtälswesen, 1889. **Weisse**, Bull. Phys.-Mathemat. de St. Pétersbourg, III., 1845. **Weisser**, Zeitsch. f. Hygiene, Bd. I., 1886. **Welch and Nuttall**, Bull. John Hopkins' Hospital, 1892. **Welcker**, Zeitschr. f. Ration. Med., 1859. **Winogradsky**, Ann. de l'Institut Pasteur, 1890, 1891; Bot. Zeitung, 1893. **Woodhead and Wood**, Compt. Rend., T. cix., 1889. **Zelinsky**, Proc. Russ. Phys. Chem. Soc., 1893. **Zopf**, Sitz.-Ber. d. Botan. Ver. d. Prov. Brandenb.: Juni, 1882; Die Spaltpilz. **Zimmermann**, Die Bakt. und Nutz. u. Trinkwässer, 1890.



## APPENDICES.

## HÆMATOZOA.

**Bardels**, *Gaz. des Hôpit.*, 1882. **Crookshank**, *Journ. Roy. Micr. Soc.*, 1886. **Cuboni and Marchiafava**, *Arch. f. Exp. Pathol.*, Bd. 13, 1880; *Atti della R. Acad. dei Lincei.*, 1881. **Danilewsky**, *La Parasitologie Comparée du Sang*, 1889; *Centr. f. Bakt. u. Parasitenk.*, 1891. **Gerhardt**, *Zeitschr. f. Klin. Med.*, Bd. 7, 1884. **Golgi**, *Archivio per le Scienze Mediche*, 1886. **Grassi and Feletti**, *Centr. f. Bakt. u. Parasitenk.*, 1891. **Klebs and Tommasi-Crudeli**, *Arch. f. Exp. Pathol.*, Bd. 2, 1879. **Kotelmaun**, *Virchow's Arch.*, Bd. 97, 1884. **Laveran**, *Compt. Rend.*, 1881; *Ibid.*, No. 17, 1882; *Traité des Fièvres Palustres*, 1884. **Leoni**, *Gazetta Medica di Roma*, 1884. **Mannaberg**, *Trans. New Syd. Soc.*, 1894. **Manson**, *Brit. Med. Journ.*, 1896. **Marchand**, *Virch. Archiv*, Bd. 88, 1882. **Marchiafava and Celli**, *Atti della R. Academia dei Lincei.*, 1884; *Fortschr. d. Med.*, Bd. 3, 1885. **Mariotti and Ciarrocchi**, *Lo Sperimentale*, T. 54, 1884. **Maurel**, *Ann. d'Hygiene*, 1883. **Richard**, *Compt. Rend.*, No. 8, 1882. **Roszahegyi**, *Biol. Centralbl.*, Bd. 2, 1882. **Sehlen**, *Fortschr. d. Med.*, Bd. II., 1884. **Sternberg**, *Bull. Nat. Board of Health*; *Washington*, 1881. **Tommasi-Crudeli**, *Arch. f. Exp. Pathol.*, Bd. 12, 1880; *Die Malaria von Rom.*, 1882; *Conférence faite à la 8, Sess. du Congrès Intern. Méd. à Copenhague*, 1884. **Torelli**, *La Malaria in Italia*, 1883. **Ziehl**, *Deutsch. Med. Woch.*, Nr. 48, 1882.

## COCCIDIA AND CANCER "PARASITES."

**Albarran**, *Comp. Rend.*, 1889. **Borrel**, *Archiv de Méd. Exper. et d'Anat. Path.*, 1890. **Bowlby**, *Brit. Med. Journ.*, 1891. **Cazin**, *Internat. Congress of Hygiene and Demog.*, 1891; *Archiv Gen. de Méd.*, 1892. **Darier**, *Compt. Rend. Soc. de Biol.*, 1889. **Delepine**, *Brit. Med. Journ.*, 1891; *Trans. Internat. Congress of Hygiene*, 1891. **Foa**, *Centralb. f. Bakt. u. Parasitenk.*, 1892. **Heidemann**, *Virchow's Archiv.*, 1892. **Leuckart**, *Parasites of Man*, 1886. **Losch**, *Archiv f. Patholog. Anat.*, 1875. **Nils Sjöbring**, *Fortsch. der Med.*, 1890. **Noeggerath**, *Beitr. z. Struktur u. Entw. des Carcinoms.*, 1892. **Pfeiffer**, *Die Protozoen als Krankheitserreger*, 1890. **Podwyssozki and Sawtschenko**, *Centr. f. Bakt. u. Parasitenk.*, 1892. **Ruffer and Walker**, *Brit. Med. Journ.*, 1892; *Journ. of Comp. Path.*, Vol. I. **Russell**, *Brit. Med. Journ.*, 1890. **Schütz**, *Munch. Med. Woch.*, 1890. **Shaltock and Ballance**, *Proc. Roy. Soc.*, 1895. **Soudakewitch**, *Ann. de l'Institut Pasteur*, 1892. **Wickham**, *Archiv. de Méd. Exper.*, 1890.





## SUPPLEMENTARY APPENDIX.

---

### EXTRACTS FROM THE FINAL REPORT OF THE ROYAL VACCINATION COMMISSION.

---

THE final Report of the Royal Commission to inquire into the subject of Vaccination was published on September 18th, 1896.\* The author desires to gratefully acknowledge the permission granted him, by the Controller of Her Majesty's Stationery Office, to make extracts bearing more especially on the history and pathology of protective inoculation and the prevention of small-pox. The reader is recommended by the author to study the whole of the report.

#### *History of Small-Pox.†*

The early history of small-pox, like that of many similar diseases, is obscure, is subject to much debate, and, save perhaps on one point, is of antiquarian interest only.

The records of the eighteenth century show that the disease was very prevalent in western Europe during the whole of that century. The records of the seventeenth century also show that small-pox was a very common disease during that century: this is especially the case as regards the latter half of the century. The statistics which exist with respect to Geneva, and various scattered statements, further show that small-pox was a well-known disease in the sixteenth century; but, except for the records which are said to exist of severe epidemics in Iceland taking place as early as 1241, as we go further back the evidence as to the existence of the disease becomes less and less clear, and indeed debatable, depending as it does largely on the interpretation of incidental

\* The report may be obtained either directly, or through any bookseller, from Eyre & Spottiswoode, East Harding Street, Fleet Street, E.C., and 32, Abingdon Street, Westminster, S.W.; or John Menzies & Co., 12, Hanover Street, Edinburgh, and 90, West Nile Street, Glasgow; or Hodges, Figgis & Co., Limited, 104, Grafton Street, Dublin.

† The heading to the extracts from the Report of the Commission are mine.  
—E. M. C.

statements in various medical and other writings. There seems, however, to be adequate proof of the prevalence of small-pox in the East, in Asia Minor and other countries, even in the earlier centuries of the Christian era.

A view very generally taken teaches that small-pox, introduced from the East, began to be common in western Europe during the fifteenth century, though perhaps existing still earlier; that it increased during the sixteenth and seventeenth centuries, especially the latter; and that it was very prevalent during the eighteenth century.

In dealing with the eighteenth century it must be borne in mind that during the second half of the century the natural conduct of small-pox, as we shall see later on, was modified by the practice of inoculation—that is, by the artificial giving of the disease by the introduction of the virus through a wound in the skin.

Our knowledge of the history of small-pox in western Europe during the seventeenth and eighteenth centuries is very largely based on the official records known as the "London Bills of Mortality." Official records bearing on small-pox are furnished by Geneva, going back as far as the sixteenth century, by Sweden, going back to the year 1749, and by some other places. Data are also furnished, especially for the latter part of the eighteenth century, by parish records in various parts of Great Britain reaching over a variable number of years, as well as by scattered statements in various works.

These Bills of Mortality form by far the most complete source of our knowledge of small-pox in England in past times; but it must be borne in mind that in respect to any contagious disease like small-pox the conditions of London were peculiar. The population was to a marked extent a moving one; a large number of persons were continually entering London or leaving it, were passing to and from it, from and to the provinces of England and other countries. Of these persons, some, coming from infected districts, brought into London fresh sources of contagion; others again, coming from districts free from small-pox, and never having had the disease, brought into London fresh material to serve as food for the disease. Further, London presented in an exaggerated degree the two features of a great city which have a great influence on the progress and characters of a contagious disease like small-pox. The crowding both of the dwelling-places and the thoroughfares, as well as the movement continually going on, multiplied the opportunities for the spread of disease, and the accompanying insanitary conditions, as well as the greater inducement to irregular living, tended to increase the severity of the disease when taken, and to heighten the mortality from it. The history of small-pox in London must not be taken as representative of the history of small-pox in England generally.

#### *Inoculation of Small-pox.*

The practice of inoculation for the small-pox—that is, the artificial introduction of the virus into the system by the insertion of fluid from a variolous pustule into wounds of the skin made for the purpose—began definitely in England towards the end of the first quarter of the



eighteenth century. Attention was directed to the matter by letters from Timoni of Athens (dated 1713) and Pylarini, published in the 29th volume of the *Philosophical Transactions* (1716), and especially by a letter from Lady Mary Wortley Montagu in 1717. Though there are indications that in Great Britain and Ireland, as in other countries, some sort of inoculation had occasionally been practised at a much earlier date, the first clearly recorded case in England is that of the daughter of Lady Mary Wortley Montagu (whose son had some time before been inoculated at Constantinople), inoculated by Maitland, in London, in April 1721. Other cases soon followed in England, and about the same time the practice was also introduced in other countries of western Europe, and into the United States of America, namely, at Boston.

It was found that the attacks induced by inoculation were as a rule milder, and very much less fatal, than the attacks of the "natural" disease, the fever and constitutional disturbance being less and of shorter duration, and the eruptive pustules much fewer: the number of these varied, being commonly a dozen or two, sometimes only two or three, sometimes a hundred or more. In some cases there was no eruption at all, the effect being limited to constitutional disturbances and to changes in the wounds of inoculation themselves; it was maintained that in such cases the disease had really been taken, and immunity against a subsequent attack secured, as in cases of natural small-pox or of inoculated small-pox manifesting itself in an eruption of pustules.

In England the practice of inoculation at its introduction, though much lauded and strongly urged by some, was bitterly opposed by others. Moreover, the initial enthusiasm in favour of it soon declined, so that in the years 1730-40 very little inoculation seems to have been practised. About 1740, however, a revival appears to have taken place: in 1746 an Inoculation and Small-pox Hospital was started in London; and during the whole of the latter half of the eighteenth century the practice may be said to have been very general. It was especially so during the last quarter of the century, the increase being at least largely due to the "improved methods" of inoculation introduced by one Sutton in 1763, and known as "the Suttonian method."

Since an inoculated person was infectious, each inoculation was a source of danger to those, not protected by a previous attack, who came into the company of, or even near, the inoculated person during the attack; and this danger was increased by the fact that the mild character of the inoculated disease permitted, in many cases at least, the patient to move about among his fellows. Moreover, as Haygarth, himself a zealous advocate of inoculation in a systematic regulated manner, points out, the beneficial results of inoculation had robbed the disease of its terrors to so great an extent that the rich and powerful no longer made the efforts which they formerly did to prevent its entrance into, or its spread in, their neighbourhood, and thus favoured its spread among the unprotected poor; so that inoculation "though eminently useful to the rich appeared to be injurious to the poor." Adding, therefore, together the cases of inoculated small-pox, and the

cases of natural small-pox of which the inoculated cases were in one way or other the cause, it seems probable that inoculation did tend to increase the *prevalence* of small-pox ; but there are no recorded data to show that this really was the case, and this supposed influence may have been counterbalanced by other influences.

The evidence as to the influence which inoculation had on the mortality from small-pox is in many respects conflicting. Haygarth, though he admits that in other parts of the kingdom the practice may have saved many lives, was persuaded that in his own part of England and Wales the deaths by the small-pox had been augmented by it ; and he points out that in London, Geneva, and other "towns in different situations and circumstances, the mortality from this distemper has increased since the introduction of inoculation." Several writers in the latter part of the last, and the early part of the present century, held a similar view. Other writers, again, opposed this view.

#### *Tradition of the Dairy-folk.*

There was at the close of the eighteenth century, if not earlier, in districts where cow-pox had appeared, a belief among the dairy-folk that those who had taken the cow-pox never took the small-pox ; and indeed one Jesty, a Dorsetshire farmer, had in 1774, in the case of his wife and sons, purposely introduced the matter of cow-pox into the human subject with the view of protecting from small-pox.

#### *Cow-pox.*

Vaccinia or cow-pox is a disease affecting milch cows, and marked by an eruption on the udder and teats. The disease can be communicated from the cow to man. Dairy-men and maids engaged in milking cows affected with cow-pox are apt to have sores of a special kind on their hands or elsewhere, the development of the sores being frequently accompanied by febrile symptoms. There can be no doubt that, in a certain number of cases at all events, such sores are the local manifestations of cow-pox ; the virus from the eruption on the cow being introduced into some scratch or other imperfection in the skin of the milker and there producing its local effects, accompanied more or less by general symptoms.

#### *Inoculation of Cow-pox.*

The practice, however, of inoculating with the matter of cow-pox, or vaccination as it was subsequently called, may be considered as dating from the publication of the "Inquiry into the Causes and Effects of the Variolæ Vaccinæ" of Edward Jenner, published in the summer of the year 1798. The practice rapidly spread, and prevailed widely in this country and other parts of western Europe during the first quarter of the present century. It was, beyond all question, so adopted in the genuine belief that it afforded protection against small-pox.

In the treatise to which reference has been made Jenner records in the first place a number (19) of cases in which a person who had accidentally taken cow-pox from the cow had never had small-pox, and appeared



incapable of taking that disease ; the insusceptibility being shown on the one hand by the failure to contract the disease after ample exposure to contagion, such as nursing and attending to or even sleeping with persons suffering from small-pox, and on the other hand by the fact that when the person in question was inoculated with the matter of small-pox in the manner then usual (the matter being tested as to its efficiency on susceptible persons) the inoculation failed to excite small-pox. In the course of the inoculation practice it had been observed that when the operation was performed upon a person who had already had small-pox, either naturally or by inoculation, the wound of inoculation, instead of developing, as it did when the operation was successful in a person who had not had the small-pox, into a vesicle and so into a pustule with the variolous characters (the development being accompanied by febrile symptoms and, save in exceptional cases, by the appearance of a smaller or greater number of variolous pustules on parts of the skin other than the seat of inoculation), presented as a rule nothing more than some slight inflammation, dying away in a few days without any other symptom, or even healed at once without any symptoms at all, local or general ; and in the exceptional cases in which further changes took place in the wound, these were not accompanied or followed by an eruption of pustules or even by the febrile and other general symptoms of small-pox. Accordingly, in cases of small-pox inoculation where it was doubtful whether the disease had been communicated, it had become not an uncommon practice to repeat the operation, in order to judge by the effects produced whether the earlier inoculation had or had not produced the disease ; and the practice, thus originating in connexion with small-pox inoculation, had come to be spoken of as the " variolous test."

In his treatise Jenner distinguishes between what he calls true cow-pox and other eruptions which he speaks of as spurious, and which he regarded as not affording protection against small-pox, although he gives no details to show that the cases quoted by him as affording protection were cases of his true cow-pox. He also developed the view that matter derived from horses suffering from the disease known as the grease is capable of giving rise to cow-pox in the cow, and indeed is the real origin of the true disease. It may be added that Jenner also expressed the opinion that the protection thus afforded by cow-pox was permanent in character.

Jenner further recorded in the same treatise how he had in 1796 inoculated a healthy boy of eight years of age in the arm with cow-pox matter taken from a sore on the hand of a dairymaid who had been infected with the disease by milking cows suffering from cow-pox. He describes the appearances subsequently presented by the wounds, and states that, six weeks afterwards, the results of inoculating the boy with variolous matter were those commonly seen to follow the inoculation of persons who had previously had the cow-pox or the small-pox : that is to say, the " variolous test " showed the boy to be insusceptible to small-pox. Some months afterwards the boy was again inoculated, but no sensible effect was produced on the constitution. Jenner then relates that subsequently, in the spring of 1798, he inoculated a child, and obtained a similar result with matter taken directly from the nipple of a cow infected

with cow-pox ; from the pustule on the arm of this child he inoculated another, and from this again several, and from one of these latter a fourth in succession, and then a fifth. To three of these the " variolous test " was applied, and it is stated with the same results.

*Woodville's Lymph.*

The experiences of Jenner did not stand alone. His results and views attracted great attention, and in the early part of the year 1799 Woodville and Pearson, who were physicians to the Small-pox Hospital in London, commenced making experiments with vaccine matter with a view to ascertain whether it afforded protection against small-pox. They arrived, like Jenner, at the conclusion that it did.

In January 1799 Woodville, having found cow-pox to be present in a " dairy " at Gray's Inn Lane, inoculated seven persons at the Small-pox Hospital with matter from one of the cows at the " dairy," and other persons with matter from sores on a dairymaid employed at the same place who had become infected from the cows. From these cases he inoculated in succession others at the Hospital, eventually to the number of many hundreds, and thus established the stock of what has been spoken of as " Woodville's lymph." Pearson also at the same time occupied himself with the question of inoculation with the cow-pox, writing a pamphlet about it. Woodville and he distributed to many persons in this country and abroad quantities of the lymph from the Hospital ; and this was the beginning of the more general practice of vaccination, for Jenner's stock of lymph, the results of which he had described in his treatise, had come to an end.

Although Woodville's " Hospital lymph " appears to have been widely distributed by himself and by Pearson, and thus to have been the source of the lymph used in various places in the early days of vaccination, it was not the only source, even in those days. Pearson also obtained lymph from cow-pox at a dairy in the Marylebone Road, and used this " in certain situations," which may be presumed to include places elsewhere than in the Hospital. He also speaks of having obtained lymph from the cow from a third source. Jenner again, who received and used some of Woodville's Hospital lymph, also obtained lymph from some other sources : for instance, from a cow at a Mr. Clark's farm in Kentish Town. Further, Woodville in 1800 speaks of his having at various times procured the vaccine virus as produced in different cows, which when used at the Hospital produced the same effects as the Gray's Inn Lane lymph. We are not justified in assuming that an account of every new source of lymph was published ; and there may have been others, it is impossible to say how many, than those just mentioned. In any case Woodville's Hospital lymph was not the only lymph used in those early days ; not only, however, was it largely used (indeed, we have no evidence of so widespread a use of lymph derived from any other source), but the use of it marks the definite beginning of the practice of vaccination ; and the history of it demands special notice.



Of the cases recorded by Woodville in his Reports, the larger number (about three-fifths) presented an important, and, as compared with Jenner's cases, a new feature, in that, in addition to the changes taking place at the seat of inoculation and constituting what Woodville called the "cow-pox tumour," which may here be spoken of as the "vaccine vesicle," an eruption over the body of a greater or less number of pustules was observed. These eruptive pustules occurred in the very first cases: of the seven cases inoculated from the cow, four, and of the five inoculated from the dairymaid, four, had such pustules; and their appearance is recorded again and again in the series, down to the case which appears last but one in the tabular statement forming part of the Reports.

Moreover, an eruption of pustules is described in certain of the cases of which accounts were published at about the same time by Pearson and many others. In some of these cases the lymph used was supplied from the Small-pox Hospital by Woodville or Pearson.

It must be admitted that these pustules were pustules of small-pox, and that, therefore, Woodville's cases, which did so much to establish the practice of vaccination, were not cases simply of cow-pox but of cow-pox mixed, so to speak, with small-pox. It has indeed been maintained that Woodville's cases were not cases of cow-pox at all—that small-pox was inadvertently introduced into the very first cases; that the history of the whole series is the history of a series of small-pox cases putting on special characters, and that therefore the lymph used and distributed by Woodville and Pearson was in reality not cow-pox lymph but small-pox lymph. A review of all the evidence available leads to no other conclusion than that, however much in Woodville's, Pearson's and other cases cow-pox was mixed up with small-pox, the lymph used and distributed by Woodville and Pearson and called by them cow-pox lymph (excluding of course all the cases, of which there were not a few, in which matter was taken not from the local "cow-pox tumour" at the seat of inoculation, but from one of the eruptive pustules) was veritable cow-pox lymph having the true characters of cow-pox lymph only.

It of course follows that the cases, both in Woodville's practice and in that of others, in which the inoculation of cow-pox matter was accompanied by an eruption of pustules, due to small-pox being present as well as cow-pox, when appealed to as showing immunity against small-pox (by the test either of exposure to contagion or of inoculation), furnished false evidence as to that immunity being due to cow-pox; it might have been due to the accompanying small-pox. So far then as the adoption of vaccination was assisted by cases of this description, it may be held to have rested on erroneous data.

#### *The Decline of Small-pox.*

One effect of the introduction of vaccination was a very great decrease in the practice of inoculation, which had become very prevalent during the later part of the previous century. And the view has been put forward

that, the prevalence of inoculation having greatly increased the amount of small-pox, the diminution of small-pox in question was the result of the decrease of inoculation.

The question how far the behaviour of small-pox in the eighteenth century and earlier was influenced by sanitary conditions, is one rendered difficult by the lack of exact information. We may distinguish between overcrowding as one insanitary condition and all other insanitary conditions, such as lack of cleanliness and the like. *A priori* we should expect that a dense population, especially one of great internal movement, and one in continual interchange with surrounding populations, by offering greater facilities for the conveyance of contagion, would lead to a greater amount of small-pox. London was a conspicuous instance of the above, and the apparent greater prevalence of small-pox in London than in the provinces may be attributed to these causes: but it would appear that the increase was felt—as indeed would, *à priori*, seem probable—rather in the constant presence of small-pox to a considerable amount at all times than in the mortality of the epidemics when these occurred. And the same seems also to be shown to a less extent in other large cities, such as Liverpool. But in this matter of dense and moving populations the eighteenth century did not differ markedly from the early part of the nineteenth. We might *à priori* expect the other acknowledged imperfect sanitary conditions of the eighteenth century to increase the fatality of, and so to a corresponding extent the mortality from, small-pox; but there is no exact evidence to confirm this supposition. If on the contrary we recognise that in the course of the eighteenth century the general mortality, the relative number of deaths from all causes, went on decreasing, and attribute, as has been done, this decrease to improved sanitary conditions, no like decrease of small-pox took place. Again, the places which were deemed the most salubrious appear to have been visited by epidemics of small-pox as severe as those which fell on unhealthy places. Thus the epidemic in Chester in 1774 was undoubtedly a severe one, and yet Haygarth writes, “The healthiness of Chester,” as shown by statistics, “must appear so very extraordinary as to be almost incredible.” And in general both the incidence of, and mortality from, small-pox seem to have been far less affected by sanitary conditions than might *à priori* have been expected.

It may be urged against the view that the decline of small-pox was due to improved sanitary conditions, in the first place, that, admitting the introduction of sanitary improvements, no evidence is forthcoming to show that during the first quarter of the nineteenth century these improvements differentiated that quarter from the last quarter, or half, of the preceding century in any way at all comparable to the extent of the differentiation in respect to small-pox. In the second place, admitting *à priori* that crowded dwellings tend to increase the liability to contagion, and so the prevalence of the disease, while other insanitary conditions tend in addition to increase the fatality among those attacked, so that insanitary conditions as a whole must tend to increase the mortality from small-pox,—no evidence is forthcoming which distinctly shows that the dependence of the prevalence of, or the mortality from,



small-pox, on the lack of sanitary conditions, was a feature of the history of small-pox during the eighteenth century.

Upon the whole, then, we think that the marked decline of small-pox mortality in the first quarter of the present century affords substantial evidence in favour of the protective influence of vaccination.

#### *Age Incidence of Small-pox.*

A study of the age incidence of small-pox mortality is very instructive. In connexion with this point it is necessary to bear in mind that experience has led to the conclusion that, whatever be the protective effect of vaccination, it is not absolutely permanent; the most convinced advocates of the practice admit that after the lapse of nine or ten years from the date of the operation its protective effect against an attack of small-pox rapidly diminishes, and that it is only during this period that its power in that respect is very great; though it is maintained that, so far as regards its power to modify the character of the disease and render it less fatal, its effect remains in full force for a longer period, and never altogether ceases. The experience upon which this view is founded is derived almost exclusively from the case of infantile vaccination. It has been supposed by some that the transitory character of the protection results from changes connected with the growth from infancy to adult years. Whether this be so or not, we have no means of determining.

No doubt, when Jenner drew the attention of the public to the value of vaccination, he believed that a single successful inoculation of vaccine matter secured absolute immunity for the future from an attack of small-pox. It is certain that in this he was mistaken. It may well be doubted whether the anticipation was a reasonable one. No such immunity is secured by an attack of small-pox, though there are few who would maintain the proposition that it is without protective influence against another attack. *A priori* there would seem to be no sound ground for expecting that vaccinia would afford more potent protection than small-pox itself. The extent of the protection afforded (assuming that there is some protective influence) could only be determined by experience. It soon became apparent that Jenner had, in the first instance, overrated the effect of vaccination. That he should thus have overestimated it is not to be wondered at, when the tendency to be unduly sanguine, which besets the discoverer of any new prophylactic, and, indeed, every discoverer, is borne in mind.

We think, taking it all together, that the evidence bearing upon the question whether the vaccinated are less liable to be attacked by small-pox than the unvaccinated, points to two conclusions: first, that there is, taking all ages together, less liability to attack among the vaccinated than among the unvaccinated; and next, that the advantage in this respect enjoyed by vaccinated children under ten years of age is greatly in excess of that enjoyed at a more advanced period of life.

In considering whether vaccination has been the principal cause of the decline, we must inquire whether the other causes suggested by those who deny the efficacy of vaccination will satisfactorily account for it.

*Effect of Sanitation.*

It is said that the decline has, in the main, been due to changes in the general conditions of life in the different parts of the United Kingdom, apart from the spread of the practice of vaccination,—amongst other things, to improvement of sanitary conditions.

It is beyond doubt that an infectious disease like small-pox is, other things being equal, more likely to spread in towns than in country districts, and more likely to spread in crowded town districts than in others not so densely populated; so that we should expect a lessened proportion of overcrowded dwellings, by diminishing the opportunities for contagion, to check the prevalence of the disease and consequently to render its mortality less.

*Effect of Isolation.*

It has been maintained that the decline in small-pox mortality is largely due to more frequent and systematic attempts to isolate those suffering from small-pox. We think an answer to this contention is to be found in the fact that it is only in quite recent years that there has been any systematic practice of isolating small-pox patients, and that it has been confined even then to a very limited number of localities. The fact to which we are about to call attention in greater detail than hitherto, that the decline in the deaths from small-pox is found almost exclusively among those of tender years, appears also to militate against the contention. The risk of contagion is not confined to children. Adults also are subject to it. If a better system of isolation had been a main cause of the reduced mortality, we should have expected to see it operate in the case of adults as well as of children. At the same time we are far from thinking, as will appear when we come to deal with that subject, that the efforts at isolation which have characterised recent years have been without a beneficial effect on small-pox mortality.

*Sanitary Legislation.*

We have already pointed out that on *à priori* grounds it is reasonable to think that improved sanitary conditions would tend to diminish the fatality of, and so to a corresponding extent the mortality from, small-pox. And there can be no doubt that the period with which we are dealing has been characterised by an improvement of this description. There has been better drainage, a supply of purer water, and in other respects more wholesome conditions have prevailed.

It may be useful at this point to furnish a brief summary of the principal Sanitary Acts which have been passed relating to the different parts of the United Kingdom.

In 1848 was passed the first great and comprehensive measure which may be called the groundwork of our sanitary legislation as regards England. The Public Health Act of 1848 was, however, principally designed for towns and populous places in England and Wales, not including the Metropolis, which was dealt with in Acts passed in the same year. The powers of local government supplied by the Act were generally an extension of those before given by sundry local Acts to



Commissioners of Sewers in the Metropolis, and to authorities in a few large towns. Many provisions corresponding to sections in the Towns Improvement Clauses Act of 1847 are found in the Public Health Act, and communities were thus enabled to obtain by a simple process powers which they could not previously obtain except by a local Act incorporating sections of the Towns Improvement Clauses Act.

In 1848 was also passed the Nuisances Removal and Diseases Prevention Act of that year, in substitution for a similar Act of 1846 which was about to expire; and in 1849 this Act of 1848 was amended. The provisions of all these three Acts extended to England, Scotland and Ireland. In 1855 a comprehensive Nuisance Removal Act was, as regards England, substituted for the Acts passed in 1848 and 1849; and in the following year there was similar legislation for Scotland. In 1860 the English Act was amended; and in 1866, by the Sanitary Act of that year (to which we shall again refer), the provisions of the English Acts of 1855 and 1860, as then amended, were applied to Ireland.

In 1855, by the Metropolitan Local Management Act of that year, provision was made for the appointment of a medical officer of health and an inspector of nuisances by every vestry and district board in the Metropolis. This provision did not extend to the City of London, where, in 1848, a medical officer of health had been appointed under power given by a local Act.

In 1858, the Local Government Act of that year, to be construed with the Public Health Act of 1848 as one Act, was passed, and took effect in all places where that Act was in force at the time of its passing; and, as regards England, these two Acts together constituted until 1872 the principal sanitary legislation on the statute-book.

There followed, however, within the next ten years many public Acts having sanitary objects, some applying to all, and some to particular, parts of the United Kingdom, besides numerous other Acts of local application. We need only now specially refer to one of these public statutes—the Sanitary Act of 1866, which was probably the most important, and applied, in part at least, to England, Scotland and Ireland. This Act, amongst other things, extended the powers of local authorities for the disposal of sewage, and, in amending the English Nuisances Removal Acts of 1855 and 1860, added to the definitions of nuisances, especially as regards crowded houses and workshops, and to the duties and powers of local authorities for their abatement, especially in the way of providing means for disinfection and places for the reception of dead bodies.

In 1867 the Public Health (Scotland) Act was passed—a comprehensive measure which consolidated into one Act, with certain amendments, the whole statute law relating to the public health in Scotland.

In 1872 a complete distribution of England into sanitary districts took place, and some further amendments were made in the sanitary laws. In 1875 these laws were consolidated in the Act of that year. In 1891 a Sanitary Act was passed relating to the Metropolis.

In 1874 an Act was passed for Ireland, containing substantially the same provisions as those which had been enacted in the case of England in 1872.

*Value of Vaccination.*

We have not disregarded the arguments adduced for the purpose of showing that a belief in vaccination is unsupported by a just view of the facts. We have endeavoured to give full weight to them. Having done so, it has appeared to us impossible to resist the conclusion that vaccination has a protective effect in relation to small-pox.

We think :—

1. That it diminishes the liability to be attacked by the disease.
2. That it modifies the character of the disease, and renders it (a) less fatal, and (b) of a milder or less severe type.
3. That the protection it affords against attacks of the disease is greatest during the years immediately succeeding the operation of vaccination. It is impossible to fix with precision the length of this period of highest protection. Though not in all cases the same, if a period is to be fixed, it might, we think, fairly be said to cover in general a period of nine or ten years.
4. That after the lapse of the period of highest protective potency, the efficacy of vaccination to protect against attack rapidly diminishes, but that it is still considerable in the next quinquennium, and possibly never altogether ceases.
5. That its power to modify the character of the disease is also greatest in the period in which its power to protect from attacks is greatest; but that its power thus to modify the disease does not diminish as rapidly as its protective influence against attacks, and its efficacy during the later periods of life to modify the disease is still very considerable.
6. That re-vaccination restores the protection which lapse of time has diminished; but the evidence shows that this protection again diminishes, and that, to ensure the highest degree of protection which vaccination can give, the operation should be at intervals repeated.
7. That the beneficial effects of vaccination are most experienced by those in whose case it has been most thorough. We think it may fairly be concluded that where the vaccine matter is inserted in three or four places, it is more effectual than when introduced into one or two places only—and that if the vaccination marks are of an area of half a square inch, they indicate a better state of protection than if their area be at all considerably below this.

*Question of Specific Protection or of Antagonism.*

When an attack of disease secures immunity or protection against another attack of disease, the two attacks are, as a rule, attacks of the same disease. Some pathologists have, it is true, of late years been led to suppose that one disease may confer some degree of immunity or protection against another different disease; but instances of this are few, and, moreover, cannot be regarded as thoroughly established. The ordinary instances of immunity are so clearly those in which the attack, natural or



artificial, which confers the immunity is of the same disease as that towards which immunity is conferred, that identity of disease has been considered as essential to the conferring of immunity. And it has been argued that it is *à priori* improbable that cow-pox should confer immunity from small-pox, seeing that the two are different diseases. Such a purely theoretical argument can have little weight against positive evidence of vaccination having actually conferred immunity. If this be definitely proved to be the fact, proof is thereby at the same time afforded that the theory is unsound, either because a particular disease may confer immunity against a different disease, or because small-pox and cow-pox are not different diseases. For the practical object with which alone we are concerned, it is not material that we should reach any conclusion upon the question what is the real source of error in the theory alluded to, supposing it to be erroneous? We shall content ourselves, therefore, with a very brief notice of the subject.

It appears to us that we may dismiss for practical purposes the theoretical questions which were discussed before us so fully. If the fact be established that the introduction of vaccine matter and the consequent vaccinia produce some effect upon the human body which renders it less susceptible to small-pox, or which modifies that disease when the small-pox virus enters the system, it will not be a strange or unwonted experience that we should be unable to explain how this comes about. Science has not yet succeeded in freeing therapeutics or kindred subjects from obscurity, or in solving all the problems which they present. The precise *modus operandi* by which a previous attack of a disease furnishes security against a subsequent attack by the same disease has not yet been elucidated. There can be no cause for astonishment, then, if we are unable to trace the steps by which vaccination exerts a protective influence, supposing the fact that it does so be established, nor is it essential that we should succeed in tracing them. Our inability to accomplish this does not seem to us to be the slightest reason for regarding with doubt the conclusions to which the facts lead us.

Professor Crookshank, than whom no one has more strongly insisted on the theoretical arguments against the protective influence of vaccination in relation to small-pox, gives it as his opinion that vaccination creates a transient antagonism to that disease. We understand his view to be that an attack of disease can only afford protection against the same disease, and that small-pox and cow-pox are not the same but different diseases. We gather, however, that, in his opinion, so long as the state of antagonism lasts, the person in whose system it exists is less likely to suffer from small-pox than he would be if the state of antagonism were wanting. This seems to us to amount in effect to the same thing as saying that during that period vaccination has conferred some protection. Whether the effect be to create antagonism or to confer protection, and whatever difference there be between the *modus operandi* in the one case and in the other, we know equally little about it. If a condition of transient antagonism to small-pox is induced by vaccination, theoretical considerations will not afford a guide of the slightest value to the conclusions how long this transient antagonism will last, or how soon it will pass away.

Experience, and experience alone, can answer that question. *A priori* we do not see that there is any better reason for supposing that it would last for two or three years than that its duration would extend to ten years.

*Cow-pox and Small-pox not Convertible.*

Jenner himself, in his first paper, advanced the view that the cow-pox and small-pox were identical with each other; and since his time numerous observers have attempted to prove the identity of the two diseases experimentally—namely, by giving rise to cow-pox in the cow through the inoculation of small-pox matter, or by the introduction of contagion in other ways. It may at once be stated that while cow-pox is readily transferred from the cow to man and back again from man to the cow, the disease in man being identical with that in the cow, small-pox cannot be transferred from man to the cow so as to give rise to a disease in the latter identical in its features with the small-pox of man. Nor can cow-pox be so transferred to man as to give rise in him to small-pox. The two diseases are not in this sense convertible.

*Small-pox Vaccine.*

In most cases the attempt to transfer small-pox from man to the cow has had simply a negative result; no obvious effect of any kind has been observed. This has been the case in the attempts to introduce the contagion through absorption by the respiratory or digestive organs, and in most of the attempts to introduce the contagion by inoculation. In certain instances these latter attempts have produced results which may be briefly described in three categories. (We may pass over the isolated experience of Thiele, who in 1838 asserted that by keeping small-pox matter sealed between glass plates for ten days before using it, and by diluting it with milk when using it for inoculation, the matter thus treated through ten removes through the human body—the cow not intervening at all—was converted into something which gave results identical with those of ordinary vaccine matter. We are not aware of any attempt to corroborate this experiment.)

The first category includes the experiments in which the inoculation of small-pox matter into the udder, or adjoining parts, of the cow gave rise at or near the seat of inoculation to a vesicle, either identical in visible characters with the ordinary vaccine vesicle produced by inoculation with the matter of cow-pox, or to a vesicle the features of which, while not corresponding wholly with those of a perfect vaccine vesicle, so closely resembled them as to justify the vesicle being called a vaccine vesicle. Further, the matter from a vesicle which at the first inoculation had not the characters of a perfect vaccine vesicle, when carried through a second or third remove in the cow, fully acquired those characters, and when transferred to man gave results indistinguishable from the ordinary vaccine vesicle. Indeed, lymph of such an origin has come into general use for vaccination purposes. Of the experiments, the best known or most quoted are those of Thiele (1838), Ceely (1840), Badcock (between 1840 and 1860), Voigt (1881), Haccius and Eternod (1890), King (1891),



Simpson (1892), and Hime (1892); but there are several others. The details of the experiment are very scanty in the cases of Thiele and Badcock, but more full in the others, especially, perhaps, those of Ceely and Haccius.

In the second category may be placed the experiments of Klein and Copeman. Klein, who had in 1879 obtained in 31 trials what then appeared simply negative results, found in a renewed research in 1892 that the result of the first inoculation in the cow of small-pox matter was not a distinct vesicle but merely a thickening and redness of the wound. Lymph pressed from the thickened wound produced, when inoculated into a second cow, a like result, but rather more marked; the thickening and reddening still further increased with a third and a fourth cow. Lymph squeezed from the wounds of the fourth cow produced in a child typical vaccine, and crusts from the child produced typical vaccine in a cow. Copeman obtained somewhat similar results; the appearances increasing in three removes and approaching those of typical vaccine, but not reaching them.

The third category consists of the results obtained in an elaborate inquiry conducted by a Commission of the Society of Medical Sciences at Lyons, with Chauveau at its head. Those results, reported in 1865, were briefly as follows:—

Inoculation of the cow with small-pox matter in any one of the 30 animals used did not give rise to a vaccine vesicle. Nevertheless a definite result was obtained; in the form, however, not of a vesicle, but of a thickening and inflammation of the wound; when a puncture was employed this became a papule. Lymph squeezed from such a papule and inserted into a second animal gave rise to a like papule; and this, again, might be used for a third animal, but often failed; and the effect could in no case be carried on through more than three or four removes.

When the inoculation was repeated on an animal in which a previous inoculation had produced such a papule, no distinct papule was formed; and, moreover, lymph squeezed from the seat of inoculation produced no effect at all when used for the subsequent inoculation of another animal. This shows that the development of the papule was the result of the specific action of the virus. The same is shown by the fact that no such papule was produced when the small-pox matter was inserted into an animal which had previously had cow-pox naturally or artificially, as well as by the fact that when an attempt was made to vaccinate, with vaccine matter of proved efficacy, an animal on which a papule had been so developed by inoculation with small-pox, the vaccination failed, though the animal had never had natural cow-pox or had never been vaccinated. The specific nature of the lymph of the papule is further shown by the fact that such lymph when used on the human subject gave rise to veritable small-pox. It has been urged that in this case the virus producing the effect was simply the old virus used in the inoculation, producing the papule and still clinging to the wound. This is disproved by the experience that lymph from a papule of the second remove also gave rise in the human subject to veritable small-pox.

Thus Chauveau and his Commission found that small-pox implanted

in the cow gave rise to a specific effect which was not cow-pox but was of the nature of small-pox, though its manifestations in the cow were different from those of small-pox in man. They also obtained similar results in attempting to transfer small-pox to the horse.

It must be admitted that the results finally obtained in some of the successful cases were indistinguishable from those of vaccination; the characters of the local vesicle, the absence of eruptive pustules and of contagiousness, show that the lymph thus apparently originating from small-pox in the hands of Ceely, Badcock, and others, was vaccine lymph. It has been urged that a vaccine vesicle making its appearance in the wound of inoculation with small-pox was due to the accidental introduction of cow-pox matter into the wound; the small-pox matter in the wound produced no effect, and the cow-pox matter its usual effect. Several considerations support this view. The cow is peculiarly susceptible to cow-pox. In some cases (Ceely, Voigt), the animal was vaccinated as well as inoculated with small-pox: thus, in Ceely's first case, the animal was inoculated with small-pox on one side of the body, and a few days after vaccinated on the other side. In many cases the experiments were conducted in an animal vaccine establishment, the stalls, the operating tables, and the assistants being those used or engaged in vaccination. It is true that in some cases at least special precautions, sterilisation of instruments and the like, were taken to avoid the accidental introduction of cow-pox; but in observations of this kind the difficulties of avoiding all such sources of error are notorious. Still the successful cases are now so numerous that it is difficult to resist the conclusion that the same accident could not have occurred in all, and that a transformation of small-pox into cow-pox—*that is to say, into the artificially inoculated cow-pox which we call vaccine*\*—really took place.

Accepting this view provisionally, it may be remarked that in most cases the transformation was sudden and complete; the small-pox virus, under the influence of the tissues of the cow, became immediately converted into vaccine virus, and this produced a typical vaccine vesicle. In some cases (*ex. gr.*, that of Hime) the transformed virus produced its effect not in the wound of inoculation, or not chiefly so, but at some little distance from it. In some cases the characters of the vesicle first formed, though sufficiently distinct to justify the vesicle being called a vaccine vesicle, were not those of a perfect vaccine vesicle, but the lymph from such a vesicle, at least after one or two removes, gave rise to most typical vaccine vesicles.

In Klein's experiments the transformation was gradual. In his fourth cow, the virus was as yet not typical vaccine, since it did not produce a typical vesicle; yet it was so far already vaccine that, transferred to the child, it produced typical vaccine (unless we suppose some accidental introduction of vaccine to have taken place). That the vesicle on the child was vaccine, and not small-pox unaccompanied by eruptive pustules, was shown not only by its characters but also by the fact that lymph from it produced typical vaccine in the cow.

In Chauveau's experiments no transformation at all took place.

\* The italics are mine.—E.M.C.



As has been urged in another place, there are no adequate reasons leading us to believe that in the human subject the small-pox virus and the cow-pox virus can so act on each other as to form a hybrid disease. But this does not preclude the view that, accepting the conclusion that the body of the cow has the power to convert small-pox into *vaccine*, the virus may exist for a while in a phase in which, while ceasing to be typical small-pox, it has not yet fully acquired the characters of *vaccine*, and we may regard Klein's results as illustrating this. In some of the experiments—for instance, those of Ceely and Voigt—the results obtained with the lymph of the vesicle produced by the inoculation of small-pox give rise to the suspicion that the lymph had small-pox qualities, as seen, for example, in the case of Ceely's assistant, Taylor; but the facts cannot be said to be more than suspicious—they are not decisive. Moreover, admitting that the vesicle itself in such cases was the result of the transformed virus, some not transformed old virus might still remain dormant in the wound, and might be present in the lymph of the vesicle, mixed with the transformed and generating virus; this old virus might have happened to be in excess on the point of the lancet which wounded Taylor.

*Small-pox Vaccine—Cow-pox Vaccine—Horse-pox Vaccine—Cattle-plague Vaccine—Sheep-pox Vaccine.*

Taking all the various facts into consideration, we seem led to the provisional conclusion that under certain conditions the tissues of the cow are able to transform small-pox into *vaccine*, that these conditions may be such as to lead to the transformation being sudden and complete, that under certain other conditions the transformation may be gradual and incomplete, and that under certain other conditions (and these seem most commonly to obtain) the transformation into *vaccine* does not take place at all. But what the above conditions are has not as yet been clearly made out. It has been suggested that one condition favourable to the transformation is extreme youth of the subject: to effect the change the animal used should be a calf of not more than three or four months old; but this is not definitely proved.

Until these favourable conditions have been clearly recognised, so that, the conditions being fulfilled, the transformation will always be secured, the conclusion cannot be regarded as indisputable. Moreover, it must be borne in mind that effects more or less closely resembling a vaccine vesicle have been at various times obtained by various observers through inoculating man or the cow or another animal with material other than that obtained from the pustules of the small-pox of man. Much discussion has taken place concerning the "grease" of the horse, which Jenner believed to be the origin of the cow-pox of the cow. Without entering into any discussion of the matter, it may be said that investigation has shown that horses do suffer from a malady which, transferred to the cow, gives rise to a vaccine identical apparently with that produced by the inoculation of the natural cow-pox. Hence this malady is spoken of as the "horse-pox," and some cases at least of so-called "grease" appear to be cases of this horse-pox. But it is at least not proved that

all the cases of "grease" which by inoculation were found to give rise to vaccine vesicles in man were cases of true horse-pox. And this at least must be said, that no investigations as complete and varied as those which have been carried out with regard to the development of vaccine vesicles through the inoculation of small-pox matter, have been carried out with regard to the alleged development of vaccine vesicles by the inoculation of other material, such as the matter from the eruptions of the sheep-pox, the cattle plague, and the like. Nor have there been like extended inquiries as to the production of vesicles resembling those of vaccine by the inoculation of small-pox matter into animals other than the cow or the horse; such results as have been obtained by observers are conflicting. There is still room for much inquiry; meanwhile it may be said that, in any case, the evidence in favour of a possible transformation of small-pox into vaccine is sufficiently strong to remove the force of the theoretical objection to the power of vaccination to secure immunity towards small-pox, on the ground that the two diseases are absolutely distinct.

#### *Risks of Vaccination.*

It must not be forgotten that the introduction into the system of even a mild virus, however carefully performed, is necessarily attended by the production of local inflammation and of febrile illness. If these results did not in some measure follow, the practice would probably fail in its protective influence. As a rule, the inflammation and illness are of a trifling character; in exceptional cases, however, they may exhibit more severity, and, as certain facts submitted to us in evidence have shown, there are cases, though these are rare, where a general eruption may follow vaccination.

In order to determine how far the risk of erysipelas is a necessary incident of vaccination, what is the extent of that risk, and how it may best be avoided, it is necessary to consider the various circumstances which may occasion erysipelas and allied diseases in the case of vaccinated children. It is established that lymph contains organisms, and may contain those which under certain circumstances would be productive of erysipelas. It is therefore possible that some contagious material (the specific virus of erysipelas, for instance,) may be conveyed at the time of vaccination, owing either to its presence in the lymph employed, or to its being conveyed by the vaccinator himself, or by those with whom the child comes in contact at the time of vaccination. We believe that the cases in which the virus is conveyed at the time of vaccination are rare. It has, however, in some instances been clearly established, the immediate occurrence of erysipelas in several co-vaccinees making it practically certain that some virus was conveyed at the time of the operation. In some instances where this has been the case, and there is every reason for believing that the contagion was conveyed through the medium of the lymph, it is nevertheless in evidence that the vaccinator did not display anything more than a slightly inflamed arm. The scrupulous avoidance of inflamed arms in vaccinifers will do much to reduce the risk of conveying erysipelas in the act of vaccination (a risk which, as we have



seen, has been proved to be a very slight one), but it is possible it would not wholly remove it.

We have dwelt upon features presented by the cases of erysipelas and various forms of septic disease which have followed vaccination, because they suggest precautions which may be adopted to lessen, if not to prevent, such evils in the future. If, for example, vaccination were performed at the patient's home instead of at a public vaccination place, the chance of disease being contracted at the time of vaccination would be to some extent diminished; and the same may be said of the inspection of the vaccinated person which takes place eight days after the operation. On these points we shall have some remarks and recommendations to make at a later stage of our report.

A study of the cases which have been made the subject of careful examination and report points to the conclusion that an exercise of greater care would largely diminish the risk, already small, of erysipelas-contagion and blood-poisoning.

Although it may be confidently hoped that by additional care on the part both of vaccinators and parents, the number of inflamed arms and of cases of erysipelas may be reduced to very few, yet it is not to be expected that such occurrences will be wholly prevented. A vaccination wound is, like one from any other cause, so long as it exists, a source of some risk.

The use of calf-lymph, though it may be supposed to be more free from the risk of conveying erysipelas, does not appear to prevent inflamed arms. Some witnesses have indeed supposed that it is attended with more risk of inflammation than the employment of that taken from the human subject. This opinion has not, however, been corroborated by some of those of widest experience.

Nothing has produced so deep an impression hostile to vaccination as the apprehension that syphilis may be communicated by it. It was at one time doubted whether syphilis could result, and it was even confidently asserted that it could not. The fact that this was possible had been fully established, and was generally acknowledged by the medical profession, before we commenced our inquiries.

The very close resemblance in certain very rare cases of the results of vaccination, whether with calf-lymph or humanised lymph, to those attributed to syphilis (a resemblance so close that it has caused in a few cases a difference of opinion whether the disease was syphilis or vaccinia) has led to the expression by Dr. Creighton of the opinion that there is some essential relationship between the two diseases. This, however, is a point of speculative, almost it might be said of transcendental pathology, upon which for practical purposes it is useless to enter. It must be sufficient to remark that, whatever may be the relationship alluded to, it exists, if it exists at all, equally between small-pox and syphilis as between vaccination and syphilis. For all practical purposes variola and vaccinia are both wholly distinct from syphilis, and their differences are, with the rarest exceptions, easily recognised. They are alike in being attended by affections of the skin and mucous membranes, and exceptionally by disease of the bones, eyes, and other parts; but in all

these it is a question of resemblance and not of identity with which we have to deal.

Only a few items of the evidence produced before us appear to require special notice : among these, the most prominent is what has been known as the "Leeds case," upon which we have heard the evidence of Mr. Ward, Mr. Littlewood and Dr. Barrs. The witnesses named regarded it as a case of syphilis, conveyed by vaccination, but all of them admitted that the course of events was most unusual. We have carefully investigated this case, and notwithstanding the opinion formed by the witnesses, there appears good reason to doubt whether it was one of syphilis. The case was made the subject of careful inquiry by Dr. Barlow on our behalf, who shared the doubt we have expressed. The view taken by the medical inspector of the Local Government Board who in the first instance investigated the case was that it was a case of hereditary syphilis. It seems certain, however, that the parents of the child whose death was in question were not in any way affected with syphilis. The vacciner also appeared to be free from any taint of that disease, and its family history confirmed this view. The co-vaccinees from the same lymph also exhibited no trace of syphilis. These facts of themselves make out a strong case against that having been the nature of the disease. Coupled with the fact that it could not have been communicated by the vaccinator himself, they seem to render it practically impossible that syphilis was the cause of death. If the symptoms exhibited had in all respects corresponded with those which are known to characterise syphilis, the proper inference might have been that there was some error in ascertaining the facts of the case. But it is beyond question that the course of events was very different in some respects from that experienced in undoubted cases of syphilis, and we think the true conclusion is that it was not a case of that disease. It may probably be classed with a few others as examples of gangrene and blood-poisoning, the direct result of vaccination, which are not to be explained by supposing the introduction of any syphilitic or other poison. Fortunately, such cases are extremely rare—so much so that the witnesses concerned knew of no case precisely parallel.

The evidence offered to us would lead to the belief that, whilst with ordinary care the risk of communication of syphilis in the practice of arm-to-arm vaccination can for the most part be avoided, no degree of caution can confer an absolute security. The rejection as vaccinifers of young infants, say below four months of age (in whom congenital syphilis may be as yet undeclared), and of adults (in whom the disease may possibly have been recently acquired) are precautions which would probably shut out almost the whole of the risk. The outbreaks of syphilis in connection with vaccination which have been mentioned to the Commission (all of which had been previously published) have occurred chiefly in arm-to-arm vaccination amongst soldiers, or from the use as vaccinifers of young infants the offspring of parents whose history was not known to the vaccinator. It must, however, be admitted that neither the examination of the vacciner if taken alone, and without a knowledge also of the parents, nor the most scrupulous avoidance of any visible admixture of blood with the lymph, are in themselves, however valuable, sufficient



absolutely to exclude risk. The evidence given by Dr. Husband, of the Vaccine Institution of Edinburgh, established the fact that all lymph, however pellucid, does really contain blood cells. Absolute freedom from risk of syphilis can be had only when calf-lymph is used ; though where the antecedents of the vaccinifer are fully ascertained, and due care is used, the risk may for practical purposes be regarded as absent.

It is obvious that the employment of calf-lymph only would wholly exclude the risks as regards both syphilis and leprosy. Respecting the latter disease, however, there appears to be reason to doubt whether any risk exists, and at any rate it does not concern the British population. Even in leprosy districts the employment of English human lymph would be, so far as leprosy is concerned, as safe as that from the calf.

There can be no doubt that vaccination ought to be postponed when erysipelas, scarlet fever, measles, or chicken-pox are prevalent in the neighbourhood of the child's residence, or, if the child is not to be vaccinated at home, either there or near the place of vaccination. Here again there would be a gain if the home was more often the place of vaccination.

It would, in our opinion, be an advantage if the postponement of vaccination were expressly permitted, not only on account of the state of the child, but of its surroundings and any other conditions rendering the operation at the time undesirable. If more discretion in this respect were possessed and exercised, we think untoward results would become even rarer than they are.

We are quite alive to the objections which may be urged against a prolongation of the period within which vaccination must be performed. It will naturally be said that a number of children, who otherwise would be protected against small-pox, would be left without that protection, and would thus be liable to suffer from the disease themselves, and be a source of danger to others. It must be remembered, however, that so long as children cannot walk, the risk of their contracting contagion is less than if they were able to move freely about and mix with other people, and that, for the same reason, the risk of their communicating contagion to others is less. We cannot trace in the statistics relating to Scotland any grounds for believing that the later compulsory vaccination age which prevails in that country as compared with England has affected, to any substantial extent, the general small-pox mortality of Scotland, though no doubt it may have led to some deaths among children under six months of age which otherwise would not have taken place.

We have already shown how satisfactory a position Germany has occupied in relation to small-pox since the year 1874. The age of compulsion in that country is the end of the next calendar year after birth. It is true that re-vaccination has been there made compulsory as well as primary vaccination ; but we think the experience of Germany is not without its bearing on the question we are now considering. Wherever the line is drawn, whether at three months or six months, it will always leave a class of unvaccinated persons. The age to be fixed is a question of policy into which many considerations must enter. If an extension of the age within which vaccination was required rendered its untoward

incidents fewer in number, and diminished hostility to the operation, it may be that on the whole it would promote the cause of vaccination, and secure, as its result, that the number of vaccinated persons would be greater than at present.

*Means, other than Vaccination, for diminishing the Prevalence of Small-pox ; and how far such means could be relied on in place of Vaccination.*

Another question upon which we are asked to report is, what means, other than vaccination, can be used for diminishing the prevalence of small-pox ; and how far such means could be relied on in place of vaccination.

The means, other than the inoculation of small-pox or cow-pox, which have been referred to by witnesses as being capable of diminishing the prevalence of small-pox, are such means as have been employed against infectious diseases generally ; they may be summarised as—(1) Measures directed against infection, *e.g.*, prompt notification, isolation of the infected, disinfection, etc. ; (2) Measures calculated to promote the public health, the prevention of overcrowding in dwellings or on areas, cleanliness, the removal of definite insanitary conditions, etc.

The principle underlying the practice of isolation with its accompanying machinery is obviously the very opposite of that which recommended the practice of inoculation ; it aims at exclusion of the disease, whereas inoculation aimed at universal acceptance by artificially "sowing" or "buying" the disease. Except in regard to the plague, our knowledge and practice of measures of isolation and quarantine against epidemics is of relatively recent growth. As the result of increased knowledge of the mode of propagation of infectious diseases, of greater sanitary activity, and under the stimulus of legislation, organised effort, more or less thorough, is now, in this as in other countries, directed against the spread of dangerous infectious diseases. Side by side with a vaccination system, means of isolation, etc., have been successfully employed to check the spread of small-pox. They have also been sometimes so employed in recent years in places where vaccination has fallen into disuse.

It will be well to commence with a brief statement of the growth of our knowledge on the subject of isolation as a means of dealing with infectious or contagious diseases. We have already adverted to the fact that small-pox is highly contagious, and that contagion from those suffering from it is the means by which the disease is propagated.

Although reference to infection appears in some of the Arabian writers, the contagiousness of small-pox attracted little attention in this country and in western Europe until the eighteenth century. Sydenham (1624-89), though he refers to the contagiousness of small-pox, did not dwell upon the matter, and did not regard it as so important an element in the spread of the disease as some peculiar constitution of the atmosphere to which he attributed epidemics. Boerhaave was the first, at the commencement of the eighteenth century, distinctly to formulate the now generally accepted doctrine that small-pox arises only from contagion.

In 1720, Mead drew up an elaborate system of notification, isolation, disinfection, etc., in view of a threatened invasion of the plague ; but no



attempt to deal with small-pox in a similar fashion appears to have been made until the last quarter of the eighteenth century. This was in all probability largely due to the adoption of inoculation as the recognised defence against small-pox, and the acceptance of Sydenham's doctrine of epidemic causation may have exercised an influence in the same direction.

No writer appears to have suggested methods of isolation, disinfection, etc., against small-pox prior to 1763. In that year Rast of Lyons published his "Reflections on Inoculation and Small-pox, and upon the means which might be taken to deliver Europe from that malady." He maintained—(1) That small-pox was not a necessary and inevitable malady; (2) That it arose only from contagion; (3) That it resembled plague in most of its features. His conclusion was expressed in these terms: "I say, that to deliver Europe from small-pox we must act upon principles directly opposed to inoculation; far from multiplying the contagion, we must keep it away by taking the same precautions and employing the same measures against that malady as have proved so successful against leprosy and the plague."

The earliest account of the practical employment of such means is from Rhode Island, U.S.A. Haygarth, on the authority of Drs. Moffat and Waterhouse, states that for many years prior to 1778 small-pox had been successfully prevented from becoming epidemic there by regulations for isolation of the infected on a neighbouring small island specially used for that purpose, and for quarantining infected vessels, destruction of infected clothing, etc. Moreover, inoculation was discouraged at Rhode Island, and those who wished to be inoculated had to go to some place away from the Island, and were not to return until there was no danger of their infecting others.

A passage in Dimsdale's work on Inoculation, published in 1781, shows that in some towns of England pest-houses were beginning to be used for small-pox. In 1784 Haygarth, of Chester, published his "Inquiry how to prevent the Small-pox," and in 1793 "A Sketch of a Plan to exterminate the Small-pox from Great Britain."

The great epidemic of small-pox at Chester in 1774, to which allusion has already been made, was the occasion of Haygarth's first attempts at organised dealing with epidemics of small-pox with a view to prevention. In his "Inquiry" he combated Sydenham's doctrine that epidemics are due to some occult condition of the atmosphere, and argued that small-pox was always spread by infection only. He further maintained that the variolous poison could be carried as an infection for a little distance only through the air, and "consequently that the small-pox may be prevented by keeping persons liable to the distemper from approaching within the infectious distance of the variolous poison till it can be destroyed." These views led him, upon the return of an epidemic in 1777, to propose a plan for the prevention of the natural small-pox, and in 1778 a society was formed to carry out the plan in Chester. The plan consisted on the one hand of a general inoculation at people's homes at stated intervals, on the ground that the inoculated small-pox was far less fatal or injurious than the natural small-pox, and on the other hand of

"Rules of Prevention" based on Haygarth's views of infection. In the report of the Society, called shortly "The Small-pox Society," dated September 1782, it is stated that in the four and a half years of its existence two general inoculations had been held, and that the deaths from small-pox had been greatly lessened. Great difficulties, however, were met with. "A large proportion of the inhabitants" refused inoculation, and a large proportion also, "being fearless, or rather desirous, that their children should be infected with the natural small-pox," refused to obey the Rules of Prevention. Hence, though the same report states that the example of Chester had been followed by Liverpool, where "a general inoculation was successfully executed in the autumn of 1781 and another in the spring of 1782," and in Leeds, where a general inoculation was held in 1781 and another proposed in 1782, with such success that the Royal College of Physicians in Edinburgh appointed a committee to inquire into "the modes of conducting the general inoculations of the poor" thus adopted in these places, the plan met with such difficulties that it was ultimately abandoned. It will be observed that a general inoculation was an essential part of the plan proposed and carried out in 1778-82; but, writing in 1784, Haygarth looked forward to being able ultimately to dispense with inoculation, and in the preface to his later edition, published in 1793, he states more definitely that the adoption of his Rules of Prevention without any general inoculation might exterminate small-pox in some country other than Great Britain. It must be remembered, however, that Haygarth entertained the opinion that the infection of small-pox could not be carried through the air above about half a yard, and that no one could be infected by the clothes of a person visiting a small-pox patient provided that he kept beyond this distance from the patient. It is obvious that if this had been established the control of the disease by isolation would be a much simpler matter than it really is.

In the *Medico-Chirurgical Review* for 1796 there appeared an account of a work by Dr. Faust, of Leipsic, entitled "An Essay on the Duty of Man to separate persons infected with the Small-pox from those in Health, thereby to effect the extirpation of that disease equally from the towns and countries of Europe," in which it was argued that the first person ill in a place is the only source from which all the rest, perhaps hundreds and thousands, become affected, and that if he were put immediately into a situation where he could not injure by contact those who had not had the disorder, the spread of the disease would be prevented.

In the same Review for 1799 appeared an account of establishments for the extirpation of small-pox. The failure of inoculation to attain the desired end is referred to, and legislation is urged to facilitate isolation. It is further stated that in 1796 the Prussian College of Physicians reported favourably to the King on the project, and that at Halberstadt it had been resolved to establish a house for the purpose. At Côte d'Or in France a similar plan had been tried with success.

In 1798 Jenner's "Inquiry" was published, and in the early years of this century inoculation began to be discouraged; for a while the prospects of



annihilating small-pox by vaccination appear to have superseded, in the minds of many, the plans of Haygarth and others. Some vaccinators, however, like Willan and Ring, still looked to methods of quarantine and to national and municipal regulations promoting isolation to exterminate the small-pox.

It is worthy of notice, too, that Haygarth himself, in a letter quoted by Dr. Cappe of York in a communication to the *London Medical and Physical Journal* (vol. iv., p. 429), dated October 13th, 1800, remarked, "An introduction of the vaccine still more than of the variolous inoculation would effectually promote the great object of my publications."

Prior to the year 1866 there was no provision made by law for enabling sanitary authorities to establish hospitals for infectious diseases, and thus to promote the isolation of such cases. The only institutions of that description then existing were the result of private effort. So far as regards small-pox there was, practically speaking, no provision for its treatment by means of isolation.

The Sanitary Act of 1866 empowered, though it did not compel, local authorities throughout England and Wales, Scotland and Ireland, to provide or to join in providing isolation hospitals for the use of the inhabitants of their districts. There was further legislation on the subject by the Public Health Act, 1875; the Public Health (London) Act, 1891; the Public Health (Scotland) Act, 1867; and the Public Health (Ireland) Act, 1878, into the details of which it is not necessary to enter. The most recent Act relating to the matter is the Isolation Hospitals Act of 1893, which applies to the small towns and rural districts of England and Wales.

#### *Stamping-out System in Leicester.*

Leicester suffered severely from small-pox in 1872, 346 deaths having been registered as caused by it. Two deaths from that disease occurred in 1873, but no other until 1877, when there were six, and one in the following year. The next year in which small-pox deaths were registered was 1881. There were two in that year, and five and three in the following years. No other death took place until 1892 and 1893, in which years the fatal cases numbered 21.

Prior to 1875 the vaccination laws were well observed in Leicester. In that year the number of children born who were unaccounted for was only some 4 per cent. Since then there has been, as we have seen, a marked and progressive decline in the number of vaccinations, especially since 1883, until at the present time 80 per cent. of the children born remain unvaccinated.

The borough hospital for infectious diseases was erected in 1871-2 outside the town; though within the last few years houses have been built in proximity to it. It appears to have been with Dr. Crane, the Medical Officer of Health in 1875, that the quarantining the inmates of an infected house, in addition to isolating the patient, originated. His successor, Dr. Johnston, established it in 1877 as a regular system. He was aided in this, after 1879, by the notification of infectious diseases then rendered compulsory by a private Act which Leicester, anticipating

most other towns, obtained in that year. Dr. Johnston reported that up to 1884 the spread of small-pox from imported cases had been arrested in 20 instances by the means he adopted.

His successor, Dr. Tomkins, though, like his predecessors, regretting the increasing disuse of vaccination, bore testimony in his annual reports to the efficacy of the measures adopted in Leicester, and expressed his opinion that had such a system been in force at Sheffield in 1887 it would not have suffered in the way it did.

In 1892 small-pox became prevalent in different parts of England, especially in Lancashire and Yorkshire. Many of the large provincial towns suffered, and Leicester amongst them. There were, in 1892-3, 357 cases of small-pox in Leicester, of whom 21, or 5·8, died; 193 households were invaded, containing 1234 persons. The first importation was by a tramp, whose disease, passing unrecognised, caused infection at a common lodging-house and at the workhouse. Eleven other importations of the disease by tramps occurred in the course of 1892-3.

Leicester suffered less than many of the other large towns which have been invaded by small-pox during recent years, both in the number of cases and in the number of deaths. In connection with this, however, a point to which we have already called attention must be borne in mind. The disease was remarkably slight there in its fatality, even as regards those who, by reason of their age, could not be affected by the change of practice in relation to vaccination. Dr. Priestley, the Medical Officer of Health, claims, in his report to the Sanitary Committee for 1893, that it was by reason of the energetic methods adopted that the disease had been prevented running riot through the town. His claim may be well founded. At all events, the experience of Leicester affords cogent evidence that the vigilant and prompt application of isolation, etc., even with the defects which were brought to light during the recent epidemic, is a most powerful agent in limiting the spread of small-pox. It is true that the system and appliances which appeared adequate for some years failed to prevent a serious outbreak of small-pox in 1892-3. We think its value was none the less real.

#### *Stamping-out System in London.*

In the Report of the Royal Commission of 1881, already alluded to, suggestions were made with regard to notification and isolation which have since been largely carried into effect. As we have said, it was considered proved that the existing small-pox hospitals had caused a spread of the disease in their neighbourhood. We cannot but think that this may in some measure account for the greatly increased mortality from small-pox in London during the 1871-72 epidemic as compared with the rest of the country. It is true that the statistics relating to England and Wales outside the Metropolis include those of other large towns where the same evil was present; but it probably did not exist there in so aggravated a form, and the effect may be neutralised by the statistics relating to smaller towns and rural districts with which they are combined. This idea has been suggested to us, as the result of the inquiry, how it has come about that whilst the Metropolis, in the decennium 1867-76, and again



down to 1885, compared so unfavourably with the rest of the country, the condition has since that date become so entirely changed? We think it is impossible to attribute this change to vaccination. There is no reason to suppose that the position of the Metropolis in respect to vaccination has, since the year 1885, become superior to the rest of England and Wales: rather the other way, as the decrease in infantile vaccination has been greater during the last few years than in the rest of England and Wales. The change, therefore, must be due to some other cause.

The hospitals which, in the opinion of the Commissioners, were propagating the disease in their neighbourhood, were in operation down to July 1882, when their Report was made. In 1877 and 1878, and again in 1881, small-pox was epidemic in London to a considerable extent.

We have stated in detail in paragraph 471 \* the steps which were taken by the Metropolitan Asylums Board in consequence of the recommendations of the Royal Commission. It will be seen that the intra-urban hospitals still continued in use, and that complaints were made in 1884 that they were spreading small-pox in their vicinity, although the number in each of them was not allowed to exceed 50. In October 1884 this number was reduced to 25. It was not, however, until 1885 that the system now in operation was inaugurated, and all cases of small-pox were treated in hospital ships. It is impossible not to be struck with the fact that it is since the year 1885 that the Metropolis has presented so satisfactory an aspect as regards small-pox mortality. The facts to which we have been calling attention certainly seem to point to the conclusion that this has been due to a system of isolation, well organised and administered, the beneficial effect of which is no longer neutralised by a spread of the disease from the hospitals in which the isolation is carried out.

Upon the whole, we think the experience of London affords cogent evidence of the value of a sound system of isolation in checking the spread of small-pox.

#### *Stamping-out System in Australia.*

The experience of isolation systems in Australia is interesting and worthy of special notice, because whilst in this country the quarantining of persons who have come in immediate contact with those suffering from small-pox has only been possible with the consent of the persons whom it was proposed to subject to quarantine, in Australia their removal to a place of isolation has been made compulsory.

Australia, by virtue of its geographical position, and the consequent separation by long sea voyage from infected ports, enjoyed for a long time a sort of natural isolation. Thus, Hirsch, in his "Historical and Geographical Pathology," vol. i., pp. 133-4 (1881), remarks:—

"The continent of Australia up to 1838 had enjoyed an absolute immunity from small-pox; towards the end of that year the disease appeared at Sydney, having been imported probably from China; it lasted, however, only a short time, and remained absent from the continent until 1868. In that year it was introduced into Melbourne by a ship, and again it spread only to a slight extent, and quickly died out.

\* Final Report.



“By a rigorous inspection of ships on their arrival, it has been found possible to prevent subsequent importations, a notable instance of prevention having occurred in 1872. Tasmania has hitherto quite escaped the disease ; so also has New Zealand, where an importation of it in 1872 was prevented by strictly isolating a vessel that had arrived with small-pox on board.”

In New South Wales, Dr. MacLaurin, who has been President of the Board of Health since 1889, informed us that the Government act on the assumption that small-pox is an exotic disease, and that every case must have come from outside the colony, and it is therefore dealt with under a quarantine Act of William IV., originally instituted for dealing with cholera. By an Act passed in 1882, notification of small-pox was made compulsory on medical men and householders under heavy penalties. At Sydney notification of small-pox is followed up by the compulsory removal of the patient and all persons who have been in the house with the patient to the quarantine station at North Head. This station is 670 acres in extent, and situated on the peninsula at the mouth of Sydney Harbour, and is seven miles from the Health Office, with which there is telephonic and telegraphic communication. The persons are conveyed to the station by a steamboat comfortably fitted expressly for the purpose, and no difficulty has been experienced in effecting their removal. It was, in Dr. MacLaurin's opinion, by carrying out this practice of isolation and quarantine that “the epidemic of 1881-82 was suppressed,” and small-pox “has never become epidemic since this plan has been adopted.” The persons who have been in the house with the patient are detained 21 days in quarantine from the date of the last possible contagion. Should a case of small-pox arise among them, those who had been in contact with such infected person would be detained for a further period of 21 days, and so on. To facilitate this, the exposed persons are distributed in separate groups within the station. They are allowed to receive letters or parcels, etc., and a telegraph operator is employed, “whose special business it is to work the telegraph at their request.” “Reasonable compensation is given by the Government for loss ;” and there are heavy penalties under the original Act whereby the quarantine is secured. The station is, according to Dr. MacLaurin, “a pleasant place to stay in, and everything is done that can be done to make the people comfortable : they have nothing whatever to do, and are free from all care, and they can spend the day pleasantly enough ; but they do not like it.” No one, however, raises any objection to the Sydney system : “the people are all very sensible about it.” In all Australian towns the same system is carried out as strictly, with the result that there was not a case of small-pox in Australia on February 5th, 1890 ; and Dr. MacLaurin is of opinion that the risk of dying of small-pox in Australia is smaller than in any other part of the world. As regards vaccination :—In New South Wales it is very little practised ; there is no compulsory Act ; and though medical opinion is in favour of it, an opinion shared by Dr. MacLaurin, it is not likely that a compulsory Vaccination Act could be passed or would be tolerated. The proportion of young persons in New South Wales who are not vaccinated is accordingly very large ; probably much more than half of those under



ten years of age are unvaccinated. Although Dr. MacLaurin favours vaccination and respects it highly, he is satisfied that the system of isolation as supervised by him is perfectly successful. As President of the Board of Health he considered it his business to produce extinction of the disease ; he does not consider vaccination a sufficiently absolute protection for such purpose ; and he is " fully of opinion that the only way in which " you can bring to an end an outbreak of small-pox, that is to say, bring " it under control, and not leave it to work itself out, is by notification " and isolation. Of course, in any small community, if you let the disease " in it will work itself out in time, because all the susceptible people will " have had it ; but the only way in which you can absolutely control an " epidemic of small-pox is by a system of notification and isolation."

Small-pox has never been epidemic in Western Australia. Only one case has occurred within the last 31 years, and that was an imported one ; quarantine was carried out, and no infection occurred ; the immunity from the disease is mainly at least due to isolation. Before 1879 vaccination was not generally practised—a great majority of those born in the colony were unvaccinated ; in that year a compulsory Vaccination Act was passed in consequence of Sir H. Ord and Dr. Waylen's representations, and in consequence of reports of small-pox in other colonies, and not on account of the existence of small-pox in Western Australia.

In Tasmania there was a compulsory vaccination law, but it was found to be inoperative because no one was appointed to conduct the prosecutions, and it has now fallen into desuetude. The same system of isolation and quarantine is exercised as in the other Australian colonies. Small-pox was for the first time introduced into Tasmania in 1887, and although preparations for isolation were inadequate, the disease was soon stamped out. Communication between Launceston and Melbourne was temporarily suspended, and to this precaution the non-invasion of Victoria was attributed. The particulars of this, the first introduction of small-pox into Tasmania during the history of that colony, are to be found in a report to the Central Board of Health by Mr. A. Mault, dated November 17th, 1887. The origin of the outbreak is not clear, but it was presumed to have been imported, probably by a ship from China, into Launceston. The earliest case reported to the Local Board of Health was on September 23rd, though it appears that earlier cases had passed unnoticed, or had been notified as measles. Thirty-three cases in all occurred, every one of which was traced to direct infection from the first case. By September 27th a temporary hospital had been erected, and thither patients and suspects to the number of 72 were removed. The last case appeared on October 13th. Other persons who had been to the infected houses were isolated in their houses and watched. Only four of the 47 persons quarantined at the station were attacked. The clothing was burnt, and very thorough disinfection of the infected houses was carried out, and the dead were interred in a special cemetery. The other colonies were communicated with, and quarantine, at first unduly rigid and afterwards relaxed, was practised against ships proceeding from Tasmania. Although vaccination had been nominally compulsory in Tasmania, it was estimated that two-fifths of the population were unvaccinated.

*Suggested Stamping-out System in the United Kingdom.*

We have no difficulty in answering the question, what means other than vaccination can be used for diminishing the prevalence of small-pox? We think that a complete system of notification of the disease, accompanied by an immediate hospital isolation of the persons attacked, together with a careful supervision, or, if possible, isolation for sixteen days of those who had been in immediate contact with them, could not but be of very high value in diminishing the prevalence of small-pox. It would be necessary, however, to bear constantly in mind, as two conditions of success: first, that no considerable number of small-pox patients should ever be kept together in a hospital situate in a populous neighbourhood; and secondly, that the ambulance arrangement should be organised with scrupulous care. If these conditions were not fulfilled, the effect might be to neutralise or even do more than counteract the benefits otherwise flowing from a scheme of isolation.

When we turn to the other branch of the inquiry, how far such means could be relied on in the place of vaccination, we find ourselves involved in questions of a much more complicated nature. We have little or no experience to fall back upon. The experiment has never been tried. The nearest approach to a trial of it has probably been in Australia. But even in the parts of that country to which we have alluded the population has not been entirely unvaccinated, though there has been a large unvaccinated class amongst it. Moreover, in applying the experience of Australia to this country, two things must be borne in mind. In the first place small-pox has only appeared from time to time, introduced from without at one or other of the ports of the country, and the several colonies of which Australia is composed are of great territorial extent, with few large centres of population. In this country small-pox is always present in some part of it. There has not been a single year without several deaths from the disease. Large centres of population are numerous, and the intercourse between them constant. In the several colonies of Australia the number of ports is not great, the vessels which enter them are comparatively speaking not numerous, and the ports from which they arrive are many days' voyage distant; and there are careful arrangements for quarantining vessels to exclude disease. The shipping which enters English ports is of vast quantity, and passengers are brought in large numbers from the continent of Europe not only daily, but it may almost be said hourly; the voyage, too, is but brief. The other matter to be remembered is, that part of the Australian system is the *compulsory* removal to quarantine for 21 days of those who have been in the house with the patient, in addition to the transfer of the patient himself to a hospital. There can be no doubt that such a system, if completely carried out, would be of the highest efficacy. But it is obvious that in this country the practical difficulties of working such a scheme in the large towns would be really insuperable, to say nothing of the difficulty of procuring legislative sanction for it.



*Value of Isolation.*

We can see nothing, then, to warrant the conclusion that in this country vaccination might safely be abandoned, and replaced by a system of isolation. If such a change were made in our method of dealing with small-pox, and that which had been substituted for vaccination proved ineffectual to prevent the spread of the disease (it is not suggested that it could diminish its severity in those attacked), it is impossible to contemplate the consequences without dismay.

To avoid misunderstanding, it may be well to repeat that we are very far from underrating the value of a system of isolation. We have already dwelt upon its importance. But what it can accomplish as an auxiliary to vaccination is one thing ; whether it can be relied on in its stead is quite another thing.

Even admitting fully the protective effect of vaccination, it does not, in our opinion, diminish the importance of measures of isolation or dispense with their necessity. We think that steps should be taken to secure a more general provision for the isolation of small-pox patients than exists at present. We have already called attention to the fact that mischievous results are likely to follow the use as a small-pox hospital of a building situate in a populous place. We think that wherever it is placed it should have sufficient space around it to enable the sanitary authority to add rapidly to the accommodation by the erection of temporary buildings.

*Compulsory Provision of Isolation Hospitals.*

Sanitary authorities are now sometimes reluctant to provide isolation hospitals. We think that, on a petition by a prescribed number of the ratepayers in a sanitary district, the Local Government Board, if satisfied that the hospital accommodation ought to be provided, should have power to make an Order for such provision.

*Compulsory Notification of Small-pox.*

We think that notification of small-pox should everywhere be compulsory, and, whenever the disease showed a tendency to become epidemic, a notice should be served by the sanitary authority upon all persons in the neighbourhood who would be likely to come within the reach of contagion, urging them to submit to vaccination or re-vaccination, as the case might be, if they had not been recently successfully vaccinated or re-vaccinated ; and attention should be called to the facilities afforded for their doing so. Attention should also be called to the importance of avoiding contact with persons suffering from the disease, or coming into proximity to them, and of avoiding contact with any person or thing which may have become infected. It is important to notice that, even where vaccination has been neglected, there is great readiness to submit to it in the presence of a threatened epidemic ; a large number of vaccinations are then obtained willingly and without opposition. Whenever

a sanitary authority has received notification of a case of small-pox, we think the fact should be at once communicated to the vaccination authority of the district in which the case of the disease has occurred.

*Regulations as to Tramps, Inmates of Lodging-houses, etc.*

Our attention has been drawn to the circumstance that outbreaks of small-pox have not unfrequently had their origin in the introduction of the disease to common lodging-houses by tramps wandering from place to place. In view of this we make the following recommendations :—

- (i.) That common shelters which are not now subject to the law relating to common lodging-houses should be made subject to such law.
- (ii.) That there should be power to the local authority to require medical examination of all persons entering common lodging-houses and casual wards to see if they are suffering from small-pox, and to offer a reward for prompt information of the presence of the disease.
- (iii.) That the local authority should have power to order the keeper of a common lodging-house in which there has been small-pox to refuse fresh admissions for such time as may be required by the authority.
- (iv.) That the local authority should be empowered to require the temporary closing of any common lodging-house in which small-pox has occurred.
- (v.) That the local authority should have power to offer free lodgings to any inmate of a common lodging-house or casual ward who may reasonably be suspected of being liable to convey small-pox.
- (vi.) That the sanitary authority should give notice to all adjoining sanitary authorities of the occurrence of small-pox in common lodging-houses or casual wards.
- (vii.) That where the disease occurs, the Public Vaccinator or the Medical Officer of Health should attend and vaccinate the inmates of such lodging-houses or wards, except such as should be unwilling to submit themselves to the operation.

*Relaxation of the Vaccination Law.*

After careful consideration and much study of the subject, we have arrived at the conclusion that it would conduce to increased vaccination if a scheme could be devised which would preclude the attempt (so often a vain one) to compel those who are honestly opposed to the practice to submit their children to vaccination, and, at the same time, leave the law to operate, as at present, to prevent children remaining unvaccinated owing to the neglect or indifference of the parent. When we speak of an honest opposition to the practice, we intend to confine our remarks to cases in which the objection is to the operation itself, and to exclude



cases in which the objection arises merely from an indisposition to incur the trouble involved. We do not think such a scheme impossible.

It must of course be a necessary condition of a scheme of this description that it should be such as would prevent an objection to the practice being alleged merely as an excuse to save the trouble connected with the vaccination of the child. We may give the following as examples of the methods which might be adopted. It might be provided that if a parent attended before the local authority and satisfied them that he entertained such an objection, no proceedings should be taken against him. Or, again, a statutory declaration to that effect before any one now authorised to take such declaration, or some other specified official or officials, might be made a bar to proceedings. We do not think it would be any real gain to parents who had no conviction that the vaccination of their children was calculated to do mischief, to take either of these steps rather than submit them to the operation.

It is in England that the point we have been recently discussing is of most practical importance, but if our suggestion were adopted the change should, of course, be made in all parts of the United Kingdom.

(Signed)      **HERSCHELL.**  
**JAMES PAGET.**  
**CHARLES DALRYMPLE.**  
**W. GUYER HUNTER.**  
**EDWIN H. GALSWORTHY.**  
**JOHN S. DUGDALE.**  
**M. FOSTER.**  
**JONATHAN HUTCHINSON.**  
**FREDERICK MEADOWS WHITE.**  
**SAM. WHITBREAD.**  
**JOHN A. BRIGHT.**

**BRET INCE,**  
 Secretary.

August 1896.

The undersigned do not find themselves able to go so far in recommending relaxation of the law as is implied. We think that in all cases in which a parent or guardian refuses to allow vaccination, the person so refusing should be summoned before a magistrate, as at present, and that the only change made should be to permit the magistrate to accept a sworn deposition of conscientious objection, and to abstain from the infliction of a fine.

We are also of opinion that, in spite of the difficulties as set forth in paragraph 533,\* a second vaccination at the age of twelve ought to be made compulsory.

**W. GUYER HUNTER.**  
**JONATHAN HUTCHINSON.**

\* Of the Final Report.

We the undersigned desire to express our dissent from the proposal to retain in any form compulsory vaccination.

We cordially concur in the recommendation that conscientious objection to vaccination should be respected. The objection that mere negligence or unwillingness on the part of parents to take trouble might keep many children from being vaccinated would be largely, if not wholly, removed by the adoption of the Scotch system of offering vaccination at the home of the child, and by providing for medical treatment of any untoward results which may arise.

We therefore think that the modified form of compulsion recommended by our colleagues is unnecessary, and that in practice it could not be carried out.

The hostility which compulsion has evoked in the past toward the practice of vaccination is fully acknowledged in the Report. In our opinion the retention of compulsion in any form will in the future cause irritation and hostility of the same kind.

The right of the parent on grounds of conscience to refuse vaccination for his child being conceded, and the offer of vaccination under improved conditions being made at the home of the child, it would in our opinion be best to leave the parent free to accept or reject this offer.

SAM. WHITBREAD.

JOHN A. BRIGHT.

W. J. COLLINS.

J. ALLANSON PICTON.

*Note.—Dr. Collins and Mr. Picton sign the above note of reservation, though they have not signed the Report. A statement of their grounds of dissent from the Report will be found in the form of an Appendix (65 pages) to the Report. They make the following recommendations:—*

In accordance with the sub-head No. 2 of the reference to the Commission, we would suggest the following as the means other than vaccination which should be employed for protection of a community from small-pox:—

1. Prompt notification of any illness suspected to be small-pox. Improved instruction in the diagnosis of small-pox.
2. A hospital, suitably isolated, of adequate accommodation, in permanent readiness, and capable of extension if required. No other disease to be treated at the same time in the same place.
3. A vigilant sanitary staff ready to deal promptly with first cases, and if necessary to make a house-to-house inspection. The medical officer of health to receive such remuneration as to render him independent of private practice.
4. Prompt removal to hospital by special ambulance of all cases which cannot be properly isolated at home. Telephonic communication between Health Office and hospital.



5. Destruction of infected clothing and bedding, and thorough disinfection of room or house immediately after removal of the patient.
6. Daily observation (including, where possible, taking the temperature and inspection for rash) of all persons who have been in close contact with the patient during his illness ; such supervision to be carried out either in quarantine stations (away from the hospital) or at their own homes.
7. Closure of schools on the occasion of the occurrence of small-pox among the scholars or teachers.
8. Hospitals and quarantine stations to be comfortable and attractive, and so administered as to secure the confidence of the public. Hospital treatment to be free to all classes, and compensation to be paid to those detained or otherwise inconvenienced in the public interest, at the public expense.
9. Tramps entering casual wards to be medically inspected, their clothing to be disinfected, and bath provided. The measures for detection and isolation of small-pox in common lodging-houses suggested in section 507 of the Report to be carried out.
10. International notification of the presence of small-pox, and special vigilance at seaports in communication with infected places, after the plan adopted in the case of cholera.
11. Attention to general sanitation—prevention of overcrowding. abundant water supply, and frequent removal of refuse.

They conclude as follows :—

We believe the methods of isolation of the infected, disinfection, and the observance of strict cleanliness, are both more successful and more legitimate methods for the State to encourage. They have the advantage of applying the preventive only where it is required ; and they do not necessitate an operation upon the person of every healthy individual.

We therefore recommend that the law be amended by the repeal of the compulsory clauses of the Vaccination Acts. But in consideration of the prevalent belief in the value of vaccination as a prophylactic for an indefinite period, we suggest that in other respects the law should be left as it is, subject, however, to such modifications as are recommended for the diminution of attendant risks. The precedent established in the case of the abolition of compulsory church rates might be followed with advantage. In that case all machinery for laying and collecting the rate was left intact though the power of enforcement was taken away. The effect of our recommendation, if adopted, would be that vaccination would continue to be provided as at present for those who desire to avail themselves of it, but efforts to secure vaccination would be limited to moral influence—in a word, the whole country would be in the position of those unions in which the guardians have abandoned compulsion.

The grounds on which we object to the enforcement of vaccination by penalties necessarily lead us to object to any method of indirect

compulsion. We regard as both inexpedient and unjust exclusion from any branch of the public service because of the refusal to submit to vaccination or re-vaccination. The injustice is perhaps most severely felt in the case of candidates for employment as pupil-teachers in public elementary schools. There are now districts in which, owing to the general opposition to vaccination, scarcely a girl or boy can be found who is legally eligible, and candidates have to be brought in at great inconvenience from surrounding districts. The existence of an exceptional case or cases in which such rejected candidates have at some time afterwards taken small-pox is in our view no justification for the continuation of this grievance. Statistics furnished to the Commission prove that large numbers of vaccinated or re-vaccinated persons have taken the disease; and we are not aware of any evidence to show that vaccinated pupil-teachers have any special immunity. If our recommendations were carried out, the danger of contagion would be greatly diminished in schools, as elsewhere.

On the whole, then, while there is much in the report of our colleagues from which we dissent, and we have accordingly abstained with reluctance from adding our signatures to theirs, we are at one with them in holding that it is unwise to attempt to enforce vaccination on those who regard it as useless and dangerous. We, however, go further, and agree with our colleagues, Mr. Whitbread and Mr. Bright, that it would be simpler and more logical to abolish compulsory vaccination altogether.



I N D E X .





# INDEX.

---

## A

- Abbé's condenser, 74
- Aberration, chromatic, 67
  - spherical, 67
- Abscess, 173
- Achorion Schonleinii, 584
- Actinomycosis, 413—447
  - bovis, 434
  - cattle to cattle, 444
  - cultivation of, 436
  - hominis, 431
  - in cattle, 429
  - in man, 426
  - transmission of, from man to lower animals, 443
- Agar-agar, 625
- Air, compressed, 24
  - examination of, 140
  - Hesse's method, 141
  - Koch's „ 141
  - Petri's „ 142
  - Pouchet's „ 143
  - Sedgwick's „ 143
- Aitken's tubes, 129, 630
- Alexines, 57
- Alum carmine, 616
- Amœba coli, 610
- Anaerobes, classified, 494
  - cultivation of, 130—133
- Aniline water, 617
- Animals Order, 1878, 455
- Anthrax, 42, 183, 191—216
  - bacillus of, 192, 197
  - in horses, 207
  - in swine, 203
  - origin and spread of, 198
  - preventive inoculation, 209
  - „ measures in, 199

- Anthrax, stamping out system, 210
- Antiseptics, 30
- Antitoxins, 56, 57
  - diphtheria, 58—62
  - septic infections, 63
  - tetanus, 62
  - typhoid, 64
- Arthrospores, 19
- Artificial fluids as media, 120
- Ascococcus, 14
  - Billrothii, 498
  - citreus, 498
- Ascomycetes, 584
- Asiatic cholera, 360
- Aspergillus albus, 588
  - clavatus, 588
  - flavescens, 588
  - flavus, 586
  - fumigatus, 586
  - glaucus, 586
  - nidulans, 588
  - niger, 587
  - ochraceus, 588
  - repens, 586
  - subfuscus, 588

## B

- Babès' incubator, 633
- Bacillus, 13, 488
  - acidiformans, 498
  - acidi lactici, 498
  - aerogenes, 499
  - — capsulatus, 499
  - aerophilus, 499
  - albus, 499
  - — anaerobiescens, 499
  - — cadaveris, 499
  - — putidus, 499

- Bacillus allantoides*, 499  
 — *alii*, 499  
 — *alvei*, 470  
 — *amylobacter*, 502  
 — *amylozyma*, 500  
 — *anaerobicus liquefaciens*, 500  
 — *anthracis*, 192  
 — *aquatilis*, 500  
 — — *fluorescens*, 500  
 — — *graveolens*, 500  
 — — *sulcatus*, 500  
 — *arborescens*, 500  
 — *argenteo-liquefaciens*, 501  
 — — *phosphorescens*, 501  
 — *aurantiacus*, 501  
 — *aureus*, 501  
 — *beroliniensis indicus*, 502  
 — *brassicæ*, 502  
 — *brevis*, 502  
 — *brunneus*, 502  
 — *buccalis fortuitus*, 502  
 — — *maximus*, 502  
 — — *minutus*, 502  
 — *butyricus*, 502, 503  
 — *cadaveris*, 503  
 — *canalis capsulatus*, 504  
 — — *parvus*, 504  
 — *candicans*, 504  
 — *capsulatus*, 504  
 — — *mucosus*, 504  
 — — *suis*, 504  
 — *carabiformis*, 504  
 — *carnicolor*, 504  
 — *carotarum*, 505  
 — *cavicida*, 505  
 — *chromo-aromaticus*, 505  
 — — *Havaniensis*, 505  
 — *circulans*, 505  
 — *citreus cadaveris*, 505  
 — *cloacæ*, 505  
 — *cœruleus*, 505  
 — *coli communis*, 344  
 — — *similis*, 506  
 — *constrictus*, 506  
 — *coprogenes fœtidus*, 506  
 — — *parvus*, 506  
 — *crassus aromaticus*, 506  
 — — *sputigenus*, 506  
 — *cuniculicida*, 228  
 — *cuticularis*, 506  
 — — *albus*, 506  
 — *cyaneo-fuscus*, 507  
 — *Bacillus cyaneo-phosphorescens*, 507  
 — *cyanogenus*, 507, 508  
 — *cystiformis*, 508  
 — *delicatulus*, 508  
 — *dentalis viridans*, 508  
 — *dentriticus*, 508  
 — *devorans*, 508  
 — *diffusus*, 508  
 — *diphtheriæ*, 332—336  
 — — *columbarum*, 336  
 — — *vitulorum*, 509  
 — *dysodes*, 509  
 — *endocarditidis capsulatus*, 509  
 — — *griseus*, 509  
 — *enteritidis*, 372  
 — *epidermidis*, 509  
 — *erysipelatis suis*, 356  
 — *erythrosporus*, 509  
 — *figurans*, 510, 511  
 — *filiformis*, 511  
 — — *Havaniensis*, 511  
 — *flavescens*, 511  
 — *flavocoriaceus*, 511  
 — *fluorescens aureus*, 511  
 — — *liquefaciens*, 511  
 — — *longus*, 512  
 — — *minutissimus*, 512  
 — — *nivalis*, 512  
 — — *non-liquefaciens*, 512  
 — — *putidus*, 512  
 — — *tennis*, 512  
 — *fœtidus*, 513  
 — — *ozænæ*, 513  
 — *fulvus*, 513  
 — *fuscus*, 513  
 — — *limbatus*, 513  
 — *gallarum*, 513  
 — *gasoformans*, 513  
 — *glaucus*, 513  
 — *gliscrogenus*, 513  
 — *gracilis*, 514  
 — *granulosus*, 514  
 — *graveolens*, 514  
 — *guttatus*, 514  
 — *hæmorrhagic septicæmia*, 231  
 — *halophilus*, 514  
 — *Hansenii*, 514  
 — *Havaniensis*, 505  
 — — *liquefaciens*, 514  
 — *helvolus*, 515  
 — *heminecrobiophilus*, 515  
 — *hepaticus fortuitus*, 515



- Bacillus Hessii*, 515  
 — *hyacinthi septicus*, 515  
 — *hyalinus*, 515  
 — *hydrophilus fuscus*, 515  
 — *ianthinus*, 516  
 — *implexus*, 516  
 — in *acne contagiosa* in horses, 516  
 — in cancer, 516  
 — *incanus*, 518  
 — in cholera in ducks, 516  
 — in choleraic diarrhœa, 516  
 — *indicus*, 518  
 — *indigenus*, 519  
 — in diphtheritic disease of calves, 516  
 — in erythema nodosum, 517  
 — in infectious disease of bees, 471  
 — *inflatus*, 519  
 — in fowl enteritis, 230  
 — in gangrene, 517  
 — in grouse disease, 517  
 — in hog cholera, 517  
 — in infantile diarrhœa, 517  
 — in intestinal diphtheria in rabbits, 517  
 — in jequirity infusion, 517  
 — in measles, 517  
 — in noma, 517  
 — in potato rot, 517  
 — in purpura hæmorrhagica, 517  
 — in putrid bronchitis, 518  
 — in "red-cod," 518  
 — in rhinoscleroma, 518  
 — in saliva, 518  
 — in swine fever, 346-352  
   — *erysipelas*, 354  
   — measles, 354  
 — *inunctus*, 519  
 — *invisibilis*, 518  
 — in whooping cough, 518  
 — *iridescens*, 519  
 — *iris*, 519  
 — *lactericeus*, 520  
 — *lactis aerogenes*, 519  
   — *albus*, 520  
   — *erythrogenes*, 520  
   — *pituitosi*, 520  
 — *leporis lethalis*, 520  
 — *lepræ*, 407  
 — *leptosporus*, 520  
 — *limbatus acidi lactici*, 520  
 — *limosus*, 520  
 — *Bacillus liodermos*, 521  
   — *liquefaciens*, 521  
   — *communis*, 521  
   — *magnus*, 521  
   — *parvus*, 521  
   — *liquidus*, 521  
   — *litoralis*, 521  
   — *lividus*, 524  
   — *luteus*, 524  
   — *maidis*, 524  
   — *mallei*, 452  
   — *megatherium*, 524  
   — *membranaceus amethystinus*, 525  
   — *meningitidis purulentæ*, 525  
   — *mesentericus fuscus*, 525  
   — *ruber*, 525  
   — *vulgatus*, 526  
   — *multipediculus*, 522  
   — *muscoïdes*, 522  
   — *mycoïdes*, 522 524  
   — *roseus*, 522 524  
   — *neapolitanus*, 522  
   — *necrophorus*, 523  
   — *nitrificans*, 523  
   — *nodosus parvus*, 523  
   — *nubilus*, 523  
   — *ochraceus*, 523  
   — *œdematis aerobicus*, 523  
   — *maligni*, 220  
   — of Belfanti and Pascarella, 523  
   — of Colomiatti, 526  
   — of Fulles, 526  
   — of Guillebeau, 526  
   — of Letzerich, 526  
   — of Martinez, 526  
   — of Nocard, 526  
   — of Okada, 526  
   — of quarter-evil, 217  
   — of Roth, 526  
   — of Sattler, 526  
   — of Schaffer, 527  
   — of Scheurlen, 527  
   — of Schou, 527  
   — of septicæmia of buffaloes, 226  
   — of guinea-pigs, 224  
   — of mice, 225  
   — of swine plague, 351  
   — of Tommasoli, 527  
   — of Utpadel, 527  
   — of Winogradsky, 527  
   — *ophthalmia*, 190  
   — *ovatus minutissimus*, 527

- Bacillus oxytocus perniciosus*, 527  
 — pestifer, 528  
 — phosphorescens gelidus, 528  
 — — indicus, 528  
 — — indigenus, 528  
 — plicatus, 528  
 — pneumoniae crouposæ, 233  
 — pneumosepticus, 528  
 — polypiformis, 528  
 — prodigiosus, 528  
 — proteus fluorescens, 529  
 — pseudo-diphtheriticus, 529  
 — — tuberculosis, 529  
 — pulpæ pyogenes, 529  
 — punctatus, 529  
 — putrificus coli, 529  
 — pyocyaneus, 529  
 — pyogenes foetidus, 530  
 — — soli, 530  
 — radiatus, 530  
 — — aquatilis, 530  
 — ramosus, 531  
 — reticularis, 531  
 — rhinoscleroma, 411  
 — rosaceus metalloides, 531  
 — rubefaciens, 531  
 — rubellus, 531  
 — ruber, 531  
 — rubescens, 532  
 — rubidus, 532  
 — sanguinis typhi, 532  
 — saprogenes, 532  
 — scissus, 532  
 — septicæmiæ hæmorrhagica, 231  
 — septicus, 532  
 — — acuminatus, 533  
 — — agrigenus, 533  
 — — keratomolaciæ, 533  
 — — ulceris gangrænosæ, 533  
 — — vesicæ, 533  
 — sessilis, 533  
 — smaragdino-phosphorescens, 533  
 — smaragdinus foetidus, 534  
 — solidus, 534  
 — spiniferus, 534  
 — spinosus, 534  
 — stolonatus, 534  
 — stoloniferus, 534  
 — striatus albus, 534  
 — — flavus, 534  
 — subflavus, 535  
 — subtilis, 535
- Bacillus subtilis similans*, 536  
 — sulfureus, 536  
 — superficialis, 537  
 — syphilis, 410  
 — tenuis sputigenus, 537  
 — termo, 537  
 — tetani, 457  
 — thelassophilus, 537  
 — thermophilus, 537  
 — tremelloides, 537  
 — tuberculosis, 378  
 — — gallinarum, 402  
 — tumescens, 537  
 — typhi abdominalis, 342—346  
 — — murium, 359  
 — ubiquitous, 537  
 — ulna, 538  
 — vacuolosis, 538  
 — varicosus conjunctivæ, 538  
 — venenosus, 538  
 — — brevis, 538  
 — — invisibilis, 538  
 — — liquefaciens, 539  
 — ventriculi, 539  
 — vermicularis, 539  
 — vermiculosus, 539  
 — violaceus, 539  
 — — laurentius, 539  
 — virescens, 539  
 — viridis pallescens, 539  
 — viscosus, 540  
 — Zurnianus, 540
- Bacteriaceæ, 480  
 Bacteria, chemical action on, 25  
 — — products of, 39  
 — composition of, 11  
 — distribution of, 29  
 — form of, 13  
 — growth of, 23, 25  
 — in cattle plague, 296  
 — in diphtheria of pigeons, 336  
 — in distemper, 358  
 — in foot and mouth disease, 300  
 — in horse-pox, 312  
 — in liquids, 83  
 — in louping-ill, 463  
 — in measles, 283  
 — in pus, 176  
 — in rabies, 460  
 — in scarlet fever, 262  
 — in sheep-pox, 298  
 — in small-pox, 285



- Bacteria in vaccine lymph, 324—326  
 — in yellow fever, 260  
 — microscopic examination of, 83  
 — nitrifying, 27  
 — pathogenic, 27  
 — saprogenic, 26  
 — stained, 85  
 — unstained, 84  
*Bacterium aerogenes*, 540  
 — *brunneum*, 540  
 — *fusiforme*, 540  
 — *gingivæ pyogenes*, 540  
 — *hyacinthi*, 540  
 — *hydrosulfureum ponticum*, 540  
 — *litoreum*, 540  
 — *luteum*, 540  
 — *merismopedioides*, 541  
 — *navicula*, 541  
 — *photometricum*, 541  
 — *synxanthum*, 541  
 — *termo*, 541  
 — *tholæideum*, 541  
 — *ureæ*, 541  
 — *violaceum*, 541  
 — *Zopfii*, 542  
*Beggiatoa alba*, 542  
 — *roseo-persicina*, 542  
 Bibliography, 639  
 Bilious fever, 183  
 Biondi's stain, 615  
 Bismarck-brown, 617  
 Blepharadenitis, 184  
 Blood-serum, 113, 114, 119  
 Borax carmine, 617  
 Botrytis Bassiana, 588  
 Bread paste, 118  
 Broncho-pneumonia, 183  
 Broth, 118  
 Bunge's method of staining flagella,  
 92
- C
- Camera lucida, 621  
 Cancer bodies, 610  
 Caoutchouc caps, 626  
 Caterpillars, disease of, 492  
 Cattle plague, 293—296  
 — tuberculosis of, 389  
 Cerebro-spinal meningitis, 184  
 Chemical action on bacteria, 25  
 — disinfectants, 32—36  
 — products of bacteria, 39
- Chemiotaxis, 54  
*Chionyphe Carteri*, 588  
 Cholera, 360  
 — bacteria of, 371  
 — comma bacilli of, 361—367  
 — diarrhœa from meat-poisoning.  
 371  
 — diarrhœa in fowls, 373  
 — nostras, 370  
 — protective inoculation, 369  
 — Ptomaines, 41  
 — spirillum of, 361  
 Chromogenic bacteria, 25  
 Cladotrachea, 480  
 Cladotrix, 479  
 — *dichotoma*, 543  
 — *Försteri*, 544  
 — *intricata*, 544  
 — *invulnerabilis*, 544  
 Classification, 475, 487, 482, 481  
*Clostridium butyricum*, 544  
 — *fœtidum*, 545  
 Coccaceæ, 480  
 Cocci, 485  
 Coccidia, 609  
 Comma bacilli, 361—367  
 Cover-glass preparations, 86  
 Cow-pox, 274—282, 312—324, 326—  
 328  
*Crenothrix Kühniana*, 545
- D
- Dacryocystis, 184  
 Damp chambers, 628  
 D'Arsonval's incubator, 631  
 Davaine's septicæmia, 228  
 De Bary's classification, 481  
 Decalcifying, 93, 615  
 Defensive proteids, 57  
 Deneke's comma bacillus, 367  
 Desiccators, 638  
 Diarrhœa, choleraic, 371  
 Diphtheria, 330, 182  
 — antitoxin in, 58—62  
 — bacillus of, 332  
 — in milk, 338  
 — in pigeons, 336  
 — Löffler's stain for, 88  
 — Ptomaines of, 46  
 Diplococcus, 14  
 — *albicans amplus*, 547  
 — *tardissimus*, 547

*Diplococcus citreus conglomeratus*,  
547  
— — liquefaciens, 547  
— coryzæ, 547  
— flavus liquefaciens tardus, 547  
— fluorescens fœtidus, 547  
— intercellularis meningitidis, 548  
— luteus, 548  
— pneumoniae, 233—238  
— — of horses, 548  
— roseus, 548  
— subflavus, 548  
Distemper in dogs, 358  
Drop-cultures, 120  
Duck cholera, 230  
Dysentery, 373

## E

Ebner's solution, 615  
Egyptian ophthalmia, 190  
Ehrlich's staining method, 89  
Electricity, 24, 127  
Embedding, 93, 615  
*Empusa muscæ*, 581  
— — radicans, 582  
Endospores, 18  
Enteric, 41, 340  
Enzymes, 48  
Eosin, 89, 617  
Epidemic disease of deer and boars,  
227  
— — of ferrets, 358  
— — of mice, 358  
Erysipelas, 185—189  
Esmarch's roll-cultures, 113  
Experiments on animals, 134, 394

## F

Farrant's solution, 621  
Favus, 584  
Filter, hot water, 624  
Flacherie, 472  
Flagella, 17, 90  
Flügge's classification, 481  
Foot rot, 464  
Form of bacteria, 13  
Foul-brood, 469  
Fowl cholera, 228  
— — enteritis, 230  
— — scab, 586  
Friedländer's bacillus, 233  
Fuchsine, 617

## G

Gangrene, 182  
Gas chamber, 127  
Gases produced by bacteria, 24  
Gentian violet stain, 617  
Giant cells, 376  
Gibbes' solution, 618  
Glanders, 451  
— — bacillus of, 452  
— — mallein in, 454  
— — ptomaine, 48  
Glycerine agar, 104  
Glycerine gelatine, 615  
*Gonococcus* of Neisser, 189  
Gonorrhœa, 189  
Gram's method, 88, 89, 97, 618  
Grease, 303  
Grouse disease, 230

## H

*Hæmatococcus bovis*, 548  
*Hæmatomonas carassii*, 605  
— — cobitis, 603  
*Hæmatoxylin*, 618  
*Hæmatozoa*, 589, 593, 599, 603  
Hardening, 93, 615  
*Helicobacterium aerogenes*, 549  
*Herpetomonas Lewisi*, 599  
Hessert's stain, 92  
Historical introduction, 1  
Horse-pox, 303, 312  
Hot air and steam, 36, 623  
Hot water filter, 624  
Hueppe's classification, 482  
— — inspissator, 630  
Hydrophobia, 459  
Hyphomycetes, 581  
*Hypodermii*, 581

## I

Illumination, 75  
Immersion system, 69  
Immunity, 50—57  
Impression preparations, 92  
Incubators, 631  
Infectious pleuro-pneumonia, 239, 247  
Influenza, 247—249  
Inspissators, 629  
Involution forms, 15  
Iodine, 618  
Isolation of micro-organisms, 139  
Israel's case, 628



## K

- Klein's micrococcus of pneumonia, 238  
 Kleinenberg's solution, 616  
 Koch's comma bacillus, 361  
 — postulates, 9  
 — serum steriliser, 629  
 — steam steriliser, 622

## L

- Leprosy, 406  
 — bacillus of, 407  
 — stamping out system, 409  
 Leptothrix, 480  
 — buccalis, 549  
 — gigantea, 549  
 Leuconostoc, 549  
 Leukæmia, 184  
 Light, effect of, on bacteria, 24  
 Lister's flasks, 128, 630  
 Lithium carmine solution, 618  
 Löffler's solution, 619  
 — stain, 88, 90  
 Louping ill, 462  
 — bacillus of, 463  
 Lutesch's stain, 91

## M

- Madura disease, 447  
 Magenta solution, 618  
 Malaria, 589  
 Malignant œdema, 220  
 Mallein, 454  
 Measles, bacteria in, 183, 283  
 Media, 99  
 Merismopedia, 14  
 Methyl violet, 619  
 Methylene blue, 618, 619  
 Micrococcus acidilactici, 550  
 — — — liquefaciens, 550  
 — aerogenes, 551  
 — agilis, 551  
 — — citreus, 551  
 — albus liquefaciens, 551  
 — amyliivorus, 551  
 — aquatilis, 551  
 — — invisibilis, 551  
 — auranticaeus, 551  
 — botyogenus, 552  
 — candicans, 552  
 — candidus, 552  
 — carneus, 552  
 — cerasinus siccus, 552

- Micrococcus cereus albus, 178  
 — — flavus, 178  
 — cinnabareus, 552  
 — citreus, 552  
 — concentricus, 553  
 — cremoides, 553  
 — crepusculum, 553  
 — cumulatus tenuis, 553  
 — endocarditidis rugatus, 553  
 — fervidosus, 553  
 — Finlayensis, 553  
 — flavus desideus, 553  
 — — liquefaciens, 554  
 — — tardigradus, 554  
 — foetidus, 554  
 — Freudenreichi, 554  
 — fuscus, 554  
 — gingivæ pyogenes, 554  
 — gonorrhœæ, 190  
 — Havaniensis, 555  
 — in abscess in rabbits, 556  
 — in Biskra button, 555  
 — in gangrenous mastitis in sheep, 555  
 — in infectious pleuro-pneumonia, 555  
 — in influenza, 555  
 — in pemphigus, 555-6  
 — in pneumonia, 236, 238, 556  
 — in pyæmia in rabbits, 556  
 — in septicæmia in rabbits, 556  
 — in syphilis, 557  
 — in trachoma, 190  
 — lactis viscosus, 557  
 — luteus, 557  
 — melitensis (Malta fever), 557  
 — ochroleucus, 557  
 — plumosus, 557  
 — pneumoniæ crouposæ, 236  
 — pyogenes tenuis, 557  
 — rosaceus, 558  
 — rosettaceus, 558  
 — salivarius septicus, 558  
 — stellatus, 588  
 — tetragenus, 558  
 — — mobilis ventriculi, 558  
 — — subflavus, 558  
 — — versatilis, 558  
 — ureæ liquefaciens, 559  
 — versicolor, 559  
 — violaceus, 559  
 — viticulosus, 559

- Micrometer, 80  
 Microscope, 65, 612  
 Microsporon furfur, 586  
 Microtomes, 94, 614  
 Miescher's tubes, 609  
 Mildew, 581  
 Milk, 120  
   — scarlatina, 265, 282  
   — tubercular, 291  
 Miquel's bulbs, 129  
 Moist chambers and cells, 121  
 Moitessier's gas regulator, 634  
 Monads, 601  
 Monas Okenii, 560  
   — Vinosa, 560  
   — Warmingii, 560  
 Mouse favus, 586  
 Movements of bacteria, 15, 24  
 Mucors, 583  
 Müller's fluid, 616  
 Myconostoc gregarium, 560  
 Myco-protein, 11
- N
- Nature of soil for bacteria, 23  
 Neelsen's solution, 89, 98, 619  
 Nicols' stain, 92  
 Nitromonas of Winogradsky, 560  
 Nutrient agar, 103  
 Nutrient gelatine, 100
- O
- Oidium albicans, 586  
   — lactis, 584  
   — Tuckeri, 584  
 Oil immersion, 70  
 Orseille, 619
- P
- Parietti's method, 148  
 Pasteur's apparatus, 130  
 Pathogenic bacteria, 27  
 Pébrine, 471  
 Pediococcus acidi lactici, 560  
   — cerevisiæ, 560  
 Penicillium glaucum, 588  
 Peronospora infestans, 582  
 Petri's method exam. of air, 142  
 Pfeiffer bodies, 610  
 Phagocytosis, 27, 55  
 Photogenic bacteria, 25  
 Photography of bacteria, 150, 168
- Photo-micrographic apparatus, 621  
 Phycomycetes, 582  
 Phylaxins, 57  
 Picric acid, 619  
 Picro-carmine, 619  
 Picro-lithium carmine, 620  
 Pilobolus, 583  
 Plague, bacillus of, 250, 252  
 Plate cultivations, 106  
 Platinum needles, 83, 616  
 Pleuro-pneumonia, 239  
 Pneumobacillus liquefaciens bovis,  
   242, 560  
 Pneumonia, 233—238  
   — ptomaines, 48  
 Potash solution, 620  
 Potato medium, 115—117  
 Pouchet's microscope, 143  
 Preservation of preparations, 93  
 Protective inoculation, 49  
   — — in anthrax, 209  
   — — in cholera, 369  
   — — in rabies, 460  
   — — in sheep-pox, 298  
   — — in small-pox, 285, 293  
   — — in swine erysipelas, 336  
 Proteus capsulatus septicus, 560  
   — hominis capsulatus, 224  
   — in gangrene of the lung, 560  
   — microsepticus, 560  
   — mirabilis, 561  
   — septicus, 561  
   — sulfureus, 561  
   — vulgaris, 561  
   — Zenkeri, 562  
 Pseudo-diphtheritic bacillus, 335  
 Pseudo-diplococcus pneumoniæ, 562  
 Psorosperms, 609  
 Ptomaines, 39  
 Pus, bacteria in, 176  
 Putrefactive bacteria, 26, 28  
 Pyæmia, 175
- Q
- Quarter-evil, 217
- R
- Rabies, 459—462  
 Rag-pickers' septicæmia, 224  
 Refraction, 65  
 Relapsing fever, 257  
 Reproduction, 18



Respiration of bacteria, 22  
 Rhabdomonas rosea, 562  
 Rhinoscleroma, 411  
 Ringworm, 585

## S

- Saccharomyces acidi lactici, 580  
 — albicans, 579  
 — anomalus, 579  
 — apiculatus, 578  
 — aquifolii, 580  
 — cerevisiæ, 577  
 — conglomeratus, 578  
 — ellipsoideus, 577  
 — exiguus, 578  
 — glutinus, 579  
 — Hansenii, 580  
 — ilicis, 580  
 — Jörgensenii, 578  
 — Ludwigii, 580  
 — Marxianus, 580  
 — membranæfaciens, 580  
 — minor, 580  
 — niger, 580  
 — pastorianus, 578  
 — pyriformis, 579  
 — rosaceus, 580  
 — sphaericus, 579  
 Safranine, 620  
 Sapræmia, 175  
 Saprogenic bacteria, 26  
 Saprolegina, 582  
 Saprophytic bacteria, 27  
 Sarcinæ, 487  
 Sarcina alba, 562  
 — aurantiaca, 562  
 — candida, 563  
 — flava, 563  
 — hyalina, 563  
 — intestinalis, 563  
 — litoralis, 563  
 — lutea, 563  
 — mobilis, 563  
 — pulmonum, 563  
 — Reitenbachii, 564  
 — rosea, 564  
 — urinæ, 564  
 — ventriculi, 564  
 Scarlet fever, 261  
 Schizomycetes, 477  
 Schlosing's membrane regulator, 632  
 Sclavo's stain, 91  
 Septicæmia, 175  
 — of calves, 227  
 — of Davaine, 224  
 — of guinea-pigs, 224  
 — of mice, 225  
 — of rabbits, 228  
 — of rag-pickers, 224  
 Serum therapy, 56  
 Sheep-pox, 297  
 Small-pox, 182, 284-293, 326  
 Smut, 581  
 Soil, examination of, 144  
 Sozins, 57  
 Sphærotilus natans, 564  
 Spirilla, 495  
 Spirillum amyliiferum, 564  
 — anserum, 564  
 — attenuatum, 564  
 — aureum, 564  
 — cholerae Asiaticæ, 361  
 — choleroïdes, 565  
 — concentricum, 565  
 — dentium, 565  
 — Finkler and Prior, 258  
 — flavescens, 565  
 — flavum, 565  
 — Günther, 566  
 — leucomelaneum, 565  
 — linguæ, 565  
 — marinum, 565  
 — Metchnikovi, 373  
 — Miller, 566  
 — nasale, 566  
 — Neisser, 566  
 — Obermeieri, 258  
 — plicatile, 466  
 — Renon, 566  
 — rosaceum, 566  
 — Rosenbergii, 566  
 — rubrum, 569  
 — rufum, 566  
 — rugula, 567  
 — sanguineum, 567  
 — saphrophiles, 567  
 — serpens, 568  
 — Smith, 566  
 — sputigenum, 568  
 — suis, 568  
 — tenue, 568  
 — tyrogenum, 568  
 — undula, 568  
 — volutans, 568

- Spirillum* Weibel, 566  
*Spirochæta*, 596  
*Spiromonas* Cohnii, 569  
 — *volubilis*, 569  
 Spontaneous generation, 3  
 Spores, 18  
 Staining spores, 90  
*Staphylococcus*, 14  
 — *cereus albus*, 178, 324  
 — *flavus*, 178  
 — *pyogenes albus*, 178  
 — — *aureus*, 176, 324  
 — — *citreus*, 178  
 — *pyosepticus*, 569  
 — *salivarius pyogenes*, 569  
 — *viridis flavescens*, 569  
 Sternberg's bulbs, 128, 630  
*Streptococcus*, 14  
 — *acidi lactici*, 569  
 — *albus*, 569  
 — *bombycis*, 472  
 — *brevis*, 569  
 — *cadaveris*, 570  
 — *coli gracilis*, 570  
 — *conglomeratus*, 570  
 — *flavus desidens*, 570  
 — *giganteus urethræ*, 570  
 — *Havaniensis*, 570  
 — *in contagious mammitis in cows*, 570  
 — *in progressive necrosis in mice*, 571  
 — *in strangles*, 571  
 — *liquefaciens*, 571  
 — *mirabilis*, 571  
 — *of Bonome*, 571  
 — *of erysipelas*, 185, 189  
 — *of Manneberg*, 571  
 — *perniciosus psittacorum*, 572  
 — *pyogenes*, 178-184  
 — *radiatus*, 572  
 — *septicus*, 572  
 — — *liquefaciens*, 572  
 — *vermiformis*, 572  
*Streptothrix*, 496  
 — *actinomycotica*, 431  
 — *albus*, 572  
 — *asteroides*, 573  
 — *aurantiaca*, 573  
 — *carnea*, 573  
 — *chromogena*, 573  
 — *farcinica*, 573  
 — *Streptothrix Försteri*, 573  
 — — *Hoffmanni*, 573  
 — — *liquefaciens*, 573  
 — — *Maduræ*, 449  
 — — *musculorum suis*, 573  
 — — *odorifera*, 573  
 — — *violacea*, 573  
 Substage condenser, 74  
 Suppuration, 48  
 Surgical fever, 182  
 Surra, 593  
 Swine erysipelas, 354  
 — fever, 46, 227  
 — measles, 354  
 Syphilis, 183, 410
- T
- Tarichium megaspermum*, 582  
 Temperature for bacteria, 24  
 Test-tube cultivations, 105  
 Tetanus, 457  
 — *ptomaine*, 41  
 Thermo-regulators, 635  
*Tilletia caries*, 581  
*Toxalbumins*, 39  
 Trachoma, 412  
 Trenkmann's stain, 91  
*Trichomonas*, 607  
*Tricophyton tonsurans*, 585  
 Tripod levelling apparatus, 627  
 Tuberculosis, 43, 375  
 — and meat, 397  
 — and public health, 391  
 — antitoxin, 64  
 — bacillus of, 378  
 — giant cells in, 376  
 — in animals, 389, 394, 399, 400  
 — in man, 387  
 Typhoid, 340  
 Typhus, 259
- U
- Ulcerative endocarditis, 183  
*Undulina ranarum*, 607  
*Uredo*, 581  
 Urine as a medium, 120  
*Urobacillus Duclauxi*, 573  
 — *Freudenreichi*, 574  
 — *Maddoxi*, 574  
 — *Pasteuri*, 574  
 — *Schutzenbergi*, 574



Urocystis occulta, 581  
 Ustilago carbo, 581

## V

Van Ermengen's stain, 91  
 Vegetable infusions as media, 120  
 Vesuvius, 620  
 Vibrio rugosa, 574

## W

Warmstage, 123, 124  
 Water bath, 624  
 — examination of, 145

Weigert's stain, 296  
 Wort gelatine, 104

## X

Xyloxylin, 616

## Y

Yeasts, 577  
 Yellow fever, 182, 259

## Z

Zooglyma, 13  
 Zopf's classification, 480







# Medical and Scientific Works

JUST ISSUED AND IN PREPARATION  
FOR EARLY PUBLICATION

BY

**W. B. SAUNDERS,**

925 WALNUT STREET, PHILADELPHIA.

\*.\* The *published* books of this "Bulletin" will be sent carriage prepaid on receipt of the respective prices.

JUST ISSUED.

SOLD BY SUBSCRIPTION.

## An American Text-Book of PHYSIOLOGY.

BY

**HENRY P. BOWDITCH, M. D.,**  
Professor of Physiology, Harvard Medical School.

**JOHN G. CURTIS, M. D.,**  
Professor of Physiology, Columbia University, N. Y. (Coll. of Phys. and Surg.).

**HENRY H. DONALDSON, Ph. D.,**  
Head-Professor of Neurology, University of Chicago.

**W. H. HOWELL, Ph. D., M. D.,**  
Professor of Physiology, Johns Hopkins University.

**FREDERIC S. LEE, Ph. D.,**  
Adjunct Prof. Physiology, Columbia University, N. Y. (Coll. of Phys. and Surg.).

**WARREN P. LOMBARD, M. D.,**  
Professor of Physiology, University of Michigan.

**GRAHAM LUSK, Ph. D.,**  
Professor of Physiology, Yale Medical School.

**W. T. PORTER, M. D.,**  
Assistant Professor of Physiology, Harvard Medical School.

**EDWARD T. REICHERT, M. D.,**  
Professor of Physiology, University of Pennsylvania.

**HENRY SEWALL, Ph. D., M. D.,**  
Professor of Physiology, Medical Department, University of Denver.

EDITED BY

**WILLIAM H. HOWELL, Ph. D., M. D.,**

Professor of Physiology, Johns Hopkins University.

This work is the most notable attempt yet made in America to combine in one volume the entire subject of Human Physiology by well-known teachers who have given especial study to that part of the subject upon which they write. The completed work represents the present status of the science of Physiology, particularly from the standpoint of the student of medicine and of the medical practitioner.

The main divisions of the subject-matter are as follows: General Physiology of Muscle and Nerve—Secretion—Chemistry of Digestion and Nutrition—Movements of the Alimentary Canal, Bladder, and Ureter—Blood and Lymph—Circulation—Respiration—Animal Heat—Central Nervous System—Special Senses—Special Muscular Mechanisms—Reproduction—Chemistry of the Animal Body.

One Handsome Octavo Volume of 1052 Pages.

PRICES: Cloth, \$6.00 net; Sheep or Half Morocco, \$7.00 net.

READY JAN. 1, 1897.

SOLD BY SUBSCRIPTION.

# ANOMALIES AND CURIOSITIES OF MEDICINE.

BY

GEORGE M. GOULD, M. D.,

AND

WALTER L. PYLE, M. D.

Several years of exhaustive research have been spent by the authors in the great medical libraries of the United States and Europe in collecting the material for this work. **Medical literature of all ages and all languages** has been carefully searched, as a glance at the Bibliographic Index will show. The facts, which will be of **extreme value to the author and lecturer**, have been arranged and annotated, and full reference footnotes given, indicating whence they have been obtained.

In view of the persistent and dominant interest in the anomalous and curious, a **thorough and systematic collection** of this kind (the first of which the authors have knowledge) must have its own peculiar sphere of usefulness.

As a complete and authoritative **Book of Reference** it will be of value not only to members of the medical profession, but to all persons interested in general scientific, sociologic, and medico-legal topics; in fact, the general interest of the subject and the dearth of any complete work upon it make this volume **one of the most important literary innovations of the day**.

An especially valuable feature of the book consists of the **Indexing**. Besides a complete and comprehensive **General Index**, containing numerous cross-references to the subjects discussed, and the names of the authors of the more important reports, there is a convenient **Bibliographic Index** and a **Table of Contents**.

The plan has been adopted of printing the **topical headings in bold-face type**, the reader being thereby enabled to tell at a glance the subject-matter of any particular paragraph or page.

**Illustrations** have been freely employed throughout the work, there being 165 relief cuts and 130 half-tones in the text, and 12 colored and half-tone full-page plates—a total of over 320 separate figures.

The careful rendering of the text and references, the wealth of illustrations, the mechanical skill represented in the typography, the printing, and the binding, combine to make this book one of the **most attractive medical publications ever issued**.

---

Handsome Imperial Octavo Volume of 968 Pages.  
PRICES: Cloth, \$6.00 net; Half Morocco, \$7.00 net.



# An American Text-Book of APPLIED THERAPEUTICS.

For the Use of Practitioners and Students.

EDITED BY J. C. WILSON, M. D.

Professor of the Practice of Medicine and Clinical Medicine in the Jefferson Medical College; Attending Physician to the Hospital of the Jefferson Medical College, to the German Hospital, and to the Pennsylvania Hospital, Philadelphia.

*The arrangement* of this volume has been based, so far as possible, upon modern pathologic doctrines, beginning with the intoxications and following with infections, diseases due to internal parasites, diseases of undetermined origin, and finally the disorders of the several bodily systems—digestive, respiratory, circulatory, renal, nervous, and cutaneous. It was thought proper to include also a consideration of the disorders of pregnancy.

*The list of contributors* comprises the names of many who have acquired distinction as practitioners and teachers of practice, of clinical medicine, and of the specialties.

## CONTRIBUTORS.

- |                                         |                                      |
|-----------------------------------------|--------------------------------------|
| Dr. I. E. Atkinson, Baltimore, Md.      | Dr. James Hendrie Lloyd, Phila., Pa. |
| Sanger Brown, Chicago, Ill.             | John Noland Mackenzie, Balt., Md.    |
| John B. Chapin, Philadelphia, Pa.       | J. W. McLaughlin, Austin, Texas.     |
| William C. Dabney, Charlottesville, Va. | A. Lawrence Mason, Boston, Mass.     |
| John Chalmers DaCosta, Phila., Pa.      | Charles K. Mills, Philadelphia, Pa.  |
| I. N. Danforth, Chicago, Ill.           | John K. Mitchell, Philadelphia, Pa.  |
| John L. Dawson, Jr., Charleston, S. C.  | W. P. Northrup, New York City.       |
| F. X. Dercum, Philadelphia, Pa.         | William Osler, Baltimore, Md.        |
| George Dock, Ann Arbor, Mich.           | Frederick A. Packard, Phila., Pa.    |
| Robert T. Edes, Jamaica Plain, Mass.    | Theophilus Parvin, Philadelphia, Pa. |
| Augustus A. Eshner, Philadelphia, Pa.   | Beaven Rake, London, England.        |
| J. T. Eskridge, Denver, Col.            | E. O. Shakespeare, Philadelphia, Pa. |
| F. Forchheimer, Cincinnati, O.          | Wharton Sinkler, Philadelphia, Pa.   |
| Carl Frese, Philadelphia, Pa.           | Louis Starr, Philadelphia, Pa.       |
| Edwin E. Graham, Philadelphia, Pa.      | Henry W. Stelwagon, Phila., Pa.      |
| John Guitéras, Philadelphia, Pa.        | James Stewart, Montreal, Canada.     |
| Frederick P. Henry, Philadelphia, Pa.   | Charles G. Stockton, Buffalo, N. Y.  |
| Guy Hinsdale, Philadelphia, Pa.         | James Tyson, Philadelphia, Pa.       |
| Orville Horwitz, Philadelphia, Pa.      | Victor C. Vaughan, Ann Arbor, Mich.  |
| W. W. Johnston, Washington, D. C.       | James T. Whittaker, Cincinnati, O.   |
| Ernest Laplace, Philadelphia, Pa.       | J. C. Wilson, Philadelphia, Pa.      |
| A. Laveran, Paris, France.              |                                      |

*The articles*, with two exceptions, are the contributions of American writers. Written from the standpoint of the practitioner, the aim of the work is to facilitate the application of knowledge to the prevention, the cure, and the alleviation of disease. The endeavor has been to conform to the title of the book—Applied Therapeutics—to indicate the course of treatment to be pursued at the bedside, rather than to name a list of drugs that have been used at one time or another.

One Handsome Octavo Volume of 1326 Pages.

PRICES: Cloth, \$7.00 net; Sheep or Half Morocco, \$8.00 net.

## BOOKS JUST ISSUED.

**DISEASES OF THE EYE. A Hand-Book of Ophthalmic Practice.** By G. E. DE SCHWEINITZ, M. D., Professor of Ophthalmology in the Jefferson Medical College, Philadelphia, etc. A handsome royal-octavo volume of 679 pages, with 256 fine illustrations, many of which are original, and 2 chromo-lithographic plates. Prices: Cloth, \$4.00 net; Sheep or Half Morocco, \$5.00 net.

The object of this work is to present to the student, and to the practitioner who is beginning work in the fields of ophthalmology, a plain description of the optical defects and diseases of the eye. To this end special attention has been paid to the clinical side of the question; and the method of examination, the symptomatology leading to a diagnosis, and the treatment of the various ocular defects have been brought into prominence.

**SECOND EDITION, REVISED AND GREATLY ENLARGED.**

The entire book has been thoroughly revised. In addition to this general revision, special paragraphs on the following new matter have been introduced: Filamentous Keratitis, Blood-staining of the Cornea, Essential Phthisis Bulbi, Foreign Bodies in the Lens, Circinate Retinitis, Symmetrical Changes at the Macula Lutea in Infancy, Hyaline Bodies in the Papilla, Monocular Diplopia, Subconjunctival Injections of Germicides, Infiltration-Anæsthesia, and Sterilization of Collyria. Brief mention of Ophthalmia Nodosa, Electric Ophthalmia, and Angioid Streaks in the Retina also finds place. An Appendix has been added, containing a full description of the method of determining the corneal astigmatism with the ophthalmometer of Javal and Schiötz, and the rotations of the eyes with the tropometer of Stevens. The chapter on Operations has been enlarged and rewritten.

**A TEXT-BOOK OF HISTOLOGY, DESCRIPTIVE AND PRACTICAL.** With 174 beautifully colored original figures. By ARTHUR CLARKSON, M. B., C. M., Edin., formerly Demonstrator of Physiology in the Owen's College, Manchester; late Demonstrator of Physiology in Yorkshire College, Leeds. Furnishing the student in one volume with all that is necessary for his equipment as an Histologist. Large 8vo. volume, strongly bound. Price, \$6.00 net.

The purpose of the book is to furnish the student of Histology, in one volume, with both the descriptive and the practical part of the science. In each chapter the structures of the various tissues and organs are first described; the student is then taken tutorially over the illustrative specimens; finally, an appendix concludes each chapter with a short account of the methods of preparation.



## BOOKS RECENTLY ISSUED.

**TEXT-BOOK OF THE PATHOGENIC BACTERIA.**

Specially written for students of medicine. By JOSEPH MCFARLAND, M. D., Professor of Pathology and Bacteriology in the Medico-Chirurgical College of Philadelphia, etc. 359 pages, finely illustrated. Cloth. Price, \$2.50 net.

The book presents a concise account of the technical procedures necessary in the study of Bacteriology. It describes the life-history of pathogenic bacteria, and the pathological lesions following invasions. The illustrations have been gathered from standard sources, and comprise the best and most complete aggregation extant.

"The author has rendered a great service to the profession in bringing out this work at this opportune time."—*The American Therapist*, Aug., 1896.

**PRACTICAL POINTS IN NURSING. For Nurses in**

**Private Practice.** By EMILY A. M. STONEY, Superintendent of the Training-school for Nurses, Carney Hospital, South Boston. 456 pages, handsomely illustrated with 73 engravings and 9 colored and half-tone plates. 12mo. Cloth. Price, \$1.75 net.

A *vade mecum* for the private nurse, and an efficient teaching-book for training-schools. Instructions for quickly *improvising* needed sick-room appliances constitute a valuable feature of the book. The *Appendix* contains, in compact form, much information that will be of great value to the nurse, including General Rules for Feeding the Sick; Recipes for Invalid Foods and Beverages; Tables of Weights and Measures; Table for Computing Date of Labor; List of Abbreviations; Dose-List; and a Glossary of 64 pages.

"The author's style is most agreeable, and she handles her subject in a way that clearly shows her complete familiarity with it."—*New York Polyclinic*, Aug. 15, 1896.

"There are few books intended for non-professional readers which can be so cordially endorsed by a medical journal as can this one."—*Therapeutic Gazette*, Aug. 15, 1896.

"This is a well-written, eminently practical volume."—*American Journal of Obstetrics*, Aug., 1896.

**THE PICTORIAL ATLAS OF SKIN DISEASES AND SYPHILITIC AFFECTIONS (American Edition).**

Translation from the French. Edited by J. J. PRINGLE, M. B., F. R. C. P., Assistant Physician to, and Physician to the department for Diseases of the Skin at, the Middlesex Hospital, London. Photo-lithochromes from the famous models of dermatological and syphilitic cases in the Museum of the Saint-Louis Hospital, Paris, with explanatory wood-cuts and text. In 12 Parts, at \$3.00 per Part. Parts I. to IV. now ready.

"The plates are beautifully executed."—JONATHAN HUTCHINSON, M. D. (London Hospital).

JUST PUBLISHED.

**A TEXT-BOOK OF BACTERIOLOGY**, including the Etiology and Prevention of Infective Diseases and an account of Yeasts and Moulds, Hæmatozoa, and Psorosperms. By EDGAR M. CROOKSHANK, M. B., Professor of Comparative Pathology and Bacteriology, King's College, London. A handsome octavo volume of 700 pages, illustrated with 273 engravings in the text, and 22 original and colored plates. Price, \$6.50 net.

This book, though nominally a Fourth Edition of Professor Crookshank's "MANUAL OF BACTERIOLOGY," is practically a new work, the old one having been reconstructed, greatly enlarged, revised throughout, and largely rewritten, forming a text-book for the Bacteriological Laboratory, for Medical Officers of Health, and for Veterinary Inspectors.

**A MANUAL OF PHYSIOLOGY**, with Practical Exercises. For Students and Practitioners. By G. N. STEWART, M. A., M. D., D. Sc., lately Examiner in Physiology, University of Aberdeen, and of the New Museums, Cambridge University; Professor of Physiology in the Western Reserve University, Cleveland, Ohio. Handsome octavo volume of 800 pages, with 278 illustrations in the text, and 5 colored plates. Price, Cloth, \$3.50 net.

In this book formal exposition has been interwoven with practical work, in the manner shown by the experience of the Author to be best suited to the needs and opportunities of the student.

The systematic portion of the book is so arranged that it can be used independently of the practical work, and aims at being itself a complete exposition of the subject, adapted to the requirements of the student of medicine.

"It will make its way by sheer force of merit, and *amply deserves to do so*. It is one of the very best English text-books on the subject."—*Lancet*.

"Of the many text-books of physiology published, we do not know of one that so nearly comes up to the ideal as does Prof. Stewart's volume."—*British Medical Journal*.

**WATER AND WATER SUPPLIES**. By JOHN C. THRESH, D. Sc., M. B., D. P. H., Lecturer on Public Health, King's College, London; Editor of the "Journal of State Medicine," etc. 12mo, 438 pages, illustrated. Handsomely bound in Cloth, with gold side and back stamps. Price, \$2.25 net.

This work will furnish any one interested in public health the information requisite for forming an opinion as to whether any supply or proposed supply is sufficiently wholesome and abundant, and whether the cost can be considered reasonable.



## JUST PUBLISHED.

---

**A TEXT-BOOK OF MATERIA MEDICA, THERAPEUTICS, AND PHARMACOLOGY.** By GEORGE F. BUTLER, PH. G., M. D., Professor of Materia Medica and of Clinical Medicine in the College of Physicians and Surgeons, Chicago; Professor of Materia Medica and Therapeutics, Northwestern University, Woman's Medical School, etc. 8vo, 858 pages. Illustrated. Prices: Cloth, \$4.00 net; Sheep or Half-Morocco, \$5.00 net.

A clear, concise, and practical text-book, adapted for permanent reference no less than for the requirements of the class-room. The arrangement is believed to be at once the most philosophical and rational, as well as that best calculated to engage the interest of those to whom the academic study of the subject is wont to offer no little perplexity.

Special attention has been given to the Pharmaceutical section, which is exceptionally lucid and complete.

**ESSENTIALS OF PHYSICAL DIAGNOSIS OF THE CHEST.** By ARTHUR M. CORWIN, A. M., M. D., Demonstrator of Physical Diagnosis in the Rush Medical College, Chicago; Attending Physician to the Central Free Dispensary, Department of Rhinology, Laryngology, and Diseases of the Chest. 200 pages. Illustrated. Cloth, flexible covers. Price, \$1.25 net.

**ARCHIVES OF CLINICAL SKIAGRAPHY.** By SYDNEY ROWLAND, B. A., Camb., Late Scholar of Downing College, Cambridge, and Shuter Scholar of St. Bartholomew's Hospital, London; Special Commissioner to "British Medical Journal" for the Investigation of the Applications of the New Photography to Medicine and Surgery. A series of collotype illustrations, with descriptive text, illustrating the applications of the New Photography to Medicine and Surgery. Price, per Part, \$1.00. Parts I. and II. now ready.

---

## FORTHCOMING PUBLICATIONS.

**SURGICAL DIAGNOSIS AND TREATMENT.** By J. W. MACDONALD, M. D., Graduate of Medicine of the University of Edinburgh; Licentiate of the Royal College of Surgeons of Edinburgh; Professor of the Practice of Surgery and of Clinical Surgery in Minneapolis College of Physicians and Surgeons; Surgeon to Wisconsin Central Railway, etc.

**TEXT-BOOK OF EMBRYOLOGY.** By JOHN C. HEISLER, M. D., Prosector to the Professor of Anatomy, Medical Department of the University of Pennsylvania.

Now Ready, Volume for 1896.

SAUNDERS'  
American Year-Book of Medicine and Surgery

COLLECTED AND ARRANGED BY EMINENT AMERICAN SPECIALISTS AND TEACHERS,  
UNDER THE EDITORIAL CHARGE OF  
GEORGE M. GOULD, M. D.

NOTWITHSTANDING the rapid multiplication of medical and surgical works, still these publications fail to meet fully the requirements of the *general physician*, inasmuch as he feels the need of something more than mere text-books of well-known principles of medical science. Mr. Saunders has long been impressed with this fact, which is confirmed by the unanimity of expression from the profession at large, as indicated by advices from his large corps of canvassers.

This deficiency would best be met by current journalistic literature, but most practitioners have scant access to this almost unlimited source of information, and the busy practiser has but little time to search out in periodicals the many interesting cases, whose study would doubtless be of inestimable value in his practice. Therefore, a work which places before the physician in convenient form *an epitomization of this literature by persons competent to pronounce upon*

**The Value of a Discovery or of a Method of Treatment**

cannot but command his highest appreciation. It is this critical and judicial function that will be assumed by the Editorial staff of the "American Year-Book of Medicine and Surgery."

It is the special purpose of the Editor, whose experience peculiarly qualifies him for the preparation of this work, not only to review the contributions to American journals, but also the methods and discoveries reported in the leading medical journals of Europe, thus enlarging the survey and making the work characteristically international. These reviews will not simply be a series of undigested abstracts indiscriminately run together, nor will they be retrospective of "news" *one or two years old*, but the treatment presented will be *synthetic* and *dogmatic*, and will include only what is new. Moreover, through expert condensation by experienced writers, these discussions will be

**COMPRISED IN A SINGLE VOLUME OF ABOUT 1200 PAGES.**

The work will be replete with original and selected illustrations skilfully reproduced, for the most part, in Mr. Saunders' own studios established for the purpose, thus ensuring accuracy in delineation, affording efficient aids to a right comprehension of the text, and adding to the attractiveness of the volume.

Prices: Cloth, \$6.50, net; Half-Morocco, \$7.50, net.

W. B. SAUNDERS, Publisher,

925 Walnut Street, Philadelphia.









71763

BIOLOGY  
LIBRARY  
G

QR41  
C8  
1897

THE UNIVERSITY OF CALIFORNIA LIBRARY

