





76  
(44)  
1



dec 1888

# RECUEIL

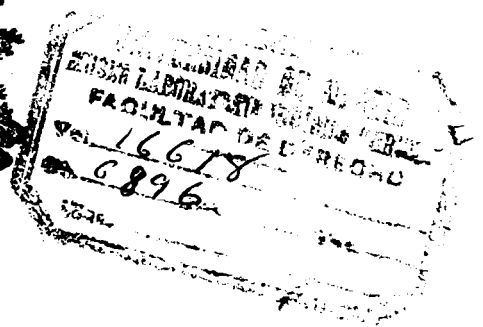
76  
(44)  
En 1

## DE PLANCHES

### DE L'ENCYCLOPÉDIE

PAR ORDRE DE MATIÈRES.

TOME HUITIÈME.



A PARIS,

Chez PANCKOUCKE, Libraire, hôtel de Thou, rue des Poitevins.

---

M. D C C. X C.





# ORDRE DES PLANCHES

## SIMPLES ET DOUBLES

*QUI* composent le huitième Volume de Planches de la nouvelle Édition in-4°. de l'Encyclopédie par ordre de matières.

**SUITE** de la deuxième division des Arts & Métiers mécaniques , relative au Texte du Dictionnaire des Manufactures & Arts, par M. ROLAND DE LA PLATIERE.

1°. Planches de supplément à celles contenues dans la sixième Livraison , lesquelles sont réclamées dans le Texte du Tome II deuxième Partie des Manufactures & Arts, concernant le CHANVRE, le COTON , la LAINE , le POIL & la SOIE.

**DIGESTEUR** pour le décreusement des Soies, une Pl. simple in-4°.

**CARRIBARY** ou NAVETTE Angloise , une Pl. simple.

**MACHINE** pour dispenser d'un Tireur de lacs , quatre Pl. doubles in-4°.

\_\_\_\_\_ nommée *la Ratière*, pour l'Art du Passementier , deux Pl. doubles in-4°. & une simple.

\_\_\_\_\_ à faire des Lacets , deux Pl. doubles & une simple.

\_\_\_\_\_ à faire des Peignes de Tifferands & autres , deux Pl. doubles & une simple.

\_\_\_\_\_ à battre & laver les Toiles , deux Pl. doubles.

**Nouvelle Méthode** pour le tirage des Soies , trois Pl. doubles & une simple.

---

2°. Planches des Arts & Métiers , concernant l'emploi des PEAUX & CUIRS , relatives au Texte du Tome III du même Dictionnaire.

**BOYANDIER** , une Pl. simple in-4°.

**CEINTURONNIER** , deux Pl. simples.

**CHAMOISEUR & MÉGISSIER** , cinq Pl. simples.

**COLLE-FORTE** , une Pl. double.

**CORDONNIER** , quatre Pl. simples & deux doubles.

**CORROYEUR** , deux Pl. simples.

**CRIBLIER** , deux Pl. simples.

**GAINIER** , six Pl. simples.

**GANTIER** , cinq Pl. simples.

**HONGROYEUR** , trois Pl. simples.

MALLETIER-COFFRETIER-BAHUTIER , trois Pl. simples.  
MAROQUINIER , cinq Pl. simples.  
PARCHEMINIER , sept Pl. simples.  
PEAUSSIER-CULOTTIER , une Pl. simple.  
RELIEUR , trois Pl. simples.  
SELLIER & BOURRELIER , quinze Pl. simples.  
TANNEUR , huit Pl. doubles & quatre simples.  
ART de refendre les Cuirs , deux Pl. doubles & une simple.

---

3°. *Dernières Planches du Dictionnaire des Arts & Manufactures.*

PELETERIE & FOURREUR , six Pl. simples *in-4°*.  
HUILE , deux Pl. doubles , *ibid.*  
SAVON , six Pl. doubles.  
TEINTURIER de Rivière , une Pl. double & sept simples.  
TEINTURE des Gobelins , deux Pl. doubles & huit simples.  
TEINTURE en Fil de Coton , une Pl. double.  
IMPRESSION des Etoffes en Laine , six Pl. doubles.  
IMPRESSION des Toiles peintes , six Pl. doubles.

---

*Planches du Dictionnaire des Amusemens des Sciences & des Arts.*

AMUSEMENS de Géométrie , dix Pl. simples *in-4°*.  
——— d'Arithmétique , deux Pl. simples.  
——— d'Astronomie , une Pl. double.  
——— de Gnomonique , huit Pl. simples & une double.  
——— de Physique , quinze Pl. simples.  
——— de Mécanique , huit Pl. simples.  
——— d'Optique , dix Pl. simples.  
——— d'Acoustique ou Musique , deux Pl. simples.  
——— de Catoptrique , six Pl. simples.  
——— de Navigation & d'Architecture , deux Pl. simples.  
PYROTECHNIE sans feu , purement Optique , & Pièces d'Artifices , trois Pl. simples.  
PIÈCES HYDRAULIQUES , une Pl. simple.  
TOURS OCCULTES ou TROMPEURS , deux Pl. simples.  
NOMBRES MAGIQUES & CARTES , deux Pl. simples.  
COMBINAISONS MAGIQUES , une Pl. simple.  
TOURS DE GIBECIÈRE , une Pl. simple.  
FIGURES DE MAGIE BLANCHE DÉVOILÉE , onze Pl. simples.

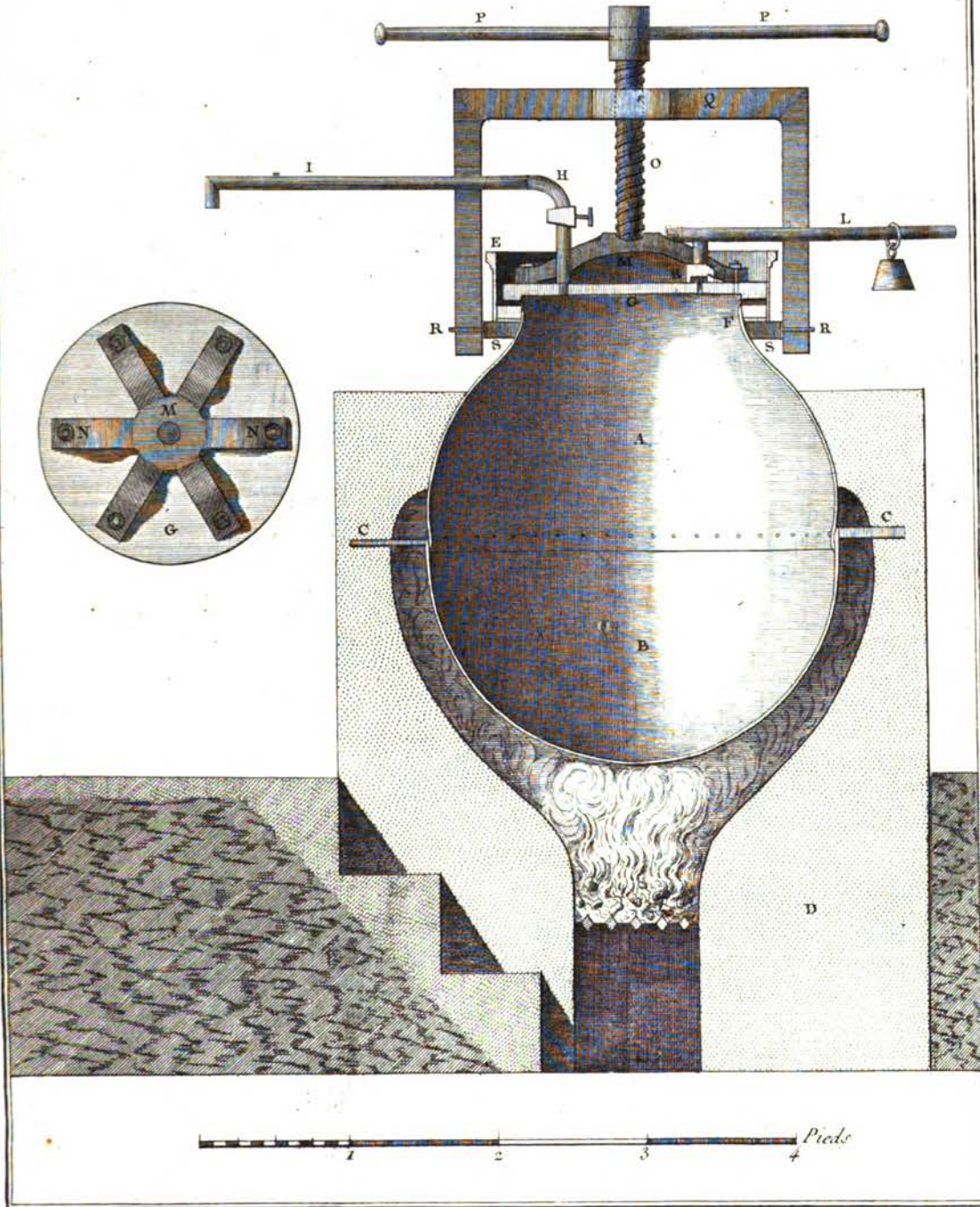
---

Ce volume contient 180 Pl. simples *in-4°* , & 54 doubles *in-4°* , lesquelles , en totalité , équivalent à 288.

*Nota. Les 54 Planches doubles seront pliées chacune avec un onglet.*



*Coupe du Digesteur pour le Décrueement des Soies selon le  
procédé de M. l'Abbé Collomb.*

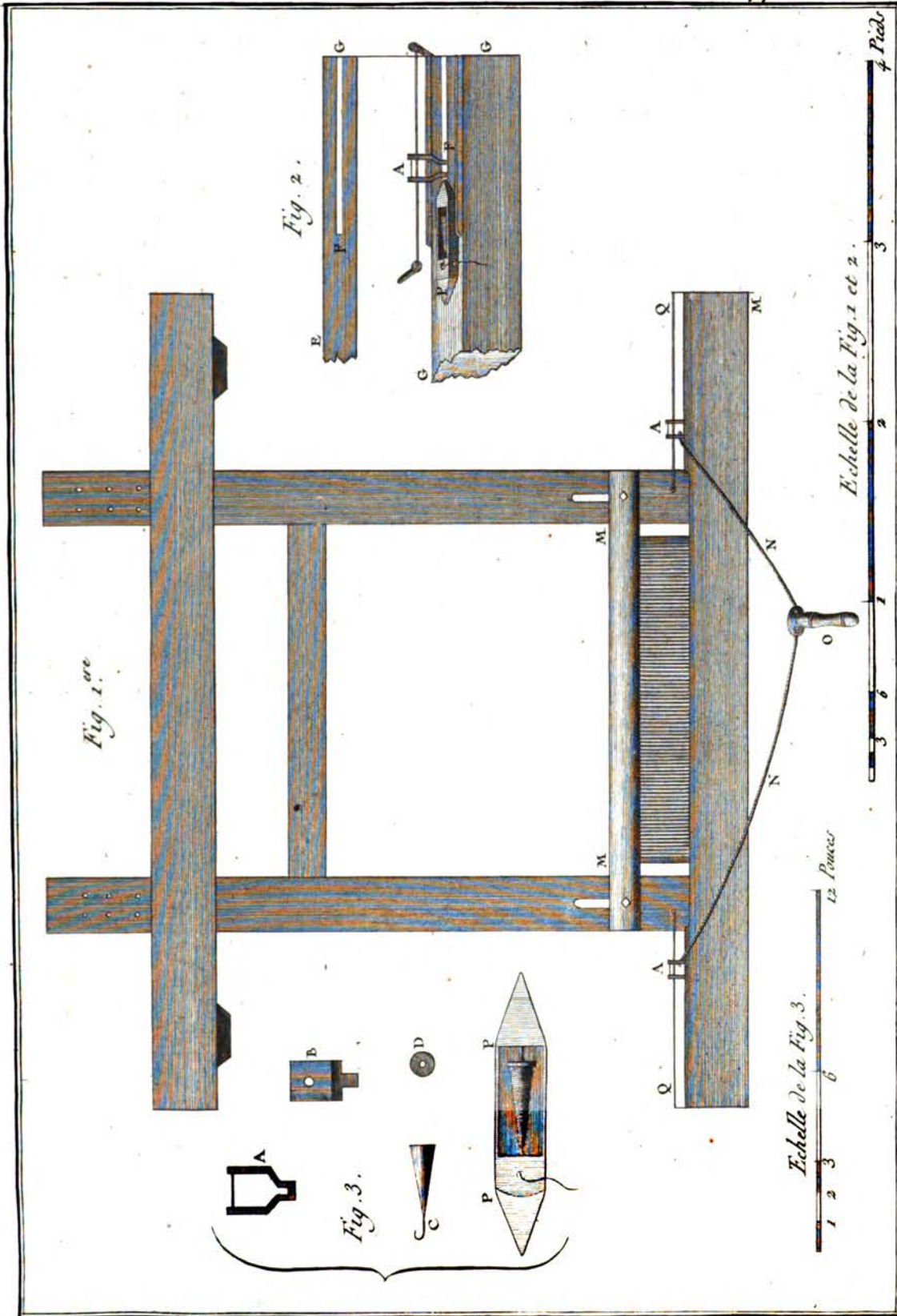


*Bessard Duvet.*

*Soierie.*

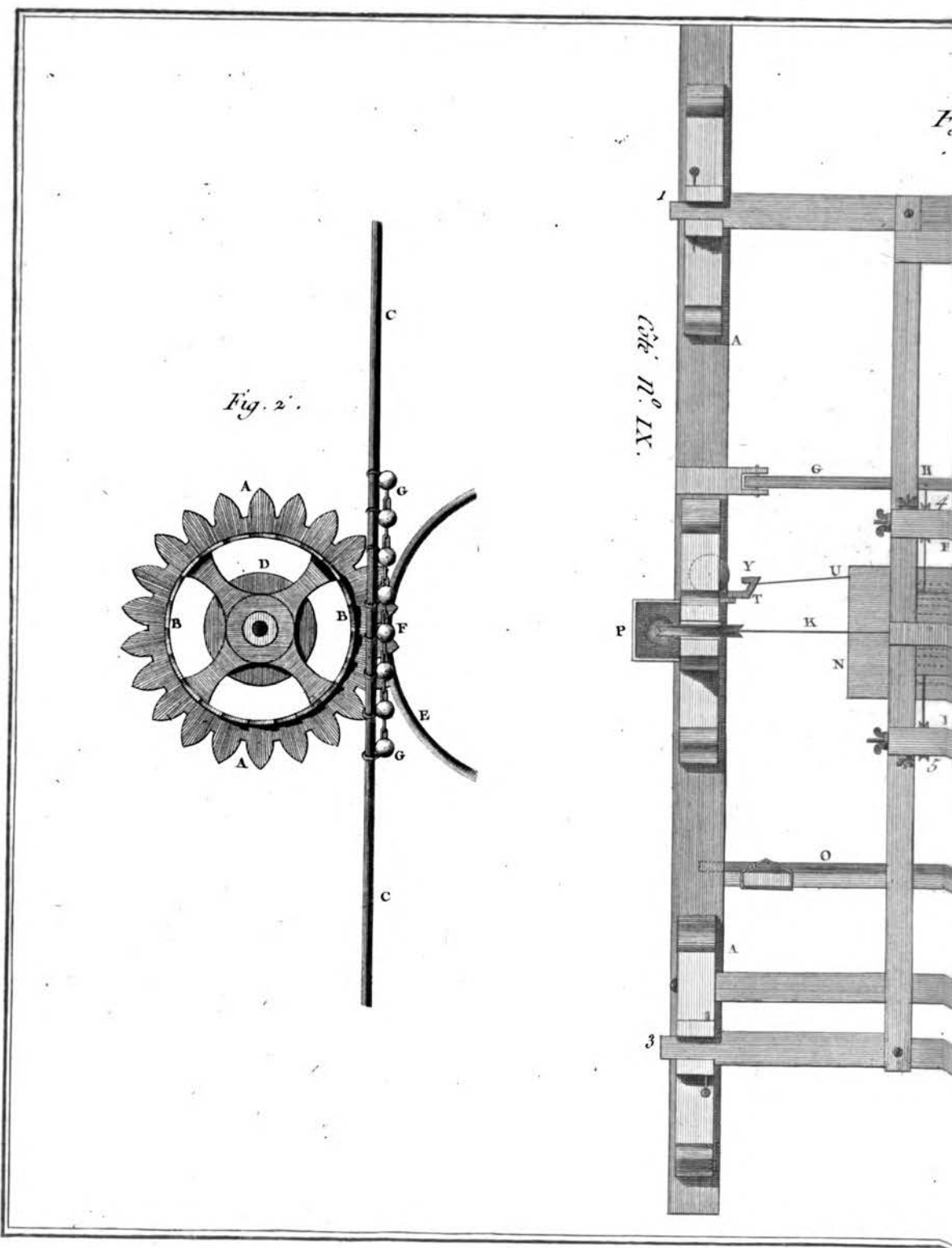
*a*



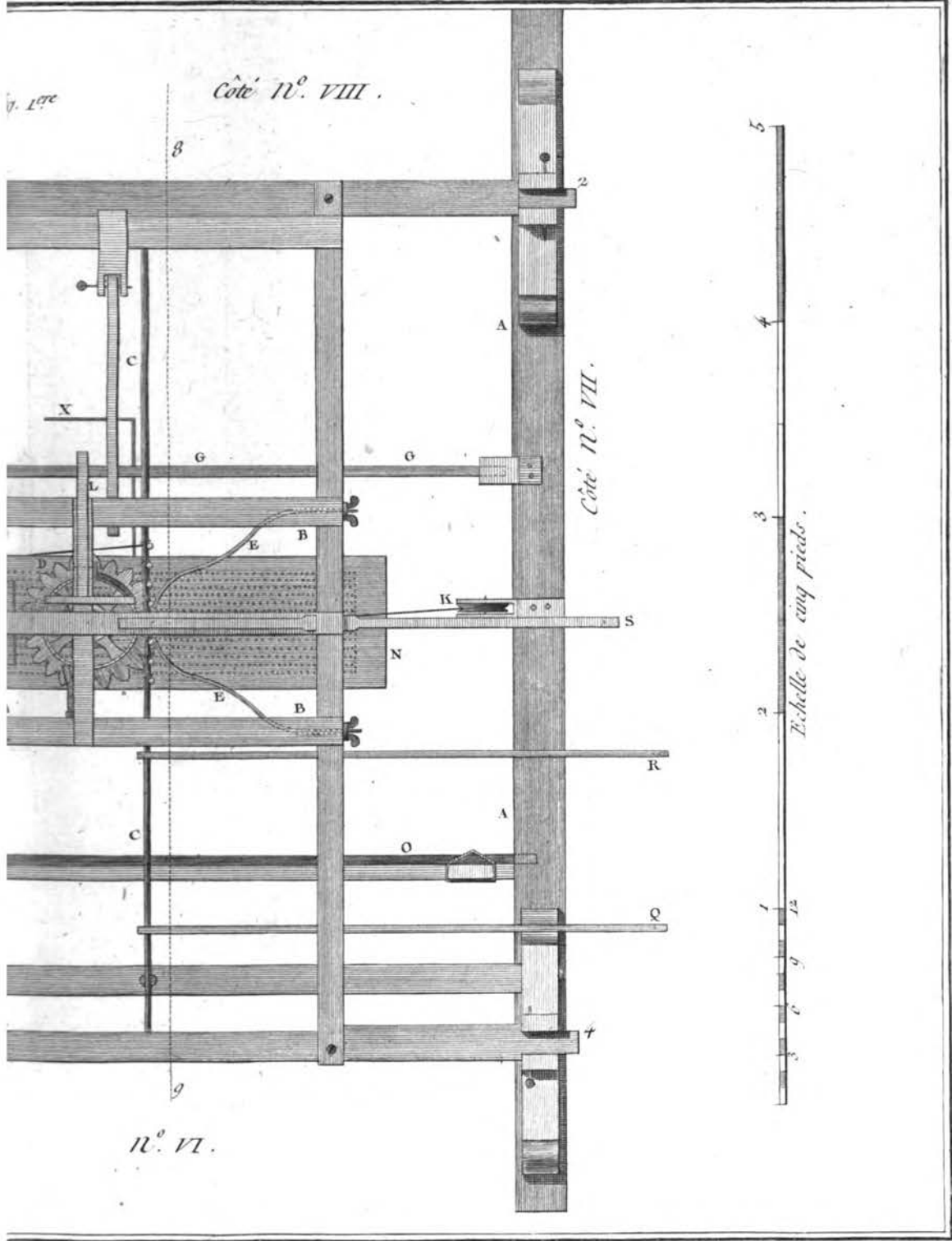








*Plan de la Machine pour distiller*



Benard Diracil.

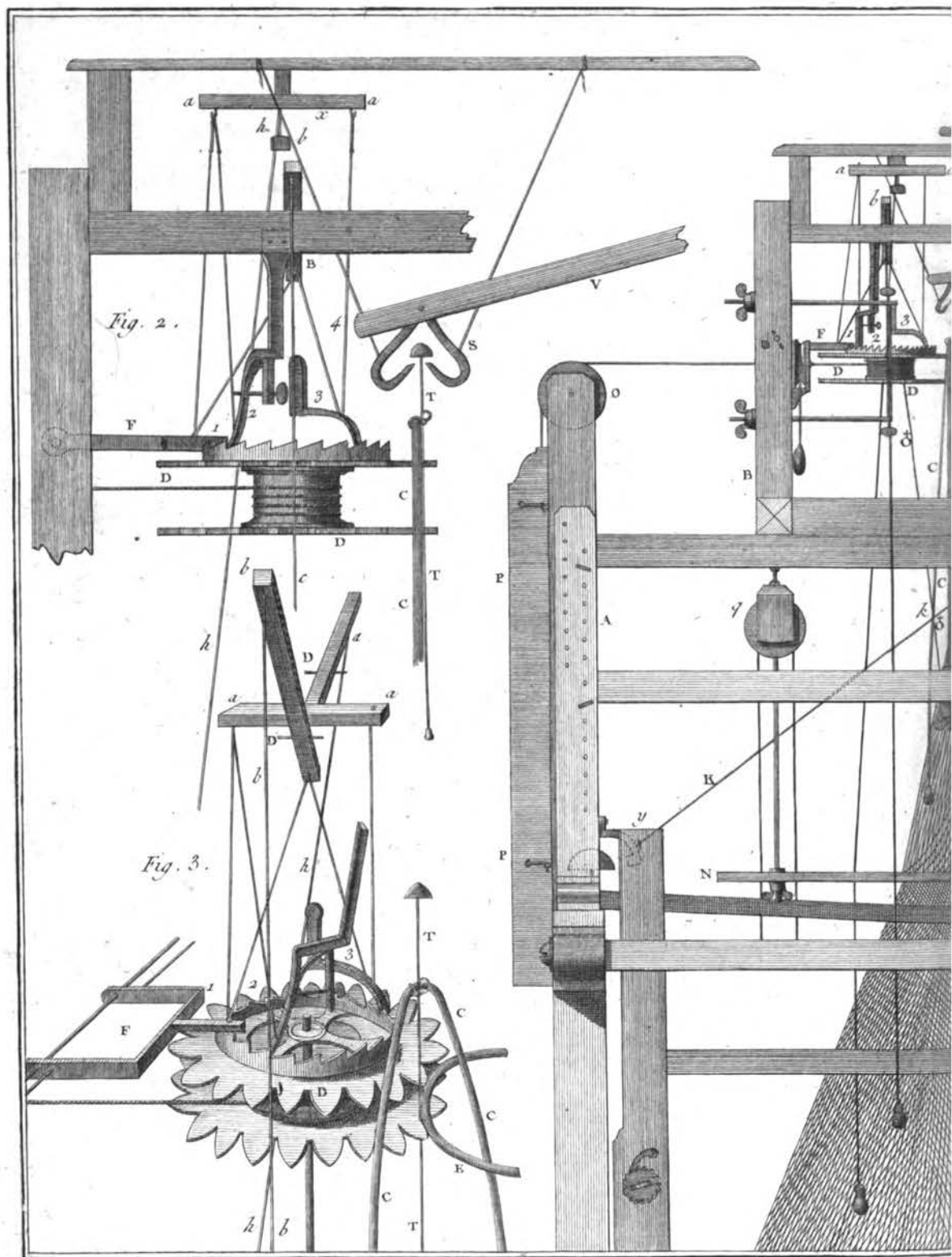
*Dispenser d'un Tireur de Lacs.*

c.

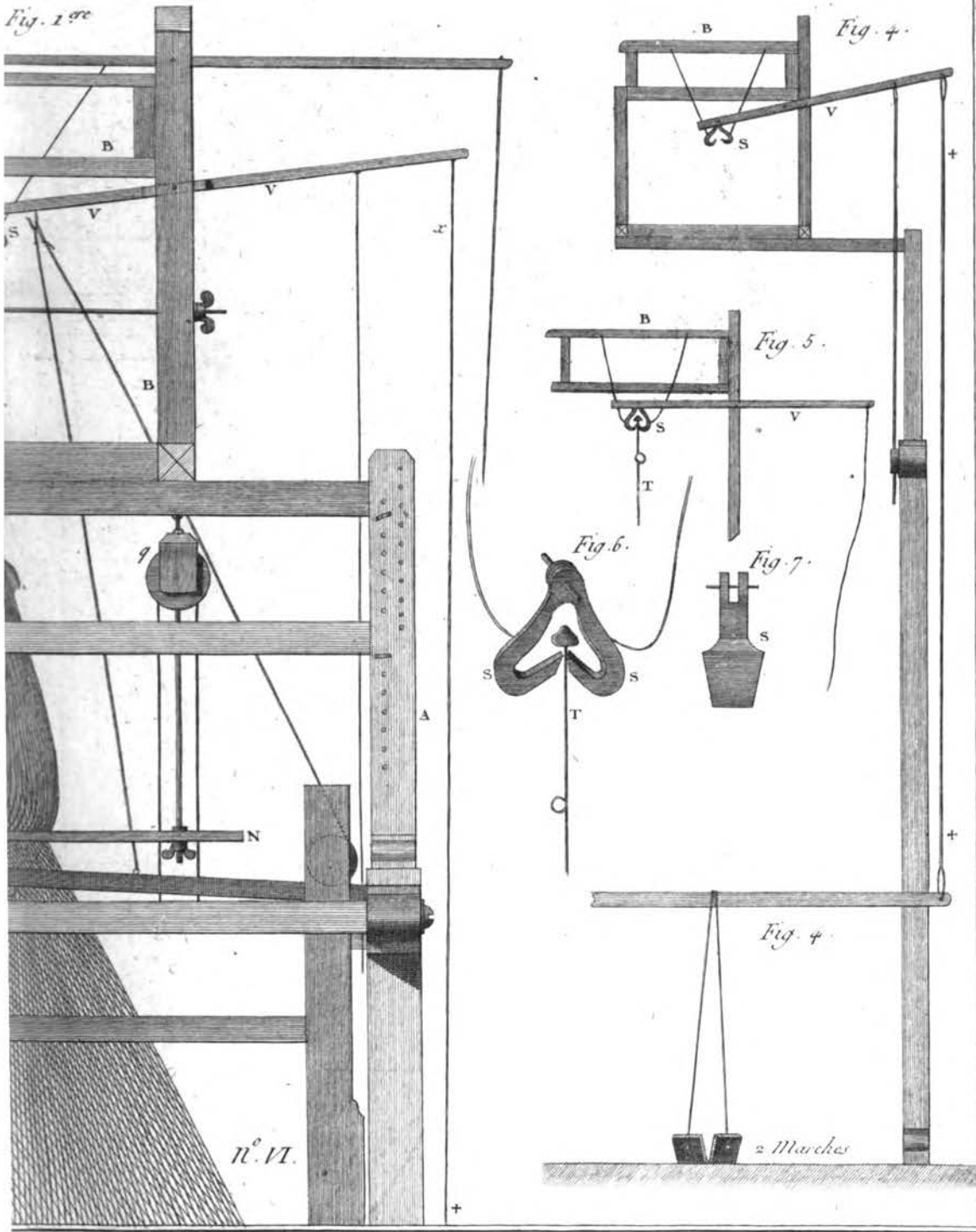






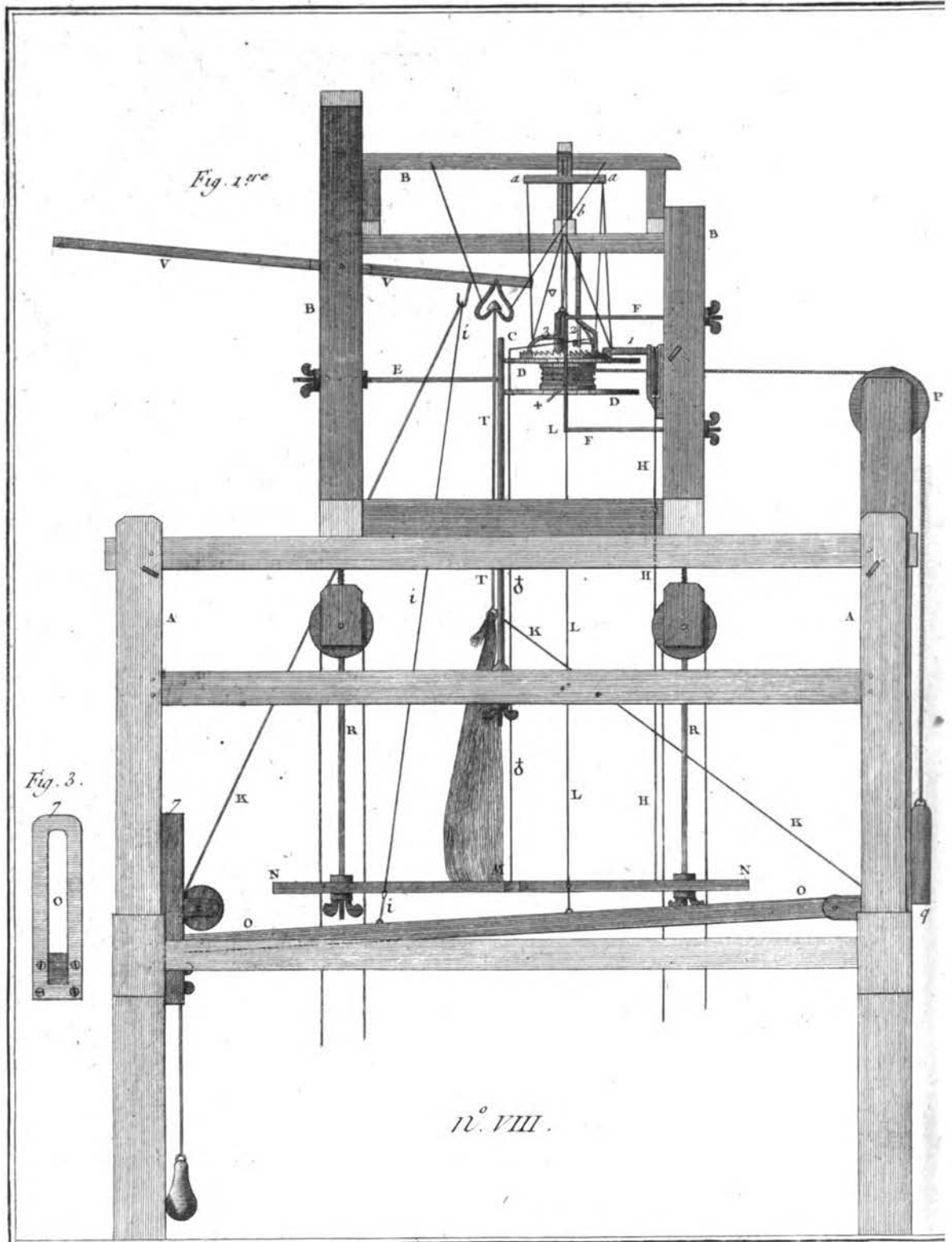


*Élévation de la Machine pour dispens*



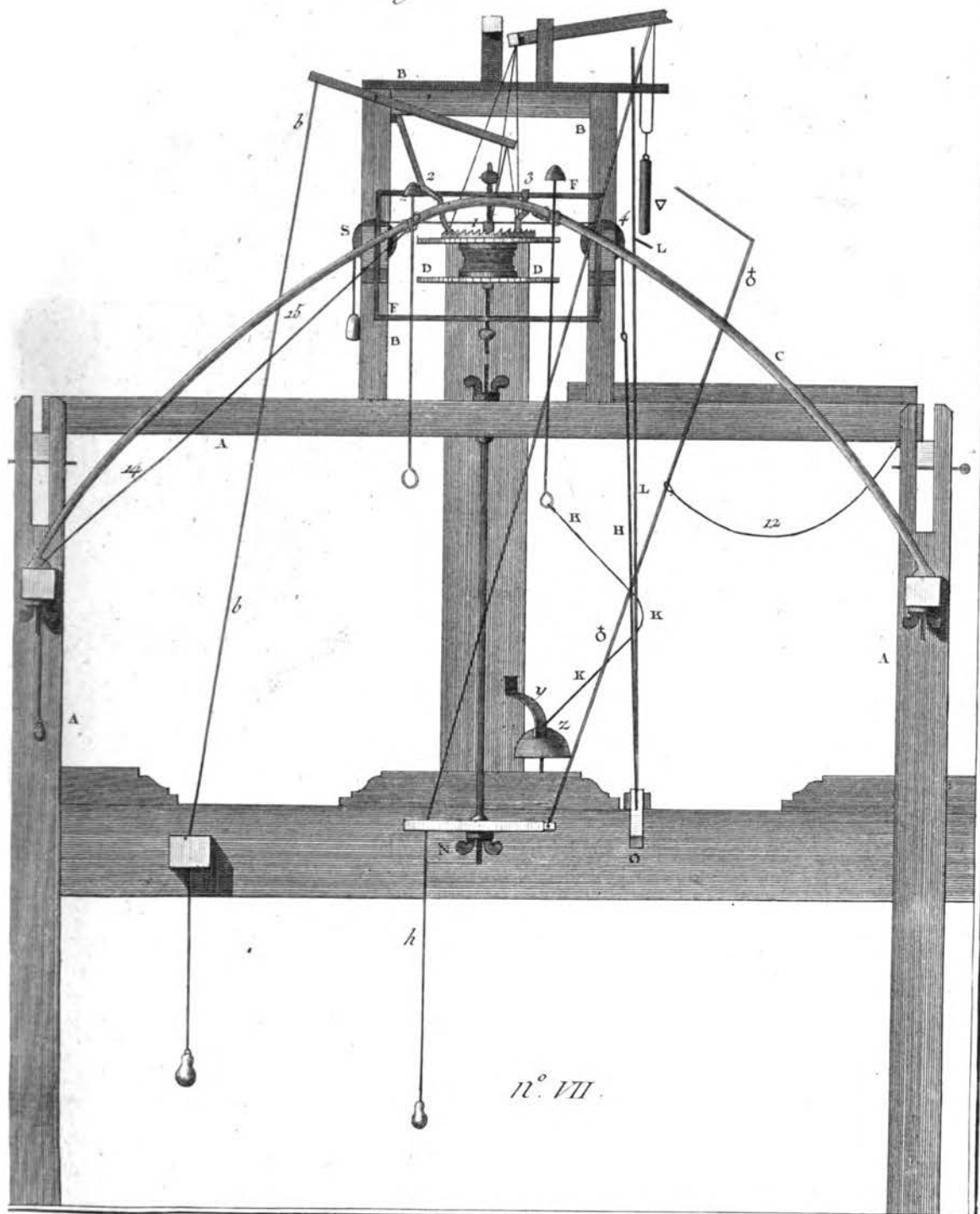
r d'u Tireur de Lacs et développemens.

d.



*Élévation et Coupe de la Machine po*

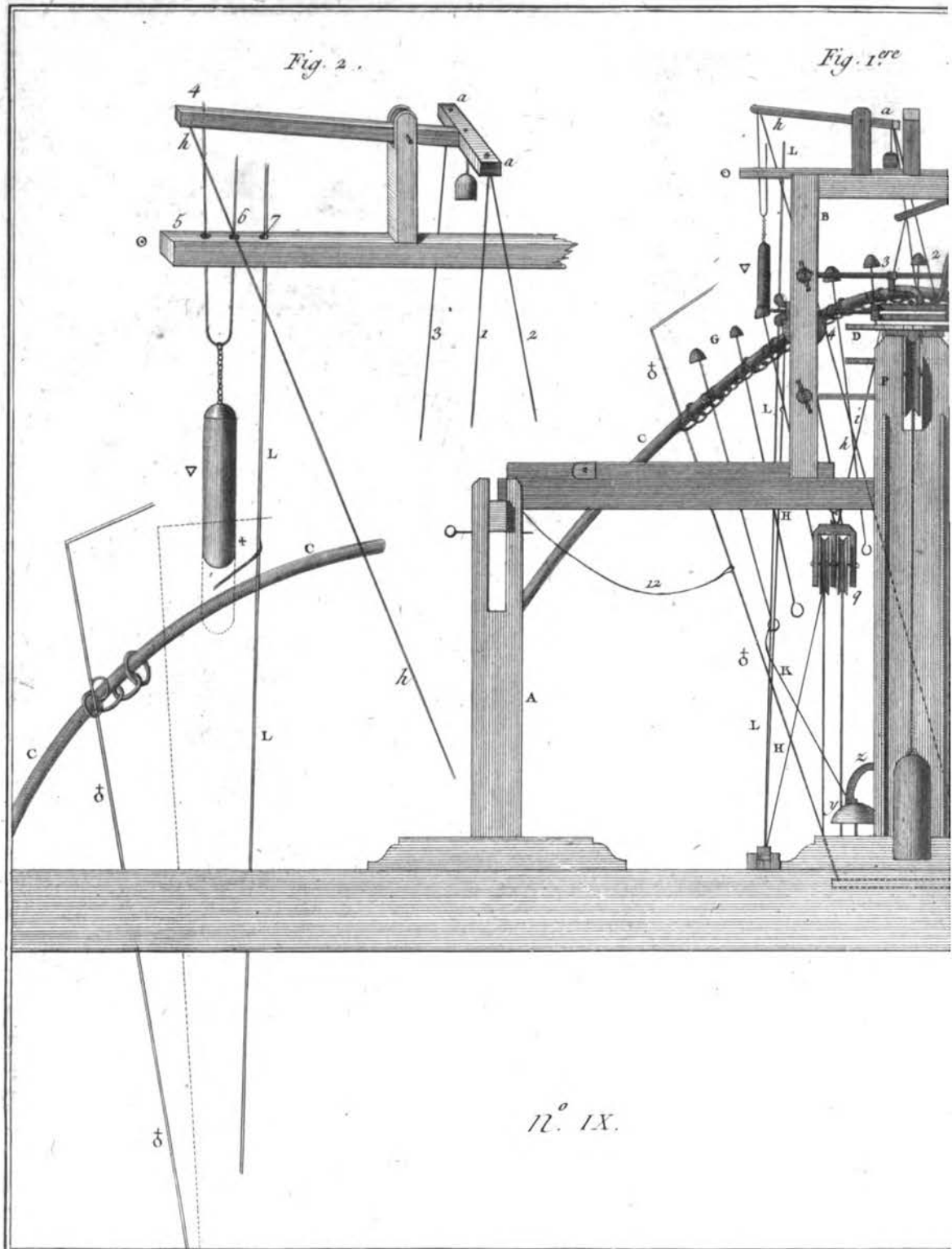
Fig. 2.



n.º VII.

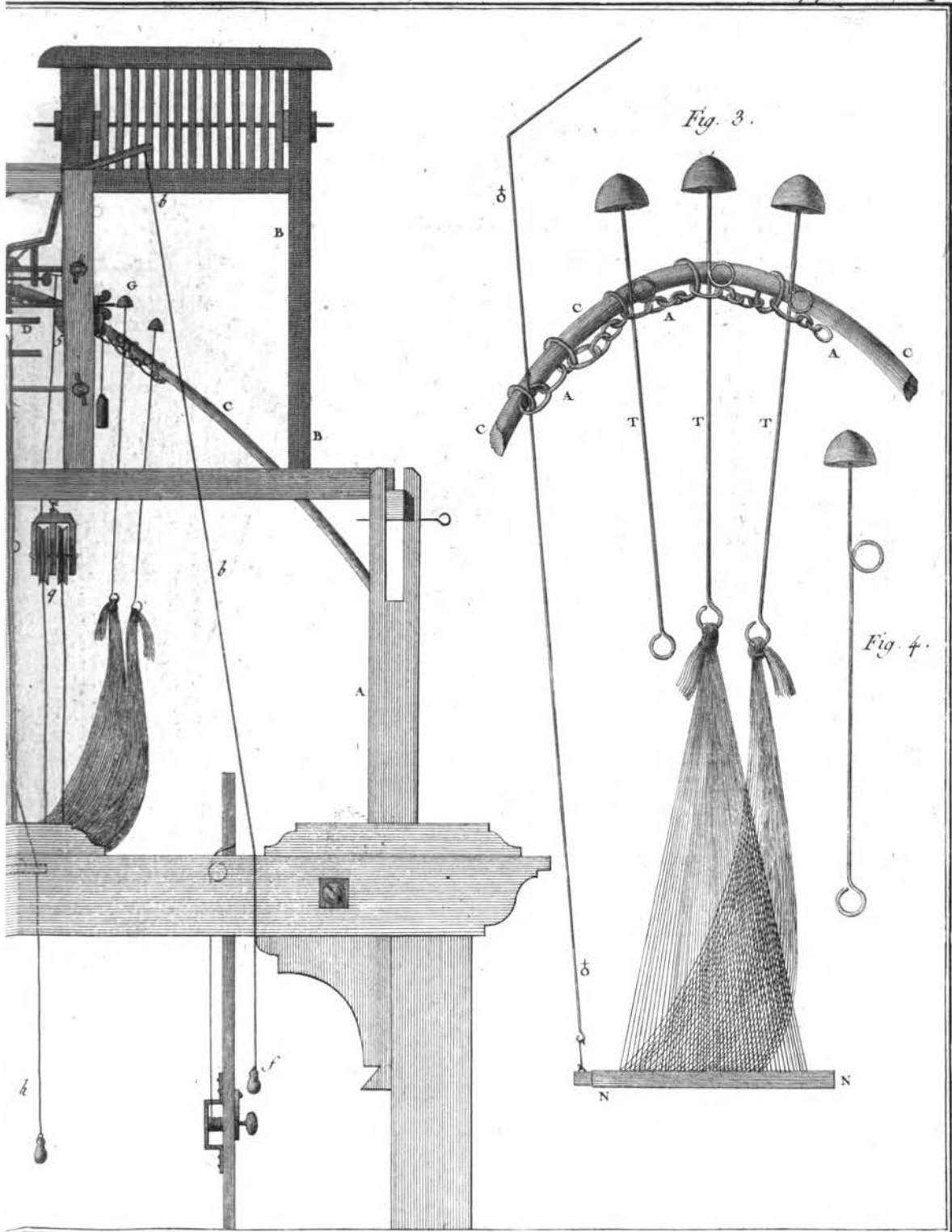
*et dispenser d'un Tireur de Lacs.*

*Beard Drexel*



12.<sup>o</sup> IX.

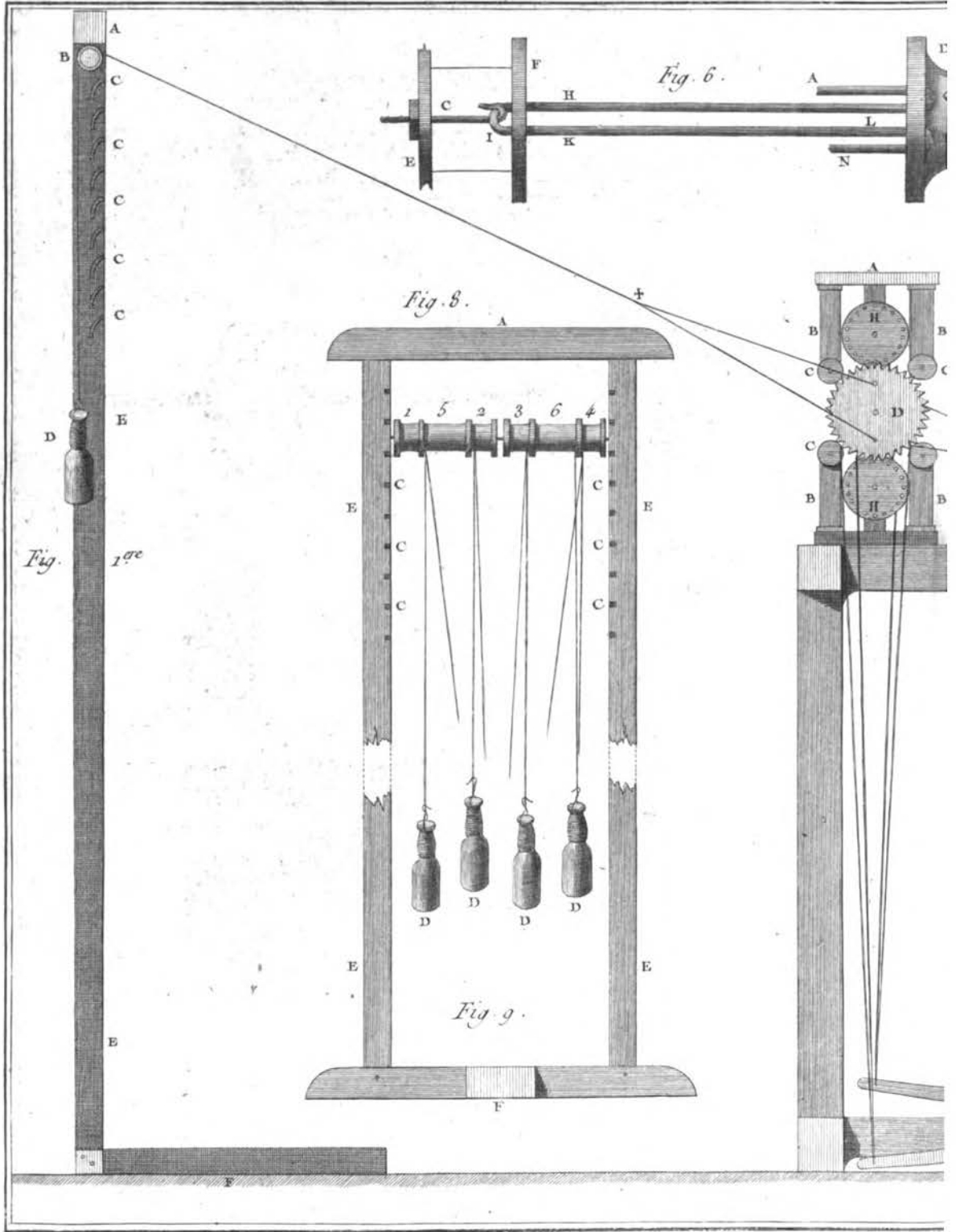
*Élévation en partie et développemens de la Me*



*Machine pour dispenser d'un Tireur de Lacs.*

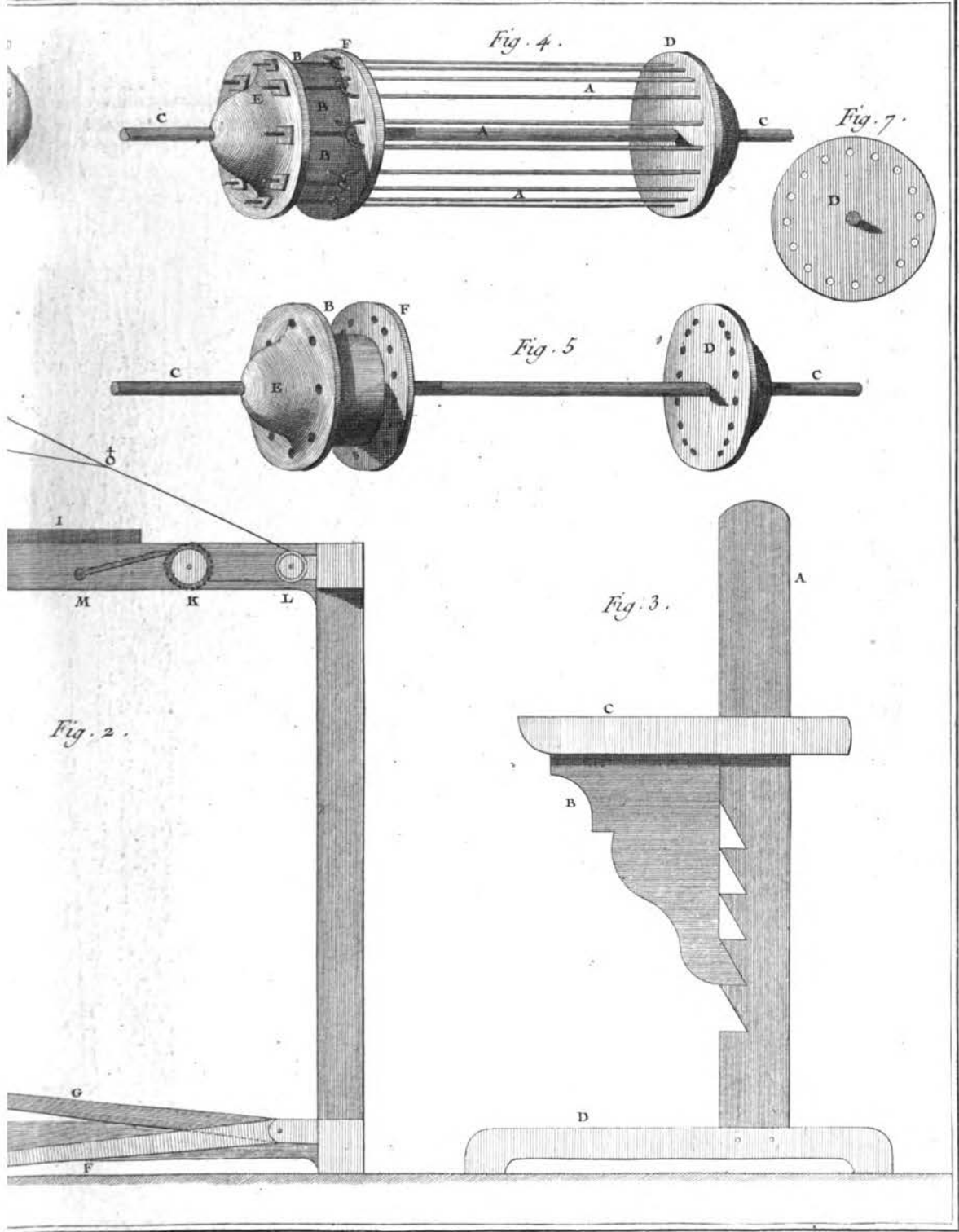
*Bonard Duceat*

*f*



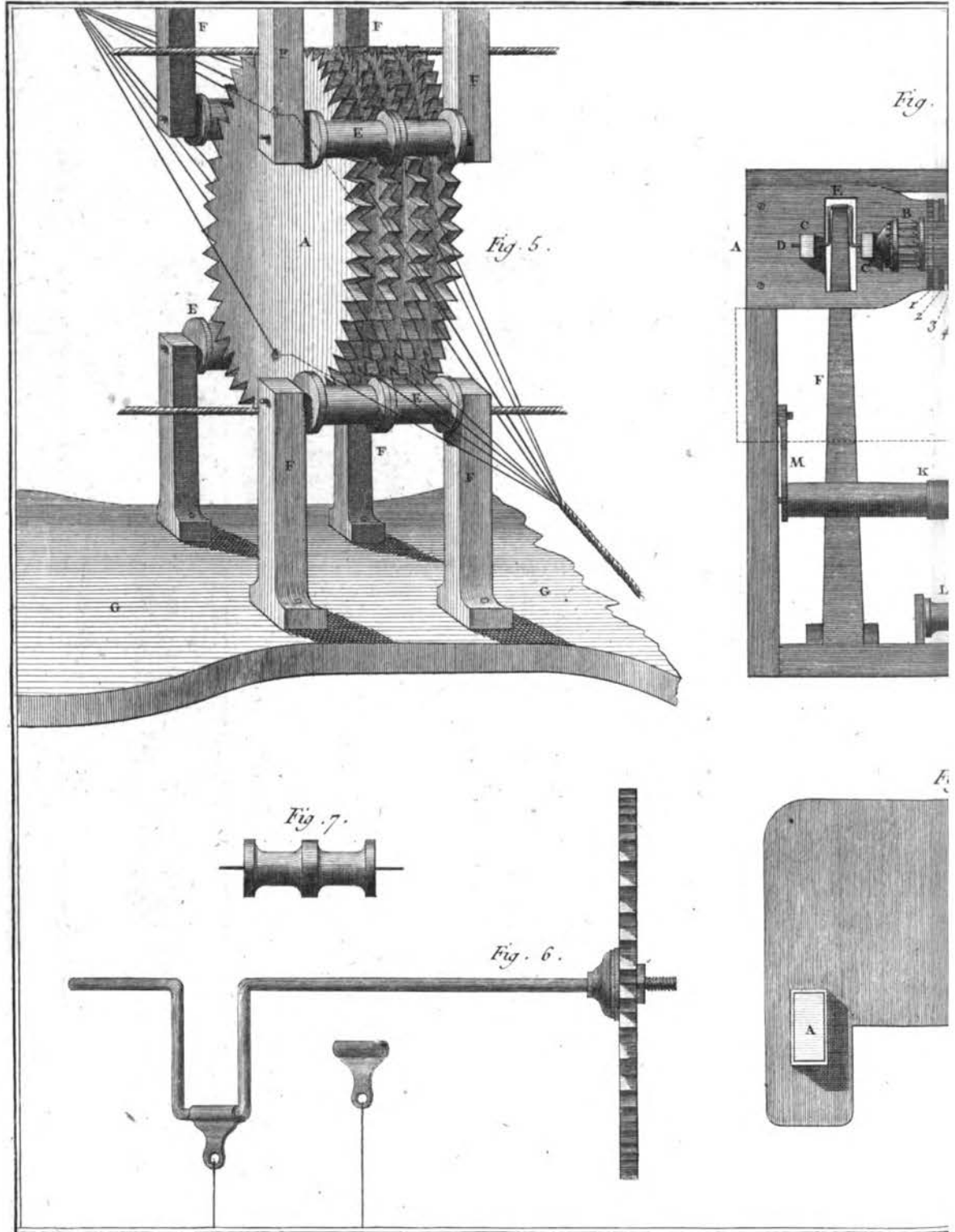
*Machine nommée la Rave*



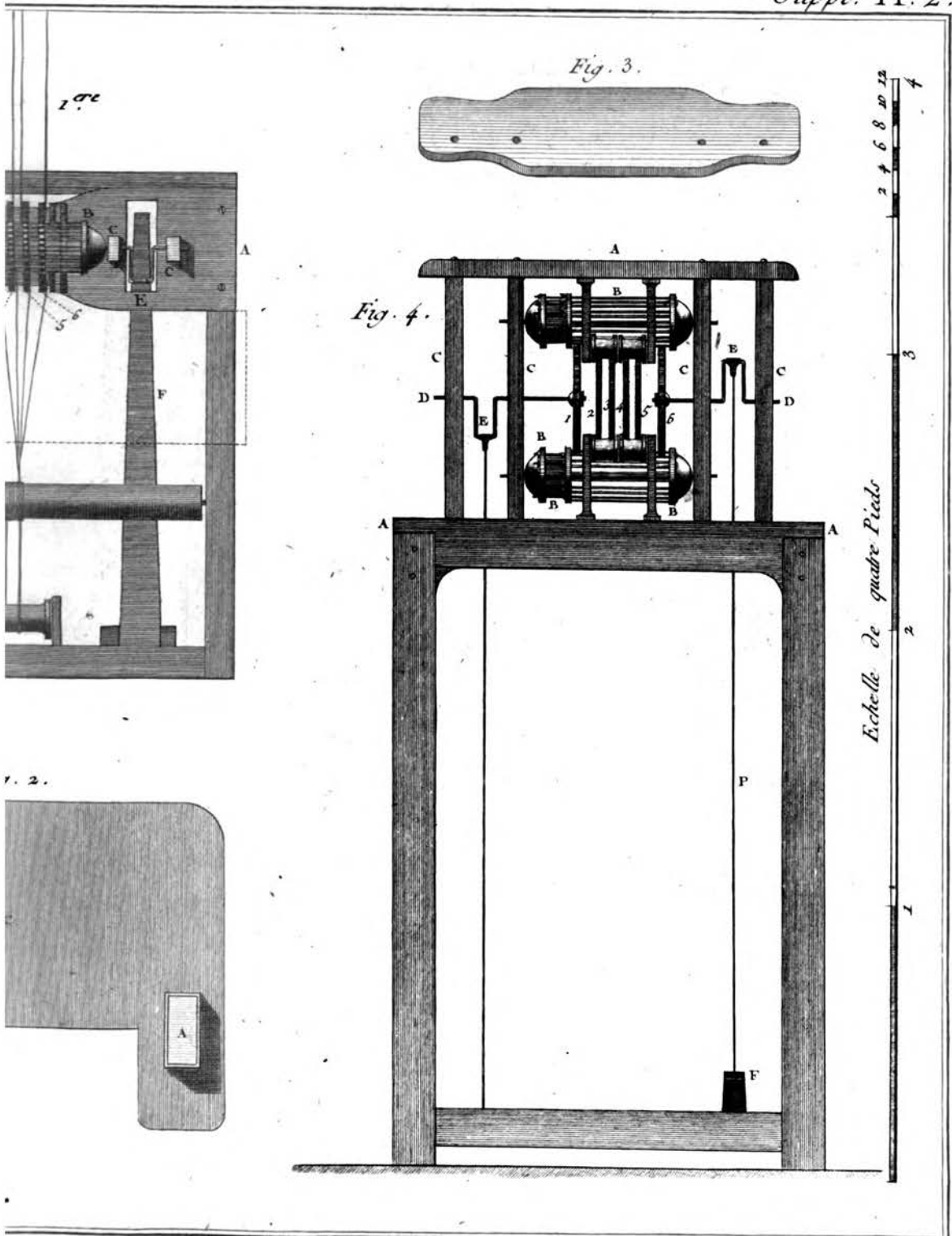


ere, et Développemens.

Bernard Duvauil.



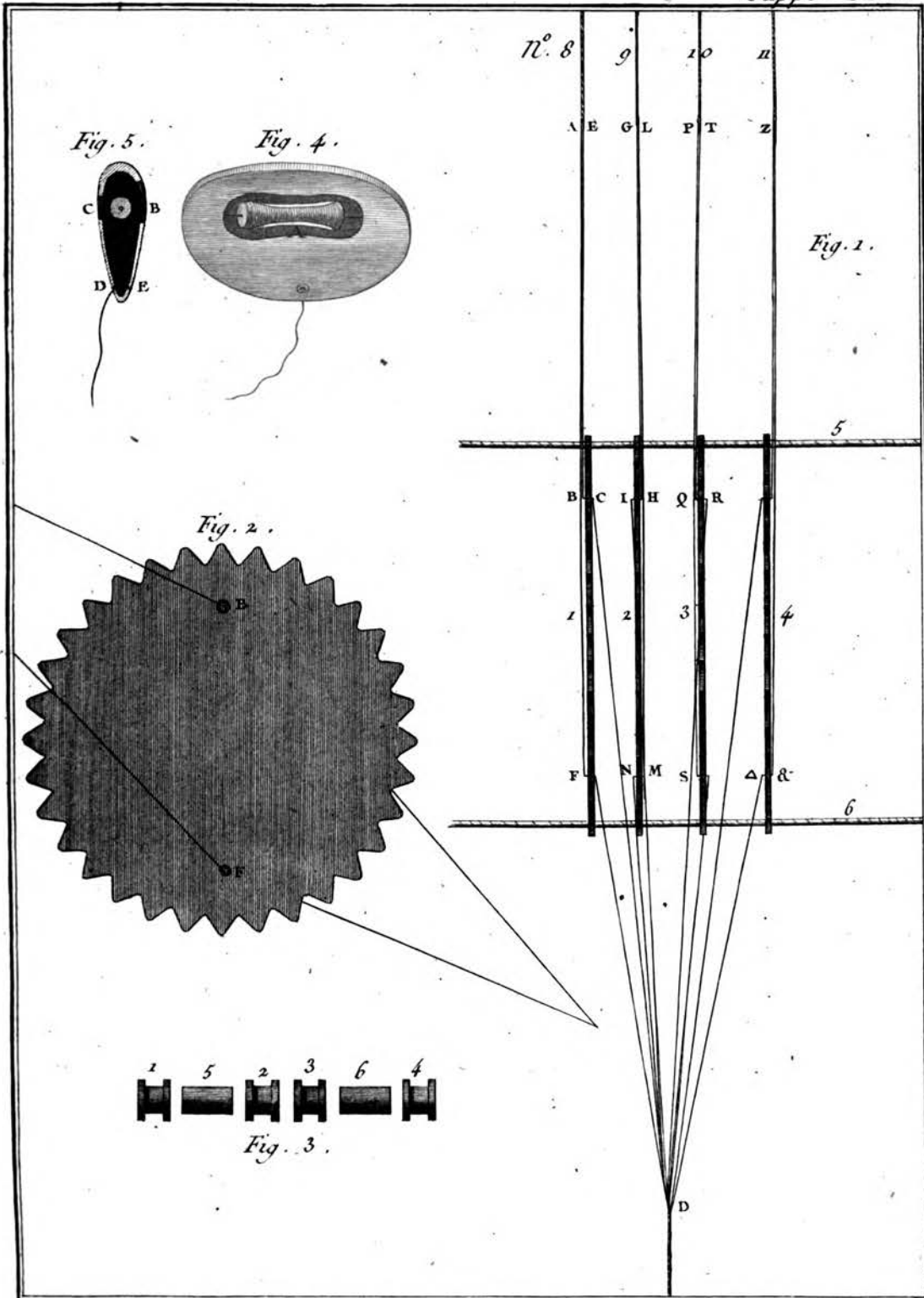
*Machine nommée la Rave*



iere et développemens

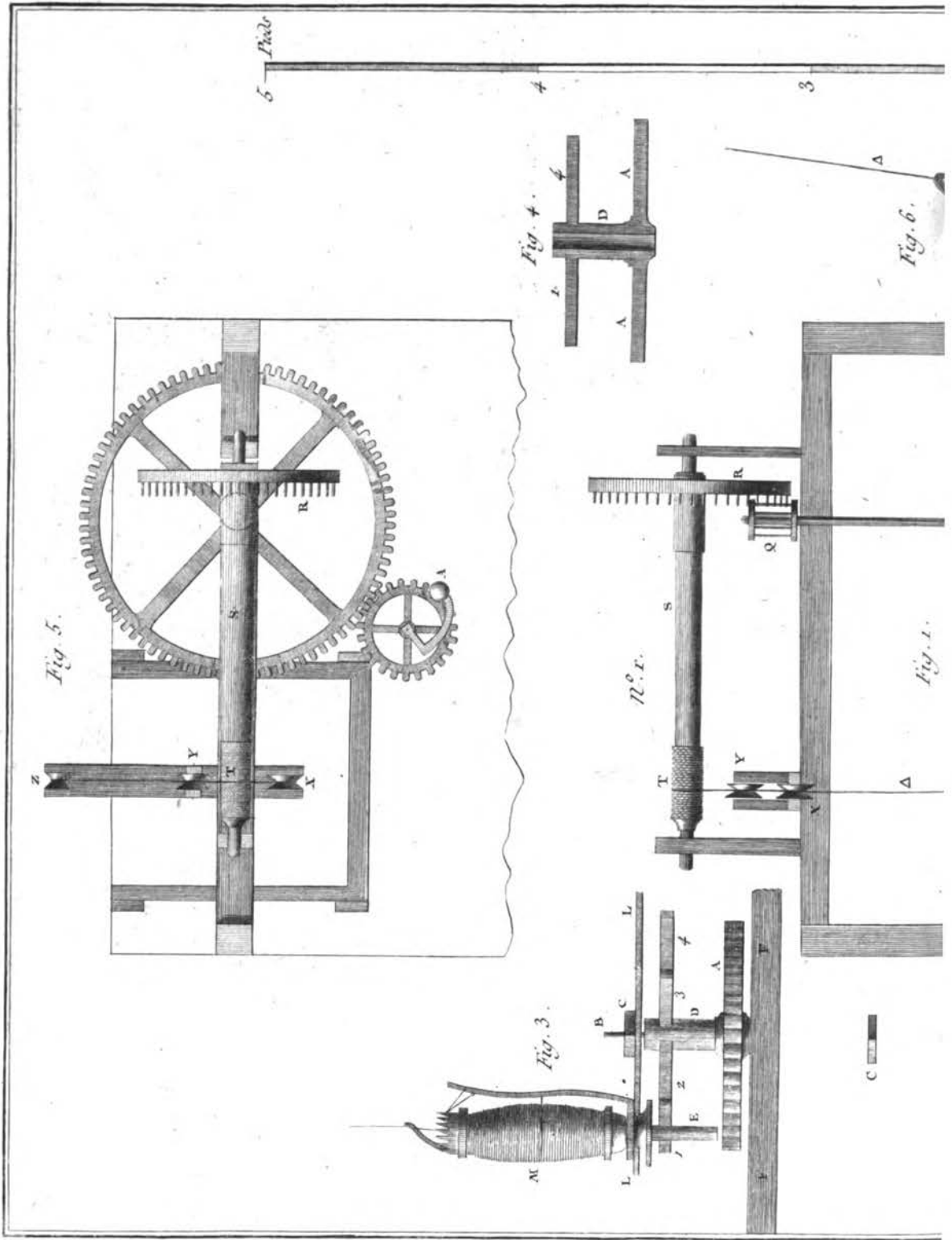
Bernard Duvet

h.

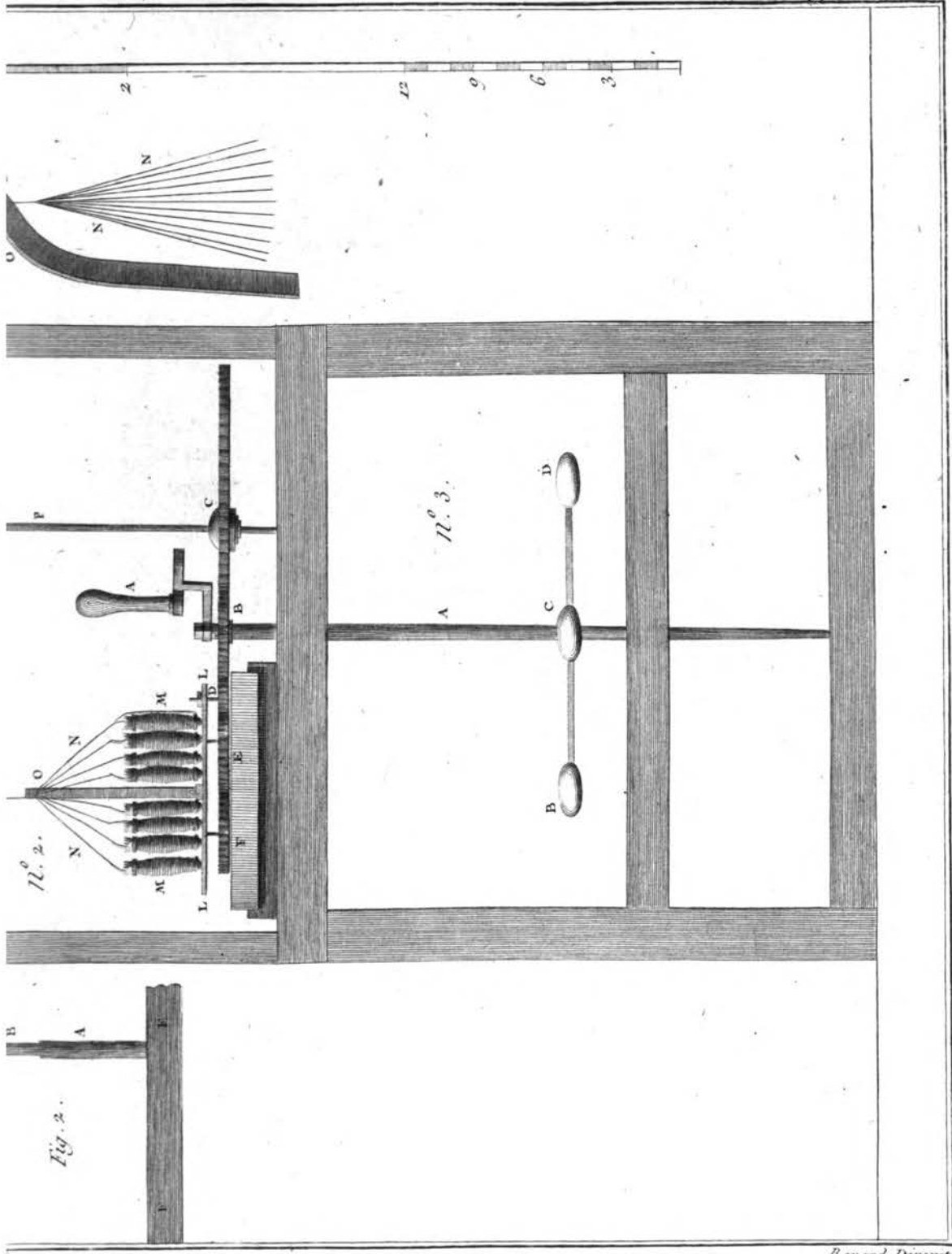


*Développemens de la Machine nommée la Ratiere.*

*Bernard Duret del.*

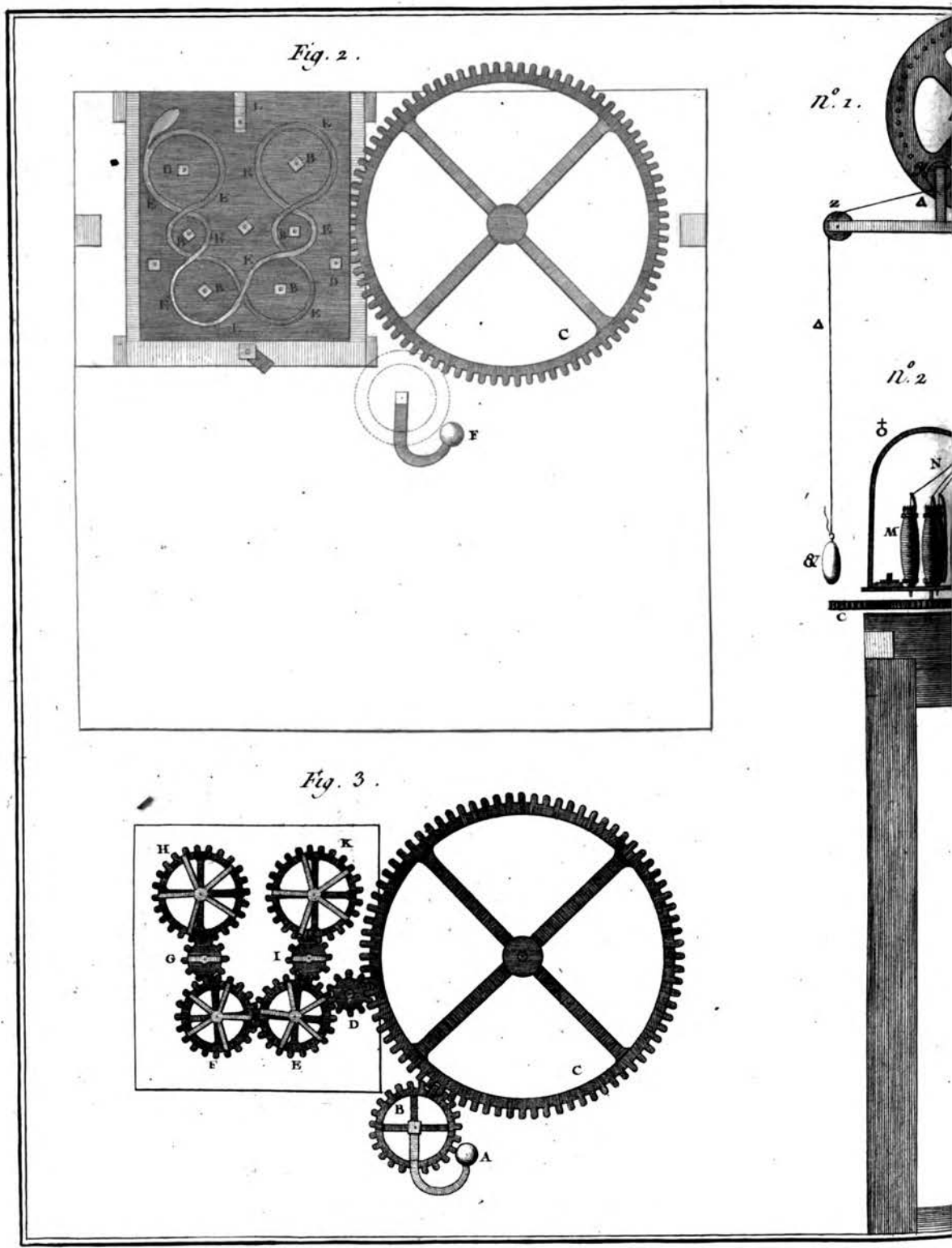


*Machine à faire des Liacs*

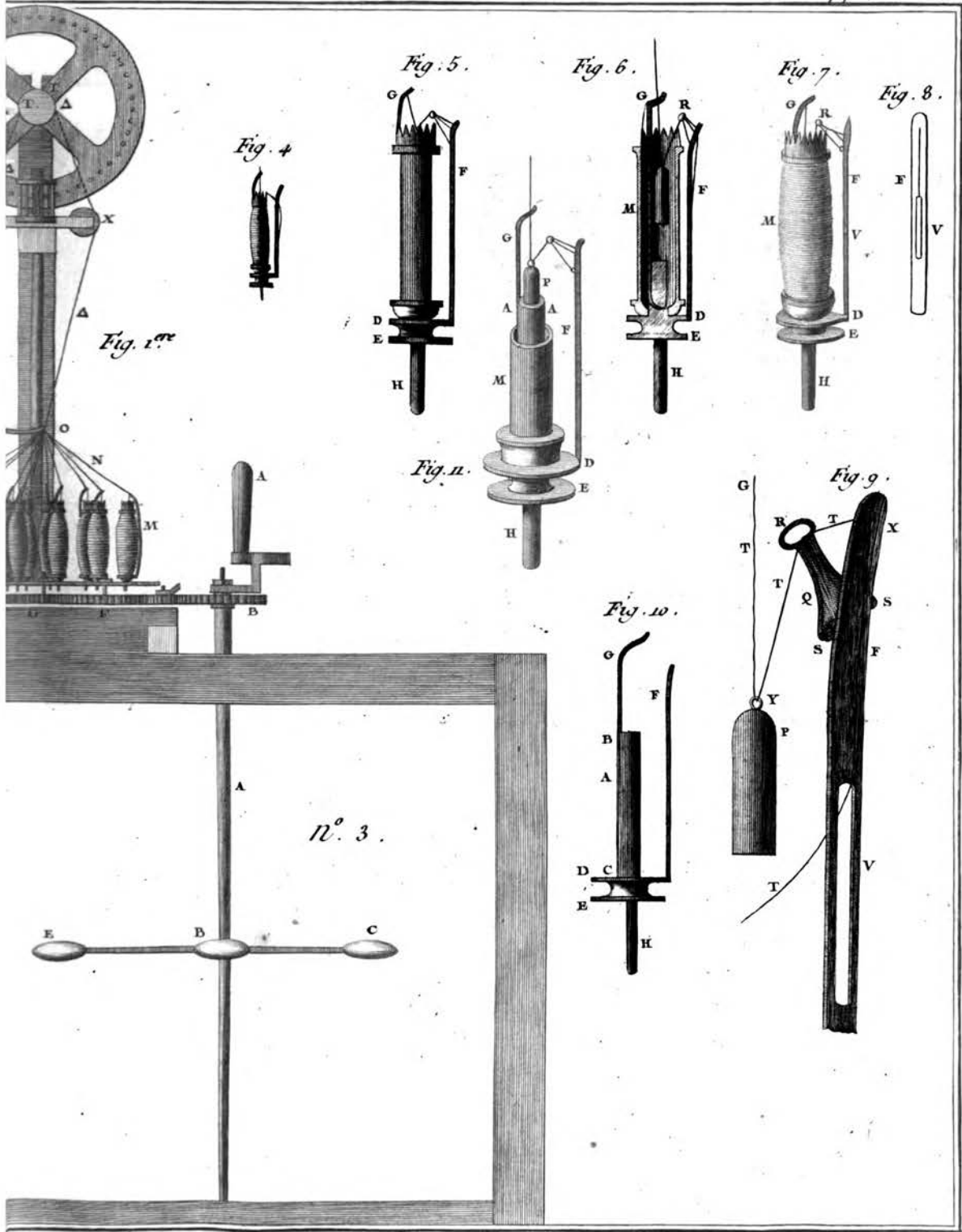


Benard Drexat.

ets et développemens.



*Machine à faire des La*

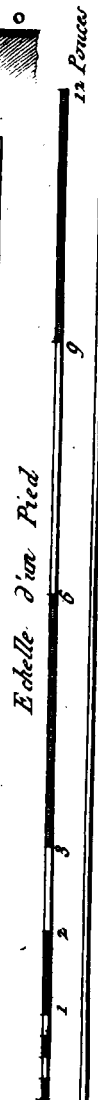
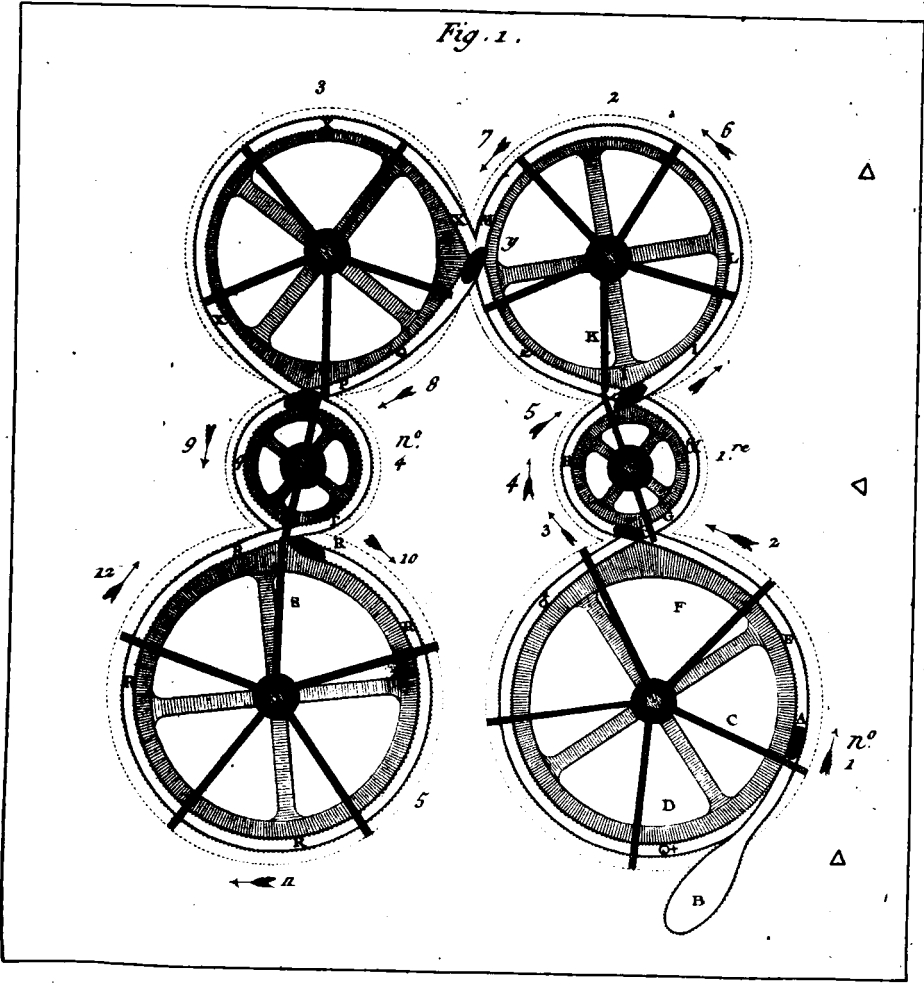
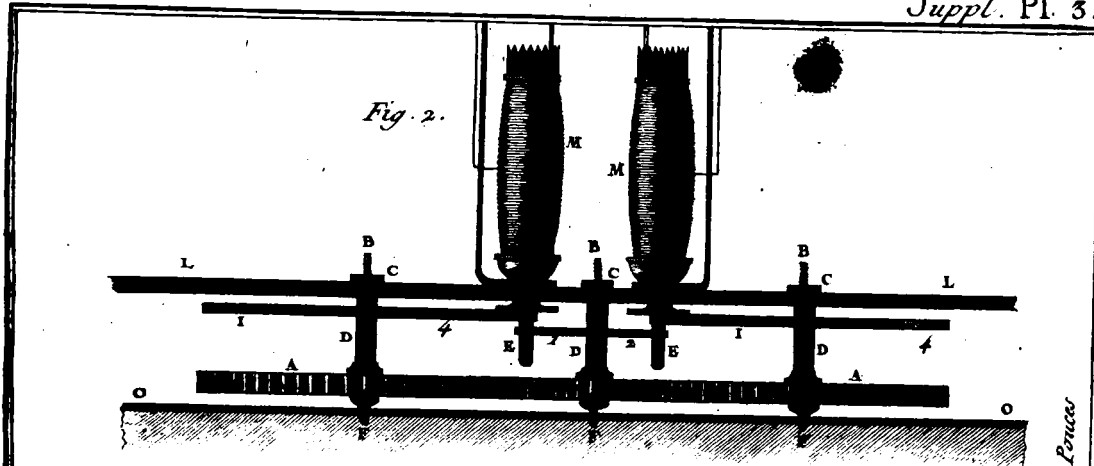


ets, et développemens.

Benard Drexel.

k.



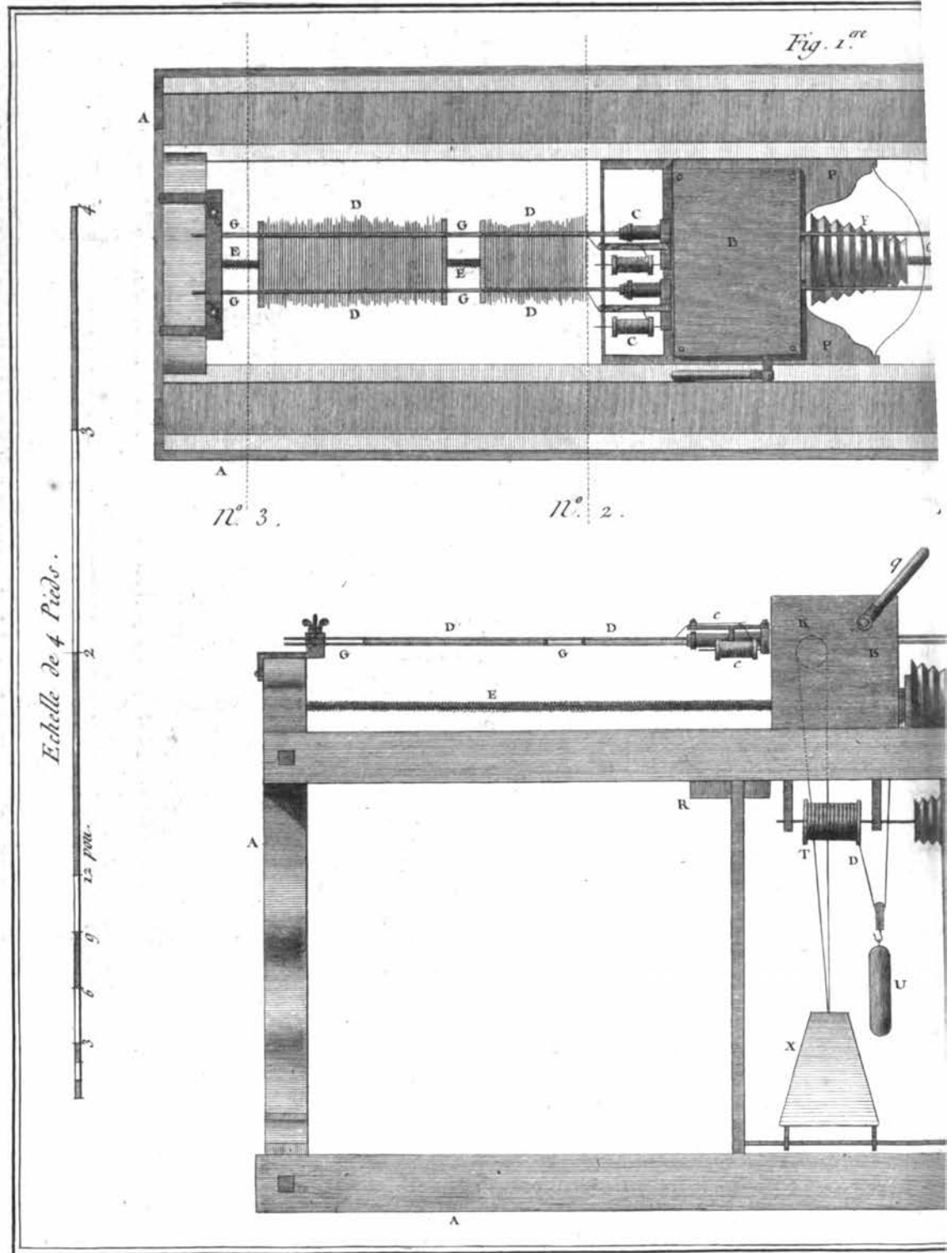


*Machine à faire les Lacets.*

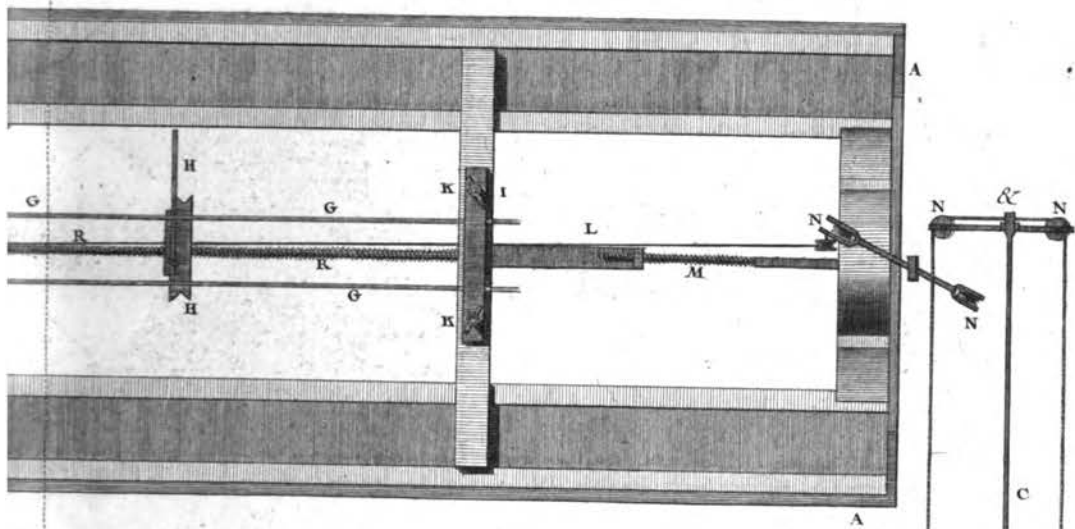
*Benard Duxcit.*

*L.*

Fig. 1.<sup>re</sup>

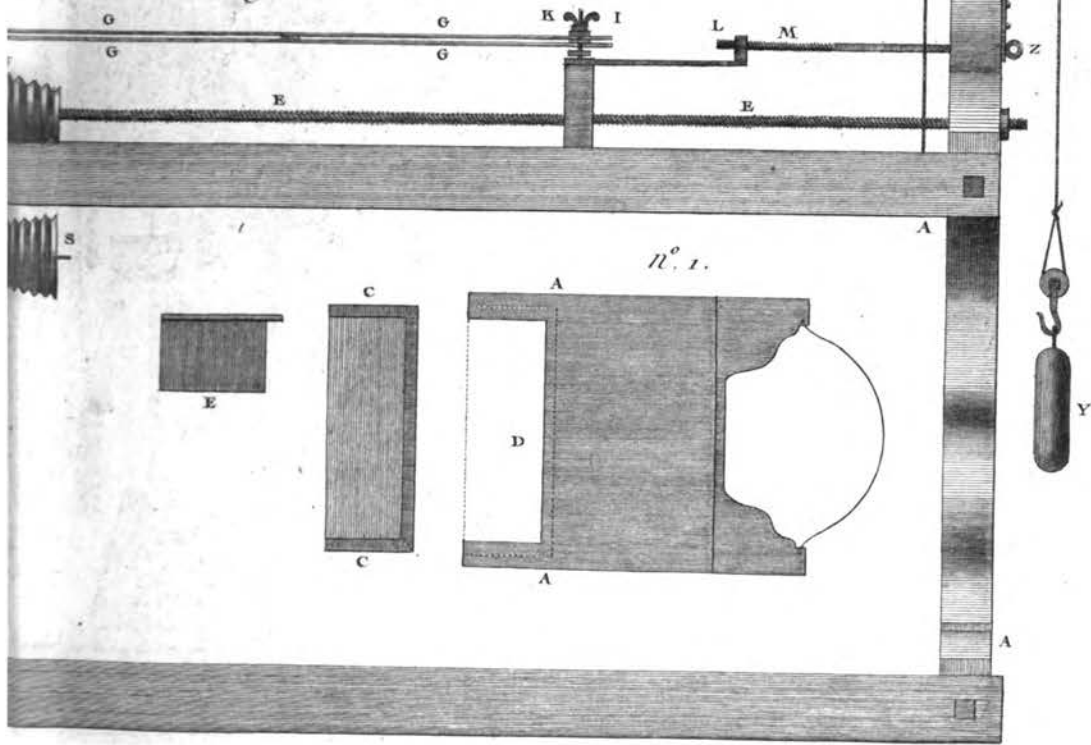


*Machine à fai*



2<sup>o</sup> 1.

Fig. 2.

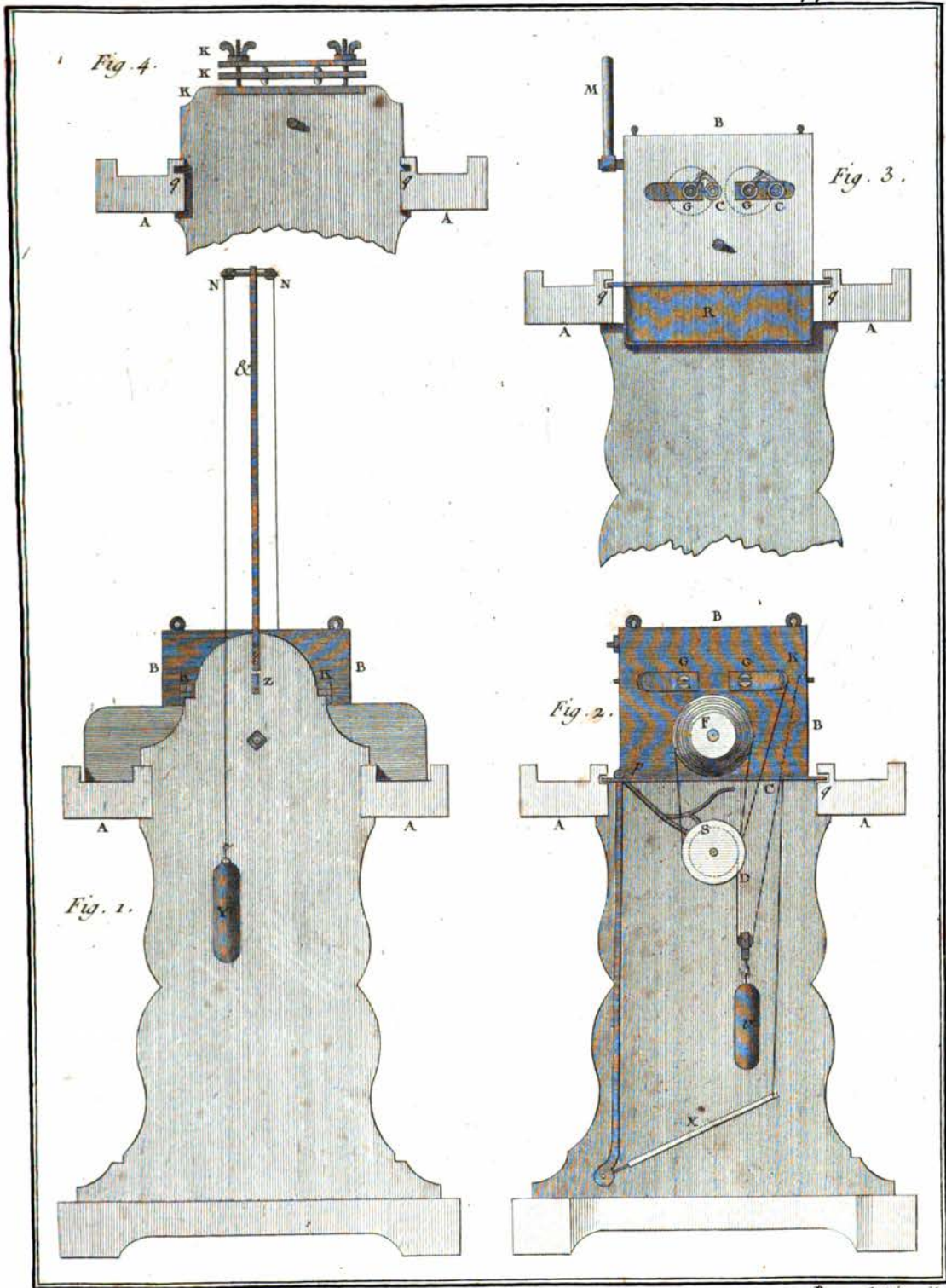


n<sup>o</sup> 1.

de des Peignes.

Bernard D'axit.

m.



*Machine à faire des Peignes.*

*Benard Directeur.*

Fig. 3.

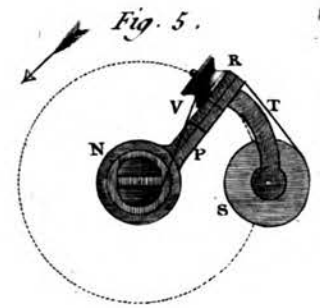
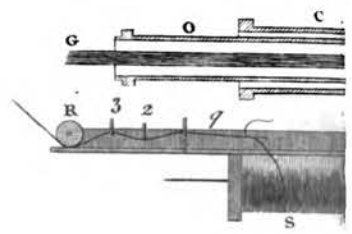
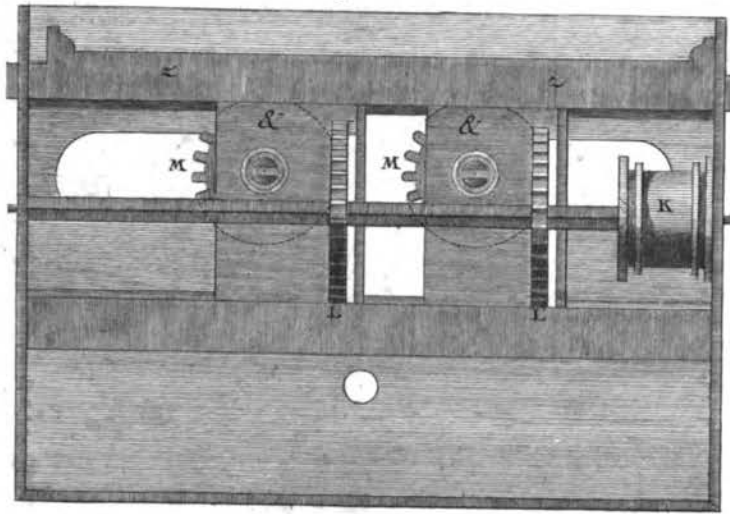


Fig. 9.

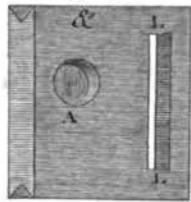


Fig. 7.

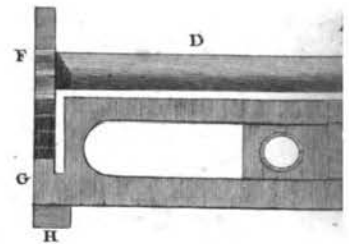
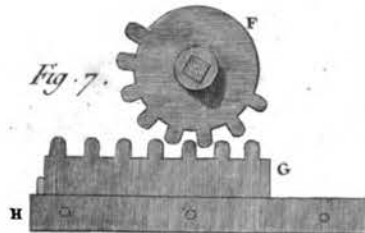


Fig. 1.



Fig. 2.

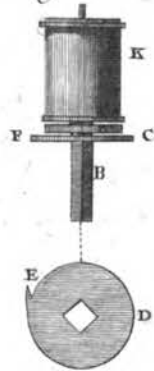


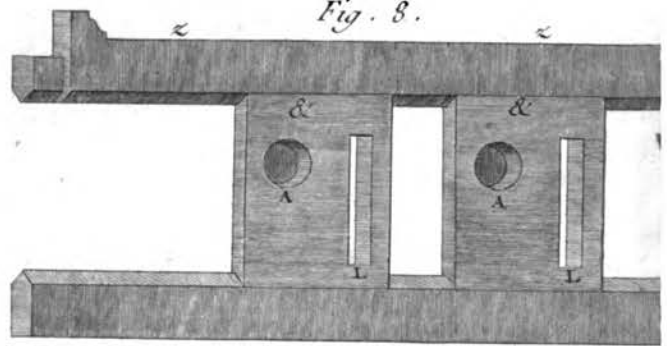
Fig. 3.



Fig. 4.

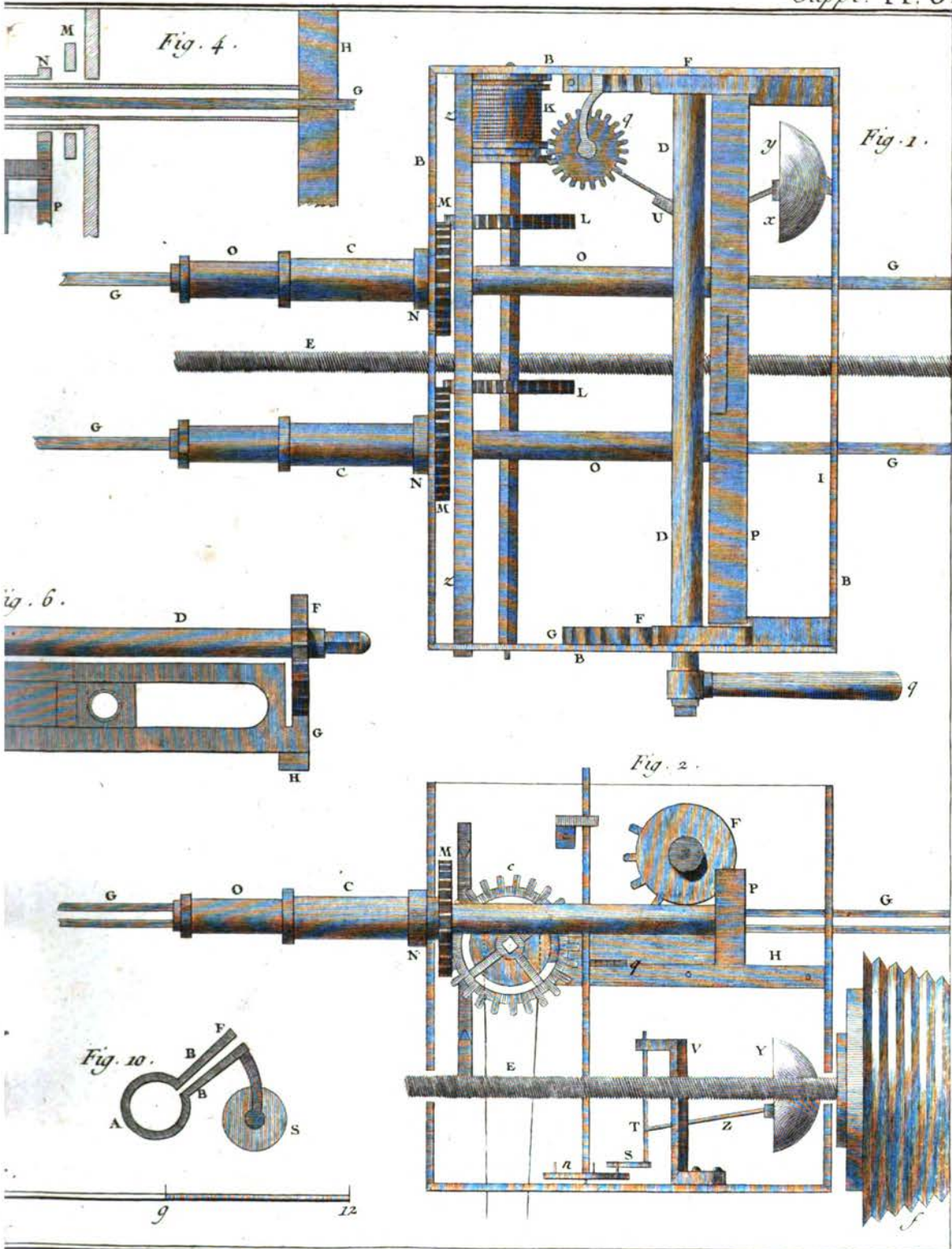


Fig. 8.



Echelle de 12 Pouces  
3 6

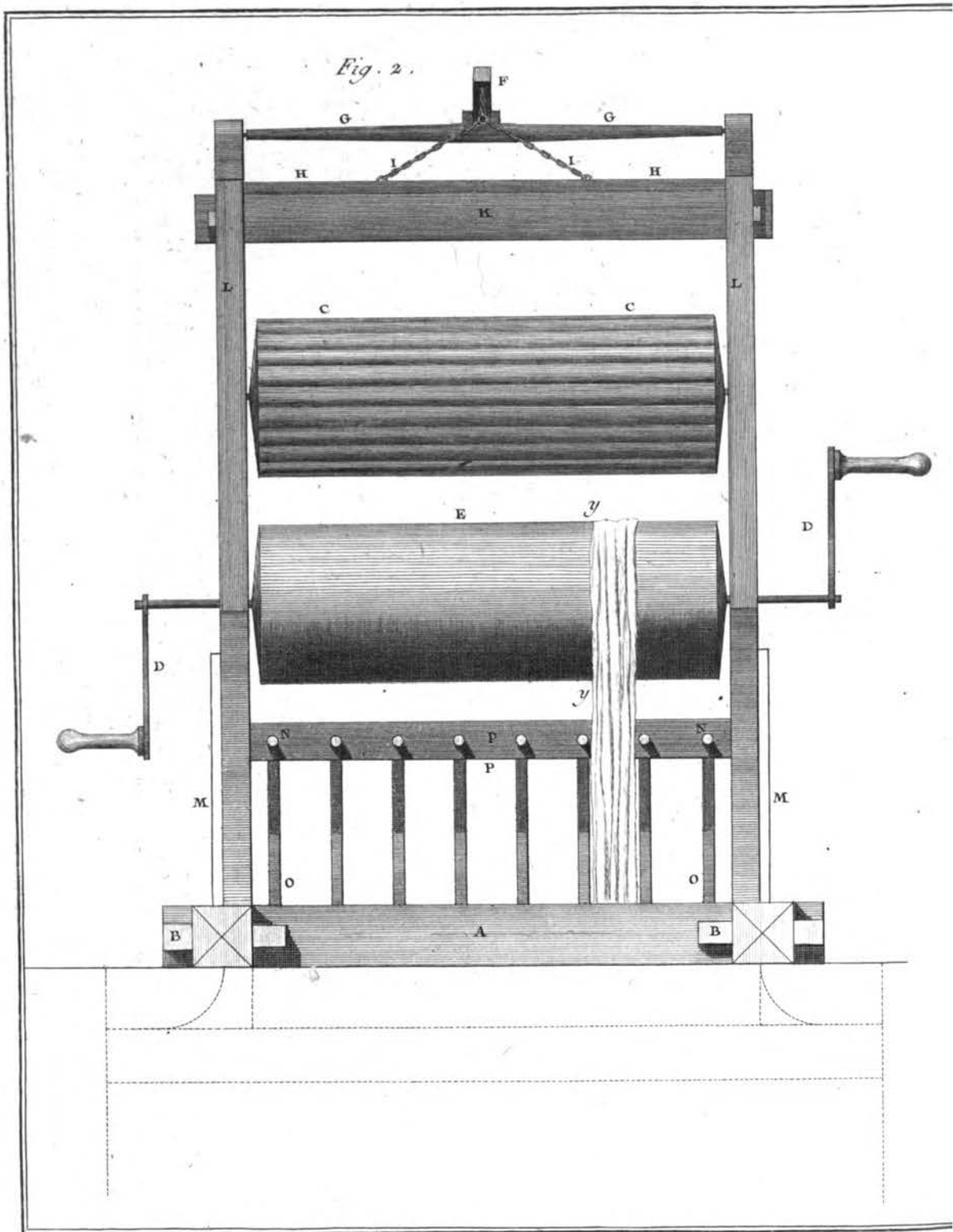
Machine à f



ire des Peignes.

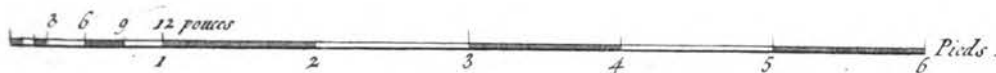
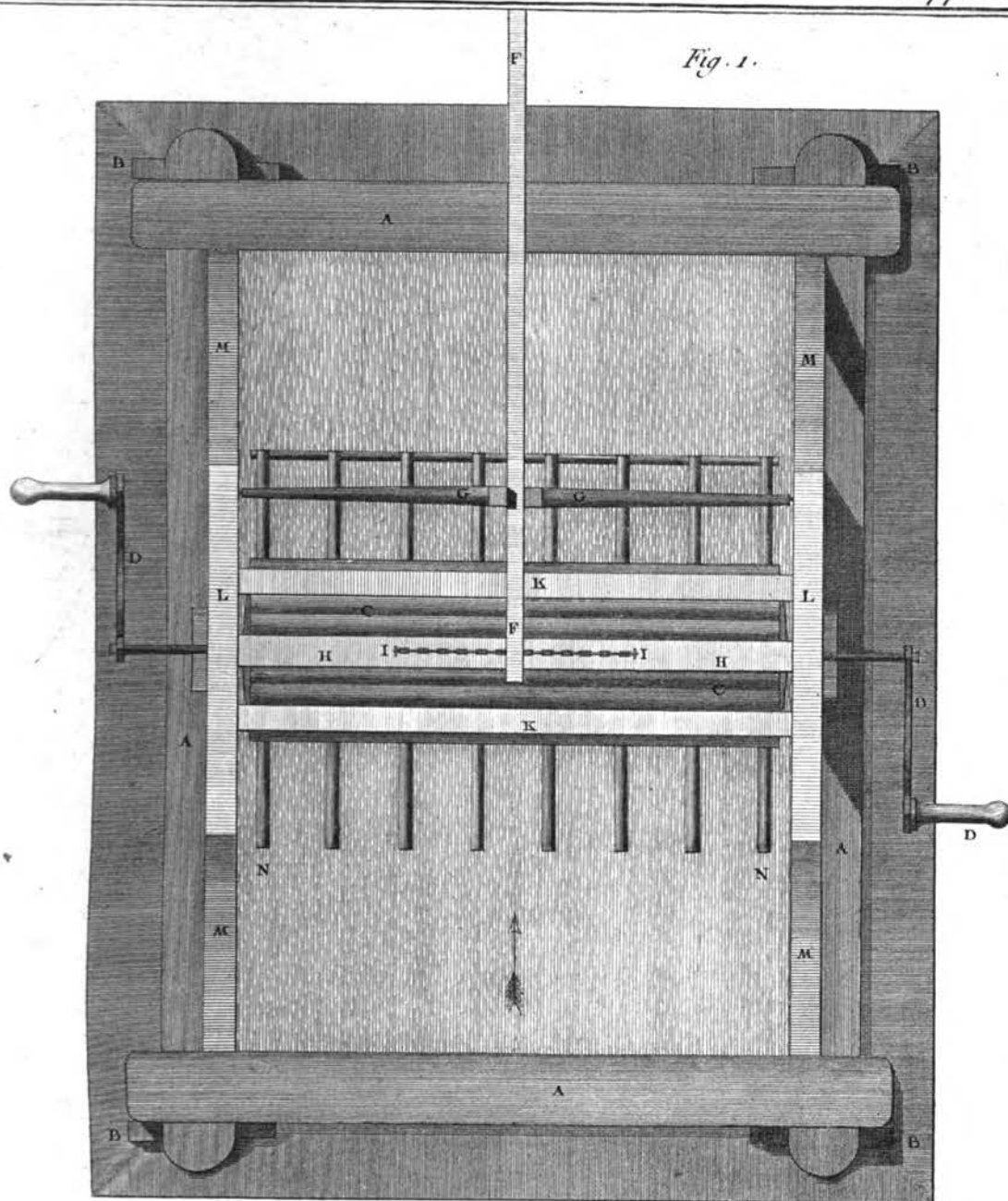
Benard Duxcit.

n.



*Machine à battre e*

Fig. 1.



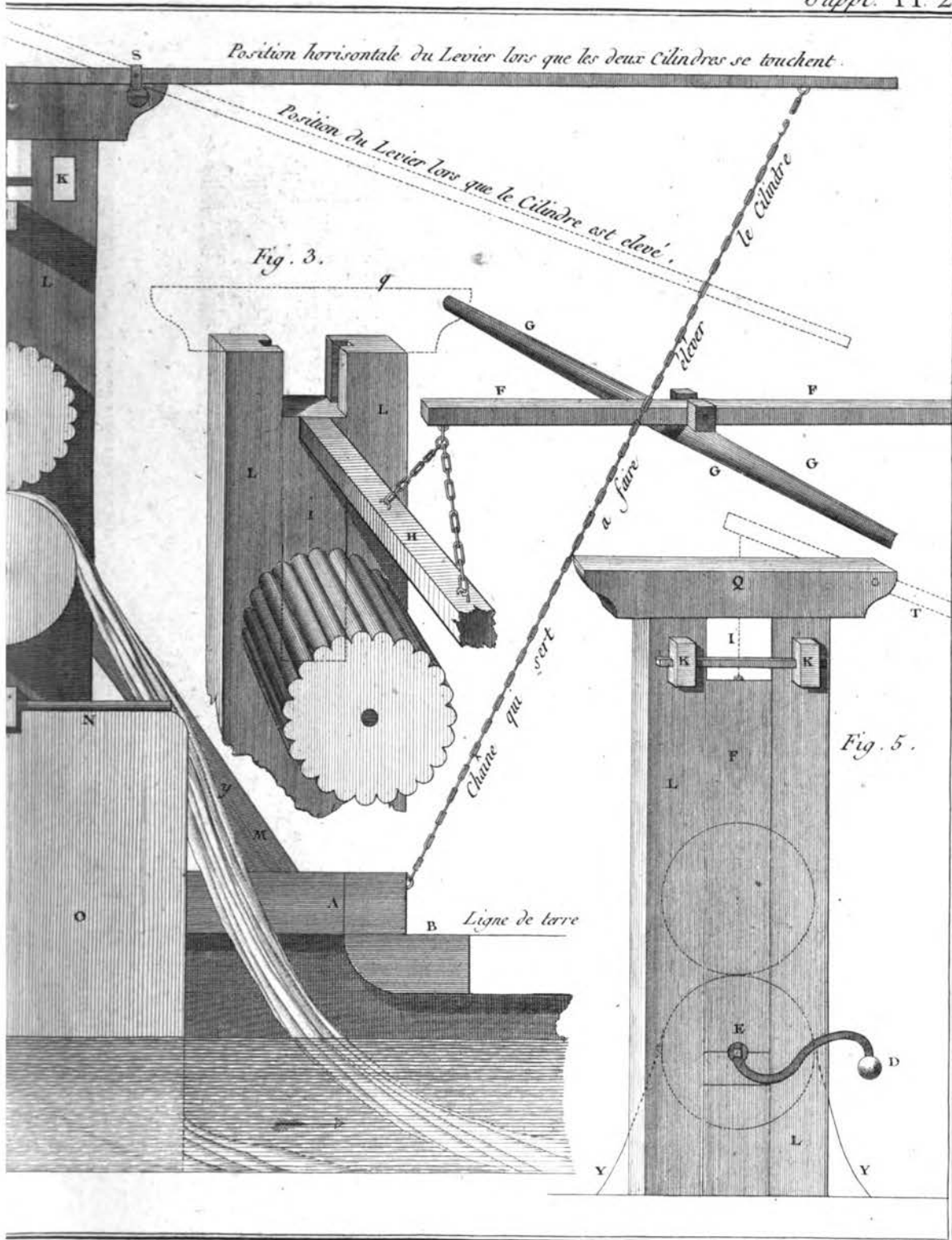
*à laver les Toiles.*

*Benard Duvau.*

o.



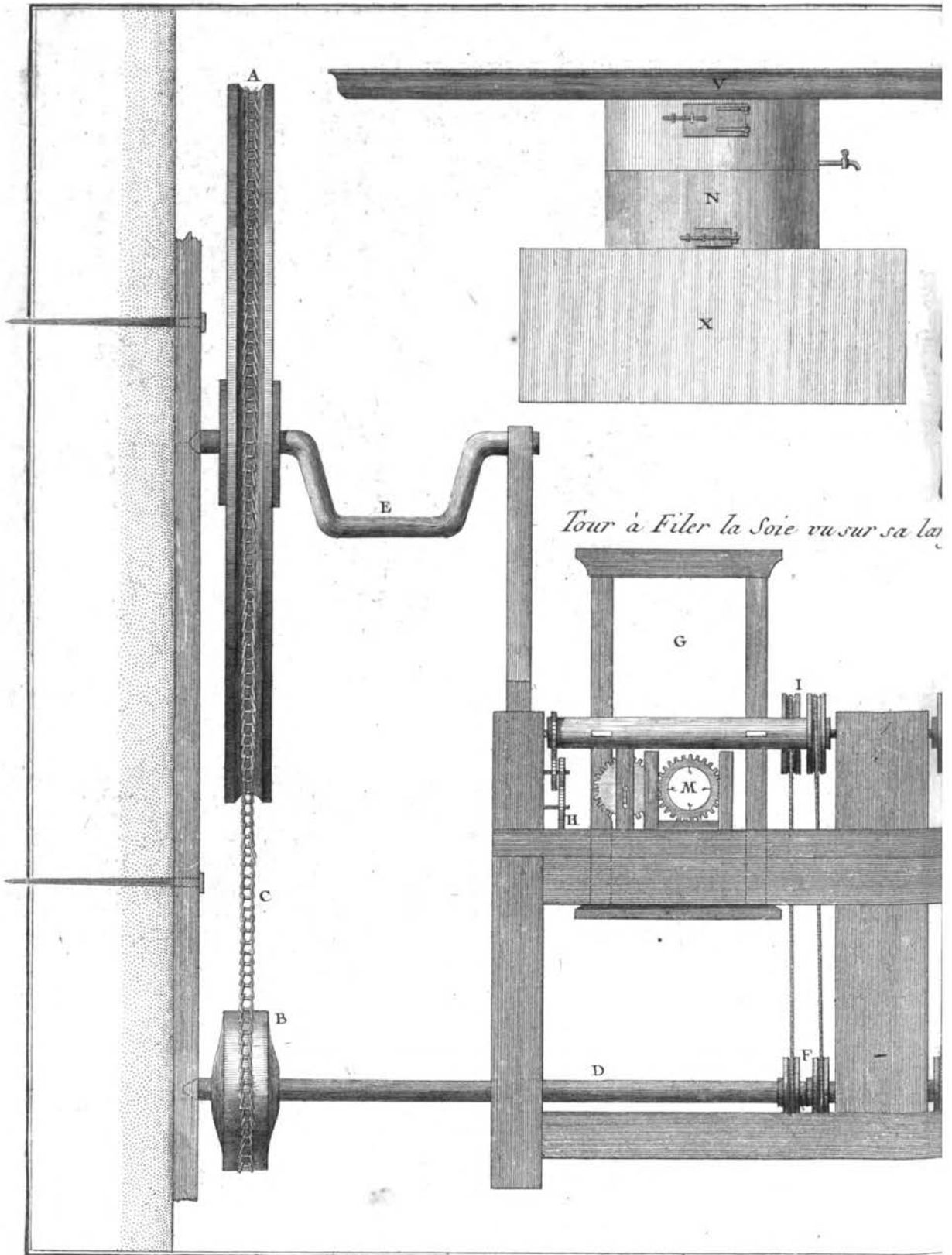




*laver les Toiles.*

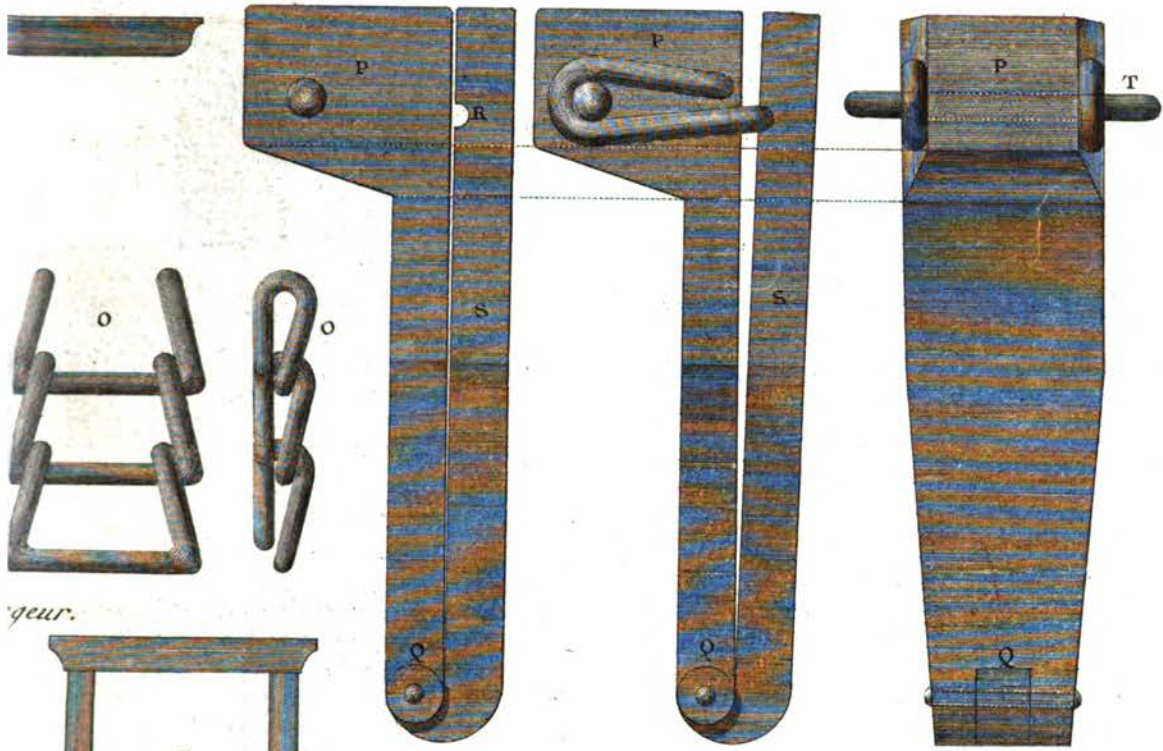
*Bonard Dorez*

*P.*

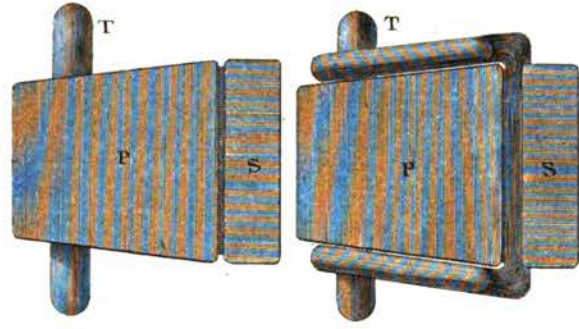
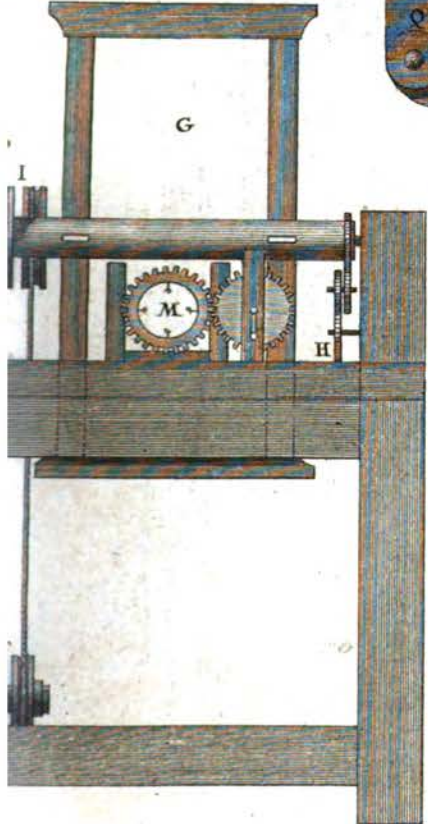


*Tour à Filer la Soie vu sur sa lat*

*Nouvelle Méthode po*



neur.



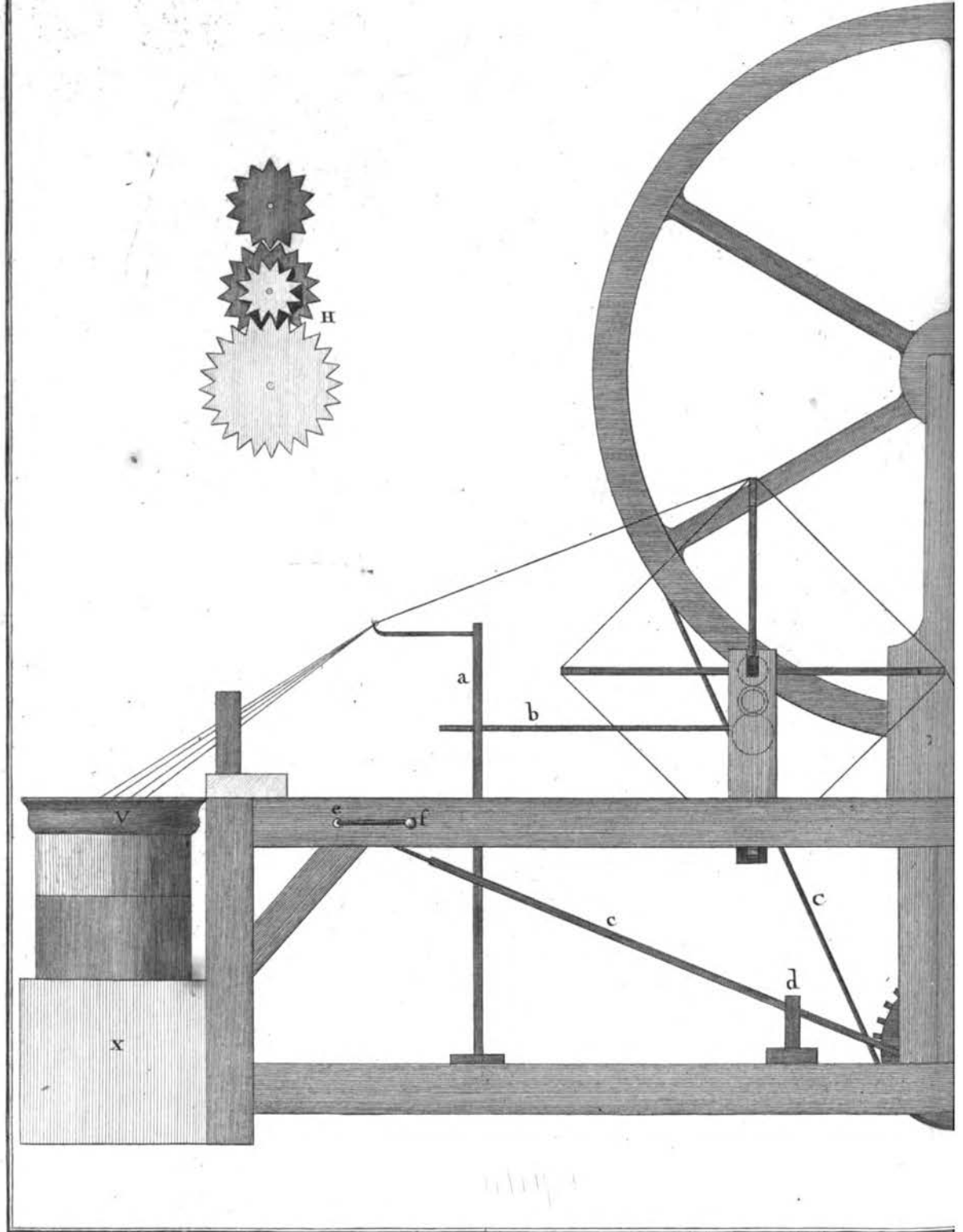
Echelle de la Matrice .  
1 2 3 Ponces

Echelle du Tour .  
1 2 3 4 Pieds

pour le Tirage des Soies.

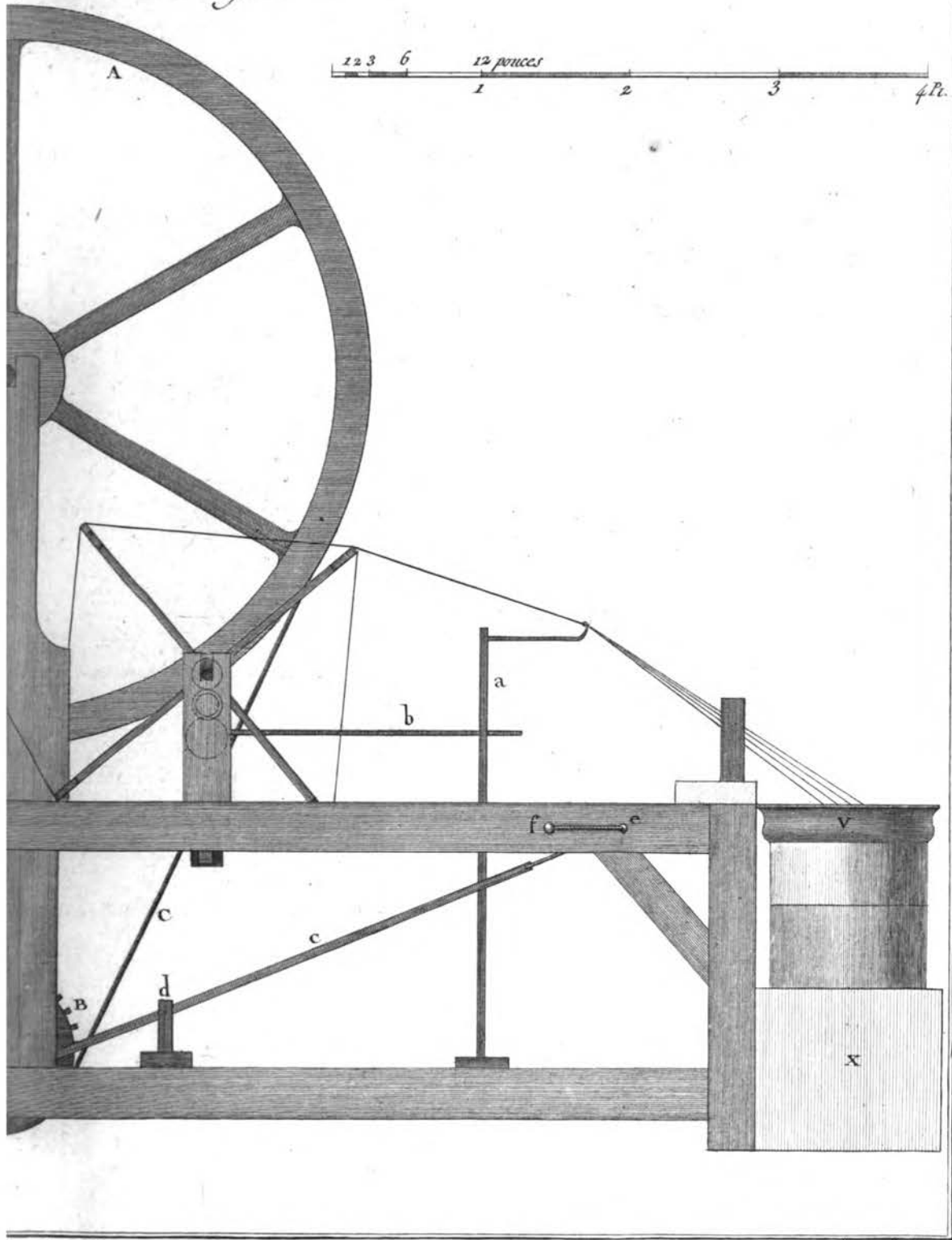
Bernard Duvet.

*Tour à Tirer la Soie*



*Nouvelle Méthode pour*

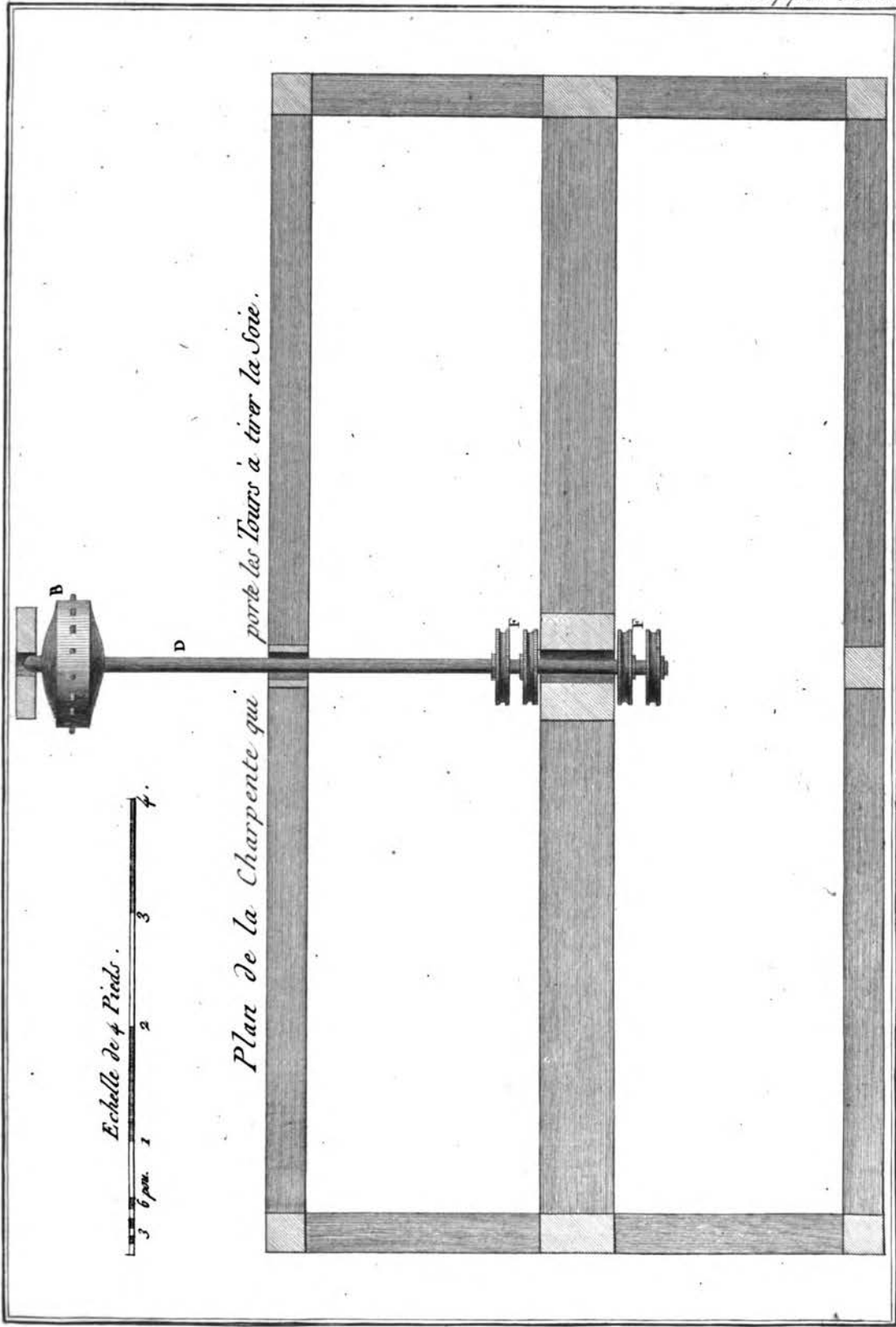
vu sur sa longueur .



le Tirage des Soies .

Bonard Invenit

r.



*Echelle de 4 Pieds.*



*Plan de la Charpente qui porte les Tours à tirer la Soie.*

*Nouvelle Méthode pour le tirage des Soies.*

*Bernard Duvareil.*

Fig. 3.

Coupe prise sur la

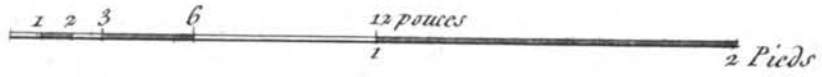


Fig. 2.

Coupe prise sur la ligne P, O  
du Plan et de l'Elevation.

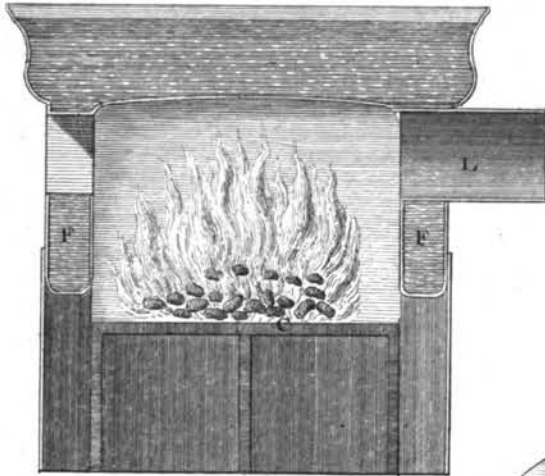
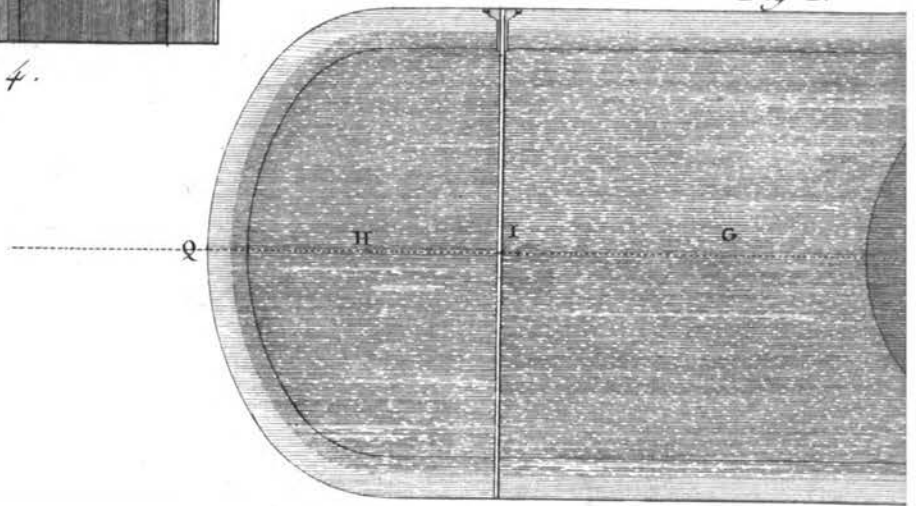


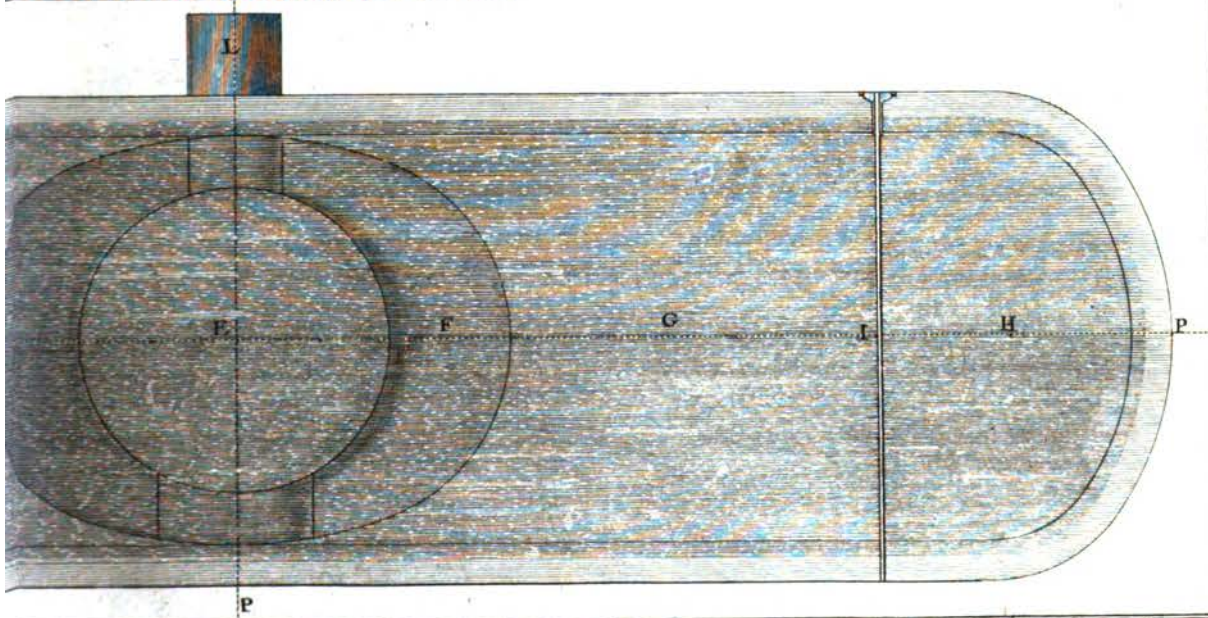
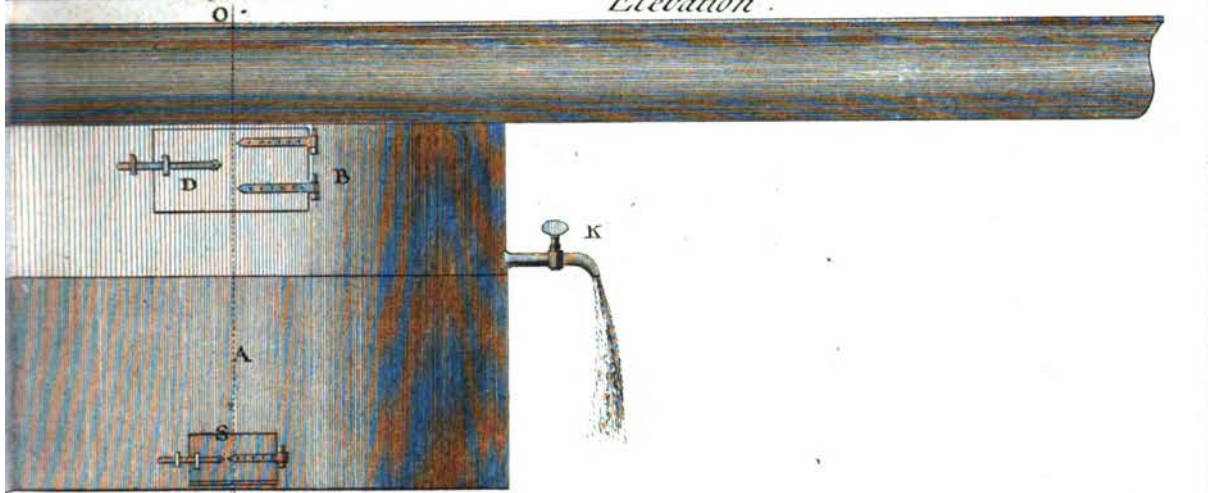
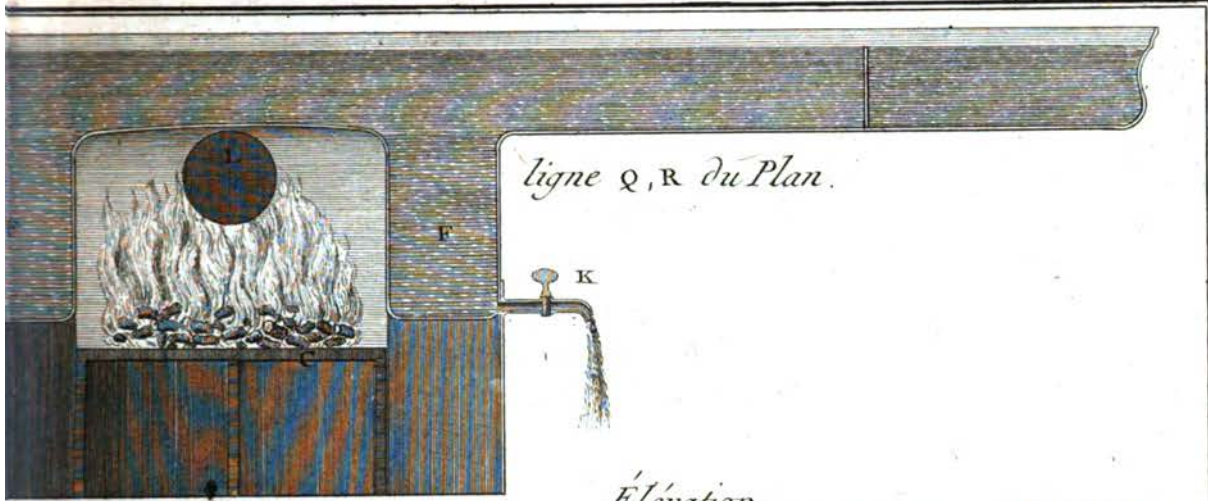
Fig. 4.

Fig. 1.<sup>ere</sup>



Nouvelle Méthode 7

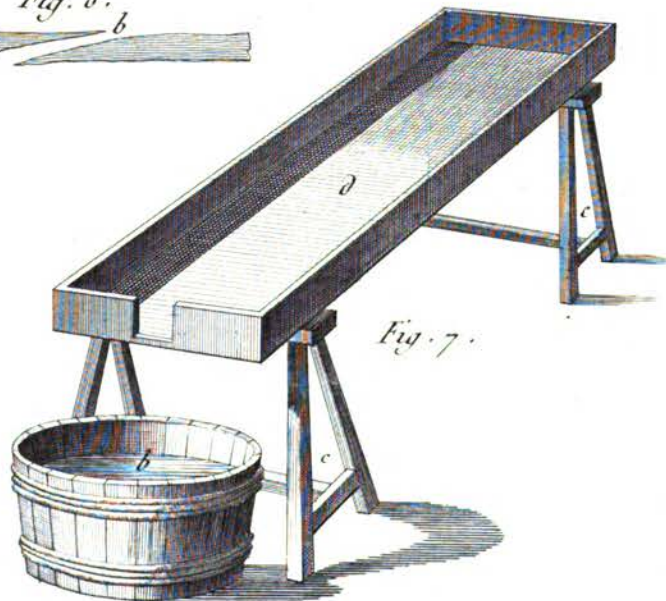
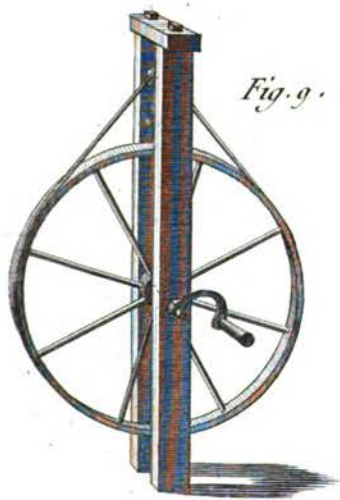
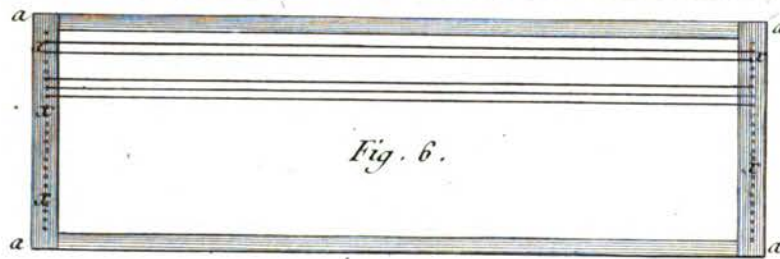
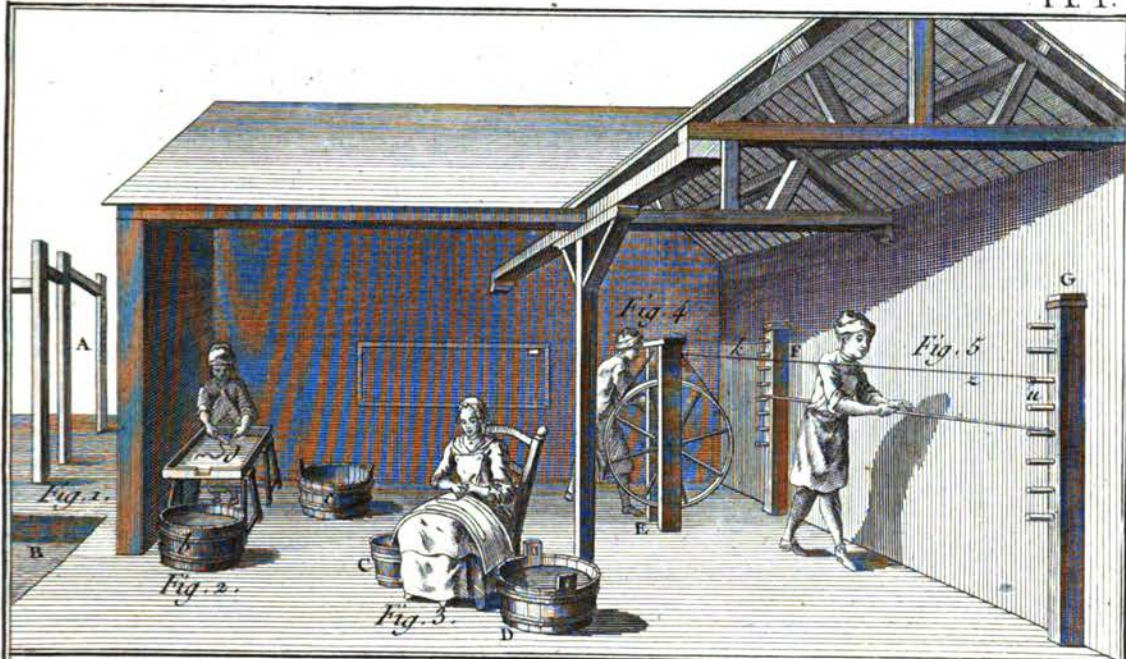




*pour le Tirage des Soies.*

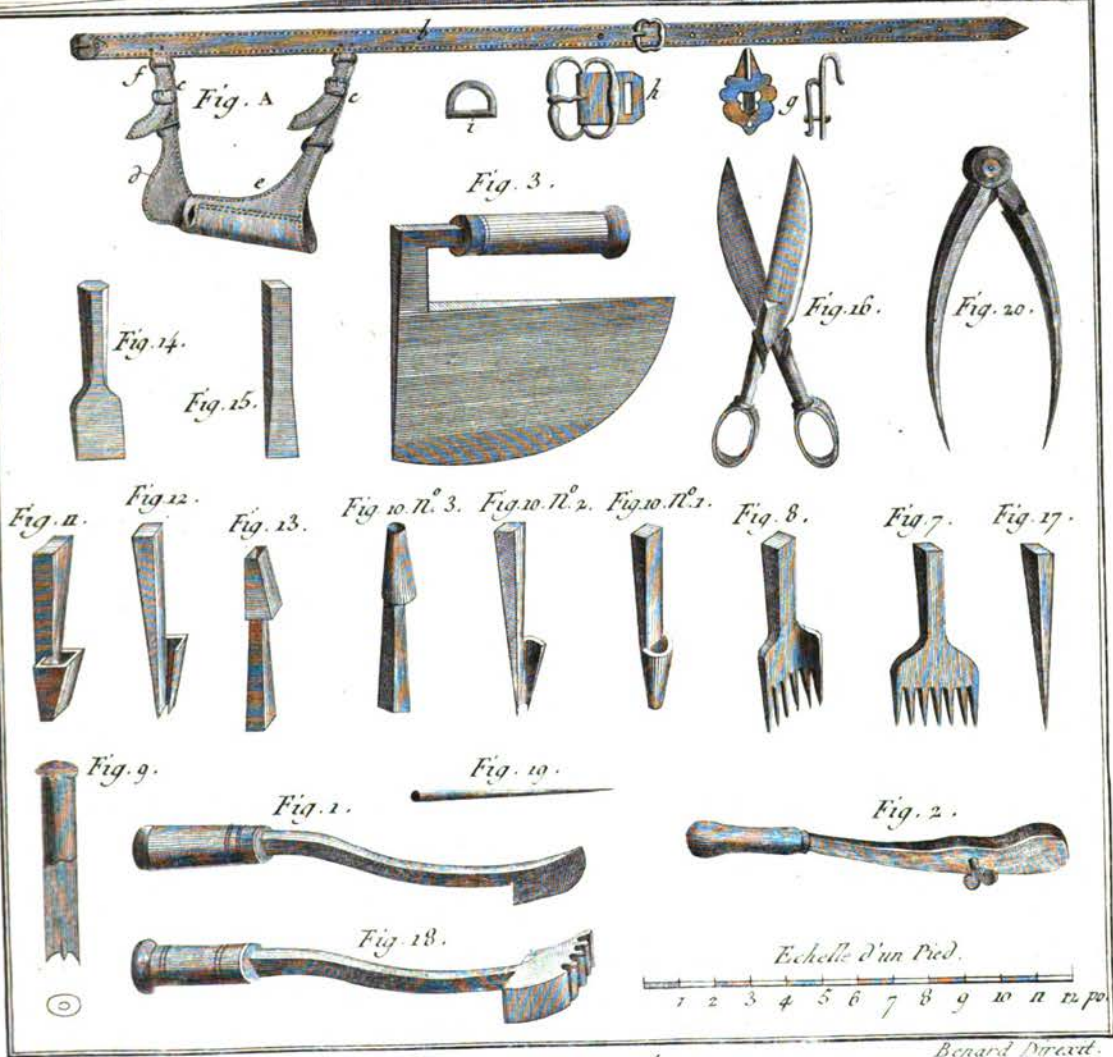
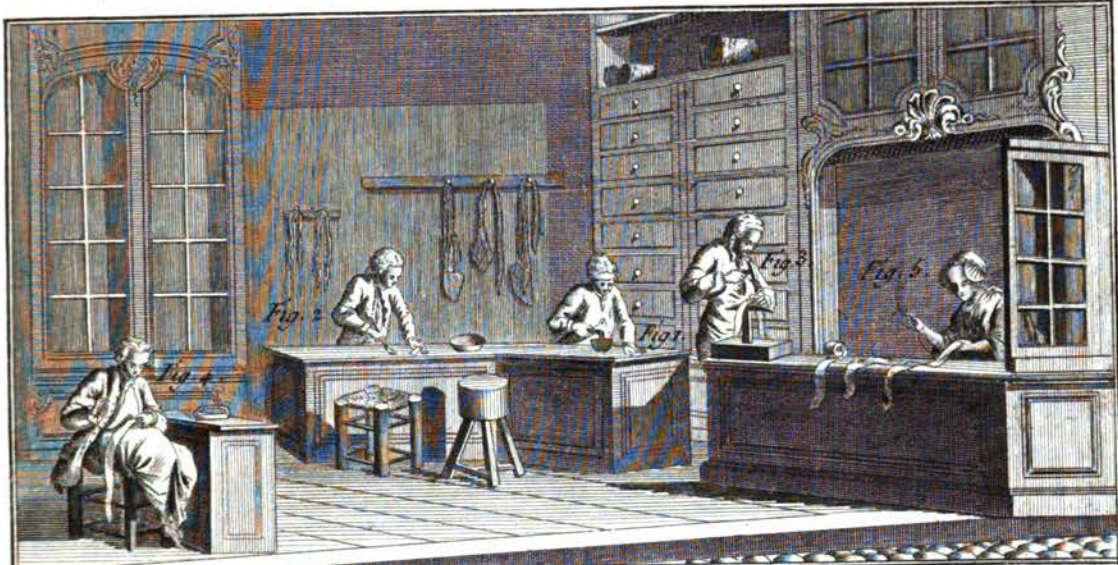
*Bernard Duvet*

*S*



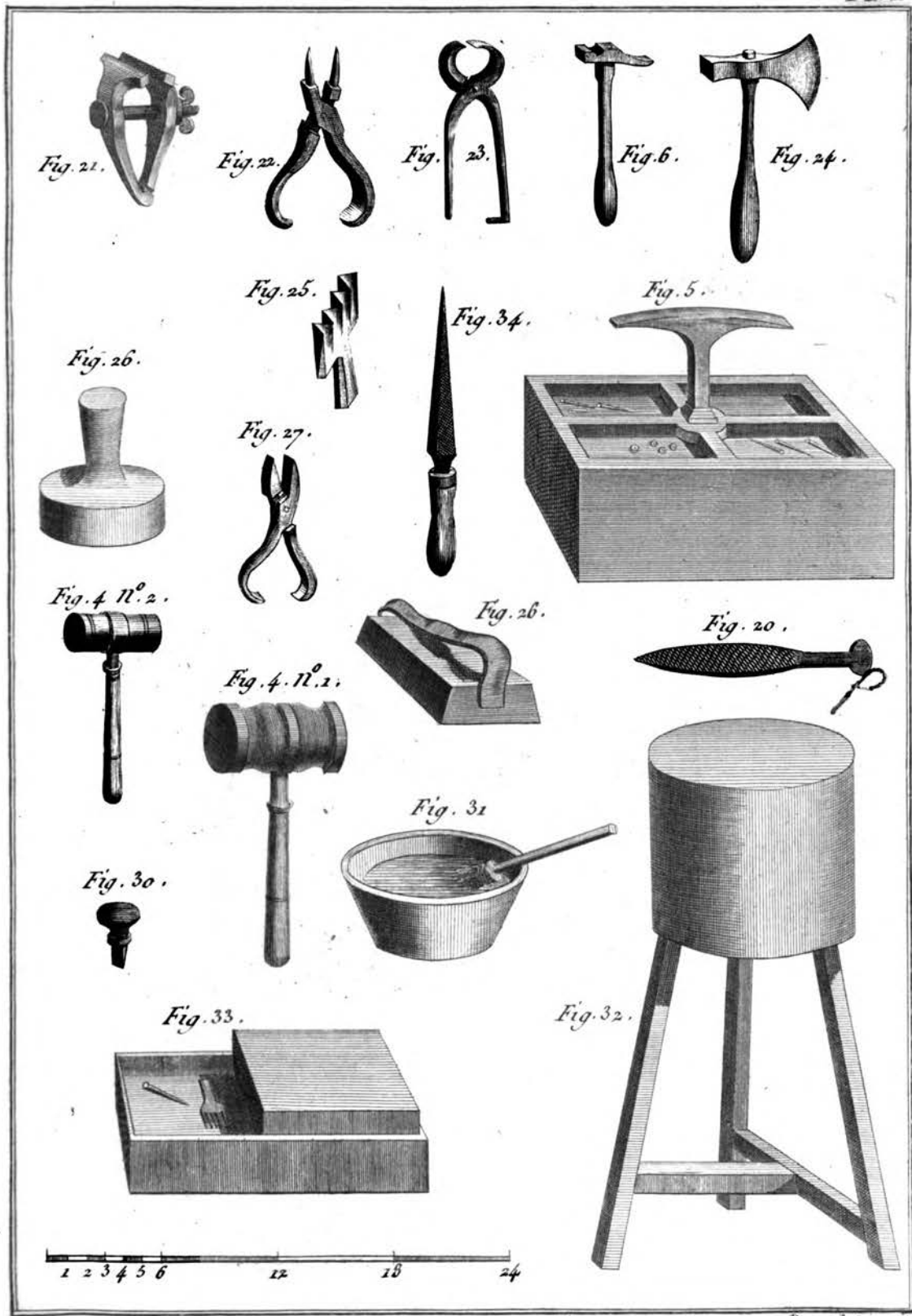
Boyaudier.

Bernard Drevet



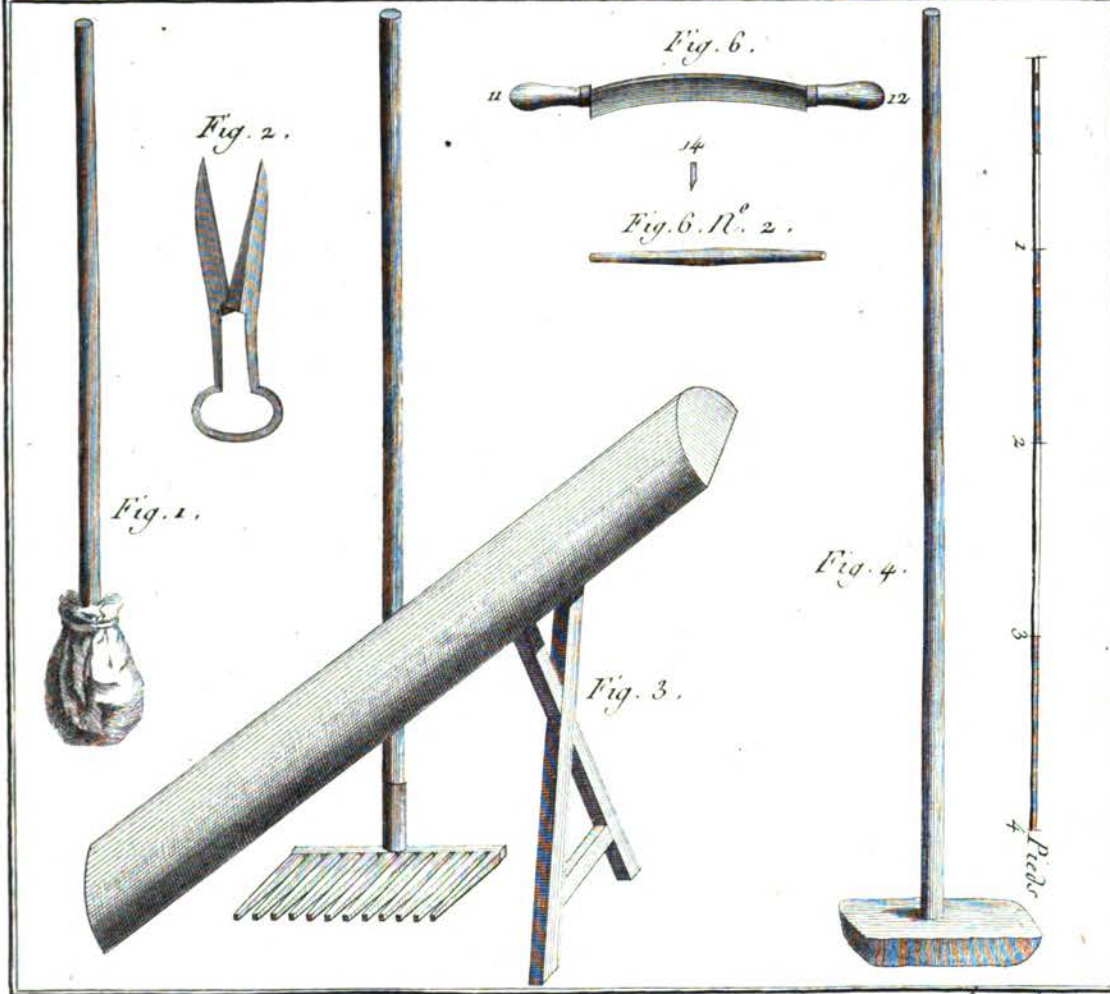
*Ceinturonnier.*

*Bernard Dorez del.*



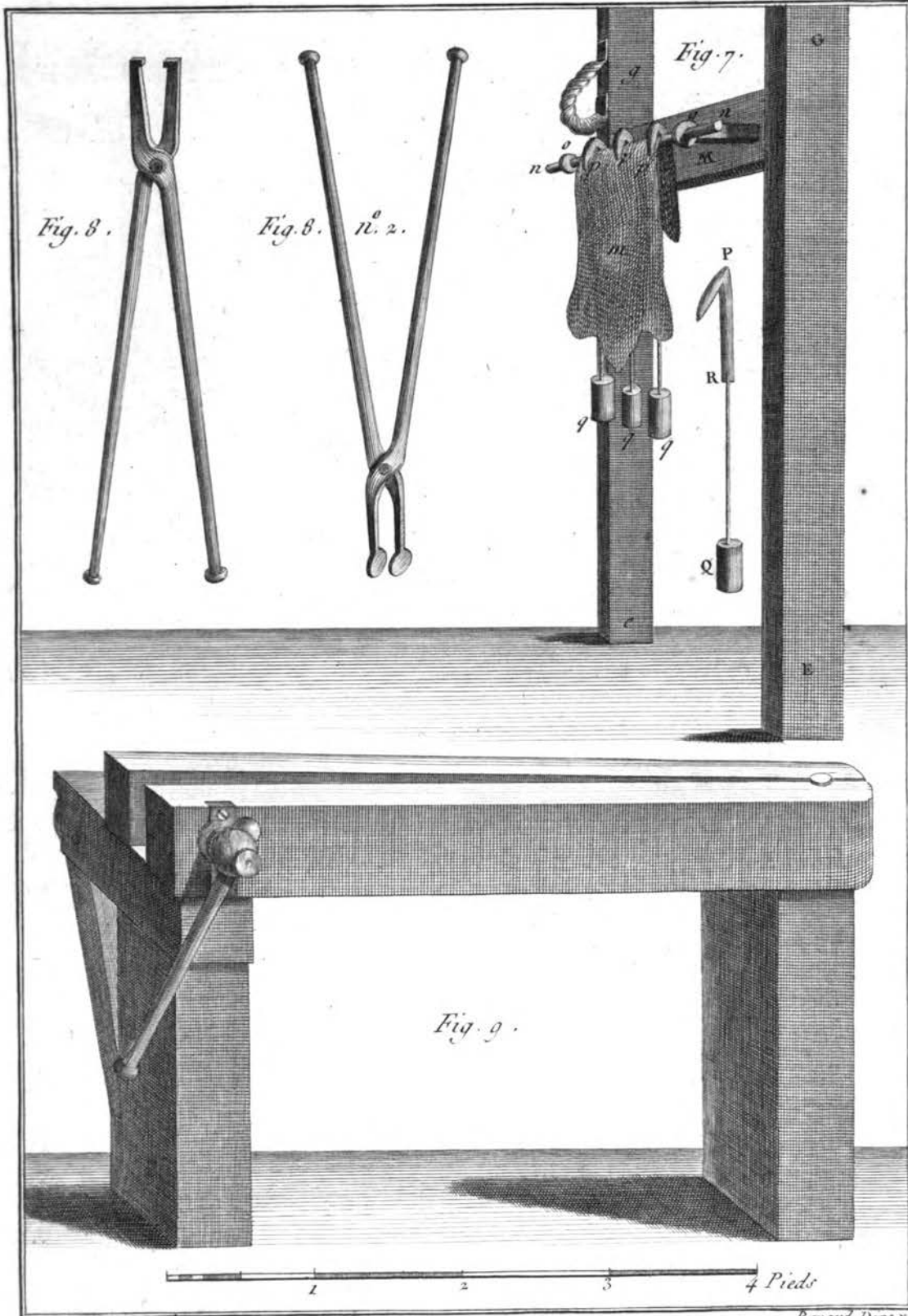
*Ceinturonnier.*

*Benard Duxid.*



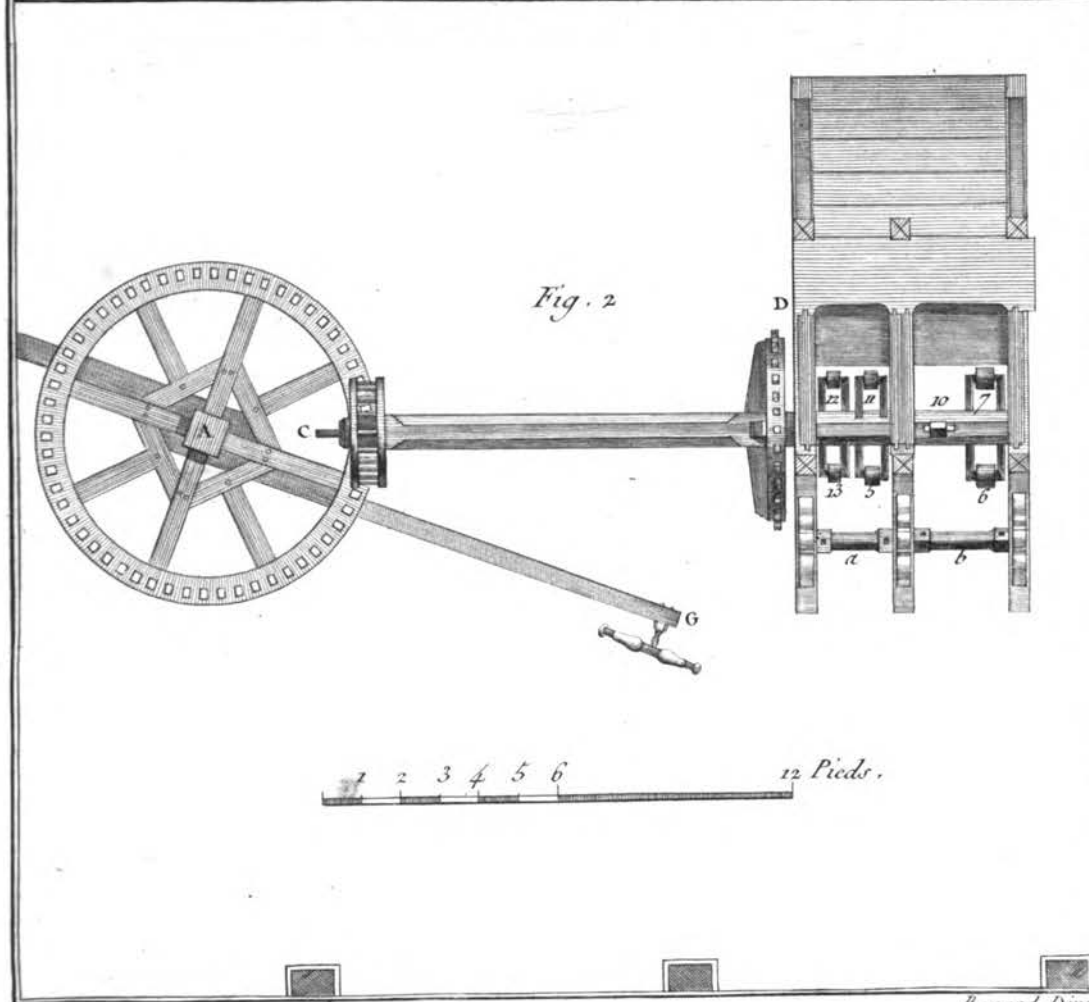
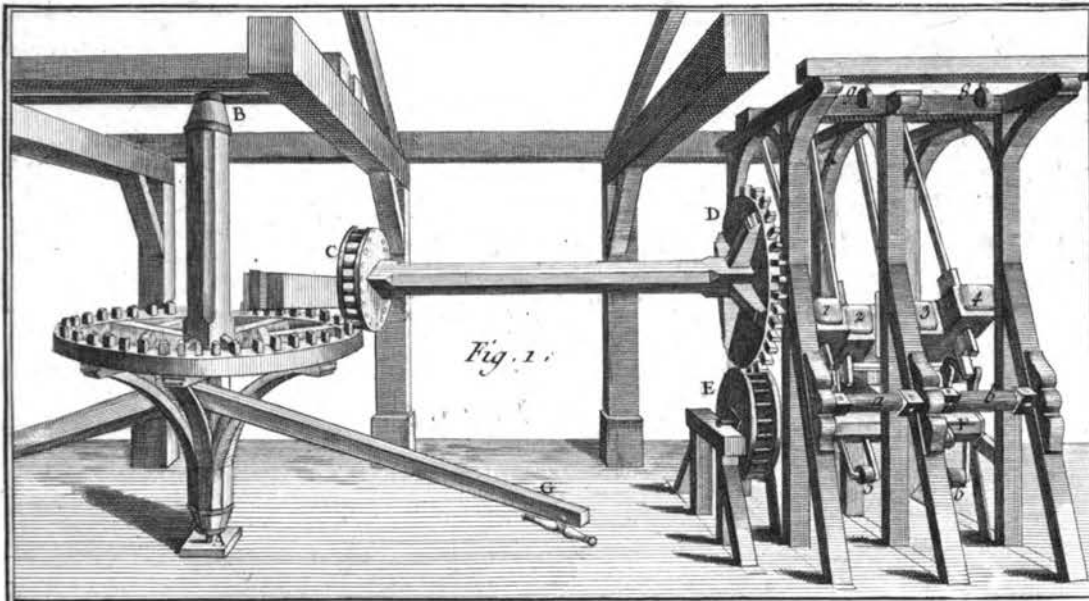
*Chamoiseur et Mégissier:*

*Bernard Duval.*



*Chamoiseur.*

Benard Drex.



*Chamoiseur, Moulin à Foulon.*

*Bernard Duvet.*

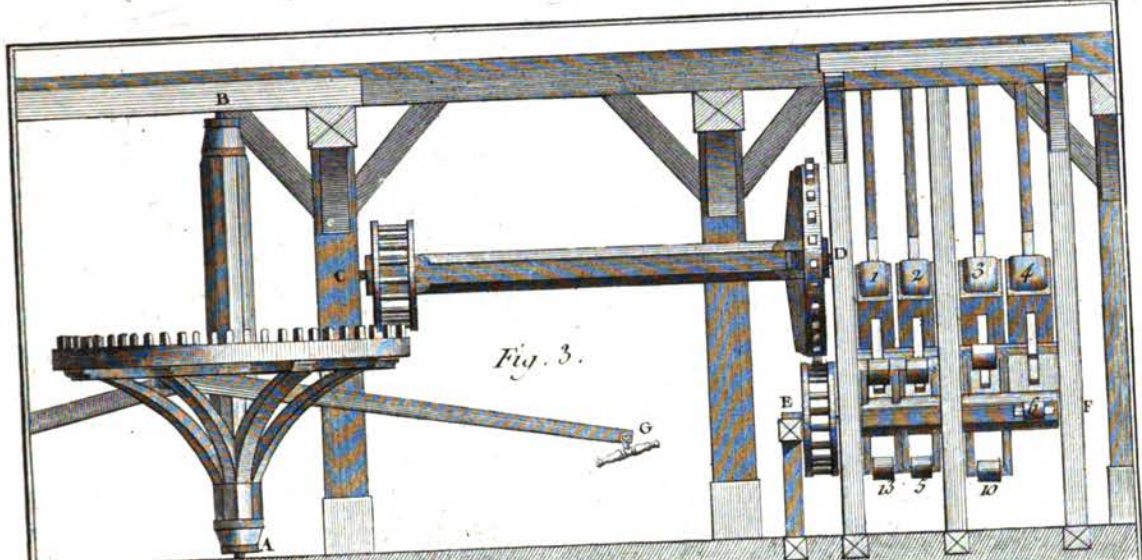


Fig. 3.

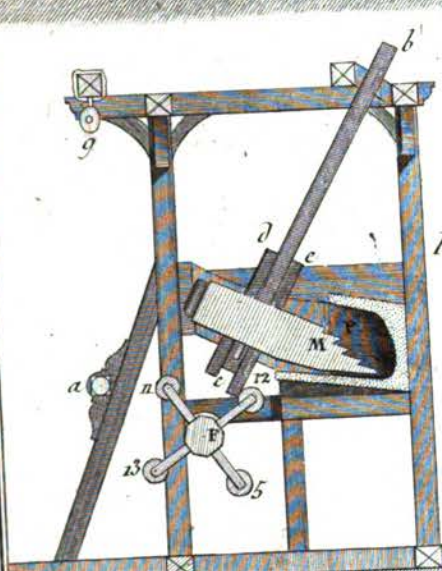


Fig. 5.

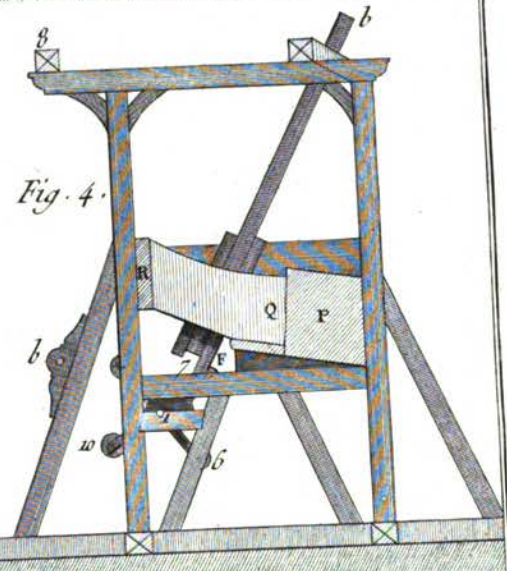


Fig. 4.

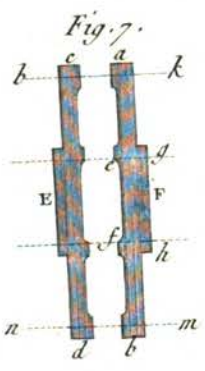


Fig. 7.

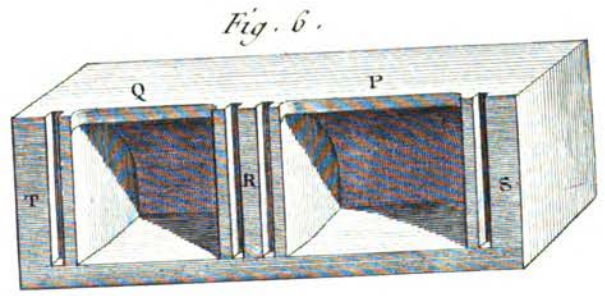
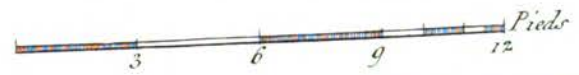


Fig. 6.



Benoist Dirc. cul

Chamoiseur, Moulin à Foulon.



Fig. 5.

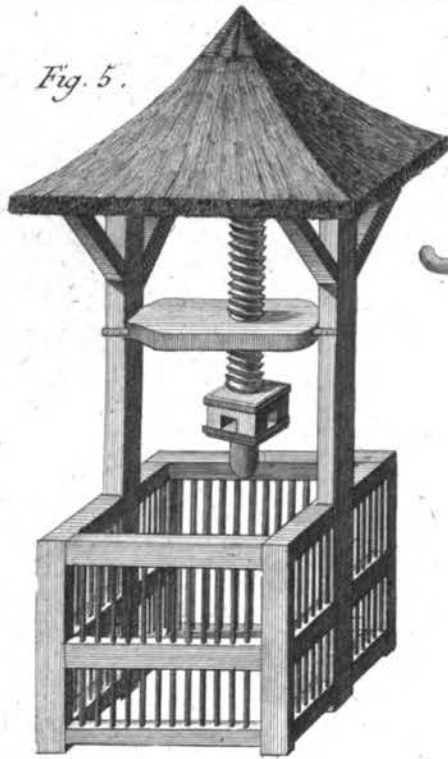


Fig. 1.

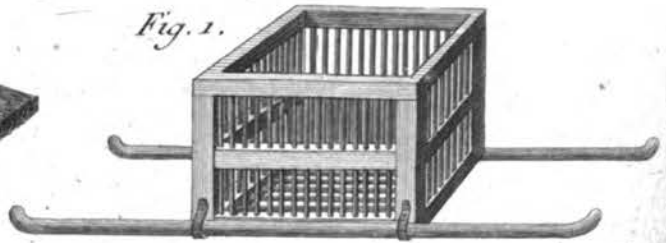


Fig. 2. A.



Fig. 2. C.

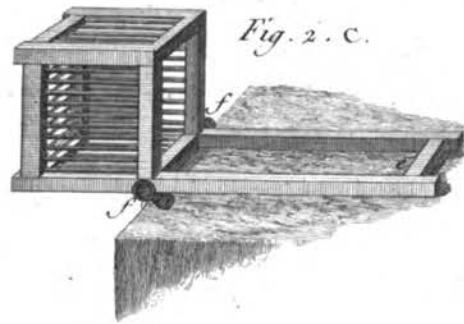


Fig. 7.



Fig. 10.

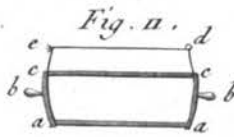


Fig. 8.

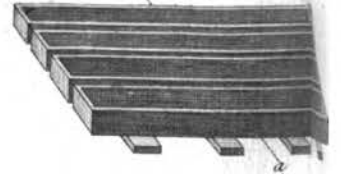


Fig. 13.

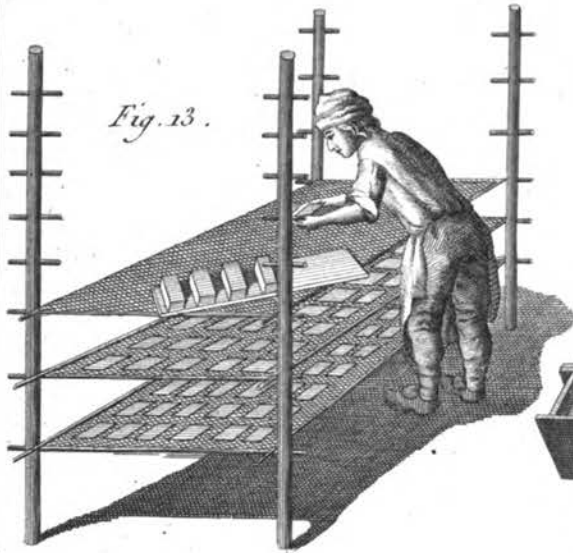
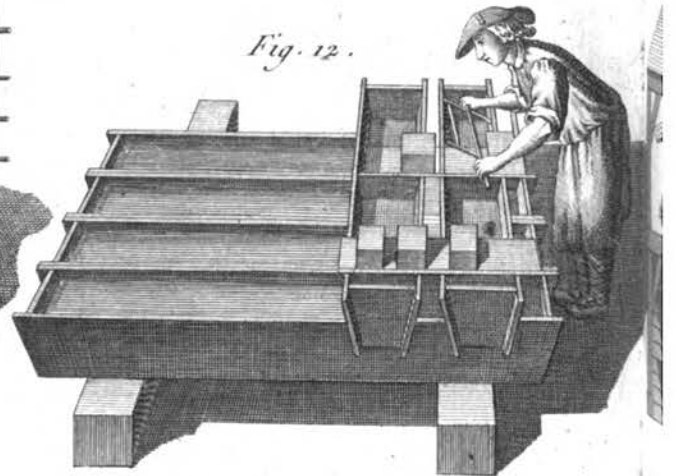
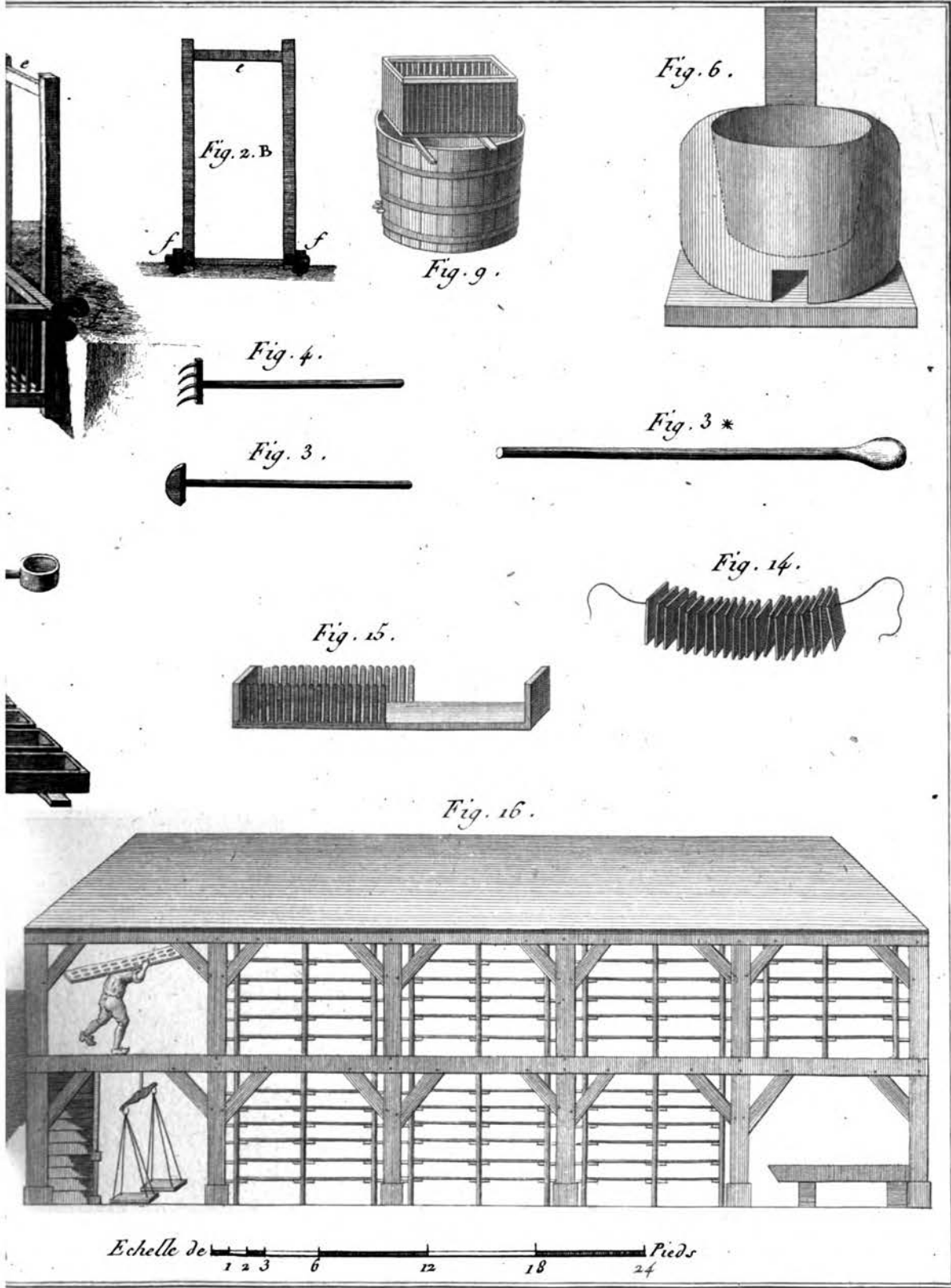


Fig. 12.

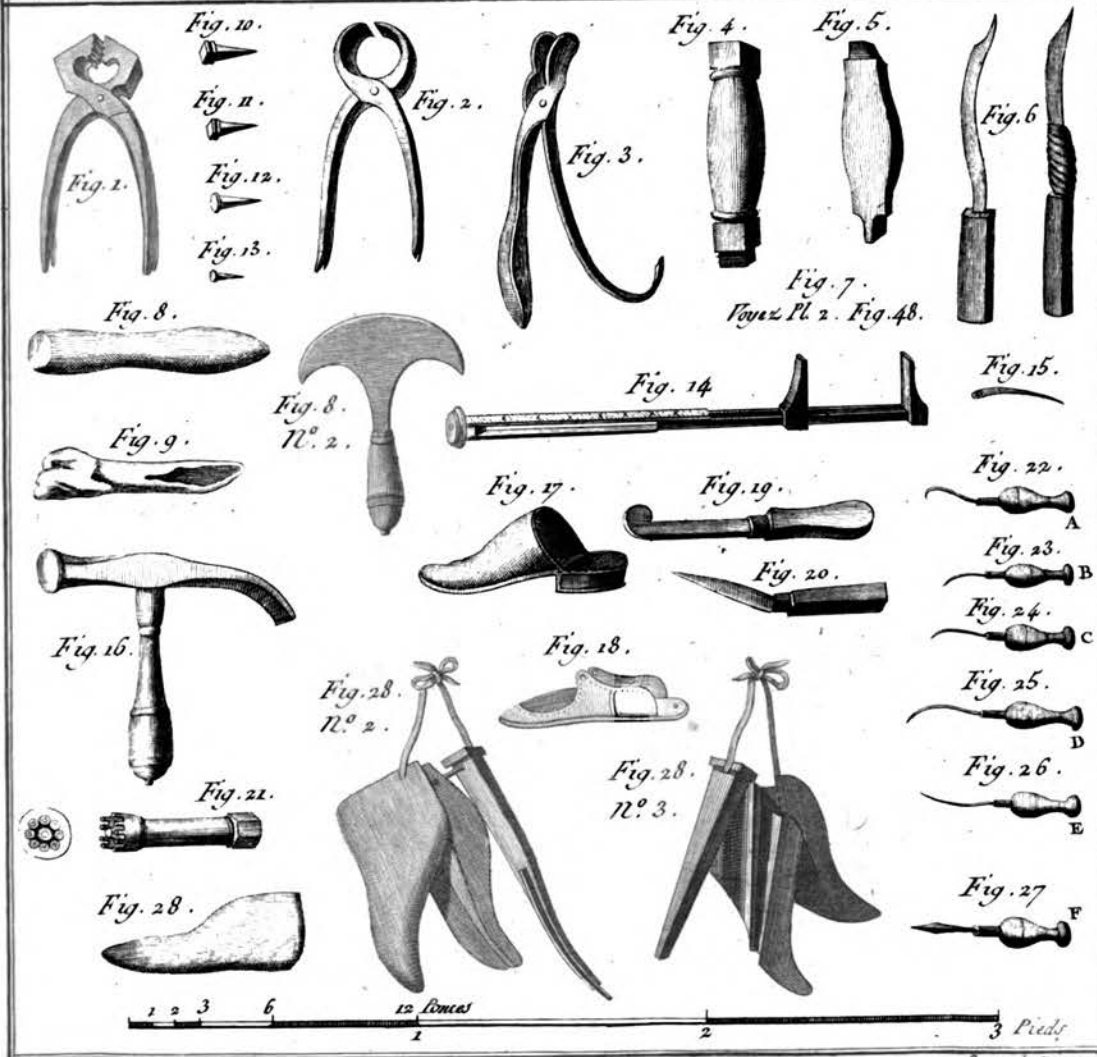
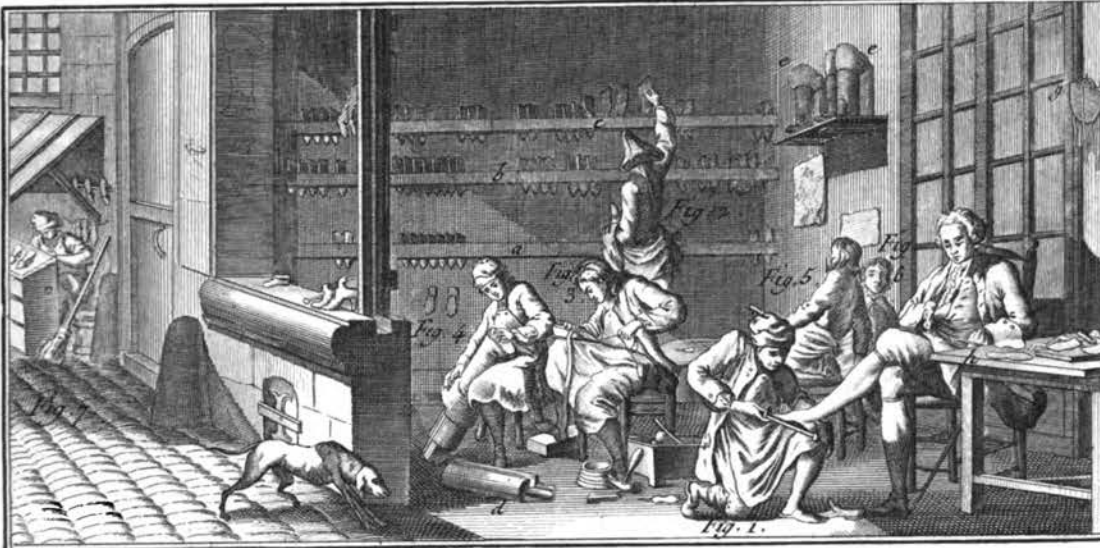


Colle...



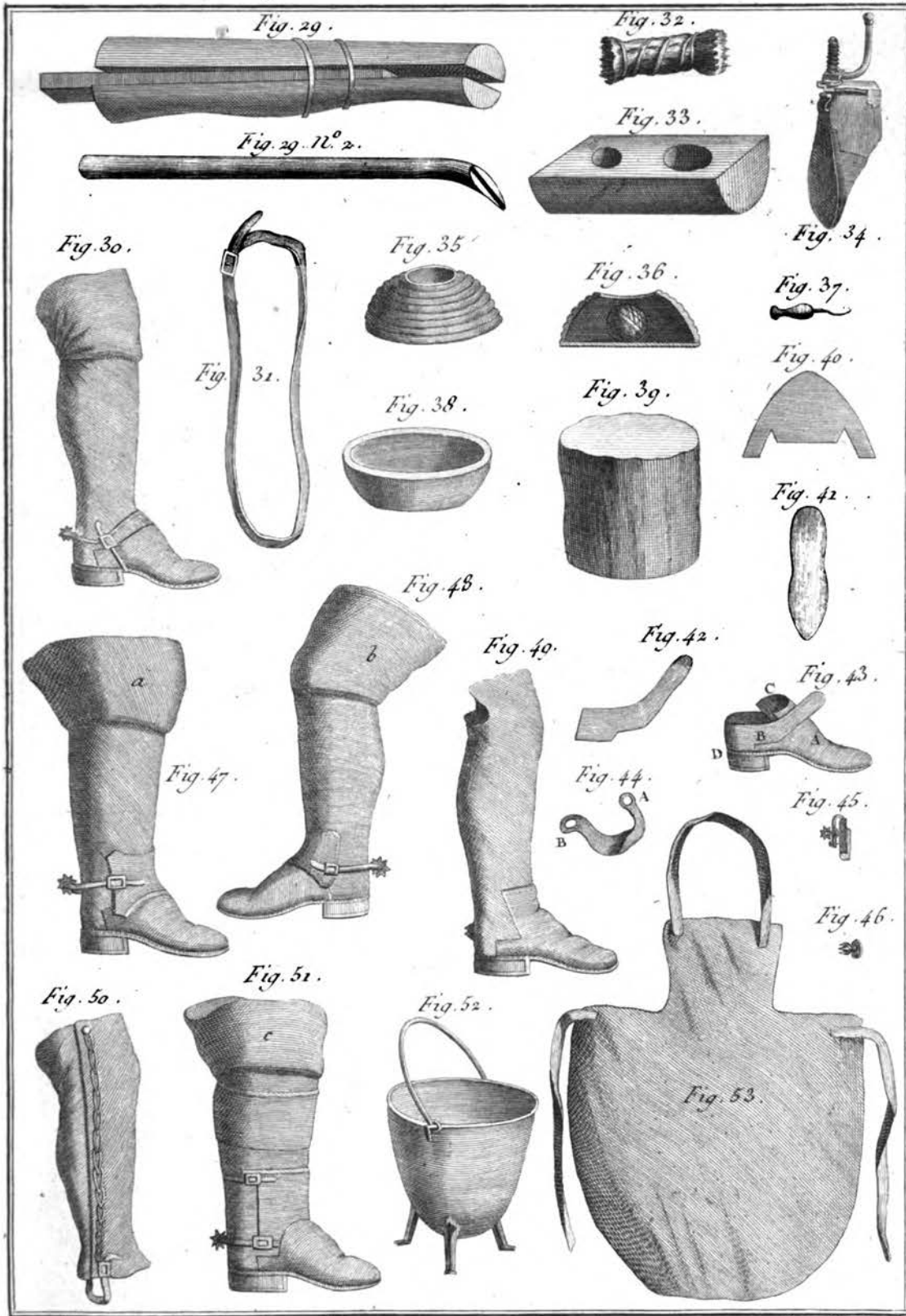
Horte . . .

Beuard Duxat



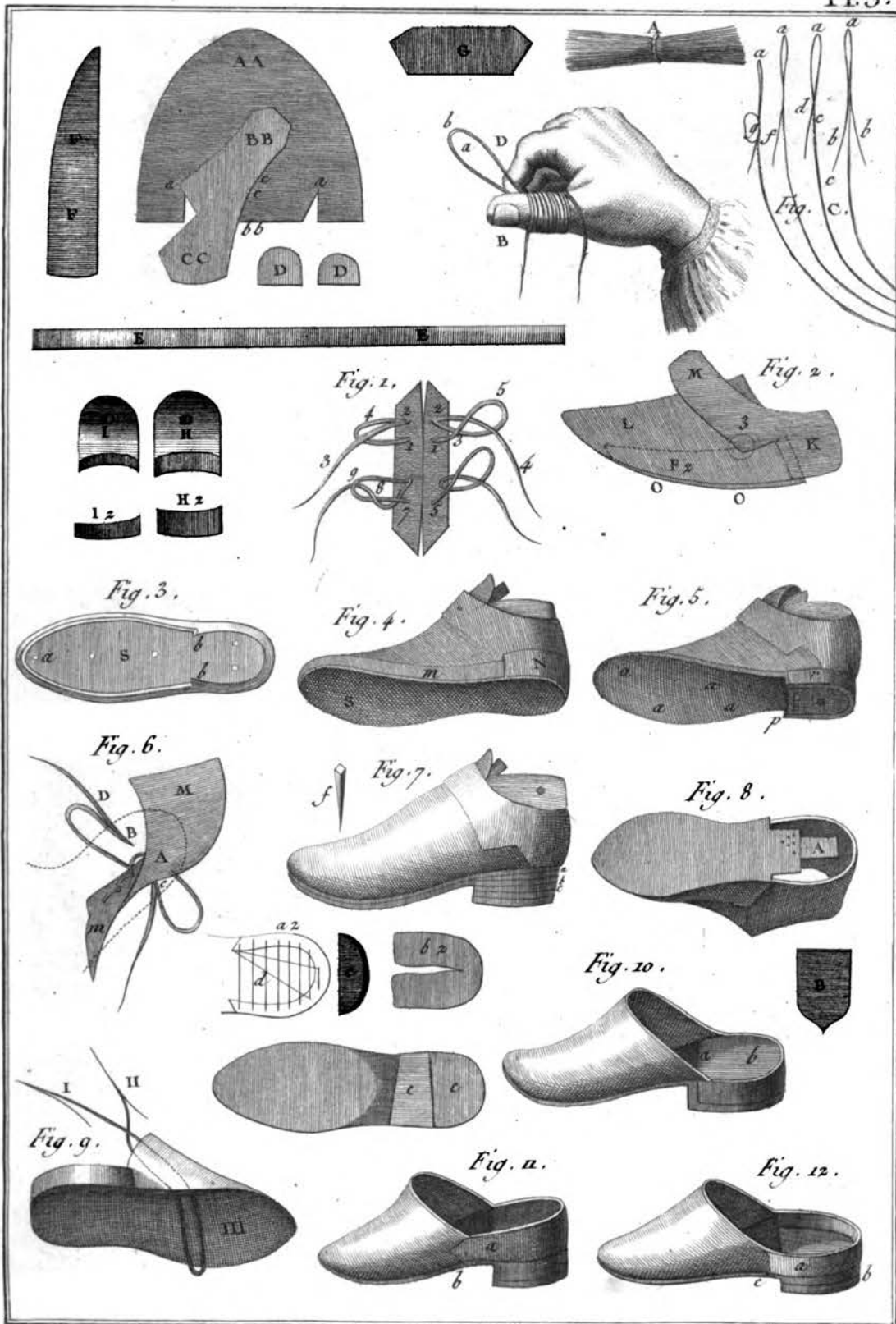
*Cordonnier et Bottier.*

*Bernard Duvault.*



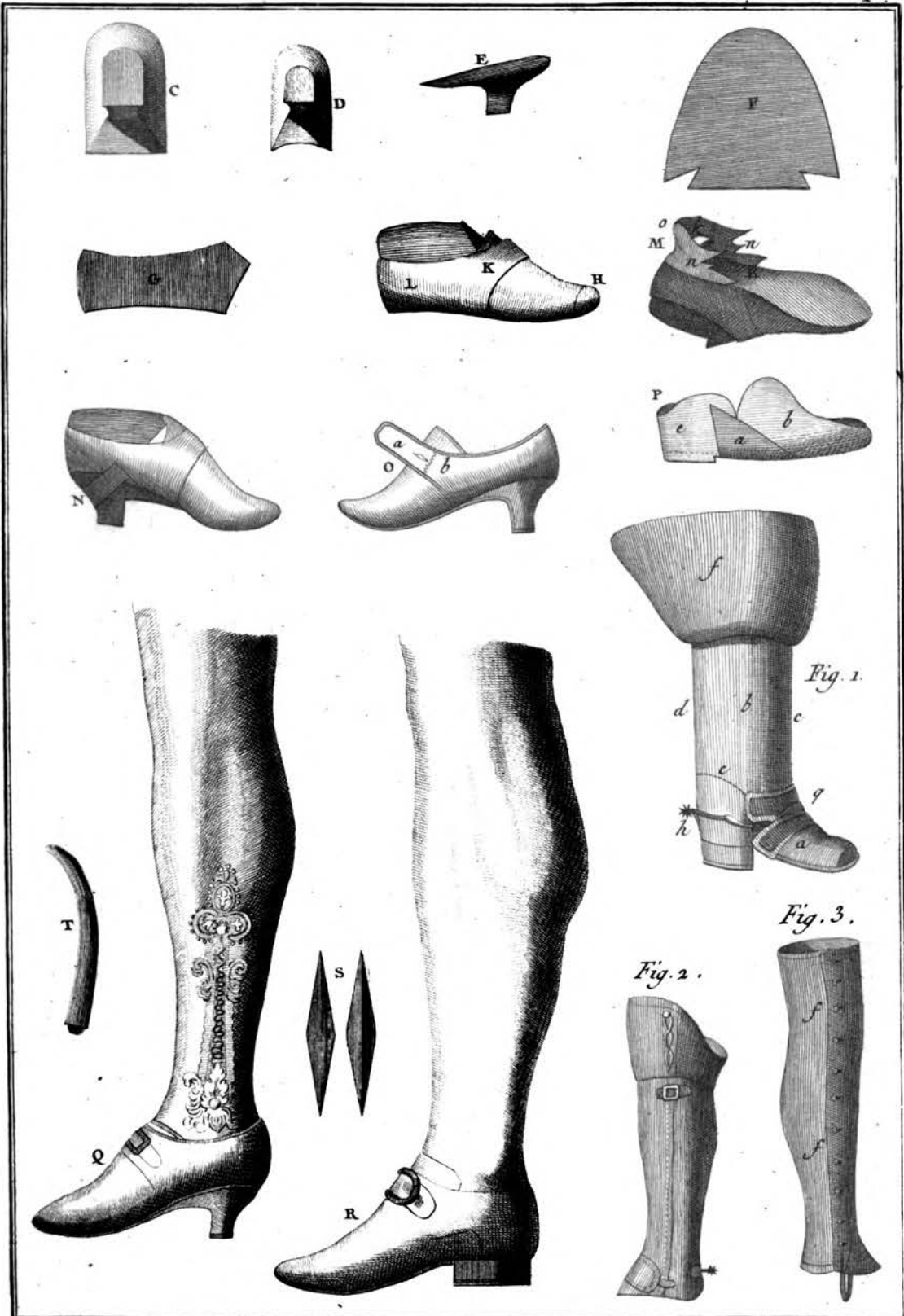
*Cordonnier et Botier*

*Benard Directeur.*



*Cordonnier.*

*Benard Diravit.*



*Cordonnier.*

*Bernard Dircxit.*

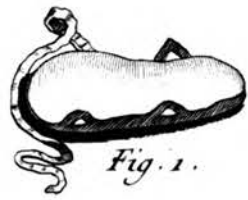


Fig. 1.

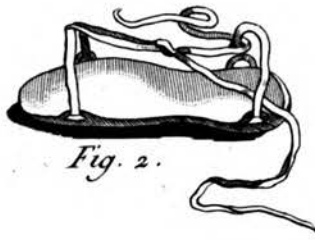


Fig. 2.



Fig. 3.



Fig. 4.

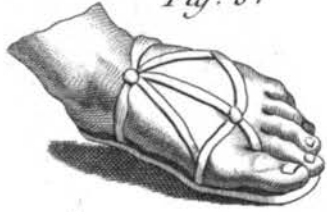


Fig. 8.



Fig. 9.



Fig. 13.

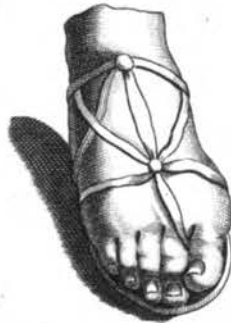


Fig. 14.



Fig. 15.



Fig. 18.



Fig. 20.



Fig. 27.



Fig. 23.



Fig. 24.



Fig. 25.

*Cordonnier, Différentes*



Fig. 21.

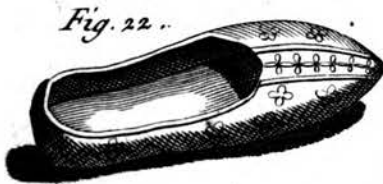


Fig. 16.

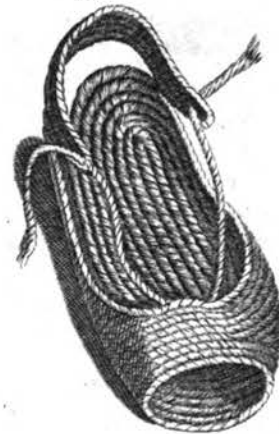


Fig. 26.



Fig. 27.



Fig. 28.



*Chaussures et Laçures Antiques.*

*Bernard Duvet.*





*Fig. 29.*



*Fig. 30.*



*Fig. 34.*



*Fig. 35.*



*Fig. 39.*



*Fig. 40.*



*Fig. 41.*



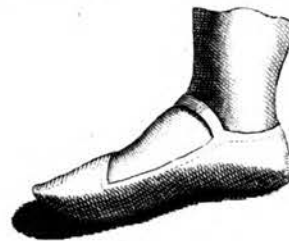
*Fig. 44.*



*Fig. 45.*



*Fig. 46.*



*Fig. 49.*



*Cordonnier, Différentes C*

Original from  
UNIVERSIDAD COMPLUTENSE  
DE MADRID



Fig. 31.



Fig. 32.

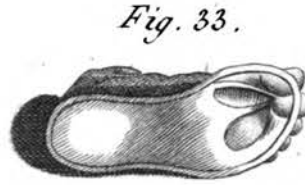


Fig. 33.

Fig. 36.



Fig. 37.



Fig. 38.



Fig. 42.



Fig. 43.



Fig. 46.

Fig. 47.



Fig. 50.



Fig. 51.

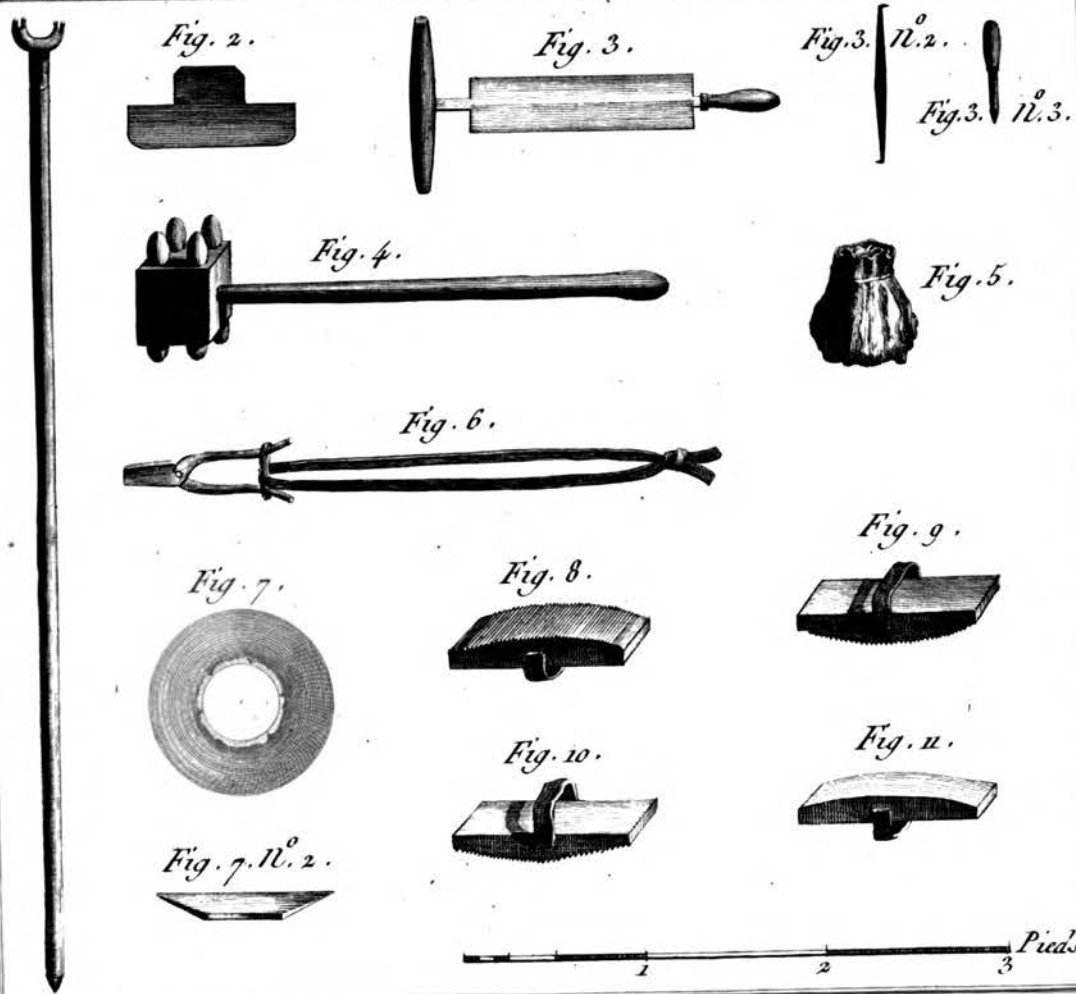
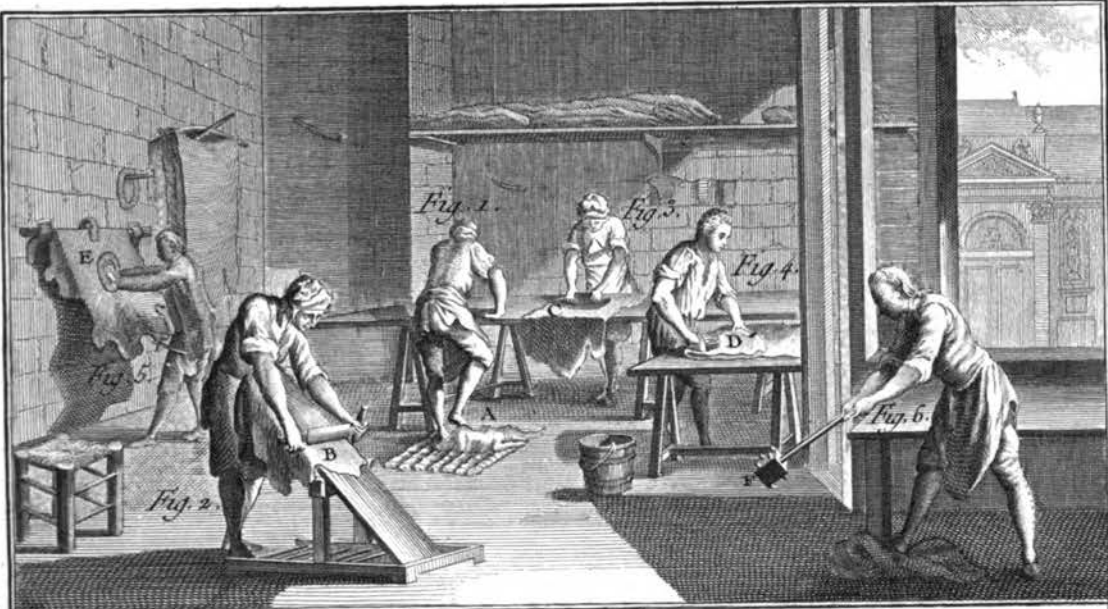


Fig. 52.



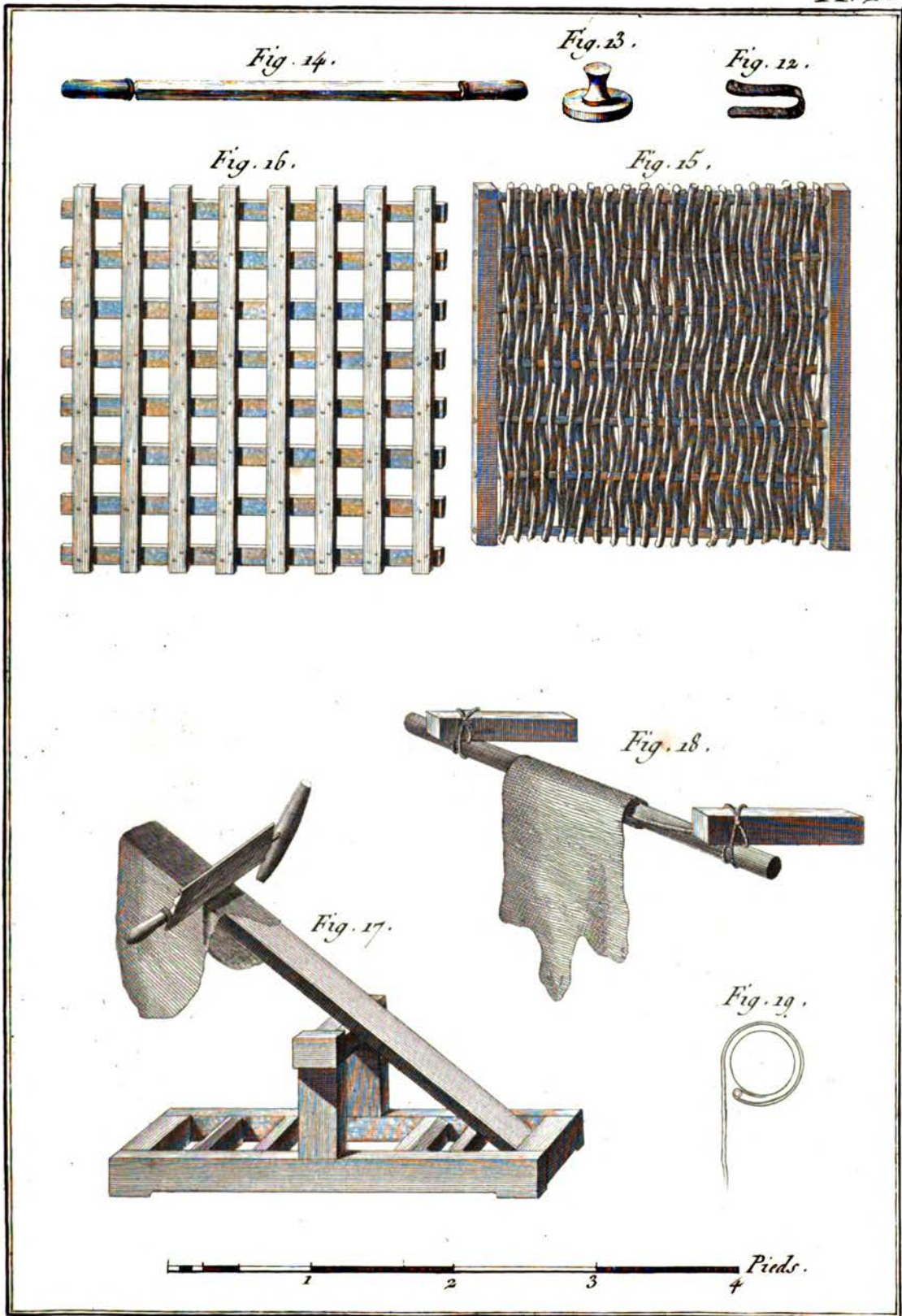
Benard Dorexit

*haussures et Laçures antiques.*



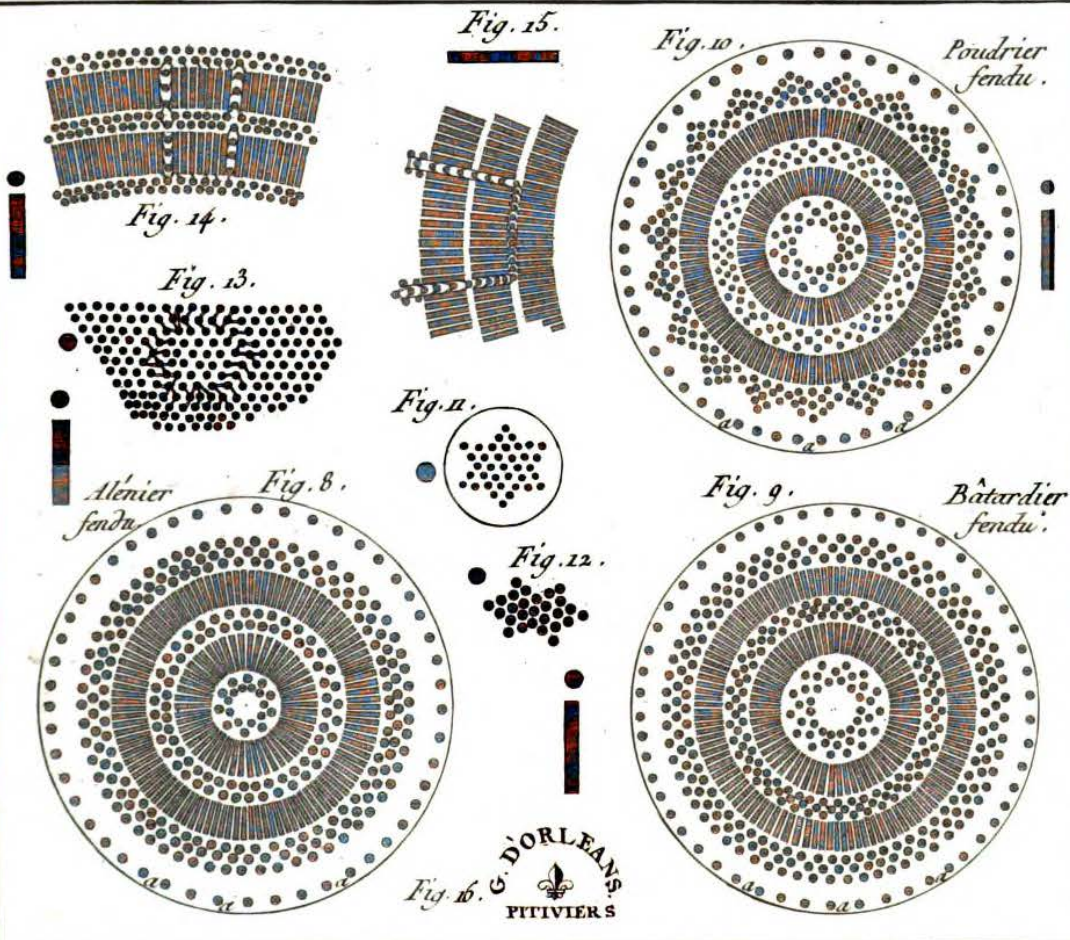
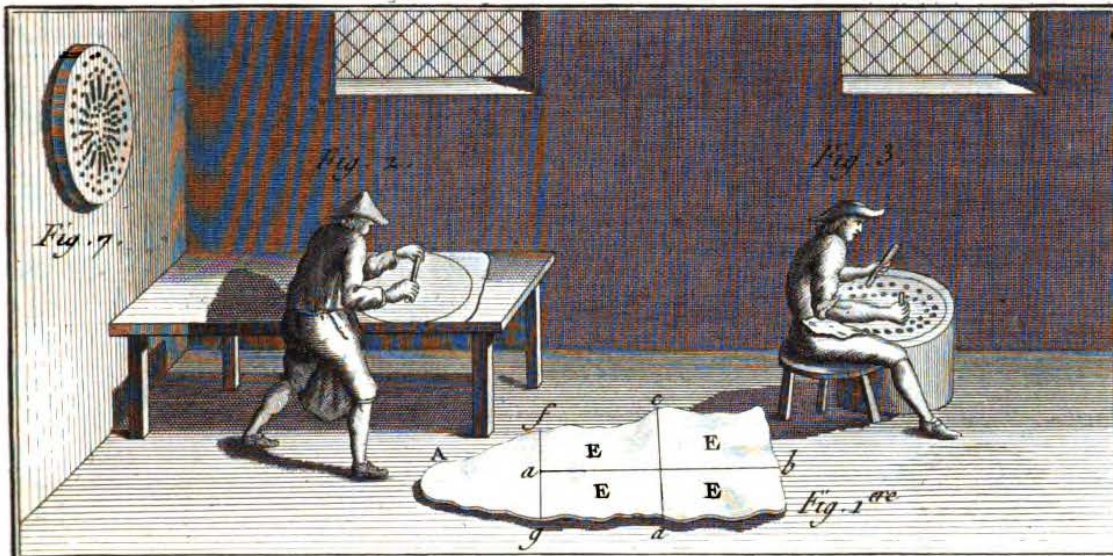
*Corroyeur.*

*Benoit Dureau.*



*Corroyeur.*

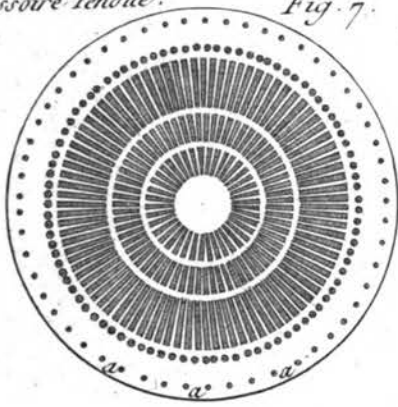
*Bernard Duvet.*



*Criblier.*

Bernard Dorez

Passoire Tendue. Fig. 7.



Pousriers. Fig. 5.

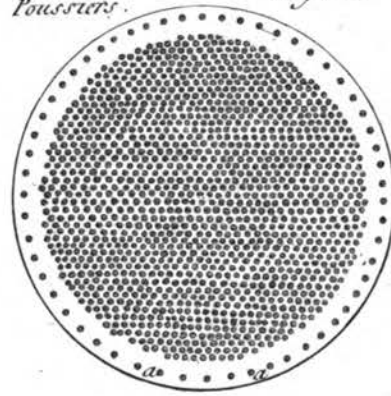


Fig. 2.

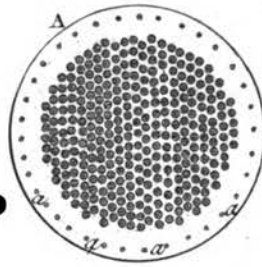


Fig. 3.

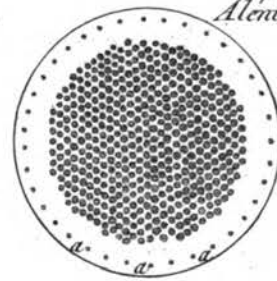


Fig. 6.

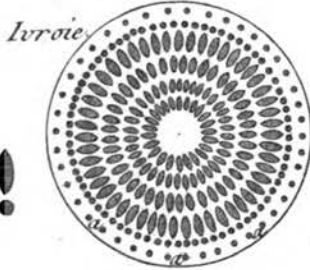


Fig. 4.

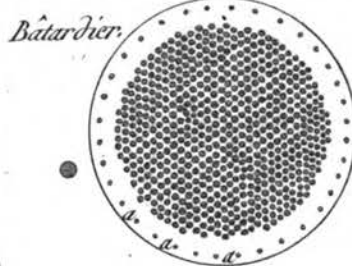


Fig. 2.

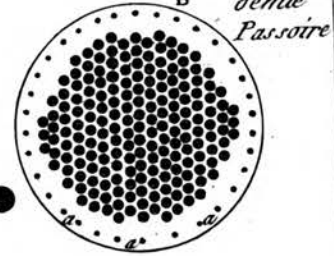


Fig. 1.

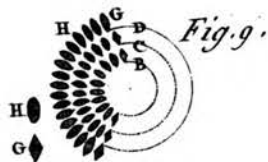
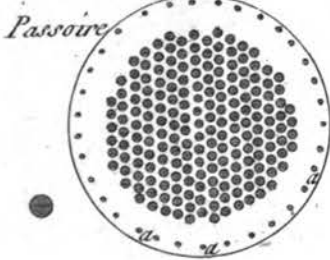


Fig. 9.

Fig. 8.

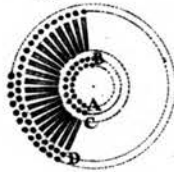


Fig. 10.

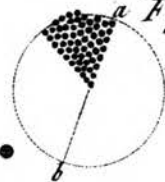
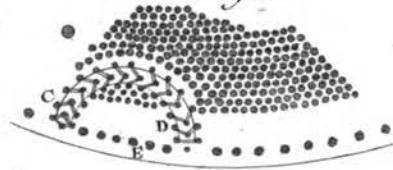


Fig. 11.



Criblier.

Benard Directeur.

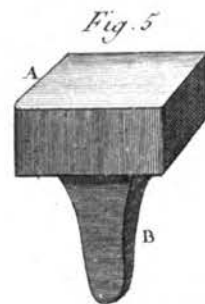
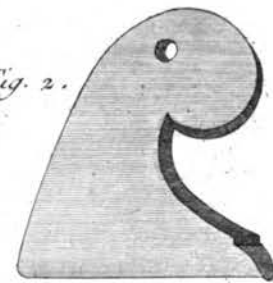
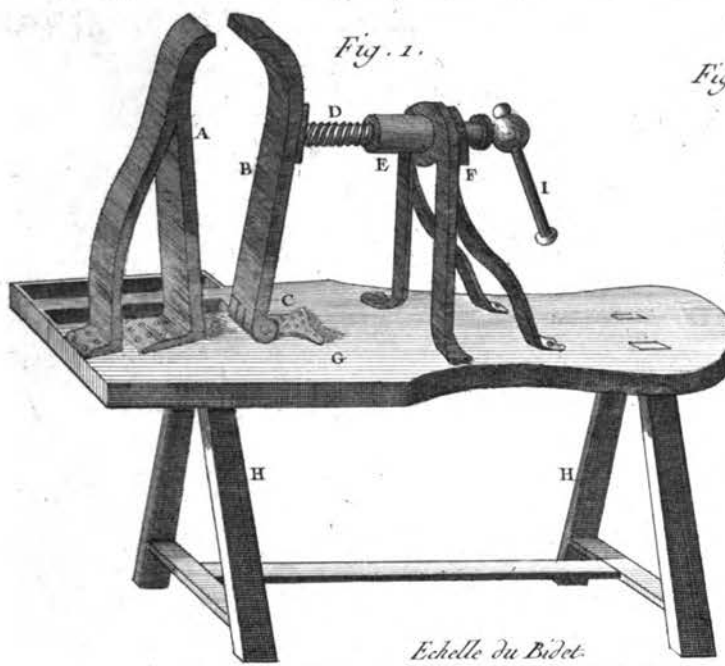
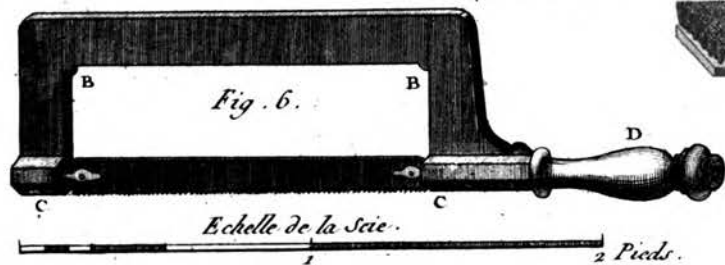


Fig. 7.

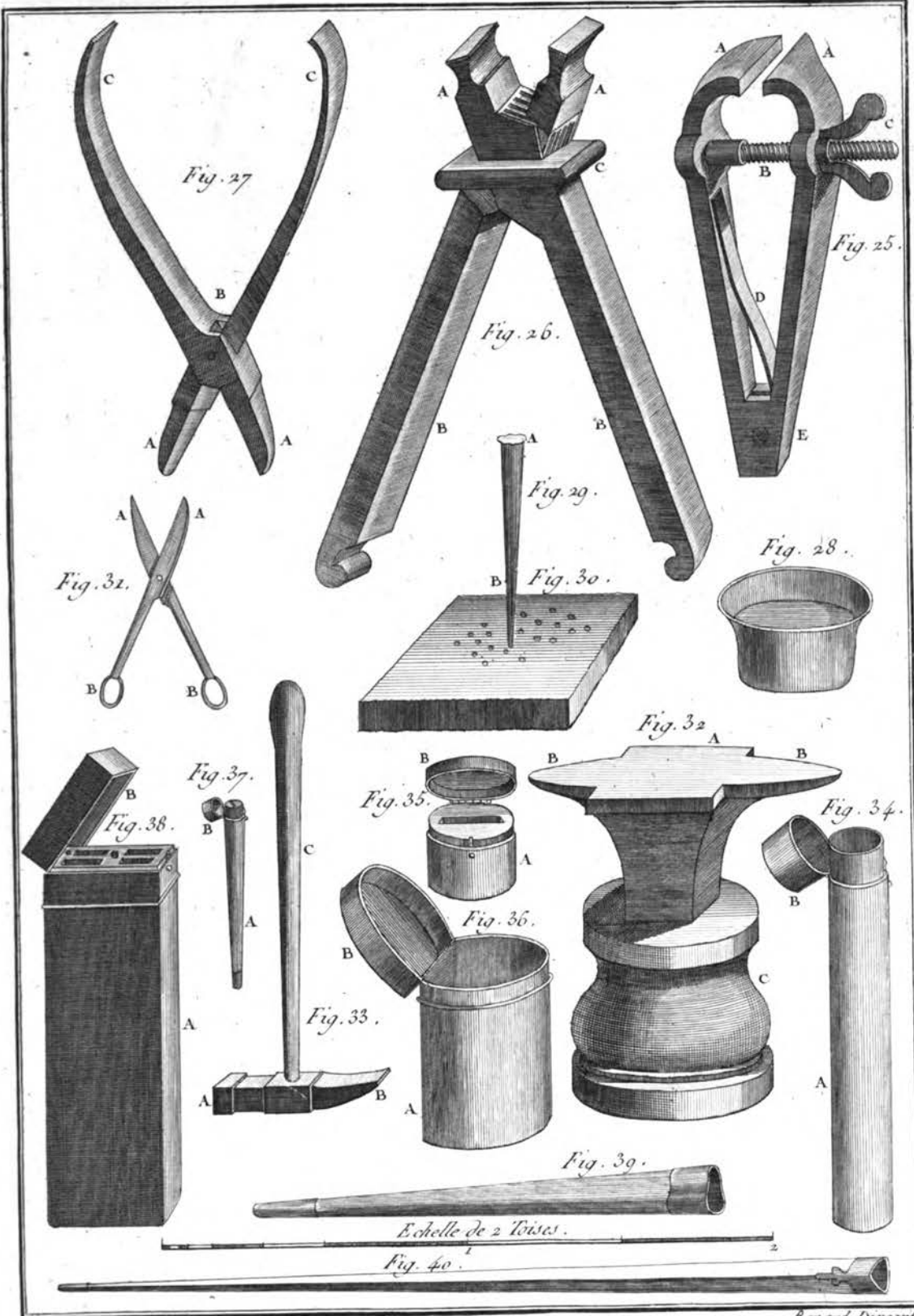


3 Pieds.

2 Pieds.

Garnier.

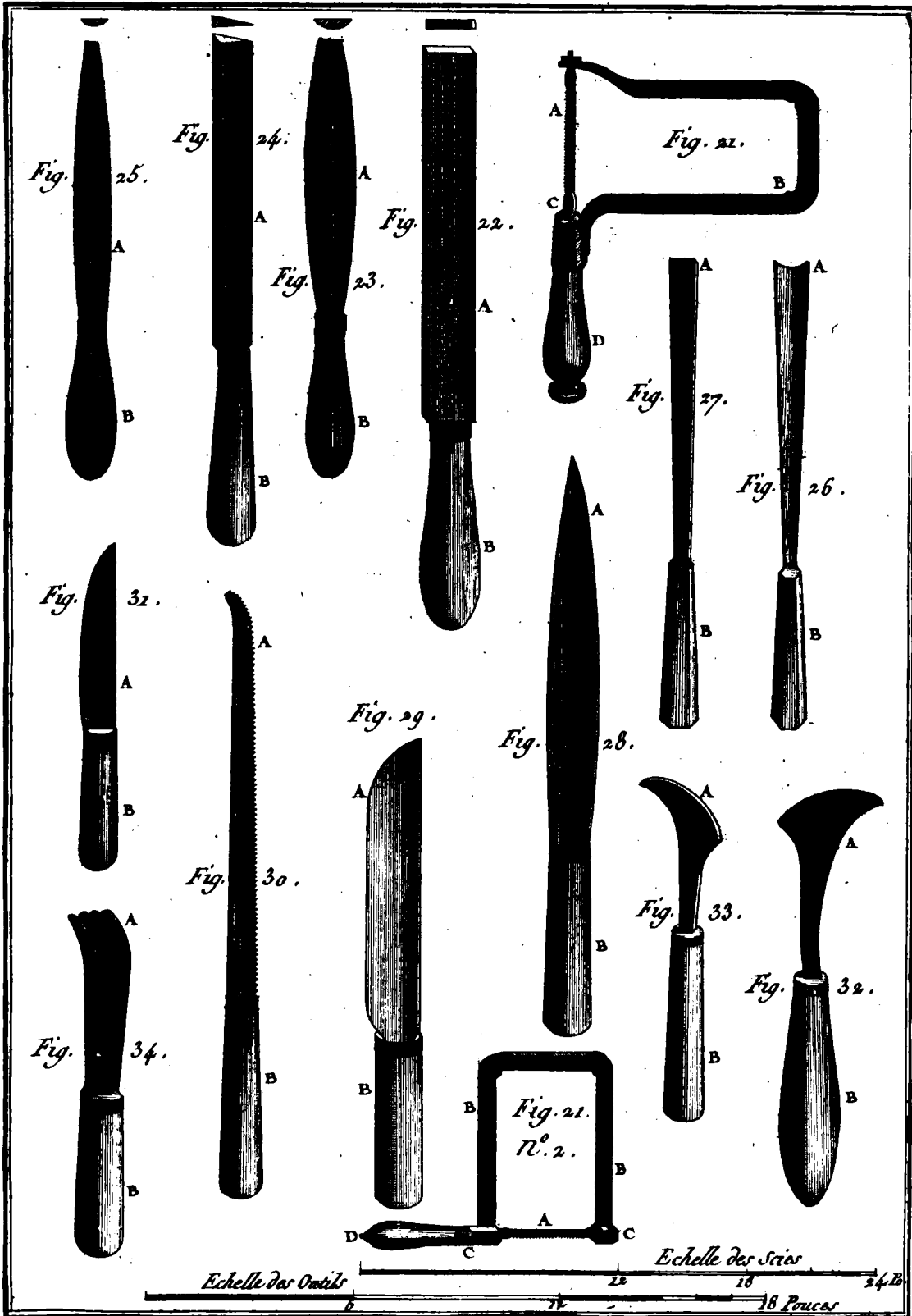
Bonard Diracel.



*Gainier*

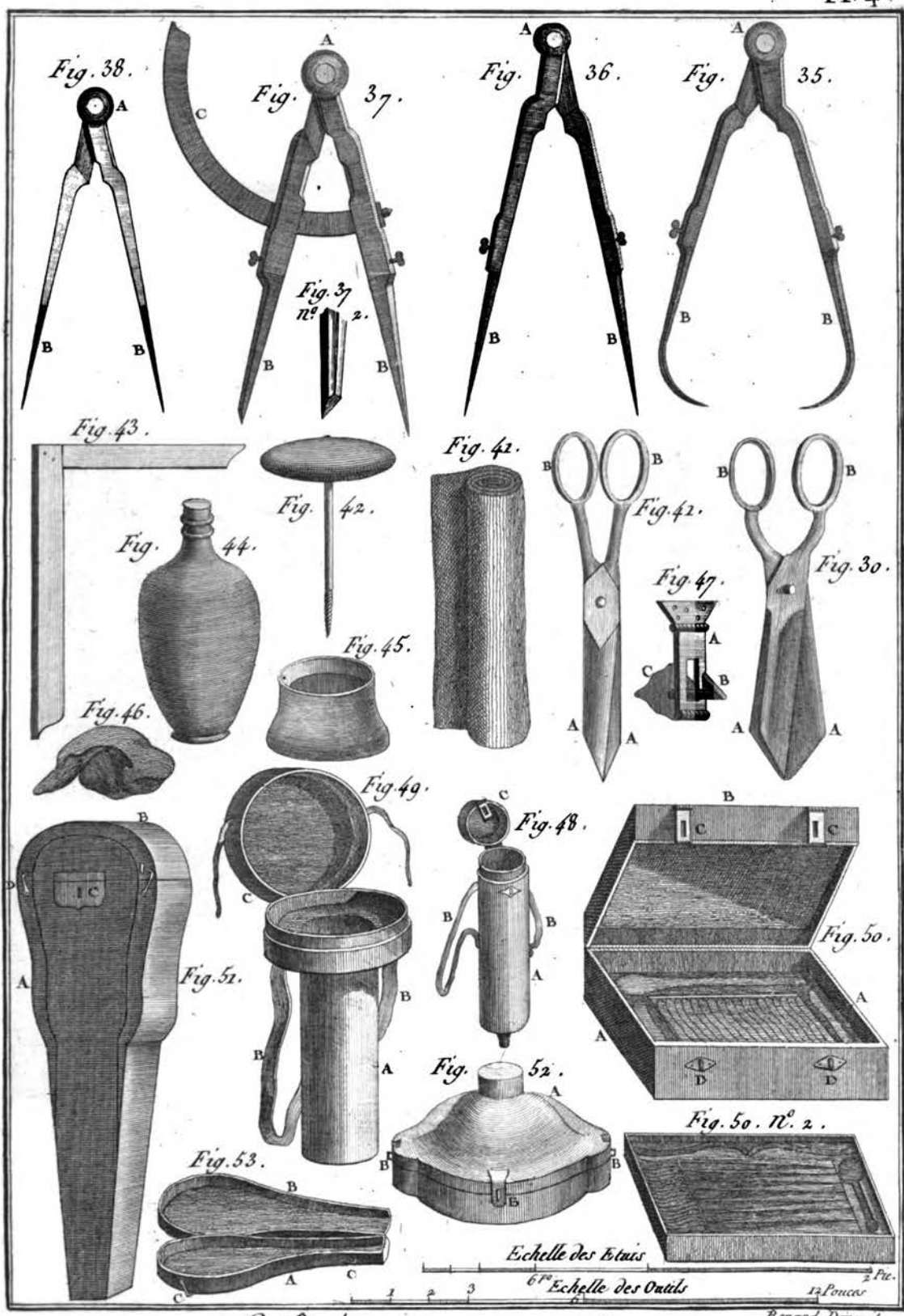
*Bonnet D'Or*



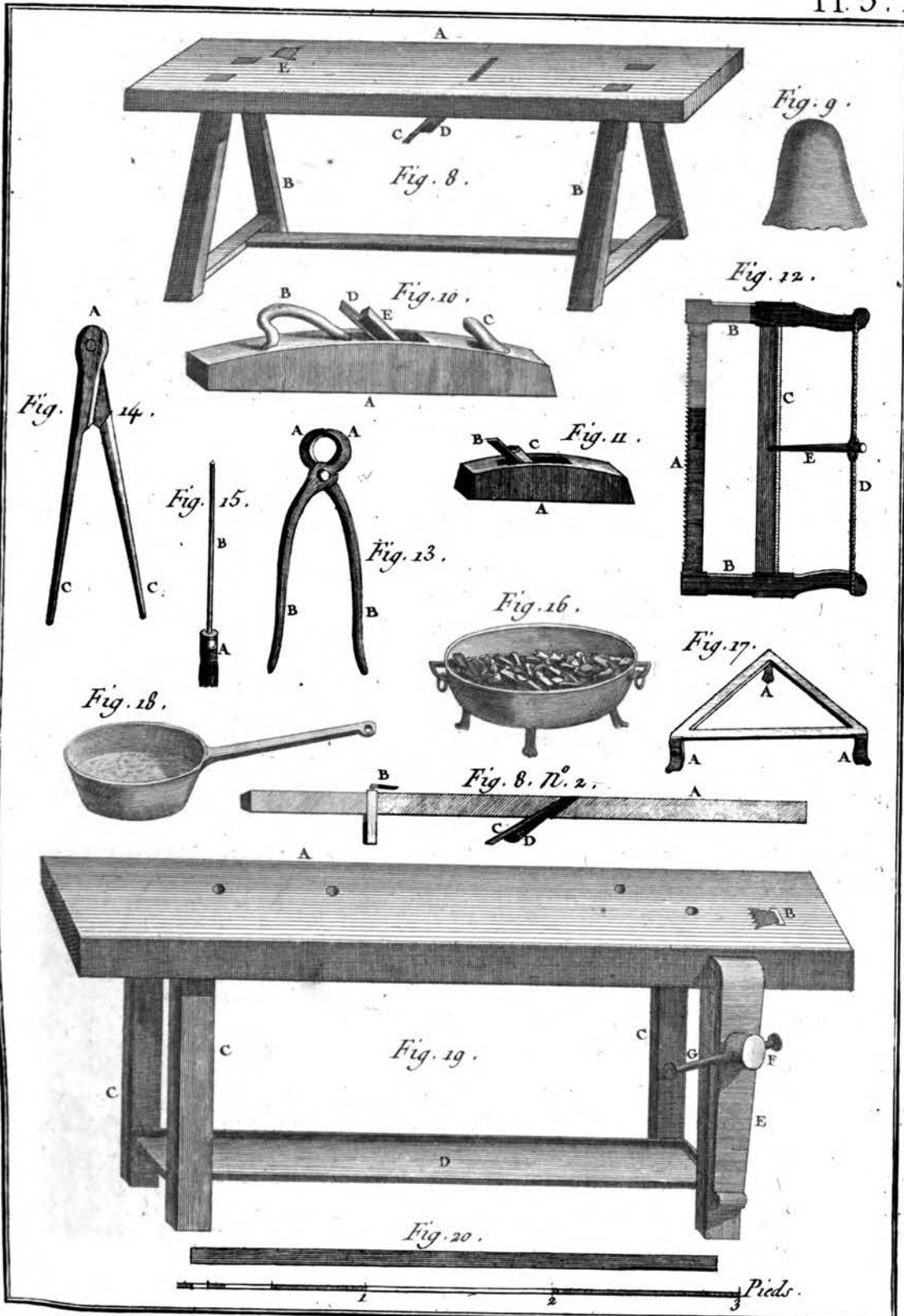


Gainier, Outils.

Benard, Dorville.  
13

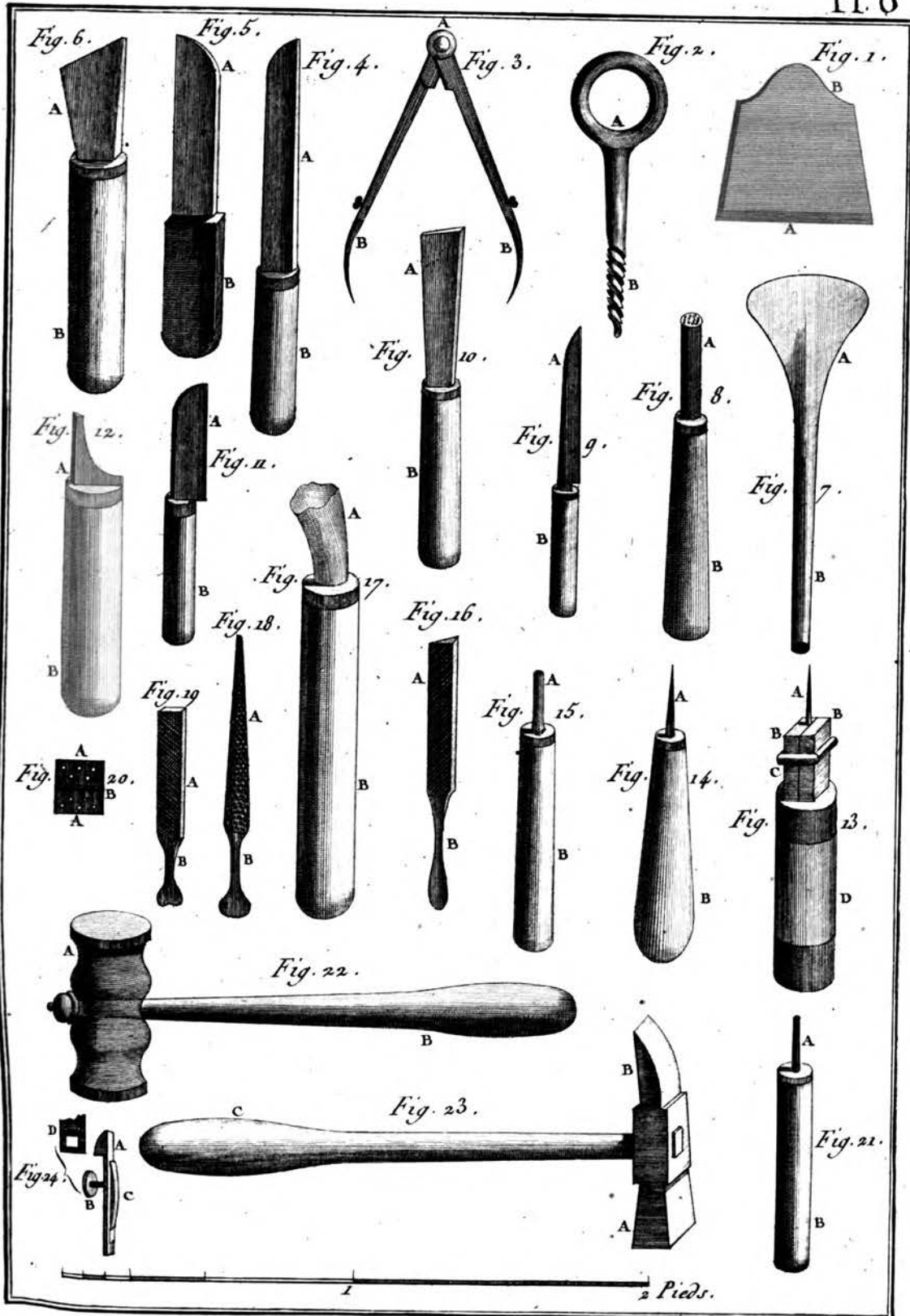


Gâinier, Ouvrages et Outils.



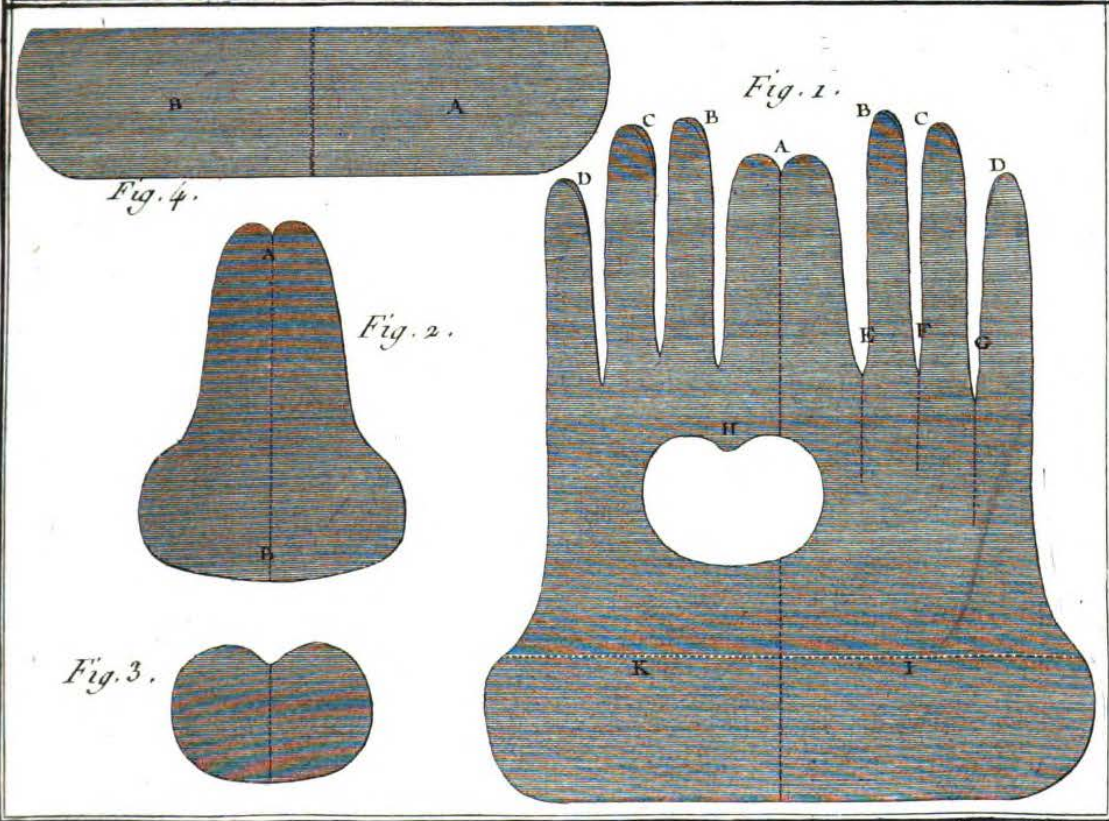
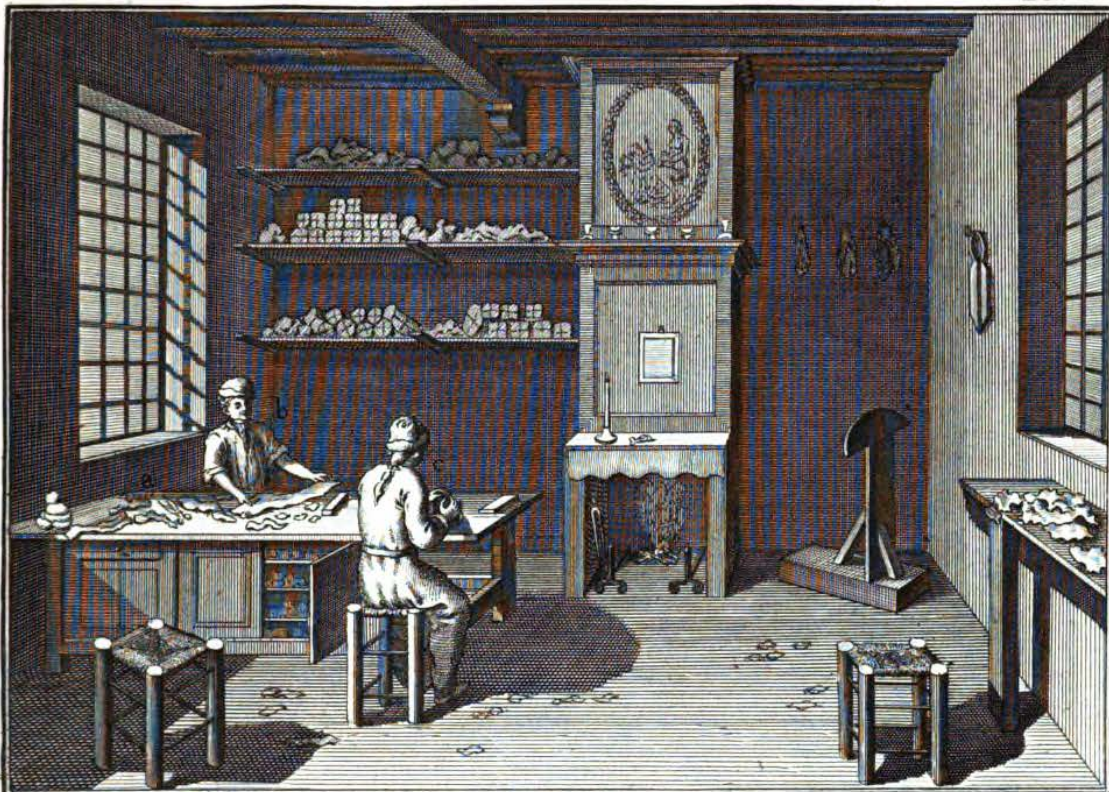
Gainier.

Benard Diresit.



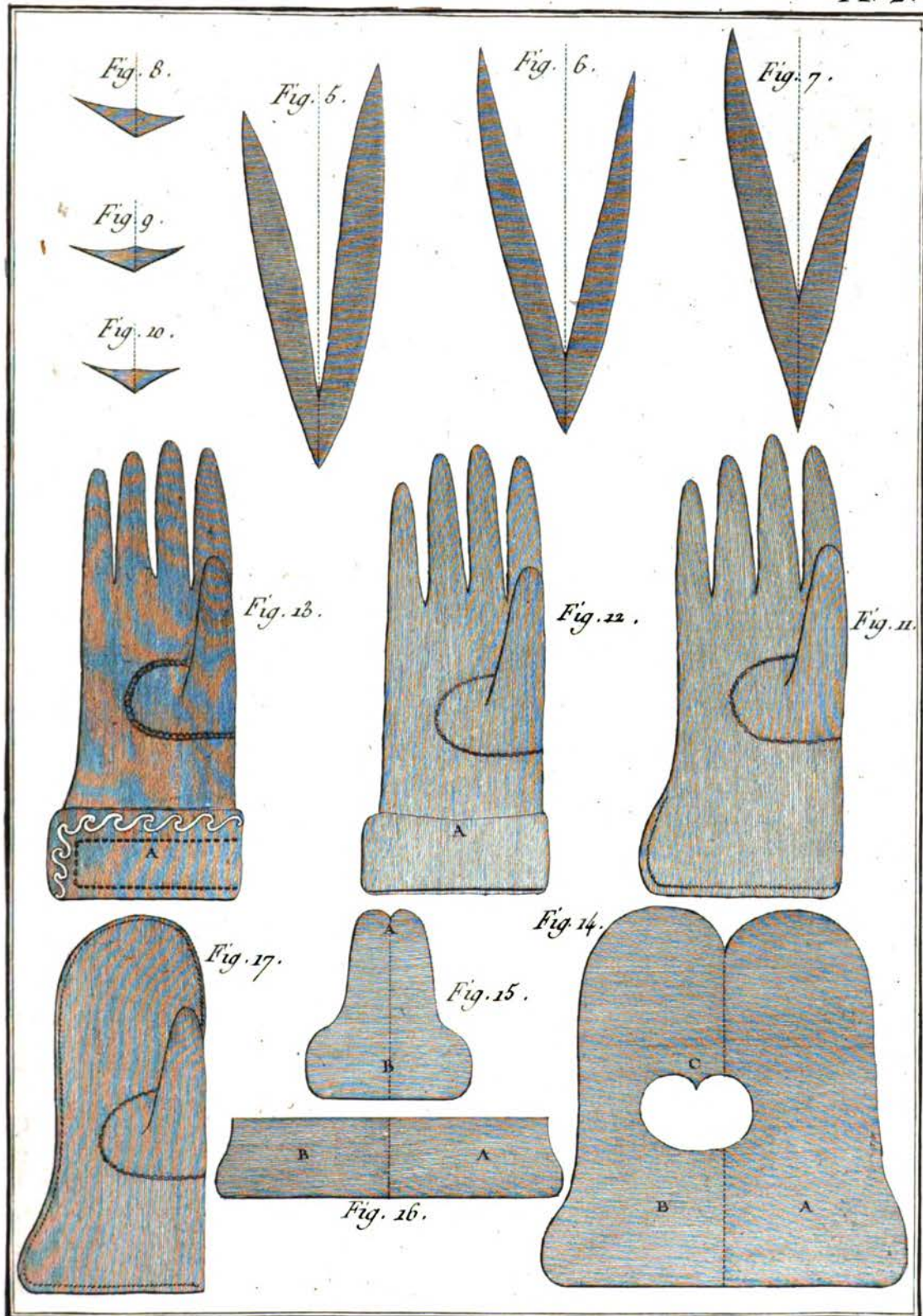
Gainier.

Benard D'excit.



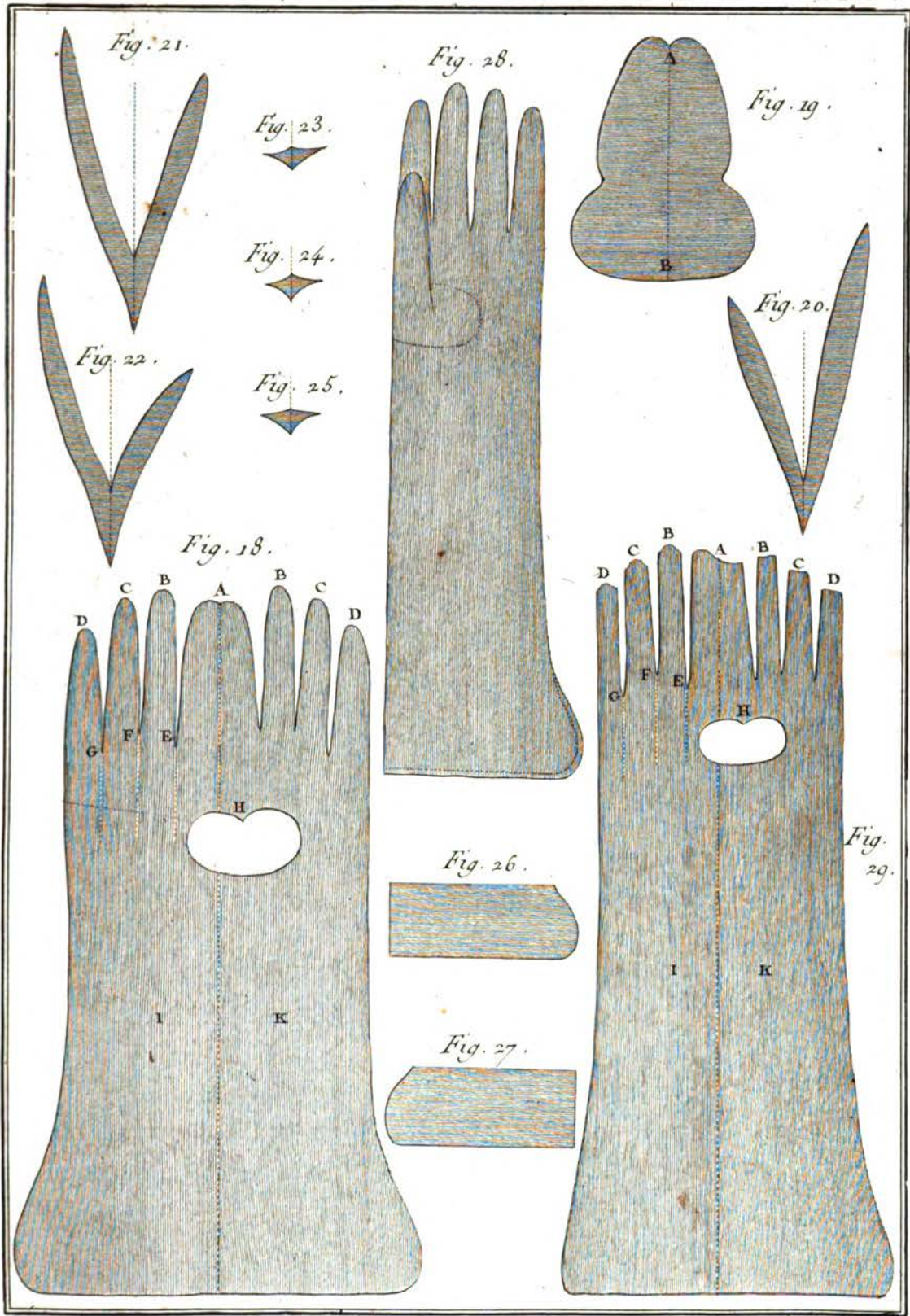
*Ganterie, Etavillon et détails de Gants d'Hommes.*

*Benard Dircxit*



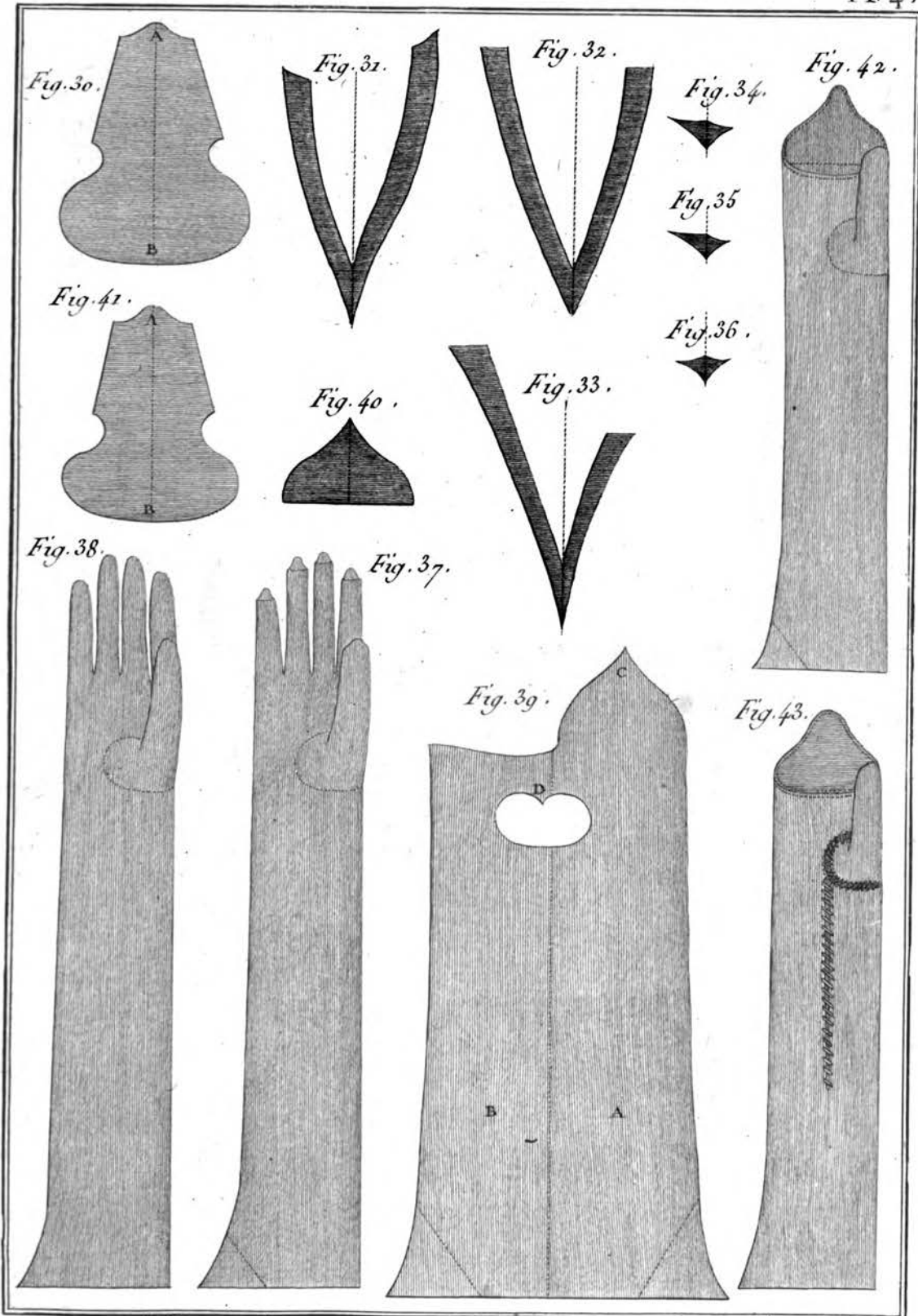
*Gantier, Gants et Mitaines d'Hommes.*

*Benard Doreur*



*Gantier, Etavillons et Développemens.*

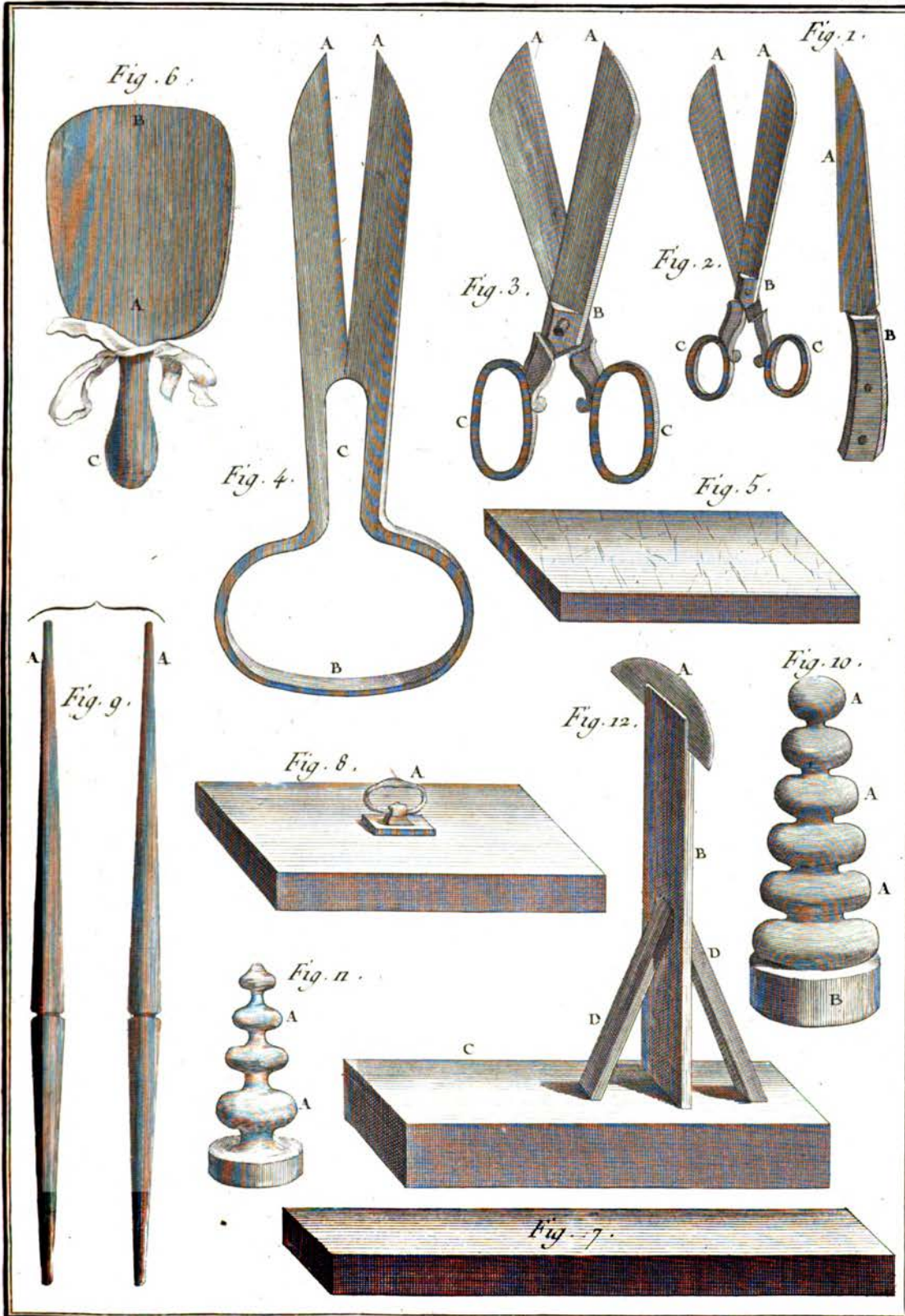
*Benard Duxoit.*



*Gantier, Gants et Mitaines de Femmes.*

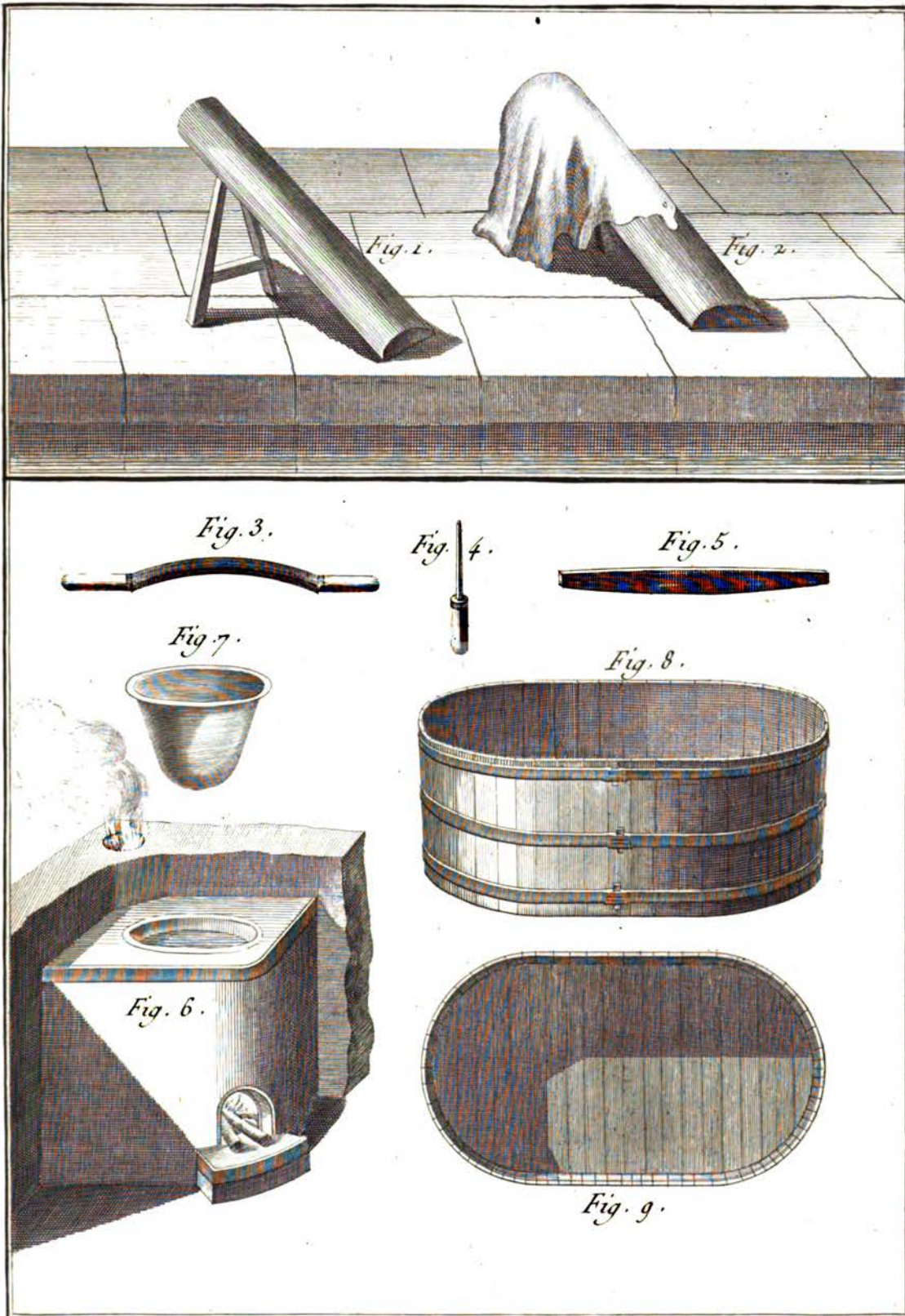
*Benard Drexel.*





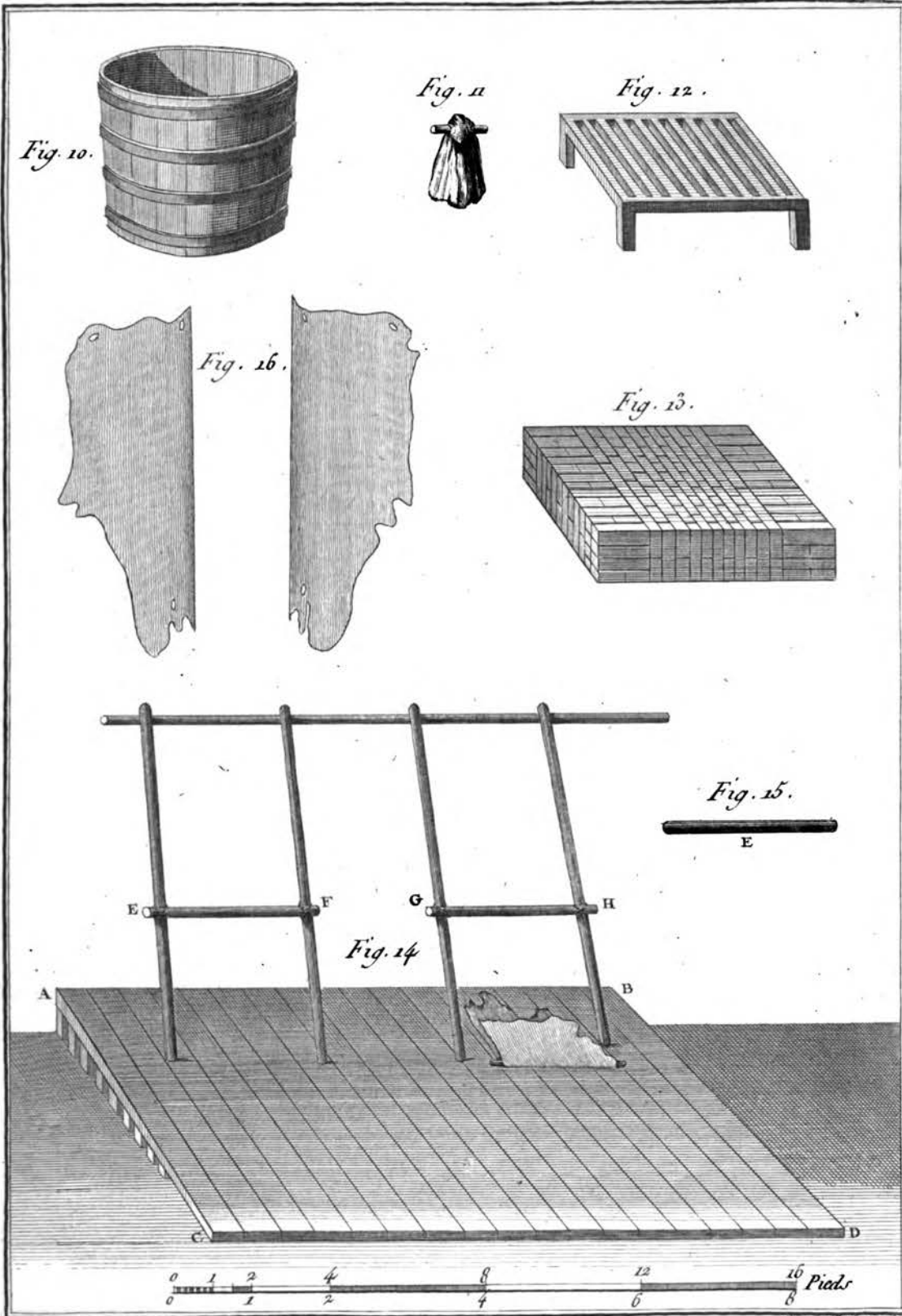
*Gantier, ouils.*

*Benard Durand*

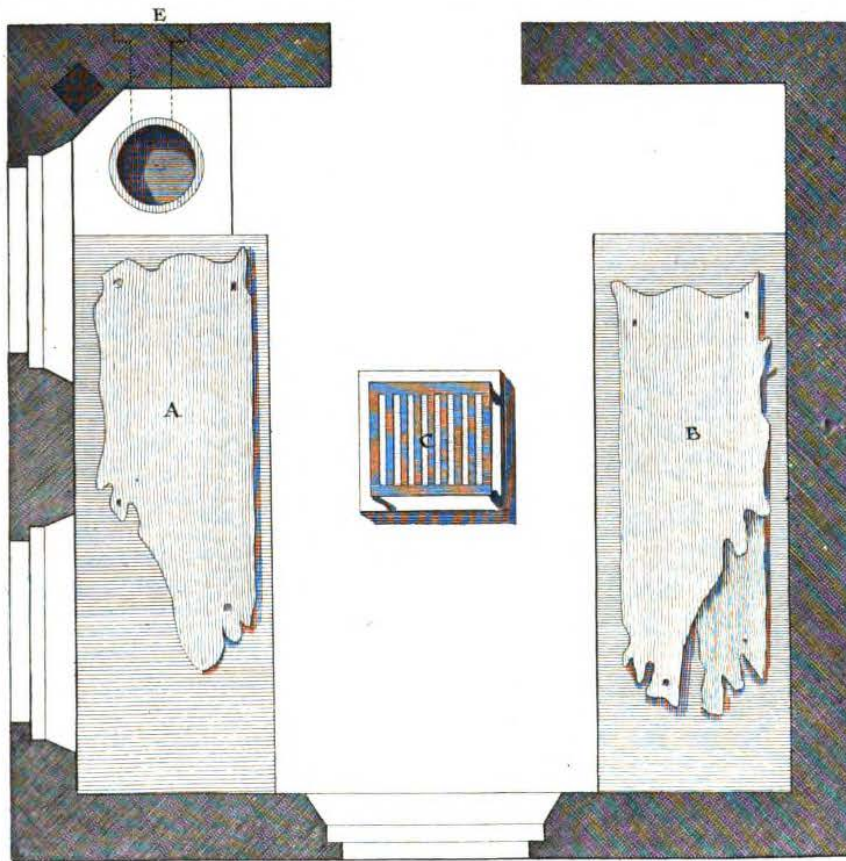
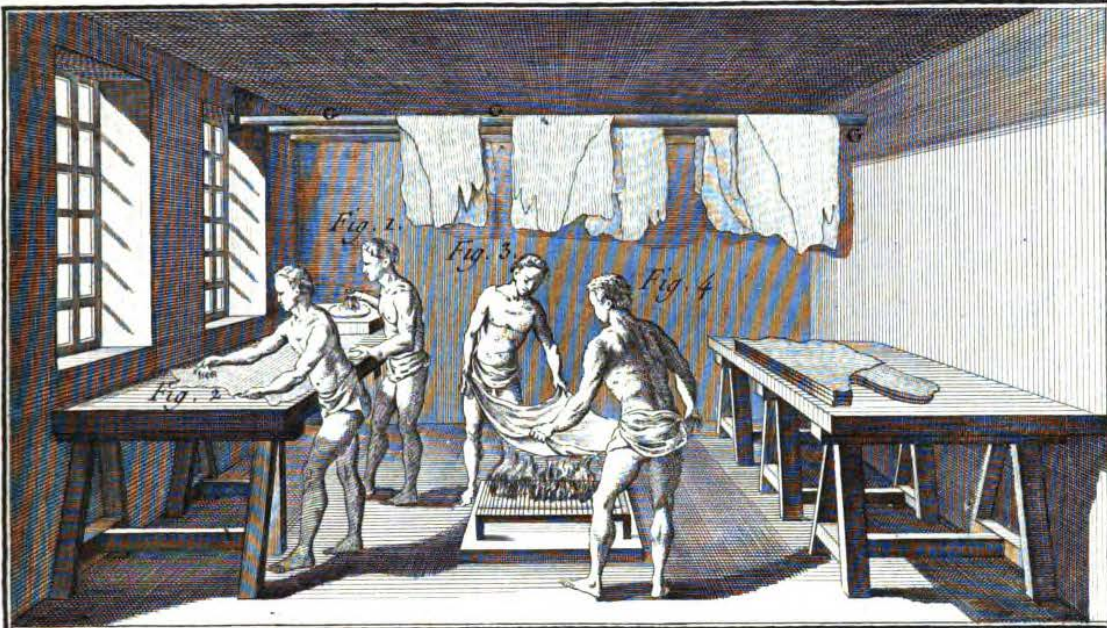


*Hongroyeur, Travail de Riviere &c.*

*Bernard Duvault*



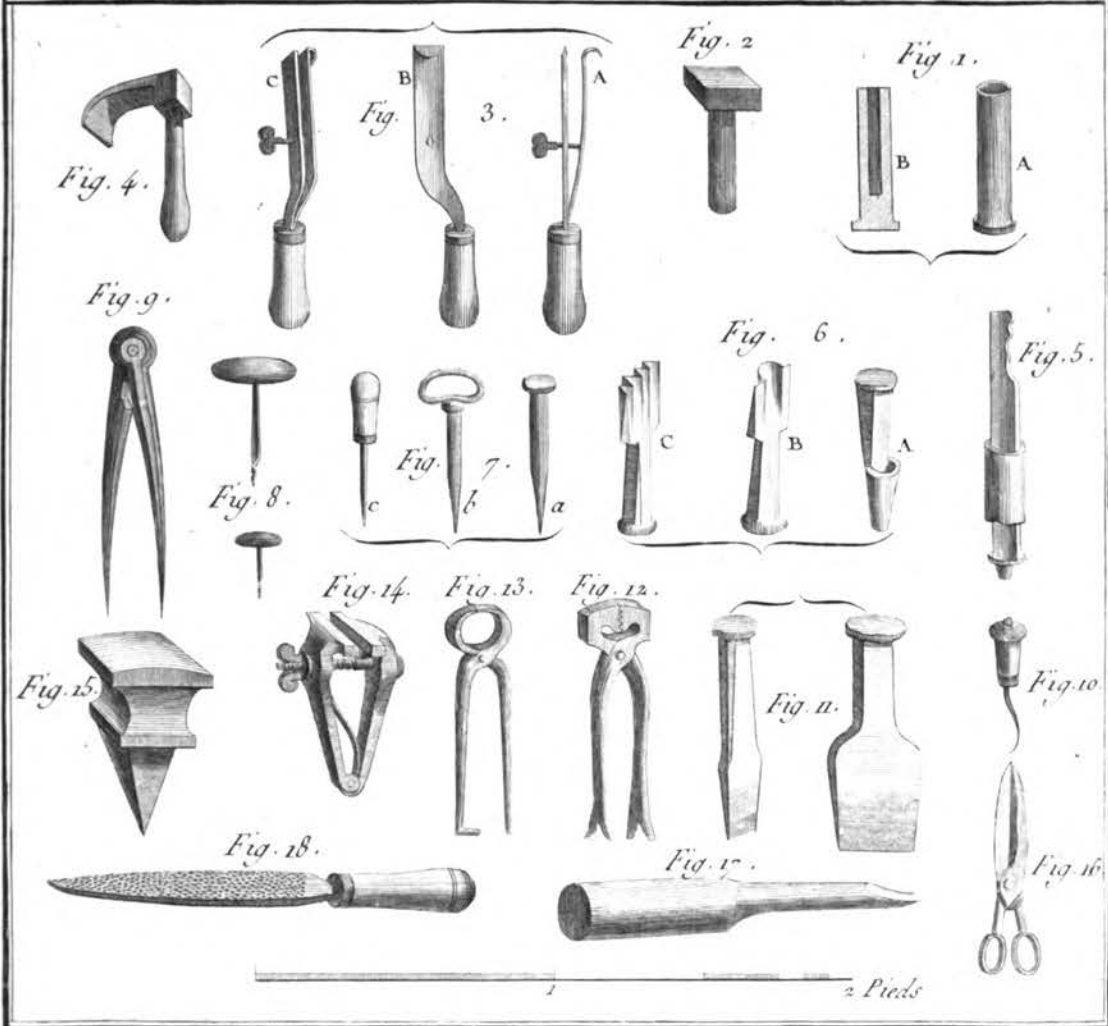
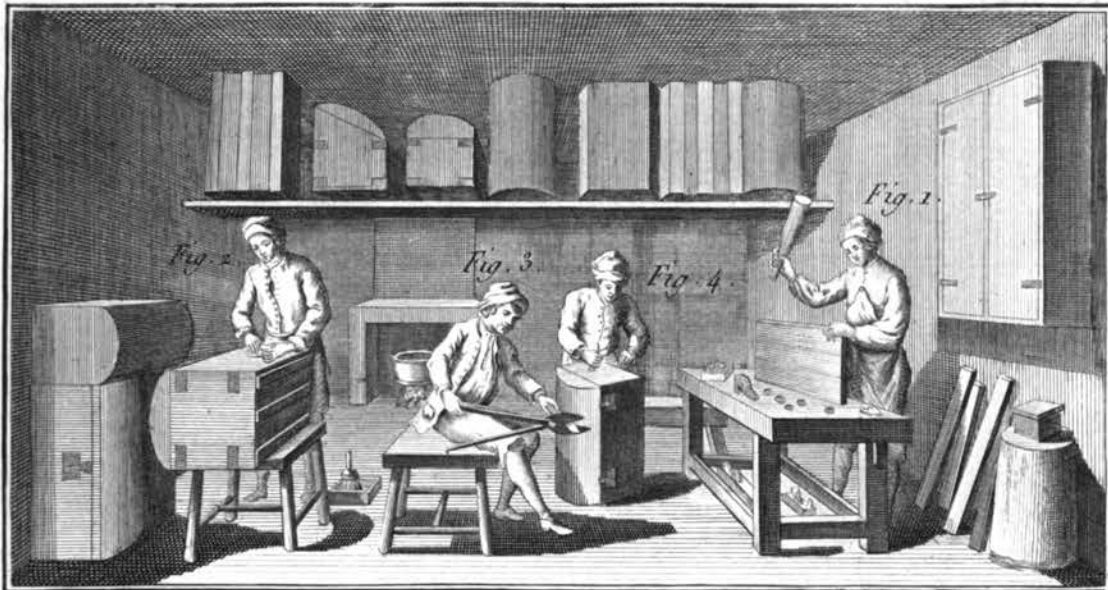
*Hongroyeur, suite de la Planche précédente et travail du Grenier.* Bernard Drexel 18.



1 2 3 4 8 12 10 20 *Pieds.*

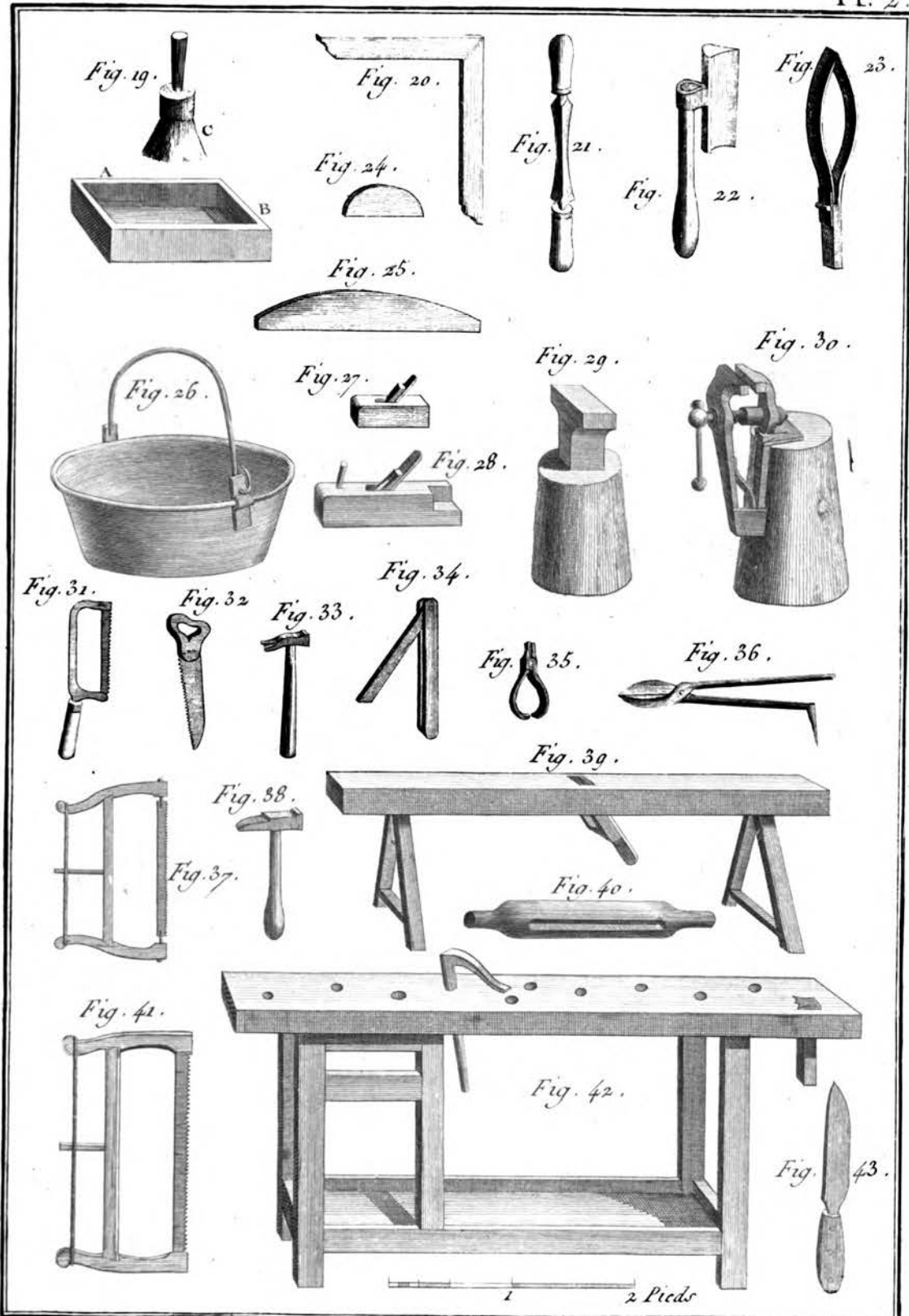
*Hengroyeur, l'opération de mettre au Suif et Plan de l'Etuve.*

*Bernard Dorez del.*



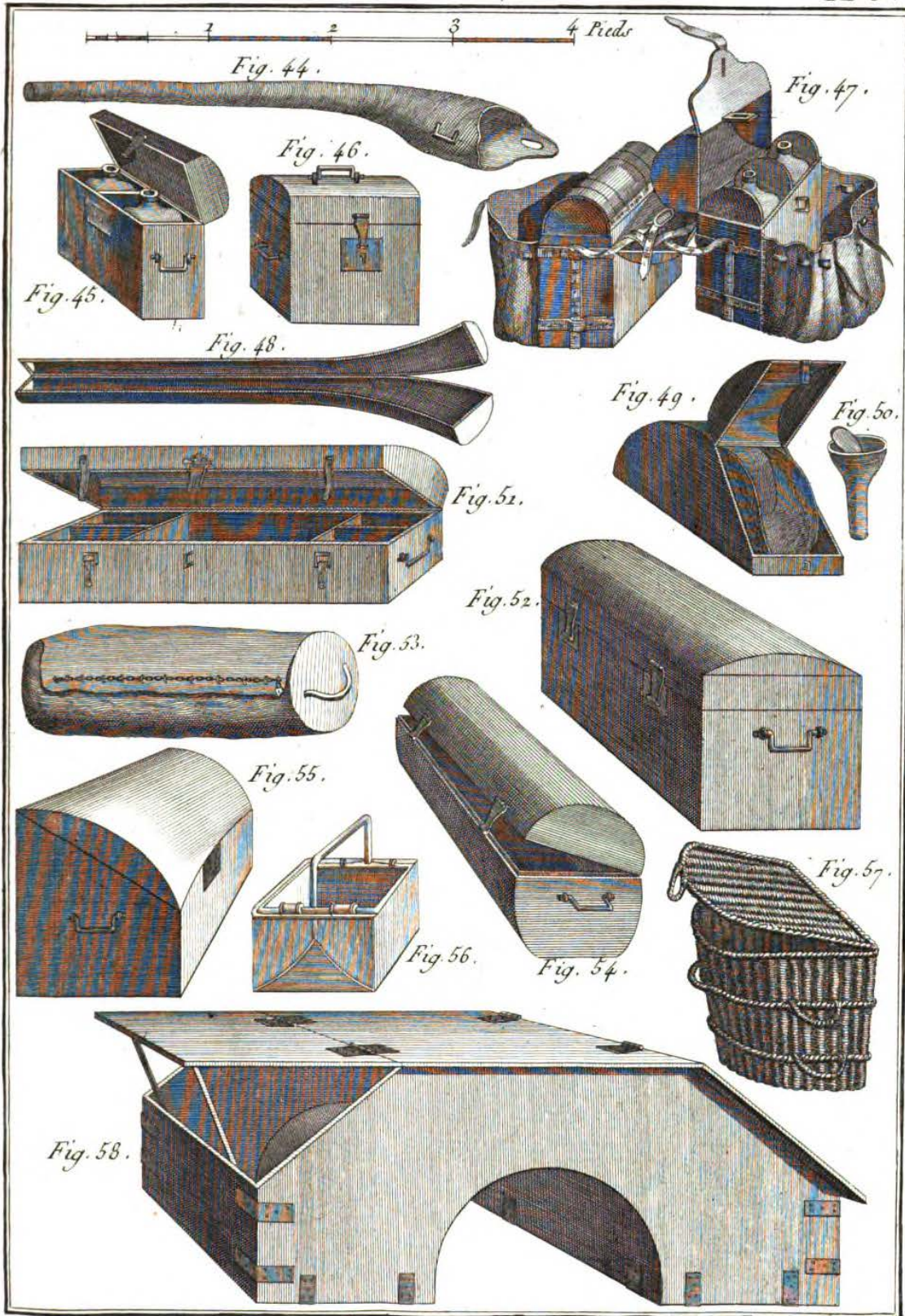
*Malleter - Coiffeur - Bahutier.*

*Benard Duxet*



Malletier, Outils.

Bernard Drevet

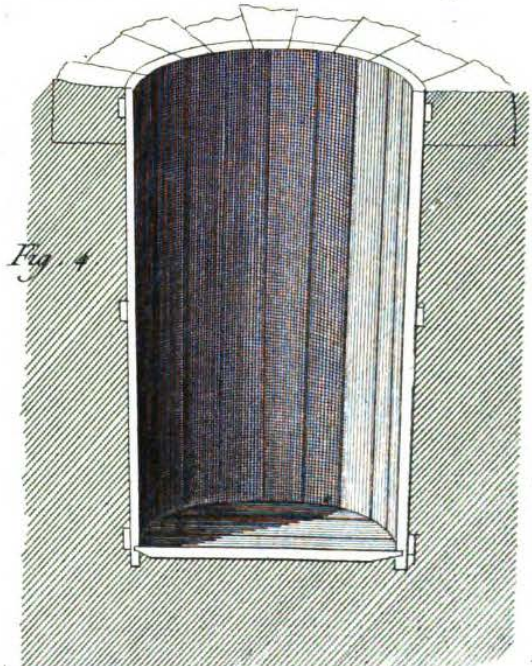
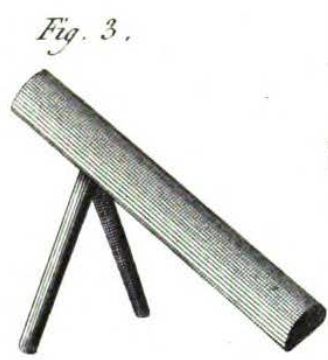
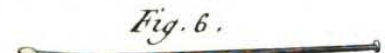
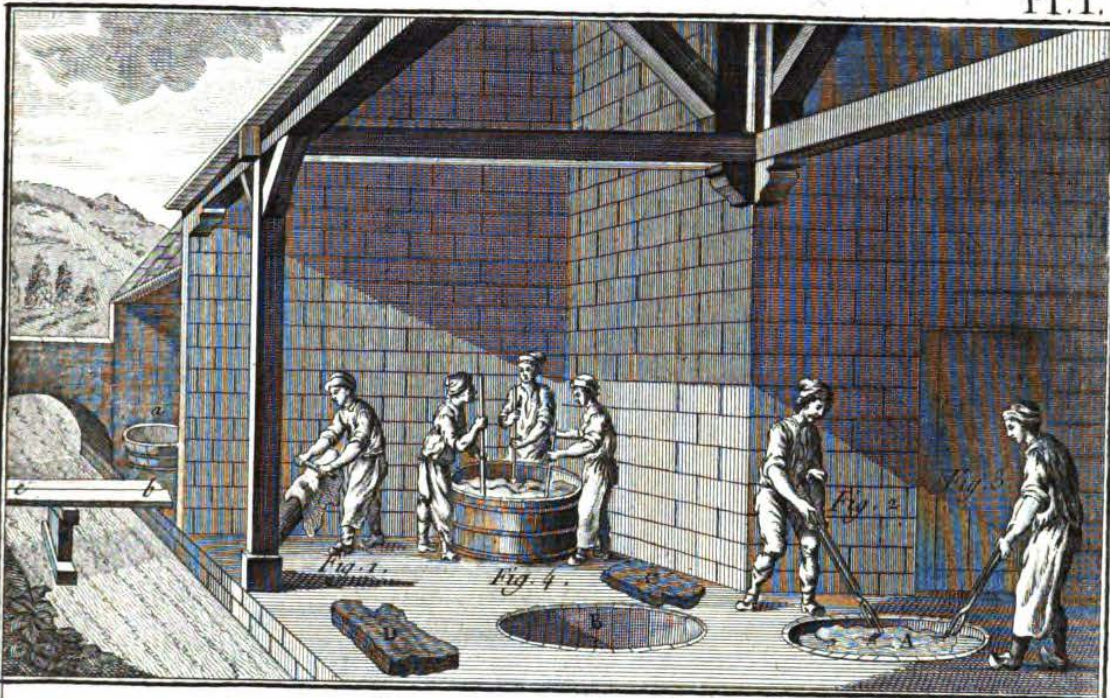


*Malletier, Ouvrages.*

*Benard Dir. et.*

Digitized by Google

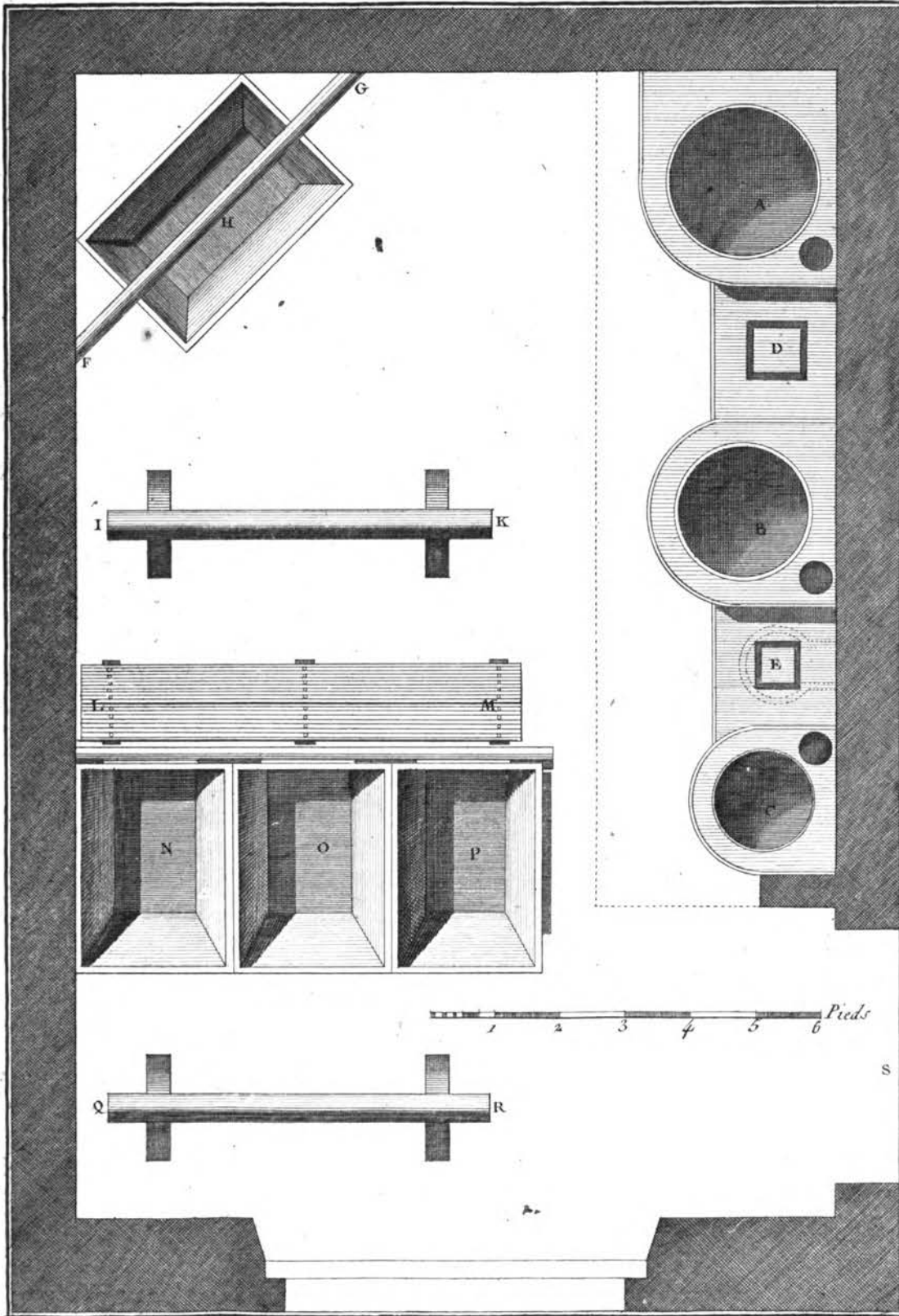
Original from  
UNIVERSIDAD COMPLUTENSE  
DE MADRID



*Maroquinier, Travail de Riviere et des Pleins.* Benard Directeur.

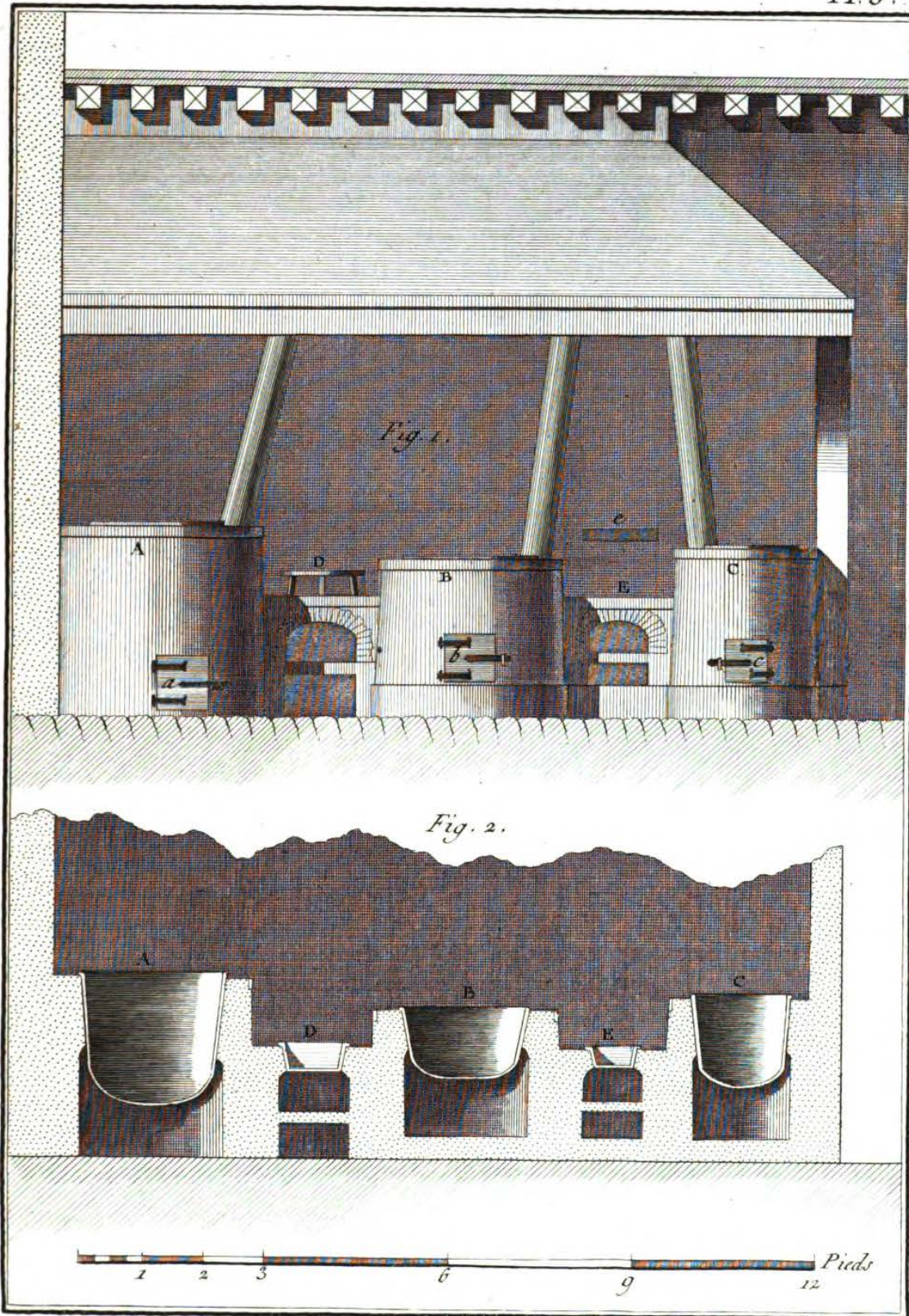
Generated on 2014-05-10 20:19 GMT / http://hdl.handle.net/2027/ucm.5320295822  
Public Domain, Google-digitized / http://www.hathitrust.org/access\_use#pd-google





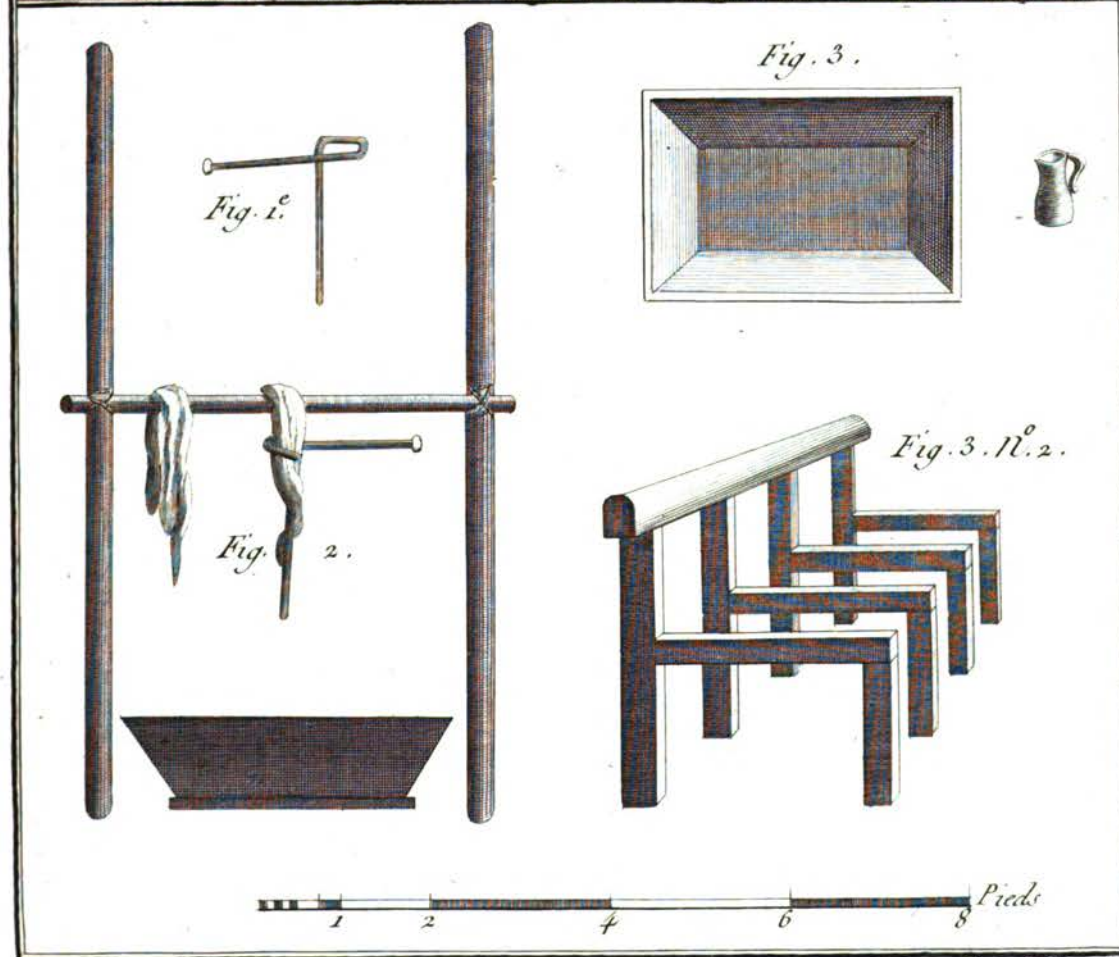
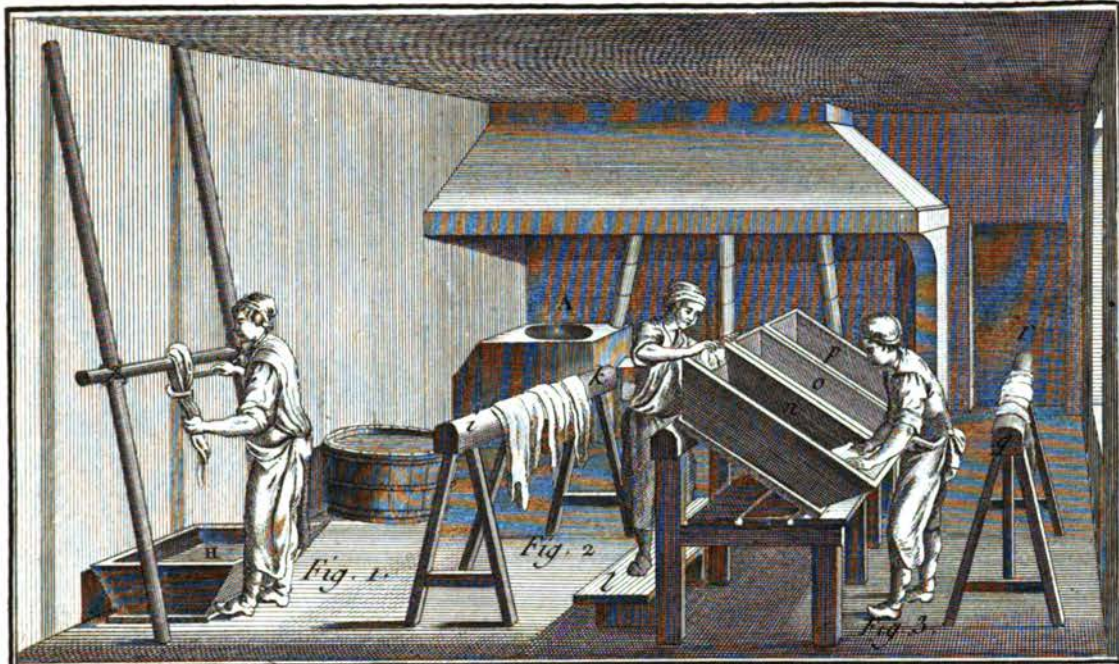
*Maroquinier, Plan Général de l'Atelier de la Teinture.*

*Benoist Duvet.*

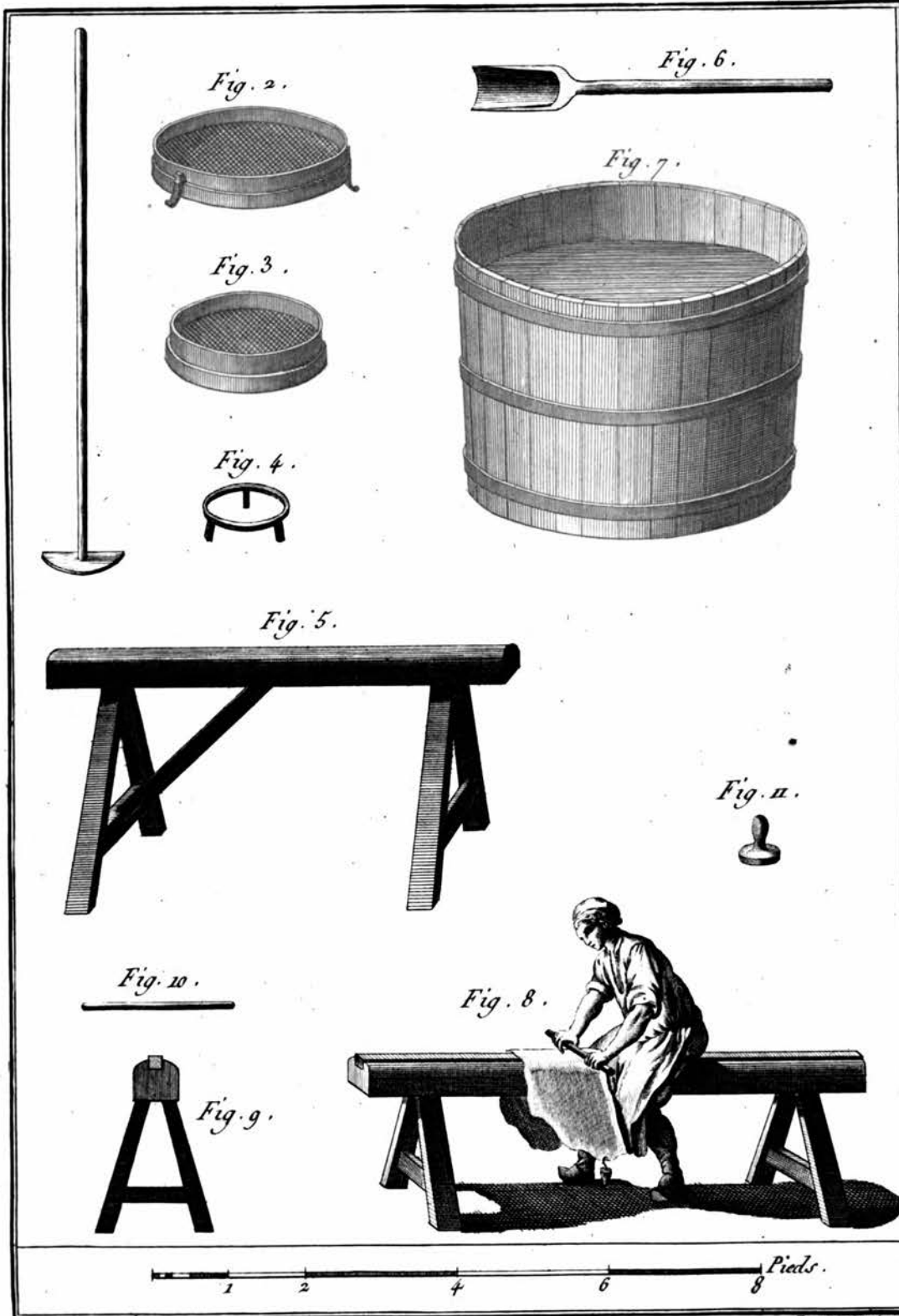


*Maroquinier, Elevation et Coupe des Fourneaux.*

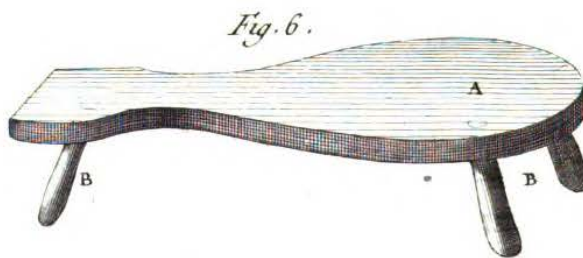
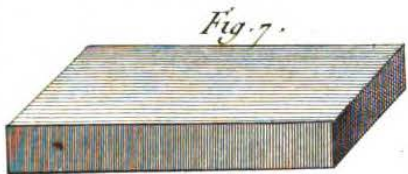
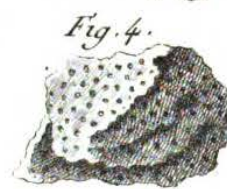
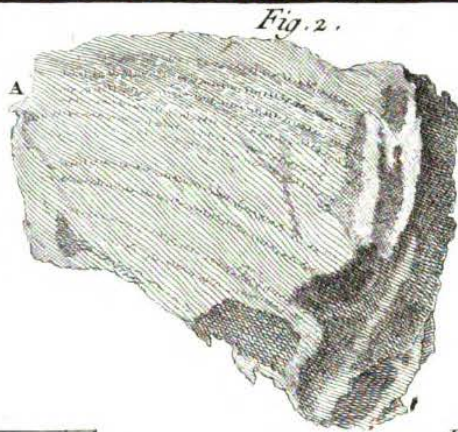
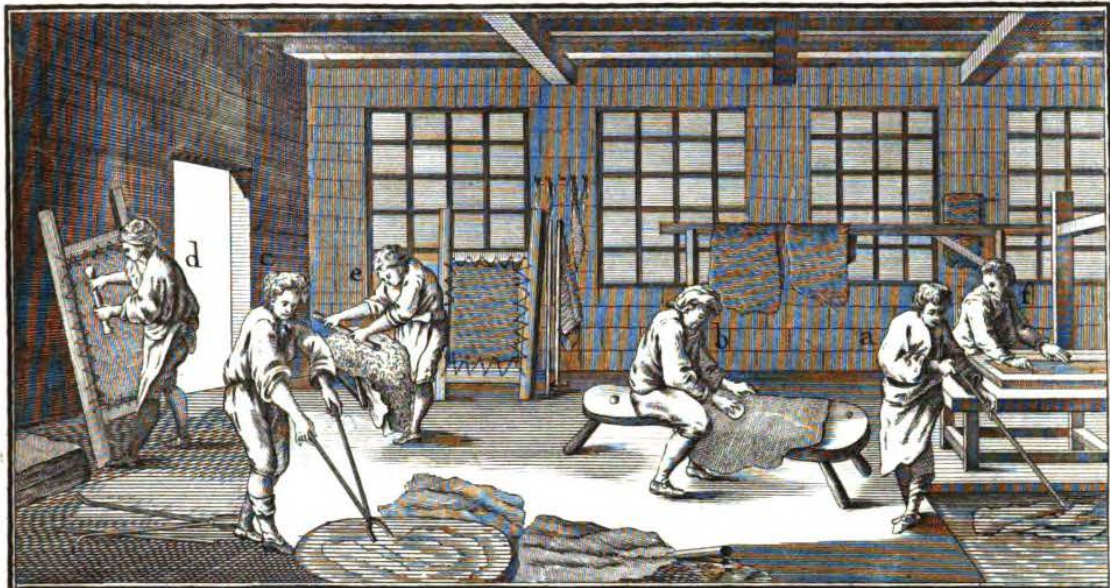
*Benoit Diraxit.*



*Maroquinier, l'opération de Teindre les Paux.* Bernard Duvet.

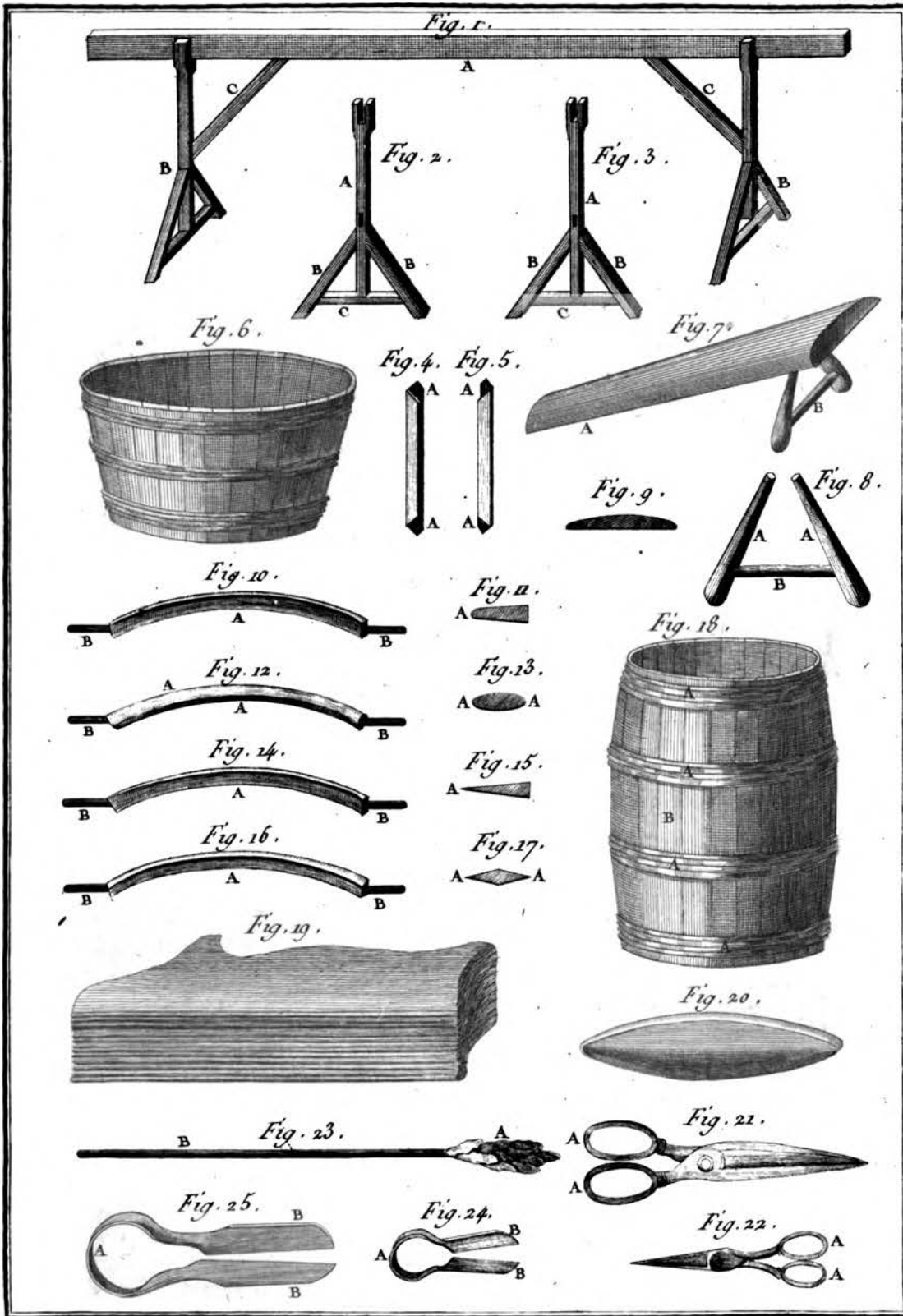


*Maroquinier, ustensilles servant à la Teinture, et l'opération de Lisser le Maroquin.* Benard Dircct.



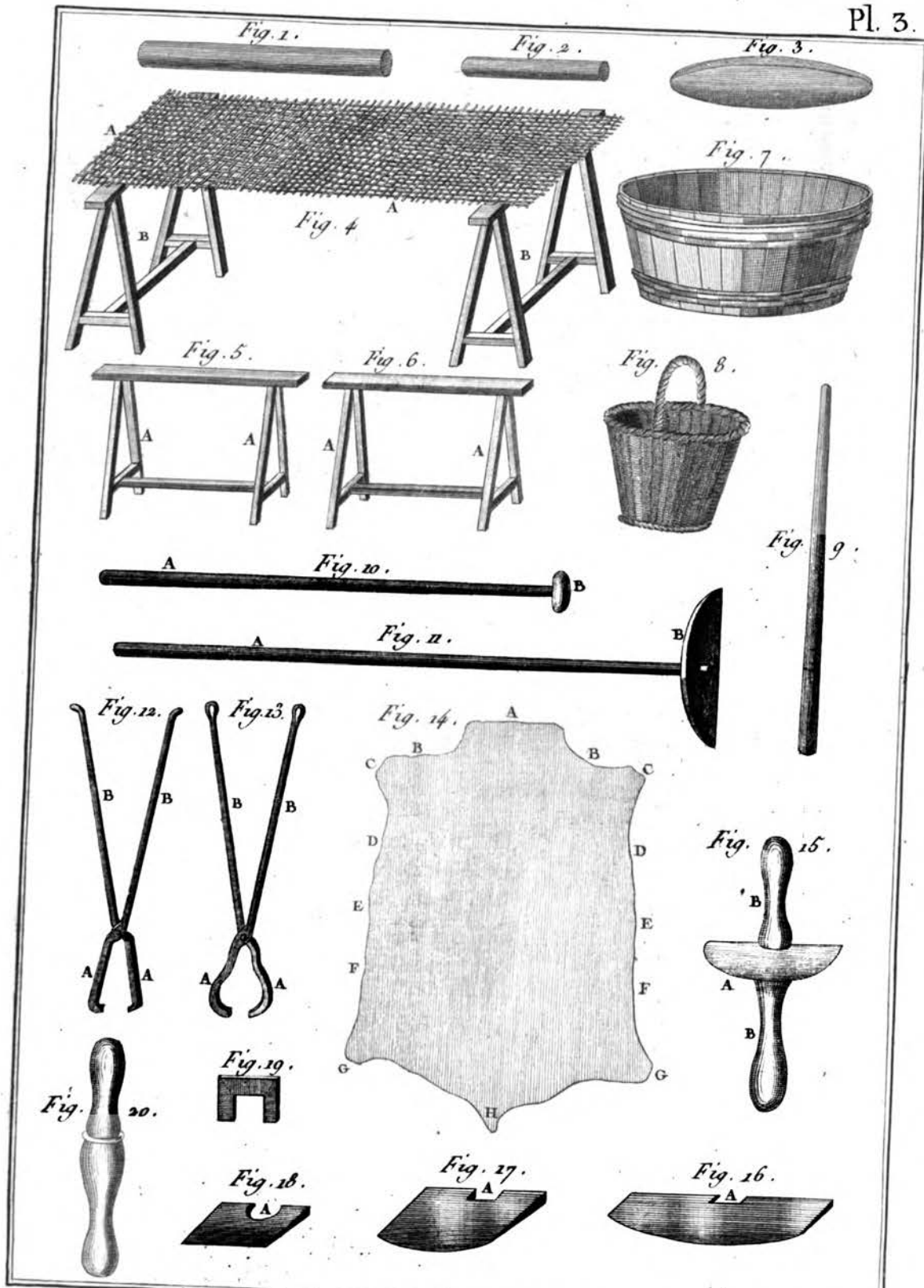
*Parcheminier.*

*Boiard Directeur.*



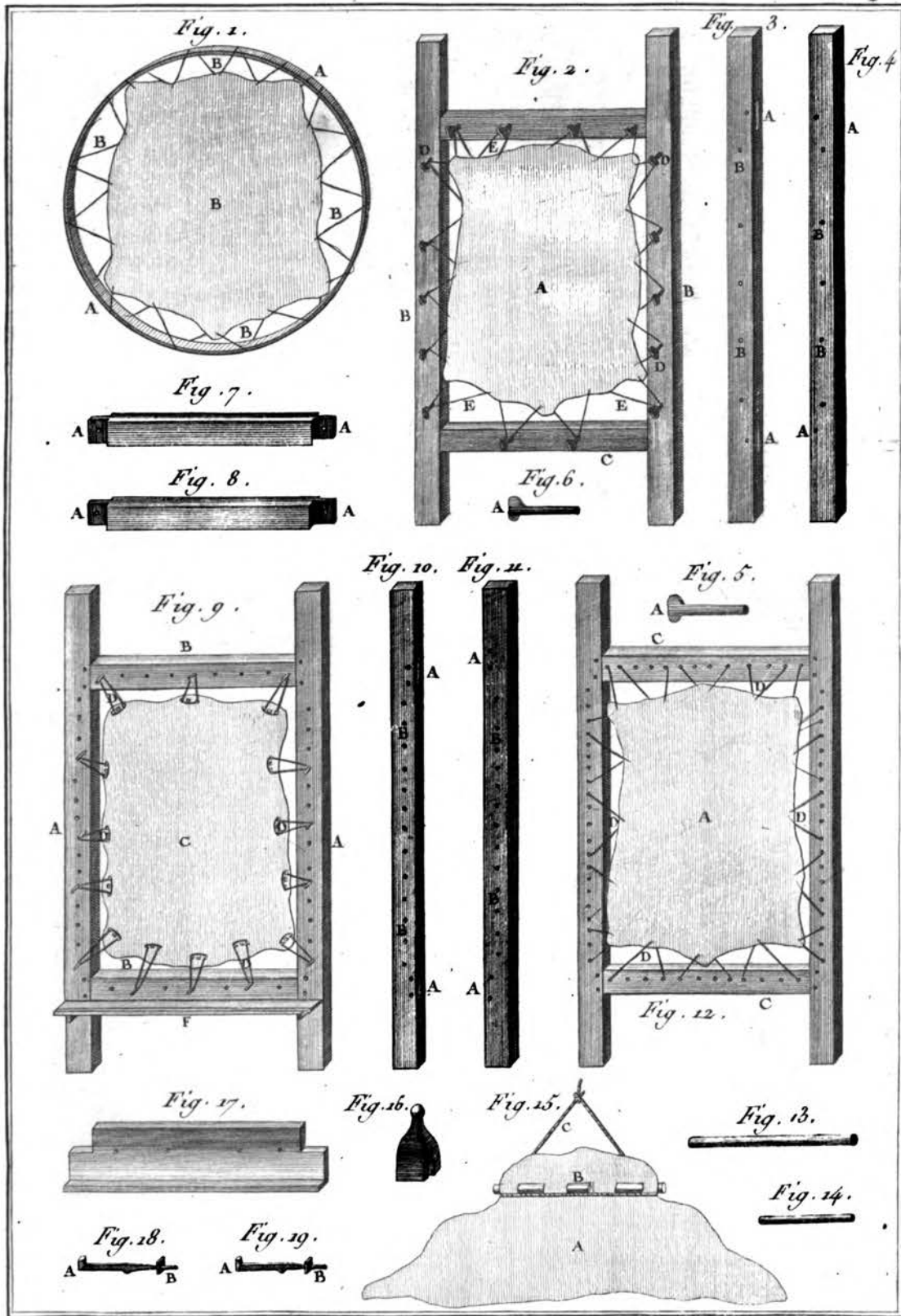
*Parcheminier*

*Bernard Duvaxil.*



*Parcheminier, Outils*

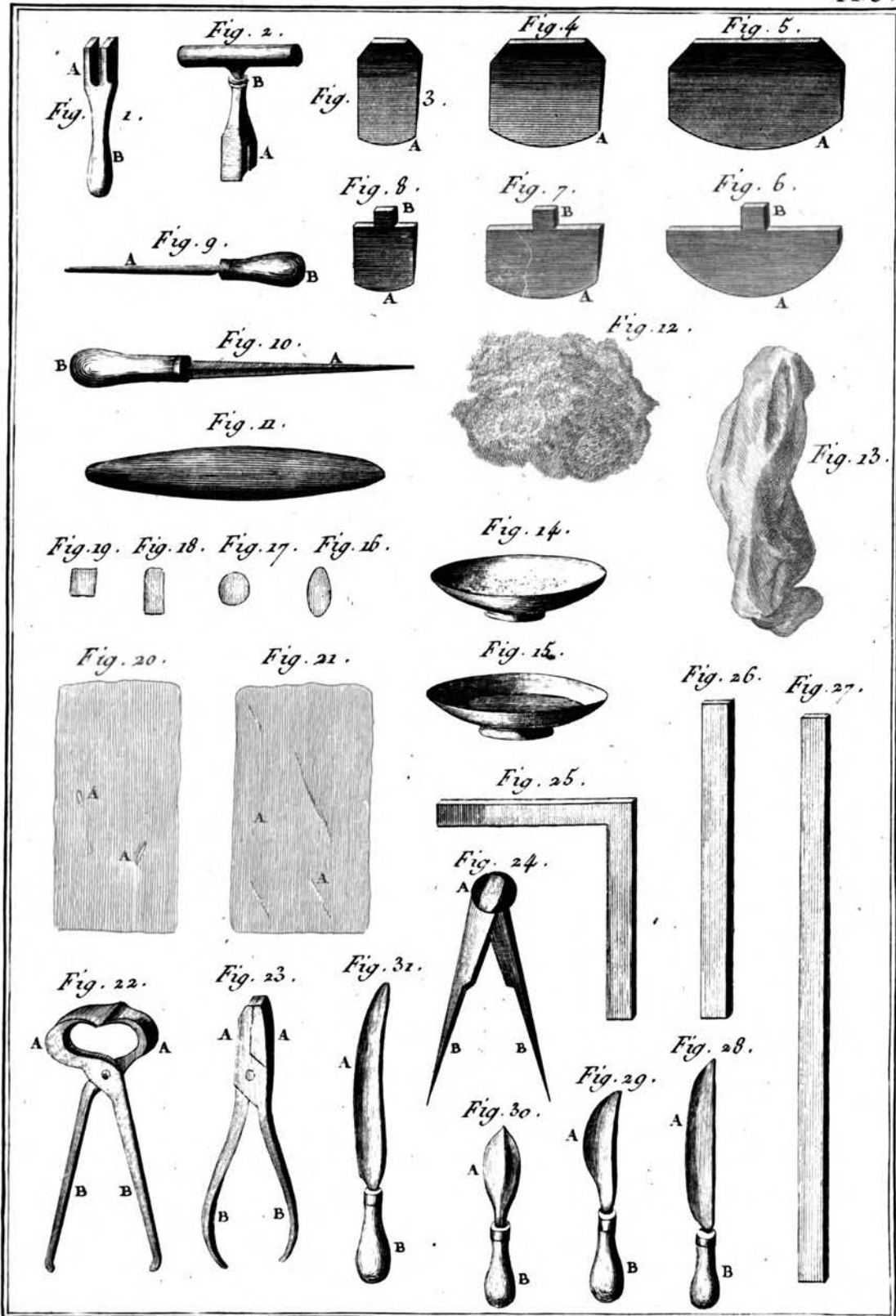
Original from *Bernard Dorez*



*Parcheminier.*

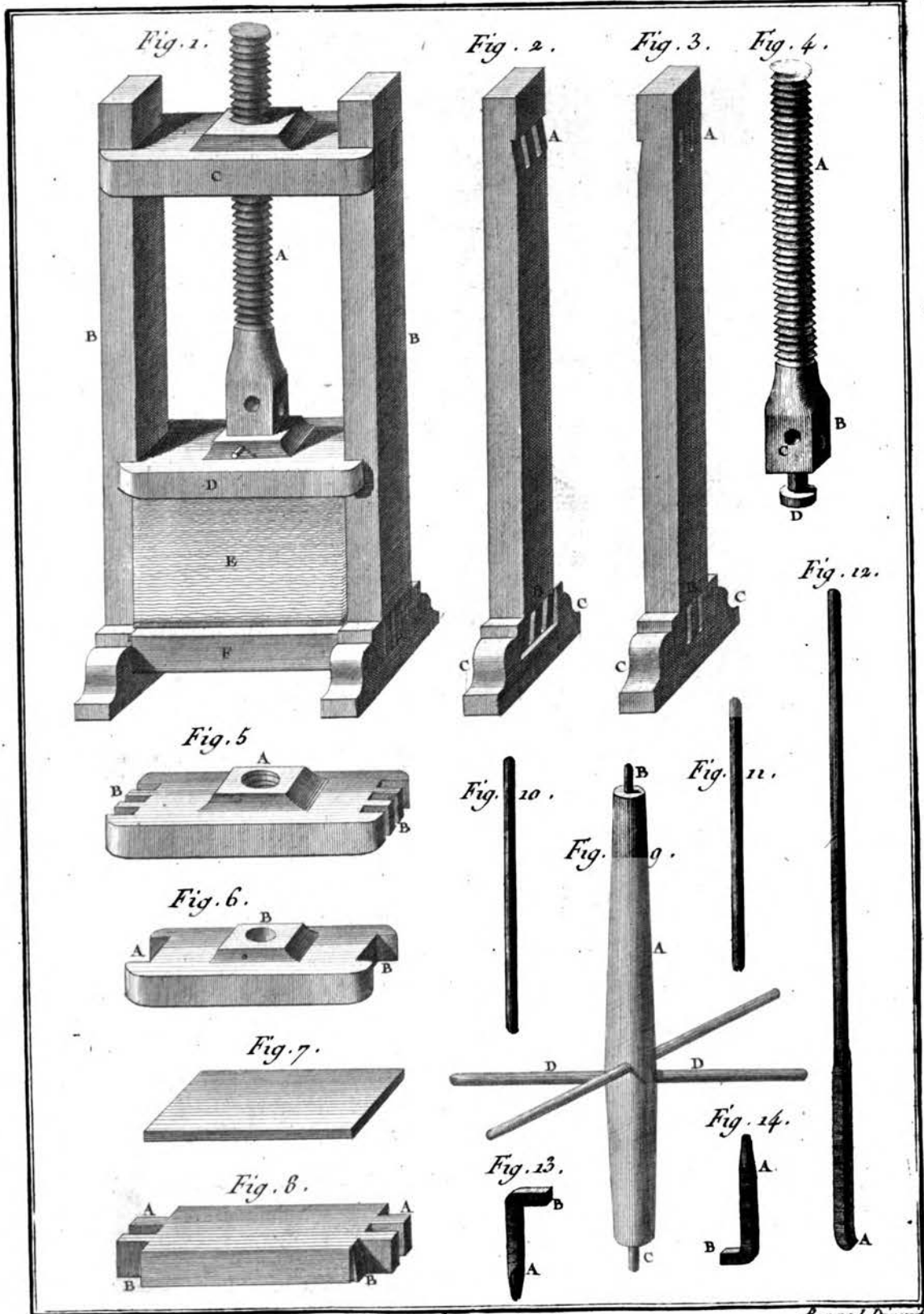
*Benard Drexel.*





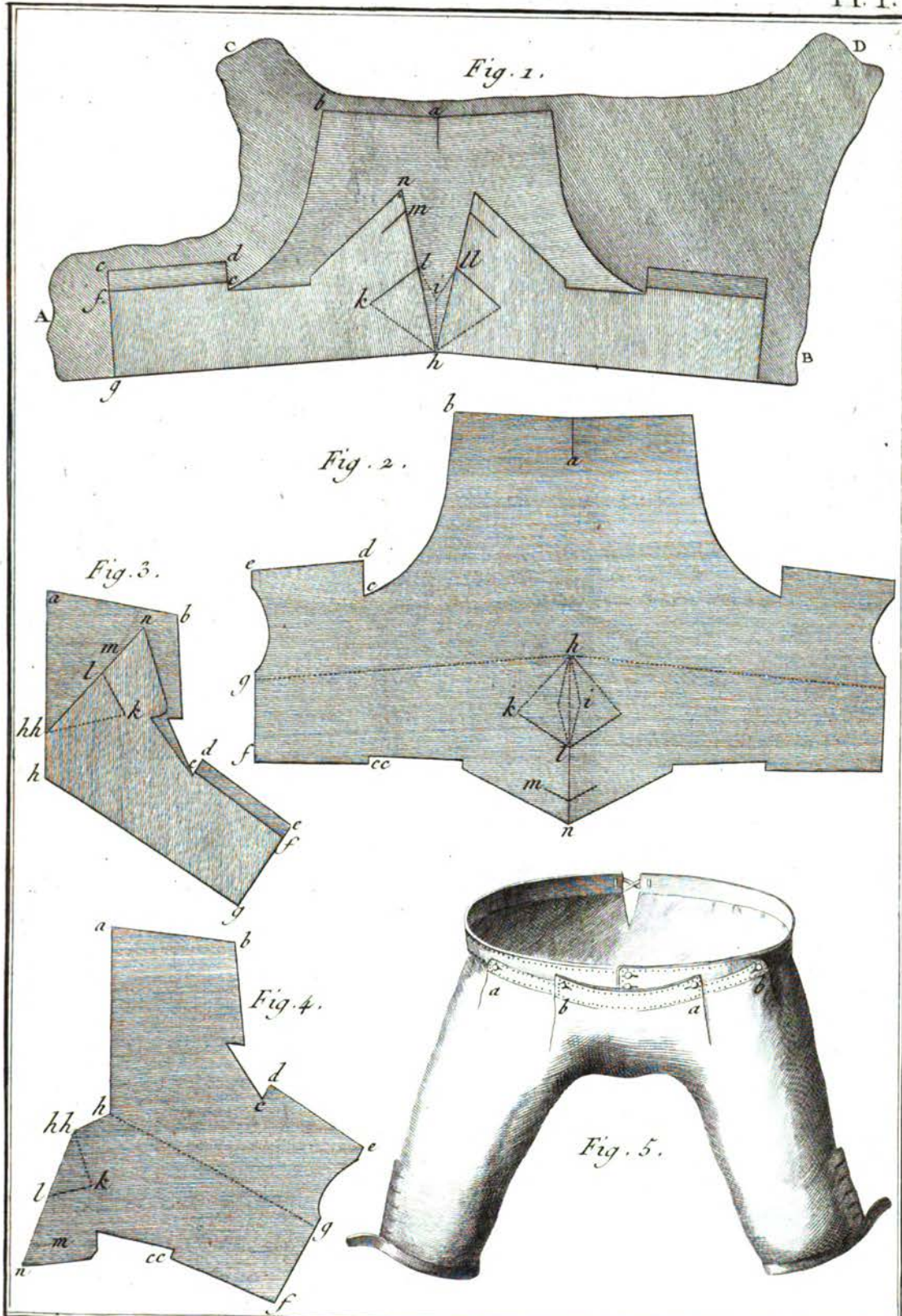
*Parcheminier.*

*Bernard Dorezil*



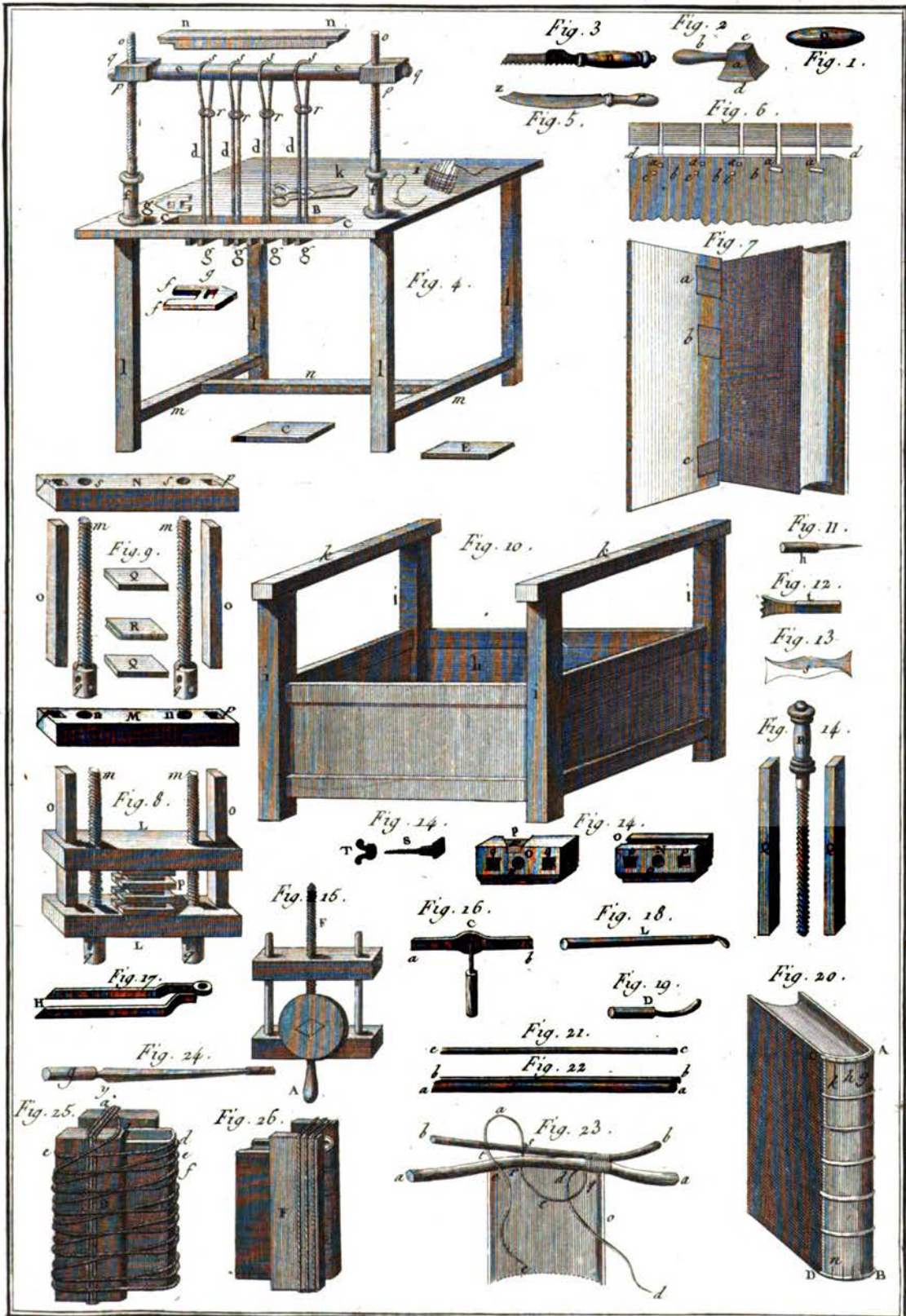
*Parcheminier.*

*Bernard Duxet.*



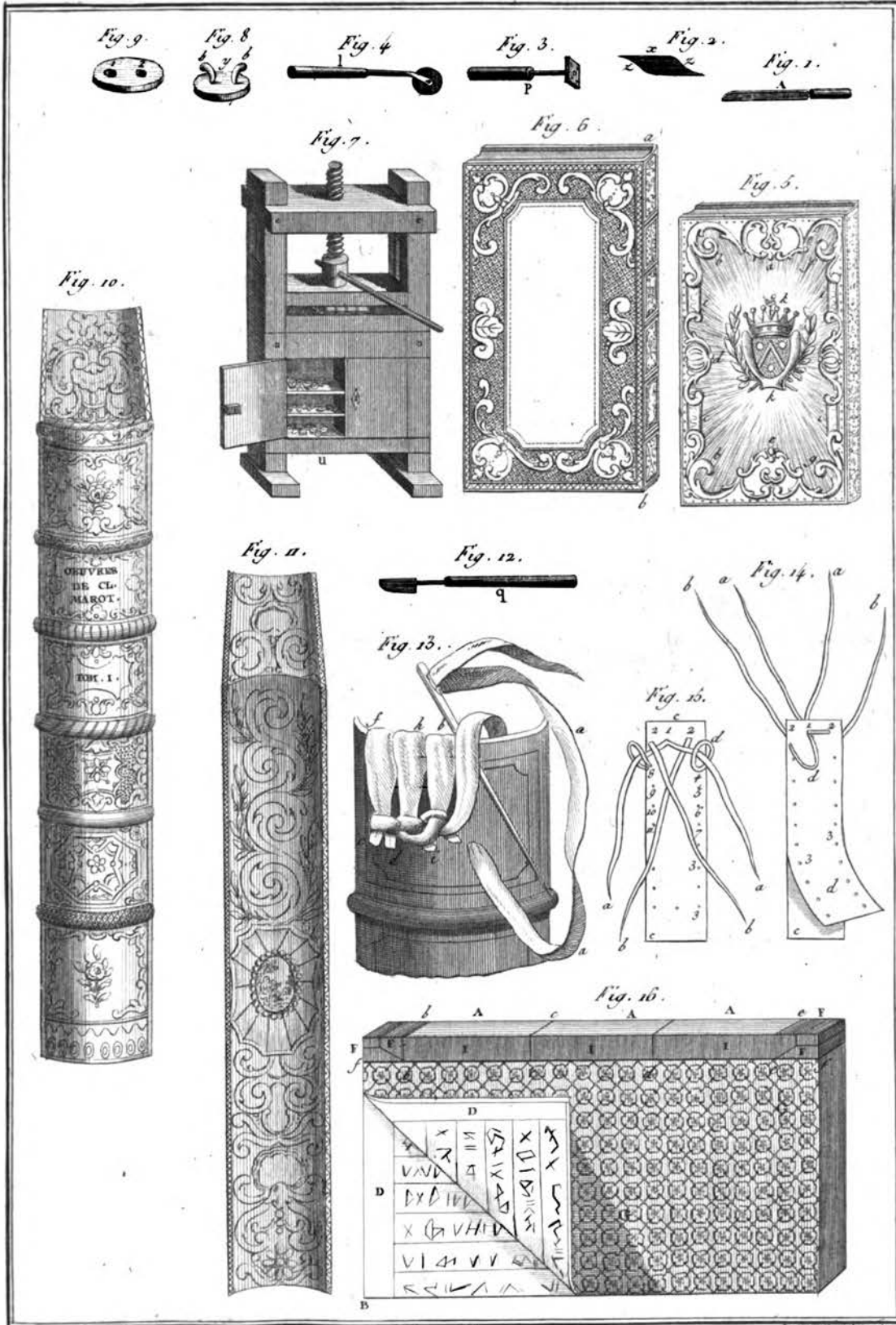
*Peausier-Culottier.*

*Benard Diresit*



Relieur.

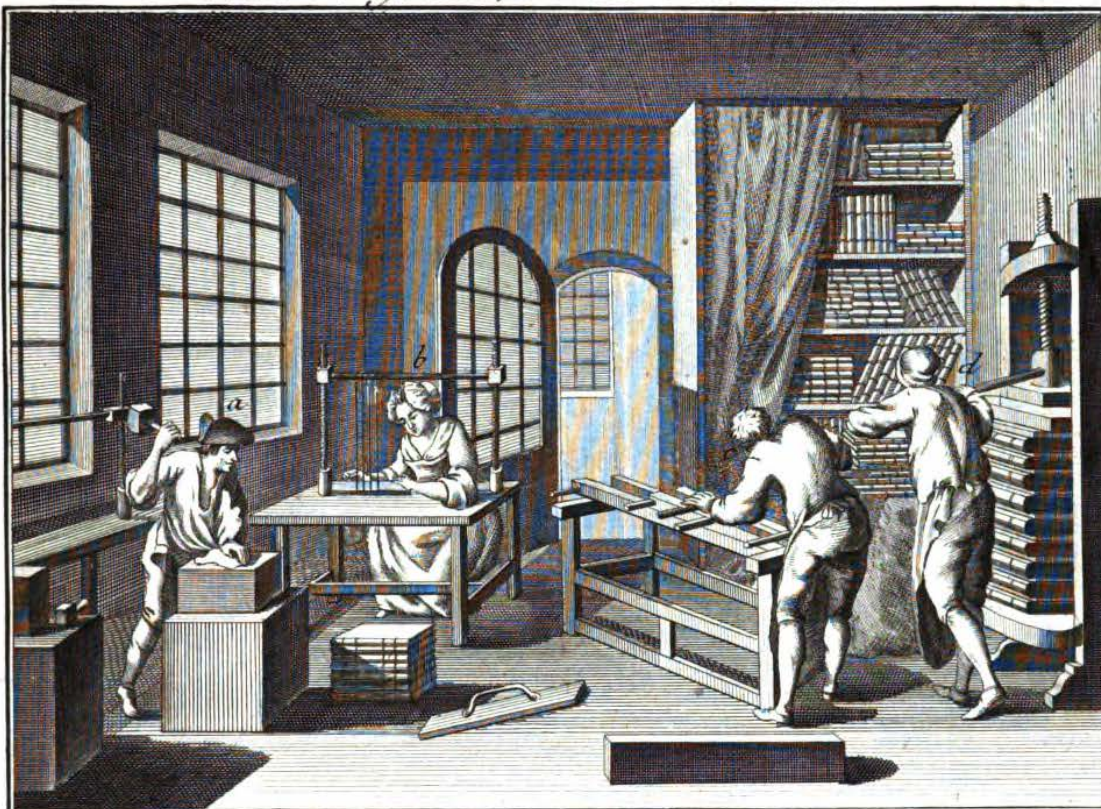
Benard Del. exat.



Relieur.

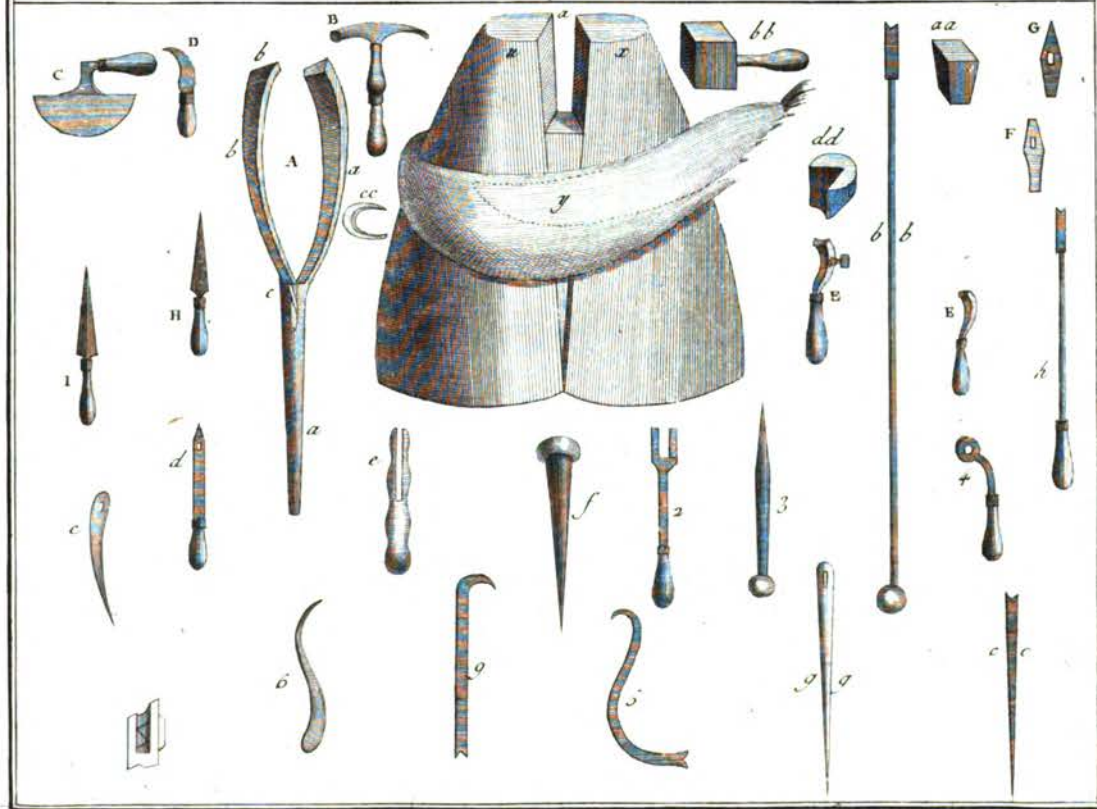
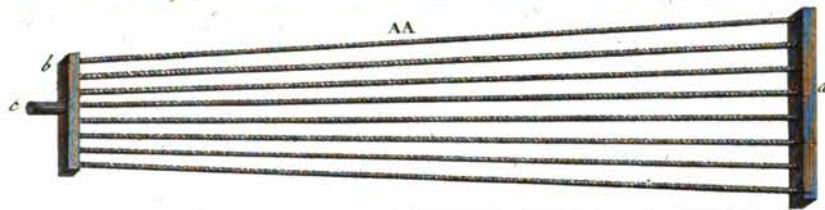
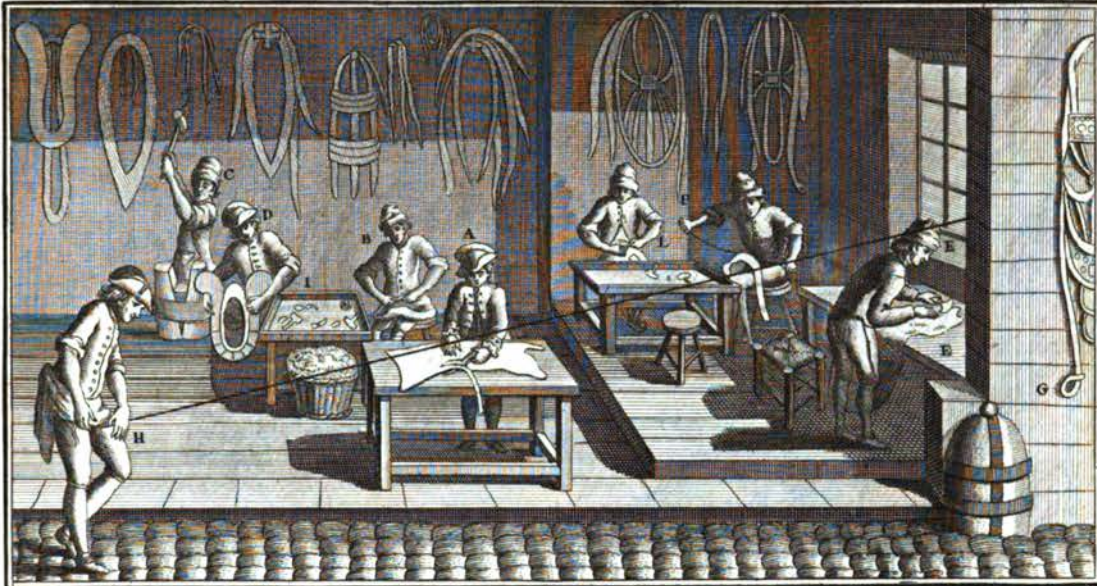
Benard Duxcit.

*Premiere Vignette, Atelier de Relieur.*



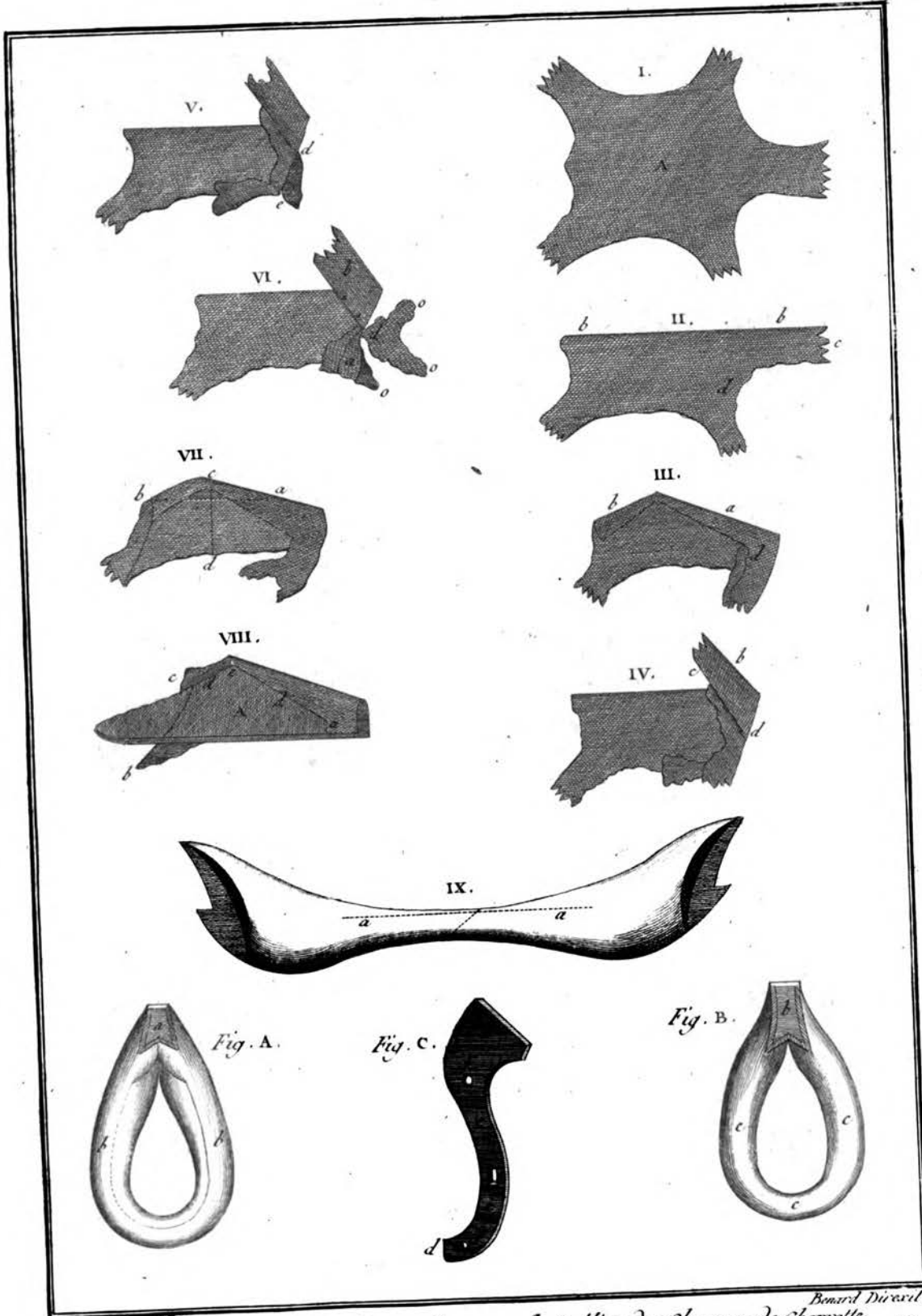
*Deuxieme Vignette, Atelier de Relieur Doreur.*

*Benard Duce.*



*Sellerie, Ateliers des deux Bourrelliers.*

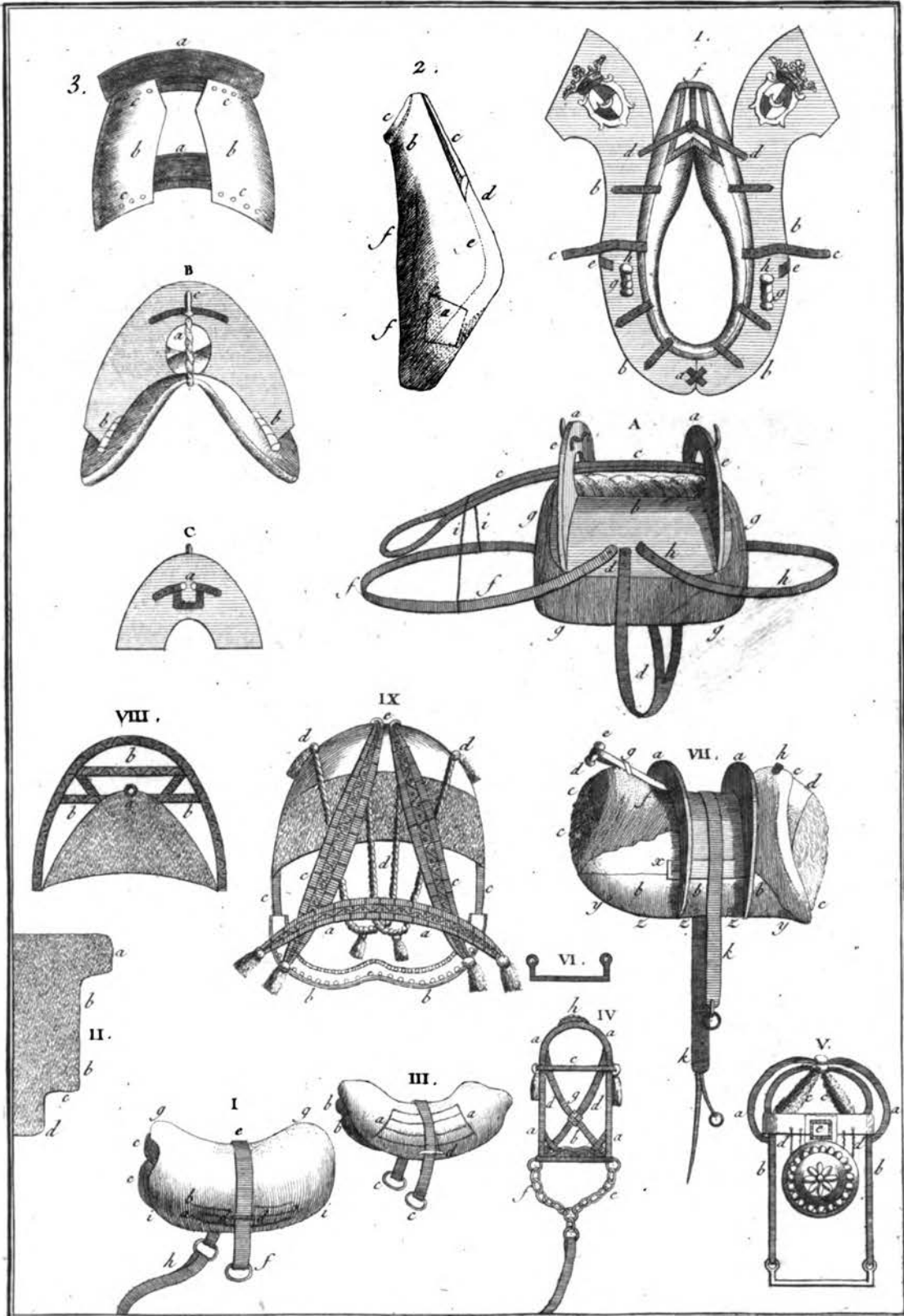
*Bonard Durazel*



Bernard Duvauil.

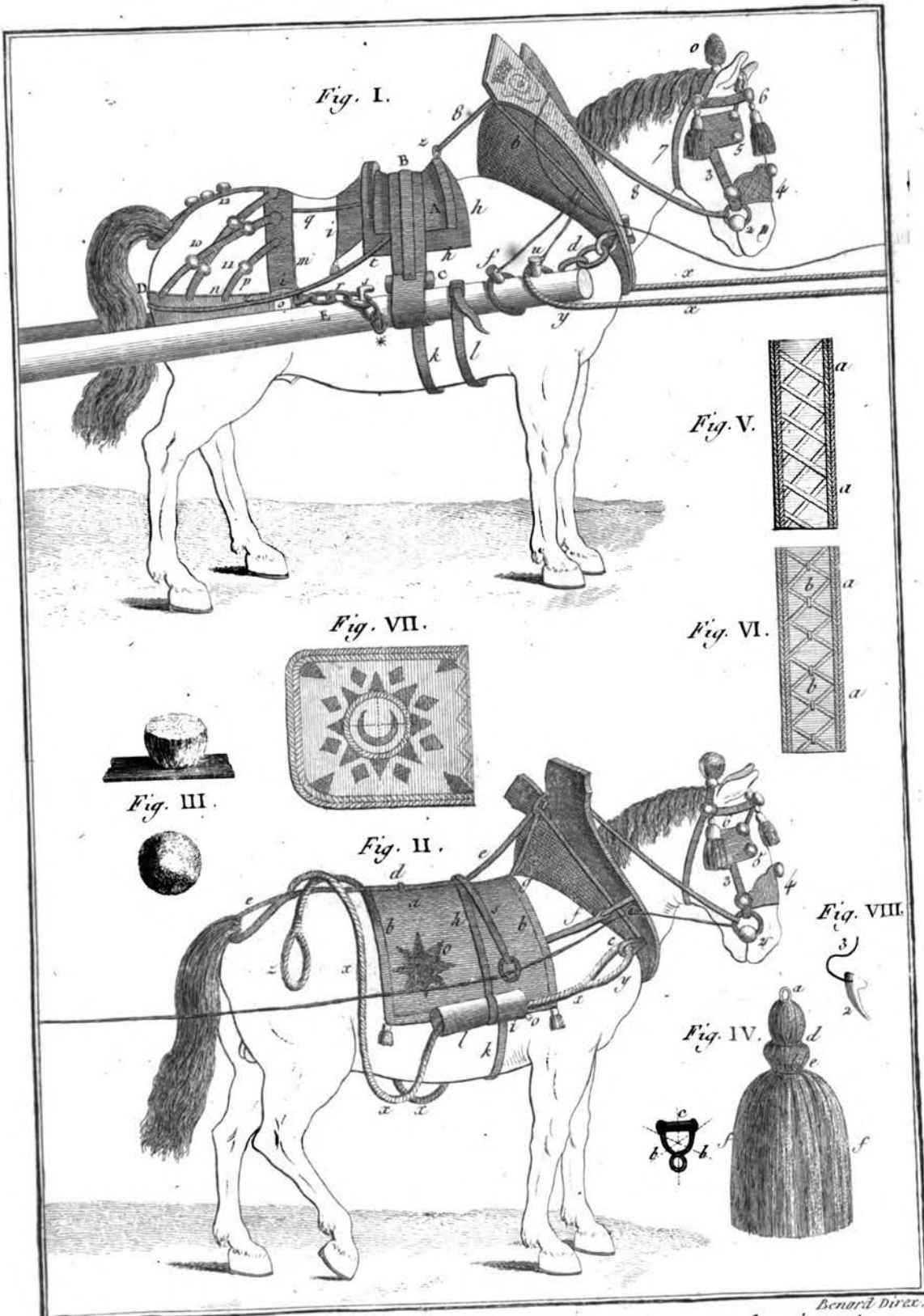
Sellier, Travail du Bourrellier pour le Collier des Chevaux de Charrette. 29





*Sellier, suite du Travail du Bourrelier pour le Collier monté, le Bât, le Pannau &c.*

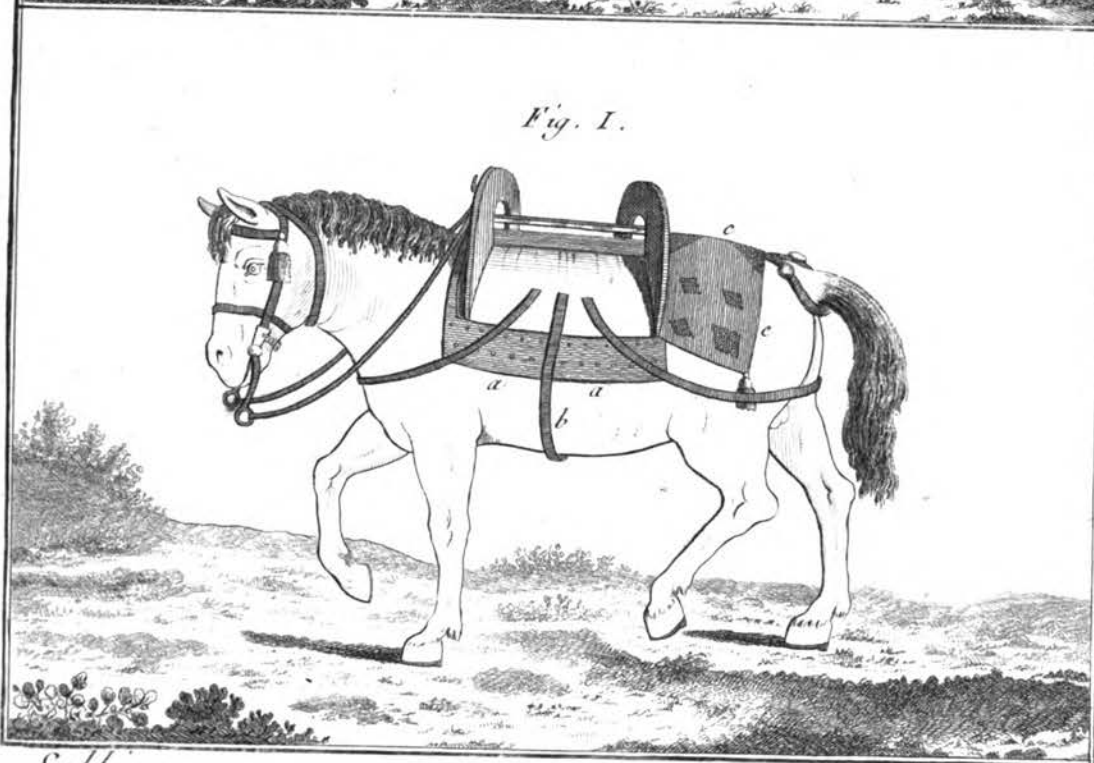
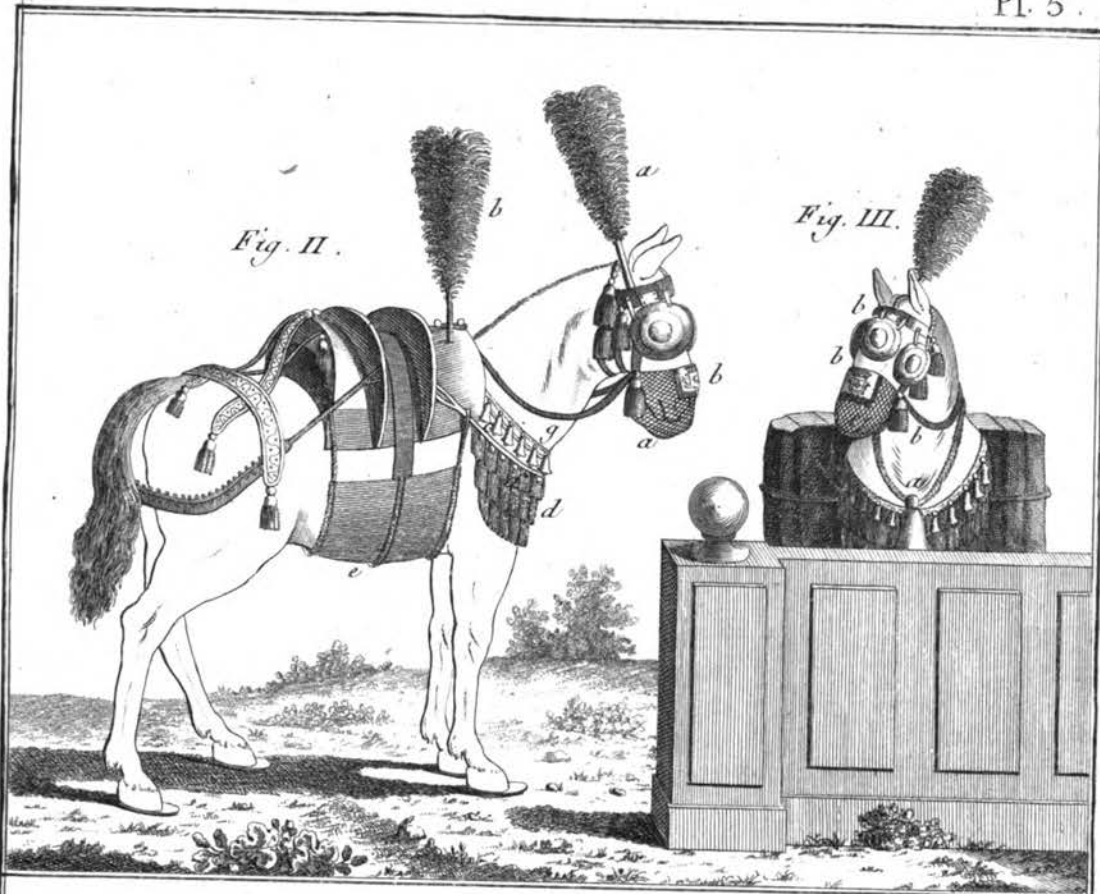
*Beuard Duxed.*



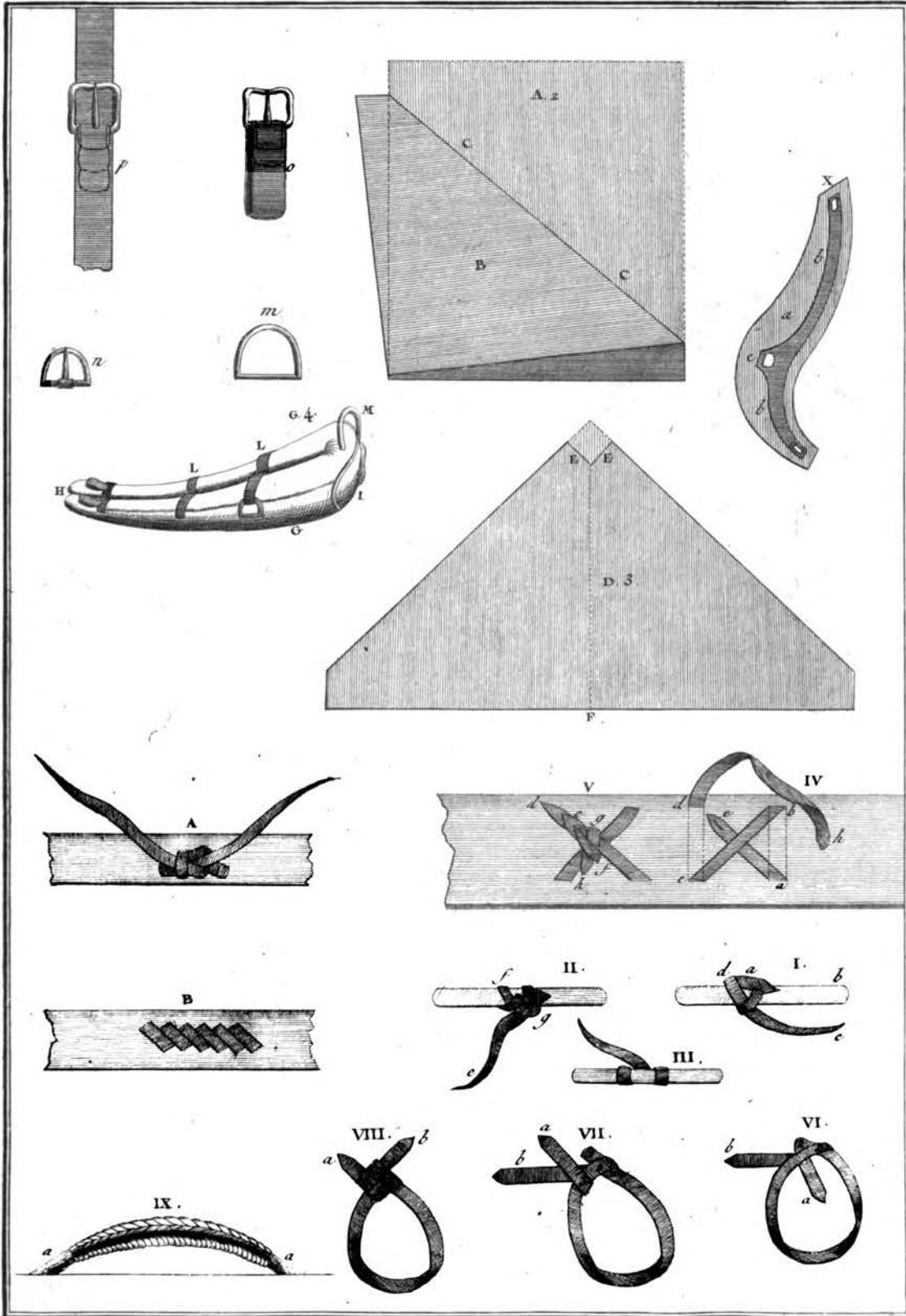
*Sellier. Travail du Bourrelier sur le Cheval de devant et le Limonier* 30.

Benard Dirce.

Generated on 2014-05-10 20:35 GMT / http://hdl.handle.net/2027/ucm.5320295822 Public Domain, Google-digitized / http://www.hathitrust.org/access\_use#pd-google

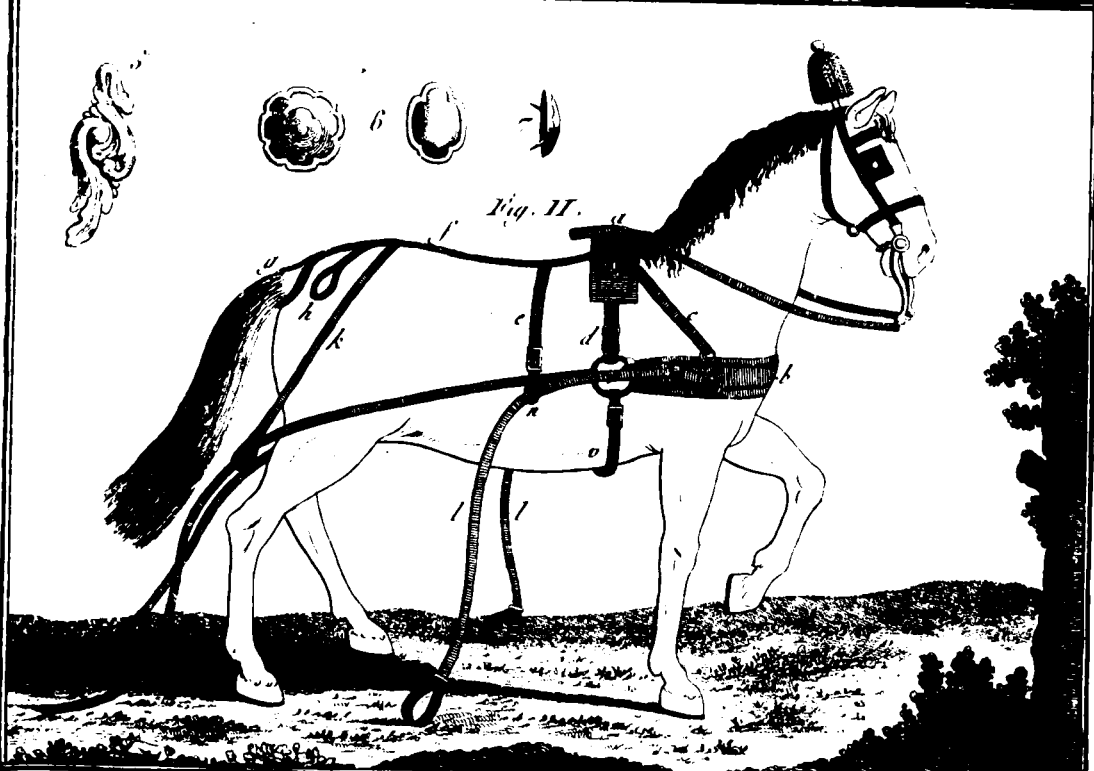
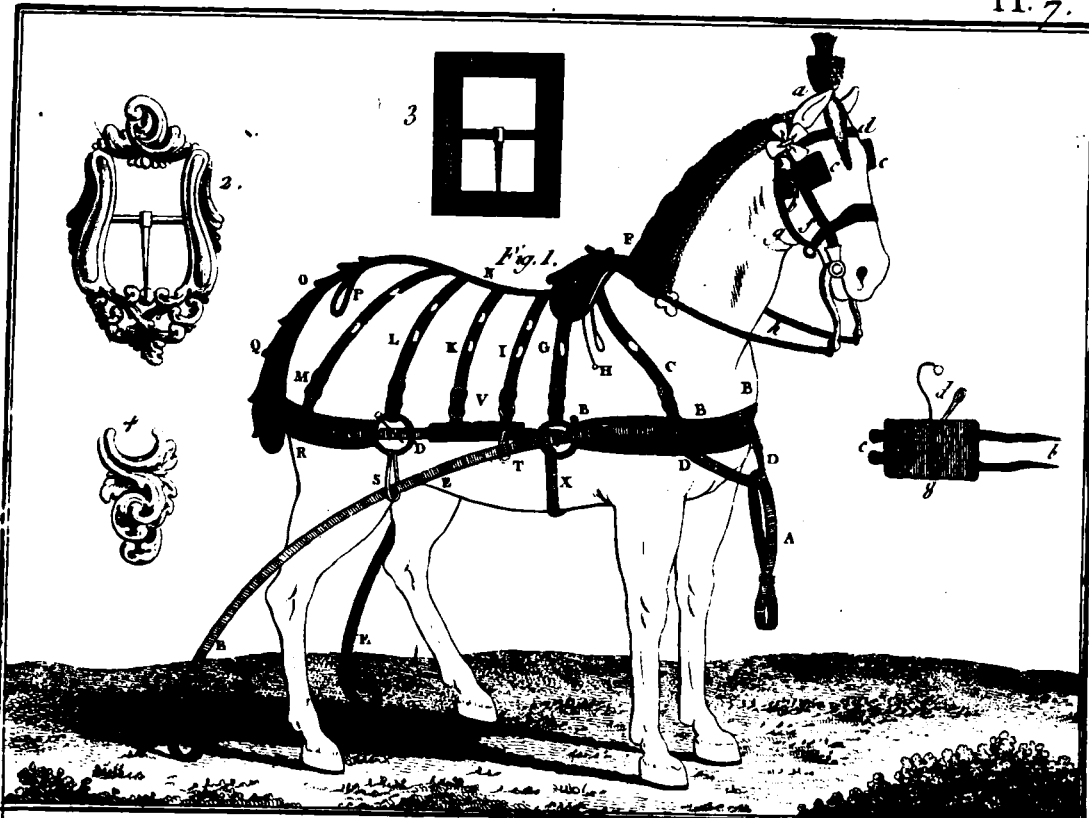


*Sellier, Travail du Bourrelleur sur le Cheval de Bât et sur le Mulet.* Benard Del.



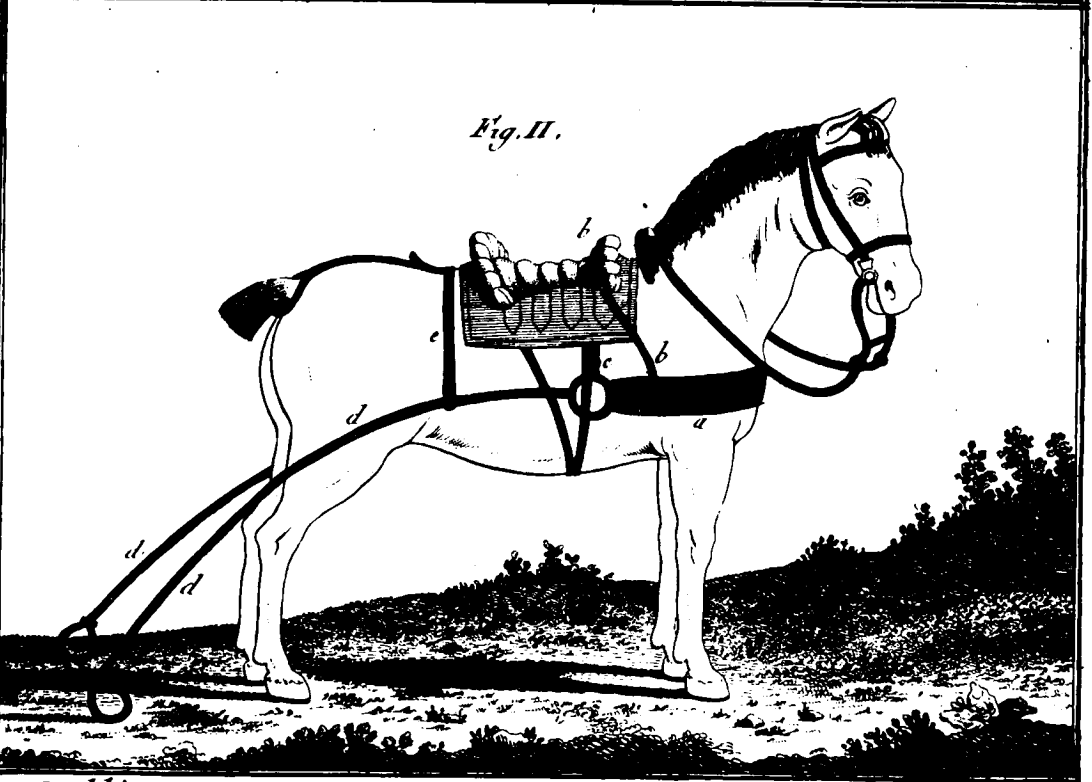
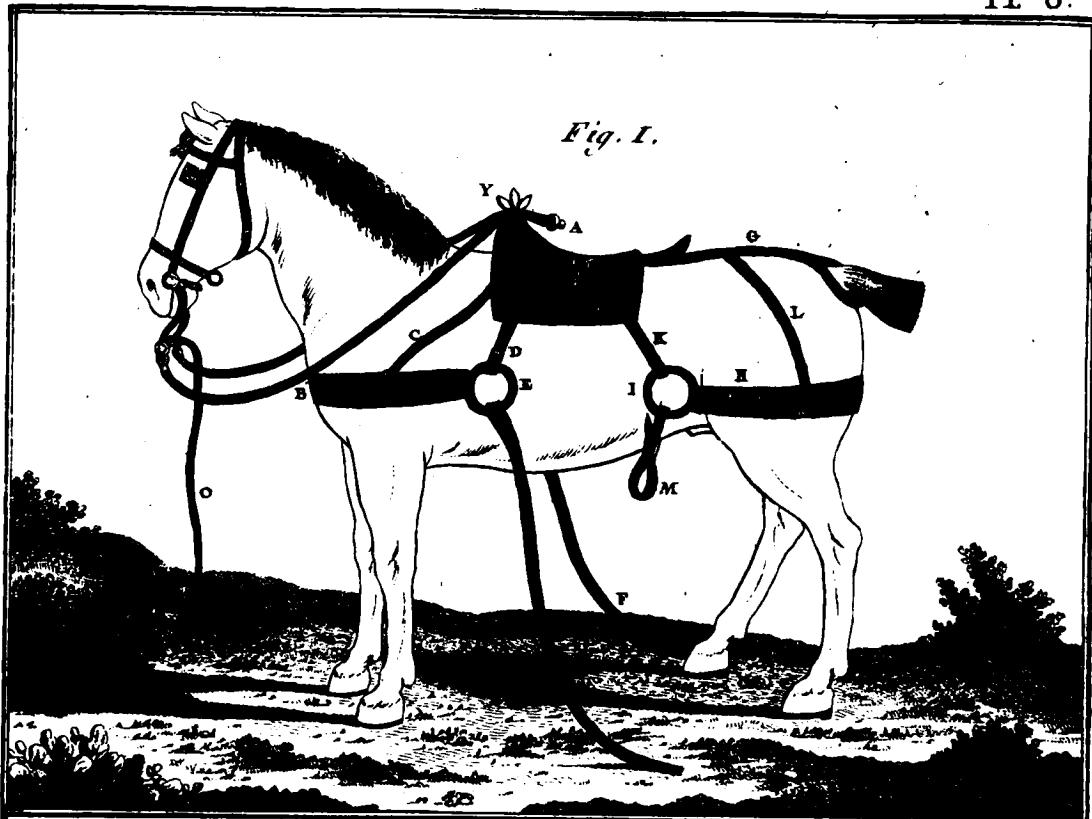
*Sellier, suite du Travail du Bourrellier.*

*Benard Doreuil.*

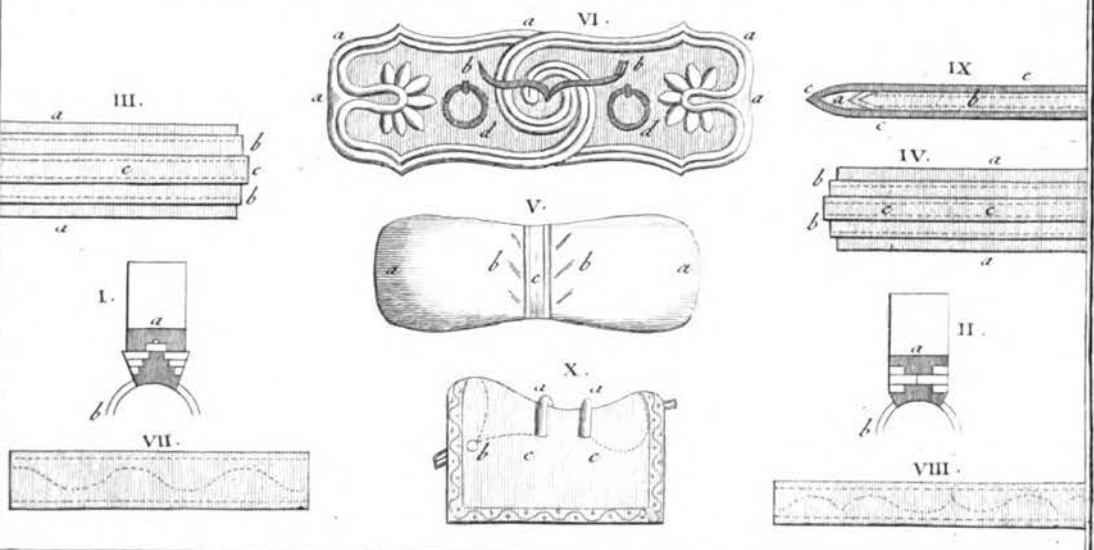
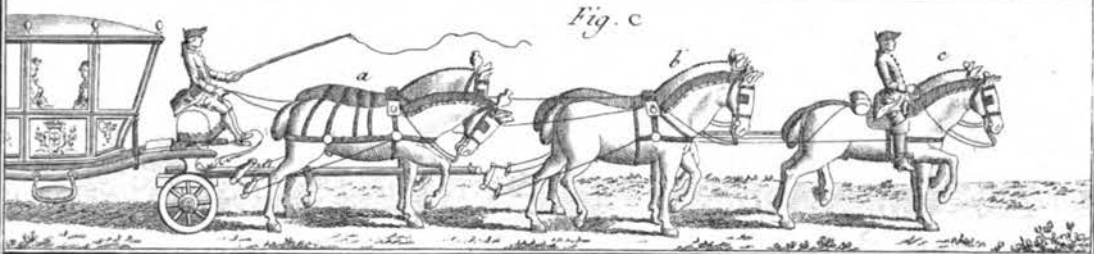
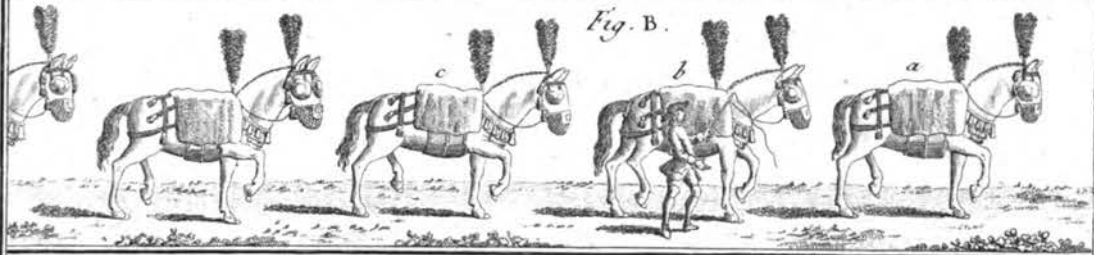
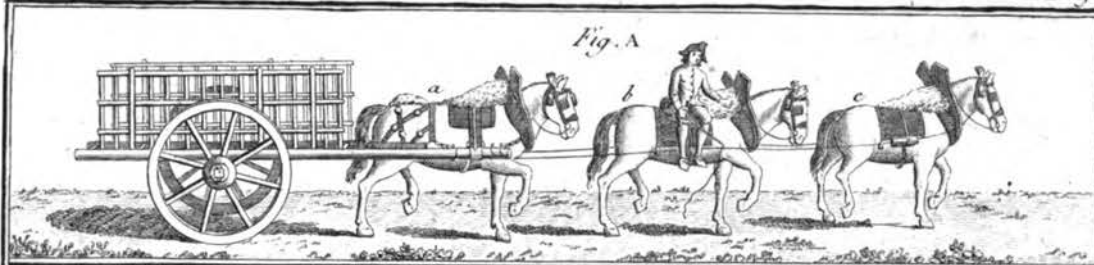


*Sellier, Travail du Bourrellier sur le Cheval de Carrosse et celui du devant.*

*Bernard Duret.*



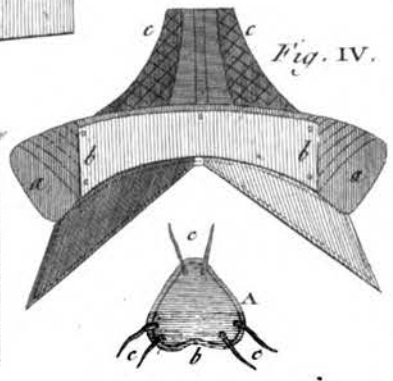
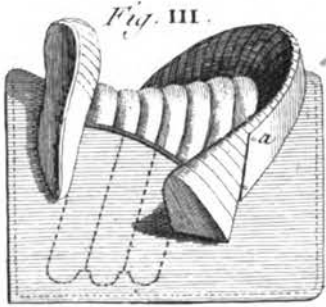
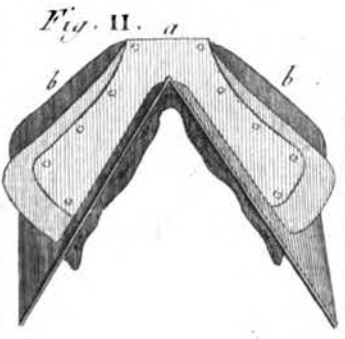
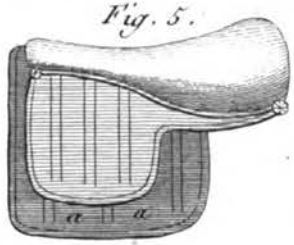
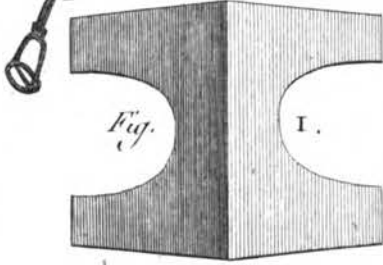
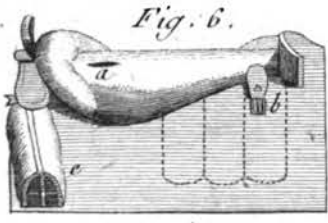
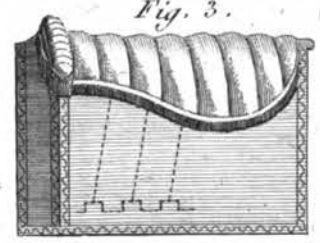
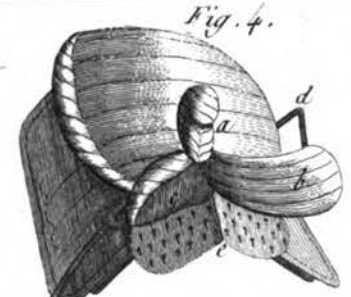
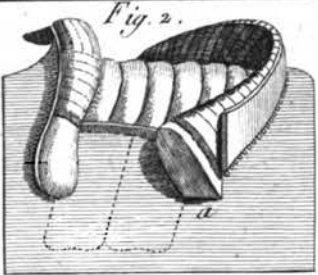
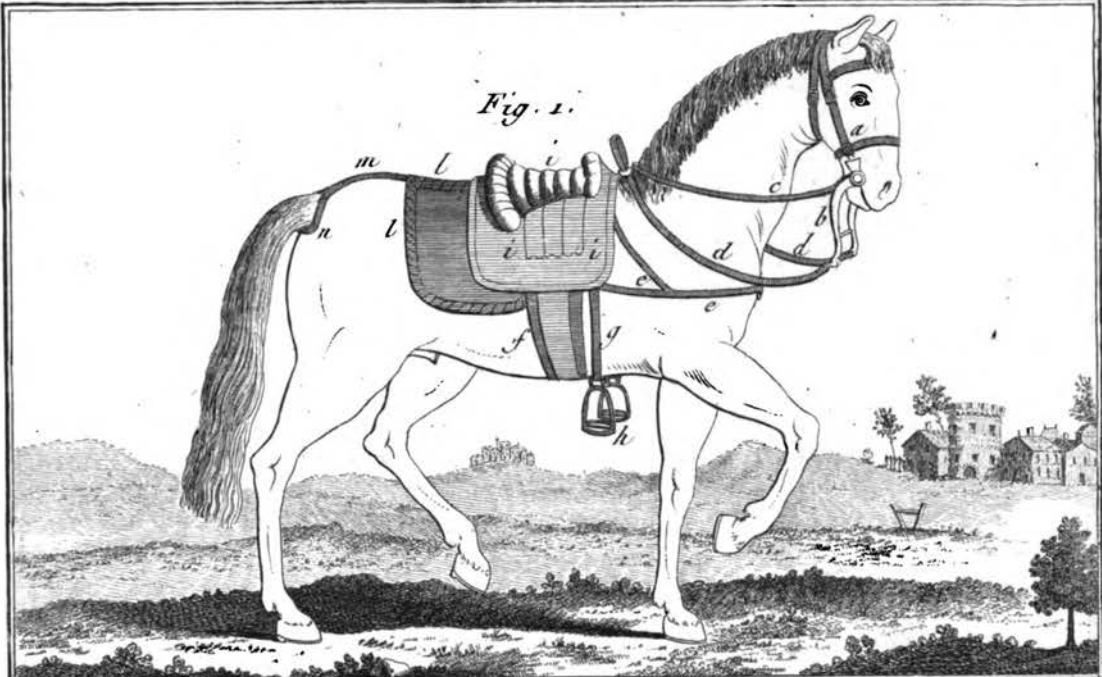
*Sellier, Travail du Bourrelier sur le Cheval de Brancard et sur le Bricollier.* Benard Dir.



*Sellier, Différens attelages, Mulets armés, et Ustensiles du Cheval.* Bernard Dorez. 33.

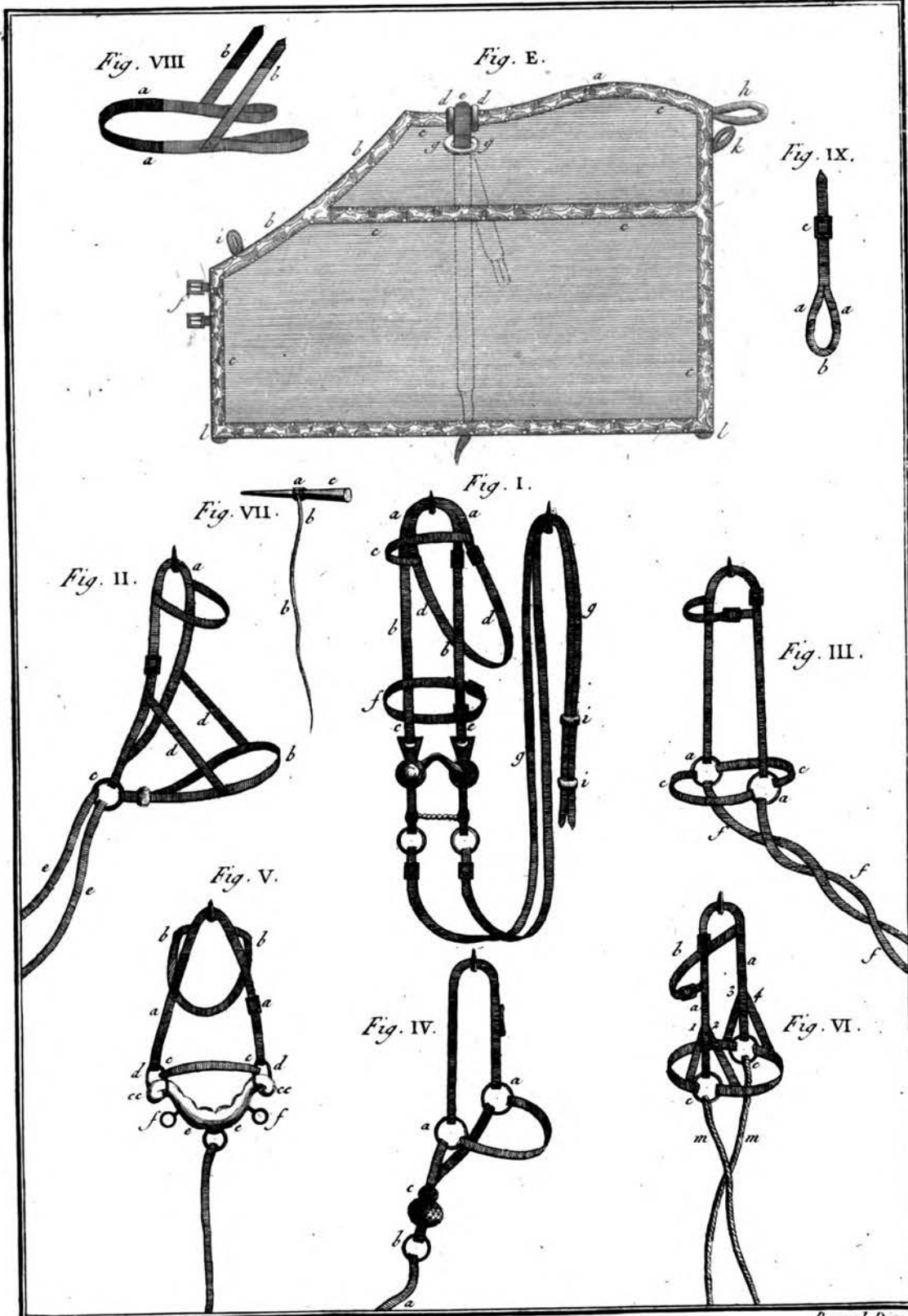






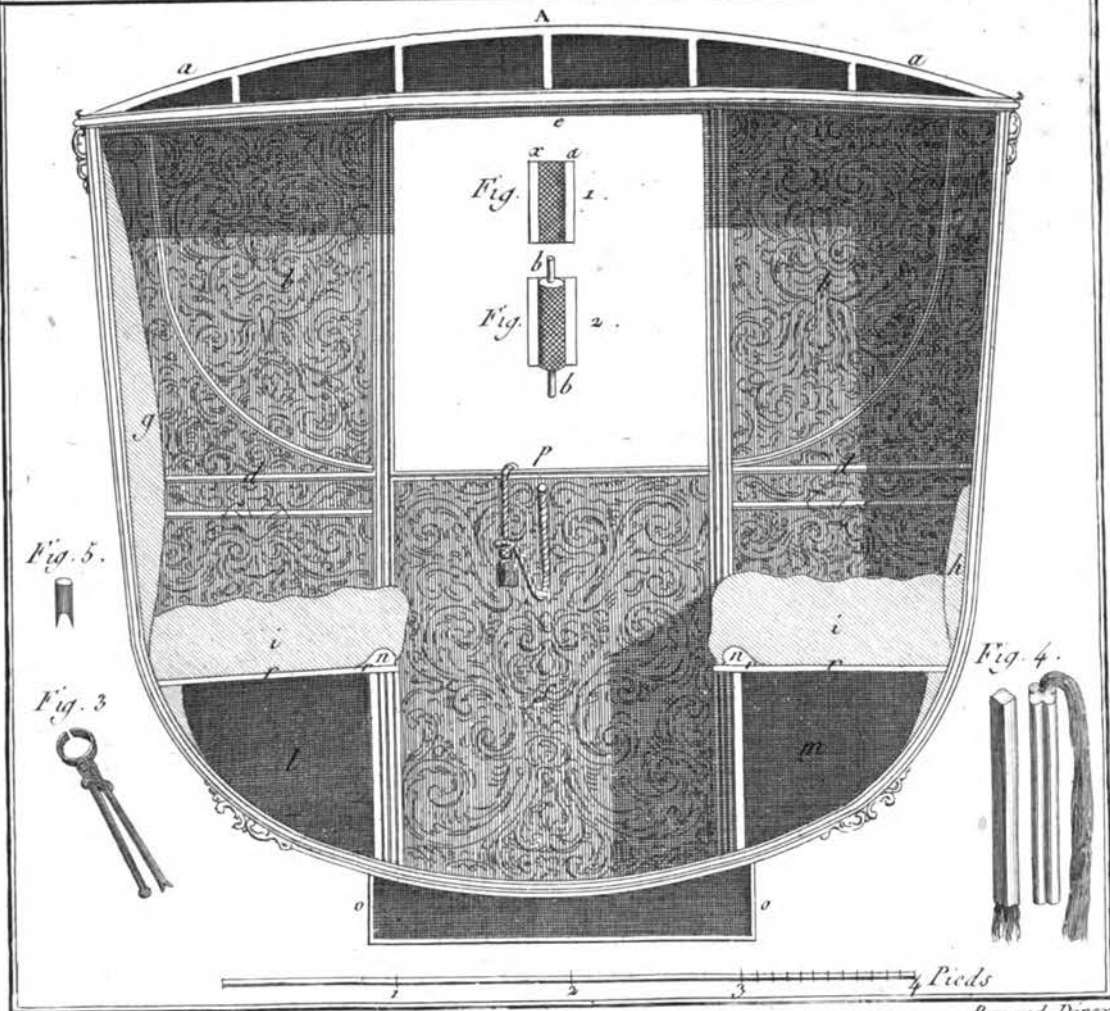
*Sellier, Cheval de Selle et bride'; et plusieurs Sells.* Benard Dixent 34.

Generated on 2014-05-10 20:37 GMT / http://hdl.handle.net/2027/ucm.5320295822  
Public Domain, Google-digitized / http://www.hathitrust.org/access\_use#pd-google



Benard Dorecat

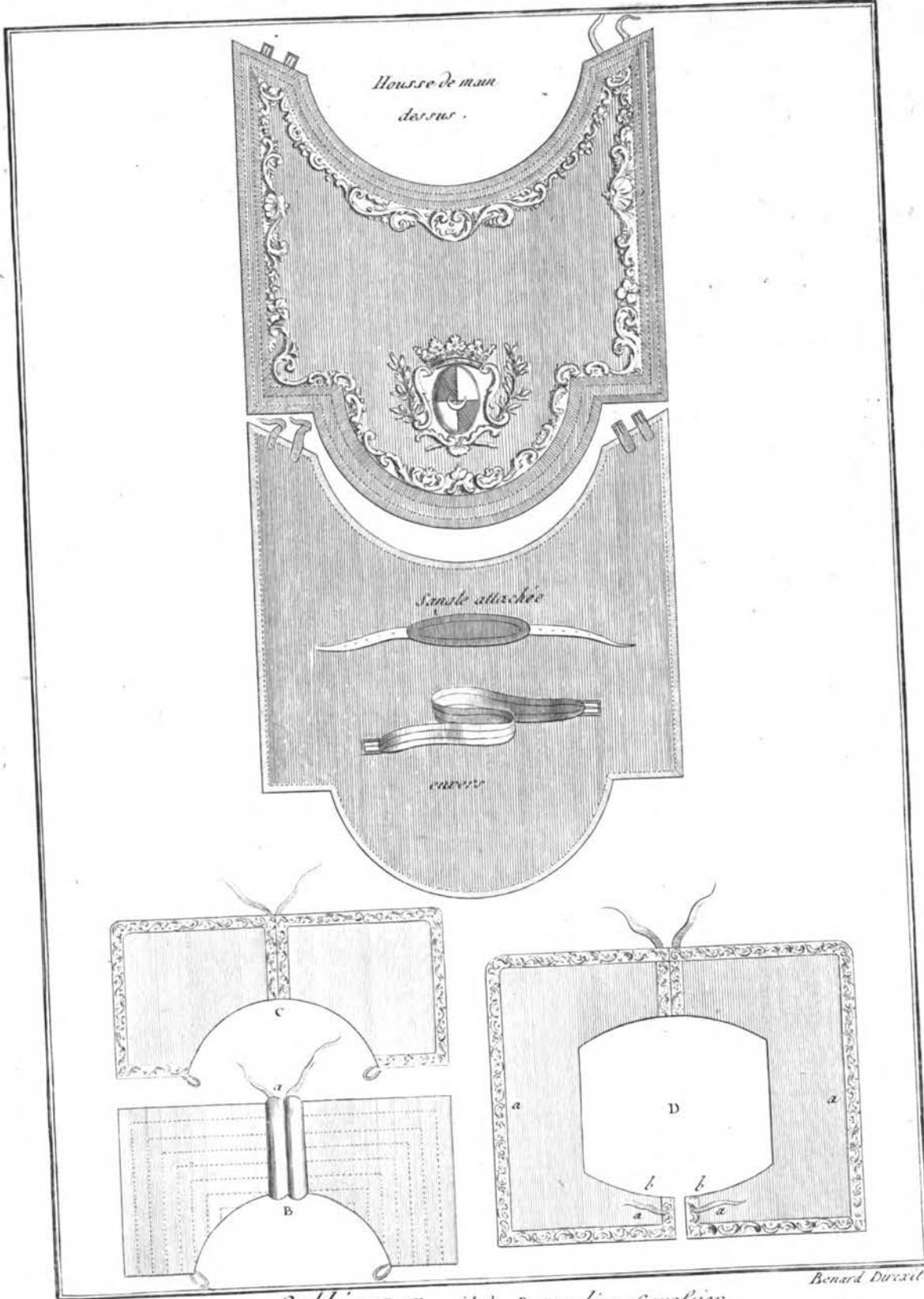
*Sellier, Couverture, Bride, Licol, &c. pour le Cheval Sellé et Bridé.*



*Sellier, Atelier du Sellier - Carrossier, Coupe d'une Berlina, &c.*

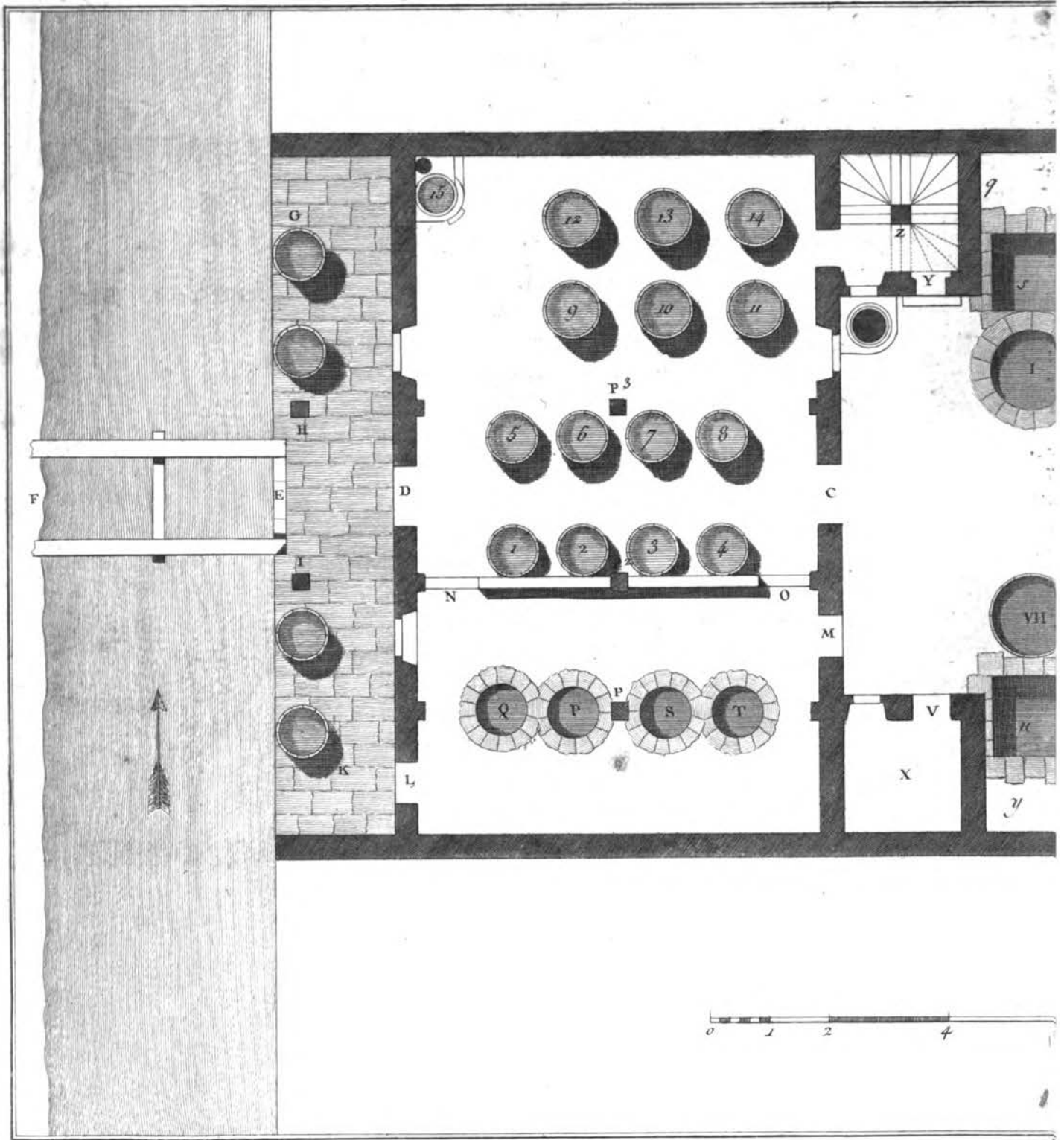
*Bernard Duvet.*



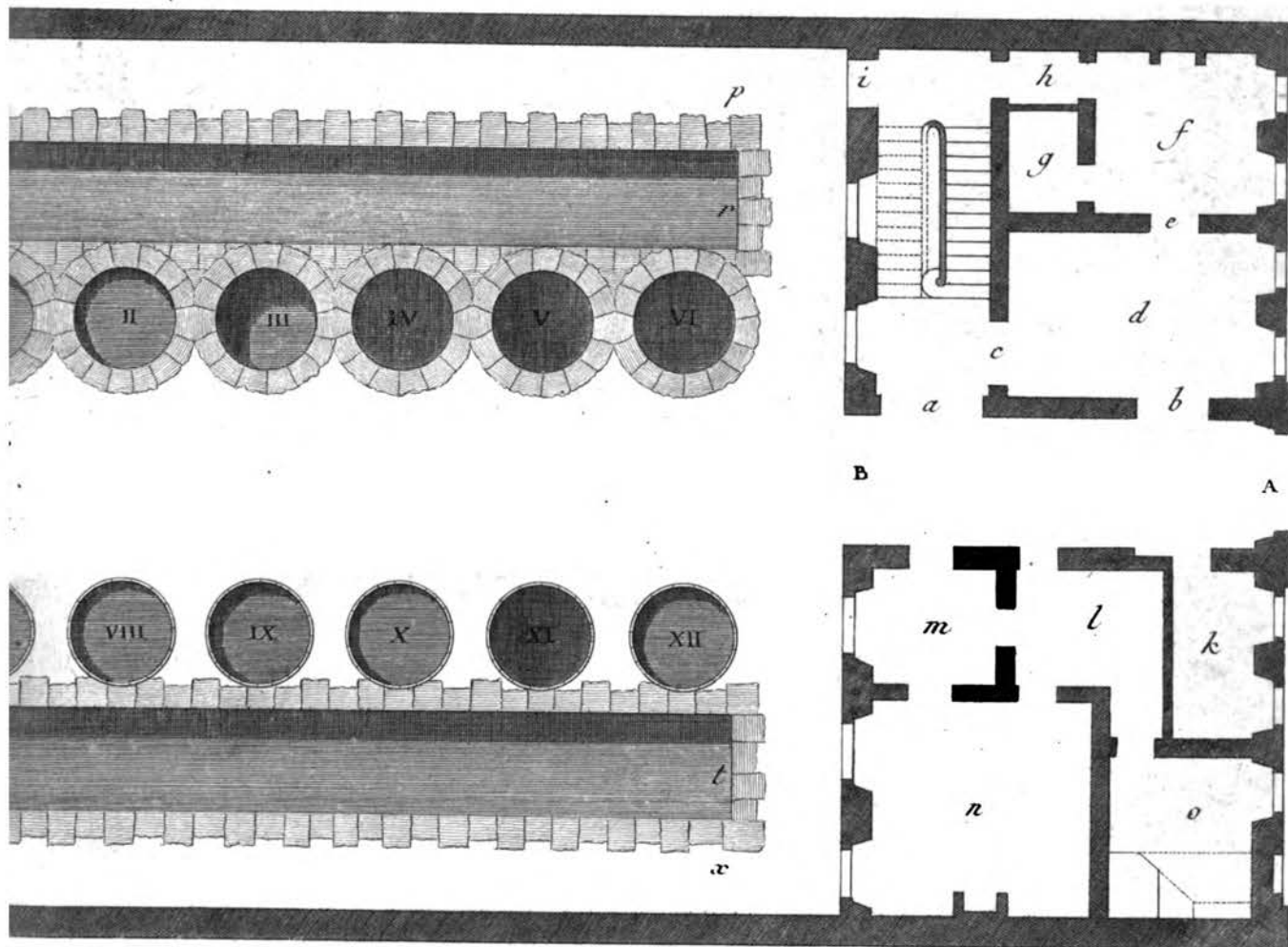


*Sellier, Travail du Bourrelier - Carrossier.*

*Bernard Duceat*



*Tanneur, Plan G*

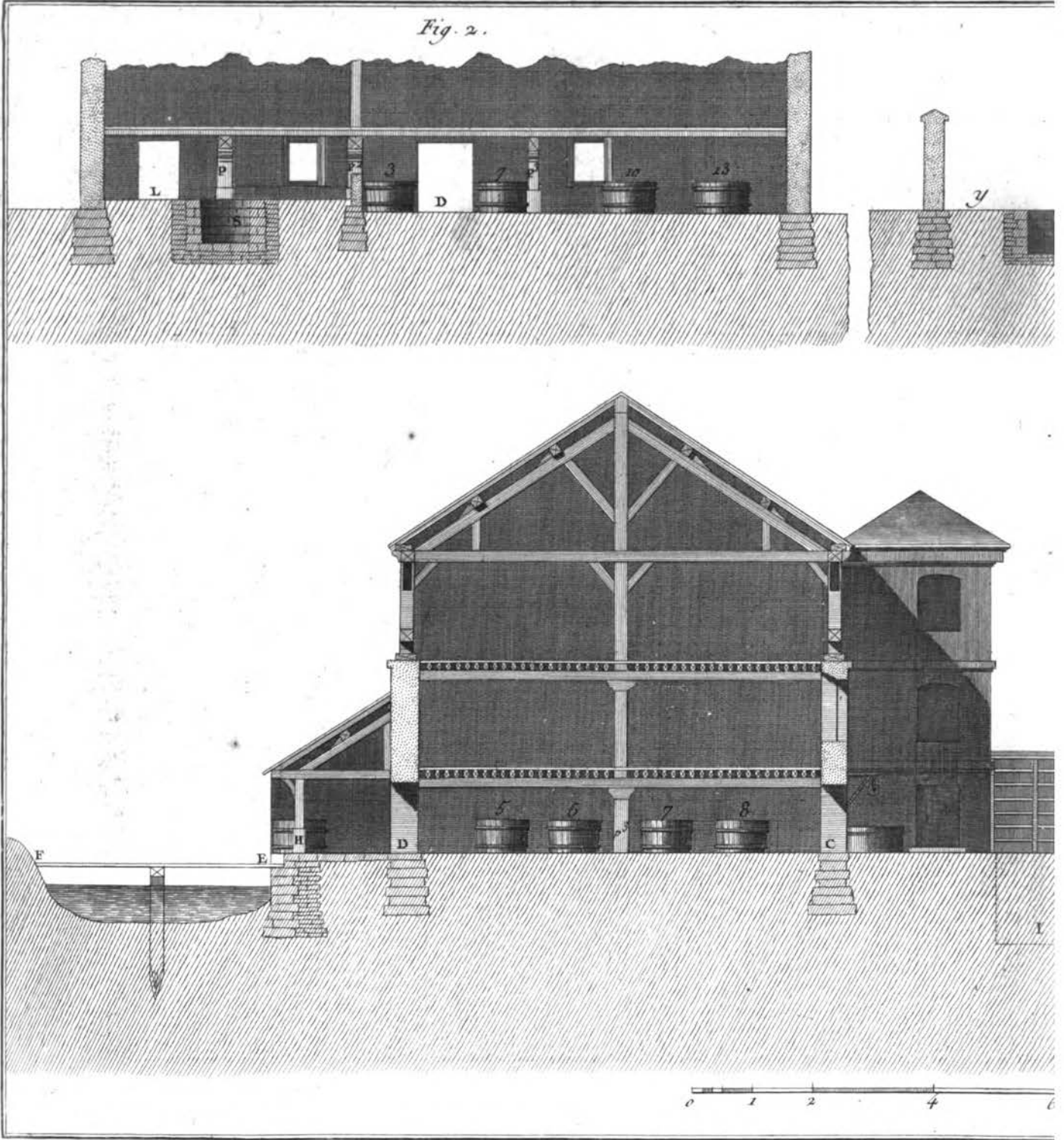


0 3 10 12 Toises

*Plan Général d'une Tannerie.*

*Benard Directeur.*

Fig. 2.



*Tanneur, Coupe Longitudin*



Fig. 3.

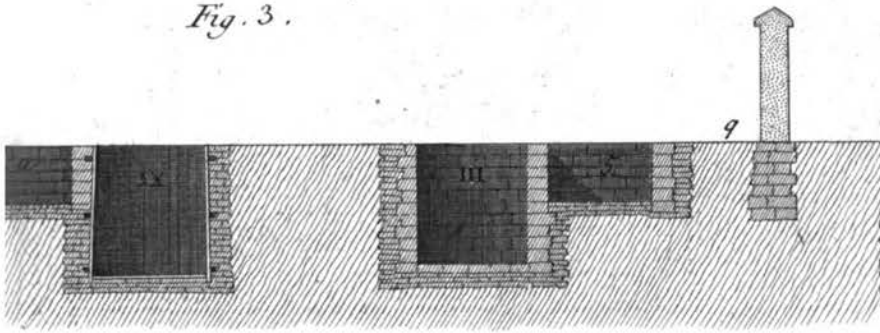
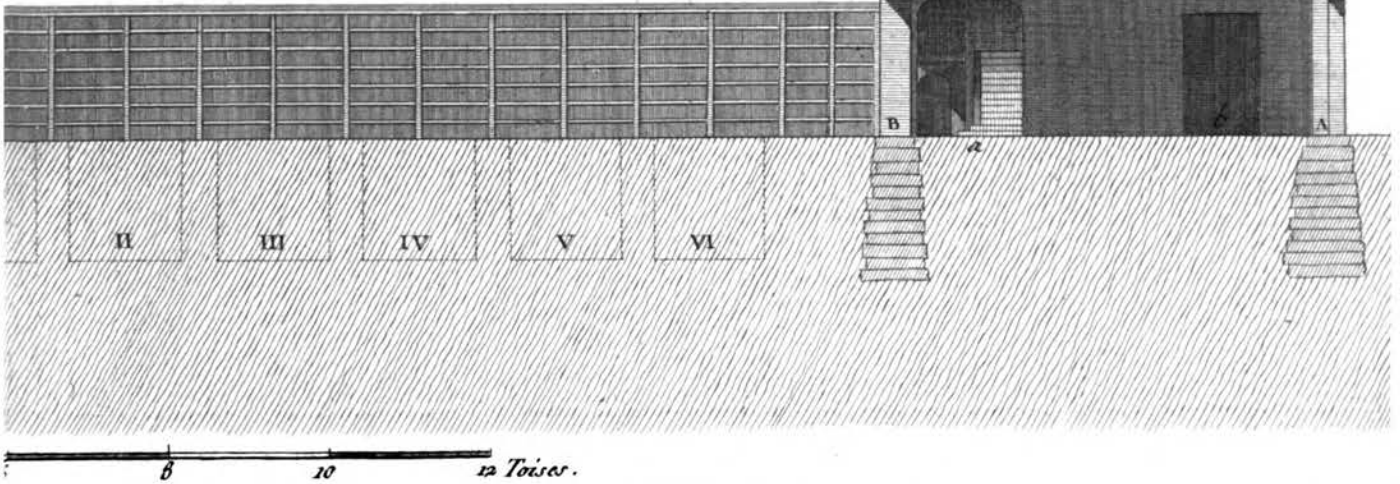


Fig. 1<sup>e</sup>.



Bernard Duvall.

alle et Transversalle de la Tannerie.

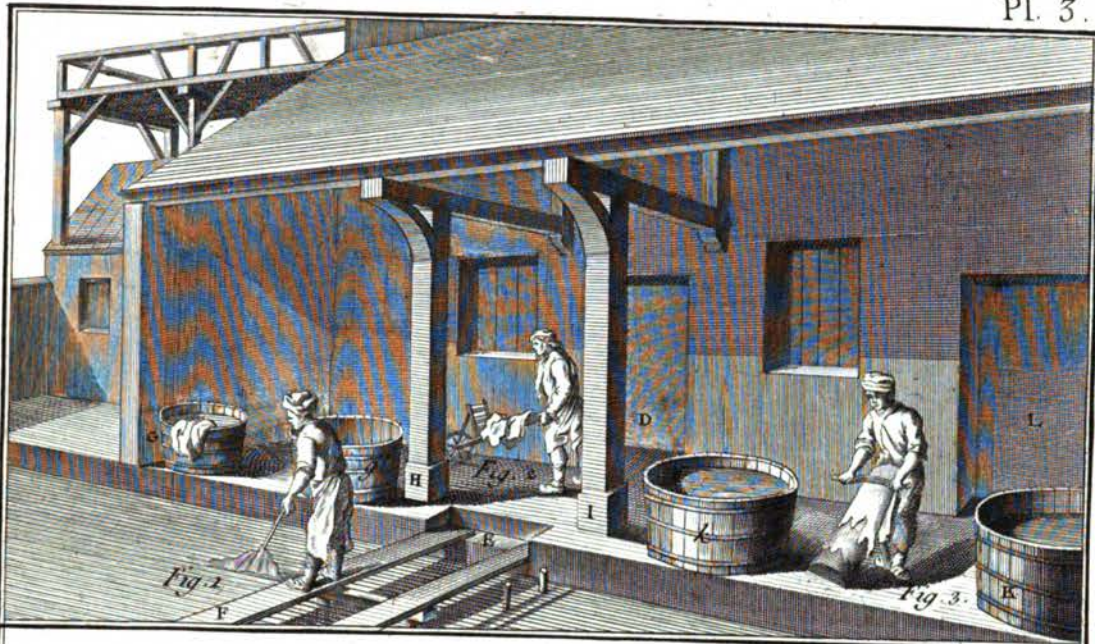


Fig. 4.



Fig. 5.



Fig. 6.



Fig. 8.

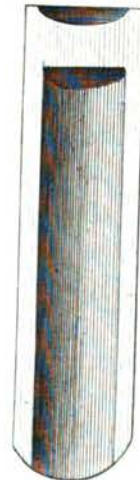


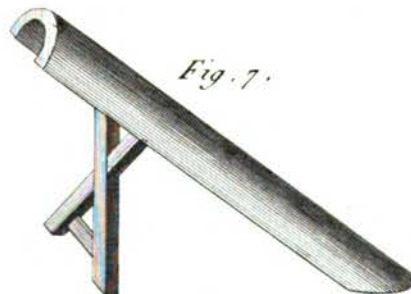
Fig. 9.



Fig. 10.



Fig. 7.



Tanneur, Travail de Riviere.

Bonard Dorez del.

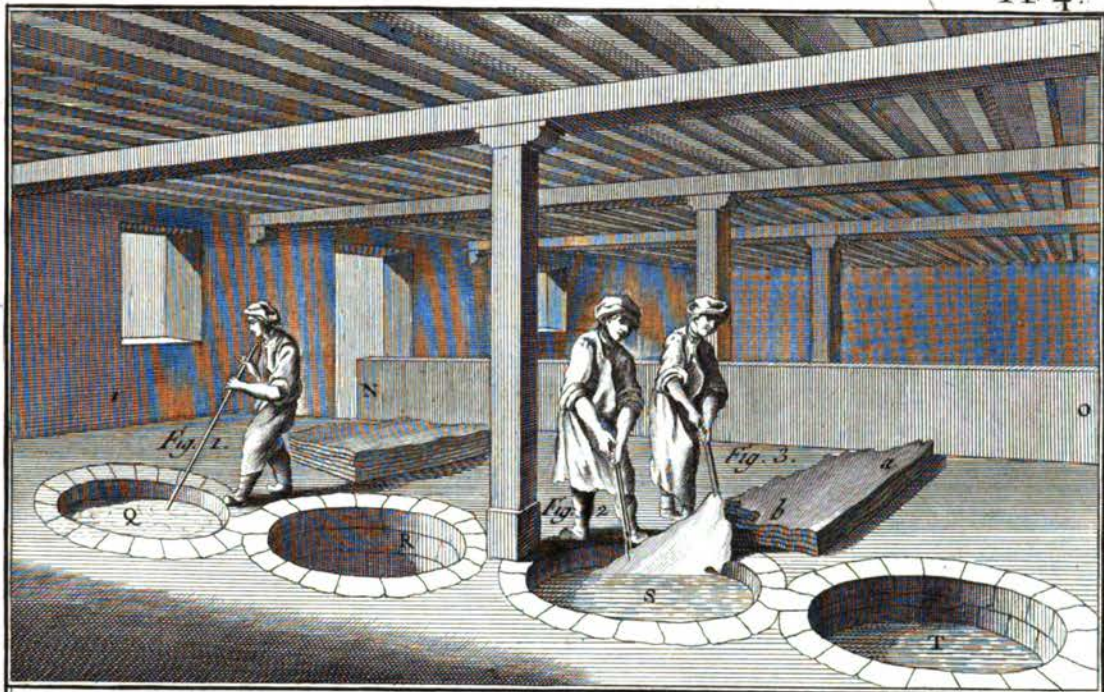


Fig. 4.



Fig. 5.

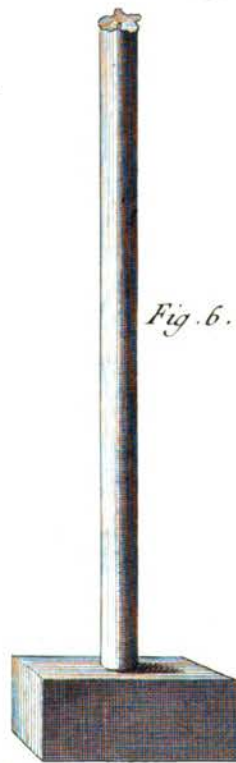
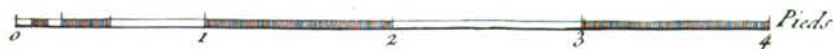


Fig. 6.

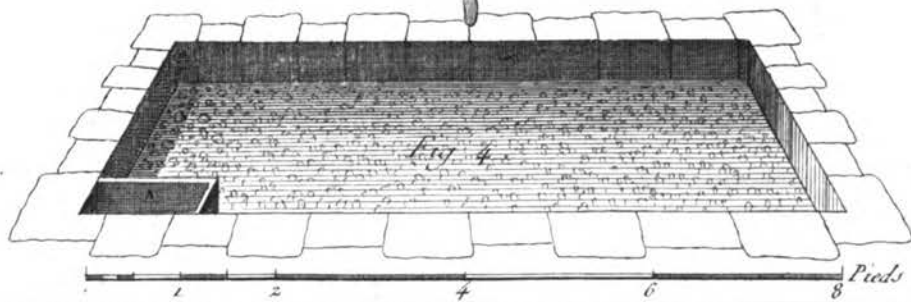
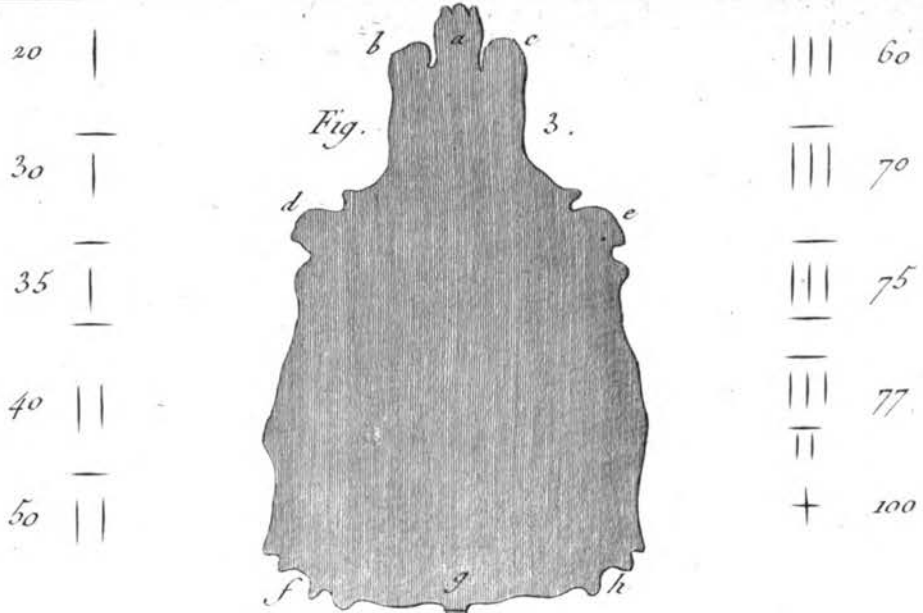


Fig. 6. Bis



Tanneur, Travail des Pleins.

Bernard Dorezil.



Tanneur, Travail des Passements.

Beuard Duvexil.

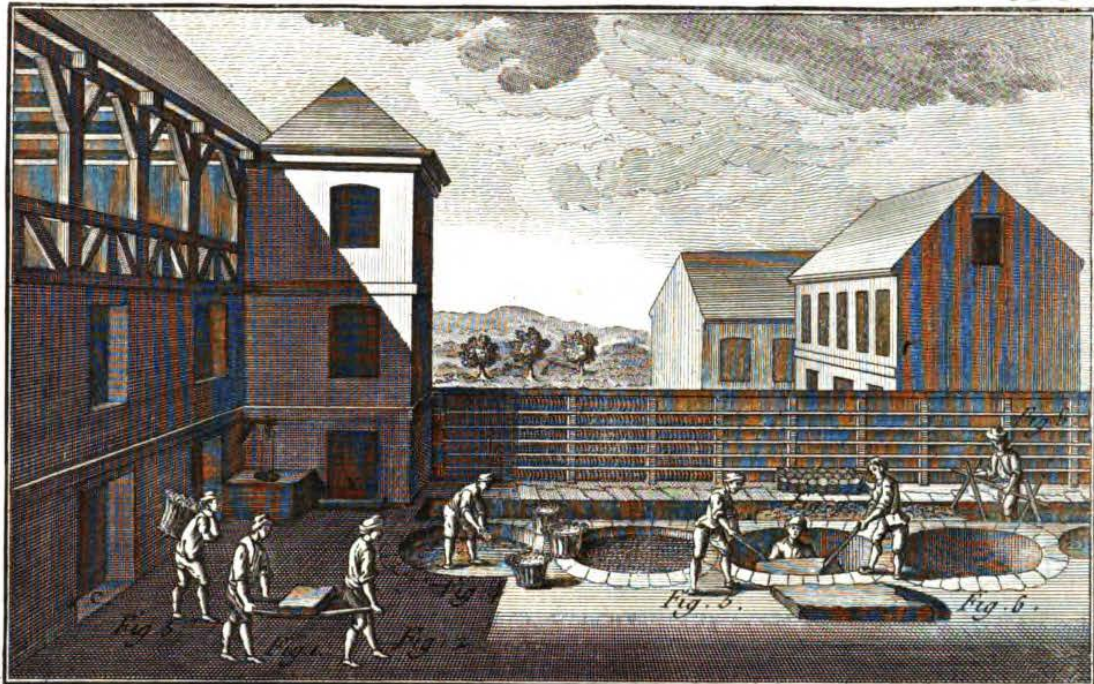


Fig. 9.



Fig. 11.



Fig. 13.



Fig. 12.

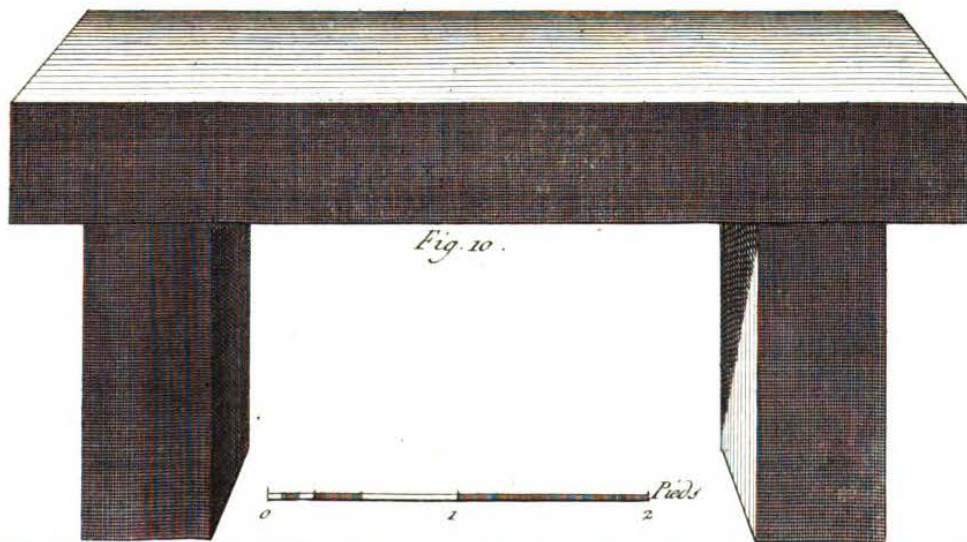
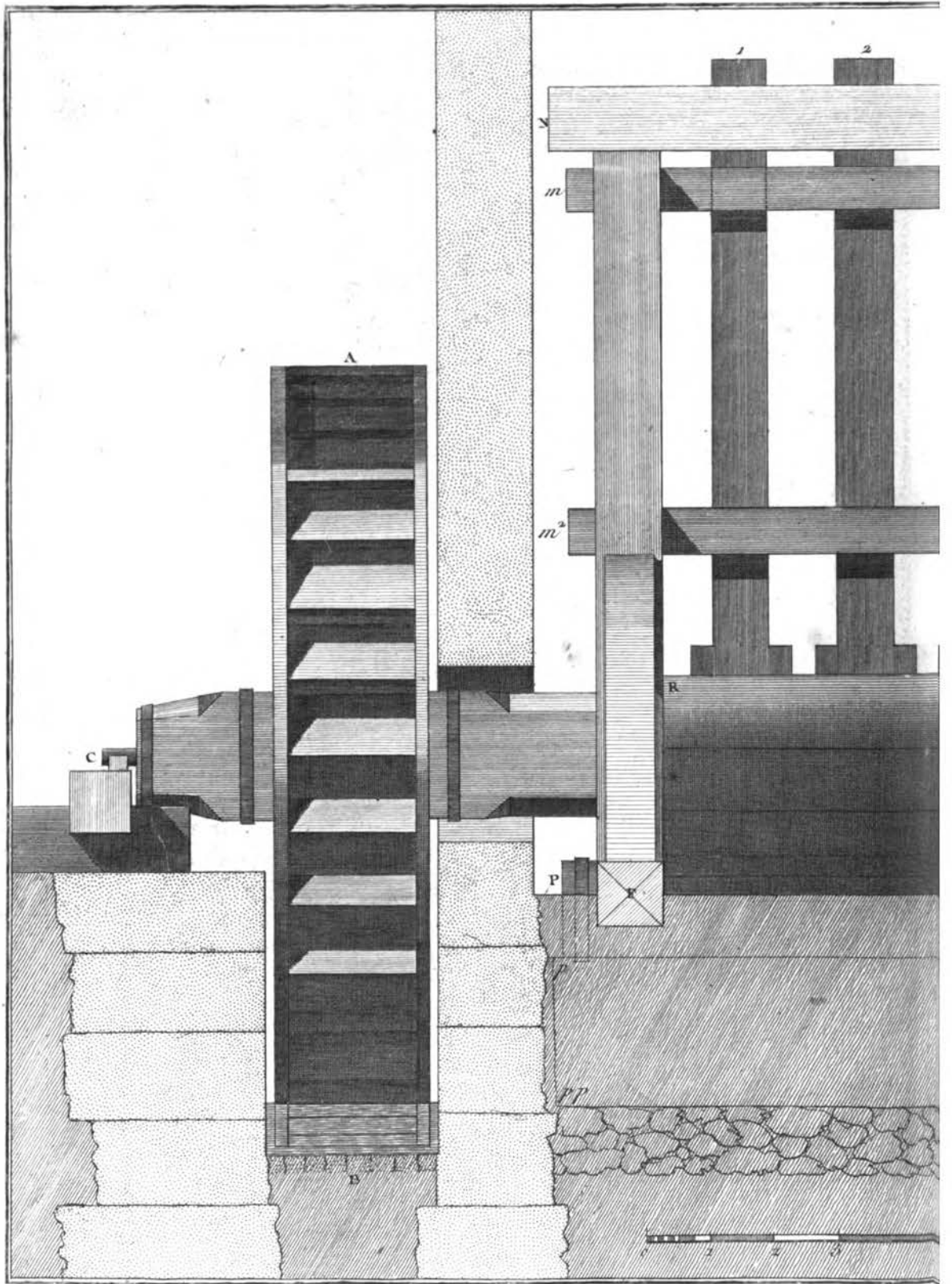


Fig. 10.

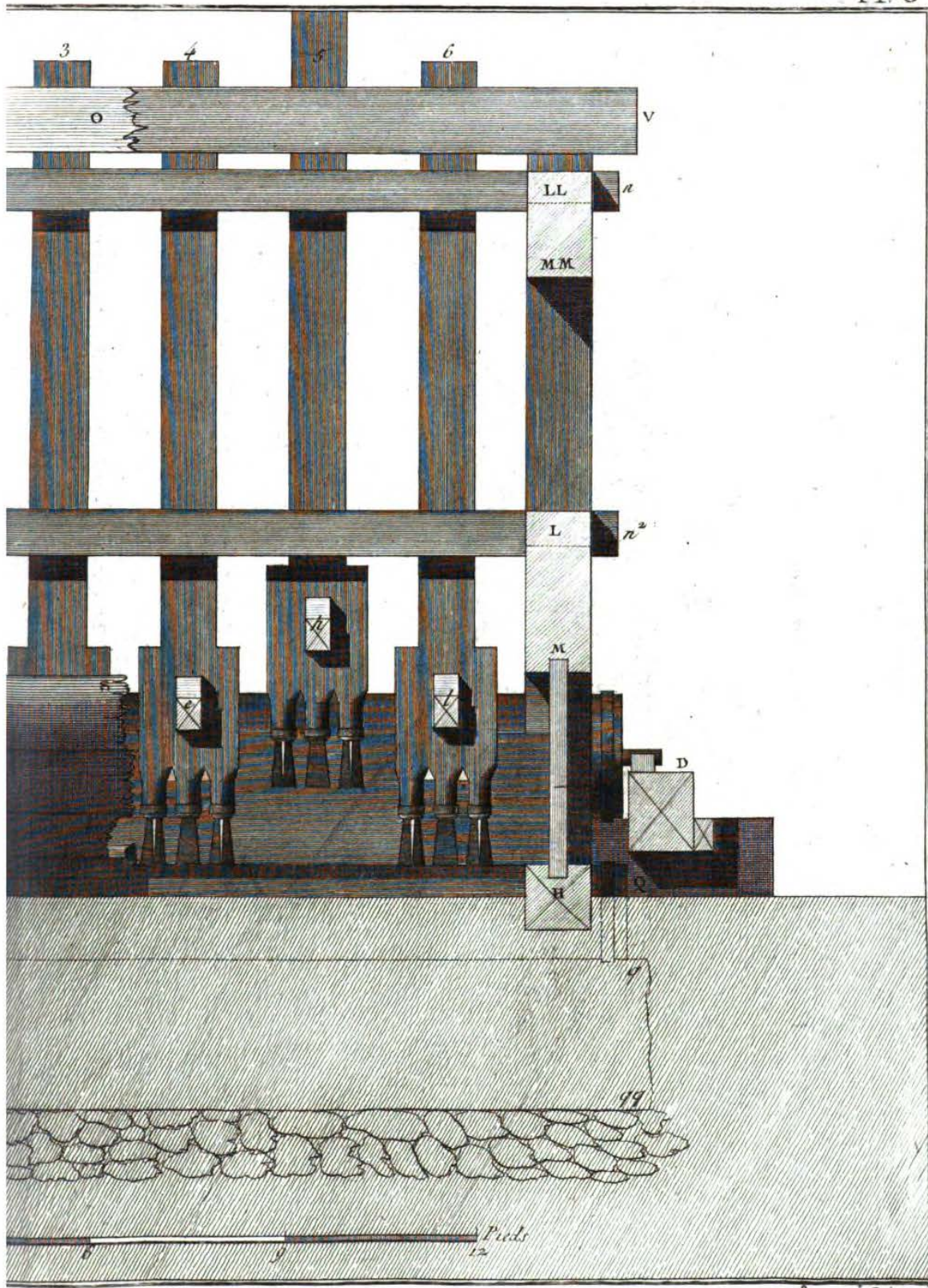


Tanneur, Travail des Fosses

Bernard Dorez del.

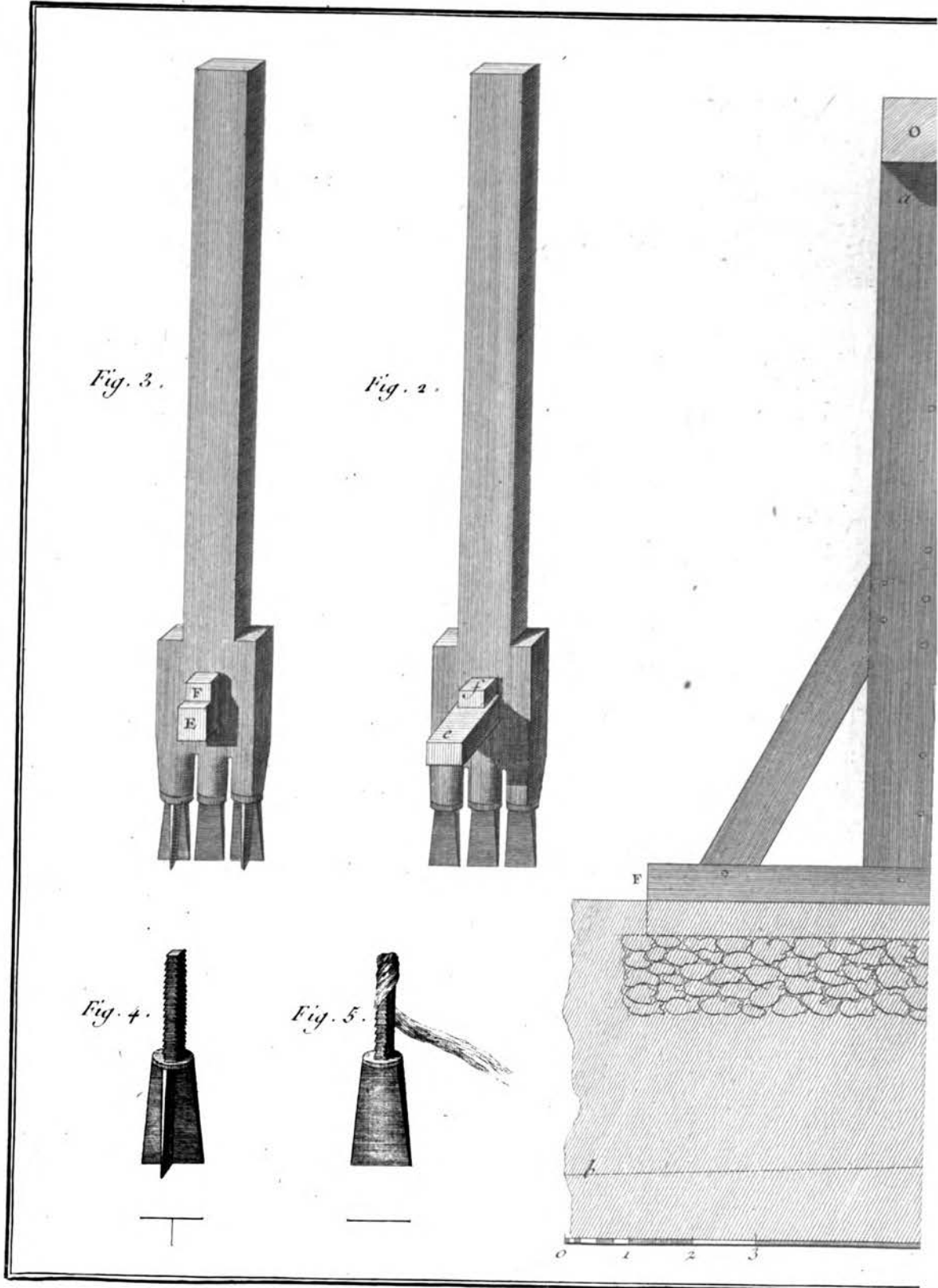


*Tanneur, Elevation Att.*



terieure du Moulin à Tan .

Benard Dirced.





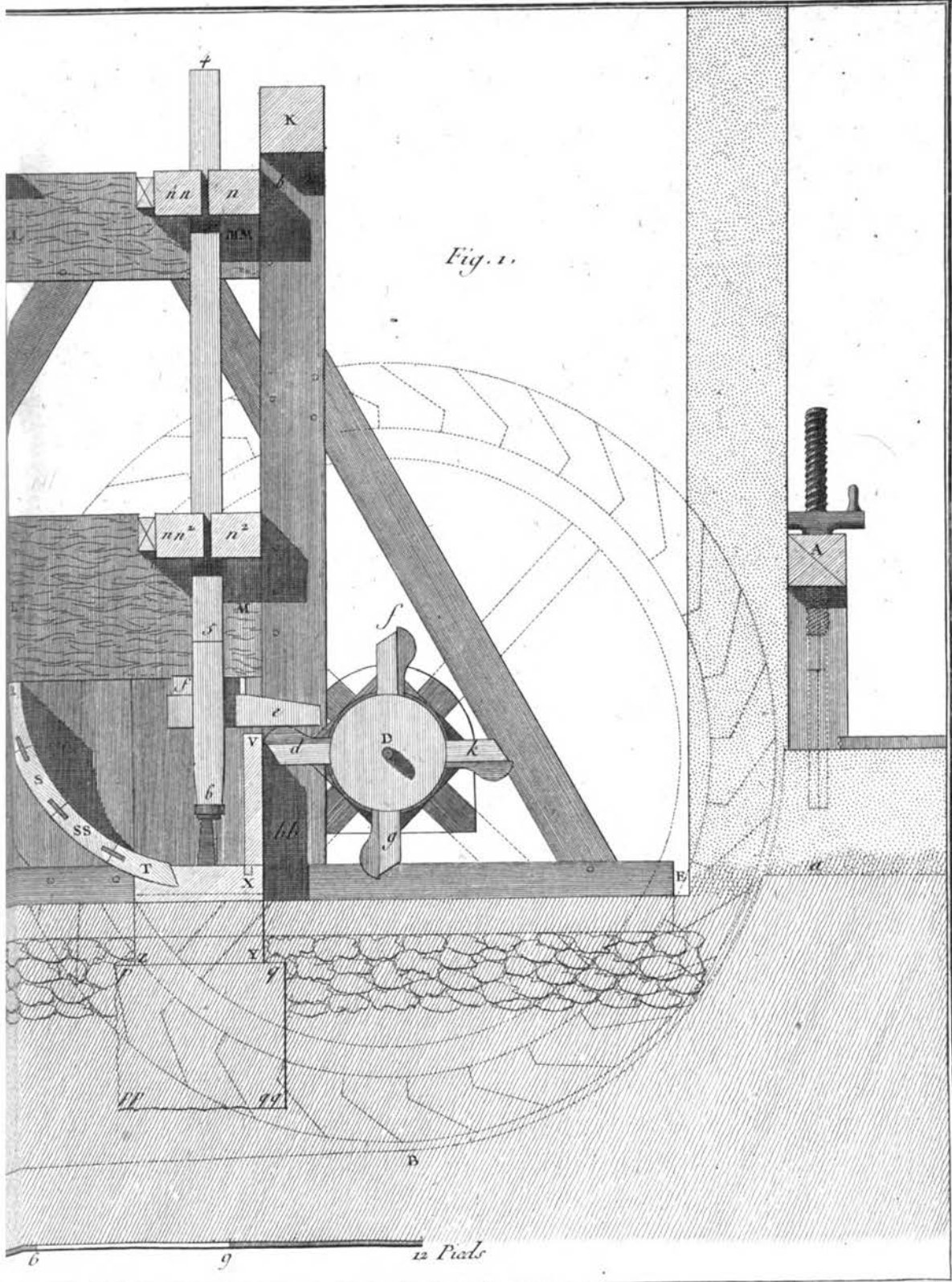


Fig. 1.

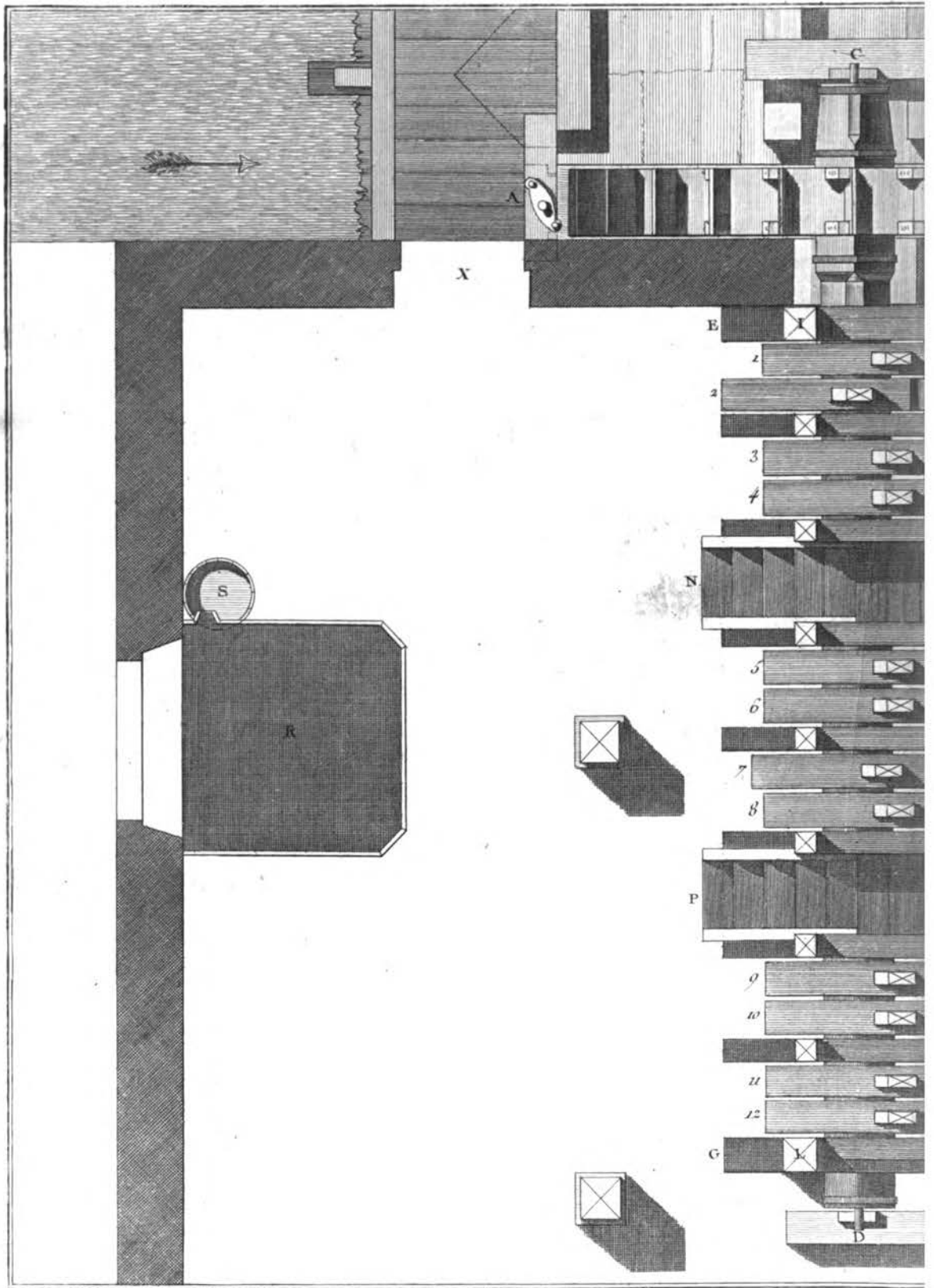
Benard Duxoit.

versalle du Moulin à Tan.

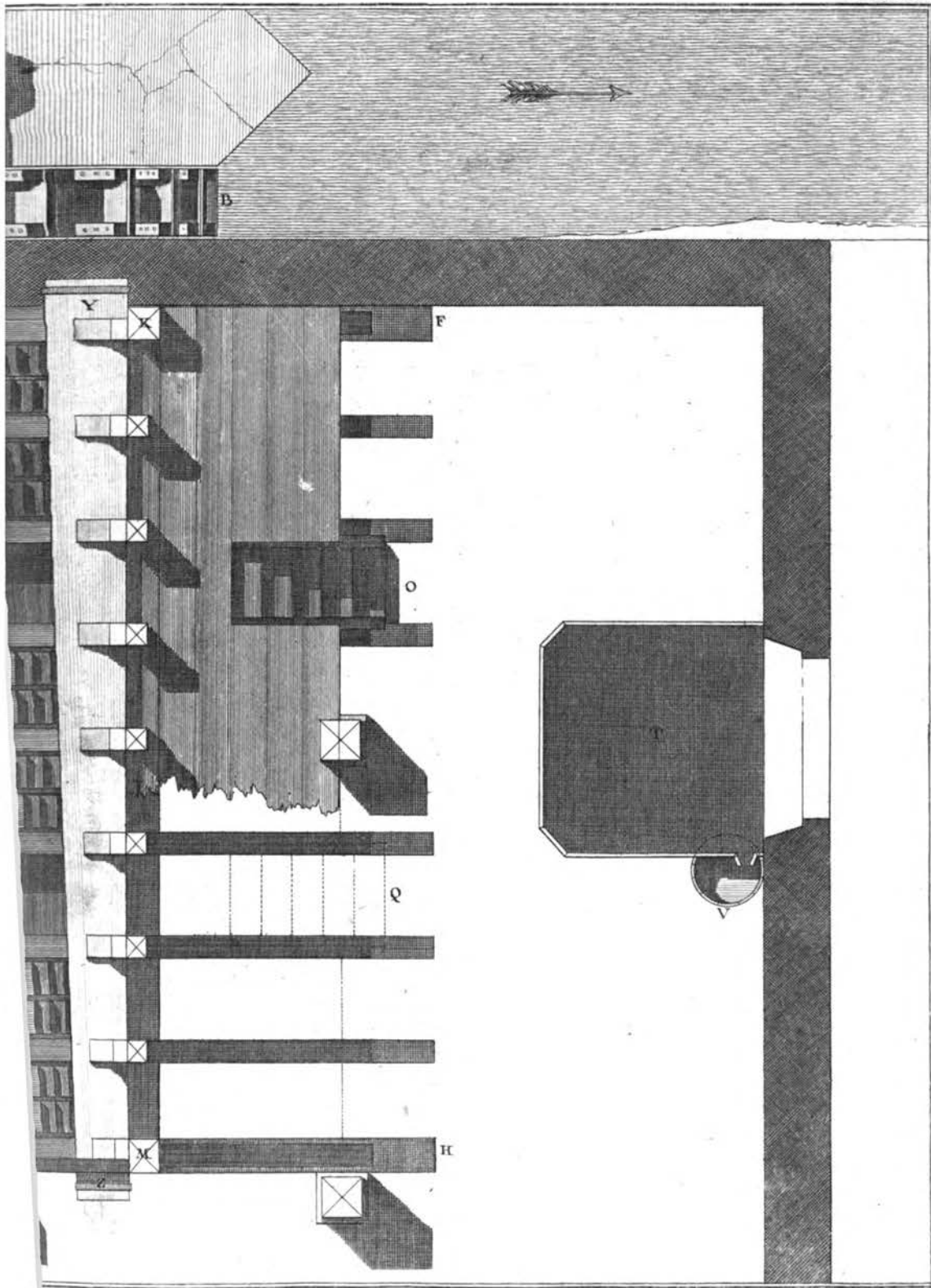
Digitized by Google

Original from UNIVERSIDAD COMPLUTENSE DE MADRID

Generated on 2014-05-10 21:12 GMT / http://hdl.handle.net/2027/ucm.5320295822 Public Domain, Google-digitized / http://www.hathitrust.org/access\_use#pd-google

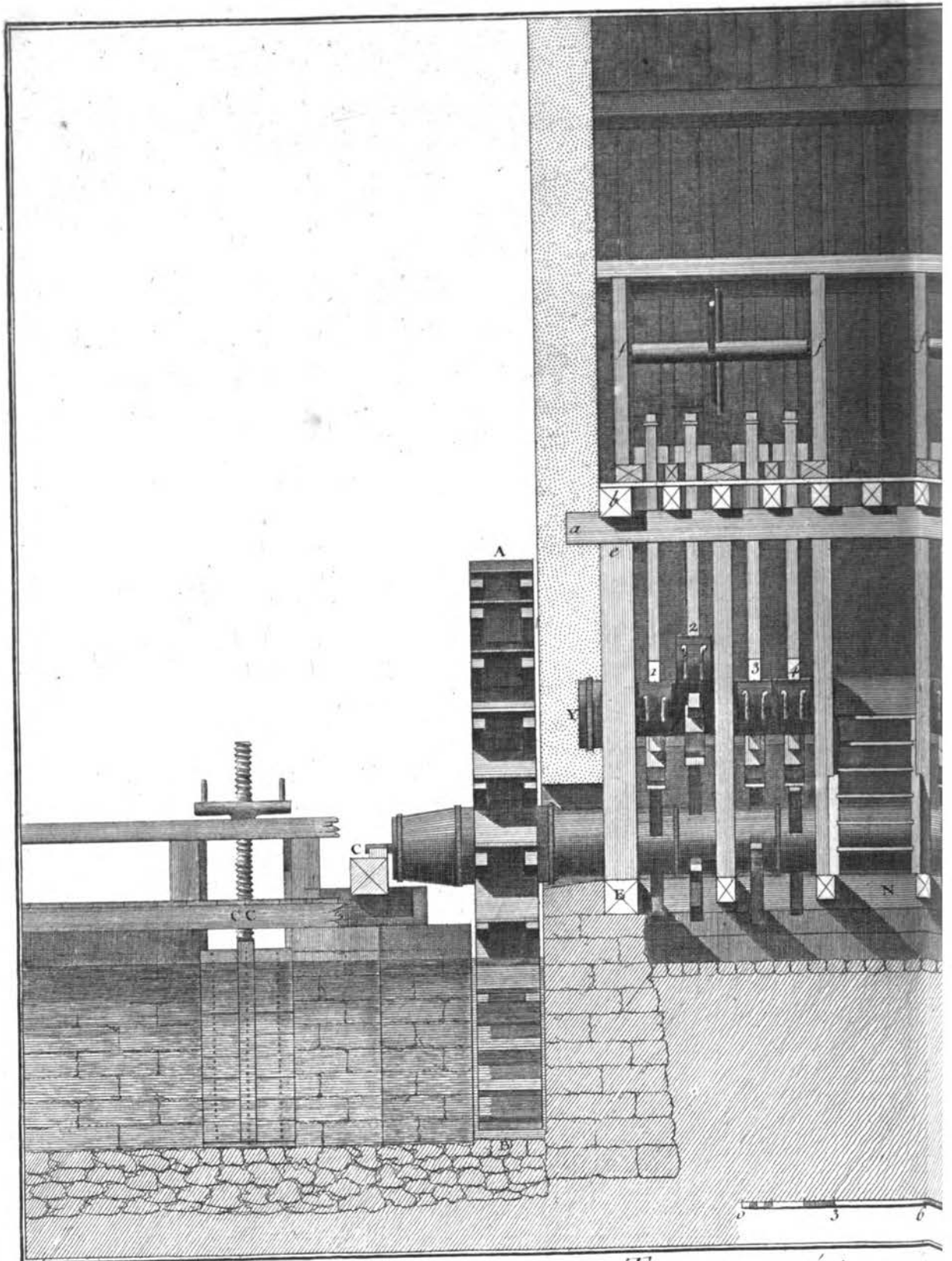


*Tanneur, Plan du*

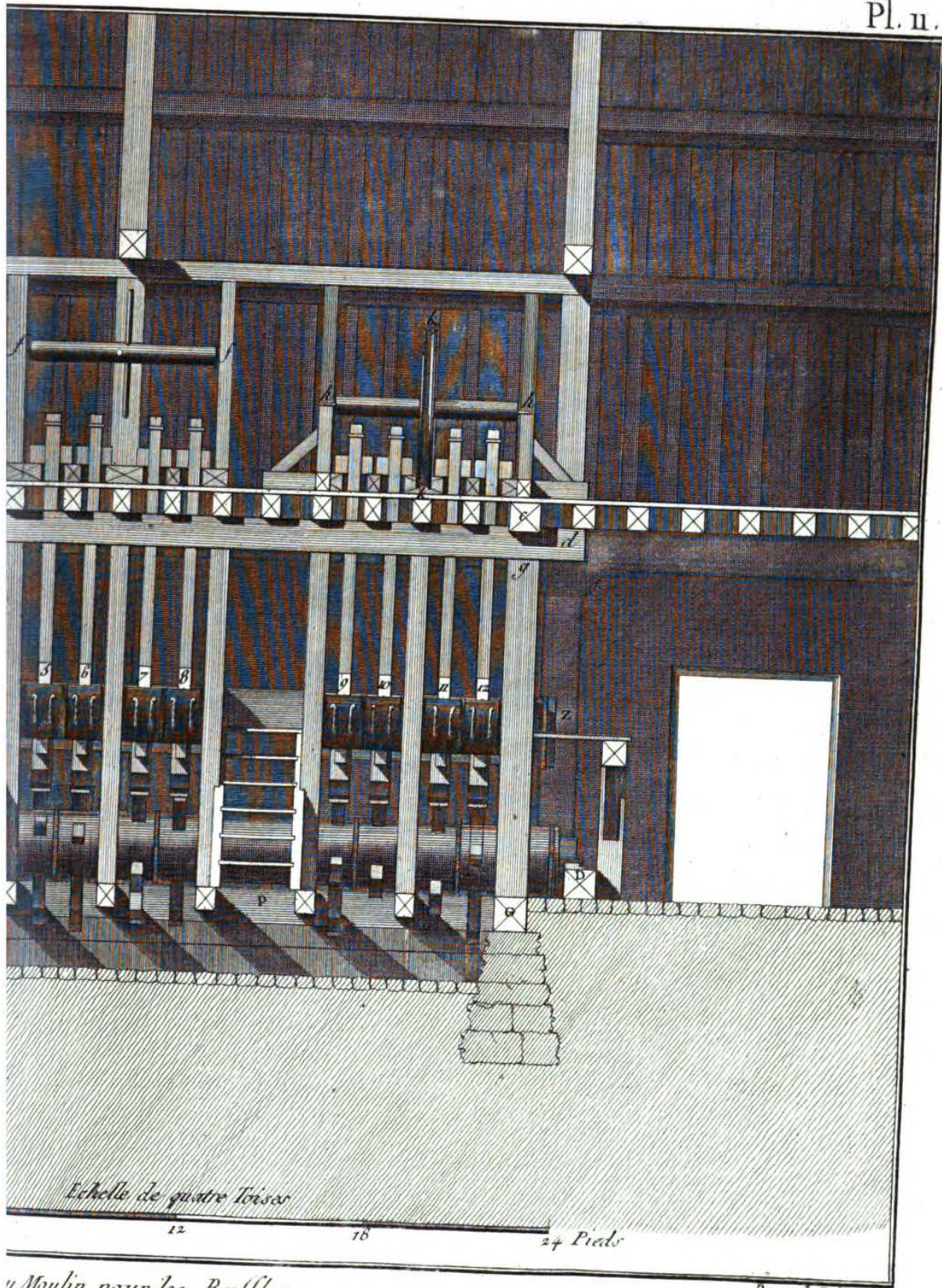


*Moulin pour les Buffles.*

*Bernard Duvard.*



*Tanneur, Élévation du*

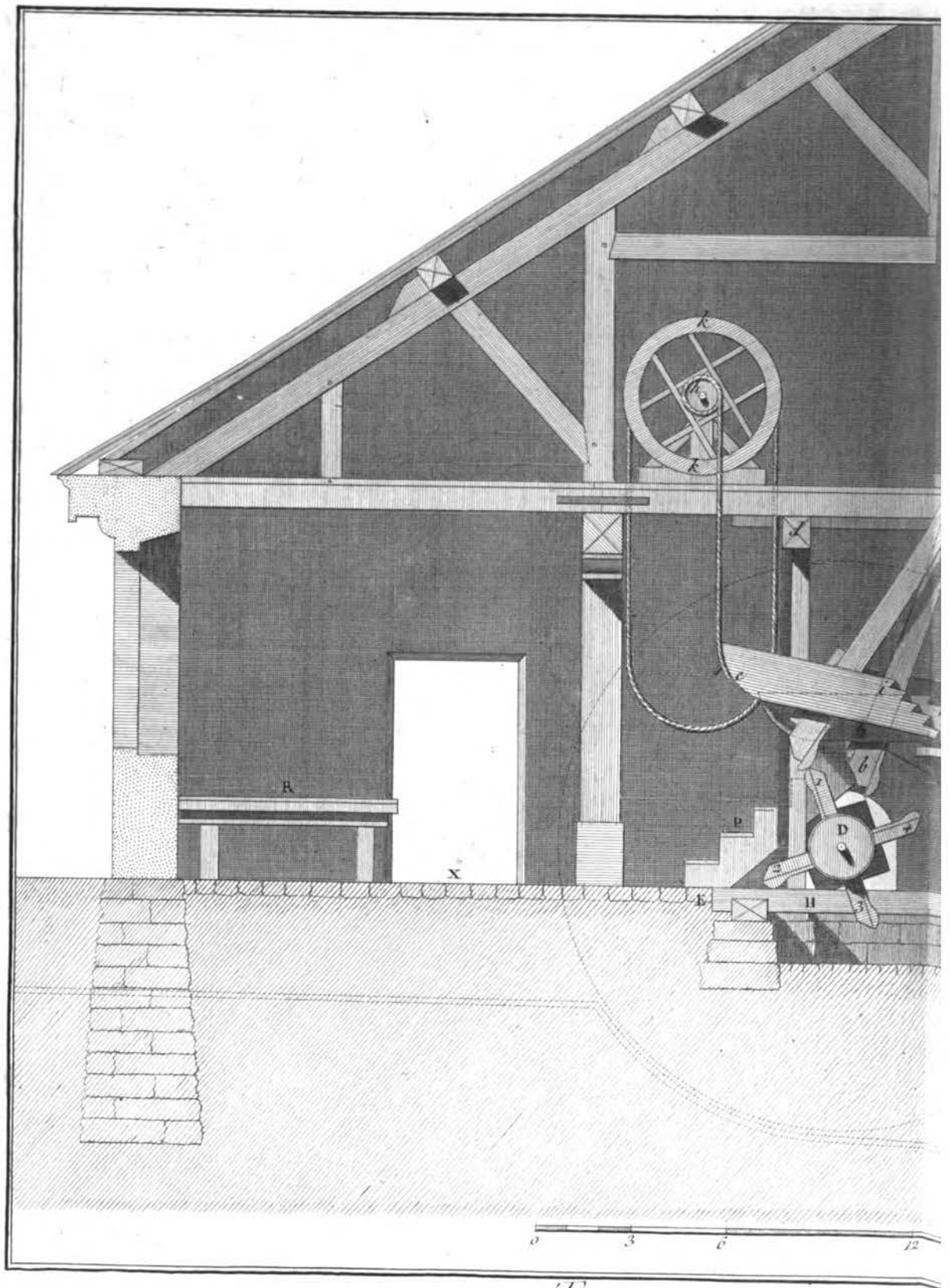


*Echelle de quatre Toises*

12                      18                      24 Pieds

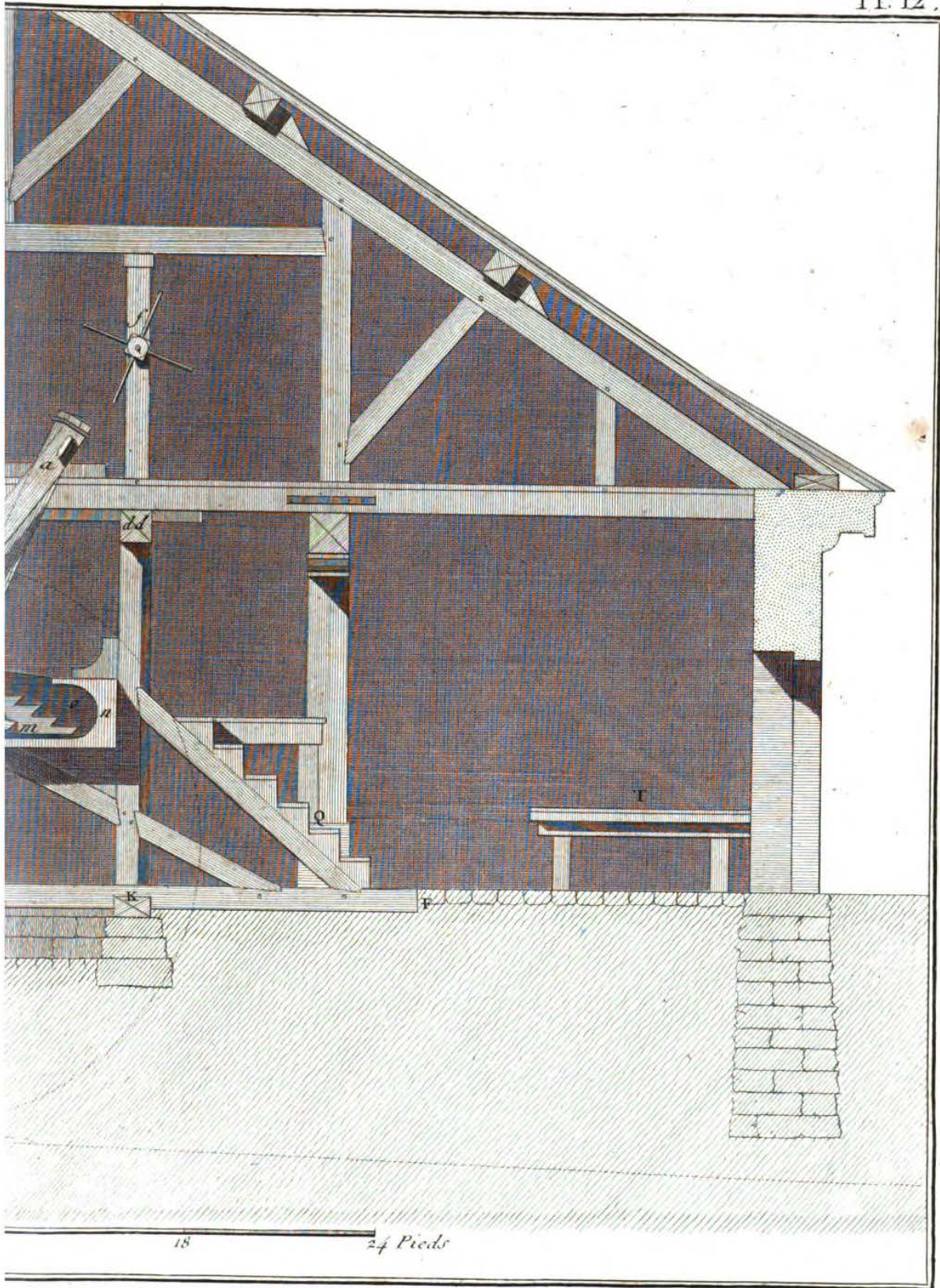
*Bernard D'axil.*

*un Moulin pour les Buffles.*



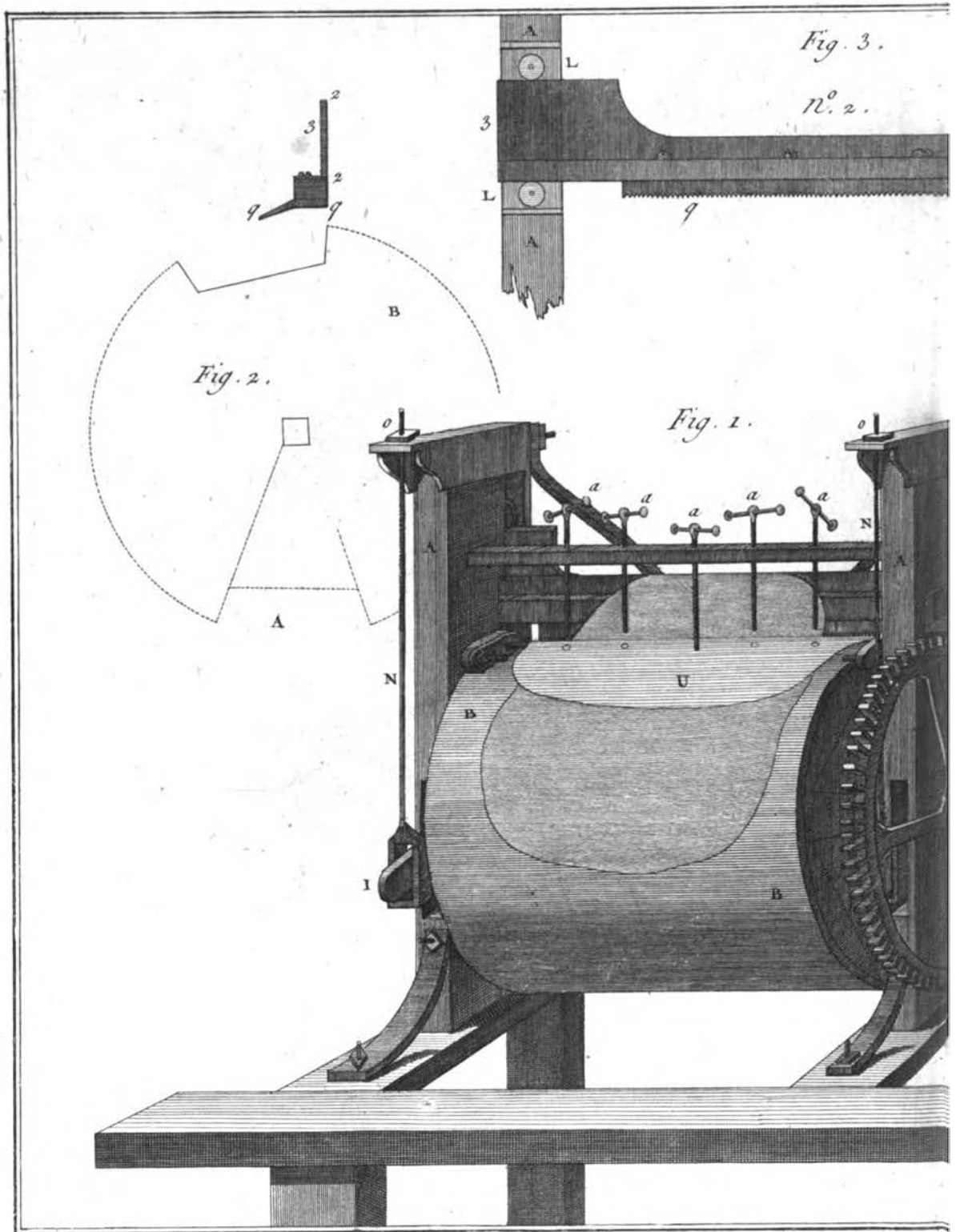
Digitized by Google

*Tanneur, Coupe transversale*  
Original from  
UNIVERSIDAD COMPLUTENSE  
DE MADRID



*elle du Moulin pour les Buffles.*

*Bernard Drevet.*



*Fig. 3.*

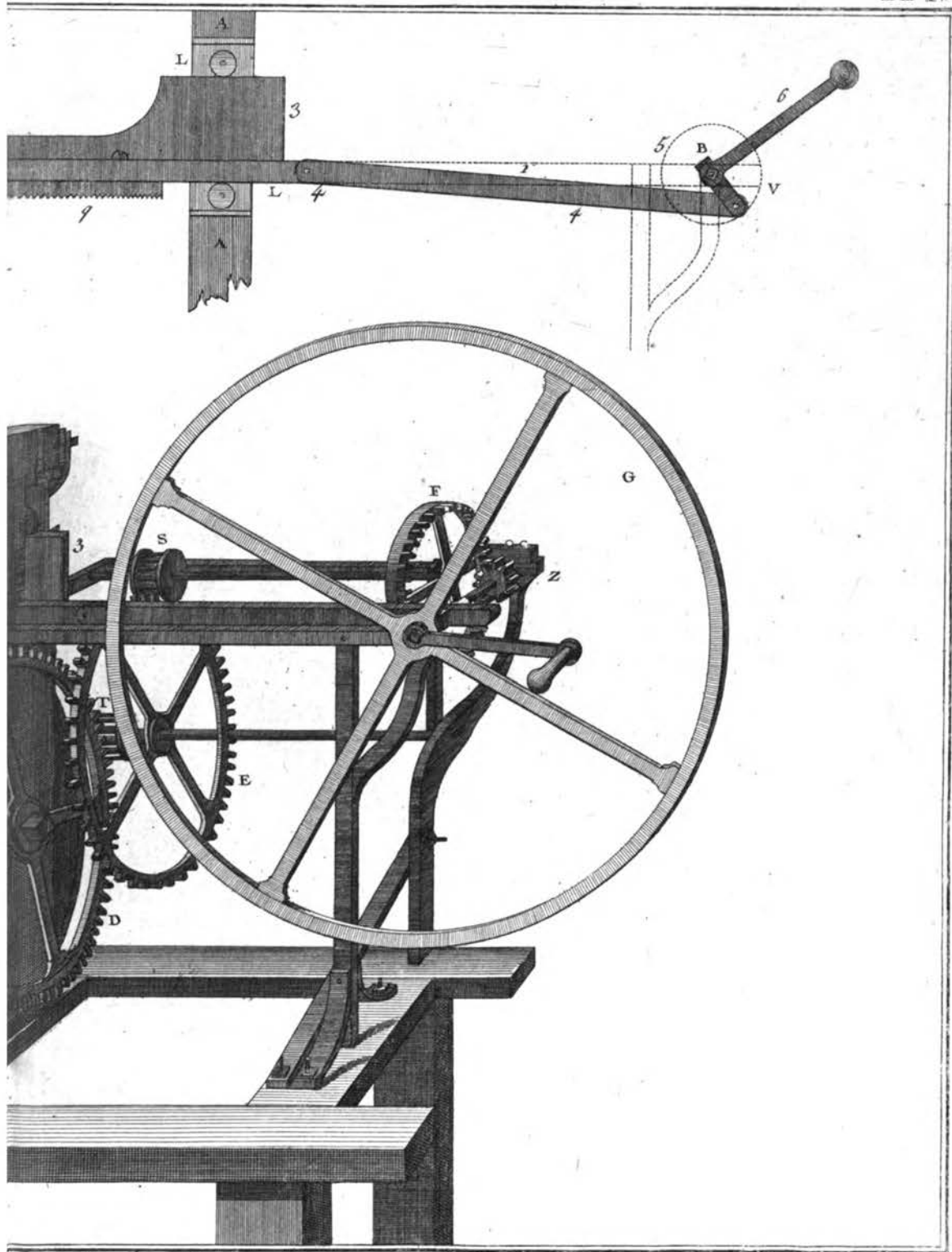
*N.º 2.*

*Fig. 2.*

*Fig. 1.*

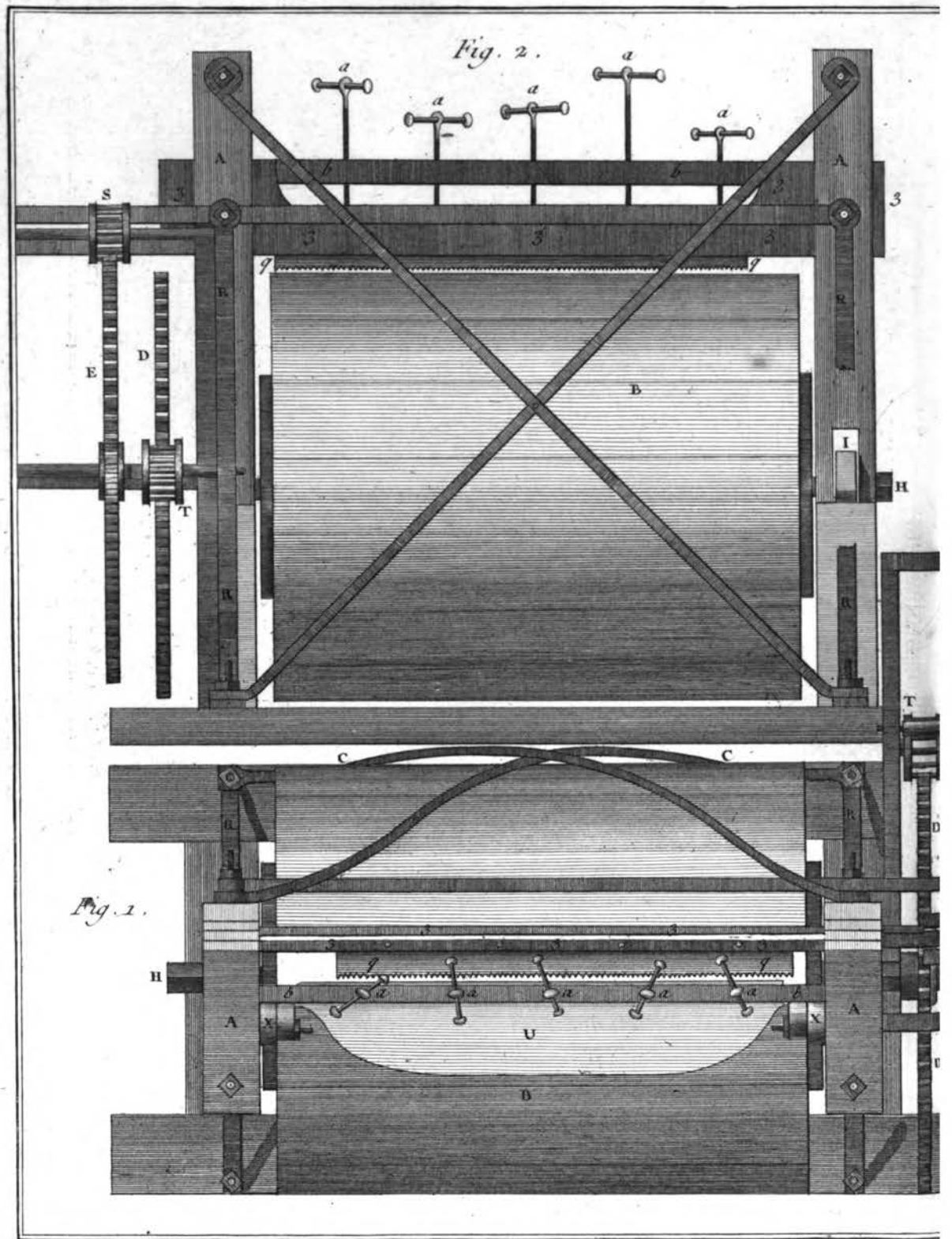
*Art de Refendre*



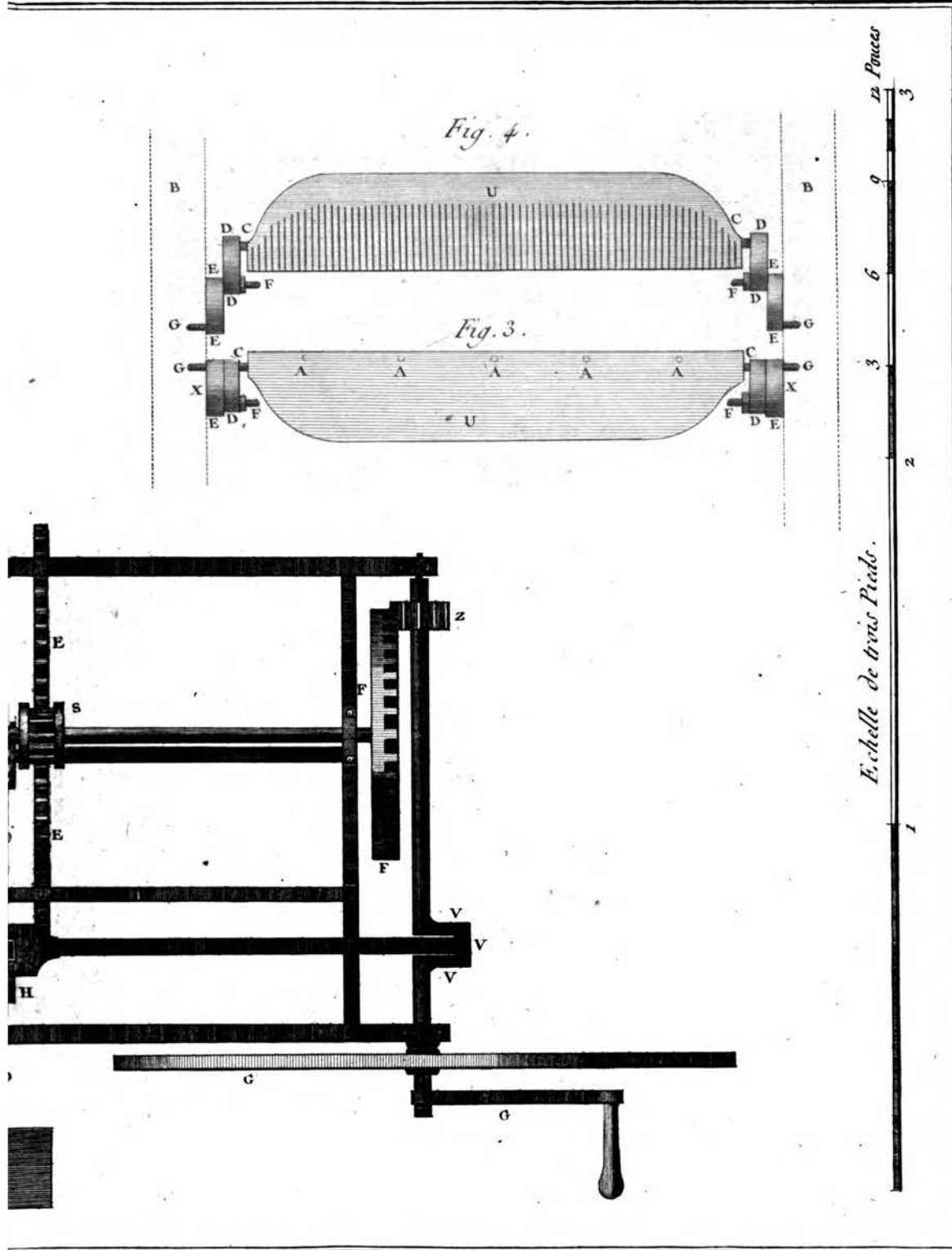


*Pre les Cuirs.*

*Bernard Duvet.*



*Art de Refe*



Bernard Duvet.

ndre les Cuirs.



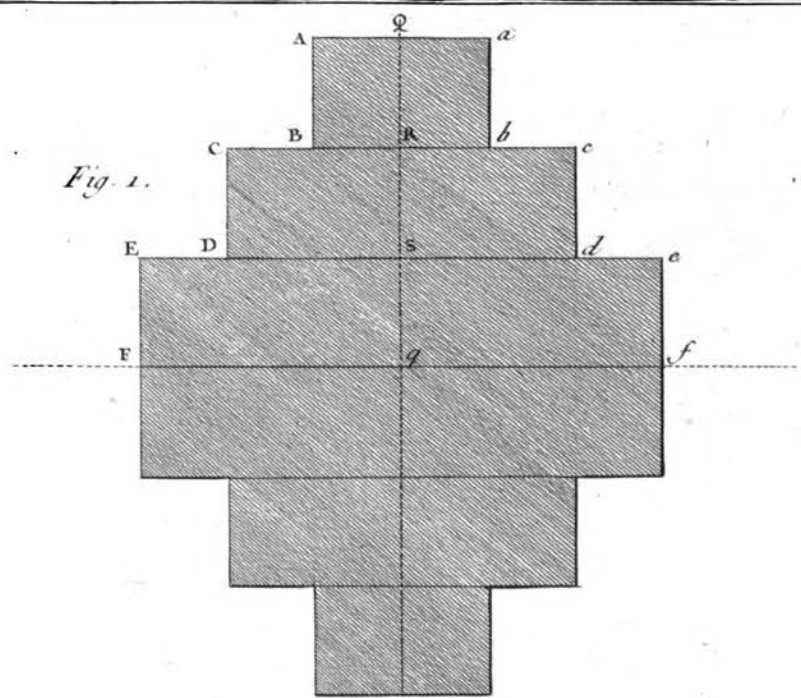


Fig. 1.

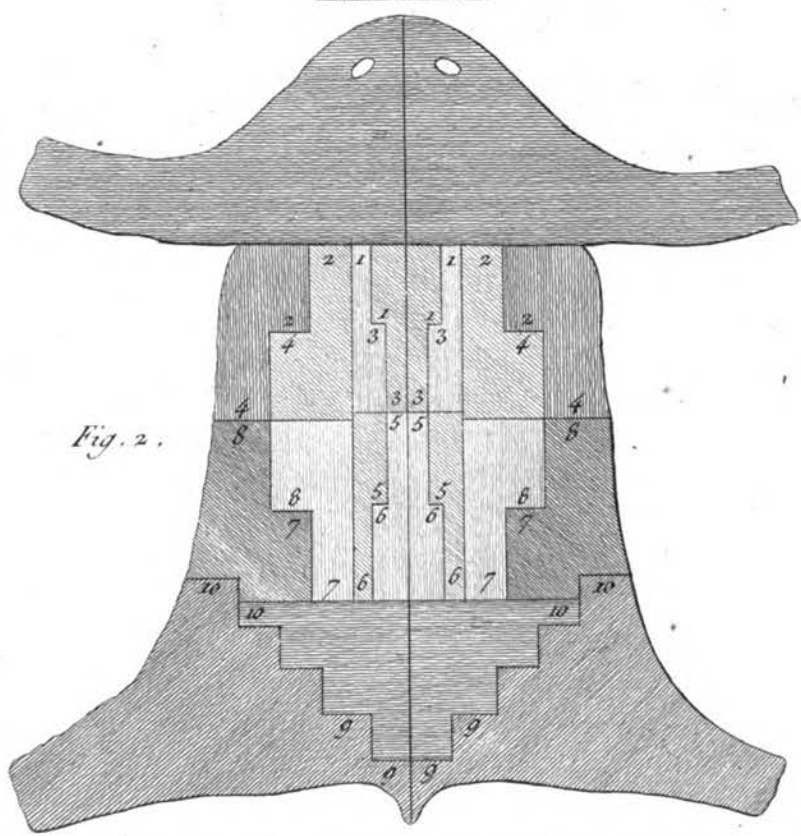


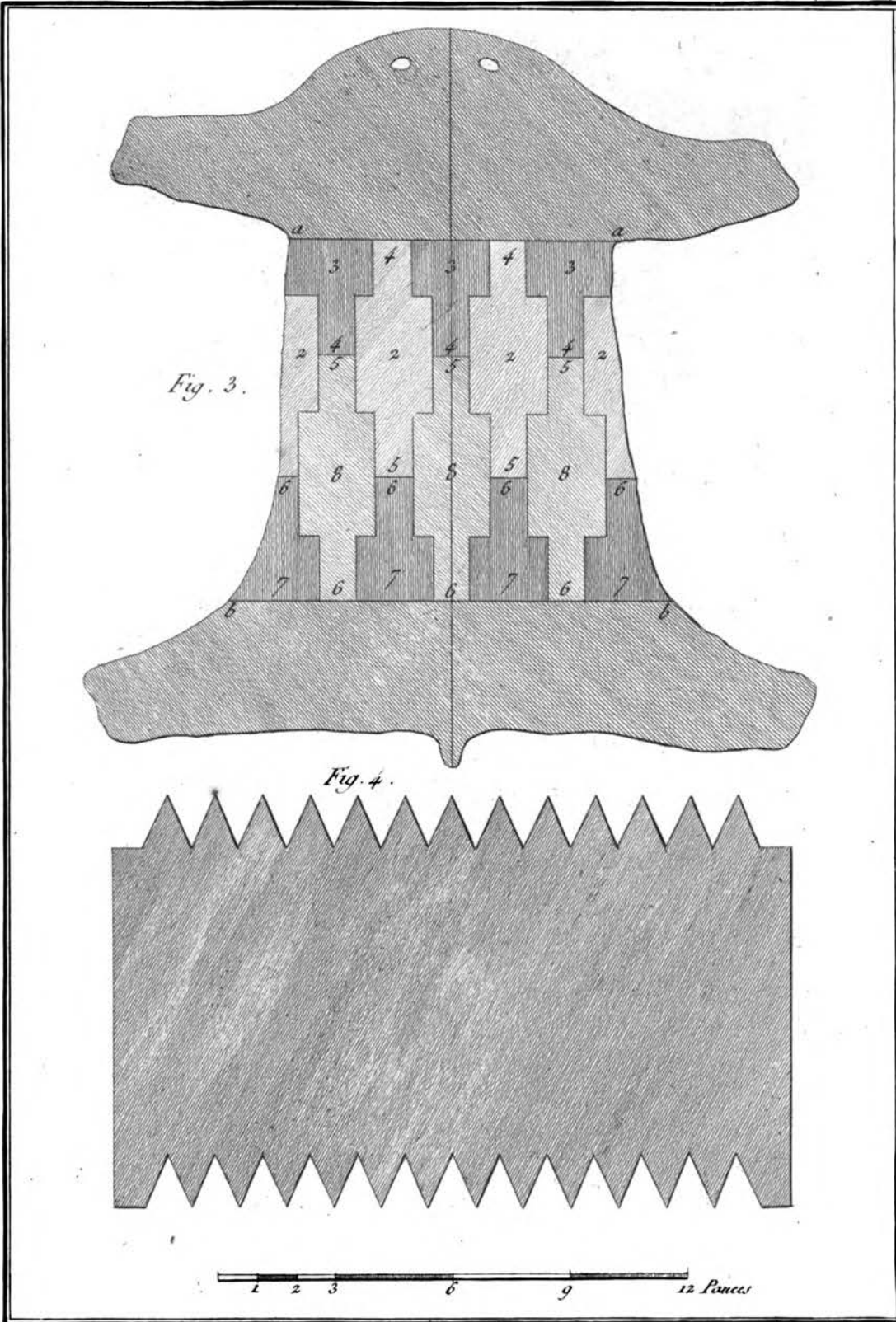
Fig. 2.



*Pelleterie et Fourreur, Coupe des Peaux.*

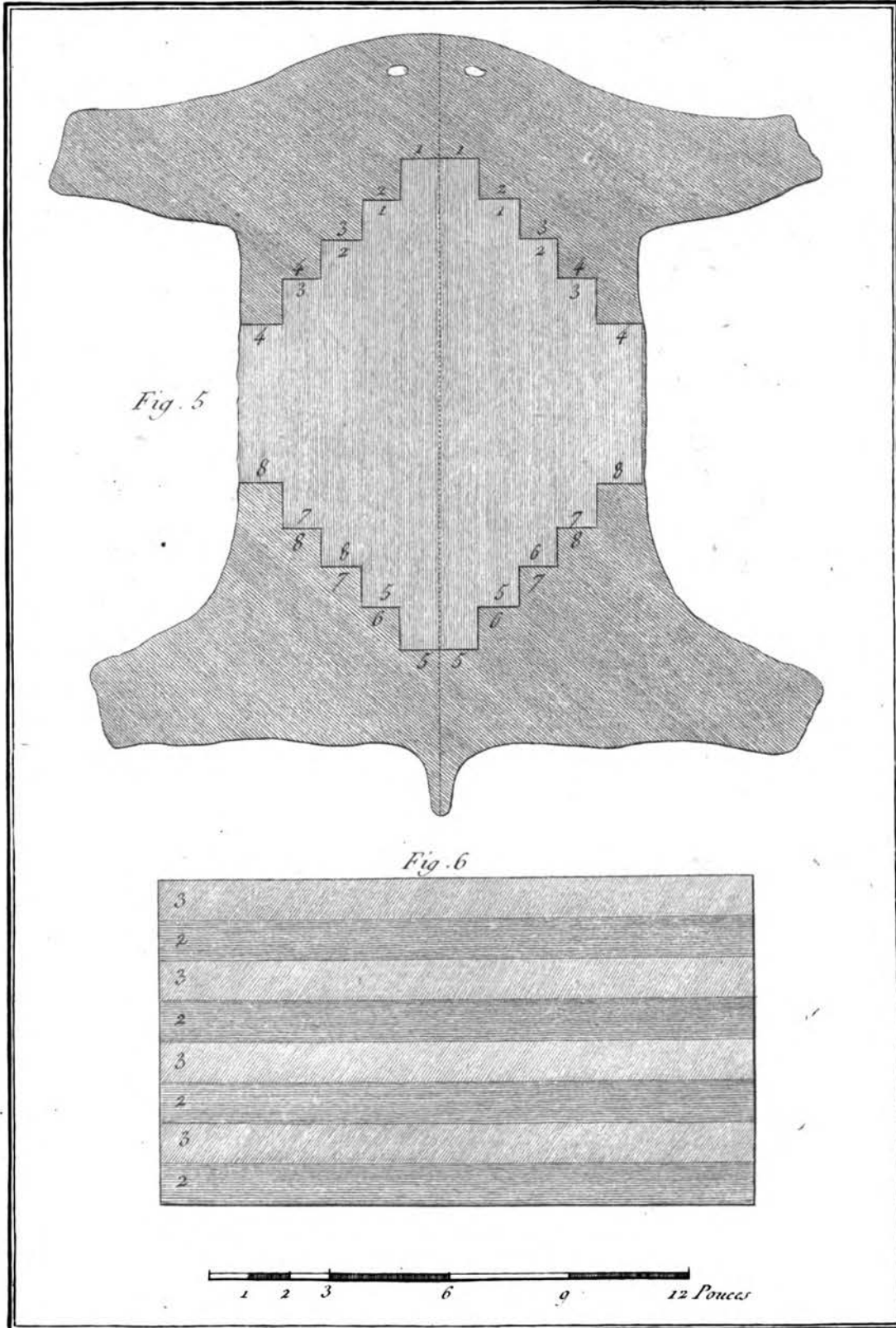
*Bernard Duvard. 48.*

Generated on 2014-05-10 21:21 GMT / http://hdl.handle.net/2027/ucm.5320295822 Public Domain, Google-digitized / http://www.hathitrust.org/access\_use#pd-google



*Pelleterie et Fourreur, Coupe des Peaux.*

*Bernard Dorez.*



*Pelleterie et Foureur, coupe des Peaux.*

*Bernard Dorevil*

49.

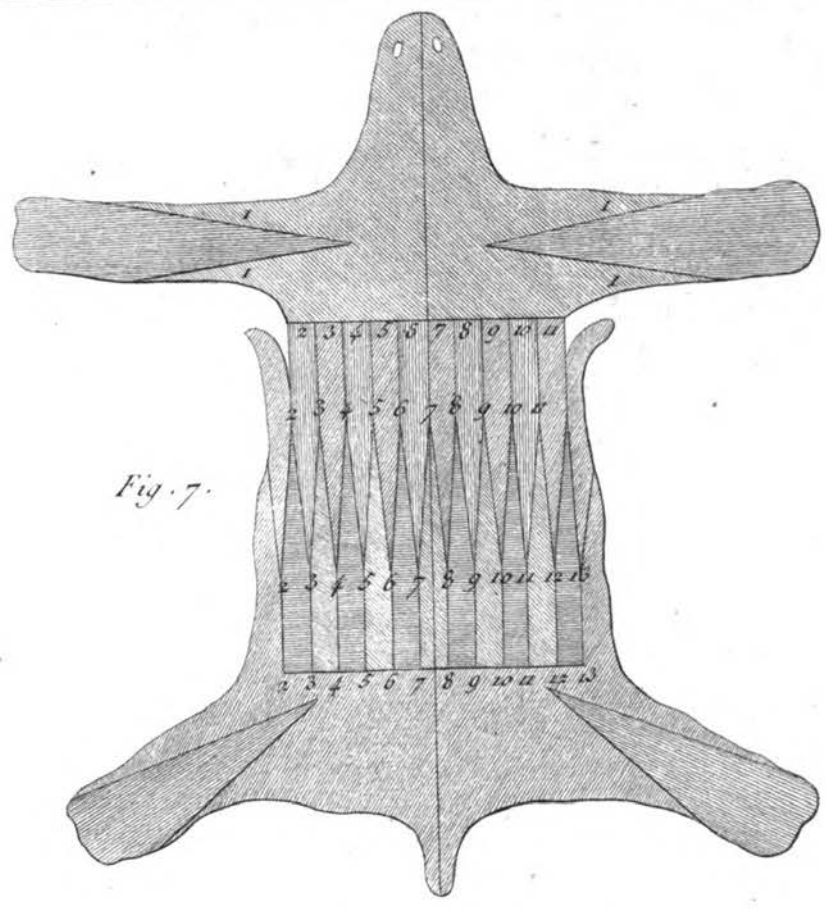


Fig. 7.

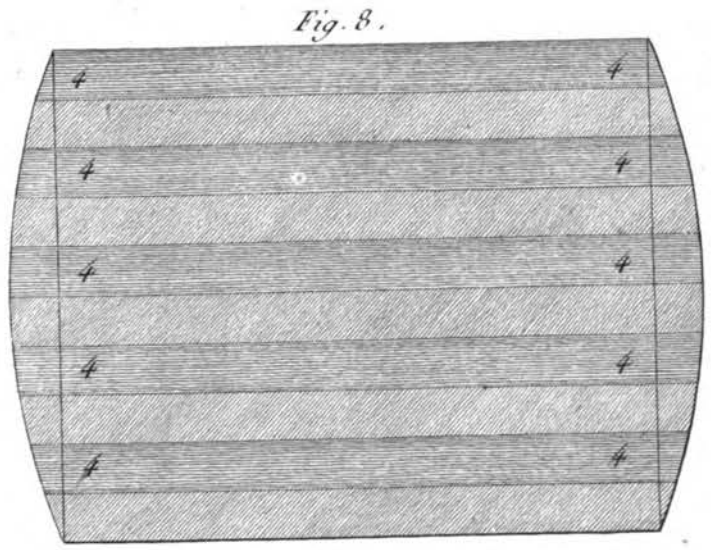


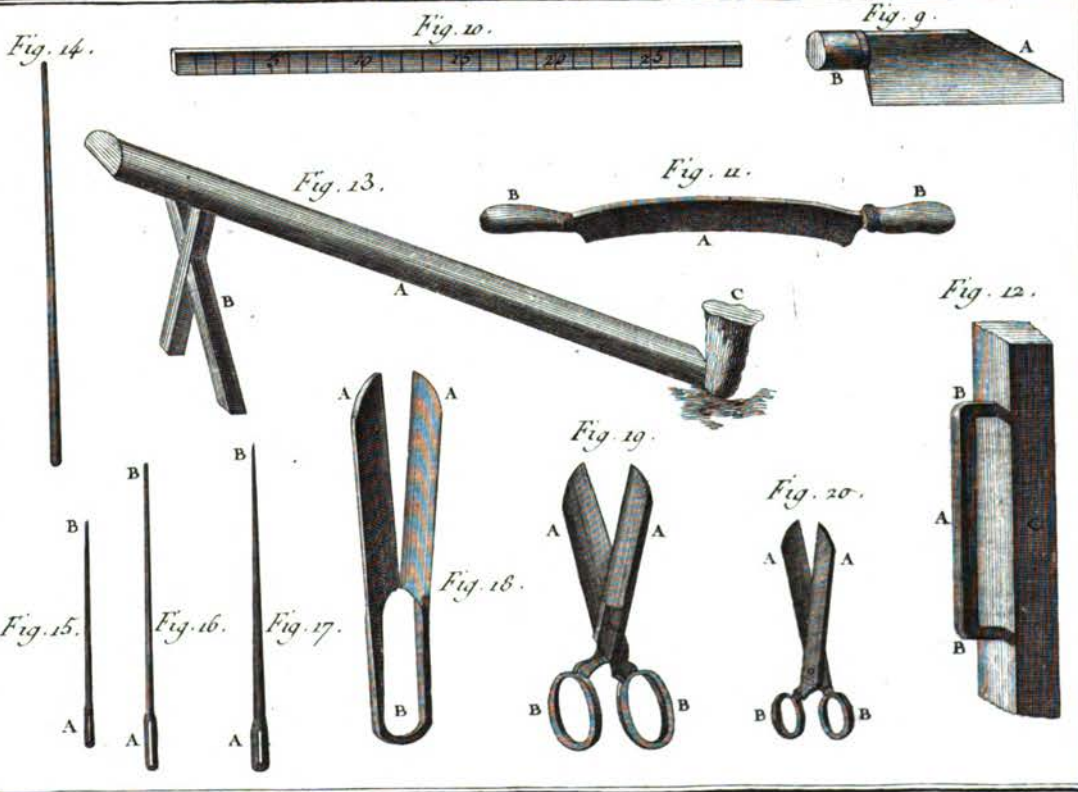
Fig. 8.



*Pelleterie et Fourreau, Coupe des Paux.*

*Benard Directeur*





*Pelleterie et Fourreur, outils.*

*Benard Doreur. 50.*



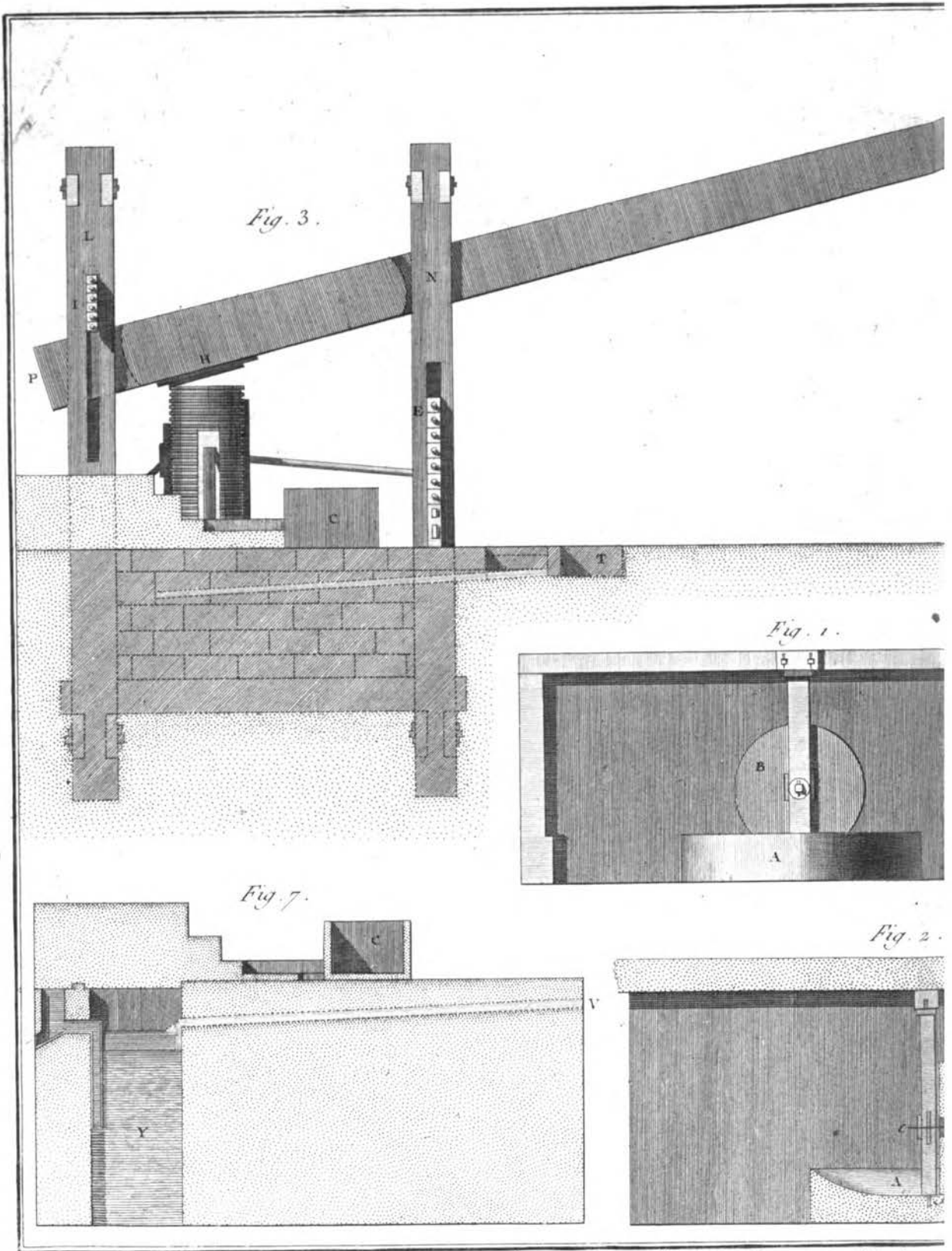


Fig. 3.

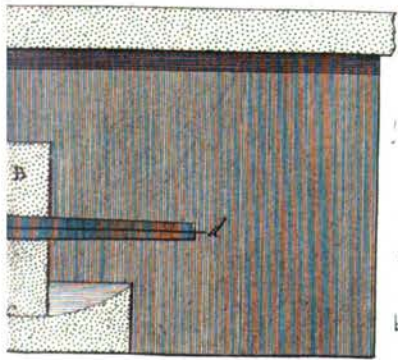
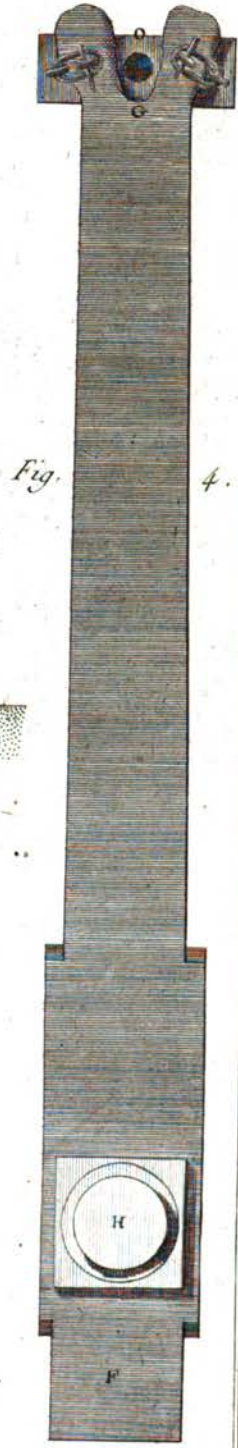
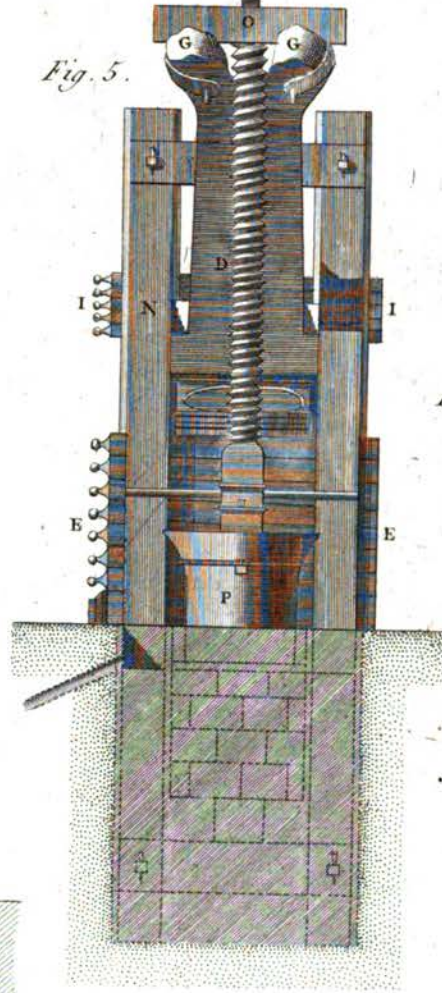
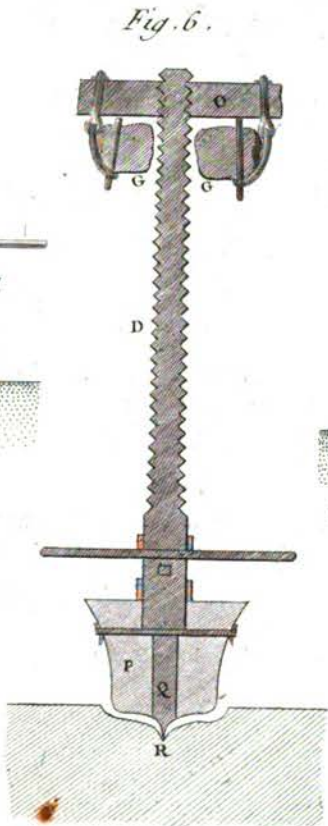
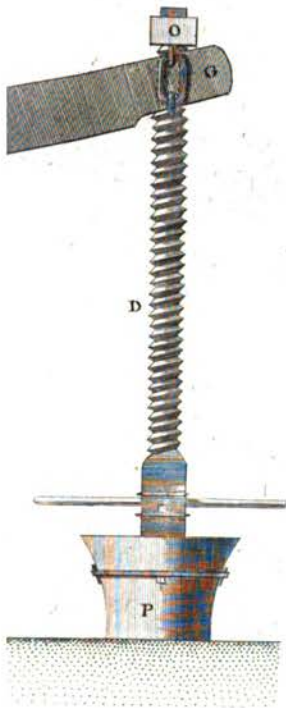
Fig. 1.

Fig. 2.

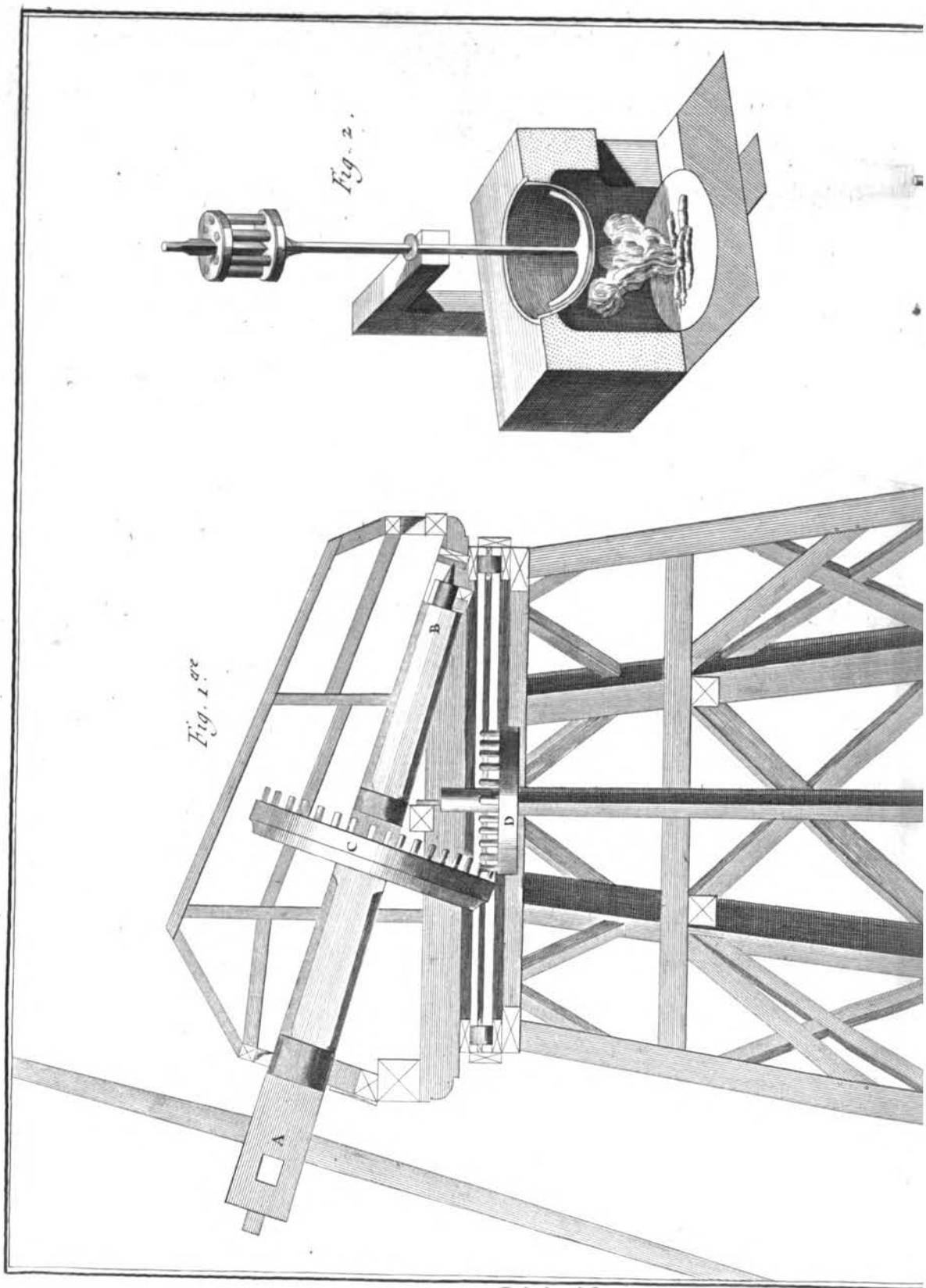
Fig. 7.

*Moulin à Huile avec Pressoir dit à gr...*  
 Original from  
 UNIVERSIDAD COMPLUTENSE  
 DE MADRID

Digitized by Google



Generated on 2014-05-10 21:24 GMT / http://hdl.handle.net/2027/ucm.5320295822 Public Domain, Google-digitized / http://www.hathitrust.org/access\_use#pd-google



Bernard Duvet.

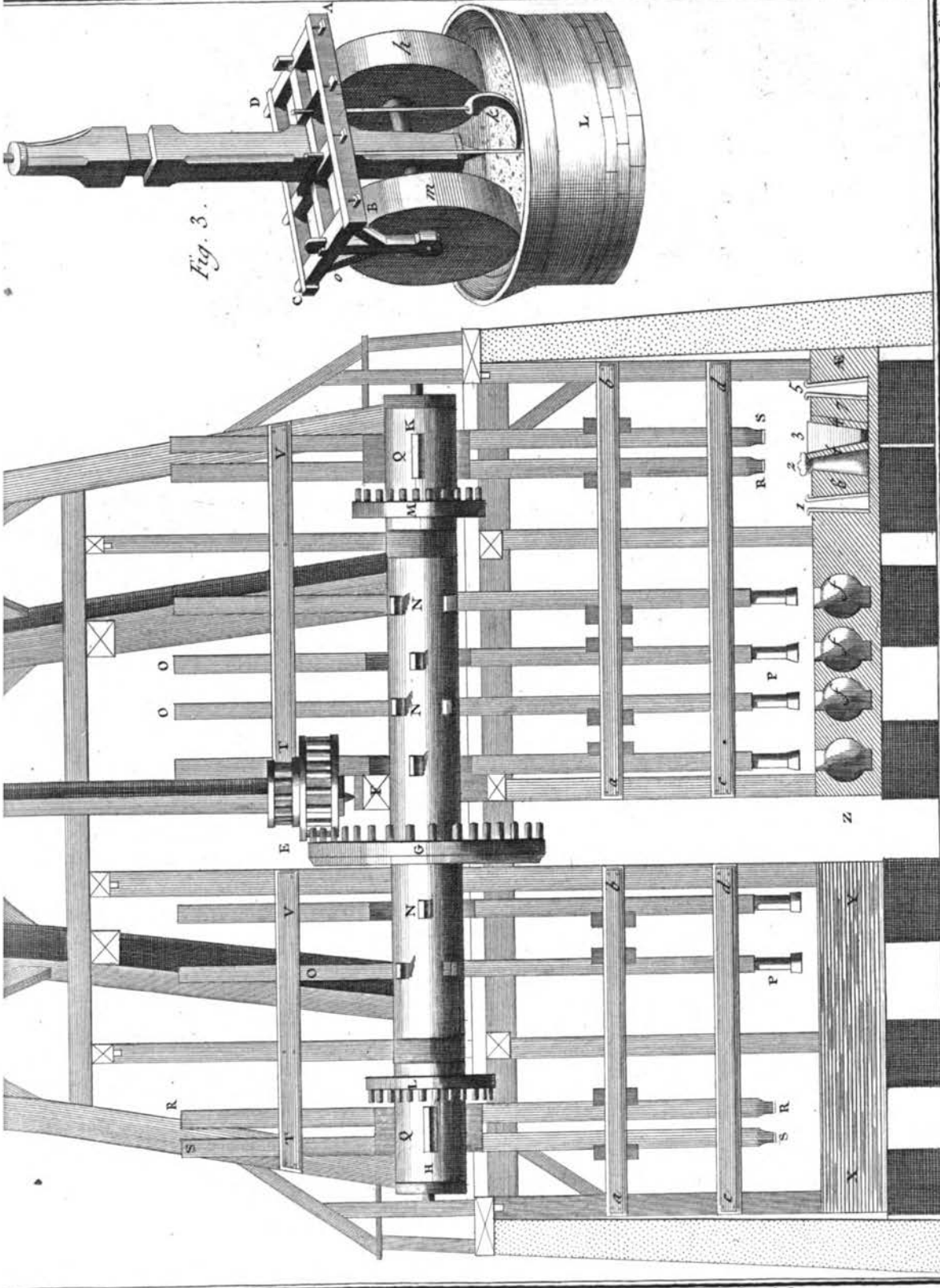
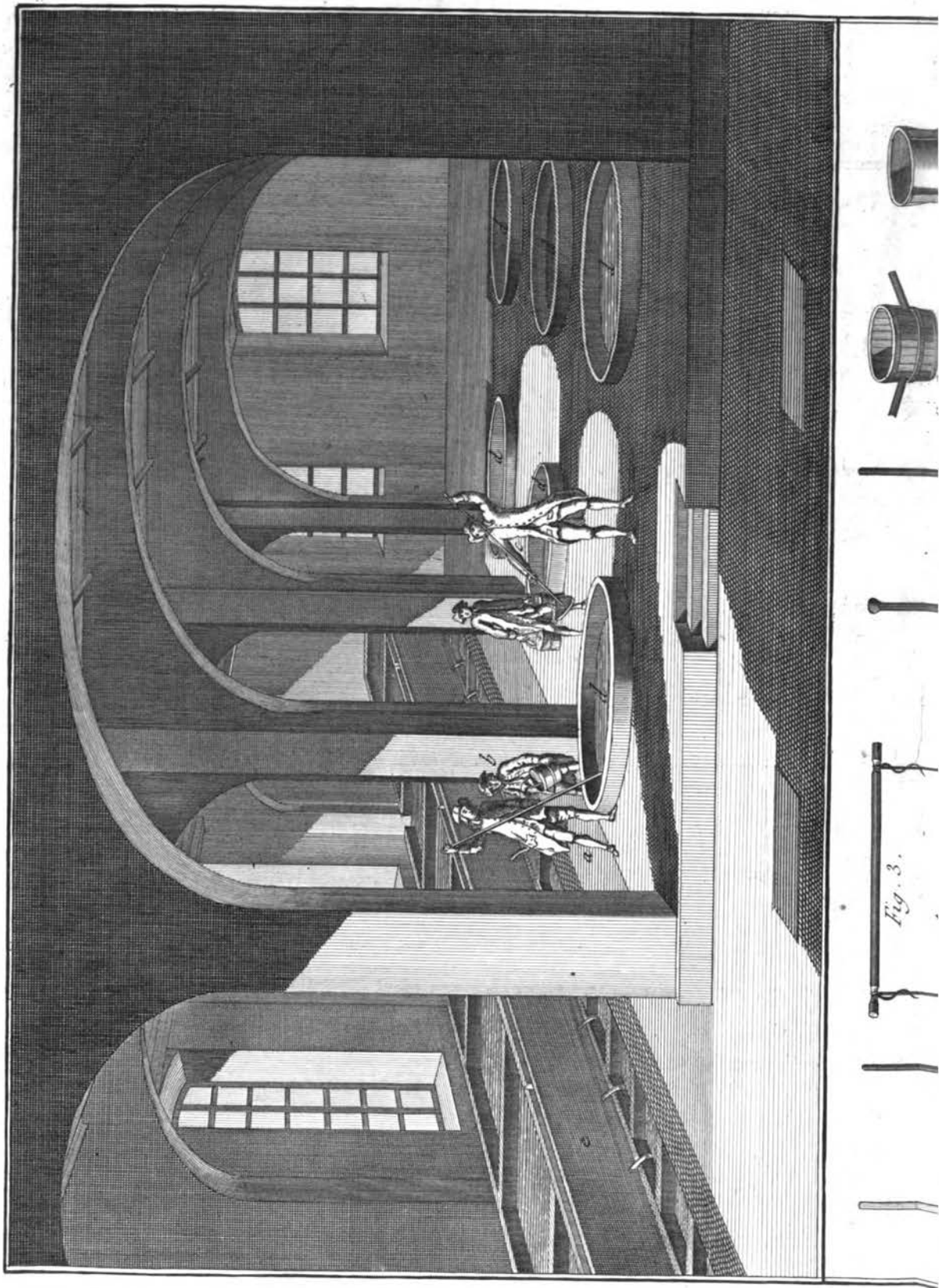
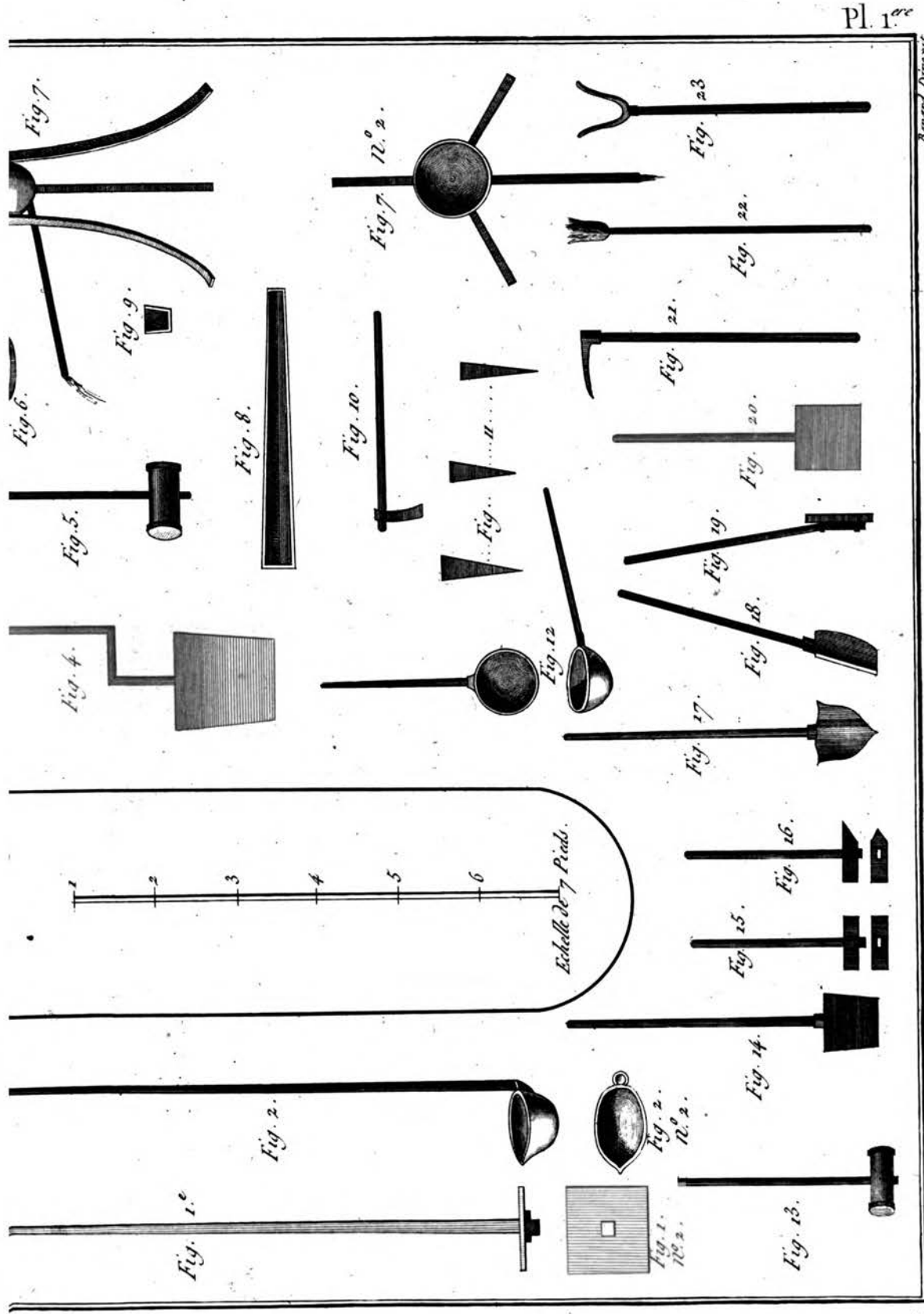


Fig. 3.

Moulin à exprimer l'Huile des Graines et développemens.



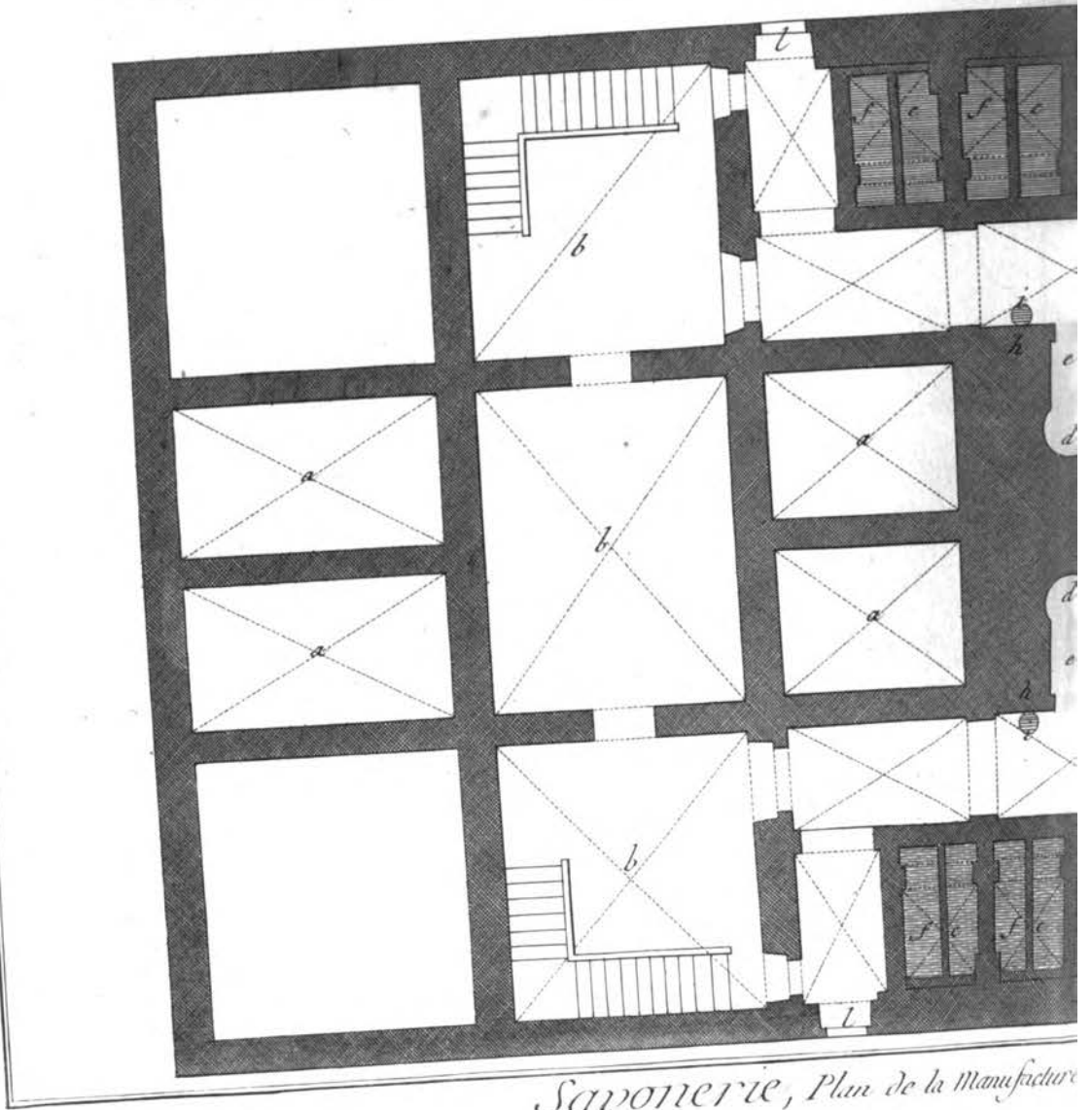


Pl. 1<sup>ere</sup>

Bonard Dorez

*Savonnerie, Différents Opérations pour la préparation du Savon et Utensiles.*





*Savonnerie, Plan de la Manufacture*

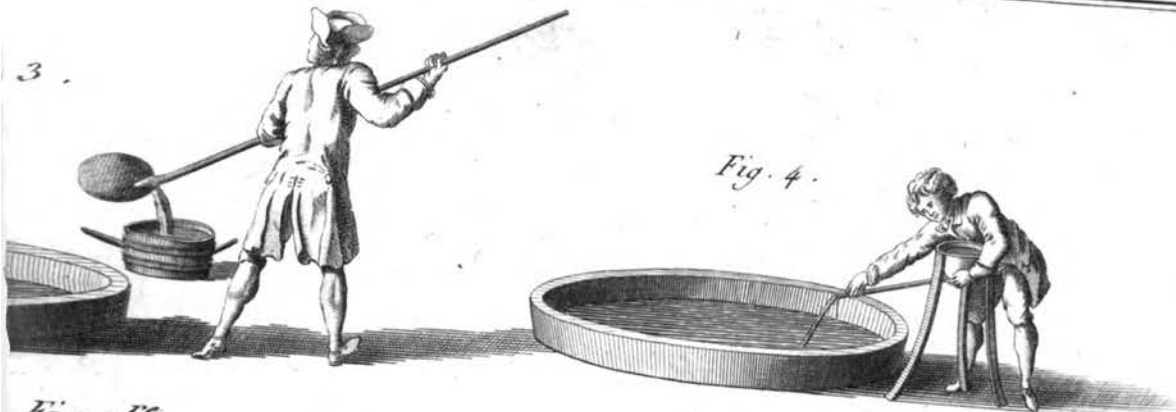
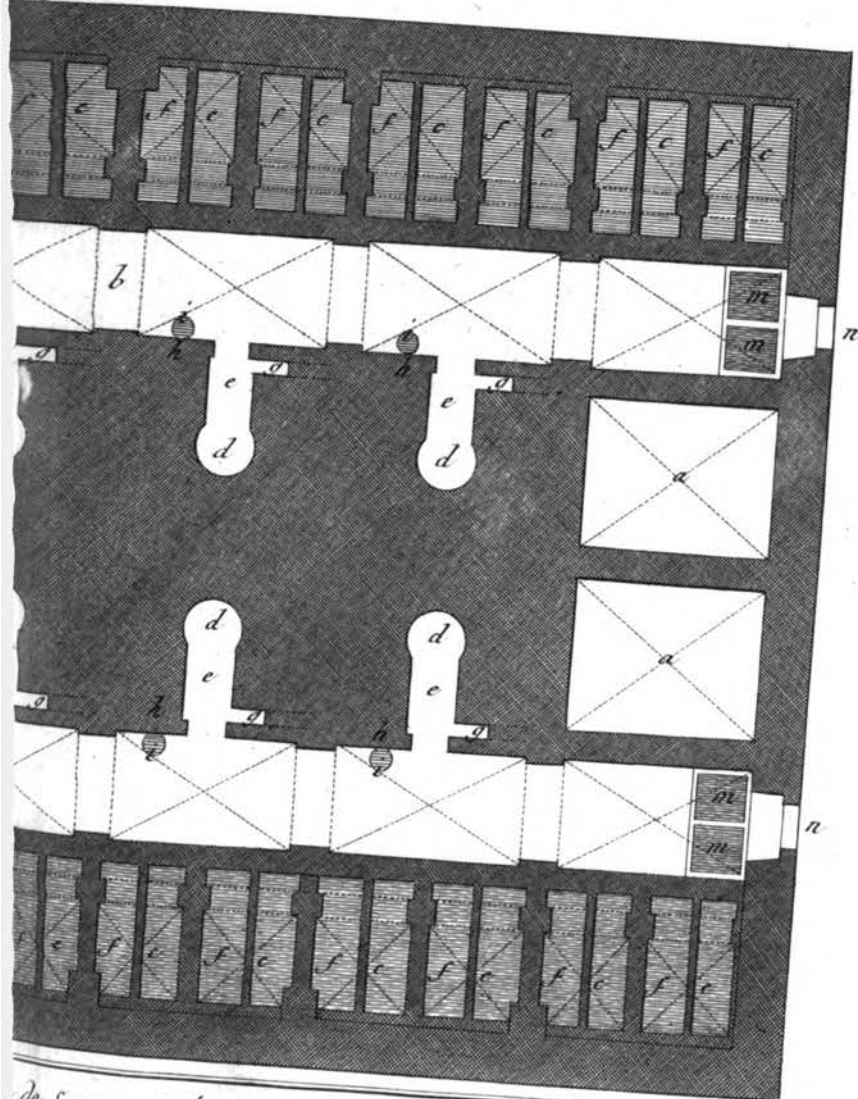


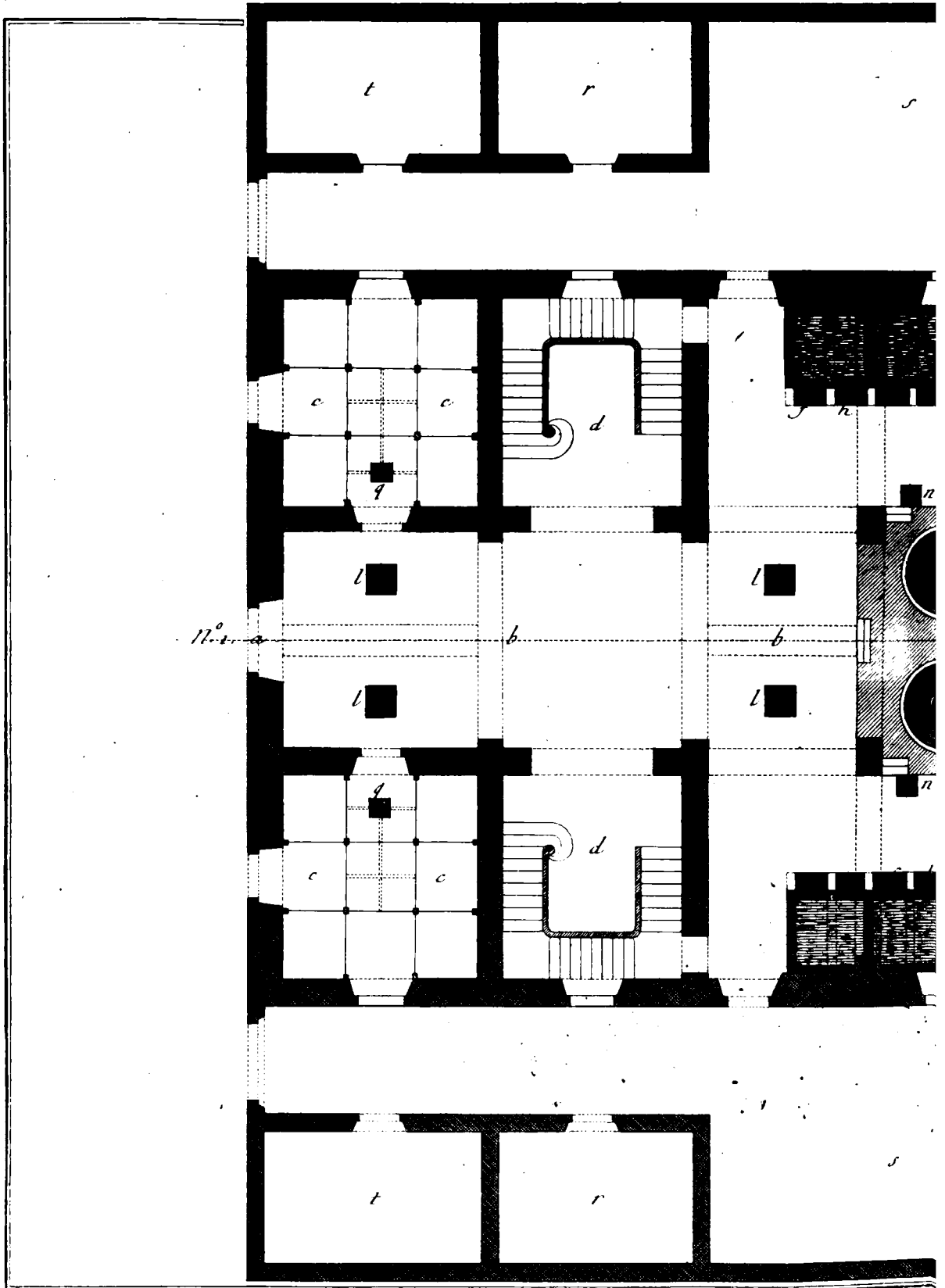
Fig. 1.<sup>re</sup>



*de Savon et Opérations pour faire le Savon*

Bernard Duvault

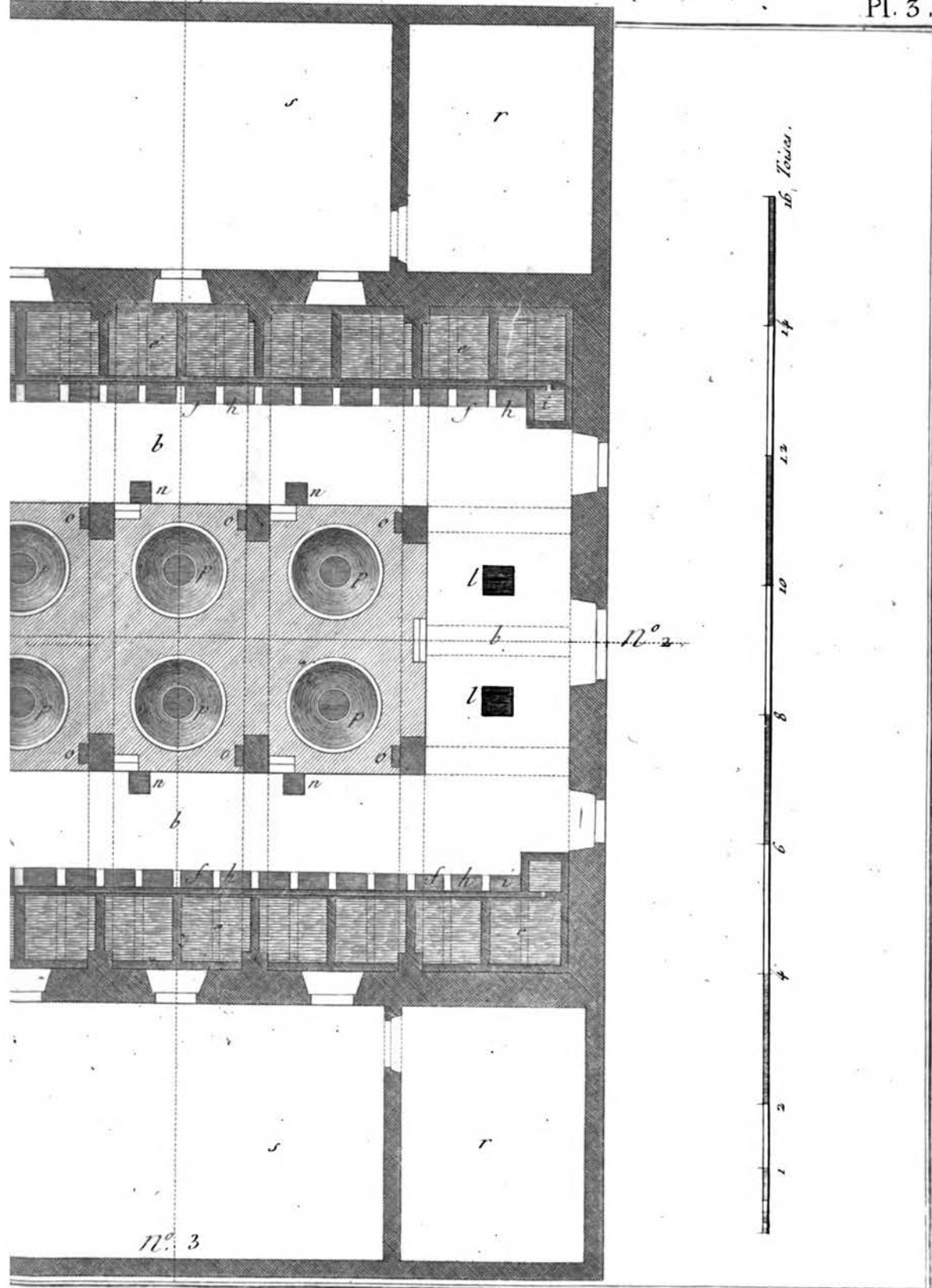
54.



*Savonnerie, Plan du Rez de Chaussée*

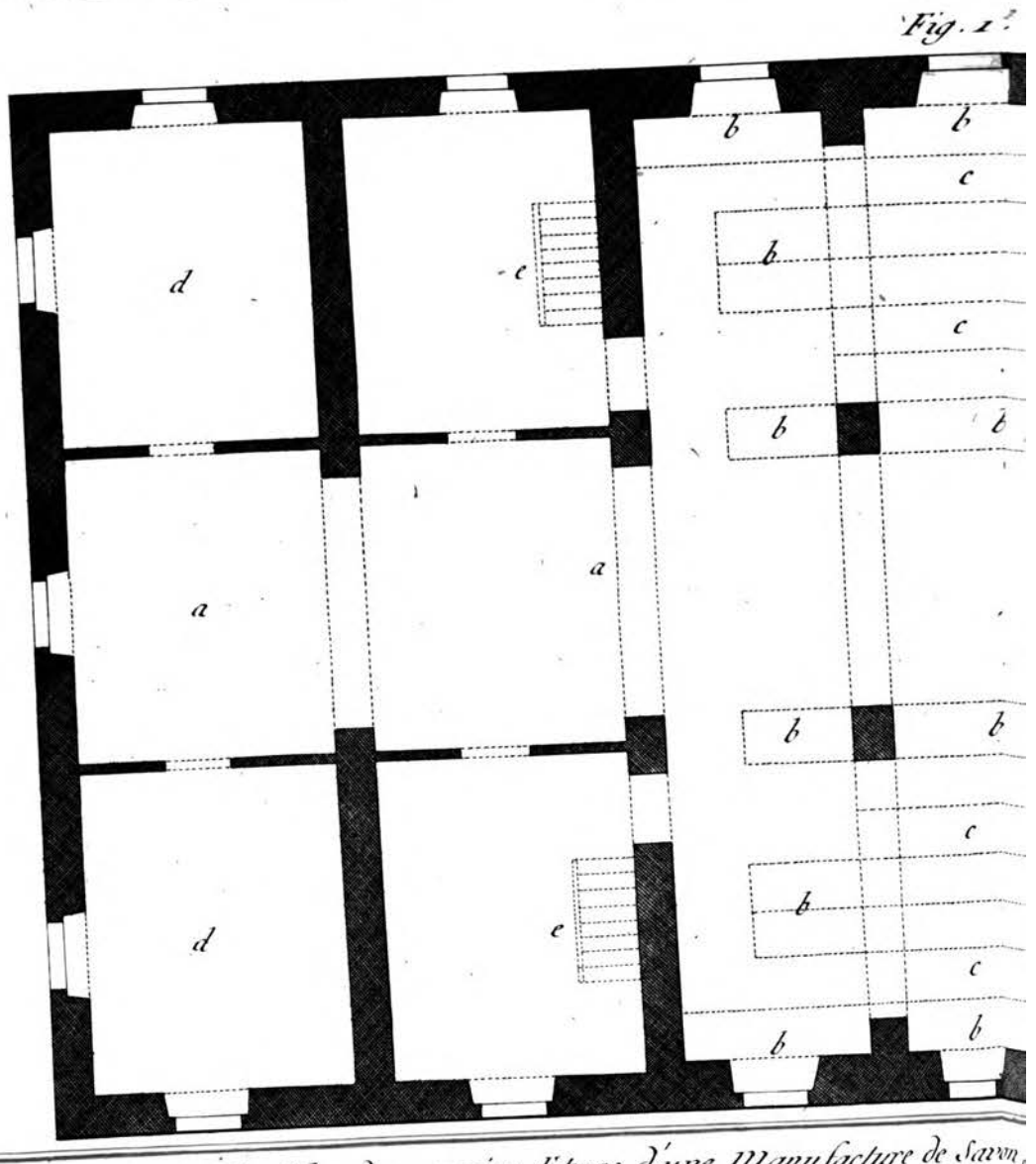
n<sup>o</sup> 4

Pl. 3.



*vue d'une Manufactory de Savon.*

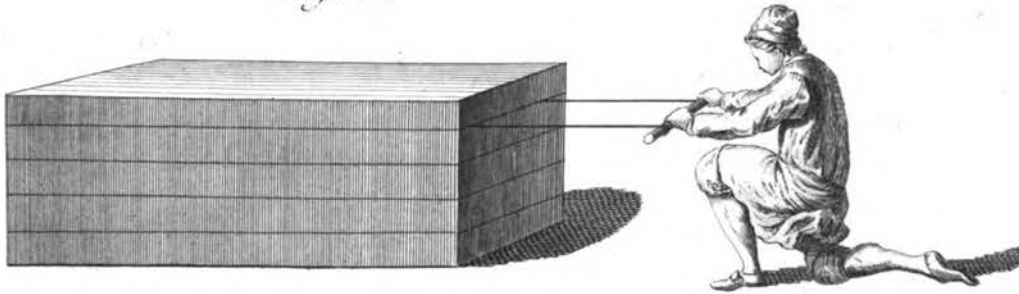
Benard Perceit  
53.



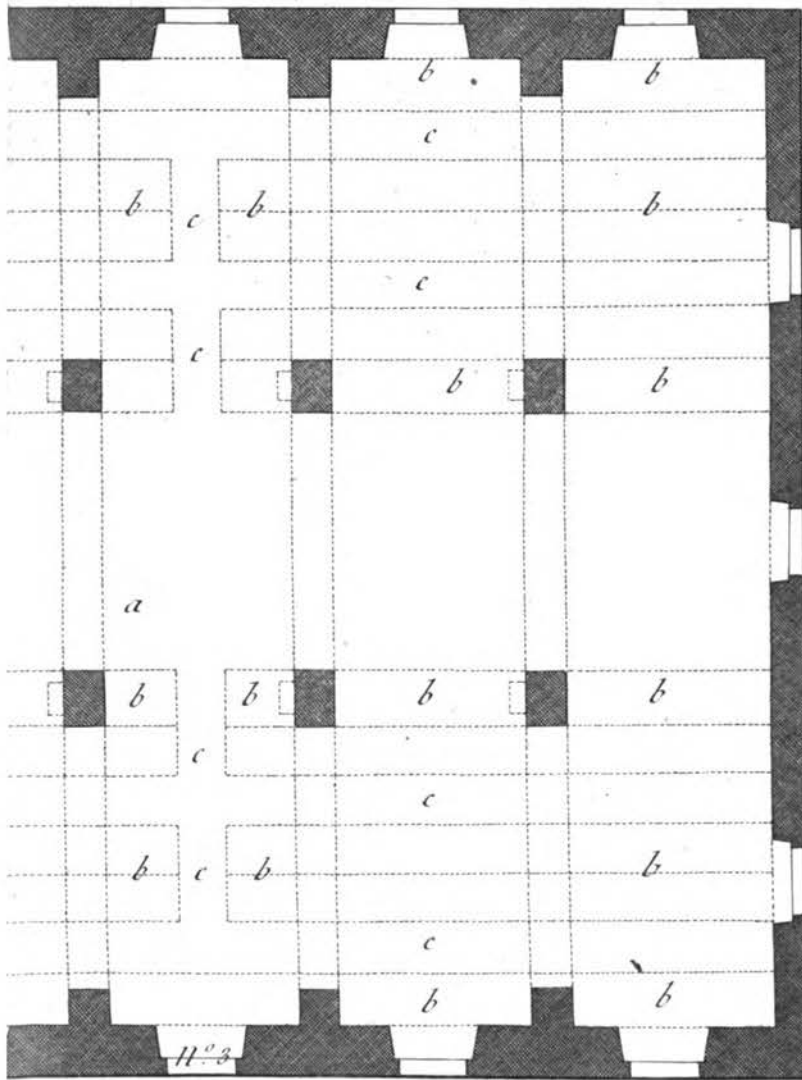
*Pl. 1.*

*Savonnerie, Plan du premier Etage d'une Manufacture de Savon,*

Fig. 3.



N. 4.



10 Toises.

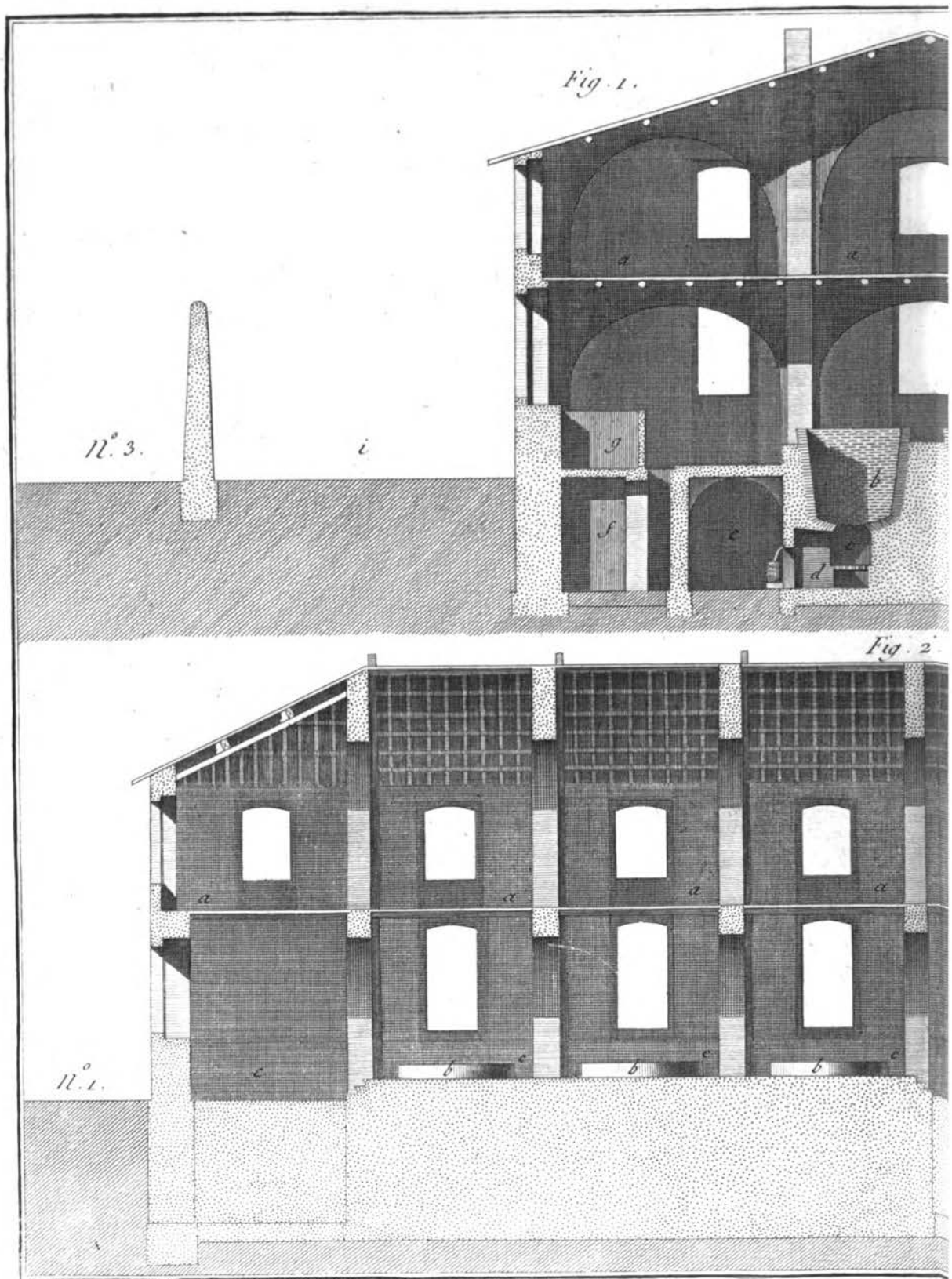


N. 2.

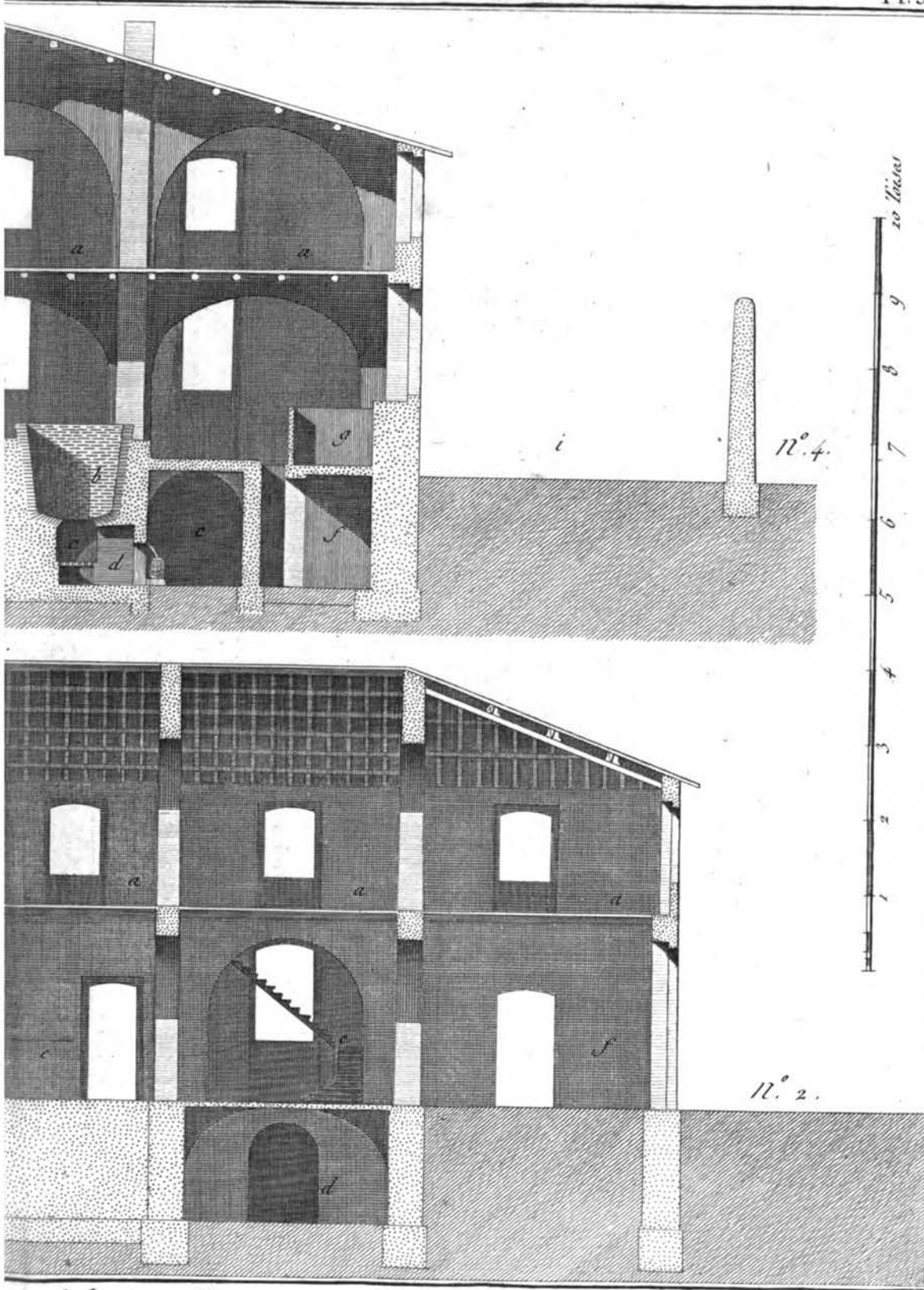
N. 3.

et Opérations pour partager également et couper le Savon.

Bernard Dorez.



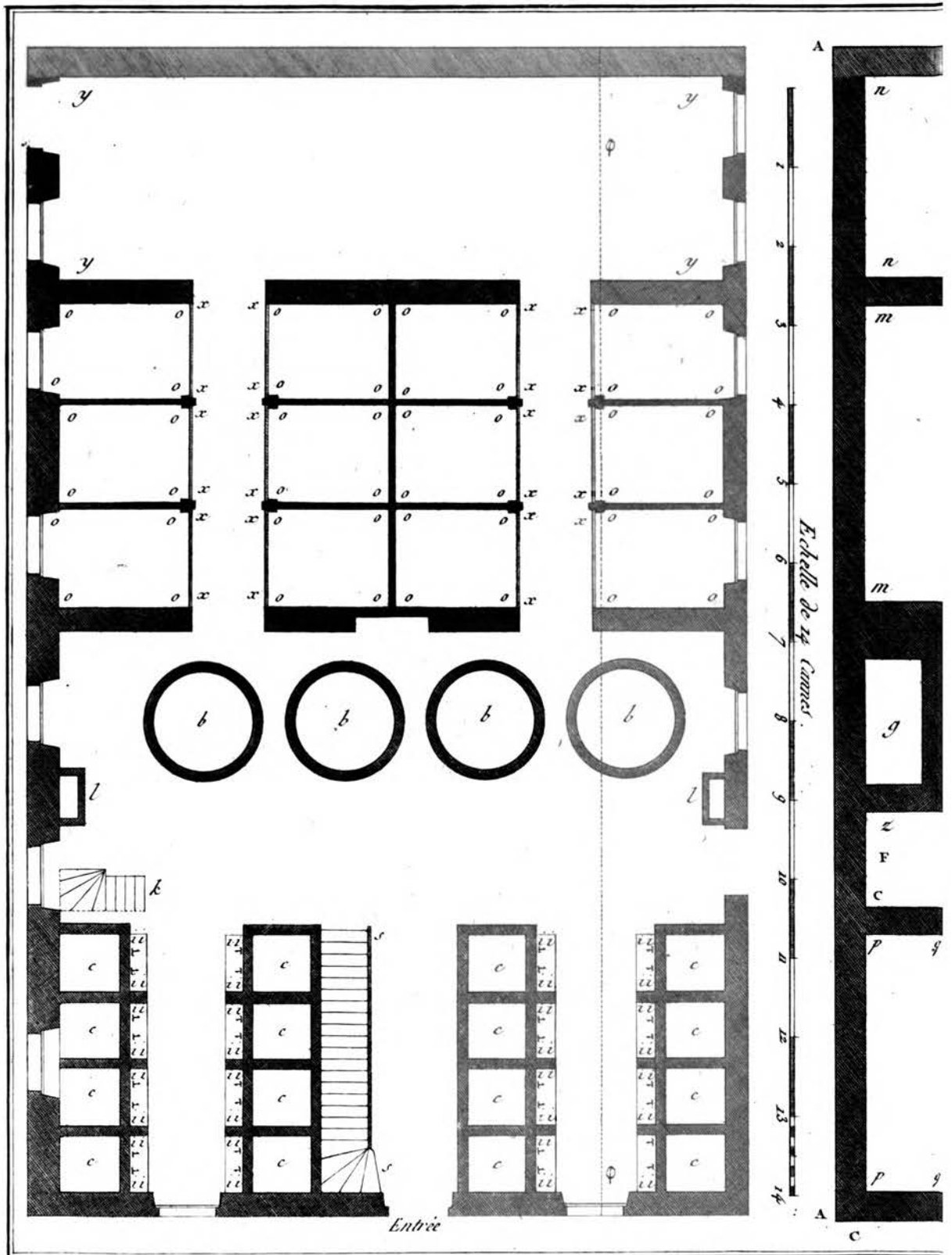
*Savonnerie, Coupe sur la longueur et Coupe sur la largeur*



Sur la longueur d'une Manufacture de Savon.

Bonard Desv. 57

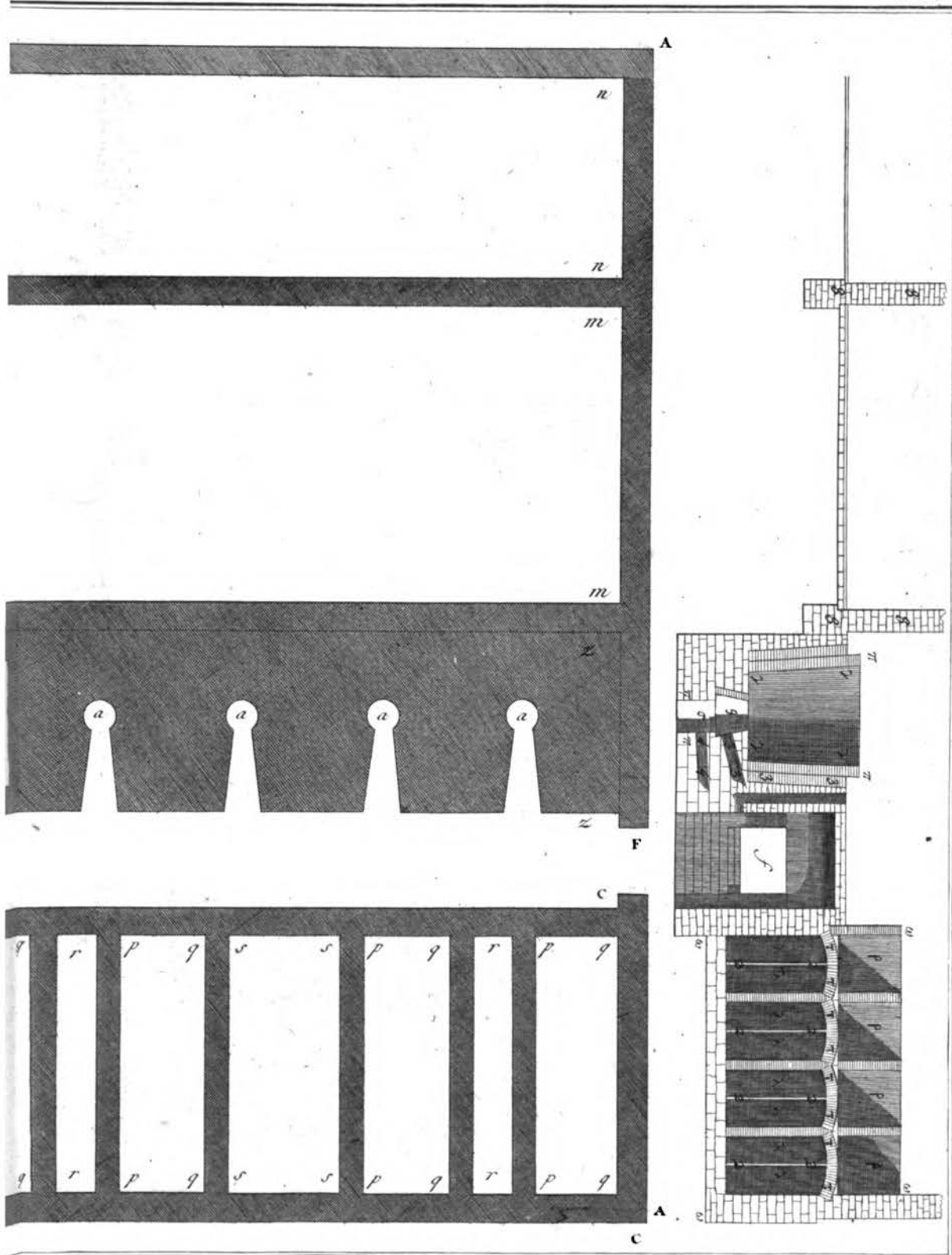




*Savonnerie, Plan et Coupe d*

Original from  
UNIVERSIDAD COMPLUTENSE  
DE MADRID

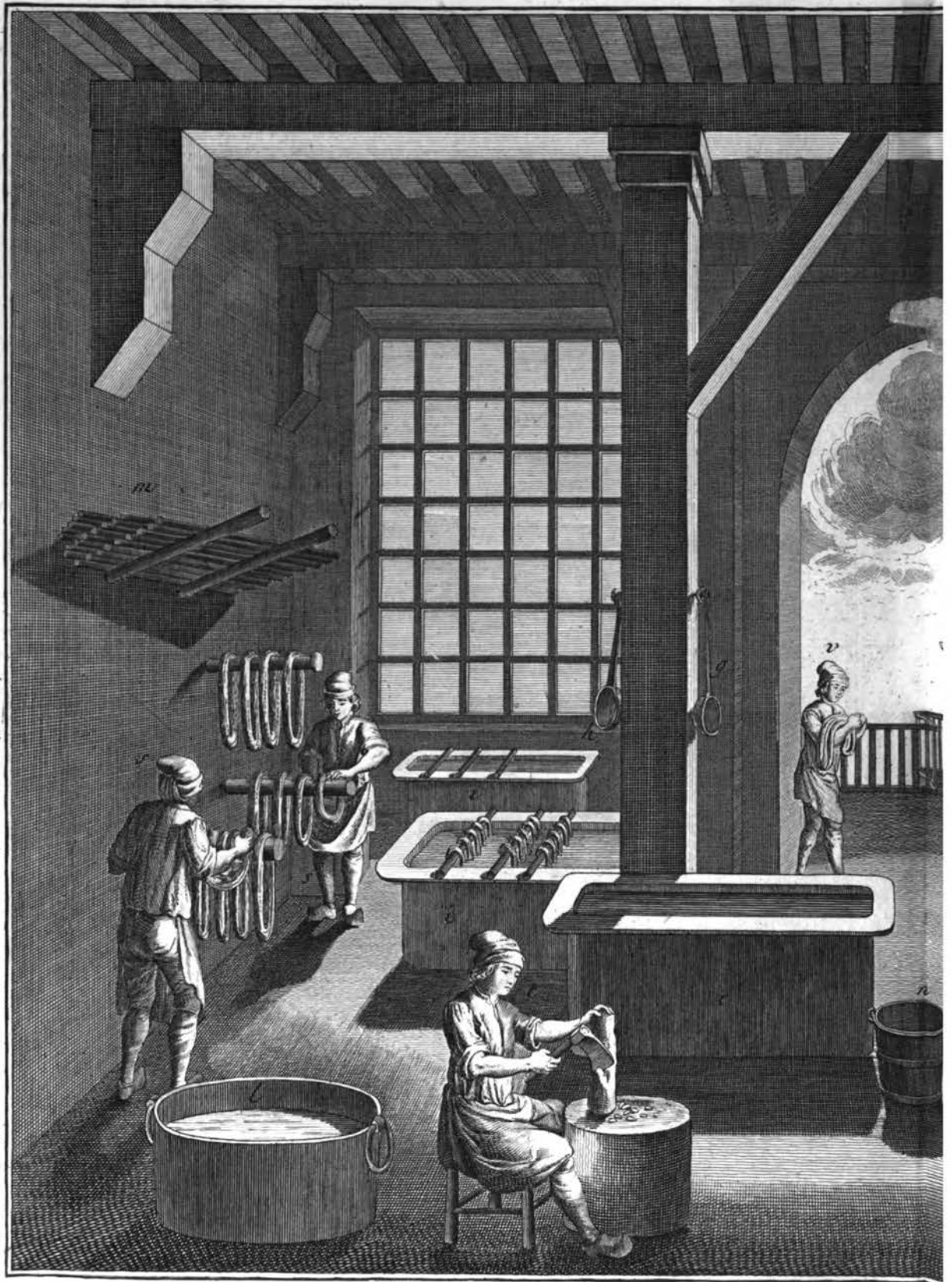
Digitized by Google



*d'une grande Manufacture de Savon*

Benard Dorez

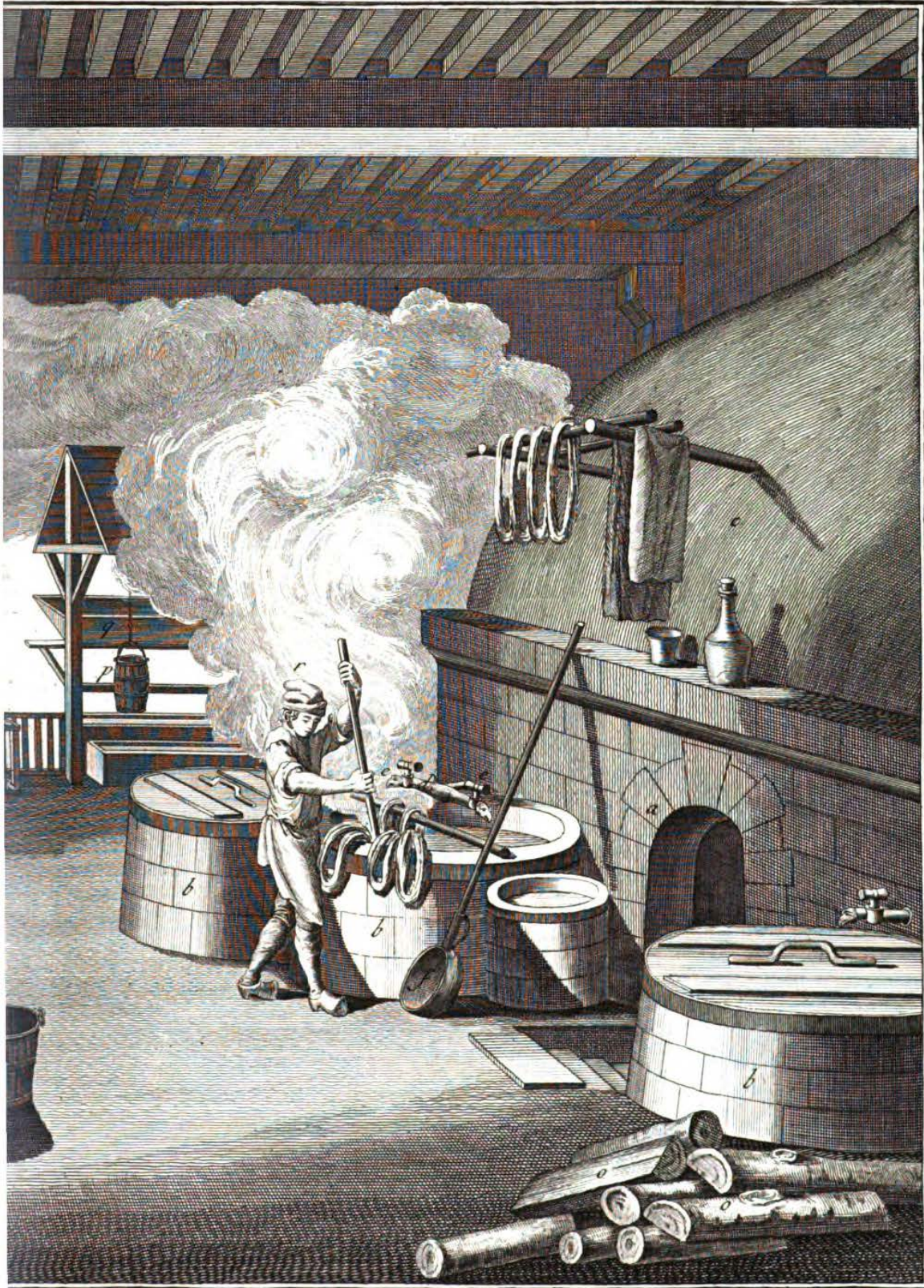
Generated on 2014-05-10 21:42 GMT / http://hdl.handle.net/2027/ucm.5320295822  
Public Domain, Google-digitized / http://www.hathitrust.org/access\_use#pd-google



*Teinturier de Riviere, Atelier et diffin*

Digitized by Google

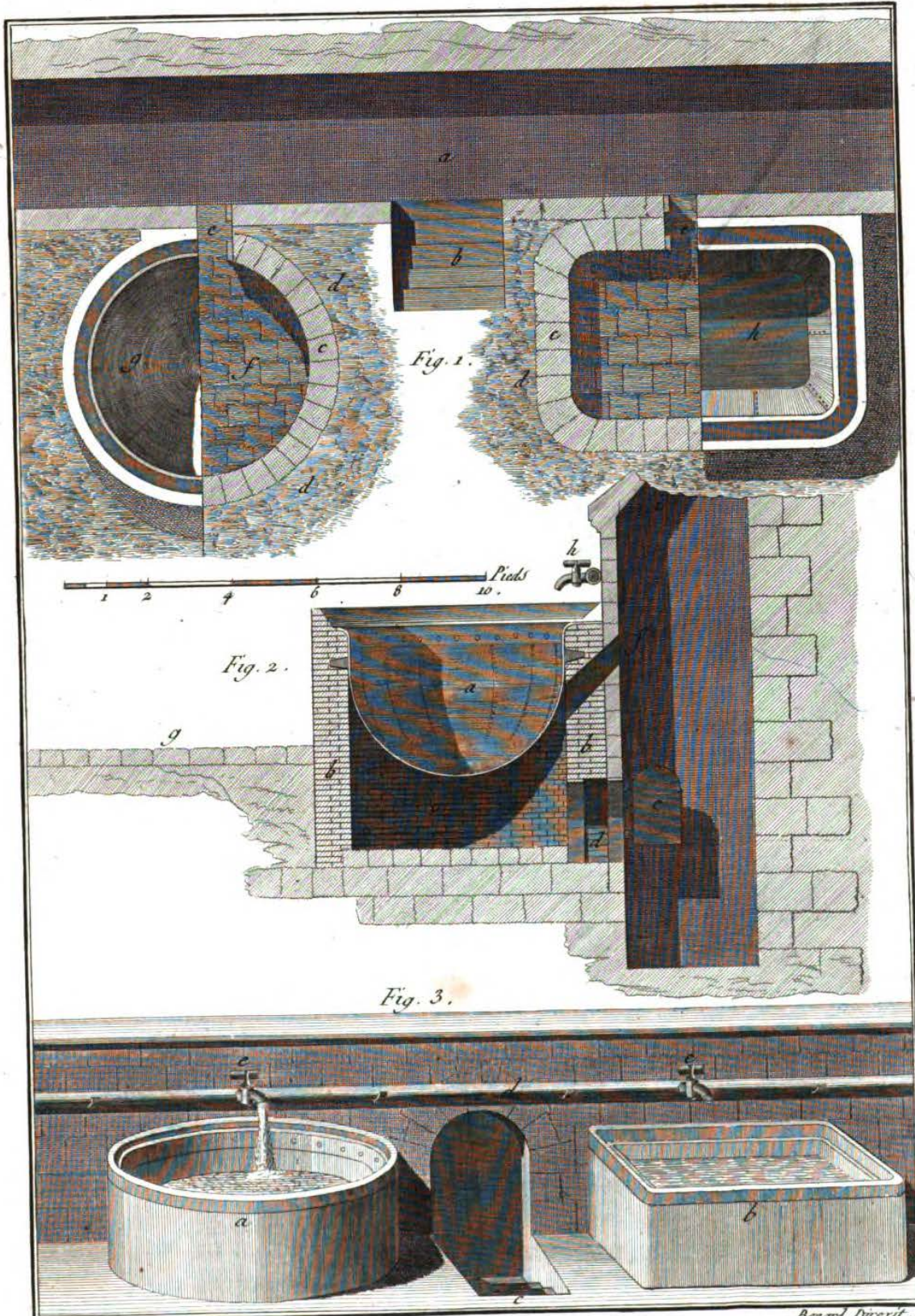
Original from  
UNIVERSIDAD COMPLUTENSE  
DE MADRID



*Étendues Opérations pour la Teinture des Soies.*

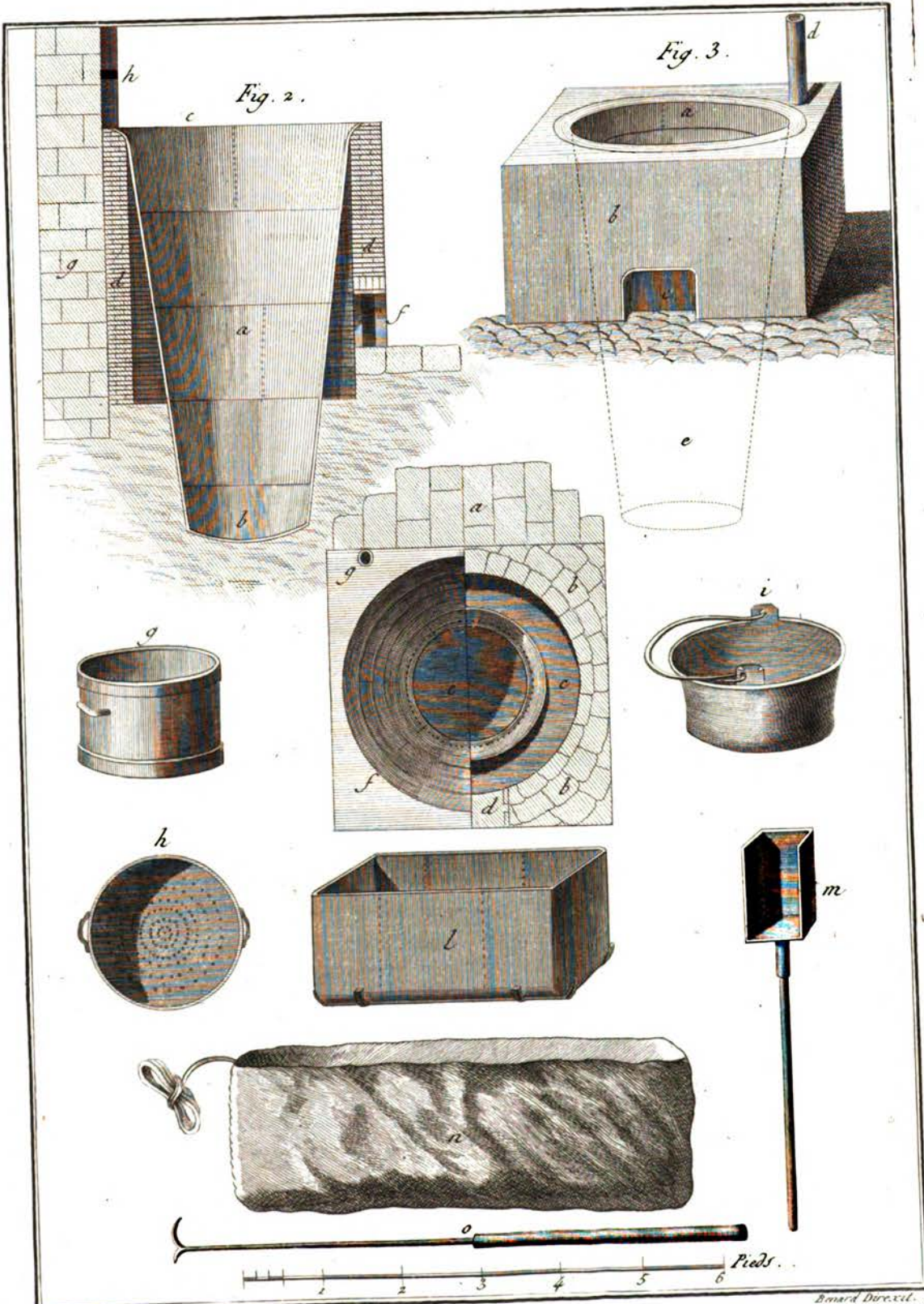
*Bernard Dorez.*

59.



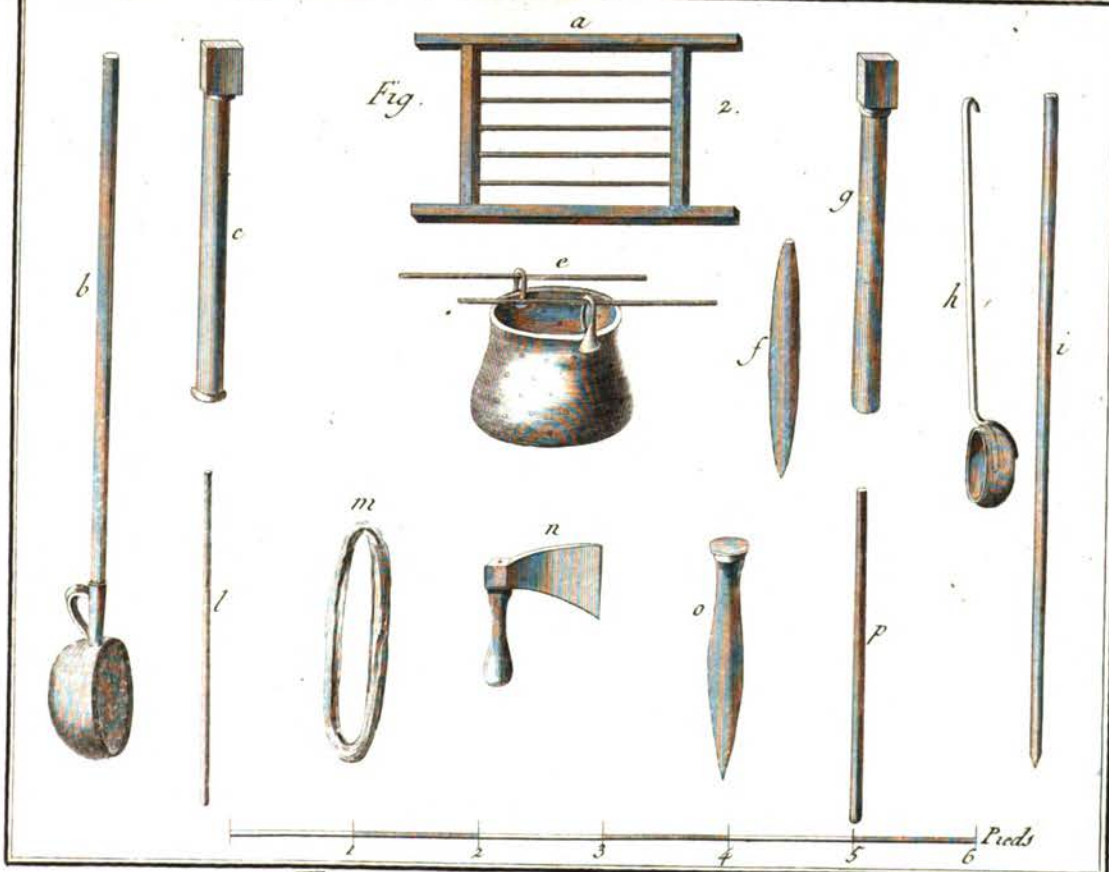
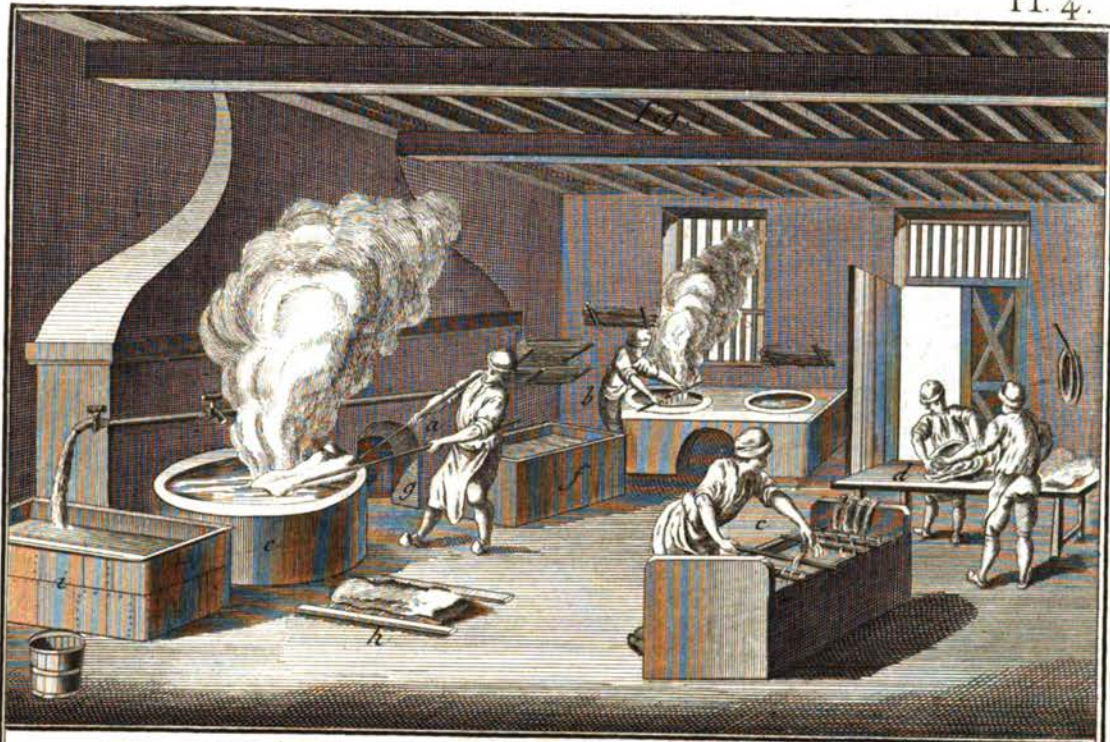
*Teinturier de Riviere, Plans, Coupe et Elevations de différentes Chaudieres.* 60.

*Bernard Duvet.*



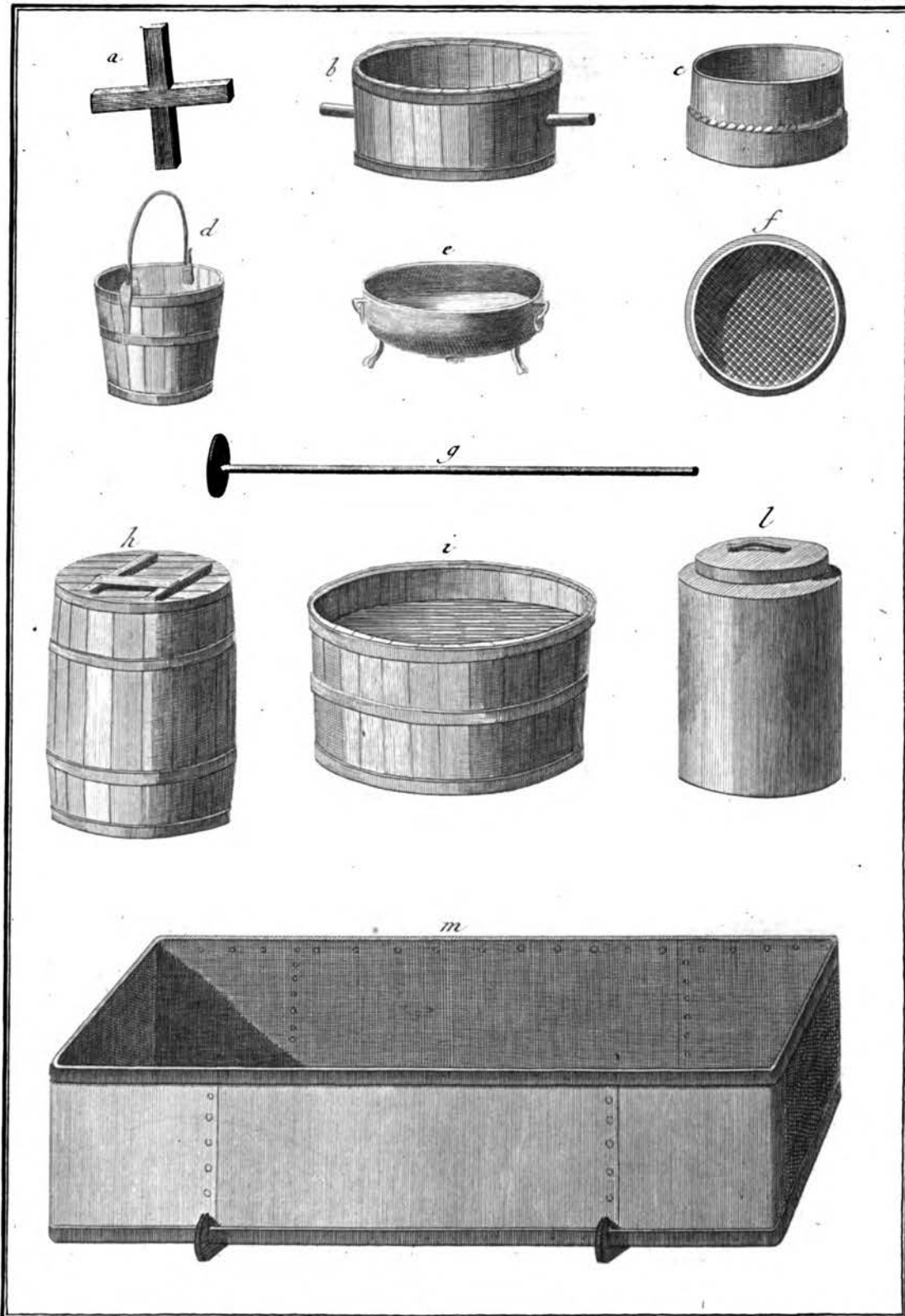
*Teinturier de Riviere, Plans, Coupe et Elevation de la Cuve pour l'Indigo.*

Bnard Dore. del. 61.



Teinturier, Atelier et Outils.

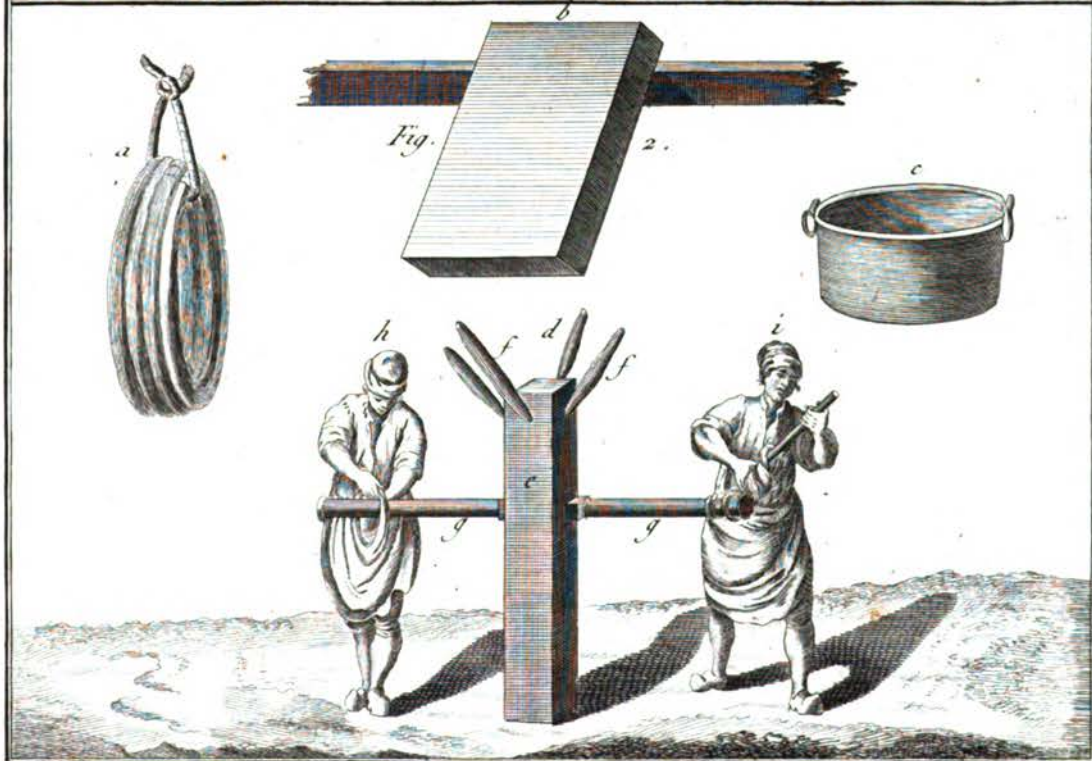
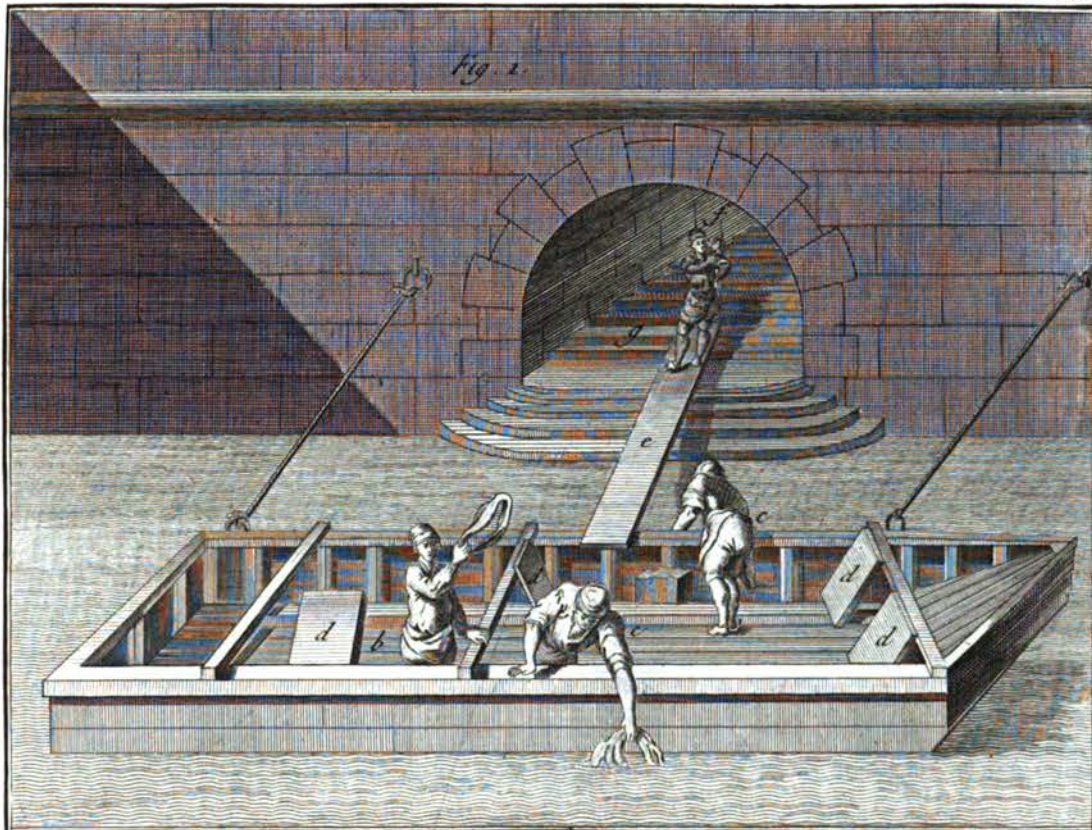
Boiard Duxet.



*Teinturier en Soie, différens Ustensiles pour la Teinture en Soie.* 62

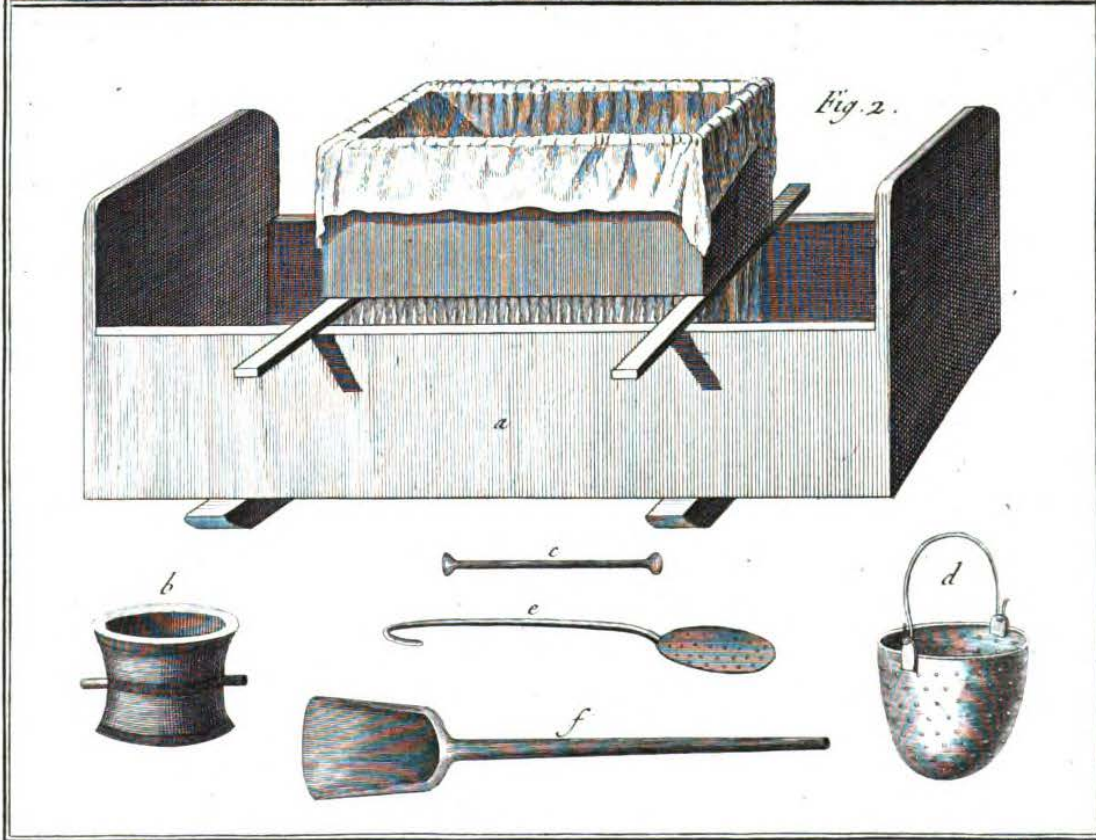
*Bernard Duvet*



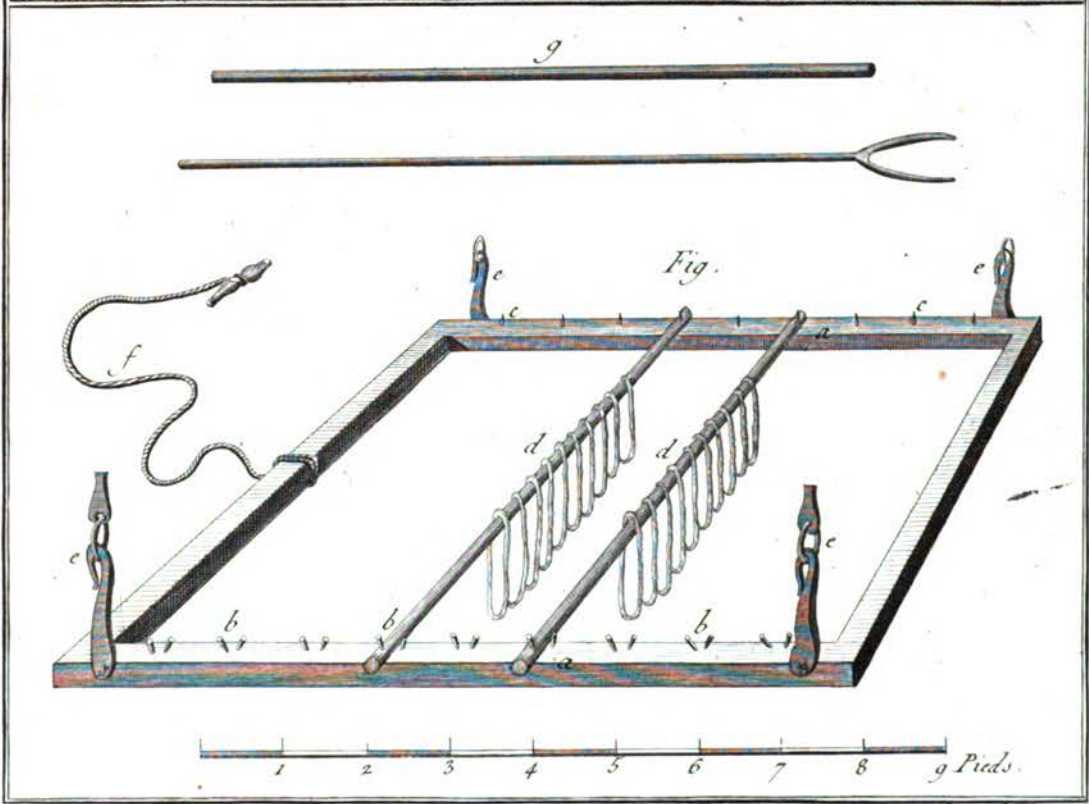
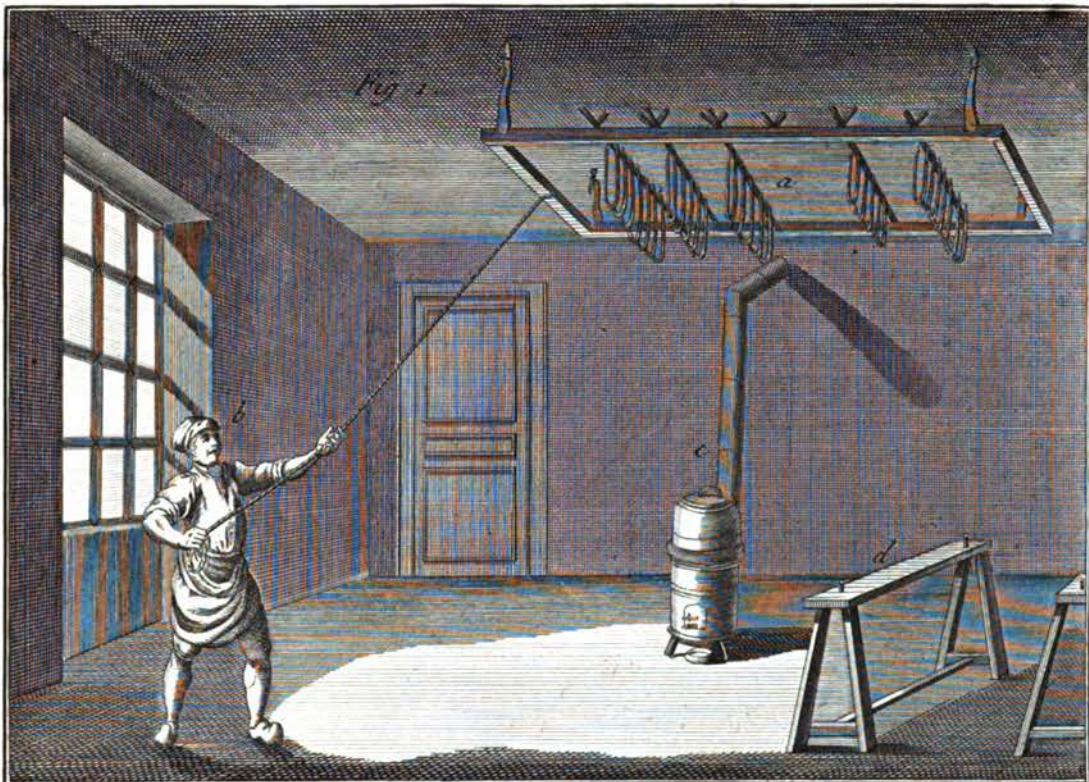


*Teinturier, Lavage des Soies à la Rivière et Service de l'Espart.*

*Bonard Inven.*

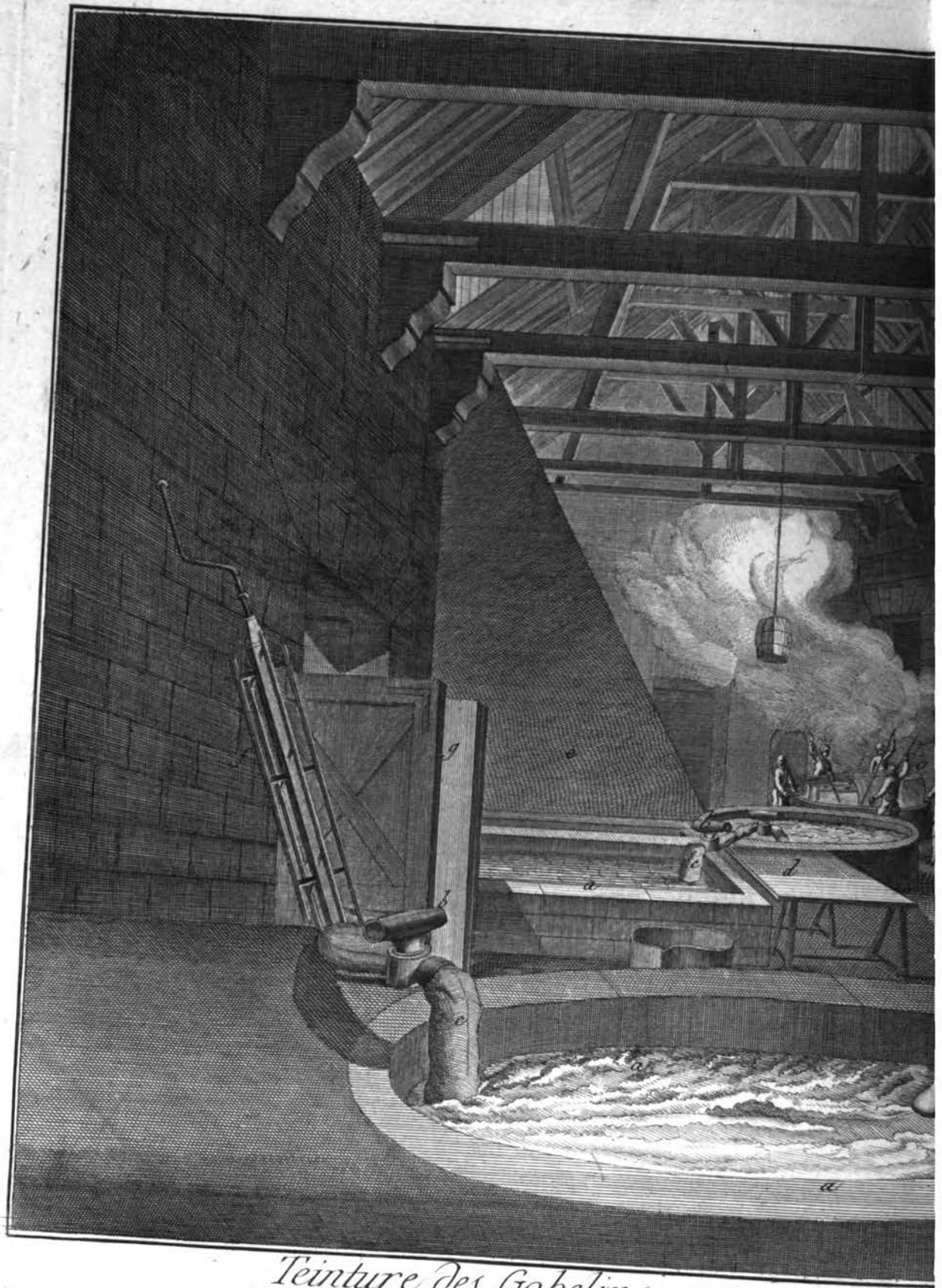


*Teinturier, différentes préparations du Safranum et Outils.* Bernard Doreux.



*Teinturier, le sechoir pour les Soies &c.*

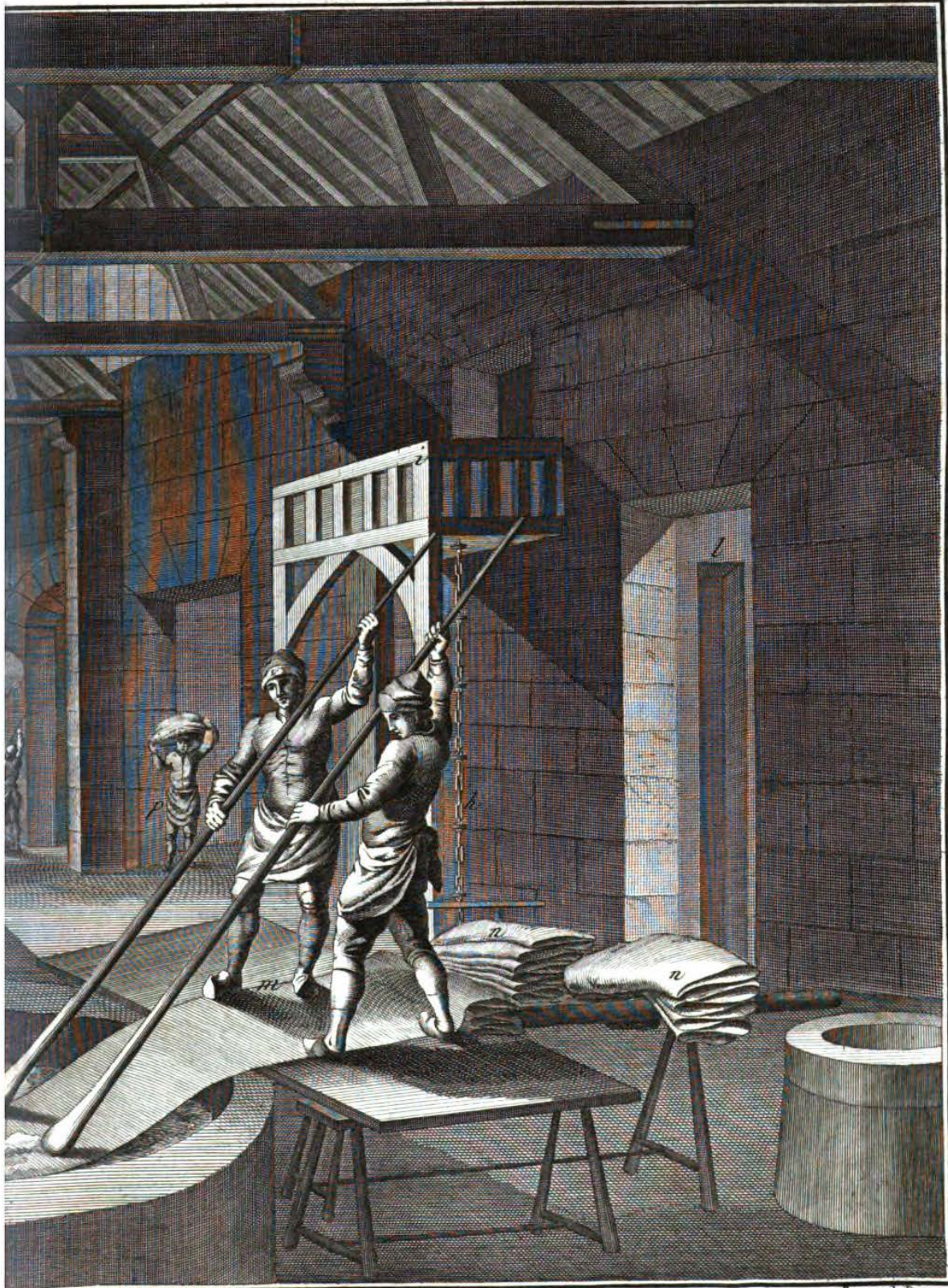
*Benard Directeur*



*Teinture des Gobelins, Atelier des Teinturiers*

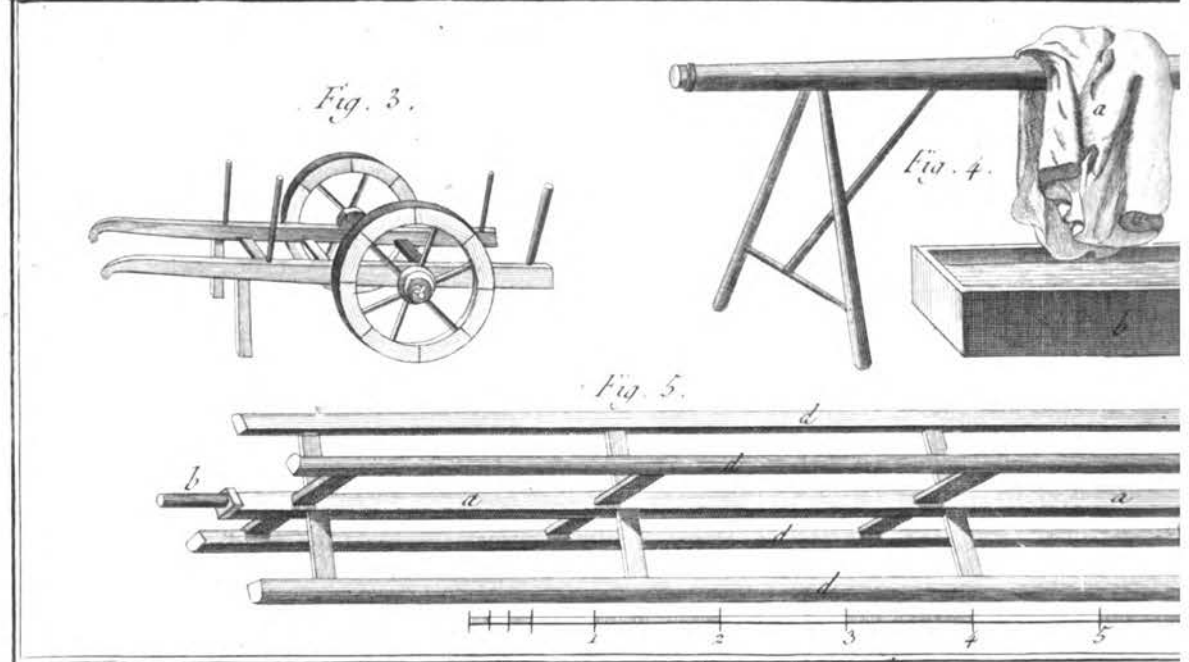
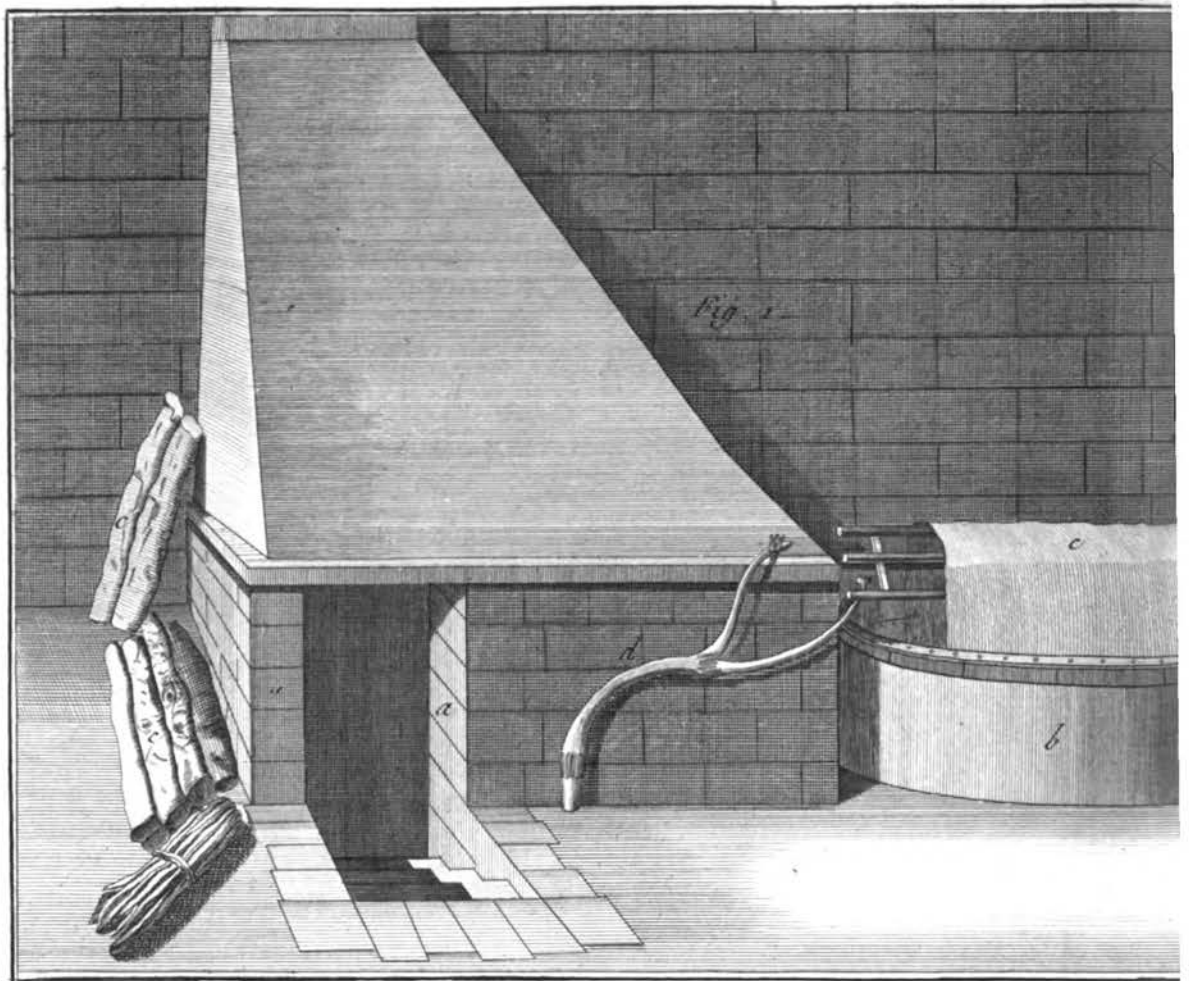
Digitized by Google

Original from  
UNIVERSIDAD COMPLUTENSE  
DE MADRID



Benard. Dorec.

*ers et Differentes Operations pour la Teinture des Etoffes*

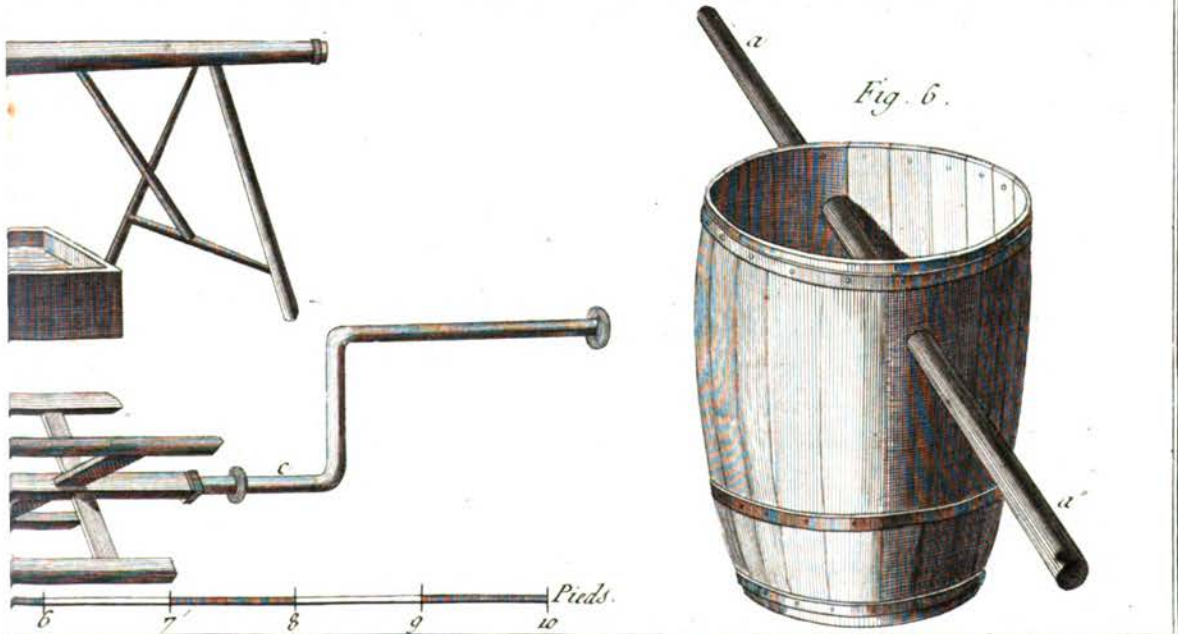
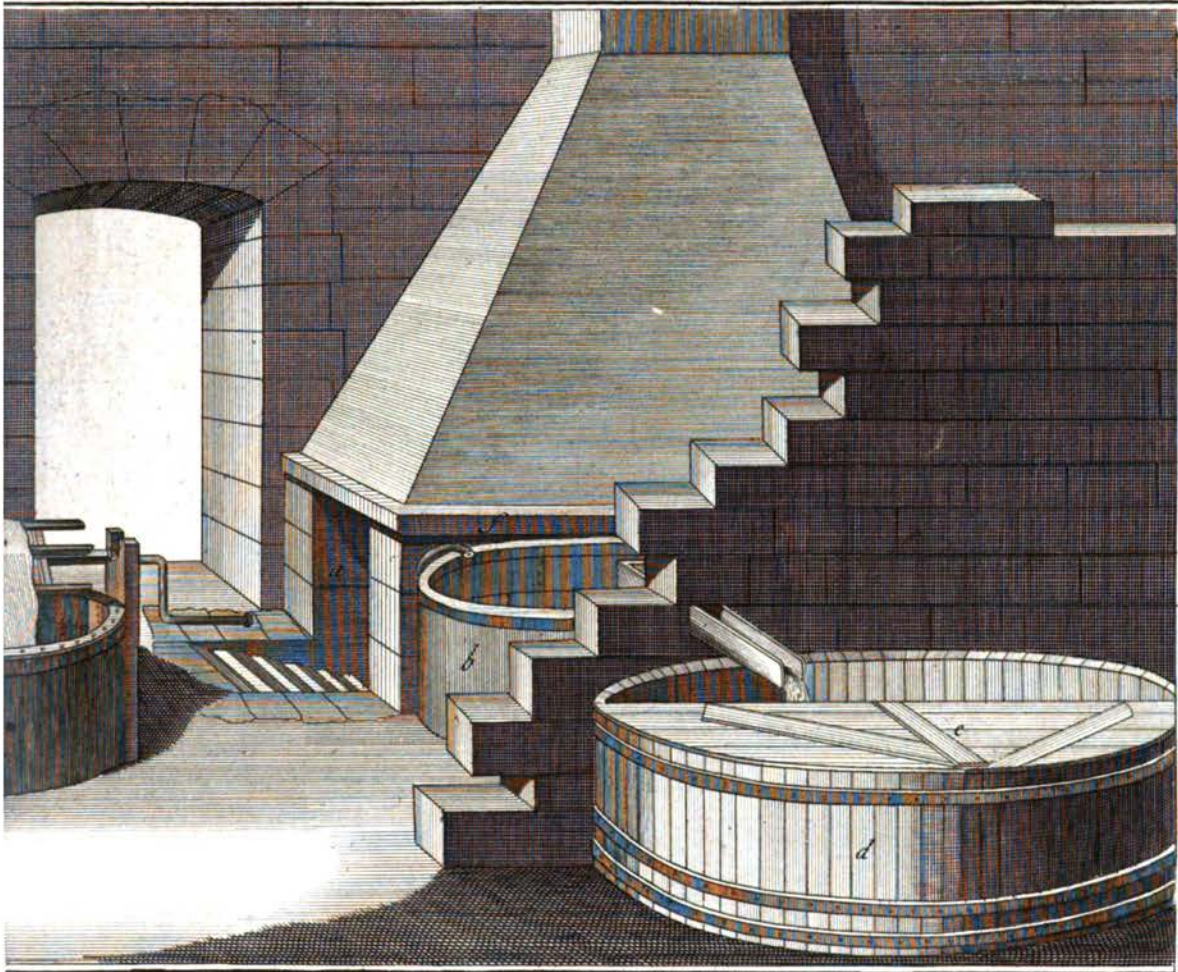


*Teinture des Gobelins, Dispositions*

Original from

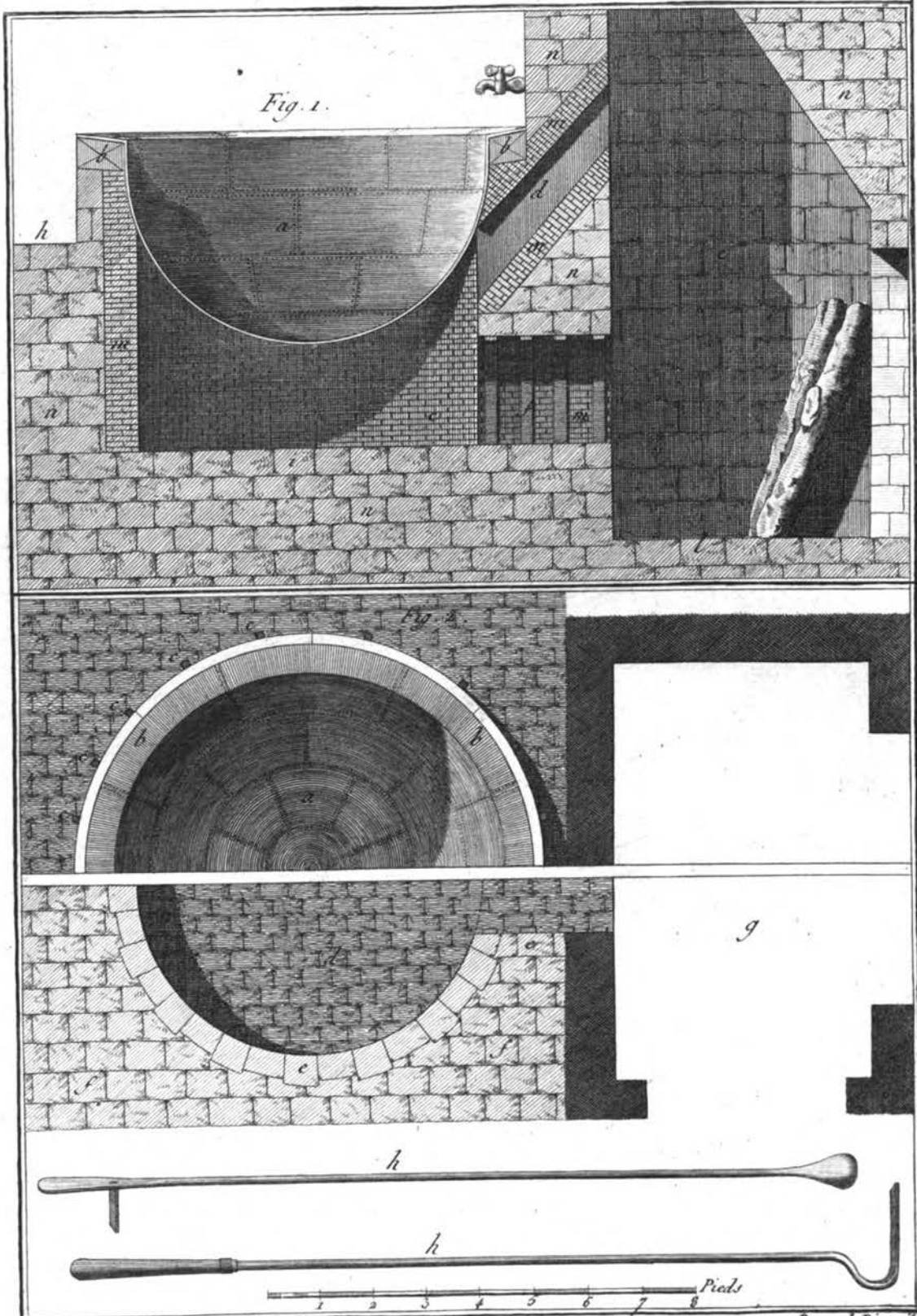
UNIVERSIDAD COMPLUTENSE  
DE MADRID

Digitized by Google



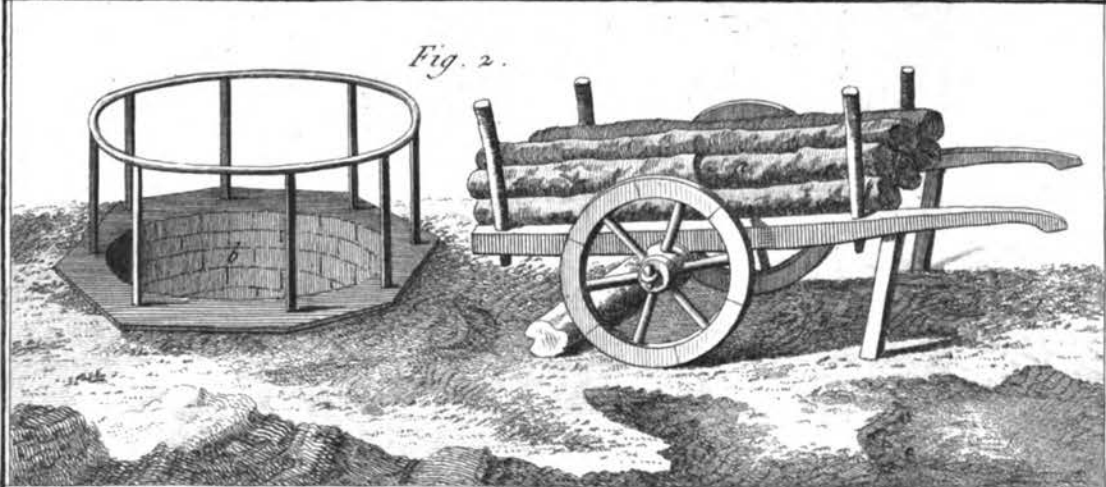
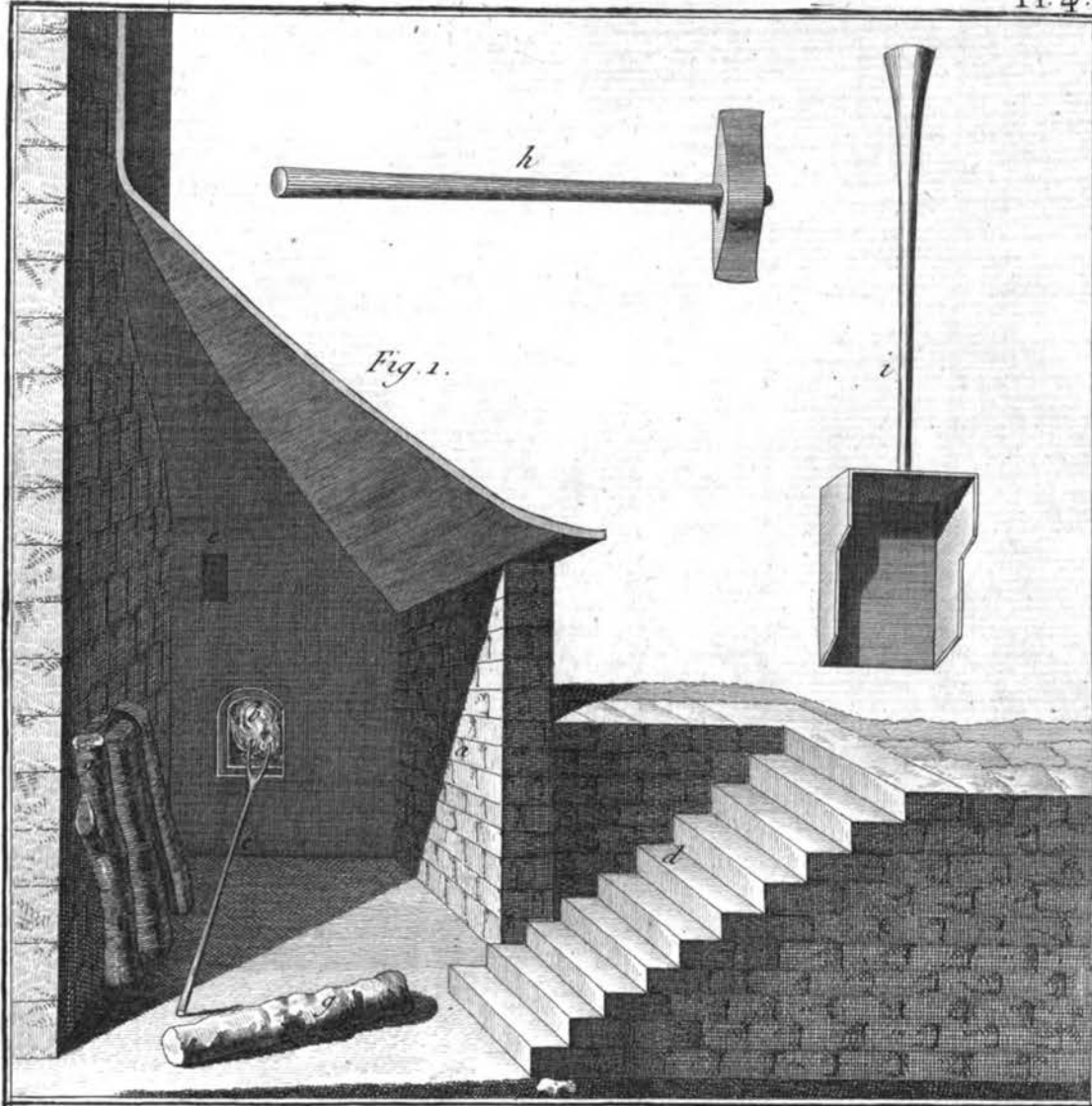
Chaudieres, Entrée des Fourneaux et Ustensiles.

Benard D'excit. 65.



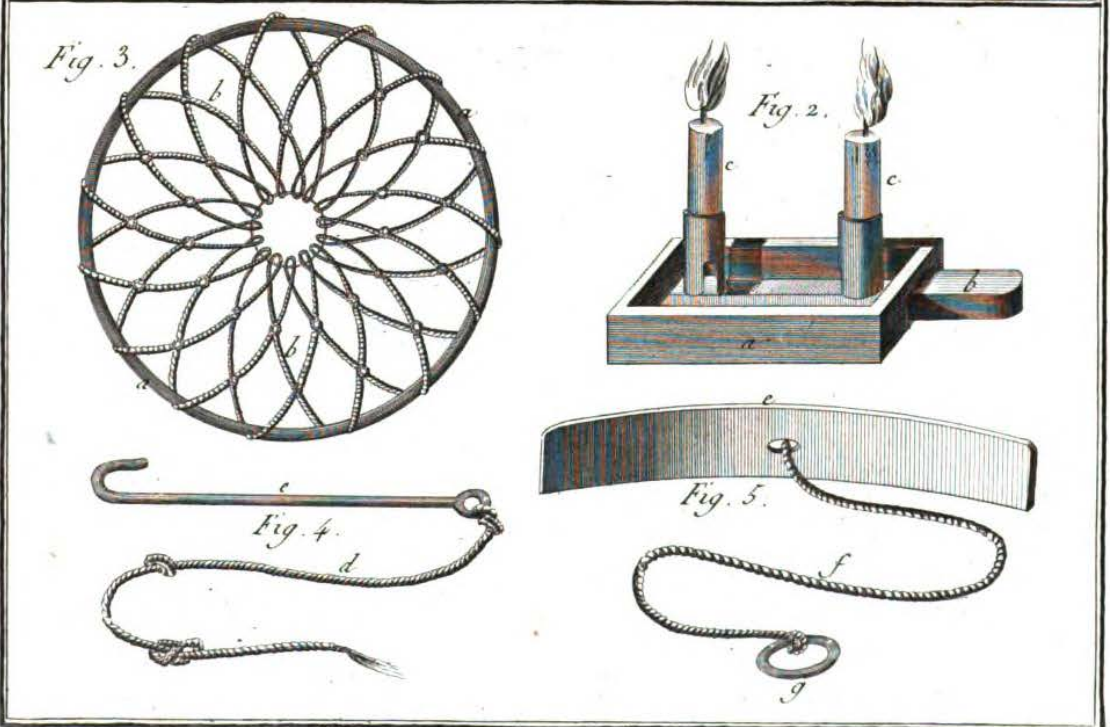
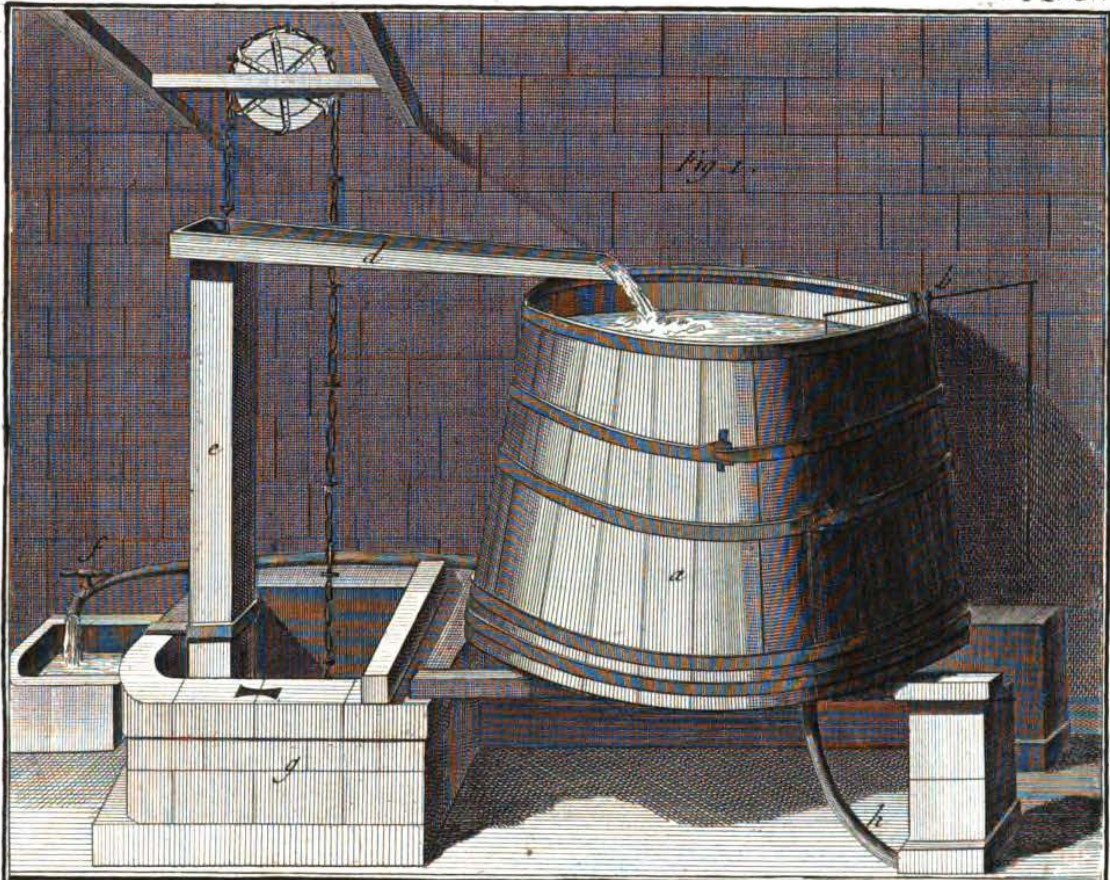
*Teinture des Gobelins, Plans et Coupe d'un Fourneau, et Outils.* 66. *Bernard Dorez del.*





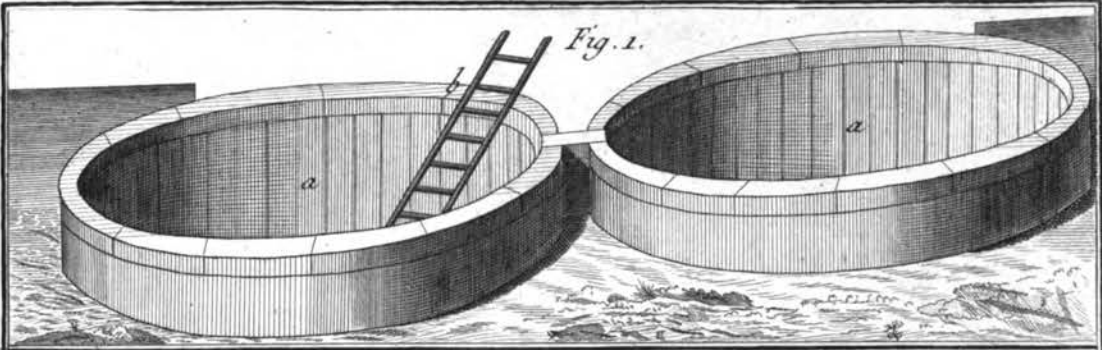
*Teinture des Gobelins, Intérieur d'un Fourneau, Outils &c.*

*Brevet Dorez.*



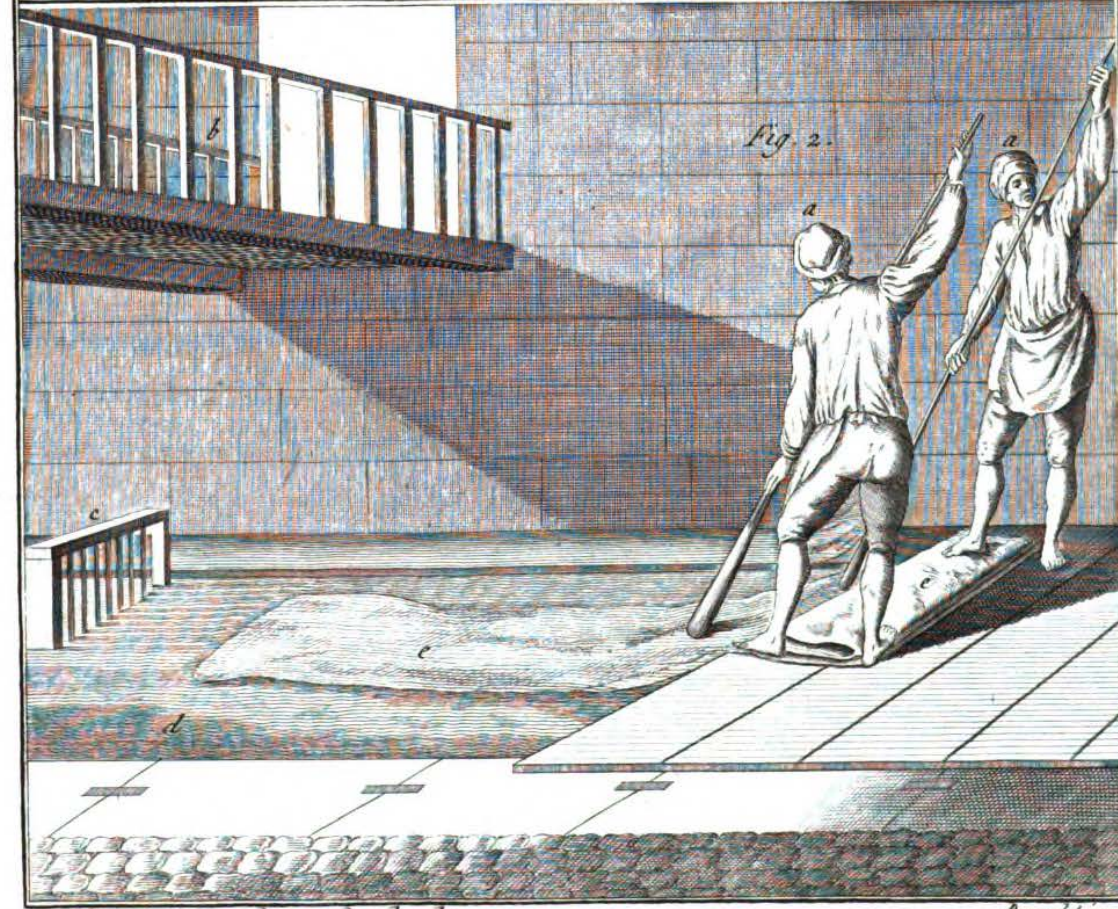
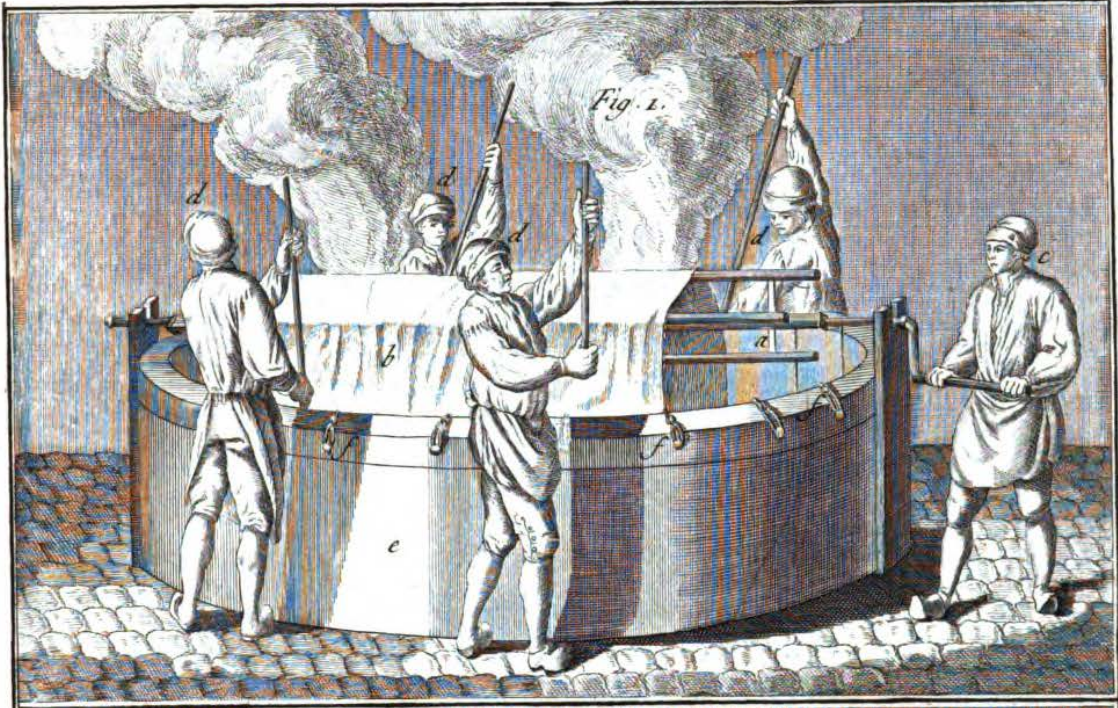
*Teinture des Gobelins, Pompe à chapelet pour remplir le petit Reservoir des eaux de la Couronne et de la Couronne.* Bernard Duvoux.



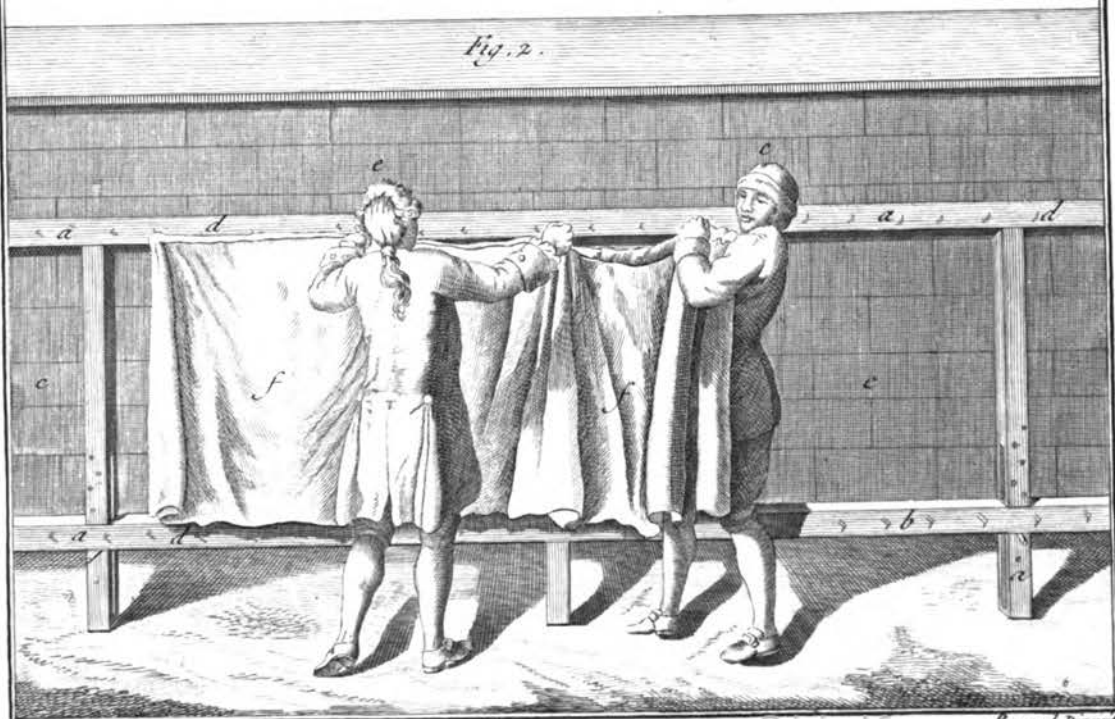
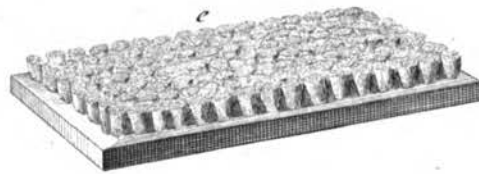
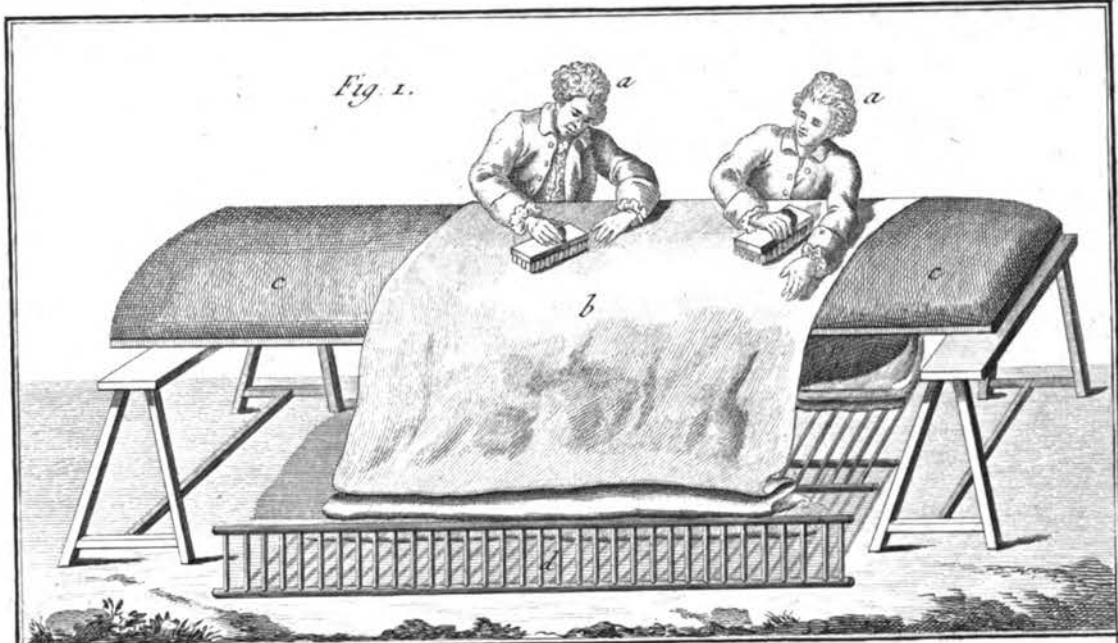


*Teinture des Gobelins, Tondeur, Outils et Caves.*

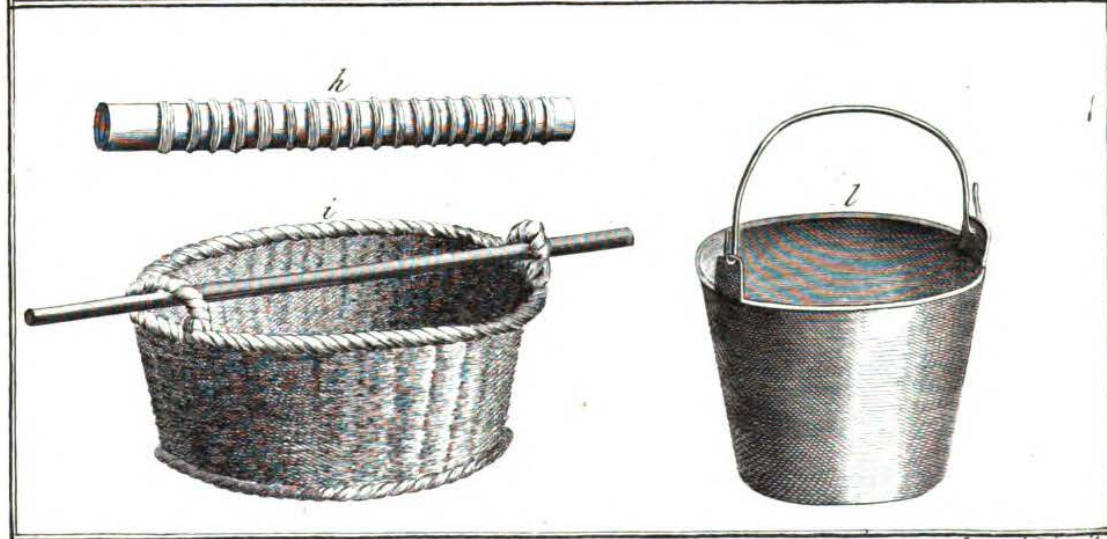
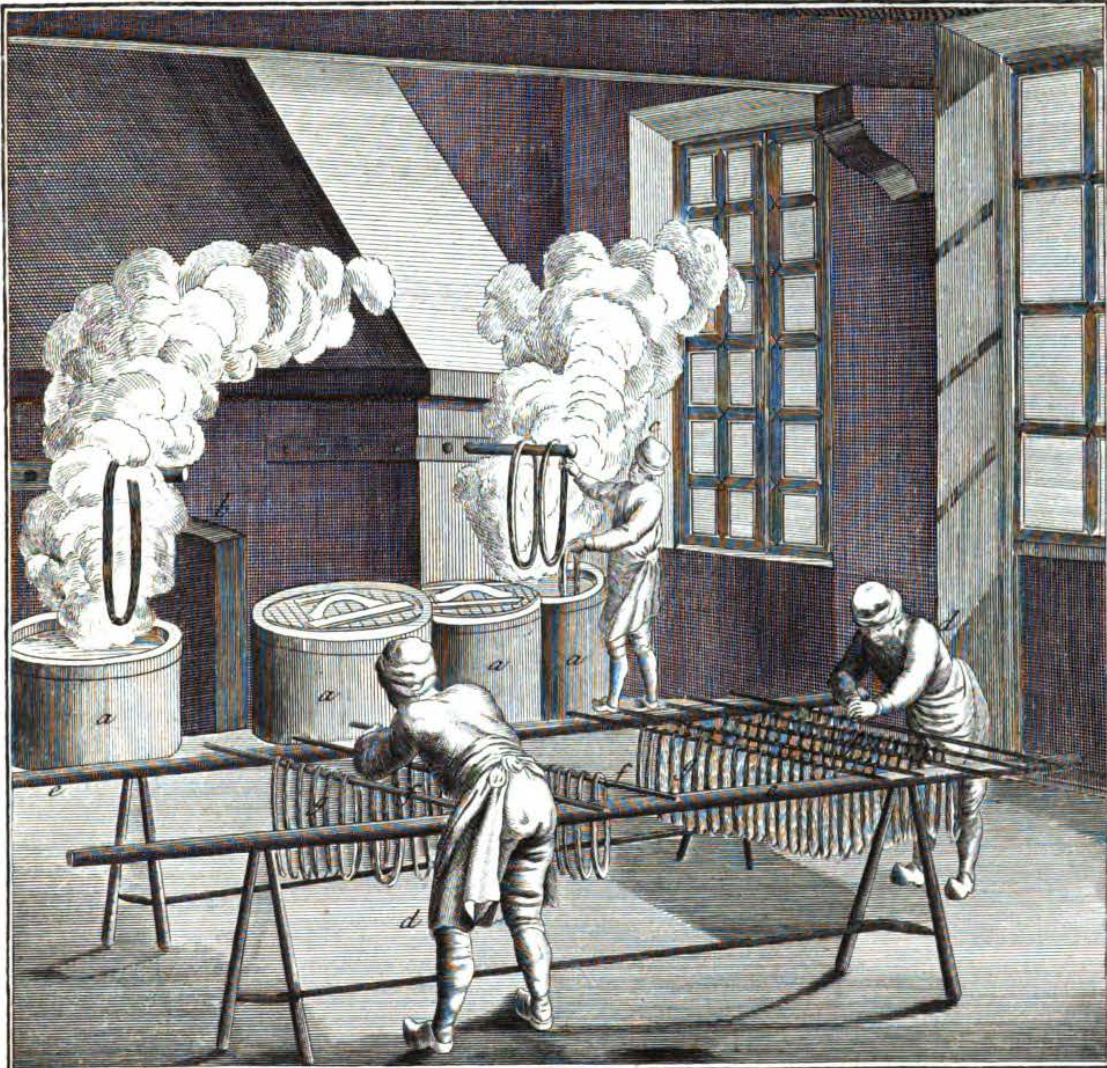
*Bernard Duvicq.*



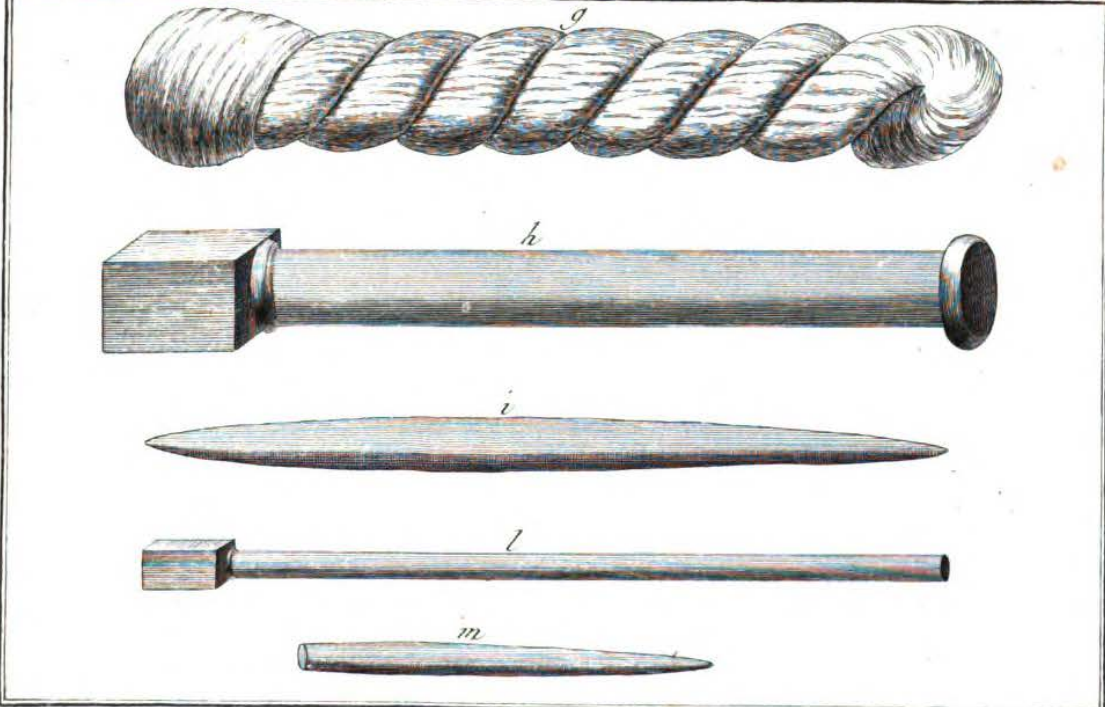
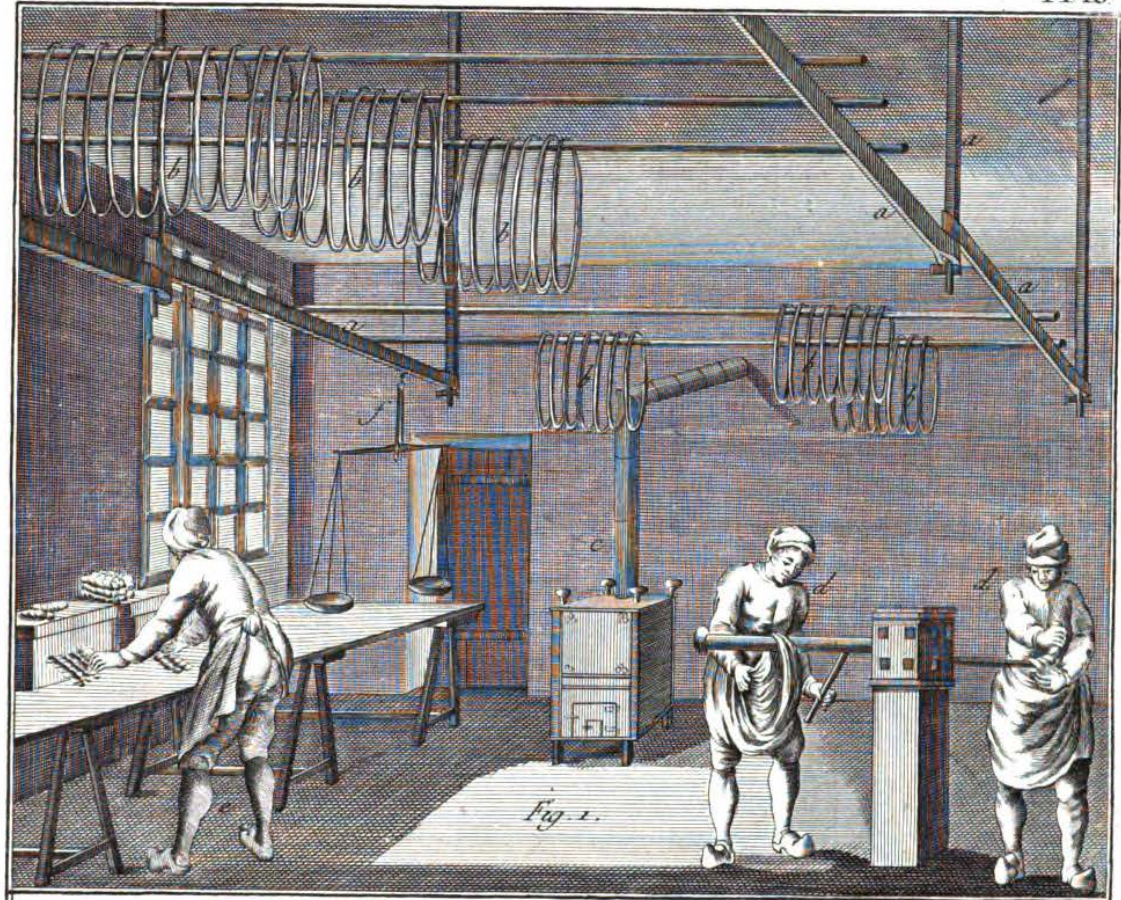
*Teinture des Gobelins, Service du Tour et Lavage de Riviere*. 68. Benard Juvet del.



*Teinture des Gobelins, Service du Couchoir et le Séchoir*  
 Original from *Bernard Dorez*  
 Digitized by Google UNIVERSIDAD COMPLUTENSE DE MADRID



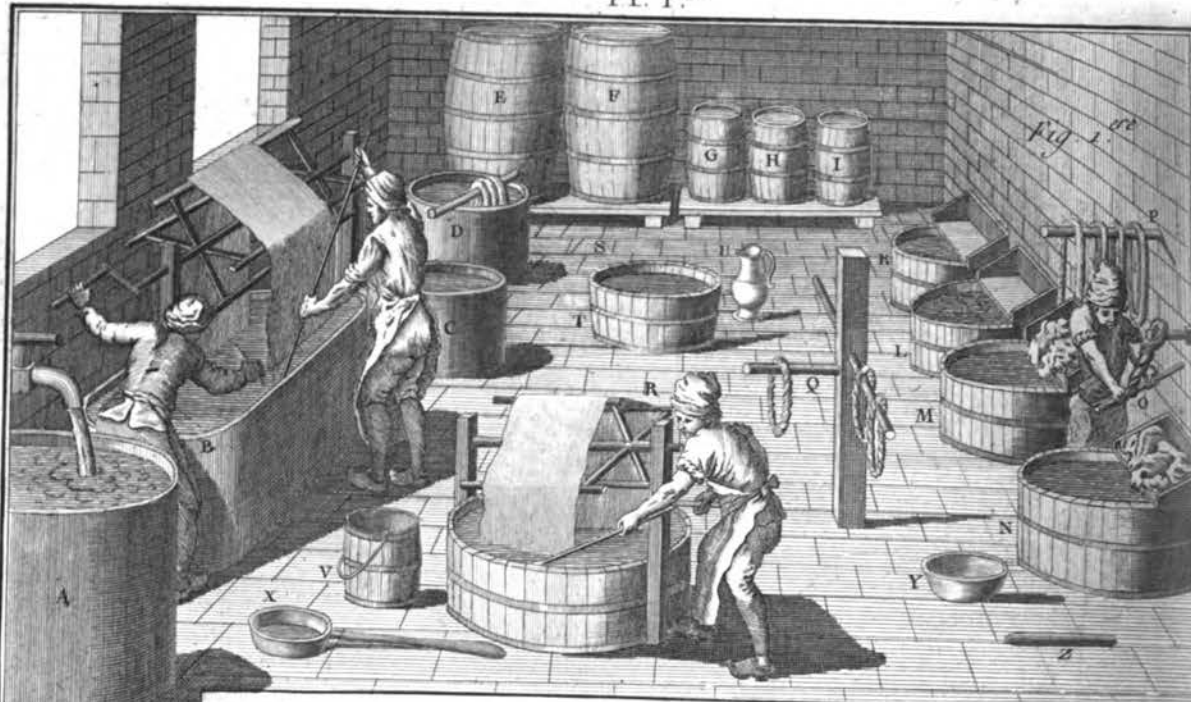
*Teinture des Gobelins, Intérieur de l'Atelier de Teinture de Laines et Soies.* Bernard Duret.



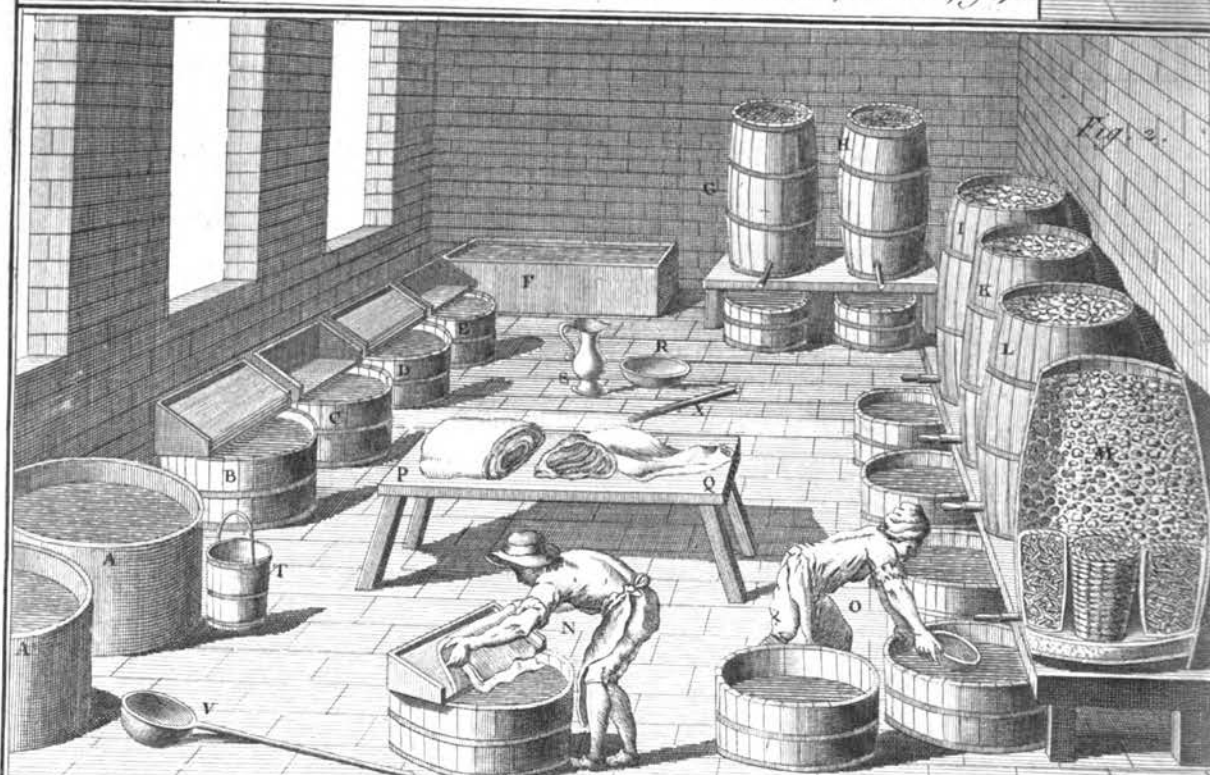
*Teinture des Gobelins, Atelier du Sechoir.*

*Bernard Dorez del.*



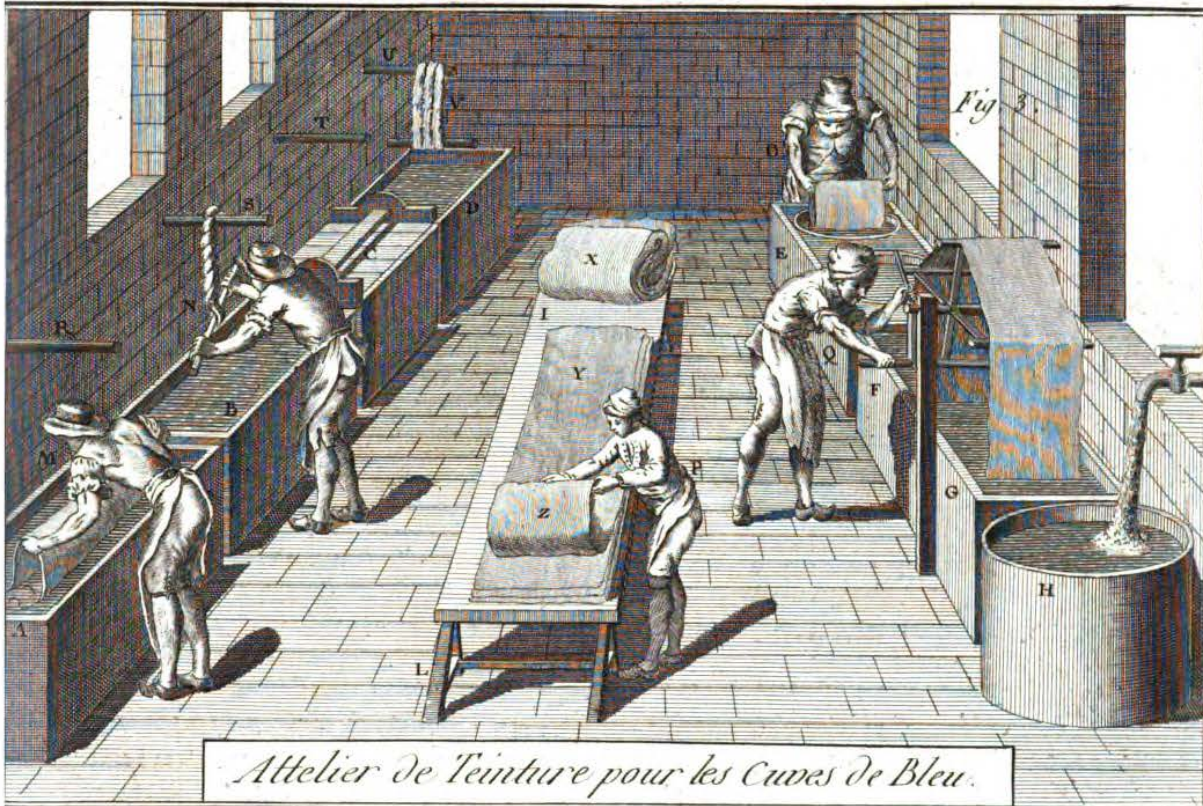


*Atelier de Teinture pour les Couleurs ordinaires, les Garençages, &c*

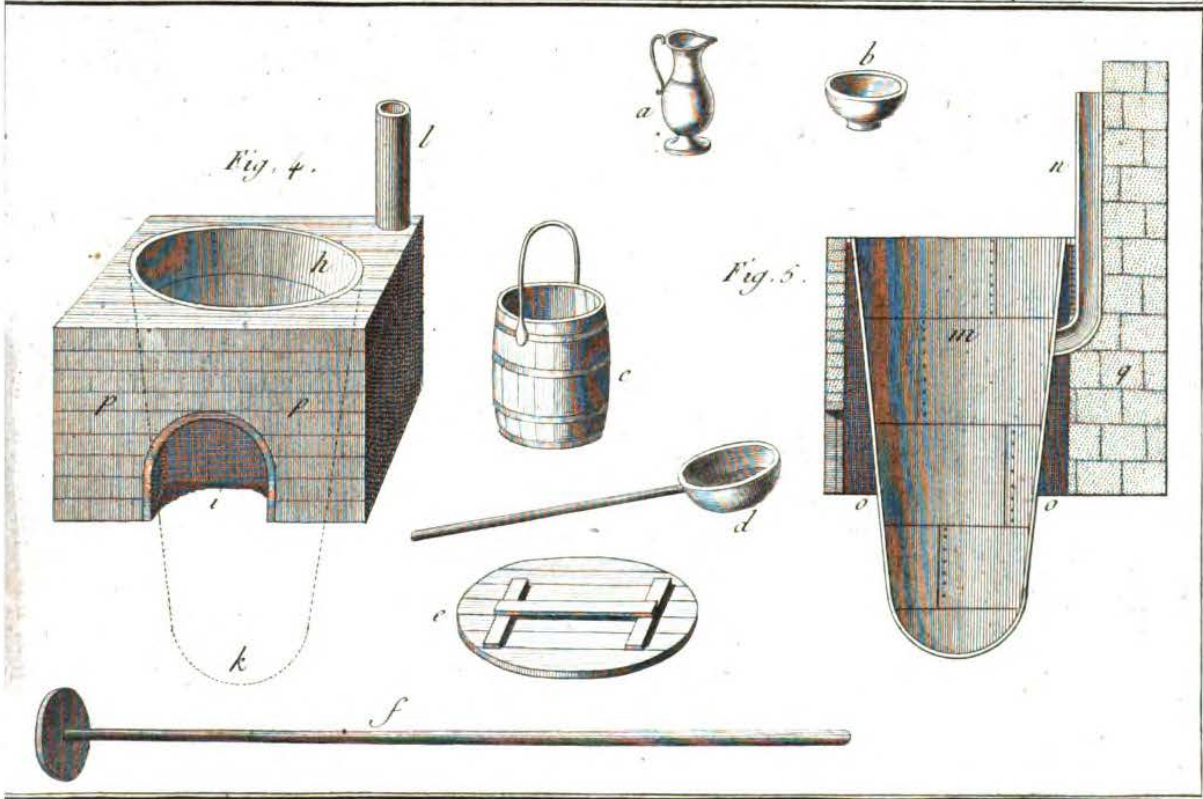


*Atelier de Teinture pour les Tones de Noir.*

*Teinture de Fil et Coton*

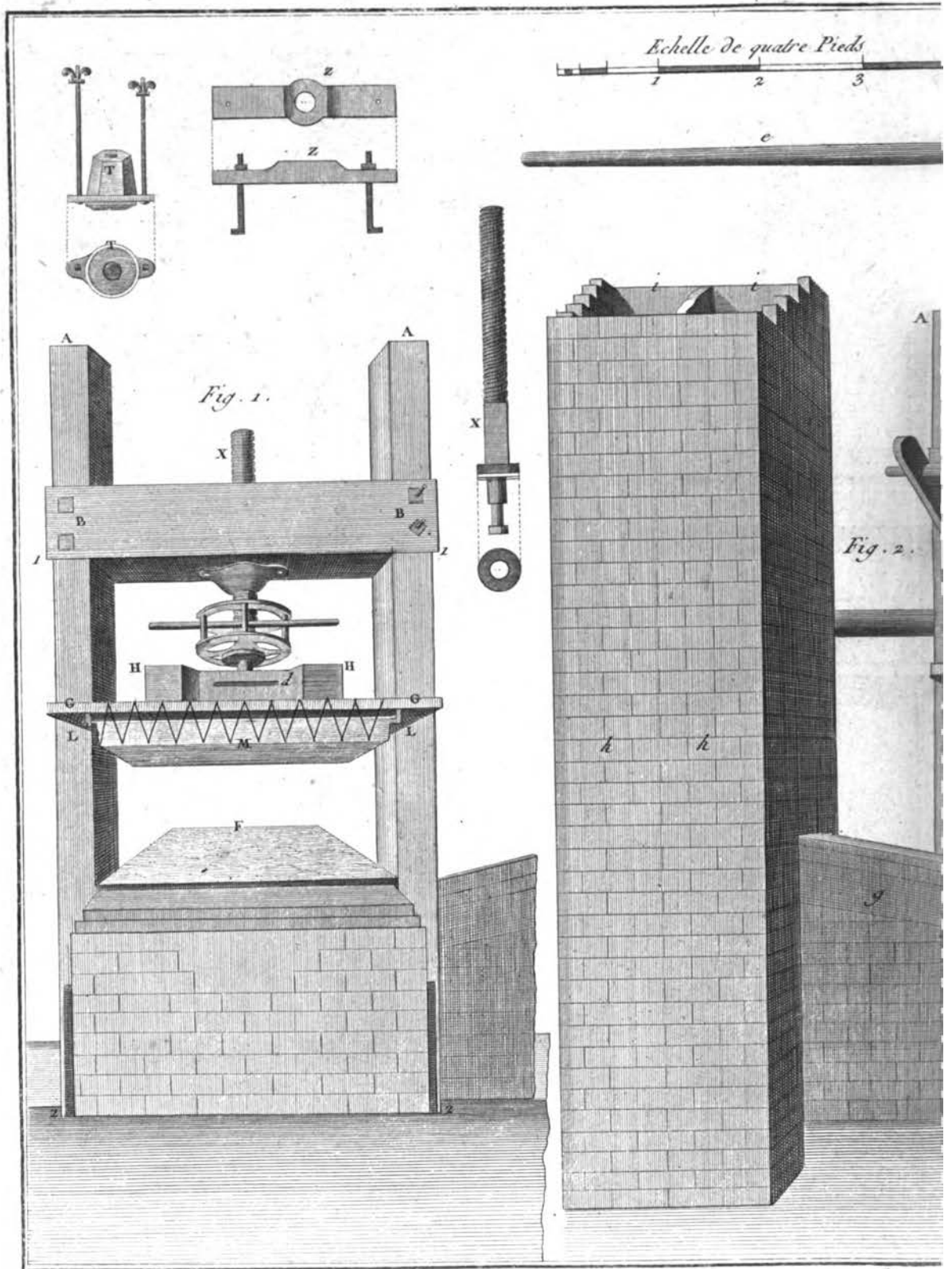


*Atelier de Teinture pour les Cuves de Bleu.*



*Différens Ateliers et Ustensiles.*

*Bernard Duvet.*



*Impression des L.*

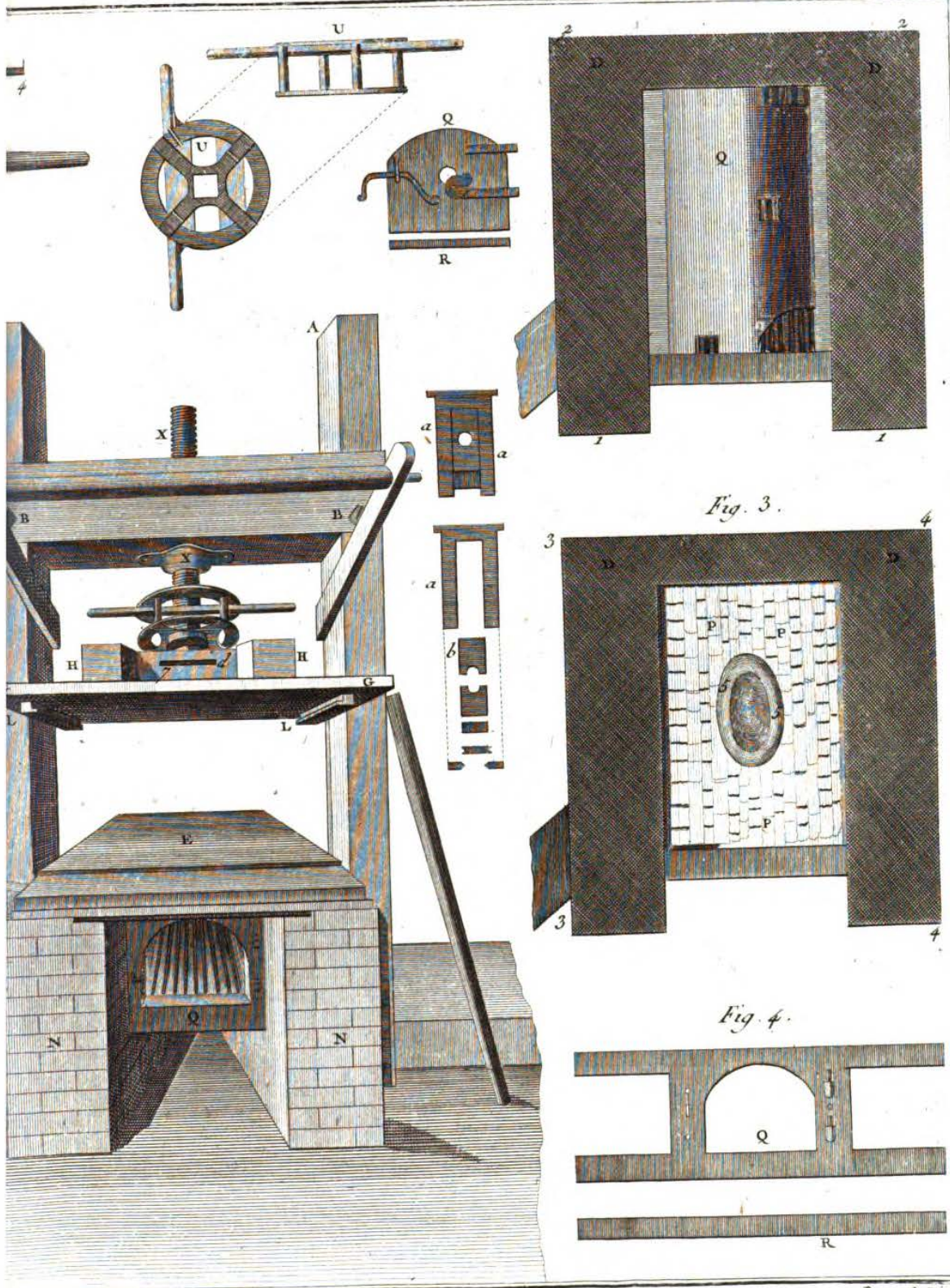
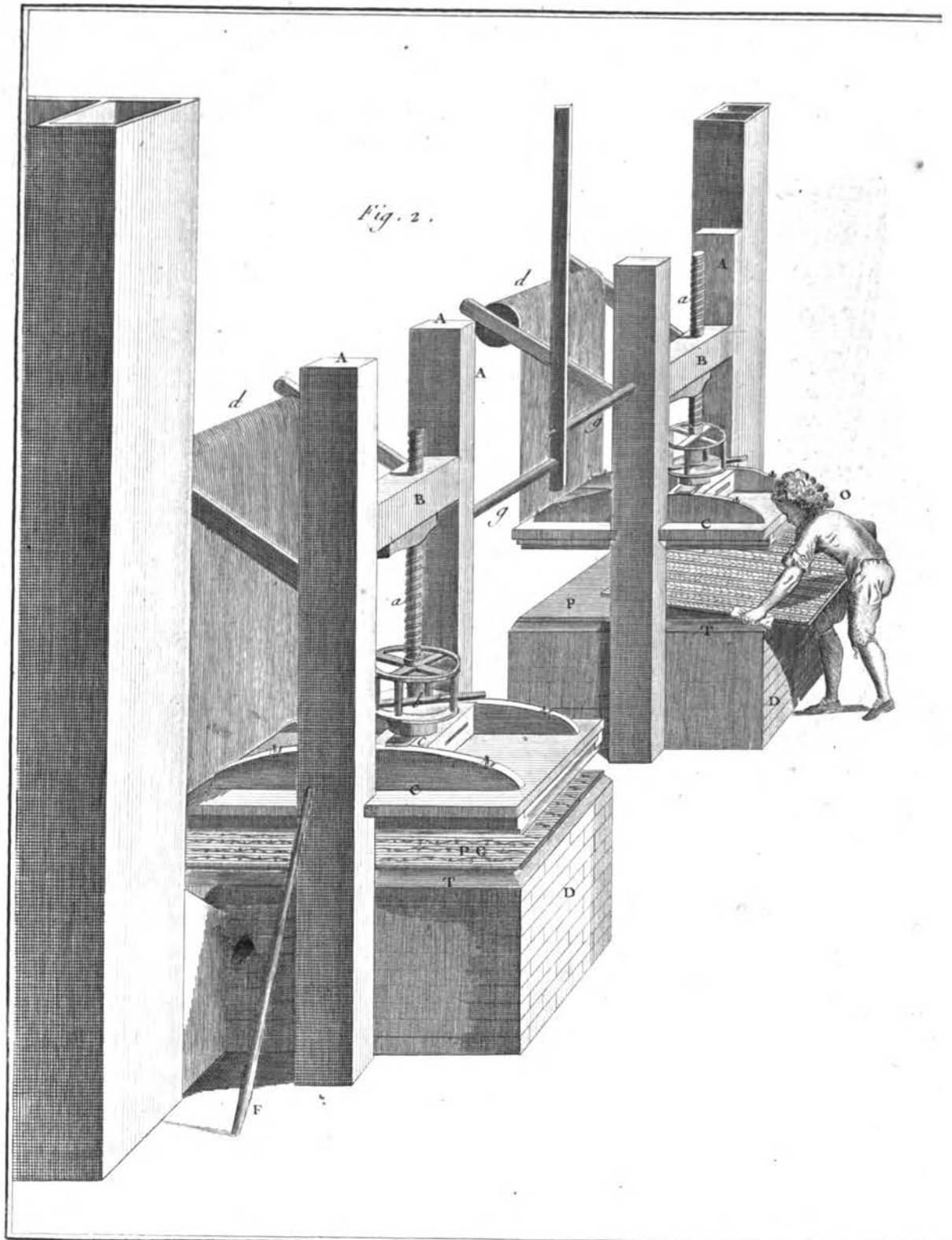


Fig. 3.

Fig. 4.

Bernard Doreuil

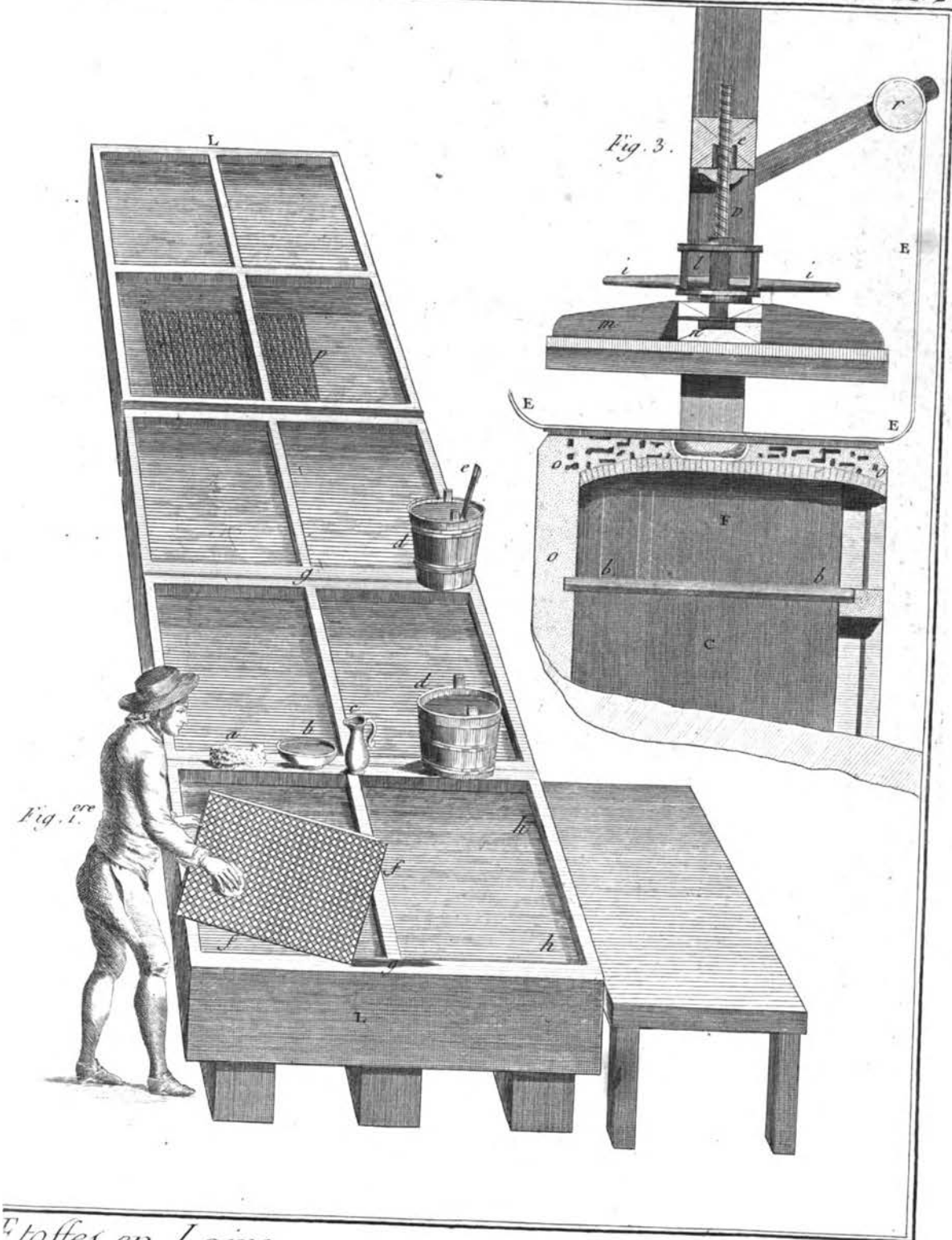
*toffes en Laine.*



*Impression des*

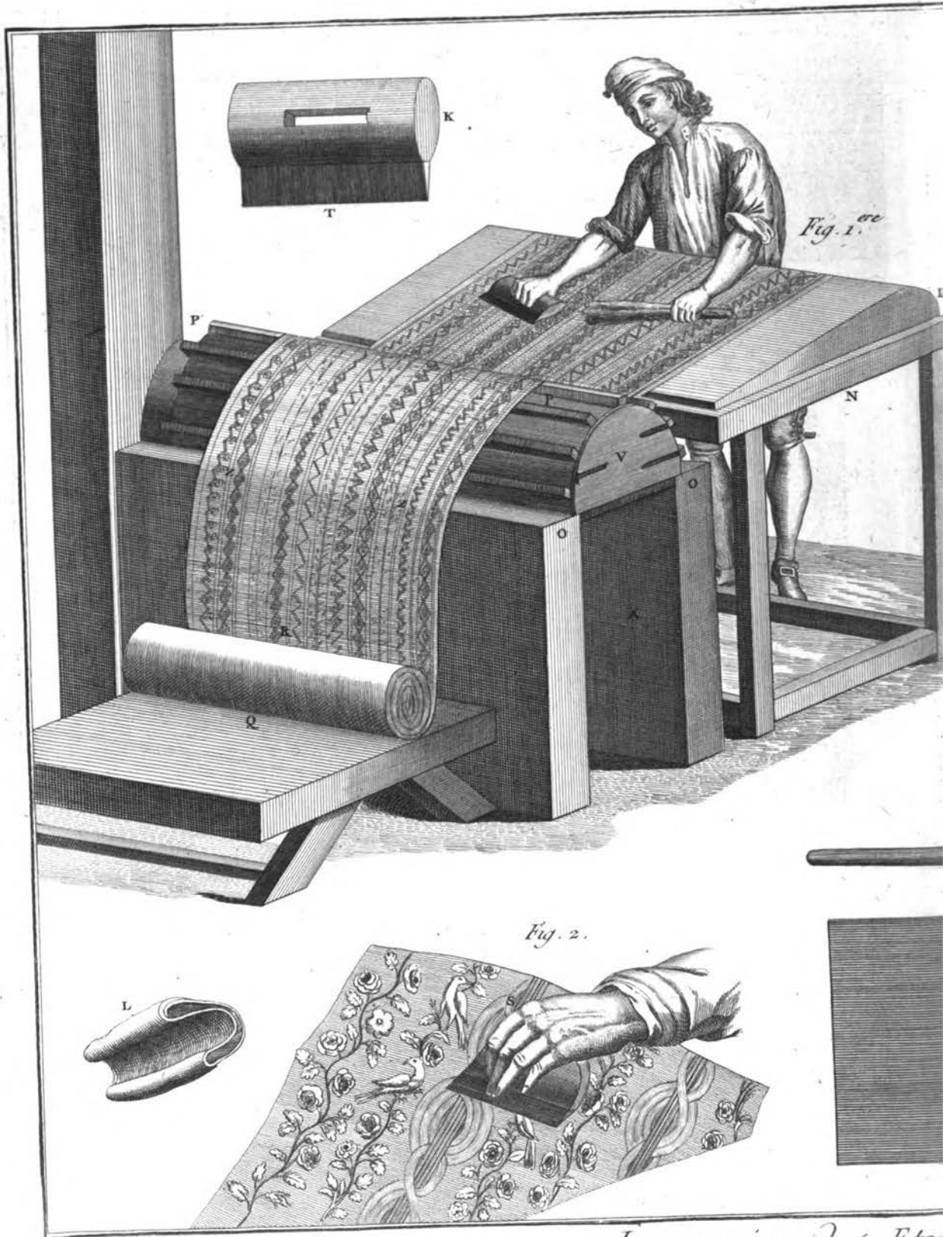
Digitized by Google

Original from  
UNIVERSIDAD COMPLUTENSE  
DE MADRID



*Etoffes en Laine.*

*Bernard Dorez.*



*Impression des Etois*

Fig. 3.

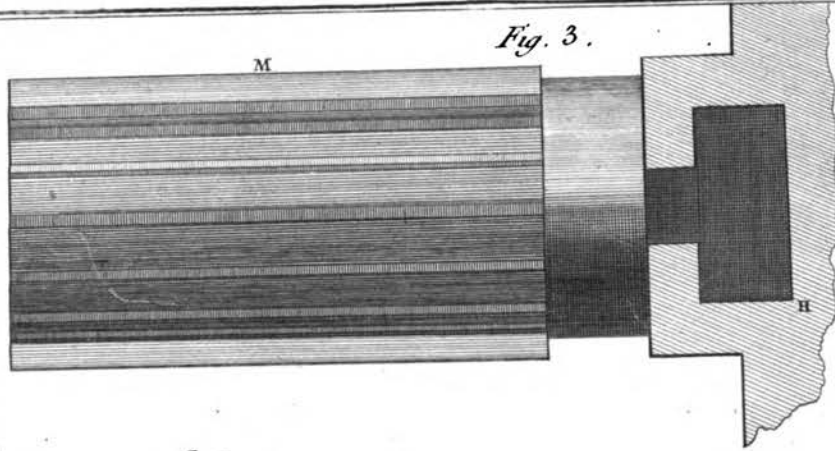
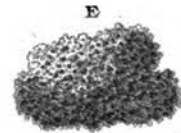
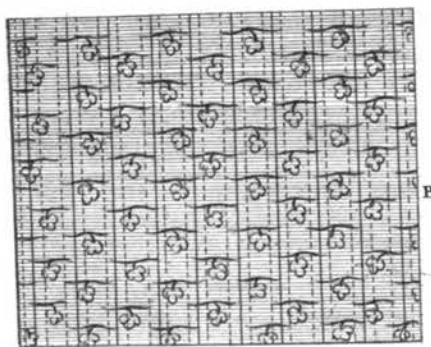
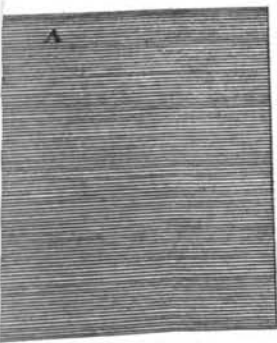
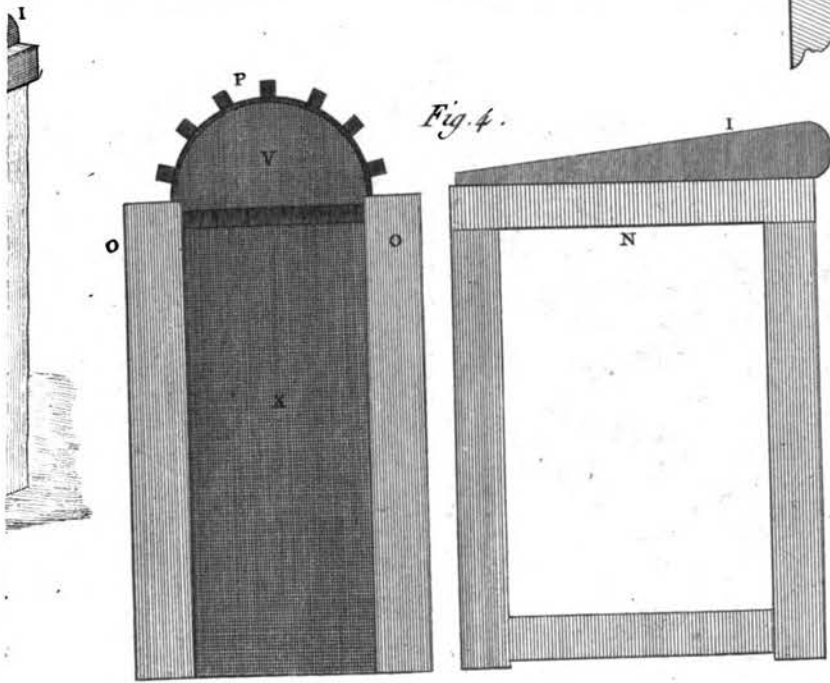


Fig. 4.

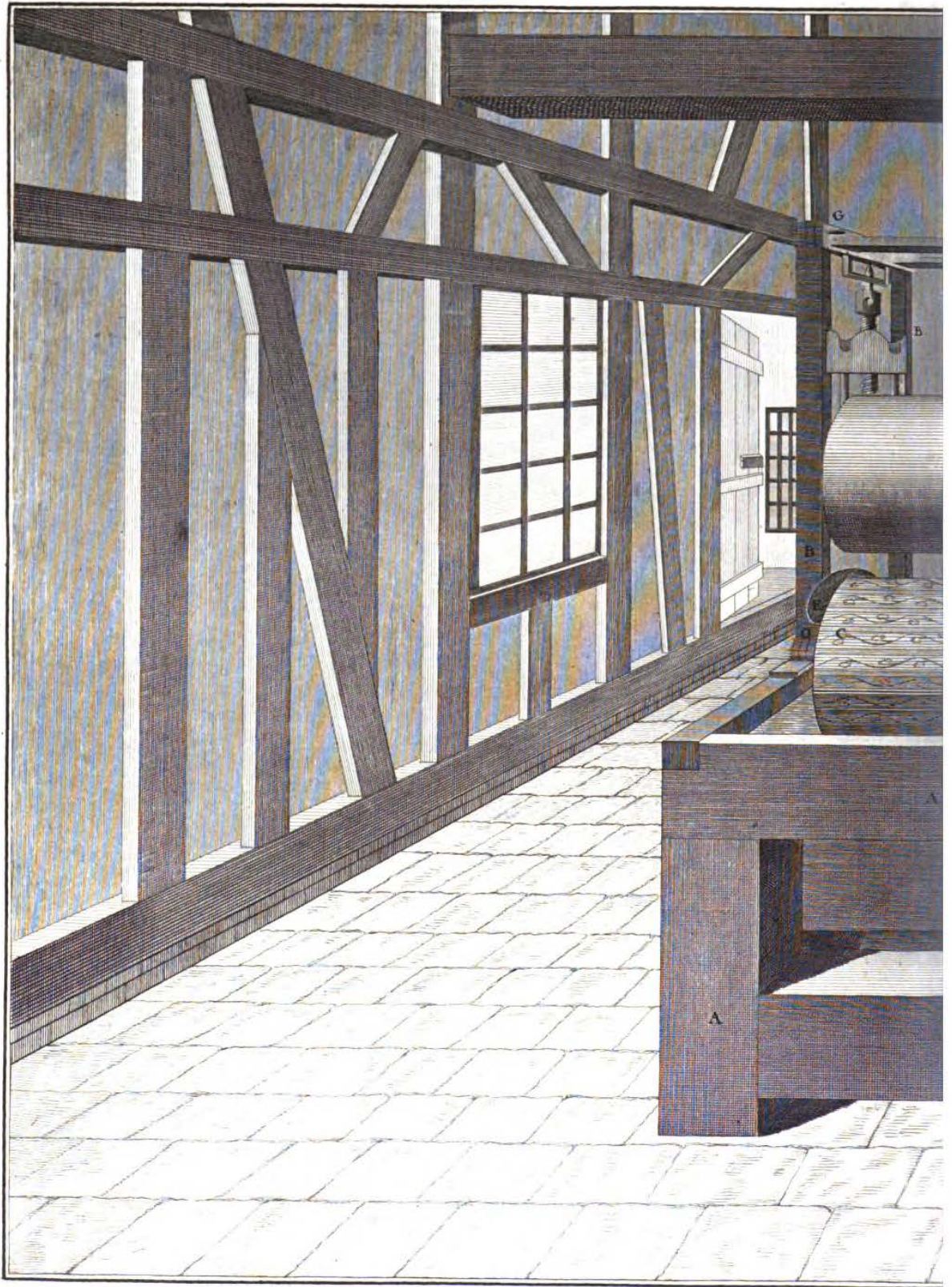


Bonard Dirault.

*Fes en Laines.*

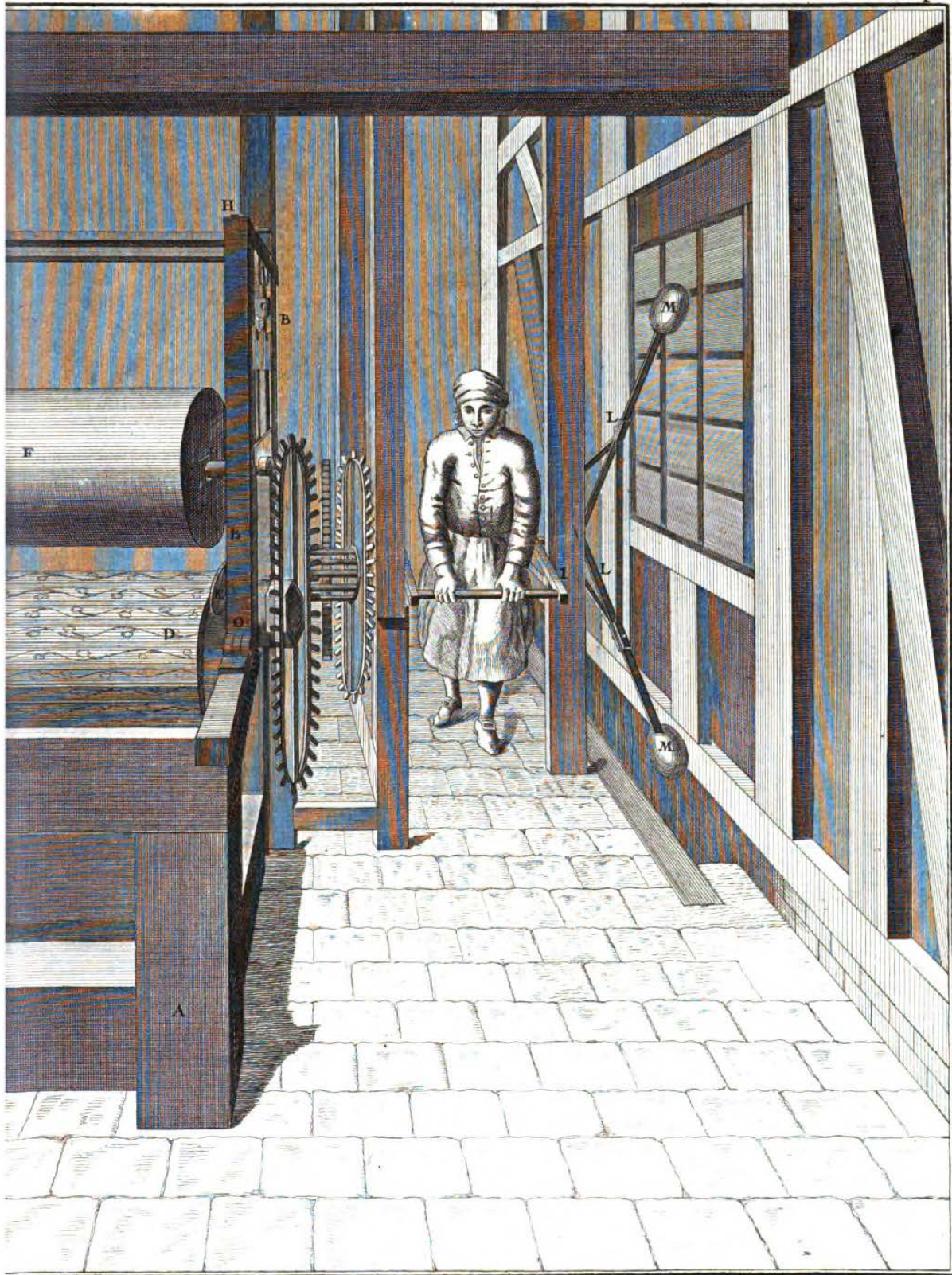
73.





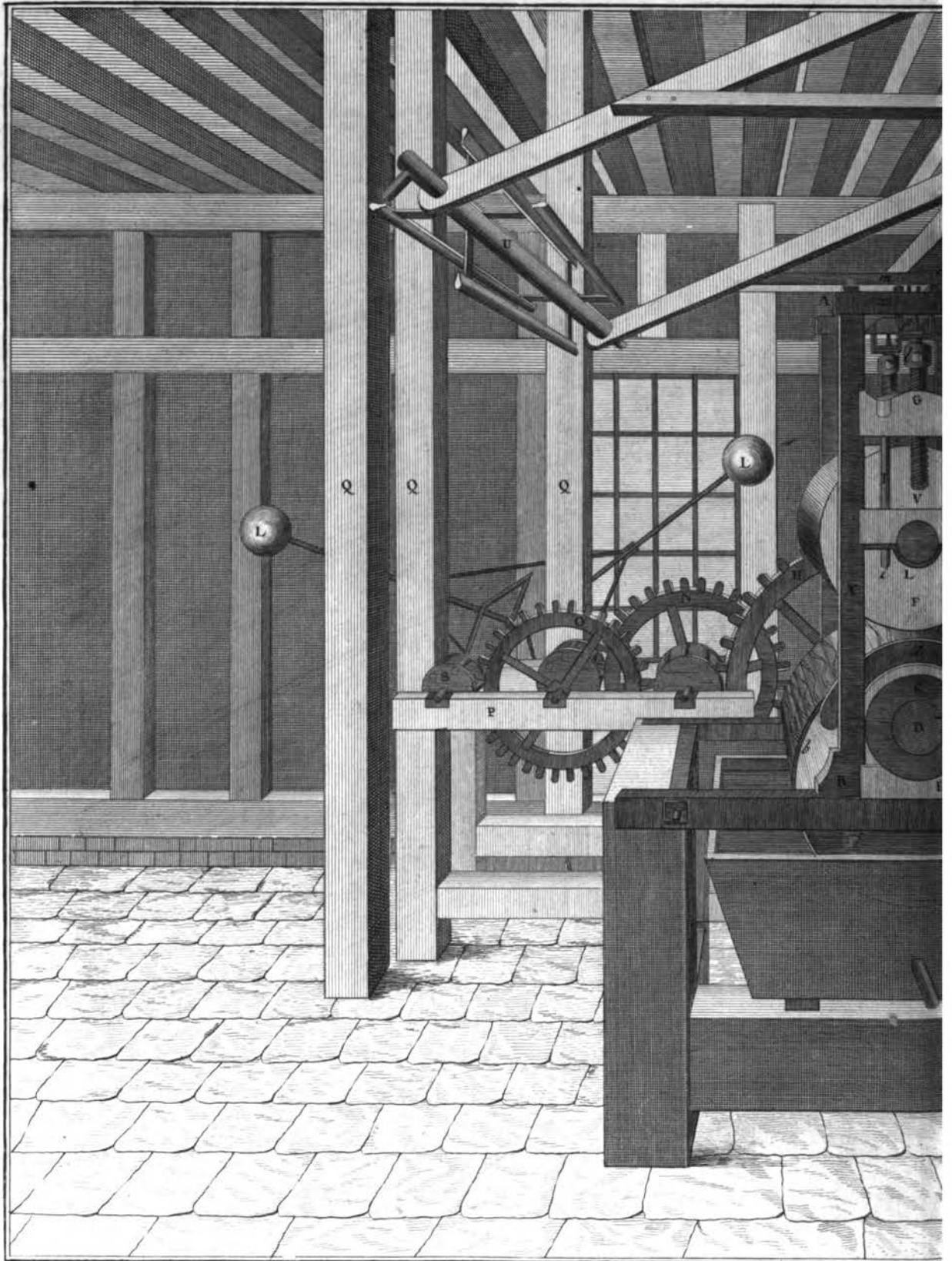
Digitized by Google

Original from *Impression des*  
UNIVERSIDAD COMPLUTENSE  
DE MADRID

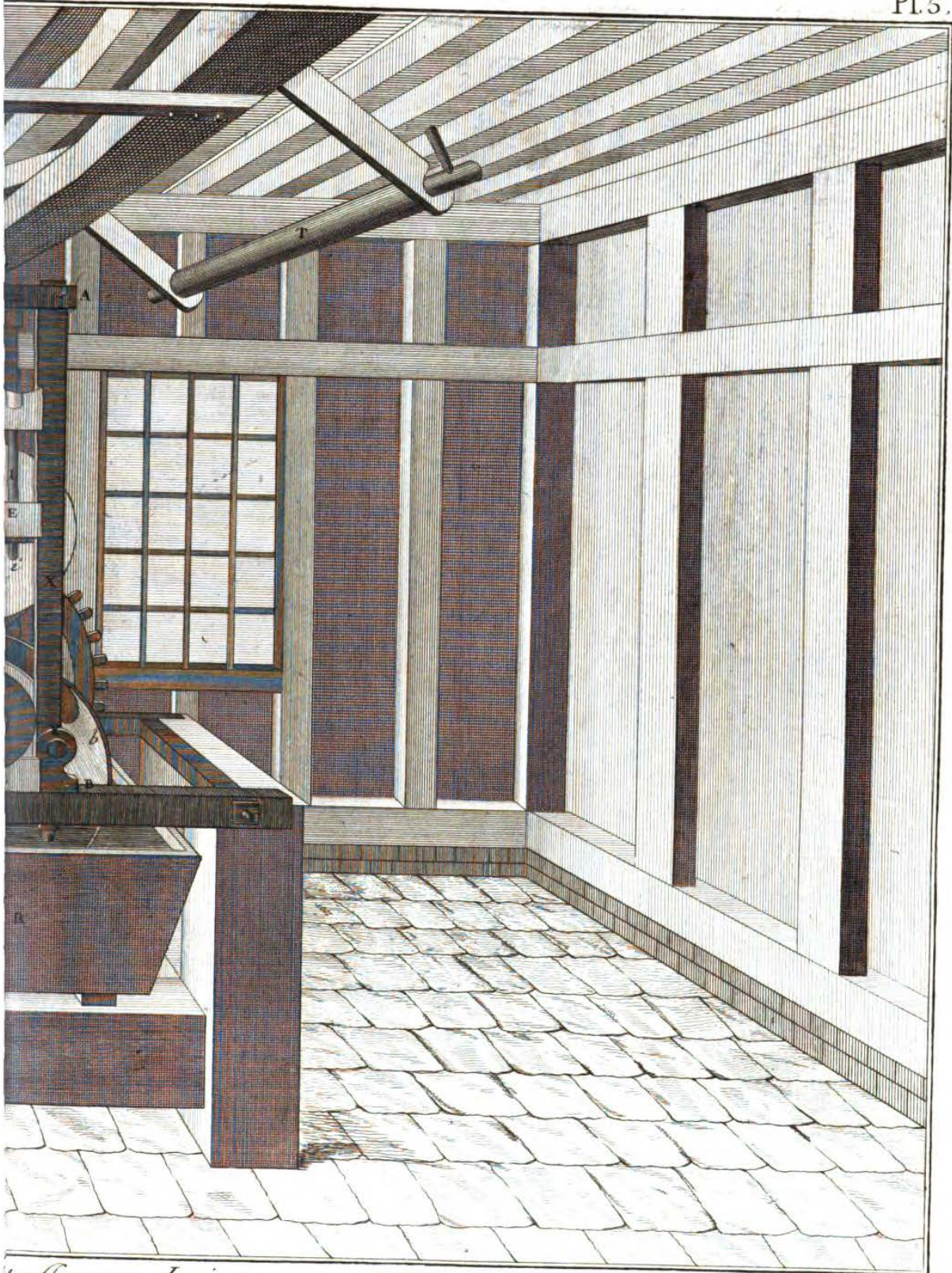


*Etoffes en Laine.*

*Bernard Duvet*



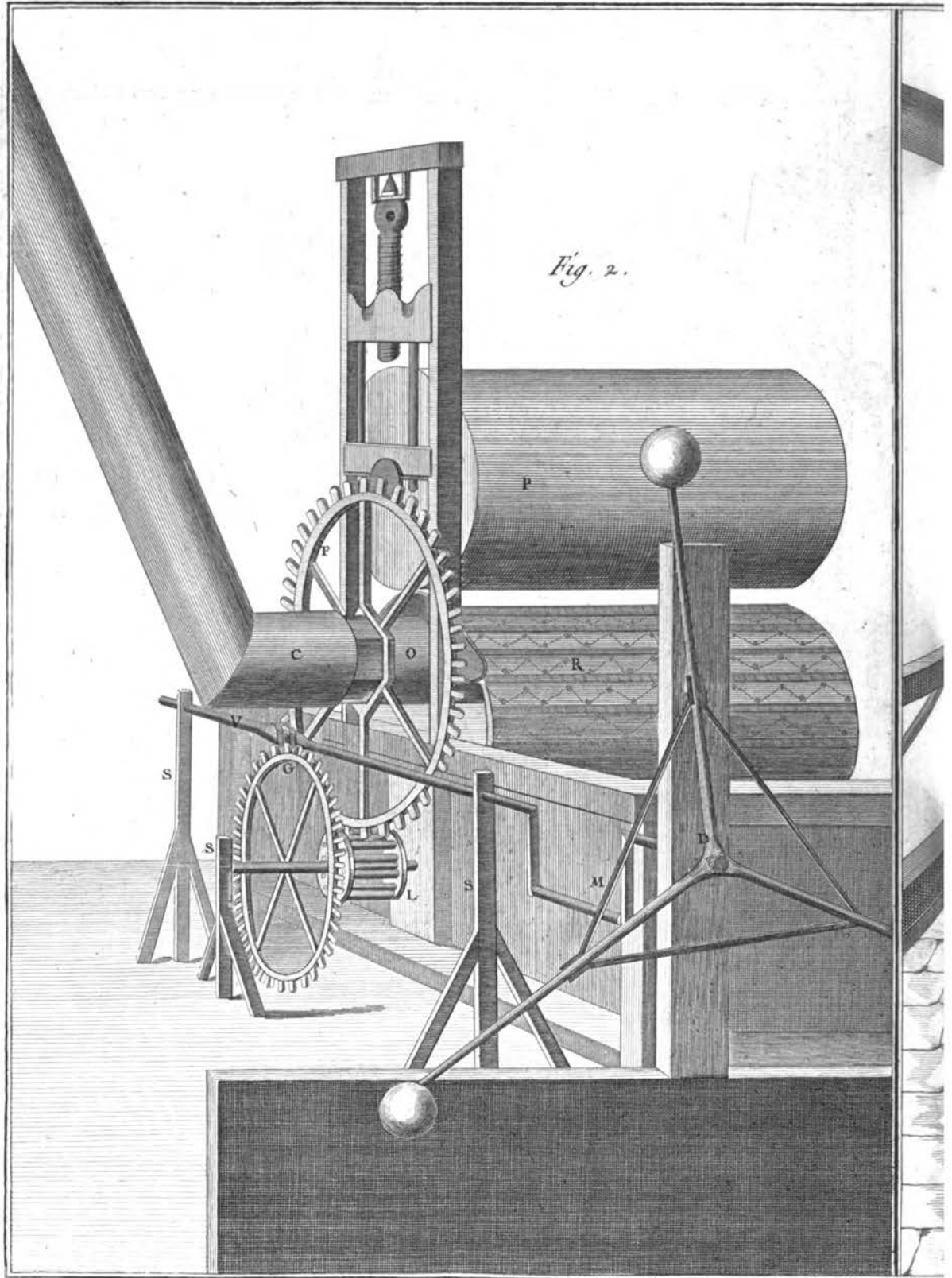
*Impression des E*



*toffes en Laine.*

*Benard Duvet*

75



*Impression des*

Digitized by Google

Original from  
UNIVERSIDAD COMPLUTENSE  
DE MADRID

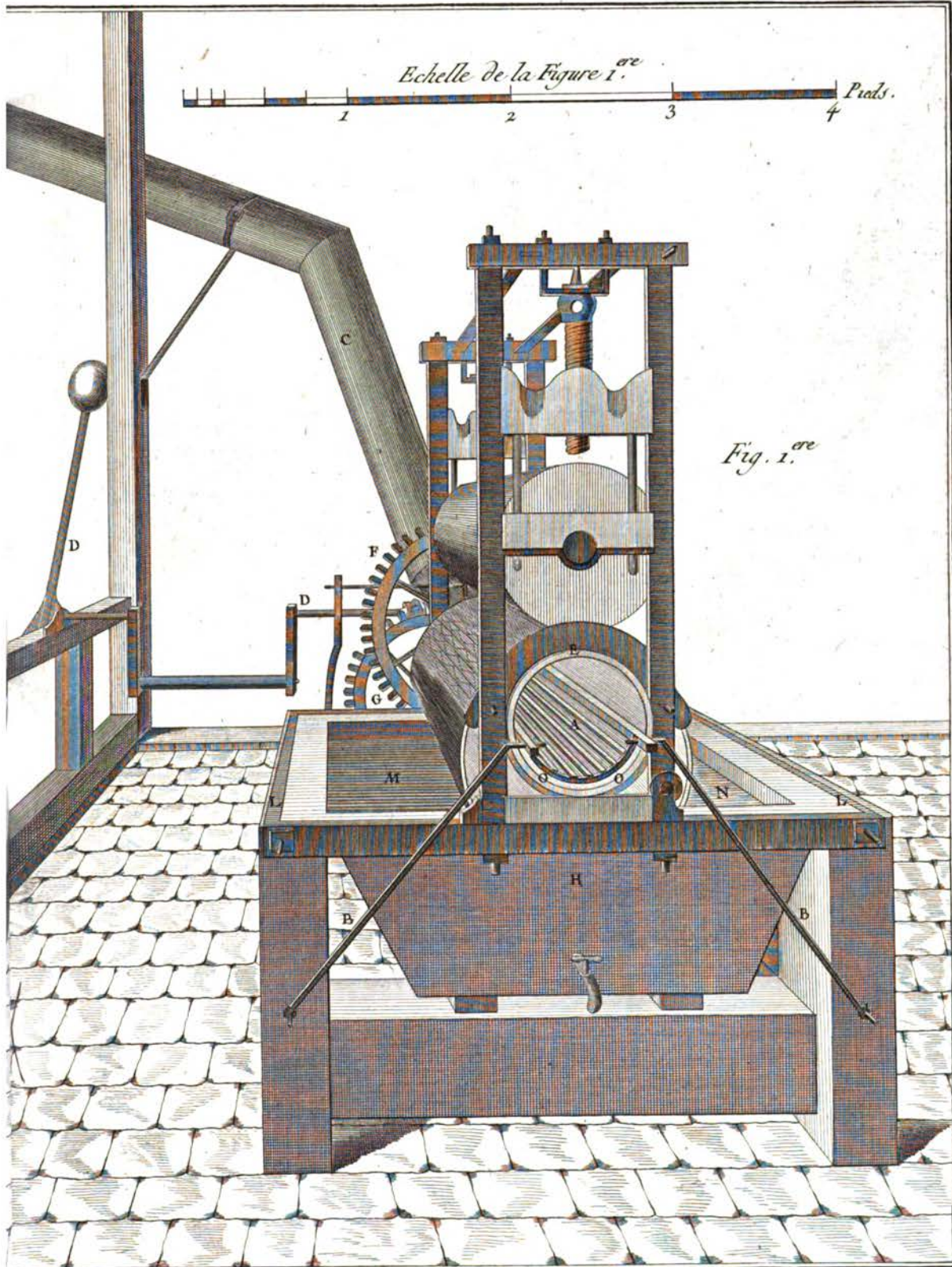
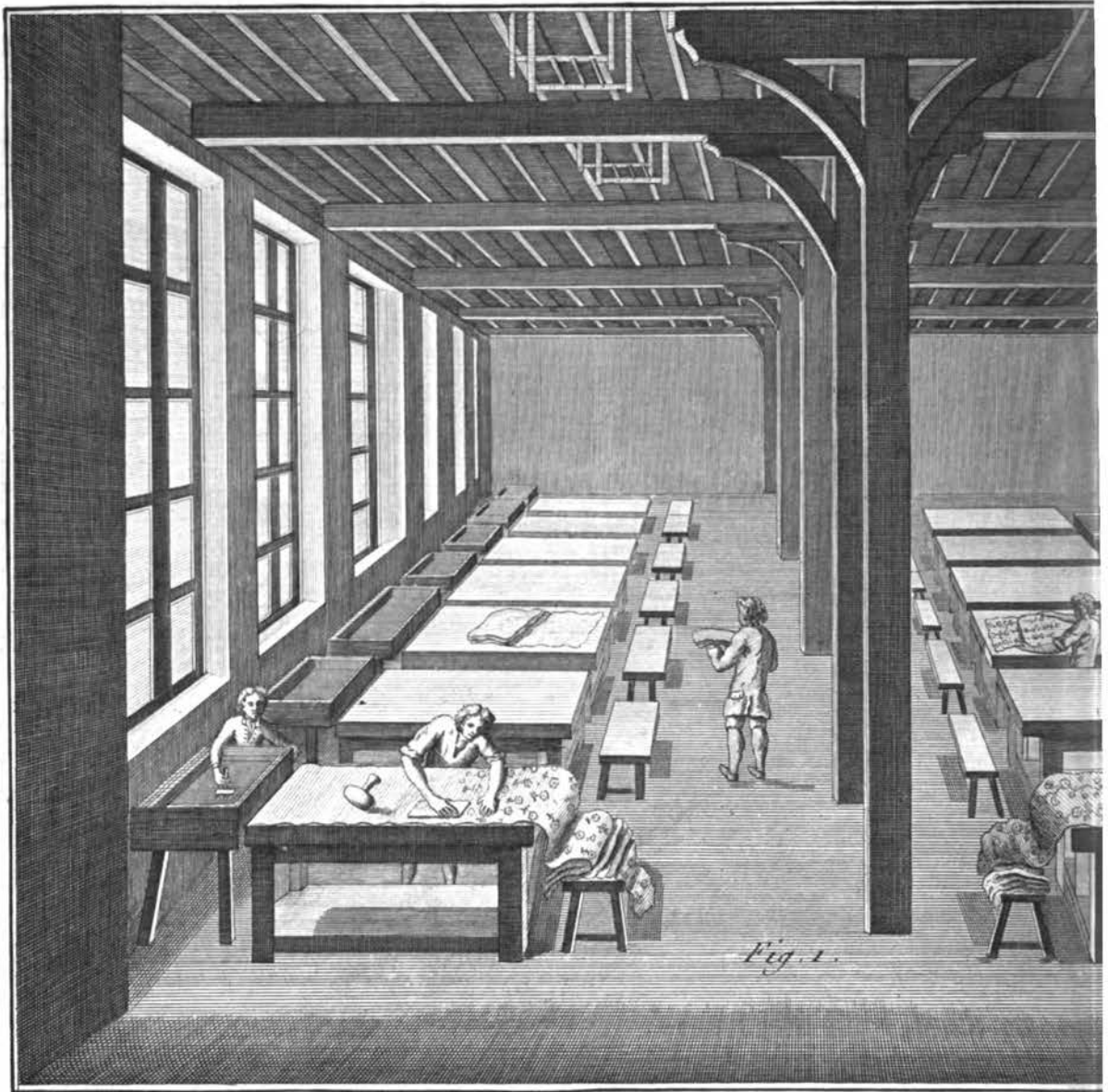


Fig. 1.ª

*Etoffes en Laine.*

Benard Dřexit

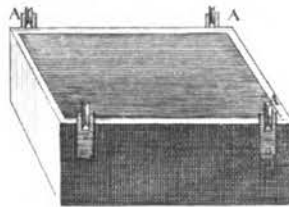


*Fig. 1.*

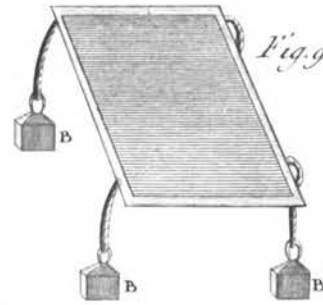
*Fig. 7.*



*Fig. 8.*



*Fig. 9.*



*Fig.*



*Atelier et Impres...*



Fig. 4.



Fig. 5.



Fig. 3.



Fig. 13.



Fig. 2.

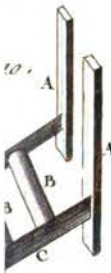
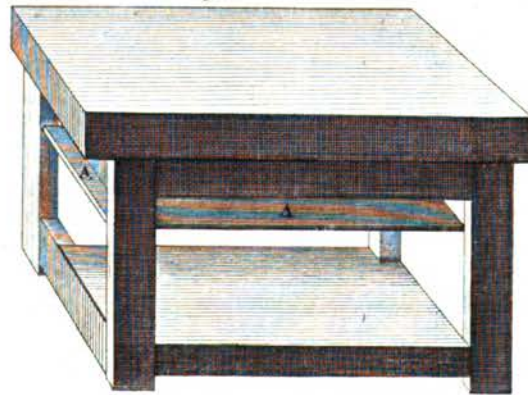


Fig. 11.



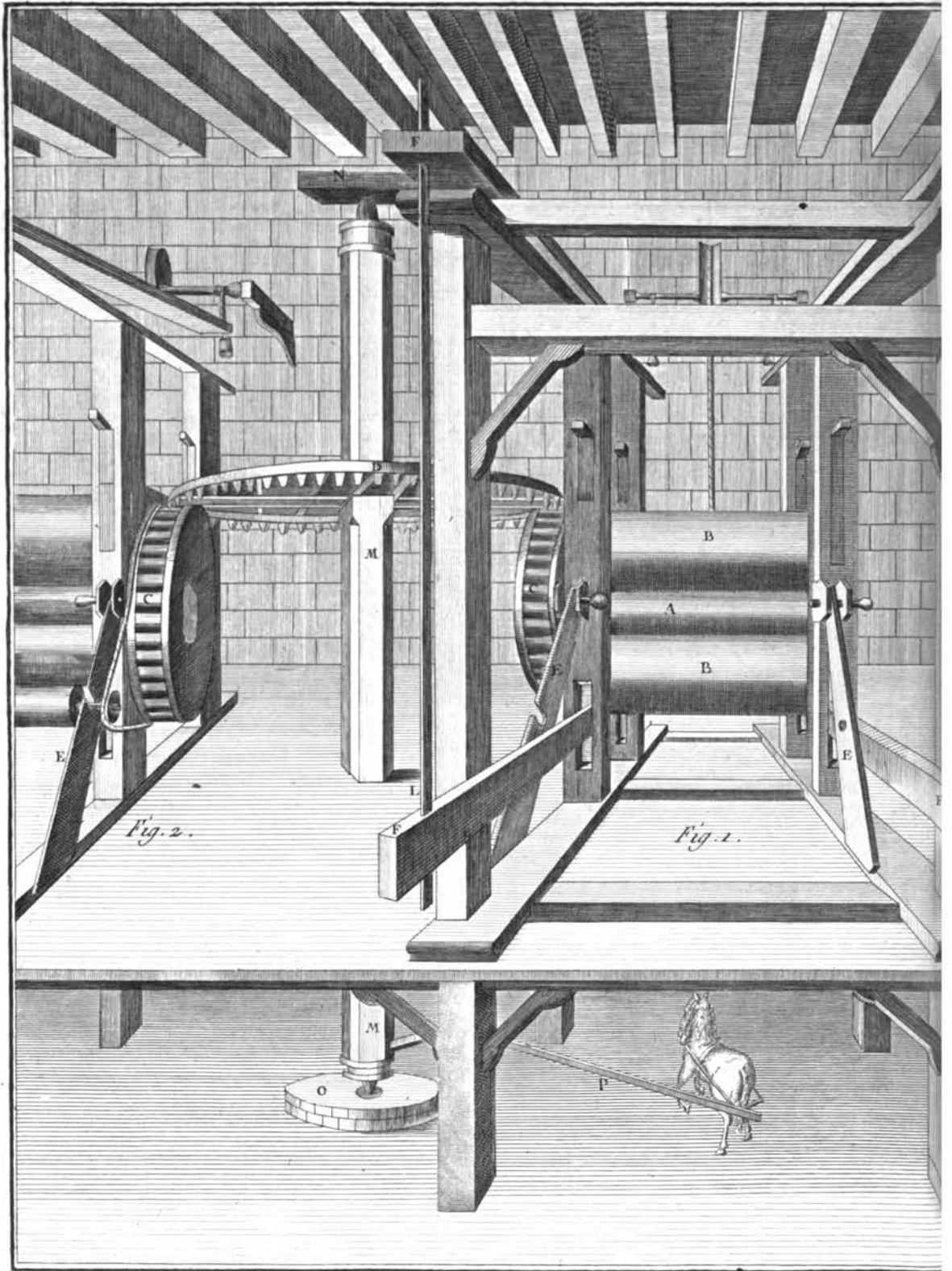
Fig. 12.



ion des Toiles Peintes.

Bernard Duvet





*Impression des Toiles Peintes*

Digitized by Google

Original from  
UNIVERSIDAD COMPLUTENSE  
DE MADRID

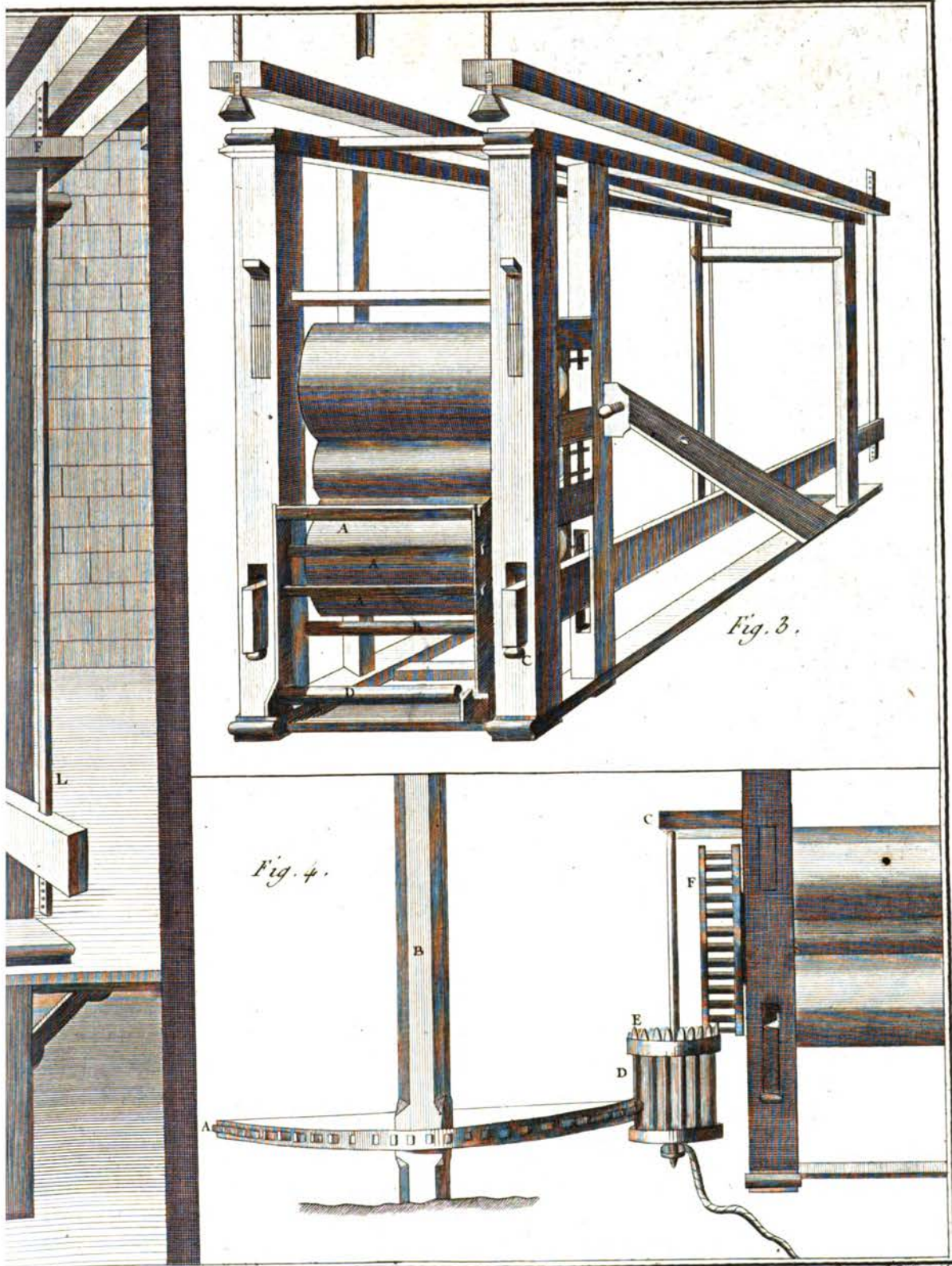
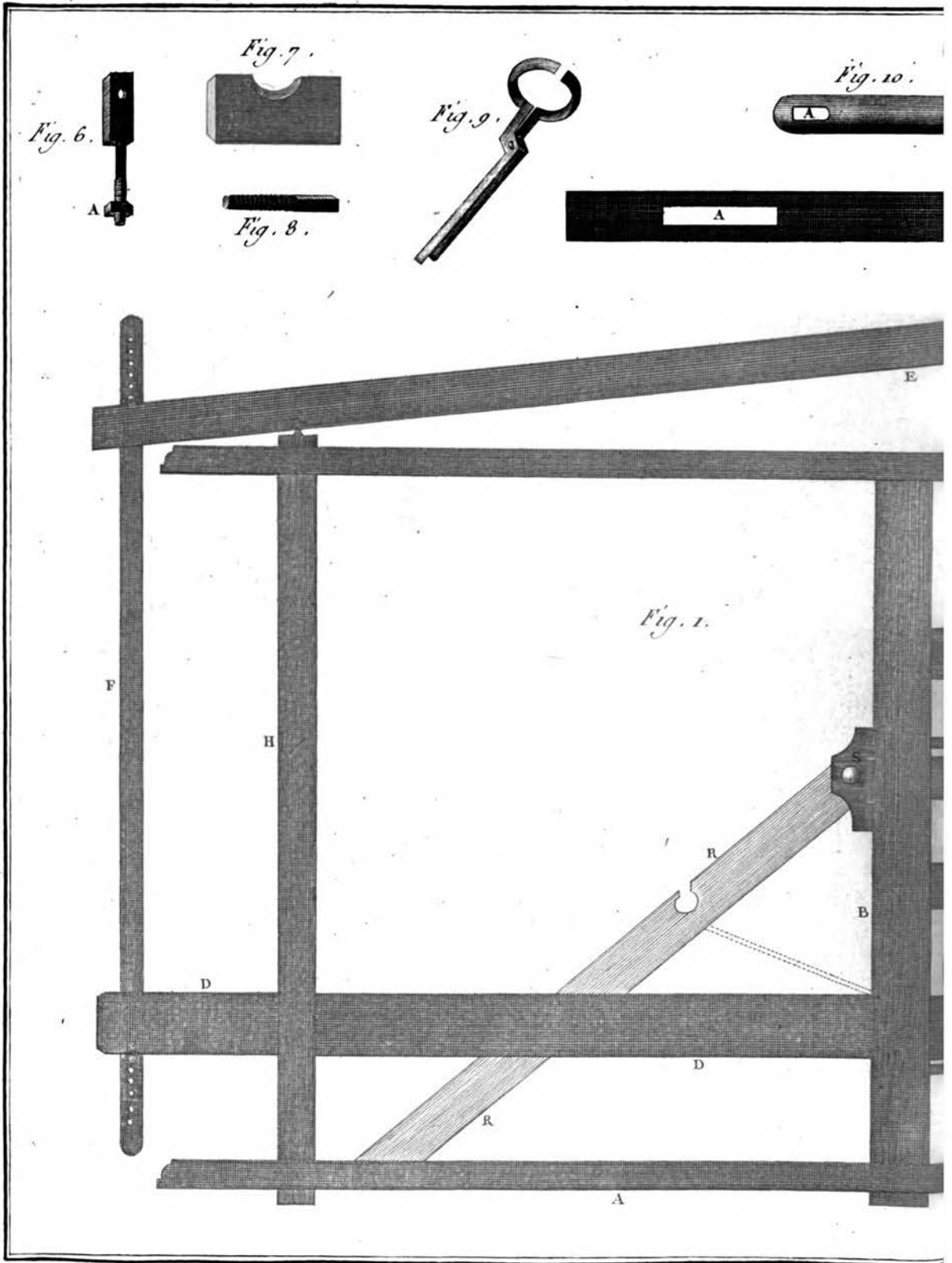


Fig. 3.

Fig. 4.

Benard Dirced.

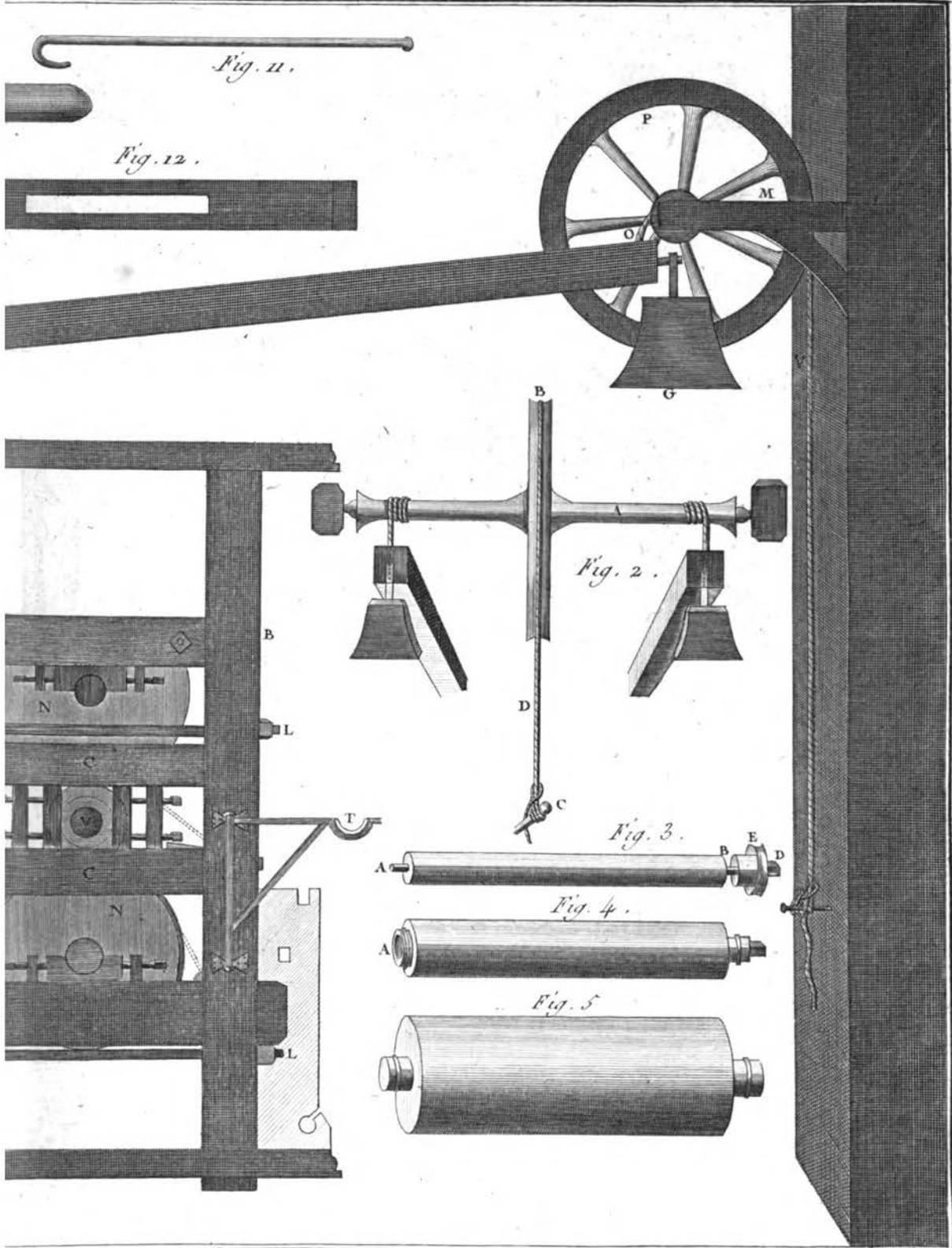
, Différentes Elevations du Cylindre à Bascules.



*Impression des Toiles Peintes*

Digitized by Google

Original from  
UNIVERSIDAD COMPLUTENSE  
DE MADRID



*Cylindre à Bascule et développemens .*

*Bernard Diracl.*

Generated on 2014-05-10 22:32 GMT / http://hdl.handle.net/2027/ucm.5320295822  
Public Domain, Google-digitized / http://www.hathitrust.org/access\_use#pd-google

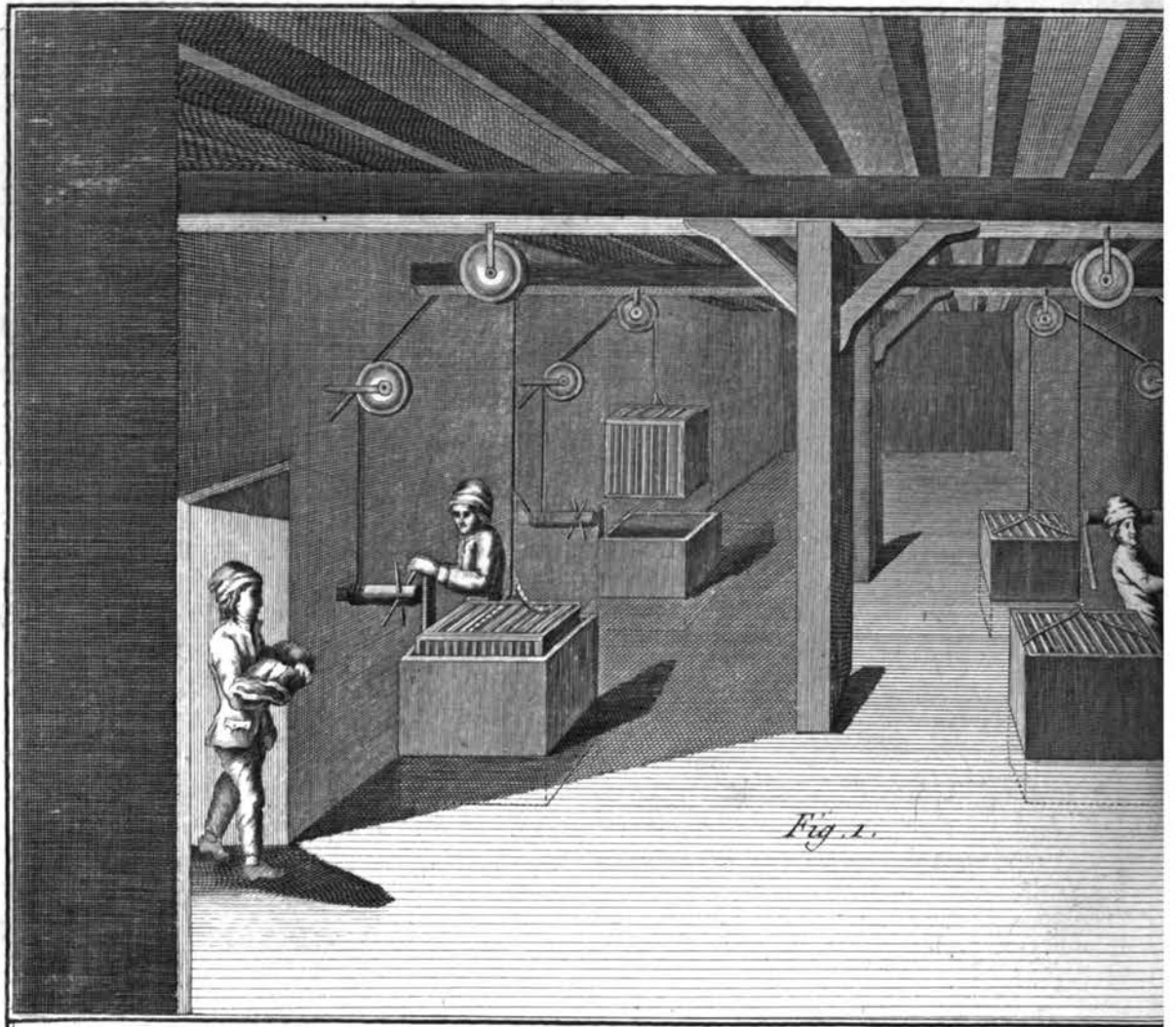


Fig. 1.

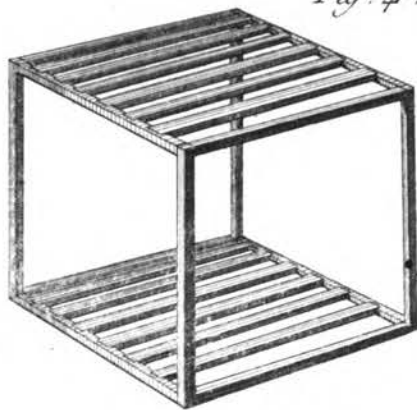


Fig. 4.

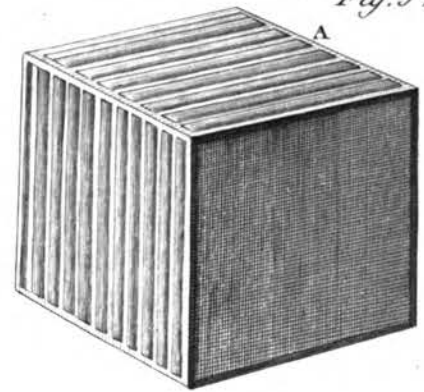
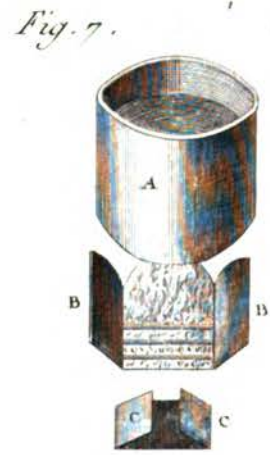
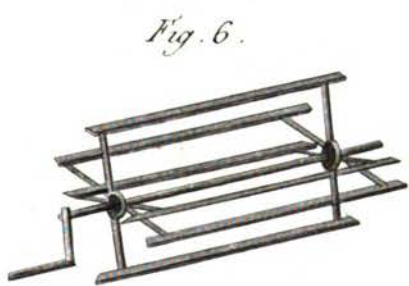
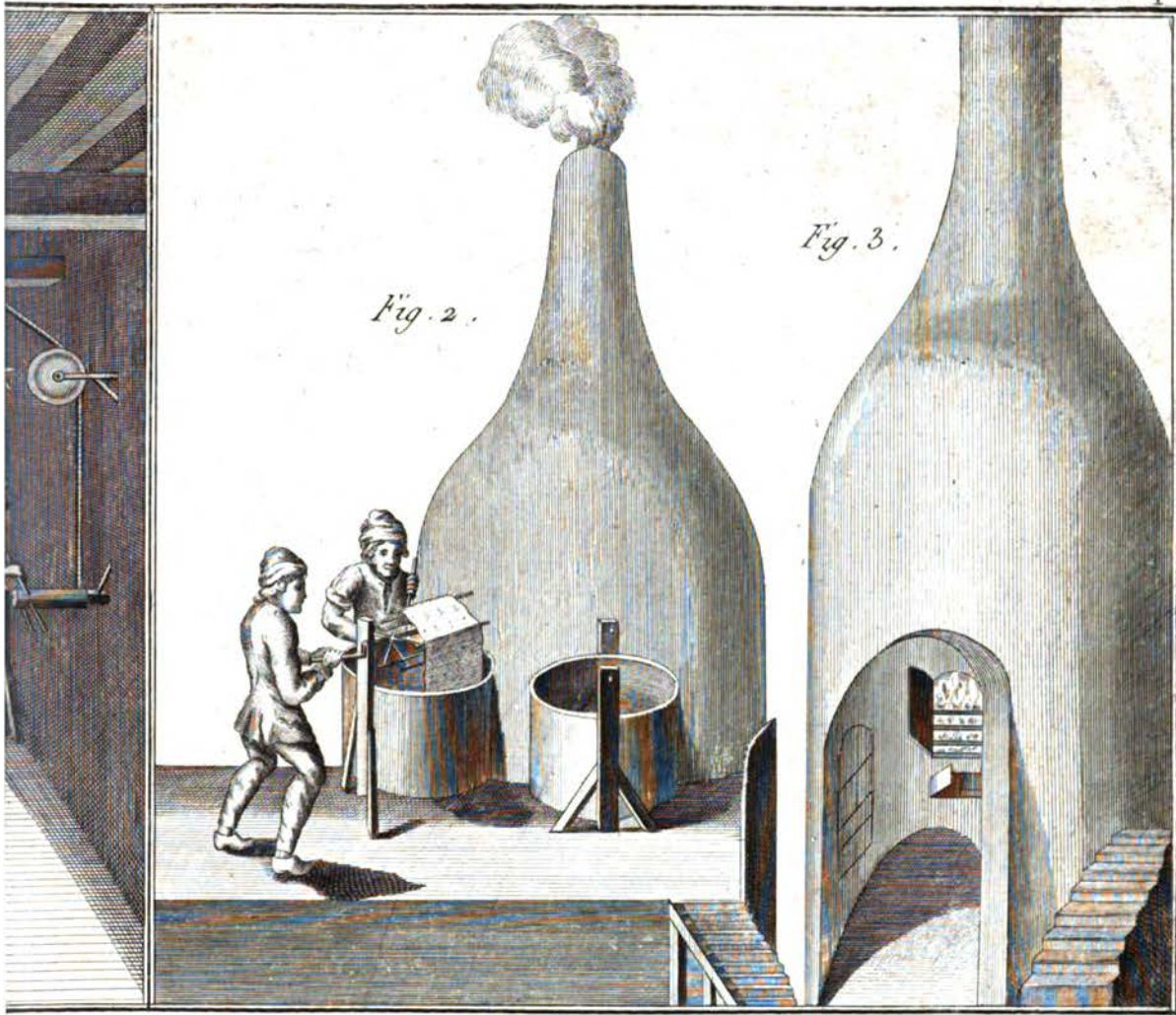


Fig. 5.

*Impression des Toiles Pe*



*Ateliers, Atelier des Cuves, et fourneaux.*

*Bernard Drevet*  
80.

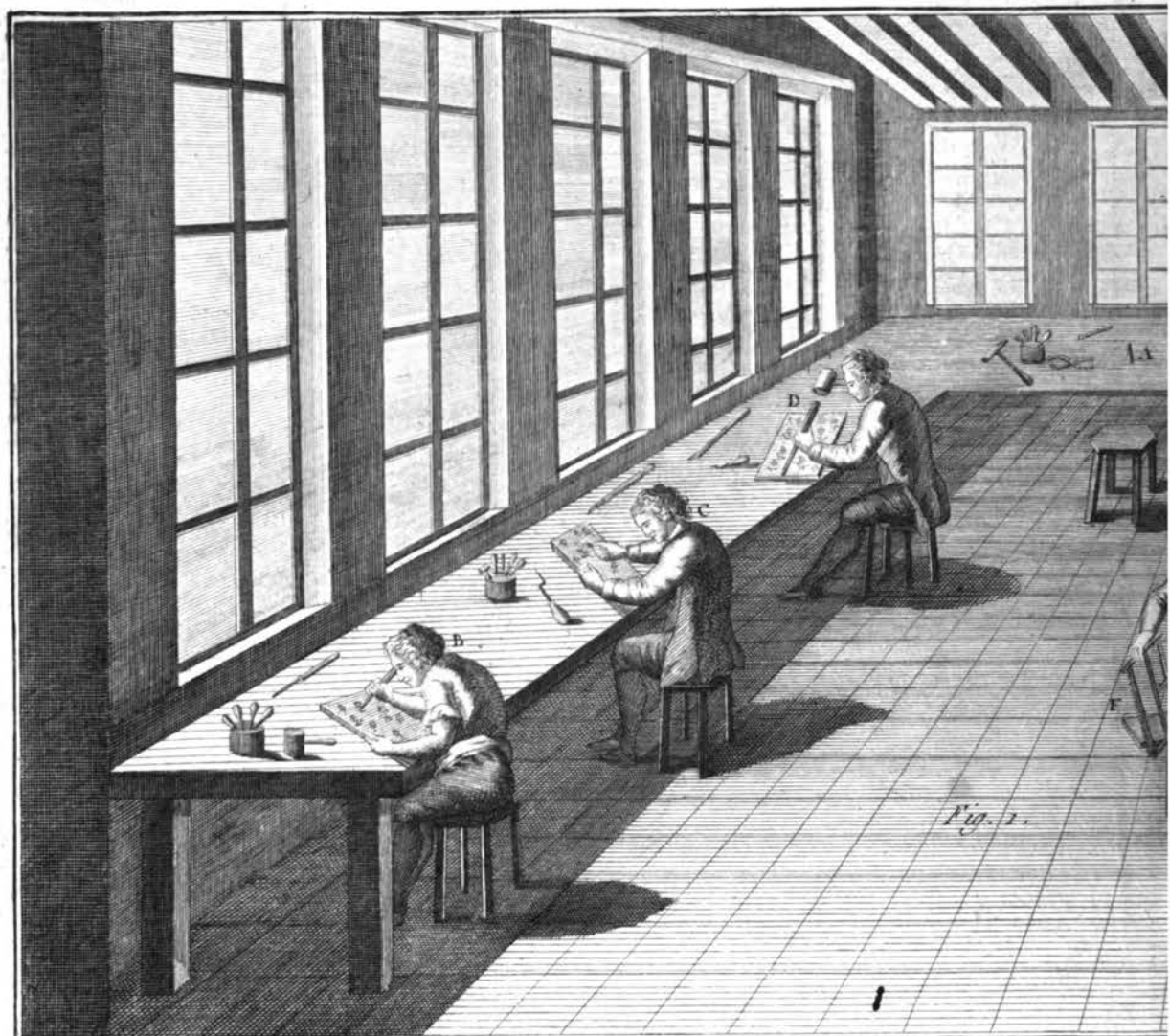


Fig. 1.



Fig. 2.

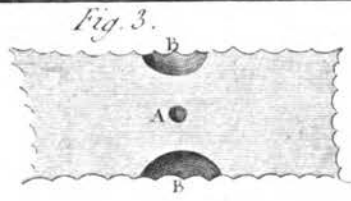


Fig. 3.

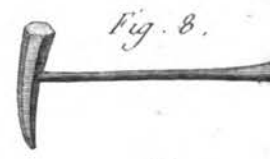


Fig. 8.

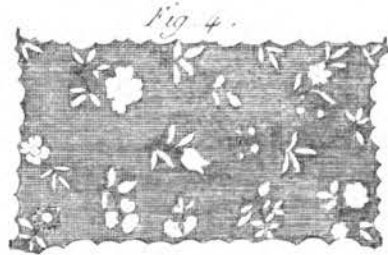


Fig. 4.



Fig. 7.



Fig. 5.

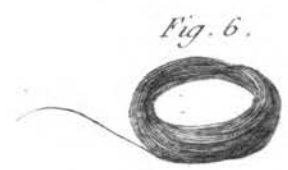
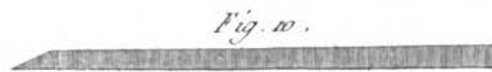
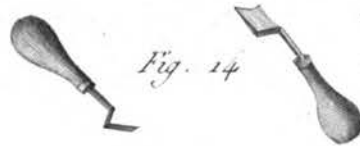
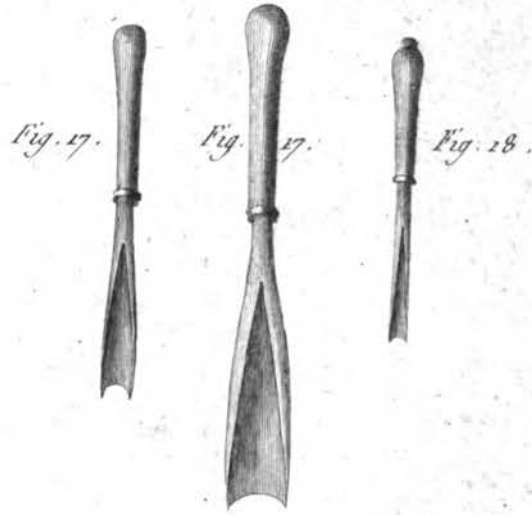


Fig. 6.

*Impression des Toiles Pe*



*Ateliers, -Atelier des Graveurs, Moulés, Outils, &c.*

*Benard. Doreur.*



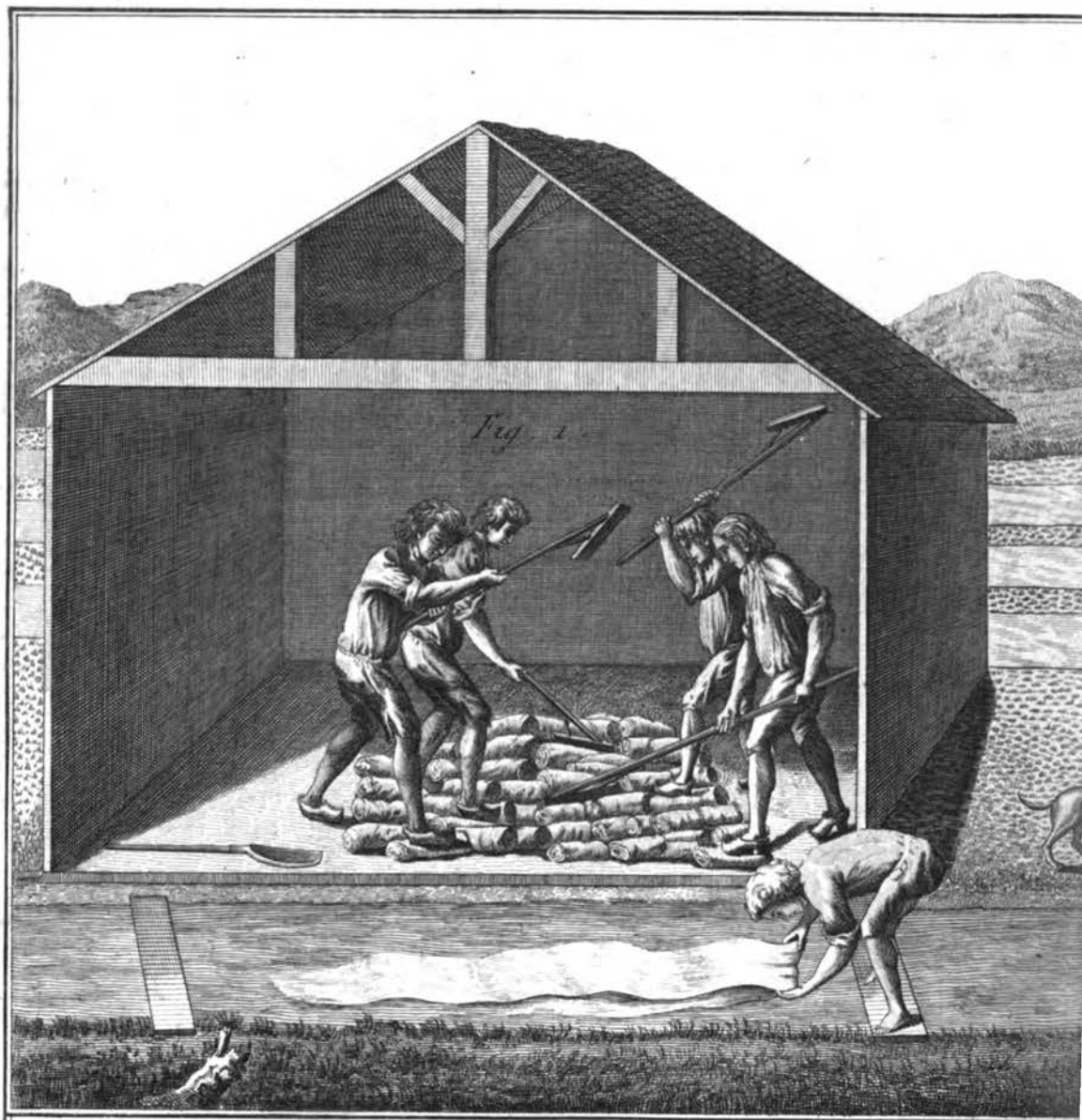


Fig. 2.

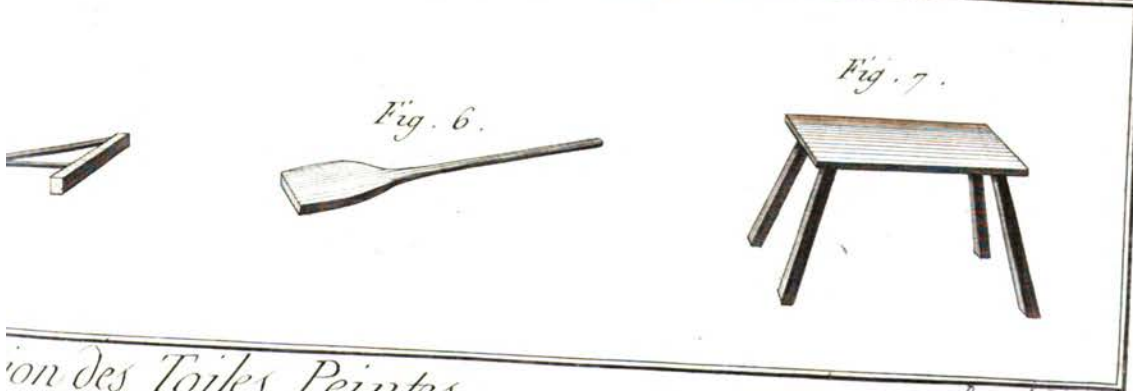
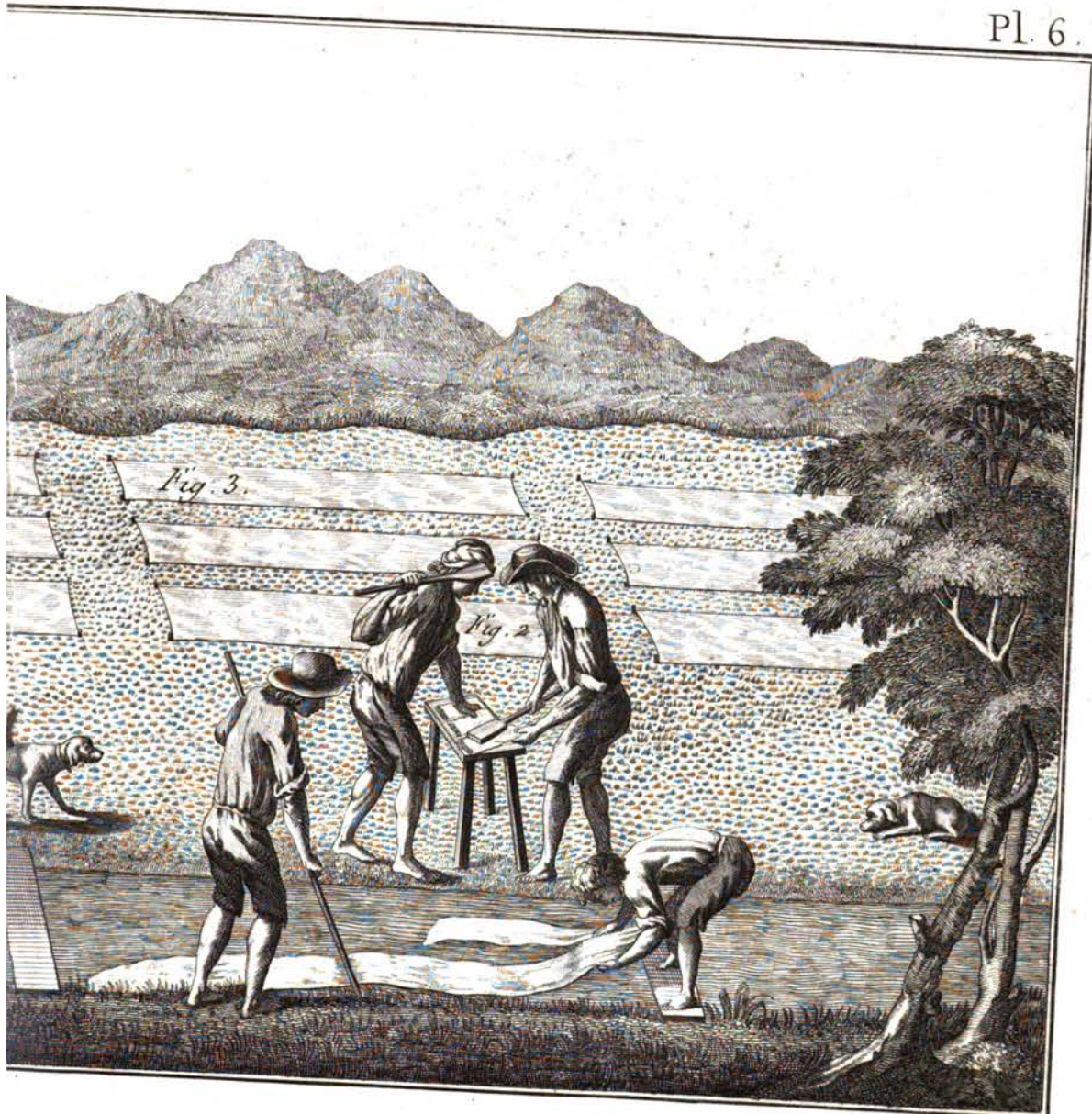


Fig. 4.



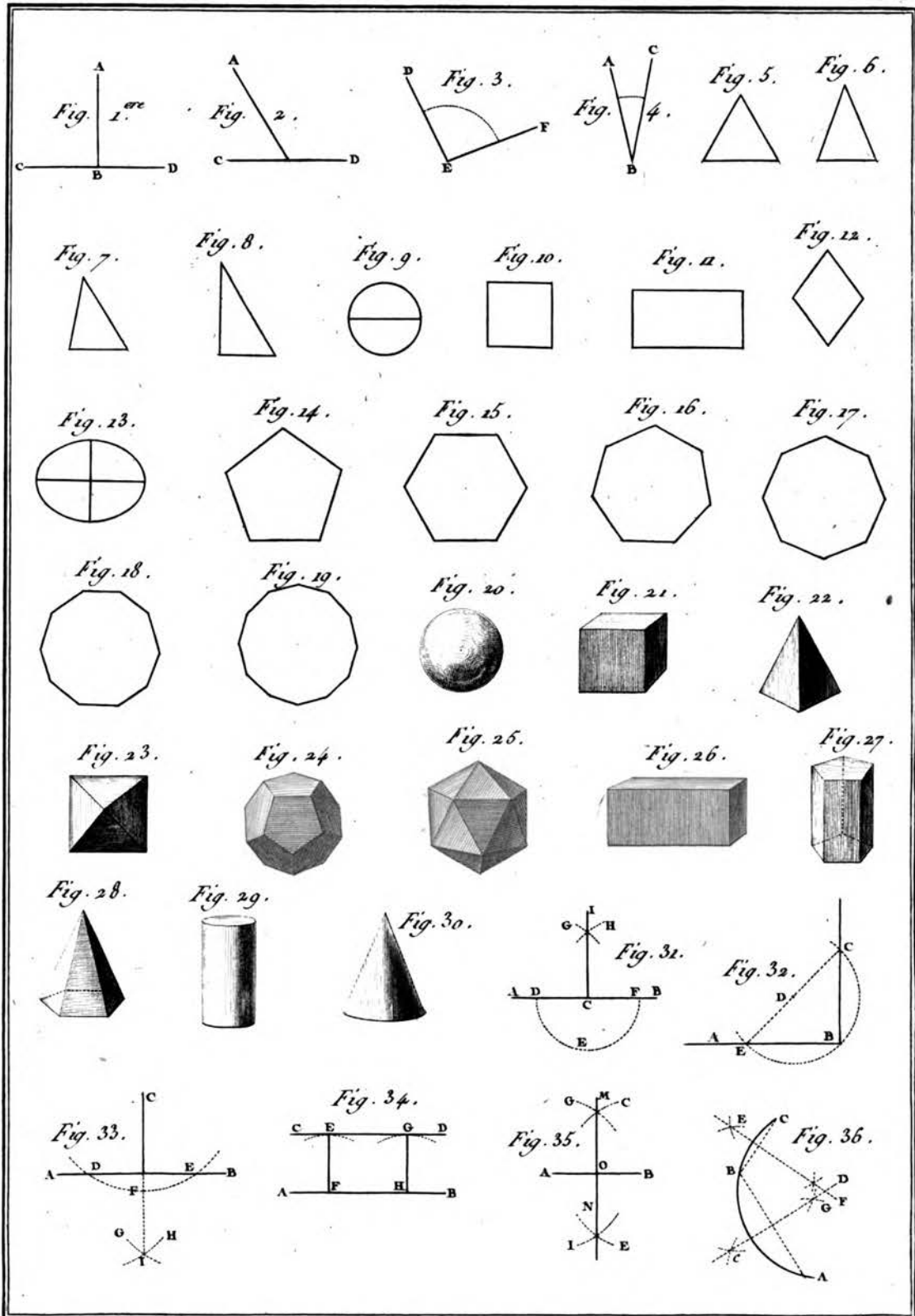
Fig. 5.

*Atelier et l'abrica*



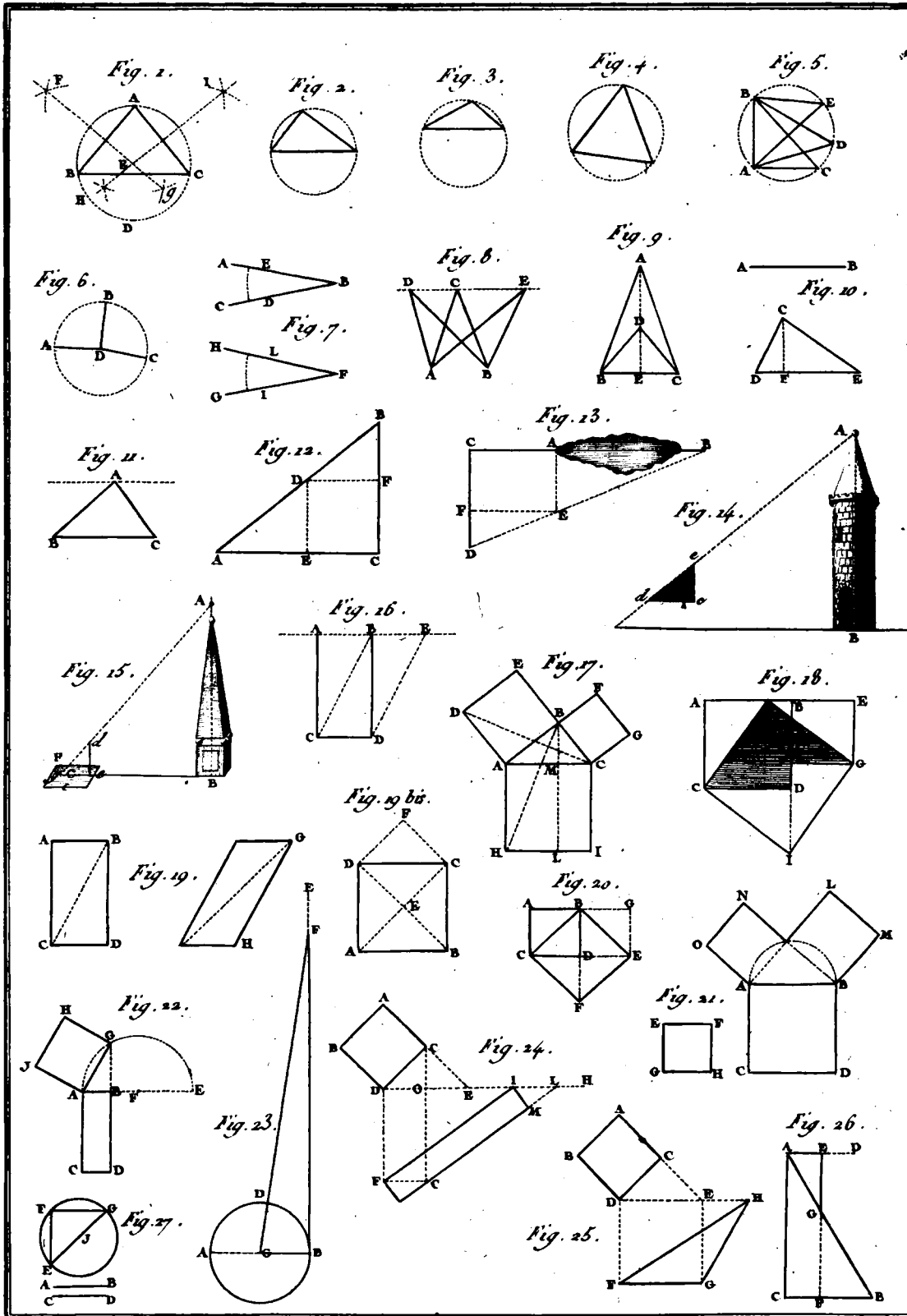
ion des Toiles Peintes.

Bernard Duvet



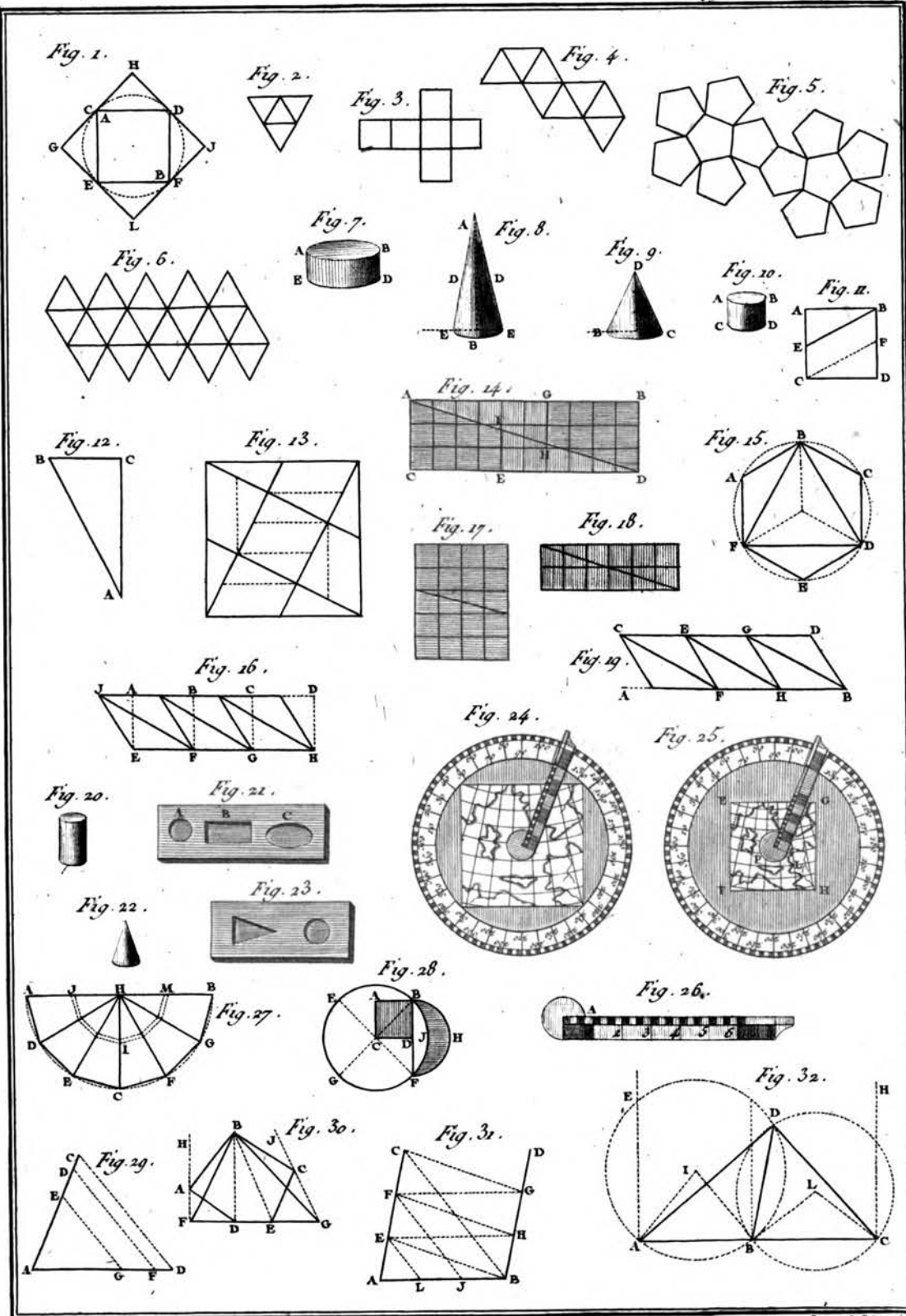
*Amusemens de Géométrie*

Benard Dixerit.



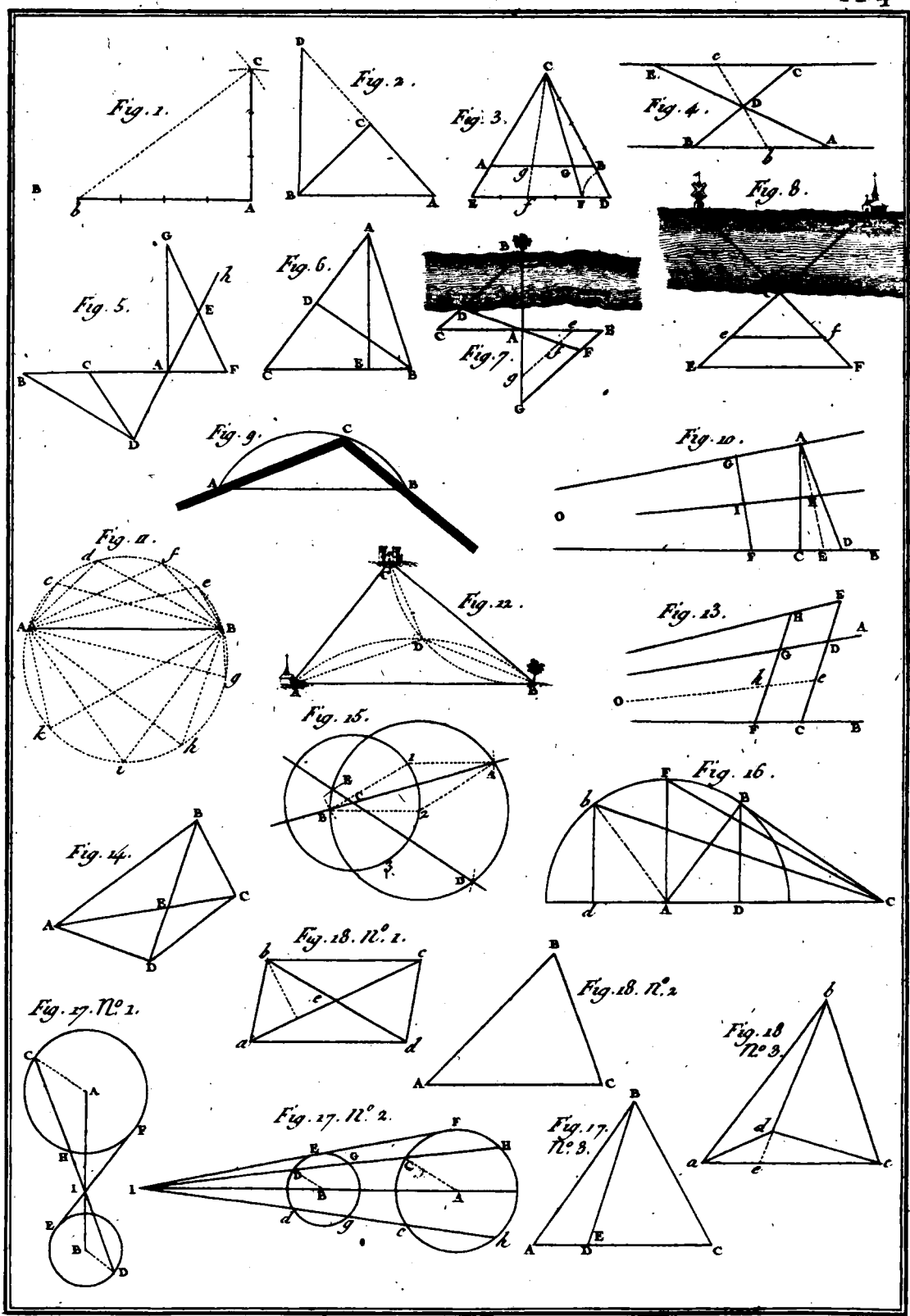
*Amusemens de Géométrie.*

*Bernard L'Évêque.*



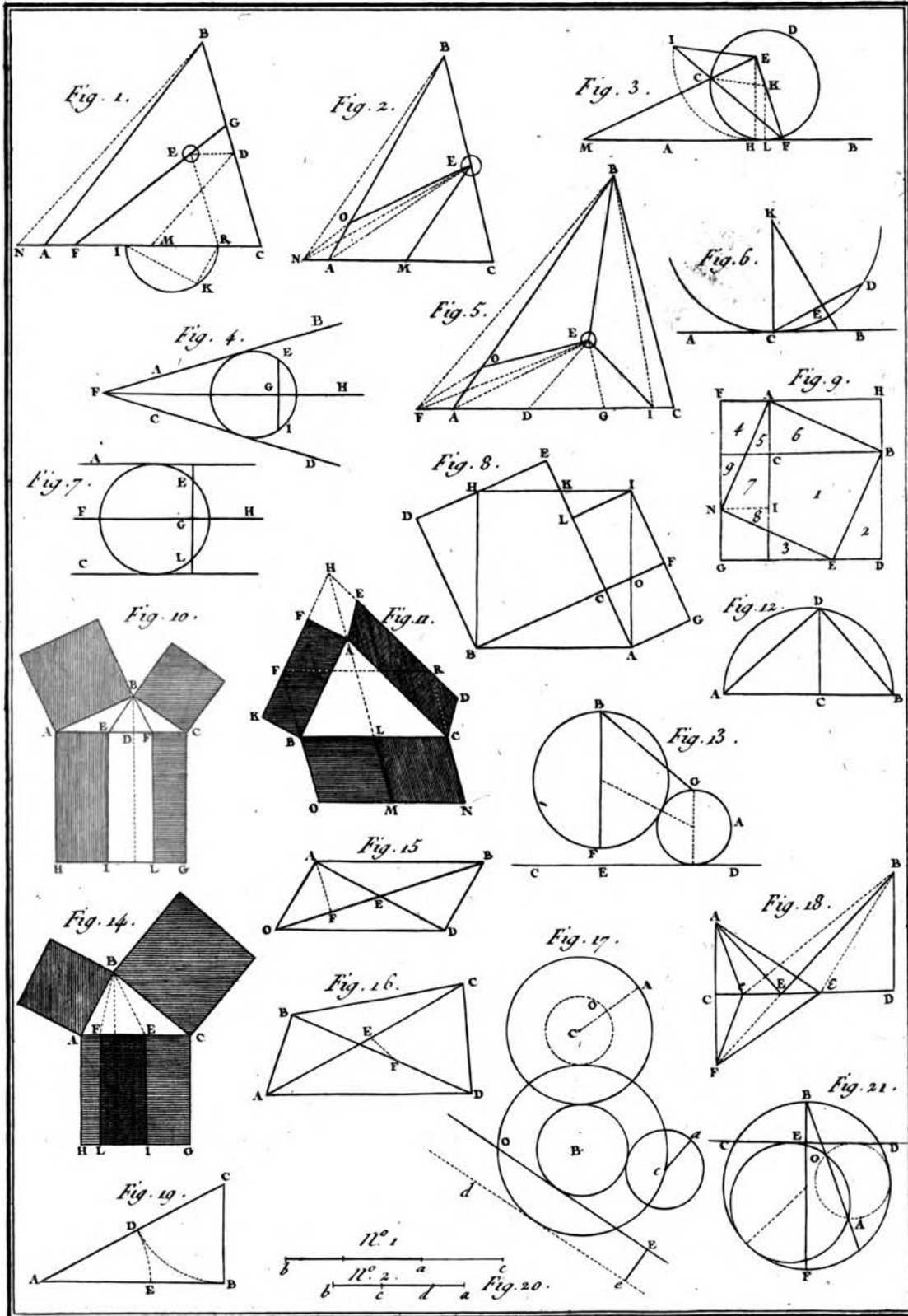
*Amusemens de Géometrie*

*Bernard Dérivel.*



*Amusemens de Géometrie.*

*Benard Düraxit*

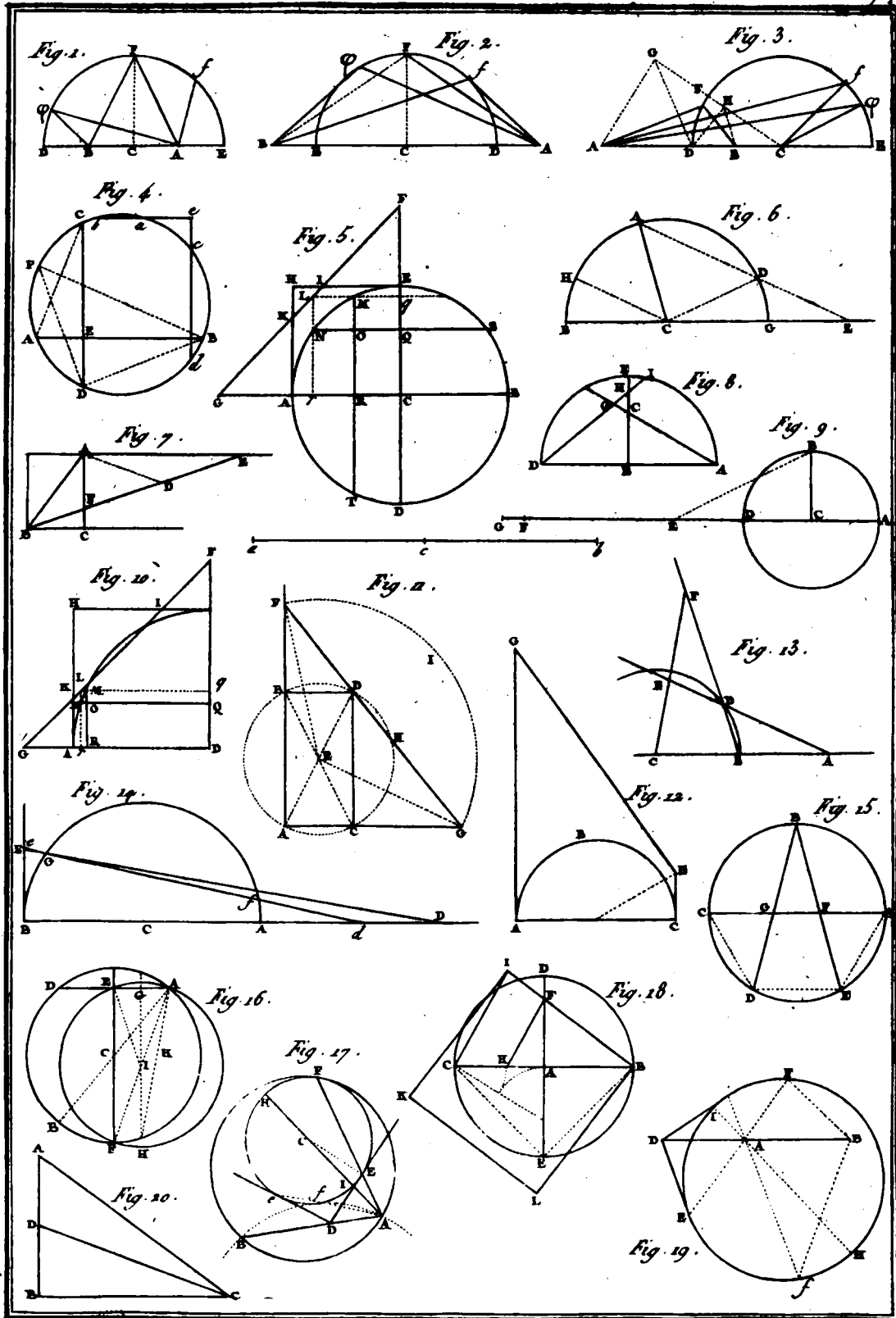


*Amusemens de Géometrie.*

Benard Doreux.

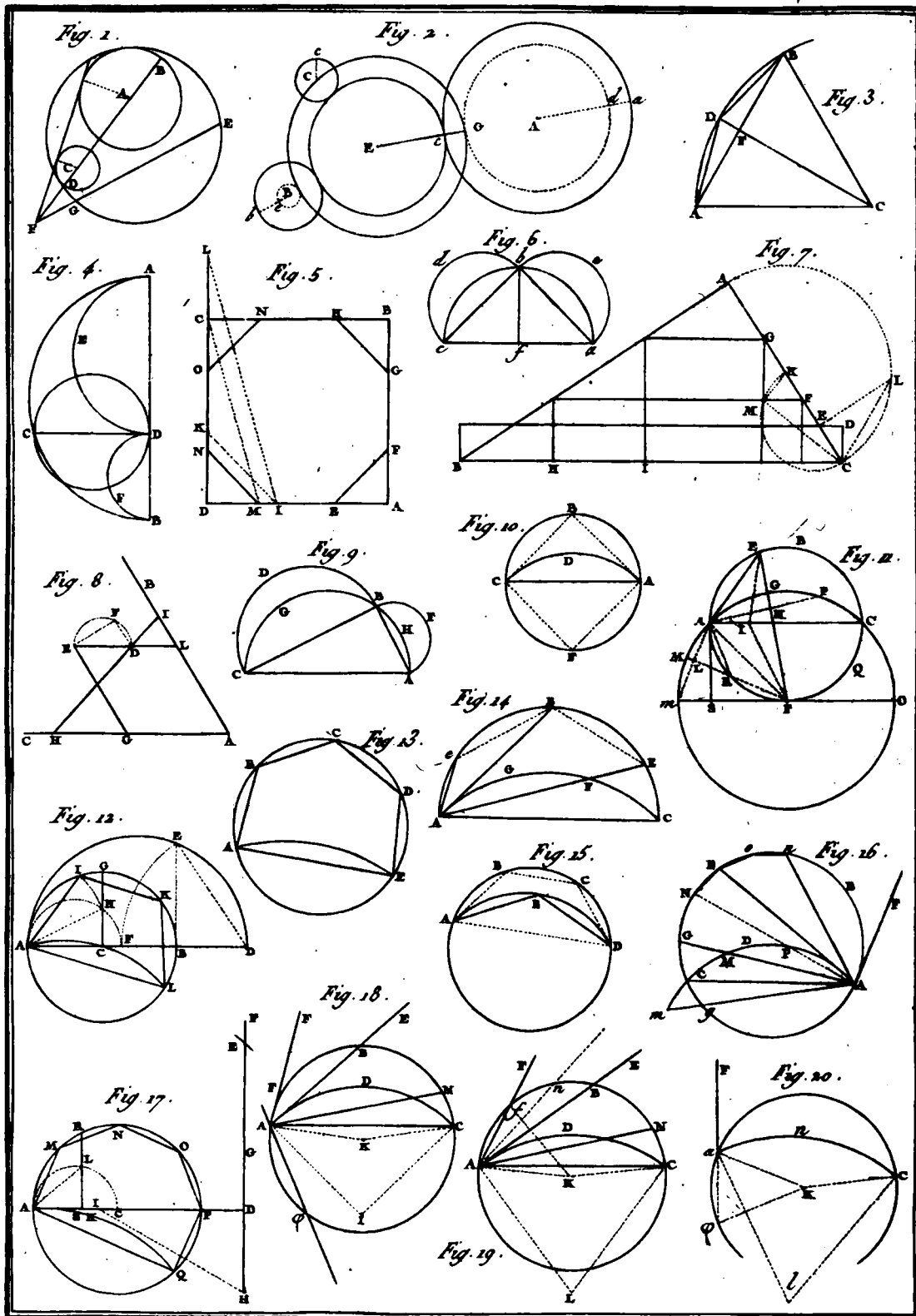






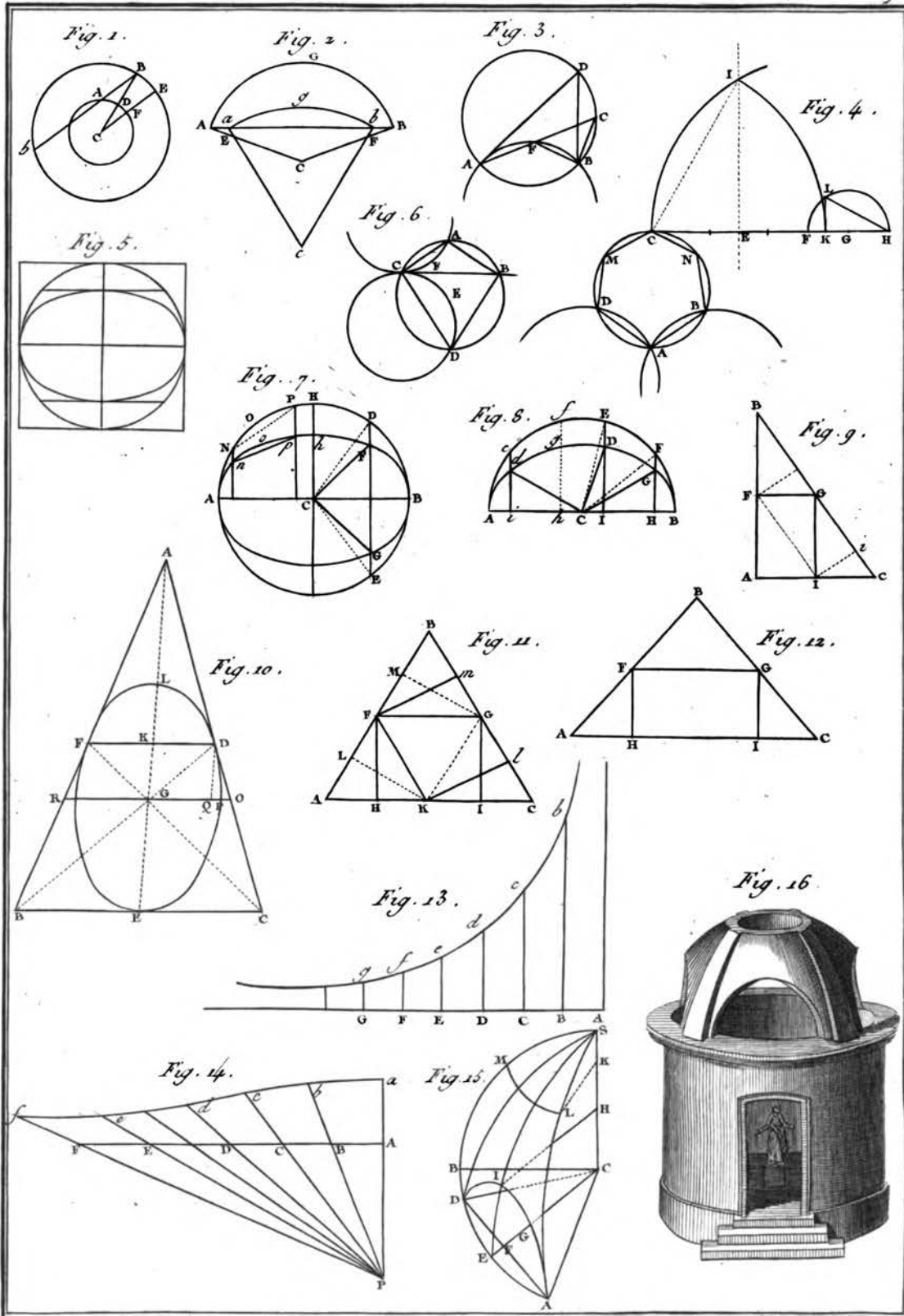
*Amusemens de Géométrie.*

*Benard Duvaut.*



*Amusemens de Geometrie.*

*Bour & Dorez.*



Amusemens de Géométrie

Digitized by Google

UNIVERSIDAD COMPLUTENSE DE MADRID

Benard Duxet

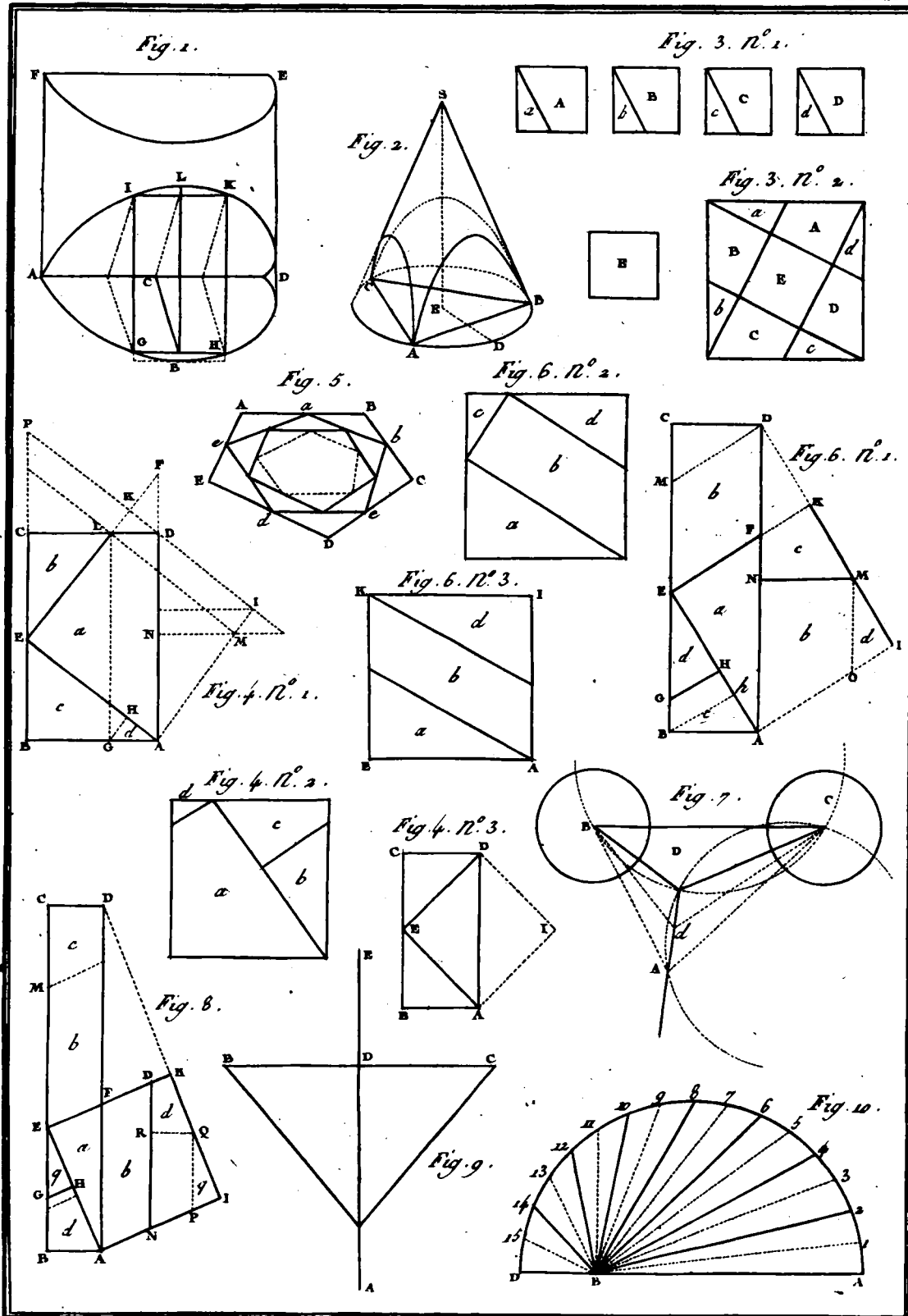


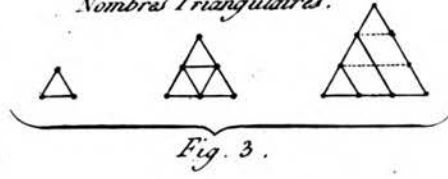
Fig. 1.

8
1/6
2/4
3/2
4/0
4/8
5/6
6/4
7/2

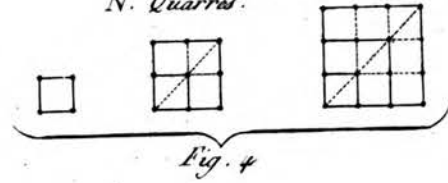
Fig. 2.

1	6	7	8	5	3	9	9
2	1	2	1	1	0	1	1
3	1	2	1	2	1	0	2
4	2	4	2	3	2	1	3
5	3	3	4	2	1	4	4
6	3	4	4	3	1	5	5
7	4	4	5	3	2	6	6
8	4	5	6	4	2	7	7
9	5	6	7	4	3	8	8

Nombres Triangulares.



N. Quarrás.



N. Pentagones.

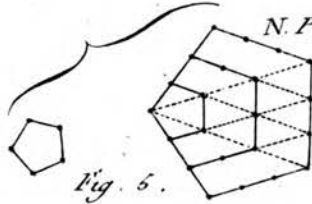


Fig. 6.

N. Hexagones.

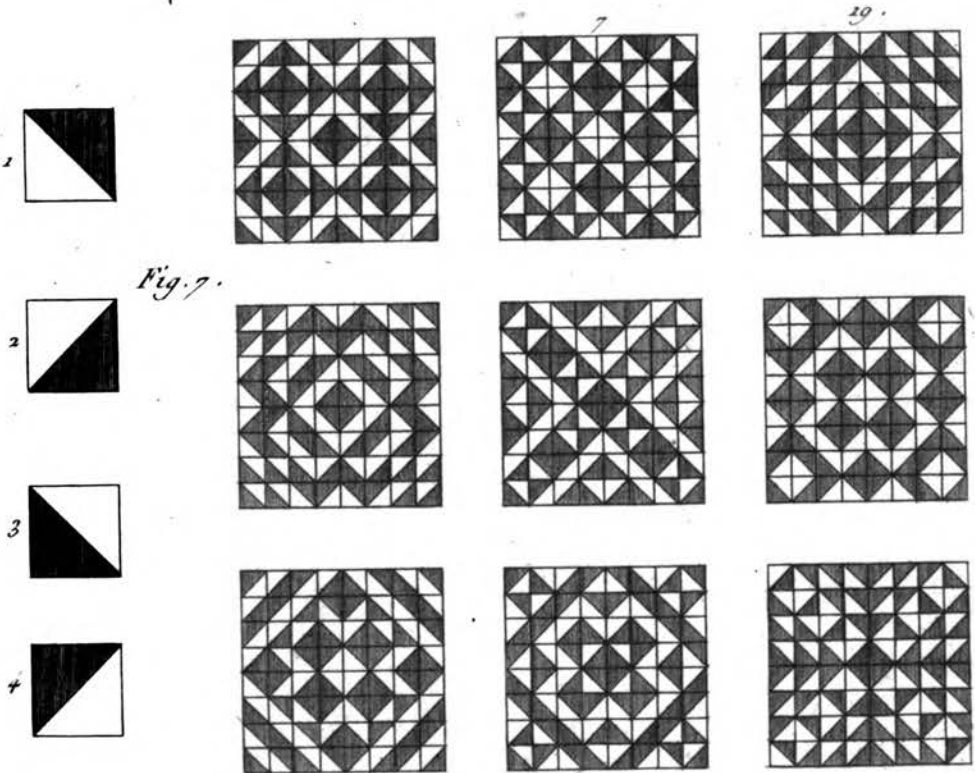
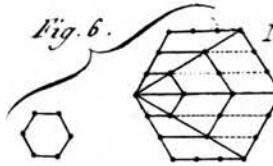


Fig. 7.

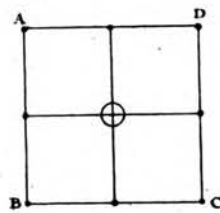
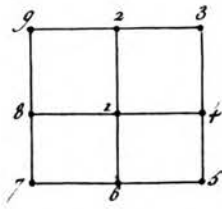


Fig. 1.

Fig. 2. N. 1.

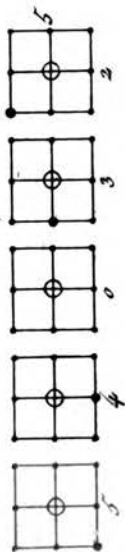


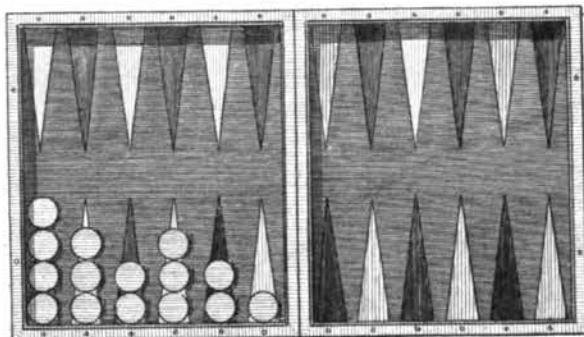
Fig. 2.

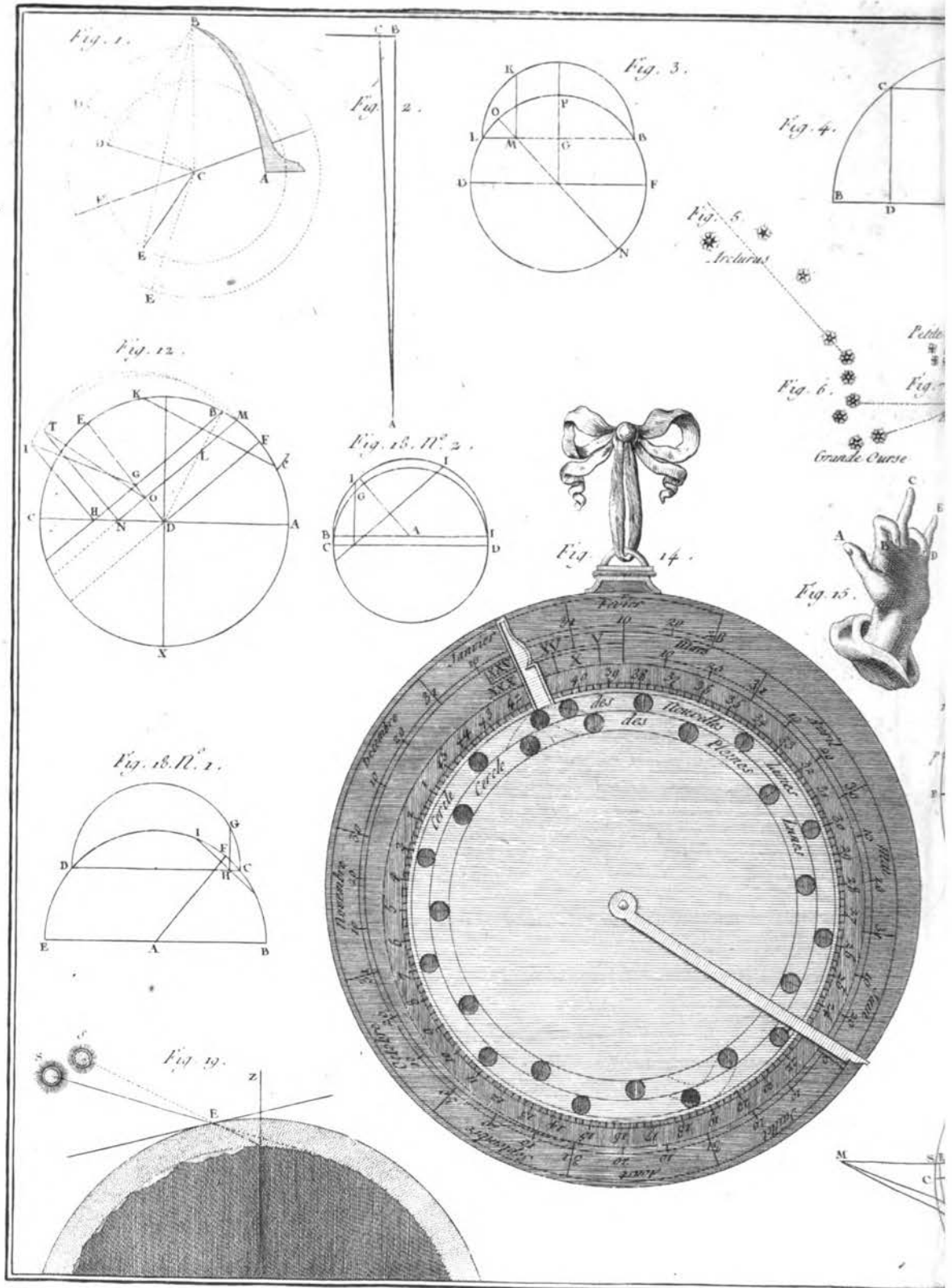
						54023.
						73592.
						42509.
						2795
						172919.

	1	1	1	1	1	1	1	1	1	1	1
N. Naturel.	1	2	3	4	5	6	7	8	9	10	11
N. Triangul.		1	3	6	10	15	21	28	36	45	55
N. Pyram. 1. <sup>re</sup>			1	4	10	20	35	56	84	120	165
N. Pyram. 2. <sup>de</sup>				1	5	15	35	70	126	210	330
N. Pyramid. 3. <sup>de</sup>					1	6	21	56	126	252	462

Fig. 3.

Fig. 4.

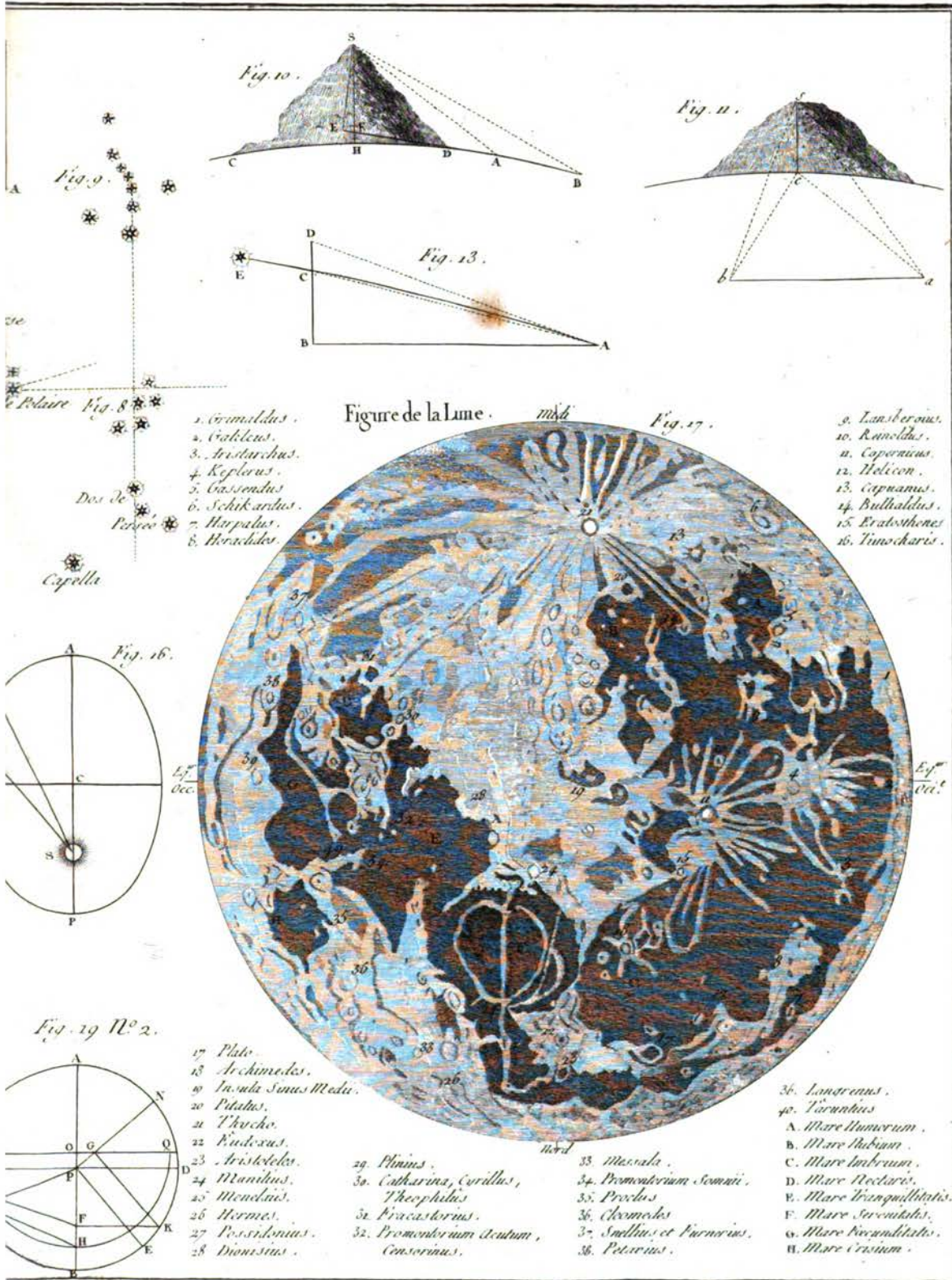




*Amusemens*

Digitized by Google

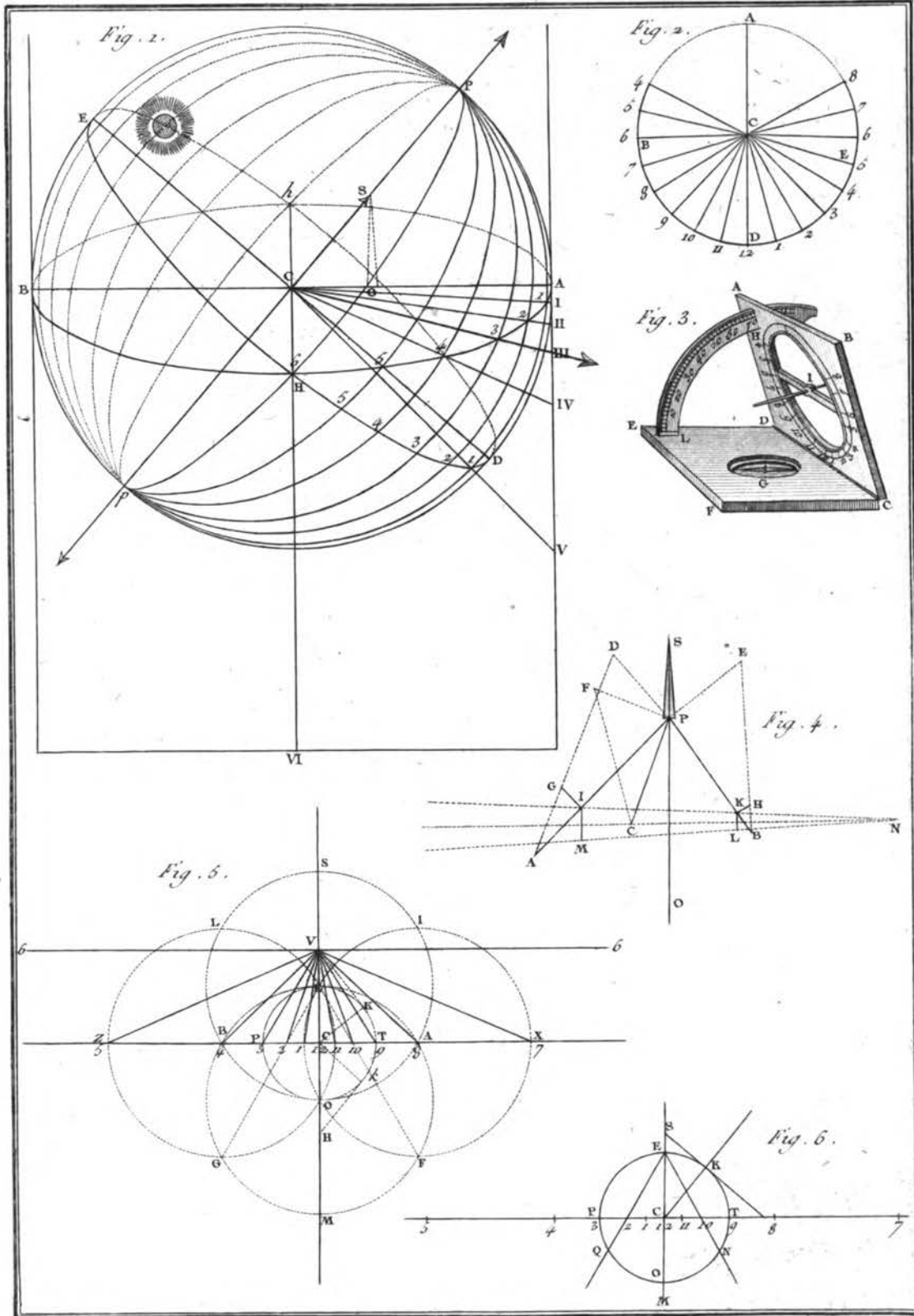
Original from  
UNIVERSIDAD COMPLUTENSE  
DE MADRID



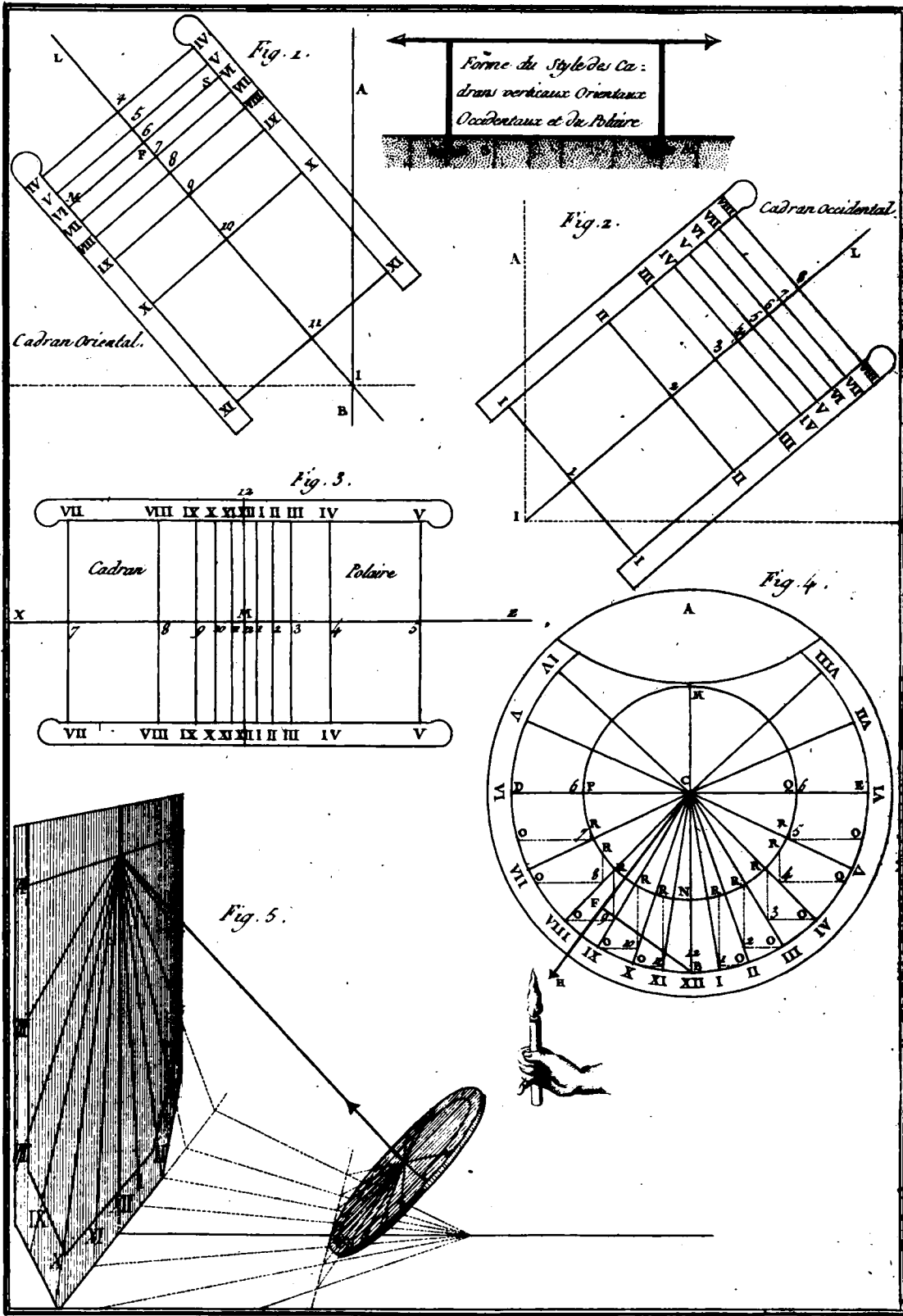
*d'Astronomie.*

*Edward Drexel*

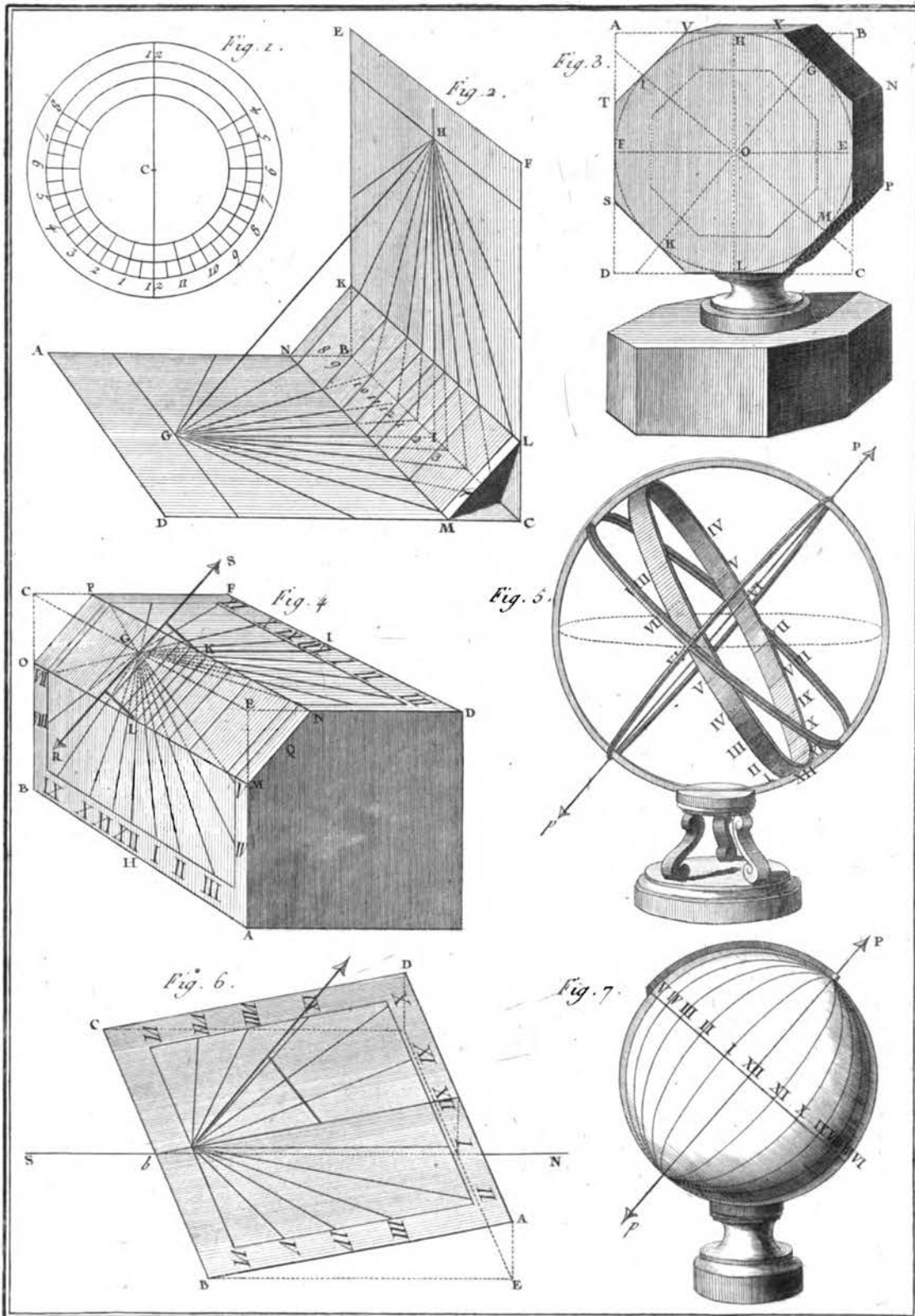




Generated on 2014-05-10 22:48 GMT / http://hdl.handle.net/2027/ucm.5320295822  
Public Domain, Google-digitized / http://www.hathitrust.org/access\_use#pd-google

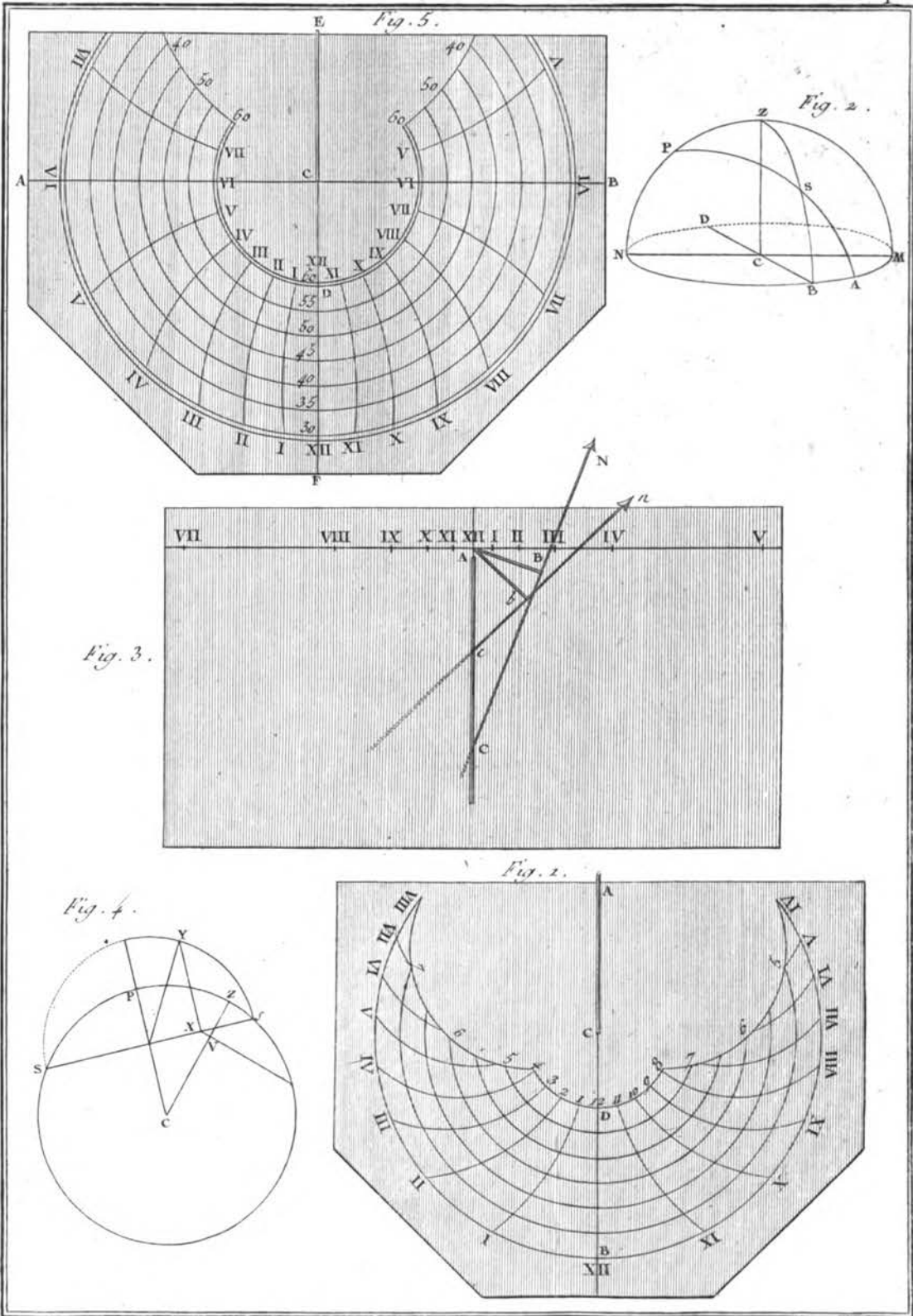


Bonard Dorezel



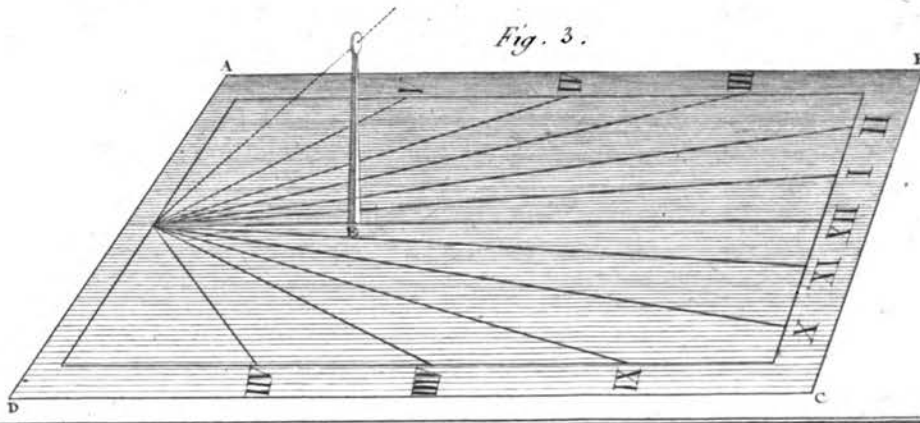
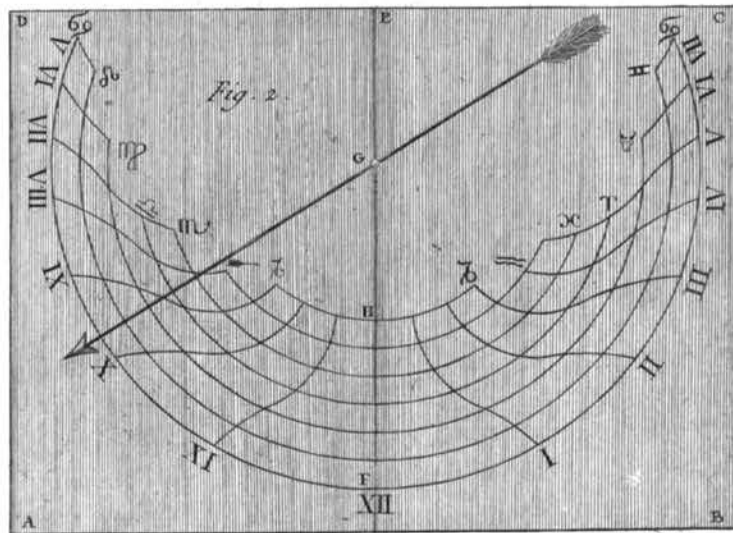
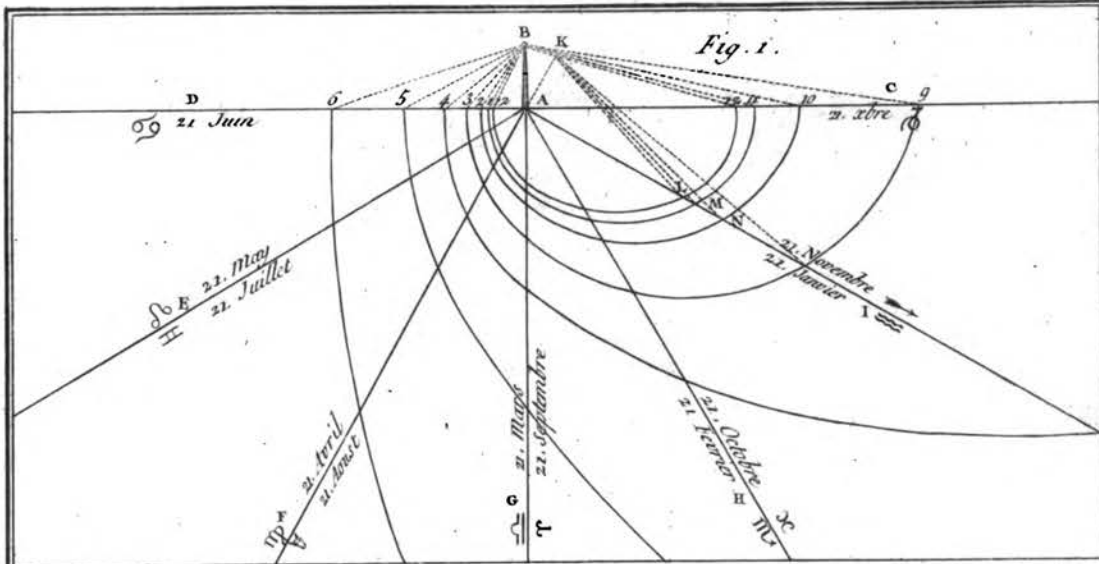
*Amusemens de Gnomonique.*

*Benard. Dircxit.*



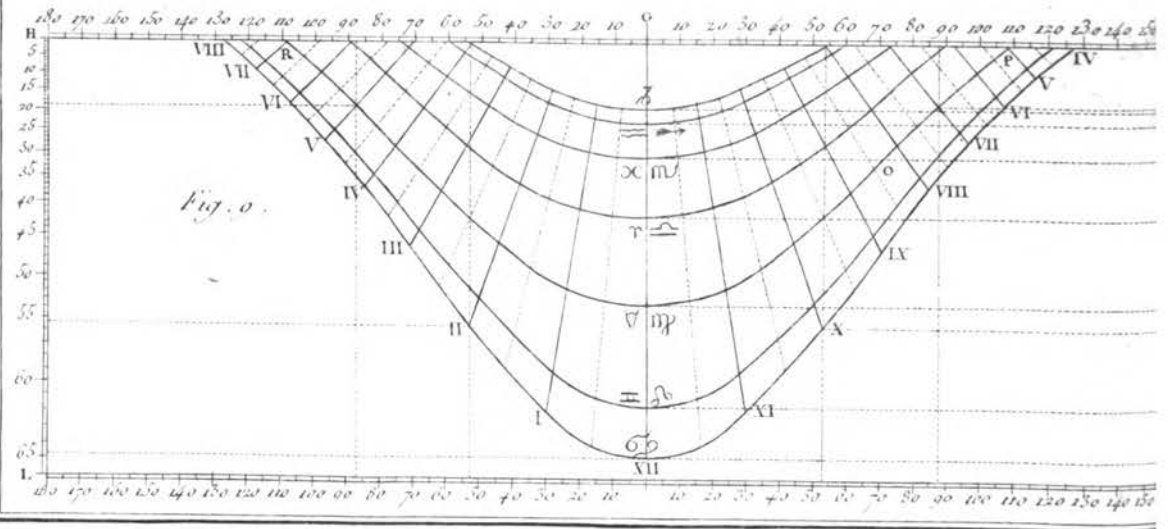
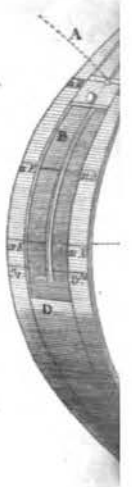
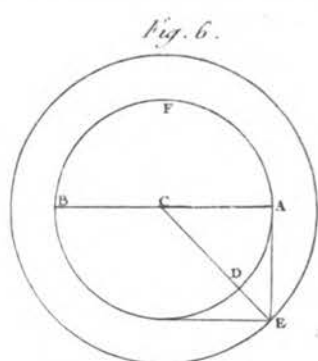
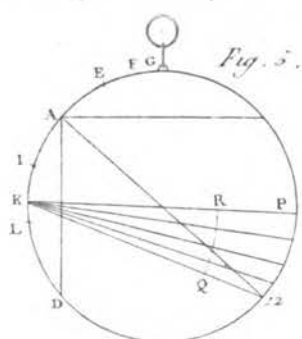
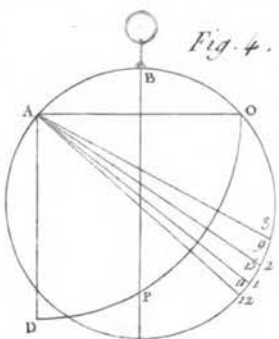
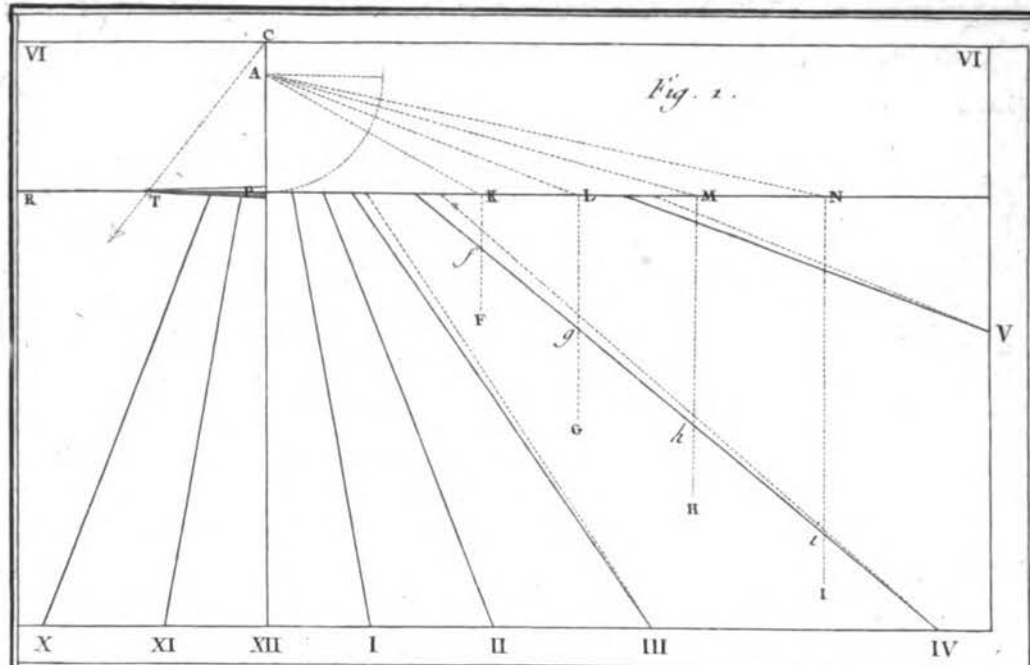
*Amusemens de Gnomonique*

Benard Durex



Amusemens de Gnomonique.

Bernard Drexel.



*Amusemens*

Fig. 2.

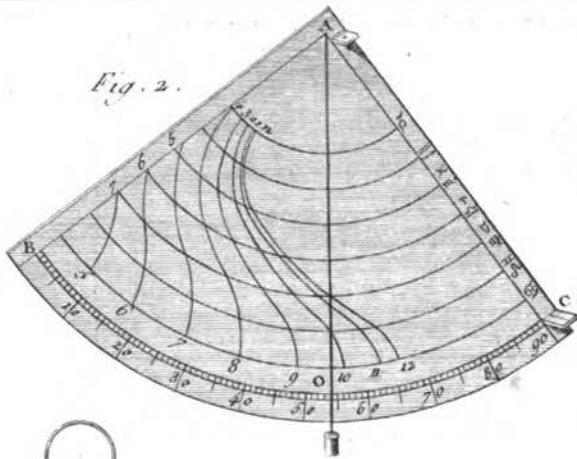


Fig. 3.

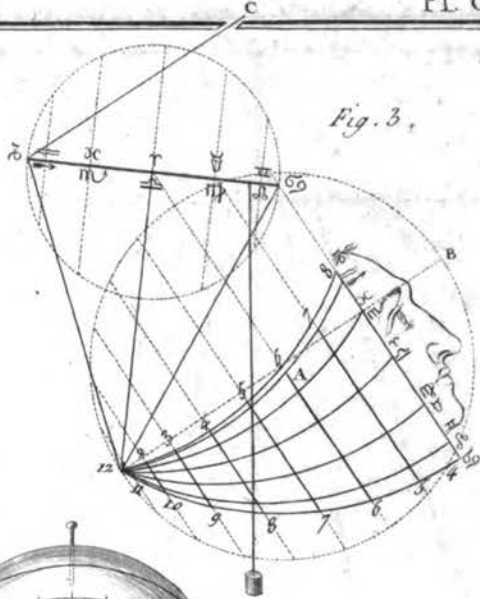


Fig. 7.

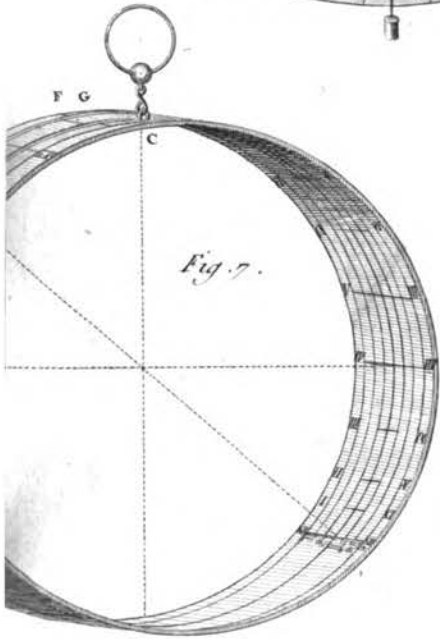
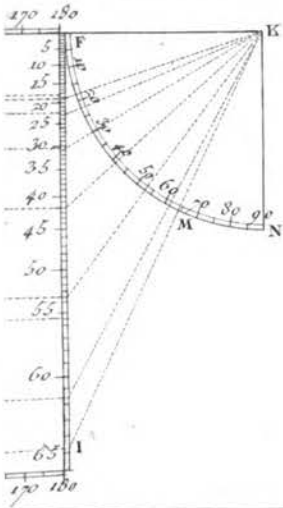
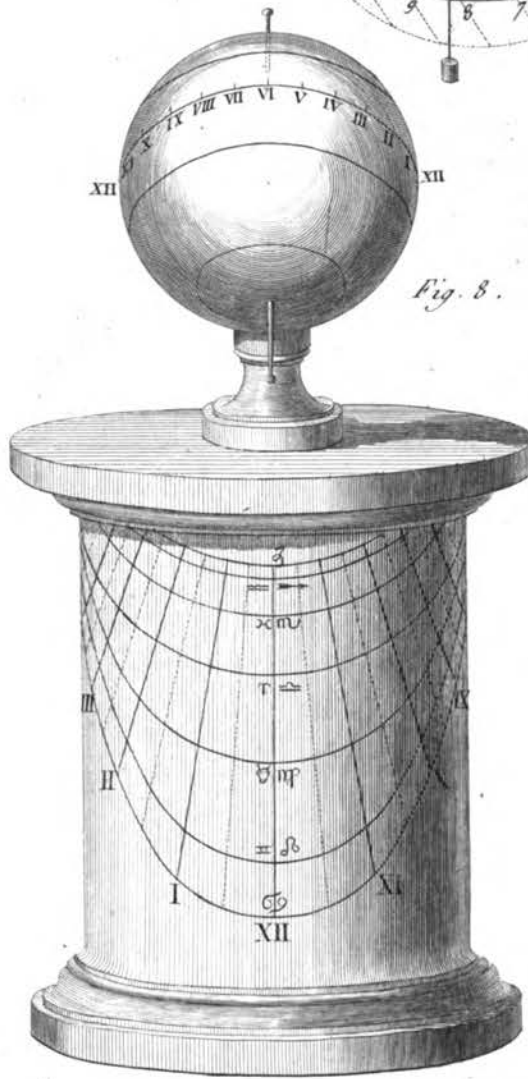
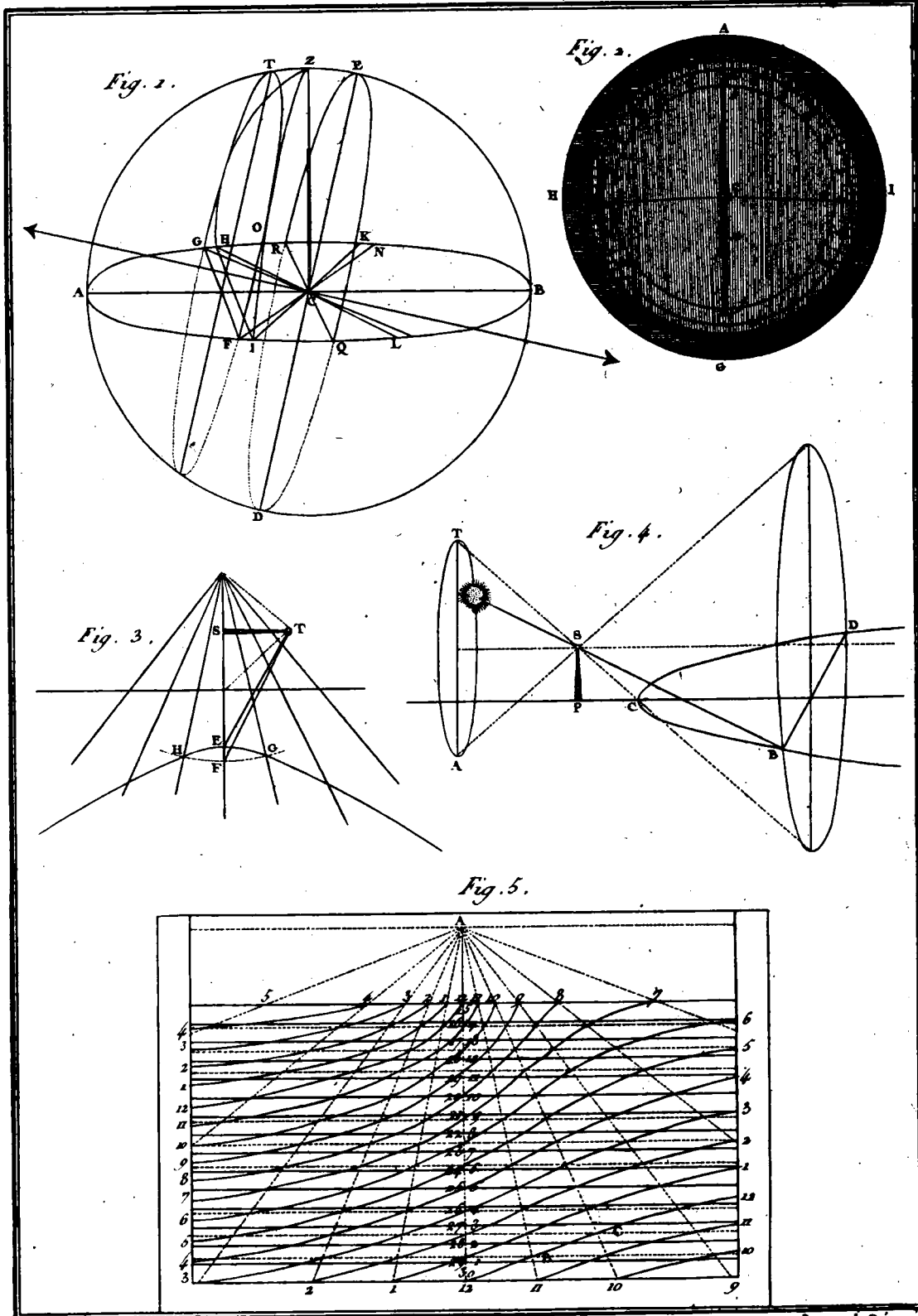


Fig. 8.



Benard Diraxel.

Gnomonique.



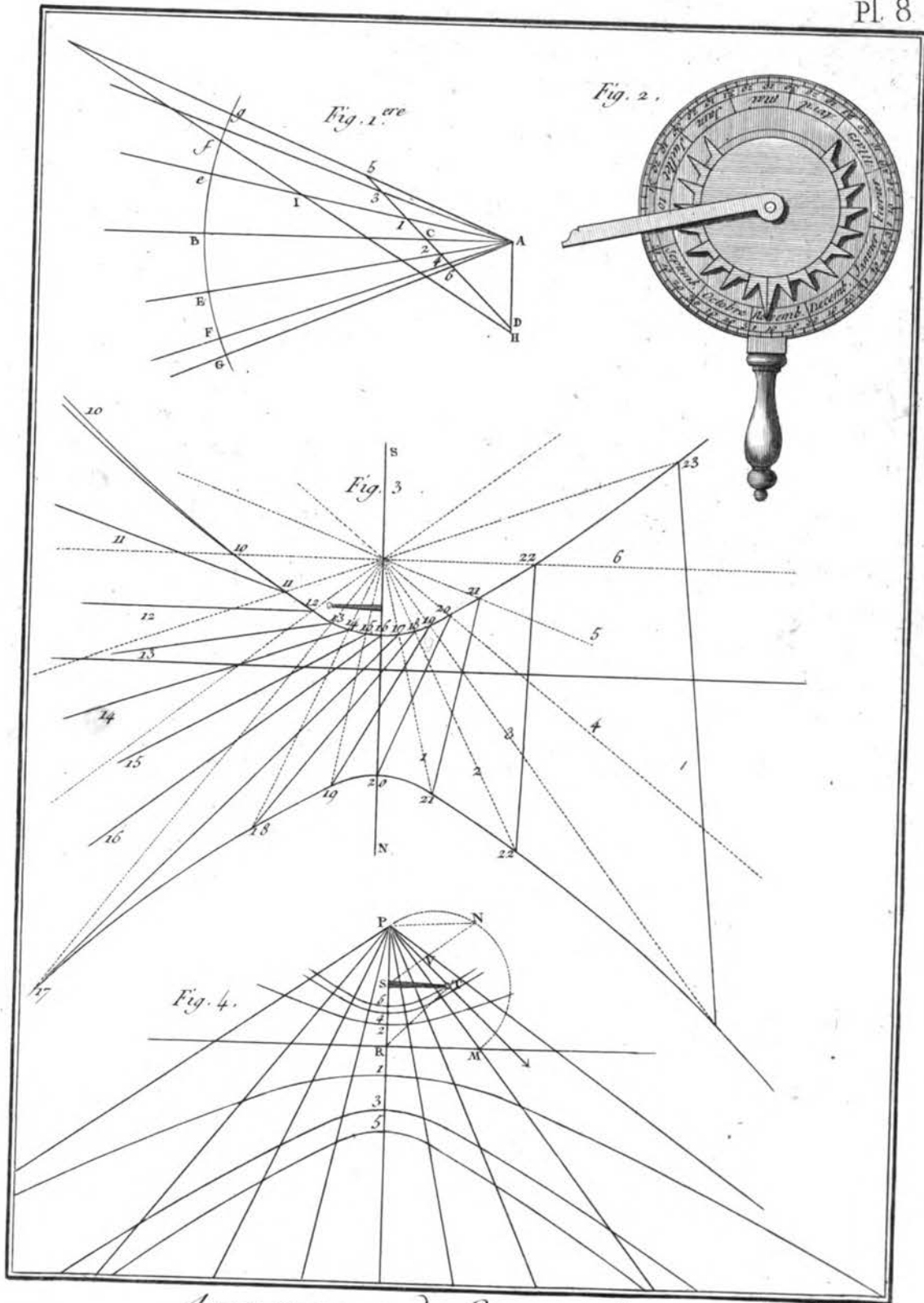
*Amusemens de Gnomonique.*

Benard Dorez.

Digitized by Google

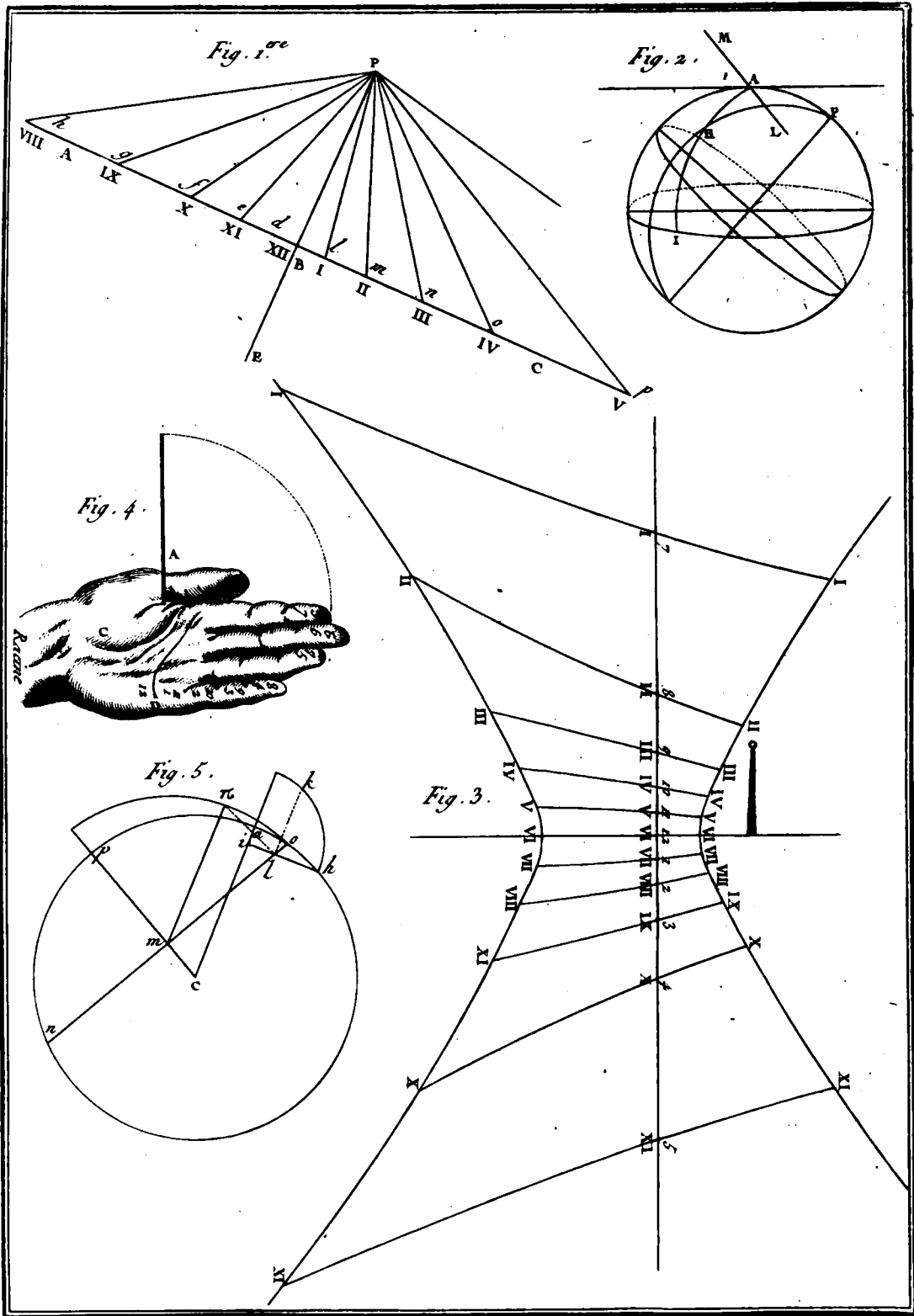
UNIVERSIDAD COMPLUTENSE DE MADRID





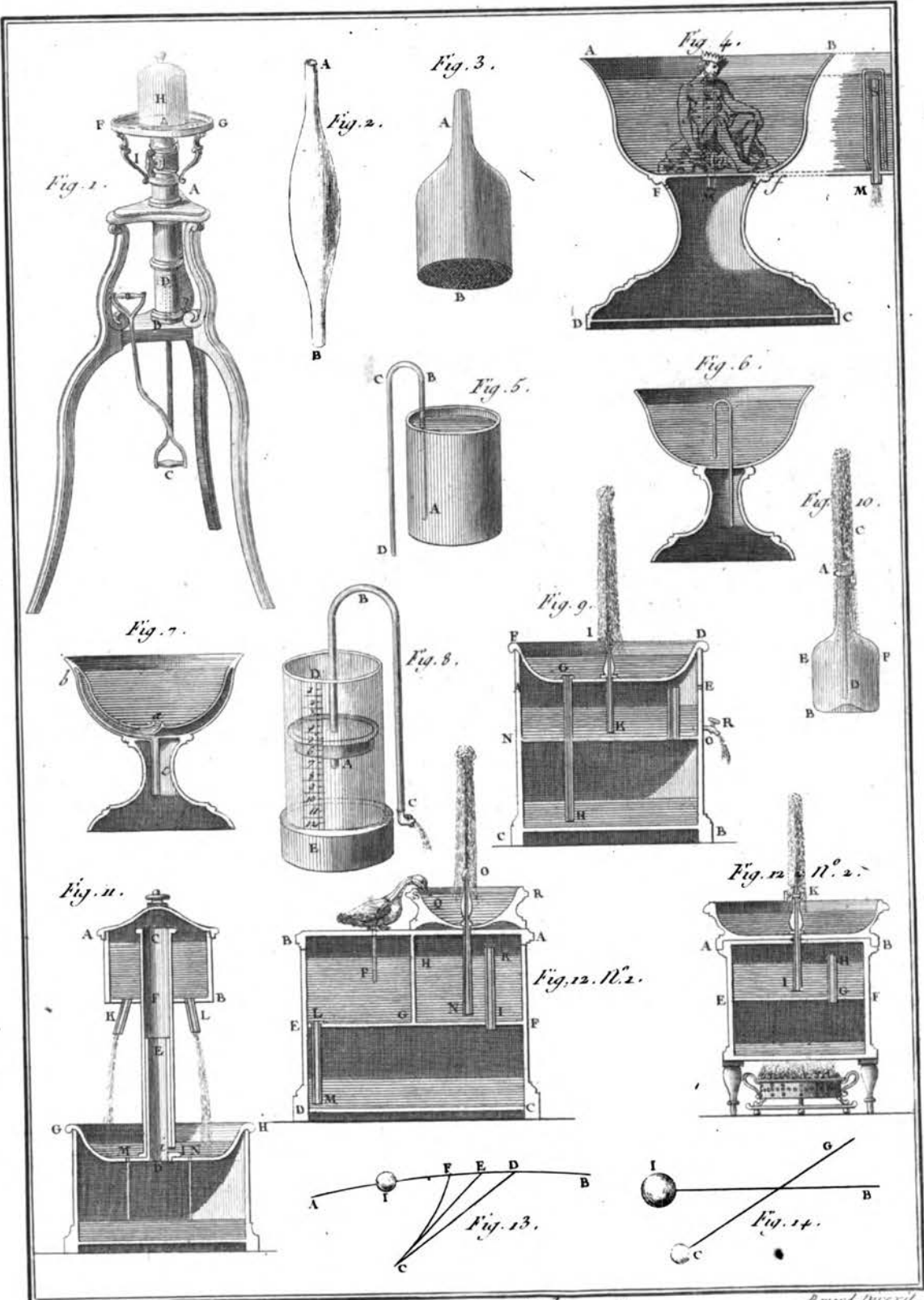
*Amusemens de Gnomonique* Bernard Diraxit.

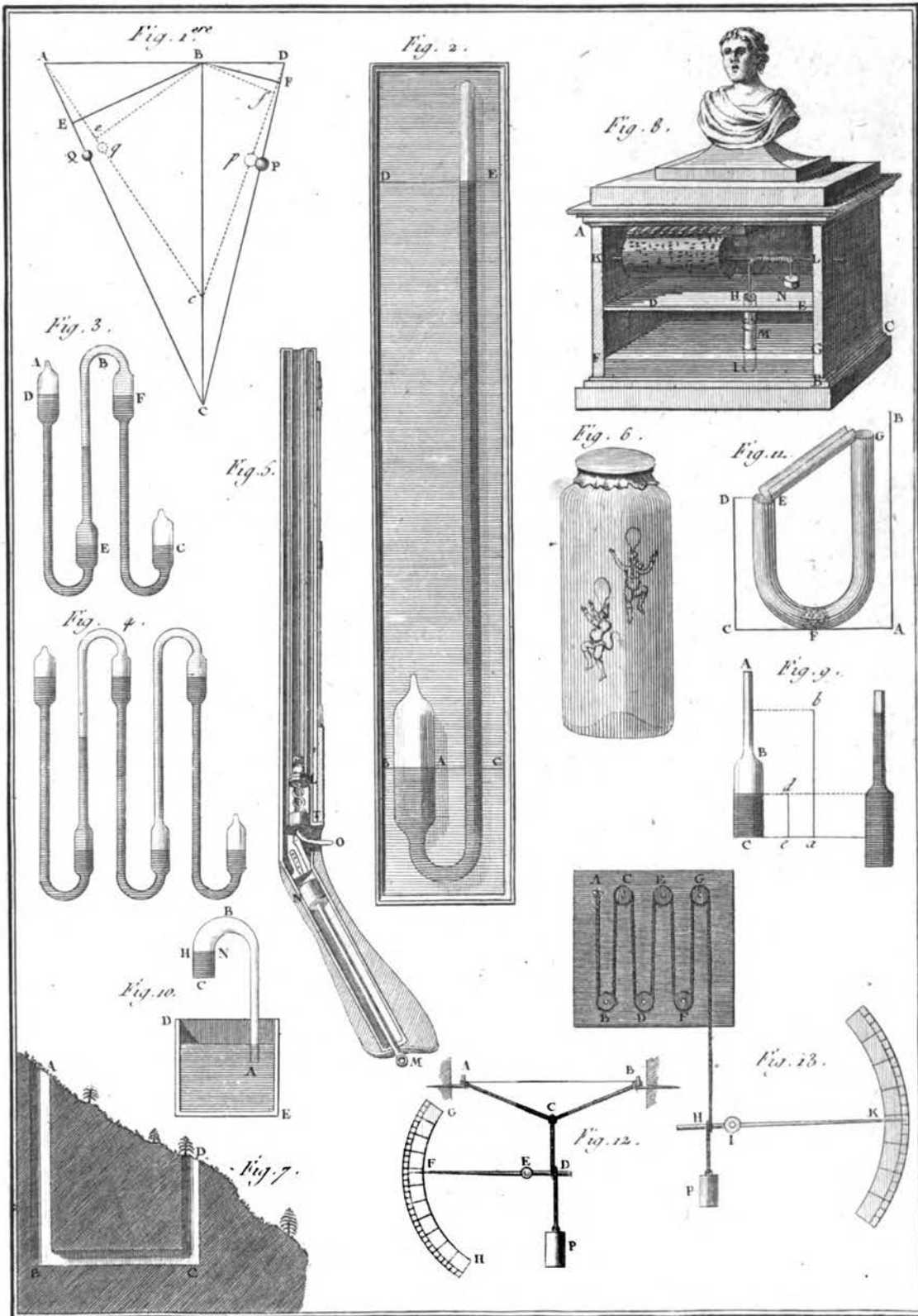
Digitized by Google Original from UNIVERSIDAD COMPLUTENSE DE MADRID

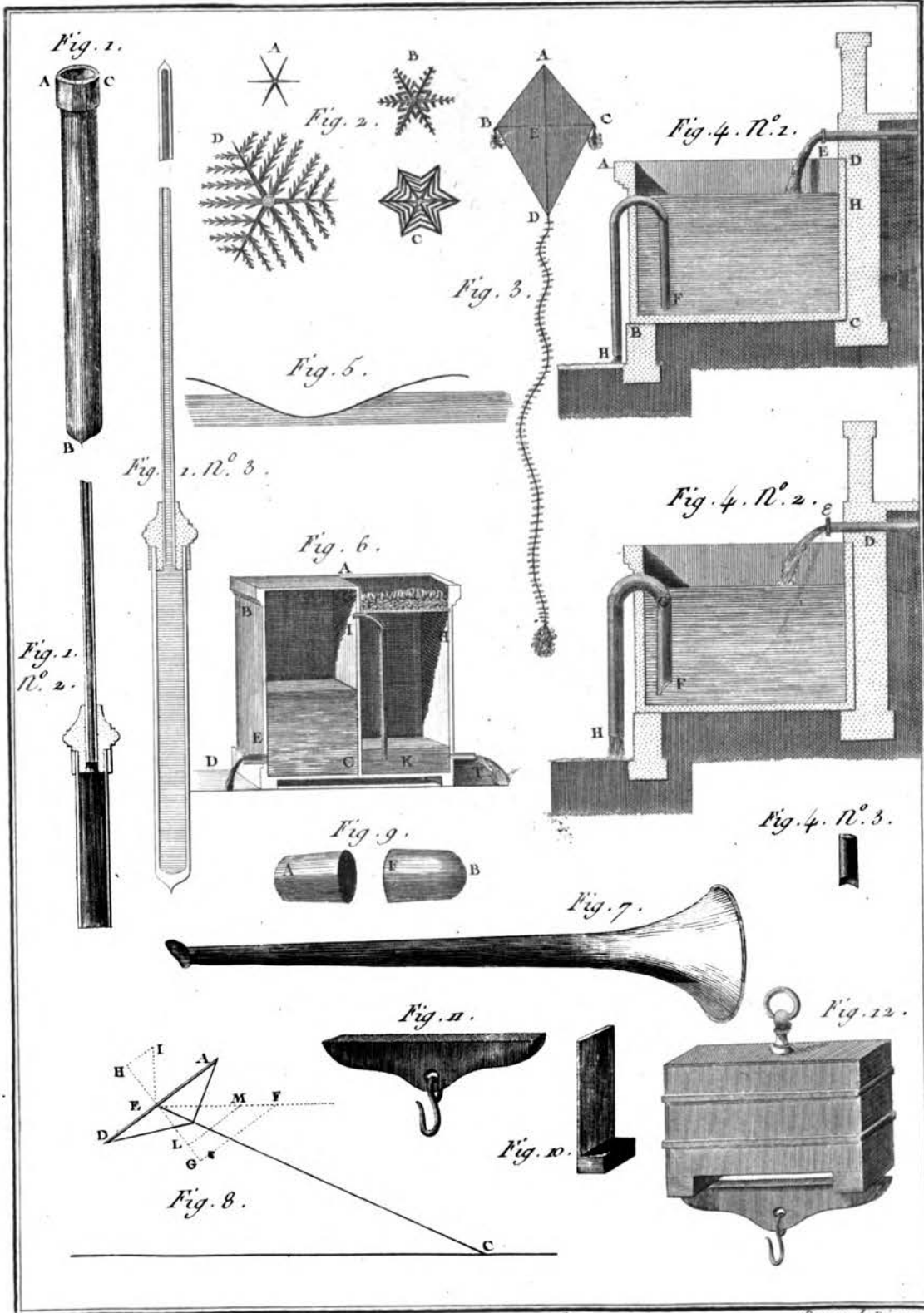


*Amusemens de Gnomonique.* Bernard Drexel.

Generated on 2014-05-10 22:51 GMT / http://hdl.handle.net/2027/ucm.5320295822 Public Domain, Google-digitized / http://www.hathitrust.org/access\_use#pd-google

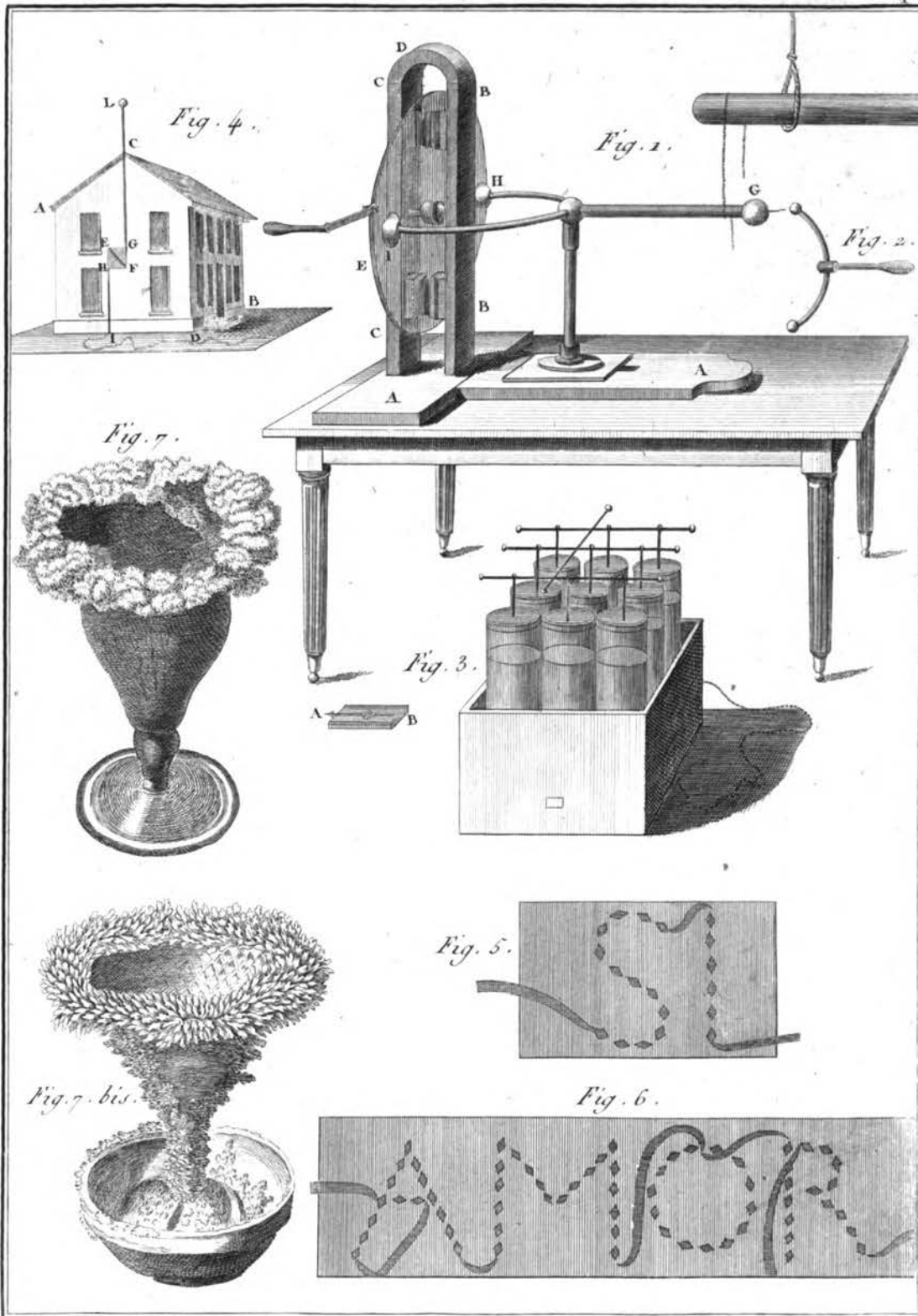






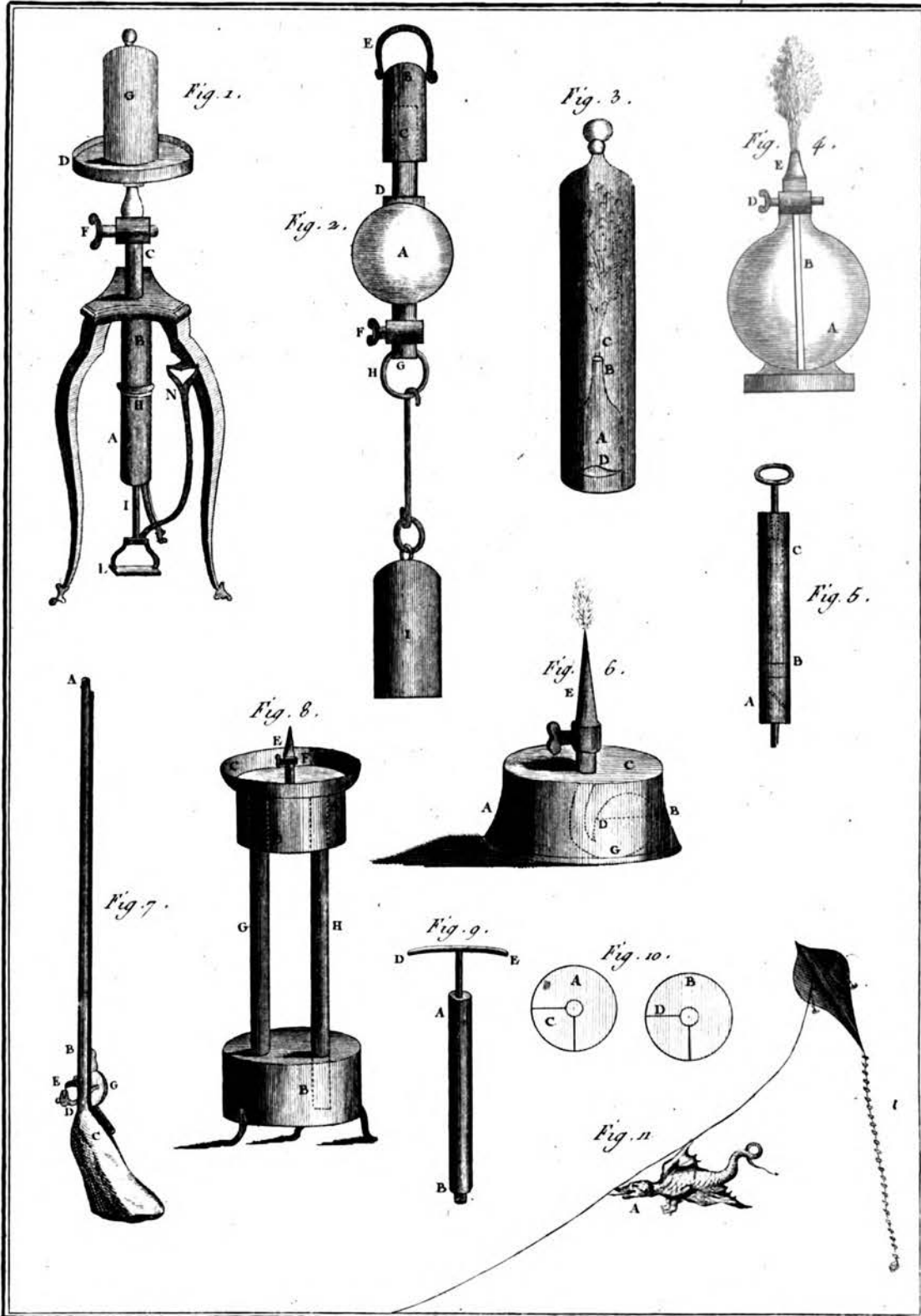
*Amusemens de Physique.*

*Bernard Dorel*



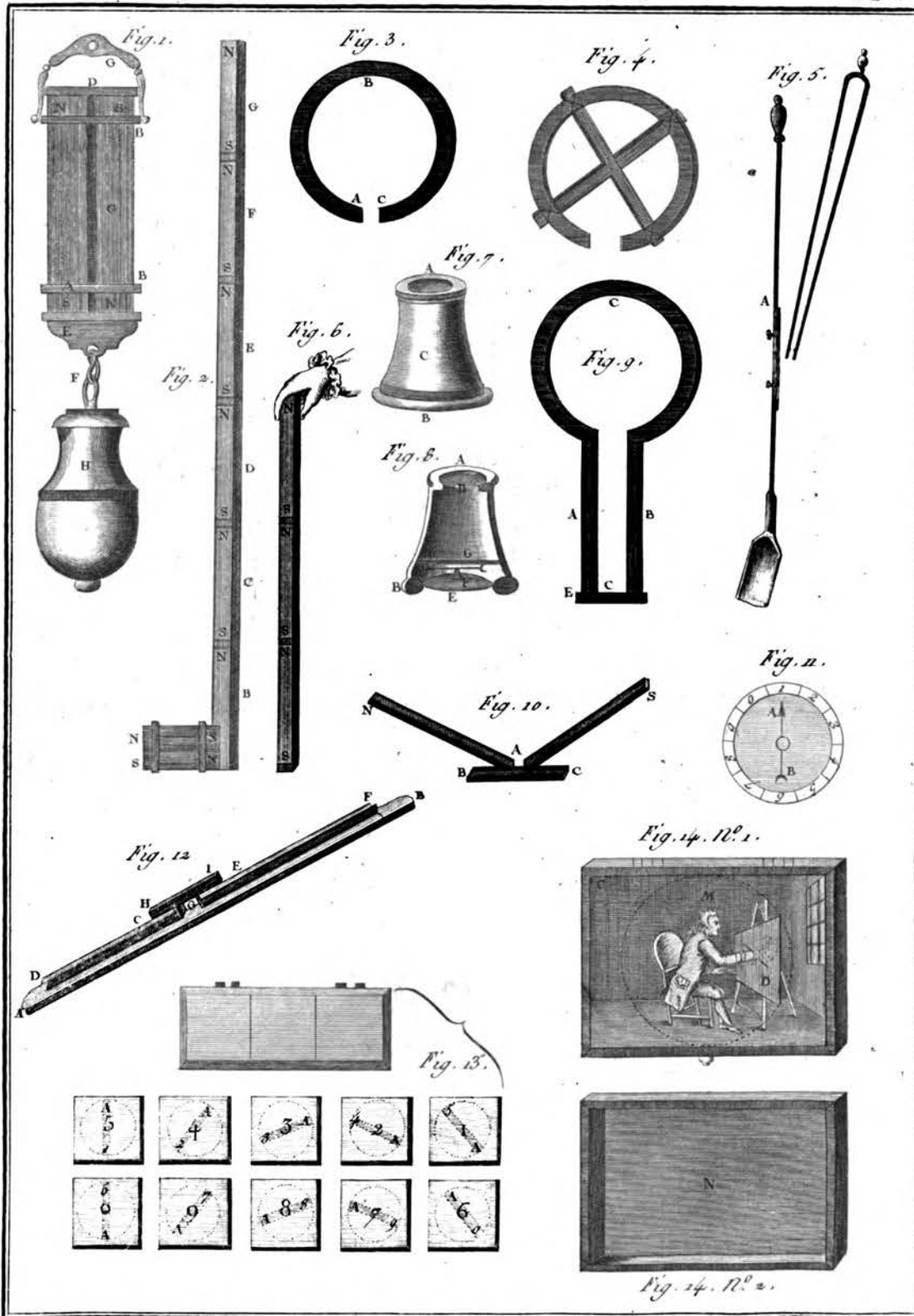
*Amusemens de Physique*

*Benoist Duvall.*



*Amusemens de Physique.*

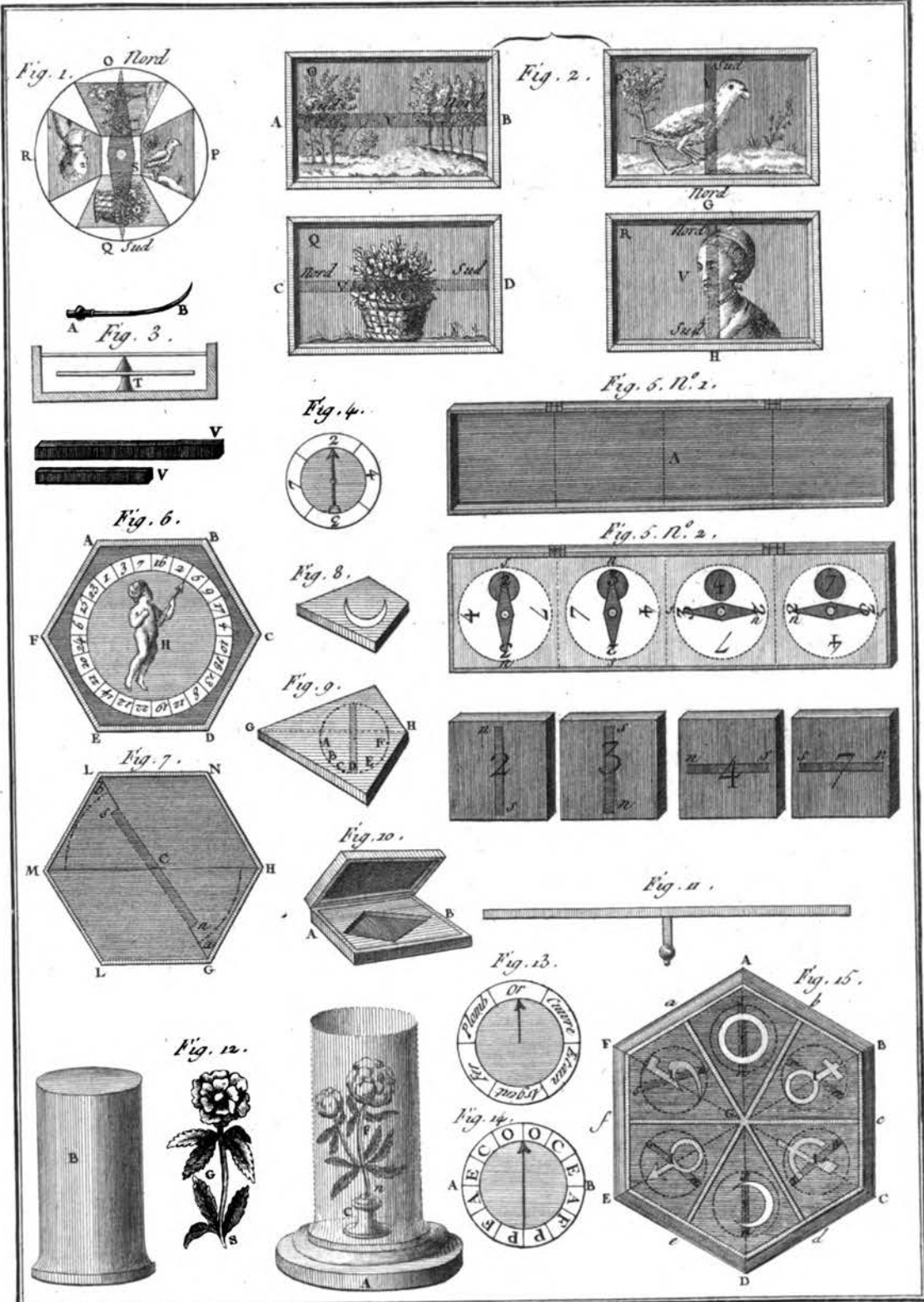
*Bernard L'écrit.*



*Amusemens de Physique.*

*Bonard. D'Arcet*

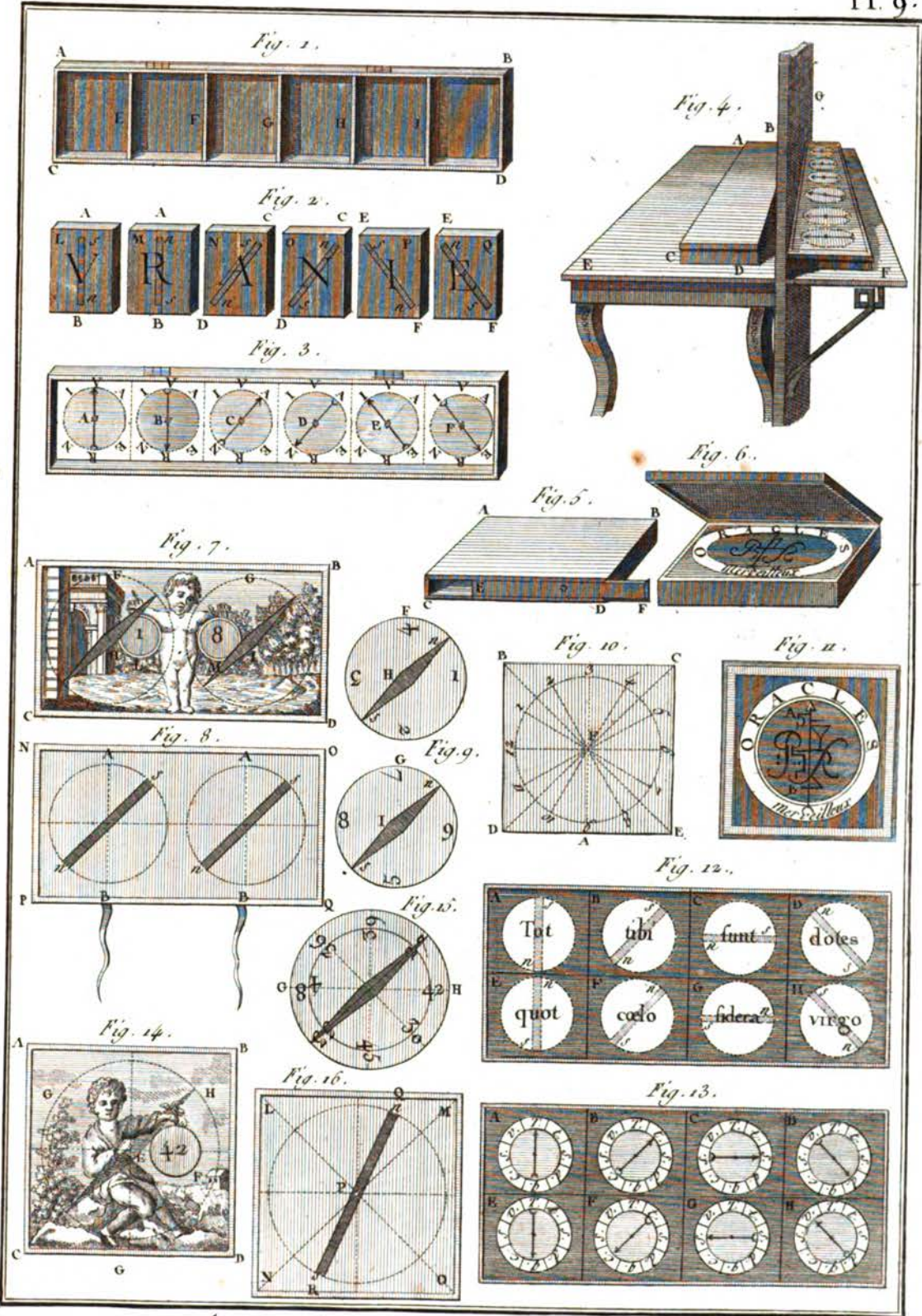




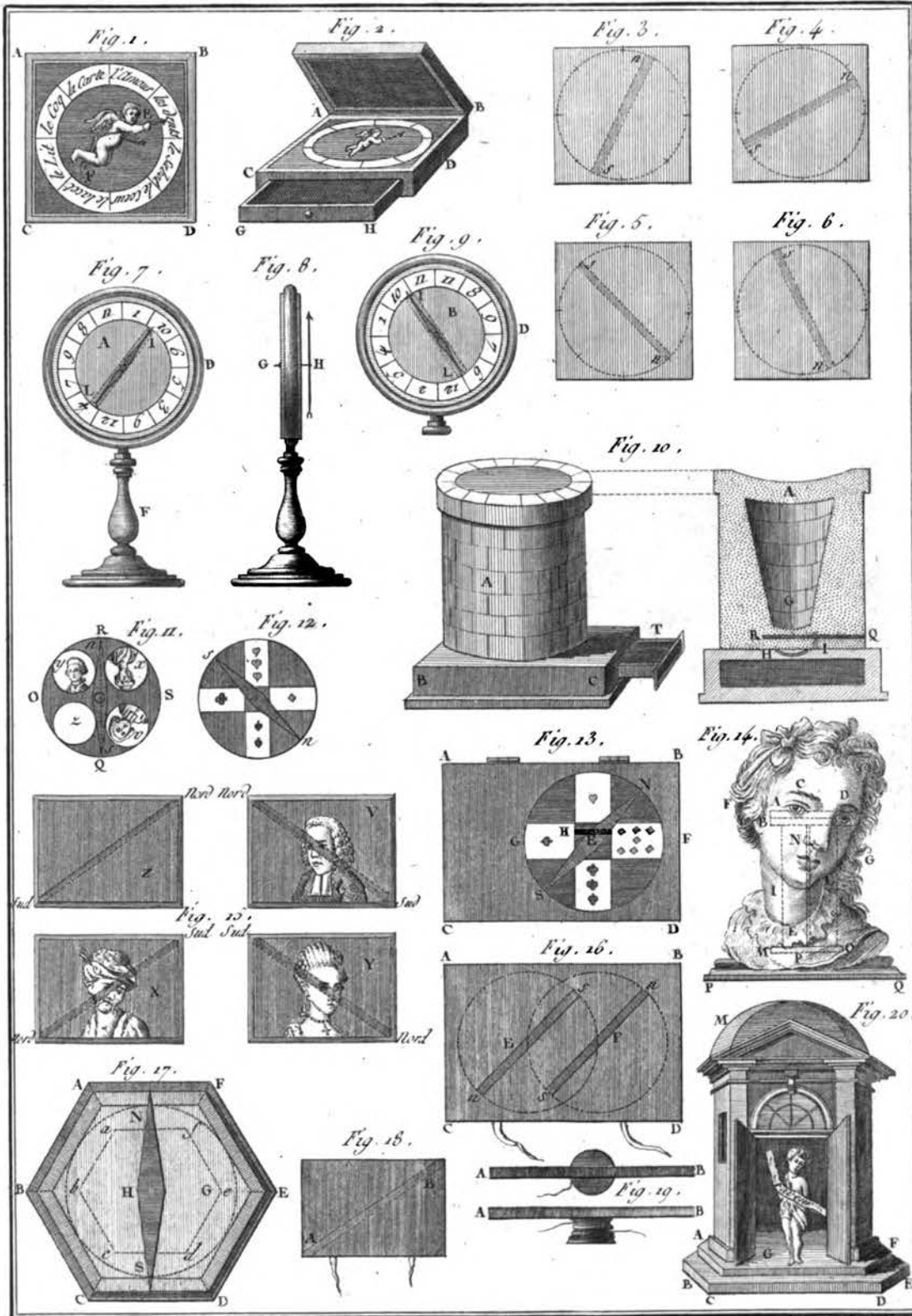
*Amusemens de Physique.*

Bonard Doreuil

Generated on 2014-05-11 15:50 GMT / http://hdl.handle.net/2027/ucm.5320295822 Public Domain, Google-digitized / http://www.hathitrust.org/access\_use#pd-google

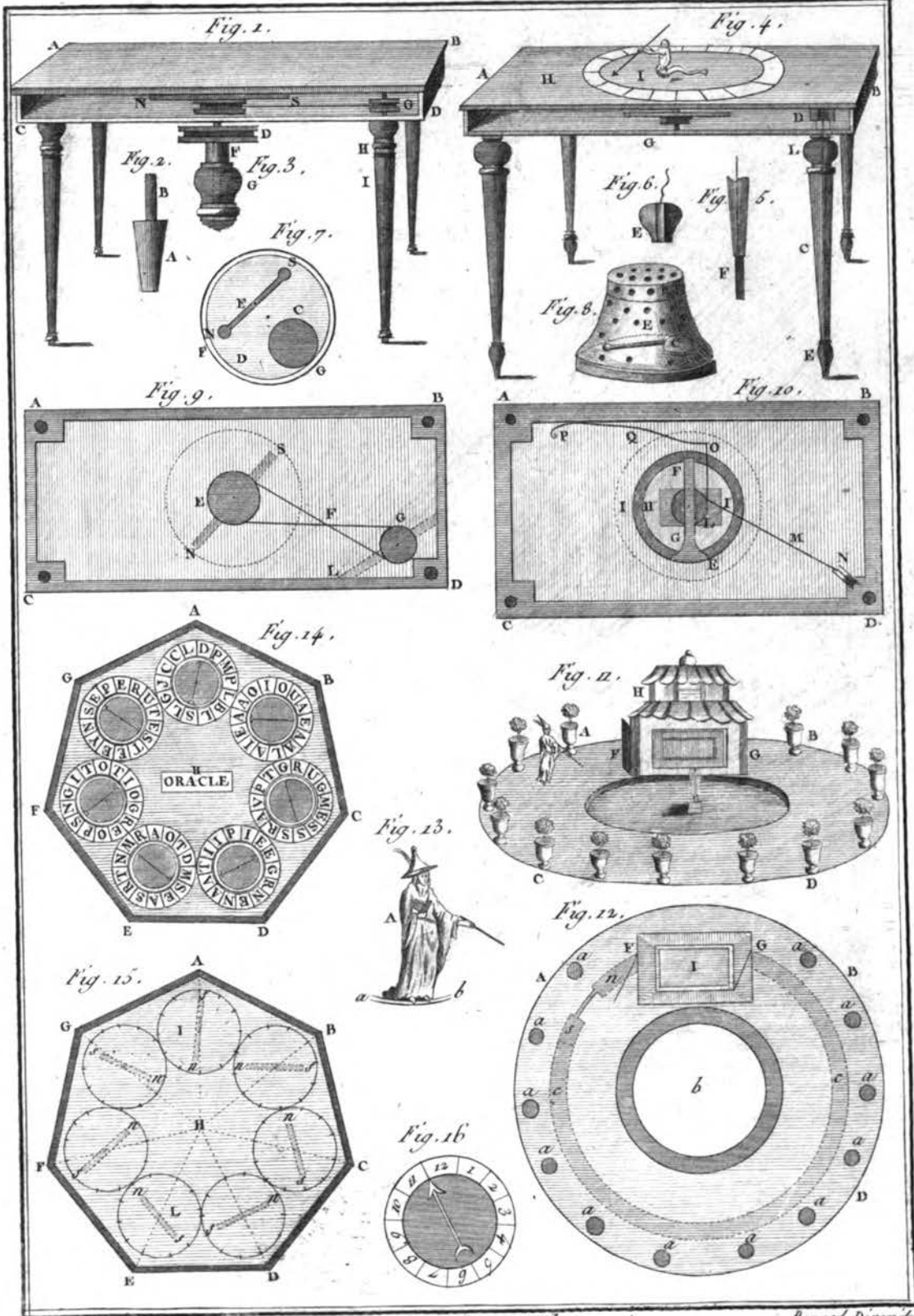


*Amusemens de Physique* Bernard Duret  
 Original from 17  
 Digitized by Google UNIVERSIDAD COMPLUTENSE DE MADRID



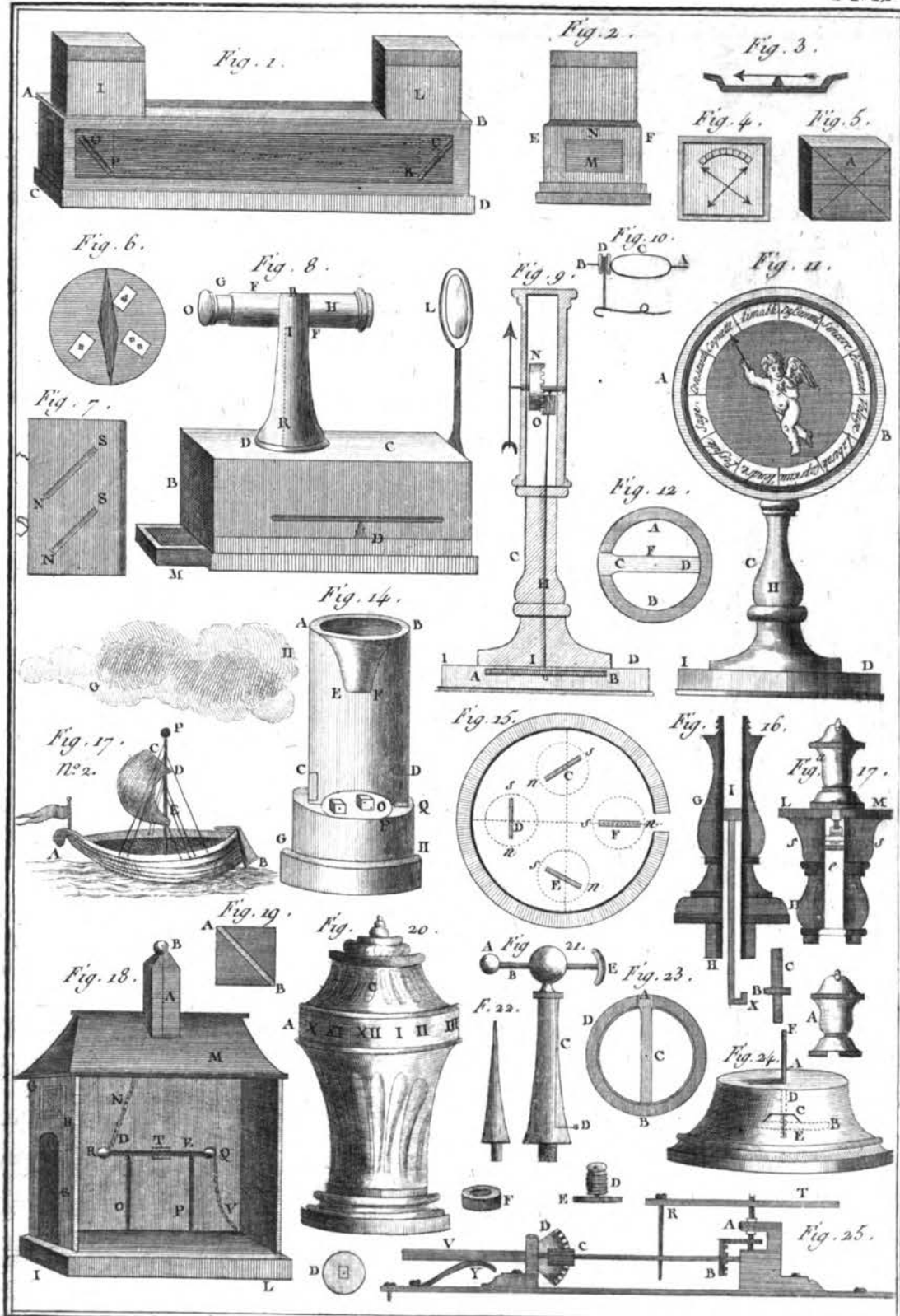
*Amusemens de Physique*

*Bernard Duvet.*



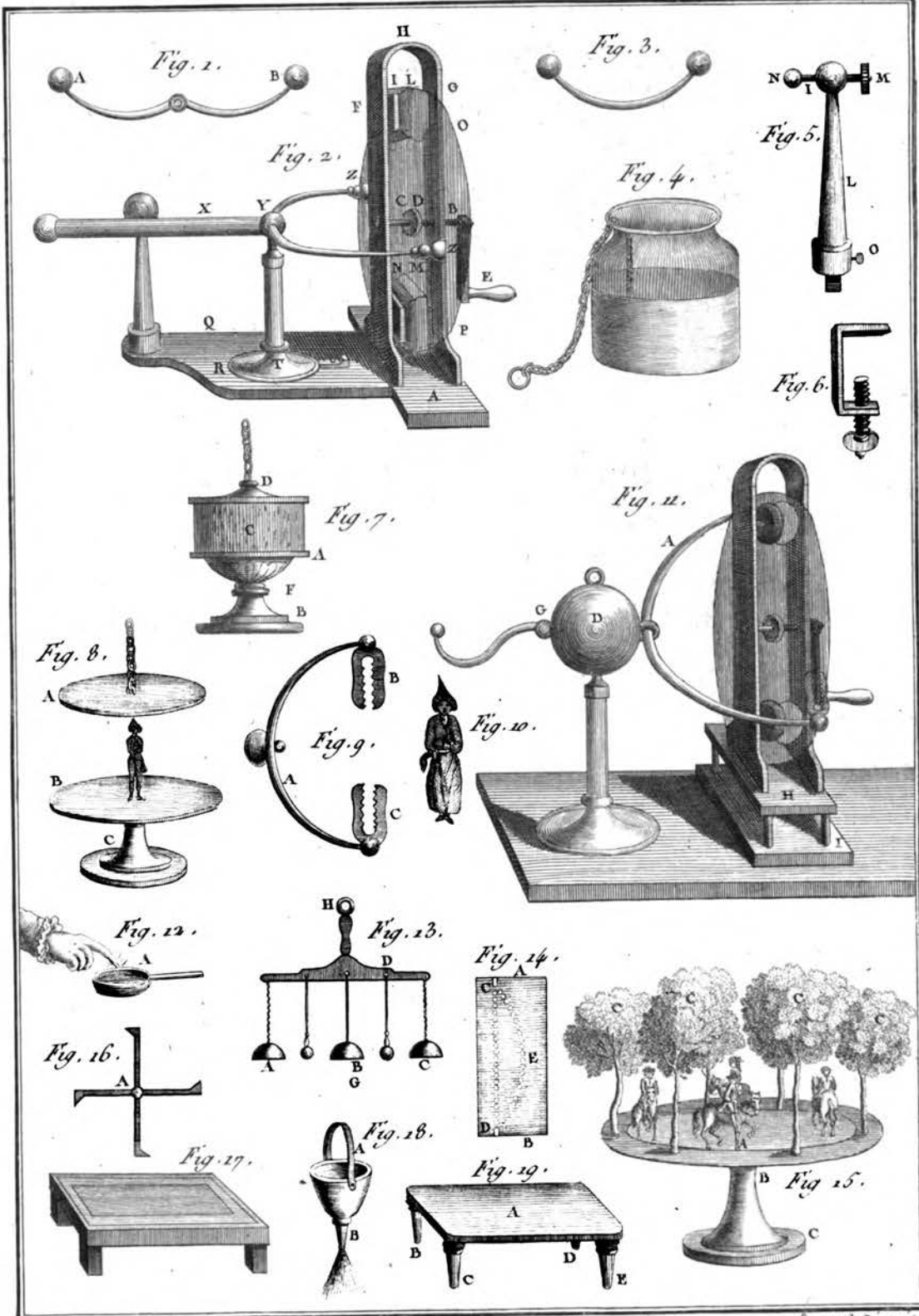
*Amusemens de Physique.*

*Benard Dircet.*



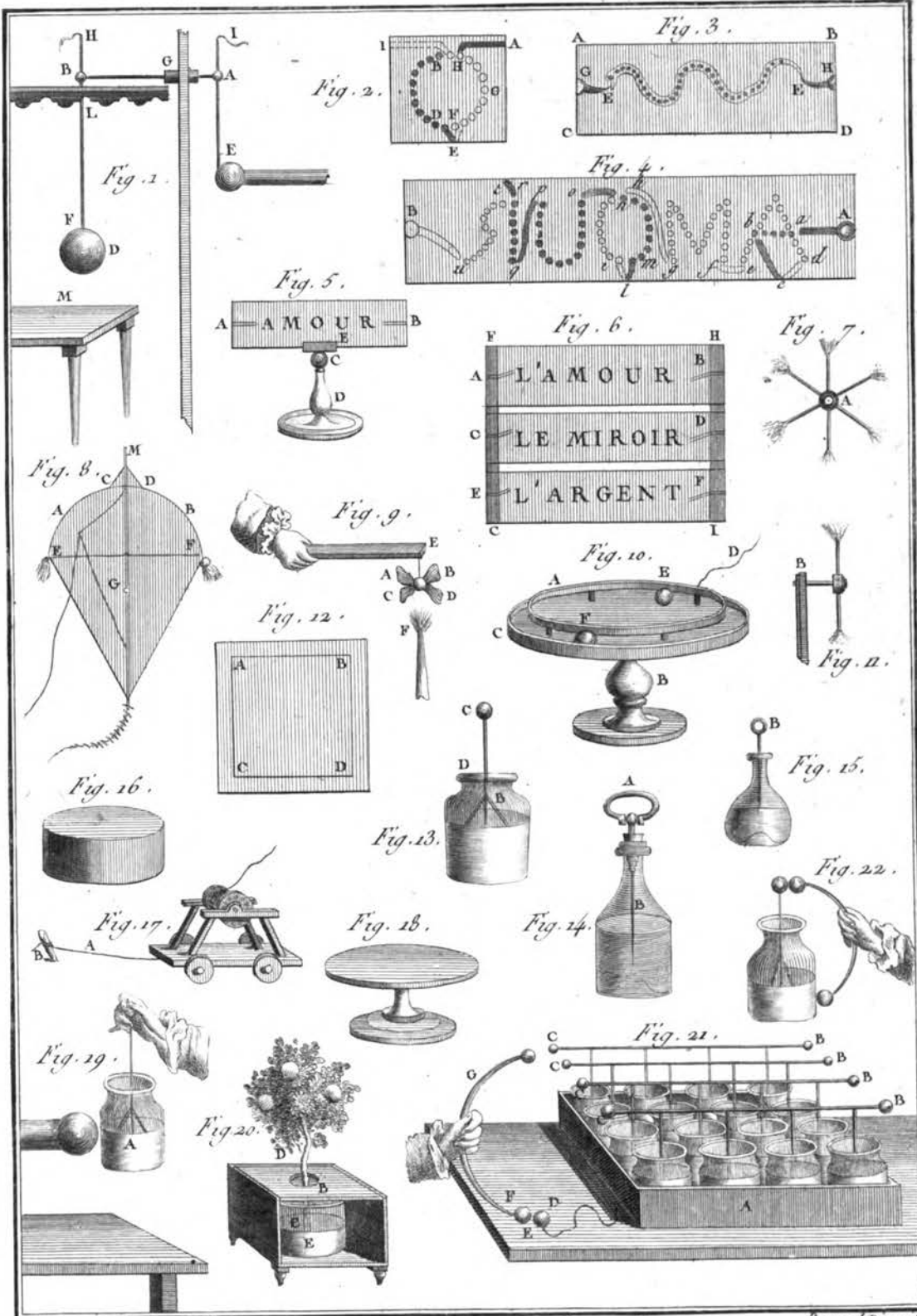
*Amusemens de Physique.*

*Bernard Directt.*



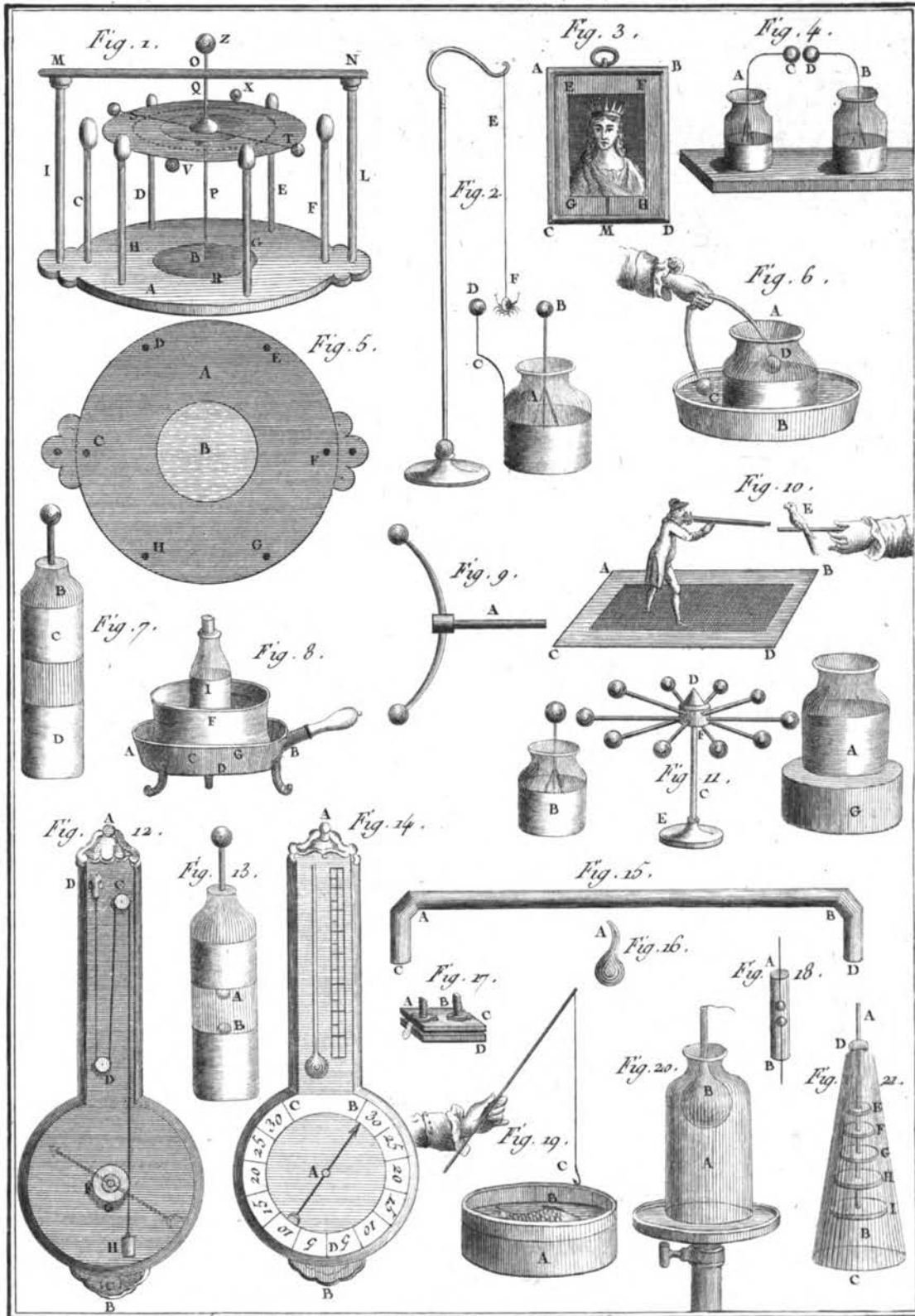
*Amusemens de Physique.*

*Beard Duxit.*



*Amusemens de Physique.*

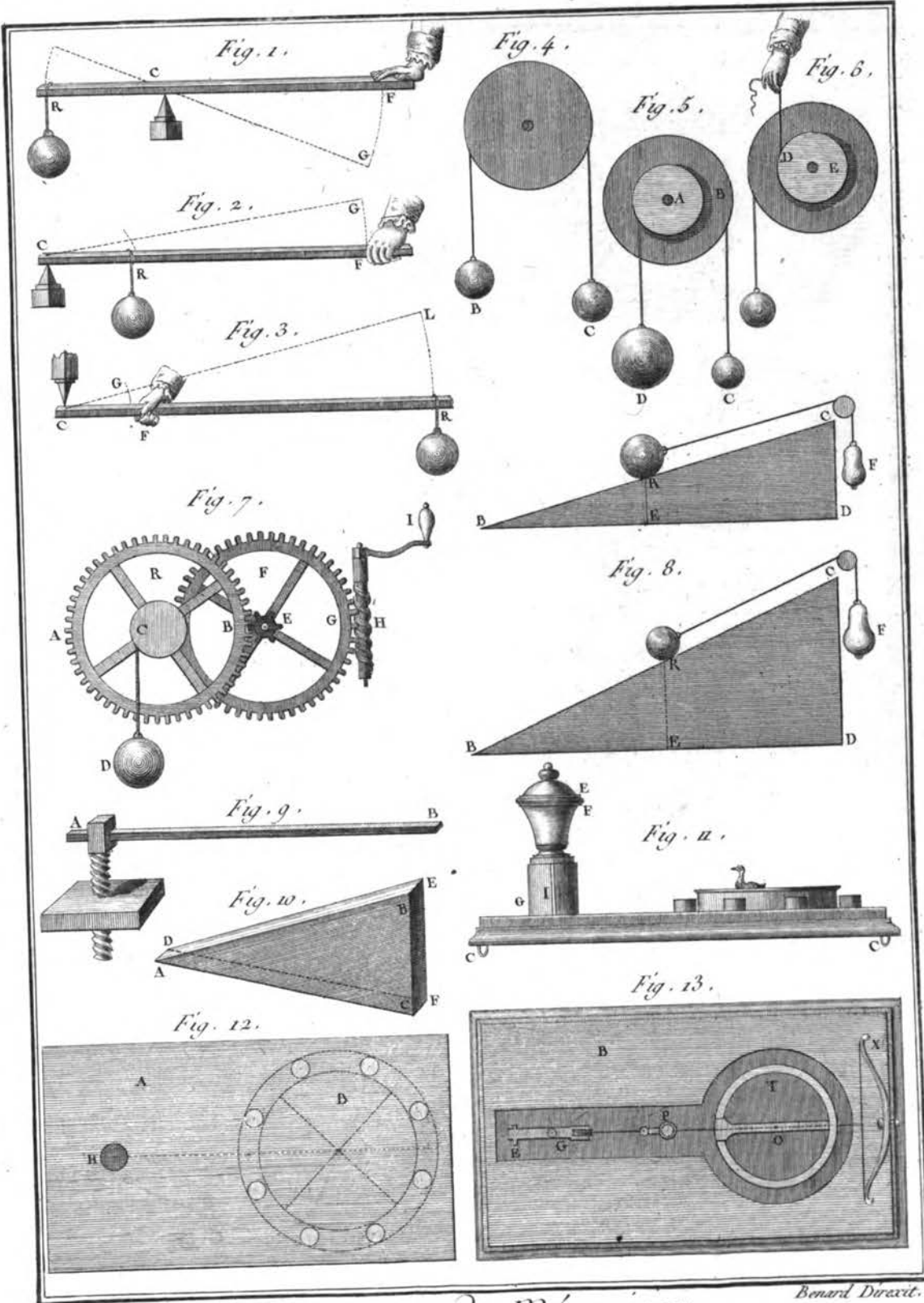
*Bonard, Directeur.*



*Amusemens de Physique.*

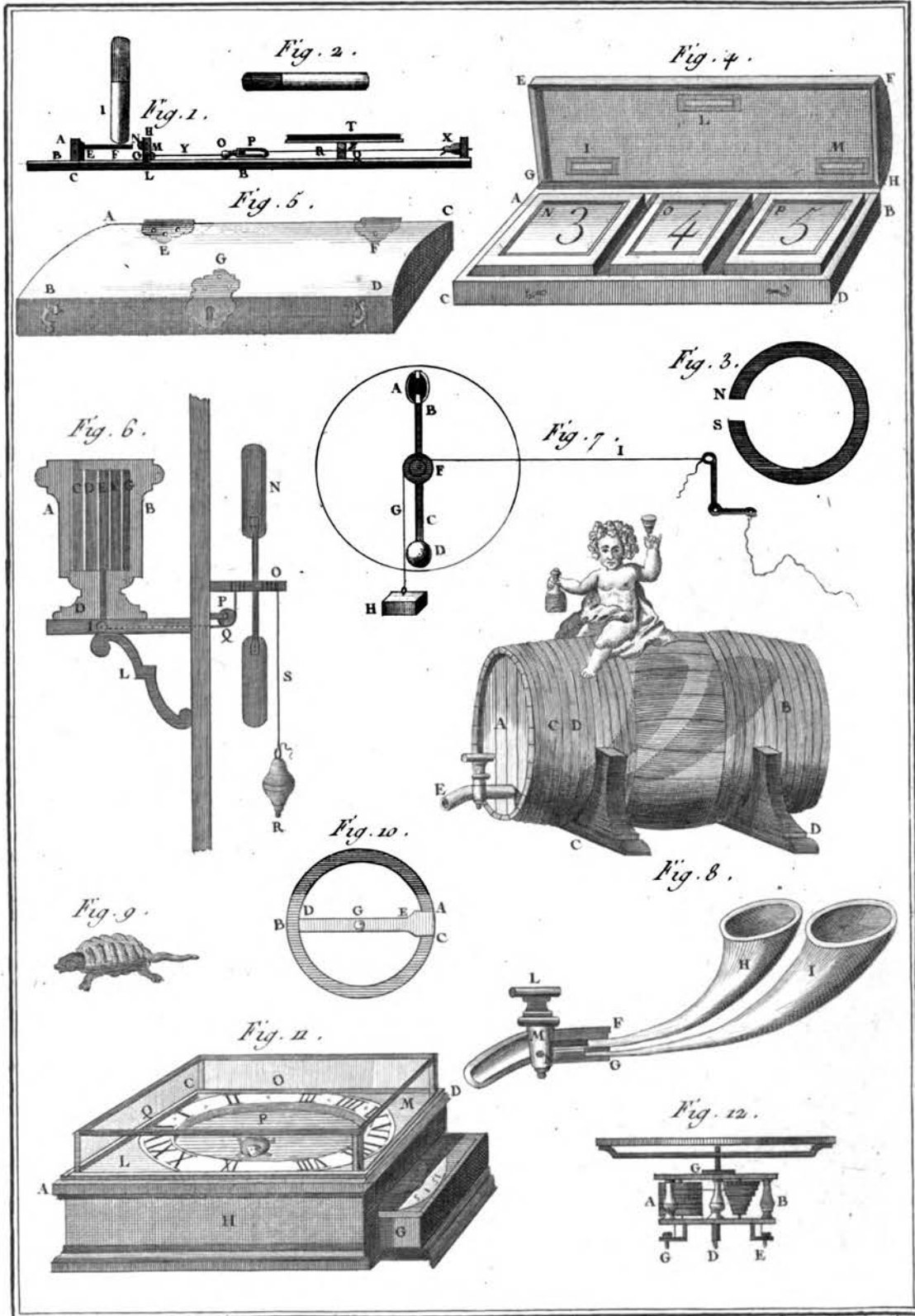
*Benard Drexel*





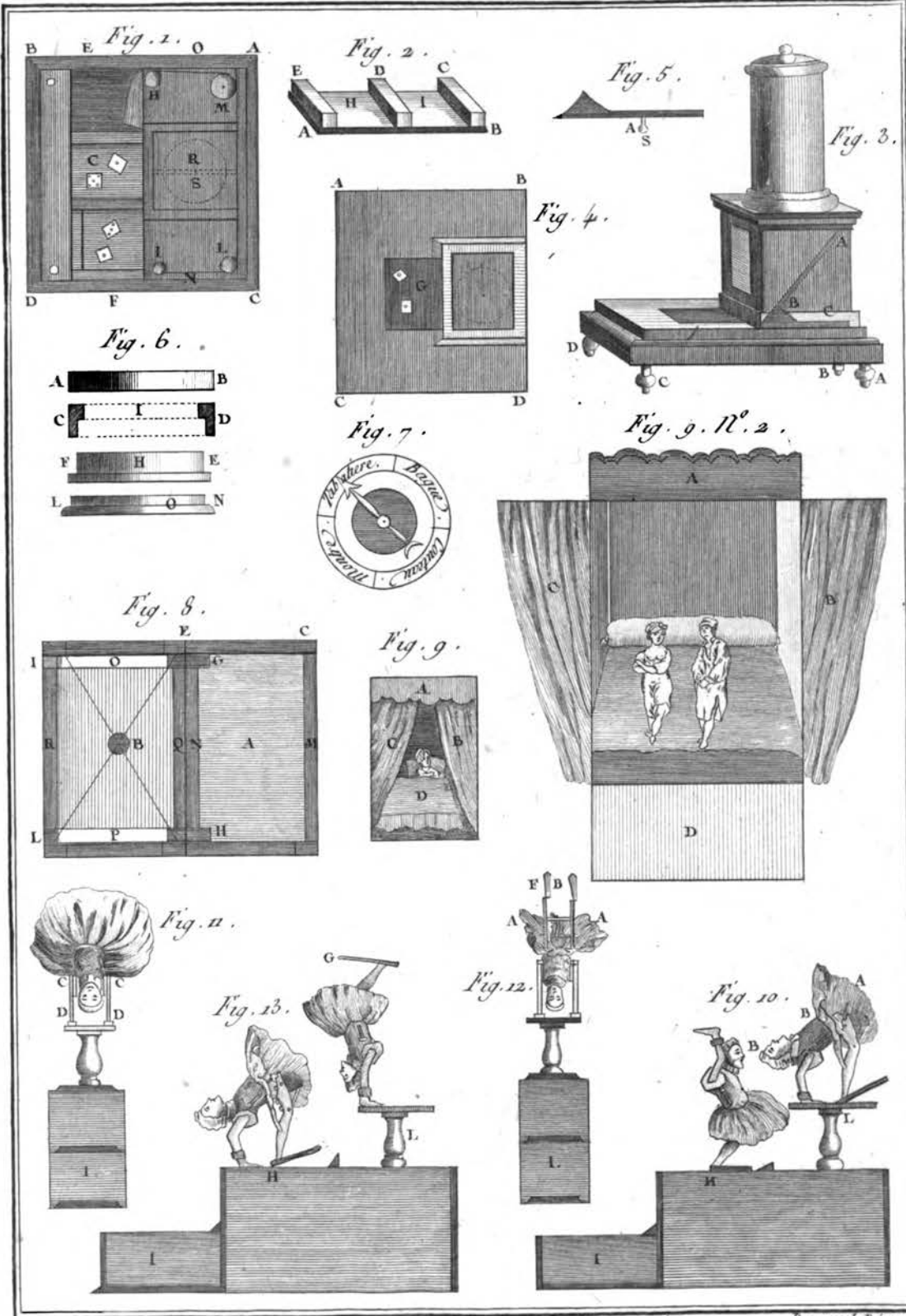
*Amusemens de Mécanique.*

*Bernard D'Arcy.*



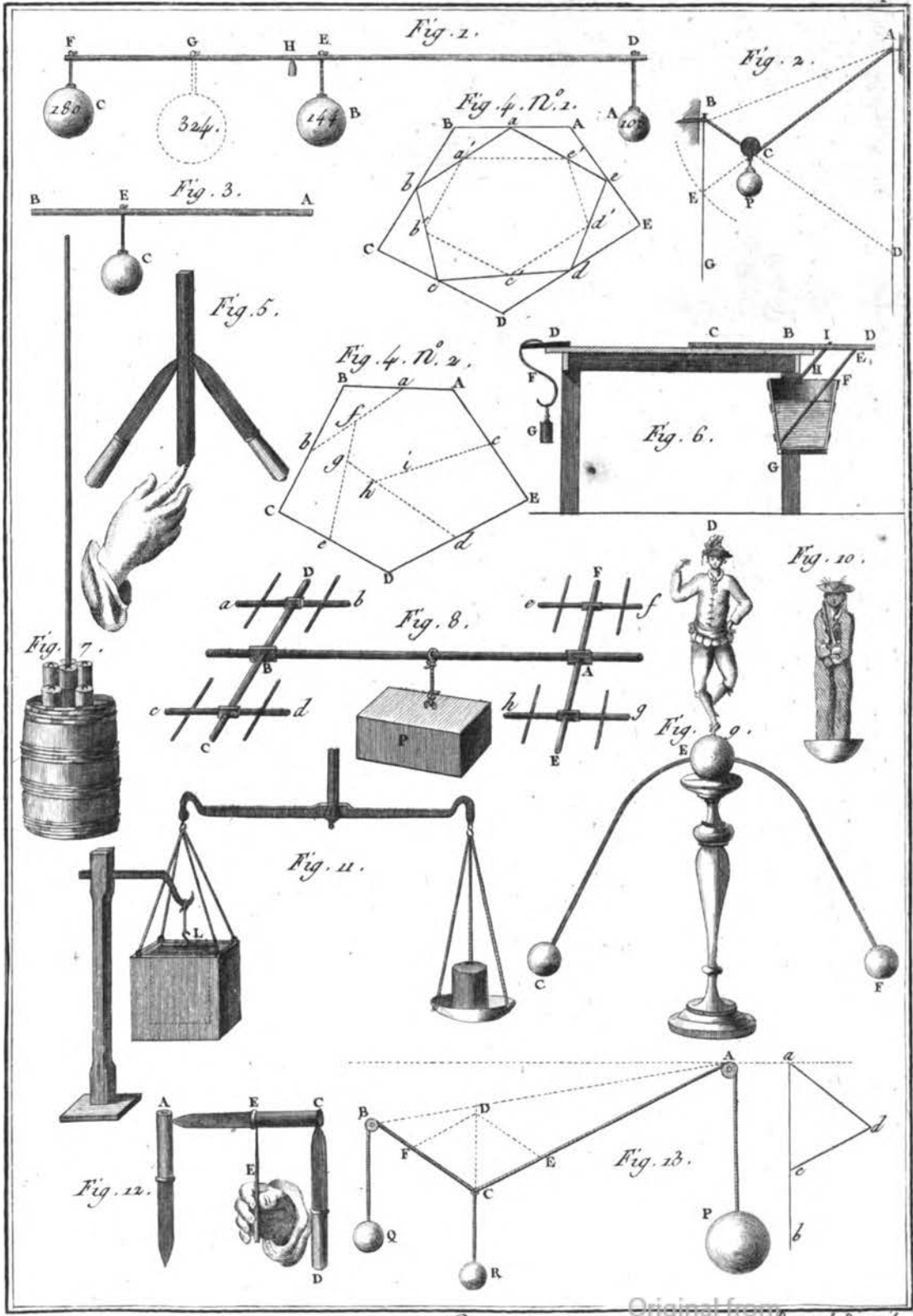
*Amusemens de Mécanique.*

*Benard Duxcit.*

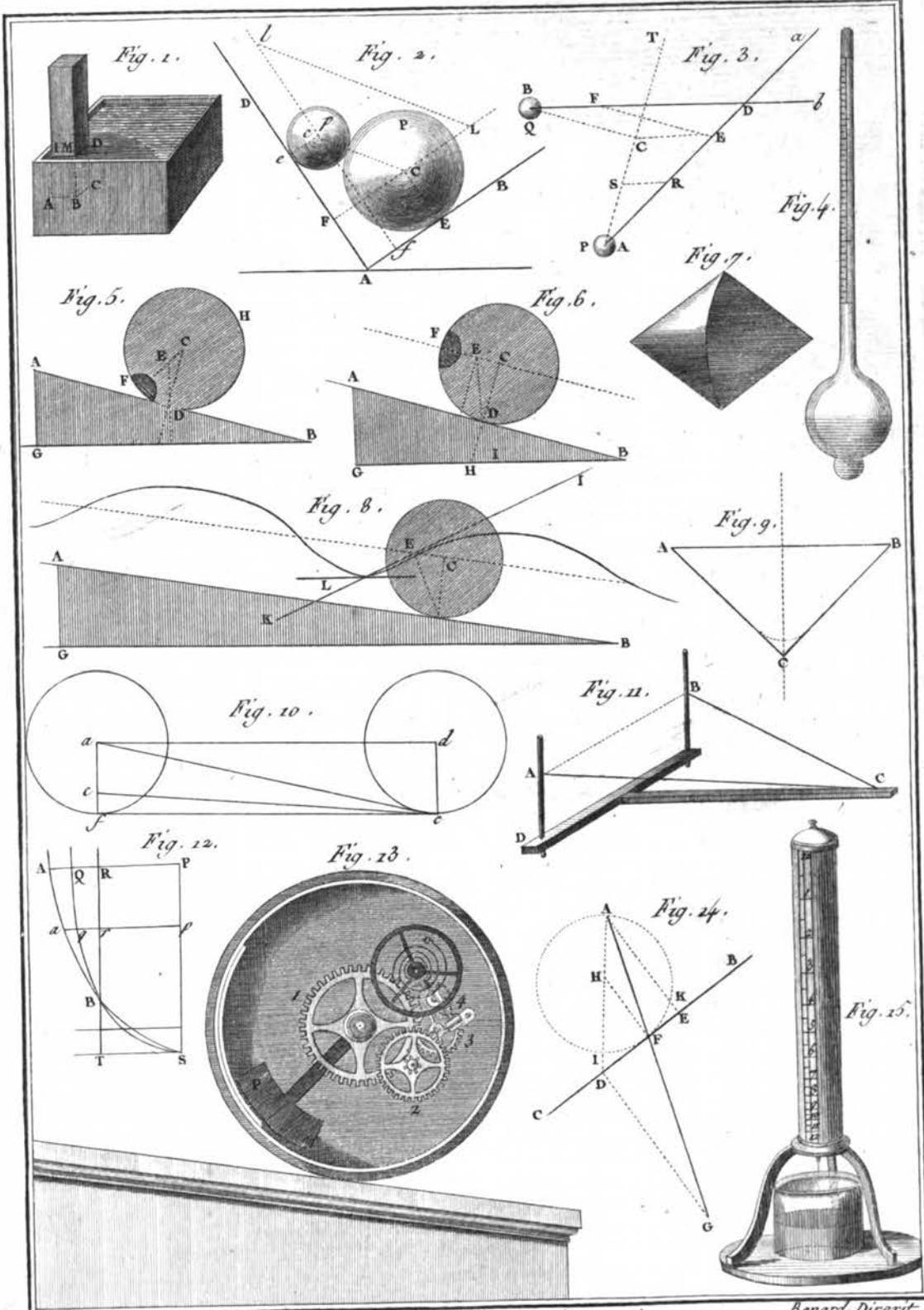


*Amusemens de Mécanique*

*Benard Drexel.*

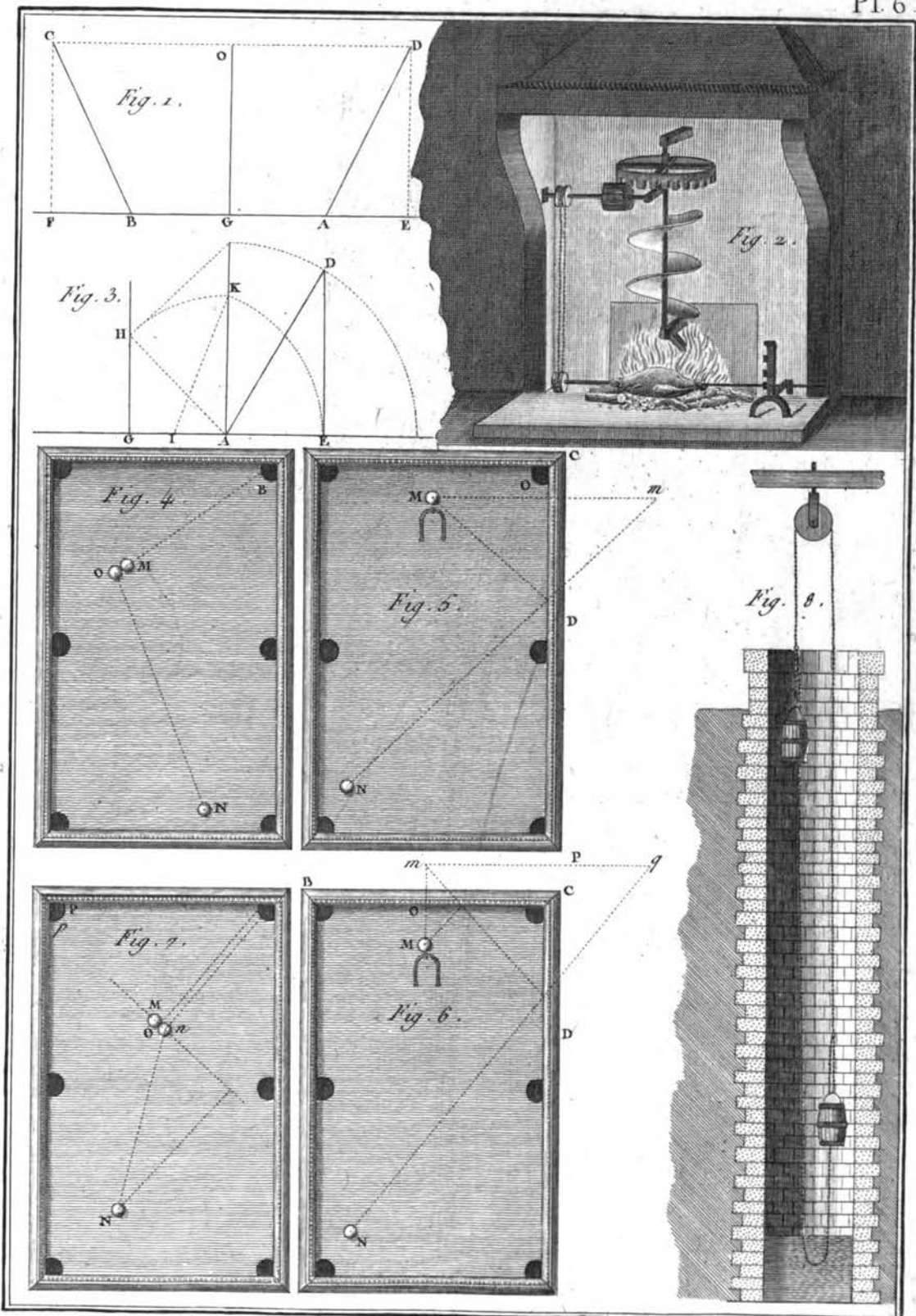


Generated on 2014-05-11 15:54 GMT / http://hdl.handle.net/2027/ucm.5320295822  
 Public Domain, Google-digitized / http://www.hathitrust.org/access\_use#pd-google



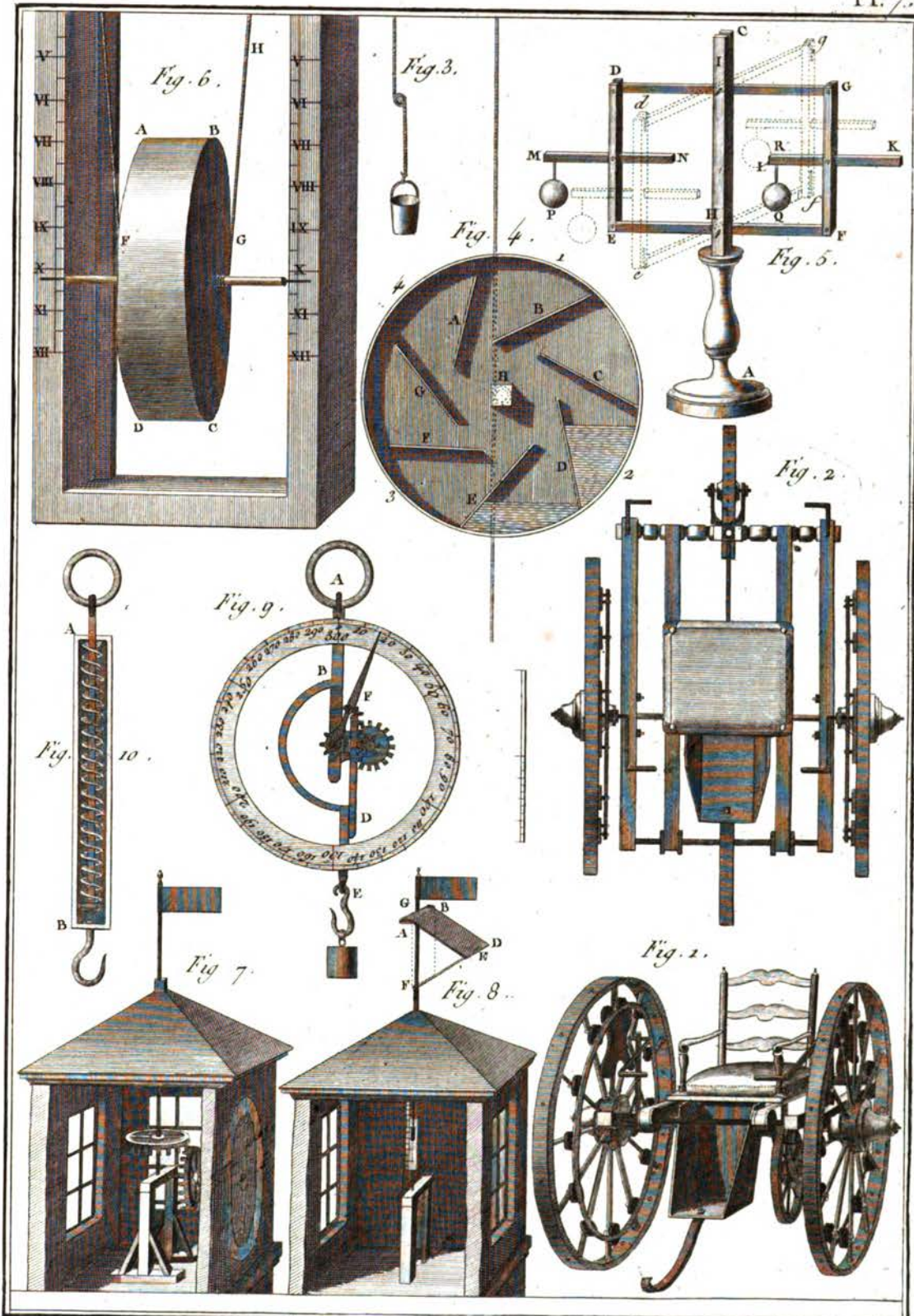
*Amusemens de Mécanique.*

*Benard Dixait.*



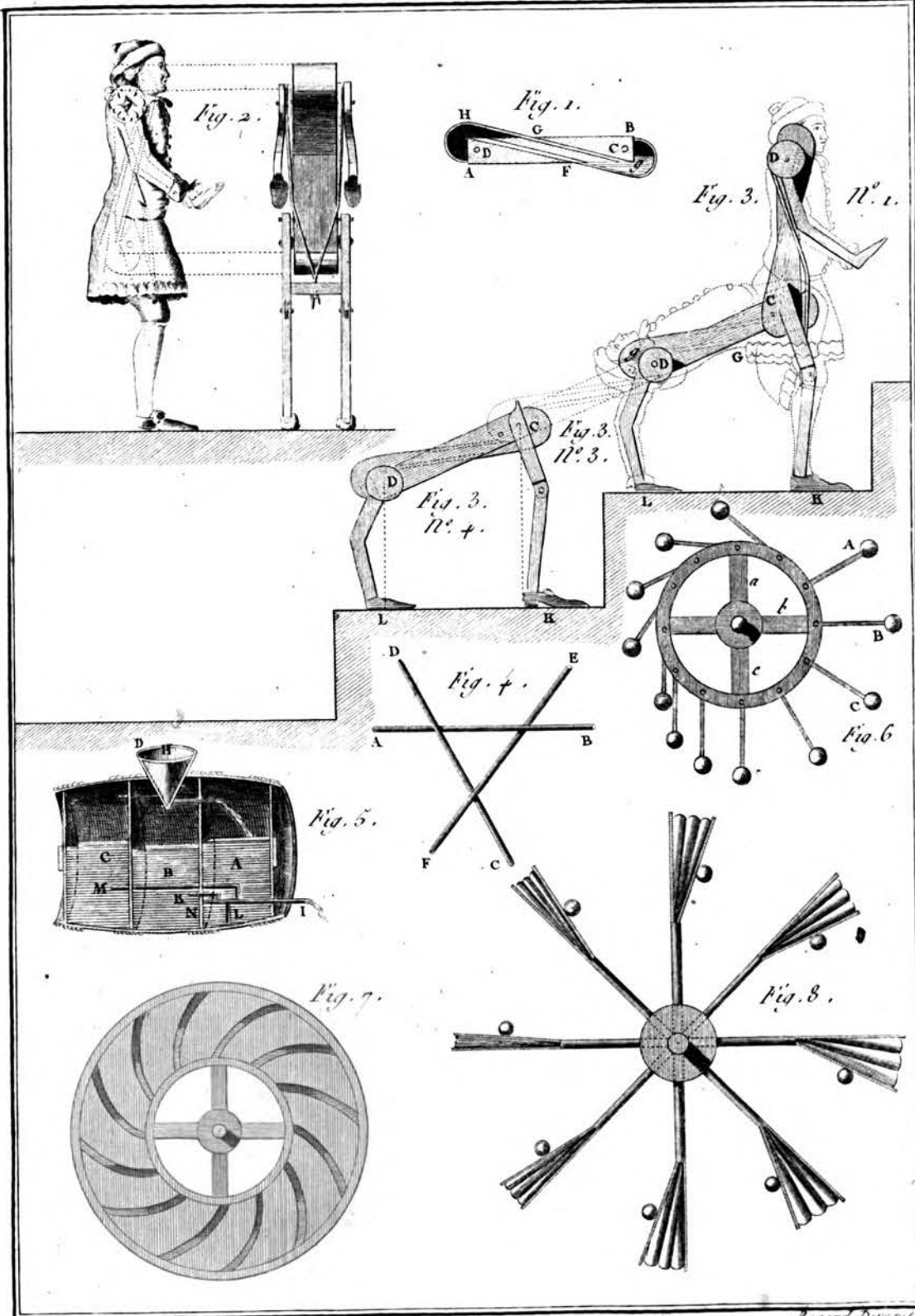
*Amusemens de Mécanique*

*Benard Duxet.*



*Anusemens de Mécanique*

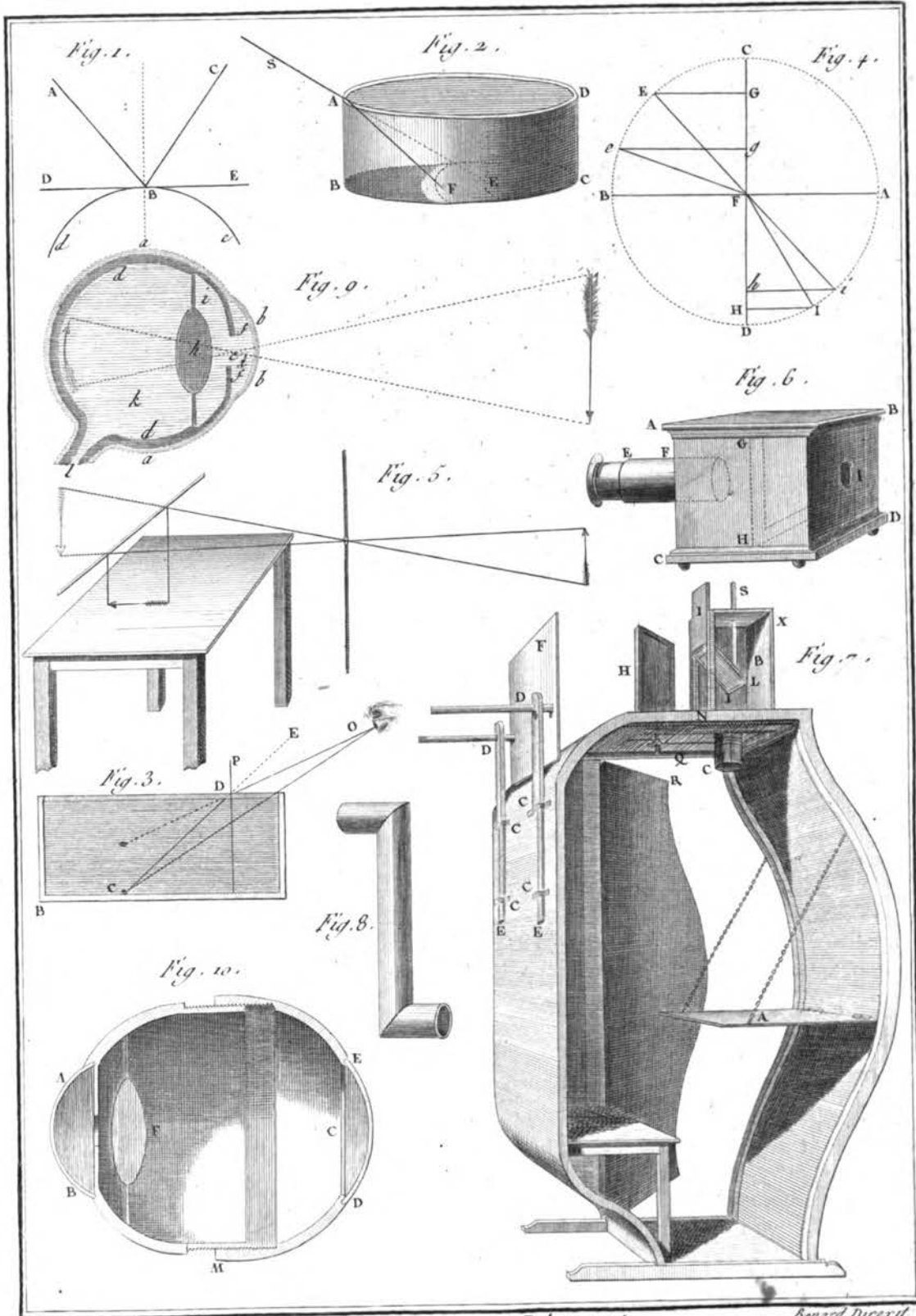
*Bonard Duxart.*



*Amusemens de Mécanique*

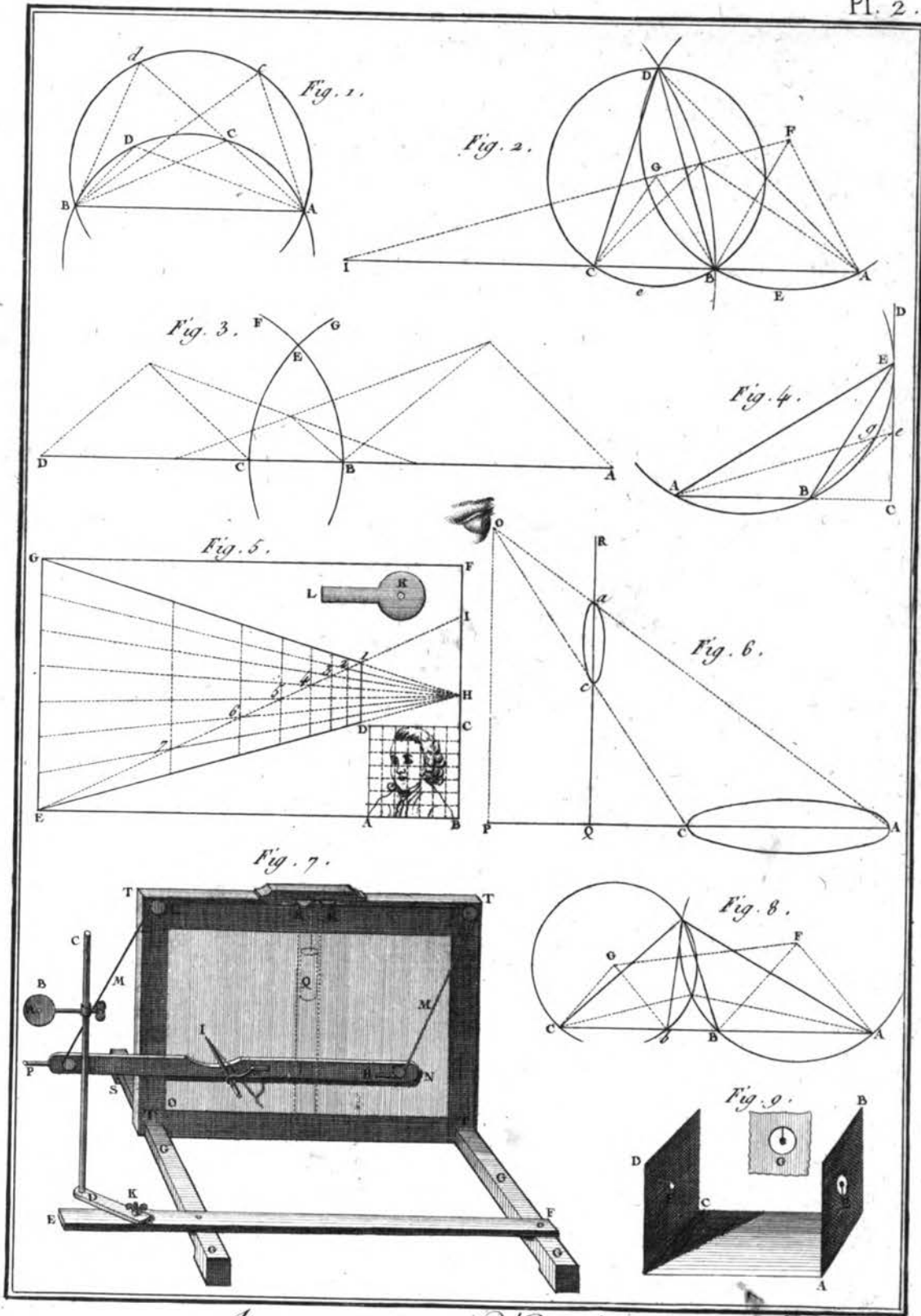
*Bonard Dorel*





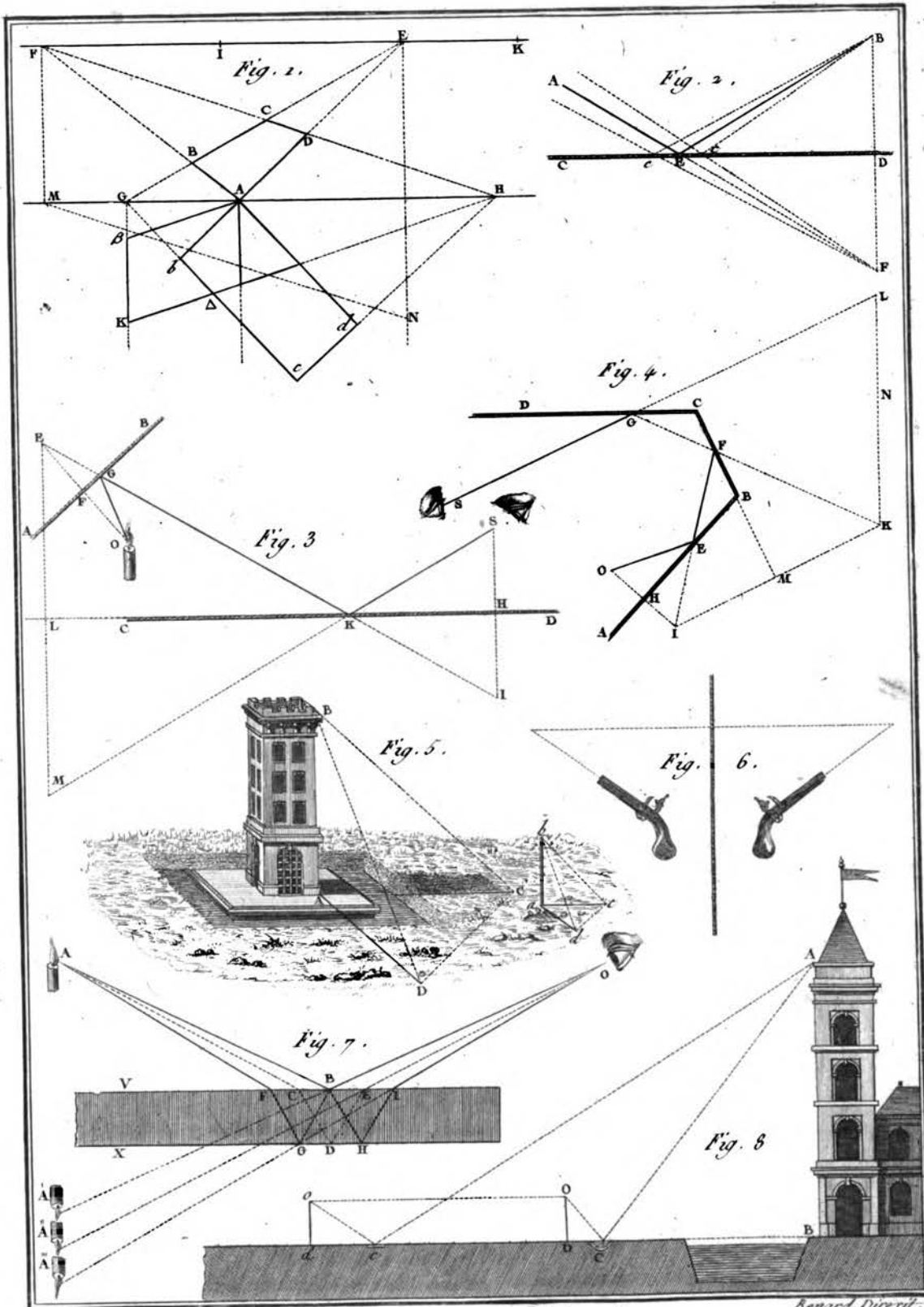
*Amusemens d'Optique*

Benard Duxat



*Amusemens d'Optique.*

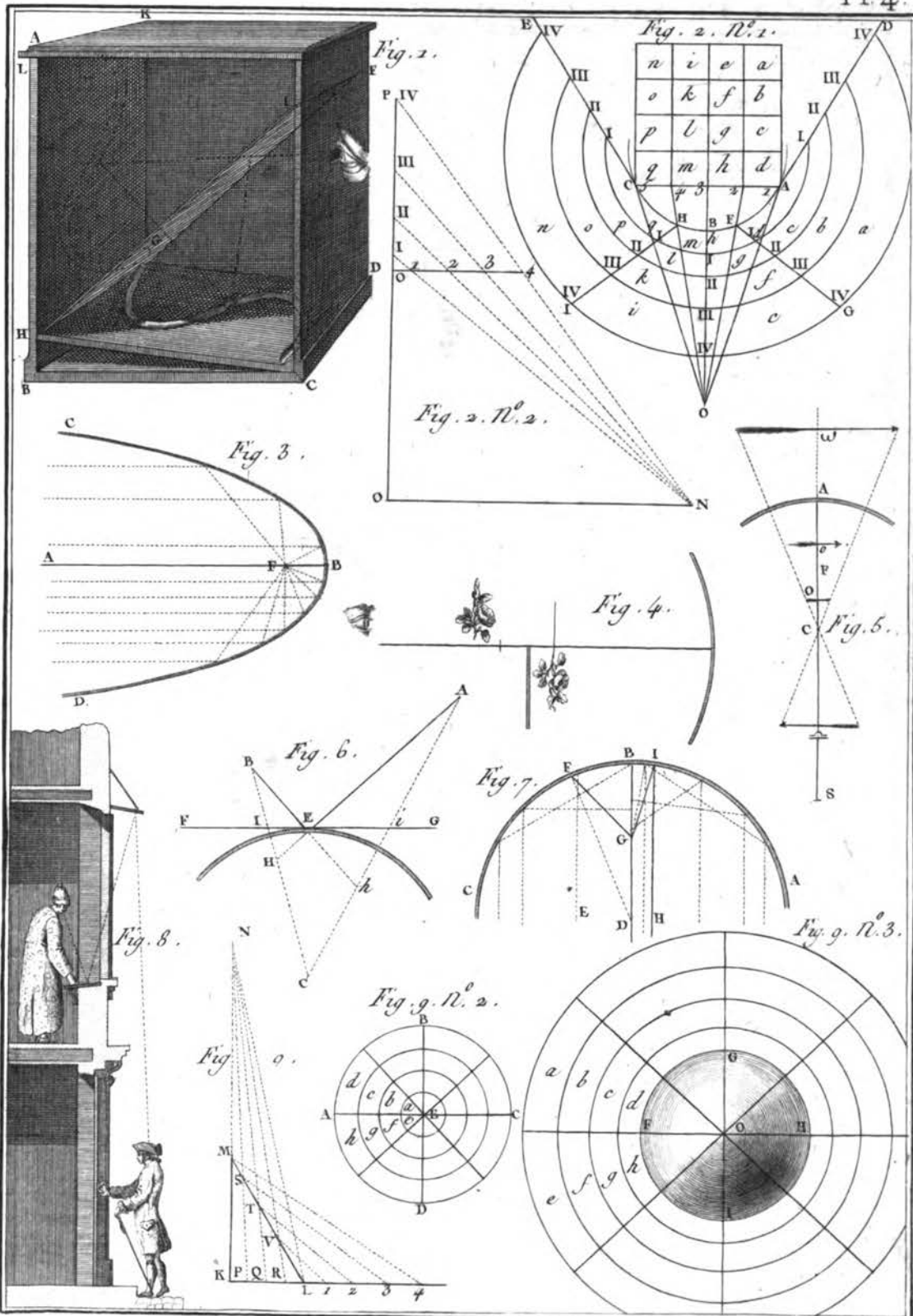
*Bernard Dinzet*



*Amusemens d'Optique.*

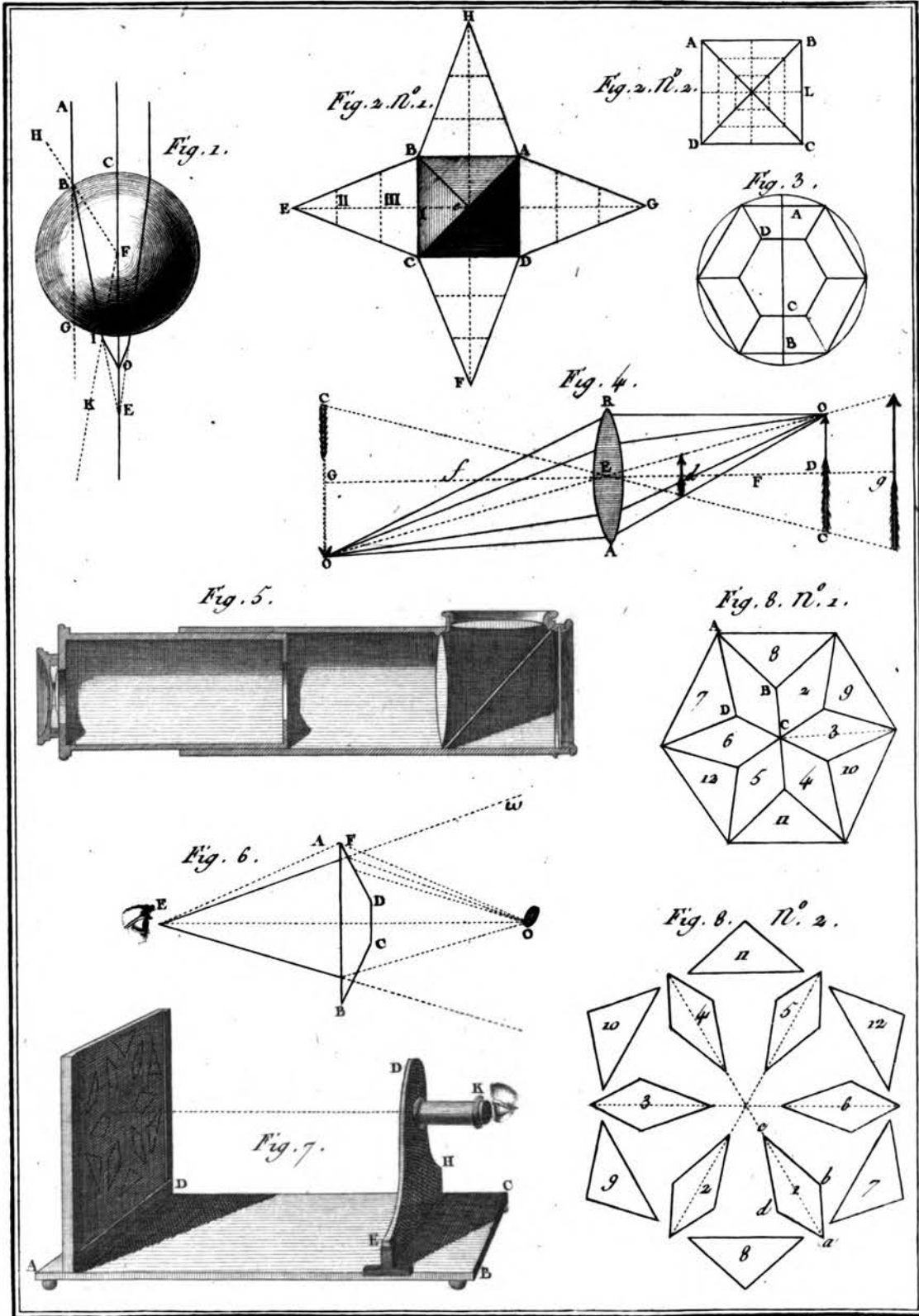
*Benard Dircet.*

Generated on 2014-05-11 16:17 GMT / http://hdl.handle.net/2027/ucm.5320295822 Public Domain, Google-digitized / http://www.hathitrust.org/access\_use#pd-google



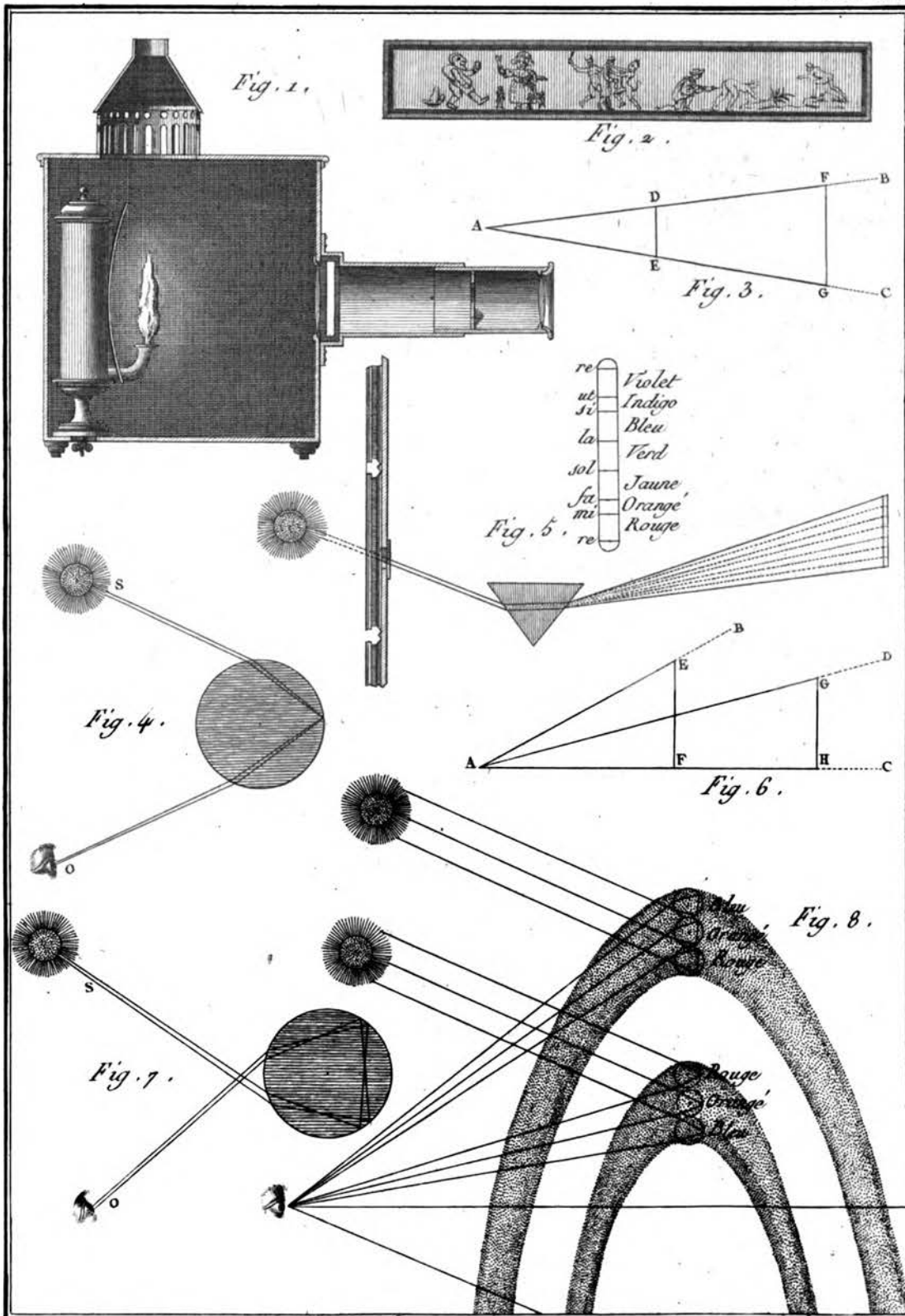
*Amusemens d'Optique.*

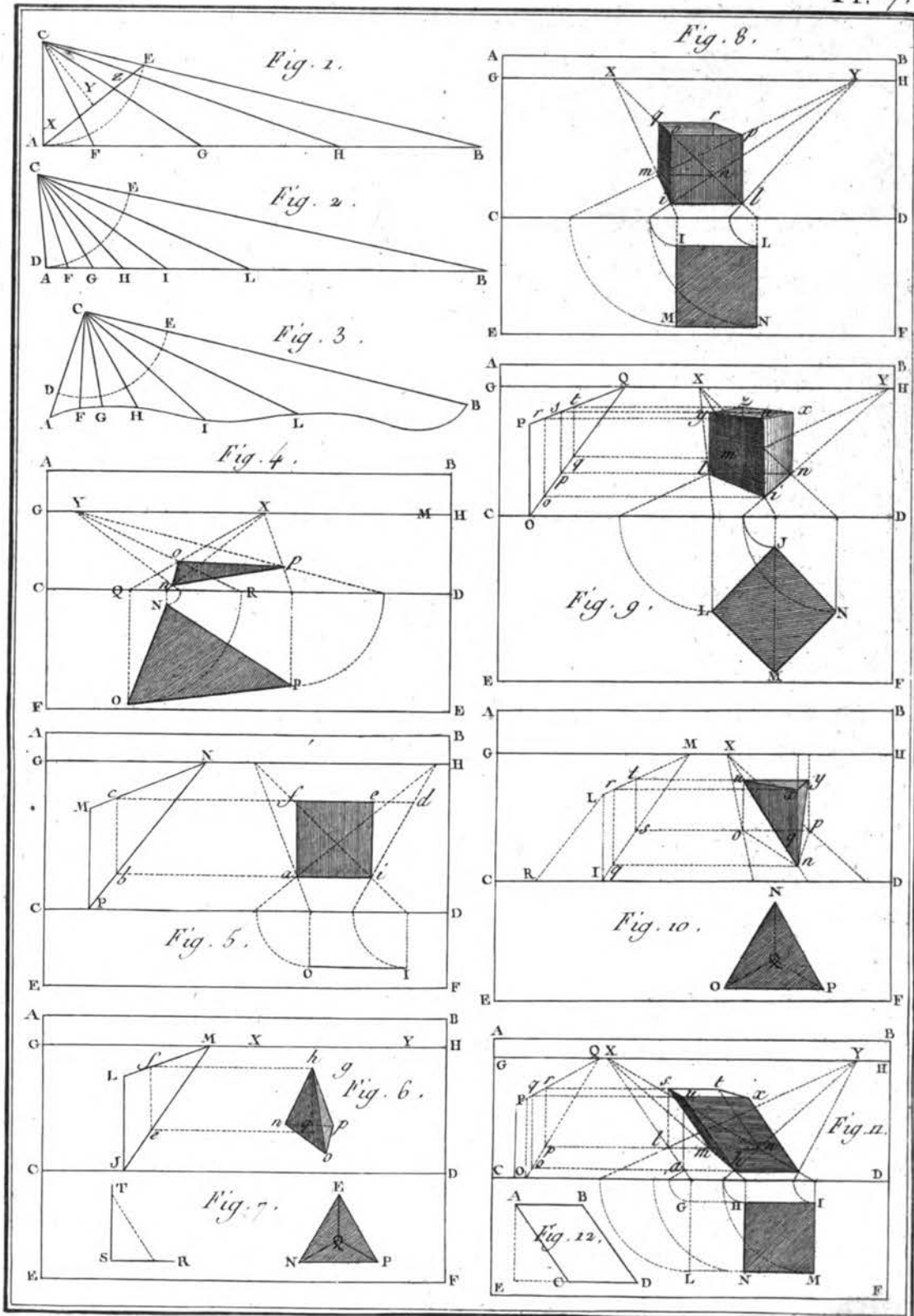
*Bernard Durrant.*



Amusemens d'Optique

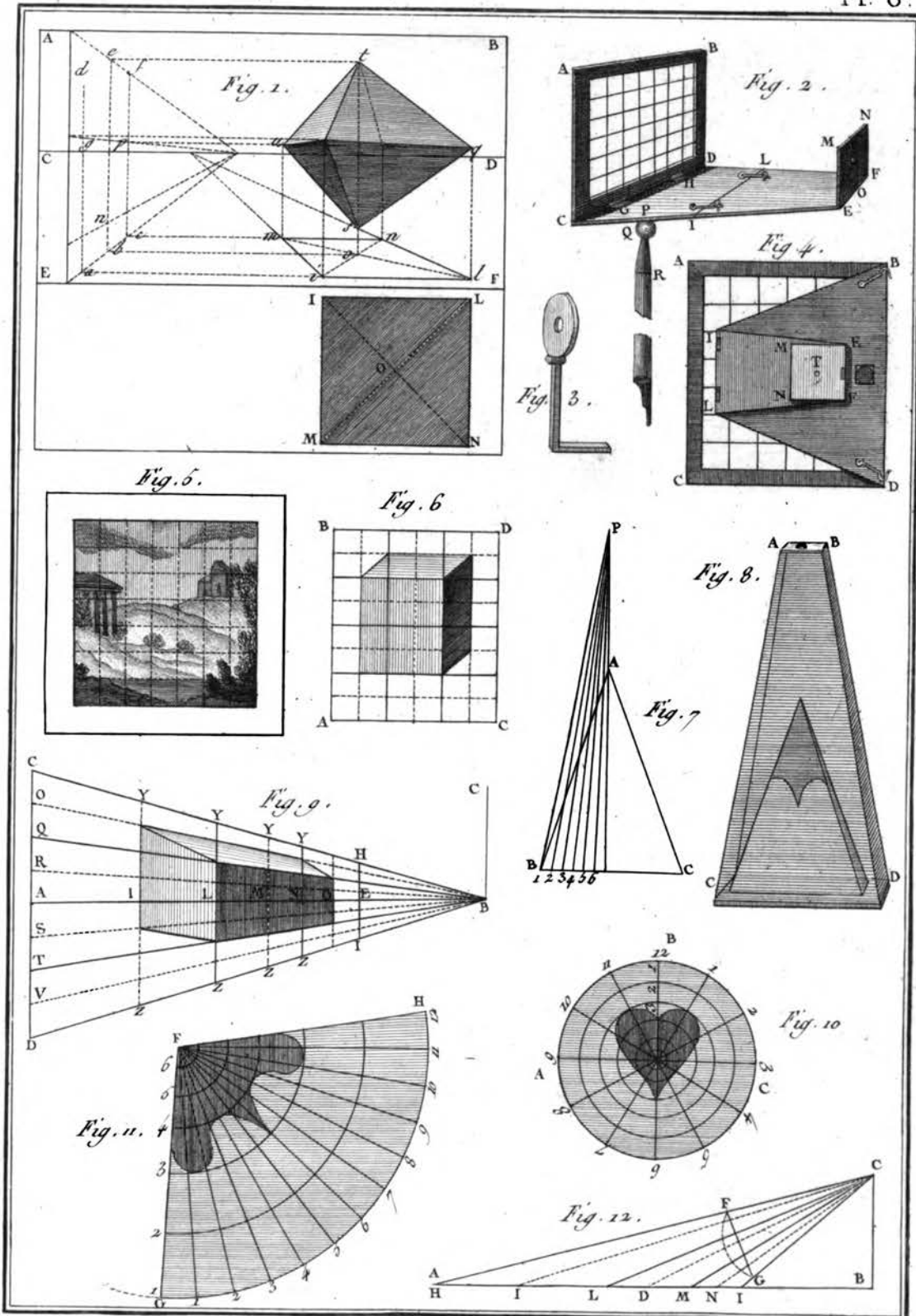
Benard Directeur





*Amusemens d'Optique.*

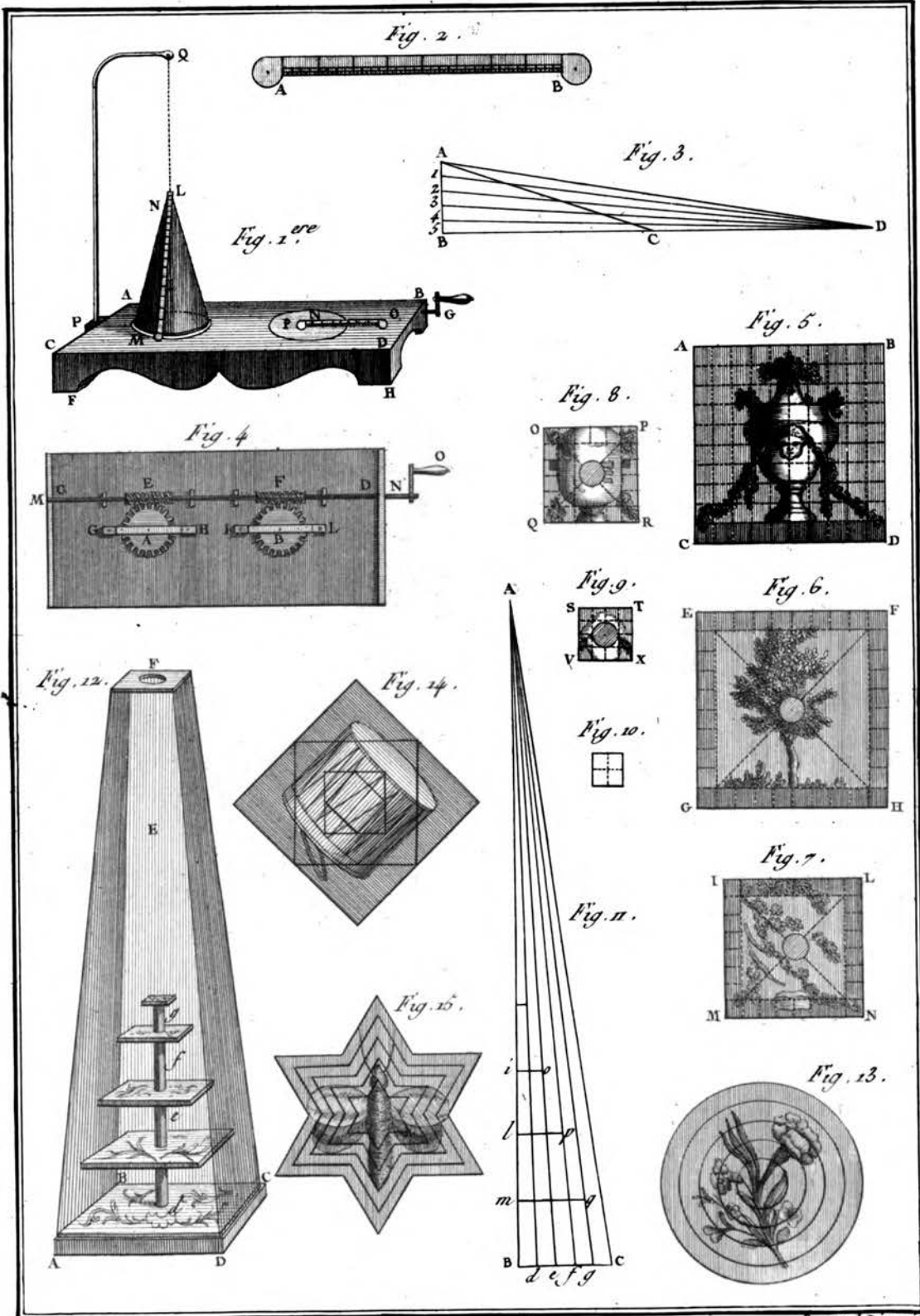
*Bernard Borelli.*



*Amusemens d'Optique.* *Bernard Drexel*

Generated on 2014-05-11 16:19 GMT / http://hdl.handle.net/2027/ucm.5320295822 Public Domain, Google-digitized / http://www.hathitrust.org/access\_use#pd-google

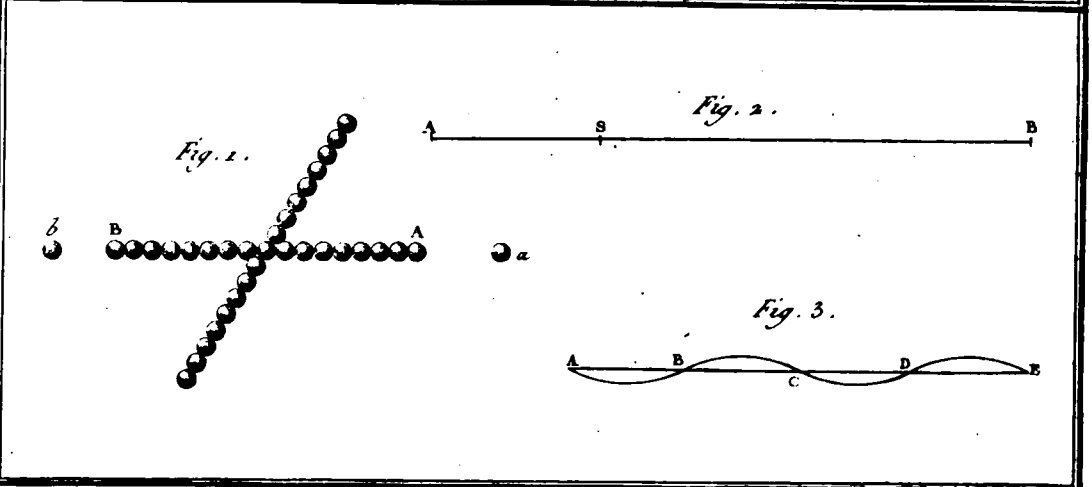
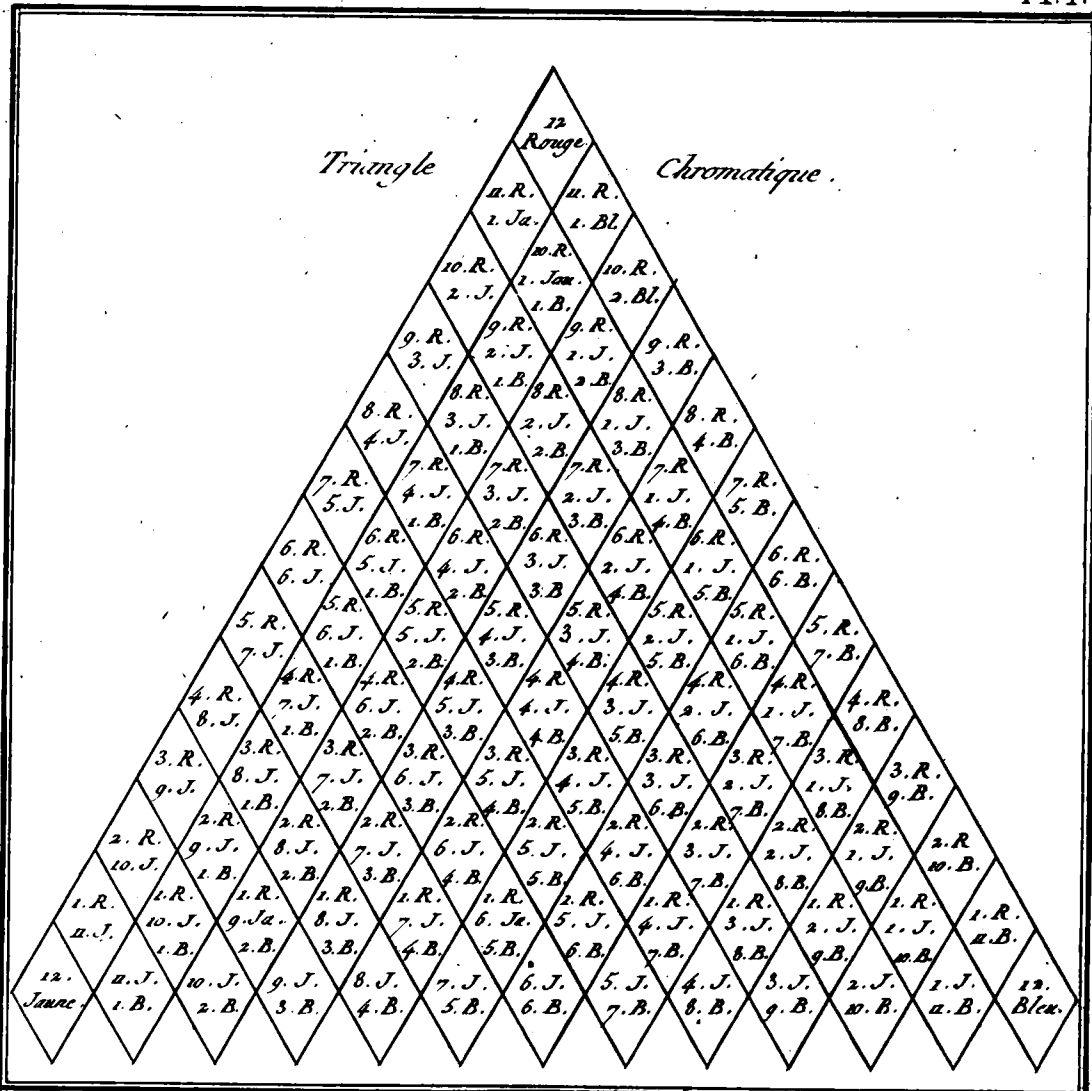




*Amusemens d'Optique.*

*Benard Durcil*





*Amusemens d'Acoustique ou Musique.*

Bernard Duret

Digitized by Google

Original from  
UNIVERSIDAD COMPLUTENSE  
DE MADRID

*Air Grec, d'un Hymne à Néméus.*



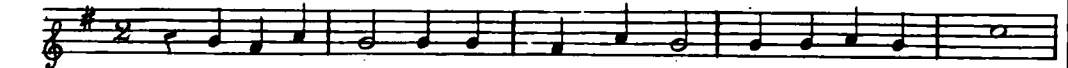
*Air Persan.*



*Air Chinois.*



*Air Huron.*



*Air Tartare.*



*Autre.*

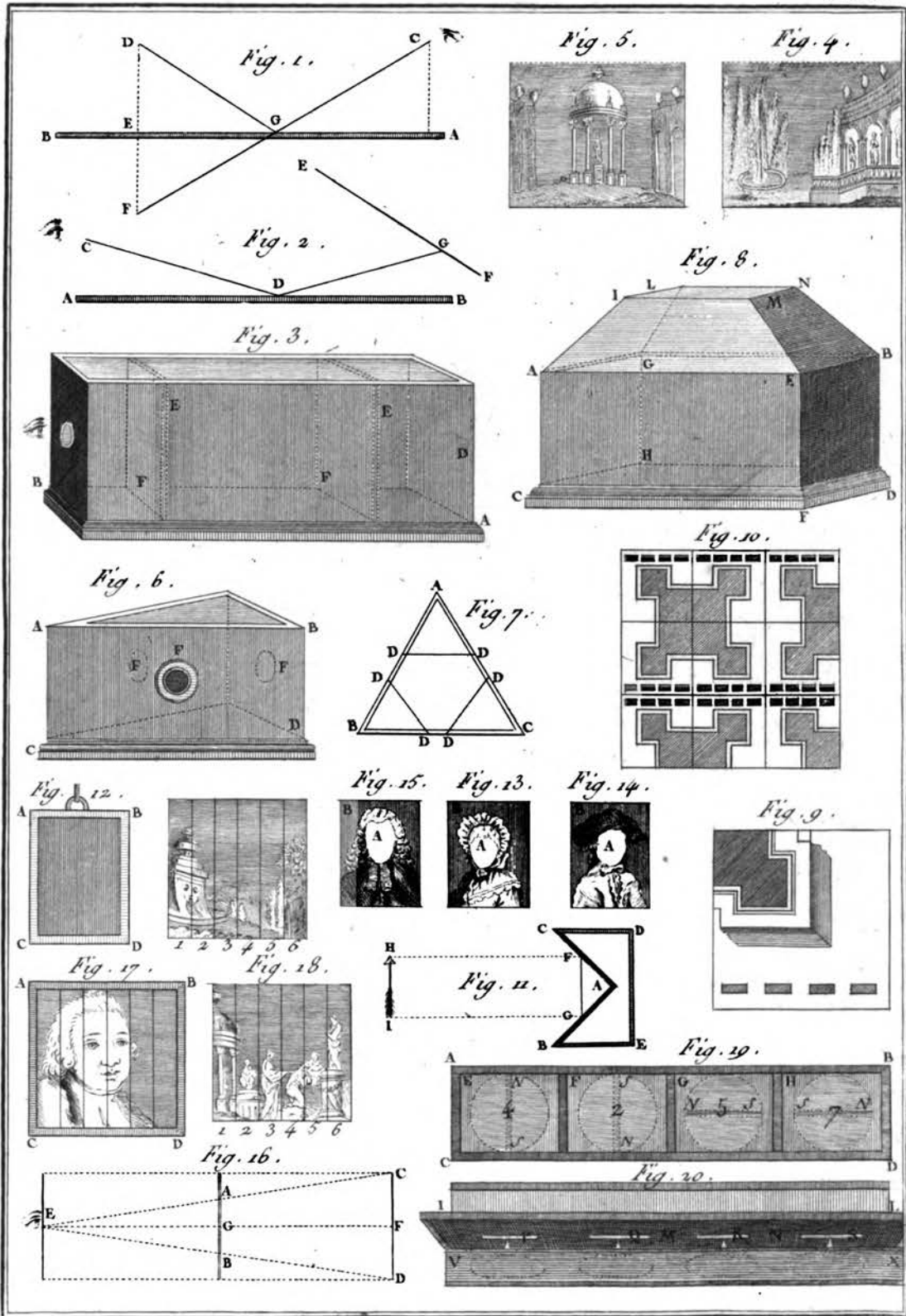


*Bernard D'Arzet.*

*Amusemens d'Acoustique, ou Musique.*

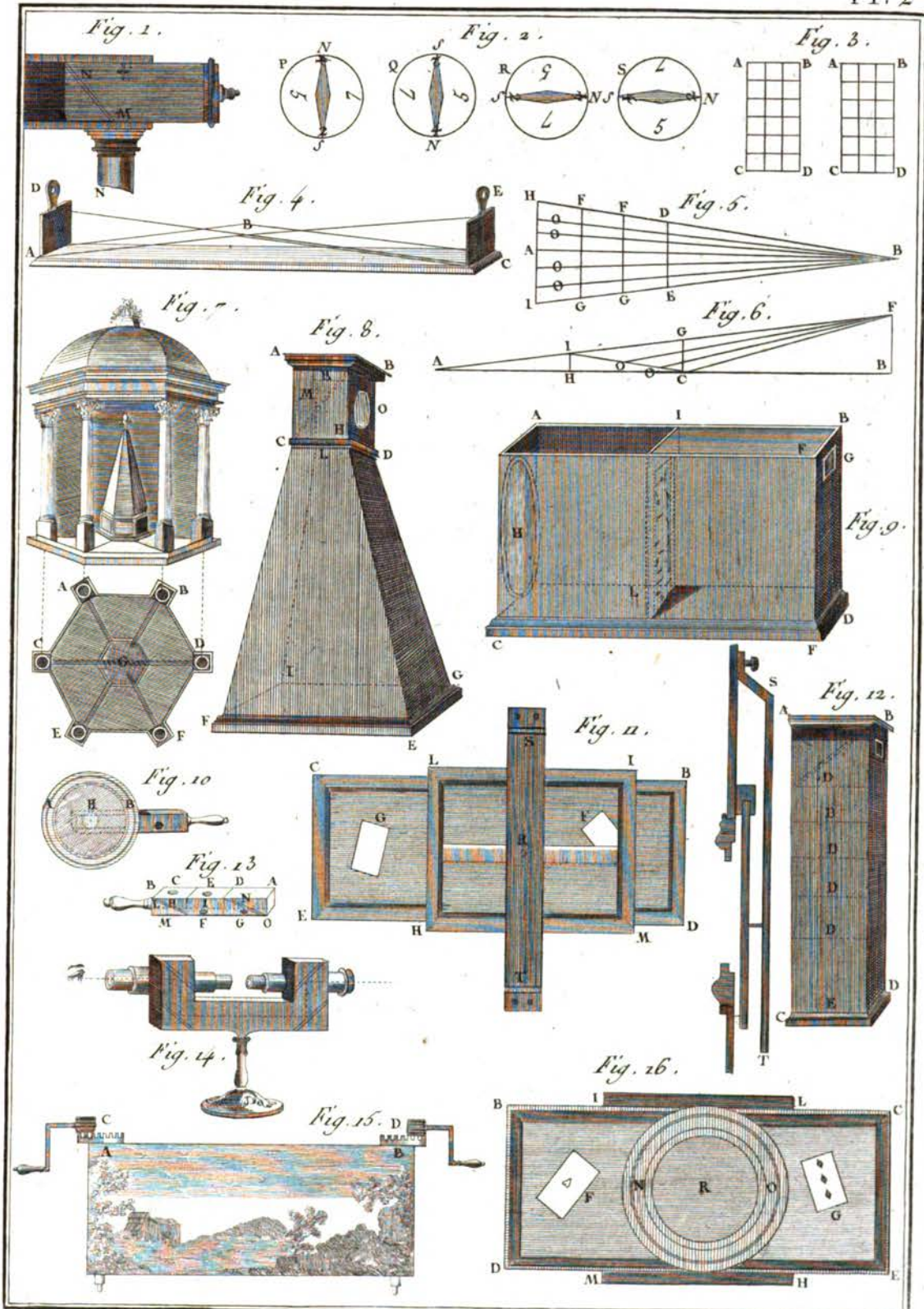
Digitized by Google

UNIVERSIDAD COMPLUTENSE  
DE MADRID



*Amusemens de Catoptrique.*

*Benard Diverdi*

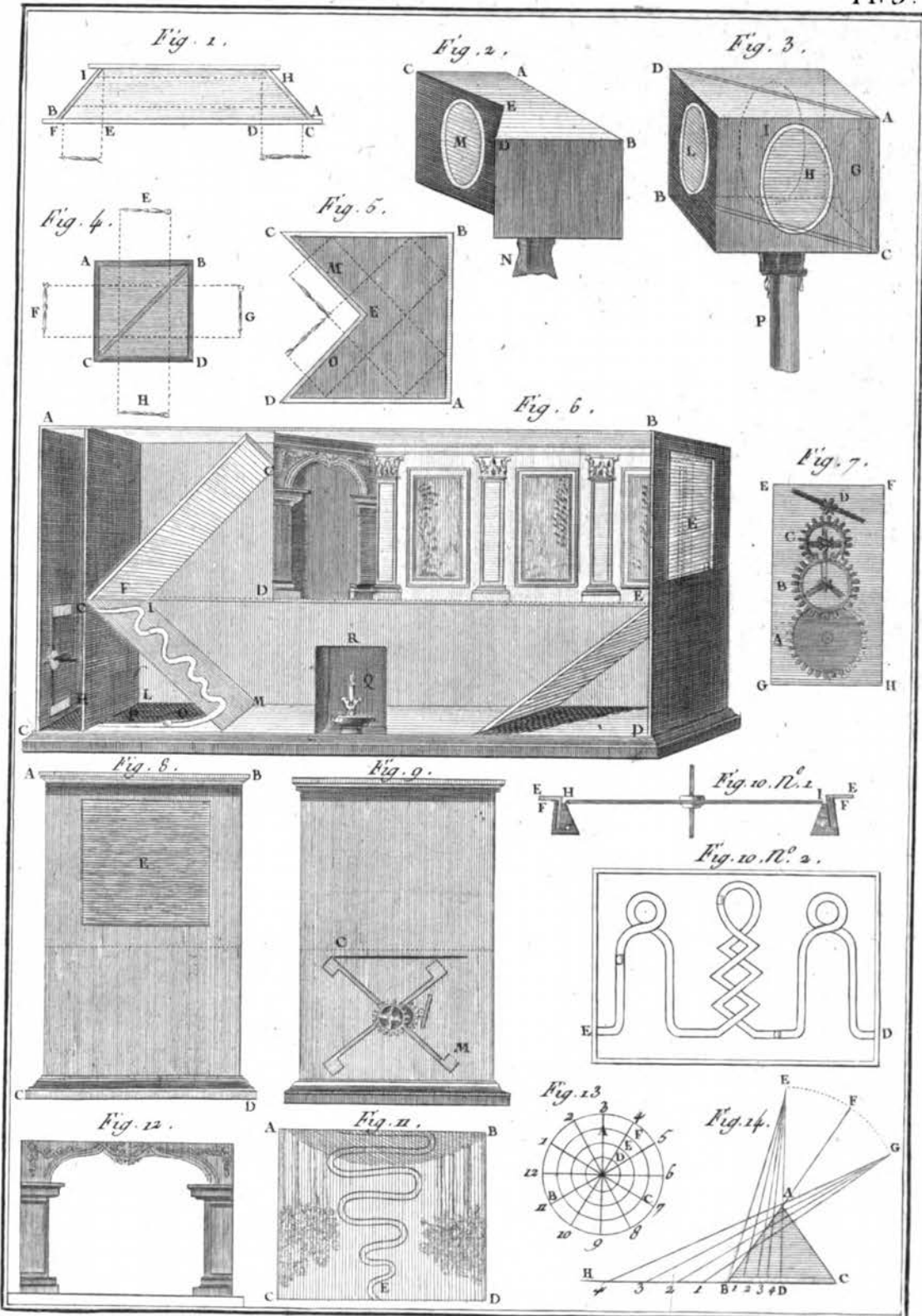


*Amusemens de Catoptrique.*

*Benard Dixerit*

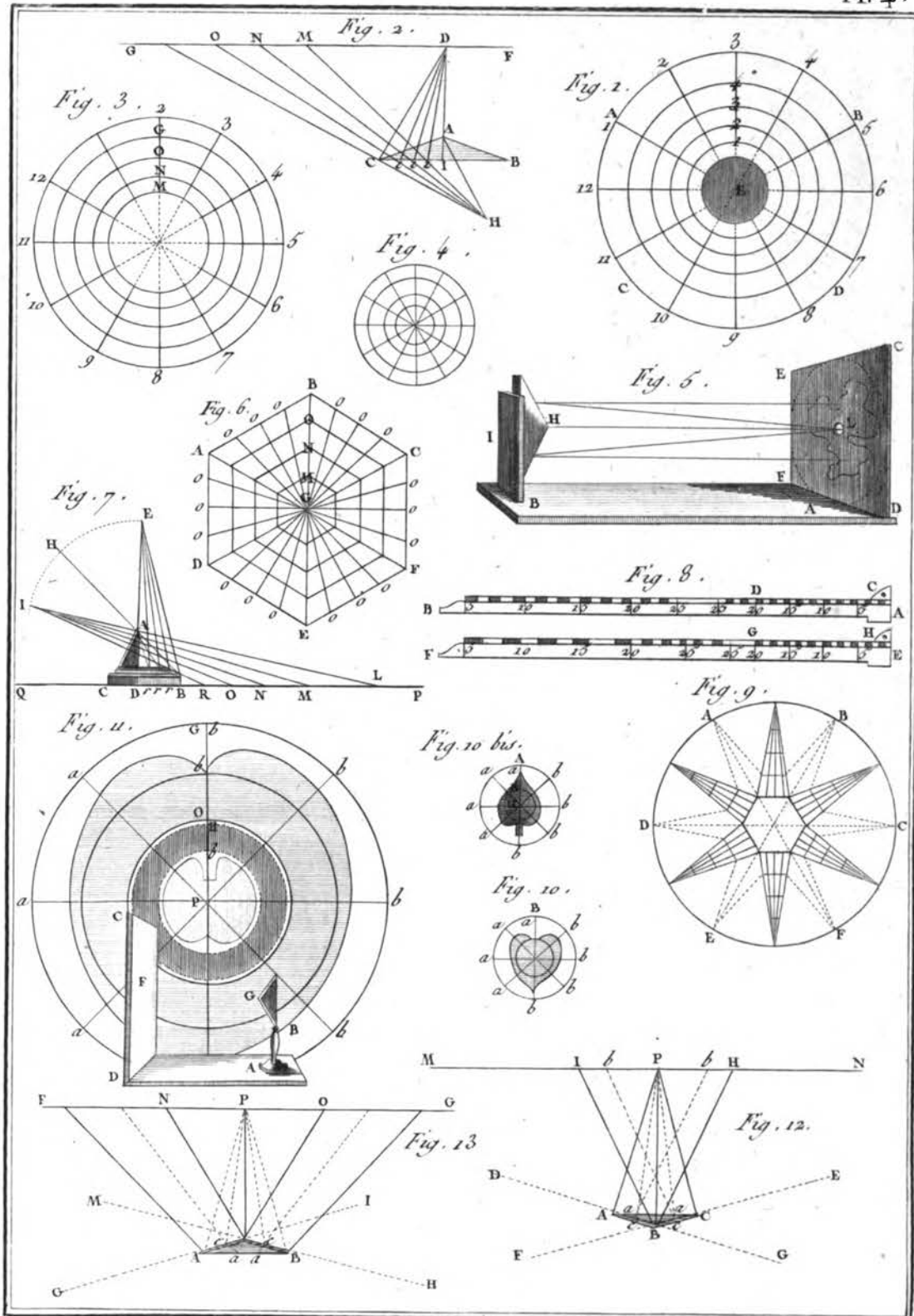
*21.*

Generated on 2014-05-11 16:20 GMT / http://hdl.handle.net/2027/ucm.5320295822 Public Domain, Google-digitized / http://www.hathitrust.org/access\_use#pd-google



*Amusemens de Catoptrique.*

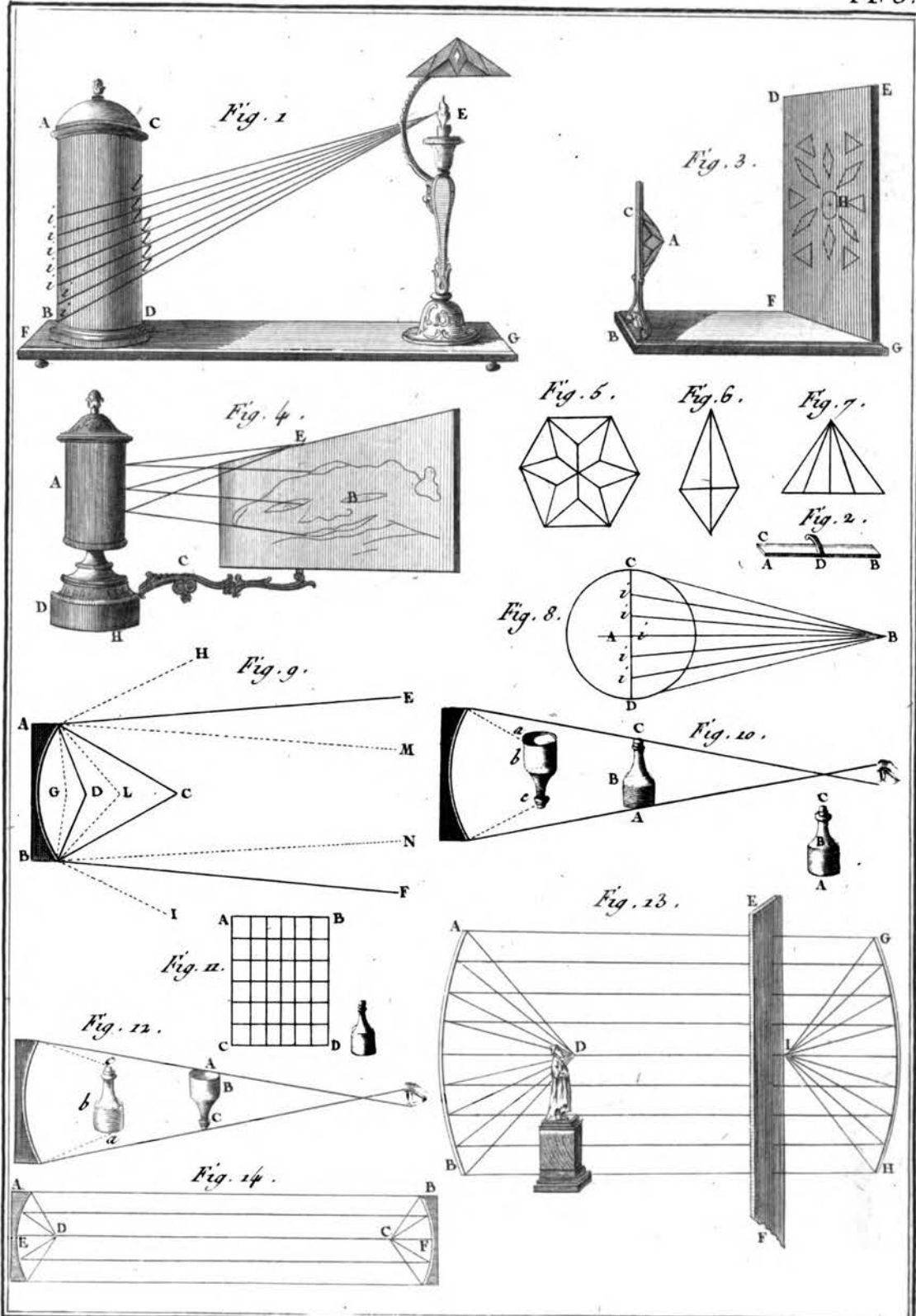
*Benard Dircat.*



*Amusemens de Catoptrique.*

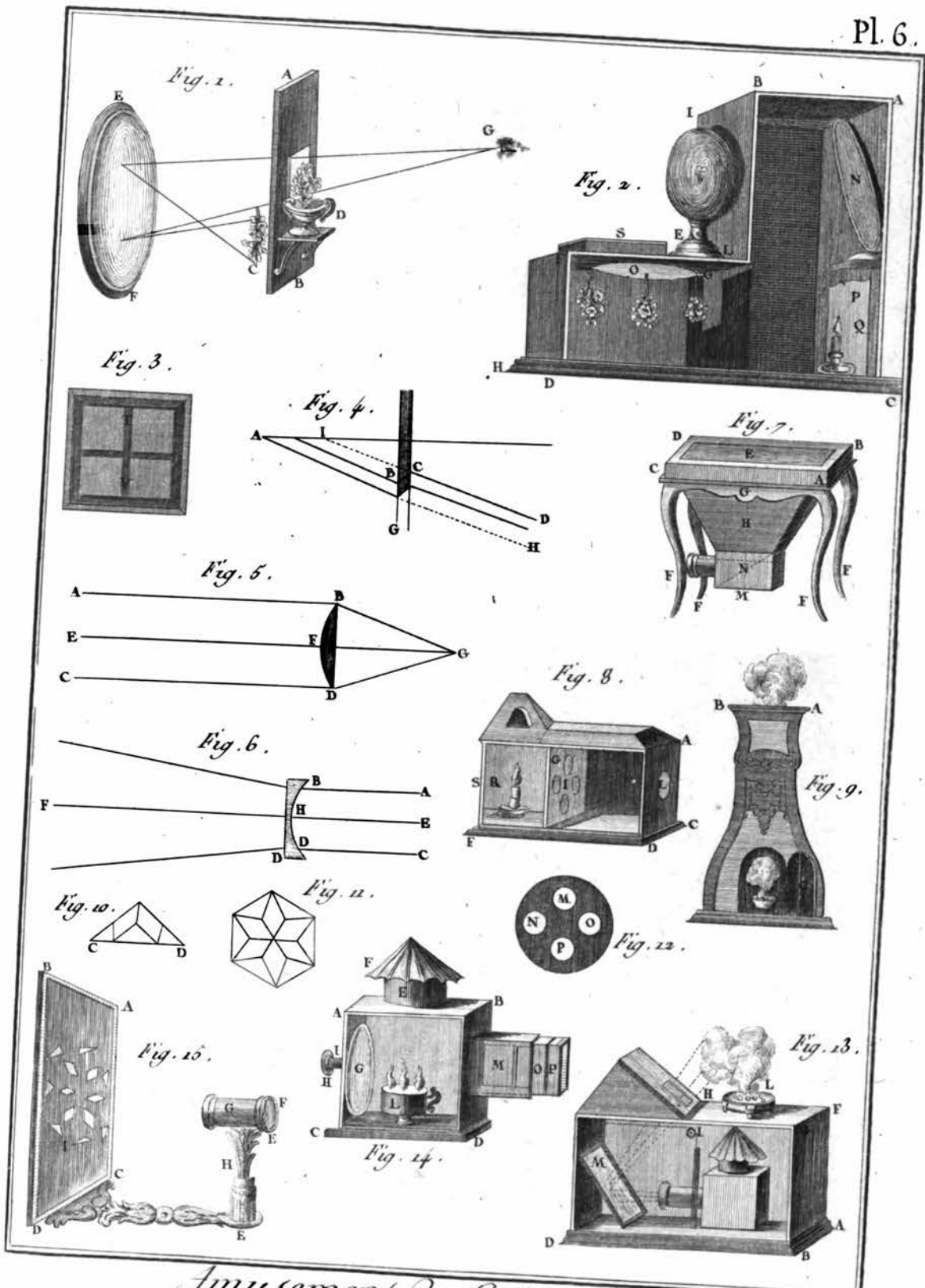
*Bernard Direxit.*





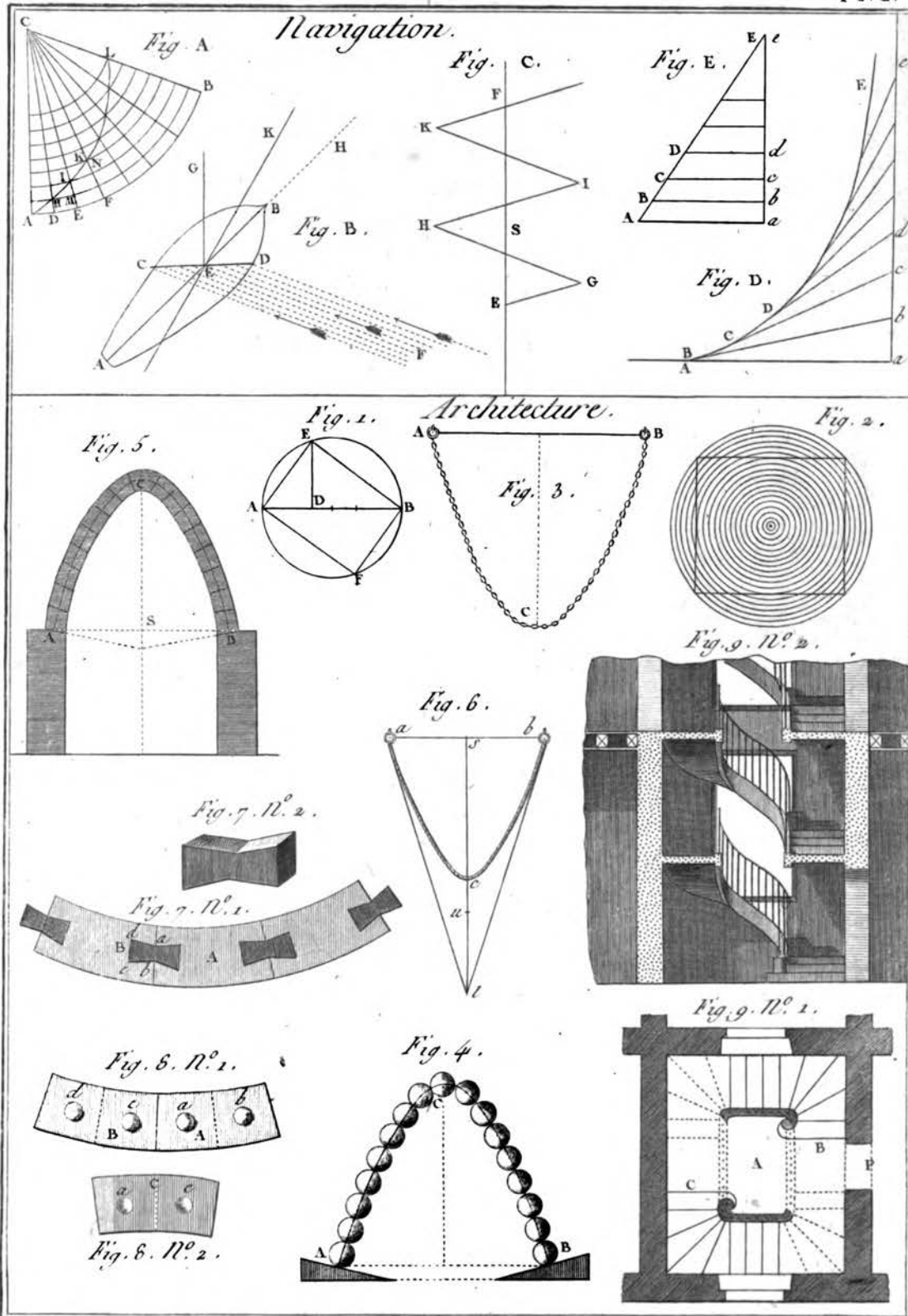
*Amusemens de Catoptrique.*

*Benard. Duxceit.*



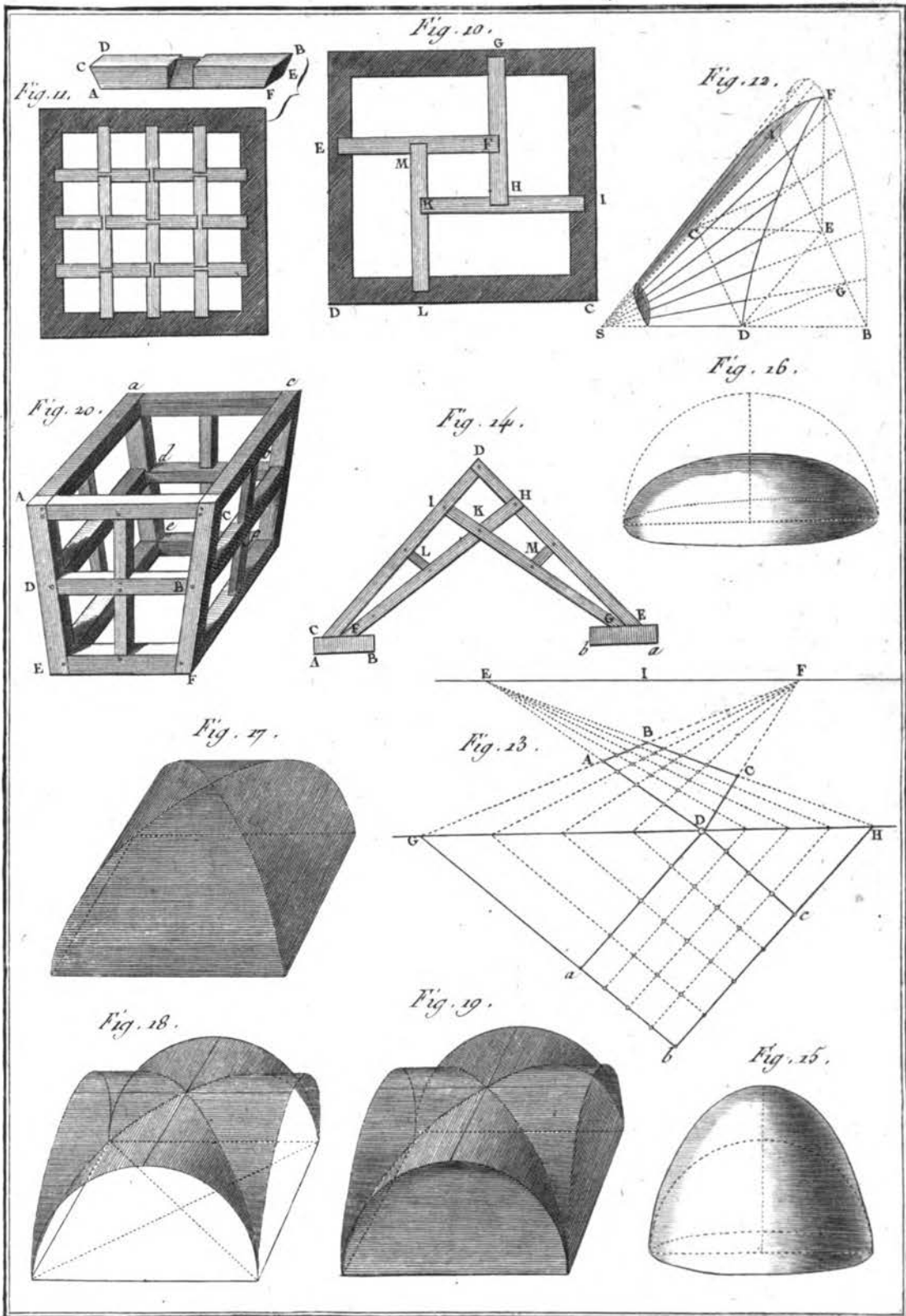
*Amusemens de Catoptrique* Benard Duxat

Generated on 2014-05-11 17:15 GMT / http://hdl.handle.net/2027/ucm.5320295822  
 Public Domain, Google-digitized / http://www.hathitrust.org/access\_use#pd-google



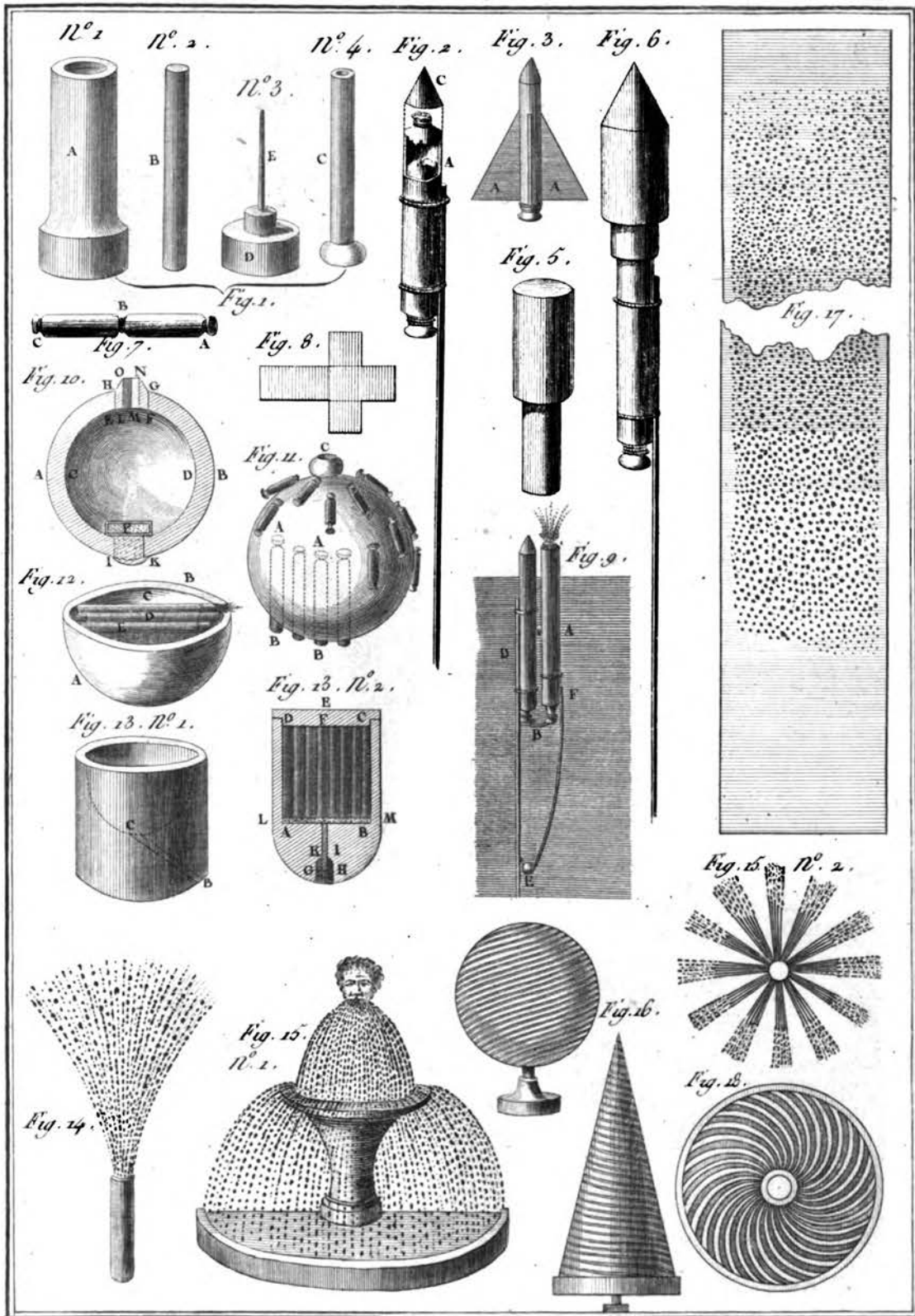
*Amusemens de Navigation et d'Architecture*

*Benard Direct.*



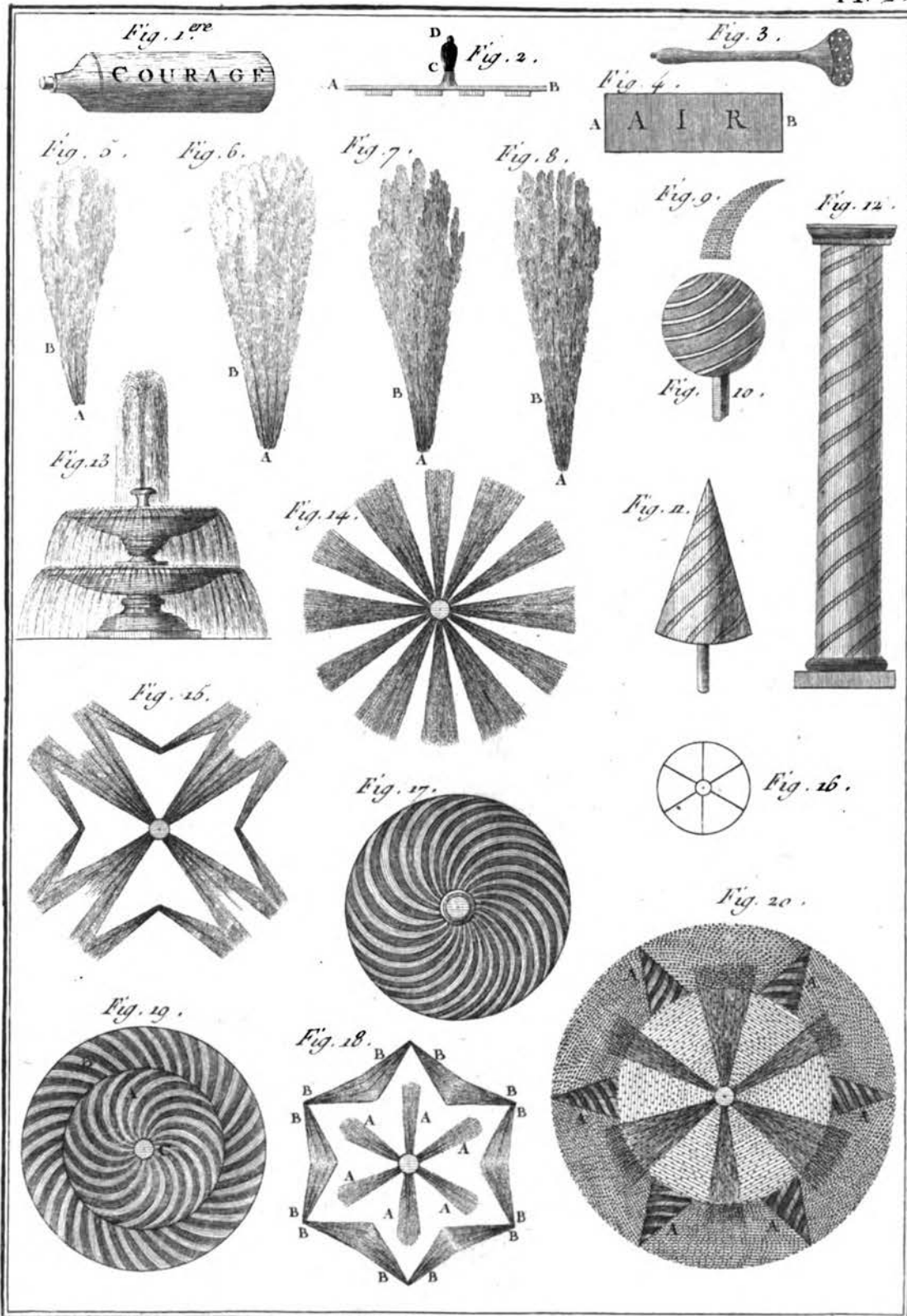
*Suite des Amusemens d'Architecture*

*Benard Directeur.*



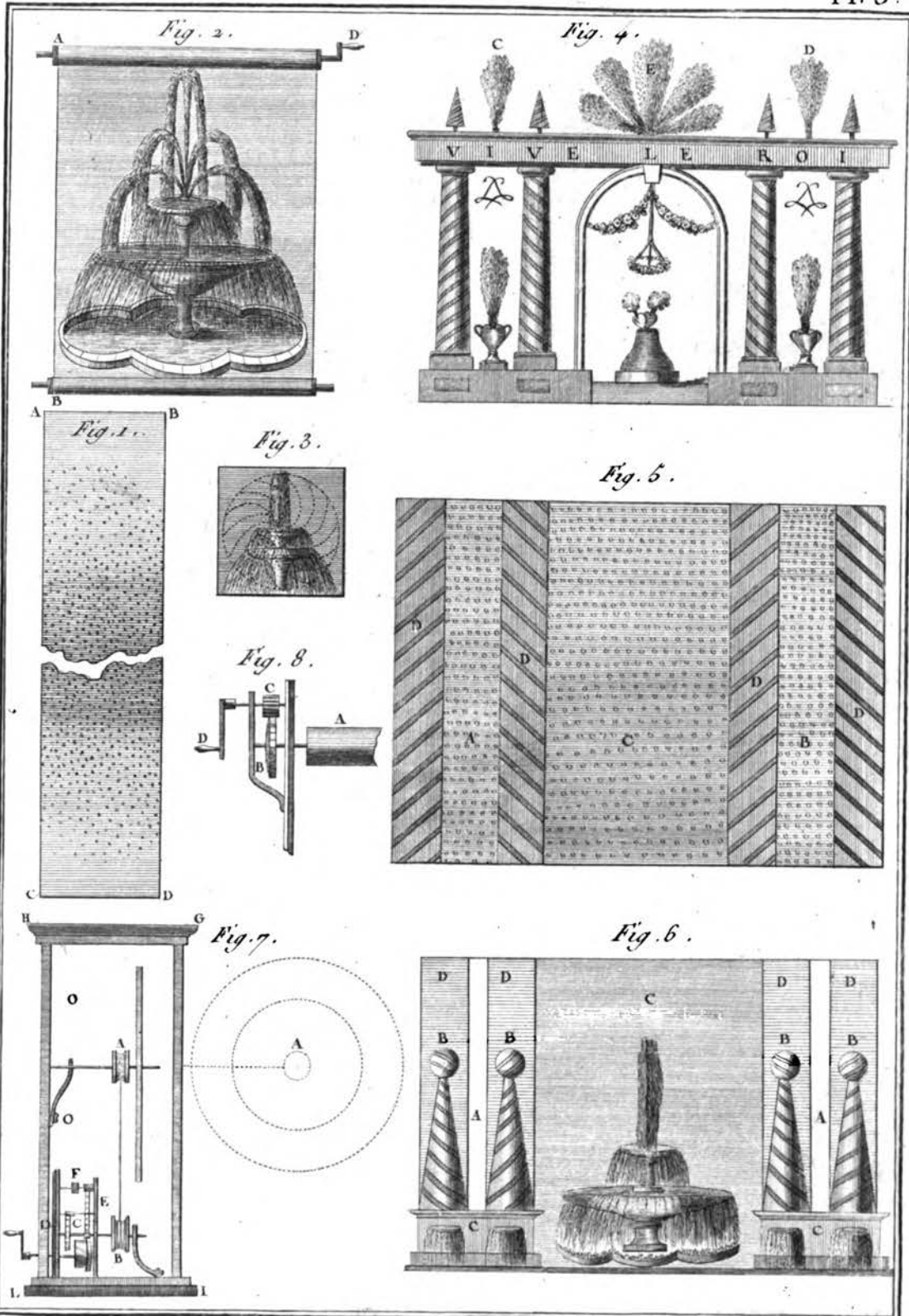
*Pyrotechnie sans feu et purement Optique*

*Bonard Directeur.*

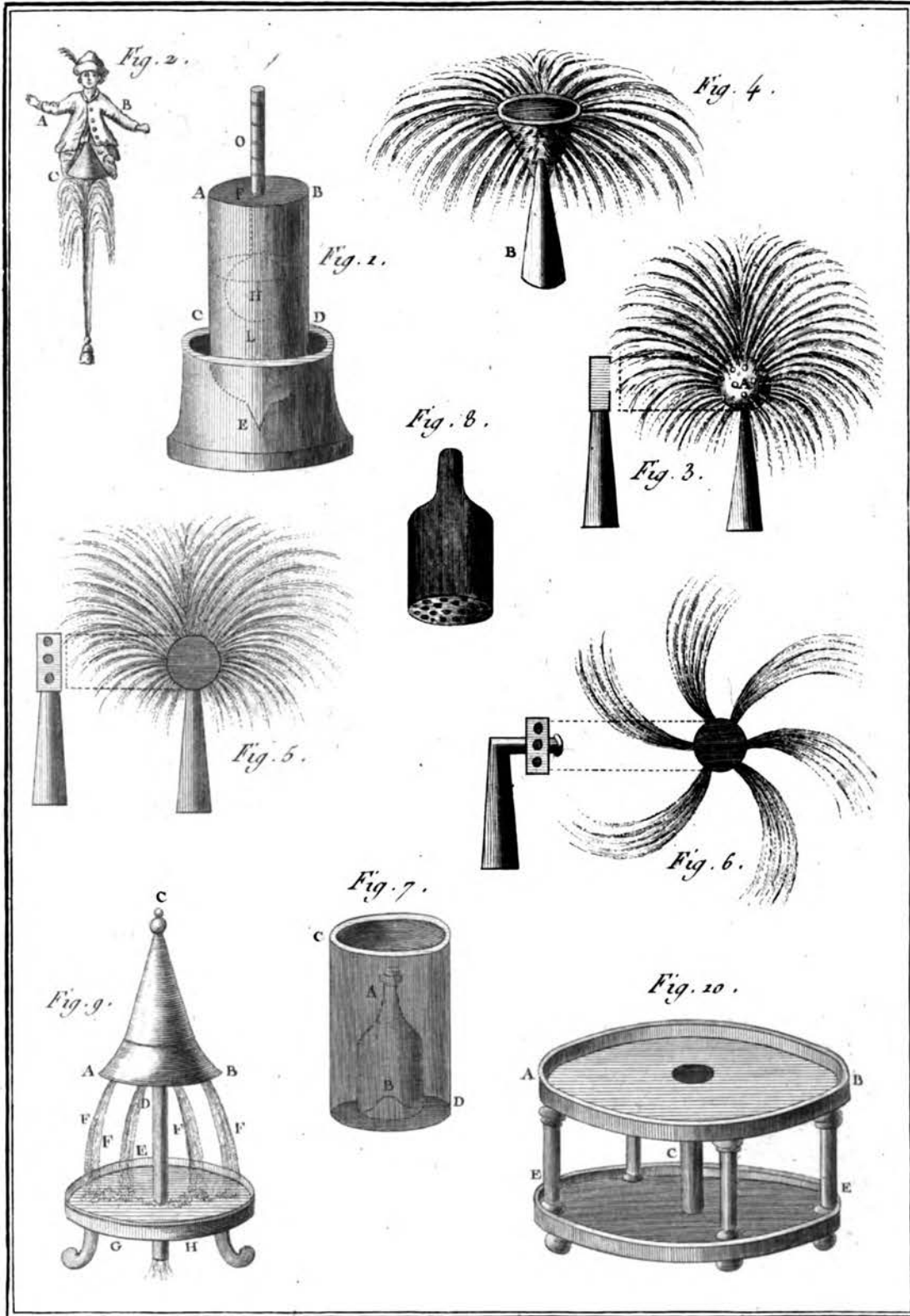


*Pieces d'Artifice*

Benard. Dircut.



*Pieces d'Artifice* Original from Bernard Duvet.



*Pieces Hydrauliques.*

*Bernard Duxed*



Fig. 2.

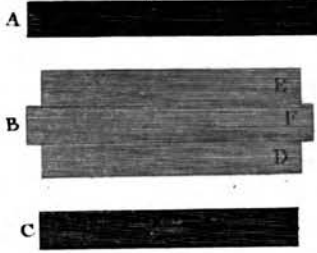


Fig. 2.



Fig. 5.

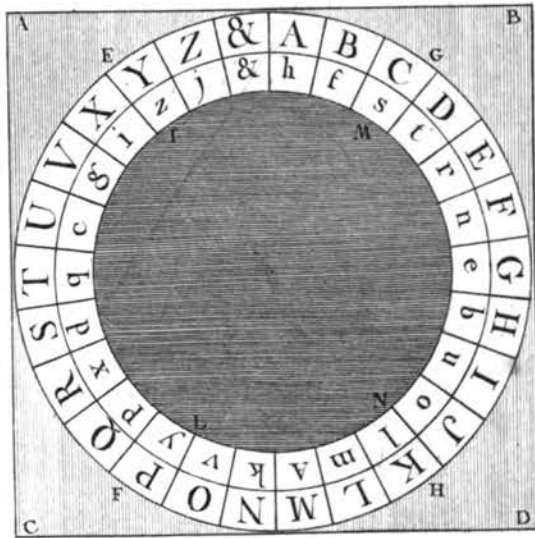


Fig. 6.

Fig. 3.



Fig. 7.

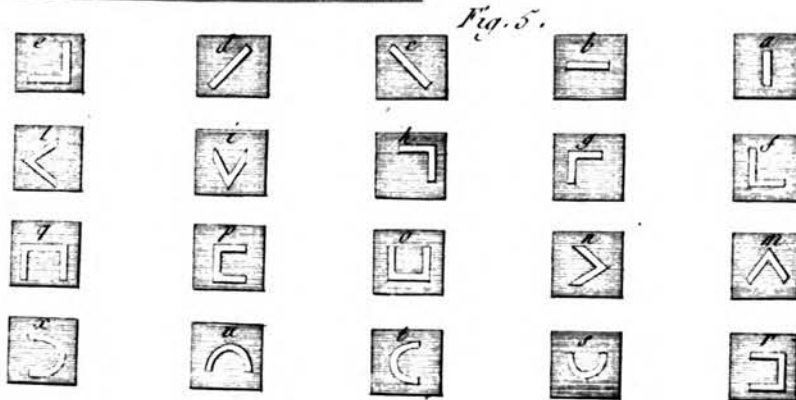
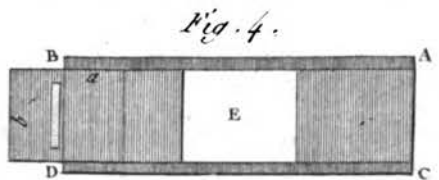
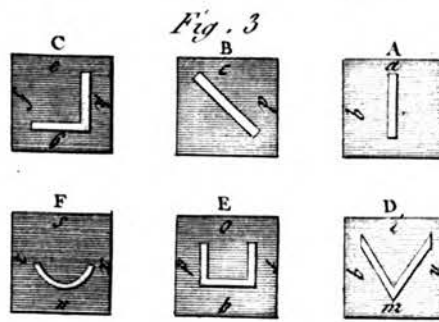
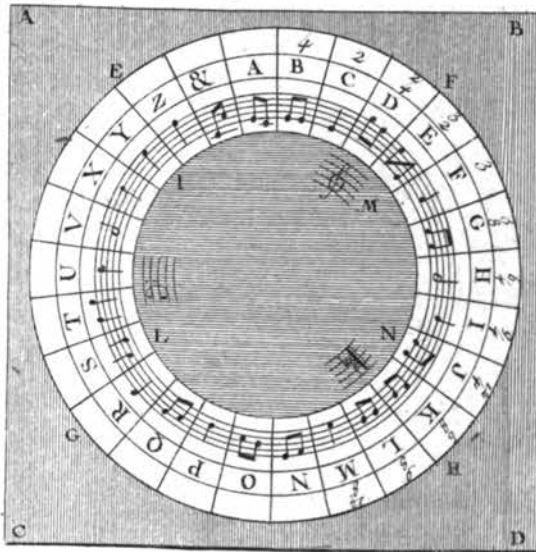
A B  
 Je  vous  prie de  me  mander si  
 vous  trouverez bon, non  très  cher ami,  
 que je  dispose  des  à  présent des  
 effets que  vous  avez offert de me  
 rendre & .  
 C D

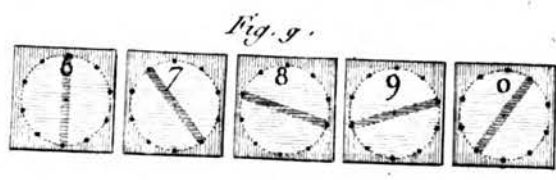
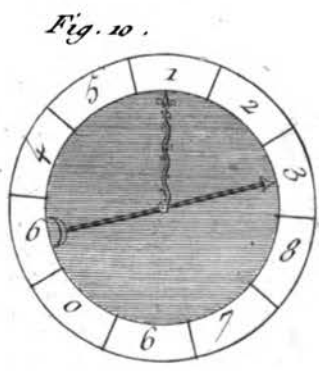
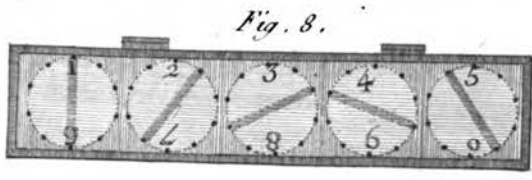
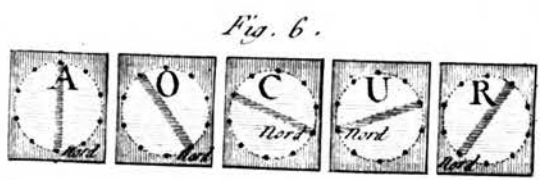
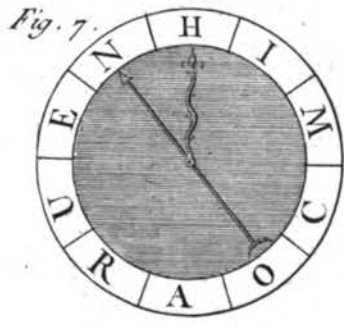
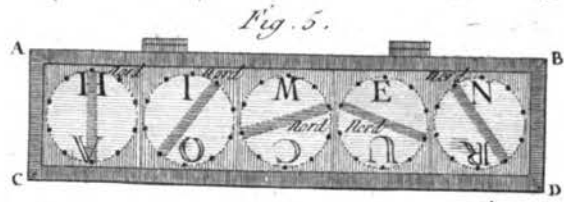
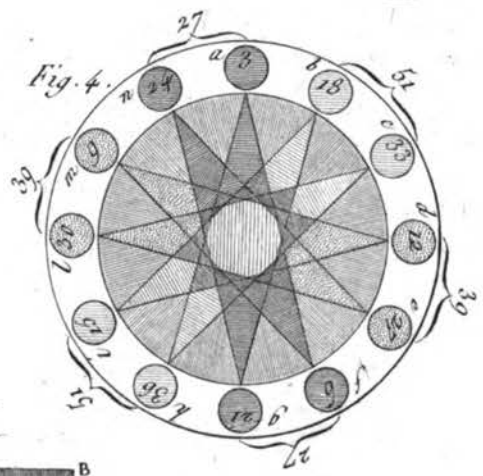
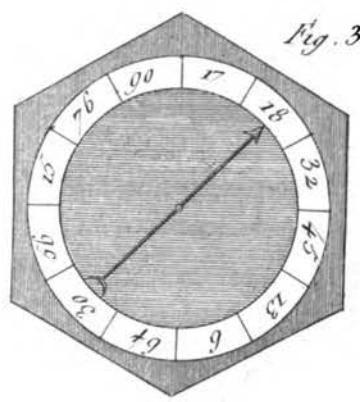
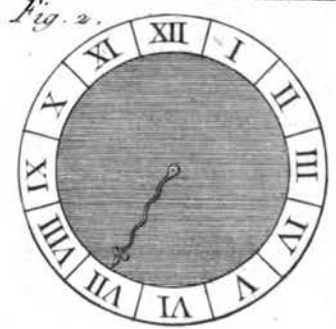
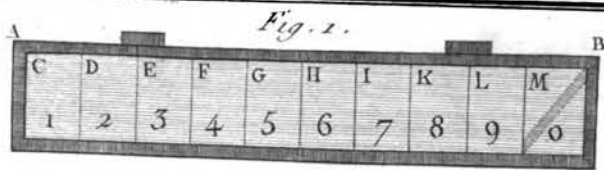
Fig. 4.



Traits Occultes ou Trompeurs.

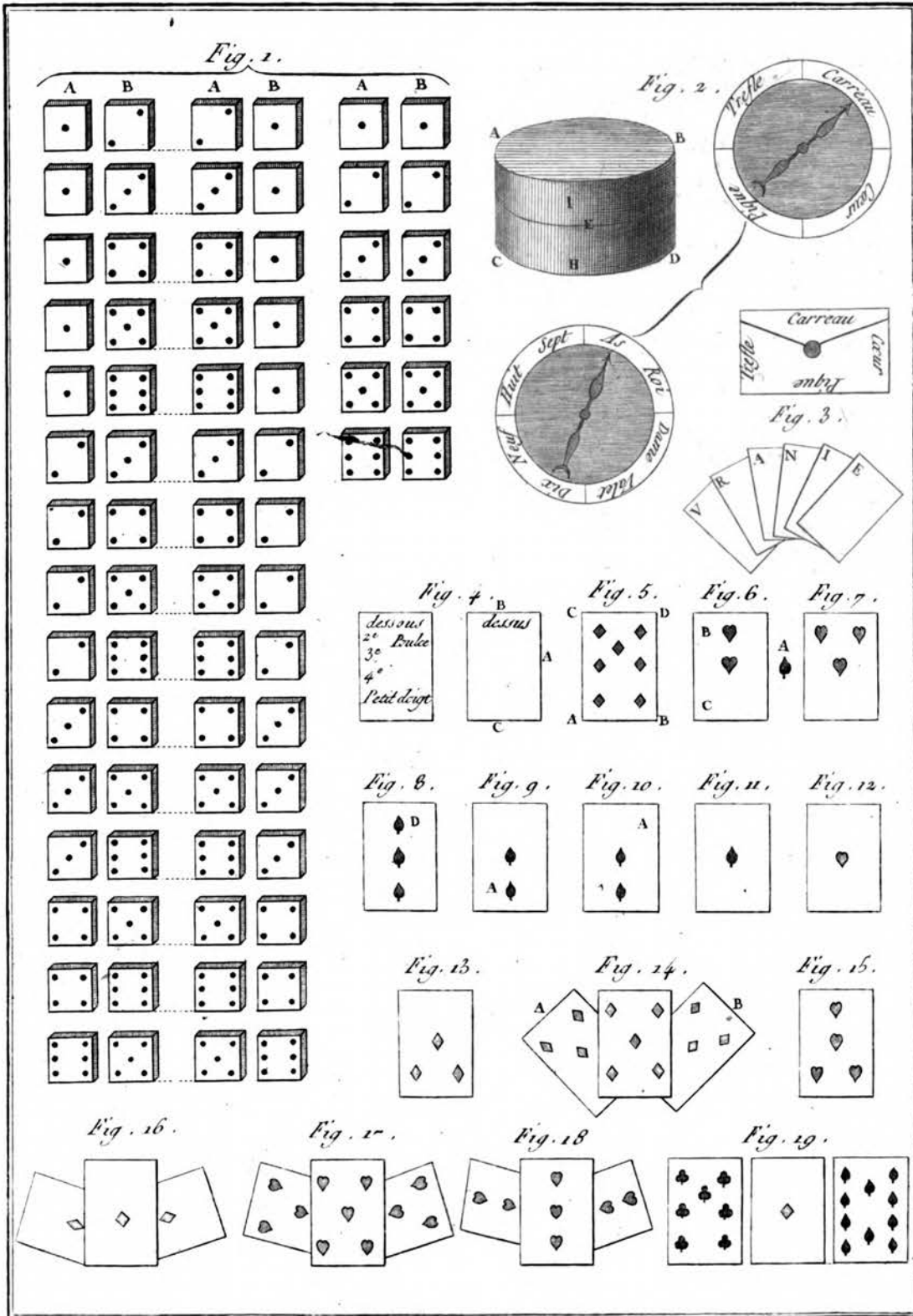
Beuard Dixerit.





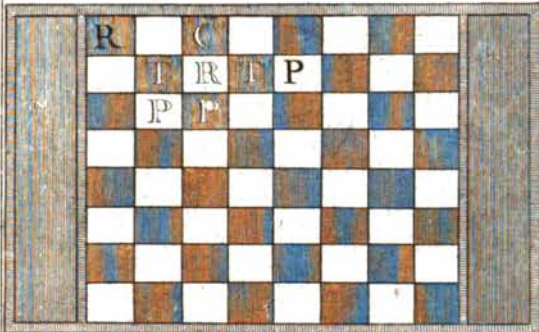
*Nombres Magiques.*

*Renard Dorez.*



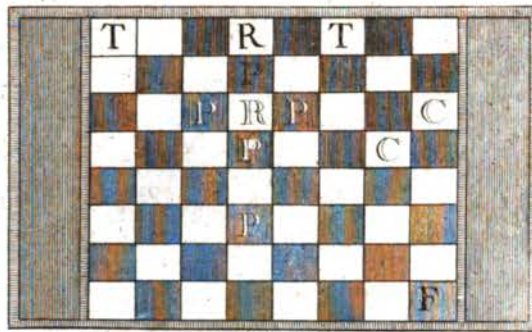
*Suite des Nombres Magiques et Cartes.*

*Fig. 2. Cote' du Noir.*



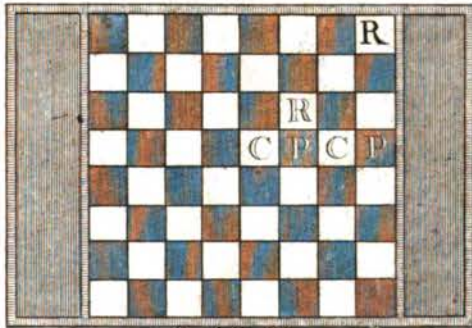
*Cote' du Blanc*

*Fig. 2. Cote' du Noir.*



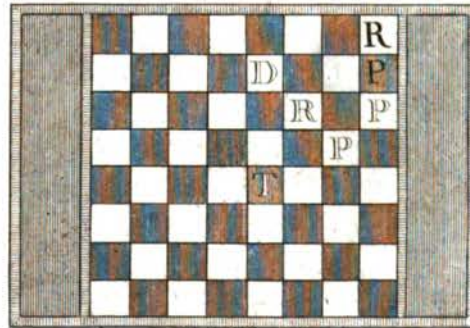
*Cote' du Blanc.*

*Fig. 3. Cote' du Noir.*



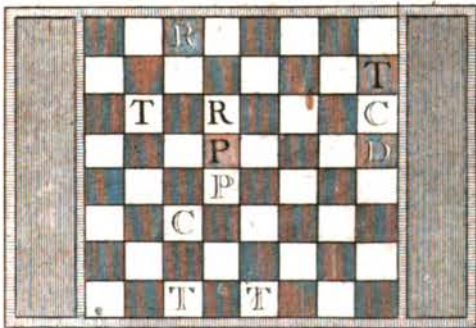
*Cote' du Blanc.*

*Fig. 4. Cote' du Noir.*



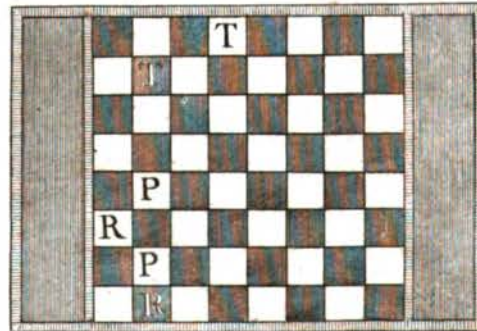
*Cote' du Blanc.*

*Fig. 5. Cote' du Noir.*



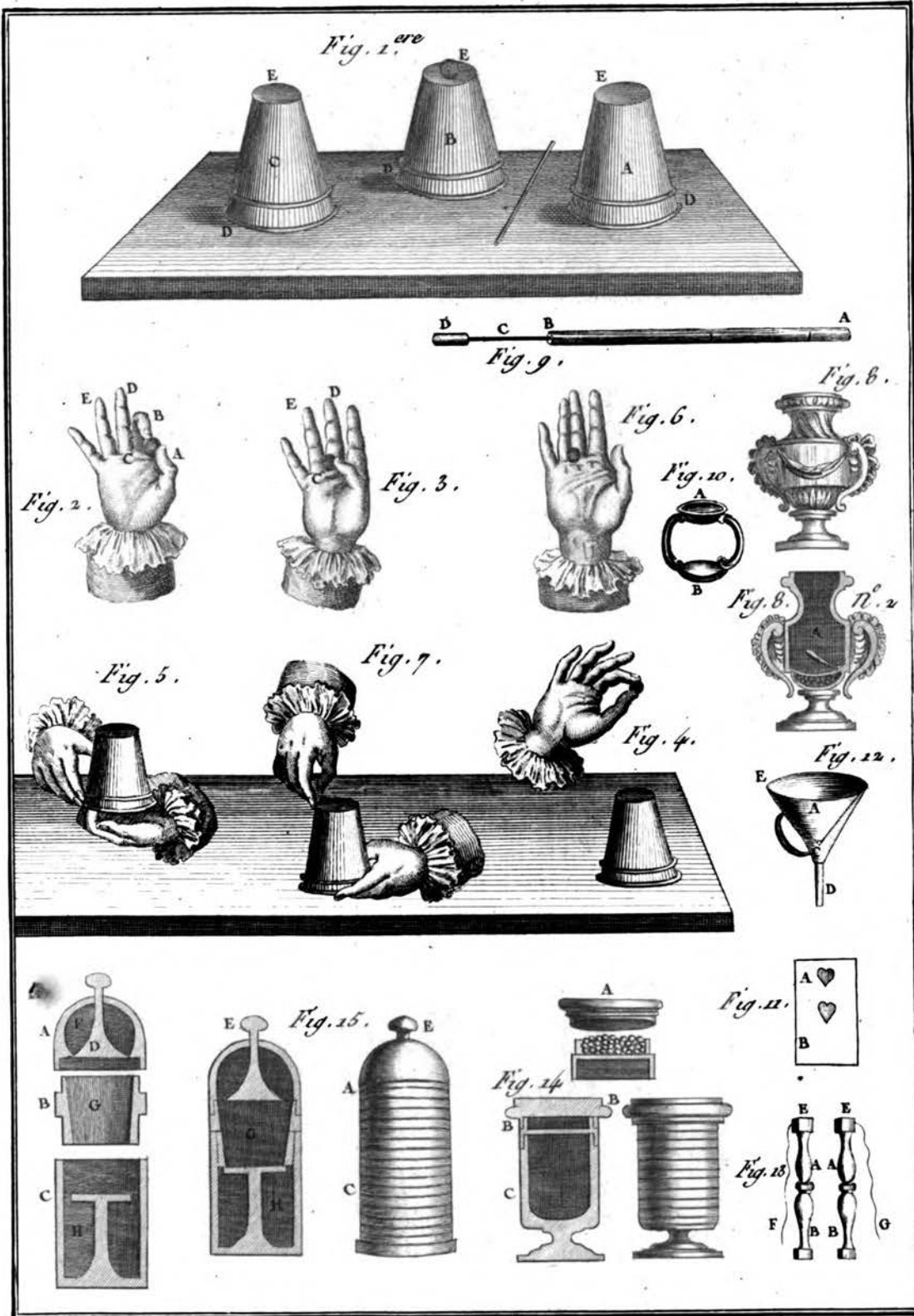
*Cote' du Blanc.*

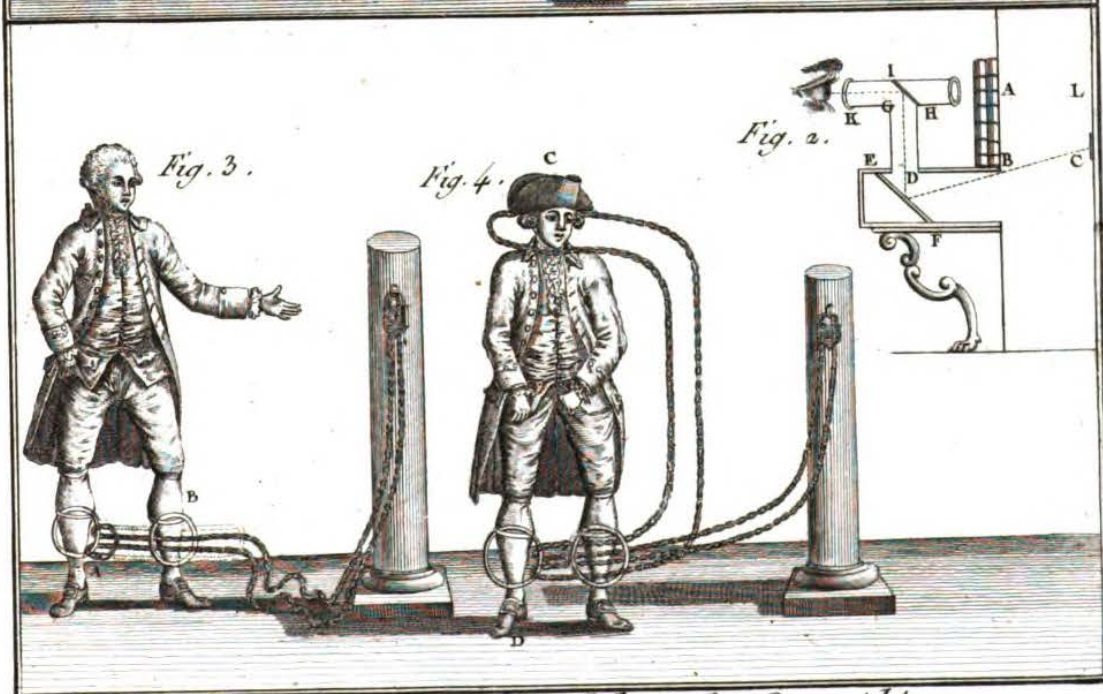
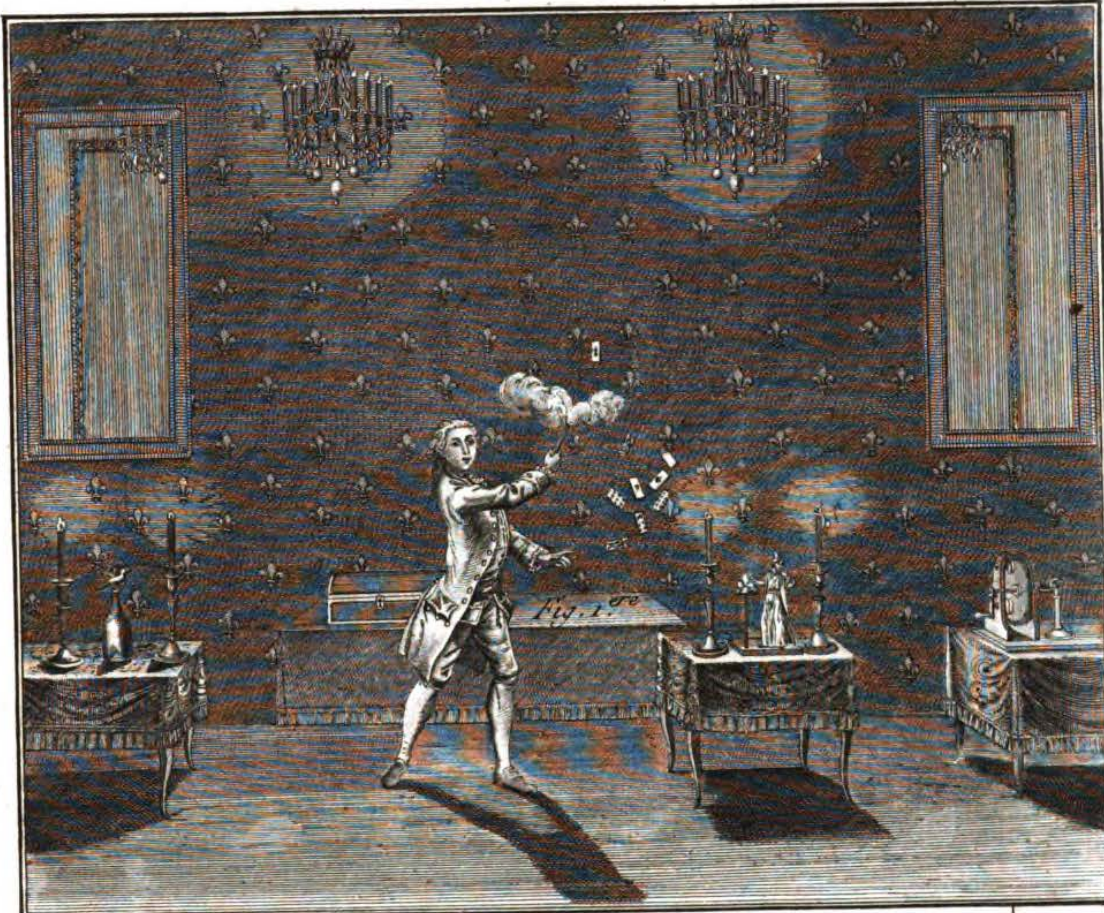
*Fig. 6. Cote' du Noir.*



*Cote' du Blanc.*

*Combinaisons Magiques.*

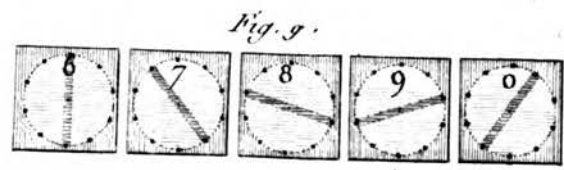
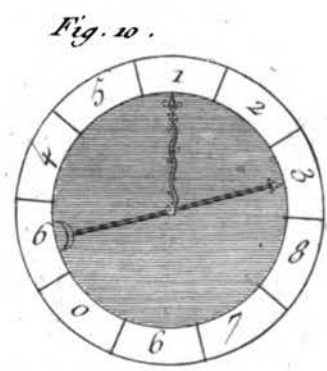
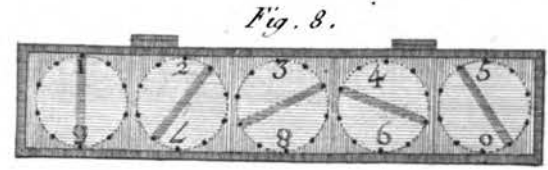
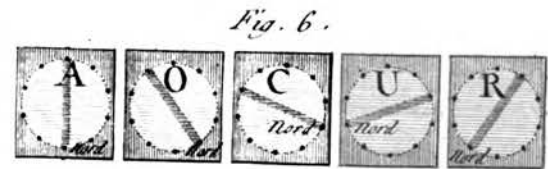
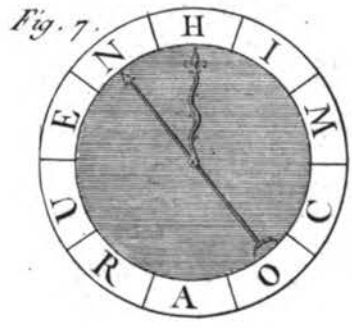
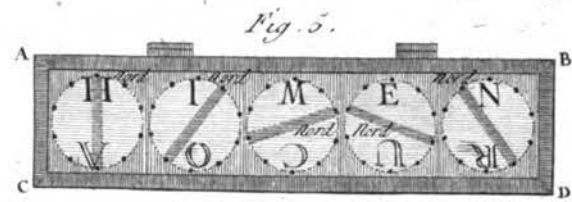
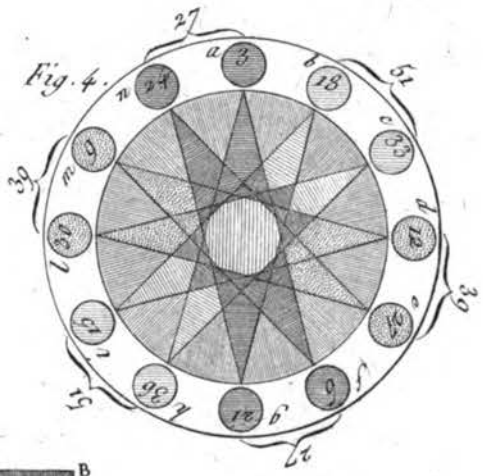
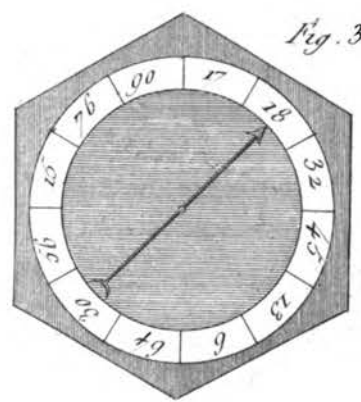
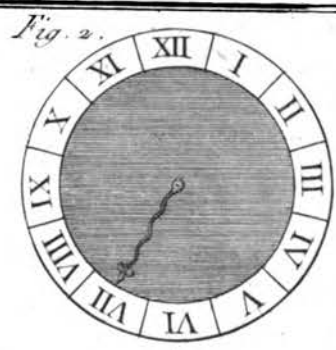
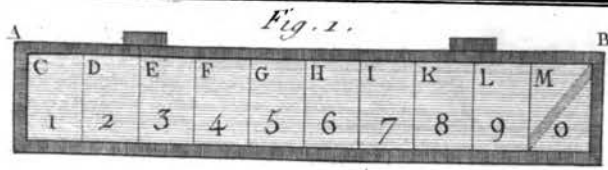




*Figures de Magie Blanche dévoilée.*

Digitized by Google

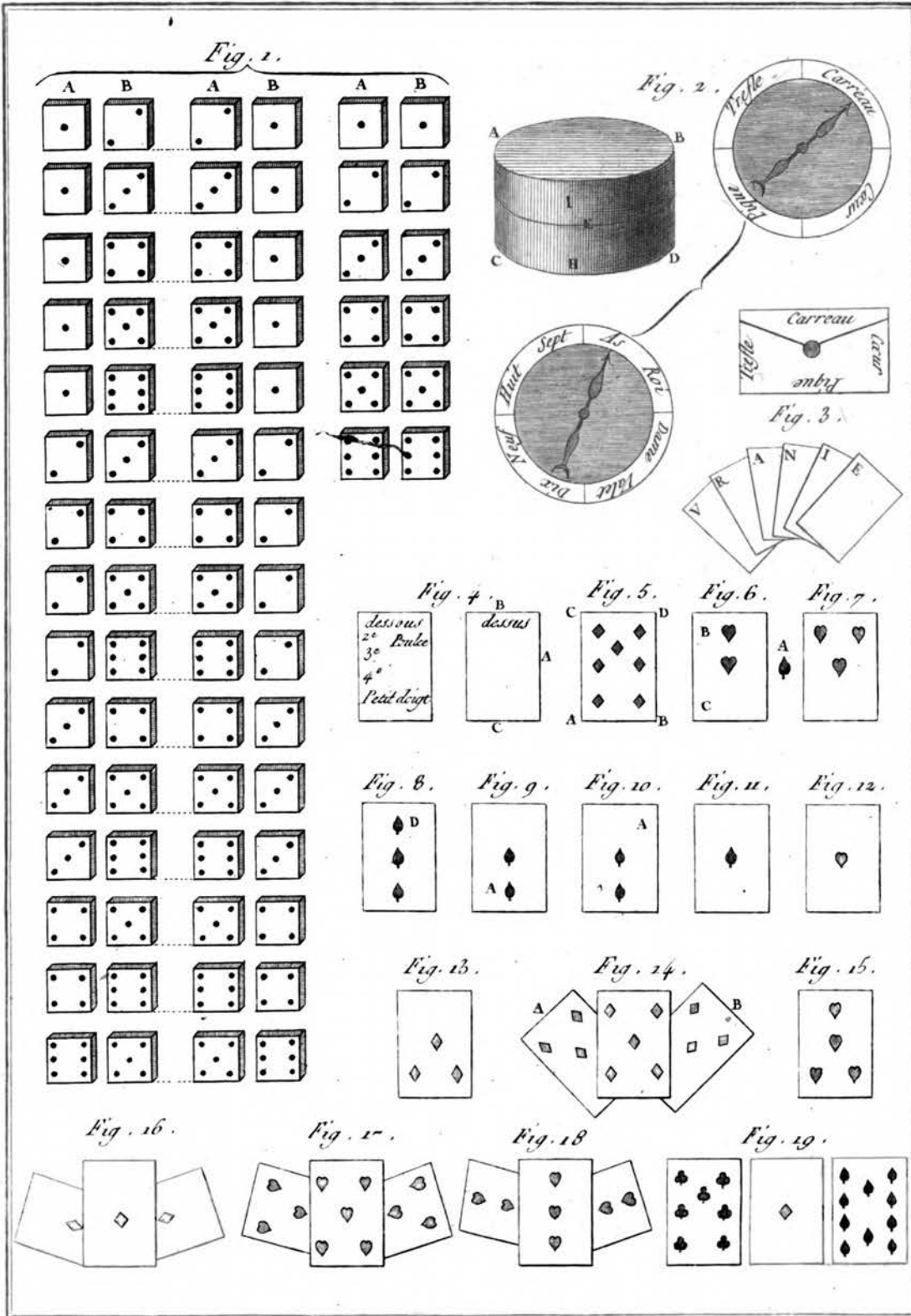
UNIVERSIDAD COMPLUTENSE  
DE MADRID



*Nombres Magiques.*

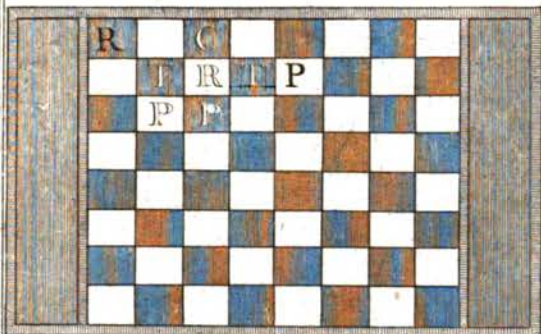
*Beard Direct.*





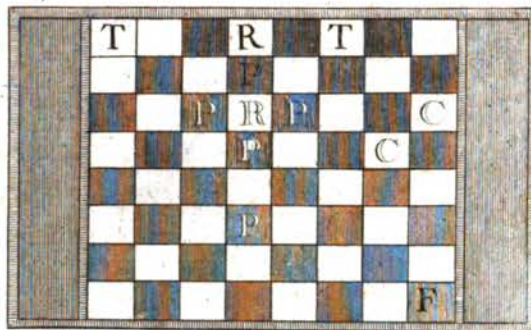
*Suite des Nombres Magiques et Cartes.*

Fig. 1. Cote' du Noir.



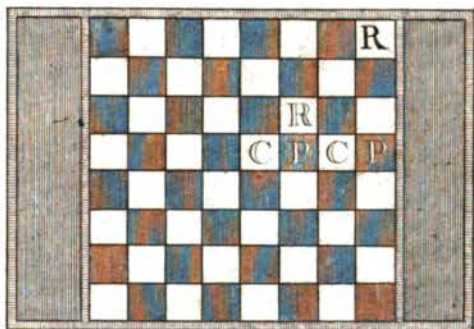
Cote' du Blanc.

Fig. 2. Cote' du Noir.



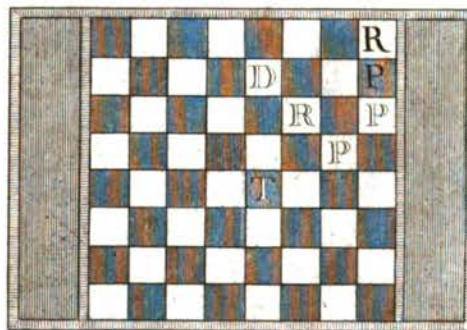
Cote' du Blanc.

Fig. 3. Cote' du Noir.



Cote' du Blanc.

Fig. 4. Cote' du Noir.



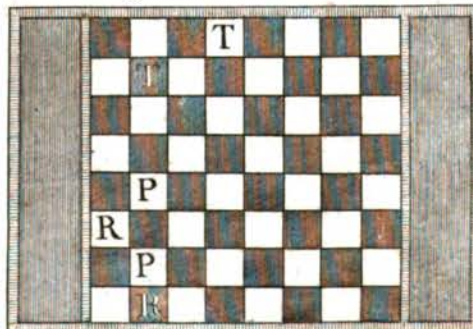
Cote' du Blanc.

Fig. 5. Cote' du Noir.



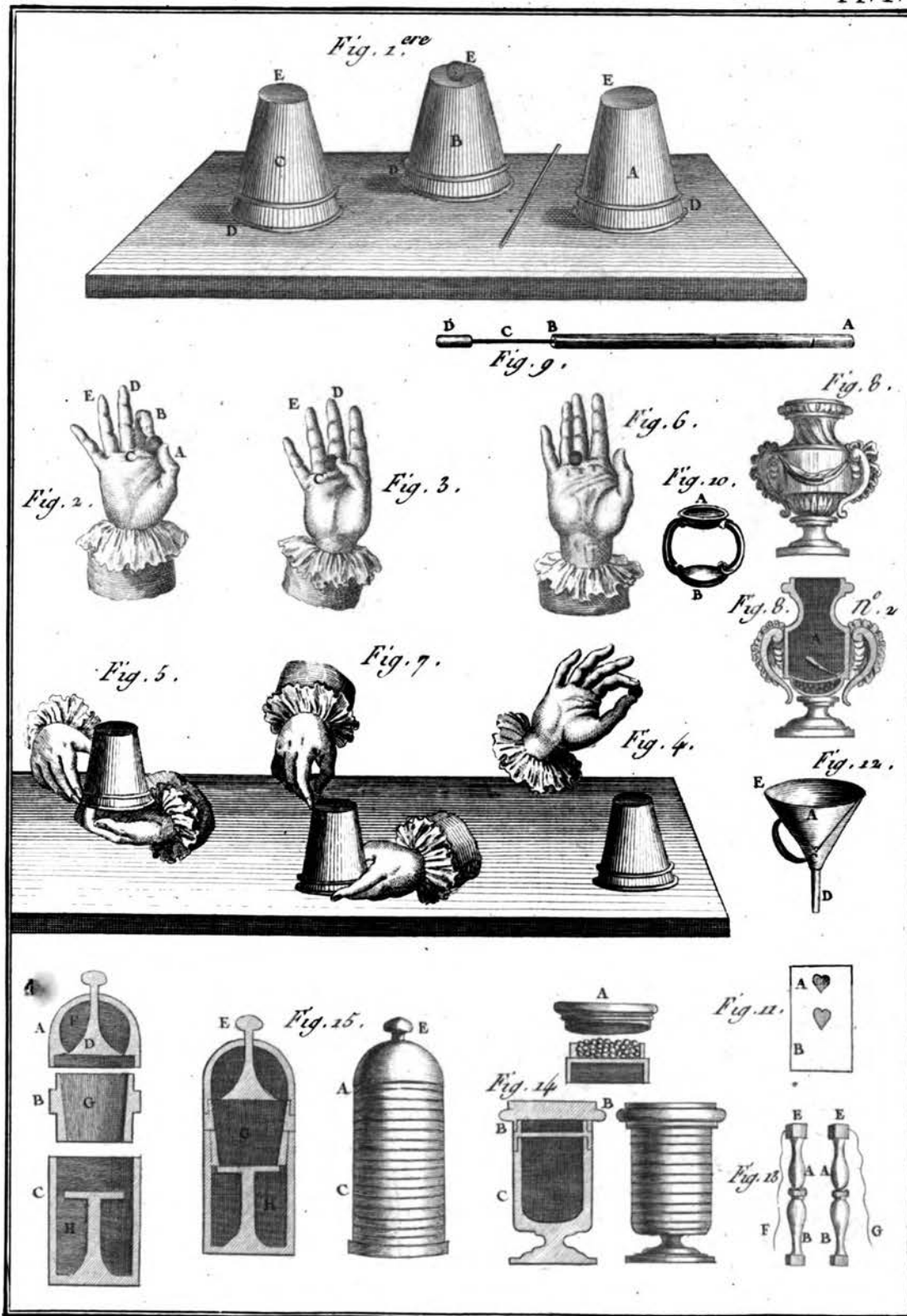
Cote' du Blanc.

Fig. 6. Cote' du Noir.

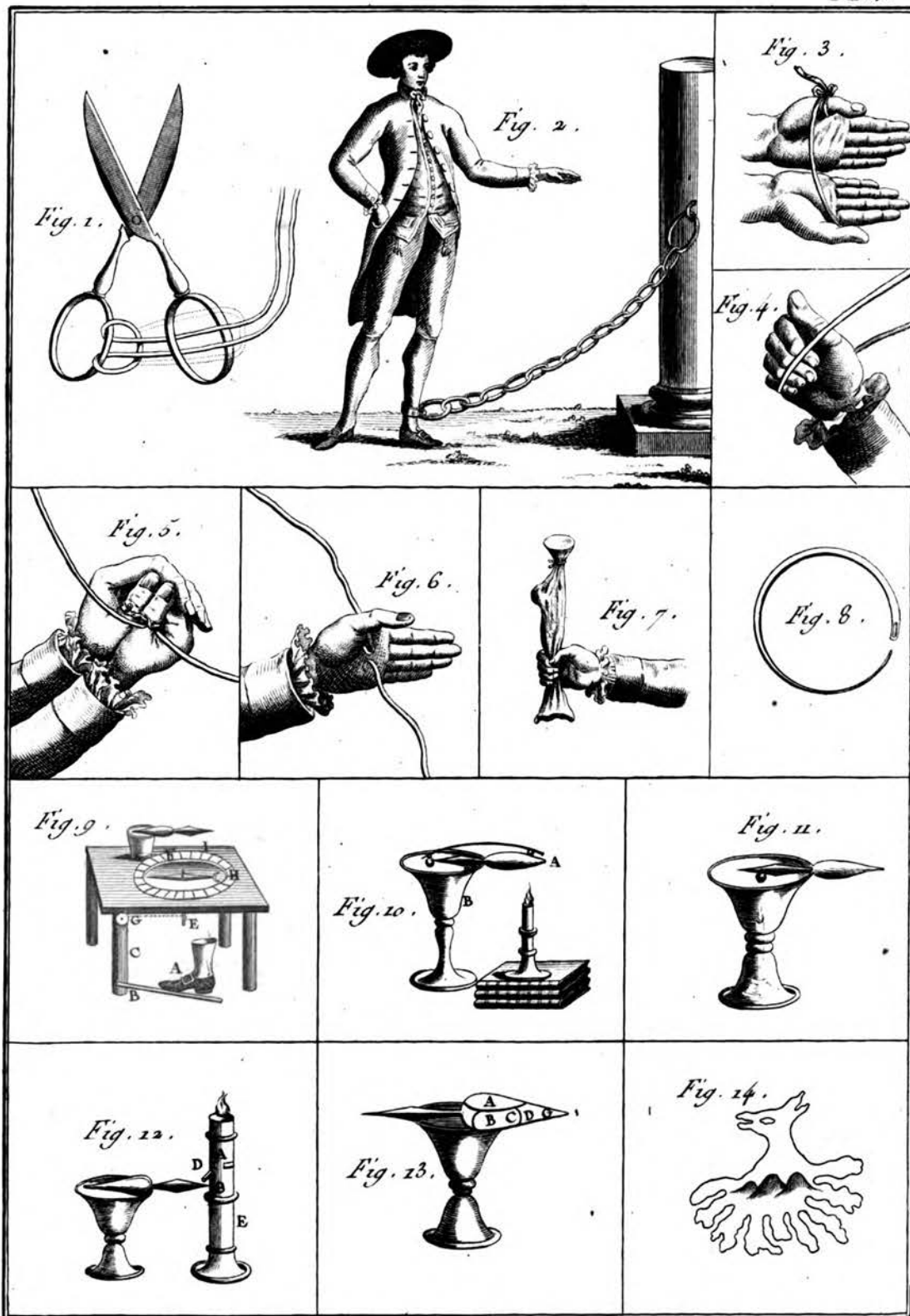


Cote' du Blanc.

*Combinaisons Magiques.*



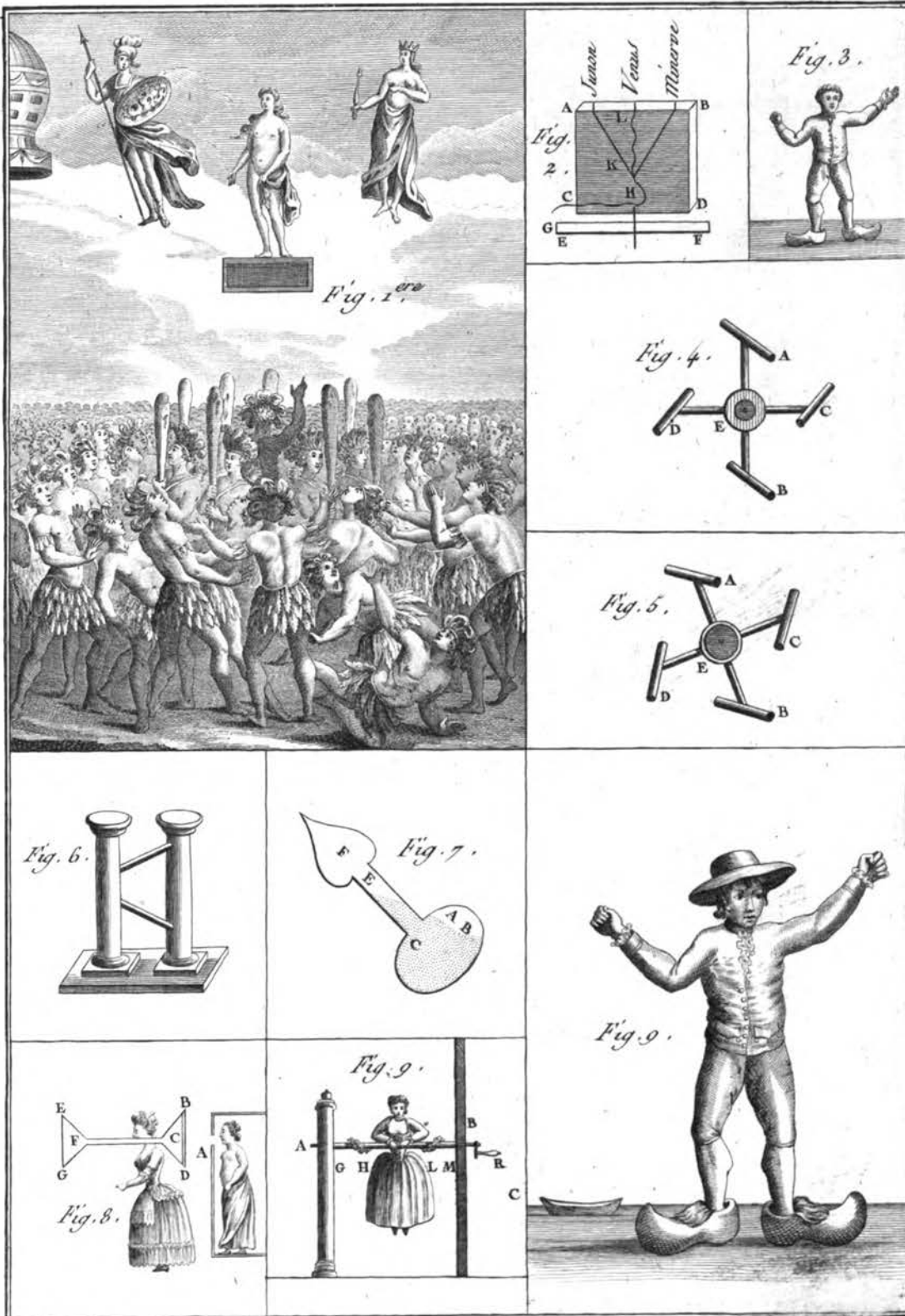
Tours de Gibeciere

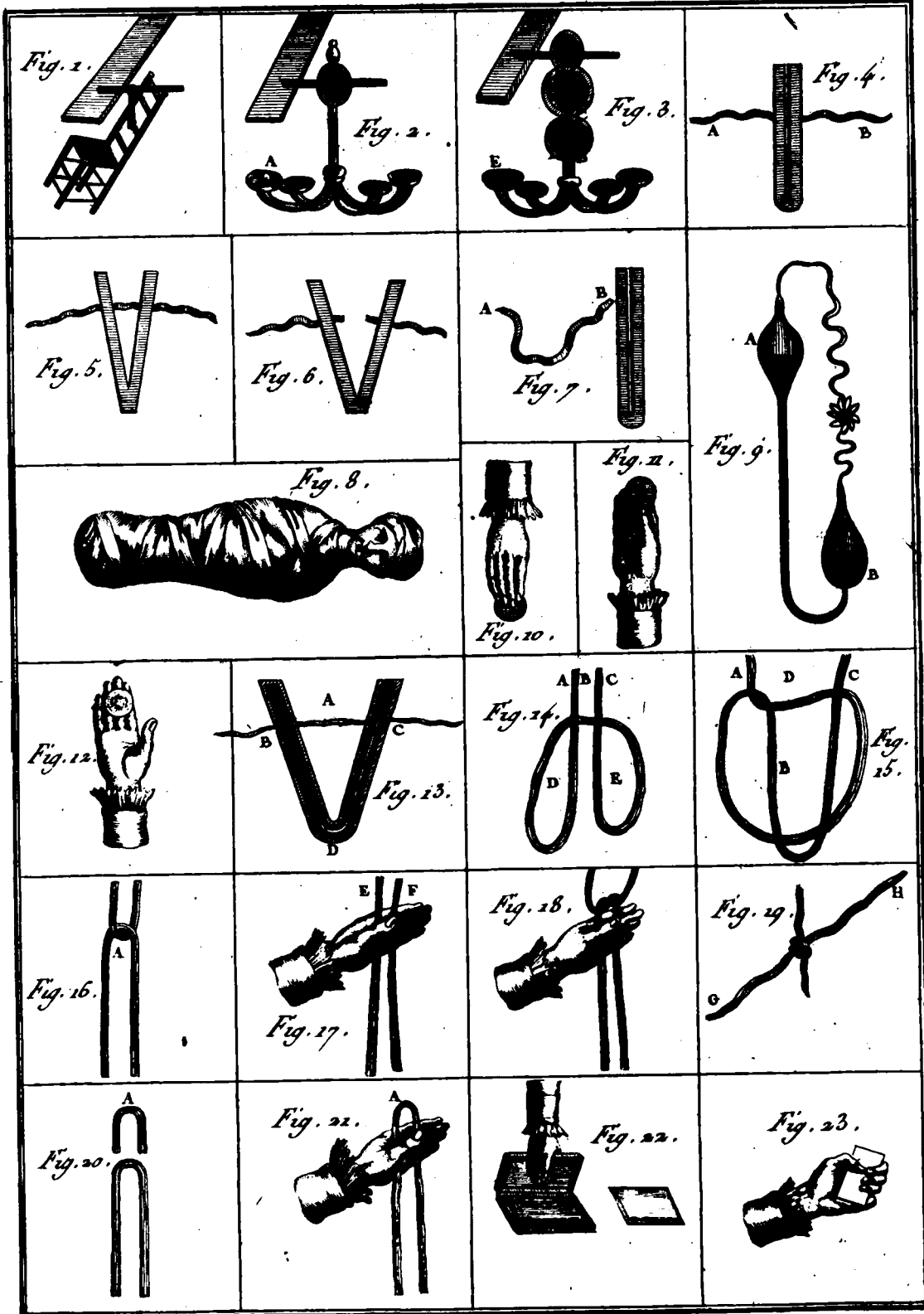


*Figures de Magie Blanche*

Digitized by Google

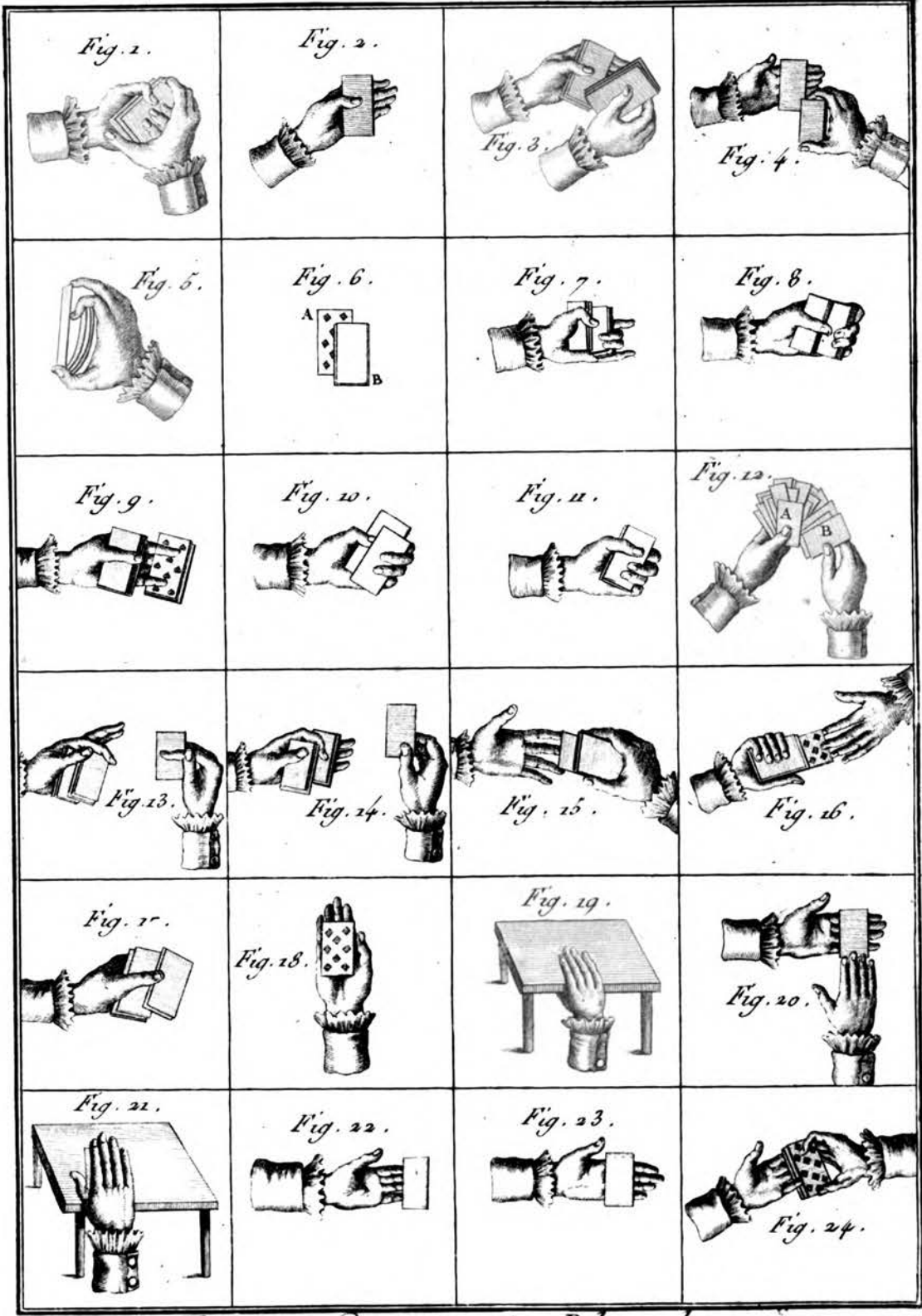
UNIVERSIDAD COMPLUTENSE DE MADRID

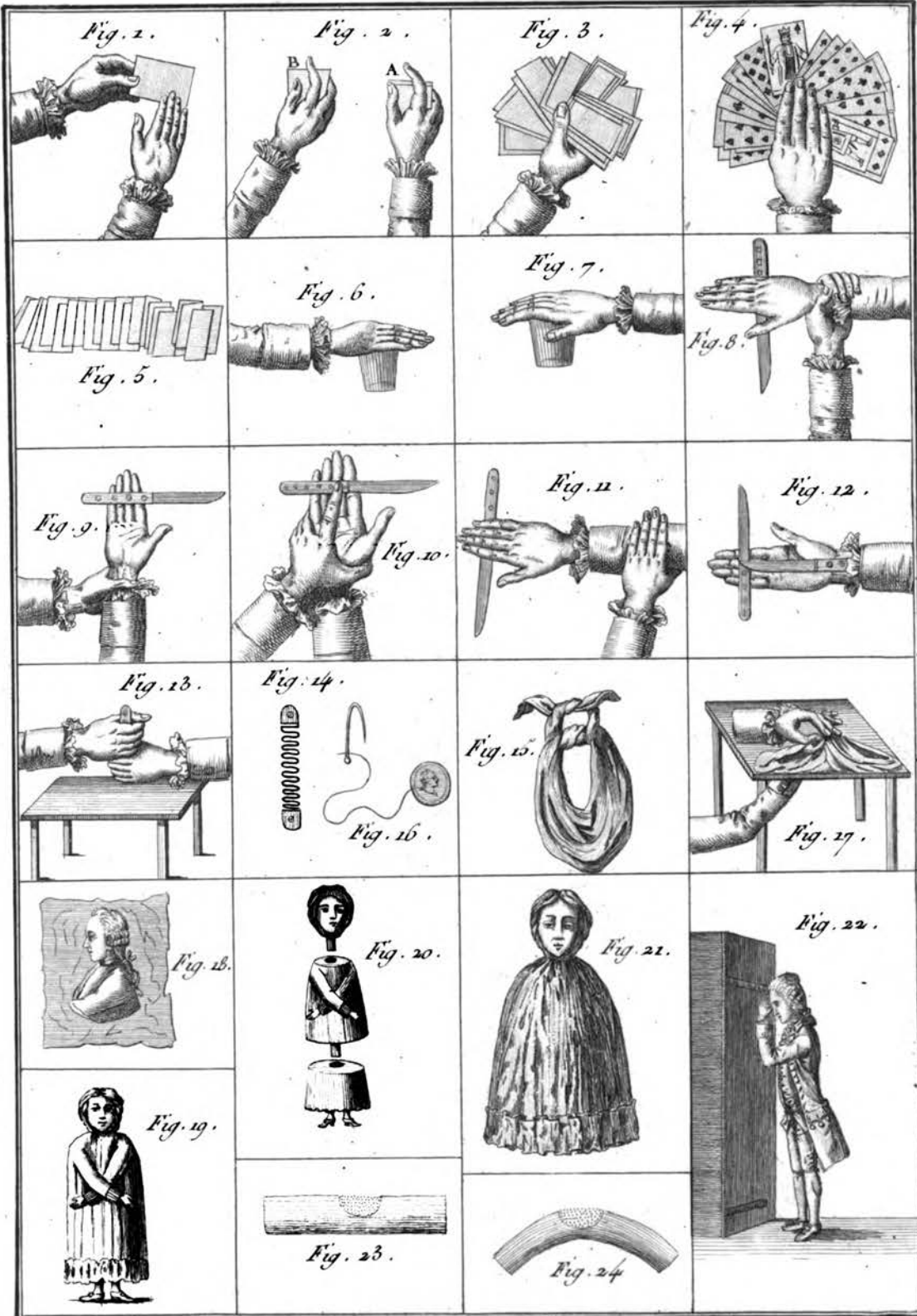




*Figures de Magie Blanche.*  
 Digitized by Google

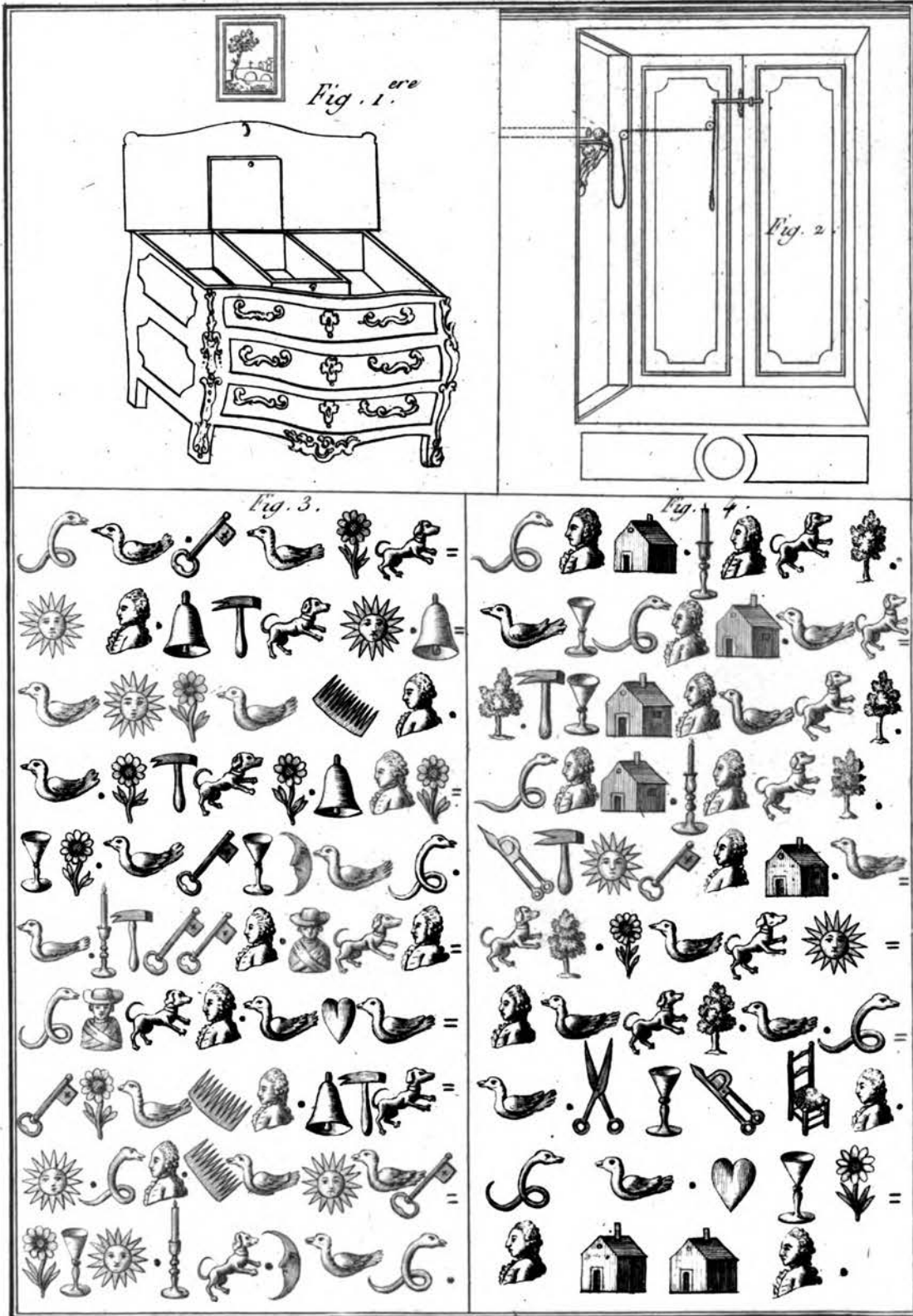
Original from  
 UNIVERSIDAD COMPLUTENSE  
 DE MADRID



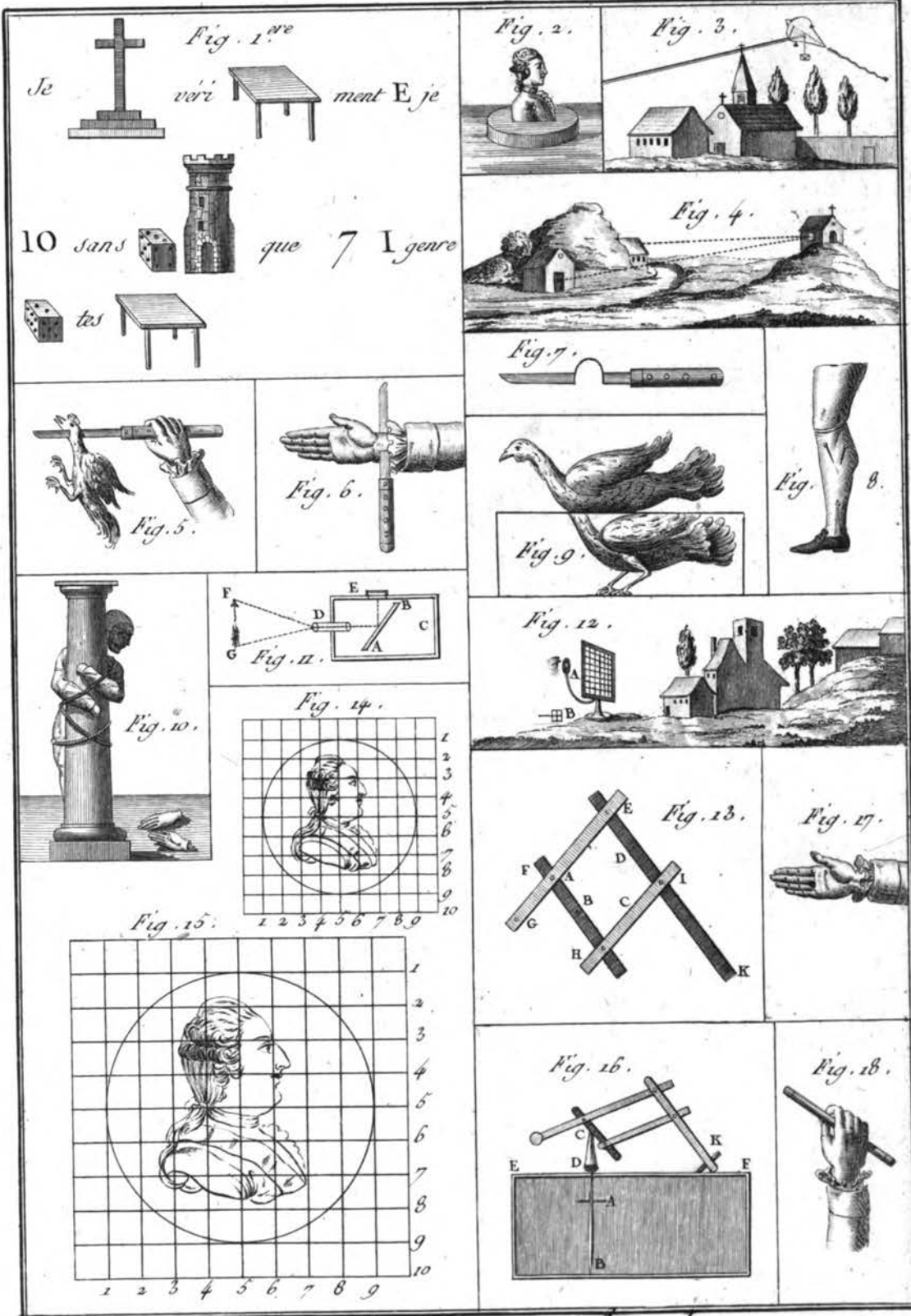


*Figures de Magie Blanche.*

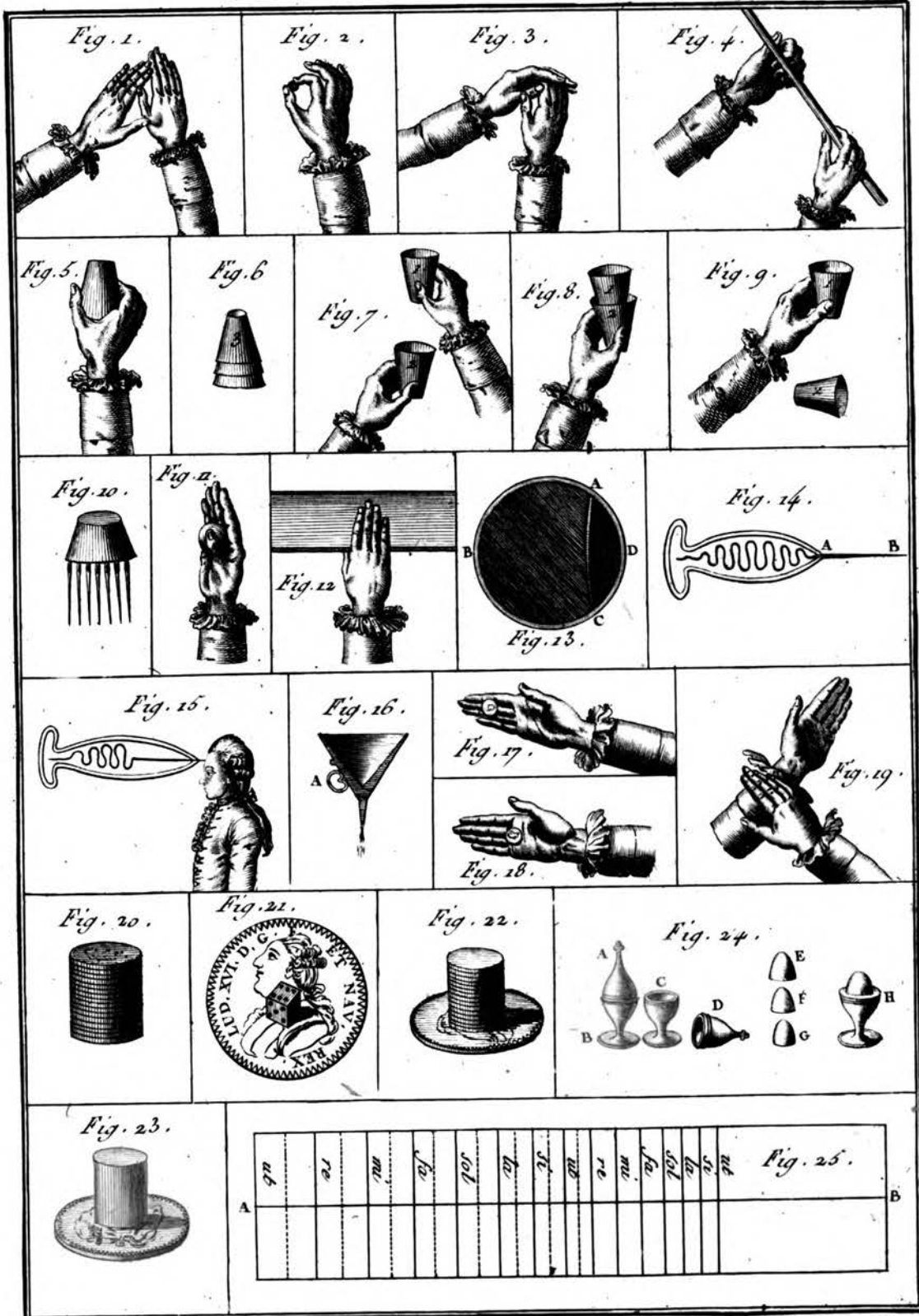




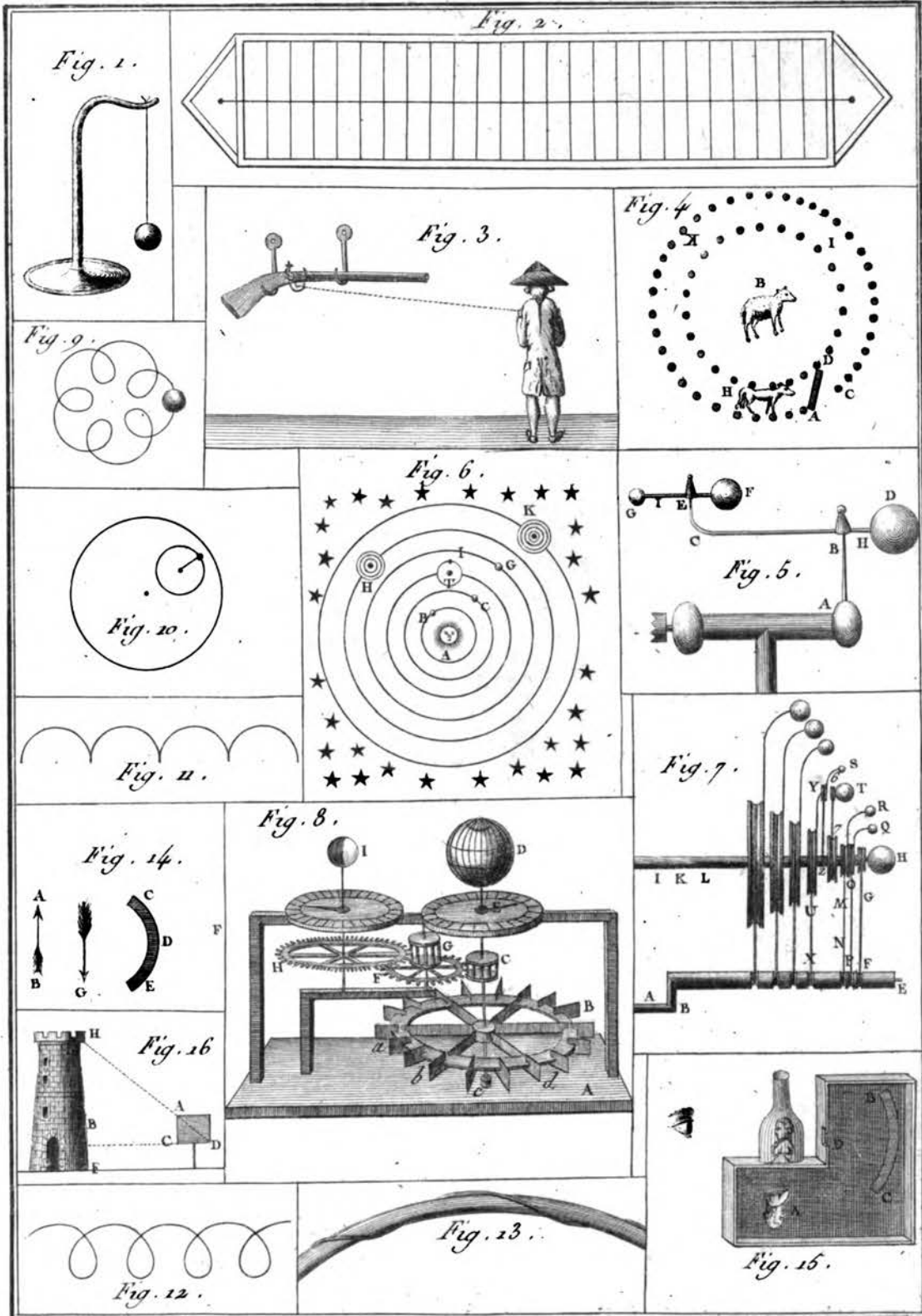
*Figures de Magie Blanche.*



*Figures de Magie Blanche.*

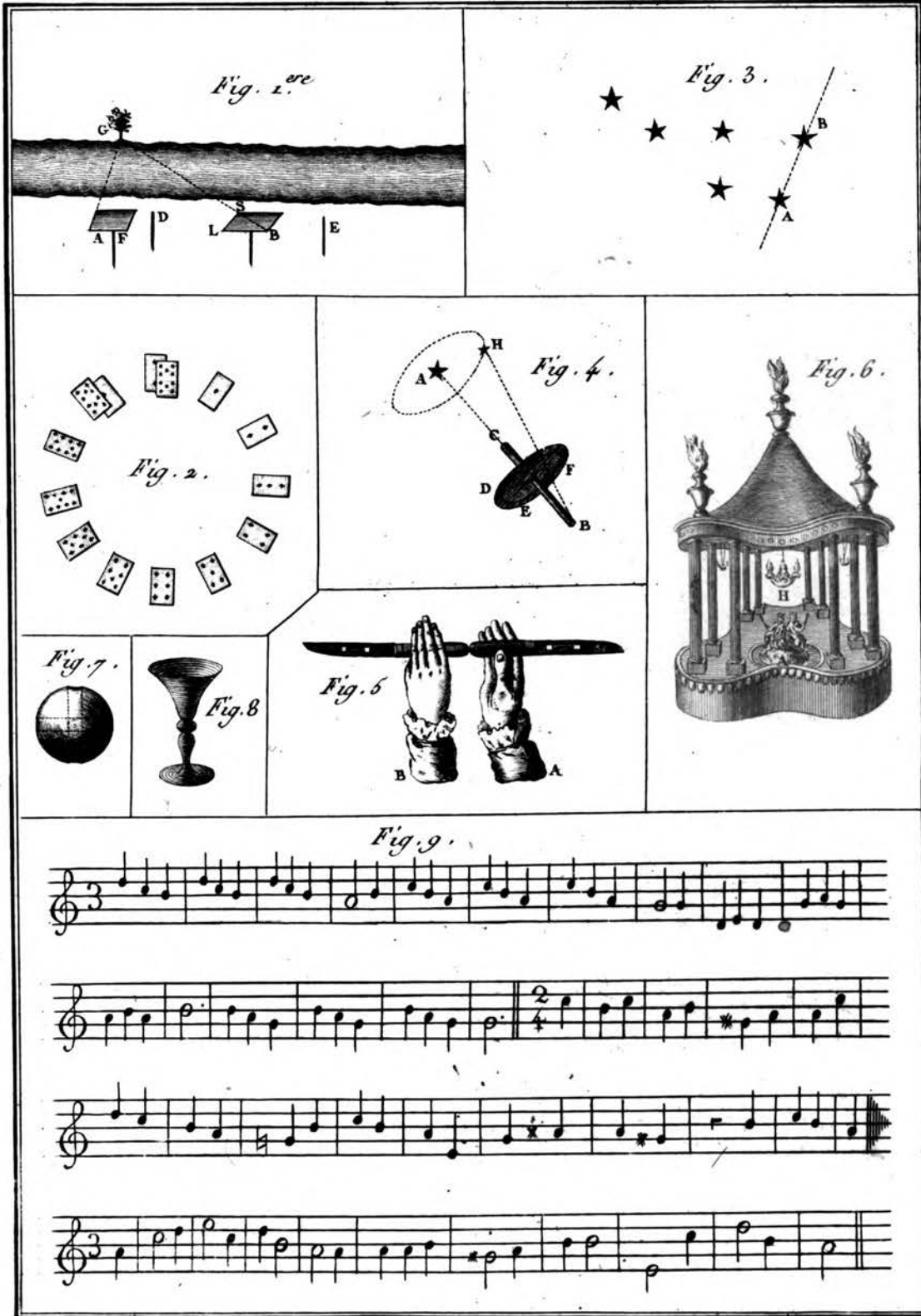


*Figures de Magie Blanche.*



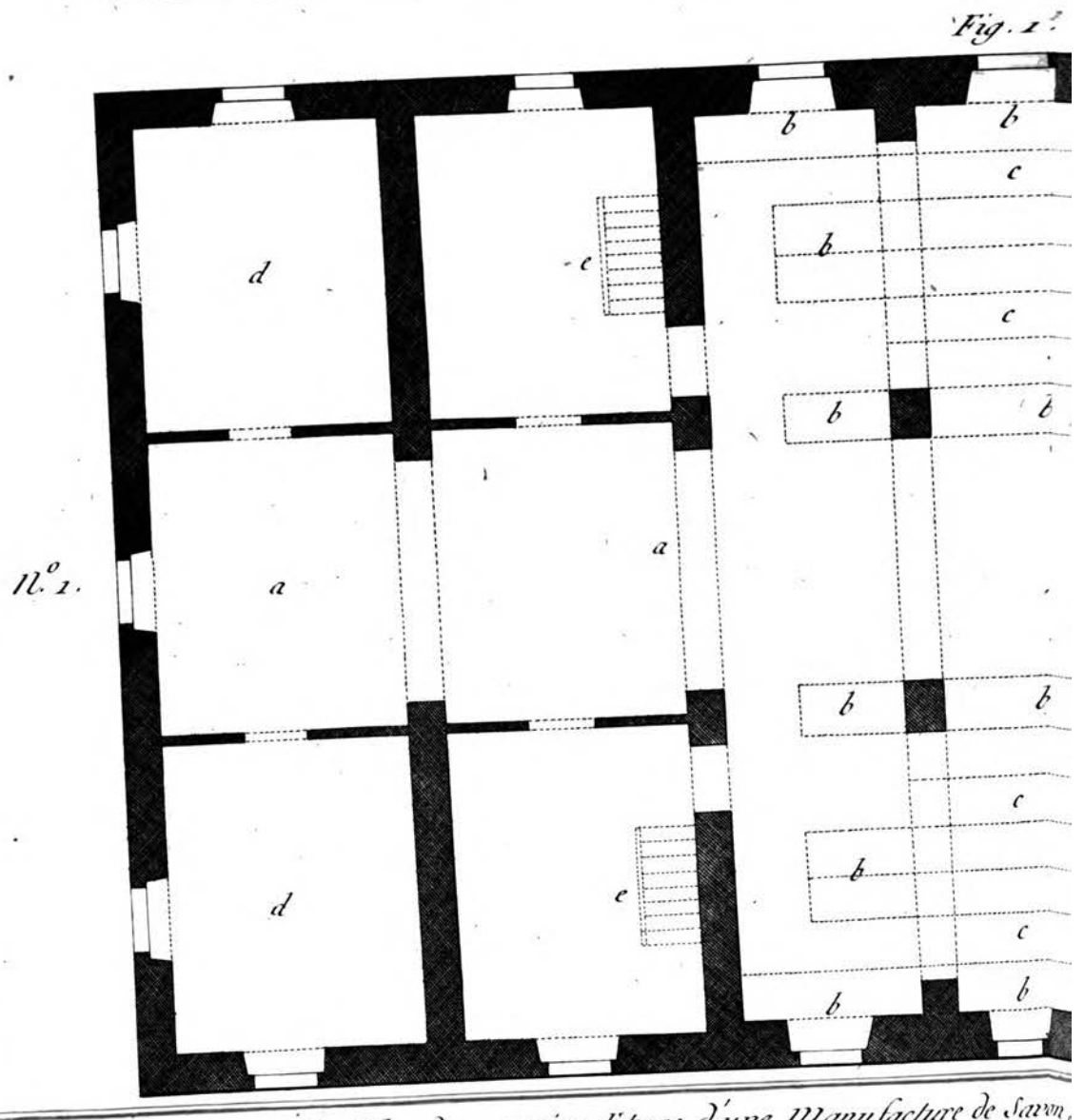
*Figures de Magie Blanche.*

*Bernard Dircet*



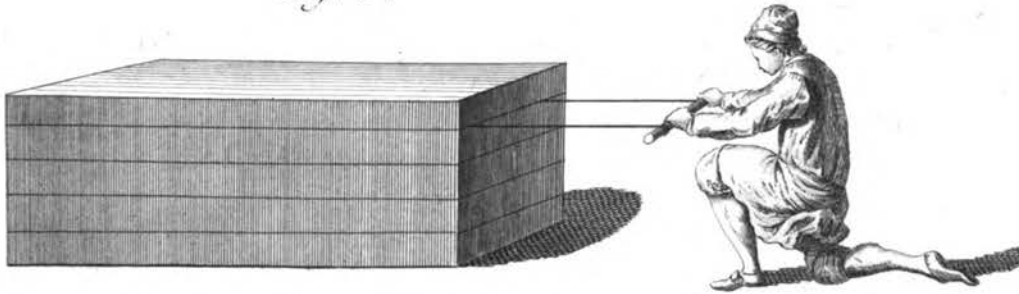
*Figures de Magie Blanche.*

*Bernard Direct.*

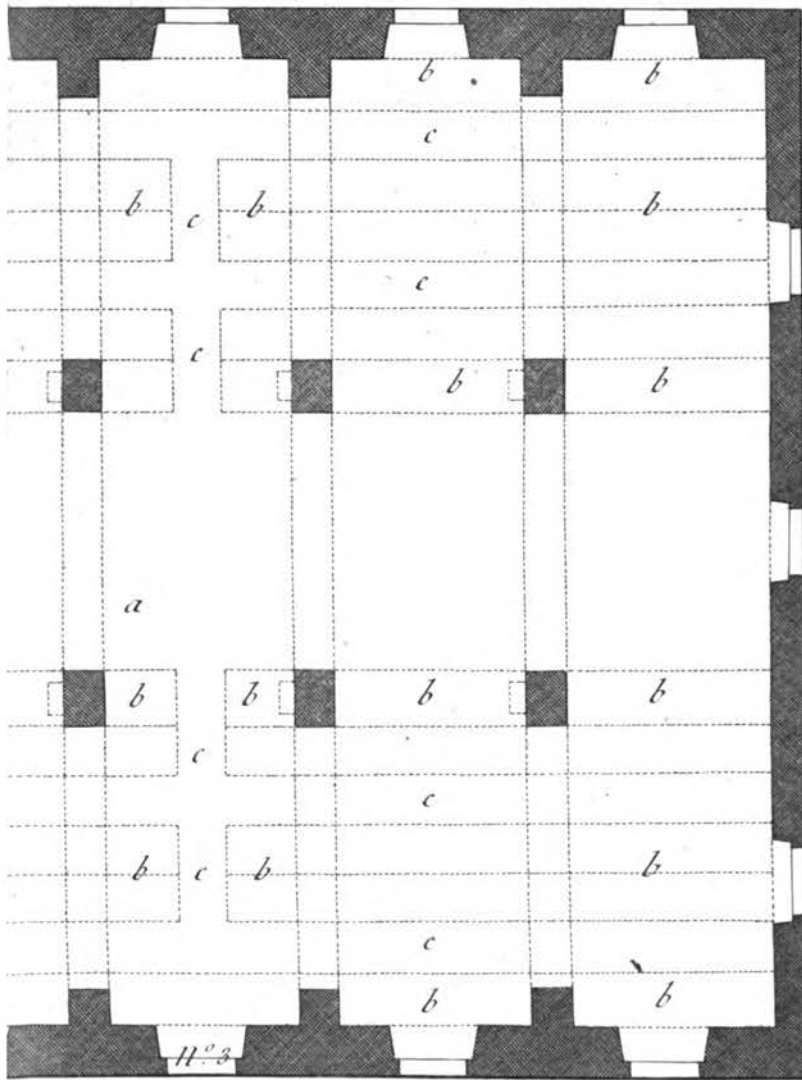


*Savonnerie, Plan du premier Etage d'une Manufacture de Savon,*

Fig. 3.



N. 4.



10 Toises.

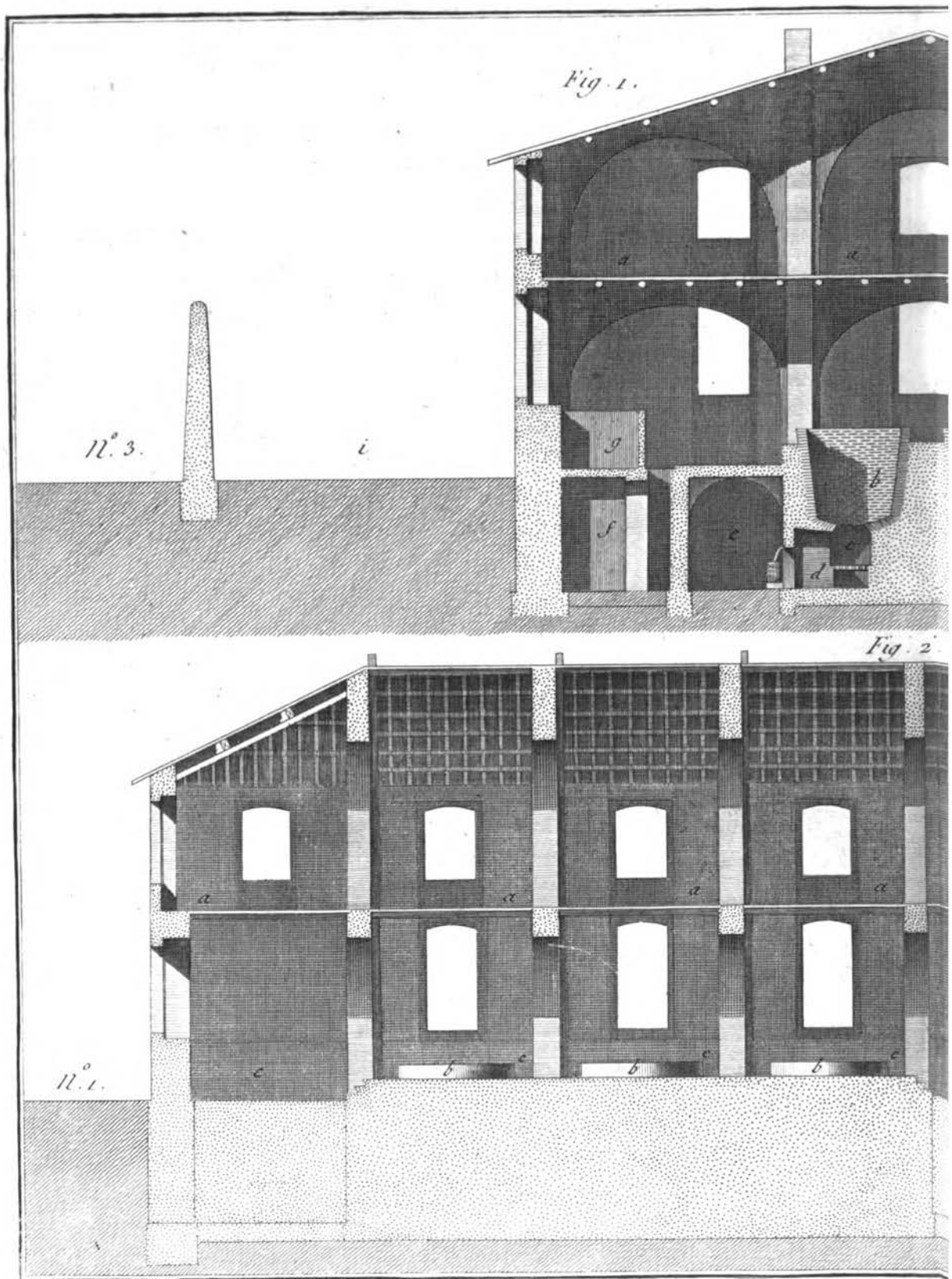


N. 2.

N. 3.

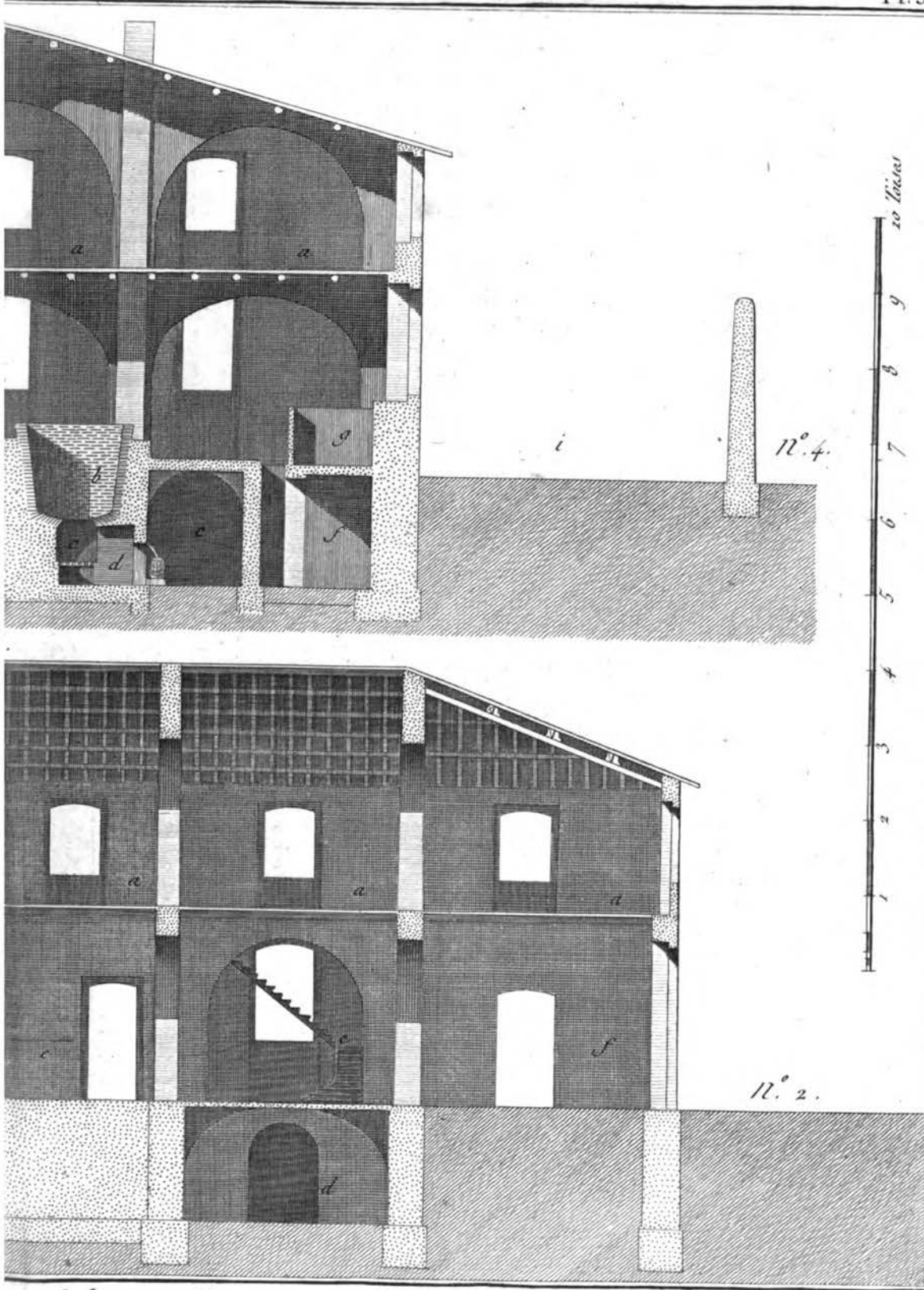
Benard Dorez.

m, et Opérations pour partager également et couper le Savon.



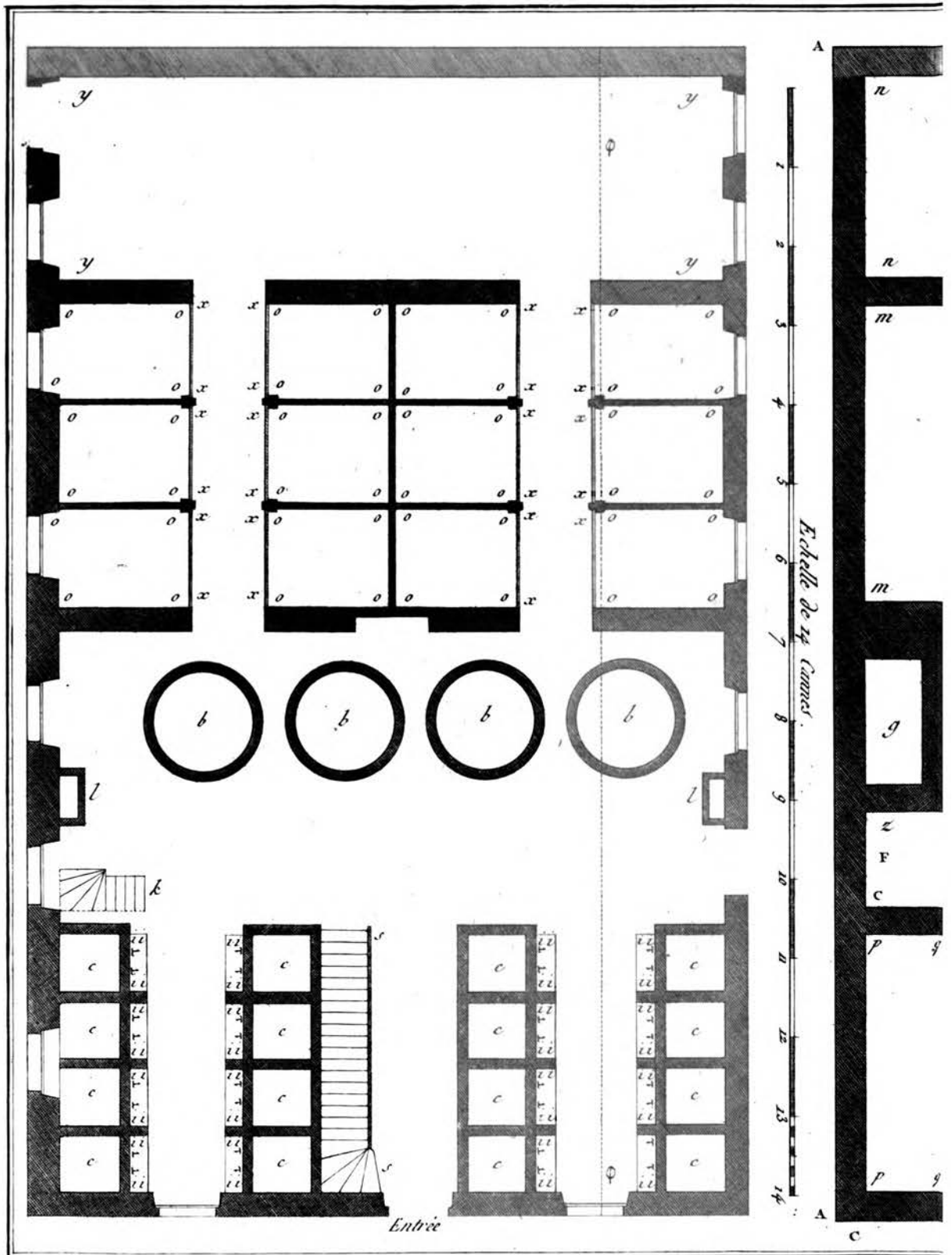
*Savonnerie, Coupe sur la largeur et Coupe*





Sur la longueur d'une Manufacture de Savon.

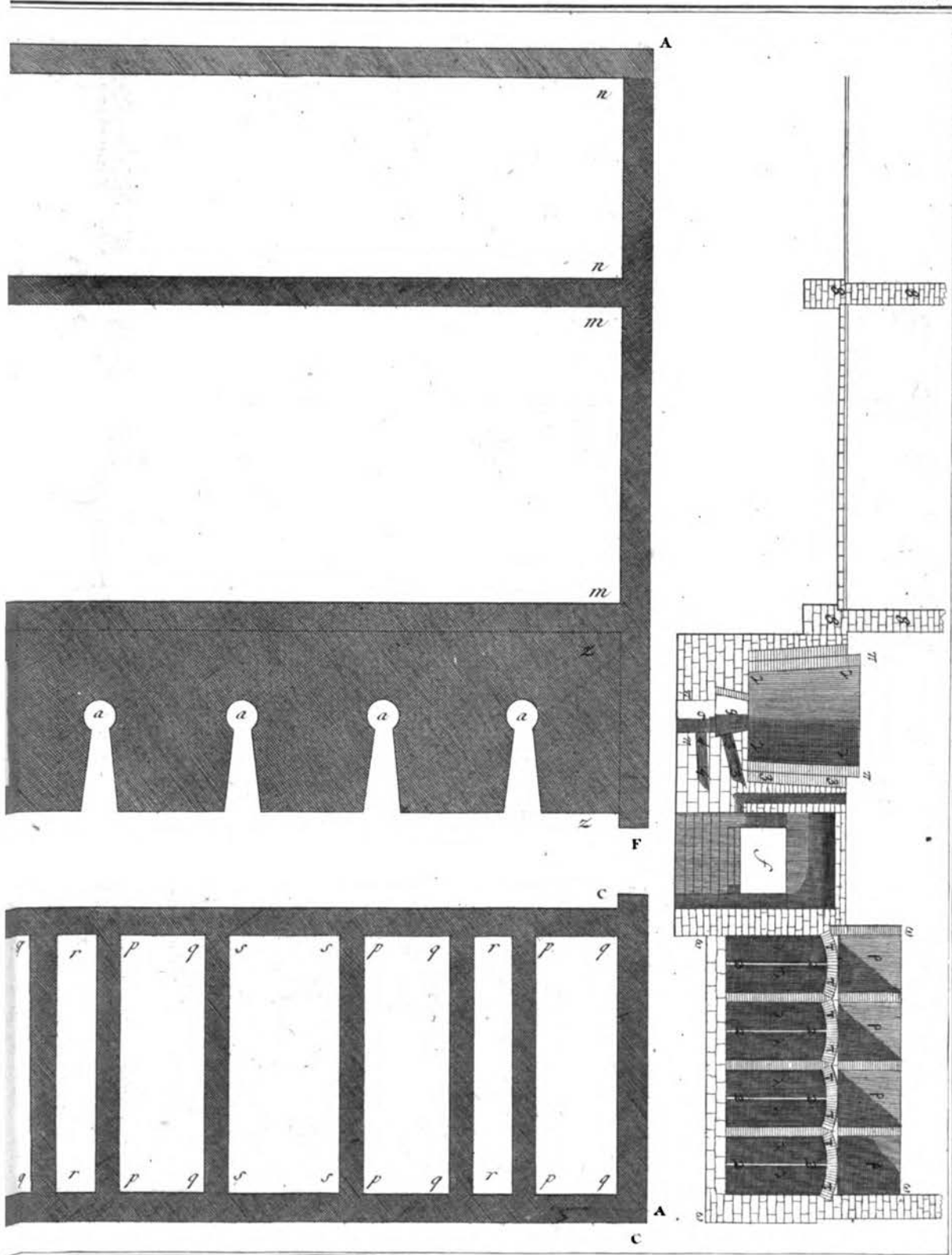
Bonard Dirced.



*Savonnerie, Plan et Coupe d*

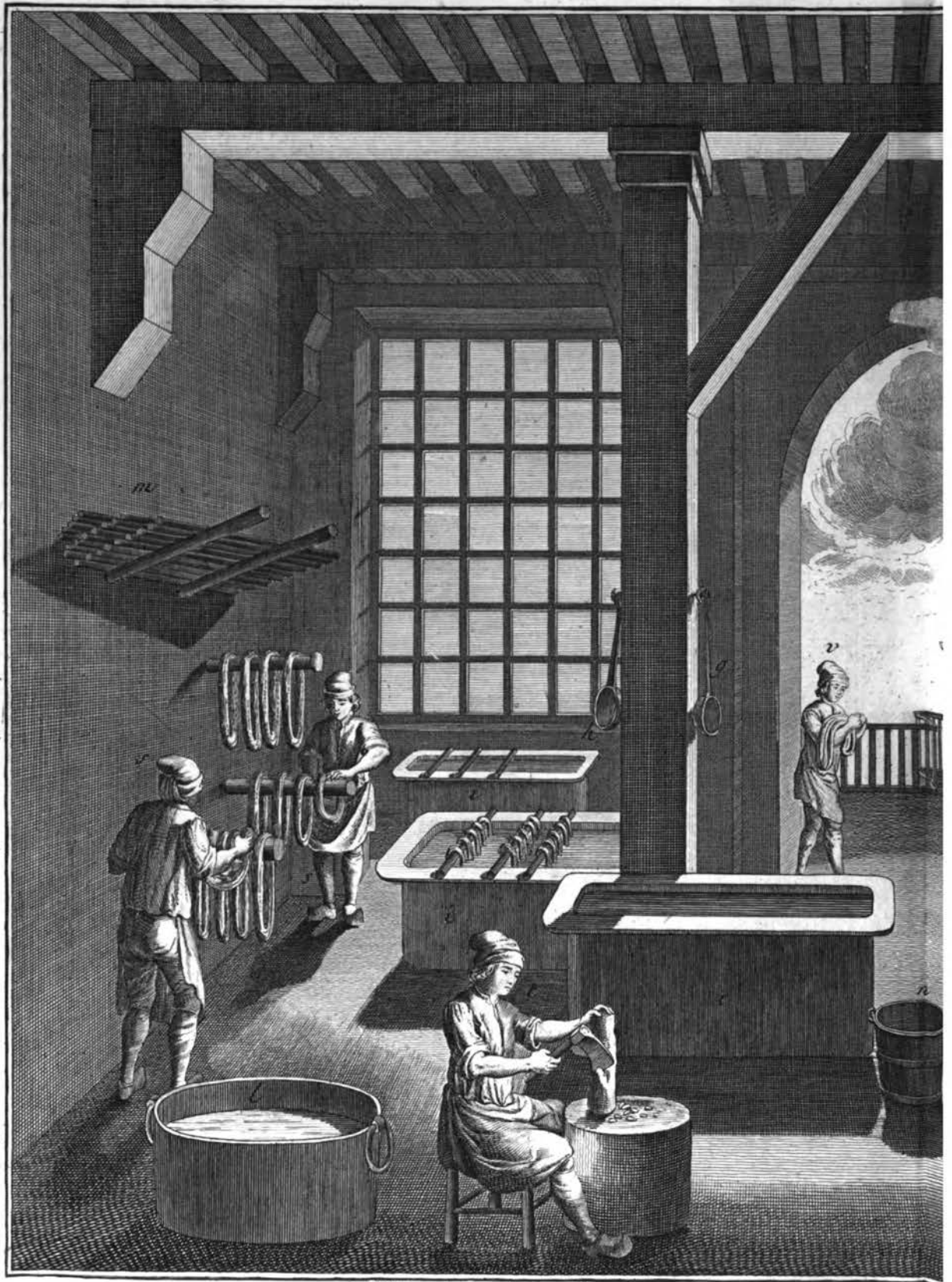
Original from  
 UNIVERSIDAD COMPLUTENSE  
 DE MADRID

Digitized by Google



*d'une grande Manufacture de Savon*

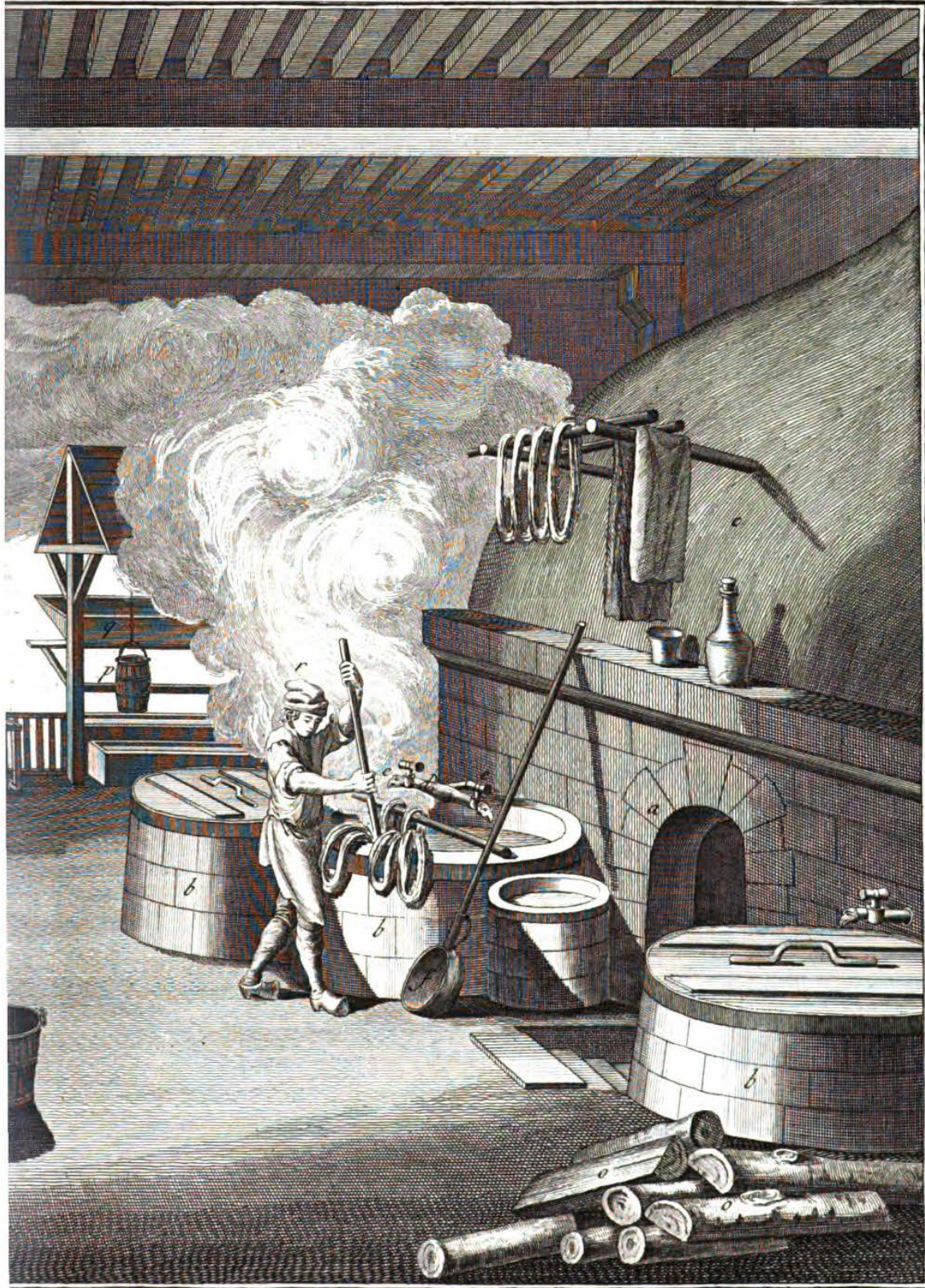
Bonard Dorez



*Teinturier de Riviere, Atelier et diffin*

Digitized by Google

Original from  
UNIVERSIDAD COMPLUTENSE  
DE MADRID



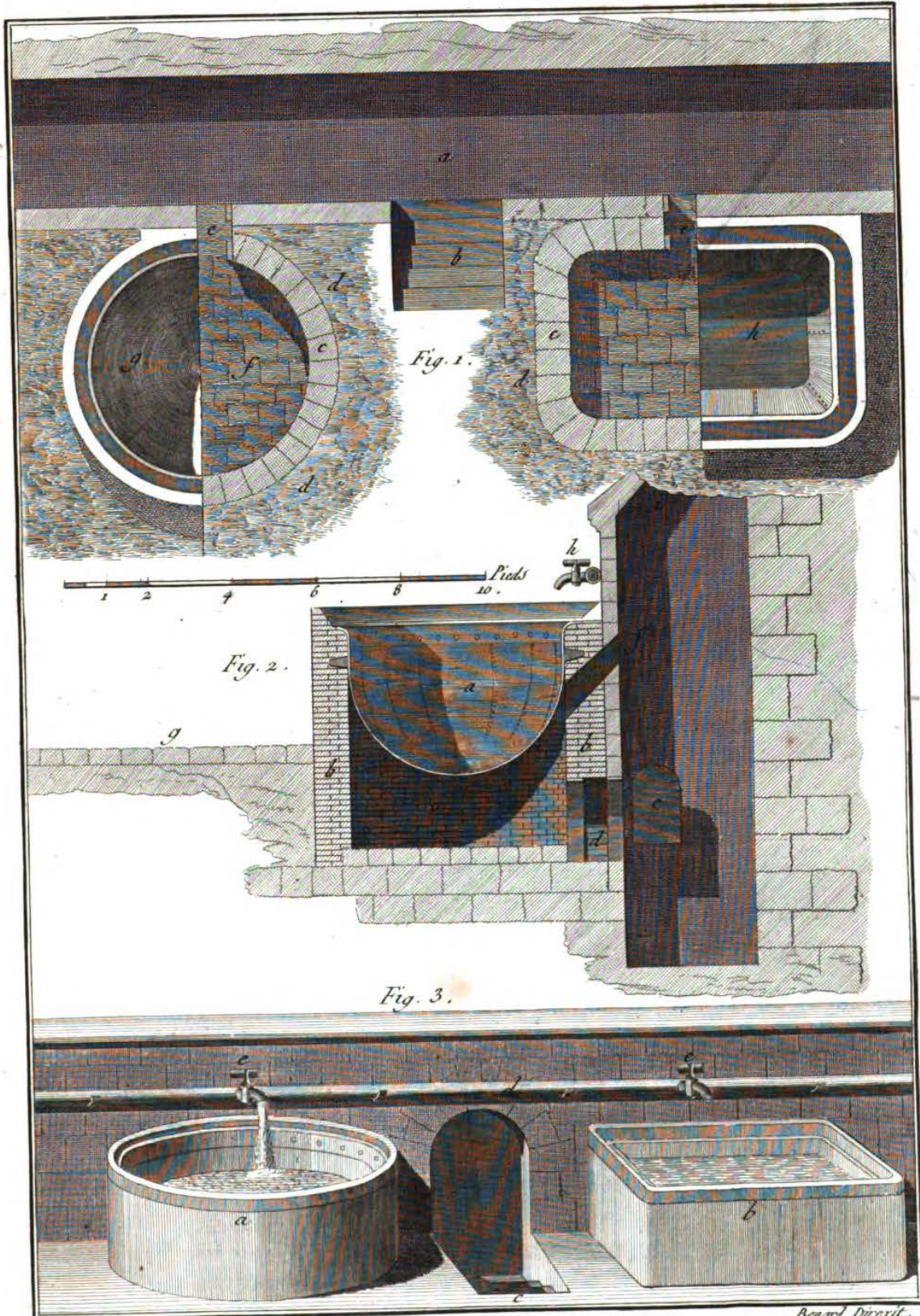
*Étendues Opérations pour la Teinture des Soies.*

*Bernard Dorez.*

59.

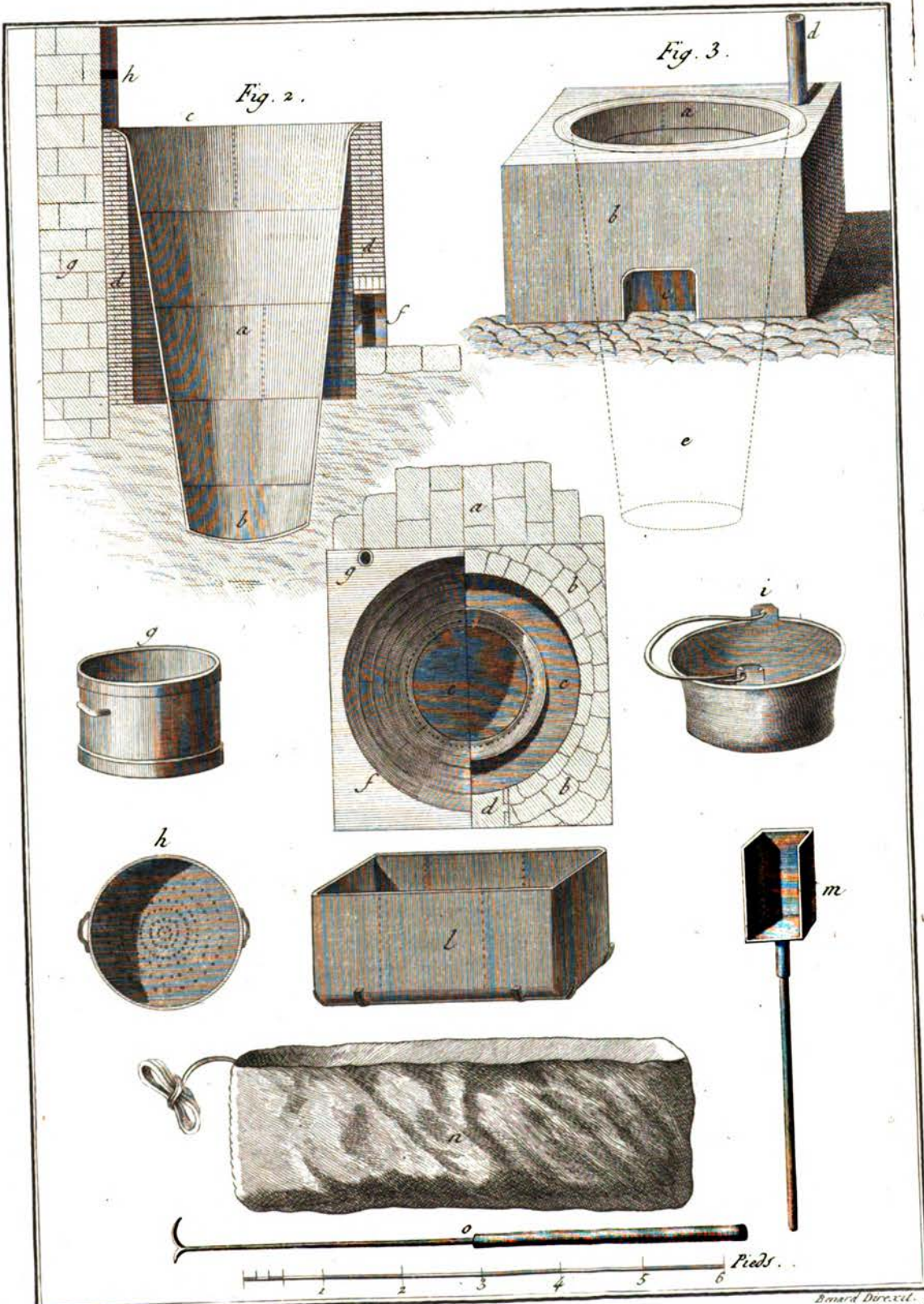
Digitized by Google

Original from  
UNIVERSIDAD COMPLUTENSE  
DE MADRID



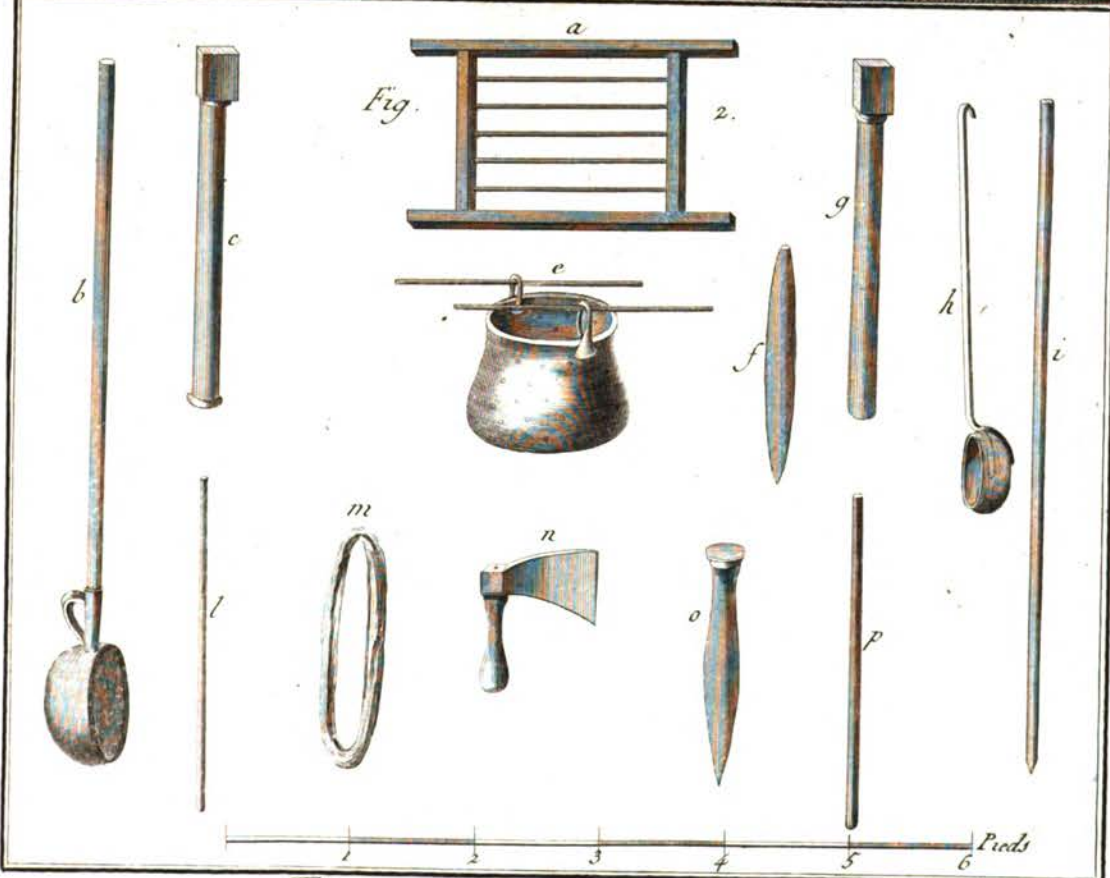
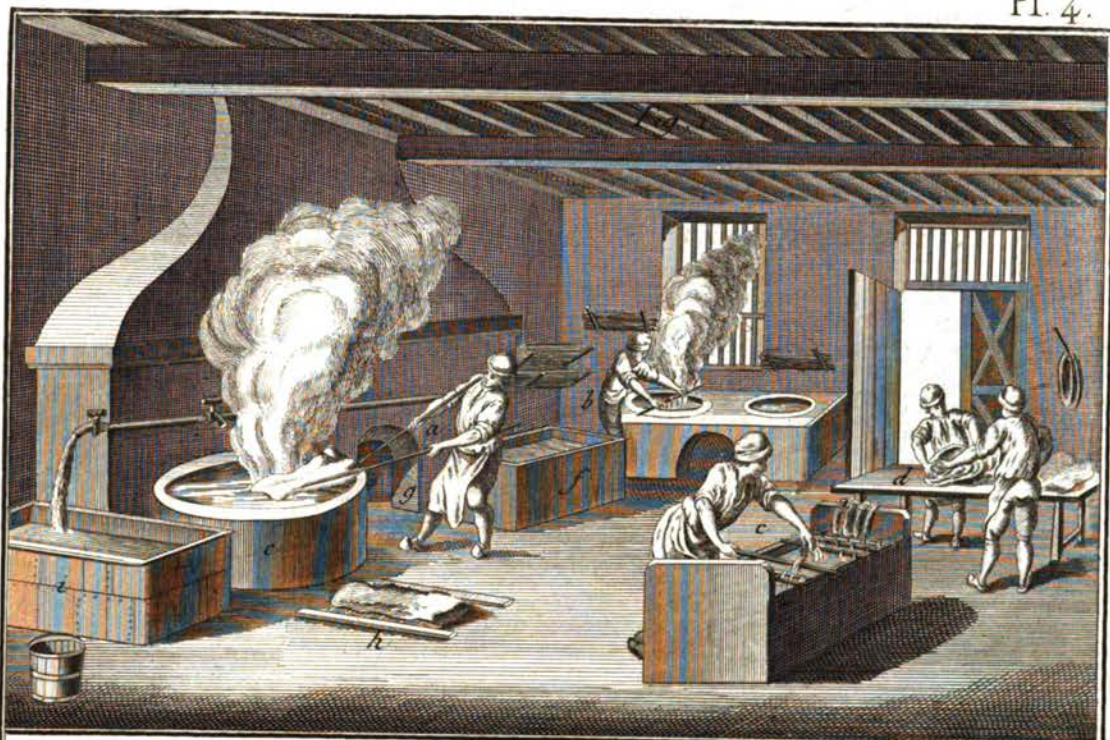
*Teinturier de Riviere, Plans, Coupe et Elevations de différentes Chaudieres.* 60.

Benard D'arcet.



*Teinturier de Riviere, Plans, Coupe et Elevation de la Cuve pour l'Indigo.*

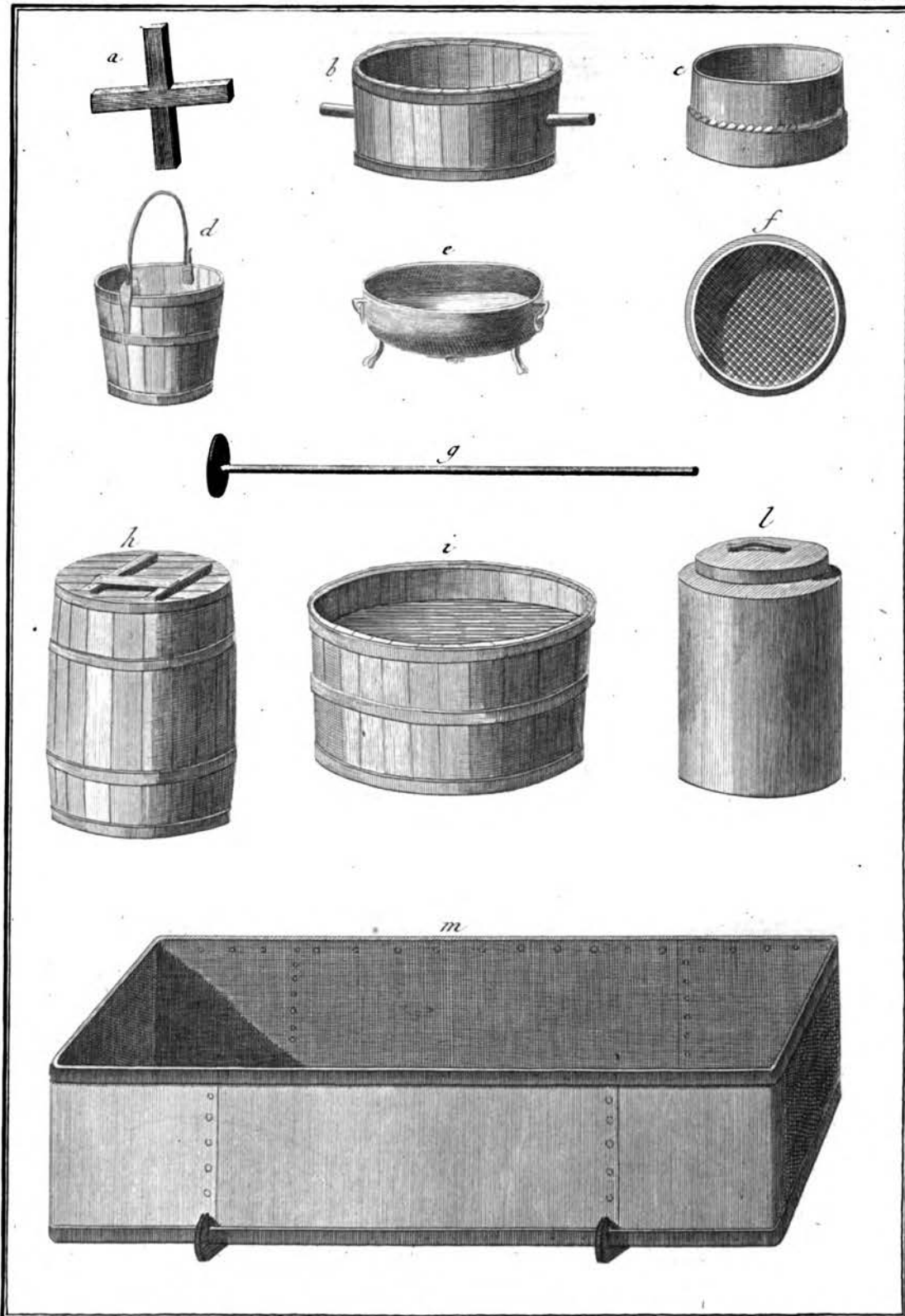
Bnard Dore. del. 61.



Teinturier, Atelier et Outils.

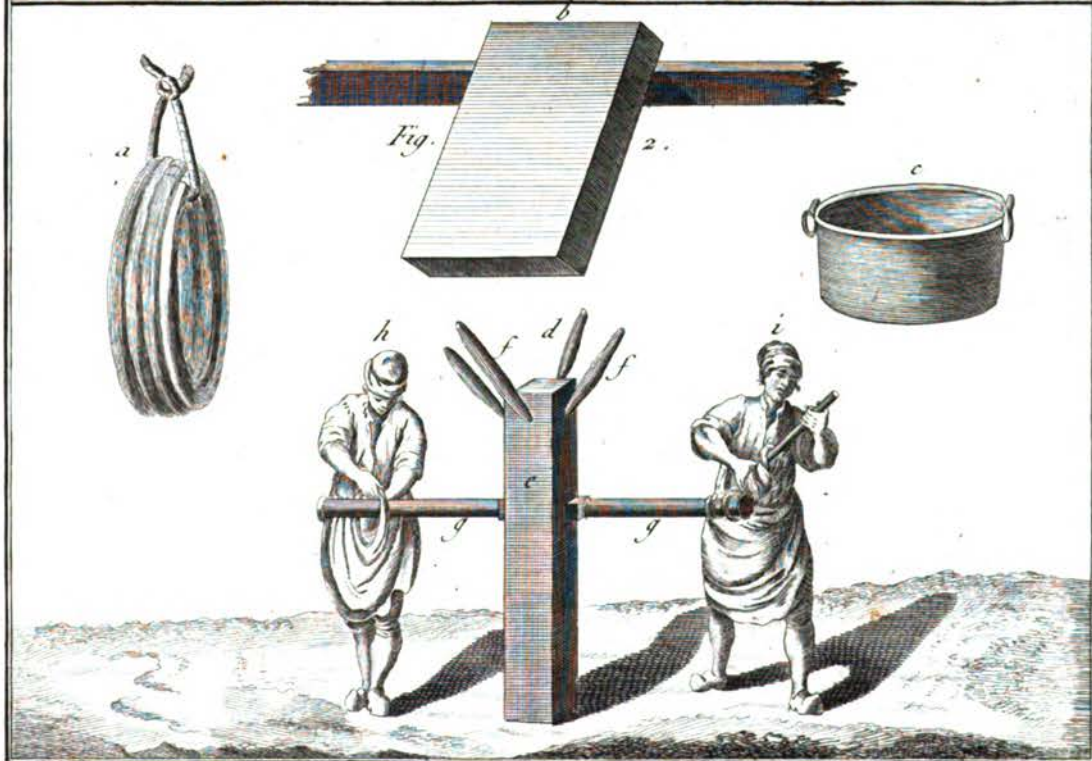
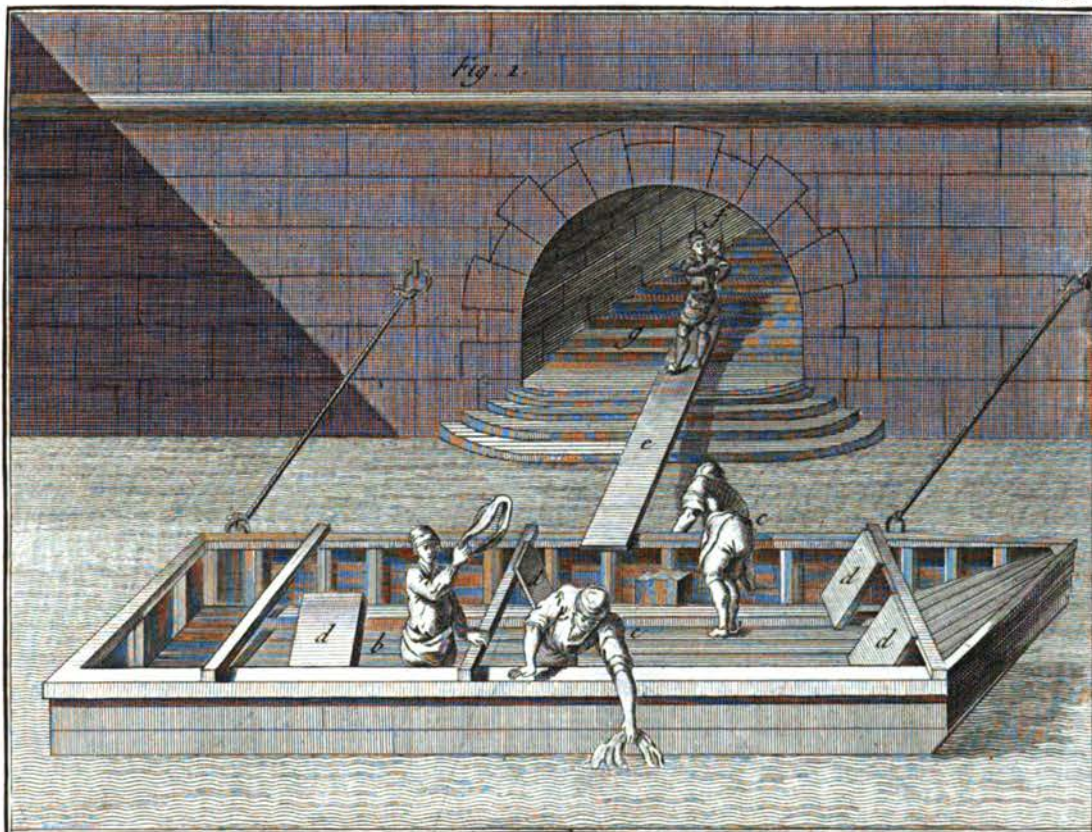
Boiard Duxet





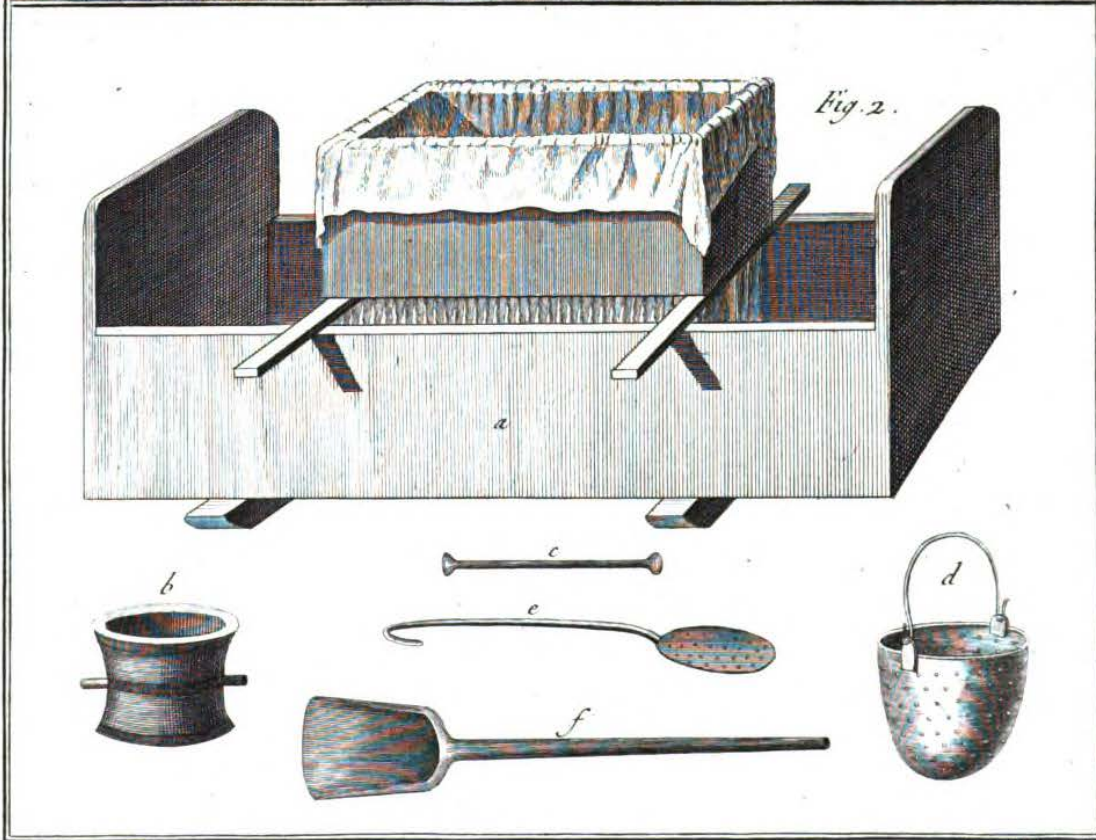
*Teinturier en Soie, différens Ustensiles pour la Teinture en Soie.* 62

*Bernard Duvet*



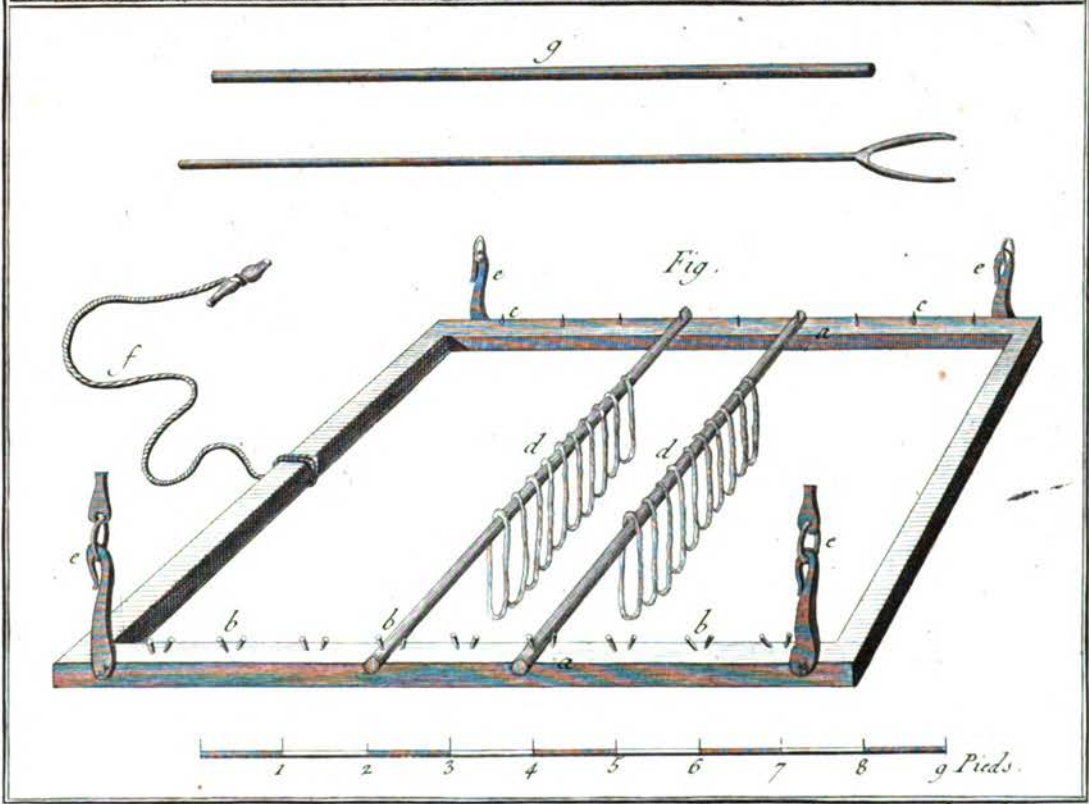
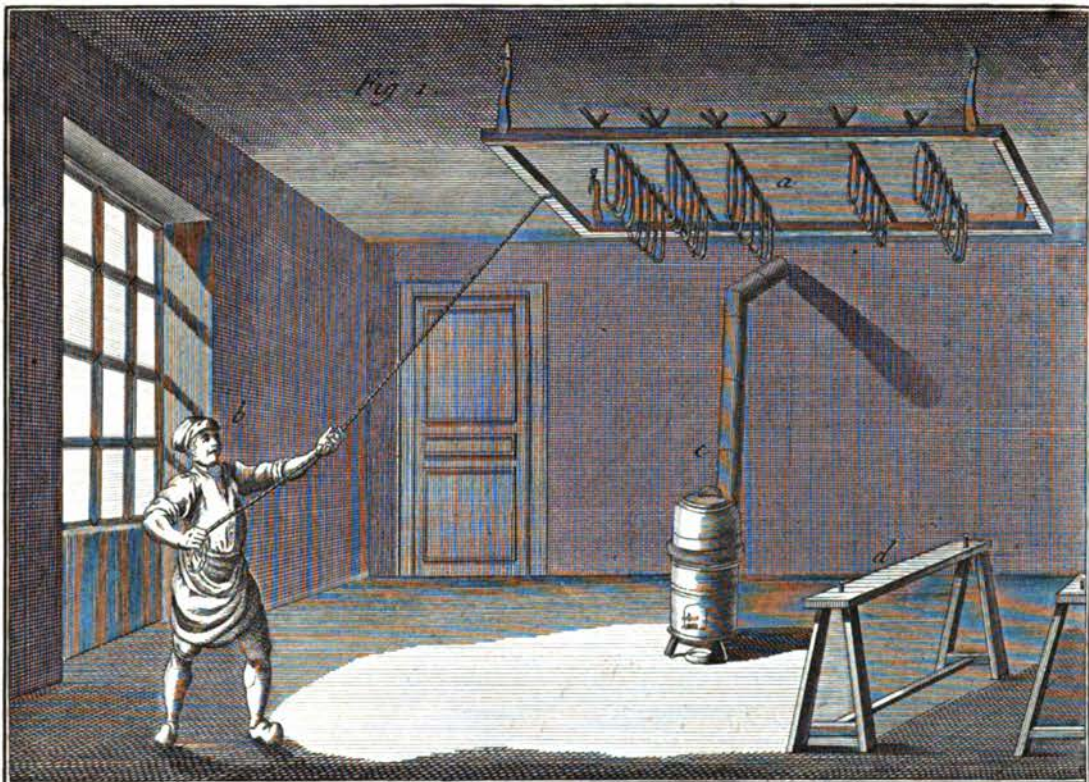
*Teinturier, Lavage des Soies à la Rivière et Service de l'Espart.*

*Bonard Inven.*



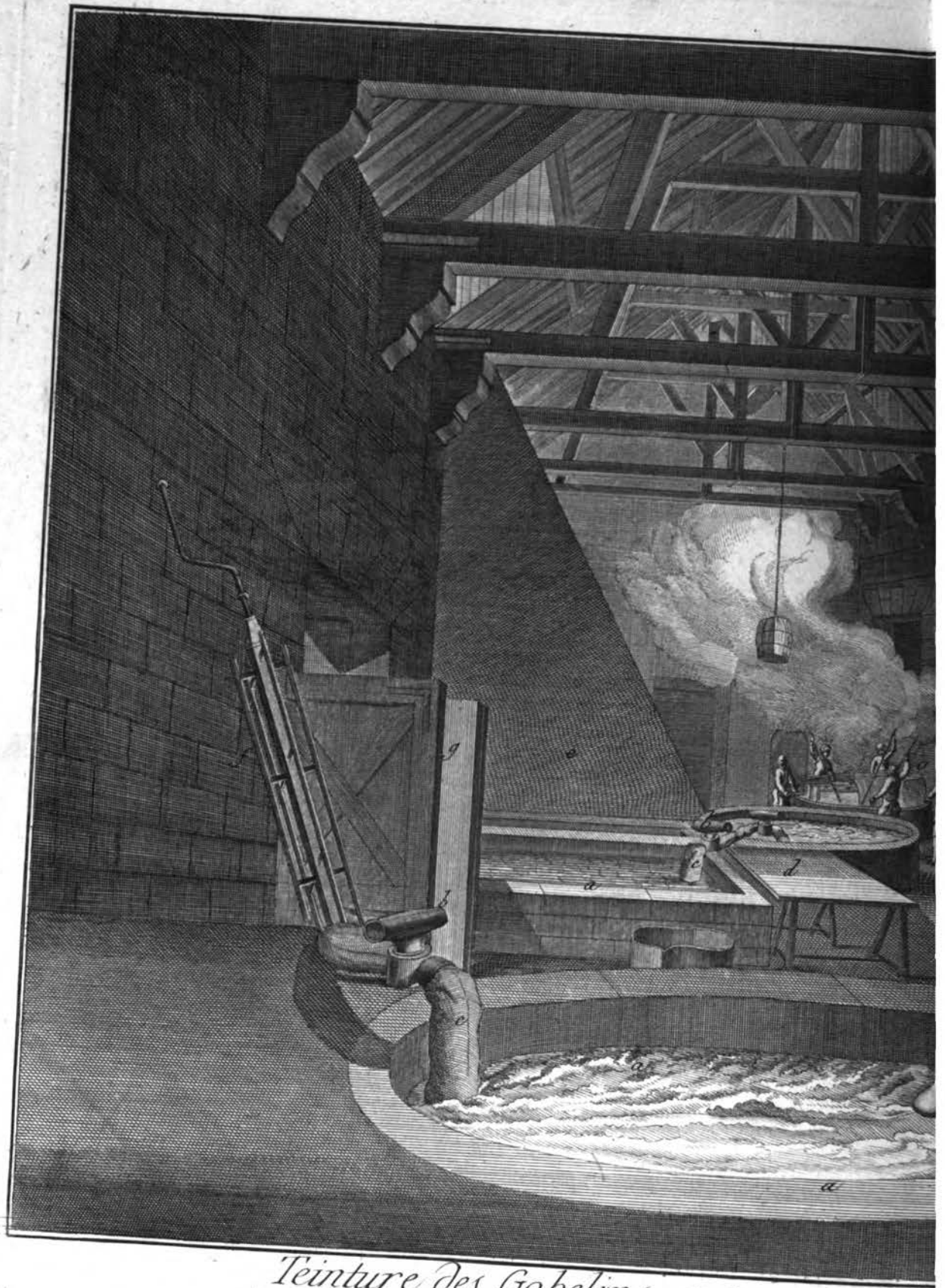
*Teinturier, différentes préparations du Safranum et Outils.*

*Bonard D'exc.*



*Teinturier, le sechoir pour les Soies &c.*

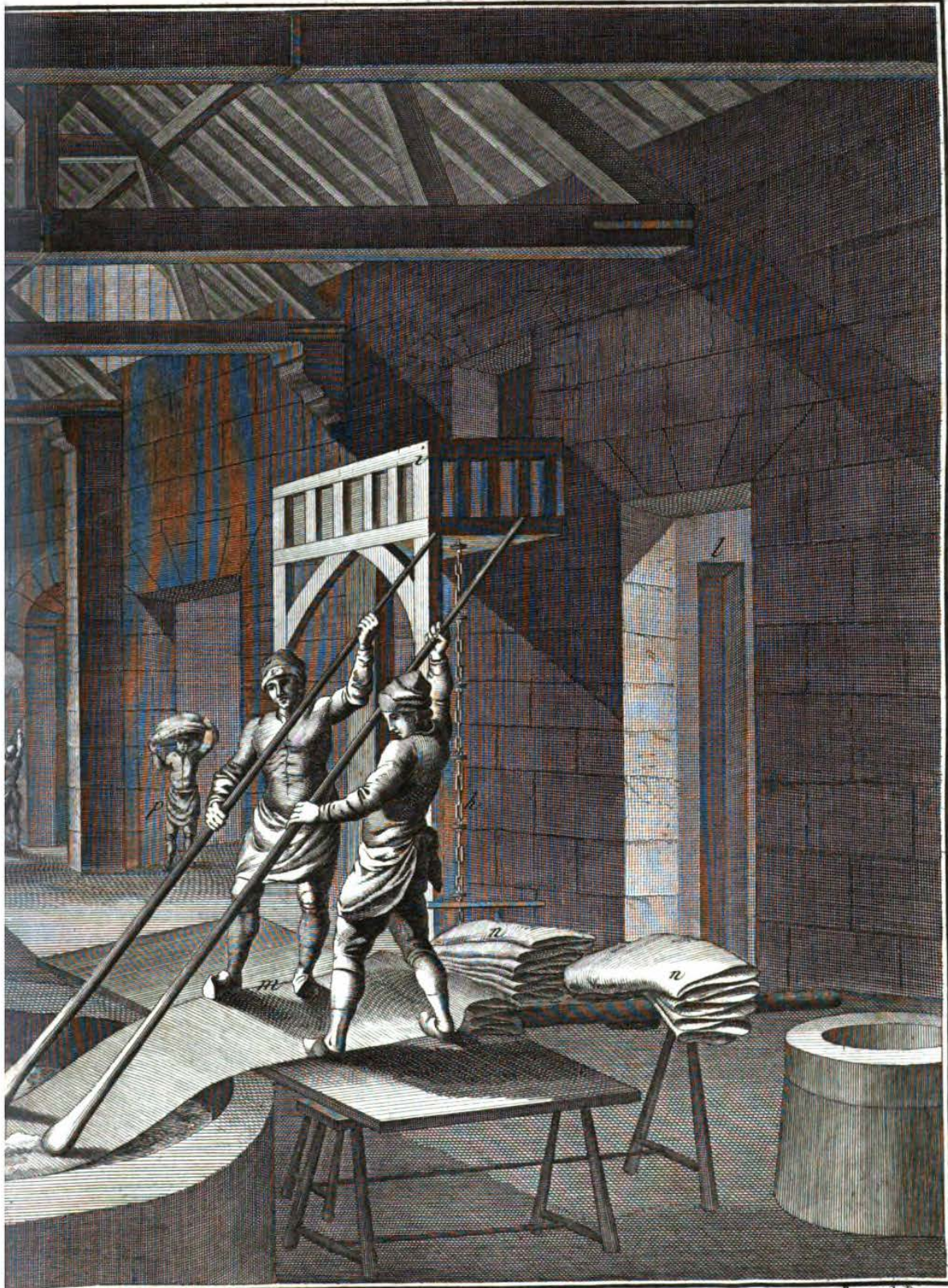
*Benard Directeur*



*Teinture des Gobelins, Atelier des Teinturiers*

Digitized by Google

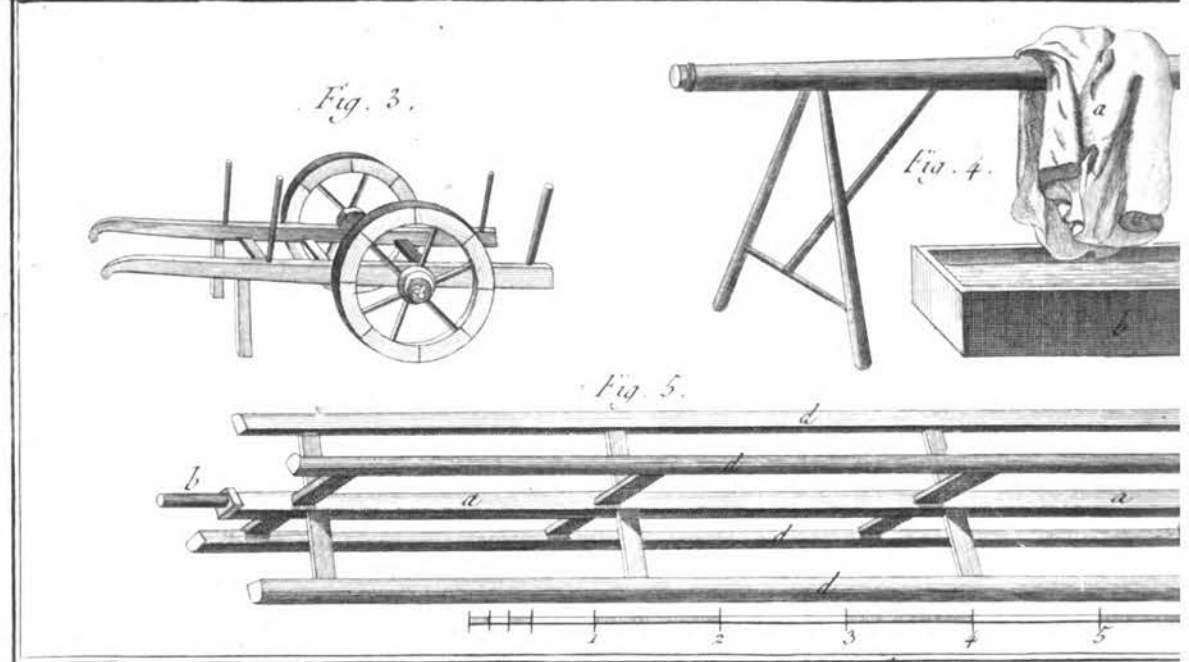
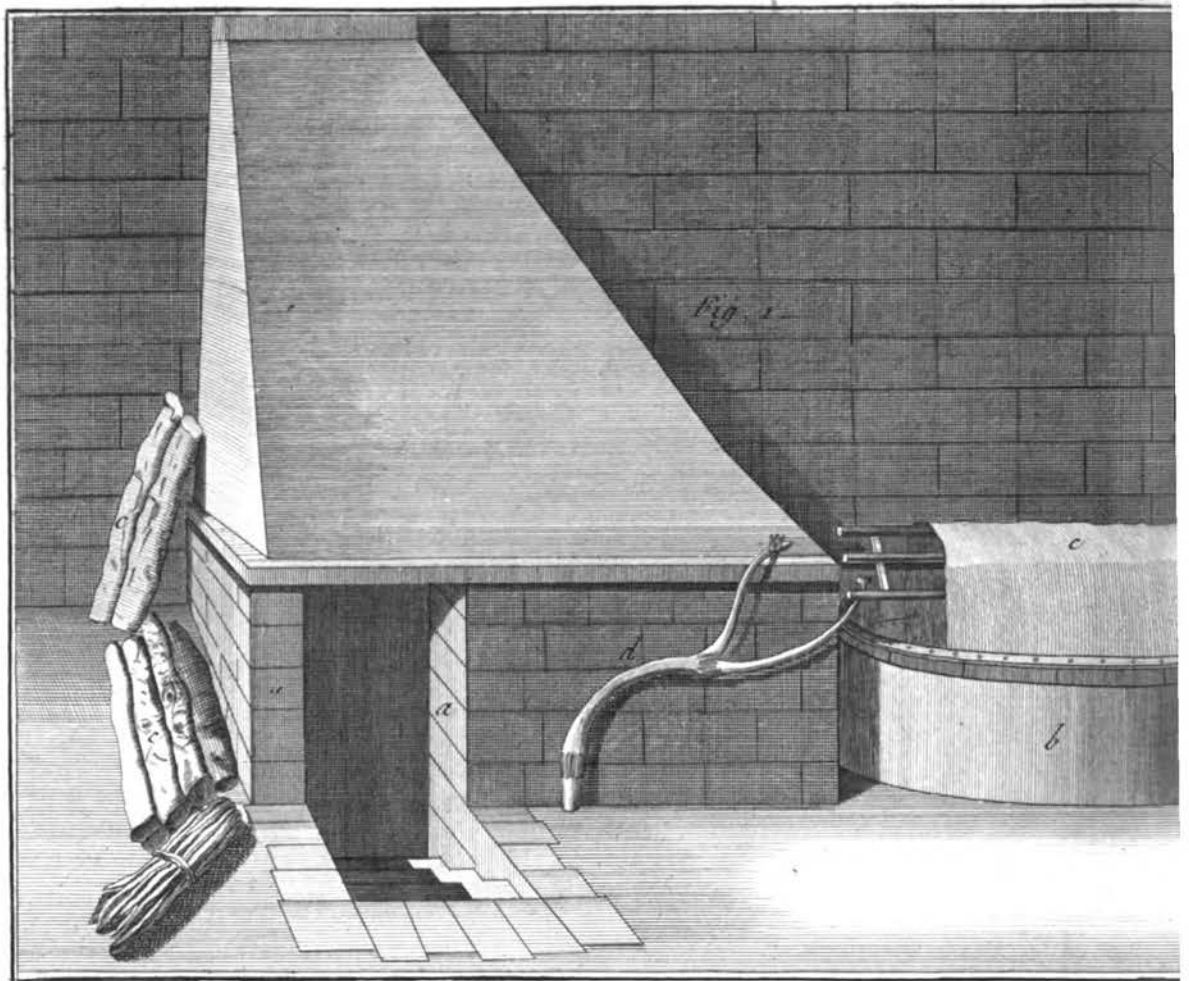
Original from  
UNIVERSIDAD COMPLUTENSE  
DE MADRID



Benard. Doree.

ers et Differentes Operations pour la Teinture des Etoffes

64.

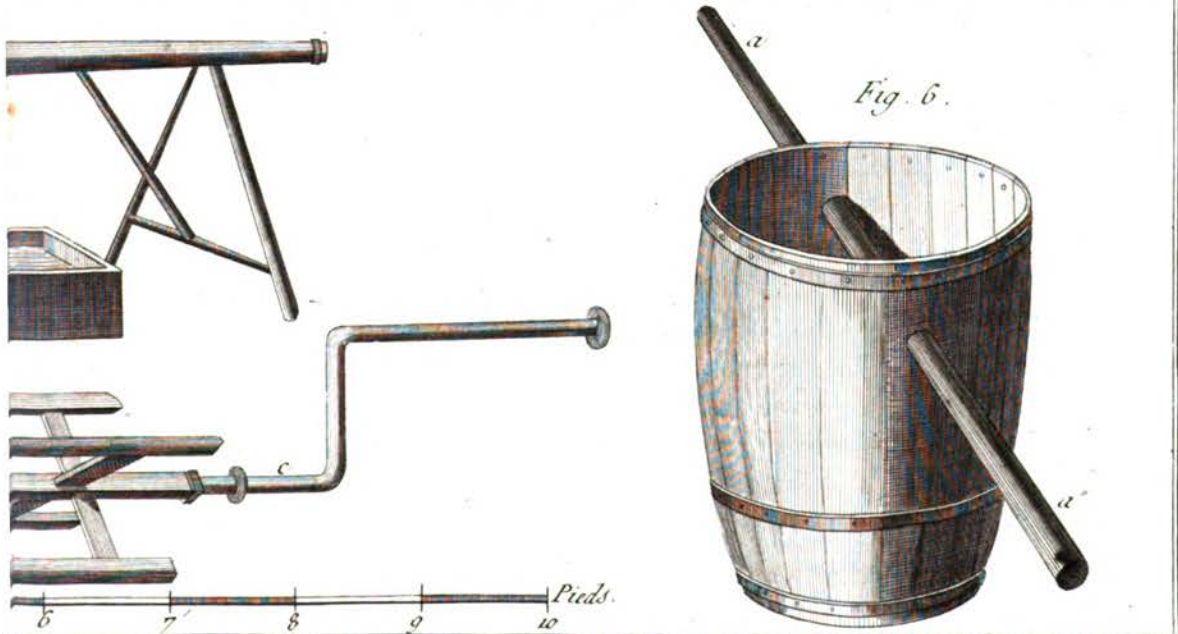
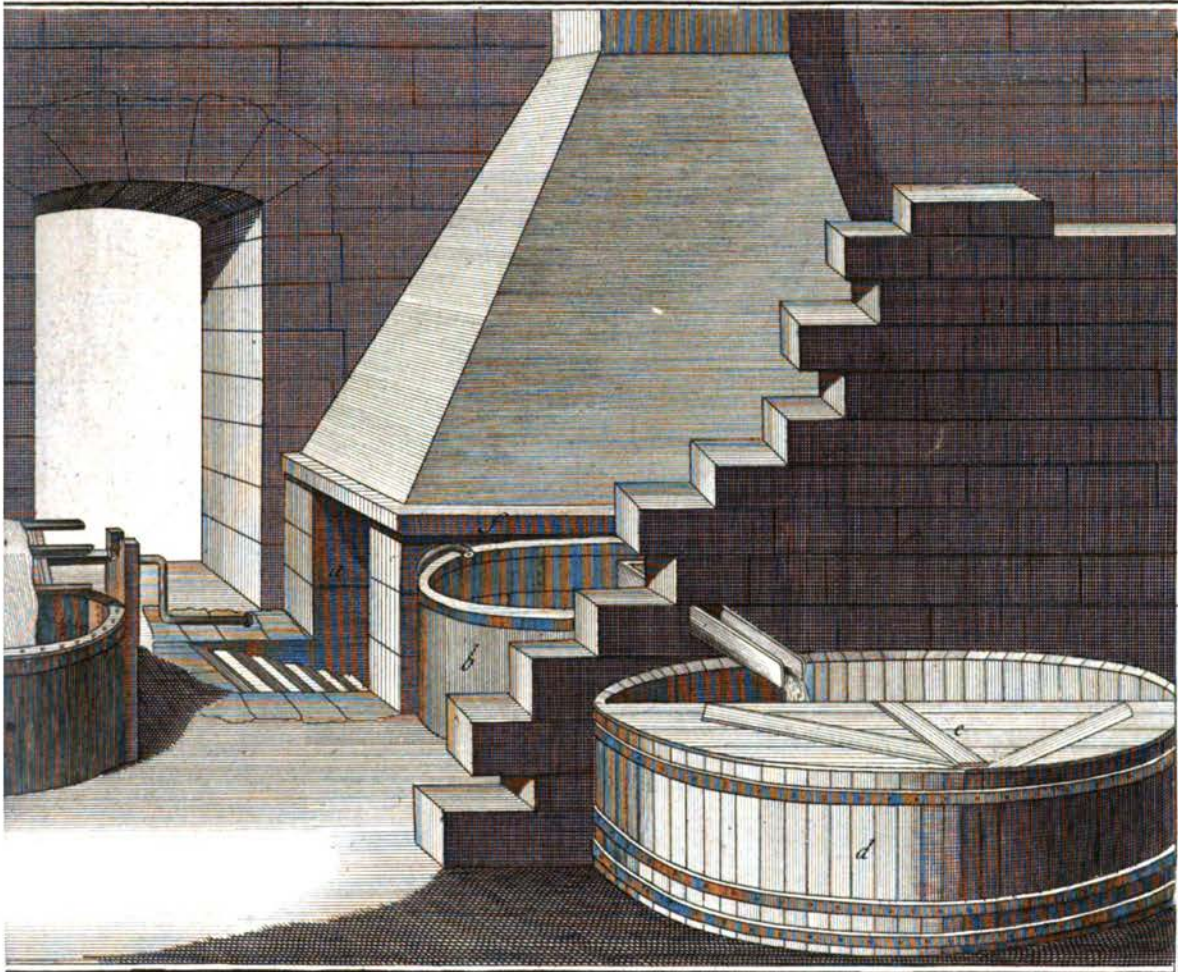


*Teinture des Gobelins, Dispositions*

Original from

UNIVERSIDAD COMPLUTENSE  
DE MADRID

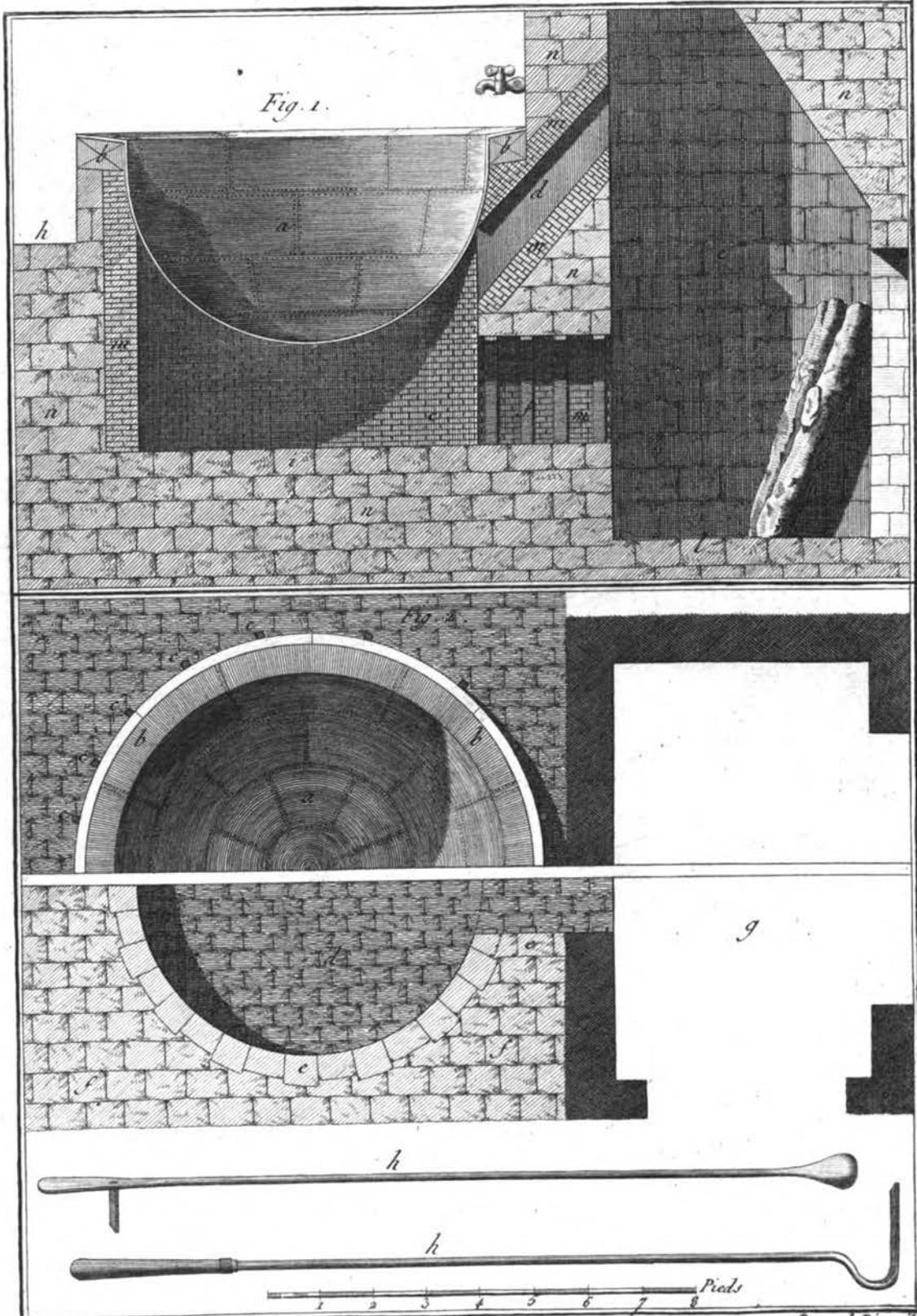
Digitized by Google



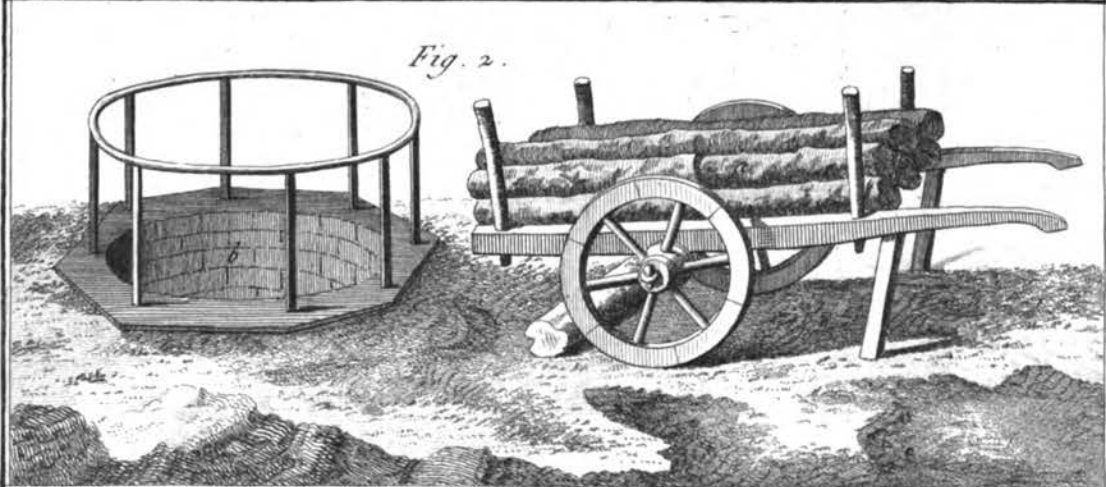
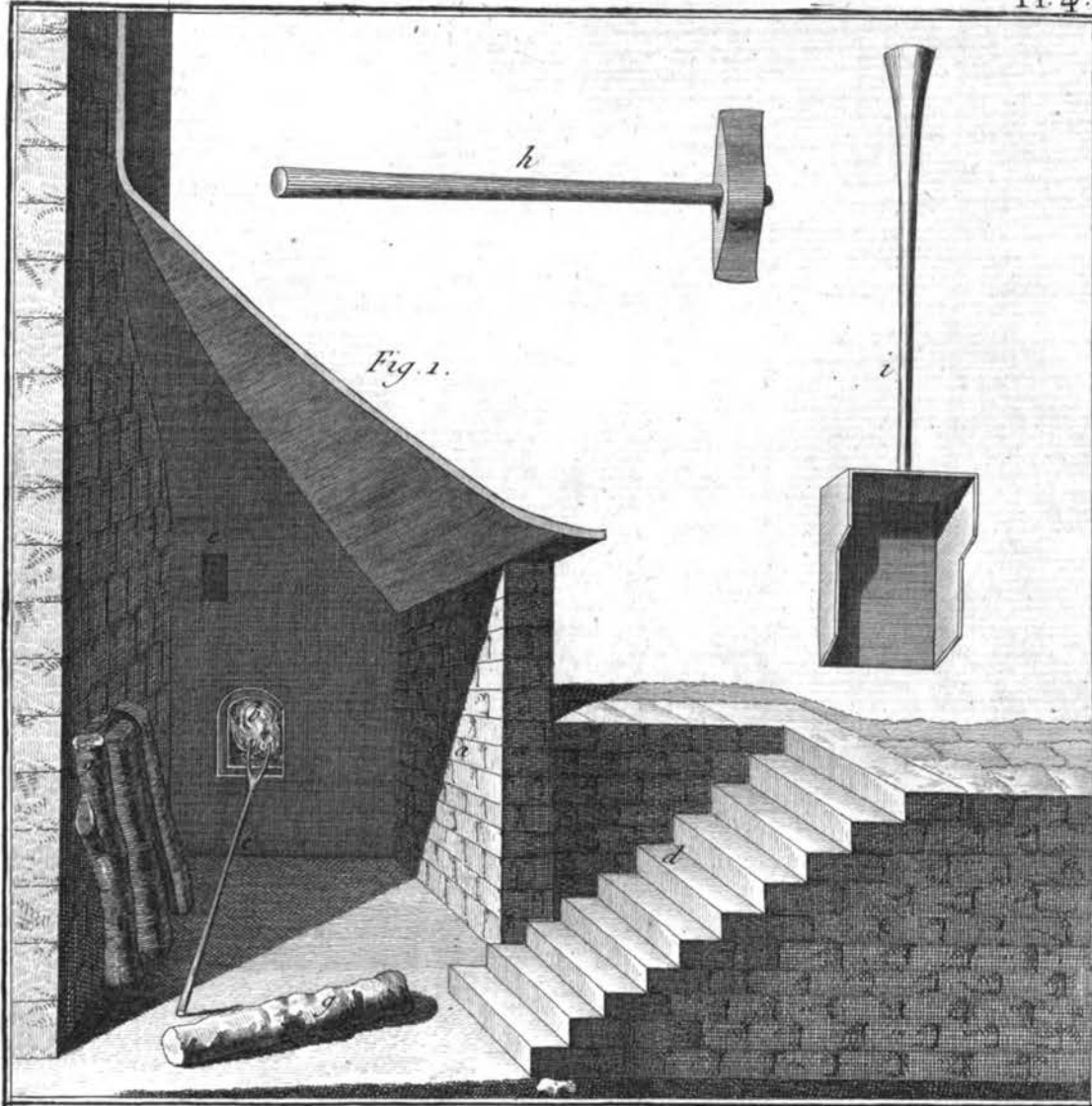
Chaudieres, Entrée des Fourneaux et Ustensiles.

Benard Duxett. 65.



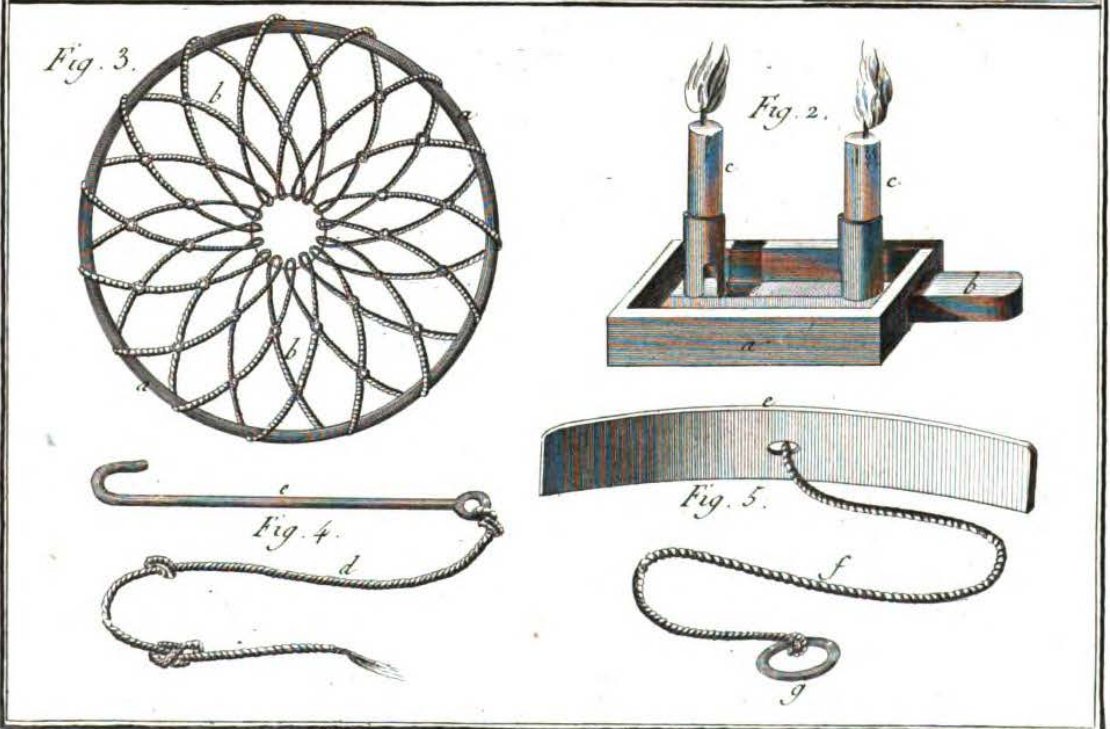
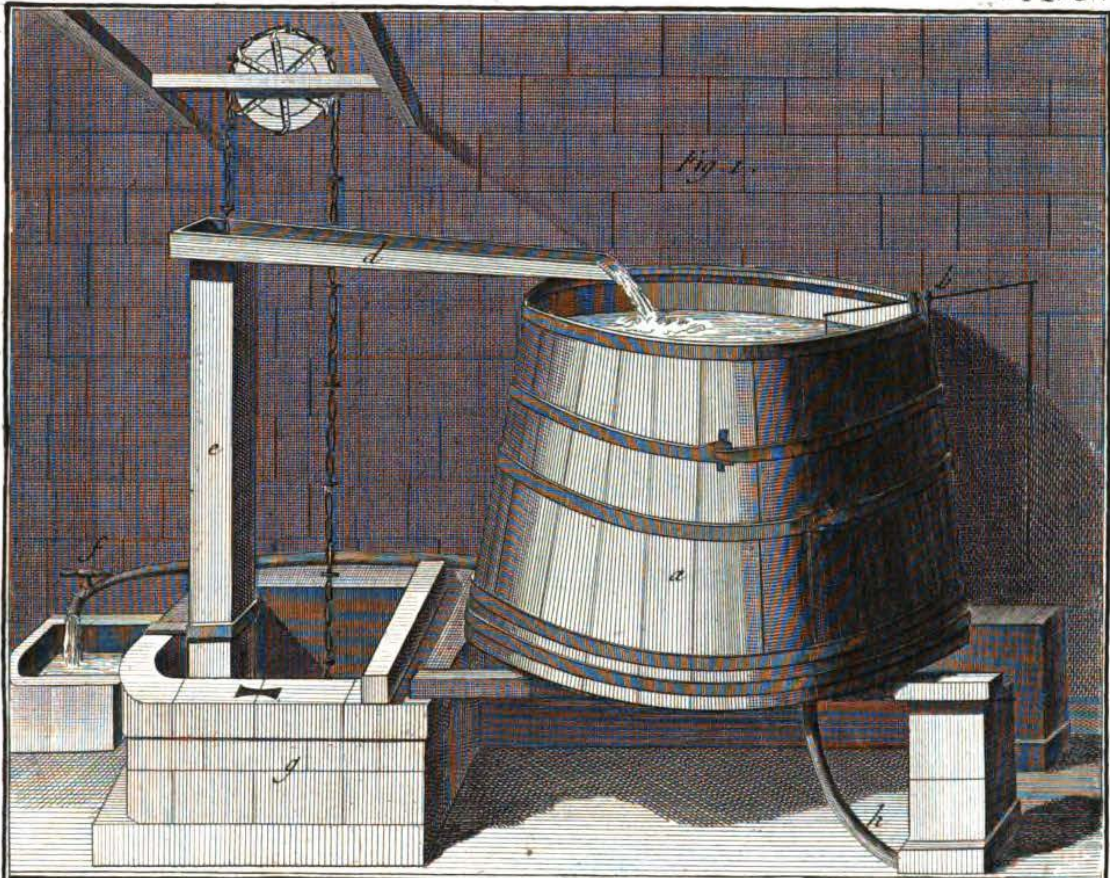


*Teinture des Gobelins, Plans et Coupe d'un Fourneau, et Outils.* 66. *Bernard Dorez del.*



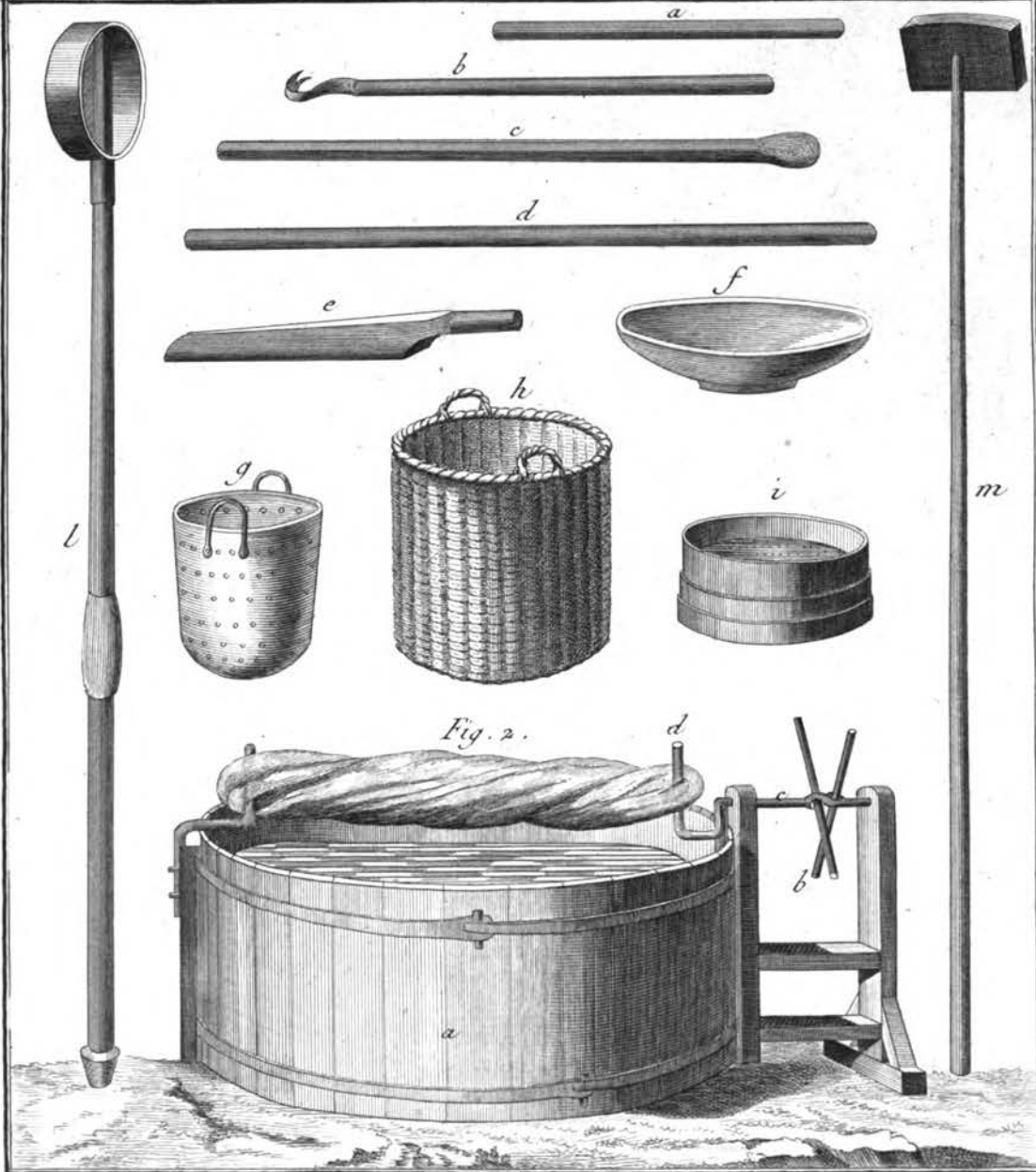
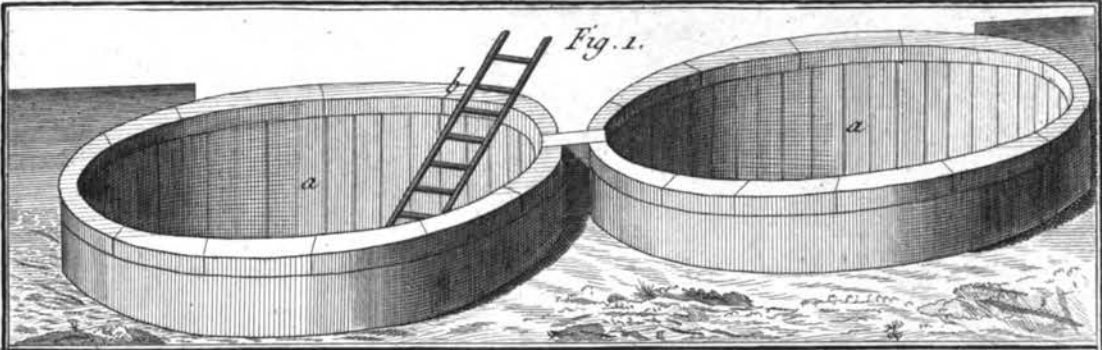
*Teinture des Gobelins, Intérieur d'un Fourneau, Outils &c.*

*Brevet Dorez.*



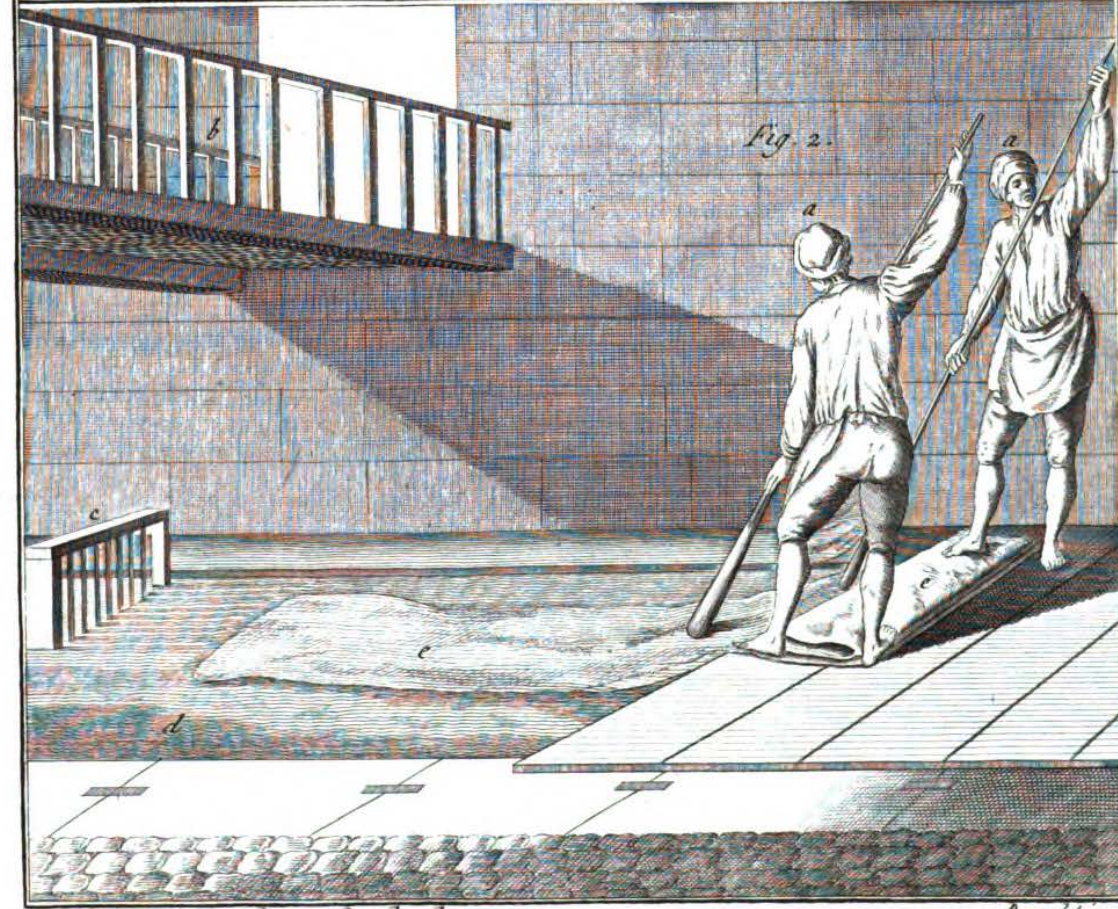
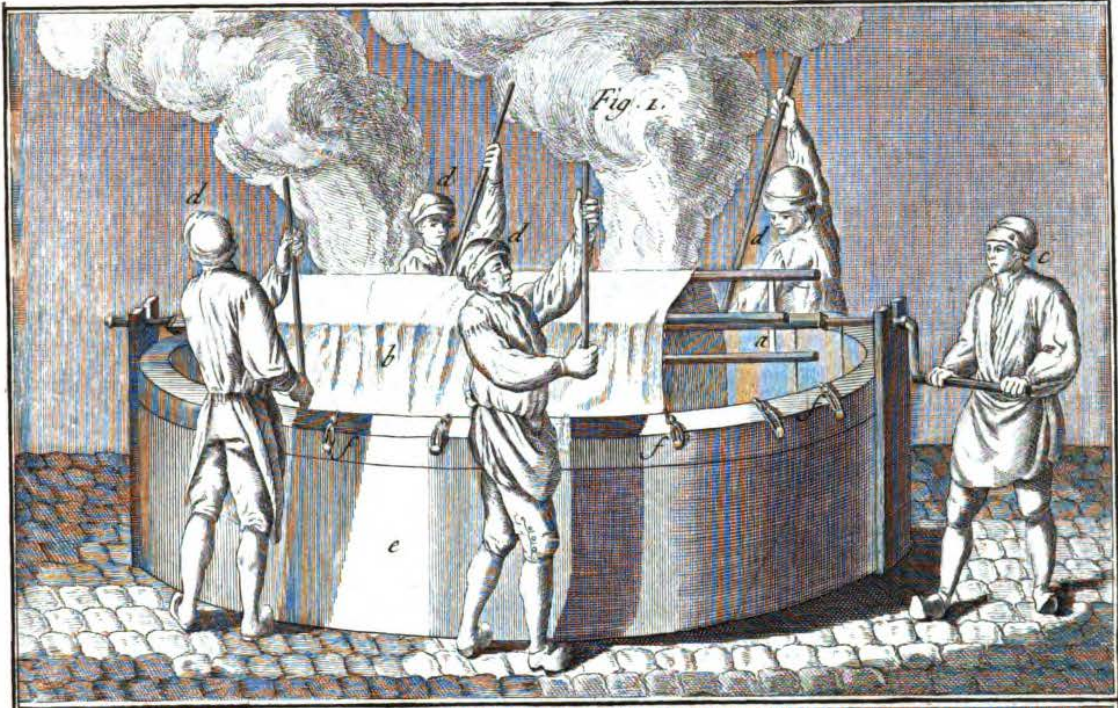
*Teinture des Gobelins*, Bernard Duvoux.  
*Pompe à chapelet pour remplir le petit Reservoir des eaux de la Couronne et de la Fontaine.* 67.  
 Digitized by Google UNIVERSIDAD COMPLUTENSE DE MADRID



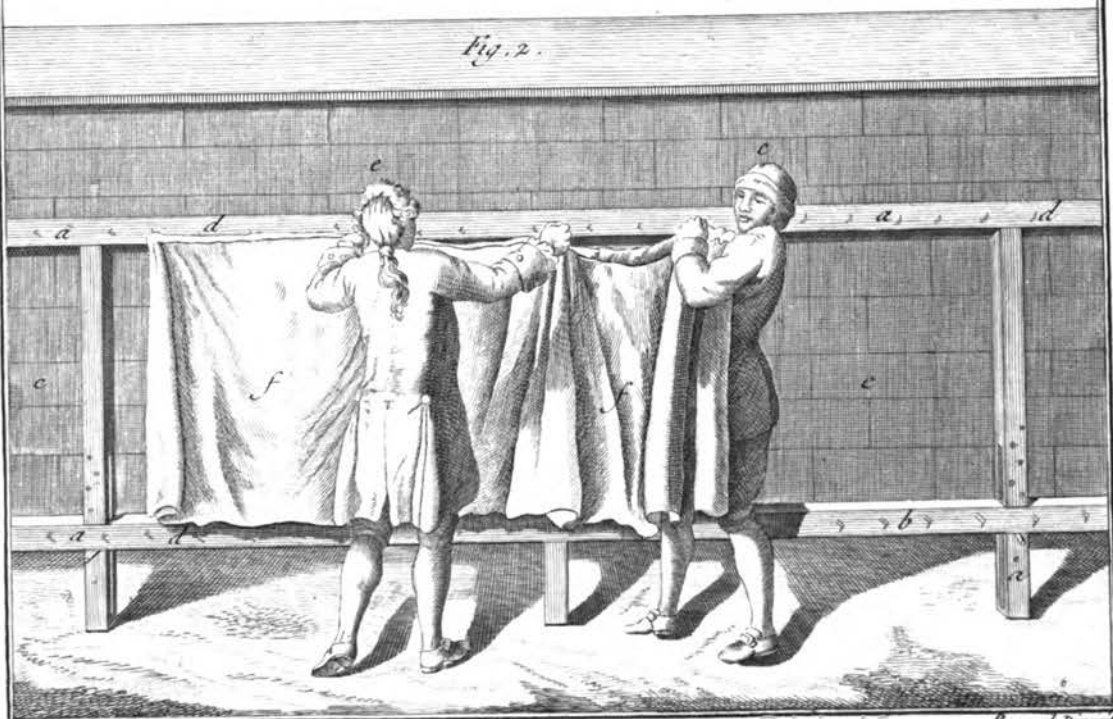
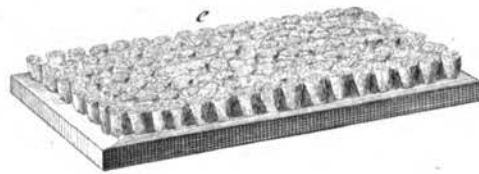
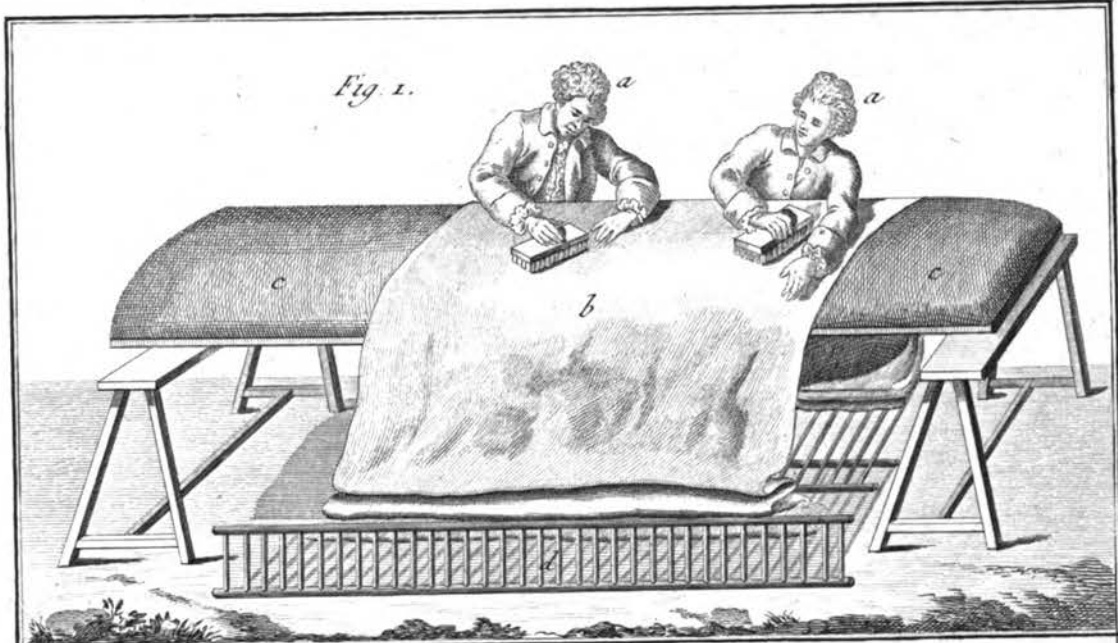


*Teinture des Gobelins, Tordoir, Outils et Cuves.*

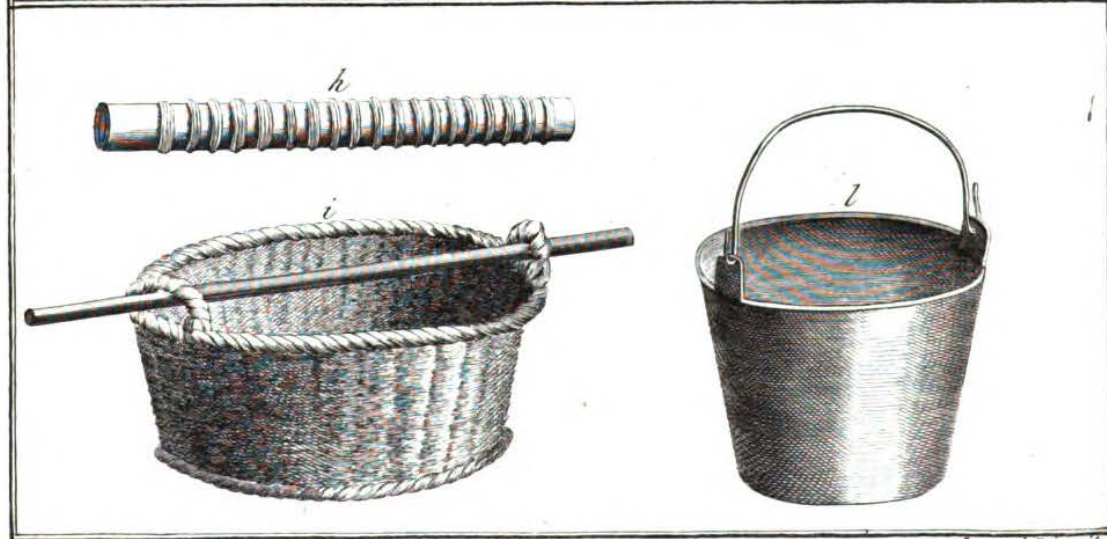
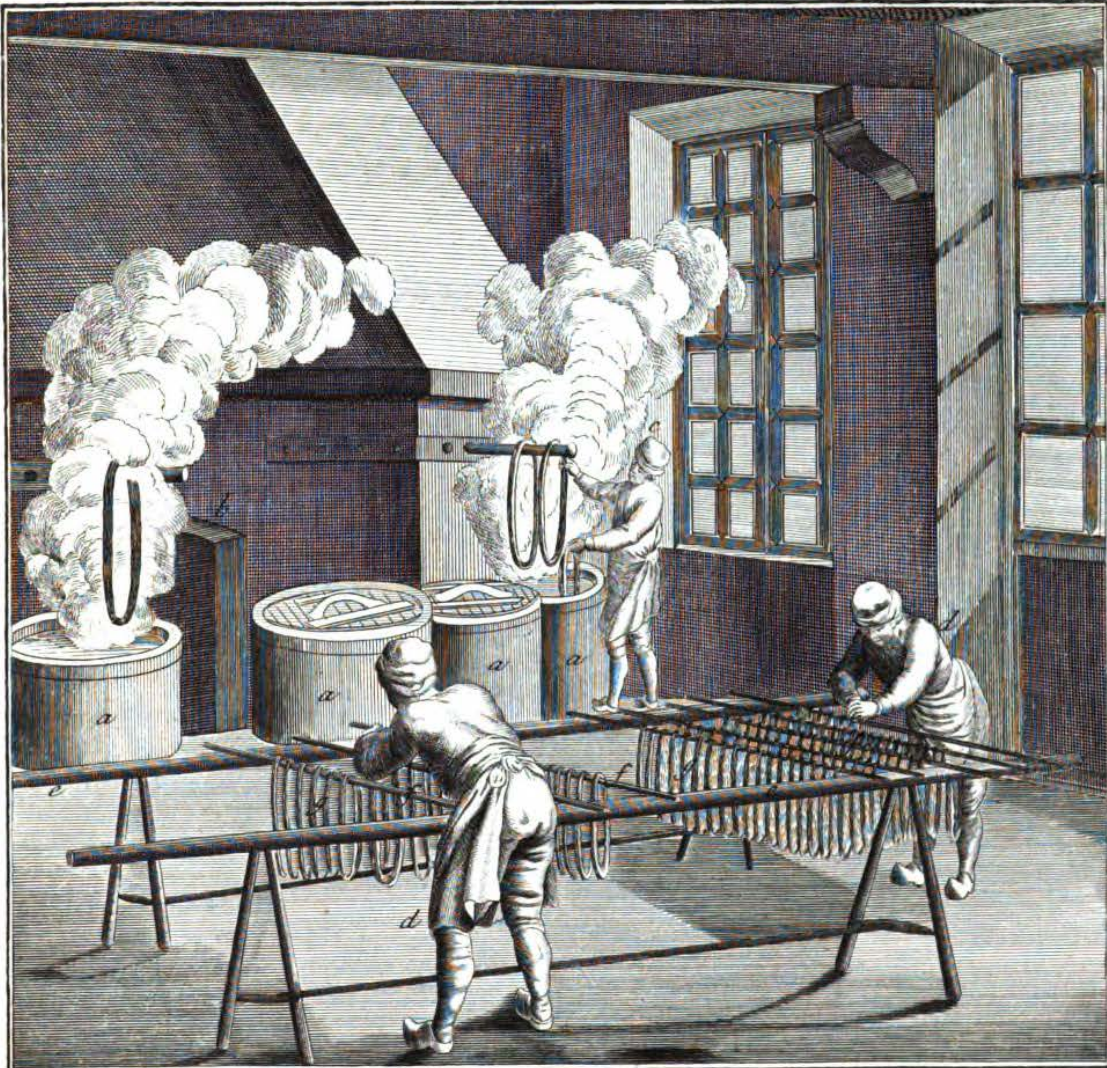
*Bernard Duvicq.*



*Teinture des Gobelins, Service du Tour et Lavage de Riviere*. 68. Benard Juvet del.

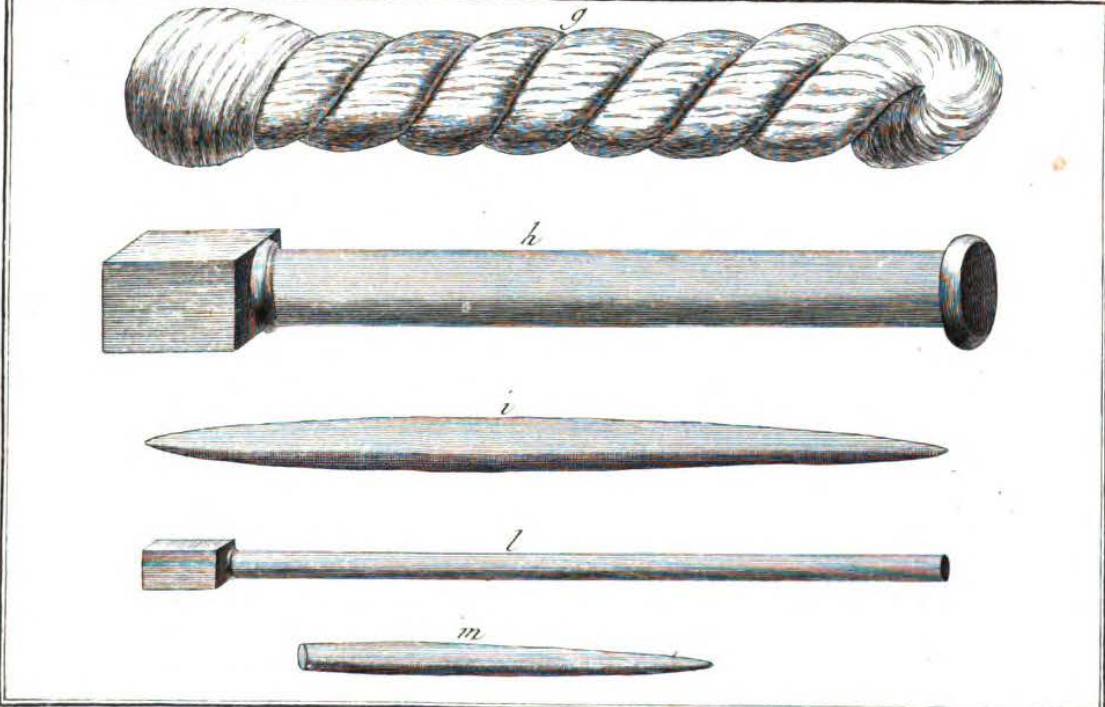
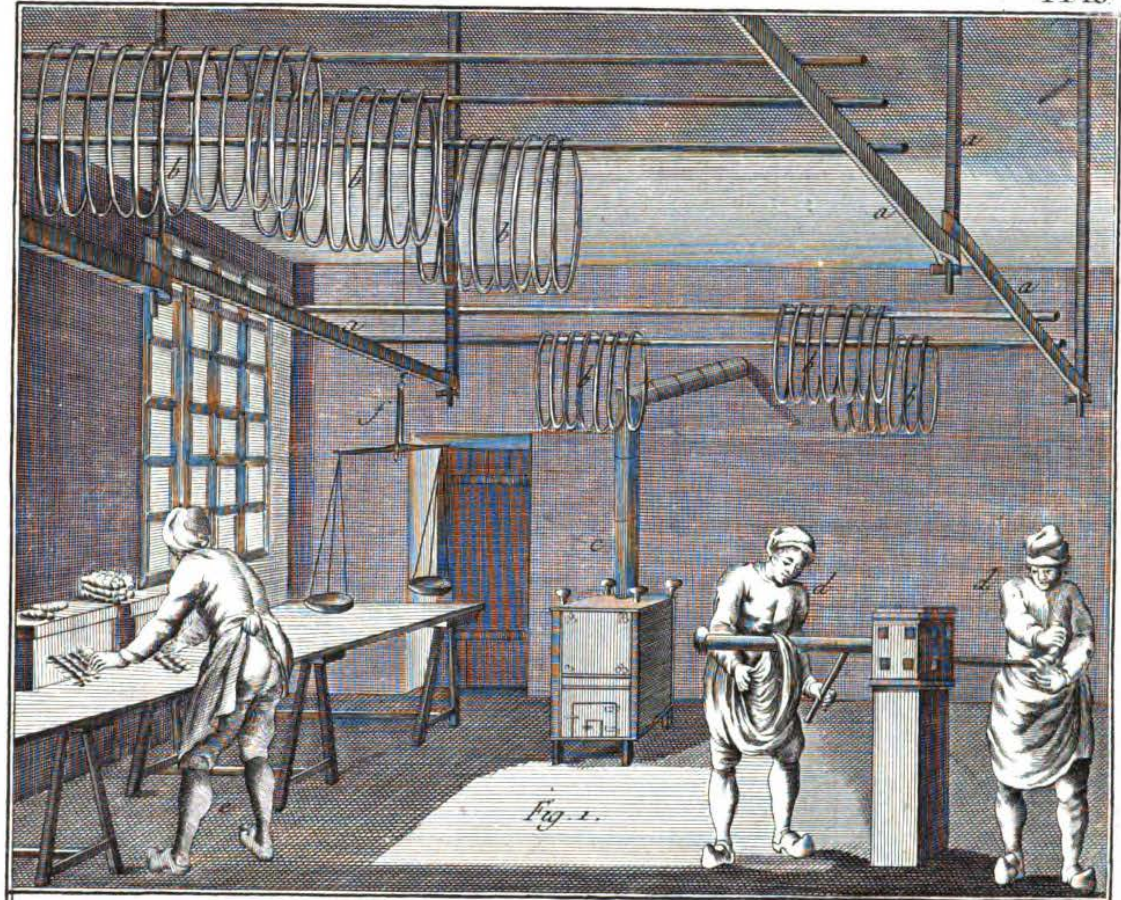


*Teinture des Gobelins, Service du Couchoir et le Séchoir*  
Original from *Bernard Dorez*  
UNIVERSIDAD COMPLUTENSE DE MADRID



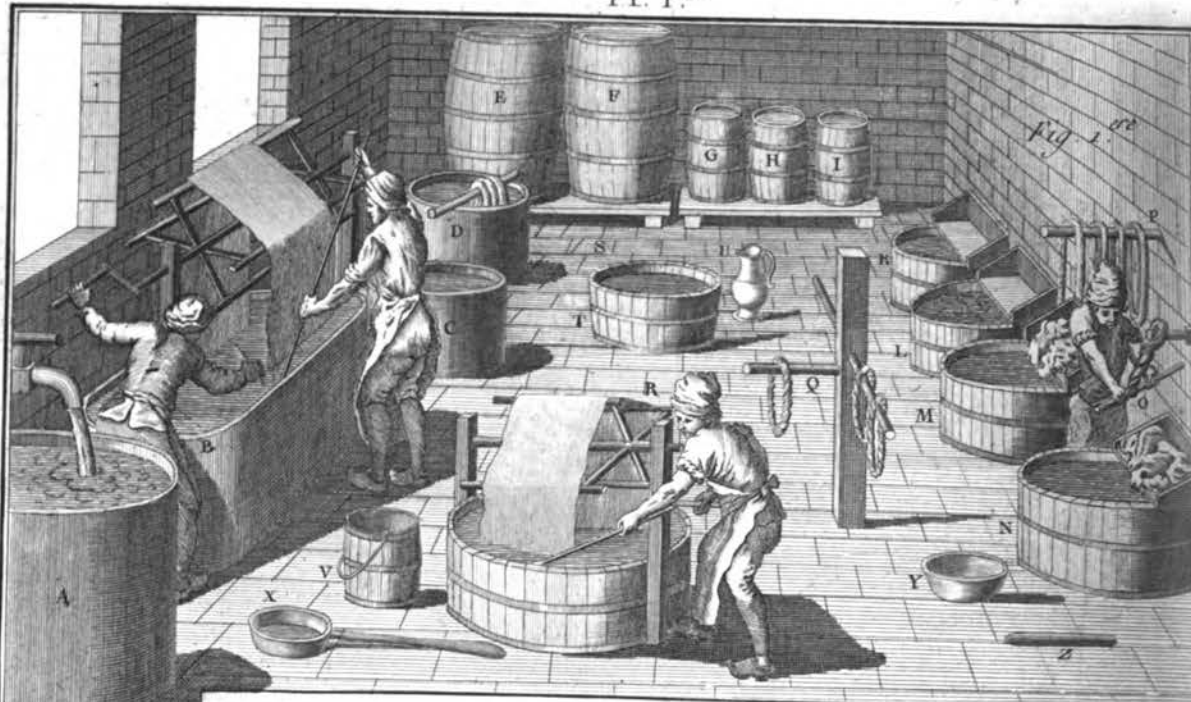
*Teinture des Gobelins, Intérieur de l'Atelier de Teinture de Laines et Soies.* Bernard Duret.



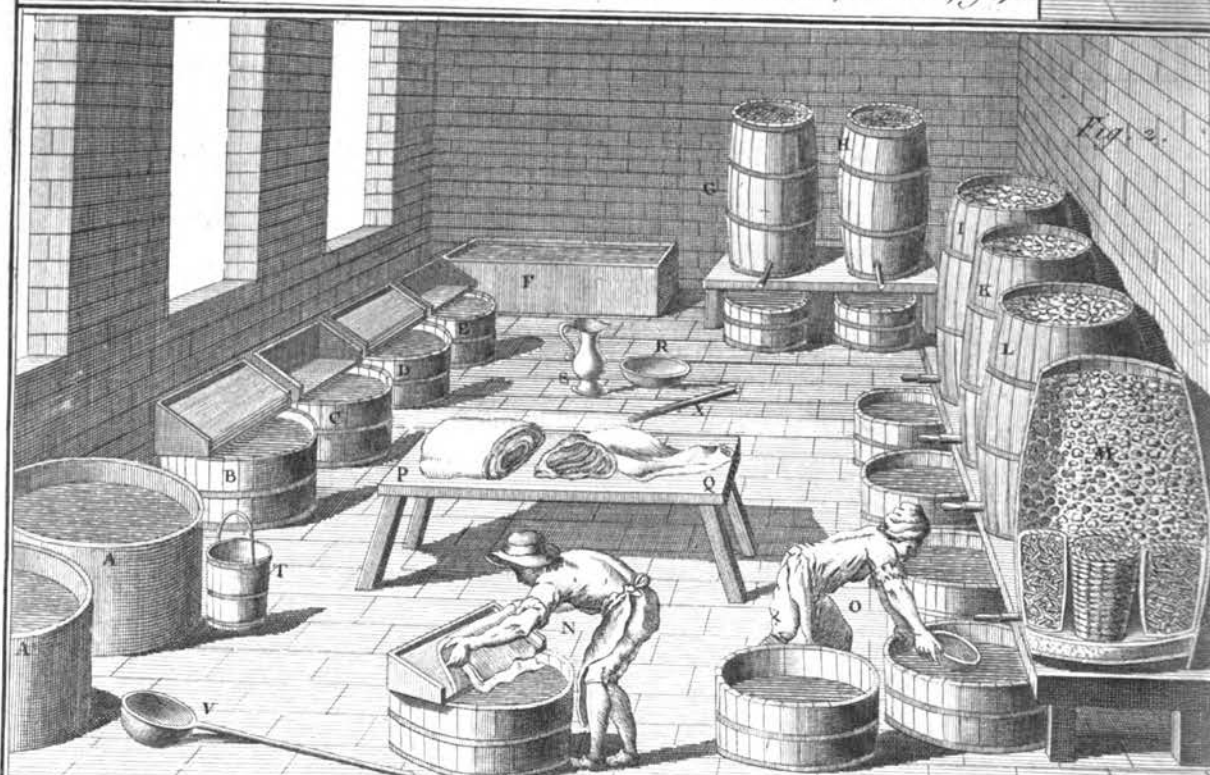


*Teinture des Gobelins, Atelier du Sechoir.*

*Bernard Dorez del.*

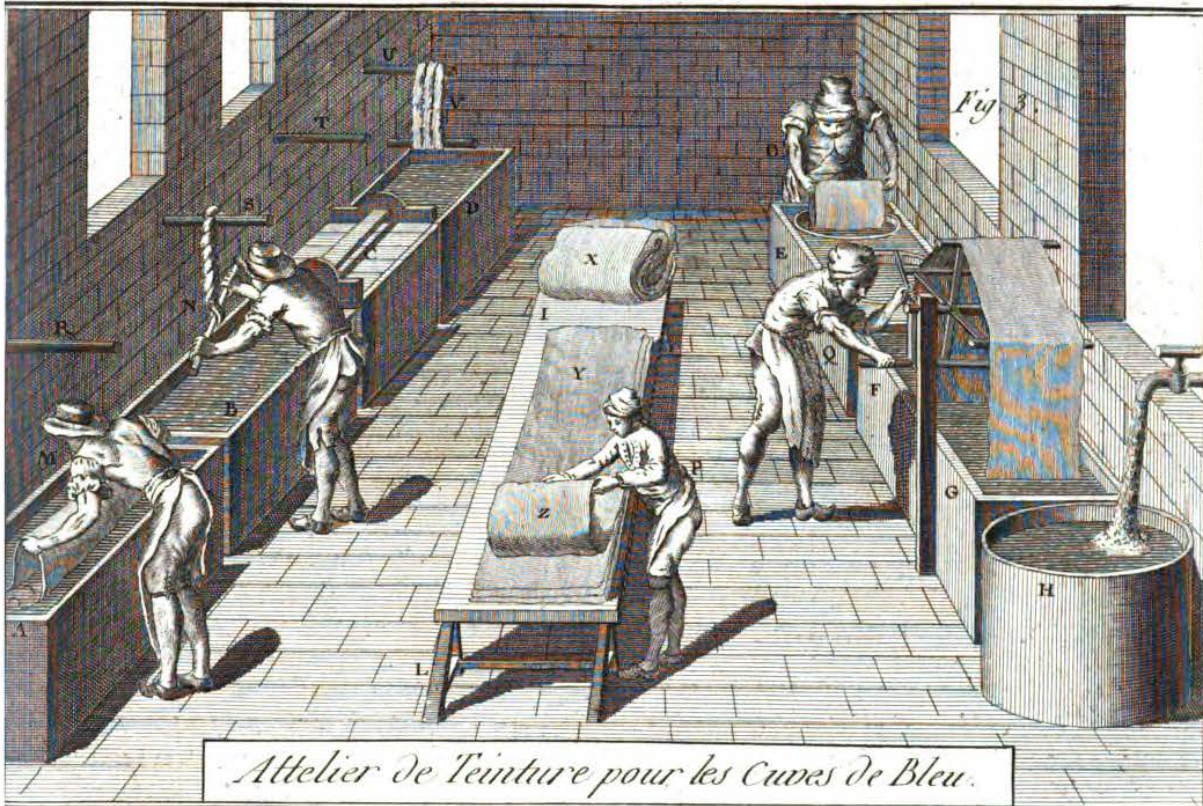


*Atelier de Teinture pour les Couleurs ordinaires, les Garençages, &c*

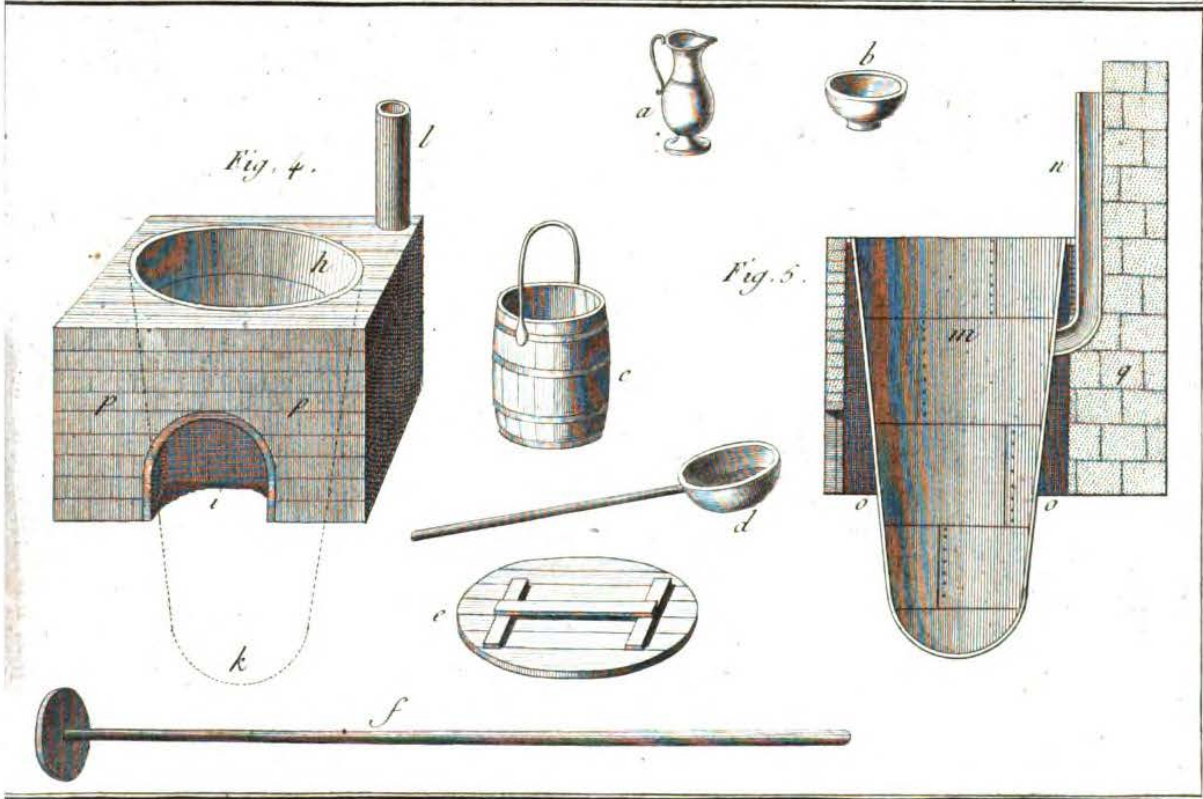


*Atelier de Teinture pour les Tones de Noir.*

*Teinture de Fil et Coton*



*Atelier de Teinture pour les Cuves de Bleu.*



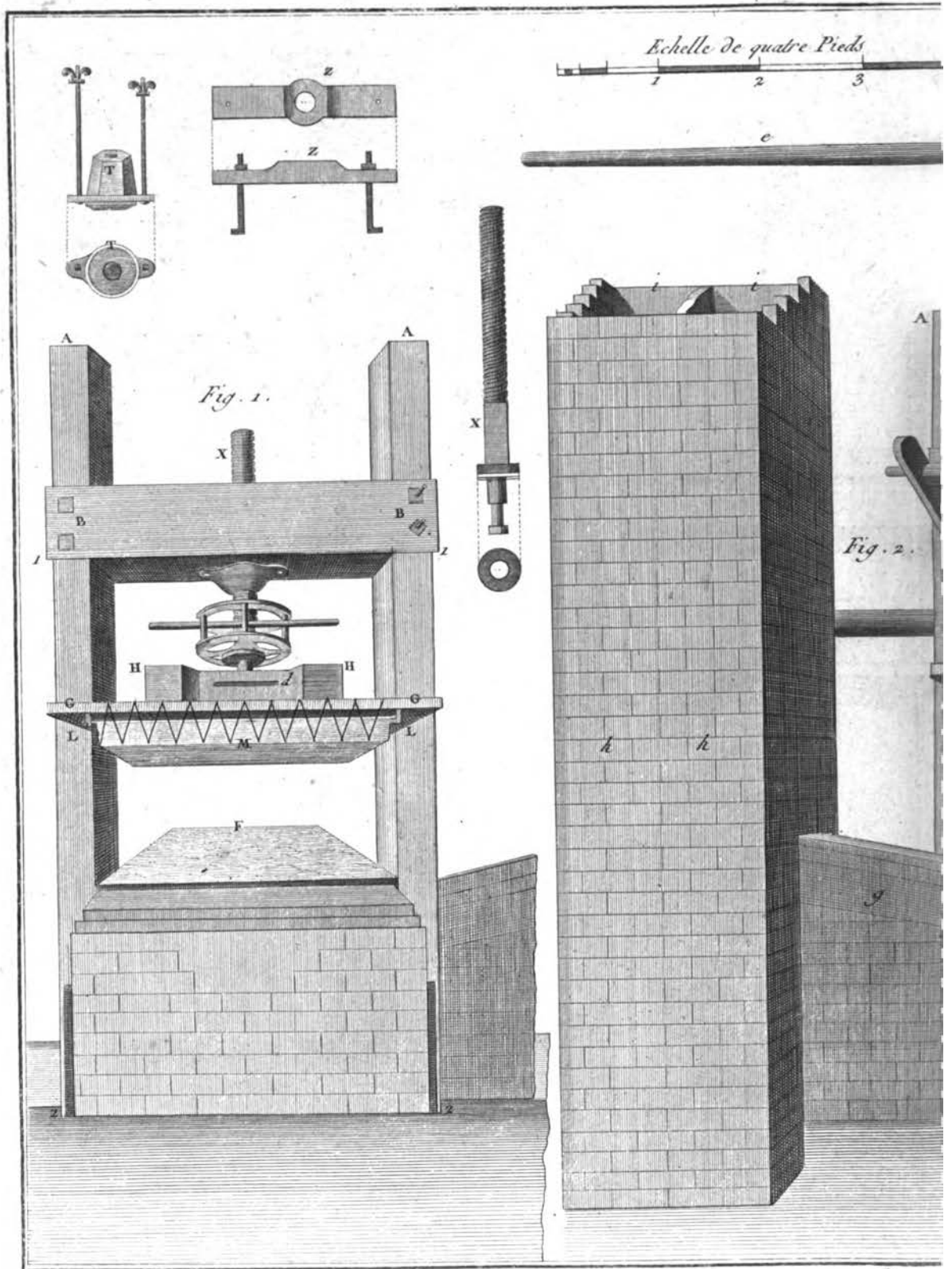
*Fig. 4.*

*Fig. 5.*

*Bernard Duvet.*

*Différens Ateliers et Ustensiles.*  
Digitized by Google

Original from  
UNIVERSIDAD COMPLUTENSE  
DE MADRID



*Impression des L.*

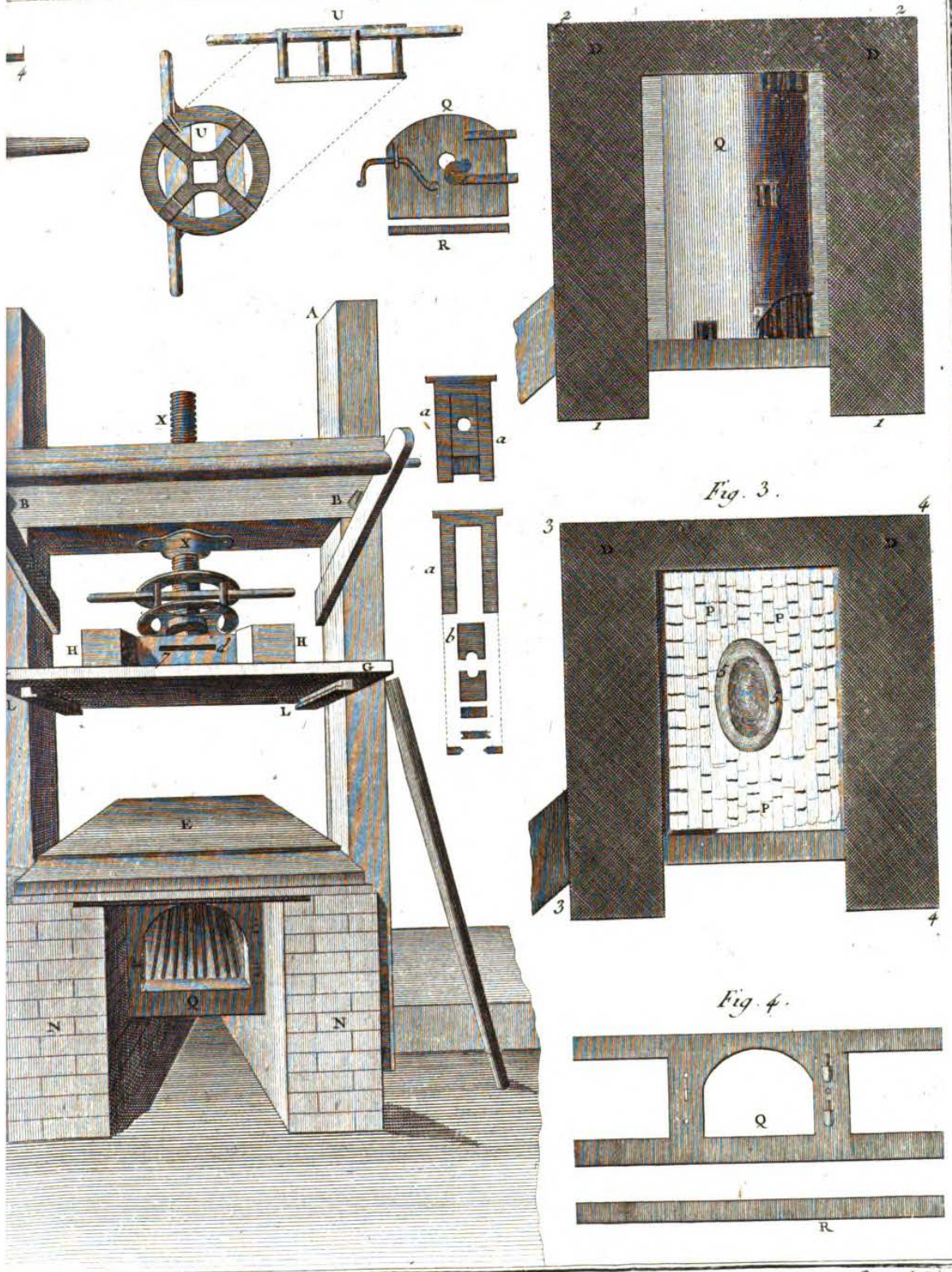


Fig. 3.

Fig. 4.

Benard Doreuil

*toffes en Laine.*

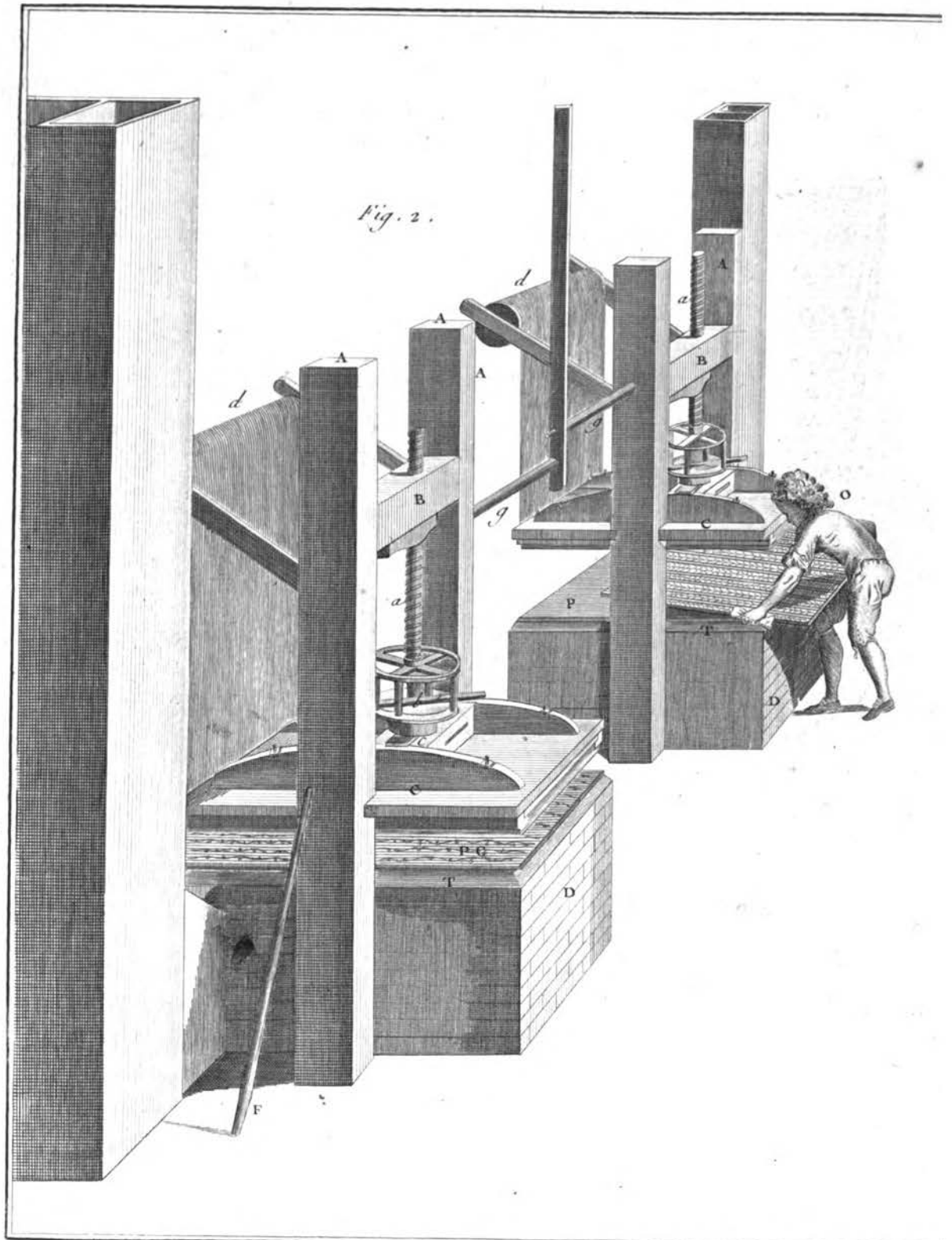
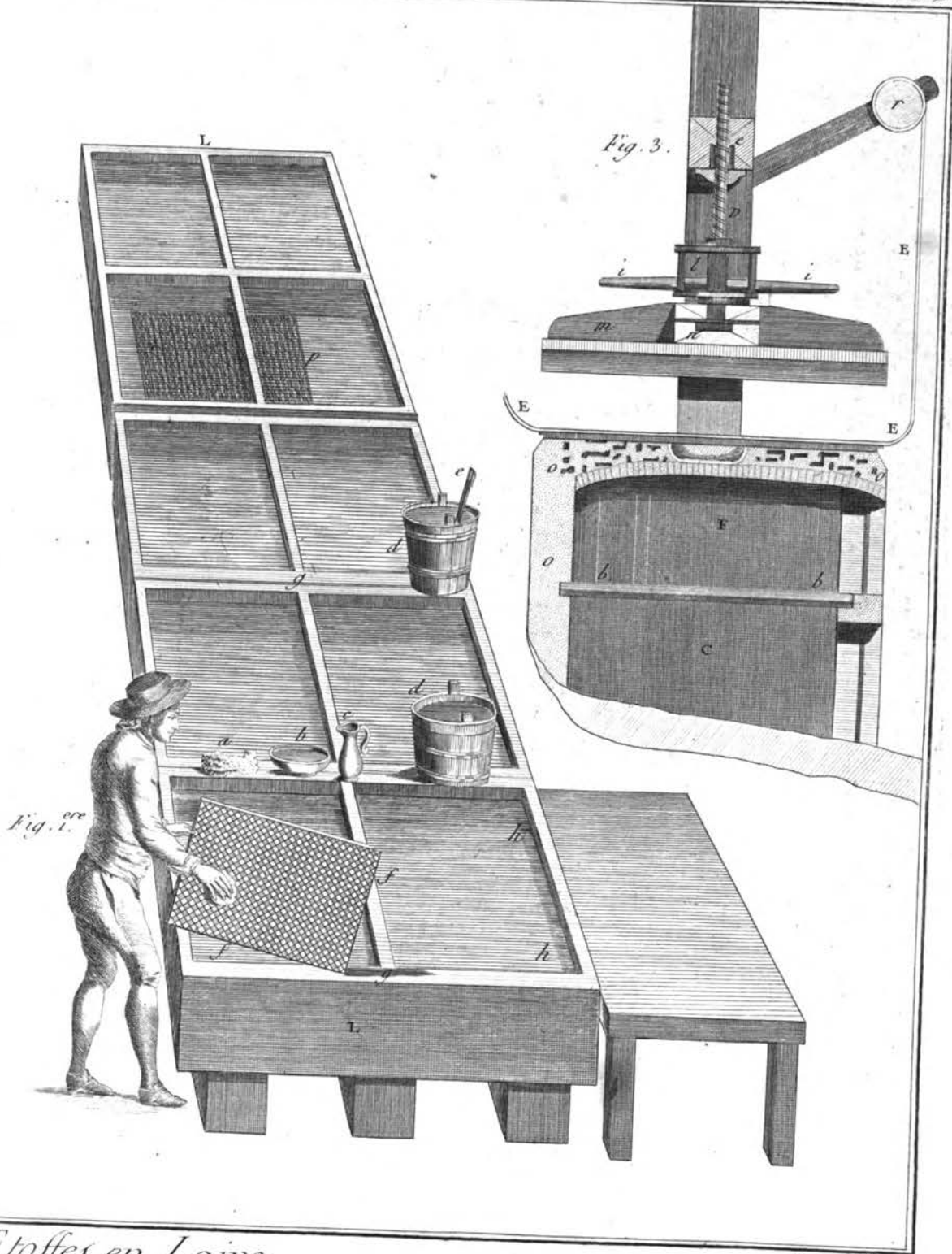


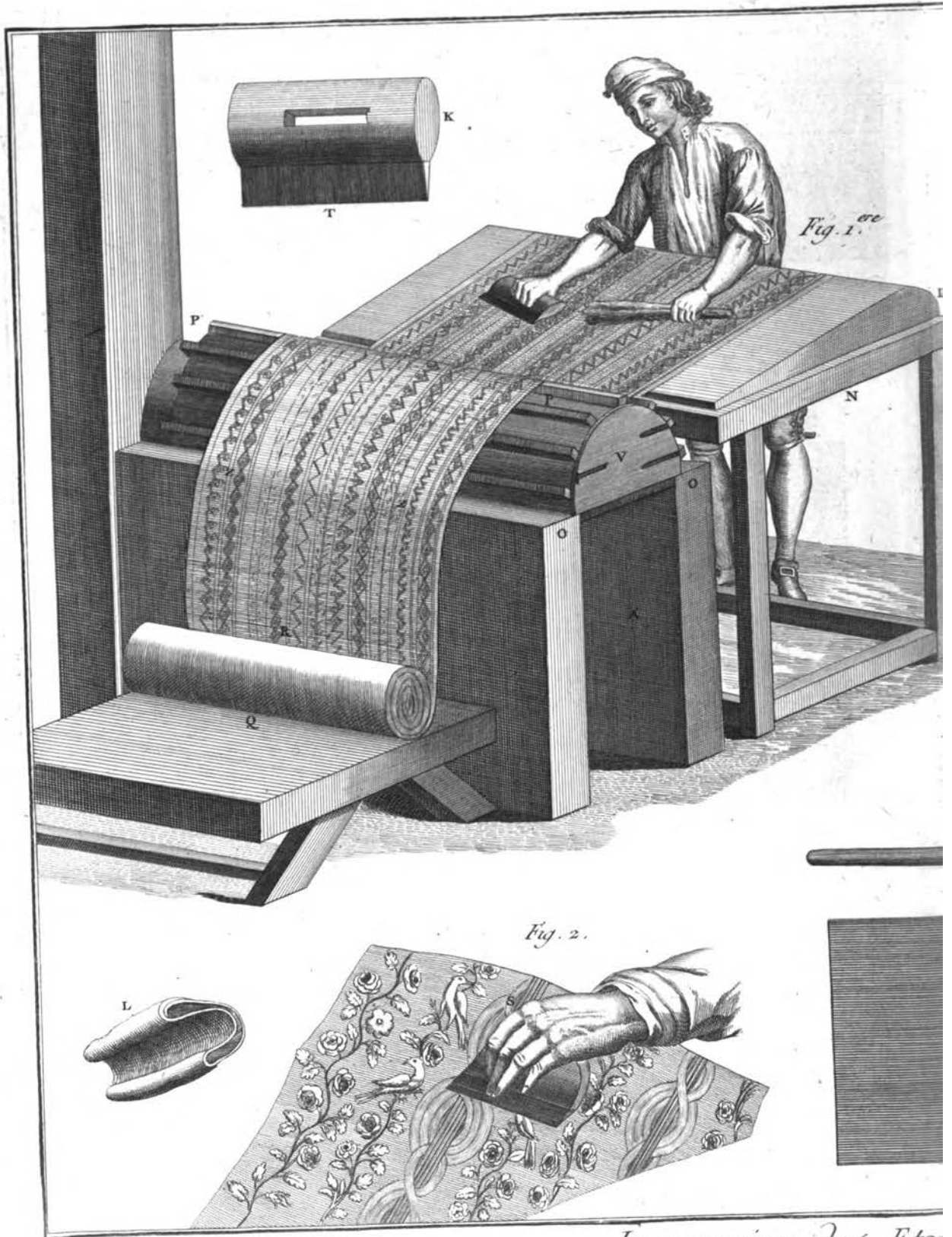
Fig. 2.

*Impression des*



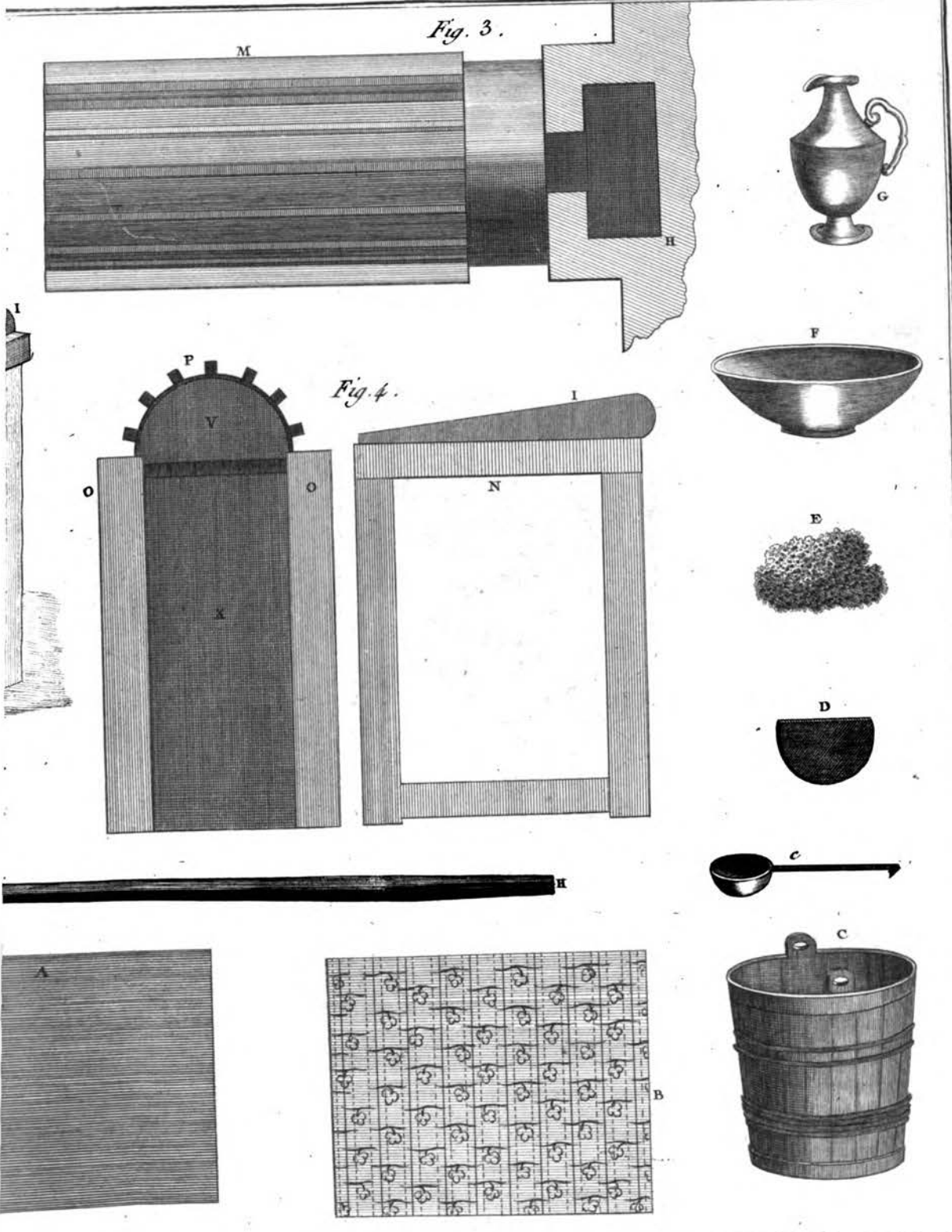
*Etoffes en Laine.*

*Bernard Dorez.*



*Impression des Etois*

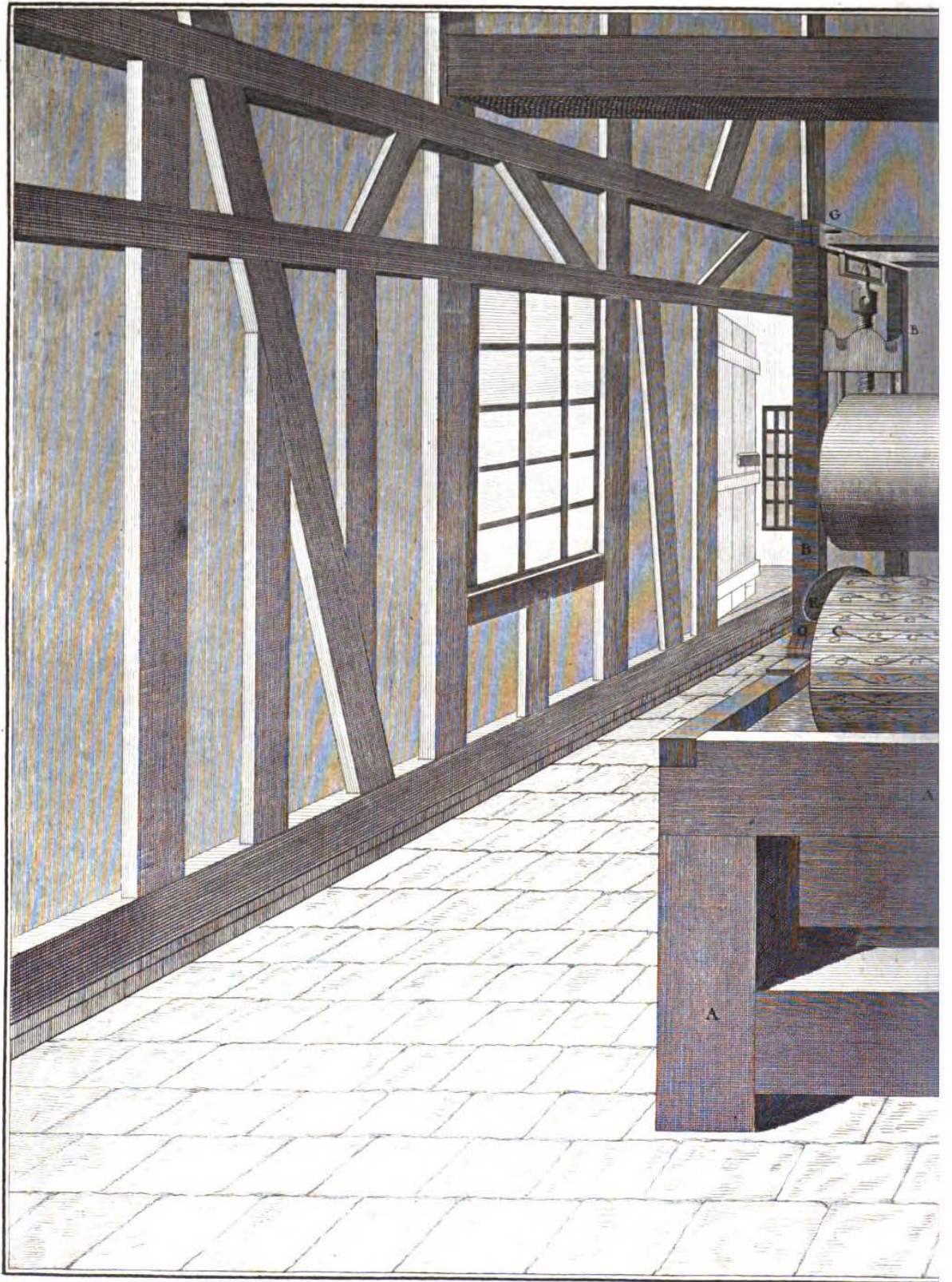




Bonard Dirault.

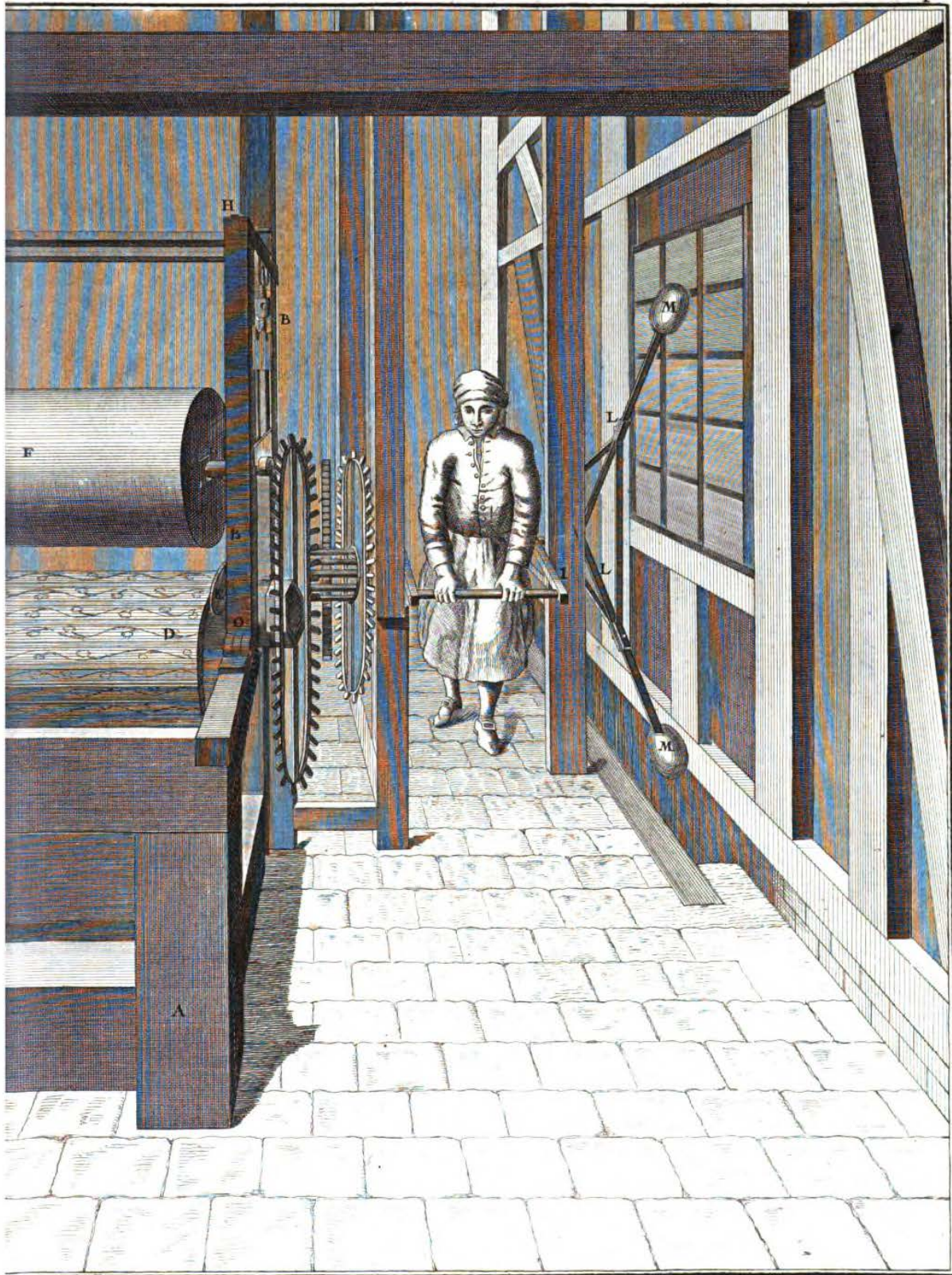
*Fes en Laines.*

73.



Digitized by Google

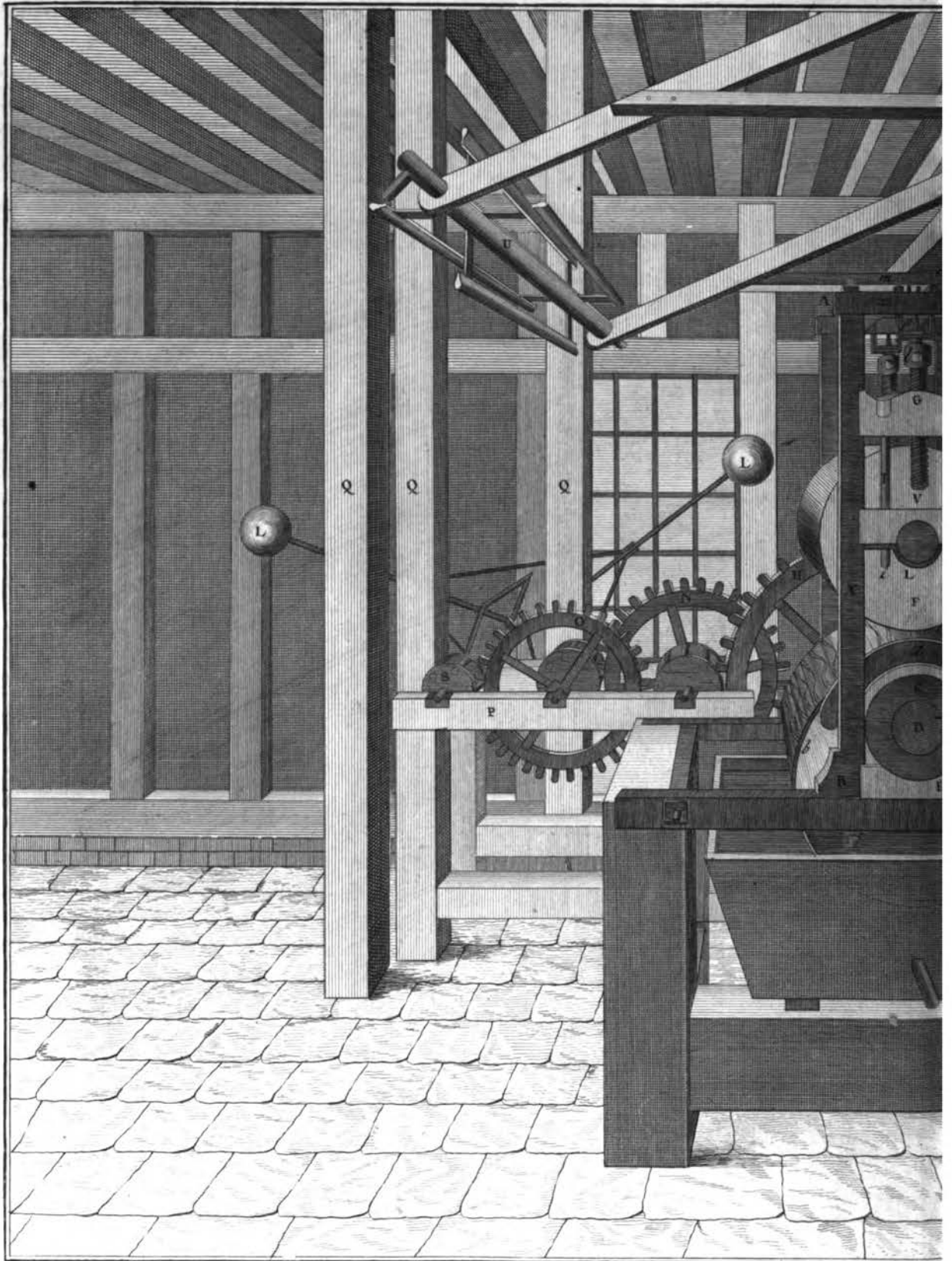
Original from *Impression des*  
UNIVERSIDAD COMPLUTENSE  
DE MADRID



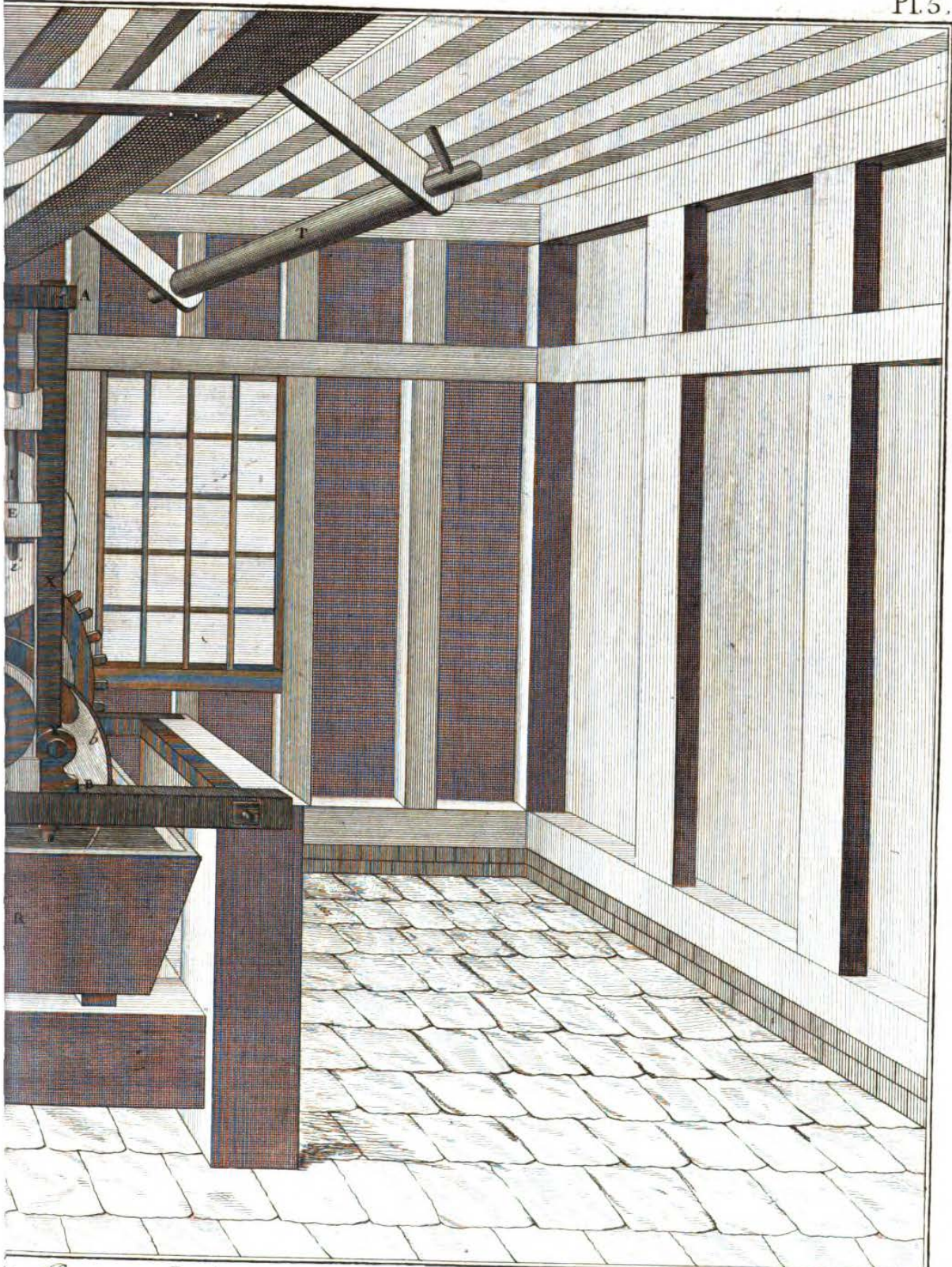
*Etoffes en Laine.*

*Bernard Dürer*

74.



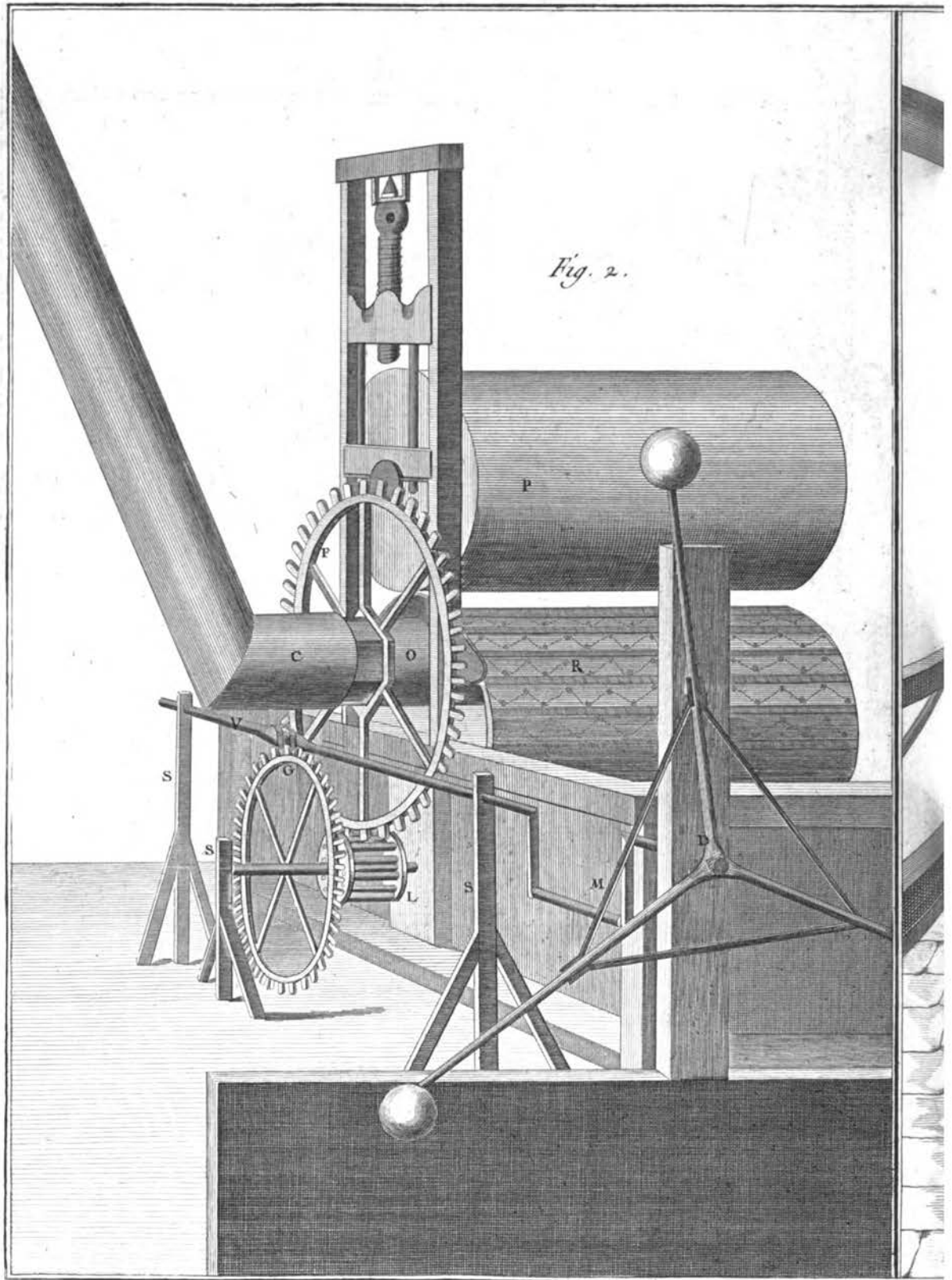
*Impression des Ecu*



*toffes en Laine.*

Benard Duvet

75



*Impression des*

Digitized by Google

Original from  
UNIVERSIDAD COMPLUTENSE  
DE MADRID

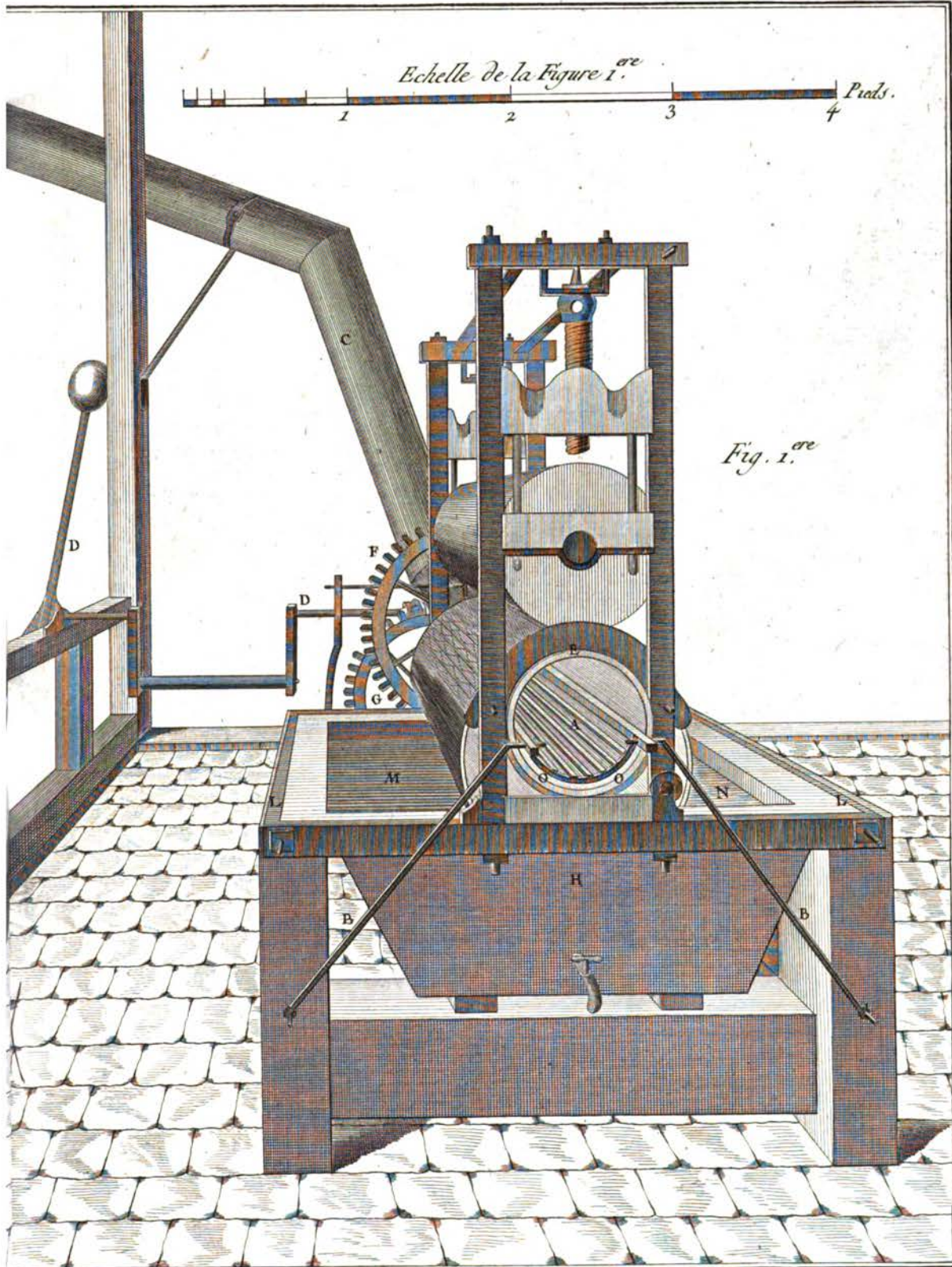
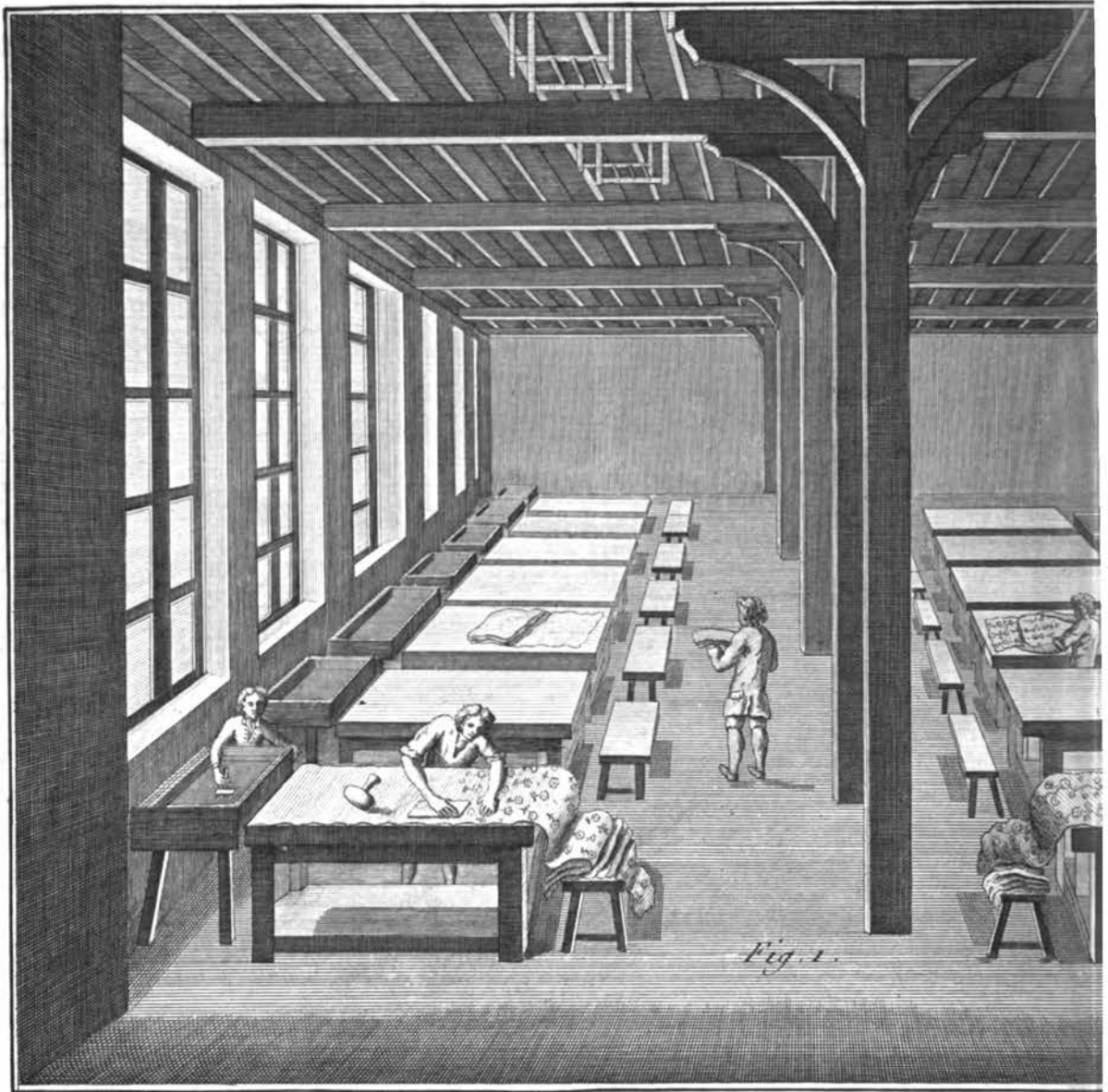


Fig. 1.ª

*Etoffes en Laine.*

Benard Dřexit

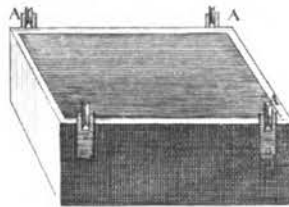


*Fig. 1.*

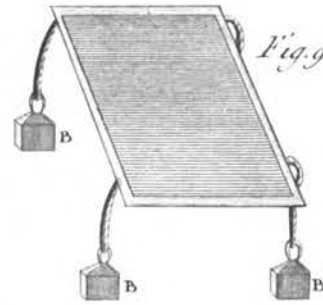
*Fig. 7.*



*Fig. 8.*



*Fig. 9.*



*Fig.*



*Atelier et Impres...*





Fig. 4.



Fig. 5.



Fig. 3.



Fig. 13.



Fig. 2.

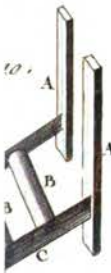
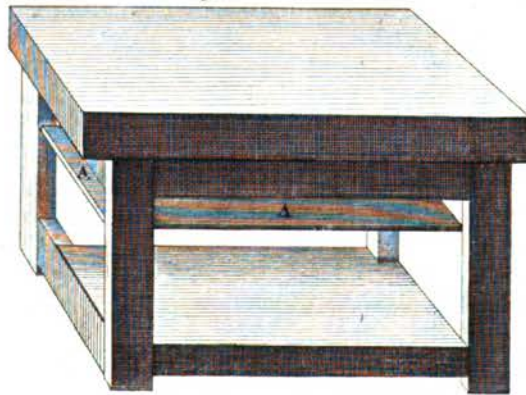


Fig. 11.

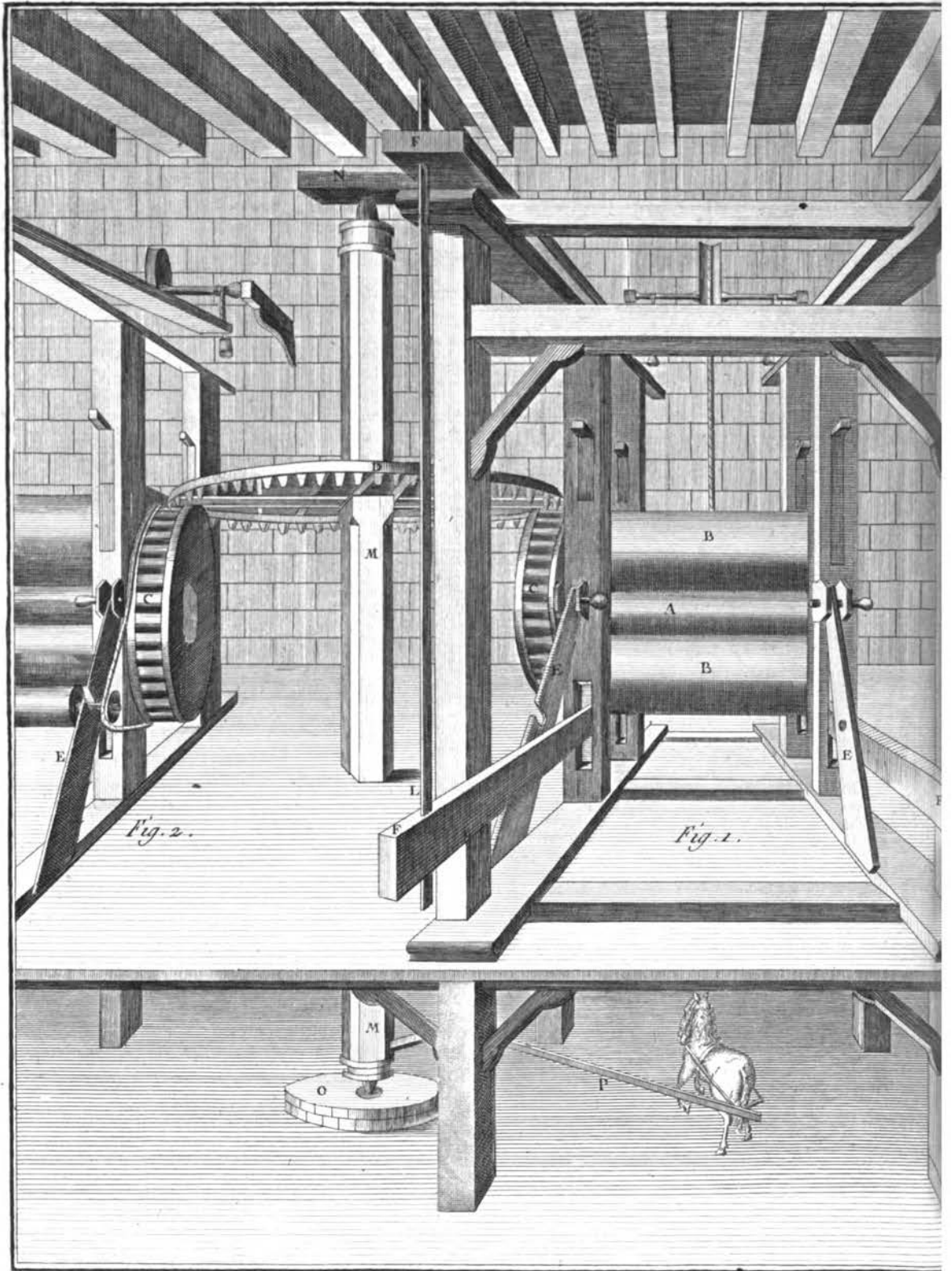


Fig. 12.



ion des Toiles Peintes.

Benoist Durast



*Impression des Toiles Peintes*

Digitized by Google

Original from  
UNIVERSIDAD COMPLUTENSE  
DE MADRID

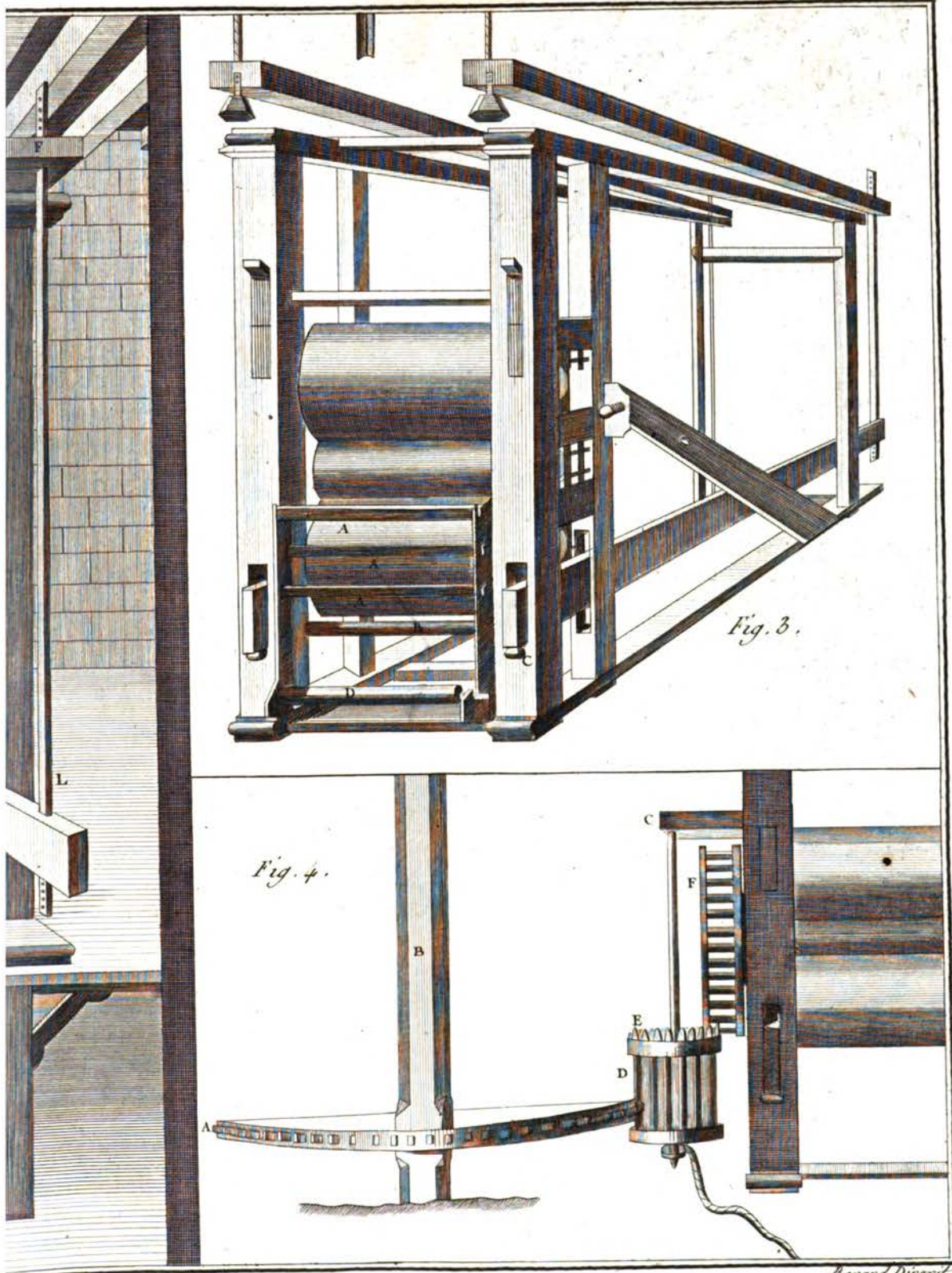
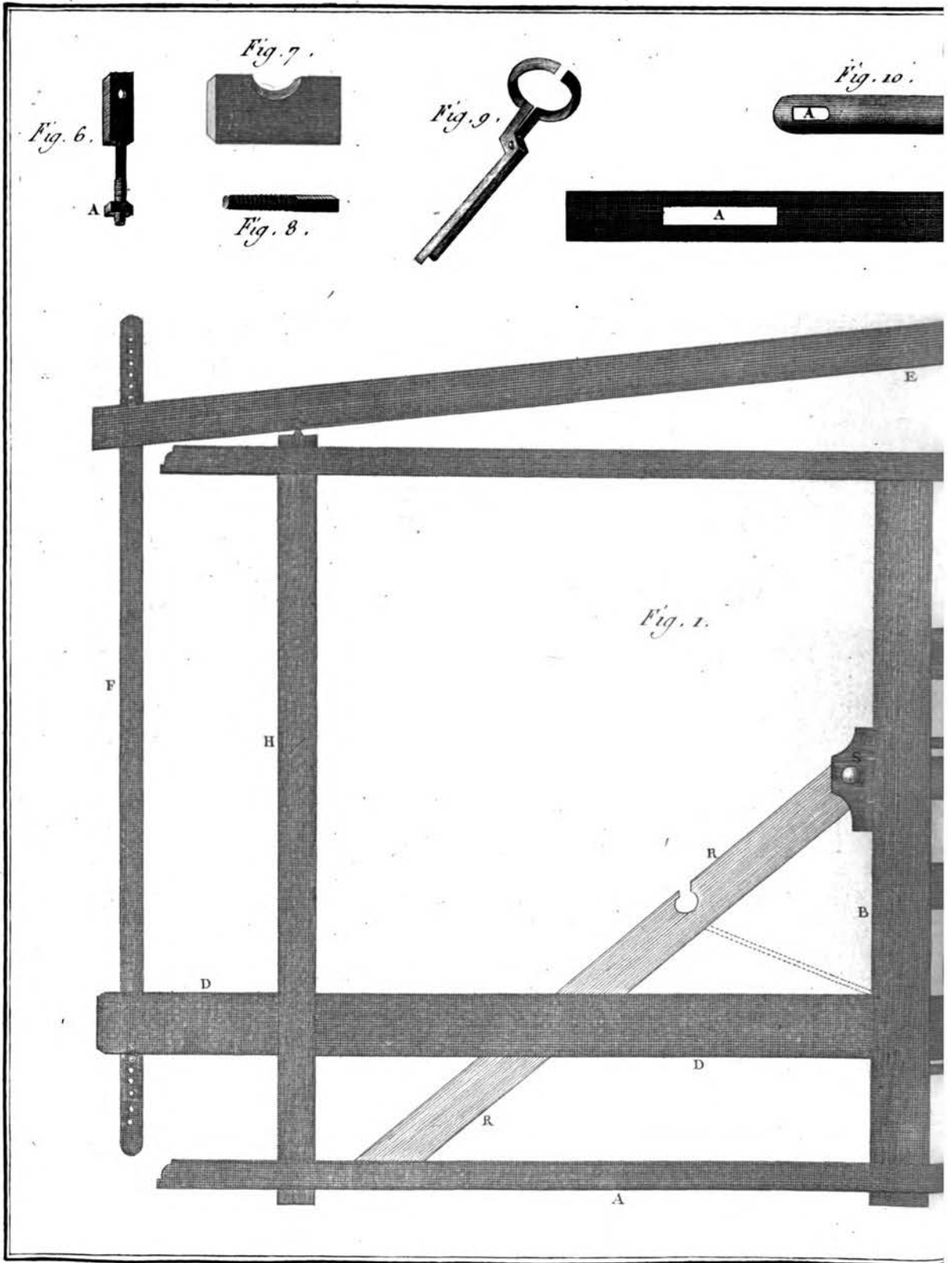


Fig. 3.

Fig. 4.

Benard Dirced.

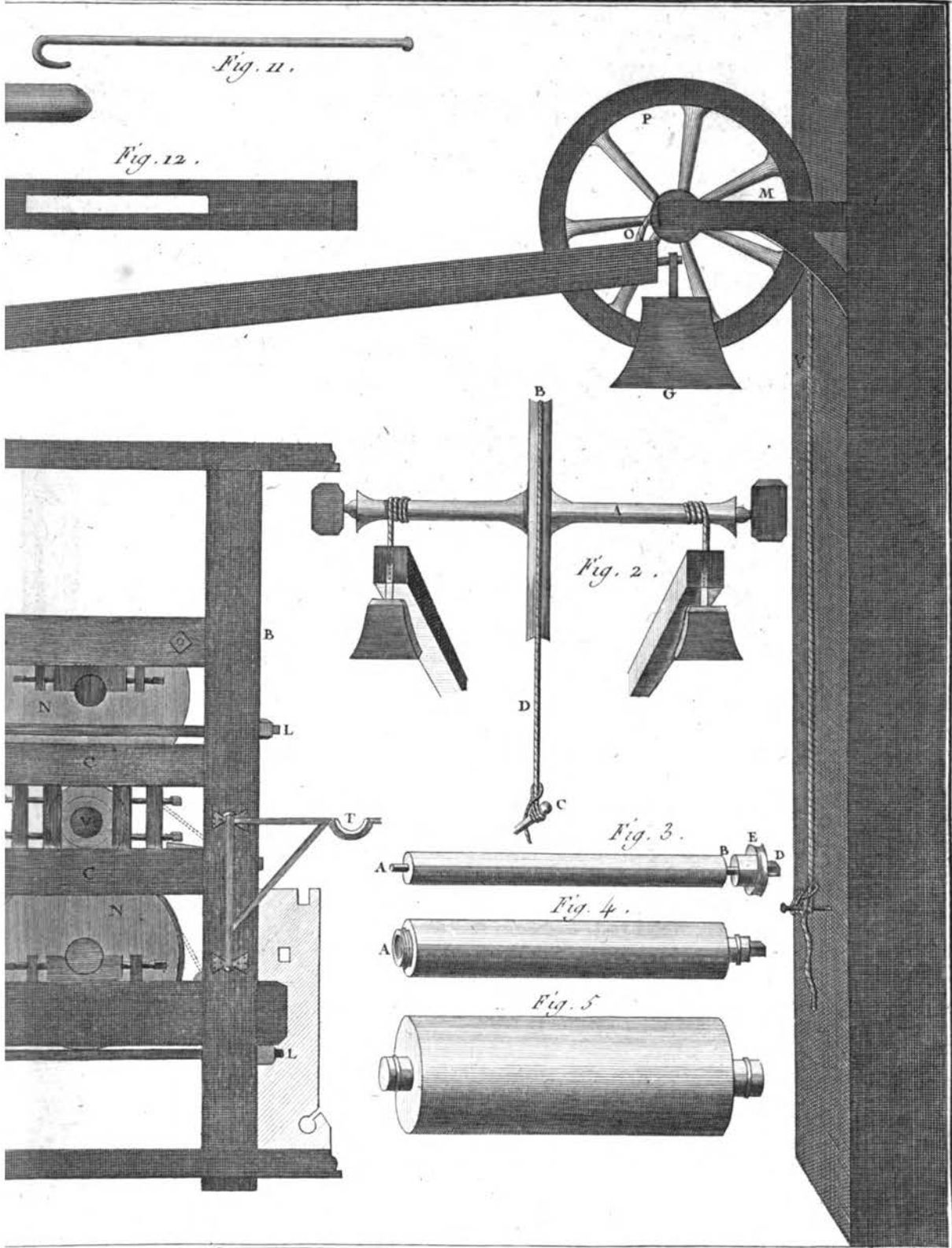
, Différentes Elevations du Cylindre à Bascules.



*Impression des Toiles Peintes*

Digitized by Google

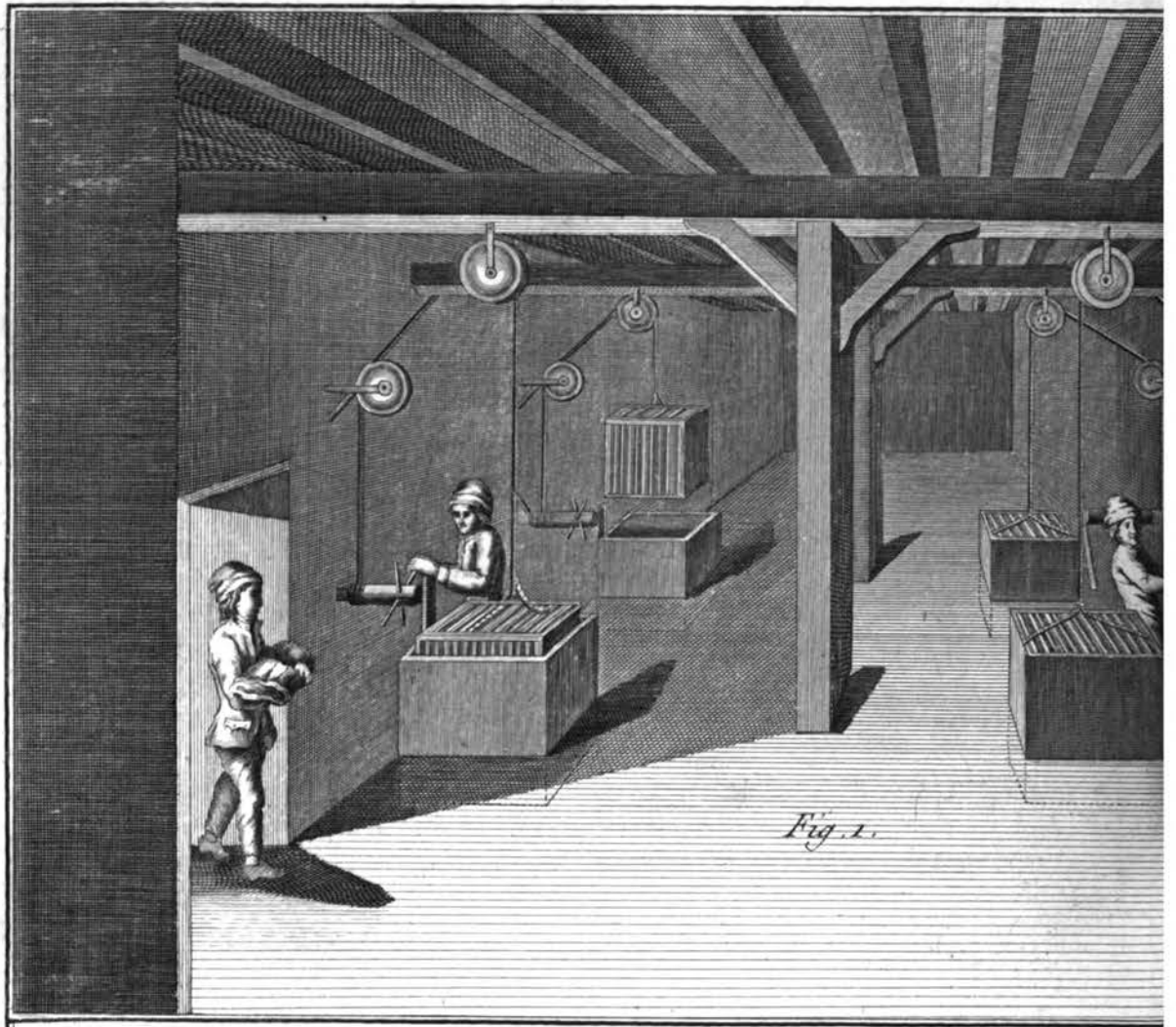
Original from  
UNIVERSIDAD COMPLUTENSE  
DE MADRID



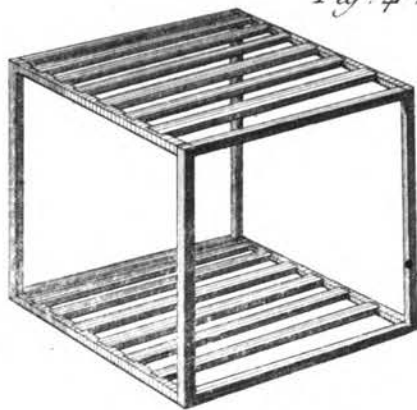
*Cylindre à Bascule et développemens .*

*Bernard Diracl.*

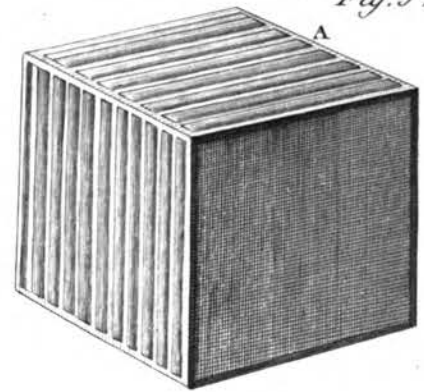
Generated on 2014-05-10 22:32 GMT / http://hdl.handle.net/2027/ucm.5320295822  
Public Domain, Google-digitized / http://www.hathitrust.org/access\_use#pd-google



*Fig. 1.*

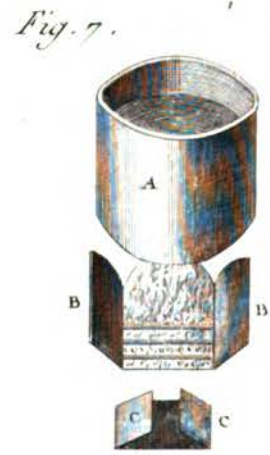
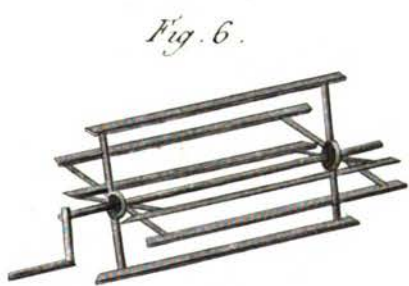
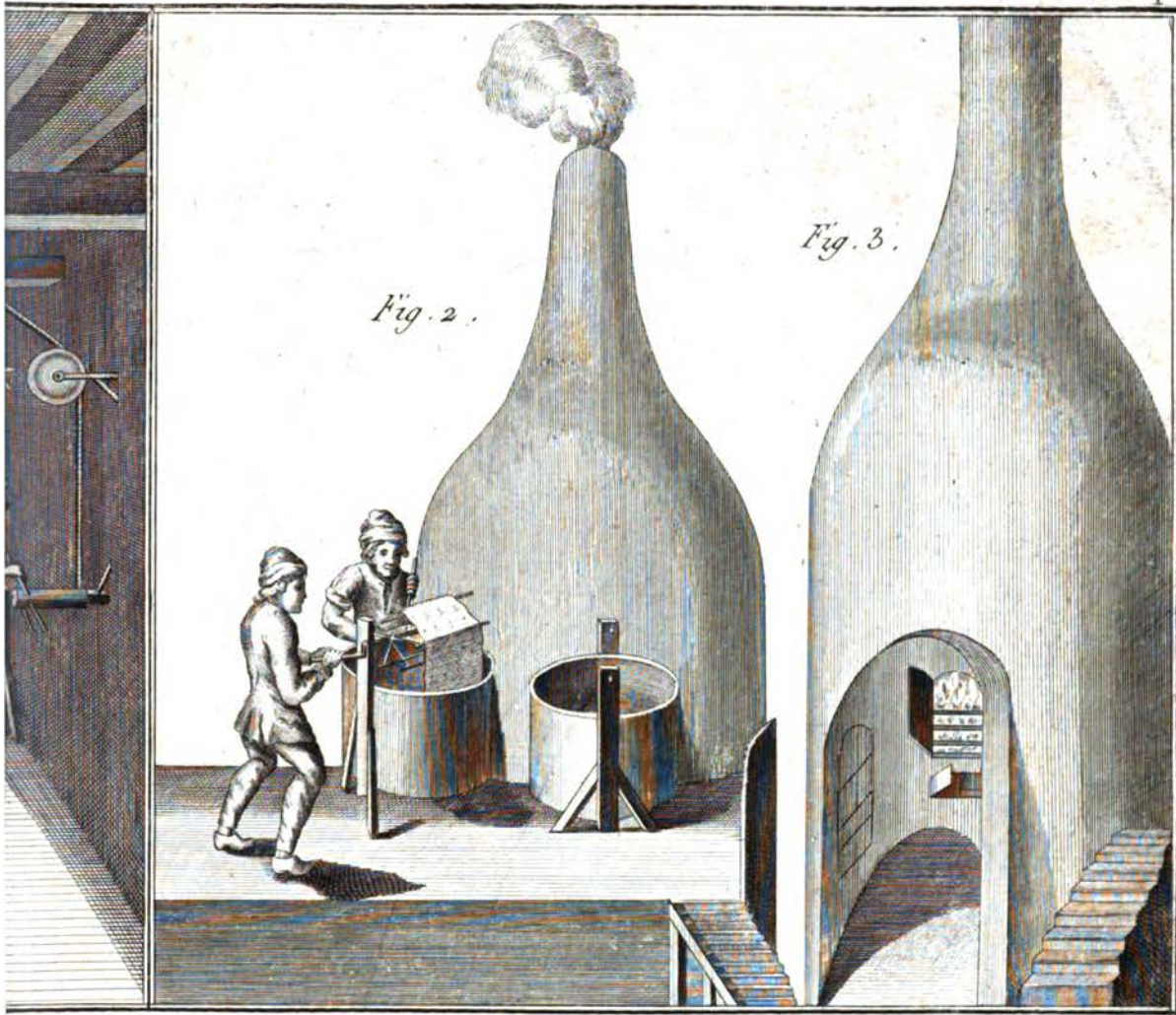


*Fig. 4.*



*Fig. 5.*

*Impression des Toiles Pe*



*Ateliers, Atelier des Cuves, et fourneaux.*

*Bernard Drevet  
80.*

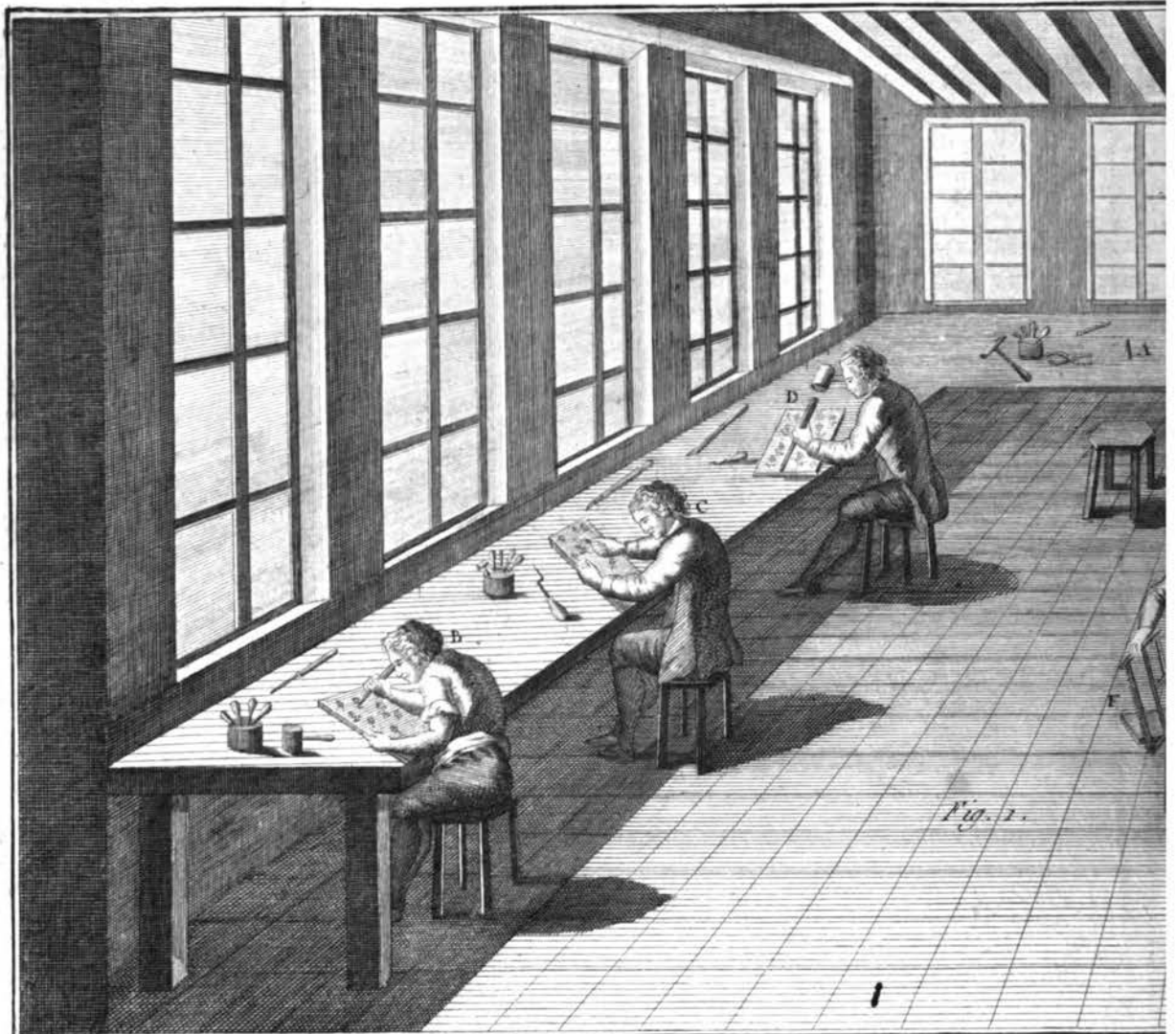


Fig. 1.



Fig. 2.

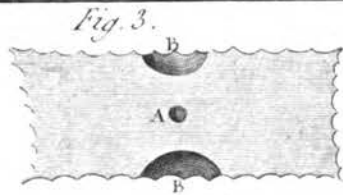


Fig. 3.

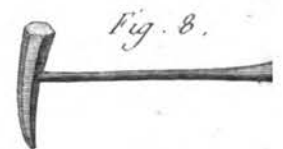


Fig. 8.

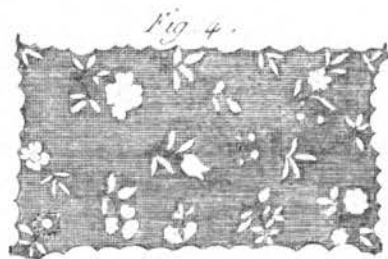


Fig. 4.



Fig. 7.



Fig. 5.

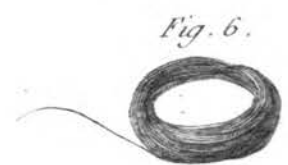
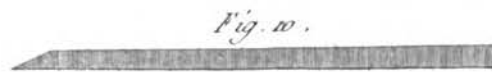
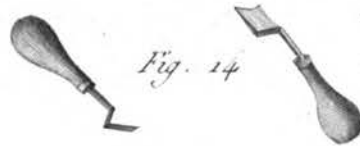
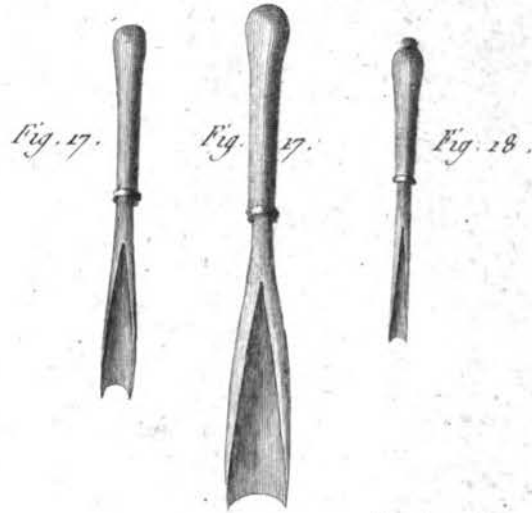


Fig. 6.

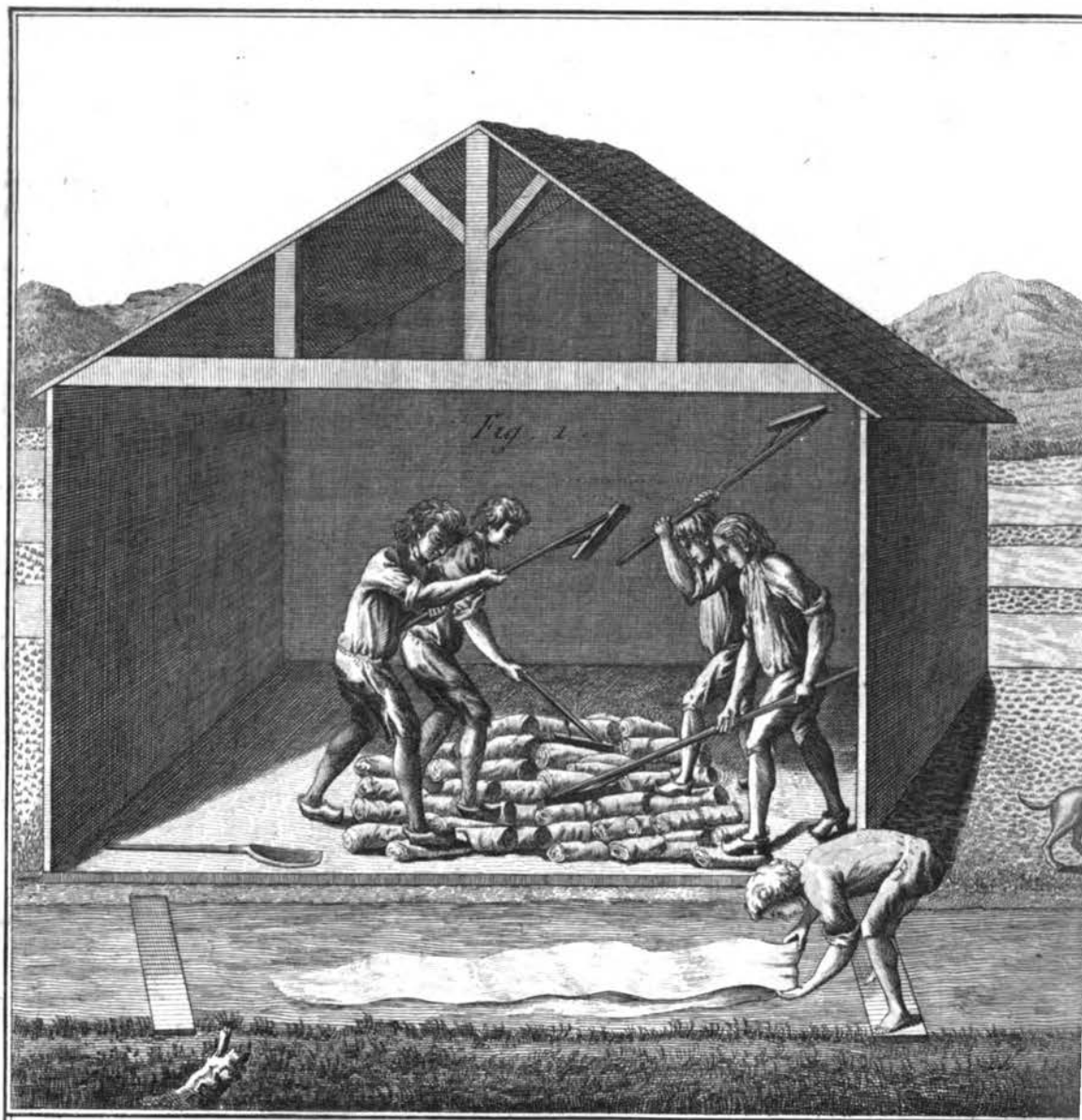
*Impression des Toiles Pe*



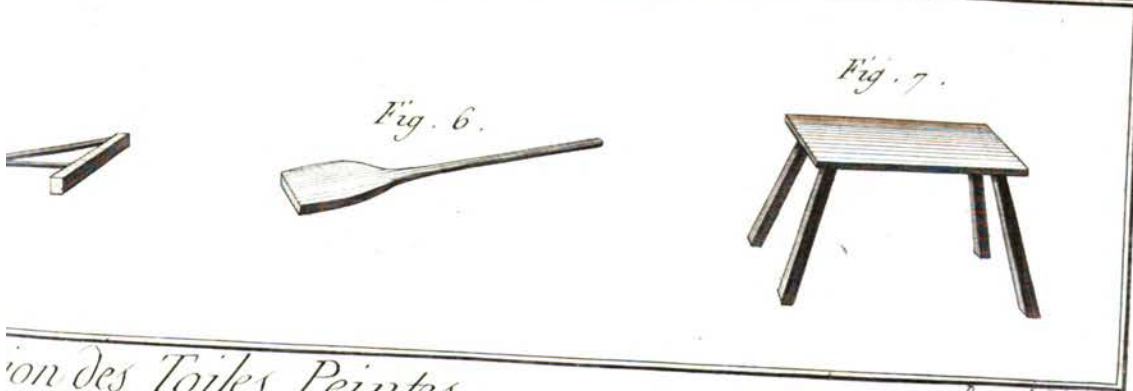


*Atelier des Graveurs, Moulés, Outils, &c.*

*Benard. Doreur.*

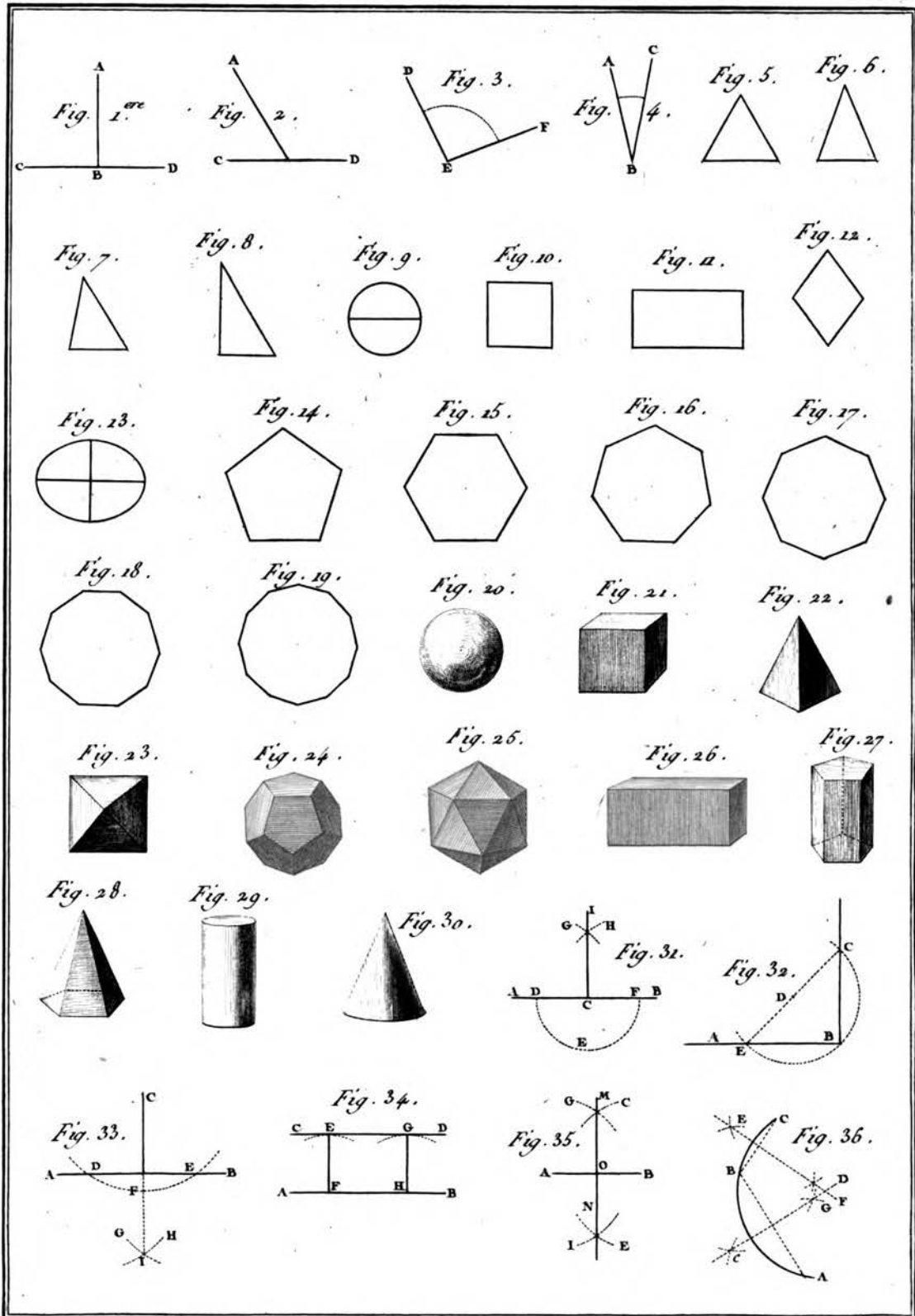


*Atelier et l'abrica*



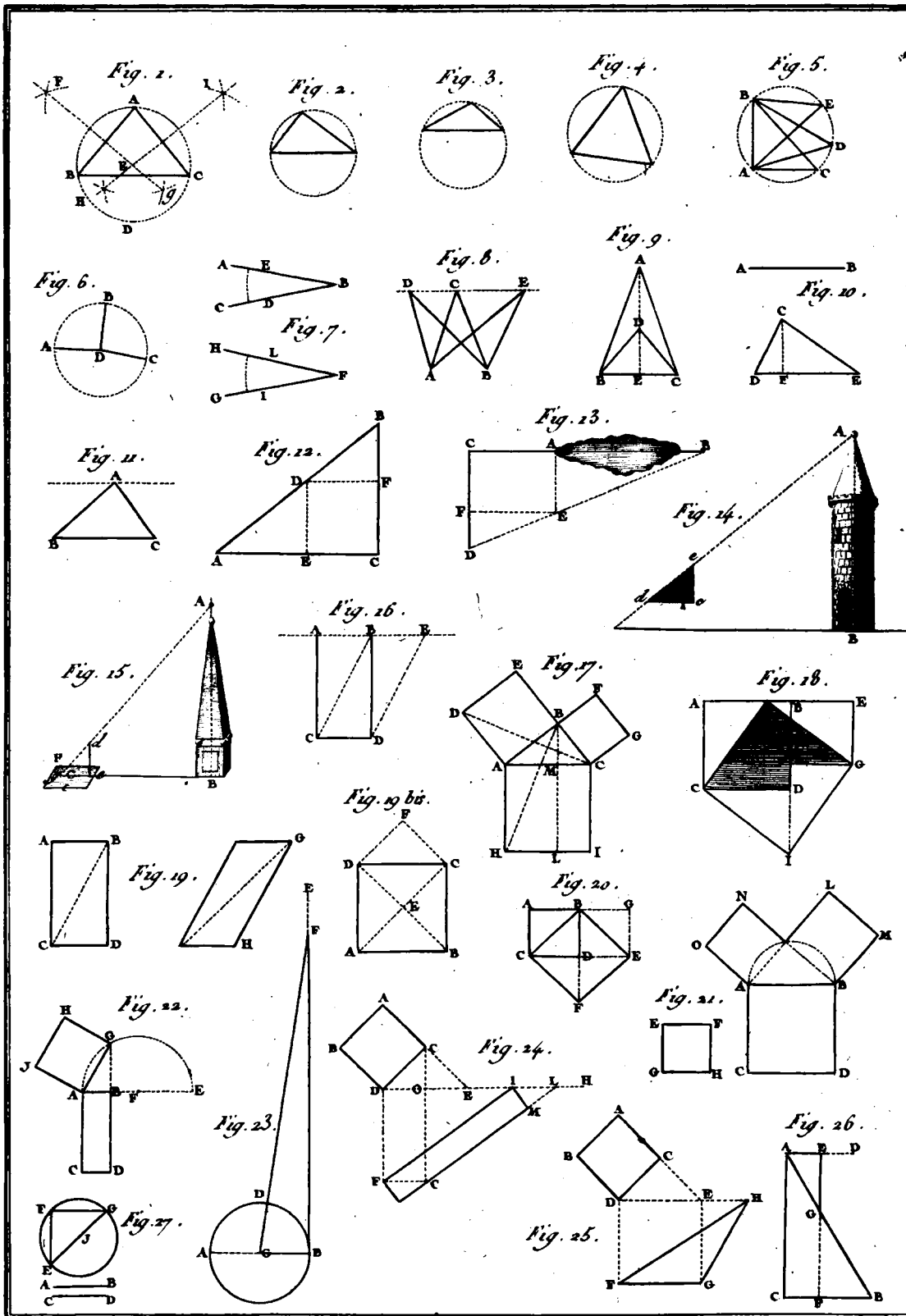
ion des Toiles Peintes.

Bernard Duvet



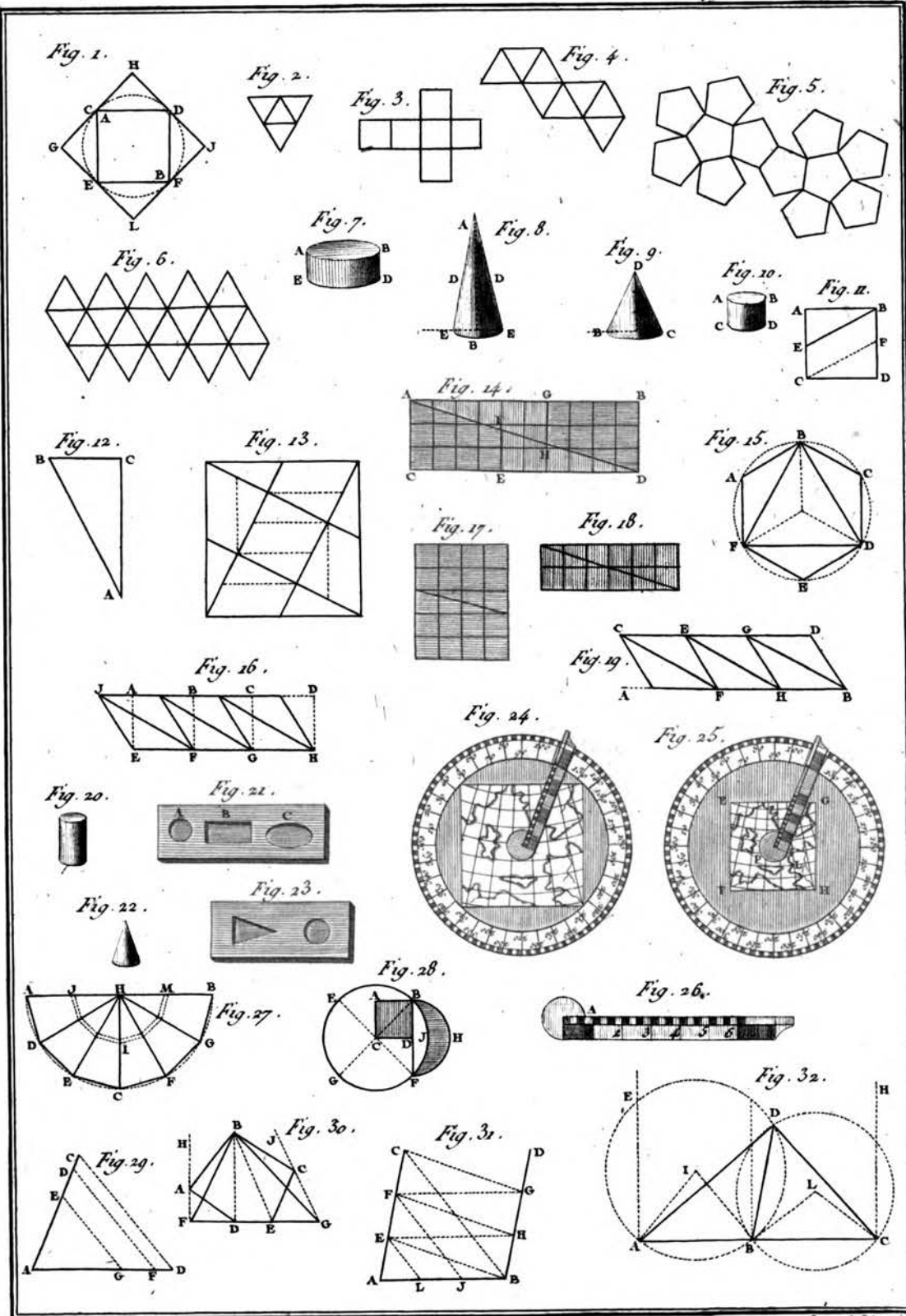
*Amusemens de Géométrie*

Benard Dixerit.



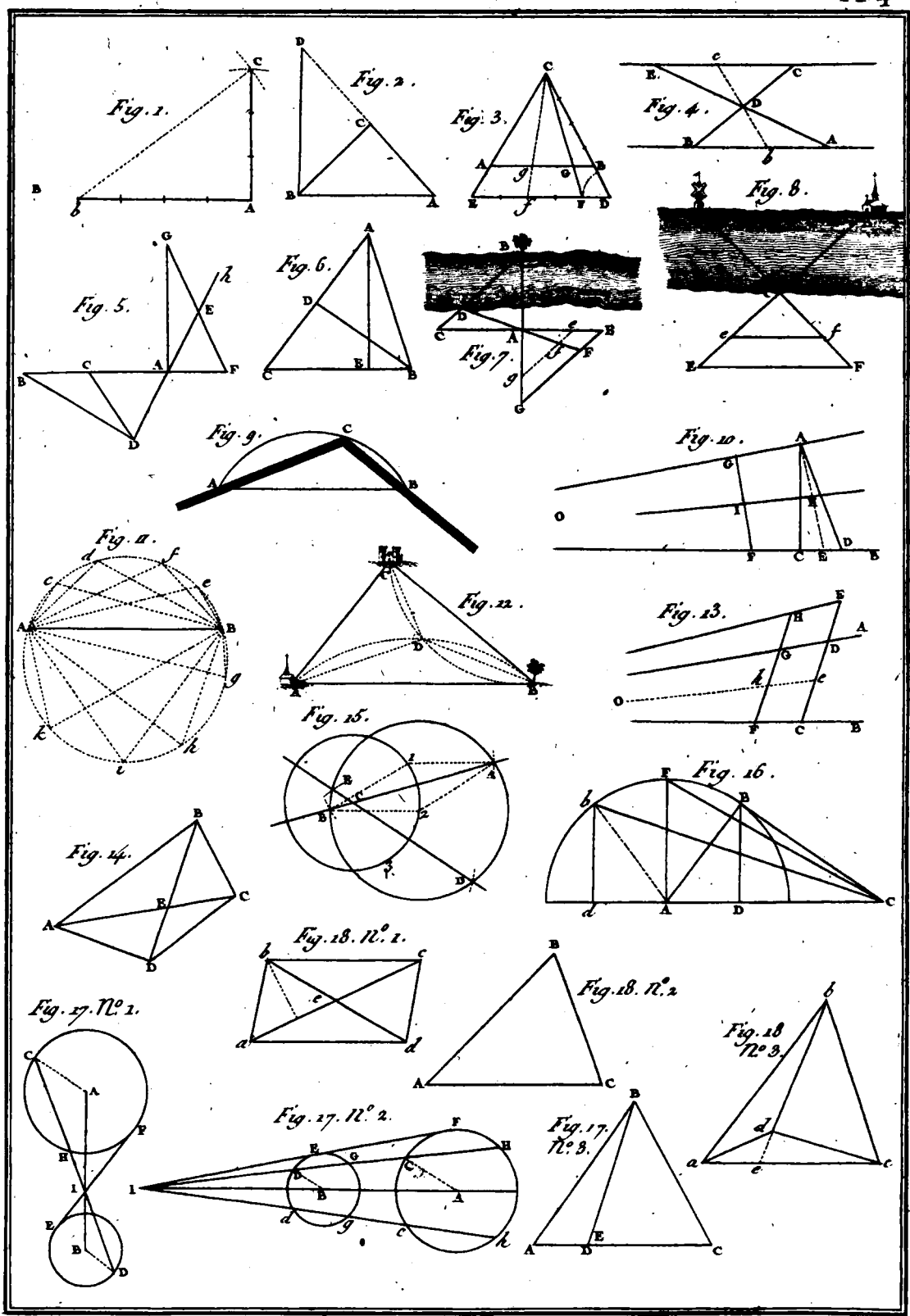
*Amusemens de Géométrie.*

*Bernard L'Évêque.*



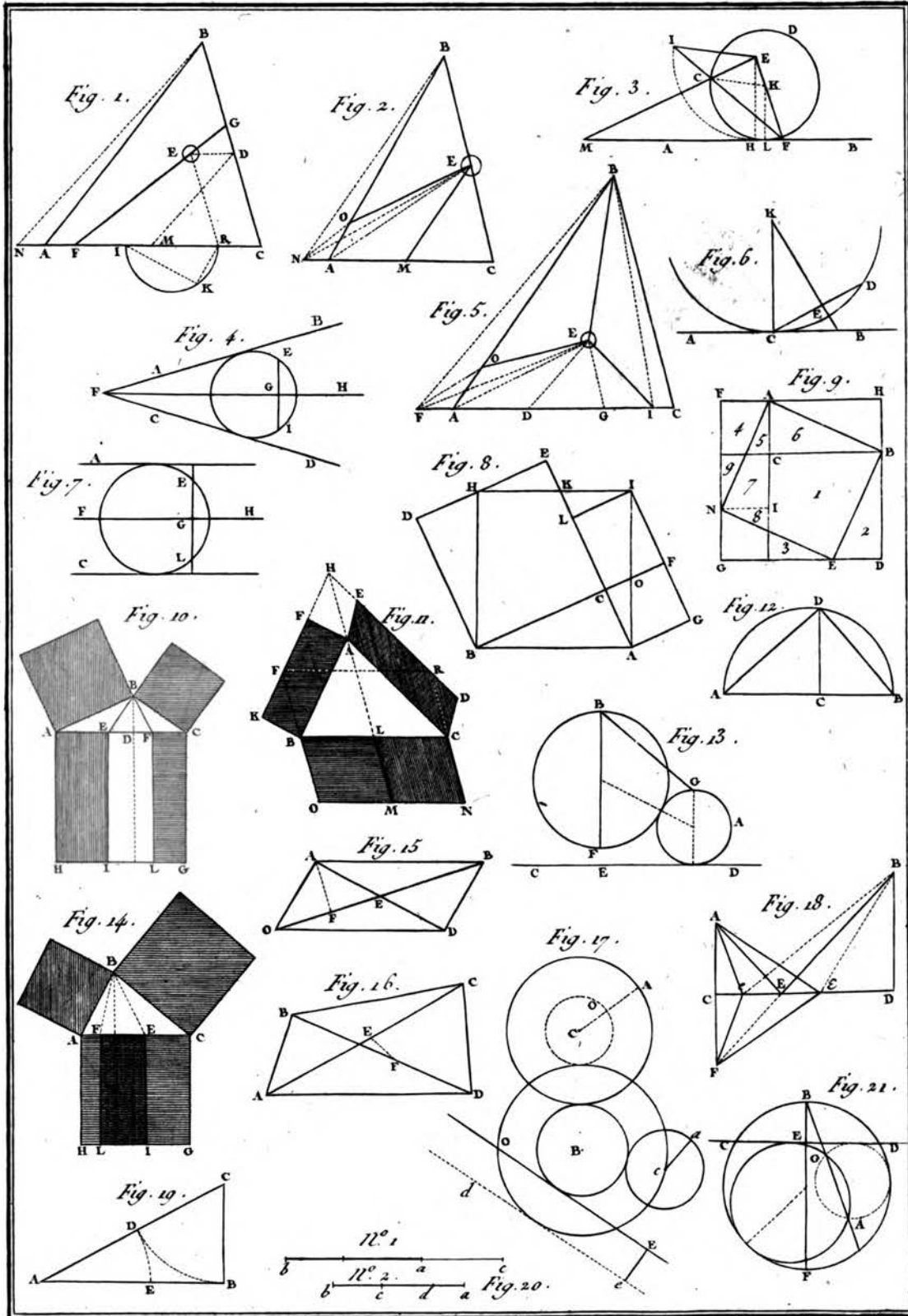
*Amusemens de Géometrie*

*Bernard Dérivel.*



*Amusemens de Géométrie.*

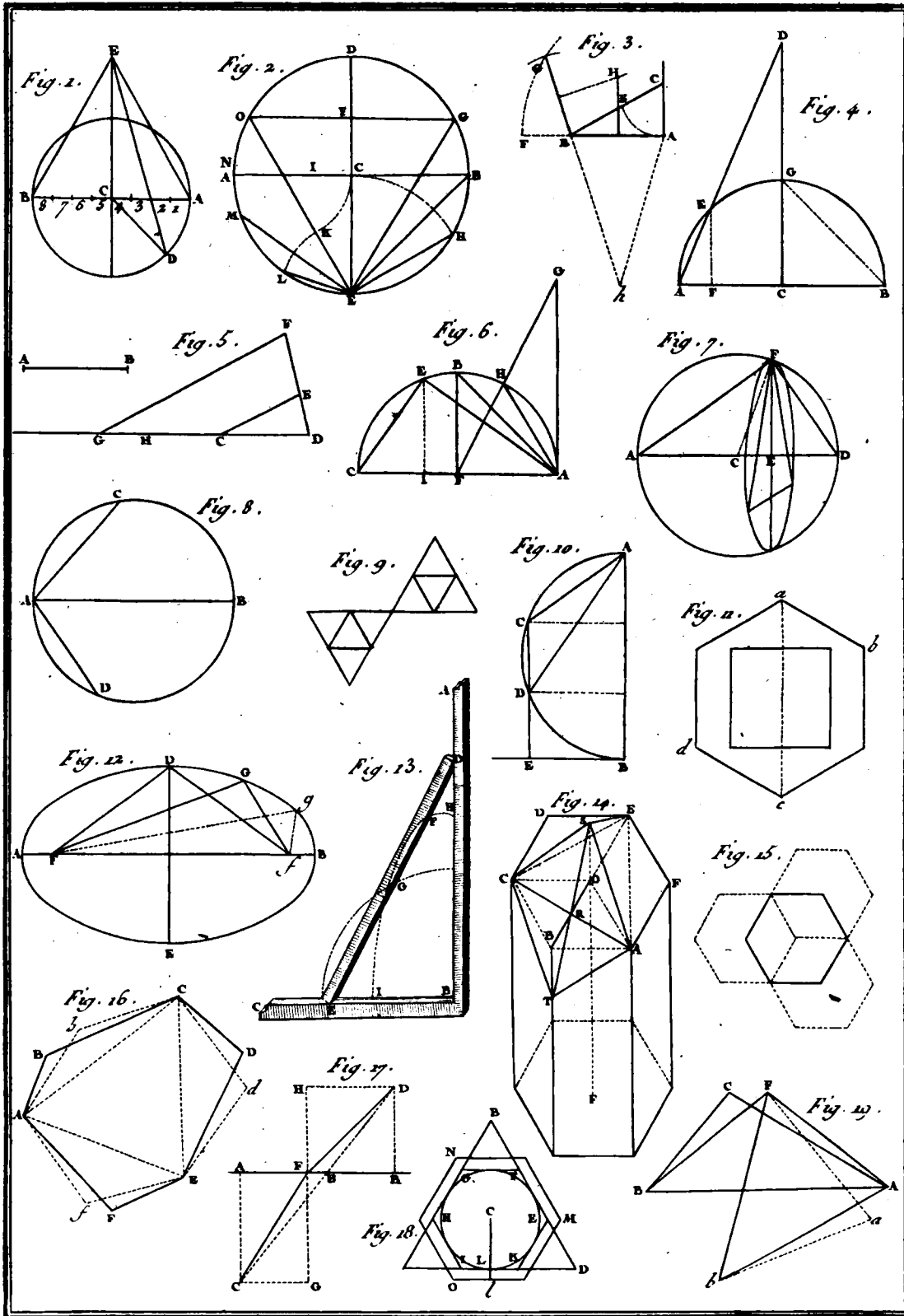
*Benard Düraxit*



Amusemens de Géométrie.

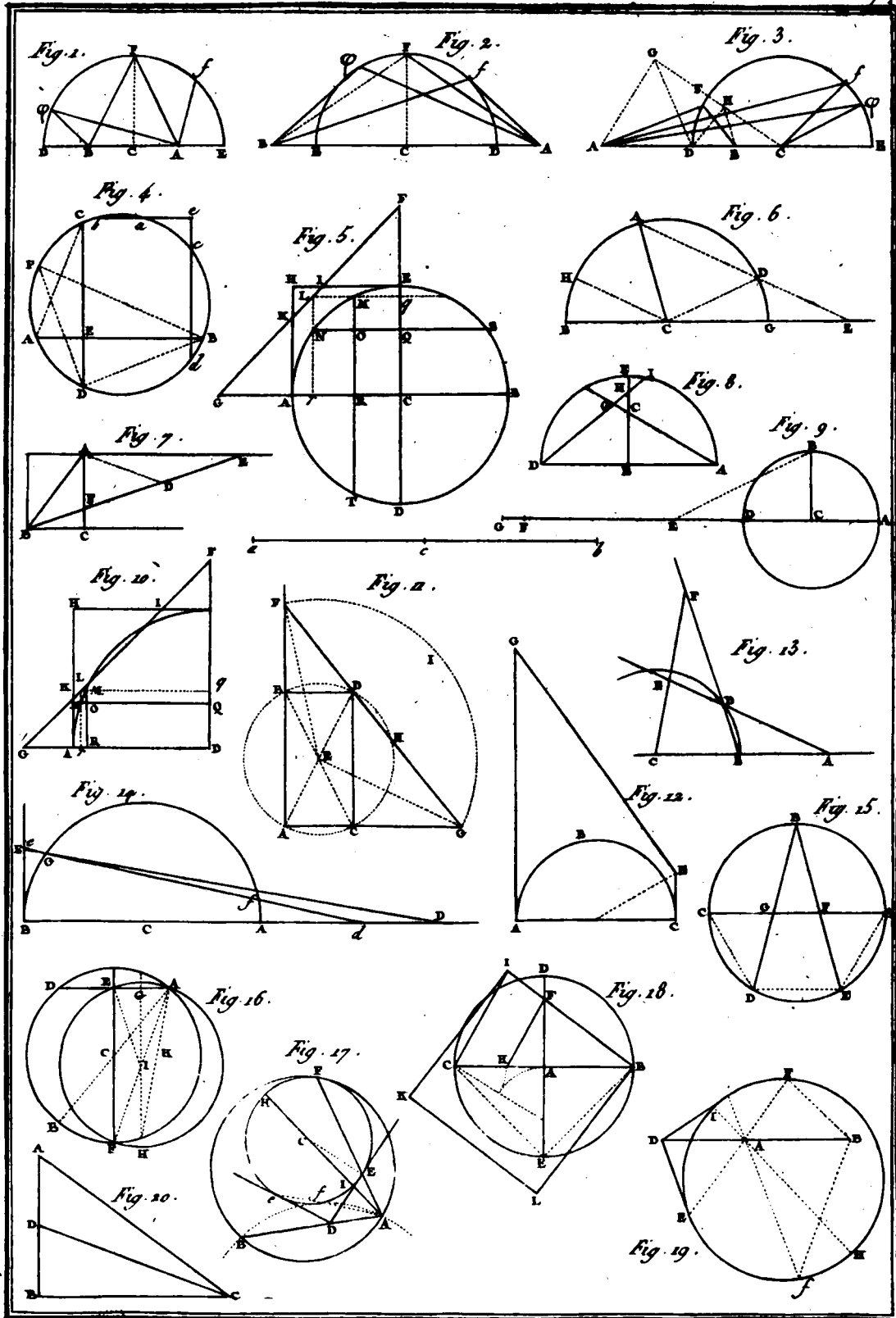
Benard Doreat.





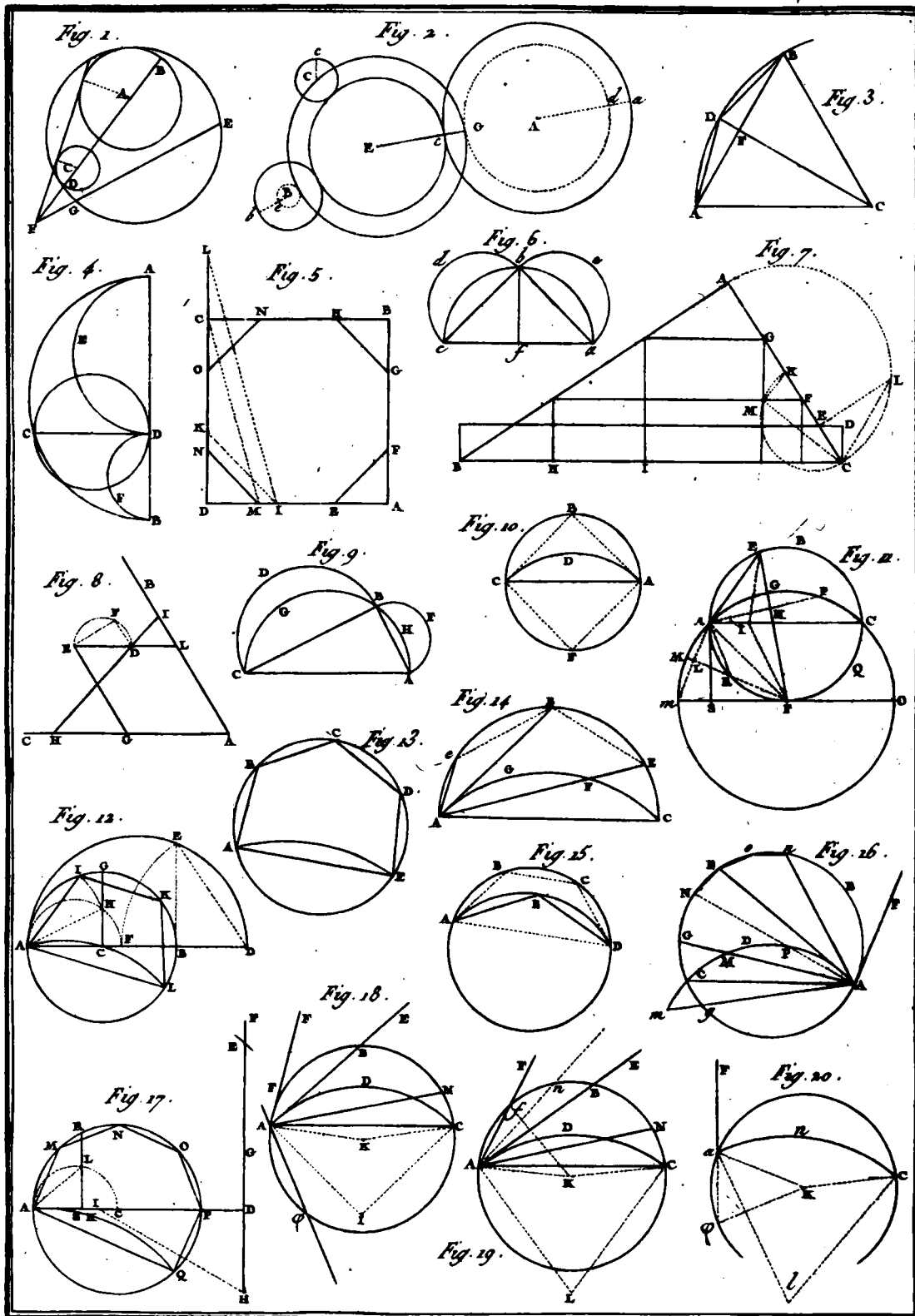
*Amusemens de Géométrie.*

*Bouard Dorexit.*



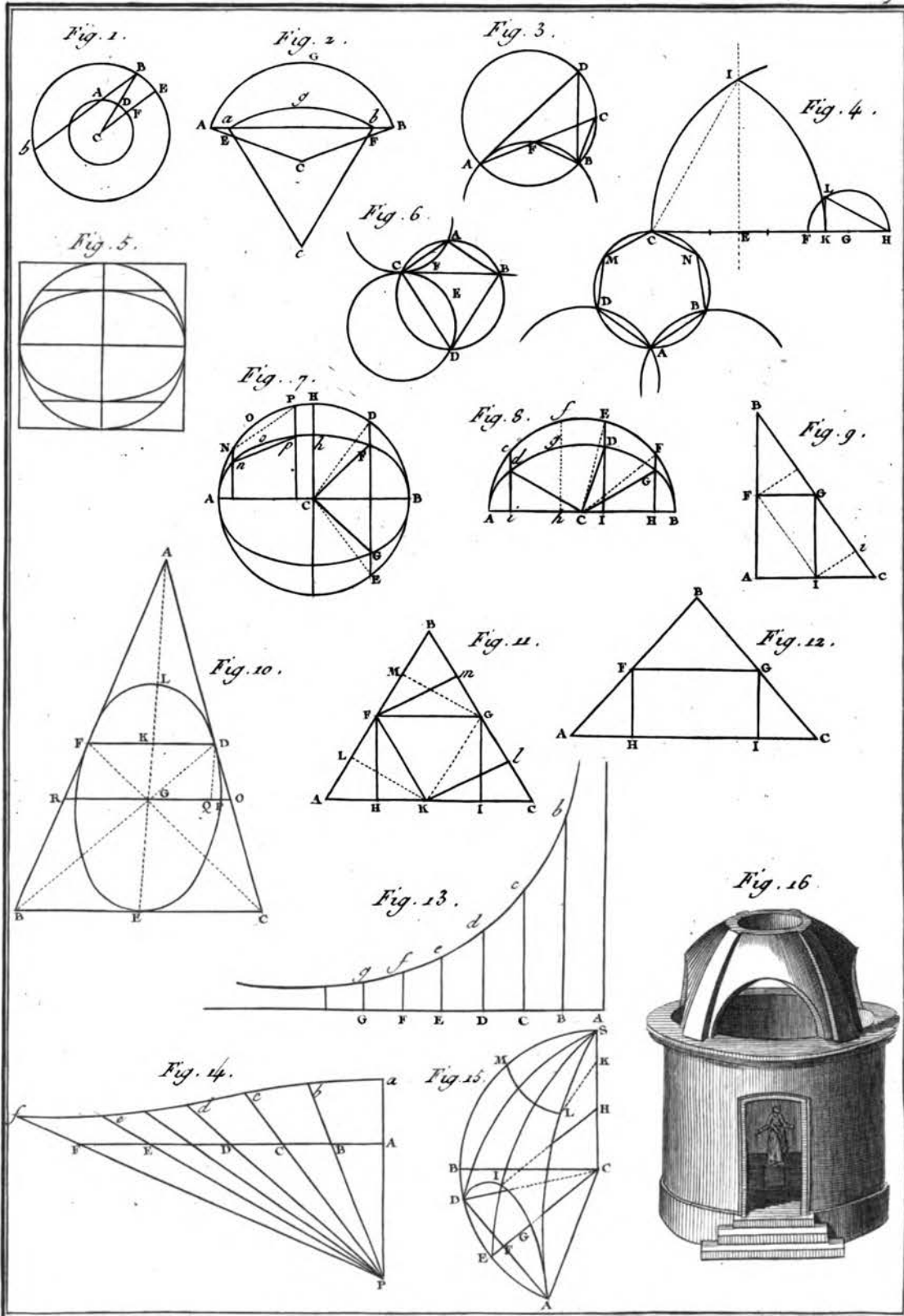
*Amusemens de Géométrie.*

*Benard Duvall.*



*Amusemens de Geometrie.*

*Bour & Dorez.*



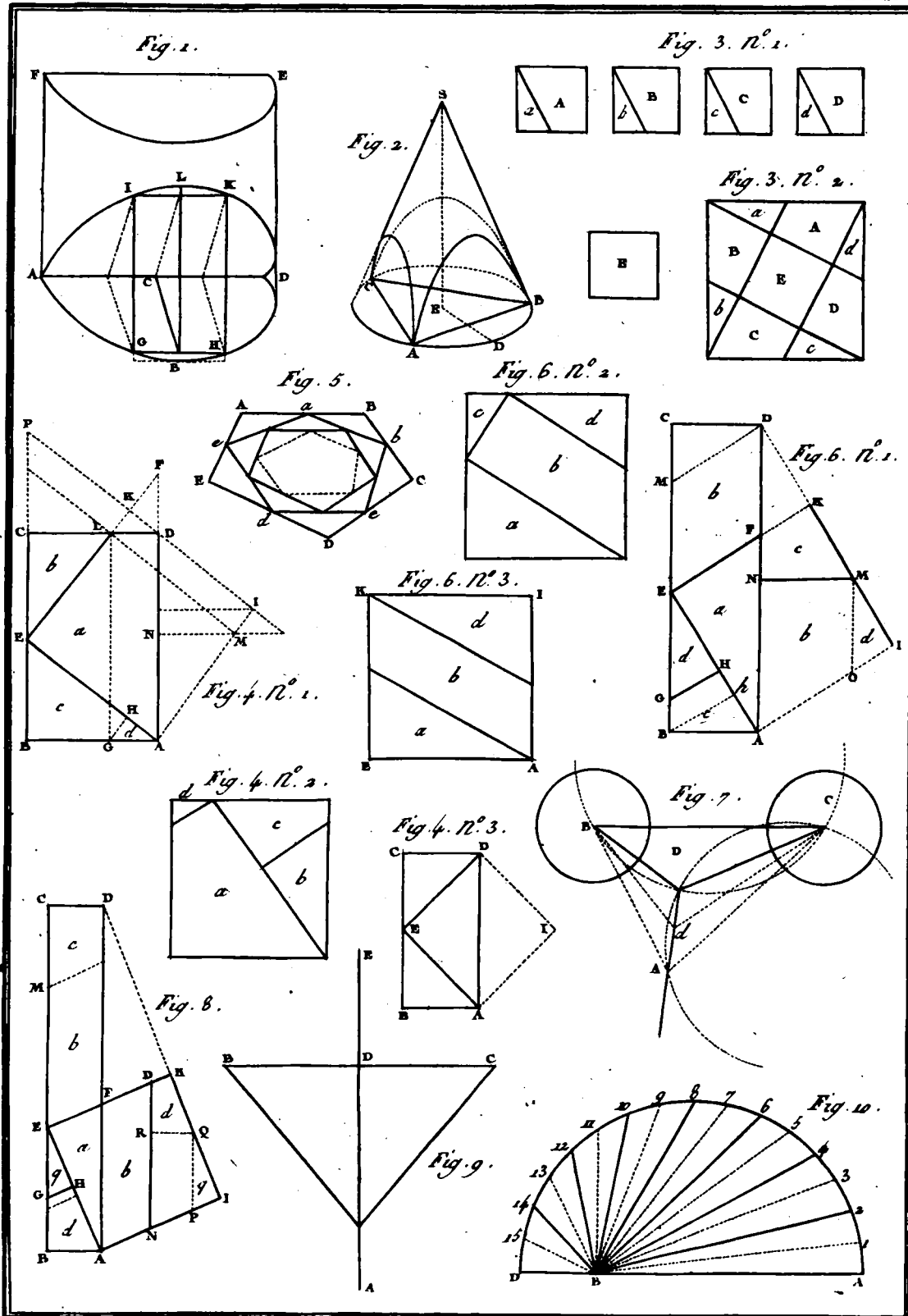


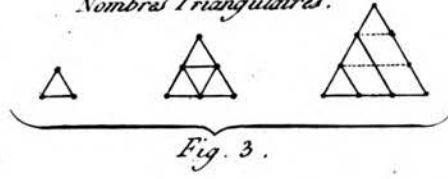
Fig. 1.

8
1/6
2/4
3/2
4/0
4/8
5/6
6/4
7/2

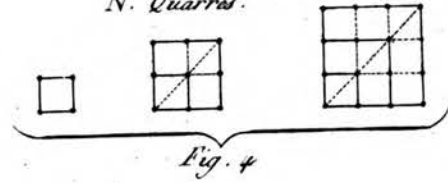
Fig. 2.

1	6	7	8	5	3	9	9
2	1	2	1	1	0	1	1
3	1	2	1	2	1	0	2
4	2	4	2	3	2	1	3
5	3	3	4	2	1	4	4
6	3	4	4	5	1	5	5
7	4	4	5	3	2	6	6
8	4	5	6	4	2	7	7
9	5	6	7	4	3	8	8

Nombres Triangulaires.



N. Quarrés.



N. Pentagones.

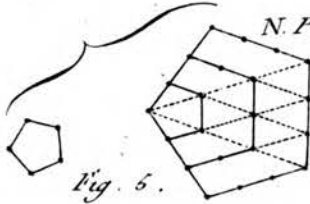


Fig. 6.

N. Hexagones.

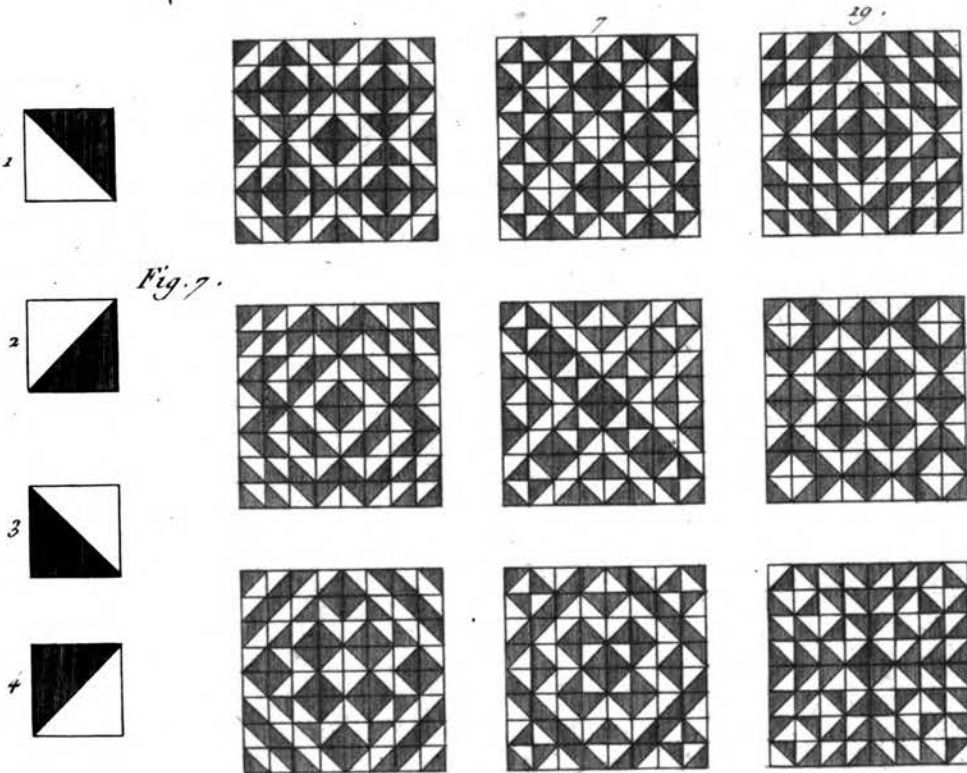
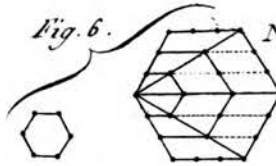


Fig. 7.

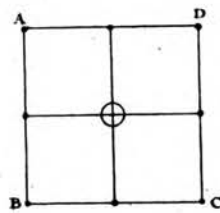
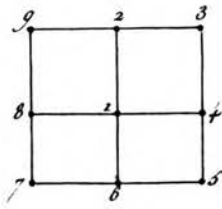


Fig. 1.

Fig. 2. N. 1.

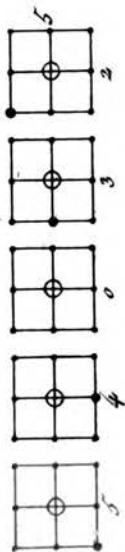
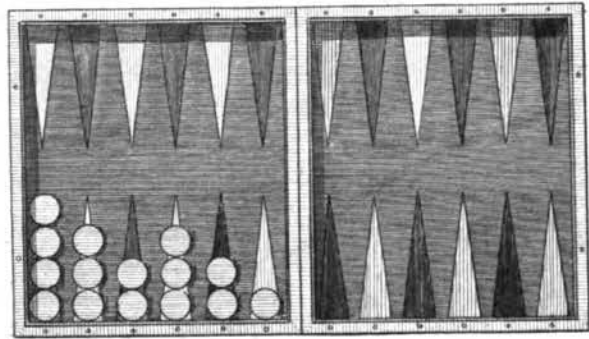


Fig. 2.

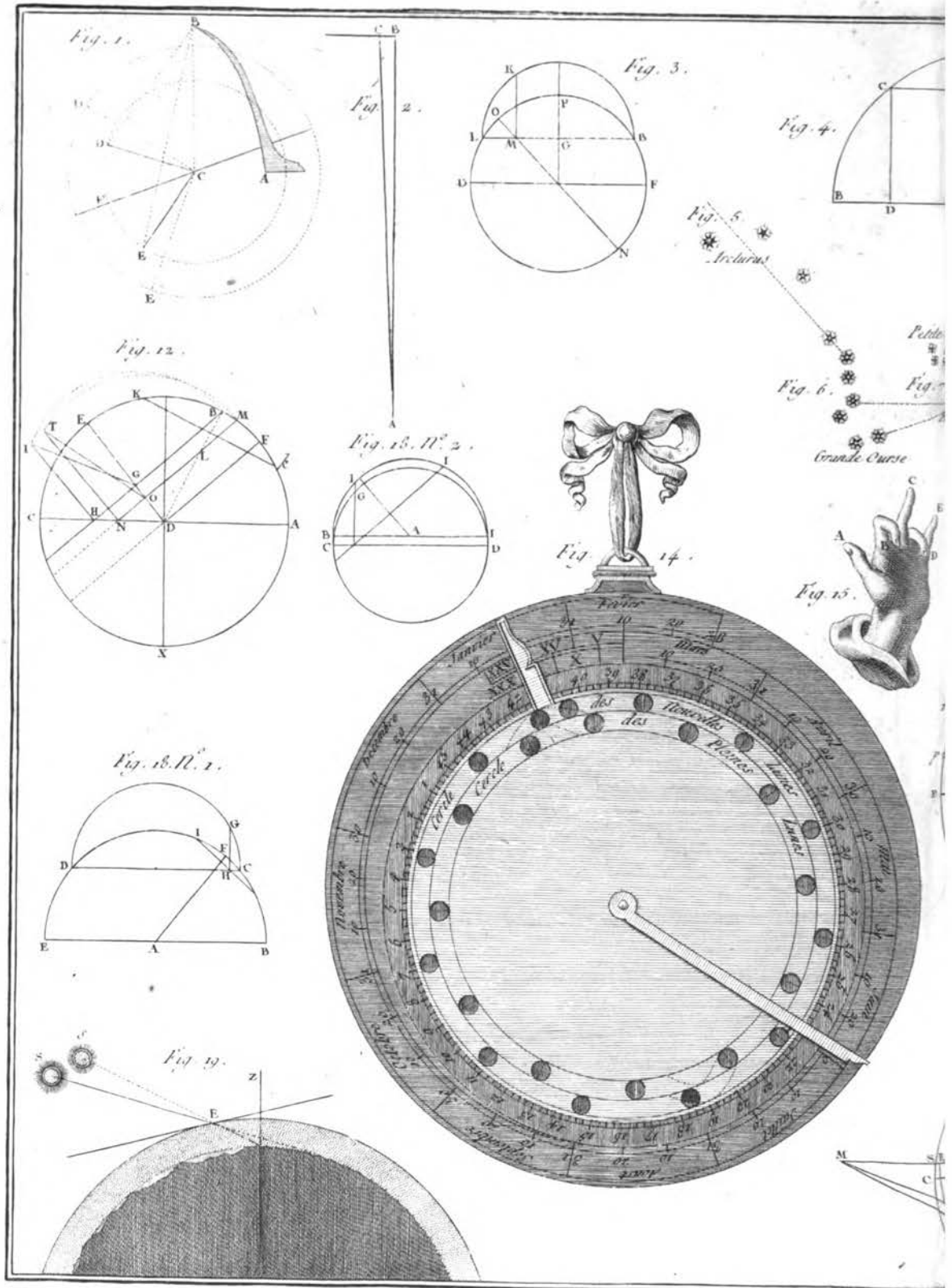
						54023.
						73592.
						42509.
						2795
						172919.

	1	1	1	1	1	1	1	1	1	1	1
N. Naturel.	1	2	3	4	5	6	7	8	9	10	11
N. Triangul.		1	3	6	10	15	21	28	36	45	55
N. Pyram. 1. <sup>re</sup>			1	4	10	20	35	56	84	120	165
N. Pyram. 2. <sup>de</sup>				1	5	15	35	70	126	210	330
N. Pyramid. 3. <sup>de</sup>					1	6	21	56	126	252	462
Fig. 3.						1	7	28	84	210	462
							1	8	36	120	330
								1	9	45	165
									1	10	55
										1	11
											1

Fig. 4.



Generated on 2014-05-10 22:47 GMT / http://hdl.handle.net/2027/ucm.5320295822  
 Public Domain, Google-digitized / http://www.hathitrust.org/access\_use#pd-google

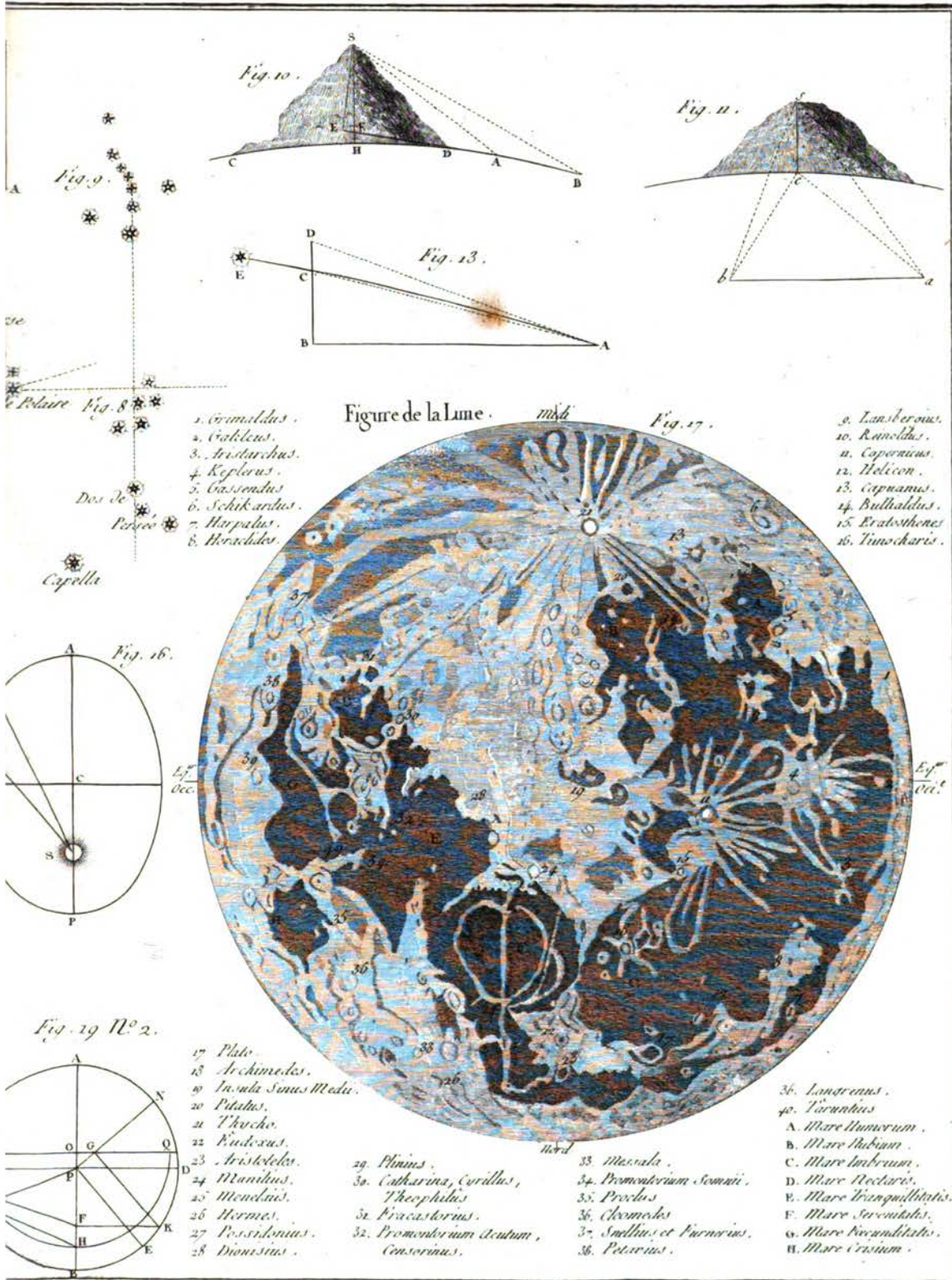


*Amusemens*

Digitized by Google

Original from  
UNIVERSIDAD COMPLUTENSE  
DE MADRID





- 1. Granulidas.
- 2. Galileus.
- 3. Aristarchus.
- 4. Keplerus.
- 5. Cassendus.
- 6. Schickardus.
- 7. Harpalus.
- 8. Herasides.

- 9. Lansbernius.
- 10. Romoldus.
- 11. Copernicus.
- 12. Melicon.
- 13. Copernicus.
- 14. Bullialdus.
- 15. Erasthones.
- 16. Tinscharis.

- 17. Plato.
- 18. Archimedes.
- 19. Inula Sinus Medu.
- 20. Pitatus.
- 21. Thvoko.
- 22. Kadusius.
- 23. Aristoteles.
- 24. Manilius.
- 25. Mendius.
- 26. Hormes.
- 27. Possidonius.
- 28. Dionysius.

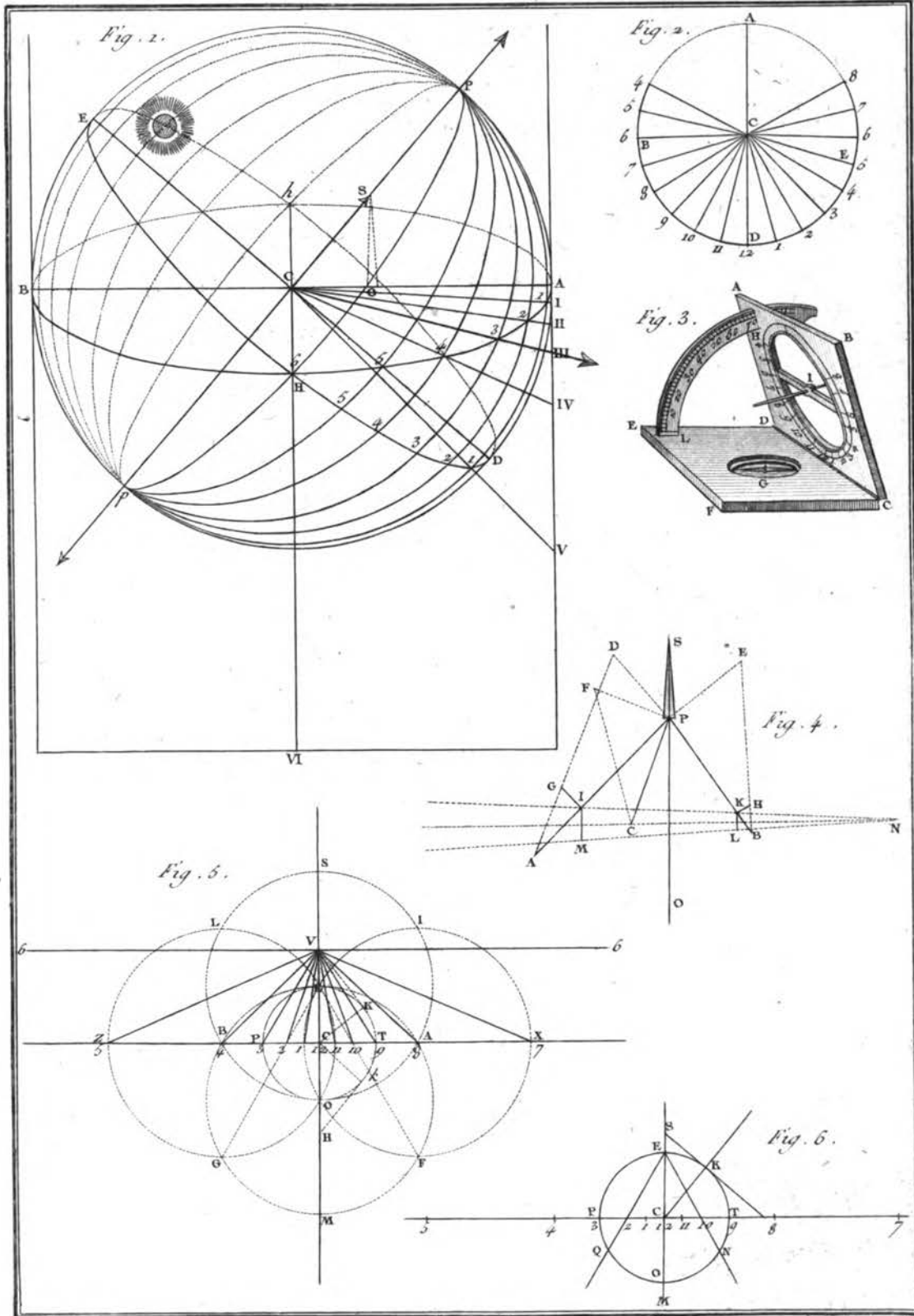
- 29. Plinius.
- 30. Catharina, Corillus, Theophilus.
- 31. Praxastorius.
- 32. Promontorium acutum, Censorinus.

- 33. Mascula.
- 34. Promontorium scotti.
- 35. Praxus.
- 36. Acrometes.
- 37. Suthus et Farnorius.
- 38. Petrus.

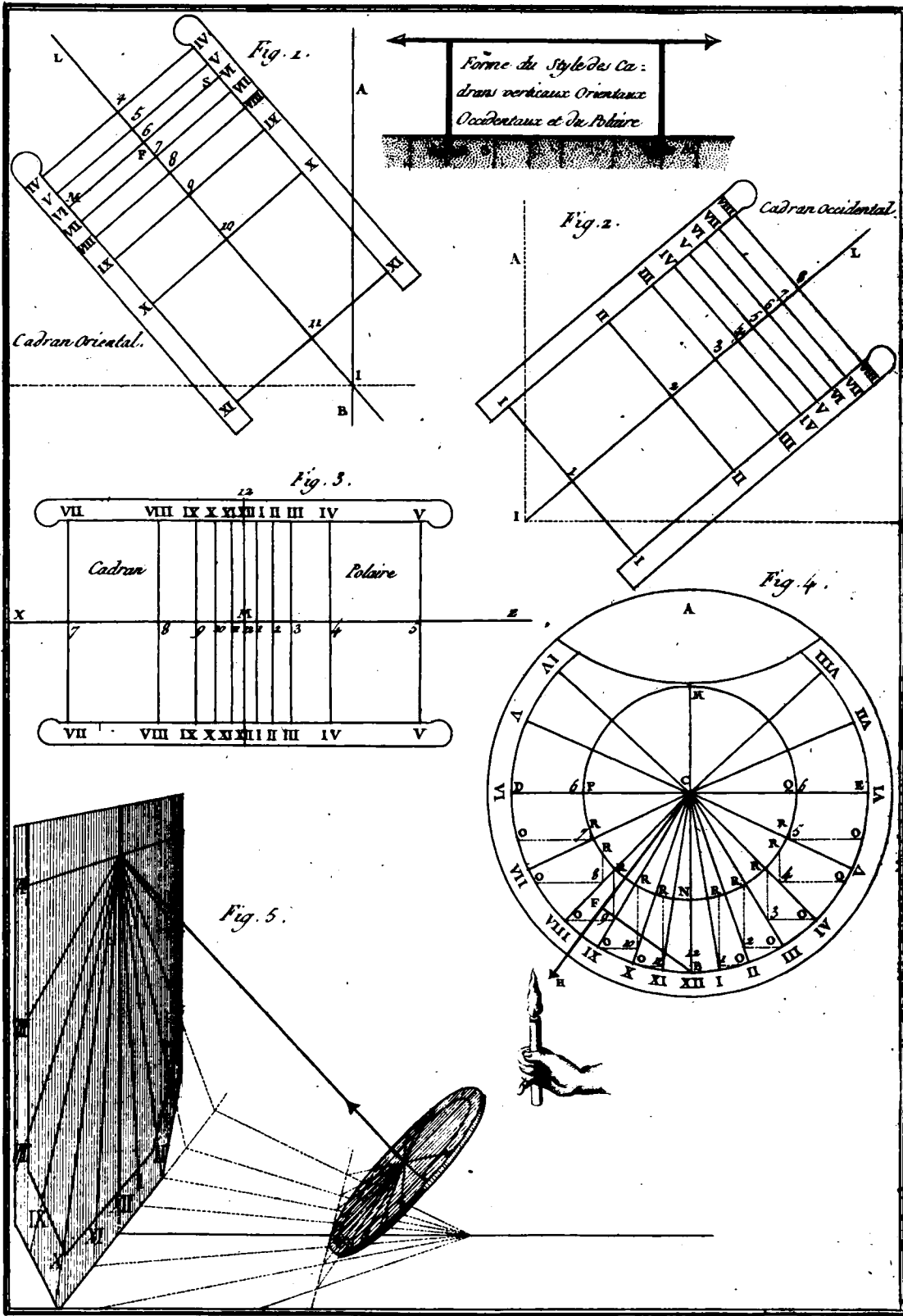
- 36. Lansbernius.
- 37. Tacantius.
- A. Mare Humorum.
- B. Mare Nubium.
- C. Mare Imbrium.
- D. Mare Nectaris.
- E. Mare Tranquillitatis.
- F. Mare Serenitatis.
- G. Mare Insularum.
- H. Mare Crisium.

*d'Astronomie.*

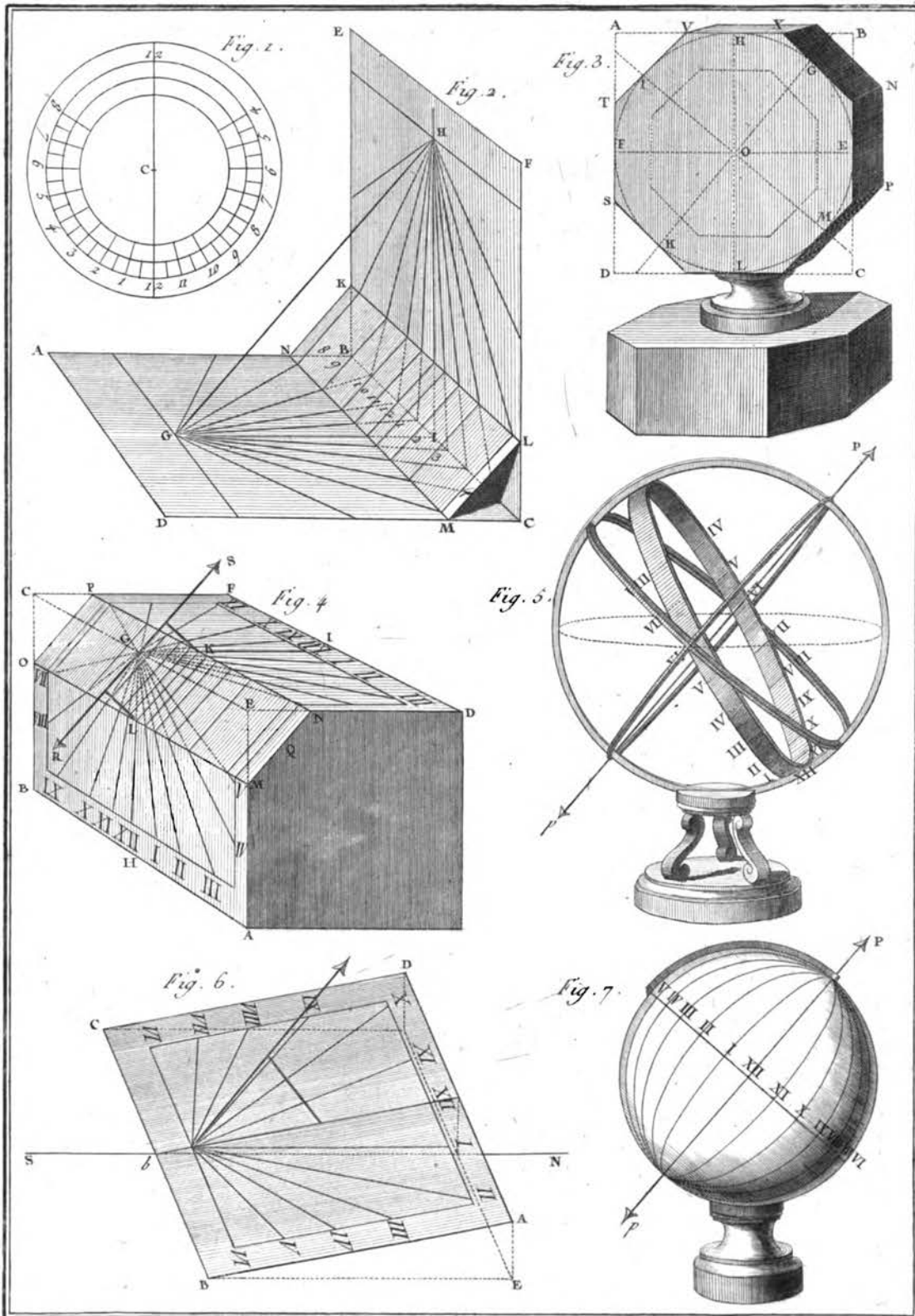
Edward Drexel



Generated on 2014-05-10 22:48 GMT / http://hdl.handle.net/2027/ucm.5320295822  
Public Domain, Google-digitized / http://www.hathitrust.org/access\_use#pd-google

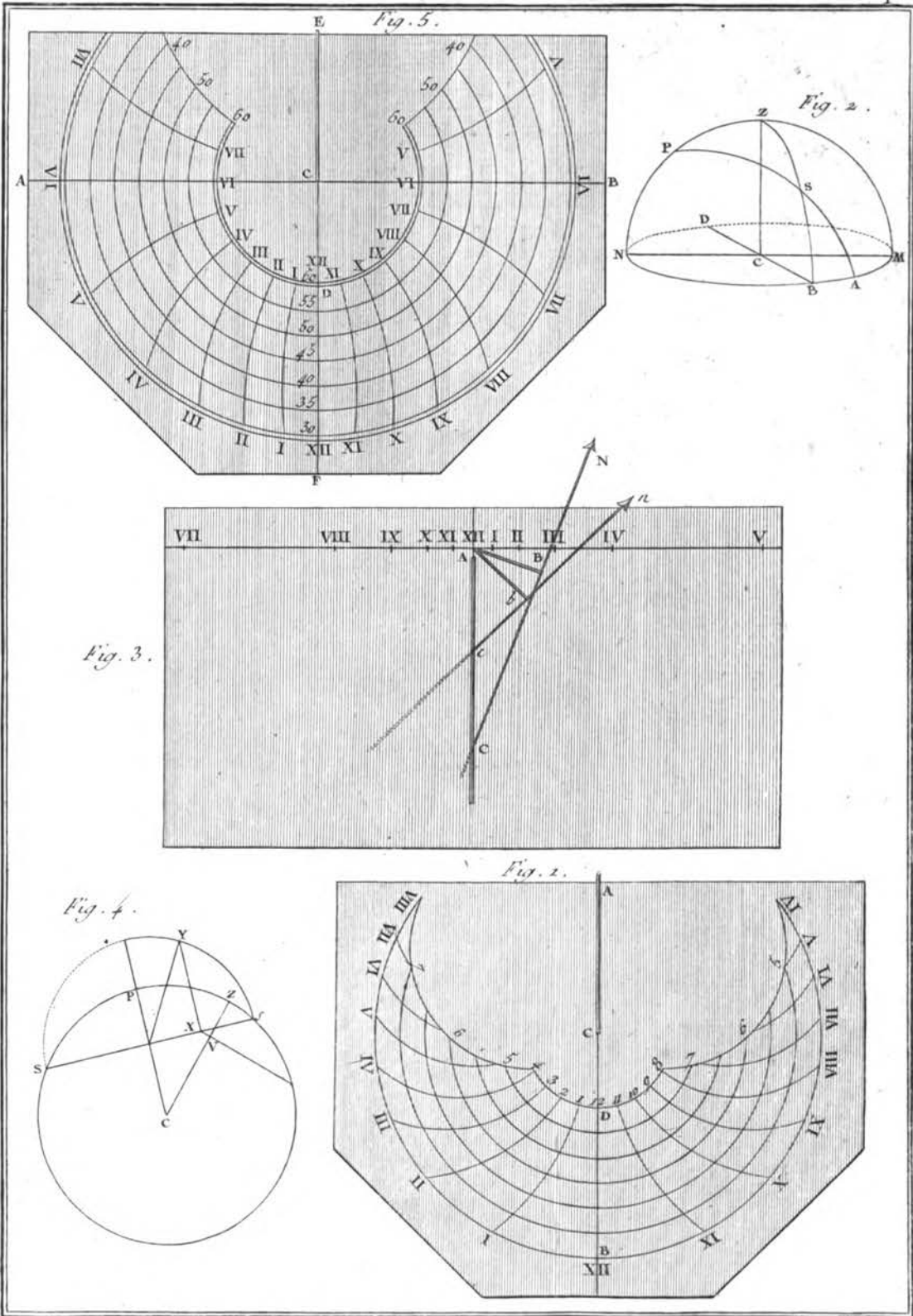


Bonard Deraxel



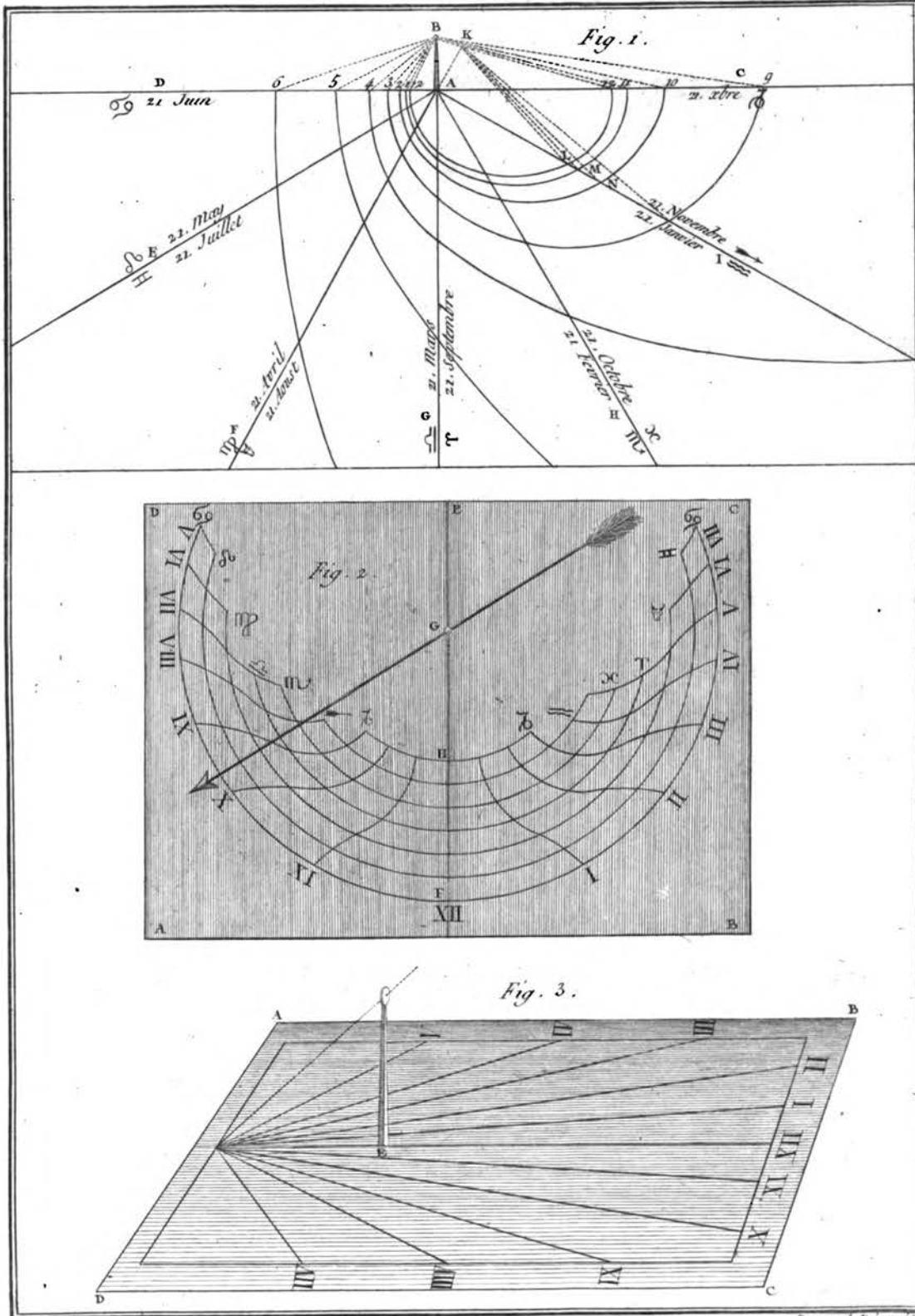
*Amusemens de Gnomonique.*

*Benard. Dircxit.*



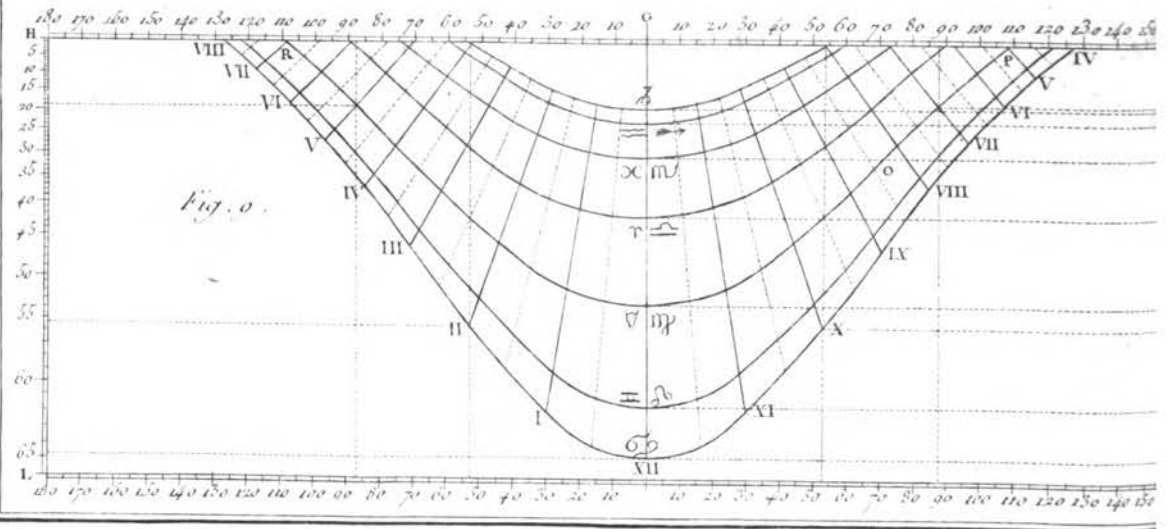
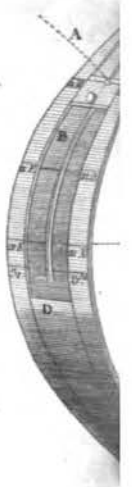
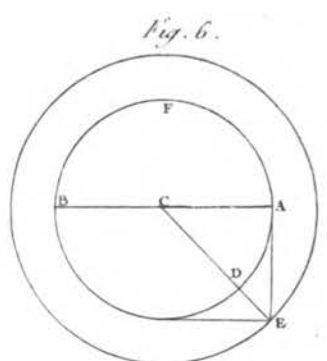
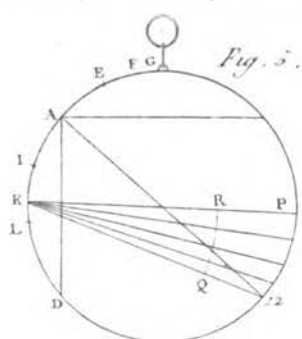
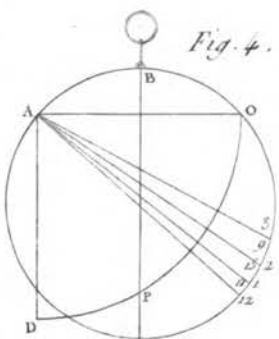
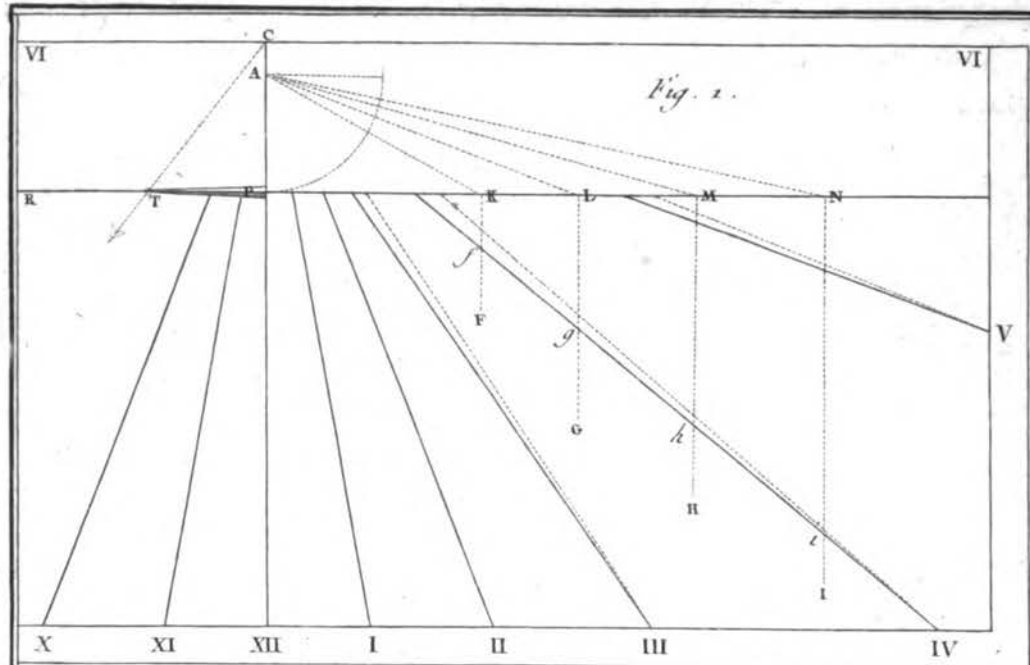
*Amusemens de Gnomonique*

*Benoist Dureau*



*Amusemens de Gnomonique.*

*Bernard Drexel.*



*Amusemens*

Fig. 2.

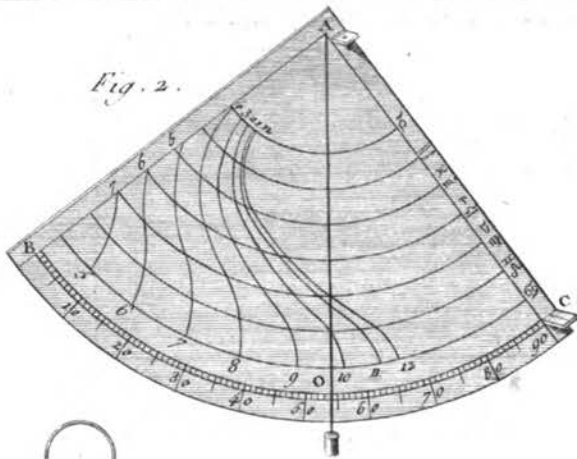


Fig. 3.

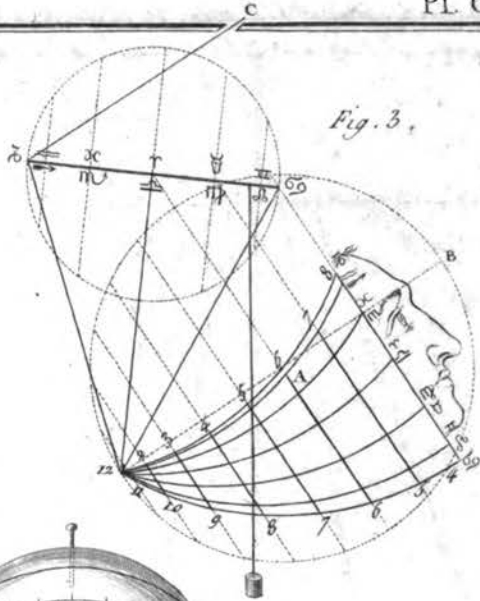


Fig. 7.

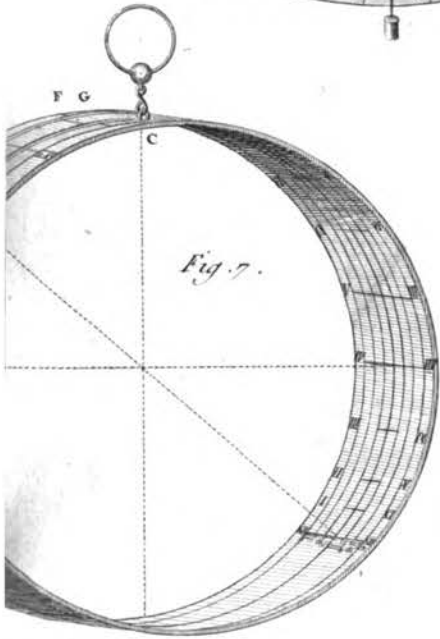
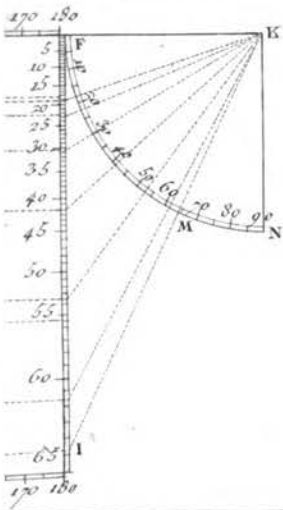
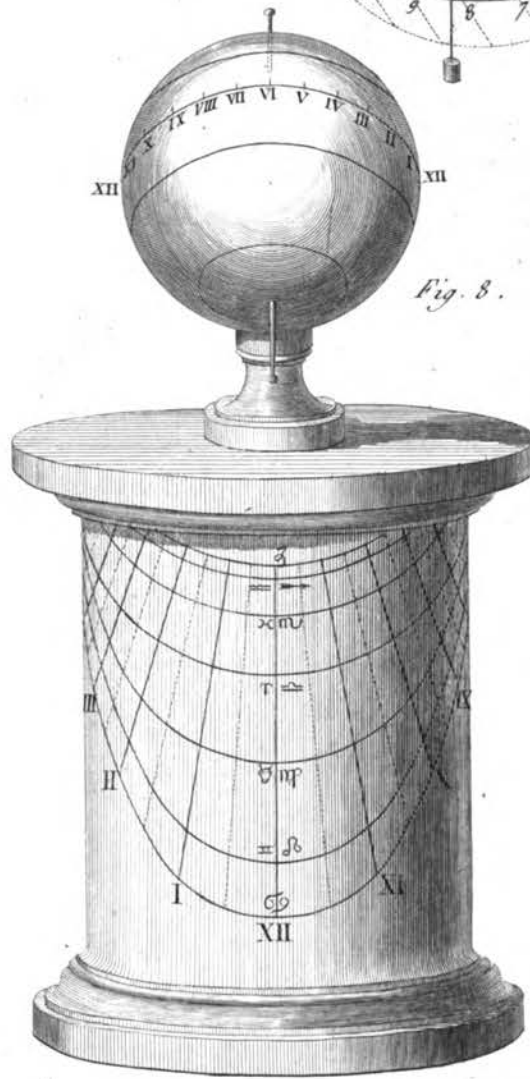


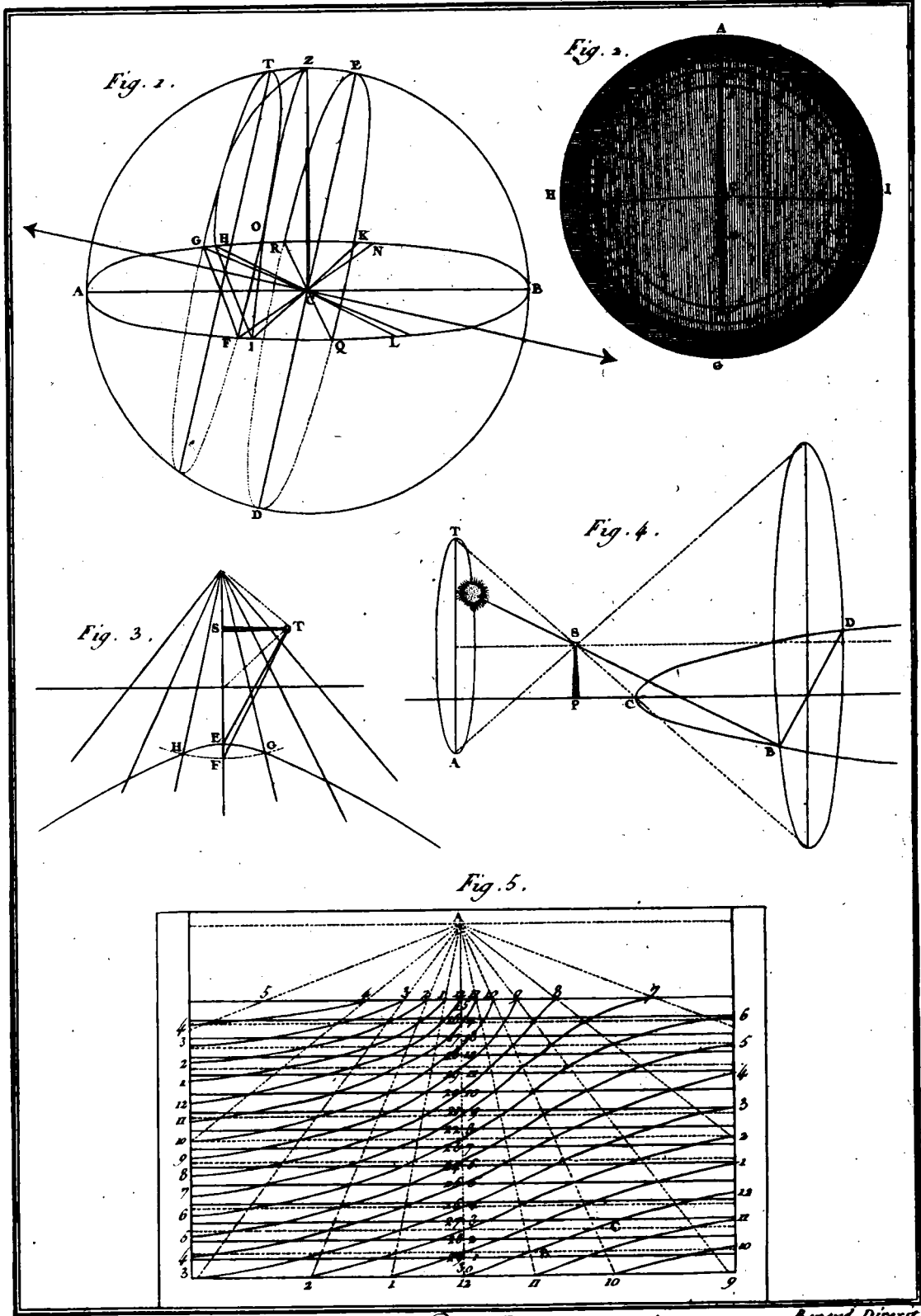
Fig. 8.



Benard Diraxet.

Gnomonique.



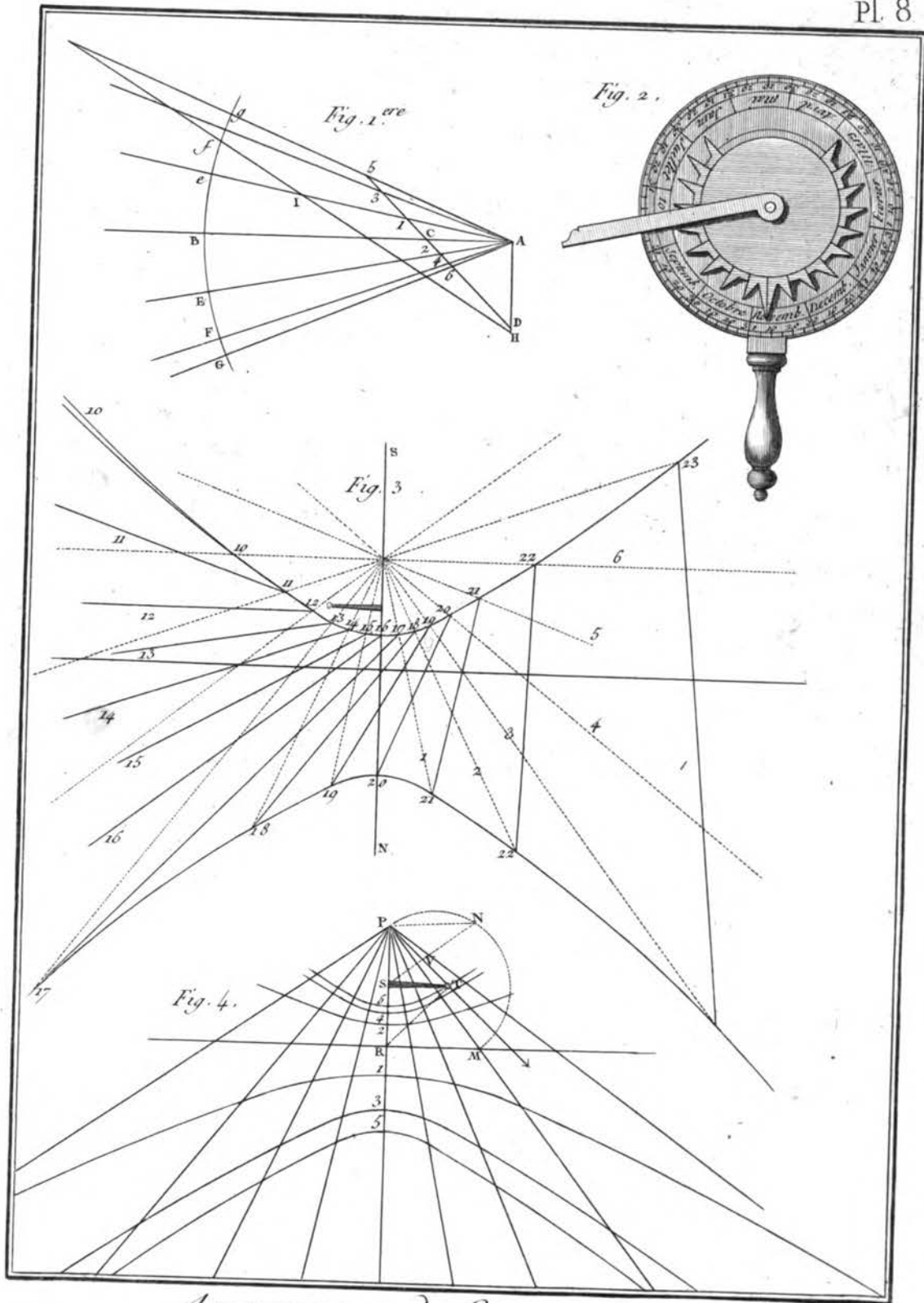


*Amusemens de Gnomonique.*

Benard Dorez

Digitized by Google

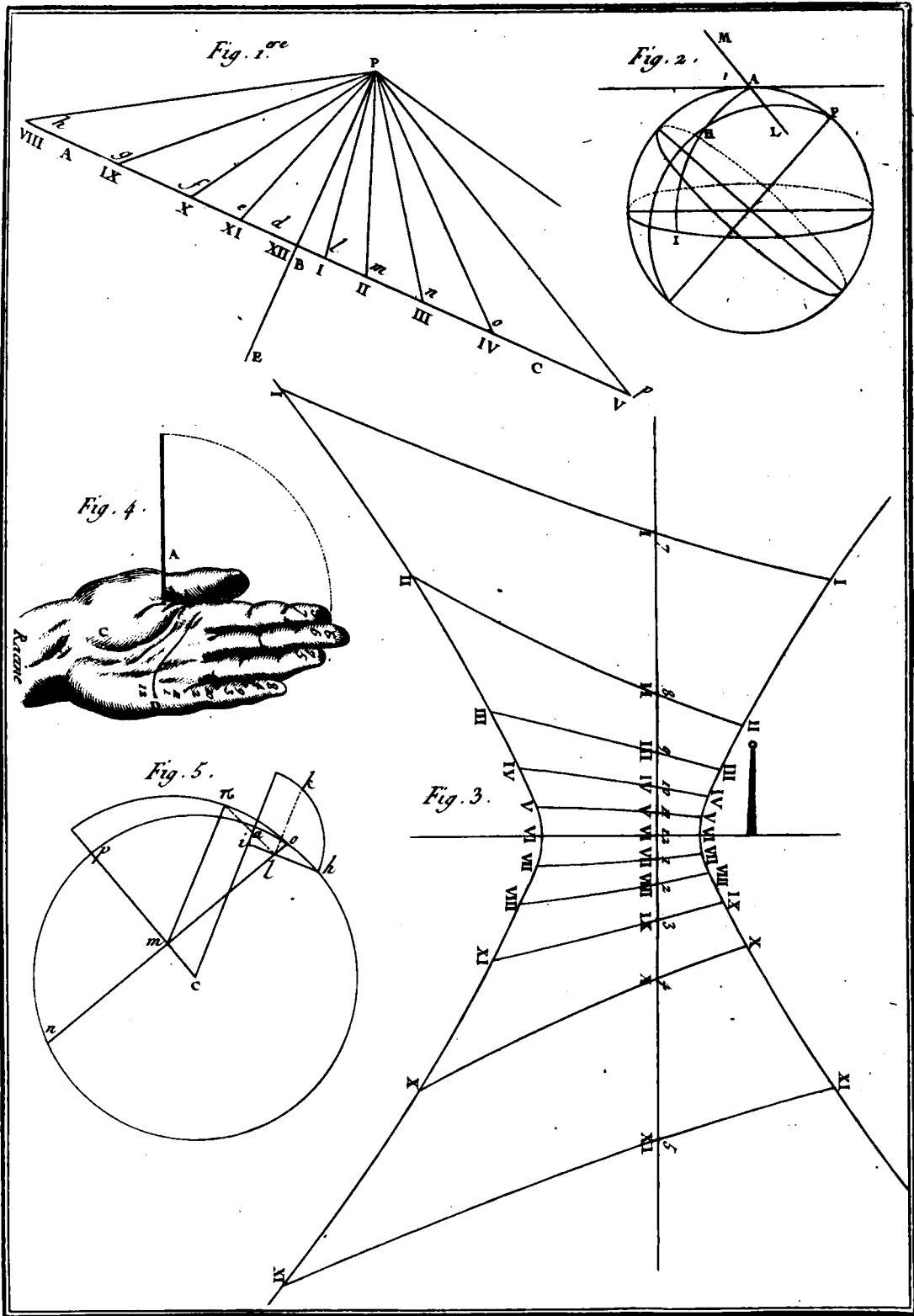
UNIVERSIDAD COMPLUTENSE DE MADRID



*Amusemens de Gnomonique* Bernard Diraxit.

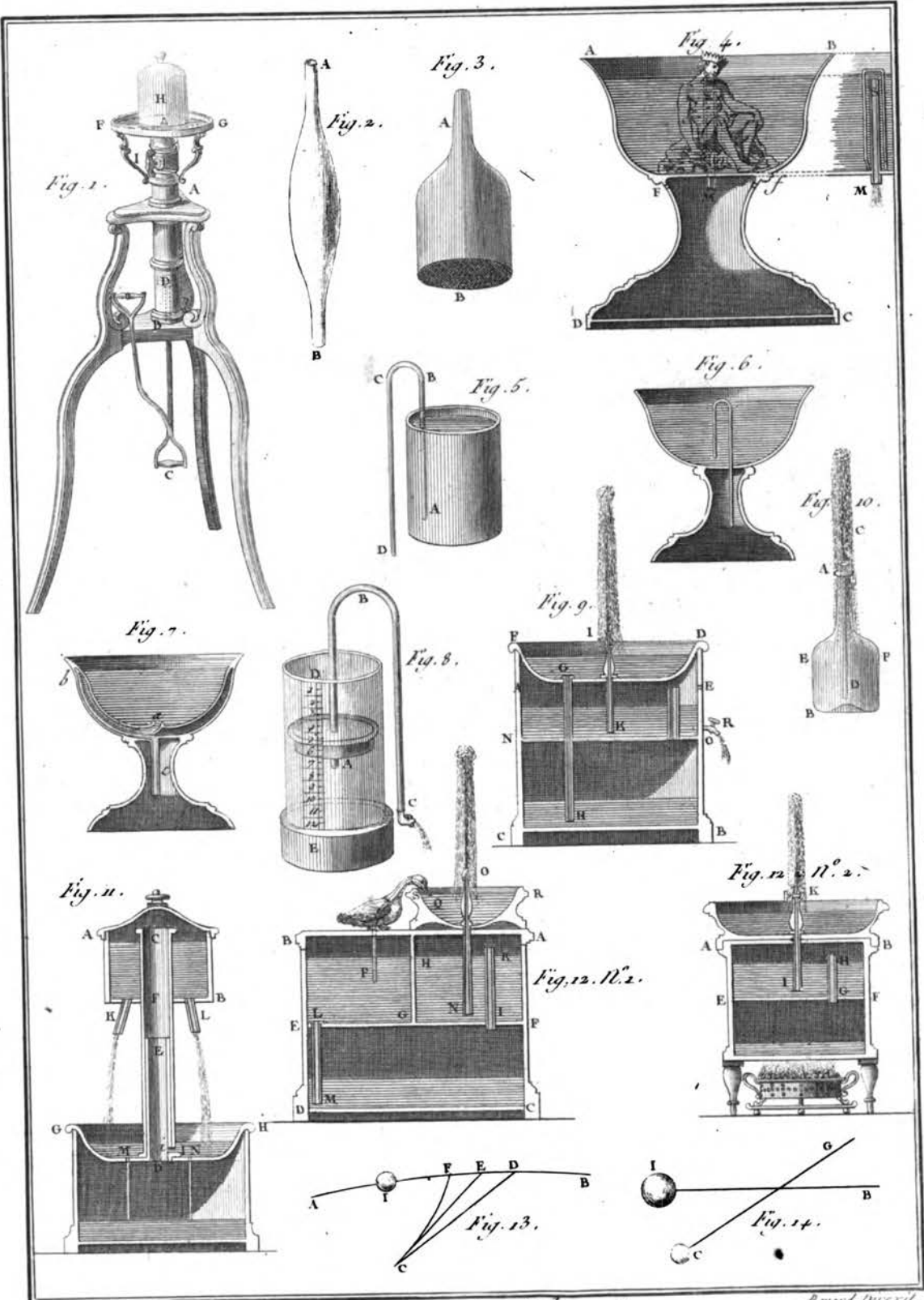
Digitized by Google

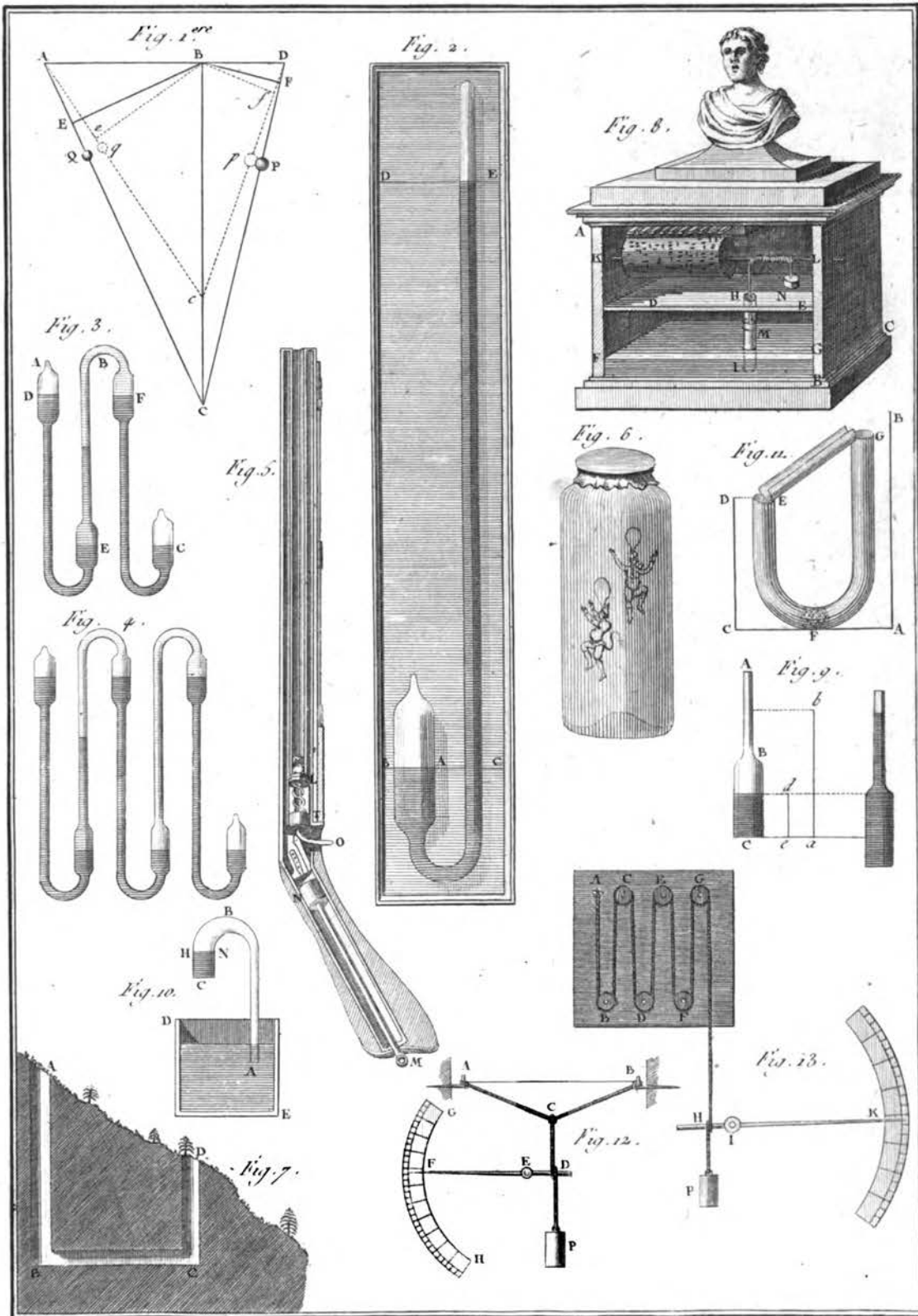
Original from  
UNIVERSIDAD COMPLUTENSE  
DE MADRID

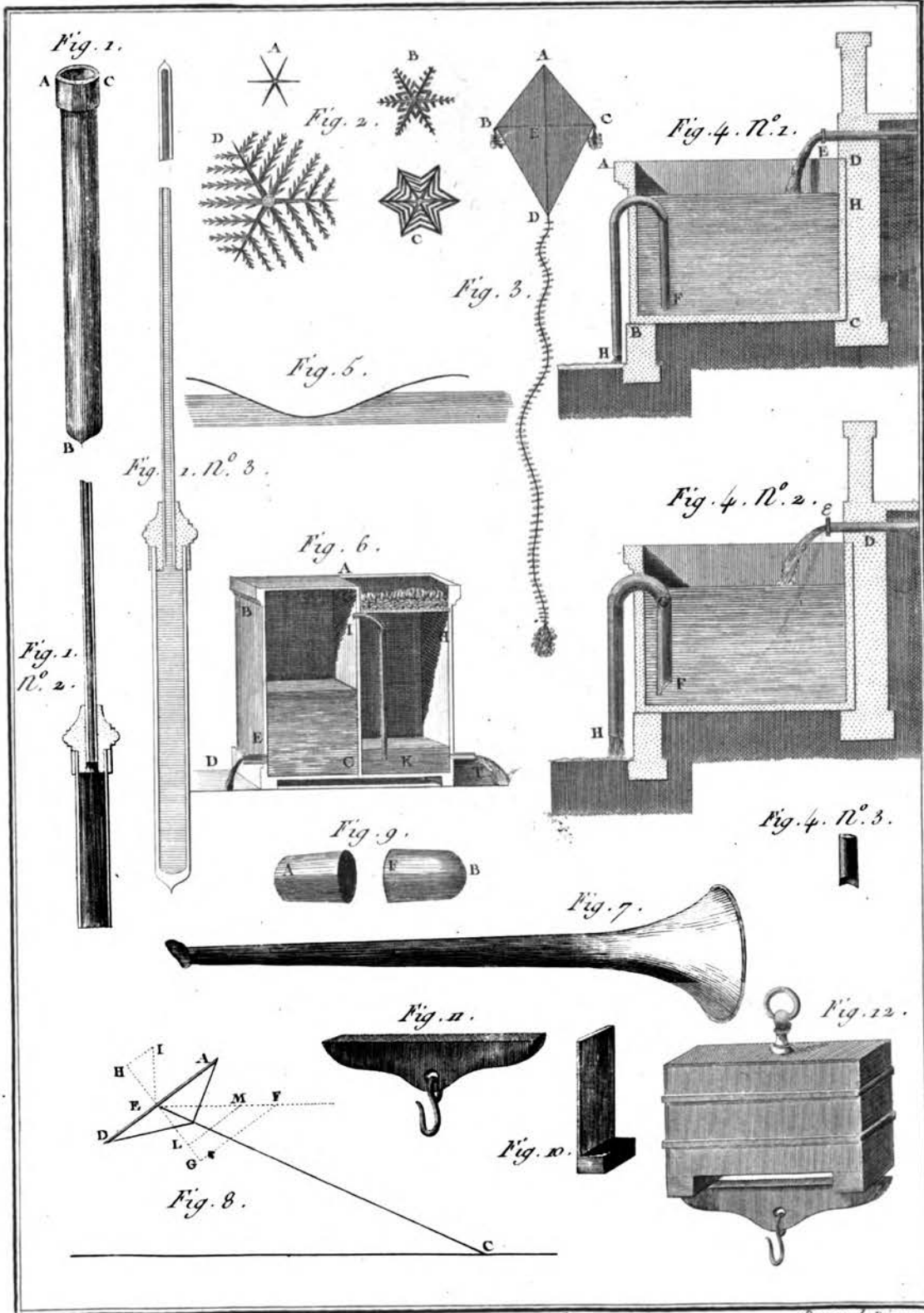


*Amusemens de Gnomonique.* *Benedict Drexel.*

Generated on 2014-05-10 22:51 GMT / http://hdl.handle.net/2027/ucm.5320295822 Public Domain, Google-digitized / http://www.hathitrust.org/access\_use#pd-google

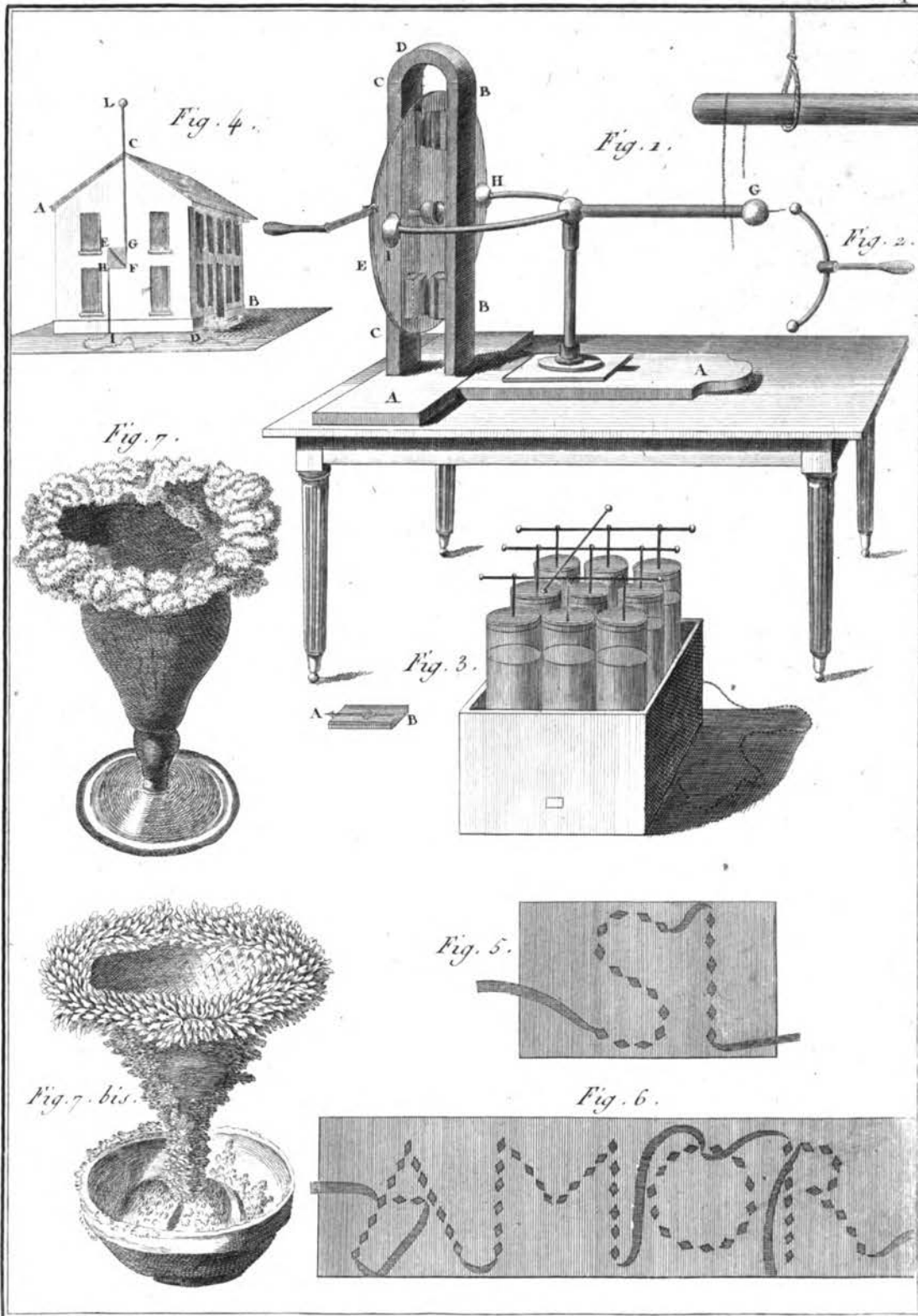






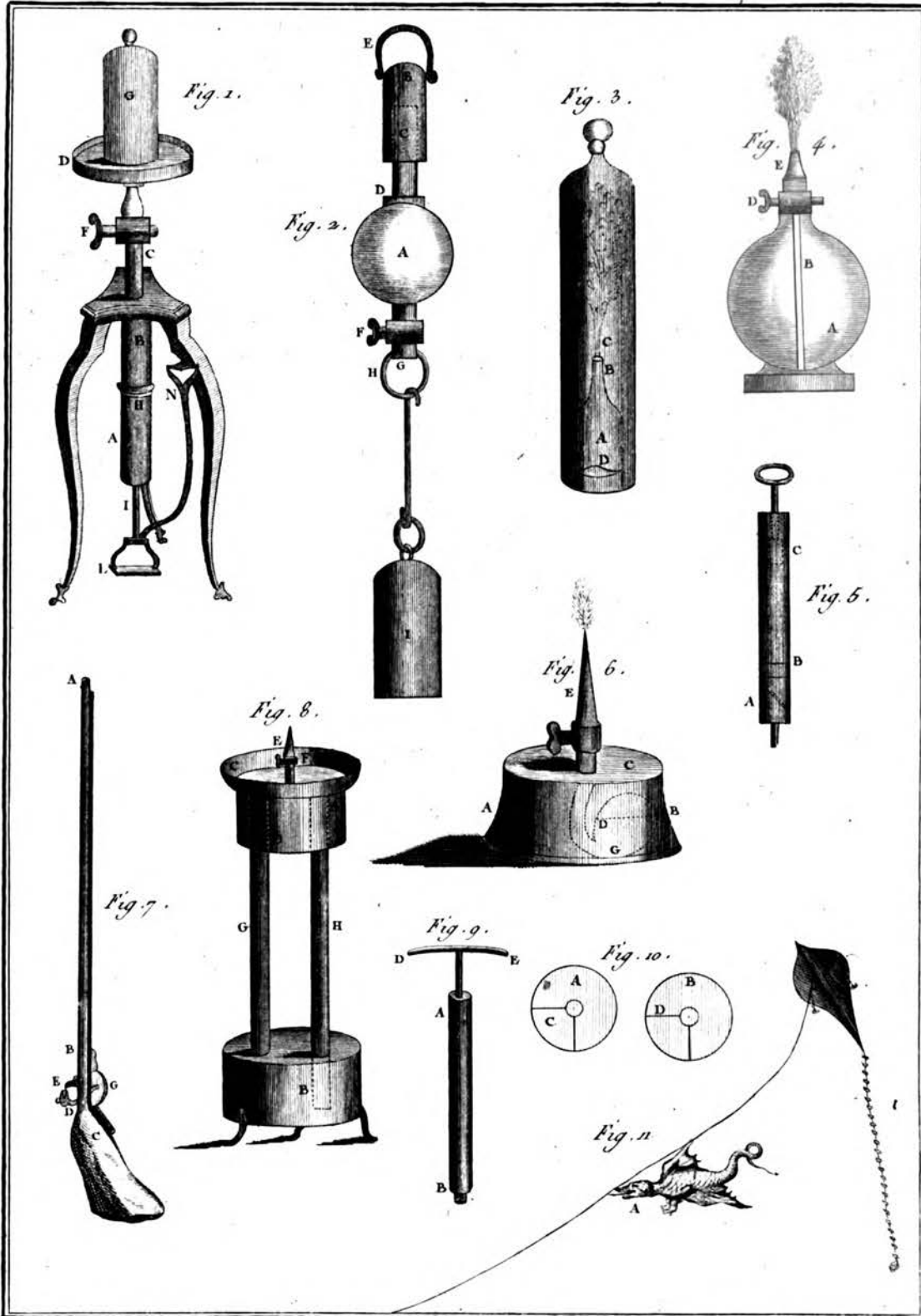
*Amusemens de Physique.*

*Bernard Dorel*



*Amusemens de Physique*

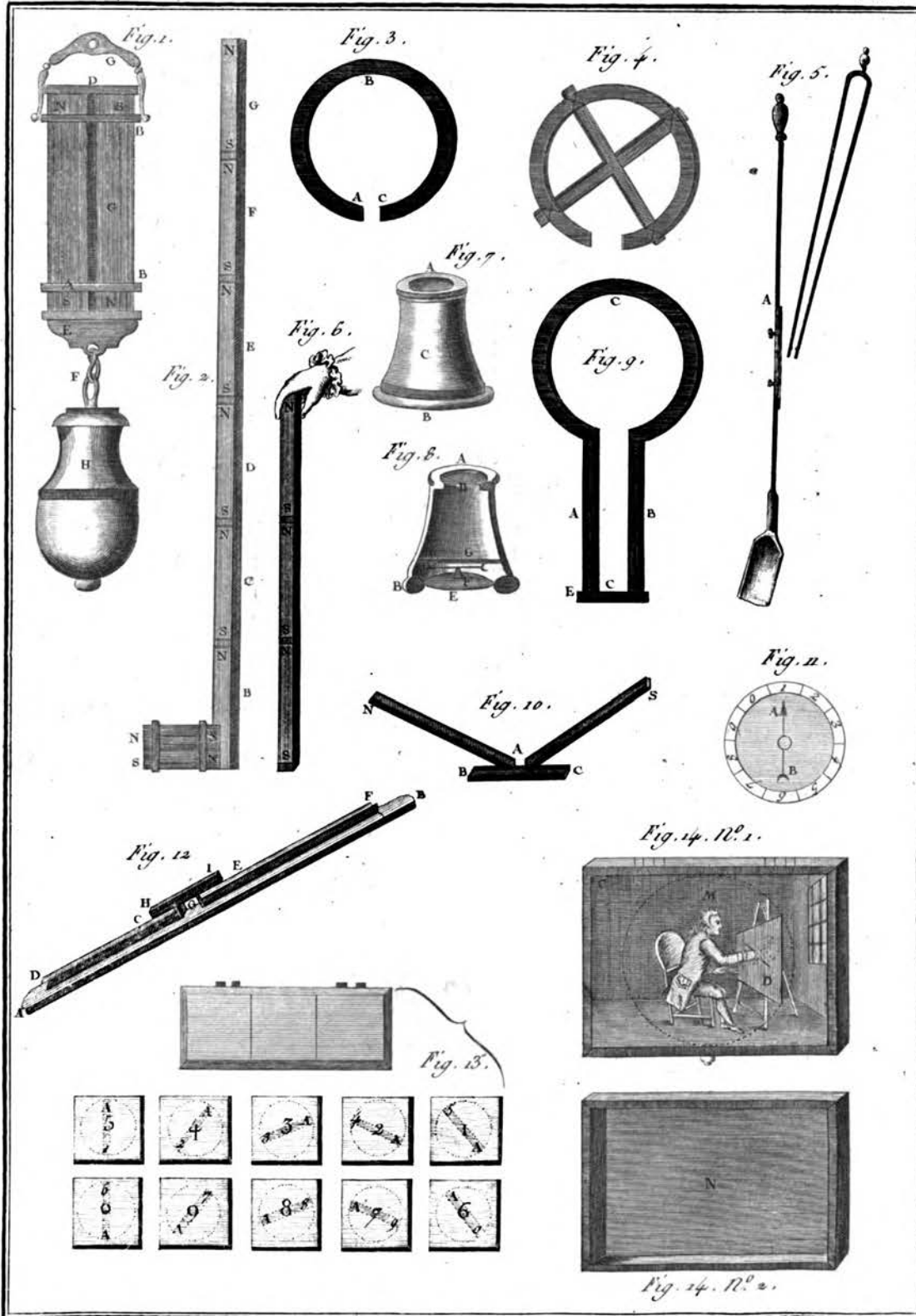
*Benoist. Diracul.*



*Amusemens de Physique.*

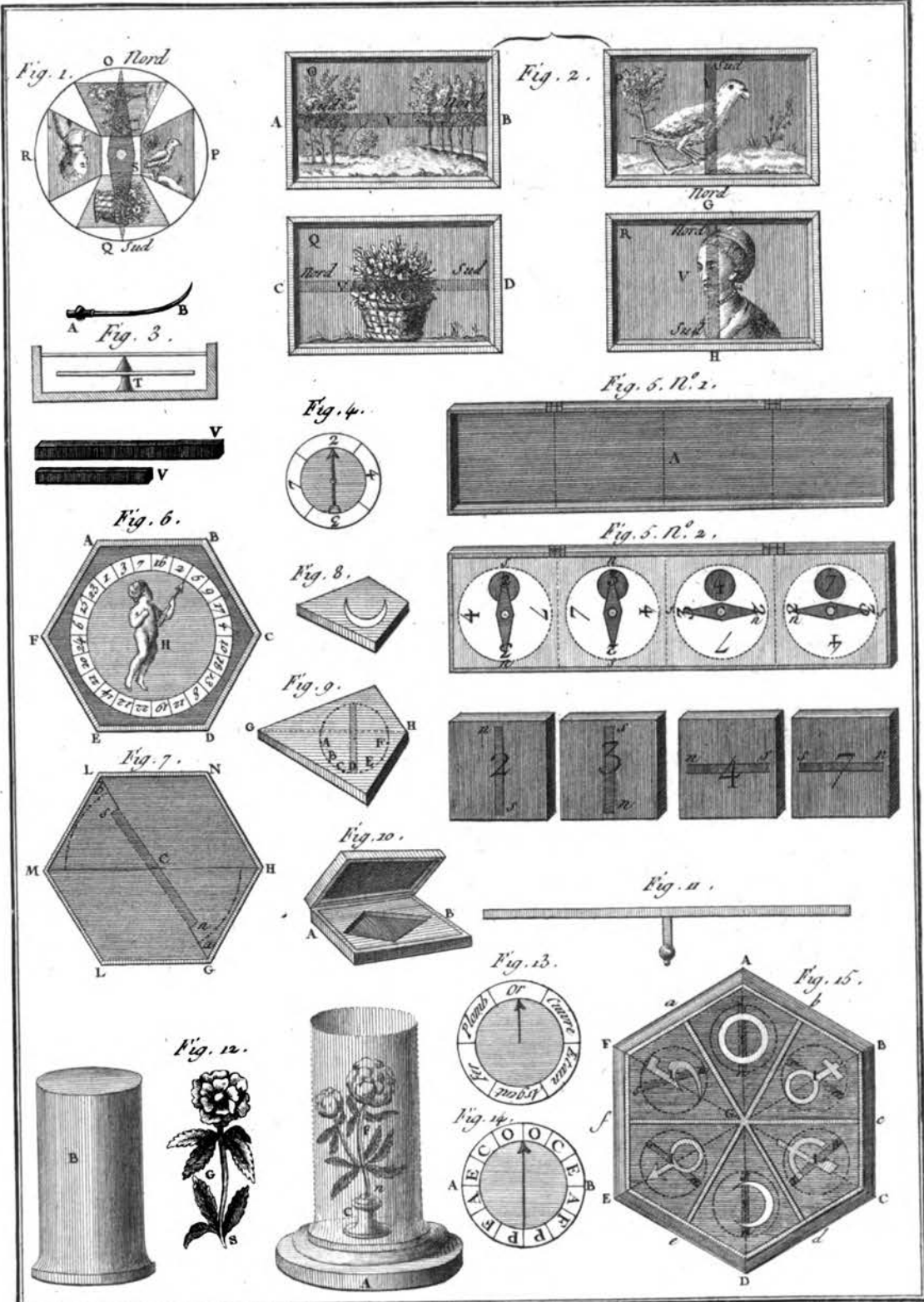
*Bernard L'écrit.*





*Amusemens de Physique.*

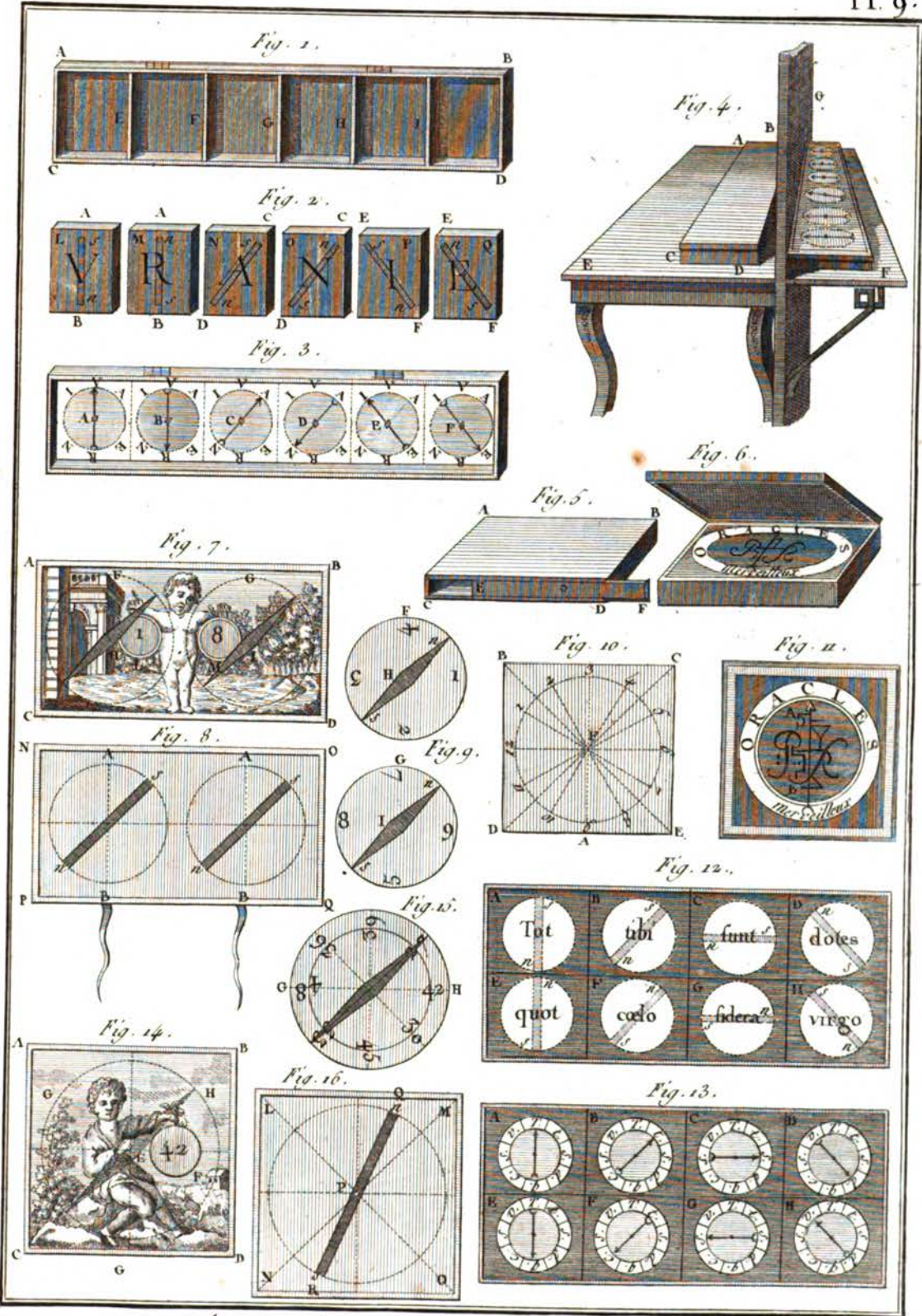
*Bonard. D'Arcet*



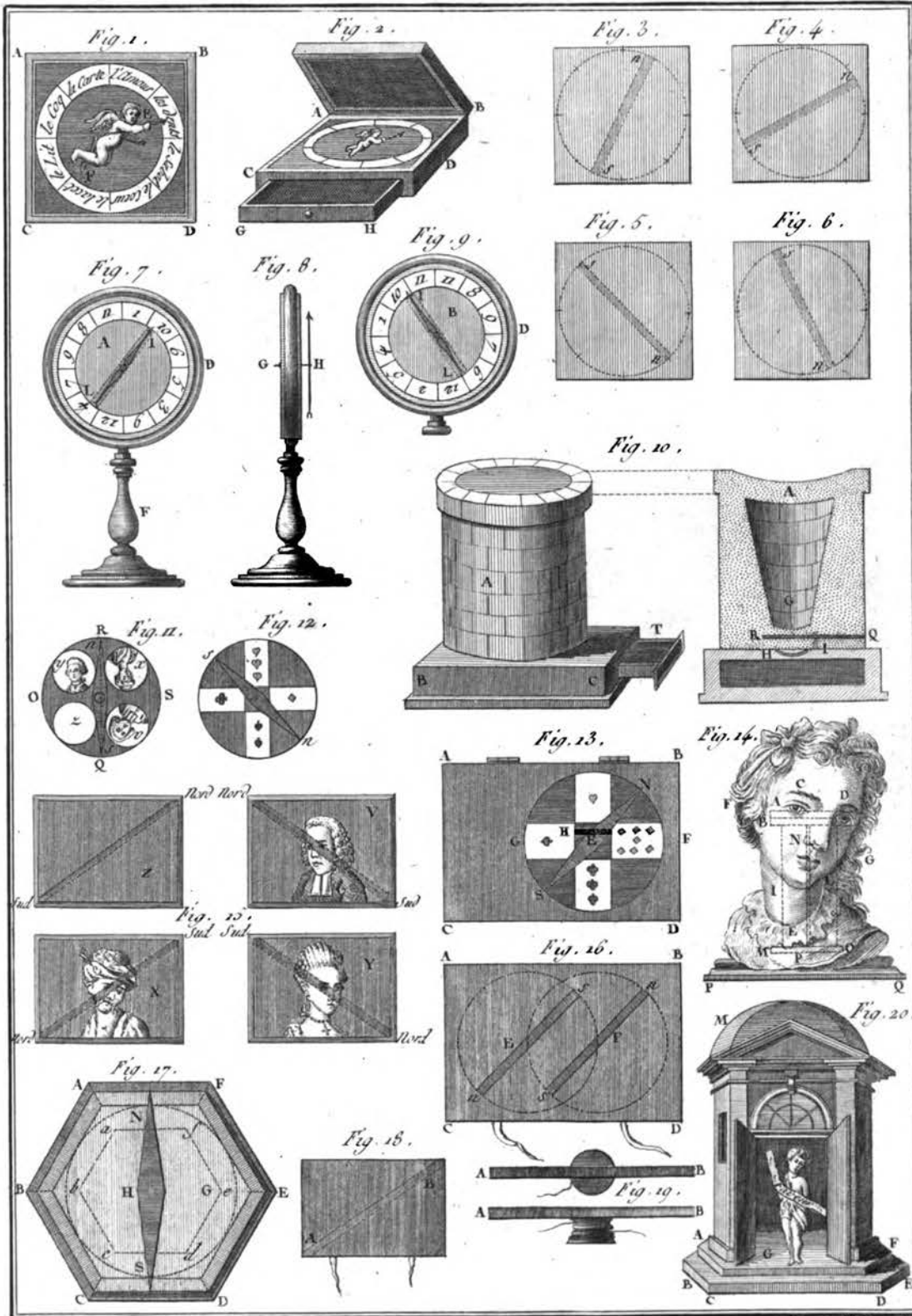
*Amusemens de Physique.*

Bonard Doreuil

Generated on 2014-05-11 15:50 GMT / http://hdl.handle.net/2027/ucm.5320295822 Public Domain, Google-digitized / http://www.hathitrust.org/access\_use#pd-google

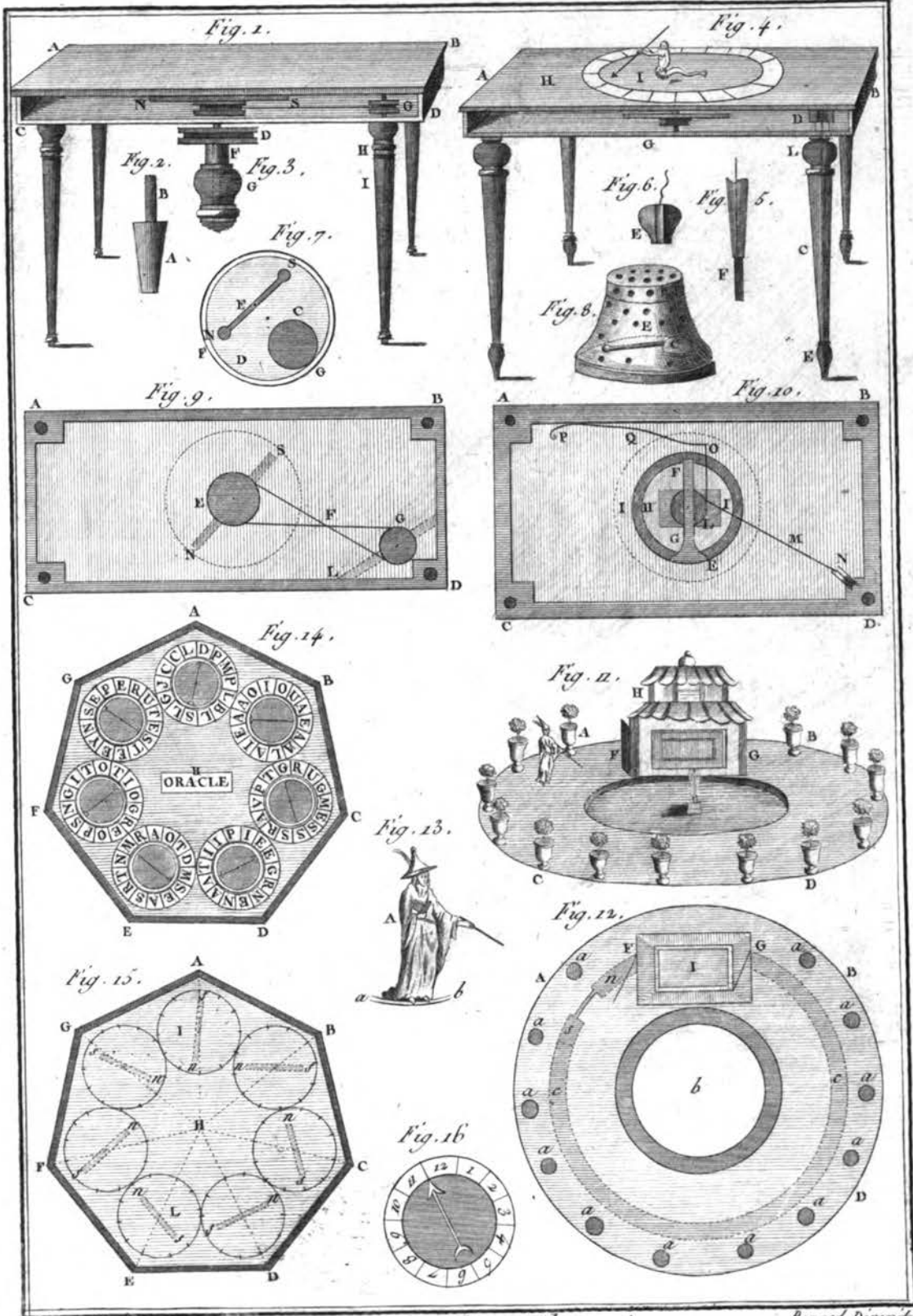


*Amusemens de Physique* Bernard Duret  
 Original from 17  
 Digitized by Google UNIVERSIDAD COMPLUTENSE DE MADRID



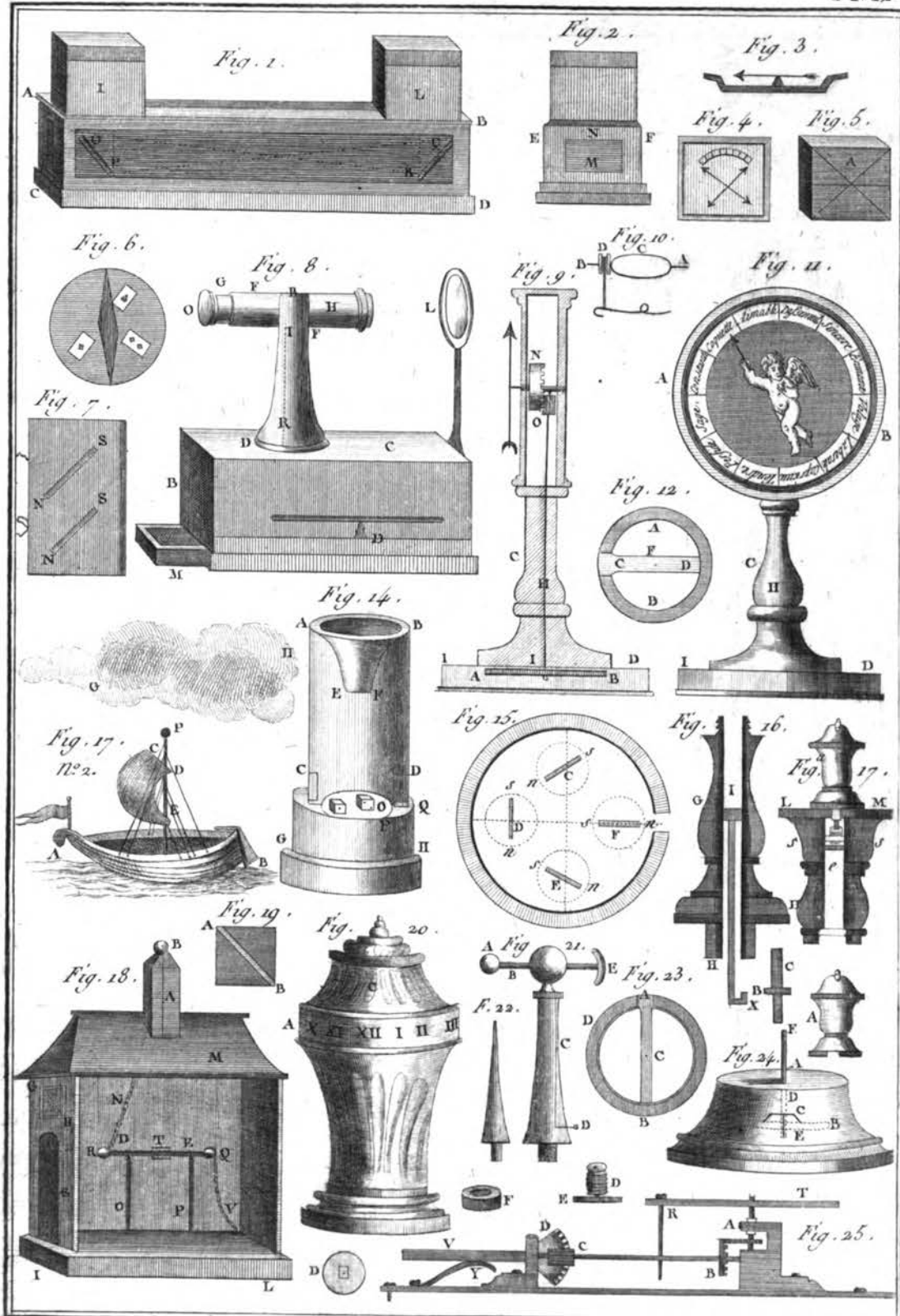
*Amusemens de Physique*

*Bernard Duvet.*



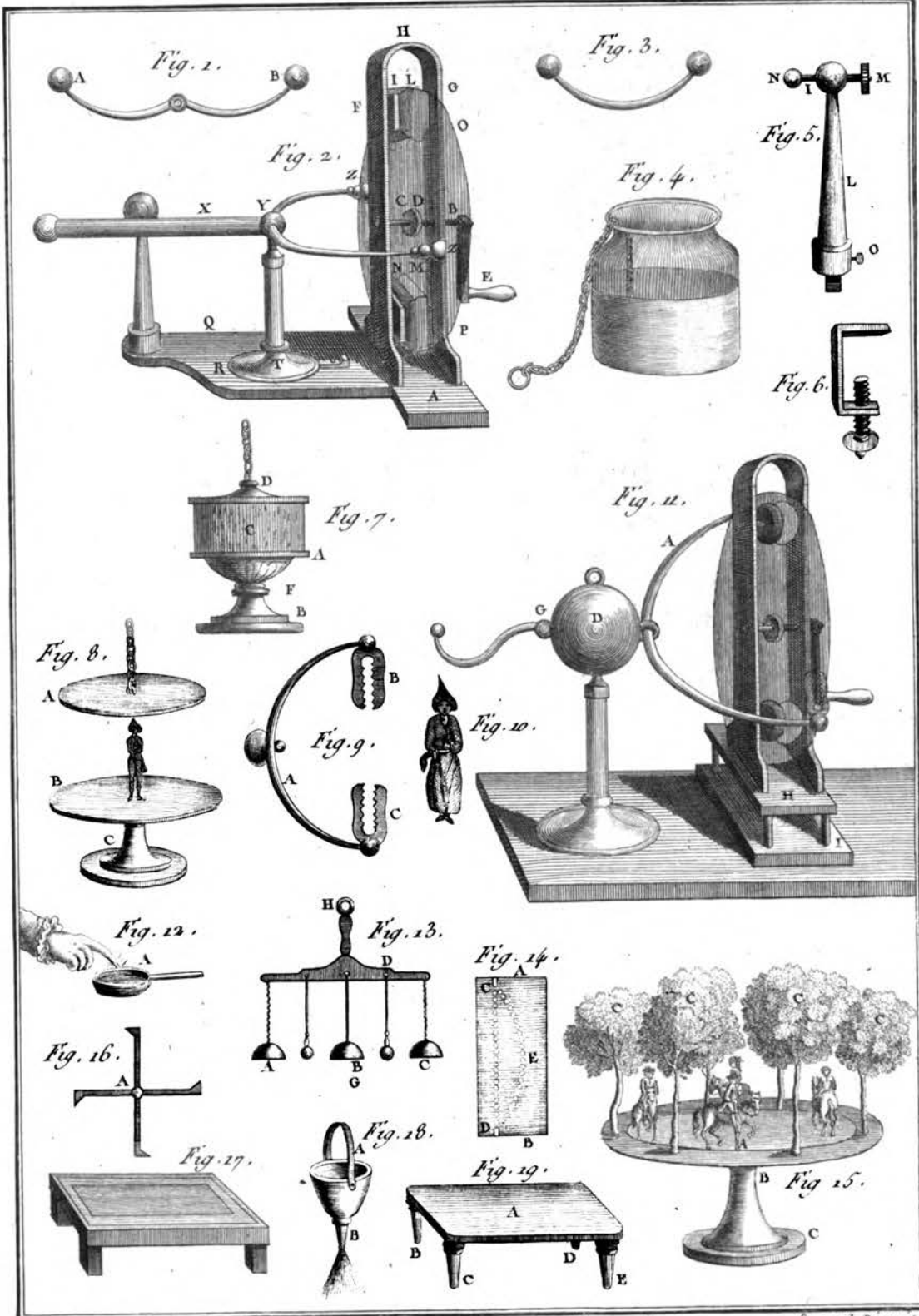
*Amusemens de Physique.*

*Benard Dircet.*



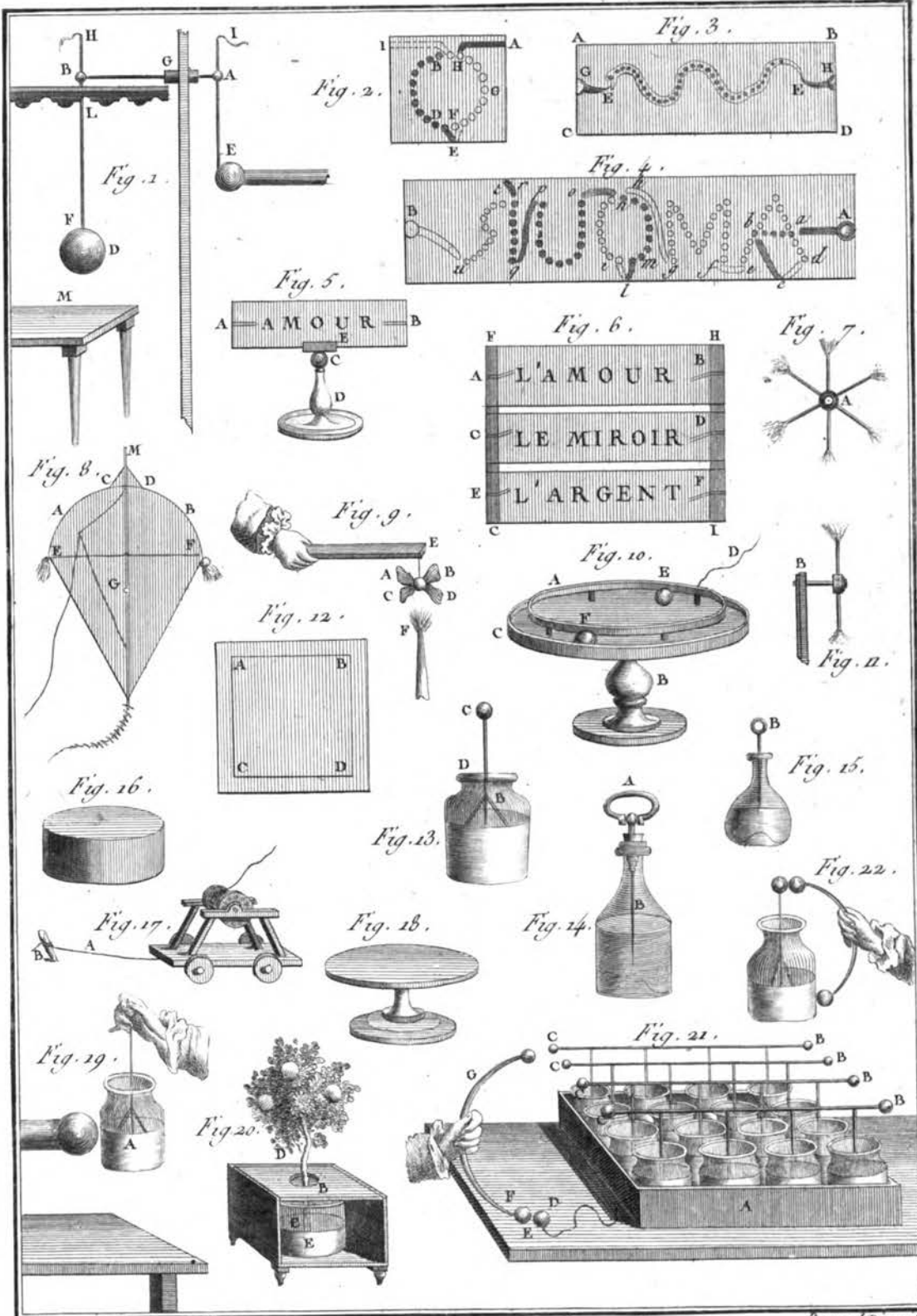
*Amusemens de Physique.*

*Bernard Directt.*



*Amusemens de Physique.*

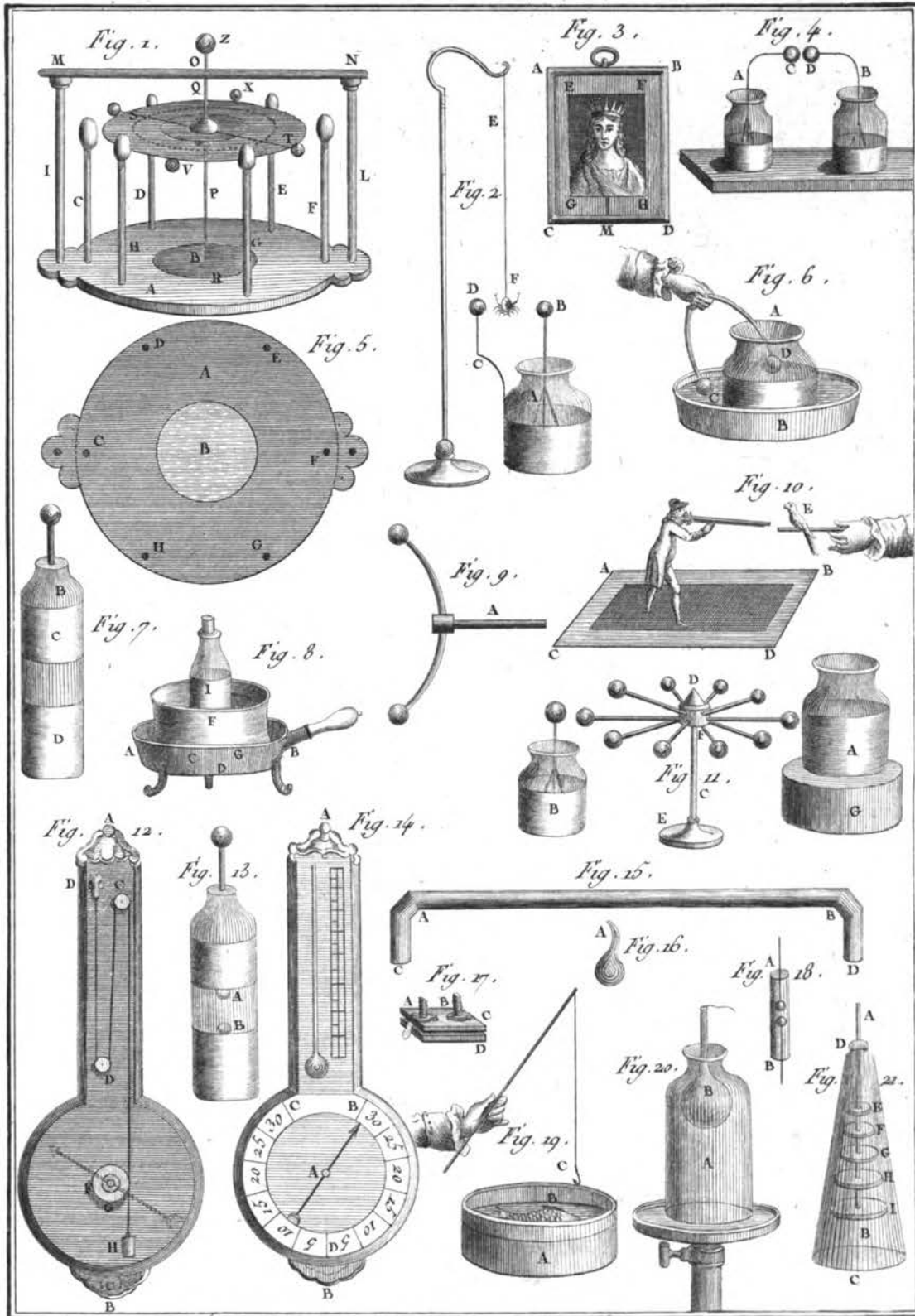
*Beard Duxit.*



*Amusemens de Physique.*

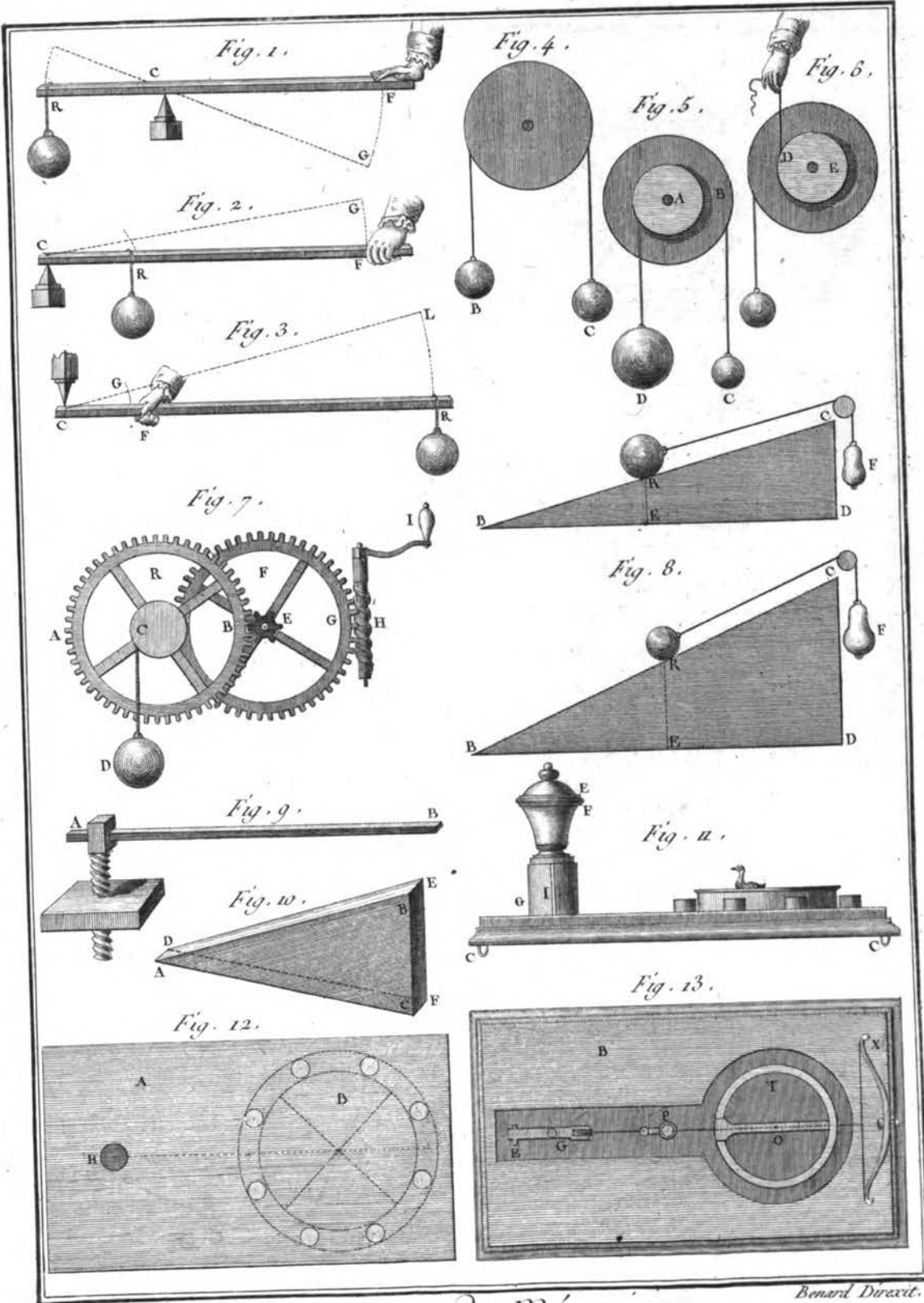
*Bonard, Directeur.*





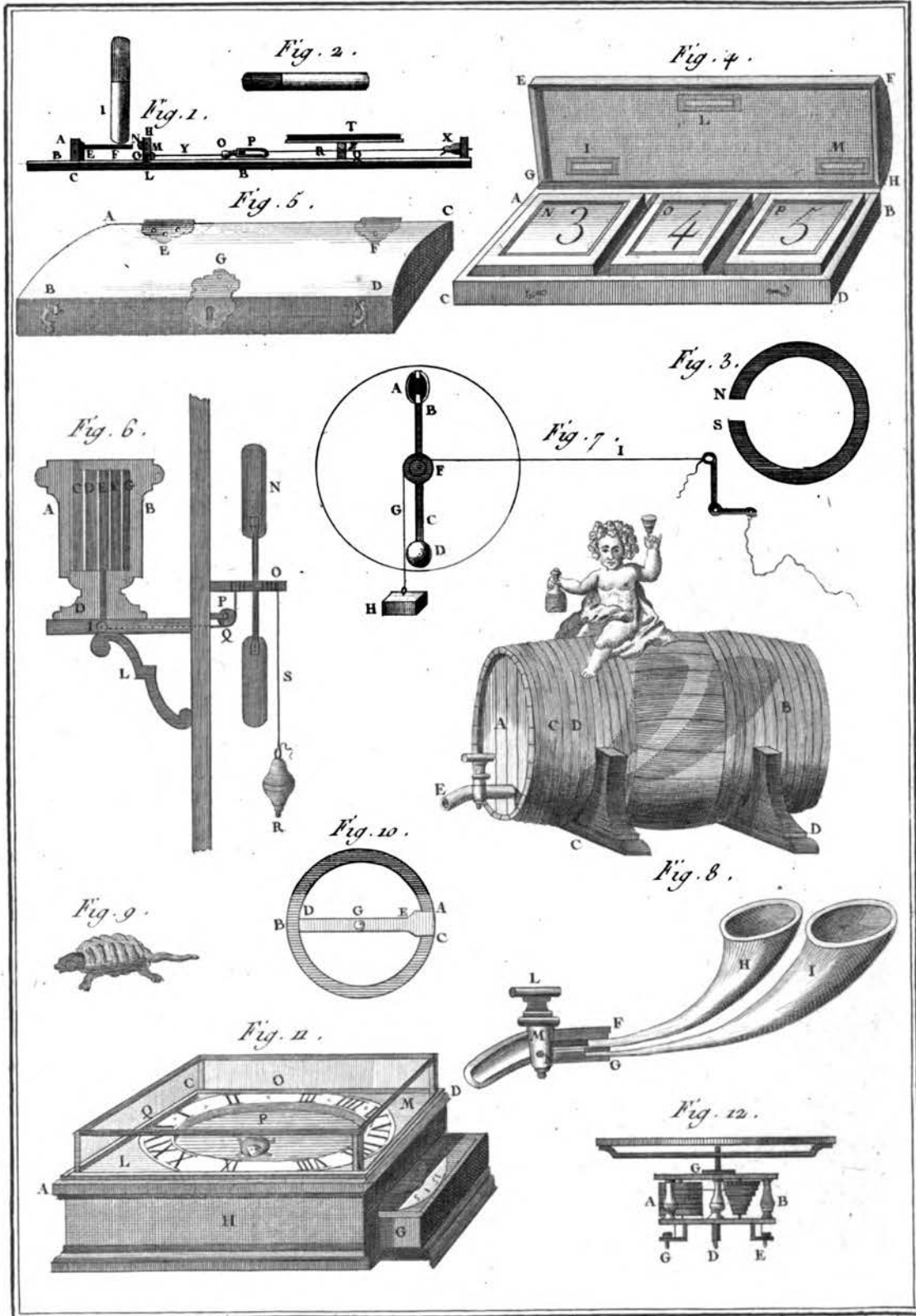
*Amusemens de Physique.*

*Benard Drexel*



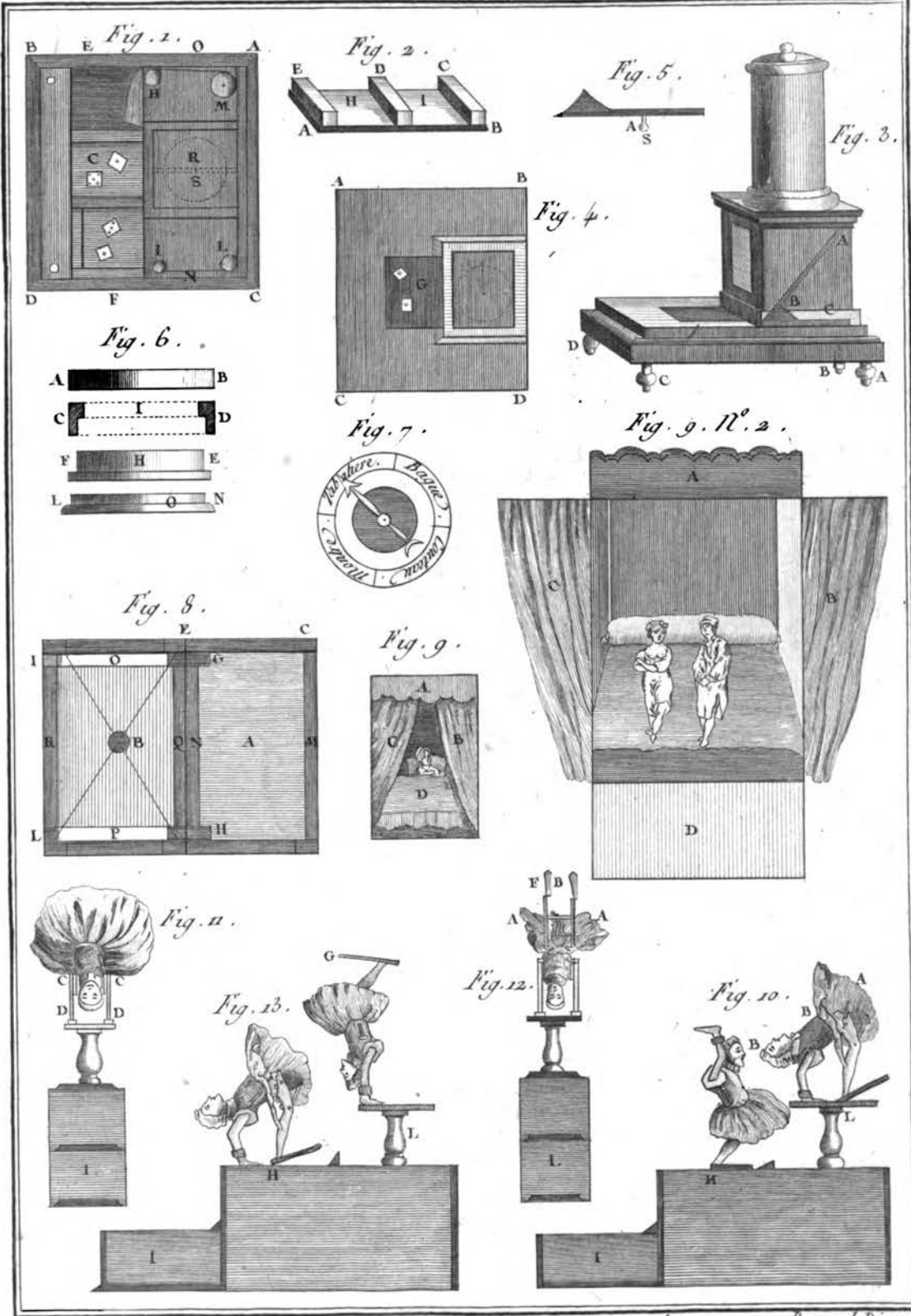
*Amusemens de Mécanique.*

*Bernard D'Araxit.*



*Amusemens de Mécanique.*

*Benard Duxcit.*

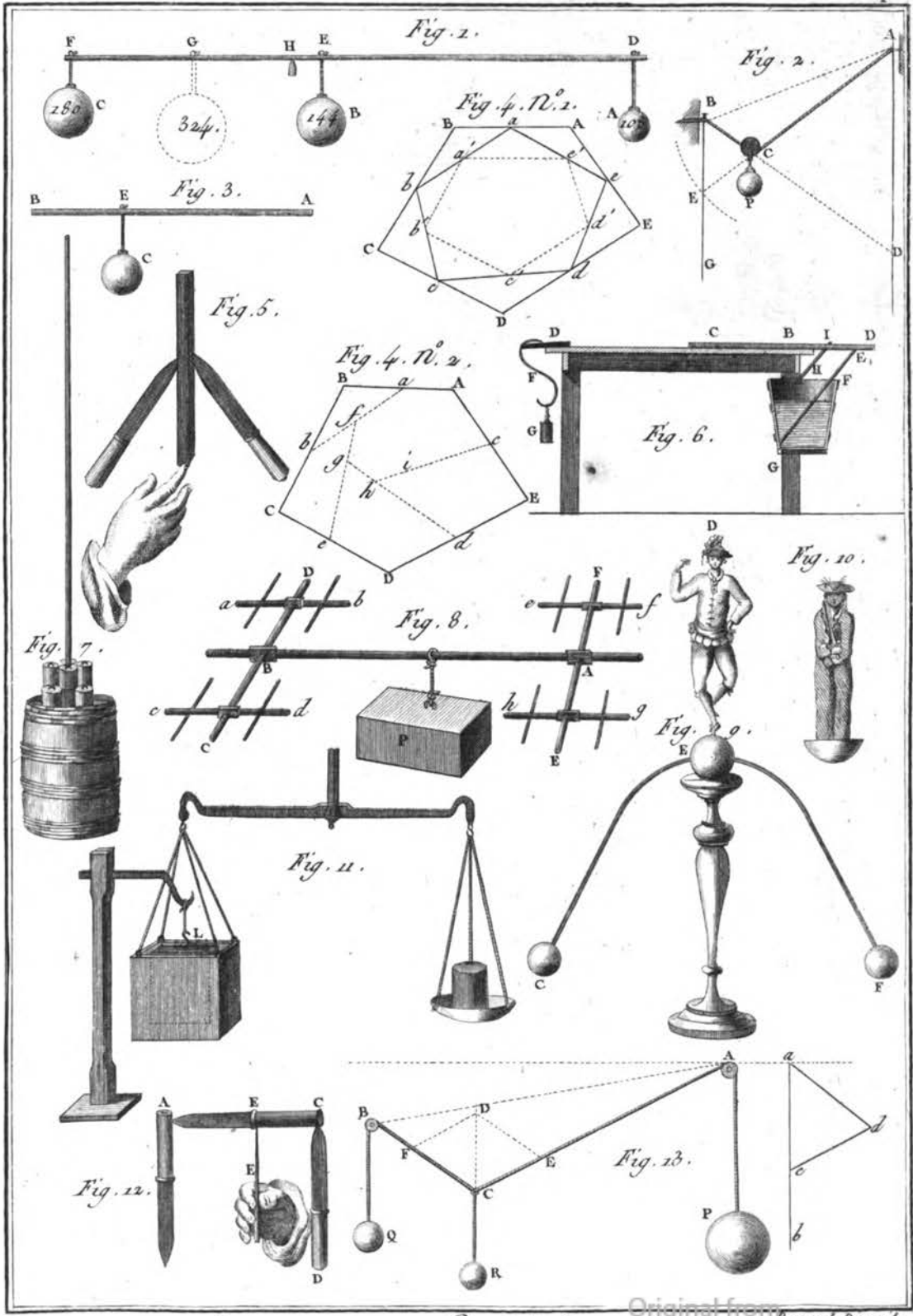


*Amusemens de Mécanique*

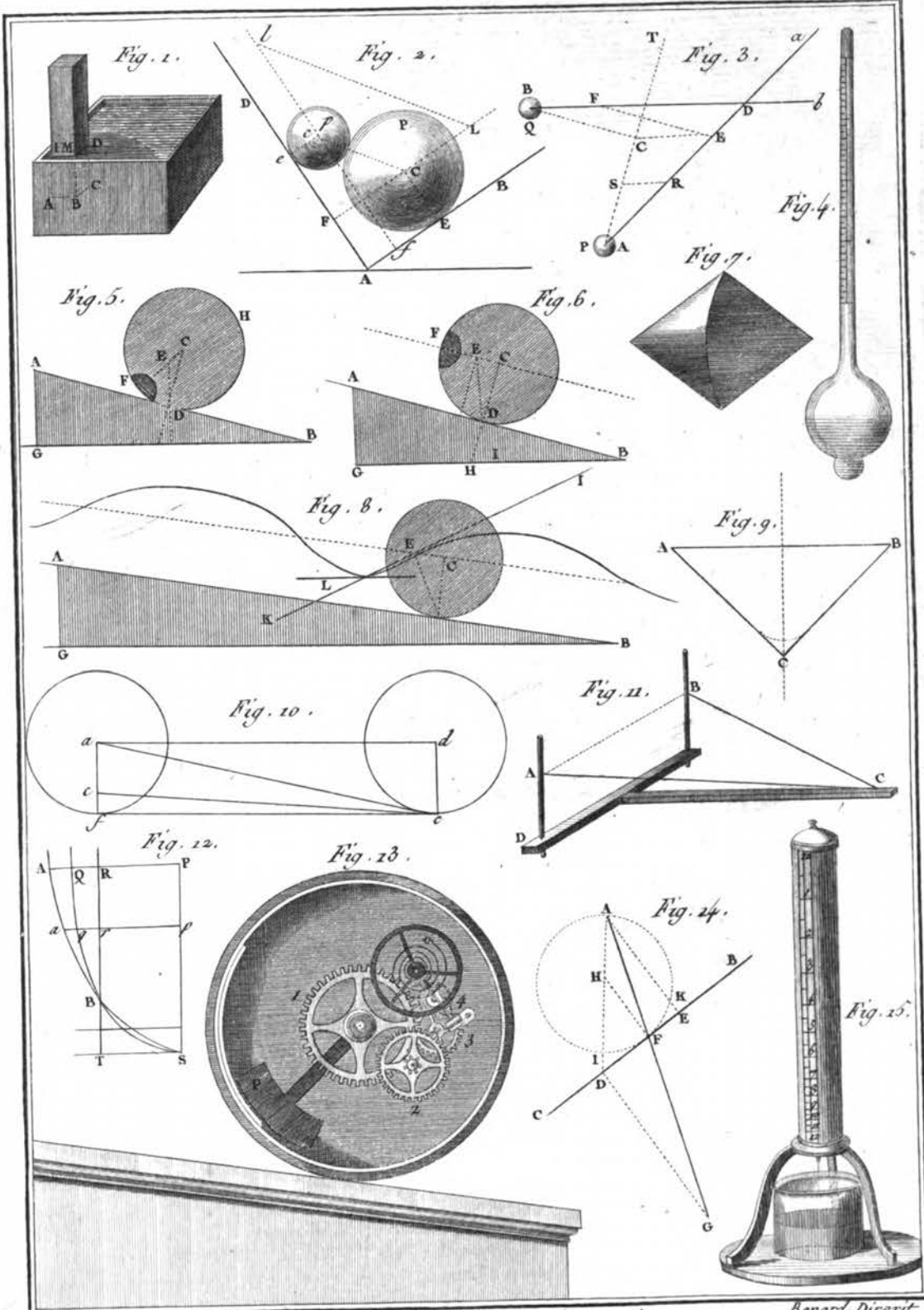
*Beuard Drexel.*

Digitized by Google

Original from  
UNIVERSIDAD COMPLUTENSE  
DE MADRID

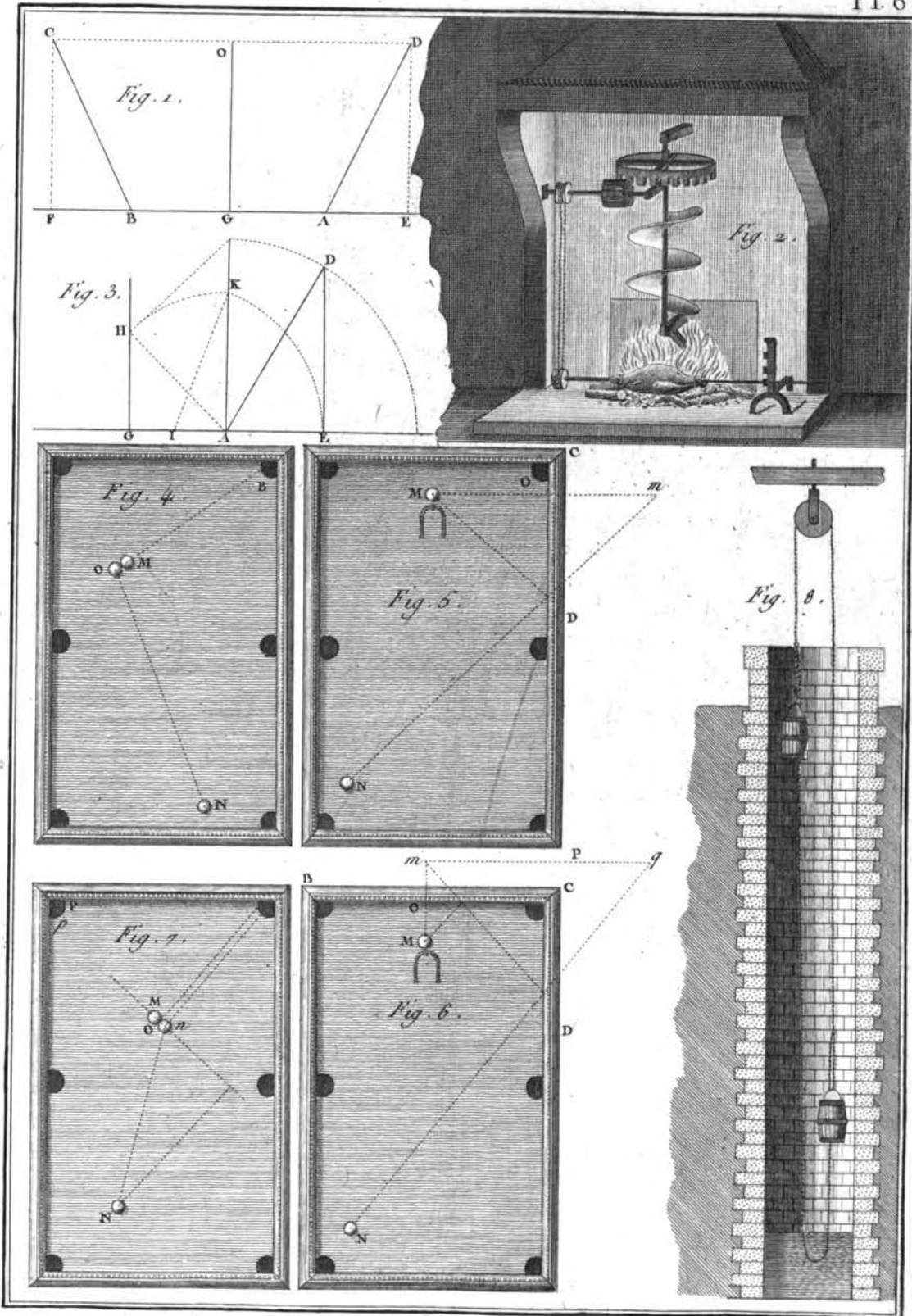


Generated on 2014-05-11 15:54 GMT / http://hdl.handle.net/2027/ucm.5320295822  
 Public Domain, Google-digitized / http://www.hathitrust.org/access\_use#pd-google



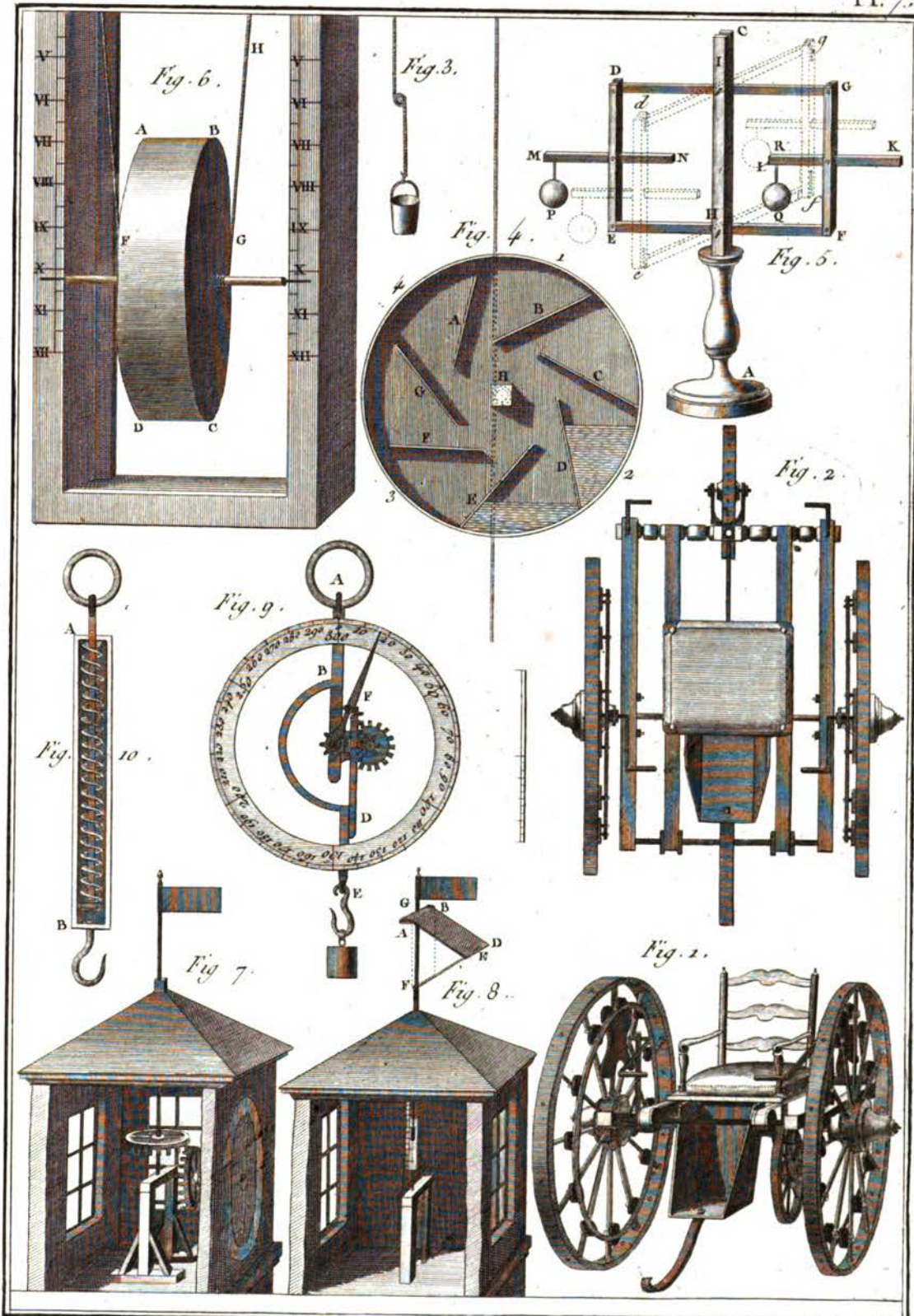
*Amusemens de Mécanique.*

*Benard Dixcit.*



*Amusemens de Mécanique*

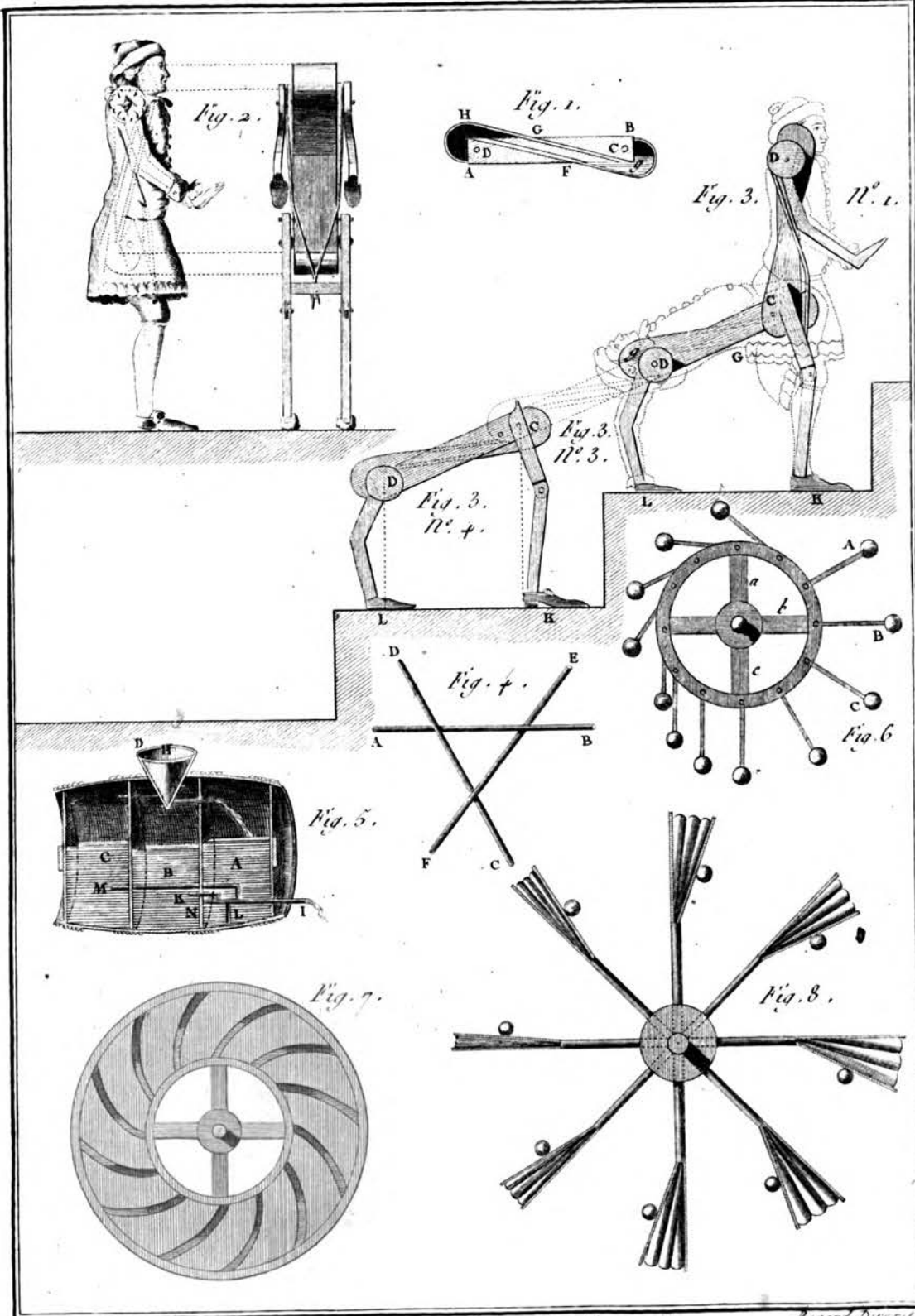
*Benard Duxet.*



*Anusemens de Mécanique*

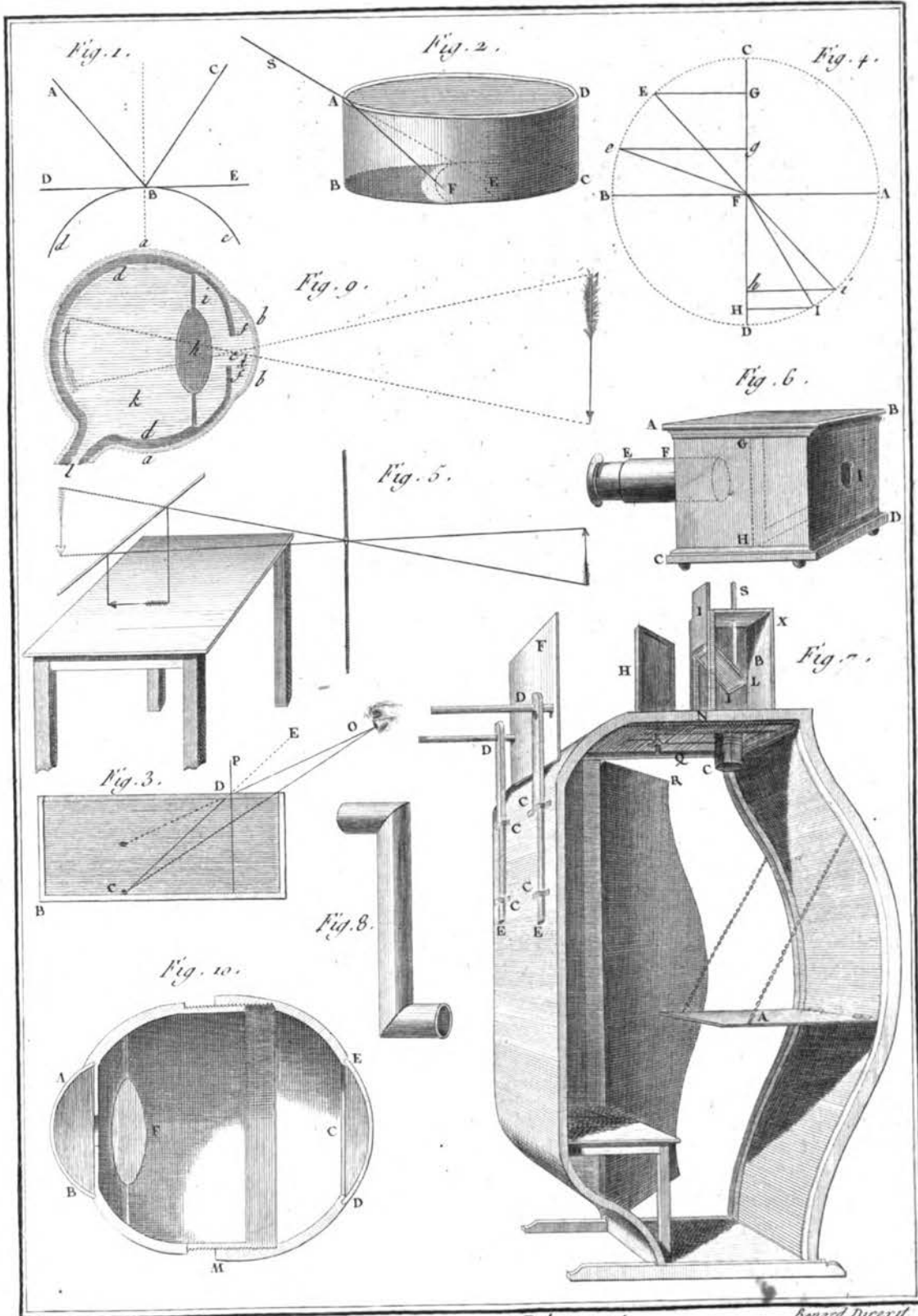
*Bonard Duxart.*





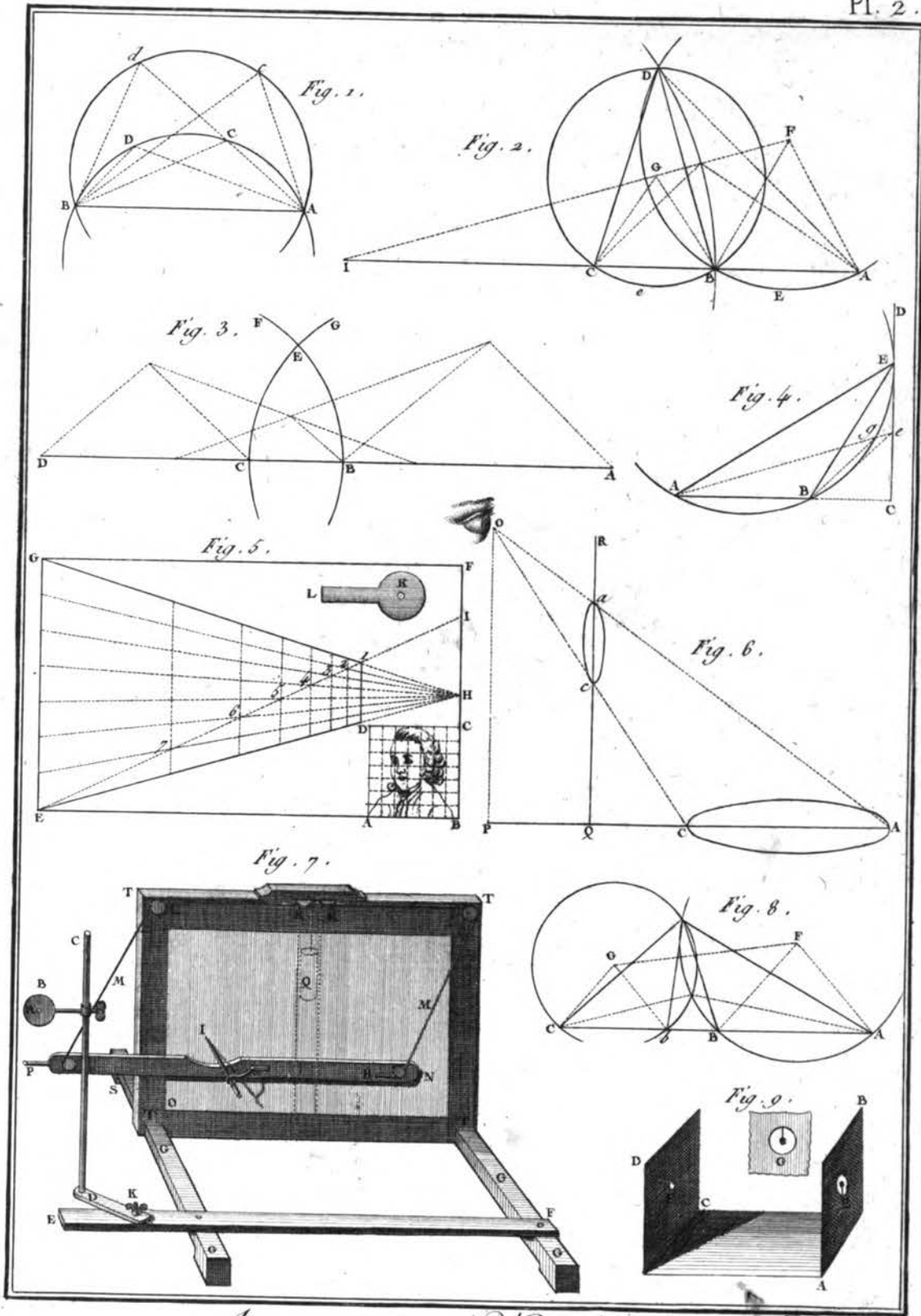
*Amusemens de Mécanique*

*Bonard Dorel*



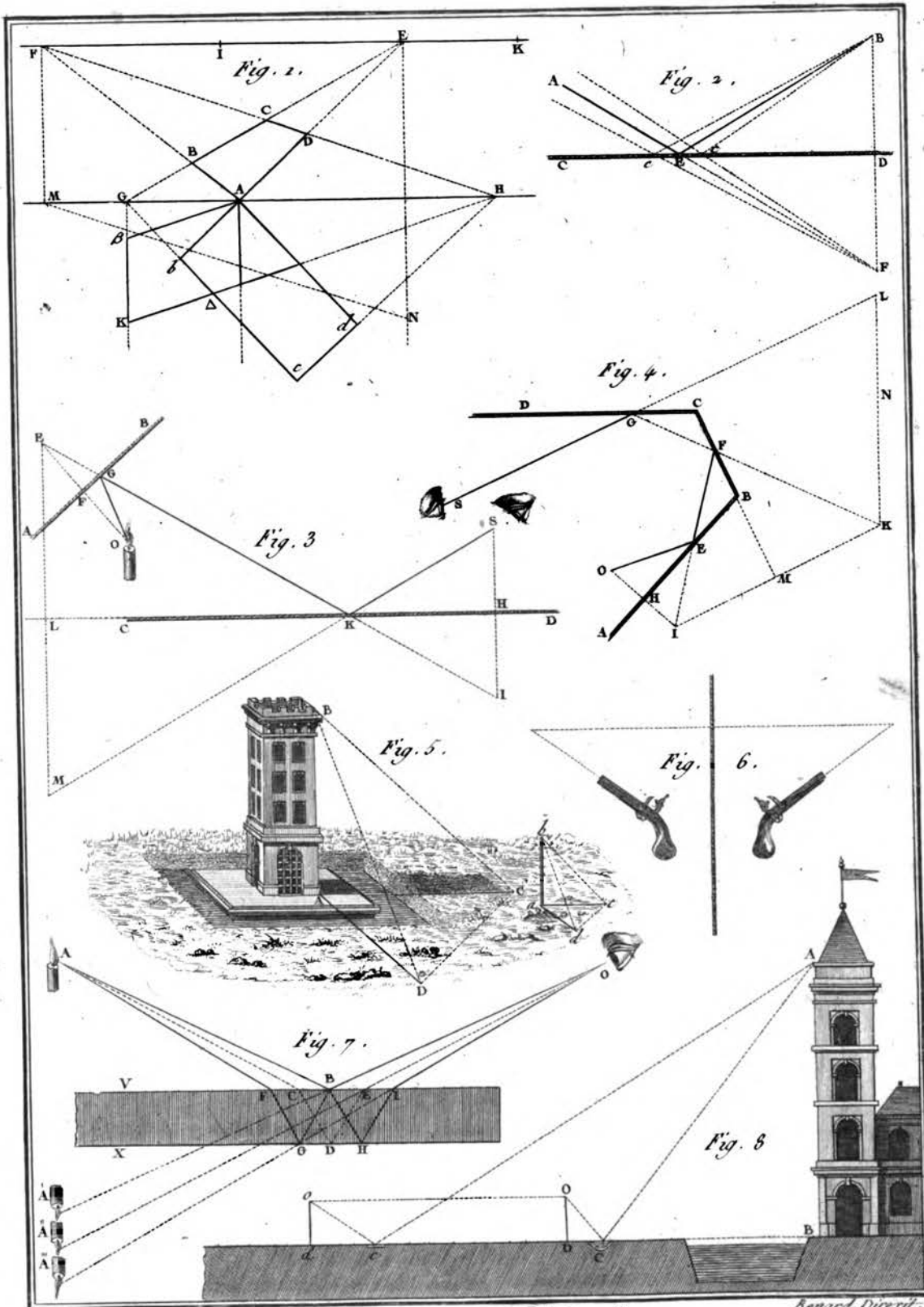
*Amusemens d'Optique*

Benard Duxat



*Amusemens d'Optique.*

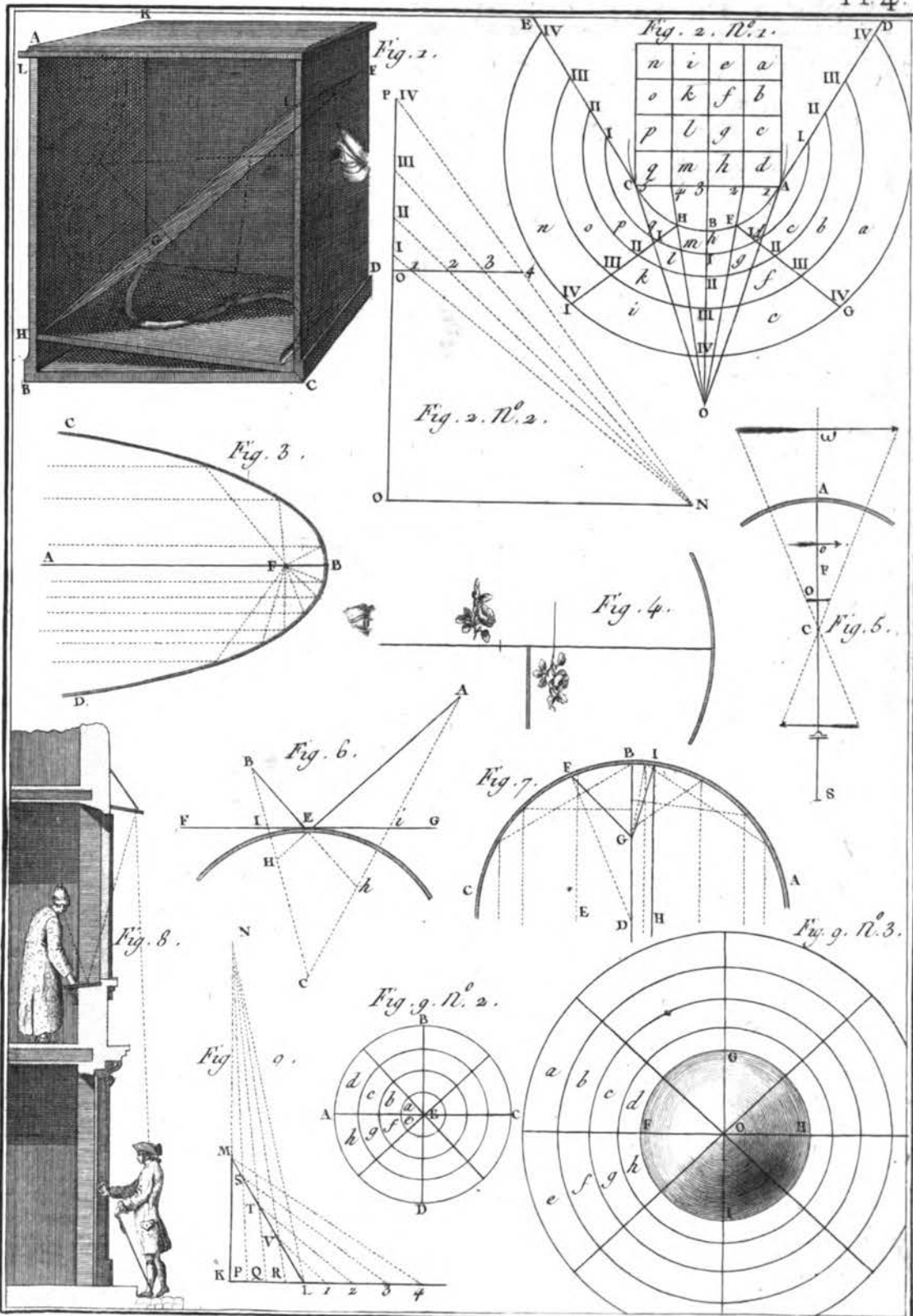
*Bernard Dinzet*



*Amusemens d'Optique.*

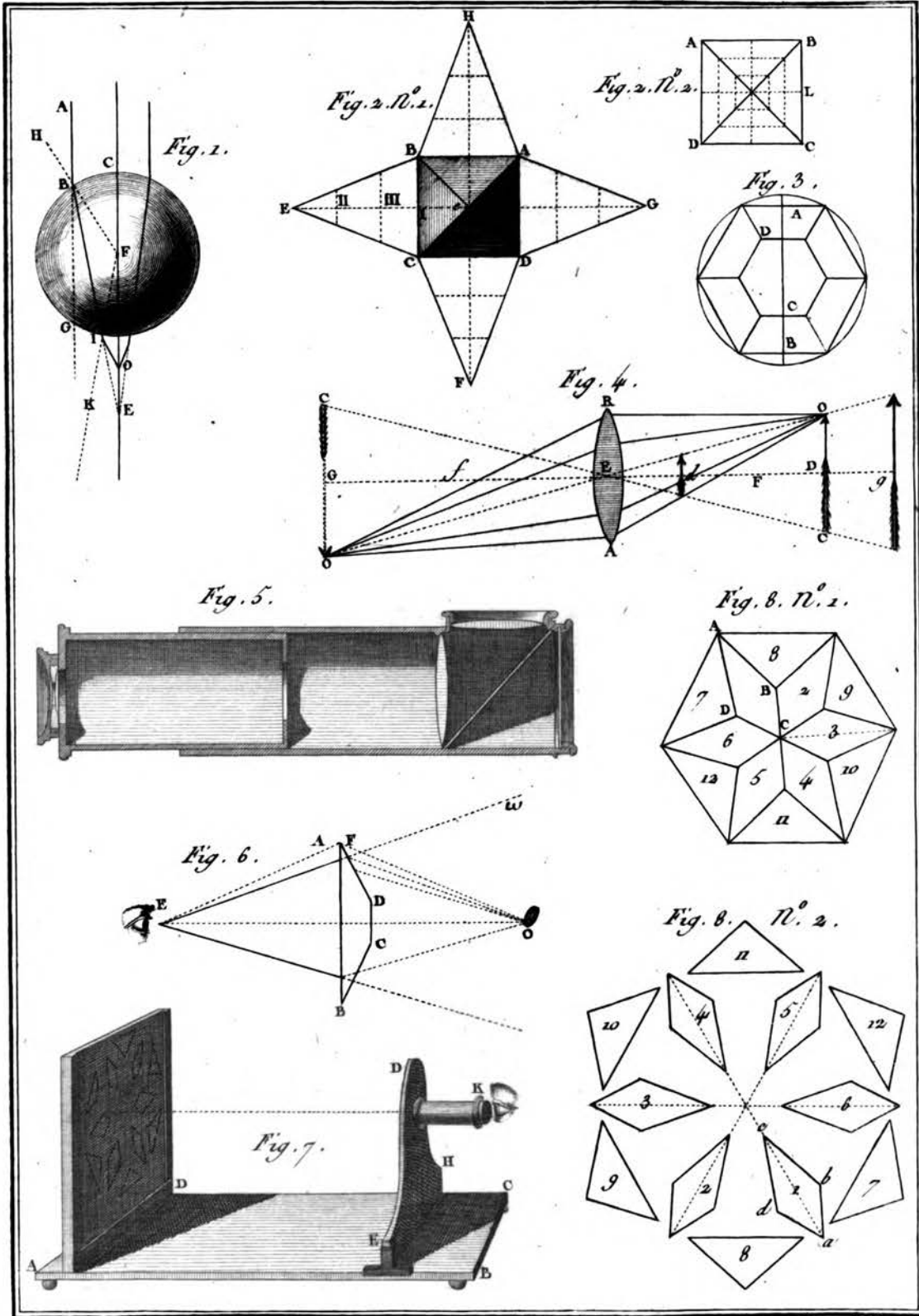
*Benard Dircet.*

Generated on 2014-05-11 16:17 GMT / http://hdl.handle.net/2027/ucm.5320295822 Public Domain, Google-digitized / http://www.hathitrust.org/access\_use#pd-google



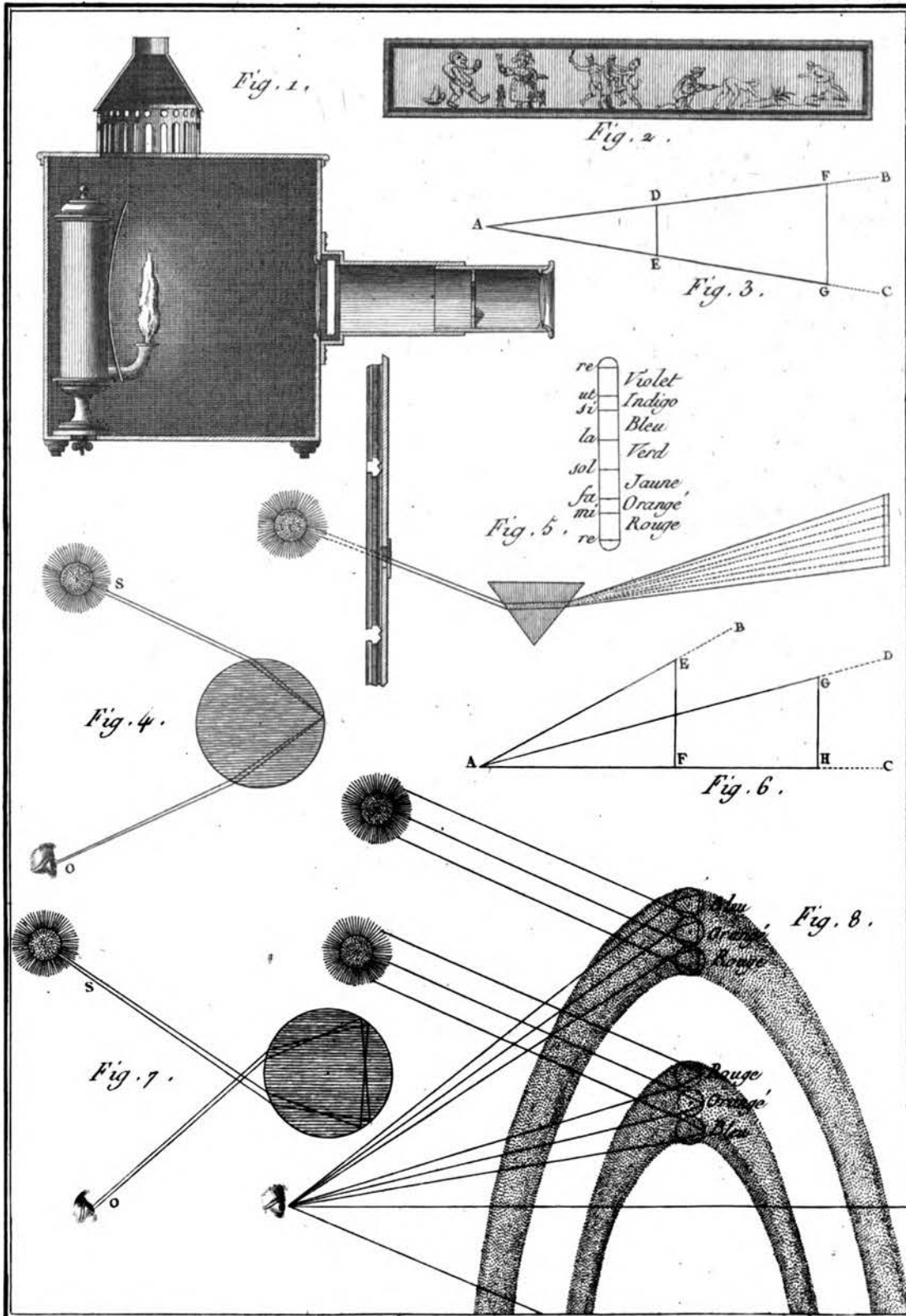
*Amusemens d'Optique.*

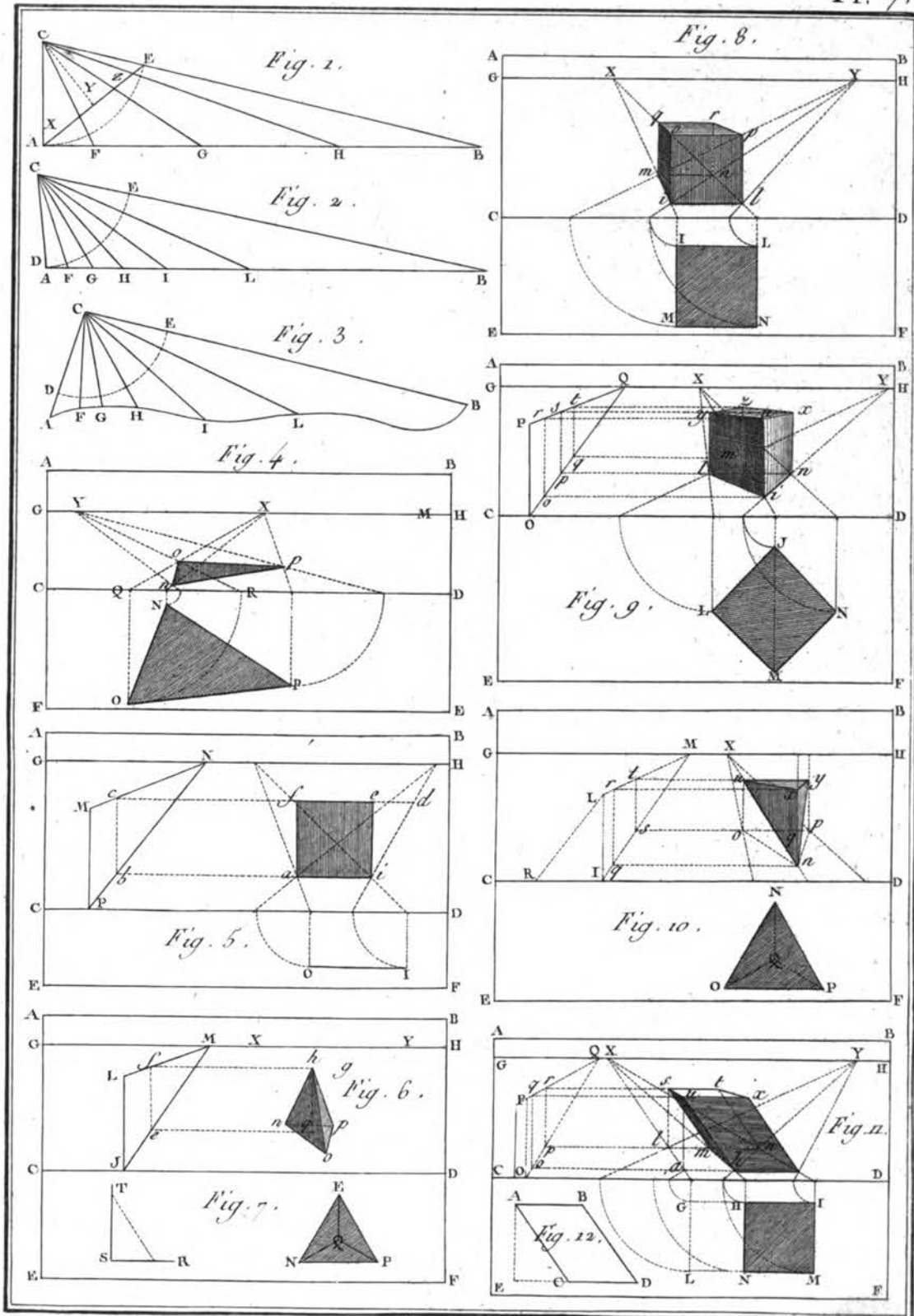
*Bernard Durrant.*



Amusemens d'Optique

Benard Directeur

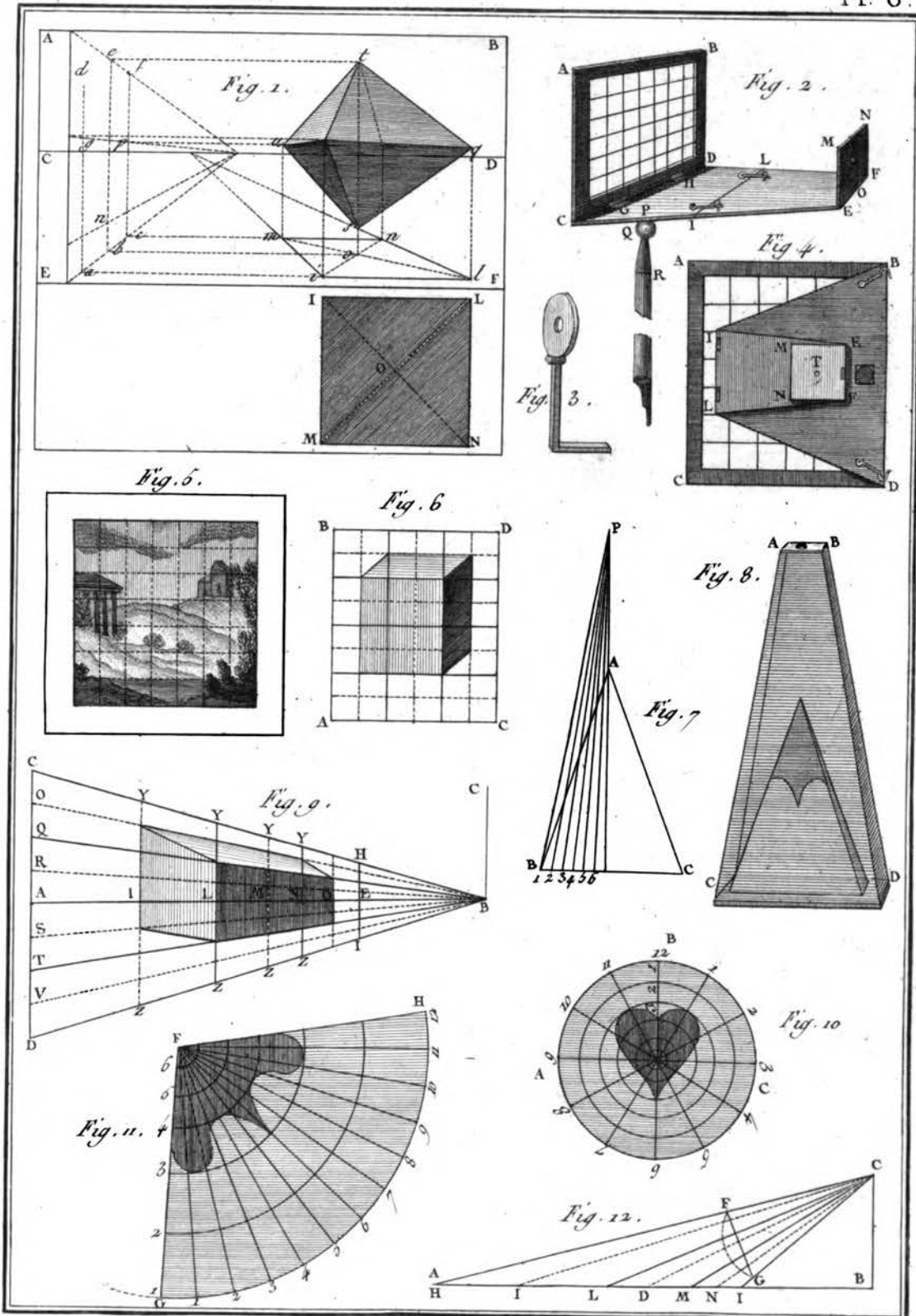




*Amusemens d'Optique.*

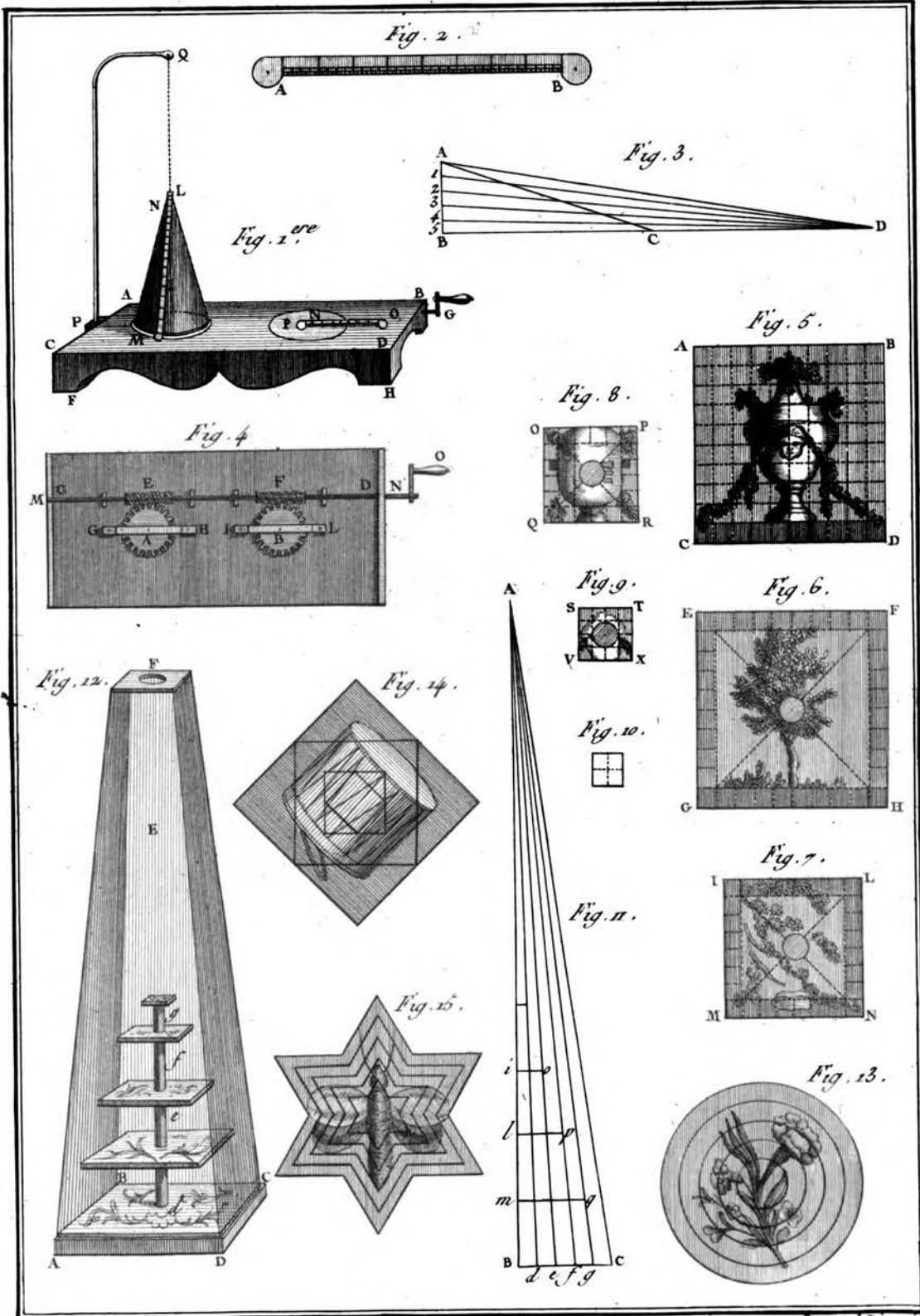
*Bernard Borelli.*





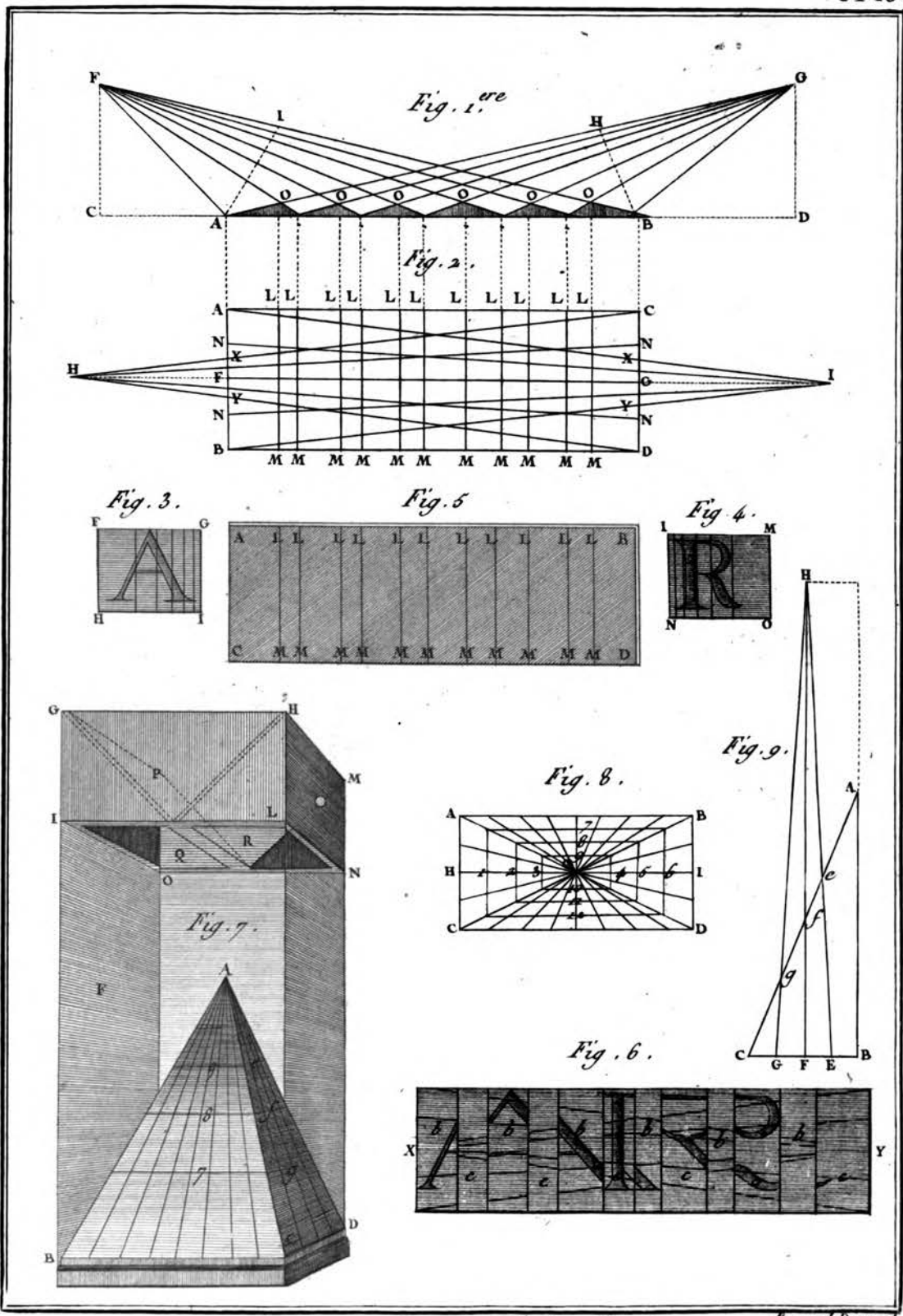
*Amusemens d'Optique.*

*Bernard Drexel*



*Amusemens d'Optique.*

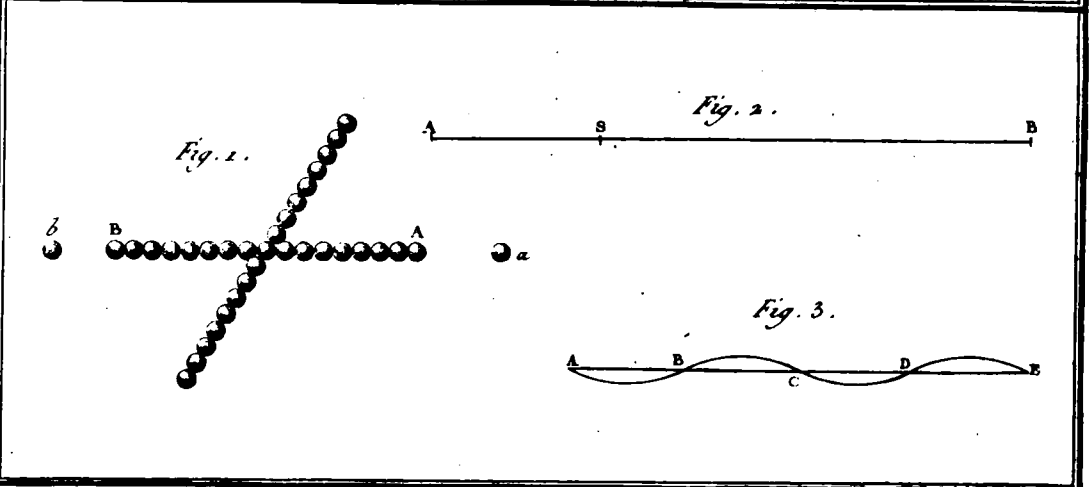
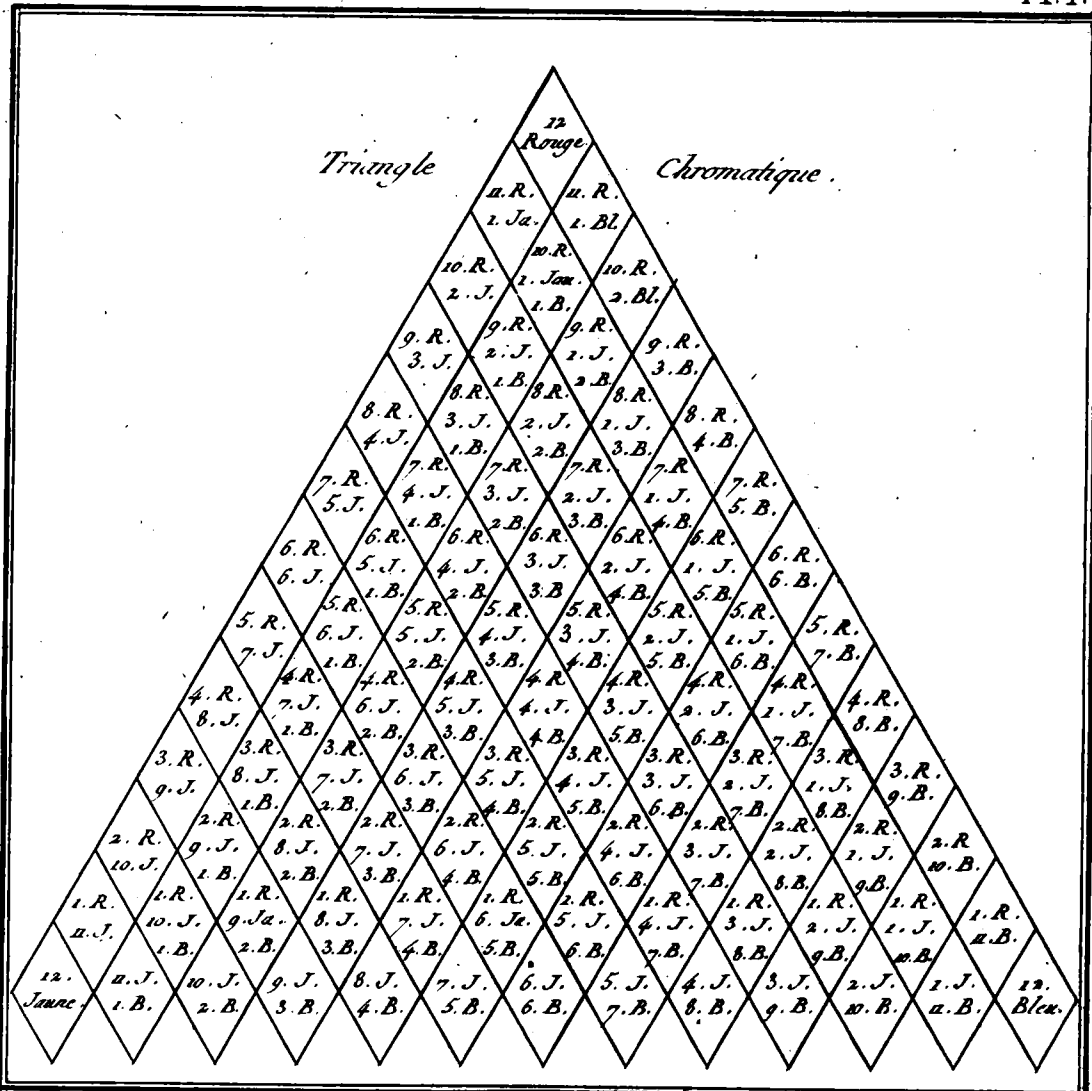
*Benard Durcel*



*Amusemens d'Optique*

Bernard Duret

Generated on 2014-05-11 16:19 GMT / http://hdl.handle.net/2027/ucm.5320295822 Public Domain, Google-digitized / http://www.hathitrust.org/access\_use#pd-google



*Amusemens d'Acoustique ou Musique.*

Bernard Duret

Digitized by Google

Original from  
UNIVERSIDAD COMPLUTENSE  
DE MADRID

*Air Grec, d'un Hymne à Néméus.*



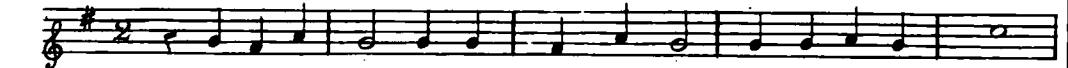
*Air Persan.*



*Air Chinois.*



*Air Huron.*



*Air Tartare.*



*Autre.*

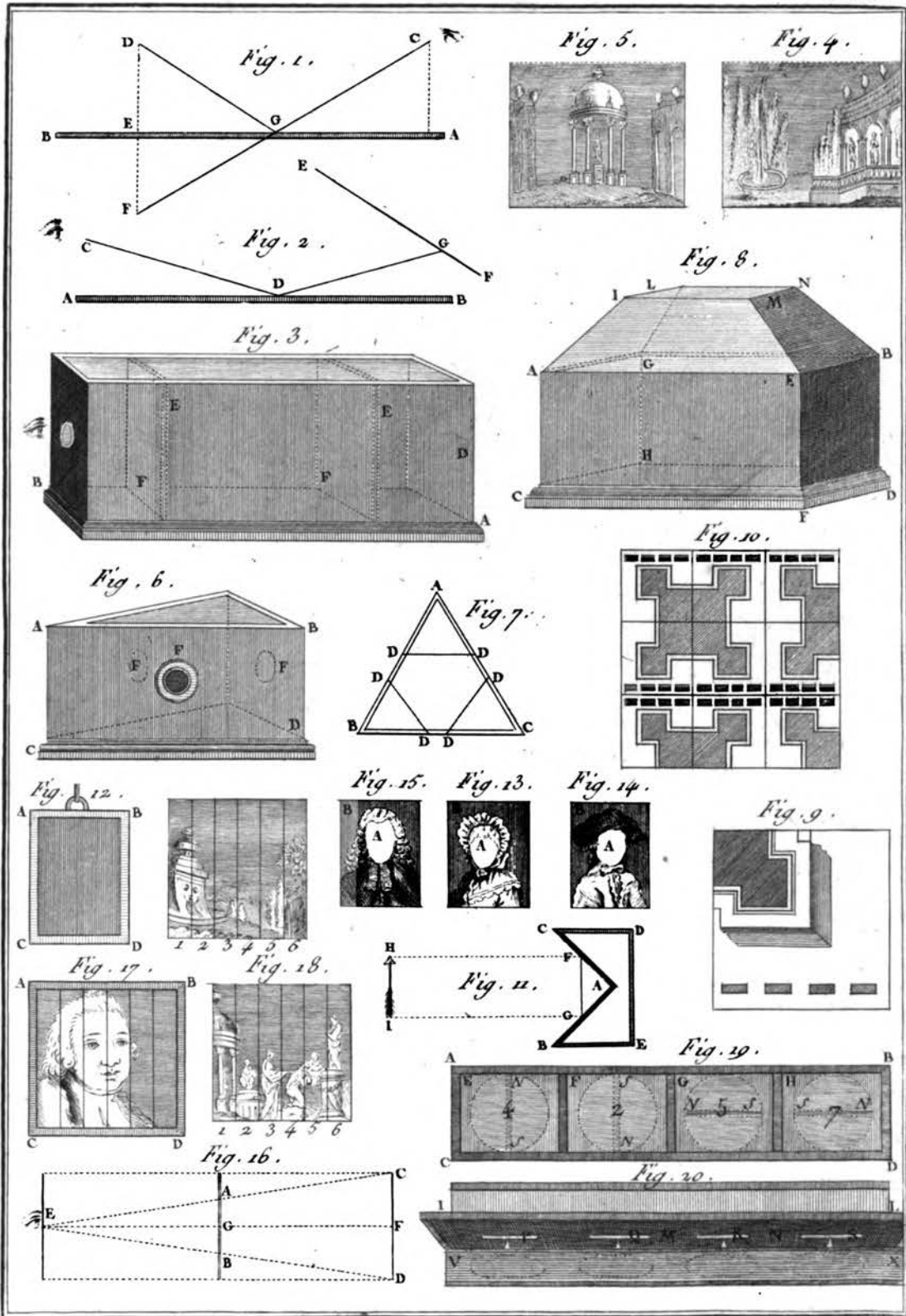


*Bernard D'Arzet.*

*Amusemens d'Acoustique, ou Musique.*

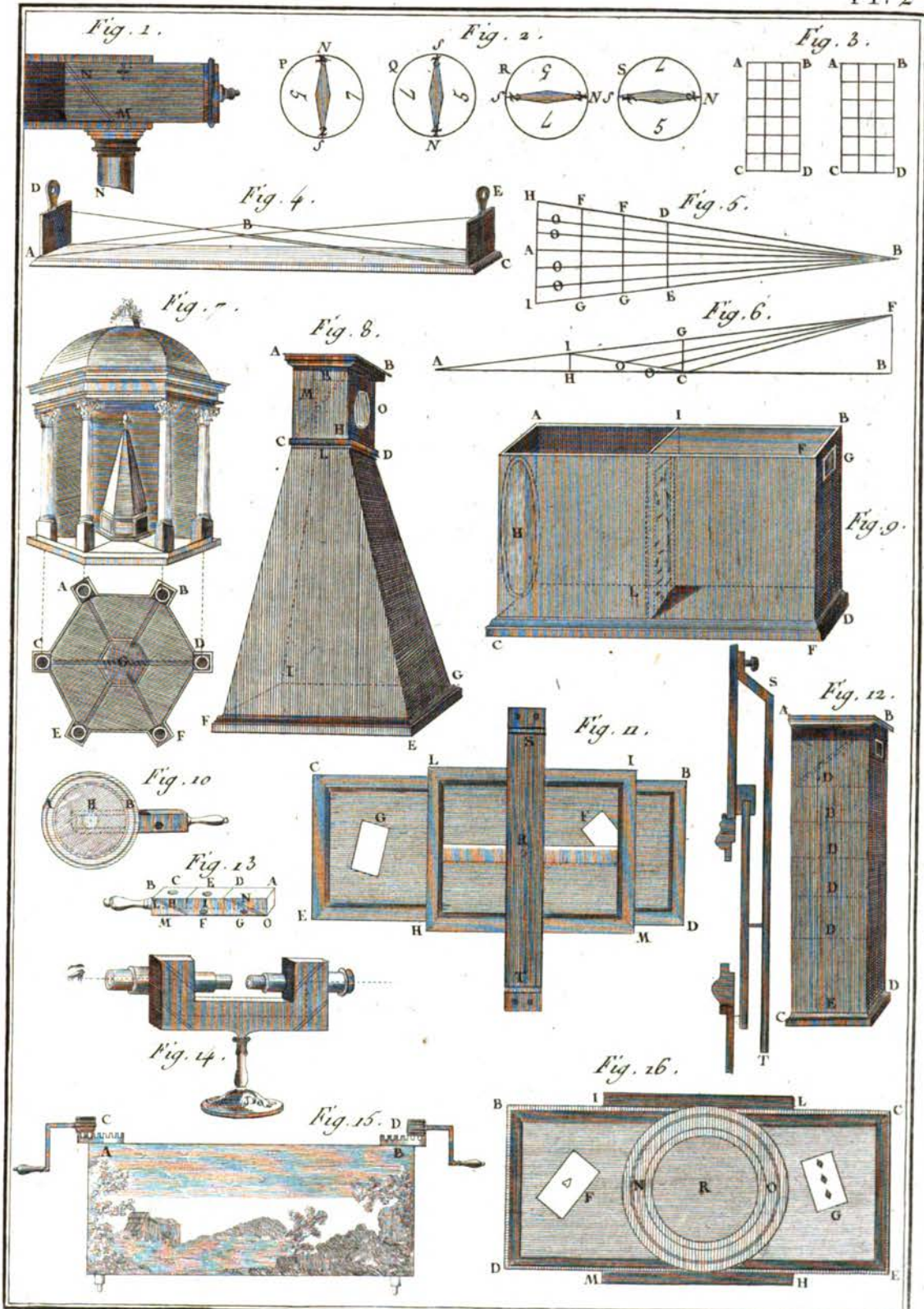
Digitized by Google

UNIVERSIDAD COMPLUTENSE  
DE MADRID



*Amusemens de Catoptrique.*

*Benard Diverdi*

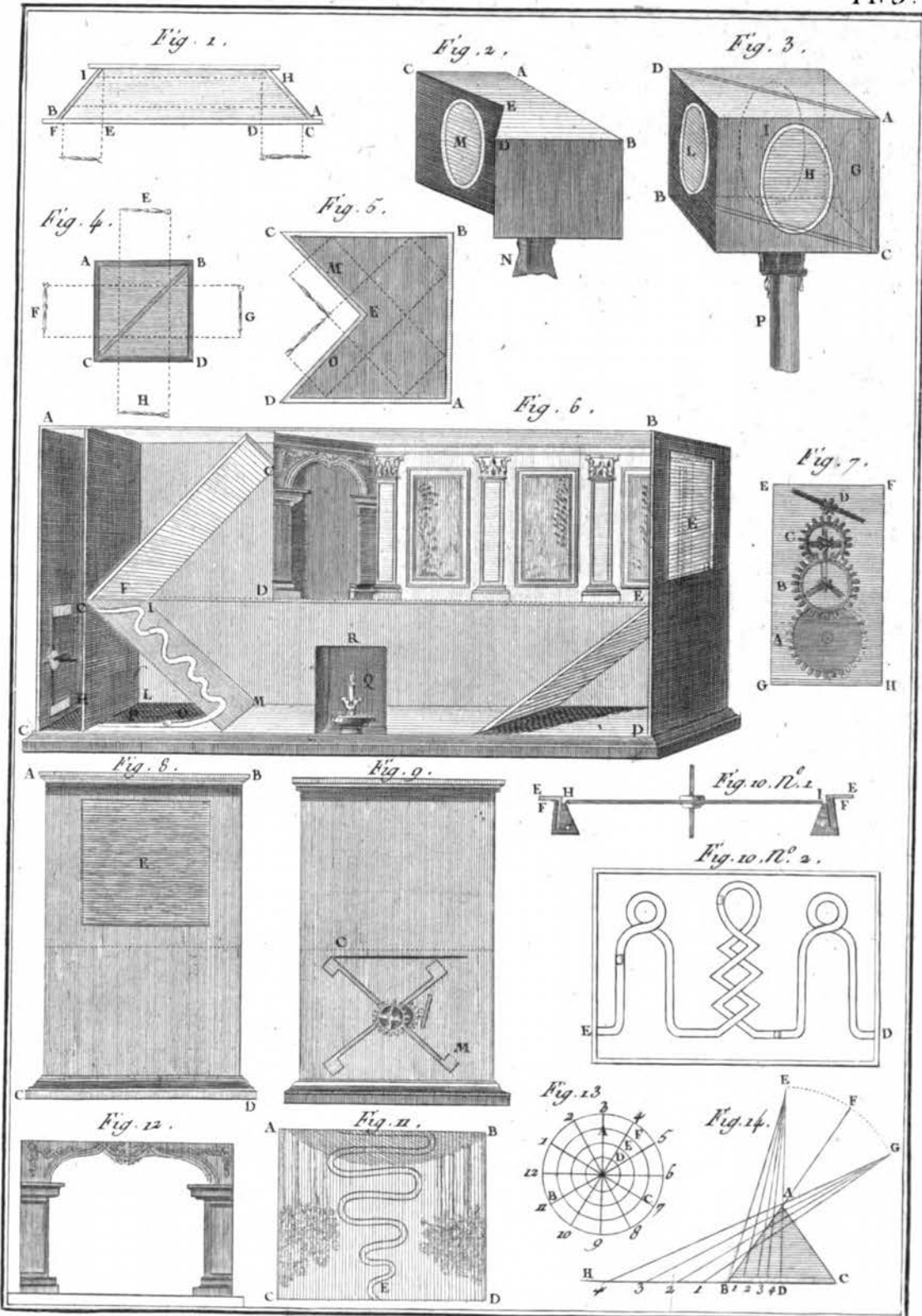


*Amusemens de Catoptrique.*

*Benard Drexel*

*21.*

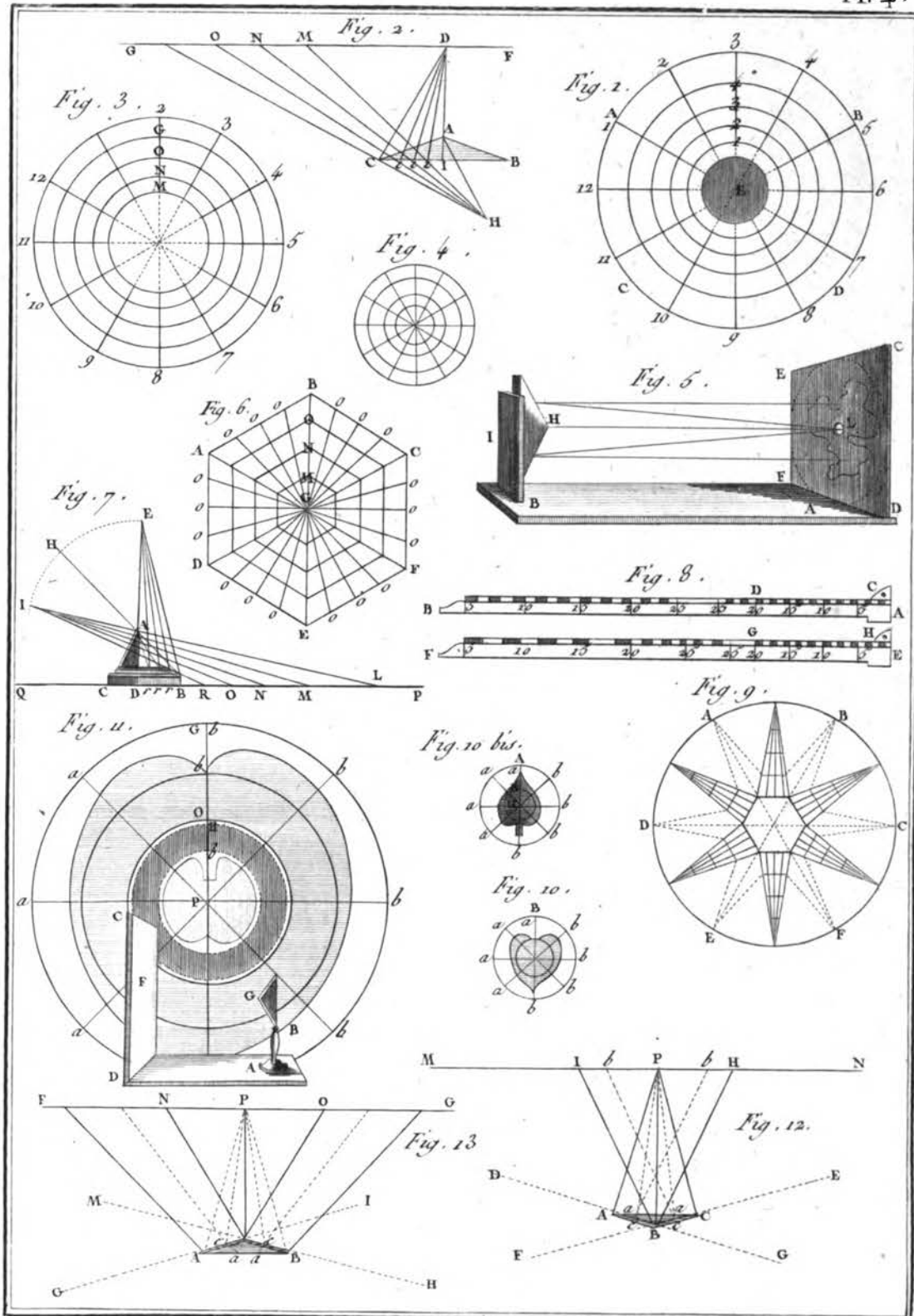
Generated on 2014-05-11 16:20 GMT / http://hdl.handle.net/2027/ucm.5320295822 Public Domain, Google-digitized / http://www.hathitrust.org/access\_use#pd-google



*Amusemens de Catoptrique.*

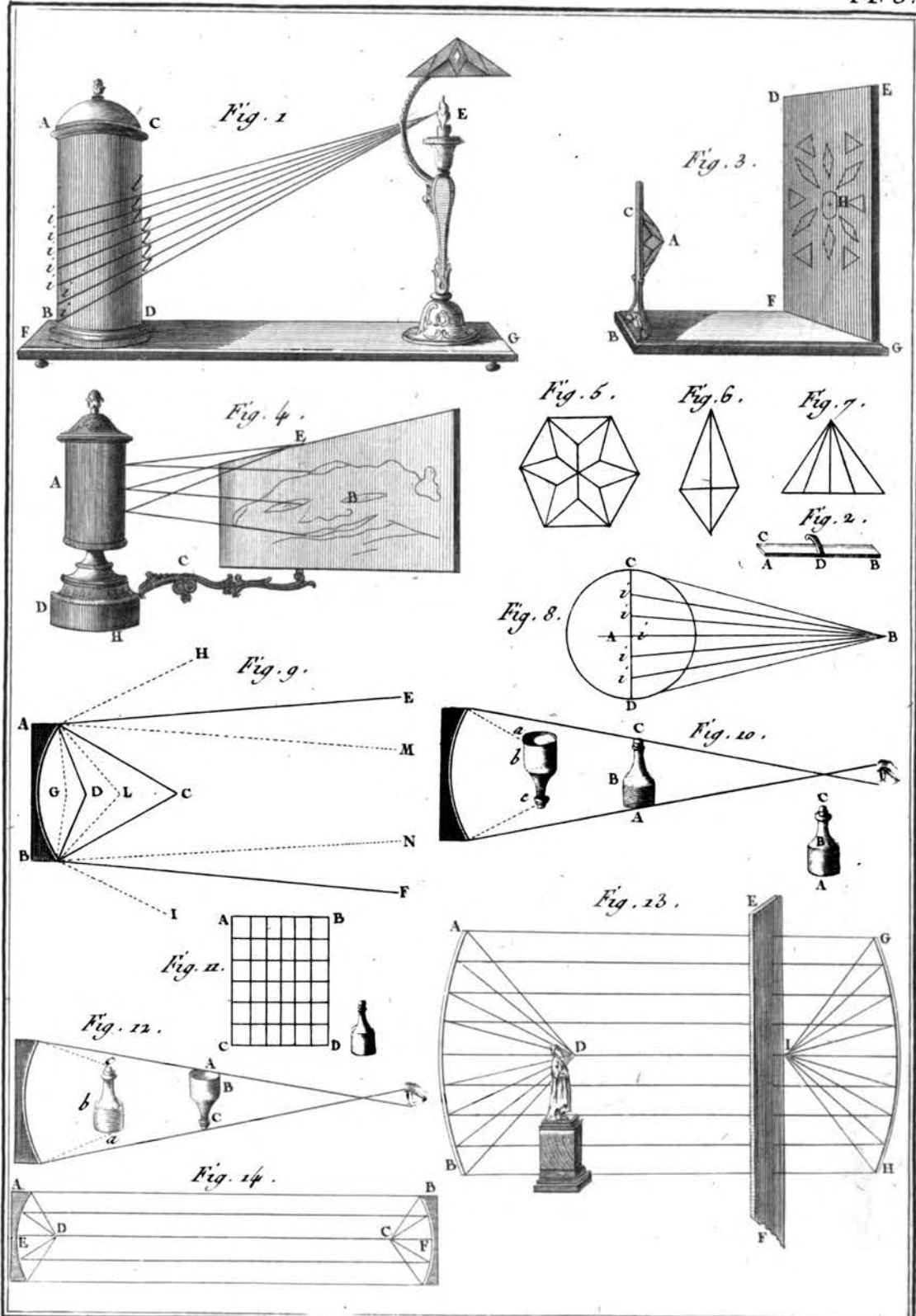
*Benard Dircat.*





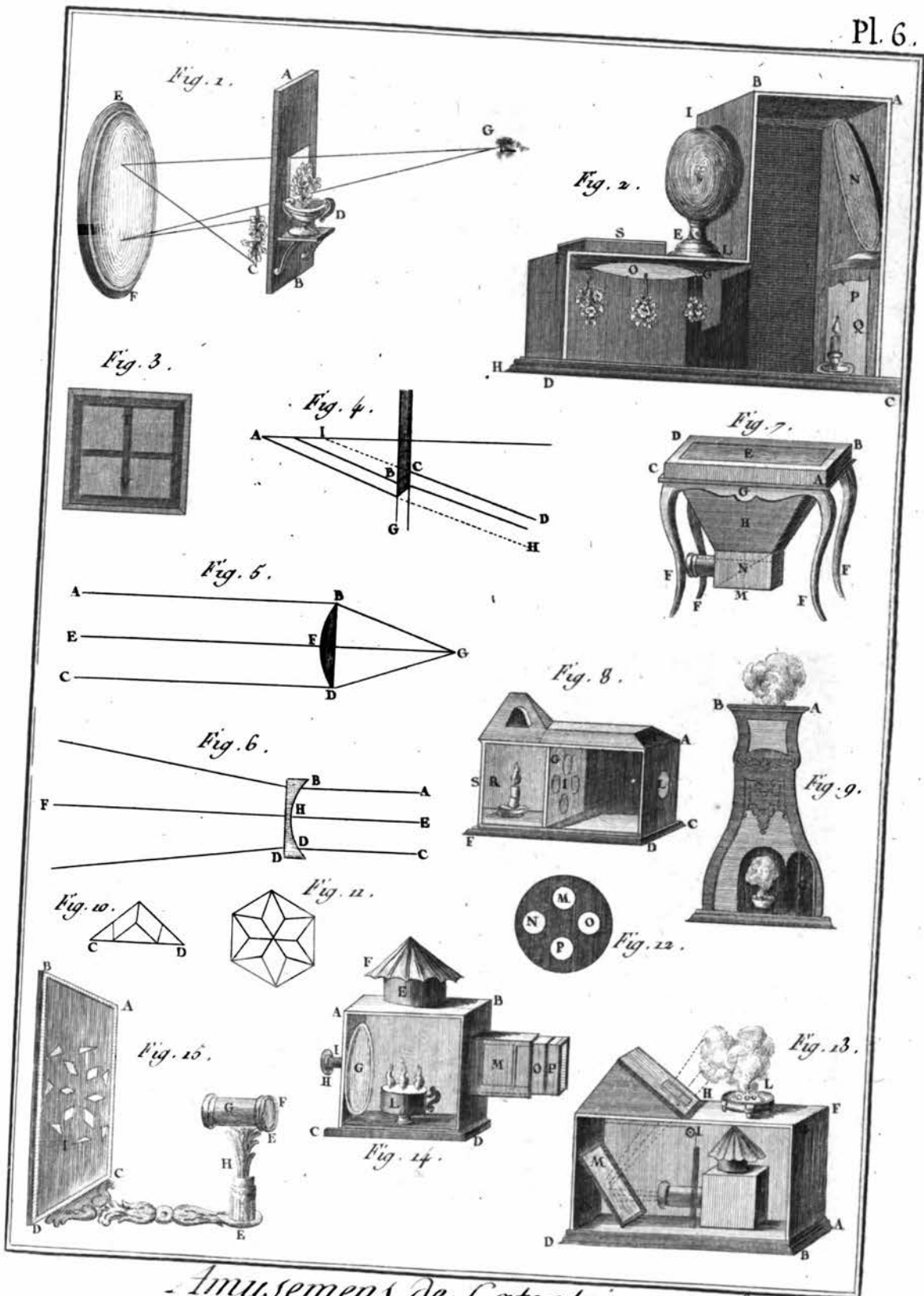
*Amusemens de Catoptrique.*

*Bernard Drexel.*



*Amusemens de Catoptrique.*

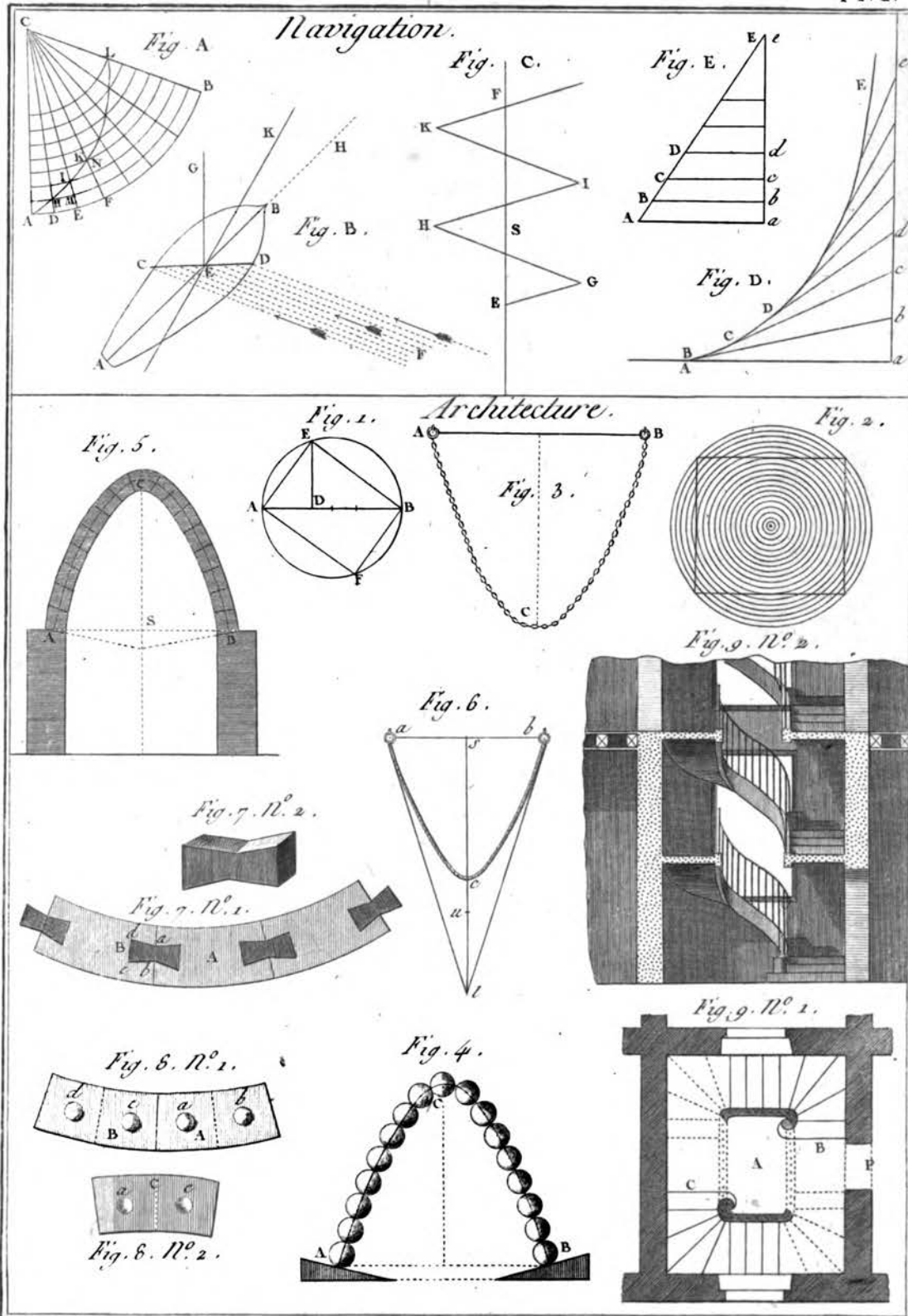
*Benard. Duxceit.*



*Amusemens de Catoptrique*

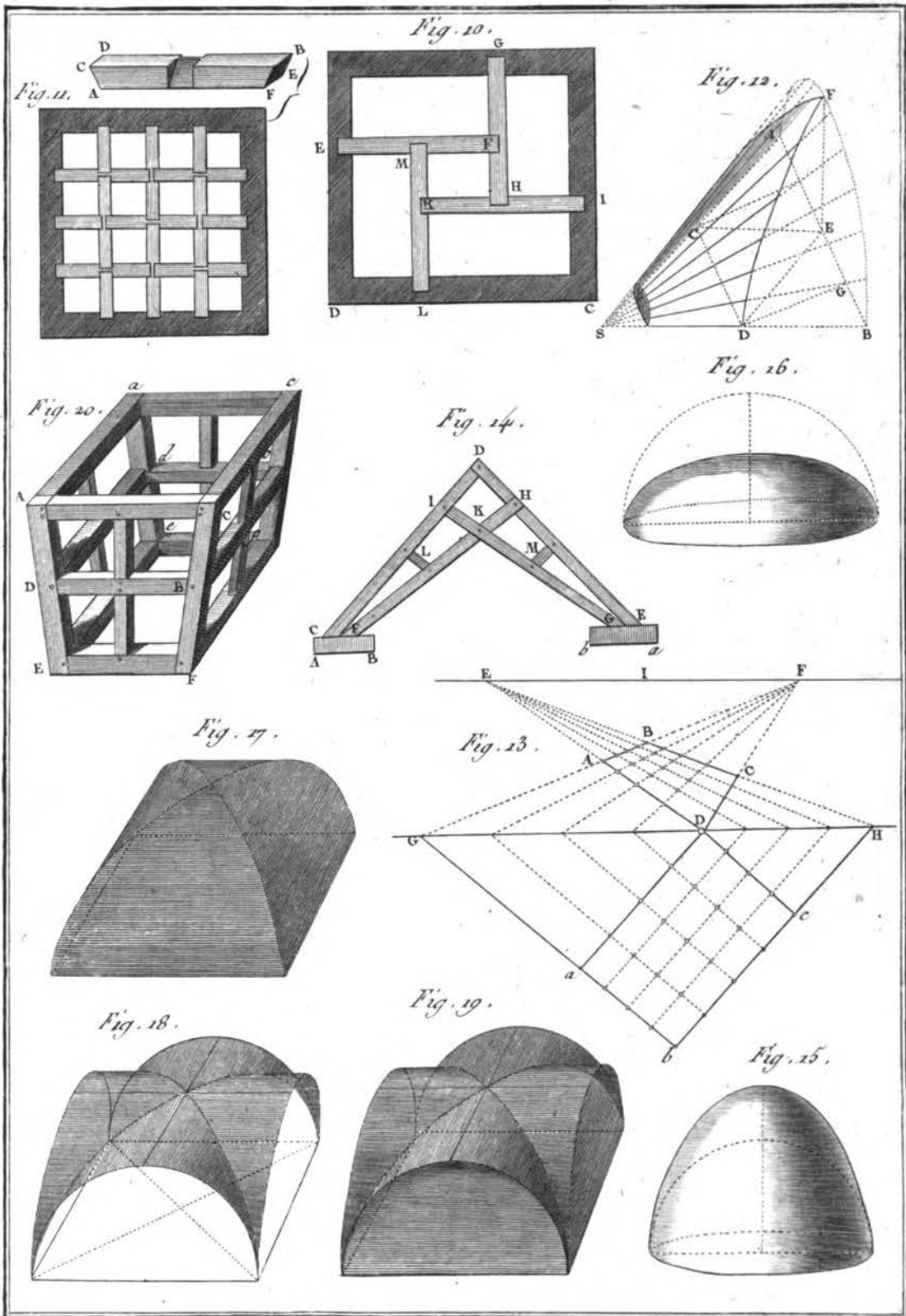
*Benard Duxat*

Generated on 2014-05-11 17:15 GMT / http://hdl.handle.net/2027/ucm.5320295822 Public Domain, Google-digitized / http://www.hathitrust.org/access\_use#pd-google



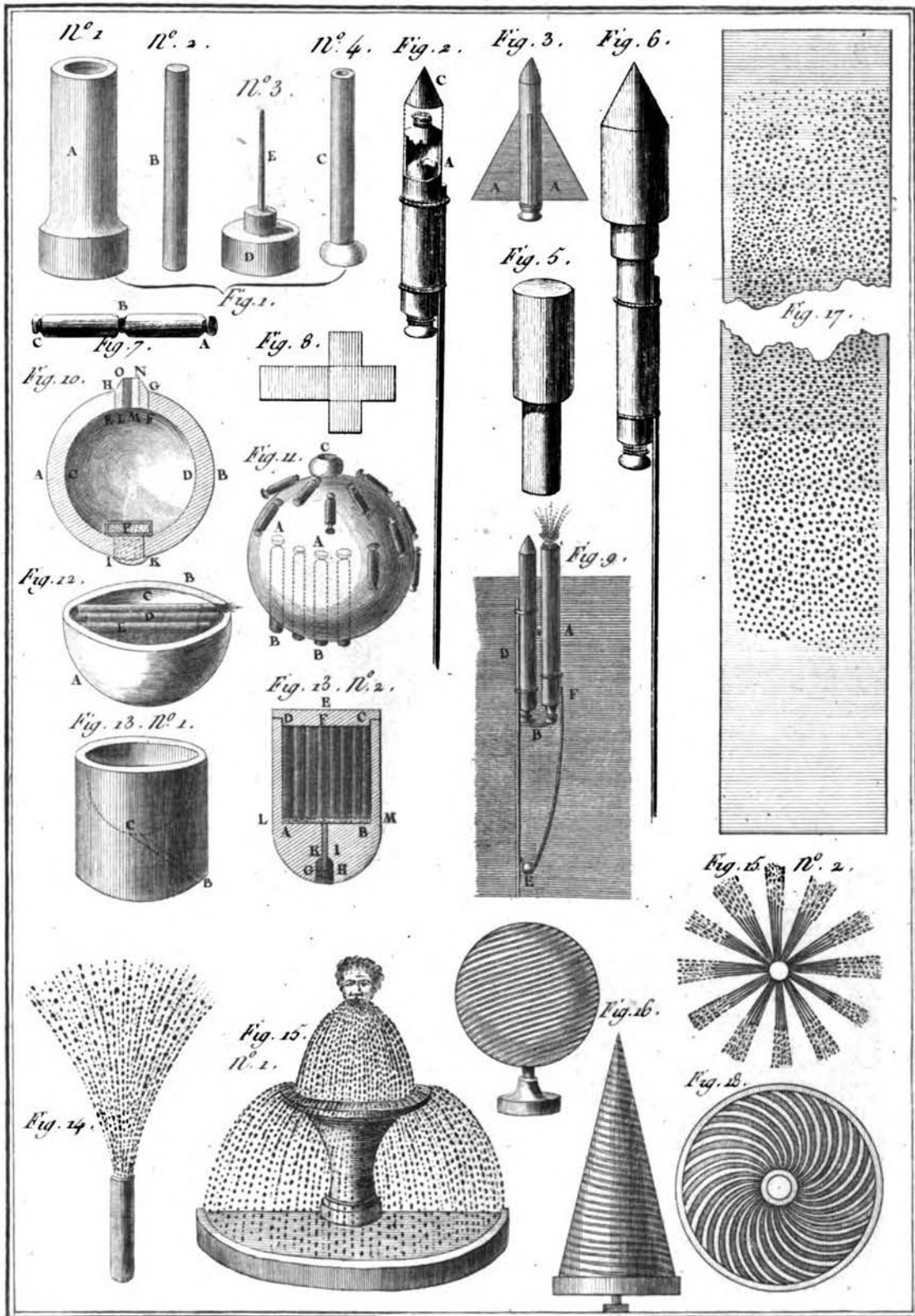
*Amusemens de Navigation et d'Architecture*

*Benard Direct.*



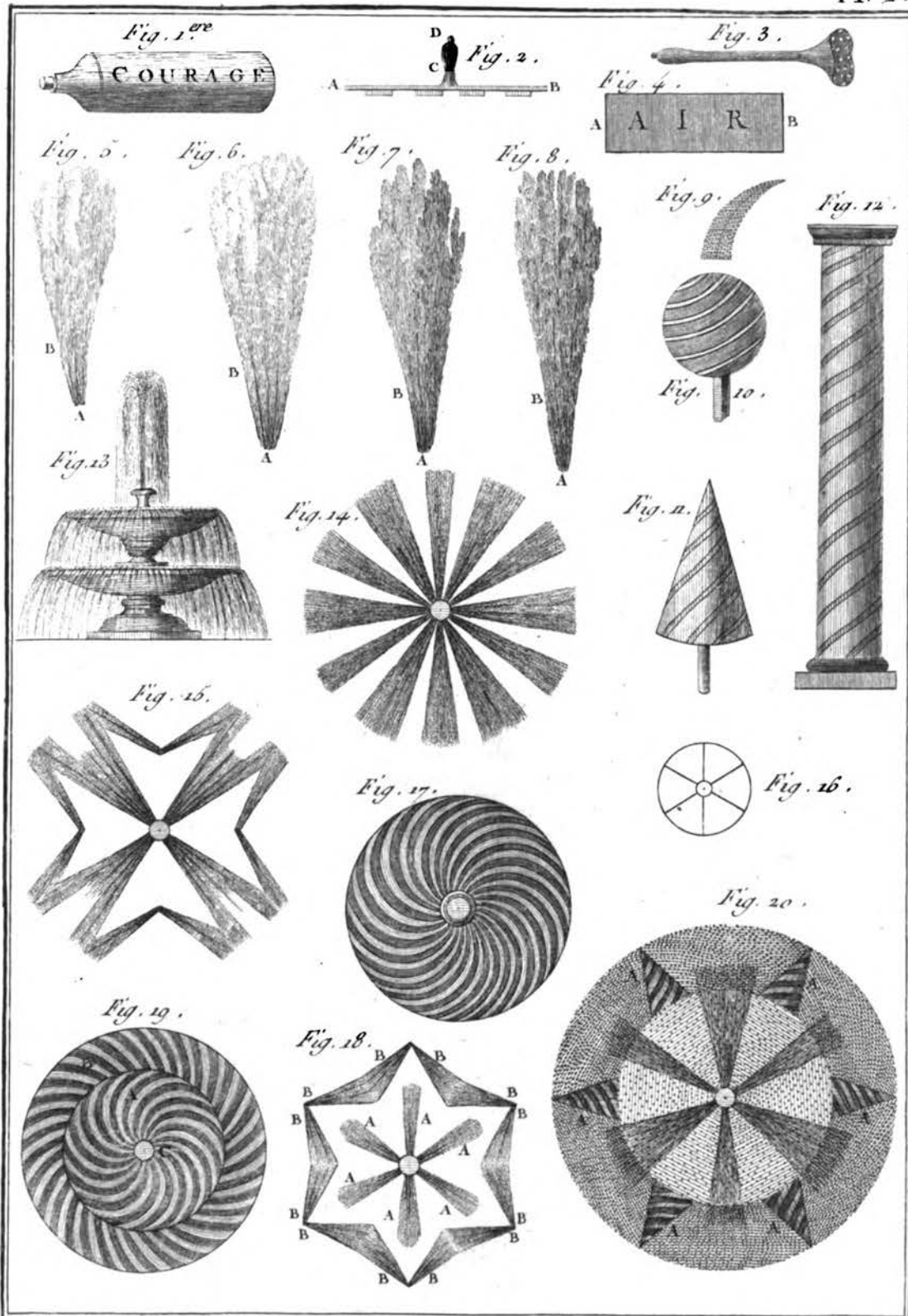
*Suite des Amusemens d'Architecture*

*Benard Directeur.*



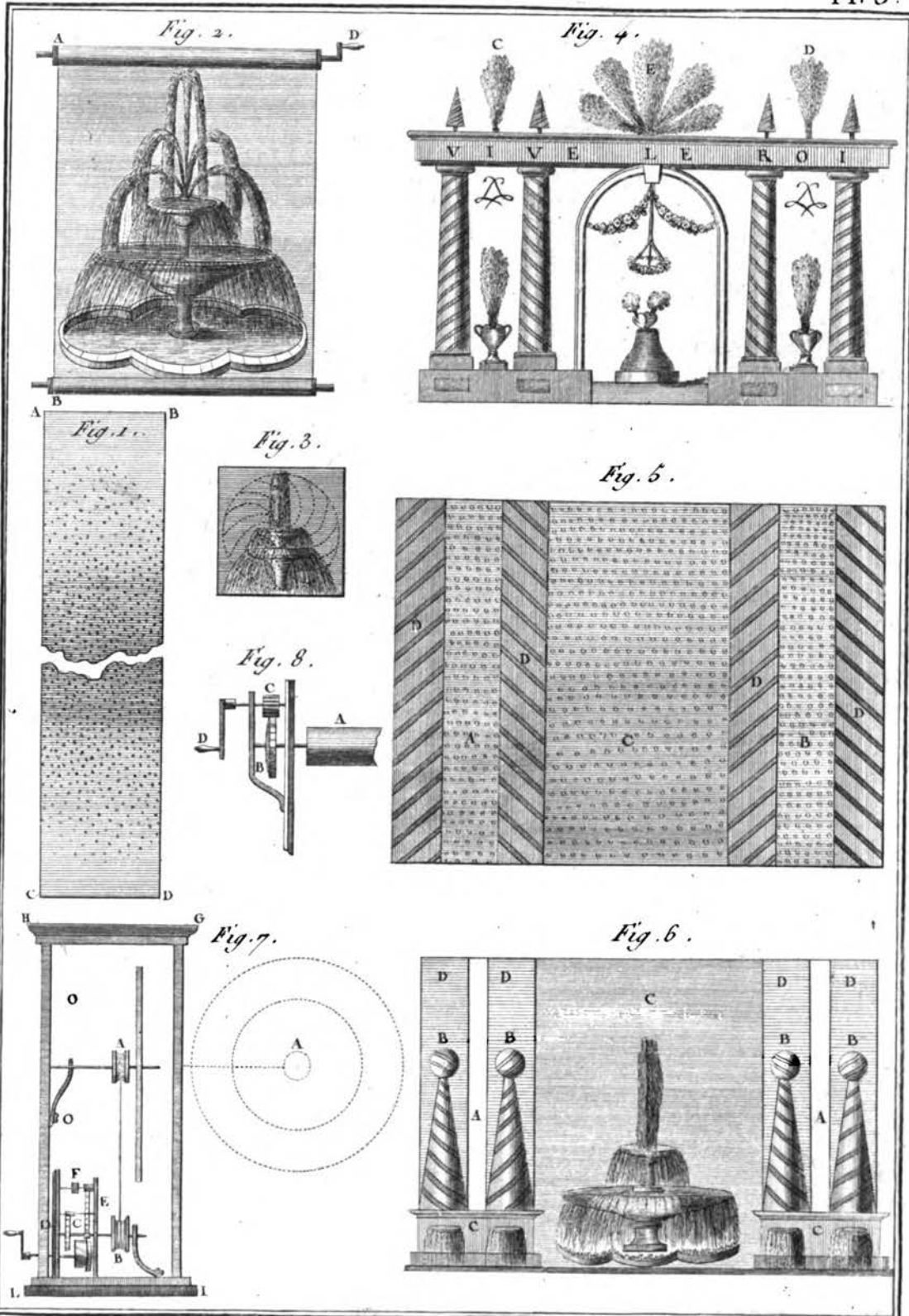
*Pyrotechnie sans feu et purement Optique*

Benard Directeur.



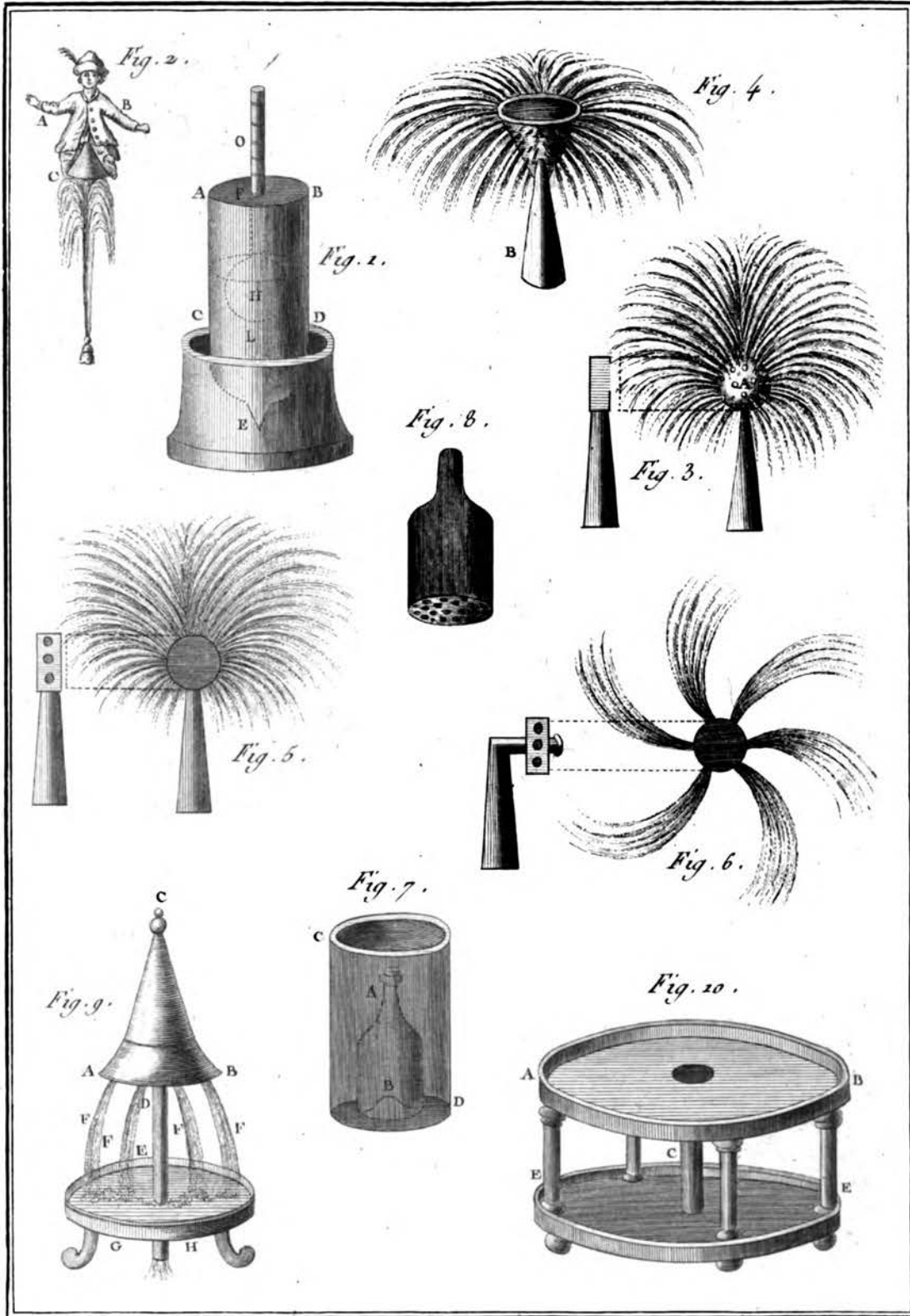
*Pieces d'Artifice*

Benard, Direct.



*Pieces d'Artifice* Original from Bernard Duret.





*Pieces Hydrauliques.*

*Bernard Duxed*

Fig. 2.

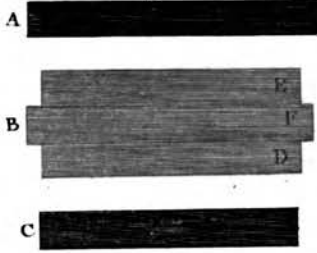


Fig. 2.



Fig. 5.

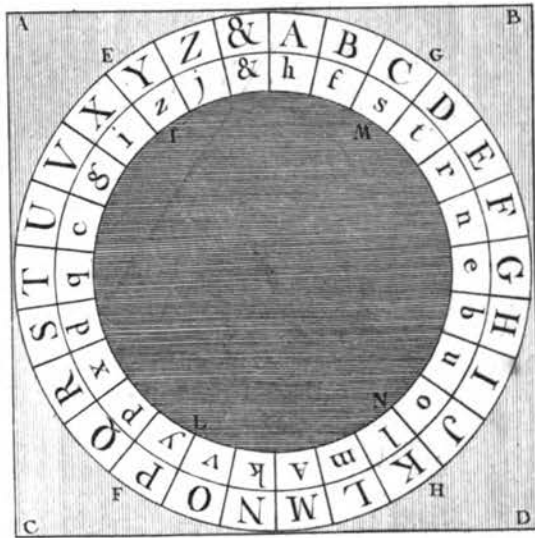


Fig. 6.

Fig. 3.



Fig. 7.

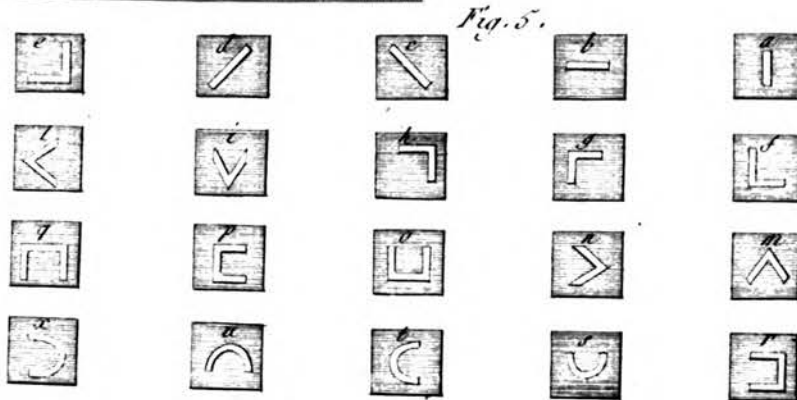
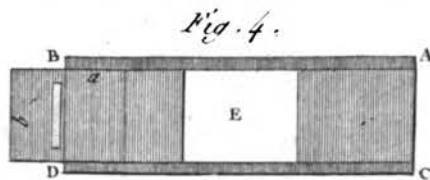
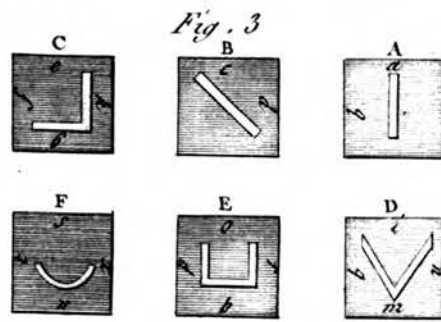
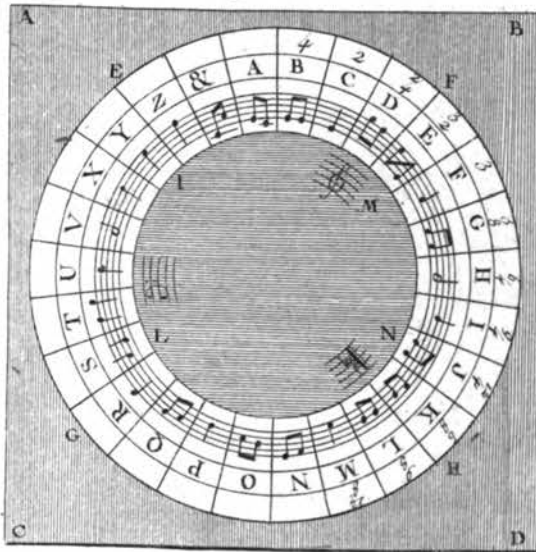
A B  
 Je  vous  prie de  me  mander si  
 vous  trouverez bon, non  très  cher ami,  
 que je  dispose  des  à  présent des  
 effets que  vous  avez offert de me  
 rendre  & .  
 C D

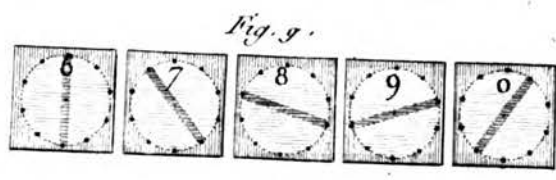
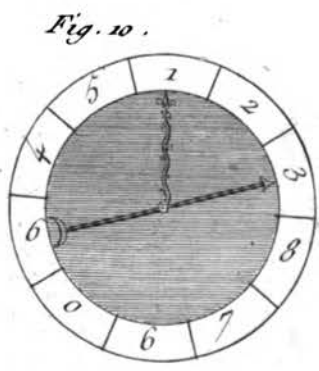
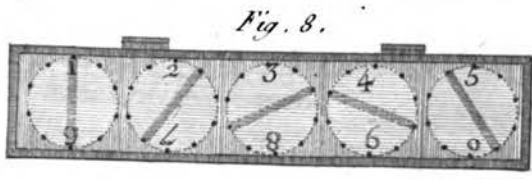
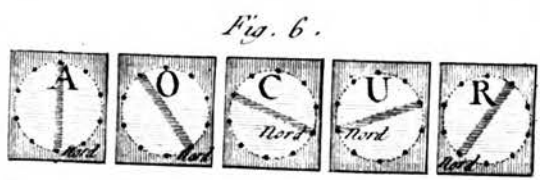
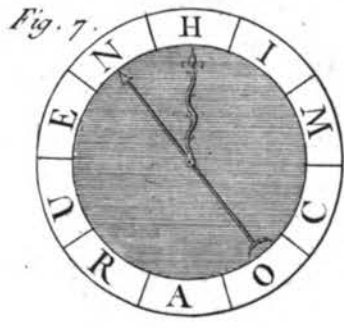
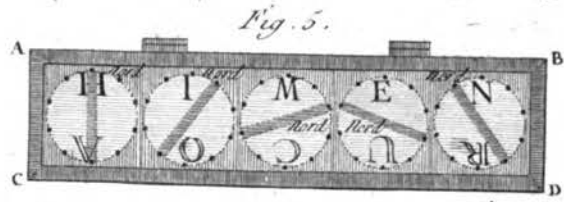
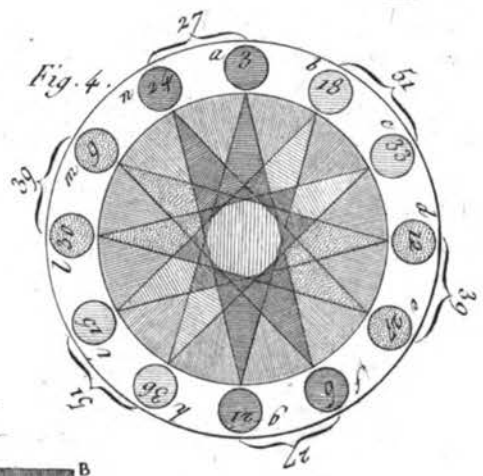
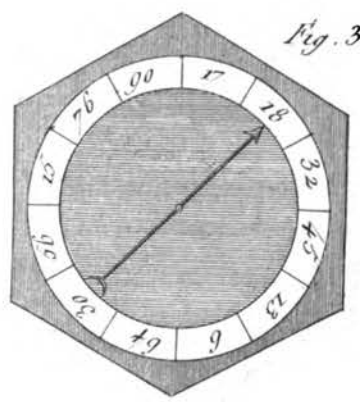
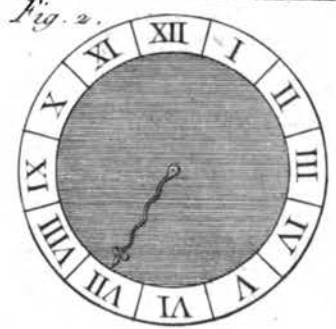
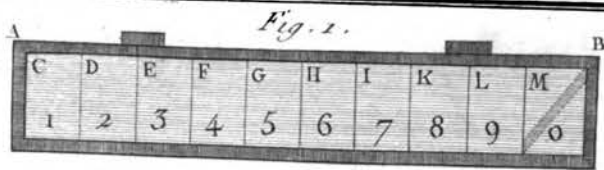
Fig. 4.



Traits Occultes ou Trompeurs.

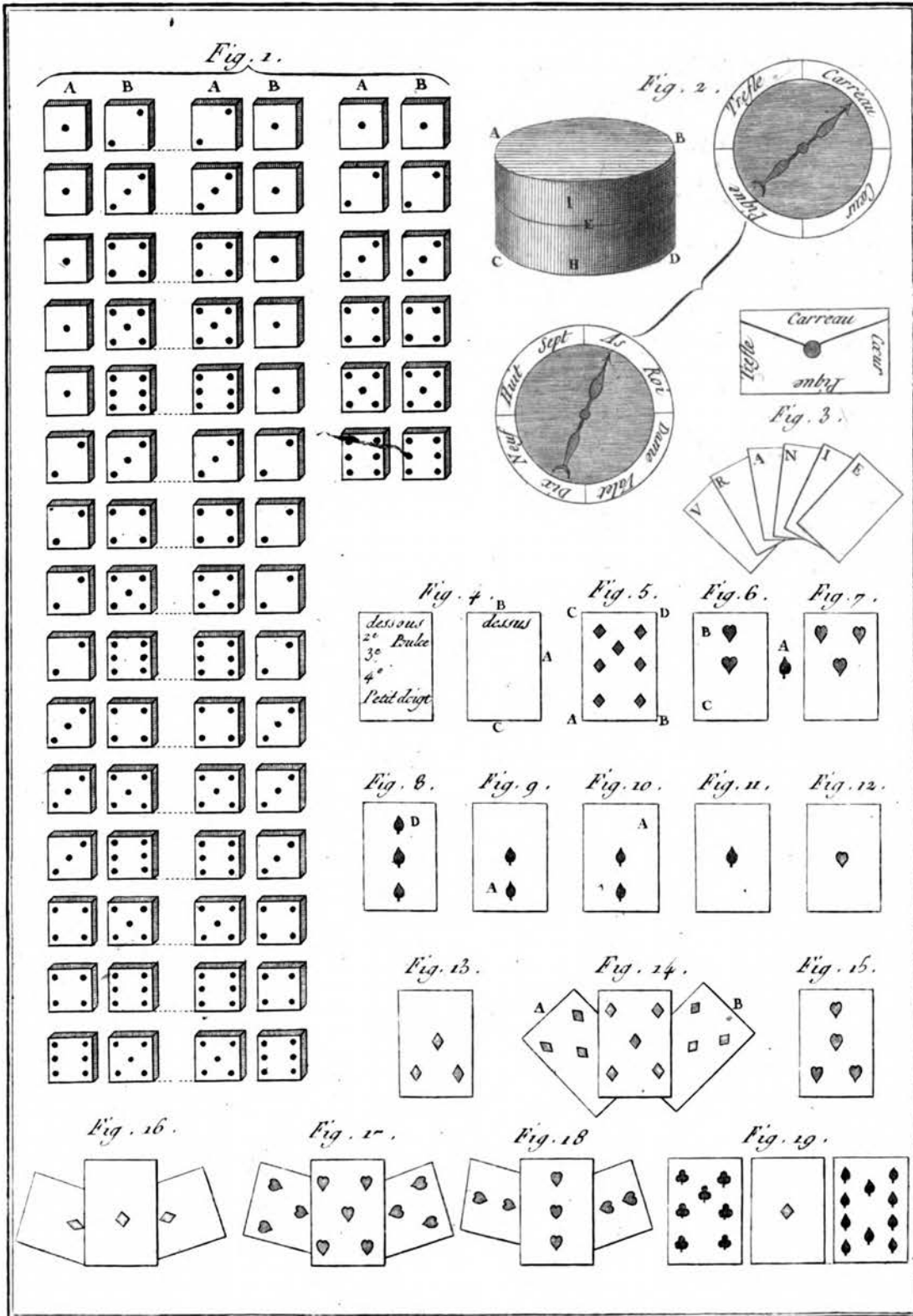
Beurd Dircxit.





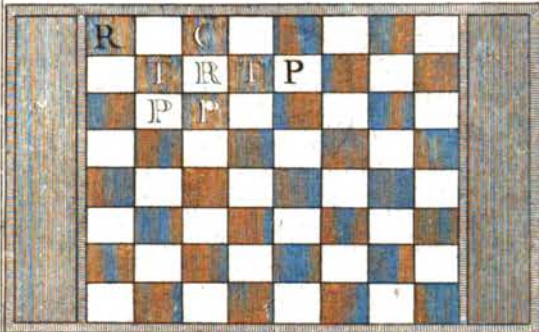
*Nombres Magiques.*

*Renard Doreat.*



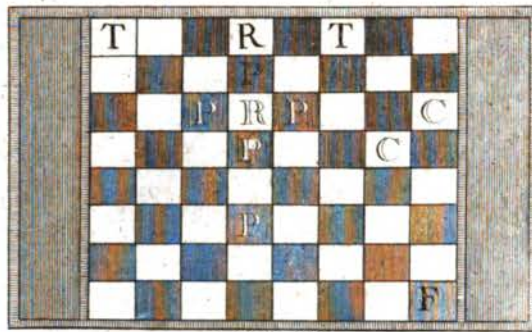
*Suite des Nombres Magiques et Cartes.*

Fig. 2. Cote' du Noir.



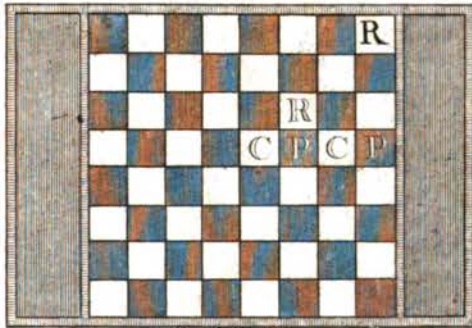
Cote' du Blanc.

Fig. 2. Cote' du Noir.



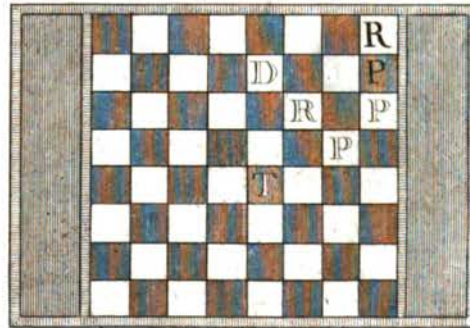
Cote' du Blanc.

Fig. 3. Cote' du Noir.



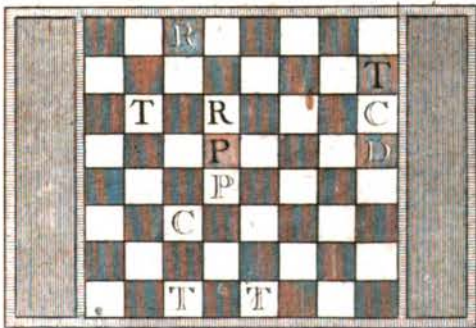
Cote' du Blanc.

Fig. 4. Cote' du Noir.



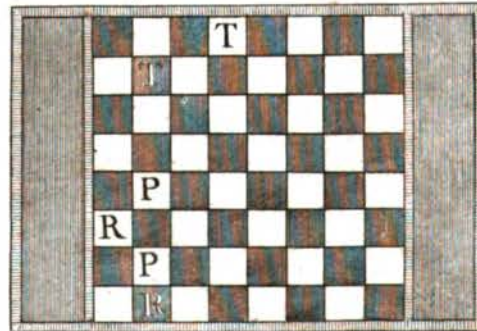
Cote' du Blanc.

Fig. 5. Cote' du Noir.



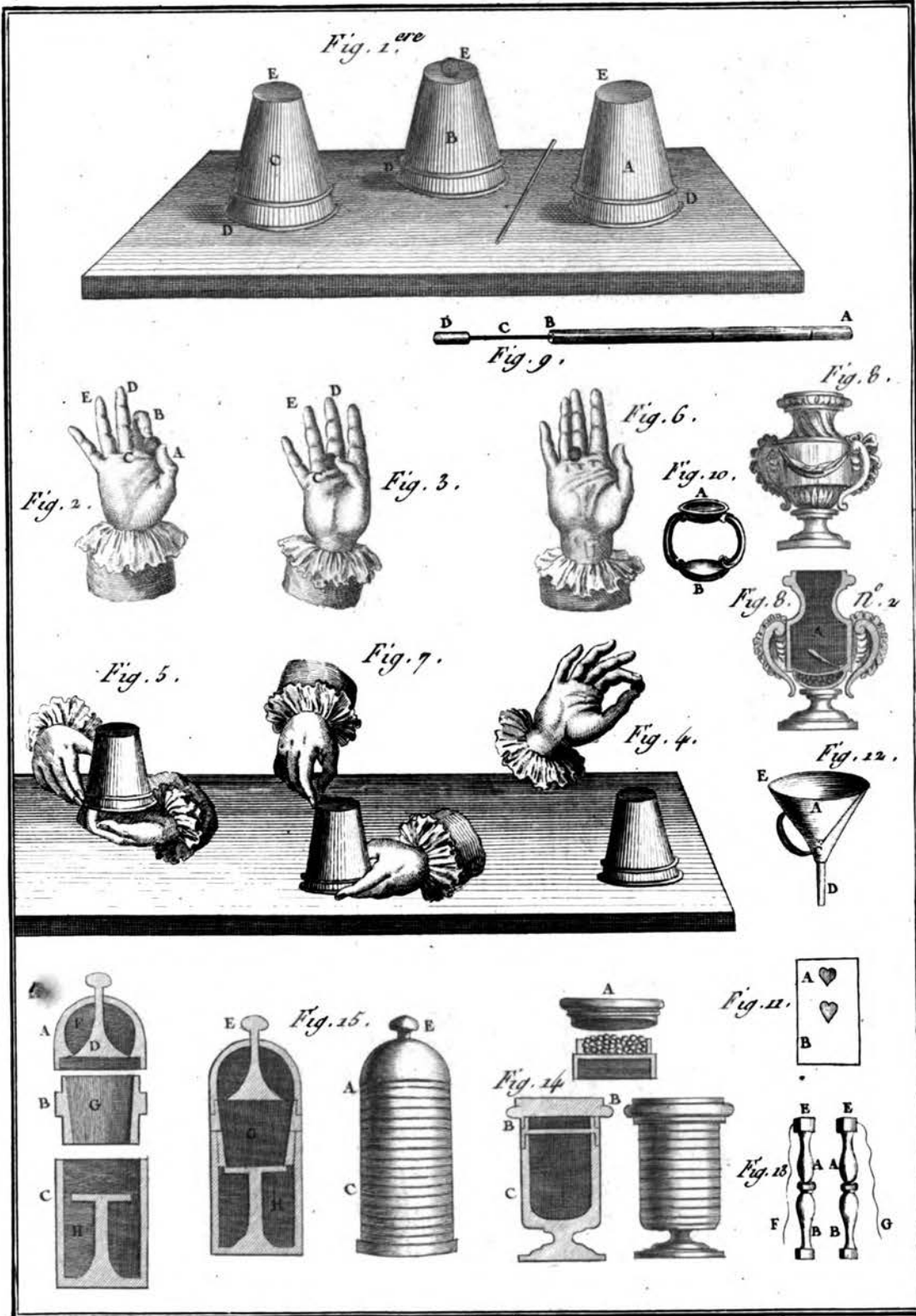
Cote' du Blanc.

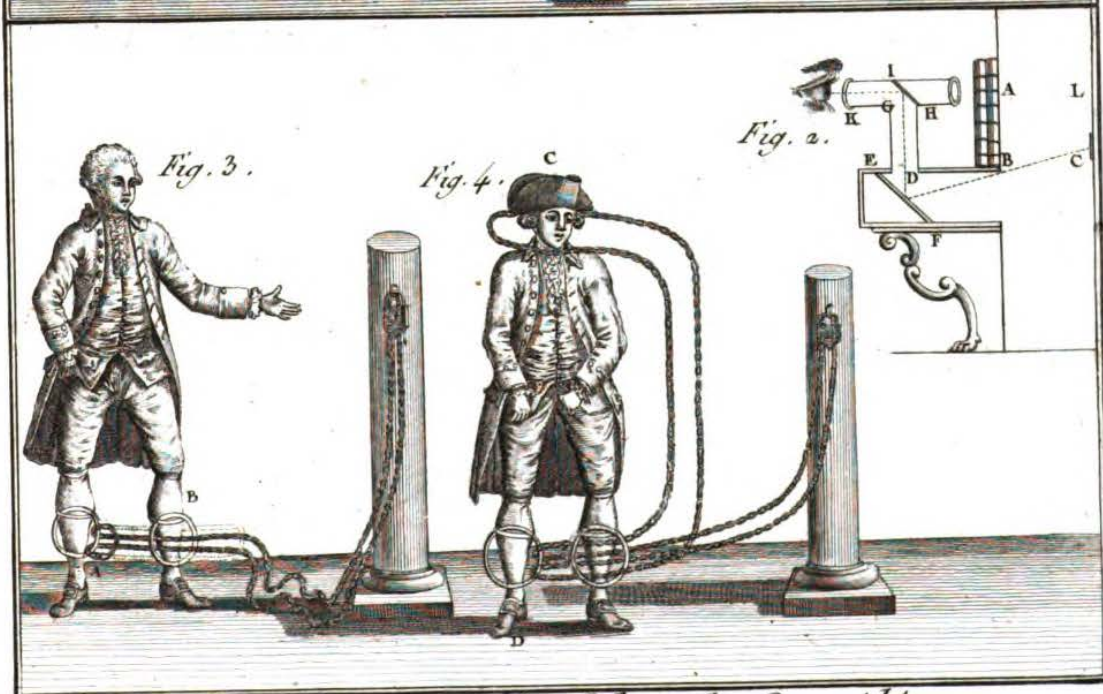
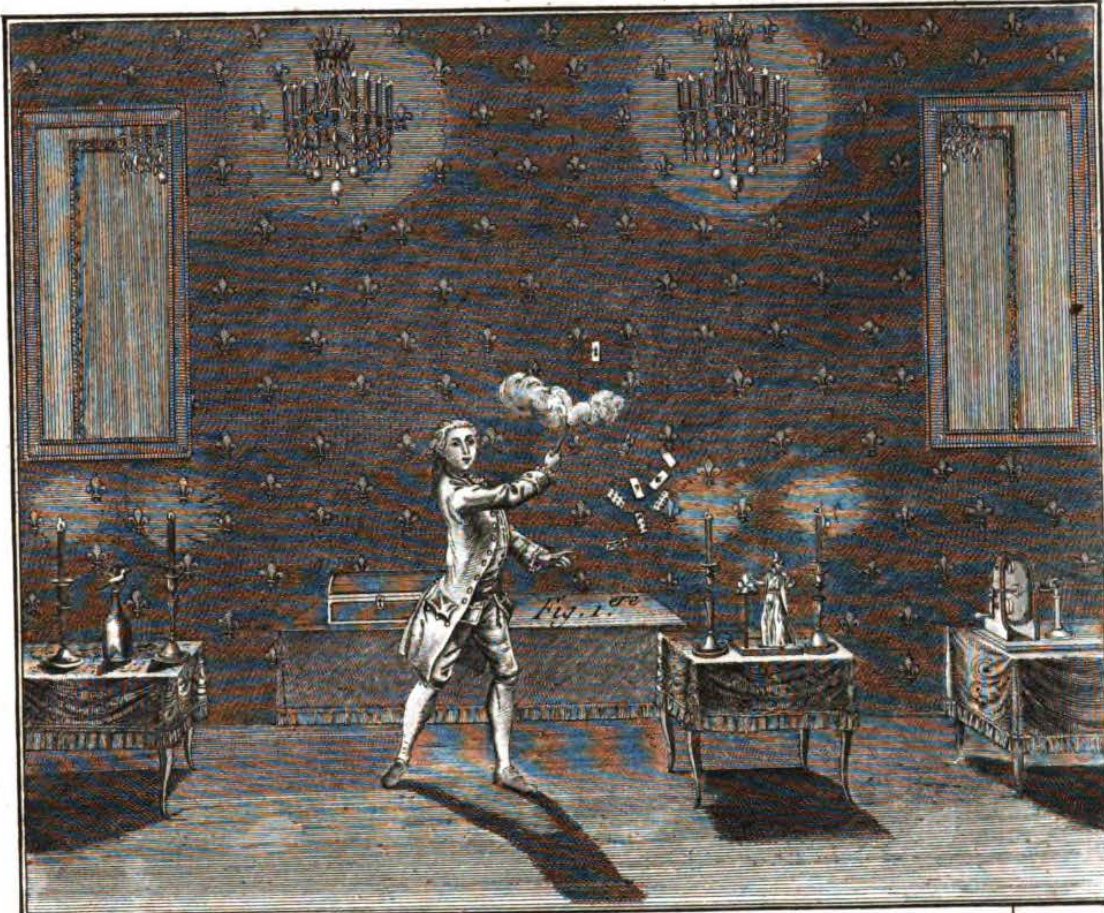
Fig. 6. Cote' du Noir.



Cote' du Blanc.

Combinaisons Magiques.



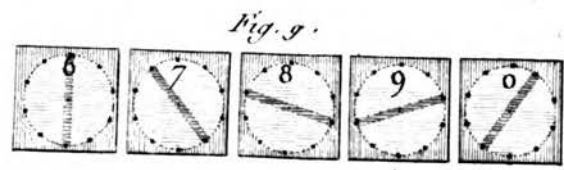
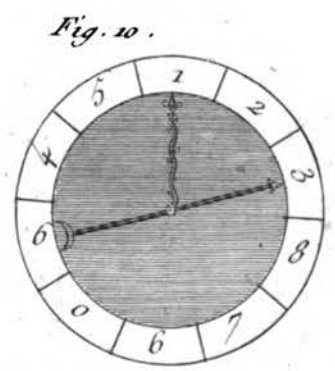
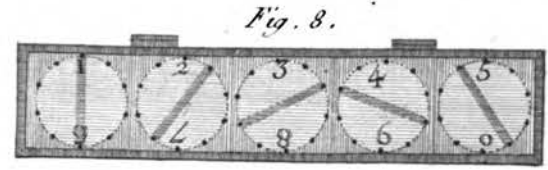
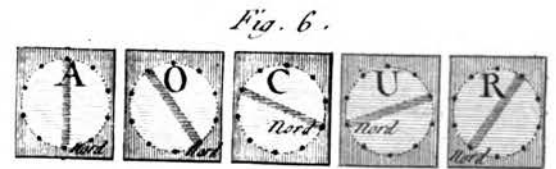
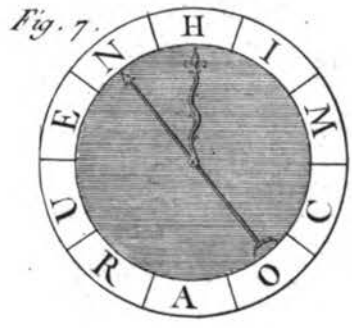
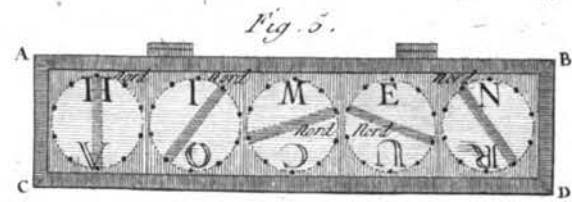
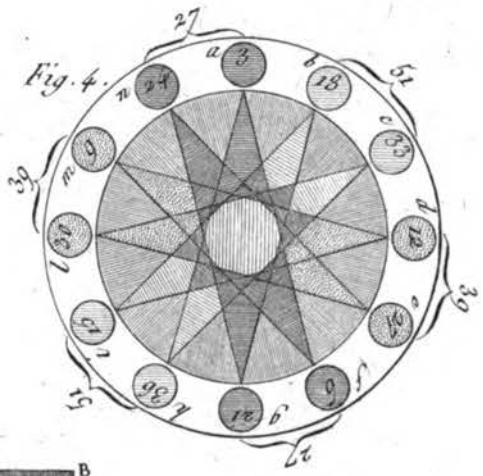
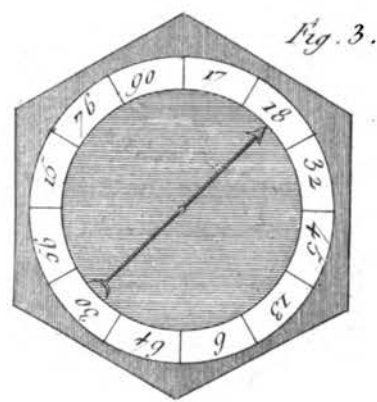
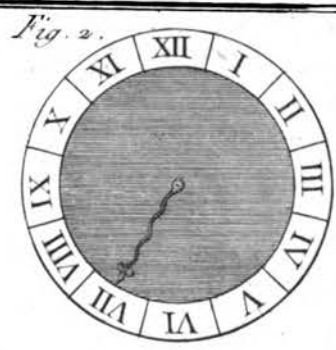
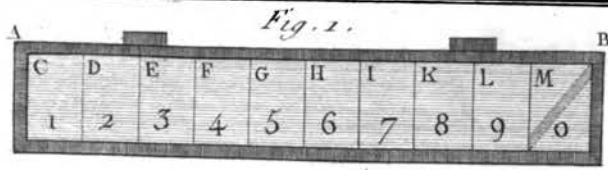


*Figures de Magie Blanche dévoilée.*

Digitized by Google

UNIVERSIDAD COMPLUTENSE  
DE MADRID

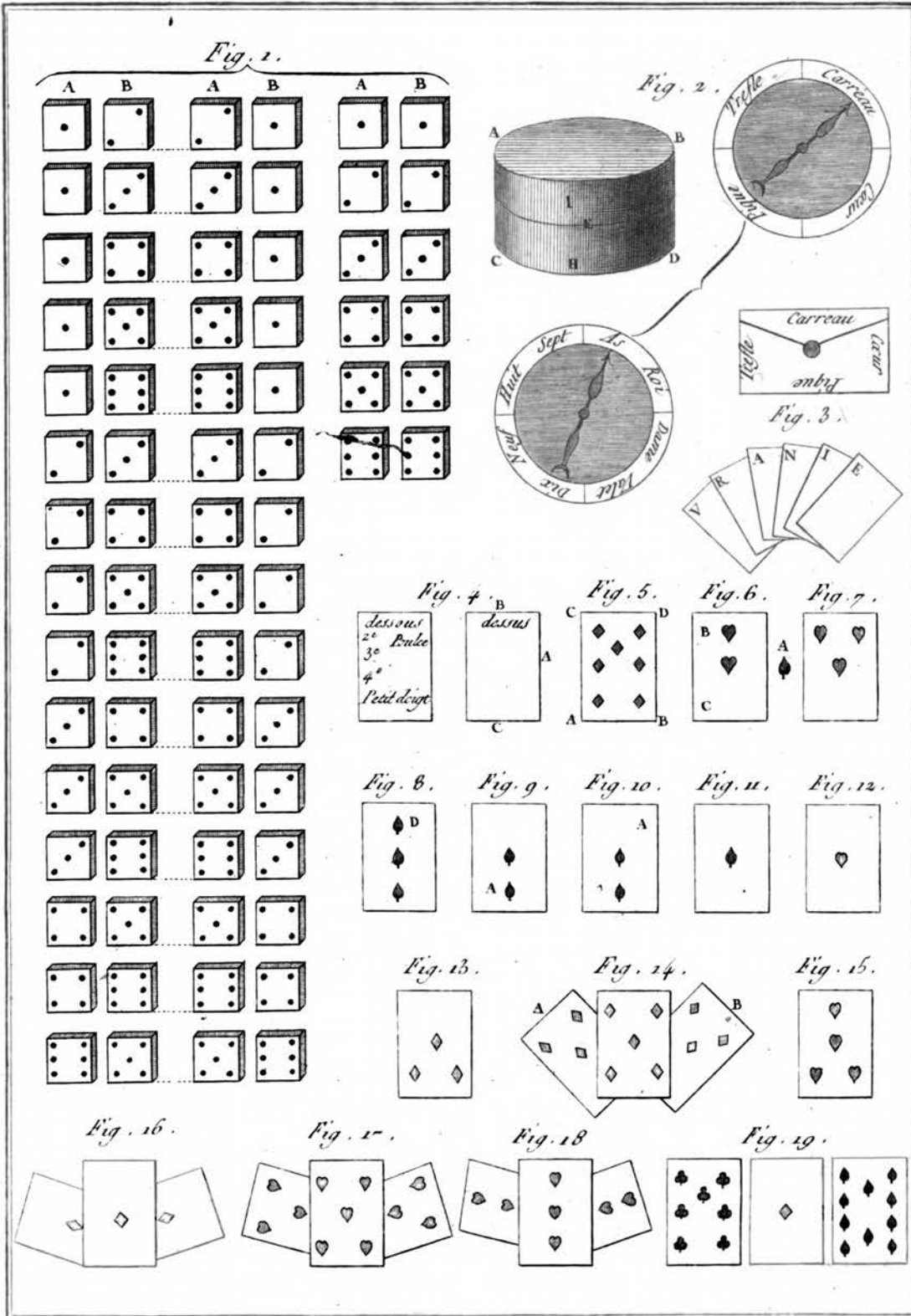




*Nombres Magiques.*

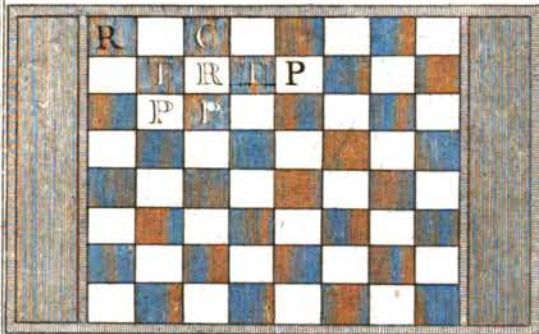
*Benard Drevet.*

Generated on 2014-05-11 17:19 GMT / http://hdl.handle.net/2027/ucm.5320295822 Public Domain, Google-digitized / http://www.hathitrust.org/access\_use#pd-google



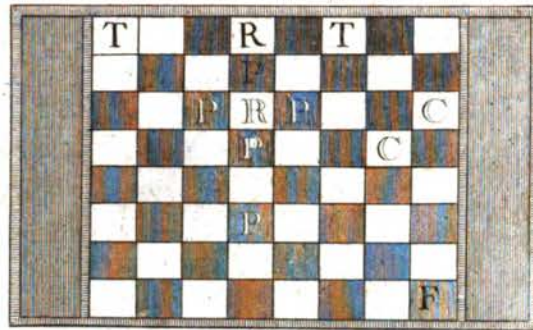
*Suite des Nombres Magiques et Cartes.*

Fig. 1. Cote' du Noir.



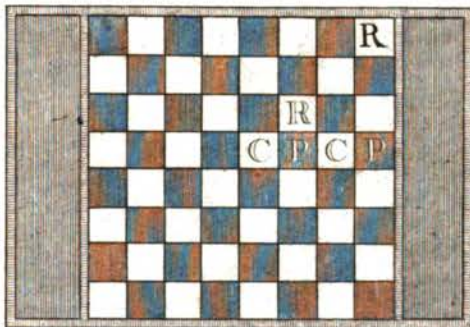
Cote' du Blanc.

Fig. 2. Cote' du Noir.



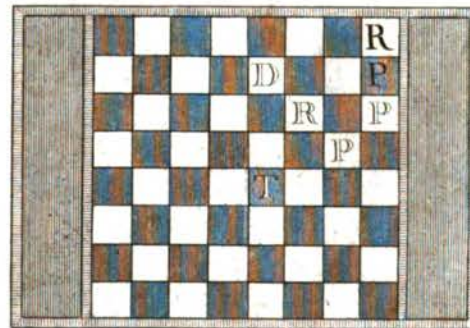
Cote' du Blanc.

Fig. 3. Cote' du Noir.



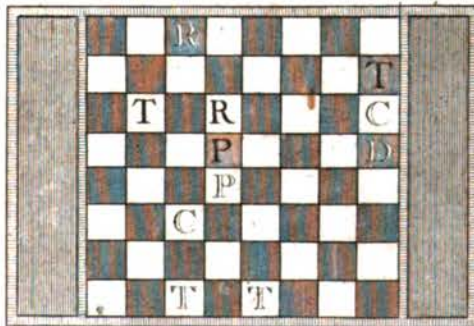
Cote' du Blanc.

Fig. 4. Cote' du Noir.



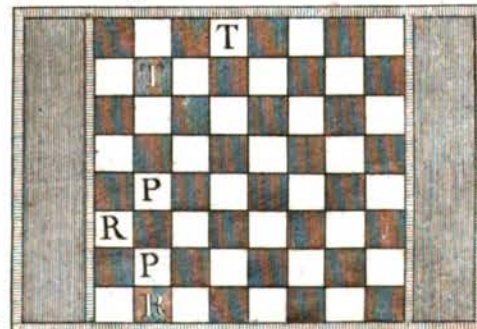
Cote' du Blanc.

Fig. 5. Cote' du Noir.



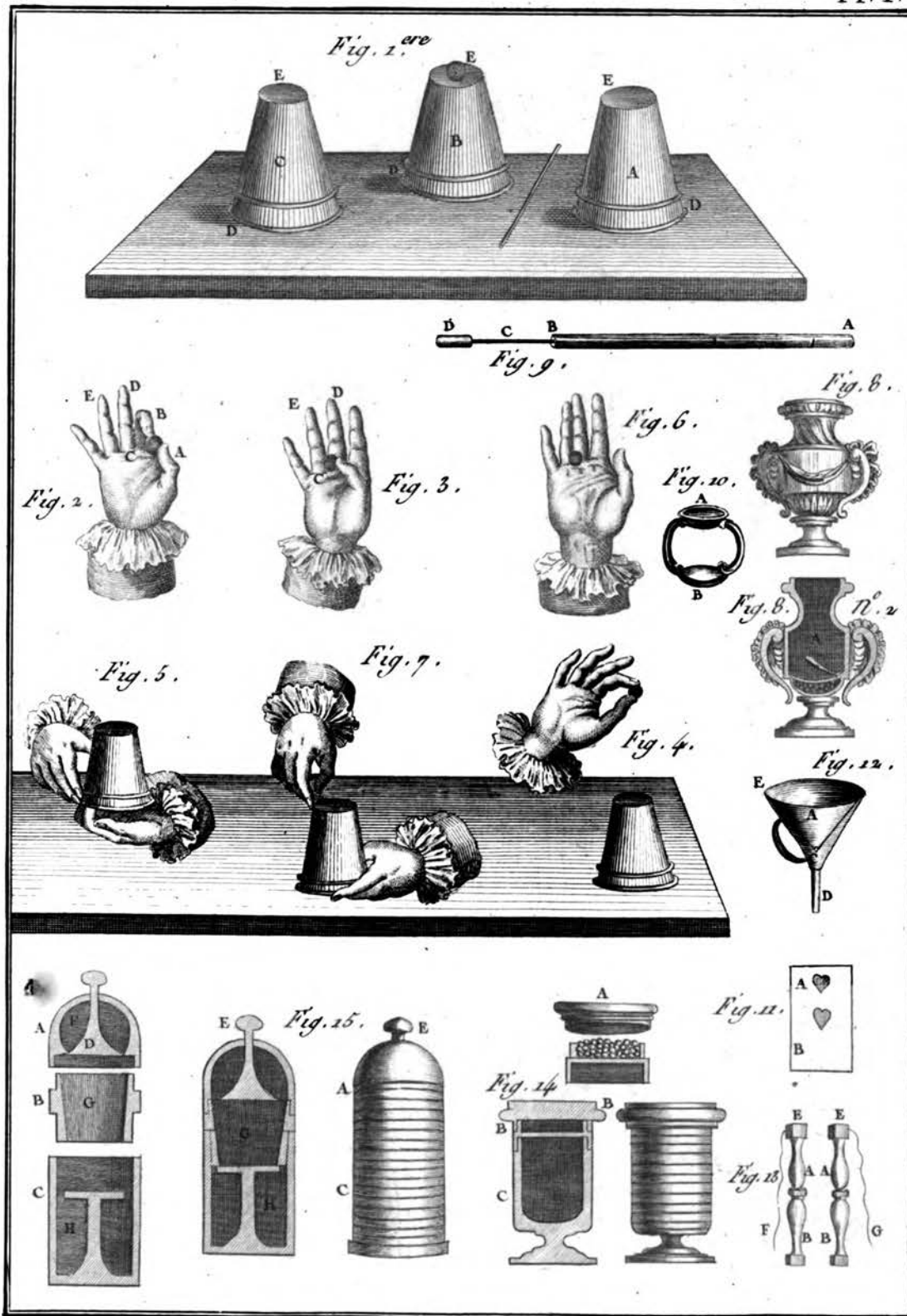
Cote' du Blanc.

Fig. 6. Cote' du Noir.



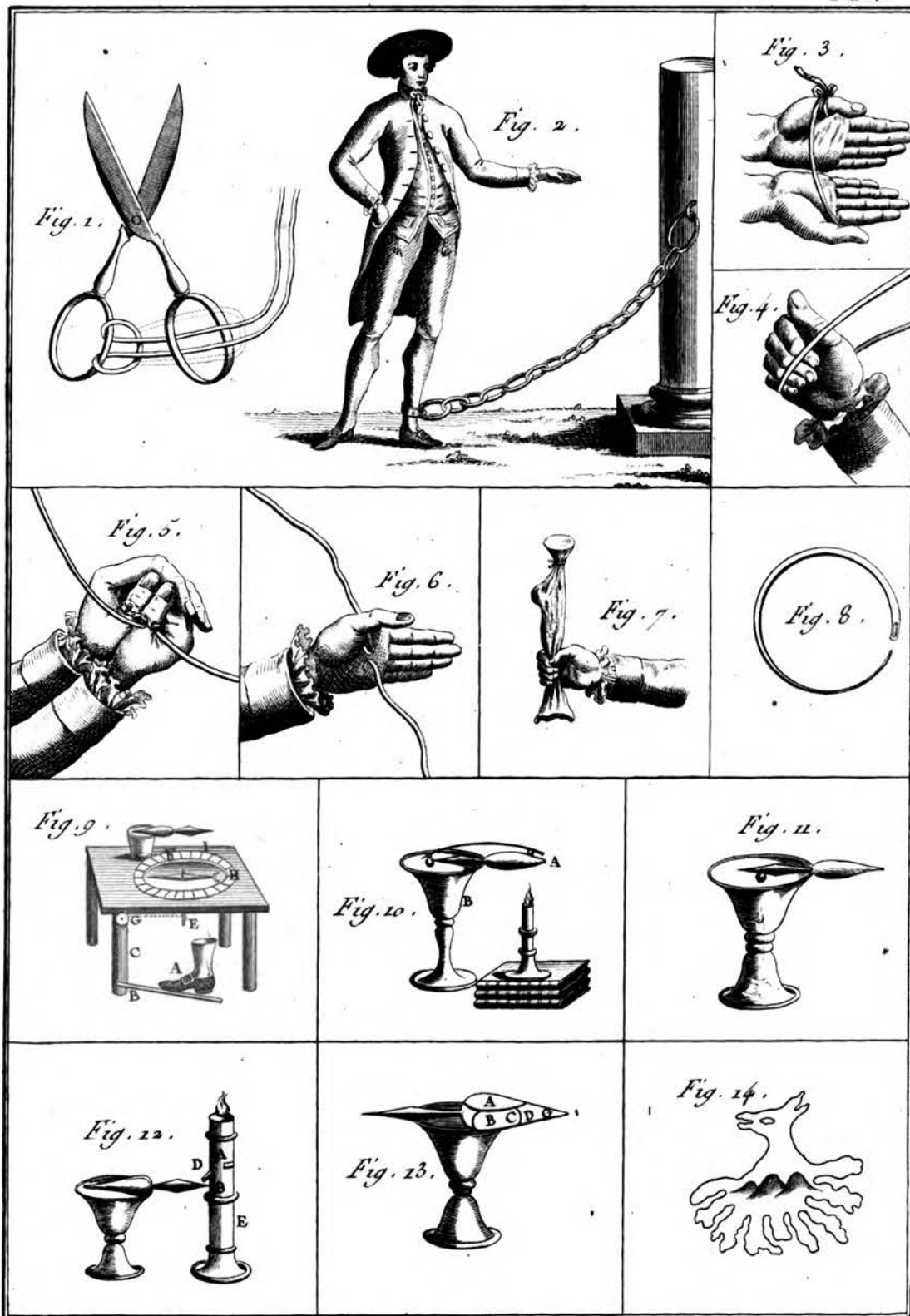
Cote' du Blanc.

Combinaisons Magiques.



Tours de Gibeciere

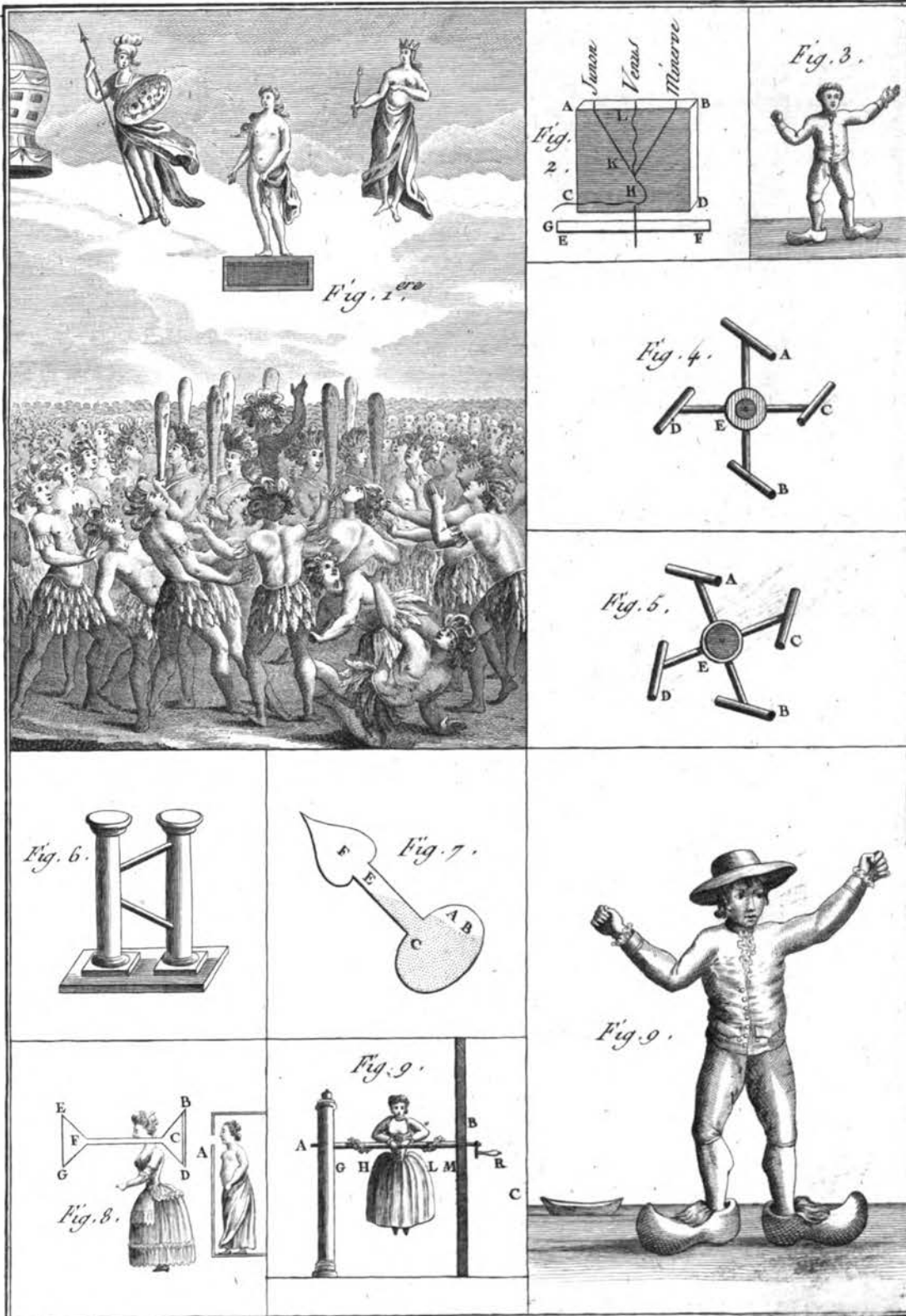
Generated on 2014-05-11 17:19 GMT / http://hdl.handle.net/2027/ucm.5320295822 Public Domain, Google-digitized / http://www.hathitrust.org/access\_use#pd-google



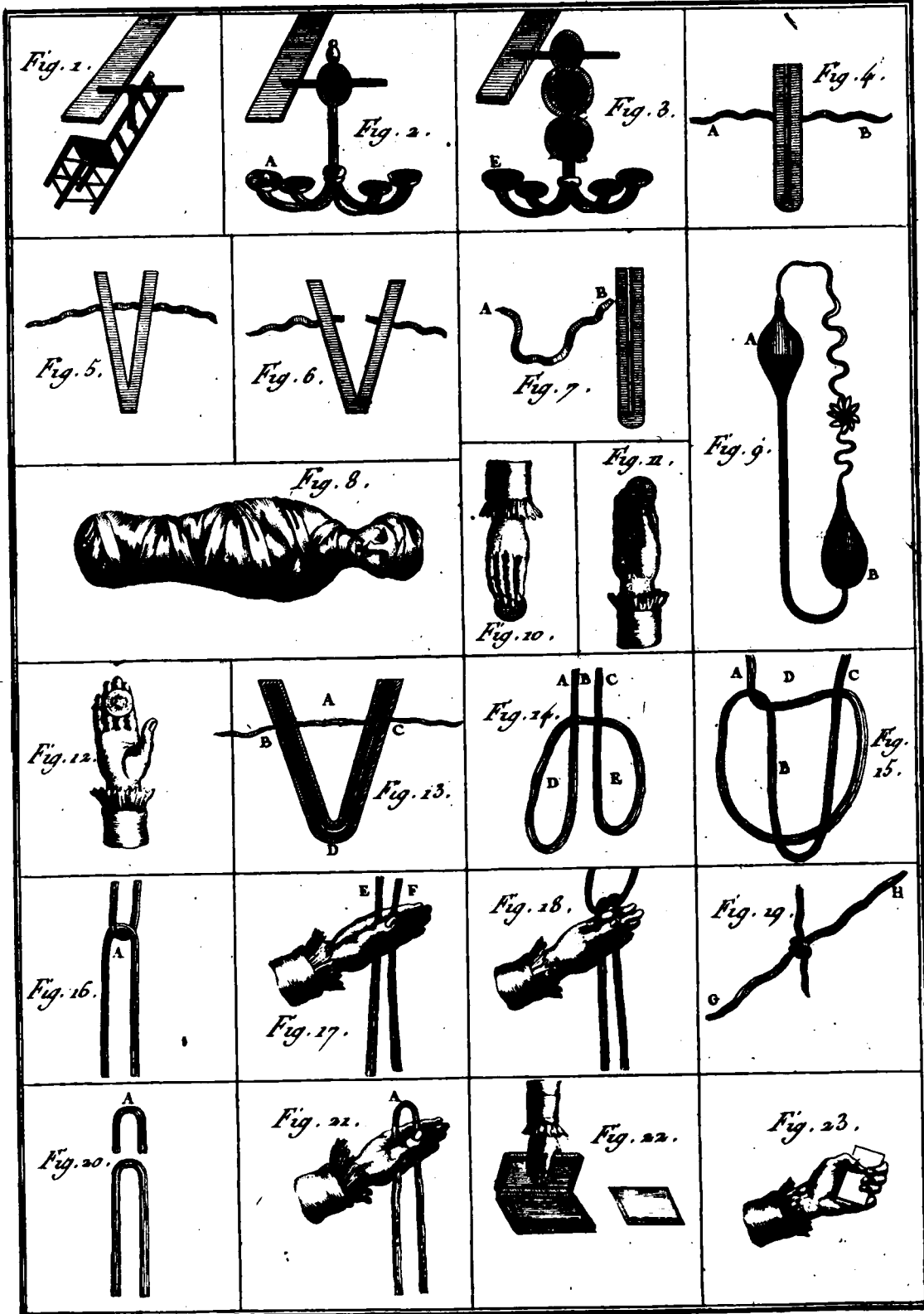
*Figures de Magie Blanche*

Digitized by Google

UNIVERSIDAD COMPLUTENSE DE MADRID

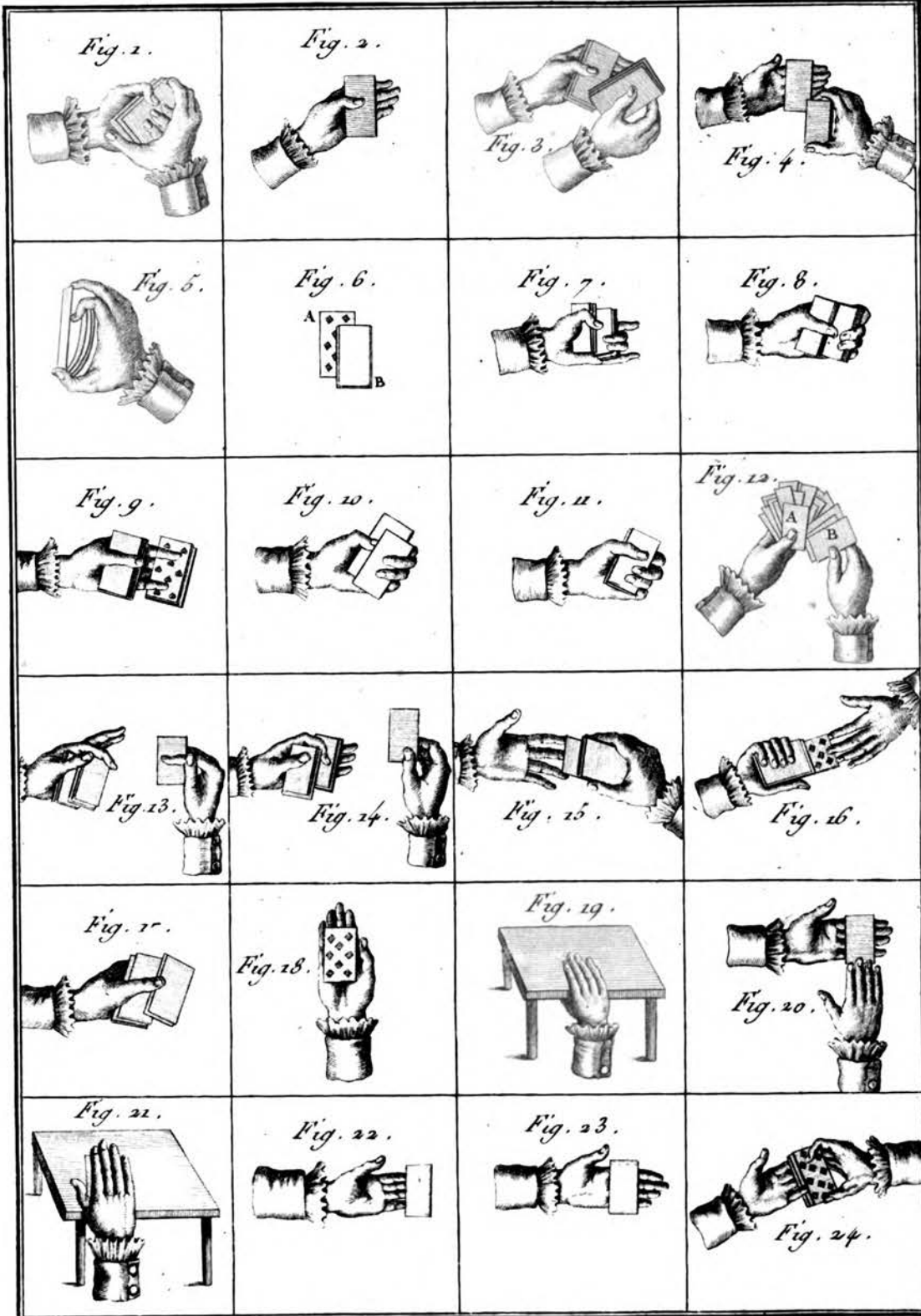


*Figures de Magie Blanche.*  
 Digitized by Google  
 Original from UNIVERSIDAD COMPLUTENSE DE MADRID

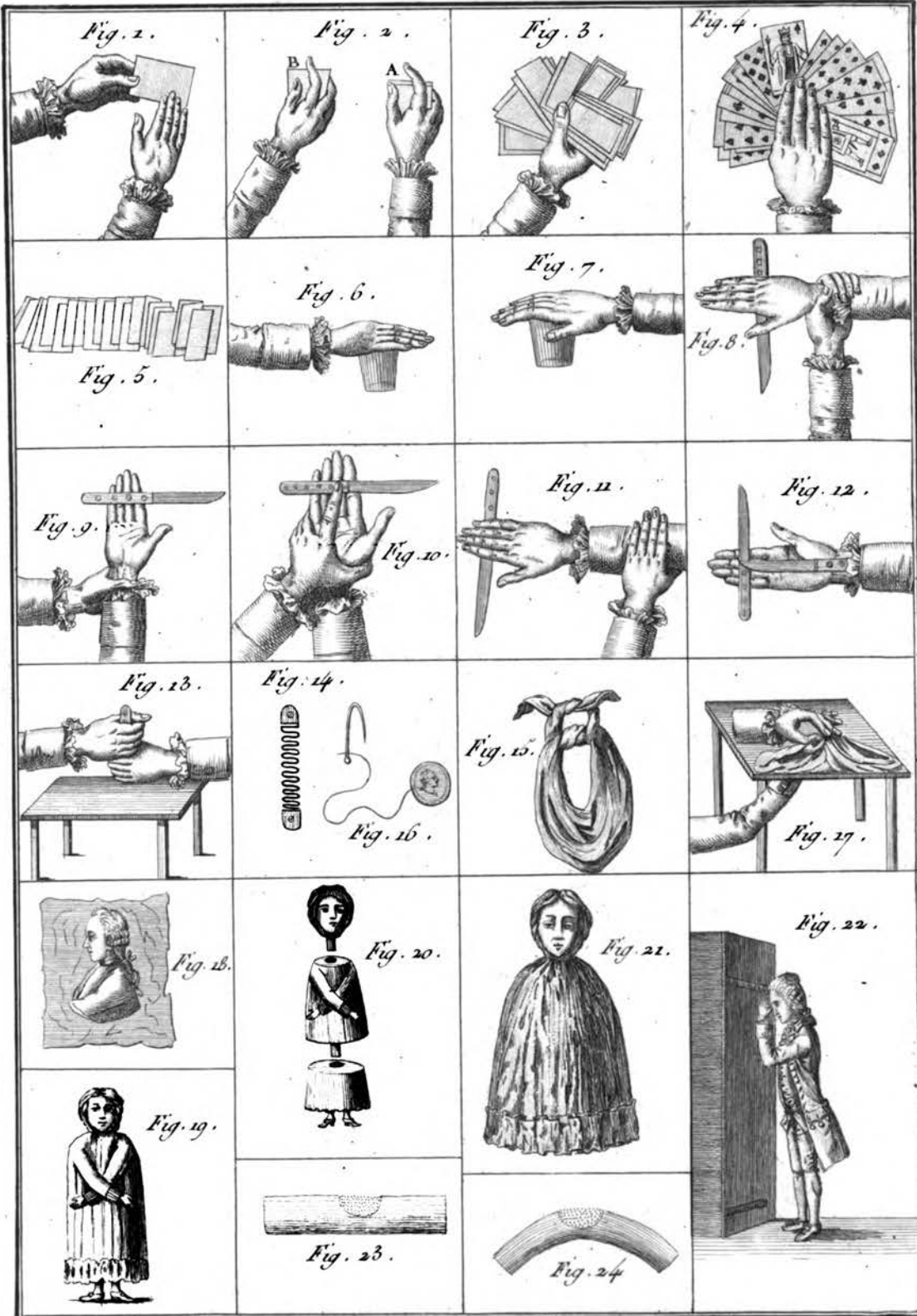


*Figures de Magie Blanche.*  
 Digitized by Google

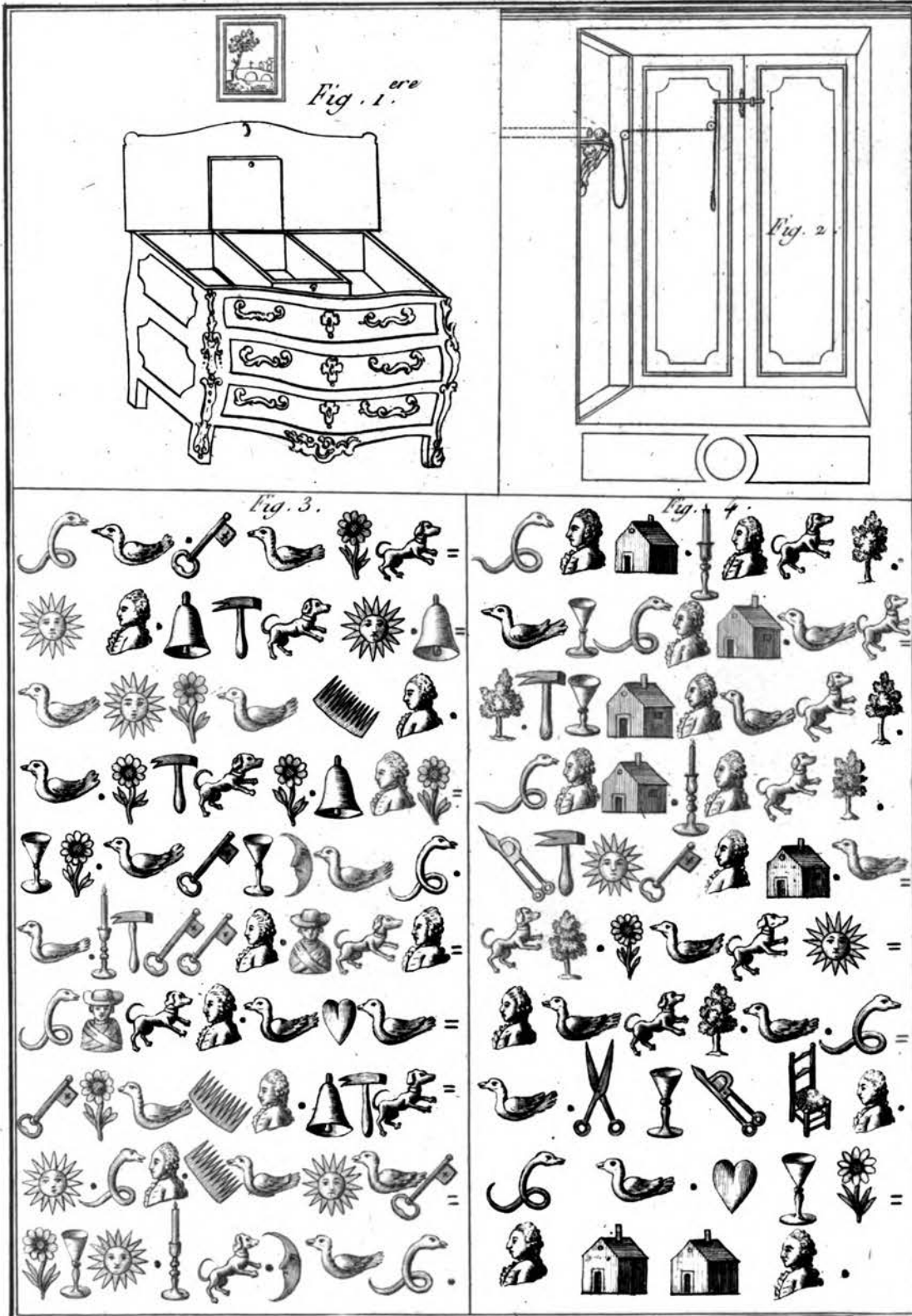
Original from  
 UNIVERSIDAD COMPLUTENSE  
 DE MADRID



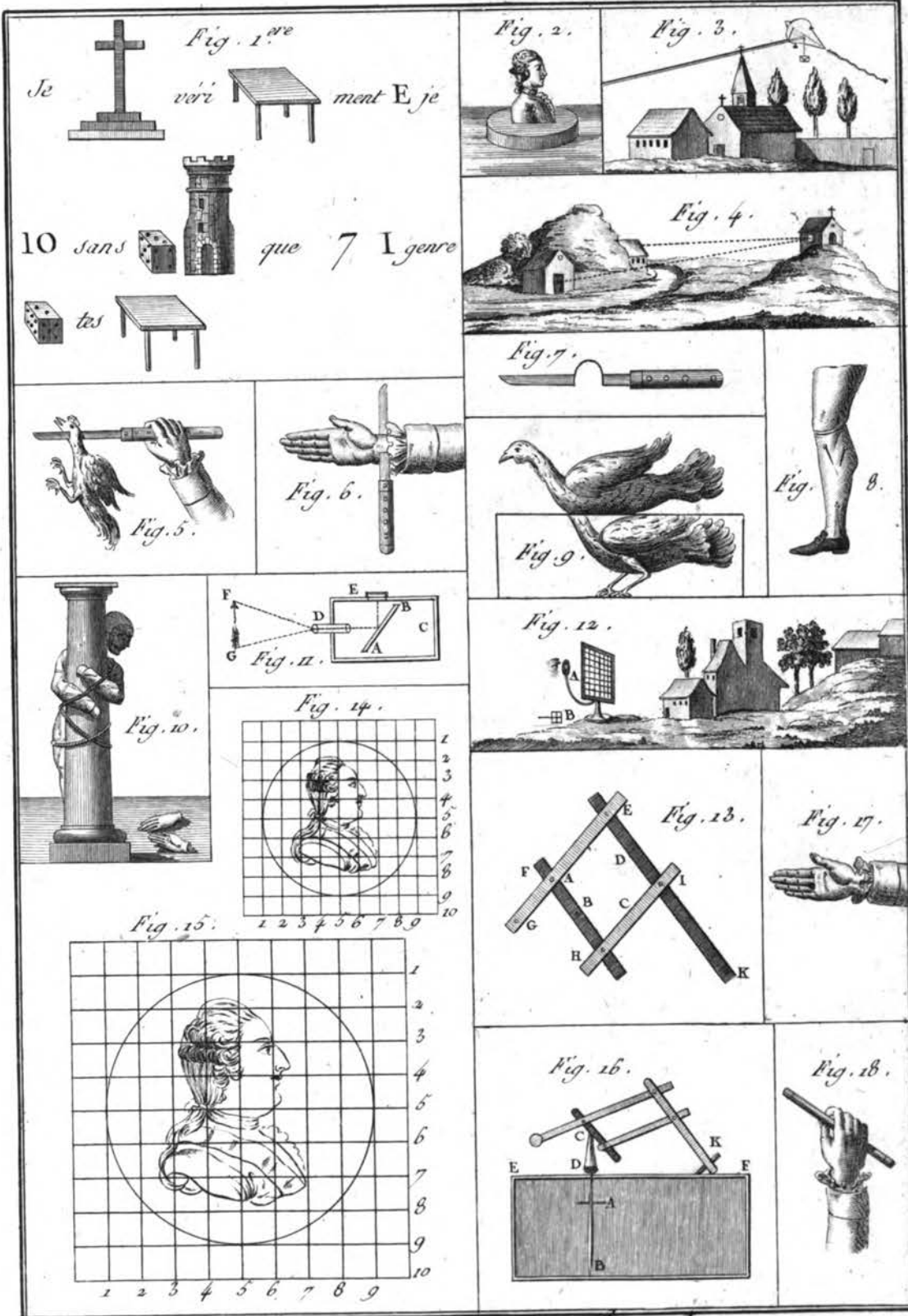




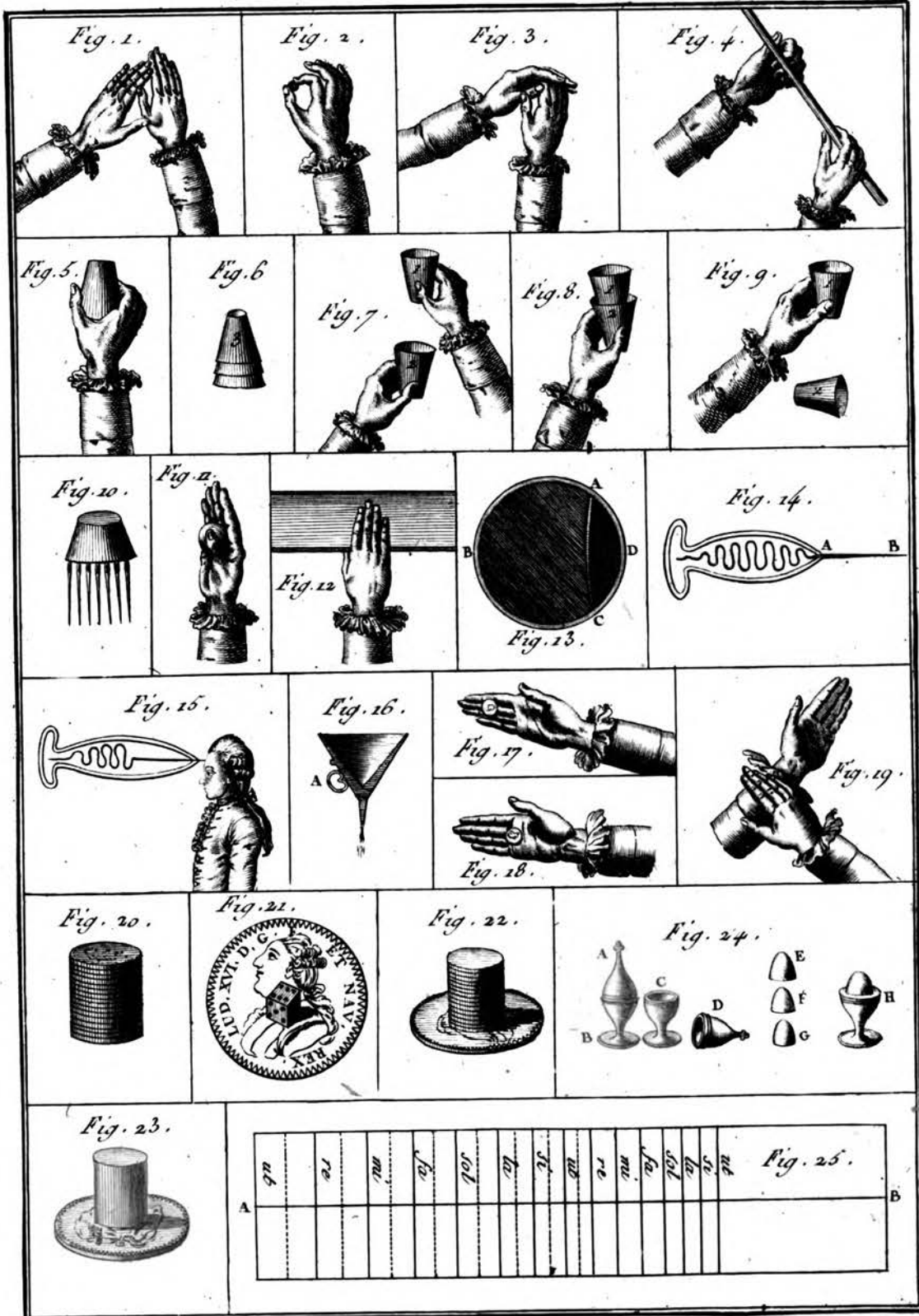
*Figures de Magie Blanche.*



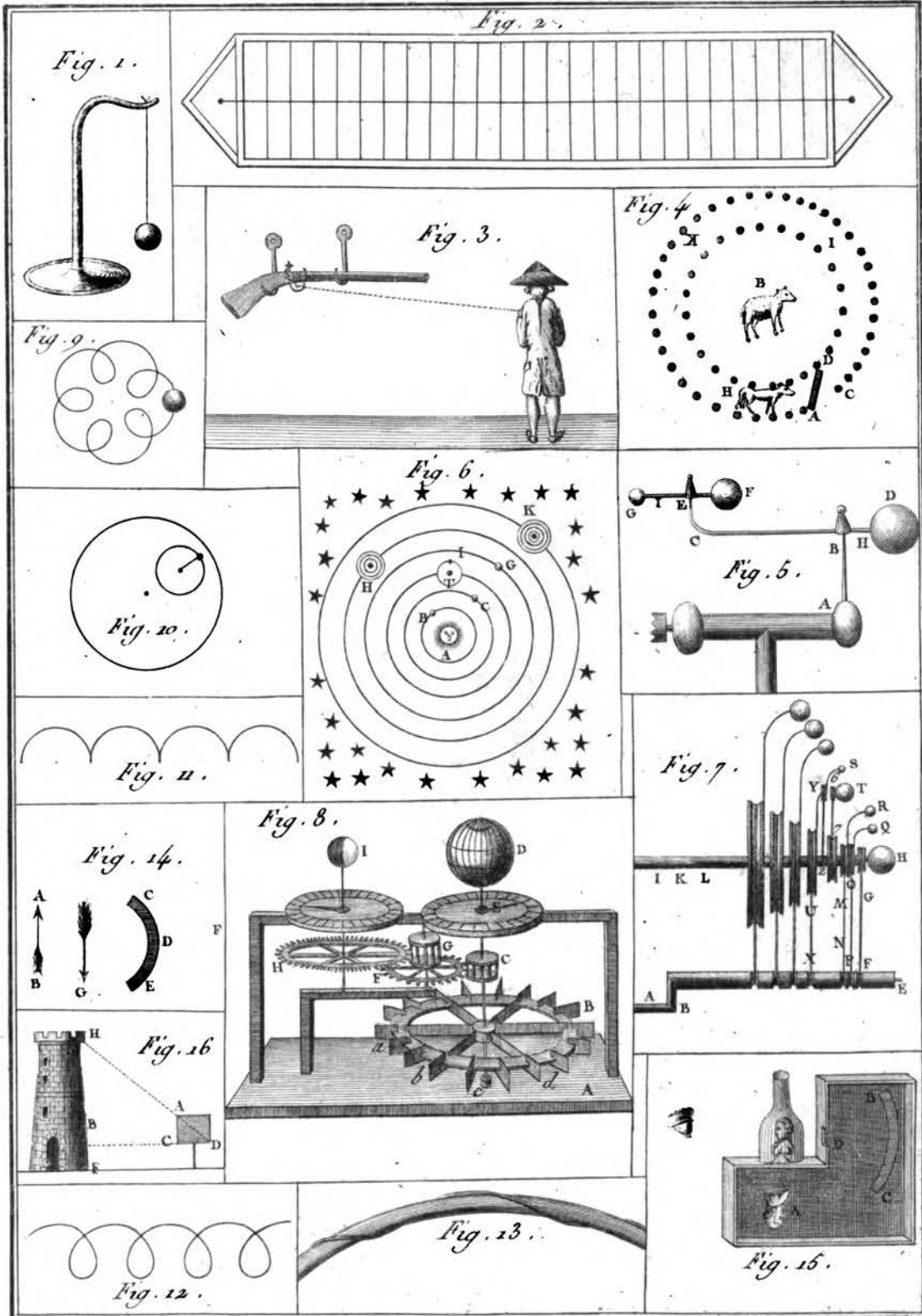
*Figures de Magie Blanche.*



*Figures de Magie Blanche.*

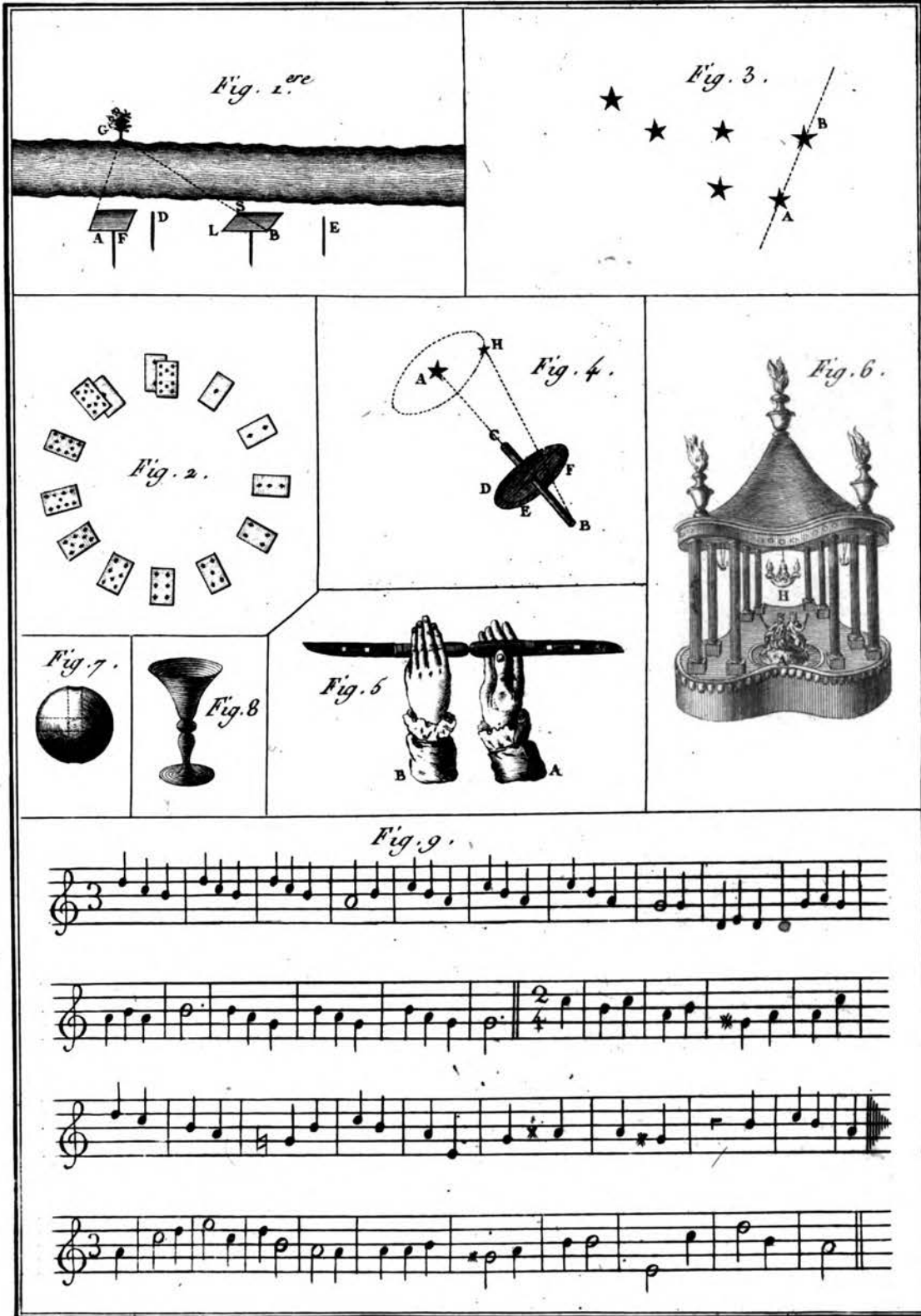


*Figures de Magie Blanche.*



*Figures de Magie Blanche.*

*Bernard Dircet*



*Figures de Magie Blanche.*

*Bernard Direct.*