

TYPES OF THE JOB ROOM

GOVERNMENT PRINTING OFFICE

1891

Z

250

.U55

LIBRARY
OF THE
Bureau of American Republics.

Case Shelf

Number

1-10

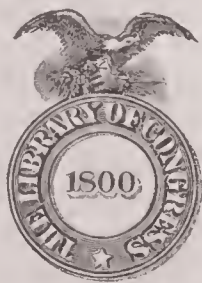

Class 220

Book 115

OFFICIAL DONATION.

SPECIMENS

OF THE

JOB ROOM TYPES,

GOVERNMENT PRINTING OFFICE.

THE
OFFICE OF
THE GOVERNMENT
PRINTING OFFICE

1891.

Z 250
.U55

JOB ROOM
GOVERNMENT PRINTING OFFICE.
1891.

15 JUL 1905
U. S. OF U.

YARGL 111
22880 70

MODERN AND OLD STYLE FACES.

F., L. & Co.

PEARL ROMAN.

THREE-NICK.

SCARCELY TWO WORKS out of ten are sent properly prepared to the press; either the writing is illegible, the spelling incorrect, or the punctuation defective. The compositor has often to read sentences of his copy more than once before he can ascertain what he conceives to be the meaning of the author, that he may not deviate from him in the punctuation; this retards him considerably. But here it does not end—he and the corrector of the press, though, perhaps, both intelligent and judicious men, differ in that which few are found to agree, and the compositor has to follow either his whim or better opinion. The proof goes to the author—he dissents from them both, and makes those alterations in print which would have rendered his manuscript copy correct.

The late Dr. Hunter, in reviewing a work, had occasion to censure it for its improper punctuation. He advises authors to leave the pointing entirely to the printers, as from their constant practice they must have acquired a uniform mode of punctuation. We are decidedly of this opinion; for unless the author will take the responsibility of the pointing entirely on himself, it will be to the advantage of the

MACK., S. & J.

NONPAREIL ROMAN No. 5.

THREE-NICK.

SCARCELY TWO WORKS out of ten are sent properly prepared to the press; either the writing is illegible, the spelling incorrect, or the punctuation defective. The compositor has often to read sentences of his copy more than once before he can ascertain what he conceives to be the meaning of the author, that he may not deviate from him in the punctuation; this retards him considerably. But here it does not end—he and the corrector of the press, though, perhaps, both intelligent and judicious men, differ in that which few men are found to agree, and the compositor has to follow either his whim or better opinion. The proof goes to the author—he dissents from them both, and makes those alterations in print which would have rendered his manuscript copy correct.

The late Dr. Hunter, in reviewing a work, had occasion to censure it for its improper punctuation. He advises authors to leave the pointing entirely to the

M., L. & Co.

NONPAREIL ROMAN No. 16.

THREE-NICK.

SCARCELY TWO WORKS out of ten are sent properly prepared to the press; either the writing is illegible, the spelling incorrect, or the punctuation defective. The compositor has often to read sentences of the copy more than once before he can ascertain what he conceives to be the meaning of the author, that he may not deviate from him in the punctuation; this retards him considerably. But here it does not end—he and the corrector of the press, though, perhaps, both intelligent and judicious men, differ in that which few are found to agree, and the compositor has to follow either his whim or better opinion. The proof goes to the author—he dissents from them both, and makes those alterations in print which would have rendered his manuscript copy correct.

MACK., S. & J.

NONPAREIL ROMAN No. 8.

TWO-NICK.

SCARCELY TWO WORKS out of ten are sent properly prepared to the press; either the writing is illegible, the spelling incorrect, or the punctuation defective. The compositor has often to read sentences of his copy more than once before he can ascertain what he conceives to be the meaning of the author, that he may not deviate from him in the punctuation; this retards him considerably. But here it does not end—he and the corrector of the press, though, perhaps, both intelligent and judicious men, differ in that which few men are found to agree, and the compositor has to follow either his whim or better opinion. The proof goes to the author—he dissents from them both, and makes those alterations in print which would have rendered his manuscript copy correct.

RYAN.

BREVIER ROMAN No. 5.

TWO-NICK.

SCARCELY TWO WORKS out of ten are sent properly prepared to the press; either the writing is illegible, the spelling incorrect, or the punctuation defective. The compositor has often to read sentences of his copy more than once before he can ascertain what he conceives to be the meaning of the author, that he may not deviate from him in the punctuation; this retards him considerably. But here it does not end—he and the corrector of the press, though, perhaps, both intelligent and judicious men, differ in that which few are found to agree, and the compositor has to follow either his whim or better opinion. The

M., L. & Co.

LONG PRIMER ROMAN No. 17.

THREE-NICK.

SCARCELY TWO WORKS out of ten are sent properly prepared to the press; either the writing is illegible, the spelling incorrect, or the punctuation defective. The compositor has often to read sentences of his copy more than once before he can ascertain what he conceives to be the meaning of the author, that he may not deviate from him in the punctuation; this retards him considerably. But here it does not end—

MACK., S. & J.

SMALL PICA ROMAN No. 10.

THREE-NICK.

SCARCELY TWO WORKS out of ten are sent properly prepared to the press; either the writing is illegible, the spelling incorrect, or the punctuation defective. The compositor has often to read sentences of his copy more than once before he can ascertain what he conceives to be the meaning of the author, that he may not deviate from him in the punctuation; this retards him considerably. But here it does not end—he and the

MODERN AND OLD STYLE FACES.

MACK., S. & J.

PICA ROMAN No. 12.

TWO-NICK.

SCARCELY TWO WORKS out of ten are sent properly prepared to the press; either the writing is illegible, the spelling incorrect, or the punctuation defective. The compositor has often to read sentences of his copy more than once before he can ascertain what he

MACK., S. & J.

ENGLISH ROMAN No. 1.

TWO-NICK.

SCARCELY TWO WORKS out of ten are sent properly prepared to the press; either the writing is illegible, the spelling incorrect, or the punctuation defective. The compositor has often to read sentences of his copy more than once before he can

MACK., S. & J.

GREAT PRIMER No. 3.

TWO-NICK.

SCARCELY TWO WORKS out of ten are sent properly prepared to the press; either the writing is illegible, the spelling incorrect, or

F., L. & Co.

BREVIER OLD STYLE No. 4.

THREE-NICK.

SCARCELY TWO WORKS out of ten are sent properly prepared to the press; either the writing is illegible, the spelling incorrect, or the punctuation defective. The compositor has often to read sentences of his copy more than once before he can ascertain what he conceives to be the meaning of the author, that he may not deviate from him in the punctuation; this retards him considerably. But here it does not end—he and the corrector of the press, though, perhaps, both intelligent and judicious men, differ in that which few are found to agree, and the compositor has to follow either his whim or better opinion. The proof goes to the author—he dissents

F., L. & Co.

LONG PRIMER OLD STYLE No. 1.

THREE-NICK.

SCARCELY TWO WORKS out of ten are sent properly prepared to the press; either the writing is illegible, the spelling incorrect, or the punctuation defective. The compositor has often to read sentences of his copy more than once before he can ascertain what he conceives to be the meaning of the author, that he may not deviate from him in the punctuation; this retards him considerably. But

MACK., S. & J.

PICA OLD STYLE No. 2.

TWO-NICK.

SCARCELY TWO WORKS out of ten are sent properly prepared to the press; either the writing is illegible, the spelling incorrect, or the punctuation defective. The compositor has often to read sentences of his copy more than once before he can ascertain what he conceives

MACK., S. & J.

ENGLISH OLD STYLE No. 2.

THREE-NICK.

SCARCELY TWO WORKS out of ten are sent properly prepared to the press; either the writing is illegible, the spelling incorrect, or the punctuation defective. The compositor has often to read sentences more than once before he can

MACK., S. & J.

GREAT PRIMER OLD STYLE No. 1.

TWO-NICK.

SCARCELY TWO WORKS out of ten are sent properly prepared to the press; either the writing is illegible, the spelling incorrect, or the

MODERN AND OLD STYLE ITALIC FACES.

MACK., S. & J.

NONPAREIL MODERN ITALIC No. 5.

THREE-NICK.

Scarcely two works out of ten are sent properly prepared to the press; either the writing is illegible, the spelling incorrect, or the punctuation defective. The compositor has often to read sentences of his copy more than once before he can ascertain what he conceives to be the meaning of the author, that he may not deviate from him in the punctuation; this retards him considerably. But here it does not end—he and the corrector of the press, though, perhaps, both intelligent and judicious men, differ in that which fear are found to

MACK., S. & J.

NONPAREIL MODERN ITALIC No. 8.

TWO-NICK.

Scarcely two works out of ten are sent properly prepared to the press; either the writing is illegible, the spelling incorrect, or the punctuation defective. The compositor has often to read sentences of his copy more than once before he can ascertain what he conceives to be the meaning of the author, that he may not deviate from him in the punctuation; this retards him considerably. But here it does not end—he and the corrector of the

RYAN.

BREVIER MODERN ITALIC No. 5.

TWO-NICK.

Scarcely two works out of ten are sent properly prepared to the press; either the writing is illegible, the spelling incorrect, or the punctuation defective. The compositor has often to read sentences of his copy more than once before he can ascertain what he conceives to be the meaning of the author, that he may not deviate from him in the punctuation; this retards him considerably. But here it does not end—

F., L. & Co.

BREVIER OLD STYLE ITALIC No. 4.

THREE-NICK.

Scarcely two works out of ten are sent properly prepared to the press; either the writing is illegible, the spelling incorrect, or the punctuation defective. The compositor has often to read sentences of his copy more than once before he can ascertain what he conceives to be the meaning of the author, that he may not deviate from him in the punctuation; this retards him considerably. But here it does not

MACK., S. & J.

LONG PEIMER OLD STYLE ITALIC No. 4.

THREE-NICK.

Scarcely two works out of ten are sent properly prepared to the press; either the writing is illegible, the spelling incorrect, or the punctuation defective. The compositor has often to read sentences of his copy more than once before he can ascertain what he conceives to be the meaning of the author, that he may not deviate from him in the punctu-

MACK., S. & J.

SMALL PICA MODERN ITALIC No. 10.

THREE-NICK.

Scarcely two works out of ten are sent properly prepared to the press; either the writing is illegible, the spelling incorrect, or the punctuation defective. The compositor has often to read sentences of his copy more than once before he can ascertain what he conceives to be the meaning of the author, that he may not deviate from him in the

MACK., S. & J.

PICA MODERN ITALIC No. 12.

TWO-NICK.

Scarcely two works out of ten are sent properly prepared to the press; either the writing is illegible, the spelling incorrect, or the punctuation defective. The compositor has often to read

MACK., S. & J.

PICA OLD STYLE ITALIC No. 2.

TWO-NICK.

Scarcely two works out of ten are sent properly prepared to the press; either the writing is illegible, the spelling incorrect, or the punctuation defective. The compositor has often to read

MACK., S. & J.

ENGLISH MODERN ITALIC No. 1.

TWO-NICK.

Scarcely two works out of ten are sent properly prepared to the press; either the writing is illegible, the spelling incorrect, or the punctuation defective. The compositor

MACK., S. & J.

ENGLISH OLD STYLE ITALIC No. 2.

THREE-NICK.

Scarcely two works out of ten are sent properly prepared to the press; either the writing is illegible, the spelling incorrect, or the punctuation defective. The

SCRIPTS.

MACK., S. & J.	DOUBLE BREVIER SPENCERIAN SCRIPT.	Caps, Lower Case, and Figures.	CABINET 18. Case Nos. 281, 282.
	<i>Most Religiously kept. They never conceived that this Rogue 15</i>		
MACK., S. & J.	DOUBLE SMALL PICA SPENCERIAN SCRIPT.	Caps, Lower Case, and Figures.	Case Nos. 283, 284.
	<i>Had promised To-morrow in Jun. Number 1546</i>		
MACK., S. & J.	DOUBLE PARAGON SPENCERIAN SCRIPT.	Caps, Lower Case, and Figures.	CABINET 19. Case Nos. 287 to 290.
	<i>Grand Mid-day Festivities.</i>		
MACK., S. & J.	FIVE-LINE PICA SPENCERIAN SCRIPT.	Caps, Lower Case, and Figures.	Case Nos. 299 to 302.
	<i>The Great Western</i>		
MACK., S. & J.	DOUBLE BREVIER SPENCERIAN SCRIPT No. 2.	Caps, Lower Case, and Figures.	CABINET 18. Case Nos. 271, 272.
	<i>At first He made naught but to day, with its Joy, Successes, and</i>		
MACK., S. & J.	DOUBLE SMALL PICA SPENCERIAN SCRIPT No. 2.	Caps, Lower Case, and Figures.	Case Nos. 273 to 276.
	<i>Sorrows, then to keep on good terms with the World promised</i>		
MACK., S. & J.	DOUBLE ENGLISH SPENCERIAN SCRIPT No. 2.	Caps, Lower Case, and Figures.	Case Nos. 277, 278.
	<i>Put their Hands in their Pockets and Slept, 21</i>		
MACK., S. & J.	GREAT PRIMER SCRIPT No. 7.	Caps, Lower Case, and Figures.	CASE ON STAND.
	<i>Curfew tells the Knell of Parting Day, the Lowing Herd 1234</i>		
MACK., S. & J.	DOUBLE SMALL PICA SCRIPT No. 8.	Caps, Lower Case, and Figures.	CASE ON STAND.
	<i>Winds slowly e'er the Lea, weary the Plowman homeward</i>		
MACK., S. & J.	DOUBLE ENGLISH SCRIPT No. 4.	Caps, Lower Case, and Figures.	CASE ON STAND.
	<i>The Tradesman's Face grew Long and Blue 32</i>		
MACK., S. & J.	THREE-LINE PICA SCRIPT.	Caps, Lower Case, and Figures.	CABINET 19. Case Nos. 295 to 298.
	<i>Scientific Investigations Rewarded 12689</i>		

SCRIPTS AND TEXTS.

	DOUBLE SMALL PICA CALIGRAPH.	Caps, Lower Case, and Figures.	CABINET 19.
BRUCE.	<i>The man who best understands the Laws of Trade, by which Demand and Supply</i> 25		Case Nos. 291, 292.
	GREAT PRIMER ROUND FACE SCRIPT.	Caps, Lower Case, and Figures.	Case Nos.
F., L. & Co.	<i>This Popular Summer Resort is situated on the 11,</i>		293, 294.
	DOUBLE PICA ROUND FACE SCRIPT.	Caps, Lower Case, and Figures.	CABINET 18.
F., L. & Co.	<i>Believing the promise of time would be</i>		Case Nos. 279, 280.
	GREAT PRIMER HANCOCK SCRIPT.	Caps, Lower Case, and Figures.	CABINET 20.
MACK., S. & J.	<i>Apply to Strangers for Charity, Acquaintances for</i> 135		Case Nos. 303, 304.
	DOUBLE SMALL PICA HANCOCK SCRIPT.	Caps, Lower Case, and Figures.	Case Nos.
MACK., S. & J.	<i>Advice, and Relatives for Nothing and you'll</i>		305, 306.
	LONG PRIMER PEN TEXT.	Caps, Lower Case, and Figures.	CABINET 27.
F., L. & Co.	Old Time is the Drollest of Wags, and Puzzles the World With his Rules, he Gave all To-day to the Wise and To-morrow he Promised 12		Case No. 414.
	PICA PEN TEXT.	Caps, Lower Case, and Figures.	Case
F., L. & Co.	To the Fools. At first he made Naught but To-day, with its Joys 35		No. 415.
	GREAT PRIMER PEN TEXT.	Caps, Lower Case, and Figures.	Case
F., L. & Co.	Successes and Sorrow, then to keep on Good Terms 26		No. 416.
	DOUBLE SMALL PICA PEN TEXT.	Caps, Lower Case, and Figures.	Case
F., L. & Co.	With the World Promised He'd make 279		No. 417.
	DOUBLE ENGLISH PEN TEXT.	Caps, Lower Case, and Figures.	Case
F., L. & Co.	A To-morrow for The Fools. 54		No. 418.

LIGHT-FACE ITALICS.

BRUCE.	LONG PRIMER HAIRLINE ITALIC.	Caps, Lower Case, and Figures.	CABINET 16.
	<i>SO THIS BRAVE KNIGHT IN ARMOR BRIGHT</i>		Case
	<i>Went gaily to the Fray; He fought the fight, but ere the Night His Soul had Passed</i>		No. 242.
MACK., S. & J.	PICA HAIRLINE ITALIC.	Caps, Lower Case, and Figures.	CABINET 29.
	<i>Love and Pride of the American Society Woman.</i>		Case
			No. 459.
MACK., S. & J.	LONG PRIMER CIRCULAR.	Caps, Lower Case, and Figures.	CABINET 16.
	<i>To be completely successful in any Business Enterprise the undertaker must be</i>		Case
	<i>thoroughly in earnest and a Master of his Trade. \$15,000.08. 1234567890</i>		No. 239.
MACK., S. & J.	PICA CIRCULAR.	Caps, Lower Case, and Figures.	CABINET 2.
	<i>One Seawallow Does not make a Summer. But a Hot Summer makes.</i>		Case
			No. 31.
MACK., S. & J.	GREAT PRIMER CIRCULAR.	Caps, Lower Case, and Figures.	CABINET 16.
	<i>Some are Born to Greatness, some have greatness 120</i>		Case Nos.
			243, 244.
F., L. & Co.	PICA VENITIAN No. 2.	Caps, Lower Case, and Figures.	Case Nos.
	<i>Success in ordinary business undertakings whether it be Printing</i>		Case Nos.
	<i>Offices or any other kind of business, it should be well 1234567890</i>		240, 241.
F., L. & Co.	BREVIER LATIN ITALIC No. 2.	Caps, Lower Case, and Figures.	CABINET 17.
	<i>LOVE AND PRIDE OF THE AMERICAN SOCIETY WOMAN.</i>		Case Nos.
	<i>The American lady loves beautiful surroundings, and takes great pride in wearing elegant underclothing</i>		255, 256.
F., L. & Co.	LONG PRIMER LATIN ITALIC No. 2.	Caps, Lower Case, and Figures.	Case Nos.
	<i>DAINTY NOVELTIES FOR COUNTRY TOURISTS.</i>		Case Nos.
	<i>A sandwich of two outer layers of feminine humanity, center inclosure, ugly masculinity</i>		257, 258.
F., L. & Co.	PICA LATIN ITALIC No. 2.	Caps, Lower Case, and Figures.	Case Nos.
	<i>Not a single Apache could be seen, but every bush and boulder seemed 8</i>		Case Nos.
			259, 260.
F., L. & Co.	GREAT PRIMER LATIN ITALIC No. 2.	Caps, Lower Case, and Figures.	Case Nos.
	<i>Grand Excursion to the Green Lawns of Marshall Hall</i>		Case Nos.
			261, 262.
MACK., S. & J.	GREAT PRIMER ITALIC No. 3.	Caps and Lower Case.	CABINET 23.
	<i>Never take the Horseshoe from the Door. Bad Luck</i>		Case Nos.
			348, 349.

LIGHT-FACE ITALICS.

F., L. & Co.	BREVIER LAW ITALIC.	Caps, Lower Case, and Figures.	CASE
	<i>WHAT ARE YOU GOING TO DO ABOUT IT</i>		
	<i>An Important Conundrum the Correct Solution of which is often most</i> 12		ON STAND.
F., L. & Co.	LONG PRIMER LAW ITALIC.	Caps, Lower Case, and Figures.	CASE
	<i>SEEKING RELIEF FROM BOREDOM</i>		
	<i>A Three Months' Tour in the Wild Western Mountains</i> 567		ON STAND.
F., L. & Co.	PICA LAW ITALIC.	Caps, Lower Case, and Figures.	CASE
	<i>Blow Winter Wind, Thou art not so Unkind</i> 1234567		ON STAND.
MAC K., S. & J.	BREVIER GOTHIC ITALIC CONDENSED.	Caps, Lower Case, and Figures.	CABINET 27.
	<i>WHEN TRADE GREW SLACK AND BILLS FELL DUE</i>		Case
	<i>The Tradesman's Face Grew Long and Blue; His Dreams were Troubled by Sheriffs.</i> 23		No. 425.
F., L. & Co.	LONG PRIMER GOTHIC ITALIC CONDENSED.	Caps, Lower Case, and Figures.	Case
	<i>NOT A DRUM WAS HEARD, NOT A FUNERAL NOTE</i>		
	<i>As his Corpse to the Rampart we Hurried, not a Soldier Discharged</i> 12456		No. 426.
MAC K., S. & J.	PICA GOTHIC ITALIC CONDENSED.	Caps, Lower Case, and Figures.	Case
	<i>A Farewell Shot o'er the Grave where our Hero was Buried.</i> 3		No. 427.
MAC K., S. & J.	TWO-LINE BREVIER GOTHIC ITALIC CONDENSED.	Caps, Lower Case, and Figures.	Case
	<i>Ellsworth the Noble, Brave, and True. Alexandria, Va.</i>		No. 428.
MAC K., S. & J.	TWO-LINE LONG PRIMER GOTHIC ITALIC CONDENSED.	Caps, Lower Case, and Figures.	Case
	<i>The Best Plan Now is to Advertise Freely</i> 3		No. 429.
F., L. & Co.	GREAT PRIMER OLD STYLE ITALIC.	Caps, Lower Case, and Figures.	CABINET 16.
	<i>Thou art Holy and Calm, Thy Soft Dewy Breath</i>		Case
			No. 247.
F., L. & Co.	DOUBLE SMALL PICA OLD STYLE ITALIC.	Caps, Lower Case, and Figures.	Case
	<i>Fills worn brow with Balmly Sleep</i> 5		No. 248.
F., L. & Co.	DOUBLE ENGLISH OLD STYLE ITALIC.	Caps, Lower Case, and Figures.	Case
	<i>Friends Tried and True</i>		No. 249.
F., L. & Co.	FOUR-LINE PICA OLD STYLE ITALIC.	Caps, Lower Case, and Figures.	Case
	<i>The Horn Sounds</i> 8		No. 250.

HEAVY-FACE ITALICS.

MACK., S. & J.	BREVIER GOTHIC ITALIC.	Caps, Lower Case, and Figures.	CABINET 16. Case Nos. 251, 252.
	<i>THE MELANCHOLY DAYS ARE COME, THE SADDEST OF THE YEAR.</i> <i>Of wailing Winds, and naked Woods, and Meadows brown and sear. Where are the Flowers 12345678</i>		
MACK., S. & J.	SMALL PICA GOTHIC ITALIC No. 2.	Caps, Lower Case, and Figures.	CABINET 28. Case Nos. 434, 435.
	<i>MEN OF REAL MORAL PRINCIPLE COMMAND THE</i> <i>Spontaneous homage of mankind. It is natural to feel attracted to them, to look up</i>		
MACK., S. & J.	DOUBLE SMALL PICA GOTHIC ITALIC.	Caps, Lower Case, and Figures.	CABINET 16. Case Nos. 253, 254.
	<i>Comical Chinamen with Artistic Costumes 1234</i>		
F., L. & Co.	NONPAREIL TITLE ITALIC.	Caps, Lower Case, and Figures.	CABINET 17. Case No. 263.
	<i>A POLICEMAN FINDS SOME VALUABLE CLUES WHILE ASLEEP.</i> <i>While he slept his brain took up the thread of his waking thoughts, and like a flash it came to him</i>		
F., L. & Co.	BREVIER TITLE ITALIC.	Caps, Lower Case, and Figures.	Case No. 264.
	<i>THE SHADOWS OF DEPARTED HOURS</i> <i>Every Moment, Lightly Shaken, runs itself in Golden Sand Harmonies 119</i>		
F., L. & Co.	LONG PRIMER TITLE ITALIC.	Caps, Lower Case, and Figures.	Case No. 265.
	<i>'TIS THREE DAYS SINCE HE TASTED FLESH.</i> <i>But to-morrow he shall break his fast upon yours, and a 189</i>		
MACK., S. & J.	NONPAREIL FULL FACE ITALIC ON SMALL PICA BODY.	Caps, Lower Case, and Figures.	CABINET 28. Case Nos. 432, 433.
	<i>THE SWORD EDGE OF WIT UPON THINGS POLITICAL</i> <i>The spirit of heartless jesting at the expense of others is the very essence</i>		
F., L. & Co.	PICA ITALIC No. 4.	Caps, Lower Case, and Figures.	CABINET 17. Case No. 266.
	<i>Dainty meal for him ye will be. If ye are beasts 5</i>		
MACK., S. & J.	GREAT PRIMER ITALIC No. 4.	Caps, Lower Case, and Figures.	Case No. 267.
	<i>Planked Shad Dinner at Marshall Hall. Shad</i>		
MACK., S. & J.	DOUBLE SMALL PICA ITALIC No. 2.	Caps, Lower Case, and Figures.	Case No. 268.
	<i>The Flowers that Bloom in the Spring</i>		
MACK., S. & J.	DOUBLE ENGLISH ITALIC No. 3.	Caps, Lower Case, and Figures.	Case No. 269.
	<i>Bring Promise of Merry Sun</i>		
MACK., S. & J.	DOUBLE GREAT PRIMER ITALIC No. 3.	Caps, Lower Case, and Figures.	Case No. 270.
	<i>Summer Opera Season</i>		

CELTICS.

F., L. & Co.	<p>NONPAREIL LIGHT-FACE CELTIC. Caps, Lower Case, and Figures.</p> <p>THE WORLD IS FULL OF FOOLS,</p> <p>And he who would not wish to see one must not only keep away from the mirror 1, 2</p>	CABINET 2. Case No. 25.
•F., L. & Co.	<p>BREVIER LIGHT-FACE CELTIC. Caps, Lower Case, and Figures.</p> <p>THE WORLD IS FULL OF FOOLS,</p> <p>And he who would not wish to see one must not only 1, 2, 3, 4, 5, 6, 7</p>	Case No. 26.
F., L. & Co.	<p>LONG PRIMER LIGHT-FACE CELTIC. Caps, Lower Case, and Figures.</p> <p>THE WORLD IS FULL OF FOOLS,</p> <p>And he who would not wish to see one must not only 1891</p>	Case No. 27.
F., L. & Co.	<p>PICA LIGHT-FACE CELTIC. Caps, Lower Case, and Figures.</p> <p>The World is full of Fools, and he who would not</p>	Case No. 28.
F., L. & Co.	<p>GREAT PRIMER LIGHT-FACE CELTIC. Caps, Lower Case, and Figures.</p> <p>The World is full of Fools, and he</p>	Case No. 29.
F., L. & Co.	<p>DOUBLE SMALL PICA LIGHT-FACE CELTIC. Caps, Lower Case, and Figures.</p> <p>The World is full of Fools</p>	Case No. 30.
F., L. & Co.	<p>NONPAREIL CELTIC No. 2. Caps and Figures.</p> <p>THE WORLD IS FULL OF FOOLS AND HE WHO WOULD NOT WISH TO SEE ONE MUST NOT</p>	CABINET 3. Case No. 33.
F., L. & Co.	<p>MINION CELTIC No. 2. Caps and Figures.</p> <p>THE WORLD IS FULL OF FOOLS. AND HE WHO WOULD NOT WISH</p>	Case No. 34.
F., L. & Co.	<p>BREVIER CELTIC No. 2. Caps and Figures.</p> <p>THE WORLD IS FULL OF FOOLS, AND HE WHO WOULD</p>	Case No. 33.
F., L. & Co.	<p>LONG PRIMER CELTIC No. 2. Caps and Figures.</p> <p>THE WORLD IS FULL OF FOOLS. AND HE 1891</p>	Case No. 34.
F., L. & Co.	<p>PICA CELTIC No. 2. Caps and Figures.</p> <p>THE WORLD IS FULL OF FOOLS, AND</p>	Case No. 35.

CELTICS AND LIGHT FACES.

F., L. & Co.	<p>GREAT PRIMER CELTIC No. 2. Caps and Figures.</p> <p>THE WORLD IS FULL OF 56</p>	<p>CABINET 3. Case No. 36.</p>
F., L. & Co.	<p>TWO-LINE PICA CELTIC. Caps and Figures.</p> <p>THE WORLD IS FULL</p>	<p>Case No. 37.</p>
F., L. & Co.	<p>NONPAREIL LIGHT-FACE. Caps, Lower Case, and Figures.</p> <p>POINTS ARE NOT OF EQUAL ANTIQUITY WITH Printing, though not long after its invention the necessity of introducing stops or pauses</p>	<p>CABINET 4. Case No. 52.</p>
F., L. & Co.	<p>BREVIER LIGHT-FACE. Caps, Lower Case, and Figures.</p> <p>POINTS ARE NOT OF EQUAL ANTIQUITY with Printing, though not long after its invention the necessity of 1891</p>	<p>Case No. 53.</p>
F., L. & Co.	<p>LONG PRIMER LIGHT-FACE. Caps, Lower Case, and Figures.</p> <p>POINTS ARE NOT OF EQUAL ANTIQUITY with Printing, though not long after its invention the 1679</p>	<p>Case No. 54.</p>
F., L. & Co.	<p>PICA LIGHT-FACE. Caps, Lower Case, and Figures.</p> <p>Points are not of Equal Antiquity with Printing, but 12</p>	<p>Case No. 55.</p>
F., L. & Co.	<p>GREAT PRIMER LIGHT-FACE. Caps, Lower Case, and Figures.</p> <p>Points are not of Equal Antiquity with</p>	<p>Case Nos. 56, 57.</p>
F., L. & Co.	<p>DOUBLE SMALL PICA LIGHT-FACE. Caps, Lower Case, and Figures.</p> <p>Points are not of Equal Antiquity</p>	<p>Case Nos. 58, 59.</p>
F., L. & Co.	<p>DOUBLE ENGLISH LIGHT-FACE. Caps, Lower Case, and Figures.</p> <p>Points are not of Equal 184</p>	<p>Case Nos. 60, 61.</p>
F., L. & Co.	<p>DOUBLE GREAT PRIMER LIGHT-FACE. Caps, Lower Case, and Figures.</p> <p>Points are not of Equal ?</p>	<p>Case Nos. 62, 63.</p>

LIGHT FACES.

F., L. & Co.	<p>NONPAREIL LIGHT-FACE EXTENDED. Caps, Lower Case, and Figures.</p> <p>THE WORLD IS FULL OF FOOLS,</p> <p>And he who would not wish to see one must not only 1, 2, 3, 4, 5, 6, 7</p>	<p>CABINET 3.</p> <p>Case</p> <p>No. 38.</p>
F., L. & Co.	<p>BREVIER LIGHT-FACE EXTENDED. Caps, Lower Case, and Figures.</p> <p>THE WORLD IS FULL OF FOOLS,</p> <p>And he who would not wish to see one must not only 22</p>	<p>Case</p> <p>No. 39.</p>
F., L. & Co.	<p>LONG PRIMER LIGHT-FACE EXTENDED. Caps, Lower Case, and Figures.</p> <p>THE WORLD IS FULL OF FOOLS,</p> <p>And he who would not wish to see one must 78</p>	<p>Case</p> <p>No. 40.</p>
F., L. & Co.	<p>PICA LIGHT-FACE EXTENDED. Caps, Lower Case, and Figures.</p> <p>The World is full of Fools, and He</p>	<p>Case</p> <p>No. 41.</p>
F., L. & Co.	<p>GREAT PRIMER LIGHT-FACE EXTENDED. Caps, Lower Case, and Figures.</p> <p>The World is Full of 99</p>	<p>Case</p> <p>No. 42.</p>
MACK., S. & J.	<p>TWO-LINE PEARL LIGHT-FACE No. 2. Caps and Figures.</p> <p>THEIR COUNTRY'S GREAT JOY AND PRIDE 1776-91</p>	<p>CABINET 12.</p> <p>Case</p> <p>No. 175.</p>
MACK., S. & J.	<p>TWO-LINE NONPAREIL LIGHT-FACE No. 2. Caps and Figures.</p> <p>UNITED STATES GOVERNMENT PRINTERS 181</p>	<p>Case</p> <p>No. 176.</p>
MACK., S. & J.	<p>TWO-LINE BREVIER LIGHT-FACE No. 2. Caps and Figures.</p> <p>TODDY DROPS, JUST DISTILLED</p>	<p>Case</p> <p>No. 175.</p>
MACK., S. & J.	<p>TWO-LINE LONG PRIMER LIGHT-FACE. Caps and Figures.</p> <p>MY FACE IS MY FORTUNE 7</p>	<p>Case</p> <p>No. 177.</p>
MACK., S. & J.	<p>TWO-LINE PICA LIGHT-FACE. Caps and Figures.</p> <p>G. P. O. BALL LEAGUE</p>	<p>Case</p> <p>No. 178.</p>
MACK., S. & J.	<p>TWO-LINE ENGLISH LIGHT-FACE. Caps and Figures.</p> <p>THE FARMERS' JOY 19</p>	<p>Case</p> <p>No. 176.</p>

LIGHT FACES.

MACK., S. & J.	<p>MIXION HAIRLINE. Caps, Small Caps, Lower Case, and Figures.</p> <p>IN HIS SANCTUM, CLEANS AND DREARY, AT THE ECHOES WEAR AND WEAR.</p>	CABINET 29. Case No. 452.
MACK., S. & J.	<p>BOURGEOIS HAIRLINE. Caps, Lower Case, and Figures.</p> <p>THE HOUSEKEEPERS ANNUAL CRUSADE BEGUN</p>	Case No. 453.
F., L. & Co.	<p>LONG PRIMER NORMAN. Caps, Small Caps, and Figures.</p> <p>UNDER THE WILLOW SHE'S LAIN WITH CARE, SANG A LONE MOTHER WHILE</p>	CABINET 28. Case No. 438.
F., L. & Co.	<p>TWO-LINE BREVIER NORMAN. Caps, Small Caps, and Figures.</p> <p>OH, GIVE ME A HOME BY THE SEA, WHERE THE 51</p>	Case No. 439.
F., L. & Co.	<p>DOUBLE PICA NORMAN. Caps, Small Caps, and Figures.</p> <p>GROWL & TABBY, SAUSAGEMEN</p>	Case No. 440.
F., L. & Co.	<p>DOUBLE GREAT PRIMER NORMAN. Caps, Small Caps, and Figures.</p> <p>MINERAL SPRING WATER \$5</p>	Case No. 441.
MACK., S. & J.	<p>TWO-LINE PEARL LIGHT-FACE CONDENSED No. 2. Caps and Figures.</p> <p>HER MAJESTY'S FAVORITE COSMETIC APPLIED TO THE ROYAL BLOODS</p>	CABINET 12. Case No. 179.
MACK., S. & J.	<p>TWO-LINE NONPAREIL LIGHT-FACE CONDENSED No. 3. Caps and Figures.</p> <p>CONTEST OVER THE BIRTHPLACE OF COLUMBUS</p>	Case No. 179.
MACK., S. & J.	<p>TWO-LINE BREVIER CONDENSED. Caps and Figures.</p> <p>RUMORS OF SHORT HOURS IN JUNE 18</p>	Case No. 180.
MACK., S. & J.	<p>TWO-LINE LONG PRIMER CONDENSED. Caps and Figures.</p> <p>GOLD HUNTING IN THE FAR WEST</p>	Case No. 180.

LIGHT FACES.

TWO-LINE PICA CONDENSED.

Caps and Figures.

CABINET 12.

MACK., S.
& J.

CONGRESSIONAL LIBRARY

Case
No. 181.

TWO-LINE ENGLISH CONDENSED.

Caps and Figures.

MACK., S.
& J.

THE NATIONAL MUSEUM

Case
No. 181.

LONG PRIMER LIGHT-FACE CONDENSED.

Caps, Lower Case, and Figures.

F., L. & Co.

I HAVE LEARNED IN MY BRIEF EXPERIENCE

That the Ways of the Average Country Editor were Indolent and Slovenly 263

Case
No. 182.

PICA LIGHT-FACE CONDENSED.

Caps, Lower Case, and Figures.

F., L. & Co.

To Sit in Solemn Silence in a Dull Dark Dock, in a Pestilential Prison

Case
No. 183.

GREAT PRIMER LIGHT-FACE CONDENSED.

Caps, Lower Case, and Figures.

F., L. & Co.

With a Life Long Lock, awaiting the Sensation of a

Case
No. 184.

DOUBLE SMALL PICA LIGHT-FACE CONDENSED.

Caps, Lower Case, and Figures.

F., L. & Co.

Short Sharp Shock, from a Cheap Chippy

Case Nos.
185, 186.

DOUBLE ENGLISH LIGHT-FACE CONDENSED.

Caps, Lower Case, and Figures.

F., L. & Co.

Chopper on a Big Black Block 1892

Case
No. 187.

DOUBLE GREAT PRIMER LIGHT-FACE CONDENSED.

Caps, Lower Case, and Figures.

F., L. & Co.

Down where the Daisies Grow

Case
No. 188.

FOUR-LINE PICA LIGHT-FACE CONDENSED.

Caps, Lower Case, and Figures.

MACK., S.
& J.

Dark Plutonian Shore.

CABINET 11.

Case
No. 174.

OLD STYLES.

F., L. & Co.	TWO-LINE NONPAREIL OLD STYLE CONDENSED.	Caps, Lower Case, and Figures.	CABINET I. Case No. 1.
F., L. & Co.	TWO-LINE BREVIER OLD STYLE CONDENSED.	Caps, Lower Case, and Figures.	Case No. 2.
F., L. & Co.	TWO-LINE LONG PRIMER OLD STYLE CONDENSED.	Caps, Lower Case, and Figures.	Case No. 3.
F., L. & Co.	TWO-LINE PICA OLD STYLE CONDENSED.	Caps, Lower Case, and Figures.	Case No. 4.
F., L. & Co.	TWO-LINE GREAT PRIMER OLD STYLE CONDENSED.	Caps, Lower Case, and Figures.	Case No. 5.
MacK., S. & J.	TWO-LINE PICA OLD STYLE CONDENSED.	Caps and Figures.	Case No. 6.
MacK., S. & J.	TWO-LINE GREAT PRIMER OLD STYLE CONDENSED.	Caps and Figures.	Case No. 6.
F., L. & Co.	TWO-LINE PEARL FRANKLIN TITLE.	Caps and Figures.	Case No. 7.
F., L. & Co.	TWO-LINE NONPAREIL FRANKLIN TITLE.	Caps and Figures.	Case No. 7.
F., L. & Co.	TWO-LINE BREVIER FRANKLIN TITLE.	Caps and Figures.	Case No. 8.

OLD STYLES.

F., L. & Co.	TWO-LINE LONG PRIMER FRANKLIN TITLE.	Caps and Figures.	CABINET 1. Case No. 9.
	THE WORLD IS FULL !!!		
F., L. & Co.	TWO-LINE PICA FRANKLIN TITLE.	Caps and Figures.	Case No. 10.
	THE WORLD IS FULL		
F., L. & Co.	TWO-LINE GREAT PRIMER FRANKLIN TITLE.	Caps and Figures.	Case No. 11.
	THE WORLD IS		
F., L. & Co.	PICA OLD STYLE.	Caps, Small Caps, Lower Case, and Figures.	Case No. 12.
	THE WORLD IS FULL OF FOOLS, and he who would not wish to see one		
F., L. & Co.	GREAT PRIMER OLD STYLE.	Caps, Small Caps, Lower Case, and Figures.	Case Nos. 13, 14.
	THE WORLD IS FULL OF FOOLS, and he who would not		
F., L. & Co.	DOUBLE SMALL PICA OLD STYLE.	Caps, Small Caps, Lower Case, and Figures.	Case Nos. 15, 16.
	THE WORLD IS FULL of FOOLS, and he who		
F., L. & Co.	DOUBLE PICA OLD STYLE.	Caps, Small Caps, Lower Case, and Figures.	CABINET 2. Case Nos. 17, 18.
	THE WORLD IS FULL of FOOLS, and he		
F., L. & Co.	DOUBLE ENGLISH OLD STYLE.	Caps, Small Caps, Lower Case, and Figures.	Case Nos. 19, 20.
	THE WORLD IS full of FOOLS, and		
F., L. & Co.	DOUBLE GREAT PRIMER OLD STYLE.	Caps, Small Caps, Lower Case, and Figures.	Case Nos. 21, 22.
	THE WORLD is full of 189		
F., L. & Co.	DOUBLE PARAGON OLD STYLE.	Caps, Lower Case, and Figures.	Case No. 23.
	The World is Full of		
F., L. & Co.	FOUR-LINE PICA OLD STYLE.	Caps, Lower Case, and Figures.	Case No. 24.
	The World is Full ?		

RUNICS.

<p>MACK., S. & J.</p>	<p>BREVIER Runic CONDENSED.</p>	<p>Caps and Figures.</p>	<p>CABINET 5. Case No. 65.</p>
<p>MACK., S. & J.</p>	<p>LONG PRIMER Runic CONDENSED.</p>	<p>Caps and Figures.</p>	<p>Case No. 66.</p>
<p>MACK., S. & J.</p>	<p>PICA Runic CONDENSED.</p>	<p>Caps and Figures.</p>	<p>Case No. 65.</p>
<p>MACK., S. & J.</p>	<p>DOUBLE BREVIER Runic CONDENSED.</p>	<p>Caps and Figures.</p>	<p>Case No. 66.</p>
<p>MACK., S. & J.</p>	<p>PICA Runic EXTENDED.</p>	<p>Caps, Lower Case, and Figures.</p>	<p>Case No. 67.</p>
<p>MACK., S. & J.</p>	<p>GREAT PRIMER Runic EXTENDED.</p>	<p>Caps, Lower Case, and Figures.</p>	<p>Case Nos. 68, 69.</p>
<p>F., L. & Co.</p>	<p>LONG PRIMER Runic CONDENSED.</p>	<p>Caps, Lower Case, and Figures.</p>	<p>Case No. 330.</p>
<p>F., L. & Co.</p>	<p>PICA Runic CONDENSED.</p>	<p>Caps, Lower Case, and Figures.</p>	<p>Case No. 331.</p>
<p>F., L. & Co.</p>	<p>DOUBLE LONG PRIMER Runic CONDENSED.</p>	<p>Caps, Lower Case, and Figures.</p>	<p>Case No. 332.</p>
<p>F., L. & Co.</p>	<p>DOUBLE GREAT PRIMER Runic CONDENSED.</p>	<p>Caps, Lower Case, and Figures.</p>	<p>Case No. 333.</p>

ANTIQUES.

F., L. & Co	NONPAREIL ANTIQUE CONDENSED No. 2. THE CURFEW TOLLS THE KNELL OF PARTING DAY The lowing Herd winds Slowly o'er the lea; the weary Plowman homeward plods his weary way and leaves 1899	Caps, Lower Case, and Figures.	CABINET 11. Case No. 159.
F., L. & Co.	BREVIER ANTIQUE CONDENSED No. 2. IT WAS A HAPPY DAY FOR US POOR MODERNS When the "Old Says" and "Ancient Sayings" were first introduced to Public notice, for without 98	Caps, Lower Case, and Figures.	Case No. 160.
BRUCE.	BREVIER ANTIQUE CONDENSED. (Old.) CONSCIENTIOUS AMUSEMENT HALL UNDER REFINED Patronage. Littlejokers and Thimblebimber's Moral Recreations. Free Admission for Sports 81	Caps, Lower Case, and Figures.	CABINET 10. Case Nos. 147, 148.
F., L. & Co.	LONG PRIMER ANTIQUE CONDENSED No. 2. HOW CANST THOU WALK THESE STREETS, Who has trod the green turf of the Prairies? How canst thou breathe this air,	Caps, Lower Case, and Figures.	Case No. 161.
F., L. & Co.	PICA ANTIQUE CONDENSED No. 2. Who hast Breathed the sweet Air of the Mountains? 1234567	Caps, Lower Case, and Figures.	Case No. 162.
F., L. & Co.	GREAT PRIMER ANTIQUE CONDENSED No. 2. Ah? 'tis in vain that with Lordly Looks thou dost	Caps, Lower Case, and Figures.	Case No. 163.
F., L. & Co.	NONPAREIL OLD STYLE ANTIQUE. ENGLAND HAS TO UNDERGO THE REVOLT OF THE COLONIES, To submit to defeat and separation, to shake under the Volcano of the French Revolution, to 1878, 679	Caps, Lower Case, and Figures.	CABINET 7. Case No. 97.
F., L. & Co.	BREVIER OLD STYLE ANTIQUE. GRAPPLE AND FIGHT FOR LIFE WITH HER GIGANTIC Enemy Napoleon, and to gasp and Rally after the Tremendous Struggle. 4123-56-7890	Caps, Lower Case, and Figures.	Case No. 98.
F., L. & Co.	LONG PRIMER OLD STYLE ANTIQUE. FILL UP EACH HOUR WITH WHAT WILL LAST, Buy up the moments as they go, the Life above, when this is past, 99	Caps, Lower Case, and Figures.	Case No. 99.
F., L. & Co.	PICA OLD STYLE ANTIQUE. Is the Ripe Fruit of the Life below. 1891. 1098. \$66,779	Caps, Lower Case, and Figures.	Case No. 100.
F., L. & Co.	GREAT PRIMER OLD STYLE ANTIQUE. Essential Oils of Honesty taken Inwardly	Caps, Lower Case, and Figures.	Case No. 101.
F., L. & Co.	DOUBLE ENGLISH OLD STYLE ANTIQUE. Narrow Minded Men. 78	Caps, Lower Case, and Figures.	Case No. 102.

ANTIQUES.

MAC K., S. & J.	AGATE ANTIQUE No. 5. THE COURSE OF TRUE LOVE NEVER DID RUN SMOOTH. Between a Vicious Dog and an Irate Prospective Father-in-law with Thick-soled Boots, Love's Course is 1398	Caps, Lower Case, and Figures.	CABINET 6. Case No. 81.
BRUCE.	BREVIER ANTIQUE No. 5. THE COURSE OF TRUE LOVE NEVER DID RUN Smooth. Between a Vicious Dog and an Irate Prospective Father-in-law with	Caps, Lower Case, and Figures.	Case Nos. 82 to 85.
MAC K., S. & J.	LONG PRIMER ANTIQUE No. 5. THE COURSE OF TRUE LOVE NEVER Did run Smooth. Between a Vicious Dog and an Irate Prospective 131	Caps, Lower Case, and Figures	Case No. 86.
MAC K., S. & J.	PICA ANTIQUE No. 5. The Course of True Love never did Run Smooth. Betw	Caps, Lower Case, and Figures.	Case No. 87.
MAC K., S. & J.	GREAT PRIMER ANTIQUE No. 5. The Course of True Love never did 187	Caps, Lower Case, and Figures.	Case Nos. 88, 89.
MAC K., S. & J.	DOUBLE PICA ANTIQUE No. 5. The Course of True Love never	Caps, Lower Case, and Figures.	Case Nos. 90, 91.
MAC K., S. & J.	DOUBLE ENGLISH ANTIQUE No. 5. The Course of True ? 1	Caps, Lower Case, and Figures.	Case Nos. 92, 93.
MAC K., S. & J.	DOUBLE GREAT PRIMER ANTIQUE No. 5. The Course of Tr	Caps, Lower Case, and Figures.	Case Nos. 94, 95.
MAC K., S. & J.	DOUBLE ENGLISH ANTIQUE. The Course of True Love 165	Caps, Lower Case, and Figures.	Case No. 96.
MAC K., S. & J.	PICA ANTIQUE No. 3. Physical Vice Destroys the Body and Ruins the Mind	Caps, Lower Case, and Figures.	CABINET 10. Case Nos. 157, 158.
F. L. & Co.	GREAT PRIMER ANTIQUE No. 6. Points are not of Equal Antiquity 1	Caps, Lower Case, and Figures.	CABINET 4. Case No. 64.
MAC K., S. & J.	DOUBLE SMALL PICA ANTIQUE. The Light Fantastic Toe Displayed	Caps, Lower Case, and Figures.	CASE ON STAND.
MAC K., S. & J.	DOUBLE GREAT PRIMER ANTIQUE. Misdirected Effort 78	Caps, Lower Case, and Figures.	CABINET 20. Case Nos. 317, 318.

ANTIQUES.

MACK, S. & J.	PEARL ANTIQUE EXTENDED. THE WORLD IS FULL OF FOOLS, And he who would not see one must not only keep away from	Caps, Lower Case, and Figures.	CABINET 3. Case No. 43.
F., L. & Co.	NONPAREIL ANTIQUE EXTENDED. THE WORLD IS FULL OF FOOLS, And he who would not wish to see one must not	Caps, Lower Case, and Figures.	Case No. 44.
F., L. & Co.	BREVIER ANTIQUE EXTENDED. THE WORLD IS FULL OF FOOLS, And he who would not wish to see one	Caps, Lower Case, and Figures.	Case No. 45.
F., L. & Co.	LONG PRIMER ANTIQUE EXTENDED. The World is full of Fools 1878	Caps, Lower Case, and Figures.	Case No. 46.
F., L. & Co.	PICA ANTIQUE EXTENDED. The World is full of Fools	Caps, Lower Case, and Figures.	Case No. 47.
F., L. & Co.	GREAT PRIMER ANTIQUE EXTENDED. The World is Full 19	Caps, Lower Case, and Figures.	Case No. 48.
F., L. & Co.	DOUBLE SMALL PICA ANTIQUE EXTENDED. Points are not of	Caps, Lower Case, and Figures.	CABINET 4. Case No. 49.
F., L. & Co.	DOUBLE ENGLISH ANTIQUE EXTENDED. Points are no	Caps, Lower Case, and Figures.	Case No. 50.
F., L. & Co.	GREAT PRIMER MODERN ANTIQUE. Where are you going, my Pretty Maid? None of	Caps, Lower Case, and Figures.	CABINET 23. Case Nos. 350, 351.
F., L. & Co.	DOUBLE SMALL PICA MODERN ANTIQUE. Your Business, sir, she said. \$18.55	Caps, Lower Case, and Figures.	Case Nos. 352, 353.

ANTIQUES.

F., L. & Co.	<p>BREVIER SKELETON ANTIQUE. Caps, Lower Case, and Figures.</p> <p>ENGLAND HAD TO UNDERGO THE REVOLT OF THE COLONIES, TO SUBMIT TO DEFEAT And Separation, to shake under the French Revolution, to Grapple and Fight for the Life with her Gigantic Enemy Napoleon. 35</p>	CABINET 27. Case No. 419.
F., L. & Co.	<p>LONG PRIMER SKELETON ANTIQUE. Caps, Lower Case, and Figures.</p> <p>FILL UP EACH HOUR WITH WHAT WILL LAST, BUY UP The moments as they go, the Life Above, when this is past, is the Ripe Fruit of the Life Below. 1234567</p>	Case No. 420.
F., L. & Co.	<p>PICA SKELETON ANTIQUE. Caps, Lower Case, and Figures.</p> <p>Dame Nature all Her Hues Celestial Blends, and Zenithward all their Coruscations Sends</p>	Case No. 421.
F., L. & Co.	<p>GREAT PRIMER SKELETON ANTIQUE. Caps, Lower Case, and Figures.</p> <p>Every Paper will Contain a Directory of Every Soul in the Town 1357</p>	Case No. 422.
F., L. & Co.	<p>DOUBLE SMALL PICA SKELETON ANTIQUE. Caps, Lower Case, and Figures.</p> <p>Giving Full Name and Age, Description, Weight and Size. 24</p>	Case No. 423.
F., L. & Co.	<p>DOUBLE ENGLISH SKELETON ANTIQUE. Caps, Lower Case, and Figures.</p> <p>No Event will be Too Small to Appear. 1234</p>	Case No. 424.
MACK., S. & J.	<p>NONPAREIL ANTIQUE No. 2 ON BREVIER BODY. Caps, Lower Case, and Figures.</p> <p>THERE IS BEAUTY IN THE BELLOW OF THE BLAST Young man, look not mournfully into the past. Wisely improve the present. It is thine. \$67.90</p>	CABINET 28. Case Nos. 436, 437.
F., L. & Co.	<p>GREAT PRIMER ANTIQUE CONDENSED. Caps and Figures.</p> <p>THE LIBERAL BACHELORS WITH GENTLE MAIDS 5</p>	CASE ON STAND.
MACK., S. & J.	<p>DOUBLE ENGLISH ANTIQUE CONDENSED No. 4. Caps, Lower Case, and Figures.</p> <p>Man wants but Little here Below 10</p>	CABINET 20. Case Nos. 313, 314.
MACK., S. & J.	<p>DOUBLE GREAT PRIMER ANTIQUE CONDENSED. Caps, Lower Case, and Figures.</p> <p>Peeps Behind the Scenes 276</p>	Case Nos. 315, 316.
MACK., S. & J.	<p>CANON ANTIQUE CONDENSED. Caps, Lower Case, and Figures.</p> <p>The Itata Surrendered 5</p>	CASE ON STAND.

EXTRA CONDENSED.

F., L. & Co.	BREVIER EXTRA CONDENSED No. 2.	Caps, Lower Case, and Figures.	CABINET 5. Case No. 70.
	TIME AND PACE HAVE NO DELIGHT TO PASS AWAY THE TIME, UNLESS TO SPY MY SHADOW		
	In the Sun, bescant on mine own beformity : and therefore since I cannot prove a Lover, to entertain these fair well-spoken days, I am deter-		
F., L. & Co.	LONG PRIMER EXTRA CONDENSED No. 2.	Caps, Lower Case, and Figures.	Case No. 71.
	MINED TO PROVE A VILLAIN, AND HATE THE IDLE PLEASURES		
	Of these days. Plots have laid, inductions dangerous, by drunken prophecies, libels and dreams, to set my brother Clarence		
F., L. & Co.	PICA EXTRA CONDENSED No. 2.	Caps, Lower Case, and Figures.	Case No. 72.
	And the King in deadly hate the one against the other. And if King Edward be as true and just as I am		
MACK., S. & J.	GREAT PRIMER EXTRA CONDENSED No. 2.	Caps, Lower Case, and Figures.	Case No. 73.
	Subtle, false, and treacherous, this day should Clarence closely be mewed up. 1891-2		
F., L. & Co.	DOUBLE PICA EXTRA CONDENSED No. 2.	Caps, Lower Case, and Figures.	Case No. 74.
	Dive, thoughts, down to my soul; go tread the path that thou		
F., L. & Co.	DOUBLE GREAT PRIMER EXTRA CONDENSED No. 2.	Caps, Lower Case, and Figures.	Case No. 75.
	Shalt ne'er return, simple, plain Clarence. I do love thee		
MACK., S. & J.	FIVE-LINE PICA EXTRA CONDENSED No. 2.	Caps, Lower Case, and Figures.	Case No. 76.
	Clarence still lives, Edward reigns		
MACK., S. & J.	PICA EXTRA CONDENSED No. 6.	Caps, Lower Case, and Figures.	Case Nos. 77, 78.
	The Toiling Grangers' Coming Reward: the Happy Farmers viewing their Crops and		
F., L. & Co.	GREAT PRIMER LATIN CONDENSED.	Caps, Lower Case, and Figures.	CABINET 13. Case No. 198.
	Old time is the Drollest of Wags and Puzzles the World with his Rules		
F., L. & Co.	DOUBLE PICA LATIN CONDENSED.	Caps, Lower Case, and Figures.	Case No. 199.
	He gave all To-day to the Wise and To-morrow \$10		

GOTHICS.

F., L. & Co.	NONPAREIL TELESCOPIC GOTHIC No. 6.	Caps and Figures.	CABINET 27.
	THE SHADES OF NIGHT WERE FALLING FAST WHEN THROUGH AN ALPINE VILLAGE PASSED A YOUTH 123456		Case No. 412.
F., L. & Co.	NONPAREIL TELESCOPIC GOTHIC No. 5.	Caps and Figures.	Case
	WHO BORE MIDST SNOW AND ICE A BANNER WITH THE STRANGE DEVICE—EXCELSIOR		No. 413.
F., L. & Co.	NONPAREIL TELESCOPIC GOTHIC No. 7.	Caps and Figures.	Case
	THE ANNE ARUNDEL COUNTY STRAWBERRIES ARE APPRECIATED IN OTHER PLACES THAN THE VICINITY OF THEIR GROWTH. ANNAPOLIS. 123		No. 413.
MAC K., S. & J.	NONPAREIL GOTHIC No. 2.	Caps.	CABINET 14.
	HUSH MONEY IS WHAT THE YOUNG HUSBAND PARTS WITH FOR PAREGORIC SOOTHING		Case No. 214.
MAC K., S. & J.	NONPAREIL GOTHIC No. 3.	Caps, Lower Case, and Figures.	CASE
	HE THAT IS THY FRIEND INDEED HE WILL HELP THEE IN THY NEED.		ON STAND.
	Words are easy like the wind. Faithful Friends are hard to find. every Man will be thy Friend whilst thou hast		
F., L. & Co.	NONPAREIL GOTHIC No. 7.	Caps, Lower Case, and Figures.	CABINET 8.
	A WASP CAME BUZZING TO HIS WORK AND VARIOUS THINGS DID TACKLE		Case
	He stung a Boy and a Dog then made a Rooster cackle: upon an Editor's cheek he settled down to drill, he prodded there an hour		No. 113.
F., L. & Co.	BREVIER GOTHIC No. 4.	Caps, Lower Case, and Figures.	Case
	THE SHADES OF NIGHT WERE FALLING FAST AS THROUGH THE SANCTUM		No. 114.
	Door there passed a fiend in human shape, who cried as soon as he reached the Editor's side, more copy		
F., L. & Co.	LONG PRIMER GOTHIC No. 4.	Caps, Lower Case, and Figures.	Case
	HAPPY THOUGHTS OF OTHER DAYS CROSSED MY MIND		No. 115.
	I thought I was a Rough Boy once more, and Felt the Presence of my Mother's Slipper		
F., L. & Co.	PICA GOTHIC No. 4.	Caps, Lower Case, and Figures.	CABINET 4.
	THEN ALL HAIL TO THE BRIGHT RISING MORN		Case
	And as the Summer Sun Beams over the Quiet Woods and Leas. 1289730		No. 51.
F., L. & Co.	GREAT PRIMER GOTHIC No. 3.	Caps, Lower Case, and Figures.	CABINET 8.
	Chasing His Satanic Majesty around a Stump 9		Case Nos. 116, 117.
F., L. & Co.	DOUBLE PICA GOTHIC No. 3.	Caps, Lower Case, and Figures.	Case Nos.
	Steamships go Daily from 15		118, 119.

GOTHICS.

	BREVIER GOTHIC No. 5.	Caps, Small Caps, and Figures.	CABINET 28.
F., L. & Co.	EVERY MAN HAS AN OPPORTUNITY TO SUCCEED, WHATEVER HIS VOCATION	\$57	Case No. 442.
	LONG PRIMER GOTHIC No. 5.	Caps, Small Caps, and Figures.	Case
F., L. & Co.	MESSRS. COGNAC AND CHAMPAGNE, BOON COMPANIONS.	189	Case No. 443.
	PICA GOTHIC No. 5.	Caps, Small Caps, and Figures.	Case
F., L. & Co.	NEVER STRIKE A MOUSTACHE WHEN IT'S DOWN	10c	Case No. 444.
	GREAT PRIMER GOTHIC No. 5.	Caps, Small Caps, and Figures.	Case
F., L. & Co.	A THING OF BEAUTY ALWAYS A JOY		Case No. 445.
	DOUBLE SMALL PICA GOTHIC No. 5.	Caps, Small Caps, and Figures.	Case
F., L. & Co.	MUCH NEEDED RECREATION		Case No. 446.
	DOUBLE ENGLISH GOTHIC No. 5.	Caps, Small Caps, and Figures.	Case
F., L. & Co.	NECESSITIES OF LIFE	\$1	Case No. 447.
	NONPAREIL GOTHIC No. 1.	Caps, Lower Case, and Figures.	CABINET 8.
F., L. & Co.	POINTS ARE NOT OF EQUAL ANTIQUITY WITH PRINTING, Though not long after its invention the necessity of introducing stops or pauses in Sentences		Case No. 120.
	BREVIER GOTHIC No. 3.	Caps, Lower Case, and Figures.	Case
F., L. & Co.	SO THIS BRAVE KNIGHT IN ARMOUR BRIGHT, Went gaily to the Fray; He fought the fight, but ere the night.	123456	Case No. 122.
	LONG PRIMER GOTHIC No. 3.	Caps, Lower Case, and Figures.	Case
F., L. & Co.	SOME VILLAGE HAMPDEN, THAT, WITH Dauntless breast, the little Tyrant of his fields withstood.	79	Case No. 123.
	PICA GOTHIC No. 1.	Caps, Lower Case, and Figures.	Case
F., L. & Co.	Intense Excitement in Camp! Woods full of Indians		Case No. 124.

GOTHICS.

F., L. & Co.	NONPAREIL GOTHIC EXTENDED. THERE IS BEAUTY IN THE BELLOW OF THE BLAST, SEE	Caps, Lower Case, and Figures.	CABINET 29. Case No. 454.
F., L. & Co.	BREVIER GOTHIC EXTENDED. THERE'S MUSIC IN THE HOWLING OF THE GALE	Caps, Lower Case, and Figures.	Case No. 455.
F., L. & Co.	LONG PRIMER GOTHIC EXTENDED. FOURTH OF JULY, DAY WE CELEBRATE	Caps, Lower Case, and Figures.	Case No. 456.
F., L. & Co.	PICA GOTHIC EXTENDED. NEVER WILL I CONSENT, NEVER	Caps, Lower Case, and Figures.	Case No. 457.
BRUCE.	BREVIER GOTHIC CONDENSED No. 5. SUPPOSED TO HAVE BECOME ENTANGLED IN A LADY'S CRINOLINE. French Marble Door-steps and Iron Scraper Missed from a Gentleman's Residence on H Street	Caps, Lower Case, and Figures.	CABINET 28. Case Nos. 430, 431.
MACK., S. & J.	BREVIER GOTHIC. DAILY THE TROUBADOUR STRIKES For More Pay and till He Receives it His Guitar He will not Play	Caps, Lower Case, and Figures.	CABINET 7. Case No. 100.
MACK., S. & J.	GREAT PRIMER GOTHIC. Her Step was Light and Airy as the Tripping	Caps, Lower Case, and Figures.	CABINET 9. Case Nos. 128, 129.
MACK., S. & J.	DOUBLE SMALL PICA GOTHIC. Of a Fairy Spanish Fandango. 1889	Caps, Lower Case, and Figures.	Case No. 130.
MACK., S. & J.	TWO-LINE BREVIER GOTHIC. FRIENDS TRIED AND TRUE 1892	Caps and Figures.	Case No. 131.
F., L. & Co.	BREVIER GOTHIC CONDENSED No. 7. BREATHED BY THE LIPS OF SLANDER MAY DESTROY A noble Reputation, have a care of What You Say and more of What You Do, for Great Effects from	Caps, Lower Case, and Figures.	CABINET 8. Case No. 125.
F., L. & Co.	LONG PRIMER GOTHIC CONDENSED No. 7. OH SLEEP THAT KNOWS NOT CARE, THAT KNOWEST NOT PAIN, Come gently breathing, Sorrow charming King, Vail from his eyes this light 25	Caps, Lower Case, and Figures.	Case No. 126.
F., L. & Co.	PICA GOTHIC CONDENSED No. 7. Oh Lovely Night, thou art Holy and Calm. Thy Soft, Dewy Breath	Caps, Lower Case, and Figures.	Case No. 127.

GOTHICS.

MACK., S. & J.	PICA GOTHIC CONDENSED. Fill Up each Hour with what will last, buy up the Moments as they pass 23	Caps, Lower Case, and Figures.	CABINET 9. Case Nos. 132, 133.
MACK., S. & J.	TWO-LINE ENGLISH GOTHIC EXTRA CONDENSED. The Toiling Grangers' Coming Reward, the Happy Farmers 219	Caps, Lower Case, and Figures.	Case No. 134.
F., L. & Co.	NONPAREIL GOTHIC CONDENSED. HE THAT IS THY FRIEND INDEED HE WILL HELP THEE IN THY NEED: Words are easy like the wind, Faithful Friends are hard to find. Every man will be thy friend whilst thou hast wherewith to spend	Caps, Lower Case, and Figures.	CABINET 7. Case No. 103.
F., L. & Co.	BREVIER GOTHIC CONDENSED. WITH CONSTANT MOTION AS THE MOMENTS GLIDE—BEHOLD In Running Life the Rolling Tide! For none can stem by Art, or stop by Power the Flowing Ocean 18945	Caps, Lower Case, and Figures.	Case No. 104.
F., L. & Co.	LONG PRIMER GOTHIC CONDENSED. BY LIGHTNING STROKE HE PAINLESS DIED Electricity Bound, Harnessed, Controlled and made Useful to Man—Girding the Earth	Caps, Lower Case, and Figures.	Case No. 105.
F., L. & Co.	PICA GOTHIC CONDENSED. Newly invented Mechanism regulating Impression constitute a Very 1234	Caps, Lower Case, and Figures.	Case No. 106.
F., L. & Co.	GREAT PRIMER GOTHIC CONDENSED. Effective, Substantial, and Quite Perfect Arrangement	Caps, Lower Case, and Figures.	Case No. 107.
F., L. & Co.	DOUBLE SMALL PICA GOTHIC CONDENSED. Welcome as Flowers that Bloom in the Spring	Caps, Lower Case, and Figures.	Case No. 108.
MACK., S. & J.	DOUBLE ENGLISH GOTHIC CONDENSED. Unrelenting Hand of Father Time 76	Caps, Lower Case, and Figures.	Case No. 109.
MACK., S. & J.	DOUBLE GREAT PRIMER GOTHIC CONDENSED. Line Our Cheeks and Temples	Caps, Lower Case, and Figures.	Case No. 110.
MACK., S. & J.	CANON GOTHIC CONDENSED. With His Inexorable Pen	Caps, Lower Case, and Figures.	Case No. 111.
MACK., S. & J.	FOUR-LINE PICA GOTHIC CONDENSED. Crowned with Flowers	Caps, Lower Case, and Figures.	Case No. 112.

CLARENDONS.

F., L. & Co.	<p>LONG PRIMER CLARENDON CONDENSED. Caps, Small Caps, Lower Case, and Figures. WESTWARD THE COURSE OF EMPIRE TAKES ITS WAY The Great West! Unbounded wealth of both Mineral and Agricultural Resources 12</p>	<p>CABINET 11. Case Nos. 164, 165.</p>
F., L. & Co.	<p>PICA CLARENDON CONDENSED. Caps, Small Caps, Lower Case, and Figures. WE ALL HAVE TO PAY the Debt of Nature. Every day some one</p>	<p>Case Nos. 166, 167.</p>
F., L. & Co.	<p>GREAT PRIMER CLARENDON CONDENSED. Caps, Small Caps, Lower Case, and Figures. WORDS STIR UP ANGER and Anger brings forth Blows</p>	<p>Case Nos. 168, 169.</p>
F., L. & Co.	<p>DOUBLE SMALL PICA CLARENDON CONDENSED. Caps, Lower Case, and Figures. This World is full of Beauty as Other 65</p>	<p>Case Nos. 170, 171.</p>
F., L. & Co.	<p>DOUBLE ENGLISH CLARENDON CONDENSED. Caps, Lower Case, and Figures. Worlds Above, and if we did our 9</p>	<p>Case Nos. 172, 173.</p>
BRUCE.	<p>LONG PRIMER CLARENDON. Caps, Lower Case, and Figures. TIMELY PRESERVATION OF THE GEMS OF THE MOUTH When the Lips of Beauty are Parted in a Smile they Disclose a Row of Pearls 1898</p>	<p>CABINET 12. Case Nos. 189, 190.</p>
MACK., S. & J.	<p>SMALL PICA CLARENDON. Caps, Lower Case, and Figures. THEN ALL HAIL TO THE BRIGHT RISING MORN And as the Summer Sun Beams over the Quiet Woods and Leas. 123456</p>	<p>CABINET 22. Case Nos. 340, 341.</p>
MACK., S. & J.	<p>NONPAREIL FRENCH CLARENDON. Caps, Lower Case, and Figures. THE COURSE OF TRUE LOVE NEVER DID RUN SMOOTH BETWEEN A Vicious Dog and an Inate Prospective Father-in-Law with Thick Shoes—Love's Course is Sometimes Decidedly Rough. 123456789</p>	<p>CABINET 9. Case No. 135.</p>
MACK., S. & J.	<p>BREVIER FRENCH CLARENDON. Caps, Lower Case, and Figures. AN EDITOR SAT AT HIS INLAID DESK, HIS BROW Was Furrowed with care; in front of Him lay a Poetic Gem that a School-girl had brought 12345</p>	<p>Case No. 137.</p>
MACK., S. & J.	<p>LONG PRIMER FRENCH CLARENDON. Caps, Lower Case, and Figures. ON THE BEAUTIES OF THE SPRING But the Editor frowned an Awful Frown while he Chewed at a Piece of String. 1834</p>	<p>Case No. 138.</p>
MACK., S. & J.	<p>PICA FRENCH CLARENDON. Caps, Lower Case, and Figures. When Knights of Old with Shields of Gold sang Merrily 36</p>	<p>Case No. 139.</p>
MACK., S. & J.	<p>GREAT PRIMER FRENCH CLARENDON. Caps, Lower Case, and Figures. Their Lay Crowned with Beautiful, Fragrant Flowers 12</p>	<p>Case No. 140.</p>
MACK., S. & J.	<p>DOUBLE ENGLISH FRENCH CLARENDON. Caps, Lower Case, and Figures. To thine Own Self be True. 189652</p>	<p>Case Nos. 141, 142.</p>

BOLD FACES AND ALDINES.

MAC K., S. & J.	NONPAREIL TITLE. LITTLE KINDNESSES LIGHTEN THE BURDEN OF Life. Kind Words and Deeds thou Should Accord when Human Backs are Bent by	Caps, Lower Case, and Figures.	CASE ON STAND.
F., L. & Co.	NONPAREIL BOLD FACE. BOARDING SCHOOLS AND YOUNG LADIES' ACADEMIES Offer Imperfect Facilities for True Learning and Tend more toward Superficial than otherwise	Caps, Lower Case, and Figures.	CABINET 10. Case No. 143.
F., L. & Co.	BREVIER BOLD FACE. THE LATEST ELEMENTS OF DESTRUCTIVENESS Cyclones and Bursting Mill-dams prevents the Monotony of Life 1289	Caps, Lower Case, and Figures.	Case No. 144.
F., L. & Co.	LONG PRIMER BOLD FACE. TO SIT IN SOLEMN SILENCE IN A DULL Dark Dock, in a Pestilential Prison with a Life Long Lock.	Caps, Lower Case, and Figures.	Case No. 145.
F., L. & Co.	PICA BOLD FACE. Money is the Root of Evil, Give me the Root \$5	Caps, Lower Case, and Figures.	Case No. 146.
F., L. & Co.	NONPAREIL ALDINE. PRINTING OFFICE DEVIL AND HIS NUMEROUS PRACTICAL PRANKS Providing a Hell of his own. Inveigling Small Boys to inspect imaginary Vermin between Column Rules 12345	Caps, Lower Case, and Figures.	Case Nos. 149, 150.
F., L. & Co.	BREVIER ALDINE. O WHERE ARE THE FRIENDS OF MY YOUTH? I CRY IN TONES of the Bard. Echo answers back and replies, They are made into Fairbanks' Best Lard	Caps, Lower Case, and Figures.	Case No. 151.
F., L. & Co.	LONG PRIMER ALDINE. SOME SEASONABLE SIGNS OF SUMMER When Ice Cream Parlors Open, and the Mosquito Tunes his Festal Lyre	Caps, Lower Case, and Figures.	Case No. 152.
F., L. & Co.	PICA ALDINE. Blythe she was and like a Fairy, and her Shoes were No. 9s	Caps, Lower Case, and Figures.	Case Nos. 153, 154.
F., L. & Co.	GREAT PRIMER ALDINE. Fraudulent Endowment Orders, \$1,000 for \$1	Caps, Lower Case, and Figures.	Case Nos. 155, 156.
MAC K., S. & J.	BREVIER DORIC. SEASONABLE SIGNS OF THE SUMMER The Mosquito Tunes his Festal Lyre, and the Mercury 12345	Caps, Lower Case, and Figures.	CABINET 20. Case Nos. 307, 308.
MAC K., S. & J.	LONG PRIMER DORIC. CLIMBS UP IN THE FAMILY THERMOMETER When Ice Cream Parlors Open for Business 123456789	Caps, Lower Case, and Figures.	Case Nos. 309, 310.

MISCELLANEOUS FACES.

F., L. & Co.	<p>TWELVE-POINT COPYGRAPH No. 3. Caps, Lower Case, and Figures. The gentle race of Flowers are lying in their 1234</p>	<p>CABINET 18. Case Nos. 285, 286.</p>
MACK., S. & J.	<p>TEN-POINT IONIC No. 2. (Scheme.) Caps, Lower Case, and Figures. THEN THIS POOR MAN BEGAN TO THINK What Power there was in Printer's Ink; jumped out of Bed and</p>	<p>CASE ON STAND.</p>
MACK., S. & J.	<p>PICA FASHION. Caps, Lower Case, and Figures. Please Take Notice Again we Present You</p>	<p>CABINET 20. Case No. 311.</p>
MACK., S. & J.	<p>GREAT PRIMER FASHION. Caps, Lower Case, and Figures. Grand Excursion to Bay Ridge 5</p>	<p>CASE No. 312.</p>
MACK., S. & J.	<p>GREAT PRIMER No. 1. Caps, Small Caps, Lower Case, and Figures. BOUND FOR Oklahoma, the Land Flowing 1235</p>	<p>CASE ON STAND.</p>
MACK., S. & J.	<p>DOUBLE SMALL PICA ROMAN No. 2. Caps, Small Caps, Lower Case, and Figures. TOILING, Sorrowing, Rejoicing 12357</p>	<p>CABINET 23. Case Nos. 355 to 362.</p>
MACK., S. & J.	<p>SIX AND NINE-POINT EXCELSIOR. Caps and Figures. COURAGEOUS ARRAY FOR EXHIBITION NEW YEAR'S DAY.</p>	<p>CABINET 13. Case No. 200.</p>
MACK., S. & J.	<p>TWELVE AND EIGHTEEN-POINT EXCELSIOR. Caps and Figures. CONSCIENCE MAKES COWARDS 77</p>	<p>CASE No. 201.</p>
MACK., S. & J.	<p>EIGHTEEN AND THIRTY-SIX-POINT EXCELSIOR, MORTISED. Caps and Figures. THE ERRORS OF LAZINESS</p>	<p>Case Nos. 201, 202.</p>
MACK., S. & J.	<p>THIRTY-SIX-POINT EXCELSIOR, MORTISED. Caps and Figures. FARMERS' LAW!</p>	<p>CASE No. 202.</p>
MACK., S. & J.	<p>FANCY INITIALS AND EIGHTEEN-POINT EXCELSIOR. Caps. GRAND, ARTISTIC, FANCY</p>	<p>Case Nos. 201, 202.</p>

SHADED FACES.

<p>MAC K., S. & J.</p>	<p>LONG PRIMER SLANTING SHADED. Caps, Lower Case, and Figures. <i>CONSIDER THE LILLIES OF THE FIELD, HOW THEY GROW, They Toil not, neither do they Spin, yet I say that Soloman in all his Glory was not Arrayed</i></p>	<p>CABINET 29. Case No. 460.</p>
<p>MAC K., S. & J.</p>	<p>PICA SLANTING SHADED. Caps, Lower Case, and Figures. <i>Seaside Resorts. Surf Bathing the Summer Recreation. Frolicing in the Waves</i></p>	<p>Case No. 461.</p>
<p>MAC K., S. & J.</p>	<p>ENGLISH SLANTING SHADED. Caps, Lower Case, and Figures. <i>Gaily Tripping, Lightly Skipping, Flock the Maidens to the Shipping 671</i></p>	<p>Case No. 462</p>
<p>MAC K., S. & J.</p>	<p>GREAT PRIMER SLANTING SHADED. Caps, Lower Case, and Figures. <i>Zimri the Beautiful had set upon a Wasp. We heard him</i></p>	<p>Case No. 463.</p>
<p>MAC K., S. & J.</p>	<p>DOUBLE SMALL PICA SLANTING SHADED. Caps, Lower Case, and Figures. <i>In Days of Old, when Knights were Bold, \$152</i></p>	<p>Case No. 464.</p>
<p>MAC K., S. & J.</p>	<p>DOUBLE ENGLISH SLANTING SHADED. Caps, Lower Case, and Figures. <i>My Love is a Rover without a Care</i></p>	<p>Case No. 465.</p>
<p>MAC K., S. & J.</p>	<p>PICA CANTONIAN. Caps, Lower Case, and Figures. The Idle Rejoiced at the News, Put their Hands</p>	<p>CABINET 13. Case No. 191.</p>
<p>MAC K., S. & J.</p>	<p>GREAT PRIMER CANTONIAN. Caps, Lower Case, and Figures. In their Pockets and Slept. 185627</p>	<p>Case No. 192.</p>
<p>MAC K., S. & J.</p>	<p>DOUBLE PICA CANTONIAN. Caps, Lower Case, and Figures. Believing the Promise 187</p>	<p>Case No. 193.</p>

SHADED FACES.

MACK, S. & J.	LONG PRIMER COPPERPLATE.	Caps and Figures.	CABINET 13. Case No. 195.
	THE CLOCK WAS STRIKING THE HOUR 123		
MACK, S. & J.	GREAT PRIMER COPPERPLATE.	Caps and Figures.	Case No. 195.
	KISMEJ DOUBTED INEZ 1926		
MACK, S. & J.	DOUBLE GREAT PRIMER GRAVERS' SHADE.	Caps and Figures.	Case No. 196.
	MUSTULIETUIE		
MACK, S. & J.	PICA ARBORET.	Caps and Figures.	Case No. 194.
	THE WONDERS OF THE PYRAMIDS		
MACK, S. & J.	THREE-LINE NONPAREIL ARBORET.	Caps and Figures.	Case No. 194.
	HAPPY LAUGHING BOYS		
MACK, S. & J.	DOUBLE PICA ARBORET.	Caps and Figures.	Case No. 194.
	DEVOTED FRIENDS		
MACK, S. & J.	DOUBLE PICA OUTLINE SHADED.	Caps.	Case No. 197.
	THE ORIGINAL AND DUPLICATE		
MACK, S. & J.	FOUR-LINE PICA OUTLINE SHADED.	Caps and Figures.	Case No. 197.
	HISTORY OF MEN		
MACK, S. & J.	FOUR-LINE PICA ORNAMENTED.	Caps and Figures.	Case No. 196.
	EMPORTUMS		

TEXTS.

MACK., S. & J.	GREAT PRIMER FANCY TEXT.	Caps and Lower Case.	CABINET 15. Case No. 223.
MACK., S. & J.	TWO-LINE SMALL PICA FANCY TEXT.	Caps and Lower Case.	Case No. 224.
MACK., S. & J.	DOUBLE ENGLISH FANCY TEXT.	Caps and Lower Case.	Case No. 225.
MACK., S. & J.	DOUBLE GREAT PRIMER FANCY TEXT.	Caps and Lower Case.	Case No. 226.
MACK., S. & J.	DOUBLE PARAGON FANCY TEXT.	Caps and Lower Case.	Case No. 227.
MACK., S. & J.	FOUR-LINE PICA FANCY TEXT.	Caps and Lower Case.	Case No. 228.
MACK., S. & J.	TWO-LINE PICA QUEEN ANN TEXT.	Assorted Caps, Lower Case, and Figures.	Case Nos. 229, 230.
MACK., S. & J.	THIRTY-SIX-POINT QUEEN ANN TEXT.	Assorted Caps, Lower Case, and Figures.	Case Nos. 231, 232.
MACK., S. & J.	TWO-LINE PICA OPEN TEXT.	Caps and Lower Case.	CABINET 13. Case No. 203.
MACK., S. & J.	TWO-LINE ENGLISH OPEN TEXT.	Caps and Lower Case.	Case No. 204.
MACK., S. & J.	TWO-LINE GREAT PRIMER OPEN TEXT.	Caps and Lower Case.	Case No. 205.
MACK., S. & J.	TWO-LINE PARAGON OPEN TEXT.	Caps and Lower Case.	Case No. 206.

TENTS.

F., L. & Co.	PICA COPPERPLATE TEXT.	Caps, Lower Case, and Figures.	CABINET 25.
	Over the Foaming Billows the Gallant Ship Skims 5		Case No. 380.
F., L. & Co.	GREAT PRIMER COPPERPLATE TEXT.	Caps, Lower Case, and Figures.	Case
	Gracefully with Canvas Fluttering 12356		Case No. 381.
F., L. & Co.	DOUBLE SMALL PICA COPPERPLATE TEXT.	Caps, Lower Case, and Figures.	Case
	Changing Scenes Flowing Pleasures		Case No. 382.
F., L. & Co.	DOUBLE ENGLISH COPPERPLATE TEXT.	Caps, Lower Case, and Figures.	Case
	Deep Emotion Expressing 65		Case No. 383.
F., L. & Co.	GREAT PRIMER CHASED BLACK.	Caps, Lower Case, and Figures.	CABINET 26.
	Offer of the Inspector of Lamp Posts		Case No. 409.
F., L. & Co.	DOUBLE SMALL PICA CHASED BLACK.	Caps, Lower Case, and Figures.	Case
	Shining Lights of Society, Gas		Case No. 410.
F., L. & Co.	DOUBLE ENGLISH CHASED BLACK.	Caps, Lower Case, and Figures.	Case
	Summer European Customs		Case No. 411.
MACK., S. & J.	DOUBLE PICA TITLE TEXT OPEN.	Caps and Lower Case.	Case
	For Years I have Swung in the Old Grey Tower		Case No. 396.
MACK., S. & J.	DOUBLE ENGLISH TITLE TEXT OPEN.	Caps and Lower Case.	Case
	Hungry and Thirsty Souls come Eat and Drink		Case No. 397.
MACK., S. & J.	DOUBLE GREAT PRIMER TITLE TEXT OPEN.	Caps and Lower Case.	Case
	Enough to Make one very Mad! Mad!		Case No. 398.
MACK., S. & J.	TWO-LINE PARAGON TITLE TEXT OPEN.	Caps and Lower Case.	Case
	Under the Willows they are Creeping		Case No. 399.

TEXTS.

MACK., S. & J.	GREAT PRIMER TREASURY.	Caps, Lower Case, and Figures.	CABINET 14. Case No. 207.
	<i>Man Wants but Little here below, but Woman Wants</i>		
MACK., S. & J.	DOUBLE ENGLISH TREASURY.	Caps, Lower Case, and Figures.	Case No. 208.
	<i>Knights of Labor, Days of Rest 712</i>		
MACK., S. & J.	DOUBLE GREAT PRIMER TREASURY.	Caps, Lower Case, and Figures.	Case No. 209.
	<i>Bald Heads vs. Hairy Bitter</i>		
MACK., S. & J.	EIGHTEEN-POINT GRAPHIC TEXT.	Caps, Lower Case, and Figures.	Case No. 210.
	<i>Flowers that Bloom in the Spring bring Promise of 22</i>		
MACK., S. & J.	TWENTY-FOUR-POINT GRAPHIC TEXT.	Caps, Lower Case, and Figures.	Case No. 211.
	<i>Life is Full of Opportunities, Grasp them 81</i>		
MACK., S. & J.	THIRTY-SIX-POINT GRAPHIC TEXT.	Caps, Lower Case, and Figures.	Case No. 212.
	<i>Oh for a Home Beside the Sea</i>		
F., L. & Co.	PICA MODEL BLACK SHADED.	Caps, Lower Case, and Figures.	CABINET 25. Case No. 384.
	<i>Constant Reiteration of the Same Ideas is Monotonous</i>		
F., L. & Co.	GREAT PRIMER MODEL BLACK SHADED.	Caps, Lower Case, and Figures.	Case No. 385.
	<i>Brightest Hopes are the Most Fleeting 4</i>		
F., L. & Co.	DOUBLE SMALL PICA MODEL BLACK SHADED.	Caps, Lower Case, and Figures.	Case No. 386.
	<i>Cackling Geese once Saved Rome</i>		
F., L. & Co.	DOUBLE ENGLISH MODEL BLACK SHADED.	Caps, Lower Case, and Figures.	Case No. 387.
	<i>Grandfather's Daily Class</i>		
MACK., S. & J.	DOUBLE LONG PRIMER ALLEMANIC.	Caps, Lower Case, and Figures.	CABINET 15. Case No. 233.
	<i>The Judge Looked Back as he Climbed the Hill and saw Maud</i>		

TEXTS.

MACK., S. & J.	GREAT PRIMER SCRIBE TEXT.	Caps, Lower Case, and Figures.	CABINET 14. Case No. 216.
	The Power that Rules the World, The Hand that Rocks the Cradle		
MACK., S. & J.	TWO-LINE SMALL PICA SCRIBE TEXT.	Caps, Lower Case, and Figures.	Case No. 217.
	Speculators on Wall Street. Bulls' and Bears' Retreat 198		
MACK., S. & J.	DOUBLE ENGLISH CONDENSED TEXT.	Caps, Lower Case, and Figures.	CABINET 25. Case No. 392.
	Warblings of the Sweet Singer of Michigan		
MACK., S. & J.	GREAT PRIMER TITLE BLACK SHADED.	Caps, Lower Case, and Figures.	Case No. 393.
	Splendid View on the Susquehanna 12		
MACK., S. & J.	DOUBLE PICA TITLE BLACK SHADED.	Caps, Lower Case, and Figures.	Case No. 394.
	Engulfed in the Mad Whirl 3		
MACK., S. & J.	DOUBLE GREAT PRIMER TITLE BLACK SHADED.	Caps, Lower Case, and Figures.	Case No. 395.
	Nothing but Brass 4		
MACK., S. & J.	DOUBLE PICA RIPPLE TEXT.	Caps, Lower Case, and Figures.	CABINET 14. Case No. 213.
	Down in a Shady Grove a Modest Violet 171		
MACK., S. & J.	DOUBLE GREAT PRIMER RIPPLE TEXT.	Caps, Lower Case, and Figures.	Case Nos. 214, 215.
	3 Little Maids from School 132		
MACK., S. & J.	ENGLISH TEUTONIC.	Caps, Lower Case, and Figures.	CABINET 15. Case No. 234.
	\$15.89. And Blushed as she gave it, Looking Down at her		
MACK., S. & J.	DOUBLE SMALL PICA TEUTONIC.	Caps, Lower Case, and Figures.	Case No. 235.
	Graceful Ankles, Bare and Brown \$1,898		
MACK., S. & J.	DOUBLE PICA TEUTONIC.	Caps, Lower Case, and Figures.	Case No. 236.
	8 Those Bloodthirsty Mosquitos 5		

TEXTS.

MACK., S. & J.	PICA SLOPING BLACK.	Caps, Lower Case, and Figures.	CABINET 26. Case No. 404.
	<i>Department Clerks and Printers, the Ten Per Center's Friend.</i> \$15.25		
MACK., S. & J.	GREAT PRIMER SLOPING BLACK.	Caps, Lower Case, and Figures.	Case No. 405.
	<i>Many Refined Sections of Washington, Swampoodle</i>		
MACK., S. & J.	DOUBLE SMALL PICA SLOPING BLACK.	Caps, Lower Case, and Figures.	Case No. 406.
	<i>Oh, Washington, the City of the God==less</i>		
MACK., S. & J.	DOUBLE ENGLISH SLOPING BLACK.	Caps, Lower Case, and Figures.	Case No. 407.
	<i>State, War, and Navy Department</i>		
MACK., S. & J.	DOUBLE SMALL PICA TITLE TEXT.	Caps and Lower Case.	Case No. 400.
	<i>Smiling Fortune makes Fools, but Miss Fortune makes Wise Men</i>		
MACK., S. & J.	DOUBLE ENGLISH TITLE TEXT.	Caps and Lower Case.	Case No. 401.
	<i>Oh, take back the Heart that Thou Gavest. Here</i>		
MACK., S. & J.	DOUBLE GREAT PRIMER TITLE TEXT.	Caps and Lower Case.	Case No. 402.
	<i>Who Killed Cock Robin? H, said the Fly</i>		
MACK., S. & J.	DOUBLE PARAGON TITLE TEXT.	Caps and Lower Case.	Case No. 403.
	<i>Washington, the City of many Trees</i>		
MACK., S. & J.	DOUBLE PICA BLACK TEXT.	Caps, Lower Case, and Figures.	Case No. 408.
	<i>Who's that Knocking at my Door?</i>		
MACK., S. & J.	THREE-LINE NONPAREIL PENCRAFT.	Caps, Lower Case, and Figures.	CABINET 29. Case No. 458.
	<i>Elegant Display of Typographical Designs 10</i>		
MACK., S. & J.	THREE-LINE NONPAREIL PENCRAFT.	Ornamental Caps, Lower Case, and Figures.	Case No. 458.
	<i>American Wheelmen's Monthly Runover</i>		

TEXTS.

F., L. & Co.	<p>BREVIER OLD BLACK. Caps, Lower Case, and Figures.</p> <p>With constant Motion as the Moments Glide, Behold in Running Life the Rolling Tide! For none can Stem by Art, or stop 146</p>	CABINET 21. Case No. 324.
F., L. & Co.	<p>LONG PRIMER OLD BLACK. Caps, Lower Case, and Figures.</p> <p>By Power the Rolling Ocean or the Fleeting Hour But Wave by Wave, pursued arrives on shore and each 12345678</p>	Case No. 325.
F., L. & Co.	<p>PICA OLD BLACK. Caps, Lower Case, and Figures.</p> <p>Great Cry and Little Wool! That is What the Man said</p>	Case No. 326.
F., L. & Co.	<p>GREAT PRIMER OLD BLACK. Caps, Lower Case, and Figures.</p> <p>When He was Shearing a Hog. Sample.</p>	Case No. 328.
F., L. & Co.	<p>DOUBLE SMALL PICA OLD BLACK. Caps, Lower Case, and Figures.</p> <p>Ancient and Modern Characters 23</p>	Case No. 329.
MACK., S. & J.	<p>LONG PRIMER BLACK CONDENSED TEXT. Caps and Lower Case.</p> <p>China's Walls are Doomed. America for Americans. The Heathen Must Go.</p>	CABINET 14. Case No. 218.
MACK., S. & J.	<p>PICA BLACK CONDENSED TEXT. Caps and Lower Case.</p> <p>For Ways that are Dark and Tricks that are Vain the Heathen Chinee is</p>	Case No. 219.
MACK., S. & J.	<p>GREAT PRIMER BLACK CONDENSED TEXT. Caps and Lower Case.</p> <p>It is the Discreet Man, not the Witty, who guides Conversation</p>	Case No. 220.
MACK., S. & J.	<p>TWO-LINE SMALL PICA BLACK CONDENSED TEXT. Caps and Lower Case.</p> <p>Twenty Creole Beauties, Egyptian Queens. Coons</p>	Case No. 221.
MACK., S. & J.	<p>CANON BLACK CONDENSED TEXT. Caps, Lower Case, and Figures.</p> <p>The Swampoodle Herald</p>	Case No. 222.

TEXTS.

	LONG PRIMER LIGHT MODEL BLACK.	Caps, Lower Case, and Figures.	CABINET 21.
F., L. & Co.	If you can pay your Debts, and do not pay them, God will put you in Hell for it. The compositor threw it in 75.		Case No. 319.
	PICA LIGHT MODEL BLACK.	Caps, Lower Case, and Figures.	Case
F., L. & Co.	National Guards' Twenty-First Annual Reception, 189		No. 320.
	GREAT PRIMER LIGHT MODEL BLACK.	Caps, Lower Case, and Figures.	Case
F., L. & Co.	Toiling, Rejoicing, Sorrowing, Onward 123		No. 321.
	DOUBLE SMALL PICA LIGHT MODEL BLACK.	Caps, Lower Case, and Figures.	Case
F., L. & Co.	He has no Desire to Influence 245		No. 322.
	DOUBLE ENGLISH LIGHT MODEL BLACK.	Caps, Lower Case, and Figures.	Case
F., L. & Co.	Sloping Ways Subverted 5		No. 323.
	PICA MODEL BLACK.	Caps, Lower Case, and Figures.	CABINET 25.
F., L. & Co.	The Liberal Bachelor with Gentle Maidens Join 234		Case No. 388.
	GREAT PRIMER MODEL BLACK.	Caps, Lower Case, and Figures.	Case
F., L. & Co.	Three Little Maids from School are We 3		No. 389.
	DOUBLE SMALL PICA MODEL BLACK.	Caps, Lower Case, and Figures.	Case
F., L. & Co.	Nine Little Indians up a Tree 23		No. 390.
	DOUBLE ENGLISH MODEL BLACK.	Caps, Lower Case, and Figures.	Case
F., L. & Co.	Hunters in Switzerland 31		No. 391.
	FIVE-LINE PICA MODERN TEXT.	Caps and Lower Case.	CABINET 15.
MACK., S. & J.	Merry Warbler.		Case No. 238.

GERMAN TYPE.

MACK., S. & J.	LONG PRIMER GERMAN NO. 3.	Caps, Lower Case, and Figures.	CASE IN HALL.
Die hohe Stufe, welche die Buchdruckerkunst unter den Erfindungen des menschlichen Geistes einnimmt, hat die Ehre die Geburtsstätte derselben zu sein, zum Gegenstande eines lebhaften noch nicht			
BRUCE.	GREAT PRIMER GERMAN NO. 90.	Caps, Lower Case, and Figures.	CASE IN HALL.
Gutenberg hat die ersten von ihm gedruckten Sachen weder mit			
MACK., S. & J.	PICA CONDENSED GERMAN TITLE.	Caps, Lower Case, and Figures.	CASE IN HALL.
Das Buch der Natur liegt seit Jahrtausenden aufgeschlagen vor dem Blicke			
MACK., S. & J.	PICA GERMAN TITLE.	Caps, Lower Case, and Figures.	CASE IN HALL.
Das Buch der Natur liegt seit Jahrtausenden aufgeschlag			
MACK., S. & J.	LONG PRIMER GERMAN TITLE.	Caps, Lower Case, and Figures.	CASE IN HALL.
Das Buch der Natur liegt seit Jahrtausenden aufgeschlagen vor			
MACK., S. & J.	TWO-LINE ENGLISH CONDENSED GERMAN TITLE.	Caps, Lower Case, and Figures.	CASE IN HALL.
Das Englische als Weltsprache			
BRUCE.	GREAT PRIMER GERMAN CONDENSED NO. 491.	Caps, Lower Case, and Figures.	CASE IN HALL.
Das Buch der Natur liegt seit Jahrtausenden aufgeschlagen			
MACK., S. & J.	DOUBLE ENGLISH CONDENSED BLACK.	Caps, Lower Case, and Figures.	CABINET 15. Case No. 237.
Washington Loan and Trust Co. \$5.70			

FIGURES.

MACK., S. & J.	NONPAREIL GOTHIC No. 3.	Regular Font—Large.	CASE ON STAND.
	1 2 3 4 5 6 7 8 9 2345 78099 080566 609797 44466609 234567540 9097570 5578890087 1234567882235		
F., L. & Co.	NONPAREIL ALDINE.	Regular Font and Figure Case.	CABINET 10. Case No. 150.
	1 2 3 4 5 6 7 8 9 10 11 22 42 31 36 37 39 43 45 78 79 98 86 51 55 68 94 2315688		
F., L. & Co.	NONPAREIL TITLE. (New.)	Regular Font.	CASE No. 143.
	1 2 3 4 5 6 7 8 9 10 11 12 13 11 15 16 17 18 19 20 25 36 55 56 67 78 18		
MACK., S. & J.	BREVIER BOLD FACE. (Old.)	Regular Font.	CASE ON STAND.
	1 2 3 4 5 6 7 8 9 0 7 8 9 10 453 6796 7904 5575214 1739666 745		
MACK., S. & J.	BREVIER DORIC	Regular Font—Large.	CABINET 20. Case No. 308.
	1 2 3 4 5 6 7 8 9 10 11 12 13 14 15 16 17 18 19 22		
M., L. & Co.	LONG PRIMER IONIC No. 2. (Scheme.)	Regular Font.	CASE ON STAND.
	1 2 3 4 5 6 7 8 9 1345 3456 23457 179725 3456789 54678314		
MACK., S. & J.	SMALL PICA GOTHIC ITALIC No. 2.	Regular Font.	CABINET 28. Case No. 435.
	1 2 3 4 5 6 7 8 9 10 2356 66569 765432 1123456 78904567 908777		
BRUCE.	DOUBLE BREVIER MODERN.	Figure Case.	CABINET 24. Case No. 372.
	1 2 3 4 5 6 7 8 9 10 11 12 13 14 15 16 17 1824		
MACK., S. & J.	GREAT PRIMER MODERN No. 3.	Regular Font.	CASE ON STAND.
	1 2 3 4 5 6 7 8 9 10 11 12 13 14 15 16 167		
MACK., S. & J.	GREAT PRIMER MODERN No. 4.	Regular Font.	CASE ON STAND.
	1 2 3 4 5 6 7 8 8 9 10 11 12 13 14 15 7890		
F., L. & Co.	GREAT PRIMER CLARENDON CONDENSED.	Regular Font.	CABINET 11. Case No. 169.
	1 2 3 4 5 6 7 8 9 10 11 12 13 14 15 16 17 18		
F., L. & Co.	GREAT PRIMER MODERN ANTIQUE.	Regular Font.	CABINET 23. Case No. 351.
	1 2 3 4 5 6 7 8 9 10 11 12 13 14 15 1624		
F., L. & Co.	GREAT PRIMER ANTIQUE.	Regular Font.	CASE ON STAND.
	1 2 3 4 5 6 7 8 9 10 26 5647 56789 6467909		

FIGURES.

MACK., S. & J. DOUBLE LONG PRIMER DORIC. Figure Case. CABINET 24. Case No. 373.

1 2 3 4 5 6 7 8 9 10 12 256

BRUCE. DOUBLE SMALL PICA ROMAN. (OLD.) Figure Case. Case No. 374.

1 2 3 4 5 6 7 8 9 10 11 12 13 149

F., L. & Co. DOUBLE SMALL PICA MODERN ANTIQUE. Regular Font. CABINET 23. Case No. 353.

1 2 3 4 5 6 7 8 9 10 46 48 5689

MACK., S. & J. DOUBLE GREAT PRIMER ANTIQUE. Figure Case. CABINET 24. Case No. 376.

1 2 3 4 5 6 7 8 9 10 123

BRUCE. DOUBLE GREAT PRIMER. Figure Case. Case No. 375.

1 2 3 4 5 6 7 8 9 10 157

MACK., S. & J. FOUR-LINE PICA ALDINE. Figure Case. CASE IN HALL.

1 2 3 4 5 6 7 8 9 05

M., L. & Co. FOUR-LINE PICA DOBIC. Regular Font. CASE ON STAND.

1 2 3 4 5 6 7 8

MACK., S. & J. FIVE-LINE PICA ANTIQUE. Figure Case. CABINET 24. Case No. 377.

1 2 3 4 5 6 7 8 9 0

MACK., S. & J. FIVE-LINE PICA IONIC. Figure Case. Case No. 378.

1 2 3 4 5 6

MACK., S. & J. EIGHT-LINE PICA ANTIQUE. Figure Case. Case No. 379.

1 2 3 4 5 6 7 5

POSTER FACES.

DOUBLE ENGLISH ROMAN.

MACK., S. & J.

Caps, Lower Case, and Figures.

Columbia, the Gem of the Ocean. 1891

DOUBLE GREAT PRIMER ROMAN.

MACK., S. & J.

Caps, Lower Case, and Figures.

The Nation's Joy and Pride!

FOUR-LINE PICA ROMAN.

MACK., S. & J.

Caps, Lower Case, and Figures.

For Rent, Potomac Flats

DOUBLE GREAT PRIMER ROMAN CONDENSED.

F. L. & Co.

Caps, Lower Case, and Figures.

Look not upon the Wine when Red

CANON ANTIQUE CONDENSED.

MACK., S. & J.

Caps, Lower Case, and Figures.

Life's Moments Swiftly Fleeting

FOUR-LINE PICA ANTIQUE CONDENSED.

MACK., S. & J.

Caps, Lower Case, and Figures.

Jogging along through the World

FOUR-LINE PICA ANTIQUE.

MACK., S. & J.

Caps, Lower Case, and Figures.

Birthplace of Columbus 15

POSTER FACES.

DOUBLE GREAT PRIMER ANTIQUE BLACK.

BRUCE.

Caps, Lower Case, and Figures.

5 Weary Travelers

DOUBLE GREAT PRIMER GOTHIC.

BRUCE.

Caps and Figures.

3 SOMNAMBULISTS

FOUR-LINE PICA MODERN.

BRUCE.

Caps, Lower Case, and Figures.

Baccarat, Royal Game

FOUR-LINE PICA GOTHIC.

BRUCE.

Caps and Figures.

OUR ENEMIES

FOUR-LINE PICA EXTENDED.

BRUCE.

Caps, Lower Case, and Figures.

Tid Bits

FIVE-LINE PICA ROMAN.

MACK., S. & J.

Caps, Lower Case, and Figures.

Grand Humbug

SIX-LINE PICA ANTIQUE CONDENSED.

MACK., S. & J.

Caps and Figures.

SO SLIM AND SLICK

POSTER FACES.

FIVE-LINE PICA ROUND GOTHIC.

MACK., S. & J.

Caps, Lower Case, and Figures.

Presidential Aspirants

SIX-LINE PICA ANTIQUE FANCY.

MACK., S. & J.

Caps and Figures.

TOM & JERRY

SIX-LINE PICA TUSCAN ANTIQUE.

MACK., S. & J.

Caps and Figures.

BLACK BIRD

SIX-LINE PICA ROMAN.

MACK., S. & J.

Caps, Lower Case, and Figures.

Whiskers, 5 Cts.

SIX-LINE PICA ROUND GOTHIC OPEN.

MACK., S. & J.

Caps.

BAY RUM!

SIX-LINE PICA ANTIQUE BLACK.

BRUCE.

Caps, Lower Case, and Figures.

Cocktails

SEVEN-LINE PICA ANTIQUE CONDENSED.

MACK., S. & J.

Caps, Lower Case, and Figures.

15 Normal Schools

SIX-LINE PICA ANTIQUE.

Caps, Lower Case, and Figures.

Battle Scenes

EIGHT-LINE PICA GOTHIC

Caps.

BAY RIDGE

TEN-LINE PICA GOTHIC CONDENSED.

Caps and Figures.

ELEPHANT

TEN-LINE PICA FRENCH CLARENDON CONDENSED.

Caps, Lower Case, and Figures.

Green, Shaded Lawns

TWELVE LINE PICA GRECIAN.

BRUCE.

Caps.

YOUNG MEN

POSTER FACES.

FOUR-LINE PICA DORIC.

CHICAGO TYPE FOUNDRY.

Caps, Lower Case, and Figures.

Loan Me a Dollar

TEN-LINE PICA GOTHIC.

Caps, Lower Case, and Figures.

Buttermilk

FIFTEEN-LINE PICA CLARENDON.

Caps.

BIG MEN

EIGHTEEN-LINE PICA FRENCH CLARENDON CONDENSED.

Caps.

ROCK & RYE

OUTLINE FIGURES.



OUTLINE FIGURES.

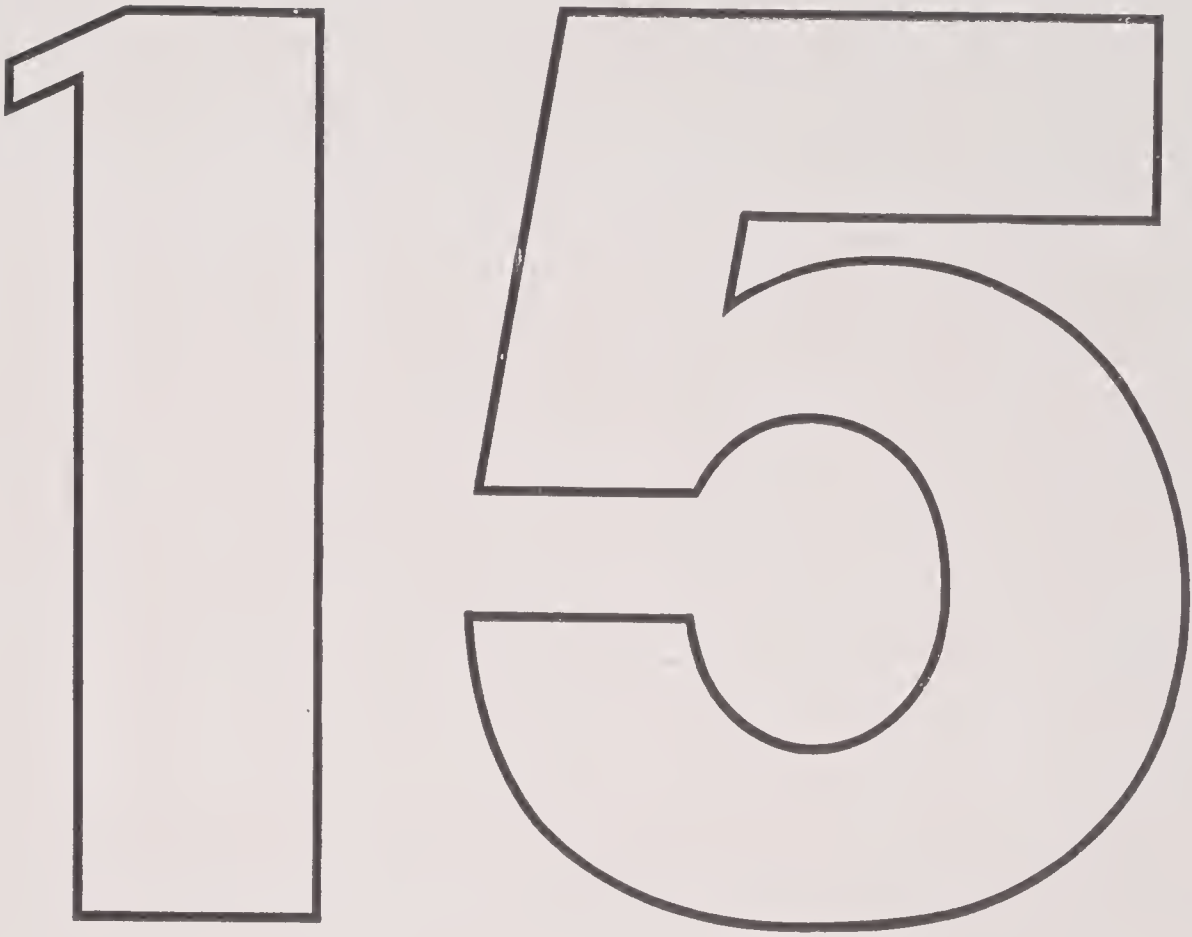

SPECIMENS
OF
CUTS, RULES, BORDERS,
LOGOTYPES,
CHECK ENDS AND ORNAMENTS.

BRASS RULES.

1
1
2
2
3
3
4
4
5
5
6
6
7
7
8
8
9
9
10
10
11
11
12
12
13
13

1
1
2
2
3
3
4
4
5
5
6
6
7
7
8
8
9
9
10
10
11
11
12
12
13
13

BORDERS.

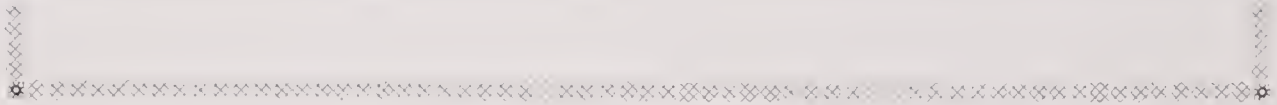

Minionette Border, No. 1.

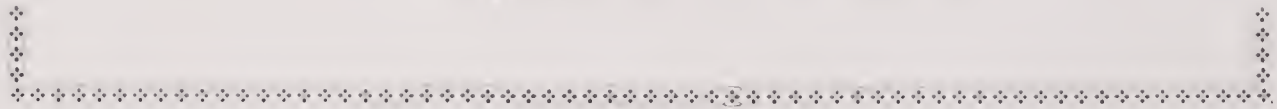

Minionette Border, No. 2.



Minionette Border, No. 3.

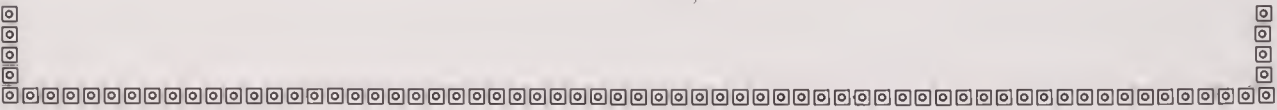

Minionette Border, No. 4.



Minionette Border, No. 5.



Minionette Border, No. 6.

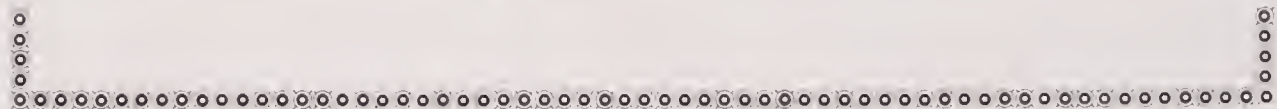

Minionette Border, No. 7.



Minionette Border, No. 8.



Minionette Border, No. 9.



Minionette Border, No. 10.



Small Pica Border, No. 11.



Small Pica Border, No. 12.



Small Pica Border, No. 13.



Small Pica Border, No. 14.

BORDERS.



Small Pica Border, No. 15.



Small Pica Border, No. 16.



Pica Border, No. 17.



Pica Border, No. 18.

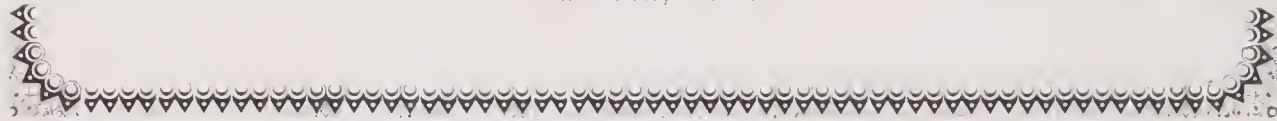

Pica Border, No. 19.



Pica Border, No. 20.



Pica Border, No. 21.

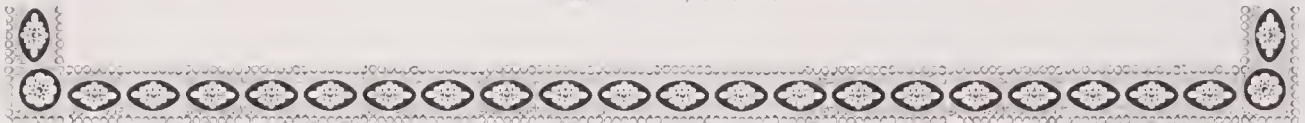

Double Small Pica Border, No. 22.



Double Pica Border, No. 23.



Double Pica Border, No. 24.



Double Great Primer Border, No. 25.



Four-line Pica Border, No. 26.

ORNAMENTAL DASH RULES.

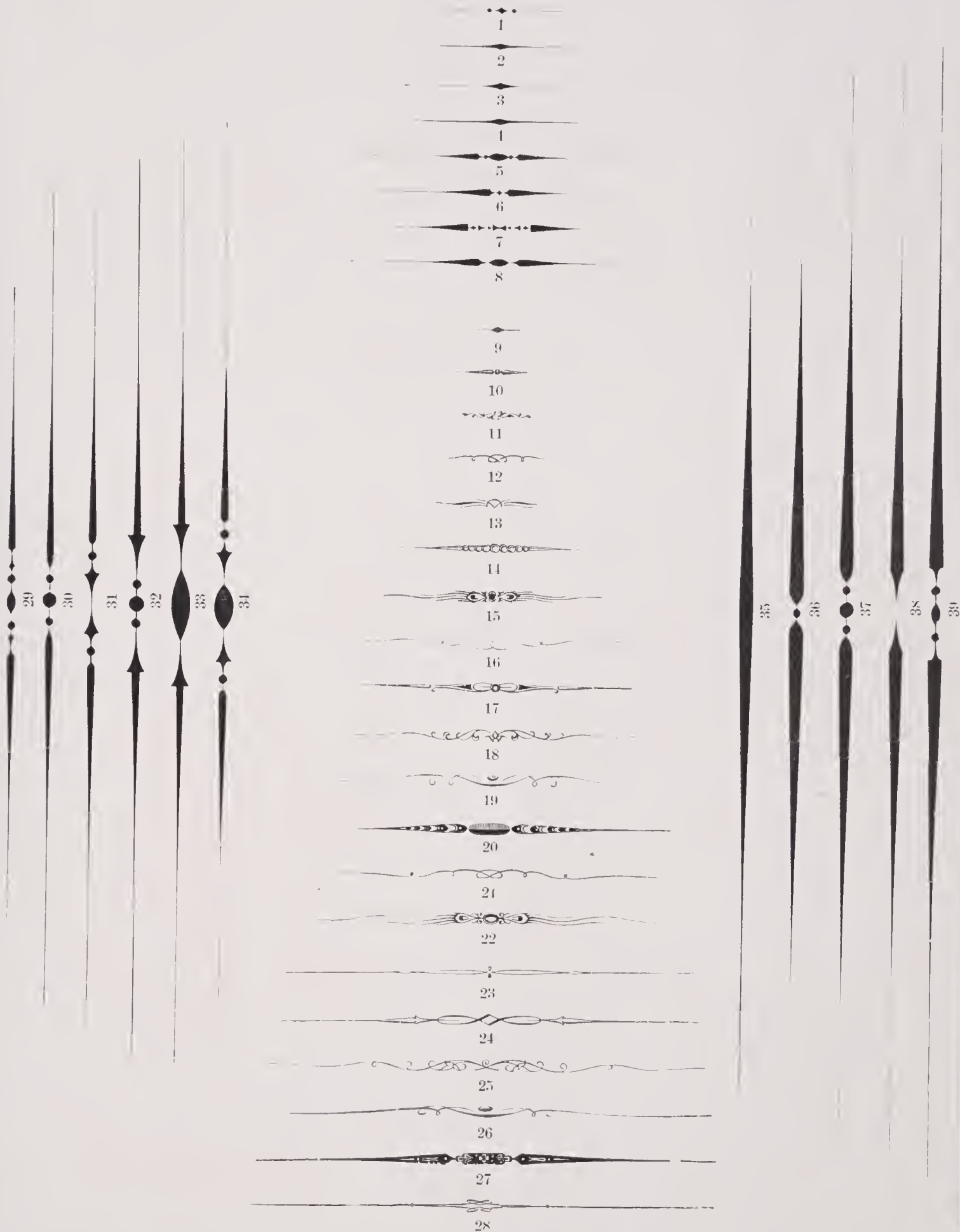

CIRCLES AND OVALS.

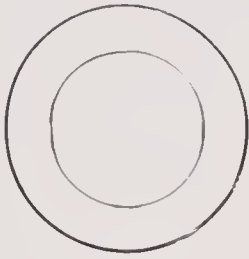

1



2



3

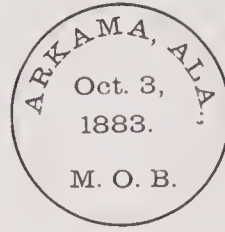

4

5

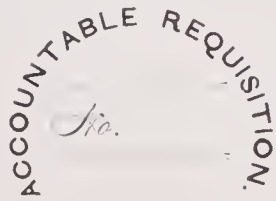

6

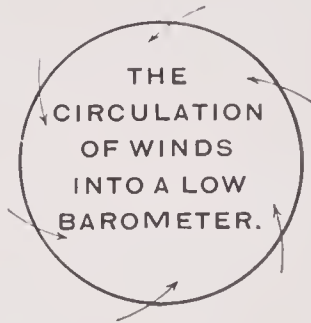

7



8



9



10



11

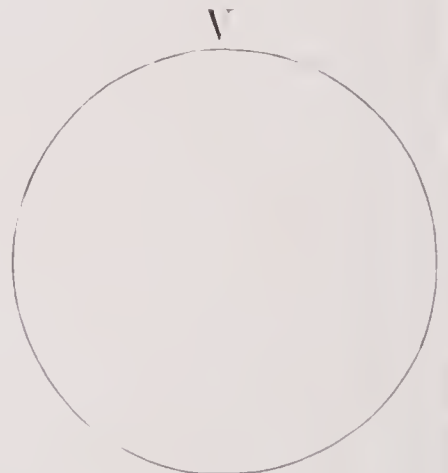

12



13



14



15

INDEXES AND BRACES.

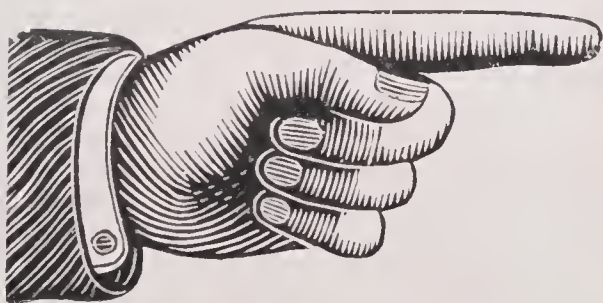
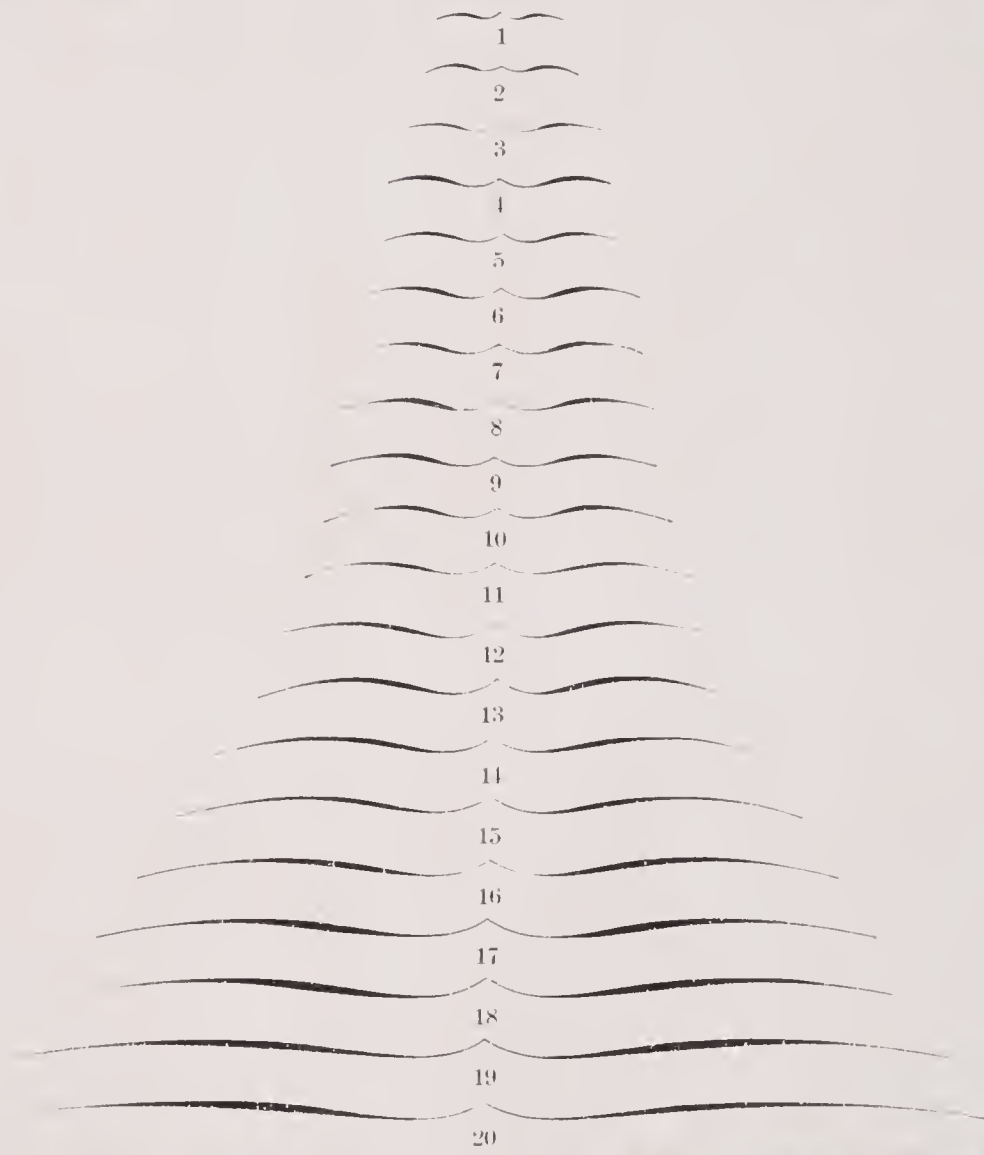
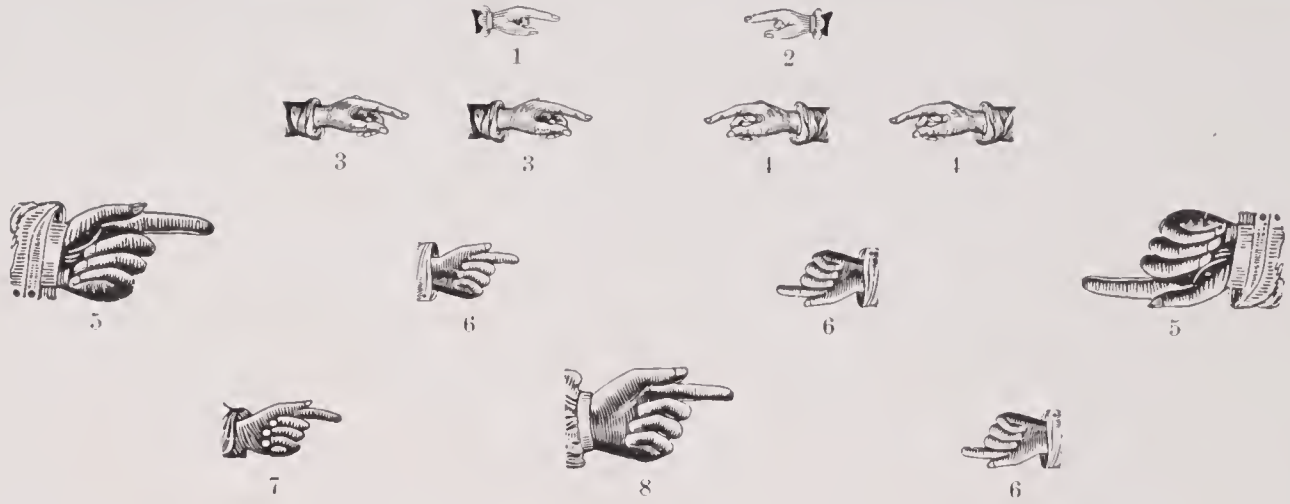

9



10

CORNER PIECES.

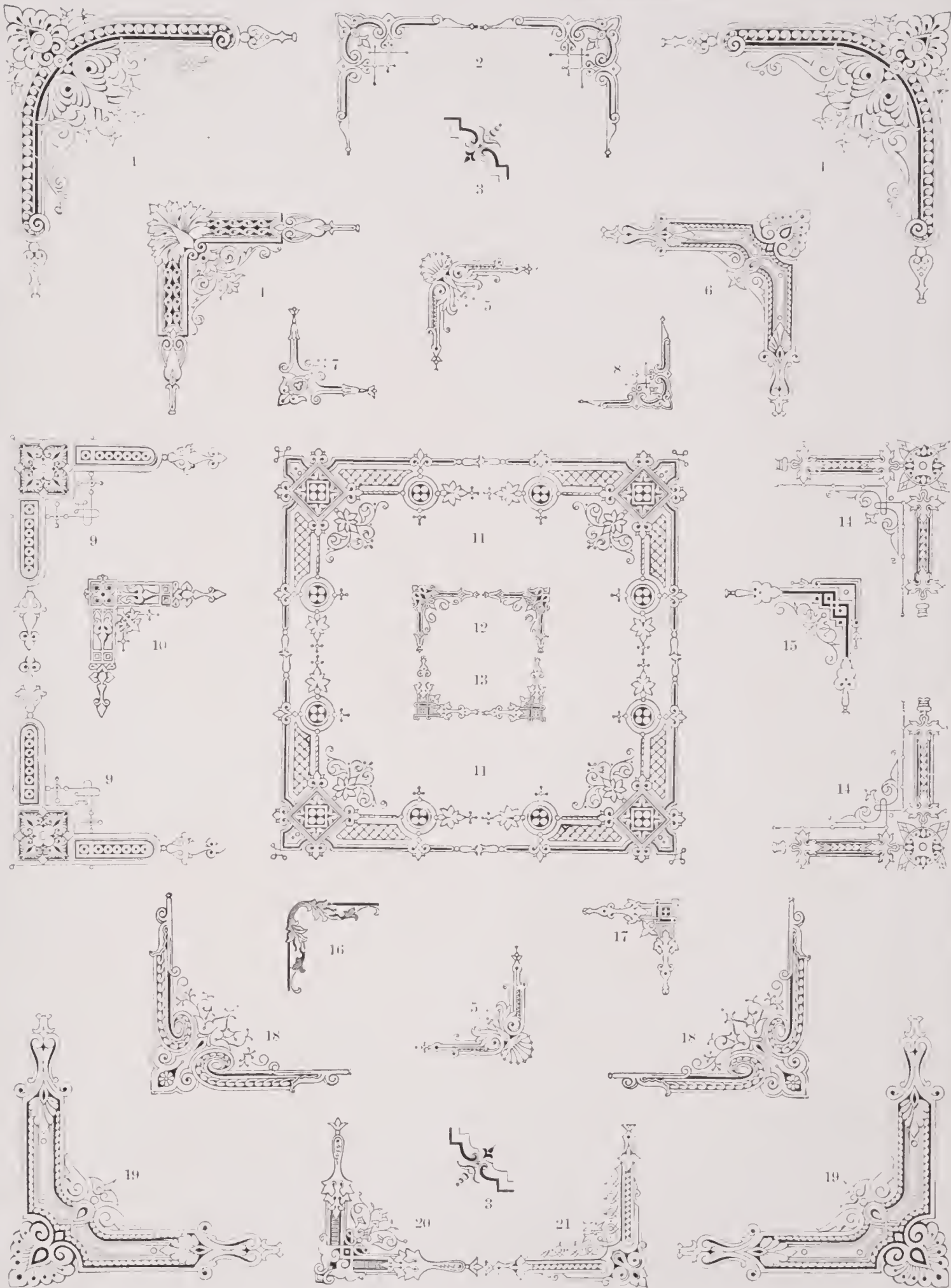

CORNER PIECES.

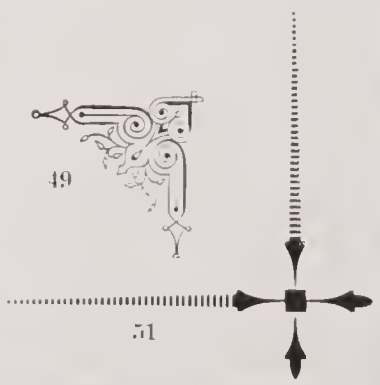
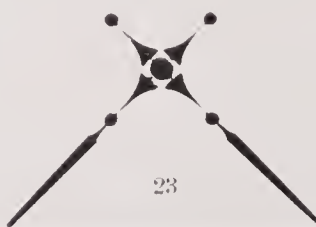
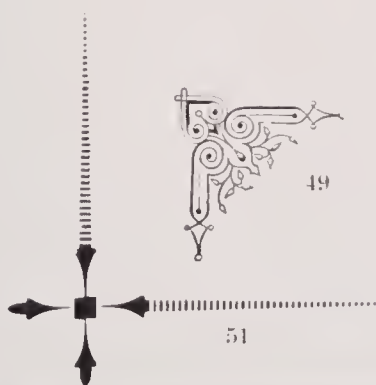
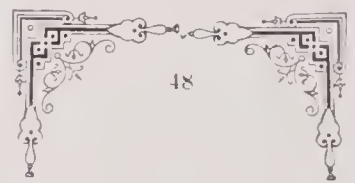
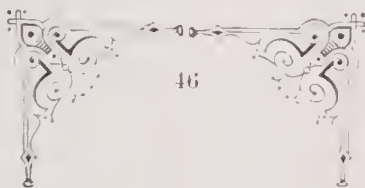
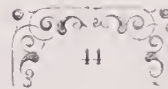
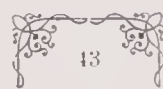
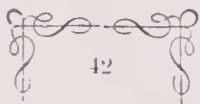
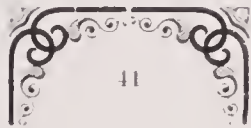
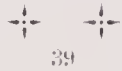
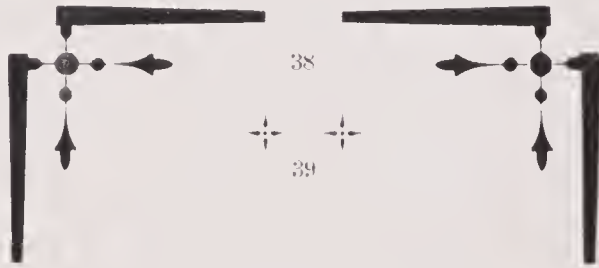
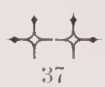
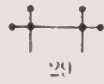
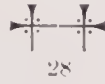
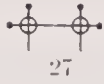
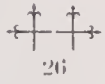
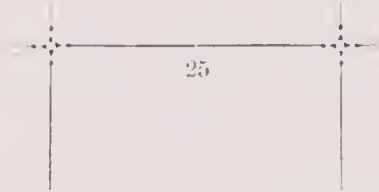
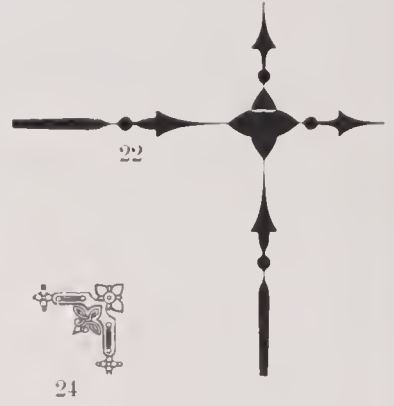
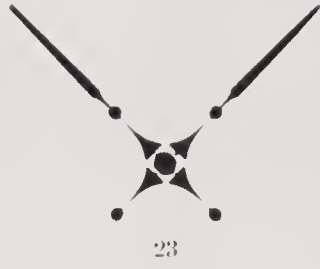
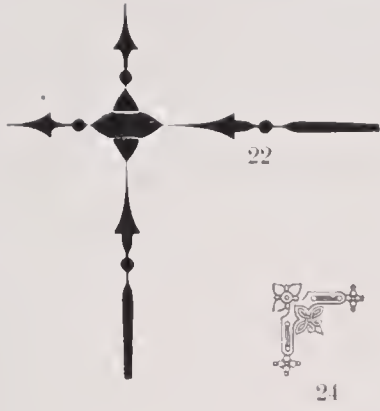

CHECK ENDS, ORNAMENTS, HEAD AND TAIL PIECES.



25



27



29



26

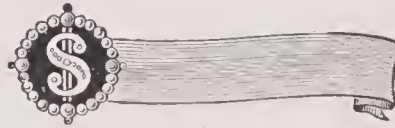

28



30



31



33



35



32



34

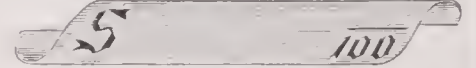

36

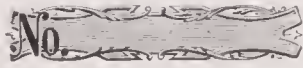

37



38



39



40



41



42



43



44



45



46



47



48



49

HEAD AND TAIL PIECES.



50



51



52



53



54



55



56



57

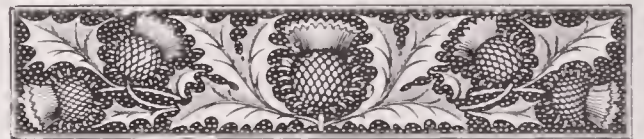

58



59



60



61



62



63



64



65



66



67

U.S. Commission of Fish and Fisheries.

Washington, D.C. _____ 18

1

Official Letters must be addressed to the "Commissioner of the General Land Office," and in applying for Letters from the office the initial Letter on the left hand corner should be referred to.



Washington, D.C. _____ 18

2

Department of the Interior,

Washington _____ 18

3

Department of Justice,

Washington, _____, 18 .

4

U. S. Patent Office,

5

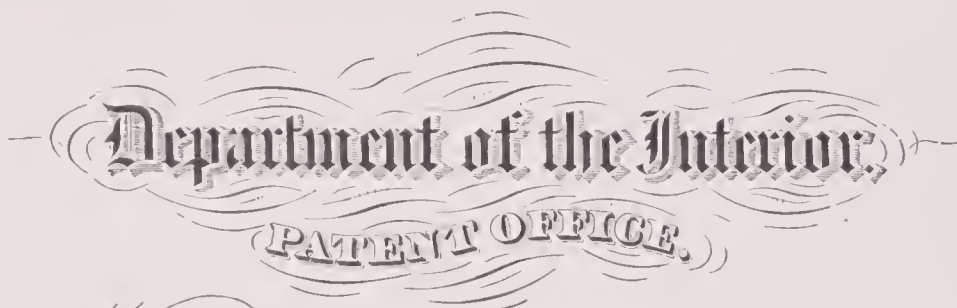

Washington, D.C. _____ 18

Chicago Post Office,

7

United States Patent Office,

8

House of Representatives U.S.

Washington, D.C. _____ 18

9



Washington, D. C. 18

10

Post Office, New York, N. Y.

11

Post Office, Cincinnati, O.

12

Post Office, Philadelphia, Pa.

13

Washington City Post Office.

14

House of Representatives U. S.

15



It is hereby certified, That

MISCELLANEOUS SEALS.



1



2



3



4

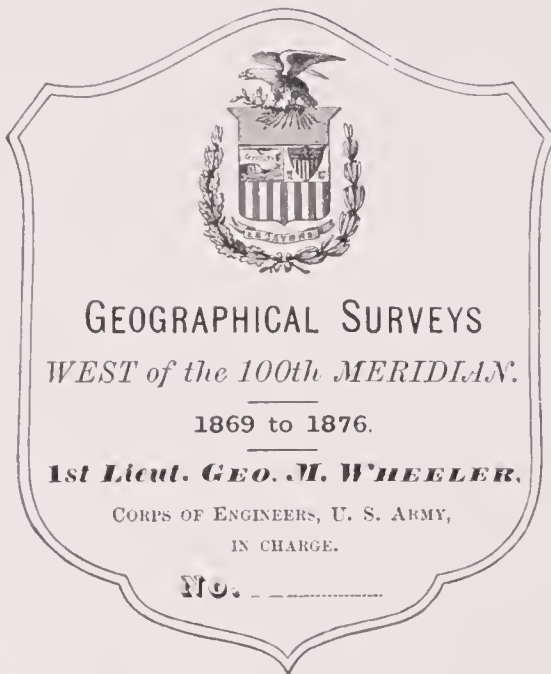

5



6



7



8



9



10



11



12

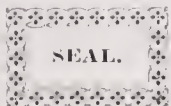

13



14

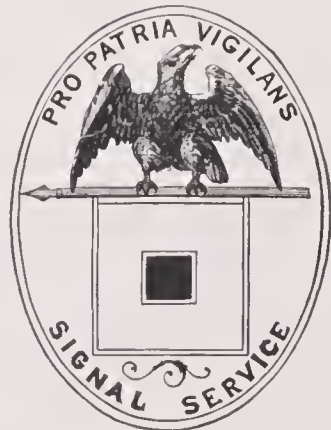

15



16

MISCELLANEOUS SEALS.



17



18



19



20



21



22



23



24



25



26



27

MISCELLANEOUS SEALS.

Corps Device and Laurel Branches

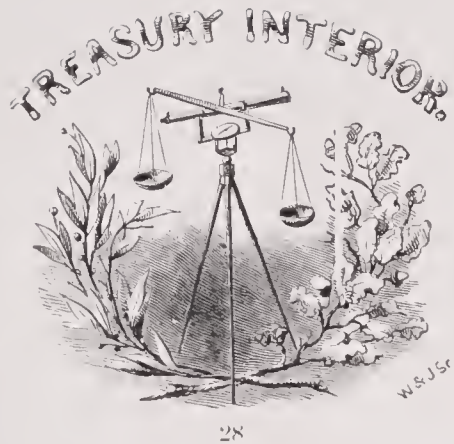

28



29



30



31



32



33



34



35



36



37



38

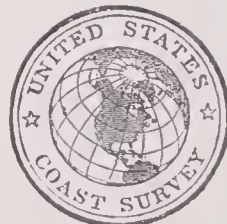

39

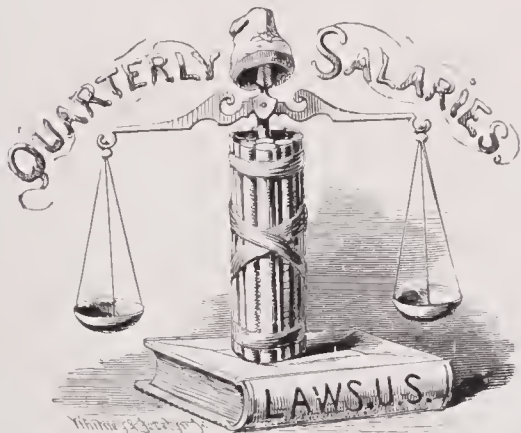

40



41



42



43



41



45

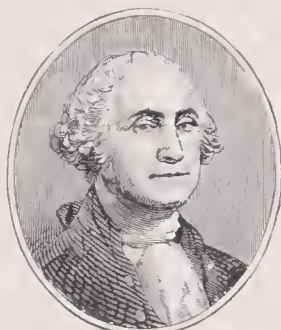

46



PENSIONS

47



48



49



50



51

MISCELLANEOUS SEALS.



52



53



51



55



56



57



58

LANDS

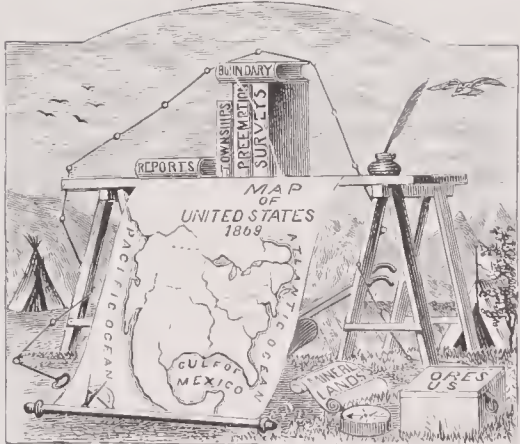

59

REDEMPTION OF PUBLIC DEBT.

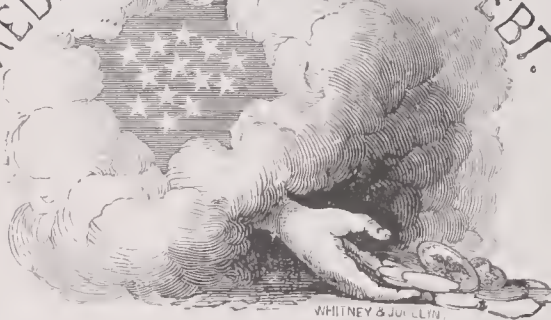

WHITNEY & JOHNSON

60



61

NAVY.

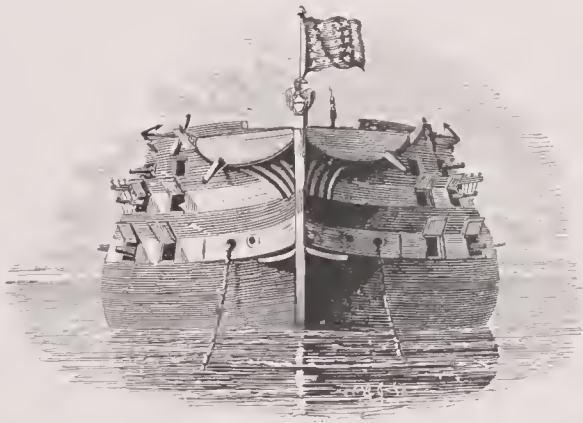

62

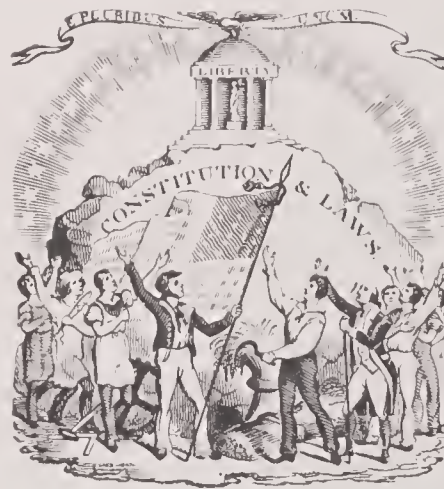

63

MISCELLANEOUS SEALS.



61



65



66

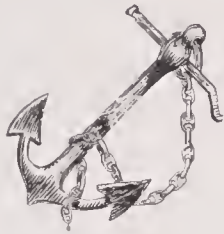

67



68



69

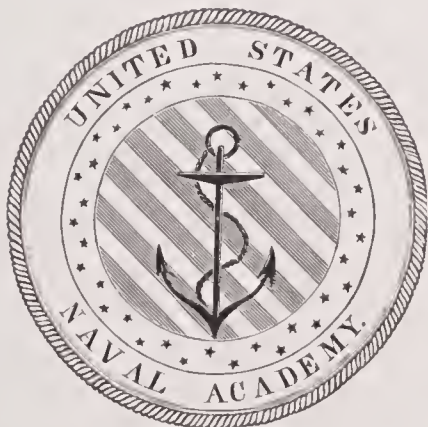

70

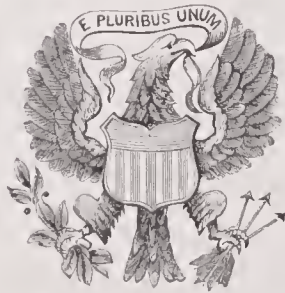

71



72

MISCELLANEOUS VIGNETTES.



1

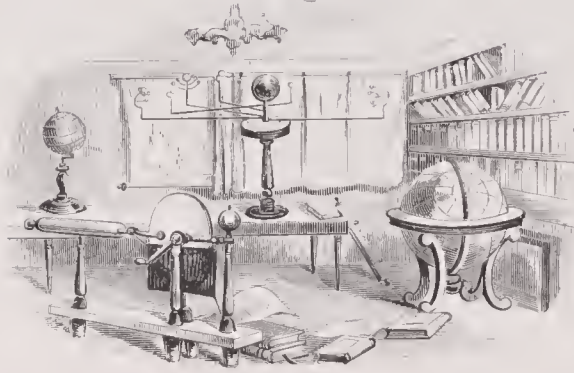

2



3



4

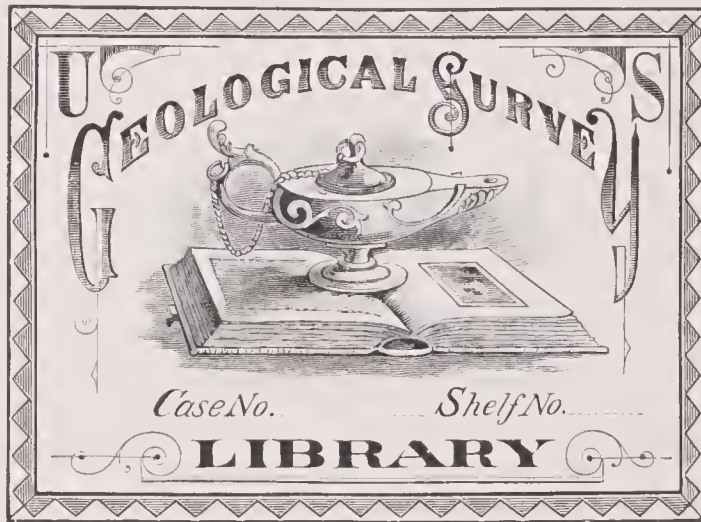

5



6



7



8



9

WAR AND NAVY VIGNETTES.



1



2



3



4



5



6



7



8



9



10



11



12



13



14



15

FLAGS.

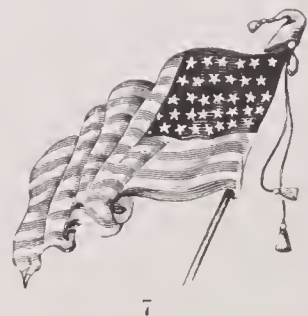
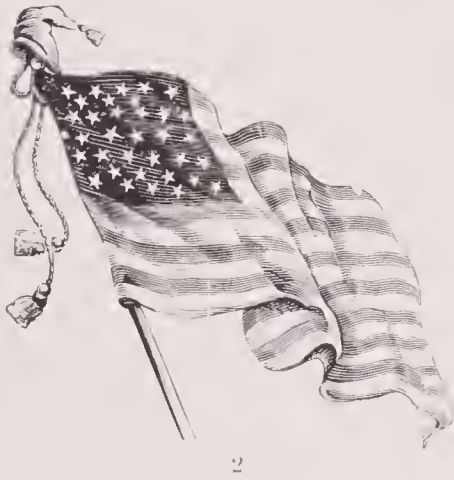
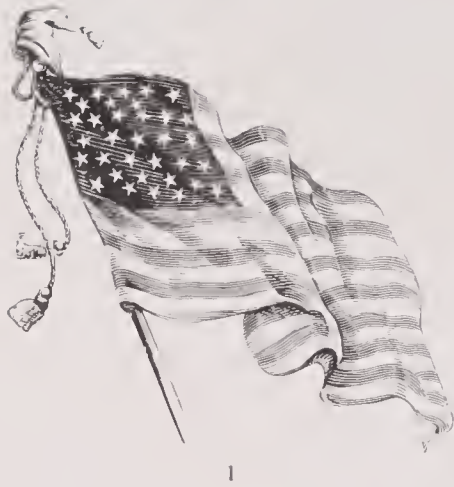

SIGNAL FLAGS.



1



1



1



1



2



2



2



2



3



3



3



3



4



4



4



4



5



5



5



5



6



6



6



6



7



8



8



7



9



10



10



9

EAGLES.



1



2



3

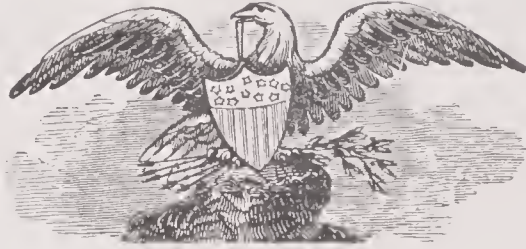

4



5



6



7



8



9



10



11

EAGLES.



12



13
For Colors.



11

EAGLES.



15

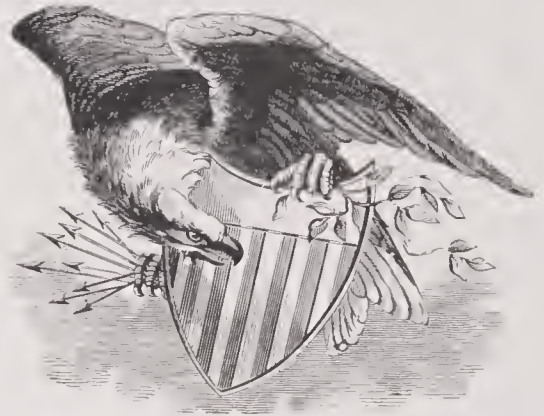

16



17



18

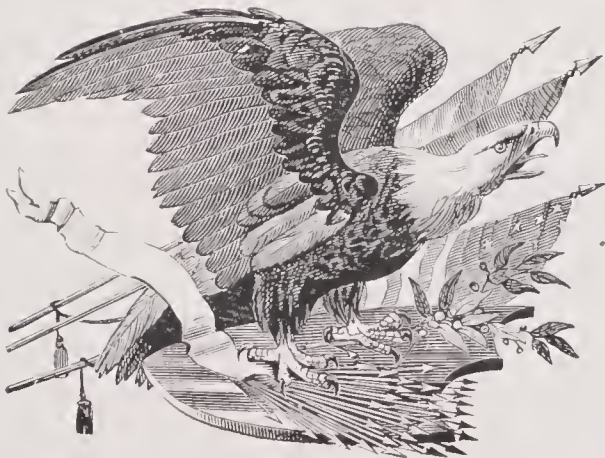

19



20

EAGLES.

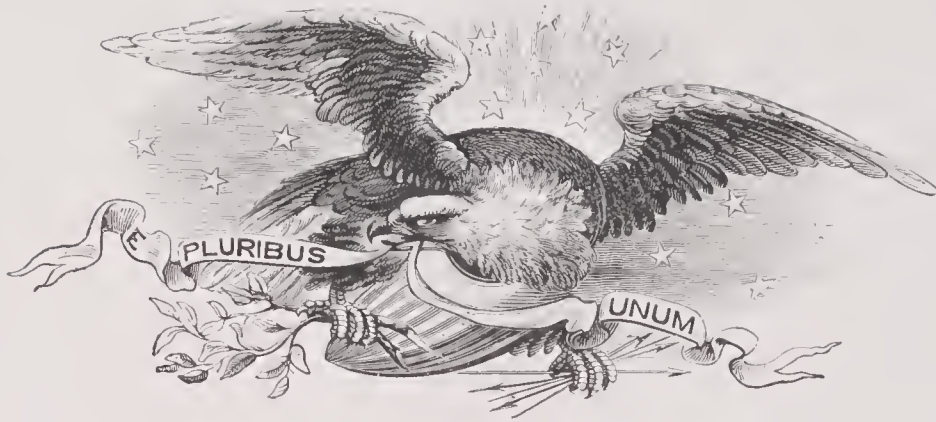

21



22



23

MISCELLANEOUS CUTS.



1



2



3



4

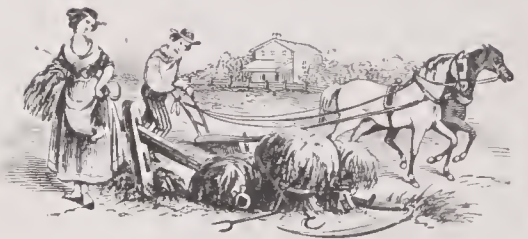

5

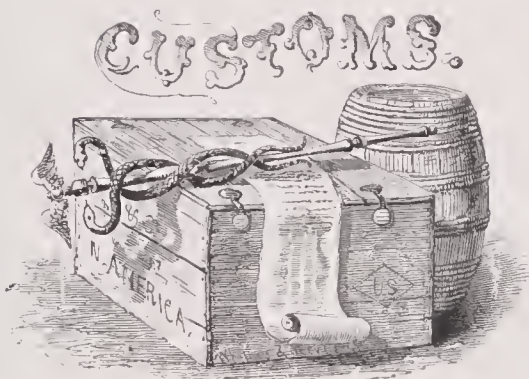

6



7



8



9



10



11

PUBLIC BUILDINGS.



1

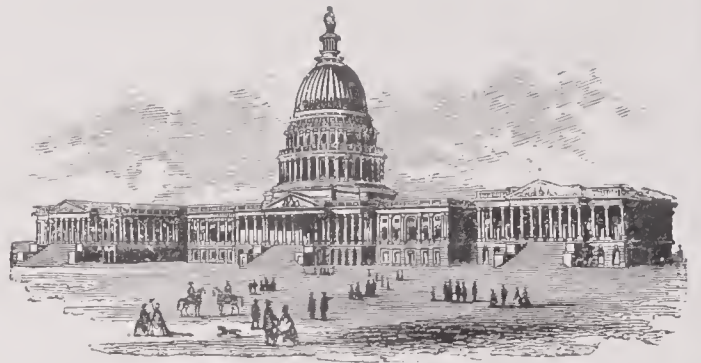

2

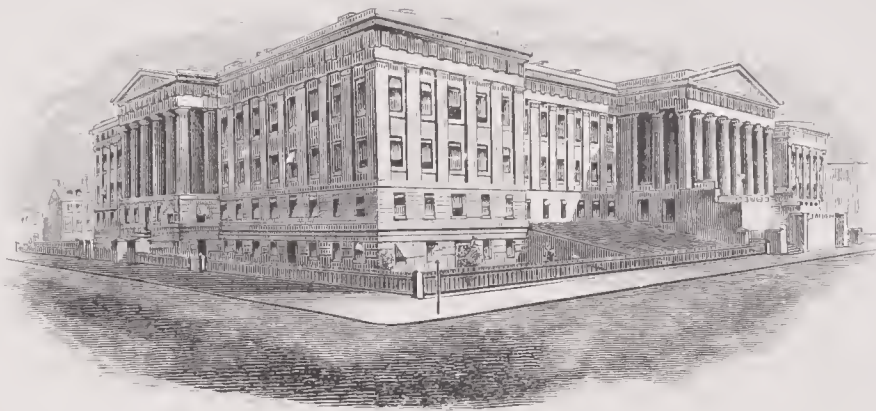

3

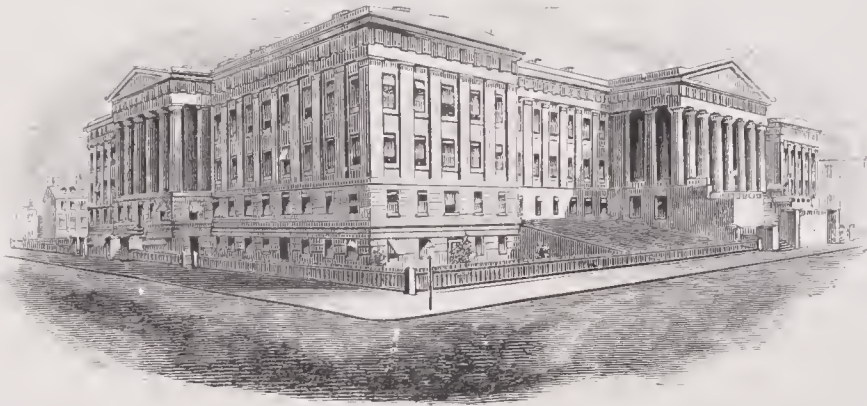

4



5



6

PUBLIC BUILDINGS.

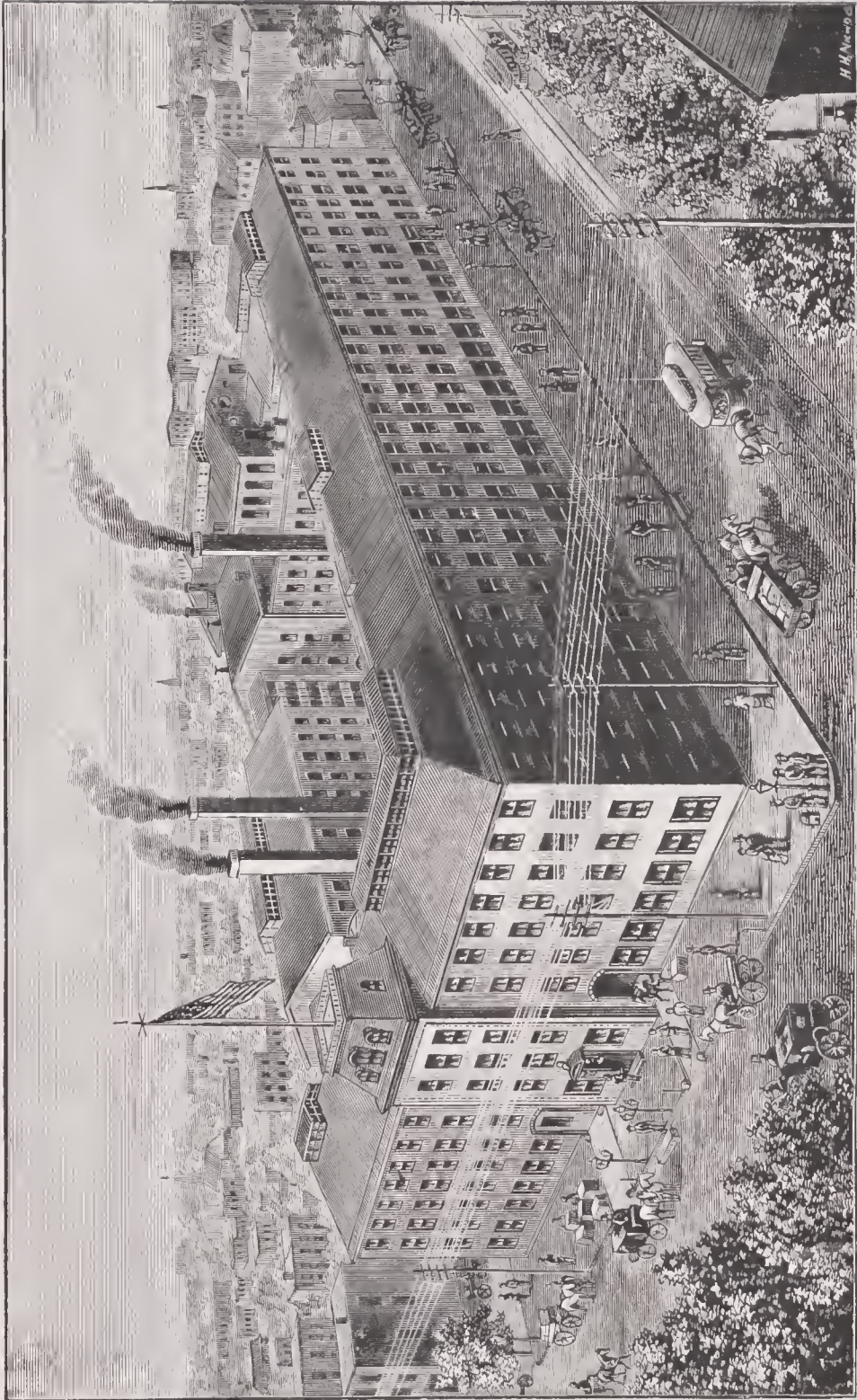

2



x



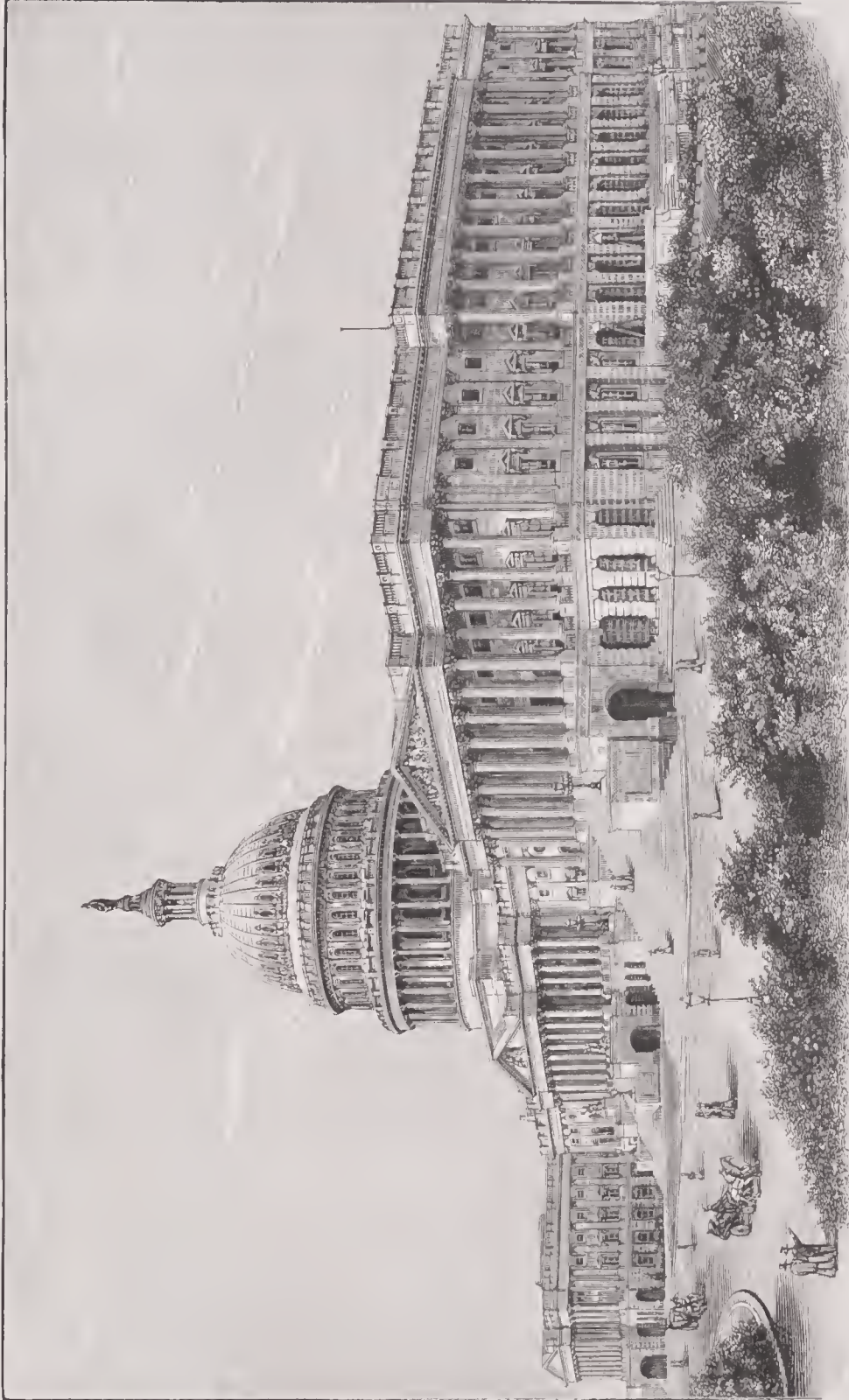

MARINE CUTS.

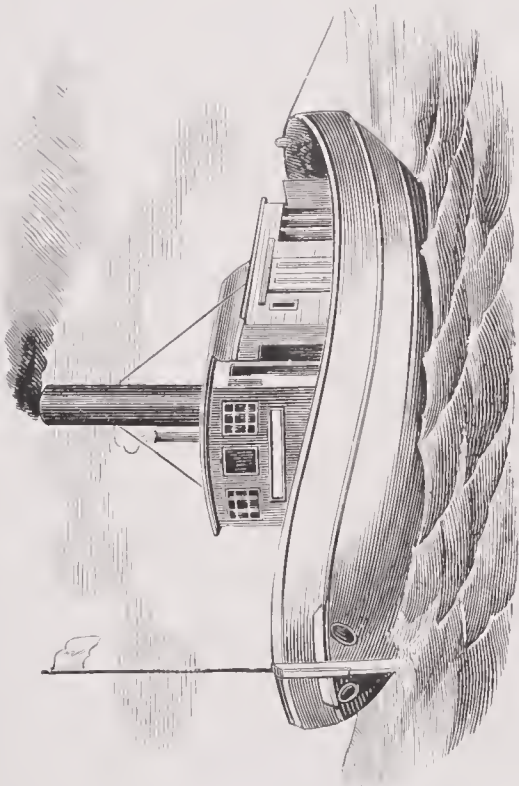

1



2

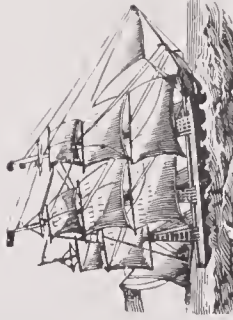

3



4

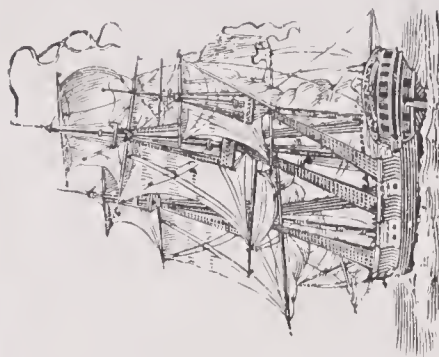

5



6

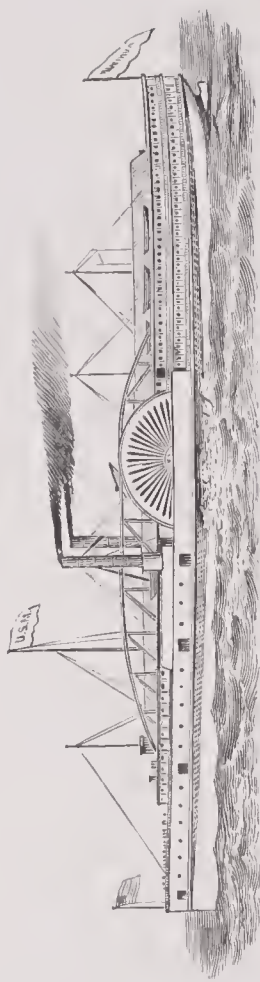

7

MARINE CUTS.

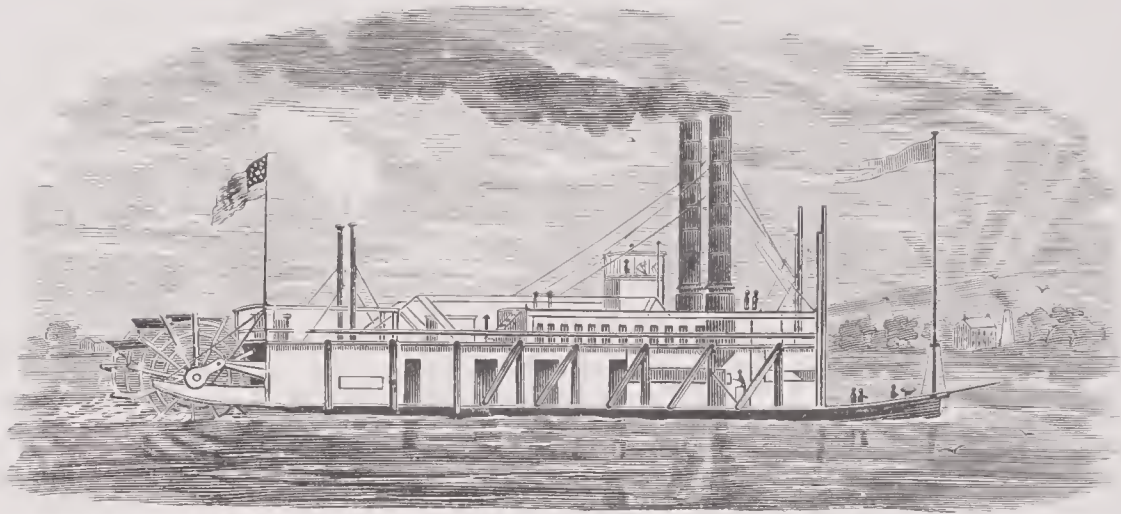

8

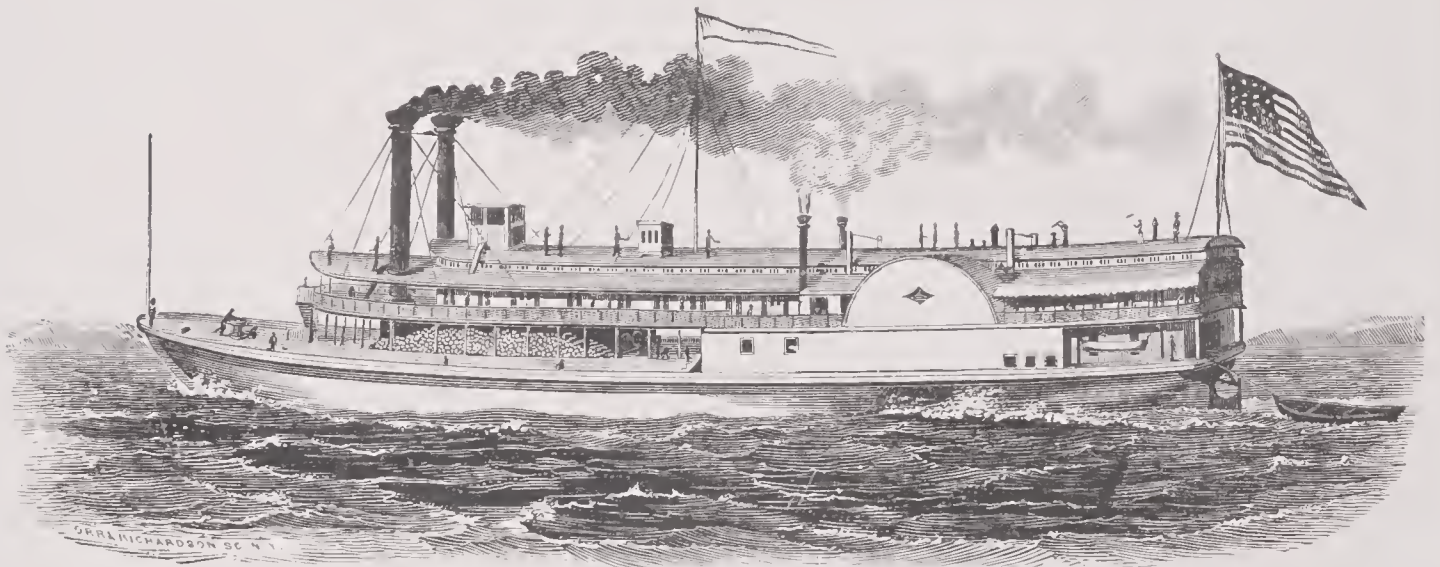

9

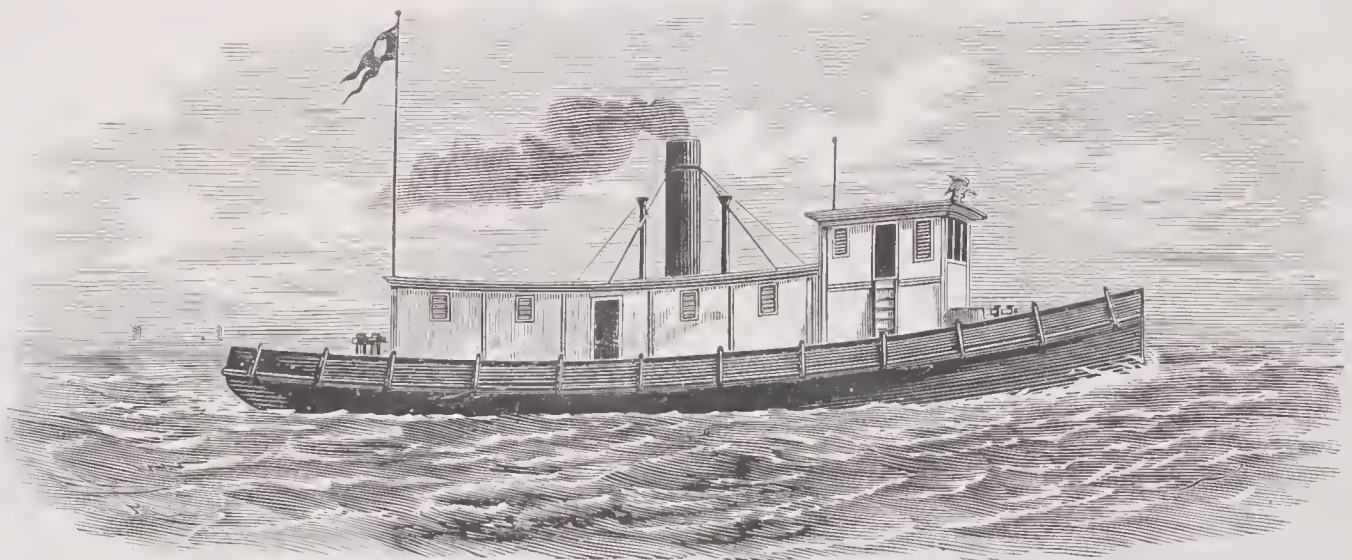

10

MARINE CUTS.

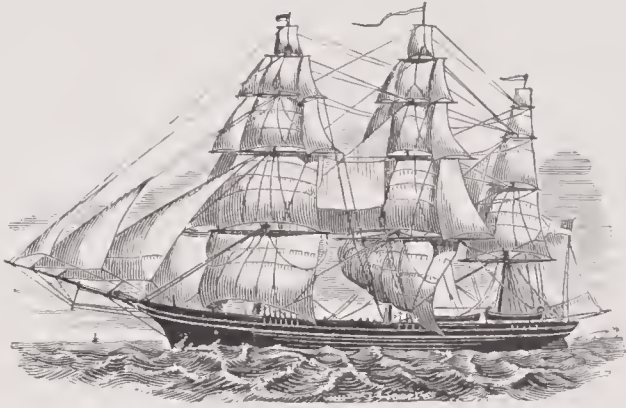

11

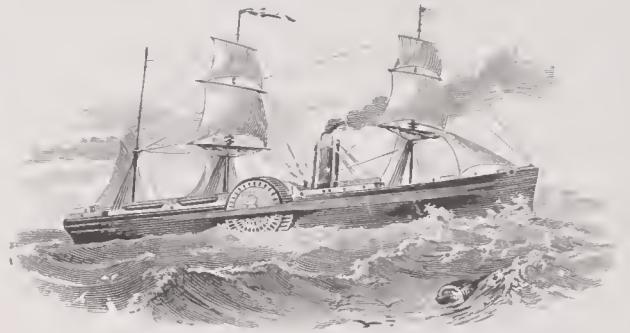

12

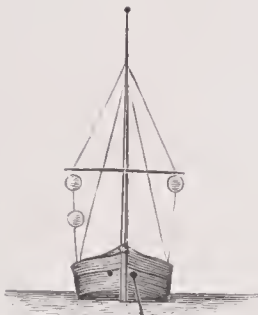

13



14



15



16



17



18

MARINE CUTS.

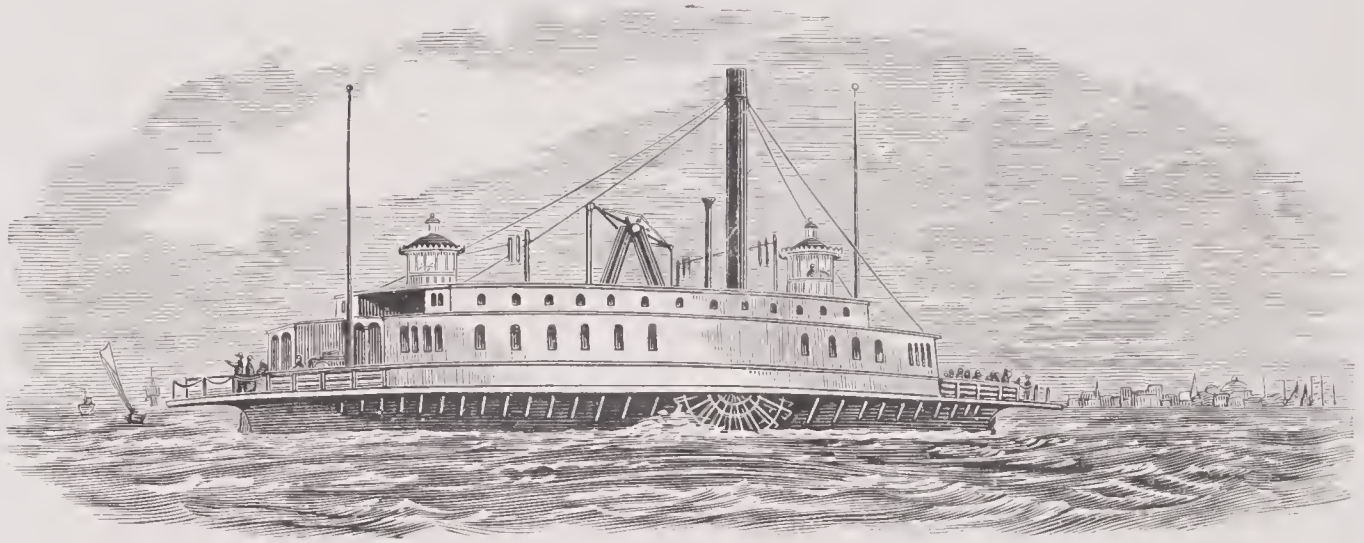

19



20

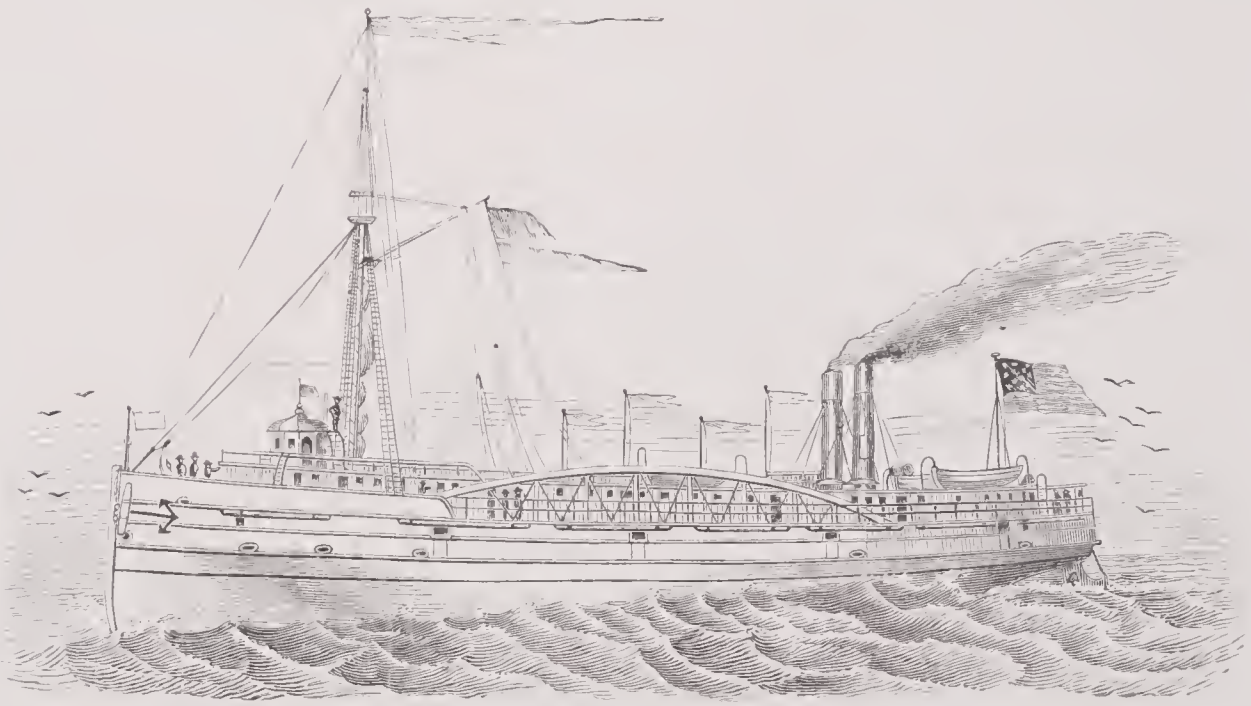

21

MARINE CUTS.

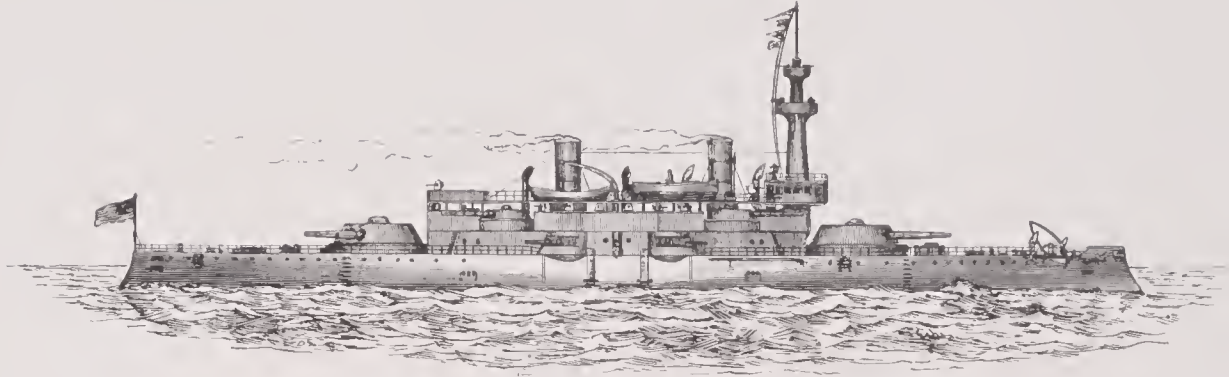

22

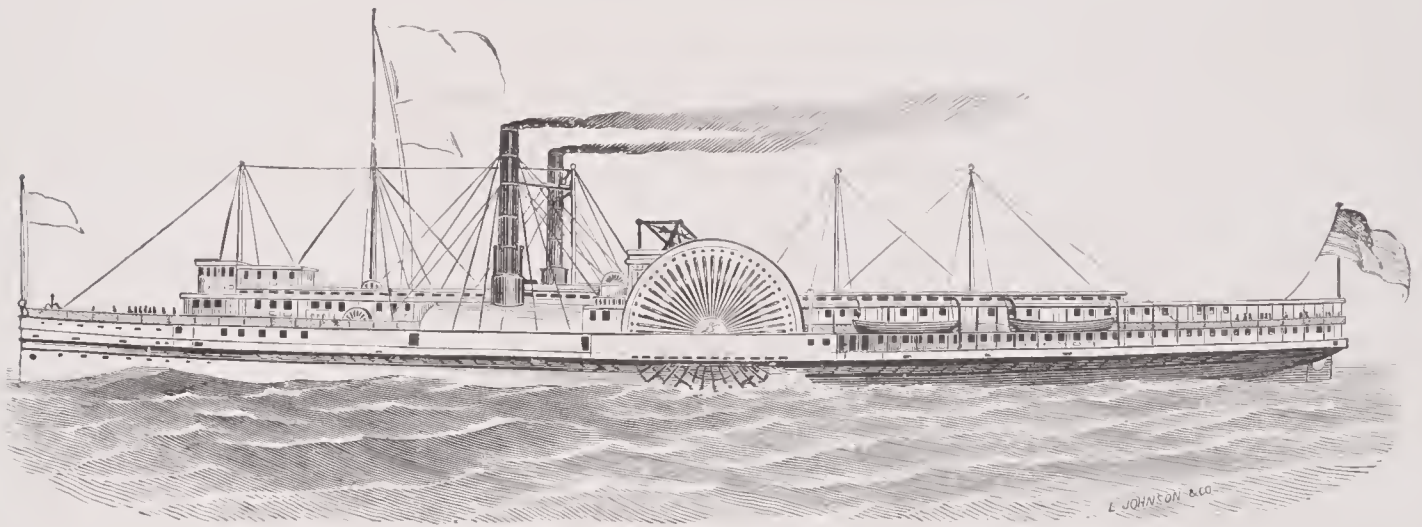

23

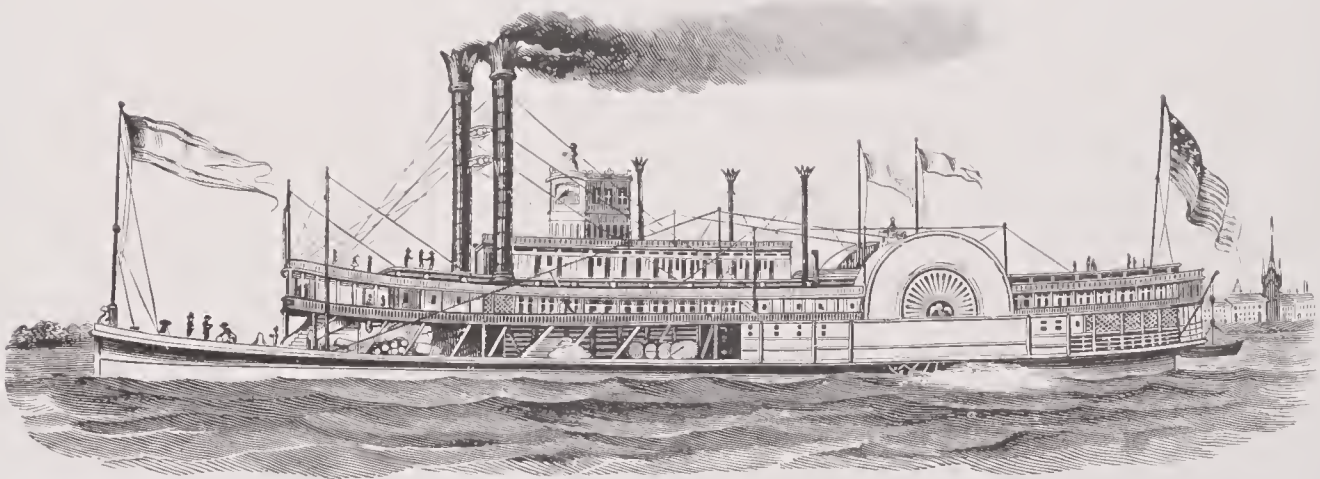

24

LIBRARY OF CONGRESS



0 038 701 830 A