

THE
JOURNAL
OF THE
ROYAL AGRICULTURAL SOCIETY
OF ENGLAND.

[v. 262

SECOND SERIES.

VOLUME THE FIRST.



PRACTICE WITH SCIENCE.

LONDON:
JOHN MURRAY, ALBEMARLE STREET.

1865.

S¹g
R8

THESE EXPERIMENTS, IT IS TRUE, ARE NOT EASY; STILL THEY ARE IN THE POWER OF EVERY THINKING HUSBANDMAN. HE WHO ACCOMPLISHES BUT ONE, OF HOWEVER LIMITED APPLICATION, AND TAKES CARE TO REPORT IT FAITHFULLY, ADVANCES THE SCIENCE, AND, CONSEQUENTLY, THE PRACTICE OF AGRICULTURE, AND ACQUIRES THEREBY A RIGHT TO THE GRATITUDE OF HIS FELLOWS, AND OF THOSE WHO COME AFTER. TO MAKE MANY SUCH IS BEYOND THE POWER OF MOST INDIVIDUALS, AND CANNOT BE EXPECTED. THE FIRST CARE OF ALL SOCIETIES FORMED FOR THE IMPROVEMENT OF OUR SCIENCE SHOULD BE TO PREPARE THE FORMS OF SUCH EXPERIMENTS, AND TO DISTRIBUTE THE EXECUTION OF THESE AMONG THEIR MEMBERS.

VON THAER, *Principles of Agriculture.*

CONTENTS OF VOL. I.—SECOND SERIES.

STATISTICS:—	PAGE ¹
Meteorology, for the six months ending December 31, 1864 ..	I
Public Health ditto ditto	V
Price of Provisions ditto ditto	VII
Weekly Average Price of Wheat	VIII
Vital Statistics for the six months ending June 30, 1866 ..	IX
Meteorology ditto ditto	XII
British Wheat sold, and Imports of Corn, &c. ditto	XV
Price of Provisions ditto	XVI
Pauperism	XVIII

ARTICLE	PAGE
I.—Royal Agricultural College of Cirencester. By C. LAWRENCE	1
II.—On Breaking up Pastures. By C. Belcher. Prize Essay ..	10
III.—On the Planting, Raising, and After-Management of Orchards, and their Various Kinds of Fruits, for Culinary and other uses, considered as Marketable Productions of a Farm adapted to the Counties of Worcester, Hereford, and Gloucester. By Clement Cadle. Worcester Prize Essay ..	18
IV.—Observations on Parasites and Parasitic Diseases as affecting Domesticated Animals. By James Beart Simonds, Professor of Cattle Pathology, Royal Veterinary College	33
V.—Lois-Weedon Wheat-Growing with Horse (or Steam) Tillage. By John Algernon Clarke	73
VI.—Covered Cattle-yards. By W. J. Moscrop	88
VII.—Ten Years of East Lothian Farming. By R. Scot Skirving	99
VIII.—Causes of Unproductiveness in Soils. By Dr. Voelcker ..	113
IX.—On Stocking Land. By the Rev. J. L. Brereton	130
X.—Professor Voelcker's Annual Report	141
XI.—On Cross-Breeding in Horses. By W. C. Spooner	148
XII.—Report on the Royal Veterinary College	166
XIII.—Statistics of Live Stock and Dead Meat for Consumption in the Metropolis. By Robert Herbert	172
XIV.—On the Composition and Nutritive Value of Palm-nut Kernel Meal and Cake. By Dr. Voelcker	176
XV.—On the Cultivation and Proper Management of Flax. By the Rev. Nathaniel M. Brown. Prize Essay	181
XVI.—Flax-Cultivation in the County of Suffolk. By H. Wells ..	194
XVII.—Remarks on the General Aspects of Flax-Culture in England and Ireland. By P. H. Frere	197
XVIII.—A Description of the Newcastle Dynamometer. By C. E. Amos	204
XIX.—The Management of Sheep Stock on Heavy and Light Land. By John Coleman. Prize Essay	239
XX.—The Reproductive Powers of Domesticated Animals. By Henry Tanner, M.R.A.C., Professor of Rural Economy, Queen's College, Birmingham	262
XXI.—Water-Supply. By the Rev. J. Clutterbuck. Prize Essay	271
XXII.—On a New Form of Disease among Lambs. By R. S. Reynolds, M.R.C.V.S.Eng., Alfreton, Derbyshire	288
XXIII.—Functions of Soda-Salts in Agriculture. By Dr. Voelcker ..	298
XXIV.—Rise and Progress of Shorthorns. By H. H. Dixon. Prize Essay	317
XXV.—On Sheep. By H. Evershed	329
XXVI.—The Comparative Profit from Making Cheese or Butter, Selling Milk, or Grazing. By W. H. Heywood. Prize Essay ..	338

CONTENTS.

ARTICLE.	PAGE
XXVII.—On Dairy-Farming. By W. T. Carrington	344
XXVIII.—Statistics of Live Stock and Dead Meat, &c. By R. Herbert	354
XXIX.—Growth of Lucerne on Thin Light Soils and Chalky Loams ..	359
XXX.—Report on the Exhibition of Live Stock at the Plymouth Meeting. By John Dent Dent, M.P., Senior Steward ..	360
XXXI.—General Report on the Exhibition of Implements at the Plymouth Meeting. By John Coleman and F. A. Paget, C.E., Cor. Mem. of the Franklin Institute, &c.	373

MISCELLANEOUS COMMUNICATIONS AND NOTICES:

1. Experiments with Peruvian Guano mixed with a small quantity of Sulphuric Acid. By J. B. Lawes, F.R.S., F.C.S.	21
2. Experiments on the Artificial Fecundation of Wheat. By J. B. Lawes, F.R.S., F.C.S.	2
3. Kohl Rabi. By Charles Lawrence	2
4. Comparative Experiment on the Use of Wheat-meal and of Linseed-cake for Fatting Sheep. By P. H. Frere	2
5. Letter on Covered Yards. By H. S. Thompson, M.P.	2

ABSTRACT REPORT OF AGRICULTURAL DISCUSSIONS:

On Town Sewage. By J. B. Lawes	220
The Breeding and Management of Sheep. By T. Ellman	406
Natural Deposits of Potash in Germany. By Dr. Voelcker	412
Flax Culture. By Beale Browne	421
Agricultural Education. By J. Chalmers Morton	436
Irrigation. By Professor Voelcker	464
Typhoid Fever in Pigs. By Dr. W. Budd	472

APPENDIX.

	PAGE
List of Officers of the Royal Agricultural Society of England, 1865-66	i, xxix
Standing Committees for 1865-66	iii, xxxi
Report of the Council to the General Meeting, December 8, 1864 ..	vi
Cash Account and Balance-sheets, from 1st July to December, 31, 1864	x—xii
Country Meeting Account, Newcastle-on-Tyne, 1864	xiii
Schedule of Prizes: Devonport and Plymouth Meeting, 1865 ..	xiv—xxv
Essays and Reports—Award for 1864-65	xxvi, lxiii
Members' Chemical Analysis and Veterinary Privileges	xxvii, lxxvii
Report of the Council to the General Meeting, May 22, 1865	xxxiii
Cash Account and Balance-sheets, from 1st Jan. to June 30, 1865	xxxvi, xxxvii
Memoranda of Meetings, Payment of Subscription, &c.	xxxviii
List of Stewards, Judges, &c., at the Plymouth Meeting	xxxix
Award of Prizes: Devonport and Plymouth Meeting, 1865	lx—lxxii
Prizes for Essays and Reports for 1866	lxxiv

GENERAL INDEX, Vols. I.—XXV.

DIRECTIONS TO THE BINDER.

The Binder is desired to collect together all the Appendix matter, with Roman numeral folios, and place it at the end of each volume of the Journal, excepting Titles and Contents, and Statistics &c., which are in all cases to be placed at the beginning of the Volume: the lettering at the back to include a statement of the year as well as the volume; the first volume belonging to 1839-40, the second to 1841, the third to 1842, the fourth to 1843, and so on.

In Reprints of the Journal all Appendix matter and, in one instance, an Article in the body of the Journal (which at the time had become obsolete), were omitted; the Roman numeral folios, however (for convenience of reference), were reprinted without alteration in the Appendix matter retained.

CONTENTS OF PART I., VOL. I.

SECOND SERIES.

STATISTICS :—	PAGE
Meteorology, for the six months ending December 31, 1864 ..	II
Public Health ditto ditto	VI
Price of Provisions ditto ditto	VII
Weekly Average Price of Wheat	VIII

ARTICLE	PAGE
I.—The Royal Agricultural College of Cirencester. By C. LAWRENCE	1
II.—On Breaking up Pastures. By C. Belcher. Prize Essay ..	10
III.—On the Planting, Raising, and After-Management of Orchards, and their Various Kinds of Fruits, for Culinary and other uses, considered as Marketable Productions of a Farm adapted to the Counties of Worcester, Hereford, and Gloucester. By Clement Cadle. Worcester Prize Essay	18
IV.—Observations on Parasites and Parasitic Diseases as affecting Domesticated Animals. By James Beart Simonds, Professor of Cattle Pathology, Royal Veterinary College	33
V.—Lois-Weedon Wheat-Growing with Horse (or Steam) Tillage. By John Algernon Clarke	73
VI.—Covered Cattle-yards. By W. J. Moscrop	88
VII.—Ten Years of East Lothian Farming. By R. Scot Skirving ..	99
VIII.—On some Causes of Unproductiveness in Soils. By Dr. Augustus Voelcker	113
IX.—On Stocking Land. By the Rev. J. L. Brereton	130
X.—Professor Voelcker's Annual Report	141
XI.—On Cross-Breeding in Horses. By W. C. Spooner	148
XII.—Report on the Royal Veterinary College	166
XIII.—Statistics of Live Stock and Dead Meat for Consumption in the Metropolis. By Robert Herbert	172
XIV.—On the Composition and Nutritive Value of Palm-nut Kernel Meal and Cake. By Dr. Augustus Voelcker	176
XV.—On the Cultivation and Proper Management of Flax. By the Rev. Nathaniel M. Brown. Prize Essay	181
XVI.—Flax-Cultivation in the County of Suffolk. By H. Wells ..	194
XVII.—Remarks on the General Aspects of Flax-Culture in England and Ireland. By P. H. Frere	197
XVIII.—A Description of the Newcastle Dynamometer. By C. E. Amos	204

CONTENTS.

	PAGE
MISCELLANEOUS COMMUNICATIONS AND NOTICES :	
1. Experiments with Peruvian Guano mixed with a small quantity of Sulphuric Acid. By J. B. Lawes, F.R.S., F.C.S.	213
2. Experiments on the Artificial Fecundation of Wheat. By J. B. Lawes, F.R.S., F.C.S.	215
3. Kohl Rabi. By Charles Lawrence	219
4. Comparative Experiment on the Use of Wheat-meal and of Linseed-cake for Fattening Sheep. By P. H. Frere	220
5. Letter on Covered Yards. By H. S. Thompson, M.P.	222
ABSTRACT REPORT OF AGRICULTURAL DISCUSSIONS :	
Lecture and Discussion on Town Sewage. By J. B. Lawes	226

APPENDIX.

	PAGE
List of Officers of the Royal Agricultural Society of England, 1865 ..	i
Standing Committees for 1865	iii
Memoranda of Meetings, Payment of Subscription, &c.	v
Report of the Council to the General Meeting, December 8, 1864	vi
Cash Account and Balance-sheets, from 1st July to December 31, 1864	x—xii
Country Meeting Account, Newcastle on Tyne, 1864	xiii
Schedule of Prizes : Devonport and Plymouth Meeting, 1865 ..	xiv—xxv
Essays and Reports—Award	xxvi
Members' Chemical Analysis and Veterinary Privileges	xxvii, xxviii

DIRECTIONS TO THE BINDER.

The Binder is desired to collect together all the Appendix matter, with Roman numeral folios, and place it at the *end* of each volume of the Journal, excepting Titles and Contents, and Statistics &c., which are in all cases to be placed at the *beginning* of the Volume: the lettering at the back to include a statement of the year as well as the *volume*; the first volume belonging to 1839–40, the second to 1841, the third to 1842, the fourth to 1843, and so on.

In Reprints of the Journal all Appendix matter and, in one instance, an Article in the body of the Journal (which at the time had become obsolete), were omitted; the Roman numeral folios, however (for convenience of reference), were reprinted without alteration in the Appendix matter retained.

STATISTICS
OF
THE WEATHER, PUBLIC HEALTH, PRICE OF
PROVISIONS, &c., &c.,
FOR THE SIX MONTHS ENDING DECEMBER 31, 1864.

*Chiefly extracted from the Quarterly Reports of the Registrar-General.—
The Corn Returns and Diagram are prepared from Official Documents
expressly for this Journal.*

ON
THE METEOROLOGY OF ENGLAND

DURING

THE QUARTER ENDING SEPTEMBER 30, 1864.

BY JAMES GLAISHER, Esq., F.R.S.,

SEC. OF THE BRITISH METEOROLOGICAL SOCIETY.

FOR a period of 39 days preceding the close of the last quarter there was an average daily deficiency of $2\frac{1}{2}^{\circ}$ of temperature, and the present quarter opened with a continuation of the same weather, with somewhat increased intensity; the deficiency of temperature to the middle of July being as large as 3° daily on the average. On the 17th July a warm period set in and continued for 25 days, and the daily temperature was in excess to $3\frac{1}{2}^{\circ}$; this was succeeded by 20 days of very cold weather, viz., from 9th August to 28th August, whose average daily temperature was 4° in defect; and it is remarkable that this deficiency of temperature fell on the nights only, the days were of their average warmth but the nights were very cold, causing the extremes of temperature to range from great heat by day to almost frost at night, and quite to frost on vegetation. A period of 12 days followed of warmth, the average daily temperature being $2\frac{1}{2}^{\circ}$ in excess; then the 10 days from September 10th to 20th, the temperature of the air was daily 2° below the average value, and the last 10 days of the quarter were in excess to $1\frac{1}{2}^{\circ}$ daily.

The mean high day temperatures in the months of July, August, and September were $75^{\circ}\cdot3$, $72^{\circ}\cdot8$, and $67^{\circ}\cdot3$, being $1^{\circ}\cdot7$ above in July, and of the same values as the average in August and September.

The mean low night temperatures in the months of July, August, and September were $51^{\circ}\cdot2$, $48^{\circ}\cdot5$, and $49^{\circ}\cdot1$, being $1^{\circ}\cdot7$ below in July, $4^{\circ}\cdot8$ below in August, and $0^{\circ}\cdot3$ above in September.

The mean temperatures of the dew-point were $2^{\circ}\cdot1$, $6^{\circ}\cdot3$, and $1^{\circ}\cdot2$ below their respective average. That in August was $47^{\circ}\cdot8$. The lowest before recorded was $51^{\circ}\cdot8$ on two or three occasions.

The fall of rain was in defect in July and August, and slightly in excess in September. It was $0\cdot3$ in. in July, being $2\cdot4$ in. in defect; $1\cdot4$ in. in August, being $1\cdot0$ in. deficient; and $2\cdot8$ in. in September, being $0\cdot4$ in. in excess.

The mean temperature of the air at Greenwich in the three months ending August, constituting the three summer months, was $59^{\circ}\cdot6$, being $0^{\circ}\cdot5$ below the average of the preceding 93 years.

THE WEATHER DURING THE QUARTER ENDING SEPTEMBER 30, 1864.

1864. MONTHS.	Temperature of										Elastic Force of Vapour.		Weight of Vapour in a Cubic Foot of Air.			
	Air.		Evaporation.		Dew Point.		Air—Daily Range.		Mean.		Diff. from average of 23 years.		Mean.		Diff. from average of 23 years.	
	Mean.	Diff. from average of 23 years.	Mean.	Diff. from average of 23 years.	Mean.	Diff. from average of 23 years.	Mean.	Diff. from average of 23 years.	Mean.	Diff. from average of 23 years.	Mean.	Diff. from average of 23 years.	Mean.	Diff. from average of 23 years.	Mean.	Diff. from average of 23 years.
July	61.8	+0.4	56.3	-1.0	51.6	-2.1	24.1	0	+3.4	0	+3.4	4.2	gr.	4.2	gr.	0.4
August	59.6	-1.1	53.3	-4.2	47.8	-6.3	24.3	0	+4.8	0	+4.8	3.7	gr.	3.7	gr.	-1.0
September	56.9	+0.5	53.2	-0.6	49.7	-1.2	18.2	0	-0.3	0	-0.3	4.0	gr.	4.0	gr.	-0.2
Mean ..	59.4	-0.1	54.3	-1.9	49.7	-3.3	22.2	0	+2.6	0	+2.6	4.9	gr.	4.9	gr.	-0.5
1864. MONTHS.	Reading of Thermometer on Grass.										Weight of Vapour in a Cubic Foot of Air.					
	Degree of Humidity.		Reading of Barometer.		Weight of a Cubic Foot of Air.		Rain.		Temperature of Water of the Thames.		Number of Nights it was		Lowest Reading at Night.		Highest Reading at Night.	
	Mean.	Diff. from average of 23 years.	Mean.	Diff. from average of 23 years.	Mean.	Diff. from average of 23 years.	Amount.	Diff. from average of 23 years.	Mean.	Diff. from average of 23 years.	At or below 30°.	Between 30° and 40°.	At or below 30°.	Above 40°.	Lowest.	Highest.
July	70	- 6	29.856	+0.055	grs.	+1	0.3	in.	64.1	0	8	23	0	35.8	0	57.7
August	65	- 12	29.918	+0.129	grs.	+5	1.4	in.	63.8	4	12	15	4	27.2	15	54.2
September	77	- 4	29.777	-0.042	grs.	-1	2.8	in.	60.6	1	10	19	1	29.0	19	62.0
Mean ..	71	- 7	29.850	+0.047	grs.	+2	4.5	Sum	62.8	5	30	57	Sum	Lowest	Sum	Highest
														27.2		62.0

NOTE.—In reading this table it will be borne in mind that the sign (-) minus signifies below the average, and that the sign (+) plus signifies above the average.

ON
THE METEOROLOGY OF ENGLAND

DURING

THE QUARTER ENDING DECEMBER 31, 1864.

BY JAMES GLAISHER, Esq., F.R.S.,

SEC. OF THE BRITISH METEOROLOGICAL SOCIETY.

THE weather at the beginning of the quarter was cold, and the average deficiency of daily temperature amounted to 2° . From the 12th October to the 29th the period was warm; an excess of temperature of $2\frac{1}{2}^{\circ}$ on the average of those days took place. A bitter cold period succeeded, continuing till the 12th November, during which a daily deficiency was experienced of no less than $5\frac{1}{2}^{\circ}$. From the 13th November to the 13th December the weather was generally warm, but there were cold periods of two and three days together; but upon the whole there was an excess of temperature averaging $2\frac{1}{2}^{\circ}$ daily. From the 14th December to the end of the quarter the weather was changeable. On the 17th the deficiency of temperature was as large as $15\frac{1}{2}^{\circ}$, and on the 20th there was an excess of 3° , followed again by a considerable deficiency, which generally prevailed; and the average defect of temperature from the 14th to the end of the month was nearly 4° daily.

The mean high day temperatures in the months of October, November, and December were $58^{\circ}\cdot 2$, $48^{\circ}\cdot 5$, and $42^{\circ}\cdot 5$, being $0^{\circ}\cdot 5$, $0^{\circ}\cdot 6$, and $2^{\circ}\cdot 8$ respectively below their averages.

The mean low night temperatures in the months of October, November, and December were $44^{\circ}\cdot 1$, $35^{\circ}\cdot 5$, and $33^{\circ}\cdot 7$, being of the same value as the average in October, and below their averages to the amount of 2° in the remaining two months.

The mean temperatures of the dew-point were $2^{\circ}\cdot 7$, $2^{\circ}\cdot 1$, and $2^{\circ}\cdot 7$ below their respective averages.

The fall of rain was in defect to the amount of 1·7 in. in October, slightly above the average in November, and showed a deficiency of 1·3 in. in December. The amounts fallen were respectively 1·1 in., 2·6 in., and 0·6 in.

The mean temperature of the air at Greenwich in the three months ending November, constituting the three autumn months, was $49^{\circ}\cdot 8$, being $0^{\circ}\cdot 3$ above the average of the preceding 93 years.

THE WEATHER DURING THE QUARTER ENDING DECEMBER 31, 1864.

1864. MONTHS.		Temperature of										Elastic Force of Vapour.		Weight of Vapour in a Cubic Foot of Air.		
		Air.		Evaporation.		Dew Point.		Air—Daily Range.		Mean.						Diffr. from average of 23 years.
Mean.	Diffr. from average of 93 years.	Mean.	Diffr. from average of 23 years.	Mean.	Diffr. from average of 23 years.	Mean.	Diffr. from average of 23 years.	Mean.	Diffr. from average of 23 years.	Mean.	Diffr. from average of 23 years.	Mean.	Diffr. from average of 23 years.	Mean.	Diffr. from average of 23 years.	
0	0	0	0	0	0	0	0	0	0	0	0	0	0	3.3	0.4	
50.5	+0.8	47.2	-1.4	43.7	-2.7	14.1	-0.5	13.0	+1.4	8.8	-0.8	2.85	-0.32	2.6	0.2	
42.0	-0.4	40.2	-1.5	37.9	-2.1	13.0	+1.4	8.8	-0.8	8.8	-0.8	2.28	-0.25	2.3	-0.3	
38.5	-0.5	36.7	-2.2	34.4	-2.7	8.8	-0.8	34.4	-2.7	8.8	-0.8	1.99	-0.24	2.7	-0.3	
43.7	0.0	41.4	-1.7	38.7	-2.5	12.0	0.0	38.7	-2.5	12.0	0.0	2.37	-0.27	2.7	-0.3	
1864. MONTHS.		Degree of Humidity.		Reading of Barometer.		Weight of a Cubic Foot of Air.		Rain.		Tempera- ture of Water of the Thames.		Reading of Thermometer on Grass.				
Mean.	Diffr. from average of 23 years.	Mean.	Diffr. from average of 23 years.	Mean.	Diffr. from average of 23 years.	Mean.	Diffr. from average of 23 years.	Mean.	Diffr. from average of 47 years.	Mean.	Diffr. from average of 23 years.	At or below 30°.	Between 30° and 40°.	Above 40°.	Lowest Reading at Night.	Highest Reading at Night.
78	-9	29.674	-0.012	5.29	0	1.1	-1.7	52.9	0	4	16	0	11	11	27.7	51.3
86	-3	29.626	-0.128	5.47	-1	2.6	+0.2	44.6	0	13	16	1	1	1	18.0	41.6
86	-2	29.863	+0.042	5.56	+4	0.6	-1.3	—	—	14	15	2	2	2	14.8	43.0
83	-5	29.724	-0.033	5.47	+1	4.3	-2.8	—	—	Sum	Sum	Sum	Sum	Sum	Lowest	Highest
										32	46	14	14	14	14.8	51.3

NOTE.—In reading this table it will be borne in mind that the sign (-) minus signifies below the average, and that the sign (+) plus signifies above the average.

STATE OF THE PUBLIC HEALTH.

1st Quarter.—The total number of deaths in the quarter was 112,133 against 112,384 in the previous summer quarter, but considerably more than in the same quarter of 1862. The annual rate of mortality in the quarter was 2·139 per cent. of the population, against the summer average of 2·000 per cent. In the country districts the mortality was 1·831 (the average being 1·713); whilst in urban populations it was 2·374 (the average being 2·253).

2nd Quarter.—The number of deaths in the three months ending 31st December was 123,458, the highest number ever registered in this quarter. The death-rate was 2·349 per cent. (against an average of 2·180). No higher death-rate has been observed in England in this quarter, excepting in 1847, 1848, and 1858. 495,520 deaths were registered in the year, the mortality being at the rate of 2·385 per cent. against 2·214, the average of the previous ten years.

PRICE OF PROVISIONS.

1st Quarter.—The average price of wheat was 42s. 3d. per quarter, which is less than in the September quarter of last year; while in the corresponding quarter of 1862 the price was 56s. 10d. The average of the highest and lowest prices of beef at Leadenhall and Newgate Markets was 5½d. per lb., and of mutton 6½d. Best potatoes ranged from 80s. to 120s. per ton at the Waterside Market, Southwark.

2nd Quarter.—Wheat sold at decreasing prices, the average for the three months being 38s. 5d. per quarter against 40s. 6d. in the corresponding period of 1863, and 48s. 2d. in 1862. The high price of meat is a matter of daily experience with all consumers; in the last quarter of 1863 beef sold on an average at 4d. to 6½d. per lb. (by the carcass) at Leadenhall and Newgate Markets, but in the quarter ending 31st December last the price ranged from 4½d. to 7d., according to quality. The wholesale price of mutton was 5d. to 7d. in the last quarter of 1863, and it was 5½d. to 7½d. in the same period of 1864. The dry summer was prejudicial to the crop of potatoes, and the price was 25 per cent. higher than in the autumn of 1863; the wholesale price of the best qualities was 60s. to 80s. in the last quarter of 1863, and rose to an average of 80s. to 95s. in the same quarter of 1864.

THE PRICE OF PROVISIONS.

The AVERAGE PRICES of Consols, of Wheat, Meat, and Potatoes; also the AVERAGE QUANTITY of Wheat sold and imported weekly, in each of the Nine Quarters ending December 31, 1864.

Quarters ending	Average Price of Consols (for Money).	Average Price of Wheat per Quarter in England and Wales.		Wheat sold in the 290 Cities and Towns in England and Wales making Returns.*	Wheat and Wheat Flour entered for Home Consumption at Chief Ports of Great Britain.*	Average Prices of		
						Meat per lb. at Leadenhall and Newgate Markets (by the Carcase).		Best Potatoes per Ton at Waterside Market, Southwark.
						Beef.	Mutton.	
1862 Dec. 31	£. 93½	s. 48	d. 2	85,522	258,095	4d.—6½d. Mean 5½d.	5½d.—6¾d. Mean 6d.	90s.—110s. Mean 100s.
1863 Mar. 31	92½	46	7	75,819	139,429	4d.—6½d. Mean 5½d.	5d.—7d. Mean 6d.	120s.—130s. Mean 125s.
June 30	93½	46	2	82,458	106,633	4½d.—6½d. Mean 5½d.	4¾d.—6¾d. Mean 5¾d.	110s.—130s. Mean 120s.
Sept. 30	93	45	7	73,920	157,582	4½d.—6½d. Mean 5½d.	4¾d.—6¾d. Mean 5¾d.	70s.—105s. Mean 87s. 6d.
Dec. 31	92½	40	6	113,397	145,823	4d.—6½d. Mean 5½d.	5d.—7d. Mean 6d.	60s.—80s. Mean 70s.
1864 Mar. 31	91	40	4	99,013	138,523	4½d.—6½d. Mean 5½d.	5½d.—7d. Mean 6½d.	55s.—70s. Mean 62s. 6d.
June 30	91½	39	7	92,569	100,102	4½d.—6½d. Mean 5½d.	5½d.—7d. Mean 6½d.	40s.—60s. Mean 50s.
Sept. 30	89½	42	3	85,234	351,079	4½d.—6½d. Mean 5½d.	5½d.—7d. Mean 6½d.	80s.—120s. Mean 100s.
Dec. 31	89½	38	5	100,833	454,436	4½d.—7d. Mean 5½d.	5½d.—7½d. Mean 6½d.	80s.—95s. Mean 87s. 6d.
Col.	1	2		3	4	5	6	7

* NOTE.—The total number of quarters of wheat sold in England and Wales for the 13 weeks ending December 31st, 1862, 1,111,787; for the 13 weeks ending March 31st, 1863, 985,649; for the 13 weeks ending June 30th, 1863, 1,073,126; for the 13 weeks ending September 30th, 1863, 960,956; for the 13 weeks ending December 31st, 1863, 1,474,160; for the 13 weeks ending March 31st, 1864, 1,287,171; for the 13 weeks ending June 30th, 1864, 1,203,406; for the 13 weeks ending September 30th, 1864, 1,108,051; and for the quarter ending December 31st, 1864 (14 weeks), 1,411,663. The total number of quarters entered for Home Consumption in the same period was respectively, 3,355,239; 1,812,585; 1,386,233; 2,048,568; 1,895,705; 1,800,806; 1,301,323; 4,564,027; and 6,362,103.

1864.—WEEKLY AVERAGE PRICE OF WHEAT FROM GOVERNMENT RETURNS.

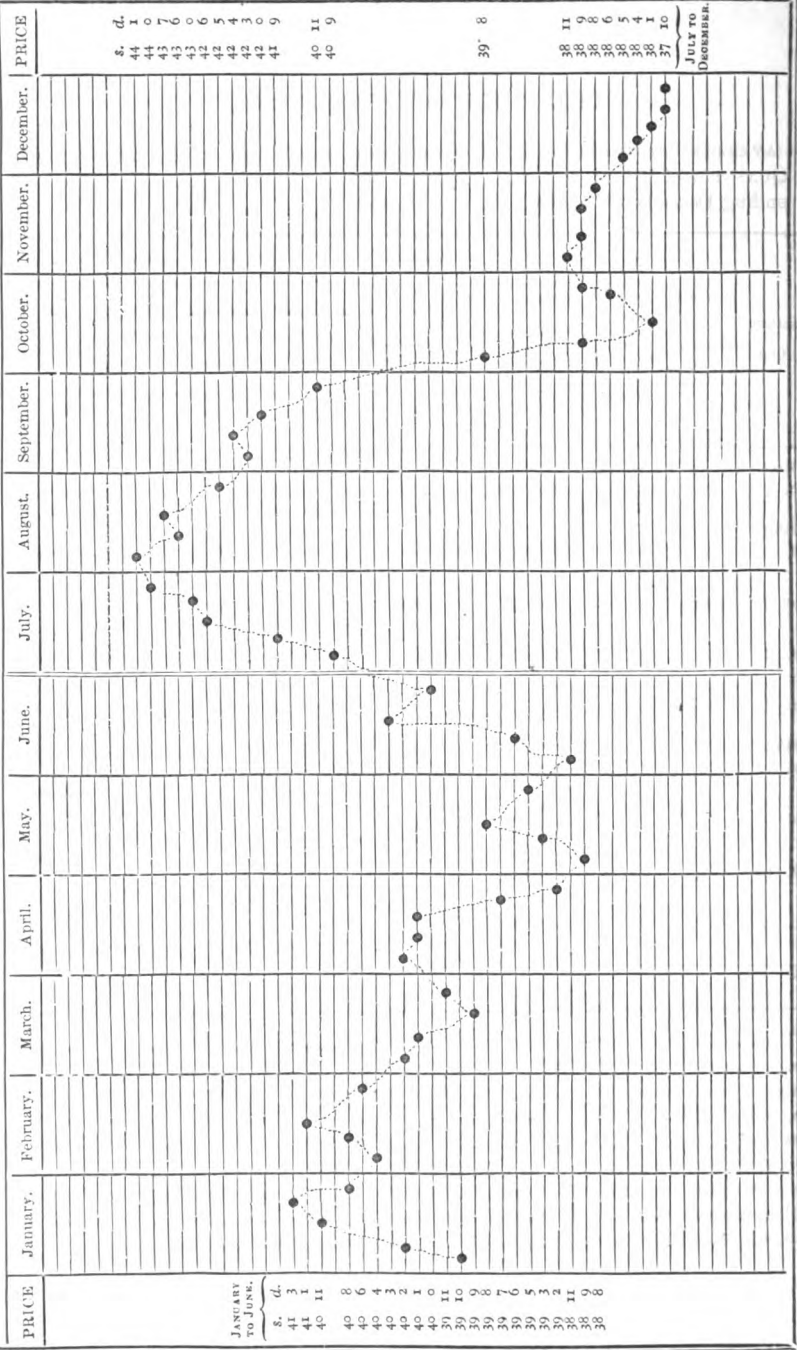

JANUARY TO JUNE.

s. d.
41 3
41 1
40 11
40 8
40 6
40 4
40 3
40 2
40 1
40 0
39 11
39 10
39 9
39 8
39 7
39 6
39 5
39 3
39 2
38 11
38 9
38

s. d.
44 0
44 1
43 7
43 6
42 6
42 5
42 4
42 3
42 0
41 9
40 11
40 9
39 8
38 11
38 9
38 8
38 6
38 5
38 4
38 1
37 10

JULY TO DECEMBER.

Average of Year
Import of United Kingdom

WHEAT.	BARLEY.	OATS.	BEANS.	PEAS.	MAIZE.	FLOUR AND MEAL.
40/5	29/11	20/2	36/3	34/0
qrs. 11,735,000	qrs. 1,676,978	qrs. 3,653,141	qrs. 4,943,111	qrs. 6,167,708	qrs. 5,427,121	qrs. 184,000,000
11,735,000	1,676,978	3,653,141	4,943,111	6,167,708	5,427,121	184,000,000

VITAL STATISTICS; METEOROLOGY; BRITISH WHEAT SOLD; IMPORTATIONS OF CORN; PRICES OF FOOD; PAUPERISM.



The matter is selected from the Reports of the REGISTRAR-GENERAL; from Mr. GLAISHER'S Meteorological Tables, and Notes on the Weather; and from Returns of the BOARD OF TRADE.

BIRTHS AND DEATHS IN THE FIRST SIX MONTHS OF 1865 IN ENGLAND AND WALES.

In the *first quarter* the number of births was 194,287. The birth-rate per annum, or proportion of children born to 100 persons living, was 3·768, against an average of 3·627. The birth-rate was high beyond any example furnished by the forty quarters of the ten years 1855-64.

In the *second quarter* the births were 192,921. The annual birth-rate for the quarter was 3·691 per cent. against an average of 3·603. It was remarkably high. In London, the birth-rate of the same three months was 3·515 per cent.; in Manchester, 3·624; in Liverpool, 4·173; in Leeds, 4·497. In Glasgow it was as high as 4·604.

In the *first quarter* the number of deaths in England and Wales was 140,646, being less than in the same period of 1864, when it was 143,030, but much greater than in that of 1863, when it was 128,096. In the March quarter of four years, 1859-62, the number varied little from 122,000.

The annual rate of mortality (*viz.*, deaths of the quarter \times 4 to 100 persons living) was 2·728, against an average in ten March quarters of 2·522. Since the March quarter of 1855, the returns supply no example of as high a death-rate, with the exception of the death-rate of the same quarter in last year, which was 2·773 per cent. Bronchitis and pneumonia, scarlatina, fever, and small-pox, prevailed both in town and country. The death-rate in the Welsh division rose to 2·951, under the influence of small-pox, scarlatina,

or other zymotic disease, which ravaged Cardiff, Llantrisant, Merthyr Tydfil, Aberdare, Neath, Swansea, &c.

In the *second quarter* the number of deaths was 116,006 against 118,121 and 116,899 in the same three months of 1863 and 1864 respectively. The returns of London in the last three springs discovered, as regards absolute numbers, a near approach to identity; but those of the kingdom generally showed a decrease in the spring of 1865; Wales, and some northern parts of England, where epidemic diseases have been rife, or active industrial operations have attracted population, being the only important exceptions. The singularly fine weather exercised a beneficial influence on the public health; and the effect would doubtless have been more marked in the death registers if the preceding March had been less cold and ungenial. The winter months, and especially March, were as remarkable for cold as the late spring season was for heat; and many bronchial affections, which the former period transmitted, ran their course to a fatal termination after the propitious change of weather had begun. The following counties may be mentioned amongst those which exhibited a decrease of deaths: Hampshire, Berkshire, Hertfordshire, Oxfordshire, Huntingdonshire, Cambridgeshire, Suffolk, Wiltshire, Cornwall, Staffordshire, Worcestershire, Warwickshire, Leicestershire, Rutlandshire, Cheshire, the East and North Ridings of Yorkshire, Cumberland, and Westmoreland. In Lancashire the deaths in the spring quarter of 1863 and 1864 were 16,541 and 16,415; in last quarter 16,806. In the West Riding of Yorkshire they were in the same periods 10,469, 9991, and 10,431. In South Wales they were 3871, 4056, 4779.

In England the annual rate of mortality for the June quarter was 2·220 per cent. (deaths to a hundred persons living) against an average of 2·191 for the corresponding quarter in ten previous years. In 1863 and 1864 the rate was 2·308 and 2·260 per cent.

The South-eastern Division, embracing Surrey, Kent, Sussex, Hampshire, and Berkshire, was the most healthy; for in it the rate of mortality was only 1·882 per cent. The next in degree of health was that which contains the South Midland Counties, where the mortality was 2·002. In four other divisions, viz., the Eastern, South Western, West Midland, and North Midland Counties, it did not rise as high as 2·1 per cent. In the North-western Counties (Cheshire and Lancashire), in Yorkshire, and Wales, it was but little under 2·5 per cent. The Registrars of Welsh districts, as in the previous quarter, reported measles, scarlatina, and small-pox as diseases that had been prevalent and fatal.

POPULATION ; BIRTHS and DEATHS ; ANNUAL BIRTH and DEATH RATES in
Ten large Towns, in the First Two Quarters of 1865.

First Quarter.

Cities, &c.	Estimated Population in the Middle of the Year 1865.	Births in 13 Weeks ending 1st April, 1865.	Deaths in 13 Weeks ending 1st April, 1865.	Annual Rate to 1000 living during the 13 Weeks ending 1st April, 1865.	
				Births.	Deaths.
Total of 10 large towns	5,524,012	53,106	42,363	38·59	30·78
London	3,015,494	28,059	21,018	37·35	27·98
Liverpool (Borough)	476,368	5,001	4,723	42·14	39·79
Manchester (City)	354,930	3,341	3,019	36·92	34·14
Salford (Borough)	110,833	1,099	772	39·80	27·96
Birmingham (Borough)	327,842	3,213	2,299	39·34	28·74
Leeds (Borough)	224,025	2,579	1,788	46·21	32·03
Bristol (City)	161,809	1,453	1,134	36·04	28·13
Edinburgh (City)	174,180	1,559	1,317	35·92	30·35
Glasgow (City)	423,723	4,738	4,115	44·88	38·98
Dublin (City)	254,808	2,064	2,178	32·51	34·31

Second Quarter.

Cities, &c.	Estimated Population in the Middle of the Year 1865.	Births in 13 Weeks ending 1st July, 1865.	Deaths in 13 Weeks ending 1st July, 1865.	Annual Rate to 1000 living during the 13 Weeks ending 1st July, 1865.	
				Births.	Deaths.
Total of 10 large towns	5,586,870	51,550	34,658	37·03	24·90
London	3,015,494	26,408	17,367	35·15	23·16
Liverpool (Borough)	476,368	4,953	3,709	41·73	31·25
Manchester (City)	354,930	3,205	2,592	36·24	29·31
Salford (Borough)	110,833	1,082	697	39·18	25·24
Birmingham (Borough)	327,842	3,195	1,651	39·12	20·21
Leeds (Borough)	224,025	2,510	1,515	44·97	27·14
Bristol (City)	161,809	1,379	869	34·21	21·56
Edinburgh (City)	174,180	1,646	1,148	37·93	26·45
Glasgow (City)	423,723	4,860	3,236	46·04	30·65
Dublin (City and some suburbs)	317,666	2,312	1,874	29·21	23·68

NOTE.—It will be observed that the above Tables show the rates to 1000 living. For rates per cent., remove the decimal point one place to the left. In the second quarter the rate of mortality in districts comprising the chief towns was 2·339 per cent.

In districts consisting of small towns and country parishes it was 2·019 per cent.

In the town districts of Scotland it was in the same quarter 2·61 per cent.

In the rural districts of Scotland 1·68 per cent.

The mortality of the aggregate population of Scotland was 2·17 against 2·22 in England.

METEOROLOGY.

January began with cold frosty weather; a warm time set in on the 4th day and continued till the 16th, during which period, though the weather was mild, the sky was cloudy, and the wind blowing a gale. From the 17th January to the end of the quarter, with the exception of short intervals at the beginning and end of February, the weather was cold for the season, sometimes to an unpleasant degree. In a cold period in January the temperature of the air was as low as 20° at many places; in February from 13° to 20° in many places, and as low as 8° at Birmingham; and in March at the equinox it was as low as 23° . In January and February snowstorms were frequent, and extended all over England and Scotland. At the end of February the weather was extremely wild and stormy; and March was cold and ungenial throughout. The mean temperature of January at Greenwich was 36.3° ; that of February and also that of March 36.6° , each being below the average of the corresponding periods in twenty-four years, and the mean temperature of March being as much as 5.4° below the average. Usually February is 2° and March 5° warmer than January; but this year the increase was not obtained. To find a March equally cold, it is necessary to go back to 1845, 1837, and 1814, when the mean temperature was above 35° and below 36° . In 1785 it was 33.9° . Towards the end of last century that month was oftener remarkable for extreme coldness than it has been in later times.

The unusually severe weather of March interrupted agricultural operations and checked vegetation; on 5th April this wintry weather ceased suddenly; and till 10th June, during a period of sixty-seven days, the temperature was, with few exceptions, above the average, the average daily excess being nearly 5° ; and the quarter was closed by a period of twenty days in which intervals of cold and warm weather succeeded each other, but with a predominance of cold. The high summer temperature of April urged vegetation to rapid growth, and soon effaced the traces of a backward season. Rain, which had been much needed, fell early in May, and in the second week of that month over the whole of the British islands. The mean temperature was above the average in each month, remarkably above it in April and May. The mean temperature of the quarter was 56.2 at Greenwich; and there is no record of any previous instance in which it was so high in the same period of the year. There was 7.2 in. of rain. The fall was deficient in April; above the average in May and June. The air was unusually dry; for though there was a great deal of rain in May, it fell in showers which were heavy, but of short duration.

METEOROLOGICAL OBSERVATIONS TAKEN AT THE ROYAL OBSERVATORY, GREENWICH.

1865. MONTHS.	Temperature of												Elastic Force of Vapour.		Weight of Vapour in a Cubic Foot of Air.			
	Air.			Evaporation.			Dew Point.		Air—Daily Range.			Water of the Thermos.		Mean.	Diff. from average of 24 years.	Mean.	Diff. from average of 24 years.	
	Mean.	Diff. from average of 94 years.	Diff. from average of 24 years.	Mean.	Diff. from average of 24 years.	Mean.	Diff. from average of 24 years.	Mean.	Diff. from average of 24 years.	Mean.	Diff. from average of 24 years.	Mean.	Diff. from average of 24 years.					
														Mean.	Diff. from average of 94 years.	Diff. from average of 24 years.	Mean.	Diff. from average of 24 years.
January ..	36.3	+0.1	-1.9	35.0	-2.0	33.0	-2.1	0	9.1	-0.6	39.0	0	0	0	0.188	-0.015	2.2	-0.2
February ..	36.6	-1.7	-2.1	34.7	-2.4	32.0	-2.7	0	10.0	-1.4	37.0	0	0	0.181	-0.022	2.1	-0.3	
March ..	36.6	-4.4	-5.4	34.5	-5.1	30.5	-6.2	0	12.9	-1.8	39.9	0	0	0.170	-0.049	2.0	-0.5	
Mean ..	36.5	-2.0	-3.1	34.7	-3.2	31.8	-3.7	0	10.7	-1.3	38.6	0	0	0.179	-0.027	2.1	-0.3	
April ..	52.3	+6.5	+5.7	48.2	+4.7	44.0	+3.8	0	24.8	+6.6	52.5	0	0	0.288	+0.039	3.3	+0.4	
May ..	56.1	+3.6	+3.2	51.7	+2.5	47.5	+1.9	0	21.6	+1.4	59.8	0	0	0.329	+0.026	3.6	+0.1	
June ..	60.2	+2.1	+1.2	55.0	+0.4	50.4	-0.3	0	23.7	+3.0	65.5	0	0	0.366	-0.006	4.1	-0.1	
Mean ..	56.2	+4.1	+3.4	51.6	-2.5	47.3	+1.8	0	23.4	+3.7	59.3	0	0	0.328	+0.020	3.7	+0.1	

Note.—In reading this table it will be borne in mind that the sign (-) minus signifies below the average, and that the sign (+) plus signifies above the average.

METEOROLOGICAL OBSERVATIONS TAKEN AT THE ROYAL OBSERVATORY, GREENWICH.

1865. MONTHS.	Degree of Humidity.		Reading of Barometer.		Weight of a Cubic Foot of Air.		Rain.		Daily Horizontal movement of the Air. Miles.	Reading of Thermometer on Grass.				
	Mean.	Diff. from average of 24 years.	Mean.	Diff. from average of 24 years.	Mean.	Diff. from average of 24 years.	In.	In.		Sum	Number of Nights it was		Highest Reading at Night.	
											At or below 30°.	Between 30° and 40°.		Above 40°.
January ..	89	+ 1	29° 405	- 0·367	grs. - 4	in. 3·3	in. +1·6	271	14	16	1	0	0	43·0
February ..	83	- 2	29° 722	- 0·080	555	1·9	+ 0·3	311	14	14	0	15·3	39·7	
March ..	82	0	29° 720	- 0·038	555	0·9	- 0·7	270	22	9	0	20·5	39·2	
Mean ..	85	0	29° 616	- 0·162	553	6·1	+ 1·2	284	50	39	1	13·1	Highest 43·0	
April ..	73	- 6	29° 954	+ 0·193	grs. 542	0·4	- 1·4	169	2	17	11	26·8	0	51·1
May ..	73	- 4	29° 768	- 0·006	534	4·4	+ 2·3	211	1	13	17	20·3	52·4	
June ..	70	- 5	30° 029	+ 0·242	534	2·4	+ 0·5	181	0	8	22	33·1	59·0	
Mean ..	72	- 5	29° 917	+ 0·143	537	7·2	+ 1·4	187	3	38	50	20·3	Highest 59·0	

NOTE.—In reading this table it will be borne in mind that the sign (-) minus signifies below the average, and that the sign (+) plus signifies above the average.

WHEAT, BARLEY, AND OATS: SALES, IMPORTS, &c.

Wheat was in flower on 10th May at Cardington; on the 22nd at Grantham; and on the 23rd at Silloth; on 13th June at Oxford; and on the 21st at Guernsey.

Wheat was in ear on 27th May at Hurstpierpoint; on the 7th at Abington; on the 14th at Grantham; on the 15th at Cockermonth and Aspley; on the 17th at Silloth; on the 18th at Penketh and Kingsley; and on the 25th at Bywell.

Barley was in flower on 17th May at Cardington; on 11th June at Aspley.

Barley was in ear on 19th May at Marlborough; on 5th June at Cardington; on 15th at Abington and Bywell; on 16th at Grantham; on 17th at Aspley; and on the 20th at Cockermonth.

Oats were in ear on 21st June at Penketh; and on the 27th at Cockermonth.

QUANTITIES of BRITISH WHEAT SOLD in the TOWNS from which Returns are received under the Act of the 27th and 28th VICTORIA, cap. 87; and their AVERAGE PRICES; in each of the first SIX MONTHS of the Years 1861-65.

	QUANTITIES IN QUARTERS.				
	1861.	1862.	1863.	1864.	1865.
	quarters.	quarters.	quarters.	quarters.	quarters.
Four weeks, ending Jan. 28	262,527	220,266	262,923	344,930	300,816
Four weeks, ending Feb. 25	197,236	242,229	239,882	306,713	298,271
Five weeks, ending Apr. 1	253,620	277,410	281,405	350,974	373,069
Four weeks, ending Apr. 29	201,551	173,174	243,552	285,286	361,501
Four weeks, ending May 27	214,432	185,356	267,587	284,601	327,694
Five weeks, ending July 1	220,608	208,042	302,897	333,201	283,528

	AVERAGE PRICES PER QUARTER.				
	1861.	1862.	1863.	1864.	1865.
	<i>s. d.</i>	<i>s. d.</i>	<i>s. d.</i>	<i>s. d.</i>	<i>s. d.</i>
Four weeks, ending Jan. 28	57 0	61 4	47 5	40 7	38 6
Four weeks, ending Feb. 25	54 4	60 0	47 3	40 8	38 3
Five weeks, ending Apr. 1	54 3	59 3	45 8	40 1	38 6
Four weeks, ending Apr. 29	56 5	58 0	45 7	40 0	39 8
Four weeks, ending May 27	55 0	58 0	46 4	39 2	41 0
Five weeks, ending July 1	53 5	54 7	46 8	39 8	41 5

AVERAGE PRICES per Quarter of WHEAT, BARLEY and OATS in the First and Second Quarters of 1865.

	Wheat.		Barley.		Oats.	
	<i>s. d.</i>	<i>s. d.</i>	<i>s. d.</i>	<i>s. d.</i>	<i>s. d.</i>	<i>s. d.</i>
First quarter	38 5	...	28 9	...	19 11	11
Second quarter	40 9	...	29 0	...	22 10	

QUANTITIES of WHEAT, WHEATMEAL and FLOUR, BARLEY and OATS,
IMPORTED into the UNITED KINGDOM in each of the first SIX MONTHS.

1865.	Wheat.	Wheatmeal and Flour.	Barley.	Oats.
FIRST QUARTER.				
	cwts.	cwts.	cwts.	cwts.
Four weeks, ending Jan. 28	517,756	165,270	480,450	300,322
Four weeks, ending Feb. 25	539,560	258,166	544,360	235,500
Five weeks, ending Apr. 1 ..	874,187	281,094	765,758	229,064
SECOND QUARTER.				
Four weeks, ending Apr. 29	616,883	278,403	500,899	527,324
Four weeks, ending May 27	2,506,790	277,701	1,144,939	901,305
Five weeks, ending July 1 ..	2,469,187	305,424	754,494	879,473
Total in twenty-six weeks ..	7,524,363*	1,566,058*	4,190,900	3,072,988

The average weekly importation of wheat was in the first quarter 148,577 cwts.; in the second quarter it was 430,220 cwts.

IMPORTATIONS of WHEAT for SIX MONTHS ended June 30: Amounts and
Proportions sent by different STATES.

	1863.	1864.	1865.
	Cwts.	Cwts.	Cwts.
Total importation	10,788,059	10,047,102	7,462,268*
From	Per Cent.	Per Cent.	Per Cent.
Russia	14	12	36
Prussia	23	23	30
Denmark	1½	4	3
Schleswig	1	1½	2
Mecklenburg	2	3	4
Hanse Towns	1½	3½	3
France	½	4½	6
Turkey and Wallachia and Moldavia	2½	2½	5
Egypt	15	4	..
United States	35	38	3
British North America	2	1½	0½
Other countries	2	2½	7½
	100	100	100

FLOUR.

	1863.	1864.	1865.
	Cwts.	Cwts.	Cwts.
Total importation	2,425,255	2,774,751	1,562,375*
From	Per Cent.	Per Cent.	Per Cent.
Hanse Towns	7	6	8
France	27	48	79
United States	57	40	7
British North America	6	4	1
Other countries	3	2	5
	100	100	100

* The totals in the two Tables slightly differ. One embraces a period of 182 days; the other, 181 days. The odd bushels in the weekly returns of wheat sold are not included in the summary.

(XVII)

IMPORTS of ANIMALS and certain ANIMAL and VEGETABLE SUBSTANCES in the
SIX MONTHS ending 30th June, 1863-4-5.

	1863.	1864.	1865.
Oxen, Bulls, Cows No.	24,108	47,966	74,392
Calves ,,	11,147	15,928	18,785
Sheep and Lambs ,,	110,636	129,350	250,212
Swine and Hogs ,,	982	18,802	38,706
Bacon and Hams cwts.	1,308,199	815,965	403,449
Salt Beef ,,	187,505	224,187	131,471
Salt Pork ,,	115,661	134,134	95,560
Butter ,,	366,341	409,203	455,752
Cheese ,,	199,016	234,176	240,503
Eggs No.	143,300,640	172,458,000	195,218,160
Lard cwts.	318,818	101,616	76,000
Potatoes ,,	837,150	235,334	411,789
Indian Corn or Maize ,,	5,175,163	1,063,916	2,076,918
Peas ,,	635,404	398,169	218,068
Beans ,,	1,001,456	481,208	436,033
Rice (not in husk) ,,	792,849	571,678	299,090
Hops ,,	66,742	59,514	38,031
Flax and Tow ,,	466,564	878,674	439,656
Wool * lbs.	70,684,679	69,935,204	87,470,008
Raw Cotton cwts.	2,134,230	3,546,968	3,108,853
Oilseed Cakes tons	38,173	36,914	40,971
Guano ,,	127,007	48,628	106,243
Bones (burnt or not burnt; } animal charcoal) } ,,	37,081	30,715	23,505

* Not including alpaca wool.

PRICE OF PROVISIONS.

First Quarter.—The price of wheat, 38s. 4d. per quarter, was less by 2s. than in the first three months of 1864, and less by 8s. 3d. than in the same period of 1863. Both beef and mutton were dear. The average price of the best potatoes at the Waterside Market, Southwark, was 91s. per ton. In the March quarter of 1863 it was 125s.; in that of 1864 it was 62s. 6d.

Second Quarter.—The average price of wheat was 40s. 6d. per quarter; a shilling higher than it was in the June quarter of last year, but 6s. less than it was in the same period of 1863. Beef by the carcase at Newgate and Leadenhall Markets was on an average 5½d. per lb., and was a halfpenny dearer than in the two previous June quarters. Mutton was 7½d. per lb.; it was 1½d. dearer than in the same period of 1864, and nearly 2d. dearer than in that of 1863. The average price of best potatoes at the Waterside Market, Southwark, was 102s. 6d. per ton, being about double the price of the June quarter of 1864, but less than that of 1863.

(XVIII)

The AVERAGE PRICES of Consols, of Wheat, of Meat, and of Potatoes; also the AVERAGE NUMBER of PAUPERS relieved on the *last day* of each Week; and the MEAN TEMPERATURE; in each of the Nine Quarters ending June 30th, 1865.

Quarters ending	AVERAGE PRICES.					PAUPERISM.		Mean Temperature.
	Consols (for Money).	Wheat per Quarter in England and Wales.	Meat per lb. at Leadenhall and Newgate Markets (by the Carcase).		Best Potatoes per Ton at Waterside Market, Southwark.	Quarterly Average of the Number of Paupers relieved on the <i>last day</i> of each week.		
			Beef.	Mutton.		In-door.	Out-door.	
1863	£.	s. d.						°
June 30	93½	46 2	4½d.—6½d. Mean 5½d.	4¾d.—6¾d. Mean 5¾d.	110s.—130s. Mean 120s.	127,852	879,241	53°0
Sept. 30	93	45 7	4½d.—6½d. Mean 5½d.	4¾d.—6¾d. Mean 5¾d.	70s.—105s. Mean 87s. 6d.	120,189	819,795	58°8
Dec. 31	92½	40 6	4d.—6½d. Mean 5½d.	5d.—7d. Mean 6d.	60s.—80s. Mean 70s.	130,072	804,941	46°8
1864								
Mar. 31	91	40 4	4½d.—6½d. Mean 5½d.	5½d.—7d. Mean 6½d.	55s.—70s. Mean 62s. 6d.	139,606	855,728	37°9
June 30	91½	39 7	4½d.—6½d. Mean 5½d.	5½d.—7d. Mean 6½d.	40s.—60s. Mean 50s.	122,717	785,825	53°1
Sept. 30	89½	42 3	4½d.—6½d. Mean 5½d.	5½d.—7d. Mean 6½d.	80s.—120s. Mean 100s.	115,698	739,341	59°4
Dec. 31	89½	38 5	4½d.—7d. Mean 5½d.	5½d.—7½d. Mean 6½d.	80s.—95s. Mean 87s. 6d.	128,322	771,879	43°7
1865								
Mar. 31	89½	38 4	4½d.—7d. Mean 5½d.	5½d.—7½d. Mean 6½d.	85s.—97s. Mean 91s.	142,329	813,371	36°5
June 30	90½	40 6	4½d.—6½d. Mean 5½d.	6½d.—8½d. Mean 7½d.	90s.—115s. Mean 102s. 6d.	125,846	776,016	56°2

PAUPERISM.

The average number of paupers relieved in-door on the last day of each week in April, May, and June, was 125,846, which is rather more than in the spring of last year, less than in that of 1863; the number relieved out-door was 776,016, exhibiting a small decrease on the pauperism of 1864, and a very great decrease on that of the same quarter in the previous year, when the number of persons who received relief was greater than in the present year by 100,000.

JOURNAL
OF THE
ROYAL AGRICULTURAL SOCIETY
OF ENGLAND.

I.—*The Royal Agricultural College of Cirencester.*

IN the useful and masterly survey of the progress of agriculture, in a late number of our Journal, written in continuation of a similar review taken by the late Mr. Pusey at an earlier date, Mr. Thompson observes:—"The commencement of the Society took place during one of those recovering fits of associative activity to which Englishmen are periodically prone." He then explains that the Yorkshire Society was formed in 1837; the Royal Agricultural Society in 1838; and the Royal Irish Improvement in 1841. To these we venture to add the Royal Agricultural College at Cirencester, organized in 1842, and incorporated by charter in 1845. The Council of the Royal Agricultural Society having recently appointed a committee to consider and report on the actual state of agricultural education, we propose to give a brief history of this Institution.

Only the elder members of our Society who are familiar with the state of the agriculture in England some thirty years ago, are able thoroughly to appreciate the progress and the improvement which have taken place in the interval.—We speak of the general condition of the kingdom, without ignoring that there existed at that day many skilful and successful cultivators of the soil and breeders of stock—men in advance of their age.—But others who bear in mind the success of the annual meetings of our Society, which, visiting every district of the kingdom, has exhibited to a class of men not generally given to migrate far from home, the best stock of every description, with a wonderful display of implements—demonstrations far more influential on the minds of farmers generally than any descriptions in print—and who further duly estimate the worth of the investigations and experiments of our agricultural chemists, and other scientific men recorded in the Society's Journal—will readily concede that the signs of progress are manifest, and that these are in great measure attributable to the exertions and influence of this Society.

The Council has, nevertheless, been recently reminded that it has hitherto neglected one important duty of those enumerated in our charter, namely, "to take measures for the improvement of the *education* of those who depend on the cultivation of the soil for their support."

While in connection with nearly all other arts, educational training appears to have become more or less systematised, we are not aware of the existence of any institution in England especially devoted to the instruction of those who require that knowledge and experience which improved agriculture calls for, with one exception.

It is remarkable that while public schools of agriculture exist in nearly every other country of Europe, the only institution of the kind in England, viz., the Agricultural College of Cirencester, should have originated in a small local farmer's club.

A brief history, then, of the origin, progress, and actual state of this establishment may be acceptable to the readers of this Journal.

This College originated in an address made by the late Mr. Robert Jeffries Brown to a meeting of the Cirencester and Fairford Farmers' Club, held in November, 1842, "On the Advantages of a Specific Education for Agricultural Pursuits."

At a subsequent meeting of the Club, held on the 29th December, 1842, at which Mr. Edward Bowly, a member of the present Council of the Royal Agricultural Society, presided, a public address was agreed on, from which the following are extracts:—

"We, constituting the Cirencester and Fairford Farmers' Club, having fully discussed and maturely considered the subject brought before us by Mr. R. J. Brown, feel that we cannot too highly estimate the importance of a specific education for those engaged in agricultural pursuits; and the great value to them of a knowledge of those sciences that are in constant operation in the cultivation of the soil, the growth of crops, and the rearing and feeding of domestic animals; and we think it most essential that the study of these sciences should be united with practical experience. The advantages of an institution of this kind to the landowner, as well as to the occupier, are too obvious to require comment; and we confidently rely on their cordial co-operation and support."

A deputation, appointed by the Club, having obtained the patronage of Earl Bathurst and other noblemen, and the principal gentlemen in the neighbourhood, attended meetings convened for the purpose at various market towns, in order to procure the support of the tenantry. The late Mr. R. J. Brown devoted nearly the whole of the following year to the task of explaining the object in view to landowners and occupiers in various parts of the kingdom, with considerable success. A public meeting was held in Cirencester, under the presidency of Earl Bathurst, in April,

1844, at which it was resolved, on the motion of the late Earl Ducie, seconded by Mr. Kearsy, a tenant-farmer, "That it is expedient to provide an institution in which the rising generation of farmers may receive instruction at a moderate expense, in those sciences, a knowledge of which is essential to successful cultivation; and that a farm form part of such institution." A committee was then formed to determine on a plan for such an institution, and on the best means of carrying it into effect.

A further meeting was held on the 1st July, 1844, at which it was reported that Lord Bathurst had offered a farm of upwards of 400 acres for a long term of years, and adjacent to it a site for the erection of the College, with some pasture-land, on a lease for ninety-nine years. The Society was then definitely formed; a president, vice-president, and trustees were appointed, and it was resolved that a Charter of Incorporation should be applied for.

The annual meeting of the Royal Agricultural Society of England was about to be held at Southampton in the course of that month, and a deputation, consisting of Earl Ducie, Mr. Holland, Dr. Daubeny, Mr. Edward Bowly, and several tenant-farmers was appointed to attend the meeting at Southampton, with the view of obtaining the sanction of the Council for a public meeting, which it was proposed to hold under the patronage of the Society, while agriculturists from all parts of the kingdom were assembled. This sanction, however, not having been given, the deputation ultimately resolved to hold an independent meeting. The late Mr. Pusey presided, and it was attended by the late Duke of Richmond, Earl Spencer, Dr. Buckland, Mr. Sotheron Estcourt, Dr. Lyon Playfair, and many others distinguished by their scientific and practical knowledge of agriculture. The views of the promoters of the College having been explained, resolutions were proposed and carried, to the effect that the institution was deserving of public encouragement and support.

By the persevering efforts of Mr. Brown and others, amongst the nobility and landowners in various parts of the kingdom, a subscription of 12,000*l.* was raised, the full amount of the capital required according to the original proposal.

A charter was obtained in March, 1845, incorporating the governors, proprietors, and donors, under the title of the "Agricultural College for teaching the science of Agriculture and the various sciences connected therewith, and the practical application thereof to the cultivation of the soil, and the rearing and management of stock."

This sum of 12,000*l.*, however, was soon found to be inadequate to the completion of the projected College, irrespective of

adequate farm-buildings, and other essential adjuncts. It was therefore provided by the Deed of Settlement, that the capital should be increased to 24,000*l.*; but after every exertion it was found impracticable to extend the subscriptions and donations beyond the amount of 20,320*l.* The expression of opinion in favour of an institution of this kind was so strong and general as to render the earlier administrators of its funds somewhat over-sanguine as to success. This led to a premature extension of the College by the immediate erection of some buildings, which it had been originally intended to leave till time should show what amount of accommodation was necessary. The day of reckoning, when it arrived, presented a result in conformity with general experience in such cases—the buildings, with all the incidents essential to the actual occupation, had involved an outlay considerably beyond the estimates.

There having existed no precedent in this country as a guide to the Committee of Management, mistakes of one kind and another were unavoidable, and admitted of correction only in the expensive school of experience. The providing of competent professors and of the domestic staff for such an institution involved an immediate annual outlay, while an adequate income from students was only prospective. The fee first fixed for the board and instruction of students was 30*l.* per annum only: a sum which about met the demands caused by the keen appetites of youngsters spending the greater part of the day in the invigorating air of the Cotswolds, leaving the interest on capital, and the cost of professors, &c., unprovided for. In the year 1848, the account at the bankers was found to be overdrawn to the extent of 10,000*l.* A meeting of the promoters of the College was convened to consider its financial condition. There appeared to be no alternative but the closing the Institution at the end of the actual session, for want of adequate support. Before that resolution was finally passed, Mr. Holland, who was in attendance as vice-president, expressed his strong and unaltered opinion of the necessity of such a school of agriculture, and his confidence in its ultimate success, adding that he would take on himself the responsibility for the existing debt. The meeting was then adjourned for further deliberation. At the adjourned meeting, the late Earl Ducie, attended, and not only supported Mr. Holland's views, but, with his characteristic liberality, stated that much more would be requisite than a mere provision against the existing debt, and that there ought to be at least an equal amount in the banker's hands to meet further outlay, without which the establishment would be too imperfect to command success. His Lordship added that he could not allow the burden to rest on Mr. Holland's shoulders alone; and ultimately

the support of the institution, with all its liabilities, actual and prospective, was undertaken jointly by himself, Earl Bathurst, Mr. Sotheron Estcourt, and the late Mr. Langston, in connection with Mr. Holland. Upwards of 30,000*l.* were thus added to the original subscriptions and donations, on the personal security of those gentlemen.

Under these circumstances, a general meeting of the original subscribers and donors was convened in London, to consider and determine on the future management of the institution. It became necessary to apply for a supplemental charter, in order to vest the management of the College in those gentlemen during the continuance of their liabilities, and to give them such security for their advances as the very limited means of the institution admitted of. This further charter was granted in July, 1849, whereby the corporation was empowered to obtain in the usual mode an additional capital of 20,000*l.* (making in all 44,000*l.*), with power in the meantime to raise funds to that amount by a mortgage of the property and effects of the College. The guarantors were thereby also appointed a committee to manage the affairs of the College as the ordinary council of the College had been authorized to do by the original charter.

The Buildings.

Of these the principal is the College itself, erected in an elevated and healthy spot facing Lord Bathurst's beautiful park, to which the students have access, while the south front commands extensive views over Wiltshire. Within the walls accommodation is provided for the residence of eighty-five students: there is a commodious dining-hall; a museum of the same dimensions, rich in specimens illustrative of the lectures on veterinary surgery and practice, geology, mineralogy, and botany; and a theatre for the delivery of lectures. Various alterations in, and additions to the College in the shape of private studies, &c., have been made, for the accommodation of a class of students resorting to the College willing to engage them.

Contiguous to the College, but in a distinct building, has been formed, out of an old barn, one of the best laboratories in England. A portion of this has been fitted up with all requisite stoves and other appliances for the special use of the Chemical Professor and his assistants; the remainder is adapted for the use of students. In the former division, our late Professors, Mr. Way and Dr. Voelcker, have performed a large proportion of those analyses which have enriched the pages of nearly every number of this Journal.

A chapel has of late been erected at the back of the College, affording ample accommodation for the students, and the entire

establishment of the College, in which morning and evening prayers are read daily by the Principal, besides the usual services on Sundays. The more ornamental portions of the chapel have been executed by private subscription.

The farm-buildings are on a large scale, and stand about a quarter of a mile from the College. Adjoining a well-arranged rickyard is an ample barn, with granary, a fixed steam-engine, thrashing, chaff-cutting, grinding, and other machinery attached; and at one end of this pile of building is the dwelling-house of the farm manager. At the other end are the implement and cart sheds. To the east are the carpenters' and smiths' shops, slaughter-house, and weighing-machine for cattle. The next row of buildings is devoted to the stables, harness-house, &c., with piggeries on the west side; and a third comprises a double row of cattle-boxes, on the west of which are two yards for store cattle, surrounded by covered sheds.

Adjoining the turnpike-road from Oxford to Bath, which intersects the farm, is a Veterinary Hospital, under the management of the Veterinary Professor, fitted up for the reception of all animals requiring operations, or treatment for disease, accident, or other ailments. The public are invited to send animals so circumstanced, which are treated at a moderate charge, in order that the students may have the advantage of ocular demonstration of disease and its treatment, by the Professor in aid of his lectures in the theatre.

In the cultivation of the farm are employed Mr. Fowler's steam-engine, plough and cultivator attached, besides an assortment of all the most improved implements.

The permanent establishment of the College, under the general superintendence of the Council, consists of the Principal, a Clergyman of the Church of England; the Farm Manager and Demonstrator; the Chemical Professor and his assistant; and Professors of Botany, Veterinary Surgery, Mathematics, and Surveying, all resident; and a Drawing Master. Gentlemen distinguished for their ability in the respective sciences connected with agriculture are secured to give occasional courses of Lectures, in addition to those of the resident staff.*

There are four Sessions in the year, in each of which a complete course of lectures is given in each department of science taught at the College. The programme for each week comprises instruction in practical agriculture, on the farm daily, commencing 6.30 A.M. Lectures are distributed over the remainder of the

* Among these the names of Dr. Anderson, Professor Gamgee, Mr. Bailey Denton, Mr. J. C. Morton, Mr. T. Duckham, Mr. J. T. Davy, Mr. R. S. Burn, Mr. Hewitt Davis, Mr. Thornhill Harris, Mr. Algernon Clarke, Mr. Baldwin, and Professor Morris, may be mentioned.

day, excepting Saturday, on the following subjects :—Chemistry, applied, organic and inorganic; botany; veterinary surgery, anatomy, and pathology; therapeutics; mechanics, mensuration, surveying, and drawing to those who desire such instruction.

Such is an outline of this Institution and its establishment, provided by the disinterested contributions and munificent supplemental support we have described, for the advantage of the rising generations of agriculturists, at a cost exceeding 50,000*l*.

To say one word on Professors. The Council in early days fortunately enlisted in the cause of agriculture the services of Professor Way, though these were lost to the College on his promotion to the post of Consulting Chemist to the Royal Agricultural Society, and subsequently were transferred to more advantageous employment for the public at large. His successor Dr. Voelcker until very recently held the two appointments conjointly, with mutual advantage to each Society. The Council have since been fortunate enough to engage the services of Mr. Church, a gentleman of considerable eminence as a chemist, who is now resident at the College.

Happily, both the late Mr. Haygarth and his successor, the present Principal, had eminently qualified themselves for this post, by cultivating a natural taste for general science to an extent unusual in members of their profession. Mr. Constable not only fulfills with zeal and energy the duties which strictly belong to his appointment, but is competent and anxious to assist students in the general course of their studies, especially those connected with practical agriculture. In furtherance of this object, he has lately prepared and published an excellent Manual, entitled 'A Guide to the College-Farm and Cultivation-Book, for the use of Students.'

There is no greater mistake than the too prevalent notion that any member of a family who has not sufficient capacity for more intellectual avocations may, with very little previous instruction, become a successful agriculturist; and that whilst most handicrafts require a seven years' apprenticeship, residence with a farmer or at this College for a year or two is an all-sufficient preparation for undertaking a farm. Our own observation would lead us to recommend any youth resolving on agriculture as his occupation in life to place himself with a tenant-farmer for a year, to acquire what may be called the Grammar of Agriculture; with this preparation he would be in a position to derive greater advantage from a two years' course of instruction at the College; after this, two years' residence with a skilful farmer, with careful daily observation and the study of the most approved agricultural literature, would form a reasonably safe foundation to work upon.

As evidence of the value of the system of training pursued in the College, we venture to make a few extracts from the concluding observations of a course of lectures delivered by Mr. Robert Russell, the Editor of the 'Highland Society's Journal' and an examiner of candidates for the diploma of that Society, which have already appeared in print. Mr. Russell observed to the students :—

" I trust you will accept this imperfect sketch of the principles on which a rotation of crops is founded, as a token of my good will towards the success of this Institution. I am only sorry that my business prevents me from entering more minutely into the subject. I am glad, however, that I have had the opportunity of visiting the College, and examining its workings. It is a great privilege, I consider, that you enjoy in being educated where you can learn all that literature or science has as yet done for the art of cultivation. The greater part of the knowledge at present available can, I am persuaded, be picked up here with less expenditure of time and labour than in any other institution, where anything bearing upon agriculture must be taught in a very indefinite way." . . . " Having had the opportunity of seeing the character and completeness of the education given at Cirencester, I confess that I have envied the privileges of its recipients. As one of the Examiners for the Highland Society's diploma, I, along with some of my coadjutors, have been struck with the rare proficiency of some of our diploma holders who were educated here. This fact so far satisfied me that this institution is effectually answering the end its supporters have in view. For my own part, I do not see any reason why you should not yearly turn out diploma holders by the dozen, instead of, as at present, in ones or twos; nor why many more of you should not take the Highland Society's diploma, were it to secure no other end than to show your parents or guardians that a good use has been made of golden opportunities. There never was so great a thirst or desire for agricultural knowledge as there is in the present day, and I do not know where it can be satisfied as at this Institution. Any honorary distinction, which you have the means of acquiring here, will certainly be looked upon as a good omen or promise of your future success in life, as it will afford a strong presumption that you will display the same diligence in business as you have done at College. . . . " I am very glad, indeed, that I have snatched a little time from business to visit this Institution. It has given me much pleasure to observe the order and discipline which prevails, and I have no doubt that, in after years, this will form one of the most pleasant and profitable aspects in which you will view your residence here. You have the best opportunity of acquiring the most liberal education; and from personal observation and examination since I came here, I am glad to find so many students far advanced in the knowledge of what relates to the Art of Agriculture."

Having received from Mr. Baldwin, the Professor of Agriculture at the Glasnevin Institution, near Dublin, written answers to an inquiry which we hastily addressed to him as he was about to enter the train after the conclusion of a course of lectures delivered to the students, we venture to make the following extracts. After stating the opportunities for daily personal intercourse with the students and Professors afforded by a residence for the delivery of two courses of Lectures in 1863 and 1864, Mr. Baldwin writes :—

" My own habits of thought and action induced me to give the fullest

consideration I was able to the internal discipline and general arrangements of the College. After fourteen years' experience of agricultural education at Glasnevin, it was natural that the College arrangements should interest me. I was anxious to study the system pursued here, not only for its own sake, but for the purpose of assisting my judgment whenever my employers should think fit to consult me regarding the Glasnevin establishment. Under these circumstances, I have no hesitation in expressing my conviction of what a student *may* do at the College. I say advisedly what a student *may* do; because you can judge an institution of this kind fairly *only* by its attentive and assiduous students. It is unfair to the Royal Agricultural College to judge it by the careless and inattentive student. Every man of experience knows there are some men whom you cannot by possibility induce to study. So it must have been, and so it must continue to be at Cirencester. But a student who is bent on acquiring a thorough knowledge of his profession, who is determined to use his best efforts to gain a good position amongst his brother farmers, who has a laudable amount of ambition to excel, who, in short, is anxious to use such abilities as the Almighty has endowed him with for his own advantage, could spend a couple of years at this College more profitably than at any place of which I have any knowledge. Apart from the scientific knowledge to be acquired at Cirencester, and the invigorating influence exerted by its class-discipline on the mind, the students acquire thus a vast amount of practical agricultural knowledge. I am unwilling to mention individual students by name, as I might omit others of equal merit, but I may add that I was invited to examine several for the College diploma in November last. I examined them on the farm for several weeks. I had an opportunity of testing their knowledge of farming acquired in the College class-rooms and on the farm. It is due to the College, and to those by whom they were instructed, to state that I have never met with young men who, during the time, had acquired so large a mass of scientific and practical agricultural knowledge. I do not believe it possible that they could in the same time have stored their minds with the same amount of knowledge of principles and practical details on the farm of any private individual. In making this remark I have no desire to undervalue the private farm as a school for practical instruction. Some of the students at the College struck me as possessing a better knowledge of the theory and practice of modern farming than any men of their age I ever met with. They will never regret the time they spent at the College; and the time will come when students of their stamp will take their place in the current of agricultural progress, and be living witnesses of the value of a sound agricultural education. It only remains for me to express a hope that the College will prosper, and fully realize the aspirations of its founders."

We have been induced to add these influential testimonies to the general efficiency of this Institution for the purposes of its foundation, not as forming part of its history, but as being highly creditable to the Principal and the regular staff of Professors.

CHARLES LAWRENCE.

Cirencester, July 27th, 1864.

II.—*On Breaking up Pastures.* By C. BELCHER.

PRIZE ESSAY.

IN treating of breaking up of pasture and its subsequent management as arable land I venture to offer my own ideas. I do not presume to think that I shall be able to lay down any new rules, or recommend any course that will be applicable to every case that may arise. All that I can do is to state the results of my experience and observation, with some information which has been kindly given to me by friends engaged, as I am, in farming. I shall also avoid the use of scientific geological terms, in referring to the various soils I may have occasion to mention, and merely describe them as they are spoken of by farmers and their labourers, believing that statements easily understood, and clearly given, and directions of a plain and practical character, best accord with the object of this Journal and the wishes of its Directors. Classing various soils under three heads, viz., Heavy, Medium, and Light Land, I propose to describe in this order different modes of breaking up and cropping, which I consider most advantageous in ordinary cases. Peculiar circumstances sometimes exist which render ordinary rules inapplicable: unless these receive special consideration the promise of success will often result in loss and disappointment.

In all cases I shall presume that, as a preliminary, the land has been well and wisely drained. Although some practical farmers still hold that grass-land as such may possibly be injured by draining, no such doubt applies to arable, except on the score of excessive outlay.

Clay Land.—The first case we have to consider is the breaking up of grass on clay or stony loam. On such land the herbage is generally of a coarse character, with here and there tufts and patches of rough grass which cattle will seldom eat, and never thrive upon. Occasionally the turf is thin, and there is an absence of the long coarse grass.

Towards the end of February the breast-plough should be set vigorously to work on the turf, that the drying winds of March may make it ready for the fire. Harrowing must precede the burning; twice over will generally suffice. Let the fires be made at equal distances, and not very far apart. The burners will, for their own convenience, generally attend to these points, especially if the work is done, as it should be, by measure and contract.* As soon as the heaps are charred through, let

* Breast-ploughing and burning usually costs from twenty to twenty-five shillings per acre; this price includes spreading the ashes.

the ashes be spread evenly on the land: if you wait until they are cold, combustion will have gone too far, and the ashes will not prove so beneficial as when a great portion of the vegetable matter is merely charred. The black ashes are better than those of a red colour. In burning, much depends upon good judgment and management; the fires burn much more slowly, and require more attention, when the weather is damp; but better ashes are then made than in the dry windy weather that frequently prevails in the month of March. As soon as the ashes are spread, horse-plough them in with a very narrow and shallow furrow. It is scarcely possible to plough the land too lightly; for ashes have always a tendency to work downwards, and it is desirable to keep them as near to the top as possible. Another horse-ploughing across the first furrows will sometimes be required, with harrowing, rolling, and the usual operations for reducing the soil to a fine tilth.

When the proper season for turnip-sowing arrives, begin by drilling swedes, turnips, rape, or a mixture of rape and turnips: either of these crops would be likely to succeed, especially with an allowance of artificial manure. Part of the ashes made from the burned turf should be reserved for drilling with the turnip-crop, unless it has been determined to use the liquid-manure-drill.

Sometimes newly-broken land does not get sufficiently pulverised to allow the drill to work freely at first. In such cases it will be better to adopt the old-fashioned plan of sowing broadcast; so that the small seeds may fall into the crevices, and be covered by the use of a chain-harrow, or the common bush-harrow; the ground should finally be made firm with an iron roller, Cambridge presser, or clod-crusher, and a good crop may then be reasonably expected.

We now come to the consumption of the first root-crop; and I would strongly advise that this should be done with sheep as early in the season as is practicable, especial care being taken that the crop be equably consumed over every part of the field. The first turnip-crop is frequently patchy, even where great care and labour have been bestowed upon it: in one spot it may be superabundant, while in another it has almost failed. In such cases a little expense in carting roots to these bare places would be repaid twentyfold. This may appear like "robbing Peter to pay Paul;" but as the two will work together in partnership for the future, it is desirable that their powers should be equalised. The addition of cake or corn to the food of the sheep when on the turnips will, of course, increase the prospects of an abundant corn-crop in the following season.

Before any horse-ploughing is commenced it will be advisable

to determine in which direction the "lands" or furrows should be, with a twofold object,—1st, for convenience in ploughing, so as to avoid crooked furrows and short turnings; and, 2ndly, for the ready escape of the surface-water. I am aware that the mention of water running down furrows may be objected to by some who think it possible in all cases to dispense with water-furrows; still, on some of the strong clays, although drained effectually, surface-water will sometimes be seen; as for instance when a rapid thaw sets in, after a deep fall of snow on hard frozen ground: therefore I would say, be on the safe side, and prepare for an exceptional case, by making water-furrows, or you may suffer loss and vexation when the rain is descending and the floods come.

In horse-ploughing for the first corn-crop experience teaches us that the furrows should be shallow; the manure from the sheep and the ashes from the burned turf will then be kept near the surface. Oats are generally preferred for the first corn-crop on newly-broken land; wheat is occasionally grown; but taking the average of cases it is best to start with the oat. With the oats sow a mixture of clover-seed and rye-grass, to be once mown, then depastured with sheep, and ploughed in the autumn for wheat; or it may be a better course to let the clover and rye-grass remain two seasons before ploughing for the second corn-crop.

On breaking up some poor grass-fields (clay soils and sub-soil) in the Vale of White Horse, in Berkshire, the following plan was adopted: the turf was merely horse-ploughed and planted with vetches, and an excellent crop was the result. After the vetches had been eaten by sheep the land was again horse-ploughed, and wheat was planted, which produced an abundant crop; then the land came into the regular farm-course. In another field of similar quality the occupier adopted the plan of breast-ploughing and burning; oats were planted, then wheat was tried, then swedes: yet all the crops for the first few seasons were either partially or wholly lost, through the ravages of wire-worms. This is the only case within my knowledge where horse-ploughing has proved better than breast-ploughing for the conversion of clay-land pasture into arable; and I mention it as an exceptional instance.

Strong Loams and deep Stone-Brash.—Strong loams and deep stone-brash lands may be classed together, because they should have similar treatment, during the first few years of cropping as arable.

As far as I have been able to ascertain, their treatment will differ from that of clay-land only on these points: that barley may sometimes be substituted for oats as the first corn-crop, and

that wheat had better be taken after the seeds have stood for one year. All new arable land has a tendency to become hollow and spongy; and if the ground is loose, wire-worms, where these abound, can more readily carry on their destructive operations. Measures should, therefore, always be adopted to keep the soil firm when under crop of any kind. I have omitted to mention beans as a crop suitable to a clay soil, because on new land they are an uncertain crop. When so planted they frequently look well at the commencement of their growth; but as the summer advances they become weak and sickly, the blossoms fall off, and at harvest, although there may be a fair quantity of haulm, but very few corn-pods appear on the stalks; still beans* may in some situations be advantageously substituted for clover after the first corn-crop.

Chalk.—In this branch of my subject I shall have chiefly to speak of those Down pastures that once exclusively occupied the long ranges of our English chalk-hills, to which of late the operation of breaking up has been most extensively applied. Friends who occupy large tracts of such soil concur with me in opinion that here also the breast-plough and fire are the best agents that can be used; and that to adopt any other course is to invite failure. One approved plan is the following:—Pare the turf as thin as possible, burn it when sufficiently dry, and, when the ashes are spread, “rafter”† the land with the horse-plough; in the autumn “rafter” again, across the first work, and plant wheat as the first crop: a turnip-crop follows, and then the field enters into the regular farm-culture. Some good cultivators, after paring and burning in the same season, plant swedes or rape and turnips, to be followed by wheat or oats. Where there is a fair chance of success, the gain of a turnip-crop, with its attendant benefits, is not to be neglected. But the judicious farmer, like the skilful physician, must have regard to every feature in the patient’s case.

Gravel on Chalk.—Some of the chalk-hills, such as those in the neighbourhood of Henley, in Oxfordshire, have a surface-soil of gravel and flints. In breaking up such lands as these, both the author and some of his acquaintance have taken the following

* It may not be generally known that *old* beans used as seed frequently produce a much better crop than *new* seed-beans. The writer could mention many remarkable instances of the kind, and is so fully impressed with the advantage of planting *old* beans, that he seldom uses any other except for experiment.

† Raftering.—This is frequently done by taking off the “ground wrest” and “turnfurrow” from an ordinary plough, and substituting a bit of wood (about 6 or 8 inches long, and 3 inches in depth) for the “turnfurrow.” With the plough so prepared, alternate strips between each furrow are left unploughed, and the furrow slices are laid on this firm unmoved ground, so that only half the land is actually moved; the work can also be done with an *unaltered* plough.

course:—The ordinary horse-plough was followed by a “Land Presser,” which forced the grassy edge of the furrow-slice to the bottom of the furrow, and at the same time made deep channels and a firm bed for the seed-corn. This “presser” consists of two heavy iron wheels, about one yard each in diameter, and a light guide-wheel, all fixed into a frame connected with shafts. One horse draws the presser after two plough-teams, and each heavy wheel works between two furrow-slices; the guide-wheel runs on the unploughed ground about one yard from the furrow. In the cases referred to, oats were sown for the first crop, and they answered well. After the oats, it was invariably found that the turf had decayed, and was reduced to vegetable mould, which was easily pulverized by ordinary methods. These gravelly soils on chalk appear to possess the property of causing vegetable matter to decay in a short time, and, where such rapid decay takes place, burning turf would be a wasteful process.

Sandy Soils.—Sandy soils never make rich pasture-land, but poor pasture on a deep sandy soil frequently makes profitable arable-land when broken up, and in bringing such into cultivation the plough and presser may sometimes be used with advantage. But here, again, the paring and burning process is the safer course to adopt. If the land has not been burnt, a deeper furrow must be given than when ashes are ploughed in, otherwise there will not be sufficient soil to pulverize for the covering of the seed-corn, if corn be the first crop. But here, again, I would advise that a turnip-crop be first grown, and consumed on the land with sheep, and then there will be almost a certainty of a good corn-crop. The treading of the sheep, apart from their manure, is generally thought to be very beneficial on fresh-broken land; the fibrous turf-roots are parted and torn to pieces by the feet of the sheep, so that they decay more rapidly, and become food for succeeding crops.

Thin Stone-Brash.—On the poor pastures of a thin stone-brash soil there is not sufficient mould to produce a thick turf; coarse patches of the worthless carnation-grass are here frequently found, the tough roots of which resist decay for a long period if ploughed down; therefore burning should be resorted to in breaking up such land. When the paring and burning has been finished and the ashes spread, a second breast-ploughing, to be followed by harrowing to separate the tough fibres, will frequently be found cheaper and better than horse-ploughing; even if a third breast-ploughing be given before the turnips are sown, the extra labour and expense will be amply repaid by the abundance of the crop. The barley which should follow this turnip-crop may either be drilled after a shallow horse-ploughing, or it may be sown after the sheep have been removed, and merely breast-ploughed in.

There a mixture of seeds should always be the third crop taken,—it is useless to expect a poor thin stone-brash soil to yield a large or profitable return, unless it receive liberal treatment.

Peaty Soils.—These lands never afford good pastures, and the hay taken from them is always of a light and poor character; as their culture is not difficult or expensive, the occupier has always strong inducement to convert them into arable. Such lands are never so easily, cheaply, or successfully brought into cultivation, as by paring and burning. Whilst gravelly soils appear to hasten the decay of vegetable substances, peaty lands seem to possess an opposite quality.

I once broke up a field of sixteen acres of well-drained peaty land with a clay subsoil, the owner of which at that time held the theory that burning vegetable matter of any kind was a wasteful process, and that the fire destroyed much matter that would be valuable if reduced to decay by natural decomposition. The turf was therefore pared off, and drawn together into large heaps; then the land was dug about five inches deep during the winter; at spring there appeared to be an excellent seed-bed; oats were drilled in, but the ravages of the wire-worm commenced as soon as the oats were planted, and the kernels from a large portion of the seed were eaten before they had time to sprout. The few plants that survived were fed off on the field by sheep; the land was worked with ploughs and harrows during autumn, and in the following spring oats were tried again; and again the crop was nearly destroyed by the wire-worms. Yet, after a while, this field showed its productive powers by growing very full crops. This case of failure may act as a warning to those who may have occasion to convert peaty pasture-land to arable. To such persons I would say, breast-plough and burn for the first turnip-crop, and then horse-plough as shallow as possible, and plant oats; after the first oat-crop turnips or swedes again (if a full crop, a portion of these roots may with advantage be removed to other land or yards); then oats again, with clover and rye-grass seeds; then let the land take its regular course on the farm, unless wheat should be considered hazardous, as it is very liable to blight and mildew on such land. Perhaps for the first few years no safer or more profitable plan could be adopted than the following, which has stood the test of experience on land such as that described:—1. Turnips; 2. Oats; 3. Grass, to be mown or fed, then (in the next year) breast-plough and burn for turnips, and so on.

General Remarks.—It may be objected by some readers, that in treating of the subject of the conversion of grass-land to arable, I have merely raised a cry of Fire! fire! It is true that I have recommended burning as the safest, cheapest, and best mode, that

can be adopted; and I do so because experience, observation, and extensive inquiry over a large district, confirm my opinion on this point. Many persons have endeavoured to prove, and perhaps have clearly shown by experiment, that nearly all vegetable matter loses some of its valuable properties when subjected to fire, and that a greater amount of manure is produced by gradual decay. Still, it must not be forgotten that by burning turf, time is gained, and a strong stimulant is secured in the first year for the fundamental crop of turnips, which, being forced to early maturity and great bulk, will probably give back to the land as manure a far greater amount of valuable matter than can have been dissipated by the burning. Ashes also act mechanically, and on strong clay-soils cause an advantageous separation of the earthy particles, and also make the soil more dry and healthy for sheep when folded thereon.

Let me suggest to clay-land farmers an inexpensive experiment—that in breaking up pasture on a strong clay-soil they should take the opportunity of clod-burning, as practised in some parts of Worcestershire* with marked success. The dried turf would, I believe, with the addition of a small quantity of coal, provide sufficient fuel to burn very large quantities of clay, and thus secure the benefit of a heavy dose of burned soil, with comparatively slight increase of cost.

I will now endeavour to meet the objections that I anticipate will be raised against my proposals for cropping newly-broken land.

It may be said that new land will yield many corn-crops in succession, and therefore to plant the less profitable green crops at first would be to reject a benefit when within our reach. Unfortunately for much land in England, and I think I may add unfortunately for many tenants also, the exhaustive system of cropping is too well known and too frequently practised to render it necessary for me to give any instruction on that head. The plans for cropping suggested by me are such as I consider likely to raise the fertility of the various soils, instead of lowering them; and I cannot believe that any system that has a tendency to reduce the standard of fertility, can possibly work for the benefit of any class for a lengthened period. Surely the farming of England cannot be right, unless year by year English land is increasing in fruitfulness. There has been, and there still is, a strong prejudice on the part of owners against breaking up pasture; and if we may judge by what has been done with newly broken-up land in many places, the objectors have full and

* 'Journal of Royal Agricultural Society,' Vol. v. p. 113; also Vol. xxiv. part 2, page 540.

sufficient reason for their opposition. Nearly every farmer could point to fields that he once knew as poor pasture; then as heavy corn-bearing land for a few years, and later and ever since as poor, very poor arable land, and "he knows the reason why." Surely, then, it is time that exhaustive systems were abandoned, and more liberal and renovating methods established in their stead.

The question of breaking up pasture, in its broader bearings, not only affects the interests of the landlord, the tenant, and the labourer, but enters so deeply into the general supply of food, and field for the employment of labour, that it more or less concerns the whole community. He who recognizes the wisdom of him who wrote that "The profit of the earth is for all: the king himself is served by the field,"* will feel the national importance of this subject.

No one, however, would advise the indiscriminate breaking up of pasture-land; there is much rich grazing-ground and whole districts in the dairy counties that ought to continue as they are; but, on the other hand, there is much grass-land that has always been unsuited for pasture, its character being such that it could not by ordinary means be made very productive either to the dairyman or grazier. This inferior land (unless rendered unfit by climate, altitude, heaviness of soil, or other peculiarity) would, if brought into cultivation, under fair restrictions and a well-regulated course of cropping, be more profitable to all parties concerned than it is at present.

On the other hand, there is much old cultivated land that would be benefited and renovated if laid to grass for a few years; so that on many farms for every field broken up another of equal extent might be devoted to pasture. Our root-crops would at all events be benefited by the exchange if, as seems likely, the difficulty which has arisen of late years of securing a good growth of turnips has been caused by the repetition of these crops on the same land. Two fields in my own occupation which once grew immense crops of swedes, now, with more liberal treatment in manure, &c., are most precarious in their yield. The swedes when planted make a good start, and a stranger would suppose them to be quite secure; but, as the summer advances, decay begins at the roots, the leaves droop, and the plants become entirely rotten when they have reached the size of a hen's egg. Would not new land be a remedy for these and innumerable other cases of a similar kind?

Little Coxwell, Faringdon.

* Eccles. v. 9.

III.—*On the Planting, Raising, and After-Management of Orchards, and their various Kinds of Fruits, for Culinary and other uses, considered as Marketable Productions of a Farm adapted to the Counties of Worcester, Hereford, and Gloucester.*
By CLEMENT CADLE.

WORCESTER PRIZE ESSAY.

IN travelling through the cider districts every observant person will be struck with the fact that in the management of our orchards there is a great want of system, and that in many respects there is room for improvement; and the occasion of the Royal Agricultural Society's visit to Worcester is an opportune moment for directing special attention to such defects. Instead of the pleasing sight of a well-regulated orchard, in which every tree is in its place, the rows coming in line whichever way you look at them, the branches being trained to a good height and kept well pruned, our visitors will remark many specimens planted without order, very seldom pruned, and oftentimes allowed to become so thick, that they get covered with moss and lose their bearing properties many years sooner than they would under proper management.

In the following remarks it will be my endeavour to carry out the division of the subject proposed in the announcement of the prize:—

1. The planting of the seed.
2. Raising the young stock.
3. The soil, aspect, and circumstances which attend successful cultivation.
4. The after-management,—including planting out, grafting, pruning, &c.
5. The various sorts of trees, with general remarks attending the subject.

1. *Planting the Seed.*

There are almost as many ways of rearing young stocks for an orchard as there are people who attempt it; for, with the exception of nurserymen who make a business of it, you seldom find two men doing it alike.

The common way amongst farmers is to transplant the young plants that come on the must (or refuse-heap left from the last year's cider-making) to some corner or out-of-the-way plot of ground, where but little attention is bestowed upon them, and they are left to take their chance. Some of the plants make good stocks, but the greater proportion grow into short stunted

trees of little value; and when these young trees are planted out, without a proper selection being made, their after-growth exhibits great irregularity, and this accounts for the diversity to be found in our orchards, in which many of the trees never attain a sufficient height for being grafted.

It may be taken as an established rule that the wild apple, or crab, is the best stock to graft upon, alike for the formation of the tree, and also for the keeping properties of the cider. The proper way is to take some crab-apples, such as are used for making vinegar, and partially grind them in a mill, taking care not to crush the kernels; the juice should then be pressed out and the pulp spread out to dry, either in a granary or loft; or if the weather is fine, it may be dried in the open air. It is important to select such crab-apples as are ripe, so as to secure the proper germination of the seed.

After the pulp is well dried it should be stored in some dry place till required for planting, care being taken to preserve it from mice, which are very fond of the sweet kernels.

Some persons prefer picking the kernels out of the crabs or apples without the crushing: this is not material, so long as care is taken to get ripe fruit selected, then to get the kernels dry, and keep them from damp, or other injury.

During the months of February, March, or April, some ground should be prepared for the seed by being well cleaned and manured. A sheltered plot in a garden is a good place, but a piece of old turf which has been trenched up early in the winter is far better. Upon the seed-bed thus prepared the kernels should be strewed in drills 1 foot or 18 inches apart, and just covered with earth; when the must-refuse is used, it should be well rubbed in the hand before being sown.

2. *Raising the Young Stock.*

Another plot of ground, either broken up pasture, as before described, or land dressed with rotten farmyard-manure, should be well prepared, and in open weather, soon after the leaves fall, the young plants should be removed to this plot, being placed in rows 30 inches apart, and 12 inches between the plants, so that the ground may be kept clean, and the young stocks attended to. It is very important that this be done in open weather, for frost is very injurious to the roots: any straggling roots may then be trimmed, but it is better not to prune the top at this stage of the growth, for, as the leaves are the lungs of the plant, every leaf is now of consequence. After being thus planted out they should be left till Midsummer, when the whole of the stocks should be gone over, and any straggling branches or side-shoots should have the end pinched off them: this will divert the sap up the main

stem during the Midsummer shoot, and the plant will have the benefit of the leaves till the following winter. These shoots should then be removed with a sharp knife, care being taken to make a smooth *up* cut. The importance of removing all branches, and roots likewise, by a smooth *up* cut, the edge of the knife being kept away from the tree, cannot be too strongly urged; for if the branch be left bruised or ragged, it holds the wet, decay ensues, and the energy of the young plant is most undesirably taxed to heal and cover the sore; whereas a smooth cut heals at once with a slight scar, and apparently little effort, nature having provided the tree with a curative power proportional to the injury received. Whether the tree should be again removed before being planted in the orchard is a much contested point; many affirm that by moving the stock every year it is in the nursery, you get a hardier and better rooted plant, but I think if the land is of good quality and kept clean they need not be transplanted more than once.

If the young stocks are to be grafted in the nursery (a plan which I do not recommend, for reasons to be noticed hereafter), it should be done in the third or fourth year of their growth. After the stock is $1\frac{1}{2}$ to 2 inches in diameter, or 5 or 6 inches in circumference, it is fit for planting out into the orchard: to attain this size under proper management on good land will take five years, but sometimes six or seven are required.

Other ways of rearing young trees, by suckers, or layers, or cuttings, may be just mentioned, but they are not to be recommended for the establishment of an orchard.

3. The Soil, Aspect, and other Circumstances attending successful Cultivation.

The best soils for the growth of apples are the strong loams and clays on the old red sandstone in Herefordshire, Devonshire, parts of Gloucestershire and of Somersetshire, and the alluvial deposits resting thereon; but some fine fruit is produced on the new red sandstone and blue lias. Pears flourish more on the new red sandstone than on any other soils, as we have abundant proof in Worcestershire.

As a general rule wherever hops are successfully grown orchards flourish, and either a good luscious cider is produced, or excellent table-fruit. The London clay produces good fruit, but it is more suitable for culinary and table purposes than for making cider, and this is generally true with the drier climate of the Eastern counties; the moist climate of the Western counties being requisite to produce that juicy fruit which is suitable for making cider.

Although the presence of lime in the soil is generally desirable

for the healthy growth of fruit, yet the apple-tree does not flourish on limestone formations: hence you seldom see any orchards in the centre of England, on the oolitic and chalk formations; and where apples are grown on a limestone soil, the cider is pale in colour and of inferior quality.

A good depth of soil is of first importance: its texture should be sufficiently tenacious to retain moisture, and not so stiff as to prevent the free passage of water and air; but where the ground is very stiff, a judicious system of drainage will be valuable. The alluvial deposits on the banks of rivers (where the stream is not too rapid to allow a due proportion of clay to be left) are often very valuable for orchards, of which examples may be seen in the vales of the rivers Severn, Wye, Lugg, and Froome. I know of an instance or two in the parish of Westbury-upon-Severn where 60*l.* and 70*l.* have been made in one season by the sale of plums grown on less than an acre of land of this description.

For the counties of Worcester, Hereford, and Gloucester, a southern aspect is the best; for, amongst other reasons, it is very important for the trees and fruit to get the full power of the sun all day. The sweetness of the fruit is in a great measure dependent upon its starch being changed into sugar, and the influence of the sun in ripening the young wood must not be overlooked.

The next best aspect is the western, its chief disadvantage being the strong winds prevalent in the autumn when the trees are covered with fruit; but if their force is broken by surrounding hills, this aspect is nearly as good as the southern.

In an eastern aspect the trees are more subject to blight, which generally is accompanied by east winds. I know this to be the case in my own neighbourhood, but I cannot account for it unless the cold east winds check the healthy action of the juices near the bark, and thus favour the production of the aphid, which is the acknowledged blight.

Frost seldom hurts the trees, unless it comes after rain when the trees are in bloom; the destruction of the wet blossoms is then certain. Orchards planted on high ground suffer less, because they dry faster than those on the lower lands, which are specially subject to spring frosts.

4. *The After-Management, including Planting Out, Grafting, Pruning, &c.*

Having fixed on a field for an orchard, either for making cider or sales at market, and attended to the rules before-mentioned with regard to draining, &c., take a cross-staff and set out in a field a large square, or rectangle, the sides being divisible by the number of yards you intend to have between your trees; place a stake to mark the place of each tree in the

two outer rows, and then fill in the centre with stakes, showing where each tree is to stand; by this means you will get the trees in rows every way, as below. The outer lines show the

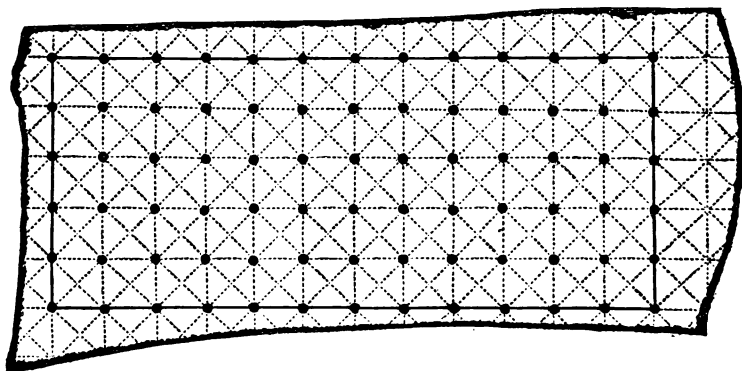

boundary of the field. The broad line shows the rectangle, 144 yards \times 60 yards. The dotted lines show the line of sight, so that, from whatever point you look at the orchard, the trees appear in rows. The portion of the field outside the rectangle can be afterwards planted on the same scheme. If you begin planting on one side, you will to a certainty fail in getting the last trees into their proper places; for if one be set but an inch out of line, it throws the next still farther out.

In planting, if the subsoil is stiff and of bad quality, the holes should be made larger and deeper than usual, the top soil being placed under the roots; but in a good loamy soil it is sufficient to make them 2 feet square, taking care to have the centre 2 or 3 inches higher than the outsides. The roots of the young trees should now be examined, and any rough, straggling portions cut off; an assistant should hold the tree in its proper position whilst some good mould is shaken amongst the roots. After it has been further covered with 5 or 6 inches of loose mould, the stock should be taken with both hands, about a foot from the ground, and slightly shaken up and down, that the loose earth may settle round the roots, care being taken not to raise it high enough for the roots to get doubled up.

It is very important to avoid the common mistake of planting the stock too deep. On stiff soils the previous depth in the nursery is sufficient; but on loose soils it is advisable to go, say 1 to 2 inches deeper. In this, as in all other agricultural operations, the good farmer will exercise his judgment. Many planters recommend that burnt ashes and other manure be thrown into the hole before planting the stock; but if the land is good, the change of soil is sufficient, under ordinary circumstances, for

some years. Any manure applied will do more good by being spread on the surface, and washed into the roots, than if placed *under* the tree, where the rain would carry it still deeper down, and waste its virtues. Neither is it advisable to place farmyard-dung or other rank manure under the roots.

Before the stock is planted the top should be cut back to within 12 or 18 inches of the fork, as this will induce the tree to throw out fresh roots. The distance to be adopted between the trees is an important but disputed point. It should be our aim that no two trees, when full grown, should touch each other, so that the distance in a great measure depends on sort, soil, &c. : about 12 yards is the average interval, and it should never be less than 10 yards. This may seem wide to those who have been in the habit of planting at 6 or 7 yards. The effects of close planting are to be seen in almost every parish: the boughs run into each other, and the trees become like a wood, and covered with moss; for want of air the herbage is destroyed, and the trees leave off bearing, and have all the symptoms of age, when they would have been most productive had the distance between them been sufficient. I can mention an instance in which the same man who, when young, assisted to plant an orchard, was employed, before he was sixty years of age, to cut down some of the same trees in consequence of their being so thick that they killed the grass under them. I was present myself, and saw that many of the boughs were interlaced one with the other for two or three yards. The fruit grown on these thick trees is only fit for making sour cider, as a great proportion of it never properly ripens.

This thin planting is no new theory. I have in my possession a book 210 years old, called 'Country Contentments,' by Jervase Markham. The author says, after writing upon small, evil-thriving, sour fruit, galls, wounds, diseases, and short life to trees—"To prevent which discommodity, one of the best remedies is the sufficient and fit distance of trees. Therefore at the setting of your plants you must have such respect that the distance of them be such that every tree be not an annoyance but a help to his fellows; for trees (as all other things of the same kind) should shroud and not hurt one another; and assure yourself that every touch of trees (as well under as above) is hurtfull. Therefore this must be a general rule in this art, that no tree in an orchard well ordered, nor no bough, nor cyon drop upon or touch his fellows." He afterwards says—"And herein I am of a contrary opinion to all them which practise or teach the planting of trees that ever yet I knew, read, or heard of, for the common space between tree and tree is ten foot; if twenty foot, it is thought very much. But I suppose 20 yards distance is small enough betwixt tree and tree, or rather too too little. For the dis-

tance must needs be as far as two trees are well able to over-spread and fill, so they touch not by one yard at least."

When the stocks are all planted, they should at once be protected from cattle and sheep, either by a triangular guard formed with three stakes and cross-bars, for which hurdle-materials are stout enough, or else with furze or bushes, bound round the tree by a withe or two, if more convenient to the farmer. The objection to the latter guard is, that in a year or so it is rubbed off by cattle, and its repair is overlooked until the young tree is peeled. Another plan is to use galvanized wire lattice-work, which can be had at 4*d.* per tree. Good stocks vary in price from 1*s.* to 2*s.* 6*d.* each: if you buy, get good stocks, and never mind the price; and be sure they are between 6 and 7 feet high.

As to the cost of planting, an orchard set out at 12 yards between each tree will take nearly thirty-four trees per acre; and as good stocks, 6 to 7 feet between root and branches, and 2 inches in diameter, will cost, say 2*s.* 6*d.* each, the expense will be as under:—

34 trees, at 2 <i>s.</i> 6 <i>d.</i>	£.	s.	d.
Planting, at 6 <i>d.</i> each	0	17	0
Protecting with timber at 1 <i>s.</i> , or with bushes at 3 <i>d.</i>	8 <i>s.</i> 6 <i>d.</i> }	1	14	0
Galvanized lattice wire, at 4 <i>d.</i>	11 <i>s.</i> 4 <i>d.</i> }			
Grafting, at 1½ <i>d.</i>	0	3	8 or with food, 1 <i>d.</i>
Pruning for first 8 years	0	17	0
		<hr/>		
		£7	16	8

If the trees be planted at 10 yards' distance, the price would be very much increased, as 48 trees would then be required, which, at the same rate, would cost 11*l.* 1*s.* 2*d.* A tenant-farmer, unless he has a lease, or a thorough confidence in his landlord, may well hesitate about making such an outlay as this, for which his prospect of return or compensation is precarious. Yet I have never met with any mention of tenant-right with respect to the planting an orchard, except that recorded by Professor Tanner, in his Report on the Agriculture of Shropshire, vol. xli. 'Royal Agricultural Society's Journal.' He there writes—"Where orchards are planted by the tenant, if he leaves the farm within eight years, the cost of the trees and interest are paid to him in full; but the compensation subsequently decreases one-eighth every year." I should strongly recommend that a clause to this effect should be adopted in the counties of Hereford or Worcester; for it would much benefit estates, and tend to their being well stocked with fruit-trees. When in an old orchard the trees are worn out, I should not recommend its being replanted, at least

with the same kind of fruit-tree. It will be better to select a new field, and fresh, unexhausted soil.

For the grafting, it will be well to employ a practised and careful hand; many such may be readily found. The general price is 1*d.* per graft, and food. For general orchard purposes I recommend cleft-grafting, after the trees are planted out. Nurserymen generally get a better price for a grafted than for an ungrafted stock, and they prefer saddle and other kinds of grafting, which is done while the tree is young. If you have the grafting done after the planting-out, you can choose your own sorts; and the trees always make better heads; they come better together, and match better in the orchard. The grafting should be done either the first or the third year after planting, and not in the second year. The reason for this is, that in the first year you cut the top back to favour the growth of the roots; and although in the second year there would be energy enough left to support the grafts, still they are not found to do so well (perhaps in consequence of the young roots taking too much of the nourishment) as if you wait till the third year, when the tree is well established.

In the third year the top should be sawn off in the month of February to keep the sap back; and at the time of grafting, in March or April, should be cut off another inch or so below the first cut; then, with the saw, make a slanting cut into the stock, and with a sharp knife cut a wedge-shaped opening into it; then take the graft, reduced to about 9 inches in length, and cut the lower end so that it just fits the cleft in the stock, and so adjust it that the graft and stock fit perfectly all the way up, keeping the tissues or inner rind of the graft exactly opposite those in the stock; it should then be gently tapped on the top with a small mallet to drive it firmly in its place; and then covered with a composition of chopped hay and clay, well tempered together, forming a ball, in the shape of an egg, round the junction of the graft and stock. This will remain for a twelvemonth; but if it does not fall off in eighteen months, it should be removed.

It is an excellent plan to have some wicker-baskets made for enclosing the graft, which, being bound to the stock below the graft, protect it from blows or gales: they can be had at a cost of about 6*d.* each. In choosing the grafts it is very important not to cut them from cankered, diseased, or even old trees; the best are taken from good bearers, about one-third grown. These may be cut as early as February, and may be kept in a damp cellar, or any moist place, or they may be pushed into the soil 3 or 4 inches deep in any piece of garden-ground. The grafts should be cut before the sap commences its spring movement.

It will very much improve the orchard if, as far as the choice

of varieties permits, the trees are grafted in rows, so that one row be assigned to a wide-spreading sort, and the next to one of more upright growth.

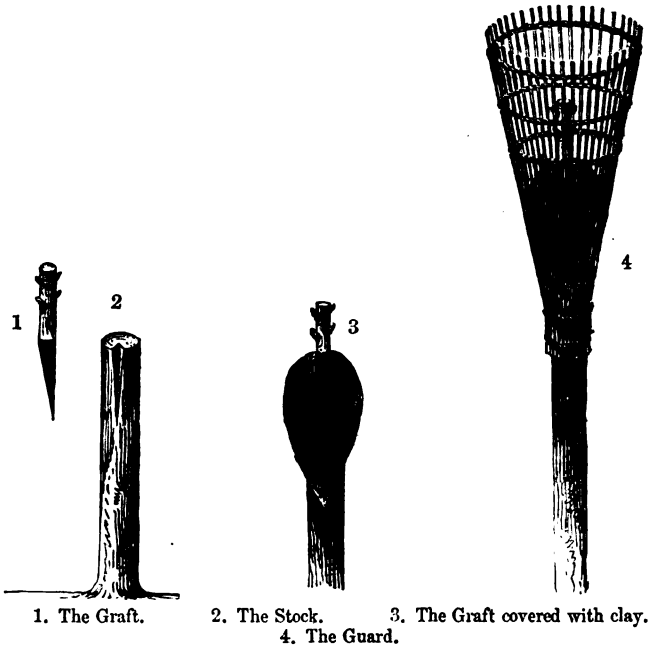

On the early pruning of young apple-trees their future growth depends. Great care is requisite to secure a well-formed head; neglect at this time is irreparable. There are generally three or four buds left on the graft, and from these the careful pruner forms his tree. These, in the second winter after grafting, should be looked over, and any branches not growing right should be removed, and also any side-shoots on the stock, and which may be diverting the sap from the graft.

Every winter, as soon as the leaves are fallen, or not later than January, the young trees should be gone over, and all cross-branches cut out; for these branches are the future limbs of the tree, and, to produce a wide-spreading head, these must radiate and spread outwards; every branch that rubs against another should also be removed. If the object be to grow table-fruit of a large size, it will be the more essential to keep the boughs thin and open, and you must not expect to get both quantity and quality. Great care is requisite in the removal of useless wood which does not bear. Pruning is too commonly either over-

done, so that the trees are weakened by too much being cut at once, or else it is neglected, and the orchard left quite to itself. Many of those who profess to understand it—and even some who have followed it for years—are unable to state any rule for their practice, it being with them quite haphazard work where to cut, and where not.

The chief object of the pruner is to keep up a supply of bearing wood in its most productive stage of growth. I have conversed with some who, as in the case of vines, advocate mid-summer pruning, with the object of throwing the sap, which would otherwise be expended on the branches to be removed, into those which are left, and thus make the fruit grown much finer. As I have not seen the system in operation, I merely call attention to it without further comment.

The main rule in pruning is to prune *every* year whilst the trees are young, and in after years never to exceed three years between each pruning. When a large quantity of cider is the chief object, much pruning is not desirable; but if quality be of importance, then the trees should be so pruned that nearly every apple may get sufficient sun to ripen it. If the fruit is required for table use, or for sale, the same pruning must be effected, and care must also be taken that the fruit be not left too thick on the tree. This is never much attended to in orchards; but what would become of wall-fruit if the trees were not properly thinned?

*The Sorts of Fruit.**—It is almost impossible to give satisfactory information on this head, because the same sort is not only known by different names in different localities, but also it assumes a widely different character under the influence of broad distinctions of soil and climate, and this is more frequently the case with pears and apples. In a tour I made last autumn in the south of Devonshire, I visited several farms in the neighbourhood of Totnes and Paignton, and amongst a great number of sorts that I there saw, I could in no instance recognise either an apple or tree as being like those I had seen before in Herefordshire, Gloucestershire, or Worcestershire; but as this Essay only applies to these counties, the matter is very much simplified. For these reasons the choice of sorts must be left in great measure to local inquiry, those which suit best one district being often in no repute in another.

But in selecting trees for producing cider or perry, it is very important not only to get those kinds which suit the district,

* Professor Johnson, in his 'Chemistry of Common Life,' vol. i. p. 314, says,—
 "In Normandy not less than 5000 differently named varieties of the acid or bitter apple are known, and grown for the manufacture of cider."

but to get a variety in their character, especially for making good cider. Thus, some of the apples should be sour, others sweet, bitter-sweet, tart, and harsh, as much of the keeping character of the cider depends upon this mixture, which also makes it fine down well. It may be remarked, that sweet or eating sorts of pears seldom make perry that will keep any length of time, or that fines well.

There is another peculiar feature in regard to sorts of fruit, viz., that each variety has its day, then gradually dies out—the trees become non-bearers, and their places are filled with new sorts. This is especially the case with the Hagloe Crab, Foxwhelp, and Skyrme's Kernel, which seldom bear or grow well now, and are nearly gone out.

LIST OF PEARS.

- Barland—Produce great; until last few years in great demand for early drinking.
- Oldfield—Produce moderate; easily fined, and of great value for bottling.
- Moorcroft—Produce moderate; very strong, making nearly the strongest perry we have.
- Longland—Produce great; perry of a very high colour.
- Red pear—Produce great; much used for bottling; valuable sort.
- Blakeney Red pear—Produce great; quantity of liquor great.
- Trump pear—Produce great; perry strong and large in quantity, but bad to keep.
- Pine pear—Produce great; perry large in quantity, but not very good in quality.
- Huffcap—Produce variable; in some districts good and used for bottling.
- Holmore pear—Produce large and of good quality in some districts.
- Taynton Squash—Produce middling; the most valuable sort for bottling.
- Thorn pear—Produce large; perry not very good, and will not keep.
- Honey pear—Produce large, but a very small pear.
- And numerous other sorts having local names, such as the Dadnor pear, Ingestone pear, &c.

LIST OF APPLES.

Those marked with (A) are good for hoarding, and those with † are good for boiling.

- Skyrme's Kernel—Tart; good for cider.
- Royal Wilding—Bitter sweet; good for cider.
- Black Foxwhelp—Moderately tart; good for cider.
- †Red Foxwhelp (A)—Moderately tart; good for cider.
- Cowan Red—Sweet; good for cider.

- †Dymock Red (*A*)—Very sweet; good for cider.
 White Norman—Bitter sweet; good for cider.
 Red Norman—Bitter sweet; good for cider.
 Hagloe Crab—Tart; good for cider.
 Pawson—Tart; good for cider.
 †Redstreak—Sweet; good for cider.
 Yellow Styre—Sweet; good for cider.
 †Hooper's Kernel (*A*)—moderately sweet; good for cider.
 †Hill Barn Kernel (*A*)—Sweet; good for cider.
 †Ribston Pippin (*A*)—Sweet; good for table and keeping.
 Golden Harvey (*A*)—Sweet; good for table and for cider.
 Siberian Harvey—Sweet; good for cider.
 Farewell Blossom—Tart and bitter; large bearer.
 Upright French—Bitter sweet; large bearer.
 Black or Red French—Bitter sweet.
 Knotted Kernel—Tart.
 Leather Apple—Hardly any taste.
 Ironsides (*A*)—Hardly any taste; good for keeping.
 †Cats'-heads (*A*)—Sweet; good for cider.
 Pigs'-eyes—Sweet.
 Downton Pippin (*A*)—Sweet; table and eating.
 †Codlings (*A*)—Sweet; good as boilers and for cider.
 †May Blooms (*A*)—Sweet; good for cider, boiling, and keeping.
 Rough Coat (*A*)—Dry and sweet; good keepers.
 Brandy Apple (*A*)—Very sweet; makes strong cider.
 †Cowarne Quinine (*A*)—Sweet; good for cider.
 †Blenheim Orange (*A*)—Very sweet; good for table.
 †Golden Pippin (*A*)—Very sweet; good for table.
 Old Pearmain (*A*)—Very sweet; good for table.
 Brown Crests—Very sweet.
 Under Leaves—Sweet; large bearer.
 Red Kernel—Sweet; good for cider.
 †Reynolds's Kernel (*A*)—Sweet; large pot-fruit.
 Newland Kernel—Bitter sweet; good for cider.
 Jackson's Kernel—Tart.
 †Sam's Crab—Tart.
 †Bridgewater Pippin (*A*)—Sweet.
 †Spice Apple (*A*)—Sweet.
 White Beach—Bitter sweet; good for cider.
 Handsome Mandy—Bitter sweet; good for cider.
 Golden Rennet (*A*)—Sweet.
 Pin Apple—Moderately tart; wood cankers.
 †Stoke Pippin (*A*)—Sweet: good bearers; pot-fruit and for cider, and numerous others.

Among the Devonshire sorts I noted the Cockagee, Styer, Royal Redstreak, Duffling, Thousand-pound-apple, Fourpenny-apple, Sheep-nose, Pocket-apple, &c. Perhaps the most general favourite with us is the Upright French, especially on sandy

soils, and where quantity rather than quality is desired, in consequence of the certainty of getting a crop every other year. Many of the sorts here mentioned have three or four different names in different districts; and some of these are the same sort only changed in name, form, and character by change of district. The finest class of fruit-trees I have ever met with are in the parish of Monkland, near Leominster, where it is quite the exception to be able to reach the fork, or part where the branches leave the trunk, and the trees attain a large size. Near the Rectory is a remarkably fine pear-tree orchard; indeed throughout the parish the fruit-trees are very large, kind, and healthy. But although each sort has its own characteristics of growth and stature, the size of the tree depends more on the nature and quality of the soil than on these peculiarities. The orchards in Worcestershire seem to get better attention than those in Herefordshire; and, from the climate being drier, they are not so much covered with moss. I was surprised to see how well they were pruned between Worcester and the parish of Rock, and also in several other places in that county which I have had occasion to visit; but I suppose the less fruit there is grown, the more it is appreciated, and therefore attended to.

I have not given any account of the diseases of trees, as I do not think there is any cure: prevention is the surest plan. Be sure not to graft from cankered wood; and the better to insure this, cut the grafts yourself, or see them cut. The blight is not under the control of the farmer; nor do I pretend to investigate its origin. As it is acknowledged to be the *Aphis*, or plant-louse, it is certain little can be done in the way of prevention; for in a few days after an east wind has reached us, the trees are covered with myriads, although in some seasons we are quite free.*

The growth of moss on the orchard-trees is more under our control, as it is favoured by damp and the want of a free circulation of air: draining and good pruning will do much to correct this evil; but it is also a good plan to wash the body and limbs of the tree with a mixture of lime and cow-dung every two or three years.

I am fully convinced, that if more attention were paid to the

* On the subject of blight Mr. Belfield states (in the 'Bath and West of England Journal,' New Series, vol. iii. p. 196) that the blight is the result of a check in the sap caused by a sudden change in the atmosphere. My own observation tends to confirm this view rather than that of Mr. Tyrrell, who, in vol. v. p. 325, of the same Journal, states that it is not always the *aphis*, but sometimes a black grub, then a green one, at other times a striped one, that infests the trees. But these grubs do not generally come till after the leaves are on the trees, consequently the damage is not so wholesale.

cultivation of apples of a large size, there would be a good sale for them to go to the manufacturing districts. In the neighbourhood of Gloucester and Worcester, many farmers make a large profit by the sale of fruit, some years getting 5s. to 6s. per pot for them. When apples are abundant they are sometimes purchased for use as a dyeing material ; but the demand is not large or important.

The following analyses show the composition of apples and pears :—

<i>Apples according to BERARD.</i>		<i>Pears according to BERARD.</i>	
Water	86·28	Water	86·25
Sugar	6·45	Sugar	6·45
Ligneous matter	3·80	Vegetable fibre	3·80
Gum	3·17	Gum	3·17
Malic acid	·11	Malic acid	·14
Albumen	·08	Albumen	·08
Chlorophyle	·08	Chlorophyle	·08
Lime	·03	Lime	·03

Apples contain 0·27 per cent. of ash, and pears 0·41, the composition of which, according to Richardson, is as follows :—

<i>Apples.</i>		<i>Pears.</i>	
Potash	35·68	Potash	54·69
Soda	26·09	Soda	8·69
Lime	4·08	Lime	7·98
Magnesia	8·75	Magnesia	5·22
Sulphuric acid	6·09	Sulphuric acid	5·69
Silicic acid	4·32	Silicic acid	1·49
Phosphoric acid	12·34	Phosphoric acid	14·28
Phosphate of sesquioxide of iron	2·65	Phosphate of sesquioxide of iron	1·96
		Chloride of sodium	trace
	100·00		100·00

An examination of these analyses suggests an explanation of a variety of facts well known amongst practical men. Thus, pears contain more lime and potash, but less silica and soda than is found in apples ; hence pears are better adapted to some situations, and apples to others. Some pear-trees bear a ton every year ; and in a ton of pears there would be upwards of 4½ lbs. of potash : thirty such crops would remove more than 1 cwt. of potash from the soil traversed by the roots of the tree ; hence it is not desirable to plant pear-trees in land deficient in potash. Apples contain a less quantity of potash, but three times as much silicic acid, and also more magnesia ; and thus we see one reason why we sometimes find one fruit flourish so much better than the other.

The resemblance between the ashes of the hop-plant* and those of apples may perhaps explain the fact previously named, that good cider is produced in the same districts where good hops are grown. Trees, when in a state of nature, prevail on soils adapted to their special requirements; for instance, when one generation dies out it is mostly replaced by another kind of tree, as is often seen in American and other forests. Chemistry has explained that this change arises from the partial exhaustion of some particular constituent in the soil; and it also warns us, in our cultivated lands, not to persist, except under special circumstances, in the cultivation of the same plant.

Orchards should be manured once in five or six years, or at farthest six to eight years; the stronger the soil the larger may be the quantity, and the greater the interval; as the lighter the soil, the more readily is the manure washed into the porous rocks below. The following would, I think, be found a good dressing for orchards, viz., a mixture of carbonate of potash, common salt, nitrate of soda, and either partially dissolved bone, bone superphosphate, or fine bone, mixed together, the bone manures being varied according to the nature of the soil. If it be light, bones may be used; if very stiff, superphosphate. A compost should also be made every year of the must or refuse-heap left from the cider-making. This is usually considered of no account because of the acetic and lactic acids present; but I have found from experience, that if hot lime is mixed with it, these acids are neutralized, and a good compost obtained by the following winter. It should be applied to the trees 2 yards beyond the extending branches, and to within 2 yards of the trunk, and not thrown close round the trunk, as is commonly done.

I have not taken any account of cherries, plums, and other fruits, which, in the counties specified, are not among the marketable productions of the farm, but generally confined to gardens. Many of the same rules apply to these fruits as to apples and pears.

*Ballingham Hall, Ross,
Herefordshire.*

* Hop ashes contain 19·41 per cent. of potash, 17·88 of silicic acid, 14·15 of lime, 5·34 of magnesia, and scarcely any soda at all.

IV.—*Observations on Parasites and Parasitic Diseases as affecting Domesticated Animals.* By JAMES BEART SIMONDS, Professor of Cattle Pathology, Royal Veterinary College.

INVESTIGATIONS of the lower forms of animal life are among those which most interest and instruct the student of Natural History; but when they have for their more immediate object an elucidation of the causes of disease they acquire an importance not otherwise belonging to them.

The study of those creatures known as parasitic has of late years been rewarded by most unexpected discoveries, and we are now enabled to understand much of that which before was mysterious and hidden. Nor is this all, for to a great extent, also, we have been furnished with the means of preventing many of the diseases which are known to be connected with the presence of parasites both in man and animals. Each diligent investigator has in his turn contributed something to our former knowledge, but yet much remains to be done. A rich harvest still awaits him who labours in this field of science.

In the following pages we purpose to speak of the parasites affecting domesticated animals in particular; to describe their structure and habits, and to deal practically with the means of either effecting their removal from the bodies of their hosts, or of counteracting their morbid influences. It may be truly said that no part of the organism is exempt from their indwelling, and that to reach their habitat many of them undergo strange migrations, and still stranger transformations, the particulars of which will, however, best appear as each creature is passed in review.

Parasites are usually divided into three classes: those which infest the skin in particular, and being *upon* an animal have hence been termed *Epizoa*; those which occupy for a given time only, while undergoing a metamorphosis, either the external, or some internal part of the body with which there is a direct communication—the *Ectozoa*; and those which inhabit the internal organs and are met with at times in every tissue of the frame—the *Entozoa*. In our description we purpose to deal with the different individuals belonging to these several classes, in the order in which they have been named.

EPIZOA.

Pulex.—THE FLEA.

The flea is too well known to require a special description either of its structure or form. It is a creature remarkable for

its agility and strength, being capable, according to computation, of leaping fully two hundred times its own length, and of moving a weight which many times exceeds that of its body.

Fleas infest various mammals and also birds, but are rarely met with on any domesticated animal, excepting the pig, the dog, and the cat. Poultry and pigeons are likewise subject to fleas, and occasionally they are present in very large numbers in old straw or thatch, and are thus brought into the cattle-sheds and pig-cotes of the farm, or even into the house itself. In a case which came under our notice some years since, we were enabled to trace their presence to the erection of some pigsties with old building-materials, and the thatching of them with *old straw*. They were erected in a meadow near to the premises, and proved to be so infested with fleas that the proprietor at last wisely determined not only on pulling them down, but on setting fire to the whole of the materials. By these means alone he succeeded in freeing his dwelling-house, and also that of a neighbour, from these troublesome parasites.

Besides instances of this kind, it has not unfrequently happened that extraordinary visitations of fleas have taken place in particular districts, the origin of which could not be traced. We were recently informed of such a case; too late, however, even for an examination of specimens to determine the variety to which the fleas belonged. The visitation assumed such proportions that not only the yards and buildings but the adjacent fields also swarmed with these troublesome insects. After remaining for three or four weeks, to the great discomfort of the family as well as of the animals on the farm, they gradually disappeared, without any means for their eradication having been adopted.

Naturalists place the flea in the order *Diptera*, sub-order *Aphaniptera*—sheath-winged and hopping diptera—and family *Pulicida*, of which it constitutes the only genus, although the varieties are numerous, amounting, according to some authors, to as many as twenty-five. The insect undergoes a complete metamorphosis, analogous in every respect to that of moths or butterflies. The female flea of man—*Pulex irritans*—is said to lay about a dozen eggs at a time, which are ovoid in form and comparatively large, bearing a strong resemblance in these particulars to the egg of the dog-flea. At first the eggs are of a whitish colour, but they soon acquire a dark hue.

The egg of the dog-flea, see Fig. 1, A., which may be taken as a type of the class, gives birth after a very short period to a larva, which is long and slender, somewhat resembling a worm in its form, and differing in no essential particular from the larva of the *Pulex irritans*. The larva, Fig. 1, B, as will be observed in the illustration, consists of fourteen

segments, including the head. These gradually increase in size towards the caudal extremity of the creature, reaching their fullest dimensions at about the tenth segment, from which they again diminish. Although the larva is not furnished with legs, it is nevertheless remarkably active in its movements, which are crawling or worm-like. The head is surmounted by two very small antennæ. The mandibles are well developed, but their precise arrangement does not admit of being clearly defined. No eyes can be detected. Each segment below the head is beset with a few stiff hairs, the number and size of which also increase towards the caudal end of the larva. On the edge of the last segment but one the hairs are so long and thickly set as to form a kind of fringe, which often projects beyond the hooklets that are here developed. A similar arrangement of them is also to be observed, but in a less degree, upon the last four or five segments. Besides this peculiarity, the extreme end of the last segment is furnished with a tuft of very fine hair, and it gives origin also to the two small hooklets previously alluded to.

FIG. 1.

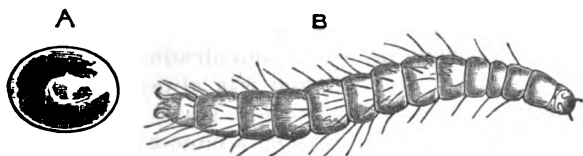

Ovum and Larva of Dog-Flea. Magnified.

It is thought by some naturalists that the larva of each variety of flea, besides inhabiting the skin of the animal to which it especially belongs, often travels to other mammals or birds, obtaining from them a supply of food suited to its rapid growth and development. According to Rymer Jones, the larva of the *Pulex irritans* attains its full size in about twelve days subsequently to quitting the egg, when it forms for itself a small cocoon, after the manner of the silk-worm, and changes into a pupa. Whatever the fact may be with reference to the larva of this flea, we can take upon ourselves to say that the larva of the *Pulex Canis* often lives double this time before the change is effected. The period which elapses before the *imago* bursts forth is said by Newman and others to range from eleven to sixteen days, a statement which our observations tend to confirm.

The Pulex Canis.—Firstly, it is necessary to remark, that as the form of the flea is modified in each individual animal whose body it inhabits, the flea of the dog can be easily distinguished from any other by a microscopical examination. The chief

points of difference between it and the *Pulex irritans* consist in the lower part of its head, and the upper and lateral parts of its prothorax being provided with a comb-like fringe. The use of this is not very apparent, but probably by the pectinate edge of the prothorax the creature is enabled to keep a firmer hold of the hairs when travelling over the body of the dog, while by that of the lower part of the head it can the more easily push aside the downy hairs so as to insert its lancets and suctorial organ into the skin to obtain its food. When located on the body, even in small numbers, dog-fleas cause considerable and persistent irritation, but do not give rise to any special form of eruption, although the dog will occasionally rub himself quite bare in places in his attempt to rid himself of their presence.

All the metamorphoses which the creature passes through are frequently completed on the skin of the dog, and hence many dogs suffer considerably from fleas for months together. A remarkable instance of this kind was brought under our notice a few years since by Mr. Austin, M.R.C.V.S., of Exeter, in which a dog had been for six months the subject of excessive cutaneous irritation. The case will be found recorded at p. 335 of 'The Veterinarian' for 1855.

Mr. Austin stated in his communication, that although the itching had existed so long, and was always very considerable, still, when the animal was brought under his care, no eruption was to be observed. On making a close examination, however, he says, "I discovered a number of little animals, unlike any I had ever seen before, upon nearly every part of the dog's body. I succeeded in getting some of these alive, mixed, however, with much dirt and scales of cuticle. I send them by a friend, and hope they will reach you before they are dead or dried up."

In commenting on this case, in the Journal alluded to, we observed, "that *more than a month had elapsed* before the small jar containing the parasites came to hand, and consequently we despaired of finding any of them alive. To our surprise, however, we found three or four still living among the mass of dirt and cuticle. A slight examination was sufficient to show that these were the *larvæ* of some insect, and the microscope at once decided that they were the *larvæ* of the dog-flea. Further search showed that there were numerous dead *larvæ* and *exuviae* present, and therefore, to facilitate our future examination, the whole mass was placed in a phial with some diluted spirit, that the organisms might be freed from the dirt, and be the more readily selected after their imbibition of the fluid. By this means we obtained specimens which rendered the history of the dog-flea perfect and com-

plete. Thus we have in our possession *ova*, showing more or less perfectly the formation of larvæ within them; *ova-cases*, from which the larvæ had escaped; *larvæ*, in different stages of growth; *exuvie*, as cast off from time to time from the growing larvæ; *pupæ*, in their various stages of change into the perfect insect; and *insects* themselves just brought into active life.*

This extract, in addition to our other remarks, so fully explains everything connected with the habitat and effects of the dog-flea, that we may proceed to speak of the means at our command to rid the animal of this troublesome parasite.

Blaine, in his 'Canine Pathology,' thus writes:—

"Washing the body well with soap-suds and directly afterwards combing it with a small-toothed comb are the most ready means of dislodging these nimble gentry. But it must be remembered that the previous washing is only to enable the comb more readily to overtake them; the water does not destroy them, for dogs who swim every day are still found to have fleas. These insects are very tenacious of life, and soon recover this temporary drowning; the comb, therefore, is principally to be depended on for their capture before they recover. But as washing is not, in many instances, a salutary practice; and as, in many others, it is a very inconvenient one, so it becomes a matter worthy of consideration how to be enabled to destroy them without these means.

"Sopping the skin with tobacco-water has been recommended; but it has only a momentary effect, and it not unfrequently poisons the dog. Innumerable other means I have tried to *drive away* fleas, but the only tolerably certain one I have discovered, is to make dogs sleep on fresh yellow deal shavings. These shavings may be made so fine as to be as soft as a feather-bed, and, if changed every week or fortnight, they make the most cleanly and wholesome one that a dog can rest on; and the turpentine in them is very obnoxious to the fleas. But, where it is absolutely impracticable to employ deal shavings, it will be found useful to rub or dredge the dog's hide, once or twice a week, with very finely-powdered resin; if simply rubbed in, add some bran." †

Besides the means recommended by Blaine, our experience in the use of a watery solution of the sulphide of potassium in the destruction of fleas and their larvæ, warrants us in strongly recommending this agent. Let the dog be sponged over with the solution, *freshly* made by adding 2 ozs. of the sulphide to a pint of water. The whole body should be covered at a time, and the sponging be repeated two or three days in succession, after which the skin should be thoroughly cleansed with soap and water.

It should be remembered, however, that where dogs are sleeping in kennels out of doors the most effectual means of ridding them of fleas will often fail for want of a complete cleansing of the kennels. These should not only be well washed, but thoroughly purified with lime-water, and it may even be necessary to do this two or three times in succession. The same care should

* 'Veterinarian,' 1855, p. 335.

† 'Canine Pathology,' p. 281.

be taken also to cleanse all sleeping-places and everything contiguous to them, where these parasites, either in their perfect form or in one or other of their metamorphoses, are likely to exist. Similar means are to be employed in ridding pigs, and pig-cotes of fleas, and especially should all the old litter be destroyed.

Pulex penetrans.—THE SAND-FLEA, CHIGGER, CHIQUE, CHIGUE, &c.

Another of the family of *Pulicidæ* is the *Pulex penetrans*, a variety from which this country is fortunately exempt. It has been said, however, to exist in the feet of sheep, and to be the means by which "foot-rot" extends in a flock, even in this country. The late Mr. Youatt, who was himself a believer in the contagiousness of this disease, thus writes:—"Some persons have imagined that foot-rot is propagated by means of animalculæ which are bred in the virus of the part, and falling on the pasture attack the feet of other sheep. They have gone so far as to describe this insect, and to give it a name—the *Pulex penetrans*. The author of this work has often sought for it in vain; and the sources of contagion are numerous, and satisfactory enough without any gratuitous supposition of the kind." *

With the question of foot-rot being viewed as a contagious disease we have not now to do; nevertheless we ought not to allow this opportunity to pass without stating that we are no converts to such a doctrine, knowing full well that the spread of the disorder in a flock depends entirely upon common causes.

Dr. Stephenson, in his 'Medical Zoology,' thus speaks of the *Pulex penetrans*:—"One of the most troublesome and noxious insects of the low regions of South America and the West India Islands is the *Chegoe*, a small species of flea, with a rostrum as long as the body, which often introduces itself into the skin of the inhabitants, usually under the nails of the toes, where it deposits its eggs, and produces malignant and occasionally fatal ulcers. It is a very minute insect, being one-fourth the size of the common flea, pale reddish-brown, semi-transparent or shining, with the legs of a pale blueish or lead colour. According to Ulloa, and his opinion is confirmed by Jussieu, there are two South American species of this insect. It is described as generally attacking the feet and legs; but, according to Capt. Hancock, it will penetrate any exposed part of the body. At first it occasions no farther uneasiness than a slight itching and heat; in process of time, however, a small bladder or membranous sac is formed, containing the nits or ova, which speedily multiply

* 'Sheep: their Breeds and Management,' p. 534.

to such a degree as to be attended by the most fatal consequences, rendering amputation necessary, and sometimes causing death.”*

In Küchenmeister's work on animal parasites, it is stated that, “according to most authors, the *Pulex penetrans* only lives as far as 29° of south latitude in the hot countries of South America, especially in Brazil; whilst Goudot found it even in the cold region of New Granada as far as Bogota. According to the journals of Count Görtz, besides sand, the flea likes to dwell in the crevices and joints of ‘pig-sties.’ Again, “Martiny gives the following notes upon it from Dobritzhofer. This animal is so small that it can only be seen by sharp eyes with a good light, for which reason the seeking for the flea after its immigration is generally left to children. It perforates the skin down to the flesh, and, concealed in its little canal, swells up into a white, globular vesicle, which in a few days may become as large as a pea, the pain constantly increasing; this is the abdomen of the female filled with eggs, or, more correctly, with larvæ. Neglect of the disorder or careless rupture of the vesicle, that is, the abdomen, by which the young are scattered in the wound, where they then mine fresh passages, leads to bad sores, to inflammation of the glands of the groin, to mortification, and, in consequence, to amputation or mutilation of the limbs, or even to death. The toes are especially attacked by the flea, although other parts of the body are also visited.”

Alluding to the treatment of cases of this kind, Küchenmeister says, “When the animal has once made an entrance, the orifice of the canal, which is marked by a red point, may be sought, the passage widened with a needle, and the flea drawn out, but without tearing it. With fresh punctures it is best to wait a day, until the occurrence of the white vesicle, that is to say, the swelling of the abdomen with the brood, allows the animal to be more readily detected. Here also I should think that touching this vesicle with oil of anise would be beneficial and kill the flea (because the respiratory stigmata are situated upon the abdomen) or compel it to wander out. The cavity remaining after extraction is treated like a simple wound. In Brazil they fill it with oil, snuff, or ashes.” †

Ixodes Ricinus.—THE TICK.

The tick is a true blood-sucking parasite, belonging to the family *Ixodida*, the class *Arachnida*, and order *Acarina*. The species or varieties are very numerous, both here and in most other countries.

* ‘Medical Zoology,’ p. 193.

† Küchenmeister's ‘Animal Parasites,’ vol. ii., p. 92.

Although ticks are met with upon every variety of domesticated animal, as well as upon several wild ones, still the *Ixodes Ricinus*, dog-tick, the *Ixodes reduvius* and the *Ixodes plumbeus*—sheep and cattle ticks—are best known in this country.

These parasites exist in most localities, but they especially abound in light, sandy, and warm districts, where brushwood, thickets, and plantations prevail. In such situations they remain secure from injury, and comparatively at rest during the intervals which elapse between the times of their obtaining a full supply of blood from the animals they attack. Prompted by hunger, however, the tick becomes more active, and will then fasten itself upon almost any animal which may come in its way. To effect this it plunges its rostrum—sucking proboscis—deeply into the skin, and thus fixed it will hang on for days together sucking the blood, until its body becomes distended to eight or ten times the original size. When filled to repletion it quits its hold, and again seeks the security of its hiding-places.

It is by no means an unfrequent occurrence for horses in such localities, while at exercise at early morn in summer, to be attacked by ticks, and consequently to return to the stables with several of the parasites upon their legs. Besides animals ticks will frequently attack birds, and they have been also known to occasionally fix themselves on man to obtain a supply of blood. It is, however, only in very rare instances, and these chiefly in dogs, that ticks exist in sufficient numbers to give rise to much irritation or suffering. Dogs taken out for sporting will often return with a large number of them fixed to their skin. This is especially the case with dogs used for rabbit-catching in the autumnal period of the year, more particularly when warm weather prevails. Ferrets, also, which are employed to drive the rabbits from their burrows, will be attacked in a similar manner. Rabbits when killed are frequently found to have several of the parasites upon them; and so also, but more rarely, are hares. Not only is this the case, but weasels and stoats are so generally affected with ticks, most of which are so small and young, that some persons have supposed that the parasites are originally bred upon these and similar wild carnivora by the parent tick depositing its ova on different parts of their bodies. It is a somewhat singular circumstance that ticks, which do not seem as a rule to show any preference for one part of the body over another, are said to congregate inside the ears and between the toes of weasels and stoats. It is supposed by some that these places are selected by the young ticks, as the animals cannot easily dislodge them from thence; while by others it is thought that the ova of the parent tick were deposited in these sites.

A few years since we met with a large number of young

ticks adhering to the head and face of a horse sent to the College for examination as to soundness. The animal had been forwarded from the country to a gentleman in town a few days before, and the parasites had not been detected until seen by ourselves, probably in consequence of their small size and brown hue, which pretty nearly approached the colour of the horse. We were enabled to obtain many specimens with their rostrum—sucking proboscis—entire, always a difficult thing to effect, in consequence of the peculiarity of its formation, and its firm insertion in the skin.

We here insert an illustration of one of these ticks, drawn on an enlarged scale from a specimen still in our possession. (See Fig. 2.)

The chief points of interest in the structure of the tick are well represented in the preceding illustration. The barbed or serrated rostrum, by means of which, as the barbs point backwards, the parasite is enabled, almost without muscular effort, to retain its hold of the skin, is clearly depicted. The externally barbed rostrum is found to sheath the mandibles, two in number. These are three-jointed, "the basal joint being internal, the second external and long, and the third short and denticulate."* The palpi, situated close to the rostrum, one on either side, are broad and large, and in some specimens would seem from their near approximation to the rostrum to be capable of embracing it. The abdomen, or body of the parasite, is formed of an exceedingly extensile membrane, whereby the creature is enabled to receive, without inconvenience, a large quantity of blood into its digestive system to be husbanded for its future wants. The legs are eight in number, and are attached to the under part of the body at its anterior half, having their places of attachment very near each other. They are of nearly equal size and length, and are furnished with seven joints. At their free extremities they are tipped with two recurved hooks, having a fan-like expansion of membrane between them. On the back of the creature, immediately behind the palpi, a cuticular shield-like

FIG. 2.

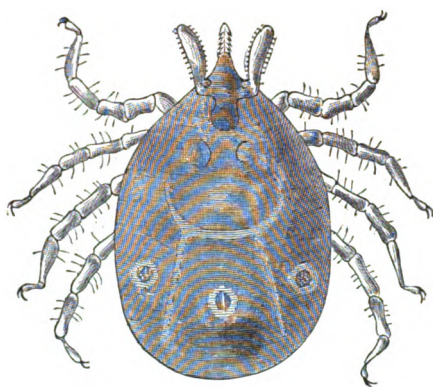

Ixodes Ricinus. Magnified.

on the back of the creature, immediately behind the palpi, a cuticular shield-like

* 'Micrographic Dictionary,' Article *Ixodes*.

plate, much darker in colour than the rest of the skin, is placed evidently to give strength to this part of the frame. On the under surface of the abdomen, just behind the last pair of legs, a circular-shaped respiratory organ exists on either side; and a little further backwards a similarly-shaped body centrally placed, having a slit in its middle, is also present. The latter named opening is the excretory outlet to both the digestive and reproductive systems (See Fig. 2).

Although, as has been stated, these parasites are comparatively harmless in this country, still, in many parts of South America they attack animals in such great numbers as to give rise to serious consequences, and often indeed to cause death. At a meeting of the Microscopical Society in 1842, Professor Busk exhibited some *living* ticks which had been sent him from Rio Janeiro as specimens of the parasite, called by the Brazilians the *Carapato*, which had been from sixty to seventy days on their passage. At a subsequent meeting of the same Society, Mr. Busk read an interesting Paper, containing much practical information, on the subject, from which we make the following extracts:—

“1. The name of *Carpato* or *Carapat* is given to the insect, in consequence of its resemblance to the seed of the *Ricinus*, which has that name in Portuguese.

“2. It is common in all parts of South America, where cattle abound.

“3. It infests cattle, horses, dogs, and sheep.

“4. It is not found on plants; and cattle generally become infested with it when feeding in open and exposed pastures, where the sun's heat is great; and it increases most in dry seasons. It is generally supposed that the insect was not seen in the Brazils previously to an excessively hot and dry summer about 1824 or 1825, since which it has multiplied amazingly. It is remarkable that cattle feeding in shady pastures and coppices are frequently quite free from the *carpato*, but will acquire it by infection from others.

“5. The mode in which it appears to cause destruction to the animal infested by it, is by the incessant irritation which prevents the animal feeding or resting, and in consequence it becomes worn out.

“6. They first appear on those parts of the skin uncovered by hair, and are then not larger than a pin's head, but make the part quite black by their numbers. They adhere so closely, that scraping them off would tear up the skin. In a short time they increase to the size of a bean, or common tick, as seen in dogs, and fix themselves promiscuously on all parts of the hide where covered with hair.

“7. The same species appears to insinuate itself, in its incipient state, upon the human body; but is not known to assume the tick form there. They adhere tenaciously to the skin, and are believed to introduce themselves below it. They are very harrassing, and even create soreness and inflammation. They generally affect persons who have been passing through woods, but are not known to be ever seen or found on trees or plants.

“8. Many thousand head of cattle are annually carried off by the *carpatoes*, and frequently a scarcity is thus caused.”*

* ‘Microscopical Transactions,’ vol. i., p. 88.

The means at our disposal for getting rid of ticks are simple and efficacious. They should not, however, be pulled off, unless existing in twos or threes, for by such means the rostrum will be left fixed in the skin, and may give rise to untoward results. Mr. Blaine, in his 'Canine Pathology,' recommends that the parasites be clipped asunder with a pair of scissors, when they will, he says, immediately retract their sucking organ and fall off.

Sponging the skin with a decoction of tobacco, saturated with salt, will generally cause them to quit their hold. A mixture also of linseed-oil and creasote, made with one oz. of the latter to four of the former, rubbed in with the point of the finger around the part where the ticks are placed, will be effectual for their removal. They are likewise very easily destroyed by touching them with oil of turpentine, but it generally happens that they still retain their hold; this, however, is a matter of little importance, because after death they can readily be detached by the slightest friction, and will then be found to come away entire.

Melophagus Ovinus.—SHEEP-TICK.

Although commonly called a tick, this well-known parasite belongs to a very different order of insects. Its natural history is so replete with interest that it may be affirmed the scientific investigator feels an ardour in his researches which is only surpassed by the desire of the practical agriculturist to rid his flock of this troublesome visitor.

The natural history and mode of development of the *Melophagus* agree with those of the *Hippoboscites*, a variety of the *Diptera*, although, like many other genera, the *Melophagus* is entirely devoid of wings. Its metamorphosis is perfect, but not completed in the same visible and well understood manner as in most insects which undergo this change. Thus the *larva* is produced from the ovum *within the body of the parent*, and changed likewise into the *pupa* before being expelled from her uterus. Insects undergoing a metamorphosis of this kind are termed *pupiparous*, in contradistinction to *oviparous* and *viviparous* creatures, as well as to those which pass through an ordinary series of metamorphoses. A single ovum at a time is transformed in the manner described, so that Melophagi multiply only by a series of single births. When first expelled, the pupa is of a yellowish colour, and easily compressible, but it soon acquires a brown hue and considerable hardness. It adheres to the wool very slightly, and principally by the sebaceous secretion of the skin of the sheep. Fig. 3 gives a magnified view of a pupa, by which it will be seen that in its general form it is egg-shaped, having, however, one of its ends truncated.

The sides of the pupa are somewhat flattened, and are marked with twelve distinct depressions, arranged in two parallel lines.

FIG. 3.

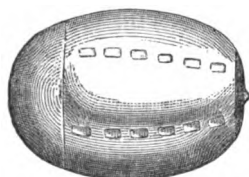

Pupa of the Melophagus.
Magnified.

Occasionally these depressions are more strongly developed on one side of the pupa than on the other. They are described as being connected with minute apertures for the transmission of air to the growing embryo; but we have never been able to satisfy ourselves by an examination of the pupa cases, either before or after the escape of the young Melophagi, that they had any such connection, or indeed that there is any opening whatever. From the central

part of the truncated extremity of the pupa a small projection rises (see fig.), which has a well developed spiracle on each side of it. These openings would appear to be the chief, if not the only means by which air can reach the embryo.

In an early stage of the development of the pupa, a similar projection is to be noticed at the rounded extremity, giving attachment to a slight membranous thread—the umbilical cord—by means of which the pupa is connected to the oviduct. In some pupæ this projection remains long after their expulsion by the parent, but it rarely persists for so long a time as the one at the opposite end. The young Melophagus when perfected makes its escape at the rounded extremity of the pupa case by raising it as an operculum at the place marked by a line in the figure.

The time which is occupied in maturing a pupa within the body of the parent seems not to have been ascertained; but seeing the rapidity with which Melophagi increase during the summer months, we conjecture that it cannot be very long. Repeated experiments enable us to express our belief that about fourteen days elapse between the birth of the pupa and the perfecting and escape of the young Melophagus from it. We cannot, however, speak with absolute certainty upon this point, in consequence of the difficulties in the way of its correct solution. It seems to be necessary for the development of the embryo that the pupa be kept not only warm, but protected to a considerable extent from the drying effects of the air, conditions which are provided for by its lying near to the roots of the wool, and being smeared over with the sebaceous secretion of the skin of the sheep. When pupæ are removed from the wool for experimental purposes, and kept at about the same natural temperature, the nearly perfected embryos will often make their escape in four or five days. After this time, under ordinary circumstances, the embryos mostly die, so that the shepherd has it in his power to destroy many Melophagi by

simply picking off the pupæ and casting them away, as well as by crushing them with his fingers.

The best account of the structural peculiarities of the *Melophagus* we have yet seen is from the pen of Mr. L. Lane Clarke, in the January number (1864) of 'The Intellectual Observer.' It enters, however, into many details of little interest to the general reader, and therefore we content ourselves by reproducing a shorter description of the parasite from the pages of the 'Micrographic Dictionary.'

"*Melophagus Ovis*: antennæ small, sunk in an eye-like cavity of the head; eyes small, oval, resembling two groups of ocelli; setæ three, enclosed in two sheath-like, hairy, unjointed organs (*labial palpi*), resembling otherwise those of *pulex*, and arising from the sides of a triangular labium. Legs robust; tarsi with two stout serrated claws, each having at its base a blunt process; accompanying the claws is an elegant feathery tarsal brush, and on the under side of the last tarsal joint is a bilobed pectinate organ."*

Figure 4, which we here insert, gives a good representation of the *Melophagus* when magnified, and shows many of the peculiarities just referred to.

FIG. 4.

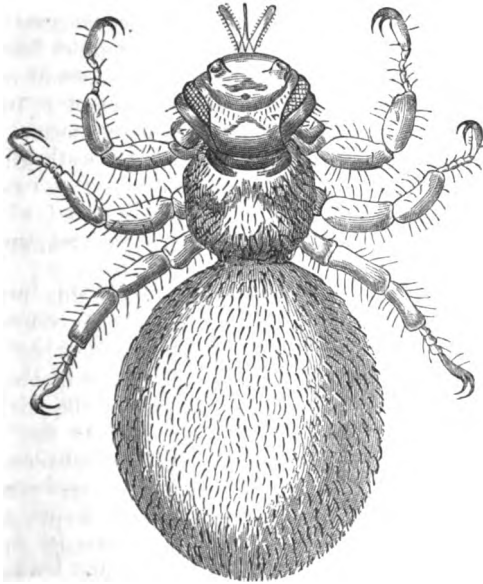

Melophagus Ovinus. Magnified.

* Article *Melophila*.

Melophagi inconvenience sheep considerably; but we have never observed any special disease of the skin to be produced by them. It is, however, imperatively necessary that they be got rid of, not only for the comfort of the animal, but for the saving of wool. During the winter few "ticks" are to be seen, but on the approach of spring they begin to procreate with great rapidity, so that by shearing-time many sheep, and especially hoggets, will often swarm with them. They are somewhat erratic in their habits, and will not only quickly travel from sheep to sheep, but likewise on to shepherds and others who have the handling of the animals. They, however, are never found to inflict any injury on such persons, but merely to produce a good deal of tickling of the skin over which they roam. Their instinct often leads them to seek a hiding-place among the hairs of the head, but even here they do not rest very long, not finding their proper habitat.

"Dipping" of sheep is the only effectual means of destroying these parasites, and the earlier in the spring, weather permitting, hoggets are dipped the better. By this means the destruction of a numerous progeny by the death of the parent Melophagi is secured, and a corresponding advantage obtained both for the comfort of the animal and the interest of the flock-master. Not only are "ticks" and many pupæ thus got rid of, but also lice and acari, the latter of which are the immediate cause of the disease known as scab. Various mixtures, more or less destructive to parasites, are employed as baths for sheep, some of which can scarcely be used with safety. Before, however, we speak of these mixtures, we purpose to add some remarks on the louse of the sheep, a parasite by no means so well known as the "tick."

Trichodectes Ovis.—LOUSE OF THE SHEEP.

This parasite is common in some districts but very rare in others. Some very extensive flock-masters seem, indeed, to be hardly aware of its existence, and in answer to our inquiries have said that they had neither seen nor heard of it. It prevails chiefly where periodical dipping is not adopted, and hence it is often present in mountain-sheep and also in sheep imported from Ireland. In many parts of the western counties of England the *Trichodectes* is by no means rare, and farmers are in the habit of using sulphuretted oil, and similar agents, two or three times a year for its destruction. It is known in these districts as the red louse of sheep; its head and thorax being of an iron colour, and its body a pale yellow, marked with dark bands.

Denny, in his '*Anoplurorum Britanniae*,' describes its chief characteristics to be—"head, nearly orbicular; clypeus rugulose

and ciliated, with stiff hairs; third joint of the antennæ the longest, and clavate; . . . eyes very small; . . . prothorax sub-conical, truncate before and behind, nearly as wide as the head; metathorax transverse, the width of the head; . . . abdomen oblong; . . . legs fulvous, rather thick; tibiæ abruptly clavate and toothed; tarsi long; ungues nearly straight." He also adds, "the only specimen of the species which I have seen was forwarded by the Rev. L. Jenyns, who took it from a sheep."

We have been more fortunate in meeting with the *Trichodectes*, and have many specimens in our possession, by which we are enabled to give the subjoined representation of it (see Fig. 5). The parasite is small, and hence the illustration is greatly magnified, and thus shows most of the characteristics mentioned by Denny.

In some cases which have come under our observation these lice have been present in very large numbers. They appear to show a preference for the inner part of the thighs, and arms, and sides of the neck of the sheep. Their location in the latter situation often induces the animal to thrust its head between the bars of gates and horizontal rails to seek relief from the irritation by rubbing, a circumstance which occasionally has led to its becoming fixed and strangled. If the wool be broken, or short, and detached in places, and if the sheep nibbles its flanks and other parts of its body, and scratches its elbows with the hind feet, as in scab, an examination should be made, which will often be rewarded by a discovery of the parasites.

Sulphuretted oil will be found efficacious in destroying these lice, besides which the use of an agent of this kind during the winter months is more prudent, as sheep cannot now be safely dipped. *In-lamb ewes* must also be freed from the parasites in the same manner. Some persons add an eighth, or even a sixth, part of mercurial ointment to the oil, which is, however, objectionable when much of the surface of the body has to be dressed over. The increased efficacy of the mixture does not compensate for the risk which is incurred. Many other agents might be named for the destruction of these lice, but it is not necessary to do so; the utility of sulphuretted oil being so well established.

FIG. 5.

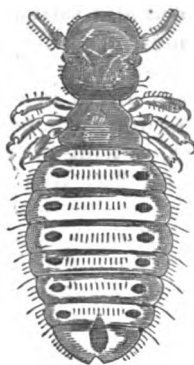

Trichodectes Ovis.
Magnified.

SHEEP-DIPPING.

The benefits arising from the dipping of sheep are universally admitted by flock-owners, not only for the destruction of parasites, but for the general health and comfort of the animal, as also for its beneficial effect upon the growth of wool.

Baths for sheep-dipping may be classed under four principal heads, viz. :—Vegetable decoctions—Arsenical solutions—Sulphuretted mixtures, and those, the antiparasitic properties of which are chiefly due to Alkaline carbolates in combination with tarry matters. Two, or sometimes more, of these compounds are, however, not unfrequently mixed together, both by farmers and manufacturers.

Vegetable Decoctions.—These preparations are multitudinous, and also variously combined. The principal agent, however, in most of them is tobacco, with which decoctions of some one or other of the following narcotic vegetables, as being the most active, are mixed in different proportions, viz. :—henbane, monkshood, figwort, hellebore, foxglove, stavesacre, &c. As a rule, vegetable decoctions are safe applications, if not too much concentrated, and they may consequently be used under circumstances unfavourable to the employment of arsenical solutions. Notwithstanding this, they are not in great request in England; but in Western Australia reliance is placed almost entirely on a decoction of tobacco mixed with sulphur, both for the destruction of ticks and lice, and also as a cure for scab—a disease which often causes immense losses in that country. The number of sheep to be dipped in Australia in a day, amounting frequently to several hundreds, calls for economy of time and labour, and hence various expedients, quite foreign to us, are necessarily had recourse to for getting over the work. The following extract from an article on sheep-dipping in that country by Mr. J. Annand, who had had considerable experience in the matter, is taken from the 'Veterinarian' for June, 1862 :—

"A bath is made which contains 1 lb. of tobacco and 1 lb. of sulphur to every 5 gallons of water, and into this the animals are plunged. The mixture is always kept as warm as the animals can bear it, avoiding of course extremes. Coppers are erected to boil the tobacco, after which the decoction is placed in a large dip or receptacle, and the sulphur is then added. These dips are constructed of various sizes, and sunk in the ground. The heat of the mixture is kept up by the addition of hot liquor, and partly by the bodies of the sheep themselves. The dips should not be too large, as there is then a greater difficulty in keeping up the temperature of the fluid. If too small, however, there is a danger of the sheep striking on the bottom, when precipitated into the receptacle from the pen above. A good size is that which will hold ten or a dozen sheep comfortably at one time.

"I enclose a sketch of the dip, yards, &c., which will assist your readers in understanding the method of using the bath.

"Having filled the bath, the first lot of sheep are sometimes thrown in one by one until it is full; but mostly they are precipitated from the pen situated above it by tipping the floor. Men are placed around the bath, who keep the sheep moving about, and occasionally, by means of crutches with which they are furnished, they push the heads of the sheep under the water. The sheep are thoroughly soaked in three or four minutes.

"The door communicating with the 'run' is then lifted up, and the sheep pushed through it into this passage. On the door being again let down the dip is ready for another lot. The sheep find their way from the 'run' into the draining-yards, which are paved and slightly inclined. These yards being two, the upper one is first filled, and the gate then shut. The lower one is next filled, and when this is done the sheep in the upper yard are allowed to go away, those in the lower one taking their place. By this plan we ensure the sheep being thoroughly drained, and also save a good deal of the dipping mixture.

"It is necessary to add fresh liquor from time to time, to keep up both the heat and proper strength, and also to supply the place of that which has been used. The amount required will depend very much upon the length of the animal's wool. The sulphur is kept floating in the bath by the agitation of the fluid, by which means it settles in the wool, acting, I have no doubt, as the chief *preventive* of scab. When this disease exists it is usual to dip the sheep again at the end of a fortnight; but in my opinion one *thorough soaking* is sufficient, if done in *hot liquor*. The tobacco is best boiled in bags, as it is then easily removed from the copper when its strength has been extracted. *Leaf* tobacco is, I think, the best; but all the common sorts are used. Many of the settlers grow their own tobacco, but rather more of this is required, it not being very strong."

Our experience in dipping sheep would have led to the conclusion that by such a summary process as here described many of the animals would be destroyed; but we are assured that such is not the case. Doubtless some are sacrificed, but the number cannot be considerable, or the plan would soon be abandoned. Indeed, we have been informed that in several parts of Australia even less care is taken than is mentioned by Mr. Annand, and that the animals are forced so hastily in small lots into pits which are sunk in the ground and filled with decoctions of tobacco, that they often plunge completely under the fluid. One thing at least we may learn from these proceedings, namely, that sheep may be totally immersed in a tolerably strong decoction of tobacco with but little risk to their lives. We are not, however, to conclude that a bath of the strength named could be safely employed, supposing it to be made with prepared tobacco of commerce. Australian leaf tobacco is employed, and the quantity used would appear to show that it is not very strong. With the shag tobacco of commerce we have rarely ventured, in making a bath, to use more than an ounce to an ounce and a half to the gallon of water. Tobacco, as is well known, varies greatly in strength, and hence it is always "better to err on the safe side." For these reasons farmers should always make their own tobacco-water, and never purchase it of the tobacco manufacturers. It frequently happens that such water is valueless, or nearly so, although it is so dark coloured as to mislead the purchaser.

The annexed wood-engravings—Figs. 6 and 7—are illustrative of the dipping bath and pens referred to by Mr. Annand. They will be found to materially assist in explaining the details of the process.

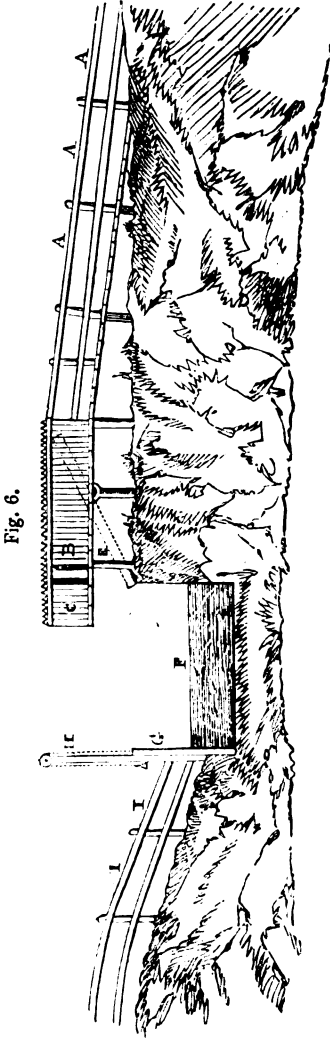

Fig. 6.

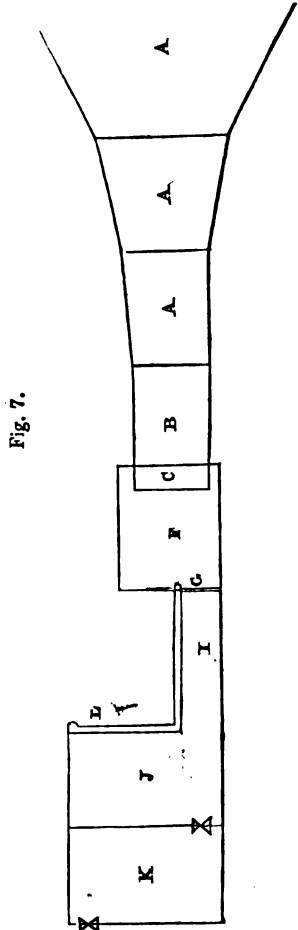

Fig. 7.

Fig. 6 shows a side-view of the yards, "dip," &c.

- AA. Yards into which the sheep are first brought.
- B. The "dipping pen." This is furnished with a moveable floor, E, secured by a bolt, which being withdrawn causes the floor to tilt, and precipitate the sheep into the bath beneath.

- c. "Decoy pen," into which 2 or 3 sheep are placed to induce the others to go forwards.
- f. The dip or bath containing the mixture.
- g. The sliding-door, communicating with "the race."
- h. Chain-pulley and weight for raising the door.
- i. i. The race leading to the draining-yards.

Fig. 7; ground plan.

The references are the same from "A" to "I" as in Fig. 6.

- j. The lower draining-yard.
- k. Upper draining-yard.
- l. A channel to receive the superabundant fluid, and carry it back into the bath.

Not only in Australia, but likewise in America, tobacco-baths are in much request. A few years since an attempt was made to introduce into this country an "extract of tobacco," manufactured by the "Southdown Company" of Boston, Mass., and patented by Mr. Jaques, for the making of "sheep-dips." It met, however, with little encouragement. The samples of the "extract" which we saw were nicely manufactured; but the article could not compete in price with our common sorts of the drug, especially when the quantity to be used—an ounce to the gallon—was taken into consideration. The "extract" is, we are told, much used in America, and with the best results.

Arsenical Solutions.—The cheapness and efficacy of these compounds have led to their very general use by flock-masters. When properly prepared and rightly used, although containing a deadly poison, they are nevertheless safe even for the dipping of lambs as well as aged sheep. Great improvements have been made in these compounds of late years, and few of them now contain arsenic, excepting in the form of an arsenite of potash. This preparation is equally as destructive to parasites as arsenic itself, but less likely to be injurious to the sheep, as its greater solubility prevents its subsiding to the bottom of the dipping tub, thus to be brought in contact with the skin of those which are dipped when the fluid is nearly consumed.

So many accidents have occurred from the careless manner in which arsenical solutions are dealt with on the premises of farmers, that it is a serious question whether they ought not to be entirely superseded by non-poisoning compounds. A little more than a year ago ten persons were poisoned at a farm at Ashby St. Ledgers, near Rugby, from a cause of this kind, and one of them, a labourer, died. Some of the arsenic, in an unexplained manner, got mixed in a pudding made by the mistress of the house for herself, family, and servants, she having on the morning of the same day assisted her son in preparing the sheep-dipping compound.

Numerous instances are also recorded of the poisoning of

animals from a want of due care in disposing of the superfluous or unused quantity of the mixture after the dipping is finished. As an example we may mention that an influential member of the Royal Agricultural Society lost *twenty-two* pigs in the summer of 1859, from the shepherd emptying the spare liquor into a yard, where the pigs were kept. The weather at the time was very hot, and the animals, driven by extreme thirst, drank some of the fluid, and soon fell a sacrifice to its poisonous effects. We have also known of cases where nearly all the ducks on a farm have been killed by the superfluous "sheep wash" being emptied into a muddy-ditch to which the birds resorted. It is likewise no uncommon thing for fish to be poisoned, if it be thrown into a pond, or even into a running stream.

Another serious drawback to the employment of arsenical solutions is the injurious effects which are produced on the hands and arms of the men engaged in the dipping. The nails of many of them are almost destroyed thereby, whilst in some unhealthy sores and ulcers of the arms follow the day's work. The men also are far too careless in protecting the lower parts of their persons from the action of the poison, often neglecting to put on an additional covering so as to keep their clothes from being soaked through with the fluid. Such serious ill-consequences have now and then resulted from this, as even to endanger life.

Much more might be said against the use of arsenical solutions for the dipping of sheep, but in an essay of this kind it is unnecessary to add to these instances of the danger which is incurred.

A useful formula for the making of an arsenical bath is as follows: Take of arsenic $\frac{1}{2}$ lb., soft soap $\frac{1}{2}$ lb., carbonate of potash 4 ozs., and water 20 gallons; boil the arsenic and the potash together in one half of the water, and dissolve the soap in the other half; afterwards mix together for use. This will make a bath sufficient for 20 sheep. It should be used moderately warm, as it will then be found to be more efficacious in the destruction of parasites, and less hurtful to the sheep, than plunging them into the fluid when cold.

Sulphuretted Mixtures.—These mixtures in their simple form being free from any deleterious agents find favour with many farmers, for the dipping of ewes while suckling their lambs. They should not, however, be depended upon for the destruction of ticks, unless combined with a narcotic vegetable decoction; that of tobacco being probably the best. The advocates of their use contend that it is only necessary to keep the sheep in the sulphur bath rather longer than the ordinary time, to have its full benefit produced, and that any failure which may arise is due to a want of precaution. We have often used a simple sulphuretted mix-

ture, and have very rarely found it productive of sufficient amount of good to warrant our recommendation of it. It is true that if the sheep are examined directly after coming out of the bath, the ticks, from their half-drowned condition, will appear to be dead or nearly so; but on the drying of the wool most of them will revive and become as active as ever.

A common sulphur bath is generally composed of soft soap, $1\frac{1}{2}$ lb.; carbonate of potash, $\frac{1}{2}$ lb.; and sulphur vivum, $2\frac{1}{2}$ lbs.; boiled together for about half an hour in 20 gallons of water. A small portion of the sulphur is dissolved by this process, but nearly the whole of it is still suspended in the fluid. The undissolved portion quickly sinks to the bottom, and consequently a mixture of this kind requires to be often stirred up. The quantity named will be sufficient for 20 sheep.

As before stated, it is absolutely necessary that the sheep be kept in the bath for four or five minutes, which makes the process a very tedious one where many have to be dipped in the day. It is also important that the mixture be used warm, or it will be even less effective. A sulphuretted bath is valuable, however, in long existing cases of scab, as it cleanses the skin, tends to break up the crusts which exist, and also to destroy some of the acari. Nevertheless, even under these circumstances, it is to be regarded as preparatory to the employment of more potent remedies for the cure of this affection. The addition of sulphur to an arsenical compound may be an advantage in some exceptional cases of parasites, but as a rule the arsenical preparation is sufficiently powerful of itself not to need any addition of the kind.

Carbolic Acid Compounds.—Baths for sheep-dipping, in which alkaline carbolates with tarry matters form the chief anti-parasitic agents, are of modern introduction. These compounds, although they may not so quickly destroy ticks as some of the arsenical mixtures, bid fair, nevertheless, to supersede them, and also many others of the older preparations, for the reason that they are innocuous to the sheep themselves, and at the same time very efficacious in the destruction of parasites in general. Some of the carbolic acid compounds possess a value also far beyond better known and more common agents, viz., that of protecting the sheep for a considerable time against the attack of flesh-flies. This prophylactic power depends chiefly on the peculiarity of their odour, which is similar to that of tar, and is long retained in the wool. Sheep dipped in these mixtures will be found to be feeding, and resting in comfort; while others, not so treated, will be incessantly tormented with flies: an advantage so obvious that it would alone suffice to recommend these compositions to the favourable notice of the flock-master. Some persons take objection to them in consequence of the tarry matter im-

parting a brownish colour to the wool. This, however, is only a temporary evil, if one at all, as the stain is easily removed by washing; indeed, it will be found to fade away of itself after a few weeks exposure to the ordinary changes of weather. The best of these compounds usually consist of carbolate of soda with tarry matters. They mix easily with water, and do no injury to the hands and arms of the sheep-dippers.

We refrain from giving any special formulæ for the making of carbolic acid compounds, because we lack practical experience of their *relative* value when mixed in varying proportions of their several ingredients. Besides it is far more to the advantage of the farmer to purchase from a respectable manufacturer than to attempt the making of them himself. Both the value and safety of very many sheep-dipping compositions depend on the proper mixing and preparing of their several ingredients; and the appliances at the disposal of the farmer are too often unequal to such an undertaking.

Having thus epitomized the subject of sheep-dipping mixtures, we pass on to make some observations on the proper period for dipping sheep, and also on the occasional ill-consequences which arise therefrom. The proper time for dipping will very much depend on the kind of sheep which are kept, and also on the system of sheep-husbandry which is carried out on the farm—things which are in a measure regulated by locality and soil. In some districts almost of necessity “breeding sheep” are kept, and “fattening sheep” in others. Besides this, all breeding flocks are not managed alike, any more than the same system of fattening is observed by all feeders of sheep.

In some parts of the country ewes are kept for breeding until they are quite worn out by age. In others about a third of the flock is changed every year by the bringing in of the ewe lambs, and letting out a corresponding number of the old and less valuable ewes; while in many the entire flock is changed every year by first fattening and disposing of the lambs, and afterwards of the ewes. It is therefore apparent that no one time can be fixed upon as being suitable to meet the requirements of each of these cases.

Where the system of buying-in ewes every year is adopted, we prefer to dip them just before their being put to the ram; say in September. This not only frees them from ticks, but also from acari, and thus affords security, to a great extent, against the scab during the succeeding winter months. Ewes kept on the farm year after year are perhaps best dipped subsequent to weaning time, in July. If, however, from the multiplicity of parasites it becomes *absolutely necessary* to dip them while suckling their lambs, care should be taken not to use an

arsenical compound. In the latter case, the lambs also must be dipped at the same time, or little or no good will result, for the ticks will soon travel from the lambs back to the ewes, and infest them as badly as before. The dipping of lambs is mostly deferred until they are weaned; but the late Lord Spencer tritely remarked in his comments on this practice, as recommended by Mr. Cleeve in an essay on "Diseases of Sheep," published in the first volume of the Society's Journal, that "It is better to dip the lambs immediately after the ewes are shorn, than after weaning. The shearing the ewes destroys or removes the ticks which were upon them, and the dipping destroys those which were upon the lambs; whereas, if it is postponed till the lambs are weaned, the wool of the ewes will then have grown long enough to shelter ticks which have come upon them from the lambs after the time of shearing."*

Sheep intended to be fatted during the winter on turnips, &c., are best dipped in the autumn or latter part of the summer; but hoggets, which had been dipped as lambs, and which are to be grass-fed during the succeeding summer, should be dipped the second time in the spring after coming from their winter keep. A neglect of this frequently causes much loss of wool, and not unfrequently attacks of scab.

Persons who in the spring of the year purchase sheep of different kinds, and in various quantities for summer grazing, should always, if possible, dip each lot directly the animals arrive on the farm, certainly before they are mixed with the former lots. If this be not done the loss, both in wool and mutton, may prove a serious matter from an attack of scab, it being well known that this disease frequently breaks out among sheep thus brought together. Farmers who merely breed, feed, and sell out from their own flocks have fewer difficulties to contend with, and hence, as a general rule, they content themselves by dipping their sheep after shearing time, when the wool is somewhat grown; a practice which may suit their peculiar case, and theirs alone.

Whatever time is selected, and this must necessarily vary in almost every individual instance, care should always be taken to avoid extreme hot and dry, as well as showery weather.

As can be easily understood, sheep are very liable to be destroyed by the use of poisonous dipping mixtures, from the deleterious agents being absorbed into their systems from the general surface of the skin. In many instances we are ready to admit that absorption is the cause of death; but after several years' experience in the matter, we are persuaded it is far less frequent than is generally supposed.

* 'Journal of the Royal Agricultural Society,' vol. i., p. 329.

Mischief results more often from hasty dipping, and the neglect of proper precautions subsequent thereto, than from absorption of the poisonous compound. When sheep are placed in the bath, and are necessarily held in an unnatural and restrained position to prevent their splashing the mixture about, the greatest care should be taken that their heads are not thrust under the fluid. Without due caution, it often happens that the animal, while struggling to overcome the restraint to which it is subjected, involuntarily and almost momentarily swallows a portion of the fluid. Hence, there are many instances where death results from asphyxia very shortly after the sheep are set at liberty; a portion of the fluid having entered the larynx. Such animals usually retire a short distance, lie down, have a distressing cough, breathe heavily, and quickly die. Occasionally, also, it is found that several of the sheep die a day or two subsequently to their having been dipped, from the local effects of the fluid upon their throat and fauces. In these cases, the corrosive action of the arsenical solution forbids all hope of cure. In a far greater number of instances, however, the poisonous draught enters the stomach, and destroys the animal by its action on the system.

A more frequent cause of death, however, is that of imperfectly squeezing the superfluous fluid from their fleeces, and allowing the animals to go almost at once on to a piece of pasture land, where they not only stand and drip, but often lie down, and thus leave a considerable portion of the arsenical mixture on the grass. Nor will the sheep refuse to eat such grass, but rather show a preference for it while it is wet, more especially in very hot and dry weather. In such a way as this, scores of sheep are often poisoned.

Sheep have also been poisoned now and then from sucking their own or each other's fleeces while still wet from the bath. This, likewise, occurs generally in hot and dry weather, when they have not been supplied with water, although unable to obtain any perhaps for many days before, in consequence of the particular position of the fields in which they had been kept.

Very fatal results have also followed from the sheep being overtaken by a drenching rain within a few hours of being dipped. In this way the dipping compound has been washed out of their fleeces and poisoned the entire herbage on which they were feeding. All these things may be easily guarded against by proper management. Their prevention is so obvious that it need not be specially mentioned in a paper of this kind; it being sufficient for our present purpose that we draw attention, in a concise manner, to the several causes which are likely to lead to a loss of sheep from dipping.

Pediculi; *Anoplura* (Denny).—LICE.

Under the generic term of *Pediculi* we recognise those *Epizoa* commonly known as lice. These parasites constitute the order *Anoplura* of Denny, being unarmed and without wings. From their great variety they are necessarily divided into several families, genera and sub-genera.

The primary division of the *Anoplura* is into the *Haustellata* (suckers) and the *Mandibulata* (masticators), of which we have examples in the genus *Hæmatopinus* and *Trichodectes* which affect domesticated animals. The former of these is easily distinguished by its elongated and narrow head and retractile sucker; and the latter by its broad and short head and strong mandibles. (See Figs. 8, 10 and 9), which represent the *Hæmatopinus* of the horse and the pig, and the *Trichodectes* of the ox.

The chief characteristics of lice are that they do not undergo a metamorphosis, have six legs, are without wings, and often also without eyes, or possess two only, which are of simple construction in comparison with those of other insects.

Although lice do not pass through a regular metamorphosis, nevertheless, in the progress of development from the embryo to the perfect insect, they are found to cast their skin, and often more than once, acquiring each time a more complete form of the body, and especially of the limbs. In these particulars these *epizoa* agree with fleas and some other parasitic insects. Küchenmeister says that "the *males* are fewer in number than the *females*; their last abdominal segment is prominent and rounded off, and furnished on its dorsal surface with a valvular opening, beset with an abundance of asperities, which serves at the same time as an anal opening and *porus genitalis*."

"The *females*, which are more numerous and larger, appear deeply notched at the apex of the last abdominal segment, and, as it were, with two lobes, between which is the anal aperture, which is surrounded with numerous hairs."*

The two genera, *Hæmatopinus* and *Trichodectes*, which we have described, not only exist separately, but often together on the same animal; but hitherto we have only found the *Hæmatopinus Suis* on the pig, and the *Trichodectes Ovis* on the sheep; nor does Denny, in his 'Monographia Anoplurorum Britanniaë,' allude to any other louse as being met with on either of these animals.

Whether the pig and the sheep are entirely exempt from all other varieties of lice, we do not take upon ourselves to decide. As a rule, however, each distinct species of animal has

* Küchenmeister on Animal Parasites, vol. ii., p. 77.

its own particular variety of louse; and it is a singular fact that the parasite shows little or no disposition to leave the body of its host for that of any other. By long cohabitation, however, the louse of one animal will occasionally travel to another of a totally different species, and not only live upon its new victim, but speedily propagate, and thus produce an attack of phthiriasis. The introduction of a lousy animal among a number of healthy ones of the same species is sure to be followed by all of them becoming sooner or later affected. The rapidity with which this sometimes takes place is very remarkable; but it appears to be always accomplished much more slowly during the winter than the summer months. This circumstance is easily accounted for, as the parasites are less active in the winter, both in their ordinary wanderings from animal to animal, and also in their powers of reproduction. It is also not improbable that some kinds of lice leave the body of one animal for that of another much earlier, than others, and this under precisely the same circumstances.

“No man, perhaps,”—writes Denny,—“ever carried his researches on the habits of the louse to a greater height than Leeuwenhoek, who allowed his zeal for science to overcome the disgust which such creatures generally produce. In order to ascertain the rapidity with which a louse can propagate its species, he tried the following experiment which I shall give in his own words:—

“The louse is so prolific an animal that it is a common vulgar saying that it will be grandfather in the space of 24 hours. This I could never believe to be the fact, but rather that it would require nearly a month for the offspring of a louse to be capable of producing young of its kind; and in order to make proof of it by experiment, I at first proposed to hire some poor child to wear a clean stocking for a week, with 2 or 3 female lice in it, and well-tied or secured at the garter, in order to see how many young ones would be produced in that space of time; but I afterwards considered that I could make the experiment with much more certainty on my own person, at the expense only of enduring in one leg what most poor people are obliged to suffer in their whole bodies during all their lives. Hereupon I put on one leg, instead of a white stocking I usually wear, a fine black stocking, choosing that colour because I considered that the eggs and the young lice thence proceeding would be more easily distinguished upon it. Into this stocking I put 2 large female lice, and cutting another black stocking into long slips, I bound it over the first, above the knee to prevent their escaping. After wearing this stocking *six* days I took it off, and found one of the lice had laid 50 eggs, and the other about 40. I opened the one which had laid the 50 eggs, and found in its body at least 50 more, and who knows how many eggs it had laid before I put it into the stocking, and how many more eggs it might have in its body which my sight could not reach? Having worn the stocking *ten days longer*, I found in it at least 25 lice of three different sizes, some of which I judged were 2 days old, others a day old, and the rest newly come out of the egg.

“To give a clearer conception of the great increase of these animals, let us suppose a person to have about his body 2 male lice and as many females, and that the females in 12 days' time lay 200 eggs; and that 6 days afterwards, out of those eggs, are produced 100 males and 100 females; and that this young brood in 18 days' time are grown to a size to propagate their kind, and that each of these young females in the space of 12 days more lays 100 eggs, and

from which in 6 days' time, other young lice are produced : upon this supposition the number of lice springing from 2 females will amount to 10,000. Thus it appears that the 2 females may in 8 weeks' time be grandmothers, and see 10,000 lice of their own offspring, which unless reduced to actual demonstration would seem incredible ; and who can tell whether in the heat of summer these creatures may not breed in half the time I have mentioned ?”

Whether these hypotheses with regard to the reproductive powers of the louse be absolutely correct or not, we see quite sufficient in the experiment itself to explain the fact of one lousy animal quickly contaminating another, and often an entire herd. Leeuwenhoek's experiments being made with lice of the human subject, the parasites found in him a proper host, and consequently his conclusions with reference to the deposit of eggs, and the time necessary for the production of the *first* hatch, would be correct. Whether similar experiments, of transposing lice of the horse or ox, to other horses or oxen, as proper hosts, would give a result confirmatory of Leeuwenhoek's suppositions of the rate of increase, remains to be proved. As yet we have had no opportunity of testing this by direct experiment. We have, however, very frequently collected the ova of the different kinds of lice, and adopted means of keeping them under daily observation, and at a temperature equal to that of the animal body, so as to determine the period of incubation. The results seem to show that the time which elapses between the deposit of the ova of the *Hæmatopinus Bovis*, for example, by the parent louse, and the birth of the young ones, is about twelve or fourteen days. We have frequently known a hatching to take place as late as the *fourteenth* day, but never after that time. On obtaining ova from the bodies of animals for a purpose of this kind, it is found that some of the young will be hatched even on the first or second day afterwards, and others at different intervals up to the date named. This variation in the time is due to the circumstance that the ova when taken are not all of the same age, and consequently the young lice are in different stages of development. It is almost impossible to distinguish the fresh-laid eggs from the older ones, so that correct conclusions as to the period of incubation can only be arrived at from the *latest* births, the ova yielding these young lice having been laid by the parent probably on the very day they were procured.

The matured ova are expelled singly from the uterus of the parent, and each one in succession is attached by a glutinous material, which is voided with it, to the lower part of a hair, near to its root. Sometimes three or four ova will be found adhering to the same hair ; but generally only one is met with. Each egg is so fixed as to leave the larger end free, which is always directed towards the point of the hair. The egg is also attached

to the hair in such a manner as to form a very acute angle with it, leaving just sufficient space to allow of the young louse grasping the hair with its claws as it makes its escape from the egg by raising the operculum at the larger end, thus securing its safety against falling off and being lost. The empty ova-cases will remain *in situ* for a considerable time after the birth of the young lice, and sometimes lead to an incorrect conclusion that the animal is still covered with "nits." They are, however, easily distinguished from perfect eggs on a slight examination.

LICE OF THE HORSE.

It has already been explained that two varieties of the louse are common to the horse—the *Hæmatopinus* and the *Trichodectes*. The former of these is much the larger. It is also darker in colour and has a longer body and head than the other. Fig. 8 gives a very faithful representation of this louse, and shows the chief peculiarities of its conformation, which will be the more apparent if the figure be compared with that of the *Trichodectes* of the ox, inserted at p. 63. The *Hæmatopinus Equi* more frequently locates

Fig. 8.

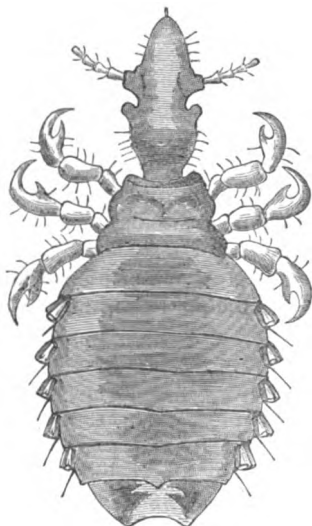

Hæmatopinus Equi. Magnified.

itself among the stiff hairs of the tail and mane than the *Trichodectes*, but it will nevertheless be often distributed over the entire body of the animal. It is not easily dislodged from its location in consequence of its sucking-organ being inserted into the skin for the purpose of obtaining its food. For this reason *Hæmatopini* produce considerable and persistent irritation; and the horse will rub himself so violently to get rid of his tormentors as very frequently to produce extensive excoriations of the skin. From the same cause his health will soon suffer, and he will quickly fall away in condition. Horses which are neglected as to grooming and feeding, or such as are suffering from ill health, are, as is well known, very susceptible to attacks of lice.

Hæmatopini, however, are often met with under the opposite circumstances; and hence search should be made for them in obscure cases of cutaneous irritation. We have frequently found these lice on horses which were at the time

in good condition, and under the best stable management, and consequently not suspected to be lousy.

Trichodectes Equi.—The broad-headed louse of the horse shows a preference for the body, and, unless present in very large numbers, seldom locates itself in the hair of the mane or tail. Its pale colour, small size, and square form, at once distinguish it from the *Hæmatopinus*. Being a masticator, it is unprovided with any sucking-organ, and consequently it does not fix itself to the skin although it lies in close contact therewith. It feeds upon the desquamating epidermis, and also upon the increased exudations that come from the skin as the result of the irritation it produces. Being fond of warmth, the *Trichodectes* rarely quits the surface of the integument during cold weather, so as to become visible by travelling up the hairs. If, however, the affected animal be placed in the sun for only a few minutes, these lice will speedily scale the hairs and appear on the surface, often in such numbers as to surprise the groom or carter. Horses affected to this extent are sure to be in impoverished condition, besides suffering considerable cutaneous irritation.

Poverty, exposure to inclement weather, innutritious food, a dirty state of skin, and similar causes, predispose animals to an attack of these lice; and consequently they are often present on horses which are turned out during the winter months. Colts whose health is impaired, and especially if they are the subjects of chronic disease, are, however, even more susceptible to them. Confirmatory of this we give the following case which has recently come under our notice.

A thorough-bred filly, between two and three years of age, was admitted into the Infirmary of the Royal Veterinary College, in consequence of a diseased state of the absorbent system, which had existed for several months. Being unbroken she had not been regularly stabled, but had had the run of a paddock in which a shed was placed. It had been noticed that of late she had suffered from cutaneous irritation, but the true cause of this was not suspected. Very shortly after her admission an examination of the skin showed that she was literally covered from head to foot with lice. Although diligent search was made, not one of the *Hæmatopini* could be found; the epizoa all being of the genus *Trichodectes*. The care and attention which this filly had received were sufficient to make it more than probable that it was not from neglect, but solely from impaired health that she had been attacked with these parasites.

The destruction of lice is not difficult; but to effectually free an animal of them it is necessary that their ova—the “nits”—be killed as well as the parasites themselves. For this purpose the antiparasitic agent must be again applied to the skin after an in-

terval of five or six days, and in some instances even a third application of it will be required after a similar lapse of time. Oleaginous preparations are very effective for the purpose, especially if mixed with sulphur and oil of turpentine, but they are sometimes objectionable on the score of cleanliness, if used upon our better bred horses. A good mixture of the kind is composed of pure neat's-foot oil, ten parts, oil of turpentine, five parts, and sulphur, two parts. In using this compound care should be taken that the animal be dressed from head to foot with it, or many of the parasites will escape unharmed.

Decoction of tobacco made by boiling from two to three ounces of strong shag-tobacco in a gallon of water, and when cold, saturating it with common salt by adding about three pounds of this agent to the gallon is a clean, safe, and very effective remedy when properly applied. The same may also be said of a saturated solution of the sulphide of potassium, which should, however, be applied to the skin as soon as made.

Mercurial and arsenical preparations ought never to be used upon the horse, so large a quantity being required to cover his skin. They possess no advantages over more simple and less dangerous agents in the destruction of lice, while they have often been known to produce serious ill-consequences, both by their local action and by their being absorbed into the system.

Both varieties of the louse of the horse are also common to the ass. They are by no means unfrequent dwellers on this animal, as may be inferred from the great privations he has so often to endure, and the sad neglect to which he is exposed. If well fed, however, and kept only moderately clean, the ass does not appear to be more susceptible to these parasites than the horse, if indeed he be so much so.

LICE OF THE OX.

Both *Hæmatopinus* and *Trichodectes* are met with on the ox; the former perhaps more frequently than on any other domesticated animal. The *Hæmatopinus*, however, chiefly inhabits the furrows of the skin on the upper part of the neck and shoulders, to which it is often confined for many weeks together. Its existence here is not necessarily connected with ill-health, nor with lowness of condition; on the contrary, it is met with on cattle that are gaining flesh, and going on perfectly satisfactorily. Especially is this the case during the winter, when the cattle are in the fodder-yards. So common, indeed, are these lice at this time, that specimens may be procured from nearly every herd which is examined; both young and old animals being equally affected. During this time of year, also, the lice are very inactive, and show but little disposition either to leave their favourite spot,

or to travel from one animal to another. Hence we find that some animals will be affected and others not, although they are all herding together, and are necessarily fed and managed the same. On the approach of spring, however, the *epizoa* lose their inactivity, become more prolific, travel to other parts of the body, and pass freely from one animal to another. Evidence of this changed state of things is soon afforded by the irritation which they produce, leading the cattle to rub themselves bare in many places, particularly about their shoulders and buttocks. This nude state of skin is not unfrequently the first thing to attract the attention of the owner, and lead him to a knowledge of the fact that the animal is lousy.

The *Hæmatopinus Bovis* is larger than his congener of the horse, and darker in colour, being usually of a deep brown hue. The depth of its colour will, however, depend very much on the amount of blood it contains. It remains firmly fixed by the insertion of its sucker into the skin for so long a time together, that it would appear to use this organ for the purpose of holding on, even after its digestive system is filled with blood.

Trichodectes Bovis.—We here give an illustration of this louse, not only to show its peculiar form, but as a type of the genus as occurring among domesticated animals. Its broad head and pale or yellowish colour at once serve to distinguish the parasite, no matter upon what part of the body, or upon what animal it may exist.

We have met with these lice in great abundance upon young cattle—yearlings in particular—and especially those that had been badly kept after being weaned. Such animals are generally low in flesh, and have a most unhealthy appearance. They suffer much cutaneous irritation, and are so unthrifty that all the food given them seems to be of no avail in improving their condition. It is also during the winter half of the year that these lice abound; and it is usually in the spring, from their rapid increase, that attention is given to rid the animals of them. No part of the body is exempt from their attack, and very often an animal will be covered all over with the parasites, causing him to rub and lick himself so continuously as to produce extensive excoriations of the skin.

When these lice are present in no very large numbers, some persons trust to the shedding of the coat as the spring

FIG. 9.

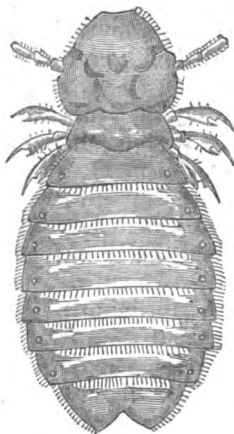

Trichodectes Bovis.
Magnified.

advances for freeing the animals from them, it being well known that with the fall of the hair many of them, together with the "nits," will be cast off. This fact is due to the circumstance, before explained, that these lice live among the hair, feeding upon the desquamating epidermis, and not upon the blood of the animal, and hence they are not fixed to the skin. It is not an unfrequent remark of such persons, "Oh! a few lice wont do any harm, they'll soon be gone when the bullocks get to grass." Dependence, however, should never be placed on the fall of the hair, for it often happens that the animals will continue to be lousy throughout the whole summer, and come back in this state to the yards in the following autumn or winter very little improved in condition.

In the application of remedies for the destruction of lice on cattle, even a greater necessity exists for avoiding all arsenical or mercurial compounds when they are present on the horse. Cattle, as is well known, are in the habit of *licking* themselves wherever their tongue can reach, and not only so, but they will also freely lick each other. In this way scores of animals have been poisoned when dressed with these and similar deleterious agents. One notable case came, many years since, under our immediate observation, in which no less than eleven yearlings were killed out of thirteen by their owner having used upon them an arsenical compound which he had procured from a druggist.

In the 'Transactions of the Veterinary Medical Association' for 1841-2, a case is recorded by Mr. H. Hutchinson, M.R.C.V.S., East Retford, in which fifteen bullocks were poisoned, one of which died, in consequence of being dressed with "a solution of arsenic and soft soap." In the 'Veterinarian' for 1843, Mr. C. Lauder, M.R.C.V.S., Dumfries, relates an instance of thirty-two animals being washed with an arsenical sheep-dip, eight of which died. An allied case is published in the 'Veterinary Record,' for 1846, by Mr. E. Musgrave, M.R.V.S., Hereford, in which two deaths occurred out of "twenty-eight cows, yearlings, and calves" that were dressed for lice.

Many other instances of the kind might be mentioned, as scarcely a year passes without similar mishaps. We will, however, content ourselves by giving one other which is replete with information and somewhat of a singular character. The case is related on the authority of Mr. R. Bowles, M.R.C.V.S., Abergavenny, who furnished us with the particulars a few years since. It appears that a notion prevails in many parts of Wales that when cattle are affected with lice, it is only necessary to smear the *base of their horns* with strong mercurial ointment, and the parasites will quickly disappear. Acting on this vulgar error, a farmer obtained some ointment and used it pretty freely upon

the horns of his cattle—some fifteen or sixteen in number. On the following day the greater part of them were found to be seriously ill, and the assistance of Mr. Bowles was sought. On investigating the case, Mr. Bowles found that the animals were poisoned with the mercurial ointment, *which they had cleanly licked from off each other's horns*. Notwithstanding all the care which was given to the cases, nearly one-half of them proved fatal, and the rest of the animals were saved with very great difficulty.

Having said sufficient, we trust, by way of caution in the use of these poisonous compounds, we shall conclude our remarks by stating that the same remedies which have been recommended for the destruction of lice on the horse are equally efficacious when applied to the ox. They should be used in the same manner, and at the same intervals of time. For cattle, however, which have to be dressed *all over*, the oleaginous compound, mentioned at p. 62, is often to be preferred to any other.

LICE OF THE CALF.

As an addendum to the preceding remarks on the lice of the ox, we may state that Denny has described a variety of the *Hæmatopinus* as existing on the calf, which differs in several respects, but particularly in the length of its abdomen and the thickness of its limbs from the louse of the older animal. He says "that the only two examples of this species which I have examined were kindly forwarded to me by Rev. L. Jenyns, who found them upon a calf. Mr. Jenyns named them *vituli*, and I have no doubt they are the species so named by Linnæus and Fabricius. It may appear somewhat strange that a young animal should have a distinct species of parasite, which is not found upon its parents; but as far as I am able to judge, such is the fact."^{*}

In the course of our investigations we have often sought for this louse, but hitherto without success. We have also had numerous specimens of lice obtained from calves sent us from different parts of the country, and these have always proved to be of the kind common to the older animals.

LOUSE OF THE SHEEP.

We insert this heading in this place for the sake of completeness, as we have in another part of this essay fully described the kind of louse met with on the sheep. The *Hæmatopinus*, as has been stated, is unknown as being parasitic to this animal, while the *Trichodectes* is also rare, excepting in particular localities.

* 'Monographia Anoplurorum Britannia,' p. 32.

Our description of the *Trichodectes Ovis* will be found at page 46 *et seq.*, and also an illustration of the epizoon, to which we beg to refer the reader.

LOUSE OF THE FIG.

One variety only of the two kinds of lice, so frequently alluded to in these pages, is met with on the pig, viz. the *Hæmatopinus Suis*. Subjoined is a magnified illustration of this epizoon, which will help to convey an idea of its formidable appearance. Its great size, broad and flat body, thick ungues, and dark brown colour at once suffice to distinguish the *Hæmatopinus* of the pig from that of any other animal. Most of these peculiarities will be observable if the figure be compared with Fig. 8, which represents its congener of the horse, both being drawn to the same scale.

FIG. 10.

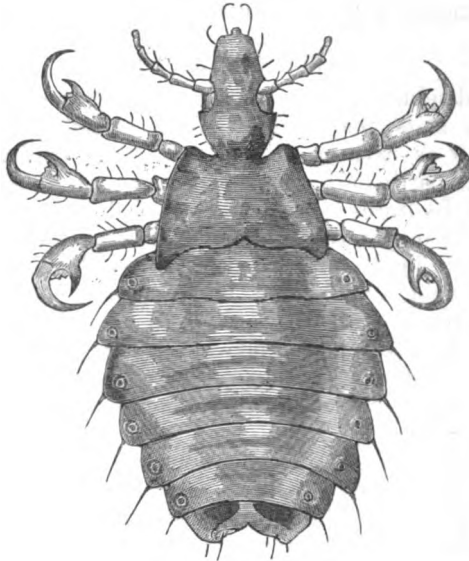

Hæmatopinus Suis. Magnified.

On many farms these parasites are but rarely seen, while on others they are of rather frequent occurrence. The cause of their absence seems not to be well understood, as it does not appear to depend on greater cleanliness nor on a better system of management. Store pigs are mostly affected, but we have seen the lice at times on fat ones. The use of barley-straw for bedding, as well as its almost exclusive employment in the fodder-yard, is generally thought to encourage their attack. This idea is not impro-

bable, for it is an admitted fact that pigs, and especially young ones, do not thrive satisfactorily if made to sleep on barley-straw, and any cause which will impair the health of an animal will at the same time predispose it to an attack of parasites.

Denny, in his remarks on this louse, says that it "is found in great numbers on swine, but it does not appear so generally spread as might be expected from the dirty habits of these animals. It most frequently occurs on those fresh imported from the sister isle. It was many months before I could obtain a single example. I had applied to both farmers and pig-butchers, neither of whom seemed to approve of the idea which I had conceived of *their* pigs being *lousy*, but referred me to those of the Emerald Isle as being sure to gratify my wishes—forgetting, I suspect, that Irish pigs come to this market to meet English buyers. I accordingly visited a colony just arrived, when I most certainly met with a ready supply, but here they were confined almost entirely to lean animals, and wherever I found a pig fat or healthy, no game were to be seen.

"In walking this species uses the claw and tibial tooth with great facility—which act as a finger and thumb—in taking hold of a single hair. The male is smaller than the female, with the abdomen shorter, sub-orbicular, and the segments lobate. The egg, or nit, is three-fourths of a line in length, of a cream-colour, and elegantly shagreened, oblong, and slightly acuminate, surrounded by a lid, which, when the young insect is ready to emerge, splits circularly."*

The *Hematopinus Suis* shows a preference for the upper portion of the neck, and the parts behind the ears, and also those between the fore-legs, where the skin is comparatively thin; being less frequently met with on the sides and hind-quarters of the animal, except when present in large numbers. It will generally be found firmly fixed to the skin, drawing its supply of blood by its haustellum, which organ is conical in shape and very prominent in this species. The irritation produced by the parasite is considerable, and cracks and sores of the skin often result from its presence; but the pig seems to regard this much less than many other animals. As a rule, however, even when existing in great abundance, *Hematopini* would appear to cause an unthrifty state of the animal rather than simple cutaneous disease. Like the *Hematopini* of the ox these lice are very often seen on pigs during the winter months when they are confined to the fodder-yard, disappearing on the approach of warm weather when the animals have a greater range and can "wallow in the mire."

* 'Anoplurorum Britannicæ,' p. 35.

The frequent existence of *Hæmatopini* in association with an inflamed and sore state of skin, led, in the days of ignorance and superstition, to the belief that the parasites buried themselves beneath the integument, and after a time made their exit from the body through the various organs. Thus Youatt remarks in his work on "THE PIG," that "Eric Viborg states that these vermin sometimes burrow their way into the flesh, and come out through the eyes, nostrils, or mouth, or have even been known to be voided in the urine."*

It is not difficult to rid pigs of lice, but, for the reasons before advanced, it is necessary to repeat the anti-parasitic agent two or three times. The sulphur liniment mentioned at page 62 is to be preferred for use on the pig, and besides this none other is likely to be required. Although the epizoa may be apparently confined to one part of the body, it is better to dress the animal all over, to make sure of the ova being destroyed, as well as the parasites themselves.

LICE OF THE DOG AND CAT.

Varieties of the *Hæmatopinus* and *Trichodectes* are the only lice, so far as we are aware, which have yet been found on either of these animals, the former being more rare than the latter. Dogs affected with lice suffer a good deal of itching of the skin. They usually fall away in condition, and have a very unhealthy appearance both of the skin and hair. Young dogs are, upon the whole, more often affected, and not unfrequently they become so when suffering from distemper, or when just recovering from this disease. We have, however, frequently met with lice on dogs which were in the most healthy state, and receiving the greatest care and attention as to feeding and management. Indeed, the pet dog of the drawing-room will now and then be attacked by these parasites; although more frequently it is the cur, which is made to inhabit dirty sleeping-places and is neglected in every possible way, that suffers from them. The irritation produced by lice often gives rise to the notion, among persons who are not very conversant with the diseases of the dog, that he is the subject of mange. A very slight examination, however, by leading to a detection of the parasites, will suffice to show the true cause of this irritation.

These same remarks are equally applicable to the cat, excepting perhaps that this animal is less frequently affected with lice than the dog.

The means which are employed for ridding other animals of lice will be found effective with these, but for many years we have

* 'The Pig,' p. 99.

adopted a very simple expedient for the purpose, which has generally proved most successful. It consists of dusting the skin over with common snuff, and two or three days afterwards well washing the animal with soap and water, and, as soon as the skin is dry, repeating the application. A second or third dressing of this kind will suffice to kill all the parasites and also their embryos, if adopted with due regard to the period of incubation of the ova. Attention must likewise be given to a restoration of the animal's health, from whatever cause it may have suffered, or he will be exceedingly liable to be again attacked by these loathsome parasites.

Acarus Folliculorum—ANIMALCULE OF THE HAIR FOLLICLE.

This parasitic animalcule belongs to the class *Arachnida*, and represents, according to Professor Owen, "the lowest organized form of the class." It has received various names both here and on the continent, the chief among which are *Demodex Folliculorum*, OWEN; *Entozoon*, afterwards *Steatozoon Folliculorum*, WILSON; *Macrogaster Platypus*, MIESCHER; *Acarus Folliculorum*, SIMON and SIEBOLD; and *Simonea Folliculorum*, GERVAIS, the last name being given in compliment to Dr. Simon of Berlin, who discovered it, in 1842, in his investigations of the disease known as *Acne* in man. Küchenmeister states that it was found by Henle at about the same time in the hair follicles of the external ear, but that Henle in describing it mistook "the tail for the head, and the feet for sucking discs composed of pads."

In 1843-4 Mr. Erasmus Wilson fully investigated the structure and habits of the entozoon, which led to his ultimately giving to the world the best account of it which we possess. He thus prefaces his description:—"After perusing the account of the *Steatozoon Folliculorum*, as given by its discoverer, Dr. Simon, I determined to proceed to a verification of his discoveries, and being provided with an instrument probably superior to that employed by Dr. Simon, I have succeeded in making out certain points of structure that had escaped his observations. I was not long in obtaining subjects; almost every face I met with supplied me with abundance, and the difficulty seems to be, not to find the creature, but to find any individual, with the exception, according to Dr. Simon, of newly-born children, in whom these animalcules do not exist."*

In the course of his researches Mr. Wilson discovered several of these parasites, seemingly identical in every respect with those of man, in the secretion of the Meibomian glands of the eyelid of

* 'Skin Diseases,' p. 728, 4th edit.

a horse which had been furnished him by my late colleague, Professor Morton. Küchenmeister also records that "Oschatz found a similar *Acarus* in the glands of the eyelids of a sheep. It was, however, broader generally, and especially in front."*

Besides these instances, we are not aware that the animalcule has yet been met with in any other domesticated animal, excepting the dog, in whom, however, it is not uncommon. In the latter part of 1843 Mr. Topping—a preparer of objects for the microscope—led by the publicity given to this question, sought for the entozoon in the dog, and found it in great abundance. The dog belonged to himself, and had long been the subject of a "pustular affection" of the skin.† Mr. Topping attributed the disease to presence of the animalcules, an opinion which was, however, combated by Mr. Wilson.

Since 1843 the parasite has been very frequently found in the dog; and in 1849 M. Leblanc, 'Médecin Vétérinaire,' Paris, described a disease of this animal ending in marasmus, and destroying the dog, in about two months, which he attributed chiefly to the existence of these creatures in immense numbers in the follicles of the skin.

In 1851 we also obtained a large number of these parasites from a dog affected with skin disease, which was accompanied by extensive desquamation of hair and cuticle, and a discharge of a dark-coloured unctuous fluid from the follicles. It was singular, however, that in this instance the dog showed little or no disposition to scratch himself, as is ordinarily the case in skin diseases. We preserved several of the parasites at the time, and give the subjoined illustration of the entozoon from specimens still in our possession.

FIG. 11.



Acarus Folliculorum.—Dog.
Magnified.

Compared with the fully developed *Acarus Folliculorum* of man, the body of that of the dog is scarcely more than half as long. This shorter length, however, does not seem to be due to immaturity, for in all the specimens which we have examined we have not met with a single deviation from this rule. With the exception of this diminished length of body, there is so close an identity in these acari that a description of one applies equally to the other. According to Erasmus Wilson the acarus of man varies in its entire length from 1-64th to 1-135th of an inch, and in the length of

* 'Küchenmeister,' vol. ii. p. 17.

† A paper relating to this discovery was read before the Microscopical Society, Dec. 20th, 1843, by Mr. A. Tulk. See 'Physiological Journal,' 1843-4, p. 124.

its abdomen from 1-88th to 1-227th, while in both extremes the width of the thorax is the same, viz. 1-555th of an inch.

"The animal is divisible into a *head*, *thorax*, and *abdomen*, the whole of these parts being well and distinctly marked. The *head* represents in form a truncated cone flattened from above downwards, and directed obliquely downwards from the anterior part of the trunk. It is composed of 2 large lateral organs, termed by Simon, 'maxillary palpi,' and of an intermediate triangular organ." . . . "The *thorax*, which is the broadest and thickest part of the animal, and somewhat tun-shaped, is flattened on its under surface. It is composed of four broad segments, which are free, and joined by a connecting membrane on the dorsum and sides of the creature, but are continuous inferiorly with the broad and strong *plastron* which covers the whole inferior surface of the thorax. The segments are somewhat convex in their antero-posterior diameter, particularly at the upper part, so that the outline of the chest in this situation has the appearance of being slightly fluted." . . . "The segmented structure of the thorax permits of a certain degree of movement in this part of the creature. The *legs*, which are eight in number, are connected with the sides of the *plastron*; each segment of the thorax sustaining one pair of these organs. They are conical in figure, the base of the cone being broad, and its apex obtusely truncated, and furnished with 3 finger-like claws. Each leg is composed of 3 segments." . . . "The legs are all of the same size." . . .

"The *abdomen* is somewhat variable in point of length. It is flattened on its under surface, and convex above, and tapers gradually from its base to its extremity, where it terminates in a rounded point. It is composed of a series of extremely narrow annular segments, which overlap each other from before backwards." . . . "The annulated structure of the abdomen, which is here described, permits it to move with considerable freedom and to curve in any direction."

Mr. Wilson closes his elaborate description of the anatomy of the *Acarus* by remarking, "In the abdomen I have traced the outline of an alimentary canal, and have seen it terminate by an infundibuliform extremity at the anus. The transparent cell-like organs seen in the abdomen of the perfect animal I regard as dilatations or convolutions of the alimentary canal; and a dark-brownish mass in the commencement of the abdomen I consider to be the liver. I have been unable to discover any sexual differences in the numerous examples which I have examined." *

The existence of these parasites in connexion with a diseased condition of the skin seems not to be admitted in the case of man; but it is a vexed question among comparative pathologists as to whether they do not give rise to a diseased state of the skin of the dog. It is well known that the dog is remarkably prone to skin diseases, several of which have but few features in common; and our experience—as has been shown—would go to prove that one at least of these affections may depend upon these parasites. Gruby has even stated that the *Acari* of man will induce disease of the skin if transferred to the dog; and that having once succeeded in so transferring them, he

* Wilson on 'Skin Diseases,' 4th edit., p. 729, et seq.

found that, "in the course of two years, they had increased so enormously that they occupied every cutaneous follicle, and the dog became in consequence quite naked." The correctness of these deductions has, however, been doubted by both Simon and Neal.

Professor Weiss, of the Veterinary School of Stuttgart, holds opinions in accordance with our own, *i.e.*, that disease of the skin of the dog is occasionally induced by these parasites. He relates cases in point, and says that the Acari ultimately destroy the hair-producing organ, so that hairs do not again grow on the bald places. It appears also that he considers it just possible that the Acari may travel after long habitation from a diseased to a healthy animal; still, as he observes, it is easy to deny the contagiousness of the affection induced by their presence. He adds, that in Haubner's experimental attempts to propagate the malady by transmission of the animalculæ, a failure occurred in both instances.

In concluding our remarks on the *Acarus Folliculorum*, we may state that the destruction of the parasite is effected with great difficulty, arising chiefly from the circumstance of its being enabled so easily to make its way to the extreme ends of the hair follicles and sebaceous glands. Success in destroying the Acari depends very much more on the manner in which medicinal agents are used than on the agents themselves. The most potent destroyers of their life may prove perfectly inert unless properly applied. Nothing short of a thorough rubbing in of whatever be used will suffice; and not only so, but it is necessary for the agent to be applied again and again. An ointment made with half a pound of lard, two ounces of tar, and four ounces of sulphur should be well rubbed in before the fire, or in the sun to assist its penetration into the follicles of the skin. The unguent should also be allowed to remain on the skin for two or three days, and more friction applied daily. When washed off, some carbonate of potash should be used with the soap and water so as to thoroughly cleanse the animal. The skin should then be dried, and recourse had again to the unguent. This treatment must be repeated for at least three or four times.

Beyond topical applications none are absolutely required, as success depends exclusively upon the destruction of the Acari and their ova. It should, however, be borne in mind that many of the parasites may survive and yet no evidence of their existence be observed perhaps for several weeks. For this reason the treatment should be repeated at certain short intervals, even in those cases where the dog appears to have recovered.

(*To be continued.*)

V.—*Lois-Weedon Wheat-Growing with Horse (or Steam) Tillage.*

By JOHN ALGERNON CLARKE.

FIRST of all, let me state the results of "Lois-Weedon wheat-growing" *with the spade*. And I would premise, that no one personally acquainted with the Rev. Samuel Smith, Vicar of Lois-Weedon (near Towcester, Northamptonshire), no one who has visited the spot, inspected the crops, and examined the soil (as I have done more than once), doubts for a moment the absolute truthfulness of all Mr. Smith's published statements of cost and produce. So that my account may be received without the least suspicion of high-colouring or suppression of unfavourable facts.

The experimental "clay piece," 3 acres in extent, had for the most part a staple only 5 inches deep, resting upon an impervious yellow and blue clay of the oolite formation. There is nothing peculiar in the aspect, situation, proximity of woodland, and so on, to render this plot an unfair sample of the land in that neighbourhood; and judging from the surrounding district, which contains hundreds of acres of apparently precisely similar soil (much of it with even a deeper staple), a fair rental for it would be about 27*s.* per acre. Twenty years ago, it was under old pasture, the turf of which was pared and taken off the land. The ground was ploughed the full depth of the 5-inch staple for oats, followed by vetches. After this came the first "Lois-Weedon" wheat, sown in triple rows, with wide fallow spaces between. These intervals were dug by hand, one spit deep, so as to bring up to the surface only a few inches of the raw clay. The second year, these well-stirred and horse-hoed fallow intervals bore the three-row stripes of wheat, and the stubble-row stripes were dug in; and so on, fallow intervals and wheat rows succeeding one another in alternate years. In the third and fourth years the spade went down a little deeper, and so, gradually and regularly for four years more, till a depth of 16 to 18 inches was reached. Mr. Smith then cultivated for the next four years with *only a single-spit digging*; and, in 1858, again returned to the trenching two spits deep, with a fresh inch or so of clay. At the present date (1865), the digging has not yet reached 2 feet in depth; a great portion is from 18 to 20 inches deep, little more than it was ten years ago. So that Mr. Smith has not been compelled to go deeper for each succeeding crop; and not a grain of any species of manure, animal, vegetable, or mineral, has ever been given to the land.

The average produce of the first eight years, beginning with the harvest of 1847, was fully 34 bushels per acre—the whole

space within the bounds of the field, whether fallow or cropped, being included in the measurement; for the next four years (1855-1858), the yield averaged $38\frac{1}{4}$ bushels per acre; and in the next four years (1859-1862) the average was 33 bushels per acre. The crop of 1863 gave no less than 40 bushels per acre—the same great yield as in 1855, and again in 1858; and the last harvest (1864) has produced 32 bushels per acre, this being the eighteenth wheat-crop in annual succession. The average yield of the last ten years has been $35\frac{3}{4}$ bushels per acre, just $1\frac{3}{4}$ bushel in advance of the average for the previous eight years. Mr. Smith reports that in the present month, January, 1865, all is going on well with the triple rows, “never better.”

As to quality, Mr. Smith has usually made the price of the best red-wheat in his market; and the quality of his latter crops has surpassed that of the earlier.

The effect on the land after all this annual corn-bearing, is that a good brown heavy loam, to a depth of $1\frac{1}{2}$ to nearly 2 feet, has taken the place of the 5-inch staple and raw clay subsoil; so that the field was pronounced by the Deputation from the London Farmers' Club in 1860, to be “as fine wheat-land as any man could possibly desire,” and to be “worth 45s. per acre.” The owner says it is now worth “at least 60s.” So far from “exhaustion” being within view, the ground has become ameliorated and amazingly enhanced in value.

Mr. Smith's yearly profit upon his outlay has also been large, though he reckons the grain at a low market-price, and sets a very moderate figure upon the straw, which is all carried away and applied as manure to other land.

With such protracted and astonishing results before their eyes, English agriculturists will surely be unworthy of their reputation if they allow the system to die without a thorough testing, in different districts, and on a broader scale. Not that they should slavishly copy the Lois-Weedon manipulation; for though the spade and fork have been employed in establishing a principle, the magic power lies in the tillage, not in the tools; and on the great scale, horse or steam power must perform the labour of cultivation. If Mr. Smith's principle be sound, the farmer has only to modify Mr. Smith's particular practice, adapting it to the means and requirements of ordinary business.

The *principle* developed by the Lois-Weedon experiment is, that “intercultural tillage” (that is, the pulverization and aeration of the ground between the rows of a growing crop) promotes the growth of the crop. In this lies the essential difference between bare-fallowing half the area of a field in narrow stripes, distributed at intervals between wheat-bearing stripes, which collectively occupy the other half, and bare-fallowing one-half part

of a field, while the other half grows wheat. The *fact* being established that at Lois-Weedon the deep and perfect husbandry of hand-tools and horse-tools together has produced, upon this principle, most profitable crops for eighteen years in succession it remains for the farmer to ascertain whether a less perfect culture by traction-implements only, will afford results, smaller of course, but of proportionate value, when the smaller expense is taken into account.

I for one resolved to find out whether the Lois-Weedon "principle"—as distinct from the Lois-Weedon "practice"—would retain its virtue out of its own neighbourhood, and on another soil; and I am of opinion that my conclusion on the point has not attracted that attention which it deserves.

My district—the South Lincolnshire "marsh" country—is noted for its fine crops as well as rich pastures; but the particular field of my experiment is by no means peculiarly fertile. The soil is an alluvial loam, rather adhesive, but readily ploughed at 6 inches depth by a pair of horses. This staple rests at 1 to 2½ feet depth, upon raw "silt" or muddy sand anciently deposited by the tides; but which, on most of the farm in question, possesses none of the exuberant fertility of some marine warps. Low-lying, flat, and naturally wet, it is partially relieved of excessive moisture by a few thorn under-drains—which are resorted to in this "dead level" tract, devoid of the "fall" necessary for scouring out permanent pipe-drains. This piece, of ten acres in extent, is considered about the worst bit of ground on the farm; average yields of wheat on this occupation—under liberal management, with well-manured root and spring-corn crops and cake-fed clovers—have varied from less than 30 up to 40 imperial bushels per acre, according as the harvests may have been meagre or abundant.

Such is the nature of the land. But I must call attention also to its *condition* at the time of commencing operations. The "Ash-tree piece" (though trees are few there) was under the plough before I was born; and had been last fallowed with a turnip-crop in 1850. Its latest dose of any species of manure whatever was 12 cartloads per acre of farmyard-dung, applied for beans in 1854. A good wheat-crop followed in 1855; succeeded by barley (not a heavy crop) in 1856. Nobody in our neighbourhood would have expected to get a crop of wheat directly after this barley—unmanured barley, which itself had followed unmanured wheat, on ground not naturally very prolific or in high condition. If the new culture could raise one decent yield upon such a piece as this, the "principle" would clearly be established; and, accordingly, my first year's experimental wheat was grown here in 1857. But this is not all; other dis-

advantages combined to enhance the severity of my test. One-third of the field was foul with couch, all of it was much pestered with buttercups; and beginning operations too late in the season, I had no time to clean it. Such was the weather, that the barley-stubble, ploughed and harrowed, gave me only a seed-bed of hard clods; yet, as it was now the end of October, and thinseeders enjoin sowing in September, I could not wait for rain, and roughly drilled my wheat-rows so thinly that the drill-man said "sowing like that was mocking the land."

Details of my husbandry shall be given by and by: what I wish to show first is, that the method adopted DID PRODUCE PAYING CROPS UNDER CIRCUMSTANCES WHICH PRECLUDED THE GROWTH OF PAYING CROPS BY ORDINARY MANAGEMENT. In May the wheat was of a good colour, but nearly two of the ten acres showed a wretchedly thin and bad plant; while everywhere the hoe encountered plenty of thistles, sow-thistles, and buttercups. An early harvest (1857) brought me a light, poor crop, with very short straw; but the ears were exceedingly good, some having 64, and a few 75 grains each. The yield (of red "Rattling Jack") was a trifle over 30 quarters, or 24 bushels per acre, and 2 pecks of light tail—the natural weight of the best being 60 lbs. per bushel. The head-corn was sold at 50s. a quarter; and deducting the merchant's charges of "portorage and discount," I received for the grain exactly 7l. 6s. 10½d. per acre. No manure being returned to the land, of course the straw must be included as a portion of the produce; and to be within the mark, I valued it at only 5s. per acre, making my total receipts 7l. 11s. 10½d. per acre. The total expenses for every operation by hand, horse, or machine, for seed, rent, tithe, rates, and income-tax, amounted to 6l. 4s. 2d.; thus leaving me a profit, even on that bad crop, of 1l. 7s. 8½d. per acre.

If the ground had not been "exhausted" before, it certainly must be in a low condition now: dare I try wheat again, as a fourth cereal crop on the same ordinary land, without an ounce of any manurial dressing? I could certainly put in my seed-corn in more reasonable style; but as a set-off against this, I could scarcely hope for another good wheat-season like that of 1857. Any way, a crop worth reaping, raised after such a flogging course, would thoroughly prove the potency of my inter-cultural tillage.

Well; after cleaning out most of the couch, "goose-grass," and butter-cups, I sowed (as before) 31 pecks on the same 10-acre field, in the beginning of October. This seeding was at the rate of 3 pecks per acre; but as from the fallow intervals left, there were only half the usual number of wheat-rows, the seed lay in each row with the thickness of 6 pecks per acre.

February and March brought the longest dry time that had been known for many years; and rolling and pressing were diligently followed up on all the wheats of the farm, except my unlucky experimental portion—this proved a great disadvantage. In April, however, my wheat was very forward and luxuriant, though chickenweed made much work for the hoe, and in the latter part of May, I actually had to “top” one considerable portion of the crop with the scythe, because there the stalks and broad flags were too high, rank, and heavy. In June, the wheat was elbow high, the flag an inch broad; and at harvest, the straw was 5 to 5½ feet long, many 6-foot straws also being found. The ears were small: it was a “bad yielding year” in the whole of this district, whatever it may have been in other parts of England; yet my crop gave exactly 30 bushels per acre of dressed corn (head and tail), with nearly a bushel of light tailing besides. The head corn, “Browick red,” weighing 60 lbs. per bushel, was sold at 39s. per quarter; my receipts for grain being 7*l.* 4*s.* 9*d.* per acre. Not wishing to make out a profit by attaching a factitious value to the straw (which, in this neighbourhood we may not sell) I put down 10*s.* per acre for it; bringing up my total receipts to 7*l.* 14*s.* 9*d.* per acre. The total expenses of every sort came to 6*l.* 11*s.* 10*d.*; leaving the balance of profit, 1*l.* 2*s.* 11*d.* per acre.

Still there had been no manurial application whatever: and to demonstrate yet further that my new management had something in it, I again sowed as before the same 10-acre field in October, 1858. This was the fifth white-straw crop in yearly succession, without manure; yet in June, my memorandum was, “wheat looks beautiful, never so well before; all standing, except here and there near the ash-trees, where it is very heavy.” At harvest the straw was 5 to 6 feet long, but the ears not quite so fine as in the year before. From the bulk of the stack, the yield was estimated at 4 quarters per acre; but the thrashing-machine told a different tale, the produce was a little over 30½ quarters, or 24½ bushels per acre of head-corn and tail, with 1½ bushel of light tail. My tillage had fully answered; because the land had produced a crop heavier than any of its predecessors. But the terribly adverse season of 1859 had refused to develop and ripen the ears as was expected: in fact, so bad and defective in quantity, weight and quality were all the wheats in my district—both light and heavy-strawed crops—that 24 to 28 bushels an acre were usual if not average yields. The head-corn (“Browick red,”) weighing 60 lbs. per bushel, was sold at 38s. a quarter; my receipts for grain being 5*l.* 18*s.* 4½*d.* The straw, estimated at 2 tons per acre, I valued at 12*s.*, making my total

proceeds 6*l.* 10*s.* 4½*d.* per acre. The total expenses were 5*l.* 18*s.* 0½*d.*; leaving me a profit of 12*s.* 4*d.* per acre.

Hoping for a more fortunate summer, I again drilled my experimental field. In May, with a singularly backward spring, the plant was thin and much nipped by frosts and winds, but it tillered very much, and was more forward than any other wheat on the farm. Hand-hoeing, when the ground was very hard, injured the wheat; and another operation with the horse-cultivator buried such long portions of the green rows that I anticipated, from this cause, a loss of at least a couple of bushels an acre. In June, after long rains and cold winds (a hurricane had much damaged all the wheats), my wheat was 40 to 45 inches high, with stout stems, broad flags, and many ears out, some of them very large. I considered the crop a fair one, though not heavy, and looked for "say 30 bushels per acre if the wheat ripen well." Such was the entry then made in my book. In the latter part of July, after great rains, the wheat was 5 to 5½ feet high; the ears long and large, many of them 6 or 6½ inches in length, with "twelve sets" of spikelets. Owing to very cold weather, deluges of rain, stormy winds, and extremely cold nights, the wheats of the district ripened late and very imperfectly; and I was doomed to suffer the disadvantage of another specially bad season for my experiment. Light though lengthy ears betokened what the yield would be; and the thrashing-day gave me but 22 bushels per acre of dressed corn, and 2½ pecks of tail. Though "Emperor" red, it was of such mean quality as to weigh only 55 lbs. per bushel, and was sold at 44*s.* 6*d.* per quarter.

The grain realized 6*l.* 3*s.* 7*d.* per acre; the crop, however, was so bulky that the straw was estimated at 2 tons (as in the previous year), and valued at 12*s.*, making the total receipts 6*l.* 15*s.* 7*d.* per acre. Deducting the total expenses, 5*l.* 10*s.* 2½*d.*, I had left a profit of 1*l.* 5*s.* 4½*d.* per acre, even for this unlucky crop of 1860. Remembering that this was *the sixth cereal crop in annual succession, and the seventh annual corn-crop* since the land had been manured, I considered the experiment conclusive in favour of the Lois-Weedon principle. Undertaken with land in an improper condition, begun at a wrong time, and unfortunate in meeting with two most disastrous seasons (locally, whatever they may have been in other parts of the kingdom) "the stripe wheat" had nevertheless brought me a profit, owing to *the low cost of cultivation pertaining to the system.*

My average yield for the four years had been 25½ bushels of dressed corn, and 3½ pecks of light tail per acre; and, sold at an average of 42*s.* 10½*d.* per quarter, it had left me a fair profit.

Had I taken the 10 acres in hand after the manured beans instead of when wheat, and the barley following that, had lowered the condition of the soil—so that, in ordinary course, it would have come in for a replenishing manured root-crop—it is self-evident that I must have reaped far better crops, even with the same unfortunate seasons. But if my four crops had not only enjoyed this advantage, but had also been smiled upon by fair average summers, I should indubitably have boasted of my 32 to 36, perhaps 40 bushels per acre, instead of the pitiful average of 25½. No reasonable mind will reject this conclusion; for my second crop, in spite of its place in the rotation and the unpropitious nature of the season, did yield 30 bushels per acre. It is demonstrated, then, that I could have grown three or four wheat-crops in annual succession that would have improved my “fair profit” into something handsome; or, in case markets had been much lower than they were, would still have rewarded me with that “fair profit.”

It is possible that hand-trenching by the spade to a depth of 18 or 20 inches, would enable my field to produce good wheat-crops in perpetuity; but as my horse tillage extended only to a depth of 9 or 10 inches, and effected but a rough pulverization compared with that of the fork, I did not expect a long series of crops. My experiment simply proves that SEVERAL PAYING WHEAT-CROPS CAN BE GROWN, ONE AFTER THE OTHER, WITHOUT ANY MANURE, PROVIDED THE LAND BE IN FAIR WHEAT-GROWING ORDER AT THE BEGINNING. How this lesson can be best applied in farm practice, I shall consider presently.

To test the endurance of the system still further, I ventured upon another sowing; but not being able to get to work before November, I drilled rather more seed. However, the terrible frost of that winter (1860-1), killed most of the plant on half the field, so that it had to be ploughed up—too late, however, for the attempted crop of mixed peas and oats; while the remainder was so thinned, that the crop, though left till harvest, was not thought worth measuring separately. Such was the termination of the experiment; but the land was not by any means “beggared-up” by my drafts upon its fecundity. For, fallowed and manured for turnips in 1862, it bore a heavy and splendid crop—which was, for the most part, eaten on the ground. A couple of acres stood for seed in 1863; while the rest produced a good crop of oats. These were seeded down with red clover; the turnip-seed plot was sown with winter tares; and both clover and tares were mown in 1864, yielding a very heavy crop of hay, in spite of the unprecedented drought. The clover-lea is now lying unbroken till the coming spring, as it may be wanted a second year to

supplement the deficiencies of the almost dried-out young "seeds."

I will now describe the *modus operandi* and verify my "totals of expenses." The wheat is drilled in triple rows, the "spaces" (A A A Fig. 1) being 10 inches each, and the "intervals" (B B) 40 inches each; so that from the middle of one wheat-stripe to the middle of the next is 5 feet. While the crop is growing, the intervals are subjected to a fallow culture; and the second year's wheat-rows are sown on what were the fallowed intervals of the first, as represented by the waved lines in the figure.

Fig. 1.

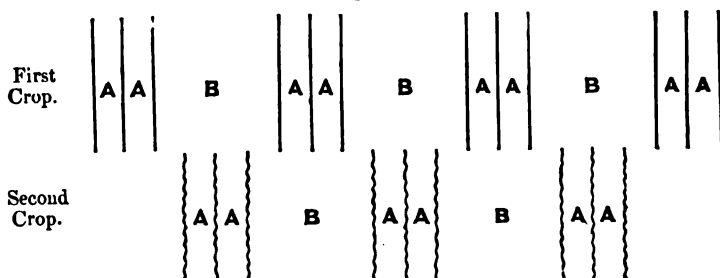

It has been said by objectors to this "stripe system" of wheat-growing, that, as the rows do not follow upon the identical places occupied by last year's stubble, the course of cropping is not really one of "wheat after wheat," but alternate "dead-fallow and wheat." Then why not sow one continuous half of your field wheat, and bare fallow the other half alternately? Because 5 acres in that case would have to yield as much produce as 10 acres on my method. My 10-acre field did yield in 1858 30 bushels per acre, measuring wheat-rows and fallow spaces together. If you choose to maintain that the wheat really occupied only half the area, then my yield was 60 bushels per acre. The fair inference from my experience is, that with the land in anything like reasonable condition at starting, several successive crops much heavier than that would have been raised, still without any manure. I should have reaped 45 to 50 quarters of corn off that 10 acres, for a number of years together: is there the slightest probability that anything like this produce could have been reaped from that field, year after year, if it had lain as 5 acres of wheat and 5 acres of fallow,—that is, that the 5 acres would have yielded at the rate of 9 to 10 quarters per acre? Whatever may be the scientific explanation, my practice affords substantial proof that tillage processes in close proximity to the growing

plants, and the free admission of air and light amongst the green and flaggy stems, do wonderfully stimulate and develop the crop, at the same time strengthening the straw and saving the grain from the damage inflicted by "lodging." For while over-heavy crops sown on the ordinary plan come up a mass of flaccid stems, too weak at bottom to spring up against the weight of rains and violent winds, the stalks of a "stripe" crop are stout, green, and strong, bearing aloft the ears to ripen and grow plump and heavy in the sunlight; and I believe it is only after late sowing that the vigorous healthy straw would be specially liable to disease from atmospheric changes.

The system is just an adaptation to grain-crops of the inter-cultural horse-hoeing and deep stirring which bring your 40 tons of mangold per acre, your fortune-making potato-crops, and your preposterous prize swedes and cabbages.

The details of management are exceedingly simple:—

1. After harvest, fork out couch from the closely-mown stubble-stripes.

2. Broadshare or scarify the fallow intervals, to keep down the annual weeds.

3. Shortly before seed-time again scarify and harrow, taking care to set the harrows so as to miss the stubble-rows.

4. Drill as follows:—Arrange the drill with four coulters, as in Fig. 2; the outside coulters A A' 5 feet apart, and the inside ones B B' 40 inches apart, leaving the spaces A B and B A' each, of course, 10 inches wide. Set the shafts in the middle of the drill, so that the horses walk upon the old stubble-rows C. The drill turns short at each end of the field, and the forward coulters (that next to the unsown ground) is used as a "marker," without sowing any seed. Thus the coulters A' has the seed shut off; but on the return course of the drill (as shown by the dotted lines, the horses walking along the stubble-rows D), it traverses in the same track as before, but with the seed running—the coulters A (that was sowing last time) being now in the position E, with its seed shut off.

Fig. 2.

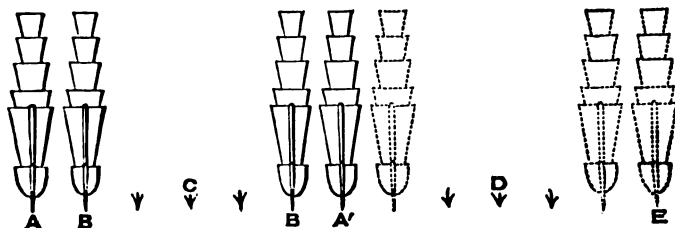

5. Sow three pecks per acre; that is, employ the same cogwheel on the barrel that would sow six pecks per acre if the rows had

been 10 inches apart over the whole ground instead of averaging 20 inches apart, as they do. Thus the wheat will *not* be thin in the rows; the small quantity of seed per acre, arising from the fewness of the rows to be sown.

6. Be sure to get the wheat in early, because of this comparatively spare seeding, and of the effect of the after-tillage in prolonging the summer growth of the crop.

7. When the wheat is well up, take a plough (with two horses "in length") once along each interval, the coulter running within 6 inches of the wheat on the "near" side, and the furrow-slice covering up the old stubble. The furrow may be 5 inches deep, without the upturned earth falling upon the wheat on the other side of the interval.

8. A subsoiler, drawn by say three horses in length, must immediately follow; breaking up the furrow bottom to a depth of 5 inches more, making a total depth of 10 inches. The fallow interval thus treated is represented at A, Fig. 3.

9. In spring, say in February or as soon as the land is dry enough after a time of frost, perform the same double operation of ploughing and subsoiling along the opposite side of the interval, as at B.

10. In March or April hand-hoe the wheat-rows.

11. In April, when the upturned furrow-slices are in a crumbling state, tear them down by passing a narrow harrow along the intervals.

12. Directly afterwards stir deeply with a good grubber, set to take a width of about 26 to 28 inches, the horses walking in length. This stage of the fallowing process is represented at C.

13. It will be necessary to go over the field with a hand-rake, to pull off any clods that may have fallen upon and buried the plants in the outside wheat-rows.

14. Horse-hoe the fallow intervals deeply, at least twice during the summer.

15. Hand-weed the wheat when requisite.

16. When the ears are fully out and in bloom, take a double-mouldboard-plough or ridge-plough up the intervals, so as to slightly or partially mould up the wheat on each side: this will prevent many stalks from being blown down by winds, or borne down by heavy rains.

Fig. 3.

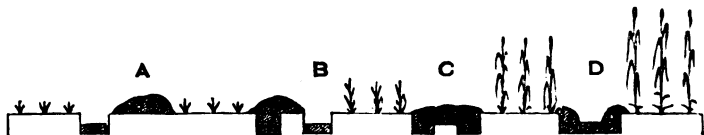

17. A subsoil-plough should break up the bottom of the furrow

left open in the middle of each interval; the state of the interval now being indicated at D.

18. The crop may be mown or bagged close to the ground; but bear in mind not to obliterate the lines of stubble by harrowing or otherwise, because these form the "guideways" for the next sowing.

In some cases, as when the ground is cloddy, it may be advisable to omit operations 16 and 17: and on the other hand, if the moulding-up has been deeply done, it may be necessary, in preparing the intervals for the next sowing, to gather the soil again into the centre of the interval, say by a "pony-plough."

As the subsoiled furrows A, B, and D, lie open to the weather for many weeks, the whole breadth of the interval, when autumn arrives, has been exposed and pulverised to a depth of 10 inches—without a raw subsoil having been laid over a buried staple—forming an uncommonly fine dead-fallowed seed-bed for the next crop.

As far as cleanliness is concerned, my operations do not give root-weeds much chance of making themselves obnoxious. In my field the couch decreased, so as to give little or no trouble; although on these alluvial soils, with moist light bottom, this pestilent plant naturally runs and mats with wonderful vigour and pertinacity. The buttercups and thistles followed suit; and though annual weeds were annoying and expensive, owing to the unusual access of air and light into every portion of the crop, yet they required less and less attention every year. Indeed, Mr. Smith, of Woolston, claims to have established this point, that non-inversion husbandry will ultimately wear out the whole brood of smothering plants which taxes the incessant hoe and spud. It is a fact that, after bearing all my successive corn-crops, my field was comparatively free from weeds, excepting those obstinate buttercups and strong-hearted thistles; that no fallowing whatever was needful for the peas and oats which came after the frost-killed stripe-wheat; and the existing clover-lea (barring a few foreign importations in the seed) will bear without shame the critical scrutiny of a botanical agriculturist.

Before tabulating the several items of expenditure averaged from all the years of my experiment, I must offer one or two explanatory remarks. For "ploughing and subsoiling" an acre of land, 3*s.* 6*d.* appears an absurdly small charge; but it is thus light, because only one furrow in each "interval,"—that is, one-sixth of the area of the field is thus tilled and paid for. Other items appear in like proportion. I am not in a district noted for low wages. During two out of the four years of my stripe wheat-growing, I paid 12*s.* per week, and in the other two years 10*s.*

and 10s. 6d. per week to men, and 6d. to 8d. to boys. Women were not engaged in the field at all. In harvest the work was done by the piece (the general farm-crops being mown or reaped at from 10s. to 14s. per acre), and some of the hands that worked on my tillage operations were the hired team-men, each at 16s. a week. I think I have not undercharged the horse labour. For every horse I put down 2s. 6d. per day (including use of implement), which should be enough, seeing that it is equivalent to 30*l.* a year for 240 working days. The men working the horses were, of course, paid for in addition. Then as to public expenses: my tithe rent-charge on arable land is about 8s. per acre, and the rates of all sorts and direct (assessed and income) taxes I set down at 7s. per acre. The proper rent for this particular field I could only average from the rents of the immediate neighbourhood, putting it at 35s.; though from the unfavourable reputation of the piece for many years, it is hardly fair to value it at so much. The account is as follows:—

Expenses per Acre.

		£.	s.	d.
August Scarifying fallow intervals	0	1	6
September Forking-out couch	0	3	0
 Scarifying and twice harrowing intervals	0	2	0
October Drilling and harrowing	0	2	5
 Seed, 3 pecks (at, say 5s. per bushel)	0	3	9
December Ploughing and subsoiling	0	3	6
Feb. and March	Ploughing and subsoiling, and removing clods } off wheat	0	3	7
Apr. and May	.. Hand-hoeing the wheat	0	1	6
	.. Harrowing and scuffling the intervals	0	1	4
May Hand-weeding the wheat	0	0	9
 Horse-hoeing the intervals	0	0	10
June Horse-hoeing the intervals, second time	0	1	0
 Moulding-up wheat	0	0	8
 Subsoiling	0	2	0
 Hand-weeding wheat	0	0	4
August Mowing and harvesting, &c.	1	1	0
 Threshing and marketing	0	10	0
	Working expenses per acre	2	19	2
	Add for rent, say 35s.; tithe, 8s.; rates and direct (assessed } and income) taxes, 7s.; making together }	2	10	0
	The total outlay per acre being	5	9	2

Doubtless a skilful application of the wire-rope and steam-driven implements would materially lower the expense as well as increase the efficiency of processes performed in my case by horses, two or three drawing in a line "tandem" fashion. Certainly, I lost produce by the kneading of so many hoofs at times

when the ground was too wet and spongy for proper working, and by the teams trampling up the wheat in turning at both ends of the field.

I will add here that my 10-acre plot was by no means favoured with attention, so as to have each operation done in the most suitable weather, no matter what might be the demands of other fields upon the farm. Instead of that, it unfortunately had to take its turn when the horses could be best spared from other labours; and, in consequence, the entries in my memorandum-book complain of the muddy ploughings, mauly subsoilings, and scarifyings, and uprooted or plastered-down portions of wheat.

And now for *the practical recommendation arising out of this experience*. Not necessarily to grow four or more wheat-crops in yearly succession on the same land; for in my experiment you see a principle tried to an extremity, just for the sake of proving the productive power of inter-cultural tillage. Not to introduce a rotation like mine as a pattern to be followed on a large scale. Suppose we take but **A COUPLE OF WHEAT-CROPS TOGETHER IN A THREE-FIELD COURSE**, that is, two years wheat, and the third year spring-corn, green crops, or what you please, the straw being returned to the land as manure in this third year. On my field, the produce on this system (as I have shown from what actually was raised on the comparatively exhausted ground) would be, with every degree of probability, 36 to 40 bushels per acre in an average season. Take a low market, say at 36s. per quarter. Then 36 bushels per acre give a return of 8*l.* 2s.; and deducting the low total cost of the crop, 5*l.* 10s., we have a balance of 2*l.* 12s. per acre for profit and interest of capital. A yield of 40 bushels an acre, at the same price, would give a surplus of 3*l.* 10s. per acre over the total expenditure. If you reckon upon the more reasonable market-price of 40s. per quarter, the yield of 36 bushels leaves a profit of 3*l.* 10s. per acre; and the yield of 40 bushels leaves a profit of 4*l.* 10s. per acre. On 300 acres arable we should have 200 acres under wheat, producing a nett annual income of 520*l.*, 700*l.*, or 900*l.*, according to whichever yield and market we met with. No manure being wanted by either year's wheat-crop, all the wheat-straw, enriched if you please with cake and corn feeding, would go to manure the remaining 100 acres of crops,—spring-corn, green food, and roots; and if it is really more profitable to grow food for live-stock than to sow large breadths of bread-corn, under the common mode of management, there can be no doubt that this 100-acre portion (with 200 acres of straw manuring it) would account for itself without any heavy deficit of expenditure over proceeds. But this manuring is not all that would be in favour of the 100 acres of cropping. Not only is the second year's wheat-

crop produced at a total outlay of 5*l.* 10*s.* per acre, but *the land is simultaneously fallowed and cleaned in readiness for the third year's mixed cropping.* The stripe-wheat relieves the green crop of its old burdensome duty of cleaning the land for succeeding crops; and no part of the 100 acres will have to undergo the usual long processes of winter and spring fallowing. Hence the expenses on such a crop of roots would be far less heavy than in the common way.

An illustration of the proposed system is afforded by the following diagrams:—

First Year.	Second Year.	Third Year.																																				
<table border="1" style="border-collapse: collapse; width: 100%;"> <tr><td>VT</td><td>B¹</td><td>W²</td></tr> <tr><td>S</td><td>O¹</td><td>W²</td></tr> <tr><td>M</td><td>W¹</td><td>W²</td></tr> <tr><td>P</td><td>W¹</td><td>W²</td></tr> </table>	VT	B ¹	W ²	S	O ¹	W ²	M	W ¹	W ²	P	W ¹	W ²	<table border="1" style="border-collapse: collapse; width: 100%;"> <tr><td>B¹</td><td>W²</td><td>VT</td></tr> <tr><td>O¹</td><td>W²</td><td>S</td></tr> <tr><td>W¹</td><td>W²</td><td>M</td></tr> <tr><td>W¹</td><td>W²</td><td>P</td></tr> </table>	B ¹	W ²	VT	O ¹	W ²	S	W ¹	W ²	M	W ¹	W ²	P	<table border="1" style="border-collapse: collapse; width: 100%;"> <tr><td>W²</td><td>VT</td><td>B¹</td></tr> <tr><td>W²</td><td>S</td><td>O¹</td></tr> <tr><td>W²</td><td>M</td><td>W¹</td></tr> <tr><td>W²</td><td>P</td><td>W¹</td></tr> </table>	W ²	VT	B ¹	W ²	S	O ¹	W ²	M	W ¹	W ²	P	W ¹
VT	B ¹	W ²																																				
S	O ¹	W ²																																				
M	W ¹	W ²																																				
P	W ¹	W ²																																				
B ¹	W ²	VT																																				
O ¹	W ²	S																																				
W ¹	W ²	M																																				
W ¹	W ²	P																																				
W ²	VT	B ¹																																				
W ²	S	O ¹																																				
W ²	M	W ¹																																				
W ²	P	W ¹																																				
a b c	a b c	a b c																																				

The parallelogram represents 300 acres, divided into twelve fields of 25 acres each. Suppose that the miscellaneous cropping occupies the four fields in column *a* for the first year, in column *c* for the second year, and in column *b* for the third year, the rotation travelling over the farm from right to left, VT may be 25 acres of vetches followed by turnips; S will be 25 acres of swedes; M, 25 acres of mangold; and P, 25 acres of pulse-corn. The turnips may be succeeded by B¹, barley; and the swedes by O¹, oats, both these crops to be sown in 3-row stripes (taking the place of wheat, for the first two years of stripe-culture). The mangold and peas or beans may be followed by stripe-wheat W¹. In the third year these four fields (B¹, O¹, W¹, W¹) will bear the second stripe-crop of wheat, W², W², W², W². There will thus be 150 acres of wheat and 50 acres of oats and barley each year. This plan admits of winter-fed roots and early vetches, but makes no provision for a clover layer. I do not know what great objection there may be to the scheme (of course on proper wheat-land, having a due proportion of clay in its composition), for if the part under stripe-corn can bring the occupier such a handsome income as I anticipate, he need not be much concerned about any larger store of forage for animals.

One important question, of course, is the practicability of executing the tillage required by such an arrangement: What would be the distribution of horse-labour throughout the year? The references in my memorandum-book relating to the 10 acres will

enable me to give an answer. The horse-labour required for 200 acres of wheat, oats, and barley would be as follows:—

Month.	Operation.	Number of Horses engaged.	Number of Days occupied.
Aug. ..	Scarifying intervals of 100 acres	9	5
Sept. ..	Scarifying ditto, 2nd time, and twice harrowing	10	6
Oct. ..	Ploughing and harrowing 50 acres (after mangolds and pulse-corn)	10	11
	Drilling and harrowing 150 acres	10	13½
Dec. ..	First ploughing and subsoiling 100 acres ..	10	10
	Ploughing 25 acres (for barley)	10	5
Feb. and Mar.	Second ploughing and subsoiling 100 acres ..	10	10
	Ploughing 25 acres (for oats)	10	5
	Drilling and harrowing 50 acres (barley and oats)	10	7
Apr. and May.	Harrowing intervals, 100 acres	2	5
May ..	Scarifying intervals, 200 acres	10	12
	First horse-hoeing or stirring intervals, 200 acres	5	6
June ..	Second ditto, 200 acres	5	6
	Moulding-up wheat, 200 acres	5	6
	Subsoiling intervals, 200 acres	10	6

Leading the corn in harvest, and delivery at market must be added.

The total number of days' work for one horse is just 1000. Now 12 horses are not an excessive force upon 300 acres arable, and at 240 days' work each, they do 2880 days' work in a year; so that the stripe-cropping would occupy a normal force of horses little more than a third of their time throughout a year. Looking at the various months, it appears that the stripe-cropping would demand team-labour for only 5 days in August, during half of September and October, half of December, one-third of February and March, a third of April and May, and half of June. This would leave ample time for the tillage of the various crops upon the 100 acres; seeing, moreover, that these crops would take much less labour than if ordinary fallowing and cleaning had to be pursued in preparing seed-beds for them.

As I have supposed barley and oats in stripes to be substituted for the first year's wheat on portions of the land, I will justify my expectation that this would answer as well as the wheat. Mr. Smith is growing these crops on the stripe principle at Lois-Weedon, the triple rows standing at every 5 feet (as the wheat-rows do), but the spaces reduced to 9 inches each, leaving 42 inches for the fallow interval. After highly-manured carrots and

mangold drawn off the land, the yield of barley has been no less than 72 bushels per acre; and of oats, just the same, namely, within a fraction of 9 quarters per acre, weighing 46 lbs. per bushel.

In conclusion, I ask for a practical testing of Lois-Weedon wheat-growing as adapted to traction tillage. Not for a rash adoption of a speculative "three-course rotation:" but first of all, for a trial on one field or plot of suitable wheat-soil. Let that field be managed as if it were under the three-course husbandry; take stripe-wheat (with a portion of oats, or barley if you like) for the first year; again, stripe-wheat for the second year; and then plough up and manure for other crops in the third year; after which, of course, two stripe-crops as before. With accounts properly kept, this would soon show what merit exists in the principle, and—do homage to the genius of Jethro Tull. I know that it is difficult to move the mind of a practical man out of its habit of settling things from general considerations. I shall be told that an extension of wheat-culture is not advisable, because roots, clover, and cattle-crops have, of late years, answered better. But what can the wheat-crops that don't pay possibly have to do with *my* wheat-crops which *will* pay? The entire case rests upon THE LOW COST OF PRODUCTION BY MY METHOD, IN COMPARISON WITH THE COST OF A WHEAT-CROP IN ORDINARY FARMING. I raise two good wheat-crops in succession for 5*l.* 10*s.* per acre each (every source of outlay included), and at the same time and for the selfsame money, I am fallowing and cleansing the ground in readiness for roots or other of the third year's crops. Can any other system show an economy of expenditure like this?

Long Sutton, Lincolnshire, January, 1865.

VI.—*Covered Cattle-yards.* By W. J. MOSCROP.

ALTHOUGH the design of this short contribution to the 'Journal of the Royal Agricultural Society' is less to discuss the merits of covered cattle-yards, than to call attention to a peculiar mode of constructing them, yet a brief recapitulation of the advantages which practically we have found to arise from their use will not be out of place, more especially as the fact is undoubted, that among the great body of farmers they have not yet attained the popularity, or even met with that appreciation which they assuredly deserve.

Whether an inquiry into the cause of this supineness would be attended with any useful result is doubtful; therefore, without

endeavouring to trace it further, we will quote from one whose experience in the erection of covered yards is second to none in the kingdom.*

“As a general rule,” he says, “I have found much prejudice against covered homesteads when first proposed, but I do not recollect one instance of dissatisfaction after they had been in use for one year.” This offers a key for the solution of the enigma, and points to this conclusion, viz.,—that prejudice arises from inexperience.

Assuming then that we have a covered yard constructed as per plan annexed, we will point out the advantages which it offers in respect of shelter, warmth, comfort—securing the health and economical maintenance of the cattle; the perfect conservation of the manure; and consequently its economical supply for the benefit of the soil.

Economical Feeding and preservation of the Health of Cattle kept in Covered Yards.

In the theory of fattening there is a well-known axiom, that “warmth is equivalent to food,” and this has been practically endorsed by many who have adopted the covered-yard system of feeding cattle.

The food which all animals consume—“burn in the lungs”—for the maintenance of vital heat, is here restricted to a minimum. Moreover, they have a dry lair, and are comfortable. They do not range uneasily about, or with staring coats, shivering, stand exposed to the “pelting of the pitiless storm,” like their less fortunate fellows in the open yard, but with comfort eat their food, in comfort rest; and for such comforts show their gratitude to their owners by their rapid development.

In an experimental trial we proved that, under cover, animals, each of which had a separate box, gained as much weight, with something under $\frac{1}{4}$ th less food, as others fed with the same description of food, but kept in the common form of court and shed, where the open part bore to the shedding the proportion of 4 to 1. The gain was nearly 1s. per head per week, which was entirely attributable to the superior warmth, comfort, and repose enjoyed by the cattle under cover.

But besides fattening on less food, animals enjoy better health and are less liable to disease under cover than when exposed in open or partially covered yards to the rigour and changes of our variable climate.

* Mr. F. Chancellor, Chelmsford.

We feel we are here treading on tender ground, as many hold an opinion directly the converse of this. Their grand mistake appears to lie in the very common supposition that covered yards necessarily involve either a close and vitiated atmosphere or a prevalence of draughts. Instances, no doubt, may be pointed out where the golden mean has not been hit, and where one or other of the above especial evils exists in a high degree; but such are the results of faulty design or bad construction, and the reasoning is manifestly unjust that condemns the principle in consequence of errors in the execution.

In a yard constructed as shown by the annexed plans, while the cattle are sheltered and comfortable, they enjoy perfect immunity alike from thorough draughts and from a vitiated atmosphere. The fluctuations of temperature in our island are frequent and wide; but the tendency of such a yard is to equalise and control that temperature, and within its precincts winter's bitter blasts and summer's intense heats are alike unknown.

The great importance of this in the economy of animal life will be readily seen. For whence comes that fatal train of maladies, coughs, catarrhs, inflammations, consumptions, but from exposure to sudden variations of temperature?—We catch cold. Granted that animals are not so sensitive as man: nevertheless, even to them, alternations of warmth, wet, and cold are most productive of disease.

That cattle kept in covered yards enjoy better health than others kept where the cover is only partial is established by abundant evidence.

In support of this view, we quote the following from a communication with which we have been favoured from Mr. J. G. Marriage, of Ham Farm, Red Hill:—"Our buildings are 130 feet by 103 feet, and afford accommodation for 190 head of stock; and to give you an idea of the health they enjoy, I may state that for the last seven years the farrier's bill has not averaged 20s. per year."

But there is yet another class of opponents to the covered-yard system, who, while admitting the general well-doing of the cattle kept in them during the winter, argue that what is then gained is lost in early summer, when the animals are turned to grass, from their great susceptibility on exposure to cold. The writer's own experience, and also that of many others whom he has addressed on this matter, is dead against this view. With much more apparent justice might it be inferred that milch-cows, which are usually kept in a much closer, warmer atmosphere, would catch cold when turned to grass; yet, as a general rule, such is not the case.

Superiority of the Manure made in Covered Yards.

By far the greater proportion of ordinary farmyard-manure consists of straw and water, the remainder being the excrements of the cattle. Under cover about 20 lbs. of straw per diem is found litter sufficient for one animal; in open yards, more than twice that quantity is required; and if, as is generally supposed, the excrements give the tone and character to the manure, it will be readily seen, why that made under cover is normally much superior to that made in the open air. We say "normally," because in the one case the original value is maintained, but in the other lost by drainage and waste.

It would be superfluous to dwell on the deteriorating influence exercised by rain-water falling on manure, or the great loss incurred by exposure to its washings. The curious in this matter will find ample information by referring to the researches of Way, Voelcker, and other modern writers on chemistry; the practical man, we opine, will be more gratified by a reference to results. From dressings of equal quantities of manure made under the same conditions as to the food and age of the animals, but in one case under cover and in the other in open yards, Lord Kinnaid obtained the following results: *—

<i>Uncovered Dung.</i>		<i>Covered Dung.</i>	
	Per Acre.		Per Acre.
1st year. Potatoes	7 tons 12 cwts.	1st year. Potatoes	11 tons 5 cwts.
2nd year. Wheat	42 bushels.	2nd year. Wheat	54 bushels.
„ Straw do.	156 stones.	„ Straw do.	215 stones.

Mr. Akers, of Black Bourton, Oxon, in a communication to the writer, says:—

“ You are aware that I have at my farm an open yard as well as my large covered yard, and when I first used the manure made in the latter I was startled to find my crops for which it had been applied so lodged as to be almost worthless. Since then I have sometimes been at considerable expense to have that made under cover and in the open either mixed or applied conjointly, so as to insure an equable crop; or when the covered-yard manure is used separately, the quantity is invariably reduced, so as to guard against my previous misfortune. I usually manage my covered manure so that it will “spit” out with the shovel when required for use, so that I have no need to haul it into a field-heap, and I consequently save the usual labour of twice filling, carting, and emptying.”

Mr. J. C. Garth, of Haine’s Hill, Berks, in reference to the covered yard of his home-farm, writes:—

“ The manure is first-rate, but as I have not made an actual trial, I cannot decidedly say how much it is better than that made in open yards; but perhaps one of the principal advantages of covered yards is the great superiority of the manure. The cattle should be littered every day, or every

* Trans. Highland Agricultural Society.

other day; the liquid is then all absorbed by the straw. The dung is good and short, and fit to be drawn on to the land without the expense and waste of making dungheaps.

"I consider this system of manure-making is also more healthy for the cattle, as in open yards the liquid runs about emitting effluvia and tainting the soil, whereas in covered yards it is all taken up by the straw."

Mr. Chancellor says:—

"The late Mr. James Beadel always stated, as the result of his lengthened experience (and he might be considered as one of the pioneers of the system), that *one* load of covered-yard manure was worth more than *two* loads of open-yard manure.

"Its tendency to get dried and heated has always been advanced as an argument against covered yards by those who have not tried them, but I never heard it used by any one who had. The truth is, it keeps infinitely moister than in open yards in a dry season. I have often seen the manure when being emptied come out like 'black butter,' and, with perhaps the exception of the top layer, quite fit to put on the land."

Mr. H. S. Thompson, says:—

"When first I began to use manure made in a covered yard, it was put on for white turnips in the usual quantity, and they were stimulated by it to an unnaturally rapid growth and excessive size, which were very prejudicial to their keeping qualities. This taught me the lesson, which has since been abundantly confirmed, that manure made under cover is fully one-third stronger than that which has been exposed to the rains of winter in open yards. Before trial it might be supposed that manure made under cover would turn out dry and mouldy, but if the quantity of straw used is in reasonable proportion to the number of live-stock kept, it will be invariably found that the manure turns out in first-rate condition. The explanation is easy, the most common cause of damage to manure being that the fertilising salts it contains are washed out by rain as fast as they are formed by the decomposition of the heap; and when these salts are all retained, the moisture will be retained also."*

The writer's experience fully bears out the above statements. In the case of animals, alike in age and fed alike, but kept in open or in covered yards, it is clear that the difference of value of the manures they make will in a great measure vary with the amount of rainfall, which not only, by its repeated washings, deteriorates the quality, but also entails the necessity for large additions of litter; but on the whole, and under average circumstances, we believe Mr. Thomson's estimate of one-third increased value will be found to be a fair one.

In a trial made on some meadow-land thoroughly exhausted by many consecutive years of mowing, the following results were obtained from the separate application of manure made in covered and open yards:—

<i>Uncovered Dung.</i>	<i>Covered-Yard Dung.</i>
15 loads per acre produced 16 cwts. hay.	15 loads per acre produced 25 cwts. hay.

* Trans. Yorkshire Agricultural Society, No. 24.

A portion left unmanured barely produced 10 cwts. per acre.

Owing to peculiar circumstances, the difference in this case was greater than on an average can be reckoned on; but this and many other similar comparative instances within the range of the writer's experience, clearly prove that the advantage arising from the superiority of the manure made in covered yards is in itself sufficiently important to warrant their very extensive adoption.

Superior Economy in the Application of Manure.

Owing to the lesser quantity of litter used, the excrements of the cattle bear a greater proportion to the whole mass when manure is made in covered yards, and after lying some little time turns out quite fit for direct application for any description of crop, whereby a very material saving of labour is effected. The quality is still further enhanced, and consequently the quantity required is further reduced, by the avoidance of the waste of soluble salts attendant on drainage and leakage after rainfall.

Assuming 20 tons of ordinary open-yard manure to be a fair dressing per acre, and that 13 tons of covered-yard manure would be quite as effective, we in this respect save the cost of the application of 7 tons per acre, which on an average is certainly not less than 3s. 6d. And besides, in ordinary practice, the open-yard manure would be carted to the fields to ferment in a heap previous to its application, and the labour involved in refilling, carting, and emptying, may be put as 4d. per ton, or 6s. 8d. per acre, showing in the aggregate a saving of 10s. per acre; and this we believe to be a very moderate calculation. Moreover the straw which is saved in the litter becomes available for food; and if there is any truth in estimates which set the feeding value of straw at 35s., and the manurial value of straw at 12s. 6d. per ton, the gain in this respect must be considerable.

Among the advocates for open yards, on the ground of the great facilities they afford for rotting down the straw, was the late Mr. Pusey; but undoubtedly his usual sagacity was at fault here. If, as he seems to make out, rain-water is indispensable in the conversion of straw into manure, the rotting process might possibly be effected with more economy by leaving in the fields all the straw not required for the cattle; its haulage to the yard, and rehaulage, plus 70 per cent. of water, to the field, would at least be saved.*

* In Mr. Pusey's excellent review of the 'Progress of Agricultural Knowledge during the last eight years,' he states they "were obliged to use a fire-engine to moisten the latter which was growing white and mouldy for want of moisture." In covered yards no such want is ever felt. See Mr. Thompson's explanation, in foregoing paper, of the reason why. Mr. Pusey, in the same article, states, "When it rains here in winter our labourers say, 'This is fine weather for making dung.'"

Reverting to the plan for covered yards before us (p. 97), it must be understood that the writer claims no merit for the conception of the design, that being most justly due to another. Having been strongly impressed with the great advantages attendant on the use of covered yards, he has for some years advocated their extension; but neither in his own designs nor in those of others had he seen the essentials perfectly attained until the summer of 1863, when business led him to the home-farm of Mr. H. S. Thompson, at Kirby Hall, Yorkshire. Previous to this he had inspected some yards of a very costly description, but with imperfect ventilation, and others where the ventilation was sufficient, but the accompaniment of draughts proved that it was obtained on a wrong principle. Among the latter may be classed a design of his own, constructed in Berks, in which the end to the south was left open; this with plenty of height secured a pure atmosphere, and all went well in calm weather, but a wind from the south, south-east, or south-west, created a great and most unpleasant draught, which was very prejudicial to the comfort and health of the stock.

The great merit of Mr. Thompson's covered yard (which was designed by himself) consists in its simplicity, which enables it, at a minimum cost, to afford shelter and warmth, with perfect ventilation and freedom from draughts—combining, in short, all the advantages which the most complicated structure can, and which so few of them do, practically afford.

This to the writer was so apparent that, when a homestead was to be reconstructed on this estate, it was decided, with the sanction of the proprietors, to adopt in principle Mr. Thompson's plan. That yard, the plans of which we give, has now been in use upwards of fifteen months, fulfilling our most sanguine anticipations, so that with the most perfect confidence we can recommend the mode and principle of its construction to the attention of all interested in this subject.

The leading feature in the plan is that the ventilation is obtained entirely from the roof. At 9 feet above the level of the paved causeway, and between the outer and middle roofs, there is an open space of about 6 inches, running all round the yard. This ensures an ample supply of fresh air, but in practice does not produce any perceptible draught. At 8 feet higher, or about 17 feet from the causeway, between the highest central roof and the two middle roofs, we have another ventilating space of 15 inches continued round the yard, through which there is a continuous draught, but so much above the level of the cattle as not to be in the least felt; here it acts only so as to draw off (as it does most effectually) the tainted air from the yard. The supply at the 9-foot level maintains the

equilibrium, and it is essential that this lower opening should not be too large in proportion to the upper one; the result is the thorough ventilation of the yard. And this, it will be seen, is effected by very simple and inexpensive means. The brickwork on which rests the tiebeam of the middle portion of the roof, is carried a few inches higher than the walls or beam supporting the roof of the outside range of buildings. This gives the open space for ventilation, and at the same time, as it carries the middle roof higher, affords opportunity for the water to be discharged from the middle to the outer roof, which in the ordinary course is received and carried away by cast-iron spouting; the central high roof also throws its water on to this middle roof, whence it is likewise carried on to the outer roof. The spouting of the outer roofs therefore carries off the whole of the water that falls on the yard. It will thus be seen that no expensive lead-gutters are required, and that the space which in ordinary constructions is usually occupied by them is utilised to give ventilation. The 15-inch space between the middle and the highest central roofs is protected by the projection of the latter to the extent of 18 inches; thus while light and air are freely admitted, the ingress of rain is prevented; and as no louvres are required, a material saving is effected.

The stable, cowhouse, &c., are also well ventilated by the following simple, inexpensive, and, we believe, novel plan. The spars, instead of being laid at one length, are divided; one part being laid from the eaves to the purlin, to which it is firmly spiked. The other part is spiked on the former, and extends from the purlin to the ridge; and as this is done on both sides of the roof, and for its entire length, it leaves a ventilating space equal in width to the depth of the spars. The tiles have sufficient overlap to prevent the rain from beating in. The ventilation is excellent, and the use of the common wooden ventilators on the ridge of the roof becomes altogether unnecessary.

The divisions between the yards and stable, cowhouse, &c., are dwarf walls 2 ft. high, finished with rails, piers being carried up to support the roofs. On the south side the walls are carried up the full height, to enclose the shops and loose boxes intended for sick animals. If thought preferable, posts could be substituted in whole or in part for the internal walls, and in that case the external walls enclosing the entire yard would alone be necessary. The posts carrying the roof are timber, and are set in stone, 18 in. base and 2 feet high. In our case the posts are oak, 16 feet long, which square about 7 inches. If larch is used no squaring is necessary, but care should be taken to select straight poles. The roof is covered with tiles, unpointed except-

ing two courses round the bottom of the high roof. Light is obtained by the spaces left for ventilation, and by glass tiles in the roof. The arrangement of the offices are as follows :—

- | | |
|---|--|
| <ul style="list-style-type: none"> a. On the plan represents 10-stalled stable. b. Hay-house. c. Corn-bin connected by spout with granary. d. Cart and implement shed with granary over. e. Chaff-house ; chaff-cutter being on the floor above. f. Straw-barn. g. Corn-barn. h. Fattening-house for 12 beasts. i. Turnip-house. j. Cow-house for 10 cows. k. Hay-house for ditto. | <ul style="list-style-type: none"> l. Calves-house. m. Piggeries. n. Poultry-house. o. Store for pig-food, with space for boiler. p. Boxes for sick animals, &c. i. Turnip-house for yards. g. Carpenter's shop. r. Blacksmith's shop. s. Harness and tool house. t t t. Yards sufficient to accommodate 32 head of cattle, allowing each animal 200 square feet of space. |
|---|--|

A satisfactory mode of cover being obtained, the internal arrangements may be varied according to requirements ; but on a farm where breeding, rearing, and fattening is carried on, we believe the arrangements of this plan will be found suitable for a farm-yard. The first essential is a provision for the maintenance of the health and comfort of the stock ; second, economy of labour in feeding ; third, facility for the removal of the manure ; fourth, economy in the construction. In all these respects this yard will bear examination.

Notwithstanding all our refinements in cattle-feeding, straw and roots are, and are likely to remain, their staple food. This being so, provision is made for the supply of these articles with the least possible expenditure of labour. With a root-house at one end of the passage, from which the cattle in the four yards are fed, and straw at the other, the labour of feeding is reduced to a minimum. The same arrangement is carried out in the fattening-house. The stable and cow-house, requiring straw in less quantities, are placed further from it, but still conveniently near, while their respective hay-houses are placed close at hand. The corner root-house also supplies roots to the cow-house. The removal of the manure is easily effected. That from the stable and other houses placed around is daily thrown into the yards, to which carts have free access for its final removal. Accommodation is afforded for sixty head of cattle and ten horses, besides the piggeries and various offices.

The cost of such a structure will vary with the price of labour and material ; but in this neighbourhood, where both are as high as in any part of the kingdom, it could be substantially completed for considerably under 1000*l*.

Under

PLAN OF FARM BUILDINGS.

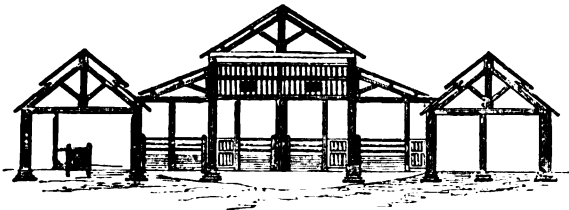

TRANSVERSE SECTION—A. B.

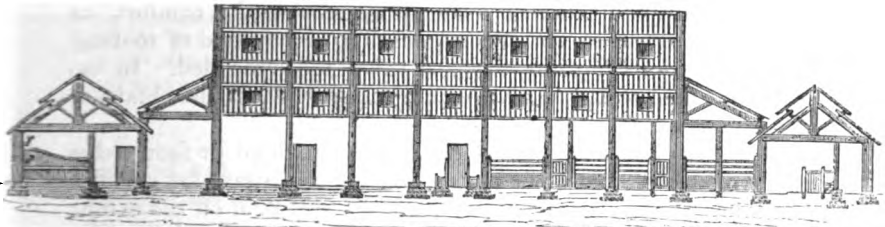

LONGITUDINAL SECTION—C. D.

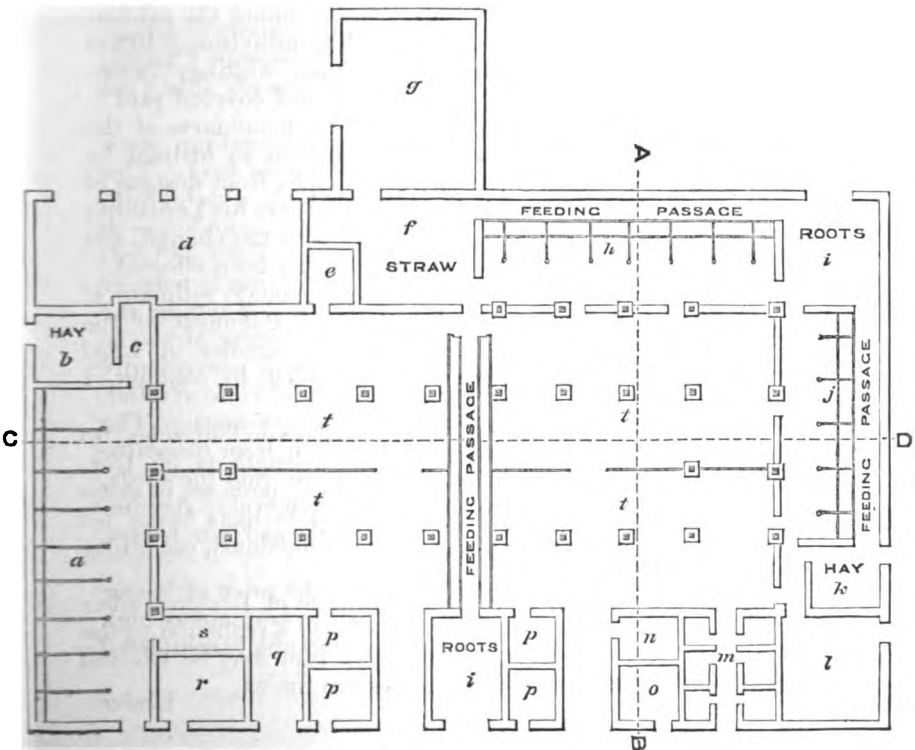

GROUND PLAN.

Scale 32 ft. to an inch.

Under existing circumstances, the foregoing communication should prove opportune matter in the 'Journal of the Royal Agricultural Society.' The low price of grain and the high price of meat will naturally induce farmers to curtail the production of the one and increase that of the other; and the great outcry for seeding-down land to grass shows that the tide has already set that way. An increase in the number of cattle will entail the necessity for enlarged buildings, and how this can be most economically obtained, whether by utilising the old or adding new, is a problem which ere long landowners will have practically to solve.

As a cheap and efficient mode of increasing the comfort, as well as the extent of the accommodation, the system of roofing over existing open yards may be safely recommended. In no other way will so large an amount of accommodation be obtained at so small a cost.

Given the familiar open yard enclosed on three or four sides by barn, stables, and other offices, having a capacity for accommodating stock dependent less upon its size than on the extent of the adjoining shelter-sheds—any landowner, by applying the principles which we advocate, may, with the thinnings of his plantations and the labour of his carpenter, double the amount of cattle-accommodation, and convert this uninviting, litter-wasting, labour-wasting, food-wasting, manure-wasting, cattle-startaring space into a comfortable, well-ventilated covered yard.

Two yards of the above description on the home-farm of the Earl of Zetland, at Upleatham, have just been so utilised by being roofed over on Mr. Thompson's principle, from designs of the writer, and a third is now in hand; and we have his Lordship's permission to say that he is much pleased with the change, and highly approves of the principle on which it has been effected.

To assist my readers in forming an approximate estimate of the cost of such improvements, I will add a statement of the quantities of work executed in covering the smaller of Lord Zetland's two yards, and of the prices at which, by contract, I can in this district get such work done.

The yard being enclosed by existing buildings on four sides, no outlay on outside walls was required. Its length is 55 feet, width 53 feet. The roofs are carried on 10 oak posts set in stone blocks; the ends of the tiebeams of the side roofs being let into the walls. The covering is of pantiles, unpointed, excepting the two lowermost courses of the main roof.

This calculation is based on the assumption of foreign timber being used in the construction of the roof, and a reduction to the extent of nearly 10 per cent. on the above sum may be effected by landowners using their own home-grown timber.

Approximately, the quantities are as follows, viz. :—

	£.	s.	d.	
35 squares roof, at 21s.	36	15	0	
38 „ tiling, at 15s.	28	10	0	
3 „ tiles, pointed	0	12	0	
10 base stones and foundations	2	10	0	
200 ft. ridge stone, at 7d.	5	16	8	
50 glass tiles	2	10	0	
	£.	s.	d.	
216 ft. 6-in. spouting	5	8	0	
Less value of 4-in. spout removed ..	2	14	0	
		2	14	0
18 ft. down pipes and heads	1	1	0	
160 ft. lin. oak posts, at 10d.	6	13	4	
Iron (bolts screw) for posts	0	10	0	
Cutting holes in walls for beam ends ..	0	5	0	
	£87	17	0	

At 6½ per cent. the interest on the above amounts to 5*l.* 14*s.* 2*d.* per annum, being a charge of 7*s.* 7*d.* per head on the 15 cattle which, since the yard was covered, it is found it will amply accommodate. Few practical men will doubt that, apart from other concomitant advantages, the benefit accruing to the animals from superior comfort will fully repay this cost.

Kirkleatham, Redcar, Yorkshire,
December 7, 1864.

VII.—*Ten Years of East Lothian Farming.*

By R. SCOT SKIRVING.

WE can well imagine that a southern Englishman, travelling for the first time to the north by the East Coast line of railway, may experience something like surprise upon passing into Scotland. He may not be of those whose conception of Caledonia is that of a region entirely covered with heather, and shrouded in mist, a land whose unbreeched inhabitants subsist upon oatmeal and whisky, and stone all those who “gather sticks” upon the Sabbath-day. Yet our traveller may have some preconceived ideas which are likely to be disturbed when he sees around him a district as dry, as thoroughly cultivated, and frequently as level, as his own. This surprise is likely to be heightened by the fact that, as he approached the northern extremity of England, he found himself passing through a cold, dreary, ungenial tract of country, which seemed a foretaste of worse things to come. Berwickshire and the Lothians have, however, no claim to represent “the land of brown heath and shaggy wood;” and their fields have long been ploughed by

Saxon cultivators, who have as little in common with the Gael, or even with the Western Celt, as the soil has with Strath Canon, or the hills of Argyshire. Yet, in spite of expanses covered with wheat or barley, with beans or potatoes, which may bear some comparison with those of the south, differences would soon be discernible in the trees and plants which indicate less of summer warmth than Kent or Sussex enjoy. No hops would be seen; and although the sweet chestnut, the walnut, and the acacia might appear as thriving trees, the two former here fail to ripen their fruit, and the latter can seldom boast of its flowers. Summer never hears the song of the nightingale; and though Christmas sees the holly bright with berries, no misletoe ever clings to the oak. As regards crops, perhaps the most marked difference is the almost total absence of the mangold, the place of which is, however, amply supplied by turnips of various kinds.*

We propose in the present paper to give some account of the fortunes of agriculture as connected with East Lothian, a portion of the above-named district, during the last decade.

Rather more than ten years ago an able article, entitled "Farming in East Lothian," appeared in this Journal, written by Mr. Charles Stevenson, editor of 'The North British Agriculturist.' That paper gave so complete an account of the system of agriculture then practised in Haddingtonshire, that the reader may safely be referred to it as the foundation and the starting-point of this paper.† Some minor changes in management have of course since taken place; and experience, or the change of times, has set aside one or two of the opinions expressed in 1853.

* It is true the mangold is cultivated to some extent in the east, and still more in the west of Scotland, but it occupies a small and a diminishing space as compared to other root-crops. In warm seasons it often produces largely, but it is extremely uncertain, and is very prone to "shoot," and run prematurely to seed. It is also found a troublesome crop to secure in autumn.

We may mention the following as a rather singular illustration of our personal experience of a crop of mangold. In 1860, we had been induced to cultivate it to a considerable extent; a field of 35 acres was sown, and produced a very fine crop; continued rain in November and beginning of December prevented its being secured in proper time, and on the 19th of the latter month it was suddenly covered by an unusually heavy fall of snow, which put an end to all hope of carrying it. It remained unlifted during the whole winter, which was one of the most severe on record, the thermometer being for some time several degrees below zero, and the mangolds of course were frozen into stone. Upon being ultimately carted in spring, the roots were blackened masses of soft pulp, which we at first imagined were as useless as turnips when in the same condition. To our surprise we found that cattle ate them with avidity, giving them a decided preference to sound roots that had been properly secured from frost, and the animals thrive well and fattened satisfactorily upon them. Probably the same chemical result may be shown by the analysis of a nearly decomposed mangold as is exhibited in the case of a rotten turnip, which looks better in the chemist's figures than the sound one; but the turnip when decayed is nauseous and uneatable, while the mangold, it would appear, becomes more inviting to bovine taste.

† See vol. xiv., No. xxxii., 1853.

Since then more manure has been purchased, and more artificial food consumed by stock; new and important implements have been introduced, and agriculture has progressed in various directions; whilst, on the other hand, it cannot be denied that in some points it has retrograded. But the chief features of change are the absolute, as well as the relative, value of cattle and corn; and, above all, the position and prospects of the occupiers of the soil. We envy the writer of 1853 his pleasing task. He was enabled, with perfect accuracy, to write as follows:—

“Never since the close of the war (1815) has the agricultural interest been in a more prosperous state in this country than at present. There is, we believe, less deduction from the rent covenanted for, than has ever been previously known. Perhaps there are not ten farmers in the county who are not paying the rent originally agreed on. We believe, also, that there is less of arrears than has been at any period, certainly since 1816.”

This prosperity, which continued for some years after 1853, owed its origin in a great degree to the rebound which followed the panic caused by the loss of the protective duties, but it was subsequently maintained by more substantial causes. There were several good harvests, that of 1852 being undoubtedly the best ever reaped, the nearest approach to it being that of 1835, whilst the crop of 1852 commanded a high price, wheat averaging 75s. 10d. per quarter in Haddington market. Then followed the stimulating influence of the Crimean war, and the potato trade (which may be said not to have existed in East Lothian before 1850) reached its height, dealers purchasing the crop as it grew, with all risks, and the expense of lifting, at 30l. to 40l. an acre, and paying to individual farmers from 1000l. to 4000l. or even 5000l. Land rose prodigiously in value, and rents probably reached their culminating point about 1855, when farms were let at an increase which ranged from twenty to a hundred per cent.

Then the tide began to turn, and the reverse side of the picture appeared in sad contrast to the brightness of the other. Farmers starting with leases of that date, and saddled with rents which experience has proved to be from 20 to 30 per cent. too high, are certainly in no enviable position; and generally the evidence lately taken before a Royal Commission on the subject of Hypothec (law of distress), shows that for several years, most farmers have been annually losing from half a rent to a whole one.

In addition to over-rent, the farmer has had to contend with a sequence of bad seasons. The harvests of 1856 and 1857 were to a great extent destroyed by rain, and since then many minor misfortunes have befallen the crops. Those of 1859 and 1864

were damaged by drought, whilst in 1861 a great portion of the potato crop was lost by disease. Of the price of grain it is unnecessary to speak; and potatoes, which at one time promised to be the farmer's sheet anchor, were almost unsaleable in 1863, and were given in large quantities to cattle. The London market, to which the bulk of the crop had hitherto been sent, was over-supplied, and the prices obtained would not pay freight and other expenses. One farmer on opening his agent's account of a truck sent to King's Cross, found, when all charges were made out, a balance of 2s. 6d. against him.

In spite of all this the struggle for land, which has sensibly slackened in other parts of Scotland, is but little diminished in East Lothian. Cold clay lands, ill-drained and in bad condition, have indeed ceased to attract; but for all good, well-cultivated farms there is still a competition sufficient to drive the occupying tenant from the field, unless in rare instances when he is specially favoured by the landlord. It is difficult to suggest any satisfactory explanation of this strange phenomenon. Hope, conceit, ignorance, disgust of some other trade, and the absence of any professional education, or the memory of former profits, may induce those who have little to lose, to risk their all; but among this crowd of adventurers are mingled men of capital and practical experience, and these, though never the highest bidders, are sometimes chosen by judicious landlords. Time will do much to correct, but probably not to remove this anomaly, which the apparent ease, wealth, and independence of rural life, the crowded state of all professions, and the limited area of our soil, all tend to maintain.

Purchased Food and Manures.

In spite of bad times, agriculture has in many respects made material progress since 1853. It is true there are few "model" farmers now-a-days. Hedges are not so regularly pruned, walls are kept in worse repair, weeds are less carefully eradicated, and fields in general may have a less tidy appearance; but the great essentials of deep and thorough cultivation and liberal manuring have not been neglected. The quantity of purchased manure has largely increased. In the article of 1853, a leading farmer, Mr. Hope, of Fentonbarns, is quoted as purchasing 1*l.* worth of manure for every acre he farmed; but now, besides a large increase of artificial food consumed by stock, the manure-bill has risen upon all the best managed farms to nearly 2*l.* per acre. In the evidence before the Royal Commission already alluded to, Mr. Henderson, of Longniddry, stated that on 750 acres he expended from 1200*l.* to 1400*l.* on portable manure, and 1000*l.* on feeding stuffs, being together from 2400*l.* to 2500*l.*

One manure-dealer told the Commission that he sold 190,000*l.* worth of manures every year to farmers in the three Lothians; and in Haddingtonshire, the arable area of which little exceeds 100,000 acres, more than 100,000*l.* are annually expended.*

Peruvian guano and bones, either dissolved or simply crushed, constitute the great bulk of this portable manure. Farmers in Scotland are very reluctant to buy any manufactured article, whether manure or feeding stuff, about the composition of which there is any mystery. Quack medicines, special sheep-dips, condiments, concentrated manures, and nostrums of all descriptions, are rejected for articles that tell what they are. The proportion in which the guano and bones are mixed varies according to the nature of the soil or the fancy of the farmer; but equal weights of each, or one-third guano and two-thirds bones, are common mixtures. As a top-dressing for young grass, nitrate of soda, from its recent comparative cheapness, has become a favourite; and for autumnal-sown wheat, rape-cake has long been considered an excellent manure.

Wages.

Increased cultivation has also involved a large additional expense under the head of labour since 1853, or if we look back to 1843 the amount will be found to be nearly doubled. By a carefully prepared statement recently published by several leading farmers in the country, it appears that the cost of labour, including the accounts of smiths, rights, &c., is 2*l.* per acre.

Upon farms where, say 15 years ago, the monthly account for female and casual labour amounted to 10*l.* the charge may now be safely estimated at 30*l.*

Seed-Corn.

In the varieties of grain cultivated there are several changes to note since 1853. Hunter's and Fenton still hold their ground as favourite white wheats, and the variety known as Mongoswell's or Hall's is also in request. Red wheats are much used: many of these, brought from the south of England, succeed admirably the first season, but are found to degenerate on being repeated. Hopetoun, once a favourite, has nearly disappeared, and the variety for late sowing known as "April" has given place to barley, as indeed all wheat has done to some extent.

Mr. Patrick Shirriff of Haddington, a veteran agriculturist, who has the merit of having formerly introduced the Mongoswell's

* When statistics are given the reader is reminded of the very limited area of East Lothian, which is rather less than that of Middlesex, and only a little larger than that of the Isle of Wight.

and Hopetoun wheat, as well as the Hopetoun oat, has for several years devoted most of his attention to experiments in wheat. In nursery fashion, he grows annually not less than a hundred varieties, including every species known to the British Islands. The practical result of this labour is the introduction of two new varieties which have already taken their place in the wheat-fields of the county. One of these is a red, the other a white wheat; both are bearded, and bear the name of the propagator.

Of barley, which is cultivated to an increasing extent, there is but one variety used, the Chevalier; whilst the oat is represented by the Potato, the Angus, the Hopetoun, the Sandy, and to a small extent, by the Black Tartarian. Of these the Potato-oat is the favourite in rich deep soils, whilst the Sandy has the merit of being least easily shaken by the wind, which frequently causes great losses in East Lothian. Hailstorms of a destructive character are, on the other hand, all but unknown; one instance only being on record, which occurred a few years ago, when the crops in several parishes were almost destroyed.

Root-Crops.

The turnip-crop has always been an important one in East Lothian, but formerly that importance rested in a great measure upon the fact that it formed the surest foundation for a remunerative grain-crop, whilst now the roots, grown for their own sakes, form the chief object of the agriculturist. Of the softer turnips the white globe occupies the largest space, but it has been to some extent displaced by the Greystone, a species recently introduced, which produces the heaviest crop of any variety. Being very soft and liable to injury from frost, its use is restricted to the early part of the season—a circumstance which must always tend to circumscribe the extent of its cultivation.

Skirving's purple-top succeeds the earlier turnips, whilst green and yellow varieties follow as the food of the farm till Christmas, when the swede becomes the reliance of the farmer, for all animals save breeding-ewes, for which white or yellow turnips are reserved.

An annual sweepstakes, which is held under the auspices of the local agricultural society, shows the following as the highest weights on the best five acres of turnips of different sorts:—Swedes, 31 tons 18 cwt.; yellow, 36 tons 10 cwt.; white, 45 tons per acre.

While the turnip-crop is thus increasing in importance, the potato has, during the last decade, created almost a revolution in the agriculture of the country, has largely contributed to the rise in the value of land, has brought very considerable sums into the district, and has attracted to it a population specially devoted

to its cultivation, an Irish immigration having followed the cherished root of the sister kingdom. One variety of the potato, the "Regent," occupies probably nine-tenths of the whole space devoted to the cultivation of the plant. Till lately Orkney Reds were much used, but as coloured varieties cannot now be sold so long as white are to be had, the fiat of the consumers has regulated the proceedings of the grower. Flukes, which command the highest price in the London markets, and are largely produced in Yorkshire, cannot be profitably grown in Scotland.

In early localities, and particularly in sandy districts near the sea, the Delmahoy Early takes the place of the Regent. This potato is planted in February or March, and sold for consumption in summer, when the ground is immediately sown with a "stolen" crop of rape upon which sheep are pastured in winter or spring. The potato is a chief cause of the largely increased bill for manures, as it receives 5 or 6 cwt. of guano and bones per acre, besides taking the lion's share of the home-made dung, thus leaving to the manure-merchant the task of making good the deficiency to other crops. The potato, however, can be profitably cultivated upon good soils without dung by using a liberal supply, say from 8 to 10 cwts. per acre, of judiciously mixed portable manures; and this fact has recently formed a subject of judicial inquiry in a protracted law-suit, which has considerably agitated, and very much divided, the agricultural mind in this county.

Stock-Farming.

Recent ill-success in husbandry has made the farmer turn an anxious eye to see if flocks and herds will restore the balance of his accounts, and certainly if hope is to be found in any quarter it must be in beef, mutton, and wool. It is, however, found almost impossible in East Lothian to lay down land in permanent pasture, as the quality of the turf rapidly deteriorates, and grass is therefore ploughed down in one or two years. Thus, though a marked increase is becoming apparent in the number of sheep kept, the additional food consists of roots, vetches, cake, and corn, and the question therefore to be solved is, whether arable land, rented at 2*l.* to 4*l.* per acre can be adapted to stock-farming, an occupation which has hitherto been carried on upon a class of farms much less heavily rented.

In reference to artificial food, the Report of 1853 says:—"Ten years ago cake and corn were used in considerable quantities; sounder views, however, on the profitableness of the employment of cake and corn are rapidly extending. Some of the best feeders in the county now make use of little cake or

corn, having been convinced that payment for the cake is not obtained, and that manure can be had cheaper in the form of guano."

It is almost unnecessary to say that this opinion is no longer held. It is, in fact, absolutely reversed. Corn has recently been given to stock in large quantities because it is cheap; but cake is still more universally a staple article of food, the manure produced by it being more valuable than that resulting from grain. Whilst cattle are now allowed more artificial food than formerly, it is also liberally supplied to sheep, whether folded on turnips during winter or on grass in summer. Several farmers now expend 3*l.* per acre for extra food on grass depastured by sheep. In one recent instance a flock-master fed 11 sheep per acre on 24 acres of young grass, at an expense for cake of 80*l.* The sheep paid for their keep, and he was enabled to continue the field in grass a second year, which without this artificial aid would have been impossible. Foreign oil-cake is more in use than home-made, which is not considered to possess superiority equivalent to its greater price; whilst we have the authority of Professor Anderson for saying that is more frequently adulterated than sea-borne cake.

Hardly any cattle are bred in the county, the north of England supplying the great majority of the oxen fed in it. They are brought by English dealers to our autumnal fairs at all ages, from calves to 3-year olds; a large proportion of them, and nearly all the heaviest, again cross the border, being carried back fat in spring to the manufacturing districts of Yorkshire and Lancashire. It is rather singular that while Scotch farmers look to the south for their supply of lean cattle, the black polled bullocks of Dumfries and Galloway are nearly all sent to England, many going to Norfolk and the Eastern counties. Thus Englishmen and Scots seem mutually to prefer animals bred at a distance, which must add considerably to their respective prices.

Breeds of Stock.

Since 1853 a weekly sale by auction for fat stock has been established in Haddington, which is found very convenient both for buyers and sellers and a great boon to local butchers, whilst a fair for store cattle in October has been instituted with great success at Linton, the whole supply of oxen being brought from England.

In the Lothians, Galloways are thought to be slow feeders, but a cross between the kindred race of Aberdeen and the shorthorn is highly esteemed; though it can very seldom be got, as the north-eastern counties are unable fully to supply their local wants.

Much discussion has recently taken place as to whether any of

the English breeds of sheep might with advantage be introduced into East Lothian.

Southdowns have long been bred in the county, several flocks having been carefully cultivated for half a century; but though well adapted to the soil and climate, they are not on the increase, and the rams are chiefly used to propagate cross-bred lambs for spring consumption. Lincolns, which were tried to a small extent, have been abandoned; but Cotswolds in limited numbers may be said to have made good their footing, whilst several farmers have resolved to try the handsome Down sheep of Shropshire. Last autumn, tempted by a temporary cheapness caused by drought in the south, several flock-masters brought 300 or 400 Hampshire Downs to East Lothian, in order to try their merits. As regards the ewes, the experiment is still in progress; but the wethers have been sold at a fair profit. Being strong sheep, they fetch large prices; but their appetite seems quite in proportion to their bulk, and their personal appearance is certainly not prepossessing. It is, indeed, difficult to imagine how this breed could establish itself in countries so near the home of the Southdown, of which it seems but an uncouth imitation.

The sheep most prevalent in East Lothian are Cheviots and half-breds. The former are chiefly fed during winter, being purchased in autumn from mountain districts. The half-bred (the produce of a Cheviot ewe by a Leicester ram) is the sheep which dots the summer pastures, and supplies the chief part of the ewes bought for breeding, though pure Cheviots are also used. Pure Leicester flocks are kept in considerable and increasing numbers, the rams of which are readily sold by auction, though at prices much below those obtained by fashionable breeders in other counties. Leicester sheep, fat for the butcher, are almost unsaleable at home, and are sent to Newcastle, where the colliers do not object to a little tallow. It is the general opinion of farmers that no stationary breeding-stock will pay unless the males can be sold for rams. Half-bred ewes are bought each September and October for about 40s. from breeders in pastoral districts who have already reared crops of lambs from them, and are sold fat during the following summer, leaving generally a shilling or two of profit for their keep, as well as their fleeces and lambs. The profit from feeding sheep during the present winter is large; Cheviots folded on turnips, with an allowance of cake or corn, leaving about 1s., and in some instances 1s. 4d. per week.

Implements.

Scotland, in all that pertains to its agricultural implements, the *cerealia arma* of the husbandman, is thoroughly utilitarian; and as a rule the machines of the farm are simpler and cheaper,

though not always so perfect, as those which surprise the spectator from their ingenuity, and almost perplex him by their numbers, at the Royal Agricultural Shows.

The fixed steam threshing-mill is a marked, and all but universal feature in every farm—the ubiquitous chimney-stalk being to the “toon” what the church-spire is to the country village; but in addition to these we have to some extent borrowed from England the locomotive threshing-mill, several of which now ply for hire, and are often found convenient.

In several important respects the furnishings of Scottish homesteads are much inferior to those of the best specimens of English farms. Apparatus for steaming food, light and useful locomotive-engines driving pulpers or chaff-cutters, mills for grinding corn, &c., are all much more common in England than in Scotland, where cattle and sheep are still for the most part fed on roots and straw given separately, frequently without the addition of corn and cake; moreover, great establishments for the manufacture of agricultural implements like those of the Croskills, Ransomes, and Howards, have no counterparts beyond the Tweed. Nevertheless, one very important implement is, we imagine, much more universally in use in the Lothians than in England, since, practically speaking, the whole corn-crop and even a portion of the bean-crop is now cut by the reaping-machine. The paper of 1853 marks the turning-point in the history of this great invention, which, after long neglect, has at length become indispensable in our harvest-field.

“The crops in East Lothian,” says the writer of the former account, “are cut principally by the sickle, occasional fields only being cut by the scythe. Last season a considerable number of Bell’s reapers were in use, but comparatively little was cut by them.”

It is with something like regret that we have to record that Bell’s machine—the parent of all really useful reapers—is now almost a thing of the past, and its posterity bear very little resemblance to their progenitor. One gentleman farmer, indeed, clings to “Bell” with true British tenacity, and with half-a-dozen of these implements reaps the crop of four large farms, containing fields which in some counties would be called mountainous. The large machines of Burgess and Key, acting on the screw principle, next occupied the farmer’s attention; but these in their turn have been superseded, and, with Croskill’s “Bell,” they now rot in corners, looking, in comparison to modern reapers, like skeletons of the Mammoth and the Mastodon among recent animals.

During the harvest of 1860, a competition of reapers was held in East Lothian, under the auspices of the local Agricultural

Society, when the pre-eminent utility of the smaller and simpler machines, founded on Hussey's principle, was at once and conclusively established. Since then, practical experience, as well as subsequent competitions, have thoroughly established the light and handy reaper, as the machine by which the crop of the county is to be cut. There are one or two farmers who still reap their crop with the sickle, and they are likely to continue to do so. No improvement was ever accepted with absolute uniformity by an existing generation. It is not long since we saw an old gentleman (a good shot and a good sportsman he was too), who, despising percussion-caps, adhered manfully to the "flint-and-steel" of his early days.

With rare exceptions, however, each farm is now furnished with a reaper, and several of the more extensive have three or four. They are all 2-horse machines; and it is found expedient that the driver should drive from a seat, and not ride, as was usual at first.

All these reapers act upon the principle of manual delivery; but, though not yet in general use, we expect soon to see a "self-deliverer" added to the implements of every large farm. In a county such as East Lothian, where labour in harvest is often scarce, and where destructive winds are only too common, it is of great consequence to be able to send a single man with a pair of horses into a large field of standing corn, and have it cut down whilst the labourers are at work in other parts of the farm. This we have repeatedly seen done with one of M'Cormack's reapers.

By reaping-machines the work is much better as well as more cheaply done than by manual labour, and the sheaves are sooner fit to be carried, since the pipes of the straw, not being bruised and crushed together as they are by the grasp of the labourer, allow the air to enter much more freely into the shock. The great majority of the reaping-machines are the work of local makers; who, besides producing as efficient implements as any in the world, are on the spot to rectify whatever may go wrong, and to stand surety for their workmanship.

Steam Cultivation.

While the reaping-machine has thus pushed the reaping-hook aside, a still more important agent, steam-power, has offered its giant assistance for the upheaving and disintegration of the soil. Passing over two earlier, but ineffectual attempts to introduce the steam-plough into the county, we must assign to Mr. Saddler, of Ferrygate, the merit of first establishing this mode of cultivation in East Lothian. Five sets of steam-apparatus are now at work, the property of tenant farmers, and, singularly enough, while

three different systems—Fowler's, Howard's and Coleman's—are represented, they may all be seen at work from one spot, being used on adjacent farms. The five owners of these ploughs are all equally satisfied with their investments, and if, after hearing what each has to say, we are asked which system is best, we are inclined to reply, with Sir Roger de Coverley, that "a great deal may be said on both sides."

While the progress of steam-cultivation may be considered as certain, it has of course its difficulties to contend with, and several of these are not common to both divisions of Great Britain. In many parts of England the smallness of the fields, the nature of the fences, and probably the want of leases—obstacles unknown in East Lothian, may interpose, whilst with us the chief impediment is the number of boulder-stones which underlie the surface of the soil. These have been for the most part already removed from the share of the ordinary plough; but just as the Great Eastern found in the Atlantic rocks unknown to ships of lighter draft, so the steam-plough falls foul of a new crop of earth-fast stones, the fertile source of breakage and delay. Then in that important item, the saving of horse-power, the northern farmer has less to gain than his brother in the south, because he has been accustomed to work his land with fewer horses; one pair to each 70 acres being the usual provision.

The distance too of the steam-plough manufactories is another, though a minor, drawback, involving a cost of from 30*l.* to 60*l.* for the conveyance by rail of a steam-apparatus, and, besides, causing much delay whenever any breakage takes place.

Plans for joint ownership in steam-ploughs, or for letting them out for hire, have not stood the test of practical experience. No one will go to the expense of preparing his land for the *occasional* use of steam, and thus, if the hired plough makes its appearance it is broken by stones; and, besides, each farmer wishes to have his land cultivated at about the same time.

The benefits conferred by the steam-plough have not, however, been confined to its direct operation. The results of its powerful and thorough cultivation have led to an inquiry into the whole subject, which has given a great impulse to deep cultivation generally. Subsoil-ploughs of various forms have been brought into requisition, and stones have been dug up till fields have been so covered with the disinterred blocks, that, for the time, they looked like churchyards.

The whole theory upon which ploughing-matches used to be conducted has been knocked on the head. Formerly the successful ploughman was he who sliced the soil into the neatest ridges, and who turned it over most compactly. The subsoil being pressed and consolidated below by the weight of the

plough, the further object seemed to be to render the surface as impervious as possible to the influence of the atmosphere, and the pattern of the whole work was apparently taken from the ploughman's own corded breeches. All this is now changed; and if the earth is but sufficiently torn, tossed, tumbled about, and, if possible, tunnelled into, it matters not how rough the work may seem.

Leases and Covenants.

While agriculture is thus advancing with the times, it presents one aspect in which little or no change has been effected for centuries. Scotland boasts, and with reason, of its system of leases, assuring, as they do, to the tenant, the possession of his farm for 19 or 21 years, and thus giving him time to reap the benefit of the large outlay which is generally made during the first half of his occupancy; and there can be little doubt that, but for such leases, it could never have emerged from its original barrenness. And yet, if these leases are the boast of Scottish agriculture, they are also its shame, betraying, by their lengthiness, their vexatious enactments, their not unfrequent inapplicability to the lands demised, and their general ignorance of agriculture, that they originated in a lawyer's office.

Their rigid prescription not only of the acreage to be assigned to each crop, but of the amount of seed to be sown, without even any allowance for the casual failure of a crop; their undue restrictions on the sale of produce, besides annoyances chiefly connected with the preservation of game, too often give them the character of the fifteenth, rather than of the nineteenth century.

How comes it, then, that such documents are tolerated by a practical and not too submissive people? Simply because they are looked upon alike by landlord and tenant as a dead letter. Still they are not altogether innoxious; they are the skeleton in the farmer's cupboard, and if he should be so unfortunate as to give offence by asserting his rights in one direction, he may always be hit in another by the enforcement of penalties incurred under the lease.

Other Changes.

Among the men connected with the soil of East Lothian, whether as owners, occupiers, or labourers, many changes have taken place since 1853. Death has removed, amongst others, those excellent, considerate landlords, the Earl of Haddington, and Mr. Hope of Luffness; the latter of whom, not long before his death, gave strong proof of his fairness by ordering the ground-game which abounded on his estate to be reduced within perfectly

harmless limits. Mr. Aitchison of Alderston has also passed away, an able man who, with great success, farmed his own property. For fully 40 years he kept a flock of Southdown sheep, frequently refreshing the blood from the Babraham stock, and gaining many prizes in agricultural shows. Mr. Brodie of Abbeymain, the leading farmer of his day, an account of whose system of management is given in the 'Journal' of 1853, has also gone from among us, and his farm is not now occupied by his family.

The competition for land has, however, been the great cause of change among the occupants of farms, the old tenants at the end of a lease being almost always outbid by strangers. Descending in the scale, we find that a still greater change is taking place among the labouring population. In former times, when son succeeded father in the occupancy of a farm, the "hinds" were as stationary as their masters, but the ties that bound them together are now nearly broken. New masters employ new men, and the old scattered cottages in which old ploughmen used to end their days are all cleared away, and the failing "hind" has to find a refuge in the town or the village, where he must live by the poor-rate and not by occasional country work. Young ploughmen seem now to seek change for the sake of change, and the hiring-market—a foul blot in the agricultural escutcheon—is every year more and more crowded by a thoughtless mob, of whom their fathers would have been ashamed.

Comparatively few East Lothian ploughmen have as yet availed themselves of the legal relief afforded to age or infirmity when combined with poverty, but the number is on the increase; and, in consequence of this, much lamentation is made over what is called a sad change in the character of the Scottish peasant. The change, we maintain, is caused by circumstances over which the ploughmen have no control whatever, and of all classes of society they are perhaps the least to blame in the matter. The fierce competition for land, and the consequent rise in the rents of farms, have driven farmers to buy labour in the cheapest market; and the landowner, pressed by the tenant for buildings to shelter horse and ox, has reduced to a minimum the dwelling-houses on his property.

Let us see the effect of this. Suppose that, there were standing on a farm somewhat dilapidated cottages, inhabited by ten families, and that the heads of some of these were past their prime. The farm is re-let, and the old occupant gives place to a new tenant at an advanced rent. New cottages are built, but in place of the ten old tenements pulled down, seven only are erected. The oldest "hinds" are dismissed, and labourers from a distance, chiefly Irish, do their work. Formerly the three extruded sexagenarians

would have ended their days in the country, working as they were able, their wages, supplemented by such aid as their relations could afford, sufficing to maintain them in comparative comfort; whereas now, they have no alternative but to shrink into a town, where no fitting work is to be found, and where they must of necessity become paupers.

We have thus endeavoured to sketch the history and the fortunes of East Lothian farming during the last ten years, the scene closing upon a tenantry struggling in days of low-priced grain with over-rented arable land. Their position has been to some extent caused by their own imprudence, but probably still more by a combination of circumstances beyond their control. Whilst certainly grave, if not desponding, farmers have not given way to despair, but are endeavouring as far as possible to adapt the agriculture of the county to the altered times; in proverbial language, "*they set a stout heart to a stay brae.*"

At the same time, however, many men who now farm because in youth they followed the profession which for generations had been that of their fathers, are resolved that no son of theirs shall be brought up to spend his life in a struggle which offers a poorer prospect of success, and a worse return for thought and capital, than any other trade or profession.

Camptown, Drem.

VIII.—*On some Causes of Unproductiveness in Soils.* By Dr. AUGUSTUS VOELCKER.

IN an uncivilised, thinly populated country, or in a colony where the backwoodman's axe has to clear the ground before anything else can be done, the agricultural settler has little or no opportunity for turning to account the knowledge of agricultural chemistry which he may chance to possess. The case is different in a highly civilized and densely-peopled country like England, where opportunities arise for the useful application of chemical principles, physiology, botany, and other branches of natural science, just in proportion as agriculture is advancing in conjunction with wealth and population. Therefore we need not wonder that many eminent and successful practical farmers should be anxious to provide a better general education for their sons than they themselves enjoyed, and to afford them instruction in the rudiments of the particular sciences which bear upon agriculture.

Fully admitting that, even in a highly civilised country, scientific attainments confer far less material benefits upon the cultivator of the soil than acquaintance with the practice of successful farmers and the possession of good business habits, we

may yet assert that neglect of chemical principles frequently leads to practical mistakes. Such mistakes are often unconsciously committed by excellent farmers, on whose authority good as well as bad practices are handed on from one generation to another.

The causes of barrenness or unproductiveness of soils are numerous: some depending more obviously on the imperfect chemical constitution of the land, may be conveniently termed chemical causes of barrenness; others, like those manifesting themselves in too close or too loose, or otherwise faulty a texture, may be termed physical or mechanical causes of unproductiveness. It is not easy to separate the one class from the other; for in reality the imperfect chemical constitution of land frequently is but the result of its bad physical condition. Thus, undrained, unmitigated clay soil, does not yield to the growing plant a sufficiency of available potash, phosphoric acid, lime, &c., and may be said to be unproductive as much on account of its lack of available plant-food, as on account of its bad physical condition.

A recognition of the cause of sterility in land often enables the intelligent agriculturist to apply the proper means of restoration. Barrenness and comparative unproductiveness may be due to a variety of causes: sometimes it arises from a deficiency in the soil of something essential to the healthy growth of plants; in another soil it is the result of the presence of something injurious to vegetation; and in a third case it is the impervious character of the land which causes it to be unproductive. Any defect must be discovered before it can be supplied, and the remedy against any injurious substance present in the land is not likely to be found so long as its precise chemical composition is unknown.

It is not a little amusing to find agricultural writers speaking of the bad chemical composition, or the poor physical character of the land as the cause of its unproductiveness. What the chemical composition of the land really is, or what is the precise nature of its poor physical character, for obvious reasons, we are not told. No wonder that plain and intelligent men lightly esteem the chemical theories and the physical explanations by which attempts are made to enlighten the agricultural mind as to the causes of barrenness of soils.

The present paper only professes to treat of certain of the causes of barrenness, which I have myself investigated more particularly.

In reviewing the inquiries purposely instituted by me, and the cases with which I became incidentally acquainted, soils appear to be barren, or more or less unproductive,—

1. When they contain something inimical to vegetation.
2. When they are deficient in one or more important constituents which enter into the organization of the living plant.

3. When they contain too large a preponderance even of a valuable ingredient, such as organic matter, sand, lime, and even clay.

4. When there is but a thin layer of soil resting on the bare rock.

5. When the land is thin and rests on an impervious and very thick clay subsoil, or on subsoils containing something injurious to vegetation.

6. When they are badly drained.

7. When they are affected by a bad climate.

Under these seven divisions, I purpose to treat the subject of the present communication.

1. *Soils are barren or unproductive when they contain something injurious to vegetation.*

There is a very ready test for ascertaining whether a soil is likely to contain an injurious constituent. All that is necessary is to put a strip of litmus-paper in contact with wet soil; if the blue colour of the test-paper turns rapidly red, the soil is certain to contain something injurious to plant-life. All good and fertile soils either have no effect upon red or blue litmus-paper, or show a slight alkaline reaction; that is to say, in a wet condition they restore the blue colour to reddened litmus-paper.

The acid reaction which some barren or unproductive soils exhibit, I find is caused,—

a. Either by an excess of organic acids (humic acids),

b. Or by the presence of small quantities of sulphate of iron—green vitriol.

Another substance which occurs in some barren soils is bisulphide of iron or iron pyrites, a compound of 2 equivalents of sulphur and 1 of iron. It is generally found in soils in which the presence of green vitriol is readily detected, and, like the latter, is a most undesirable soil-constituent. The simultaneous occurrence of these two compounds is explained by the fact that green vitriol is the result of the oxydation of iron pyrites in contact with air and moisture, the iron of the iron pyrites becomes converted into protoxide of iron, and the sulphur into sulphuric acid, which, combining together, produce sulphate of iron or green vitriol. Even as small a proportion as $\frac{1}{2}$ per cent. of green vitriol renders a soil almost barren; and on land containing little more than 1 per cent. nothing whatever can grow.

In many unproductive soils I have found protoxide of iron in considerable quantities, and scarcely any red peroxides—a sure indication of poor cultivation. This, however, in many instances, may be greatly improved by better drainage, subsoiling, grubbing, and other mechanical operations tending to

admit the air more freely into the soil. Protoxide of iron manifests itself by the bluish-grey or dark-green colour which may be noticed in many clay subsoils and stiff tenacious soils improperly cultivated. A change of colour from blue to reddish-brown is justly regarded as a sure sign of improved condition, for it indicates the transformation of protoxide into peroxide of iron, and tells of the free admission of air into the land.

Protoxide of iron being as insoluble in water as peroxide, can hardly be regarded in itself as a plant-poison; it is rather a test of the absence of atmospheric oxygen from the soil. The readiness with which protoxide of iron unites with more oxygen and produces red oxide, is seen in the rapid change of colour which blue clay dug out of a drain assumes superficially within a few hours on exposure to the air. Protoxide of iron, indeed, is one of the most delicate tests for oxygen, and thus, though it is not injurious to plants in the same sense as green vitriol, which is readily soluble in water, nevertheless, its presence implies a complete exclusion of the air, without which vegetation cannot remain in a healthy state for any length of time.

Chloride of sodium, or common salt, generally occurs in an injurious proportion in land recently reclaimed from the sea, or in soils inundated by the sea. It is true, that some grasses and maritime plants grow well enough on such spots; but cereals, roots, clover, and other forage crops, do not grow well on land constantly kept in a very wet state, and do not ripen unless the heat of the sun during the summer months has had a fair chance of penetrating the surface-soil, and expelling any superabundance of moisture. Soils recently reclaimed from the sea, or land accidentally saturated with sea-water exhibit in dry weather white efflorescences, which consist mainly of common salt, as may be readily ascertained by the taste. Although the soil originally is impregnated with but a dilute solution of salt, the evaporation from the surface in dry weather causes the liquid brought upwards by capillary attraction to become by degrees charged with salt to such an extent, that portions crystallize out in the shape of a white saline efflorescence which is injurious to vegetation. I am acquainted with land which, irrigated purposely with sea-water, under the mistaken idea of improving it, has been rendered unproductive for several seasons in succession.

In some soils in India and Hungary nitrates of potash and soda, two very valuable salts, occur in proportions injurious to vegetation. Like solutions of common salt, nitrates give rise to saline efflorescences, which invariably indicate an unhealthy condition of the land, and frequently destroy vegetation altogether. Common salt, nitrates of soda and potash, it is well known, are used as manuring agents; nevertheless they are injurious when

their proportion in a soil is such as to produce white saline efflorescences.

Lest it should be thought that the preceding remarks apply more to imaginary cases than to real ones, I may be permitted to give some illustrations representing instances of barren soils which have been actually brought under my notice.

Soils abounding in organic (humic) acids are very common in all peaty districts. From a large number of analyses of such soils, I will select only one, from Meare near Bridgewater:—

Analysis of Peat Land.

	Dried at 212°.
*Organic matter (abounding in humic acids) ..	97·760
Oxides of iron and alumina	·536
Carbonate of lime	·855
Magnesia	·144
Potash	·131
Soda	·065
Phosphoric acid	·053
Sulphuric acid	·051
Silica	·405
	<hr/>
	100·000
*Containing nitrogen	1·428

In its natural state this soil contained no less than 88 per cent. of water. The percentage of mineral matter, and more especially that of phosphoric acid, is very trifling, and the excess of organic acids is incompatible with a healthy vegetation. Lime and marl, as is well known, have the power of neutralising the humic acids in such peaty soils. They add, moreover, to the mineral matter of the soil, and certainly are the best means of improving it.

I will next place before the reader

An Analysis of Soil from the Haarlem Lake, in Holland.

	Dried at 212° F.
*Organic matter and water of combination	14·71
Oxides of iron and alumina	9·27
Sulphate of protoxide of iron (green vitriol)	·74
Bi-sulphide of iron (iron pyrites)	·71
Sulphuric acid united with oxide of iron as basic sulphate of iron	} 1·08
Sulphate of lime	1·72
Magnesia	·73
Phosphoric acid	·27
Potash	·53
Soda	·32
Chloride of sodium	·09
Insoluble siliceous matter (clay)	69·83
	<hr/>
	100·00
*Containing nitrogen	·52
Equal to ammonia	·62

This soil abounds in all the mineral elements which enter into the composition of the ashes of plants, and is especially rich in phosphoric acid; it moreover contains a considerable proportion of organic matter capable of yielding on decomposition rather more than $\frac{1}{2}$ per cent of ammonia, but unfortunately it is impregnated with sulphate of iron, which neutralises all its useful properties, rendering it unproductive.

An interesting circumstance may be mentioned in connection with the field from which this soil was taken. Before it came into the hands of its present proprietor, the land was only slightly scratched on the surface as a preparation for the next crop, and then produced scanty but still remunerative crops. Not satisfied with that yield, Mr. Wilson, an enterprising Englishman, the present owner of the land, ploughed deep, and, to his astonishment, found this attempt to improve its productiveness result in a complete failure of his corn-crop. A heavy dressing of farmyard-manure proved equally unsuccessful, or rather aggravated the evil; for after the application of the dung even the deeper-rooting weeds were affected, and nothing but surface weeds would grow. This curious circumstance led to a chemical examination, which was committed to me.

The preliminary examination showed at once that there was present some injurious substance, for the wetted soil strongly discoloured the blue litmus-paper. The acid reaction I found was caused by sulphate of iron, and I also succeeded in detecting sulphide of iron, or iron pyrites. As long as the land was left unploughed, the latter constituent was not brought to the surface, and most of the iron existing there originally was no doubt gradually removed into the subsoil by the rain, which accounts for the better crops when the subsoil was unstirred. By deep cultivation the sulphide of iron was turned up, and air admitted into the soil more freely, which had the effect of oxydizing the iron pyrites, and changing it into green vitriol. As the available mineral elements and soluble salts in the land were already rather in excess of the amount which is beneficial, the dressing of farmyard-manure, containing a good deal of soluble matter, could only aggravate the evil.

The proper remedy for such a state of things is a heavy dressing of lime, marl, or chalk; for quicklime, or the lime in marl or chalk, decomposes sulphate of iron, and uniting with the liberated sulphuric acid, gives rise to gypsum—a useful fertiliser—and to oxide of iron, which occurs in all fertile soils. In the case before us, my recommendation to apply a heavy dressing of lime was adopted with complete success.

Since green vitriol, as well as iron pyrites, sometimes occur in subsoils, care should be taken to test the subsoil, before the opera-

tion of subsoil ploughing is commenced, for such injurious matters, which it is better not to bring to the surface.

The particulars here related afford a complete answer to those who maintain that chemical analyses of soils are of no use whatever to the farmer.

The following analysis shows the

Composition of a Soil reclaimed from the Sea on the Hampshire Coast.

Water	5.45
Organic matter and water of combination	9.93
Oxides of iron and alumina	7.18
Sulphate of protoxide of iron (green vitriol)	1.39
Bi-sulphide of iron (iron pyrites)78
Sulphate of lime34
Magnesia51
Chloride of sodium04
Potash and soda83
Insoluble siliceous matter	73.55

100.00

The constitution of this soil is very similar to that reclaimed from the Haarlem Lake; the remarks on the preceding analysis, therefore, apply with equal force to this, which is given as an example of the occurrence of land in England poisoned by green vitriol.

More recently I had an opportunity of inspecting a field near Sandy in Bedfordshire, a portion of which was so completely sterile, that not a weed nor a single blade of grass could be seen on it. The following is its analysis:—

Composition of a completely Barren Soil from Sandy, in Bedfordshire.

	Dried at 212° F.
Organic matter and water of combination	4.27
Oxides of iron and alumina	3.84
Phosphoric acid09
Sulphate of lime85
Magnesia96
Potash and soda47
Sulphate of iron (green vitriol)	1.05
Sulphide of iron (iron pyrites)56
Insoluble siliceous matter (chiefly sand)	87.91

100.00

Here again we find sulphate as well as sulphide of iron in appreciable quantities. Tested with litmus-paper, this soil showed a strong acid reaction, and when heated in a platinum capsule gave off pungent fumes of sulphurous acid. Soils in a healthy condition, it may be remarked, when heated, do not give off pungent vapours, smelling like those of a lighted sulphur match. This is in itself a tolerably sure sign of the presence of injurious iron compounds.

The colour of this soil was dark grey, almost black, and yet it will be seen the proportion of organic matter in it is not large. The dark colour was therefore due not so much to organic matter as to finely divided sulphide of iron. In such a state of division, very little of it imparts a dark grey colour, and particularly obnoxious properties, to a large mass of soil.

Where such dark soils occur, the air in the neighbourhood at times is charged with foetid vapours, smelling faintly like rotten eggs. This smell is produced by the action of the carbonic acid of the air upon the black sulphide of iron in the soil. Acids, not excepting the weak carbonic acid, in the diluted state in which it occurs in the atmosphere, on the point of mixture disengages from sulphide of iron sulphuretted hydrogen, a gas highly injurious to vegetable as well as animal life. Chemical reactions are generally intensified by elevation of temperature, and thus the emission of sulphuretted hydrogen from land impregnated with black sulphide of iron, is greater in summer than in winter. In my opinion, sulphuretted hydrogen does more mischief than even green vitriol, for direct experiments made by Dr. Christison and others have shown that, even in a highly diluted state, sulphuretted hydrogen is injurious to vegetation, and, in a more concentrated state, is capable of destroying vegetable life as readily as that of animals.

All saline matters which are very soluble in water, as noticed above, are injurious to vegetation when they occur in the soil in too large a proportion. The practical question is, What is too large a proportion? An answer has been given lately to this question in the highly interesting scientific experiments on the nutrition of plants by Professor Knop of Leipsig, who found that solutions containing in all not more than 1 part of soluble mineral matter to 1000 parts of water are fully as strong as liquids should be from which plants are to derive food and grow luxuriantly. In solutions stronger than this, plants either grow languidly or die altogether, although the same mineral substances are employed which, in a highly diluted state, are most active promoters of vegetation. If such be the case with solutions, my own experience leads me to infer that the soil itself should not contain more than $\frac{1}{10}$ th per cent. of such soluble substances, and therefore that soils which contain several per cent. of common salt, nitrate of lime, or chloride of potassium, are unfit to maintain vegetable life in a healthy state.

I have met with several extraordinary soils, upon which nothing would grow, evidently because they were overcharged with soluble saline matters. An example of that kind is given in the subjoined analysis:—

Composition of a Soil impregnated with Salt and Nitrates.

Moisture	10.86
*Organic matter	4.84
Oxides of iron and alumina	11.28
Phosphoric acid	2.35
Equal to bone-earth	(5.08)
Carbonate of lime	5.21
Nitrate of lime	2.32
Containing nitric acid	(1.526)
Chloride of sodium	11.61
Chloride of potassium	2.31
Insoluble siliceous matter	49.22
	100.00
*Containing nitrogen24
Equal to ammonia29

We have here a large proportion of common salt, and also chloride of potassium and nitrate of lime, two salts still more soluble in water than chloride of sodium. The nitrate of lime is evidently a product of the oxydation of animal matter, the presence of which in this curious soil, is distinctly evidenced by the simultaneous occurrence of phosphate of lime (bone-earth) in considerable quantities. We have here presented to us a true nitre-earth, which, valuable as it is unquestionably when applied as a manure, is far too rich in saline constituents to be cultivated like an ordinary soil.

In concluding this section of the subject, it may be well again to mention briefly the various matters and conditions which render some soils barren or unproductive. They are the following:—

- a. Superabundance of organic (humic) acids.
 - b. Sulphate of iron (green vitriol), even when present in the soil in small quantities.
 - c. Sulphide of iron (iron pyrites), and especially finely divided black sulphide of iron, which, in the smallest proportions, is most pernicious to plants.
 - d. Abundance of protoxide of iron, and absence of peroxide, indicating a bad physical condition of the land.
 - e. Chloride of sodium (common salt) in proportions of $\frac{1}{10}$ th per cent. and upwards.
 - f. Nitrates and all soluble saline matter, in quantities exceeding small fractions of 1 per cent. of the whole mass of soil.
2. *Soils are unproductive when they are deficient in one or more constituents found in the ashes of our cultivated plants.*

By far the greatest number of soils, as we find them in this and other countries, are poor in phosphoric acid; for which reason phosphates in an available condition are generally useful as fertilisers. In some soils this deficit is very marked. Thus in the following analyses we have merely traces of phosphoric acid:—

Composition of Soils deficient in Phosphoric Acid.

	Sandy Soil.		Clay Soils.	
Moisture	10.06	..	12.37
Organic matter	3.02	7.69	..	8.07
Oxides of iron and alumina	4.34	13.36	..	14.45
Phosphoric acid07	.04	..	.01
Sulphate of lime10	.17	..	.14
Carbonate of lime17	.24	..	none
Potash and soda26	1.65	..	1.21
Magnesia41	.46	..	.37
Insoluble siliceous matter	91.63	66.33	..	63.38
	<hr/>	<hr/>	<hr/>	<hr/>
	100.00	100.00	100.00	100.00

I have selected for illustration one sandy and two clay soils, in order to show that the same defect may exist in soils of diametrically opposite physical characters.

Those who pretend to form a *just* estimate of the agricultural capabilities of soils by mere classification and examination of their mechanical condition make as great a mistake as men who hastily form an opinion of the quality of a sample of guano or superphosphate by handling and smelling it.

Experience, indeed, shows that there are poor clays as well as poor sands, and on the other hand rich clay soils and very fertile sands. If we examine carefully these differences in the only way in which they can be examined with certainty, that is, by chemical analysis, we often find the relative productiveness of different soils to be intimately connected either with an abundance or a deficiency of phosphoric acid.

Another substance which sometimes only exhibits traces, and often occurs in too small a proportion, is lime. The practice of liming and marling which prevails in many districts of England is a proof of the want of lime in many light as well as heavy soils. In the following Table I have incorporated the analyses of various kinds of soils which are all benefited by the direct application of lime or chalk:—

Composition of Soils deficient in Lime.

	No. 1.	No. 2.	No. 3.	No. 4.
	Sandy soil from Kent.	Stiff Pasture from Somersetshire.	Clay soil from Demarara.	Peaty land from Kenmoor, Somersetshire.
Moisture	7.03	..
Organic matter	3.62	16.80	12.58	55.32
Oxides of iron and alumina	7.50	16.08	11.10	13.08
Phosphoric acid13	..	.48	.06
Sulphuric acid11	1.20
Lime43	.75	.13	.97
Magnesia49	1.56	.33	.54
Potash and soda48	.45	.52	1.02
Insoluble siliceous matter	87.35	64.36	67.72	27.81
	<hr/>	<hr/>	<hr/>	<hr/>
	100.00	100.00	100.00	100.00

This list might have been much extended, but the preceding examples will suffice in illustration of the deficiency of lime in peaty, clay, sandy, and pasture soils.

The want of alkalis, more especially of potash, is, I believe, a far more common cause of the comparative sterility which characterises some land than is generally believed to be the case. If we look at the composition of the ashes of all farm-produce, we shall find that a very large proportion of their ashes consists of potash. This constituent, of course, must be supplied either by the soil or in the manure with which the latter is dressed. Root-crops especially leave ashes rich in potash; and as turnips are often grown on land naturally poor in alkalis, with purely mineral superphosphate of lime, and nothing else, and the produce is sometimes sold off the land, or not consumed entirely upon it, the land may thus become drained of its available potash to an injurious extent. Perhaps the failure of roots on land which formerly produced good crops may have something to do with the gradual exhaustion of their available alkalis.

At any rate it is well to remember that many soils are very poor in alkalis, and that in all fertile soils the amount of potash and soda is always considerable.

It is a prevailing idea that light sandy land alone is likely to be deficient in potash; and it is true that this want does not so frequently affect clay land; but at the same time it is no less a fact that some clays are almost as poor in alkalis as the worst kinds of sandy soils. In proof of this I may give the sub-joined recent analyses of mine of a strong clay and a light sandy soil:—

Composition of a Strong Clay and a Sandy Soil.

	Strong Clay Soil.	Light Sandy Soil.
Moisture	4·01	..
Organic matter and water of combination	8·51	6·92
Oxides of iron and alumina	11·24	6·43
Phosphoric acid	·06	·11
Sulphuric acid	·19	..
Lime	none	·65
Magnesia	·46	·39
Alkalis (potash and soda)	·45	·33
Insoluble siliceous matter	75·08	85·17
Chiefly	(clay)	(sand)
	100·00	100·00

In these two soils potash and soda are evidently deficient; at the same time it will be noticed that both are poor in phosphoric acid, that there is no lime in the clay, and but little in the sandy soil.

Unproductive soils are seldom deficient in one substance only:

for this reason many cannot be made fertile by the application of manures which, like lime, supply only one material. Sandy soils, more especially, often stand as much in need of lime as of phosphoric acid or of potash. Their general deficiency in all these important elements of fertility is clearly seen in the following analysis, showing the

Composition of a Poor Sandy Soil.

Moisture	4.78
Organic matter	1.03
Oxides of iron and alumina	1.72
Lime19
Magnesia10
Potash23
Soda	none
Phosphoric acid04
Sulphuric acid12
Carbonic acid and chlorine	traces
Insoluble siliceous matter	91.79
Consisting of:	
Silica	89.32
Alumina	1.81
Lime	none
Magnesia36
Potash15
Soda15
	100.00

It will be seen at a glance that this is a hungry soil, which requires lime as well as phosphoric acid and alkalis. As long as we do not possess a cheap source of potash, well made yard-dung, liberally applied, seems to be our only generally available resource for maintaining or increasing the productiveness of soils as poor and defective as this. It is upon soils of that character that town-sewage produces the best economical result, when applied in large quantities.

We have seen in this section that soils often are unproductive because they are deficient

- a. In lime.
- b. In phosphoric acid.
- c. In potash, or,
- d. In two or more of these important ash-constituents of plants.

3. *Soils are barren or unproductive when they contain a large preponderance of organic matter, or of sand, lime, or even of pure clay.*

The most fertile soils, such as alluvial-deposit or warp land, may be regarded as intimate mechanical mixtures of clay, lime, sand, and organic matter, in which no one of these essential com-

ponents preponderates, so as to give the mixture the character of a clay or sandy soil, or to show in too marked degree the properties of lime or organic matter.

On the other hand, sterility or comparative unproductiveness is often caused by such a preponderance in the soil of one of these. Each of these ingredients of all fertile soils possesses special chemical and physical properties conducive to the development of plants, and it will be readily understood how essential to luxuriance of growth is their intimate and nicely-proportioned mixture, such as we find it in alluvial soils.

The following Table illustrates the composition of soils which are unproductive on account of the preponderance of one of the four chief materials of all soils:—

Composition of unproductive Peat-land, Clay, Calcareous and Sandy Soils.

	No. 1.	No. 2.	No. 3.	No. 4.
	Calcareous Soil.	Sandy Soil.	Clay Soil.	Peaty Soil.
Moisture	2·65
Organic matter and water of com- bination	4·56	7·94	49·07
Oxides of iron and alumina	·780	5·93	10·95	10·88
Carbonate of lime	73·807	·39	·86	2·29
Magnesia	·825	..	·26	·75
Potash and soda	traces	·28	·39	·90
Phosphoric acid	·242	..	·10	·06
Sulphuric acid	1·546	..	·30	1·04
Silica	16·710	86·19
Insoluble siliceous matter (fine clay)	6·090	..	79·20	35·01
	100·000	100·00	100·00	100·00

4. *Soils are unproductive when a thin layer rests on the bare rock.*

I am acquainted with several localities where the soil is of excellent quality, but too near to the rock to be productive. We should bear this in mind in discussing the state of agriculture in different counties or districts, as this obstacle will baffle the utmost skill of the agriculturist though he might fertilise the barren sand or reclaim the unhealthy swamp.

5. *Soils are unproductive when they rest on impervious or extensive clay subsoils, which are not easily drained efficiently.*

A good deal of clay land, I believe, is unproductive solely because it rests on impervious stiff clay, probably 30 or 40 feet in thickness. Ordinary drainage, I fear, although it improves the character of such clay land to some extent, does not make sufficient impression upon its physical condition. Clay soils of that description occur in the lias formation, where they are known as scouring-land, on account of the tendency of the herbage to scour sheep and cattle. Some time ago I made an analysis of

notoriously bad land from Shepton-Mallet, Somersetshire. The soil contained in 100 parts :—

Moisture	4.54
Organic matter and water of combination	14.40
Oxides of iron and alumina and phosphoric acid	14.45
Sulphate of lime26
Carbonate of lime	14.80
Magnesia96
Potash and soda93
Insoluble siliceous matter (chiefly clay)	49.66

100.00

This soil had rather a dark colour which was due partly to protoxide of iron, partly to the large proportion of organic matter, which enters into its composition. Although not injurious in itself, an excess of organic matter, as well as of protoxide of iron, indicates a condition of the land which is unfavourable to the healthy growth of plants. In a porous, well-cultivated soil, freely penetrated by the atmosphere, the accumulation of organic matter never becomes excessive, nor does such a soil contain much protoxide of iron. The presence of the latter in considerable proportions always shows that the soil is not sufficiently aerated to produce a healthy and nutritious herbage.

Chemically considered this soil contains an abundance of all the mineral elements which enter into the composition of the ashes of plants, and it is found in practice that farmyard-manure does not produce any marked effect upon it, which shows plainly that it is not the want of plant-food that renders it unproductive. These lias lands rest upon a clay bed of great depth which approaches very near to the surface.

In many instances, therefore, under-drainage, besides taking off the surface water, produces little alteration in the condition of the surface soil, for the simple reason that it is too thin, and the clay sub-soil bed too tenacious and too deep to be penetrated to any extent by the ameliorating influence of the atmosphere. These tenacious soils are consequently damaged by excess of water and coldness, which retard vegetation and make it very gradual during the early months of the year.

5. *Soils are unproductive when the Drainage is defective.*

Under this head I need not offer any observations, for it is now perfectly well known that bad drainage is a frequent source of sterility in land, which has only to be thoroughly drained in order to become permanently improved.

6. *Soils are unproductive when their physical characters are bad.*

An actual case lately brought under my notice will best

illustrate this part of my subject. A correspondent wrote to me last spring from Churchdown, near Gloucester.

“SIR,—I have this day forwarded to you a bottle of earth for analysis. The land has been laid down to permanent pasture five years, the first year or two it grew luxuriant crops, but now it is almost worthless, although it has been dressed with different kinds of compost. With the analysis, please to give me your opinion what sort of manure would be most likely to bring it to a state of fertility.”

On analysis the soil yielded the following results:—

Moisture	4·04
Organic matter and water of combination	11·66
Oxides of iron and alumina and phosphoric acid	16·67
Carbonate of lime	10·03
Magnesia	1·38
Potash and soda	1·01
Insoluble siliceous matter (clay)	55·21
	<hr/>
	100·00

The soil ought to yield good crops, for it contains all the elements of food required by plants. It certainly is not unproductive because it is deficient in any one element of vegetable food, but I believe, because its physical condition is such as not to allow the plants to avail themselves of the food which is unquestionably present in the soil. It contains, it will be seen, a good deal of organic matter, and is a very stiff and retentive soil, difficult to drain. Surface water is removed readily enough by drainage from such land: this is one thing; but to make it sufficiently porous by draining to allow the water and after it the air to pass through the soil, is quite another matter. The soil appears to have grown luxuriant crops a year or two after it was laid down in permanent grass, and then to have become almost worthless. I can readily understand this, and have no doubt, if the land were again broken up, its previous fertility would be restored without the addition of any manure. Retentive clay-soils having a composition like this do not require manure, but must be penetrated by air, which is freely admitted when land is broken up. In the course of a year or two, however, the pores of such land again became closed up; and in consequence of the exclusion of the air, and not for want of mineral food, vegetation becomes languid in growth.

On land like this it is only waste to apply manures, especially if the season should be dry. Artificial, such as guano or ammoniacal salts, then do positive harm; and in wet but warm seasons, water itself is the best means of developing, so to speak, the natural resources of the land and encouraging the growth of

the herbage. It is not for me to say whether it is profitable to put such land down in permanent pasture or to break it up and adopt upon it a rotation suited to heavy clay land; but of this I am quite certain, that the *steam-cultivator* would do wonders on these cold, stiff clays, for they contain, practically speaking, an inexhaustible store of mineral food of plants, which, however, has to be unlocked as it were by the air. The more roughly stiff clays are broken up the better; the less the farmer meddles with the land when once broken up, the more effectually the air will find access into the land. No implement can possibly pulverise clays so effectually as air and frost, if time be allowed.

Having spoken at some length of a variety of conditions which appear to me to affect the fertility of land, my subject perhaps may be usefully brought to a close by a brief statement of what in my opinion the chemical analysis of soils can determine, and what it necessarily must leave undecided.

In the first place I would remark, that the chemical analyses of soils can give very decided answers to the following questions:

1. Whether or not barrenness is caused by the presence of an injurious substance, such as sulphate of iron or sulphide of iron?

2. Whether soils contain common salt, nitrates, or other soluble salts, that are useful when highly diluted, but injurious when they occur too abundantly?

3. Whether or not barrenness is caused by the preponderance of—

- Organic matter, or
- Lime, or
- Sand, or
- Pure clay?

4. Whether sterility is caused by the absence or deficiency of—

- a. Lime.
- b. Phosphoric acid.
- c. Alkalies, especially potash.
- d. Or available mineral (ash-constituents) matters generally?

5. Whether clays are fertile or barren?

6. Whether or not clays are usefully burnt and used in that state as manure?

7. Whether or not land will be improved by liming?

8. Whether it is better to apply lime or marl or clay on a particular soil?

9. Whether special manures, such as superphosphate or ammoniacal salts, can be used (of course discreetly) without permanently injuring the land, or whether the farmer should rather depend upon the liberal application of farmyard-manure that he may restore to the land all the elements of fertility removed in the crops?

10. What kind of artificial manures are best suited to soils of various composition?

11. Whether deep-ploughing or steam-cultivation is likely to be useful as a means of developing the natural stores of plant-food in the soil?

12. Whether the food of plants in the soil exists in an available or inert condition?

On all these points, chemical analysis can give reliable information, provided the results are rightly interpreted. The best answer to a question does not necessarily convey useful information to him who puts it: in the same way the most careful analysis of a soil does not always give a satisfactory answer even on points which a chemist can pronounce with some degree of assurance. A knowledge of chemistry does not put the analyst of a soil into possession of that amount of acquaintance with practical agriculture which is necessary to enable him to interpret analytical results, and to recognise their bearing upon purely practical matters. In the hands of a chemist perfectly ignorant of the first rudiments of practical agriculture, soil-analyses, it appears to me, are about as useful as, without comment, they are to a farmer who does not know the difference between phosphate and sulphate of lime, or between potash and soda.

There was a time when I thought, with many other young chemists, that soil-analyses would do everything for the farmer; three or four years of further experience and hard study rather inclined me to side with those men who consider that they are of no practical utility whatever; and now, after eighteen years of continued occupation with chemico-agricultural pursuits and, I trust, with more matured judgment, I have come to the conclusion that there is hardly any subject so full of practical interest to the farmer as that of the chemistry of soils,—the longer and more minutely soil-investigations are carried on by competent men, the greater, I am convinced, will be their practical utility.

As pointed out in the preceding brief summary, already a good many practical questions may be put to the agricultural chemist with propriety, which I should have hesitated or altogether refused to answer three or four years ago.

It remains for me now to mention briefly some points relating to barrenness of soils on which chemical analysis cannot supply any definite information.

It cannot decide, amongst others :—

1. Whether barrenness is caused by defective drainage.

2. To what extent sterility is affected by a bad physical condition of the land.

3. How far unproductiveness is connected with the climate, aspect, and elevation of the land in question.

4. That a soil is barren simply because there is too little of it, or

5. That it is unproductive simply because a thin surface soil rests on a stiff clay-subsoil of great depth.

6. What is the relative productiveness of different soils.

There are other matters in connection with this subject on which soil-analyses cannot possibly give any information. It is well to bear in mind that some matters affecting the fertility of land can be most positively decided by analysis, and others not; for if this is neglected the agriculturist will not reap the practical benefit which the chemical examination of soils is well calculated to confer in most cases.

12, *Salisbury Square,*
London, E.C., Jan. 1865.

IX.—*On Stocking Land.* By the Rev. J. L. BRERETON.

MY DEAR MR. FRERE,—

IN complying with your request that I would send you some account of my farm, I must ask you to make allowance for the unprofessional character of my statement. It is, however, to the best of my knowledge, correct; and the valuations have been revised and approved by men of experience and repute as practical farmers. Though I do not profess to be an adept in the art of farming, I have for some years followed it as a pursuit of much interest; and if I have not realised a profit equivalent to the cost and trouble bestowed, I think I have learnt some of the conditions under which farming in England may be hopefully carried on, as not only a pleasant but a remunerative occupation. An opinion seems now to be rapidly spreading through England, that the plants which the farmer grows will not yield him so much profit as the animals he feeds. Whilst free trade and cheapened transport have greatly affected the value of corn, animal productions—such as fresh meat, milk, butter, and wool—command a sale that justifies the use of even the more costly grain in providing them. The moist climate of North Devon had led me for some years to anticipate this opinion, and to think that my neighbours were wrong in making corn the principal object of their industrious efforts; a gradual impoverishment of themselves and their land seemed to me too probable a result from

persisting in their system. I was aware how much, in my native county of Norfolk, under the four-course system, the growth of corn had been increased by interposing a large growth of food for stock, and how this multiplication of the stock had been still further promoted by the purchase of food grown elsewhere, especially oil-cake. But I believed that the time was coming when, even in Norfolk, the stock would be found to be most remunerative, and that, consequently, the farmer would only grow corn so far as it harmonises with the profitable keeping of stock. Under such management much valuable manure would be made, which would indefinitely increase the productive powers of the land; and (unless prices changed) the increased production, whether ripened into straw or used in a green state, would still further increase the amount of the stock reared or fed. But under these circumstances a total change would take place in the relations of capital and land. Hitherto the question has been, How many acres can be most profitably cultivated by a limited capital? Henceforth it will rather be, How much capital can be profitably expended on a limited area?

I have no doubt that these and similar questions have suggested themselves to you and many others. For myself, they have guided my course for the last few years, and have led to the following result, which, if you think it of any value, you are very welcome to publish.

My glebe consists of about 30 acres of grass-land, which used to let at a rent of 55*l.* I have farmed it for some years in connection with various parcels of land which I have temporarily rented in the neighbourhood. The general result has been that from keeping an extra quantity of stock, and particularly from folding sheep with corn upon my grass, its value has been considerably increased.* It would be perhaps a fair account of previous improvement to value its gross rent for the present year at about 3*l.* per acre, or 100*l.* In order to make myself as free as possible of tillage farming, I have for some time used sea-sand

* The sheep are all Long-wools. We have in Devonshire a class of these valuable sheep known as "Notts." There are two if not three divisions of this old breed: the "Bampton," the "South Ham," and perhaps the hornless "Dartmoor." They have, of course, been much intermixed with the Leicesters ever since Mr. Bakewell gave to that particular class of the English Long-wools their superiority and notoriety. But the greater delicacy or "fineness" of the Leicesters has made many of the Devonshire flock-masters cling to the old breed, which have better constitutions. I have, for some years, taken pains to procure good ewes of the old stock, and have put to them some of the best Cotswold and Lincoln rams. The result has been very satisfactory, and you will see from my accounts that the thirty rams I sold last year averaged more than 6*l.* each. As they were all sold to farmers in the neighbourhood, these were not fancy prices; and I am told that my "New Devons" are thought likely to make a very valuable flock.

instead of straw as bedding for cattle. I have also used a compound meal (the ingredients of which I subjoin*) as the principal accessory to the grass and hay. The turnips I have purchased were all used for the sheep; none for the bullocks and horses. The oats and straw bought were for the stables. My practice has been to charge the whole cost (including labour) of the stables to the farm, and to credit the farm with 12s. per week for every horse used for riding or carriage. In order to increase my hay-crop, I hired some other grass-land, the rent for which is included in the charge for fodder.

Statement of Farm Accounts on the Glebe, West Buckland; from Oct 1st, 1863, to Oct. 1st, 1864.

A. COST OF STOCK.

By Valuation Oct. 1863 :—

		<i>Bullocks.</i>					
		£.	s. d.	£.	s. d.	£.	s. d.
2	Kerry cows in-calf	16	0 0				
4	Devons	40	0 0				
3	Yearlings	19	10 0				
1	Calf	3	0 0				
		<hr/>		78	10 0		

		<i>Horses.</i>					
		£.	s. d.	£.	s. d.	£.	s. d.
2	Brood-mares	62	0 0				
2	Cobs, 4 and 5 years	66	0 0				
2	Carriage-ponies	40	0 0				
1	4-year-old filly	25	0 0				
3	3-year-old fillies	76	0 0				
2	2-year-old (colt and filly)	30	0 0				
2	Yearling colts	20	0 0				
5	Sundry ponies	37	0 0				
		<hr/>		350	0 0		

		<i>Sheep.</i>					
		£.	s. d.	£.	s. d.	£.	s. d.
45	Ewes, at 59s.	132	15 0				
32	Old ewes, at 50s.	80	0 0				
41	Ewe-lambs, at 35s.	71	15 0				
40	Ram-lambs, at 60s.	120	0 0				
3	Rams, at 100s.	15	0 0				
		<hr/>		419	10 0		
						848	0 0

By Purchase during the year :—

		<i>Bullocks.</i>					
		£.	s. d.	£.	s. d.	£.	s. d.
7	Dairy cows and 4 calves			113	2 6		
				£961	2 6		

* *Cattle-food.*—I have for four or five years been in the habit of buying linseed, wheat, peas, beans, maize, barley, and oats, and grinding them in about equal proportions with one cwt. per ton of aniseed and fenugreek. The present cost of my mixture is about 11l. per ton.

Stocking Land.

133

	£.	s.	d.	£.	s.	d.
Brought forward				961	2	6
<i>Horses.</i>						
1 Pony	12	0	0			
<i>Sheep.</i>						
4 Kentish ewes, at 40s.						
77 Devon Nott. ewes, at 49s.						
80 " " 50s.						
30 " " 57s.						
1 Cotswold ram, at 25l.						
1 Lincoln " 25l.						
1 " " hired 30l.						
Journeys and expenses for rams } _____	574	3	0			
12l.. .. .						
				586	3	0
				<u>£1547</u>	<u>5</u>	<u>6</u>

B. EXPENDITURE DURING THE YEAR.

Rent and taxes	100	0	0			
Labour	251	6	10			
Manures:—						
Sea-sand for bedding	57	17	11			
Other manures	26	16	0			
				84	13	11
Purchased Food:—						
Hay by valuation Oct. 1863 ..	90	0	0			
Cattle-food	300	0	0			
Roots	100	0	0			
Straw, oats and hired keep ..	167	4	7			
				657	4	7
Tradesmen's bills	36	6	9			
				1129	12	1
Hay and turnips in stock, Oct. 1st 1864, by } valuation	305	0	0			
				<u>824</u>	<u>12</u>	<u>1</u>
				<u>2371</u>	<u>17</u>	<u>7</u>

C. SALES AND VALUATION.

Sales:—						
<i>Bullocks.</i>						
4 Bullocks and 1 calf	77	17	6			
Milk at 11d. per gallon	140	1	0			
				217	18	6
<i>Horses.</i>						
Brood-mare and 2 cobs	130	0	0			
2 Ponies	17	0	0			
Keep of 3 stable-horses, at 12s. } per week	96	12	0			
				243	12	0
				<u>461</u>	<u>10</u>	<u>6</u>
Carry forward				<u>£461</u>	<u>10</u>	<u>6</u>

Stocking Land.

	£.	s.	d.	£.	s.	d.
Brought forward	461	10	6			
<i>Sheep.</i>						
31 Rams by auction	184	17	6			
64 Draft ewes	149	19	6			
Sheep killed for the house..	21	3	0			
	<hr/>			356	0	0
				<hr/>		
				817	10	6
Valuation :—						
<i>Bullocks.</i>						
12 Cows, 1 yearling and 4 calves	193	16	0			
<i>Horses.</i>						
1 Brood-mare	25					
2 Carriage-ponies	30					
1 5-year-old mare	35					
3 4-year-old mares	150					
2 3-year-old „	50					
2 2-year-old „	40					
4 sundry ponies	47					
	<hr/>			377	0	0
<i>Sheep.</i>						
210 Ewes, at 63s.						
21 Fat sheep, at 50s.						
37 Ewe lambs, at 45s.						
32 Ram „ at 80s.						
1 Cotswold ram, 25 <i>l.</i>						
1 Lincoln „ 25 <i>l.</i>						
4 “New Devon” rams, 20 <i>l.</i>						
Wool 150 <i>l.</i>						
	<hr/>			1144	15	0
				<hr/>		
				1715	11	0
				<hr/>		
				£2533	1	6
				<hr/>		
Farm—Creditor	2533	1	6			
„ —Debtor	2371	17	7			
	<hr/>					
Balance	£161	3	11			

Showing a profit of 161*l.* 3*s.* 11*d.*, in addition to the manure, which is valued at “not less than 200*l.*”

I am aware that the above statement is open to many challenges ; but being an accurate account of transactions recorded and classified for my own satisfaction, and not for publication, it may perhaps be the most suggestive form in which to put before your readers the gross result of farming on the principle of purchasing corn, &c., to feed stock. I will add a few explanations in anticipation of some of the queries that may be raised.

The Valuations.—The first of these was made by myself and my bailiff, towards the end of 1863. It was afterwards revised, item by item, by the late Mr. George Burden of Kerscott, who was esteemed as one of the best farmers, and I must add, in memory of his recent death, one of the best *men* in North Devon. The second valuation was made by Mr. Mortimore of Warkleigh, whose judgment and experience both as a farmer and valuer are recognised with great confidence throughout the district. The standard of the two valuations is not, I believe, very different. I mean that the excess of the later valuation is not to be attributed to any exceptional rise in prices, but to the increased value of the animals themselves, owing in the sheep to careful drafting, and in horses, sheep, and bullocks, to the growth of young stock, and to their generally improved condition in consequence of the liberal expenditure on food and attendance.

The Labour.—This item will appear less exceptionally high if viewed in reference to the capital rather than the acreage with which it is connected. It represents the whole expense of supervision, attendance on the stock, cartage of manure, haymaking, &c. I have, it is true, paid higher wages than the neighbourhood, but have, I think, had a proportionate return of cheerful work. In attendance upon stock, it is of course possible to reduce the cost of labour very much by organisation and regularity. In this I acknowledge that I see how very great improvement might be made on my farm; but I have been much occupied in other matters myself, and the importance of these things is not always perceived, and very seldom enforced by subordinates. It is the coachman only who is likely to see that all the harness is adjusted to the team. The uninterrupted attention required to ensure economy either in a small or large farm is generally the secret of the real farmer's success and the amateur's failures; in my own case, if I do not quite acknowledge failure, I can see daily that my affairs might have been much more economically managed; but my only means of controlling waste has been a steady adherence to certain principles. I have thought that the true economy of labour was to be found, not in lower wages, but in a higher quality of workmen.

The following analysis of my labour-bills may give some explanation of the amount incurred:—

		£.	£.	s.	d.	
Weekly labour ..	{	Stables (approximately)	36	163	15	11
		Sheep	32			
		Bullocks	32			
		(Steam-engine, hay and manure	64			
Supervision			40	0	0	
Horse-labour (hired)			43	12	9	

Sand.—Passing to the next item of expenditure, the principal

manure purchased has been sea-sand. This has been used as bedding for bullocks, horses, and sheep, instead of straw. It cost me 6s. 8d. per ton, as I have to draw it 8 miles. Speaking roughly, I think that for bedding purposes the ton of sand goes as far as the ton of straw, while the latter costs me 30s. per ton. Except in the stables, I do not like to see any straw used for litter, though it has not been easy to break through the feeling of the attendants that the comfort of the animals required its use. The economy, however, of converting straw into food instead of litter seems so great, that I have persevered in the use of the sand; and I think my bailiff and men would generally now give it the preference. The effect of the manure has been very striking: in the last very dry summer, 22 acres yielded fully 45 tons of hay; the quick action of the sand-manure has been noticed much by the neighbouring farmers; it has also been found that the sheep can be pastured upon the ground very much sooner after the sand, than after straw-manure. This distinction may depend upon the salt which it contains. The remarkable healthiness of my stock, in spite of the number kept to the acre, may perhaps be attributed to the free use of this sand; though something is due to the high situation on the borders of Exmoor, and much to the healthy action of the slaty subsoil.

Quantity of Stock to the Acre.—The balance-sheet does not of itself explain the number of stock kept on the 30 acres, because it does not give the dates of all the purchases, or the quantity of extra land, the temporary hire of which is included in the general charge for purchased food. But I think I can say with certainty that the average number of sheep kept during the year upon the 30 acres has been 150. For a few weeks there were less than this number, in order to favour the hay-crop; but after the hay season there were, for some weeks, as many as 300 on the glebe.

As a general rule, the ewes have a range of about 6 acres to 80 head. During the winter they have chaff, turnips, and a little meal. The present allowance (the highest in the year) is, for 80 ewes on the glebe,—

	<i>s.</i>	<i>d.</i>
½ lb. of meal each, at 1½d.	4	2 a day.
½ ton of roots, 14 lbs. a-piece, at 12s.	6	0 "
90 lbs. of chaff (¼ hay, at 4l. 10s., }	3	0 "
¼ straw, at 30s.)	3	0 "
	13 2 or 2d. a day for each ewe.	

Another lot of ewes in better condition, and having a better range of pasture, are receiving only ½ lb. of meal and 5 lbs. of roots, without any chaff. During the summer months the ewes graze in large folds, frequently changed, so as to allow the grass to freshen behind them. According to the weather, they will lie in

the same plot from six days to three weeks. My own judgment is, that by constantly interchanging the fold and the scythe, the necessary range, even of breeding-ewes, may be very much lessened. In wet weather, we have trouble with their feet if they are allowed to tread the ground overmuch. But I am gradually forming yards to be asphalted, in which I propose to have them always fed in very wet weather, allowing them the open pasture at other times. I think the scythe or mowing-machine should be constantly at work; during the past year I was cutting grass with the machine from the beginning of May to the middle of November. In the spring and autumn the mown grass has been further cut into chaff, with straw for the bullocks and horses; but the sheep have had it carried to their troughs fresh cut.

The 70 lambs were with their mothers to the beginning of June; I then hired a piece of clover for them for one month. On the 1st of July they came back to the glebe, and have ever since been upon it in two pens, 38 ewes and 32 rams. Since the 1st of July, the ewe lambs have been over about 10 acres of ground, in part twice (the scythe intervening), in folds of $\frac{1}{4}$ to $\frac{1}{2}$ of an acre: the ram lambs have been kept rather closer. The ewe lambs had about $\frac{1}{4}$ lb. of meal each from June to October, then $\frac{1}{2}$ lb., and since Christmas $\frac{1}{2}$ lb., the maximum allowed to ewes. The rams began with the same quantity, but were pushed forward more quickly, and from October to the present time have been getting rather more than 1 lb. each. On the day I write (Jan. 21st), I have ascertained that the following are the actual allowances:—

32 ram hogs:—		<i>s. d.</i>
5 cwts. of roots, at 12s.		3 0 a day.
36 lbs. meal, at 1 $\frac{1}{4}$ d.		3 9 "
15 lbs. chaff		0 6 "
		7 3 or 2 $\frac{1}{4}$ d. per sheep a day.
37 ewe hogs:—		<i>s. d.</i>
5 cwts. of roots		3 0 a day.
18 lbs. meal		1 10 $\frac{1}{2}$ "
15 lbs. chaff		0 6 "
		5 4 $\frac{1}{2}$ or 1 $\frac{1}{2}$ d. per sheep a day.
Attendance on—		
80 ewes.		
32 ram hogs.		
37 ewe hogs.		

149 sheep. One man's wages, 12s. a week, or 1d. a week per sheep.

These allowances represent the highest cost of keep during the year; and I find that they correspond very nearly with the allowance at the corresponding period of last year. The bullocks are having 10 lbs. of the mixed food, and the horses 4 lbs., with hay and straw chaff, but no roots.

The following memorandum of the consumption of food on the 14th of October will represent very nearly the average consumption of meal in the year :—

	lbs.
20 fattening ewes	28
32 ram lambs	36
38 ewe lambs	12
6 bullocks	60
2 ditto	9
5 horses	20
	165

Milk.—The charge for milk, 11*d.* per gallon, is I am told higher than the average price of new milk. I have found that in buying or selling new milk in small quantities in this village, the price has been generally 3*d.* a quart; but as the greater part was used or converted into butter in my own family, and the skim-milk consumed by lambs, colts, &c., was charged to the farm at 3*d.* a gallon, the price of 11*d.* may perhaps be higher than the average, and so represent on my balance sheet an unreasonable profit. But if so, it explains itself.

The cows have generally been bought fresh-calved, and milked so long as their milk seemed to pay for their food, and then fatted. We have thought that, fed upon meal, they lay on more fat while milking than when fed on roots. In one case I fatted a cow and some sheep on meal and water alone, but without very accurately noting the comparative cost. The cow, however, was considered to have done remarkably well, and the beef was unusually juicy. Her allowance was 12 lbs. of food, with water *ad libitum*. I mean to repeat this experiment, and have ordered two cows just dry to be put on the same allowance; their cost would be 15*d.* per day, besides attendance. My bailiff thinks they require a small quantity of chaff in addition to the meal, in order to assist them in raising the cud; but not for the sake of bulk, which is sufficiently supplied by water—as nutriment is by the various ingredients of the meal.

Roots.—The turnips purchased during the year have cost about 12*s.* 6*d.* per ton, and about 150 tons have been consumed on the glebe. This quantity had been thought by my bailiff necessary both for the ewes, and more especially for the rams he was preparing for sale, but I think that the same money expended in meal would have gone further: I have not, however, wished to depart too abruptly from the track of experience; though it is clear that the circumstances of the case are so altered by the relative cheapness of corn and dearness of cattle that the cautious observers of precedents may be more likely to mislead than the more adventurous.

Thus much I think I can assert as to the result of some persevering experiments in the new direction:—

1. That it is quite possible to feed animals on purchased food alone.

2. That a mixture of the common grains and pulse, *e. g.* linseed, pease, beans, wheat, &c., may be made for 10*l.* per ton, which will fatten any animal.

3. That the addition of seasoning (aniseed and fenugreek are those that I have used for five years) at an additional cost of 1*l.* per ton appears to pay well in the added relish and the improved condition of the animals.*

4. That doubling the quantity of linseed, though raising the price, probably gives quite a proportionate increase to the value of the mixture.

5. That by the use of this meal the farmer may fearlessly increase his stock without adding to his acres; and yet, by that increase of stock, must greatly increase the productiveness of his farm. This consideration both suggested and replied to the following exclamation of a neighbouring farmer: “Mr. Brereton, if you’*m* doing all this on 30 acres, I’*m* thinking what’s to become of the landlords.”

6. That the use of sea-sand as bedding will enable the farmer either to dispense with straw, or to use it more profitably as food; and that besides possessing, according to its quality, manurial properties, the sand acts as a purifier of the land, and seems to allow of a closer herding of stock than might be otherwise safe.

7. That sheep may be folded on grass with great advantage, if some shelter and dry treading is provided in adjacent yards during excessively wet weather; but the bullocks and horses do best in yards and sheds, the grass grown after the fold being cut by the scythe and carried to them.

The success of such stock-farming as I have advocated must evidently turn upon the acquirement of good judgment in the selection of stock—a faculty which will henceforth assume increased importance in the training of the young farmer. I should like therefore to append to this statement a few words on the subject of agricultural education, in which you know I am much interested. Without for one moment wishing to decide the question, *adhuc sub judice*, of the advantage of combining special learning with general—of preparing a boy at once for the duties of manhood and for those of his own calling—I cannot help protesting against the summary manner in which this ques-

* Two years ago, when I was at some pains to test the value of fenugreek on two lots of six bullocks, the fenugreek *appeared* to do good; but the weigh-bridge did not justify this appearance, which probably rested on a keener appetite and greater consumption of straw-chaff.—P. H. F.

tion is sometimes disposed of. On the one hand we have men of high authority pronouncing it as a dictum, if not an axiom, that only general education can be given by teachers in public institutions; but that special education (except in the case of the learned professions) must be "picked up" in actual life. On the other hand the requirements of this actual life are deemed so urgent, that others are disposed to force youths into it before they can possibly have obtained anything like a complete general education. If a plan can be suggested whereby the preparation for business could be combined for a year or two with the general education, surely the advocates of the latter ought to encourage it. But it is said that special education, except in contact with actual business, is often found to be delusive and mischievous. Why not then maintain or even enforce that contact? By actual business is meant profit and loss in *bonâ fide* transactions. There is, at least, as much to be learnt by losing as by winning, and it is commonly said that a man must burn his fingers who would learn to handle the difficulties of life successfully. It is not necessary, therefore, that a farm or a workshop should pay in order to be instructive, but it is necessary that profit should be aimed at, and the causes of failure be honestly ascertained and publicly avowed. If live stock are at present the principal source of profit and loss to the farmer, it is clear that a thorough knowledge of its value is a most important part of his training. This value varies, 1st, with the age, development, and quality of the animal; 2nd, with the state of the market. It is one thing to know what the current price of meat or wool is, and this is in our days easily ascertained without any actual intercourse with a market; it is another thing to know what, according to this market price, is the value at any time of several animals, singly or in lots.

That this knowledge may be better learned upon a farm stocked and conducted for the purpose of giving this instruction, than picked up in actual life even under favourable circumstances, seems to me, at least, a reasonable anticipation, till it shall have been disproved by experience. I am, therefore, taking into consideration how this element of instruction may best be introduced into our proposed county college, which will aim at teaching so much of farming as a youth just over sixteen years of age may learn without giving up his general studies.

There can, I think, be no greater difficulty about exercising a class of young men in estimating the weight of animals, than in training a squad of riflemen to judge distances. If the purchase of lean stock and the public sale of fat stock be part of the system pursued, it will not be hard further to exercise the judgment as to the *capabilities* of animals, and these two considerations—weight and capabilities—determine value. Apart from

the superior judgment of the experienced instructor, estimates of value would be tested by actual purchases and sales, and would be verified to a considerable extent by the weighbridge, and the measuring-tape, when placed in skilful hands.

Appropriate prizes may be given so as to excite the spirit of emulation as far as is desirable, or even forms of sweepstakes might be devised which would give to each student a keener interest in a particular animal, and bring him directly into contact with profit or loss dependant on judgment in stock. Thus in one branch of his practical education, which is of great and growing importance, the agricultural student while still at college might obtain valuable training, and one of the objections of practical men to general education, as being a disqualification for special business, might be lessened. At least that contempt for trade, or shame of shop, which I think the public-school education in England has too much promoted, might be broken through if a knowledge of some of the arts and sciences necessary to an honest livelihood were combined with those that are essential to an honourable life.

I am yours truly,

J. L. BRERETON.

*Rectory, West Buckland, South Molton,
Devon.*

X.—PROFESSOR VOELCKER'S *Annual Report.*

During the past season I had the honour of delivering before the members of the Royal Agricultural Society two lectures :—

1. On atmospheric food of plants.
2. On the chemical composition and properties of water.

In consequence of the interest which was thus excited, I have since received a larger number of specimens of water for analysis than at any previous time.

Amongst the samples examined by me several were found to be quite unfit for drinking.

I find that the drinking-water supplied in towns is generally much better than that used in the country, a difference which is attributable to the prevalence of surface wells, and to defective drainage.

Water which smells in the least degree disagreeably, or which holds in suspension light flocculant matter, or does not become perfectly bright on standing for 6 hours, or which is distinctly yellow in appearance, should at any rate be regarded with suspicion, and should be carefully examined before it is employed for domestic use.

The pollution of our rivers by sewage not only entails a waste of fertilizing matter, but likewise disseminates the germs of disease along their banks.

Whether the sewage of towns can be profitably applied to the land or not, is a question to which a general answer cannot be given; for much depends on local circumstances, such as the position and chemical character of the land, &c. It is clear, however, to my own mind that the sewage of towns must not be allowed to find its way into our rivers, and that the soil is its natural and most effectual deodorizer.

The streams in the neighbourhood of lead and copper mines often contain in suspension fine particles of ores, and by their overflow cause serious mischief to the land by the deposit of metaliferous mud. An instance of great injury caused to horses and cattle by the sediment of a stream in a mining district was brought under my notice some time ago. On examining this sediment I found in it not only lead, but likewise a considerable quantity of copper and arsenic.

Whilst speaking of accidental poisoning, I may say that two cases of lambs poisoned by wheat steeped in arsenious acid were the subject of examination in the past season.

A good many suspected poisoning cases were referred to me, but with the exception just named, in no instance could poison be detected.

It is worthy of notice that most of my correspondents attributed the cause of the loss of their live stock to the linseed and cotton cake which they used. In the last twelve months a considerable number of feeding-cakes have been sent me by members of the Society, and my attention has been especially called to an unusually large mortality in lambs, in certain districts. Many cakes were found to be largely adulterated with cheap refuse, such as rice-dust, pollard, oat-dust, and other mill-refuse. But whilst it is quite possible that in some cases the suspected cakes may have really done mischief, I am bound to say that in most cases the mortality alluded to could not be referred to the bad condition or poisonous character of the cake upon which the lambs were fed.

At the same time, the experience of the past year has greatly strengthened the opinion which I expressed some time ago, namely, that stale and *mouldy* cakes frequently act as rank poisons, even when given to stock in moderate quantities.

On the subject of the effects of mould or fungi in cakes, corn, and feeding materials generally, we have as yet but very little precise information. As this is a subject admitting of positive experimental proof, I venture to recommend it to the consideration of the Veterinary Committee.

It is very desirable to ascertain more definitely the physiological effect of mouldy feeding substances upon the health of animals, and the precise chemical character of the feeding materials which have had a prejudicial effect on sheep, horses, and cattle, by experiments specially devised by your Veterinary and Chemical Committees, with this object.

At the request of the Chemical Committee, I have carried out the following field-experiments:—

a. On the Efficacy of Salt as a Fertilizer.

A series of experiments with salt upon mangolds was tried in Oxfordshire. The same series was repeated in Bedfordshire.

The unusually dry summer, I regret to say, completely spoiled the experiments in both instances.

The effects of salt were also tried upon oats, barley, and clover-seeds, but without any marked results.

b. Manuring Experiments upon Swedes and Turnip.

A series of field-experiments upon swedes and turnips with a variety of artificial manures, carried out on light land in Bedfordshire, was, I regret to say, completely spoiled by the failure of the root-crop.

c. Field Experiments on Clover-seeds.

The following manures were tried upon clover and seeds during the past season:—

- | | | |
|-----|--------------------------|---|
| 1. | Nitrate of soda, | applied at the rate of 4 cwt. per acre. |
| 2. | Sulphate of ammonia | ” ” |
| 3. | Mineral superphosphate | ” ” |
| 4. | Common salt | ” ” |
| 5. | No manure | ” ” |
| 6. | Muriate of potash | ” ” |
| 7. | Sulphate of potash | ” ” |
| 8. | Sulphate of lime | ” 20 cwt. per acre. |
| 9. | { Mineral superphosphate | { 4 } cwt. per acre. |
| | { and nitrate of soda | { 4 } |
| 10. | { Mineral superphosphate | { 4 } |
| | { and muriate of potash | { 4 } ” |

These were tried on two farms in Shropshire, also in Bedfordshire, and in Northumberland.

In the three first-mentioned localities the clover-crop was scarcely worth making into hay, and the experiments consequently were a complete failure.

The last-mentioned series, undertaken under my direction by Mr. Jacob Wilson, of Woodharn Manor-house, Morpeth, were more successful, I am happy to say. The results will be published in a future separate paper in the Journal, but I may mention that super-

phosphate of lime, in conformity with Mr. Lawes's experience, decidedly favoured the development of the clover-plant, whilst nitrate of soda and sulphate encouraged in a marked degree the growth of the grasses in the mixed clover and grass-seeds. Sulphate of lime also showed a beneficial effect in this case, probably on account of the deficiency of lime in the field in which the experiment was tried.

Neither sulphate nor muriate of potash produced any great effect upon seeds, but in conjunction with superphosphate, muriate of potash gave a very considerable increase.

A different set of experiments were tried upon a clover-field in Bedfordshire.

This field was in high condition, and the clover-plant upon it was uniformly and unusually strong.

The manures which were used were:—

1. Nitrate of soda applied at the rate of 3 cwt. per acre.
2. " " 1½ cwt. per acre and 4 cwt. of superphosphate.
3. Common salt, 6 cwt. per acre.
4. " " 3 " "
5. No manure.
6. " "

The two unmanured portions of this clover-field produced the large crop of 2 tons 10 cwt. 80 lbs. and 2 tons 11 cwt. and 8 lbs. of clover-hay respectively.

3 cwt. of salt had no effect; 6 cwt. of salt slightly diminished the produce; and the nitrate of soda alone and the mixture of nitrate of soda and superphosphate gave only a very inconsiderable increase in the produce.

It follows from these experiments that the land was in too high a condition for experimental purposes, and that beyond a certain maximum produce, determined by season, climate, and the presence of an ample supply of all the elements of fertility required for the perfection of the crop, we cannot increase it by the administration of an additional quantity of manuring matter.

d. Experiments on Top-dressings upon Oats and Barley.

A number of experiments were made, under my directions, by Mr. Pocock, of Wanston Manor, Micheldover, Hampshire. Their results confirm my belief in the beneficial effect of nitrate of soda and superphosphate on the barley-crop grown on chalky soils.

Probably Mr. Pocock will prepare a paper on the subject, to be read on one of the weekly meetings of the Society.

For the forthcoming volume of the Journal I have in preparation papers on the following subjects:—

1. On the composition of mangolds grown with different quantities of salt.
2. On some causes of sterility in soils.
3. Experiments on top-dressings for wheat.
4. On the variations in the composition of palm-nut kernel meal and cake.

Supply of Potash-Salts.

The discovery of a new and comparatively-speaking cheap source of potash, at Strassfurt, in Saxony, induced me to order a quantity of crude potash-salts from Germany, for experimental purposes. These salts contain about 20 per cent. of sulphate of potash, and are likely to prove of considerable service for turnips and clover on light land.

The dry season unfortunately spoiled the experiments with these potash-salts, which I instituted in several places during the past season.

In consideration of the great practical importance and the scientific interest connected with this discovery of an abundant source of potash, I lately visited Strassfurt, and inspected its extensive salt-mines in which the potash-salts occur.

The manufacture of potash began at Strassfurt about three years ago, and brought about 14,000 workmen to the place. At the time of my visit I found no less than fourteen potash-works in operation at Strassfurt, amongst them one belonging to an English firm. In the adjoining county of Anhalt, which I did not visit, I was told there are six or eight such manufactories.

Should potash be found to have a decidedly beneficial effect upon some of our crops, which I think is likely to be the case under particular circumstances, I have no doubt that these extensive deposits will supply potash in a crude form in abundance at a cheap rate.

Experiments on the effects of potash on light sandy soils, usually deficient in that alkali, can alone decide whether or not potash can be economically used as a manuring agent.

The inquiries which I made in Germany respecting the experience of farmers who tried the crude potash-salts of Strassfurt do not enable me to say positively that they had a decidedly beneficial or contrary effect. The fact is that as yet our experience is far too scanty for deciding this question.

Night-Soil and Sewage of Foreign Towns.

On the occasion of my recent visit to Germany I took an opportunity of inquiring into the disposal of human excrements on the Continent, and found that their utilization is attended with pecuniary loss to the towns of Germany and Flanders. All

attempts to convert them profitably into marketable fertilizers have proved abortive; the townspeople at Frankfort, Dresden, Leipzig, Antwerp, Brussels, and Berlin have to pay for the removal of the contents of the cesspools; and the question how to dispose of these economically, without creating a nuisance, is as much agitated in Germany as it is in England at the present time.

The Cattle-Melon.

The failure of the turnip-crop has brought into greater prominence the cultivation of the cattle-melon. A specimen of this new vegetable yielded on analysis the following results:—

Composition of Cattle-melon.

Water	90.66
*Albuminous compounds (flesh-forming matters) ..	1.66
Sugar, mucilage and digestible fibre	5.74
Woody fibre (cellulose)	1.17
Mineral matters (ash)77
	100.00
*Containing nitrogen265

It has been supposed that the cattle-melon is equal in nutritive properties to mangolds, but this is a mistake, as will be seen by comparing the composition of another specimen of cattle-melon, analysed by me some time ago, with that of yellow globe mangolds.

Composition of a specimen of Cattle-melon and of Yellow Globe Mangold-wurzel.

1. General Composition.

	Cattle-melon.	Yellow Globe Mangold.
Water	92.030	88.450
Organic matters	7.350	10.524
Mineral matters (ash)620	1.026
	100.000	100.000

2. Detailed Composition.

Water	92.030	88.450
*Soluble albuminous compounds619	.887
†Insoluble albuminous compounds156	.104
Sugar and mucilage	4.661	7.538
Woody fibre (crude)	1.914	1.995
Soluble mineral matters540	.952
Insoluble mineral matters080	.074
	100.000	100.000
*Containing nitrogen099	.142
†Containing nitrogen025	.017
Total nitrogen124	.159
Equal to albuminous compounds (flesh-forming matters)775	.991

The proportion of water in the cattle-melon, as in other succulent vegetable productions, is subject to considerable variations; as far as my experience goes, it is much larger than in mangolds, approaching more nearly to the character of white turnips.

Analyses.

The number of analyses made for members of the Society during the past season was a full average. Amongst the analyses the following are of interest to the feeder of stock.

Composition of Pea-shells.

Moisture	13·68
Oil	1·09
*Albuminous compounds (flesh-forming matters) ..	7·12
Mucilage, starch and digestible fibre	21·65
Woody fibre (cellulose)	53·71
Mineral matters (ash)	2·75
	100·00
*Containing nitrogen	1·14

The nutritive value of pea-shells is not great; still, it will be seen, that they contain some starch, a little oil, and 7 per cent. of flesh-forming matters, and as this is a cheap food, it may be given to cattle in time of scarcity with advantage.

Composition of Locust-meal.

A sample of locust-meal, on analysis, gave the following results:—

Moisture	12·61
Oil	1·08
Albuminous compounds (flesh-forming matters) ..	5·87
Sugar	44·30
Tectin, mucilage and digestible fibre	26·13
Woody fibre (cellulose)	7·14
Mineral matters (ash)	2·87
	100·00

Locust-beans, as will be seen, are very rich in sugar, and consequently very sweet and fat-producing; in the shape of meal they may be added with great advantage to other less palatable nutritious food, such as palm-nut kernel meal.

Biscuit-meal.

Under this name a meal is now sold by the Metropolitan Farina Company, at the price of 9*l.* a ton.

A sample of biscuit-meal analysed by me had the following composition :

Moisture	8.70
Oil	1.61
Albuminous compounds (flesh-forming matters) ..	10.12
Starch, dextrine and sugar	76.90
Cellulose (woody fibre)58
Mineral matters (ash)	2.09
	100.00

Rice-meal.

Rice-meal varies much in composition, for the commercial article sold under that name contains variable, and often large proportions of the husk of rice, which possesses little or no nutritive properties.

A sample of rice-dust lately analysed by me had the following composition :—

Moisture	8.83
Oil and fatty matters	9.50
*Albuminous compounds (flesh-forming matters) ..	12.75
Starch, mucilage and digestible fibre	50.69
Woody fibre (cellulose)	10.14
†Mineral matters (ash)	8.09
	100.00
*Containing nitrogen	2.04
†Containing silica	3.17

Rice-dust contains a good deal of a nicely-tasting yellow oil, which no doubt adds much to the fattening properties of rice-meal; but the price at which this meal is usually sold in the market, in comparison with the more nutritious barley-meal, is far too high.

AUGUSTUS VOELCKER.

12, Hanover Square, London,
December, 1864.

XI.—On Cross-Breeding in Horses. By W. C. SPOONER.

It is now nearly five years since I discussed the subject of cross-breeding in the pages of this Journal, vol. xx., with more particular reference to the breeding of sheep; my paper excited some little attention, and I had no reason to complain of the criticism it received. In the mean time, I have seen no cause to doubt the truth of the principles then advocated, or the facts adduced in their support. I propose, therefore, at the present time, to show the applicability of those principles to

the horse, more particularly the saddle-horse, and I hope to illustrate this branch of the subject with equally strong examples. Amongst the points I sought to establish were the following:— That the influence of the male or female parent is not capricious; but yet not always alike: in the majority of instances the male parent governs the size and external shape of the offspring (particularly in the back and hind-quarters), whilst the female influences the constitution, the nervous system, and often the head and fore-quarters—the case being, however, occasionally reversed. That this combination, which may be more of a mechanical than a chemical union, by no means implies such an equal division of influence, as the mingling of two fluids, in which case the offspring would be unlike either parent, but a *juste milieu* between the two, and there could be no handing down of type from one generation to another. It is rather such a fusion of two bodies into one that both defects and high qualifications are passed on from parent to offspring with a sort of regular irregularity, resembling the waves of the sea—each parent having the remarkable power of propagating ancestral peculiarities, though latent in itself. Thus it is that strong characteristics are handed from one generation to another; so that if we seek by careful selection to remove a defect or propagate a good quality, we may calculate that a large number, perhaps the majority of the offspring, will meet our wishes, and by weeding out the remainder and pursuing this course for several generations we may accomplish our design. This view will further explain how it is that defects not seen in the first cross, being kept down as it were by the superior influence of the improving parent, re-appear in the next generation, and serve to deter timid breeders from continuing the experiment, or arm the opponents of crossing with strong but fallacious arguments against going beyond the first cross.

I pointed out that, owing to the superior influence of the male parent, the effect of the first cross in sheep was very considerable, bringing greater size, often longer wool, earlier maturity, and a propensity to fatten; or, in other cases, superior quality of mutton. Many persons who go thus far are deterred from going any farther by the very numerous failures which result from pairing together animals of the first cross, and consider that pure breeds only should be perpetuated; I adduced, however, various examples to show that crossing might be carried much farther, even to the extent of establishing altogether a new breed, possessing qualifications which, although derived from them, yet neither of the parent breeds alone exhibited. I instanced the cases of the Improved Hampshire, the New Oxfordshire, and the Shropshire, and more particularly the flocks of

Mr. Humphreys, as affording successful illustrations of the practice.

Special reference was made to Mr. Humphreys, who, starting with two of Mr. Jonas Webb's best prize Southdown rams, kept steadily to sires of his own stock, occasionally purchasing fresh Hampshire ewes, until in the course of 20 years he had established a first-rate breed, all of which were descended on one side from Mr. Jonas Webb's Southdowns. This example, as well as that of Mr. Rawlence of Wilton, who now scarcely ranks second to Mr. Humphreys, seems to show that the use of males and females possessing a similar amount of breeding is much more to be depended on than the system pursued by others who cross with the Sussex when their sheep are getting too strong or coarse, and with the old Hampshire when they are getting too small.

I now further propose to inquire whether this system, which is so successful with sheep, is one altogether to be condemned with *horses*; always assuming that cross-breeding, to be successful, must be undertaken with a distinct and defined object, and assigning the highest praise and the first rank to those who maintain intact the purity of our best established breeds.

An opinion is very commonly entertained that there are only two pure breeds of horses in this country (ponies excepted), viz., the thorough-bred and the heavy cart-horse,—all the rest being but modifications of these races in various degrees. It is, however, probable, that long before either of these extremes were known among us there existed a native breed of a very useful kind, pure examples of which are now scarcely to be met with. The *pack-horse* with his drooping hind-quarters, good shoulders, strong fore-legs, and sure action, existed in England for centuries before the Barb and the Arab were imported for the chase or the race-course by the Stuarts, or the introduction of carriages had led to the use of Flanders mares brought from the neighbouring continent; these heavy horses, with their high action, slow but sure and staunch, being naturally much prized for helping the ponderous coach out of the deep ruts of the high roads or along the miry lanes. The heaviest of the race were greatly in demand not only for tilling the strong lands but for drawing the cumbrous road-waggon before even the six-mile-an-hour luggage-van was introduced as a novelty and an innovation. I have before me one of Morland's striking sketches which reminds me forcibly of my boyish days, when the slow but sure approach of one of these ponderous vehicles with its eight or twelve ton load, heralded perhaps by a cloud of dust ever stirred up by the heavy feet of the ten or twelve massive animals that moved it onward at the rate of some

two miles an hour, never failed to command attention. It was a sight to behold these leviathans settle into their work after a short respite in the midst of a steep hill; the burly waggoner, too heavy to walk, and scorning to ride in his waggon, was mounted on one of those strong sure-footed ponies, usually white or pie-bald, which have long since disappeared. A crack from his long whip would send in to the collar with a 20-horse power the ten hairy-legged but powerful brutes whose broad backs were rendered still broader in appearance by the absence of tails, for each horse was docked close to the stump, under the absurd idea that their strength would thereby be increased.

It is difficult to imagine that this waggon, which seemed to the people of the day to be one of the institutions of the country, was itself formerly looked on as a newfangled novelty, which superseded the once universal, now well-nigh forgotten pack-horse.

There are but few specimens remaining of the pure pack-horse breed which has been quite neglected and overlooked by agricultural societies; and, consequently, whilst the mares have for a while proved valuable for breeding half-bred hunters with the thorough-bred horse, the males have been gelded and used up. This original or ancient race has no doubt been modified considerably in size, according to the fertility of the soil on which it might be raised; being sometimes developed into the strong upstanding harness-horse, and at others dwindling down to the plain but useful galloway, as seen in many remote districts, and particularly in the little horses used in the Irish cars. The Welsh pony and the Clydesdale cart-horse, the latter enlarged by rich pasturage and perhaps a cross, probably represent the opposite extremes of this same breed.

In less civilised ages the most useful horse was that which could most readily be adapted to all purposes; and there is no good reason why, even in modern days, the more ancient breed, equally pure and more serviceable than the blood-horse or dray-horse, should be altogether neglected, not only by our sporting men, but by the patrons of our agricultural societies; particularly since magnificent hunters have been the result of the cross between the thorough-bred horse and the old pack-horse mare. It will be useful to point out the peculiarities which distinguish the two breeds, with a few explanatory remarks on the component parts of the animal which by their varying proportions constitute those peculiarities.

The skeleton is formed of bone, which owes its solidity to the fact that it is composed of one-half or upwards of earthy matter, so deposited in cartilaginous cells as to render the bones strong and resisting, and adapted not only to support the weight of the animal, and to protect from injury the vital organs, but to serve

as a framework for the attachment of muscles, sinews, and ligaments. The bones of the limbs are for the most part cylindrical, and motion is effected by means of joints at the extremities of the bones, which are secured by powerful non-elastic ligaments. The bones are much smaller in the thorough-bred than in the cart and intermediate breeds, though generally more compact, and the joints also are by no means so wide, but admit of more longitudinal motion. With this diminished size there is, of course, less surface to sustain the weight of the body.

The sinews resemble the ligaments in appearance, and like them are non-elastic; they are attached to the bones, and serve to communicate motion to them from the muscles to which they are joined or from which they appear to spring. Both ligaments and sinews are smaller in the thorough-bred than in other horses. The muscles and the flesh are the same, and are the seat of the motive power, motion being produced by the contraction of the fibres of which the muscles are composed. The strength is the result both of the size and the number of fibres, whilst the extent of motion depends on the length of the muscles and their fibres. Of course the length of the bones corresponds to that of the muscles, and although the joints in the thorough-bred have less surface, they admit of more motion.

The pack-horse may be thus described:—The prevailing colours of the breed were bay and brown, which, with the usual accompaniments of black legs, denoted a good and hardy constitution, yet other colours, such as greys and blacks, were to be found occasionally. Among the chief peculiarities were the good and flat fore-leg with its well developed back sinew or flexor tendon, the good and sound foot, and capital shoulders and forehead. The neck muscular, but not thick and heavy, was fairly arched, and the head, of moderate size, was well set on. This form was accompanied, as we might expect, with good and safe action in the walk and trot; the horse rarely stumbled, and only fell from overwork and exhaustion. Whilst the heavier and coarser specimen of this breed was capable of carrying his five-hundredweight load throughout a long journey, the lighter and more active was used as the ordinary saddle-horse or even as the hunter of the day. Many of these animals were extraordinary trotters, and, as good trotters are generally good walkers likewise, the quality was greatly prized and encouraged; and thus a race of trotters was bred which, no doubt, were the ancestors of the celebrated American trotting-horses, such as the "Tom Thumbs" of later days. Although these horses were deep in the chest and ribs, the hind-quarters were comparatively inferior, the hips were often ragged, the tail set on low, and sometimes the hocks were rather too straight. The celebrated trotting-horses of Norfolk were evidently

not true pack-horses, although perhaps allied to them: they had, no doubt, a touch of Spanish blood and possibly of the Thoroughbred.

Let us now, as a contrast, glance at the peculiarities of the thoroughbred horse. Racing, no doubt, existed in this country long before, but received a new impetus from the introduction of the Barb, the Arabian, and the Turk. The sires which were at first imported, quickly established the great superiority of the Eastern blood as regards speed, and when mares followed at a later date in smaller numbers, they no doubt still further added to the speed of the English racehorse.

The modern blood-horse is of much greater average size than the Arab or the Barb either of the present or the past; and a doubt exists whether this is entirely due to selection and nurture, or in part to the early crossing with the native mare; in any case, it cannot be denied that every thoroughbred horse in the kingdom, from the highest to the lowest, is to the extent of more than nineteen-twentieths descended from the Eastern horse. This foreign influence was not, however, derived from one strain only, for the pedigree of 'Eclipse' himself shows that besides his descent from the Darby *Arabian* and Godolphin *Barb*, he had five or six crosses of the *Turk*; and we have a strong conviction that the improved native horse, made up of the ancient British, the Spanish, and the Barb, is entitled to some share in the honours of his parentage. Be this as it may, the present English thoroughbred horse has proved himself faster than any of the breeds from which he is sprung; and although many doubts have been cast of late on his powers of endurance in comparison with the smaller horse of some fifty years ago, and the practice of training and racing has been severely criticised, yet there is good reason to suppose that our first-class winners are as stout as most of those which have preceded them.

The thoroughbred English horse, in common with the Arabian, possesses no doubt more muscular vigour, as well as nervous energy, than any other kind of horse.* In addition to this he

* From time to time it has been suggested, with the view of improving our breed of thoroughbred horses, and particularly their staying qualities, to resort again to the original or parent breeds; but not to mention the ill-success of such attempts when made, it must be evident that the tendency of this cross would be to diminish the size and to shorten the stride, and probably to render the action too high; we can therefore scarcely expect breeders for the turf to adopt the advice. At the same time it must be acknowledged that the Arab has been more successful with half-bred and under-bred mares than the third-class cast-off racer, inasmuch as with undeniable bottom there has been a hardier constitution, better fore-legs, and higher action from this cross. Where the dam has been of sufficient bone and size, many good hunters and handsome harness-horses have been so bred, and still more frequently capital ponies and galloways; indeed, this is one of the best modes of improving the breed of ponies. Arabs have, in

has a deep chest capable of admitting the large amount of air which the demands of the system require under severe exertion. By natural conformation and by artificial training all superfluous weight is removed, and thus he is capable of covering more ground in his stride, and of repeating these strides more frequently than any other horse, as well as of continuing his extreme efforts for a longer period without tiring. The heart and the brain of such a horse are comparatively larger than in other breeds, the bones, though smaller, are more compact, the skin of a thinner and finer texture, and the blood-vessels more developed. These advantages, however, are not without certain drawbacks. The delicacy of the skin causes the animal to be extremely susceptible of cold, he is consequently less hardy and requires more food to keep up the animal temperature, so that it is difficult to keep flesh on a thorough-bred horse unless he is kept warm ; moreover, the carcass being smaller, the stomach and intestines are not so large, and consequently the food must be more concentrated and nutritious to keep up this supply of warmth.

The difference as respects hardiness is strikingly shown between the foal of the cart-mare and the thorough-bred. Whilst the former is strong, sturdy, and fleshy, the latter is comparatively puny, thin, and susceptible of the least cold ; the former, by means of the dam's milk, can be kept in first-rate order, whilst the latter requires artificial assistance as soon as it can be rendered. The fact is that the digestive apparatus is more powerful in the one than in the other—it can assimilate more nutriment from nutritious food, and subsist on rough diet on which the other would starve. This it is which renders it so expensive to rear the blood-colt, and this distinction prevails throughout life, and extends in a lesser degree to the half-bred, as compared with the cart-horse. The thorough-bred has yet other faults ; as a rule, he is slighter and weaker in the fore-legs, he goes closer to the ground, is often a bad walker, and an indifferent trotter, and is more liable to stumble and fall than the coarse-bred horse. How can it be otherwise ? He is bred to win a race, from parents who have been winners ; the elevated and rounded action that makes a good hack or charger, would shorten his stride and impair his chances ; although if he has good legs and sufficient size and substance, the very fact of his being too slow for racing ought to be rather a recommendation as a hunting-stallion than otherwise, yet who would give him credit for stoutness if he had never been fortunate enough to win a race ; or what chance would he have for a prize at our agricultural shows when judged by

proportion to their size and weight, larger bone and sinew than the majority of our thorough-breds, and I have often observed their beneficial influence in the second and third generation both with hunters and other horses.

those who can recognise at a glance a Derby favourite, or the winner of the St. Leger?

The term *stoutness* in racing phraseology means endurance connected with speed; it has nothing to do with size and weight, as a tyro might suppose: a great horse is often speedy but a craven at heart, whilst most of the stoutest race-horses of the last century were little more than galloways in size, and such too are the untiring Arabs of the Desert. No judge, therefore, can tell a stout horse by his appearance—it is necessary to know his performances before this can be determined; for, however perfect the symmetry and powerful the frame, if he is only good for a mile he is not stout.

The improvement effected in the size and probably in the speed of the thorough-bred horse is no doubt very great, and every year produces some wonderful examples of first-class winners; yet I will venture to say that nowhere else throughout Nature where the same care and vigilance is bestowed on the rearing of animals, are the blanks so many and the prizes so few. To justify this perhaps startling assertion, let us endeavour to trace the career of the, say, fifteen hundred or more thorough-bred foals which are annually dropped. These foals are reared from mares of undeniable pedigree, and for the most part of good size, very many among them being winners. The majority are begotten by first-class horses, who have either been great winners themselves or have beat great winners before they have themselves broken down, or, better still, have proved themselves the sires of great winners as well as winners themselves. Both care and expense are lavishly bestowed on the fifty or sixty sires, the two thousand brood-mares, and also on the foals themselves as soon as they are dropped. The dam's milk is sustained with the most nutritious food, and the foal is fed with the best as soon as it can masticate. It is an error to suppose that either the mare or the foal is pampered or enervated by undue care; the well-kept paddock affords every facility for taking exercise, and those who have witnessed the sprightly and incessant gambols of the young animal will acknowledge that the muscles and sinews of the thorough-bred foal are called into play much more than those of the cart-horse. Yet, with all this care, what becomes of these costly toys? The greater number go into training at two years old or earlier, no small percentage having previously disappeared from disease or accident, and very many succumb to the numerous maladies and mishaps that occur in the training-stable. After this ordeal the trials begin; and then some are condemned as too slow and others as too small, some are mercifully shot out of the way, others submitted to the auctioneer's hammer, and many

a colt that has cost 200*l.* to rear is sold for less than 10*l.*, and perhaps is dear at the price. The majority thus sold are colts and fillies that have never raced, many have given way in the joints or sinews, whilst some are rejected for their shortcomings in the actual race as two-year-olds, although many a horse which was unsuccessful at that age has proved a prize-winner afterwards. It is difficult to say how many of those foaled actually make their appearance on the race-course, but the difference in numbers between the entries and the starters for the Derby will afford some slight criterion. At all events, a little reflection will satisfy us that the number of first-class, or even second-class, horses annually brought to maturity is very small, and justify our assertion that the blanks far outnumber the prizes.

How can we explain such a falling off, that the offspring probably to the extent of 70 per cent., should prove inferior to both the sire and dam? The answer may be found in the fact that although our first-class race-horses are large and powerful animals, yet they are descended from ancestors considerably smaller than themselves, and Nature makes a constant effort to return to the original type. But for this natural law there is no telling what size our thorough-bred horses might reach, for the constant effort of the breeder is to raise large colts, and it is almost an axiom with many men that although a good *little* horse is all very well, a good *big* horse is a great deal better. In fact, the little horses, which are sometimes greater winners, are rather low than small, and usually have considerable length of muscle as well as depth of chest and substance, to compensate for their want of height. When, therefore, there are such constant efforts to outstep Nature, we cannot wonder that failure should be so frequent a result.

There is a striking contrast between Derby horses and their numerous relations who figure at country races, and when the short racing-career of these large colts is over and they are devoted to the stud it is astonishing how large they become and how much they girth.* They look the very incarna-

* Although as a rule half-bred and threeparts-bred horses have more bone, and are larger in the girth than thorough-breds, yet the latter increase surprisingly in girth when thrown out of training and devoted to the stud. My friend Mr. Barrow, Veterinary Surgeon, of Newmarket, has kindly furnished me with the measurements of a number of first-class stud-horses now under his care at Newmarket. Amongst others "Longbow," "Toxophilite," "Thunderbolt," and "Muscovite," all of whom were upwards of 16 hands, and exceeded 6 feet in girth, and measured on the average 8 inches round between the knee and the fetlock. The chest of the thorough-bred is always comparatively deep and capacious, Mr. Barrow considers that the capacity of the chest increases after serving mares and from wearing no rollers, or anything to interfere with the proper expansion of the chest. It must be borne in mind that the horses here mentioned are peers of their order.

tion of vigour and of strength, and it is probably their look that induces so many breeders to think that from such a sire any amount of substance can be secured which can reasonably be expected in the weight-carrying hunter. They forget, however, how large a percentage of their progeny are but "weeds," even when these sires are put to picked thorough-bred mares; and how very rarely the services of a horse of this stamp can be secured for half-bred mares. The great bulk of travelling thorough-bred stallions must necessarily be third-class horses, long in the carcass, long in the legs, weak in the sinews, unfit for any other purpose than the stud; and such are the horses that assist in deteriorating our breed of saddle-horses, and render horse-breeding so frequently unprofitable.

Let it not, however, be supposed that I undervalue the importance of "blood" in the hunter, the hack, and the harness-horse; I only dispute the doctrine that we should rely mainly or solely on the sire for its introduction, and then only for the first cross. It is a well-established fact, that the Eastern blood amalgamates with the native breeds of the country extremely well; it can be traced in the form, and still more in the courage and endurance, even in the third and fourth generation.

I must now recall attention to the general principles of cross-breeding, viz., that while the male governs the size (not mere height), the vital functions and the nervous system are influenced most by the female. If there be any truth in this doctrine, it must be as essential to attend to the pedigree of the mares as to that of the sire. But here all is left to chance; and whether she is taken from the plough-tail, the van, or the omnibus, no matter, so long as the sire is thorough-bred. Let us consider how the system works on some of our best mares. A farmer has a valuable mare that has been tested by many an arduous run. She is by a thorough-bred horse out of a half-bred mare, and, valuable as she is, she is a shade too light, or, at any rate, would be worth more money if she were equal to a little more weight. He is induced to put her to a thorough-bred horse, and the progeny is, of course, seven-eighths thorough-bred, but, according to my experience, mostly an unprofitable weed. We might go a step further back, to the stronger half-bred mare, and trace the process of deterioration farther; but the final issue is the same—the propagation of a race of weeds. This is the real root of the evil which is affecting our breeds of horses,—an evil not to be remedied by the abolition of two or three year old races, or by the substitution of longer distances, or by any of the many suggestions with which, when political intelligence flags, our daily papers teem. Races for two-year-olds may be objectionable or otherwise, and eight-mile gallops may be excellent or

cruel; but, so long as racing is supported by the public as a pastime, the former will not be abolished nor the latter restored.*

Do away with the excitement of the struggle, and by greatly lengthening the race render its finish the slowest part of the contest, and people will be contented to read the result in the newspapers at home. Let us suppose that the racing of two-year-olds was altogether abolished, and that the Derby was contended for by four-year-olds, what would be the result? The expense of keeping racehorses would be enormously increased, perhaps to the extent of 100,000*l.* per annum. And after all, even if these innovations could be introduced, they would altogether fail in their professed object—that of improving the stoutness of the thorough-bred horse.†

We frequently hear of horses that are very speedy for a mile, but fail altogether in a longer race. Now, on what does this want of stamina or stoutness depend? and, secondly, can it be discovered or ascertained by the external conformation of the animal? The speed of the horse depends on the length of the stride, and the frequency or rapidity with which these strides can be repeated, and in proportion to these efforts is the demand made on the organs of respiration and circulation and on the nervous system. Excessive speed is, therefore, in itself one cause of its short duration, inasmuch as it exhausts the vital powers. In many cases the locomotive and vital powers may not be well balanced: the former may be those of a first-class, and the latter those of a second-class animal. To a certain extent this want of bottom can be ascertained by the conformation, but to a certain extent only. If the horse is very leggy, light in the carcass, and narrow or deficient in depth of chest, the probability is that he is speedy, but not enduring. Sometimes, however,† an animal shows none of these faults of form, and yet, though speedy for a

* The system of racing at two years old, whilst it is always trying and often fatal to the fore-legs and joints of the young animals, does not appear to be injurious to the *constitution*; for we have numerous instances of famous stud-horses living to a good age, although they have raced thus early. That stout and successful sire the "British Yeoman," the winner of the first prize at the Royal Agricultural Society's show at Chelmsford in 1856, fourteen years previously had won four large stakes as a two-year-old, and the following year ran fourth for the Derby.

† If some of our stoutest thorough-breds have been discarded in consequence of their not being speedy enough to win short races, what has become of these horses, whose services would have been so valuable for half-bred mares? I rather believe that speed and stoutness are mostly combined in great winners, as in "Eclipse" and "King Herod" of old, and, at the present day, in "Stockwell" and "Blair Athol," the latter of whom unquestionably won his great races by his stoutness, for he was probably equalled in speed for half the race by several of his competitors. Surely the St. Leger, and other still longer races, must in nine years out of ten be won by stout horses, and as such horses are always used for the stud afterwards, they must have handed down to their posterity their stoutness as well as their speed.

mile, is unable to "stay." The cause is here, no doubt, beyond our ken; though it is, no doubt, due to deficiencies in the vital and nervous systems, and especially to the latter. To discover its existence, we presume, is the object of the advisers of four and eight mile races.

In the absence of proof, we much question whether the first-class racehorses of the present are inferior in endurance to those of former days. Why should they be so? They are descended from the best mares and the best horses, which have no doubt handed down with their speed that endurance and strength of constitution which contributes so much to make a winner. Want of endurance is not the defect of this race; put a feather-weight on the back of a weed, and in a light country he will probably beat the most valuable half-bred hunter, even in a long run; and yet with all this he is nearly valueless.

Next to the very first-class racehorses—the twenty prizes amongst a thousand blanks—there is no kind of horse of which this country has such reason to be proud as the half-bred, three-parts, and seven-eighths bred hunters, the highest combination in nature of strength and speed. Deriving speed and courage from their Eastern progenitors, bone and substance from their northern ancestors, and action in all their paces from the blending of the two races, they are nearly perfect and decidedly most generally useful.

When a breed of sheep or of bullocks has reached this point, we seek to perpetuate their excellences by consorting parents who on both sides possess them, avoiding, of course, too great consanguinity. We do not resort, as a rule, again and again to the original breeds from whence the improvement has been built up. Why, then, should horses be an exception to this rule? Why, although the mares of this stamp are considered well adapted for breeding, are the males condemned to be castrated, as unfit for that purpose? By such practice we not only lose the services of the males in transmitting their good qualities, but deprive one-half the mares of the opportunity of breeding animals as strong and valuable as themselves. The practice is, no doubt, in many respects a matter of convenience; for weight-carrying hunters are more tractable, and always, as geldings, command good prices; whilst it is hard to compete with the constant supply of ready-made stallions—good, bad, and indifferent—from racing stables, so long as their friends and owners can persuade breeders of horses and agricultural authorities that the goodness of the fore-legs is of little account, or that a bad thorough-bred stallion is better than a good half-bred.

Referring again to the general principles which have been laid down respecting the influence of either parent on the off-

spring, and considering that the temper, nervous system, vital powers, and constitution, usually follow the dam, if the question be put, "Given a certain amount of breeding, which side would you prefer it to come from?" we unhesitatingly say, if it cannot be had from both sides, by all means let us have it from that of the dam, that her courage, nervous system, and vital powers may be, if possible, joined with the great bone and sinew of the coarser sire. If this system were more frequently pursued, we might breed weight-carrying horses from well-bred though rather light mares, and sometimes even from the best of the three and four year old mares cast out of the racing stable as not being good enough. By such means our cavalry would be far better mounted than at present, and we might, without difficulty, retain just as much breed as is requisite and desirable.* I do not, however, recommend such violent crosses as that of the cart-stallion with the thorough-bred mare, though not unfrequently successful; or the reverse case, which, with a few noted exceptions, produces more failures.

As examples are always more telling than precepts, I propose to adduce a few instances of successful breeding with half-bred horses and well-bred mares.

To begin with my own experience. I rode a mare for some twelve years without her making a mistake; she was good in all her paces, a fair hunter, an excellent jumper, and a capital hack. She was bred by my father out of a threeparts-bred mare (a good hunter) by a young half-bred horse, pedigree unknown or forgotten. Her dam afterwards bred three other colts by thorough-bred sires, none of which proved of any value. They could not carry weight, and none of them paid the expense of breeding.

2. A rather heavy but active and useful cart-mare, belonging to the same owner, bred two colts by thorough-bred horses, neither of which repaid expenses: they had the bodies of the dam and the legs of their sires.

3. One of my friends had, some years since, a splendid trotting mare that he justly regarded as a pearl of great price, for she had

* An inspection of our cavalry regiments will strikingly illustrate the evils of the present system. I had an opportunity a twelvemonth since of looking over a rather large number of cast cavalry-horses offered for sale by auction in a garrison town, and found that nineteen out of twenty were extremely faulty. In most, although the carcasses were sufficient, the legs were totally unfit to carry the weight a cavalry horse is called upon to sustain. Crooked legs, weak sinews, deficient bone, small joints, sickle hocks, the evident result of the union of the two bodies of a thorough-bred horse and a coarse or cart mare, was almost the universal rule; and they presented a strong contrast to the animals that in my experience used to be cast some thirty years ago when half-bred stallions were far more numerous than at present, and horses were bred from parents possessing on both sides the qualifications sought to be perpetuated.

substance, showed plenty of breed, and was good in all her other paces as well as the trot. After some years she was devoted to the stud, and bred five foals, the first by a good half-bred horse and the others by different thorough-bred horses. Her first foal showed much more substance than any of the others, made a good price, and is a valuable animal at the present day. Not one of the others repaid expenses; one proved a clever animal for a light weight, but none possessed sufficient substance to be anything like as valuable as the mare.

4. Another of my acquaintance some years since had a small but very neat mare almost thorough-bred. He put her to a large Yorkshire trotting stallion, and sold the produce at three years old for sixty pounds; when afterwards he put her to thorough-bred stallions the stock were all deficient in substance, and consequently unprofitable.

5. A farming friend had a capital fast mare, somewhat small, and rather more than half-bred; he put her to the last-named stallion, about onefourth-bred: the produce, a mare now in my possession, is very clever and somewhat larger than her dam. Though too hot for the hounds, she is a capital hack as well as an invaluable harness-mare. I consider this to be a successful example of breeding from two parents, both well, but neither thorough-bred. The dam of my mare was next put to a thorough-bred horse, and produced a foal which had not nearly the value of the first, gave out in the fore-legs, and was last seen in a London cab. The sire referred to invariably got good animals when put to well-bred mares, and useful ones when coarser mares were employed.*

6. Another of my acquaintance some years since gave 50*l.* for a mare apparently threeparts-bred, which now in her old age is such a model of symmetry that she attracted my special attention when recently exhibited at a local show. She proved to be a good hunter for an average weight, but before she could establish her character, became lame, was devoted to the stud, and has bred many colts. One of these, by a thorough-bred horse, became a very clever and valuable hunter for a moderate weight; the other colts were mostly by a light and rather leggy but very active

* This horse was the son of "Performer," and the grandson of "Old Pretender," by "Fireway" (celebrated trotting stallions of their day), out of a threeparts-bred mare, having the strains of "Forester" and "Hambletonian." "Old Pretender" trotted 15 miles within the hour, with 15 stone on his back, whilst "Fireway" did 2 miles in 5 minutes. It is matter of very great regret that this breed of horses has not been kept up in all its integrity, and that trotting-matches have been allowed to sink into disreputable and low hands. Probably the cruelty that was often connected with these time-matches, in which the same horse was backed to go, say, from London to York, or to Exeter, in some short time, led to their being discountenanced by the more respectable lovers of the horse.

Suffolk cart-horse, with good flat fore-legs and good feet. The oldest of these, which promised to be a capital jumper and a good weight-carrying hunter, was bought by a farmer (a heavy weight in the hunting-field) for 50*l.*, and after exhibiting his qualifications in a good run, was resold for 100*l.* on the same day. The new owner, hearing afterwards that he was got by a cart-horse, felt somewhat disgusted and parted with the horse for 80*l.* to a dealer, who very soon disposed of him for double this sum. The other two colts by the same horse are very promising. Although such a strong cross as this is not to be recommended, it is worthy of note as an example of the powers of the mare to transmit her qualities of speed and endurance to her offspring, so as to render them good hunters.

7. A late master of hounds in a neighbouring county rode for some years a threeparts-bred stallion, that besides being a first-rate hunter was also used somewhat extensively as a stud-horse. His stock was almost universally good and remunerative to the breeders.

8. To these examples may be added some strong cases, kindly communicated to me by Mr. H. Overman, of Weasenham, Norfolk:—

“H. K. S——, Esq., of W——, Norfolk, had two horses of extraordinary good qualities as weight-carrying hunters; they had great pace and endurance, and were good performers. He rode them in Norfolk, Northamptonshire, and Leicestershire, and refused 700 guineas for the two. Their dam was a thoroughbred mare that ran well in the Oaks, and their sire was a half-bred cart-horse and hackney, with fine shoulders, good action, strong loin, deep girth, and good thighs and legs.”

9. Mr. Overman adds: “I used the same horse to two mares of my own, one a well-bred Irish mare. She threw a filly, which I sold for 100 guineas, and has since made nearly 200. The other mare was threequarter-bred, and she threw a colt which turned out one of the best performers I ever saw. I sold him to H. B——, Esq., of Norwich, for his brother in Surrey for 130 guineas, and 400 guineas have since been refused for him.

10. “One of the best horses now in Lord H——’s hunting-stables was by a Norfolk hackney out of a half-bred hunting-dam. We find in Norfolk if we put our Norfolk hackney to a well-bred mare with size, she is sure to throw a good animal. ‘Tom Moody,’ the property of Mr. J——, of Hopton, was not thoroughbred, neither was Mr. Goold’s ‘Shackaback;’ and these two horses are the sires of scores of good and valuable horses in this county.”

He adds: “The late Mr. Theobald, of Stockwell, in Surrey, always said that it was much better to put the hackney horse to

the blood mare than to adopt the reverse plan; the former course being almost sure to bring a good animal. A blood mare, the property of an uncle of mine, bred seven foals by hackney and cross-bred horses, and all proved animals worth a good deal of money."

My purpose in adducing these examples is to show that useful horses almost always, and valuable ones very frequently, can be bred as hack, hunters, and carriage-horses by using the half or threeparts-bred stallion with well-bred mares, so as to secure a sufficient amount of substance to carry weight. Not that we can thus breed horses of greater value than by using the thorough-bred stallion with suitable mares, for we can scarcely have too much breed, provided we have sufficient substance; but by following the system recommended, if we do not succeed in getting higher prices, we shall at any rate have fewer failures.

We have seen that with regard to sheep at least three different and valuable breeds have been inaugurated by cross-breeding, careful selection, and constant weeding; and the prevailing opinion is, that these possess certain desirable qualifications which render them more profitable than their parent races. Still there are those who deny this, and contend that there are pure breeds of sheep that can supply every requisite. Be that as it may, the case is much stronger with regard to the horse; for there is no one who would contend that the qualifications of a first-class weight-carrying hunter can be met with in any one pure or original breed, or that it can be otherwise secured than by the well-assorted alliance of blood and bone. Surely, then, if with sheep we can succeed in the course of twenty years in establishing a distinct breed, we can with equal or greater ease establish a breed of horses that will support with ease a six-foot guardsman with his heavy accoutrements, and dash into the charge with all the speed and spirit induced by the influence of a full equivalent of blood derived from both parents. The French are already trying this system; and if we are remiss, will in a few years surpass our cavalry in its most essential characteristic. There can be no reason why the defects which crop out after the first cross should not be as readily extinguished in the horse as in the sheep.

It is as well to notice, that valuable as is the Norfolk trotting stallion, when put to well-bred mares for breeding hacks, he is as a rule too deficient in size to get dragoon-horses, or those weight-carrying hunters which have been the glory of our land.

One argument adduced by the advocates of the universal employment of the full-blood sire is somewhat plausible, and has not perhaps been sufficiently disposed of. They say, it is desirable to have a pure-blood on one side at least, so that defects apper-

taining to the progenitors, but not apparent in the parents, may not, as in mixed pedigree, reappear in the offspring. This argument is good to a certain extent, but it applies equally to each parent, and if it can be dispensed with in the case of the mare in order to secure size and bone, it may also be given up for equal advantages in that of the sire, who would not have been devoted to the stud unless in addition to his pure lineage on one side, he had derived from the other some rare hunting qualifications and sterling merits which it would be most desirable to perpetuate.

CONCLUSIONS.

We have endeavoured in our preceding remarks to establish the correctness of the following points:—

(a) That the use of the thorough-bred horse or mare has greatly improved the coarser bred in speed and in bottom. That the blood has amalgamated exceedingly well with other breeds, and that the good results of even one cross only has been seen in various degrees and for several generations.

(b) That the effect of crossing with the thorough-bred is to increase the supremacy of the nervous and the muscular systems, and is more particularly shown in the fuller development of the thighs, the hind-quarters, and the elongation of the muscles generally. But that with these advantages the bones, joints, ligaments, and sinews are smaller and less powerful, and the action, although quickened, is rendered lower and less safe. The ability for jumping and for carrying heavy weights without injury to the joints and sinews, is greatly diminished. The skin is also rendered thinner and more liable to abrasion, the carcass smaller, and there is a diminished capability for putting on flesh.

(c) That so long as suitable mares with sufficient substance can be procured, the breeder of hunters should, on the rare occasions when they are offered, avail himself of the services of a first-class thorough-bred stallion, or even one of the second class, provided he has hunting qualifications,—good substance, or good high action in the trot or walk.

(d) If, going a step further in the same direction, the breeder seeks to put the female progeny to the blood-horse, he will most frequently fail; the offspring becoming too light; whilst if he had availed himself of the half-bred or threeparts-bred stallion (the grandson of a great racehorse), his stock having the same amount of breeding as the dam, would have afforded him a fair chance of realising a high price, and failing this, a comparative certainty of a fair sale for the cavalry, or for the general market.

(e) Having duly recognised the claims of thorough-bred horses of the first and second class, we can only advise, with regard to the third and inferior classes, that their services be altogether dispensed with, their place being taken by three-fourths, or half-bred stallions, possessing bone, substance, and good hunting qualifications. And it is such animals as these that deserve encouragement from our great Agricultural Societies.

For the encouragement of horses of this stamp we should be glad to see prizes offered for the best seven-eighths, three-fourths, and half-bred stallions, so that the owners of promising horses might be induced to delay the operation of castration until the animals had undergone the ordeal of the show-yard, and the prize-winners might be launched into the world with the Society's approval. Some of the prizes for ponies might well be dispensed with to provide money, if it be wanting, for this more important purpose. At any rate, it may be hoped that the Council of the Royal Agricultural Society will remove the impediments which shut out such a horse as "British Statesman," the first-prize winner at Battersea, and the second at Leeds, from competing at Newcastle among the stallions for breeding-hunters. The flaw in his pedigree, one-eighth, gave him, no doubt, more bone, sinew, and substance generally, and rendered him fit to carry an extra stone in weight, qualifications which doubtless gained him the prize of 20*l.*, offered by the gentlemen hunting the North Staffordshire hounds, for the best stallion for hunting horses.

This suggestion is not meant to imply that prizes for thorough-bred stallions should be dispensed with: on the contrary, if the state of the Society's funds permit, separate prizes should be offered for thorough-bred sires, adapted—

1. For getting Hunters ;
2. For Carriage Horses ;
3. For Park Horses, Chargers, or Hacks.

Prizes in each of these classes would then be assigned to animals differing much in character, but no longer, as at present, to the best racehorse, or according to the rather puzzling and peculiar condition of the prize-sheet, "to the horse best calculated to perpetuate the breed of the sound and the stout thorough-bred horse for general stud-purposes." Such a horse must unquestionably be neither more nor less than the sire of the greatest racehorses of the day.

But if this is too wide range for an Agricultural Society, the Managers of the Islington horse show may take this hint into consideration.

Those of our readers who were present at the splendid exhibition of thorough-bred stallions in the Agricultural Hall last summer, must have been struck with the great variety that

obtains in the shape and action of the thorough-breds then exhibited, and might, without any assistance from the judges, point out the particular horses with suitable characteristics for each of the several purposes above mentioned. "Caractacus" and "Nutborne" may be taken as correct examples of the true *race-horse*. The sprightly "Neville," with his splendid knee-action, may be regarded as the proper sire of the charger and the park-hack, whilst the powerful "Warlike," with his compact frame, is the very type of a weight-carrying hunter, so far as a blood-horse can be one. "Newcastle," the favourite of the judges, might put in a claim either as a hunting-sire for a moderate weight, or, with his fine action and good legs, as the sire of a charger or park-hack; and he probably gained his honours because he was thought to combine best in his own person the several and diverse qualifications required by the conditions of the prize-sheet. There were also some fine showy animals, with long arching necks and grand action, that might properly be considered as suitable sires for high-bred carriage-horses.

XII.—*Report on the Royal Veterinary College.*

THE Governors of the Royal Veterinary College have the pleasure of transmitting to the Council of the Royal Agricultural Society the Annual Report for the past year.

The Governors can assure the Council that the same means which they have hitherto found effective for imparting to the students in the College scientific information upon the diseases and treatment of cattle, sheep, and pigs, as part of the regular education that the College affords, have been perseveringly and successfully carried out.

Four lectures per week, in addition to demonstrations and practical instruction, have been delivered by the Professor of Cattle Pathology. The arrangement pursued in these lectures is scientific, and, as far as the means at the disposal of the Professor permit, practical and demonstrative.

The Governors have sought further opportunities for illustrating disease, and would willingly connect the education afforded by the College more closely with the practical teaching of Cattle Pathology, which can be obtained only in the country; hitherto the Governors have been compelled to rest satisfied with the inculcation of scientific knowledge illustrated as far as the opportunities of the College would admit, but to leave the general application of this knowledge to be more largely studied elsewhere.

In order to test the advancement made by the pupils in their studies, examinations are held from time to time rather upon the tutorial than the professorial system, and at the close of the sessional course of lectures a more searching and general examination is held.

At the end of the second sessional course of lectures—that is, in the second year of the pupils' studies—an examination, called the final examination, takes place, which if not passed to the satisfaction of the Professors, the student does not receive his certificate, entitling him to present himself before the Court of Examiners of the Royal College of Veterinary Surgeons, the possession of whose diploma constitutes him a legally qualified member of the profession.

By the rules of the College it is provided that every student so presenting himself shall be examined in the anatomy, physiology, and pathology of the ox, sheep, and pig, as well as of the horse and dog, for the same space of time as in the other divisions of his studies; and his rejection or otherwise is made to depend equally on his answers to the questions propounded in this section as in the others.

In order to stimulate the students, and to encourage their ready concurrence in the discipline of the College, the Governors have of late years revised the terms of competition for the "Coleman Medal," with which are connected first and second prizes, and a certificate of merit, as well as a third prize for the three students who shall pass the best examination at the close of their studies, conducted by the Professors. Hence it will be seen that due care has been taken that the pathology of cattle shall receive the same degree of attention in this examination as the other branches of instruction.

The number of students who entered the College during the year was fifty—this being the average number; thirty-nine students presented themselves before the Court of Examiners of the Royal College of Veterinary Surgeons; thirty-seven passed, and two only were rejected.

The Governors trust that the Council of the Royal Agricultural Society will perceive from this statement that the system of education in the College is well calculated to provide the agricultural community with veterinary surgeons competent to treat the diseases of their cattle on the established principles of medical science, whereby great losses are averted.

The Governors, having observed the increase of diseases among cattle and sheep, arising from attacks of parasites, especially the entozoa, have afforded every facility to Professor Simonds for pursuing an intricate and important inquiry on this subject; and they learn with satisfaction that, in addition to the

lecture given by him last year before the Society, he is prepared to furnish the agricultural community with further information through the pages of the Society's Journal.

The Governors have also observed with satisfaction that the Lecture which the Professor recently delivered before the Society on the smallpox in sheep was duly appreciated; and they trust that his exertions may assist in the prevention of this fatal malady, and thus render an important service both to agriculturists and the public generally. The report of the Vaccination of Sheep, alluded to last year by the Governors, has been sent in to the Government. In making this remark, the Governors would observe, that they have been informed that neither of the Commissioners, Mr. Marson, resident surgeon of the Smallpox Hospital, nor Professor Simonds, anticipated other than a negative result from their experiments, and that this opinion was communicated to the Government prior to the commencement of the investigation. For fuller information of the proceedings of the Commission, the Governors would direct the attention of the Council to the Report which has very recently been published by the Government.

During the past year a more satisfactory supply of morbid specimens, illustrative of various diseases, has been received from veterinary surgeons, and also from agriculturists; but so strong is the sense of the Governors of the necessity for illustration, that they have placed 50*l.* in the hands of the Principal for the purpose of procuring additional specimens for the instruction of the students in cattle pathology.

The number of patients which has been admitted into the College Infirmary during the year has somewhat exceeded the average. Among the cases of interest may be enumerated the following. A young Hereford bull, affected with umbilical rupture, complicated with a fungoid growth from the navel, the result of injury to the cord at the time of birth. The animal was operated upon with success, and after his recovery was returned to his owner with every indication of his becoming useful for stock purposes.

Two sheep, subject to the disease known in Sussex by the vulgar term of "goggles," a name probably given from a peculiar expression of the eye of the animal, especially in an advanced state of the disease, have also been received. The affection proved fatal in both instances after the animals had been about a month in the infirmary; and although a most searching *post-mortem* examination was instituted in both cases, the precise nature of this singular disease remains to be ascertained. The term "goggles" has been used as synonymous with *vertigo*, the malady in which an hydatid exists in the brain of

the animal: the cause of the vertigo, however, is patent, but that of the other disease is still hidden. Many practical agriculturists assert that the disease is hereditary, and, if once introduced into a flock, can never be eradicated except by the destruction of the whole flock; they also hold the opinion that the disease occasionally passes by the immediate offspring, but shows itself in the second or third generation. These facts and opinions prove the necessity of further research; but this cannot be carried on successfully without the co-operation of flock-masters, since a long-continued series of experiments and observations may be requisite; the Governors therefore would be glad to invite, through the intervention of the Council, the attention of sheep-owners to this subject, in the hope that some may be found who will afford the requisite facilities for investigation.

Among the animals which afforded most valuable information for the pupils, mention may also be made of a cow affected with scrofula. The animal was only three years of age, and the disease had evidently been inherited from her parents. The Governors are informed that a few years ago this disease was by no means unfrequent among even the purest bred cattle which were exhibited at the Society's Shows; but that, owing to the inspection conducted by their Professors, and the disqualification of the infected animals, few instances of the disease now occur.

A bull also, which died in the infirmary, afforded the students the opportunity of seeing an original case of abscess in the liver, in which nature made an effort to discharge the pus through the medium of the lungs; the progress of the disease, and the immediate cause of the death of the animal, were thus practically illustrated.

Another instructive case was that of a cow affected with a large abscess in the chest, associated with the absorption of a considerable portion of the bones of the sternum.

In a practical as well as a medical point of view cases such as are here mentioned are of great importance in the education of the student, as they not only afford the Professor an opportunity of making clinical remarks upon their nature and consequences, but also upon the modifications and the progress of disease in different animals.

During the year a large number of the members of the Society have sought advice from the College on various subjects connected with the health of their cattle, sheep, and pigs; such advice has been promptly rendered and acknowledged in most instances, as having been of great value. Investigations also have been made by Professor Simonds on various farms, which

have been attended with beneficial results in checking the progress of disease.

Notwithstanding the great public excitement which has existed with regard to epizootic diseases among cattle, the Governors are assured that both pleuro-pneumonia, and also the mouth and foot disease, have been less rife than in many former years, and that the first-named malady has been brought far more under control. In several instances pleuro-pneumonia has, the Governors hope and believe, been effectually checked in its progress by the adoption of the advice tendered by their Professor.

Although what may be called the established epizootics have been less prevalent, a peculiar disease of the nature of *diphtheria* has affected pigs in several parts of the country. This disease, however, has apparently passed its climax, and seems now to be on the decline. The sanitary measures recommended by the Professors were attended with marked benefit by keeping the malady in check; but further investigations into its pathology are required, and in this, as in other analogous cases, the Governors invite the co-operation of the Society.

Notwithstanding the advance which the science of cattle pathology is making under the system of co-operation which exists between the Royal Agricultural Society and the Royal Veterinary College, the Governors have had under consideration the question of rendering the College—if possible—even more effective; and they entertain hopes of being able hereafter to adopt still more effectual measures for the promotion of the common objects of the College and the Society. In order, however, to effect the objects which the Governors have contemplated, it is necessary that they should engage the co-operation, consult with, and in great measure be guided by the opinions of the veterinary profession generally, which can only be obtained by private communication with the leading members of that body, many of whom have been educated at the College.

The Governors of the College, who are also members of the Council of the Agricultural Society, will be able to inform the Council, that at no period since the system of co-operation between the two bodies was established have the Governors paid more attention to the advancement of their common objects than during the present year, or have made greater exertions in this sense.

The Governors desire, in conclusion, to draw the attention of the Members of the Council of the Royal Agricultural Society to the substance of several standing orders which they have adopted. One of these orders is to the effect: That at the commencement of each session some special subject of cattle-

pathology, for investigation by the Professors, be determined upon by the Governors of the College; and that suggestions upon this subject be invited from the Veterinary Committee of the Royal Agricultural Society, and that these subjects be treated in the Annual Reports of the Royal Veterinary College to the Royal Agricultural Society.

By another standing order the Governors have directed that a prize medal be given annually to the student who shall pass the best examination on cattle-pathology.

The Governors have already mentioned, in connexion with this subject, that the sum of 50*l.* out of the funds of the College will be annually appropriated for the purchase of diseased animals.

Not satisfied, however, with this arrangement, and conscious that without the voluntary co-operation of stock-masters it must prove inadequate, the Governors have further resolved upon tendering to the public the advantages which the following resolution conveys, viz. :—

That diseased cattle, sheep, or pigs, although the property of a *non-subscriber*, may, at the direction of the Principal, be admitted to the Infirmary of the College for treatment, free of all cost, except for their keep, at the rate of 1*s.* per night each for cattle, and 6*d.* per night each for sheep and pigs; provided that authority shall be given, in writing, by the owner to the Principal, at the time of admission, to have destroyed or to sell any such animal in the event of its not being taken from the College after two days' notice to the owner for its removal.

In order to provide adequate accommodation for the increase of patients to the Infirmary under these regulations, the Governors have erected several new boxes and sheds for diseased cattle and sheep at considerable cost to the funds of the College.

The Governors of the Royal Veterinary College trust that the substance of this Report, as explained—if explanation is necessary—by the Members of the Council, who are also Governors of the College, will satisfy the Royal Agricultural Society that the Governors are pursuing the objects common to the two bodies with unabated attention and increased vigour.

C. N. NEWDEGATE, *Chairman.*

EDWARD KERRISON.

Royal Veterinary College, Camden Town, Sept. 1864.

XIII.—*Statistics of Live Stock and Dead Meat for Consumption in the Metropolis.* By ROBERT HERBERT.

ALTHOUGH the Metropolitan Cattle Market was extensively supplied with most breeds of beasts during the last six months of 1864, there was a great deficiency in the weight of meat disposed of—indeed, fully half of the stock on offer was beneath the middle quality. The severe drought experienced during the summer months, and the consequent want of grass, and the serious deficiency in the turnip-crop over the whole of our grazing districts, compelled the graziers to purchase large additional quantities of linseed and cake, and had great influence upon prices. At one period really prime Scots and crosses produced as much as 6s. per 8 lbs.; and even the more general range in their value was 5s. 6d. and 5s. 8d. per 8 lbs. These high rates fully justified our anticipations. From the circumstance that beasts have fattened slowly during the last three or four months, and that the numbers in the stalls in our leading counties are very moderate for the time of year, it is evident that there is little or no prospect of any important decline in current rates between this and the close of the Norfolk “season.” During the six months only 60,350 beasts arrived in the Metropolitan Market from Lincolnshire, Leicestershire, and Northamptonshire, against 66,510 head in 1863, and 74,570 in 1862. The deficiency in the arrivals from the above districts was not confined to numbers only, since fully one-third of them were only fit for second and third class consumption. From the eastern districts an increased number of beasts was reported; but the comparative excess in the supply arose solely from many of the graziers being compelled to dispose of a portion of their stock much earlier than usual. Other parts of England furnished a very middling show of stock, both as to number and quality. From Scotland, however, the arrivals were a full average, and in wonderfully fine condition; indeed, scarcely an inferior bullock arrived from that quarter. The drought in Scotland was much less severely felt than in England; the turnip and potato crops have turned out well, and of good quality; and stock generally has fattened quite as rapidly as in the most favoured seasons. Ireland furnished only 7079 beasts, against 11,280 in 1863, and 14,820 in 1862. As the Irish stock has shown no improvement, sales have progressed slowly, at moderate rates.

The annexed return shows the quarters from whence the supplies of beasts were derived in the last six months of the last five years:—

District Bullock Arrivals.

Last half of year.	Northern Districts.	Eastern Districts.	Other parts of England.	Scotland.	Ireland.
1860	66,140	9500	20,500	1151	7,852
1861	71,450	2500	9,700	4586	14,340
1862	74,570	5050	19,620	3307	14,820
1863	66,510	3850	21,250	3213	11,280
1864	60,350	8400	19,400	3625	7,079

This is certainly a most unsatisfactory statement as a whole. The consumption in London is increasing every year; prices have continued to improve; and even the excessive importations from the Continent have failed to affect the value of English stock. The question, therefore, of an adequate supply of food has become a serious one, more especially as the foreign arrivals, with very few exceptions, are still very deficient in quality. The foreign sheep have shown very little improvement, although some few of them have sold as high as 78s. and even 80s. each. They still continue, however, to carry a large quantity of internal fat. Foreign calves, which now form three-fourths of the supplies, have sold steadily; and fair prices have been made for pigs, although the importations exceeded all previous years. The arrivals into London were shipped from the under-mentioned ports:—

Imports of Foreign Stock into London during the last Six Months of 1864.

From	Beasts.	Sheep.	Lambs.	Calves.	Pigs.
Amsterdam	372	1,473	2	61	..
Antwerp	122	32	..	754	369
Boulogne	152	15	..	175	4,675
Bremen	5,386	1,890	172	1	..
Cadiz	139
Calais	60	88	1,433
Dordt	2,990	15,467	3,333	51	18
Dunkirk	127	157	2,579
Gibraltar	605
Hamburg	1,829	25,406	154	44	3,415
Harlingen	9,900	26,912	1,491	2,437	10,324
Havre	1
Lyston	20
Medemblik	2,393	30,628	1	228	4
Nieu Dieppe	249	2,140	..	258	8
Oporto	392
Ostend	632	503	31	515	575
Rotterdam	22,198	92,849	3,177	12,021	7,403
Tonning	28,898	29,342	3,043	3	..
Vigo	587
Total	76,992	226,657	11,464	16,793	30,803

Here we have a total supply from abroad of no less than 362,709 head, an increase of 23,630 head on 1863. It will be perceived that nearly 29,000 beasts were shipped from Toning, but of this large number about 20,000 were only fit for grazing purposes. Rotterdam comes next in importance. The Dutch stock, however, was very inferior in quality to that imported in 1862 and 1863. The same remark may be applied to the arrivals from most other quarters; consequently, the addition to our supply of animal food was comparatively small. Rather a large business has been passing in foreign pigs. For the most part they have arrived in fair condition, but the prices realised for them have been very low, viz. from 3s. 8d. to 4s. 2d. per 8 lbs. The imports of foreign stock into the United Kingdom during the last six months of the under-mentioned years were:—

Imports into the United Kingdom.

Last half of year.	Beasts.	Sheep and Lambs.	Calves.	Pigs.
1863	61,435	241,209	17,497	18,936
1862	57,356	250,140	19,610	17,279
1861	59,049	266,249	19,715	25,919
1860	59,817	243,804	19,594	21,510

The aggregate supplies of each kind of stock exhibited in the great Metropolitan Cattle Market in the last six months were:—

	Head.
Beasts	177,944
Cows	3,221
Sheep and lambs	769,814
Calves	17,967
Pigs	19,306

In the four previous seasons, ending with 1863, the show of stock was as follows:—

Total Supplies of Stock Exhibited.

Last half of year.	Beasts.	Cows.	Sheep and Lambs.	Calves.	Pigs.
1860	145,420	3015	762,740	15,766	15,470
1861	149,750	3187	774,260	12,441	20,116
1862	159,450	3148	759,671	12,579	18,220
1863	168,232	3127	761,070	14,822	17,550

The lowest average value of inferior beasts in 1864 was 3s. 6d.; of middling stock, 4s. 6d.; and prime, 5s. 6d. per 8 lbs. The heavy arrivals from the Continent prevented any rise of moment in the former quotation; but in the latter there was an advance

of 6*d.* per 8 lbs. Sheep were the turn dearer. Lambs sold at from 5*s.* 6*d.* to 8*s.*; calves, 4*s.* to 5*s.* 10*d.*; and pigs, 3*s.* 6*d.* to 5*s.* per 8 lbs., to sink the offal. The following selection from the six months' averages will illustrate the recent rise in prices:—

Average Prices of Beef and Mutton.

Per 8 lbs., to sink the Offal.

BEEF.

	1860.	1861.	1862.	1863.	1864.
	<i>s.</i> <i>d.</i>	<i>s.</i> <i>d.</i>	<i>s.</i> <i>d.</i>	<i>s.</i> <i>d.</i>	<i>s.</i> <i>d.</i>
Inferior	2 8	3 0	3 2	3 4	3 6
Middling	4 0	4 0	4 0	4 2	4 6
Prime	5 4	5 0	4 10	5 0	5 6

MUTTON.

	1860.	1861.	1862.	1863.	1864.
	<i>s.</i> <i>d.</i>	<i>s.</i> <i>d.</i>	<i>s.</i> <i>d.</i>	<i>s.</i> <i>d.</i>	<i>s.</i> <i>d.</i>
Inferior	3 2	3 2	3 8	4 0	4 2
Middling	4 6	4 6	4 8	5 0	5 2
Prime	5 10	5 8	5 6	5 10	5 10

Although the supply of rough fat has been very moderate, the demand for it has been heavy at 2*s.* 1½*d.* and 2*s.* 1*d.* per 8 lbs. The great falling off in the exports of tallow from St. Petersburg, as well as from Australia, the Cape, &c., has had very little influence upon the value of fat. That article has consequently ceased to be of much profit to the butchers.

Fair average supplies of meat have been on sale in Newgate and Leadenhall Markets. Generally speaking, the trade has ruled steady, at comparatively high rates. Beef has realised 2*s.* 10*d.* to 5*s.*; mutton, 3*s.* 6*d.* to 5*s.*; lamb, 5*s.* to 7*s.* 4*d.*; veal, 3*s.* 8*d.* to 5*s.* 4*d.*; pork, 3*s.* 4*d.* to 5*s.* per 8 lbs. by the carcass.

Letters from Holland and Germany state that unusually heavy shipments of stock will be made to England in 1865. The want of adequate supplies of food in both countries does not favour the impression entertained in some quarters, that these supplies will reach us in improved condition. It may therefore be safely assumed that we shall have high rates for both beasts and sheep for several months. The few shorn sheep disposed of in the metropolis have sold at 1*s.* 2*d.* per 8 lbs. below those in the wool. This wide difference must be attributed to the scarcity of wool in the country, notwithstanding that the arrivals

from our colonies and foreign ports in 1864 were on a very extensive scale. The three years' importations were:—

	1862.	1863.	1864.
	Bales.	Bales.	Bales.
Colonial	345,605	375,010	430,395
Foreign	222,063	220,316	240,512
Total	567,668	595,326	670,907

The exports to the Continent were only moderate, consequently the bulk of the importations passed into consumption in this country. It may be remarked, however, that, whilst foreign and colonial wools have receded in value, owing to the high rates prevalent in the discount market, English qualities have been on the advance, with more than usual activity in the demand. The quotations for home-grown wool in the metropolis at the close of the last two years were:—

	1863.				1864.			
	Per lb.				Per lb.			
	s.	d.	s.	d.	s.	d.	s.	d.
Fleeces:—								
South Down hoggetts	1	10½	to	1 11½	...	2	0	to 2 1½
Half-bred hoggetts	2	0	to	2 0½	...	2	5	to 2 6
Kent fleeces	1	11	to	1 11½	...	2	2	to 2 2½
South Down ewes and wethers	1	8	to	1 9	...	1	11	to 2 0
Leicester ditto	1	9½	to	1 10½	...	2	1	to 2 2
Sorts:—								
Clothing picklock	1	9½	to	1 10	...	2	0	to 2 0½
Prime and picklock	1	8½	to	1 9	...	1	10	to 1 10½
Choice	1	7	to	1 8	...	1	9	to 1 9½
Super	1	6	to	1 6½	...	1	6	to 1 6½
Combing:—								
Wether matching	1	11	to	1 11½	...	2	1½	to 2 2
Picklock	1	9	to	1 9½	...	2	0	to 2 0½
Common	1	5	to	1 6	...	1	8	to 1 10
Hog matching	2	0½	to	2 1½	...	2	2	to 2 3
Picklock matching	1	8½	to	1 9	...	2	0	to 2 2
Super ditto	1	5½	to	1 6½	...	1	8	to 1 10

The high prices still demanded for cotton are calculated to give considerable support to the value of wool, even though the present year's clip may turn out equal to that of last season.

XIV.—On the Composition and Nutritive Value of Palm-nut Kernel Meal and Cake. By Dr. AUGUSTUS VOELCKER.

THIS, comparatively speaking, new feeding-material is the residue obtained on submitting to strong pressure the oleaginous kernels of the palm-nut. These kernels are encased in a thick brown shell of woody matter, and this is surrounded by a deep

orange-coloured pulp, from which the palm-oil of commerce is produced by gentle pressure.

The bulk of palm-nut kernels, which is nearly white, is covered by a thin brownish layer of woody fibre, and in consequence of which palm-nut meal has a light brown or dirt-coloured appearance.

The size of these kernels varies from that of a hazel-nut to that of a small pigeon-egg; they are very hard, nearly inodorous, rather insipid to the taste, and very rich in fatty matters, possessing the consistency of butter, and useful property of not readily turning rancid. The extraction of the fatty matters necessitates the reduction of the kernels into a tolerably fine powder, and the application of powerful crushing-machinery and gentle heat. Notwithstanding these means, the cake or meal left in the presses contains usually a larger proportion of fat than is found in linseed, rape, and most other kinds of oil-cakes.

I first became acquainted with this meal in the spring of 1861, when a sample was sent to me for analysis by Messrs. Alexander Smith, and Co., Kent Street Oil-mills, Liverpool.

The analysis furnished the following results:—

Moisture	7.49
Fatty matters	26.57
*Albuminous compounds (flesh-forming matters) ..	15.75
Starch, mucilage, sugar and digestible fibre	37.89
Woody fibre (cellulose)	8.40
Mineral matters (ash)	3.90
	100.00
*Containing nitrogen	2.52

It appears from these results,—

1. That this meal was very rich in ready-made fat. In the best linseed-cake the percentage of oil rarely amounts to 12 per cent., and 10 per cent. may be taken as a fair average. The palm-kernel meal analysed by me thus contained more than twice as much fatty matter, and theoretically is much superior to oil-cake as a direct supplier of fat.

2. The proportion of flesh-forming (nitrogenous) matters is fully as large as in the best barley-meal, but much less than in linseed-rape- or cotton-cake; nor is it equal to that found in peas, lentils, and other leguminous seeds.

3. The amount of indigestible woody fibre is but small.

4. It contains about as much mineral matter as cereal grains, and thus is not particularly noted for bone-producing qualities.

From these remarks it may be gathered that palm-nut-kernel meal is not so well adapted for the rearing of young stock as for

fattening animals, and that it surpasses almost all other articles of food in its theoretical value as a fat-producer. The proximate composition of articles of food unquestionably affords useful indications of their properties; but such indications are insufficient to determine with certainty the real nutritive value of food. Analysis may point out the existence of a large amount of oil or fat in a substance, but it does not decide whether these matters, as in the castor-oil beans or croton beans, possess medicinal properties, or whether, like linseed- or rape-oil, they are available in the animal economy for the production of fat. On these and other points that readily suggest themselves to feeders of stock desirous of using a hitherto untried food, practical experience has to be appealed to for a final decision. Fully impressed with the propriety of submitting palm-nut meal to a sufficiently decisive experimental test before giving a definite opinion of its economical value, I procured a supply from Messrs. Smith, which I placed in the hands of Mr. Coleman, the late manager of the farm attached to the Royal Agricultural College, Cirencester. I expected in the course of three or four months to have reported on the result; however, more than a year elapsed before the feeding experiments could be said to have been fairly concluded.

Well-fed animals, liberally supplied with succulent, sweet roots, good linseed-cake, hay, and other palatable food, it is well known, do not relish a change, if the substituted food happens to be less palatable than that to which they have been accustomed. Palm-nut meal is certainly not so nice to the taste as linseed-cake or swedes and hay; some difficulty consequently was experienced in inducing animals to eat it, and neither the cow-man nor the person in charge of the pigs possessed the requisite patience to give the meal a fair trial, and both declared it to be little better than sawdust. After repeated attempts to overcome the prejudice of the cow- and pig-man, the meal was consigned to the granary, where it remained for nearly ten months. By that time the store of oil-cake was almost consumed, the supply of roots ran short, and the price of all feeding-materials was very high. Under these circumstances an application for a fresh supply of oil-cake for the use of the sheep was not very favourably received by Mr. Coleman, who gave the shepherd liberty to use the despised palm-nut meal. Probably somewhat stinted in food, the sheep took to the palm-meal at once, and after a few days ate it up greedily, and, what is more, throve upon it remarkably well. All who had seen the sheep before they had received palm-nut meal, and after they were fed upon it for only a short time, were unanimous in attaching a very high value to this meal. The shepherd, indeed, soon learned to prefer it to the best linseed-cake, and had the

satisfaction of getting the first prize for fat sheep at the Gloucestershire Agricultural Society's Show.

The success in the sheep-feed paved the way to a more favourable reception of the palm-nut meal than it received on the outset from the part of our cow-man, who now found that 3 to 4 lbs. a day not only increased the quantity of milk, but likewise greatly enriched its quality. I need hardly say that, in consequence of this favourable experience, large quantities of palm-nut meal were subsequently consumed on the College-farm.

By degrees this meal found its way amongst agriculturists; and all who have given it a fair trial speak in the highest terms of its fat- and milk-producing properties.

During the last year a good many samples were sent to me for examination from various parts of the country. The following Table shows the composition of 6 samples of

PALM-NUT KERNEL MEAL.

	No. 1.	No. 2.	No. 3.	No. 4.	No. 5.	No. 6.
Moisture	7·49	6·91	6·69	7·52	7·02	7·21
Fatty matters	26·57	26·50	23·92	22·68	19·95	22·79
*Albuminous compounds (flesh-forming matters)	15·75	14·93	15·25	16·75	17·01	15·56
Mucilage, starch, sugar and digestible fibre ..	37·89	31·20	40·62	32·14	33·76	36·24
Woody fibre (cellulose)	8·40	16·13	10·40	17·49	18·70	14·90
Mineral matters (ash) ..	3·90	4·33	3·12	3·42	3·56	3·30
	100·00	100·00	100·00	100·00	100·00	100·00
*Containing nitrogen ..	2·52	2·39	2·44	2·68	2·72	2·49

It will be seen that all 6 samples are very rich in fatty matter, which accounts for the marked effect which the meal has upon the production of a rich milk; moreover, the fatty matter has about the same consistency as butter, and hardly any smell, which probably explains why a good tasting and sufficiently hard butter is produced from the milk of cows fed upon it.

The two first-mentioned samples contained no less than 26½ per cent., and the other four from 20 to 24 per cent. of ready-made fat.

This is a very large percentage of the most valuable of all food-constituents in an economical point of view. If it be borne in mind that 1 part of ready-made fat or oil is equivalent to 2½ parts of starch, and that good wheat or barley seldom contains more than 60 to 65 per cent. of starch and analogous heat- and fat-producing constituents, the superiority of palm-meal as a fattening food will clearly be recognised.

Taking 24 per cent. as the average proportion of fat, and mul-

tipling this by $2\frac{1}{2}$, we obtain 60 per cent. as the starch-equivalent for the fat in palm-kernel meal. Add to this 35 per cent. in round numbers of other heat- and fat-giving matters, such as sugar, gum, mucilage, &c., and we shall get that which is equivalent to 95 per cent. of fat-producers against 65 in wheat or barley.

Neither is this meal deficient in flesh-forming matters; and although for young growing stock, the admixture in an equal proportion of beans, peas, or other leguminous food rich in nitrogenous matters, is advisable, for fattening stock, the 15 or 16 per cent of flesh-forming matters occurring in palm-meal are quite sufficient for carrying on the fattening process successfully.

At the present time palm-nut meal sells at 6*l.* a ton, in quantities of 2 tons and upwards, delivered at Liverpool, or at 6*l.* 17*s.* per ton or upwards delivered by rail in London, and is produced in England, as far as I know, only by Messrs. Alexander Smith and Co., Kent Street Oil-mills, Liverpool. Palm-kernels appear also to be crushed at Hamburg, from whence the residue left in the presses is occasionally imported into England in the shape of cake and of meal.

All the samples of foreign palm-kernel meal and cake which I had occasion to analyse I found greatly inferior to the Liverpool meal, as will appear from the following analysis, showing the

COMPOSITION OF FOREIGN (HAMBURG) PALM-NUT CAKE AND MEAL.

	CAKE.		MEAL.	
	No. 1.	No. 2.	No. 1.	No. 2.
Moisture	12·91	8·84	10·77	10·84
Fatty matters	9·48	11·27	13·79	12·49
*Albuminous matters (flesh-forming substances)	18·25	17·93	13·75	14·06
Mucilage, starch, sugar and digestible fibre	39·16	40·79	42·67	43·56
Woody fibre (cellulose)	16·90	16·85	15·17	15·32
Mineral matters (ash)	3·30	4·32	3·85	3·73
	100·00	100·00	100·00	100·00
*Containing nitrogen	2·92	2·87	2·20	2·25

The chief difference between the English-made and imported samples of palm-nut meal consists in the very much larger proportion of fatty matter that occurs in the former samples.

Foreign palm-nut meal sells at a lower price than English, but will generally be found the dearer of the two if the quality be duly taken into account. The Hamburg meal has lately been the subject of feeding-experiments in Germany, by Professor Stöckhard of Tharandt, who gives a most favourable report of its

fattening properties. This distinguished Agricultural chemist also speaks highly of it as a food for milch-cows.

The experience of English and continental feeders thus confirms the opinion which I first expressed on the strength of an analysis with some degree of diffidence, and leaves no doubt of the fact that in palm-kernel meal we possess a most valuable and economical addition to the list of feeding-stuffs.

11, Salisbury Square, Fleet Street, E. C.

XV.—*On the Cultivation and Proper Management of Flax.* By the
Rev. NATHANIEL M. BROWN.

PRIZE ESSAY.

THE climate of Great Britain and Ireland is very variable, and a superabundance of rain in both countries often renders the labours of the husbandman unremunerative. In Ireland, particularly, the four years ending with 1863, were almost continuously wet, and, as a natural consequence, the white-crop harvests have been very deficient both in quantity and quality. The dampness of our atmosphere arising from our insular position (a feature in the climate which is supposed to be latterly on the increase) has long ago convinced us in Ireland that we cannot compete successfully with dryer and warmer countries in the production of cereals, and especially wheat; and has frequently induced the inquiry, Would it not be wiser for the farmers to restrict the growth of wheat, and try a larger annual acreage of those crops which are better adapted to our climate? Within the last few years this question has not only often been put, but an affirmative answer has been given, and straightway acted upon. To such a climate, FLAX has been found to be remarkably well adapted; and the farmers of the north of Ireland have more than compensated themselves for the recent failure of their cereals in this respect, by the extensive cultivation of this valuable crop. In Ireland alone, during the year 1863, it has been computed that no less than *four millions sterling* have been raised by the growth of flax; a ready sale at good prices having been obtained in all the market towns of Ulster. From the growing demand occasioned both by the scarcity of cotton (which is likely to be felt for years to come), and the preference now given to linen, it is more than probable that high prices may long continue. For some years past, no crop in Great Britain or Ireland has given as

large a return per acre as flax, the produce in money being from 20*l.* to 30*l.*, and occasionally even as high as 40*l.* No wonder that statesmen, landed proprietors, and enterprising merchants have exerted themselves to secure by flax-culture the same advantages for the south and west of Ireland which have hitherto enriched the north. That the farmers of England and Scotland should also share in this source of wealth is neither impossible nor improbable. Vast quantities of fibre are still imported from the continent to keep our mills going; and if our friends at home could only be induced to raise a sufficiency of the article, they might put into their own pockets millions of pounds which are now sent out of the country. Knowing that the soil of England and Scotland is as well suited to the produce of flax as that of the most of Ireland, I am encouraged to call the attention of the Royal Agricultural Society of England to the proper cultivation and management of the plant, in the hope that its influence may induce the farmers of Great Britain to give a full and fair trial to the crop that has so largely benefited Ireland.

Soil.—The soil best adapted to the growth of flax is a free and friable loam on a clay bottom. Clay land that has been well and deeply cultivated for years will suit well also; and if favoured with light rains shortly after the seed is sown, so that the *braird* is brought forward *evenly*, will, generally speaking, yield a heavier and more remunerative crop than loam. On no soil is the fibre as tough and the yield as great as on clay; but the drawback is that the plant misses oftener than on loam. Clay ground is not easily pulverised after the second week in April; and if the seed be cast among hard clods, it will lie there without germinating for weeks, whereas a warm kindly soil, highly pulverised, will start it into vegetation within six or seven days. One great point to be secured is to get the seed all *struck at once*. If parts of the field get into *braird* before others have even got into *bud*, the crop will come forward in *different lengths*—it will not ripen evenly; and if the green and the ripe be taken up at the same time, the one must be sacrificed to the other, both in the water and in the mill. The late growth will have run up to its height so rapidly during the heat of the latter part of the season, that it will not have tenacity and stamina to stand the strain of working with the earlier growth.

Since the best lands for flax are those which have a retentive subsoil, they are apt to hold water; therefore, to insure a crop, they should be thoroughly drained. Flax can, from the very first, bear any amount of rain that may fall upon it, if the water get freely away; but it will not bear without injury, even for a day, stagnant water gathered round its stems.

A sub-soil of sand, red "till,"* or sharp gravel, is about the worst suited to this plant of all that could be named. Upon a sharp "croft,"* I have *occasionally* seen a *good* crop, and *frequently* a *fair* crop, especially if it has had a long previous *rest*; but for the most part it is not a favourable soil for a full return.

Run-out bog, having a kindly gray top, with a good clay well-drained bottom, will produce a good crop, but it should not be too poor. It would be well for it to have passed through two manurings at the least. The older the ground the better, if it has been laid out in good condition; especially if it has never borne flax before—or at least for a considerable number of years.

During the spring and summer months the weather in Ireland is for the most part showery, so that the strongest and heaviest clays are seldom left to bake and harden to such a degree that vegetation is thereby destroyed. This, however, is not the case in some of the counties in the South and East of England. There drought frequently injures not only the flax-crop, but all the staple products of the husbandman. In such circumstances it is wisest to avoid all labour in wet weather. The flax-grower should not allow the foot of either man or horse to be set upon his clay-ground whilst it is saturated with rain. He should plough in the autumn, and only once, but with a deep and heavy furrow. The furrow-slices of the stiffest clay will be "mannered" and mellowed by the influences of winter; and when the genial spring weather has brought up the soil to the happy medium between the "wet" and the "dry," then without delay let the ground be thoroughly pulverised. A *second* ploughing is not to be recommended; the *grubber* will much more safely and advantageously do the work, driven at right angles and diagonally through the furrow-slices of the previous autumn. On no account must the cool damp bottom be opened up to the parching winds of March, and yet the furrow-slices must not remain unbroken, lest "interstices" remain beneath the seed. Upon all such spots drought would at once seize and check the growth of the plant. The two things most desirable in a clay soil, or indeed in any soil, are *pulverisation* and *consolidation*. The clay lands of those counties that are most exposed to drought should be extra-rich with manure that is assimilated with the soil. Such ground soon clothes itself with the braird, so as to resist the effects of drought, and even in the driest seasons is apt to force the crop when well

* "Croft" land is a light pebbly loam, generally found in an elevated position; it is sharp, warm ground, that requires much manure, and often has a subsoil of sand to the depth of 3 or 4 feet; of late years it has answered best for the potato-crop. "Till" is reddish brown earth, having the appearance of sand, but having no sharp or gritty substances in it; it is soft, dull, and unproductive when raised, and often forms the impervious "pan" beneath the vegetable mould.

started, in spite of all adverse influences, up to the desired length. Tough and tenacious clay may be advantageously "cut" and opened by an application of shells, marl, lime, or even common sharp sand; but such an application should precede the sowing of flax by at least a couple of years.

Many of the farmers in the North of France *irrigate* their flax in its early and medium stages; but the practicability and benefit of such a process are very doubtful. Hand-labour could not accomplish the work required after sunset (the best time for irrigation), and the crushing of wheels and horse-hoofs would be detrimental to the plant at any stage. On parched clay the water would not sink so as to reach the flax-roots, but would be carried off by evaporation in the course of a few hours. Let the land (if clay) be worked when dry, kept close and cool in the bottom, be thoroughly pulverised and consolidated, sown ere the natural moisture has escaped, and closed in over the seed with a heavy roller, and the need of irrigation will not be felt either in England or Ireland.

Condition of the Soil—The condition of the soil is most favourable when one white crop has been taken off either old lea or manured ground. Capital flax is often grown on wheat-stubble, the previous crop having been either potatoes or turnips, the former being preferable. But the heaviest yield and the finest sample is always expected after an oat-crop that has been grown on a rich and very old lea. The crop which follows wheat and manuring may look as well upon the foot, and perhaps better, for it is generally more bulky; but the other, following the oats or wheat on the old lea, will tell best in the mill, and will prove the most satisfactory in the market.

Many hand-manures are spoken of as useful for strengthening the crop, but such top-dressings render very doubtful service. They may no doubt, at a certain stage, accelerate the growth, but such forcing seldom or never gives satisfaction in the mill. Any sudden and unmaturing growth is apt to be carried away among the *shoves*. Lime, though condemned in some quarters, will not do harm, but good, if incorporated with the soil for a year previously; and salt applied a month before sowing will keep up the crop till it be thoroughly ripened.

In some counties of England farmers are in the habit of ploughing in manure at the close of autumn, when a flax-crop is to follow. In Ireland this is seldom or never done; it has been tried in some instances, but never with marked success. The new manure is not sufficiently rotted and incorporated with the soil, and such management is apt to occasion a "cloudy" and uneven crop, the flax being rank and green where there is a lump of manure, but light and yellow where there is none.

Ashes are the only manure that can be safely ploughed in, the same season with the crop, and that at least three months before the sowing. Flax demands that all manure should be *assimilated* with the soil.

Preparation of the Soil.—In ordinary friable lands—such as loams or crofts—there are two modes of preparing the soil that are about equally approved of: 1st., to plough in November across the ridges as if for green crop. This ploughing should be very deep and heavy. Then about the 1st of March when the ground has been mellowed with the frost, to harrow well and plough again in the direction of the permanent ridges. This ploughing should be very shallow. It is merely to secure a fine mould for the seed. After the second ploughing a month will elapse before sowing, during which time the seeds of annuals will have germinated and budded, so that they can be killed afterwards by the action of the harrow. During the second ploughing is the time to sow salt, if it be deemed necessary to prevent the crop from lodging. The 2nd plan is to plough but once, and that about the middle of January. Then at sowing-time to cross the furrows with a grubber, and harrow well before the seed is cast in. In either case the ground should be thoroughly picked and cleaned; for no crop abhors weeds more than flax. Little narrow ridges and inequalities in the surface should, as a general rule, be avoided. The harrow pulls the hard clods into these furrows, and from among these an aftershot or late growth is sure to spring up, which never comes to be of any value. Flats or lands 16 feet wide, or where the soil is well drained, of 21 feet, will be the most suitable, and will afford but few receptacles for the dry clods or coarse mould. In every case the roller is an indispensable implement, and the heavier the better. Some condemn the two ploughings because they open up the bottom too much, which should always be kept close and cool. But a heavy roller consolidates the ground sufficiently, and at the same time renders the top fine and even. For greater exactness in sowing a good ploughman should mark or score off the different flats so that they are all of the same breadth before the last turn of the harrow, and the last round of the roller. Then the ground is ready for the seed.

Deep cultivation is advisable for the following reasons:—

1. The prevalent opinion that the roots of flax are very shallow is a mistake. It has a very fine and minute tap-root that penetrates the soil to a considerable depth, but which is invariably broken at pulling-time.
2. If the cultivation were not deep, the disintegrating influences of the winter frost would benefit nothing but the mere surface.
3. Shallow cultivation is the very worst for both very wet, and

very dry weather. In very wet weather, the extra rain does not get away from the roots of the plant; and in very dry, the soil, touched by the tap-root, becomes baked like a brick. Deep cultivation allows the extra rain to pass down from the roots at once, as through a filter, and in drought enables the plant to be fed by capillary attraction from the moisture that lies below the baking influence of a strong sun.

Seed.—The seed most sought after in Ireland for many years past is that from Riga. It has been found to be well adapted to almost all classes of flax-growing soil. It is supposed also to produce a longer crop than other kinds of seed upon ground of only medium strength. English seed, however, of the first year, carefully reared from Riga seed, is much cheaper, and for many years past has proved most satisfactory. American seed, though once in repute, is little sought after now, and consequently is hardly to be procured. Dutch seed is excellent for some kinds of land, and if sown upon suitable ground, will produce a heavier yield than any other. It requires the strongest and richest soil, for poor or even medium ground will not bring it up to the desired length. On fat land it is in less danger of “lodging,” and even though it does go down for a few days before the pulling, it is less liable to be injured than Riga or any other kind.

Sowing.—According to the nature of the soil the seed may be advantageously committed to the ground from the second week in April to the second or third week in May. In the southern counties of England it may be sown a fortnight or three weeks earlier. With this as with almost any crop, other things being equal, early sowing is ever the best. The moderate heat which will then attend upon the young and tender growth of the plant will permit it to mature and “make,” as it gradually gains in length; whereas if it be late sown, the great heat during its early stages brings it precociously forward, makes it spring up too rapidly to its height, and thereby renders it less productive in the mill. Moreover, the early sown will be first ready for the mill and for the market; no small consideration where so many are usually contending for their “room” in scutching, and where the opening prices of the season are not unfrequently the best. A week’s delay in sowing may throw a man a fortnight behind in pulling and steeping; and during these two weeks so many of his neighbours may forestall him in the mill, that he may be a couple of months behind time in reaching the market. Such delay is a serious inconvenience to small farmers of limited capital who require money for their November payments. On the other hand early sowing is not unattended with danger. If the “braird” have risen before the spring frosts are all past, it may become so effectually nipped that it will never recover. All things con-

sidered, the second and third weeks in April may be regarded as about the safest and most advantageous time for sowing.

To sow flax-seed well requires a practised hand. Many a man who can sow grain well will here utterly fail. Cloudy sowing is most objectionable. On the thin spots the plant will grow longer, coarser, and more branchy at the top; on the thick spots shorter and finer and liable to ripen earlier, so that there will be two qualities of flax which will not work together with any advantage. Thin sowing has its advocates and so has thick; but an extreme on either side should be carefully avoided. A medium "cast" evenly scattered is most to be recommended. If the seed be sown too thick it will not grow the desirable length; and if to draw it up to a full height, you put it upon very strong land, you are likely to have it lodged before it is ripe—the greatest evil that can befall this crop. On the other hand, if it be sown too thin it will spring up coarse in the stalk and fibre, forked in the top, and will be laden with bolls.

After many experiments, the quantity of seed that is most approved by the best growers is about nine pecks to the English acre, or a Riga barrel to the Irish acre. In some of the English counties the seed is drilled. Such a process is never attempted in Ireland, nor would it be considered advisable. The centre and sides of each drill are liable to grow two different qualities of flax—coarse and fine, and very frequently also long and short. All that is gained by superior cleanliness, either by hoeing between the drills or otherwise, is a minor consideration; and to secure a crop of uniform length and quality, there is no method of sowing to be compared with the old "broadcast."

The ground should be rolled flat and smooth before sowing, to prevent the little drills cast up by the "tines" of the harrow, casting the seed off into the adjoining little furrows. In a fall of rain and while the ground is wet the seed should never be committed to the soil, for the feet of the horses will "poach" the ground, and the harrow will carry off the seed and deposit it in lumps upon the head ridges and foot ridges. Moreover, a clay soil harrowed in rain invariably forms a *crust* when it gets the sun, which is most detrimental to the brairding of flax. Very dry weather, on the other hand, while the soil is parched, is also to be avoided for sowing. In the finer mould the seed would germinate; in the coarser it would wait for the rain, and thus the dreaded evil of different lengths would present itself from the first. A condition of soil sufficiently dry for pulverisation, and sufficiently damp to produce vegetation in an oily seed, is the best conjuncture for sowing. If a genial shower should fall a couple of days or so after sowing it would generally prove

highly beneficial, as it insures a simultaneous "strike" of the seed.

Weeding.—Flax must be carefully tended from first to last. Neglect at any stage will ruin the crop. All kinds of weeds should be removed before the crop passes 6 inches in height. After that the stem becomes hard and retains the bend or "set" it may get from being trodden upon. Weeders should face the wind, and tread upon the plant with bare feet only; and thus treated it will soon rise again from the ground and show no sign that a foot has been set upon its neck. Of all weeds I know of none more injurious than "spurrey." With its merciless tendrils it clasps every stalk, and chokes them almost to death. Worse still, it bids defiance to all weeding.

Pulling and Rippling.—The time to pull flax is before it is absolutely and completely ripe. Some, however, act foolishly in taking it up whilst it is yet green—thinking that the sample of dressed flax is more silky and oily. By this they lose much more in quantity than they gain in quality. It is well to allow the under leaves of the stalk to be withered, two-thirds of the stalk to be yellowed and bare, and the capsules to be changed to a light brown before pulling. Then the crop will be most remunerative both in fibre and seed. Eight active hands will be sufficient to pull a Cunningham acre (equal to $1\frac{1}{3}$ imperial acre) in a day. They should place the handfuls slightly across each other, and separate in the sheaves, to make it the more easy to handle them at the rippling.

In several counties of the North of Ireland farmers ripple none of their flax. They affirm that the process injures the ends of the "strick," and renders the dressed flax dry and bristly. In other counties, however, they ripple all, save vast quantities of precious seed for crushing and feeding—and look upon their flax after all as but little impaired. The climate of Ulster being very damp and changeable, the farmers of that flax-growing province have never upon a large scale attempted to rear flax-seed for sowing purposes. For crushing and feeding only have they taken off the bolls. By rippling the flax at the time of pulling, the bolls can be conveniently had for these objects, and thus the crop, without being stacked, is ready for the dam or rettery at once.

Where seed for sowing is not the object, the following details as to the speediest and cheapest method of taking off the bolls or capsules may not be uninteresting:—The best rippling-comb is made of round iron $\frac{3}{4}$ of an inch in diameter. The teeth should be at least 16 inches long, blunt in the point, $\frac{1}{4}$ of an inch asunder, and set in a row 18 inches long. The following direc-

tions for placing or fixing the comb for use may be serviceable. Take a cart to the field when the flax is being pulled; take off the wheels, and lay the body flat upon the ground; let the comb be fixed to a strong piece of wood like a short plank, bind this plank hard and fast across the box, tying down each end to the arm of the axle that is lying on the ground; then one man can take up his place between the shafts, and another facing him behind, and they can pull their handfuls alternately through the same comb. Twice through is enough for any handful. The seed drops into the box, which can be emptied when full into sacks, and the balls carted into the open "shed" or "winning" loft. After being rippled the flax should be carted at once to the steeping-dam. If it be allowed to stand for any length of time, the wounded tops will blacken in the stook, and the fibre will be more or less injured. Whether rippled or not, it is a mistake to allow the pulled flax to remain for days in the stook. If it were possible it would be all the better to have the whole crop taken up on the same day, and in a few hours rippled and committed to the water. The bolls should be deposited in a dry, airy place, and frequently turned. When dry they can be broken and the seed separated from the husks, which with the refuse seed, make capital food for almost all the animals of the farmyard. If there be no convenient way of drying the bolls they can be taken at once to a common kiln, dried and ground in a mill, husks and seed together; and in that way though the seed is lost either for sowing or crushing, yet the very best kind of provender is secured.

In some parts of England the farmers dry or "win" their pulled flax for some days in the field, in the same manner almost as a white crop, and then put it for a time into narrow stacks, that the seed before being taken off may ripen and mature upon the stalks or straw. Where the quality of the seed is a matter of great importance (as it always is in seed for sowing), this mode of managing the flax when pulled is to be highly commended. It is the only method in which first-class seed can be secured; and although it is the opinion of some that the quality of the fibre is much impaired by allowing the seed to ripen thus upon the straw, yet it will be found, after sufficient experience, that this is a mistake.

Many again consider that the farmer should go no farther than the pulling of the flax; that at that stage his skill generally ends, and that then the factor, spinner, or manufacturer, should step in, purchase the flax when pulled, if not on the foot, and carry through the remainder of its management by his skilled labour. This is an admirable *theory*, and if it could be got to work satisfactorily, would no doubt be advantageous to all parties. But in Ireland it

has been tried and has utterly failed, the merchants who made the attempt having been obliged to give it up. Two crops, as similar as possible on the foot, may be very dissimilar in their yield. Say one is grown upon a very old pasture, or upon ground that never produced flax previously; the other upon strong well-tilled land, that carried a similar crop some four or five years before. To the eye both seem much alike. The best judge perhaps could not tell which is the better crop, and the proprietor of the one might expect as high a price from the manufacturer as the owner of the other. Yet in reality the crop grown on the ground that till a year ago had been an old pasture, is likely to turn out to be twice as valuable as the other. This one stumbling-block was fatal to the whole scheme.

Moreover the expense of carting flax-straw to dams or rettories at a great distance, and the difficulty of getting sufficient spreading ground or drying apparatus for great quantities of steeped flax in any one spot, are additional impediments that stand in the way of the application of the theory.

Steeping.—Pits for steeping should always have a clay bottom; all spa-water should be avoided, also water that comes off any kind of mineral ore. Bog-water, if it comes from a clay bottom and has no taint from decaying timber (which might discolour the flax) is unobjectionable. This water makes the fibre what is called *blae* in the north of Ireland, a colour that is highly prized by the buyers and spinners. It is all the better if the dam be filled with water several weeks before the flax is put in. The action of the atmosphere softens the water, and the heat of the sun warms it. This mellowed and almost tepid water acts rapidly upon the woody stalk, and renders the fibre silky and oily. Cold spring-water will take double the time, and after all will fail to do the work anything like as well. No definite time can be specified for watering. Much depends on the heat of the weather, and much on the quality of the water. From 9 to 14 days is the average length of time. To take it out of the water just at the nick of time is the nicest and most important piece of management connected with the whole crop. The following is a good test: lift a "beet" out of the middle of the dam, open it, take up 5 or 6 stalks with both hands; bend them as if to break them across; if they break freely, break them in *two* places about 6 inches apart, and try to pull out the wood from the centre of the fibre; if the wood comes away easily and clean, the flax is watered; if it still clings to the fibre with some degree of tenacity, it will require to remain some time longer. Dams should neither be too deep nor too broad. They are deep enough if they receive one row of "beets" inserted on their butt-end at an angle of 45 degrees, and hold a sufficiency of water to cover

the flax well, when it is weighted down with tough sods or smooth stones; and they are inconveniently broad if a man cannot throw out the watered flax from the centre to either side. Too much of the water should not be run off the dam before casting the flax out, for if it has been covered with sods, the earthy and sandy particles must be carefully washed off every beet before it leaves the water. If these be left, they would adhere to the fibre, and perhaps eventually eat it through. The watered flax, moreover, cannot be too tenderly handled; lifting it rudely, pulling it over hard substances, standing upon it, tossing it about with forks and "grapes," are all excessively injurious, and must by all means be strictly avoided.

Some years ago, in many parts of Ulster, flax was steeped in tepid water. The process was highly spoken of at the time; but, somehow or other, it has latterly been discontinued. In our flax-growing province at present retteries are all but unknown. This is no proof, however, that tepid water is not the best for steeping flax. The expense of getting up retteries has largely militated against their use. The wonderfully successful application of hot water of medium and equable temperature, both in Belgium and England, is presumptive evidence that Ireland, though she may stand well on the score of growing flax, is nevertheless behind the age in her cold-water mode of "steeping." One of the most important agricultural problems of the day, in the solution of which the farmers of both England and Ireland are concerned, is, How can the farmers of these countries continue to steep their own flax, and yet do so at moderate expense in tepid water, according to the method adopted by the most approved retteries of Belgium?

Spreading.—When the flax is thrown out of the water it should not be allowed to remain any length of time in the heap. One day in the heap is more trying to it than two in the water. As many hands should be got together as will spread the whole lot the day it leaves the water. The carters should lift it gently, and lay it down in single beets behind the spreaders at easy distances. A careful person should loose the beets and lay them close up to the spreaders' hands. The layer of flax on the grass should not be thick, and should be well shaken asunder with a very gentle hand. The butts and tops should be kept level, and none of it should be broken or left lying across the rest. The field on which it is spread should be a soft close pasture if possible, but if that is not to be had, any other field that is clean and level in its surface will suit the purpose. Should the flax have been taken out of the water somewhat *hard*, a short time longer on the grass will be a compensation; but if it has got too

much of the water, it must only remain on the grass till it is fully dry.

Lifting and drying.—Let a dry, sunny, and, if possible, a breezy day be selected for taking up the flax off the grass. If it be taken up damp, it will occasion a world of trouble afterwards. If perfectly dry, it may be bound in beets at once, and in the evening put into a long “rack.” The “rack” is constructed by setting a long range of beets up perpendicularly on their butt ends, making the range about 5 or 6 beets broad, and on the top of these building other beets slanting down on either side like the roof of a house. If a little damp, the flax may be set up for some hours in “gaits,” *i.e.*, loose sheaves spread out very wide at the base, and held together by a band at the very top. Afterwards it can be properly tied up and put into the “rack.” In this form it might stand safely for weeks, if carefully watched and kept up. Moreover it is important to get it thoroughly crisp and dry, for otherwise the fibre will be largely cut down and carried away in the mill. No artificial drying process, on *kilns* or otherwise, has ever answered the purpose; and therefore these are never resorted to now by experienced persons. The fibre has been frequently injured thereby to the extent of one-fourth of its value. If the mill is not ready to take up the parcel when it is perfectly dry, it is better to shift it from the “rack” and put it into a round stack, thatching and roping it carefully. It can stand then safely for any length of time, and in all weathers; and the stacking is a process that is generally supposed to improve the quality of the fibre.

Dressing or milling.—This last process, with which the farmer is concerned, is carried out sometimes by the hand and sometimes by machinery. Hand-scutching is supposed to get more weight out of the same quantity of raw material; but flax thus dressed never commands so high a price as that cleaned by machinery. Among mills the farmer should select one driven by light water. Such machinery is easy upon the fibre, and carries away little but the “shoves.” On the other hand, where there is a large number of scutchers, and where heavy water is required to give sufficient impetus to a vast array of “scutching-handles,” much of the good flax is “hagged” down and cast off among the tow, especially if the beets have any dampness about them. The system of cleaning flax by what is called “half-labour,” is sometimes not very profitable to the farmer. The proprietor of the mill gets the one-half of the price of scutching for the use of machinery, and the scutchers get the other half for their labour. This drives the working-men sometimes to pass over the flax without cleaning it out thoroughly, that by the greater

weight they may earn the more wages. Competition, however, rectifies this abuse; for the mill-proprietor knows full well that if he fail in discharging his duty faithfully, honestly, and satisfactorily to the public, the public will soon hand over its custom to others.

It has long been the opinion of machinists and scientific men that our common old-fashioned scutch-mills might be improved, and ought to be improved. Several patents have been taken out within the last few years for flax-cleaning machines on a new principle. The North of Ireland has not been behind in these laudable efforts; none of the new patents, however, has yet had complete success. What their ingenious and enterprising inventors (who deserve to succeed) may bring them to in the end it is hard to say; but up to the present time the old simple "scutching handles" seem to be in the highest favour both with millers and farmers, and even with the merchants themselves.

Owing to the extra growth of flax in Ireland during the last two or three years, many new mills were erected. These had in some instances to be "manned" with inexperienced hands. Hence the outcry that has been raised among the merchants in some districts about ill-cleaned flax; and hence the losses that farmers have met with in many cases from poor prices and from inferior yield.

The yield of flax to the acre is very variable, according to circumstances. The Riga barrel of seed (the safest for all but *very strong* land), which is sufficient to sow an Irish acre,* will commonly give a return of from 5 cwt. to 10 cwt. on ground well cleaned and cultivated. Such weight at 70s. or 80s. per cwt., the present range of prices for good scutched flax, pays well, and forms a sufficiently strong inducement not only to the farmers of the south and west of Ireland, but also to the farmers of England and Scotland, to review their systems and rotations, and consider whether (like the men of Ulster) they could not, with profit to themselves and to the community, introduce a crop in its order, that is easy upon the soil, thoroughly adapted to our variable climate, and is more remunerative by 100 per cent. than any other crop that the Irish farmer can raise.

Fairy Fort, Limavady, Derry.

* 3 Irish = 5 English acres nearly.

XVI.—*Flax-Cultivation in the County of Suffolk.* By H. WELLS.

THERE is no doubt that, with few exceptions, the heavy clay-lands of Suffolk, when clean and in good condition, are capable of growing crops of flax of a very good and strong fibre, such as are remunerative but not exhausting to the land; but the bad farmer, whose farm is not well up to the mark, will do himself no good by the attempt, since the preparation of the land is of as much importance as its character.

Soil.—The soil best adapted for flax is of a loamy nature, of good staple, and rather adhesive than otherwise, but not too strong; lands calculated to produce a redundancy of straw in white-straw crops, such as newly broken pastures after they are well cultivated and in good tilth, are particularly well suited for its growth, as you need not be afraid of getting the flax-crop too stout; it is, therefore, the most certain crop on all lands of this description, particularly in wet seasons, which frequently prove most injurious to cereal crops. Nearly all soils, however, that will produce good beans and good wheat, will unquestionably grow good flax if properly prepared for it; light and sandy lands, or any soil not calculated to yield a good crop of straw, must be avoided.

Course of Cropping.—Our experience has taught us that, taking an average of seasons, flax can be grown to a greater profit after clover-land wheat, which had been well manured for the wheat-crop, than in any other course. The land then has the chance of being well cultivated as soon as the wheat-crop is harvested, or at the first convenient moment, and since the flax-crop rarely remains on the land more than four months, every chance is afforded for a second cultivation at the season best suited for cleansing and enriching the soil. It is an indisputable fact that flax is the best possible preparation for barley, which will thus yield not only a larger quantity, but a superior quality also; whilst by this arrangement the farm is not deprived of a crop of straw. Flax grown in this course pays the farmer so well, that he can afford to lay out a fair share of the returns in the purchase of artificial food for feeding cattle, or use the flax-seed to such an extent as to keep the land in first-rate condition. Good flax can also be grown after barley or oats in lieu of a bean-crop, and it is a good preparation for wheat, since the flax generally leaves the land in good tilth; care must then be taken not to sow so much seed-wheat per acre as you would usually do. No one should attempt to grow an over-large breadth of flax, neither should it be grown on the same land more than once in eight years; if it be grown on the fallow-shift, as a general rule

one-fourth of that shift would be as much as could profitably be spared from farms that *are properly stocked*.

Preparation of the Soil.—If flax is grown instead of beans or peas, the land may be treated in like manner as for those crops; that is to say, if your barley-stubble be as clean as land ought to be which has borne but one crop after a fallow. But if more be required, run some sort of a broadshare or skim-plough through the land about two inches deep, in September; harrow it well and burn the stubble on small heaps, as the ashes are very beneficial to the growth of flax, then take the first chance of getting on the manure in September, or early in October, when it will go on well; good crops of flax can, however, be grown after barley without any skim-ploughing or breaking the stubble, if the land is clean. Simply plough in the manure as early as November, at a depth of four to five inches, this will be quite sufficient for any barley-stubble which had been properly tilled in the previous year.

When flax is grown *after wheat* in lieu of a root-crop, or long-fallow, if the wheat-stubble *is clean*, plough it up as early as possible in September, not less than seven inches deep, and in October or early in November, plough it back at the *same depth*; no more tillage will be required till the time of sowing, and then the use of the harrows will probably be sufficient. But if the *wheat-stubbles* require cleaning, and the weather is fine, a Biddell scarifier or a like implement may be used; then when the field has been well harrowed and clod-burnt to a moderate extent only, plough in the ashes at once about *three* inches deep, and in the month of October or not later than November, give a second ploughing about five inches deep; the ashes will then be in a proper position when the seed is sown. In no case should the last ploughing be given later than December, as a fine surface, resulting from winter-moulds, is most beneficial to this crop, or indeed indispensable in dry seasons, as you have no fear about securing a plant on lands in this condition. In any case, whether the following season be wet or dry, you are by this plan better prepared than by any other. It is not essential to have a great depth of mould at the time of sowing, a fine surface with sufficient moisture being much preferable to lands worked about late in the spring, and exposed to sharp drying days in February and March.

Seed.—The best Riga barrel-seed, once grown in England, will provide the best seed for sowing and general purposes, and its use may be continued as far as the third or even the fourth year. Eight pecks per acre is sufficient if drilled in rows; or nine pecks if sown broadcast; during the last two seasons the small turnip-flies have done so much harm to the plants when

young, that to guard against their ravages it is found best in all cases where practicable to drill it in rows six inches apart on the flat, using every endeavour to get the land perfectly level before drilling, in order that the seed may all be deposited at the same depth, and may germinate all at the same time, so as to prevent the two growths which may frequently be seen. It has been found much easier and cheaper to keep the flax-crop clean when in rows than by the broadcast system. The time of planting ranges from the third week in March till the end of the first week in April.

Harvesting.—The best time to commence pulling is when the stems begin to present a golden colour halfway up, and the small leaves brush off; the seed is then beginning to turn brown. The cost of pulling varies from 8s. to 10s. per acre; if the sheaves are tied up in a uniform size, and the weather fine, they do not require many days' groundage before they are fit to be put on narrow stacks; a long groundage and exposure to wet after pulling is very injurious to both grower and consumer. The farmer suffers by the loss of weight, the manufacturer by that of strength and colour.

Rippling.—In Ireland a process is adopted called rippling, which detaches the seed-bolls from the stalk in a half-green state, thus rendering the grain in many cases unfit to be used as seed or even stored. In Suffolk we find it best to stack the crop for a time before taking the seed off; it has then a value of from 6*l.* to 7*l.* per acre—no inconsiderable addition to the return made by the flax-crop. The chief part of our seed goes to Ireland for sowing, and the buyers there at all times request us not to send them seed thrashed immediately after the harvest. I believe it is the general opinion in Ireland that if the seed is allowed to ripen in the straw it will greatly injure the quality of the fibre. In this county experience has shown us that such is not the case, a conclusion which is fully borne out by the 'Belfast Linen Circular,' which reports that the price of Irish flax ranges from 32s. to 80s. per cwt., while the present value of English flax is from 58s. to 80s. per cwt., none being worth less than 58s. per cwt., and that is what is called drawings, or rather the loose refuse-flax.

Steeping.—The Irish plan of steeping flax in cold water has been found after a thorough trial to be quite unsuited to this country; it was in some instances a signal failure where farmers have undertaken to steep their own straw—a dry and hard fibre was produced, with very little spinning quality. If the same straw had been steeped in tepid water of *even temperature*, according to the practice of the largest retteries in the county of Suffolk, there is no doubt that the quality would have been such as to bear an improved value of from 10*l.* to 15*l.* per ton. The

prejudice which once existed against steeping in tepid water is now quite removed, as the *money value* obtained plainly shows its advantages. A considerable outlay is indeed required for providing the plant, &c., in the first instance, but our manufacturers have been quickly reimbursed from the superior quality of the flax which by this process they are enabled to produce.

XVII.—*Remarks on the General Aspects of Flax-Culture in England and Ireland.* By P. H. FRERE.

VARIOUS circumstances have contributed of late to recall our attention to the culture and management of flax, a subject which in 1851 excited an interest that the rising prices of corn subsequently diminished. At that time the late Sir James Graham, Mr. (now Sir Edward) Kerrison, Messrs. Marshall, and others, actively promoted the growth of this crop, which was brought under the notice of our Society by Mr. Druce, who has steadily continued its culture on a moderate scale up to the present time. The establishment of associations was then discussed in many neighbourhoods, but the then existing law of partnership opposed serious obstacles to such enterprises.

The prices of corn have now fallen back to their former low level, flax is more in demand, and fetches higher prices than ever; and if the root or bean crop which it would displace be now of increased importance, from the advanced prices of meat, we have more land in a high condition, and consequently able to bear a flax-crop without injury, even though, as seems desirable, it receive no direct application of manure for the crop.

If the English farmer turns his thoughts in the direction of flax-growing, the preceding papers will readily give him the general information which he may require as to soil, climate, and cultivation, &c., but they will disclose some discrepancies between English and Irish practice, which may depend chiefly on physical, but partly on social distinctions.

If he be a man of energy and skill, he may possibly, acting alone, grow, rett, and scutch his own flax on the Irish plan, and reap a manufacturer's profit from his venture if he be happy enough to turn out first-rate fibre; and he may convey his produce—some 5 or 6 cwt. per acre—to a distant market at no very great cost. But he will have to call in the aid of skilled labour, which will be costly; his risk will be great; he will socially, if not legally, become a nuisance by tainting the air and the streams around, and his attention will be unduly turned away from his general duties on his farm.

Apart from this, following Mr. Druce as a guide, he may grow a few acres yearly, though he has to send his straw some 30 miles to a rettery; and, under such circumstances, he will naturally pay particular regard to the seed. According to Mr. Druce, he may then hope to realise these returns:—

	£	s.	d.
For seed, say 20 bushels, at 9s.	9	0	0
„ 2 bushels inferior, at 6s.	0	12	0
Straw, 1½ ton, at 3 <i>l.</i> 10s.	5	5	0
	<hr/>		
	14	17	0

But if this isolated course of proceeding be not inviting, the alternative must be joint action of one of two kinds: either owners and occupiers of the soil must act in concert with manufacturers and capitalists, or those interested in the land may associate themselves together to undertake the whole venture.

Any manufacturer and capitalist acting by himself would find some difficulties in his path. 1st. Because he will want some guarantee that flax will continuously be grown to his hand. 2ndly. He will require a large supply of water, some of which must be soft water. 3rdly. He will wish for a considerable extent of drying meadows, even if he adopt modern processes. Lastly, he will have to purify his refuse-water before it is returned to our rivers, an obligation which the public will not pass lightly over at the present moment.

On these grounds it is almost indispensable that the manufacturer should secure the co-operation of a large landowner, who may provide the site (and buildings), have the control of a supply of water, and provide an outlet for it upon the land, when tainted; furnish the meadows required, and so regulate the tenure of the adjacent farms, that the occupiers may be in a position to supply the works with flax.

So far as my inquiries have at present extended, I believe that the best specimen of concerted action of this kind will be found at Eye, in Suffolk, on the estate of our President, Sir E. C. Kerrison, who, as we have seen, was among the first promoters of the flax-movement in 1851.

At that time an association was formed around Eye, in which the late Sir Edward Kerrison, as well as his son, took a leading part, with the special object of giving employment to a redundant population. The clergy, the leading townsmen, and the farmers around joined in the work, the necessary buildings were erected, and a gradually extending supply of flax was secured. By degrees the management came into the hands of the Messrs. Chase, two of the original associates, who now buy the flax of the growers, and manage the entire industrial enterprise. About a year ago

their old works were burnt down, and the difficulties which thereon arose were only surmounted by the offer of Sir E. Kerrison to erect new works at his own cost on a more eligible site, which he provided at the distance of half a mile from the town. These new works, which I have lately visited, are approaching their completion, the buildings being finished, and the machinery at work in the scutching department, though some of the arrangements connected with the retting have still to be organised.

I have little doubt, though I cannot speak with authority, that the fire, though disastrous in itself, will have served to provide us with a good model for imitation in these works, in which the lessons derived from past experience will be embodied; and, although a detailed account may well await their completion, still a slight survey of their general aspect may be of immediate use to those who possibly are looking around, and considering whether they can adopt a similar course.

These first-class works can turn out 10 tons of fine flax-fibre per week, or 500 in the course of the year, and would consequently require a supply of about 3000 tons of flax-straw, the produce of, say, 2000 acres of land.

They require a constant daily water-supply of 3000 barrels of 36 gallons each, a small portion of which should be soft water.

It will be desirable that 40 or 50 acres of meadow-land should be available for drying the flax.

It is also important that some sandy land at a lower level should be at hand, to receive and purify the refuse-water before it is returned to adjacent streams. The cost of the requisite buildings and vats will amount to about 2500*l.* The machinery and plant will probably cost about 2000*l.*

The following is the course pursued by the Messrs. Chase:— After the flax has been pulled and stacked by the farmer, and continued in the stack until it is thoroughly dry, they purchase both seed and straw, and furnish a machine and attendants to strip off the seed at the farm for the charge of 8*s.* per acre. The average crop is said to be 1½ ton of straw, worth 4*l.* 10*s.* per ton, and 4½ stacks of seed, worth 33*s.* per sack. The average return to the farmer is therefore about 14*l.* per acre.

The flax-straw on its arrival at the works is weighed on a weigh-bridge, and then stacked, to await its turn in the vats. The latter will not be in use during the winter months, and should therefore have sufficient power to furnish in six months a year's supply for the scutching department.

Warm water, derived from the condensed steam, being used in the vats, the process of steeping is complete in four days, instead of occupying two or three weeks. The straw when steeped passes

through a system of heavy rollers, while a current of fresh water is playing upon it, by which means the glutinous matter is separated from the fibre. This operation creates the chief demand for water, which need not be soft. In ten minutes the rollers have done their work, and the straw is laid on grass simply to dry; as soon as this is effected it is stored in a dry chamber. From thence it is taken as required, and passed under heavy ribbed rollers, to break the woody fibre. It is then slightly cleansed, and tied up in convenient handfuls by girls, called "strikers," as preparatory to passing into the scutcher's hands. Seventy girls in the strikers' room prepare the supply for 56 scutching-mills.

The arrangement of the "scutching-room" (188 feet long, by 31 feet broad) deserves more particular description.

A long shaft, actuated by the steam-engine, runs the whole length of the room, and sets in motion the mills, which revolve, like windmills, at right angles to the shaft, the end of their arms being furnished with wooden beaters, which in form resemble the blade of a razor.

An iron partition runs lengthways down the room, so placed that the ends of the beaters as they revolve pass through vertical openings left in this partition. On the one side of the partition we have the axis and chief part of each of the mill-wheels, and on the floor the shives, or shoves, which are carried away by the beaters. On the other side, in a series of three-sided iron boxes, stand the scutchers, with a long wooden table and a passage beyond them. The beaters belonging to each compartment are further boxed off by a low false partition, almost in contact with them, having a horizontal slit at a convenient height. Through this slit the scutcher inserts his handful of flax, and by dexterous manipulation often repeated, secures the removal of every particle of the woody covering from the flax fibre. The men generally work in pairs, the less experienced hand giving a preparatory dressing, the other finishing the work.

An accurate record is kept every week of the work which each hand turns out, and of the amount of material which he consumes to produce a given quantity of fine fibre.

A certain standard is assumed, say, that from the flax already shrunk by retting, drying, and breaking, one-fifth of fine fibre should be produced; shortcomings or improvements on this standard are then recorded.

A good hand will turn out 40 stone per week, inferior hands about 30, novices less than that. When both quantity and quality of workmanship are taken into account it is evident that wages must assume a wide range, and the skilful and careful workman meet with much encouragement.

Recent improvements have added materially to the value of the refuse derived from this first operation.

It is now taken to the "carding-room," and passed round a large carding-drum begirt with lesser carding-wheels working one into the other. These teasers, bristling with short metal pegs, which interlace as they revolve, sever most of the remaining fibre from the wood, so that by the aid of two such sets of wheels a second-class fibre is produced, worth 20*l.* per ton.

The refuse from this second operation undergoes yet a third process, which produces a material which paper-makers purchase at 6*l.* per ton.

The residue is simply shives, or shoves, but these have virtue enough in them to furnish all the fuel required by the boiler of an engine capable of working up to 90 horse-power; they constitute about two-third of the flax-straw as originally delivered.

We thus see that in Suffolk there is a well-established system of flax management, under which the farmer is content to harvest his flax and sell it in the straw in the autumn. Yet Mr. Brown, according to Irish experience, characterises such a system as impracticable.

The climate of Ireland probably offers an impediment to such a course, to which Mr. Brown has not adverted. In our drier districts, the straw stands in the stack for two or three months, and dries and improves the while; in a more rainy and damp country it is desirable to get it into steep as quickly as possible, for it might blacken if stacked. Here, then, we see a physical ground of difference which will not be easily surmounted.

But Mr. Brown rests his case chiefly on the extreme difficulty of rightly estimating the value of the produce in its raw state, and consequently of maintaining a good understanding between the buyer and the seller, if the produce is marketed in such a form. This objection cannot be disposed of at once, and suggests several points for investigation, and much matter for reflection.

In the first place, might not the farmer, without meddling with the bulk of his crop, rett a sample, and sell according to that sample, regulating his own demands and guiding the merchant's judgment by its apparent quality? for otherwise he is as much or even more in the dark, than when he buys or sells a crop of corn standing.

Next let us consider in the rough how the position of the Suffolk farmer, who, on an average, sells his ton and a half of flax-straw, the produce of an acre, to the works for 6*l.* 15*s.*, differs from that of a successful Irish grower who carries his produce through the first stage of manufacture. Assuming that the latter

also gets $1\frac{1}{2}$ ton of straw per acre, it would seem that he may make from it, say, $4\frac{1}{2}$ cwt. of fine fibre, which at 70s. per cwt., would bring him 15l. 15s. Now, if his extra expenses are roughly set at 1l. per cwt., he will realise 11l. 5s. by his fibre, apart from the value of the tow and shoves, that is to say, he would apparently make a very good trade profit by the trading risk which he incurs.

The above statement has no pretensions to accuracy, its aim being simply to avoid an over-statement of the produce, or an under-estimate of the cost of labour required.

According to a recent Irish account, published in the 'Gardener's Chronicle' of Dec. 31, 1864, the dressing of flax costs 1s. per stone, or 8s. per cwt. This charge probably does not include steeping, which may nearly double the expense, and still leave a good margin for our estimate of 1l. per cwt.

Again, in the instance quoted, the fine fibre, yielding 6 cwt. per English acre, was sold at 80s. per cwt. I have only assumed a yield of $4\frac{1}{2}$ cwt. of fine fibre, and a price of 70s. per cwt., and have left out of account the inferior flax and tow, the value of which, in that case, was fully one-fourth of that of the fine flax; yet we still get the difference between 11l. 5s. and 6l. 15s. as extra profit for the more adventurous farmer.

These expenses moreover, are here calculated on a basis adapted to hand-labour, whilst the introduction of machinery uniformly cheapens the process, if it somewhat impairs the value of the produce. The Suffolk flax-fibre seems to make as good a price in the market as the best Irish produce, and it is therefore a question whether the machinery there employed is wasteful, or the straw, as there grown, less yielding. In the flax-crop, as it would seem, the difference in the value of the raw material is far greater and far less evident than in any other produce with which the farmer has hitherto dealt; and this difference is connected with various and diverse causes,—the soil itself, its management, climate, the rotation adopted, the maturity given to the seed, &c. &c. So that while Mr. Druce, an able and experienced farmer, gets only 3l. 10s. or 3l. 15s. per ton for his straw, and the Suffolk farmers average 4l. 10s., the best agriculturists in Flanders make 7l. 10s. and 8l. of their crop of straw, and grow from 2 to $2\frac{1}{2}$ tons per acre; securing, it must be admitted, only half as much seed as is harvested in England, but that of a first-rate quality.*

Mr. Arthur Marshall, of Leeds, informs me that in Yorkshire 5 cwt. per acre is reckoned above an average yield, and 40s.

* These details are derived from the elaborate reports on the Prize Farm in the French Department "Le Nord," published in the 'Journal d'Agriculture Pratique.'

per cwt. a good price, present prices being exceptional in consequence of the dearth of cotton. He further states that the practice of buying crops in the straw is regularly established in Yorkshire, and answers very well. "No doubt," he writes, "the purchaser runs some risk from the flax not turning out as well as he expects, but such variations are more due to different seasons than to different growths."*

If the English farmer turns to growing flax, it may take him some time to get a thorough insight into the bearings of this new branch of his business: 1st, to ascertain the actual value of his straw, and, so long as he is eclipsed by Flemish competitors, to make out why it is inferior; and 2ndly, to get for it, with all its variations, and uncertainties, a fair market-price. Such considerations naturally indicate the importance of a healthy competition in the market for raw flax, a point which it may not be so easy to secure in this as in other branches of trade.

If English farmers should find that the Irish system of selling the fine flax rather than the straw is more remunerative in the long-run, but that individual action has many drawbacks, they may be tempted to form associations among themselves for carrying on the flax through its first stage of manufacture; and the success of two modern enterprises in their hands, viz., the Blood-manure Company and the Islington Hall Company, would give some encouragement to such a scheme. A flax-retting Company would, however, in one important respect stand in a different relation to agricultural shareholders from that occupied by a Manure Company; for it would have to *buy* raw produce of them, not *sell* to them the manufactured article. Now, whilst sales to shareholders are beneficial, and have a tendency to keep up the quality of the goods sold, purchases from them present a more doubtful aspect, and speaking with a recollection of the surprise I have felt at the prices made by the barley grown on the home-farm of a large brewer, I confess I should not envy the Manager who had to buy an inferior crop from an influential Director.

Apart from such warnings as these, it is but natural that English farmers, with modern facilities, and the modern spirit of enterprise, should form associations to secure to themselves the full value of their flax, in the fibre, if not in the straw, and at the same time to fathom and prove their shortcomings as growers,

* Mr. Marshall adds that they use a sort of clover-drill which distributes the seed very evenly; for broad-cast sowing does not answer except the sower is accustomed to sowing *linseed*.

by the light of Flemish experience, with a view to their gradual removal.

Under any circumstances, it is highly satisfactory to find that mutual confidence can subsist in England between the buyers and sellers of flax-straw, under which prices are realised by the grower, which, if they do not realise our highest aspirations, are at present undoubtedly remunerative.

XVIII.—*A Description of the Newcastle Dynamometer.*

By C. E. AMOS.

THE annexed engraving represents a photographic view of the Newcastle Dynamometer, used for testing the force required to work the steam-plough exhibited at the Newcastle Meeting of this Society.

On page 409, Part II., Vol. xxv., the necessity for an instrument of the kind is shown, and the following description is there given. "The instrument consists of a strong wooden frame mounted upon carriage-wheels, having on its centre a strong vertical cast-iron socket. A cast-iron screw column, fitted with a fly-nut, drops into this socket, and moves freely in it, and the column can be raised or lowered by the fly-nut. To the top of the column is fitted a long arm of wood, by a joint at the centre, so that either end can be raised or depressed. The arm thus possesses a movement both horizontal and vertical, like that of a transit instrument. At each extremity of the arm a pulley is placed, which turns freely on vertical pins, the centres of these pulleys being 18 feet apart. At the centre of the arm is a central pulley with a vertical spindle, carried by two strong springs. These springs are so placed that they deflect the central pulley 12 inches out of a straight line between the other two. The rope passes over the end pulleys and under the central one, so that the deflexion of the unloaded rope is 12 inches. The instrument being fixed in a position between the engine and the cultivator, the tractive force on the rope is shown by the deflexion of the middle pulley becoming less. The greater the tractive force the less the deflexion of the rope."

I will endeavour to explain the construction and principle of action of this machine somewhat in detail by the aid of the following diagrams :—

In diagram Fig. 2, A and B represent two pulleys placed 18 feet apart. M is also a pulley placed between them, the distance M f being 12 inches. P is a standard carrying a strong spring, S, the extreme end of which carries the pulley M.

The

Fig. 1.

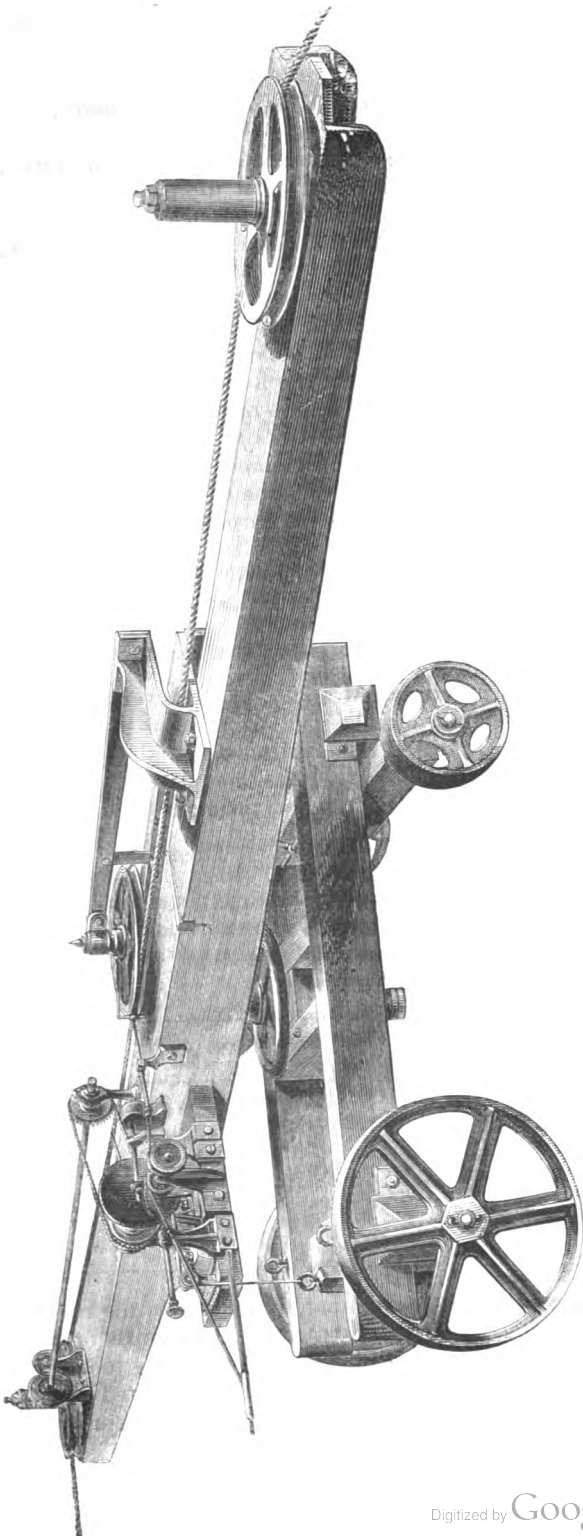

The spring S in the position shown exerts no force, but is capable of being urged forward until the pulley M would arrive at *e*; and if in the latter position it exerted a force, say of 100 lbs., at *a* its force would be 20 lbs., at *b* 40 lbs., at *c* 60 lbs., and at *d* 80 lbs.

We will suppose that a wire-rope attached to a steam-engine passes partly round the pulleys A, M, and B, dragging a plough or other implement attached to the end of the rope beyond B. It will be at once perceived that the force of the engine and the resistance of the implement, acting in opposite directions, will cause the spring S to be deflected towards *f*, and when the force of the engine, the resistance of the implement, and the resistance of the spring S are in equilibrium, then the slightest further addition to the force employed will cause the implement to move, the spring to yield, and the pulley M to move in the direction M *f*. For any assigned position of the pulley M, the amount of the forces of traction and resistance may be ascertained by the formula $\frac{\sqrt{m^2 + n^2}}{2n} \times t = F$. Where *m* = the distance A *f* (Fig. 2), *n* = the distance between M and *f*, at whatever point M may be found; *t* = the resistance of the spring S at that point; and F = the forces of traction and resistance equal the strain on the wire-rope. For example, if M assumes the position *c* (Fig. 2), in which case the resistance of the spring is 60 lbs., then M *f* = 6 inches, and A *f* = 108 inches. Then $\frac{\sqrt{108^2 + 6^2}}{2 \times 6} \times 60 = 540.8$ lbs. = F = the strain on the rope; and similarly for other positions of M. The following Table exhibits the different magnitudes of the strain or tension of the rope corresponding to the various positions *a*, *b*, *c*, *d*, *e*.

Position.	Resistance in lbs.	Strain on Rope in lbs.
<i>a</i>	20	108.4
<i>b</i>	40	270.7
<i>c</i>	60	540.8
<i>d</i>	80	1080.7
<i>e</i>	100	2700.5

It is important to observe that the strain of the rope does not vary proportionally to the distance of M from its original position, or, what is the same thing, proportionally to the resistance of the spring. If a scale of numbers were inserted instead of the letters *a*, *b*, *c*, *d*, *e*, *f*, and an index placed on the spring at M, the strain

Fig. 2.

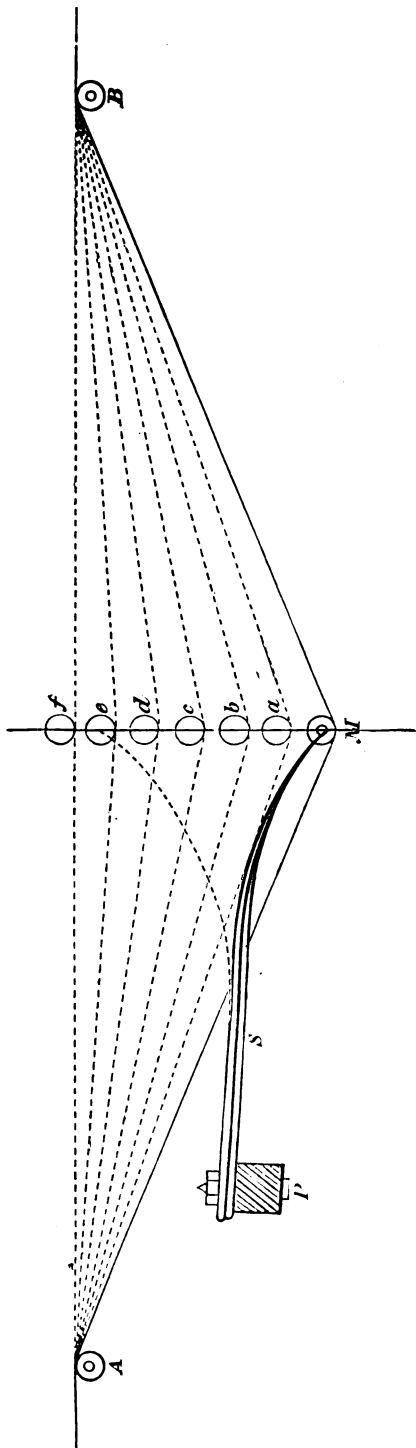

strain on the rope might be read off at any time. In passing, it may be mentioned that no force on the rope would ever raise the pulley M to f , or place the three pulleys A, M, and B in a straight line. Such are the leading principles in the dynamometer shown in the engraving.

In experimenting upon the force required to work field-implements, it is found that from numerous causes the resistance is ever-varying, and the observer has much difficulty in determining the average or mean force employed, because an index placed as at the pulley M continually shifts with the resistance. To overcome this difficulty, contrivances have been resorted to, most of which have obtained the results in too complicated a manner for general use in our experiments.

To our French neighbours we are indebted for an invention called the "Totalisateur," a machine which enables us to obtain, in a simple manner, answers and results which before its introduction involved tedious and lengthy calculations.

The principle of the invention may be thus briefly explained. The machine may be said to consist of two parts; the first has a progressive motion imparted to it corresponding in some exact ratio with the progression of the implement on trial, and it is provided with a counter which affords the means of recording the exact distance which the implement has travelled; and so far is simply a "perambulator" for measuring distances. One of the principal features in this part is a "disc-plate," having a plane surface, and to that "disc-plate" the motion before spoken of is given.

The second part consists of arrangements for determining the resistance caused by the implement, and this is effected by a small "*disc-wheel*" carried on centres, as will be hereafter explained (Fig. 4). The edge of it is placed lightly in contact with the plane face of the "disc-plate" before-mentioned, and thus by means of rolling friction, the revolution of the plate will cause the "*disc-wheel*" to turn, except when the edge of the "*disc-wheel*" is in the centre of the "disc-plate." The adjustment is such that the "*disc-wheel*" occupies this latter position when there is no resistance from the implement; but as resistance takes place, the "*disc-wheel*" is moved from the centre towards the periphery of the "disc-plate," to a distance which increases with that resistance; as the resistance decreases, the wheel returns again towards the centre, and whatever position the "*disc-wheel*" may be in when removed from the centre, a circular motion will be imparted to it by the "disc-plate," with a velocity depending upon its then distance from the centre of that plate: hence it will be seen that the velocity of the "*disc-wheel*" will correspond with the amount of resistance of the implement.

The operation of the whole will perhaps be more clearly explained by a numerical example. Suppose the disc-plate to make one revolution while the implement travels over 100 feet, and that the resistance of the implement, when equal to 100 lbs., causes the "disc-wheel" to be drawn from the centre towards the periphery of the disc-plate a distance equal to its own radius, then it will revolve in the same time as the "disc-plate;" and in that case $100 \text{ lbs.} \times 100 \text{ feet} = 10,000$ units of power (10,000 lbs. raised 1 foot high), will represent the force expended in moving the implement 100 feet.*

Again, if the resistance of the implement be 200 lbs. the disc-wheel will be drawn from the centre of the disc-plate a distance equal twice the radius of that wheel, and it will make two revolutions while the disc-plate makes one revolution, that is to say, while the implement moves through 100 feet. The power expended is now $2 \times 100 \times 100 = 20,000$ units, or 20,000 lbs. raised 1 foot high; hence each revolution of the "disc-wheel" represents 10,000 units of power expended or work done, and it will be so, *whether the resistance be constant or variable*. The instrument is provided with dials and indices, whereby the number of revolutions made by the "disc-wheel" in any given time is shown, and the power expended during that time can be ascertained.

For example, we will suppose that an experiment occupying ten minutes has been made with a field-implement, and at its close the number of revolutions made by the disc-wheel is shown by the dial-plates of its counter to be 530.5.

Then let 530.5 = the revolutions of disc-wheel during the experiment.

10,000 = units of power represented by one revolution of the "disc-wheel."

10 = the minutes occupied in the experiment.

and 33,000 = units of power, which are equal to 1 horse-power.

Then the result will be, $\frac{530.5 \times 10,000}{33,000 \times 10} = 16$ horse-power nearly.

* This results from the mathematical truth that the circumferences of circles are proportional to their radii. If, therefore, the disc-wheel move a distance equal to its radius, as from i to e , and remain there in contact with the revolving plate, each point in its circumference will in that position consecutively be brought into contact with a point in the inner dotted circle on the disc-plate as the latter revolves; and since the circumference of this dotted circle and the disc-wheel are equal, the revolutions of the plate and wheel will occupy the same time. If the disc-wheel moves to f , where $if = 2ie$, the circumference of the outer dotted line is double that of the disc-wheel, which, consequently, revolves twice for one revolution of the disc-plate.—P. H. F.

The following diagram (Fig. 3) will perhaps assist the foregoing description of the "Totalisateur."

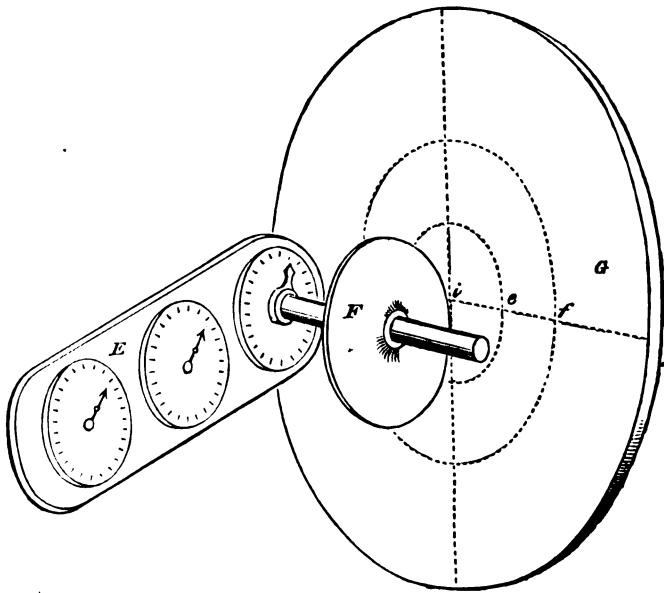

Fig. 3.

- G The dial-plate, which is in constant rotary motion, its velocity being in some given ratio with the velocity of the implement. This plate has generally a counter connected with it, to show the space which the implement has traversed.
- F The disc-wheel, in contact with the face of the disc-plate G: the resistance of the implement, by suitable arrangements, causes the wheel, F, to move from *i* towards *f* on the face of the plate G.
- E The counter, with its dial-plates: by these the revolutions of the disc-wheel are recorded.

It would appear an easy matter to apply the instrument just described to the dynamometer under consideration, as rotation might be given to the disc-plate (G, Fig. 3) by communicating-machinery from the pulley A, Fig. 2; and a modified force of resistance might be imparted to the disc-wheel F, Fig. 3, from the end of the spring S, Fig. 2, in such a manner that as the resistance increased the wheel would be carried from the centre of the disc-plate towards its periphery, and thus fulfil the conditions required.

Such would be the case if equal increments of strain on the rope round the pulleys A, M, B, Fig. 2, caused equal deflexions of the spring S. It is evident, however, from the table given on

page

Fig. 4.

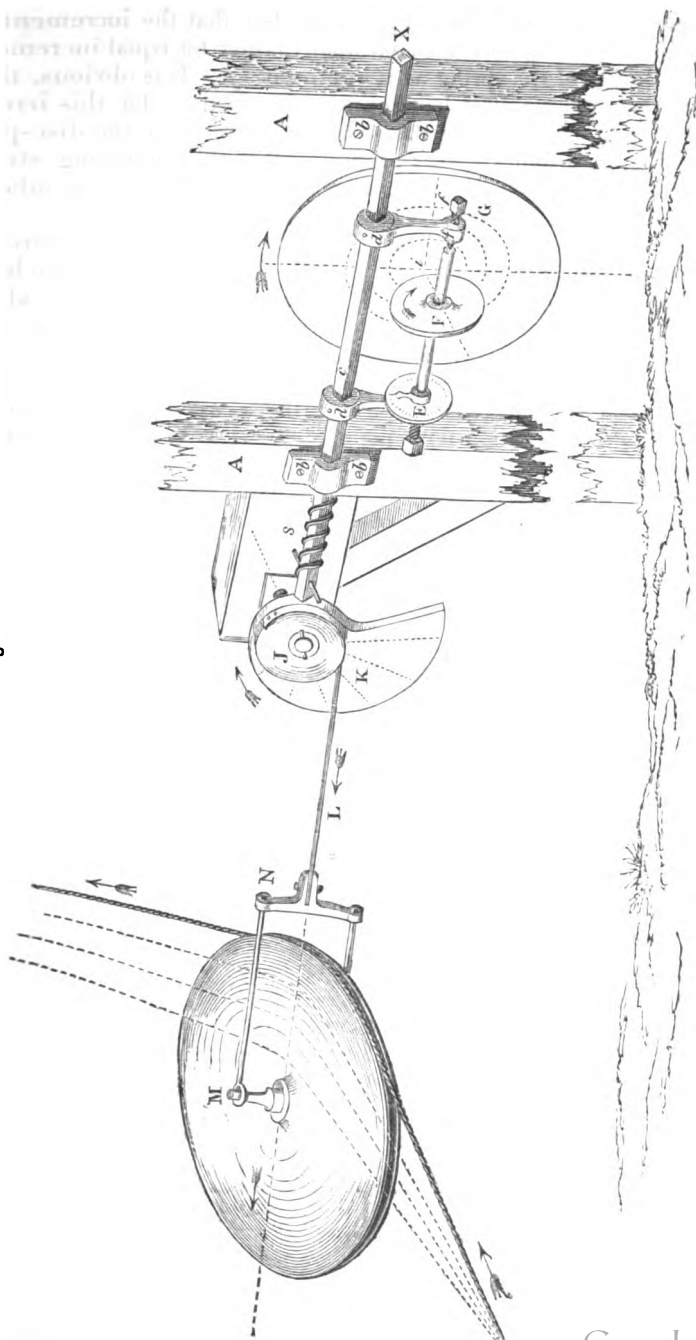

page 206, that such is not the case, but that the increments of strain on the rope become continually larger for equal increments of deflexion of the spring as it approaches f . It is obvious, then, that some device must be adopted to compensate for this irregularity, and to make the disc-wheel F move over the disc-plate G, Fig. 3, through spaces proportional to the increasing strains on the rope. The diagram, Fig. 4, will show how this adaptation of the "Totalisateur" has been effected.

In Fig. 4, G represents the disc-plate, A A represent parts of the framing for carrying the instrument, to which are fixed two bearing-blocks, $b \ b$, through which the bar c slides freely, on this bar are keyed two arms $d \ d$, and through the ends of each of these a screw is passed, the pivot-points of which carry the spindle upon which the disc-wheel F and the index of the counter E are fastened; while a spring s , upon the bar, retains the whole in position with the disc-wheel F at the centre of the disc-plate G, when all is in a state of rest.

M is the central pulley of the dynamometer, which for perspicuity is shown with the resisting spring (S, Fig. 2) removed. J is a plain block-wheel revolving on a fixed pin, and to the edge of that wheel a thin riband of steel, L, is fastened, partly round it and from it to the crossbar N, which is connected by rods with the centre of the pulley M. K is a cam, fastened to the block-wheel, and revolving with it upon its centre.

It will be seen that the end of the bar c , now in a state of rest, presses upon the inferior diameter of the cam K, and when the strain is put on the wire-rope, the pulley M is deflected in the direction of the arrow on its left, the block-wheel J, and the cam K, are turned round by the action of the riband L, and the superior diameter of the cam K, continually increasing, compresses the spring s , and forces the bar c , with its adjuncts, towards X, and the disc-wheel F, is carried onwards from i towards f , on the surface of the disc-plate G.

The cam K is constructed in such a manner that its ordinates increase in a manner corresponding to the decreasing deflexions of the spring S (Fig. 2) when approaching f , so that the disc-wheel F is moved by the action of the cam over the surface of the disc-plate G, with velocities which are in exact accordance with the increasing or decreasing strain on the wire-rope. Hence the results may be read on the counter, E, in the manner before described.

MISCELLANEOUS COMMUNICATIONS AND NOTICES.

1.—*On Experiments with Peruvian Guano mixed with a small quantity of Sulphuric Acid.* By J. B. LAWES, F.R.S., F.C.S.

IN Vol. xxv., Part 1, of the 'Journal of the Royal Agricultural Society' (1864), Professor Voelcker published a very valuable paper on Peruvian Guano, and concluded with some practical suggestions for increasing its efficacy by rendering soluble a considerable portion of the nitrogenous matter and phosphates which, in its natural state, exist in it in an insoluble condition. Every farmer of the present day is well acquainted with the importance of Peruvian guano as a manure, and knows what a high price he is required to pay for it; and as there is but little probability of a reduction in its cost, any suggestions for economising its use are deserving of careful consideration, and of being put to the test of careful experiment, more especially so since the present agents of the Peruvian Government have removed the restrictions which were formerly imposed upon the dealers in guano, and now permit them to employ it in the manufacture of compound manures.

Professor Voelcker's suggestion is to render soluble a larger amount of the phosphoric acid and nitrogenous matter of the guano, by mixing with it about 5 per cent. of its weight of sulphuric acid. During the past season I made some experiments upon swedes with Peruvian guano so prepared; and although the season of 1864 was very unfavourable for roots, and the produce was not more than half a good crop, the results obtained are not without interest.

Four experiments, making two pairs of two each, were made. In each case 8 tons of farmyard-manure were employed per acre. In the first experiment 200 lbs. of Peruvian guano, in its natural state, and in the second the same amount mixed with a small quantity of sulphuric acid, were used in addition. The third and fourth experiments were, respectively, exactly the same as the first and second, excepting that to each of them there was a further addition of 2 cwts. of superphosphate of lime per acre. 200 lbs. of Peruvian guano were employed per acre in each case. The guano was finely sifted, and that which was to be artificially prepared was well mixed with 20 lbs. of sawdust, which had been previously saturated with a mixture of 12 lbs. of sulphuric acid

and 10 lbs., or 1 gallon, of water. The guano, or guano-mixture, as the case might be, was sown by hand on the top of the dung before it was ridged in, and the seed was drilled on the ridges, alone in experiments 1 and 2, and with the superphosphate of lime in experiments 3 and 4.

Table I. shows the results of experiments 1 and 2, without the superphosphate.

TABLE I.

Plots.	Manures per Acre.	Number of Roots. per Acre.	Produce per Acre.		
			Roots.	Leaf.	Total.
			Tons. cwt. qrs. lbs.	Tons. cwt. qrs. lbs.	Tons. cwt. qrs. lbs.
1	8 tons Farmyard-Manure 200 lbs. Peruvian Guano .. }	14,397	9 1 1 4	1 3 3 18	10 5 0 22
2	8 tons Farmyard-Manure 200 lbs. Peruvian Guano, mixed with 12 lbs. Sulphuric Acid diluted with 1 gallon of Water, and absorbed by 20 lbs. Saw- dust }	13,092	8 2 2 7	1 3 1 12	9 5 3 19
	Difference ..	1,305	0 18 2 25	0 0 2 6	0 19 1 3

It is seen that there were about $18\frac{3}{4}$ cwt. more root, and about $\frac{1}{2}$ cwt. more leaf with the guano without, than with the guano with sulphuric acid. There were also about 1300 more roots per acre without, than with the acid. The season was, as already said, very unfavourable for growth, and the difference of the produce in the two cases is comparatively small; but, such as it is, it certainly does not show any beneficial effect from the use of the acid.

Table II. shows the results of two experiments parallel in every respect with the two former, excepting that with the dung and guano of the one, and with the dung and prepared guano of the other, superphosphate of lime was also employed.

In this experiment the result is almost exactly as much in favour of the prepared guano as it was against it in the former case. Taking the one set of experiments against the other, therefore, it would appear that in the particular season in question the effect of a given amount of guano was about the same with and without the addition of the sulphuric acid.

It may be noticed, in passing, that the beneficial effects of superphosphate of lime in preserving the plant in a bad season, are very apparent in the much greater number of plants grown per acre when it was used.

TABLE II.

Plots.	Manures per Acre.	Number of Roots per Acre.	Produce per Acre.		
			Roots.	Leaf.	Total.
3	8 tons Farmyard-Manure 200 lbs. Peruvian Guano 2 cwts. Superphosphate of Lime	14,818	Tons. cwt. qrs. lbs.	Tons. cwt. qrs. lbs.	Tons. cwt. qrs. lbs.
			8 7 3 2	1 2 1 0	9 10 0 2
4	8 tons Farmyard-Manure 200 lbs. Peruvian Guano, mixed with 12 lbs. Sulphuric Acid diluted with 1 gallon of Water, and absorbed by 20 lbs. Sawdust. 2 cwts. Superphosphate of Lime	15,932			
			9 5 3 2	1 3 0 14	10 8 3 16
	Difference ..	1,114	0 18 0 0	0 0 3 14	0 18 3 14

Although the results so far obtained do not show any beneficial effect from the admixture of the sulphuric acid with the guano I propose to repeat the experiments with roots again this year, and to extend the trial to other crops.

Taking into consideration both the cost of the acid and the expenses of mixing, the preparation of Peruvian guano, as above described, would probably add nearly 20 per cent. to the cost of the nitrogen and phosphates it contains. Unless, therefore, the process be found to augment the efficacy of the guano in more than that proportion, there would be no gain to the farmer in using the mixture instead of the guano in its natural condition. It is obviously very important, therefore, to give the matter a fair and careful trial.

Rothamsted, February, 1865.

2.—Experiments on the Artificial Fecundation of Wheat.

By J. B. LAWES, F.R.S., F.C.S.

IN Part I. of the 'Journal of the Royal Agricultural Society' for 1864 (p. 258) there is an abstract of an account given in the 'Journal d'Agriculture Pratique,' of methods proposed by M. D. Hooibrenk for increasing the produce both of corn and fruit-trees by means of a process of artificial fecundation. The value of M. Hooibrenk's discovery is said to have been verified by a Commission appointed by the Minister of Agriculture of France. The increase recorded as due to the process was (if

reduced to English standards of quantity), in one experiment, from 34 to 46, and in another from 36 to 39 bushels of wheat-grain per acre; and, what is more extraordinary, as the result of a process applied so late in the period of growth as that of flowering, the recorded increase in the produce of straw was in the one case as much as from 1848 to 2728 lbs., and in the other from 2059 to 2240 lbs. per acre. A process which involves no outlay for manure, is so simple and easy of application, and the results of which were vouched for by such high authority, seemed, at any rate, worth a careful trial, and I therefore submitted it to one in the course of last summer.

Before, however, describing the experiments and their results, it may be well to make a few remarks on the conditions essential to the attainment of successful and reliable results in field experiments generally, and upon the state of the plots selected for the trials with M. Hooibrenk's process.

If the object of an experiment be to compare the effects of different manures, or of any other means of increasing the crop, the general condition of the soil, its evenness, and the characters of the season in which the experiment is made, must each and all be taken into account. The land may be in too high or in too low a condition for the purpose; the plots may appear to be pretty uniform both in quality and condition, and yet if they were all treated in the same manner, instead of differently, they would probably give very different amounts of produce over equal areas; or the season may be much more favourable, or unfavourable, for the effects of one of the modes of treatment that is to be compared with others, than would be the case taking the average of a number of years.

It is seldom that the opportunity occurs of selecting duplicate plots for a comparative experiment, the history of which for many years past is accurately recorded, and the evenness of which or otherwise can therefore be accurately ascertained. Such an opportunity was, however, at command for the purposes of the trial of Mr. Hooibrenk's process. Plots were selected from among those on which wheat had been grown at Rothamsted for many years in succession by the use of the same manure applied year after year on the same land. By reference to the report on the experiments in question, published in the last two Numbers of this Journal, it will be found that, in most cases, duplicate experiments were made with the same manure, the duplicate plots being designated "a" and "b" respectively. Three pairs of these plots were selected, namely, 12a and b, 13a and b, and 14a and b; and in order to show how far the duplicate plots were in equal condition, and, therefore, properly comparable with one another, the average produce of wheat per acre per

annum on each over 12 years, 1852-1863, is given in the following Table (I):—

TABLE I.

AVERAGE PRODUCE of WHEAT per Acre per Annum on Duplicate Plots. Over 12 Years, 1852-1863.

Plots, &c.	Dressed Corn.		Offal Corn.	Total Corn.	Straw (and Chaff).	Total Produce (Corn and Straw).
	Quantity.	Weight per Bushel.				
12a	Bush. Pks.	lbs.	lbs.	lbs.	lbs.	lbs.
12a	35 0 $\frac{3}{4}$	58·2	146	2194	3932	6126
12b (duplicate of 12a)	35 0 $\frac{3}{4}$	58·3	156	2207	3962	6169
Difference	0·1	10	13	30	43
13a	34 1 $\frac{1}{2}$	58·6	154	2165	3945	6110
13b (duplicate of 13a)	34 3 $\frac{1}{2}$	58·6	159	2203	4033	6236
Difference	0 2 $\frac{1}{2}$..	5	38	88	126
14a	34 3 $\frac{1}{2}$	58·3	161	2191	3983	6174
14b (duplicate of 14a)	35 0 $\frac{3}{4}$	58·4	150	2205	4019	6224
Difference	0 1 $\frac{1}{2}$	0·1	11	14	36	50

Thus, taking the average over 12 years, the duplicates, in each case, give almost identical results. It is true that in individual years the difference was sometimes much greater. For instance, to take the most extreme case which the 12 years afford, in 1855 the difference between the plots *a* and *b* amounted in each case to about 3 $\frac{1}{2}$ bushels of dressed corn, and from 3 $\frac{1}{2}$ to 4 cwt. of straw per acre, the advantage always being with the plot *b*; and for several years afterwards the plots *a* gave in their turn the higher produce, until the inequality had been in a great degree compensated. From these facts it is evident that even when the greatest care is taken there may sometimes be a considerable difference in the produce of plots treated as far as possible in the same manner, arising from circumstances of the season over which we have no control. It will, at the same time, be admitted that the plots *a* and *b* were, upon the whole, in a very uniform condition, and well suited, therefore, for the purposes of an exact comparative experiment.

The duplicates being again manured exactly alike as in former years, plots 12a, 13a, and 14a were submitted to M. Hooibrenk's process; whilst plots 12b, 13b, and 14b were not so treated. In accordance with the directions given, the mode of proceeding was as follows:—To a rope long enough to stretch across the plot to be operated upon, pieces of woollen twist 2 feet in length

were attached so close as to touch each other, thus forming a sort of fringe 2 feet in depth. Before use the wool was smeared with honey, and the rope, thus prepared, was stretched across the plot and trailed over the growing crop when in bloom in still weather. It was thus drawn up each of the plots to be operated upon on July 2nd, down on July 4th, and up again on July 6th. Table II. gives the produce obtained with, and without the process of artificial fecundation.

TABLE II.

PRODUCE of WHEAT per Acre on Duplicate Plots, one Artificially Fecundated and the other not.

Harvest 1864.

Plots, &c.	Dressed Corn.		Offal Corn.	Total Corn.	Straw (and Chaff).	Total Produce (Corn and Straw).
	Quantity.	Weight per Bushel.				
	Bush. Pks.	lbs.	lbs.	lbs.	lbs.	lbs.
12a Artificially Fecundated ..	44 1 $\frac{3}{4}$	62·6	99	2881	4315	7196
12b Not ,, ..	44 3	62·4	93	2882	4356	7238
Difference	0 1 $\frac{1}{4}$	0·2	6	1	41	42
13a Artificially Fecundated ..	42 2 $\frac{3}{4}$	63·2	88	2786	4480	7266
13b Not ,, ..	43 2 $\frac{3}{4}$	63·4	111	2882	4620	7502
Difference	1 0	0·2	23	96	140	236
14a Artificially Fecundated ..	41 0 $\frac{1}{2}$	63·1	149	2740	4003	6743
14b Not ,, ..	41 3 $\frac{3}{4}$	62·8	110	2745	4107	6852
Difference	0 3 $\frac{1}{2}$	0·3	39	5	104	109

It is seen that in neither of the three trials was any increase of produce obtained by means of the fecundating process. Indeed, there was in each case rather more without it, though the difference was so slight that it might arise from causes unconnected with the treatment.

It may, perhaps, be said that, as the season was one of much more than average productiveness and the crops were all unusually large, it was unfavourable for such an experiment. In answer to this objection, it may be stated that the land is capable of growing more produce still, and that all of these plots did grow considerably larger crops in the previous year, 1863, as may be seen by reference to the report in a former Number of the Journal, as above referred to.

In conclusion, it may be remarked that it would seem our

neighbours, the French agriculturists, are now going through a stage which in this country was passed through some few years ago. The artificial application of electricity, seed-steeping, and other marvels, which were to double the produce of our fields at little cost, have had their day with us; but the British farmer is still toiling on as formerly, earning his bread by the sweat of his brow and the liberal use of manure, without which he does not find his crops increase.

3.—*Kohl Rabi*.—By CHAS. LAWRENCE.

THOUGH we found this root useful and a favourite food of all stock we discontinued growing it three or four years ago, in consequence of the hands required for setting it out at a busy season of the year. In consequence of the then cost of the seed it was treated like cabbage, sown in a seed-bed and planted out. Inasmuch as it required only half the distance between the plants as compared with cabbage, planting several acres occupied too much time. The cost of the seed having been considerably reduced, in contemplation of the possible fulfilment of the prognostics of a dry, hot summer, and dried-up pastures in the autumn, we drilled three acres with two pounds of seed per acre. We sowed early, and had an abundant plant, which was cut out, leaving plants 18 inches apart. The crop was nearly stationary for three months during the unusual drought; but it was never touched by the fly, which entirely destroyed two successive sowings of swedes; more remarkable still, it was not attacked by the grub, which was so destructive during the past season to all other root-crops, and which was abundant over the entire surface of the farm. The bulk of the crop was greatly checked by the absence of rain during the most effective period of growth. We put on it, in fold, 143 young sheep the end of August. After they had been on the ground three weeks and five days, we added sixty more, making 203. These finished off the three acres in five weeks and three days, the crop thus lasting nine weeks. The plants were eaten off without pulling, and were perfectly consumed, even to the sucking the juices from the tops of the stems. The sheep had some mixed chaff to run back on. Our shepherd reported that he had never known young stock thrive so well, both in flesh and wool.

The freedom from all attack by the insect-tribe during such a summer as the last is so material a consideration that we have thought it desirable to communicate that fact to our brother farmers, and to recommend their sowing a few acres of this seed

any time in March or the beginning of April, as a very useful refuge from dried-up pastures late in the summer and autumn.

Cirencester, Dec. 17th, 1865.

NOTE.—In 1860 I advocated the drilling of kohl rabi, and stated how well the crop then resisted the *wet* season, yielding about 15 tons per acre on light land.

It has never failed me since, and is, in this *dry* season, as good or better than ever. My crop is designed for ewes and lambs in February and March; and my eleven acres are my sheet-anchor for some 300 ewes, and probably 430 lambs. It was sown between May the 19th and the middle of June: less than 2 lbs. of seed per acre was used. I have only one new hint to give,—that rather a coarse green variety, which will carry a good deal of top, is to be preferred for winter use. I shall certainly act on Mr. Lawrence's suggestion, and have an early sowing likewise for use in August.

P. H. FRERE.

4.—*Comparative Experiment on the Use of Wheat-meal and of Linseed-cake for Fattening Sheep.* By P. H. FRERE.

THE consideration of the relative value of corn and of cake at the present moment, induced me to try the following experiment. By having duplicate pens, one of Shearlings and one of Hoggetts, I have been enabled to compare the merits of sheep of different ages and breeds, as well as to check the results obtained. The Hoggetts employed were improved Eastdowns of my own breeding; the Shearlings (the produce of Southdown ewes by Westdown rams) were bought from off Ilsley Down on the 19th of November last, at 42s. per head.

Two good even pens of five were selected from each breed, neither the largest nor the smallest in the flock being taken. One lot both of Hoggetts and Shearlings received 1 lb. of linseed-cake per head per day; the other two lots had 1½ lb. of wheat-meal and ¼ lb. of cotton-cake. All four lots received 1 lb. per head per day of cut clover-hay, and as much of green food or roots as they would eat; at first they had drum-head cabbage; at the end of December weeks swedes were given instead; and since January 28 they have had mangold. I was surprised to find that at first both the two pens fed with cake ate more green food than the others, the 5 sheep consuming daily 6 stone instead of 4 stone. This difference continued till swedes were substituted for cabbage, since which time the consumption has been very

nearly equal, the Shearlings more uniformly cleaning out their trough than the Hoggetts. I may remark that valuable as the cabbage is for milk, we did not think it equal even to inferior swedes or mangold for grazing purposes.

The linseed-cake cost 10*l.* 10*s.* per ton, or 7½*d.* per head per week, the same amount as the wheat-meal if reckoned at 1*s.* per stone. The cotton-cake made an extra cost of 1*d.* per head per week.

When brought home from the field, each pen was weighed together on a weigh-bridge, with the following result:—

					cwts.	qrs.	lbs.
Cake Shearlings	6	1	0
„ Hoggetts	6	0	0
Corn Shearlings	6	1	0
„ Lambs	6	0	6

The Shearlings at this time were not fit to kill; at the present time it is reckoned that the sheep are nearly equally good; that the Hoggetts have the advantage over the Shearlings, but that there is no perceptible difference between the lots on corn and those on cake. The sheep were rather disturbed by removal into new quarters, to make room for the ewe flock, about the 24th of January; this slightly affected their weights on the 6th February. The following Tables will speak for themselves:—

SHEEP FED ON LINSEED-CAKE.

Shearlings.

Number.	December 26, Total Weight.	January 9, Gain.	January 23, Gain.	February 6, Gain.	February 20, Gain.	Total Increase.
	lbs.	lbs.	lbs.	lbs.	lbs.	lbs.
1	141	2	7½	4	8	21½
2	123	0	8	2	4½	14½
3	126½	0½	10	9	3	22½
4	135½	(- 1½)	5	14	1	20
5	133½	0	8	5½	7	20½
		2½	38½	34½	23½	99

Hoggetts.

1	133	5½	6½	12	4½	28½
2	114	3	6½	8½	6	24
3	115	1	7	3	5	16
4	137½	0½	7	8	5½	21
5	123	1	6½	5½	5½	18½
		11	33½	37	26½	108

SHEEP FED ON WHEAT-MEAL.

Shearlings.

Number.	December 26, Total Weight.	January 9, Gain.	January 23, Gain.	February 6, Gain.	February 20, Gain.	Total Increase.
1	129½	3½	9	3½	6	22
2	129½	0	6	3½	5	14½
3	132½	5	6½	3½	7½	22½
4	124	(-1½)	10	(-3)	8½	18½
5	132	3	8	9½	2½	23
		11½	39½	20	29½	100½

Hoggets.

1	121	2½	6½	6	5½	20½
2	120	8½	1½	1	7½	18½
3	127	12	5	3	8½	28½
4	119	7	5	5	5½	22½
5	134	(-1)	3	6	7½	16½
		30	21	21	34½	106½

The fattening flock in the field receive 1½ lb. of wheat and barley meal mixed half and half, and ½ lb. of cotton-cake; on the other hand they have barley-straw chaff instead of clover-hay. In my experiment I introduced the use of clover-hay to adapt my proceedings to Mr. Lawes' standard diet for sheep; I also refrained from mixing wheat and barley, because mixtures are as objectionable when definite results are sought for by experiment, as they are beneficial in general farming practice. This antagonism between the requirements of scientific investigation and of approved practice is one of the difficulties that beset the path of agricultural progress.

I am, on the whole, satisfied with my success in converting my own produce into meat and manure, neither hoarding my corn nor increasing the glut of a depressed market.

5.—*Letter on Covered Yards.* By H. S. THOMPSON, M.P.

To THE EDITOR.

"MY DEAR SIR,—You ask my opinion of covered farmyards, especially with reference to the question of cost. I send you, by way of reply, the following remarks, partly extracted from a paper I wrote for the Yorkshire Agricultural Society on this

subject, purposely avoiding all details of construction, which have been so well handled by Mr. Moscrop.

“ The arguments in favour of covered yards may be stated under the following heads :—

“ 1. Health and condition of live stock.

“ 2. Goodness of manure.

“ 3. Economy of management.

“ Under the first head it may be confidently stated that the experience of those who have tried covered yards is uniformly in their favour, if properly constructed. The roofs of farmyards ought to be high, and provided with means of thorough ventilation, so that the temperature within cannot rise much above that of the outer air. Where this is the case, the stock are *sheltered* but not *tendered*; and after several years experience of both systems, I can speak positively to the fact that, the same kind of stock, with the same allowance of food, are decidedly healthier, and turn out in spring in much better condition from covered than from open yards.

“ The second head is, however, the one on which I would lay the most stress. No farmer will dispute the assertion that ‘ manure is the mainstay of good farming;’ and it is equally undeniable, that the very best of manure, if exposed long enough to the washing of rain, becomes perfectly useless for the nutrition of plants. But it is difficult to measure the actual loss experienced during a few months of rainy weather; and no calculation can be so satisfactory as actual trial. When first I began to use manure made in a covered yard, it was put on for white turnips in the usual quantity, and they were stimulated by it to an unnaturally rapid growth and excessive size, which were very prejudicial to their keeping qualities; and taught me the lesson, which has since been abundantly confirmed, that manure made under cover is fully one-third stronger than that which has been exposed to the rains of winter in open yards. Before trial, it might be supposed that manure made under cover would turn out dry and mouldy; but if the quantity of straw used is in reasonable proportion to the number of live stock kept, it will be invariably found that the manure turns out in first-rate condition. The explanation is easy, the most common cause of damage to manure being that the fertilizing salts it contains are washed out by rain as fast as they are formed by the decomposition of the heap, and when these salts are all retained, the moisture will be retained also.

“ The only case where the advantage of covering yards is questionable, is on a large sheep-farm to which little grazing-land is attached. On the Wolds of Yorkshire and Lincolnshire such farms are numerous, and the quantity of straw grown is out

of all proportion to the horned stock kept. The few cattle wintered have, therefore, to trample mountains of straw into the semblance of manure, and without the assistance of snow or rain it could not be accomplished. But even in these extreme cases it may be doubted whether wintering more cattle, and thus improving the quality of the home-made tillage, might not be more profitable in the long run, than carting out hundreds of loads of wetted straw, and laying out large sums in the purchase of bones, guano, *et hoc genus omne*.

“The third head to be mentioned is the improved economy of management. In covered yards the manure is so much richer in quality, and so free from weak outsiders, that there is no necessity for carting it into heaps in order to ferment it down to a uniform mass. It is ready for use when wanted in the field; and being protected from sun, wind, and rain, it is *safe until wanted*. All the expense, therefore, of carting to the heap, unloading at the heap, and turning in the heap is entirely saved.

“The question of cost remains to be considered. This will vary to some extent with the kind of roof adopted. I have ascertained by trial that a substantial roof, covered with ordinary roofing-tiles, may be erected for 5s. per superficial yard of ground roofed over. Each superficial yard of covered space will, on a well-stocked farm, produce annually a cubic yard of well-made manure, worth, if the animals be well-fed, at least 5s.; consequently, if manure made under cover be one-third better than that made in the open air, the outlay of every 5s. in roof will produce 1s. 8d. per annum,—in other words, will bear interest at the rate of 33 per cent., independently of the improved condition of the stock and the saving in the cartage of manure. The accuracy of this result depends on the soundness of the assumption that manure made under cover is improved in value one-third, which is, of course, an approximation only; and though I am convinced of its truth in my own case, it remains to be proved whether it will hold good when applied generally. But whether on more extensive trial the percentage of improvement be found to be 20 or 30 per cent. there can be no doubt that the improved value is sufficient to make the subject one of great interest to both owners and occupiers of land.

“The above-mentioned cost of 5s. per square yard of area enclosed will only hold good in those cases where the yard to be covered is entirely surrounded by buildings, and where, consequently, no new brickwork is required. On the other hand, when a new set of buildings has to be made, the cost of the covered yard (calculated as above) will not be all additional expense, as there will be a considerable set-off in the reduced extent of the other buildings. No open sheds for the yard-stock will now be necessary, and by good management the whole ‘*quadrilateral*’ may be

reduced in size. In lately erecting a new set of buildings for a farm of about 230 acres I found that covering a farmyard of 90 ft. by 55 ft. enabled me so to alter the arrangement of the other buildings that, whilst giving entire satisfaction to the tenant, the cost of the whole building was not sensibly increased.

“The chief value of my plan for roofing farmyards (described by Mr. Moscrop) consists in the mode of obtaining a large proportion of light without windows, ventilation without draught, and both one and the other without expense. The principle of ventilation is an entirely new one, and opposed to the general theory on the subject. It is to admit the bulk of the ventilation from *above* instead of below, and to secure a sufficient change of air by having an uniform width of opening all round the upper roof, so that there is always a current across the upper part of the building though unfelt below. A small but sufficient opening is left just above the heads of the animals to prevent any stagnation taking place there. To any one who will take the trouble of visiting one of my yards so constructed, I will undertake to prove that this principle secures to its occupants complete shelter without draught or smell, and a temperature scarcely above that of the external air, which, until better informed, I shall venture to call *perfect* ventilation.

“I am, my dear Sir, yours faithfully,

“H. S. THOMPSON.

“Kirby Hall, Feb., 1865.”

ABSTRACT REPORT OF AGRICULTURAL DISCUSSIONS.

—♦—

Meeting of Weekly Council, Wednesday, February 15th. The President, SIR E. KERBISON, M.P., in the Chair. Mr. J. B. LAWES, of Rothamsted, St. Albans, delivered a Lecture on the subject of Town Sewage, considered with reference to its applicability and value for agricultural purposes.

LECTURE AND DISCUSSION ON TOWN SEWAGE.

Mr. LAWES said: The utilisation of sewage has of late occupied a large share of public attention. During the last two sessions of Parliament two Committees have sat, and they have reported very voluminously on the subject. There has also been a great deal of discussion in newspapers; and very recently Baron Liebig and Mr. Morton have favoured us with their views, one in a report addressed to the Lord Mayor of London, the other in a paper read before the Society of Arts, the latter being followed by a discussion which extended over two nights. Looking at the whole question of sewage, we cannot be surprised at so much interest being taken in it by the population of the towns generally, and more especially by the inhabitants of London. Immense sewage-works have lately been carried on, and as the expense has pressed rather heavily on the ratepayers, it is not astonishing that they should listen with rather credulous ears to those who tell them that in the sewage they possess a mine of wealth, which, if properly worked, will repay them for all the outlay they have incurred.

Now, ten years ago I read a paper before the Society of Arts on the composition and the utilization of the sewage of London, and it was followed by a discussion of great interest. The question then was whether sewage should be used in a solid or a liquid form. The advocates for its use in a solid form were there represented, and supported their views; but I think I may say that nearly all those who had paid any close practical attention to the subject of manures, felt quite satisfied that the manufacture of a solid manure could not be profitably carried out by a process which, while it preserved the least valuable parts of sewage, allowed the most valuable to escape. It required the expenditure of something like 60,000*l.*, at Leicester, to prove that those who took the latter view were correct. At the present time we have no advocates for a solid manure from sewage; the battle still rages, but it is whether the liquid sewage shall be applied in large quantities, and chiefly to grass; or in small quantities to arable land and to all crops?

In a discussion of this kind, the first question that arises is What is sewage? or rather, What is the composition of sewage? If the Royal Commission, of which I have been a member for some years,

has done no other service, it has at all events rendered some benefit to the country, by carefully gauging the sewage of Rugby. For nearly three years the sewage of that town, which is collected in a large reservoir tank, has been sampled, and samples of it have been transmitted almost weekly to Professor Way for analysis, and in a table before you you see some of the results. The composition of sewage is, for convenience sake, estimated by chemists according to the number of grains of ammonia per gallon which it contains. If you look at Table I. you will observe that in 1861, 1862, and 1863 the composition

TABLE I.

VARIATION in the COMPOSITION of the RUGBY SEWAGE at different times.

		Ammonia.		Total Solid Matter.	
		Grains per Gallon.	Lbs. per 1000 Tons.	Grains per Gallon.	Lbs. per 1000 Tons.
1861	Highest	15·64	500·5	216·5	6928
	Lowest	2·99	95·7	37·6	1203
	Mean of 24 analyses ..	6·39	204·5	75·1	2405
1861-2	Highest	11·38	364·2	129·3	4138
	Lowest	2·55	81·6	50·5	1616
	Mean of 34 analyses ..	5·95	190·4	80·3	2570
1862-3	Highest	12·81	409·9	269·9	8637
	Lowest	3·14	100·5	62·2	1989
	Mean of 35 analyses ..	7·08	226·5	103·2	3302

varies very much indeed at different periods of the year, and also somewhat in different years, the highest amount of ammonia in 1861 being $15\frac{1}{2}$ grains, and the lowest about 3; the highest in 1862 about $11\frac{1}{2}$, and the lowest about $2\frac{1}{2}$; and the highest in 1863, $12\frac{1}{2}$, and the lowest 3; but taking the mean of the three years, you will find that the variation is not very great, the amounts being respectively about $5\frac{1}{2}$, 6, and 7 grains. In 1862, which was the year when the amount of ammonia was lowest, there was the greatest amount of rain; and I should observe that Rugby is a town which has been sewered upon the modern principles. In Table II. (p. 228) you will find that with 60 tons of water per head per annum the sewage-water is estimated to contain $6\frac{1}{2}$ grains of ammonia per gallon; this is the quantity which is found in the Rugby sewage, and the water supply and rainfall are there estimated at about 60 tons per head per annum. Further on you will see the calculated quantity of ammonia in each gallon of sewage, where the rainfall and water-supply amount to 70, 80, 90, and 100 tons per head per annum. I believe the average sewage of the metropolis will approach the latter amount.

And now comes the question, How are we to apply this sewage to grass, or to arable land? The authorities on the subject, those, I mean, who have written or spoken with any acquaintance with it, and whose opinions may therefore be regarded as having some weight, have

almost all declared that in their opinion the difficulties attending the systematic application of sewage to arable land are so great that it is only applicable on any comprehensive scale to grass.

TABLE II.

AMMONIA per Gallon, and estimated Value of the CONSTITUENTS in one Ton of SEWAGE at different Dilutions, reckoning 12½ lbs. of Ammonia per Head per Annum from all Sources.

	Ammonia per Gallon.	Value per Ton.
	Grains.	d.
If 60 tons of fluid per head per annum	6·51	1·67
70 " " " " " " "	5·58	1·43
80 " " " " " " "	4·88	1·25
90 " " " " " " "	4·34	1·11
100 " " " " " " "	3·91	1·00
Hofmann and Witt—mixed sample of dry weather sewage from Savoy-street sewer	8·21	2·11
The same if diluted with two-thirds its volume of rainfall and subsoil water	4·93	1·27

Baron Liebig has, indeed, expressed a different opinion, and I will give you his exact words, because I am going to make some remarks on his views. Baron Liebig is a great chemical authority, he is a very great man, and his words deserve careful attention. He says, "The full value of sewage and of its separate constituents can only be got at when it is employed on arable land." He then goes on to show why sewage cannot be applied properly on grass-land. He assumes first of all that on sandy soils, such soils as it is proposed should receive the sewage of London—I mean the Maplin Sands—you would require to put on twelve times as much of the constituents in sewage as you could take off in a crop; for example, that if you wanted to get a crop of 4 tons of hay, you must put on the land the ingredients of 48 tons of hay; after which, he says, that in order to take off 4 tons of hay annually, you must put on the land 2430 tons of sewage per acre. This being the quantity which he considers will contain the ingredients removed annually by the 4 tons of hay. Now, I should like to ask any agriculturist present whether if you put on the ingredients of a crop you can take them all off in this way? For instance, if you apply 1 cwt. of guano, can you at once take off 11 bushels of wheat and its proportion of straw? The manufacturers of artificial manures will supply you with the ingredients of a bushel of wheat, including ammonia, for a shilling. If you could take off a bushel of wheat directly the ingredients were applied, farming would indeed be a very good business, and the farmer would then have no difficulty in selling wheat for 5s. per bushel; but on this point theory says one thing and practice another.

I am not surprised that the Lord Mayor of London, and the Corn, Coal, and Finance Committee of the City should be pleased at the value placed upon this sewage by Baron Liebig. They say, "We are losing

a very valuable property;" but they forget that it is the agriculturist who has to decide what is its value. This is not a question of science merely; it is a question of practice with science; and a man of science cannot ensure that if you apply certain ingredients to the soil, you will be able to take off the anticipated crop. At Rugby we seldom got more than 1 ton of hay from 1000 tons of sewage, and according to this we should require 4000 tons of the Rugby sewage to produce 4 tons of hay. Of the London sewage, if it is found to be as diluted as I estimate it to be, 6800 tons would be required for the same purpose, although Baron Liebig says that 2430 tons would be sufficient.

Let us now consider for a moment the application of sewage on arable land. Baron Liebig's view is this: "You agriculturists are," he says, "great robbers; you know nothing about your own business; you get oil-cakes and manures from all parts of the world, robbing other soils, and at the same time you let all the sewage of London run into the sea; while robbing other soils you are impoverishing your own;" and, he goes on to say, "if you will only mix the sewage of the metropolis daily with 275 tons of superphosphate of lime, or nearly 100,000 tons a year, you will have a manure just suited to arable land, because on arable land you only take off part of the produce of the soil; while in the case of grass land, when you make your hay you take it all away." In theory it may be all very well to say that you should apply the sewage to arable land in such quantities as will compensate the exhaustion due to the removal of corn; but in practice the thing is impossible. Examine the question with regard to phosphoric acid—one of the most important constituents to return to the soil—I estimate that if you were cultivating a farm on the four-course system, and removed from it 30 bushels of wheat and 35 bushels of barley per acre, and were to consume all the other crops on the land, not purchasing cake or artificial manures, the waste thus caused might be supplied by the application of 7 lbs. of phosphoric acid per acre per annum; if you were to distribute the sewage of London so as to balance such waste, you must distribute it over eleven million acres, or about the whole quantity of arable land of England.

I believe the Corn and Coal Committee think that the sewage of London should be distributed over an area of five or six hundred thousand acres. I do not know why that quantity has been chosen; but it would supply between four and five hundred tons per acre, which is not a very large dressing. To distribute even that amount would require an enormous capital, and the thing would not answer unless agriculturists could afford to pay 2*d.* per ton. The advocates of these schemes always speak of the price at which they could afford to sell, instead of what the farmer could afford to give. Now, the question is, could agriculturists afford to give 2*d.* a ton for sewage?

I know there are some who say that the Rugby experiments are a complete failure. They say that we have converted the Rugby land into a complete swamp, though we have only used 3000 tons of sewage in some places, 6000 in others, and 9000 in others. But it is

impossible to please these gentlemen unless we take off the land in a single crop all the ingredients we put on in sewage. That this is quite impossible is clearly shown both by common experience and by the results of careful experiments made at Rothamsted with both natural and artificial manures, and the whole question of profit turns upon that. At Rugby the tenants of the land were quite willing to supply us with sewage at rates which averaged 1d. per ton the year round; as they found by experience that they could not get a penny out of it.

TABLE III.

SEWAGE applied, and GREEN GRASS obtained, per Acre per Annum, in Experiments made at RUGBY.

SEASONS 1861, 1862, and 1863.

Season.	PLOT 1. Unsewaged.	PLOT 2. 3000 Tons Sewage.	PLOT 3. 6000 Tons Sewage.	PLOT 4. 9000 Tons Sewage.
Five-Acre Field.				
	Tons. cwt. qrs. lbs.	Tons. cwt. qrs. lbs.	Tons. cwt. qrs. lbs.	Tons. cwt. qrs. lbs.
1861	9 5 3 5	14 16 3 8	27 1 0 10	32 16 3 8
1862	8 3 1 10	27 18 0 18	34 10 0 19	32 9 2 22
1863	4 18 3 13	22 5 0 11	34 18 1 27	37 0 2 5
Average ..	7 9 1 9	21 13 1 12	32 3 1 0	34 2 1 12

Ten-Acre Field.				
	Tons. cwt. qrs. lbs.	Tons. cwt. qrs. lbs.	Tons. cwt. qrs. lbs.	Tons. cwt. qrs. lbs.
1861	8 18 0 15	15 16 3 2	22 15 2 12	26 13 3 12
1862	16 10 0 25	27 11 0 20	32 2 1 14	31 12 1 20
1863	8 0 3 19	25 5 1 8	30 11 2 12	34 19 1 21
Average ..	11 3 0 10	22 17 3 1	28 9 3 13	31 1 3 18

Average of the Two Fields.				
1861, 62, & 63	9 6 0 24	22 5 2 7	30 6 2 6	32 12 0 15

SEASON 1864 (without Sewage).

Five-Acre Field.				
1864	1 14 3 26	2 17 2 20	5 12 0 18	5 13 3 20

Ten-Acre Field.				
1864	3 1 2 0	5 12 1 15	7 4 0 9	6 11 0 11

If you look at Table III. you will see what was the average amount of produce which we got in three years. When we put on the land 3000 tons of sewage, we obtained about 21½ tons of produce in one case, and in another nearly 23 tons; from 6000 tons of sewage we got in one case 32½ tons of produce, and in another 28½; and from 9000 tons of sewage we got only 34 tons of produce in one case, and only 31 in another. As we increased the amount of sewage, the amount of produce did not increase in equal proportion. In reference to all kind of manuring, two and two do not make four, or anything like it.

If 5000 tons of sewage were used on the acre, the grass, when converted into milk, should produce, at 8d. per gallon, from 30l. to 35l. per acre. I think it possible, therefore, taking the Rugby sewage as the standard of quality, that a farmer who gave something like a halfpenny per ton might obtain a profit, though I should hesitate to affirm that he would do so if he gave much more.

There are some places in the immediate vicinity of large towns where the land is very favourably situated for the application of sewage, and such cases are of course favourable as regards the question of a profitable return to the towns. Taking the average of conditions, I don't think a farmer could do very wrong in giving a halfpenny per ton; but he would do very wrong if he were to give 2d., or even a 1d. the year round, because the experience of all those who have used sewage is against its being worth any such sum.

As regards the question whether sewage can be profitably applied on arable land, I would observe that it has been more or less a failure wherever it has been so used. At Alnwick, Rugby, and Watford, those who applied it for that purpose have almost ceased doing so on account of the difficulties and expense to which they have been subjected. It cannot be applied to arable land except by the hose, and the wear and tear of the hose, and the cost of labour, have proved to be very serious.

In conclusion, I would advise that sewage to be used by open runs for grass land in quantities of four or five thousand tons per acre, and as far as practicable to produce milk. Under such circumstances I repeat that I do not think a farmer could suffer much harm if he gave a halfpenny a ton for it; but I should not advise him to give more. (Hear, hear.)

Dr. VOELCKER said the views of Mr. Lawes on this subject appeared to him perfectly sound, and in accordance with agricultural experience. That gentleman alluded to the fact that it was vain to hope to recover at once all the manuring constituents which were put in the land through the medium of sewage. Sewage did not stand alone in that respect; every other kind of manure presented the same peculiarity. Whether they used the most concentrated artificial manures, such as guano or superphosphates, or whether they used common stable-dung, in order to get a remunerative crop they must in some cases put in the land five times, in others ten times, in others even a hundred times as much as they took out of it. If a farmer were to put not more manure on his land than is taken out of it in a crop of wheat or roots, he would

soon be ruined. It had been asserted that soils had a certain fixed power of absorbing sewage manure; but he contended that the power was not fixed, but depended on a great variety of circumstances, and, amongst others, on the concentration of the liquid. If, for instance, they were to express the absorptive power of a particular soil of known composition by a symbol, the value of that symbol would alter for every degree of dilution. The concentration of the liquid, therefore, affected the absorption. Generally speaking, soils took up more fertilizing matter from concentrated than from dilute liquids; and a highly dilute liquid would take out of some soils more of certain constituents—for example, potash—than it brought upon them. This he proved in the case of Alderman Mechi's heavy clay-land. He thought experience was in favour of applying large doses of sewage to sandy soils, or soils which were very poor in fertilizing substances. For a long time he maintained that sandy soils were grateful for any kind of manure, and for any quantity of sewage. If a small quantity were put on them, they felt the effect; if a larger quantity were applied, the result was better; while what many might consider an excessive dose yielded the most remunerative crop. When the soil had been thoroughly soaked, a large store of fertilizing matters was brought by degrees to the surface, and with a growing grass-crop was put into circulation. Large quantities of water were thrown off by the grass leaves, a circulation of the liquid took place through capillary attraction, and the sewage was brought to a considerable depth to the surface to strengthen and nourish the plant. Hence it was that grass-crops were so materially benefited by the use of dilute liquid-manures like sewage. As regarded arable land, he was confident that farmers could not, except under very special circumstances, apply sewage beneficially. There might be exceptional cases; for instance, for the growth of mangold-wurzel, in large quantities liquid-manure in the shape of sewage might in very warm and dry summers be used with advantage. The soaking of poor soils in very dry springs might also be of use for corn-crops, not excepting wheat. But when they had to deal with such a large bulk of liquid manure, they must not regard exceptional cases, but make provision for ordinary ones; and he was quite confident that sewage would never be largely used for arable soils or as a manure like farmyard-manure. He would only add, that if farmers wished to use superphosphate, they should put it on the soil and leave the rain to wash it in, and not put it first into the sewage, and then apply both together to that land.

The Earl of LONGFORD said: Mr. Lawes had observed that he thought farmers might afford to give a halfpenny per ton for sewage. He should like to know whether he thought that sewage could be delivered at that rate?

Mr. J. C. MORTON said he had within a few days received letters on this subject from three correspondents. One was from Mr. Campbell, of Rugby, saying that in the paper which he had lately read before the Society of Arts justice had hardly been done to Mr. Lawes's sewage experiments at Rugby, and declaring his entire confidence in those experiments, and his personal knowledge of the fitness of the methods

used, both agriculturally and chemically, for arriving at a trustworthy result. Again, Mr. Crockford, farming in Sussex, had pointed out to him an inaccuracy of Baron Liebig's, inasmuch as in his recent estimate he had taken credit for the full ammonia power of urea in the sewage, while in the case of guano he had not allowed the urea any agricultural value whatever. That was clearly an inconsistency, and one which struck a damaging blow at the conclusions of the Baron. Another correspondent had told him that during the past year he had applied in a garden 300 gallons of diluted blood every week, and that he had seen no effect whatever, except when he had first mixed the blood with a dung-heap and left it to ferment. That seemed to show that sewage-manure should be applied in the state in which it would already contain food for plants, and not left to decompose in the soil. All the evidence on this subject showed that sewage should be applied to sandy land, and applied in such large quantities that plants would be able to take whatever they required; and he thought the result of the application of blood-manure which he mentioned supported that view.

Dr. CRISP thought that we were very much in the dark on this subject, not having sufficient statistics for our guidance. He believed that the investigation was yet in its infancy, and that hereafter all the sewage, by proper combinations, would be made available for agricultural purposes. He thought that it was a matter of common sense, for all animals, without exception, derived their nourishment directly or indirectly from the vegetable kingdom, and it was intended that their excreta, as well as their bodies in various forms of matter, should return to the earth. The first speaker said that sewage could not be applied to arable land, and yet he told them that sandy land would bear any amount of it, which appeared to him an inconsistency. There was in England a vast quantity of sandy land; he knew vast districts where, as was sometimes said, "the seed of one field was blown into another," and he apprehended that on such land sewage would be very beneficial. As a medical man, he wished to say a word or two upon the bearing of the sewage question on public health. He did not go the same length as his friend Dr. Cobbold, who supposed that the germs of entozoa would be disseminated to a fearful degree, and who apprehended dire results if human excreta were spread over the land; he ventured to say that one worm prevailed to a great extent; he alluded to the *oxyuris vermicularis*. That worm directly it left the human body emitted its eggs by tens of thousands, and it might not be long before those eggs found their way into the animal system. It might be impossible to tell precisely what effect the distribution of sewage would have on the public health, but the question was certainly one of vast importance to the community at large, and he hoped that it would not be overlooked. The eggs of this worm (the *oxyuris*) differed materially from those of the worm in the lungs and windpipe of sheep (*strongylus filaria*), for in the latter the young worms generally escaped from the egg at the time of extrusion, or soon after, but in the worm in question (the human entozoon) the eggs were immature, and it was a long time before they attained the vermiform state.

Mr. FRERE said that farmyards were not exempt from dangers of the same kind as those which had just been mentioned. He should like to know whether Dr. Crisp apprehended some new danger; and whether the eggs in question were destructible by fermentation? *

Dr. CRISP replied that the eggs to which he alluded never entered farmyard-manure, and that he had no data to guide him with respect to the action of fermentation upon them.

The CHAIRMAN said: Being obliged to leave the meeting to attend a deputation, he wished to say one or two words before doing so. He thought great value was to be attached to the discussions which took place on that important subject. The lecture of Mr. Lawes, and one which had lately been delivered on the same subject by Mr. Morton, were of great interest, tending as they did to prevent exaggerated notions from being taken up, either on the one side or on the other, by ratepayers, who might be led to expect immense returns from the sale of their sewage, or by farmers, who might expect enormous profits from the use of sewage. It had just been remarked that they were still much in the dark about this question. To a certain extent that might be the case; but still important and careful experiments, extending over two or three years, had been made at Rugby and elsewhere. He himself had seen the Edinburgh meadows, and he could bear out the testimony of Mr. Morton, that so far as they had proceeded, nothing could have been more successful, 350 acres of land having proved sufficient to feed 2000 cows. It appeared to him that there were very good reasons why the Edinburgh experiments should have been more successful than some others. The soil was peculiarly fitted for the experiments, being of a lightish character; and the circumstance of the ground sloping as it did was strongly in its favour, inasmuch as that prevented the sewage from remaining on any spot long enough to sour the herbage on that spot. Any person who had a manure-drain opening into a field must have observed that the grass was more apt to become rank just at the outlet of the drain than in any other part; and an overdose of manure remaining in a place where it was stagnant was almost sure to have a bad effect on the quality of the grass. The question had been mooted, whether ploughed land might generally be brought under the influence of sewage. He did not think Mr. Lawes said it could not. He merely quoted Baron Liebig's authority on the matter, and said, in opposition to it, what he (the Chairman) believed was true, that, generally speaking, grass-land would most benefit by sewage. In Belgium he had seen clovers on light land brought forward extremely well through the application of sewage; and he had seen an enormous quantity of potatoes produced by the same means on land of that description. It was possible that sewage might by degrees be applied with advantage on some of the sandy ploughed soils of this country; but on the whole, he thought it

* The Chinese use human excreta to a great extent. The Belgians, too, use the sewage largely as a manure, but I am not aware that either of these people are more troubled with entozoa than their neighbours; but I speak guardedly upon this subject. The worm spoken of (*oxyuris*) does not directly affect human life, but there were others of greater import.—Dr. C.

most probable that the view entertained by those who had paid most attention to the subject, namely, that sewage was most adapted for grass-lands, would ultimately prevail. Perhaps one great advantage of that discussion would be that it might lead those who now insisted so much on the great value of sewage to make arrangements for lowering the price, so that experiments might be made on a large scale.

Mr. ACLAND, M.P., thought that the experience gained in water-meadows might be turned to good account in discussing this question of sewage, and expressed a hope that, with a view to the enlargement of that experience, the Council would direct that further experiments be made, to be recorded in the Journal. In the West of England, farmers were at present quite in the dark as to whether the benefit of the irrigation of their meadows was due to solid manure or liquid manure, or indeed any manure at all, contained in the water. So far as his own experience went, it tended in the direction pointed out by Mr. Lawes. A tenant of his father's applied sewage in an elaborate manner to his mangold-wurzel and his swedes, but he did not think the results were very encouraging; and certainly the general experience of farmers in the West of England showed that anything like a dilution of farmyard-manure was useful on grass, and not on arable land. The experiments of Mr. Huxtable led to the conclusion that sewage should be applied chiefly by gravitation, and that if it were applied by any more expensive process, it was extremely doubtful whether a penny or a halfpenny per ton could be got back.

Sir JOHN JOHNSTONE, M.P., said he understood Mr. Lawes to contend that sewage was especially applicable for rye-grass and other strong feeders, and on that point he quite agreed with him. In the case of a large lunatic asylum in the vicinity of York—he himself was chairman of the visiting committee—the superintendent had endeavoured to utilise the sewage on the arable part of the grounds attached to the institution. The land in question was under spade cultivation to the extent of 24 acres, and the soil was a rather sandy one. The sewage was not exactly liquid, everything in the shape of deposits being carefully preserved and afterwards applied with hose to the soil. On that land there had been grown an abundance of mangold-wurzel, potatoes, cabbages, and strawberries. No doubt the successful application of liquid manure in that case resulted in a great degree from constant care, spade-cultivation, and patient labour. There are about 550 persons residing in the establishment, and 25,000 gallons of spring-water, from the kitchen, the washhouse, the bath, &c., are daily finding their exit. A large portion of the sewage is put on other land—old grass—for the hay-crop.

Mr. THOS. SCOTT said he was well acquainted with the effects of sewage irrigation in England, Ireland, and Scotland, and had made many experiments himself, and—in common, he believed, with all practical men—he had arrived at the conclusion that flooding was the only profitable mode of applying sewage. Nothing, he believed, had done so much to mislead the Corporation of London, on this subject, as the being furnished with mere analyses of the constituents of sewage. Some years ago, having the management of an estate of 1000 acres

at Wimbledon, including a lake of upwards of 20 acres, he laid down pipes for 6 acres of grass-land, which he "sperged" with lake-water, and at the same time he applied the same process to 6 acres of grass-land in another part, with sewage-water, his object being to see what would be the difference between the two; and the result was that the lake-water produced as much effect as the liquid sewage. (Hear, hear.) The labour of applying the sewage, including interest on plant, was about 38s. per acre per annum, and the extra value of the produce was estimated at only 32s. The whole sewage was now applied profitably to about 10 acres, by flooding, instead of to 125 acres, to which it was originally intended to apply it by a contour channel, which he had formed upwards of a mile long. The original intention of this irrigation was simply to intercept the sewage of Wimbledon from an ornamental lake on a residential estate, as we now desire to divert it from all our rivers and streams, and even from our ditches; and, by double draining, even the stiffest soils can always be made a filtering medium for this purpose, sometimes with a profit, and invariably with a successful sanitary result.

Mr. FAWCETT said: Having some years ago incurred considerable expense in constructing tanks for the purpose of saving the liquid manure of his farmyard, and having afterwards applied it, especially on grass-land, he wished to give the results. When he applied that liquid manure during wet weather to a reasonable extent on grass-land, he found it very beneficial; but when he put it on grass-land in dry weather, and particularly if the weather were hot, it burnt and destroyed the grass, and inflicted great loss. Even taking into account the number of wet days that they had in this climate from the beginning of the year to the end, there was a very considerable period during which liquid manure could not be applied to grass-land. On that point he spoke from experience, and not from any theoretic ideas. They could not possibly apply sewage in hot dry weather without doing serious injury to the grass.

Lord FEVERSHAM (who had succeeded Sir E. Kerrison in the chair after his retirement) said he believed it was well known that liquid manure should always be applied in dripping weather.

Mr. FAWCETT said he found that the number of days on which he could apply liquid manure was comparatively few, and the result was that he gave up applying it because he found it unprofitable. A gentleman had remarked that he thought it might be applied to sandy soils to any extent beneficially. He had tried that, and had found that such was not the case; for where his men applied it to mangold-wurzel or turnips, or any young plants, it killed them. It is also an important point to observe that if liquid manure be applied to a very large extent on grass-land, even in wet weather, the grass produced is of so coarse a character that neither cattle nor sheep will readily eat it. In short, there are many practical reasons why the use of sewage is unprofitable. The farm to which he had alluded is his own property, situate in Westmoreland, where there is a fair quantity of rain; he mixed some of the sewage with once or twice its bulk of water, and having tried it with various kinds of grass, and under various circum-

stances, he never found any benefit unless it were put on the land in wet weather.

Mr. BLACKBURN said his experience with regard to liquid farmyard-manure was entirely opposed to that of Mr. Fawcett. He had found that the warmer the weather was when it was applied, the greater was the amount of the crop. He had selected such grasses as were most suited for the application of liquid manure; as regarded warm weather, it was a mere question of dilution.

Mr. FAWCETT observed that he had been speaking of ordinary meadow-grasses.

Mr. BLACKBURN said ordinary meadow-grasses did not appear to him adapted for irrigation, on account of the enormous waste. They do not grow upright, and consequently the lower leaves are excluded from the air, and became yellow; whereas, upright-growing grasses allow the air to get underneath. In Mr. Scott's distribution of sewage at Wimbledon by hose and jet, the mode he adopted of driving it through the air in a thin jet would be the most effectual means of creating smell, wasting the ammonia, and losing power. He would be glad to hear from Mr. Lawes whether the value of the sewage rises as the proportion of water diminishes.

Mr. LAWES: Yes.

Mr. BLACKBURN: If a given quantity of sewage contained only twenty tons of water, would it be three times as valuable as if it contained sixty?

Mr. LAWES: More than that.

Mr. BLACKBURN said, that being so, it would be well for towns to take some measure for preventing the present excessive waste of water, and to turn all the surface water and subsoil drainage from the sewers into the natural channels.

Mr. LAWES: That is a question for the towns, not for agriculturists.

On the motion of Lord Feversham, seconded by Mr. Scott, a vote of thanks was given to Mr. Lawes for his lecture.

Mr. LAWES, after acknowledging the vote, proceeded to reply briefly to some of the remarks made in the course of the discussion. He said: Of course, in discussing the subject of sewage, they must take the sewage as they found it, and also assume that it was to be used continuously, summer and winter, day and night. Under other circumstances they might put a totally different value upon it. In the case of water-meadows—a subject referred to by Mr. Acland—there was a clear liquid; but if they analysed it, they would find the kind of ingredients which were beneficial to plants. One gentleman seemed to think that some day there would be found some means of using sewage more profitably on arable land. It had been tried and tried and tried, without any good result. Lord Essex, after using it largely upon arable land, had ceased to use it. Lord Robert Montagu and other gentlemen had spent a good deal of time in declaring, before the Society of Arts, that the Rugby experiments were a failure. It was all very well to say that; but he could affirm that the produce obtained at Rugby from a given amount of sewage was very much greater than that obtained at Edinburgh. He was satisfied that the produce from 1000

tons of sewage far exceeded that obtained from the same quantity of sewage at Edinburgh; and if those gentlemen who proposed to take the London sewage to the Maplin Sands calculated upon getting more than was got at Rugby, in some of the most favourable experiments they might find themselves mistaken. He did not deny that it would be quite possible, by means of a hose and jet, to have obtained a greater produce of grass, and more milk from a given weight of grass if every particle of grass had been cut the moment it was ready, regardless of all practical considerations; but such a result would only mislead agriculturists. The object of the Rugby experiments was to obtain scientific accuracy in all that related to the gauging and analysis of the sewage, the weights of the grass and milk, and a practical result in that part which related to the cutting and consumption of the food.

Mr. AGLAND, M.P., said he should be sorry if it went forth on Mr. Lawes's authority that there was nothing more to be learnt by a careful study of the phenomena of irrigation. He for one was by no means prepared to admit that; and he believed that the effect of irrigation was not exactly in proportion to the amount of manurial matter contained in the water. Mr. Pusey's opinion was that in many cases the effect of irrigation was chiefly due, not to the manurial matter contained in water, but to temperature; Mr. Robert Smith's opinion tended in the same direction; and there was a great deal of difficulty floating in men's minds on that subject, which could only be removed by investigation on the part of the authorities in such matters. Some time ago Mr. Lawes told him that he intended to investigate the subject.

Mr. LAWES said he had intended to do so, but unfortunately he lived 25 miles from London; and one effect of the Artesian system was to dry up the springs in his neighbourhood. He believed, however, it would be found that the action of water was due principally to the ingredients contained in it, though the enormous amount of water used was apt to make one fancy that that was not the case. But he agreed with Mr. Acland, that it is very desirable that the subject should be further investigated.

XIX.—*The Management of Sheep Stock on Heavy and Light Land.*

By JOHN COLEMAN.

PRIZE ESSAY.

THIS is certainly a most important subject at a moment when, from the low price of corn, it is evident that the English farmer must increase his live-stock, and look for profit rather from this source than from his grain. This country, with its humid climate and great variety of soils, seems peculiarly adapted for the growth of wool and mutton—the meat best suited to the taste of the English people, and less subject to foreign competition than beef—while the prospects of our trade encourage us to anticipate high prices in meat of all kinds. It is, therefore, of the highest importance for every one of us to examine into, and compare his own management with that of others, so as to ascertain whether he is pushing this part of his business to the utmost, whether his practice is scientific and economical, and whether he is making the most of the opportunities at command; or, to enter more into details, he must see that he breeds the sheep which are best suited to the climate and soil, that the food and treatment they receive are calculated to bring the highest return, and that as many are kept as is consistent with profit. We have only to look around us to feel satisfied that there is great variety of practice even under very similar conditions, and that there frequently exists a lamentable ignorance of those natural laws which cannot be outraged with impunity.

In discussing this subject I propose to treat first of the management of sheep on light soils, because these may be considered their natural *habitat*; and as many points to be described will apply equally to sheep on heavy or light soils, I shall not repeat such matter when speaking of the second part of the subject.

Kind of Sheep.

This is a question so dependent upon local circumstances, that it cannot be decided without reference to special localities. Generally speaking the native sheep of a district have points of adaptation, the result of acclimatizing influences, that render them more suitable, when improved by care and judgment (and sometimes when crossed), than any totally different race would prove; hence we find in all the great sheep districts a tolerably distinct type of sheep, and these are only blended together in what may be called border counties. However imperfect such flocks may appear, considered simply as specimens of sheep, they possess qualifications which render them of infinite value

in the peculiar country they inhabit. Sheep bred upon the Romney Marshes, are an example of this: crosses with more refined breeds have been repeatedly tried, but have been abandoned, since the produce invariably lost somewhat of the hardy character which renders them so peculiarly suitable to that exposed country.

At the present day our aim is to combine plenty of wool, weight of carcase, aptitude to feed, and good quality of flesh—points that are not united in any of the old distinct breeds. Thus, wool and carcase are found in such long-woolled breeds as Leicesters, Lincolns, and Cotswolds, but the quality of the flesh is so inferior as to limit the chief demand for such mutton to our manufacturing districts. The Southdown gives us the perfection of quality, but the frame is small and the fleece light, and such animals, except in a limited district, are not profitable farmer's stock. For the production of mutton and wool on soils favourable for sheep culture, breeds derived from a cross of the Long and Short-wools—such as the Shropshire, the Oxfordshire, and the Down Leicester sheep—will generally prove most profitable. Care and judgment is, however, required to maintain the form and character of breeds so comparatively recent; still, under good management, they will probably continue to increase.

The Shropshire sheep are peculiarly valuable in the West Midland Counties, and are rapidly increasing over that considerable area; they follow the Down rather than the Long-wool in character, possessing a moderately heavy fleece, of a close, thick texture, admirably adapted to protect them from the weather; they are very hardy, prolific, and produce a fine quality of mutton. The Oxfordshire sheep exhibit more of the Long-wool character, with less symmetry; they are larger, with fatter backs, and more open and longer wool; they are hardy, and moderately prolific; and are well suited to the arable soils of Oxfordshire and the adjoining counties; these sheep were originally derived from a cross of the Cotswold and Hampshire Down; they come to maturity early, and, when well done from birth, come out at from 12 to 14 months old, weighing 20 lbs. a quarter, and cutting 7 to 8 lbs. of wool.

In the drier climate, and in the lighter soils of the Eastern Counties, we find a great variety of cross-bred sheep, many of which trace back to the old Norfolk black-faced sheep. To quote from a recent writer in the 'Mark-lane Express,' "Though the pure-bred Norfolks are never seen, traces of the old blood are to be found in more than half the flocks of the county. The remaining qualities of the breed which are perpetuated are not to be despised. They impart a great frame, hardihood, and strength of constitution, and wonderful milking properties." When we

add to the above the early maturity and heavy jacket resulting from the influence of Long-wool blood—not pure Leicester, but Cotswold or improved Lincoln—we have, as might be expected, a very selling description of sheep. The Down Leicesters are in some instances preferred; their great aptitude for fattening renders them valuable, but they have not the size, hardy character, or weight of wool which cause the cross-bred sheep above described to find such general favour with the tenant-farmers of Norfolk. In the Lothians the first cross between the Cheviot and Leicester is generally considered to pay better than anything else.

Since no general rule can be laid down where so much must depend upon soil, climate, &c., we may remark generally that, other things being equal, that sheep will pay best that grows the greatest amount of flesh on a given quantity of food, and comes to maturity in the shortest time; but it must be remembered that in proportion as the kindly qualities of an animal are developed, its strength of constitution and ability to stand hard treatment is lessened, and therefore the amount of cultivation of our sheep in any district must depend in great measure upon the care and attention which we can bestow upon them.

A Breeding Flock.

Light arable farms, or mixed arable and grass-land farms, are most suitable for a breeding flock, whether kept alone, or together with a feeding flock. It is needless to prove that a breeding flock must here pay better than working dry stock, because a review of the prices of store stock, both sheep and cattle, during the last few years, will show that, too often, the breeder comes in for the lion's share of the profits. Even if at the present moment the two courses were equally profitable, it would still be our duty and interest to practise breeding on suitable land, if we duly regard the rapidly increasing wants of the country. Unfortunately we have no statistics to refer to as to the actual number of breeding sheep kept in the country, and their comparative increase from year to year, and, in the absence of such tests, we are met by most conflicting evidence. The probability is that we have slowly increased, especially during the last few years, in consequence of the great improvements in Highland farming; but that this increase has not been at all proportionate to our wants, and that in many instances a much heavier stock may be kept with advantage, is beyond question.

Hitherto farmers have supposed that a bellyful of turnips was necessary for a breeding animal, and have based their calculations on their stock of roots that were to be thus wasted.

The past winter has taught us to give these roots in a healthier form, eking out the supply by a nice admixture of other food supplied in a palatable form. I have lately inspected a flock of Hampshire Down ewes that did not have a root before lambing. They ran on grass land during the day, being hurdled at night, so as to dress and improve the pasture. Morning and night they got trough-food, consisting of straw and hay-chaff, two-thirds of the former to one-third of the latter; bruised oats, and palm-nut meal; the cost of the artificial food amounted to 2½*d.* a head weekly; not one ewe died during the winter, and I never saw animals in a more promising state for lambing. This subject will be more fully entered upon when discussing the management of the ewe.

A flock kept for breeding fat stock should be closely culled, so as to be always young; 3 or 4 lambs from each ewe is sufficient. The draft ewes are thus always good in the mouth, and vigorous, and will readily feed, and come out at little expense, equal in value to the young ewes that take their place, instead of being got rid of at a sort of casualty price, when old and broken-mouthed. Then, again, a young flock will stand trying circumstances much better than old crones. The lambs will come stronger, and grow lustier; indeed, there is every reason in favour of this system. The only exception is in favour of very valuable animals kept for breeding males. In such cases a favourite ewe is often put to the ram as long as she can keep life together; and no doubt this is right, as some ewes prove themselves wonderful mothers. In a flock of 200 we should introduce 50 to 60 shearling ewes annually, to replace the regular draft and any unsound or barren animals. Great care should be exercised in examining the flock to see that all the ewes that have wintered badly, and not done their lambs well, be withdrawn.

Choice of Sires.

There are many points connected with ram-breeding which would be out of place in this essay, which treats of ordinary flocks; yet, even for these, the importance of procuring good males to secure symmetrical form and quality of flesh, is undoubted. The recent high price of long wool has tempted some flockmasters to neglect the form, in their eagerness to secure a heavy jacket. Let us remember that the greatest master of the art of sheep-breeding built up the beautiful Dishley sheep out of the coarse, ill-formed Leicester, principally, if not entirely, by selecting those animals that exhibited quality and symmetry. We must look, therefore, that we have the neat, well-shaped head, moderately full neck, oblique shoulders, wide chest, straight back, springing ribs, good fore and hind flank,

meaty twist, &c. &c. On such a frame we must have a springing pelt and a good jacket. To obtain this we must not grudge 15 or 20 guineas for a shearling ram to be used in a pure flock, though for cross-breeding well-shaped males may be had for less money. Such rams should be sought for from those who do not overfeed for shows or sale, or disappointment and loss will ensue. The difficulty of reducing over-fed rams to a working condition is very great, and they are very liable to be carried off by inflammatory attacks; at the best, delicacy of constitution is propagated.

Before proceeding to the general management of the ewes, it may be well for us to consider how far we can modify our cropping with a view to increase our sheep stock.

Cropping.

Many will, of course, suggest the laying down of land to grass. But though mutton is, perhaps, never so economically produced as on rich pastures or even on moderate clay lands laid down to grass in a moist climate, still dry and light soils are not generally suitable for permanent sward; and in such districts mutton may be more economically, as well as more extensively, produced by alternate cropping with the aid of the plough. Even under the old four-course shift, the clovers and root-crops have been known to carry from 2 to 3 sheep per acre over the course; and some changes may be suggested that will secure a larger proportion of sheep food. One of the most obvious is to leave our seeds down for two, or perhaps three years. Wherever we can grow clover with tolerable success, a good mixture of seeds carefully selected and properly sown, will yield much valuable sheep food for at any rate two years; especially if we fold them with sheep eating oilcake or other artificial food rich in potash, and apply a light coat of farmyard manure either the first or the second winter. Not only may we thus secure a large amount of food, but, by reducing the acreage under the plough, we can lessen our teams, a most desirable saving of expense.

In the north and north-west of England, and in many parts of Scotland, the climate is peculiarly favourable for the growth of artificial grasses, and this practice is largely on the increase. In the southern and eastern counties, however, especially on the thinner soils, there is often difficulty in keeping the clover-root beyond the first year. According to Baron Liebig's view, it has exhausted all the potash within reach, and accordingly dies away. What remains—rye-grass, a little hop trefoil, and Dutch clover—often make but a patchy crop, which is hardly worth retaining for a second year. In such cases, I should advise

eating off all the spring growth, then ploughing the land, and planting a crop of rape, spring vetches, or early turnips, applying artificial manures liberally, and being careful to secure a fine and tolerably firm seed-bed. I have known this to be carried out with success, a considerable increase of sheep-keep over the old four-course rotation being obtained, inasmuch as the seeds afford much keep for the ewes in a mild autumn, and a fair fold in spring, whilst the land is made ready for wheat with very little preparation. We have generally plenty of time for operations, since the rape, turnips, &c., do not require to be sown until the middle of June. The wheat, on light land in good condition, may go in any time before Christmas. The wheat may be followed by the root-break, if we do not care about corn, or we may now sow barley, supposing the land to be in thorough condition. We will, for the sake of illustration, take roots next. A considerable portion of the land, if clean, as it should be, may be manured as soon as the wheat is off, and worked for vetches, of which a succession of crops should be sown, with a little winter barley or winter oats, to help make up a crop. The practice of sowing winter barley, if this crop is grown, eating down bare in spring, and then leaving for a corn crop, has been successfully tried in some cases; and it might follow the wheat, or at any rate a portion of it. The success of such a plan has not been sufficiently established for us to speak with any certainty about it.

Where the climate is not very severe, a few acres of the cleanest portion of the stubble may be sown with *Trifolium incarnatum*, which only requires to be lightly harrowed in, and affords very useful keep for ten days or a fortnight before the vetches are ready. Rye may also be sown, but it is not a favourite crop of mine, as it soon gets coarse, and is never very nourishing.* I would not put any spring vetches on this break, as they would occupy too valuable space. As soon as the winter crops are consumed, the land is well cultivated; the vetch roots, &c., collected and burnt; and either swedes, hybrids, or hardy turnips sown. On light soils I have seen famous crops of swedes after vetches.

Our mangold land will be taken in this course; for this crop good deep winter cultivation is necessary, and no expense should be spared to secure a heavy crop. The fifth crop will be either

* In the bleak and dry Eastern Counties, rye is almost indispensable for the large flock-master. It stands drought well, can be fed twice, and yet leave ample time to prepare for a turnip or rape crop, which then succeeds best on a stale furrow. A new cultivator, by Headley of Cambridge, breaks up this and ryegrass land very well for roots. A high authority on sheep remarks, "It is the flock-master's fault if the rye gets coarse."—P. H. F.

oats or barley, according to soil and climate, with seeds, which need hardly extend over the whole of this break, but may be usefully supplemented by pulse crops. The course reduced to a tabulated form, stands thus :—

1. Vetches, roots, &c., &c.
2. Oats or barley, part seeded down.
3. {Seeds, mown and fed, or fed entirely.
Pulse crops.
4. {Seeds fed, then rape, or late turnips, &c.
After pulse, vetches and supplementary forage crops.
5. Wheat.

If it is desired to have more corn, we may take a barley crop after the wheat, and thus make a six years' course. The farmyard manure would, if possible, be divided between the roots and seeds, or possibly all applied to the seeds, the soil being enriched by artificial food consumed on seeds, vetches, and root crops.

General Management of Ewes.

We now come to the very pith of our subject. The precise period at which the ram should be put to the ewes depends upon climate, nature of the soil, and supply of spring food. In exposed and late districts it is a mistake to have the lamb early, as there it is easier and cheaper to keep the lamb inside than out of the ewe. At the time of going to the ram the ewes should be in good and rather mending condition; the strength of the lambs and the proportion of doubles depends greatly upon this. At the same time the soil, as affecting the quality of the food, enters into this question. I remember a circumstance that may be cited in confirmation of this. A Berkshire farmer, dissatisfied with the produce of his Hampshire Down ewes, purchased a score of Shropshire ewes from a farm where the average produce was always an excess of fifty per cent. He wintered them well, and was disappointed when they only produced one lamb each: evidently the nature of his food was unfavourable to the production of doubles. If the ewes are poor and are suddenly put upon very forcing food, blood is made too rapidly and the ewes are likely to turn from the ram. Rape is said to have this effect, although when the ewes are strong and healthy a moderate amount of such food, as a change, is very beneficial. The plan of using "teasers" is good when the males are very valuable and the feeding-grounds lie adjacent to the homestead. The rams are also sometimes kept from the ewes during the day and turned together at night; but this is hardly to be recommended, as ewes may possibly be missed. As a general rule the ram may remain with the ewes, having 1 or 2 lbs. of oilcake daily, or a handful

of beans. A night fold of rape, rape and mustard, or early turnips, affords a capital change after the ewes have range over the stubbles, seed-grounds, and pastures during the day, and may be safely used to enable the farm to carry a larger breeding flock.

As winter comes on the ewes may be kept in thriving condition on a little dry food, hay, or straw, in addition to a very moderate quantity of roots. The practice formerly so common of stuffing breeding ewes with roots is most extravagant, most unnatural, and most unhealthy. A good turnip year in Norfolk was invariably followed by a bad lambing season. The great secret of management, and one of the simplest means of increasing our sheep stock, is to do with the minimum of roots and the maximum of dry food, as straw, chaff, &c., making the latter palatable, if necessary, with a small quantity of artificial food. It is stated in Morton's 'Cyclopædia of Agriculture' that a ewe will consume daily from one-third to one-fourth of its live weight of roots, when supplied with these alone, *i. e.* from 25 to 30 lbs. daily. Of this bulk of food nine-tenths is water; the temperature of which water, in the winter, is seldom many degrees above the freezing point. How much of the food of the animal must be burned away, so to speak, in order to raise this mass to the temperature of the body? If, moreover, the animal is lying or standing on wet ground, which can hardly be avoided, the body becomes so chilled externally as well as internally that the fœtus is starved: a number of dead, or pot-bellied, and weakly lambs is the result, especially from shearling ewes. The only wonder should be that any escape. An interesting proof of the chilling effects of large quantities of roots was given by Lord Berners during a discussion on the management of sheep at Hanover-square. He said: "One day I found in a yard twenty or thirty bullocks tied up and shivering dreadfully. I asked the man in attendance what was the cause of this? And he replied, 'Oh yes, they always be so after eating so many turnips.' I at once ordered the quantity of turnips to be reduced and gave the animals dry food, and there was no more shivering afterwards."

The object of this essay is to point out the best means of increasing sheep stock. Here, then, is one way: we must make one acre of turnips keep twice as many sheep as hitherto, in a far more healthy condition. Last winter in too many cases the difficulty was to find any roots at all; but great and lasting good may be anticipated from the evil then felt. I saw many flocks during the past winter living on damp chaff, with a little artificial food, and doing as well as could be wished, with every prospect of a healthy produce and plenty of milk. I have long desired to see an economical plan of pulping roots devised, as the animal might then be induced to eat a large quantity of straw-chaff, rendered

palatable and nutritious by a small addition of artificial food. Nor would such a system be so extravagant as at first it might appear. Let us assume, by way of example, that our crop of turnips equals 15 tons per acre, and that, instead of 20 lbs. per head, we give 10 lbs. (amply sufficient), with 1 lb. of straw-chaff, and $\frac{1}{4}$ lb. a day each of artificial food, and it follows that 100 sheep will consume an acre in 33 days, and 7 cwt. of extra food will be spent on each acre, besides $1\frac{1}{2}$ ton of straw; so as considerably to increase our produce of corn, besides the chief object of keeping a heavier stock of breeding sheep in a healthy state.

That ewes will do well upon a very moderate supply of roots and well-harvested straw, even without any extra help, may be gathered from both experience and analogy. In-calf cows can be kept in good condition, when dry, upon 25 to 30 lbs. of roots with straw-chaff. A cow is ten times as heavy as a sheep, and consequently, were the digestive apparatus precisely similar, about 3 lbs. of roots would suffice; but Mr. Lawes has recently shown, in his valuable lecture before the Dublin Society, that in consequence of a difference subsisting in the proportion of intestines and stomachs, cattle can consume a coarser and more bulky food than sheep, whilst sheep again may be fed with a less nutritious food than pigs. He shows that for 100 lbs. weight, the ox has $11\frac{1}{2}$ lbs. stomach and only $2\frac{3}{4}$ lbs. of intestines; the sheep $7\frac{1}{2}$ lbs. of stomach and $3\frac{1}{2}$ lbs. intestines; whilst the pig has only $1\frac{1}{3}$ lb. stomach to 6.2 lbs. of intestines. Thus the ox is enabled to take a larger proportion of woody fibre in his food than sheep, and sheep than pigs. The latter again feeds principally upon starch or allied materials, known to be acted upon by the secretions of the intestines. The sheep, again, requires more starchy food than the ox, as is evidenced by its having a larger proportion of intestine; therefore, in dealing with oxen and sheep, we must modify our proportions of food. If we double the roots and halve the straw, we shall have a mixture that the digestive system can act upon. I should, therefore, propose 6 to 8 lbs. of roots and 1 to $1\frac{1}{2}$ lbs. of straw per diem; and if these materials could be united as pulp and chaff, I believe they would be readily eaten and supply the animal with a good wholesome food.

We are now, however, discussing the management of sheep on light land, when it must be remembered that the sheep will be folded on the land. The fields being generally large, and often removed from the farm buildings, the system of pulping would often be attended with inconvenience and expense, and therefore impracticable. Here, then, we may assume that the old system of folding and gnawing is to be followed. We may still advantageously limit the consumption of roots, though hardly to the same extent. I have known the following plan

answer well, particularly on limestone soils, where the surface often becomes dirty in moist weather. In a sheltered corner of the turnip-field, a straw-yard is constructed with hurdles. When portable steam-thrashing machinery is employed, it will save labour if we put a good barley or oat rick here. Thrash out early. Stack and thatch the straw so as to form a shelter wall on the most exposed side. The pen being well littered, and a sufficient number of racks supplied, the ewes are driven in every night, so that whatever the weather may be, a comparatively dry and warm lair is secured. The racks are filled up with sweet straw, of which the remains are used next morning to litter the pen. The most sceptical would be convinced that there is something good in well-harvested straw, if he saw the way in which the ewes will wait to be admitted, and then charge straight for the racks, where they soon bury their heads, and are eagerly engaged in consuming the tenderer portions of the straw, leaving little but the coarser lower stems. When filled, they will lie down completely satisfied, and in a much happier, healthier state than if out on the wet land digesting a bellyfull of turnips.

Here, as elsewhere, success depends upon good management. The straw must be carefully "made." The corn cut before it is dead ripe (as far as is practicable), and supplied at different seasons with reference to its feeding value and the condition of the ewe. Thus barley-straw, as least valuable, may be used first; if it has any seeds in it, so much the better. We may here remark that barley not intended for malting, may advantageously be cut before becoming so dead ripe; in the condition known as red streak, both grain and straw would be more valuable. Barley straw will do until near Christmas; then oats and bean-straw, if grown, may be substituted; the latter, with the pods on, being often very nutritious, and particularly suitable for very severe weather; and lastly, towards lambing, sweet pea-straw will prove as valuable as much of the seed hay, which often consists of little else than over-ripe bents. When the forward ewes are within a fortnight of lambing, some good hay may be used in equal quantities with the pea-straw. It is not absolutely necessary—indeed, we can easily replace it by artificial food—but if we can spare a little hay, sheep will now pay well for it. If we grow mangolds—and, climate permitting, we ought always to do so—the tops spread on the land will form a good change of food for a few hours daily, if they are well withered before being eaten. If exposed to a frost or two, so much the better. I have repeatedly heard of losses from scour when ewes were put on mangold-tops, which I attribute to want of care in providing that the leaves are

well withered, and that plenty of straw and rock-salt are supplied.

I advocate the use of a small quantity of artificial food, especially for the shearling ewes; it may not be necessary or desirable to begin this too soon in the winter; if the lambing commences towards the middle or end of February, we may do very well until Christmas without extra help; after which it will often prove most beneficial and remunerative from increase in the wool, finer condition of produce, and manure left on the land. Now too that the price of grain is so low, it is especially desirable to make our crops walk to market, if we can only do so profitably. A mixture of beans or peas, barley, wheat, or oats, and palm-nut meal, would answer the purpose admirably. I here subjoin the analysis of each:—

	Peas.	Barley.	Palm Nut Meal.
Moisture	14.1	14.0	7.21
Oil and fatty matters	2.0	22.79
Flesh-formers	23.4	14.0	15.56
Starch, gum, sugar, &c.	50.0	54.0	36.24
Woody fibre	10.0	14.0	14.90
Ash	2.5	2.0	3.30
	100.00	100.00	100.00

Many other mixtures might be named, which would possess equal feeding properties. Some may object to the barley as being of too heating a nature; but, used in the small proportions I propose, it would cause no injury. I have named the above as an illustration of the sort of combination that is desirable, and also as being very cheap. The Lincolnshire flockmasters frequently give their ewes from $\frac{1}{2}$ to 1 lb. of linseed cake daily during winter, and, although the cost is considerable, they consider they are repaid in the wool, healthy condition, and increased value of manure.

It may be argued that whilst home-grown produce is so low, foreign materials should not be bought; but the advantage of the mixture consists in the large amount of ready-made fat, which is not to be found in home-grown food; and Mr. Lawes, in the same lecture from which I have quoted, states that he considers fat or oil possesses about $2\frac{1}{2}$ times the value of starch for the purposes of respiration, or the storing up of fat in the body. Used in the small proportion I propose, the large percentage of fatty matter in the palm-nut meal will warm the animal and keep it healthy.

The present cost of the three articles is as follows:—

	£.	s.	d.	
Peas	0	8	0	per cwt.
Barley	0	6	6	„
Palm-nut meal*	0	6	6	„
	<hr/>			
	1	1	0	= 7s. per cwt.

Calculating a quarter of a pound a day to each ewe from Christmas to April 1st, when we may transfer such food to the lamb, the cost will only amount to 1s. 7d. a head; and if we double the amount, and allow half a pound a head, probably a more judicious as well as more liberal allowance, it will only amount to 3s. 4d. a head, a sum that will be amply repaid us in the improved condition of ewe and lamb, whilst the value of the manure will remain as clear profit.

Whatever rules we may lay down on paper, success only attends on good management; thus the result of the lambing will depend on the care, attention, and judgment displayed in tending the flock. We hear of great losses both in ewes and lambs; and the thoughtless expression of good and bad luck is commonly used as settling the matter. We may not always be able to trace the cause, and at times it may be altogether beyond our control, and unavoidable; otherwise we should find that at some time or other during pregnancy, the ewe had been subjected to very unfavourable conditions, and the seeds of disease laid which spring out into activity as soon as the lamb is born. Thus shortness of food and wet lair may lay the foundation of consumption long before its fatal effects are visible; and it should always be remembered that the most cultivated animals are those which suffer most severely from bad treatment.

I pass over the operations of lambing with very few remarks. The value of a faithful, active, and experienced shepherd, will then be clearly seen. The farmer must make every exertion to provide all that is desirable in the way of food and shelter on arable farms. I prefer a moveable ewe-pen, intended for the ewe and produce, to be made in a sheltered part of the field where the food is growing. The lambs should not be made delicate by too close confinement; accordingly after the third day it is well, weather permitting, to turn them out for an hour or two, and thus gradually harden them off. The shepherd should be provided with simple remedies, and Nature left to herself as much as possible.

* Palm-nut meal, as manufactured by Alexander M. Smith and Co., Liverpool, is sold at 6*l.* a ton, and 10*s.* may be taken as representing the average cost of carriage.

Mr. Wood, in his valuable lecture before the Wayland Society, gives several recipes for the treatment of inflammation, garget, &c., very good no doubt; but every intelligent shepherd who acts under an educated master, will be ready with simple medicines to treat such cases. I have found considerable benefit from the use of aconite in cases of inflammation—2 to 3 drops in half a pint of water, repeated every 3 hours. Opium, again, is a valuable medicine when properly used; good gruel, and a little stimulant, such as warm ale or gin, will be found useful in cases of exhaustion. The ewe should always have access to water. Though to a thoughtful man this may appear self-evident, shepherds will sometimes neglect this point, and the consequences are very serious. The supply of roots should be moderate, that of dry food plentiful. Stuffing now will not make up for bad feeding at an earlier period; indeed, overloading the stomach only makes the ewe uncomfortable, and prevents an easy birth.

But enough on this subject. Take care to have a good honest shepherd who is fond of his sheep; and, if he knows his business, let him have his own way, and do not work him off his legs for want of a little extra help; many a man has neglected his lambs from sheer exhaustion; sleepless nights soon tell upon the frame; and, if a man is overworked, how can we expect that constant attention which is so important at such a time? The master's eye must be continually open; and especially must he insist upon a rational mode of treatment, and not allow any ignorant prejudices to interfere with success. Unfortunately, shepherds too often get their own way, and are allowed to indulge their superstitious fancies because the master is not practically acquainted with his business, and has no knowledge of physiology and pathology, two most useful studies. This is a forcible illustration of the necessity for a thorough education, both in principles and practice.

For the first month the lamb depends entirely upon its mother for support, and hence it is of the utmost importance that the ewe should possess a good flow of healthy milk. As soon as she is well recovered from lambing, generous food may be supplied in increasing quantity as the lamb grows. A small quantity of mangold will now be a help to the milk. By the end of the month the lamb is able to pick a little, and we may therefore proceed to consider the management of the lamb.

Whatever be the ultimate destination of the lamb, whether for breeding or feeding, it should be kept constantly thriving, that is, always supplied with a sufficiency of suitable food to develop the frame. At first this must be done through the mother; hence the importance of having the ewe in a sound and healthy condition; if the ewe is poor, forcing food will often cause the

lamb to scour. Constant attention is required to ascertain that the lamb thrives, for great evil results if it goes wrong only for a day or two. The lambs, now some weeks old, may lie out at nights during fair weather; but if it is very rough and wet, some shelter is most desirable. A few thatched hurdles properly fixed will form a useful shelter.* There cannot be a more insane policy than underfeeding ewes and lambs; if, therefore, our natural produce run short, we must increase the quantity of artificial food. Bruised oats and bran, when cheap, are excellent materials to add to the mixture already named. As soon as the lamb can eat, it should be allowed to run through lamb hurdles, and nibble the turnip-tops, or have the first pick at the natural grass, rye, or whatever food we are consuming, and at the same time be introduced to artificial food. A mixture of dust oilcake, nut-meal, bran, and bruised oats will be very suitable, to which we might add a small percentage of ground locust-beans, malt, or coarse sugar.

The troughs should be so made that, whilst the lamb can freely feed, it cannot get into the troughs. I have effected this by nailing round spars from the side to a middle rail, at such distances as to allow the head only to enter. The quantity of such food at first consumed will be very small, but the animal soon learns to eat; and this knowledge is a solace when the milk falls off, or when the critical period of weaning has arrived. Before that time has come we may safely let them have as much artificial food as they can consume, taking care to have plenty of trough room.

It is desirable that the ewes and lambs should have a change of food. On an arable farm we should have rye, or, perhaps, Italian rye-grass, *Trifolium incarnatum*, mixed seeds, and the earlier crops of winter vetches, to be followed by spring turnips. With all these crops a feed of mangold may be advantageously used.

Weaning may take place when the ewes and lambs are on winter vetches. Early weaning is best for both ewe and lamb. If the lambs at three months old can eat corn, and we have a prospect of supplying suitable food, then wean. But rules are useless, as different breeds require different treatment, and we can only state what we believe to be generally true. Castration should take place before this. I prefer searing at about eight or ten weeks, as a safer and more humane practice than drawing. The success of the latter process is much influenced by weather; when the wind sets in very cold losses are common; whereas, whatever the weather, I have never lost a lamb from searing. Another

* An old waggon, half loaded with straw, forms a useful addition to these shelter hurdles.—P. H. F.

point is, that in drawing, a considerable quantity of blood is often lost which must weaken the lamb; the lamb is stronger for being cut late, and the purse more developed, shows better.* In Wiltshire, Hants, and other places, it is a regular business, and the operator appears on the farm at a fixed date, taking you in his rounds, and emasculates, not only lambs, but any animal on the farm that may be condemned, with an amount of skill, and an almost certainty of success, that few veterinary surgeons could exceed, or even attain to. Weaning may be done in a variety of ways. The Hampshire plan is the simplest. The lambs are shut forward, a double row of hurdles being used for three or four days, after which both ewe and lamb become reconciled to the change. If the plan of complete separation is decided on, the ewes should be removed rather than the lambs, as the latter are accustomed to their food, and likely to do best if left undisturbed.

Now comes a question of great importance, especially as influencing the number of sheep we can keep. I refer to *open feeding* or *close folding*. In many of the best sheep districts—Lincolnshire, Hants, Wilts, &c.—the latter practice is adopted, and can be strongly recommended in all cases where we keep sheep for the butcher. But if we want to grow large animals—an object with ram-breeders—we must stock light, give great range and frequent change, bringing other stock to finish up the bulk of the produce, and, I need hardly add that, with the best management, much food is wasted. The ordinary stock-farmer cares not for extraordinary size, indeed it is often a positive objection; he must keep as many as his land will rear, and must try to grow them even, and this can best be done by a system of close folding. The folding system has many advantages. The land gets evenly manured, the food is made the most of, and in the case of mixed crops—the artificial grasses, for example—the stock can be made to eat everything. The animals get a regular supply daily, which can be increased or decreased according to the state of the weather and the wants of the flock. The lambs are not at one time gorged with luxuriant feed, and at another pining in comparative scarcity. By keeping the lambs in hurdles the shepherd has them much more under his control, and if he finds that they are not doing as they ought, an alteration is easy. The crop,

* A high authority on sheep-breeding writes to me—"I am as much opposed to this process as can be; I believe the drawing process at two or three weeks old to be the safest and least painful to the lamb. We once tried the searing, and it was done by a very skilful man, yet we lost a great number of lambs. We never lost a lamb from drawing last year, nor have we this, although the season was so unfavourable, and some of the lambs were five weeks old before they were cut."

My own experience of drawing agrees with this statement. Easterly winds must of course be avoided. I have, however, successfully seared "culls" from the lot of ram lambs.—P. H. F.

rapidly passed over, grows up again without check, and is not liable, as in the open system, to be nibbled down as soon as it shoots. This, in the case of clover, is very injurious, often destroying the plant, whilst at the same time such food is very unhealthy, causing scour, &c.

The folding system answers best where a variety and constant succession of crops are grown. Some of the best sheepmasters recommend two, and even three, changes a day. Thus from vetches to seeds makes an admirable change, or, where it is grown, to sainfoin. We need not despair, however, if we are unable to secure so much change, as by care and attention lambs may be done very well on vetches, provided they are eaten off when about eight or nine inches high, and when comparatively young, the lambs being supplied with a moderate quantity of artificial food, and a constant supply of water and rock-salt. If there is good sound grass-land, a change to this will be very desirable.

Water-meadows, which have been much extolled, are of doubtful value, especially after wet-growing springs; lambs frequently scour very much on such food, the grass being in an unripe condition. A few acres of water-meadow are very useful, if the subsoil is porous, as a run for the ewes and lambs; but we should be careful to give plenty of dry food, to correct the too laxative effect of the raw grass. The first two months after weaning will settle the question as to the sort of mutton we shall turn out; if we can keep the lambs thriving during this period we have little afterwards to fear. It is a most critical time, and we must not grudge pains and vigilance. The fold must be changed twice a day, if necessary. Shepherds who have been accustomed to the open-field system often object on account of the trouble it entails; but it is worth all this, and all the extra expense. We have the choice of nets or hurdles. The former are cheaper and more easily shifted, but not so suitable for small folds. The large folds common in Lincolnshire, where we often see one or two acres hitched off, are wasteful, as much food is trodden down, and the land cannot be evenly manured.

Mangolds kept late into spring are now often invaluable, and never in the way—they are as good as corn.

Feeding off the seeds, instead of laying them for hay, affords much useful keep, and lambs generally do well when eating off the first crop. The second crop is not always so healthy. But this again is often caused by want of management. On the chalk soils a mixture of hop trefoil and Dutch clover has been found very useful, and on such food the lambs are said to thrive better when eating the second crop than the first, probably

because the Dutch clover, which is a comparatively slow-growing plant, is more abundant and more matured. A small area of *Trifolium incarnatum* is worth planting where soil and climate is suitable, as it affords good keep for a few days, but, being of a stalky nature, should be eaten young. Winter barley makes a useful change, as described before. Vetches sown in succession are most valuable—two sowings in autumn, one early in September, the second in October; and two in spring, beginning in February, if possible; they will thus last from the middle of May to the middle of July. A few acres of cabbages will now be found most useful, and should be secured at any cost. Rape and vetches sown together will introduce the lamb to a new food, and avoid a sudden change, which is bad. Then rape, afterwards rape and turnips mixed, and so on to turnips and swedes, which latter should form the main winter crop. It will be found very desirable to introduce the lamb gradually to new food; hence the advantage of mixing rape with the last breadth of vetches, turnips with rape, and swedes with the turnips. Kohl-rabi has been much approved in some quarters, but its thick rind and woody stem are not in its favour; and where we can grow good turnips and swedes I should prefer them, as being more useful and less costly.

Perhaps my ideas will be better explained by supposing a farm of 400 acres of arable land growing 100 acres of roots, and carrying 300 ewes and as many lambs, all to be fed out. Twenty acres of vetches, sown at four different periods, with the folding of about 40 to 50 acres of good seeds, will supply food from May till the middle of July for the lambs after weaning, the ewes cleaning up behind: 4 to 5 acres of cabbage, part to be consumed by cattle, will make a good change; 8 to 10 acres of rape and vetches—1 bushel of vetches, and 2 to 3 lbs. of rape—will form a good mixture. These should be sown at twice, with an interval of about a fortnight, and will supply food for a month or more. A few acres of rape and turnips mixed, in addition, would carry the lambs through September, provided we give a fold of seeds in the morning and the rape, &c., at night. At this time we may introduce more chaff; chopped hay and straw will do well if cut fine and perfectly sweet: 10 to 12 acres of good turnips will carry the lambs to December, when swedes may be commenced.

It is difficult to estimate the quantity of swedes required for tegs: a crop of 16 tons per acre will last 300 tegs a week, according to the ordinary plan of cutting; but probably ten to twelve days if they were pulped. If the use of the pulper is to be recommended for store sheep, much more do we believe in it for the young fattening animal. It may be necessary to use a larger proportion of roots; but there will still be a great saving over the

system of slicing, though it must be granted that this is an immense advance on the old system of making tegs, with their shelling-teeth, gnaw their victuals. This question is one of great importance. The value of mutton is high; the cost of growing roots is increasing. We must do our utmost to make the most of such expensive food. Sheep will readily eat pulped roots: the labour part of the question is the great difficulty. On a large scale horse-power may be economically employed, as I have before pointed out.

Very serious losses sometimes occur when sheep are first put on swedes: especially is this the case if the roots are in a growing condition. The explanation is simple: they are unripe, and consequently deficient in sugar, whilst the nitrogenous matter, probably combined in an unhealthy form, irritates the bowels. A strong evidence of the correctness of this view was given at a recent discussion before the Maidstone Farmers' Club, when it was shown that locust-beans—a food very rich in sugar—had stopped this dangerous scour. This leads us to very important practical considerations. Root-crops should never be consumed until fully matured; and hence it follows that early-planted well-grown turnips will do animals better at a certain period than swedes. Swedes and mangolds will, as a rule, be greatly improved by storing for a few weeks, as the ripening process then goes on more rapidly, and there is a considerable increase of sugar and soluble materials.

When soil and climate are favourable, it will generally pay to keep our produce until ready for the butcher; and the better in reason we can feed from birth the sooner will they be matured and the greater our return, because less will have been wasted in respiration. It is the nimble ninepence we have most of us to look to in these days of expensive farming. If the climate is cold and the land much exposed, as is the case on the West Country downs, we cannot make much of winter feeding in the field, and shall do well to push our lambs as much as possible through the summer, and sell to more lowland farmers at the autumn fairs. In this way lambs have been sold at 48s. to 50s. and upwards. A heavy stock of ewes can be kept, as there is abundance of winter food. The Wiltshire and Hampshire management of lambs is excellent, though perhaps in some instances they are forced more than is for the interest of those who purpose wintering them.

The last point of importance to which I would here call attention is the keeping the skin and wool clean and healthy. Too often the first dipping of the lamb is left till late in the summer, and the vermin that more or less infest their bodies are allowed to worry them for months. The first dipping should take place

soon after weaning; the second towards autumn. Numerous dressings are employed. Those that contain arsenic, mercury, &c., are objectionable, since it is well known that such materials absorbed by the skin into the system are not beneficial; putting out of the question the possibility of a serious accident, if the men are not careful. Again, a strong alkali is combined with arsenic to cause the latter to become soluble, or rather to mix with the water, which dries up the wool. Lately a valuable addition has been made to our list in 'Cliff's antiseptic fluid,' a preparation of carbolic acid. It has been tried largely for scab, with as great success as the mercury and tobacco-washes, which are depended upon in the colonies, and is much cheaper and easier to use. As an antiseptic it is very powerful. A number of sheep badly affected with scab were placed upon a small island, and four healthy sheep, once dipped in this fluid, turned amongst them. Unprotected, they must have become scabbed in three or four days; but so powerful was the dressing as an antiseptic, that it was ten weeks before they became affected; by this time the protective power was dissipated. This experiment was tried by Professor Brown, and is so important that I do not apologise for inserting it here.

Management of Sheep on Strong Land.

Mr. Alfred Hughes, in his lecture before the Society in Hanover-square, endeavoured to show that by adopting a certain rotation of crops, sheep might be wintered on an arable farm of strong land. I do not think he proved his point. In the comparatively dry climate in which his experience had been gained it might be possible; but, generally speaking, I believe sheep stock cannot be profitably kept on strong land, if it be all arable. The crops may be so arranged that the treading of the sheep does not destroy all chance of the next crop; but the animals standing so much on a damp soil cannot thrive: therefore, in considering this question, I shall assume that a considerable portion, at least one-third, of the strong-land farm is grass. The rotation of crops suggested by Mr. Hughes is in many respects a very judicious one. The plan of growing first two corn-crops and then two roots in succession is undoubtedly wise, whether we feed the crops on the land or draw them off. Seeds are sown down in oats and are followed by roots. The ley is not ploughed till spring, and affords a dry surface during winter, besides a good deal of useful autumn keep. Moreover, on such soils wheat is seldom to be depended upon after clover; the land is often so hard that it cannot be properly ploughed.

The first point that must be attended to is thorough drainage; sheep will not thrive if there is stagnant water in the soil. Both

the grass land and the arable must be thoroughly drained. Supposing this is done, and the land well worked and exposed to the action of the air, the growth of a large breadth of summer and autumn forage-crops will be desirable, so that the lambs may have a good succession of food, and plenty of change. Clay land in summer, in good condition, will do for sheep extremely well. The growth of a good breadth of mangolds and some swedes, to be carted off and stored for winter use, is also advisable. During winter the breeding ewes should live on the grass land chiefly, running at large during the day, and being either folded at night, and fed with some corn-chaff, and a few roots, if such can be spared, or, which is to be preferred for the sake of the sheep, lying in a strawyard, and thus making valuable manure. The alternative to be adopted depends upon circumstances, such as the severity of the climate; amount of natural shelter in our grass grounds; the condition of the grass land, which, if out of condition, will be much improved by sheep-folding; the kind of sheep we keep, and our resources as to litter, which is often a scarce article on farms of which a considerable proportion is pasture. Care should be taken to leave some autumn grass; and this there will be an opportunity of doing, if we have a good acreage of fodder-crops, rape, early turnips, &c., on the ploughed land to help carry the sheep. The plan of pulping a few roots, and mixing with straw-chaff, will help the ewes very much, and, if there is a little grass left for them to gnaw, they will keep in good condition. Much, of course, depends upon the quality of the land and the nature of the sheep. The Romney Marsh land carries the hardy sheep of that country through the winter without any extra food, and they keep in good condition; but such grass land is the exception.

The strawyard at night recommends itself for many reasons. Animals lying warm will not consume so much food; they are kept in when the ground is frosty, and prevented eating the frozen grass, which sometimes causes scour, and, as mentioned before, a good deal of straw is thus trodden into manure. Standing flocks are not so common on clay farms as on light soils. Under bad management, and especially if the soil is undrained or imperfectly drained; sheep are very liable to diseases, especially that of rot in the liver, which has often proved very fatal; consequently if sheep are kept at all, the ewes are brought in, every fall, and dam and lamb fed out the following summer. This course of proceeding, from which we can seldom realise the maximum profits, is faulty; it is also unnecessary if we manage well. I recommend a breeding flock as the most remunerative. The question as to the kind of sheep to be kept is one that must be left to experience to decide. The Hamp-

shire Down ewes are very hardy, and, if we want marketable tegs, we can get them by using a Long-woolled ram, Cotswold, or Lincoln; and such lambs can be either wintered or sold in the autumn, when they will prove very attractive to the light-land farmer, who will bid high for such wool-growing, mutton-making tegs. Some cross of this kind will often prove more profitable than breeding pure stock. Of course this necessitates our going to the breeding country for our stock ewes; but there are generally those who have spare ewes to dispose of, and, if we take two lambs, and then feed, it will be as good a system as any we know of.

The way to increase our sheep stock on strong land is to grow a greater breadth of summer forage, improve the quality of the grass by thorough drainage and manuring, so as to develop a mixed herbage, and use a moderate quantity of artificial food with chaff of hay and straw.

I cannot concur with those who imagine that sheep cannot be kept in a healthy condition on strong land. No doubt dry upland will grow them faster, but they will do well on strong soils, if properly managed. The question of selling our lambs, either fat or in store condition in the autumn, or else of wintering them, must depend on the proportion of arable land, and its ability to grow good swedes and mangolds; and also on the existence of suitable sheds and yards, with a sufficiency of straw. If lambs are well summered it will answer to finish them off in the house or yards, provided we have food; but often the horned stock will require all we can spare, and we must provide liberally for the ewes during and after lambing. Clay land is often slow in making a start, and we cannot feed vetches, &c., till near June; we have thus a long spring to tide over.

There can be no question that under careful management sheep will thrive faster in yards, than even on dry, light land, and consume considerably less food. Mr. Alfred Ruston, who has for years thus wintered large numbers of sheep, believes that sheep will pay better than beasts. He found that 6 tegs would tread as much straw into manure as a bullock, and eat as many roots as a store beast worth 12*l.* 10*s.* to 14*l.*; and that 1 acre of mangolds (amount of crop not mentioned) kept 25 sheep from December 1st to April 15, and that he made his mangolds pay 12*l.* 11*s.* 3½*d.* per acre, and the hay and straw 3*s.* per head. Many people are prejudiced against wintering sheep in fold-yards, on account of their liability to foot-rot. If the feet are neglected there will be lameness, which must seriously interfere with the animal's progress. The outer walls of the hoof constantly growing, and being subject to no wearing action, will curl inwards, and lameness is inevitable; but if the feet are carefully pared close down when

the sheep go into the yards, and looked at every three weeks or a month, I am satisfied, from my own experience, that there need not be more lameness, if so much, as the same sheep would undergo if folded on the land; for wet, soft soil gets between the claws, becomes dry and hard, and is a fruitful source of lameness. In addition to this care of the hoof, the supply of litter is most important. In confirmation of this I quote from Mr. W. Delf, of Great Bentley Hall, near Colchester, who, in a letter to Mr. Ruston, says, "It will be supposed that the foot disease is the great difficulty to contend with. To combat this enemy, it will be necessary to pare every foot closely before placing the sheep in the yard, and again at intervals of time not greater than three weeks, accomplishing with the knife what under other circumstances would be effected by the wear of the horn on the land." Again, Mr. Fryer, who has constantly yarded sheep, says: "I ought to refer to a difficulty I had on two occasions with foot-disease. Once I attributed it to a deficiency of litter, allowing the sheep's feet to come too closely in contact with the heating manure; and the other time, to sending out the sheep for an hour or two in the middle of the day for a run over a stubble-field. I found that small clods and stubble frequently got between the claws, and, drying hard on the warm manure, occasioned lameness." Mr. Alfred Ruston, in his lecture before the Central Farmers' Club, from which the above extracts are taken, says: "During the whole of last winter (1860) I don't suppose I had more than a dozen lame sheep (out of 400) whilst they were in the yards. This winter I have had more, as many of them came lame into the yard, in consequence, I suppose, of the wetness of last summer. I may, however, say there have been much fewer cases in the yards than occurred previously to their coming in. I find it is very essential to keep a thin layer of dry straw over the yard. In wet days we litter twice a day, and in fine days once; but we only use a small quantity at a time, so as just to keep the heat of the manure from rising to injure their feet, and to prevent them treading on wet straw during the day."

This evidence is, I think, conclusive that with proper care sheep may be successfully wintered in yards. Nor is it necessary, or even in all cases desirable, that the sheep should be placed in walled yards; indeed, it has been found that close yards do not answer very well, as the manure is apt to ferment. Folds may be made at any dry sheltered spot near to where the food is produced. Seeds not to be broken up until spring, or dry grass land, afford a good site. The straw may be carted at any convenient time, and used to form two sides of the yard where most exposed, the opposite sides being left open. A yard 10 yards by 20 yards

would be a suitable size, as it would hold about 50 sheep, so as to allow each animal about 4 square yards. Strong extra-sized hurdles will be required. The chaff and corn may be prepared at the buildings, and brought twice a day by a donkey-cart and boy, the roots being prepared on the spot. A great quantity of manure may thus be made, probably very near its destination; it will require turning once or twice, and will then be found in excellent order for applying the following autumn.

Pulping will be found a great improvement over slicing, and with yard-fed sheep it will be unattended by such difficulties as we have noticed with regard to the open field.

There is one point to which allusion has not hitherto been made, and that is, increasing the proportion of pasture on strong land, especially in a moist climate. Under such circumstances a considerable proportion is desirable, though half at least of the farm should be arable, as otherwise we cannot provide straw and roots for winter keep. If grass is properly drained and well treated; if periodically dressed with manure, compost, and possibly artificials; and if during summer sheep graze, eating artificial food, it is astonishing how much good winter keep such land will produce for the ewes. The utter neglect of our grass land which we too often see is a sad blot upon English agriculture, and in the present day such neglect is ruinous, for nothing will pay so well for capital properly laid out. I am aware that practical difficulties often exist. It is a work of time to secure a sward, and during a portion of that time a very unremunerative produce is returned; so that the farmer who has no lease, and no help from his landlord, may well hesitate about laying down land to grass; but he need not doubt about the advantage of treating the old land liberally.

I believe that the principal means of increasing sheep stock on strong land, is to so arrange the cropping as to secure a large surface and succession of summer green food, such as vetches, rape, early turnips, and cabbage,—the latter being particularly adapted for strong soils,—and to provide for the winter by the judicious use of mangolds (climate permitting), or swedes, with plenty of dry food. The breeding ewes may be kept in a healthy state on the grass land during winter; whilst the fattening stock (tegs), if kept on, may best be fed in strawyards.

XX.—*The Reproductive Powers of Domesticated Animals.* By
HENRY TANNER, M.R.A.C., Professor of Rural Economy,
Queen's College, Birmingham.

VARIOUS circumstances concur at the present time to invest the rearing of farm stock with especial interest, more particularly when we consider the difficulties associated with breeding from pedigree animals. Although but imperfect explanations can be given of many of the points involved, an examination of the subject may serve to diminish these difficulties, and open up for consideration certain modifications of practice which will enable the breeder to meet them without fear.

The natural habits of animals are well adapted for the preservation and perpetuation of each species. Those which are weakened by disease or enfeebled by age are displaced by younger and more healthy rivals, and the result is that each species is perpetuated in its greatest vigour, and with healthy constitutions. Local circumstances—such as the quality of the soil and the peculiarities of climate—influence the development of these animals; and thereby we have local breeds established especially suited to certain districts. The variations which thus naturally arise are perfectly consistent with, or rather are conducive to, healthy growth; and within certain limits nature permits, and even favours, a deviation from typical forms, to meet the varying peculiarities of soil and climate. Thus, where the soil is luxuriant we have large native breeds; where the land is hilly, we have smaller and more active animals; where the climate is severe the more hardy varieties are found, the animals attaining that kind and degree of development and vigour which is best suited to the circumstances under which they are placed.

Under domestication we take these animals under our control, and modify their character to suit our requirements. Instead of the active roaming life which they naturally lead, accompanied with a slow growth, but large muscular development, we require animals capable of rapid growth to luxuriate upon our richer pastures, or consume our more abundant crops, and to supply an increased growth of those parts most valuable for food. In short, we produce unnatural developments to meet our special requirements. No doubt they are most desirable modifications, but it must be remembered that they are unnatural; and in proportion as we depart from the natural type, in the same degree do we find difficulties arising to check our onward course. The skill of the breeder is thus constantly tested, and the highest proof of success is the attainment of the peculiar development required with the least sacrifice of constitutional strength. But the natural character remains throughout, struggling to regain the ascendancy,

and if any want of judgment should be shown in the management, the race gradually reverts towards its original character.

The improver of any local breed naturally directs his attention to the attainment of that symmetry of form which is indicative of an increased aptitude for fattening—a deep, broad chest, well-arched ribs, a broad and level back, with well-formed muscles of the fore and hind quarters, and a soft and mellow skin.

Modern improvements—such as draining, farm-buildings, and fences—by limiting the influence of climate, have extended the range within which special breeds can be successfully and economically reared; nevertheless there are still many neighbourhoods to which the improved local breeds are better adapted than the more celebrated stock of other districts. We cannot look upon these improved breeds as possessing any permanent character, for so powerful are the influences of soil and climate, that, with the most judicious management, it is impossible in some cases to maintain the character of the flock or herd, without going back to the original district for fresh blood.

In a previous communication * I have discussed at some length the accumulation of hereditary power which takes place in pedigree stock, but we must clearly distinguish between such a concentration of hereditary power and the exercise of the breeding faculty. In numerous instances animals distinguished for their symmetry, and possessing every peculiarity which is desirable for the production of meat, and moreover by their line of descent possessing great fixity of type, are valueless for breeding purposes, because of their inability to exercise their reproductive powers. These animals are like a machine of beautiful construction, capable of turning out the finest products with the greatest economy, but that a motive power is wanting to render it available. Such is the position of many of our most valuable pedigree animals, and it will be interesting to inquire how far the difficulty may be overcome.

Unfortunately excellence has been attained in too many cases by a great sacrifice of constitutional strength, which renders these animals an easy prey to various forms of scrofula, affections of the lungs and digestive organs, which are too often accompanied or closely followed by a deficiency in the supply and quality of the milk, and finally by weakened and imperfect breeding powers.

The free exercise of the body exerts a most important influence upon the functions of life. Muscular growth is almost as dependent upon exercise as it is upon the nutriment from which it is produced. Nature has implanted in all young animals a

* 'Journal of Royal Agricultural Society,' First Series, vol. xxii. p. 1.

strong desire for that exercise of the body by which their growth can be best promoted; and this is particularly shown by the uncontrolled delight which they manifest when liberated from a bondage against which nature rebels. The advantages which arise from variations of the surface, and especially in the change from level to hilly land, are great; for they give a breadth to the chest, and strength to the lungs, which is not otherwise obtainable. The invigorating atmosphere of hilly land has also a very beneficial influence upon the health. If we notice the vigorous health possessed by our mountain breeds of cattle and sheep, we see what it is that we require engrafted into our improved stock to bring them to their highest point of value. In our mountain stock we have muscular development, a rich juicy meat, vital energy to protect the system against disease, and enable its various functions to be performed in the most healthy manner. In our improved breeds we have symmetry, and an aptitude for fattening which renders them economical to the farmer. Can we not amalgamate these qualities more completely than we have done, and by giving to well-bred stock greater freedom for exercise, a modified diet, and a purer atmosphere, rear them in a manner calculated to promote their healthy growth and constitutional strength?

The winter management of pedigree stock also demands our attention, for it is more than probable that in this particular serious injury is occasioned. The varying seasons of the year are not without their influence upon animal life. The system requires the invigorating action of cold to brace up the body against the enervating influence of the heat by which it is succeeded. In how many cases are our best animals wintered in buildings which favour their ripening condition and blooming appearance, but at the same time enfeeble the system, and thereby undermine the health and predispose to disease, especially of the lungs, the animals being unfitted for being turned out to graze in the spring. When shelter is provided, available at the option of the animal, and accompanied by liberal feeding, the healthy condition of the stock in the spring will offer a marked contrast to that of animals which have had too much protection, and have lived in a less pure atmosphere. I consider that much of the delicacy of constitution and predisposition to disease, which is complained of in high-bred stock, may be traced to such injudicious management.

An enfeebled condition of the breeding organs is one of the first sources of trouble for the breeder. It seldom precedes, but often accompanies, that delicacy of constitution to which reference has been made. Instead of the females breeding in a regular manner, we find them come into season again and again, after

most irregular intervals. This results from one of the following causes: either the female does not become impregnated, or else the embryo is imperfectly developed. The non-impregnation of the female may generally be traced to an excessive fatness in one or both of the animals, and an absence of constitutional vigour. The breeding powers are most energetic when the animals are in moderate condition, uninfluenced either by extreme fatness or leanness. The impregnation of the female is in some cases prevented by natural defect or malformation; but I am strongly inclined to believe that such cases are comparatively rare.

Many animals are condemned as barren which are only temporarily so, in consequence of injudicious feeding and management, or relatively so, in consequence of the male being unsuited, from too close proximity of blood, or from both animals being deficient in constitutional vigour. Examples of each of these cases are frequent. Some very well-bred heifers which had been condemned as barren, because, after very persevering trials with various bulls, they failed to breed, I placed for four or five months upon poor hilly pastures, to bring them down in condition, and immediately after this they bred without difficulty. Captain J. T. Davy has communicated to me some similar instances in which most hopeless cases of barrenness were overcome by turning the heifers upon poor common land with a young bull. He states that in other cases the same result has been attained by working the heifers in the plough, like oxen, after which there has been no trouble in getting them to breed. I am also informed by Mr. Strafford of another instance in which apparent sterility has been successfully overcome. The late Mr. Jonas Webb purchased a valuable cow from the herd of the late Lord Spencer for a moderate sum of money, in consequence of her being condemned as barren. After the purchase she was driven from Wiseton to Babraham, a distance of between 100 and 120 miles, and within a short time she bred. 'Dodona,' the cow in question, when a heifer, produced twin-calves, and subsequently she produced another calf, but, as she then ceased to breed, she was sold. A change of climate, however, brought her again into breeding condition, and at the time of her decease no less than 160 valuable animals could be traced to this cow, which had been sold on two occasions as barren. Mr. Webb had an almost parallel case in 'Celia,' which, under somewhat similar treatment, after being condemned as barren, had a progeny of over 180 traced to her at the time of her death. These results were all gained by somewhat severe treatment, whereby unhealthy accumulations of fatty matter, previously existing in the body and impeding generation, were taken up into the system for the support of life.

I have known cases in which heifers which could not breed were exercised daily, by being led about for a certain length of time ; but this treatment is seldom sufficient to reduce those accumulations which impede generation. Highly satisfactory results have been gained by a thorough change of climate, when the stock were sent to hilly districts where the air is bracing, and they have to take plenty of exercise.

Barrenness may also be traced to too close relationship, or a similarity of temperament. This is, however, a qualified barrenness, to be overcome by proper selection on the part of the breeder. The fat condition of the male animal, and his want of constitutional vigour, are frequently the chief causes of difficulty. I have known of bulls, which had become valueless for breeding purposes, being worked upon the land in carts, and thereby rendered serviceable.

I believe that we have the condition of successful reproduction very much under our own control, and that the cases of legitimate barrenness, either on the part of the male or female, are much more rare than we imagine. I know that animals which are naturally capable of breeding can be rendered incompetent by adopting a special course of treatment ; and I consider that in our usual system of management we very much retard and interfere with the healthy performance of this natural function of animal life.

For the purpose of more fully investigating the causes of barrenness, I have examined* the ovaries of several heifers which were, after very careful trial, condemned and killed as barreners ; and I have every reason to believe that by far the larger proportion were naturally quite competent for breeding, and that in the majority of cases nonimpregnation arose from the seminal fluid never reaching the ovum, which was ready for fertilisation, or from that fluid not being of a healthy character. In some cases in which the ova were to all appearance perfectly healthy, the tubes—whereby the seminal fluid should have been conveyed—were so overcharged with fatty matter that impregnation was rendered impossible. In other cases the ovaries were in an unhealthy condition, either one or both having to a great extent wasted away. Sometimes one of the ovaries had been suffering from atrophy, and the other in such an irritable and sensitive condition that it might be almost described as inflamed ; and under such circumstances the formation of a healthy ovum could scarcely be expected. In other instances the ovaries had become considerably enlarged, in consequence of a fatty degeneration of

* In the prosecution of this examination, I have received great assistance from Dr. Atchley of Bristol, to whom my best thanks are due.

these organs having taken place. I have not sufficient data before me to trace these several results to their respective causes, except in some of those cases in which a fatty degeneration of the ovaries had taken place.

Through the kind help of Mr. Reece, of Ross, and Mr. Thos. Duckham, of Baysham Court, near Hereford, this fatty degeneration of the ovaries has been traced to the use of food rich in sugar. I have every reason to believe that the action of sugar, in its various forms, is most important in its influence upon the generative system; and I think there is just cause for considering that any animal may by its use be rendered incompetent for propagating its species. Since my attention has been drawn to this fact, numerous instances have come under my observation, tending to confirm this opinion. From among the cases which I could mention it will probably be sufficient for me to state that of a breeder of some eminence, who, with a view to an improvement in the condition of his herd, added molasses to the dry food he gave to his stock. It certainly produced the result he anticipated, for their improvement in appearance and general condition was most satisfactory; but this was accompanied by an influence he had never expected; for his stock, which had always realised high prices as breeding stock, now, with very few exceptions, proved to be valueless for that object, male and female being alike sterile. As soon as this was discovered the supply of molasses was stopped. But whilst the animals which had not been under its influence maintained the original character of the herd, as being good breeding-stock, it is very doubtful if any of the stock which had been fed for any length of time upon food mixed with molasses ever regained their breeding powers. It is more than probable that a fatty degeneration of the ovaries took place, from which they would but slowly recover under any ordinary treatment.

In another case in which molasses had been used for some heifers which were fattening, it had the effect of suppressing those periodical returns of restlessness which prevent heifers feeding as well as steers; and it kept them so steadily progressing during the whole period of their fattening, that the result was highly satisfactory. If, therefore, upon further trial, we find sugar influential in checking the reproductive functions, we can at any rate exercise a proper discretion in its use; and whilst avoiding it for breeding animals, we may encourage its employment when cows or heifers have to be fattened.

The action of sugar upon the human system is very similar. The negroes in the sugar-plantations are said to lose all power of reproduction during the sugar-harvest, and are permanently influenced, although in a lesser degree, by the juice of the cane, which

they are so fond of chewing ; there is also reason to believe that the negroes have become relatively more productive with the diminished growth of sugar. It is also probable that the French and Turks, by their excessive use of sugar and sweetmeats, render themselves far less prolific than they otherwise would be. I have also reason to believe that some of those who have adopted the Banting system will find that the decreased use of sugar, whilst it will lessen their personal weight, will at the same time have a tendency to increase their parental responsibilities. Until my attention had been drawn to this action of sugar upon the reproductive powers, I was not aware that its influence had been previously acknowledged ; but I find that this has been observed by Continental physiologists, of whom it will be sufficient for me to mention Moleschott and Provençal.

It would be premature for me to attempt any explanation of the manner in which sugar exerts this powerful influence upon the animal system. We shall probably find that it has a twofold action, it may not only produce a fatty degeneration of the ovaries in the female ; but by the glandular excitement it causes, it may also favour a re-absorption, of the seminal fluid of the male, and thereby the desire for breeding be diminished, if not finally destroyed. That sugar has a powerful influence upon the reproductive powers scarcely admits of a doubt ; but it is most important that we should be more fully acquainted with its action. We shall, however, find that other agencies produce a somewhat similar tendency to fatty degeneration, if not in the ovaries, at least in the surrounding parts, whereby the healthy ova of females fail to be fertilised in a natural manner ; or when they have been fertilised they are, from the same cause, subsequently aborted. It is also probable that in some cases in which the female possesses healthy ovaries, and yet in consequence of the defective powers of the male fails to breed, a very unnatural excitement takes place in her that induces an irritability which is fatal to impregnation. In these, and similar cases, the removal of the clitoris of the vulva (as spoken of by Mr. E. Bowly, of Siddingington, in vol. xix. of this Society's Journal, page 151) would allay this excitement, and thereby favour successful breeding. This is, however, a practice which few would be disposed to recommend ; and Mr. Bowly rather mentions the fact of the operation than advises its adoption.

The moderate use of salt is also stated to have a powerful effect upon the breeding powers of animals. Moleschott states that the favourable effect of common salt upon the formation of blood and upon nutrition, also produces an influence upon sexual life. Boussingault found that bulls which in their food receive a large addition of common salt show a greater inclination to cover ; and

Roulin states that the females of our domestic animals are rendered less productive by want of salt. No evidence as to this action of salt has come under my own observation, still I think it probable that we shall find the more general use of salt very important and beneficial in its action upon breeding-stock. When salt is used for any animal producing milk, care must be exercised not to allow it to be taken in such quantity as to check the production of milk; for a free supply would speedily stop this secretion.

The general system of diet must also be looked upon as taking its share in influencing the reproductive functions. When the fall of rain has been small, and the herbage more than usually parched, we find unusual difficulty in getting ordinary farm-stock to breed. A dry dietary is very unfavourable for breeding-animals, and very much retards successful impregnation. On the other hand, rich, juicy, and succulent vegetation is very generally favourable to breeding. Apart, therefore, from the direct influence of the food given, it is certain that the condition in which it is consumed materially influences the breeding powers of stock.

Little is as yet definitely known as to the comparative influence of different kinds of food upon breeding-animals; but the information we possess leads us to desire further evidence. We know that the healthy semen of male animals, with few (if any) exceptions, contains a large proportion of albuminous matter, in the form of vitellin and albuminate of soda; and it follows as a natural consequence, that unless these bodies are present in the food, although they may for a time be supplied by exhausting the animal system, still his career cannot long be maintained without prejudice to the animal, and disappointment to the breeder. The presence of phosphorus is also essential; and it has been observed that food rich in phosphorus, such as the leguminous seeds—peas, beans, vetches, &c.—are especially valuable in promoting the fertility of breeding-animals. It may also be stated that although a moderate supply of fatty matter is desirable in the food, still it should be limited, so as to prevent any unhealthy accumulations of fat in or about the breeding organs; and it should always be accompanied by food rich in albuminous matter.

The influence of climate upon the health of our domesticated animals has never received that attention which it merits. I have already made some reference to the effect of a change of climate upon the breeding powers; and I may add that the beneficial influence extends both to male and female. The results which have attended the importation of English stock which had been exported to other climates, or their immediate descendants, show that considerable advantage is often realised in this manner,

and the practice is probably capable of extension. It is, however, well worthy of an inquiry, whether we do not possess in our own country sufficient variation of climate and district to accomplish the desired results at less cost. There is undoubted evidence to show that we may thus engraft upon our stock greater constitutional strength.

The formation of milk is intimately connected with the reproductive powers. The secretion of milk is dependent upon the activity of the mammary glands; and these are either under the direct influence of the breeding organs, or else they sympathise very closely with them. Those animals which breed with the least difficulty yield the best supplies of milk, and produce the most healthy and vigorous offspring. Now, it must be admitted, that, however much we have improved the symmetry and feeding-power of stock, we have suffered them to deteriorate in value as breeding animals, by the decrease of their milking capabilities. In proportion as we adopt a more natural system of management, for the purpose of keeping stock in a healthy and vigorous breeding condition, so shall we reap the indirect benefit of a better supply of milk. It is true that a deficiency in the yield of milk may be met by other resources, but since a short supply of milk is indicative of, and associated with, enfeebled breeding powers, every care should be taken to obviate this defect.

There are few subjects connected with agricultural literature which offer such a scope for inquiry and research as that which I have now discussed; for whether we look upon the reproductive powers of domesticated animals from a practical point of view or as a scientific inquiry, we have very strong inducements to investigate the subject more completely. The varying circumstances under which barrenness can be produced or removed; the influence of various kinds of food upon the breeding capabilities, and also upon the production of milk; the circumstances which favour or check abortion; the conditions which regulate the sex of the offspring,—these, and many kindred subjects, demand careful consideration. There is a vast amount of valuable information upon these points diffused amongst the members of the Royal Agricultural Society, which, if collected, would open up an important field for scientific research. This can only be accomplished by a co-operative movement; and it is with the hope of promoting such a result that I have brought this subject under consideration. May I add that I shall be pleased to receive any communications, or register any well-authenticated facts bearing upon these subjects, which may be forwarded to me, addressed as below. I shall be glad to hear of any instances of barrenness which have been, or still are, under special treat-

ment, whether such proceedings have been successful or otherwise, and especially where the animals may on some future occasion offer the opportunity for an examination.

Clifton, Gloucestershire.

XXI.—*Water-Supply.* By the Rev. J. CLUTTERBUCK.
PRIZE ESSAY.

ALL water-supply, whether surface or subterranean, whether naturally issuing aboveground from springs, or artificially reached by wells or shafts, is derived from the rainfall. Therefore, in treating of the possibility of improving the water-supply in rural parishes for agricultural and domestic purposes, the question resolves itself into the economical use or application of quantities which vary, but of which the amount may to a certain extent be ascertained. The amount and distribution of rainfall yearly attracts more attention, and many sources of information are open to the public. The tables of Mr. Glaisher and Mr. Symons show an increase of rainfall with the longitude westward, the influence of altitude, and other physical features; so that in some localities there is such an abundant and continuous rainfall as to exclude them from the scope of such an inquiry as this.

Though rainfall is reduced to, and treated with reference to, averages, the economical increase of water-supply has rather respect to a minimum, or to quantities, in excess at certain seasons, to be made available when the ordinary average supply falls short. Taking Mr. Symons's published averages of rainfall in England at 30 inches, by excluding all above 30 inches as beyond the limit of this inquiry the average is reduced to about 25 inches, the minimum at any place being 16·91 inches.

These facts should be noted, though the variations in the quantity that falls at any given season make it difficult to base any calculation on the gross quantity falling during the year. Subterranean water depends on the quantity percolating below a certain depth; the gross rainfall has a greater influence on surface supply. The difficulty alluded to is shown in a remarkable manner by the records of Dalton's gauge, kept by Mr. Dickinson, which registers the water percolating 3 feet below the surface. The average rainfall at the same place for 29 years was 22·5, the percolation 7·5; the 10 years ending 1863 gave 25·8 total fall, percolation only 5·9; showing that in the longer period the average summer rainfall was in arrear and that in winter was in excess, while in the shorter period the case was reversed.

It will be necessary to notice separately surface and subterranean water, The former comprehends all water retained in ponds whether natural or artificial, that received or collected from roofs of buildings, stored in tanks and the like, or water thrown from the surface of the soil; subterranean water, all that sinks below the surface, accumulates in permeable strata, and thence issues in springs where vent is given to it.

SURFACE-WATER.

First, as to water collected from the roofs of buildings. This is obviously a simple process, requiring good and well-arranged spouting, with sufficient tank-storage. In the construction of farm-buildings where this supply is needed, it may repay the outlay to increase the area of water-catch beyond the absolutely necessary extent of roofing, and to adopt the covering from which rain-water is most readily and copiously thrown. Thatched roofs are beyond the scope of any calculation. Zinc, iron, lead, or any metal, slates, hard-burned Staffordshire tiles, will throw off the greater portion of all rainfall. Ordinary tiles, when dry, absorb a considerable amount of water: a shower represented by 3-100ths of an inch would be thrown from the surface of the first-named substances and absorbed by a tile. This would be repeated on the falling of every summer shower; and a calculation based on the known daily rainfall of the summer of 1864, allowing for only one shower on the days when rain was noted, gives for the 5 months from June to October inclusive, an aggregate loss of 1 inch of rain by the absorption of tiles, or about 25 gallons for every 100 square feet of roofing.

If we take the Flemish Farm at Windsor—which is covered with tiles—as an instance, the roofing may be estimated at 15,000 square feet; there would then be a loss of 7500 gallons of water, filling a tank 12 feet square by 8 feet deep. This may seem a trifling quantity, but it would be of great value in some places in seasons such as 1864.

In retentive soils, tanks for cottages may be made at a small cost by sinking casks into the ground, though brick-built tanks will necessarily be cheapest in the end; this is one of the improvements in cottage homes which never should be omitted, even where well water is abundant. Open ponds, sunk into a clay subsoil, will, at certain seasons, receive the soakage from the surrounding soil; even those which are artificially puddled retain their water in a way difficult to explain when the natural evaporation and artificial exhaustion by cattle and other uses is taken into account. This phenomenon, for such it may be called, is very remarkably illustrated by surface ponds on the highest ridges of the chalk downs, known as dew-ponds.

Dew-Ponds.

These ponds are chiefly constructed on the highest ridges of the chalk range, whether in down or under arable cultivation, for the purpose of supplying water to the sheep stock during the summer months. In a known instance, the increase of these ponds on an extensive farm, high on the chalk range, has been made the subject of arrangement between a landlord and an incoming tenant, with a view to the introduction of steam-cultivation. Though careful and wide-spread inquiry, with repeated personal observation, have failed to clear up the difficulties presented by the sustained supply of water in these ponds, notwithstanding the drain on them by the daily demands of sheep and other stock, the following facts may be relied on, and will tend to show their great value to the flockmasters of a district where many breeding flocks are sustained during the summer months, when a good supply of water is essential to their well-being. Natural springs, as supplies, are out of the question on the summit of the chalk range, since the chalk water-level lies from 100 to 400 feet beneath these ponds.

The site selected is generally at the highest elevation on the ridges or spurs of the chalk hills, where they can receive no run of surface-water, though instances may be found where they are placed near roads on hill-sides, and so receive the run after heavy rains; of the former alone here it is proposed to speak, as they present phenomena not easily accounted for by recognised physical causes.

These ponds are constructed by persons of experience and skill. At the spot selected an excavation is made in the surface of the chalk, either round or rectangular, from 30 to 40 feet or more in diameter, from 4 to 6 feet deep. The bottom, of a basin shape, is covered in portions with clay carefully tempered, mixed with a considerably quantity of lime to prevent the working of the earth worms. As the portions are finished they are protected from the action of the sun and atmosphere by a covering of straw; when the whole bottom of the pond is so covered with an efficient and impermeable coating or puddle, a layer of broken chalk is placed upon it to prevent its injury by cattle or other means. Their cost varies from 30*l.* to 50*l.* When all is finished, water is introduced by artificial means. If there is a fall of snow, this is collected and piled up in the pond, as the readiest and least expensive method of accomplishing the object. During the falling of the snow in January, 1865, with a strong wind blowing, flaked or wattled hurdles were so placed that the drifting snow accumulating against them readily filled a pond on one of the highest ridges of the chalk range of hills. Ponds so constructed

and filled have been known for periods of twenty or thirty years never to become dry; the summer of 1864 was a notable exception, in which, during the months of April, May, June, July, and August, a less quantity of rain fell in the neighbourhood in question than for the thirty years preceding, and dew was noted deficient. A calculation, based on carefully obtained facts, shows that in 40 days, ending July 14th, 1864, a pond lost (by measurement of its surface and depth) 13,500 gallons of water; adding the known rainfall, 0.9, on the slopes and surface of the pond—1800 gallons—we have a total of 15,300. Calculating the consumption of a flock of sheep, 500, at $\frac{1}{2}$ gallon per head per day; the quantity used by cottagers at 600 gallons; the evaporation, as tested by experiments, at 9000; the sum stands thus:—

Water lost by pond	13,500	}	15,300
Rainfall	1,800		
Consumed by Sheep	10,000	}	19,600
Cottages	600		
Evaporation	9,000		
Not accounted for				4,300

It is believed that $\frac{1}{2}$ a gallon per day does not represent sufficient water for each sheep's consumption. It was found that a flock of ewes on dry food consumed 10 pints, or $1\frac{1}{2}$ gallon per day, in the winter of 1864-5. Taking only $\frac{3}{4}$ of a gallon, the consumption would be equal to the whole loss. The concurrent testimony of many shepherds bears out this supposition.

Apart from all such calculations, shepherds say that they see vapours gathering over the ponds; and a person of undoubted intelligence assured the writer that he has seen the vapours drawn to the ponds, as to a centre, when unmoved by wind. It is readily acknowledged that this subject requires further investigation; but, as a fact, the value and endurance of the supply to these ponds can hardly be denied. In many parts of the chalk range—especially where partially covered with woodlands—these ponds are not known, and here they might be profitably introduced; and it is believed that they would be found valuable on all high and exposed districts where summer supplies of water are needed.

The collection of surface-water from drains in a *clay subsoil*, even where the contour of the ground favours such an arrangement, must be precarious. These drains do not run except after heavy rainfalls; ponds which retain their water during a long period might be filled by these means, but, in the absence of supply from land or other springs, the quantities so stored would be likely to fail,

Pumping water from a stream would seem to be too obvious a remedy to need much notice; yet I may state that a large mansion, tenanted by several families in succession, lost its tenants for lack of good water-supply: until at length, under the advice of the writer, an effectual remedy was found by raising a supply through filtering-beds into a tank from an adjacent and frequently turbid stream.

Land-Springs.

Land-spring is a term generally applied to sources of water which are found in or flow from superficial beds of gravel or drift, lying on an impervious substratum. Since many districts throughout England are entirely dependent on such sources for their supply of water they require further notice. Very many of our most ancient towns and other places of early habitation are placed on drift-gravel, probably from the facility with which water is thence obtained. The older part of London, and the city of Oxford, on different geological formations, are noteworthy examples of towns so supplied, until they were extended beyond their ancient limits, or until these sources, as is often the case, became tainted by infiltration from sewers, cesspools, and the like. Most of the higher ground on the London clay, such as Hampstead, Highgate, Harrow, Bushey Heath, and the Bagshot district—where a better-defined formation overlies the London clay—are examples of this kind of supply. In the Bagshot sands, in consequence of their great depth and wide development, by taking advantage of the levels at which water is thrown out by bands of clay alternating with the sand-beds and by turning to account the undulations of surface, large lakes or ponds are formed, such as Virginia Water. At Bear Wood, a dam being thrown across a valley, the water collected in an ornamental lake serves to drive the agricultural and other machinery of the Home Farm,—an example of economising waste water which is worthy of especial notice. In the London and Hampshire Basins this character of supply is not entirely confined to the limits of the London clay *in situ*, but extends to the higher ridges of the chalk, which are frequently capped with traces of the tertiary formations, so that water is frequently retained in gravels by which they are covered or upheld in surface-ponds. The chalk district is, therefore, marked by the gathering of the population either on these higher levels or else in the valleys in which run the streams which issue from the subjacent chalk stratum. In the former of these a rigid economy in the use of water is forced on the agricultural and other population, as, on the failing of the supply, no resource is left but the streams in the valleys, or very deep wells, from which water

is necessarily raised with great labour. No districts suffered more from lack of water to man and beast, during the summer of 1864, than the higher ranges of the chalk, from the failing of the dew-ponds on the downs and all other surface supplies. The failure being due to the quantities actually drawn from them suggests an increase in the number of these ponds, or their adoption in localities where they have not been tried, especially where they would be easily formed in the tenacious soils found on the upper levels. There is sometimes a waste of water in these localities where it might be turned to good account. The beds of sand or gravel and the clay on which they rest, are frequently drained by means of shafts or dumb-wells, sunk through them to the surface of the chalk, into which the water freely sinks from the drains which converge to them as a central outfall. Necessary as draining is, this water might often be stored in ponds sunk through the gravel into the clay, with an arrangement of pipes to prevent its rising above a certain level, or subterranean tanks might be formed where the clay is of sufficient thickness below the gravel. Where the beds of gravel are deep and extensive, it is obvious that water may be led away from a hill-side and form a perennial stream of the greatest value.

This is well illustrated on the well-known Tiptree Hall Farm. When first occupied by Mr. Alderman Mechi, land-springs issued from the slightly-rising ground to the north of the house, the weepings of which generated a peat-bed. Deep drains were driven into the hill-side, cutting through the margin of the gravel into the clay beneath, whence so large a quantity of water was gathered into one head as to supply all the ordinary wants of the homestead, and furnish a volume sufficient to carry out at all seasons the system of irrigation coextensive with the farm, whilst its overplus carries health and comfort to a once fever-stricken district in its course below. As the utilization of this water is instructive, so in the source whence it flows a lesson may be learned as to the geological and physical conditions under which a like supply may be turned to good account elsewhere.

The village of Tiptree stands on an extensive bed of drift-gravel and sand, resting on the tertiary clay, naturally drained by streamlets which flow down the shallow valleys or depressions by which it is flanked or intersected. As in all such cases, the subterranean water is upheld in the soil at an angle above its outfall, varying with, and dependent on the closeness of the sand or gravel in which it lies. The water in the village wells stood, in the autumn of 1864, 16 or 18 feet above the artificial and ever-flowing vent given to it by Mr. Mechi's drains. It is on record that, when these drains were first dug, many, if not all,

the wells in the village were more or less affected. If the supply were less, and it was necessary for the sake of Tiptree farm and establishment to economise the supply (and this may serve as a general illustration), a well (call it of depression) on a large scale might be sunk near the centre of the gravel-bed, whence the greatest body of water might be raised by artificial means, or allowed to pass by gravitation from the well to the lower levels by some simple contrivance providing for the shutting off the water at pleasure. Such sources of water, when practically perennial, are often said to yield an undeviating volume; a periodical gauging would show that the quantity is in the ratio of the natural exhaustion and replenishment by rainfall.

It should be noted that sands and gravels are speedily replenished; as gravelly soils, from their silicious and stony character, preclude such an absorption of water as takes place in loams, chalk, and other substances after a period of drought. Careful observation and frequent measurements have shown that wells in sand and gravel are replenished by a heavy summer shower; whereas it requires from 2 to 3 inches of continuous autumn rainfall to replace the evaporation of the summer in the soils of a more tenacious character.

No general rules can be laid down for dealing economically with sources or supplies of water held in drifts or gravels which flow aboveground as landsprings, unless they are founded on the ascertained geological condition, whether of the gravel-beds themselves or of the surface of the clay on which they rest.

The gault, Kimmeridge, Oxford, lias, and other clays—which are of the character of marls, as in the new red sandstone—present, when their surface is exposed, a corrugated character. The Keythorpe system of drainage is based on this fact; if we may judge by the present river action on the gault in the valley of the Thames, this condition has probably a fluvatile origin. Be that as it may, the cutting through one of these subterranean stanks or ridges will often lay a large tract immediately dry. This was the case in the city of Oxford, when a system of deep sewer-drainage was attempted, by which the house-wells were laid dry through a considerable district, till the stank of clay cut through was restored by artificial means, when the water was restored also. The section, A (see next page), made at the time, is given as a good illustration. When, under such circumstances the water-level has been affected, the wells have been sunk into the subjacent clay; but the water held in the clay is often so surcharged with mineral substances as to render it unfit for use. If the water is not too much reduced in the drift, the bottom of the well should be enlarged, as a sort of subterranean tank, rather than pierce the clay under any circumstances. The surface, or

A.—SECTION OF UNDERGROUND NATURAL STANKS, OR UNUNDATIONS, ON THE SURFACE OF OXFORD CLAY AT OXFORD.

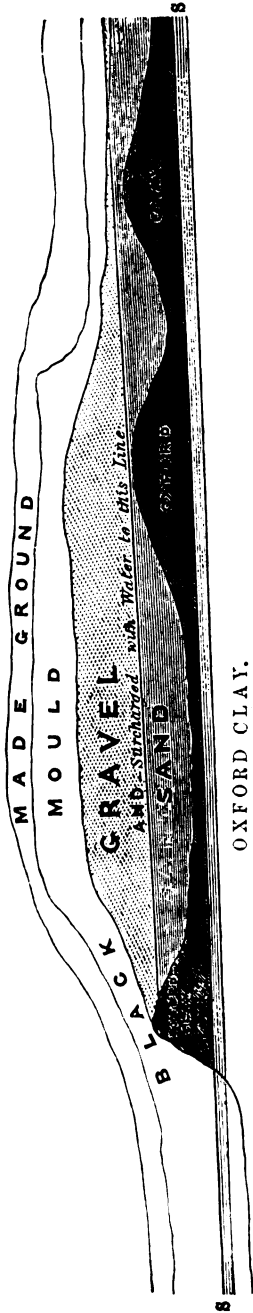

(B) SEWER IN CUTTING OF WHICH THE GRAVEL WAS DRAINED AND THE WELLS IN IT DRIED.

B.—SECTION OF THE LONDON BASIN, FROM WATFORD TO LONDON, SHEWING THE HEIGHT TO WHICH WATER RISES IN WELLS BETWEEN THOSE PLACES.

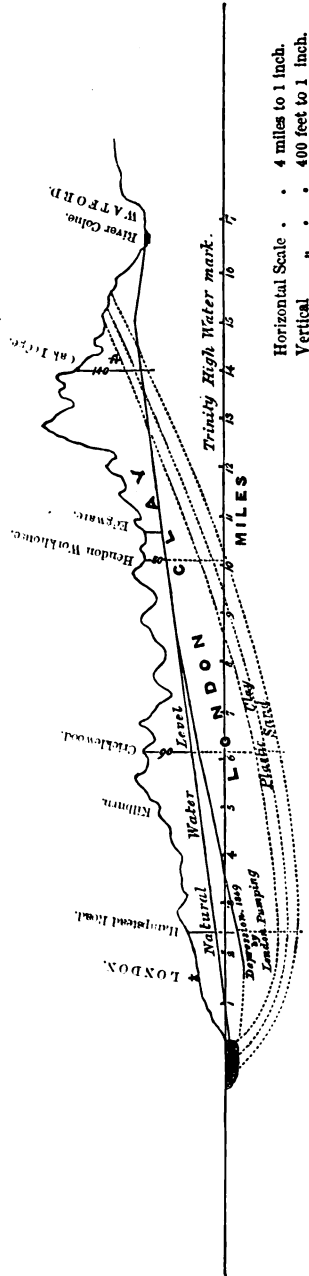

rather landspring, supplies of water are often undervalued, and great expense is incurred in sinking to deeper sources.

ARTESIAN WELLS.

Dr. Buckland, in his 'Bridgewater Treatise,' defines artesian wells as "perpetually flowing fountains, obtained by boring a small hole through strata that are destitute of water into lower strata loaded with subterranean sheets of this important fluid, which ascends by hydrostatic pressure through pipes let down to conduct it to the surface." As there are very many cases in which the water does not attain the surface of the ground, the name artesian has been applied to such, because they do not present all the conditions in the above definition; besides which, their construction so far differs, that a shaft, as of an ordinary well, must be sunk below the level attained by the water, from which it must be raised by artificial means. All the deep wells in London are of this character.

There is a very common impression that water may be obtained in any locality by boring, if it be carried to a sufficient depth. Immense sums of money have been thrown away in such attempts, and in other cases the quality of the water when obtained renders it unfit for use. These wells should never be sunk without a knowledge of the local geological conditions on which their success depends. The most experienced geologists may be deceived by anomalous conditions of the substrata, which cannot be foreseen. It may be useful to mention some localities and strata where boring for water is most likely to succeed or to fail.

It has been ascertained that water naturally rises in these wells to the mean level between the highest source of supply and the ultimate natural outfall. This is exemplified in the London and Paris basins; the one outfall being the River Thames below London, the other the sea at or about Havre. Under London the level has been depressed to the amount of 60 feet; at Paris the famous artesian fountain of Grenelle has been slightly affected by the newly-bored well at Passy. In illustration of the former, a section, B, is given of the ascertained height to which water rises in artesian or artesian wells on a certain line in the London basin, which, with certain modifications, will show the way in which water will rise in other localities; though, for all ordinary practical purposes, the best guide will be the known height to which water will rise in such wells where the experiment has been made. In the absence of such a guide, this may be calculated on the principle illustrated by the section. The water will be found to rise to the surface wherever the level of the surface falls below the angle described by the subterranean water-level. This, notwithstanding the unnatural depression caused by London pumping,

is the case at Tottenham, Tooting, Uxbridge, and other places. The depth to which the borings must be carried varies considerably. The subterranean geology of London and its immediate environs, as an example of the condition of the London basin extending from Essex to Hampshire, will be best understood by plans and sections published by Mr. R. W. Mylne, C.E.

Water will rise in artesian or artesian wells throughout the London basin, where the chalk is covered by the London or plastic clays. Though ruled by various outfalls, and disturbed in some cases by faults, the height it will attain may be made a matter of calculation: the great difficulty is the thickness of the upper strata, especially where the surface of the clays rises in hills and ridges, or where they are covered by the Bagshot sands. If, by way of example, a line from Basingstoke to Colchester be taken, where at the former place the water in the chalk stands 240 feet above Trinity high-water mark; at Strathfieldsaye, $6\frac{1}{2}$ miles distant, in a well sunk by the late Duke of Wellington for the use of the villagers, 300 feet down to the chalk, the water rises to within 15 or 20 feet of the surface, which may be 150 feet above Trinity high-water mark; at Bear Wood 350 feet to the chalk, the water stands about 120 feet above Trinity high-water mark; at Cricklewood, where this line intersects that of the section given, the water is 60 feet above Trinity high-water mark and 270 feet to the chalk; at Tottenham 70 feet above Trinity high-water mark, and 140 to the chalk; at Witham (the outlay here was 150*l.*), 306 feet to the chalk, water within a few feet of the surface, about 120 feet above Trinity high-water mark; at Colchester, 143 feet to the chalk, water about 5 feet above high-water mark.

In the Hampshire basin, though geologically the same as that of London, the condition of the chalk, probably from greater disturbance, cannot be relied on as a source of supply for artesian wells. A well dug on Southampton Common to a great depth was a gigantic failure. Again, at Portsmouth Dockyard the chalk was reached at 400 feet, and pierced an additional 500 feet without success. But here considerable quantities of water are obtained for the supply of the Dockyard by boring into the beds overlying the tertiaries, a district too small to come within the scope of our subject as connected with the interests of agriculture.

Following our inquiry into the supplies to be procured by boring, according to the geological series, the next in order is the gault clay, which occupies a rather narrow slip of country, more or less, from Dorsetshire to the Wash. It is also developed in the Isle of Wight, under the Sussex Downs, and in Yorkshire. The artesian wells at Cambridge, sunk through the gault into the lower greensand, are a notable instance of success. The

water, once flowing to the surface, does not now attain that level by a few feet; their depth is said to be from 130 to 140 feet. The water from wells sunk through the gault is slightly ferruginous, as might be expected from the nature of the greensand, whence it rises. At Grenelle, where there are the same geological conditions, the water is often used for hospital purposes, and it is a practice to place glass vessels in the flowing water, where they acquire a yellow tint. As the water in the lower greensand has no defined outfall, and as the depth of the gault clay varies, no rule can be laid down. The greensand will generally be reached under 150 feet, the water will seldom rise to the surface, therefore shafts must usually be sunk, into which the water will rise. This is the case at Hinxworth, near Baldock, and many other places where the geological conditions are the same. Care must be taken not to sink for water where the lower greensand is absent, as in many parts of Oxfordshire and the Vale of White Horse. Instances of failure have occurred at Tetsworth, where the gault rests on the Kimmeridge clay.

As the gault clay underlies the escarpment of the upper greensand, or chalk, the most obvious source of water-supply to the surface of the gault is from the springs which flow from, or generally above the junction of these strata. Reservoirs might easily be formed for whole districts by the common and united action of landowners to secure water of the best quality. Water rises by gravitation from such a source to the top of Adwell House, near Tetsworth. The town of Aylesbury is now seeking such a supply from the chalk range near Tring. These valuable waters, which might in many places be far more profitably used, now run into the Ouse or the Thames.

Next in order is the Kimmeridge clay. The same hindrance as arises from the absence of the greensand below the gault is found where the Kimmeridge rests on the Oxford clay. It was by overlooking this fact that at least 2000*l.* was needlessly expended in boring a well, over 500 feet deep, at the Lunatic Asylum near Aylesbury. At Abingdon there is an instance of water obtained by boring through the Kimmeridge clay into the coralline oolite, the whole depth, partly into the latter stratum, being about 60 feet. The water is slightly impregnated with sulphuretted hydrogen and iron, which it is believed is the case elsewhere. It supplies a drinking-fountain in one of the back-streets of Abingdon.

No really successful instance of an artesian well in the Oxford clay has fallen under my immediate observation. Its widely-extended surface and position on the lower oolitic strata are physical features which point to it as lacking good water, and as likely to derive a supply by boring through it to the oolitic rock

beneath. If the well or boring were carried deep into the sub-jacent rock and were perpetually flowing, the water might be cleansed of its impurities ; but those specimens which I have met with and tested have been hopelessly impure.

Lower in the oolitic series there are instances of successful artesian borings. Thus at Bourn, in Lincolnshire, a large supply has been obtained from borings through the Forest marble and Bradford clays, to a depth of about 90 feet, whence the water overflows the surface. The distribution and presence of these clay-beds and the frequent faults in the oolitic strata are so complicated, that it is impossible to lay down any rules for guidance.

The same may be said of the lias clays which underlie the oolitic rocks. The marlstone, generally charged with water, which intervenes between the upper and lower lias clays, would seldom yield its water except to wells sunk in the ordinary way. At Chipping Norton the lower lias clay was pierced to the depth of 500 feet, in the hope of obtaining water from the underlying new red sandstone formation : the attempt was abandoned at that depth. Again, much the same may be said of the red sandstone formation, which forms so large a part of the surface of western England, though it may and often does yield its subterranean water when deeply pierced. At York water so raised was too much charged with iron and other mineral substances to be of any real value. The well-known salt and other mineral springs in this formation point to the probability of their existence elsewhere.

As artesian wells derive their supply from deep-seated or main-springs, the existence of such sources of water has, to a certain extent, been anticipated, though it is quite necessary to speak separately of main-springs.

MAIN-SPRINGS.

As the term land-spring is usually applied to sources of water flowing from superficial beds of drift, sand, or gravel, resting on impervious substrata, the term main-spring usually indicates those deep-seated supplies found in the recognised geological formations, such as the chalk, greensands, oolitic, some beds of lias, new red sandstone, and any other stratum into which the water, falling on its surface, will freely sink through cracks or crevices, forming beds of water which rise in these strata till they find vent in valleys and depressions, and so form the natural perennial sources of rivers, or hidden supplies, which are reached by sinking shafts or wells, whence water is raised by artificial means.

To advance our knowledge of the presence of these supplies, the localities and depths at which they may be found, their eco-

nomical use, and the means which will afford increased facilities in obtaining them, is the chief object of this communication.

The water-bearing formations above the chalk are generally of so superficial a character, and so complicated in their geological structure, that no definite rule can be laid down as to the water they contain. The elaborate Reports published by the General Board of Health on the proposed supply of water to London from the Bagshot sands in 1850, are a sufficient guide to those who wish to investigate that question. Though these sands in some localities are of considerable thickness, and from the alternation of the sands with clay beds throw out water at various levels, they very often represent sources of land-springs.

The *chalk formation* occupies a large surface of the east and south of England, and may be said (if we include the tertiary-beds by which it is partially covered) to extend from the Chiltern range to the German Ocean. This is the chief source of the water supplied to the Thames and many other rivers. The water falling on its surface where exposed, or where covered with pervious beds of gravel, sinks into this stratum and forms a subterranean bed of water, the surface of which has been called the chalk-water level. The depth at which water may be reached in the chalk may be made a matter of calculation. Take the level of any known spring or outfall, and then allow for an inclination of 10 feet per mile at least as the inclination of the water-line, it will be found that the surface-line of the subterranean water dips towards its nearest vent, the angle of inclination being ruled by the friction or resistance encountered by the water in its passage through the stratum. As the subterranean supply is replenished, this line will rise at an angle increasing with its distance from the vent.

A section, C (see next page), based upon absolute measurement and frequent observation, through a long period, is given to illustrate this phenomenon. If the level of water in two wells situate in a line to the outfall be ascertained, the water will be reached in a well to be made midway between them at the mean depth of the two; and this will be true of all wells sunk in any water-bearing stratum at all like the chalk. The raising of water from the chalk in the upper levels, where the water-level lies 300 or more feet below the surface, must be laborious and expensive. An Indian magnate, the Maha Rajah of Benares, intrusted to my friend, Mr. E. A. Reade, C.B., a sum of money to be employed for the benefit of the poor, on an object not of a religious character. He expended it on a well in the chalk, 358 feet deep, furnished with simple but most serviceable machinery for raising the water—large buckets, chains passing over iron sheaves, wound up by a winch and flywheel. Contrivances, such as a

C.—SECTION SHEWING THE WATER LINE IN A SERIES OF WELLS IN THE CHALK AT VARIOUS PERIODS, FROM MEASUREMENT.

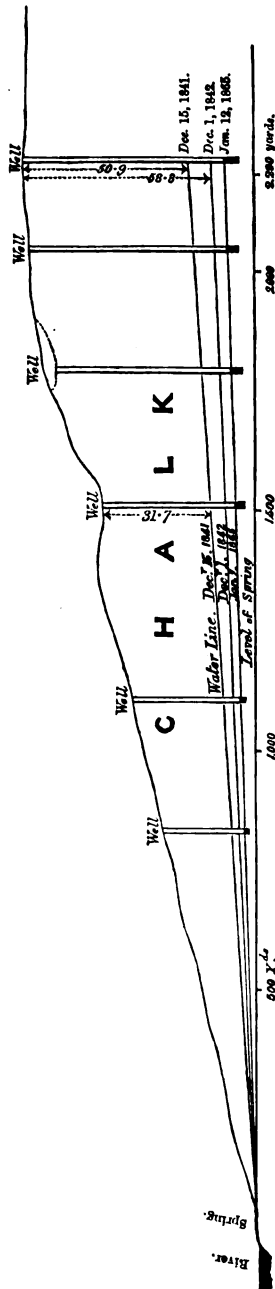

Horizontal Scale . . . 1 inch to 100 yards.
 Vertical " 60 feet to 1 inch.

The periods given are only by way of Example; if all the measurements were given, the whole space between the upper and lower line would be occupied, and so condensed.

donkey-wheel, as shown at Carisbrook, are often used ; but for a common well the simpler the machinery the better. Boring from the bottom of a chalk-well is sometimes resorted to with success ; but it must be remembered that the water will not rise higher than the level at which it stands already in the well, though the bore-hole will quicken the supply. It is better, if the well has been made sufficiently deep, to enlarge the bottom in a bell-shape, or if a great quantity of water is required, to drive adits, if there seems no local reason to the contrary, in a direction *from* the known outfall of the water.

The upper greensand immediately underlies the chalk or chalk-marl. Its development is very irregular ; in some places it attains the thickness of 140 feet ; in other localities it is scarcely to be traced. Like the chalk, it freely absorbs the water falling on its surface : its water-bed is ruled as that in the chalk, but it is far more accessible ; indeed there is no stratum where water is more regularly distributed or purer in quality. In sinking wells in this stratum care must be taken not to pierce the gault clay below, lest the quality of the water should be affected. The lower greensand is separated from the upper by the impermeable bed of gault clay : the lower greensand is permeable to water. Though the beds of which it consists vary considerably in their condition and in their capacity of absorption, sometimes a continuous water-level may be traced. It is often necessary to enlarge the bottom of the well to secure sufficient subterranean storage, as the wells, when exhausted, are slowly replenished. Very great care must be taken not, under any circumstances, to pierce the underlying Kimmeridge clay. If the Portland oolite underlies the greensand, and should the supply from the latter be insufficient, water may be sought in the oolite below, though the water of the greensand is usually of better and purer quality. When the Portland oolite overlies the Kimmeridge clay, the same caution will apply. Under no circumstances should the surface of the clay be pierced. There is a great similarity in all the oolitic strata as regards the supply of water, yet no strata present more difficulties and anomalies in the quantities yielded. This is to be attributed to the unequal thickness of the limestone and oolitic seams of rock, interlaced by beds of clay of most variable thickness and power of upholding water.

The Portland and coralline oolite are limited to a small area, and in many places consist merely of isolated patches, capping the surface of the Kimmeridge or Oxford clay. In such case the spot fixed on may materially influence the supply. In a known case it was desired to obtain water for a farmstead : a well was sunk to suit the convenience of the site, on which the buildings were to be erected ; the water-supply was insufficient. It was pointed

out that the surface of the clay dipped in a certain direction, and that the well should be sunk near the margin of the oolitic rock in the direction of the dip. This was done, and water was obtained in abundance. This principle should be kept in view in seeking a supply of water throughout the oolitic range and the upper beds of the lias, where permeable beds rest on clay whose surface dips in a known direction. The presence of water under such circumstances is marked by the springs which issue from the hill-sides at the junction of these beds. The lower oolitic series, separated from the middle or coralline by the Oxford clay, which overlies the lias, is one of the principal water-bearing formations of England. Like the chalk, its surface is furrowed by frequent valleys, down which its waters find vent in perennial streams; though, unlike the chalk, its substance is interlaced with bands of clay of varying thickness, which throw out the water at every variety of level. These bands, besides the faults caused by disturbance, make it exceedingly difficult to determine the supply of water, and consequently the means which will afford the greatest facilities for obtaining it. It often happens that in one locality there are several distinct beds of water, either to be traced in wells, or to be seen, as indicated by springs issuing from the hill-sides. Such, for instance, is the case at Stonesfield, in Oxfordshire, where three distinct beds of water are found at various levels, at about 15, 50, and 100 feet from the surface respectively; none, except the lowest, which rests on the lias clay, yielding a large amount of water, but each sufficient for ordinary domestic purposes. The only obvious way of increasing the supply to the upper wells is the enlargement of the lower chamber, care being taken to avoid the hazard of sinking below the surface of the clay at the bottom. Agricultural drainage often decreases the subterranean supply to these strata; yet water running from the surface of the clays, which often cover large tracts, sometimes sinks by natural swallow or swilly holes into the permeable rock beneath, at the margin of the clay. These natural features might be assisted by simple artificial means to the increase of the supply to these strata.

Many of the valleys of this formation rest on upper lias clay. If, as in some cases, the base of the valley is the lower lias, the intervening marlstone, usually charged with water, adds another source of water to the district. Such valleys are well fitted for the storage of water, such as in the reservoirs which supply the summit-levels of the Oxford Canal, which have never yet failed. From the marlstone, as from the partings of clay in the oolite above, springs issue at so high a level above the foot of valleys, as to enable farmsteads, other establishments, and villages, to be supplied with water by gravitation, delivered through pipes or

open cuttings into troughs or tanks. Moreover the fall of water facilitates the use of hydraulic rams, by which reservoirs and whole establishments, as at Blenheim, Cornbury Park, Sarsden, and other places, are supplied with water at comparatively small cost. The delivery of water throughout the oolitic series favours the extension of this practice in a district where sinking for water through limestone and other rocks is an expensive process. It has been said that the marlstone intervenes between the upper and lower lias clays. This, if the lower beds of limestone or lias lime are excepted, is the only deep-seated source of water in the lias formation.

The new red sandstone, beneath the lias, which forms so large a portion of the surface of England to the west, contains large quantities of water; but much of it is excluded from ordinary uses by the mineral salts and impurities with which it is charged. The levels at which it is found in the upper marls or in the substance of the extensive sand-rock varies very much: in some cases the underground passage of the water is very free, in others very much confined. The exhaustion by mines is also a cause of disturbance to the supply. Though very many towns are supplied from deep wells in this stratum, where large quantities are required, as at Liverpool, recourse is had to storage at higher levels in the older formations, where rainfall is in excess and the physical features of the country favour this arrangement. The variable quantities and quality of the water, as ruled by the local geological condition of the new red sandstone, make it impossible to point out any rules except those which are suggested by local experience for increasing such supplies for agricultural or domestic purposes.

The increased rainfall, as well as the geological condition of the older formations, place the district to the west of the new red sandstone (as was suggested in the opening remarks) beyond the limit of this inquiry.

The writer, in revising the foregoing pages, finds that what he has said on a subject which has long engaged his attention has assumed the character of an essay on the water-supply of a great part of England rather than the specific point on which information was required; nevertheless, feeling the importance of the whole question, he has determined to submit this notice to the judgment of the Royal Agricultural Society.

Long Wittenham, Abingdon.

XXII.—*On a New Form of Disease among Lambs.*

By R. S. REYNOLDS, M.R.C.V.S.Eng., Alfreton, Derbyshire.

A NEW form of disease has appeared of late among the lambs near Mansfield, and also in this district (nine miles apart), and some other neighbourhoods, to which I will not presume to give a name. Its increasing prevalence and the serious losses which it has occasioned during the last four or five years have induced me to make its pathology my study, the results of which I now place at the service of the agricultural public.

The flocks I have been called upon to attend are principally of the Lincoln and Leicester breeds: those consisting of the improved Shropshire, with a trace of the old forest sheep of this locality—a hardier race—though not thoroughly exempt, are much less susceptible than the long-wooled sheep. I have seen the malady upon the limestones of Derbyshire, and also upon the forest sand-land of this neighbourhood. It chiefly occurs amongst farmers who keep their stock well, and force their lambs upon dry food, in addition to the natural and artificial grasses, from the time they are separated from the ewes.

Wherever this disease has occurred, I find that the management of the lambs has corresponded in its general features, and been pretty nearly as follows:—From weaning-time they are pastured in dry upland situations; if the summer is dry they are removed every three or four days from one pasture to another, on account of the slow growth of the herbage. They have a daily allowance of one quarter to one-third of a pound of dry food, which consists of crushed barley, linseed-cake, oats, and pods of locust-bean—some flocks being supplied with one of these constituents, some with another, and some with a combination of all, in which the two first named always preponderate. It has never occurred when cake has been given alone.* The crisis of the disease is always brought about by the fall of the autumnal rains, the most especially marked effects arising if the rain has been accompanied by a warm genial atmosphere, producing a “flush of grass.” A change to turnips is also frequently followed by an outbreak of the malady. In a day or two after the fall of rain, or the removal on to turnips, several of the lambs are seen to purge, but they do not appear seriously ill until the diarrhœa has lasted from three to six days, when they gradually sink and die, apparently exhausted.

If the owner is a good practical farmer he is confident that the

* I have this week been to see a flock of lambs suffering from this disease, which has had a liberal allowance of linseed and cotton-cakes mixed (the first I have known to be affected when supplied with cake alone). Aug. 5th, 1865.

diarrhœa, which his opiates and cordials have had no effect in checking, is something more than common "skit," or diarrhœa, and he now calls in the aid of a veterinary surgeon, who is informed that from weaning-time to about a week, ten days, or it may be a month prior to the first indications of illness, the flock was considered to be in excellent health, but that latterly they have gone off in condition. The veterinary surgeon will find several of the lambs which have been more recently attacked still suffering from diarrhœa. This is the leading symptom, the evacuations which run from the lambs in a frequent and copious stream consisting of a watery fluid tinged green by particles of undigested food. To a casual observer the flock does not appear to ail very much; but when quietly watched they manifest an air of listlessness, pervading the whole flock, and many are seen to be troubled with a short "pecking" cough. Those that purge are dull and dispirited, but still continue to eat, and in them thirst is so great that they greedily lick up any moisture they can find in ruts and other hollows. The remaining constitutional symptoms presented by those in the first stage of disease are a dry muzzle, hot mouth, quick, weak, and thready pulse, respirations accelerated, urine of a light colour, voided frequently and in large quantities, the visible mucous membranes somewhat pallid, but having their larger vessels injected; the appetite does not utterly fail, nor is the function of rumination totally suspended. All the symptoms become aggravated as the last stage approaches; the wool is easily detached from its follicles, separation from the flock precedes uncertainty of movement and semicoma, then death shortly supervenes.

I have made many post-mortem examinations, and observed that the appearances found in any one case are common to all. When I slaughtered for that purpose animals in the last stage of the disease, I noticed, first, the small quantity of blood which flowed from the wound; next, the rapidity with which it formed a soft anæmic coagulum; then that death shortly followed, with scarcely an expiratory struggle. The carcase at first sight appears to be pretty well nourished, but a closer inspection shows that this apparent condition is due to the disposal of a very fair quantity of fat in the usual subcutaneous situations, whilst the muscular tissues are remarkable for their pallid appearance and evident atrophy. In the thoracic cavity the lungs are found blanched, the heart contains soft coagula, but both organs are *structurally healthy*. There is no evidence of filaria (thread-worms) in the trachea or bronchial tubes. The contents of the abdominal cavity are remarkably pale, the pallor being due to atrophy of the coats of their involuntary muscles; indeed so attenuated are the walls of the intestines that a very slight amount of force is sufficient to

rend them, their mucous lining membrane being so structurally disintegrated as to separate at the slightest touch. The pallid liver is soft, pulpy, and of large size from congestion; its substance can be broken down by the finger with the greatest ease. In the stomach is a quantity of semi-fluid ingesta, whilst the intestines contain a large quantity of green-coloured fluid, mixed with particles of undigested food. The kidneys are found congested, but surrounded by a quantity of fat; the omentum also contains a fair amount of fat. The coats of the bladder are extremely thin; indeed so attenuated do they become, that in several instances rupture has taken place either before death or very soon after: this, as well as the biliary cyst, are usually found full of abnormally light-coloured secretion.

Considering the age and breed of the animals, the season of the year, the general management of the flocks, the symptoms presented, and the post-mortem examination, the practical conclusion at which I arrived was, that the malady chiefly depends on a defect in the nitrogenous element of nutrition, arising either from the insufficiency of supply or the incapacity of the young animal to assimilate the flesh-forming elements in the condition in which they are given. In order to be clearly understood, I must make a few general remarks on Food.

Food may be theoretically regarded as consisting of two principles or elements having a two-fold operation to perform. The one, the hydro-carbonaceous or heat-forming material, of which nitrogen forms no part, is necessary to maintain, by its combination with oxygen in the system, the natural standard of animal heat: this principle, if supplied in excess, is stored up in the form of fat, to be employed in the generation of animal heat if the supply from external sources should at any future time fail. The other, the nitrogenous or tissue-forming principle, is required to build up the growing organism as its development advances, and also to replace tissues disintegrated by the natural molecular waste of the body or the results of extraordinary exertion. The operation of this principle is sometimes distinctively called "nourishment." If the supply of this principle exceeds the immediate requirements of the system it is not stored up for future use (except the small amount available for increasing the richness of the blood), but passes out with the excretions and is the chief source of ammonia in them. On the proper balance of these two elements in the food, the health and well-being of every animal depends. This balance, however, must be variously adjusted to suit it, not only to animals of different ages, but also of different breeds. We have reason to think that a greater proportion of the nitrogenous principle is required in the suckling than in the adult, and (from the enfeebling influence of a delicate

constitution on the digestive organs) in the improved breed than in the wilder and hardier races. It is also essential that these principles should be given in such a *condition* that they can be assimilated by the nutritive organs of the animal to which they are supplied according to its requirements; and the capacity for assimilating food will further vary at different ages and in different breeds. It is then, I repeat, to some defect in the nitrogenous element supplied in the food that I attribute the enormous losses sometimes sustained among lambs in the autumn season.

In proof that a good supply of nitrogen is essential to animals, especially during their growth, it may be shown that all parts of the body which possess a decided shape contain nitrogen; hence we may infer that this element has to perform certain important functions in reference both to the formation and nutrition of the tissues. The most convincing experiments and observations have proved that this nitrogen can be derived from no other source than the food; consequently a larger supply is needed in youth, when the frame has to be built up, than in mature age, when the existing organism has only to be maintained. If we refer to the constitution of milk, the natural provision for the young animal, we find that in it the hydro-carbonaceous principle bears to the nitrogenous principle the proportion of only two to one, whereas in the food of adults it generally bears the proportion of six to one; and thus, whilst on the one hand science has led us to the conclusion that more than an average supply of nitrogen is required to build up the frame, on the other it indicates that a larger supply is provided by nature for that end.

Breed has some effect also in the production of this disease. Short-wooled sheep will thrive upon dry arid pastures, exposed to the inclemency of winter and the drought of summer; but the sheep principally kept upon the forest land of this neighbourhood, though originally of this class, have, for the sake of improving the clip of wool, been so repeatedly crossed with Leicesters or Lincolns, that they require a better supply of food than the hardier and purer original breed. Leicester sheep have a greater development of lax, extensible cellular tissue in the soft solids; their vascular and nervous systems are more sluggish and inactive; they have also a greater tendency to fatten, but are incapable of bearing exposure or hardship.

Mr. Karkeek, in his 'Essay on Fat and Muscle,' says, "that in proportion as an animal increases in fat will the organs of nutrition become diminished in size; it follows that by pursuing the system of breeding from fatted animals, or those having a tendency to fatten, *function* must react upon organisation, and at last those qualities become not only increased but fixed in the race." Therefore, in the continued endeavours to produce a breed

of sheep possessing a disposition to accumulate fat, the early arrival at maturity is increased, and the animals are earlier ready for the market; but all this takes place at the expense of robust health, and the improved breeds are far more susceptible to the effects of inclement weather and deficiency of a proper supply of food. I am of opinion that in sheep of such improved breeds the disposition to accumulate fat is evinced *before* the animals arrive at maturity, and a diminution of the nutritive organs takes place before the tissues are thoroughly developed. It is necessary for the proper nutrition of the muscular structures, especially during their development, that they should be subjected to exertion; but the improved breeds of sheep, whose temperament is sluggish, are inactive and averse to motion, and their tissues do not attain that degree of firmness which is characteristic of robust health.

I also conclude that the herbage indigenous to the fertile pastures of Lincolnshire and Leicestershire is richer in flesh-forming substances than that upon the cold and comparatively poor land of Derbyshire; and the sheep, therefore, are necessitated to endeavour to attain the natural standard of their race upon food which, considering their powers of assimilation, is not rich enough in nitrogenous matter to enable the blood to meet the demands of the system.

The occurrence of the disease in the autumn of the year is also an argument in favour of my theory. Dry summer weather is very unfavourable to the fresh growth of herbage, and animals at pasture are obliged to eat old dry innutritious grass from hedgerows or any other places where they can find it, after cropping the small amount of fresh nutriment afforded by their scanty pastures; their supply of flesh-forming materials is thus again decreased. I have the authority of Boussingault and Voelcker for stating, that when vegetables have matured their seeds the nitrogen they contain is diminished, and when they are dried it is reduced to its minimum. Since the outbreak of the disease quickly follows upon abundant rains and genial weather, or upon the removal to turnips, we are led further to infer that the blood, already attenuated by containing a small amount of fibrin and albumen, on being further diluted by the introduction of a large quantity of moisture taken up in quickly-grown succulent herbage and roots, becomes of too small specific gravity, and the elimination of the superabundant water by the mucous membrane of the alimentary canal is one of nature's efforts to restore the vital fluid to a normal consistency.

As regards the general management of the flock, it is well known that imperfect nourishment quickly embarrasses the digestive functions, producing loss of tone in those organs. The object

of good feeding should be *not to fatten* young animals, but to give strength and tone to the vital forces, which, established during the growing period of life, enable the animal to withstand many external agencies that tend to alter the form, structure, and composition of the tissues, and predispose to disease.

Let us see whether these indications have been complied with in the management of the flocks in question. The farmers of this locality who breed and rear Lincoln and Leicester sheep, know that in order to make up for the inferiority of their home pastures the lambs must be supplied with dry food from the time of weaning. Is then the dry food, generally so provided, capable of supplying the deficiency, without becoming in some measure productive of disease? I am of opinion that wherever the disease in question has occurred, the dry food contained too great an amount of hydro-carbonaceous material, whilst the constituents necessary for building up and replacing the other tissues have been insufficiently furnished. The dry food chiefly consisting of about equal parts of crushed barley and linseed-cake, of good quality, from one-fourth to one-third of a pound of the mixture being allowed per sheep per diem, calculated roughly, we may say that in addition to the quantity of tissue-forming substances obtained from innutritious grass, each sheep daily receives into its system, by the supply of dry food, about one-fifteenth of a pound of nitrogenous principle. Should oats be substituted for either of the other articles of food, the percentage of flesh-producing aliment would not be materially affected, but if locust-pods were used it would be considerably diminished. It would require a far greater physiologist than I am to determine theoretically whether the nutritive elements introduced from every source are adequate to repair the natural waste of the body and build up the growing organism. In my opinion, which is based upon a careful consideration of the symptoms and post-mortem appearances, if due regard be paid to the quality as well as the quantity of the supply—they are not.

The leading symptom of the disease, excessive diarrhoea, can only be due to one of two causes—either to irritation in some part of the alimentary canal, or it is an effort of nature to throw off from the blood some material detrimental to the normal qualitative or quantitative condition of that fluid, whereby it is rendered unfit to serve its proper purpose in the animal economy. The post-mortem examinations did not disclose evidence of irritation in any part of the intestinal tube, therefore there remains but the inference that the blood is not in a condition fitted to supply the demands of the system upon it. The specific gravity of the blood may be lessened if the constituents supplied to it by the food are insufficient to repair

the waste and build up new structures; and the introduction of quickly-grown succulent herbage or roots throws a large quantity of water into the blood, so as to dilute that fluid, then, since the blood is in every way subservient to the requirements of the organism, nature is called upon to discharge the superabundance and endeavour to sustain it at a gravity compatible with its toleration in the vessels, by evacuating some of the watery constituents through the medium of the intestinal mucous membranes. The uncertain staggering gait is a sign that the nervous system is not being supplied with blood of proper quality, or, in the last stage, of sheer debility and exhaustion. The continuance of the appetite until near the approach of death is due to the demands of nature seeking to restore the blood to its normal standard. The excessive thirst which only occurs in the animals violently purged is, no doubt, an effort to restore the quantity of the circulating fluid, diminished by the copious fluid evacuations and increased renal secretion, as these eliminations are themselves endeavours of nature to restore the quality of the blood.

The post-mortem appearances also separately establish the fact of an abnormal condition of the vital fluid. The small quantity of blood which flowed when one of the affected animals was slaughtered, it is fair to suppose, bore some relation to that contained in the body, diminished by evacuation of the more watery parts; the easy death indicated general emaciation, as the soft quickly-formed æmemic coagulum did the small proportion of fibrine. The presence of a fair quantity of subcutaneous and intervisceral fat is proof that death does not result from absence of the essential elements for the generation of animal heat. The pale, emaciated, and atrophied condition not only of the muscles, both voluntary and involuntary, but also of all the tissues that derive their materials of formation and regeneration from the albuminoid constituents of the blood, shows how inadequate has been the supply of "nourishment" derived from the food to compensate for the wear and tear of the system. They further show that nature endeavours to meet the exigency by supplying the blood with material previously stored up in the form of muscular and other proteinoid tissues, or, in other words, by internal nutrition. If any reader entertain doubts with regard to this process of nutrition from within, I must refer him to the translations of Mr. Ernes, published in the 'Veterinarian' for 1863, pp. 573 and 636, where he will find convincing proofs of the soundness of this theory. I attribute the cough to partial atrophy of the involuntary muscles of respiration. The degenerated state of the tissues of the alimentary mucous membranes is attributable to the want of proper nutrition, coupled with the increased amount of exertion to which they had been

subjected in eliminating the superabundant moisture from the blood:

The light-coloured pulpy congested condition of the liver arises, as I conceive, from structural disease, supervening on functional derangement; such derangement being caused by the undue exertion of the liver in its assimilating action upon the nitrogenous substances of food, especially if supplied in a condition ill-adapted to the requirements of the young animal. Also when the liver by disease has become incompetent to act upon the imperfect albumen, which is the immediate product of the digestive process, this albumen is not fitted for its introduction into the blood, and a great part of it is evacuated in the urine. (*Vide* Carpenter's 'Manual of Physiology,' pp. 306, 307.) The deteriorated state of the blood supplied to the organ for the nourishment of its own tissues, would also further tend to its disintegration.

Such are my grounds for believing that a deficiency in the supply of tissue-forming material has been one great cause in the production of this disease.

We will now consider more in detail whether the *condition* in which that material was supplied may not also have exerted a bad influence. Unquestionably the healthy growing animal has the power of assimilating as much of the albuminous principle as is requisite, provided it be given in a suitable form. But however plentiful may be the supply, unless it is duly acted upon by the assimilative power of several glandular organs (of which the liver is one) it is not rendered fit to be a component of the blood, and consequently being of no use in the economy, is cast out in the urine as effete material. I maintain that the liver of a growing lamb at the time of weaning has not arrived at its full power of action, and that this defect is especially manifested in reference to its function of preparing albuminous materials to become constituents of the blood, unless these are supplied in a certain condition, of which the caseine of milk is the best example. The immature organ, in endeavouring to exert its specific action upon albumen supplied in a condition fitted only for the requirements of an adult sheep, is overtaxed, derangement in its function succeeds, which in turn gives place to structural disease, and in a short time the organ is incapacitated from performing this assimilative action upon *any* part of the albumen of the food.

By practical experience many shepherds and farmers know that when it is necessary to supply lambs with dry food from the time of weaning, they do better upon peas or beans than upon any other kind of diet, a small quantity of linseed-cake being generally combined with those leguminous seeds, on account of its greater fat-forming qualities, and proportionately increased as the lambs

advance in size and strength. I have never heard or known of a flock of lambs being attacked with the disease in question when they have had a supply of beans or peas, whether combined or not with other articles of food. This fact I consider very greatly favours my theory; for by reference to the table given below it will be seen that beans and peas contain a greater percentage of albuminous or nutritive material, in proportion to hydro-carbonaceous matter, than any other article of food usually given to stock.* But further, chemists tell us that the seeds of leguminous plants, such as beans, peas, and lentils, contain a nutritive material called vegetable caseine, which, although it has the same composition as vegetable albumen and gluten obtained from the cereal grains, grasses, &c., differs from those substances in chemical properties. Vegetable caseine is so called because of its analogy to the caseine of milk, from which the sucking animal has to derive the whole of its flesh-forming nourishment, and the existence of such analogy obviously points to such seeds as proper food for animals when first weaned.

I have stated that if there is a greater preponderance of the fat, over the flesh-forming constituents in the food than is compatible with the age and strength, it tends to the production of disease. Many farmers in this neighbourhood, though their land is comparatively poor, do not force their lambs by giving any dry nutriment until they are put upon turnips, and their flocks are not so liable to this disease as those of their neighbours, who are better keepers. It may be argued that this makes against my theory, since a small quantity of dry nitrogenous food must be better than none at all. In answer I must say that, as a rule, these same small farmers who do not force their lambs, keep flocks which are not of so improved a breed, and therefore do not require the same amount of nutriment for their proper growth and development; that moreover their lambs will probably have not been run so thickly together, and thereby will have had a better chance of obtaining nutriment from the herbage, besides other advantages consequent on a less artificial mode of life.

Whenever lambs kept in a more artificial state are supplied

* Table showing the quantity of nitrogenous and heat-producing matters in several articles of food:—

	Parts per cent. of Dry Albuminous Substances.	Parts per cent. of Heat-producing Substances.
Lentils	25·00	46·75
Beans	23·30	48·48
Peas	23·40	50·07
Linseed cake	31·40	66·00
Oats	13·60	55·48
Barley	13·21	56·14
Rye	13·81	61·03
Meadow Hay	8·01	66·48
Swede turnips	1·62	10·35

with dry food, that food, unless it is composed principally of beans or peas, is liable to disturb the equilibrium which should subsist between the fat-producing elements and those which form the tissues of the frame, and a tendency to disease is the result. If it be remarked that linseed-cake is as rich in either principle as leguminous seeds, and the question be raised why lambs cannot do equally well upon that alone, I can only say that shepherds tell me that, given by itself, it is too forcing—why, I cannot tell, unless it is that legumes contain their nutritive elements in a form more susceptible of being assimilated by young lambs.

As regards treatment, curative means are of little avail after diarrhoea has fully set in. To the animals purged as well as to those apparently well, stimulants should be given; for if my theory is at all correct, the vital powers of the animal must be kept up by artificial means long enough for the introduction and assimilation of nutritive aliment. For a long time subsequent to a thorough change in the diet and to medicinal treatment deaths will occur among some of the animals, at first apparently well: this cannot cause very great surprise, when the weakened condition of the whole of the digestive and assimilative organs in all or most of the sheep exposed to such influences is borne in mind. As regards diet, unquestionably the introduction of some easily-digestible nitrogenous matter is the first consideration. Peas or beans, with bran and a small proportion of linseed-cake, I conceive to be the best mixture of dry food for the affected lambs. They may either be turned upon old pasture land, or upon a large turnip break—and in either case be supplied with a limited quantity of chopped turnip-roots, and good sweet hay *ad libitum*; the latter, though it contains more heat-forming than nitrogenous elements, I deem the best vehicle for supplying the amount of fibre essential for the digestion of a ruminant. I also find that it is very beneficial to protect them from the inclemencies of the cold, rainy, autumnal nights, for there is always a greater mortality after exposure to such weather. Of course it is essential to keep them from water. I have known instances where, having had access to a pond, they have gone in and drank until they died upon the spot.

The fearful mortality that occurs when once the disease has commenced, in spite of all modes of treatment, shows that medicine and nutritious food are then but of little avail, because the assimilative organs are become so diseased as to have little or no action on the aliment, and life hangs on so slender a thread that a little extra exposure or increase of debility is fatal. Prevention, therefore, rather than cure, must be our aim; and for this our best reliance is in a fair supply of easily-digestible nitrogenous food from weaning-time to the following spring. I do not speak confidently, but several shepherds and farmers have con-

firmed my opinion by stating that when their lambs have been supplied with beans or peas, combined with cake and bran, their flocks have enjoyed immunity from this disease; whereas, when the cereal grains have been substituted for the leguminous seeds, the flocks upon the same farms have been affected. But in all cases a veterinary surgeon should be consulted, as only a scientific man and one thoroughly conversant with disease can properly judge what medicinal and dietary treatment can be most advantageously employed in the different stages of the disease.

In conclusion, may I be permitted to remark, that if the agriculturist has sometimes occasion to complain of the incompetence of the veterinary surgeon when called upon to treat his sheep, the farmer himself is chiefly to blame, for he does not employ the professional man to treat the common run of diseases which affect his flock, and consequently does not enable him to obtain a general knowledge of their constitution. Only when disease in an unusual form devastates the flock are his services required, and then he is expected to treat promptly, scientifically, and successfully animals with which he is so little acquainted. Even then his aid is not sought till the nostrums of the shepherd and the empirical cordials of the druggist have been exhausted, and many of the survivors in the diminished flock are beyond the reach of medical treatment.

Alfreton, Derbyshire.

XXIII.—*On the Functions of Soda-Salts in Agriculture.*

By DR. AUGUSTUS VOELCKER.

IN an agricultural point of view soda and its salts are far less important fertilising agents than potash and its saline combinations.

The published ash-analyses of every variety of agricultural produce show that all cultivated plants without exception contain much more potash than soda. This is not due merely to accident, or, as might be supposed, to a wider and more abundant distribution of potash than of soda in the mineral kingdom, for the rule holds good even when plants are grown on soils in which the proportion of soda greatly exceeds that of potash. It matters not what the composition of the soil is on which a crop of wheat, oats, turnips, &c., is raised; invariably the amount of soda in the ashes of these and other plants will be found to be quite insignificant in relation to that of potash.

Plants appear to have not only the power of taking up potash

from the soil, but also of retaining this alkali and using it for building up the living organs of the plant.

Soda and its saline combinations unquestionably are also taken up by plants from the soil and circulated throughout the vegetable organism, but it is questionable whether soda, like potash, is ever transformed in conjunction with carbon, hydrogen, nitrogen, and other elements, into a living organ, in which the properties of the alkali are no longer recognisable, but are as completely changed as those of hydrogen, or carbon, or oxygen when entering into chemical combination with each other.

It is true we find soda-salts, more especially common salt, in almost every kind of agricultural produce, and their presence is commonly regarded as a proof that they are absolutely necessary for the very life and growth of our cereal and forage crops. The mere presence of certain constituents in plants does not, however, prove that these constituents are indispensable. Such a conclusion is only established when the withdrawal of one or more elements of nutrition, or the substitution of others in their place, is marked uniformly by an unhealthy growth and final failure. Thus we know positively that no plant can grow healthily without phosphoric acid or potash, since numerous attempts to find a substitute for them have all been totally unsuccessful. Hence our present state of knowledge entitles us to consider these two substances to be essential ash-constituents of all plants.

On the other hand, the fact that mangolds, or grass, contain a good deal of common salt when the soil on which they are grown is naturally rich in salt, or has received a good dressing of it, does not by any means prove that salt is necessary; or even that it is, or may be, a useful manure for these crops.

Like other soluble substances common salt and most other soda-salts are readily absorbed by the rootlets of plants and conveyed into their sap, where they probably have important functions to perform in the living plant. What these special functions are we have yet to learn; all we know is that salt is taken up by plants, and under certain conditions which require yet to be more clearly defined, has a remarkably good effect upon vegetation. Notwithstanding the large increase in the produce of corn or roots which has in many cases been realised by the use of salt, and its general presence in almost all plants, its base—the soda—cannot be regarded as essential to the luxuriant growth and maturity of plants. In many ash-analyses, made by our best and most trustworthy analytical chemists, soda is not mentioned at all, and merely traces of chloride of sodium are given. Ash-analyses in which soda does not occur are not isolated or exceptional cases, but may be readily found on looking over a list of such analyses endorsed by the names of Boussingault, Fresenius,

Way, and other chemical authorities, who have failed to find soda in the ashes of some crops and only insignificant quantities in others.

It is further worthy of notice that whilst the amount of phosphoric acid or potash in our crops within certain limits varies but little, the proportion of common salt in green crops and grass, and cereals in an unripe condition, appears to be regulated entirely by accidental circumstances and to vary greatly. Thus in land like the salt-marshes the herbage is richer in this constituent than in upland districts, and on this account more relished by cattle than ordinary herbage. Again, mangolds that have received a heavy dressing of salt invariably contain a good deal of salt, more especially in their leaves, whilst roots grown without salt are comparatively poor in it.

The difference between potash and soda in this respect is striking. No plant as yet has been found in which potash was entirely absent, and though a soil may contain but little of this alkali, plants have the power of extracting it and assimilating it—that is, using it for the building up of their own organism. Soda and its combinations, on the other hand, when present, occur in variable proportions in the sap of plants. Soda compounds do not appear to enter into such intimate organic combinations with carbon, hydrogen, nitrogen, and other elements, as potash and its combination. It is worthy of notice that common salt never occurs in perfectly ripe seeds, such as the grain of wheat, barley, oats, even when the land upon which they are grown has been heavily top-dressed with common salt, and the analysis of the whole plant, root, stem, leaves, and unripe seed, shows its presence in considerable quantities. Common salt, and soda-salts in general, as it would appear, circulate in the plant, assisting, in all probability, the assimilation of other inorganic or soil constituents without becoming themselves integral parts of the living plant.

It may further be mentioned that Professor Knop of Leipzig has succeeded in growing and maturing peas, beans, Indian corn, oats, barley, wheat, and other plants, in watery solutions from which he excluded all salts of soda. Lastly, it is well known to every practical agriculturist that soda compounds as a class certainly do not belong to our most efficacious manures; and it is certain that the beneficial effects which nitrate of soda and a few other soda-salts produce are mainly due to their acid, and not to their basic constituents.

In the preceding remarks I have sufficiently stated the reasons which induce me to regard soda as a non-essential ash-constituent of plants. I have dwelt rather longer on this matter than may be deemed necessary, because I think the time has arrived

when attention should be prominently directed to the distinction between essential and non-essential ash-constituents which I have been in the habit of drawing for more than eight years. The development of the doctrine of vegetable nutrition demands that such a distinction should be made, both in a qualitative and quantitative sense—that is to say, it is desirable that we should know positively not only what soil-constituents are absolutely necessary for the growth of our cultivated crops, but also what is the amount of each ash-constituent that has to be regarded as indispensable for bringing our various crops to maturity, and what is the amount which may be considered as superfluous or accidental.

Although I do not look upon chloride of sodium and soda-salts in general as essential ash-constituents of plants, I am far from denying the beneficial effect which salt is capable of producing in particular cases. Indeed, my own experience leads me to admit that salt is a useful and cheap manure, which, judiciously applied, frequently yields a large increase of corn, roots, or hay, and seldom does any harm.

On porous sandy soils, roots, especially when the season happens to be dry, are apt to pass so rapidly through all the stages of growth that their leaves begin to drop before they have had time enough on the one hand to collect atmospheric food, and on the other to accumulate mineral matter from the soil in sufficient quantity for the development of an abundant crop of bulbs. On such soils the application of 3 or 4 cwt. has given me a large increase in roots, and 7, 8, or even 9 cwt., so far from doing any harm, increased the produce of mangolds by $2\frac{1}{2}$ to 4 tons per acre. On the other hand, it does mischief when it is applied in excessive doses (and such I consider all quantities exceeding 5 cwts. per acre), to stiff, wet, clay soils, and soils generally which are cold, and which bring their grain, root, and grass crops slowly to maturity, for salt has a remarkable tendency to prolong the period of vegetation, and delay the arrival of maturity, and consequently, when it is misapplied, the crude juices circulating in the unripe leaves are not sufficiently elaborated or ripened, within the period during which the roots can be left in the field, for the production of a large and heavy crop.

As common salt certainly has the power of prolonging the period during which our cultivated crops can be kept growing in the field, much advantage can be derived from its use by the intelligent agriculturist, who, bearing in mind the circumstances under which it is desirable to prolong the life of plants, will chiefly employ it as a top-dressing or otherwise when he has to do with light, porous, and naturally dry soils.

This useful property of common salt is probably common to

all very soluble salts that are not positively poisonous, but none is so cheap and so innocuous as this, and therefore so well calculated to discharge this important function.

∴ It will be seen that the value of a fertilizing agent does not always depend upon the fact that it is an essential element of nutrition; the substance which we apply to the land with a view of increasing our crops may have no value whatever as a direct fertilizer, and may, as is the case with chloride of sodium, not even make its appearance in our grain-crops, and yet it may be instrumental in materially raising the produce of wheat.

Again, such non-essential salts in general may nevertheless play an important part in the nutrition of plants by assisting the solution and uniform distribution of fertilizing constituents which occur in the soil in a sparingly soluble or insoluble condition. It is well known to chemists that chloride of sodium exercises such a dissolving action upon several bodies, and thus it is not too great a stretch of fancy to assume that it will act beneficially in the field by dissolving and rendering available earthy fertilizing constituents which without its aid will remain in an inert condition for a long time.

The remarkable changes which solutions of salts of *potash* undergo in passing through different soils naturally leads us to suspect that similar changes take place when dilute solutions of *soda-salts* are filtered through a soil.

We know, indeed, that soda to some extent, though, in comparison with potash, only to a small extent, is absorbed by most soils, and that its absorption, like that of ammonia, potash, phosphoric acid, &c., is mainly due to chemical action, and not merely to physical attraction.

All soils possess a wonderful capacity of adapting or converting crude fertilizing substances into combinations fitted to support the process of nutrition of plants. The changes which soluble fertilizers undergo in contact with soils of various characters are frequently quite unexpected. The results of filtration experiments are very much influenced by the composition of each individual soil operated upon, and by the strength and even the quantity of the saline solution brought into contact with it. We must, therefore, be careful how we attempt to deduce from the results of special experiments an universal or natural law of husbandry. The results of such experiments are not without value; they hold good, however, only under the particular conditions under which they were performed in the laboratory, and probably many more years of hard study and conscientious self-denying work on many intelligent practical observers will still be required, before our knowledge of the mysterious process of vegetable nutrition will be much advanced.

ABSORPTION OF SODA.

With a view of throwing, if possible, further light on the functions of soda-salts, and more especially of common salt, in relation to the soil and the crops grown upon it, I have made some experiments similar to those recorded in my paper on the 'Absorption of Potash by Soils of known Composition,' and have now the pleasure of laying before the Society a further instalment of soil studies, similar to those which will be found in previous volumes of this Journal.

Experiments with a solution of Chloride of Sodium.

In the following four experiments $\frac{1}{2}$ lb. (3500 grains) of soil were in each case introduced into a glass-stoppered bottle, four deci-gallons of water containing in solution 41.52 grains of chemically pure chloride of sodium were then poured upon the soil and left in contact with it for four days, during which time this mixture was shaken up at intervals and then allowed to settle. The clear liquid was then syphoned off and passed through fine filtering-paper. In separate portions of the perfectly clear filtered solution the following substances were then determined by well-known and approved analytical processes that need not be described here in detail:—

Soluble silica; oxides of iron and alumina (together); lime; magnesia; potash; soda; sulphuric acid; phosphoric acid, and chlorine.

The amount of sulphuric acid found in the analysis was combined with its equivalent proportion of lime, and calculated for the whole four deci-gallons. The chlorine found was combined with the magnesium, potassium, sodium, and with the remainder of the lime found in each analysis.

EXPERIMENT NO. 1.—*With a solution of Chloride of Sodium on a Calcareous Soil.*

The soil employed in this experiment was a chalk-marl, containing carbonate of lime in a greatly preponderating proportion, with but little clay and organic matter, as will be seen by the following analysis, which gave in 100 parts:—

Moisture	3.62
Organic matter	4.23
Carbonate of lime	67.50
Oxides of iron and alumina	7.54
Magnesia44
Potash and soda79
Insoluble silicious matter	15.88
Chlorine and phosphoric acid	traces

100.00

X

The salt-solution, as already stated, originally contained, in four deci-gallons, 41·52 grains of pure chloride of sodium. The liquid, which had been left for four days in contact with the soil, contained, after filtration, in four deci-gallons:—

	Grains.
Soluble silica	·36
Oxides of iron and alumina	·16
Chloride of sodium	36·24
Chloride of potassium	1·04
Chloride of magnesium	·30
Chloride of calcium	6·04
Sulphate of lime	7·55
Phosphoric acid	traces
	51·69

The chlorine contained in the solution used in the experiment amounts to 25·16, and the chlorine found in the filtered soil-solution amounts to 26·57, and is distributed amongst the various constituents as follows:—

	Grains.
Chlorine united with sodium	21·99
Chlorine united with magnesium	·23
Chlorine united with potassium	·49
Chlorine united with calcium	3·86
	26·57
Total chlorine found	26·57

Consequently no absorption of chlorine whatever took place; the filtered liquid contained 1·41 of chlorine in excess over the quantity contained in the salt-solution before filtration, which slight excess no doubt is due to the small quantities of chlorides which occurred in the soil.

It will be seen that whilst the whole amount of chlorine passed through the soil in combination with magnesium, potassium, and calcium, some soda was retained by it. The amount of soda fixed by the soil is but small, for

	Chloride of Sodium.	Soda.
Before the experiment the salt solution contained ..	41·52 =	22·00
After contact with soil	36·24 =	19·20
Difference	5·28 =	2·80

Thus 3500 grains of this calcareous soil absorbed only 2·8 grains of soda contained in 5·28 grains of chloride of sodium, or 1000 grains absorbed only 0·8 of a grain of soda.

If we compare this result with the action of arable soils upon potash-salts, we find that the soil has far less attraction for soda than for potash. For instance, this same calcareous soil, of which 1000 grains in the preceding experiment absorbed only 0·8 of a grain of soda, in a similar filtration experiment made

with chloride of potassium, absorbed 3·578 grains of potash per 1000 of soil. This, no doubt, is one of the reasons why soda-salts as a class are far less energetic manures than their corresponding potash-salts. If a soil is manured with common salt and by the action of rain a dilute solution of salt is produced, a good deal of the salt will remain undecomposed in the ground. In the moist soil the salt exercises but a weak influence, which, however, produces a sufficiently marked effect upon the produce in the long run.

EXPERIMENT NO. 2.—*With a Stiff Clay Soil.*

This soil was poor in lime, and contained but little sand, capable of being separated by washing and decantation. It furnished, on analysis, the following results:—

Mechanical Analysis.

Moisture	3·91
Organic matter and water of combination	4·80
Clay	78·13
Lime	2·19
Sand	10·97
	<hr/>
	100·00

Chemical Analysis.

Moisture	3·91
Organic matter and water of combination	4·80
Oxides of iron and alumina	7·85
Phosphoric acid	·04
Carbonate of lime	2·08
Sulphate of lime	·15
Magnesia	} 32
Alkalies and loss	
Insoluble silicious matter	80·85
	<hr/>
	100·00

Four deci-gallons of the salt-solution, after four days' contact with the soil, contained:—

	Grains.
Soluble silica	·36
Oxides of iron and alumina	·28
Chloride of sodium	34·88
Chloride of potassium	1·80
Chloride of magnesium	1·35
Chloride of calcium	3·80
Sulphate of lime	1·36
Phosphoric acid	·08
	<hr/>
	43·91

The total amount of chlorine found in the liquid after filtration
x 2

through the soil is 25·42, which is divided amongst the four chlorides as follows :—

Chlorine in union with sodium	21·13
Chlorine in union with magnesium	1·01
Chlorine in union with potassium	·85
Chlorine in union with calcium	2·43
	<hr/>
	25·42

This corresponds almost exactly with 25·16—that is, the quantity of chlorine in the 42·51 grains of salt contained in four deci-gallons of the solution employed in these experiments.

In this case a little more soda was absorbed than in the preceding experiment :—

	Chloride of Sodium.	Soda.
Before the experiment the salt-solution contained ..	41·52 =	22·00
After contact with soil	34·88 =	18·48
	<hr/>	<hr/>
Difference	6·64 =	3·52

1000 grains of soil consequently absorbed 1·057 grain of soda.

EXPERIMENT NO. 3.—*On a fertile Sandy Loam.*

This soil on analysis yielded the following results :—

Moisture	2·95
Organic matter and water of combination	6·75
Oxides of iron and alumina	6·10
Carbonate of lime	1·22
Alkalies and magnesium	1·20
Insoluble siliceous matter (sand and clay)	82·22
	<hr/>
	100·44

The qualitative analysis of this soil showed, moreover, that it contained distinct traces of chloride of sodium.

3500 grains of soil and four deci-gallons of salt-solution were treated as before with the following results :—

The clear filtrate after contact with the soil contained :—

	Grains.
Soluble silica	·12
Oxides of iron and alumina	·20
Chloride of sodium	37·36
Chloride of potassium	1·72
Chloride of magnesium	·30
Chloride of calcium	4·60
Sulphate of lime	·96
Phosphoric acid	traces
	<hr/>
	45·26

The filtrate contained, in conformity with Experiment No. 1,

a slight excess of chlorine, amounting to 1·49 grain, again showing that, whilst soda is retained in the soil, the whole of the chlorine of the salt-solution passes through it.

The actual quantity of chlorine found in the liquid after contact with the soil amounted to 26·65 grains, which were divided amongst the four chlorides as follows :—

	Grains.	
Chlorine in combination with sodium	22	67
Chlorine in combination with magnesium	23
Chlorine in combination with potassium	81
Chlorine in combination with calcium	94
	26·65	
	Chloride of Sodium.	Soda.
Before the experiment the salt solution contained ..	41·52	= 22·00
After contact with soil	37·36	= 19·79
Difference	4·16	= 2·21

1000 grains of the sandy fertile loam consequently absorbed only 0·62 of a grain of soda.

EXPERIMENT NO. 4.—*On Pasture Land.*

The analysis of this soil yielded the following results :—

Moisture	2·420
Organic matter	11·700
Oxides of iron and alumina	11·860
Carbonate of lime	1·240
Sulphate of lime	·306
Phosphoric acid	·080
Chloride of sodium	·112
Potash (soluble in acid)	·910
Soluble silica	4·090
Insoluble siliceous matter	67·530
	100·248

The experiment was in this instance carried out in precisely the same manner as before.

The clear filtrated solution, after contact with soil, on analysis, gave the following results :—

	Grains.
Soluble silica	·12
Oxides of iron and alumina	·28
Chloride of sodium	34·92
Chloride of potassium	·72
Chloride of magnesium	·47
Chloride of calcium	5·30
Sulphate of lime	·41
Phosphoric acid	traces
	42·22

The chlorine in 41·52 of salt contained in four deci-gallons of salt-solution amounts to 25·16 grains.

Chlorine found after contact with soil, 25·27; that is almost precisely the same quantity originally present in the solution.

The chlorine in the filtered liquid occurs as follows:—

Chlorine in combination with sodium	21·19
Chlorine in combination with potassium	·34
Chlorine in combination with magnesium	·35
Chlorine in combination with calcium	3·39
	<hr/>
	25·27

	Chloride of Sodium.	Soda.
Before contact with soil the salt-solution contained ..	41·52	= 22·00
After contact with soil	34·92	= 18·50
	<hr/>	<hr/>
Difference	6·60	= 3·50

Thus 1000 grains of pasture-land absorbed in this experiment exactly 1 grain of soda—the same quantity as was taken up by the soil in Experiment No. 2.

EXPERIMENT NO. 5.—*Absorption of Chloride of Sodium on a Marly Soil.*

In this experiment a stiffish clay-marl was used. It was found on analysis to contain in 100 parts:—

Moisture	4·72
Organic matter and water of combination	11·03
Oxides of iron	9·98
Alumina	6·06
Carbonate of lime	12·10
Sulphate of lime	·75
Magnesia and alkalies	1·43
Soluble silica (soluble in caustic potash)	17·93
Insoluble siliceous matter (chiefly clay)	36·00
	<hr/>
	100·00

The salt-solution used in this experiment slightly differed in strength from that employed before, and contained, in four deci-gallons, 40·32 grains of chemically pure chloride of sodium.

3500 grains of soil, and four deci-gallons of salt-solution, were employed, and the experiments carried out precisely as before.

In the four preceding analyses of the salt-solution left in contact with soil, the determination of the organic matter was not attempted. In this and the next experiment a separate portion (one deci-gallon) of the clear liquid was evaporated, and the residue carefully dried at 300° Fahr. until it ceased to lose its

weight. The organic matter was then destroyed by heat and the residue analysed in the usual manner.

Calculated for four deci-gallons, the salt-solution after contact with soil contained :—

Organic matter	2·520
Soluble silica	·100
Oxides of iron and alumina	·080
Sulphate of lime	1·428
Carbonate of lime	2·172
Chloride of sodium	33·642
Chloride of potassium	·538
Chloride of magnesium	·460
Chloride of calcium	5·758
Phosphoric acid	·038
	46·736

One deci-gallon evaporated to dryness gave 11·625 grains of residue dried at 300°; this gives 46·500 grains for the whole salt-solution, and agrees very well with the sum-total of the constituents found in the detailed analysis.

The chlorine, I may observe, was determined in a separate portion, and not in the residue left on evaporation.

Calculated for four deci-gallons,

The amount of chlorine found was	24·696
Chlorine in the 40·32 of chloride of sodium contained } in 4 deci-gallons of solution }	24·467
Difference	·229

No chlorine whatever it will be seen was absorbed, and the amounts found in the solution, before and after the experiment, were almost identical.

The chlorine was thus distributed amongst the different basic substances dissolved by the salt-solution from the soil :—

Chlorine in combination with sodium	20·413
Chlorine in combination with potassium	·256
Chlorine in combination with magnesium	·344
Chlorine in combination with calcium	3·683
Total chlorine found	24·696

Absorption of soda by the marly soil took place as follows :—

	Chloride of Sodium.	Soda.
Before contact with 3500 grains of soil, 4 deci- } gallons of salt-solution contained }	40·320	= 21·366
After contact	33·642	= 17·878
Difference	6·678	= 3·488

1000 grains of soil accordingly absorbed 0·996 of a grain of soda, or very nearly 1 per mille.

EXPERIMENT No. 6.—*On a Sterile Ferruginous Sandy Soil.*

The last experiment with chloride of sodium was tried upon a soil distinguished from the others by its sterile character; it contained an excessive proportion of oxide of iron, much quartz—sand, little clay, and mere traces of lime.

The analysis yielded the following results:—

Moisture	1·43
*Organic matter	3·39
Oxides of iron and alumina	12·16
Carbonate of lime	·15
Alkalies and magnesia	·46
Insoluble siliceous matter	82·41
Sulphuric and phosphoric acid	traces
	<hr/>
	100·00
*Containing nitrogen	·21
Equal to ammonia	·25

The salt-solution, containing 40·320 grains of pure chloride of sodium, left in contact with the soil for four days, gave the following results:—

Organic matter	2·180
Soluble silica	·160
Oxides of iron and alumina	·122
Chloride of sodium	36·222
Chloride of potassium	·818
Chloride of magnesium	·304
Chloride of calcium	·608
Sulphate of lime	1·070
Phosphoric acid	·040
	<hr/>
	41·524

	Chloride of Sodium.	Soda.
Before the experiment, 4 deci-gallons of salt-solution contained	40·329	= 21·366
After contact with 3500 grains of soil	36·222	= 19·193
	<hr/>	<hr/>
	4·098	2·173

1000 grains of this soil consequently absorbed 0·62 of a grain of soda.

A separate deci-gallon, on evaporation, left 10·33 grains of residue dried at 300° Fahr., which gives 41·320 grains per four deci-gallons, a result which agrees as closely as can be expected with the results obtained in the above detailed analysis.

If we calculate the amount of chlorine in the four chlorides mentioned in the analysis of the liquid after contact with soil, we find:—

Chlorine combined with sodium	21·976
Chlorine combined with potassium	·386
Chlorine combined with magnesium	·228
Chlorine combined with calcium	·388
	<hr/>
Total chlorine found in fixed salts	22·978

The chlorine contained in the original 40·32 grains of chloride of sodium dissolved in four deci-gallons of water amounted to 24·467, and as 22·98 grains of chlorine only were recovered in the heated residue from four deci-gallons of salt-solution, it might appear that 3·487 of chlorine had become absorbed by this soil. This, however, was not the case; for a direct determination of chlorine in a portion of the salt-solution not evaporated to dryness, gave 24·402 of chlorine for four deci-gallons, or almost the identical quantity present in the original salt-solution.

No chlorine, therefore, whatever became fixed in the soil; and the question arises what had become of the missing 3·487 grains of chlorine. No bases were left in the residue obtained on evaporation with which the chlorine could have been united, and the examination readily showed that this amount of chlorine did not exist in a free or uncombined state.

A minute investigation of this curious dissipation of chlorine, which gradually took place during the evaporation of the liquid by heating the residue to redness, showed that a portion of the chlorine in the filtered salt-solution was combined with ammonia, which of course must have long been present in the soil under experiment.

A direct ammonia determination fully verified this supposition, for, on distilling this soil with a solution of caustic potash, I found that it contained ·103 per cent. of free ammonia. For the filtration experiment 3·500 grains of soil were used; this quantity consequently contained 3·605 grains of ammonia, which is more than sufficient to combine with the chlorine not recovered in the heated residue. The 3·487 grains of chlorine which remained over and above the quantities united with sodium, potassium, magnesium, and calcium, correspond to 5·255 grains of chloride of ammonia, containing 1·669 of ammonia.

ACTION OF SALT ON PERUVIAN GUANO.

A distinct proof is here given that common salt has the power of liberating ammonia from soils that have been highly manured with rotten dung, Peruvian guano, and other ammoniacal manures, which in sandy soils especially exist in feeble combinations, that readily undergo decomposition when brought in contact with a solution of salt. In the case before us, a portion of chloride of sodium acted upon these feeble ammonia combinations, pro-

ducing on the one hand soda, which became fixed in the soil; and on the other, chloride of ammonia, which passed into solution.

This analytical result throws light on the function of salt in agriculture. It is well known that salt is most beneficially applied to light land, after a good dressing with farmyard-manure, alone or in conjunction with Peruvian guano, and that its application under these circumstances is particularly useful to wheat and grain crops in general. Practical experiments on a large scale have shown, indeed, that by salt alone a large increase of grain was produced on land in good heart—that is, that had been previously well manured. In this case the application of salt evidently has the effect of liberating ammonia and rendering it available for the immediate use of our cereal crops, which we know from experience are much benefited by it.

On land out of condition, salt must not be expected to produce such a favourable effect, and as this manure no doubt is sometimes put upon land exhausted by previous cropping, in which, therefore, it does not find ammoniacal compounds upon which it can act, one reason becomes evident why salt is inefficacious as a manure in some cases, whilst in others its beneficial effects are unmistakeable.

Peruvian guano and salt is a favourite dressing with many farmers, and justly so. It has been supposed by agricultural writers that the benefits resulting from this mixture are due to the property of salt to fix ammonia; I have shown, however, elsewhere, that good Peruvian guano does not contain any appreciable quantity of free ammonia, and, moreover, that salt does not fix ammonia.

Whilst theory has erred in ascribing to salt a power which it does not possess, the practice of mixing guano with salt is one which can be confidently recommended. So far from fixing ammonia, salt rather tends to liberate and disseminate through the soil the ammonia contained in the Peruvian guano applied to the land, which then becomes fixed by the soil.

It is worthy of notice that the soil employed in Experiment No. 6, received a liberal dressing of Peruvian guano in the preceding year, and retained, as shown by analysis, an appreciable, though small amount of ammonia in a loose state of combination. On the addition of a solution of salt, a portion of the ammonia entered into union with an equivalent proportion of chlorine of the chloride of sodium and passed into solution, whilst the soda of the decomposed chloride of sodium became fixed in the soil. The admixture of salt to Peruvian guano thus increases the efficacy of the latter, and on this account proves economical in practice, especially on light land.

The soils used in this series of experiments absorbed the following quantities of soda by 1000 grains:—

	Soda. (No. of Grains.)
1. Calcareous soil800
2. Stiff clay	1.057
3. Fertile sandy loam620
4. Pasture land	1.000
5. Marly soil996
6. Sterile ferruginous sand620

Compared with the amount of potash which the same soils removed from solutions of chloride of potassium, these quantities are small, since, speaking generally, they are not more than one-third or one-fourth as large.* In every instance, however, an appreciable quantity of chloride of sodium was decomposed, and gave rise to soluble chlorides of potassium, magnesium, and calcium; and in the case of the ferruginous sand, chloride of ammonium was formed in addition and passed into solution.

My experiments agree with those of other observers, and prove that common salt is certainly an effectual means of eliminating mineral food from the soil and placing it at the disposal of the growing plant.

EXPERIMENTS WITH SULPHATE OF SODA.

1. *On a Marly Soil.*

The same soil which was used in the Experiment No. 5, with chloride of sodium, was tested to ascertain its power of removing soda from its sulphate. 3500 grains of the marly soil were put into a stoppered bottle and mixed with four deci-gallons of a solution containing 44.93 grains of anhydrous sulphate of soda. The greater portion of the liquid, after standing upon the soil for four days, was drawn off, filtered, and subsequently analysed.

Two deci-gallons of the clear solution, when evaporated to dryness, gave a residue, weighing 25.650 grains, dried at 300° Fahr.

The total solution accordingly gave 51.30 grains of solid matter.

The residue left, on evaporation, was analysed, and deter-

* 1000 grains of soil removed from solutions of chloride of potassium, the following quantities of potash:—

	Potash in grains.
1. Calcareous soil	3.578
2. Clay soil	3.970
3. Fertile sandy loam	2.626
4. Pasture land	3.758
5. Marly soil	3.373
6. Sterile sand	1.465

3500 grains of soil, and four deci-gallons of solution of sulphate of soda were left in contact for four days, and the experiment carried out precisely as before.

The analysis of the filtered liquid, after contact with soil, calculated for four deci-gallons, gave the following results:—

Organic matter	3.240
Soluble silica	1.20
Oxides of iron and alumina and traces of phosphoric acid	1.00
Sulphate of lime	1.714
Sulphate of magnesia642
Sulphate of potash812
Chloride of sodium680
Sulphate of soda	39.696
	47.004

By direct evaporation of two deci-gallons of the clear solution, 23.45 grains of solid residue, dried at 300° Fahr., were obtained; this gives 46.90 for the total solution, and agrees very closely with the sum-total of the constituents found in the analysis of the dried residue.

This soil, under precisely similar conditions, absorbed less soda than the marly soil:—

	Sulphate of Soda.	Soda.
Before the experiment, 4 deci-gallons of liquid contained	44.930	= 19.617
After contact with 3500 grains of soil	39.696	= 17.329
Difference	5.234	= 2.288

Accordingly 1000 grains of this sandy sterile soil absorbed only 0.653 of soda.

The sulphuric acid in the liquid after filtration through the soil is distributed as follows:—

22.364 grains are united with soda	
.373 " " " " " " "	potash
.421 " " " " " " "	magnesia
1.008 " " " " " " "	lime

24.166 grains of sulphuric acid altogether.

Before filtration the solution contained 25.312 grains of sulphuric acid; consequently 1.146 grain was not recovered in the fixed and heated residue.

I have pointed out already that this soil contained ammonia in a state of combination, which enabled me to expel readily an appreciable quantity by distillation with caustic potash. A portion of sulphuric acid, originally united with soda, evidently passed into the filtered liquid in combination with ammonia. As sulphate of ammonia, like all salts of ammonia, is volatile at a high temperature, none could be retained in the strongly-heated

residue of the filtered liquid; this residue consequently contained less sulphuric acid than the liquid from which it was obtained.

This view is sanctioned by the result of a direct sulphuric acid determination made in the filtered liquid after contact with the soil. Calculated for four deci-gallons, I found 25·552 grains of sulphuric acid; and as but 24·166 of this quantity were united with lime, potash, soda, magnesium and soda, 1·386 grain of sulphuric acid remained over which could only have been united with ammonia.

Like a solution of common salt, though in a minor degree, a solution of sulphate of soda had the power of separating from this soil, and rendering soluble, an appreciable amount of ammonia.

EXPERIMENT WITH NITRATE OF SODA ON MARLY SOIL.

In my last experiment I employed a solution of nitrate of soda and the same marly soil that was used in several preceding experiments.

1750 grains of this soil were shaken up in a bottle with one deci-gallon of a solution containing 24·92 grains of nitrate of soda. After standing three days the liquid was filtered off, and in it the proportions of lime, potash and soda, and of nitric acid, were accurately determined; the first three by the usual methods of analysis, the last by Pugh's process. Two separate nitric acid determinations gave closely-agreeing results.

The following results were obtained in this analysis:—

	Before Filtration, the Solution contained				After Filtration, the Solution contained			
Nitric acid	15·82	15·715
Soda	9·10	9·569
Potash	·420
Lime	2·408
				24·92				28·112

This soil yielded to water alone small quantities of chloride of sodium, of potash, and of carbonate of lime, which accounts for a little more soda being found in the liquid after contact with soil than occurred in the original solution of nitrate of soda.

Within a small fraction, the proportions of nitric acid in the original solution and the liquid after filtration through the soil are identical.

It appears thus, that in this experiment neither nitric acid nor soda were absorbed.

11, *Salisbury-square, Fleet-street, London, E.C.*

XXIV.—*Rise and Progress of Shorthorns.* By HENRY H. DIXON.

PRIZE ESSAY.

A quiet day with Bakewell and the Longhorns — The Holderness cows — The Teeswaters — Earliest bulls in the Shorthorn Herd-Book — Original Durham breeders — The Maynards' bullocks — The Brothers Colling — The Durham ox — The Barmpton and Ketton sales — Diffusion of shorthorns — Bates — Mason — Whitaker — Sir C. Knightley — The Cherry Cross — The Booths — Indirect causes of Shorthorn progress — Progress in England — Neglect of milking qualities — Progress in Scotland — Result of crosses with its native breeds — Aberdeenshire "cross-breeds" — Effect on Falkirk trade — Progress in Ireland, on the Continent, in the Colonies — Fancy prices — Conclusion.

MODERN history has been much too sparing of its prose pictures of pastoral life. A great general or statesman has never lacked the love of a biographer; but the thoughts and labours of men who lived "remote from cities," and silently built up an improved race of sheep or cattle, whose influence was to be felt in every market, have had no adequate record. One slight sketch is nearly all that remains to us. We can go back, through its guidance, to the days when Bakewell was a living name, and Dishley the head-quarters to which all the best breeders of farm-stock made resort. The scene rises up through the dim vista of more than a hundred years. There are the willow clumps which were cut on a seven years' rotation; the water-meadows, which grew four grass-crops in the season; the mimic Dutch canal, which supplied the sluices and carried boats laden with produce and manure between different parts of the farm, and on whose sluggish stream turnips were floated down to the stock, and washed in the course of their sail! 'Two-Pounder' is brought out by the shepherd, with all the respect due to such a patriarch of the long-wools. Will Peet is on parade with the black cart-stallion; and John Breeder and Will Arnold, hazel-wand in hand, have gathered the herd into a corner of the Long Pasture, and listen eagerly for any word that may be dropped about their favourites. In the business-room there are not only skeletons but pickled carcasses of sheep, whose points were most after their breeder's heart; but he shows with no less relish some beef joints, the relics of his "Old Comely," which died at twenty-six, and the outside fat of a sirloin fully four inches thick.

The latter were his longhorn trophies, and no man could boast of a herd with deeper flesh and lighter offal. In his eyes, the breed was fated to represent the roast beef of Old England for ever and aye; and the thought that the very glory of their heads would be objected to as taking up too much room in the straw-

yards, and that a race with shorter horns and earlier maturity from "the banks of the stately Tees" would ruthlessly push them from their place and reduce them to a mere fraction in the Midlands, never vexed his soul. Their hold of public favour had been long and sure, and their greatest triumph was to come. If "Two-Pounder" had then the reputation of earning 800 guineas in one season and serving some picked home ewes as well, the Dishley bull "Two Penny" was fated to make the herd of Fowler of Rollright, and swell its sale average to 81*l.* 14*s.* 3*d.* for fifty-one!

Longhorns of some kind or another, and generally with good milk-marks and the faculty of fattening at a great age, were at this period the farmers' friends. They excited the admiration of Dr. Johnson in Derbyshire, and led him to note that his host, "whose talk is of bullocks," sold one of them for 100 guineas. As good prices were obtained for the *armenta fronte latâ*,—those blacks with white backs which Sir A. Ramsay took to Scotland as a cross for the Aberdeenshire, and whose horn practice in Garstang market was duly felt and recorded by Pennant as he journeyed towards the Hebrides. Farther north, the Lortons had such wide-spreading horns that they were taught from calves to incline their heads at an angle on entering the byre. The Lake district could also boast of the white Lysicks, "whose horns and lofty carriage made them suitable for topping the Yorkshire dealers' lots;" and their neighbours, the Lamplugh Hawkies, bore a strong affinity, both in colour and look, to the white and mottle-faced Herefords.

The Holderness, a fine, large-framed breed, with good backs, long quarters, remarkably clean, straight legs, and well-developed udders, grazed in the district north of the Humber. Many of them were white, with blue or bay flecks; but the largest number were dark mouse and white, and, as was natural from their proximity to Hull and their general appearance, they were thought to be of Dutch origin. Milk was their speciality, and Mr. Curwen was wont to value the dairy produce of his twenty at 25*l.* a year. Under the local name of "Teeswaters," the shorthorns, to which the Holderness seemed to bear most affinity in character, had got a strong hold in Durham several years before the close of the century; but still it was not until "The Durham Ox" commenced his six years of caravan life in 1801 that the doom of the longhorns was virtually sealed.

The Teeswater were cattle of great substance, but somewhat ungainly in form, and were thought to give less but richer milk than the Holderness. The fragments of history on which their origin rests are somewhat shadowy and uncertain. Some contend there from that they must be of Dutch origin, and only another

version of the Holderness; and others, with equal zeal, that their tap-root is to be found in the West Highlands, or that the earlier breeders always fell back on its bulls for a cross if they thought that their herd was losing constitution. There is certainly some confirmation of this opinion in the peculiarly sharp horns and ink-black noses which will appear at intervals. The admirers of the 'Princesses' make good "the claims of long descent" as far back as 1739, on Stephenson's farm at Ketton; and it is also said that the ancestress of the 'Duchesses' roamed in Stanwick Park two hundred years ago, and that none of the tribe had been out of the Northumberland family until Charles Colling bought them. Be this as it may, the Teeswaters' capability of development, which the St. Quintin, the Pennyman, and the Milbank families were among the first to recognise, had suggested itself to many a longheaded Durham farmer as well as the Brothers Colling; but private herdbooks were hardly in vogue, and the patient pilgrimage of Coates, through sunshine and shower, with his grey pony and saddlebags, has not had the effect of tracing the breed farther back than four crosses beyond "Hubback" (319), who was calved in '77.

If the red and white Studley bull (626), bred by Sharter of Chilton, and the founder of the Gwynne or "Princess" tribe, may claim to be the "Abraham of shorthorns," James Brown's red bull (97), and Jolly's bull (337), are very early names on the roll. Seventeen or eighteen crosses separate the "Duchesses" from the one, and the Maynard and Mason tribes are in direct descent from the other. The Herdbook bull numbers, we may here observe, run through fifteen volumes, from "Abelard" (1) to "Zinc" (21,135).* Only 710 bulls were registered in the first volume, which was published in 1822; but the fifteenth, which brings the registration up to the close of 1862, shows an accession of 1959 in two years, and also contains about 2700 cows and as many heifer calves, the whole of which are contributed by 832 breeders.

The germ of this wonderful array must have been considered an "improved" county breed as far back as 1787. Hutchinson of Sockburn had then a cow good enough to be modelled for the cathedral vane, and had also beaten Robert Colling in a bull class. Other Durham breeders stood proudly on their family tribes. The "Lizzies" were with Charge of Newton, and Rose's and Fisher's stock can be traced to Cornforth of Barforth. Robert Colling had set his seal to Hill of Blackwell's herd, and nearly all the best men were dipping into the blood of Milbank

* The sixteenth volume, which has just been published, brings the numbers up to "Zealous" (23,252).

of Barningham. It was from his sort that there sprang the "old yellow cow by 'Punch,'" which was grand-dam of "the white heifer that travelled." The Maynards were also in the front rank, and it became their sound family custom to pitch eight bullocks and as many heifers in Darlington market, on the first Monday of March, as a sample of the Eryholme pastures. The bullocks were from four to five years old, with fine, wide horns, good bone, and very deep flesh; and they were keenly looked out for, year after year, on the pavement opposite the King's Head. Maynard's "Favourite" tribe was very early in repute, and Charles Colling (who had previously picked up his "Cherry" or "Peeress" tribe in Yarm market) never rested till he had bought the cow and her calf, "Young Strawberry," by Charge's "Dalton Duke" (188). He then changed the cow's name to "Lady Maynard," and it was upon her tribe that he used the Galloway or "alloy blood," through grandson of "Bolingbroke," (280), which made the highest average in its hour of trial at Ketton. Her descendants were also crossed most successfully with "Foljambe" (263), the sire of "Phoenix," the dam of the bull "Favourite" (252), who was in his turn the sire of the thousand-guinea "Comet" (155). "Hubback" (319) has always been considered the great regenerator of Shorthorns; but he did not do Charles Colling so much good as "Foljambe," who was from a "Hubback" cow, and he was parted with at the end of two seasons.

The aim of the Brothers Colling was to reduce the size and improve the general symmetry and flesh-points of their beasts. "Beauty," sister to "Punch" (531), had spread their fame beyond the county; and in 1799 "the Durham Ox," by "Favourite" (252) came out first at Darlington with his half-sister of the "Duchess" tribe. The latter was quite as great a wonder in her way, and confirmed Mr. Bates's fancy for the sort which was hereafter to be linked with his name. The subsequent travels of the Ox brought a large bull trade to Ketton and Barmpton. It would have been strange if they had not, as his live-weight was 216 stones of 14 lbs., and that not got by unwieldy bulk, but by the ripeness of all his points. He ultimately dislocated his hip and was slaughtered, and, curiously enough, his show career ended at Oxford, where, nearly a third of a century later, that of the Royal Agricultural Society began.

Even at the Ketton sale in 1810 the taste for shorthorns was confined within a narrow compass, as Durham, Yorkshire, Lincolnshire, Northumberland, and Westmoreland were the only counties which purchased. Some of the few survivors of the assembly on that day still speak of "Comet" as the most symmetrical bull they have ever seen. He was not very large,

but with that infallible sign of constitution, a good wide scorpion frontlet, a fine placid eye, a well-filled twist, and an undeniable back. His price caused breeders everywhere to prick up their ears. They had already heard of Fowler refusing 1000 guineas for a longhorn bull and three cows, as well as for a cow and her produce of eight seasons; but never of one bull achieving that sum. The spirit south of the Humber was fairly roused at last, and when, eight years after, the Barmpton herd came to the hammer, the representatives of four or five more counties were found at the ring-side. The Rev. Thomas Harrison and Mr. Edmonds of Boughton had often talked to Lord Althorp, Sir Charles Knightley, and Mr. Arbuthnot, in the Pytchley Club or woodlands, of the great day at Ketton, and his lordship sent a commission to Barmpton for three heifers and a bull; while a Nottinghamshire and a Leicestershire man joined in the highest-priced lot, "Lancaster" (621 guineas), which had some five crosses of "Favourite" (252) in his veins.

For many years previous to this sale Mr. Bates had been breeding shorthorns by the Tyne side, and bringing his beasts, as Sir Hugh Smythson had done before him, to periodical scale-tests. Still he does not seem to have struck out any especial herd-line for himself till he took up his fancy for the "Duchess" tribe. Charles Colling assured him that the cow which he bought in 1784 out of Stanwick Park was the best he ever had or ever saw, and sold him her great-granddaughter "Duchess," by "Daisy Bull" (186). She was the prelude to Mr. Bates's purchase of "Duchess 1st," by "Comet" (155), the only "Duchess" at the Ketton sale, and a very cheap lot at 186 guineas, as, independently of her produce, her new owner left it on record that she gave 14 lbs. of butter (21 oz. to the lb.) per week for six weeks after calving.

"Belvedere" (1706), of the "Princess" tribe, was the bull which Mr. Bates selected to "bring out the 'Duchesses.'" He was small and plain, and with rather rough shoulders, but as soft as a mole in his touch. The Brothers Colling had a most faithful disciple in the Kirklevington philosopher, as his celebrated show bull "Duke of Northumberland" (1940) was by "Belvedere," dam by "Belvedere;" and was thus bred on precisely the same principle as four of their leading animals, "Comet" and "The Ox," "Punch" and "Broken Horn,"—rather an instructive comment on the popular timidity which eschews even an approach to in-breeding. Mr. Bates led the shorthorn ranks of the Royal Agricultural Society both at Oxford and Cambridge, and it was his lot to breed the second one thousand guinea bull, and to fashion the model of the moulds in which such cows as "Second Grand Duchess," "Oxford 15th,"

and "Duchess 77th," were duly cast and quickened. Still no one contributed more towards shorthorn progress than Mason of Chilton, who got rid of the open shoulders and improved the forequarters generally. His sale in 1829 was to breeders quite a season of refreshing after a long and dreary drought. Earl Spencer took heart of grace, and bought a bull and sixteen cows and heifers; and Captain Barclay (who began in 1822) laid a still more solid foundation with "Lot 20, 'Lady Sarah.'" The fame of Kearney's bull (4144) in Ireland, which was well known to be of this stock, although he went over without a pedigree, brought buyers across the Channel. Mr. Latouche would not leave "Monarch" (2324) at 270 guineas; Mr. Robert Holmes, of county Meath, raised his best tribes from Lots 1 and 8, "Victoria," own sister to "Monarch," and "Britannia" by "Monarch;" while the stock of "Highflyer" (210 guineas) marked the commencement of a zealous novice in Kent.

Whitaker of Burley held his first sale soon after. He had always gone for milking tribes in his quiet Yorkshire valley, and laid much stress upon the purchase of "Magdalena," by "Comet" (155), the only cow which was kept out of the Ketton sale catalogue. The Americans, and more especially Colonel Powell and the Ohio Company, had heard of her and her 32 quarts a-day in their repeated visits to Burley. They generally left Yorkshire with the belief that "a man might ride four hacks to death in the North, and not find twenty such cows as Mr. Whitaker's;" and they were among his best customers for a series of years.

Sir Charles Knightley gradually became quite a Whitaker to the Midlands, when he gave up hounds about 1818, and laid himself in with the "Rosy" and "Ruby" tribes, and his friend Arbuthnot's bulls. He always said that it was "quite an acquired taste," but he took to it with singular heartiness. He strove to put shoulders on his cattle as perfect as those of his own hunters, "Benvolio" and "Sir Marinel," Beautiful forequarters, gay carriage, general elegance, and a strong family likeness distinguished his tribes, and their fine milking powers placed them (like "Cold Cream" and "Alix," at the Royal Home Farm) at the head of many a dairy. "A Fawsley fill-pail" soon passed into a herd proverb; and a dip into the blood of the "Earl of Dublin" (10,178), and the "Friars"—White or Grey—was pretty sure to make one.

The "Old Cherry," by "Pirate" (2430), tribe, which came originally from William Colling of Stapleton, was in high force when "Gainford" (2044) had spread those hind-quarters among the Cumberland fair lots, which the graziers told at a glance, and valued at a good pound more, and when Mr. Crofton had

taken such rare prize heifers by him and "The Provost" (4846) to the Highland Society and other shows. Colonel Cradock liked the sort for their size and milk, and they "nicked" well both with the Booth and the Bates blood. Crossed with "Grand Duke" (10,284), they founded the "Cherry Dukes," and "Duchesses;" and it was to "Mussulman" (1525) that John Booth sent his celebrated "Bracelet," and had "Buckingham" (3239) for his reward.

The Booth family began at Studley, about 1790, with Teeswaters and "Twin Brother to Ben" (660); and lengthening the hind-quarters, filling up the fore-flank, and breeding with a view to that fine deep flesh and constitution which bears any amount of forcing, have been their especial aim. It was the late Mr. Richard Booth's opinion that no bull had done his herd so much good as "Albion" (14), of "the alloy blood," and Mr. Whitaker and Mr. Wetherell were quite with him on the point. It may be said that shorthorns generally have grown smaller in frame, and that there is perhaps not that rich coat and uniformity of character which marked some of the earlier herds; but still those who can make the comparison from memory are fain to allow that, in their flesh-points and general weights, the breed knows no decay. What the Brothers Colling were in earlier days, the Brothers Booth have been in later. If the elder could boast of "Necklace," with the wondrous crops, and "Bracelet," in whom none could find a fault, save a trifling deficiency in the fore-rib, it was left to the younger to keep up the type with the beautiful "Charity," whose twist and hind-legs might have been modelled from, and to follow it up with "Plum Blossom," "Nectarine Blossom," "Queen of the Ocean," and "Queen of the May." Richard Booth and Crofton might be said to have initiated the modern plan of keeping beasts far more in the house, and preparing them specially with a view to shows. No blood has been more widely spread than that of "Warlabby" and "Killerby" throughout the United Kingdom, or commanded a finer bull-hiring trade; and it was from "Buttercup," a daughter of "Barmpton Rose," and crossed with Booth's "Jeweller" (10,354) that "Butterfly" sprang, the chief foundress, with "Frederick" (11,489), of the Towneley herd, whose victories in the store and fat shows combined are wholly without parallel.

Such are a few of the leading points of the shorthorn history of more than seventy years. Herefordshire has held stoutly by its native breed; North Devonshire and North Wales are true in the main to their little reds, and their massive runts; the Polls, the West Highlanders, and the Ayrshires are in possession of many old Scottish strongholds, but still the shorthorns have been

spread broadcast, and wherever they have gone they have generally superseded the native breed, or gradually improved it away. Jobbers began at first to buy large lots in Durham and Yorkshire, and to drive them south on speculation. They were so eagerly looked for at the different fairs, or picked up by farmers on the road, that before they had been many days on march their owners often found themselves like generals without an army, or with only the culls in their ranks. Railroads also helped to bring out sales, and gave facilities to bull hirers and bull and heifer buyers; while the periodical publication of the 'Herd Book' has also tended in no slight degree to establish an exchange of minds among breeders, and to concentrate attention on to different sorts of blood. With such a stimulus it is not wonderful that the shorthorns have fairly outflanked the Devons on the south side of their county and invested the greater part of Cornwall, whose breeders have been fond of them, more or less, since Mason's sale, and consider that they have "quite stolen a year" by their use. Crossed with the Devon, they have won a Smithfield gold medal; they are gradually encroaching on the county limits of the Sussex, and on the "blood-red dairies" of Essex, Norfolk, and Suffolk; in the cheese districts of Cheshire, Gloucestershire, and Wilts, scarcely any other breed is used; and it is calculated by experienced Smithfield salesmen that rather more than two-thirds of the average number of beasts (331,164) which came to the London market in 1863-64, were either pure shorthorns or shorthorn crosses. In reference to this increase, an old English breeder writes: "When I began, there was no pure bred shorthorn bull within seventeen miles of me, whereas now there is one in every parish."

It is nevertheless very generally considered that beef-making has been reduced to a science with pure shorthorns, and that milk-yielding has been neglected. Attention has also been drawn to the fact that many of the London dairymen are using Dutch cows. It may, however, be urged in reply, that the largest Scottish dairyman regularly uses shorthorn bulls to cross his Ayrshires and other cows, and that Dutch cows newly imported can be bought at about half the price of common dairy cows. Still, good milking pedigrees do not command an extra price, and, in fact, any allusion to them in a sale catalogue is rather regarded as an apology for doubtful or unfashionable blood. "Something to give milk for the house" is too often spoken of as a mere humble adjunct, and "not worth dwelling upon," at the end of a row of high-bred cows and heifers, many of which are systematically dried off to keep them in bloom for shows or visitors, while their calves are provided with a nurse. A young heifer is selected with a view to well-covered flesh-points, early maturity,

and fine mellow handling; and there is none of that Ayrshire acumen at work which gives laws for the exact shape of a "milking vessel," which likes a peculiar feather extending from that "vessel" up the twist, and large veins from it under the belly, and which will even reject "a dairy bull" if his false teats are not of the proper shape and exactly in position. This test may have been carried to an extreme, and cows with badly formed "vessels" may have sometimes turned out good milkers; but still it is this strict attention to milking-points (which among shorthorn men generally stops short at a light neck and a big udder) combined with bean-meal, which makes the Ayrshire cow such a perfect fill-pail for her size; whereas, on this side of the Border, we virtually make sure of the shambles, and too often play at "hit or miss" with the dairy.

Scotland also furnishes a most remarkable example of shorthorn beef development. Mr. Robertson, of Ladykirk, was perhaps the earliest patron of the breed, when he bought "Broadhooks" from Robert Colling, and "Ladykirk" (355) from Charge. General Simson established a small herd in Fife,—principally by Charles Colling's "North Star" (458),—but sold it off the week before the Barmpton sale, almost entirely to bidders from the Border counties. Mr. Rennie, of Phantassie, also took a decisive lead when the fine arable expanses of East Lothian were only whin and heather. In 1810 he spoke of the breed as "wider and thicker in their form, and therefore yielding the most weight and the greatest quantity of tallow." Mr. Stirling, of Keir, and Mr. Boswell, of Kingcausie, were also great improvers, and none did more in the North of Scotland than Captain Barclay, with his "shorthorns, not shorthorned," as he always made a point of explaining. Cows and bulls were imported direct from Holland to Banffshire very early in the century, and Mr. Rennie's white bull, "Jerry," was turned to still better account in the Ellon district. In 1830 some of the North Highland farmers did not even know a shorthorn by sight, whereas now no less than four first-prize Royal English bulls are to be found between Caithness and Stirling, and a small farmer within those limits, only occupying a second-class farm of 130 acres, has been known to give 75 guineas for an eight or nine months' bull-calf. Scottish shorthorns have crossed the Border to some purpose in their turn. The "Queens" and the "Roses" of Athelstaneford were often foremost among the best at the shows of the Royal Agricultural Society; and out of only 26 Scottish entries in the 167 at Newcastle, there came one third, four second, and three first prizes, besides one high and two ordinary commendations.

Wedded as the Scotch once were to the West Highlanders and "the heavy blacks" of Angus and Galloway, it is to the short-

horn that they now look for at least seven-eighths of the great beef supplies, which are poured by the cattle and dead-meat trains, as well as by the steamers, from Aberdeenshire, Banffshire, and Morayshire, into the English markets.

Even the traveller in "the wind-swept Orcades" and the Shetland Isles can trace the conquest of "the red, white, and roan." The Shetland cow, which after a long course of the finest lowland pasture is thought to "die well" at $2\frac{1}{2}$ cwt. neat, will respond with a calf which looks nearly as big as herself at five months, and will fetch its 11 guineas at sixteen. So highly is this cross valued, that at present an endeavour is being made (such as is said to have answered *sub rosâ* with the "Angus") to permanently enlarge the Shetland cattle by letting the heifer receive her first impregnation from a shorthorn. In some of the islands the latter is fast driving out the native breed on all the better farms; and in the Orkneys, where the farmers were working on a mixed foundation of West Highland, Devon, and original Orkney, the price of yearling crosses has been raised by its use nearly 400 per cent. In Caithness "cross-bred" cows have quite superseded the old cows of the country, and thanks to the introduction of shorthorns more than thirty years ago by the late Mr. William Horne and "Shirra Traill," and the most scientific and careful rearing, the high keepers can all reckon on 1*l.* a month for their yearlings at Georgemas fair time. In Morayshire also there was once not "a spotted beast" to be found, whereas now more than three-fourths of the cattle at the Elgin monthly market are shorthorn crosses, and it is, in fact, now almost impossible to execute an extensive commission for the "old Morayshire horned breed." The Forglen breed in Banffshire is quite "crossed out" by them, and in Aberdeenshire nearly every "cross-bred" cow has more strains of pure blood than would satisfy the 'Herd Book.' The breadth of turnips has increased enormously throughout the three "beef counties," and although McCombie's black beasts from the Alford district have no equals in the Smithfield Christmas market, Buchan has disowned its original blacks and brindles, and has quite fallen into the fashion. Many of the leading Aberdeenshire breeders will now finish off from forty to seventy, where they were once content with half-a-dozen, and generally sell them off at rather more than two-and-a-half years old for 30*l.* Apart from any prize-winning prestige, exceptional specimens a year older will fetch their 50*l.*, and a two-year-old steer has recently reached 94*l.* 10*s.* by auction. Many of the Scottish feeders breed as well as buy, and in Aberdeenshire they have a wide choice, as one herd owner alone has fifty or sixty pure shorthorn bull-calves for sale in the course of the season.

The bulls are used principally to "cross-bred," but also to West Highland and polled cows. With the latter they make a very beautiful cross, and correct the sluggish maturity of the Galloway blood; and an ox of this kind recently beat everything for the Cup at Birmingham, and was the second best ox or steer at Islington, when the winners were drawn out for the Gold Medal. The Shorthorn West-Highland cross is also becoming very popular. As yearlings, the produce are nearly as big as their dams, and quite as hardy, but (unlike the shorthorn-poll) the second cross is apt to fall off both in flesh and milk. The best beast in the yard at Liverpool last Christmas was a four-year-old bullock thus bred, and it produced 1,641 lbs. of beef and tallow.

Shorthorn crosses are creeping up the hill-sides in the North, where it was once thought impossible for any beast but a West Highlander or "Hieland Humley" to live. Even in the shire of Angus, which Hugh Watson, of Keillor, made for more than thirty years the great rallying ground of the polls, the farmers, as in Morayshire, are very largely supplied with store calves and yearlings each autumn from the milk valleys of Yorkshire and Lancashire. Fife cattle have retreated before them, and lost their classes at the Highland Society, and the Lothian farmers no longer look out keenly for the polls at Falkirk, whose two autumn trysts furnish the surest evidence of shorthorn progress. The polls have nearly disappeared from the Muir; and the shorthorn crosses which form the staple of the supplies are bought up to go north; while the West Highlanders are sent south as "fancy cattle" to the English parks.

Falkirk is very largely supplied, not only with Yorkshire calves, but capital shorthorn crosses from Ireland. Lord Ross, of County Longford, imported Teeswaters into that country, even before the Brothers Colling had made themselves a name. The Chilton sale was, as we have shown, the great Irish starting-point, but a few years before that Mr. Fitzgerald and Mr. Archbold had purchased several animals from Mr. Champion, of Blyth, and thus introduced for the first time pedigreed shorthorns into the country. Now nearly 180 shorthorn bulls, and more than half of them yearlings, may be seen at the Dublin Easter show. The greater part of them are of Booth blood. This is not to be wondered at, as for more than twenty years the best Killerby and Warlaby bulls have been over there for a season, until at last the English breeders, when the home supply fails or is priceless, are fain to go over themselves in search of a "pure Booth."

France has been more or less a customer for several years, and the breed has had no stouter champion than Mons. St. Marie. The late king sent commissions to Burley, Leyfields, Wiseton,

and elsewhere; and the Emperor has not only hired bulls from Warlaby, but purchased thirty females a few years since at upwards of a hundred guineas each. Bulls have been gradually distributed into many departments of France; and no one could walk down the Poissy rows in 1862 and fail to note how, in a land devoted to boiling-beef parts, they had asserted the British sirloin, and how no native breed, save the massive white or cream-coloured Charolais, could hold its own against them in the crosses. Germany has not given such high prices, and has cared less for blood. The King of Wurtemberg's agents were in the market as far back as 1824, and the Emperors of Russia and Austria in later years. Sweden came out more spiritedly last season than she had ever done before; and Spain has bought some bulls to put better points on the Andalusian cattle. The King of Sardinia has also been a purchaser, and so has the King of Holland, whose agents went more especially for bulls from Yorkshire.

Still it is to America that breeders have generally looked for their most spirited customers. As far back as 1797 a Favourite (252) cow was sent over, and returning at the end of thirteen years, became the foundress of the "Cambridge Roses;" and Stephenson's "Princess" tribe also struck root in Cayuga County, New-York. The Ohio Company followed in the steps of the Illinois, and Colonel Powell, and purchased rather with a view to milk than beef, a feeling which has always made America incline more especially to the Bates blood.

The society of Shakers did not grudge four hundred guineas for "Captain Balco" (12,546), and the "Grand Dukes" 1st and 2nd, each crossed the Atlantic with 1000 guineas on their heads. Messrs. Becar and Morris, and Thorne, by their daring rivalry, gave such a fillip to the Ducie sale in 1853, that although there were fifteen more lots, the average only fell 8s. short of the Ketton, which reached 151l. 8s. for forty-seven. It was here that Captain Gunter bought the cow and calf, 67th and 70th, which restored the Duchess blood to Yorkshire. Here, too, the Americans threw all previous speculation into the shade by giving 700 guineas for "Duchess 66th," and an average of 516 guineas for those six lots, whose bull-produce have come over twice since then, and have been bought up so eagerly in England and Wales. Our own colonies have not been laggards, but still Canada has caught but little of the American spirit, and Van Diemen's Land was the first spot which gave shorthorns a welcome at the antipodes, when it imported bulls in 1831. The Boldens introduced them at Port Phillip nine years later, and Geelong in 1858 was the scene of the death of the unbeaten 1200 guinea bull, "Master Butterfly," on his way under a hot sun to a cattle-show.

Prices may at times have been wild and fanciful, and 250 guineas may seem an extravagant bull-hire, but still buying good beasts and holding to approved tribes, even at a large outlay, is the most profitable policy in the long run. There is some method in the "madness" which would give 125 guineas for "Oxford 11th" as a calf, 250 guineas for her as a three-year-old, and 500 guineas for her as a cow, on the only three occasions that this dam of "Fifth Duke of Oxford,"—the first-prize aged bull at Chester, and a 300 guinea purchase at six-months-old,—was brought into the sale-ring. When we look back to the calm foresight of the Brothers Colling; the courageous confidence of Mason, the Rev. Henry Berry, and Whitaker; "Tommy Bates," and all his animated lectures on touch and form in his pastures, or on the show-ground; "A quiet day at Wiseton;" the dashing cow and heifer contests between Towneley, Booth, and Douglas; the victories of "Duchess 77th" and "The Twins;" the dispersion of the late Jonas Webb's herd at the steady, paying average of 55*l.* 10*s.* for 145; the brilliant gathering which appraised the "Butterflies"; the 8180*l.* at Willis's Rooms for seventeen Grand Dukes and Duchesses; and then scan the result in so many fairs and pastures, we may well feel that shorthorns have repaid all the money, thought, and labour which have been expended upon them. Still, in one way only can their supremacy be made permanent,—by always keeping in mind the rule by which our first breeders have been guided, that "a good beast must be a good beast, however it has come; but that it is to pedigrees alone that we can trust for succession."

10, *Kensington Square, W.*

XXV.—*On Sheep.* By H. EVERSLED.

OWING to the drought of 1864, the root-crop was deficient everywhere, and especially on the dry soils of the southern chalk district, where the scarcity of the roots so alarmed breeders that at the great autumnal fairs the prices of store lambs, compared with recent years, showed a reduction amounting to 30 per cent., and there was almost an equal fall in the price of breeding ewes—and this, with mutton at 5*s.* to 6*s.* per stone, and wool at 2*s.* to 2*s.* 6*d.* per lb.

Lambs therefore paid unusually well for wintering, although the market for them in the spring of 1865 was seriously affected by the unfavourable weather and by a panic in the wool-trade. The following shows that "well bought is half sold."

200 lambs, which cost 22*s.* 6*d.* on September 12th, were kept on leas and stubble until November 3rd, then on turnips until December 19th, when 50 of them were drafted to another flock

getting a little cotton-cake. On the 3rd February fattening commenced with linseed-cake in addition and cut swedes. On the 7th of April the 50 tegs were put on rye with mangolds, and they were sold on the 4th of May at 61s. each.

The remaining 150 lambs were wintered as stores at little cost, on inferior turnips uncut; they were put on rye from March 8th till May 4th, when they were valued at 48s. each.

The district just referred to became so exhausted of its stock that at some of the later fairs the number of lambs and of ewes exhibited was less than one-fourth of the average. But in Essex, on six adjoining farms, including that from which I write, the number of sheep wintered has been greater than these heavy lands ever carried before. This has been effected by the extension of a system of management often practised on heavy land, that of eking out a scanty supply of green food by a liberal allowance of straw, chaff, and grain; which happily were good in quality, as well as plentiful and low in price in 1864.

By these means we were enabled last winter to keep 1500 sheep on about 650 acres of arable, and 350 acres of dry upland pasture—chiefly park surrounding a mansion. The arable land does not very well bear folding in winter, as a preparation for spring corn. Neither climate nor soil are favourable to turnips, and notwithstanding our efforts in assisting nature, our crops of turnips, rape, or swedes, are never first-rate, and sometimes very bad. Strong stubbles, good beans, clover-seed, and mangold, are the specialties of the locality, and they indicate heavy land, corn-growing, and yard-feeding. Sheep have been generally “conspicuous by their absence,” though even the heavy-land farmer is glad to winter a yard of them, instead of cattle, that he may keep some at least of the stock that pays best.

In the autumn of 1864 our root-crops consisted of some white turnips and rape, eaten by the ewes in September, and of a very bad crop of mangold, the whole of which was reserved for the ewes at lambing-time. In this predicament we wintered about 1000 half-bred lambs, more than 400 ewes, and some fattening sheep. All, except the fattening sheep, were folded on the stubbles, and allowed a daily run on the park of about an hour for each flock. The freshest grass was reserved for the ewes, and a very meagre bite remained for the lambs; in fact, except for a few weeks in autumn, the parks afforded them little or nothing except exercise and water.

The flocks were divided between three separate farms, and their food was prepared at the respective homesteads. The treatment was in every respect similar; we shall therefore only notice in detail the management at one farm.

The following details are taken from our ‘Live Stock Book’ :—

September 29th.—352 lambs in the Parks, on a little cotton-cake and some oats, until November 4th, when they were folded on a wheat-stubble. Gave them 5 bushels of meal daily, mixed with 468 lbs. of straw-chaff. Cost 3½*d.* each per week for meal.

December 20th.—Increased the food to 6½ bushels of meal and 1 bushel of oil-cake.

December 18th :—

	lbs.
2½ bushels of maize crushed and boiled	143
4½ bushels of mixed meal	200
1 bushels of oil-cake	50
	393

Cost 5½*d.* per week for corn and cake; chaff 2¼ lbs. each, between these and the ewes, the lambs eating rather less than 2 lbs. each.

Eight pounds of rock-salt licked up by the 352 lambs per week.

January 23rd.—The food was increased to 7½ bushels of meal, 2 bushels oil-cake, 2 bushels rape-cake.

Mixture of Corn.		Cost per stone (14 lbs.).	
		s.	d.
Wheat	4 parts	1	0
Barley	4 „	0	10
Oats	2 „	1	0
Maize	4 „	0	10
		1	4½
		0	9

EXTRACTS FROM STOCK-BOOK.

Lambs.

Payments.	£.	s.	d.	Remarks.
Nov. 4th, 1864.				Total cost of keeping 352 lambs for 24 weeks, 298 <i>l.</i> 4 <i>s.</i> 3 <i>d.</i>
352 lambs, cost at date, 30 <i>s.</i> 9½ <i>d.</i> each	542	2	3	Cost per head, 16 <i>s.</i> 11 <i>d.</i>
Cost of keeping 24 weeks to April 21st, 1865.				Cost, food only, 14 <i>s.</i> 11 <i>d.</i>
Corn and cake, as per granary book	245	16	9	Value of the manure reckoned at one-fifth the cost of the corn and cake, 49 <i>l.</i> 3 <i>s.</i> 4 <i>d.</i>
Cutting 25 tons of chaff, at 6 <i>s.</i>	7	13	0	Cost of the lambs, per head, 2 <i>l.</i> 7 <i>s.</i> 8 <i>d.</i>
Grinding 96 qrs. 6 bush. of corn, at 9 <i>d.</i>	3	12	6	Value of manure per head, 2 <i>s.</i> 10 <i>d.</i>
Attendance, at 19 <i>s.</i> 10 <i>d.</i> per week	23	16	0	No charge made for the straw-chaff eaten on the land.
Horse-labour, at 6 <i>s.</i> per week	7	4	0	
Coal, 3 <i>s.</i> 2 <i>d.</i> per week	3	16	0	
Use of 21 troughs, at 3 <i>d.</i> each per month	1	11	6	
Use of 180 hurdles, at 1 <i>d.</i> each per month	4	10	0	
1½ cwt. of rock-salt	0	4	6	
	840	6	6	

The tegs would probably have been sold at a profit in April ; they were, however, put in grass and clover, and were fattened in the summer.

Good wheat, barley, oat, and bean straw, was cut into fine chaff and sifted by a steam-power chaff-cutting machine made by Maynard, of Whittlesford. The chaff dressed from the grain was also used.

The main points in the preparation of the food are to use sweet straw cut fine and sifted, and to soften, without wetting it too much, by using a sufficient quantity of boiling liquid. One-fourth to one-half of the meal should be boiled (or steamed) into soup, thrown on the chaff, and the heap chopped over and well mixed with a wooden rake. Then stir and mix in the remainder of the meal and ground cake, and round up the heap. If properly prepared, the chaff becomes exceedingly sweet and palatable. It should be free from lumps of meal, or pudding, and equally moistened and cooked by proper mixture of the boiling liquor throughout the heap.

Maize-meal makes the best soup ; barley-meal makes a sticking paste that does not mix well with the chaff.

With Riche's and Watts's American grist-mill we grind from 30 to 40 qrs. of corn a day, as fine as it is needed for sheep or cattle, reducing the grinding account to a comparatively small sum.

The proportions of the different kinds of grain were varied, from time to time, for the sake of that change of diet which is so conducive to health.

Linseed-cake, though relatively dear food, was probably a wholesome addition. Rape-cake, at 6*l.* per ton, was the cheapest ingredient ; it was crushed fine and added dry. The sheep ate their food as usual, in spite of this rather bitter addition.

Oat-meal was relatively dear, but it is easy of digestion and wholesome. Wheat-meal was at first used sparingly, but the proportion was gradually increased, because, though costing more per stone than barley or maize, we became aware that, in nutritive value, it was decidedly superior.

Maize should not form more than one-fourth of the mixture of corn and cake, and it should be boiled ; dry maize-meal induces a feverish condition, unless used very sparingly.

A continuance of low prices for grain will oblige the English farmer to modify his system of feeding, and the preparation and use of his own produce on his own farm, will become an important branch of his business.

Under the system we have detailed the health of the sheep was very satisfactory. In two flocks of 300 lambs each the first loss that occurred was at the end of January, when a lamb tumbled into the drinking-pond and was drowned.

With regard to the ewes, they had the same mixture of food as the lambs. As long as the pastures afforded them anything, they received $\frac{1}{2}$ lb. to $\frac{3}{4}$ lb. of meal and cake. After Christmas they had 1 lb. of corn and cake daily, and about $2\frac{1}{2}$ lbs. of straw-chaff.

On January 7th they were removed from the arable land to the pastures, and housed in a well-littered yard at night. We then made a slight change to less stimulating food, substituting for 1 bushel of meal 4 bushels of pollard and a load of mangold daily. We were careful to let the ewes have access to water at all times: without this precaution there would have been risk of abortion, from their drinking to excess. The lambs began to drop the first week in February.

The judicious use of corn and dry food in feeding ewes is generally followed by a good crop of lambs—as was the case in the present instance. When roots are plentiful we give about 6 lbs. a head daily to the ewes, and $\frac{1}{2}$ lb. of corn and cake with straw-chaff.

In the case of a teg, weighing about 8 stones, it is easier to fatten him on 12 lbs. of roots daily, and 1 lb. of corn and cake with chaff, than on $1\frac{1}{2}$ lb. of the latter without the roots.

The use of dry food alone is costly and trying to the constitution of young or weakly animals. A teg, out of condition, would not bear it, while a sheep in good health and appetite would thrive. A yard of culled ewes, fed on dry food only, without succulent vegetables, fattened rapidly and paid for their food.

I do not record this example of sheep-farming for its general economy, but as an instance of reliance on dry food in a case of emergency; proving that a sheep-farmer is not without resource under a failure of roots, while he has stacks of good straw on his farm.

To complete this picture of exceptional management, it should be stated that some of the stubbles folded last winter had been badly farmed, and were very much out of condition. The crops that followed, including peas, beans, oats, rape, and roots, were all strikingly benefited by the fold. Those who have experienced the slow and expensive routine of bringing an exhausted farm into good cultivation and condition, will understand the advantage of saving time in the process. Artificial manure is not the right remedy for this land. The manure-cart travels slowly, and cannot easily be set in motion at all without roots. The sheep-fold in such a case can hardly cost too much.

This narrative may be supplemented by a few remarks on the general economy of sheep-farming.

For the maintenance of an ewe flock during the whole year, some modification of the usual four-course rotation is required in order to provide summer food.

Throughout the southern chalk district of England, which is essentially a breeding district, the summer run for ewes is either found on the native Downs or is provided artificially by sainfoin layers, by tares and clover, and in some instances by water-meadows. On the lightest soil the produce of artificial grasses is not great in hot summers, but the run even of inferior pasturage, if water is provided, enables you to keep an ewe flock through the summer. By laying up less of the "seeds" to a hay-crop, and on suitable soils, by laying down grasses for two or three years' layer, a considerable addition might be made to the number of breeding flocks.

Where the rain-fall exceeds an average, an increase in the extent of pasture-land is desirable; but on other soils and climates arable farming is much more productive, and probably yields a larger balance of profit.

No greater benefit could be conferred on the light-land farmer than the introduction of some forage-plant, which would be to the sands what sainfoin is to the chalk. We have seen lucerne hanging on the side of a steep sand-hill in Surrey, green and luxuriant when other vegetation was scorched into hay, its deep roots finding their way into a subsoil moist from the drainage of higher land. This plant affects a warm free soil, and is only productive under liberal feeding.*

Other crops which help to bridge over the awkward summer months are, on heavy land, early turnips and rape, sown at intervals in May; and the cabbage, which by successional planting, will produce food at all periods of the year. It is especially adapted to dry climates, because though a great water-drinker, it draws a large supply from the subsoil. The crop may be obtained at almost any period of the year that it may be required. On farms where food is scarce in July, August, and September, I recommend the following system:—Sow the first week of August, re-set the plants in October, plant out in March.

Early varieties, as the early York, may be sown in March in seed-beds, or even drilled in the field, and will be fit for use in autumn and winter. If cabbages are removed, instead of being eaten on the land, the stalks will produce sprouts in spring, useful for ewes and lambs. The large Drumhead, however, does not sprout well.

At the present date (July 17th) my fattening ewes are doing very well on winter beans, cut for them by a chaff-cutter in the field; and as the land needs the fold, this summary way of disposing of the crop may possibly pay as well as harvesting it.

The following example of fast-cropping on warm land in an

* See Mr. Clayden's Letter on Lucerne—the last paper.—P. H. F.

early district presents the most rapid succession of crops that has come under my personal observation. All the green crops were folded off by sheep fed on cake or corn; they were kept clean by constant hoeing, and the seasons were favourable:—

8 crops in four years.	}	1854. Wheat, stubble ploughed once and sown with rye.
		1855. Rye, followed by turnips after three ploughings.
		1856. Canadian oats, stubble ploughed once and sown with turnips,
		1857. Peas, followed by turnips.
		1858. Wheat, stubble ploughed once and sown with rye, 1859. Swedish turnips, after one ploughing.

These crops were quite successful.

Heavy-land farmers say it is cheaper to buy corn for stock than to grow roots for them. But under liberal farming the cost per ton is reduced, because the expenses are not increased in the same proportion as the crop, and land kept in high order will bear the removal of a crop of roots without the injury to the succeeding crop of corn which occurs on land in bad heart. Corn may have been formerly grown at a profit without what is now called high farming, which is, however, indispensable to the successful cultivation of green crops. Nothing can be more evident than the immense and cumulative advantages derived from keeping the land in high condition and employing a large capital; not only do we secure increased production, but greater economy in the means of production.

Age at which Sheep should be slaughtered.

Both the producer and the consumer have a common interest in the growth of the greatest weight of mutton at the least expense of food and time. This can only be done by skill in feeding animals that come early to maturity. Putting an animal into good condition is like filling a tub with a hole in it. It is necessary to pour in faster than the contents run out, and the quicker this is done the less the waste. The first office of food, after building up the body, is to support the wear and tear of life. It is only when food is supplied in excess of what is required for that purpose that the animal begins to fatten. The earlier the process of fattening commences and the sooner it is over the greater is the economy in the use of food, because the least possible quantity of it has been used for the support of the body. This is true as a general principle; but rapid feeding implies rich and expensive food, and it may suit the general management and economy of some farmers to bring the animal to a certain age and growth on cheap food. This is the case on poor pasturage and in breeding districts; though rapid feeding with corn is also resorted to as a means of improving poor land. There is positive loss both to producer and consumer when sheep are

slaughtered before they are fully fat, which happens when food is scarce or mutton unusually dear.

The following is a contribution from an able pen on a subject which has attracted popular notice in these times of dear meat:—

“The consumption of lamb is not so wasteful as might at first sight appear, because the young animal, if highly fed, is ripe for the butcher before it has received any check in its development by those constitutional changes which form breaks in the progress of all animals towards maturity. The season of the year is also then generally favourable for obtaining good economical results from a liberal use of the richest food. But neither the seasons nor the constitution of the sheep allow us to maintain continuously, with profit, such a high rate of feeding. Rich food, therefore, would not be so liberally used but for the trade in lamb, and our store of mutton-making materials would be so far diminished. Fewer breeding ewes would probably be kept if a larger portion of their produce had to be supported for a longer period, so that if the butcher had heavier carcasses on the average, their numbers would be diminished.

“If we admit that the lamb at birth is chargeable with nearly two-thirds of the cost of feeding a ewe for a year (the wool paying the balance), and that this *charge* falls twice as heavily on a carcase of 40 lbs. as on one of 80 lbs., still we should bear in mind that the ewe (except so far as she is *doing* her lamb) is a handy and thrifty animal, and sustains life much more economically than a hoggett, when first encountering the cold and wet of autumn.

“The question, therefore, practically resolves itself into this, Is it more economical, on the whole, to keep for a year, say from June 1, a larger number of lambs, to be sold fat the following year, or to keep nearly a like number of ewes in excess, in order to produce fat lambs? Which requires most food for a year's keep, a hoggett, or a ewe with her lamb? Which gives the best return?”

This seems to me to be a correct and logical view of a subject which is worthy of further illustration and discussion in detail.

Assuming that a lamb costs 10s. at its birth, whether it is to be killed as lamb at 5 stones, or as mutton at 10 stones, then the incidence of what we may call this poll-tax is 2s. per stone on lamb, and only 1s. per stone on mutton. The chief item of the extra cost of lamb is food; and it appears to be a rather popular notion that by giving up the wasteful process of making fat lamb, we should necessarily have food on hand for the growth of heavier carcasses, saving the extra 1s. per stone, or rather spending it in the production of mutton.

On this view it must be concluded that the community is

indebted to those feeders who abstain from killing lambs that are fit for the knife, preferring to bring them to a greater weight as tegs. But this is not a sound conclusion. It would, in fact, benefit the community by increasing the supply of meat, if these feeders killed their lambs and bought for "finishing" some of the half-fat tegs that are slaughtered for want of food to complete their fattening. Bringing sheep to the knife prematurely as regards condition is wasteful; and on the other hand killing them young, after rapid feeding, is in many respects economical.

It was a national gain when an improved system of feeding brought "tegs" to market at almost the same weight as had previously been reached when a year older. The same principle applies, as already shown, to the fattening of lambs, which by rapid and economical feeding (which could not be profitably continued if they lived longer) are brought to a weight of 5 stones in five months; while Down or half-bred sheep, under any ordinary and economical system of feeding, are not fattened to more than 10 or 11 stones in fourteen or fifteen months.

It may also be observed that many ewes which would be killed half-fat, after rearing store lambs, are now kept on to breed fat lambs, and are then fattened, with their lambs, to a greater weight, with richer food than would otherwise have fallen to their share; so that fat lambs, which on a superficial view appear to diminish the supply of meat, are found really to increase it.

It is obvious that the high price paid for lamb is an encouragement to the feeder and breeder, without which he would not use the same quantity of cake, oats, white peas, pollard, &c. To expect more mutton by giving up lamb, would be as fruitless as to expect to get more grapes, at the natural season, by giving up those that are forced.

The supply of meat depends on the number and condition of the animals brought to market, and this is ultimately regulated by the ability of farmers to find food for them. The stock of sheep, though not so large as the increasing population requires, is already sufficient to overtax the present food-supply, and in adverse seasons, especially in dry springs and summers, it becomes necessary to lessen the number of mouths by sending sheep to market half-fat.

To increase the head of sheep-stock is a matter of no practical difficulty. The present emergency arises from a scarcity of *matériel*. The problem to be solved is how to enlarge the supply of vegetable food by increasing the amount of capital employed in farming.*

* A comprehensive paper, by Mr. Morton, 'On Increasing the Supplies of Animal Food,' was published in the tenth volume of the First Series of this Journal, Part II.

In close connection with the subject of early maturity, and inseparable from it, is that of breed; for unless the animal is of the right temperament and constitution, much of the food given to it is thrown away. However thoroughly this may be understood in theory, it cannot be said to have received on all sides practical recognition, while we see at every fair and market so many animals of inferior breeds.

I remember no other such instance of perfect indisposition to fatten as in a little flock of ornamental sheep from the Hebrides. It is perhaps worth quoting as an example of the influence of breed. They and their progeny have lived for ten years in our pastures, while ten generations of other sheep have in turn become mutton. But the native wildness of the little hill-sheep does not abate. Fifty times a day they are scared into frantic flight by some imaginary danger, flying in close ranks and facing round at last to watch the supposed foe with their gleaming eyes. The wear and tear of their little lives must be excessive.

From this wild temper to the placid disposition of the mutton-making Leicester there is a long gradation. Observing the extremes, it would be well to remember by what successive steps they are connected, and to avoid every drop of ungentle blood.

But there are other characteristics of greater importance than a mere disposition to fatten, such as constitution, rapid growth, fertility, suckling qualities, wool, &c. And it is because these qualities are so essential to profit, that we find many shrewd breeders preferring what may be termed the "homely virtues," even at some small sacrifice of those points which constitute the highest standard of form.

Gosfield Hall, Halsted.

XXVI.—*The Comparative Profit from Making Cheese or Butter, Selling Milk, or Grazing.* By W. H. HEYWOOD.

PRIZE ESSAY.

ON a little consideration of this subject it will appear that the comparative profits of these methods of farming must necessarily depend, in a great measure, on the nature of the soil, as well as the situation, &c., of the respective farms to be compared; therefore it is obvious that it will be the fairest test to deal with cases that are somewhat analogous as regards the quality of the soil, and are also on a par as regards other advantages.

With this view I propose to state approximately the actual results on several farms of equal size of the same description of soil, and situate in the same locality, but farmed in the three several ways, namely, cheese and butter making, milk-selling and grazing, rather than to write an essay not based on actual practice.

In the first place, I may explain that, as butter-making forms the chief feature on comparatively few farms of any size, and as the expenses, stock kept, risks, and general results are, so far as my experience goes, very similar to those of cheesemaking, in both instances the skill of the dairymaid having much to do with the profits, I have represented butter and cheese making by one case of the latter, and have added a case of milk-selling, which is now becoming a much more extended system of farming than it formerly was, especially since our towns have grown so large, and railways have made them so easy of access for produce requiring a quick despatch. Before their introduction, milk had of necessity to be produced in the vicinity of its consumption; but, as the market is now thrown open, a system of farming is now practicable in almost any part of the country, that equals, if it does not surpass, in profit any other kind of management.

I propose at the same time to show the respective merits of the different methods as regards their effects upon the land upon which they are practised; this, I consider, is an item of as much importance as the immediate pecuniary return.

The land in question is of a mixed kind, varying from a strong soil upon a clay subsoil to a dry friable loam on sand and red sandstone. The rents average from 35*s.* to 40*s.* per statute acre; the tithes and parish-rates being about the customary average, say, respectively, 3*s.* per acre, and 2*s.* 6*d.* in the pound on the assessment.

I will first take the case of the cheese-farm, 200 acres, upon which the stock is 50 milk-cows, 50 ewes (which, with their lambs, are fed off fat), 5 horses, 30 pigs, reared up and fattened, and 12 to 15 young horned-cattle, consisting of calves, yearlings, and two-year-olds. The farm is self-supplying as regards all food for stock, having sufficient land under plough, viz., 45 acres in 15-acre shifts—ley-oats, turnips, and wheat—to grow the oats, turnips, and straw required, in addition to the old meadow-hay. The value of the produce of this farm is considerably over the average, on account of the superior quality of the cheese made, which has sold at prices varying from 75*s.* to 85*s.* per cwt., the quantity made being also large.

The financial results of this farm have been as follows:—

<i>Produce.</i>	£.	s.	d.
9 tons 7 cwts. 2 qrs. of cheese, at 80 <i>s.</i> per cwt.	750	0	0
70 lambs, at 27 <i>s.</i> 6 <i>d.</i>	96	5	0
Profit on 50 ewes and wool, at 15 <i>s.</i>	37	10	0
15 acres of wheat, at 12 <i>l.</i>	180	0	0
Profit on 30 pigs, at 5 <i>l.</i>	150	0	0
	£1213	15	0

<i>Expenses.</i>		£.	s.	d.
Rent, 200 acres, at 40s.	400	0	0
Tithes, at 3s. per acre; rates 2s. 6d. on assessment	58	15	0
Wages.—5 men, at 40l.	£200		
2 lads, at 20l.	40		
Extra men	26		
Harvesting	30		
		—	296	0 0
Tradesmen's bills, 52l. 10s.; grass-seeds, 22l. 10s.; other	95	0	0
seeds 20l.			
Paid on improvement account, including draining, 40l.	125	0	0
boning, 60l.; and repairs, 25l.			
Contingent expenses	50	0	0
		—	1024	15 0
Profit	£189	0	0

For the object of comparing the relative profits of cheese or butter making with those derived from milk-selling, I fortunately am enabled to select a farm—the one last described—on which both methods have been practised by the same tenant, who is an excellent farmer. It was managed as a cheese-farm up to four years ago with the results stated above: since that time, in consequence of the advantage of a railway-station within one mile of the farm, and twelve miles from the market-town, the tenant has sold his milk, delivered at the station, at 1s. 10d. per dozen quarts, keeping the management of the farm in other respects precisely as before, the stock and expenses remaining also the same, except that reduction in the number of pigs fattened is reduced.

The result, under the system of milk-selling, is as follows:—

<i>Produce.</i>		£.	s.	d.
*Milk of 50 cows, at 1s. 10d. per dozen quarts	1065	0	0
70 lambs, at 27s. 6d.	96	5	0
Profit on 50 ewes and wool, at 15s.	37	10	0
15 acres of wheat, at 12l.	180	0	0
Profit on 10 pigs, at 5l.	50	0	0
		—	1428	15 0

<i>Expenses.</i>		£.	s.	d.
As per statement in cheese-making account	1024	15	0
Add cost of exchanging cows to keep up supply of milk	100	0	0
at certain seasons			
		—	1124	15 0
Profit	£304	0	0

On the grazing-farm referred to the stock is 60 cows, 100 ewes (whose lambs are fed off fat), 4 horses.

* More milk is produced per cow in consequence of the supply being kept up throughout the year by exchange of cows and artificial feeding.

The result is as follows:—

<i>Produce.</i>		£.	s.	d.
Profit on 60 cows, at 12 <i>l.</i>	720	0	0
140 lambs, at 27 <i>s.</i> 6 <i>d.</i>	192	10	0
Profit on 100 ewes and wool, at 15 <i>s.</i>	75	0	0
15 acres of wheat, at 12 <i>l.</i>	180	0	0
		1167 10 0		
<i>Expenses.</i>		£.	s.	d.
Rent, 200 acres, at 40 <i>s.</i>	400	0	0
Tithes, 15 <i>l.</i> ; rates, 43 <i>l.</i> 15 <i>s.</i>	58	15	0
Wages.—4 men, at 40 <i>l.</i>	£160		
1 man, at 20 <i>l.</i>	20		
Extra man	13		
Harvesting	20		
		213 0 0		
Tradesmen's bills, 32 <i>l.</i> 10 <i>s.</i> ; grass-seeds, 22 <i>l.</i> 10 <i>s.</i> ; other seeds, 20 <i>l.</i>	75	0	0
Paid on account of improvements, including draining, 40 <i>l.</i> ; boning, 60 <i>l.</i> ; and repairs, 25 <i>l.</i>	125	0	0
Paid for oil-cake	50	0	0
Contingent expenses	30	0	0
		951 15 0		
Profit	£215	15	0

The three systems will therefore stand as follows:—

	Receipts.			Expenses.			Profits.		
	£.	s.	d.	£.	s.	d.	£.	s.	d.
Cheese or butter making ..	1213	15	0	1024	15	0	189	0	0
Grazing	1167	10	0	951	15	0	215	15	0
Milk-selling	1428	15	0	1124	15	0	304	0	0

It thus appears that the experience of this district is decidedly in favour of milk-selling; but before coming to a definite conclusion on the subject, the strain put upon the land by the two systems—milk-producing and fattening—has to be taken into account.

I feel that the grazing account may require some little explanation to some whose experience may be somewhat different. The profit of 12*l.* per head on the cows may be thought excessive. I can, however, but state that such is the annual average profit realised by a number of graziers in this immediate neighbourhood, who buy in lean but healthy short-horns, at an average of 10*l.* to 12*l.* per head, in the first two months of the year. They then freshen them on straw, turnips, and a little cake, putting them out a little each day—weather permitting—until spring, by which time they have fairly begun to grow; and when a flush of grass comes they do not, like cows newly bought, lose time in making a start. They are then grazed through the summer, tied

up in October to turnips, ground-oats, oil-cake, and straw, and sold from the middle of December to the middle of January at 22*l.* to 24*l.* per head. The extent of land may also seem small for the number of beasts and sheep kept; but this is accounted for by the circumstance that all the grass-land is available for pasture, only a small quantity of hay being required for the horses. Again, the practice is to break up a fresh turf-field every year for ley-oats, to be succeeded by turnips, which, aided by the moist climate of the district, is always a very heavy crop, averaging from 33 to 38 tons per statute acre; hence the large amount of winter-keep from so small an extent of arable land.

The item of 50*l.* for cake may also appear small, but I may state that cake is not used as the chief article for fattening beasts, but rather as conducive to their health and as an aid to the corn and turnips, which are mainly relied upon for fattening them. The sheep and lambs get no cake.

I may also further state that of the 60 cows grazed, not more than 50 are tied up in the autumn, as the remainder either go out from grass or as calvers, of which there are always a few, and which pay equally well, regard being paid at the time of purchasing that they are right in their milking-organs.

But I should hardly do justice to the merits of this system of grazing by simply giving the practical results of my own neighbourhood, and comparing them financially with those of cheese or butter making and milk-selling. Grazing has collateral advantages in many forms that do not show themselves in such a comparison, but which assume so large an amount in the aggregate, that though milk-selling excels it in direct profit by, say 88*l.* 5*s.* per annum on a farm of 200 acres, I yet consider that in the main grazing is the preferable system, as I will endeavour to show.

In the first place, I consider that the apparent margin in favour of milk-selling may fairly be reduced somewhat on account of the extra risks attending the system from the more general tendency to delicacy and sickness of milking as compared with fattening cows. Again, we must not overlook the risk of making bad debts with the milk-dealers, who, as a body in the large towns, are not the best of payers. In saying this I do but speak the experience of milk-producers. Again, under the system of grazing, the farm will regularly increase in fertility, as a much greater portion of the nutriment, either extracted from the ground or artificially supplied, is then returned to it again by the animal, than under the system either of cheese-making or milk-selling. If, then, we suppose a tenant to have a lease for, say twenty-one years, at a fixed rent, the progressive improvement of his farm under grazing will yearly increase his crops of beef,

mutton, and corn; and with improved condition of land comes decrease of expense in cultivation; and thus his profit will yearly go on increasing, the ultimate result being most beneficial alike to himself and his landlord.

As regards the labour attending the practice of these systems of farming, that of grazing has a decided advantage over the others, not only in out-door labour, as shown in the accounts of expenditure, but also in the labour and responsibility saved in-doors, since the care and management of milk in any way entails much of both, and requires an amount of skill that has often to be remunerated at a very high rate.

One of the best indications of the progressive improvement attendant on this system of grazing is obtained by one simply observing the very great difference in the quality of the dung-heaps collected under the respective systems, the comparatively cold, aqueous appearance of that produced from milking-stock contrasting remarkably with the fermenting, oily nature of that collected from fattening-beasts. The effect of this difference upon the farm must be obvious to any one. In fact, I have myself watched its progressive effect under good management with extreme satisfaction, seeing the ordinary condition of the farm rise gradually to that of high cultivation; the weeds disappearing as the crops become stronger, and the land being more easily worked as it becomes more disintegrated by the more luxuriant growth of the herbage upon it. Here I cannot but state the particular attention paid by the farmers of this district (North Cheshire) to the mode of seeding down their pastures, which, coupled with the clean fallow or green crop, is undoubtedly, after draining, the foundation of all good farming, and the secret of success in the cases now under my notice. By attention to this particular, a sod is obtained by the aid of bones, which, after a few years' growth, is equal to that produced in the ordinary way by twenty years' ley; and experience shows me that a good sod that breaks up oily and mellow through the action of the fibres of luxuriant herbage, conduces more to a good and inexpensive course of crops than any manure that can possibly be applied artificially, to say nothing of the economy of restricting the need for such manures; for, after all, artificial manures are but a defective substitute for the elements as naturally combined in a virgin soil.

Holding these views, and considering the present scarcity and consequent high price of beef and mutton, I cannot commend too strongly a system so conducive to the mutual advantage of both tenant and landlord as that of grazing.

Dunham Massey, Altricham.

XXVII.—*On Dairy-Farming.* By W. T. CARRINGTON.

THE importance of the question how pasture-land may be turned to the best account, encourages me to state the results of my experience and observation as a dairy-farmer resident in the Midland Counties.

Practically speaking there are many circumstances, natural or social, which guide and limit the farmer's choice.

For dairying generally it is necessary that the pasture-land be well supplied with good water, free from garlic or other strongly-flavoured herbs, and contiguous to the homestead; further, it is imperative that there be a properly-constructed dairy, and a store-room for cheese, if it be made.

It is highly desirable that part of the farm should be arable, to supply roots and straw for the cows in winter, though with strong land in a damp climate that portion should not exceed one-third of the whole. For such tillage, however, thorough drainage is an indispensable preliminary.

If roots are not grown, the cows must either be wintered on hay, which is very expensive, or else they must be sold, at a probable reduction of 5*l.*, every autumn; and cows which are changed every year are rarely found to do well.

Farms which are all in grass are generally small, and in the hands of needy unenterprising tenants, the fields being small and intermixed, the fences objectionably wide and irregular, though a high fence, affording shelter from sun, wind, and rain, is preferable on a dairy farm to the close-cropped hedge which suits corn-fields.

If the object in view is to make cheese, the pasture must further be capable of making it *good*, for low-priced cheese cannot be remunerative.

There are some districts in England which are especially renowned for their cheeses, and doubtless those which produce *peculiarly fine cheese* enjoy certain natural advantages. I believe, however, that the quality of the cheese is generally much more dependent upon its making and keeping than on soil, &c., and that with proper management, good, if not fine cheese may be made on land of almost every description.

Another theory is often advanced, that improving the pasture-land by draining, and the application of bones, lime, or guano, spoils the quality of the cheese.

This view may suit the purpose of those who are not disposed to lay out their money in improving their pastures, but experience shows that it is a mischievous fallacy. In support of this opinion I may mention that at the Royal Agricultural Society's meeting, held at Chester in 1858, all the principal prize-takers stated that

they had used bones to a very large extent on their pastures. In every district the best cheesemakers are generally those who expend the most in improving their grass. Where artificial manures are extensively used, the cheese may require a different system, and more care in its management, but its quality will be superior.

There is an immense drain upon the mineral resources of the land entailed by any system which turns upon the sale of milk, either in its natural or manufactured form; so that where two adjoining fields of equal quality are grazed, the one with dairy stock and the other with feeding stock, the difference in condition will in a few years be quite apparent; therefore, unless the dairy-pastures are liberally dressed with manures, they will soon become perceptibly poorer. This objection to dairying has, however, lost much of its importance since modern science has placed the mineral stores of the earth so largely within our reach.

A large proportion of our dairy-pastures is very much in need of a judicious outlay for both draining and manures. There is little use in applying manures to wet pastures on which the water stagnates; and, again, drainage is not of much utility, unless followed up by a liberal outlay in manures, to effect a thorough change in the herbage; otherwise, the aquatic plants and grasses struggle on, though deprived of their food by drainage, and in some cases the produce is actually lessened.

It is much to be regretted that from ignorance and supineness, want of capital, or insecurity of tenure, our pastures are so much neglected; for it is my decided opinion that money judiciously laid out on the grass-land brings in a more certain, if a less quick, return than when expended in the growth of corn.

ANNUAL YIELD OF MILK.

Before a comparison can be made between the results of different systems of management, the annual yield of milk must be estimated; and this is so variable, so dependent on the class of cows kept, and still more so on their treatment, that it is difficult to give a correct average.

The yield per cow per annum ranges from 400 to 600 gallons; though in particular instances, under liberal treatment, even the latter quantity may be considerably exceeded. If, however, we make allowance for the number of heifers which a large dairy always includes, for the home consumption of which no account is taken, take the case of moderate pastures—the proper basis for all general calculations—and 535 gallons may be considered a fair average. This agrees with the account given by Mr.

Harrison, of Frocester Court, of his seven years' experience from a dairy of fifty to eighty cows, and I do not consider this a high return.

SALE OF MILK.

If the farm is so situated that the milk can be disposed of without extra expense at 8*d.* per gallon, there can be no question that this is the most profitable way of dealing with it: this would give a return of nearly 18*l.* per cow, the labour and expense attendant upon cheese and butter making being avoided; although, on the other hand, to keep up a continuous supply of milk, more costly food would have to be provided in winter, and cows occasionally exchanged at a loss.

CHEESE-MAKING.

If the milk be made into whole-milk cheese, the 535 gallons of milk would probably produce 4½ cwts. of cheese, being at the rate of rather more than a gallon of milk to a pound of cheese. 4½ cwts. of cheese, at 65*s.* per cwt., would produce 14*l.* 1*s.*, to which may be added for whey-butter and bacon, 2*l.* more, giving a total return of 16*l.* 1*s.*, or rather more than 7½*d.* per gallon. In the low average taken, allowance is made for that portion of the milk which is usually devoted to the feeding and rearing of calves at the early part of the season. The price of 65*s.* per cwt., about 7*d.* per lb., is no more than a fair average price, such as good cheese at three months' old has for some years readily commanded.

Mr. Harrison realised between 6½*d.* and 7*d.* per gallon, or 15*l.* per milking-cow, without including the value of the calf. This return can certainly be exceeded on the best-managed farms in good dairy districts.

In the Statistics of dairy practice, recorded by Mr. Egerton Harding, of Old Springs, Market Drayton,* the average weight of cheese produced from a dairy of cows, during eleven years, is given at rather less than 4 cwts. each; but a considerable quantity of milk and milk-butter were sold each year.

The average value of the produce of each milking-cow is given at 15*l.* nearly, but the price of whole-milk cheese is quoted excessively low, the average price during the whole period being only 5½*d.* per lb., whilst during the last two years of the experiment, 1861 and 1862, the prices obtained were only 4*d.* and 4½*d.* per lb. Fine dairies of cheese, in those two years, fetched more than 2*d.* per lb. in excess of that price.

I have suggested the making of whole-milk cheese because it

* See Vol. XXIV., Part II., First Series.

is by producing everything of the best quality that the British farmer is best enabled to meet foreign competition. I do not mean to say that some cream may not be occasionally taken off at the latter end of the year, or when the milk is very rich from high feeding, but a very great deal of cheese is made of which the value is greatly lessened by its being robbed of a portion of its butter.

In a former volume of this journal, Dr. Voelcker has stated, as the result of his experiments, that the highest profit may be obtained by making all the cream into butter, skim-milk cheese being made from the residue. The price, however, which he puts upon such cheese, 50s. per cwt., is much higher than can be commonly obtained; indeed I much doubt whether, in competition with American cheese, even 3*d.* per lb. could always be obtained. This point, however, is especially connected with making butter.

Much larger results than those here assumed may, however, occasionally be realised by cheese-making when skilfully carried out. At the large cheese-fair held annually at Leicester, early in October, Mr. Nuttal, of South Croxton, pitched last year 12 tons of cheese, of first-rate quality, which was sold altogether at over 8*d.* per pound. This was that portion (about two-thirds) of his yearly make, from some 85 cows, which was ripe at the beginning of October. He attributed his large make of cheese, in that unfavourable season, in a great measure, to the use of 30 tons of palm-nut meal, of which he spoke very highly. I have myself used a quantity of this food for dairy cows; the large proportion of oil which it contains renders it peculiarly adapted for producing rich milk. It has been growing into favour since it was noticed by Dr. Voelcker in this Journal two years ago.

THE PRODUCTION OF BUTTER.

If, as before, we take 535 gallons as the average yield of milk, with ordinary keep we may reckon on 200 lbs. of butter per cow, being at the rate of nearly 22 pints of milk to 1 lb. of butter. A less quantity of milk would be required if the cows were liberally supplied with rich food, as in the experiments recorded by Mr. Horsfall, or where a breed especially adapted for butter-making was kept. But the quantity I have named is a good average weight. 200 lbs. of butter, at 1*s.* 1*d.* per lb., would amount to 10*l.* 16*s.* 8*d.*

The skim-milk may be either made into cheese, when it would produce about 300 lbs. weight, or it may be used in rearing calves or fattening pigs. In either case, as it is fairly valued at 4*l.* 4*s.*, which, added to 10*l.* 16*s.* 8*d.* the value of the butter, would give a total return of 15*l.*, or about 6½*d.* per gallon.

There are however many dairy-farms, situated within easy

reach of large towns, where, from the daily demand for fresh butter, 15*d.* to 16*d.* per lb. may be obtained, and each extra penny in the price of the pound of butter adds 16*s.* 8*d.* to our estimate of the annual return.

Of summer stall-feeding I will only remark that where the farm consists principally of arable land, or meadows irrigated by sewage, it will probably be the most profitable way of keeping dairy cows; but the milk should either be sold or made into butter. Where there is a great demand for milk the arable land under special treatment may be made to produce an immense amount of succulent green food, but the soiling system will not, I believe, be generally adopted.

FATTING STOCK.

On some farms a quantity of dairy cows are kept for the purpose of feeding calves for the butcher; under good management a return of from 5*d.* to 6*d.* per gallon may be obtained by this way of disposing of the milk, without incurring the chief expense of a dairy.

Again, in some districts, many farms are devoted to the rearing of young stock, which are allowed to suck their dams for some months. Though by this method the first-class Herefords, Devons, and Short-horns are reared, the actual profit is far below that which might be derived from dairying where the farm is well adapted for it. It is, however, difficult to introduce a new system into any neighbourhood, where its management is not thoroughly understood, and it is difficult to obtain servants with a knowledge of either milking or cheese-making.

GRAZING.

We have yet to notice the rich first-class feeding pastures.

Arthur Young, writing more than fifty years ago, estimated that the best grazing land would feed a large ox and a Lincolnshire sheep per acre; there is, I believe, but little of such land now to be found. Whilst the produce obtained from arable land has, since the last century, been nearly doubled, the grass-land has from neglect too often absolutely deteriorated.

To fatten a large beast and a sheep, one acre and a quarter would now be generally required, and such land as this is readily let for 3*l.* per acre. A large Short-horn or Hereford will here fatten without the aid of artificial food, and will pay 5*l.* for the four months' keep from April to August. A second lot of feeders will then be procured, and, with the aid of some extra food, be made moderately fat at the latter end of the year. Including the profit derived from feeding sheep, a gross return of 6*l.* to 7*l.* per acre may thus be realised.

Large cart-horses, suited to the London and Manchester markets, are also commonly reared on land of this description, which grows them rapidly, and brings them to the required size and strength.

There is a great deal of pasture-land which might be made of excellent feeding quality by the spirited application of manures. We should, however, rather compare the pastures which yield a moderate average of cheese or butter with second-class feeding land on which the grass must be supplemented with oilcake, at a cost from 30s. to 40s. per head, to make it fatten an ox.

It will be found that a dairy-cow requires one-third more grass-land to run upon when she is in full milk, than she would require if feeding only. On a moderately good dairy-farm, a fair proportion of which is in tillage, it takes full three acres of grass to maintain a dairy-cow through the year. On second-class dairy-land four acres would be required. When the dairy-pastures consist of rich feeding-land, a much less quantity would suffice. The gross returns of dairy-produce, taken at 16*l.* per cow, would therefore come, in the first case, to nearly 5*l.*, in the second case, to 4*l.* per acre; and on rich feeding-land, as much as 6*l.* or 7*l.* per acre; though, to obtain these results, a considerable outlay in artificial food and manures would generally be necessary.

Some upland districts are rendered quite unsuitable for tillage by the wildness of the climate, yet when they are in pasture the great cost of keeping the stock through a long winter, and other drawbacks, make dairying a questionable course to adopt. A quantity of yearling and two-year-old heifers should here be bought for summer grazing, and sold in autumn; if it be not found more profitable to keep a large breeding-stock of long-woolled sheep, selling off the wedder lambs and draft ewes every autumn.

MANAGEMENT OF A STAFFORDSHIRE FARM.

I can best explain my views by describing somewhat in detail the system of management with which I am most familiar, taking the case of a farm of cold strong land, situated in the Midland Counties, containing 300 acres, let for about 30s. per acre, of which two-thirds are pasture and meadow, and the remainder arable. The land is not well adapted to sheep, and the pastures are not sufficiently rich to fatten cows or bullocks, without the aid of a considerable quantity of artificial food. I think I can show that by far the most profitable mode of occupying such a farm (provided that the ordinary requirements are supplied) will be by keeping a large dairy of cows, and endeavouring to make whole-milk cheese of first-rate quality. If the arable land be thoroughly drained, it will provide straw and roots for the winter's keep of

the dairy cattle, and clover, Italian ryegrass, vetches, and cabbage, for their use in summer and autumn. Without such drainage cold clay-land cannot be cultivated in an efficient manner.

The 200 acres of turf-land may be divided as follows:—120 acres, in convenient enclosures, and well supplied with good water, shade, and shelter, as the regular summer pasture for the dairy cows; 30 acres as permanent meadow, to be manured every year, and mown for hay; the remaining 50 acres, least conveniently situated, and least adapted for dairying, will provide a summer's run for the yearling and two-year-old heifers, and farm-horses, and for a moderate quantity of sheep. By the use of cake and crushed corn to the value of, say, 100*l.*, fifty dairy-cows would be well kept, *besides rearing from twelve to twenty heifer-calves every year.*

I lay particular stress upon this point in consequence of the serious losses to which dairymen have been of late years subject from infectious disease—a consideration which has acquired additional force since the outbreak of the cattle murrain. The foot and mouth complaint, which is very prevalent amongst drift cattle every spring, and highly contagious, is a very serious complaint when it attacks cows in full milk; and should the owner be so fortunate as to escape the loss of any of the animals affected, it still entails a great diminution in the yield of milk, even if the animals are not lost. Again, from pleuro-pneumonia the dairy-farmer has much more to fear than the grazier, because his cattle are necessarily congregated together, and they cannot be so readily disposed of to the butcher. When this disease attacks a dairyman's herd, it is not uncommon for him at once to send all the apparently healthy animals for sale to a distant market, and thus the disease is spread.

My father and myself have for many years had upwards of one hundred dairy-cows, but by adopting the plan of rearing a sufficient number of heifer-calves, and scarcely ever buying stock in the market, we have been most fortunate in escaping infectious disease. One or two partial attacks of the foot and mouth complaint have occasioned us slight losses, but from more serious disease we have altogether escaped. The spread of contagious disease is greatly due to the filthy state of the trucks used in the conveyance of cattle by railway. I regret that the Cattle Diseases Bill, introduced last session of Parliament, was not allowed to become law.

The greater portion of the cows calve in March and April. The best and earliest of the heifer-calves are reared; they will require their mothers' milk for two or three weeks at least, and may then be fed either with skim-milk and oatmeal, or sweet whey and wheaten or rice flour, with what hay and oilcake they

will eat. Care should be taken to keep the calf-houses clean and well ventilated. As soon as the weather becomes warm, the calves should be allowed to run in a sheltered paddock; at three months old the suckling may be discontinued, but they should still have an allowance of $\frac{1}{2}$ lb. to 1 lb. of linseed-cake per day. If they are kept healthy and growing from birth, as they may be by a judicious use of linseed-cake, the best of them will be big enough to come into the dairy at two years and two months old. If kept uniformly well, they will then be as good as those a year older in ordinary condition, and will prove more profitable to the dairyman. A few of the calves, at the commencement of the season, which are not wanted for rearing, may be fattened; but, when cheese-making is in full operation, all the remainder of the calves will be sold as soon as dropped, at about 1*l.* each.

The cows, after they have calved, should have a daily allowance of four or five pounds of crushed corn or cake, with hay and roots or grains, until there is an abundant supply of grass for them. They will then have the run of the 120 acres of pasture, but they should be divided into at least two herds. Dairy cows do much better in not very large herds; they tread the ground less, and the weaker ones are not so much knocked about. Should they require it, they will be supplied with mown clover, rape, and vetches, or other green food, in the summer and autumn, until the middle of September, when the cabbage will be ready for use.* This is a most valuable food for dairy-cows, and by its aid a large quantity of cheese may be made in the last three months of the year, when otherwise the cows would be almost dry. The cabbage grown from autumn-sown plants will generally be best for early consumption in the months of September and October, after that time it will be over-ripe, and its quality will be deteriorated. Autumn-sown plants should be planted nearly a yard apart every way. Where cabbage is spring-sown, those kinds should be selected which are of early maturity. The Swedenburgh cabbage I consider the best for this purpose. The seed should be sown on a warm border early in March: 1 lb. of seed will produce plants enough to set out two acres. The plants should be planted, about two feet apart, in the latter end of May or beginning of June, damp weather being chosen for this purpose. If the winter be mild, cabbage will keep till February or March, but exposure to severe frost damages its quality very much. Cabbage is a gross feeder, and will repay a dressing of 4 cwts. per acre of Peruvian guano, in addi-

* The danger of "hoove" from grazing clover with dairy cows is so great, that it should be mown either for hay or for immediate consumption. It may be grazed by young stock if it stands for a second year; the alsike is especially adapted to this purpose.

tion to a fair coat of farm-manure. Where the land is perfectly sound, I prefer planting on the flat, the crop is less liable to suffer from drought.

Six shifts of 16 acres each, distributed as follows, will meet these requirements :—

	Acres.	
(1.)	16	Wheat.
(2.)	{	6 Cabbage.
		10 Turnips, swedes and mangold.
(3.)	16	Oats or wheat, with <i>seeds</i> .
(4.)	{	8 Italian ryegrass, mown or fed.
		8 Red clover, &c., twice mown.
(5.)	16	Oats.
(6.)	{	8 Oats and vetches, for green fodder in July and August.
		8 Rape and vetches, for green fodder in August and September.

The cows are allowed to go dry soon after Christmas, a rest from milking of two or three months being indispensable. They will then be fed principally on straw, with roots. Should the supply of roots be scanty, the deficiency may be supplied by the use of brewers' grains, cake, or corn, in addition if required. I do not recommend cooked food for store cattle, it is unnatural, and weakens the digestive powers, so that the stock do not thrive so well afterwards when turned out to grass. Where the supply of good straw and roots is abundant, the extra expense entailed in the chopping straw for dairy-stock is not always repaid. If besides whole roots twice a day, plenty of straw be given them in the racks, they will pick out the best of the straw, and the stumps will be available for litter. In exceptional seasons, like that of 1864, and when the utmost economy had to be exercised in the use of fodder, the benefit of chopping was undoubted.

The extra expense entailed by milking dairy-cattle must not be overlooked. Five or six effective milkers will be required for fifty cows; and it is important that all should milk quickly and thoroughly well, otherwise the cows become dry much sooner, and great loss is occasioned. The master's superintendence is necessary to see that this is properly carried out. This expense cannot be put at less than 30*l.*, or 5*l.* for each effective milker. It is an operation that must be performed with regularity, and every other farm-work must give place to it. The milking-machines yet brought out, however ingenious, have at present, I regret to say, entirely failed to achieve the desirable result of lessening the labour of this process. When an equable temperature of from 60° to 70° is required in the Dairy and Store-room, this can best be maintained by the use of warm-water pipes placed round the walls, communicating with a boiler at the back of the kitchen fire. Where this cannot be conveniently arranged, a separate boiler may be set up for the purpose of heating the

water. The first cost of the pipes is somewhat heavy; but when, as in many cases, the water can be heated without extra fires, the advantage is very great, the dust, trouble, and expenditure of fuel, from a stove, being avoided. These remarks, however, apply rather to making butter than cheese.

Skilled dairy-servants readily and deservedly obtain high wages; their cost, including board, &c., on the farm in question, would not be less than 50*l.* per annum. This, with a charge of 30*l.* for milking, of 20*l.* for wear and tear of dairy-utensils, heating-apparatus, &c., would bring the extra expense attendant upon dairying on this farm to 100*l.* per year, or 2*l.* per cow. I have taken the average yield on such a farm at $4\frac{1}{3}$ cwts. per cow, or 16*l.* per head per annum, although where a very superior quality of cheese is made, an increased return would be obtained, with some aid furnished by the arable land, &c. The amount realised farm Cow-stock alone on this farm would therefore be—

	£.
Produce of 50 cows, at 16 <i>l.</i> each	800
Sale of 35 young calves, at 1 <i>l.</i> each	35
15 cows sold every year, at 11 <i>l.</i> each	165
	£1000
Deduct extra expenses of dairying	100
or 18 <i>l.</i> per cow.	£900

SUMMARY.—1. It appears that on very first-rate pasture, worth upwards of 3*l.* per acre, $1\frac{1}{4}$ acre will graze a bullock and a sheep, besides making a second lot moderately fat before Christmas, with the aid of oilcake. It will give a gross return of 6*l.* or 7*l.* per acre.

2. $1\frac{3}{4}$ acre of such land would, if it suited, keep a milch-cow, and give a gross return of 9*l.* per acre, with an extra cost of 1*l.* to 2*l.* for dairy expenses, and some aid in fodder and roots from arable land or by purchase.

3. On ordinary pasture, worth 30*s.* to 40*s.* per acre, 3 to 4 acres will be required to keep a milch-cow, so as to yield, on an average, 535 gallons of milk per annum.

4. If the milk can be sold at 8*d.* per gallon, that will be the best means of disposing of it. The dairy expenses will then be diminished, but the cost of keep, &c., increased. The gross annual return would be 18*l.* per cow, besides the calf.

5. If whole-milk cheese be *successfully* made ($4\frac{1}{3}$ cwt. at 65*s.*), a return of 7*d.* to $7\frac{1}{2}$ *d.* per gallon, or 16*l.* to 17*l.* per cow, may be obtained.

6. From 535 gallons of milk, about 200 lbs. of butter may commonly be made; worth, at 13*d.* per lb., 10*l.* 16*s.* 8*d.* By

rearing calves, fattening pigs, or making cheese with the skim-milk, a further sum of 4l. 4s. per cow may *possibly* be secured. This makes 15l. per cow, or about 6½d. per gallon. Every extra penny in the price per lb. of the butter, adds 16s. 8d. to the yearly return.

7. By fattening calves for the butcher, 5d. to 6d. per gallon may be realised with less outlay and trouble.

8. The profits made by rearing first-class Herefords for the butcher (cow and offspring, after running together, being sold fat) are probably far below those derived from dairying.

9. The exhaustion of the soil by the sale of cheese or milk is not to be overlooked; but neither are our modern resources for the enrichment of our pastures by artificial means to be forgotten.

10. Dairy expenses vary between 1l. to 2l. per cow.

11. Supplementary food to the value of 40s. must generally be given to the cow to secure a first-rate return of produce.

Hollington, Uttoxeter.

XXVIII.—*Statistics of Live Stock and Dead Meat, and Wool.*

By ROBERT HERBERT.

COMPARED with several previous years, the supplies of English beasts on sale in the great metropolitan market have been limited, and the condition but middling. The foreign imports, however, have continued to increase; hence the total is very little below that of the corresponding period in 1864. The want of condition in nearly all breeds, and the great consumption going on, have considerably influenced prices. At one time the best Scots and crosses could not be purchased under 5s. 4d., and even 5s. 6d. per 8 lbs., and it is now pretty certain that those special breeds have not seen their highest range. The great abundance of pasturage food, and the prospect of a very large growth of roots, may add considerably to the weight and quality of the stock brought forward during the remainder of the year. Nevertheless, when we consider the inroads that of late years have been made upon our stock of cattle in the United Kingdom, more especially in England, it seems difficult to determine at what point the upward movement in prices will be arrested.

Fortunately, very few losses have been sustained by disease in any of our leading grazing-districts, but we understand that just at the end of June a kind of gastric fever broke out amongst the cows and heifers in various parts of the country, which, unless speedily checked, is likely to lessen our supplies materially.

In the six months, Norfolk, Suffolk, Essex, and Cambridgeshire furnished 7,710 head of beasts less than in 1864. The falling off from other parts of England amounted to 2,410, but from Scotland there was an increase equal to 1,879 head. The receipts from Ireland showed a deficiency of 223 head. The Scotch bullocks have made their appearance in wonderfully fine condition; indeed, in many instances the buyers have described them as "too good." The Irish beasts, on the contrary, have not exhibited the slightest improvement in quality. A few well made-up beasts have arrived from Holland and France, as well as from Prussia, but the actual weight of meat has been small in comparison with the large numbers of stock imported. The result is that even increased importations have had very little influence upon prices, and our impression is that even much larger arrivals from the continent would not prevent a further advance.

Notwithstanding that our 114,000 head were derived from abroad, the supplies of sheep during the six months were very moderate, viz., 614,766 head, against 622,330 in the corresponding period in 1864. If we deduct the foreign supplies, the actual quantity of English sheep disposed of did not exceed 500,630 head. In other words, the deficiency in the arrivals from our own districts is equal to nearly 500,000 per annum! Need we feel surprised, then, that prices have ruled very high, or that the flockmasters are holding back a portion of their supplies to consume the immense growth of turnips, swedes, &c. In many parts of the country more turnips will be grown this year than can possibly be consumed.

Prime sheep, from their great scarcity, have sold briskly from 6s. to 6s. 6d. per 8lbs. In numerous instances, even much higher currencies have been realised by the salesmen. Inferior breeds have risen considerably in price, and even the German sheep have sold at from 22s. to 44s. each. The foreign sheep, as a whole, have shown very little improvement in quality.

There has been a moderate, but by no means active, inquiry for lambs. In the early part of the season, the best lambs sold at 8s., but at the close of June the rates ranged from 6s. to 7s. 4d. per 8lbs. As regards quality the season may be considered a favourable one.

Scarcely any English calves have been brought forward, but nearly 10,000, received chiefly from Holland, have been exhibited in good condition. The veal trade was steady, at rates varying from 4s. 2d. to 5s. 4d. per 8lbs. The foreign calves continue great favourites with the butchers, as they "die" remarkably well.

Pigs have sold somewhat freely, at steady rates, although

32,582 head have been imported from abroad. This is the largest number ever received from the continent in six months.

The beasts hitherto received from Lincolnshire, Leicestershire, and Northamptonshire have been in fair condition. The numbers now in the pastures in those districts are not equal to last season, consequently, future arrivals will be only on a moderate scale. Possibly, however, as the supply of natural food is abundant, the quality of the beasts may show a steady improvement.

The following return shows the ports from which stock was shipped to London in the six months:—

Imports in the first Six Months.

From	Beasts.	Sheep.	Lamba.	Calves.	Pigs.
Aalborg	1,160
Aarhuns	562	44
Amsterdam	46	21	..
Antwerp	413	2,034	..	784	663
Boulogne	2,255	5,948	8,919
Bremen	398	4,878	9	113	..
Cadiz	886
Calais	78	1,469	..	61	1,497
Carril	100
Copenhagen	20
Corunna	429
Dordt	359	2,608	599	19	2
Dunkirk	482	5,412	3,557
Gluckstadt	23	659
Gothenburg	128	4	..	16	..
Hamburg	3,313	38,825	4,627
Harburg	150	1,458	64	120	418
Harlingen	9,165	4,463	210	223	231
Oporto	560
Ostend	999	6,212	12	525	413
Rotterdam	18,951	40,166	7,549	8,111	12,211
Vigo	444
Total	40,921	114,136	8,443	9,993	32,582

We here find a total import equal to 206,075 head. This enormous supply, be it observed, represents the total importations into London only. In the corresponding period in the previous six years the annexed supplies were imported:—

Last half of year.		Beasts.	Sheep and Lamba.	Calves.	Pigs.
1855	18,526	19,930	8,872	409	
1860	17,193	76,415	7,965	2,492	
1861	22,045	46,674	6,187	4,309	
1862	11,462	49,332	9,459	883	
1863	16,701	91,206	11,445	1,229	
1864	29,460	85,920	10,392	14,212	

The aggregate supplies of stock exhibited and disposed of in the metropolitan market were :—

Total Supplies of Stock Exhibited.

Last half of year.	Beasts.	Cows.	Sheep and Lambs.	Calves.	Pigs.
1861	109,812	3005	604,650	6,560	15,952
1862	116,735	3054	631,672	8,259	17,407
1863	120,045	3005	628,072	10,449	16,435
1864	131,694	3014	622,330	9,935	17,679
1865	130,977	3086	614,766	12,189	16,028

The following return shows the extent of the arrivals of English, Irish, and Scotch beasts into London during the half-year :—

District Bullock Arrivals.

Last half of year.	Northern Districts.	Eastern Districts.	Other parts of England.	Scotland.	Ireland.
1860	4000	68,520	21,420	5,033	1477
1861	4700	64,060	17,700	8,712	256
1862	400	68,420	29,290	9,794	2545
1863	470	66,940	16,330	9,610	1664
1864	62,170	19,980	9,918	2740
1865	1000	54,460	17,570	11,797	2517

Average Prices of Beef and Mutton.

Per 8 lbs., to sink the Offal.

BEEF.

	1855.	1860.	1861.	1862.	1863.	1864.	1865.
	<i>s. d.</i>	<i>s. d.</i>	<i>s. d.</i>	<i>s. d.</i>	<i>s. d.</i>	<i>s. d.</i>	<i>s. d.</i>
Inferior	3 4	3 6	3 4	3 0	3 4	3 6	3 10
Middling	4 4	4 6	4 4	4 0	4 4	4 6	4 8
Prime	5 0	5 6	5 0	4 8	5 0	5 0	5 2

MUTTON.

	1855.	1860.	1861.	1862.	1863.	1864.	1865.
	<i>s. d.</i>	<i>s. d.</i>	<i>s. d.</i>	<i>s. d.</i>	<i>s. d.</i>	<i>s. d.</i>	<i>s. d.</i>
Inferior	3 6	3 10	3 8	3 6	3 10	3 8	4 4
Middling	4 4	5 2	5 0	4 6	4 8	4 6	4 10
Prime	5 0	6 2	5 10	5 4	5 6	5 2	5 10

Newgate and Leadenhall have been but moderately supplied with each kind of meat. The trade has been far from active, yet

prices have continued to advance. Beef has sold at from 3*s.* *Gd.* to 4*s.* 10*d.*; mutton, 4*s.* 4*d.* to 6*s.*; lamb, 5*s.* 8*d.* to 7*s.*; veal, 4*s.* to 5*s.*; and pork, 3*s.* 4*d.* to 5*s.* 4*d.* per 8*lbs.* by the carcase.

Considering the enormous importations from our colonies, the wool-trade has been moderately active. At the last public sales, nearly 150,000 bales were disposed of, at slightly reduced rates; and in August, 120,000 bales will be submitted for competition. English wools, though in short supply, have receded in value about $\frac{1}{2}$ *d.* per lb. The five months' importations in the present and two previous years were:—

	lbs.
1863	50,700,605
1864	51,577,556
1865	61,676,417

The exports in the same period were:—

	1863.	1864.	1865.
	lbs.	lbs.	lbs.
Colonial	15,387,405	12,356,099	21,283,840
Foreign	6,165,504	3,012,000	23,758,766
Total	21,552,909	15,368,099	25,758,766

It will be perceived that whilst the imports this year have considerably increased, the demand on Continental account has been very active. Home-grown wools are selling as follows:—

	Per Pack of 240 lbs.			
	£.	s.	£.	s.
Fleeces:—				
South Down hoggetts	20	0	to	21 10
Half-bred hoggetts	23	0	to	24 10
Kent fleeces	22	0	to	24 0
South Down ewes and wethers	20	0	to	21 0
Leicester ditto	22	0	to	22 10
Sorts:—				
Clothing picklock	22	0	to	23 0
Prime and picklock	20	0	to	20 10
Choice	19	0	to	19 10
Super	18	0	to	18 10
Combing:—				
Wether matching	23	0	to	24 0
Picklock	18	10	to	19 10
Common	17	0	to	18 0
Hog matching	23	0	to	24 0
Picklock matching	18	10	to	19 10
Super ditto	17	0	to	19 0

XXIX.—*On the Growth of Lucerne on Thin Light Soils and Chalky Loams.*—Letter to the Editor.

MY DEAR SIR,—As you were pleased with the crops of lucerne which you saw growing on my thin chalky land, and ask for some account of their management, I have much pleasure in complying with your request.

My practice is to sow this crop after the land has been thoroughly well fallowed, highly manured, and sown with turnips, which are consumed on the land by sheep eating corn or cake; the land is then ploughed two or three times in the spring, thoroughly pulverised, and the growth of small weeds (if there are any) encouraged. The lucerne is then sown about the second week in May *without any corn*; 25 lbs. per acre will generally insure a good plant, which is very important: 20 lbs. of this is drilled at about 7 inches apart, and the remainder, that which is emptied from the drill, is sown broadcast on the marks made by the drill-coulters, before the land is harrowed; by this means the ground is well covered, and the small annual weeds are kept under by the crop. If the season is favourable, the field will give a nice cut for the scythe at the end of August or beginning of September, or else it may be fed with sheep or cattle; but it should not be depastured too closely. During the ensuing winter the lucerne should receive a good dressing of rich farmyard-manure, and in the spring some artificial manure would be very serviceable. In the second season a good fair produce may be expected, but the plant will not be in perfection till the following year. It requires a good dressing every year, and nothing pays better for it, as it will last six or eight years, and every year give three good cuttings. The first, even in our backward eastern climate, is ready for the scythe by the middle of May, and will yield 8 or 10 tons of excellent green food, equivalent to 2 tons of hay. From its roots searching very deep for their sustenance, it is not so much affected by drought as the generality of plants, and shoots up almost immediately after the scythe, yielding, in about eight or ten weeks, another cutting of nearly two-thirds the weight of the first; and again, after a like interval of time, another cutting. This, of course, will not be so productive as either of the two former; but it may be confidently expected that the produce of the second and third cuttings will together equal the first crop. The crop is chiefly consumed by horses, the first cutting being much relished by them; and, with the exception of sainfoin, it is the most hearty and nutritious green food that can be given. Horses are not so fond of the second or third cuttings as of the first, but still it is very valuable food, considering the difficulty of finding

green food for stock in a dry season, and the certainty which a field of lucerne gives you of securing a good second and third cutting, however dry the season may be.

It is generally supposed that lucerne should be well hoed every year—a very expensive process; but if care be taken that the land is well prepared, and thus a full plant be got, and supplied every year with a good dressing of manure, hoeing may be dispensed with, and success ensured. After good crops have been cut consecutively for six or eight years, if the land be ploughed to a *good depth*, a skim-coulter being used to bury the grass from the edge of the furrow, no fear of a good crop of oats need be entertained; in fact, after such a rest from corn as the land has had, two good crops may be taken in succession, should this be convenient for bringing the lucerne-land into the same course of cropping with the remainder of the field.

I may sum up my letter by saying, that in my opinion no farmer should be without a plot of lucerne in due proportion to the size of his farm, and that I am sure no person who has ever *laid down a piece properly* will ever again be without it.

I am, my dear Sir, yours very truly,

JOHN CLAYDEN.

Littlebury, June 19, 1865.

XXX.—*Report on the Exhibition of Live Stock at the Plymouth Meeting.* By JOHN DENT DENT, M.P., Senior Steward.

IN writing the Report on the Live Stock exhibited at the Society's Show at Plymouth, I am bound to record with satisfaction the gracious visit to the Show-yard which was paid by their Royal Highnesses the Prince and Princess of Wales upon Wednesday, the 19th of July. By the Members of the Society who were present, and by the officials in charge of the Yard, and by thousands of the loyal population of the West country, the honour of this visit was fully appreciated; and we all gratefully acknowledge the public recognition of the services of the Society thus made by the heir-apparent to the throne. Indeed, I feel sure that nothing will more gratify the farmers of Great Britain than to find His Royal Highness following the footsteps of his father, and bringing to bear upon agricultural pursuits a similar degree of care and judgment.

There were many, in and out of the Council, who said that the Show at Plymouth must be a failure; that a single line of railroad and an inaccessible locality would prevent the breeders of stock from putting in their usual appearance, and that the

funds of the Society would most likely suffer from the thin attendance of spectators. I am happy to report that these gentlemen were mistaken, and that the Meeting was not only one of the most successful in a pecuniary sense, but also one of the pleasantest ever held by the Society. It was worth a long journey to enjoy the lovely views from the Show-Ground itself. We could see the French and English iron-clad ships lying side by side under the shelter of the Breakwater; Mount Edgcombe, with its verdant slopes, and other pleasant hill-sides, dotted with handsome houses, and shaded by green woods. We had, too, a glorious week of summer weather, and a goodly muster of the beauties of Devon and Cornwall round the rings. Those who cared not for the beauties of scenery, and were only intent upon agricultural pursuits, found in the Yard an unequalled show of the Devon and Channel Island breeds, and every other class of cattle, sheep, and pigs, at least adequately represented.

I may mention as one of the pleasantest features of the Newcastle and Plymouth Meetings, the service held on Sunday morning in the Cattle-Yard. In each case the contractor for first-class refreshments kindly placed his tent at our disposal, and the room was filled with an attentive, and, as far as outward appearance could indicate, a reverent and devout congregation, composed of herdsmen, shepherds, London police, and officers of the Society, gathered from every part of the kingdom. The service this year was short, and admirably selected, the sermon plain, practical, and well adapted to the occasion; and the only drawback was the want of printed copies of the service for the use of the congregation. I know that I am expressing the feelings of my brother stewards as well as my own, when I say that it is our hope that this service, so happily commenced, may form a permanent portion of the week's proceedings.

In reviewing the cattle exhibited I propose to take the classes in the order of the catalogue, and, wherever I can, I shall give the opinions of the Judges in preference to my own; but in certain cases I have not received from them any reports, and have merely the award of prizes to guide me.

SHORTHORNS.

Mr. Drewry, Mr. Robinson, and Mr. Thompson, of Anlaby, were judges of the Shorthorns, which numbered 92 entries, as compared with 175 last year. We missed that grand class of old bulls, which was one of the most attractive features of the Newcastle Show, for at Plymouth this class and that of the two-year-olds was but poorly represented. A red and white bull belonging to Mr. Sharpe, and bred by the late Jonas Webb, was first in the

aged class; whilst in the two-year-olds another red and white bull, bred in Devon, held the same place. The Judges thus comment upon the latter bull:—"The bull to which we awarded the first prize was a very true-made animal, but not quite so good in quality as we could have wished." The Yearling Bull Class was decidedly better than the older bulls. In this and the next class Mr. Fawkes, of Farnley, took the first prizes with two bulls, own brothers, being by "Lord Cobham," a bull bred by Lord Zetland, out of "Fatima," very handsome in colour, and firm in flesh. The judges say of the yearlings, "We had some very superior animals in this class. The bull which we placed first was very far before any of the others. The one placed second, Mr. Booth's 'Commander-in-Chief,' from his age and condition, is not calculated to please the multitude, who are not in the habit of seeing animals in store condition. The third," a bull belonging to Mr. Walker, of Birmingham, "Battersea First Fruits," and of Jonas Webb blood, "was a very good one. We commended several in this class."

I may here say that, whatever be the difference of opinion as to the merits of the animals, Mr. Booth and his late uncle deserve credit for showing "Commander-in-Chief" at this Show, and "Prince of Battersea" at Newcastle in useful working condition, and not overlaid and disguised with fat; and some courage on the part of Judges is required to recognise the merits of an animal which is only in useful, not in show condition.

Class IV., with the exception of the first and second animals, belonging respectively to Mr. Fawkes and Sir A. de Rothschild, and the reserve, a roan calf of Mr. Garner, the Judges did not consider a good lot.

The female Shorthorns were better than the males, and the Cow Class was not inferior to that shown at Newcastle. The Judges describe it as "a very good one, in which we had great difficulty in arriving at a decision." And indeed, out of ten animals shown, seven are mentioned in the award. Yorkshire was well represented by the first-prize cow, "Corinne," belonging to Mr. Wood, and by "Frederick's Farewell," from the Towneley herd, belonging to Mr. Tennant. Mr. Stratton was second with "Diadem," and commended with "Maid of Honour;" and Mr. Sharpe, the owner of the prize aged bull, was third with "Elegant." Lady Pigot held the reserve number with "Perfume," a white cow, also from the Towneley Herd.

In Class VI., "Lady Fragrant," Mr. Booth's heifer, which takes the first prize, has grown into a great beauty, and, to my mind, was the most stylish Shorthorn exhibited.* The Judges

* Since the above report was written, the Judges at the Yorkshire and Durham County Shows have adjudged "Lady Fragrant" the prizes for the best Shorthorn exhibited.

report that the Yearling Heifers were a very superior class, and the commendations speak for themselves. Several of the competitors appeared in the Calf Class at Newcastle, and have certainly grown into beautiful heifers. Lord Feversham's "Princess," Mr. Wood's red twins, Sir Anthony de Rothschild's roan and red, were all distinguished as calves at Newcastle, and again carry off honours here, in company with a beautiful red and white of Mr. Tennant's, also from the Towneley herd, but going back on the father's side to Captain Gunter's "Duchess" blood. There was not much to remark upon in the Heifer-Calf Class.

HEREFORDS.

I was accused of not doing justice to the Herefords shown at Newcastle. I acknowledge, however, that those exhibited at Plymouth were not surpassed by any other breed. The only fault I find is that the older bulls were over-fed and inactive. Indeed, from their great weight and want of exercise, it was difficult to get them exhibited in the ring; and the men in charge did not like the parade twice a day. The Aged Bulls were a very grand class. The Judges, Messrs. Druce, Yeomans, and Pye, describe this as "A very good class of animals, the first prize, Mr. Read's 'Peremptorily,' being compact, with perfect symmetry and heavy flesh; the third prize, Mr. Baldwin's 'Battersea,' was much out of condition." The classes generally of bulls were good; massive in form and firm in flesh, and well sustaining the character of rent-paying animals. Indeed, I should say that the Herefords and Mr. Stratton's Shorthorns look more like farmers' cattle than any stock exhibited in the classes of Shorthorns, Herefords, or Devons. The Hereford cows have a tendency to grow patchy, and lose their shape, which the Shorthorn and Devon men seem to have corrected in their breeds of cattle. The Judges, however, describe this class as a "good one, containing superior specimens in size, quality, and character." The Two-year-old Heifers contained three very superior animals, which obtained the prizes: Mr. Baldwin's "Miss Hastings;" the second, Mr. Pitt's heifer; and Major-General Hood's "Crown Princess." In fact, each class of Herefords contained many excellent animals. The Yearling Heifers were described by the Judges as "an extraordinarily good class, giving us some difficulty to decide, the animals being strong in numbers, of great size, and good in character." And as a proof of their excellence, I may mention that every animal in the class was noticed by the judges; and the same honour was paid to the class of Calves. The Hereford entries numbered 52, as against 42 at Newcastle; and there is no doubt

that in the number exhibited there were few inferior animals, and many of the very highest quality, reflecting the greatest credit on their exhibitors.

DEVONS.

There can be no question that the show of Devons was the feature of this year's exhibition. The gay, lively-headed bulls, so full of grace, so active in their movements, and full of wild spirit, which more than once led to an upset of bull, herdsman, and spectators—the cows, heifers, and calves so full of quality, so perfect in their backs and ribs, so clean in the head, so short of offal, and altogether so aristocratic in their mould, made the Devon ring a constant source of attraction. I could find no fault but one, and that was want of size; and this is a deficiency, which in these days of dear meat is not easily condoned on the plea of superior quality or purity of breed. The beef, no doubt, is excellent; but there is not enough of it.

There were in all 89 entered for the Society's prizes, and 34 for the Local; and the best names amongst the Devon breeders carried off the prizes; the Davys, the Quartleys, the Turners, the Farthings, and the Royal Farm, being all represented. Perhaps the pairs of cows and heifers, and the grand old bull "Viscount," with the cow and calf in his company, were the most striking part of the Devon show. But I shall not venture on individual criticism, and only remark that it was worth a journey to Plymouth to see so many beautiful cattle, and so many Devon exhibitors satisfied with the awards.

I regret much that I have not a report from the Judges mentioning more particularly the merits of the animals exhibited; Mr. Franklin, the only one from whom I have heard, merely writing in general terms that they "were more in number and better in quality than at any previous meeting of the Society, and decidedly the best classes in the yard at Plymouth." But as a proof of this general excellence, the Judges commended all the animals in the classes of two-year old bulls, cows, yearling heifers, and heifer calves, showing that it was not singular, but general merit which pervaded the Devon classes.

SUSSEX AND OTHER BREEDS OF CATTLE.

Although the Sussex cattle were much better here than at Newcastle, and though amongst the "other breeds" were some good specimens of the Suffolk polled, and a grand old Longhorn bull from Warwickshire, himself one of the greatest curiosities of the show, I must still question the advisability of giving prizes to the amount of 100*l.* for Sussex cattle so far from home, where only 12 animals were exhibited by three

exhibitors ; or 125*l.* amongst the various breeds, for 11 animals, shown by four persons. I may quote from the Report of the Judges (the same gentleman who acted for Herefords), that the Sussex cattle, "though short in number, were good in size, symmetry, and quality." Of the various breeds they say : "A poor collection of animals, short in numbers, various and diversified in breed, character, and quality."

In this class the President, Sir E. Kerrison, M.P., deserves thanks for sending several of the Suffolk polled cattle, a very useful breed, to the improvement of which he has devoted much attention.

CHANNEL ISLAND BREEDS.

I believe we should have done better to have left out the Sussex, or "the other breeds," and to have given prizes separate for Jersey and for Guernsey cattle, instead of placing them both in the same class. My view is confirmed by the Report of the Judges, Messrs. Dumbrell and Le Cornu, who write,—

"These classes, representing the two breeds of Jersey and Guernsey, are well filled; and generally the animals exhibited display a marked improvement on those shown on former occasions. The aged bulls are of no mean merit, some animals showing unquestionable form and character. The younger bulls are, with few exceptions, only moderate, and not in any way equal to the former class. There are some excellent cows and heifers of both breeds, and the competition is very severe, showing the great improvement resulting from the efforts which the Channel Islanders have of late years been making to combine beauty of form, with the quality for which the breeds are so remarkable, viz., richness of dairy-produce. But, if either of the classes has a claim to special notice, it is the Heifer Class. We do not hesitate to express it as our opinion that the first prize is taken by as good a specimen of the Jersey breed (Mr. Eli Nicoll's 'Brownny,' 2 years and 5 months-old), as any which ever came under our notice.

"In closing these remarks, we would beg to draw the attention of the Council to the difficulty which exists in awarding prizes in a mixed class; for although the Channel Islands are very closely allied as regards locality, their breeds of cattle are totally different; and we would respectfully suggest that should the entries, in future, be as numerous as on the present occasion, some distinction should be made in the classification so as to encourage separate competition for each breed."

I cordially concur in these remarks, and I trust that the Council may follow out this suggestion whenever the show is held within reach of the Channel Islands exhibitors. The Americans now buy so freely of these cattle, that the prices are very much raised, and the value placed upon them by their owners seems justified by the ready sale of many of the cattle exhibited.

I have only to mention one other breed of cattle which was brought under our notice by the prizes given by the Local Committee—the South Hams. The cows and heifers exhibited in

these classes were somewhat coarse and capable of improvement in quality, but possess great frames, and are apparently good milkers. If the bullocks are easily fattened, as I am informed, the breed would appear to be a useful farmers' stock, and more likely to pay rent than the elegant Devons. I am sorry that the Society had not offered the prizes for this breed of cattle, which possesses so many good points, rather than for the "other established breeds."

Before closing my remarks upon the Cattle Classes, I must again enter my protest against the mistake made by our breeders of fashionable stock, in so entirely neglecting the milking properties of their cattle. Amongst the Shorthorn, Hereford, and Devon Classes, we had perfect models of female symmetry in every point but one,—that which provides sustenance for the offspring. The feminine character is lost, and we are year by year showing mere cylinders of beef. What a contrast were the graceful well-formed udders of the Jersey and Guernsey cows to the malformations which disgraced some of the prize cattle in the fashionable classes.

The Channel Islanders obtain early maturity for their purpose; the beautiful prize heifer, but 2 years and 5 months-old, had borne a calf, and her udder was as gracefully and truly formed as any nature ever made. In the fashionable breeds we are losing fast the most beautiful characteristic of the sex, and, as I believe, from nothing but over-forcing and carelessness on the part of the breeder. Our shows would gain in interest if the bulls could step out easily and majestically; and if our cows and heifers were indeed the milky mothers of the herd. But now, amongst the aged bulls, to walk as far as the ring is a matter of serious difficulty, and to parade once or twice round it a painful task, for they resemble some gouty specimens of the human race, whose tempers and figures are alike destroyed by over-feeding, and the sufferings consequent thereupon. But serious as are these difficulties, it would be a yet harder task to get a pail of milk from a whole class of cows!

HORSES.

The weakest department of the Plymouth Show was that assigned to Horses. One stallion only appeared for the 100*l.* prize given for the best Thoroughbred horse, and this was "Motley," by "Touchstone," now 14 years old, and although a nice animal, not a horse of the highest quality or style. The Pony Classes also, which it had been hoped would have formed a feature of the Western Show, were filled with a curious mixture of animals, creating but little interest, and not much desire to possess them; indeed, amongst the riding-horses generally, the

want of merit was conspicuous. Mr. Parrington writes to me on behalf of himself and the other Judges :—

“ The horse most like a stallion to get hunters was a roarer, and disqualified ; and we were obliged to award the prize to a very light airy horse, not a weight-carrier himself, or likely to get horses up to weight ; the second prize to an inferior horse ; and we could not find a third worthy of a prize. The winning hunter brood-mare was a good animal, the rest moderate, and the foals particularly light and bad. All the ponies exhibited were very moderate, with one exception, and that a mare-pony, the prize taken in Class CXXI. In the Four-year-old Hunter Class were nine entries, but only six competitors ; there were three good animals, two horses and one mare, the others weeds. We awarded the prize to the mare (No. 414), the second prize to a brown horse, and highly commended No. 417, a very good horse, but approaching rather too near the stamp of a harness-horse. In the Five-year-old Class only one horse was shown, and that a very good one. Of the roadsters exhibited two were disqualified, being over the height named in the condition. The class was very poor.”

The three prize-taking hunters exhibited by Mr. Battams, and the highly commended 4-year-old, belonging to the Rev. A. C. Thynne, were all by “ Kingmaker ;” and I should think the Devonians must regret having allowed so good a stock-getter to go out to Australia ; for there can be no question that the horses got by him were the best worth notice in the Yard. Some difficulty arose about the chesnut mare-pony mentioned by the Judges ; she was entered in the Exmoor Class, and being by a thoroughbred horse out of a pony, an Exmoor exhibitor protested against her ; but the Stewards did not feel that they had sufficient evidence to prevent their confirming the decision of the Judges.

The entries for Agricultural Horses were more numerous, and of greater merit : the Class of Aged Stallions was tolerably well filled, and there were some fine powerful horses, especially amongst the Clydesdales. The younger class was not remarkable. One or two useful horses were shown amongst the stallions suited to a hilly district, and the prize-horse, which came from the county of Durham, found a new owner in an Australian. There were some good Suffolk horses in an entry numerically poor ; I would suggest that we should allow the Suffolks to compete with other horses, except in their own particular districts ; and then offer more prizes, dividing the agricultural stallions into classes for 2, 3, 4-years, and aged horses. The prize cart-mare exhibited had twin living foals sucking her, an unusual sight in a Show-yard. There were some very fine young mares, though the entries were few.

Professor Varnell thus reports as to the soundness of the horses shown :—

*To the Stewards of the Horse Department of the Royal Agricultural Show,
Plymouth, July, 1865.*

GENTLEMEN,

I beg to hand you a brief Report of the comparative amount of disease of an hereditary nature, affecting the horses exhibited at the Royal Agricultural

tural Society's Show, Plymouth. The number, including all classes, is, I believe, ninety-two; of these, three only were affected in the wind, two of which belonged to the Class for Agricultural Stallions and one to the Class for Hunter Stallions. It is gratifying to observe that no disease of an hereditary nature was observed in the eyes of any of the horses exhibited; but disease of the hocks is more prevalent, including what is termed bone and bag spavins, and curbs. These cases amount to about 7 per cent., which must be looked upon as a large percentage. Shelly, flat, and brittle hoofs were by no means numerous. I observed these in four instances only, viz., two in the Suffolk Stallions, and two in the Class of Agricultural Stallions shown for the local prizes.

I am, Gentlemen,

Your obedient servant,

GEORGE VARNELL.

I may here call the attention of the Council to the question of disqualification. Ought we not in justice to our Judges and to the public, whom we profess to protect by our veterinary examination, to post up the disqualification and the cause of it over the horse disqualified? No doubt the severity of our veterinary examination keeps many horses from the Show-yard, and renders the show less attractive than it would be, were we not so strict; but, on the other hand, we profess to protect the public against hereditary disease, and I believe that though our Show-yard may not have as many horses as some others, yet that we have steadily lessened the number of diseased horses exhibited. To label a stallion as a roarer, or affected with hereditary disease, must of course seriously depreciate his money value, and so far inflict a pecuniary loss upon his owner—which is not the case in a disqualification of pigs shown over age, or sheep improperly shorn, where the money value of the animal remains unaltered, although the character of the owner may suffer. The question is a difficult one, and, although it perhaps would have been right to post up the disqualifications, yet I did not like to do it without the express sanction of the Council, and I believe it is a matter to which their attention should be called. There is no doubt that the veterinary examination is a great obstacle with exhibitors; I am sure that it is carried out carefully and prudently by Professor Varnell, and I should be sorry to see it discontinued, because I think it is the duty of the Society to discourage unsound animals, rather than to bring together a great show of horses. At present the Horse-show is the least successful part of our undertaking; the expense of railway travelling, and the length of time during which valuable horses are detained, and, above all, the fear of the veterinary examination, rendering owners of thoroughbred stallions or of first-class hunters unwilling to exhibit.

It was hinted that the boxes for horses were capable of improvement, but no suggestions on the subject were made; on this question, and that of the payment to be made for boxes, the Council will always be ready to listen to any opinion expressed

by exhibitors. The men in charge of the horses were very civil and attentive, and Thomas Gilby, the head man in the Horse-department, kept all in good order, especially on the day when the Prince and Princess visited the Show-yard.

SHEEP.

Amongst the Sheep the Leicesters made a very good show,—there being 76 rams and 8 pens of ewes, as against 60 rams and 5 pens of ewes at Newcastle. Some excellent sheep were shown in all classes, and the blood of Mr. Sanday was very successful, although the prize-shearling was descended on both sides from the much-esteemed flock of the late Sir Tatton Sykes. The West-country farmers are fond of Leicester blood, and took no inconsiderable part in the competition, showing some good sheep, although the prizes went to the old-established flocks of Mr. Borton, Mr. Creswell, Colonel Inge, Mr. Stamper, and a new name, Mr. Dabbs, who showed a sheep bred by Mr. Sanday. The general impression was that the Leicesters exhibited were quite up to the mark, and even superior to those exhibited at of former shows.

The Cotswolds were numerically weak, and few good sheep were exhibited, though they had the honour of attracting Her Royal Highness the Princess of Wales's attention, by their beautifully clean white fleeces. Mr. Aylmer, one of the Judges, writes of them :—

“The Cotswolds as a class were the worst I ever saw, all the best breeders being absent—such men as William Hewer, R. Game, W. Game, William Lane, &c.—the rule for clipping the sheep naked in the first week in April having frightened them all out of the market. I did not consider one sheep in the lot worth the amount of the prize.”

Lincoln sheep never come out at the Royal Show in such number or form as to show their real character. The Lincoln flockmasters think the prices obtained for their rams a sufficient test of their excellence, and they know that a Lincoln sheep does not show well without his fleece. Lincoln breeders say, “if you wish to see our sheep, come to Lincoln April fair.” The ewes shown were a very indifferent, ill-matched lot. Mr. Aylmer says :—

“The Lincoln and other Long Wools were a very mixed lot. Mr. Sym had some very useful sheep, a shearling very good indeed, but he should have been in the Leicester Class. Mr. Marshall's were a plain lot of Lincoln sheep, but useful, with their Lincoln character about them ; some of his old rams were thick-fleshed useful sheep.”

Mr. Clarke, another judge, says much the same of the rams, and finds great fault with the ewes.

Of the Oxfordshire Downs, the Judges, Messrs. Horley and Gough, say :—

“The numbers are comparatively small, but there are some very good specimens of the breed, which possess quality and aptitude to fatten, rendering them most desirable for those flockmasters who make size and early maturity their leading principle; but, while they possess great size and mutton-giving properties, they lack the uniformity which should be apparent in each distinctive breed.”

Of Shropshires the same Judges say :—

“This is one of the largest and most important classes in the Yard, the number of entries being

“ Shearling rams	43
“ Aged ditto	19
“ Yearling ewes	10

“This, upon reference, will be found to exceed the number of entries in 1864 by 7 pens. The breed is well represented by many of the specimens shown, which exhibit the best characteristics that have brought this breed into notoriety. The character and type on the whole is good, but there are a few exceptions, and breeders will best serve the interests of this class of sheep by paying all the attention possible to uniformity, which is the attribute most calculated to assist their natural good qualities, and render them still more attractive to flockmasters generally. The Class of Aged Rams was particularly good.”

There can be no doubt that in the last-named classes of sheep there is some want of agreement as to type among different breeders, and this want of uniformity appears to be the weak point in breeds, which, to an unprejudiced eye, appear most valuable as producers of both mutton and wool.

When we go to the Southdown pens we are struck with their uniformity, although there is some difference and improvement as to size. Lord Walsingham, who, with the shepherd, seems also to have inherited the mantle of Mr. Jonas Webb, is again very successful amongst the rams in both classes. His sheep are very handsome and big, and are shown in the perfection of condition. Mr. Waters, Mr. Rigden, and Sir Thomas Lennard exhibited good sheep, and the Judges, Messrs. Fookes and Turner, considered all the classes to be well represented. The ewes shown by the Duke of Richmond were perhaps the most beautiful pen of sheep in the Show-yard. There was an air of refinement and of purity of breed about them unsurpassed by any other animals, unless, perhaps, by some of the females in the Devon Classes.

The same Judges took the Hampshire Down Classes, and report on them :—

“A very decided improvement, Mr. Rawlence taking the first and third prizes, with sheep of wonderful size and quality, and good wool; Mr. Arnold taking the second prize. Amongst the Aged Rams, Mr. Rawlence again takes the first prize with a very good sheep of the true character of the Hampshire breed; while the Shearling Ewes were well represented by some pens of extra-

ordinary sheep, of immense size, and very closely shorn in every part, from the same flock; Mr. Canning taking the third prize with a very nice pen."

If the Southdowns are the aristocracy of the South country sheep, the Hampshire Downs well represent the thriving yeoman or farmer. They were certainly amongst the best and most profitable looking of all the sheep shown, and, under the careful management of their present breeders, bid fair to shine in quality quite as much as in usefulness. Size, substance, hardihood, and quality are what flockmasters require in these days of dear mutton, and the Hampshire Downs, as shown at Plymouth, seem very likely sheep to furnish what is needed.

Those who delight in curiosities must have been rewarded by a sight of some of the local breeds of sheep; the Exmoor and Dorset horned rams, with their curling horns, were quite magnificent. The Dartmoors were shown in the wool, strange long-sided animals without horns, with mottled or white faces, and unwashed fleeces like door-mats. But if the rams really clip from 21 to 28 lbs. of wool each, and the shearling ewes 14 lbs., and these fleeces are obtained when they are running on the moors, I do not know that the farmers there could find a more useful breed. The three breeds of Dartmoor, Dorset, and Exmoor were well represented, and certainly very interesting. But by far the worst sheep shown were the South Hams; they were diverse, one pen like very bad Cotswolds, another like thin-skinned bad bred Leicesters; and the 2 rams were worse than the ewes. I hope the South Ham farmers will have learned something from the show, and that when we visit the West country again, we may see more of their useful cows and none of their bad sheep.

The Stewards suggest that the date of clipping sheep should be altered to "after the 1st of May," rather than the 1st April. The growth of wool on highly-kept sheep in these months is so great, that there is much difficulty in arriving at a conclusion whether sheep have been fairly shorn. At present the duties of the inspectors of shearing are attended with much difficulty, and though the glaring cases which attracted attention at Worcester have been checked, still we feel that we have not yet arrived at a satisfactory position. I have good reason to believe that very nearly all the sheep in one class had a good share of wool taken off their flanks and other points, one evening after the inspectors had seen them and proposed to pay them another visit. Indeed, the marks of the shears and the different shade of wool were very visible even to an unpractised eye.

PIGS.

The show of pigs was generally acknowledged to be a very good one, the entries numbering 119 as against 136 at Newcastle,

I was sorry to see several notices of disqualification affixed to pens in this department.

Mr. Squarey, one of the Judges, reports to me as follows:—

“The animals exhibited were on the whole of superior quality, and without surpassing, certainly maintained the distinctive excellences of the various breeds, as indicated at former exhibitions of the Society.

“From the locality of the show it followed that the number of animals exhibited was generally not large. Classes LXXXVIII., XCIII., and XCIV. were, however, well represented. The absence of competition was specially apparent in the local classes.

“The animals which particularly called for attention were No. 828, Class LXXXVIII. (to which the first prize was awarded); No. 860, Class XCII.; and No. 897, Class XCIV. The Judges remarked that the characteristics of the large and small breeds were in many cases scarcely sufficiently defined.

“Ten pens of animals were disqualified by the veterinary surgeon on account of their being older than described.”

In concluding my Report I think I may fairly congratulate the Society on its Annual Show. Financially, Plymouth stands fourth on the list, and the success of the meeting presents another argument against the centralisation of our Shows, and in favour of their peripatetic character. The men of the West have still a good deal to learn, although the excellence of their stock in several departments took us by surprise. There did not appear to be the same hearty interest taken in the Show itself, that was evinced last year at Newcastle. The people who came on the shilling-days made a pleasant holiday, but did not carefully go over the lists of stock exhibited, as the North countrymen did last year; and we may suppose from the deficiency in the sale of catalogues (the money received at Plymouth being 342*l.* as against 724*l.* at Newcastle, and 510*l.* at Worcester), either that the education of the working classes in the Western is inferior to that in the Northern and West Midland districts, or that the love of agricultural pursuits is not so fully developed: At the same time all the officers of the Society felt deeply grateful for the kindness and hospitality they received from the authorities and inhabitants of the three towns; and to the Local Committee we feel bound to tender our best thanks for the admirable Show-yard provided, and for the readiness with which they met all our suggestions.

I cannot close my Report and resign my office as Steward of Stock, without an expression of regret that the time has passed so quickly by; and I shall always look back with pleasure to the pleasant weeks at Worcester, Newcastle, and Plymouth, and think gratefully of the friendships made there.

Ribston Hall, July 29, 1865.

XXXI.—*General Report on the Exhibition of Implements at the Plymouth Meeting.* By JOHN COLEMAN and F. A. PAGET, C.E.

THE reports of Judges on the different classes of implements, for which prizes were offered at this meeting, may well be accompanied by a few general remarks, for the information of those who were not present. The Show-yard, enclosing 35 acres 30 poles, was situated at Pennycomequick, on a site close to, and on the right of the Saltash-road, and about one mile from the railway stations of Plymouth and Devonport. The situation was not only commodious and convenient, but commanded an exquisite panorama of the town and bay, Mount Edgumbe, and the undulating country around. The ground occupied by the Show-yard was originally in six fields; but the hedges had been carefully grubbed and levelled, and a broad road, 200 yards long, so laid down as to secure an entrance in the centre of the southern boundary. A siding from the Cornwall Railway, constructed for the occasion, landed visitors, stock, and implements, within a few yards of the entrances. The visitor, after passing the Post-office, the Secretary's office, and other official buildings, found himself in a large open space of gently-rising green sward, commanding a view on the right of the machinery in motion—not so large a display as it will be next year, but still presenting a respectable appearance, whilst to the left his eye would range over a succession of implement-sheds; and if he walked forward he found a broad avenue with, first, implement-sheds on either hand, then departments for stock, and at the extreme end the extensive ring, surrounded on three sides by horse-boxes. If the eye became dazed, and the head distressed with the multitude and variety of the objects close at hand, he had but to turn and gaze upon a landscape which can find few rivals, and has perhaps never been equalled at a previous gathering of the Royal Agricultural Society.

In accordance with the programme of the Society, the same classes of implements that competed at Leeds came round for trial at Plymouth. These were drills, manure-distributors, horse-hoes, mowing and reaping machines, hay-machines, and horse-rakes, and carts and waggons. The land selected for the trials comprised about 70 acres, part of the Woodford Farm, belonging to the Earl of Morley, and tenanted by Mr. Cork, situated on the road to Plympton, about $3\frac{1}{2}$ miles from the Show-yard. It was approached by road and rail, a temporary station having been erected at Marsh Mills, on the Plymouth and Tavistock line, within sight of the grounds, which consisted of three arable fields and one meadow. The largest, 20 acres in

extent, had been prepared for the reapers, half with rye after oats—a good upstanding crop; the remainder was in oats after clover, a remarkably heavy crop much laid and twisted. This field was tolerably square, but rather too much on a slope, and altogether insufficient for the trial of so large an entry of machines. A second field of 19 acres was partly in clover—an over-ripe crop, much beaten down, which was reserved for trying the mowers—and partly ploughed and harrowed in readiness for the drills, distributors, &c. A third field was drilled with roots for the trial of horse-hoes, grubbers, &c. The meadow was at some little distance on the other side of the line, and nearer to the Marsh Mill Station; there, in a low wet spot, subject to flooding, and called the Marsh, were reserved 15 acres of heavy grass, with a very rough bottom, containing a considerable quantity of dead grass, bad to cut, and likely to afford an excellent opportunity for a severe trial.

A comparison of the number of entries at Leeds and Plymouth will show that manufacturers have not been idle, and that a lively demand for the home and foreign trade is kept up.

As nearly as we can gather from the reports of the Leeds trials, the two lists of entries may thus be contrasted:—

	Leeds.	Plymouth.
Drills of various kinds	33	66
Water-drills	2	3
Drill-presses	4	4
Dry manure distributors	8	8
Liquid ditto	3	6?
Horse-hoes	29	42
Horse-hoes for thinning turnips .. 2	2	1
Mowing-machines (not stated)	...	13
Combined machines (not stated)	...	8
Reaping-machines, manual	9	25
Reaping-machines, self side-delivery	8	10

It will thus be seen that the Judges had a heavy task before them; and in consequence of unavoidable delay from one day being thoroughly wet, and a further loss of valuable time in selecting implements (with regard to which a suggestion is made in the Report on Mowers and Reapers, which deserves attention), the awards were not made until the Tuesday in the Show week.

This Report, which embraces a short description of the more prominent machines, renders it unnecessary for us to do more than allude to the general position of this important branch of agricultural mechanics, and to the progress which has been made since Leeds. In many respects this has been considerable. The gearing has been simplified, friction and draught have been much reduced, and weight and size

brought within a reasonable compass. In the class of reaping-machines with self side-delivery, this improvement is most marked, and we are disposed to believe that eventually a modification of this principle will to a great extent supersede the manual machines. The tendency of all improvements in agricultural machinery is to relieve the labourer of the heavier drudgery of his calling; and to rake off in a heavy crop is probably almost as hard as to work the treadmill. Since Leeds, the sheaf-delivery has been invented, and the better machines of this sort are admirably adapted for crops of medium bulk. Some objection has been urged against this system on the ground that those crops which require to lie for a time before being tied up are better in swarth. But this advantage is more apparent than real, as the sheaf is laid so lightly and fanned out so nicely that the sun and air can penetrate almost, if not quite, as well as if the corn lay in swarth. A more valid objection exists in the irregular size of the sheaf in variable crops. One maker has attempted to obviate this by making the rake controllable by the driver, but at present the attempt has not proved very successful.

The mowing trials were principally carried out on Friday, the 14th July, a lovely day, and the exertions of the Stewards, Judges, and other officials, to secure a full, fair, and satisfactory contest were rewarded with success. Thirteen machines were brought into competition, most of them possessing great merit, and many noticeable for very ingenious mechanism. The chief alterations since Leeds appear to consist in devices of various kinds to render the knife-bar flexible, and give it, so to speak, an independent power of adapting itself to irregularities of surface, ridge, and furrow, as also to enable the driver, either by hand or foot, to raise the whole or either end of the knife; and in one case to alter the angle of the knives without lifting the bar. With all these thoughtful appliances the weight has been decreased, until in some case it appeared almost as though the implements were too light to face and stick to heavy work. It should be remembered by the makers that, although a racer prepared for trial may possibly win, unless a machine can earn a good character for durability, the public will not endorse the decision of the Judges. It was perhaps fortunate for both public and Judges that the trials were so severe, that only the machines with staying powers had any chance of a place; at the same time it may be well to explain that, in all these trials both of mowers and reapers, the Judges very properly did not regard the quantity of work done in a given time, nor pit one machine against another: had they done so, the merits of horses and driver must have had to do with the result, and the size of the cutter-bar. The dynamometer trials afforded most of the data required.

A mowing-machine, with a 4 ft. to 4 ft. 6 in. knife, will do plenty of work in a day if well driven and horsed; the question is, which machine will do the best work? It is satisfactory to be able to state that the work of all the mowers was infinitely superior to manual work, and effected, as we shall see by the following calculation, at a considerable saving per acre:—

Cost of machine 20l. :—	Per Acre.			
	s.	d.	s.	d.
Interest according to acreage to be mown, from 1	0	to	1	6
Horse-labour „	1	0	1	0
Oil „	0	3	0	3
Manual labour „	0	6	0	6
	<hr/>			
	2	9	to	3 0

Report of the Judges on Drills, Manure-distributors, Horse-hoes, Hay-making Machines, and Horse-rakes.

When selecting for trial the various Implements exhibited at Plymouth, we were agreeably surprised at their numbers. The workmanship of most of them was of a very superior description, and the work in the fields during the trials generally very good.

The principal novelty that came under our notice was the application of springs to the Drill and Horse-hoe levers, patented by Mr. Sainty, and manufactured by Messrs. Garrett and Sons, which obviates the necessity of weights, and more efficiently effects the object of keeping the coulters to their work. The raising and lowering the levers is also accomplished more simply by a hand-bar, which also acts as a press-bar, thus dispensing entirely with weights, chains, ordinary press-bar, ratchet-gear, and hind-roller, to carry the levers. The action of the spring was considered by us a very great improvement on the ordinary method, as upon the coulters coming in contact with a stone, &c., the spring would check the tendency to jump, and cause it to resume its proper place more quickly. The draught of the Implement was, in our opinion reduced very considerably by this novel arrangement—say from one-fourth to one-third—which is a very important feature.

We had several small Hay-making Machines, which we believe will prove very useful and efficient Implements, and at about two-thirds of former prices.

We commenced with the trials of Drills for general purposes, of which we had nine—a very good class: but while we praise these Drills and their performance, we do not approve of the combination which is found necessary, as their cost is about equal to that of both a corn-drill and a manure-distributor, and they are not nearly so convenient, or light and portable. We think that for the future the prize in this class might very properly be dispensed with.

Of ordinary Corn-Drills we tried fourteen, and most of them were good and efficient implements.

Of Corn-Drills for small occupations we tried fourteen. This was also a very good class.

Of Drills for hillside delivery we only tried two (which were very good), but nearly all the corn and small occupation drills were adapted for drilling up and down hill, the seed being regulated by the use of a small wheel in the barrel in ascending, and a larger one in descending.

Of Drills for Turnips and other Roots on the flat we tried fifteen implements. This was a very good class.

Of Turnip-Drills on the ridge we tried eight implements, and found this a useful class, but with great variation in price, viz., from 21*l.* 10*s.* down to 5*l.*

We had only three Water-Drills. All worked tolerably well. We gave each a prize in proportion to its merits.

Of Drills for small seeds we tried four, of which three were very efficient implements.

Of Drill-Pressers four were set to work, but the soil was not in a proper state for the trial of these implements, being merely a loose fallow fresh ploughed. The test was, nevertheless, equally fair for all.

Of Distributors for dry manure we tried eight. This we found a very good and efficient class. We considered that Mr. Chambers's barrel delivered the manure in the best and most regular manner. Mr. Sainty has improved his implement by the introduction of a barrel of mixed metal, manufactured by Messrs. Garrett and Sons, which is not liable to rust and corrode.

In the class of Horse-Hoes for general purposes we tried nine implements on the growing rye, and six of them on turnips. This we also found a very good class. Some of them hoed the turnips very well, but the trials were not so satisfactory among the corn, as it was badly drilled.

Eighteen single-row Horse-Hoes were tried, and the operation being so very simple, we found considerable difficulty in selecting the best from so large a number; but considering that, as in the work, so in the implement, simplicity, combined with strength, good workmanship, and cost, were the merits to be desired, we have awarded the prizes to those implements that appeared to us to combine these qualities in the highest degree.

Of single-row Grubbers we tried nine, finding some of them really very good and efficient implements. The remarks on single-row horse-hoes apply equally to this class.

We had only one Horse-Hoe for thinning turnips brought to the trial-field—that exhibited by Messrs. Eaton and Sons; there being no competition, we awarded to it half the amount placed at our disposal.

Of Hay-making Machines we tried sixteen on hay or grass in the same state in which it was left by the mowing-machines. Their mode of working was very varied, but, on the whole, this class has been much improved since the trial at Leeds, particularly by the introduction, by some of the manufacturers, of smaller, lighter implements, at considerably lower prices, which are very useful, and work without any material diminution of the breadth of ground taken. After having tried the whole of this class, we selected four of the best machines, giving as much ground as we could to each; we then changed their positions and worked them side by side until the field was finished, when we divided the amount at our disposal according to their respective merits.

Of Horse-Rakes we tried eighteen, on the same land where we tried the hay-makers, and so thoroughly satisfied were we with one trial, that we had no difficulty in deciding which were the best implements.

GENERAL PURPOSE DRILLS.

Article.	Stand.	Name of Exhibitor.	Price.	Award.
			£. s. d.	£. s.
1069	86	Priest and Woolnough	41 10 0	10 0
1887	120	Hornsby and Sons	38 15 0	8 0
378*) 379†)	26	James Coultas, junior	39 10 0	7 0
1070	86	Priest and Woolnough	27 10 0	Highly Commended.
380	26	James Coultas, junior	27 10 0	Commended.
622	46	R. and J. Reeves	37 5 0	Commended.

* Drill.

† Steerage.

CORN-DRILLS.

Article.	Stand.	Name of Exhibitor.	Price.	Award.
			£. s. d.	£. s.
1379	108	John Sainty	28 10 0	8 0
1071	86	Priest and Woolnough .. .	28 14 0	7 0
382	26	James Coultas, junior .. .	32 10 0	5 0
1888	120	Hornsby and Sons .. .	29 15 0	Highly Commended.
718	52	A. W. Gower and Sons .. .	33 0 0	Commended.
719	52	A. W. Gower and Sons .. .	30 10 0	Commended.

SMALL OCCUPATION-DRILLS.

1380	108	John Sainty	16 10 0	6 0
1072	86	Priest and Woolnough .. .	16 10 0	5 0
1889	120	Hornsby and Sons .. .	17 10 0	4 0
955	78	George Lewis	17 10 0	Highly Commended.
2256	131	Holmes and Sons	17 10 0	Highly Commended.
384	26	James Coultas, junior .. .	20 10 0	Commended.

HILLSIDE DELIVERY.

386	26	James Coultas, Junior .. .	18 0 0	7 0
2257	131	Holmes and Sons	19 10 0	3 0

TURNIPS AND OTHER ROOTS ON THE FLAT.

1073	86	Priest and Woolnough .. .	30 10 0	8 0
387	26	James Coultas, junior .. .	25 0 0	7 0
1891	120	Hornsby and Sons	25 0 0	5 0
668	46	R. and J. Reeves	14 0 0	Highly Commended.

TURNIPS AND OTHER ROOTS ON THE RIDGE.

724	52	A. W. Gower and Son .. .	11 0 0	8 0
1074	86	Priest and Woolnough .. .	19 0 0	7 0
726	52	A. W. Gower and Son .. .	5 0 0	5 0
670	45	R. and J. Reeves	12 10 0	Highly Commended.

WATER-DRILLS.

671	46	R. and J. Reeves	36 0 0	8 0
672	46	R. and J. Reeves	26 10 0	7 0
389	26	James Coultas, junior .. .	28 0 0	5 0

DISTRIBUTORS OF LIQUID-MANURE.

671	46	R. and J. Reeves	36 10 0	10 0*
-----	----	--------------------------	---------	-------

* The only liquid-manure drill or cart that had an efficient stirrer attached.

DRILLS FOR SMALL SEEDS.

Article.	Stand.	Name of Exhibitor.	Price.			Award.	
			£.	s.	d.	£.	s.
1893	120	Hornsby and Sons	26	10	0	6	0
1075	86	Priest and Woolnough	24	0	0	4	0
390	26	James Coultas, junior	26	0	0	Highly Commended.	

DRILL-PRESSERS.

732	52	A. W. Gower and Sons	9	9	0	6	0
1135	91	William Gerrans	12	12	0	4	0

DRY-MANURE DISTRIBUTORS.

1382	108	John Sainty	16	10	0	8	0
1076	86	Priest and Woolnough	16	10	0	7	0
1895	120	Hornsby and Sons	13	0	0	Highly Commended.	
391	26	James Coultas, junior	14	0	0	Commended.	

HORSE-HOES FOR GENERAL PURPOSES.

1381	108	John Sainty	16	0	0	6	0
1077	86	Priest and Woolnough	23	10	0	5	0
95	7	William Smith	8	10	0	4	0

SINGLE ROW HORSE-HOES FOR RIDGE AND FLAT.

286	21	Carson and Toone	3	5	0	4	10
751	56	E. Page and Co.	3	10	0	3	0
96	7	William Smith	3	13	0	2	10
709	51	John Davey	4	2	6	Highly Commended.	
848	63	James Bowden	2	10	0	Highly Commended.	
1101	89	Robert Tinkler	3	10	0	Commended.	

SINGLE ROW GRUBBERS.

286	21	Carson and Toone	3	10	0	6	0
1101	89	Robert Tinkler	3	10	0	4	0
848	63	James Bowden	2	10	0	Highly Commended.	

HORSE-HOE FOR THINNING TURNIPS.

443	29	Eaton and Sons	6	6	0	5	0
-----	----	----------------------	---	---	---	---	---

HAYMAKING-MACHINES.

Article.	Stand.	Name of Exhibitor.	Price.	Award.
481	32	J. and F. Howard	£. s. d. 11 11 0	£. s. 6 0
478	32	J. and F. Howard	16 10 0	5 0
1593	112	Robert Boby	14 15 0	4 0
1793	116	W. N. Nicholson	16 7 6	Highly Commended. Commended.
176	12	A. and T. Fry	14 0 0	

HORSE-RAKES.

483	32	J. and F. Howard	8 10 0	6 0
753	56	E. Page and Co.	8 10 0	4 0
713	51	John Davey	6 15 0	Highly Commended. Commended.
3189	170	Thomas Alcock	8 0 0	

JOHN HICKEN.
A. H. JOHNSON.
FRANCIS SHERBORN.
JOHN THOMPSON.
ROBERT DYSON.

As some further particulars respecting the principal implements that received the prizes may be interesting to the reader, we may note that Mr. John Sainty, of Burnham, Norfolk, bears off the honour of novelty in drills as Messrs. Hornsby do in reapers. The light and clever arrangement of springs, by which we get rid of the heavy, inconvenient press-bar and weights, &c., may be considered an important constructive detail. It has already been adopted by several of the large farmers in Norfolk, and is capable of being fitted to any ordinary corn-drill at a small cost. One of the great advantages in this application is that if the coulters are thrown up from any disturbing cause—a stone, hard ground, &c.,—they settle to their proper depth again much more rapidly than if merely weighted. The springs act on each lever with a pressure varying from 1 to 12 lbs. The drill is considerably lightened, and the raising or lowering the coulters can be effected more readily than by the old system. Messrs. Garrett manufactured for Mr. Sainty, and accordingly the working parts of these implements were excellent.

The principal improvements in Priest and Woolnough's drills and hoes, which have received nine prizes, may be shortly noticed, as consisting in the use of tin funnels of uniform diameter, instead of the old tins and chains for conducting the seed, which have a side-play by means of a novel ball-and-socket joint. In order to obtain uniform pressure on each coulter the levers are mounted on horizontal bars; the front coulters being attached to the foremost bar, and the back coulters to the hinder bar. The

parts are made to a uniform gauge and weight to get an equal pressure. On light and mixed soils weights are not required. In the trial at Plympton the drill went to work without any weights whatever. The patent shoes of chilled cast-iron, secured to the coulter by a peg, may next be mentioned. It is claimed that they do away with the necessity for removing the coulters, as they are easily renewed; they are made of different shapes, to spread the seed more or less as required.

In order to take up the coulters, multiplying wheels are used, by means of which the levers of the largest drills may be lifted up with ease. An important addition is made to the ordinary fore-steering, by which the guide-man obtains a greatly-increased leverage on rough and strong soils. A chain is fastened to the steering at either end, having the other end wound round a sheaf-pulley. On the shaft of this pulley is fixed a handle, by which the man steers, and by this arrangement it is calculated that six times as much purchase is gained as by the ordinary front-handle plan.

In the horse-hoe, for which this firm obtained the second prize, is the same arrangement of levers, on two bars instead of one, as formerly; the greater leverage causes the hoes to penetrate hard ground more easily. There was certainly room for this improvement, as in the old horse-hoes the knives would only enter, and stand against strong weeds when the soil was already well pulverised. Saintry's springs, however, form the most efficient levers, and the hoes were steadier in their work than most of the other large hoes.

Hornsby and Sons, so well known as makers of drills, on this occasion did not rise to the first place in any of the classes except in the case of small-seed drills. The general-purpose drill may be noticed, although, as the Judges very properly remark, two distinct implements, to do the different operations are often preferable, and not more costly. These machines consist of so many parts that a careless man may not easily find them when wanted; there is also a saving of horse-draught by having two implements. In Hornsby's drill the coulter-bars are raised or lowered by screw and bridle at each end, whereby more or less pitch can be given them for light, strong, or hard land. The levers have cast-iron coulters with a separate chilled point, which can be easily replaced. The coulters, &c., are raised by means of a worm and wheel, which fix themselves in any position, rendering it easier for the man to take up the drill than before. By one lever both manure-box and coulters are thrown in or out of work at the same moment. There are two jacks for raising the box to change the speed-wheels, and an indicator showing the exact position at which the

wheels should be set; which last forms a valuable feature for many situations. The manure-barrel delivers evenly, keeps clean, and will of course sow a large or small quantity; and lastly, the levers have improved joints to fasten them to the drill, and one set screw releases them for change of position or taking off, in place of a set screw and bolt, as hitherto in use.

James Coultas, jun., first came into notice at the Leeds meeting as exhibiting a good drill, which has been since much improved. He is mentioned several times, and stands first for a very useful drill for hill-side delivery, which without any alteration, is equally suitable for the flat. The seed-box is so cushioned that its contents cannot escape, and the receiver, taking the seed from the cup, is provided with a wing to catch any corns which might otherwise fall through. The manure-delivery pipes are of copper to prevent corrosion, and the toothed wheels are protected by shields, as are also the outer coulters. The manure is kept moving by a sliding stirrer in the narrowest part of the box, where it would otherwise be likely to choke. The wheels run on patent hooded arms. The fore steerage is very simple, and all the motions run in brasses.

Robert and John Reeves maintain their reputation for Liquid Drills and Distributors, taking the two first prizes for water-drills, on T. Chandler's system, improved by being fitted with a patent cylinder, in which the cups are not merely attached to the cylinders, but made a part of them, and are thus not broken off when passing the bottom, as formerly was sometimes the case. The first machine can be used as a simple liquid-distributor, and in this form received the only prize awarded for that class.

The competition in Horse-hoes was considerable, and in the single-row class, large. Messrs. Carson and Toone keep up the position they gained at Leeds with the implement, which can be used without alteration both as a hoe and grubber. This hoe is steady in its work, and will not easily clog. At the same time the arrangement of broad cutting-knives and tines with merely points, ensures everything being cut, and the surface thoroughly disturbed. The three knives can be replaced with grubbing-tines, that may be worked to stir the soil between the rows of roots late in the season, and often with great effect.

The two Hay-making Machines exhibited by Messrs. Howards made superior work, and are strong, clever implements. The relative position of the fork barrels to themselves and the wheels remains the same in whichever direction the teeth revolve. The alteration of the gear for the forward and backward action is effected by a simple eccentric movement, similar to the back action in Whitworth's lathe, the screw-key being used as a

lever. This backward action requires that the teeth should be some $1\frac{1}{2}$ inch nearer the ground; and this is effected by the back eccentric movement, which at once drops the fork barrels to the increased distance required. The axle in these machines is a solid bar of steel, which is found to be strong, and not liable to bend. In the 1st Prize Machine the gearing can be cleaned without removing the wheels; two split pins being taken out, each fork barrel can be made to slide forward. The form of the tines is good. The forward action effects a complete separation of the grass, and the back action leaves the crop light and loose. We believe the merits of these two machines were pretty equal. The Judges approved of the smaller and cheaper one as more generally useful.

Boby's Machine, to which the 3rd Prize was awarded, is a very useful implement, strong in make, of simple construction, and at a reasonable price. No experiments were made as to the comparative draught of these machines.

The entry of Horse-rakes was large; but Messrs. Howards' were so manifestly superior, that the decision as to the 1st Prize was a very simple business. This rake has been considerably improved since Leeds. The central axle of solid steel, which carries the wheels, and affords attachment to the shafts, also acts as a fulcrum, on which the teeth, when raised, are balanced: in fact the front part becomes a counterbalance as soon as the act of raising commences, the pointed ends of the teeth become perpendicular, and thus empty easier and more rapidly than if the fulcrum were not changed. By a simple arrangement of the patent leverage, the teeth when in work are raised above the central axle, and can thus adapt themselves to irregularities of surface; at the same time the front part of the rake, on which the teeth are suspended, is held in position by a self-acting movement of the lever. This is an ingenious and novel arrangement. The teeth are curved, or sickle-formed, made of steel and tapered, and combine strength and lightness. The second prize goes to the same locality, being awarded to Messrs. Page, for a strong, useful rake. The leverage is easy. The teeth are of oval steel, and very strong.

Several implements were exhibited with a seat for the driver; but as the draught appeared to be sensibly increased, and the man cannot empty a heavy crop nearly so well, it does not appear that this arrangement is satisfactory.

The Judges' Report on Mowing and Reaping Machines.

We commenced our duties on Wednesday, July 12th, by selecting from the different stands in the Show-yard such machines as the exhibitors had entered

for competition, allowing them to send everything they wished, provided only that two machines of precisely similar construction were not exhibited by the same firm. Much valuable time was consumed in looking over some 200 stands, and it was quite the afternoon before we reached the trial grounds. We beg to suggest, for the consideration of the Council, that in future this part of the programme be altered, and that all implements entered for competition be taken from the yard to the trial grounds, and collected in classes the day before the Judges commence work, so that they can at once examine the collection, select those qualified for trial, and arrange their work to the best advantage.

The importance of the class of implements upon which we were to pass sentence, and the growth of their manufacture since the Society's trials at Leeds, may be judged of from the fact that we had 35 reaping machines, 8 combined mowers and reapers, and 13 mowing machines sent to the field for competition; and, with a few exceptions, all were well-made, efficient implements, that can be recommended with confidence, varying considerably in details, and adapted for different conditions of crops, according to the peculiarities of the district for which each was specially intended. We wish particularly to state that our awards are not to be considered as condemning all the unsuccessful machines as useless; but that, under the circumstances of the trial, and, as far as we could judge generally of the implements as brought before us, we considered that the machines to which we awarded the prizes and commendations were on the whole the best.

Competition and experience have in many instances brought the merits of different implements very much on a par. Many a really good machine was unavoidably passed over because superseded in matters of detail, although such machine in its own district might be the best for the farmer to purchase, inasmuch as its fittings could be easily renewed, and serious delays in the case of accidents avoided.

Having selected and classified the implements, we took a survey of the ground; and a first glance convinced us that whilst the 15 acres of meadow, and the considerable area of clover, would afford a severe and satisfactory trial for the mowers, and combined machines working as mowers, the 20 acres of oats and rye on the hill side were insufficient for such a prolonged test of the reapers as this important class demanded. The Inspectors appointed by the Society have, doubtless, done their best, arable land being quite the exception in the county of Devonshire. The fields are also generally small and irregular.

The oats were very bulky, long, and much laid and twisted. It was at once evident that the cutting of such a crop would be a severe trial, and that the machine that could make respectable work here would do anywhere.

The reapers were divided into the following classes:—

	Value of Prizes.
	£.
1st. Machines with self side-delivery	40
2nd. Machines without self side-delivery (<i>i. e.</i> Manual's)	20
3rd. For combined reaping and grass mowing	20
4th. One-horse reapers	20

In order to make a selection of the better implements, it was determined to give the entries in each class a preliminary trial round two sides of the oats; and as the machines with manual delivery (1 and 2-horse) were the most we took them first.

Considering the very difficult nature of the cutting, and that many of the machines, having the platform on the left side of the pole, were obliged to cut

up the hill, which was wrong for the lay of the crop, the work was generally better than could have been expected. None attempted a full cut, for though the knife could have severed the straw, the attendant could not rake off the crop; even when, on the average, only from one-half to two-thirds of the full width was taken, the labour was fearfully severe; moreover, the corn was left in irregular quantities, and much scattered.

The inferiority of the manual reapers, as compared with those having self-delivery, was very apparent. The severe and incessant labour of the attendant; the fact that the corn was in many cases unavoidably thrown against the standing crop, thereby knocking down portions, the heads of which would be cut off at the next round of the machine; the necessity for at once tying up the crop, whatever its condition—all prove that these machines, though more largely employed than any others, on account of their low cost, are not, in their present condition, to be recommended.

The modifications introduced by Messrs. Hornsby, whereby the man's labour is greatly lightened by a self-acting delivery-platform, leaving the sheaf at the side and clear of the horses, showed to great advantage in this tangled crop, and was generally admired. The tipping platforms, which we believe to be new since Leeds, demand a passing notice. Some of these, as in Messrs. Samuelson's Eclipse Reaper, are fixed upon an axis near the centre of the platform, and are tipped by the man's foot raising the front; this leaves an opening, and in a heavy-laid crop, the straw forces itself between the knife-bar, and the under side of the platform when thus raised, and tends to clog the machine. In a light standing crop such tipping platforms materially assist the workman; but in such a case as that before us, they are better fixed at a moderate angle; therefore it is desirable that they should be made both to tip or remain fixed. The "slatted" platforms of Wood and of Hornsby, which are attached to the knife-bar frame, by a hinge, and are lifted by the man's foot when required, made better work; whilst Cuthbert, with a fixed platform and a revolving roller behind, made very good work; and he was personally commendable for the extraordinary skill with which he used the rake.

After the "Manual" machines had thus been drafted, the combined reapers and mowers went through a similar process. Eight of these competed; their work, with some exceptions, was unsatisfactory; and although they are decidedly improved since Leeds, especially when used as mowers (as hereafter will be shown), we are inclined to endorse and re-echo the doubt then expressed by the Judges, "whether the object sought for by this combination has as yet been economically obtained." We would not discourage farmers from purchasing the best of these machines, provided their work is principally mowing grass, for which they are excellently adapted; but when there is also a large acreage of corn to be cut, we believe it will answer better to have independent machines.

Ten self side-delivering machines put in an appearance. Mr. Hellard was the only thoroughly unsuccessful performer; he exhibited a two and a three-horse machine, similar in principle, combining a reel and fans, which knocked out the corn, a fixed platform and a large revolving roller, intended to assist the corn from the knife on to a travelling web, but which, in reality, formed a complete obstacle, and caused the machine to block up, and roll down the corn. We trust this exhibitor will turn his attention to the simplifying of his apparatus.

The preliminary trials being concluded, the remainder of the oats and the rye were divided into 30 lots, of about half an acre each, and the final trials were made. Eight machines were tried in:—

CLASS I.

Machines with Self Side-Delivery.

Name of Exhibitor.	Description.	Number in Catalogue.	Price of Machine.
			£.
Samuelson and Co. ..	Sheaf-delivery (new implement)..	1	30
Samuelson and Co. ..	Very similar to above, but stronger	2	35
Hornsby and Sons ..	Swathe-delivery	1901	34
Beverley Iron Works ..	3-horse swathe-delivery	315	42
Beverley Iron Works ..	2-horse swathe-delivery	316	37
W. A. Wood	Sheaf-delivery	44	28
Burgess and Key	McCormack's Automaton, sheaf-delivery	2020	34
Burgess and Key	McCormack's Automaton, sheaf-delivery, improved by exhibitors	2021	34

Our award is given below, together with the tables prepared by Mr. Amos, (See Tables A and B), showing the comparative draught of three of the machines; and we proceed to give a short description of each in their order of merit.

No. 1901, *R. Hornsby and Sons*.—May be described as a Swathe self-acting side-delivery Reaper, with a revolving reel adjustable up or down, backwards or forwards to suit the nature of the crop. The delivery is effected by three endless chains, set with steel forks, travelling on a slanting platform, at the end of which are pulleys placed in a diagonal position. The swathe was fairly laid clear of the horses' track, the heads generally all one way. The height of the cut is adjusted by means of a toothed quadrant; the driving-crank pin being globular can act freely although the knife-bar may be altered in position; the pinton of the first motion can be thrown out of gear, so that when travelling no gearing whatever is at work. The draft of this machine was considerable; the work both in the oats and rye was excellent.

The comparative advantage of a swathe or sheaf delivery is a question that will greatly depend upon the condition of the crop—tying is easier from a well laid sheaf—but where, as in the case of oats, or barley with seeds, the crop requires to lie for some time, the swathe, as delivered by this machine, certainly leaves the grain in a preferable condition for drying, and less likely to be injured by rain than when in sheaf.

Samuelson's and Co. No. 1 Self-Raking Reaper, is somewhat lighter in draft than the old reaper No. 2, and made capital work, laying a regular sheaf. In cases where the oats lay away from the machine or were much twisted, the heads, falling over the upper part of the rake-fan, were occasionally carried upwards as the rake was elevated by the cam; but considering the condition of the crop, the work was well done; the rakes travel at a moderate speed, and collect and deliver the corn from the platform without violence. The draft is moderate, and the construction simple and good. We preferred this machine to No. 2, as making rather better work, and costing 5*l.* less. The chief novelty in these machines consist in the mode of delivering the cut grain, which is effected by means of 2 rakes pivoted to a vertical shaft, having a slow rotary motion imparted to it by suitable gearing, the platform has the shape of a quadrant; its radius being the length of the cutting bar, and its centre the same point as that of the vertical shaft on which the rakes are hung. The modus operandi is as follows:—As the reaper advances the revolving rakes dip alternately into the standing crop and first incline the grain towards the cutters, then sweep it round the quadrant-

shaped platform, and leave the sheaf lying on the ground removed some 5 feet from the standing grain. These rakes are timed in such a way as to make a sheaf for every 11 feet 6 inches advance of machine; but this speed, and consequently the size of sheaf, can be altered. To assist the operation of laying the grain towards the cutters, and also, perhaps, to add steadiness to the revolution, two reel arms are also pivoted to the vertical shaft at right angles to the rakes. These revolve with the rakes, but are set some 12 inches above the platform, so as not to remove the sheaf from it, but merely lay the grain towards the knife. In very heavy crops these reel arms may be replaced by rakes, when a sheaf will be thrown out at every 5 feet 9 inches advance of the machine, in which case they will lie almost touching, and thus secure to a certain extent whatever advantages may be claimed for swathe-delivery; while in very light crops one rake only may be used, and the sheaves will then be 23 feet apart, centre to centre. The knife works on the "double throw" principle, that is to say, it runs through two fingers instead of one at each revolution of the crank. The object being simply to halve the speed of the shafts, and so decrease wear and tear in the bearings. The smooth rotary motion of the delivery apparatus and the manner in which rakes and reel arms enter into the corn is commendable.

Nos. 315 and 316, *The Machines exhibited by the Beverley Iron Works*, are upon the same principle, though considerably improved, as Crosskill's Leeds Prize Reaper. The horses work behind, and the machines charge into the crop, laying the swathe right or left. These machines are much liked in their own district. The platform is fixed at a lower angle than formerly, and there are alterations in the reel and driving gear. We preferred the 2-horse machine as more manageable, considering that an 8-foot cut leaves too large a swathe. The stubble was not cut close or evenly, and the front travelling wheel which supports the platform clogged occasionally. We noticed that the reel knocked out some of the oats. These machines were not tried with the dynamometer, but the draft was evidently considerable, and the work, though on the whole well done, was inferior to that of Hornsby's machine.

Messrs. Burgess and Key exhibited Nos. 2020 and 2021, the former being the original M'Cormack's Automaton Reaper, first introduced into this country in 1862. We will confine our remarks to 2021, as it was an improvement on 2020, the weight and size being reduced, and the machine being made more manageable, so as to work easily with 2 horses. The size of the sheaves can be regulated by change wheels. This machine cut well, but delivered badly, the rake sweeping off the corn with a jerk, owing to its too great velocity; it was noticeable that a sensible check was given to the machine each time the rake came on to the platform; where the corn was laid badly, portions of the sheaf were elevated by the rake. There is considerable merit in this reaper, and we hope to see it improved in those points to which we have alluded—it certainly appears to us a better machine than 2020.

No. 44, *W. A. Wood's Reaper*, though an ingenious piece of mechanism, did not work satisfactorily. This is a sheaf-laying machine, working somewhat in the same way as the Automaton Reaper. It is furnished with a revolving rake and reel acting independently of each other. The former in its revolution comes unpleasantly near the driver, and serious accidents are to be apprehended. The driver can control the rake, and thus regulate the size of the sheaves, a matter of considerable importance in a variable crop. The draught of this machine is moderate and the price reasonable.

Our award in this class was as follows:—

	£.	s.	d.	
To Messrs. Hornsby and Sons, No. 1901	Prize of	25	0	0
To Samuelson and Co., No. 1	Ditto	15	0	0
		<hr/>		
		40	0	0

TABLE A.—SELF SIEVE-DELIVERY.

(The width of cut named here is 3 inches less than the actual width.)

Exhibitor's Name.	Number of Stand. Article.	Number of Article.	Width of Cut.	Length of Cut in Feet.	Quantity cut in Square Feet.	Time of Cutting.	Draught in lbs.	Speed of Horses.		Units of Power expended to do the Work.	Units of Power to cut one Square Foot.	Quantity the Machine would cut in Acres per Hour.	Horse-power.	Price of Machine.
								In Feet per Minute.	In Miles per Hour.					
R. Hornsby and Sons ..	120	1901	4 9	855	4061	4 10	215	205	2.33	184,281	45.4	1.34	1.34	34
Samuelson and Co. ..	1	1	4 9	993	4716	3 55	149	253	2.87	147,884	31.3	1.66	1.14	30
Burgess and Key ..	124	2021	4 5	825	3644	3 26	211	240	2.72	174,272	47.8	1.46	1.54	34

TABLE B.—TWO-HORSE REAPERS.

(The width of cut named here is 3 inches less than the actual width.)

Exhibitor's Name.	Number of Stand. Article.	Number of Article.	Width of Cut.	Length of Cut in Feet.	Quantity cut in Square Feet.	Time of Cutting.	Draught in lbs.	Speed of Horses.		Units of Power expended to do the Work.	Units of Power to cut one Square Foot.	Quantity the Machine would cut in Acres per Hour.	Horse-power.	Price of Machine.
								In Feet per Minute.	In Miles per Hour.					
R. Hornsby and Sons ..	120	1903	4 9	831	3948	4 8	214	201	2.29	177,911	45.07	1.31	1.3	23
R. Hornsby and Sons ..	120	1904	4 9	843	4005	4 2	157	209	2.37	132,655	33.1	1.37	.997	18
J. L. Bowhay ..	19	260	5 0	846	4230	3 46	157	225	2.56	133,182	31.5	1.55	1.07	24

CLASS II.

Machines without Self Side-Delivery.

Seven machines were selected for this trial, viz:—

Name of Exhibitor.	Number in Catalogue.	Price.
		£. s.
Bowhay	260	24 0
Cuthbert's	377	24 0
W. Brenton	608	23 0
Dicker	852	22 0
Picksley, Sims and Co.	1662	22 10
Hornsby and Sons' semi-manual	1903	23 0
Hornsby and Sons' manual machine	1904	18 0

Messrs. Hornsby's, No. 1903, described as a semi-manual side-sheaf delivery reaper, is the great novelty of the class ; first exhibited at the Hereford meeting of the Bath and West of England Society in June, and considerably altered and improved since, it made capital work, and proved its superiority over all "Manual" Reapers, and its capacity for dealing with every variety of crop. Reference to Table B will show that these advantages are gained at the cost of considerable draft, but the saving of labour to the man, the increased opportunities given him for collecting the corn, the delivery of an even sheaf, clear of the horses' track, are all points of great importance.

In districts where the crops are as a rule heavy and laid, manual machines are difficult to work, and self-acting machines, as hitherto constructed, cannot be adapted to the variations of the crop ; this combination of Hornsby's meets the difficulty. We believe that the makers will be able to effect considerable improvements, and possibly so construct a machine that it will deliver either a swathe or sheaf as required. We can only say that, in the trials of Plymouth, this machine distanced all competitors, and was very much admired by the public. It may best be described as a combination of the grated drop-sheaf delivery platform, with the steel-forked endless chains already described. The workman, pressing a treadle, raises the grated platform to receive the corn ; when sufficient is cut he allows the platform to drop, the endless-chains travelling in an oblique direction enter between the slats of the platform and carry off the sheaf to the side whilst the man is collecting a fresh portion of the crop. The raker can regulate the size of the sheaves, and does his work with comparative ease. The gearing and cutting parts are precisely similar to No. 1901 already described. Possibly the endless-chains jerk the corn along rather more than is absolutely necessary—all such matters of detail will be improved upon.

Messrs. Hornsby's, No. 1904, is a purely manual reaper, furnished with the open-slatted tipping platform working with a hinge. The dividing-board is broad, and projects backwards over the platform. By this arrangement the corn is collected more easily and left well clear of the standing corn, a point of considerable importance. The advantage of the open-slatted platform consists in its lightness, and the fact that the stubble catches the sheaf, and thus assists in the delivery, so that the man can quickly raise the grating to receive the next sheaf. The corn is also delivered without a jerk. The draft of this machine was considerable.

Messrs. Picksley and Sims, No. 1662, is a light well-made machine, with a "pendulum" sling to lessen the friction of the connecting-rod, a main driving-wheel of large dimensions, and a balance-platform, the backward half of which tips from the weight of the sheaf, and regains its position by a counterpoise.

In the heavy oats this did not act well, the weight being vertical, and therefore possessing little power at the point when the platform having tipped requires to be brought back.

In a light crop we have no doubt this well-made machine would prove very successful. We can only repeat here that in such heavy crops tipping platforms are impracticable.

Cuthbert's, No. 377, appears to be a strong and simple machine, an improved form of the old Hussey reaper, with a rigid platform fixed at a low angle, at the back of which is placed a small roller, intended to assist the raker in pushing off the sheaf. The friction of the knife-bar is reduced by a long pendulum sling. The sheaves were well laid.

Although, as above stated, we consider that tipping platforms are useless in a heavy crop, nevertheless, we are of opinion that a provision should be made for tipping, as in all moderate crops such an arrangement is a great improvement.

W. Brenton's, No. 608, was another improvement on Hussey's invention. The peculiarity in this machine consists in a revolving roller, 8 inches in diameter, which is put in motion by a foot-lever raising one end and pressing together two smooth wooden riggers. This roller is intended to help the corn from the knife on to a fixed platform. In the laid crops of oats it was of little use, and appeared to be placed too high.

Bowhay, No. 260, with 5 ft. 6 in. knife, has the platform in two parts; the front part is raised by the foot, the hind portion by a lever worked off the front; the arrangement is ingenious. The knives are peculiar, and remind us of the old Bell's machine, having no finger-points. The lower knife-bar being fixed, the upper one oscillating over it and kept down close to the fixed bar by screws. The cutting was well done.

Lastly, *Dicker's Reaper*, No. 852, with a spring platform, made fair work, cutting and delivering well. Here, again, the knife-bar works by a pendulum instead of a slide-bar.

Our award in this Class was as follows:—

			£.	s.	d.	
To Messrs. Hornsby and Sons, No. 1903	Prize of	10	0	0
To Messrs. Hornsby and Sons, No. 1904	Ditto	5	0	0
To Messrs. Pickley, Sims and Co., No. 1662	Ditto	5	0	0
				<hr/>		
Highly Commended, Cuthbert, No. 376.				20	0	0

CLASS III.

Combined Reaping and Mowing Machines.

The trial of combined machines appears next on the list; but, as we shall have to speak more fully of this class as mowers, it will only be necessary here to briefly note their performances as reapers. Out of the eight machines entered, the Judges selected only five as worthy of a second trial, viz., Messrs. Hornsby's, Wood's, Kearsley's, Bamlett's, and Barber's; Burgess and Key's machine, though it mowed very creditably, was so defective as a reaper in the preliminary trial that it did not again appear, and Messrs. Samuelson's machine did not distinguish itself in either capacity. Both Hornsby and Wood made good work; the latter with much the smallest draft.

Bamlett's, No. 688, is a strong well-made machine very steady in its work, cutting well, and leaving a good sheaf. The driver can, as in the mower, instantly regulate the cutting height of the knife, raising either end independently of the other—a very useful arrangement for ridge-and-furrow land; this alteration can be made without stopping the machine. The height of the tilting platform can be adjusted for either laid or standing corn, or set so level that the sheaf can be delivered without tilting, and the risk of choking from

the corn getting in between the platform and knife thus avoided. The gearing is shielded to prevent dirt falling in; the position of the draft-pole is readily altered for mowing or reaping, and the machine is generally well made.

In *Messrs. Hornsby's*, No. 1905, the alterations for reaping consist in the insertion of a slow-speed pinion, a seat more convenient for the raker, a fresh dividing-board, very similar to that used in their manual reapers, and the drop-sheaf grated platform already described. The cutting-bar can be projected 6 inches, so as to give room for the horses to walk clear, and yet allow the knife a full cut; and thus we see that in all respects it is a very excellent combination capable of making good work of either kind.

Wood's Machine, No. 45, is worked with one horse in shafts; but we think that, for practical purposes, a pole and pair of horses would be preferable. The machine is light and well made, and though, as a reaper, it made inferior work as compared with the manual machines of this firm, yet, as a combination, we consider it very creditable.

Barber's, No. 692. This machine, which may be considered as an assisted "manual," was provided with a reel with the object of assisting in bringing the corn to the knife, thus lightening the labour of the workman and enabling him to devote more of his attention to the delivery of the sheaf from the platform. The reel was not very successful in the laid corn, but no doubt was of some use, and the machine made fair work.

CLASS IV.

One-Horse Reapers.

A large entry, including several machines that were evidently much too large and heavy for one horse. We think that some reduction as to the length of the knife bar might be introduced for this class. In awarding the prizes we selected those machines that did good work, and were really of light draft. It will be seen that we passed over *Messrs. Hornsby's*, 1906, which is similar in construction to 1903, and made excellent work, simply on the ground that it was not a suitable machine for one horse. Nine machines competed, *Messrs. Hornsby* (2), *Wood*, *Samuelson*, *Cuthbert*, *Picksley* and *Sims*, *R. Page*, *J. Wright*, and *Bamlett*. (See Table C).

Wood's, No. 46.—Properly came under the head of a one-horse Reaper, being a very light machine of easy draft, which cut and laid the sheaf well. The open-slatted platform is very similar to that employed by *Messrs. Hornsby*, only rather lighter, and the working parts are remarkably well proportioned and well put together.

Samuelson's, No. 7 Eclipse Reaper, with a tilting platform, is a simple and efficient machine, principally noticeable for the peculiar adaptation of the "double throw" principle. In this machine advantage is taken of the slow-speeded crank-shaft to raise the motion with one pair of wheels only, viz., the driving wheel and a pinion. By this arrangement the framework, which is wholly iron, is greatly reduced and simplified. The cut in this reaper is 5 feet wide and the grain is caught on and delivered from the tipping or tilting platform; the weight is under 6 cwt. We regret that time did not allow of our testing this machine with the dynamometer, as the simplicity of its gearing and its easy motion lead us to anticipate light draft and little friction.

Messrs. Hornsby's, No. 1907, to which we awarded the 3rd prize is very similar to *Wood's* machine as to the tipping platform, but requires more power to do the same work; it is on exactly the same principle as 1904, only smaller.

R. Page's, No. 1058, made good work, but consumed too much power.

R. Cuthbert's, No. 376, a heavy machine, too much for one horse, made very creditable work. The sheaf being left very even.

Bamlett's, No. 690, a strong useful machine, too heavy for one horse, made fair work.

TABLE C.—ONE-HORSE REAPERS.

(The width of cut named here, is 3 inches less than the actual width.)

Exhibitor's Name.	Number of Stand.	Number of Article.	Width of Cut.	Length of Cut in Feet.	Quantity cut in Square Feet.	Time of Cutting.	Draught in lbs.	Speed of Horses.		Units of Power expended for do the Work.	Units of Power to cut one Square Foot.	Quantity the Machine would cut in Acres per Hour.	Horse-power.	Price of Machine.
								In Feet per Minute.	In Miles per Hour.					
R. Hornsby and Sons	120	1907	ft. 4 9	870	4132	min. sec. 4 3	144	215	2.44	125,976	30.3	1.26	.938	£. s. 16 16
R. Cuthbert and Co.	25	376	4 9	1014	4817	3 46	134	269	3.06	135,864	28.2	1.74	1.09	22 0
W. A. Wood	5	46	4 3	990	4208	3 49	88	259	2.94	86,633	20.6	1.52	.687	*18 0

* With extras.

Our award in this Class was as follows:—

	Prize of	£.	s.	d.
To Messrs. W. A. Wood, No. 46	8	0	0	
To Messrs. Samuelson and Co., No. 7	7	0	0	
To Messrs. Hornsby and Sons, No. 1907	5	0	0	
	20	0	0	

Highly commended: Cuthbert, No. 376.

Mowing Machines.

The trials in this class were divided into those for simple mowers and those for combined machines, as mowers. The crop was of a character calculated to prove the efficiency of different implements under difficulties, being heavy, with an uneven bottom, and a quantity of dead bottom grass. The ground had not been mown for some years, and no care had been exercised to prepare the surface by rolling, &c. Lots were drawn, and the ground marked out into strips; as the heaviest and worst cutting portions fell to the lowest numbers, the selected machines were afterwards worked on the same ground, so that a fair comparison could be made. The plan adopted was for each machine to cut twice round its plot, and then to be tested once round by the dynamometer. Thirteen machines competed as mowers. (See Tables D and E).

A. C. Bamlett of Thirsk, No. 681, a strong useful mower, furnished with a large front travelling wheel which appeared to give steadiness to the frame, and enabled the machine to be backed readily. The cutting was very even though hardly low enough, and the points occasionally clogged. Knife cuts 4 ft.

Burgess and Key, No. 2016, a new implement, which contains several improvements, the most noticeable being that the connecting rod is nearly in a line with the knife; this arrangement is rendered possible by having all the gear work, the crank shaft, and the connecting-rod packed up in a small compass, and placed very near the ground, so as to traverse the narrow track cleared by the track-board during the preceding bout. Generally speaking it is necessary in order to prevent clogging to place the crank shaft considerably higher than the knife, and the angular thrust of the connecting rod is attended with some friction. The knife bar is flexible, the machine is very light, and, as will be seen, the draft moderate. The work was defective for two reasons, the finger points were too short and thick, so that the dead grass continually caught on these points and blocked the knife, and the whole machine appeared deficient in rigidity. The knife rose and jumped in its work and left an uneven bottom. We commend this machine for its ingenuity, and moderate price, but we much fear that in heavy difficult crops it is too light to do well. We may notice that the low position of the crank shaft, &c., did not once cause the machine to clog, and that this arrangement may be regarded as good.

Samuelson's, No. 3, a new implement, was not successful. As with the last, the dead grass continually choked the knife. It is a well-made machine, somewhat novel in arrangement and construction. The frame is of iron, so arranged that the bearings carrying each of the shafts form a part of the frame, and are not bolted on in the usual manner. By this means the shaking loose of bolts and nuts is avoided; but, on the other hand, there is an increased risk that, through the breakage of some insignificant part, a large portion of the machine may be damaged. The cutting-bar is hinged for cutting on side-ling ground, and attached to the frame in front of the driving-wheels. The apparatus for lifting the cutting-bar is simple and ingenious, consisting of a lever, standing up in front of the driver's foot, to be pressed if necessary. Similarly the machine is put in and out of gear by a movement of the foot, and the mower is thus under perfect control, whilst the attention of the driver is not taken from his horses. A strong spring fixed to the pole eases the

cutter-bar when passing over inequalities of surface. The cut is 4 feet wide, and the draft, as tested by the dynamometer, extremely light for two horses. The grass was not cut very low or even, and it appeared to us that the machine was not heavy enough to stand to its work, though in a moderate crop it would, doubtless, have made good cutting. The finger-points were rather short.

Barber's Machine, No. 691, also claims to be a novelty. The finger-bar is flexible, and can be raised at either end, independently of the other, or the whole knife can be raised to pass over cut grass, or again can be brought into an upright position for travelling. The track-board separates the cut from the standing grass, and leaves the former light. It cut fairly, but clogged repeatedly. Price 22l.

J. and W. Dicker, No. 853. The working parts of the machine are too near to the ground, and clogged when going over the cut grass. The draft also was very considerable. Price 32l.

"*Child's American Clipper Machine*," No. 945. By means of a lever connected with the inside shoe, the workman can change the direction of the fingers and knives from a level cut to one at an angle of 30°. This is very ingenious. The work was, however, inferior, the bottom left uneven and high.

Samuelson's, No. 5, made better work than No. 3. The cutter-bar is placed behind the driving-wheel, but, as will be seen by the Table, the draft was great.

H. Kearsley exhibited a strong, well-made machine, No. 458, which made good work, cutting evenly and tolerably low. We were much pleased with the steady motion of this mower.

Picksley and Sims, with No. 1660, cut badly at first, but improved the second round, and left off creditably.

Bumlett, No. 682. This, his second machine, is very similar to No. 681, only the framework is of iron, and the fore-wheel is dispensed with, and the machine is somewhat lighter. An accident occurred to this machine, which, though repaired, may probably have affected the work, which was hardly equal to his first trial.

W. A. Wood, No. 41. A well-made machine; light, both as to weight and draught. This maker adheres to the wooden frame, believing that it renders the machine more elastic than those made entirely of iron. The knife-bar is attached to the frame by a joint, it is supported and carried by a strong spring and a slotted brace running backwards and clasping the main axle of the machine. The freedom which this arrangement allows to the cutter-bar enables it to adapt itself to inequalities of ground. The knife can be raised by a double-lever action, so as to clear mown-grass, or can be set upright for travelling, and kept in that position without supplementary attachment. Outside the shoe is a small graduating wheel, which regulates the distance of the knife-bar from the ground. We commend this wheel, as it tends to reduce friction. By reference to the subjoined Tables it will be seen that this machine cut with a very moderate expenditure of power—a fact due, we believe, in great measure, to the attention bestowed upon the proportions of the various parts of the machine.

W. A. Wood's, No. 42, is the old machine that gained the prize at Leeds, and differs from the last by having the knife-bar rigid, and by the absence of the graduating wheel. It appears to be a strong, useful machine, but did not cut so close or even as No. 41, and consumed more power. The finger-points in both machines are long, tapering, and sharp at the points.

Burgess and Key's old machine, No. 2015, with rigid knife-bar, that must be removed when travelling. Here we had weight and steadiness, and, consequently, very good work was accomplished. The ground was not cut quite so close as by one or two others, but the work was very even and creditable.

TABLE D.—MOWING MACHINES (1st day).
(Three inches deducted from width of each Cut).

Exhibitor's Name.	Number of Article.	Width of Cut.	Length of Cut in Feet.	Quantity cut in Square Feet.	Time of Cutting.	Draught in lbs.	Speed of Horses.		Units of Power expended to do the Work.	Units of Power to cut one Square Foot.	Quantity the Machine would cut in Acres per Hour.	Horse-power.	Price of Machine.
							In Feet per Minute.	In Miles per Hour.					
Bamlett, A. C.	681	ft. 4 3	627	2665	min. sec. 2 13	314	283	3·21	196,828	73·8	1·65	2·7	\$ 26 0
Burgess and Key	2016	4 0	1104	4416	3 49	263·4	289	3·28	290,835	65·8	1·59	2·31	20 0
Samuelson and Co.	3	3 9	1224	4590	5 9	155·5	238	2·7	190,314	41·4	1·23	1·12	20 0
Dicker, J. and W.	853	4 3	522	2218	1 46	511	295	3·35	266,747	120·2	1·73	4·57	32 0
Childes, B. A.	945	3 9	1143	4286	3 48	308·1	300	3·41	353,715	82·5	1·55	2·82	22 10
Samuelson and Co.	5	3 9	1038	3892	3 19	308	313	3·56	319,474	82·1	1·61	2·92	21 10
Picksley, Sims, and Co.	1660	4 0	927	3708	3 5	335	300	3·41	310,566	83·7	1·65	3·05	*22 0
Wood, W. A.	41	4 0	1125	4500	3 21	267·4	336	3·8	300,872	66·8	1·85	2·72	22 0
Hornsby, R., and Sons	1900	4 3	969	4118	3 8	432·8	309	3·5	419,372	101·8	1·81	4·06	22 0
Kearsley, H.	458	4 3	1083	4603	3 19	337	326	3·7	364,826	79·2	1·91	3·33	22 10
Barber, D. H.	691	3 10	1023	3921	3 18	355	310	3·52	363,341	92·7	1·63	3·34	22 0
Burgess and Key	2015	4 3	1068	4539	3 13	339·5	332	3·77	362,575	79·8	1·94	3·42	25 0

* With an extra knife, 23l. 10s.

In the above we have as the results of the careful trials with the dynamometer, carried out by Mr. Amos, a variety of facts interesting to the public and we hope useful to the makers themselves. Difference in the closeness of cutting would of course influence the draft, but when we see that the units of power required to cut a square foot varies from 41·4 in the case of Samuelson's No. 3 machine, to 82·1 in his No. 5, and went up to 120·2 in the case of Dicker, it is evident that there must be defects in mechanical proportions in the arrangement of some of the machines to which makers should direct their attention. Messrs. Hornsby and Sons are rewarded with a Second Prize in spite of their too heavy draught, in consequence of the excellent work they made and the strength and probable durability of their machines. It is apparent

that if we find two mowers making equally good work, both well made efficient machines, we ought to give the preference to that which takes the least draught, and when this difference is so considerable as in the case of Wood and Hornsby (86·8 units to 101·8), there could be no doubt.

We beg particularly to direct the reader's attention to the tenth column in the Tables, as that shows the comparative power required to cut a square foot independent of the length of the knife-bar. An unit of power represents the force required to lift 1 lb. 1 foot high. It may be mentioned, in explanation that the actual width was assumed to be the length of the knife less 3 inches, as on an average machines cannot cut closer than that.

TABLE E.—MOWING MACHINES: SECOND TRIAL (in Clover).

Exhibitor's Name.	Number of Article.	Width of Cut.	Length of Cut in Feet.	Quantity cut in Square Feet.	Time in Cutting.		Draught in lbs.	Speed of Horses.		Units of Power expended to do the Work.	Units of Power to cut one Square Foot.	Quantity the Machine would cut in Acres per Hour.	Horse-power.	Price of Machine.
					min.	sec.		In Feet per Minute.	In Miles per Hour.					
Kearsley, H.	458	4 3	438	1861	1 50	215.2	238.9	2.71	94,247	50.64	1.4	1.56	22 10	
Wood, W. A.	41	4 0	441	1764	1 31	200	290.8	3.30	88,165	49.9	1.6	1.76	22 0	
Burgess and Key	2015	4 3	456	1938	1 23	260.2	294	3.34	118,671	61.2	1.72	2.32	25 0	
Hornsby, R., and Sons	1900	4 3	462	1963	1 26	313.35	322.4	3.66	144,771	73.75	1.88	3.06	22 0	

TABLE F.—MOWING AND REAPING MACHINES (COMBINED). Working as Mowers.
(Three inches deducted from width of each Cut.)

Exhibitor's Name.	Number of Article.	Width of Cut.	Length of Cut in Feet.	Quantity cut in Square Feet.	Time in Cutting.		Draught in lbs.	Speed of Horses.		Units of Power expended to do the Work.	Units of Power to cut one Square Foot.	Quantity the Machine would cut in Acres per Hour.	Horse-power.	Price of Machine.
					min.	sec.		In Feet per Minute.	In Miles per Hour.					
Hornsby, R., and Sons	1905	4 3	495	2104	1 30	536.7	330	3.75	265,694	126	1.93	5.36	26 0	
Wood, W. A.	45	4 0	486	1944	1 36	267	304	3.45	130,021	66.9	1.67	2.46	25 0	
Burgess and Key	2023	4 3	492	2091	1 28	301	336	3.82	148,028	70.8	1.96	3.06	28 0	
Bamlett, A. C.	688	4 3	492	2091	1 42	351	290	3.29	172,547	82.5	1.7	3.07	32 0	
Barber, D. H.	692	4 3	510	2208	1 29	349	344	3.91	177,816	80.5	2.05	3.63	26 0	
Kearsley, H.	459	4 3	501	2129	1 37	274.6	310	3.52	137,588	64.6	1.81	2.58	26 10	
Samuelson and Co.	6	4 3	474	2014	1 29	333.6	319	3.62	158,133	78.5	1.87	3.23	26 0	

Hornsby, No. 1900, a strong, heavy machine, which made splendid work, cutting very low and even, and leaving the cut grass well separated from the standing crop. The peculiar features in *Hornsby's* machines consist in the finger-bar being connected to the main frame by a ball and socket, or universal joint, allowing the cutter-bar to be carried up and down by a front castor-wheel over the undulations of the land. The height of cut is also altered by the setting of this front castor-wheel. The dividing board is so arranged that it leaves a clear track 18 to 20 inches wide next the standing grass, along which the horses and the driving-wheels pass at the next round. It is also provided with a sledge block, to press the swathe gently down and prevent its being blown about; this is more useful in clover than in grass. The draught of this machine was very much greater than that of *Wood's* machine. It was not easy to determine the reason for this. No doubt the difference in weight would have some slight effect, but the various parts of the machine can hardly be properly adjusted to each other. We are inclined to consider that too much stress should not be laid upon the question of draught; slight differences in this respect may be overlooked provided we have an efficient machine; but when, as in our case, we found two machines cutting equally well, with such a great difference in draft, this necessarily influenced our decision. *Wood* carries his finger-bar partly off the ground by a small friction-wheel, whereas the whole weight of *Hornsby's* heavy bar presses on the ground.

As the Society's prize list specifies that the machines are to be "for natural and artificial grasses," it was determined to test in the clover the four machines that had distinguished themselves in the grass. This clover was old and much twisted. The results of this second trial appear in Table E. The cutting was considerably easier, and all the machines did creditably. The draft, however, stood much in the same proportion as before.

Our award was as follows:—

	£.	s.	d.
To Messrs. W. A. Wood, No. 41 Prize of	10	0	0
To Messrs. Hornsby and Sons, No. 1900 .. Ditto	8	0	0
To Messrs. H. Kearsley, No. 458 Ditto	7	0	0
	<hr/>		
	25	0	0

Highly commended: Burgess and Key, 2015.

Combined Mowers and Reapers tried as Mowers.

Eight machines competed in this class, and the trial was very successful; better work was made by some of these than by the mowers, which can only be explained by the fact that the combined implements are heavier, more rigid, and steadier in their work; and we are more and more convinced that strength of parts is of more importance than lightness. Lots were drawn as before; we remark as follows:—

Samuelson and Co.'s, No. 4, precisely similar in construction to the mower, No. 3. The work was not perfect, the grass was cut unevenly and left in ridges.

Bamlett, No. 687. Much the same as No. 681. Made good work; the grass cut off evenly; rather more left than was desirable.

Kearsley's, No. 459. Made good work, but grass not cut quite so close as it might have been.

W. A. Wood's, No. 45. Made excellent work, cutting very close and even, and leaving a well-cleared track, not so wide as *Hornsby*, but sufficient to allow the implement to work clear of the cut grass.

Barber's, No. 692. Made very creditable work. The finger-bar is flexible, and adapts itself to inequalities of surface. The alteration to a reaper is simple. As a mower this machine appeared to advantage.

Bamlett's second machine, No. 688, which corresponds closely with the grass mower, No. 682, made very good work.

In No. 2023, *Burgess and Key* exhibited a capital machine; the cutting was very clean; but the grass left nearly over the whole surface is perhaps not so well as if it were put together, and a clean track left.

Hornsby and Sons, No. 1905, again made capital work. Apart from draft, the only slight defect in this machine appeared to be that the shoe is rather too wide, and pushes down the grass, so that a sort of narrow ridge is left at the next bout. This was so slight that it was hardly noticeable, and in every other respect this machine made splendid work. In construction, it is precisely similar to their mower, No. 1900. We gave *Hornsby, Wood*, and the *Burgess and Key* a second trial, making the machines follow each other; the work of the two first was so good that it was difficult to decide between them which was the best; *Burgess and Key* cutting well, but not so perfectly true. We may say that the work of all the machines in this class as mowers was highly commendable. (See Table F.)

It is right to add a word of explanation. We gave *Messrs. Hornsby's* machine the first place, not because we approve of its heavy draft, but because as a combined machine, both as mower and reaper, it made the best work, and because it is strong and well-made, and likely to stand its work well; but we particularly wish to draw attention to the comparison of its draught with that of *Wood and Bamlett's*. Either *Hornsby's* machine is not properly proportioned, or the working parts must be bound, the mere weight of the machine can have but little to do with the draft, and our experiments with mowers showed us that drawn along out of work, with the knife going, the difference between *Hornsby and Wood* was very slight.

Our award was as follows:—

		£.	s.	d.
To <i>Messrs. Hornsby and Sons</i> , No. 1905	.. Prize of	8	0	0
To <i>Messrs. W. A. Wood</i> , No. 45	.. Ditto	7	0	0
To <i>Messrs. A. C. Bamlett</i> , No. 688	.. Ditto	5	0	0
		<hr/>		
		20	0	0

Highly commended: *H. Kearsley*, 459. Commended: *H. D. Barber*, 692.

We cannot conclude our Report without expressing our satisfaction at the progress which has been made towards perfecting mowers and reapers, a class of machines likely to prove of great advantage to the farmer, as labour becomes scarce.

We should have liked a more extended trial of the Reapers, as various points of interest might have been elicited; at the same time we had sufficient opportunity to enable us to satisfy ourselves as to the comparative merits of the different machines, and we cannot but feel that the severity of the trials will do good by exposing the mistake of employing too light a construction. We beg to offer our best thanks to the Stewards for their courtesy and prompt attention to all our requirements.

H. B. CALDWELL.
EDWD. WORTLEY.
GILSON MARTIN.
F. J. BRAMWELL.
JOHN COLEMAN.

Report on Carts and Waggon.

The competition in Carts and Waggon was very considerable, and their general construction was simple and good. There was little of novelty to notice. Several exhibitors from Devonshire, amongst whom we specially mention *T. Milford and Son*, *George Milford*, and *Frank P. Milford*, showed a class of carts and waggon well suited to the hilly country as regards size, position of the body, balance, &c.; and we regret that the Local Com-

mittee omitted to encourage these exhibitors by offering a prize, as their carts, though admirably suited for local purposes, are under great disadvantages when they compete against those designed for general use.

CLASS VIII. (Waggon) was divided into two divisions, viz., Pair-horse and other waggon. In the former, the Prize of 20*l.* was divided between the Beverley Iron and Waggon Company, W. Ball and Son, and Thomas Milford and Son, in the proportion of 10*l.*, 6*l.*, and 4*l.* The Beverley Waggon is extremely strong and light, turns in a short space, and is provided with a double break; a well-made, useful implement. That of Ball and Son is strong, well made; and the Devonshire Waggon had a strong plank side and a good break; George Milford was commended for a strong and cheap waggon in this class.

In the second division we awarded to Messrs. Hayes and Son the whole of the money, 10*l.*, for their light, well-made waggon, with a wide and roomy body, constructed with a strong foundation of English oak and elm-plank sides, and fitted with fixed sideboards. It has curved head and tail ladders for carrying loose hay and corn, easily removed when not required. The front wheels back under the body, and the waggon turns in the room it stands upon. The hind wheels are large, and the construction ensures lightness of draught. A powerful break can be applied to both hind wheels without stopping the horses. Price, complete, 30*l.* 10*s.*

The Yorkshire Prize Waggon, with loose side and end boards (318), exhibited by the Beverley Company, we highly commended, considering it a strong, well-made waggon, fitted with oak soles, red deal sides, and patent wheels. Price, complete, 34*l.* This waggon is fitted with drag-chain and shoe.

The competition in carts was very good. This Class consisted of four divisions, viz., 1, Single-horse Carts; 2, Two-horse Carts; 3, Harvest Carts; and 4, Market Carts on springs; 10*l.* being allotted to each.

Division 1 (Single-horse Carts) contained numerous entries. Messrs. Hayes were again in the front rank, receiving a prize of 4*l.* 10*s.* for No. 551; a good cart, constructed with strong oak frame and elm-plank sides. The harvest-raves are in three parts, and the sideboards loose. The tipping-lever is on a good principle, not liable to get out of order. The wheels are high, with patent iron stocks, and solid iron axle throughout. Price, 14*l.* We assigned a prize of 3*l.* to Messrs. Woods and Cocksedge for No. 415, a light cart, smaller than the last, but well made, and reasonable in price (10*l.* 10*s.*). Ball and Son came in for a third prize of 2*l.* 10*s.* for No. 924. Price 15*l.* A strong, well-built cart. The Beverley Company were highly commended for article 322.

Division 2 (Two-horse Carts). Of this kind of cart, which is suitable for hilly countries, but not so generally useful as the last, there were several exhibitors. Messrs. Hayes again took the first prize of 4*l.* 10*s.* for No. 552, of similar construction to 551, only larger and stronger. Price 15*l.* 15*s.* It has fixed sideboards, plated with iron, which we think an improvement, inasmuch as loose sideboards are seldom to be found when wanted, and are apt to warp and get out of form. This cart has head and tail ladders, in place of raves, strong wheels with 4½-inch tires, and iron axles throughout. A prize of 3*l.* was awarded to 2279, Messrs. Milford's entry, a strong, useful cart, well suited to a hilly country, having high wheels and a good tipping apparatus. Price, with harvest ladder, 16*l.* The Beverley Company exhibited a strong, durable cart (323). Price, complete, with harvest frame, 18*l.*—rather dearer than is desirable—to this we awarded the third prize of 2*l.* 10*s.* To Frank P. Milford, for No. 562—a strong, durable cart, we gave a high commendation. We also commended No. 578, exhibited by George Milford, as a good cart.

In CLASS III. (Harvest Carts) the Beverley Company maintained their reputation for producing a capital cart of this description, which enables the

farmer to carry loose grain as readily and economically as with a waggon, and is most useful on a farm. This cart (325) has a large, light, and low body. Price 16*l*. We awarded it a prize of 4*l*. 10*s*. The remainder of the money was divided between Hayes and Son, for No. 553; and A. and T. Fry, No. 187, in the proportion of 3*l*. to the former, and 2*l*. 10*s*. to the latter. Both are useful carts; that of Messrs. Hayes being the cheaper, and in some respects preferable.

CLASS IV. (Market Carts). We preferred Messrs. Pickering's cart (2150), although the more costly, as a strong, well-made, serviceable cart. This is the same cart that took the first prize at Leeds. Cost 21*l*.; prize, 6*l*. The Beverley Company came second, with No. 326; a remarkably cheap cart. 13*l*. And are highly commended for 328, very similar to the last, but larger.

A novelty was exhibited by Frank P. Milford, in a two-horse tipping-waggon (No. 957); the fore part being wound up by means of a screw. This was ingenious, and appeared to answer well; but for the general purposes of the farm it would be of doubtful advantage, though it might be of use in carting coals.

WAGGONS.

Number of Article.	Name of Exhibitor.	Description.	Prize.		
			£.	s.	d.
317	Beverley Iron and Waggon Company	Pair-horse Waggon ..	10	0	0
921	William Ball and Son	Ditto	6	0	0
2275	Thomas Milford and Son	Ditto	4	0	0
546	Hayes and Son	Other Waggons	10	0	0
318	Beverley Iron and Waggon Company	Ditto	Highly Commended.		
575	George Milford	Pair-horse Waggon ..	Commended.		
2276	Thomas Milford and Son ..	Other Waggons	Commended.		

CARTS.

551	Hayes and Son	Single-horse Cart	4	10	0
415	Woods and Cocksedge	Ditto	3	0	0
924	Ball and Son	Ditto	2	10	0
552	Hayes and Son	Two-horse Cart	4	10	0
2279	Thomas Milford and Son	Ditto	3	0	0
323	Beverley Iron and Waggon Company	Ditto	2	10	0
325	Ditto	Harvest Cart	4	10	0
553	Hayes and Son	Ditto	3	0	0
187	A. and T. Fry	Ditto	2	10	0
2150	Robert Puckering and Co. ..	Market Cart on springs	6	0	0
326	Beverley Iron and Waggon Company	Ditto	4	0	0
322	Ditto	Single-horse Carts	Highly Commended.		
962	Frank P. Milford	Two-horse Carts	Ditto.		
328	Beverley Iron and Waggon Company	Market Cart on springs	Ditto.		
2278	Thomas Milford and Son	Single-horse Cart	Commended.		
578	George Milford	Two-horse Cart	Ditto.		

There were several peculiarities in the arrangements of the leverage for tipping carts; some of these were acted upon by spring bolts, and were decidedly clever, but liable to get out of order. A plan for putting the tail-board out of the way under the cart by a spring catch was also clever, but open to the same objection, as being sure to get wrong in careless hands.

In all agricultural implements, and especially in a class so liable as this to rough work and careless handling, simplicity of construction, strength of parts, and durability of material, are the chief points that merit the attention of Judges.

JOHN THOMPSON.
JACOB WILSON.

Report on Miscellaneous Implements.

THE Show of Implements was large. The Catalogue numbering 4023 articles, and our principal makers were well represented. Of the 256 exhibitors, Devon contributed 37, Cornwall 7, and Somersetshire 6. We were directed to confine our attention to such novelties as do not come into the different classes for which prizes are given by the Society. Formerly any implement that appeared decidedly meritorious was open to the award of a Medal or Commendation. In our awards we have endeavoured to act up to our instructions as nearly as possible. We think that the Show as compared with Newcastle was rather conspicuous for novelties. We proceed to describe the different articles to which we awarded Medals and Commendations.

A Broadcast Seed Machine (No. 734), invented and manufactured by A. W. Gower and Son, provides for the separate sowing of the clover and ryegrass seeds at the same time, and by the same motion. It is 4 yards wide and consists of 2 separate boxes, with false bottoms to regulate the proportions of seed. This is likely to prove a valuable implement, as the great difference in the bulk and weight of the clover and ryegrass prevents even distribution from the same box. Price 5*l.* 15*s.*

Pugh's Patent Cheese-making Machine (No. 879), manufactured by Francis Mellard of Uttoxeter, for cutting, gathering, pressing, and vating of curds, is a most ingenious apparatus, displaying much thought in its construction, and calculated materially to economise labour in cheese-making. A short description will not be out of place. The apparatus consists of a circular pan, made of tin, copper, brass, or any suitable material, with improved taps in the side for drawing off the whey at intervals as required. This pan, mounted on an iron frame, turns on an axis, and may be tilted at pleasure to cause the whey to run off quickly. Above the pan and supported by 2 iron uprights and a cross beam an improved and effective system of leverage is provided, which gives pressure to a vertical rod or rack to which is attached the perforated pressing-plate or sinker. This sinker is lowered into or raised out of the pan by means of a chain and ball of equal weight with the vertical bar or sinker, which act precisely like the weights attached to a sash window. To enable the dairyman to get at the curd more readily, the pressing-plate when raised may be placed in a perpendicular, horizontal, or inclined position, by means of a novel and self-acting movement. It is also made to revolve, that it may be more easily cleaned. The machine is mounted on rollers and can be readily moved about; by removing the pan, which is done in a few seconds, it can be made to pass through a 30-inch doorway. The knives for cutting up the curd are novel and ingenious, somewhat resembling the screw of a steamship. They revolve upon a centre in the pan, and such is their construction that whilst one half of the knives are cutting the curd downwards, the other half are cutting it upwards, and by reversing the motion a contrary action is obtained. The objections to revolving knives are in this arrangement entirely removed. After the whey has been expelled—forced up through the

perforations of the presser—the presser is made use of to press the curd into the vat: the cheese-making is thus completed in one vessel, which, we believe, has never before been attempted. The machine is simple and easily managed by a dairymaid—wheels, cogs, and complicated machinery being avoided; it occupies less space, is more portable, and requires less labour than any other. The pressure upon the curd (increasing as it descends) is perfectly self-acting, and can be regulated from 1 cwt. upwards, so that the dairymaid can attend to other duties whilst the curd is gathered by the machine. It is said, but we had no means of proving the statement, that more curd and of a richer quality is obtained, than under the old process of cheese-making. That this machine will economise labour is apparent, and that all the operations are simple and cleanly. The curd is not touched by the hands till it leaves the apparatus in the form of cheese. The machines are made in different sizes, and sold at prices within the reach of any dairy-farmer.

A. Tubular Churn, invented by Thomas A. Jebb of Buffalo, New York, and manufactured by I. G. Avery, of 135, Regent Street, is a decided novelty, and likely to prove very valuable. During the process a current of air is introduced, which helps the separation of the fatty globules, and the temperature can be regulated according to the season by tubes for hot or cold water. The churn consists of a tub, through the cover of which are inserted two water-tubes closed at the bottom, and an air-tube open throughout. These tubes are placed near the sides of the tub, but do not reach the bottom. The vertical spindle is armed with dashers, the upper blades of which revolve in the space between the water and air tubes, whilst the lower blades extend to near the sides of the vessel and revolve under the bottom of the tubes. The dashers are bevelled, and are finest at upper edge; an arrangement that helps to keep the butter rising and prevents its being smeared at the bottom of the tub. Motion is given to the shaft by means of a crank handle and bevel wheels. A fly-wheel fixed on the top of the spindle, steadies the motion and assists the operation. Butter can be churned from either sweet cream or new milk. In the trial that we witnessed, a sample of beautifully granulated butter was produced in four minutes from sweet cream. The buttermilk was completely removed at one washing, and the churn is readily cleaned, being very simple, all the working parts being readily removed. Churn No. 1, to produce from 1 to 20 lbs. of butter, costs 4*l.* 4*s.*; larger sizes are more expensive. According to the evidence of Dr. Voelcker who has paid much attention to this subject, this churn produces the butter entirely by mechanical means—a manifest advantage. Butter that forms in that perfect granulated condition is likely to keep well. Altogether we highly approve of Jebb's Tubular Churn.

Semicircular Pomeltrees, invented by E. Edmunds of Rugby, and exhibited by Ransom and Sims. This is a newly-invented pomeltree or main draught bar for applying the draught of horses, &c., to ploughs, harrows, cultivators, and other implements. It is made of wrought iron, and consists of a semicircular bar of iron, at each end of which is a hook for attaching the ordinary whippetrees. This bar is strutted with a tubular rod through which a bolt passes and keeps it firm.

On the semicircle a wheel or pulley travels, and to this pulley a hook is attached for forming the connexion with the implement. Owing to this arrangement the draught is always regular; and the draught line always passes through the centre of the circle, whatever position the pomeltrees may take, owing to one horse being in advance of the other, their leverage remaining equal. On turning at the land's end, the pomeltree clears the horses' legs, as one end follows the outside horse, and the other end draws away from the inside horse: they thus never tread on it, or get entangled in the traces. Another advantage is that any irregularity in the draught does not immediately affect the steady motion of the implement, as the point of attachment is not rigid, the pulley allowing of slight sideway motion without moving the implement.

This is especially important in setting out ploughing and in laying the tops or crowns of ridges. Such is a short description of this simple attachment, which we believe will prove very useful. We did not see the pomeltree at work, but were informed by Mr. Ransome that they employ them at all their ploughing competitions, as the men decidedly prefer them to the ordinary whippetree. Price 12s. 6d.

A Combined Flax-breaking and Scutching Machine (No. 883), invented and manufactured by George Parsons for the West of England Engineering and Coker Canvas Company, appeared to us a combination deserving notice; simple, strong, portable, and not unreasonable in price, viz. 63*l*. Should the growth of flax ever again find favour with the English farmers, and there are sound arguments to recommend it, a portable machine to travel from farm to farm during the winter and prepare the flax, leaving all the woody matter or rather its ashes—for the refuse from the scutching mills goes a long way to fuel the engine—on the land, would be a decided boon. The machine may be described as consisting of a rectangular framework, on which, through the centre and running from end to end, is a strong spindle, which carries four scutching mills, and a pair of fluted rollers for breaking the flax, the latter preparing as fast as the mills can clear. Five men or women and one boy would work the machine, and 4 cwt. of fibre can be dressed in a day. Three to four-horse power is required to drive all the mills.

Sketchley's Universal Joiner (No. 1957), exhibited by W. S. Underhill, is likely to prove valuable on large estates, as it is capable of efficiently performing the various operations of sawing, planing, moulding, tenoning, and boring, and is so steady in its work that the table may be placed on the ground without being fixed in any way. The saw table-frame is very strong and fitted with a 2½-inch spindle and fast and loose pulley. The table top has a rising and falling power of 9 inches, and the fence required in planing or moulding runs the whole length of the table, moves back 11 inches, and can be set to any angle. Attached and working on the fence is a slide clamp for tenoning with adjusting screw, which will take in wood of any size up to 11 inches by 8, and slide over the top of the saws.

The planing disc—which is most ingenious—is 30 inches diameter, and carries 6 planes, which work when the wood is moved both backwards and forwards; it has been lately improved by the insertion of gouges to carry away superfluous wood. This disc replaces the largest saw, and the table and fence are so adjustable that boards up to 11 inches wide and any thickness, from ¼ to 11 inches, can be planed with the greatest nicety.

The drunken saw, which works on the opposite end of the spindle, is most useful; for by a single operation, grooves can be made from ½ to 2½ inches wide, and 3 inches deep. The large saw will cut up to 12 inches. The whole apparatus is adapted for working up planks, into doors, window-frames, floor-boards, &c. The planing was beautifully done, and with great rapidity. We should perhaps notice that this machine is not entirely novel, as it was exhibited at Newcastle last year, but did not obtain the notice of the Judges. We therefore considered ourselves justified in awarding a medal.

Alfred E. Pierce—Stand No. 95—exhibited such a variety of novelties (24 in all), many of them somewhat crude, but displaying a considerable ingenuity, that we were glad to be able to award a silver medal for his collection of galvanised and japanned cattle-troughs, which were strongly made and moderate in price, as well as handy to move about. Amongst other curiosities was a Shepherd's House or Portable Granary (1174), constructed of self-supporting and bending corrugated galvanised wrought-iron. The lap of the iron on the roof wanted a little alteration, otherwise this appears a rather useful shepherd's house for the lambing season. In summer time such a shed would get fearfully hot. Price 18*l*.

The last medal in this Class was awarded to Messrs. Holmes and Son, for article 2268, described as a Rotary Harrow or Twitch Extirpator, invented by T. Everett of Stoley, improved and manufactured by the exhibitors. Perhaps neither this nor the churn came within the strict letter of our instructions; but as we saw the implement at work, and were greatly pleased with its performances, and as the whole body of our colleagues expressed a strong opinion in its favour, we could not pass it over unnoticed. Its construction and gearing are very similar to that of a haymaker, only it covers much less ground, and is more strongly made. It consists of a series of rings, on the circumference of which are attached, at rather close intervals, strong cross-bars of iron carrying 3 tines about 6 inches long; the teeth, slightly curved forwards, resemble the tines of a dung-fork. The bite of the wheel is ensured by fixing a number of sharp points which project about 4 inches from the tire, these are easily removed when the machine is required to travel on the road. It is adapted to pass over the surface of light land after the plough and drag, in order thoroughly to comminute the surface and bring up the disturbed couch without breaking it. It works with a back action, and leaves the weeds on the top and thoroughly separated from the soil. The forks being driven fast the soil is completely disturbed. It is not adapted to stony or stiff soils, as the tines would bend, and we could not secure that open condition that would allow of complete pulverisation at one operation, and the couchgrass would be broken. This machine was easily worked by 2 horses. Price 10*l*. We commend it to the consideration of light-land farmers who are bothered with running weeds.

The Earth Closet Apparatus, price 1*l*. 5*s*. invented and manufactured by White and Co., of 29, Bedford Street, Strand, London, being the working parts of a closet (on Moule's system of deodorising and utilising excrementitious matter by means of dry earth), adapted for labourers and others living in the country, we considered a valuable novelty deserving of a high commendation. The working parts of a closet being obtained, a country carpenter can fit it up at the same cost as an ordinary privy. The seat is made self-acting, pressure causes a sufficient quantity of mould or ashes to be let down from the store into the first receptacle, and when that pressure is removed the same is discharged, covering up the fæces and preventing smell or loss of any kind. The box may be emptied once a week. It is urged by some that cottagers are so dirty in their habits that they would not take the necessary trouble to supply the earth and remove the soil; but self-interest will dictate the advantage of looking after such valuable manure, and a little oversight on the part of the landlord is all that is necessary. In a sanatory point of view this is a most important question.

Patent Steel Crank Shield, invented by Messrs. Ashby and Jeffery, we commended as likely to prove serviceable for encasing weak or worn cranks. They are case hardened and durable. Price 12*s*. 6*d*. to 15*s*. each.

Commendations were awarded to George P. Dodge for India-rubber Vulcanised Driving-bands, and to *Webb and Sons* for Leather Machine-bands.

We must not omit to notice a novelty exhibited by Messrs. Garrett and Son, and described as a Machine for Bruising and reducing Wheat and other Straw to fodder. The object being to crush and smash all the shell knots and entire straw of both cereal and leguminous crops. The straw is fed in to a drum, and carried round between the surface of the drum and iron projections which come close down, and in passing the smashing takes place at a great expenditure of power. Any invention that has for its object the more complete preparation of straw, is at any rate interesting. Our restrictions prevent us from doing more than thus briefly alluding to this machine.

We append a tabular list of articles, to which we awarded Medals and Commendations.

No. of Art.	Exhibitor.	Description of Implement.	Price.	Award.
734	A. W. Gower and Son .	Broadcast Seed Distributor . . .	£ s. d. 5 15 0	Silver Medal.
879	Francis Mellard . . .	"Pugh's" Patent Cheese-making Machine . . .	13 15 0	Ditto.
38	J. G. Avery	"Jebb's" Tubular Churn	4 4 0	Ditto.
637	Ransomes and Sims	"Edmunds's" Semicircular Pommeltrees	0 12 6	Ditto.
883	West of England Coker Canvas Company	Flax-breaking and Scutching Machine	63 0 0	Ditto.
1957	W. S. Underhill	"Sketchley's" combined Sawing, Planing, Moulding, and Boring Machine	95 0 0	Ditto.
1151	Alfred E. Pierce	Improved Cattle-troughs	1 6 0	Ditto.
2268	Holmes and Sons	Rotary Harrow	10 0 0	Ditto.
2340	White and Co.	Earth Closet Apparatus	1 5 0	Highly Commended.
143	Ashby and Jeffery	Steel Crank Shield	0 12 6	Commended.
2654	George P. Dodge	India-rubber Vulcanised Driving-bands	Ditto.
2796	Webb and Sons	Leather Machine-bands	Ditto.

JACOB WILSON.
JOHN COLEMAN.

The Judges desire to take this opportunity of expressing their acknowledgments to the Council for the liberal arrangements made for their comfort and convenience during the Show. This Report would be incomplete if we omitted to notice the great, and, upon the whole, successful exertions of the Railway Companies, and especially the South Devon Line, to facilitate and carry out the arrangements of the Society. The transit of Implements and Stock to the Show was well and punctually effected, and, considering the capabilities of the line, we believe that the passenger-traffic was well arranged.

The exertions of Mr. Elphick, Field-manager, and of the Messrs. Moon, in carrying out the details of the field-trials, merit acknowledgment, as they enabled the Judges to make the best of the scanty means at command.

It is to be hoped that when these important classes of implements again come before the Society in competition, such arrangements may be possible as will ensure a trial on a more extended scale. It would have been more satisfactory in the present case if, in the decisive trials (we speak now only of the Mowing and Reaping Classes), each machine could have been put to do a fair day's work; the driver drawing his lot and setting to work with his pair of horses, just as he would on a farm, and cutting down his plot the best way he could, but without any assistance. It is true that for this purpose a larger area, unavoidably attended with increased expense, would be necessary. But so great are the interests at stake—from the influence of the awards both on exhibitors and the public—that it becomes of the utmost importance that the trials should be thoroughly exhaustive and conclusive.

ABSTRACT REPORT OF AGRICULTURAL DISCUSSIONS.

—♦—

Meeting of Weekly Council, March 22nd, 1865. The President,
SIR E. KERRISON, Bart., M.P., in the Chair.

THE BREEDING AND MANAGEMENT OF SHEEP.

Mr. T. ELLMAN said: Allow me in the first place to express my regret that I have not before been an attendant at these meetings. The best proof I can give of the interest which I have taken in them is my willingness to introduce this subject for discussion when invited to do so. I will not attempt to treat of other breeds of sheep than the Southdown, because the range of a farmer's experience hardly allows him opportunity for becoming familiar with the habits of all, and even many kinds of sheep. I hope that other members present will take up the subject where I leave it. The training, the character, and history of any race of animals, the influence that situation, climate, and soil, as well as management, exert on the appearance, constitution, and disposition must not be overlooked. So treacherous are these agencies, that experience gained in one county may be of little avail in another; the Norfolk man, when transferred to the Southdown hills, becoming, as it were, a child again; and the Southdown man being equally at sea if removed to Leicestershire. Such differences would soon have become apparent if the flock of the late Mr. Jonas Webb had travelled to the Southdown, or my flock to Babraham. And here let me pause to express my high respect for the late Mr. Jonas Webb, between whom and myself no spark of jealousy ever arose, but the best of feeling ever subsisted. So great, indeed, is the effect of climate and soil, that the fine flavour of the Southdown mutton may be changed in time to the coarse, tallowy meat of the Leicester or other long-woolled sheep. Nor will the flesh alone be interfered with, but the wool and every other feature will become assimilated to those of the natives of the different localities. Whatever advantages may accrue to Southdowns from their removal to inland counties, the increase of size will be accompanied by some falling off in the quality of the meat, and if their fattening properties are brought into greater activity, their appetites, perhaps, are also awakened by just looking over the hedge and seeing how their neighbours, the Leicesters, feed in the adjoining field. It should not be inferred, however, that Southdown sheep when fed on rich pastures cannot retain the properties which recommend them for general purposes, but unless fresh blood from the Sussex Downs is frequently introduced into those breeding flocks which are removed into other districts, both the shape and the quality of mutton and wool will be changed, and the hardness of the animal interfered with.

A remarkable case in point occurred in France some years ago, when I sent some Leicester sheep to a French farmer. The ewes,

60 in number, were purchased of Mr. Golding, of Beddington, the rams, 4 yearlings, from Sir C. Knightley. The wool of these sheep was enormously heavy, the ewes cut 10 lbs. each, the rams, 14 lb. each. These sheep being managed after the fashion of the Normans, the wool grew less every year, that of their progeny still lighter. In six years they clipped only 3 lbs. of very bad wool; the fourth generation became long-legged, their bodies differing from the original stock, but resembling the native-bred Norman sheep, with which they had had no relationship. After this failure a Southdown ram was used, and the stock improved. Yet they soon mingled with the common flocks of the country, it being found impossible to maintain these Leicester sheep upon poor soils with bad management.

Let me further quote a remark of a London sheep salesman, who looked over the pens of fat sheep with me at the Smithfield Club meeting in 1858. The trimming and jockeying was so cleverly done that we could not but admire the skill displayed; the fatness and weight of each sheep was marvellous, considering that they were called Downs; but what most astonished the salesman was that they possessed no more quality as mutton than the Leicesters which were by their side; nay, that they were *equally unfit for food*.

A statement made to me by Mr. Thomas, the eminent butcher of Charing Cross, will further illustrate these remarks, who, contrasting a sheep of mine with a fat Leicester, observed that when he had sold the Leicester haunches, which themselves were not of the best quality, the other three-fourths of the carcase were put into the tallow tub, whilst of my sheep every inch was sold as the best quality.

And here let me quote, as a witness to the importance of keeping Southdowns pure, the high authority of Mr. Anderson, late manager for the Duke of Bedford, at Oakley. This gentleman was so successful in infusing Cotswold blood into his Leicesters, that he won the prize of a gold medal at Smithfield Show with some animals which I was disposed to regard as the best Leicesters I ever saw. He considered that this cross improved the constitution of his flock; but on the other hand, when speaking of Southdowns, for which he had a great partiality, he said I cannot touch them with any cross without rendering them unfit for their purpose, and one important purpose of the breed is to secure a hardy sheep, capable of eating up parings, sheep which, if put for a while upon short commons, will not give way in flesh.

For the butcher, no doubt a cross between the Southdown and Leicester will always be serviceable, and will pay the farmer well when wool is making a long price; indeed, the whole question often turns upon the price of wool. The improved Lincoln affords, on the whole, the most valuable cross with the Southdown.

Apart from the Southdown, where can we look for purity of breed? where shall we find a so-called established breed that has not an admixture of Southdown blood? With respect to the Cotswolds, we have it on the authority of Mr. Jones, the agent of the late Duke of Norfolk, that they were originally crossed with the Downs: the Oxford Down is a useful, but confessedly cross-bred sheep. What again shall we say of the Shropshires? At the Canterbury

show it was forcibly recalled to my recollection that thirty years ago I had sent some Down tups to Mr. Whitmore, in Shropshire, when I came across some of his sheep there exhibited. I then expressed some of my misgiving to my companion, who exclaimed, "What! do you doubt the purity of Mr. Whitmore's breed?" To which I could only say that I did not know whether he had lately made a change, but if not, I *knew* of an admixture in the blood.

It is said, I know, that by careful breeding a new type and character may be established; my objection to this is that life is not long enough to effect or test this design, and though various crosses may be useful for a time, it is impossible in the long run to make the impure pure.

If we attempt to trace the origin of the Southdown breed of sheep, their natural character at once indicates that they are a mountain race, and well adapted for the Southdown hills; and we may fairly infer, in the absence of any authentic statement, that they hardly existed in this island before the Roman invasion. In fact, but little was heard of them before the Norman Conquest; but from the earliest times the Southdown hills, with their short fragrant pasturage, and dry and healthy situation, must have been the most natural home for these sheep. The first distinct record concerning this breed relates that about 200 years ago sundry flocks feeding on these Downs were annihilated by a disease called smallpox, which was imported from Holland. From this date more attention was paid to avoid mixing this breed, and pains were bestowed on its improvement.

Mr. Arthur Young, in speaking of the Southdown sheep, in 1788, much admired their hardy constitution, their usefulness in manuring the land, and the fine flavour of the mutton. In 1794, when continuing those essays which all the world have admired, he speaks of the Southdown sheep as natives, which for many ages had existed upon these Southdown slopes. It was not, however, until my father turned his attention to their improvement that any remarkable features developed themselves, either in symmetry of carcase or general character. They were described thus early as speckle-faced by Arthur Young, and as ill-shaped by my father, who thus had a most difficult task set before him, that of producing good form, aptitude to fatten, and a fixed general character.

His enterprising spirit, encouraged by the patronage of the leading agriculturists of the day—the lords of Woburn, Holkham, Ashbridge, and Beechwood, &c., and further sustained by a strong sense of duty, enabled him to overcome every obstacle, and to merit the eulogy so feelingly expressed by the Duke of Richmond at the Smithfield Club meeting, in 1832, just after his death. In several points my father's aim differed from that of his distinguished contemporary, Bakewell, the founder of the improved Leicesters. It was Bakewell's desire to obtain the maximum of mutton with the minimum of bone; he disregarded wool in comparison with mutton, and was an advocate for rapid developments. My father, on the other hand, objected to forcing the young stock, and was anxious to maintain strength of constitution, and though in the onset he was driven to a little in-breeding, from the

difficulty of obtaining good animals from other flocks, yet as the work of improvement advanced, he acted otherwise.

By such means my father succeeded in rearing a breed of sheep which I believe will never require to be crossed with any other race for the sake of improvement, which from its hardy constitution and activity is adapted to very thin mountain-land, which from the wool fitting tight and close to the back is able to resist cold and wet; is unrivalled in the quality of the meat, and may be recommended without hesitation for exportation to any clime or soil, from the tropics to the snowy regions of the North, if obtained from one of the Sussex hills.*

Such being the merits of the Southdowns, they have become favourites in the Midland Counties, and having increased in size on good rich pastures, have been found highly profitable, and have become naturalised in almost every district. Still, when confined to flat and feeding soils their character is gradually altered, and the deterioration of the mutton follows as a natural consequence; results which can only be prevented by continual renovation by fresh blood.

I have no wish to disparage any other breed of sheep, but I may remark without offence that the long-wools interfere with the grazing of bullocks, whilst the Southdowns live where the ox would scarcely exist. Even the addition of 5 sheep per acre on a good ox-pasture materially interferes with the grazier's success, for the nibbling sheep picks out all the best of the keep, and, if I may use the comparison, gets all the meat out of the pudding. In Sussex no sheep are allowed to feed with grazing bullocks.

THE MANAGEMENT OF SHEEP IN SUSSEX.

There is so much that is peculiar in our district, that a Midland, or even a Hampshire farmer, would be puzzled how to manage for the best. One great point is that the Down must be close fed, otherwise the herbage will become coarse.

In summer the sheep are kept upon the Downs with the aid of a fold of tares or rape, the rape being sown at intervals, beginning from the 1st of May. This cropping is found a good preparation for wheat on our arable land, and to the growth of wheat we still adhere, in spite of present prices, for we cannot alter our system. Artificial manures are found to be a desirable supplement in the growth of green crops.

For weaning purposes vetches and rape are preferred, seeds being considered "doubtful" food. The wether lambs are commonly sold off at Lewes fair, and are pushed on for the market on sainfoin, to which a moderate allowance of oilcake or oats may well be added, the buyer being duly informed of the keep to which the lamb has been accustomed. Our lambs are brought out into the field at a very early age, it being a common saying with our shepherds: "Don't tender the lamb, they do best in the open."

* It may be stated, that in Scotland Mr. Watson experienced fewer casualties with Southdowns than with Cheviots.

In the selection of rams there is much room for judgment and discretion, although they commonly run in the flock indiscriminately to the number of 6 or 7. Discrimination should be used in selecting rams, that we may obviate *slight* defects in particular ewes; but if any one be decidedly faulty, she should be at once discarded; neither should the shepherd be listened to for a moment, if, after she has got rather *fresh*, he wants to put her back into the flock.

With respect to the buying or hiring of rams, my experience prompts me to make this suggestion. Let a farmer go to a show to select a *breeder*, but not a *ram*. Prize-getting and stock-getting (I say it without wishing to find fault with this or any other Society), appear unhappily to be not easily reconcilable. Once, at a show, I ventured to ask the late Mr. Webb: "Did you ever know the best sheep get the prize, because I never did?" and he replied, with his quiet smile, "The Judges, no doubt, know better than we do."

Farmers are too often stingy about securing good rams, to their own injury. Cases have occurred in my own district in which I have been enabled to be of some little service to some of my neighbours who were fresh comers, and from want of skill in selection were owners of very indifferent flocks. I ventured to say to them, "Will you allow me to take your flocks in hand, with the understanding that I shall be paid for any outlay I make only according to the results obtained?" In one case, when my offer was accepted, I at once drafted the ewes of a flock of 370, and sent some rams of my own. The result I obtained was an increase in the proceeds above the former season of 300*l.*, with an outlay of 80*l.* for cake, or a clear gain of 220*l.*

I will now add a few hints on the autumn management of ewes. Rape is one of our most available crops, but if given in a wet season, without the addition of dry food, its use is apt to bring on inflammation of the uterus; the liver is, in the first instance, affected, general debility follows, and the liver complaint soon extends its influence to the region of the stomach, and is conveyed to the uterus. In such cases opium is the best remedy, or a preparation called "the Shepherd's Friend," but the use of common salts is to be avoided, as they irritate the bowels. The danger from fever after parturition is much increased by confinement; so much so, that a question arises whether this fever is not contagious. I had 16 ewes taken ill one morning in a barn, of which six died before noon. I then ordered them to be removed into an open yard, and the veterinary surgeon, when he came, said that but for this I should probably have lost them all.

Hoggets should be well kept in winter, 1 pint of oats being a useful addition to their common fare. In the late trying season I have kept them successfully without any roots or cut wheat-straw, slightly salted, and wheat-meal, at a cost of 6*d.* per week.

In conclusion, let me observe that the flockmaster must make his choice between wool and mutton. One or other must be to some extent sacrificed, for generally the sheep which have most wool have the least flesh, and *vice versâ*.

If the present exceptional price of wool continues, no doubt the long-woolled breeds will be much run after; but when the market readjusts itself, those breeds which afford mutton of the first quality will again be in the ascendant.

Professor COLEMAN (late of Cirencester), expressed his regret that the name and reputation of Mr. Ellman had not secured a larger attendance at that meeting. There were some points in the excellent address which they had just heard with which he did not quite agree: for instance, the extreme importance assigned to purity of breed. In his opinion fixity of type might in time be imparted to a breed of mixed origin by careful rejection of unfavourable specimens. The Shropshire sheep is an instance of success in such arrangement, for no doubt originally some Southdown blood had been infused into the breed. The Southdowns themselves had improved of late, as they lost somewhat of their roving character. The Hampshire again, another offshoot of the Southdown, have acquired a valuable character, and combine purity both of mutton and wool. With respect to the keep of sheep, it is important that the lamb should live well for the first 3 months, and be supplied with a variety of food, the changes which are made in its diet being effected gradually. Winter-barley and winter-oats, combined with vetches, are very useful as early keep. These may be followed by spring vetches, sown with an admixture of rape; then next in succession rape sown alone, and later rape with an admixture of turnips. These succulent crops may all be used in conjunction with seeds. Judgment should be shown in the management by supplying the mown food a little at a time, instead of gorging the racks; besides this green food the lamb should receive some trough food. From the time it is 1 month old a mixture of oats, peas, linseed-cake, and bran, may be recommended. Many farmers show ill-placed stinginess in feeding their flocks—not that forcing is to be recommended—a course which, as pursued by ram-breeders, has been a curse to flockmasters; but a generous diet should be given from the first, and maintained without a check, any check being specially injurious to long-woolled sheep, though all breeds suffer. A question has arisen whether swede-turnips are suitable for ewes when in lamb, and, in his opinion, they may properly be given 6 weeks before lambing; but not only these, but all roots should be used in moderation, and may advantageously be pulped and given together with cut straw. If liberality and discretion were more generally combined in the management of sheep, we should hear much less of good and bad luck.

Colonel CHALLONER remarked that he had bought 100 ewes and 2 rams from Mr. Ellman, sen., from which he had bred in-and-in, and found that in 3 generations the produce became more like a roe deer than the original sheep. He inquired of Mr. Ellman whether in his judgment swedes could be recommended for ewes after lambing; and, secondly, as he was in the habit of buying Welsh sheep, how sheep should be kept going up to the age of 2 or 3 years, so as to secure mutton of prime quality.

Mr. ELLMAN, in reply, observed that brooding in-and-in gives

quality, but that new blood must be got to maintain size. He considered the use of swedes for ewes just after lambing to be a dangerous practice. They should not be had recourse to until the whites are done. It is good management to give these turnips on grass, and to let them "welt," or become dry from exposure to the sun and air; indeed, but for the game, he should hardly ever put roots into "pies," for he had known large uncovered heaps of white turnips keep good till April. He would make no other suggestion in reply to Colonel Challoner's second inquiry, but that cake and corn must be used in moderation.

Meeting of Weekly Council, Wednesday, March 29th. The President, Sir E. KERRISON, M.P., in the chair. A Lecture was delivered by Dr. VOELCKER ON

NATURAL DEPOSITS OF POTASH IN GERMANY.

Dr. VOELCKER said: Next to phosphoric acid, potash is unquestionably the most important mineral constituent of the ashes of plants. It is important for a variety of reasons. First, because it is found in a preponderating quantity in all such ashes. Next, because it facilitates the assimilation of a variety of other mineral matters which are carried into the vegetable organism in the shape of potash salts—a class of salts which is not distinguished, generally speaking, by great solubility. We have strong reason to believe that, in the shape of silicate of potash, silica, so largely required by all cereals, is carried into the vegetable organism.

Hitherto potash has been obtained mainly from the ashes of plants, Russia and North America having furnished our supplies. Potash, or rather carbonate of potash, is known by the name of vegetable alkali; and the very name implies that it enters very largely into the composition of all vegetable substances. Recently however—that is, within the last five years—new sources of potash have been discovered in Germany, in an extensive salt-mine explored about 1851. The salt-mines to which I now refer are of great national importance to Prussia; they occur in the neighbourhood of Stassfurth, a place about ten English miles from Magdeburg, and are so extensive, that persons who are well entitled to express an opinion on the subject, describe the mines of Stassfurth as vieing in importance with the celebrated salt-mines of Galicia, those of Bohemia, and those of Wieliczka, which are of such great national importance to Austria. Now, it is in these salt-mines that the natural deposits to which I allude, in the shape of a variety of crude salts of potash, are found.

On account of the agricultural importance of these potash-salts, I visited, last autumn, in company with Dr. Gilbert, the salt-mines of Stassfurth. I descended them, so as to obtain an idea of the extent of the natural deposits, and I was highly impressed with their importance, as well as charmed with the appearance of the enormous masses of almost chemically-pure rock-salt.

The salt there, as in so many other places, occurs in the new red sandstone formation. The surface consists of alluvial deposits, which

are followed by red marls and variegated or mottled marls and clays, to the depth of about 100 feet. Then comes an extensive bed, or rather a series of beds, of anhydrite and gypsum. On descending further we came to a number of beds of saliferous marl or clay, strongly impregnated with salt; and immediately below these beds of marl we met with layers or beds, about 200 feet in extent, containing a variety of salts, some of which are remarkably beautiful in appearance, shining and glistening in some parts, dull in others, but always distinguished by a peculiarly bitter taste.

These are the potash deposits; from them at present a very large quantity of potash is manufactured, both for agricultural purposes and for the gunpowder manufactories; for manufacturers of gunpowder now use German potash-salts, decomposing them with Chilian nitrate of soda, and thus obtaining by a double decomposition chloride of sodium, or common salt, and nitrate of potash, which is in every respect equal to the Indian nitre. The variegated or mottled salts containing potash are called, in Germany, skim-salts, because they have to be skimmed off, or removed from above the extensive salt deposit of almost pure rock-salt.

Below these 200 feet of potash deposits, or crude potash-salts, occur a number of beds of impure rock-salt, the impurities being chiefly gypsum and anhydrite in veins, in some places passing through the rock-salt, and in others interspersed with it, giving it a somewhat dirty colour. Then we find a deep and as yet unfathomed layer of almost pure rock-salt. The first experiment in boring was made in 1839, and the trial continued till 1851, when a depth of 1851 feet was reached without getting to the bottom of the rock-salt, which was discovered at the depth of 760 feet below the surface. Thus the pure rock-salt is at least 1000 feet in thickness.

A specimen which I picked up will give you some idea of the purity of the salt. You will observe that it is perfectly transparent; it does not attract moisture, even on a very damp day, and this is due to its great purity. The analysis made by Professor Rammelsberg of Berlin gives $97\frac{1}{2}$ per cent. of chemically-pure chloride of sodium, and no chloride of magnesium, which causes ordinary salt, including some varieties of table-salt, to become damp on exposure to the air.

Since 1855 the mines of Stassfurth have been in full operation, and have furnished annually above 50,000 tons of pure salt, besides a large quantity of impure salt, which is used for agricultural purposes, and in giving cattle a relish with their food.

These mines of potash-deposit have a peculiar interest for agriculture, but they have likewise been a perfect mine of discovery to the scientific chemist, presenting well-defined chemical compounds previously unknown to the mineralogist. I refer here more especially to one salt—a natural salt here found in very large masses—which has been called carnallite, after Mr. Von Carnall, the director of some Prussian mines. It is from this combination, which is distinguished by a different form of crystallization from ordinary rock-salt, that potash is chiefly obtained. It occurs sometimes in beautiful white crystals, which look almost like sugar-candy. This carnallite is a

combination of chloride of potassium, or muriate of potash, as it is called in commerce, with chloride of magnesium and water. Its composition is as follows:—

Chloride of magnesium	31·46
Chloride of potassium	24·27
Chloride of sodium	5·10
Chloride of calcium	2·62
Sulphate of lime	0·84
Oxide of iron	0·14
Water	35·57
	100·00

It is a definite chemical combination of 1 equivalent of chloride of potassium, 2 equivalents of chloride of magnesium, and 12 of water. In some layers this carnallite is of a beautiful rose colour; in others it is of an intensely blood-red colour.

Besides the carnallite, we have several other minerals in the salt deposits. One of a yellowish colour is a salt which, on exposure to the air, runs at once into a liquid. On this account it has been called tachhydrite. This is a combination of chloride of calcium with chloride of magnesium and water. Then we have another description, which is of a white appearance—boracite, containing boracic acid. These salts are of great scientific interest, because they throw light on the manner in which these extensive salt-mines—mines which are believed to extend over a surface of at least 18 geographical miles, and perhaps to connect some of the salt-deposits in Wurtemberg with those of Prussia—were deposited.

I have before me a highly interesting work on these salt-mines by Dr. Reichardt, Professor of Mineralogy and Chemistry in the University of Jena, in which he points out that these salt-deposits are identical with the salts in the motherlays of ordinary sea-water. After the ordinary pure common salt has been separated from these lays, there remains a liquid which crystallizes only on the application of a large amount of heat; and this liquid contains the identical salts which are here deposited above the pure rock-salt. We also find in these crude salt-deposits bromine, which is a well-known constituent of sea-water. Indeed, these salts smell of sea-water—so much so, as to make you fancy that you are in the neighbourhood of the sea-shore.

I now pass on, in order to bring more prominently before your view the agricultural bearing of the products which are now manufactured at Stassfurth from these skim-salts. For several years after the mines were discovered, the skim-salts were thrown aside, no use having been found for them. They, however, interested the scientific inquirer, who was struck with the large, though varying proportion of potash found in them. I have here two analyses to which I will now merely allude, my object being that you may see the variations in the amount of salt-deposits, and more especially in the amount of potash. Suffice it to say, that the chloride of potassium amounts on the average to 13 per cent. There is mixed with this 22 per cent. of chloride of magnesium, 10 per cent. of sulphate of magnesia, 3 per cent. of

common salt, and no less than 24 per cent. of water, which chloride of magnesium readily attracts from the atmosphere. For five years nothing was done with these salts, but they were considered a great nuisance to the neighbourhood, poisoning the streams and the land. At length the attention of manufacturers was directed to them.

Wherever there is a refuse of which nobody else can make anything, it generally falls into the hands of the agriculturist, who is fond of buying what is cheap, and often fancies that he obtains a good result because he spends little money on his purchase. The trials made of the crude potash-salts were unfavourable in every instance—a fact for which we can readily account if we look at their constitution. Chloride of magnesium is a highly deliquescent salt; it is very strong and pungent; it destroys vegetable matter, and, like many other very soluble salts which cannot be fixed in the soil, is unquestionably injurious to vegetation.

It was not until three or four years ago that a German chemist, Dr. Frank, succeeded in obtaining much purer salts of potash from these crude skim-salts. By a peculiar process of crystallization, Dr. Frank succeeded in producing muriate of potash containing from 20 to upwards of 80 per cent. of pure chloride of potassium. At the present time there are four principal varieties of salts of potash manufactured at Stassfurth. The first quality contains from 80 to 85 per cent. of chloride of potassium, and last autumn it was sold in Germany at 12*l.* a ton; the second quality contains 60 per cent., and is sold at about 7*l.* a ton; the third quality, containing from 40 to 50 per cent. makes 6*l.* a ton; the fourth and last quality contains from 20 to 24 per cent. of sulphate of potassium—not chloride of potassium—and is at the present time sold in Germany at 3*l.* a ton. Nos. 1 and 2, the first and second qualities, are sent almost entirely to England, and used for producing nitrate of potash by a double decomposition already referred to. The chloride of sodium remains in solution, and this is afterwards evaporated and disposed of to the neighbouring farmers. There is always a little nitrate left in the crude salt, obtained from the gunpowder manufactories which make their own nitrate. I would recommend this matter to the consideration of agriculturists living in the neighbourhood of such manufactories. Numbers 3 and 4 are used chiefly for agricultural purposes; and perhaps the fourth quality more especially deserves the notice of the agriculturist, inasmuch as the third is too dear, at any rate at the present time, and also contains chloride of potassium, which absorbs moisture, and cannot be kept dry for any length of time, nor be spread out evenly with the hand or sown by the manure-drill. In the fourth quality potash occurs as sulphate of potash, and the salt is consequently dry, and better suited for agricultural purposes. Crude salts of sulphate of potash, containing from 20 to 24 per cent. of pure sulphate, as a dry powder, can now be obtained in a tolerably fine condition; for lately German manufacturers have dried the salt hard, and passed it through millstones. I have before me an analysis of good sulphate of potash; and I have made one myself of a sample which, for experimental purposes, I obtained last year. My analysis does not coincide with that

which has been published by Dr. Frank: I found rather more potash, but also a larger proportion of chloride of magnesium than is given in Dr. Frank's analysis. Hence it is possible that the salts which we had last year for experimental purposes were not so dry as they unquestionably are when prepared like the sample which Dr. Frank analyzed.

When I saw these salt-mines, I also paid a visit to the potash-works, and I was not a little surprised to find no less than 14 separate establishments in active operation, making potash as fast as they could from these skim-salts. Among them I found one belonging to a manufacturer from Glasgow, who was competing with the German manufacturers, I was told, quite successfully. In the neighbouring Duchy of Anhalt a similar deposit of salt occurs, and there we have already six potash works in full operation. Stassfurth alone produced about 250 tons of crude potash-salts daily. I have not been told what quantity is furnished by the mines of Anhalt, but there can be no question that the deposit there is very large, and that it will be rendered available as soon as there is really a demand for potash in agriculture; and that demand will surely be made as soon as it can be shown to the farmer that he can realise a profit by its use as a manure.

In visiting several agriculturists of eminence in the neighbourhood of these salt-mines—and there are some very large farmers in the vicinity of Magdeburg, cultivating their thousands of acres, chiefly for the purpose of supplying beetroot to the sugar manufactories abounding in the district—I was very anxious to ascertain with what degree of practical success these potash-salts have been applied; but I failed to get anything like definite results. Some were highly pleased with them; others had obtained no result; others, again, thought they might have done good. Indeed, as in the case of many other untried manuring substances, I met with a variety of opinions, but on the whole they were favourable. I resolved then to try some of the potash-salts on a larger scale this year; and I hope, on a future occasion, to have to report to the Society on some experiments which I think will be more successful than those which were undertaken last year by myself, by Mr. Frere, and by several of my friends, but failed in consequence of the dryness of the season. I hold in my hand a paper which gives the results of the application of potash to beetroot; also the results of the application of potash in conjunction with superphosphate, and the results of the application of guano, and a variety of other manures. The inference which the manufacturer draws from these results is, that sulphate of potash has produced a highly favourable effect, even when used in so small a quantity as 2 cwt. per acre. In looking over the results, however, with a critical eye, I cannot draw the same inference from them. There were two experiments without manure in which the variations of the soil on the two plots were greater than the excess produced by the application of sulphate of potash over the unmanured portion producing the smallest quantity of roots. I draw the natural inference, that the variations of the soil in the different parts of the field might account for the excess attributed to the application of sulphate of potash. I am, however, still deeply

impressed with the importance of potash-salts in agriculture; and for this reason I speak quite as frankly of the uncertainty attaching to the subject as I would gladly speak of any definite result.

What we require for the present is an extensive series of experiments with these potash-salts on the crops most likely to be benefited by them—grown upon soils which do not, like clay, contain, as a rule, a good deal of potash. I would suggest for practical experiment the following crops,—turnips and swedes, and then potatoes and clover. I would especially recommend potash-salts for light, sandy soils. Those soils are generally deficient in potash; and I am not at all sure that a good deal of the disease in turnips, and root-crops generally, is not due, in a measure at least, to the almost exclusive use of superphosphate of lime as a manure on light land. The disease in turnips is far less conspicuous in light land when only half a dressing of superphosphate is used, and half a dressing of common farmyard manure. In farmyard dung, and in liquid manure, we have a considerable quantity of potash; and in light soils I believe potash must be supplied in one way or other. It is on soils of that character that clover frequently fails. I am not prepared to say that clover sickness is in every instance caused by the absence of potash; but certain it is that potash must be present in the soil, or the crop will not grow luxuriantly. Potatoes likewise require a considerable addition of potash on sandy soils. There is a greater chance of potash being removed under the cultivation of potatoes than when corn-crops are grown.

In looking at the results which potash-salts have produced, I was struck with some analyses of Dr. Grouven of Salzmünde, the director of an agricultural experiment station, as we call establishments in Germany similar to that of Mr. Lawes in England. Dr. Grouven analysed, some years ago, the ash of sound clover and of diseased clover. In 100 parts of the ash of sound clover he found potash 35·5, or 35½, and of soda 7; in 100 parts of the ash of diseased clover he found 3·32—that is, in round numbers, only one-tenth as much potash—and of soda 8·7. He likewise analysed the ash of sound, of partly decayed, and of very rotten beetroot. In 100 parts of the ash of sound beetroot he found 30·5 of potash, 2·23 of soda, and 1·76 of magnesia; in the ash of that partly decayed he found 26·78 of potash, 73 of soda, and 43 of magnesia. The ash of the diseased roots contained only 19 per cent. of potash. Now from these interesting analyses I think we may derive the useful lesson that, unless there is potash present in the soil, our roots are liable to get diseased; and for this reason it is that I would especially suggest extensive trials with potash-salts for root-crops.

These, then, are the principal points which I intended to bring under your notice to-day. I may observe, in conclusion, that some of the crude salts are now on their way to England; and Mr. Frere will no doubt, in due time, report upon the results which he hopes to obtain from a number of experiments that he is about to try. I, too, have instituted some experiments that I shall report upon at a future time.

There is only one other point to which I may refer, it is the increasing favour with which these salts are regarded by agriculturists in Germany. A few days ago I received a letter informing me that orders had been procured by Dr. Frank, who was the first to establish potash works, for upwards of 3,000 tons of crude potash-salts. Thus, at any rate, should there ever be a real deficiency of potash, we have in these extensive mines of Germany a supply which will make up the deficiency, and we need not be afraid therefore that the land of England may become exhausted of its potash. Phosphoric acid has been supplied, and can be supplied in still larger quantity if there is really the demand; and I have no doubt that potash, should it be required, can be supplied from the mineral deposits of Germany, and probably of other countries where they will be discovered on further search. It is not a little remarkable that, just as a demand increases, our national sources of supply also increase, and, for aught I know, we may have here in England these very skim-salts which we now import from Germany. At any rate, the new red sandstone formation—the same formation in which the salt-mines of Germany occur—is the spot in which to look for these potash-salts.

Mr. P. H. FRERE wished to be informed whether in the form of chloride of potassium the salt would be objectionable.

Dr. VOELCKER did not think it would be objectionable; but sulphate of potash would be better, because it dissolved more gradually, and supplied the plants with sulphuric acid, which was a great advantage.

Professor WILSON observed that the meeting must be of one mind in reference to the subject introduced by Dr. Voelcker—that it is one of vast importance to agriculturists. He would not attempt to speak dogmatically as to the principles that ought to guide them in manuring, they must all admit that the true principle of manuring was to supply to the soil those substances which they knew to be necessary for the growth of their crops. And if they trusted to analyses of ashes of plants, they must be struck with the very large proportion in which potash existed in all cultivated plants. Potash was essentially the alkali of vegetable life, as soda was the alkali of animal life. For many years past, however, it appeared to him that they had been going upon rather a wrong system in manuring; they had been giving very large doses of one necessary ingredient, but either totally omitting or else applying very small doses of another ingredient that was equally necessary, as he believed potash to be. Consequently their results had fallen short of those which might have been obtained by an outlay of the same amount of money more judiciously applied. The produce of the soil was determined rather by that constituent which was in defect than by that of which the supply was largest. If a soil is analysed there is as great difficulty in detecting the potash, as in detecting the phosphoric acid, for they exist in about the same proportion in soils; and yet they had been going on the system of adding considerable doses of phosphoric acid to the soil, and small doses of potash. There had been a difficulty in obtaining sufficient potash, and giving it in such proportions as farm-crops required. A search after potash in different countries had been prosecuted for many

years past, but hitherto without any very great amount of success; and the occurrence of potash in the salt-formations of Prussia appeared to him to be a matter of vast importance in two ways: first of all, it insured a certain supply of potash for our fields at a moderate price; and secondly, it appeared to him to offer very great inducements and encouragement to continue the search for potash at home.

In this country we possessed deposits of salt in immense quantities. They were to be found in three districts. In Worcestershire they presented themselves in the shape of brine-springs. In Cheshire they had been worked for centuries as rock-salt; and within the last twenty years they had been found largely deposited on the shores of the Lough of Belfast, at Carrickfergus. Now, all these deposits in the British islands occurred in exactly the same geological formation as the deposits at Magdeburg. That being the case, he had great faith that if carefully sought for similar deposits would be found in this country. No doubt all these deposits of salt had originated in the water of the sea, which, it is pretty well known, always contains about the same constituents. He was firmly impressed with the idea, therefore, that the same salts of potash would be found in the salt-deposits in England as had been discovered in Prussia. So strongly had the necessity of obtaining fresh sources for the supply of potash been felt, that in the year 1851 a very eminent French chemist, who happily for science was still alive—he referred to M. Balard—brought before the Juries of the Great Exhibition of Hyde-park his process for obtaining these salts from the mother-liquor (*eau mère*) of sea-water. On the coast line of the Mediterranean, salt was obtained by the evaporation of sea-water, the chloride of sodium crystallising out of it, when it was evaporated to a certain density. Then the mother-liquor, which was of a bitter character, was usually thrown away, just as those substances were formerly thrown away in Prussia. M. Balard, thinking it ought not to be so treated, investigated the subject, and brought before the Council a beautiful and simple process for extracting the potash from the waste liquor, then regarded as a noxious product. The proposal was deemed by the members of the Jury (Class 2) to whom it was submitted, to be of such importance that they presented to M. Balard one of the few Council medals that were given at that Exhibition. The manufacture has been conducted since then only to a limited extent, but that was owing to the fact that the evaporation could not be carried on so extensively as to satisfy the requirements of the manufacturers and agriculturists. Here, however, they found the article prepared to their hands. Nature had herself done on a large scale what M. Balard's process could only do on a small one; and we may look forward to having our fields fertilised by the addition of potash, as we had been for many years past endeavouring, to enrich them by the addition of phosphoric acid.

With regard to the difference in quality in these substances, he agreed with Dr. Voelcker, that the low-priced salt would probably be best fitted for agricultural purposes. We did not want to pay for manipulation or for any special purity, provided there was nothing noxious in it to counteract its good effect. He had only one remark

to make in regard to the low-priced article containing the sulphate of potash. He observed that it also contained 60 per cent. of chlorides; and these would keep it pretty well as moist as the chloride of potassium itself would do. Of course the percentage of potash was that which should determine our choice.

Further, he concurred in what Dr. Voelcker had said respecting the probable causes of a great many of the diseases of plants. The failure of our crops, especially turnip and clover crops, was in many instances, no doubt, materially due to the absence of that proper equilibrium in the food supplied to them which was necessary for their healthy development. And with reference to the experiments that had been tried, before we could rely absolutely upon any of them, we ought to take rather more precautions in satisfying ourselves that all the conditions under which the experiments had been made were equal. For, first, we had the character of the soil to consider; secondly, the nature of the climate; thirdly, the sort of crops to be grown; and, fourthly, the materials used. And rarely were all these conditions satisfactorily fulfilled.

Mr. FRERE wished to take the opportunity of mentioning, for the information of potato-growers, the one point that came out in the dry season of last year, from his own small experiment. The exact record of that experiment had unfortunately been lost, in consequence of the death of his farm-manager; but this point came out in a very marked way—that the only plot, besides that manured with farmyard dung, that could resist the drought at all, was the one which had received a dressing of superphosphate, and probably also a similar dressing of those alkaline salts, salts of potash. Where potatoes were grown on a sandy soil, therefore, and farmyard manure ran short, he would recommend a mixture of superphosphate and those crude potash-salts, he should say, under correction of Professor Voelcker, at the rate of four or five cwt. per acre of each.

Dr. VOELCKER was desirous of supplying an omission which he had inadvertently made in the concluding portion of his lecture. He recommended the following formula for experiment, with crude potash-salts, upon light soils, for turnips, potatoes, and clover:—1st, use the salts alone at the rate of three cwt. per acre; 2nd, apply three cwt. of common salt per acre, in order to ascertain how much was due to the common salt, and how much to the potash contained in the German salts; 3rd, use three cwt. of crude potash-salts, with three cwt. of superphosphate; 4th, use three cwt. of common salt and three cwt. of superphosphate. The reason he suggested the use of superphosphate in conjunction with salts of potash was because these were known to be very important materials, and also because the only trial which last year gave him a good result upon clover was made with a mixture of sulphate of potash and superphosphate. Indeed, the two together—sulphate of potash and superphosphate—produced a very material increase in the clover-crop.

Colonel CHALLONER proposed a vote of thanks to Dr. Voelcker for his very lucid and useful lecture.

The Hon. A. VERNON, in seconding the motion, observed that not

only the members of the Royal Agricultural Society, but the whole agricultural world, must derive great benefit from the services rendered by Dr. Voelcker, in whom were so singularly united all the qualities required for scientific investigation.

Meeting of Weekly Council, May 11th. Sir EDWARD KERRISON, Bart., M.P., President, in the Chair. Mr. BEALE BROWNE introduced the subject of

FLAX CULTURE.

Mr. BROWNE said: This is a small congregation to preach to; but I believe the remarks which are made here go forth to find a large circulation in the agricultural world. I shall endeavour to treat this subject, not scientifically, but in a purely practical and, I trust, popular manner. I propose then first, to show the nature of soils suited for flax, and next to make some observations upon the seed of flax, its growth and manipulation.

My experience of flax, which now extends over a good many years, has satisfied me that land which is deficient in lime is far better adapted to its cultivation for the fibre than land that is rich in lime. For example, on the Cotswold Hills, where we are on a limestone—the oolite—we grow magnificent seed, but a very inferior fibre; and you will invariably find that where you grow the best fibre you grow the worst seed. I have grown three-quarters of flax-seed to the English acre in Gloucestershire, and a very, very fine seed it was—but such a crop, however, cannot be safely reckoned on by any man. In Ireland, on the other hand, my produce has never exceeded 12 bushels, and the seed has not been nearly so good. In Gloucestershire, again, the straw is almost like a stick, whilst in Ireland the stalk is pliant, and the fibre is of a beautifully silky nature, and is quite delightful to handle. We have in Ireland, especially in the south and west, a great deal of land that is deficient in lime; in fact, we can do but little with it until it has been limed. Flax therefore offers special advantages in that part of the kingdom, because you can thus produce a profitable crop, or even two in succession, upon land that would produce nothing else. In addressing a large meeting lately held at Tralee I dwelt upon this point, referring to the beautiful crop produced last year on such lands, and to the equally fine prospect for the present year. I limed the land in question after taking off the flax, and it will now be ready for nearly any crop. The soil is alluvial, and nearly barren, so that when we have cut off the grass and ploughed, we are not troubled with weeds; therefore its management is wholly different from that of ordinary lands.

On lands that have been in cultivation I have generally found that flax does better after wheat than any other crop. Besides ploughing in autumn, we just move an inch or two of the surface by means of a skim-plough previous to sowing the seed; and when that has been done I have never experienced any trouble whatever in weeding the crop, which grows so rapidly that it completely overcomes the weeds.

If, however, you sow it in ordinary stale ground the weeds get a start, the flax is overpowered, and no power on earth can weed it afterwards.

The next matter to be considered is the kind of seed ; and I may observe that a good deal of nonsense has been spoken and written about Riga seed. I have tried it often, and think that, after having been sown a few years in England or Ireland, it is far, very far superior to the seed you get direct from Russia. Then, with regard to the pulling of the flax. In Ireland they make a great mistake by sacrificing the seed. They pull it when it is in a green state, and water it at once. Now it is obviously impossible for all flax-growers to pursue this plan ; moreover, if everybody watered the flax directly it was pulled, how would you be able to keep your staff of hands on all the year ? We therefore, as they do in Belgium, pull our flax with the seed in it, stack it, thrash out the seed in the winter, next proceed to retting the plant, and scutching it, and thus we keep our hands steadily employed for the whole year.

The flax-instructors in Ireland are a class of men who are very highly paid, and, I am sorry to add, very ill-taught, for in many instances they are teaching the farmers the old-fashioned and erroneous plan of treating the flax. First of all, they recommend the pulling of it without saving the seed, and where they do save the seed they recommend that most absurd and ridiculous method of rippling. I need hardly say to you that the rippling-machine merely takes off the pods, and that you have the trouble of getting the seed out of the pod afterwards. They have a machine provided with conical rollers, with which they get out the seed ; but in using it there is a danger of crushing the seed. I have no doubt that the safest and best plan is to lay down the flax in small bundles and beat out the seed with a bat—a simple piece of wood about 15 inches long and 2 or 3 inches wide.

With respect to machines for scutching flax, I am unable to discover that a single improvement has been effected during the past ten years. I am using the old scutching-stocks, and my friend, Mr. Arthur Marshall, is using the same. He has twenty-eight of them running at this time. The only improvement I observe in the manipulation of flax, in the course of ten years, is that now adopted at Patrington, which my friend, Mr. Marshall, has kindly permitted me to mention. I allude to the wet-roller. Instead of putting the flax on the grass and watering it, as soon as it comes from the pits—and whether it be the hot or the cold water system it is the same—it is passed through very powerful rollers, which squeeze out all the water. They never grass it now ; but a quantity of little stakes are put into the ground, round which the flax is twined, and when it becomes dry it is tied again in bundles and taken to the mill to be broken and scutched, or it may be ricked at your convenience.

My object being, not to give a set lecture, but simply to throw out a few hints that may elicit discussion, I may mention that some years ago I myself invented a machine designed to perform the whole of these processes of flax-dressing—to break up the flax without the

human hand, to scutch it, and even to hackle it ready for the spinner, all in one operation. I so far succeeded that I could do it with a well-chosen piece of flax; but before our mechanists are reproached with lagging behind in the machinery applied to flax, it should be remembered that flax varies much in length and in strength. Consequently, though I found that with one piece I could carry the operation out by the machine very fairly, another piece not so strong would be torn all to pieces, whilst one that was much stronger was hardly acted upon at all. The difficulty is, that you rarely find two pieces of flax that are of exactly the same description. My machine did not answer, and I had to give it up.

I may here mention that I have a letter from my manager, who has visited Mr. Marshall's works at Patrington, where he was kindly allowed to remain for three days to get all the information he could gather. He tells me that they are employing not less than 160 people at the flax-mills there, and have twenty-eight scutching-stocks running. But to show you how flax varies, and that you cannot lay down any exact data, though you may strike an average, let me state that it appears that whilst one man at Patrington produced 113½lbs. of clean flax in one day's work of ten hours—a quantity such as I never heard of before, showing that the flax was extraordinarily good—another man could only produce 35lbs. in the same time.

To speak of the cultivation of flax as the panacea for the ills of Ireland, is in my opinion the greatest nonsense in the world; and it is very hard fairly to draw a line with regard to the profits on flax-growing so as not to mislead the public. I find one writer—I hope not from interested motives—stating the profits to be enormous. On the other hand, there was a leader in the 'Evening Standard' a few days ago, which showed that the growth of flax was a dead loss. How can we reconcile such conflicting statements?

I consider 5 cwt. of clean flax to the English acre to be a good yield, such as we do not often grow. The profit after all depends on careful manipulation; because the same flax that, badly handled, may not be worth more than 35*l.* a-ton, makes 60*l.*, if properly handled.

With regard to the market for flax, the poor, unfortunate flaxgrower finds himself very much in the hands of the local merchant—a circumstance that has much retarded the cultivation of flax in the county of Limerick. The people were encouraged by the proprietors to grow flax, when there was only one person there who had a flax-mill. I myself grew in Tipperary, a few years ago, as fine a description of flax as was ever raised; and I sent it a distance of twenty miles to this mill. It was fairly worth 3*l.* a ton; yet I was offered 1*l.* a ton for it. It was worth more than that to thatch my ricks with. I hesitate not to say that this firm has done more than anybody else to stop the growth of flax in that country, for the growers are entirely at their mercy. On the other hand, many farmers grow flax very imperfectly. They hear what others obtain for flax which has been properly treated, and then feel aggrieved because they cannot realise the same price. My experience in the growth of flax is, that grown after wheat, on the average of years, it will pay better than the crop of wheat. In Gloucesters-

tershire, I am perfectly satisfied this year to put a hundred acres into flax, simply for the seed, using the straw for the thatching of sheds and buildings. It will pay me fifty per cent. better than any wheat that I grew either last year or the year before.

Mr. Hall Dare has placed in my hands a letter which he has received from a gentleman of my own name at Limavady, in the county of Kerry. He has become a member of this Society, and seems to take a warm interest in the growth of flax. What he says entirely corroborates my statement—that last year the yield of flax was very short in the North of Ireland, and the crop inferior, owing to the dry season. He states that the farmers were in many instances without water for steeping a good crop; and this difficulty must arise, under the process they adopt there. If they followed our plan of carrying it over to the next season they would avoid the inconvenience, and have an ample supply of water during the winter and spring months. He speaks of the way in which merchants have been blamed for conspiring to keep down prices: “Knowing that the farmers had a double quantity in some cases on hand, and that they must sell, I have reason to believe that the buyers in many places, if not the merchants, were not above suspicion.” He further states that there is nearly a third less seed sown this year. Now, it is one of the drawbacks to the growth of flax that they have been growing it in districts where there is not an open market, and that they have been at the mercy of one or two buyers. The fact is they ought to send their produce to Leeds, or some other English market. I, for my part, should not dream of selling my flax in Ireland, unless it be in Belfast. But these men do not know where the great markets are. They therefore dispose of their produce in their own localities, and there is no doubt they are excessively robbed.

The writer of this letter also speaks disparagingly of the quality of the Riga flax-seed, which he says is worse than it has been for the last ten years. Now, they are almost mad about this seed in Ireland, and will hardly sow anything else. It is all very well for a change, but I would rather use the seed after it has been grown for two or three years in England.

I do not know that I have any more hints to throw out; but I shall be happy to answer any questions, as far as I am able.

Professor VOELCKER inquired on what ground Mr. Browne rested the assertion, that a deficiency of lime in soils was favourable to the growth of flax?

Mr. BEALE BROWNE: Upon the experience of ten years. He was no chemist, but for that period he had found that upon the oolite soils of Gloucestershire he could not grow a good quality of flax; whereas upon lands in Ireland—in the counties of Tipperary, Limerick, and Kerry—which were wholly deficient in lime, but lay upon the sandstone, he grew an inferior seed, but a magnificent silky fibre.

Professor VOELCKER said he knew by observation that the soils on the Cotswold Hills contained lime, but at the same time a large proportion of clay. They were heavy soils, and he was rather inclined to think that it was the excess of clay, not the presence of lime, which

was injurious to the growth of flax. Flax, it is well known, delights in light silicious soils, and such soils are very generally deficient in lime. He could hardly venture to say, therefore, that the deficiency in lime, in the case of light soils, was favourable to the growth of flax: nor, on the other hand, that the presence of lime in calcareous clays on the Cotswold Hills was injurious. He was rather inclined to think that a moderate quantity of lime would be favourable to the growth of flax, if otherwise the mechanical condition of the land was such as would enable the plants to draw their nourishment from the land, so that an occasional dressing of lime would have a beneficial effect upon the lightest soils on which flax is grown. He admitted the advantage of growing flax upon some land which happens to be deficient in lime.

Mr. BEALE BROWNE: Upon the soils in Ireland, of which I have been speaking, nothing else could be grown without the application of lime. They would not even get the seed back again. He considered it a great advantage, then, that in this part of Ireland, where there was a deficiency of lime, they could grow remunerative crops of flax when they could grow nothing else.

Professor VOELCKER: If that be the fact, it is a very important one, and worth keeping in mind.

Mr. FREEE inquired whether, in the western part of the county of Limerick, the soil was not rather of a clayey than of a light nature, whilst it had the character of being very deficient in lime. If that were so, its suitability for flax could not arise from its sandy character.

Mr. BEALE BROWNE observed that the land to which he alluded in Kerry, Limerick, and Tipperary was almost in a wild state—in fact, it was nearly peat. To a depth of 6 or 8 inches, it was composed almost entirely of roots, while underneath there was clay, but wholly deficient in lime. His difficulty in breaking up this barren land was to get sufficient tilth to put in the seed. The point he wished to impress upon gentlemen was, that a crop of flax, and that of a very high quality, could be raised upon land where nothing else could be grown.

Professor COLEMAN said, that however interesting it might be to hear of what was done in Ireland, yet in this Society it was more important to draw attention to the practicability of introducing flax into this country in the place of a cereal crop. Mr. Beale Brown had stated that the value of the fibre varied from 35*l.* to 60*l.* a ton, according to the management; that it required the most careful and delicate manipulation; and that the processes connected with the dressing of the fibre, removing the woody matter, &c., were best carried out by hand-labour. There were two great difficulties in the way of the tenant-farmers in this country. They could never hope, with their numerous other duties on the farm, to be able to give that attention to the manufacture of flax which would result in producing the best fibre. Then the question was, whether it was likely to prove sufficiently remunerative to induce capitalists to establish mills. He had very little experience of his own on the subject; but

he had the advantage of the experience of a gentleman living in the neighbourhood of Calne, who had been scutching flax for the last ten years, and who summed it up shortly by saying, that if he had known as much when he began as he did now, he would never have had anything to do with it, for to him it had been anything but a profitable speculation. He would like to know how far the experience of others tallied with this report; and whether, supposing the cultivation of flax was taken up by the farmers on the lighter soils of England, it was likely that mills would be established. With regard to the difference in quality of the fibre of the flax grown on the Cotswold Hills and in Ireland, might not that be attributable rather to the difference in the climate than to the difference in the character of the soils? On the eastern coasts of England, where the soils are more favourable to the culture of flax, being of a light loamy nature, would not the much drier climate materially influence the quality of the fibre?

MR. BEALE BROWNE: Of course flax delights in moisture, and the more moist the climate the better the fibre, and the greater its length. Still I have no doubt whatever that the quality of the fibre depends upon the soil. A greater length of fibre was to be got in a moist, than in a dry climate. Last year, being a dry season in the north of Ireland, the flax was much shorter than in the south, and that was entirely owing to the drought. Flax is a very thirsty plant, but it may be grown in an inch of soil upon a turnpike-road, if only the power of watering it daily is provided. The eastern coast, being peculiarly dry, would not be so suitable for flax in ordinary years as the western coast where there is much more moisture.

MR. MAGUIRE, M.P. for Dungarvon, said that he had some personal knowledge in reference to the growth of flax in the south of Ireland; that he believed it was of the utmost importance to establish factories in that part of the country, and that they must try to render the three provinces of Connaught, Leinster, and Munster, independent of grain-crops, or they would be constantly coming to Parliament and appealing *ad misericordiam* for aid. Entertaining a strong feeling on this subject, he, with some other gentlemen in Cork, had established a company for the spinning and weaving of flax, and they had erected a large spinning-mill, which would contain on the 1st of January next 12,000 spindles. They were also establishing a weaving-factory. To give indirect encouragement to the growth of flax, they last year arranged that a portion of their funds should be applied in the following manner. Having erected a scutching-mill, they induced the agricultural body of the city and county of Cork to establish a market for flax, and they scarcely ever allowed a single load of flax to go out of the market without purchasing it. So that in the course of about five months they purchased from 2,000*l.* to 3,000*l.* worth of flax. This was brought to them in every conceivable state. Some of it was scutched, and that very badly; and some again was in the straw.

He could give no scientific opinion with regard to the particular soil that would grow flax the best, but he had heard from the buyers, the farmers, and other persons with whom he had been in communication on the subject, that last year good flax was grown

in every part of Ireland, and on every description of soil; but that there was a failure to a certain extent in the quality of the fibre, not because it was badly grown, but because it was badly handled. There was a great want of moisture last year in Ireland.

The farmers had completely lost the knowledge of the growth of flax in many parts; and the machinery for their education or training in the matter was very imperfect indeed. The Government promised 3,000*l.* for establishing inspectors, but they acted so clumsily that the training or teaching had not reached the farmers as a body. Some of the farmers were very ignorant, whilst many of those whom the instructors endeavoured to teach were obstinate, and would have their own way. They did not understand the process of steeping, and the result was that in many instances flax which was admirably grown, and, if properly steeped, would have produced a large price, realised a very small sum. Indeed, the manager of his company had informed him that it would be little more difficult to make a fibre out of copper wire than out of some of the flax which was brought to the mill. So badly was it steeped, that it was fit for nothing but the manufacture of coarse bags.

He believed that in Ireland there was a wonderfully wide field for the growers of flax. For the purpose of obtaining information to guide him in the formation of the company at Cork, he had visited Belfast and the north of Ireland. At Belfast the price of flax had ranged from 50*l.* to 250*l.* a ton, but the latter price was never reached by flax grown in Ireland; it was for that produced in France and Belgium, where the cultivation was carried on as a perfect science. The ground was prepared with the most wonderful care, especially in the weeding, and by this means flax had become in those countries one of the most valuable articles they produced. He saw several bags in the stores of the millowners, which were worth 250*l.* a ton. The Irish farmer would be pleased if he could get 60*l.* a ton; but he had seen in the manufactories of the north of Ireland native-grown flax that realised 70*l.* and 80*l.* a ton; and he was told that flax of that kind came from all parts of the country. He was sorry to say that the disappointment caused by the circumstance to which he had referred was likely to check the growth of flax in Ireland this year. The Government were again bungling, for their inspectors did not receive their diplomas until a week after the last day on which flax should be sown. A number of farmers who, in consequence of want of experience and causes over which they had no control, were unsuccessful last year, would not grow flax again this year. Others, however, who had succeeded, or who had watched the successful experiments of their neighbours, would devote themselves to its cultivation; and in future he believed that flax-growing in the south of Ireland would be on a far better basis than heretofore.

One word with regard to the north of Ireland. Even there they had much yet to learn. At this moment there was not only an overgrowth of flax in that district, but a reckless sacrifice of that which should be returned to the land, namely, what the plant itself had extracted from the ground. The steep-water was all thrown away;

thus one of the most valuable means of restoring the fertilizing properties of the soil was utterly lost.

Mr. J. G. MARSHALL, of Leeds, was extremely glad to hear from Mr. Beale Browne his opinion from experience that flax could be grown as a profitable crop. His own experience, both as a consumer of flax imported from various countries, and as being concerned in the growth of flax in the north-eastern part of England, led him to conclude that there was no country better adapted than this to the growth of flax. With respect to the influence of climate, his impression was that the climate of Flanders was suited to the production of the finest descriptions of flax, and it was from there he got the finest descriptions. Its climate was drier than that of England; and this exposed it to the inconvenience of frequent losses arising from the long continuance of dry weather in the spring. That was the case at the present moment in both Holland and Belgium. Ireland had a very moist climate, and produced flax abundantly; but it was not so fine as the Belgian flax. English flax seemed to occupy a middle position between the two. It was not so fine as the Belgian, but superior in quality to the Irish; and, taking the two circumstances of quality and quantity of produce into account, he should say there was no country better, or, perhaps, so well adapted for the growth of flax as England. Again, flax could be produced in this country close to the best markets, with the best means of communication, with all the advantages of a ready application of capital and skill to the improvement of the processes of the manufacture, and there appeared to be no reason why the culture of flax should not be carried much farther. It appears to have gone quite out of cultivation of late years. It used to be grown amongst us by the small farmers; but when the large-farm system came into general adoption it fell off, and perhaps it would now be impossible to introduce it extensively upon the same plan as in Ireland, where it was carried on individually by the small farmers. English farmers would not probably give that time and attention by which alone the requisite skill can be attained. We had therefore to fall back upon the flax-rettery system. The whole operation of steeping and cleaning the fibre was performed in the rettery. Although some trials of that sort had not been successful in England, others were now progressing satisfactorily, and he saw no reason why the system should not be largely extended. Judging from experience, if we could produce and bring to market a fair crop of flax-straw, at about 10*l.* or 12*l.* an acre, he thought a flax-rettery would be a good undertaking. An intermediate agency had been introduced in a part of Yorkshire, where the small flax-merchant would purchase 30 or 40 acres of flax, and apply the labour of his family to it in the winter; and that in some districts would be practicable and profitable. Considering what had been said with regard to the very great variations in the value of flax, owing to the mode of handling it, he thought they might fairly hope that some improvement applicable to the treatment of flax, analogous to that which had been effected by the cotton-gin in that manufacture, might be adopted, so as at once to

greatly diminish the waste in the processes, and to increase the value of the produce.

The PRESIDENT said, considering the great importance of this subject, and knowing Mr. Beale Browne has had great experience relating to it, I had hoped that he would have entered more minutely than he has done into the general question of the culture and management of flax, which I believe is very little understood in England. He has mentioned the kinds of soil upon which flax mostly succeeds the best. My experience in the matter, which is now of some duration—and I have as large a rettery, perhaps, upon my property as any in England—is that, putting aside alluvial soils, flax generally flourishes best upon loamy soils with a clay subsoil; certainly not upon the lighter soils. But I think, upon the whole, that climate has much less influence than soil on the growth of flax. I am not saying that a certain amount of moisture is not necessary; for this year, in the eastern part of England, the flax will probably have to be ploughed up in consequence of the extreme drought. Still, as a rule, with a small amount of rainfall, upon a loamy soil capable of growing wheat and beans, flax may be grown in England almost as well as in Ireland, where the quantity of rain is so much greater. In Ireland, as Mr. Maguire has mentioned, considerable interest has for some time been manifested in the growth of flax. The fibre of flax grown there is, I believe, in a general way, of a finer texture than the fibre of much that is produced in this country. With regard to seed, however, we know that in Ireland they cannot grow so large an amount per acre as we can upon our drier English soils. The reason that in Ireland flax fetches so variable a price, as has been mentioned by Mr. Maguire, is very evident. The management is principally in the hands of the smaller farmers, who ret and scutch their own flax, and, in many cases, do not half ret or scutch it. They put it in ponds, ditches, and places of that description, where only part of it is properly steeped. They have little or no capital, consequently they do not possess the means of perfecting the retting process, and when prices are not good they are obliged to sell their flax whatever its state may happen to be. In my opinion it is impossible for flax to be grown profitably to any great extent over a country—whether in England or Ireland—unless there be in the neighbourhood where it is grown, retteries or manufactories of some description capable of receiving and preparing it. I do not agree with what Mr. Beale Browne says, “that machinery is not applicable for the preparation of flax-straw.” I consider that very great improvements have of late years been effected in the machinery employed in the manufacture of flax; and I think that it is preferable to steep the plant in warm water rather than in cold, unless it be in particular streams.

Anyone who is acquainted with Belgium must be aware that the chief reason why flax is so exceedingly valuable there, is the extraordinary excellence of the water in the river Lys, and some other streams in which the retting process is carried on. They are very particular in Belgium on this head. They ret the flax twice over, in order

to make it as perfect as possible; and, throughout, the greatest care is taken in the operation. If, then, you could take the flax to a rettery conveniently situated, where it would be retted carefully, by being put through the warm-water process, and thoroughly steeped, a great deal more profit would be realised than by individuals taking it up in a small way and attempting to do that which they have neither time nor knowledge sufficient to enable them successfully to accomplish.

The conclusion I arrive at is, that flax is a valuable part of our cropping. The time has gone by when people talked of the land being ruined by this or that particular crop. I believe that flax is not an exhausting crop—at all events that it is not more exhausting in itself than other crops. It should be taken after clover-ley, wheat, or barley stubble; but no indolent or bad farmer can grow flax profitably, for the mere fact of his land being imperfectly cultivated, or not in good tilth, would prevent his growing it with success. In Belgium it has been found that if they grow it oftener than once in 7 or 8 years, although they inundate the soil with fresh manure, they are unable to produce the same length of straw. I hope that many of the restrictions provided against the culture of flax will, by degrees, and by means of discussions such as the present, be removed by the landlords who are now most opposed to it; for I am satisfied it will form, and indeed does form, a portion of the cropping, which is very valuable in some places; and I quite agree with Mr. Beale Browne that in certain seasons, with wheat at a certain price, the flax-crop would be infinitely more remunerative than wheat.

In the course of this discussion reference has been made to Calne, and a gentleman there has been spoken of as having engaged unsuccessfully in the scutching of flax. Well, I have received a letter from a company at Calne, and they say that the acreage of flax-cultivation, within a circle of 60 miles around Calne, increased threefold between 1863 and 1864; that they are giving from 12*l.* to 17*l.* an acre for flax; that from 1½ to 2 tons of straw to the acre is about the usual quantity grown, with 16 bushels of seed per acre, or sometimes in that locality from 20 to 24. They also mention the curious fact that during last year, when a want of rain, and consequent absence of turnips, was much felt, and it was a difficult thing to keep a flock of sheep, that a flock of 300 breeding-ewes was kept for 13 weeks, in first-rate condition, upon a bushel of linseed steeped and a bushel of meal daily, mixed with straw cut into chaff, and they had neither roots nor hay during that period. The seed I look upon as possessing most valuable feeding properties, and, when mixed with bean-meal, I think it is preferable to cake. The farmer who grew flax would have the seed at his hand unadulterated; and, if he chose to sell it, he would obtain the means of purchasing a great deal more artificial manure than his wheat-crop, if sold at last year's price, would enable him to do.

In the eastern part of England, and especially in Suffolk, where I reside, the surface of flax-cultivation has increased in 17 years from 5 acres to 3000 acres; and apparently it is increasing still at an equal rate. That increase is attributable to the influence of the mills which are established there. We are fortunate in having no monopoly in

that respect; and I believe that if the price paid at the mills ceased to be remunerative, that moment the farmers would stop the growth of flax. In our district the grower has no scutchers to keep on hand; a comparatively small outlay is required; the crop occupies only four months on the land, which can be immediately afterwards cleared and cultivated, and you can put a crop of turnips into it. Therefore it is one of those crops which all who are interested in the better cultivation of the land are bound to try, if possible, or at any rate induce persons in different neighbourhoods to make the experiment. On no account, however, would I recommend any one to do that, unless he is so situated that he has a regular and certain market at hand to which to send his flax. It is far too bulky an article to send long distances, and for want of a mill at a convenient distance it might be kept until it is not worth more than 1*l.* per ton. In England hand-scutchers are very rare indeed; in fact, it is almost impossible to get them.

I have to thank Mr. Maguire for his attendance on this occasion; we are all glad to see him here, as well as so experienced a man in the manufacture of flax as Mr. Marshall.

Mr. BEALE BROWNE could not agree with Sir E. Kerrison when he stated that the machinery for flax-dressing had been improved. Hot-water retting did not employ machinery, and that system he had tried, and given it up. He wished to impress upon them, that the finest quality of flax produced in the world was that which was grown in the neighbourhood and retted in the waters of the Lys. Being about to move his flax-mills from Gloucestershire to Kerry, and to erect them on a larger and more extensive scale, he had gone down to Patrington, simply to ascertain whether the new pieces of machinery that were talked of were worth having, and he was informed by Mr. Arthur Marshall that they were not, and that he was increasing his old stocks. Consequently, the flax-mills which he began to work with ten years ago were those which he was moving from Gloucestershire to Kerry, where they would be erected without the slightest alteration, under the auspices of Mr. Marshall, of Patrington. He mentioned this lest people might be induced to purchase machinery which would turn out after all to be worthless. With regard to the feeding of cattle, his experience was that flax-seed mixed with peas, beans, or barley fed an animal quicker than anything else. He agreed, therefore, in the importance of having the seed as a cheap and nutritious food for cattle.

Professor WILSON, of Edinburgh, alluding to the question of soils, said there was good evidence to show that almost every class of soil, supposing it to be properly tilled, was suitable for flax, but he agreed with Sir Edward Kerrison, that soils known as loams, containing a certain mixture of clay and sand, were those which, under proper tillage, would give the best crops of flax; as indeed they would of most other cultivated plants. He admitted that wheat was probably the best preparation for a flax-crop; but he could not go with Mr. Browne, when he said that they should not plough deeply, but use a skim-plough to move two or three inches of the surface. This was contrary to all good cultivation.

Mr. BEALE BROWNE explained that the ground should be ploughed previous to the skimming.

Professor WILSON: With regard to the action of the soil upon the fibre of the plant, he believed that the fibre depended more upon the technical treatment which it received, than upon the soil in which it was grown; and this view was confirmed by what Mr. Maguire had stated as the result of his observation in Ireland. Climate had, of course, a certain effect upon flax. Still, here again, he thought the technical treatment had much more to do with the fibre than the mere difference in the quality of the plants. Mr. Brown had told them that flax was a thirsty plant, and would therefore necessarily grow better in a moist than a dry climate. That he (Professor Wilson) could not admit. On the contrary, he should say that of all our cultivated plants flax was the least thirsty. If the flax-plant were examined, it would be seen to exhibit, when well developed, a large amount of fibrous roots, which penetrated the soil in all directions, and sucked in as much moisture as was required. But it was the smallest-leaved plant that we cultivated; and if it absorbed moisture, it must also get rid of the moisture somehow, and it could only do that by means of its leaves.

Professor COLEMAN: And by its stems.

Professor WILSON: Perhaps; though the functions of the bark are very different from those of the leaves. Still it had as small an evaporating surface as any plant that we grow on our farms. In Belgium, where the best descriptions of flax were grown, the climate was even drier than in our own eastern counties. It was a dry climate, and flax was a plant that was indigenous to dry soils, not to soils charged with moisture. Again, he might observe that flax grew better upon the east than on the west coast of Ireland, that is to say, in the drier parts than in the very moist parts.

Passing on to the subject of the preparations for gathering in the crops, he thought a great improvement might be made in the mode of harvesting. Old Roman writers, of 2000 years ago, described the processes for cultivating, harvesting, and preparing flax as almost substantially the same as those now practised in Ireland; there had not been any practical improvement during the last 2000 years. Upon looking at a flax-plant, it would be seen that the fibre, which was the thing sought after, reached from the crown of the root to the extreme point of the plant itself; and the whole of that fibre, in its extreme length, and in as unbroken a state as possible, was what they wanted to obtain. The present process of hand-pulling was a very tedious, difficult operation, especially in districts where the cultivation of flax had been newly introduced. People were sent into the fields to pull it up in handfuls, and lay it down to dry. Why should the flax-crop be pulled up by the roots when no other crop was so treated? It was then taken in that state, and steeped for a certain period; next it underwent the process of scutching, the object of which was to separate it into two parts—the fibre of the plant and the woody centre, or “boon.” In knocking off the roots the fibre itself was always more or less injured; then it required more

space, and was more expensive to manipulate: the steeping process was longer and less certain than if the roots had been removed by mowing. He saw no reason, then, why flax should not be mown. If the ground were well tilled, as it might be, kept well weeded, and a roller passed over it after the seed was in, they would get a perfectly smooth surface, and at the right time for gathering he would mow it; he would even put on a mowing-machine, and cut it as close to the ground as he could. By doing this the roots would be left in the soil. Thus, too, by a better agency than that of the scutching-machine, the fibre would be separated from the useless woody part of the root, and when the plant was put into the steep it would have an opening already cut, by means of which moisture could be absorbed, and the juices washed out more thoroughly than by the process now resorted to. The effect would be to accelerate the whole process, and save something like 15s. or 20s. an acre.

A further advantage would be that the plant would steep much more equably; for what was now wanted was power to regulate the steeps better. With regard to steeping itself, he quite agreed with Sir Edward Kerrison, that a regular temperature which was under control was desirable, and he was of opinion that the hot-water system of steeping was infinitely preferable to the cold-water system. In Ireland it was impossible to grow flax profitably or well under the system there adopted, because the steeping could never be equable. It was well known, and Professor Voelcker would confirm him in this, that in the process of fermentation, large masses could be controlled much more easily than small. A large steep like the river Lys was much more equable in its temperature than the little pits which were dug all around the country in different parts of Ireland in all descriptions of soils, and into which water from the bottom, the sides, and the top, found its way, so that it was really impossible to steep the flax in those districts in a proper manner: for one part was not retted, but *rotted*, and absolutely destroyed, whilst another part would not be retted at all. He believed the operation would never be scientifically and properly conducted until the steeps were regulated just as the fermenting-tuns were in breweries and distilleries. Flax, as they were aware, was a bundle of minute fibres bound together by an albuminous mucilaginous substance—that is to say, a vegetable substance containing nitrogenised matter; and all they had to do, if they wanted to get a fine sample of flax, was to destroy this, or wash it out. He held that washing or dissolving it was better than destroying it, because they could control the former operation, and not the latter. If they did this they would have as fine samples in England as there were in Belgium.

The river Lys was a large body of water that was almost equable in its temperature, and very soft in quality. There the greatest attention was paid to the business of flax-dressing, and was amply repaid by the superior article they turned out, and the credit it had acquired in the markets of the world. The people were well instructed, and knew perfectly what they were about, whilst our poor fellows were lacking in these advantages.

Again, he saw no reason why seed should not be grown at the same time as the fibre. He believed the matured fibre was better operated upon than the immatured fibre. Mr. Brown had spoken of the rippling process. That, he believed, was pretty well exploded; but he would suggest whether rollers could not be used profitably to take the boll off the stem. He would, however, use plain, not toothed rollers.

Linseed no doubt was a capital substance for feeding purposes, but he could not help thinking that it would be bad policy to use it in that way. Linseed contained 30 per cent. of oil, worth from 25*l.* to 30*l.* a tun. Would it not, therefore, be much preferable to squeeze out the oil, and use the cake, than give their cattle an article which they could sell at 30*l.* a tun? An equivalent for oil could be given in the shape of hydro-carbons and starchy substances, which would have the same effect at a less cost. Therefore, he thought they should press their linseed, sell the oil, and use the cake with some substance that was as rich in hydro-carbons as the oil which they had expressed from the seed.

Mr. FREER asked what Mr. Browne thought might be the feeding value of the bolls?

Mr. BEALE BROWNE replied that, so far as his experience went, the chaff of the flax-plant was not of much value. He mixed it with straw and hay, but it was of such little value that, even in Ireland, he was using it as common litter for his cattle.

Professor WILSON: The bolls contain a considerable portion of nitrogenous compounds.

Mr. BEALE BROWNE: In pulling the flax they got a good deal of dirt with it, and that is one reason why I do not use the bolls.

The PRESIDENT: With reference to the suggestion that the flax should be mown, the objection to that is that three-fourths of the seed would probably be lost.

Mr. BEALE BROWNE: In noticing the various processes in vogue, I have omitted to touch upon one topic—the influence of chemical science. Chemistry will probably by-and-by do more for the proper manipulation of flax than any machinery. He had had leading chemists with him at various times carrying out experiment upon experiment; and it was to Dr. Voelcker, and men of science like him, that he looked for the accomplishing of this object rather than to all the machine-makers put together.

Sir WALTER STIRLING felt at a loss to conclude, from the observations of the several speakers, whether the growth of flax in England was to be condemned or recommended. It had been shown how advantageous in many points of view, and amongst them in the feeding of cattle, was the flax-crop; but the conclusion at which Sir Edward Kerrison had arrived seemed to indicate what he had always heard really constituted the impediment to the cultivation of flax in this country—namely, that there were neither convenient markets nor mills. It would seem, therefore, to be utterly useless to enter into the consideration of the best mode of steeping or scutching, or any of the other technical modes of treatment that were best known to the manufacturers, if the growers of flax could not reach the manufac-

turers, and there were no mills ready at hand for its proper treatment. In the course of last summer a speech was delivered by Lord John Manners, in Leicestershire, which placed the culture of flax in so pleasing a light in respect of profit, that one would have supposed that English farmers would take to the growth of flax to such an extent that it would supersede the wheat-crop. But how did it turn out? In the county of Kent, where he resided, several attempts were made on a small scale. For example, on a neighbouring estate to his own, a gentleman grew sufficient flax to make a table-cloth, and being high sheriff of the county he sent it for the dinner-table of the Grand Jury at the assizes. Well, they had had these curiosities. But the general answer which he had received on the subject was just that with which Sir E. Kerrison had closed his able remarks. If the culture of flax could be practically adopted for the benefit of the farmers; if it could be recommended as ensuring a fair return of profit for their capital, skill, and labour, well and good. But if it could not, then they might say of the flax-crop what the medical man observed respecting the cucumber: the best mode of dressing the cucumber, said he, is to employ so much oil, so much pepper, so much vinegar, &c., and then, when the process is finished, the whole should be thrown out of window! He hoped, however, that they were not coming to such a conclusion as that on the present occasion; though he should like to know in what direction it was advisable to go; whether they were to advance, or hold their hand and wait until things were in a better position with regard to mills, markets, and manufacturers.

Mr. MAGUIRE, M.P., said: A scutching-mill established in any locality would be a complete protection for the farmer; for when once the flax was converted into a marketable article it was of such small bulk that it could be sent to any part of the country at very little cost. In Cork they could say to the farmers, "We do not ask you to grow flax, we are independent of you;" for they could get down from Ulster a ton of flax worth 60*l.* or 70*l.*, at a cost of 25*s.* only for carriage. And if they did nothing more with the produce than make it into yarn they could send a bale of it of the value of 300*l.* or 400*l.* up to Belfast, the seat of the manufacture, for 25*s.* a ton by the steamer. If the farmer were within a distance of 10 or 12 miles from a scutching-mill he would be perfectly independent. Flax was a good and paying crop, but not unless they could convert the straw into a portable manufactured article.

The PRESIDENT: Before a vote of thanks is proposed to Mr. Beale Browne, I think I may say generally that it is the opinion of those who are interested in the cultivation of flax in England, and this has been ably put by Mr. Maguire, that neither in this country nor in Ireland do we recommend farmers to grow flax unless they have markets for it, and there are companies or individual manufacturers near at hand who would undertake the scutching, dressing, and preparation of the fibre.

On the motion of Mr. Wells, seconded by Mr. H. Wilson, a vote of thanks was passed to Mr. Beale Browne.

Meeting of Weekly Council, May 17th. The President, Sir E. C. KERRISON, Bart., M.P., in the Chair. Mr. J. CHALMERS MORTON read a Paper on

AGRICULTURAL EDUCATION.

The paper to be read this morning is, I fear, of a very different order from those which generally and most worthily engage attention at the weekly meetings of this Society, for I have no unusual agricultural experience to relate, nor any new facts or observations to describe. It is indeed an argument rather than a history which I have ventured upon—one, too, which is, I believe, liable to be considered, either, on the one hand, as too general and discursive for an audience of practical agriculturists; or, on the other, as too pointedly levelled at the recent resolutions of the Council on its subject, to be within the competence of a mere ordinary member of the Society at any except our annual general meetings. On this point, however, I must at once declare that it has not been my wish to discuss this subject controversially at all, and that I shall make no reference whatever to what the Council have, after their ample and prolonged discussion of it, thought it right to do.

I hope, indeed, that I may be allowed at the close of my statement to point out where and how, as it seems to me, the influence of the Royal Agricultural Society in the promotion of agricultural education may be most usefully applied, but this I shall do with no reference whatever to the plan which has been already adopted, and no desire to bring that plan under discussion now. The *object* of this paper principally has been to determine and place in the order of their relative importance the elements of a good agricultural education; and especially to ascertain and indicate where it is that the existing agricultural education thus appears to be deficient. The *plan* of the paper accordingly has been—1st, so to describe the business of the farmer as to illustrate the abilities and qualities he must possess and exercise during its successful prosecution; 2nd, to consider the educational process by which these abilities and qualities may be best acquired; 3rd, to give such illustrations as I have been able to collect of the progress and existing state of agricultural education among us; and, 4th, to consider what may be practicable or desirable in the further promotion of it.

THE OCCUPATION OF THE FARMER.

1. *First, then, of the Occupation of the Farmer.*—Agriculture is an art or manufacture. It is also a business or a trade. And people have of late years got into the habit of calling it a science. By this last designation it can however of course be meant only that the facts which make up the experience of the farmer—like those indeed of every other experience whatsoever—are recognised by men of science as in perfect keeping with the known laws of Nature. There is nothing in the field or feeding-house of which a thousand examples in other departments of observation have not been studied and recorded. To the physiologist, the chemist, the botanist, and entomo-

logist, the "mystery" of agriculture, thus, has disappeared. Everything is the illustration or fulfilment of a general law, of which examples are seen everywhere. Agriculture, though not a science, has thus at length become a museum, as it were, of facts, and instances, and specimens, in the classification of which students of all the sciences have been successfully at work, so that every part has now the light upon it of well-defined relationship with scientific truth.

If this be a correct account of agriculture as a so-called science, how is it with agriculture as a trade? There is here an even more complete explosion of the idea of anything exceptional or mysterious. The relationship of the farmer to him of whom he hires the land, which is his manufactory—to those of whom he purchases the labour he directs—to those who are his customers—and to those of whom he is the customer—is of the ordinary kind, dependent for its establishment and maintenance on the ordinary principles of human nature, and requiring only such protection from without as an equitable administration of the law secures for it. There is no longer any idea that, beyond the mere administration of justice between man and man, the Commonwealth requires any other protection of this or any other industry than Nature has afforded it, whether in the soil, the climate and position of the country, or in the energy, the conscience, and the self-interest of its inhabitants. The differences, however, between agriculture and other trades, though they may be only matters of detail, are very considerable indeed. They are dependent mainly on the fact that to the farmer harvest comes but once a year; that, indeed, several years are generally needed before the full return from many agricultural investments can be realised; that landlord, tenant, and labourer live here in closer conscious *neighbour-hood*, than landlord, tenant, and labourer in the case of any other industry; and generally, that the business is territorial, dealing with the whole surface of the country, and often the sole provision for its inhabitants. The perishable nature of agricultural products is another circumstance impressing some degree of peculiarity on the trade in them. But apart from, and indeed in spite of all these peculiarities, the fact remains that the business relations of the farmer are and ought to be similar to those of all other tradesmen, and that he depends for his success in his dealings with his customers upon the very same qualities of industry, honesty, good judgment, resolution and promptitude, which secure success elsewhere.

But agriculture is especially a manufacture and an art, dependent on professional intelligence and skill; and here, of course, we come upon the essential features which distinguish it. I believe that I am right in saying that its chief and ruling characteristics have arisen from the fact that throughout it has to do with LIFE. A great deal hinges upon this. A higher than any merely material force is indeed thus wielded by the farmer, but in effect it rather limits and defines his powers than widens them. He is not an artist or a manufacturer, the only limit to whose handiwork is his fancy or his will. He is hedged about by forces which are beyond him to resist; many of

them beyond him to control or even guide. All that he can do is to prepare, and watch, and help. Nature outside pursues her course—rain and sunshine, heat and cold come and go—regardless of his purpose. The seeds of weeds, of parasites, of disease, of mischiefs of all sorts, are everywhere; and always ready for a fitting seed-bed, where they will grow to his great injury or even ruin. *His* seeds, and the plants and animals he breeds from them, are not only the prey of all these mischiefs—not only subject to all the influences of our ever-changing climate, but they themselves are living creatures independent of him, possessing as species and even as individuals, characters and tendencies which are realised and carried out, one may say, in spite of him. All indeed that seems to remain his own is his power of choice—the power of selecting the objects he shall cultivate—the power of choosing the times and seasons of the various operations by which, after long experience of their natural history, he finds that he can promote their growth. This perhaps is rather understating his ability, but the distinguishing features of his occupation certainly are those which I have named. It has to do with living things, having tendencies, and characters, and wills, as you may almost say, of their own; fed, too, not only artificially, but by Nature, responding sensitively to natural as well as artificial influences, and thus susceptible, not only of injury, but of nourishment, recovery, and cure, through circumstances and forces which the farmer cannot guide, for which indeed he does little more than make ready, watch and wait.

To be a good and successful agriculturist, therefore, needs not only familiarity with the ordinary routine of farm practice, and both industry and promptitude in its direction; it needs especially (1), the quality of patience by which her full share of the farm work is given to Nature to accomplish; and it needs especially (2) the exercise of quick-sighted observation, by which the earliest natural indications of what is going on, the earliest intimations of the natural tendency and movement, whether to the good or bad, are detected in the living creatures with which the farmer has to deal. Intelligence, activity, and promptitude in carrying out the routine of operations are necessary in every other business as well as that of farming; but none other, unless it too have equally to do with life, so needs the exercise of quick-sighted, careful, habitual observation for its successful prosecution; and in none other is there so much need of patience—I do not mean contentment, but a willingness to wait for the full effect of the costless influences of Nature. A quick and watchful eye, and prompt activity at the proper time, have to be united with the faculty of waiting till the proper time, in order to good agriculture.

Many an example, both mere incidents and whole lives, could be quoted in illustration of the need of both these qualities. Many of us have, I daresay, seen men of strong will (of course not bred to the business, or experience would have taught them better) tearing resolutely on in pursuit of the object which they had set themselves, regardless of weather, prejudices, habits; enforcing the material

result by steam if horses would not do, by imported hands if the home-bred labourers were insufficient—in the end correcting at great cost their blunders, and confessing that the knot had been generally cut rather than untied—that difficulties had been swept out of the way rather than overcome—that the mere enemy, so to speak, and not the enemy, had been conquered, and that the natural method by which men as well as mere material are converted, and by which things of themselves come round, hinging satisfactorily on the new element which may be introduced, is not only the cheapest, but the most efficient in the end. On the other hand, of course it must be confessed that every neighbourhood will furnish instances enough, and those, too, of men who have been bred to the business, where the natural method, as I have called it, has tended to listlessness and idleness, and ended in Nature not being used at all, but left almost altogether to herself.

These remarks have indicated and suggested rather than described the well-educated agriculturist. He needs, first, such a perfect and detailed acquaintance with the treatment of the soils, the plants, the animals which he cultivates, as experience, and in fact apprenticeship, can alone confer. And when you consider how many agencies he employs—working-cattle, steam-power, labourers—what a magazine of mechanism there now is in agricultural machinery—on what a variety of soils, under what a variety of climates in this country he is placed—of how many plants and animals he needs to know the cultivation—how quickly in order to their successful management he needs to recognise and act on every aspect which they severally present under every variety of condition as to disease or health—how patiently, moreover, he has to deal with the living creatures which he thus has under his care, it must be plain to you that long and habitual practice and experience can alone confer the ability, or rather aptitude, which as a practical agriculturist he needs.

Then, as to the business arrangements which he has to conduct;—there is, as I have said, his relationship to be defined with the owner of the land, by which the returns for investments, bearing fruit often many years after the expenditure, may be secured to him; and there is the relationship to be maintained with the labourer, so that willing and intelligent services on one side may be secured by reasonable, firm, and friendly bearing on the other; and there is the market skill, by which especially the right articles for purchase are selected, and also by which they are fairly bought and sold; and thus in the business of the farmer there is ample scope for judgment and resolution, for both decision and kindness of character, and for a skill and promptitude which are to be acquired of course in full only by experience, but which are needed from the very beginning of his career.

Lastly, there is the light of science, in the midst of which he ought to walk—no longer a slave to mere routine, but a freed man, acting intelligently within the known limits imposed by Nature's laws—perceiving the scope and tendency of every act that he directs—able therefore himself to suggest the improvements of which his art is

capable, or at any rate to judge aright of those helps and alterations which others may offer or suggest.

It is, however, undoubtedly significant—partly perhaps of the existing educational status prevalent amongst farmers—certainly of the fact that barely a single generation has yet passed away since the labours of so many scientific men in the field of agriculture commenced, and certainly also of the paramount importance of technical and commercial ability, that is of skill and shrewdness for success in farming—that while we have amongst us maxims which insist on the importance of knowing the details of the business both in the field and in the market, there are none that I know of which urge the value of scientific knowledge.

I have heard often enough that there is a “rent” difference between the words “go” and “come” in agriculture, so that the farmer hiring land who can show and teach his labourers how to do it, is as well off as the yeoman owning the land he cultivates, who depends upon a bailiff. And we often hear, too, of the rent of a farm being “picked up outside the fences,” *i. e.*, made by market ability. But there is no such maxim in assertion of the commercial value of an acquaintance with the agricultural relations of the sciences. The tendency is still the other way. More than once, for instance, I have overheard that “a farmer with a chemical head is sure to have an empty pocket.” Of course such an idea has arisen from examples where the failure has been owing, not to a knowledge of chemistry, but to an ignorance of agriculture—examples, too, most probably where there has not been much greater knowledge of science than of practice.

If this part of my paper be concluded by a reference to an example illustrative of what has been set forth, it may be said that no one has more perfectly exemplified the attitude of the well-educated agriculturist in the midst of the natural and artificial aids and difficulties around him than the late Jonas Webb, of Babraham. No one knew better than he the limits imposed by Nature on the agriculturist, and few accomplished more within those limits, or did it better. The condition both of his farm and of his stock bore ample witness here. A wonderfully quick, almost instinctive insight, as it seemed, guided him in the management of both; and the energy of his character and tenacity of his resolution—by which it was that Babraham, neither a pastoral nor a grazing farm by nature, nevertheless became celebrated for its flocks and herds—were tempered by kindness and wisdom, the fruit both of natural cordiality and of experience. I may refer to him too as an example of success not only in the art of agriculture, but in the business of farming. No one ever commanded more willing service from his labourers, and no one could ever have received more cordial co-operation from his neighbours—and power to engage the sympathies of others in this way is of first-rate importance in the professional character of the agriculturist. And I will add that his intelligent and cordial admiration of the successful efforts of men of science to throw light on the experience of the farmer was not only of direct advantage to him by the freedom from prejudice which it conferred; but this, together with his genial manly bearing—also the

fruit of education—gave him a weight and influence with others which is certainly one of the most valuable educational results that can be named, and one from the want of which farmers have suffered perhaps more than any other class.

THE EDUCATIONAL PROCESS.

2. *Agricultural Education.*—We come now, in the second part of this paper, to consider the educational process by which the agriculturist is to be qualified for his profession. How can those faculties be best educated, that knowledge best conferred, that skill best acquired, which the farmer needs? This is the question for consideration. It must, however, be confessed that notwithstanding the attempt just made to define in a systematic manner the equipment which the farmer needs, no sooner do we begin to consider the way in which it is to be obtained than speculation fails us, and we are fain to fall back on actual experience as offering the only safe guidance to the answer which is sought.—Of course the boy must go to school, whatever may be his future occupation; and, no doubt, the discipline, both of school life and of school work—the habits, on the one hand, of obedience and regularity, and on the other of perseverance and resolution which thus arise—together with the actual knowledge and ability acquired—remain with him through life to his great advantage, whether he is to be a farmer or not. I do not pretend to discuss the relative merits in these respects of the various plans of scholastic training which have been advocated. Their bearing on a future good manhood is, of course, a far higher subject than the one which occupies us now. I presume, however, that in this room we have to do not with good manhood, but with the much humbler subject of good agriculture; and the elementary schooling of the boy can have but little direct or special relationship to the ultimate profession of the farmer. But, even if this were otherwise, I should not suppose schools, designed especially for farmers' sons, or for those of their sons who are to be farmers, to be at all desirable. There surely is some advantage in boys of town and country origin commingling in school life. Rather than have the sons of farmers educated as a class, it would be better they should go where the peculiarities and self-conceit of home life may be rubbed off, and some knowledge be acquired, from the beginning, that good sense and agreeable companionship exist in other professions as well as agriculture.

Neither ought we to forget that agriculturists are a very various body, socially. The so-called *class* of tenant-farmers does, indeed, include differences almost as great in their way in regard to social position as the so-called "class" of landowners, which includes in its lower ranks 40s. freeholders. The school education, therefore, of the boy who is to be a farmer, which, of course, ought always to be as good and liberal as is compatible with the necessities of after life, is necessarily extremely various, according to the wealth and position of his parents, and the consequent social position, wealth, and leisure, which he himself may ultimately command.

On all these grounds it appears to me that elementary, general, and

so-called middle-class education, is scarcely an agricultural subject at all; and the only remark I shall venture to make upon it, where it is intended as an introduction to the agricultural profession, is that good training in an ordinary school affords perhaps less scope for encouraging habits of observation than is desirable in the education of a boy intended to be a farmer; and also (to put it solely on professional grounds), considering the international relations which now obtain amongst agriculturists, there is probably less attention generally paid to learning French and German than there ought to be. As to the former point, I think it would be a useful supplement to the ordinary school exercises, if the study of Botany and Entomology were encouraged and directed from a pretty early age, and the practice of drawing from Nature taught. A boy who, besides acquiring a certain acquaintance with the features, the history, the habits, and relations, of certain plants and insects, has actually produced a series of drawings of both from Nature in every stage of growth, from seed and egg respectively, must have gone through a very useful—agriculturally useful—training of his powers of observation.

I leave, however, the subject of mere school training and come to the question before us. And the first remark to be made is that agricultural education to be perfect must begin early on a farm. Let me here say, by the way, that while there is doubtless some good done by a discussion of this subject on a public occasion of this kind, yet I believe it to be good chiefly as influencing the two or three per cent.—a mere leaven, but still no doubt a leaven—who enter agriculture as a profession from other walks of life. And, indeed, in my humble opinion, the influence of the Royal Agricultural Society over this great subject, as a whole, is most likely altogether overestimated. It will certainly be greater, for example, in the case of the intelligent and well-educated tenant than in that of the “smock-frock” farmer of fifty acres, who is little more than a labourer; but, taking the former case, let us ask ourselves whether such a man, with the fourteen or sixteen years’ experience of what is necessary for agricultural success, which he has had since his marriage, is likely to ask for guidance or advice from any one whatever as to the education (I am speaking now strictly of agricultural education) which he shall get or give his son whom he destines to succeed him, and whose requirements for such a position he must believe himself to know so much better than any other person.

The fact is, that in agriculture, far more than in any other trade or occupation, the present generation of practitioners has been bred and educated by the last, and is engaged in the education of the next. There are more now probably than ever who are entering agriculture as the business of their life from other ranks and occupations, but it still is true, and probably will be always true, that the bulk of farmers have been bred by farmers; and whatever faults there may be in the consequent upbringing of so large a portion of the middle-class population in this country, I must confess my belief that it is a fortunate thing for all who are dependent on the cultivation of the land for their support that this is so. I would, indeed, state it as the keynote of

pretty nearly all I have to say upon this subject, that I believe it to be a fortunate thing for landowners, a fortunate thing for labourers, and a fortunate thing for the next generation of tenant-farmers, that the education of farmers from childhood upwards is almost entirely in the hands of farmers—that is, under their direction.

There is, perhaps, no one who would hesitate—certainly none who would hesitate less than I should—to accept the picture which any large-hearted public-spirited owner of, say, half a county, might draw to himself of a model body of tenantry—I say few would hesitate to accept such a picture drawn by such a man as truly representing the chief end and goal of real agricultural progress; but even for him and for the accomplishment of his benevolent desires I believe it to be a fortunate thing that the education of the future generation of his tenantry, who are to be so many steps onwards in the progress to that goal, is directed and determined not by himself, but by the present generation of his tenantry, whom he may believe to be still far short of the goal in question. For, before all things, it is necessary that whatever education be adopted for them, it should, as its result, confer professional ability and skill. The education he might desire for them might turn out unselfish gentlemen, able, intelligent, courageous; but in addition to all this it must turn out farmers who can pay their rent, and make their business answer also for themselves and for their labourers, or the whole thing will be a failure. And I, therefore, feel certain that it is well that the education of the next generation of farmers is almost entirely in the hands of, *i. e.*, determined by, men who must know better than any other class what is needed for professional success. It is of such men certainly that I would in the first place take counsel in reference to the professional education of any son of mine whom I destined for a farmer. It is their judgment that should determine the time when he must close his school life and begin his life upon a farm; and all I should contend for (if necessary against them, though I believe they would heartily acquiesce) would be, first, such an arrangement of his school life as should, with a certain degree of educational completeness (on the importance of which Mr. Dyke Acland has rightly insisted), turn to the best account the school term allowed him; and, secondly, such an arrangement of his life upon the farm as should, without interfering with his acquirement of habits of practical skill and judgment, leave room and time for his acquirement of that larger, more liberal, and, in fact, scientific mastery of the various subjects included in farm practice which will lift him from the rank of a mere journeyman cultivator to that of a Master Agriculturist.

It is to the second of these points that I have now to confine myself; and, as I said, the life upon a farm needs to begin early in order to perfect agricultural education. I do not attempt to prove this by an induction of examples—for it is impossible to collect the 10,000 instances which would be necessary for this purpose—but the opinions of experienced men are the result of just such an induction, however unconsciously they may have been arrived at. And some such opinions I proceed to quote. The late John Smith, of Bowdown

Farm, near Tetbury, in Gloucestershire, farmed between 1760 and 1800. His annual journals and letters, which I have seen, prove him to have been a shrewd, intelligent, and leading man among the agriculturists of that time, and he enjoyed a correspondence with men in ranks much higher than his own. In a letter of his to Major Ogilvie, of Forfarshire, there occurs the following passage, which, however extravagantly worded, is, I think, worth quoting on this subject. He says simply enough:—

“I never knew a learned man who was a good farmer, and therefore I never lamented the want of an education. The time of life to make men scholars, is the time for observation in the farming line; and it rarely happens that a man can be a proficient in that business unless he be trained to it from his youth.”

This was written, let us recollect, long before the agricultural relations of the sciences had been worked out. He even adds:—

“I would take a man that can neither read nor write, to make a farmer, sooner than I would the most learned man. The former has no knowledge but what comes from Nature, and of good natural parts. The latter prides himself upon his reading and his education, by which he thinks of pulling Nature out of her course, and so of outdoing everybody.”

This is quoted as the utterance of a shrewd, intelligent, and successful farmer, notwithstanding the utter absurdity and folly of which many will pronounce it guilty, simply because of the trustworthy good sound sense which I contend that it also displays. If I were addressing agricultural students, or felt in any degree responsible for their success in after life, as, if their teacher, I should be, I would not utter one word in praise of scientific instruction, if they were to infer from it that it could in any degree dispense with the absolute and paramount necessity of practical knowledge and skill, and of that long-continued patient observation of Nature and of practice from early years by which they can be best secured. But it is plain that the old farmer, however right he was to insist upon the need of a knowledge “that comes from Nature,” could have known little of science, which he here refers to under the words “learning” and “education,” if he supposed that its tendency was to make men try to put Nature out of its course, and so outdo everybody. Science, which teaches us the limits imposed by Nature, is, on the contrary, the guarantee of true modesty and humility.

I quote now a more modern example of a judgment on the point under discussion. The following story was told me long ago by the Rev. J. C. Clutterbuck, of Abingdon, and it has always seemed to me full of useful truth on the subject of agricultural education. It is some years since I first put it into print, and it then immediately went the round of the papers; nevertheless, I tell it once more:

“A young man fresh from the University, who had taken cordially to the position of a country gentleman—and, among other occupations, had adopted that of agriculturist—was riding round his land one morning with a neighbour of long experience and well-proved practical ability and judgment as a farmer. He listened with docility and good-will to the instruction and advice that were given to him; and, struck by the wisdom and good sense of his companion's discourse, he at length exclaimed, ‘Ah, Mr. —, I wish I knew as much as

you do.'—'Make yourself perfectly easy on that score, my dear fellow,' was the reply; 'you never will.'—The one was fresh from the schools, and the other had spent all his life in the fields, and yet there was neither mock modesty in the speech of the one, nor arrogance in the answer of the other. Mr. — did not finish his reply:—'I have been accustomed,' he might have said, 'to be amongst plants and animals, constantly riding and walking on the soil which supports them both, since I was a child. Ever since I can remember I have had to do with the tillage of the land, the cultivation of crops, the management of live stock. There is not an aspect of weather, land, or life, so far as the live stock of the farm are concerned, which I have not habitually witnessed, realised, and studied. That of which instances and striking cases may be observed by you is foreseen or recognised by me in its first beginnings almost as if by instinct. Long familiarity with the details of my occupation, beginning, too, with the mind of a child which has hardly any other impression on it to weaken the sensitiveness with which its early knowledge is received, gives me, almost unconsciously, and without the effort of any special attention such as you must exercise, those intimations of fitness or of unfitness, of quality and condition, whether of soil, or crop, or animal, on which the right direction of our business of course depends.' Mr. — was perfectly correct; it is an immense advantage to an agriculturist, as to the follower of any other occupation, to learn that occupation young."

'Take now the recently declared opinions on this subject of living men. One of the most intelligent and successful farmers in the West of England tells me:

"I left school myself before I was fourteen, and went at once to assist in every operation that might be going on, taking the milking-pail morning and evening, seeing the cattle foddered properly, and lending a helping hand. I have never found a boy in the way after leaving school, and should quite despair of his making a man of business unless he had to mix with everything that moved before he was sixteen or seventeen."

A North Lincolnshire correspondent, with forty years' experience of the life of a tenant-farmer, who is well known and respected in his county, says:—

"I attribute my success, under the good providence of God, in the first place, to getting to know the practical part of farming in my youth, and following that up with tolerably industrious habits."

A leading Norfolk farmer says:—

"I have not been unsuccessful, but I attribute that success in a great measure to the thorough practical knowledge obtained during apprenticeship."

An experienced Kentish farmer writes:—

"My experience confirms the opinion that boys who begin early to learn the practical part of farming, have great advantages over those even who are sixteen or seventeen before they leave school."

He adds:—

"I invariably answer [requests for advice about the education of a boy who is to be a farmer] by saying:—Send the lad as near as you can to the place you think he is likely to settle in as a farmer—select the man who has the character of being the best farmer in his locality; and, if you can find such a thing as a money-making farmer in the present day, get him to take him and treat him as one of his family."

Lastly, Mr. Clare Sewell Read, whose name is well known in this room, says:—

“My individual experience is simply this: I was sent for six years to a common commercial school at Norfolk, and when I was just fifteen I left school, and passed the next five years in learning farming at home. From twenty to twenty-eight, I was engaged in managing farms and estates in various parts of the country, and I fancy in those eight years I gained more information, and a better knowledge of practical agriculture, than I should if I had passed my whole life in Norfolk.”

And similar testimony to any extent could be quoted from every county in the kingdom; but, indeed, it is not wanted, for surely it must be easy to convince a man that a sound agricultural education not only includes, but *is* instruction in the art and business of agriculture.

Of course this is not all that is desirable, but it is the thing that is required. And if there be any displeasure at my occupying the time of this meeting with the assertion of a truth so obvious as this, I must say that, obvious as it is, it has seemed to me as if it were sometimes in danger of being forgotten. I venture therefore to submit to those who are interested in this subject of agricultural education, that the young men whom they are anxious to equip aright for their agricultural career have to gain their living by it; and that therefore the aim and end of agricultural education must be professional ability. I picture to myself the case of a young man with the 2000*l.* or 3000*l.* on which he is to depend as a farmer, well educated—guaranteed as such by all the distinctions that the Universities can award him, a proficient even in the various sciences with which agriculture is directly connected:—He must be upwards of twenty years of age, but he is not yet a farmer, and taking him, as for the purposes of this argument I am entitled to do, to be an average specimen of human nature, I venture with some confidence to tell him that a thorough good farmer he never will be. For agriculture is an art and not a science, and the years he has spent till now on schooling, chemistry, and botany, ought most of them to have been devoted to his apprenticeship to the business by which his 3000*l.* are to maintain him and his future family. A large and liberal education is, doubtless, an immeasurable benefit to any man; but it is simply mischievous and cruel—and will ultimately come to be so judged by the young man whose case I have supposed—to attach to the words “agricultural education,” as a professional guidance for him and such as he is, any other than the simply professional meaning which they bear. I entirely agree, therefore, with the authorities already quoted, in insisting on the need of an early apprenticeship to farming, as being the essential substance of an agricultural education.

The testimonies I have quoted are, however, mere extracts from fuller statements, and the writers would, I believe, all agree with me in adding a good deal to the bare assertion of such a truism as this; and perhaps the best way of making such additions will be to point out the difference between the Norfolk and the Kentish correspondents last quoted. The latter would send his boy into the district where he is

ultimately to farm; Mr. Sewell Read would send him to a distance from home, and he attributes the chief advantage of his own agricultural education to its having been obtained in many different parts of the country. I believe in the latter statement, and the advice which it conveys, as the safer and the better of the two. And seeing that it is generally impossible to obtain in this way that wider experience which is desirable, it becomes the more necessary that the agricultural student should learn the inner truth which underlies the varying particulars and shades of agricultural and all other experience, so that the essence of every act that he directs, and of every fact that he observes, may be understood apart from the wrapping of mere circumstances which disguises it. This inner truth is the subject matter of scientific teaching. The sciences of dead and living matter—chemistry, botany, physiology, and others—these certainly are part of a sound agricultural education, because they include and classify, and thus truly represent the facts with which the farmer daily has to do. Any agriculturist who is also to a certain extent a botanist, a chemist, a physiologist, has his mind as well as his mere hands and eyes occupied with his business, and his judgment is surer, safer, and more confident in unusual or untried circumstances, not only because it acts upon this inner truth which circumstances disguise to the mere outward eye—but also because by larger exercise and freedom it has thus itself become an instrument of greater aptitude and power.

I ought perhaps to beg pardon for occupying time with truisms of this kind, and I will therefore conclude this part of my statement with a short reference to the way in which the practical and scientific parts of a complete agricultural education may be best obtained. It is the desirableness of uniting the two that makes institutions of the class of the Royal Agricultural College so valuable. Such institutions should, in my opinion, be not scientific but agricultural colleges. Their purpose, aim, and end, are to turn out agriculturists; their business is to teach agriculture—agriculture, certainly, and therefore anything that will throw light on agriculture also. It is, however, difficult, and perhaps impossible, to give this preponderating importance to instruction in farm practice in any scheme for the arrangement of the time of sixty or eighty young men at an institution of this kind, and therefore I am inclined to think that the best result will be obtained where such colleges receive young men after three or four years' residence upon a farm at home or elsewhere. They would at the College have for a year or two opportunities of becoming acquainted with the sciences, and their relations to the art and business of the farmer, while at the same time the routine of work upon the College farm would keep fresh their familiarity already acquired with the practical details of farming. Failing this, the alternative is that such institutions as the Cirencester College should be placed in districts such as Norfolk and East Lothian, which are full of young men learning farming, and where perhaps Mr. Paget's half-time system might be brought to bear, so that a certain portion of time being devoted to practical work upon the several farms, a remainder would be available during which students of agriculture could

assemble from all the farms around as students of the several sciences taught at one central institution for the purpose.

I may mention that in Scotland it is not uncommon, and it is desirable everywhere, for young men having become acquainted by several years' practice with the work of the farm, to enter the office of an accountant at Edinburgh for a year or more, where they also have opportunities of attending scientific classes at the University and elsewhere—thus uniting the two most influential additions that can be made to the equipment of a thoroughly accomplished agriculturist.

I am well aware this is but scanty treatment of my subject; but, indeed, no other is possible within the time allowed me; and I have accordingly done little more than aim at a certain degree of *fairness* in my discussion of it, by giving that same prominence here, in the scheme for the education of the farmer, to the importance of practical instruction and skill, which it most assuredly has in the actual experience of life. Had there been time I could have urged at greater length, and of course with much greater force, the professional advantages, both direct and indirect—*i. e.*, both as actually affecting the operations of the farm, and as giving a higher social and professional influence and standing to the farmer—of that more liberal and scientific knowledge of agriculture which can be obtained only by a union of scientific with practical instruction. To this point, especially, though no doubt, also to the correction of other faults and imperfections in this paper, the discussion following it will in all probability be directed; all therefore that I shall at present add is the following conclusion, to which I think a full consideration of the subject leads.

A young man of twenty-one or twenty-two about to enter on a farm is unusually well qualified both to make his business answer for himself, and to make it respectable in the eyes of others, if, having up till fifteen or sixteen been well educated at school, he has since that time been resident on a farm, or, what is better, resident on more than one farm, obtaining a practical acquaintance both in the field and in the market-place with all that the farmer orders and his labourers *do*; and who during the last year or two has been at such a college as Cirencester; especially if during all this time upon these farms he has been taking some interest in those sciences taught at college to which agriculture is especially related,—and especially, I will add also, if all along he has also taken a *reasonable* degree of interest in all the social as well as strictly professional duties, occupations, and enjoyments of country life.

Perhaps even now he had better pass a year with a salesman, accountant, or other professional man, and learn by practice the order, economy, and punctuality of a well-conducted business before he enters on business for himself. And I do not doubt that, supposing a young man to have no more than 2500*l.* or 2600*l.* at his disposal, it will have, nevertheless, ultimately well answered his purpose, though so much as 500*l.* or 600*l.* has been spent by him if necessary in this way, and his capital thus diminished to this extent.

THE EXISTING STATE OF AGRICULTURAL EDUCATION.

3. Our third subject is the existing state of agricultural education in this country. If this is to be measured by results, a great advance may be generally claimed as having been achieved during the past thirty or forty years. No doubt there are exceptional poor clay-land districts of small farms in the country, whence neither landlord, tenant, nor labourer—neither producer nor consumer—get much more per acre than they did half a century ago. But it is impossible for any agricultural historian to avoid the conclusion that on the whole the productiveness and fertility of the country have largely increased within living memory. And accordingly the pictures which our agricultural historians—Mr. Thompson and the late Mr. Pusey—have drawn, are sufficiently indicative of the fact that more bread and meat are now grown annually in England than it has ever before yielded.

By way of datum line for comparison, I may here give a short account of what might be called, from all I have heard of it, one of the example farms of Europe—the Wilhelmina Polder, in the province of Zeeland, Holland, which includes 3000 acres, and was enclosed from the sea nearly sixty years ago. Mr. van den Bosch—a shareholder in that property from the beginning, and all the time the resident manager of it, who is himself both a highly-educated gentleman and a good practical farmer—has all along kept accurate accounts of this thoroughly well-organised estate. The land is alluvial, and nearly all more or less clayey; it is all arable, and is cultivated in six farms upon the plan of a long and carefully observed rotation of crop, in which, besides our annual English crops, madder occupies an important place. From the decennial averages which have been struck, it appears that the property is gradually increasing in fertility. Thus, comparing the 10 years, 1821-30, with the 10 years, 1851-60, 30 years asunder, I am told that the average produce of wheat per acre has increased from 31 to 36 bushels; of rye, from 31 to 35; of oats, from 61 to 62; of barley, from 50 to 55 bushels; while the returns of beans and peas have been stationary. It is, perhaps necessary to add that some considerable additions of rather poorer soil have been made to the original area during the interval, so that the average increase of the same soil ought properly to be put somewhat higher than these figures represent. It must be admitted also that an alluvial soil, naturally fertile, is not the best on which to look for increased returns; nevertheless, I am inclined to think that there are few districts in this country, though generally managed in a much less systematic manner, where, owing to land-drainage, guano, artificial manures, and purchased cattle-food, the increased fertility is not much greater than it has been observed to be on this, one of the largest and best managed farms upon the Continent. If, for example, the Cotswold district be taken for comparison—where we have a comparatively poor thin soil, benefited but little by land-drainage, which is undoubtedly the greatest fertiliser of all—there is ample evidence to prove that the wheat-crop, for instance, which in the early part of this century did not exceed 2 quarters an

acre, is now more nearly $3\frac{1}{2}$ over the whole area; and Mr. Bowley states that the produce of mutton in that district is double what it used to be, the sheep being brought out at a year old, weighing as much as they used to do at two years old. So much for produce. Rents, on the other hand, have doubled within fifty years; and the expenditure on labour, taking for example a fairly characteristic farm of 600 acres within the district, of which I have the figures since 1774, has increased fourfold. On this farm it was 8s. an acre up to 1787, 10s. 6d. an acre up to 1794, 13s. an acre up to 1800, and between 1853 and 1863 it has averaged 30s. an acre, besides beer.

This is but a scanty illustration of a great subject; but I do not think it is necessary to lead a laboured proof by collecting the multitude of examples which would easily be forthcoming to show the increased productiveness of English agriculture during the present century. This will be easily admitted by every one; and if professional agricultural education is to be measured by results of this kind, we may fairly put in a claim for considerably increased professional ability during the period in question. Unfortunately, however, for the optimists, it is extremely difficult to draw with accurate discrimination the proper inference on this point from the facts before us. We have had land-drainage very extensively adopted as a fertiliser, and we have had some millions of tons of guano added to the soil, and some millions also, I presume, of artificial manures applied during the period under review. There can be little doubt that experience has, during this period, taught farmers the policy of greater liberality and outlay in the treatment of the land than used to be considered the safe and proper thing; but the increased produce thus obtained cannot be put down altogether to increased professional ability or to better agricultural education.

For there are three things contributing to this result:—1st, the natural quality of the land; 2nd, the character of the machinery and material available for its proper cultivation; and 3rd, the quality and character of the judgment, skill, and mind brought to bear on the management of the whole. The quality of the land, notwithstanding Liebig's warnings, may be safely pronounced at least as good as ever it has been. The machinery and material available for its cultivation have wonderfully increased in efficiency and value, and this alone would account for the increased produce obtained, even though the professional ability of the tenant-farmers of the present day should be pronounced no higher than that of their immediate predecessors. I therefore leave any attempt at determining the point under discussion by reference to results, and fall back on testimony. And I submit it, as at least deserving the serious consideration of all who are interested in improved agricultural education, that while the testimony of experienced men, many of whom can speak from personal knowledge of two preceding generations, is quite unanimous and clear as to the immense strides made by the general body of farm tenantry in general education, intelligence, and social position, there is not by any means such certainty or unanimity as to their standing in respect of pro-

fessional education and ability—in short, as to whether the sons are better *farmers* than their fathers. The general impression among those whom I have consulted is that the professional and technical ability when much inferior means were at the disposal of the farmer was at least as great in days gone by as it is now.

I have been in the habit, for twenty years and more, of troubling those who are known to be the leading agriculturists and the leading agricultural authorities in every county in the kingdom, with circular questions on pretty nearly every agricultural subject, whether of annual or only occasional interest, that has arisen during that period; and the question of agricultural education has been the subject of a correspondence of this kind during the past few weeks—so that I am able to speak with some confidence of the existing status, on the scale both of general education and of professional ability, of the great body of English agriculturists, according to the best men among themselves. And I repeat it—the universal testimony is, that while there are large districts in this country where the tenantry have long been well-educated men, yet over the whole country the general advance of the tenantry, on the score of general intelligence, education, and social standing, has been very great during the past two generations. The following are examples of the replies which have been received.

Mr. Fewster, of Nailsworth, Gloucestershire, whom I have known all my life both as a public-spirited philanthropist and as a man in constant business relations with the Cotswold farmers, says:—

“Looking back from my point of view, embracing a retrospect of two generations, the advance of the agriculturist in education, in general intelligence, and in social standing, is enormous, and the advance is still progressive. Comparing the present generation with their fathers, the mental and moral improvement is very striking.”

In the same district another, himself a tenant-farmer, says:—

“I consider the present tenant-farmer, in point of education, social standing, and real intelligence, to be far superior to the past generation of farmers; of unassuming manners and little exterior show, he is too often looked down on with slight and contempt by his professional or mercantile and trading neighbour, who himself, perhaps, possesses but a very small share of the other's sound sense and real intelligence, and employs less than one-eighth of the capital in his calling.”

From Kent I hear:—

“The present generation of farmers is far superior in education (but not in wealth) to the last. Most of our Poor-law Unions in this part of Kent have farmers as chairmen and vice-chairmen of the Boards of Guardians. The same may be said of the different Highway Boards, and we cannot be said to be purely an agricultural district. These facts will show you, better than an opinion, that the education of farmers has kept pace with that of other classes.”

Mr. Spearing, of Oxford, says:—

“There is no doubt, I think, but that the farmers of the present generation are better educated, and more alive to the advantages of a good education, than the last.”

Mr. Burbery, of Kenilworth, says :—

“ I believe the past generation of farmers gave their sons greater educational advantages than they had had the benefit of themselves ; and I observe farmers of the present day who have the means, are desirous of giving their sons a useful general education.”

In Warwickshire, Mr. Adkins, of Milcote, says :—

“ There are countless instances where the son’s intelligence or social bearing is in no degree superior to his parent’s ; but, speaking generally, the present generation of farmers is far in advance of the last generation in education, and therefore in intelligence.”

In Norfolk, Mr. Clare Sewell Read declares :—

“ There can be little doubt that, as far as education and general intelligence are concerned, farmers of the present day are greatly in advance of the past generation.”

From North Lincolnshire I hear :—

“ No doubt the present generation are much better educated than any former, particularly the smaller farmers, though many of the more respectable class of the last generation were well-educated men, and their social standing has not so much altered as in some counties.”

In Yorkshire, Mr. Stevenson, of Thirsk, writes :—

“ My opinion is that the farmers of the present generation are considerably superior to those of the past—more intelligent, better educated, and occupying a higher social position.”

And Mr. Outhwaite, of Bainesse, Catterick, says :—

“ The present generation of farmers in this neighbourhood are both far better educated, and much more anxious for general information than the last. Forty years ago the tenant-farmers could read very imperfectly, kept very inaccurate accounts, and never left their homes except to market. Now, every farmer of 50 or more acres of land takes at least one newspaper weekly, attends some club or reading-room, and is ready to take part in any discussion that may arise at the market dinner-table on agricultural subjects. I remember the time when any order, however absurd, sent from the landlord or his steward, would be implicitly obeyed. Now, it would be read over, considered, and discussed, and, if found injurious to the tenant-farmer, petitioned against, and published in newspapers.”

Lastly, I quote Mr. Dods and Mr. Grey, of Dilston, as to Northumberland. The former says :—

“ The present generation of farmers are better educated, are more alive to the benefits of education, and have better opportunities of conferring these advantages on their sons than any previous generation.”

And Mr. Grey, of Dilston, than whom no one in this country is better entitled to the respectful regards of English agriculturists for his long and honourable agricultural career, speaking of the Hexham Farmers’ Club, which he many years ago established, says :—

“ The existence of such a club in a rural district, comprising 221 members, with a library of 489 volumes, besides several agricultural periodicals, is a strong fact in proof of the better education and increased knowledge of the present generation :—

‘ We’ve fallen on better times ; men read and think ;
Our good forefathers used to fight and drink.’

At least so it was with the dwellers on the Borders, the cultivation of whose fields and stock is now thought to be somewhat exemplary."

Very many more testimonies of equal authority and identical character could be quoted to prove that the farmers of this country have put, and still place, the greatest value upon a good school education, and want no guidance or incentive on that point at all. Only let their business be profitable, enabling them to obtain for their sons the education they would gladly give them, and the next generation of tenant-farmers will be still better educated than the present, without any external help. It is for this reason that I believe the owner of any large estate has the best security for the character of the next generation of his tenantry, both for general intelligence and for professional ability, in the fact that their education is in general almost entirely in the hands of the present generation of his tenantry, who know better than anybody else what is best for the circumstances in which they are placed. And it is for this reason, too, that I firmly believe the promotion of good general and liberal preliminary education for farmers' sons to be best served by those who are urging increased attention to that professional agricultural education on which farm profits depend. Make these certain, and there need be no fear of a school-bill being grudged.

If, however, there is ample testimony to the fact that the general education of the present generation of farmers and their sons is higher than that of the preceding generation, there is no such universal belief that professional education is being equally attended to. On the contrary, it would appear that there is a great and growing lack of practical and professional knowledge in young farmers or young men who are to become farmers. They are very apt to take to their horse, and dog, and gun, and to the pleasures of a country life, and shirk the practical apprenticeship to it which used to be more generally insisted on.

Thus Mr. Dudding, of Wragby, Lincolnshire, who believes in the superior intelligence of the present generation, adds:—

"That the practical part of the business of a farmer is in advance, I do not believe. The young men of my father's time, forty or fifty years ago, were accustomed to ploughing, grooming their own horse, and attending to a certain quantity of stock—in fact, taking part in any of the practical work on the farm. Now this is very different: not one in ten of the higher class of farmers would be capable upon commencing business, of directing from his own practical experience the various operations on his farm."

Mr. Ruston, of Chatteris, Cambridgeshire, says:—

"As far as my own observation enables me to form an opinion, I should say farmers' sons are far better versed in mathematics, in mental and moral philosophy, and the higher departments of a good general education, than they are in the scientific branches of agriculture. I consider the requirement of the present day is professional education, and it needs to be thorough. A farmer ought to have an intelligent reason for everything he does, and not, as is often the case, 'leap in the dark.' To possess this he must be educated accordingly."

Mr. Clare Sewell Read, of Norfolk, comparing the younger of the present generation with the past, says:—

“As sound practical farmers, I don't think they are much improved; but, of course, their knowledge of the principles and science of agriculture must be greater.”

And in Sussex Mr. Ellman says:—

“I believe that the present race of farmers are not so well informed upon the general working of the land as the last generation, but we possess many appliances which formerly were unknown.”

He adds:—

“I may say that I know of no young man in this neighbourhood, of the age of twenty-two, who is capable of conducting a large farm to advantage unless entirely trusting to an experienced bailiff. Even at a maturer age, few who are liberally educated can manage of themselves. I am quite prepared to prove my assertion, that any education which entices the mind from the avocations of a farm must inevitably weaken the object, and mislead the practitioner into a labyrinth of difficulties.”

It thus appears to be the general opinion that the present generation of young men among the tenantry, to whom, on the score of general intelligence, every body concedes a much higher social position than their fathers had, possess no such superiority as regards that professional ability or skill to which one is at first disposed to attribute the advance which English agriculture has undoubtedly of late years exhibited.

AGRICULTURAL SOCIETIES.

Two other indices occur to me as likely to point out the truth on this subject. The one is the statistics of agricultural societies in this country, which, however, have but a doubtful relationship to it; and the other is the amount of sales which publishers have obtained for agricultural works. Of the first, connected with which I have collected a lot of information, which, however, is still unfortunately incomplete, I will here only say that the great number and success of local agricultural societies, and especially of the discussional Farmers' Clubs, is to be taken as an indication rather of the interest in, and anxiety for, professional information which prevails, than as a proof that there is nothing more to be desired or required in the professional education of the farmer. I see, for example, that Dr. Voelcker and Professor Coleman, Professor Buckman, too, and others, are frequently applied to by local clubs for lectures on various departments of agricultural science and practice. Professor Church, of the Agricultural College, has, I see, undertaken to teach a class of members of the Kingscote Farmers' Club, who have sought his help, so much of the science of chemistry as explains agricultural experience. Of course one soon learns that these clubs are very often the result of public-spirited effort on the part of comparatively few individuals in each county; yet, even so, their existence proves that there is already spread over the country an agency which this Society may, if it chooses, use in any effort it may make for the prosecution of professional agricultural education. For this reason an attempt has been made during the last few weeks to collect information regarding these societies. Information has been received about 120 such societies in England—not one-third, probably, however, of the

existing number—and I will endeavour to make the list complete before sending it to Mr. Hall Dare, in case for this or any other purpose of communication with the great body of English farmers it should be found useful here.

SALES OF BOOKS.

Of the question of the sale of agricultural books—which, of course, affects the question of general education quite as much as it does that of professional education—(and I hardly need say that while especially anxious that this Society should do what it can to promote professional agricultural education, I have sought for information at large, and simply in order to ascertain the truth, being most cordially willing to learn the lessons which it teaches, whatever they may be)—on the question of agricultural book-sales, I have information from Messrs. Black, of Edinburgh; Blackie, of Glasgow; Fullarton, of Edinburgh; Longmans, Ridgway, and Routledge, of London. I also applied for information to Messrs. Blackwood, of London and Edinburgh, who are the publishers of Mr. Henry Stephens's valuable agricultural works, and I am very sorry, indeed, that there is no information on this subject from them, because I cannot add to my list Mr. Stephens's 'Book of the Farm,' which is one of our standard agricultural works, and has doubtless as large a sale as any book of its class.

I also applied to Mr. Churchill, one of the leading publishers of medical works, for information on the sales of professional works to the members of a thoroughly well-educated profession, that there might be some standard of comparison by which to estimate the indication afforded by the figures of the agricultural publishers. Twenty years ago Mr. Churchill brought out a set of professional manuals on Anatomy, Surgery, Chemistry, Physiology, Materia Medica, &c., by such men as Golding Bird, Erasmus Wilson, Ferguson, Taylor, Fownes, Carpenter, and Royle. The number in the Census-tables connected with the medical profession in England and Wales in 1861 was about 36,000, of whom, however, only 15,000, or thereabouts, are doctors, surgeons, and apothecaries. The sale of Mr. Churchill's seven manuals up to the present time has been in all 103,500, or on an average 14,800 of each. They were all designed for the medical student. This is the only fact which needs to be quoted in illustration of the relation of the publisher to a thoroughly well-educated profession. I doubt not the experience of Messrs. Churchill is paralleled by that of other publishers of medical books.

But compare this with the experience of the publishers of agricultural books, who have so much larger a constituency. First, however, what is their public? There were 30,000 landowners, 250,000 farmers, 16,000 farm-bailiffs, and 500 (so-called) agricultural students in England and Wales in 1861. But many landlords fill public offices, under which they are returned, and so the tabular number is in this case declared defective. It is probable, however, that there may be some of the class who might be better described as small farmers cultivating their own land, and this would, perhaps, diminish the number of the class on whom the agricultural publisher would depend. Take, therefore, 30,000 as the true number. As to

farms—of every 1000 holdings in ten English counties, there were only 220 over 100 acres each. I take, therefore, only 20 per cent. of the whole number in the Census returns to be available as purchasers of agricultural books. To 30,000 landowners, therefore, add 50,000 farmers, and some 10,000 farm-bailiffs and agricultural students, and you have 90,000 altogether. If to this there be added the corresponding numbers in Scotland and Ireland, we may assume that the "public" of an agricultural publisher in this country numbers at least 120,000 persons.

Now, what are the sales of agricultural books? Messrs. Longman have sold about 9000 copies of Loudon's 'Cyclopædia of Agriculture,' since 1825. Fullarton has sold 9500 copies of his 'Rural Cyclopædia,' published 1848-52, in four vols., at 20s. each: and 5500 of his 'Farmers' Cyclopædia,' published in 1853-56, price 40s. Blackie has sold 8500 copies of the 'Agricultural Cyclopædia,' published in 1856, in two vols., for 3*l.* 16s. Of Professor Low's excellent book on 'Practical Agriculture,' the first edition of which was published in Edinburgh, Longmans have since sold 5091 copies up to June, 1864.

Of other books I add the following list:—

	Price.	Sold.	Published.
	s. d.		
<i>Messrs. A. & C. Black.</i>			
Mr. Wilson's British Farming	800	1860
<i>Messrs. Blackie & Co.</i>			
Webb's Farmers' Guide	3 6	1,000	1839
The Agriculturist's Calculator	8 0	10,000	1851
Professor Wilson's Farm Crops	13 0	3,000	1859
New Farmer's Almanac	1 0	9,000	Annually
<i>Messrs. Fullarton.</i>			
Farmer's Cash-book	7 6	1,500	..
<i>Messrs. Longman.</i>			
Handbook of Dairy Husbandry	1 6	2,000	..
,, Farm Labour	1 6	1,000	..
Low's Domesticated Animals	300	..
,, Landed Property	1,300	..
,, Breeds of Domesticated Animals	200	..
The remainder of the Editions of Professor Low's work have been disposed of to Bohn.			
<i>Messrs. Ridgway.</i>			
Mr. C. W. Johnson on Fertilisers	{ about 6,000 }	1844
Rev. S. Smith's books on Lois-Weedon Husbandry	..	7,000	{ 1849 and 1856
Squarey's Agricultural Chemistry	750	1841
Main's Farmer's Manual	2,000	1847
Morton on Soils	2,000	1837
Cottage Farmer's Assistant	4,000	1845
Johnson and Shaw's Farmer's Almanac during twenty-four years, 373,000; averaging .. .	1 0	15,570	per annum.

	Price.		Annual Sale.
	s.	d.	
<i>Messrs. Routledge.</i>			
Sibson's Agricultural Chemistry	1	6	430
The Sheep, the Pig, and Cattle (each)	1	0	750
The Horse, by Cecil and Youatt	1	0	1500
Small Farms, by Martin Doyle	600
Feeding and Manures, by C. Sibson	1	0	850
The Horse, by Stonehenge	18	0	500
Mr. Mechi's How to Farm Profitably	5	0	500
Young Farmer's Calendar	10	6	300

I beg to thank the publishers of these works for so frankly giving me these illustrations of the demand for agricultural works. Of course there is a large number of other books addressed to farmers which have not had anything like the success of these. But I think that even here, considering the very large public to which these books are addressed, and the contrasted demand for professional books in the medical world, we have evidence rather of an imperfect than of a satisfactory state of professional education in that of agriculture. If I lay the burden of the smallness of the reading public for agricultural books to the discredit of professional rather than general education, it is partly because that public includes 30,000 landowners as well as 60,000 English farmers.

I believe the result of the whole inquiry to be, that it is the promotion of professional rather than of general education, that is most needed in the English agricultural world.

WHAT CAN THE AGRICULTURAL SOCIETY DO?

We come lastly to consider how this Agricultural Society may best promote the improvement of agricultural education in this country, and I shall not tax your patience for more than five minutes longer.

Three-and-twenty years ago a lecture on the importance of professional education for agriculturists was delivered by the late Robert Jeffries Brown of Cirencester, before the local Farmers' Club at Fairford, and a most admirable result ensued upon his advocacy and subsequent energetic labours. The Royal Agricultural College has long been at once a splendid illustration of the power of a local farmers' club when once its interest is aroused, and a most useful educational agency for the advantage of the agricultural community, for which we have to thank, not only the intelligence and energy of its founders, but much public spirit and self-denial since. I do not refer at any length to its past services or present efficiency, for both are related by Mr. Lawrence in the current number of our Journal, but its history certainly may be cited as a proof that our local farmers' clubs may be most usefully taken into alliance with this Society in connexion with the work of agricultural education which is before it.

What has to be done? There are probably 30,000 farms of 200 acres and upwards in this country, occupied, therefore, by men of

a certain substantial middle-class in society, whose sons may thus command a fair middle-class education. If their professional life averages as much at thirty years, then 1000 young men of this class are every year drafted in this country from the rank of agricultural student or apprentice to that of professional agriculturist. Now, we may assume that there is at least a period of three or four years in the student or apprentice life of each when educational stimulus and guidance would be professionally useful; and it thus appears that there is always a constituency of 3000 or 4000 young men in England open to that educational influence which this Society might, and, as I believe, ought to exert. To apply the rein and spur to this large body, therefore, is the work which has to be done.

How is it to be done? I know no other way of offering the stimulus and guidance which are needed than the old-fashioned plan of offering prizes to candidates, and determining their relative merit by examination. It is hardly possible, no doubt, for any dispassionate observer to avoid the conclusion that the guidance of experience, and the stimulus of desired professional success, and of looked-for good social position, are really the guidance and the stimulus by which agricultural education is, and always will be, efficiently promoted in this country. Nevertheless, it is consistent with all experience, both that valuable prizes and distinctions to be won at competitive examinations, are an effective addition to the natural rewards which education confers upon the student; and that the programme of trustworthy examiners is an effective addition to the natural guidance which experience confers upon instructors.

I have, indeed, heard it asserted that this system of examination and reward is wholly inapplicable to the agricultural student or apprentice. It is alleged that there is no possibility of testing agricultural knowledge and efficiency except in actual practice. The objection might be made with exactly equal force to those examinations through which naval officers take their successive steps in rank, and there certainly it is altogether untenable. But, indeed, I am quite certain that all who have had any experience in agricultural examinations, whether they be professors determining the industry and capacity of a student before he is passed, or agents ascertaining the ability and qualifications of a bailiff before he is engaged, must admit the power of an examiner to ascertain whether any candidate for the rewards at his disposal has been a diligent and successful agricultural student or apprentice.

In order, then, to carry out a system of examinations of this kind, which I believe would be perfectly efficient in agriculture as it is in other professions, I would have this Society seek the alliance of the leading local farmers' clubs. The whole country is divided into eight or ten—I do not know how many—districts, which the Society visits in rotation. There are active farmers' clubs in each, with lots of vitality and energy. The Hexham, Newcastle, and Penrith Farmers' Clubs in the north; the Wirral Farmers' Club in Cheshire, the Midland Farmers' Club in Birmingham, the Kingscote Farmers'

Club in Gloucestershire, the Hungerford, the Dorchester, the Botley, the Maidstone Farmers' Clubs, and many others, in the south. Any of these, I am persuaded, or where there is more than one in any of the Society's districts—then two or more united—could, and I believe would, readily accept a commission from this Society in connexion with this subject. It is surely not an extravagant supposition that in every one of the districts on the Society's list 100*l.* could be annually collected through the local clubs in each from landowners and others interested in agricultural prosperity, to be awarded by the Society's examiners, in substantial scholarships and prizes, to the most intelligent agricultural students belonging to each district. If only ten or a dozen young men in every district should at first come forward to claim these rewards, great good would be done. But I cannot doubt that, stirred up by the local agencies, which would secure just that kind of publicity which the scheme requires, largely increased numbers would ultimately strive for the honours and substantial advantages of success at the local Royal Agricultural Society's professional examinations.

I do not, however, pretend to discuss this matter in any detail. No doubt there are plenty of difficulties in the way, but none insuperable, as I believe. At any rate, I earnestly hope that this great Society, which has successfully accomplished one most serviceable piece of professional education during its career—I mean, educated the great body of the landowners of this country into a taste for agricultural pursuits—will make the effort which is expected from it to promote the professional education of those who are still more directly dependent upon the cultivation of the land for their support.

Mr. RAYMOND BARKER proposed a vote of thanks to Mr. Morton for his varied and interesting lecture.

Mr. DENT, M.P., in seconding the motion, said, there could be no question as to the very great value and the very great fairness of the lecture. He thought the observations in the early portion of the lecture, as to the requisites for making a good farmer, were particularly valuable. The great difficulty was to educate farmers so as to enable them to cultivate land with ability and profit. Having sat for a short time on the Education Committee of the Royal Agricultural Society, he must say that the more they had studied that question the greater seemed to be the difficulties with which it is surrounded. The chief difficulty lay in this, that, while you wished to give a good education in general subjects at school, you desired also that early habits of observation should not be impaired, but rather, if possible, strengthened, during the school period; and he could quite understand that to keep a boy too long at school might tend to injure his powers of observation. But, then, speaking from his own experience of farmers—men who farmed from 200 to 250 acres—he should say that few of them kept their children at school for even a fair amount of time, while a very large number of boys left school almost as early as labourers' sons, their education being of a very meagre and indifferent description. The worst feature of the case, perhaps, was that when these boys left school it was merely to go on their fathers' farms, and

thus they did not obtain any experience of farming beyond the range of a circle of 10 or 12 miles. That was a very great drawback. If farmers' sons after leaving school could go out for a time and see something of what was going on at a distance from their homes, a very great point would be gained.

The best way for that Society to encourage education was by the institution of scholarships, rather than the giving of prizes. There was a suggestion thrown out on that point by Mr. Morton, which had occurred to another very active member of the Society, who was on the Education Committee, namely, that they should call in the assistance of farmers in different localities, and that, in fact, scholarships should be instituted by local authorities acting in conjunction with the Council of that Society.

Within the last twenty years he had seen twelve young men either succeeding to farms or preparing to succeed to them, not one of whom, as he believed, ever went away from his father's farm to learn the business of farming. He had endeavoured to impress on farmers in his neighbourhood the advantages to be derived from pursuing a different course; but he was always met with the remark that the sons were such useful, reliable, and steady fellows—and he could certainly endorse that account from observation—that they could not be spared.

In some letters which had been published on this subject in the 'Agricultural Gazette,' he found the writers making great complaints that the young farmers of the present day were too fond of amusement, and did not stick sufficiently close to work. He did not think the Society could cure that which was rather a tendency of the age. The race of farmers was, in fact, getting much larger than it had been. Many young men were now going into farming as a pleasant occupation; and having a good capital, perhaps they thought that one of the pleasantest parts of farming life was to take some share in the amusements of the hunting-field.

Mr. HOLLAND, M.P., expressed the pleasure he had felt in listening to Mr. Morton. As regarded the mode in which Mr. Morton proposed to improve the educational position of the future farmers, he thought they must all agree with him as to the connexion which should exist between the Royal Agricultural Society and the local societies. The education of the future farmers was of course mainly in the hands of their relatives, so many of whom were members of local Societies. If, therefore, the Royal, acting in concert with these Societies, were enabled to send examiners through the country, the educational wants of farmers might be supplied without the creation of much further machinery than that which at present existed. Mr. Dent had alluded to the fact that while young men were employed in farming they took their recreation like other people who lived in the country. There was no harm in that; on the contrary, good would result from men being called together and passing over tracts of country which they might otherwise never visit. But they must look at another circumstance. Education was entering more largely into agriculture than ever; and in this country it invariably happened that a large additional

amount of capital was employed in a trade into which improved education entered. Capital and education combined were entering into the farming business, and one result would inevitably be a diminution of the number of small farms. Men of capital and education would not be satisfied with farms of 100 or 150 acres. This being the case, it would be found that the introduction of machinery which was now requisite for the working of such farms, and the appliances of science in connexion with agriculture, must have full and fair play; if, therefore, that Society desired to be prepared for the great changes in the agricultural world arising from the improvements which were being made, it must, either by co-operation with local Societies or in some other manner, aim at improving the education of the farmer. If they looked to the advantage of the future farmer, they must endeavour to supply him with science in connexion with agriculture to a much greater extent than it had been supplied hitherto. Although, as Mr. Morton remarked at the commencement of his lecture, the harvest only occurred once in the year, yet the preparation for the harvest, and the preparation for the after-crops, would be advanced to such an extent by the improvements which were now being made in agriculture, that the inconveniences of weather, and many of those evils to which farmers had hitherto been subject, would, perhaps, ere long, be in a considerable degree avoided. On these grounds he thought they ought all to aim at securing an improved education for the sons of farmers.

Dr. CRISP believed that until the Government established an agricultural college, there would never be a proper system of education for the agriculturists of this country. He should like to see a college in London, with a regular staff of professors, and a museum attached. Many students would then be enabled to take a degree, and the beneficial effects of such an institution would extend throughout the country. The advantage of giving prizes was very doubtful. At Guy's Hospital the prize system had been discontinued because it was found that when a student had to work himself up almost exclusively on any special object, the devotion of so much time to that object was injurious to him in after life.

Professor COLEMAN said that a man must be educated in the practical details of farming: for unless he was brought up to understand every single point in practice, he would very likely fail to make a profit. While he fully admitted that students should be enabled as far as possible to see a variety of practice, and not be left entirely to the farm on which they were brought up, he maintained that a knowledge of scientific principles was equally important. If a man was to keep a-head in the present day, he must understand the reason for every detail of practice, and must look carefully at every new process in farming.

Having had much to do with the education of a great many young men in the College at Cirencester, where he was formerly a pupil, he had seen the great difficulties under which young men laboured when they had come there without that general preliminary education which alone could enable them to grasp the scientific truths that were pre-

sented to them. He had seen, especially in the earlier days of that institution, young men entering who left the general school at about fourteen or fifteen. Having afterwards lived for three or four years on their fathers' farms, and, he was afraid, spent a large portion of their time in hunting and shooting, they had then come to the institution perfectly unprepared to take advantage of the opportunities of improvement which were offered to them; in fact, the knowledge which they should have acquired passed completely over their heads. Therefore, while he fully admitted the great importance of practical details, he thought it was also very important that there should be a good general education, and that boys should not leave school to gain a knowledge of the practical details of farming at such an early period as had been suggested by Mr. Morton.

Mr. MOORE did not quite agree with some of the previous speakers in the opinion that sporting contributed to the improvement of the young farmers. He maintained that young men should go upon a farm to learn the business, and while there should stick to it. There was such a tendency in outdoor occupation to create a disinclination for reading and office work, that he made it his rule never to take a pupil without a distinct understanding that there should be no sporting during the time he might be with him. Whatever self-denial and self-discipline they were thus called upon to exercise, he believed they would be the better for in after life. Whatever might be done by the Society to further agricultural education in this country, he hoped they would not mix themselves up with the question of the general education of the people; because, although there was a class of farmers who undervalued education, and felt little concern for their sons in that respect, yet he was happy to say that that class was rapidly diminishing. As a body, the farmers were becoming as anxious as any other class to avail themselves of the advantages of education.

The other day he visited the Agricultural College at Cirencester, and Mr. Constable mentioned to him that the Farmers' Club at Kingscote had recently made an arrangement, by which Mr. Church, the chemist at the college, was to deliver a series of lectures in connexion with that Society, and extending over a considerable period; and he added that a large number of farmers' sons had put their names down with subscriptions of five guineas a-piece to pay for these lectures. He, Mr. Moore, did not by any means undervalue the local Societies; but the great mistake connected with them was, that they had generally confined themselves to shows of live stock, &c. Eight or ten years ago, he had assisted in the establishment of a library at Farringdon, and in connexion with that they had a course of lectures in the winter, the attendance at which had varied from fifty to seventy. The effect of that institution had, he believed, been very beneficial. Still, he must say that the books in the library were not read so much as he could wish. If the Royal Agricultural Society could in any way help forward a movement of that kind, they would be doing a great good to the agricultural community.

Sir WALTER STIRLING said, it seemed to him that the question was one between practical intelligence and scientific acquirements; whether,

in short, they could dispense with practical industry by setting up scientific inquiry as the *primum mobile*, or cardinal feature, of the whole system. In his view farming was not to be considered as a science, but rather as an industry. Therefore, the greatest practical intelligence must be essential to carrying it on. How did they generally regard the operations of a gentleman farmer? Why nine times out of ten as a complete failure. And why? Because from his birth and his habits he did not possess the practical experience which the common farmer possessed in an eminent degree. Persons employed in the useful arts and purposes of life were by no means the better for the knowledge of either the use of the globes, or trigonometry, or the higher departments of science. On the contrary, we knew they were the worse for these; inasmuch as such acquirements gave them a vast amount of conceit and pretension, which rather interfered with their practical intelligence and their ability to achieve success in the particular profession they might have embraced. It was the same with regard to manufactures. The successful manufacturer, say the calico-printer, had but a very small knowledge of the analysis of colour, or understood mauve or magenta, chemically speaking. Most likely he made his fortune by not knowing them. Of this they had a recent example in that great and clever man, whom all must remember with respect and reverence, he meant Mr. Cobden. He was a failure in his own profession: at all events he did not acquire a fortune as a cotton-manufacturer—and most likely it was owing to the circumstance, viz., that his ideas soared above the technical requirements of his original occupation—were too high, and his education superficial.

Mr. HOLLAND, M.P., alluding to the remarks of Mr. Moore on the subject of libraries, suggested that it would be a great advantage if in circulating the books they were accompanied by a brief synopsis of their contents.

The CHAIRMAN said, the subject of agricultural education had become one of real national importance. There was a Royal Commission inquiring into middle-class education, and of course that would include an inquiry into the position of the farmer so far as his education was concerned. He could not agree with Dr. Crisp that the best thing to do would be to establish an Agricultural College and Museum supported by the State, or that the State should interfere in the matter in any way whatever. They might rely upon it that the best museum that a farmer's son could have was the farm itself, where he was to learn his business practically. He concurred with Mr. Morton, then, that it was upon the farm that the boy must learn his work; a farm, moreover, at some distance from the locality in which he would afterwards reside. But Mr. Morton had scarcely allowed sufficient time for the boy's early education, and seemed to think that he ought to leave school or college early to go to the farm. Unless he got a good education, and thereby awakened in his mind the desire to obtain further knowledge on subjects connected with the employment of his after life, unless he was interested in various ways in education generally, there was little in the life of a farmer's son to encourage him to

continue his studies. It was of immense importance, therefore, that the farmer should, in the first instance, receive a liberal education, in order that he might, from his own desire and impulse, continue, when on the farm, the studies in which he had been engaged at school. As contributing towards this object there was, perhaps, hardly a better plan than that which had been suggested by Mr. Moore; viz., that when farmers' sons were grown up they should have opportunities afforded them for hearing lectures on agricultural subjects, and have access to a good library. It was not in the power of many farmers to send their sons to college for two or three years, as suggested by Mr. Morton, before taking a farm. In the absence of this, the plan recommended by Mr. Moore was certainly worthy of consideration. In fact, the Royal Agricultural Society intended shortly to open communications with farmers' clubs in England, with a view to interesting them on this question of agricultural education, and, if possible, to establish a common action respecting it. The whole question was very fairly and ably argued in the lecture, and he was sure they were much indebted to Mr. Morton for it.

A vote of thanks was then passed to Mr. Morton.

Meeting of the Weekly Council, Wednesday, May 31. The President, Sir E. KERRISON, M.P., in the chair. Professor VOELCKER delivered a lecture on

IRRIGATION.

Professor VOELCKER said: Last year I had the pleasure of delivering in this room a lecture on the qualities of good drinking-waters, and waters used for general domestic purposes. To-day it will devolve upon me to speak more particularly of the character of waters best adapted for irrigation; and at the outset I wish to remind you that it is foreign to my present purpose to speak of the various systems of irrigation, or to enter into practical details with which farmers who practice irrigation are better acquainted than I can possibly be. Although I am always happy to give advice on subjects in which I can see a connecting link between the man of science and the practical farmer, I do not think it incumbent on me, as your consulting chemist, to treat of purely practical matters, such as the application of water, after it has reached the farm, to the land.

I think I can more profitably occupy your attention to-day by speaking on the general principles that ought to guide us in the application of water for the irrigation of land; and in doing so I must briefly allude to the great variety of opinion which prevails with regard to the cause of the efficiency of different kinds of water.

Some ascribe its beneficial effects altogether to the matters dissolved in the waters. We hear some asserting that none but muddy, or foul waters, are fit for irrigation; whilst we have the trustworthy evidence of men who have applied perfectly clean and bright water to their lands with the most excellent effect. Again, we find some maintaining that water ought to be soft in order to produce a beneficial effect; others state that hard waters are best adapted for irrigation. Some

ascribe the fertilizing value to the carbonic acid dissolved in the water. Others even maintain that it is the carbonic acid in the water which does the mischief which is occasionally observed. Further the warmth of the water is by some considered the sole fertilising agent, whilst others do not hesitate to say that temperature has nothing to do with the beneficial effects. I might have alluded to other matters, as showing that there is a great diversity of opinion prevalent upon this subject, but it is not necessary. Let us then inquire which of these views are right, and which are evidently founded on misconceptions or prejudice.

To render my subject more perspicuous, it may perhaps be well to glance for a moment at the action of waters on soils, for I have noticed that in all the papers which treat on the causes of the efficiency of water for irrigation, the soil is left altogether out of consideration; yet a very few illustrations will show you at once that it is in vain to discuss merely the qualities of water, without reference to the quality of the soil. We know that in this immediate neighbourhood, on the London clay, heavy showers of rain, which in a measure irrigate the land—for sometimes the water remains for days upon our meadow lands—have more effect than even London manure. It is a well-known fact that in bad seasons—that is, when there is little rain in the spring—manures applied to the land have no effect; and in the favourable seasons, when heavy rains fall during the spring months, manures are not required, because the rain does more good than all the manures the farmers can possibly apply to land so tenacious as the London clay. Here evidently the water dissolves the fertilising matter out of the soil. It must render soluble a very large quantity, for we obtain a large produce of grass. On the other hand, we find that even on well-manured soils of a purely sandy character, the water, when it falls copiously in the spring, has the effect of washing-in such soluble matters as nitrate of soda, and even guano. Whilst, then, on sandy land pure water does produce a decidedly beneficial effect, on other land it may have the contrary effect; and further, what pure rain-water does will also in a measure be done by natural spring-waters. Let us then glance for a moment in a general way at the action of water on the soil, to assist us in arriving at a satisfactory conclusion with regard to the water which is most useful for irrigation.

In the first place, I notice that water carries air into the soil. I say *into* the soil, for I take it to be a well-recognised principle that on irrigated meadows the water should not merely flow over the soil, but also percolate through the soil. The soil, for this reason, must be porous; not only its surface drained, but its under-drainage must be either naturally good, or rendered perfect by art. In bringing down air then into the soil, and with it fertilising matter—ammonia and carbonic acid—from the atmosphere, water also carries along with it chemical agents, which render both organic and mineral fertilisers soluble and fit to become food for plants. First, the organic matters are rapidly destroyed by the oxygen of the air; the nitrogenous substances are converted into nitrates, which we know have a most powerful stimulating effect on the growth of all vegetable produce.

The nitrates, which invariably occur in all drainage-waters, and which are also found in all natural spring-waters, are evidently the products of the oxydation of organic matter originally present in the soil.

There is a wise provision that no organic filth should accumulate. The air which is carried down in the water, bringing oxygen into immediate contact with those organic remains, destroys them, and converts an obnoxious material into one that is of the greatest value.

The change which water produces on a variety of mineral matters is no less important. I just now observed that all natural water (rain-water as well as spring-water) invariably contains carbonic acid in solution. This carbonic acid acts as a solvent for many mineral matters which are insoluble in pure water. Coming from rocks that contain small quantities of phosphate of lime, it dissolves this important constituent, and renders them available for the use of the plants. Again, water charged with carbonic acid decomposes some of our natural silicates, and renders them available as plant-food. Lastly, water carries warmth into the soil. It is well known to all scientific men that water is heaviest and densest at 40° —that is 8° above the freezing point. When the air is at 32° , the water as it cools, instead of becoming denser and sinking, actually rises in the upper layer of the soil; the colder particles of water rise higher until they are at 32° , when a sheet of ice is formed, which preserves the water below at 40° , so that under ice the temperature of water is at least 8° higher than that of the air during frost.

On an average, perhaps, the temperature of our natural spring-waters may be said to be about 10° above that of the air during the months in which irrigation is practised, though we find in them great variations. Some that feel cold during the summer, and warm during the winter, when tested with a thermometer will be found of a uniform temperature throughout the year; they are not affected by the temperature of the atmosphere. I take it that such waters, other circumstances being equal, are particularly useful for irrigation, as they convey into the soil and to the roots of the plants a considerable degree of warmth. These may be said to be some of the chief benefits that arise, speaking generally, from the percolation of water through the soil.

I now pass on to speak more especially of the most desirable qualities of water used for irrigation. I will take them in the order in which they are useful to the farmer. The best water for irrigation is no doubt sewage-water; because it is a natural water, which contains refuse excrementitious matters, that are exceedingly useful fertilising agents. In no natural waters do we find the amount of ammonia or of phosphoric acid that occurs even in the most dilute sewage; and as ammonia and phosphoric acid, perhaps also potash (which occurs in sewage in appreciable quantities), are fertilisers of the greatest importance, we ought not to waste them, but apply them to the land, if possible. The organic matters, in percolating through the soil, are converted into nitrates, the greater portion of which, no doubt, is rapidly taken up by the succulent produce which

is best suited to irrigated lands. Rye-grass ought to be extensively, and perhaps exclusively, grown on soils adapted for irrigation, in order that the soluble matters, as soon as they become available, may be elaborated into vegetable produce, and that good food, after being produced on the land, may not be afterwards washed away. Do, however, what we will, we cannot prevent altogether the waste of a great deal of fertilising matters in the drainage of irrigated fields. This is a great fact, well known to those who have seen the irrigated meadows on Lord Hatherton's estate at Teddesley, in Staffordshire. I have strong reason for believing that drainage-water is occasionally more useful for irrigation than the natural spring-waters of the locality.

On highly-manured fields we cannot doubt that water, in passing through the land, actually takes out more than it imparts to the soil. It is quite true that in other instances the water itself conveys food to the land; but when the land is highly-manured, or if the soluble matters are, as in the case of sewage, brought on the land in great abundance, a great deal of fertilising matter will pass away in the drainage-water. In proof of this I may mention two analyses of water, that I find in the third Report of the Commission which sat to inquire into the best mode of distributing the sewage of towns. That Report states, at page 48, that the sewage, when applied to the soil, contained in solution 44·87 grains per gallon of soluble matter; the drainage from the soil contained 37·52; thus showing that a considerable quantity of soluble matter is retained in the sewage. It is true that most of the ammonia has been absorbed (or transformed), for the 5·74 grains originally present in the sewage became reduced to 1 grain; still there is 1 grain in a gallon left. What is of yet greater importance is this fact,—that whilst the sewage contains no nitric acid, the drainage contains no less than 4 and a fraction per cent. derived from nitrogenous matter, or even from ammonia; for I believe that ammonia is capable of oxydation, and of being largely converted into nitric acid, which is perhaps the very best form in which it can be presented to the growing plant.

In several drinking-waters, fitted rather for irrigation, I have found a large proportion of nitric acid—indeed the presence of appreciable amounts of nitric acid can be detected in all natural springs. We have very scanty information upon this subject, which is one that I should like thoroughly to investigate. I should like to ascertain what quantity of water goes on to the land in the natural rainfall, or the natural springs that are made to flow over it; what quantity passes out of the drain in the drainage-water, because the settlement of this question will throw light upon the exhaustion of soils, of which we have heard so much. It is impossible to restore to the land with profit all that we take out of it. The natural sources of loss are far greater than those occasioned in our fields by the removal of the produce. Perhaps it will clear our ideas on the subjects of exhaustion and permanent deterioration of our fields if this subject is thoroughly investigated. I therefore purpose to go thoroughly into it, and examine not only the waters that are best fitted for irrigation, but also the drainage-water; and I stand in need of

the assistance of some practical men who would undertake to apply gauges for measuring the quantity of water that falls on the land and the quantity that passes through the drains on a given area.

Sewage-water, then, is no doubt the most useful water for irrigation. But here differences of opinion are sometimes expressed. Some maintain that a perfectly bright and clear sewage is best adapted for irrigation. Others say that the muddier the sewage is, and the more suspended matter it contains, the better. I contend that a moderately clear sewage is the better, because that which contains much suspended matter is apt to produce on the surface of the soil, especially if not very porous, a silicious film, which dries and chokes up the pores of the soil, and in this way does mischief. If the coarser particles are skimmed off by the sewage being allowed to pass through a grating, and the whole suspended matter finds its way into the land, it will do good, if properly distributed. We need not be particular in filtering the water to a nicety, but should be careful not to allow too much of the suspended matter to flow on the land, especially if it is not a purely sandy porous soil, on which sewage application is most efficacious. As a matter of curiosity, I have brought with me a sample of the Maplin Sands, to which I am inclined to think irrigation with sewage will be useful. It is supposed that this sand contains some clay—not much, and also some other fertilising matters.

I now pass on to another description of water, next in point of efficacy to sewage. Nile water conveys a vast amount of fertilising matter to the naturally sterile plains on the banks of that river. Some time ago I made an analysis of Nile water, taken both at the rise of the flood and when the flood was at its height. At the latter stage the quantity of solid matter carried along is four times as great as at the time when the Nile begins to rise, and it is chiefly in the deposit of this solid matter that the fertilising action consists. Apart from this deposit Nile water contains only 10 grains per gallon of solid matter in solution, and perhaps the application of these muddy rivers can hardly be called irrigation proper; it is more the warping than the irrigating of land. Suffice it, then, to say that muddy streams which contain large quantities of suspended mineral, as well as organic matter, are chiefly useful in depositing new soil.

I pass on now to another description of water—that of waters which have an equal temperature throughout the year. Water of that kind is considerably warmer in winter than the atmosphere of our fields. We have some observations made upon this point by Mr. Whitley, of Truro, in Cornwall; also by Mr. Robert Smith, who has examined several springs in Exmoor, in Devonshire. Both these gentlemen are of opinion that the temperature of irrigation-water during the spring months is 10° higher than the temperature of the air. Thus a considerable quantity of heat is carried into our soils. Waters of a uniform temperature generally come from deep springs; and deep springs generally contain more mineral matter in solution. If water passes through a thin layer of soil or rock, it has not much time to dissolve the mineral matter. When it percolates through a large body

of soil and an extensive layer of rock, it dissolves more mineral matter; and that is doubtless another reason why waters that are warm in winter are more beneficial for irrigating purposes than those the temperature of which is influenced by that of the air.

I do not think hardness in water is prejudicial to irrigation. I can, indeed, give practical evidence to the contrary. Some of the irrigated meadows in the neighbourhood of Cirencester, and in other parts of Gloucestershire, are irrigated with very hard water, and the effect produced on them is marvellous. I can conceive that on some land the lime that is conveyed to it in the shape of water is of no advantage; but I cannot conceive how lime in water can have an injurious effect. Let me give you an illustration showing how apt men are, who perhaps take a little too much credit for their practical sense, to theorise, notwithstanding their strong protestations to the contrary. Practical writers on the subject of irrigation have remarked that soft waters are good, because their softness is due to a soapy constituent—potash or some kind of alkali. Now chemical examination shows that soft water generally contains no traces of alkali. It is the hard waters which usually contain the most potash and soda, for the simple reason that, as they traverse soil or rock, potash and soda must be dissolved at the same time as the mineral substances, which they take up. As a matter of fact I may mention that it is the hard waters that contain alkalis, not those which feel greasy and soft; these last are soft simply because of the absence of mineral matters, such as lime, oxide of iron, and magnesia.

The best spring-waters for irrigation are those which contain the largest quantity of fertilising matters, especially mineral matters, in solution, and which contain also the most heat, and are thus in the best condition for yielding to the soil over which they pass both food and warmth.

In conclusion, I would allude briefly to the waters which either are altogether unfit, or else require special treatment to fit them for irrigation. Such are the waters which rise from peaty or boggy ground; these positively do harm. I have found it stated that it is the tannin dissolved in the water that does mischief; but this is evidently a mistake. Tannin is a substance which is very rapidly affected and destroyed by atmospheric influences; so that in tanning care must be taken to bring the materials used as soon as possible in contact with liquids containing tannin. We use solutions containing tannin as a test to ascertain the presence of oxygen. Tannin, then, is evidently not the injurious thing which it is sometimes supposed to be, when it is present in peaty waters. Nor are the organic acids which are known to the chemist under the name of ulmic or humic acids as injurious in water as some have considered them. In peaty waters the quantity of these acids is but small; and it is very doubtful whether they produce any injurious effect upon vegetation. But there is very frequently present in peaty water sulphate of iron, or green vitriol; and this is the constituent that does all the mischief. Waters containing this ingredient are recognised by the ochrous deposit they produce in their channel-bed. Sometimes waters which flow through

even a small portion of soil, especially if it be calcareous, are deprived of this ochrous matter, and become again fit for irrigation; but in nine cases out of ten it is the sulphate of iron which occurs in waters rising in peaty localities that does the mischief. In the specimens of peaty soil which I exhibit you can see the sulphate of iron crystallizing out. My attention has frequently been directed to the injury caused to vegetation by such waters. A few days ago the Rev. Mr. Clutterbuck sent me, from his park near Abingdon, such a sample. Then, again, waters which contain too large an amount of saline matters are injurious for irrigation. Among these I may mention sea-water, for I could adduce two or three instances in which, to my knowledge, when tried for irrigation, it has turned out a complete failure, and for two or three years has rendered the soil sterile.

I promised at the beginning of this lecture to confine my attention to the qualities of waters; and having mentioned some qualities which are most desirable for irrigation, and others which we ought to avoid, and having further alluded to some waters which are injurious on account of their deleterious substances, I think I have pretty well exhausted the subject.

Sir JOHN JOHNSTONE, M.P., said that some years ago he used for the purpose of irrigation, water that came from the moors, which proved so deleterious that he was obliged to give up using it. At the time he was under the impression that the injury was caused by the tannin in the water; and he considered it a great advantage that they had in that Society an opportunity of having such mistakes corrected. The mischief was no doubt due to the ochrous matter which the water deposited in the soil. He wished to add, in confirmation of the Professor's remarks on drainage-water, that he had some meadows in the neighbourhood of Leominster, where the same water had been used three times, and the last application seemed as successful as the first.

In reply to a question from Mr. FERRIS,

Professor VOELCKER said,—in some of the waters that passed through the primary rocks, the amount of potash is considerable, five or six grains per gallon. That is a larger portion than occurs in sewage. No doubt a great deal of the benefit derived from some natural water is due to the presence of potash.

The CHAIRMAN said Professor Voelcker's lecture was very valuable, directing, as it did, the members to the different kinds of water that were most available for irrigation. He agreed with him that hard waters, particularly such as he had seen in the counties of Dorset and Wilts flowing from chalk, were exceedingly valuable. They were, indeed, far more valuable than those soapy and soft waters which some people had supposed to produce the greatest effects in irrigation. The Professor had wisely separated what he called warped lands—that is, lands on which such deposits were formed as came from the Nile, or might be found in Lincolnshire and some other English counties—from lands to which irrigation was applicable. Irrigation, strictly speaking, consists in the passing of water as rapidly as possible through land without leaving a film behind. He quite concurred with the lecturer that where the thinned water of sewage came naturally, if

it contained its fair proportion of ammonia, it would be the more valuable for passing rapidly, and not choking the pores of the soil through which it passed. What had been said about the injurious effects of sulphate of iron and peaty waters was most important, and lectures of that kind, borne out by personal knowledge, were calculated to be most useful in preventing the expenditure of money on irrigation with water which would do more harm than good.

There was another important point, having reference to water from drains. At that moment Mr. Bailey Denton was very anxious that inquiries should be made with regard to the supply of water, which of late years had been much changed by the drainage throughout the country. That gentleman was of opinion that in some cases, in consequence of the water being drained away, the rainfall had been lessened, and the difficulty of obtaining water increased, and that hence there was a necessity for using and storing our drainage-water as much as possible. This appeared to him a very valuable hint. It was already established that water which passed through highly-fertilised land was more valuable than water which did not naturally contain much ammonia. Probably before long an inquiry would have to be instituted, as to the manner in which the dams, which had been long maintained at certain heights, should be altered, in order to enable people to avail themselves more easily of the water supply. The water now came out at a doubly and trebly rapid pace; yet there was no possible means of altering the height, because the law did not permit it. There must be an inquiry with the view of enabling agriculturists to use the rainfall more extensively than they have done. In conclusion, he must repeat that he considered the lecture which had been delivered one from which agriculture was likely to derive great benefit.

Sir J. JOHNSTONE, M.P., said many of the meadows in the neighbourhood of the Humber called "salt-meadows," were very good for fattening animals. He should like to hear from the lecturer some explanation of that.

Professor VOELCKER said he knew a good many salt-meadows on some parts of the coast. The quantity of salt that was brought upon the land was very small, but it was sufficient to produce a decidedly useful effect. Let it be remembered that for agricultural produce a small quantity of salt was of very great use, whilst a large dose was invariably injurious. Such a quantity as would be conveyed to land by the spray of sea-water was no doubt beneficial. Indeed, he believed that the addition of some salt to sewage would be of great benefit to the feeding qualities of grass.

Every kind of refuse may with benefit be put in the water, and then applied to the land, which has a wonderful deodorising power. He was led to make this remark by knowing that the chairman took a great interest in the cultivation of flax. Steep-water was a very great nuisance, and the only way of disposing of it was to carry it over a moderate area of soil. All other deodorizers were either too expensive or not available. Even a small area of soil completely deodorised the most fetid liquid, and a large portion of the fertilising matter was

left in the land. On the previous Saturday he visited Mr. Marriage's farm, and was perfectly astonished to find that the water there, after passing through some fields, and being used twice over again, was brought into such a state that he would not have had the slightest hesitation in drinking it. Although it was originally sewage, it had become better for drinking than many drinking-waters which he had had sent to him to be analysed.

The CHAIRMAN observed that what the Professor had just said about flax-water was borne out by his own experience. Some time ago he had a difficulty in getting rid of the water which came from the flax, and which was most disagreeable. At last some steam-pumps were put up. About 1,500 barrels of flax-water a day were now discharged on five or six acres of sandy land, and the water which flowed into the river from that land was as pure as it could possibly be.

Meeting of the Weekly Council, Wednesday, June 14th. MR. RAYMOND BARKER in the Chair. Dr. W. BUDD, of Clifton, delivered his

LECTURE ON A TYPHOID FEVER IN PIGS.

Dr. BUDD said: I feel that as a medical man chiefly concerned with diseases in the human subject, I lay myself open to the charge of presumption in attempting to speak of diseases in animals before an agricultural audience, and especially in the presence of so distinguished a veterinarian as my friend Professor Simonds. I must rely for my vindication on the following facts: 1st, that the particular disease of which I am about to show some results is one of the greatest scientific importance; 2nd, that, although it has been incidentally noticed in veterinary and scientific journals, it has never, so far as I am aware, been scientifically and systematically described;* and 3rd, that within the last few years it has been the cause of enormous mortality among pigs in various parts of the kingdom,—a mortality which is still proceeding, and which, if I may depend upon the statements of persons connected with the pig-trade, is likely to affect materially the price of pork. I need scarcely observe that in these days of dear meat anything that may affect the supply of food for the working classes is matter of national concern.

Another motive for bringing this disease under your notice is, that the opportunities for prosecuting the inquiry further have passed out of my hands. This fever, which was apparently very rife in my neighbourhood at one time, has now died out; and I am extremely anxious that the few rudiments which I have brought together should not be allowed to perish, but be placed in the hands of more competent persons than myself, or persons having a larger field for investigations of this kind.

It may simplify what I have to say if I at once state that the

* Unless a statement in the last edition of Röhl's 'Lehrbuch der Pathologie und Therapie der Haustiere,' article 'Gastrischer Fieber,' to the effect that all the domestic animals are subject to a fever attended by ulceration of the intestine, be supposed to include this malady, I have met with no mention of it anywhere. Röhl's book contains, however, no special description of this disease in the pig.

conception I have formed of this particular disorder is that it is of a typhoid character. Most of you, no doubt, are sufficiently familiar with the disease called typhoid fever, and sometimes gastric fever, in man. That disease is attended and characterised by a peculiar ulceration of the intestinal follicles. So with the disease in the pig: it, too, is a typhoid fever, characterised and attended by a peculiar series of ulcerations of the intestine, which are in some respects the very counterpart of the ulcerations found in the human intestine, so that the two may be considered exact pathological equivalents; the differences between them, more especially as touching the order of their distribution, are, however, too serious to allow us to suppose that they are the common effect of a single specific poison. My idea is that the two maladies are not identical, or not interchangeable; that is to say, that the typhoid fever of the pig is not communicable to man, nor that of man to the pig. The pig-fever stands towards the typhoid fever in man in just the same sort of relation that small-pox in sheep stands to human small-pox. My first acquaintance with the disorder I owe to Professor John Gamgee, of the Veterinary College, Edinburgh. In August last he wrote me a short note to say that a very remarkable and fatal outbreak of true typhoid fever had occurred among pigs in Edinburgh; that the disease had been attended by ulcerations of the intestinal canal, the precise counterpart of those attendant on fever in man; that the disorder had been imported into Edinburgh by stock from Wolverhampton, but had been extinguished by measures which, as I gathered from his note, had been directed against contagion. He closed his note by offering to send me specimens, or a whole pig, if I desired it. Feeling that it was a case in which, if in any, it was advisable to "go the whole hog," I telegraphed to him to send me a pig entire. The weather was very hot at the time, so that when the pig, which was despatched in accordance with this request, reached me, it was in an advanced stage of decomposition. That, however, did not prevent me from examining it and ascertaining that the colon was beset by numerous ulcers.

I heard nothing more of the malady for six or eight months, when a friend of mine, a medical practitioner in the neighbourhood of Bristol, wrote me to say that the pigs in Clifton Workhouse were all dying of intestinal fever; that out of a lot of ten pigs which had taken the disorder, six had died, and the remaining four were not likely to recover. Next day I went over to see the patients, and had an opportunity—the only one I have had—of observing the disease in the living subject. I saw them from day to day until they died; and I could not give you a better idea of what I saw than by saying that the disease is the exact counterpart of typhoid fever in man, though more rapid and more deadly; but in other respects singularly like.

I will say a word or two on the history of these ten pigs. They had been purchased in Bristol market about a week before the first symptoms showed themselves, and when brought to the workhouse they appeared to be in perfect health. In the course of four or five days one or two of them began to droop and exhibit signs of illness. The earliest death occurred on the fourth day after the first symptoms

were observed. As it is quite likely that the earliest symptoms had escaped notice, the animal had probably been ailing longer than that. The others died at various periods of the disorder, ranging from the 8th to the 10th, 12th, 16th, and the longest survivor lingered until the 20th day.' The outbreak lasted in the whole about six weeks.

I have said that the symptoms resembled in a general way those of typhoid fever in man. The pig began to droop and shivered, more or less, distinctly, suddenly became very prostrate, lost its appetite, got thirsty, and seemed very unwilling to be disturbed. The master of the workhouse believed that in the first stage of the disorder these pigs suffered from headache; and though this seems to be a curious statement, I have no doubt that it was a correct one; for one could hardly fail, from their heavy look, the fixed way in which they held their heads, and the resistance they offered to their heads being disturbed, to come to the same conclusion. These first symptoms were either attended or soon followed by profuse diarrhoea: this is one of the leading features of the disease. The discharges were at first of a light yellow, and strikingly resembled the light ochre-yellow discharges that belong to typhoid fever in man. As the disease advanced various modifications in the colour of the evacuations ensued. They became more or less of a dark green, and towards the end in many cases of a deep chocolate or dirty red, which tinge arose from the occurrence of hemorrhage in the intestinal ulcerations. Since it is important in a disease like this, where investigations are new, to fix upon outward signs that may lead to its early recognition, I will refer to a symptom I regret not having witnessed myself, but which, as I am told, is a constant characteristic of the disorder in its early stage. On, apparently, the second, third, or fourth day, the skin of the pig between and around the ears became of a red colour, passing into various shades of purple or violet. This red tinge gradually spreads over the whole surface of the animal, and is especially conspicuous on the flanks and other parts not much covered with hair; and it appears to have earned for the malady a particular sobriquet. Two or three pig-factors visited these pigs, and they at once said, "Oh! we know this disease well enough; we call it the *soldier*," from a fancied resemblance in the skin of the pig to the military red.

As the disease advanced, diarrhoea became very profuse; the prostration increased, and I fancy that delirium supervened. The pigs seemed to me to be quite out of their mind, if one may say so. In the later stages of the disorder there is another circumstance which is more or less a characteristic of it. Many of these pigs became partially paralysed in their hinder extremities, and so weak as not to be able to stand. The evacuations became involuntary; the weakness gradually increased; and the animal sank. So much for the symptoms during life.

* [Through the kindness of the owner, I was enabled to make a more

* The passage included in brackets did not form part of the original lecture. For the accompanying illustrations we are indebted to the British Medical Association.

or less complete *post mortem* examination in six of the cases; and it is on the results thus obtained that the following observations are based.

The only strikingly characteristic morbid changes were seated in the intestinal canal. These were in every sense remarkable. Described in general terms, they may be said to consist of a series of ulcerations of peculiar character, variously distributed over the intestinal tract, from the stomach to the rectum inclusive.

The first stage of the local affection appears to be marked by the development (amid all the phenomena of acute inflammatory disturbance), in the substance of the mucous membrane and in the submucous tissue, of an adventitious deposit (or cell-growth, rather), resembling, in many of its characters, the well-known yellow matter of human typhoid fever.

The seat of this new formation is marked by circular or oval patches, varying in diameter from a quarter of an inch to two inches, which attract the eye by their striking contrast in colour to the surrounding membrane, and by their standing in relief upon it. (Figs. 1a, p. 476, and 1b, p. 477.)

The tinge of these patches varies from brownish yellow, through chocolate, to deep violet.

In a more advanced stage, the corresponding mucous membrane is found fretted with numerous small ulcers, or has entirely disappeared over the whole extent of the morbid deposit, which then forms the base of the sore. These two extremes were well shown in two stomachs taken from pigs which died at different stages of the disease. (See Figs 1a, p. 476, and 2, p. 479.)

In some specimens, the ulcers now appear in the form of deep excavations. In the greater number, however, the ulcerative process is concurrent with an exuberant outgrowth of the new formation already described, and in such wise that the ulcerations present a series of more or less fungoid elevations on the surface of the mucous membrane. A similar tendency, but in slighter degree, is exhibited in certain cases of typhoid fever in man. The resulting changes, in fact, form the subject of one Cruveilhier's most effective plates. In the pig, this tendency to exuberant vegetative outgrowth, in the cases which have fallen under my observation, reached its maximum in the stomach, as may be seen by Fig. 2, p. 479. In this stomach, it will be observed, there are five ulcers, varying in diameter from a third of an inch to about an inch and a half. Like the ulcers generally, they are either circular or oval in shape. These ulcers are not only raised much above the level of the surrounding membrane, but are bounded by everted edges, which project, mushroom-like, considerably beyond the base or pedicle of the outgrowth. They resemble nothing so much—and the parallel is in more than one way deeply suggestive—as a series of cancerous ulcerations which I once saw in the colon of a woman who had died of cancer of that gut and of the mesentery. The surface of these ulcers was apparently in organic connexion with the vessels of the part; the morbid matter by which it was constituted being of a deep violet colour, from infiltration with blood.

The drawing Fig. 3 (p. 481) exhibits the disease in a very different phase—a phase which I take to be that of retrogression and beginning of repair. It comprises the large intestine and lower end of the ileum of a pig which died on the twenty-sixth day of illness. The

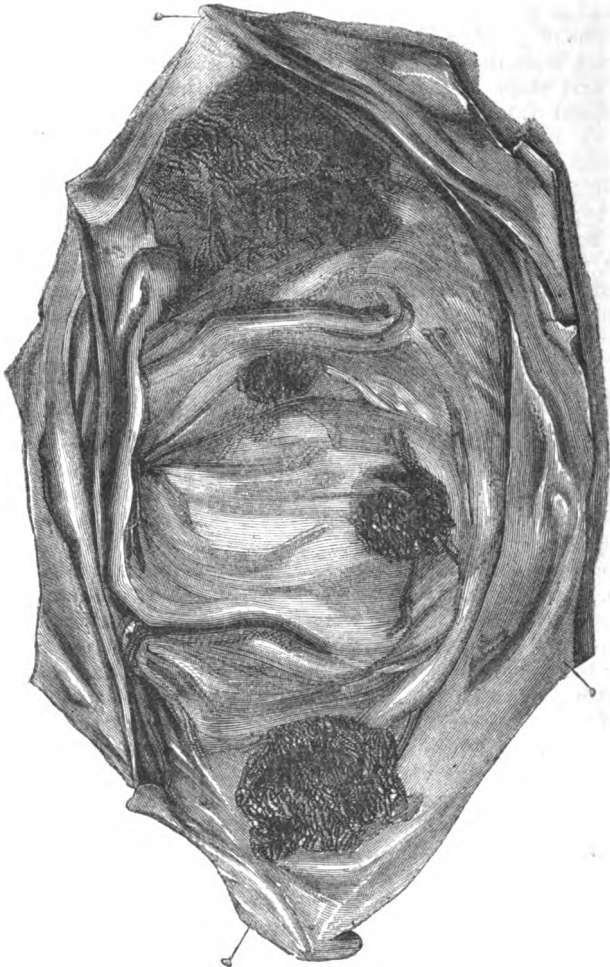

Fig. 1 a.—Stomach of Pig, shewing first stage of disease.

appearance of the diseased parts is in the highest degree peculiar. Viewed at a little distance, the gut looks exactly as if a number of thin discs of calumba-root had been stuck on to it. A friend prefers to liken them to the discs of a leathery sort of lichen, with which most persons must be familiar, as infesting the bark of certain trees.

As applied to a large proportion of the patches, this comparison also is extremely apt. Some few among them, on the other hand, recall to mind the characteristic crusts of syphilitic rupia—a fact which, again, is suggestive of many things.

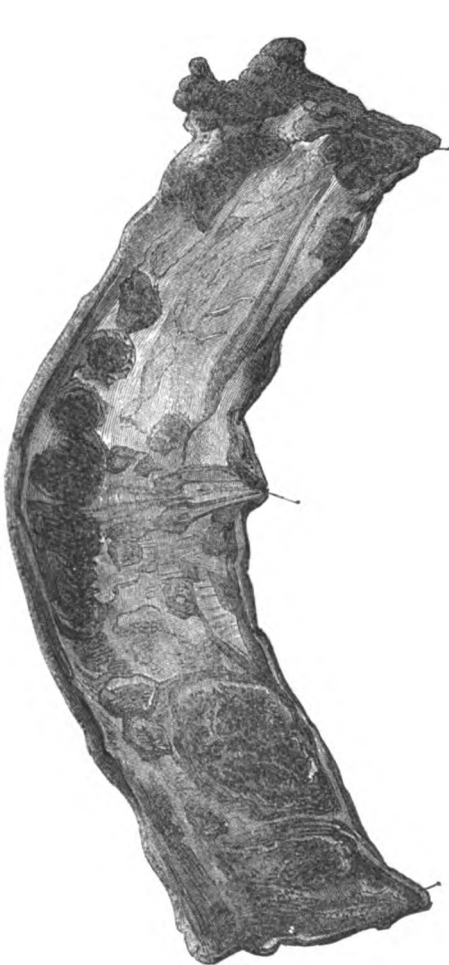

Fig. 1 b.—Portion of Intestine, shewing first stage of disease.

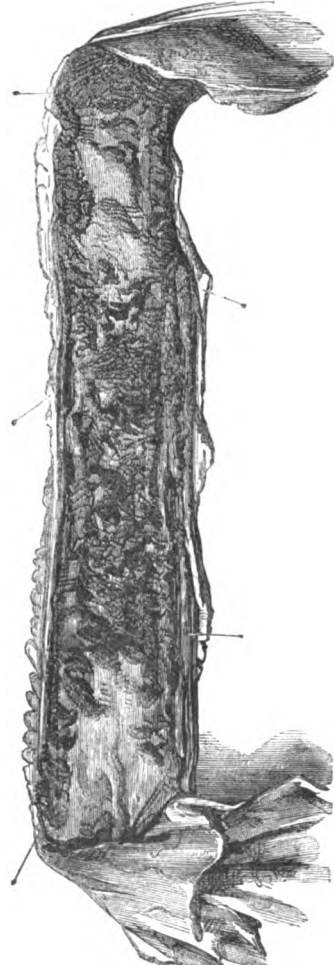

Fig. 5.—Intestine, with Croupal Exudation.

The material of these peculiar looking excrescences is formed by the adventitious matter already spoken of as constituting the original basis of the ulcerations. From being soft, spongy, and succulent, this material has become much drier and firmer, having now much about the consistence of tolerably firm cheese. Under the microscope,

its original cellular character is seen still to exist; the whole mass being, in fact, made up of well-defined microscopic cells. (Fig. 4.)

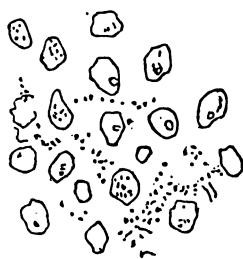

Fig. 4.—Cells from Deposit in Intestine.

On using a little gentle traction, the individual disc may be easily detached from the underlying membrane, leaving a surface which, although wanting in the polish and velvety appearance of the surrounding area, is exactly on a level with it.

I have suggested that these patches probably exhibited the disease in a retrogressive stage—the stage preliminary to repair. I infer this partly from the history of the case from which the specimen was taken, and partly from the morbid appearances themselves.

The pig to which this intestine belonged lived to the twenty-sixth day; and, a week before its death, gave every sign of approaching convalescence. Appetite had returned; diarrhœa had nearly ceased; the animal had become more lively; and nearly every symptom of the fever proper had disappeared. At this juncture pleuropneumonia of the right lung supervened, and speedily proved fatal. After death, the greater part of this lung was found in a state of hepatisation, and its whole surface covered by a soft, recent, yellow false membrane.

The condition of the patches themselves was still more indicative of a reparative tendency. In the early and middle stages of the disease, these patches were highly vascular; their surface was an open ulcer; and the surrounding membrane, where the morbid changes were severe, was often much thickened and deeply injected. In the stage before us, the patches were no longer in the condition of open sores, but had become hardened into *crusts*; and the surrounding vascularity had for the most part entirely faded away. When torn off by gentle traction, the underlying membrane seemed only to require a new epithelium to be restored to a sound condition.

The various appearances which I have here attempted to describe represent the different phases of what may be called the typical form of the local affection. In some cases, in addition to these, a condition of intestine is found which is the precise counterpart of human dysentery. The drawing Fig. 5 (p. 477) represents the lower part of a small intestine, which for a length of eight inches or more is coated with a thick layer of that form of exudation which the Germans call “croupal,” and which is characteristic of dysentery in its severest form. One of the large intestines exhibits appearances of the same character, associated with extensive sloughing and ulceration of the mucous membrane. These dysenteric alterations are, as far as I have seen, always attended by that great thickening of the gut, from sub-mucous infiltration, with which those who are practically acquainted with the morbid anatomy of dysentery are so familiar.

The large intestine is the chief—in some cases the exclusive seat of the disease. In the case, for instance, from which this drawing was taken, the three small ulcers in the lower part of the ileum represented

in the drawing, and three small chocolate-coloured circular spots, without breach of surface, in the stomach, were the only discernible morbid changes above the ileo-cæcal valve. (Fig. 3, p. 481.) The colon, on the contrary, in the same pig, was so extensively diseased



Fig. 2.—Stomach of Pig, shewing Vegetative Outgrowths connected with Ulcers.

that, from this valve to the anus, there was scarcely a square inch of membrane that was not beset by the characteristic patches.

If we put aside the cases in which the lower end of the ileum is in a dysenteric condition, the stomach is the part which, next to the colon, suffers most. The alterations which this organ presents in some cases are, as we have seen, as severe as they are remarkable.

The ulcerated patches which occur in the small intestines are few in number, and for the most part exhibit the disease in a much slighter form. Sometimes there are only two or three altogether, which in that case are generally seated in the large Peyer's patch, which in the pig, as in man, lies immediately above the ileo-cæcal valve. Sometimes, in addition to these, some fifteen or twenty more may be counted, variously distributed through the length of the gut, but for the most part occupying its middle third.

In the intestine, the disease seems to originate, chiefly, in the isolated follicles. Peyer's patches, which occur only in the small intestine, often either escape altogether, or are only affected in a partial and quite irregular manner. Sometimes, in the immediate neighbourhood of an ulcer seated on an isolated follicle, a Peyer's patch may be seen in the normal state; at other points, one end of a patch is affected by the disease, while the other remains entirely free from it.

The condition of the œsophagus I have not investigated. Judging from what occurs in human typhoid it is more than probable that this tube participates in the disorder.

I have remarked, that the only perfectly characteristic morbid appearances attaching to this malady are found in the intestinal canal. It is worth noting that the spleen, which in some stages of human typhoid fever undergoes such a marked modification, presents here no perceptible deviation from its normal state. The same may be said of the liver, with this exception, that in one or two instances I have seen a thin layer of adventitious deposit occurring in irregular patches immediately under the peritoneal coat of the organ. More than once I have observed a similar deposit under the pleura also. I have not had time to subject this deposit to a minute examination; but its colour and general appearance would suggest the idea of its being identical with the adventitious deposit which precedes the stage of ulceration in the intestine.

Various degrees of passive congestion and of pleuropneumonia are the only other morbid changes I have found in the lung. I must confess, however, that I have not examined this organ with quite the same care which I have bestowed on the intestinal canal.

In one case there were several ounces of limpid serum in the pericardium; but, with this exception, the heart presented nothing abnormal.

The kidneys exhibited appearances worthy of note. In all the cases which I have examined, these organs were a good deal congested—more variegated in colour than in the healthy state; and, in some instances, their surface was thickly beset by ecchymoses. These alterations must be familiar to most as a frequent attendant on malignant fevers, and as generally associated with acute albuminuria in the living subject.

For want of time, the nervous centres were not examined in any instance.]

Now these are all the facts that have come immediately within my own knowledge. In what I have to add, depending as it does more

or less upon the testimony of unscientific persons, I must speak with more reserve. But if the information which has reached me can be relied upon, there are two points of very great importance in the

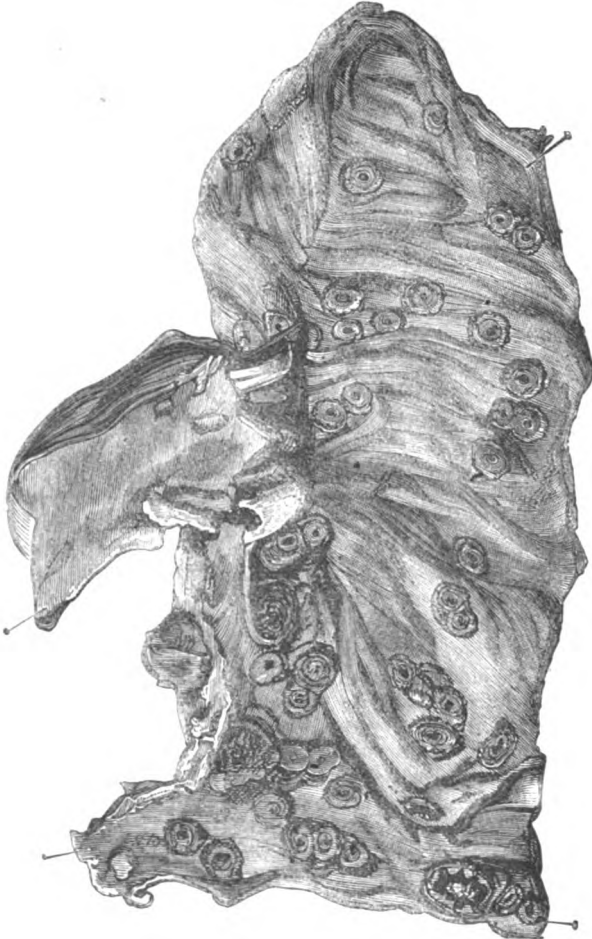

Fig. 3.—Portion of Large Intestine. Stage of Retrogression and commencing Repair.

natural history of the disorder; the first, that it is virulently contagious; the second, that it is quite peculiar to the pig. I have heard of instances where it has swept away all the pigs in the homestead; yet no other creature on the farm, whether man or beast, suffered in the slightest way. So that it really seems to be a disorder peculiar to the pig. This I need scarcely say is a fact of very great scientific interest.

The disease appears to have been known to pig-factors in Bristol and its neighbourhood for a considerable number of years; but in their experience until lately it only occurred in sporadic or isolated cases. Within the last year or two, however, it has become epidemic. I am almost afraid to repeat all that I have heard about it; but two or three men largely concerned in the pig-trade have assured me that from 10,000 to 15,000 pigs have died in the south and south-west of England of this disease in the course of the last eighteen months; and if that be the case, surely it is high time that the disorder should be seriously investigated.

I would here offer a *conjecture* as to the causes of this disease having become so rife during the last two years. Within ten or fifteen years it has been ascertained that typhoid fever in man is much more prevalent in dry seasons than in wet; in fact, that it never becomes widely epidemic over the whole kingdom except in very dry seasons. The reason I believe to be this. All those contagious disorders are caused by organic poisons, which are thrown off from the body in various forms. In these typhoid fevers they are thrown off by the bowels in a liquid state. Now, in the liquid state all these poisons perish very quickly. But there is a fundamental law which has never been sufficiently dwelt upon in relation to all these epidemic disorders, which is this, that when once these poisons pass into a dried state, if they can be kept dry, they will retain their powers for almost any period. Thus we are all familiar with the fact that dry vaccine matter will keep good for many years. Now my conjecture is that the poisonous germs thrown off in this disorder of the pig within the last two years have, in consequence of the great dryness of the seasons, been preserved to a much larger extent than common in the dry state, and in that way have been disseminated over the country.

In bringing these observations to a close I shall make one or two suggestions of a practical kind, because this is an eminently practical Society, and your object is to turn the knowledge here acquired to practical and useful purposes. I venture, therefore, to say a word or two on the subject of Prevention. I have stated my belief that this disease is the counterpart of typhoid fever in man. Now it is quite a settled point that this fever is a contagious disorder, chiefly propagated by discharges from the bowels. Now if the two diseases are the analogues one of the other, the same would hold good of the disorder in the pig. I believe that it is a contagious disorder, and that it is propagated mainly by the discharges from those sores in the intestines which constitute the specific character of the disease. It is the poison which finds its way through the system of the animal, and is thence cast out upon the ground. If pigs in the early stage of the disorder are sent by steamboat, they taint the steamboat. In like manner they taint the market, the sty, and the drains of the sty. The suggestions, then, which I would offer are these:—

- 1.—Try to recognise the disorder in its earliest stages.
- 2.—Separate the sick from the uninfected without the least delay.
- 3.—And—this is fundamental to my mind—immediately slaughter the affected animals.

4.—All these precautions will be in vain if you do not destroy the infectious discharges from the intestines of the diseased pigs.

You may separate the sick from the uninfected, but if in dry weather you turn your healthy pigs at the end of two or three weeks into the sty or the yard where the others had been ill, you will find the disorder break out anew.

And now permit me to express a hope that the Royal Agricultural Society will take up this matter, and place the investigation in the hands of my distinguished friend Professor Simonds, than whom there is no man in Europe more competent to conduct such an inquiry. The members of this Society have great opportunities. You know that mankind is infested, to a fearful degree, by that remarkable group of disorders which are called epidemics—small-pox, scarlet fever, typhoid fever, and typhus fever. Many physicians—wrongly I think—have pronounced them to be inscrutable. You have in animals epizootic diseases, that are the exact counterparts of these, analogous in their nature, propagated and destroying life in the same way. But in studying these diseases in animals you have the enormous advantage that all the problems which suggest themselves may be put to the test of experimental investigation. You know we cannot experiment upon men and women as we can upon pigs and bullocks. I think this disorder among pigs is one of the most interesting of the whole group; and I believe that if it were subjected, as opportunity occurs, to the test of experimental inquiry, results would come out that would not fail to be of the highest value to the agriculturist, whilst they would also possess great scientific interest in their bearing on kindred diseases in man, of a far higher and still wider range.

The CHAIRMAN said he had listened with very great satisfaction to the observations of Dr. Budd, and added that in his neighbourhood in Berkshire there had during the last few months been an immense mortality among pigs. The disease was of a most extraordinary character, and from all he could learn it developed itself without any premonitory symptoms, and carried off its victims quite suddenly.

Dr. BUDD believed it probable that, from the virulence of the poison, the disease was sometimes mortal at so early a stage that, as in the case of small-pox in man, the patient died without throwing out the eruptions. A certain proportion of pigs might die in the same way before the local disease had had time to develop itself in its characteristic form.

Professor WILSON inquired how the red tinge in the cuticle about the ears and those parts of the body which had little hair was to be recognised in a black pig. He presumed the pig-dealers must have some means of detecting it even in that case.

Dr. BUDD said the ten pigs of which he had been speaking were not black, and he could not answer the question.

Professor SIMONDS said that although attention had been more especially directed to this disease within the last three years, there could be no question that it had existed in a form unrecognised by medical men for a very considerable time. It was in the early part

of 1862 that the attention of the veterinary profession, and of himself in particular, was first called to this matter, in consequence of a virulent outbreak of the malady in the county of Berks. The first pigs he then saw were some belonging to Mr. Charles Cantrell, which had received the very best treatment from the time of their being born; and he confessed that when he saw them he was completely taken aback, and scarcely knew what disease he was dealing with. He had never seen anything of the kind before; for although he quite agreed with Dr. Budd as to there being ulcerations in the mucous membrane, and chiefly in the larger intestines, still in this instance there was a great deposit on the membrane, and it was only by removing these deposits that he was enabled to see that there were any ulcerations.

Dr. BUDD.—It was the same in my case.

Professor SIMONDS.—These deposits were—as Dr. Budd has said—like fungi on a tree, or the scar on a horse's leg after the operation of firing, or slices of the columba-root. But they prevailed to a far greater extent than any of these similes would convey to the mind. They existed to such an extent, indeed, as absolutely to obliterate the passage through the intestines, and more than one pig died from a rupture of the intestines, for the feculent matter could not pass through the colon in consequence of the amazing amount of deposit. Other pigs showed less of these characteristics, and in these instances the ulcerations were well marked, and chiefly confined to the large intestines. Very shortly after, he heard that many other pigs in the neighbourhood of Windsor had taken the disease, and as a very considerable number had died in the county that year, and he had observed the affection chiefly among Berkshire pigs, he began to imbibe the notion that they were more susceptible of the disease than others. Subsequent experience had shown him the fallacy of this conclusion, and he now thought there was no difference whatever with regard to breeds of pigs, all being, in his opinion, equally susceptible to the influence of the contagion. Suffice it to say, that from 1862 to the present time the disease had been extending throughout the whole country, and he did not know a single county that was not suffering more or less from the affection. Certainly it existed in all the southern, midland, and most of the northern counties, for he had seen animals from all those districts. It was for this reason that in the Report of the Governors of the Royal Veterinary College to this Society last year the following paragraph was introduced:—

“Although what may be called the established epizootics have been less prevalent, a peculiar disease in the nature of diphtheria has affected pigs in several parts of the country. This disease, however, has apparently passed its climax, and seems now to be on the decline. The sanitary measures recommended by the Professor were attended with marked benefit by keeping the malady in check; but further investigations into its pathology are required, and in this, as in other analogous cases, the Governors invite the co-operation of the Society.”

He quoted this passage to show that the Council had not only been alive to the existence and ravages of the disease, but had been exceedingly anxious to receive information and support from the various

members of the Society. The disease was therein spoken of as being of the nature of diphtheria, and it was so described because he had found that the deposits upon the mucous membrane in the early stages of the malady bore a close analogy to the deposits which were seen in diphtheria—(Dr. Budd: "Certainly.")—and he did not see why in a diphtheroid disease those deposits might not be in any part of the intestinal track, as well as upon the fauces. In fact, the deposit might exist in various parts of the body. He made that observation because he had seen again and again in pigs deposits taking place upon the pharynx, the fauces, and the epiglottis, precisely in the same manner as in the human subject. This showed, at all events, that pigs were susceptible of that particular class of affections.

With reference to the contagiousness of the disease he quite agreed with Dr. Budd, and further he agreed that in dry seasons it was probably more contagious than in wet, and for the reason Dr. Budd had explained. Perhaps the "*materies morbi*" breaks up if it be in a fluid, like sewage. He found, however, that it was contagious as well in winter as in summer—(Dr. Budd: "True")—that it made as much progress in wet weather as in dry, but that pigs differed considerably in their susceptibility to its action. In his experience the disease rarely attacked aged pigs; it had in some cases spared all the old pigs on the farm, whilst it had swept off nearly the whole of the young ones. He could not admit, therefore, that the farmer was likely to lose all his pigs when his herd was attacked. Animals that were upwards of six months old resisted the disease in a most remarkable manner. With regard to the means by which the morbid matter might be propagated, he thought it was most likely to be propagated through the medium of the atmosphere. That other agents might also be conductors of it he would not dispute; but he came to the conclusion which he had stated from the circumstance that he had seen the disease existing upon hill-farms where the country all around was open, and where there was no possible communication between that and other farms. He had seen it also among pigs that were kept in the best possible manner, and fed upon the best possible food, and that lay in houses that might rather be called parlours for pigs to dwell in than styes. The animals were washed two or three times a week, and treated with the greatest care, just as if the owner had intended to send them for exhibition to a cattle-show. This was a fact of some value—because it indicated, not only that pigs thus well managed were susceptible of the affection, but that no precaution gave security to the animal; and especially was the fact of value when he contrasted it with another to which he would allude. In one of his visits to the country for the purpose of investigating the disease, he saw a large number of pigs on one farm that were the subjects of the affection. These were chiefly young pigs that had been bred upon the farm—and of all the mismanaged animals he ever met with, they were the worst. They were running about in the mud, and dwelling in places that were as filthy as any the imagination could picture. As soon as the young pigs were weaned they were fed exclusively upon bran and water. Thus were brought into

operation a number of causes that must tend to produce disease and render the animals susceptible. But, curious to relate, in that particular instance, the disease was not more fatal than in the case of pigs which had been managed in the directly opposite manner. It would appear, therefore, so far as his observation went, that susceptibility depended not so much on management as on age. Why young pigs should be susceptible, and old pigs not, he could not say.

With respect to the character of the disease he quite agreed that it was of the nature of typhoid fever; that was to say, it belonged to that class of diseases which were termed zymotic; and he also held that it had a close likeness to typhoid fever in the human subject. Though not identical, they were diseases of the same class and the same family; they bore as strong a resemblance to each other as one fungus bore to another fungus. As to the duration of the malady, he was inclined to believe that it ran its course far more rapidly in the pig than typhoid fever did in the human subject—(Dr. Budd: "Decidedly.") And further, that the disease might have its beginning and ending in the course of four or five days—(Dr. Budd: "Clearly.") When, however, they got the disease in that form it was not to be expected, on making a *post mortem* examination, that large deposits would be found on the mucous membranes, or very extensive ulcerations. It would appear, indeed, that the animals were killed by the large mass of morbid matter which had entered into their organisms. It was in those cases particularly that the changes of colour in the skin—red here and red there—especially about the ears and the upper part of the neck, and also on the back and sides, were seen. In addition to that it would invariably be found that the conjunctival membrane of the eye was intensely reddened. Sometimes, too, though that was more rare, the eye would be bloodshot. If a *post mortem* examination were made, a patch of intense inflammation would probably be found in the stomachs as well as in the intestinal canal; and when that was observable, not unfrequently there would be a thin layer of lymph of a dirty or yellowish-white colour, spread over it, which, if scraped off, would disclose the presence of inflammatory action of the most intense nature on that particular spot. If the animal had taken a dose of arsenic, or some other mineral or highly-irritating poisonous agent, the inflammatory action could not be greater.

Frequently, however, there were no deposits, and scarcely any apparent change in the mucous membrane. Of this he had seen examples within the last month in some well-managed pigs in Bedfordshire, some of which had died in the early stages of the affection, even as soon as the third day. Those cases were marked by effusions of blood here and there, and in one case the capsule of the kidney was thus affected. More generally the serous membrane of the abdomen and the lining membrane of the left side of the heart were spotted, clearly showing that it was a blood-disease, and that the contaminated blood had left its vessels and produced the petechial spots that had been described. In the case in question the disease was introduced by some store-pigs bought in market. The influence of contagion was thus clearly shown.

Having observed the disease in the early as well as in the more advanced stage, and examined all the connecting links between the two extremes, he nevertheless felt that he had a very great deal indeed to learn with regard to the true pathology of the disease. He considered that it was allied to typhoid fever, whilst analogous to, and partaking of, the nature of diphtheria. The symptoms had been most accurately described by Dr. Budd; and it was important that farmers should early recognise their existence. There could be no doubt that in many cases the animals showed indications of headache. They were ill at ease, and he had heard it said that as soon as they were attacked, there was a peculiar pricking up of their ears. In some instances they loathed food; and in all cases the appetite was fastidious, if it were not entirely lost. The breathing was not much disturbed, and the pulse gave little or no sign of the malignancy of the disease. As a rule, the body was very hot, particularly in some places, and usually, but not invariably, the extremities were cold. At the commencement the bowels were constipated, whatever might be the kind of food on which the animals lived. Later in the disease, certainly on the third day, diarrhoea supervened; the evacuations were of a peculiar character; not copious, but constant—a teaspoonful at a time ten times in an hour. The feculent matter having passed off, the fluid discharged contained a quantity of broken-up lymph, which was of a dirty white, and proceeded from the scabs in the intestinal canal.

With regard to the discolouration of the skin of the black pig, it was difficult perhaps to say, when the vessels of the skin were congested; but if the skin was particularly hot and unusually dark, he thought it might be inferred that there was a determination of blood to the vessels of the skin. With reference to the duration of the disorder, he had never himself seen it protracted beyond seven or eight days. There was no doubt that it produced death speedily, and that, speaking generally, its duration was remarkably short. As to the spread of the affection from the pig to other animals, he did not think there was the least risk of that; for it was a singular fact, which science might one day throw light upon, that there were certain victims to certain special poisons, and that a disease which would kill the ox could not be spread to the sheep, and the contrary. In regard to the means of preventing the affection, of course the sooner the disease was recognised and the animals were got rid of the better. By that means a large source of mischief was cut off. Cleanliness could not be too strictly insisted on. The places where the pigs had been kept should be thoroughly washed—floors, walls, and drains; and no sound animals should be put there for weeks after the others had left. As a medical means of preventing the disease, he had found great benefit to result from the use of small quantities of a very homely remedy, namely, sulphur, on account of its antiseptic action. It should be put into the animals' food twice or thrice in the week. In treating the disease, sulphate of soda should be freely used.

Mr. FRERE suggested that carbolic acid, being an antiseptic, might be useful.

Professor COLEMAN mentioned that he had been lately informed of

three cases in which it had been used with advantage internally and externally.

Professor SIMONDS had had no experience of carbolic acid internally administered; though externally applied to diseases of the skin he had found it efficacious.

Dr. BUDD wished to add that he believed this particular disorder was propagated chiefly by the discharges from the intestinal canal, and that persons who got the matter about their shoes were frequently the unconscious agents for conveying the disease from one place to another. At present the complaint was very rife in the South of Ireland, from whence vast importations of pigs took place into the port of Bristol.

END OF VOL. I.—SECOND SERIES.

Royal Agricultural Society of England.

1865.

President.

SIR EDWARD C. KERRISON, BART., M.P.

Trustees.

ACLAND, SIR THOMAS DYKE, BART., *Killerton Park, Exeter, Devonshire.*
BERNERS, LORD, *Keythorpe Hall, Leicester.*
BRAMSTON, THOMAS WILLIAM, M.P., *Skreens, Chelmsford, Essex.*
CHALLONER, COLONEL, *Portnall Park, Staines, Middlesex.*
FEVERSHAM, LORD, *Helmsley, York.*
MARLBOROUGH, DUKE OF, *Blenheim Park, Oxford.*
PORTMAN, LORD, *Bryanston, Blandford, Dorset.*
POWIS, EARL OF, *Powis Castle, Welshpool, Montgomeryshire.*
RUTLAND, DUKE OF, *Belvoir Castle, Grantham, Lincolnshire.*
SHELLEY, SIR JOHN VILLIERS, BART, M.P., *Maresfield Park, Sussex.*
SPEAKER, THE RT. HON. THE, *Ossington, Newark-on-Trent, Notts.*
THOMPSON, HARRY STEPHEN, M.P., *Kirby Hall, York.*

Vice-Presidents.

BARKER, THOMAS RAYMOND, *Hambledon, Henley-on-Thames, Oxfordshire.*
CHICHESTER, EARL OF, *Stanmer Park, Lewes, Sussex.*
DOWNSHIRE, MARQUIS OF, *East Hampstead Park, Bracknell, Berkshire.*
EGMONT, EARL OF, *Cowdray Park, Petworth, Sussex.*
EVERSLEY, VISCOUNT, *Heckfield Place, Winchfield, Hants.*
EXETER, MARQUIS OF, *Burleigh House, Stamford, Lincolnshire.*
HILL, VISCOUNT, *Hawkstone Park, Salop.*
HOBBS, W. FISHER, *Boxted Lodge, Colchester, Essex.*
HOOD, MAJOR-GEN. THE HON. A. NELSON, *Cumberland Lodge, Windsor, Berkshire.*
JOHNSTONE, SIR JOHN V. B., BART., M.P., *Hackness Hall, Scarborough, Yorkshire.*
MILES, SIR WILLIAM, BART., M.P., *Leigh Court, Bristol, Somersetshire.*
WALSINGHAM, LORD, *Merton Hall, Thetford, Norfolk.*

Other Members of Council.

ACLAND, THOMAS DYKE, *Sprydoncote, Exeter, Devonshire.*
AMOS, CHARLES EDWARDS, 5, *Cedars Road, Clapham Common, Surrey.*
ARKWRIGHT, J. HUNGERFORD, *Hampton Court, Leominster, Herefordshire.*
BARNETT, CHARLES, *Stratton Park, Biggleswade, Bedfordshire.*
BARTHROPP, NATHANIEL GEORGE, *Hacheston, Wickham Market, Suffolk.*
BOWLY, EDWARD, *Siddington House, Cirencester.*
BULGER, JAMES WENTWORTH, M.P., *Downes, Crediton, Devonshire.*
BURGESS WILLIAM, *Brentwood, Essex.*
CANTRELL, CHARLES S., *Riding Court, Datchet, Bucks.*
CATHCART, EARL, *Thornton-le-Street, Thirsk, Yorkshire.*
CHESHAM, LORD, *Latimer, Chesham, Bucks.*

- CLAYDEN, JOHN, *Littlebury, Saffron Walden, Essex.*
 DENT, J. D., M.P., *Ribston Hall, Wetherby, Yorkshire.*
 DRUCE, JOSEPH, *Eynsham, Oxford.*
 FORTESCUE, EARL, *Castle Hill, Southmolton, Devonshire.*
 GIBBS, B. T. BRANDRETH, *Halfmoon Street, Piccadilly, London, W.*
 HAMOND, ANTHONY, *Westacre Hall, Brandon, Norfolk.*
 HOLLAND, EDWARD, M.P., *Dumbleton Hall, Evesham, Worcestershire.*
 HOSKYNs, CHANDOS WREN, *Harewood, Ross, Herefordshire.*
 HUDSON, JOHN, *Castleacre Lodge, Brandon, Norfolk.*
 HUMBERSTON, PHILIP STAPYLTON, M.P., *Mollington, Chester, Cheshire.*
 HUTON, WILLIAM, *Gale Burton, Gainsboro', Yorkshire.*
 JONAS, SAMUEL, *Chrishall Grange, Saffron Walden, Essex.*
 KERRISON, SIR EDWARD CLARENCE, Bart., M.P., *Brome Hall, Scole, Norfolk.*
 KINGSCOOTE, COLONEL, M.P., *Kingscote, Wootton-under-Edge, Gloucestershire.*
 LAWES, JOHN BENNET, *Rothamsted, St. Albans, Herts.*
 LAWRENCE, CHARLES, *Cirencester, Gloucestershire.*
 LEIGH, LORD, *Stoneleigh Abbey, Warwickshire.*
 MACDONALD, SIR ARCHIBALD KEPPEL, Bart., *Woolmer Lodge, Liphook, Hants.*
 MILWARD, RICHARD, *Thurgarton Priory, Southwell, Notts.*
 PAIN, THOMAS, *Ugford Cottage, Salisbury, Wilts.*
 POPE, EDWARD, *Great Toller, Maiden Newton, Dorset.*
 RANDELL, CHARLES, *Chadbury, Evesham, Worcestershire.*
 RIGDEN, WILLIAM, *Hove, Brighton, Sussex.*
 RIDLEY, SIR MATTHEW WHITE, Bart., M.P., *Blagdon, Cramlington, Northumberland.*
 SANDAY, WILLIAM, *Holmepierrepoint, Notts.*
 SHREWSBURY AND TALBOT, EARL OF, *Ingestre Hall, Staffordshire.*
 SHUTTLEWORTH, JOSEPH, *Hartsholme Hall, Lincoln.*
 SMITH, ROBERT, *Emmett's Grange, Southmolton, Devon.*
 TORR, WILLIAM, *Aylesby Manor, Great Grimsby, Lincolnshire.*
 TOWNELEY, LIÉUT.-COLONEL CHARLES, *Toumeley Park, Blackburn, Lancashire.*
 TREDEGAR, LORD, *Tredegar, Newport, Monmouthshire.*
 TURNER, GEORGE, *Beacon Doumes, Exeter, Devonshire.*
 VERNON, HON. AUGUSTUS H., *Sudbury, Derby.*
 WALLIS, OWEN, *Overstone Grange, Northampton.*
 WELLS, WILLIAM, *Redleaf, Penshurst, Kent.*
 WESTERN, SIR THOMAS B., Bart., *Felix Hall, Kelvedon, Essex.*
 WILSON, HENRY, *Stowlangtoft Hall, Bury-St.-Edmunds, Suffolk.*
 WILSON, PROFESSOR, *Iver, Uzbridge, Bucks.*
 WYNN, SIR WATKIN WILLIAMS, Bart., M.P., *Rhuabon, Denbighshire.*

Secretary.

H. HALL DARE, 12, *Hanover Square, London, W.*

Editor—P. H. FRERE, *Dungate, Cambridge.*

Consulting-Chemist—DR. AUGUSTUS VOELCKER, 11, *Salisbury Square, E.C.*

Veterinary-Inspector—JAMES BEART SIMONDS, *Royal Veterinary College, N.W.*

Consulting Engineer—JAMES EASTON, OF C. E. AMOS, *Groce, Southwark, S.E.*

Seedsmen—THOMAS GIBBS AND CO., *Corner of Halfmoon Street, Piccadilly, W.*

Publisher—JOHN MURRAY, 50, *Albemarle Street, W.*

Bankers—THE LONDON AND WESTMINSTER BANK, *St. James's Square Branch, S.W.*

STANDING COMMITTEES FOR 1865.**Finance Committee.**

HOOD, Maj.-Gen. the Hon. A. NELSON.	HOBBS, WM. FISHER.
BARNETT, CHARLES.	TORR, WILLIAM.
BRAMSTON, T. W., M.P.	

House Committee.

THE PRESIDENT.	CHALLONER, Colonel.
CHAIRMAN of Finance Committee.	GIBBS, B. T. BRANDRETH.
CHESHAM, Lord.	HOBBS, WM. FISHER.
BRAMSTON, T. W., M.P.	

Journal Committee.

CATHCART, Earl.	ACLAND, T. DYKE.
FORTESQUE, Earl.	HOLLAND, ED., M.P.
SPEAKER, The Rt. Hon. THE.	HOSKYNs, C. WREN.
SHELLEY, Sir J. V., Bt., M.P.	MILWARD, RICHARD.
JOHNSTONE, Sir J. V. B., Bt., M.P.	THOMPSON, H. S., M.P.
KERRISON, Sir E. C., Bt., M.P.	WALLIS, OWEN.
MACDONALD, Sir A. K., Bt.	

Chemical Committee.

CATHCART, Earl.	HOLLAND, ED., M.P.
VERNON, Hon. A. H.	HOSKYNs, C. WREN.
JOHNSTONE, Sir J. V. B., Bt., M.P.	HUMBERSTON, P. S., M.P.
KERRISON, Sir E. C., Bt., M.P.	HUXTABLE, Ven. Archdeacon.
MACDONALD, Sir A. K., Bt.	LAWES, J. B.
ACLAND, T. DYKE.	THOMPSON, H. S., M.P.
ARKWRIGHT, J. H.	WELLS, WILLIAM.
DENT, J. D., M.P.	

Veterinary Committee.

HOOD, Maj.-Gen. the Hon. A. NELSON.	HAMOND, ANTHONY.
JOHNSTONE, Sir J. V. B., Bt., M.P.	HOBBS, WM. FISHER.
MILES, Sir Wm., Bt., M.P.	PAIN, THOS.
BARKER, THOS. RAYMOND.	SIMONDS, Professor.
CHALLONER, Colonel.	SPOONER, Professor.
DENT, J. D., M.P.	THOMPSON, H. S., M.P.
GIBBS, B. T. BRANDRETH.	WELLS, WILLIAM.

Stock-Prizes Committee.

WALSINGHAM, Lord.	JONAS, SAMUEL.
HOOD, Maj.-Gen. the Hon. A. NELSON.	MILWARD, RICHARD.
BARNETT, CHARLES.	PAIN, THOMAS.
BARTHROPP, NATHANIEL G.	POPE, EDWARD.
CLAYDEN, JOHN.	RANDELL, CHAS.
DENT, J. D., M.P.	RIGDEN, WM.
DRUCE, JOSEPH.	SMITH, ROBERT.
GIBBS, B. T. BRANDRETH.	SIMONDS, Professor.
HOBBS, WM. FISHER.	TORR, WILLIAM.
HOLLAND, ED., M.P.	TURNER, GEORGE.
HUDSON, JOHN.	WALLIS, OWEN.

Implement Committee.

CHESHAM, Lord.	GIBBS, B. T. BRANDRETH.
HOOD, Maj.-Gen. the Hon. A. NELSON.	HAMOND, ANTHONY.
VERNON, Hon. A. H.	HOBBS, WM. FISHER.
KERRISON, Sir E. C., Bt., M.P.	HOLLAND, ED., M.P.
MACDONALD, Sir A. K., Bt.	HOSKYNS, C. WREN.
MILES, Sir WM., Bt., M.P.	RANDELL, CHARLES.
AMOS, C. E.	SHUTTLEWORTH, JOSEPH.
ARKWRIGHT, J. H.	THOMPSON, H. S., M.P.
BARNETT, CHARLES.	TORR, WILLIAM.
CANTRELL, CHAS. S.	WALLIS, OWEN.
CHALLONER, Colonel.	WILSON, Professor.

General Plymouth Committee.

FEVERSHAM, Lord, Chairman.	DENT, J. D., M.P.
FORTESCUE, Earl.	GIBBS, B. T. BRANDRETH.
POWIS, Earl of.	HOBBS, WM. FISHER.
CHESHAM, Lord.	HOLLAND, E., M.P.
PORTMAN, Lord.	HOSKYNS, C. WREN.
TREDEGAR, Lord.	KINGSCOTE, Col., M.P.
HOOD, Maj.-Gen. the Hon. A. NELSON.	MILWARD, RICHARD.
LOPES, Sir MASSEY, Bart., M.P.	MOON, JOHN.
VERNON, Hon. A. H.	PAIN, THOMAS.
MACDONALD, Sir A. K., Bart.	PLYMOUTH, Mayor of.
RIDLEY, Sir MATTHEW WHITE, Bart., M.P.	POPE, EDWARD.
ACLAND, T. DYKE.	RANDELL, CHARLES.
ARKWRIGHT, J. HUNGERFORD.	SHUTTLEWORTH, JOSEPH.
BARNETT, CHARLES.	THOMPSON, H. S., M.P.
BOWLY, EDWARD.	TORR, WILLIAM.
BRAMSTON, T. W., M.P.	TREMAINE, JOHN.
CANTRELL, CHARLES S.	TURNER, GEORGE.
CHALLONER, Colonel.	

* * The PRESIDENT, TRUSTEES, and VICE-PRESIDENTS are Members *ex officio* of all Committees.

MEMORANDA.

ADDRESS OF LETTERS.—The Society's office being situated in the postal district designated by the letter **W**, members, in their correspondence with the Secretary, are requested to subjoin that letter to the usual address.

GENERAL MEETING in London, in December, 1864.

GENERAL MEETING in London, May 22, 1865, at Twelve o'clock.

MEETING at Plymouth, in 1865.

MONTHLY COUNCIL (for transaction of business), at 12 o'clock on the first Wednesday in every month, excepting January, September, and October: open only to Members of Council and Governors of the Society.

WEEKLY COUNCIL (for practical communications), at 12 o'clock on all Wednesdays in February, March, April, May, June, July, and November, excepting the first Wednesday in each of those months, and during adjournment: open to all Members of the Society, who are particularly invited by the Council to avail themselves of this privilege.

ADJOURNMENTS.—The Council adjourn over Passion and Easter weeks, when those weeks do not include the first Wednesday of the month; from the first Wednesday in August to the first Wednesday in November; and from the first Wednesday in December to the first Wednesday in February.

DISEASES OF Cattle, Sheep, and Pigs.—Members have the privilege of applying to the Veterinary Committee of the Society; and of sending animals to the Royal Veterinary College, on the same terms as if they were subscribers to the College.—(A statement of these privileges will be found in the present Appendix.)

CHEMICAL ANALYSIS.—The privileges of Chemical Analysis enjoyed by Members of the Society will be found stated in the Appendix of the present volume.

LOCAL CHEQUES.—Members are particularly requested not to forward Country Cheques for payment in London; but London Cheques, or Post-office Orders on Vere-street (payable to H. HALL DARE), in lieu of them. All Cheques are required to bear upon them a penny draft or receipt stamp, which must be cancelled in each case by the initials of the drawer. They may also conveniently transmit their Subscriptions to the Society, by requesting their Country Bankers to pay (through their London Agents) the amount at the Society's Office (No. 12, Hanover Square, London), between the hours of ten and four, when official receipts, signed by the Secretary, will be given for such payments.

NEW MEMBERS.—Every candidate for admission into the Society must be proposed by a Member; the proposer to specify in writing the full name, usual place of residence, and post-town, of the candidate, either at a Council meeting, or by letter addressed to the Secretary.

PACKETS BY POST.—Packets not exceeding two feet in length, width, or depth, consisting of written or printed matter (but not containing letters sealed or open), if sent without envelopes, or enclosed in envelopes open at each end, may be forwarded by the inland post, if stamped, at the following rates:—

For a packet not exceeding 4 ounces (or quarter of a pound) . . .	1 penny
" " " 8 " (or half a pound)	2 pence.
" " " 16 " (or one pound)	4 "
" " " 24 " (or one pound and a half)	6 "
" " " 32 " (or two pounds)	8 "

[And so on in the proportion of 8 ounces for each additional 2d.]

*. Members may obtain on application to the Secretary copies of an Abstract of the Charter and Bye-Laws, of a Statement of the General Objects, &c., of the Society, of Chemical and Veterinary Privileges, and of other printed papers connected with special departments of the Society's business.

Royal Agricultural Society of England.

GENERAL MEETING,

12, HANOVER SQUARE, THURSDAY, DECEMBER 8, 1864.

REPORT OF THE COUNCIL.

THE Council have to report that during the past half-year the Society has lost by deaths and resignations 35 of its members, while 478 new members have, during the same period, been enrolled on its lists, which is now constituted as follows:—

78 Life Governors,
80 Annual Governors,
1373 Life Members,
4465 Annual Members,
17 Honorary Members,

making a total of 6013.

A new list of the Governors and members of the Society having been published in the last number of the Journal, the Council submit to the members on this occasion the following schedule, showing the districts to which they belong:—

ENGLAND.—	Number of Members.	Amount of representation in the Council.
Beds	41	1
Berks	148	2
Bucks	73	3
Cambridge	56	1
Chester	121	1
Cornwall	48	
Cumberland	60	
Derby	113	1
Devon	124	5
Dorset	88	2
Durham	176	
Essex	147	4
Gloucester	202	4
Hants	164	2
Carry forward	1561	26

ENGLAND.—	Brought forward	Number of Members.	Amount of representation in the Council.
		1561	26
Hereford		154	2
Herts		100	1
Hunts		37	
Kent		220	1
Lancaster		177	1
Leicester		63	1
Lincoln		199	4
Middlesex		350	2
Monmouth		44	1
Norfolk		152	4
Northampton		103	1
Northumberland		419	1
Notts		137	3
Oxon		122	3
Rutland		13	
Salop		166	1
Somerset		149	2
Staffs		131	1
Suffolk		136	2
Surrey		188	1
Sussex		153	4
Warwick		160	2
Westmoreland		22	
Wilts		133	1
Worcester		170	1
York		293	6
Total		5552	72
WALES.—			
Anglesea		8	
Brecon		11	
Cardigan		11	
Carmarthen		24	
Caernarvon		12	
Denbigh		27	1
Flint		32	
Glamorgan		38	
Merioneth		7	
Montgomery		17	1
Pembroke		32	
Radnor		9	
Total		228	2
SCOTLAND		86	
IRELAND		79	
CHANNEL ISLANDS AND ISLE OF MAN		17	
FOREIGN COUNTRIES		51	
General total		6013	74

This schedule will enable those friends of the Society and of agricultural improvement generally, who reside in districts where the number of members is below the average, to remedy the evil by recommending to the Council for election the names of candidates who will no doubt be ready to avail themselves of the numerous advantages offered by the Society, and by their personal influence aid in the dissemination of the valuable information afforded in the pages of the Journal, in the lectures delivered to the members, and in the show-yard at the Country Meetings.

The Council have elected Mr. Wm. Burgess, of the firm of Burgess and Key, to fill the vacancy caused by translation of Major-General the Hon. A. N. Hood to the list of Vice-Presidents of the Society.

The half-yearly statement of accounts to the 30th of June, 1864, has been examined and approved by the Auditors and Accountants of the Society. The finances were never in a more satisfactory condition than at present, the sum of 2000*l.* having been lately added to the funded capital of the Society, which now amounts to 18,768*l.* 1*s.* 10*d.* stock in the New Three per Cents.

The Council have appointed a Committee to consider the subject of the "Improvement of the Education of those who depend upon the Cultivation of the Soil for their Support;" and in order to obtain information on this important subject, the Council have offered a Prize of 50*l.* for an Essay on Agricultural Education, and they have authorised their Educational Committee to invite examining bodies, such as the Universities of Oxford and Cambridge, the Royal College of Preceptors, the Society of Arts, &c. &c., to appoint one of their members to confer with the Committee.

The Meeting at Newcastle-upon-Tyne, was highly successful in the amount and character of the live stock and implements. The means for testing the power given off by agricultural machinery having this year been perfected in a striking and satisfactory manner, by the consulting-engineer, Mr. Amos (of the firm of Easton and Amos), who invented a Dynamometer, a description of which will appear in the Journal, the Council deemed it right to appropriate a large amount of money to the trials of Steam-Cultivators; and feel convinced that the members generally have every reason to be satisfied that this was a judicious appropriation of the funds of the Society, and a

thorough test of the advance of this most important branch of Agricultural Machinery.

The General Meeting of the Society, held in the show-yard, conveyed to the Mayor and Corporation of Newcastle, and to the Local Committee who had so zealously co-operated with the Council on the occasion, their cordial thanks for the kind attention they had paid to the wishes of the Society, and the admirable manner in which they had made every arrangement required for promoting the success of the meeting. The Society are indebted to some railway companies for the arrangements they have made at their annual show, but regret to say that in some instances facilities have not been afforded to Exhibitors for the conveyance of Stock at a reasonable rate.

The Council have decided that the Plymouth Meeting shall be held in the week commencing Monday, the 17th of July, and the Prize-Sheets will shortly be ready for distribution. Land for the trial of drills, manure-distributors, mowing, haymaking, and reaping machines, and horse-rakes, has been already placed under the necessary cultivation, and prizes amounting to 440*l.*, will be offered among these classes of Implements, and 2815*l.* for Stock.

The Council have from time to time been favoured with various communications from Earl Russell, Her Majesty's Secretary of State for Foreign Affairs, the substance of which has been made public in the published proceedings of the Meetings at which they were read.

Professor Simonds has delivered a Lecture before the Members of the Society on Small-Pox in Sheep, which will appear in the Journal of the Society.

The Governors of the Royal Veterinary College have presented their annual report, by which it appears that more animals have been admitted into the Hospital of the College for treatment; also that there have been more consultations—and that other arrangements have been made tending to the further development of the Veterinary art in respect to the Pathology of Cattle, Sheep, and Pigs.

By Order of the Council,

H. HALL DARE,

Secretary.

SOCIETY OF ENGLAND.

xi

FROM 1ST JULY TO 31ST DECEMBER, 1864.

CR.

	£.	s.	d.	£.	s.	d.
By Expenditure :—						
Establishment—						
Official Salaries, Wages, &c. ..	327	6	0			
House Expenses, Rent, Taxes, &c. ..	309	13	5			
				636	19	5
Journal :—						
Printing (2 Numbers) ..	1,086	12	7			
Delivery and Advertising (do.) ..	181	10	0			
Stitching (do.) ..	149	18	7			
Wrappers (3 Numbers)	27	0	0			
Prize Essays	80	0	0			
Other Contributions	39	4	5			
Editor's Salary	250	0	0			
				1,814	5	7
Chemical :—						
Consulting Chemist's Salary				150	0	0
Veterinary :—						
Annual Grant to Royal Veterinary College ..				200	0	0
Postage and Carriage				19	15	5
Advertisements				10	9	0
Sundries				39	13	3
Two new Dynamometers				290	0	0
Subscriptions returned (paid in error)				3	2	0
						3,164 4 8
By Stock :—						
Purchase of 2279l. 4s. New 3 Per Cents.	2,000 0 0
By Country Meetings :—						
Newcastle				9,720	13	2
Plymouth				18	0	0
						9,738 13 2
By Balance in hand, Dec. 31, 1864 :—						
Bankers				280	10	2
Secretary				12	8	11
						292 19 1
						£15,195 16 11

31ST DECEMBER, 1864.

ASSETS.		£.	s.	d.
By Cash in hand		292	19	1
By Deposit Account at Bankers		1,000	0	0
By New 3 per cent. Stock 18,768l. 1s. 10d. cost		17,881	11	1
By Books and Furniture in Society's House		2,000	0	0
By Plymouth Meeting			18	0 0
<i>Mem.</i> —The above Assets are exclusive of the amount recoverable in respect of Subscriptions in arrear 31st December, 1864, which at that date amounted to 831l.				
				£21,192 10 2

Examined, audited, and found correct, this 25th day of January, 1865.

(Signed) }

 WILLIAM COPELAND ASTBURY,
 HENRY CORBET,
 WILLIAM COHEN,

Auditors on the part of the Society.

ROYAL AGRICULTURAL SOCIETY OF ENGLAND.

YEARLY CASH ACCOUNT, FROM 1ST JANUARY TO 31ST DECEMBER, 1864.

Cr.

	£.	s.	d.	£.	s.	d.
To Balance in hand, 1st Jan. 1864:—						
Bankers	443	12	6			
Secretary	17	13	5			
				461	5	11
To Income, viz.:—						
Dividend on Stock	481	5	5			
Interest on Deposits	61	13	7			
Subscriptions:—						
Governors' Annual	415	0	0			
Members' Life-Compositions	849	0	0			
Members' Annual	4,080	7	0			
	5,144	7	0			
Journal:—						
Sales	149	18	3			
Advertisements	63	18	9			
Legacy from the late Beriah Botfield, Esq.	213	17	0			
	10	10	0	5,914	13	0
To Country Meetings:—						
Worcester	7	5	0			
Newcastle-on-Tyne	12,340	18	1	12,348	3	1
				£	18,724	2 0
By Expenditure:—						
Establishment:—						
Official Salaries and Wages	654	12	0			
House Expenses, Rent, Taxes, &c.	678	18	11	1,233	10	11
Journal:—						
Printing	1,086	12	7			
Stitching	149	18	7			
Delivery, Advertising, &c.	288	17	0			
Wrappers	27	0	0			
Prize Essays	80	0	0			
Literary Contributions	39	4	5			
Wood Engravings	3	17	0			
Editor's Salary	500	0	0	2,175	9	7
Chemical:—						
Consulting Chemist's Salary (3 qrs.)	225	0	0			
Grant for Investigations	200	0	0	425	0	0
Veterinary						
Postage and Carriage				208	19	6
Advertisements				63	18	11
Sundries				24	1	0
Subscriptions returned (paid in error)				56	12	3
Two Dynamometers				18	3	0
				230	0	0
By Stock:—						
Purchase of 2279l. 4s. 0d. New 3 } per Cent.						4,495 13 2
						2,000 0 0
By Country Meetings:—						
Worcester Meeting				55	0	0
Newcastle-on-Tyne				10,862	9	9
Plymouth				18	0	0
By Balance in hand, 31st Dec., 1864:—						
at Worcester	1,000	0	0			
at Bank	280	10	2			
Bankers	12	8	11	1,292	19	1
Secretary				£	18,724	2 0

January 25, 1865.

A. N. HOOD, Chairman of the Finance Committee.
QUILTER, BALL, & Co., Accountants.

COUNTRY MEETING ACCOUNT, NEWCASTLE-ON-TYNE, 1864.

RECEIPTS.

	£.	s.	d.
Subscription from Newcastle	2,000	0	0
Admissions to Show Yard	9,043	14	7
Sale of Catalogues	729	6	6
Implement Exhibitors' Payments for Shedding	772	2	0
Non-Members' Fees for entry of Implements*	39	0	0
Fees for entry of Live-Stock	452	5	0
Fees for Horse Boxes	224	0	0
Fees for entry of Wool and Butter	3	0	0
Fees for Nurse Cows	12	0	0
*Fines for non-Exhibition of Live-Stock	20	10	0
*Extra lines in Implement Catalogue	43	10	0
Sale of Hay, Straw, and Green Food	30	17	6

£12,370 5 7

EXPENDITURE.

	£.	s.	d.
Show and Trial Yards, hire of Hurdles, Turnstiles, &c.	3,244	15	9
Repairs to Engineering Plant, Pump, Carriage, &c.	110	6	10
Judges: Implements, 218 <i>s.</i> ; Stock, 390 <i>s.</i> ; Wool, 20 <i>s.</i> ; Butter, 4 <i>s.</i>	622	0	0
Consulting-Engineer's Assistants	173	7	5
Veterinary-Inspector and Assistant, and Inspector of Shearing	78	18	0
Police: Metropolitan, 175 <i>s.</i> , 10 <i>s.</i> , 6 <i>d.</i> ; Borough, 10 <i>s.</i>	185	10	6
Clerks and Assistants: Secretary, 39 <i>s.</i> , 1 <i>s.</i> , 6 <i>d.</i> ; Hon. Director, 35 <i>s.</i> , 16 <i>s.</i> ; Bankers, 24 <i>s.</i> , 5 <i>s.</i>	99	2	6
Assistant Stewards of Implements	50	8	0
Foremen of Departments	63	6	8
Yardmen and Watchmen, 220 <i>s.</i> , 9 <i>s.</i> , 6 <i>d.</i> ; Labourers, 44 <i>s.</i> , 18 <i>s.</i> ; Grooms, 20 <i>s.</i>	285	7	6
Index-Clerks and Money-takers, 77 <i>s.</i> , 14 <i>s.</i> ; Door-keepers, Money-changers, 31 <i>s.</i> , 10 <i>s.</i>	109	4	0
Lodgings for Stewards, Implement Judges, Inspectors, Engineers, &c.	169	12	0
Refreshments for ditto	89	8	3
Catalogues: Implements, 22 <i>s.</i> , 1 <i>s.</i> ; Awards, 14 <i>s.</i> ; Stock, 124 <i>s.</i> , 5 <i>s.</i> ; and Awards, 83 <i>s.</i> , 13 <i>s.</i> , 6 <i>d.</i> ; Sellers, 25 <i>s.</i> , 14 <i>s.</i> , 6 <i>d.</i> ; Pecking-cases, 13 <i>s.</i> , 4 <i>s.</i> , 6 <i>d.</i>	482	18	6
Printing—Prize-sheets, Certificates, Admission-Orders, Tickets, Railway Papers, Labels, Circulars, Programmes, &c.	274	11	4
Advertising—Newspapers, 156 <i>s.</i> , 19 <i>s.</i> , 5 <i>d.</i> ; Railways and Bill Posting, 110 <i>s.</i> , 2 <i>s.</i>	266	1	5
Postage and Carriage, 68 <i>s.</i> , 7 <i>s.</i> , 5 <i>d.</i> ; Stationery, 17 <i>s.</i> , 9 <i>s.</i> , 9 <i>d.</i>	85	17	2
Hay, 109 <i>s.</i> ; Straw, 180 <i>s.</i> ; Green Food, 346 <i>s.</i> , 17 <i>s.</i> , 6 <i>d.</i>	631	17	6
Land for Steam Cultivation	350	0	0
Horse Hire, 242 <i>s.</i> , 17 <i>s.</i> ; Hire of Brake, Cabs, &c., 457 <i>s.</i> , 1 <i>s.</i>	297	18	0
Hire of Fire Engines, 117 <i>s.</i> , 16 <i>s.</i> , 6 <i>d.</i> ; Hire of Steam Engines, 4 <i>s.</i> , 4 <i>s.</i>	16	0	6
Making Road, 20 <i>s.</i> ; Surveying 12 <i>s.</i> , 12 <i>s.</i> , 6 <i>d.</i>	32	12	6
Water Supply, 46 <i>s.</i> , 1 <i>s.</i> , 10 <i>d.</i> ; Plumber's bill, 19 <i>s.</i> ; Hire of Tanks, 5 <i>s.</i>	70	1	0
Coal, 117 <i>s.</i> , 7 <i>s.</i> , 1 <i>d.</i> ; Clay, 2 <i>s.</i> , 4 <i>s.</i> ; Tarrad Line, 2 <i>s.</i> , 7 <i>s.</i> , 1 <i>d.</i> ; Forks, Rakes, &c., 2 <i>s.</i> , 1 <i>s.</i> , 9 <i>d.</i> ; Hire of Tent, 7 <i>s.</i>	24	19	11
Official Staff			
Petty Payments			7 16 6
Prizes—Implements, 550 <i>s.</i> ; Stock, 264 <i>s.</i> ; Medals, 56 <i>s.</i> , 16 <i>s.</i>			17 0 6
			3,250 16 0
By Balance			211,027 19 1
			1,342 6 6
			£12,370 5 7

Remaining unpaid Fines, £13 10*s.*; Lines, £42.

WM. FISHER HOBBS, } Finance Committee.
WM. TORR, }
H. HALL DARE, Secretary.

Debonport and Plymouth Meeting, 1865 :

IN THE WEEK COMMENCING MONDAY, JULY 17.

SCHEDULE OF PRIZES.**I.—LIVE-STOCK PRIZES OFFERED BY THE SOCIETY.**

(ALL AGES CALCULATED TO JULY 1ST, 1865).

Reference Number in Certificates.		First Prize.	Second Prize.	Third Prize.
	CATTLE,			
	SHORT-HORNED.			
Class.		£.	£.	£.
1	Bull, above three and not exceeding six years old	25	15	5
2	Bull, above two and not exceeding three years old	25	15	5
3	Bull, above one and not exceeding two years old	25	15	5
4	Bull-Calf, above six and not exceeding twelve months old	10	5	..
5	Cow, above three years old	20	10	5
6	Heifer, in-milk or in-calf, not exceeding three years old	15	10	5
7	Yearling Heifer	15	10	5
8	Heifer-Calf, above six and under twelve months old	10	5	..
	HEREFORD.			
9	Bull, above three and not exceeding six years old	25	15	5
10	Bull, above two and not exceeding three years old	25	15	5
11	Bull, above one and not exceeding two years old	25	15	5
12	Bull-Calf, above six and not exceeding twelve months old	10	5	..
13	Cow, above three years old	20	10	5
14	Heifer, in-milk or in-calf, not exceeding three years old	15	10	5
15	Yearling Heifer	15	10	5
16	Heifer-Calf, above six and under twelve months old	10	5	..
	DEVON.			
17	Bull, above three and not exceeding six years old	25	15	5
18	Bull, above two and not exceeding three years old	25	15	5
19	Bull, above one and not exceeding two years old	25	15	5
20	Bull-Calf, above six and not exceeding twelve months old	10	5	..
21	Cow, above three years old	20	10	5
22	Heifer, in-milk or in-calf, not exceeding three years old	15	10	5
23	Yearling Heifer	15	10	5
24	Heifer-Calf, above six and under twelve months old	10	5	..

Reference Number in Certificates.		First Prize.	Second Prize.	Third Prize.
CATTLE—continued.				
SUSSEX.				
Class.		£.	£.	£.
25	Bull, above one and not exceeding six years old ..	15	10	..
26	Cow, above three years old	15	10	..
27	Heifer, in-milk or in-calf, not exceeding three years old	15	10	..
28	Yearling Heifer	15	10	..
CHANNEL ISLANDS.				
29	Bull, above two and not exceeding six years old	20	10	5
30	Bull, above one and not exceeding two years old	20	10	5
31	Cow, above three years old	20	10	5
32	Heifer, in-milk or in-calf, not exceeding three years old	20	10	5
OTHER ESTABLISHED BREEDS.				
<i>Not including the Short-horn, Hereford, Devon, Sussex, or Channel Islands.</i>				
33	Bull, above two and not exceeding six years old	15	10	..
34	Bull, above one and not exceeding two years old	15	10	..
35	Cow, above three years old	15	10	..
36	Heifer, in-milk or in-calf, not exceeding three years old	15	10	..
37	Yearling Heifer	15	10	..
HORSES.				
38	For the THOROUGH-BRED STUD-HORSE, having served Mares during the season 1865, which, in the opinion of the Judges, is best calculated to improve and perpetuate the breed of the sound and stout Thorough-Bred Horse for General Stud Purposes	100	25	..
HUNTERS.				
39	Stallion, Thorough-Bred, suitable for getting Hunters, whose regular charge for serving half-bred Mares during the season 1865 has not exceeded Five Guineas	30	20	10
40	Brood Mare, with foal at foot, or in-foal, for breeding Hunters	20	15	5

Reference Number in Certificates.		First Prize.	Second Prize.	Third Prize.
	HORSES—continued.			
	HACKNEY.			
Class.		£.	£.	£.
41	Blood Mare, with foal at foot, or in-foal, for breeding Hackneys	20	10	5
	PONIES.			
42	Stallion, not exceeding 14 hands	15	10	5
43	Mare, not exceeding 14 hands	10	5	..
	AGRICULTURAL HORSES.			
	AGRICULTURAL.			
	<i>Not qualified to compete as Suffolk.</i>			
44	Stallion, foaled before the 1st of January, 1863 ..	25	15	10
45	Stallion, foaled in the year 1863	20	10	5
46	Mare and Foal	20	10	5
47	Mare, three years old	15	10	..
48	Filly, two years old	15	10	..
	SUFFOLK.			
49	Stallion, foaled before the 1st of January, 1863 ..	20	10	..
50	Stallion, foaled in the year 1863	15	10	..
51	Mare and foal	20	10	..
52	Filly, two years old	15	10	..
	SHEEP.			
	LEICESTER.			
53	Shearling Ram	20	10	5
54	Ram of any other age	20	10	5
55	Pen of Five Shearling Ewes, of the same flock ..	15	10	5
	COTSWOLD.			
56	Shearling Ram	20	10	5
57	Ram of any other age	20	10	5
58	Pen of Five Shearling Ewes, of the same flock ..	15	10	5

Reference Number in Certificates.		First Prize.	Second Prize.	Third Prize.
	SHEEP—continued.			
Class.	LINCOLN AND OTHER LONG-WOOLLED.	£.	£.	£.
	<i>Not qualified to compete as Leicesters or Cotswolds.</i>			
59	Shearling Ram	20	10	5
60	Ram of any other age	20	10	5
61	Pen of Five Shearling Ewes, of the same flock ..	15	10	5
	OXFORDSHIRE DOWN.			
62	Shearling Ram	20	10	5
63	Ram of any other age	20	10	5
64	Pen of Five Shearling Ewes, of the same flock ..	15	10	5
	SOUTHDOWN.			
65	Shearling Ram	20	10	5
66	Ram of any other age	20	10	5
67	Pen of Five Shearling Ewes, of the same flock ..	15	10	5
	SHROPSHIRE.			
68	Shearling Ram	20	10	5
69	Ram of any other age	20	10	5
70	Pen of Five Shearling Ewes, of the same flock ..	15	10	5
	HAMPSHIRE AND OTHER SHORT-WOOLLED.			
	<i>Not qualified to compete as Southdowns or Shropshires.</i>			
71	Shearling Ram	20	10	5
72	Ram of any other age	20	10	5
73	Pen of Five Shearling Ewes, of the same flock ..	15	10	5
	SOMERSET AND DORSET HORNED.			
74	Shearling Ram	15	5	..
75	Ram of any other age	15	5	..
76	Pen of Five Ewes, of any age, of the same flock ..	10	5	..
	SOUTH HAMS.			
77	Shearling Ram	15	5	..
78	Ram of any other age	15	5	..
79	Pen of Five Ewes, of any age, of the same flock ..	10	5	..

Reference Number in Certificates.		First Prize.	Second Prize.
	SHEEP—continued.		
	DARTMOOR—(in Wool).		
Class.		£.	£.
80	Shearling Ram.. .. .	15	5
81	Ram of any other age	15	5
82	Pen of Five Ewes, of any age, of the same flock ..	10	5
	EXMOOR—(in Wool).		
83	Shearling Ram.. .. .	15	5
84	Ram of any other age	15	5
85	Pen of Five Ewes, of any age, of the same flock ..	10	5
	PIGS.		
86	Boar of a large white breed	10	5
87	Boar of a small white breed	10	5
88	Boar of a small black breed	10	5
89	Boar of the Berkshire breed	10	5
90	Boar of a breed not eligible for the preceding classes	10	5
91	Breeding Sow of a large white breed	10	5
92	Breeding Sow of a small white breed	10	5
93	Breeding Sow of a small black breed	10	5
94	Breeding Sow of the Berkshire breed	10	5
95	Breeding Sow of a breed not eligible for the preceding classes	10	5
96	Pen of three Breeding Sow-Pigs of a large white breed, of the same litter, above four and under eight months old	10	5
97	Pen of three Breeding Sow-Pigs of a small white breed, of the same litter, above four and under eight months old	10	5
98	Pen of three Breeding Sow-Pigs of a small black breed, of the same litter, above four and under eight months old	10	5
99	Pen of three Breeding Sow-Pigs of the Berkshire breed, of the same litter, above four and under eight months old	10	5
100	Pen of three Breeding Sow-Pigs of a breed not eligible for the preceding classes, of the same litter, above four and under eight months old ..	10	5

II.—IMPLEMENT AND MACHINERY PRIZES OFFERED BY THE SOCIETY.

		I. DRILLS.	£.
For the Class of	1.	General Purpose Drills	25
Ditto	2.	Corn Drills	20
Ditto	3.	Ditto for small occupations	15
Ditto	4.	Ditto for hill-side delivery	10
Ditto	5.	Turnips and other roots on the flat	20
Ditto	6.	Ditto ditto ridge	20
Ditto	7.	Water Drills	20
Ditto	8.	Drills for small seeds	10
Ditto	9.	Drill Pressers	10

II. MANURE DISTRIBUTORS.

For the Class of	1.	Distributors for dry manure	15
Ditto	2.	Ditto. for liquid manure	10

III. HORSE HOES.

For the Class of	1.	Horse Hoes for general purposes	15
Ditto	2.	Single-row Horse Hoes for ridge and flat	10
Ditto	3.	Single-row Grubber	10
Ditto	4.	Horse Hoes for thinning turnips	10

IV. MOWING MACHINES.

For the Class of	Mowing Machines for natural and artificial grasses ..	25
------------------	---	----

V. HAYMAKING MACHINES.

For the Class of	Haymaking Machines	15
------------------	----------------------------	----

VI. REAPING MACHINES.

For the Class of	1.	For cutting, with self side-delivery	40
Ditto	2.	For cutting the corn, without self-delivery	20
Ditto	3.	For combined reaping and grass mowing	20
Ditto	4.	One-horse Reapers	20

VII. HORSE RAKES.

For the Class of	Horse Rakes	10
------------------	---------------------	----

VIII. WAGGONS.

For the Class of	1.	Pair-horse Waggon	20
Ditto	2.	Other Waggon	10

Special Prizes.

		£.
IX. CARTS.		
For the Class of 1. Single-horse Carts		10
Ditto 2. Two-horse Carts		10
Ditto 3. Harvest Carts		10
Ditto 4. Market Carts on springs		10

X. MISCELLANEOUS.

Awards to Agricultural articles, and essential improvements therein
(10 silver medals)

III.—SPECIAL PRIZES OFFERED BY THE LOCAL COMMITTEE
OF DEVONPORT AND PLYMOUTH.

Reference Number in Certificates.	CATTLE.	First Prize.	Second Prize.
	DEVONS.		
		£.	£.
Class. 101	Bull, Cow, and their offspring, the latter not to exceed nine months old on the 1st July, 1865, the Cow to have been <i>bona fide</i> the property of the Exhibitor two years previous to the 1st July, 1865	30	15
102	Pair of Cows, in-milk or in-calf, exceeding three years six months old on the 1st July, 1865 .. (Contributed by Breeders.)	20	10
103	Pair of Heifers, in-milk or in-calf, not exceeding three years six months old on the 1st July, 1865	20	10
104	Pair of Heifers, not exceeding two years six months old on the 1st July, 1865 (Contributed by Breeders.)	15	8
105	Pair of Heifers, not exceeding one year six months old on the 1st July, 1865	15	8
106	Pair of Bull-Calves, not exceeding nine months old on the 1st July, 1865 (Contributed by Breeders.)	20	10
	SOUTH HAMS.		
107	Bull, exceeding three and not exceeding five years old on the 1st July, 1865	15	10
108	Bull, exceeding one and not exceeding three years old on the 1st July, 1865	15	10
109	Cow, in-calf or in-milk, exceeding four years old on the 1st July, 1865	10	5
110	Heifer, in-calf or in-milk, not exceeding four years old on the 1st July, 1865	10	5
111	Heifer, not exceeding two years six months old on the 1st July, 1865	6	3
112	Heifer, not exceeding one year six months old on the 1st July, 1865	6	3

Reference Number in Certificates.		First Prize.	Second Prize.
	HORSES.		
	AGRICULTURAL.		
	<i>Not being Suffolk or Clydesdale, adapted for a Hilly District.</i>		
113	Stallion, not exceeding eight years old	15	10
114	Mare or Filly, not exceeding seven years old ..	10	5
	HUNTERS.		
115	Mare or Gelding, four years old	15	10
116	Mare or Gelding, five and not exceeding six years old	15	10
	ROADSTERS.		
117	Mare or Gelding, five or six years old, not less than 14 nor exceeding 15 hands 1 in.	10	5
	PONIES.		
	DARTMOOR.		
118	Stallion, not exceeding 13½ hands	10	5
119	Mare, not exceeding 13 hands	10	5
	EXMOOR.		
120	Stallion, not exceeding 13½ hands	10	5
121	Mare, not exceeding 13 hands	10	5
	PIGS.		
	LARGE BREED.		
122	Boar, Sow, and their litter, all to have been bred by the Exhibitor, the litter not to exceed twelve weeks old on the 17th July, 1865	10	5
	SMALL BREED (<i>Black</i>).		
123	Boar, Sow, and their litter, all to have been bred by the Exhibitor, the litter not to exceed twelve weeks old on the 17th July, 1865	10	5

Reference Number in Certificates.		First Prize.	Second Prize.
	BUTTER.		
	—		
Class.		£.	£.
124	12 lbs. of Scald Cream Butter, made and printed in pounds and half-pounds	5	3
	—		
	WOOL—(Washed).		
	—		
	<i>(Five Fleeces each).</i>		
125	Leicester	2	..
126	Cotswold	2	..
127	Lincoln	2	..
128	Southdown	2	..
129	Shropshire	2	..
130	Hampshire and other Short-woolled	2	..
131	Dorset	2	..
132	South Hams	2	..
133	Dartmoor	2	..
134	Exmoor	2	..

CONDITIONS RELATING TO LIVE STOCK.

1. No bull above two years old will be eligible for a prize unless certified to have served not less than three different cows (or heifers) within the three months preceding the 1st of June in the year of the Show.

2. No cow will be eligible for a prize unless certified to have had a live calf, either between the date of entry and that of the Show, or within the twelve months preceding the date of the Show.

3. No heifer, except yearlings, entered as in-calf, will be eligible for a prize unless she is certified to have been bulled before the 31st of March in the year of Show, nor will her owner afterwards receive the prize until he shall have furnished the Secretary with a further certificate that she produced a live calf before the 31st of January in the subsequent year.

4. All foals must be the offspring of the mare along with which they are exhibited for the prize.

5. The ewes in each pen must be of the same flock.

6. Sheep exhibited for any of the prizes (except Dartmoor and Exmoor sheep, which must be shown in the wool) must have been *really and fairly shorn bare* after the 1st of April in the year of the Exhibition; and the date of such shearing must form part of the Certificate of Entry. Two Inspectors will be appointed by the Council to examine the sheep on their admission to the Show-Yard, with instructions to report to the Stewards any cases in which the sheep have not been *really and fairly shorn bare*.

7. The three sow-pigs in each pen must be of the same litter.

8. The breeding sows in Classes 91, 92, 93, 94, and 95, shall be certified to have had a litter of live pigs within the six months preceding the Show, or to be in-pig at the time of entry, so as to produce a litter before the 1st of September following. In the case of in-pig sows, the prize will be withheld until the Exhibitor shall have furnished the Secretary with a certificate of farrowing, as above.

9. No sow, if above eighteen months old, that has not produced a litter of live pigs, shall be eligible to compete in any of the classes.

10. The Judges of pigs will be instructed, with the sanction of the Stewards, to withhold prizes from any animals which shall appear to them to have been entered in a wrong class; and to affix a placard of disqualification to the pens of those animals.

11. All pigs exhibited at the country meetings of the Society shall be subjected to an examination of their mouths by the Veterinary Inspector of the Society; and should the state of dentition in any pig indicate that the age of the animal has not been correctly returned in the Certificate of Entry, the Stewards shall have power to disqualify such pig, and shall report the circumstance to the Council at its ensuing monthly meeting.

12. If a litter of pigs be sent with a breeding sow, the young pigs must be the produce of the sow, and must not exceed three months old.

13. No horse shall be exhibited without a certificate from a Member of the Royal College of Veterinary Surgeons, as to the state of the animal with reference to hereditary diseases, particularly those of the respiratory and visual

organs; which certificate shall accompany the Certificate of Entry; but that the above shall not supersede the usual examination by the Society's Veterinary Inspector.

14. A form of certificate will be sent to every Exhibitor of horses, to be filled up by a Member of the Royal College of Veterinary Surgeons, certifying to the soundness of every horse exhibited, without which such horse shall not be admitted into the Yard.

15. The ponies in Class 43, and the hunters and hacks in Classes 115, 116, 117, 119, and 121 must all be ridden during the Show, and must therefore be provided with saddles and bridles.

16. A charge of 1*l.* for the accommodation of a horse-box will be made for each entry of horses in Classes 38, 39, 40, 41, 42, 44, 45, 46, 49, 50, 51, 113, 115, 116, 117, 118, 120.

17. A charge of 10*s.* will be made for the accommodation of a stall for each entry in Classes 43, 47, 48, 52, 114, 119, 121.

RULES OF ADJUDICATION.

1. As the object of the Society in giving prizes for neat cattle, sheep, and pigs, is to promote improvement in *breeding* stock, the Judges in making their awards will be instructed not to take into their consideration the present value to the butcher of animals exhibited, but to decide according to their relative merits for the purpose of *breeding*.

2. If, in the opinion of the Judges, there should be equality of merit, they will be instructed to make a special report to the Council, who will decide on the award.

3. The Judges will be instructed to withhold any prize if they are of opinion that there is not sufficient merit in any of the stock exhibited for such prize to justify an award; should, however, the question of disqualifying a whole class arise, the Judges shall consult with the Stewards of the yard, and their joint decision shall be final.

4. The Judges will be instructed to give in a *reserved number* in each class of live stock; viz., which animal would, in their opinion, possess sufficient merit for the prize in case the animal to which the prize is awarded should subsequently become disqualified.

5. In the classes for stallions, mares, and fillies, the Judges in awarding the prizes will be instructed, in addition to symmetry, to take activity and strength into their consideration.

6. The Judges will be instructed to deliver to the Director their award, signed, and stating the numbers to which the prizes are adjudged, before they leave the yard.

CONDITIONS RELATING TO MACHINERY.

STEAM-ENGINES.

All engines must be fitted with a steam-indicator, in addition to the ordinary spring-balance.

DRILLS.

The general purpose drills, both for large and small occupations, must be adapted for all kinds of corn, seeds, and manures.

HORSE HOES.

The horse hoes for thinning turnips should be adapted to set them out at various widths, and leave the plants in such a state that they can ultimately be singled by hand.

MANURE DISTRIBUTOR.

The manure distributor will be preferred which is best adapted for distributing any kind of artificial manure, when in a moist or dry state, and which is capable of adjustment for the delivery of any quantity from 3 to 40 bushels per acre.

* * Forms of Certificate for entry, as well as Prize-Sheets for the Plymouth Meeting, containing the whole of the conditions and regulations, may be obtained at the Office of the Society, No. 12, Hanover Square, London, W.

DATES OF ENTRY.

CERTIFICATES for the entry of Implements for the Plymouth Meeting must be forwarded to the Secretary of the Society, No. 12, Hanover Square, London (W.), by the 1st of May, and Certificates for the entry of Live Stock by the 1st of June. Certificates received after those respective dates will not be accepted, but returned to the persons by whom they have been sent.

The Prizes of the Royal Agricultural Society of England, and all Prizes offered by the Devonport and Plymouth Local Committee, are open to general competition.

Essays and Reports.

AWARD FOR 1864.

MISCELLANEOUS CLASS.

The Prize of 10*l.* was awarded to the Rev. NATHANIEL M. BROWN, Fairy Fort, County Derry, for his Essay on the Cultivation and Management of Flax.

Members' Privileges of Chemical Analysis.

THE Council have fixed the following rates of Charge for Analyses to be made by the Consulting Chemist for the *bonâ-fidè* use of Members of the Society; who (to avoid all unnecessary correspondence) are particularly requested, when applying to him, to mention the kind of analysis they require, and to quote its number in the subjoined schedule. The charge for analysis, together with the carriage of the specimens, must be paid to him by members at the time of their application.

No. 1.—An opinion of the genuineness of Peruvian guano, bone-dust, or oil-cake (each sample)	5s.
„ 2.—An analysis of guano; showing the proportion of moisture, organic matter, sand, phosphate of lime, alkaline salts, and ammonia	10s.
„ 3.—An estimate of the value (relatively to the average of samples in the market) of sulphate and muriate of ammonia, and of the nitrates of potash and soda	10s.
„ 4.—An analysis of superphosphate of lime for soluble phosphates only	10s.
„ 5.—An analysis of superphosphate of lime, showing the proportions of moisture, organic matter, sand, soluble and insoluble phosphates, sulphate of lime, and ammonia	£1.
„ 6.—An analysis (sufficient for the determination of its agricultural value) of any ordinary artificial manure	£1.
„ 7.—Limestone:—the proportion of lime, 7s. 6d.; the proportion of magnesia, 10s.; the proportion of lime and magnesia	15s.
„ 8.—Limestone or marls, including carbonate, phosphate, and sulphate of lime, and magnesia with sand and clay	£1.
„ 9.—Partial analysis of a soil, including determinations of clay, sand, organic matter, and carbonate of lime	£1.
„ 10.—Complete analysis of a soil	£3.
„ 11.—An analysis of oil-cake, or other substance used for feeding purposes; showing the proportion of moisture, oil, mineral matter, albuminous matter, and woody fibre; as well as of starch, gum, and sugar, in the aggregate	£1.
„ 12.—Analyses of any vegetable product	£1.
„ 13.—Analyses of animal products, refuse substances used for manure, &c.	from 10s. to 30s.
„ 14.—Determination of the “hardness” of a sample of water before and after boiling	10s.
„ 15.—Analysis of water of land drainage, and of water used for irrigation	£2.
„ 16.—Determination of nitric acid in a sample of water	£1.

N.B.—*The above Scale of Charges is not applicable to the case of persons commercially engaged in the Manufacture or Sale of any Substance sent for Analysis.*

The Address of the Consulting Chemist of the Society is, Dr. AUGUSTUS VOELCKER, 11, Salisbury Square, London, E.C., to which he requests that all letters and parcels (postage and carriage paid) should be directed.

Members' Veterinary Privileges.

I.—SERIOUS OR EXTENSIVE DISEASES.

No. 1. Any Member of the Society who may desire professional attendance and special advice in cases of serious or extensive disease among his cattle, sheep, or pigs, and will address a letter to the Secretary, will, by return of post, receive a reply stating whether it be considered necessary that Professor Simonds, the Society's Veterinary Inspector, should visit the place where the disease prevails.

No. 2. The remuneration of the Inspector will be 2*l.* 2*s.* each day as a professional fee, and 1*l.* 1*s.* each day for personal expenses; and he will also be allowed to charge the cost of travelling to and from the locality where his services may have been required. The fees will be paid by the Society, but the travelling expenses will be a charge against the applicant. This charge may, however, be reduced or remitted altogether at the discretion of the Council, on such step being recommended to them by the Veterinary Committee.

No. 3. The Inspector, on his return from visiting the diseased stock, will report to the Committee, in writing, the results of his observations and proceedings, which Report will be laid before the Council.

No. 4. When contingencies arise to prevent a personal discharge of the duties confided to the Inspector, he may, subject to the approval of the Committee, name some competent professional person to act in his stead, who shall receive the same rates of remuneration.

II.—ORDINARY OR OTHER CASES OF DISEASE.

Members may obtain the attendance of the Veterinary Inspector on any case of disease by paying the cost of his visit, which will be at the following rate, viz., 2*l.* 2*s.* per diem, and travelling expenses.

III.—CONSULTATIONS WITHOUT VISIT.

Personal consultation with Veterinary Inspector 5 <i>s.</i>
Consultation by letter 5 <i>s.</i>
Consultation necessitating the writing of three or more letters.	10 <i>s.</i>
Post-mortem examination, and report thereon 10 <i>s.</i>

A return of the number of applications during each half-year being required from the Veterinary Inspector.

IV.—ADMISSION OF DISEASED ANIMALS TO THE VETERINARY COLLEGE; INVESTIGATIONS, LECTURES, AND REPORTS.

No. 1. All Members of the Society have the privilege of sending cattle, sheep, and pigs to the Infirmary of the Royal Veterinary College, on the same terms as if they were Members of the College; viz., by paying for the keep and treatment of cattle 10*s.* 6*d.* per week each animal, and for sheep and pigs "a small proportionate charge to be fixed by the Principal according to circumstances."

No. 2. The College has also undertaken to investigate such particular classes of disease, or special subjects connected with the application of the Veterinary art to cattle, sheep, and pigs, as may be directed by the Council.

No. 3. In addition to the increased number of lectures now given by Professor Simonds—the Lecturer on Cattle Pathology—to the pupils in the Royal Veterinary College, he will also deliver such lectures before the Members of the Society, at their house in Hanover Square, as the Council shall decide.

No. 4. The Royal Veterinary College will from time to time furnish to the Council a detailed Report of the cases of cattle, sheep, and pigs treated in the Infirmary.

Royal Agricultural Society of England.

1865-66.

President.

THE RIGHT HONOURABLE LORD TREDEGAR.

Trustees.

ACLAND, SIR THOMAS DYKE, Bart., *Killerton Park, Exeter, Devonshire.*
BERNERS, LORD, *Keythorpe Hall, Leicester.*
BRAMSTON, THOMAS WILLIAM, *Skreens, Chelmsford, Essex.*
CHALLONER, Colonel, *Portmell Park, Staines, Middlesex.*
DENISON, The Rt. Hon. John Evelyn, *Ossington, Newark-on-Trent, Notts.*
FEVERSHAM, LORD, *Helmsley, York.*
MARLBOROUGH, Duke of, *Blenheim Park, Oxford.*
PORTMAN, LORD, *Bryanston, Blandford, Dorset.*
POWIS, EARL OF, *Powis Castle, Welshpool, Montgomeryshire.*
RUTLAND, Duke of, *Belvoir Castle, Grantham, Lincolnshire.*
SHELLEY, SIR JOHN VILLIERS, Bart., *Maresfield Park, Sussex.*
THOMPSON, HARRY STEPHEN, *Kirby Hall, York.*

Vice-Presidents.

BARKER, THOMAS RAYMOND, *Hambleton, Henley-on-Thames, Oxfordshire.*
CHICHESTER, EARL OF, *Stanmer Park, Lewes, Sussex.*
DOWNSHIRE, MARQUIS OF, *East Hampstead Park, Bracknell, Berkshire.*
EGMONT, EARL OF, *Cowdray Park, Petworth, Sussex.*
EVERSLEY, VISCOUNT, *Heckfield Place, Winchfield, Hants.*
EXETER, MARQUIS OF, *Burleigh House, Stamford, Lincolnshire.*
HILL, VISCOUNT, *Hawkstone Park, Salop.*
HOBBS, W. FISHER, *Boxted Lodge, Colchester, Essex.*
HOOD, Major-Gen. the Hon. A. NELSON, *Cumberland Lodge, Windsor, Berkshire.*
JOHNSTONE, SIR JOHN V. B., Bart., M.P., *Hackness Hall, Scarborough, Yorkshire.*
MILES, SIR WILLIAM, Bart., *Leigh Court, Bristol, Somersetshire.*
WALSINGHAM, LORD, *Merton Hall, Thetford, Norfolk.*

Other Members of Council.

ACLAND, THOMAS DYKE, M.P., *Sprydoncote, Exeter, Devonshire.*
AMOS, CHARLES EDWARDS, 5, *Cedars Road, Clapham Common, Surrey.*
ARKWRIGHT, J. HUNGERFORD, *Hampton Court, Leominster, Herefordshire.*
BARNETT, CHARLES, *Stratton Park, Biggleswade, Bedfordshire.*
BARTHOPP, NATHANIEL GEORGE, *Hacheston, Wickham Market, Suffolk.*
BOWLY, EDWARD, *Siddington House, Cirencester.*
BURGESS WILLIAM, *Brentwood, Essex.*
CANTRELL, CHARLES S., *Riding Court, Datchet, Bucks.*
CATHCART, EARL, *Thornton-le-Street, Thirsk, Yorkshire.*
CHESHAM, LORD, *Latimer, Chesham, Bucks.*

- CLAYDEN, JOHN, *Littlebury, Saffron Walden, Essex.*
 DENT, J. D., M.P., *Ribeton Hall, Wetherby, Yorkshire.*
 DRUCE, JOSEPH, *Eynaham, Oxford.*
 FORTESCUE, EARL, *Castle Hill, Southmolton, Devonshire.*
 GIBBS, B. T. BRANDRETH, *Halfmoon Street, Piccadilly, London, W.*
 HAMOND, ANTHONY, *Westacre Hall, Brandon, Norfolk.*
 HOLLAND, EDWARD, M.P., *Dumbleton Hall, Evesham, Worcestershire.*
 HOSKYNES, CHANDOS WREN, *Harewood, Ross, Herefordshire.*
 HUDSON, JOHN, *Castleacre Lodge, Brandon, Norfolk.*
 HUTTON, WILLIAM, *Gate Burton, Gainsboro', Yorkshire.*
 JONAS, SAMUEL, *Chrishall Grange, Saffron Walden, Essex.*
 KERRISON, SIR EDWARD C., Bart., M.P., *Brome Hall, Scole, Norfolk.*
 KINGSCOTE, Colonel, M.P., *Kingscote, Wootton-under-Edge, Gloucestershire.*
 LAWES, JOHN BENNET, *Rothamsted, St. Albans, Herts.*
 LAWRENCE, CHARLES, *Cirencester, Gloucestershire.*
 LOPES, SIR MASSEY, Bart., M.P., *Marristow, Roborough, Devon.*
 MACDONALD, SIR ARCHIBALD KEPPEL, Bart., *Woolmer Lodge, Liphook, Hants.*
 MILWARD, RICHARD, *Thurgarton Priory, Southwell, Notts.*
 PAIN, THOMAS, *Ugford Cottage, Salisbury, Wilts.*
 POPE, EDWARD, *Great Toller, Maiden Newton, Dorset.*
 RANDELL, CHARLES, *Chadbury, Evesham, Worcestershire.*
 RIGDEN, WILLIAM, *Hove, Brighton, Sussex.*
 RIDLEY, SIR MATTHEW WHITE, Bart., M.P., *Blagdon, Crumlington, Northumberland.*
 SANDAY, WILLIAM, *Holmepierrepoint, Notts.*
 SHREWSBURY AND TALBOT, Earl of, *Ingestre Hall, Staffordshire.*
 SHUTTLEWORTH, JOSEPH, *Hartsholme Hall, Lincoln.*
 SMITH, ROBERT, *Emmett's Grange, Southmolton, Devon.*
 TORR, WILLIAM, *Aylesby Manor, Great Grimsby, Lincolnshire.*
 TOWNELEY, Lieut.-Colonel CHARLES, *Towneley Park, Blackburn, Lancashire.*
 TREDEGAR, Lord, *Tredegar, Newport, Monmouthshire.*
 TURNER, GEORGE, *Beacon Downes, Exeter, Devonshire.*
 VERNON, Hon. AUGUSTUS H., *Sudbury, Derby.*
 WALLIS, OWEN, *Overstone Grange, Northampton.*
 WELLS, WILLIAM, *Redleaf, Penshurst, Kent.*
 WESTERN, SIR THOMAS B., Bart., M.P., *Felix Hall, Kelvedon, Essex.*
 WILSON, HENRY, *Stowlangtoft Hall, Bury-St.-Edmunds, Suffolk.*
 WILSON, JACOB, *Manor House, Woodhorn, Morpeth, Northumberland.*
 WILSON, PROFESSOR, *Iver, Uxbridge, Bucks.*
 WYNN, SIR WATKIN WILLIAMS, Bart, M.P., *Rhuabon, Denbighshire.*

Secretary.

H. HALL DARE, 12, *Hanover Square, London, W.*

Editor—P. H. FRERE, *Dungate, Cambridge.*

Consulting-Chemist—DR. AUGUSTUS VOELCKER, 11, *Salisbury Square, E.C.*

Veterinary-Inspector—JAMES BEART SIMONDS, *Royal Veterinary College, N.W.*

Consulting Engineer—JAMES EASTON, or C. E. AMOS, *Grove, Southwark, S.E.*

Seedsmen—THOMAS GIBBS and Co., *Corner of Halfmoon Street, Piccadilly, W.*

Publisher—JOHN MURRAY, 50, *Albemarle Street, W.*

Bankers—THE LONDON AND WESTMINSTER BANK, *St. James's Square Branch, S.W.*

STANDING COMMITTEES FOR 1865-66.

Finance Committee.

HOOD, Maj.-Gen. the Hon. A. NELSON. HOBBS, WM. FISHER.
BARNETT, CHARLES. TORR, WILLIAM.
BRAMSTON, T. W.

House Committee.

THE PRESIDENT. CHALLONER, Colonel.
CHAIRMAN of Finance Committee. GIBBS, B. T. BRANDRETH.
CHESHAM, Lord. HOBBS, WM. FISHER.
BRAMSTON, T. W.

Journal Committee.

CATHCART, Earl. ACLAND, T. DYKE, M.P.
FORTESQUE, Earl. HOLLAND, ED., M.P.
DENISON, The Rt. Hon. J. E. HOSKYNs, C. WREN.
SHELLEY, Sir J. V., Bt. MILWARD, RICHARD.
JOHNSTONE, Sir J. V. B., Bt., M.P. THOMPSON, H. S.
KERRISON, Sir E. C., Bt., M.P. WALLIS, OWEN.
MACDONALD, Sir A. K., Bt.

Chemical Committee.

CATHCART, Earl. DENT, J. D., M.P.
VERNON, Hon. A. H. HOLLAND, ED., M.P.
JOHNSTONE, Sir J. V. B., Bt., M.P. HOSKYNs, C. WREN.
KERRISON, Sir E. C., Bt., M.P. HUXTABLE, Ven. Archdeacon.
MACDONALD, Sir A. K., Bt. LAWES, J. B.
ACLAND, T. DYKE, M.P. THOMPSON, H. S.
ARKWRIGHT, J. H. WELLS, WILLIAM.

Veterinary Committee.

HOOD, Maj.-Gen. the Hon. A. NELSON. HAMOND, ANTHONY.
JOHNSTONE, Sir J. V. B., Bt., M.P. HOBBS, WM. FISHER.
MILES, Sir WM., Bt. PAIN, THOS.
BARKER, THOS. RAYMOND. SIMONDS, Professor.
CHALLONER, Colonel. SPOONER, Professor.
DENT, J. D., M.P. THOMPSON, H. S.
GIBBS, B. T. BRANDRETH. WELLS, WILLIAM.

Stock-Prizes Committee.

WALSINGHAM, Lord. JONAS, SAMUEL.
HOOD, Maj.-Gen. the Hon. A. NELSON. MILWARD, RICHARD.
BARNETT, CHARLES. PAIN, THOMAS.
BARTHROPP, NATHANIEL G. POPE, EDWARD.
CLAYDEN, JOHN. RANDELL, CHAS.
DENT, J. D., M.P. RIGDEN, WM.
DRUCE, JOSEPH. SMITH, ROBERT.
GIBBS, B. T. BRANDRETH. SIMONDS, Professor.
HOBBS, WM. FISHER. TORR, WILLIAM.
HOLLAND, ED., M.P. TURNER, GEORGE.
HUDSON, JOHN. WALLIS, OWEN.

Implement Committee.

CHESHAM, Lord.
 HOOD, Maj.-Gen. the Hon. A. NELSON.
 VERNON, Hon. A. H.
 KERRISON, Sir E. C., Bt., M.P.
 MACDONALD, Sir A. K., Bt.
 MILES, Sir Wm., Bt.
 AMOS, C. E.
 ARKWRIGHT, J. H.
 BARNETT, CHARLES.
 CANTRELL, CHAS. S.
 CHALLONER, Colonel.

GIBBS, B. T. BRANDRETH.
 HAMOND, ANTHONY.
 HOBBS, Wm. FISHER.
 HOLLAND, ED., M.P.
 HOSKYNS, C. WREN.
 RANDELL, CHARLES.
 SHUTTLEWORTH, JOSEPH.
 THOMPSON, H. S.
 TORR, WILLIAM.
 WALLIS, OWEN.
 WILSON, Professor.

General Bury Committee.

Sir E. C. KERRISON, Bt., M.P., Chairman.
 POWIS, Earl of.
 CHESHAM, Lord.
 FEVERSHAM, Lord.
 PORTMAN, Lord.
 TREGGAR, Lord.
 HOOD, Maj.-Gen. the Hon. A. NELSON.
 VERNON, Hon. A. H.
 BARNETT, CHARLES.
 BOWLY, EDWARD.
 BURY, The Mayor of.
 BRAMTON, T. W.
 CANTRELL, CHARLES S.
 CHALLONER, Colonel.
 CLAYDEN, JOHN.

DENT, J. D., M.P.
 GIBBS, B. T. BRANDRETH.
 GREENE, E.
 HOBBS, Wm. FISHER.
 HOLLAND, E., M.P.
 HOSKYNS, C. WREN.
 MILWARD, RICHARD.
 PAIN, THOMAS.
 RANDELL, CHARLES.
 SHUTTLEWORTH, JOSEPH.
 THOMPSON, H. S.
 TORR, WILLIAM.
 WILSON, HENRY.
 WILSON, Major.

* * * The PRESIDENT, TRUSTEES, and VICE-PRESIDENTS are Members *ex officio* of all Committees.

Royal Agricultural Society of England.

GENERAL MEETING,

12, HANOVER SQUARE, MONDAY, MAY 22, 1865.

REPORT OF THE COUNCIL.

SINCE the last General Meeting in December 41 members have died; and the names of 220 members have been removed from the list by retirement, nearly the whole number of these having joined the Society for the Newcastle Meeting only; while 3 Governors and 95 members have been elected, so that the Society now consists of

79 Life Governors,
81 Annual Governors,
1386 Life Members,
4190 Annual Members,
16 Honorary Members,

making a total of 5752.

The Council have elected Sir Massey Lopes, Bart., M.P., a Member of Council, in the room of the late Mr. Buller, M.P.

The half-yearly statement of accounts to 31st of December, 1864, has been examined and approved by the auditors and accountants of the Society, and, together with the Balance-sheet for the whole year 1864, and a statement of the Country Meeting for Newcastle-upon-Tyne, has been published in the last number of the 'Journal.' The funded capital has been increased by a further investment of 2000*l.*, and now stands at 21,027*l.* 19*s.* 6*d.* in the New Three per Cents.; 1000*l.* remains on deposit with the Society's Bankers, and the current cash-balance in their hands on the 1st instant was 1981*l.* 17*s.* 2*d.*

Members will have observed in the accounts for 1864, the item of a legacy of ten guineas left by the late Beriah Botfield, Esq., M.P.. the first instance of a bequest to the funds of the Society.

Papers have been read at the Weekly Meetings by Mr. Lawes on Sewage ; Mr. Ellman on the Management of a Breeding Flock of Sheep ; Professor Voelcker on Natural Deposits of Potash in Germany ; Mr. T. Beale Brown on Flax ; Mr. Morton on Agricultural Education.

The Council, in deciding upon the course of action to be pursued on the important subject of Education, have found it attended with much difficulty ; and, indeed, considerable diversity of opinion has been expressed as to the best mode of procedure. The Council, after much deliberation, have decided for this year to limit their prizes to candidates examined at the Local Examinations held by the Universities of Cambridge and Oxford. They consider that sufficient attention has not hitherto been given to the general education of the sons of Agriculturists. A good sound education once obtained, special education may be properly rewarded. The groundwork of Chemistry, Botany, Zoology, Geology, and Mechanics, and the study of Mathematics, are included in the subjects for examination both of Cambridge and Oxford. To candidates, who shall be recommended by any member of the Royal Agricultural Society of England, and who must be persons in some way dependent on the cultivation of the land for their support, or intending to make agriculture their profession, the Council offer the following prizes, viz. :—100*l.* in prizes amongst those who shall pass the Cambridge or Oxford Senior or Junior Examinations ; 100*l.* to those at the Cambridge and Oxford Examinations who, having passed the preliminary Examination, shall have distinguished themselves in Mathematics, Mechanics, Chemistry, Physics, Botany, Zoology, or Geology. In addition to these prizes, the Committee are in negotiation with the authorities at Cambridge, in order that papers bearing upon special subjects connected with Agriculture may be set at the next examination in December. Should these negotiations be successful, a sum of 60*l.* will be offered for two papers, one on Agricultural Chemistry, and one on Mechanics as applied to Agriculture ; which papers will be prepared by gentlemen appointed by the Royal Agricultural Society of England, and reported upon by them. Candidates of any age may compete for these special prizes.

The objects which the Council hope to attain are to improve sound general education, and to encourage proficiency in such

branches of science as are applicable to the study of Agriculture, and calculated to prepare the mind of the student for the proper reception of that practical education which can only be completed by observation of the working of a farm, where he may be enabled to test the value of such theories as may be presented to him.

The Council have resolved that the Implement and Stock Prize sheets for the following year shall in future be prepared at the November Council and reconsidered in December, in order that members and the public may have them at an earlier period than heretofore.

The Contract for the Show-yard Works has been under the attentive consideration of the Committee, and the Council have appointed a surveyor, who will form an estimate of the value of the works at Plymouth, and advise the Council as to the desirability of purchasing a large portion of the plant and materials, which are at present hired annually from the Contractor.

The arrangements for the Plymouth Meeting, to be held during the week, commencing Monday, 17th July, are progressing satisfactorily.

A very large entry is already made of Implements, and the entries for Stock, which will close on the 1st of June, promise to be equally numerous.

The Show-yard will be open as under :—

						<i>s.</i>	<i>d.</i>
Monday	5	0
Tuesday	2	6
Wednesday	2	6
Thursday	1	0
Friday	1	0

The Council have determined that the Country Meeting in 1866 shall be held at Bury St. Edmunds.

The district for the Country Meeting of 1867 will include the counties of Derby, Leicester, Lincoln, Nottingham, and Rutland.

By Order of the Council,

H. HALL DARE,

Secretary.

SOCIETY OF ENGLAND.

xxxvii

FROM 1ST JANUARY TO 30TH JUNE, 1865.

CR.

	£.	s.	d.	£.	s.	d.	£.	s.	d.
By Expenditure:—									
Establishment—									
Official Salaries and Wages, &c.	327	6	0						
House Expenses, Rent, Taxes, &c.	290	18	10						
				618	4	10			
Journal:—									
Printing	392	6	0						
Delivery and Advertising	130	4	6						
Prize Essay	10	0	0						
Other Contributions	86	4	0						
Editor's Salary	250	0	0						
				868	14	6			
Chemical:—									
Grant for Investigations, 1865 ..	200	0	0						
Consulting Chemist's Salary ..	150	0	0						
				350	0	0			
Agricultural Education:—									
Printing and Postage				15	9	4			
Postage and Carriage				46	15	5			
Advertisements				3	17	3			
Sundries				19	2	0			
Subscriptions (paid in error) returned				2	0	0			
							1924	3	4
By Stock:—									
Purchase of 2259 <i>l.</i> 17 <i>s.</i> 8 <i>d.</i> New 3 per Cent. ..				2000	0	0			
							2000	0	0
By Country Meetings:—									
Newcastle				116	1	10			
Plymouth				2302	19	6			
							2419	1	4
By Balance in hand June 30th, 1865:—									
Bankers				1367	5	6			
Secretary				38	13	2			
							1405	18	8
							£7749	3	4

30TH JUNE, 1865.

ASSETS.			£.	s.	d.	£.	s.	d.	
By Cash in hand			1,405	18	8				
By Deposit Account at Bankers			1,000	0	0				
By New 3 per cent. Stock, 21,027 <i>l.</i> 19 <i>s.</i> 6 <i>d.</i> cost ..			19,881	11	1				
By Books and Furniture in Society's House			2,000	0	0				
						24,287	9	9	
<i>Mem.</i> —The above Assets are exclusive of the amount recoverable in respect of Subscriptions in arrear 30th June, 1865, which at that date amounted to 480 <i>l.</i>									
Less at Credit of Plymouth Meeting							950	5	6
							£23,337	4	3

Examined, audited, and found correct, this 2nd day of August, 1865.

(Signed) W. COPELAND ASTBURY. } *Auditors on the part of*
 WILLIAM COHEN. } *the Society.*

QUILTER, BALL, & Co., Accountants.

MEMORANDA.

ADDRESS OF LETTERS.—The Society's office being situated in the postal district designated by the letter **W**, members, in their correspondence with the Secretary, are requested to subjoin that letter to the usual address.

GENERAL MEETING in London, in December, 1866.

GENERAL MEETING in London, May 22, 1866, at Twelve o'clock.

MEETING at Bury St. Edmunds, in 1866.

MONTHLY COUNCIL (for transaction of business), at 12 o'clock on the first Wednesday in every month, excepting January, September, and October: open only to Members of Council and Governors of the Society.

WEEKLY COUNCIL (for practical communications), at 12 o'clock on all Wednesdays in February, March, April, May, June, July, and November, excepting the first Wednesday in each of those months, and during adjournment: open to all Members of the Society, who are particularly invited by the Council to avail themselves of this privilege.

ADJOURNMENTS.—The Council adjourn over Passion and Easter weeks, when those weeks do not include the first Wednesday of the month; from the first Wednesday in August to the first Wednesday in November; and from the first Wednesday in December to the first Wednesday in February.

DISEASES of Cattle, Sheep, and Pigs.—Members have the privilege of applying to the Veterinary Committee of the Society; and of sending animals to the Royal Veterinary College, on the same terms as if they were subscribers to the College.—(A statement of these privileges will be found in the present Appendix.)

CHEMICAL ANALYSIS.—The privileges of Chemical Analysis enjoyed by Members of the Society will be found stated in the Appendix of the present volume.

LOCAL CHEQUES.—Members are particularly requested not to forward Country Cheques for payment in London; but London Cheques, or Post-office Orders on Vere-street (payable to H. HALL DARE), in lieu of them. All Cheques are required to bear upon them a penny draft or receipt stamp, which must be cancelled in each case by the initials of the drawer. They may also conveniently transmit their Subscriptions to the Society, by requesting their Country Bankers to pay (through their London Agents) the amount at the Society's Office (No. 12, Hanover Square, London), between the hours of ten and four, when official receipts, signed by the Secretary, will be given for such payments.

NEW MEMBERS.—Every candidate for admission into the Society must be proposed by a Member; the proposer to specify in writing the full name, usual place of residence, and post-town, of the candidate, either at a Council meeting, or by letter addressed to the Secretary.

PACKETS BY POST.—Packets not exceeding two feet in length, width, or depth, consisting of written or printed matter (but not containing letters sealed or open), if sent without envelopes, or enclosed in envelopes open at each end, may be forwarded by the inland post, if stamped, at the following rates:—

For a packet not exceeding	4 ounces	(or quarter of a pound)	1 penny
"	"	8 "	(or half a pound) 2 pence.
"	"	16 "	(or one pound) 4 "
"	"	24 "	(or one pound and a half) 6 "
"	"	32 "	(or two pounds) 8 "

[And so on in the proportion of 8 ounces for each additional 2d.]

* Members may obtain on application to the Secretary copies of an Abstract of the Charter and Bye-Laws, of a Statement of the General Objects, &c., of the Society, of Chemical and Veterinary Privileges, and of other printed papers connected with special departments of the Society's business.

SHOW AT PLYMOUTH,
JULY, 1865.

STEWARDS OF THE YARD.

Stock.
JOHN D. DENT, M.P.,
CHARLES RANDELL,
EDWARD BOWLY.

Implements.
WILLIAM TORR,
EARL CATHCART,
WILLIAM SANDAY.

Forage.
JOHN MOON.

Honorary Director of the Show.
B. T. BRANDRETH GIBBS.

STOCK JUDGES.

Short-horns.
GEORGE DREWRY,
JOSEPH ROBINSON,
JOHN B. THOMPSON.

**Hereford, Sussex, South Hams Cattle,
and other Established Breeds.**

J. DRUCE,
G. PYE,
WILLIAM YEOMANS.

Devons.
J. E. JONES,
EDWARD L. FRANKLIN,
SAMUEL UMBERS.

Channel Islands.
JAMES DUMBRELL,
MOSES GIBAUT,
CHARLES P. LE CORNU.

**Thorough-breds, Hunters, Hackneys,
and Ponies.**

CHARLES BARNETT,
WILLIAM YOUNG,
THOMAS PARRINGTON.

Agricultural and Suffolk Horses.

G. KERSEY COOPER,
JAMES STEEDMAN,
THOMAS BROOKS.

Leicester Sheep.
LUKE BORMAN,
THOMAS TWITCHELL,
JOHN PAINTER.

**Cotswold, Lincoln, and other Long-
wooled Sheep.**

HENRY BATEMAN,
HUGH AYLMER,
CHARLES CLARKE.

Oxfordshire and Shropshire Downs.
THOMAS HORLEY, JUN.,
R. J. NEWTON,
EDWARD GOUGH.

**Southdown, Hampshire, and other
Short-wooled Sheep.**

HENRY FOOKES,
J. S. TURNER,
HENRY OVERMAN.

**Exmoor, Dartmoor, South Hams,
Somerset, and Dorset Sheep.**

JAMES HOLE,
EDWARD POPE,
PHILIP HALSE.

Figs.
THOMAS TROTTER,
SAMUEL DRUCE,
ELIAS P. SQUAREY.

WOOL JUDGES.

THOMAS CLAYTON,

JASON GURNEY.

BUTTER JUDGE.

T. LITTON.

*Award of Live-Stock Prizes at Plymouth.***Inspectors of Shearing.**

H. BONE,

J. B. WORKMAN.

Veterinary-Inspectors.

PROFESSOR SIMONDS,

PROFESSOR VARNELL.

Assistant.—R. L. HUNT.**IMPLEMENT JUDGES.****Drills, Manure Distributors, and Horse****Hoes.**

JOHN HICKEN,
A. H. JOHNSON,
FRANCIS SHERBORN,
JOHN THOMPSON,
ROBERT DYSON, C.E.

Mowing and Reaping Machines.

H. B. CALDWELL,
E. WORTLEY,
GILSON MARTIN,
T. J. BRAMWELL, C.E.,
JOHN COLEMAN.

Haymaking Machines and Horse Rakes.

JOHN HICKEN,
A. H. JOHNSON,
FRANCIS SHERBORN,
ROBERT DYSON, C.E.

Waggons and Carts.

JACOB WILSON,
JOHN THOMPSON.

Miscellaneous.

JACOB WILSON,
JOHN COLEMAN.

Consulting-Engineer.

C. E. AMOS.

AWARD OF PRIZES.

NOTE.—The Judges were instructed, besides awarding the Prizes, to designate as the *Reserved Number* one animal in each Class, next in order of merit, if it possessed sufficient merit for a Prize—in case an animal to which a Prize was awarded should subsequently become disqualified.

CATTLE.*Short-horn Bulls and Bull Calves.*

ROBERT SHARPE, Courtlands, East Grinstead, Sussex: **FIRST PRIZE, 25*l.***, for "Lord Chancellor," red, 4 years 1 month 3 weeks 3 days-old; bred by the late Jonas Webb; sire, "Usurer" (19,035); dam "Red Rose;" sire of dam, "Marmaduke (14,897)."

EDWARD BOLITHO, Trewidden, Penzance, Cornwall: **SECOND PRIZE, 15*l.***, for "Favourite" (19,727), roan, 3 years 1 week 2 days-old; bred by Messrs. Hosken and Son, Loggans, Hayle, Cornwall; sire, "Prince Frederick" (16,734); dam, "Agnes 2nd;" sire of dam, "Cheltenham" (12,588).

AUGUSTUS CORYTON, Pentillie Castle, Saltash, Cornwall: **THIRD PRIZE, 5*l.***, for "Holwood," roan, 3 years 3 months 1 week-old; bred by R. O'Dogherty, Talvans, Landrake, Cornwall; sire, "Henry 1st" (11,571); dam, "Duchess 2nd;" sire of dam, "Broad Hinton."

- JOHN CLAYDEN**, Littlebury, Saffron Walden, Essex: the *Reserved Number*, to "Marquis Cornwallis 2nd" (20,292), red with a little white, 4 years 2 months 1 week 5 days-old; bred by exhibitor; sire, "Sir Charles" (16,948); dam, "Miriam;" sire of dam, "Snowball" (15,309).
- JOHN STRANGER FORD**, Luson, Holbeton, Ivy Bridge, Devon: **FIRST PRIZE**, 25*l.*, for, "Duke of Devonshire," red and white, 2 years 5 months 2 weeks 2 days-old; bred by Mr. Widdicombe, Hay, Ugborough, Ivy Bridge; sire, "Duke of Devonshire;" dam, "Matchless;" sire of dam, "Garrard's Bull."
- JOHN CHARLESWORTH**, Headfield, Dewsbury, Yorkshire: **SECOND PRIZE**, 15*l.*, for "Baron Blencow" (19,267), white, 2 years 8 months 3 weeks 1 day-old; bred by R. F. Housman, Lune Bank, Lancaster, Lancashire; sire, "Royal Windsor" (18,784); dam, "Strawberry Duchess;" sire of dam, "Duke of Buckingham" (14,428).
- JOHN CLAYDEN**: **THIRD PRIZE** 5*l.*, for "Knight of North Essex" (20,079), roan, 2 years 6 months 4 weeks 1 day-old; bred by exhibitor; sire, "Marquis Cornwallis" (18,337); dam, "Diadem;" sire of dam, "Sir Charles" (16,948).
- LORD KINNAIRD**, Rossie Priory, Inchtute, Perthshire, the *Reserved Number*, for "Lord Louis," roan, 2 years 11 months 3 weeks 6 days-old; bred by exhibitor; sire, "Lord Privy Seal;" dam, "Louise 2nd;" sire of dam, "Champion."
- FRANCIS HAWKSWORTH FAWKES**, Farnley Hall, Otley, Yorkshire: **FIRST PRIZE**, 25*l.*, for "Friar Tuck," roan, 1 year 10 months 2 days-old; bred by exhibitor; sire, "Lord Cobham" (20,164); dam, "Fatima;" sire of dam, "Inkerman" (13,068).
- THOMAS CHRISTOPHER BOOTH**, of Warlaby, Northallerton, Yorkshire: **SECOND PRIZE**, 15*l.*, for "Commander-in-Chief," roan, 1 year 1 month 1 week 6 days-old; bred by the late R. Booth, Warlaby; sire, "Valasco" (15,443); dam, "Campfollower;" sire of dam, "Crown Prince" (10,087).
- ZACCHEUS WALKER**, Birmingham: **THIRD PRIZE**, 5*l.*, for "Battersea First Fruits," roan, 1 year 10 months-old; bred by exhibitor; sire, "First Fruits" (19,751); dam, "Miss Battersea;" sire of dam, "Earl of Hardwicke" (14,476).
- LORD WALSINGHAM**, Merton Hall, Thetford, Norfolk: the *Reserved Number*, to "Lord Lovel 2nd," white, 1 year 11 months 4 days-old; bred by exhibitor; sire, "Lord Lovel" (20,192); dam, "Tulip 3rd;" sire of dam, "Havelock of Lucknow" (16,242).
- FRANCIS HAWKSWORTH FAWKES**: **FIRST PRIZE**, 10*l.*, for "Friar Bacon," roan, 10 months 3 weeks 4 days-old; bred by exhibitor; sire, "Lord Cobham" (20,164); dam, "Fatima;" sire of dam, "Inkerman" (13,068).
- SIR ANTHONY DE ROTHSCHILD**, Bart., Aston Clinton, Tring: **SECOND PRIZE**, 5*l.*, for "Corporal," roan, 9 months 3 weeks 1 day-old; bred by exhibitor; sire, "Captain Cheery;" dam, "Statira 4th;" sire of dam, "Rifleman."
- GEORGE GARNE**, Churchill Heath, Chipping Norton, the *Reserved Number*, to "Plymouth Candidate," roan, 10 months 1 week 4 days-old; bred by exhibitor; sire, "Cynric" (19,542); dam, "Peach;" sire of dam, "Havelock" (14,676).

Short-horn Cows and Heifers.

- JOHN WOOD, Stanwick Park, Darlington: FIRST PRIZE, 20*l.*, for "Corinne," roan, 4 years 11 months 4 weeks-old, in-calf; bred by exhibitor; sire, "Cardigan" (12,556); dam, "Carmine;" sire of dam, "Prince Arthur" (13,497).
- RICHARD STRATTON, Walls Court, Bristol: SECOND PRIZE, 10*l.*, for "Diadem," roan, 3 years 5 months 3 weeks-old, in-milk and in-calf; bred by exhibitor; sire, "Warwick" (19,120); dam, "Lotus;" sire of dam, "Buckingham" (15,700).
- ROBERT SHARPE, Courtlands, East Grinstead, Sussex: THIRD PRIZE, 5*l.*, for "Elegant," red roan, 3 years 2 months 1 week 4 days-old, in-milk; bred by Mr. Noakes, Brockley Court, Croydon, Surrey; sire, "Cherry Duke 3rd" (15,763); dam, "Fuchsia;" sire of dam, "Hatcliffe" (12,997).
- EMILY LADY PIGOT, Branches Park, Newmarket, Cambs, the *Reserved Number*, for "Perfume," white, 3 years 2 months 1 week 1 day-old, in-milk and in-calf; bred by Colonel Towneley, Towneley, Burnley, Lancashire; sire, "Baron Hopewell" (14,134); dam, "Pride;" sire of dam, "Valiant" (12,253).
- THOMAS CHRISTOPHER BOOTH, Warlaby, Northallerton, Yorkshire: FIRST PRIZE, 15*l.*, for "Lady Fragrant," roan, 2 years 4 months-old, in-calf; bred by the late R. Booth, of Warlaby, Northallerton; sire, "Lord of the Valley" (14,837); dam, "Lady Blithe;" sire of dam, "Windsor" (14,013).
- JOHN LOGAN, Maindee House, Newport, Monmouthshire: SECOND PRIZE, 10*l.*, for "Charlotte 4th," roan, 2 years 3 months 2 days-old, in-calf; bred by exhibitor; sire, "Duke of Knowlmers" (19,623); dam, "Charlotte;" sire of dam, "Noble Arthur" (16,621).
- EMILY LADY PIGOT: THIRD PRIZE, 5*l.*, for "Lady of Rosalea," rich roan, 2 years 4 weeks-old, in-calf; bred by exhibitor; sire, "Prince Alfred" (13,494); dam, "White Ladye;" sire of dam, "Valasco" (15,443).
- RICHARD STRATTON: the *Reserved Number*, to "Garland," roan, 2 years 3 weeks 3 days-old, in-calf; bred by exhibitor; sire, "Young Windsor" (17,241); dam, "Gratitude;" sire of dam, "Buckingham" (15,700).
- LORD FEVERSHAM, Duncombe Park, Helmsley, Yorkshire: FIRST PRIZE, 15*l.*, for "Princess," roan, 1 year 9 months 5 days-old; bred by exhibitor; sire, "Vesuvius;" dam, "Lady in White;" sire of dam, "Skyrocket."
- ROBERT TENNANT, Scarcroft Lodge, Leeds, Yorkshire: SECOND PRIZE, 10*l.*, for "Miss Farewell," red and white, 1 year 3 months 2 weeks 1 day-old; bred by Colonel Towneley, Towneley Park, Burnley; sire, "Duke of Wharfdale;" dam, "Frederick's Farewell;" sire of dam, "Frederick."
- JOHN WOOD: THIRD PRIZE, 5*l.*, for "Clotilde," red, little white, 1 year 11 months 4 weeks-old; bred by exhibitor; sire, "Knight Errant" (18,154); dam, "Chloe;" sire of dam, "Cardigan" (12,556).
- WILLIAM HOSKEN AND SON, of Loggans Mill, Hayle, Cornwall, the *Reserved Number*, to "Carnation," roan, 1 year 5 months 4 days-old; bred by exhibitors; sire, "Prince Frederick" (16,734); dam, "Miss Fisher;" sire of dam, "Lord of the South" (13,216).
- THOMAS EDWARD PAWLETT, Beeston, Sandy, Beds; FIRST PRIZE, 10*l.*, for "Charmer 8th," roan, 11 months 2 weeks-old; bred by exhibitor; sire, "Prince James" (20,554); dam, "Charmer 7th;" sire of dam, "Highthorn" (13,028).

SIR ANTHONY DE ROTHSCHILD, Bart. : SECOND PRIZE, 5*l.*, for "Little Cherry," rich roan, 11 months 1 week 2 days-old; bred by exhibitor; sire, "Mountebank;" dam, "Cherry Ripe;" sire of dam, "Magician 2nd" (10,486).

RICHARD STRATTON, the Reserved Number, to "Brilliance," roan, 11 months 3 days-old; bred by exhibitor; sire, "Lamp of Lothian" (16,356); dam, "8th Duchess of Gloucester;" sire of dam, "His Highness" (14,708).

Hereford Bulls and Bull Calves.

JAMES MARSH READ, Elkstone, Cheltenham : FIRST PRIZE, 25*l.*, for "Colesborne," red, white face, 3 years 4 months 1 week 2 days-old; bred by exhibitor; sire, "Caliban" (1163); dam, "Washington;" sire of dam, "Carlisle" (923).

JOHN ALBERT HOLLINGS, The Hillend, Hereford : SECOND PRIZE, 15*l.*, for "Chieftain 2nd" (1917), red, white face, 4 years 11 months 3 weeks-old; bred by the late J. Rea, Monaughty, Knighton, Radnorshire; sire, "Wellington" (1112); dam, "Gertrude;" sire of dam, "Chieftain" (930).

JOHN BALDWIN, Luddington, Stratford-on-Avon, Warwickshire : THIRD PRIZE, 5*l.*, for "Battersea," red, white face, 3 years 11 months 2 weeks-old; bred by Charles Vevors, Ivington Park, Leominster; sire, "Corn Exchange" (1935); dam, "Pigeon;" sire of dam, "Young Sir Andrew" (1471).

JAMES MARSH READ : the *Reserved Number*, to "Peremptorily," red, white face, 3 years 5 months 3 weeks 1 day-old; bred by exhibitor; sire, "Caliban" (1163); dam, "Beauty;" sire of dam, "Dodmore" (1217 A).

THOMAS DUCKHAM, Baysham Court, Ross, Herefordshire : FIRST PRIZE, 25*l.*, for "Commodore" (2472), red, white face, 2 years 10 months 3 weeks 2 days-old; bred by exhibitor; sire, "Castor" (1900); dam, "Carlisle;" sire of dam, "Albert Edward" (859).

WILLIAM STALLARD, Brockhampton, Ross, Herefordshire : SECOND PRIZE, 15*l.*, for "Chieftain the 3rd," red, white face, 2 years 9 months 3 weeks 1 day-old; bred by exhibitor; sire, "Chieftain 2nd" (1917); dam, "Gweny 2nd;" sire of dam, "Chieftain" (930).

JAMES MARSH READ : THIRD PRIZE, 5*l.*, for "Sultan," red, white face, 2 years 10 months 1 week 5 days-old; bred by the late J. Rea, Monaughty; sire, "Sir Benjamin" (1387); dam, "Sultana;" sire of dam, "Grenadier" (961).

JOSEPH RAWLE PARAMORE, Dinedor Court, Hereford : FIRST PRIZE, 25*l.*, for "Dinedor," red, white face, 1 year 8 months 2 weeks 5 days-old; bred by exhibitor; sire, "Jew" (2266); dam, "Young Countess;" sire of dam, "Carlisle" (923).

EDMUND WRIGHT, Halston Hall, Oswestry, Salop : SECOND PRIZE, 15*l.*, for "Sir John," red, white face, 1 year 9 months 1 week 5 days-old; bred by exhibitor; sire, "Silver Horn" (2213); dam, "Sweetmeat;" sire of dam, "Magnet 2nd" (989).

WILLIAM TUDGE, Adforton, Leintwardine, Herefordshire : THIRD PRIZE, 5*l.*, for "Douglas," red, white face, 1 year 7 months 3 weeks-old; bred by exhibitor; sire, "Pilot" (2156); dam, "Dainty;" sire of dam, "The Doctor" (1083).

- WILLIAM STALLARD**, Brockhampton, Ross, Herefordshire, the *Reserved Number*, to "Soothsayer," red, white face, 1 year 8 months 2 days-old; bred by exhibitor; sire, "Chieftain 2nd" (1917); dam, "Queen's Gilliflower;" sire of dam, "The Doctor."
- JOHN MONKHOUSE**, The Stow, Hereford: **FIRST PRIZE**, 10*l.*, for "Grandee," red, white face, 10 months 3 weeks 5 days-old; bred by exhibitor; sire, "Chieftain;" dam, "Grand Duchess;" sire of dam, "Madoc."
- JOSEPH RAWLE PARAMORE**: **SECOND PRIZE**, 5*l.*, for "Trueboy," red, white face, 9 months 4 days-old; bred by exhibitor; sire, "Portly" (2165); dam, "Cherry;" sire of dam, "Hotspur" (972).
- HENRY RAWLINS EVANS, jun.**, Swanstone Court, Dilwyn, Leominster, Herefordshire, the *Reserved Number*, to "Lord Taunton," red, white face and mane, 11 months 3 weeks 3 days-old; bred by exhibitor; sire, "Chatham" (1914); dam, "Gentle 2nd;" sire of dam, "Rambler" (1046).

Hereford Cows and Heifers.

- JOHN BALDWIN**: **FIRST PRIZE**, 20*l.*, for "Duchess of Bedford 2nd," red, white face, 3 years 9 months 1 week-old, in-milk; bred by T. Roberts, Ivington Bury, Leominster; sire, "Sir Thomas;" dam, "Duchess Bedford;" sire of dam, "Arthur Napoleon."
- JOHN WALKER**, Westfield House, Holmer, Hereford: **SECOND PRIZE**, 10*l.*, for "Longwaist," red, white face, 8 years 3 months-old, in-calf; bred by exhibitor; dam, "Duchess;" sire of dam, "Governor."
- JOHN WALKER**: **THIRD PRIZE**, 5*l.*, for "Holmer Lass," red, white face, 6 years 4 months 3 weeks 1 day-old, in-calf; bred by exhibitor; sire, "Wallace;" dam, "Duchess;" sire of dam, "Governor."
- THOMAS OLVER**, Penhallow, Gram-pound, Cornwall, the *Reserved Number*, to "Blossom," red, white face, 10 years-old, in-calf; bred by the late T. Longmore, Buxton, Salop; sire, "Young Walford (1820)."
- JOHN BALDWIN**: **FIRST PRIZE**, 15*l.*, for "Miss Hastings 2nd," red, white face, 2 years 11 months 2 weeks 1 day-old, in-calf; bred by T. Roberts, Ivington Bury, Leominster; sire, "Sir Thomas;" dam, "Lady Hastings;" sire of dam, "Master Butterfly" (1313).
- GEORGE PITT**, Chadnor Court, Dilwyn, Leominster, Herefordshire: **SECOND PRIZE**, 10*l.*, for his red, white face, 2 years 6 months 2 weeks 2 days-old, in-milk; bred by exhibitor; sire, "Hatfield;" sire of dam, "Milan."
- MAJOR-GENERAL THE HON. A. NELSON HOOD**, Cumberland Lodge, Windsor, Berks: **THIRD PRIZE**, 5*l.*, for "Crown Princess," red, white face, 2 years 9 months 4 weeks 2 days-old, in-milk; bred by exhibitor; sire, "Ajax" (1843); dam, "Juno;" sire of dam, "Brecon" (918).
- JOHN WALKER**, Westfield House, the *Reserved Number*, to "Westfield Lass," red, white face, 2 years 5 months 3 weeks-old, in-calf; bred by exhibitor; sire, "Nutmeg;" dam, "Nel Gwynne;" sire of dam, "Darling the Second."
- EDMUND WRIGHT**, Halston Hall, Oswestry, Salop: **FIRST PRIZE**, 15*l.*, for "Marchioness," red, white face, 1 year 10 months-old; bred by exhibitor; sire, "Hero" (2039); dam, "Noble;" sire of dam, "Garrick" (1248).
- JOHN MONKHOUSE**: **SECOND PRIZE**, 10*l.*, for "Fairy Queen," red, white face, 1 year 10 months 2 days-old; bred by exhibitor; sire, "Chieftain;" dam, "Fairy;" sire of dam, "Formidable."

PHILIP TURNER, The Leen, Pembridge, Leominster, Herefordshire: **THIRD PRIZE**, 5*l.*, for "Queen of the Vale," red, white face, 1 year 11 months 2 weeks 5 days-old; bred by exhibitor; sire, "Bolingbroke" (1883); dam, "Marchioness;" sire of dam, "Bertram" (1513).

JOHN HUNGERFORD ARKWRIGHT, Hampton Court, Leominster, Herefordshire, the *Reserved Number*, for "Spot," red, white face, 1 year 8 months 3 weeks 3 days-old; bred by exhibitor; sire, "Sir Oliver 2nd" (1733); sire of dam, "Mortimer" (1328).

MAJOR-GENERAL THE HON. A. NELSON HOOD: **FIRST PRIZE**, 10*l.*, for "Princess Mary," red, white face, 10 months 1 week 5 days-old; bred by exhibitor; sire, "Deception;" dam, "Maud;" sire of dam, "Windsor."

JOHN MONKHOUSE: **SECOND PRIZE**, 5*l.*, for "Josephine," red, white face, 11 months 3 weeks 6 days-old; bred by exhibitor; sire, "Chieftain;" dam, "Violet;" sire of dam, "Madoc."

THOMAS DUCKHAM: the *Reserved Number*, to "Darling," red, white face, 7 months 3 weeks-old; bred by exhibitor; sire, "Commodore" (2472); dam, "Delight;" sire of dam, "Pope" (527).

Devon Bulls and Bull Calves.

JOHN SOBEY, Trewolland, Liskeard, Cornwall: **FIRST PRIZE**, 25*l.*, for "Sobieski" (728), dark red, 4 years 8 months 2 weeks 4 days-old; bred by exhibitor; sire, "Duke of Chester" (404); dam, "Brown" (1196); sire of dam, "Alfred" (138).

JAMES DAVY, Flitton Barton, North Molton, Devon: **SECOND PRIZE**, 15*l.*, for "Duke of Flitton 2nd," red, 3 years 2 months 1 week 4 days-old; bred by exhibitor; sire, "Duke of Flitton 1st;" dam, "Flower;" sire of dam, "Earl of Exeter."

JOHN AZARIAH SMITH, Bradford Peverill, Dorchester, Dorset: **THIRD PRIZE**, 5*l.*, for "Constitution," red, 3 years 4 months-old; bred by exhibitor; sire, "Exchange" (627); dam, "Rachel" (2307); sire of dam, "Palmerston" (476).

LORD CLINTON, Heanton, Tatchville, Beaford, Devon: the *Reserved Number*, to "Baronet," brown, 4 years 11 months 2 weeks 5 days-old; bred by exhibitor; sire, "Pasmore's Baronet;" dam, "Profit."

VISCOUNT FALMOUTH, Tregothnan, Probus, Cornwall: **FIRST PRIZE**, 25*l.*, for "Sunflower," dark red, 2 years 4 months 4 weeks 1 day-old; bred by exhibitor; sire, "Duke of Chester" (404); dam, "Flower;" sire of dam, "Uncle Tom" (328).

JAMES HOWARD BULLER, Downes, Crediton, Devon: **SECOND PRIZE**, 15*l.*, for red, 2 years 10 months 2 weeks-old; bred by the late T. W. Buller.

WALTER FARTHING, Stowey Court, Bridgewater, Somerset: **THIRD PRIZE**, 5*l.*, for "Osborn," red, 2 years 4 months 3 weeks-old; bred by Mr. Osborn, Norton, Taunton; sire "Sir Peregrine."

JOHN JACKMAN, Hexworthy, Lawhitton, Launceston, Cornwall: the *Reserved Number*, to "Garibaldi," red, 2 years 3 months 3 weeks 3 days-old; bred by J. Bodley, Stockley Pomeroy, Crediton, Devon; sire "Champion" (588A); dam, "Favourite" (1985); sire of dam, "Napoleon" (462).

GEORGE TURNER, Beacon Downes, Exeter: **FIRST PRIZE**, 25*l.*, for "Banting" red, 1 year 3 months 4 days-old; bred by exhibitor; sire "The Liberal;" dam, "Fanny Fern."

- GEORGE TURNER: SECOND PRIZE, 15*l.*, for "Magnum Bonum," red, 1 year 4 months 1 week 5 days-old; bred by exhibitor; sire, "The Liberal;" dam, "Vaudine."
- JOHN BODLEY, Stockley Pomeroy, Crediton, Devon: THIRD PRIZE, 5*l.*, for "Lincoln," red, 1 year 6 months 1 week-old; bred by exhibitor; sire "Champion" (588); dam, "Myrtle" (2191): sire of dam, "Emperor" (193).
- JOHN AZARIAH SMITH: the *Reserved Number*, to "Hercules;" red, 1 year 4 months 1 week-old; bred by exhibitor; sire "Constitution;" dam, "Young Hebe" (2450); sire of dam, "Davy's Napoleon III. (464).
- WILLIAM TAYLOR: FIRST PRIZE, 10*l.*, for "Profit's Duke," red, 11 months 1 week 2 days-old; bred by exhibitor; sire, "Duke of Flitton;" dam, "Profit;" sire of dam, "Nelson."
- WALTER FARTHING: SECOND PRIZE, 5*l.*, for red, 11 months 4 weeks 1 day-old; bred by exhibitor; sire, "Sir Peregrine;" dam, "Cheerful."
- JAMES DAVY: the *Reserved Number*, to "Duke of Flitton the 3rd," red, 8 months 1 week-old, bred by exhibitor; sire, "Duke of Flitton 2nd;" dam, "Picture;" sire of dam, "Napoleon 3rd."

Devon Cows and Heifers.

- JAMES DAVY: FIRST PRIZE, 20*l.*, for "Empress;" red, 5 years 3 weeks-old, in-calf; bred by exhibitor; dam, "Empress;" sire of dam, "Eclipse."
- WILLIAM TAYLOR: SECOND PRIZE, 10*l.*, for "Beauty," red, 5 years 8 months 5 days-old, in-milk; bred by J. Meron, Brinsworthy, North Molton, Devon; sire, "Davy's Napoleon; dam, "Lovely."
- JOHN QUARTLY, Champson Molland, South Molton: THIRD PRIZE, 5*l.*, for "Stately," red, 5 years 6 months-old, in-calf and in-milk; bred by exhibitor; sire, "Duke of Chester;" dam, "Flower;" sire of dam, "Sultan."
- JOHN QUARTLY: the *Reserved Number*, to "Handsome," red, 7 years 6 months-old, in-milk and in-calf; bred by exhibitor; sire, "Duke of Sussex;" dam, "Prettypaid;" sire of dam, "Baronet."
- MAJOR-GENERAL THE HON. A. NELSON HOOD: FIRST PRIZE, 15*l.*, for "Rose of Denmark," red, 2 years 11 months-old, in-milk; bred by exhibitor; sire, "Colonel" (387); dam, "Fancy" (703); sire of dam, "William."
- JOHN QUARTLY: SECOND PRIZE, 10*l.*, for his red heifer, 2 years 6 months-old, in-calf; bred by exhibitor; sire, "King of the Bretons;" dam, "Sylph;" sire of dam, "Butterfly."
- JAMES DAVY: THIRD PRIZE, 5*l.*, for "Lady Bess," red, 2 years 2 months 3 days-old, in-calf; bred by exhibitor; sire, "Duke of Flitton 1st," dam, "Young Symmetry;" sire of dam, "Napoleon 3rd."
- THOMAS PALMER, Norton, Stoke Climsland, Launceston, Cornwall: the *Reserved Number*, to "Graceful," brown, 2 years 6 months 4 weeks 1 day-old, in-calf; bred by exhibitor; sire, "Lord Kerry; dam, "Duchess;" sire of dam, "Havelock."
- JAMES DAVY: FIRST PRIZE, 15*l.*, for "Symmetry," red, 1 year 7 months 1 week 4 days-old; bred by exhibitor; sire, "Duke of Flitton 1st;" dam, "Old Symmetry;" sire of dam, "Eclipse."
- JOHN QUARTLY: SECOND PRIZE, 10*l.*, for his red heifer, 1 year 6 months-old; bred by exhibitor; sire, "Warrior;" dam, "Stately; sire of dam, "Duke of Chester."

- JAMES DAVY : THIRD PRIZE, 5*l.*, for "Young Cherry," red, 1 year 7 months 1 week 1 day-old; bred by exhibitor; sire, "Duke of Flitton 1st;" dam, "Cherry;" sire of dam, "Napoleon 3rd."
- GEORGE TURNER, Beacon Downes, Exeter; the *Reserved Number*, to "Lady Evelyn," red, 1 year 6 months 1 week-old; bred by exhibitor; sire, "Devonian;" dam, "Lady Devon."
- WALTER FARTING : FIRST PRIZE, 10*l.*, for his red heifer, 8 months 1 day-old; bred by exhibitor; sire, "Viscount;" dam, "Verbena;" sire of dam, "Duke of Somerset."
- JOHN AZARIAH SMITH : SECOND PRIZE, 5*l.*, for "Picture," red, 10 months 1 week 3 days-old; bred by exhibitor; sire "Constitution;" dam, "Honest;" sire of dam, "Honest Tom."
- WILLIAM TAYLOR : the *Reserved Number*, to "Curly's Duchess," red, 8 months 3 weeks 5 days-old; bred by exhibitor; sire, "Duke of Flitton," dam, "Curly;" sire of dam, "Derby."

Sussex Bulls.

- JOHN AND ALFRED HEASMAN, Angmering, Arundel, Sussex : FIRST PRIZE, 15*l.*, for "The Duke" (97), red, 4 years 6 months 1 week-old; bred by exhibitor; sire, "Marquis" (16); dam, "Buttercup" (297).

Sussex Cows and Heifers.

- JOHN AND ALFRED HEASMAN : FIRST PRIZE, 15*l.*, for "Battersea" (729), red, 4 years 5 months-old, in-milk, bred by exhibitors; sire, "Marquis" (16); dam, "Hopeful" (180).
- JOHN AND ALFRED HEASMAN : SECOND PRIZE, 10*l.*, for "Lily" (684), red, 5 years 5 months 2 weeks-old, in-milk; bred by exhibitors; sire, "Marquis" (16); dam, "Snowdrop" (265); sire of dam, "Sladeland."
- GEORGE JENNER, Parsonage House, Udmore, Rye, Sussex : the *Reserved Number*, to "Fillpail," red, 4 years 5 months 1 week 5 days-old; bred by exhibitor; sire, "Challenger;" dam, "Old Fillpail;" sire of dam, "Stonham Bull."
- JOHN AND ALFRED HEASMAN : FIRST PRIZE, 15*l.*, for "Plymouth," red, 2 years 6 months 3 weeks 4 days-old, in-calf; bred by exhibitors; sire, "Viscount" (77); dam, "Butterfly" (640); sire of dam, "Marquis" (16).
- TILDEN SMITH, of Knell Farm, Beckley, Staplehurst, Sussex : SECOND PRIZE, 10*l.*, for "Betty," red, 2 years 5 months-old, in-calf; bred by exhibitor.
- GEORGE JENNER : the *Reserved Number*, to "Selmes," red, 2 years 5 months 2 weeks 3 days-old, in-calf; bred by exhibitor; sire, "Challenger;" sire of dam, "Stonham."
- JOHN AND ALFRED HEASMAN : FIRST PRIZE, 15*l.*, for their red heifer, 1 year 5 months 3 weeks 4 days-old; bred by exhibitors; sire, "The Duke" (97); dam, sire "Gentle" (574).
- JOHN AND ALFRED HEASMAN : SECOND PRIZE, 10*l.*, for their red heifer, 1 year 5 months-old, bred by exhibitors; sire, "The Duke" (97); dam, "Ada" (628); of dam, "Marquis" (16).
- GEORGE JENNER : the *Reserved Number*, to "Beauty," red, 1 year 3 months 3 weeks 3 days-old; bred by exhibitor; sire, "The Earl," dam, "Beauty Cow;" sire of dam, "Stonham Bull."

Channel Islands Bulls.

- ALBERT LE GALLAIS, of La Moie House, St. Aubin's, Jersey : FIRST PRIZE, 20*l.*, for "Butterfly," grey and white, 2 years 7 months-old (Jersey or Alderney); bred by T. Filleul, Boulivot, Grouville, Jersey; dam, "Cowslip."
- CLEMENT PALLOT, St. Saviour's, Jersey : SECOND PRIZE, 10*l.*, for "The Prince," brown, 2 years 4 months 2 weeks-old (Jersey); bred by B. Watts, St. Saviour's; sire, "Noble."
- GEORGE FOOTE, Ashburton House, St. Andrew's, Guernsey : THIRD PRIZE, 5*l.*, for "Conqueror," fawn brindled and white, 2 years 5 months-old (Guernsey); bred by Hilary Simon, Maison-de-haut, St. Andrew's.
- GEORGE FOOTE: the *Reserved Number*, to "Lord of the Isles," fawn and white, 3 years 3 months-old (Guernsey); bred by the late J. Demouplied, Monnaie-de-haut, St. Andrew's.
- CLEMENT PALLOT : FIRST PRIZE, 20*l.*, for "Imperial," brown, 1 year 3 months 2 weeks-old (Jersey); bred by exhibitor; sire, "Billy;" dam, "Marigold."
- CHARLES ROBIN, Mon Plaisir, St. Peter's Port, Guernsey : SECOND PRIZE, 10*l.*, for "Prince of Wales," red and white, 1 year 9 months 3 weeks-old (Guernsey); bred by Mr. Quertier, Pedvin's Farm, St. Peter's Port, Guernsey.
- HENRY LE FEUVRE, of Les Nièmes, St. Peter's, Jersey : THIRD PRIZE, 5*l.*, for "Duke," fawn, 1 year 3 months 3 weeks 1 day-old (Jersey or Alderney); bred by Moses Gibaut, Mainland, St. Lawrence, Jersey.
- MAJOR GEORGE SIDNEY STRODE, Newnham Park, Plympton, Devon: the *Reserved Number*, to "Sir Joshua," mouse and white, 1 year 11 months 1 week 4 days-old (Jersey); breeder unknown.

Channel Islands Cows and Heifers.

- FREDERIC BROWNING, La Patrimoine, St. Lawrence, Jersey : FIRST PRIZE, 20*l.*, for "Betsy," dark brown, 7 years-old (Jersey), in-milk; breeder unknown.
- PHILIPPE GAUDIN, St. Martin's, Maufant, St. Helier's, Jersey : SECOND PRIZE, 10*l.*, for "Jolie," red brown, little white spots, 8 years 4 months-old (Jersey), in-milk; bred by exhibitor.
- HENRY DE JERSEY LE LACHEUR, of Norgiots, St. Andrew's, Guernsey : THIRD PRIZE, 5*l.*, for "Mary," light red and white, 6 years 7 months-old (Guernsey), in-calf; bred by John Le Hury, Croute, St. Peter's Guernsey.
- DANIEL GOODLAND, Haviland, St. Peter's Port, Guernsey: the *Reserved Number*, to "Fawn," light red and white, 6 years 3 months-old (Guernsey), in-milk; bred by exhibitor.
- ELI NICOLLE, La Fontaine, Trinity, Jersey : FIRST PRIZE, 20*l.*, for "Brown," light brown, 2 years 5 months-old (Jersey), in-calf; bred by exhibitor; sire, "Noble."
- HENRY LE FEUVRE : SECOND PRIZE, 10*l.*, for "Cowslip," brown and white, 2 years 9 months 2 weeks-old (Jersey or Alderney), in-calf; bred by exhibitor; sire, "Butterfly;" dam, "Primrose."
- PHILIPPE GAUDIN : THIRD PRIZE, 5*l.*, for "Petite Jolie," red brown, white spots, 1 year 10 months 3 weeks-old (Jersey), in-calf; bred by exhibitor.
- HENRY LE FEUVRE, the *Reserved Number*, to "Matchless," grey and white, 2 years 4 months-old (Jersey or Alderney), in-calf; bred by exhibitor; sire, "Butterfly;" dam, "Pomona."

Bulls of other Established Breeds.

- RICHARD HEMMING CHAPMAN, Upton, Nuneaton, Warwickshire: FIRST PRIZE, 15*l.*, for "Old Sparkenhoe," dark brindled, white back, 5 years 3 weeks 1 day-old (Longhorn); bred by Col. Inge, Thorpe Constantine, Tamworth; sire, "Tom L 8;" dam, "Fillpail, F.Y. 1;" sire of dam, "Old Rollwright."
- SIR EDWARD KERRISON, Bart., Brome Hall, Scole, Suffolk: SECOND PRIZE, 10*l.*, for "Eclipse," dark red, 4 years 4 months 1 week-old (Suffolk Polled); bred by Mr. Wolton, Newbourne, Woodbridge, Suffolk; sire, "Nonpareil;" dam, "Cosselt;" sire of dam, "Bullfinch."
- SIR EDWARD KERRISON, Bart.: FIRST PRIZE, 15*l.*, for "Hero," dark red, 1 year 1 month 1 week-old (Suffolk Polled); bred by exhibitor; sire, "Rifleman;" dam, "Duchess."

Cows and Heifers of other Established Breeds.

- SIR EDWARD KERRISON, Bart.: FIRST PRIZE, 15*l.*, for "Violet," red, 6 years-old (Norfolk Polled), in-milk and in-calf; bred by Mr. Birkbeck, address unknown; sire, "Holkham;" dam, "Beauty."
- SIR EDWARD KERRISON, Bart.: SECOND PRIZE, 10*l.*, for "Susanna," red, 5 years 2 months-old (Suffolk Polled), in-calf; bred by Mr. Goodcheram, Monedown, Wickham Market.
- REV. JOSEPH LLOYD BRERETON, West Buckland, South Molton: the *Reserved Number*, to his red, 3 years 5 months-old (Kerry), in-milk; breeder unknown.
- RICHARD HEMMING CHAPMAN: FIRST PRIZE, 15*l.*, for "Brindled Beauty," brindled, white back, 2 years 3 months 2 weeks 3 days-old (Longhorn), in-calf; bred by exhibitor; sire, "Old Sparkenhoe;" dam, "Young Fillpail;" sire of dam, "Lord Warner."
- SIR EDWARD KERRISON, Bart.: FIRST PRIZE, 15*l.*, for "Susan," red, 1 year 9 months 3 weeks 4 days-old (Suffolk Polled); bred by exhibitor; sire, "Rifleman;" dam, "Flora."
- SIR EDWARD KERRISON, Bart.: SECOND PRIZE, 10*l.*, for "Bella," red, 1 year 4 months 3 days-old (Suffolk Polled); bred by exhibitor; sire, "Eclipse;" dam, "Susanna."

HORSES.

Thorough-bred Stud Horse.

- JOSEPH CASSON, Middleton Lodge, Uphall, Linlithgowshire: FIRST PRIZE, 100*l.*, for "Motley," brown, 14 years-old; bred by Mr. Rickaby (address unknown); sire, "Touchstone;" dam, "Lanercost" mare, out of "Caroline," by "Whisker."

Hunter Stallions.

- ROBERT GEORGE LUXTON, Brushford, Wembworthy, Devon: FIRST PRIZE, 30*l.*, for "The Bald-faced Stag," chesnut, 10 years-old; bred by General Peel; sire, "Harkaway;" dam, "Palma;" sire of dam, "Plenipotentiary."

JOHN TREMAYNE, Sydenham House, Lew Down, Devon : SECOND PRIZE, 20*l.*, for "Paul Clifford," bay, 7 years-old; bred by Mr. R. Bethell; sire, "Cotherstone," dam, "Wait Awhile;" sire of dam, "Sir Isaac."

Hunter Brood Mares.

WILLIAM BARRETT, Puddaven, Totnes, Devon : FIRST PRIZE, 20*l.*, for "Kitty," brown, aged; breeder unknown.

THE REV. JOSEPH LLOYD BRERETON, West Buckland, South Molton : SECOND PRIZE, 15*l.*, for "The Countess," chesnut, 11 years-old; bred by Mr. Wright, Buxton, Norfolk; sire, "Teddy the Tyler;" dam, "Congress;" sire of dam, "Emilius."

RICHARD H. WATSON, Dorsley, Totnes, Devon : THIRD PRIZE, 5*l.*, for "The Banker's Pet," bay, aged; breeder unknown; sire, "Belzoni."

GEORGE RABY, Poole Hall, Menheniot, Cornwall : the *Reserved Number*, to "Miss Romford," light bay, 11 years-old; bred by R. H. Watson, Dorsley, Totnes; sire, "Lascelles;" dam, "Lady Romford;" sire of dam, "The Bishop of Romford's Cob."

Hackney Brood Mares.

CHARLES TRELAWNY, Plymouth : FIRST PRIZE, 20*l.*, for "Wren," bay, black points, 14 years-old; bred by exhibitor; sire, "Giovanni;" dam, "Tiny;" sire of dam, "Master Robert."

RICHARD H. WATSON : SECOND PRIZE, 10*l.*, for "Bridesmaid," bay, aged; breeder unknown; sire, "Royal William."

CHARLES FRANKLIN, Bicken Hall, Taunton, Somerset : THIRD PRIZE, 5*l.*, for "Useful," dark brown; bred by J. Smith Hewish, Barnstaple; sire, "Rainbow."

Stallion Ponies.

CHARLES ANDERSON MOORSHEAD, Widney Court, Plymouth : FIRST PRIZE, 15*l.*, for "Sultan," grey; imported from India.

EDWIN MAUNDER, of Heaselly Mill, North Molton : SECOND PRIZE, 10*l.*, for "Young Bobby," bay, 5 years-old; bred by exhibitor; sire, "Bobby," dam, "Peggy."

Mare Ponies.

SAMUEL SAMPSON, Park, Broadwoodkelly, Winkleigh, Devon : FIRST PRIZE, 10*l.*, for "Alice Bray," 5 years-old, dark bay or brown; bred by G. Cross, Sotterleigh, Wangford, Suffolk; sire, "Venison," dam, "Fanny."

JOHN HONY TREHANE, Stockton, Callington, Cornwall : SECOND PRIZE, 5*l.*, for "Princess," bay, 4 years-old; bred by Mrs. W. Trehane, Tavistock; sire, "Tavydale;" dam, "Jessie."

Agricultural Stallions (not Suffolks).

THE DUKE OF BEAUFORT, Badminton, Chippenham, Wilts : FIRST PRIZE, 25*l.*, for "Sir Robert," brown, 7 years-old (Clydesdale); bred by J. Scott, Stanleymuir, Paisley, N.B.; sire, "Young Watty;" dam, "Guess;" sire of dam, "Clyde."

THE REV. STEPHEN TERRY, Dummer, Basingstoke, Hants : SECOND PRIZE, 15*l.*, for "Waverley," bay, 4 years-old (Clydesdale); bred by Mr. Walker, Govan, Glasgow; sire, "Sir Walter Scott."

- WILLIAM ELPHICK**, Cricksea Lodge, Burnham, Essex : **THIRD PRIZE**, 10*l.*, for "Boxer," red roan, 5 years-old (Essex); bred by exhibitor; sire, "Boxer;" dam, "Dapper;" sire of dam, "Britain."
- WILLIAM WALKER**, Colne, St. Ives, Hunts : **FIRST PRIZE**, 20*l.*, for "Young Conqueror," brown, 2 years-old (Lincolnshire); bred by J. Browell, Bury Ramsey, Hunts; sire, "Heart of Oak;" dam, "Pincher;" sire of dam, "Farmer's Glory."
- JAMES ORAM**, Shellingford, Faringdon, Berks : **SECOND PRIZE**, 10*l.*, for "King of the Vale," blue roan, 2 years 1 month-old; bred by J. Rose, Marston, Devizes; sire, "Samson;" dam, "Violet;" sire of dam, "Young Prince."
- HENRY HITCHCOCK**, Chitterne Allsaints, Heytesbury, Wilts : **THIRD PRIZE**, 5*l.*, for "Albert," chesnut, 2 years-old (Wiltshire); bred by exhibitor; sire, "Champion;" dam, "Violet;" sire of dam, "Farmer's Glory."

Agricultural Mares and Foals (not Suffolks).

- JAMES SLEE BULT**, Dodhill House, Kington, Taunton, Somerset : **FIRST PRIZE**, 20*l.*, for "Brown," brown, 9 years-old (Wiltshire); bred by W. H. Hitchcock, Chitterne, Heytesbury, Wilts; sire, "Lion;" dam, "Diamond."
- JOHN LOGAN**, Maindee, Newport, Monmouthshire : **SECOND PRIZE**, 10*l.*, for "Stout," dark bay, 5 years-old; bred by exhibitor; sire, "Jamie;" dam, "Smiler."
- GEORGE ELLIOTT**, Swilley Farm, Plymouth : **THIRD PRIZE**, 5*l.*, for "Blossom," grey, 7 years-old; bred by exhibitor; sire, "Grey Castle;" dam, "Diamond;" sire of dam, "Samson."

Agricultural Mares (not Suffolks).

- JAMES SLEE BULT** : **FIRST PRIZE**, 15*l.*, for "Bessy," bay, 3 years-old; bred by W. H. Hitchcock, Chitterne, Heytesbury, Wilts; sire, "Brown;" dam, "Lion."

Agricultural Fillies (not Suffolks).

- MAJOR-GEN. THE HON. A. NELSON HOOD**, Cumberland Lodge, Windsor : **FIRST PRIZE**, 15*l.*, for "Rose," bay, 2 years 3 months-old (Clydesdale); bred by exhibitor; sire, "Britain;" dam, "Young Sally;" sire of dam, "Farmer."
- GEORGE ELLIOTT** : **SECOND PRIZE**, 10*l.*, for "Alma," dark brown, 2 years-old; bred by exhibitor; sire, "Earl Grey;" dam, "Alma."

Suffolk Stallions.

- SIR EDWARD KERRISON**, Bart., Brome Hall, Scole, Suffolk : **FIRST PRIZE**, 20*l.*, for his dark chesnut, 3 years 4 months-old; bred by Mr. Giles, Croxton Park, Thetford; sire, "Champion;" dam, "Bonny."
- ALFRED HUGHES**, Thorness, Cowes, Isle of Wight : **SECOND PRIZE**, 10*l.*, for "Carisbrooke," chesnut, 4 years-old; bred by C. Sawyer, Tunstall, Suffolk; dam, "Dapper;" sire of dam, "Captain."
- WILLIAM HENRY WALKER**, Wennington, Romford, Essex : **FIRST PRIZE**, 15*l.*, for "Hero," chesnut, 2 years-old; bred by exhibitor; sire, "The Hero," dam, "Violet."

WILLIAM TAYLOR, Harptree Court, Blagdon, Somerset: SECOND PRIZE, 10*l.*, for "Rob Roy," chesnut, 2 years-old; bred by exhibitor; sire, "Napoleon;" dam, "Brenda."

Suffolk Mares and Foals.

SIR EDWARD KERRISON, Bart.: FIRST PRIZE, 20*l.*, for "Lady Jane," chesnut, 6 years-old; breeder unknown.

THE REV. FREDERICK SANDYS WALL, of Bradley Wood, Newton Abbott, Devon: SECOND PRIZE, 10*l.*, for "Doughty," chesnut, 14 years-old; bred by Mr. Wainwright, Troston Hall Farm, Bury St. Edmund's.

Suffolk Fillies.

SIR EDWARD KERRISON, Bart.: FIRST PRIZE, 15*l.*, for "Worcester Diamond," chesnut, 2 years 6 months-old; bred by exhibitor; sire, "Nonpareil;" dam, "Beauty;" sire of dam, "Duke."

SAMUEL CLAYDEN, of Linton, Cambridgeshire: SECOND PRIZE, 10*l.*, for "Ruby," chesnut, 2 years-old; bred by exhibitor; sire, "Emperor;" dam, "Blossom;" sire of dam, "Samson."

SHEEP.

Leicester Rams.

JOHN BORTON, Barton House, Malton, Yorkshire: FIRST PRIZE, 20*l.*, for his 1 year 3 months-old; bred by exhibitor.

ARTHUR DABBS, Seckington, Tamworth: SECOND PRIZE, 10*l.*, for his 1 year 3 months 1 week-old; bred by exhibitor; sire of dam, "Sanday's W."

LIEUTENANT-COLONEL WILLIAM INGE, Thorpe Constantine, Tamworth, Staffordshire: THIRD PRIZE, 5*l.*, for his 1 year 4 months-old; bred by exhibitor; sire, "C. N."

JOHN BORTON: the *Reserved Number*, to his 1 year 3 months-old; bred by exhibitor.

ROBERT WARD CRESWELL, Ravenstone, Ashby-de-la-Zouch, Leicestershire: FIRST PRIZE, 20*l.*, for his 3 years 4 months-old; bred by W. Sanday, Holmpierrepont, Nottingham.

JOHN BORTON: SECOND PRIZE, 10*l.*, for his 2 years 3 months-old; bred by exhibitor.

ROBERT WARD CRESWELL, THIRD PRIZE, 5*l.*, for his 2 years 4 months-old; bred by exhibitor.

JOHN BORTON: the *Reserved Number*, to his 3 years 3 months-old; bred by exhibitor.

Leicester Ewes—Pens of Five.

THOMAS STAMPER, Highfield House, Oswaldkirk, Yorkshire: FIRST PRIZE, 15*l.*, for his 1 year 3 months 2 weeks-old; bred by exhibitor.

JOHN BORTON: SECOND PRIZE, 10*l.*, for his 1 year 3 months-old; bred by exhibitor.

LIEUTENANT-COLONEL WILLIAM INGE: THIRD PRIZE, 5*l.*, for his 1 year 4 months-old; bred by exhibitor; sire, "C. N."

JOSEPH GOULD, Poltimore, Exeter: the *Reserved Number*, to his 1 year 4 months 2 weeks-old; bred by exhibitor.

Cotswold Rams.

THOMAS WALKER, Stowell Park, Northleach, Gloucestershire: FIRST PRIZE, 20*l.*, for his 1 year 3 months 2 weeks-old; bred by exhibitor.

JOHN GILLETT, Fawler, Charlbury, Oxfordshire: SECOND PRIZE, 10*l.*, for his 1 year 4 months 1 week-old; bred by exhibitor.

JOHN GILLETT: THIRD PRIZE, 5*l.*, for his 1 year 4 months 1 week-old; bred by exhibitor.

JOHN GILLETT: the *Reserved Number*, to his 1 year 4 months 1 week-old; bred by R. Lane, of Cottage Farm, Northleach, Gloucestershire.

JOHN GILLETT: FIRST PRIZE, 20*l.*, for his 3 years 4 months 1 week-old; bred by R. Garne, of Aldsworth, Northleach, Gloucestershire.

THOMAS BEALE BROWNE, Salperton Park, Andoversford, Cheltenham, Gloucestershire: SECOND PRIZE, 10*l.*, for his 2 years 2 months 1 week 6 days-old; bred by exhibitor.

JOHN GILLETT: THIRD PRIZE, 5*l.*, for his 3 years 4 months 1 week-old; bred by R. Lane, Cottage Farm, Northleach, Gloucestershire.

JOHN KING TOMBS, Langford, Lechlade, Gloucestershire: the *Reserved Number*, to his 3 years 4 months-old; bred by exhibitor.

Cotswold Ewes—Pens of Five.

THOMAS BEALE BROWNE: FIRST PRIZE, 20*l.*, for his 1 year 3 months 2 weeks-old; bred by exhibitor.

JOHN WELLS, Hampnett, Northleach, Gloucestershire: SECOND PRIZE, 10*l.*, for his 1 year 3 months 2 weeks-old; bred by exhibitor.

JOHN WELLS: THIRD PRIZE, 5*l.*, for his 1 year 3 months 2 weeks-old; bred by exhibitor.

JOHN WELLS: the *Reserved Number*, to his 1 year 3 months 2 weeks-old; bred by exhibitor.

Lincoln and other Long-woolled Rams.

THOMAS BUMPSTEAD MARSHALL, Branston, Lincoln: FIRST PRIZE, 20*l.*, for his 1 year 3 months 2 weeks-old; bred by exhibitor.

THOMAS BUMPSTEAD MARSHALL: SECOND PRIZE, 10*l.*, for his 1 year 3 months 2 weeks-old; bred by exhibitor.

JOHN LYNN, Church Farm, Stroxtan, Grantham, Lincolnshire: THIRD PRIZE, 5*l.*, for his 1 year 4 months-old; bred by exhibitor; sire, "Worcester 2nd Prize;" sire of dam, "Royal Leeds."

JOHN LYNN: the *Reserved Number*, to his 1 year 4 months-old; bred by exhibitor; sire, "Worcester 2nd Prize;" sire of dam, "Royal Leeds."

JOHN LYNN: FIRST PRIZE, 20*l.*, for his "Silver Royal," 2 years 4 months-old; bred by exhibitor; sire, "Battersea Royal."

THOMAS BUMPSTEAD MARSHALL: SECOND PRIZE, 10*l.*, for his 3 years 4 months-old; bred by exhibitor.

THOMAS BUMPSTEAD MARSHALL: THIRD PRIZE, 5*l.*, for his 4 years 4 months-old; bred by exhibitor.

CHARLES WILLIAMS, Carlton-le-Moorland, Newark: the *Reserved Number*, to his 2 years 3 months-old; bred by exhibitor; sire, "Noel."

Lincoln and other Long-woolled Ewes—Pens of Five.

THOMAS BUMPSTEAD MARSHALL: FIRST PRIZE, 15*l.*, for his 1 year 3 months 2 weeks old; bred by exhibitor.

The Rev. JOSEPH LLOYD BRERETON, West Buckland, South Molton: SECOND PRIZE, 10*l.*, for his 1 year 3 months-old; bred by exhibitor.

Oxfordshire Down Rams.

JOHN BRYAN, Southleigh, Witney, Oxfordshire: FIRST PRIZE, 20*l.*, for his 1 year 4 months-old; bred by exhibitor.

JOHN BRYAN: SECOND PRIZE, 10*l.*, for his 1 year 4 months 2 weeks-old; bred by exhibitor.

JOHN BRYAN: THIRD PRIZE, 5*l.*, for his 1 year 3 months 2 weeks-old; bred by exhibitor.

JOHN BRYAN: the *Reserved Number*, to his 1 year 3 months 2 weeks-old; bred by exhibitor.

GEORGE WALLIS, Old Shifford, Bampton, Faringdon: FIRST PRIZE, 20*l.*, for his 2 years 5 months 2 weeks-old; bred by exhibitor.

GEORGE WALLIS: SECOND PRIZE, 10*l.*, for his 2 years 5 months 2 weeks-old; bred by exhibitor.

CHARLES HOWARD, Biddenham, Bedford: THIRD PRIZE, 5*l.*, for his 2 years 4 months 2 weeks-old; bred by exhibitor.

Oxfordshire Down Ewes—Pens of Five.

THE DUKE OF MARLBOROUGH, Blenheim Palace, Woodstock, Oxfordshire: FIRST PRIZE, 20*l.*, for his 1 year 4 months-old; bred by exhibitor.

CHARLES HOWARD: SECOND PRIZE, 10*l.*, for his 1 year 4 months 2 weeks-old; bred by exhibitor.

CHARLES HOWARD: THIRD PRIZE, 5*l.*, for his 1 year 4 months 2 weeks-old; bred by exhibitor.

HENRY OVERMAN, Weasenham, Rougham, Norfolk: the *Reserved Number*, to his 1 year 4 months-old; bred by exhibitor.

Southdown Rams.

LORD WALSINGHAM, Merton Hall, Thetford, Norfolk: FIRST PRIZE, 20*l.*, for his 1 year 4 months-old; bred by exhibitor.

LORD WALSINGHAM: SECOND PRIZE, 10*l.*, for his 1 year 4 months-old; bred by exhibitor.

LORD WALSINGHAM: THIRD PRIZE, 5*l.*, for his 1 year 4 months-old; bred by exhibitor.

THE DUKE OF RICHMOND, Goodwood, Chichester, Sussex: the *Reserved Number*, to his 1 year 4 months-old; bred by exhibitor.

LORD WALSINGHAM: FIRST PRIZE, 20*l.*, for his 2 years 4 months-old; bred by exhibitor.

LORD WALSINGHAM: SECOND PRIZE, 10*l.*, for his 2 years 4 months-old; bred by exhibitor.

JOHN WATERS, Motcomb, Eastbourne, Sussex: **THIRD PRIZE, 5*l.***, for his 2 years 4 months-old; bred by exhibitor.

JOHN WATERS: the *Reserved Number*, to his 4 years 4 months-old; bred by the late Jonas Webb.

Southdown Ewes—Pens of Five.

THE DUKE OF RICHMOND: FIRST PRIZE, 20*l.*, for his 1 year 4 months-old; bred by exhibitor.

LORD WALSHINGHAM: SECOND PRIZE, 10*l.*, for his 1 year 4 months-old; bred by exhibitor.

THE EARL OF RADNOR, Coleshill, Highworth, Wiltshire: THIRD PRIZE, 5*l.*, for his 1 year 4 months-old; bred by exhibitor; sire, "Battersea and Webb" (94).

THE DUKE OF RICHMOND: the *Reserved Number*, to his 1 year 4 months-old; bred by exhibitor.

Shropshire Rams.

THOMAS MANSELL, Adcott Hall, Shrewsbury: FIRST PRIZE, 20*l.*, for "Mansion," 1 year 4 months-old; bred by exhibitor; sire, "Maccaroni."

JAMES AND EDWARD CRANE, of Shrawardine, Shrewsbury: SECOND PRIZE, 10*l.*, for their 1 year 3 months 2 weeks-old; bred by exhibitors; sire, "Nobleman;" sire of dam, "Juckea."

THOMAS MANSELL: THIRD PRIZE, 5*l.*, for his 1 year 3 months 2 weeks-old; bred by exhibitor; sire, "Maccaroni;" sire of dam, "Laurel."

JAMES AND EDWARD CRANE: the *Reserved Number*, to their 1 year 3 months 2 weeks-old; bred by exhibitors; sire, "Chieftain;" sire of dam, "Celebrity."

COLONEL R. DYOTT, Freeford, Lichfield, Staffordshire: FIRST PRIZE, 20*l.*, for "Beaufort," 2 years 3 months 1 week-old; bred by exhibitor; sire, "Pattern."

EDWARD THORNTON, Pitchford, Shrewsbury: SECOND PRIZE, 10*l.*, for "Pitchford Volunteer," 2 years 3 months 2 weeks-old; bred by exhibitor.

SAMPSON BYRD, The Lees Farm, Stafford: THIRD PRIZE, 5*l.*, for "Young Quality," 4 years 3 months 2 weeks-old; bred by exhibitor; sire, "Quality;" sire of dam, "Old Patentee."

FRYCE WILLIAM BOWEN, Shrawardine Castle, Shrewsbury: the *Reserved Number*, to "Lord Clifden," 3 years 3 months 2 weeks-old; bred by exhibitor.

Shropshire Ewes—Pens of Five.

JAMES AND EDWARD CRANE: FIRST PRIZE, 20*l.*, for their 1 year 3 months 2 weeks-old; bred by exhibitors; sire, "Chieftain;" sire of dam, "Celebrity."

EDWARD HOLLAND, Esq., M.P., Dumbleton Hall, Evesham: SECOND PRIZE, 10*l.*, for his 1 year 4 months-old; bred by exhibitor.

LADY WILLOUGHBY DE BROKE, Compton Verney, Warwickshire: THIRD PRIZE, 5*l.*, for her 1 year 3 months 1 week 2 days-old; bred by exhibitor; sire, "Young Patentee."

LORD WENLOCK, Bourton Cottage, Much Wenlock, Salop: the *Reserved Number*, to his 1 year 4 months-old; bred by exhibitor.

Hampshire and other Short-woolled Rams.

- JAMES RAWLENCE, Bulbridge, Wilton, Salisbury, Wiltshire: **FIRST PRIZE**, 20*l.*, for "Berwick," 1 year 6 months-old; bred by exhibitor.
- MATTHEW ARNOLD, Westmeon, Petersfield, Hampshire: **SECOND PRIZE**, 10*l.*, for his 1 year 5 months 1 week-old; bred by J. and M. Arnold, of Westmeon, Petersfield, Hampshire.
- JAMES RAWLENCE: **THIRD PRIZE**, 5*l.*, for "The Duke," 1 year 6 months-old; bred by exhibitor.
- MATTHEW ARNOLD: the *Reserved Number*, to "Brown Ben," 1 year 5 months 2 weeks-old; bred by J. and M. Arnold, of Westmeon, Petersfield, Hampshire; sire, "Big Ben."
- JAMES RAWLENCE: **FIRST PRIZE**, 20*l.*, for "Catch 'em alive," 3 years 6 months-old; bred by exhibitor.
- MATTHEW ARNOLD: **SECOND PRIZE**, 10*l.*, for his 4 years 5 months-old; bred by J. and M. Arnold, of Westmeon, Petersfield.
- STEPHEN KING, Bockhampton Farm, Lambourne, Berks: **THIRD PRIZE**, 5*l.*, for his 2 years 4 months 2 weeks-old; bred by exhibitor.
- JAMES RAWLENCE, the *Reserved Number*, to "Blair Athol," 2 years 6 months-old; bred by exhibitor; sire, "Maccaroni."

Hampshire and other Short-woolled Ewes—Pens of Five.

- JAMES RAWLENCE: **FIRST PRIZE**, 20*l.*, for his 1 year 6 months-old; bred by exhibitor.
- JAMES RAWLENCE: **SECOND PRIZE**, 10*l.*, for his 1 year 6 months-old; bred by exhibitor.
- WILLIAM BROWNE CANNING, Elston, Devizes, Wiltshire: **THIRD PRIZE**, 5*l.*, for his 1 year 4 months 2 weeks-old; bred by exhibitor.
- JAMES RAWLENCE: the *Reserved Number*, to his 1 year 6 months-old; bred by exhibitor.

Somerset and Dorset Horned Rams.

- THOMAS DANGER, Huntstile, Bridgewater, Somersetshire: **FIRST PRIZE**, 15*l.*, for his 1 year 6 months-old; bred by exhibitor.
- ALFRED J. PITFIELD, Eype, Bridport, Dorsetshire: **SECOND PRIZE**, 5*l.*, for "Young Noble," 1 year 6 months 2 weeks-old; bred by exhibitor; sire, "Constitution."
- ALFRED J. PITFIELD: **FIRST PRIZE**, 15*l.*, for "Constitution," 3 years 6 months 2 weeks-old; bred by exhibitor; sire, "Hardware."
- ALFRED J. PITFIELD: **SECOND PRIZE**, 5*l.*, for "Noble," 3 years 6 months 2 weeks-old; bred by exhibitor; sire, "Hardware."

Somerset and Dorset Horned Ewes—Pens of Five.

- THOMAS DANGER: **FIRST PRIZE**, 10*l.*, for his 1 year 6 months-old; bred by exhibitor.
- ALFRED J. PITFIELD: **SECOND PRIZE**, 5*l.*, for his 1 year 6 months 2 weeks-old; bred by exhibitor; sires, "Noble," "Constitution," and "Duke."

South Hams Rams.

- JOHN WILCOCKS, Cleeve, Ivybridge, Devon: **FIRST PRIZE**, 15*l.*, for his 1 year 3 months 3 weeks 2 days-old; bred by exhibitor.

GEORGE DEWDNEY, Baccamoore, Plympton, Devon: FIRST PRIZE, 15*l.*, for his 3 years 4 months-old; bred by exhibitor.

South Hams Ewes—Pens of Five.

JOHN WILCOCKS: FIRST PRIZE, 10*l.*, for his 4 years 4 months 1 week 3 days-old; bred by exhibitor.

RICHARD COCK CLARK, Butshead, St. Budeaux, Plymouth: SECOND PRIZE, 5*l.*, for his 3 years 4 months 2 weeks-old; bred by exhibitor.

Dartmoor Rams.

JAMES DREW, Artiscoombe, Tavistock, Devon: FIRST PRIZE, 15*l.*, for his 1 year 4 months-old; bred by exhibitor.

ROBERT MAY, Grendon, Tavistock: SECOND PRIZE, 5*l.*, for his 1 year 4 months 2 weeks-old; bred by exhibitor; sire, "Dr. Marks."

ROBERT MAY: the *Reserved Number*, to his 1 year 4 months 2 weeks-old; bred by exhibitor; sire, "Dr. Marks."

ROBERT MAY: FIRST PRIZE, 15*l.*, for "Sam," 4 years 4 months-old; bred by T. Squire, North Brenton, Lamerton, Devon.

THOMAS SQUIRE, North Brenton, Lamerton, Devon: SECOND PRIZE, 5*l.*, for "Young Samson," 2 years 3 months 2 weeks-old; bred by exhibitor; sire, "Samson;" sire of dam, "Dr. Marks."

ROBERT MAY: the *Reserved Number*, to "Garibaldi," 5 years 5 months-old; bred by J. Palmer, of Great Close, Bridestowe, Devon.

Dartmoor Ewes—Pens of Five.

JAMES DREW: FIRST PRIZE, 10*l.*, for his 1 year 4 months-old; bred by exhibitor.

JAMES MARCH, Widewell, Tamerton Foliot, Plymouth: SECOND PRIZE, 5*l.*, for his 4 years-old; bred by exhibitor.

THOMAS MUNFORD, of Purps Straugh Prior, Plympton, Devon: the *Reserved Number*, to his ages various.

Ezmoor Rams.

EDWIN MAUNDER, Heaselby Mill, North Molton, Devon: FIRST PRIZE, 15*l.*, for his 1 year 4 months-old; bred by John Thorne, Northradworthy, North Molton.

JOHN PASSMORE, Fyldon, North Molton: SECOND PRIZE, 5*l.*, for his 1 year 4 months-old; bred by exhibitor.

EDWIN MAUNDER: FIRST PRIZE, 15*l.*, for his 3 years 4 months-old; bred by exhibitor.

WILLIAM TAYLOR, Harptree Court, Blagdon, Somerset: SECOND PRIZE, 5*l.*, for "Forester," 3 years 3 months 2 weeks-old; bred by R. Smith, Emmett's Grange, South Molton, Devon.

JOHN QUARTLY, Champson Molland, South Molton, the *Reserved Number*, to his 3 years 4 months 2 weeks-old; bred by exhibitor.

WILLIAM TAYLOR: FIRST PRIZE, 10*l.*, for his 1 year 3 months 2 weeks-old; bred by exhibitor.

JOHN PASSMORE, Fyldon, North Molton: SECOND PRIZE, 5*l.*, for his 1 year 4 months-old; bred by exhibitor.

FIGS.

Bears of a Large White Breed.

- WILLIAM BRADLEY WAINMAN, Carhead, Cross Hills, Yorkshire: **FIRST PRIZE**, 10*l.*, for "The Arch Trespasser," about 3 years 2 months-old (Carhead); breeder unknown.
- RICHARD DICKIN, 161, Old Road, Stockport, Lancashire: **SECOND PRIZE**, 5*l.*, for "Marquis," 2 years 8 months 2 weeks 3 days-old; bred by A. Carswell, Park House, Butley, Macclesfield, Cheshire; sire, "John;" dam, "Gipsy Queen."
- RICHARD ELMHIRST DUCKERING, Northorpe, Kirton Lindsey, Lincolnshire: the *Reserved Number*, to "Victor," 3 years 10 months 4 weeks 1 day-old; bred by J. Harrison, Heaton Norris, Stockport; sire, "Sampson;" dam, "Betay."

Bears of a Small White Breed.

- RICHARD DICKIN: **FIRST PRIZE**, 10*l.*, for "Blair Athol," 2 years 9 months 1 day-old; bred by Mr. Wainman, Carhead, Cross Hills, Yorkshire.
- SAMUEL GEATER STEARN, Brandeston, Wickham Market: **SECOND PRIZE**, 5*l.*, for "Champion," 2 years 7 months-old (Suffolk); bred by A. Hayward, Woodbridge, Suffolk.
- GEORGE MUMFORD SEXTON, Whersted Hall, Ipswich, Suffolk: the *Reserved Number*, to "Lord Clyde," 10 months-old (Suffolk and Yorkshire); bred by exhibitor; sire, "The Clipper;" dam, "Queen of the East;" sire of dam, "Sir Colin."

Bears of a Small Black Breed.

- SAMUEL GEATER STEARN: **FIRST PRIZE**, 10*l.*, for "Black Prince," 11 months 1 week 3 days-old (Suffolk); bred by exhibitor; sire, "Negro;" dam, "Jet;" sire of dam, "Prince."
- GEORGE MUMFORD SEXTON: **SECOND PRIZE**, 5*l.*, for "Breadalbane," 1 year 2 months 6 days-old; bred by exhibitor; sire, "Battersea Prince;" dam, "Charmer;" sire of dam, "Shortnose."
- GEORGE MUMFORD SEXTON: the *Reserved Number*, to "Prince of Wales," 1 year 2 months 3 weeks 5 days-old; bred by exhibitor; sire, "Young Negro;" dam, "Bumptious;" sire of dam, "Terror."

Bears of the Berkshire Breed.

- ARTHUR STEWART, Saint Bridge, Gloucester: **FIRST PRIZE**, 10*l.*, for "Gloucester Lad," black, little white, 1 year 2 weeks 2 days-old; bred by exhibitor; sire, "Tim Whiffler;" dam, "Topsy;" sire of dam, "Massa."
- WILLIAM YELLS, Round Robin Farm, Highworth, Wiltshire: **SECOND PRIZE**, 5*l.*, for black and white, 7 months 2 days-old; bred by exhibitor; sire, "King of Newport;" dam, "Handsome;" sire of dam, "Surprise."

Bears of any other Breed.

- RICHARD ELMHIRST DUCKERING: **FIRST PRIZE**, 10*l.*, for "Cultivator," white, 2 years 1 week-old (middle); bred by T. M. Richardson, Hibaldstow, Kirton Lindsey; sire, "Eclipse;" dam, "British Queen;" sire of dam, "Wentworth."

WILLIAM BRADLEY WAINMAN: SECOND PRIZE, 5*l.*, for "Dexter Chief," white, 8 months 3 weeks-old (Carhead middle); bred by exhibitor; sire, "Bend Sinister;" dam, "Happy Link."

Breeding Sows of a Large White Breed.

WILLIAM GAMON, The Green, Thornton-le-Moor, Chester: FIRST PRIZE, 10*l.*, for "Lady Havelock," 2 years 9 months 1 week 1 day-old, in-pig; breeder unknown.

RICHARD ELMHIRST DUCKERING: SECOND PRIZE, 5*l.*, for "Royal Victress," 2 years 7 months 2 weeks-old, in-pig; bred by exhibitor; sire, "Victor;" dam, "Fanny Fern;" sire of dam, "Great Britain."

WILLIAM BRADLEY WAINMAN: the *Reserved Number*, to "Rival Hope," about 3 years 10 months-old; breeder unknown.

Breeding Sows of a Small White Breed.

JOHN BULTEEL, of Pamflete, Ivy Bridge, Devon: FIRST PRIZE, 10*l.*, for his 1 year 4 months 2 weeks 2 days-old; bred by Lieut.-Col. Kingscote, Kingscote, Wootton-under-Edge.

GEORGE MUMFORD SEXTON: SECOND PRIZE, 5*l.*, for "Snowdrop," 1 year 2 months 1 week 3 days-old (Suffolk and Yorkshire), in-pig; bred by exhibitor; sire, "Snowball;" dam, "Windsor Lass."

SAMUEL GEATER STEARN: the *Reserved Number*, to "Victoria 2nd," 3 years 2 months 3 weeks 2 days-old (Suffolk); bred by exhibitor; sire, "Marquis;" dam, "Victoria 1st;" sire of dam, "Duke."

Breeding Sows of a Small Black Breed.

SAMUEL GEATER STEARN: FIRST PRIZE, 10*l.*, for "Black Bess," 10 months 2 weeks 4 days-old (Suffolk), in-pig; bred by exhibitor; sire, "Negro;" dam, "Queen of the West;" sire of dam, "Prince."

GEORGE MUMFORD SEXTON: SECOND PRIZE, 5*l.*, for "Princess of Wales," 1 year 2 months 3 weeks 5 days-old (Suffolk), in-pig; bred by exhibitor; sire, "Young Negro;" dam, "Bumptious;" sire of dam, "Terror."

GEORGE MUMFORD SEXTON: the *Reserved Number*, to "Blink Bonny," 1 year 1 month 2 weeks 2 days-old (Suffolk), in-pig; bred by exhibitor; sire, "Battersea Prince;" dam, "Charmer's Daughter;" sire of dam, "Shortnose."

Breeding Sows of the Berkshire Breed.

ARTHUR STEWART: FIRST PRIZE, 10*l.*, for "Snowdrop," black, little white, about 3 years-old; bred by exhibitor; sire, "Black Jack;" dam, "Mrs. Swindon;" sire of dam, "Duke of Gloucester."

ARTHUR STEWART: SECOND PRIZE, 5*l.*, for "Young Sally," black, little white, 11 months-old, in-pig; bred by exhibitor; sire, "Tim Whiffler;" dam, "Aunt Sally;" sire of dam, "Jim the Blacksmith."

ARTHUR STEWART: the *Reserved Number*, to "Miss Whiffler," black, little white, 1 year 5 months 1 day-old, in-pig; bred by exhibitor; sire, "Tim Whiffler;" dam, "Mrs. Bobtail;" sire of dam, "Jim the Blacksmith."

Breeding Sows of any other Breed.

RICHARD ELMHIRST DUCKERING: FIRST PRIZE, 10*l.*, for "Queen Bess," white, 1 year 10 months 3 weeks 6 days-old (middle), in-pig; bred by exhibitor; sire, "Victor;" dam, "Beauty;" sire of dam, "Eclipse."

WILLIAM GAMON, The Green, Thornton-le-Moor, Chester; **SECOND PRIZE, 5*l.***, for "Dewdrop," white, 2 years 1 month 1 week 3 days-old (middle), in-pig; breeder unknown.

WILLIAM BRADLEY WAINMAN: the *Reserved Number*, to "Happy Link," white, 3 years 7 months 1 week 6 days-old (Carhead middle), in-pig; bred by exhibitor.

Breeding Sow Pigs of a Large White Breed—Pens of Three.

RICHARD ELMHIRST DUCKERING: **FIRST PRIZE, 10*l.***, for "Rose, Shamrock, and Thistle," 7 months 3 weeks 3 days-old; bred by exhibitor; sire, "Cultivator;" dam, "Fanny Fern;" sire of dam, "Great Britain."

WILLIAM BRADLEY WAINMAN: **SECOND PRIZE, 5*l.***, for 7 months 5 days-old; bred by exhibitor.

Breeding Sow Pigs of a Small White Breed—Pens of Three.

SAMUEL GEATER STEARN: **FIRST PRIZE, 10*l.***, for "The Three Sisters," 7 months 2 weeks 3 days-old (Suffolk); bred by exhibitor; sire, "Prince of Wales;" dam, "Victoria 2nd;" sire of dam, "Marquis."

GEORGE MUMFORD SEXTON: **SECOND PRIZE, 5*l.***, for "Happy-go-Lucky," 7 months 3 weeks 1 day-old; bred by exhibitor; sire, "The Clipper;" dam, "Cato."

Breeding Sow Pigs of a Small Black Breed—Pens of Three.

GEORGE MUMFORD SEXTON: **FIRST PRIZE, 10*l.***, for "We are Beauties," 7 months 1 day-old; bred by exhibitor; sire, "Young Shortnose;" dam, "Worcester Princess;" sire of dam, "Terror."

GEORGE MUMFORD SEXTON: **SECOND PRIZE, 5*l.***, for "Never give up," 7 months 1 day-old; bred by exhibitor; sire, "Young Negro;" dam, "Worcester Princess;" sire of dam, "Old Shortnose."

SAMUEL GEATER STEARN: the *Reserved Number*, to "Three Niggers," 5 months 6 days-old (Suffolk); bred by exhibitor; sire, "Negro;" dam, "Jet."

Breeding Sow Pigs of the Berkshire Breed—Pens of Three.

WILLIAM YELLS: **FIRST PRIZE, 10*l.***, for black and white, 7 months 2 days-old; bred by exhibitor; sire, "King of Newport;" dam, "Handsome;" sire of dam, "Surprise."

JOHN KING TOMBS, Langford, Lechlade, Gloucestershire: **SECOND PRIZE, 5*l.***, for black and white, 6 months 2 weeks 3 days-old; bred by exhibitor.

SAMUEL WIDDICOMBE, Hay, Ugborough, Ivybridge, Devon: the *Reserved Number*, to his black and white, 5 months 2 weeks 2 days-old; bred by exhibitor; dam, "Miss Exeter;" sire of dam, "Prince."

Breeding Sow Pigs of any other Breed—Pens of Three.

GEORGE MANGLES, Givendale, Ripon, Yorkshire: **FIRST PRIZE, 10*l.***, for his white, 5 months 1 week-old (Yorkshire middle); bred by exhibitor; sire, "Bendigo 3rd."

WILLIAM BRADLEY WAINMAN: **SECOND PRIZE, 5*l.***, for his white, 7 months 3 days-old (Carhead middle); bred by exhibitor.

**PRIZES OFFERED BY THE LOCAL COMMITTEE OF
PLYMOUTH AND DEVONPORT.**

CATTLE.

Bull, Cow, and Offspring of the Devon Breed.

WALTER FARTHING, Stowey Court, Bridgewater, Somersetshire: **FIRST PRIZE**, 30*l.*, for his bull, "Viscount," red, 5 years 7 months 2 weeks-old; sire, "Sir Peregrine;" dam, "Molly;" sire of dam, "William." Cow, "Jenny," red, 4 years 5 months 2 weeks-old; sire, "Sir Peregrine;" dam, "Lovely;" sire of dam, "Duke." Offspring, "Young Jenny," red, 6 months-old; all bred by exhibitor.

SAMUEL PRIDHAM, Pool Farm, Cheriton Fitzpaine, Devonshire: **SECOND PRIZE**, 15*l.*, for his bull, "Young Champion," red, 2 years 8 months 1 week-old; sire, "Champion" (588); dam, "Symmetry;" sire of dam, "Emperor." Cow, "Chance," red, 6 years 2 months 1 week 3 days-old; sire, "Monarch" (460); dam, "Rose;" sire of dam, "Emperor." Offspring, "Monarch," 8 months 2 weeks 5 days-old; all bred by exhibitor.

Pairs of Cows of the Devon Breed.

WILLIAM TAYLOR, Harptree Court, Blagdon, Somersetshire: **FIRST PRIZE**, 20*l.*, for "Lovely," red, 12 years 9 months 2 days-old, in-calf; bred by R. Merson, Brinsworthy, North Molton; dam, "Dairymaid;" sire of dam, "Albert;" and for "Vaudine," red, 8 years 7 months 1 week-old, in-milk; bred by George Turner, Beacon Downes, Exeter; sire, "Palmerston;" dam, "Wallflower;" sire of dam, "Duke of York."

WALTER FARTHING: **SECOND PRIZE**, 10*l.*, for "Pink," red, 6 years 6 months-old, in-milk and in-calf; bred by Sir A. A. Hood, Bart., St. Audries, Bridgewater; and for "Petherton," red, 3 years 6 months 2 weeks-old, in-milk and in-calf; bred by R. Farthing, North Petherton, Somersetshire.

JAMES TREMAIN, Trevarthian, Newlyn, Ladock, Cornwall: the *Reserved Number*, for "Rose," red, 8 years 3 weeks 5 days-old, in-milk and in-calf; sire, "Red Rose;" dam, "Queen of the West;" and for "Favourite," dark red, 3 years 6 months 2 weeks 1 day-old, in-calf; sire, "Red Rose;" dam, "Queen of the West;" bred by exhibitor.

Pairs of Heifers of the Devon Breed.

JOHN BODLEY, Stockley Pomeroy, Crediton, Devonshire: **FIRST PRIZE**, 20*l.*, for "Gentle Annie," red, 3 years 3 months 3 weeks-old, in-calf; sire, "Champion" (588); dam, "Pink" (2236); sire of dam, "Monarch" (460); and for "Gaylass," red, 3 years 1 week 2 days-old, in-calf; sire, "Champion" (588); dam, "Rose" (2318); sire of dam, "Albert" (360); both bred by exhibitor.

JOHN AZARIAH SMITH: **SECOND PRIZE**, 10*l.*, for "Honest," red, 3 years 2 months 3 weeks 2 days-old, in-milk and in-calf; sire, "Honest Tom;" dam, "Picture" (2231); sire of dam, "Duke of Sussex" (406); and for "Yellowbat," red, 3 years 3 months-old, in-milk and in-calf; sire, "Exchange" (627); dam, "Yellowbat" (3438); sire of dam, "Duke of Devonshire" (621); both bred by exhibitor.

VISCOUNT FALMOUTH, Tregothnan, Probus, Cornwall: **FIRST PRIZE, 15*l.***, for "Lily Bell," red, 2 years 2 weeks 2 days-old, in-calf; sire, "Sir Colin;" dam, "Lily;" sire of dam, "Uncle Tom" (328); and for "Bonny Lass," red, 2 years 4 months 3 weeks-old; sire, "Duke of Chester" (404); dam, "Bloomer" (541); sire of dam, "Earl of Exeter" (38); both bred by exhibitor.

GEORGE TURNER, Beacon Downes, Exeter: **SECOND PRIZE, 8*l.***, for "Hilda," red, 2 years 5 months 2 weeks 2 days-old, in-calf; sire, "Champion;" dam, "Pearl;" and for "Violet," red, 2 years 4 months-old, in-calf; sire, "Van Tromp;" dam, "Beatrice;" both bred by exhibitor.

WILLIAM TAYLOR: **FIRST PRIZE, 15*l.***, for "Sir William's Peggy," red, 1 year 5 months 3 weeks 5 days-old; sire, "Sir William;" dam, "Peggy;" sire of dam, "Duke;" and for "Salisbury's Lovely," red, 1 year 4 months 1 week-old; dam, "Young Salisbury;" both bred by exhibitor.

JOHN BODLEY: **SECOND PRIZE, 8*l.***, for "Violet," red, 1 year 5 months 3 weeks 2 days-old; sire, "Champion" (588); dam, "Stately" (1653); and for "Famous," red, 1 year 5 months 2 weeks 2 days-old; sire, "Champion" (588); dam, "Careless" (1838); sire of dam, "Monarch" (460); both bred by exhibitor.

Pairs of Bull-calves of the Devon Breed.

GEORGE TURNER: **FIRST PRIZE, 20*l.***, for his red calf, 5 months 3 weeks 3 days-old; sire, "Leotard;" dam, "Piccolomini;" and for his red calf, 6 months 1 week 3 days-old; sire, "Leotard;" dam, "Vaudine;" both bred by exhibitor.

JOHN BODLEY: **SECOND PRIZE, 10*l.***, for his "Earl of Eldon," red, 8 months 1 week 4 days-old; sire, "Conqueror;" dam, "Stately" (1653); and for "Volunteer," red, 7 months 2 weeks 5-days-old; sire, "Conqueror;" dam, "Young Crafty;" sire of dam, "Champion;" both bred by exhibitor.

JOHN AZARIAH SMITH, Bradford Peverell, Dorchester, Dorsetshire: the *Reserved Number*, for "Newcastle," red, 4 months 4 weeks-old; sire, "Volunteer" (747); dam, "Young Hebe" (2450); sire of dam, "Napoleon 3rd" (464); and for "Worcester," red, 2 months-old; sire, "Volunteer" (747); dam, "Rachel" (2307); sire of dam, "Palmerston" (476); both bred by exhibitor.

Bulls of the South Hams Breed.

GEORGE DEWDNEY, Baccamoore, Plympton, Devon: **FIRST PRIZE, 15*l.***, for "Hero," light red, 4 years 1 week-old; bred by Mr. Cudlip, Casey Town, Tavistock.

THOMAS ROWELL CORNISH, Wolfsgrove Farm, Bishops Teignton, Teignmouth, Devon: **SECOND PRIZE, 10*l.***, for "Crochet Second," red, 3 years 1 month 1 week 3 days-old; bred by W. Rendle, jun., Lower Netherton, Coombe, Teignmouth; sire, "Crochet;" dam, "Queen of the Valley."

WILLIAM COAKER, Charleton Court, Kingsbridge, Devon: **FIRST PRIZE, 15*l.***, for "Admiral," dark red, 2 years 2 months-old; bred by exhibitor.

GEORGE DEWDNEY: **SECOND PRIZE, 10*l.***, for "Nelson," red, 1 year 9 months 1 week-old; bred by T. Pearse, Leigh Ford, Plymstock, Devon.

JOHN ANTHONY, Yealmpton, Devon: the *Reserved Number*, to "Rifleman," brindle, 1 year 1 week-old; bred by exhibitor; dam, "Brindle."

Cows of the South Hams Breed.

WILLIAM COAKER: **FIRST PRIZE, 10*l.***, for "Cheerful," bright red, 9 years 9 months-old, in-milk and in-calf; bred by exhibitor.

RICHARD SOWTON, Yealmpton, Devon : SECOND PRIZE, 5*l.*, for "Starhead," red, white spots; 6 years 7 months-old, in-milk and in-calf; bred by exhibitor.

THOMAS VOSPER, Merafield, Plympton : the *Reserved Number*, to "Hardwicke," light red, 6 years-old, in-milk; bred by Messrs. Willing, Hardwicke, Plympton.

Heifers of the South Hams Breed.

JOHN ANTHONY, Yealmpton, Devon : FIRST PRIZE, 10*l.*, for "Maid of the Mill," red, 3 years 9 months 1 week 5 days-old, in-calf; bred by exhibitor; dam, "Tulip."

GEORGE COAKER : SECOND PRIZE, 5*l.*, for "Young Beauty," light red, 3 years 5 months 1 week-old, in-calf; bred by exhibitor; sire, "Prince;" dam, "Beauty."

WILLIAM ADAMS, Centry, Kingsbridge, Devon : FIRST PRIZE, 10*l.*, for his red, 1 year 2 months 2 weeks 3 days-old; bred by exhibitor; dam, "Cherry."

ELIAS FORD, Abbotskerswell, Newton Abbot : SECOND PRIZE, 5*l.*, for "Cherry," light red, 1 year 4 months 2 weeks 5 days-old; bred by exhibitor; sire, "Teighnarvey."

ELIAS FORD : the *Reserved Number*, to "Daisy," light red, 1 year 3 months 3 weeks-old; bred by exhibitor; sire, "Bickham."

HORSES.

Agricultural Stallions.

JOHN HENDERSON, Horsley Hill, South Shields, Durham : FIRST PRIZE, 15*l.*, for "Victor," bay, 3 years-old; bred by exhibitor; sire, "England's Glory;" dam, "Damsel;" sire of dam, "Farmer's Glory."

EDWIN SHINNER, jun., Stretchford, Staverton, Totnes, Devon : SECOND PRIZE, 10*l.*, for "Young Nelson," black, 4 years-old; bred by Messrs. Northcott, Upcott Barton, Tavistock; sire, "Robin Hood;" sire of dam, "Ringleader."

Agricultural Mares or Fillies.

JOHN ANTHONY, Yealmpton, Devon : FIRST PRIZE, 10*l.*, for "Bessie," grey, 4 years-old; bred by exhibitor; sire, "Blythe;" dam, "Charlotte;" sire of dam, "Galipoli."

JOHN LOGAN, Maindee House, Newport, Monmouthshire : SECOND PRIZE, 5*l.*, for "Bright," roan, 7 years-old; bred by the Pen-y-darn Iron Company, Glamorganshire.

Hunter Mares or Geldings.

GEORGE BLAND BATTAMS, Kilworthy, Tavistock, Devon : FIRST PRIZE, 15*l.*, for "Millie," brown, 4 years 3 months-old (mare); bred by Mr. Hill, Tavistock; sire, "Kingmaker."

GEORGE BLAND BATTAMS : SECOND PRIZE, 10*l.*, for "Sultan," black, 4 years 3 months-old (gelding); bred by T. Shepherd, Stratton, Bude, Cornwall; sire, "Kingmaker;" sire of dam, "Screwetton."

THE REV. ARTHUR CHRISTOPHER THYNNE, Penstowe, Stratton, Cornwall: the *Reserved Number*, for "Warwick," dark bay, 4 years-old (gelding); bred by T. Hancock, Pyeworthy, Holsworthy, Devon; sire, "Kingmaker;" sire of dam, "Royal William."

Hunter Mares or Geldings.

GEORGE BLAND BATTAMS: FIRST PRIZE, 15*l.*, for "Milford," dark brown, 5 years-old; bred by Mr. Haynes, Milford, Hartland, Devon; sire, "Kingmaker."

Roadster Mares or Geldings.

THOMAS PALMER, Borough, Kelly, Tavistock, Devon: FIRST PRIZE, 10*l.*, for his dark chesnut, 5 years-old (filly); bred by exhibitor; sire, "Kingmaker;" dam, "Pat," sire of dam, "Sir Hercules."

THE REV. JOSEPH LLOYD BRERETON, West Buckland, South Molton: SECOND PRIZE, 5*l.*, for his chesnut, 6 years-old (mare); breeder unknown.

Dartmoor Pony Stallions.

THOMAS KINSMAN BICKELL, Corn Market Inn, Tavistock: FIRST PRIZE, 10*l.*, for "Little Wonder," dark bay, 7 years-old; bred by Thomas Milman, Lydford, Tavistock; sire, "Forest Ranger;" dam, "Forest Lass."

WILLIAM GRIFFIN, Lamerton, Tavistock: SECOND PRIZE, 5*l.*, for "Kohinoor," dark bay, 8 years-old; bred by T. Egging, Collacombe Barton, Tavistock; sire, "Pretty Boy;" dam, "Little Flashing Polly."

Exmoor Pony Stallions.

JOHN ABRAHAM, The Villa, Bude Haven, Cornwall: FIRST PRIZE, 10*l.*, for "Bagatelle," bright bay, 7 years-old; bred by exhibitor; dam, "A-la-mode."

CHARLES WILLESFORD, Tavy Cottage, Tavistock: SECOND PRIZE, 5*l.*, for "Prince," dark chesnut, 9 years-old; bred by F. W. Knight, Simonds Bath, Exmoor, Bampton, Devon.

Exmoor Pony Mares.

HIRAM BARTLETT HAMBLING, Dodbrook, Kingsbridge, Devon: FIRST PRIZE, 10*l.*, for "Sally," dark chesnut, 5 years-old; bred by Mr. Smeridge, Farley, Halwell, Devon; dam, "Pony."

WILLIAM SALTER, North Tawton, Barton, Devon: SECOND PRIZE, 5*l.*, for "Mulum in Parvo," bay, 8 years-old; bred by exhibitor; sire, "Sir Arthur."

SAMUEL WIDDICOMBE, Hay, Ugborough, Ivybridge: the *Reserved Number*, to "Polly," bay, 4 years-old; bred by W. Furneaux, Horsebrook, South Brent, Devon; sire, "Favourite."

PIGS.

Boar, Sow and Litter, of a Large Breed.

RICHARD E. DUCKERING, Northorpe, Kirton Lindsey: FIRST PRIZE, 10*l.*, for his boar, "Hero," white, 2 years 7 months 2 weeks-old; sire, "Victor;" dam, "Fanny Fern;" sow, "Countess of Leicester," white, 3 years 2 months-old; sire, "Great Britain;" dam, "Fanny Fern;" litter 1 month 3 weeks 2 days old.

Boar, Sow and Litter, of a Small Black Breed.

SAMUEL G. STEARN, Brandeston, Wickham Market, Suffolk : **FIRST PRIZE, 10*l.***, for his boar, "Uncle Tom," 1 year 6 months-old ; sire, "Havelock ;" dam, "Jet ;" sire of dam, "Prince ;" sow, "Black Rose," 2 years 2 months 2 weeks 3 days-old ; sire, "Sambo ;" dam, "Gipsy Queen ;" sire of dam, "Negro ;" litter 2 months 6 days-old.

GEORGE MUMFORD, Sexton, Wherstead Hall, Ipswich, Suffolk : **SECOND PRIZE, 5*l.***, for his boar, "Prince," 1 year 3 months 3 weeks-old ; sire, "Battersea Prince ;" dam, "Black Bess ;" sire of dam, "Negro ;" sow, "Royalty," 4 years-old ; sire, "Northey ;" litter 2 months 1 week-old.

WOOL.

Five Fleeces.

THOMAS HARRIS, Stony Lane House, Bromsgrove, Worcestershire : the **PRIZE of 2*l.*** for his Leicester ; shorn May 20th, from sheep 14 and 15 months-old.

CHARLES BOBY, Alton Hall, Stutton, Ipswich, Suffolk : the **PRIZE of 2*l.*** for his Southdown ; shorn May 10th, from sheep 15 months-old.

DAVID REYNOLDS DAVIES, Mere Old Hall, Knutsford, Cheshire : the **PRIZE of 2*l.*** for his Shropshire ; shorn April 4th, from shearlings.

CHARLES HOWARD, of Biddenham, Bedford : the **PRIZE of 2*l.*** for his Short-wool ; shorn June 30th, from ewe tegs.

ROBERT MAY, Grendon, Tavistock, Devon : the **PRIZE of 2*l.*** for his Dartmoor ; shorn beginning of June, from sheep 15 months-old.

EDWIN MAUNDER, Heaselby Mill, North Molton, Devon : the **PRIZE of 2*l.*** for his Exmoor ; shorn June 14th.

BUTTER.

Twelve Pounds Scald Cream.

JOHN WIDDICOMBE, of Torrhill, Ivybridge, Devon : **FIRST PRIZE, 5*l.***

THOMAS BURNAFORD, of Tamerton Foliot, Plymouth : **SECOND PRIZE, 3*l.***

IMPLEMENTS.

DRILLS.

PRIEST and WOOLNOUGH, Kingston-upon-Thames, Surrey : the **PRIZE of TEN POUNDS**, for their Lever Drill, for general purposes, 6 feet wide ; the grain or seed may be either drilled with the manure, or separate from it, as required.

RICHARD HORNSBY and SONS, Spittlegate Iron-works, Grantham : the **PRIZE of EIGHT POUNDS**, for their Drill, for general purposes, for depositing corn

and seed with or without manure; it has wrought-iron levers, India-rubber tubes, and is capable of depositing from 3 to 40 bushels of artificial manure per acre as required.

JAMES COULTAS, JUN., Spittlegate, Grantham: the PRIZE of SEVEN POUNDS, for his 6 Feet 6 Inch 12-Row General Purpose Drill. And for his Fore-carriage Steerage.

JOHN SAINTY, Burnham, Lynn: the PRIZE of EIGHT POUNDS, for his Corn and Seed Drill; manufactured by Garrett and Son, of Leiston Works, Suffolk. The exhibitor's application of a spring to each lever, instead of the ordinary weights, renders the action much more efficient and regular, and reduces the draught, weight, and cost.

PRIEST and WOOLNOUGH: the PRIZE of SEVEN POUNDS, for their Lever Corn-Drill, 7 feet wide. For drilling grain or seeds in rows at any distance apart, and fitted with improved iron levers and patent coulters.

JAMES COULTAS, JUN.: the PRIZE of FIVE POUNDS, for his 7 Feet 6 Inch 14-Row Corn Drill. Price 28*l*.

JOHN SAINTY: the PRIZE of SIX POUNDS, for his Corn and Seed Drill, for small occupations; manufactured by Garrett and Son, of Leiston Works, Suffolk.

PRIEST and WOOLNOUGH: the PRIZE of FIVE POUNDS, for their Lever Corn Drill, for small occupations, 5 feet wide. For drilling grain or seeds in rows at any required distance apart, and fitted with improved iron levers and patent coulters.

R. HORNSBY and SONS: the PRIZE of FOUR POUNDS, for their Corn and Seed Drill, for small occupations; will deposit corn and seed at any depth or distance apart.

JAMES COULTAS, JUN.: the PRIZE of SEVEN POUNDS, for his 5 Feet 9-Row Corn Drill, for hill sides. Price 18*l*.

HOLMES and SONS, Prospect-place Works, Norwich: the PRIZE of THREE POUNDS, for their Prize Occupation Drill for Hill Sides; invented by J. Belfield, Esq., of Paington, and improved and manufactured by the exhibitors. Fitted with wheel steerage, by which the drill is kept from sliding or slipping down so as to displace the distances of the rows when working on a hill-side.

PRIEST and WOOLNOUGH: the PRIZE of EIGHT POUNDS, for their Drill for Turnips and Manure, on the flat, 7½ feet wide; fitted with improved manure-barrels and steel scrapers for drilling guano, superphosphate, &c., in rows, or distributing it broadcast if required.

JAMES COULTAS, JUN.: the PRIZE of SEVEN POUNDS, for his 6 Feet 6 Inches, 3, 4, 5, and 6-Row Turnip, Mangold, and Manure Drill.

R. HORNSBY and SONS: the PRIZE of FIVE POUNDS, for their Drill, for Turnips or other roots, on the flat, capable of depositing from 3 to 40 bushels of artificial manure per acre.

A. W. GOWER and SONS, Hook, Winchfield, Hants, and Market Drayton, Salop: the PRIZE of EIGHT POUNDS, for their Two-coulter Ridge Manure Drill for Turnips and Mangolds.

PRIEST and WOOLNOUGH: the PRIZE of SEVEN POUNDS, for their Drill for Turnips and Manure, on the ridge, fitted with improved manure-barrel and steel scrapers for guano, superphosphate, bones, &c., and with concave iron rollers to form the ridge, and small rollers to follow after the seed.

- A. W. GOWER and SONS:** the PRIZE of FIVE POUNDS, for their Two-coulter Ridge Drill for Turnips and Mangolds; this is the Leeds Prize Drill divested of the manure boxes, &c.
- B. and J. REEVES, Bratton, Westbury, Wilts:** the PRIZE of EIGHT POUNDS, for their Patent Liquid-manure, Corn, and Seed Drill, 6 feet wide; adapted for sowing 8 rows of liquid manure, 2 to 10 hogsheads per acre, with corn or seeds; it is also arranged for sowing liquid manure from tanks, piggeries, &c., broadcast.
- R. and J. REEVES:** the PRIZE of SEVEN POUNDS, for their 4-Row Patent Liquid-manure and Seed Drill, 6 feet wide; invented by T. Chandler, of Aldbourne, improved and manufactured by the exhibitors. Adapted for sowing liquid manure from cattle-sheds, piggeries, &c., or artificial manures mixed with water, from 2 to 6 hogsheads per acre. Fitted with the exhibitor's new patent cylinder, which prevents the cups from breaking.
- JAMES COULTAS, JUN.:** the PRIZE of FIVE POUNDS, for their 6 Feet 6 Inch 4-Row Turnip, Mangold, and Liquid-manure Drill; invented by Thomas Chandler, of Aldbourne, improved and manufactured by the exhibitor.
- R. HORNSBY and SONS:** the PRIZE of SIX POUNDS, for their Small Seed and Rye-grass Drill.
- PRIEST and WOOLNOUGH:** the PRIZE of FOUR POUNDS, for their Grass-seed Drill, for horse-power. For drilling clover, rye-grass, sainfoin, and other grass seeds, in rows at 3½ inches apart, the light and heavy seeds being drilled from separate boxes, so that the required quantity of each may be properly mixed and regularly sown.
- A. W. GOWER and SONS:** the PRIZE of SIX POUNDS, for their Patent Drill Presser for Two Furrows; invented by A. and B. S. Gower, of Market Drayton; and manufactured by the exhibitors.
- WILLIAM GERRANS, Tregony, Grampound, Cornwall:** the PRIZE of FOUR POUNDS, for his Land Presser Drill; invented by William Hensman and Son; improved and manufactured by Turner and Bishop.
- PRIEST and WOOLNOUGH:** HIGHLY COMMENDED for their Lever Drill, for general purposes, for small occupations, 4½ feet wide. The grain or seeds can be either drilled with the manure, or separate from it, as required; it may also be used as a corn drill without manure.
- HORNSBY and SONS:** HIGHLY COMMENDED for their Corn and Seed Drill. It has received a special prize for vulcanized India-rubber tubes and fore-carriage steerage.
- GEORGE LEWIS, Kettering, Northamptonshire:** HIGHLY COMMENDED for his Steerage Corn and Seed Drill. Can be steered to the greatest nicety; and by applying the smallest pressure to the lever, the flow of seed is stopped, and the coulters taken out of the ground at the same instant.
- HOLMES and SON:** HIGHLY COMMENDED for their Small Occupation Drill for Corn and Seeds, 10-Rows.
- R. and J. REEVES:** HIGHLY COMMENDED for their 4-Row Patent Economical Manure and Seed Drill, 6 feet wide; adapted for sowing all kinds of artificial manures in their pure state, or mixed with a small quantity of ashes, from 4 to 20 bushels per acre. Fitted with regulator for hilly land.

- R. and J. REEVES :** **HIGHLY COMMENDED** for their 4-Row Patent Manure and Seed Drill, for ridge ; has concave self-acting roller for ridges, and plain wood roller to follow the seed.
- JAMES COULTAS, JUN. :** **HIGHLY COMMENDED** for his 7 Feet 27-Row Small Seed and Rye-grass Drill.
- R. and J. REEVES :** **COMMENDED** for their 11-Coulter General Purpose Patent Manure, Corn, and Seed Drill, 7 feet wide ; will sow from 6 to 50 bushels per acre of artificial manure.
- JAMES COULTAS, JUN. :** **COMMENDED** for his 4 Feet 6 Inch 6-Row General Purpose Drill, for small occupations.
- A. W. GOWER and SON :** **COMMENDED** for their 15-Coulter Corn and Seed Drill.
- A. W. GOWER and SON :** **COMMENDED** for their 13-Coulter Corn and Seed Drill.
- JAMES COULTAS, JUN.,** **COMMENDED** for his 4 Feet 6 Inch 8-Row Corn Drill, for small occupations.

MANURE DISTRIBUTORS.

- JOHN SAINTY :** the **PRIZE** of **EIGHT POUNDS**, for his Manure Distributor ; invented by Thomas Chambers, Jun., of Calkirk, Norfolk, and manufactured by Garrett and Son, of Leiston Works, Suffolk. The delivery-barrel is made of a peculiar metal, not affected by the most pungent manures.
- PRIEST and WOOLNOUGH :** the **PRIZE** of **SEVEN POUNDS**, for their Manure Distributor, for damp or dry manure. For sowing broadcast guano, superphosphate, &c., in a moist or dry state, and in large or small quantities, and fitted with improved manure-barrel and steel scrapers.
- R. and J. REEVES :** the **PRIZE** of **TEN POUNDS**, for their Patent Liquid-manure, Corn, and Seed Drill, 6 feet wide ; adapted for sowing 8 rows of liquid manure, 2 to 10 hogsheads per acre, with corn or seeds ; also for sowing liquid manure from tanks, piggeries, &c., broadcast.
- HORNSBY and SONS :** **HIGHLY COMMENDED** for their Improved Manure Distributor, for depositing dry manure in small or large quantities, as desired.
- J. COULTAS, JUN. :** **COMMENDED** for his 7 Feet Manure Distributor, for dry manures.

HORSE HOES.

- JOHN SAINTY :** the **PRIZE** of **SIX POUNDS**, for his Lever Horse-hoe ; invented and improved by the exhibitor, and manufactured by Garrett and Son, of Leiston Works, Suffolk. Fitted with the exhibitor's springs, as described above.
- PRIEST and WOOLNOUGH :** the **PRIZE** of **FIVE POUNDS**, for their Patent Lever Horse-hoe, for general purposes ; for hoeing between the rows of all drilled crops of grain or roots on heavy or light land, on the flat or ridge.
- WILLIAM SMITH, Kettering, Northamptonshire :** the **PRIZE** of **FOUR POUNDS**, for his Improved 12-Row General Purpose Steerage Horse-hoe ; with a new patent fastener for the hoe ; the handles of the hoe are moveable.
- CARSON and TOONE, Warminster, Wilts :** the **PRIZE** of **FOUR POUNDS TEN SHILLINGS**, for their Single-row Horse-hoe (B), with Hoes and 2 Tines

so arranged that no standing crop can be injured in working. Invented by the late Hugh Carson, of Warminster; improved and manufactured by the exhibitors.

ROBERT TINKLER, King Street, Penrith, Cumberland: the PRIZE of FOUR POUNDS, for his Light Land Drill Grubber; improved and manufactured by Jonathan Stalker.

EDWARD PAGE and Co., Bedford: the PRIZE of THREE POUNDS, for their Combined Horse-hoe, 5-Tined Grubber, and Moulding Plough.

WILLIAM SMITH: the PRIZE of TWO POUNDS TEN SHILLINGS, for his Single-row Horse-hoe, for Ridge and Flat.

CARSON and TOONE: the PRIZE of SIX POUNDS, for their Horse-hoe (B), as described above.

EATON and SONS, Twywell Works, Thrapston, Northamptonshire; the PRIZE of FIVE POUNDS, for their Patent Turnip Thinner and Horse-hoe combined. Adapted as a horse-hoe for two rows of turnips or beans, and with the revolving hoes will bunch out the plants at 9, 12, or 15 inches in one row, or flat hoe turnips.

JAMES BOWDEN, Chagford, near Exeter: HIGHLY COMMENDED for his Horse-hoe.

JOHN DAVEY, Crasthole, near Devonport, Cornwall: HIGHLY COMMENDED for his Parallel Expanding Horse-hoe, for Single Row on the Ridge or Flat; fitted with self-acting harrow, three wheels, and hill-side steering. Can be used as a turnip-rooter, cutting two rows at one time.

ROBERT TINKLER, King Street, Penrith, Cumberland: COMMENDED for his Light Land Drill Grubber; improved and manufactured by Jonathan Stalker.

MOWING MACHINES.

W. A. WOOD, 77, Upper Thames Street, London: the PRIZE of TEN POUNDS, for his Grass Mowing Machine, for two horses; will cut one acre per hour, and pass through a 5-feet gate.

HORNSBY and SONS: the PRIZE of EIGHT POUNDS, for their Improved Mower, for natural and artificial grasses.

HENRY KEARSLEY, Ripon, Yorkshire: the PRIZE of SEVEN POUNDS, for his Two-horse Grass Mower; well adapted for cutting level or uneven surfaces; will cut 1 acre per hour.

HORNSBY and SONS: the PRIZE of EIGHT POUNDS, for their Improved Combined Reaper and Grass Mowers.

W. A. WOOD: the PRIZE of SEVEN POUNDS, for his Combined Mowing and Reaping Machine.

A. C. BAMLETT, Thirsk, Yorkshire: the PRIZE of FIVE POUNDS, for his Two-horse Combined Mowing and Reaping Machine. The driver can instantly regulate the cutting height at either end of the cutter-bar.

BURGESS and KEY, 95, Newgate Street, London: HIGHLY COMMENDED for their Mowing Machine, for Natural and Artificial Grasses.

HENRY KEARSLEY: HIGHLY COMMENDED for his Two-horse Combined Reaper and Mower.

D. H. BARBER, Leicester Buildings, King Street, Liverpool: COMMENDED for his Combined Mowing and Reaping Machine. The reaping platform can be attached or detached by simply removing three bolts.

HAYMAKING MACHINES.

- J. and F. HOWARD**, Britannia Works, Bedford: the PRIZE of SIX POUNDS, for their Double-action Haymaking Machine (marked S (H)); intended for small occupations.
- J. and F. HOWARD**: the PRIZE of FIVE POUNDS, for their Double-action Haymaking Machine (marked H H); a size larger than the preceding, and recommended as the most useful size.
- ROBERT BOBY**, St. Andrew's Works, near Bury St. Edmund's, Suffolk: the PRIZE of FOUR POUNDS, for his Patent Double-action Haymaking Machine.
- WILLIAM NEWZAM NICHOLSON**, Trent Works, Newark, Notts: HIGHLY COMMENDED for his Patent Haymaking Machine, No. 1.
- A. and T. FRY**, Temple Gate, Bristol: COMMENDED for their Double-action Haymaking Machine; invented and improved by Theodore Grace, of Bristol, and manufactured by the exhibitors.

REAPING MACHINES.

- R. HORNSBY and SONS**: the PRIZE of TWENTY-FIVE POUNDS, for their Self-acting Swathe-delivery Reaper.
- SAMUELSON and Co.**, Britannia Works, Banbury, Oxon: the PRIZE of FIFTEEN POUNDS, for their Self-raking Reaper; invented by Owen Dorsey, of America; improved and manufactured by the exhibitors. Delivers the corn in sheaves by means of automatic rakes.
- R. HORNSBY and SONS**: the PRIZE of TEN POUNDS, for their Reaper. Fitted with improved chain-delivery, for delivering sheaves of any size, on the side of the machine, and free of the horse-track.
- R. HORNSBY and SONS**: the PRIZE of FIVE POUNDS, for their Reaper, with grated drop-sheaf apparatus. The sheaves are partly delivered by the stubble.
- PICKSLEY, SIMS, and Co.**, Leigh, Manchester: the PRIZE of FIVE POUNDS, for their Two-horse Reaping Machine. Will cut 5 feet 9 inches wide.
- W. A. WOOD**: the PRIZE of NINE POUNDS, for his One-horse Reaping Machine. Cuts $4\frac{1}{2}$ feet swathe; the platform is made of grates or bars, so as to allow the stubble greatly to assist the raker in discharging the cut grain.
- SAMUELSON and Co.**: the PRIZE of SEVEN POUNDS, for their One-horse "Eclipse" Reaper. Cuts 5 feet wide, with tilting platform.
- R. HORNSBY and SONS**: the PRIZE of FIVE POUNDS, for their One-horse Reaper. Fitted with grated drop-sheaf apparatus so arranged that the stubble assists the delivery.
- ROBERT CUTHBERT and Co.**, Bedale, Yorkshire: HIGHLY COMMENDED for their One or Two-horse Reaping Machine; invented by Hussey, of America, improved and manufactured by the exhibitors. Has a high travelling wheel, with a patented conical surface, so as to take away the side strain.

HORSE RAKES.

- J. and F. HOWARD**: the PRIZE of SIX POUNDS for their Horse Rake (marked X X); the teeth, when in work, are raised from the central axle, and are thus left free to adapt themselves to the irregularities of the surface.
- E. PAGE and Co.**, Bedford; the PRIZE of FOUR POUNDS, for their Improved Horse Hay, Corn, and Stubble Rake (marked H R 24); the teeth are of oval steel, and very strong. Width to extremities 8 feet 10 inches, space cleared 7 feet 9 inches.

JOHN DAVEY: HIGHLY COMMENDED for his Portable Horse Rake; so constructed that the rake can be turned (in two parts), on the axle, for passing through narrow gateways; it clears 8 feet 6 inches of land.

THOMAS ALLCOCK, Ratchliffe-on-Trent, Notts: COMMENDED for his Horse Rake.

WAGGONS.

THE BEVERLEY IRON AND WAGGON COMPANY, Beverley, Yorkshire: the PRIZE of TEN POUNDS, for their Prize Pair-horse Waggon.

WILLIAM BALL and SON, Rothwell, Kettering, Northamptonshire: the PRIZE of SIX POUNDS, for their Light Two-horse Waggon; to carry three tons.

THOMAS MILFORD and SON, Thorverton, Cullompton, Devon: the PRIZE of FOUR POUNDS, for their 3 or 4-Horse Prize Waggon, with plank side, improved break, double shafts, tires 4-inch, and harvest lades complete.

HENRY HAYES and SON, Scotgate Works, Stamford, Lincolnshire; the PRIZE of TEN POUNDS, for their Prize Pair-horse Waggon, which will turn in the room it stands upon. Has oak frame and plank sides; fitted with break to hind wheels.

THE BEVERLEY IRON AND WAGGON COMPANY: HIGHLY COMMENDED for their Yorkshire Prize Waggon, with Loose Side and End Boards.

GEORGE MILFORD, Thorverton, Cullompton, Devonshire: COMMENDED for his Improved Plank Side Pair-horse Waggon.

T. MILFORD and SON: COMMENDED for their Two-horse Tipping Waggon; for tipping the whole load, or dividing it in as many heaps as may be thought convenient; invented by Thomas Milford, jun., and manufactured by the exhibitors.

CARTS.

HAYES and SON: the PRIZE of FOUR POUNDS TEN SHILLINGS, for their Light Single-horse Cart; with loose sideboards; 34-inch wheels; solid iron axle.

WOODS and COCKSEGE, Stowmarket; the PRIZE of THREE POUNDS, for their light One-horse Cart.

W. BALL and SON: the PRIZE of TWO POUNDS TEN SHILLINGS, for their One-horse Cart.

HAYES and SON: the PRIZE of FOUR POUNDS TEN SHILLINGS, for their Prize Two-horse Cart, having broad fixed rungs instead of loose sideboards.

T. MILFORD and SON: the PRIZE of THREE POUNDS, for their Two-horse Cart, with tipping apparatus, lades, and side shelvings complete.

THE BEVERLEY IRON AND WAGGON COMPANY: the PRIZE of TWO POUNDS TEN SHILLINGS, for their One or Two-horse Cart.

THE BEVERLEY IRON AND WAGGON COMPANY: the PRIZE of FOUR POUNDS TEN SHILLINGS, for their Prize Harvest Cart, with Fore and End Ladders.

HAYES and SON: the PRIZE of THREE POUNDS, for their Improved Harvest Cart; wheels protected from clogging; fore and end ladders.

A. and T. Fry, Temple Gate, Bristol: the PRIZE of TWO POUNDS TEN SHILLINGS, for their Harvest Cart with bent shafts; invented by J. Hannam, Esq., of Burcot Park, improved and manufactured by the exhibitors.

ROBERT PUCKERING and Co., Beverley, Yorkshire: the PRIZE of SIX POUNDS for their Prize Market Cart.

- THE BEVERLEY IRON AND WAGGON COMPANY :** the PRIZE of FOUR POUNDS for their Prize Market Cart on Springs.
- THE BEVERLEY IRON AND WAGGON COMPANY :** HIGHLY COMMENDED for their Prize of Model One-horse Cart with Harvest Raves.
- FRANK P. MILFORD, Haldon Works, Kenn, Exeter :** HIGHLY COMMENDED for their Prize Two-horse Farm and Road Cart, for General Purposes.
- THE BEVERLEY IRON AND WAGGON COMPANY :** HIGHLY COMMENDED for their Improved Market Cart on Springs.
- T. MILFORD and SON :** COMMENDED for their Prize One-horse Cart.
- GEORGE MILFORD :** COMMENDED for his Improved Plank Side Two-horse Cart.

MISCELLANEOUS.

- A. W. GOWER and SON :** a SILVER MEDAL, for their Broadcast Seed Machine, 4 yards wide; has two separate boxes, one for the clover-seed and the other for rye-grass seed.
- FRANCIS MELLARD, Uttoxeter, Stoke-on-Trent, Staffordshire :** a SILVER MEDAL for his Patent Cheese-making Machine, for cutting, gathering, pressing, and vating of curds; invented by Charles H. Pugh, of Uttoxeter, and manufactured by the exhibitor.
- JOHN GILBERT AVERY, 135, Regent Street, London :** a SILVER MEDAL, for his Tubular Churn, making butter from perfectly sweet cream or new milk in three minutes; invented by Thomas A. Jebb, of Buffalo, New York, and manufactured by the exhibitor.
- RANSOMES and SIMS, Ipswich :** a SILVER MEDAL, for their Registered Semi-circular Pomeltrees; invented, improved, and manufactured by E. Edmunds, of Rugby. The action of the pulley travelling on the circle always secures a direct line of draught, however unequally the horses may work.
- THE WEST OF ENGLAND ENGINEERING COMPANY, Martock, Somerset :** a SILVER MEDAL, for their Combined Flax-breaking and Scutching Machine.
- W. S. Underhill, Newport, Salop :** a SILVER MEDAL, for Sketchley's Combined Sawing, Planing, Moulding, Tenoning, Grooving, and Boring Machine. It will cut and plane boards up to 11-inch wide, and strike any shape mould up to 5-inches wide.
- ALFRED E. PEIRCE, 75, Bridge Road, Hammersmith, near London :** a SILVER MEDAL for his Cattle Trough; invented and improved by the exhibitor, and manufactured by T. Whitfield and Co., of Birmingham.
- HOLMES and SONS :** a SILVER MEDAL for their Rotary Harrow or Twitch Extirpator; invented by T. Everett, of Stoley, and improved and manufactured by the exhibitors. Consists of a number of teeth fitted to a series of rings, and driven at a great speed by gearing covered completely from grit and dirt; the grass is efficiently freed from the soil and left on top.
- WHITE and Co., 29, Bedford Street, Strand :** COMMENDED for their Earth Closet Apparatus; invented and manufactured by the exhibitors.
- ASHBY and JEFFERY, Stamford, Lincolnshire :** COMMENDED for their Set of Patent Steel Crank-Shields.
- GEORGE P. DODGE, 79, Upper Thames Street, London :** COMMENDED for his India-rubber Vulcanized Machine Bands.
- WEBB and SON, Combs, near Stowmarket, Suffolk :** COMMENDED for their Assortment of Leather Machine Bands, Buckets, and Hose.

Essays and Reports.

AWARDS FOR 1865.

CLASS II.

The only Essay sent in was not considered deserving of the Prize.

CLASS III.

The Prize of 25*l.* was awarded to Mr. JOHN COLEMAN, of South Fields, Wandsworth, S.W., for his Essay on Sheep Stock.

CLASS IV.

The Prize of 25*l.* was awarded to Mr. HENRY HALL DIXON, of 10, Kensington Square, W., for his Essay on the Rise and Progress Shorthorns.

CLASS V.

The Prize of 25*l.* was awarded to Mr. WILLIAM HENRY HEYWOOD, of Dunham Massey, Altrincham, Cheshire, for his Essay on the Comparative Profit of making Cheese and Butter.

CLASS VI.

The Prize of 20*l.* was awarded to the Rev. J. C. CLUTTERBUCK, of Long Wittenham, Abingdon, Berks, for his Essay on Water Supply.

CLASS VII.

The Prize of 20*l.* was awarded to Mr. A. BAILEY DENTON, of Stevenage, Herts, for his Essay on Farm Buildings.

CLASS IX.

The Prize of 10*l.* was awarded to Mr. WILLIAM LITTLE, of Bunker Hill, Lambton, Fence Houses, Co. Durham, for his Essay on Cross-breeding of Cattle.

Essays and Reports.—PRIZES FOR 1866.—All Prizes of the Royal Agricultural Society of England are open to general competition. Competitors will be expected to consider and discuss the heads enumerated.

I. FARMING OF LEICESTERSHIRE.

FIFTY SOVEREIGNS will be given for the best Report on the Farming of Leicestershire.

The leading geological features and the character of the soil in different localities should be briefly described. Reference should be made to any older records of the state of agriculture in the county.

The live stock kept, their breeds, numbers, and management; the state of the pasture land—its enrichment or impoverishment, drainage, manuring, decrease (to secure an admixture of arable) or increase (from the influence of recent prices); the management of arable land as subsidiary to pasture; the state of farm-buildings, woods, and plantations, fences, to be discussed; characteristic farms to be described; improvements, lately made or still required, to be stated.

II. FARMING OF WORCESTERSHIRE.

FIFTY SOVEREIGNS will be given for the best Report on the Farming of Worcestershire.

The subject to be treated as for Prize I., but with special reference to the Management of Hop-grounds and Orchards, and to the varied arable lands within the limits of the county.

III. TOWN DAIRIES.

TWENTY-FIVE SOVEREIGNS will be given for the best Essay on Town Dairies.

The comparative advantages and drawbacks of a Dairy in a town rather than at the distance of a few miles; the influence of crowded buildings on the health of the cows, or on the milk they produce, to be considered. Suggestions for feeding and general management, and the sale of milk, &c., &c., to be offered.

IV. MOUNTAIN BREEDS OF SHEEP.

TWENTY SOVEREIGNS will be given for the best Essay on Mountain Breeds of Sheep.

The effects of the increase of Cross-breeding among Hill Sheep-Farmers to be considered. Have the pure races merits which ought to preserve them from extinction in certain localities?

**V. THE LEAVES OF PLANTS WITH REFERENCE TO THEIR
POWER OF RESISTING DROUGHT.**

TWENTY SOVEREIGNS will be given for the best Essay on this Subject.

Peculiarities in the colour, texture, development, &c., of Leaves to be treated of as indicative of their being suited to dry soils and climates. The soil, manures, and management suggested by this criterion to be stated.

**VI. THE IMPROVEMENT OF WASTE LANDS CONNECTED
WITH MINES.**

FIFTEEN SOVEREIGNS will be given for the best Essay on this Subject.

Improved Farm Management to meet the peculiar wants of Men and Animals connected with the Mines; and likewise the assignment of such allotments as the Miners would be able and willing to cultivate, are to be discussed.

**VII. THE USE TO A FARMER OF A MAGNIFYING GLASS
OR SIMPLE MICROSCOPE.**

FIFTEEN SOVEREIGNS will be given for the best Essay on this Subject.

The use of the Glass to be shown for detecting Impurities in samples of Seeds, Feeding Stuff, or Manures; Disease, as affecting the Roots, Stems, or Leaves of Plants; or for determining the quality of Grain, Roots, or Textile Materials.

VIII. ANY OTHER AGRICULTURAL SUBJECT.

TEN SOVEREIGNS will be given for the best Essay on any other Agricultural Subject.

Reports or Essays competing for the Prizes must be sent to the Secretary of the Society, at 12, Hanover Square, London, on or before March 1, 1866. Contributors of Papers are requested to retain Copies of their Communications, as the Society cannot be responsible for their return.

RULES OF COMPETITION FOR PRIZE ESSAYS.

1. All information contained in Prize Essays shall be founded on experience or observation, and not on simple reference to books or other sources. Competitors are requested to use foolscap or large letter paper, and not to write on both sides of the leaf.
2. Drawings, specimens, or models, drawn or constructed to a stated scale, shall accompany writings requiring them.
3. All competitors shall enclose their names and addresses in a sealed cover, on which only their motto, the subject of their Essay, and the number of that subject in the Prize List of the Society, shall be written.*
4. The President or Chairman of the Council for the time being shall open the cover on which the motto designating the Essay to which the Prize has been awarded is written, and shall declare the name of the author.
5. The Chairman of the Journal Committee shall alone be empowered to open the motto-paper of any Essay not obtaining the Prize, that he may think likely to be useful for the Society's objects; with a view of consulting the writer confidentially as to his willingness to place such Essay at the disposal of the Journal Committee.
6. The copyright of all Essays gaining Prizes shall belong to the Society, who shall accordingly have the power to publish the whole or any part of such Essays; and the other Essays will be returned on the application of the writers; but the Society do not make themselves responsible for their loss.
7. The Society are not bound to award a prize unless they consider one of the Essays deserving of it.
8. In all reports of experiments the expenses shall be accurately detailed.
9. The imperial weights and measures only are those by which calculations are to be made.
10. No prize shall be given for any Essay which has been already in print.
11. Prizes may be taken in money or plate, at the option of the successful candidate.
12. All Essays must be addressed to the Secretary, at the house of the Society, on or before the 1st of March, 1864.

* Competitors are requested to write their motto on the enclosed paper on which their names are written, as well as on the outside of the envelope.

Members' Privileges of Chemical Analysis.

THE Council have fixed the following rates of Charge for Analyses to be made by the Consulting Chemist for the *bonâ-fide* use of Members of the Society; who (to avoid all unnecessary correspondence) are particularly requested, when applying to him, to mention the kind of analysis they require, and to quote its number in the subjoined schedule. The charge for analysis, together with the carriage of the specimens, must be paid to him by members at the time of their application.

No. 1.—An opinion of the genuineness of Peruvian guano, bone-dust, or oil-cake (each sample)	5s.
„ 2.—An analysis of guano; showing the proportion of moisture, organic matter, sand, phosphate of lime, alkaline salts, and ammonia	10s.
„ 3.—An estimate of the value (relatively to the average of samples in the market) of sulphate and muriate of ammonia, and of the nitrates of potash and soda	10s.
4.—An analysis of superphosphate of lime for soluble phosphates only	10s.
„ 5.—An analysis of superphosphate of lime, showing the proportions of moisture, organic matter, sand, soluble and insoluble phosphates, sulphate of lime, and ammonia ..	£1.
„ 6.—An analysis (sufficient for the determination of its agricultural value) of any ordinary artificial manure	£1.
„ 7.—Limestone:—the proportion of lime, 7s. 6d.; the proportion of magnesia, 10s.; the proportion of lime and magnesia	15s.
„ 8.—Limestone or marls, including carbonate, phosphate, and sulphate of lime, and magnesia with sand and clay ..	£1.
„ 9.—Partial analysis of a soil, including determinations of clay, sand, organic matter, and carbonate of lime	£1.
„ 10.—Complete analysis of a soil	£3.
„ 11.—An analysis of oil-cake, or other substance used for feeding purposes; showing the proportion of moisture, oil, mineral matter, albuminous matter, and woody fibre; as well as of starch, gum, and sugar, in the aggregate ..	£1.
„ 12.—Analyses of any vegetable product	£1.
„ 13.—Analyses of animal products, refuse substances used for manure, &c. from 10s. to 30s.	
„ 14.—Determination of the “hardness” of a sample of water before and after boiling	10s.
„ 15.—Analysis of water of land drainage, and of water used for irrigation	£2.
„ 16.—Determination of nitric acid in a sample of water	£1.

N.B.—The above Scale of Charges is not applicable to the case of persons commercially engaged in the Manufacture or Sale of any Substance sent for Analysis.

The Address of the Consulting Chemist of the Society is, Dr. AUGUSTUS VOELCKER, 11, Salisbury Square, London, E.C., to which he requests that all letters and parcels (postage and carriage paid) should be directed.

Members' Veterinary Privileges.

I.—SERIOUS OR EXTENSIVE DISEASES.

No. 1. Any Member of the Society who may desire professional attendance and special advice in cases of serious or extensive disease among his cattle, sheep, or pigs, and will address a letter to the Secretary, will, by return of post, receive a reply stating whether it be considered necessary that Professor Simonds, the Society's Veterinary Inspector, should visit the place where the disease prevails.

No. 2. The remuneration of the Inspector will be 2*l.* 2*s.* each day as a professional fee, and 1*l.* 1*s.* each day for personal expenses; and he will also be allowed to charge the cost of travelling to and from the locality where his services may have been required. The fees will be paid by the Society, but the travelling expenses will be a charge against the applicant. This charge may, however, be reduced or remitted altogether at the discretion of the Council, on such step being recommended to them by the Veterinary Committee.

No. 3. The Inspector, on his return from visiting the diseased stock, will report to the Committee, in writing, the results of his observations and proceedings, which Report will be laid before the Council.

No. 4. When contingencies arise to prevent a personal discharge of the duties confided to the Inspector, he may, subject to the approval of the Committee, name some competent professional person to act in his stead, who shall receive the same rates of remuneration.

II.—ORDINARY OR OTHER CASES OF DISEASE.

Members may obtain the attendance of the Veterinary Inspector on any case of disease by paying the cost of his visit, which will be at the following rate, viz., 2*l.* 2*s.* per diem, and travelling expenses.

III.—CONSULTATIONS WITHOUT VISIT.

Personal consultation with Veterinary Inspector	2 <i>l.</i> 2 <i>s.</i>
Consultation by letter	1 <i>l.</i> 1 <i>s.</i>
Consultation necessitating the writing of three or more letters.	10 <i>s.</i>
Post-mortem examination, and report thereon	10 <i>s.</i>

A return of the number of applications during each half-year being required from the Veterinary Inspector.

IV.—ADMISSION OF DISEASED ANIMALS TO THE VETERINARY COLLEGE; INVESTIGATIONS, LECTURES, AND REPORTS.

No. 1. All Members of the Society have the privilege of sending cattle, sheep, and pigs to the Infirmary of the Royal Veterinary College, on the same terms as if they were Members of the College; viz., by paying for the keep and treatment of cattle 10*s.* 6*d.* per week each animal, and for sheep and pigs "a small proportionate charge to be fixed by the Principal according to circumstances."

No. 2. The College has also undertaken to investigate such particular classes of disease, or special subjects connected with the application of the Veterinary art to cattle, sheep, and pigs, as may be directed by the Council.

No. 3. In addition to the increased number of lectures now given by Professor Simonds—the Lecturer on Cattle Pathology—to the pupils in the Royal Veterinary College, he will also deliver such lectures before the Members of the Society, at their house in Hanover Square, as the Council shall decide.

No. 4. The Royal Veterinary College will from time to time furnish to the Council a detailed Report of the cases of cattle, sheep, and pigs treated in the Infirmary.

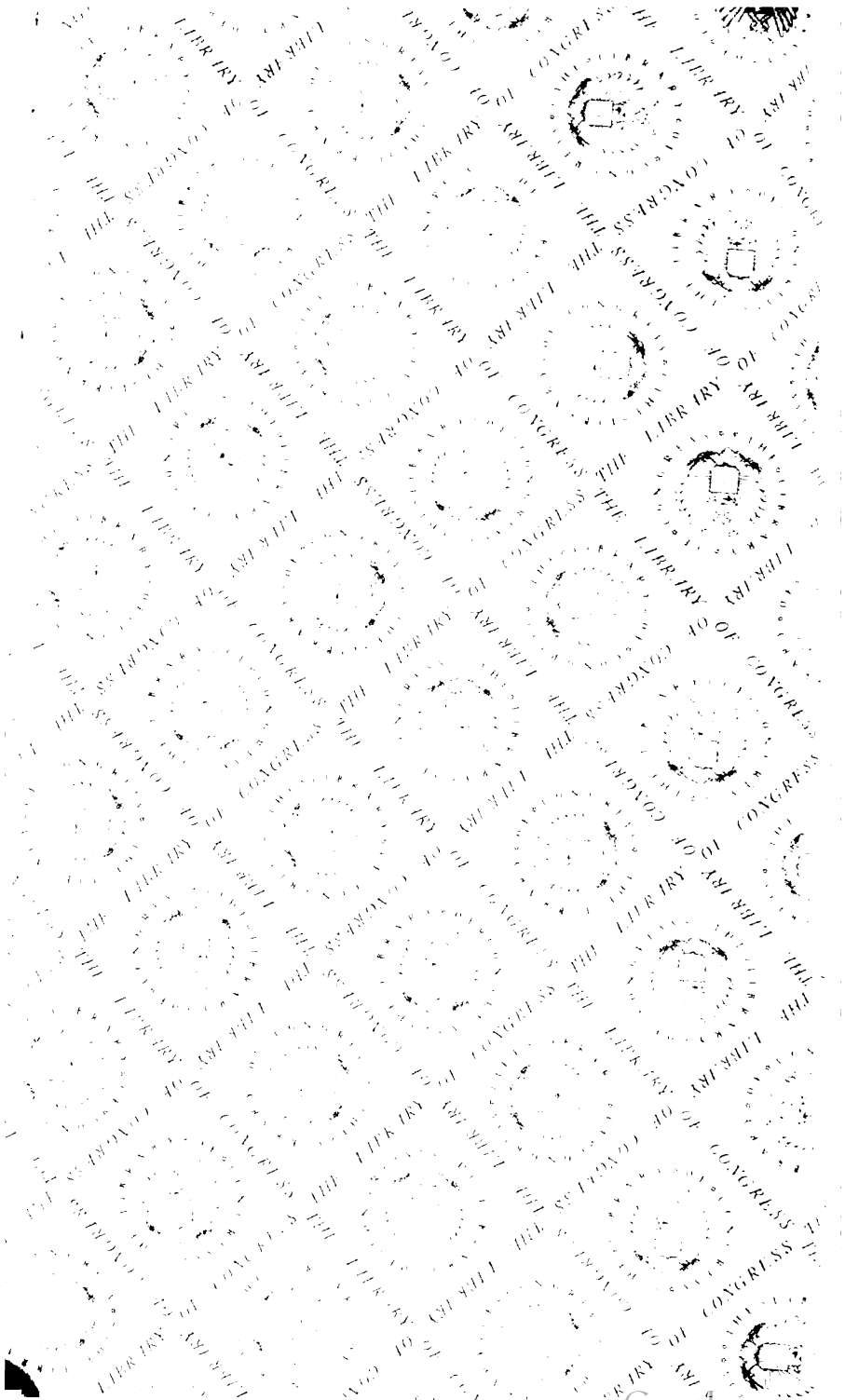



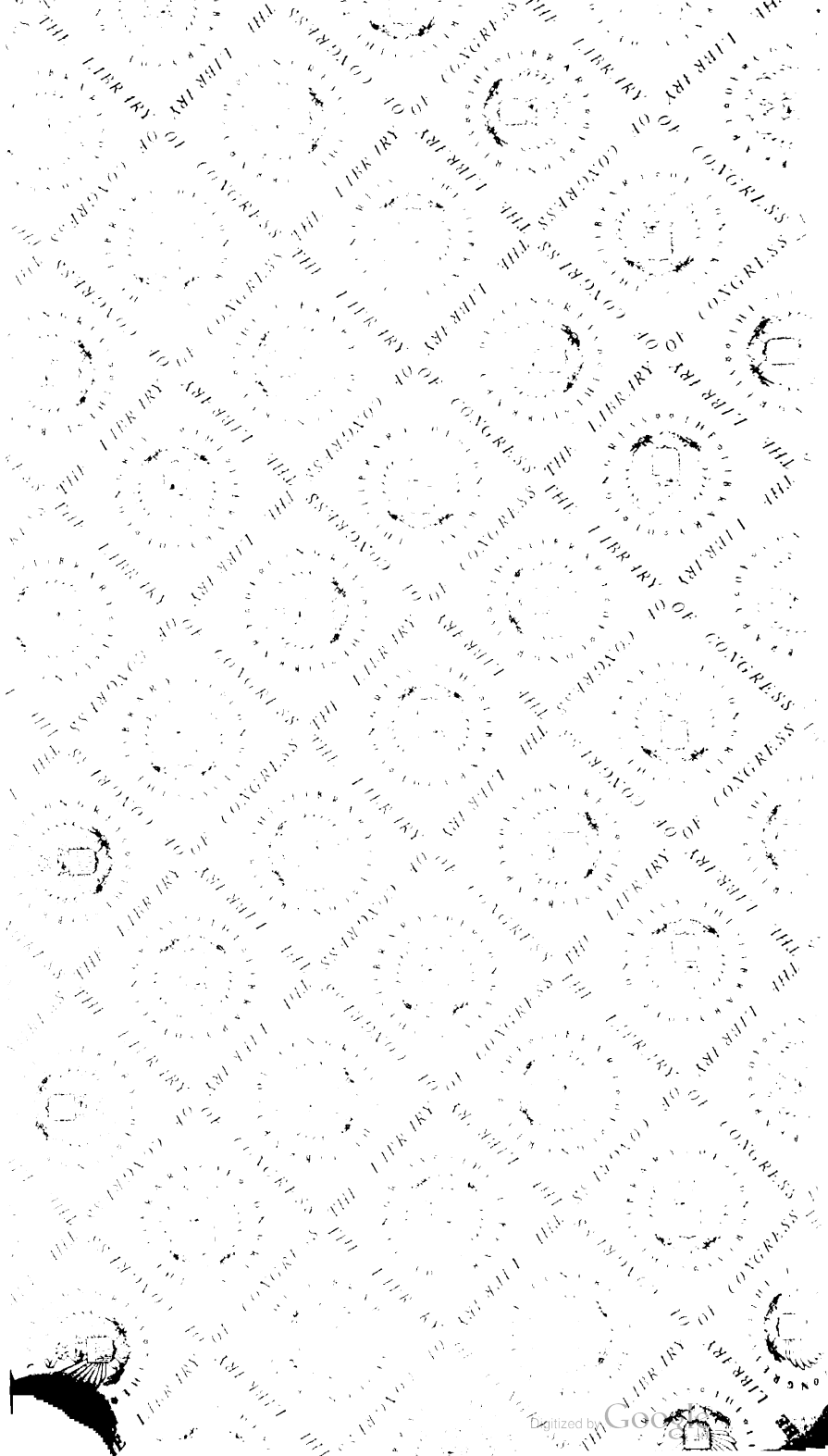

LIBRARY OF CONGRESS



00026916562