





---

---

BARTLETT'S  
ACOUSTICS AND OPTICS.

---

---





ELEMENTS  
OF  
NATURAL PHILOSOPHY.

BY  
W. H. C. BARTLETT, LL. D.,  
PROFESSOR OF NATURAL AND EXPERIMENTAL PHILOSOPHY IN THE UNITED STATES  
MILITARY ACADEMY AT WEST POINT.

---

II.—ACOUSTICS.  
III.—OPTICS.

---

SECOND EDITION, REVISED AND CORRECTED.

NEW YORK:  
PUBLISHED BY A. S. BARNES AND COMPANY,  
No. 51 JOHN-STREET.  
CINCINNATI: H. W. DERBY AND COMPANY.  
1856.

---

Entered according to Act of Congress, in the year One Thousand  
Eight Hundred and Fifty-two,

By W. H. C. BARTLETT,

In the Clerk's Office of the District Court of the United States for the Southern District  
of New-York.

---

J. P. JONES & CO., STEREOTYPERS,  
183 William-street.

G. W. WOOD, PRINTER,  
51 John-st., cor. Dutch.

## P R E F A C E .

---

THOSE who are familiar with the subjects of which the present volume professes to treat, will readily recognize the sources whence most of its materials are drawn. In the use of these materials, no distinction of principle is made between SOUND and LIGHT. Both are regarded and treated as the effects of certain disturbances of that particular state of molecular equilibrium which determines the ordinary condition of natural bodies ; the only difference being in the media through which these disturbances are propagated, and in the organs of sense by which their effects are conveyed to the mind. The study of ACOUSTICS is, therefore, deemed to be not only a useful, but almost a necessary preliminary to that of OPTICS.

In the preparation of the part relating to Sound, great use was made of the admirable monograph of Sir JOHN HERSHEY, published in the *Encyclopædia Metropolitana* ; and whenever it could be done consistently with the plan of the work, no hesitation was felt in employing the very language of that

eminent philosopher. Much valuable matter was also drawn from Mr. AIRY's Tracts, and from the labors of Mr. ROBISON and M. PESCHEL.

In addition to the works of the authors just cited, those of Mr. CODDINGTON, Mr. POWELL, Mr. LLOYD, Sir DAVID BREWSTER and M. BABINET were freely consulted in constructing the part relating to Optics.

# TABLE OF CONTENTS.

---

## ACOUSTICS.

	Page
Introductory Remarks and Definitions, . . . . .	9
Waves in general, . . . . .	20
Velocity of Sound in Aeriform Bodies, . . . . .	24
Velocity of Sound in Liquids, . . . . .	38
Velocity of Sound in Solids, . . . . .	44
Pitch, Intensity, and Quality of Sound, . . . . .	47
Siren, . . . . .	49
Divergence and Decay of Sound, . . . . .	54
Molecular Displacement, . . . . .	58
Interference of Sound, . . . . .	61
New Divergence and Inflexion of Sound, . . . . .	70
Reflexion and Refraction of Sound—Echos, . . . . .	75
Hearing Trumpet, . . . . .	90
Whispering Galleries and Speaking Tubes, . . . . .	91
Musical Sounds, . . . . .	94
Vibrations of Musical Strings, . . . . .	97
Monochord, . . . . .	111
Vibrating Columns of Air, . . . . .	114
Vibrations of Elastic Bars, . . . . .	126
Vibrations of Elastic Plates and Bells, . . . . .	128
Communication of Vibrations, . . . . .	131
The Ear, . . . . .	135
Music, Chords, Intervals, Harmony, Scale, and Temperament, . . . . .	137
Table of Intervals, . . . . .	143
Table of Intervals with the Logarithms, . . . . .	154

## OPTICS.

	Page
Introductory Remarks and Definitions, . . . . .	167
Reflexion and Refraction of Light, . . . . .	171
Table of Refractive Indices and Refractive Powers, . . . . .	176
Deviation of Light at Plane Surfaces, . . . . .	176
Deviation of Light at Spherical Surfaces, . . . . .	188
Deviation of Light by Spherical Lenses, . . . . .	201
Deviation of Light by Spherical Reflectors, . . . . .	211
Spherical Aberration, Caustics and Astigmatism, . . . . .	216
Oblique Pencil through the Optical Centre, . . . . .	220
Optical Images, . . . . .	222
The Eye and Vision, . . . . .	232
Microscopes and Telescopes, . . . . .	238
Common Astronomical Telescope, . . . . .	245
Galilean Telescope, . . . . .	246
Field of View, . . . . .	248
Terrestrial Telescope, . . . . .	250
Compound Refracting Microscope, . . . . .	252
Astronomical Reflecting Telescope, . . . . .	253
Gregorian Telescope, . . . . .	254
Cassegrainian Telescope, . . . . .	256
Newtonian Telescope, . . . . .	257
Dynameter, . . . . .	257
Camera Lucida, . . . . .	261
Camera Obscura, . . . . .	263
Magic Lantern, . . . . .	264
Solar Microscope, . . . . .	265
Chromatics, . . . . .	266
Color by Interference, Color of Gratings, . . . . .	267
Table of Wave Lengths, . . . . .	276
Colored Fringes of Shadows and Apertures, . . . . .	282
Colors of Thin Plates, . . . . .	284
Colors of Inclined Glass Plates, . . . . .	290
Colors of Thick Plates, . . . . .	291

TABLE OF CONTENTS.

7

---

	Page
Color from Unequal Refrangibility, . . . . .	293
Dispersion of Light, . . . . .	298
Table of Dispersive Powers, . . . . .	301
Chromatic Aberration, . . . . .	302
Achromatism, . . . . .	305
Internal Reflexion, . . . . .	309
Absorption of Light, . . . . .	311
The Rainbow, . . . . .	314
Halos, . . . . .	321
Polarization of Light, . . . . .	322
Polarization by Reflexion and Refraction, . . . . .	327
Polarization by Absorption, . . . . .	334
Double Refraction, . . . . .	335
Circular Polarization, . . . . .	345
Chromatics of Polarized Light, . . . . .	348





# ELEMENTS OF ACOUSTICS.

---

§ 1. THE principle which connects us with the external world through the sense of hearing, is called SOUND; and that branch of Natural Philosophy which treats of sound, is called ACOUSTICS.

To explain the nature of sound, the laws of its propagation through the various media which convey it to our ears, the mode of its action upon these organs, the modifications of which sound is susceptible in speech, in music and in unmeaning noise, as well as the means of producing and regulating these modifications, are the objects of acoustics.

§ 2. All impressions derived through the senses, immediately follow and may, therefore, be said to arise from peculiar conditions of relative motion among the elements of which certain parts of our physical organization are constructed. These conditions are mainly determined by the internal state of the bodies with which we are in sensible contact. It becomes important, therefore, to look somewhat into the constitution of natural bodies, and especially to inquire into the structure of the atmosphere, the main vehicle of sound to the beings which inhabit it, and of that vastly more subtile and refined medium, called ether, through which we derive our sensations of *heat*, *light*, and *electricity*.

§ 3. We have already referred, in the introduction to the first volume, to Boscovich's views upon this subject, and shall now give some illustration of the mode in which,

according to that distinguished philosopher, all bodies are formed.

Exponential curve;

For this purpose let us resume the exponential curve as exhibited in the annexed figure, and which Boscovich sup-

Fig. 1.

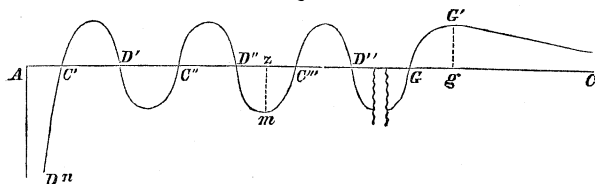

Attractive ordinates;  
Repulsive ordinates;

Neutral points;

Temporary molecule;

Permanent molecule;

When permanence exists.

poses to represent the law and intensity of the action of one atom of a body upon another. We have seen that the ordinates of those portions of the curve which lie above the line  $A C$ , denote the attractive, while the ordinates of the portions below, represent the repulsive energies of an atom  $A$  for another atom situated anywhere upon this line. That at the points  $C', D', C'', D''$ , in which the curve intersects the line  $A C$ , the reciprocal action of the atoms reduces to nothing, and the atoms become neutral. Also that an atom situated at  $D', D''$  or  $D'''$  and the atom  $A$  constitute a temporary *molecule*, while the *molecule* formed of the atoms  $A$  and  $C', A$  and  $C''$ , or  $A$  and  $C'''$ , has a certain degree of permanence, resisting compression and dilatation, and tending to regain its original bulk when the distending or compressing cause is withdrawn. But this permanence only obtains when the disturbing force is such as to change the interval between the atoms by a distance less than that which separates the consecutive positions of neutrality; for if the molecule  $A C''$ , for example, be compressed into a less room than  $A D'$ , the atom originally at  $C''$ , will not return to that point, but will be attracted by  $A$ , and the molecule will tend to collapse into the bulk  $A C'$ . If  $A C''$  be stretched beyond the bulk  $A D''$ , it will tend to take the dimension  $A C'''$ . The only molecule that cannot be permanently changed by compression is  $A C'$ .

The component atoms of molecules thus constituted are, when in a state of relative equilibrium, in a condition of inactivity upon each other. The approximation or separation of the atoms by the application of some extraneous cause, gives rise to the exertion of the repulsive or attractive forces inherent in the atoms, and thus these forces may be said to be excited or brought into action. The compression or dilatation is the *occasion*, not the *efficient cause* of the attractions and repulsions among the atoms.

How the reciprocal actions among atoms are excited.

§ 4. The intensity of the atomical forces determines the form of the exponential curve. If a very moderate force produce a sensible displacement of the atoms, the ordinates  $E'd'$ , and  $E'd$ , on each side of the position  $C'$ , of inactivity, must be short, and the exponential curve will cross the axis very obliquely, in order that the ordinates expressing the attractive and repulsive forces may increase slowly. If, however, it require great force to produce a sensible compression or dilatation, the curve must cross the axis almost perpendicularly. But in every case it must be remarked, and the remark is most important, that when the compression or distension bears a small proportion to the distance between the neutral positions of the atoms, the degree of compression or distension will be sensibly proportional to the intensity of the disturbing force. For, when the displacement  $D'E$  or  $D'E'$  is very small in comparison to  $C'D'$ , the elementary arc  $dD'd'$  will sensibly coincide with a straight line, and the ordinates  $E'd$  and  $E'd'$ , be proportional to the compression  $D'E$  or distension  $D'E'$ . That is to say, because action and

Form of the exponential curve determined.

Fig. 2.

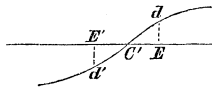
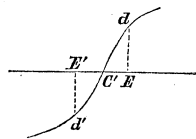
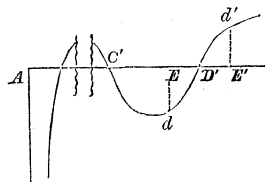

Fig. 3.



Small compression and distension.

Fig. 4.



$E'd$  and  $E'd'$ , be proportional to the compression  $D'E$  or distension  $D'E'$ . That is to say, because action and

Their  
consequences.

reaction are equal, a *disturbed atom will be urged back towards its position of neutrality by a force whose intensity is proportional to the distance of the atom from that point.*

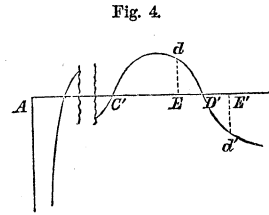

Perpetual oscillation;

Moreover, supposing the atom *A*, Fig. 4, to be kept stationary, and the points *E*, and *E'*, to mark the limits of the disturbance of the other atom, this latter will return to its position of neutrality *D'*, with a living force due to the action of the force of restitution over the path *E D'*, or *E' D'*; it will, therefore, pass the point *D'*, after which the direction of the action will be reversed, the living force will be destroyed, the atom will again return to its position of neutrality, which it will pass as before, and for the same reason, and thus be kept in perpetual oscillation. But the action between the two atoms of the molecule being reciprocal, the atom *A* will not remain stationary, but will move in the same direction as the disturbed atom and tend to preserve its neutral distance, and the oscillation that would otherwise continue will, therefore, be checked.

Checked.

Action of the simplest molecule on an atom.

§ 5. Let us next take the case of a molecule of the simplest constitution, to wit, one composed of two atoms, and examine its action on a third atom situated on the prolongation of *X Y*, joining its elements.

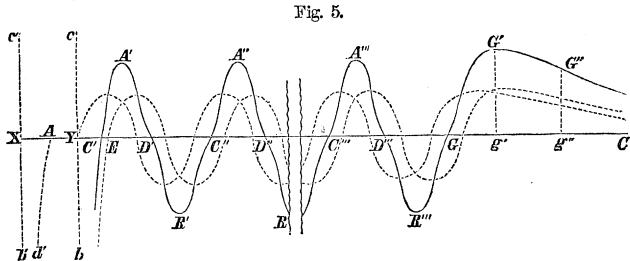

First case;

Suppose a molecule *X Y*, composed of the two atoms *X* and *Y*, which are placed, the former at *A*, and the lat-

ter at the last limit of cohesion  $C'$ , Fig. 5. The dotted and waving curve beginning at  $Y$  and running towards  $C$ , will represent the exponential curve of the atom  $X$ , in that direction, while the similar curve beginning at the point  $E$ , will represent that of the atom  $Y$ , and the full curve  $C' A' D' R' C'' A''$  &c., of which the ordinate corresponding to any point of the line  $A C$ , is equal to the algebraic sum of the ordinates of the dotted curves corresponding to the same point, will be the exponential curve of the molecule  $X Y$ , and will give the action of the molecule upon a third atom placed any where on the line  $A C$  beyond  $Y$ . The curve has been carefully constructed according to the conditions of the case, and shows by simple inspection how different the action of even the simplest molecule is from that of a single atom. The neutral positions of an atom with respect to this molecule will be at  $A, C', D', C'', D''$  and so on to  $G$ . A curve having a cusp at  $A$ , the middle point of the distance  $X Y$ , and diverging so as to be asymptotic with the lines  $cb$  and  $c'b'$ , will give the law and intensity of the action on an atom situated between  $X$  and  $Y$ .

Exponential curves of the component atoms;

That of the molecule;

Neutral positions of an atom with respect to this molecule ;

§ 6. If instead of placing the atoms at a distance apart equal to that of the last limit of cohesion from  $A$ , as in the last case, we had supposed them separated by the distance  $A C''$ , Fig. 1, the resulting exponential curve would have been still more unlike that of a single atom ; for in that case

Second case;

Fig. 6.

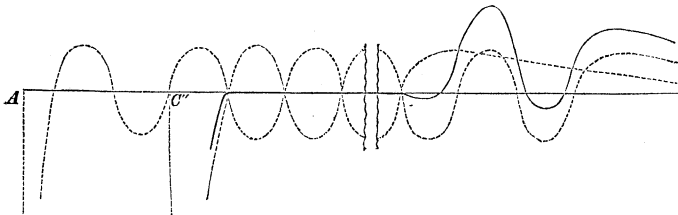

several of the attractive branches, Fig. 6, of one of the atomical curves would have stood opposed to the repulsive branches of the other, and the molecule thus rendered in-

Resulting action on an atom.

active on a third atom till the latter be removed nearly to the furthest limit of the scale of corpuscular action. This third atom will, therefore, admit of considerable latitude of displacement without much opposition or any great effort to regain its primitive position; a fact we often see exemplified in the class of liquid bodies.

Exemplification.

Third case;

§ 7. Let us now take the molecule composed of two atoms placed at the limits  $A$  and  $C''$ , Fig. 1, and examine its action on a third atom somewhere on the line  $BB'$ , which bisects at right angles the distance  $AC''$ . Suppose the third atom placed at  $z$ . Join  $z$  with  $A$  and  $C''$ , and construct the single atomical curves of  $A$  and  $C''$  in reference to  $z$ , and suppose the atom  $z$  in Fig. 7, to have a position with respect to  $A$  and  $C''$ , corresponding to any position between  $D''$  and  $C'''$ , Fig. 1; thus situated, it will be repelled both by  $A$  and  $C''$ , Fig. 7. In a pair of dividers take the ordinate  $zm$ , Fig. 1, and lay it off from  $z$ , on the prolongations of  $Az$  and  $C''z$ , Fig. 7, and construct the parallelogram  $z m n m'$ ; the diagonal  $zn$ , will represent in direction and intensity the action of the molecule  $A C''$  on the third atom. Draw a perpendic-

Construction;

Construction of the exponential curve giving the action of a molecule on an atom.

Fig. 7.

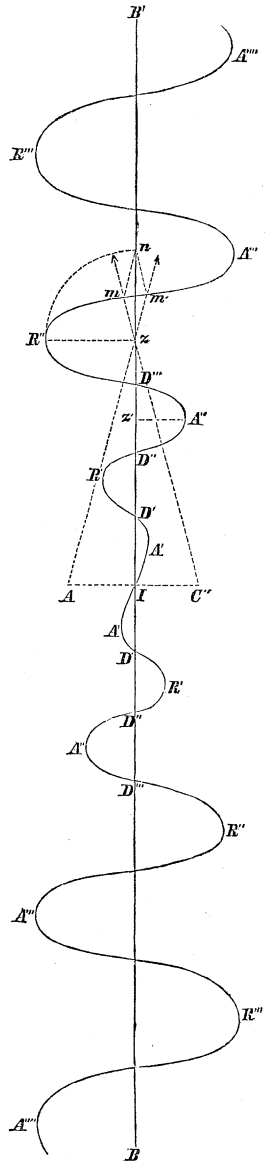

Draw a perpendic-

ular to  $B B'$  through the point  $z$ , and take the distance  $z R''$  equal to  $z n$ , the point  $R''$  will be one point of the exponential curve of the molecule  $A C''$  in the direction  $B B'$ . Other points being determined in the same way, the waved lines of Fig. 7 will indicate the action sought; the ordinates of the branches  $A', A'', A''', \&c.$ , on one side of  $B B'$ , denoting attractions, while those of the branches  $R', R'', R''', \&c.$ , on the opposite side, denote repulsions. We see that this action differs remarkably from that of a single atom. The curve has, to be sure, like that of a single atom, many alternations of attractions and repulsions, but these alternations become less marked as they approach the molecule; and instead of insuperable repulsion at the greatest vicinity  $I$ , we find there a neutral point. Moreover, in approaching the molecule, the repulsive action ceases at  $D'$ , where attraction begins and continues, so far as there is any action, all the way through to  $D'$  on the opposite side of  $A C''$ . This molecule is ever active when approached along the line  $B B'$ , except at certain neutral positions where the direction of the action is reversed, and is easily penetrable in this direction, whereas along the line  $A C''$  it exerts little or no action within certain limits, and is capable of an infinite repulsion within its last limit of cohesion. Thus we see that even in this simplest constitution of a molecule, the action on an atom is susceptible of great variety by mere difference of position and distance between its component atoms; and it would be easy to show that while the law of the atomic action in all bodies is the same, the reciprocal action of the molecules compounded of these atoms may be unspeakably various according to the relative position and distance of the component atoms.

Action differs greatly from that of an atom.

Law of atomic action the same in all bodies. Reciprocal action of molecules infinitely various.

Fig. 8.

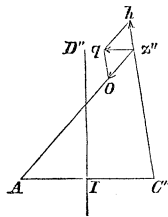

§ 8. Confining, for the present, the motion of the third atom to the plane of the lines  $A C''$  and  $B B'$ ,

Action of a molecule on an atom.

Fig. 7, we see that when it is at  $z$ , it is repelled by the molecule  $A C''$ ; when at  $z'$  it is attracted, and the action is reduced to nothing at the point  $D''$ . When the atom is drawn aside from its neutral position  $D''$ , say to  $z''$ , Fig. 8, it will be repelled by  $C''$  and attracted by  $A$ , because the distance from the former

Fig. 8.

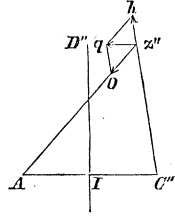

will be diminished, while that from  $A$  will be increased. Take  $z'' h$  to represent the intensity of the repulsion and  $z'' o$  that of the attraction; complete the parallelogram  $o z'' h q$ , and we shall find the molecule urged to its neutral position  $D''$  by a force whose intensity and direction are represented by the diagonal  $z'' q$ ; so that, so far as the action in the plane  $A C'' D''$  is concerned,  $D''$  is a position of stable equilibrium, and the three atoms  $A$ ,  $C''$  and  $D''$  will constitute for moderate displacements a permanent molecule, presenting an elementary surface having length and breadth. The same would be true were the third atom placed at  $D'$  or  $D'''$ , &c., Fig. 7.

Constitution of an elementary surface.

Oscillation of the disturbed atom;

The disturbed atom when at  $z''$  being urged back to its place of neutrality by the molecule  $A C''$ , will reach that point with a certain amount of living force, due to the action of the force of restitution over the path from  $z''$  to  $D''$ ; it will, therefore, pass to the opposite side of  $D''$ , where the action being in the opposite direction, its living force will be destroyed, after which it will be brought back and made to oscillate about  $D''$  as long as  $A$  and  $C''$  are stationary. But while the third atom is on the side  $z''$ , that at  $C''$  will be repelled by it, and that at  $A$  attracted; the contrary will be the case when the atom is on the opposite side from  $z''$ , so that the atoms of the molecule  $A C''$  will also oscillate, and obviously in such manner as to cause the neutral position to follow the displaced atom.

That of the atoms of the molecule.

Explanation of figure;

§ 9. Now conceive a triangle  $A C'' C_i''$ , each of whose



sides is equal to a distance at which two atoms may form a permanent molecule, and suppose an atom to be placed at each vertex; these atoms will form a permanent molecule. Place a fourth atom at the vertex  $D''$ , of a pyramid of which the base is the elementary plane formed by the first three atoms, and each of the edges about the vertex is equal to a distance necessary for two atoms to

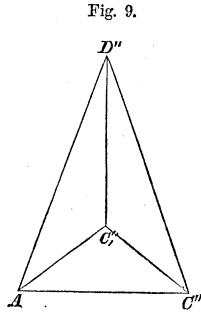

Fig. 9.

Explanation.

form a permanent molecule. It will be obvious, from what has already been said, that the fourth atom or that at the vertex cannot be disturbed without being resisted and urged back to its neutral place by the action of the molecules which form the base; for, if it be moved aside in either of the plane faces of the pyramid, it will, § 8, be opposed by the force of restitution due to the action of the molecule of two atoms in the same plane; and if moved out of these planes, its distance from one at least of the atoms in the triangular base must be altered, thus exciting a force of restitution. What has been said of the atom at the vertex of the pyramid is equally applicable to each of those in the base when considered in reference to the three others, and hence the four atoms  $A, C'', C''', D''$ , form a permanent molecule; and from its capability to resist the approach of a fifth atom, another molecule or particle, in every direction, we derive the idea of an elementary solid, having length, breadth and thickness. A disturbance of any one of the four atoms will put the others in motion, and it will appear on the slightest consideration that the directions of these motions will be such as to cause the neutral positions to shift in the direction of the atoms which have been disturbed from them.

Permanent molecule of four atoms;

Elementary solid.

Disturbance will cause the neutral points to follow the disturbed atoms.

§ 10. What has been said of the action of atoms to form molecules may easily be shown to be true of the reciprocal action of molecules to form particles, and of

Same reasoning applies to molecules and particles.

particles to form the bodies which, in all their endless variety of physical characters, come within the reach of our senses. And according to this view, the characteristic peculiarities of all bodies are to be understood as arising solely from differences in the action which their atoms, molecules and particles are capable of exerting on each other, and upon those of the bodies with which they may be brought into sensible contact.

Reciprocal action  
of elements  
confined to small  
distances.

But it must be remarked that all these differences of action are confined to small and insensible distances which lie within the limits of physical contact. At all considerable distances we find nothing but the action of gravitation, of which the intensity is proportional to the number of atoms or the mass directly, and to the square of the distance inversely.

The most subtle  
body  
conceivable;

§ 11. The most subtle and attenuated body of which we can form any conception, according to Boscovich, is one composed of atoms arranged at distances from each other equal to that which determines the furthest limit of cohesion, or that beyond which gravitation begins. But such a body, when abandoned to itself, would shrink into smaller dimensions in consequence of the gravitating force between the atoms not adjacent to each other, and the contraction would continue till the repulsions which it would develop between the contiguous atoms had increased to an equilibrium with the compressing action, when the body would take its permanent form.

When it would  
take its  
permanent form;

Ether.

Such we may suppose to be the constitution of that ethereal medium which pervades all space, permeates every body, and connects us with the objects of whose existence we are made conscious through the sense of sight.

Structure of the  
atmosphere;

§ 12. A body similarly constituted, but in which the atoms are replaced by molecules or particles arranged at distances less than the furthest limit of cohesion may give us an idea of the physical structure of our atmosphere. Here as in the last case the molecules cannot occupy their

neutral positions because of the forces of gravitation existing between those molecules more remote from each other than the furthest limit of cohesion, which force will cause the elements to crowd together; but we have seen that when the elements of a body are brought closer than those neutral positions which constitute permanence, the adjacent elements will repel, and can come to rest only when these antagonistic forces of attraction and repulsion balance. Add to these considerations the attraction of the earth for this fluid, and the equilibrium of any molecule will be found to result from the mutual destruction of the weight of the superincumbent column of molecules extending to the top of the atmosphere, and the repulsive action of the molecule in question for that immediately above it; and since the weight of the pressing column decreases as we ascend, the density must diminish in the same direction, all of which we know to be confirmed by the indications of the barometer.

Its molecules cannot be in their neutral positions;

Conditions of its equilibrium.

§ 13. Passing to the denser bodies, whether of the organic or inorganic class, as vegetable or animal tissue, water, clay, glass, gold, we find variety of structure without difference in the principles of aggregation. All are built up of the same ultimate atomic elements, grouped into molecules, the molecules into particles, and the particles into the various bodies whose places in the scale of gradation, from the hardest to the softest solid, from the most viscous liquid to the most subtile gas, are determined solely by the intensity, range and direction of the atomic actions which mark their internal structure.

All bodies composed of the same ultimate atomic elements;

Their characteristic properties determined.

§ 14. All bodies in nature are physically connected with each other. Those plunged into the ocean are united by sensible contact with its common element. So of the bodies which exist in the atmosphere. The atmosphere rests upon the ocean, and that ethereal medium which permeates the atmosphere and the ocean, and extends

All bodies physically connected.

Physical connection maintained by ocean,

Atmosphere,  
ether.

throughout all space, carries this connection to the heavenly bodies.

Disturbance of a  
single particle  
is transmitted  
throughout  
space.

The disturbance of an atom, molecule or particle, will alter its relative distances from the neighboring elements; the molecular forces on the side of the shortened distances will increase, while those on the opposite side will diminish. The equilibrium which before existed will be destroyed, and the adjacent elements must also be disturbed; these will disturb others in turn, and thus the agitation of a single element will be transmitted throughout space, and impart motion, in a greater or less degree, to the elements of all bodies.

Motion affects  
the mind  
through organs of  
sense;

§ 15. Among the bodies thus affected are certain delicate and net-like ramifications of nervous tissue, which are spread over portions of our organs of sense. These nerves partake of the agitations transmitted to them from without, and by some mysterious process, call up in the mind impressions due to the external commotion. The structure and arrangement of these nerves differ greatly in the different organs, and while they are all subjected to the general laws which control the corpuscular action of bodies, yet each individual class is distinguished by peculiarities which determine them to appeal to the mind only when addressed in a particular way. We hear, feel and see by the operation of a common principle—motion; of this, there is endless variety in perpetual existence among the elements of the media in which we are immersed; and, according as one or another of the organs of sense becomes involved in the particular motion adapted to excite the mind to action, will our sensation become that of sound, light, heat, or electricity.

All our  
impressions due  
to a common  
principle—  
motion.

#### OF WAVES.

All sensations  
dependent upon  
motion.

§ 16. All sensations derived from our contact with the physical world depend, according to this view, upon the

state of relative motions among the elements of bodies ; and we now proceed to consider those motions which are suited to produce the sensation of sound, and we must be careful to distinguish between the properties of solids and fluids in this respect.

Those proper to produce sound.

Conceive a perfectly homogeneous solid, that is, one in which the particles occupy the vertices of regular and equal tetrahedrons, and suppose its elements in a state of relative repose. A single particle being disturbed from its place of rest, through a very small distance, compared with the tetrahedral edges, will be urged back by the action of the surrounding elements with an energy which is, § 4, proportionate to the disturbance. This particle will, when abandoned to itself under these circumstances, describe about its position of rest as a centre, an ellipse, or perchance, a circle, or right line, the extreme varieties of the ellipse whose eccentricities are respectively zero and unity. Moreover, the time of describing a complete revolution will, Mechanics, § 180, be constant, no matter what the size of the orbit within the limits supposed ; and the mean velocity of the particle will, therefore, be directly proportional to the length of the orbit, or to any linear element of the same, as that of the semi-transverse axis. The disturbed particle being acted upon by its neighbours, these latter will experience from it the action of an equal and contrary force ; they must, therefore, move and describe similar orbits ; and the same will be true of the particles next in order, till the disturbance becomes transmitted indefinitely. The disturbance must take place in all directions from the primitive source, because the displacement of a single particle from its position of rest breaks up the equilibrium on all sides ; and the disturbance must be progressive, since it is to an actual displacement of a particle that the forces are due which give rise to the displacement in others. It follows, therefore, that while the first disturbed particle is describing its elliptical orbit the disturbance itself is being propagated from it in all directions, and that at the instant this

Orbit of a disturbed particle ;

Time of description constant ;

Mean velocity ;

Neighboring particles describe similar orbits.

Disturbance transmitted in all directions.

Disturbance is progressive ;

First particle having made one circuit, another just begins to move;

particle has completed one entire revolution, and begins a second, the disturbance will have just reached another particle  $A_2$ , in the distance, which particle will then begin for the first time to move, so that these two particles will during subsequent revolutions about their respective centres always be at the same angular distance from their starting points; when the first particle  $A_1$  has completed its second revolution, and the particle  $A_2$  its first, the disturbance will have reached a third particle  $A_3$ , still further in the distance, which begins its first revolution when  $A_2$  begins its second, and  $A_1$  its third, and so on indefinitely.

A third begins to move.

Space including particles in all positions in their orbits;

Now, after the disturbance has reached the particle  $A_2$  it is plain that the particles between  $A_1$  and  $A_2$  inclusive will be in all possible situations in their respective orbits. For example, taking the instant in which  $A_1$  first returns to its starting point, it will have described three hundred and sixty degrees, the consecutive particle an arc less than this, the next particle, in order, an arc still less, and so on till we reach  $A_2$ , which will only just have begun to move. If then, we conceive a series of concentric spheres

Fig. 10.



whose radii are respectively  $A_1, A_2, A_1, A_3, A_1, A_4, \&c.$  it is obvious that

Fig. 11.

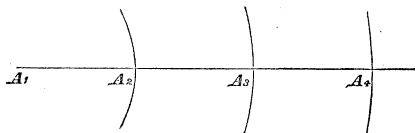

Illustration.

Explanation of wave length.

within the space included between these spherical surfaces, the particles will be in every possible stage of their circuits around their respective centres, and will, as we pass from surface to surface, be found moving in all possible directions in the planes of their several orbits; and the same would obviously be true, if the radii of any two consecutive surfaces had been increased or diminished by the same length, the only difference being that the particles at the new position

of the surfaces, instead of being at the origin or places of rest from which they began their respective circuits, would occupy places more or less remote but equally advanced from these points. Thus, for example, had the radii been taken  $A_1 A_2 + \frac{1}{4} A_2 A_3$ , and  $A_1 A_3 + \frac{1}{4} A_2 A_3$ , then Wave length not restricted to any particular position. would the particles at the new surfaces have been at an angular distance from their respective places of primitive departure equal to  $90^\circ$ , but the surfaces would still have included between them in the direction of the radii, particles in every possible state of progress in their circuits, the particle at the origin of departure being in this case at a distance from the surface of the smaller of the second set of spheres equal to three-fourths of the difference between the radii of any two consecutive spheres of the first set.

This particular arrangement of the particles of any body arising from the disturbance of one of its elements, and by which, after a certain lapse of time, all possible positions around their respective places of rest are occupied by the particles, in the order of succession, at the same time, is called a *Wave*. Wave. The distance, in the direction of the radii, between any two of the consecutive spherical surfaces above described, is called the *length* of the wave.

The term *phase* is used to express both the particular displacement and direction of the motion of a particle in any wave. Phase. A *wave length*, therefore, Wave length. is that interval of space which comprises particles in every possible phase.

Particles which have equal displacements and motions, in the same direction, are said to be in *similar phases*; Similar phases. when the displacements and motions are equal and opposite, the particles are said to be in *opposite phases*. Opposite phases.

The surface which contains those particles of a wave which are in similar phases, is called a *wave front*. Wave front; In sound this last term will be used to denote the surface containing those particles which are, for the first time, In sound. beginning to move from their places of rest.

In fluids the particles are not, as in solids, invariably connected, but admit of free motion among each other. When, therefore, a fluid particle is disturbed, it acts on

the surrounding particles as on detached masses, and having given up its motion after the manner of one body colliding against another, it comes to rest and continues so till disturbed again by some extraneous cause; in the meantime, the surrounding particles move to assume with respect to it their positions of relative rest; other particles, more remote, partake in turn of this momentary movement; one particle after another comes to rest, and thus, but a single wave, denominated a *pulse*, is transmitted throughout the medium. If, however, instead of abandoning the fluid particle after impressing upon it its primitive motion, it were moved to and fro, like air before a vibrating spring, waves would succeed each other in fluids as in solids, the circumstances of wave recurrence being determined wholly by the action of the disturbing cause.

Pulse.

Wave recurrence dependent on disturbing cause.

Whence we experience the sensation of sound;

Of light;

Of heat.

A wave transmitted through any medium tends to throw the elements of all bodies which it meets in its course into a similar condition of wave motion. When the elements composing the nervous membranes of the ear become involved in certain of these motions, transmitted through the atmosphere or other medium with which the ear is in contact, we experience the sensation of *sound*; when the nerves of the eye partake of a similar class of waving motions conveyed through the ether, we have the sensation of *light*; and when the waves are of that particular character to agitate the surface or cutaneous nerves, the sensation becomes that of *heat*.

#### THE VELOCITY OF SOUND IN AERIFORM BODIES.

§ 17. Now, it is important to distinguish between the rate according to which the disturbance is propagated, and that with which each particle describes its orbit about its place of rest. The first is called the *wave velocity*, the second the *velocity of the wave element*. The first determines the interval of time from the instant of primitive disturbance to that which marks the beginning of motion

Velocity of wave propagation; velocity of a particle. The first determines an interval of time;



of any remote particle; the second, the quantity of action communicated to this particle. The wave is but a *form* or *shape*, occurring, in the regular lapse of time, at places more and more remote from the place of first agitation, as from a centre, while the particles whose relative positions determine this form, never depart from their places of relative rest but by distances which are quite insignificant in comparison with the lengths of the waves. The wave velocity is called the velocity of *sound*, of *light*, of *heat*, or of *electricity*, according to the sense to which the waves address themselves. We now proceed to investigate the velocity of sound, and shall begin with the aeriform bodies, taking the atmosphere first.

The second a quantity of action.  
Wave is a form or shape.  
Excursions of particles very small as compared with a wave length.  
Wave velocity is the velocity of sound, of light, &c.

From the definition of a wave, § 16, it follows that during the time in which the wave element, or single particle *a*, of air, describes one entire revolution in its orbit, the front of the wave will have progressed over the distance *a a'*, equal to a wave length. Denoting therefore, the wave velocity by *V*, the length of the wave *a a'*, by  $\lambda$ , and the time required for an element to make one complete circuit by *t*, we shall have, Mechanics Eq. (2),

Fig. 12.

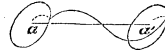

$$V = \frac{\lambda}{t} \dots \dots \dots (1). \text{ Value for wave velocity.}$$

§ 18. The time *t*, is, as we have seen in Mechanics, § 180, independent of the distance of the particle from its place of rest, and is determined by the acceleration due to the intensity of the central force at the distance unity. This intensity, in the case of sound, is the resultant of the antagonistic action of the force of disturbance and that of restitution, and as the latter is always constant for the same medium at the distance unity, or any other given degree of displacement, the value of *t* must result from the character of the disturbing force. Thus when the par-

The time *t*, dependent upon the character of the disturbing force.

ticle  $a$ , is made by any extraneous force to describe a path about its position of rest, the adjacent particles  $b, c, d, e$ , will be thrown into motion, and will only return to their places of departure after  $a$  has been restored by the force of disturbance to its position of rest; and since the

Illustration.

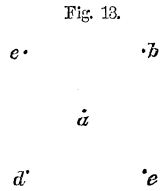

Fig. 13.

places occupied at any instant by the particles  $b, c, d, e$ , depend upon that of the particle  $a$ , the rate of motion of the former particles in their respective orbits, and therefore the value of  $t$ , will be determined by the greater or less rapidity with which  $a$ , is made to move under the action of the disturbing force. The motions of the particles  $b, c, d, e$ , regulate in turn those of the next particles in order, and so on indefinitely, so that the disturbing force regulates the value of  $t$ , for all particles however remote from the primitive agitation at  $a$ .

True for all particles however remote from the primitive agitation.

$V$  independent of the disturbing force.

§ 19. With the value of  $V$  it is not so; this is independent of the disturbing force. We have seen, § 12, that when in a state of relative rest, the elements of any medium are maintained in that condition by the opposing forces of repulsion between adjacent elements, and of attraction between those which are separated by a distance greater than that which determines the furthest limits of corpuscular action. These forces are equal and opposite. Denote the sum of the repulsions of the particles which occupy a unit of surface by  $E$ . Conceive a plane  $AB$ , passed through the medium, and the particles on the side  $X$  to be removed; those distributed over a unit of surface of the opposite side will be pressed against the plane by a force equal to  $E$ , and to keep the plane from moving would require the application of an equal and contrary force. But this

Illustration.

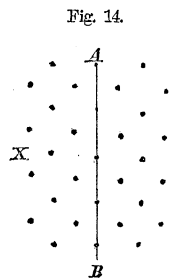

Fig. 14.

force, in the case of the atmosphere, is measured by the weight of a column of mercury whose base is unity, density  $D_{ii}$ , and height  $h$ , or by  $D_{ii} \cdot g \cdot h$ ; whence

$$E = D_{ii} \cdot h \cdot g \dots (2) \text{ Measure of the elastic force of the atmosphere.}$$

The second member measures the Elastic force of the medium.

§ 20. Let  $AB, CD, EF$ , &c., be the positions of several strata of particles of air at rest and of which the molecular forces are in equilibrio; and suppose them surrounded by a tube whose axis is perpendicular to their surfaces. If the stratum  $AB$  be moved by any extraneous cause towards the

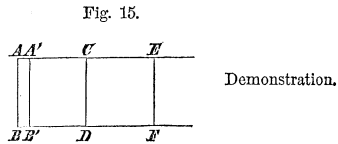

stratum  $CD$ , the latter will move under the action of the increased repulsion between it and the stratum  $AB$ . Suppose the stratum  $AB$  to take the position  $A'B'$ , at the instant the stratum  $CD$  begins to move. The distance  $AA'$ , will, from the views already given of the constitution of a fluid, be indefinitely small.

Denote the distance  $AC$  by  $x$ ;  $A'C$  by  $x_1$ ; and the elastic force exerted by the air in its state of rest on a unit of surface by  $E$ ; then supposing the cross section of the tube uniform, and its area equal to  $a$ , according to Mariotte's law

$$a x_1 : a x :: a E : a E_1 \text{ Mariotte's law.}$$

in which  $E_1$  denotes the elastic force exerted by the air on a unit of surface between  $A'B'$  and  $CD$ ; whence

$$E_1 = E \cdot \frac{x}{x_1} \text{ Elastic force of the compressed air.}$$

The stratum  $CD$  is urged forward by the elastic force

$E'$ , and is opposed by the elastic force  $E'$ ; its motion will therefore be due to

Moving force acting on a stratum;

$$a(E' - E) = a E \frac{x}{x_i} - a E = a E \cdot \frac{x - x_i}{x_i};$$

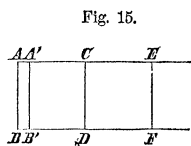

which is the moving force. And denoting the mass of the stratum  $CD$  by  $m$ , the acceleration due to this force, or the velocity generated in a unit of time, will be

Velocity due to this force;

$$\frac{a E}{m} \cdot \frac{x - x_i}{x_i};$$

and the velocity  $v$ , generated in an elementary portion of time  $t$ , equal to that during which the stratum  $AB$  moves to the position  $A'B'$ , will be given by the relation

Velocity in small time  $t$ ;

$$v = \frac{a E}{m} \cdot \frac{x - x_i}{x_i} \cdot t,$$

Velocity imparted to the stratum  $CD$ .

Mechanics § 83, which is obviously the velocity with which the stratum  $CD$  will be thrust from its state of rest, and is analogous to that imparted to a stratum of fluid pressed through an orifice in the bottom of a vessel containing a heavy fluid.

The mass of the stratum  $CD$  will be the same whether we regard it concentrated into the plane  $CD$ , or expanded in both directions half way to the adjacent strata; in which case, its volume would be  $a \cdot x$ , and it would have an actual density equal to the mean density of the whole of the fluid mass; for the same being supposed of all the other strata, the matter of the fluid would become continuous. Denoting the mean density of the air under consideration by  $D$ , we therefore have

Mass of a stratum of air.

$$m = D \cdot a \cdot x$$

which substituted in the above equation, and writing

therein  $x$  for  $x_i$  in the denominator, from which it does not sensibly differ, we have

$$v = \frac{E}{D} \cdot \frac{x - x_i}{x} \cdot \frac{t}{x} \quad \text{Velocity imparted to stratum } CD;$$

Now at the end of the time  $t$ , the stratum  $AB$  has reached the position  $A'B'$ , and the stratum  $CD$  begins to move; that is to say, the disturbance has been propagated over the distance from  $A$  to  $C = x$ , in the time  $t$ . Hence, denoting the velocity of this propagation, which is that of the wave motion, by  $V$ , we have

$$V = \frac{x}{t},$$

or

$$\frac{t}{x} = \frac{1}{V};$$

this in the last equation gives

$$v = \frac{E}{D \cdot V} \cdot \frac{x - x_i}{x} \dots \dots \dots (2)' \quad \text{Molecular velocity;}$$

which may be written

$$V \cdot v \cdot \frac{x}{x - x_i} = \frac{E}{D}.$$

Here  $V$ , is the wave velocity and  $v$ , the actual velocity of a stratum of air, and for the indefinitely small time  $t$ , these may be regarded as constant; but the spaces  $x$  and  $x - x_i$  are described with these velocities in the same time, and hence

$$x - x_i : x :: v : V$$

whence

$$v = V \cdot \frac{x - x_i}{x} \quad \text{The same in other terms;}$$

and this substituted above gives

$$V^2 = \frac{E}{D}$$

therefore

Wave velocity.

$$V = \sqrt{\frac{E}{D}} \dots \dots \dots (3)$$

whence we see, that *the wave velocity in the same medium, at a constant temperature and under a constant pressure, will be constant*, being equal to the square root of the ratio obtained by dividing the elastic force of the medium by its density. Replacing  $E$  by its value as given in Eq. (2), the above reduces to

Same in other terms;

$$V = \sqrt{g \cdot h \cdot \frac{D_{II}}{D}} \dots \dots \dots (4).$$

§ 21. The density  $D$ , of the atmosphere or any other elastic medium, corresponding to any barometric column  $h$ , and temperature  $t$ , is given by Equation (240)' Mechanics; that is, by

Atmospheric density;

$$D = \frac{D_I}{30^{\text{in}}} \cdot \frac{h}{1 + (t - 32^\circ) \cdot 0,00208}$$

and this substituted in equation (4), for  $D$ , gives

Wave velocity for given temperature and pressure.

$$V = \sqrt{g \cdot 30^{\text{in}} \cdot \frac{D_{II}}{D_I} \cdot [1 + (t - 32^\circ) \cdot 0,00208]} \dots (5).$$

in which  $D_{II}$  denotes the density of mercury, and  $D_I$  that of the atmosphere at  $32^\circ$  Fah., the atmosphere being under a pressure of 30 inches of mercury.

Barometric height.

§ 22. The quantity  $h$ , does not appear in Equation (5); from which we are to infer that the velocity is indepen-

dent of the atmospheric pressure, as it should be ; for, an increase of pressure will increase the elastic force  $E$ ; but this will increase the density  $D$ , in the same ratio, so that, Equation (3), the velocity should remain unchanged. But an increase of temperature under a constant pressure dilates the air, and therefore reduces  $D$  for the same value of  $E$ . Hence, all other things being equal, the velocity of sound should be greater in warm than in cold air ; greater in summer than in winter, and this is what is indicated by the quantity  $t$ , in Equation (5).

Velocity of sound independent of atmospheric pressure;

Velocity greater in warm weather than in cold.

§ 23. If in Equation (5) we make  $t = 32^\circ$ , we find

$$V = \sqrt{g \cdot 30 \cdot \frac{D_{in.}}{D}} \dots \dots (6).$$

The density of distilled mercury at  $32^\circ$  Fah. is, Mechanics, § 275, equal to 13,598, and that of air at the same temperature, and under a pressure of 30 inches = 2.5, of mercury is 0,001304 ; and the mean value of  $g$  is, Mechanics, § 72, Eq. (22), equal to 32,1808, which values in Equation (6) give

Tabular values for the above data.

$$V = \sqrt{32,1808 \cdot 2,5 \cdot \frac{13,598}{0,0013}} = 915,69 \dots \dots (6)'$$

Velocity of sound without increase of temperature.

which would be the velocity of sound in our atmosphere under a pressure of 30 inches of mercury and at the temperature of freezing water, were it separated from admixture with all other media.

§ 24. But it must be remarked that the value of  $E$ , in Equation (3), which is one of the important elements of this estimate, is assumed to be given by the weight due to the height of the mercurial column. Now, this only measures the pressure due to the grosser elements of atmospheric air, and takes no account whatever of the elasticity

Increase of temperature; or ethereal vibration, produced by sonorous waves.

Elasticity due to the ether.

due to that vastly more subtle and refined atmosphere of ether which permeates the air, glass, and torricellian vacuum, and which, therefore, presses alike on both ends of the barometric column. A motion among the atmospheric strata will give rise to a similar motion in this ether; the equality in its elasticity on opposite sides of the strata in the direction of the motion will be disturbed; this inequality will develop a reciprocal action among the strata of ether and those of the atmosphere itself; hence,  $E$ , in Eq. (3), is too small, and consequently  $V$ , is also too small.

Denote by  $K$ , a constant co-efficient which, when multiplied into  $E$ , as indicated by the barometer, will give the true elastic force as it actually exists; then will Equation (5) become

Corrected value for velocity.

$$V = \sqrt{g \cdot 30 \cdot \frac{D''}{D'} \cdot K \cdot [1 + (t - 32^\circ) \cdot 0,00208]} \dots (7).$$

or, replacing the value of the first three factors as given by Equation (6)',

Velocity as affected by ethereal waves, or increase of temperature. Co-efficient of barometric elasticity,  $K$ .

$$V = 915,69 \cdot \sqrt{K \cdot (1 + (t - 32^\circ) \cdot 0,00208)} \dots (7)'$$

The quantity  $K$ , may be called the *co-efficient of barometric elasticity of the air*.

To find the constant  $K$ ,  $V$ , must be known.

§ 25. To find the value of  $V$ , corresponding to any temperature  $t$ , it will be first necessary to know that of  $K$ . But  $K$ , being constant, if the value of  $V$  be found for any particular state of the air, that of  $K$ , will result from equation (7)'.

$V$ , affected by wind;

The velocity  $V$ , is the rate of travel of the front of the wave from a disturbed particle of air taken as an origin. When the wind blows, the whole mass of air, and there-



fore this origin, has a motion of translation; and to find  $V$  experimentally, the observations should be so conducted as to eliminate the disturbing effect of the wind.

To understand how this may be done, suppose an observer placed at  $A$ , midway between two stations  $B$  and  $C$ , and the wind to blow from  $B$  to  $C$ . Denote the velocity of the wind by  $v$ ; then will the velocity with which sound will travel from  $B$  to  $A$ , be  $V + v$ , and from  $C$  to  $A$ , it will be  $V - v$ , the mean of which is obviously  $V$ .

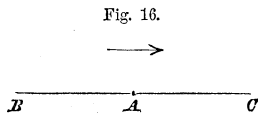

To eliminate therefore the effect of the wind, let four remote stations  $B, C, D, E$ , be so chosen that the line connecting  $C$  and  $B$ , shall be perpendicular, or nearly so, to that joining  $E$  and  $D$ , and place an observer at the intersection  $A$ . At the stations  $B, D, C, E$ , let signal guns be fired in succession, and the observer at  $A$  note, by a stop watch, the intervals of time between his seeing the flash and hearing the report. The distances from  $A$ , being carefully measured and each divided by the corresponding interval in seconds, will give a value for  $V$ . The mean of these values and the reading of the thermometer, which must also be noted, being substituted in Eq. (7)', the value of  $K$  will result.

The experiments of MOLL, VANBEEK and KUYTEN-BROUWER, performed in 1823, over a distance of 57839 feet, in a dry atmosphere, at the temperature of 32° Fahr., gave a mean value of  $V = 1089,42$  English feet. These values substituted in Equation (7)' give

$$K = \frac{(1089,42)^2}{(915,69)^2} = 1,4154.$$

which in Eq. (7)' gives the general value of

$$V = 1089,42 \sqrt{1 + (t - 32^\circ) \cdot 0,00208} \dots \dots (8).$$

To find  $V$  experimentally;

Effect of wind eliminated;

Experiments performed;

Resulting value of  $K$ .

Final value of the velocity  $V$ .

Principle of heat.

§ 26. This vibratory motion among the elements of ether, giving rise to a secondary system of waves, by which the propagation of sound is accelerated, constitutes the principle of *heat*. And to ascertain to what degree a Fahrenheit thermometer would be affected were it suddenly transferred from a perfectly stagnant atmosphere to one agitated by sound waves, could the mercury take instantaneously the bulk which would enable its ether to vibrate in unison with that of the sound wave, it would only be necessary to find the value of  $t - 32^\circ$ , in Equation (5), after substituting for  $V$  and  $\sqrt{g \cdot h \frac{D}{D'}}$ , their respective values 1089,42 and 915,69. Solving the equation with reference to  $t - 32^\circ$ , and introducing these values, we find,

Amount of latent heat rendered free.

$$t - 32^\circ = \frac{1}{0,00208} \left[ \left( \frac{1089,42}{915,69} \right)^2 - 1 \right] = 199,71.$$

Difference between computed and observed velocity explained.

This is called the amount of heat given out by an element of air during its condensation in a sound wave. It was to the increased elasticity imparted to air by this sudden change of a portion of its heat from *latent* to *free*, that Laplace first attributed the great disparity between the computed and observed velocity of sound.

Effect on the stratum  $CD$  resumed.

§ 27. Before proceeding further we must remark, that nothing has been said of the conduct of the stratum  $CD$ , after it was impelled forward from its place of relative rest by the action of the stratum  $AB$ , which was brought by the disturbing cause, say the motion of a rigid plane, to the position  $A'B'$ .

Fig. 15.

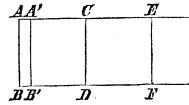

Two cases may arise;

Two cases may occur: either the stratum  $AB$  may be retained in the position  $A'B'$ , or the disturbing plane may, by an opposite movement, leave this stratum unsupported from behind. In the first case, if the medium be

First case;

homogeneous, the masses of all its particles will be equal, and the velocity impressed upon those in the stratum  $CD$  will, by the principle of the collision of elastic masses, be transferred undiminished to those in the stratum  $EF$ , after which the stratum  $CD$  will come to rest; and the same of the succeeding strata in front: Mechanics, § 247; so that there will simply be a pulse, transmitted along the direction in which the primitive disturbance acted. In the second case, the stratum  $A'B'$ , being left unsupported from behind, by reason of rarefaction, will be thrust backward by the superior elasticity of the medium in front, and this return or backward motion will take place in all the strata in front, in the same order of time and distance from the original disturbance as in the instance of the forward movement; so that a second pulse will be transmitted in the same direction as before, only differing from the first in the backward motion among the particles.

In first case a single pulse transmitted in the direction of the disturbance;

In the second case another pulse also transmitted in the same direction.

§ 28. It is easy from the known velocity of sound, to compute the distance between two places which may be seen, the one from the other; and for this purpose let a gun be fired at one place, and the interval of time between seeing the flash and hearing the report at the other be carefully noted. This interval, expressed in seconds, multiplied by  $1089,42 \sqrt{1 + (t - 32^\circ).0,00208}$ , will give the distance expressed in English feet. The value of  $t$  will be given by the Fahr. thermometer.

Distances computed by the velocity of sound;

Method explained.

Accuracy slightly affected by wind;

The accuracy of this determination will of course be affected by the wind, should it be blowing at the time. To ascertain the probable amount of this influence, let  $A$  be a station midway between the places  $B$  and  $C$ , and suppose the wind to be blowing from  $B$  to  $C$ , with

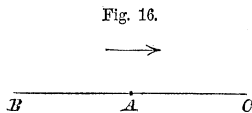

a velocity denoted by  $v$ ; denote the distance  $BA = CA$  by  $S$ , then will the actual velocity of sound from  $B$  to  $A$ , be  $V + v$ , and from  $C$  to  $A$ , be  $V - v$ ; and the intervals

Influence of wind determined;

of time observed at *A*, between the flash and report from *B* and *C*, will be, respectively,

Intervals of time  $\frac{S}{V + v}$ , and  $\frac{S}{V - v}$ .

or developing these expressions,

First interval;  $t_1 = \frac{S}{V} \left[ 1 - \frac{v}{V} + \frac{v^2}{V^2} - \&c. \right]$ ,

Second interval;  $t_2 = \frac{S}{V} \left[ 1 + \frac{v}{V} + \frac{v^2}{V^2} + \&c. \right]$ ;

Now, the most violent hurricane moves at a rate less than one-tenth that of sound; so that the neglect of the terms involving  $v^2$ , would in the worst case only involve an error less than  $\frac{1}{9}$ th, and in the ordinary cases likely to be selected for experiment their influence would be quite inappreciable. Neglecting these terms, we see that one of these intervals will be just as much too great as the other is too small, and the true interval, denoted by *t*, will be a mean between them. Hence,

True interval;  $t = \frac{t_1 + t_2}{2} = \frac{S}{V}$ ,

OR

Resulting formula for distance.

$S = V \cdot t \dots \dots \dots (9)$ .

Example.

*Example.* On the occasion of firing a salute of 13 minute guns at Newburgh, the mean of the intervals between noting the flash of each gun and hearing the report at West Point, N. Y., was 36,2 seconds; and the temperature of the air, as given by a Fahr. thermometer, was 76°; required the distance from West Point to Newburgh.

Distance from West Point to Newburgh.

$S = t \cdot V = 36,2 \cdot 1089,42 \sqrt{1 + (76^\circ - 32^\circ) \cdot 0,00208}$

$$S = 36,2^s \cdot 1089,42 \sqrt{1,0915}$$

and by logarithms :

36,2 . . . . .	1,5587086		Computation.
1089,42 . . . . .	3,0371954		
1,0915, ( $\frac{1}{2}$ ), . . . . .	<u>0,0190118</u>		
41,202 feet. . . . .	4,6149158		
5280, feet in 1 mile, ac. . . . .	<u>6,2773661</u>		
7,8034 miles, . . . . .	<u>0,8922819</u>		

§ 29. We have seen that the velocity of sound through the air is independent of the barometric pressure, and experiments show it to be sensibly unaffected by its hygrometrical state of moisture and dryness; the actual weather characterised by fog, rain, snow, sunshine; the nature of the sound itself, whether produced by a blow, gunshot, the voice or musical instrument; the original direction of the sound, whether the muzzle of the gun is turned one way or the other; the nature and position of the ground over which the sound is conveyed, whether smooth or rough, horizontal or sloping, moist or dry.

Velocity independent of disturbing cause, state of the atmosphere, nature of the ground, &c.

§ 30. Resuming Eq. (7), and denoting by  $V'$  and  $V''$  the velocities of sound through any two gases whatever, by  $K'$  and  $K''$  their co-efficients of barometric elasticity, and by  $D'$  and  $D''$  their densities; then, supposing the barometric column exposed to the pressures of the gases to be 30 inches, and the temperature of the gases to be the same and equal to  $t$  degrees, will, Eq. (7), give

Velocity of sound in two gases;

$$V' = \sqrt{g \cdot 30^{in} \cdot \frac{D''}{D'} \cdot K' [1 + (t - 32^\circ) \cdot 0,00208]}$$

Value in first;

and

$$V'' = \sqrt{g \cdot 30^{in} \cdot \frac{D''}{D''} \cdot K'' [1 + (t - 32^\circ) \cdot 0,00208]}$$

Value in second;

Dividing the first by the second, we have

Velocities compared.

$$\frac{V'}{V''} = \sqrt{\frac{K'}{K''} \cdot \frac{D''}{D'}} \dots \dots (10).$$

Conclusion.

That is, the velocities of sound in any two gases, at the same temperature, are to each other as the square roots of their coefficients of barometric elasticities directly, and densities inversely.

From Equation (10) we readily obtain

$$\frac{K'}{K''} = \frac{V'^2}{V''^2} \cdot \frac{D'}{D''} \dots \dots (11).$$

Atmospheric air and hydrogen;

Taking one of the gases atmospheric air, and the other hydrogen, and assuming the velocity of sound in hydrogen, as determined by the experiments of VAN REES, FRAMMEYER and MOLL, to wit, 2999,4 English feet, we have, after substituting the known values of the quantities in the second member,

Ratio of their constant coefficients;

$$\frac{K'}{K''} = \left( \frac{2999,4}{1089,42} \right)^2 \cdot 0,0688 = 0,5215.$$

Inference;

Hence the coefficient of barometric elasticity of air is nearly double that of hydrogen; a result which appears to indicate that the velocity with which sound is propagated through gases is in some way dependent upon their *chemical* or *physical* constitution. This would seem but the natural consequence of the views of Boscovich.

Conforms to Boscovich's theory.

### VELOCITY OF SOUND IN LIQUIDS.

Experiments on liquids.

§ 31. From the experiments of CANTON, OERSTED, and others, liquids as well as gases are found to be both com-

pressible and elastic ; and are therefore fit media for the transmission of sound. From the experiments of COLLADON and STURM, on what may be regarded as pure water, SIR JOHN HERSCHEL deduces the compression of this fluid, by one standard atmosphere, to be  $0,000049589 = e$ ; that is to say, an increase of pressure equal to that arising from a column of mercury having an altitude of 30 inches and temperature of  $32^{\circ}$  Fahr., will produce a diminution in the bulk of water equal to  $\frac{49589}{10000000000}$  of the entire volume which it had before this increase.

Experiments on pure water;

Deduction.

§ 32. The quotient  $e$ , arising from dividing the diminution of volume, produced by the pressure of a standard atmosphere, by the entire volume before the compression, is the *measure of compressibility*.

Measure of compressibility.

§ 33. The quotient obtained by dividing the compressing force, by the degree of compression, when not accompanied by a permanent change in the molecular arrangement of any body, is the measure of the *body's elastic force*. Denoting by  $B$ , the standard barometric pressure, the elastic force  $E$ , will be given by  $E = \frac{B}{e}$ .

Measure of elastic force.

§ 34. Let  $AB$ , and  $CD$ , be two consecutive strata of water, and suppose the stratum  $AB$ , to have been suddenly moved by some disturbing cause to the position  $A'B'$ . Denote the distance  $BD$  by  $x$ , and  $B'D$  by  $x_1$ , then, regarding the area of the stratum as unity, will the difference of volume between  $ABCD$  and  $A'B'CD$ , be represented by  $x - x_1$ , and the degree of compression referred to the original volume, by

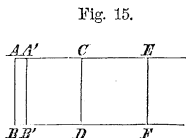

Fig. 15.

Illustration ;

$$\frac{x - x_1}{x}$$

Degree of compression;

Compressing  
force;

and the force  $E_i$ , necessary to produce this compression will, § 4, be given by the proportion

$$e : \frac{x - x_i}{x} :: B : E_i$$

in which  $B = g \cdot D_{ii} \cdot h$ , denotes the pressure due to a standard atmosphere, being the weight of a column of mercury whose density is  $D_{ii}$  and height  $h$ . Whence

Its value,

$$E_i = \frac{B}{e} \cdot \frac{x - x_i}{x} .$$

Combined  
pressure on a  
stratum below  
the surface;

But any stratum of water situated below the surface is already subjected to the pressure of the atmosphere, and that arising from the weight of the column of the same fluid above it. Denoting this combined pressure by  $p$ , we shall have the stratum  $A'B'$ , and therefore  $CD$ , since the resistance to compression arises from the reaction of the latter, urged forward toward  $EF$ , by  $E_i + p$ ; but the motion of  $CD$  is resisted by the pressure  $p$ , whence the moving force becomes  $E_i + p - p = E_i$ . The mass of the stratum  $CD$  will, § 20, be

Moving force on  
a stratum;

$$D \cdot \omega$$

Mass of a  
stratum;

whence the acceleration due to the moving force, or the velocity generated in a unit of time, becomes, after substitution for  $B$ , its value,

Velocity  
generated in a  
unit of time;

$$\frac{E_i}{Dx} = \frac{g \cdot h \cdot D_{ii}}{e \cdot D} \cdot \frac{1}{x} \cdot \frac{x - x_i}{x} .$$

Velocity in an  
elementary  
portion of time.

and the velocity  $v$ , imparted to the stratum  $CD$ , in an elementary portion of time  $t$ , will be given, Mechanics, Eq. (9), by the equation



$$v = \frac{g \cdot h \cdot D_{11}}{e \cdot D} \cdot \frac{t}{x} \cdot \frac{x - x_1}{x}$$

Its value;

but, § 20,

$$\frac{t}{x} = \frac{1}{V}, \text{ and } \frac{v}{V} = \frac{x - x_1}{x},$$

which substituted above gives, § 33, after clearing the fraction and extracting the square root,

$$V = \sqrt{\frac{g \cdot h \cdot D_{11}}{e \cdot D}} = \sqrt{\frac{E}{D}} \dots \dots \dots (12) \quad \text{Wave velocity in water;}$$

and substituting the numerical values of  $g = 32^f, 1808$ ;  $h = 30^m = 2,5$ ;  $D_{11} = 13,598$ ; and denoting by  $K$ , what we have before termed the co-efficient of barometric elasticity, we finally have

Numerical values of data;

$$V = \sqrt{\frac{32,1808 \cdot 2,5 \cdot 13,598}{0,000049589 \cdot D}} \cdot K = 4696,86 \sqrt{\frac{K}{D}} \quad (13) \quad \text{Resulting wave velocity;}$$

in which  $D$  must be taken from the table given in § 272, Mechanics, corresponding to the temperature of the water. If the temperature of the water be  $38^{\circ}, 75$  Fahr.  $D$  will be unity, and if we assume  $K = 1$ , then will

$$V = 4696,86.$$

Velocity when density and constant coefficient are each equal to unity.

§ 35. A careful and doubtless most exact experimental determination of the velocity of sound in water was made in 1826, by M. COLLADON. After trying various means for the production of sound under water, he adopted the bell, as giving the most instantaneous and intense sound, the blow being struck about a yard below the surface by means of a metallic lever. The experiments were made

Experiments of Colladon;

Explanation; at night, the better to avoid the interference from extraneous sounds, and to enable him to see the flash of gunpowder which was fired simultaneously with the blow. To receive the sound from the water and convey it to the ear, a thin cylinder of tin, about three yards long and eight inches in diameter, was plunged vertically into the water, the lower end being closed and the upper end, to which the ear was applied, open to the air. By means of this arrangement he was enabled to hear the strokes of the bell under water across the entire width of the Lake of Geneva from Rolle to Thonon, a distance of about nine miles.

Mean of intervals; § 36. From 44 observations, made on three different days, it appears that the distance of 44249,3 feet was traversed in 9,4 seconds, this being the mean of the intervals between the instant of seeing the flash and receiving the sound at the cylinder, the greatest deviation from which of any single observation not exceeding three-tenths of a second; which gives

Velocity of sound in water; 
$$V = \frac{44249,3}{9,4} = 4707,4 \dots \dots (14)$$

Four times as great as in air. thus making the velocity of sound in water more than four times as great as in air.

Experimental determination of the constant  $K$  for water; § 37. The mean temperature of the water, taken at both stations and midway between them, was 46°,6 Fahr. and its specific gravity was found to be exactly that of distilled water at its maximum density, viz.: unity, the expansion arising from the excess of temperature being just counterbalanced by the superior density due to the saline contents. This circumstance furnishes at once the means of finding the numerical value of the coefficient  $K$ ; for by making  $D=1$ , in equation (13), and equating the resulting value of  $V$ , and that given above, we have

$$K = \left( \frac{4707,40}{4696,86} \right)^2 = 1,00449,$$

Value of  $K$ ;

which differs but little from unity, and from which we infer that there is but little heat developed in the transmission of sound through water. And the experiments hitherto made indicate that this is also true of other liquids. To find the velocity of sound in any liquid it will only be necessary to know its compressibility. A valuable table of the compressibility of different liquids is given by Sir JOHN HERSHEY, in his Treatise on Sound, Encyc. Met., Vol. 1, p. 770.

Inference with regard to liquids.

§ 38. In these experiments of M. COLLADON, it was found that the sound of the bell when struck under water if heard at a distance had no resemblance to its sound in air. Instead of a continued tone, a short sharp sound was heard like two knife blades struck together; it was only within the distance of about six hundred yards that the tone of the bell could be distinguished.

Different tones of sound in water and air.

§ 39. M. COLLADON also found that sound in water does not, like sound in the air, spread round the corners of interposed obstacles. In air, a listener situated behind a projecting wall or corner of a building, hears distinctly, and often with very little diminution of intensity, sounds excited beyond it. But in water this was far from being the case. When the tin cylinder, or hearing tube, before mentioned, was plunged into water at a place screened from rectilinear communication with the bell, by a wall running out from the shore, and whose top rose above the water, a very remarkable diminution of intensity was heard in comparison with that observed at a point equally distant from but in direct communication with, the bell, or "out of the *acoustic shadow*."

Sound in water not audible around corners as in air.

The reason of this apparently singular phenomenon will appear further on.

Acoustic shadow.

## VELOCITY OF SOUND IN SOLIDS.

Solids propagate sound better than gases or liquids;

Same formula employed;

Difference in structure of solids and liquids;

Consequences of this difference;

Solids differ from each other in molecular arrangement;

Effect upon the velocity of sound.

§ 40. Solids, when elastic, are even better adapted for the transmission of sounds than gases or liquids. But for this purpose, they should be homogeneous in substance and uniform in structure. The general principle upon which the propagation of sound through solids depends is the same as in liquids; and the same formula, Eq. (12), may be employed when the intensity of the specific elastic force  $\frac{B}{e}$ , § 33, of the solid is known. There are, however, two very important particulars in which they differ. First, the molecules of liquids admit of a permanent change of relative position among themselves; those of a solid are, on the other hand, as before remarked, § 16, subjected to the condition of never permanently altering their relative arrangements without altering their physical character. Second, each particle of a liquid is similarly related to those around it in all directions; while every particle of a solid has distinct sides and different relations to space and surrounding particles. Hence arise a multitude of qualifying circumstances, which modify the propagation of sonorous waves through solids, which have no place in liquids, and peculiarities of wave motion become, therefore, possible in the former which are impossible in the latter.

§ 41. Solids differ much among themselves in the particulars here referred to. Thus, the cohesion of the particles of crystallised bodies differs greatly on their different sides, as the facility with which they admit of cleavage in some directions and not in others, shows. They have different elastic forces in different directions, and thus the velocity of sound through them must depend, Eq. (12), upon the direction in which the sound is transmitted. A disturbed particle in a perfectly homo-

geneous medium becomes the centre of a series of concentric spherical waves which proceed outwards with equal velocities in all directions. But if the elastic force and density of the medium vary in different directions from the place of disturbance, Equation (12), shows that the shape of the wave front will no longer be spherical. It will be elongated or drawn out in the direction along which the elastic force is greatest and density least, and conversely. Like effects will arise when the elasticity and density both increase or decrease, but unequally.

Medium not homogeneous;

Wave front not spherical;

§ 42. Thus, conceive a solid whose density, estimated in the direction  $AC$ , is represented by  $D_1$ , and in the direction  $AB$  by  $D_1(1+c)$ ; and suppose the density to vary gradually from one of these directions to the other, and the law of this variation to be expressed by

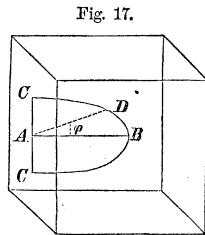

Illustration;

$$D = D_1(1 + c \cdot \cos \phi), \dots \dots (15)$$

Intermediate density;

in which  $D$  denotes the density in any intermediate direction as  $AD$ , and  $\phi$  the angle which that direction makes with that of greatest density or with  $AB$ . Also, let the elastic force in the direction  $AC$  be  $E_1$ , and that in the direction  $AB$ , be measured by

$$\frac{E_1}{1 - c};$$

Elastic force in direction of greatest density;

and suppose the elastic force, denoted by  $E$ , in the intermediate direction  $AD$ , to be given by the relation

$$E = \frac{E_1}{1 - c \cdot \cos \phi} \dots \dots (16)$$

Same in intermediate direction.

Dividing Eq. (16), by Eq. (15), we find

Ratio of intermediate density and elastic force;

$$\frac{E}{D} = \frac{E_i}{D_i} \cdot \frac{1}{1 - c^2 \cdot \cos^2 \phi}$$

and substituting this in Equation (12), and replacing  $V$  by its measure  $r$ , the space passed over in a unit of time by the front of the wave, we have

Radius vector of wave front;

$$r = \sqrt{\frac{E_i}{D_i(1 - c^2 \cdot \cos^2 \phi)}} \dots \dots (17).$$

Wave front Ellipsoidal.

This, since all the factors except  $1 - c^2 \cdot \cos^2 \phi$ , are constant, is the polar equation of an ellipse referred to its centre as an origin; so that the shape of the wave front is ellipsoidal.

Velocity of sound in various solids.

§ 43. By a series of experiments similar in principle to those already referred to, and which it is unnecessary to detail, it is found that the following are the velocities of sound in different solids, that in air being taken as unity, viz.: Tin =  $7\frac{1}{2}$ ; Silver = 9; Copper = 12; Iron (steel?) = 17; Glass = 17; Baked Clay (porcelain?) = 10 to 12; Woods of various species = 11 to 17.

Duplication of sound.

It was found by HERHOLD and RAFFR, that when a metallic wire 600 feet long, stretched horizontally and held at one end between the teeth, was struck at the other, two distinct sounds were heard; the one transmitted through the wire, teeth and solid materials of the head, to the auditory nerves, the other through the air. A similar duplication of sound was observed by HASSENFRATS and GAY LUSSAC from a blow struck with a hammer against the solid rocks in the quarries of Paris; that propagated through the rock arriving almost instantly, while that transmitted by the air lagged behind.

§ 44. From this it is easy to estimate the time required

to transmit the effect of a force applied at one end of a solid, or arrangement of solids, to the other. In iron, for instance, the effect of a push, pull or blow, will be propagated towards its point of action at the rate of 11090 feet a second after its first emanation from the motor. For all moderate distances, therefore, the interval is utterly insensible. But Sir JOHN HERSHEY remarks, that if the sun were connected with the earth by an iron bar, no less than 1074 days, or nearly three years, must elapse before the effect of a force applied at the former body could reach the latter. Yet the force actually exerted by the mutual gravity of the sun and earth may be proved to require no appreciable time for its transmission.

Time required to transmit the effect of a force.

Examples ;

Sun and earth.

#### PITCH, INTENSITY AND QUALITY OF SOUND.

§ 45. We have seen that the velocity of sound, in the same homogeneous medium, is constant; and that the particles in any one wave, or set of waves, arising from the same disturbance, all perform their revolutions in equal times. And hence, Equation (1), the waves flowing from the same agitating cause are of the same length, no matter to what distance they may have been transmitted. This length of wave, Equation (1), varies directly as the time of revolution of a single particle. In proportion as this time is shorter, so will the wave be shorter, and in proportion as it is longer, will the wave be longer. And since the particles of the auditory nerves vibrate in harmony with those of the waves which agitate them, the number of recurrences of the same condition of these nerves, in a given time, will depend upon the length of the waves. The greater or less number of these recurrences determines the character of the sound; in proportion as this number is greater will the sound be less grave or more acute, and in proportion as it is less, will the sound be less acute or more grave. This particular character of

Velocity constant in a homogeneous medium;

Wave length independent of position;

But varies directly as the time of revolution of a particle.

Acute and grave sounds.

Pitch.	sound by which it is pronounced to be grave or acute, more grave or more acute, is called the <i>Pitch</i> .
Time of revolution of a particle depends on disturbing cause.	The time of vibration of a single particle in any wave depends, §18, upon the disturbing cause. The waves projected through the air by the sluggish vibrations of the coarse and heavy strings of the largest violins, called " <i>double bass</i> ," are, therefore, long, and the corresponding sound is grave; while the waves produced by the more rapid vibrations of the fine and tense strings of the violin proper, are shorter, and the sound is acute. In the latter case the pitch is high; in the former low; and hence the terms high and low notes in musical instruments.
Short and long waves;	
High and low notes.	
Wave length independent of excursions of particles;	§ 46. A wave being once excited, the time of vibration of any one of its particles, and therefore the length of the wave itself, becomes wholly independent of the distance to which the particle may recede from its place of relative rest. But, in order that the time may not vary, those particles must move at the greatest rate which make the greatest excursions. Hence, there may exist many waves of the same length while the particles of one possess very different velocities from those of another. The quantity of action in each particle being equal to half of its living force, or equal to half the product of its mass by the square of its velocity, the particles of air in these different waves will assail the auditory nerves with very different efforts; and this it is which constitutes the distinction we observe between two sounds of the same pitch possessing different degrees of <i>intensity</i> , or, as it is usually expressed, different degrees of <i>loudness</i> . Thus, when the string of a violin or of a piano is drawn aside and abandoned to itself, it will vibrate about its position of equilibrium for some time, and finally come to rest. The sound, which at first is loud, gradually dies away, and ultimately ceases. But we only hear one constant pitch as long as the string moves bodily to and fro. It is easily shown that the time of each vibration of the string is the same from the beginning to the end of the
Waves may be equal in length while the particles have different velocities;	
Quantity of action in particles different;	
Intensity or loudness;	
Examples, violin, piano.	



motion; the lengths of the sonorous waves impressed upon the air must, therefore, be invariable, and hence the constancy of pitch. On the contrary, the distance by which the string departs from its place of rest in each vibration, gradually diminishes, and so does that of the aerial particles, whose motions are regulated by those of the string; this explains the gradual decay of the sound.

§ 47. Sounds may have the same pitch and intensity and yet be very different. We never confound, for example, the sound of a trumpet with that of a violin, notwithstanding these sounds may have the same degree of acuteness and loudness. And this fact gives rise to a distinction of *quality*.

Thus far nothing has been said of the peculiarities which mark the mode of vibration of the elements of a sonorous wave; whether, for instance, the particles describe elliptical, circular, or rectilinear orbits; whether the planes of these orbits are perpendicular, inclined, or parallel to the direction of the wave propagation. Nor has it been necessary to discuss these particulars, since the velocity, pitch and intensity are wholly independent of these considerations. But while the amplitude and time of vibration of the particles of the auditory nerves, induced by different sonorous waves, may be the same, thus inducing a constant intensity and pitch, yet the corresponding sensations may derive a peculiarity of hue, so to speak, from the variations in the mode of molecular motions above referred to, sufficient to account for the distinction of quality.

§ 48. To ascertain what length of wave corresponds to our sensation of a particular pitch, we must have the means of measuring the lengths of different waves. These are furnished in an elegant little instrument called the *Siren*; a device of Baron COGNIARD DE LA TOUR. In this instrument the wind of a bellows is emitted through

Siren;

a small hollow tube *A*, before the end of which a circular disc *B*, pierced with a number of equal and equidistant holes arranged in the circumference of a circle concentric with the axis of motion *C*, is made to revolve. The

Fig. 18.

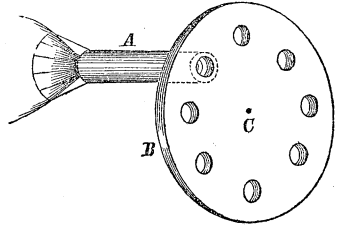

Construction and use explained;

the tube through which the air passes is so situated that the holes in the disc shall pass in rapid succession over its open end and permit the air to escape, being at the same time so near to the plane of the disc that intervals between the holes serve as a cover to intercept the air. If the holes be pierced obliquely, the action of the current of air alone will be sufficient to put the disc in motion; if perpendicular to the surface it must be moved by wheel work, so contrived as to accelerate or retard the rotation at pleasure. The bellows being inflated and the disc put in motion, a series of rapid impulses are communicated to the air in front of the holes; and, when the rotation is sufficiently rapid, a musical tone is produced whose pitch becomes more acute in proportion as the velocity of rotation increases. To show that the air of the bellows only acts as a mass in motion to impress by its living force successive blows upon the external air, the bellows may be replaced by a reservoir of water, the liquid being under sufficient head to cause it to spout through the holes of the disc as they come successively in front of the duct pipe; the effect is the same.

Bellows may be replaced by a reservoir of water;

Connected with the axis of rotation of the disc are a stop-register, which indicates the number of revolutions, and a stop-watch, to mark the time in which these revolutions are actually performed. The instrument being put in motion and accelerated to the desired pitch, the register and watch are relieved from the stops, and after

Stop-register and stop-watch;

the sound has continued for any desired length of time, Reading of the dial plates noted; the stops are again interposed, and a simple inspection of the dial plates of the watch and register will give the time and number of revolutions.

Now, suppose the disc to be pierced with  $m$  holes, the number of revolutions to be  $n$ , and the number of seconds to be  $T$ . The number of impulses, and therefore the number of waves, will be  $m \cdot n$ ; and the number of waves produced in one second will be

$$\frac{m \cdot n}{T} \cdot \quad \text{Number of waves in one second;}$$

But these waves, generated in one second, occupy the entire distance denoted by  $V$ , the velocity of sound; and hence, denoting by  $\lambda$ , the wave length, we have the relation, Equation (8),

$$\frac{m \cdot n}{T} \cdot \lambda = V = 1089,42 \cdot \sqrt{1 + (t - 32^\circ) \cdot 0,00208}. \quad \text{Formula;}$$

whence,

$$\lambda = \frac{1089,42 \cdot T \cdot \sqrt{1 + (t - 32^\circ) \cdot 0,00208}}{m \cdot n} \dots (18). \quad \text{Value for wave length.}$$

*Example.* Suppose the revolving disc to be pierced with Example; 100 holes, the time of rotation 20 seconds, the number of revolutions in this time 102,4, and the temperature of the air  $84^\circ$  Fahr. Then will

$$m = 100; n = 102,4; T = 20^\circ; t = 84^\circ,$$

which in Equation (18), give

$$\lambda = \frac{1089,42 \cdot 20 \cdot \sqrt{1 + 52 \cdot 0,00208}}{100 \cdot 102,4} = 2,24 \quad \text{Value of } \lambda.$$

Results of experiments;

thus making the length of the wave two and a quarter English feet, nearly.

The results of the experimental researches of M. Bior, on this subject, are given in the following table :

		Number of vibrations in one second.	Length of resulting wave in English feet.
Table.	}	1 . . . . .	1091,34
		2 . . . . .	545,67
		4 . . . . .	272,83
		32 . . . . .	34,10
		64 . . . . .	17,05
		128 . . . . .	8,52
		256 . . . . .	4,26
		512 . . . . .	2,13
		1024 . . . . .	1,06
		2048 . . . . .	0,53
		4096 . . . . .	0,26
		8192 . . . . .	0,13

Lowest audible pitch.

Highest audible pitch.

Results vary with experimenters.

§ 49. From these experiments it has been inferred that the lowest pitch audible to the human ear, is that produced by a wave whose length is 34,10 English feet, and of which there are generated, in one second of time, 32 in number ; and that the highest audible pitch is given by a wave whose length is 0,13 of an English foot, or about one and a half English inches, and of which 8192 are generated in a second. But in such experiments much must depend upon the ear of the experimenter ; we know that this organ differs greatly in different persons, even among those who are unconscious of any defect in their sense of hearing. Some have contended for a high probability that a body making 24000 vibrations in one second, produces a sound which, to a fine ear, is distinctly audible ; and M. SAVART, by means of a rotary cog-wheel, so arranged that each tooth should strike a piece of card, found that 12000 strokes on the card in one second, pro-

duced a sound perfectly audible, as a musical tone of high pitch. Although different authorities differ in regard to the powers of the ear, they nevertheless all agree in ascribing to them a limit. And thus, of the almost endless variety of waves which must, from the existence of ceaseless sources of disturbance, pervade the air, our organs of hearing appear to excite the mind to impressions of those only whose lengths range within certain prescribed limits. Nor is this limitation peculiar to the ear. We shall have occasion, when speaking of light, to remark the same thing of the eye. We shall find that when, from too small or too great lengths, the waves of *ether* lose the power of stimulating the optic nerve to the sensation of light, they nevertheless do, when addressed to other organs, give rise to the further and obvious sensations of heat. And to what extent we are unconsciously influenced by those agitations of surrounding media which fall beyond the range of the ordinary senses to appreciate, it would be out of place here to inquire.

Powers of the ear limited;

Same true for the eye;

Our senses cannot appreciate all agitations;

§ 50. There is nothing in the constitution of the atmosphere to prevent the existence of wave pulses incomparably shorter and more rapid than those of which we are conscious; and we are justified in the belief that there are animals whose powers in this respect begin where ours end, and which may have the faculty of hearing sounds of a much higher pitch than any we actually know from experience to exist. And it is not improbable that there are insects endued with a power to excite, and a sense to perceive, vibrations of the same nature as those which constitute our ordinary sounds, yet of wave dimensions so different, that the animal which perceives them may be said to possess a different sense, agreeing with our own in the medium by which it is excited, yet entirely unaffected by those slower and longer vibrations of which we are sensible.

The sensations of some animals probably begin where ours end;

Such animals may be said to possess a different sense.

## DIVERGENCE AND DECAY OF SOUND.

Wave always spherical in homogeneous media;

And sound heard equally in all directions;

Not true when density and elastic force vary;

Illustrated by tuning fork;

§ 51. We have already stated, § 16, that when the primitive agitation of a medium is confined to a small space, the initial wave front is of a spherical shape, and we have seen, Equation (12), that the sound wave proceeds with equal velocity in all directions in which the density and elastic force are the same. In all homogeneous media, the wave front will, therefore, retain its sphericity to whatever distance it may be propagated, and a sound produced at a given point, as from the blow of a hammer, or the explosion of gunpowder, will be heard equally well in all directions.

§ 52. When, however, sounds proceed from a series of points situated upon the surface or face of a solid, the body of which interposes to prevent the existence of equal density and elastic force in all directions from the points of disturbance, this equality of transmission in all directions no longer obtains. This is well illustrated by an experiment due to Dr. YOUNG. A common tuning fork, a piece of steel, whose shape is represented in the figure, being struck sharply and held with its handle *A* against some hard substance, is thrown into a state of vibration, its branches *B, B*, alternately approaching to and receding from each other. Each branch sets the particles of air in motion, and a sound of a certain pitch is produced. But this sound is very unequally audible in different directions. When held with its axis of symmetry vertical and at the distance of about a foot from the ear, and turned gradually about this axis, it is found that at every quarter of a revolution, the

Fig. 19.

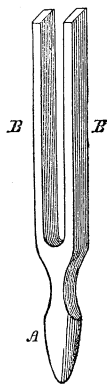

sound becomes so faint as scarcely to be heard, the audible positions of the ear being in planes  $EE$  and  $OO$ , perpendicular and parallel to the broader faces of the fork; the inaudible, in planes  $E'E'$  and  $O'O'$ , making with the first, angles of  $45^\circ$ .

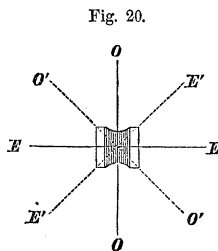

Fig. 20.

Audible and inaudible positions of the ear.

§ 53. To resume the consideration of sound propagated from a central point. The intensity or loudness of sound is, § 46, determined by the living force with which the particles of a medium in sensible contact with the ear act upon the auditory nerves. At the primitive point of disturbance the living force is impressed by the disturbing cause, and is transferred from the particles of one wave to those of another without loss, provided the molecular arrangements of the medium in the process are not permanently altered, Mechanics, § 64, which is the case in all elastic media, such as the air and other gases when not confined. The sum of the living forces of the particles in a wave must, therefore, be constant, to whatever distance the wave be propagated, and equal to double the quantity of action expended by the disturbing motor. The living force of any single particle is equal to the product of its mass into the square of its velocity, and from the nature of the wave, § 16, the living forces of all the particles on any spherical surface whose centre is the point of primitive disturbance must be equal to each other; for the velocities are equal, and the medium being of homogeneous density, the masses of the particles have the same measure.

Loudness of sound determined;

No loss of living force in elastic media;

Sum of living forces of particles in a wave constant;

Same true for any spherical surface;

Denote by  $R$  the radius of any spherical surface intermediate between the interior and exterior limits of the wave in any assumed position, by  $n$  the number of particles on the unit of surface, then will the number of particles on the entire sphere be

Illustration;

Number of  
particles on a  
spherical surface;

$$n \cdot 4 \pi R^2,$$

and the sum of their living forces

Sum of their  
living forces;

$$n \cdot 4 \pi R^2 \cdot m V^2;$$

in which  $V$  denotes the velocity common to all the particles, and  $m$  the mass of a single particle.

For another spherical surface, whose radius is  $R'$ , and the common velocity of whose particles is  $V'$ , we will have

Same for another  
spherical surface;

$$n \cdot 4 \pi R'^2 \cdot m V'^2.$$

Living forces  
equal;

Now, if these spherical surfaces occupy the same relative places in the wave in any two of its positions, be their distances from the centre of disturbance ever so different, these living forces must, from what is said above, be equal; whence we have, after dividing out the common factors,

Consequence;

$$R^2 \cdot m V^2 = R'^2 \cdot m V'^2$$

or resolving into a proportion

$$m V^2 : m V'^2 :: \frac{1}{R^2} : \frac{1}{R'^2}.$$

Rule first;

That is to say, *the intensity of sound varies inversely as the square of the distance to which it is transmitted.*

Rule second.

Again, the particles describe their orbits in equal times; their greatest velocities will, therefore, § 16, be proportional to their greatest displacements, and *the intensity of sound to the squares of these same displacements.*

§ 54. The greatest distance to which sounds are audible does not admit of precise measurement. It depends



principally upon the absolute intensity of the sound itself, Sound heard further in dense media; the nature of the conducting medium, and the delicacy of hearing possessed by individuals. Generally speaking, a sound will be heard further, the greater its original intensity, and the denser the medium in which it is propagated.

The greatest known distance which sound has been carried through the atmosphere is 345 miles, as it is asserted that the very violent explosions of the volcano at St. Vincent's have been heard at Demerara. Greatest known distance in air; Sound travels further and more loudly in the earth's surface than through the air. Heard further and louder on earth's surface than in air; Thus, for instance, in 1806, the cannonading at the battle of Jena was heard in the open fields near Dresden, a distance of 92 miles, though but feebly, while in the casements of the fortifications it was heard with great distinctness. So also it is said that the cannonading of the citadel of Antwerp, in 1832, was heard in the mines of Saxony, which are about 370 miles distant. Instances;

When the air is calm and dry, the report of a musket is audible at 8000 paces; the marching of a company may be heard on a still night, at from 580-830 paces off; a squadron of cavalry at foot pace, 750 paces; trotting or galloping at 1080 paces distant; heavy artillery, Report of a musket; travelling at a foot pace, is audible at a distance of 660 paces, if at a trot or gallop, at 1000 paces. March of cavalry; A powerful human voice in the open air, at an ordinary temperature, is audible at a distance of 230 paces, and Of artillery. Captain Parry tells us that in the polar regions a conversation may be easily carried on between two persons a mile (?) apart. Human voice.

## MOLECULAR DISPLACEMENT.

To find the distance of a particle from its place of rest at any instant;

§ 55. Let us now seek an expression for the distance of any molecule from its place of rest, at any time, during the transmission of wave motion. This displacement obviously depends upon the intensity of the disturbing cause, the distance of the molecule under consideration from the place of primitive disturbance, the velocity of wave propagation, and the time elapsed since the primitive disturbance was made.

Supposed displacement of an assumed particle;

Disregarding, for the present, the diminution of the amplitude of vibration due to the loss of living force in the successive molecules as we proceed outward from the source of sound, let

$A$ , be the point of primitive disturbance, and  $B$ , the place of rest of any assumed molecule. Denote by  $x$ , the distance of  $B$  from  $A$ , and by  $V$

the velocity of wave propagation. At the expiration of the time  $t$ , after the instant of primitive disturbance at  $A$ , let the wave front be at  $W$ , and the molecule at  $B$ , be disturbed by the distance  $Bb$ . The distance of  $W$  from  $A$ , will be  $V. t$ .

Consequent displacement of another;

Now, from the nature of the motion transmitted, any other molecule whose place of rest is  $C$ , beyond  $B$ , must experience an equal displacement  $Cc$ , at the expiration of the time  $t + t'$ , which is as much in excess over the time required for the wave front to reach  $C$ , as the time  $t$ , was over that required to reach  $B$ . In other words, the displacements must be equal for successive molecules whose places of rest are at equal distances behind the wave front; and hence the displacement must be a function of this distance, that is, of  $V. t - x$ ; and denoting the displacement by  $d$ , we may write

Displacement a function of the distance  $V. t - x$ .

Fig. 21.

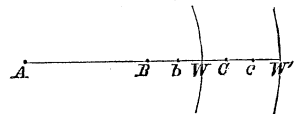

$$d = F (V \cdot t - x);$$

First value of displacement.

in which  $F$ , denotes the form of the function to be employed.

Moreover, from the definition of a wave, the nature of the function  $F$ , must be periodic; that is to say, it must, within a given interval of time, pass through all its possible values, and resume and repeat these values in the same order during the following equal interval of time. This is a property possessed by the circular functions, and hence we may write the above

$$y \sin \left[ 2 \pi \cdot \frac{V \cdot t - x}{\lambda} \right]$$

Its form;

in which  $2 \pi$ , denotes the circumference of a circle whose radius is unity, and  $y$  the radius of the small circle of which the sine of some one of its arcs will give the displacement sought. The radius  $y$ , is equal to the greatest displacement of a molecule in the same wave; for, a simple inspection will show that the function takes its maximum value when the quotient,

$$\frac{V \cdot t - x}{\lambda},$$

When a maximum;

becomes equal to one-fourth, or to any odd multiple of one-fourth; the value being in that case

$$y \cdot \sin 90^\circ, \text{ or } y \sin 270^\circ, \text{ or } y \cdot \sin 450, \text{ \&c.} = y. \quad \text{Maximum value.}$$

But the intensity of sound diminishes as the square of the distance from its source increases; and the intensity being directly proportional to the square of the greatest displacement, § 53, if  $a$ , denote the radius of the small circle at the distance unity from the source of primitive disturbance, we have

Law of variation of intensity of sound;

Expression of  
the law;

$$\frac{1}{(1)^2} : \frac{1}{x^2} :: a^2 : y^2 = \frac{a^2}{x^2}$$

OR

Radius of the  
circle whose sines  
give the  
displacements;

$$y = \frac{a}{x},$$

which substituted for  $y$  above, gives

Second value of  
displacement;

$$d = \frac{a}{x} \cdot \sin \left[ 2 \pi \cdot \frac{V \cdot t - x}{\lambda} \right].$$

The quantity  $V \cdot t$ , denotes the linear distance of the front of the wave or pulse from the source;  $V \cdot t - x$ , the distance of the molecule's place of rest from the wave front; and when this distance contains the length  $\lambda$ , either a whole number of times, or a whole number of times plus one-half,  $d$  becomes zero. When the remainder, after the division of  $V \cdot t - x$ , by  $\lambda$ , becomes  $\frac{1}{4}$  or  $\frac{3}{4}$ , &c., the value of  $d$  becomes  $\frac{a}{x}$ ,— its maximum value.

When it is zero;

When a  
maximum.

If the arc

$$2 \pi \cdot \frac{V \cdot t - x}{\lambda},$$

Arbitrary  
quantity;

be increased by an arbitrary quantity  $A$ , it is plain that we may assign to  $A$ , such a value as to cause any given displacement, and therefore the maximum displacement, to occur at a given place and time. Introducing this arbitrary quantity, we finally have the general equation

Final value of  
displacement;

$$d = \frac{a}{x} \cdot \sin \left[ 2 \pi \cdot \frac{V \cdot t - x}{\lambda} + A \right] \quad \cdot \quad \cdot \quad \cdot \quad (19)$$

in which  $\frac{a}{x}$ , determines the intensity of the sound;  $\lambda$ , its

pitch; and  $A$ , the particle whose place of rest is at a distance  $x$  from the source, to have any particular displacement at the expiration of the time  $t$ .

Meaning of the quantities.

## INTERFERENCE OF SOUND.

§ 56. We have seen, in Mechanics, that a body may be animated by two or more motions at the same time; that the ultimate result of these motions, as regards the body's position, will be the same as if these motions had taken place successively; and that one or more of these motions may be destroyed at any instant without affecting in any wise the others. These coexistent motions, estimated in any given direction, become, as it were, superposed upon each other, and when very small, give rise to a principle known as the "*coexistence and superposition of small motions*"; a principle most fruitful of results in sound and light. By it we are taught that when the excursions of the parts of a system from their places of rest are very small, any or all the motions of which, from any cause, they are susceptible, may go on simultaneously without disturbing one another.

Body animated by two or more motions.

Coexistence and superposition of small motions;

What it teaches;

The truth of this important principle will appear from its application to the particular case in question.

Its truth established;

It has been shown, § 4, that when a molecule of any body is very slightly disturbed from its place of rest, as in the case of sound, the forces exerted upon it by the surrounding molecules give rise to a resultant whose intensity is proportional to the amount of displacement. This displacement may arise from the action of a single or from several causes operating at the same time; but in every case, the expression which gives the value of the resultant action must be a function of those which express the values of the partial actions, and, like each of these latter functions, being proportional to the displacement it is capable of producing must, as well as

Explanation;

Partial, as well as entire functions must be linear;

the partial functions, be linear. In any such function, if we attribute a slight change to one of the disturbing causes, the corresponding change in the displacement must be proportional thereto; and whether the change in all the partial causes, or in the functions which measure them, be simultaneous or successive, the final result will be the same; for, the change in the entire function in the first case must be equal to the algebraic sum of the partial changes in the second. To those familiar with the calculus, it will be sufficient to say, that the first power of the total differential of the sum of a number of functions, is always equal to the first power of the sum of the partial differentials.

Conclusion;

We conclude, therefore, that the function which gives the displacement may be broken up, so to speak, into several partial functions equal in number to that of the disturbing causes; that these partial functions will be similar to each other and to the entire function; and that this latter will be equal to the algebraic sum of the former.

§ 57. To illustrate:

Illustration;

let the straight line  $AB$ , be the locus of a series of molecules in their positions of rest; the fine waved line  $a'b$ , that of the same

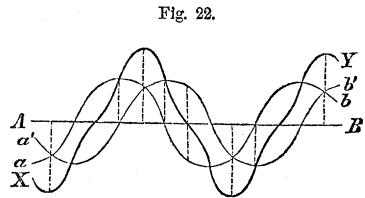

Partial waves;

particular instant of time, when disturbed and thrown into a wave by the action of some single cause; and the waved line  $a'b'$ , that of the same molecules at the same instant had they been thrown into a different wave under the operation of some other insulated action. If these disturbing causes had acted simultaneously, the locus of the disturbed molecules would be represented by the heavy waved line  $XY$ , constructed in this wise: At the various points of the line  $AB$ , erect perpendiculars

Construction of resultant wave.

and produce them indefinitely; lay off from  $AB$ , on these perpendiculars, distances equal to the sum or difference of the corresponding ordinates of the component curves, according as these curves intersect the perpendiculars on the same or on opposite sides of the line  $AB$ ,—the points thus determined will be points of the resultant curve, which will give the law of displacement at the instant of time in question. Were there three, four, &c., component curves, the resultant curve would be determined by the same rule.

Resultant curve;  
Same for three or more components.

§ 58. Taking it, then, as a fact, that the disturbance of every molecule produced by the coexistence of two or more causes will be the algebraic sum of the disturbances which they would produce separately, let us consider the nature of the displacement produced by the superposition of the action of *two* waves of the same length on the same molecule, the waves being supposed to come from any directions whatever.

Resultant action of two equal waves on a particle;

We shall have for the displacement of the molecule by the first wave, Eq. (19),

$$a' = \frac{a'}{x} \cdot \sin \left[ 2 \pi \cdot \frac{V \cdot t - x}{\lambda} + A' \right]; \dots (20)$$

Displacement by the first wave;

and by the second,

$$a'' = \frac{a''}{x} \cdot \sin \left[ 2 \pi \cdot \frac{V \cdot t - x}{\lambda} + A'' \right]; \dots (21)$$

Same by the second;

in which  $a'$  and  $a''$ , determine the intensities of the sound in the two waves at the unit's distance; and  $A'$  and  $A''$ , the places of the maximum displacement at the expiration of the time  $t$ .

Fig. 22.

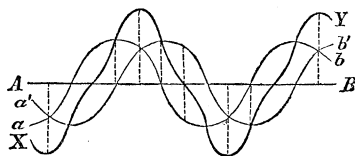

Illustration;

Operations indicated; Taking the sum, and developing the circular function by the usual formula for the sine of the sum of two arcs, we find, after reduction,

Sum of displacements; 
$$d+d'=\frac{(a'\cos A'+a''\cos A'')}{\omega}\sin\left[2\pi\frac{V.t-\omega}{\lambda}\right]+\frac{(a'\sin A'+a''\sin A'')}{\omega}\cos\left[2\pi\frac{V.t-\omega}{\lambda}\right].$$

and making,

Supposition; 
$$a\cos A=a'\cos A'+a''\cos A'',\dots(a)$$

$$a\sin A=a'\sin A'+a''\sin A'',\dots(b)$$

Notation; the above becomes, after writing  $d$  for the total displacement,

Total displacement; 
$$d=\frac{a}{\omega}\left[\cos A\sin\left(2\pi\frac{V.t-\omega}{\lambda}\right)+\sin A\cos\left(2\pi\frac{V.t-\omega}{\lambda}\right)\right];$$

replacing the quantity within the brackets by its equal, viz.: the sine of the sum of the two arcs, we have

Same; 
$$d=\frac{a}{\omega}\sin\left[2\pi\frac{V.t-\omega}{\lambda}+A\right]\dots(22)$$

Squaring Equations (a) and (b) and taking the sum, we find,

Transformations; 
$$a^2=a'^2+a''^2+2a'a''\cos(A'-A'')\dots(23)$$

and dividing Equation (b), by Equation (a), we obtain

Reductions; 
$$\tan A=\frac{a'\sin A'+a''\sin A''}{a'\cos A'+a''\cos A''}\dots(24).$$

Conclusions; From Equation (22) we see that the length of the resulting wave is the same as that of the partial waves; but the value of  $A$  in that equation differing from  $A'$ ,



and  $A''$ , Equation (24), shows that the maximum displacement for a given molecule does not take place with the same value of  $t$ , as for either of the component waves.

The maximum displacement  $\frac{a}{\omega}$ , which determines the intensity of the sound, in the resultant wave, is given by Equation (23) to be

$$\frac{a}{\omega} = \frac{1}{\omega} \cdot \sqrt{a'^2 + a''^2 + 2a'a'' \cdot \cos(A' - A'')} \dots (25)$$

General value of this displacement;

which depends upon the arc  $A' - A''$ . Its greatest value is obtained by making  $A' - A'' = 0$ , in which case we have

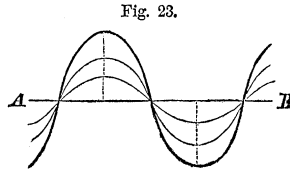

When this value is greatest;

$$\frac{a}{\omega} = \frac{a' + a''}{\omega};$$

Greatest value;

its least value results from making  $A' - A'' = 180^\circ$ , in which case

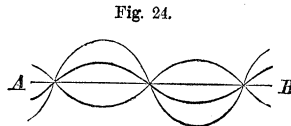

When this value is least;

$$\frac{a}{\omega} = \frac{a' - a''}{\omega}.$$

Least value;

In the first case Equation (24) gives

$$\tan A = \frac{(a' + a'') \cdot \sin A'}{(a' + a'') \cdot \cos A'} = \tan A' = \tan A'';$$

First case;

whence  $A$ , is equal to  $A'$ , and to  $A''$ , and the maximum displacement will occur at the same place and at the same time in the resultant wave, and in both component waves.

In the second case, if we substitute in Equation (24)  $A' = 180^\circ + A''$ , we find

Second case;  $\tan A = \frac{(a'' - a') \cdot \sin A''}{(a'' - a') \cos A''} = \tan A'' = \tan(A' - 180^\circ) = \tan A';$

Conclusion; that is,  $A$  is equal to one at least of the arcs  $A'$  and  $A''$ , and the greatest displacement in the resultant wave will occur at the same place and time as in one of the component waves.

Intensity of sound supposed equal in component waves; § 59. If the intensity of sound in the component waves be supposed equal at the place of superposition, then will  $a' = a''$ , and Eq. (25) becomes

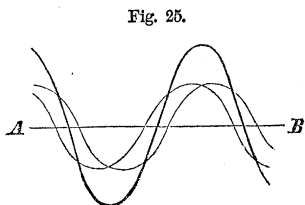

Consequence;  $\frac{a}{x} = \frac{2a'}{x} \cdot \cos \frac{A' - A''}{2} \dots \dots \dots (26)$

and Equation (24) reduces to

Reduction;  $\tan A = \frac{\sin A' + \sin A''}{\cos A' + \cos A''} = \tan \frac{A' + A''}{2},$

or,

Value of arbitrary constant;  $A = \frac{A' + A''}{2} \dots \dots \dots (27).$

When  $A' - A'' = 0$ , then will Eq. (26) give

Supposition;  $\frac{a}{x} = \frac{2a'}{x}$ , and  $A = A' = A'';$

Illustration. that is, the intensity of sound in the resultant wave is quadruple that in either of the equal component waves; and the greatest displacement will occur at the same time and place in the component and resultant waves.

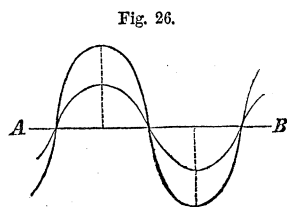

If  $a'$  and  $a''$  continue equal, and we make  $A' - A'' = 180^\circ$ , Supposition; then will Equation (26), give

$$\frac{a}{\omega} = 0; \dots \dots \dots (26)'. \text{Consequence;}$$

Silence produced;

or in words, one of the equal sounds will destroy the other. Thus it appears that two equal sounds reaching the same point may be in such relative condition that one will wholly neutralize the other, and the two produce perfect silence. This phenomenon is called the *Interference* of sound.

Fig. 27.

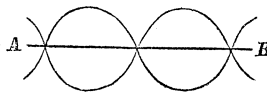

Interference of sound.

With any other values for  $A'$  and  $A''$  than those which give  $A' - A'' = 180$  or  $0^\circ$ , Eq. (26), shows that

$$\frac{a}{\omega} < \frac{2a'}{\omega};$$

Result of partial coincidence of two sound waves.

that is, the sound in the resultant wave is less than quadruple that in either of the equal component waves.

§ 60. To ascertain the precise relation between two equal waves, which will cause one to destroy the other, make, in Equation (20),

Conditions that will cause two equal waves to neutralize each other.

$$A' = A'' \pm 180^\circ = A'' \pm \pi$$

and we have

$$a' = \frac{a'}{\omega} \sin \left[ 2\pi \frac{V \cdot t - x}{\lambda} + A'' \pm \pi \right],$$

but

$$\pi = \frac{2\pi \cdot \lambda}{2 \cdot \lambda}$$

Transformations;

and this substituted above, the equation becomes

Resultant displacement;

$$d' = \frac{a'}{a} \cdot \sin \left[ 2\pi \cdot \frac{V \cdot t - x \pm \frac{1}{2}\lambda}{\lambda} + A'' \right]$$

Conditions in words.

which becomes identical with Equation (21) by writing  $a$ , for  $a \mp \frac{1}{2}\lambda$ . That is to say, *one wave will destroy another of equal length and intensity, provided the first*

*be in advance or in rear of the second, by half the length of the wave.* And since the retardation of a whole length of a wave, two whole lengths, three whole lengths, &c., produces no alteration in an undulation, it is obvious that a retardation of  $\frac{3}{2}\lambda$ ,  $\frac{5}{2}\lambda$ ,  $\frac{7}{2}\lambda$ , &c., will produce the same effect as a retardation of  $\frac{\lambda}{2}$ : and thus

two waves will destroy each other if the maxima of vibration be the same, the waves be of the same length, and transmitted in the same direction; provided, one follow the other by one half, three halves, five halves, &c., of a wave length. If the waves do not proceed in the same direction, they will interfere only at the point of union, the above conditions being fulfilled.

When waves interfere only at point of union.

Same considerations applicable to three or more equal waves;

§ 61. The same process of combination may be applied to three, four, &c., waves of equal lengths. Thus let there be the Equations

$$d' = \frac{a'}{a} \sin \left[ 2\pi \cdot \frac{V \cdot t - x}{\lambda} + A' \right]$$

Equations to be used;

$$d'' = \frac{a''}{a} \sin \left[ 2\pi \cdot \frac{V \cdot t - x}{\lambda} + A'' \right]$$

Fig. 27.

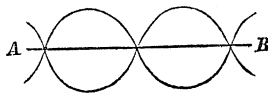

$$d''' = \frac{a'''}{x} \sin \left[ 2\pi \cdot \frac{V \cdot t - x}{\lambda} + A''' \right]$$

Operations performed;

adding these, developing the sine of the sum of the two arcs within the brackets, collecting the common factors and denoting the resultant displacement by  $d$ , we have

Fig. 28.

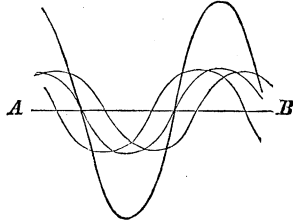

Illustration;

$$d = \frac{a}{x} \cos A \cdot \sin 2\pi \cdot \frac{V \cdot t - x}{\lambda} + \frac{a}{x} \sin A \cdot \cos 2\pi \cdot \frac{V \cdot t - x}{\lambda},$$

Resultant displacement;

or

$$d = \frac{a}{x} \sin \left[ 2\pi \cdot \frac{V \cdot t - x}{\lambda} + A \right];$$

The same;

in which

$$\begin{aligned} a \cos A &= a' \cos A' + a'' \cos A'' + a''' \cos A''' = X \\ a \sin A &= a' \sin A' + a'' \sin A'' + a''' \sin A''' = Y \end{aligned}$$

$$a = \sqrt{X^2 + Y^2}; \quad \tan A = \frac{Y}{X}.$$

Notation.

§ 62. Although it is possible for two waves of sound, whose lengths are the same, to neutralize each other, it is not so when the waves have unequal lengths; for, Eq. (22) was deduced by making  $V$

Fig. 29.

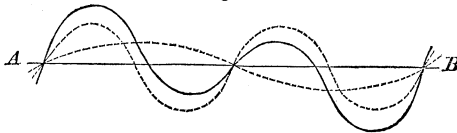

Two unequal waves cannot neutralize each other;

Illustration;

and  $\lambda$  the same in the two component waves, the sum of  $d'$  and  $d''$  being in that case reducible. If these conditions were not fulfilled, this sum would not be reducible, and there would be the two arcs

Explanation;

$$2\pi \frac{V'.t - \alpha}{\lambda'}, \text{ and } 2\pi \frac{V.t - \alpha}{\lambda},$$

Conclusion  
respecting  
unequal waves;

in the final value for  $d$ , with different coefficients, which could not be made equal to zero at the same time. The values of  $V$ , will, to be sure, be the same in any two waves of sound, but this need not be so with those of  $\lambda$ ; and in waves which produce light, in which subject we shall have most occasion to refer to the doctrine of interference, the values of  $V$ , as well as those of  $\lambda$ , may differ. The discussions of waves of different lengths may, therefore, be kept perfectly separate, as the combined effect of such waves will be the same as the sum of their separate effects, without the possibility of their destroying or modifying one another.

## NEW DIVERGENCE AND INFLEXION OF SOUND.

Any disturbed  
particle causes  
subsequent  
disturbance in  
another;

§ 63. We have seen that every disturbance of a molecule at one time is truly a cause of disturbance of another molecule at some subsequent time. All the molecules in a wave front become, therefore, simultaneously centres of disturbance, from each one of which a wave proceeds in a spherical front, as from an original disturbance of a single molecule. Thus, in the wave front  $AB$ , a molecule at  $\alpha$  becomes a new centre of disturbance as soon as the wave front reaches it; and if with a radius equal to  $Vt$  a circle be described, this circle will represent a section of the spherical wave front proceeding from  $\alpha$ , with the velocity  $V$ , at the end of the interval of time denoted by  $t$ . And the same being true for the molecules  $\alpha'$ ,  $\alpha''$ , &c., of the primitive wave, there will result a series of intersecting circles

Same true for all  
particles in a  
wave front;

Illustration;

Fig. 80.

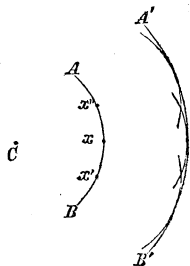

having equal radii, and the larger circle  $A'B'$ , Construction of resultant wave front; tangent to all these smaller circles, will obviously be a section of the main wave front at the expiration of the interval  $t$ , after it was at  $AB$ . Any molecule situated at the intersection of the smaller circles will obviously be agitated by the waves transmitted to it from molecules at their respective centres; and the resultant displacement will, § 55, § 56, be the algebraic sum of the displacements due to each when superposed. Resultant displacement of a particle;

Hence, to find the disturbing effect of any wave upon a given molecule at a given time, *divide the wave into a number of small parts, consider each part as a centre of disturbance, and find by summation the aggregate of all the disturbances of the given molecule by the waves coming from all the points of the great wave.* Rule.

The cause which makes the disturbance of a single molecule at one instant the occasion of the simultaneous disturbance of an indefinite number of surrounding molecules at a subsequent instant, is called the principle of *new divergence*, of which frequent use will be made in the subject of light. Principle of new divergence stated;

§ 64. Let us trace the consequences of this principle in its application to the passage of sound through apertures and around the edges

of objects. Take a partition  $MN$ , through which there is an opening  $AB$ , and suppose a spherical wave of sound to proceed from a centre  $C$ . Only that portion of the wave which comes against the opening

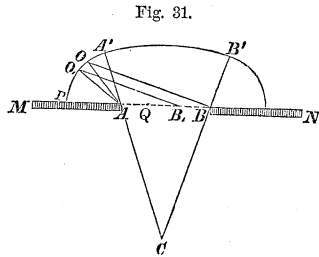

Fig. 31.

Its application to the passage of sound through apertures and around corners;

can pass through, and the wave front on the opposite side of the partition will be found by taking the different points of the segment  $AB$ , within the opening as centres, and radii equal to  $Vt$ , and describing a series of elementary arcs, and drawing a curve tangent to them. Illustration;

Explanation and construction;

all. That portion of this tangent curve included between the lines  $CA'$  and  $CB'$ , drawn from  $C$ , and tangent to the limits of the opening, will obviously be the arc of a circle having  $C$  for its centre. The elementary circles described about the limits  $A$  and  $B$  as centres, cannot be intersected

Fig. 31.

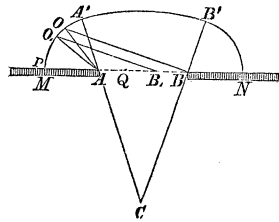

Sound that is not reinforced by particles from the primitive wave;

at points exterior to the angle  $A'CB'$  by those described with equal radii from points of the wave front lying between  $A$  and  $B$ ; the wave front within the angles  $A'AM$  and  $B'BN$ , will have their centres at  $A$  and  $B$  respectively; and the sound proceeding from these points will be diffused over the arcs  $A'M$  and  $B'N$  without reinforcement from molecules of the same primitive wave.

Sectors wherein the sound is due to superposition of waves from the edges;

But other waves from  $C$  reaching the opening in succession, a spherical wave diverging from  $B$ , and of which the radius is  $BO$ , will be overtaken by a subsequent one from  $A$ , having for its radius  $AO$ ; so that, the intensity of sound in the angle  $A'AM$  will result from the superposition of the disturbances from  $B$  and  $A$ . The same will be true of the sector  $B'BN$ .

Intensity increased by coincidence;

Now, if  $BO - AO$ , be equal to  $\lambda, 2\lambda, 3\lambda, \dots n\lambda$ , in which  $n$  is a whole number, then will the intensity of the sound be increased above that due to either of the component waves. But if  $BO - AO$ , be equal to  $\frac{1}{2}\lambda, \frac{3}{2}\lambda, \dots (n + \frac{1}{2})\lambda$ ,  $n$  being still a whole number, the component waves will interfere at  $O$ , and the intensity of the sound will be lessened at that point by the prevention there of the disturbance due to either of these two component waves.

Decreased by interference.

Points taken between the edges;

Taking another molecule  $B_1$ , nearer to  $A$ , the wave from  $B_1$ , will interfere with the wave from  $A$ , but at a point  $O_1$ , nearer to the partition, in order to preserve the difference  $B_1O_1 - AO_1$ , the same as before,



to wit,  $(n + \frac{1}{2})\lambda$ . Assuming other points in succession nearer to  $A$ , we shall find the interference to take place at molecules still nearer to the partition; and finally, when we come to a molecule  $Q$ , in the main wave front whose distance  $AQ$ , from  $A$  is equal to  $(n + \frac{1}{2})\lambda$ , the interference will occur at a molecule situated against the partition at  $P$ .

Now, making  $n = 0$ , in which case  $AQ$  will equal  $\frac{1}{2}\lambda$ , and applying

$\frac{1}{2}\lambda$  from  $a$  to  $a_1$ ,

the waves from  $a$  and  $a_1$ , will inter-

fere at  $P$ . Applying  $\frac{1}{2}\lambda$ , from  $b$  to  $b_1$ , the waves from  $b$  and  $b_1$ , will also interfere, at the partition; and in the same way it may be shown that all the partial waves from molecules in the distance  $AQ$ , will interfere with those from the molecules in the distance  $QD$ ,  $QD$  being equal to  $AQ$ . Commencing the same process at  $D$ , we see that the opening may be such that on applying  $\frac{1}{2}\lambda$  from  $a'$  to  $a'_1$ , this latter point  $a'_1$ , may be in the position from which there can be no new divergence to interfere with that from  $a'$ ; and the same for the whole of the arc  $DB$ , of the main wave. This latter is, therefore, left, as it were, undisturbed, and sound from it may or may not be audible at  $P$ , depending upon the extent of this arc and the intensity with which the sound reaches the opening.

The distance  $AQ$  is equal to  $\frac{1}{2}\lambda$ . But  $\lambda$ , we have seen, § 48, varies with the pitch, whence the sound heard at  $P$ , will depend upon its pitch and the size of opening through which it may pass.

§ 65. From what precedes we see that at the line  $AO$ , Fig. 31, there begins, as it were, an *acoustic shadow*, which deepens more and more as we approach the partition towards  $P$ , where the sound becomes least audible. This bending of sound around the edges of an opening is called the *Inflexion of sound*.

Fig. 32.

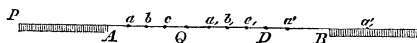

Illustration;

Explanation of results;

Sound heard at partition depends on pitch, and size of opening.

Acoustic shadow cast.

Inflexion of sound.

Case of sound bending around corners;

§ 66. When the opening is continued indefinitely in one direction only, we have the case of sound bending around a corner. But when the opening is continued indefinitely in one direction, there can be no arc of the main wave as  $DB$ , (last figure), without a corresponding arc  $D_1B_1$ , further on, to neutralize it in part at least by interference, and hence, were the component sounds of the same intensity at the point of superposition, they would produce perfect silence, and no sound could be heard at  $P$ .

Fig. 33.

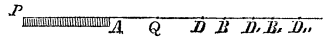

Explanation;

The sound from the main wave is of the same intensity throughout on reaching the corner; the new diverging waves leave their respective centres, which are distributed along the front of the main wave, with equal intensities; they can only interfere after having travelled over routes which differ by  $\frac{1}{2}\lambda$ ; the intensity of sound varies inversely as the square of its travelled distance; and the intensities cannot be equal at the places of interference, and therefore can only partially neutralize each others' effects. This is shown by Equation (26)', in

No perfect neutralization;

which  $\frac{a}{w}$  is zero, only because  $w$ , under the conditions there imposed, is the same denominator for  $a'$  and  $a''$ .

Grave sounds more audible than the acute;

In sound,  $\lambda$  varies, as we have seen, § 48, from a few inches to many feet, and as the difference of intensities in the interfering waves will be greater as  $\lambda$  is greater, the graver sounds would be heard, under the circumstances we have been considering, more audibly than the more acute. If the lengths  $\lambda$ , were insensible in comparison with the route travelled, there would be but little inflexion; since, in that case, the intensities of sound in the interfering waves would be sensibly the same, and it would require but a slight obliquity from the direct course of the main wave to make a difference of route  $BO - AO$ , Fig. 31, equal to  $\frac{1}{2}\lambda$ , necessary for one wave sensibly to destroy the other.

Case of little inflexion.

An auditor placed behind a wall at  $P$ , would hear the bass notes from a band of music playing at a position  $A$  on the opposite side, much more distinctly than the acute notes. At  $P$ , the notes of the tuba, for instance, might be heard distinctly, while those of the octave flute would be lost to him. In passing from the position  $P$  to  $O$ , he would catch in

Fig. 34.

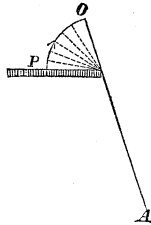

Person behind a wall listening to a band of music;

succession the higher notes in order of the ascending scale, and finally, when he attained a position near the direct line  $A O$ , drawn from  $A$ , tangent to the corner, he would hear all the instruments with equal distinctness, if played with equal intensity and emphasis. The facts and explanations here given have an important application in the subject of optics.

Position whence all the instruments are equally audible;

If we suppose the lengths of sonorous waves propagated through water to be much shorter than those through the air, we have here a full and satisfactory explanation of the phenomenon observed by M. COLLADON, mentioned at the close of § 39. Indeed, taking the acoustic shadow there referred to as established, it must follow as a consequence, from the principle of new divergence, that the lengths of the sonorous waves in liquids are shorter than in air.\*

Foregoing deductions conformable to experiments

REFLEXION AND REFRACTION OF SOUND—ECHOS.

§ 67. There is no body in nature absolutely hard and inelastic. Whenever, therefore, the molecules of a vibrating medium come within the neutral limits of those forming the surface of any solid or fluid, they will agitate the latter with motions similar to their own, and a pulse will be transmitted into the solid or fluid with a velocity determined by its density and elastic force.

Disturbed particles of one body agitate those of another, and transmit a pulse.

\*See Appendix No. 1.

References;

§ 68. Referring to the transmission of sound through air, and resuming Equation (2)', we have, after substituting the value of  $V$ , as given by Equation (3),

Velocity of a particle;

$$v = \sqrt{\frac{E'}{D}} \cdot \frac{x - x_1}{x} = V \cdot \frac{x - x_1}{x}.$$

Now, by reference to § 34, it will be seen that

Excess of condensation;

$$\frac{x - x_1}{x},$$

expresses the excess of condensation on one side of a molecule over that on the opposite side. Making

Expressed by an equation;

$$\frac{x - x_1}{x} = C,$$

the above Equation may be written

Velocity of a particle;

$$v = C \cdot \sqrt{\frac{E'}{D}} \dots \dots \dots (28).$$

Rule for homogeneous media.

In the same homogeneous medium  $E$  and  $D$  are constant, whence we conclude\* that *the actual velocity of a molecule, which is the same as that of the stratum to which it belongs, is directly proportional to the excess of condensation on one side of it, over that on the opposite side.*

When a particle will come to rest.

When, therefore, by the forward movement of a molecule the condensation becomes equal on opposite sides, the molecule comes to rest, and remains so till again disturbed by some extraneous force. This explains why it is that a pulse transmitted through a medium of uni-

form density sends back no disturbance, but leaves every molecule behind in a state of rest. The living force impressed upon any given stratum is transferred to the next one in front, and this to the next in order, and so on indefinitely.

Living force transferred.

§ 69. When the stratum  $AB$  is moved by some source of disturbance to  $A'B'$ , the stratum  $CD$  will move in

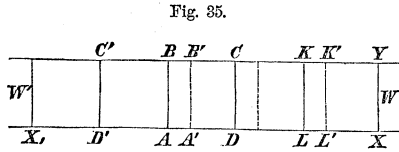

Fig. 35.

Stratum disturbed;

A pulse transmitted in direction of disturbance;

the same direction, and a pulse will be transmitted onward towards  $W$ , the excess of condensation being on the same side of the moving stratum as the place of the original disturbance. But a shifting of the stratum  $AB$  to the position  $A'B'$ , leaves the excess of condensation which acts on the stratum  $C'D'$  on the opposite side from  $AB$ ; the stratum  $C'D'$  will therefore close in upon  $A'B'$ , and the same occurring in succession with all the strata on the side towards  $W'$ , a pulse will be transmitted in an opposite direction from that which begins with the motion of  $CD$ . Thus, every case of an original disturbance of a molecule will give rise to two pulses proceeding in opposite directions, with the same velocity, the two pulses differing only in this, viz.: in the one the wave velocity will be in the same direction as that of the molecules, and in the other in an opposite direction.

And also one in opposite direction;

Every disturbance produces two pulses:

Their difference.

§ 70. The elastic force  $E$ , of two media in contact and at rest, must be the same; otherwise motion would ensue.

Elastic force of two media in contact and at rest.

When, therefore, in the progress of a pulse, it reaches a stratum  $XY$ , of a density different from that of those which precede it, Equation (28), shows that for the same excess  $C$ , of condensation, the velocity of the stratum will be altered; that is, the actual motion of the molecules will either be accelerated or retarded. If the new stratum

Effect when the moving stratum meets one of greater density;

tum be of increased density, the next preceding stratum  $KL$ , will be checked in its progress by the greater mass of  $XY$ , and brought to rest before it reaches its neutral distance from that behind; the excess of elastic force thus retained will react upon the next preceding stratum which has already come to rest, and will thus give rise to a return pulse in which the velocity of propagation and that of the molecules will be in the same direction.

Effect when moving stratum meets one of less density.

If, on the contrary, the new stratum have a diminished density, the motion of  $KL$  will be accelerated, the density in front of the next preceding stratum will become less than that between those behind which have come to rest; these latter strata will therefore move forward in succession, and thus a return pulse will be produced as before, but with the difference, that the velocity of propagation and that of the molecules will be in opposite directions.

Wave meeting a medium of different density is resolved into two;

§ 71. It follows, therefore, that when a pulse or wave of sound in any medium reaches another medium of greater or less density, it is at once resolved into two, one of which proceeds on through the second, while the other is driven back through the first medium.

Cause of this resolution.

This division of an original pulse into two others, arises entirely from the reciprocal action of the two media on each other. If the media be perfectly elastic, there can be no loss of living force, and the sum of the intensities of sound in the component pulses will be equal to that of the original pulse. If the media be not perfectly elastic, there will be a loss of living force, and the sum of the intensities of the component pulses will be less than that of the original pulse.

Incident, refracted, and reflected pulses.

The original pulse is called the *incident*; that transmitted into the second medium, the *refracted*; and that driven back through the original medium, the *reflected* pulse.

Echo.

To an ear properly situated, the reflected pulse will be audible, and is, for this reason, called an *echo*. The sur-

face at which the original pulse is resolved into its two component pulses, is called the *deviating surface*.

Deviating surface;

§ 72. To find the law which regulates the direction of the reflected pulse; let  $AM$  be a portion of the front of an incident spherical pulse, so small that it may be regarded as a plane. Draw  $MA''$ ,  $A'N$  and  $AO$ , normal to the pulse, and suppose the latter, moving in the direction from  $N$  to  $A'$ , to meet the face  $EG$  of a second medium. Each molecule of the pulse as it recoils from the surface  $EG$ , becomes the centre of a diverging spherical pulse which will, Eq. (28), be propagated with the velocity of the incident pulse. Accordingly, when the portion  $M$  reaches the face of the second medium at  $A''$ , the portion  $A$  will have diverged into a spherical pulse whose radius is  $AB = A''M$ . In like manner, if  $A'M'$  be drawn parallel to  $AM$ , the portion diverging from  $A'$  will, in the same time, have reached the spherical pulse whose centre is  $A'$  and radius  $A'B' = A''M'$ . The same construction being made for all the points of the incident pulse as they come in succession to the deviating surface, the surface which touches at the same time all these spherical surfaces will obviously be the front of the reflected pulse. But because  $A'B'$  and  $AB$  are respectively proportional to  $A'N$  and  $A''M$ , and as this is true for any other similar lines drawn from points of the deviating surface to the corresponding points of the incident and reflected pulses, this tangent surface is a plane. Moreover, since  $AB$  is equal to  $MA''$ , and the angles  $AMA''$  and  $A''BA$  are right, the angles  $MAA''$  and  $BA''A$  are equal, and the incident and reflected pulses make equal angles with the deviating surface.

Direction of the reflected pulse determined;

Fig. 86.

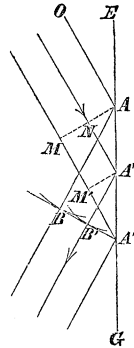

Explanation and construction;

Incident and reflected pulses make equal angles with deviating surface.

Any line which is normal to the front surface of a

Ray of sound.

Angle of incidence;

Angle of reflexion;

These angles equal.

pulse, is called a *ray of sound*. The angle  $NAD$ , which the normal to the incident pulse makes with the normal to the deviating surface, is called the *angle of incidence*. The angle  $BAD$ , which the normal to the reflected pulse makes with that to the deviating surface, is called the *angle of reflexion*; and because the angle made by two planes is equal to that made by their normals, we conclude from the foregoing, that *in the reflexion of sound, the angles of incidence and of reflexion are equal*.

Fig. 37.

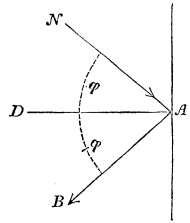

Direction of the refracted pulse determined;

§ 73. The law which determines the course of the refracted pulse is equally simple, and is deduced in a manner analogous to the preceding.

Let  $AM$  be an inclined elementary plane pulse, incident upon a deviating surface  $EG$ , at any instant. In the interval of time during which the point  $M$  is moving from  $M$  to  $A''$ , the agitation which begins at  $A$  will have reached some spherical surface within the second medium of which  $AB$  is the radius; and in like manner, the agitation which begins at  $A'$ , will have reached some spherical surface of which  $A'B'$  is the radius, by the time the portion of the incident pulse at  $M'$ , will have passed on to  $A''$ ; and the same of intermediate points of primitive disturbance on the deviating surface between  $A$  and  $A''$ , the first and

Fig. 38.

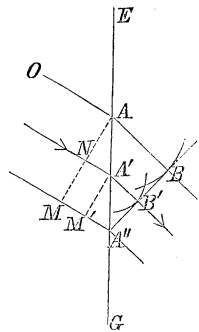

Construction and explanation.

last points of incidence. The surface tangent to all these spherical surfaces will be the front of the transmitted or refracted pulse; and because  $AB$  and  $A'B'$  are respectively proportional to  $A''M$  and  $A'N$ , this surface is a plane.



The angle  $N'AD$ , made by the normal to the refracted pulse and that to the deviating surface, is called the *angle of refraction*. Denote the angle of incidence  $NAD$ , which is equal to the angle  $MAA''$ , Fig. 38, by  $\phi$ ; and the angle of refraction  $N'AD$ , which is equal to the angle  $AA''B$ , Fig. 38, by  $\phi'$ ; then will

$$\begin{aligned} MA'' &= A''A \cdot \sin \phi; \\ AB &= A''A \cdot \sin \phi'; \end{aligned}$$

and dividing the first by the second

$$\frac{MA''}{AB} = \frac{\sin \phi}{\sin \phi'};$$

but  $A''M$  and  $AB$ , being described in the same time, Explanation; the first by the incident, the second by the transmitted pulse, are respectively proportional to the velocities in the two media. Denoting the velocity of the incident pulse by  $V$ , and that of the transmitted pulse by  $V'$ , we have

$$\frac{V}{V'} = \frac{MA''}{AB} = \frac{\sin \phi}{\sin \phi'}$$

Ratio of velocities of incident and refracted sound;

whence

$$\sin \phi = \frac{V}{V'} \sin \phi', \quad \dots \quad (29).$$

That is to say, in the refraction of sound *the sine of the* Rule. *angle of incidence is equal to the sine of the angle of refraction multiplied into the ratio obtained by dividing the velocity before incidence by that after refraction.*

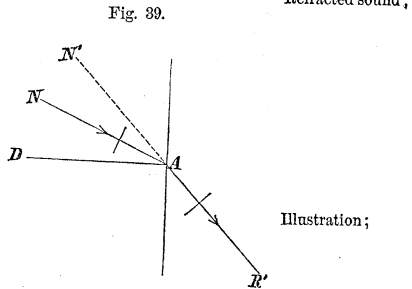

Application to  
air and water;

Thus, if sound proceed through the atmosphere at 32° Fahr., and be incident upon the surface *A B*; of water at the same temperature, then will  $V = 1089,42$ ,  $V' = 4707,4$ , and

$$\frac{V}{V'} = \frac{1089,42}{4707,4} = 0,23142$$

Illustration;

which in Eq. (29) gives

$$\sin \phi = 0,23142 \cdot \sin \phi'$$

or

$$\frac{\sin \phi}{0,23142} = \sin \phi' \dots \dots \dots (30).$$

Example;

Now, suppose the angle of incidence *R I N*, to be given, say 30°. With the point of incidence *I*, as a centre and radius unity, taken from any scale of equal parts, describe the circumference of a circle; from a table of natural sines take the sine of 30°, and by means of the same scale lay it off from *I* to *H*; through *H* draw *H O* parallel to the normal *N I*, and through the point *O*, in which this parallel meets the circumference and the point of incidence *I*, draw *R I*. This gives the incident ray. Divide the sine of 30° by 0,23142, this will give the sine of  $\phi'$ ; lay off its value from *I* to *H'*, and draw *H' O'* parallel to *N I*; join the point in which this parallel cuts the circumference with the point of incidence *I*, and we have the direction of the refracted ray *I R'*.

Construction of  
incident and  
refracted rays.

When sound  
cannot pass into  
a second  
medium;

§ 74. The sine of an angle can never exceed unity. When, therefore, the angle of incidence becomes so great that its sine divided by the ratio of the velocities exceeds unity, refraction, or which is the same thing, the passage of sound from one medium to another in which its velocity is greater, becomes impossible. In the case of air

Fig. 40.

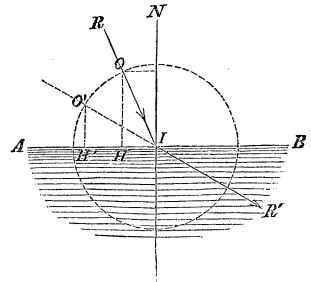

and water, the limit of the greatest angle of incidence corresponding to which we have any transmission of audible sound to the second medium, is found from Equation (30) by making  $\sin \varphi' = 1$ , which gives

$$\sin \varphi = 0,23142$$

or,

$$\varphi = 13^\circ 22'.$$

Its value.

§ 75. When the sound is thrown back from the surface separating the two media and continues in the first medium, the velocity retains the same value, but its sign will be changed. This will make  $V' = -V$ , and

$$\frac{V}{V'} = -1,$$

Ratio of velocities of incident and reflected sound;

which reduces Equation (29) to

$$\sin \varphi = -\sin \varphi',$$

or

$$\varphi = -\varphi'$$

the law of reflexion as given in § 72.

Fig. 41.

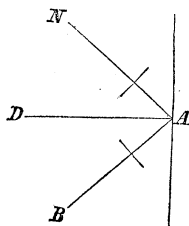

Angle of incidence equal to that of reflexion.

Fig. 42.

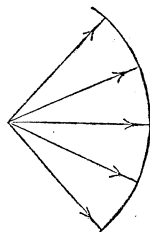

Diverging sound;

Intensity diminishes;

§ 76. When the pulse proceeds in a homogeneous medium from a point of disturbance, it takes a spherical shape, the normals all meet at the centre of the sphere, and the rays are then said to *diverge* from a point, in which case the sound becomes less intense as it proceeds.

Converging sound;

When in the progress of the pulse it retains its spherical shape, but any portion of it becomes so modified as to present its concavity in front, the rays will meet at some point in advance, and are said to *converge*; the sound will become louder and louder as it progresses, and finally, when it reaches the point of union of the rays, it will attain its maximum intensity; for in this position the living force, which was before distributed among the molecules of an extended pulse, is concentrated in the few molecules of a very contracted pulse.

Fig. 43.

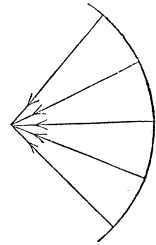

Intensity increases;

Illustration of divergence and convergence of sound;

§ 77. To illustrate, conceive a disturbance to take place at the focus  $F$ , of an ellipsoid; a pulse will proceed from this point in all directions. Any two rays, as  $FD$  and  $FE$ , will, from the law of reflexion just explained and the geometrical properties of the ellipsoid, pass to the other focus  $F'$ , as will also the portion of the pulse included between

Fig. 44.

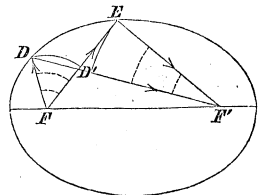

Decreases in loudness before reflexion;

these rays and which is reflected at the surface  $DE$ . The living force impressed upon the molecules in the vertex of the angle  $DFE$ , will, as the pulse proceeds from  $F$ , become more and more diffused, and when the pulse reaches the point  $D$ , this living force will be distributed among the molecules of the surface  $DD'$ . After reflexion, the concavity of the pulse is turned to the front, its extent becomes less and less as it approaches the second focus, and the living force of its molecules will be more and more concentrated; till finally, when the pulse reaches the focus  $F'$ , the living force of a single molecule will be a maximum, and will be capable of producing the greatest impression upon the ear.

Increases after reflexion;

Maximum intensity.

What has been said of the portion of the pulse within the sector  $DFE$ , is equally true of any other sector and of the whole spherical pulse; so that all the sound which originated in the focus  $F$ , will, after reflexion, be concentrated in the focus  $F'$ .

All the sound from one focus concentrated in the other.

§ 78. When a spherical pulse is incident upon a plane deviating surface, it will be easy from the principles now explained to construct both the refracted and reflected pulses. For this purpose, let

Spherical pulse incident on a plane surface.

$AB$  represent the deviating surface;  $D$ , the point of primitive disturbance;  $DC$ , any incident ray;  $CG$  and  $CR$ , the corresponding refracted and reflected rays respectively. From the point  $D$ , draw  $ED$ , perpendicular to the deviating surface. Extend the refracted ray  $CG$ , back till it meets this line in the point  $H$ . At the point of incidence  $C$ , draw  $CM$  parallel to  $ED$ . Denote the angle of incidence  $DCM = CDE$  by  $\varphi$ ; the angle of refraction  $MCH = CHE$  by  $\varphi'$ ; the distance  $DE$  by  $f$ ; and the distance  $HE$  by  $f'$ . Then will

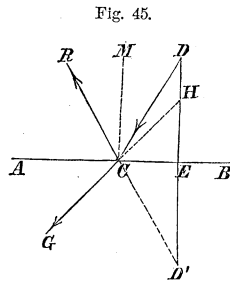

Fig. 45.

Construction of the refracted and reflected pulses.

$$f \tan \varphi = CE = f' \tan \varphi'$$

whence

$$f' = f \cdot \frac{\tan \varphi}{\tan \varphi'} = f \cdot \frac{\frac{\sin \varphi}{\cos \varphi}}{\frac{\sin \varphi'}{\cos \varphi'}} = f \cdot \frac{\sin \varphi}{\sin \varphi'} \cdot \frac{\cos \varphi'}{\cos \varphi};$$

Equations;

making, Equation (29),

$$m = \frac{V}{V'} = \frac{\sin \varphi}{\sin \varphi'}, \dots (31). \text{ Transformations;}$$

Operations performed;

and substituting for  $\cos \varphi'$  and  $\cos \varphi$ , their values  $\sqrt{1 - \sin^2 \varphi'}$  and  $\sqrt{1 - \sin^2 \varphi}$  and eliminating  $\sin \varphi'$  by its value  $\frac{\sin \varphi}{m}$ , we finally have

$$f' = f \cdot m \cdot \sqrt{\frac{1 - \frac{\sin^2 \varphi}{m^2}}{1 - \sin^2 \varphi}} \dots \dots \dots (32).$$

Direction of refracted ray determined.

The distance of the point  $D$  from the deviating surface and the nature of the two media on the opposite sides of the latter being given, the value of  $f$ ,  $V$  and  $V'$  will be known; and assuming the direction of the incident ray  $DC$ , the angle  $\varphi$  also becomes known, and the value of  $f'$ , which determines the point  $H$ , will result from Equation (32), and the direction of the refracted ray  $HCG$ , will thence become known.

For the reflected ray,  $V$  and  $V'$  become equal with contrary signs, and  $m$  will be equal to minus unity. This will reduce Equation (32) to

$$f' = -f;$$

Point from which the reflected rays will diverge;

that is to say, all the reflected rays will diverge from a point  $D'$ , as far behind the deviating surface as the point  $D$  of disturbance is in front of it. The reflected pulse will, therefore, be spherical.

Reflected pulse spherical;

From the point  $D$  as a centre and radius  $DK$ , equal to that of the spherical pulse at any instant, describe the arc  $OKO'$ ; this will represent a section of the incident pulse by a plane normal to the deviating surface. Make the distance  $ED'$  equal to  $DE$ , and with  $D'$  as a centre, and radius  $D'K'$  equal to  $DK$ ,

Illustration;

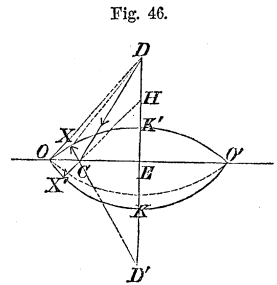

describe the arc  $OK'O'$ ; this will represent a section, Construction of points in the refracted and reflected pulses. by the same plane, of the reflected pulse. Draw any incident ray as  $DC$ ; through the point  $H$ , given by the value of  $f'$  in Equation (32), and the point  $C$ , draw  $HC$ , which being produced will give the refracted ray  $CX'$ ; through  $D'$  draw the line  $D'CX$ , and multiply the intercepted portion  $CX$  by the ratio of the velocities  $V'$  and  $V$ , and lay off the product from  $C$  to  $X'$ , and we have the point  $X'$  of the refracted, corresponding to the point  $X$  of the reflected pulse. An ear situated at  $X'$  will hear the direct sound transmitted along the ray  $DX$ , and an Position whence the direct sound and the echo are both audible; echo of the same sound reflected at the point  $C$ ; the interval of time, or number of seconds intervening between the two, being equal to

$$\frac{DC + CX - DX}{1089,42 \sqrt{1 + (t^\circ - 32^\circ) \cdot 0,00208}},$$

Time between the impressions;

on the supposition that the sound is transmitted through Position whence the transmitted sound is heard. the atmosphere, and the linear distances are estimated in English feet. An ear situated at  $X'$  will hear the transmitted sound at the instant the one at  $X$  will receive the echo.

§ 79. An *echo* is always produced when the ear is When an echo is produced; able to distinguish the direct sound from that which is reflected. A good ear will perceive about nine successive sounds in one second of time; that is to say, the sounds must succeed each other at intervals of one-ninth Powers of the ear; of a second in order to be heard singly. The sound and the echo are to be regarded as successive sounds, of which the latter will be distinctly heard if it fall upon the ear after this organ has conveyed to the mind a distinct impression of the former. Time between a sound and its echo; The interval of time between the sound and its echo, depends upon the difference of route travelled by the direct and reflected sound, and the least difference  $x$  for a distinct echo, will result from the Equation

Least difference of route for a distinct echo;

$$\frac{1^s}{9} = \frac{x}{1089,42 \sqrt{1+(t^\circ - 32^\circ) 0,00208}};$$

or, taking the temperature of the air at 32°,

Same at 32°.

$$x = \frac{1089,42}{9} = 121,04.$$

Sound and echo distinctly perceptible;

When the difference of routes exceeds this distance, the interval of time between the two impressions upon the ear becomes distinctly perceptible; and in proportion as that difference becomes less than  $x$ , will the impression of the echo begin before that of the direct sound ends; and this overlapping, as it were, of impressions will give rise to confusion, which will continue to a greater or less extent till the difference of routes becomes so small as to afford no sensible interval between the instants that mark the beginning of both impressions, in which case the echo will strengthen the effect of the direct sound.

Echo causes confusion;

Effect of sound strengthened by echo;

Illustration;

§ 80. Let an observer place himself at  $O$ , midway between the plane walls  $AB$  and  $CD$ , of which the distance apart is some 250 feet or more. The sounds which he utters will be reflected back to him by the two walls, and having traversed equal distances will reach him at the same instant; they will, therefore, reinforce each other, and he will hear one distinct echo. Now let him move towards one of the walls. At first he will perceive little or no difference of effect, but presently one echo will seem to lag behind the other, confusion will soon follow, and this will continue till twice the difference of his distances from the two walls becomes equal to or greater than 121 feet, when he will hear two distinct echos, which will separate more and

Fig. 47.

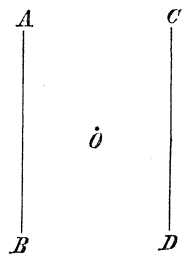

Person assuming different positions between two walls;

one distinct echo. Now let him move towards one of the walls. At first he will perceive little or no difference of effect, but presently one echo will seem to lag behind the other, confusion will soon follow, and this will continue till twice the difference of his distances from the two walls becomes equal to or greater than 121 feet, when he will hear two distinct echos, which will separate more and



more from each other as he progresses; when he gets within sixty feet of the nearest wall, the first echo will begin to confound itself with the sound of his voice heard directly; he will now enter a second space of indistinctness, from which he will emerge at a distance from the wall of about fifteen or twenty feet.

§ 81. It thus appears that reflecting surfaces situated at different distances from a speaker may throw back to him numerous echos of the same sound. Of this many remarkable instances are recorded. At Lurley-Fels, on the Rhine, is a position in which a sound is repeated by echo seventeen times. At the Villa Simonetta, near Milan, is another where it is repeated thirty times. An echo in a building at Pavia used to answer a question by repeating its last syllable thirty times. The rolling of thunder has been attributed to echos from clouds situated at unequal distances from an auditor; and the propriety of this view has been sustained by the observations of ARAGO, MATTHIEU and PRONEY, while experimenting upon the velocity of sound. They found that when the weather was perfectly clear the reports of their guns were always single and sharp; whereas when the sky was overcast or a single cloud of any extent was present, they were frequently accompanied with a long continued roll like that of thunder, and occasionally a double sound would arrive from a single shot.

But it is proper to remark that the rolling of thunder admits of another explanation. Thunder is caused by a disturbance of electrical equilibrium in the atmosphere; experience shows that this takes place over a long and sinuous line, the different points of which are at unequal distances from the auditor, and the sounds from these points can, therefore, only reach him in succession and without sensible intervals.

§ 82. When reflected sound and that proceeding directly from the same source, are made to fall upon the

Effects observed.

Surfaces at different distances reflect many echos of same sound;

Several remarkable instances;

Experiments;

Rolling of thunder.

Reflected sound may increase the effect of direct sound;

ear simultaneously, or nearly so, they strengthen each other and become audible in positions where neither could be heard separately. The *Speaking Trumpet* affords an illustration of this. The Speaking Trumpet is a funnel-shaped tube, of which the object is to throw the voice beyond its ordinary range. In its best form it is parabolic.

Illustrated by the speaking trumpet;

It is a geometrical property of the parabola that a line  $FT$ , drawn from the focus  $F$ , to any point  $T$  of the curve, and another  $TK$ , drawn from  $T$  parallel to the axis  $FA$ , make equal angles with the tangent line to the curve at  $T$ . A portion of

Fig. 48.

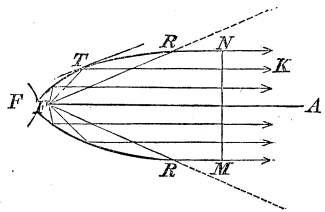

Its construction and use explained;

the diverging rays of sounds proceeding from a mouth at the focus  $F$ , will be reflected by the trumpet in directions parallel to the axis  $FA$ ; and the living forces of the aerial molecules which, without the trumpet, would have been diffused over that portion of the spherical surface on the outside of a cone of which  $FR$  and  $FR$  are the most diverging elements, become, by its use, concentrated within the limits of a circle whose diameter  $MN$ , is equal to that of the trumpet's mouth, and superposed upon the living forces arising from the action of the direct sound. The axis of the trumpet being directed upon a person at a distance, sounds of audible intensity may thus be conveyed to him, which he could not hear from the unassisted organs of speech.

By its use sounds are rendered audible that could not be heard without it.

§ 83. The *Hearing Trumpet*, which is intended to assist persons who are hard of hearing, is similar to the speaking trumpet; but the operation is reversed. The rays of sound enter this instrument at the larger

Fig. 49.

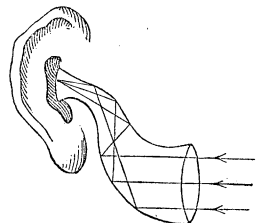

Hearing trumpet;

opening and are so reflected as to become united at the smaller end, which is inserted into the ear. Construction and use;

§ 84. *Whispering Galleries*, so called from the fact that the faintest whisper uttered at one point may be distinctly heard at another and distant point, without its being audible at intermediate positions, depend upon the operation of the same principle, to wit, the convergence of the rays of sound by reflexion. The best form for these galleries is that of the ellipsoid of revolution. In such a chamber two persons, one in either focus, could keep up a conversation with each other which would be inaudible at other points. The ear of Dionysius is celebrated in ancient history; it was a grotto cut out of the solid rock at Syracuse, in which a person placed at one point could hear every word, however faintly uttered, in the grotto. It was doubtless of a parabolic shape. Whispering galleries;  
Best form.  
Ear of Dionysius.

The same principle is employed in the construction of *Speaking Tubes*, used for the purpose of communicating between different apartments of the same building, now coming into very general use.

§ 85. Halls for public speaking, such as lecture rooms, theatres, churches, and the like, should be so constructed as to diffuse the sounds that are uttered throughout the space occupied by the audience, unimpaired by any echo or resound. Were the speaker to occupy constantly the same position, the parabolic form would, on theoretical grounds, undoubtedly be the best; but in debating halls, where every speaker occupies a different position from another, these conditions are very difficult to fulfil, especially when the room is large. Every-

thing should be avoided that would at all interfere with Principles on which they should be constructed.

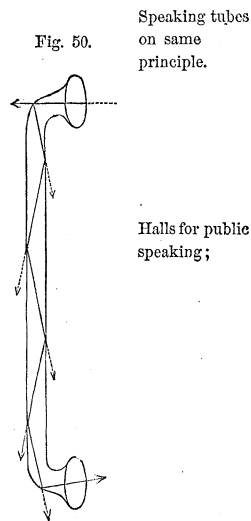

the uniform diffusion of sound, and especially all needless hollows and projections which are likely to generate echos.

Experiment;

The following experiment will illustrate, in a very simple manner, the consequences arising from the reflexion of the rays of sound from the interior of a parabola.

Illustration;

Place a watch in the focus  $A$  of a parabolic mirror  $MN$ , and all the rays of sound that fall on the concave surface will be reflected in the direction indicated by the arrows. The ticking of the watch will be plainly heard within the space  $MNO P$ , in which the rays fall, but it will not be audible at a small distance on either side.

Fig. 51.

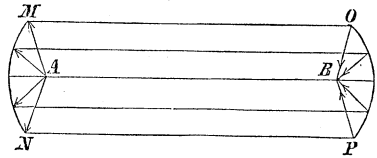

Explanation.

Now place a second reflector  $O P$ , opposite to the former, and at some distance from it; the rays of sound will be received by it and thrown into the focus  $B$ . If the ear, or, better still, the mouth of a hearing-trumpet, be applied to this point, the ticking of the watch will be heard as plainly as at  $A$ .

Partition walls;

§ 86. While it is important to diffuse sound uttered or in any way produced, uniformly, so as to render it distinctly and equally audible in all directions, it is also necessary to prevent its passage from one apartment to another for which it was not intended. Partitions are usually made of solids; but solids, if elastic, such as wood, metals, and stone, are, as we have seen, better adapted to transmit sound than air itself; an essential condition, however, for this transmission is homogeneity of substance and uniformity of structure. Where

How constructed to prevent the transmission of sound.

these are wanting a sonorous pulse transmitted through a solid is ever changing its medium, and soon becomes broken up by reflexion and refraction, retardation and

acceleration, into a multitude of non-coincident waves, and these from the laws of interference must, to a greater or less extent, destroy each other's effects. Examples of interference of sound;

As an instructive instance of this stifling effect on a sonorous pulse, we may mention the example afforded by a tall glass filled with champagne. As long as the effervescence lasts and the wine is full of bubbles, the glass cannot be made to ring by a stroke on its edge, but will give a dead and puffy sound. As the effervescence subsides the tone becomes clearer, and when the liquid is perfectly tranquil, the glass rings as usual. On re-exciting the bubbles by agitation, the musical tone again disappears. Glass of champagne;

So of a solid or union of several solids, in which there are frequent changes of density and elasticity, and especially where there is a want of adhesion among the different parts; sound penetrates these with great difficulty, and materials so united as to satisfy to the greatest extent possible the condition of non-homogeneity should, therefore, be employed whenever it is an object to prevent the transmission of sound. The influence of carpets, curtains, and tapestry hangings, in preventing reflexion and echos in large apartments, is due to the causes above mentioned. The mixture of the unelastic fibres of the cloth with its numerous layers of entangled air, intercepts and deadens the sonorous waves before they reach the more solid and elastic media behind. Heterogeneous solids; Carpets, curtains, &c.

## MUSICAL SOUNDS.

- Audible sounds produced;      § 87. Every impulse mechanically communicated to the air or other elastic medium is, as we have seen, propagated onward in a wave or pulse; but in order that it may affect the ear as an audible sound, a certain force and suddenness are necessary. The slow waving of the hand through the air is noiseless, but the sudden displacement and collapse of a portion of that medium by the lash of a whip, produces the effect of an explosion. The impression conveyed to the ear will depend upon the nature and law of the original impulse, which being altogether arbitrary in duration, violence and character, will account for all the variety observed in the continuance, loudness and quality of sound. The auditory nerves, by a most refined delicacy of mechanism, appear capable of analyzing every pulsation, and of appreciating the laws which regulate the motions of the molecules of air in contact with the ear; and from this arise all the qualities—grave, acute, harsh, soft, mellow, and nameless other peculiarities which we distinguish between the voices of different individuals and different animals, and the tones of different musical instruments—bells, flutes, cords, &c.
- Impression on the ear depends upon;      § 88. Every irregular impulse communicated to the air produces what we call *noise*, in contradistinction to musical sound. If the impulse be short and single, we hear a crack; and as a proof of the extreme sensibility of the ear, it is to be remarked that the most short and sudden noise has its peculiar character. The crack of a whip, the blow of a hammer against a stone, the explosion of a pistol, are perfectly distinguishable from each other. If the impulse be of sensible duration and irregular, we hear a crash; if long and interrupted, a rattle,
- Auditory nerves analyze pulsations: whence grave, acute, &c. sounds; and tones of musical instruments.
- Noise;
- Crack;
- Crash;

or a rumble, according as its parts are less or more continuous. Rumble.

§ 89. The ear retains for a portion of time after the impulse is communicated to it a perception of excitement. Continuous sound produced; If, therefore, a short and sudden impulse be repeated beyond a certain degree of quickness, the ear loses the intervals of silence and the sound appears continuous. The probable frequency of repetition necessary for the production of continuous sound is stated to be not less than sixteen times in a second, though the limit will be different for different ears. The frequency of repetition necessary.

§ 90. If a succession of impulses occur at exactly equal intervals of time, and if all the impulses be exactly similar in duration, intensity, and law, the sound produced is perfectly uniform and sustained, and takes that peculiar and pleasing character called *musical*. In musical sounds there are three principal points of distinction, viz.: the pitch, the intensity, and the quality. Musical sounds; Of these the pitch depends, as we have seen, solely upon the frequency of the repetition of the impulses; the intensity, on their violence; and the quality, on the peculiar laws which regulate the molecular motions in any particular instance. Pitch, intensity and quality; All sounds, whatever be their intensity or quality, in which the elementary impulses occur with the same frequency, have to the ear *the same pitch*, and are said to be *in unison*. Sounds having same pitch, or in unison. It is on the pitch alone that the whole doctrine of harmonics is founded.

§ 91. The means by which a series of equidistant impulses can be produced mechanically upon the air are very various. Musical sounds mechanically produced; If a toothed wheel be made to turn with a uniform motion while a steel or other spring is held against its circumference with a constant pressure, each tooth as it passes will receive an equal blow from the spring, and this being communicated to the air, a wave of sound will proceed from the place of collision. The

The siren; number of such blows in a second will be known when the angular velocity of the wheel and the number of teeth upon its circumference are known, and thus every pitch may be identified with the number of impulses which produce it. The Siren, another instrument by which the same results may be evolved, has been described in § 48. A series of broad *palisades*, placed edgewise in a line running from the ear, and equidistant from each other, will reflect the sound of a blow struck at the end nearest the auditor, producing a succession of echos which reach the ear at equal intervals of time, thus producing a musical note whose pitch will be determined by the number of reflexions in each second of time. This number will be equal to the quotient arising from dividing the velocity of sound by twice the distance between two adjacent palisades. A similar account may be given of the singing sound produced by a bullet while moving through the air and turning rapidly about its centre of inertia. The angular motion of the bullet being uniform, the actual velocity of its surface on one side will be greater than that on the other, and any inequality in the figure of the bullet will be made to vary its action upon the air periodically, thus producing a musical sound.

A series of palisades;

Whistling of a bullet.

Most ordinary way of causing musical sounds;

§ 92. The most ordinary way of producing musical sounds is to set in vibration elastic bodies, as stretched strings and membranes, steel springs, bells, glass, columns of air in pipes, &c., &c. All such vibrations consist in a regular alternate motion to and fro of the molecules of the vibrating body, and are performed in strictly equal portions of time. They are, therefore, adapted to produce musical sounds by communicating that regularly periodic initial impulse to the aerial molecules in contact with them, from which such sounds result. We proceed to consider their modes of production, and especially in the first and last named cases, these being the most simple.

Modes considered.



VIBRATIONS OF MUSICAL STRINGS.

§ 93. If a string or wire be stretched between two fixed points, and then struck or drawn aside from its position of rest and suddenly abandoned, it will vibrate to and fro till its own rigidity and the resistance of the air bring it to rest; but if a *fiddle bow* be drawn across it, the vibrations will be renewed and may be maintained for any length of time, and a musical sound will be heard whose pitch will depend upon the greater or less rapidity of the vibrations.

Thus, if  $MN$  be any stretched cord, struck at right angles to its length at  $O$ ,

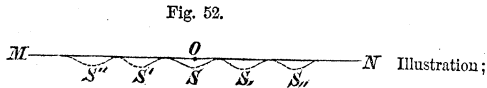

it will be suddenly bent at that point into the curved or waved shape indicated by the dotted line  $S$ , which shape will run along the cord in both directions till it meets with some obstruction to its further progress, when it will be either wholly or partly reflected, and return upon its course in a manner and for the reasons to be explained presently, the successive positions in the diverging motion being  $S'$ ,  $S''$ , &c., on the one side, and  $S$ ,  $S''$ , &c., on the other.

Wave runs along the cord in both directions;

§ 94. To find the velocity with which the wave runs along the cord, it is plain that we may either regard the cord as continuous, or as being composed of a series of detached points, kept in relative position by their mutual attractions for each other, each point being loaded with the mass of so much of the cord as extends half way on either side to the adjacent point, and of which the length is equal to the distance between any two consecutive points.

To find the velocity of this wave motion;

Illustration;

Suppose  $MN$  to be the cord's position of rest, and the wave to proceed in the direction from  $C$  to  $D$ ; let

Suppositions;

the point  $A$ , be just on the eve of motion and the place  $B'$ , the position of the point  $B$  at the same instant. While, therefore, the actual motion of the point  $B$  has been from  $B$  to  $B'$ , that of disturbance has been from  $B$  to  $A$ .

Fig. 53.

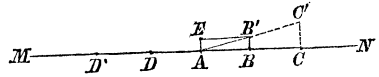

The duration of these simultaneous motions is indefinitely short; the motions themselves may, therefore, be regarded as uniform. Hence, denoting the actual velocity of the point  $B$  by  $v$ , and the velocity of the disturbance by  $V$ , we have

Consequences;

$$v : V :: B B' : A B.$$

$$v = V. \frac{B B'}{A B}$$

or, denoting the angle  $B A B'$  by  $\phi$ , in which case,

$$\frac{B B'}{A B} = \tan \phi,$$

we find,

Velocity of a point of the cord;

$$v = V. \tan \phi \dots \dots \dots (33).$$

Tensions of parts of the cord;

The tension of the cord between  $A$  and  $B$ , acts to draw the point  $A$ , from  $A$  towards  $B$ , and the tension between  $A$  and  $D$  acts to draw the same point from  $A$  towards  $D$ . Denote the tension of the cord when at rest by  $C$ , that between  $A$  and  $B'$  by  $C'$ , then because the tension of the same portion of the cord will be proportional to the length to which it is stretched, will

$$C : C' :: AB : AB'$$

Relation of tensions  $C$  and  $C'$ ;

whence

$$C' = C \cdot \frac{AB'}{AB},$$

and this being resolved into two components, one acting from  $A$  to  $E'$ , at right angles to  $MN$ , the other in the direction of  $MN$ , will give for the first

$$C' \cdot \sin \varphi = C' \cdot \frac{BB'}{AB'} = C \cdot \frac{BB'}{AB} = C \cdot \tan \varphi, \quad \text{Components of } C';$$

$$C' \cdot \cos \varphi = C' \cdot \frac{AB}{AB'} = C;$$

the second will be destroyed by the tension from  $A$  to  $D$ , while the first will alone produce motion in  $A$ , and is, therefore, the motive force. Denote by  $w$ , the weight of a unit's length of the cord while at rest, then will the mass with which  $A$  is loaded be expressed by

$$\frac{w}{g} \cdot AB, \quad \text{Mass on which the motive force acts;}$$

in which  $g$  denotes the force of gravity; and the acceleration due to the motive force will be

$$\frac{C \cdot g \cdot \tan \varphi}{w \cdot AB}; \quad \text{Acceleration due to the motive force;}$$

and therefore the velocity of  $A$ , in the small time  $t$ , which velocity will be equal to that of  $B'$  when  $D$  begins to move, will be given by the relation

$$v = \frac{C \cdot g}{w} \cdot \tan \varphi \cdot \frac{t}{AB}. \quad \text{Velocity of a particle in small time } t;$$

But

$$\frac{t}{AB} = \frac{1}{V},$$

and denoting by  $L$ , half the length of the cord whose weight is equal to the tension  $C$ , we have

Value of tension  $C$ ;

$$C = 2 w. L,$$

which values substituted above give

Velocity of particle in small time  $t$ .

$$v = \frac{2 g L. \tan \phi}{V};$$

and replacing  $\tan \phi$  by its value found from Equation (33), gives

$$V^2 = 2 g L,$$

or

Velocity of wave along a cord;

$$V = \sqrt{2 g L}. \dots \dots (34).$$

Rule.

That is to say, *the velocity with which a wave or pulse will run along a tense cord is constant, and equal to that acquired by a heavy body in falling in vacuo, under the action of its own weight, through a height equal to half the length of the cord whose weight is equal to the tension.*

Example;

*Example.* A cotton thread 73 feet long and weighing 904 grains, is stretched by a weight of 12840 grains; with what velocity will a wave move along this cord?

First

$$904 : 12840 :: 73 : 2 L,$$

whence

Computation;

$$2 L = \frac{73 \cdot 12840}{904} = 1036,83.$$

Second

$$V = \sqrt{2g \cdot L_i} = \sqrt{32,18 \cdot 1036,83} = 182,64^f.$$

Wave velocity  
along the cord;

§ 95. Substituting the above value for  $V$ , in Equation (33), the latter becomes

$$v = \sqrt{2g \cdot L_i} \cdot \tan \varphi, \dots \dots (35)$$

Velocity of a  
point of the cord;

from which it appears that the actual velocity of a point of the cord is directly proportional to the tangent of the inclination of the cord, at that point, to the cord's position of rest; and when this condition ceases to obtain, as it does when the pulse comes to lighter and more movable portions, or encounters obstacles less movable than the rest of the cord, it will be divided into two, one of which will continue to move in the same direction while the other will run back, or be reflected, and produce a kind of echo, just as in the case of a wave of air encountering a medium whose molecules are either more movable or less so than those of air.

Pulse moving  
along a cord  
resolved into  
two;

If one end of the cord be fixed at  $M$ , its molecules adjacent to those in contact with the fixed obstacle tending, when the pulse reaches the latter, to move at right angles to the cord's length, will be resisted by the stationary molecules; the reaction will throw them to the opposite side, and this reaction extending to the molecules behind, the pulse will pass to the opposite side of

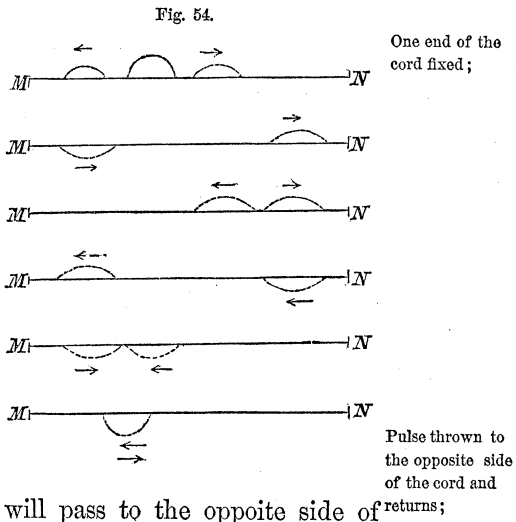

Both ends of the cord fixed;

Reflected pulses meet and conspire;

Separate and are again reflected;

Meet a second time at the point of primitive disturbance;

Cord brought to rest.

the cord and return along its entire length, following after the direct pulse in the same direction. If the second end be fixed, the direct pulse proceeding towards it will conduct itself in the same way; the reflected pulses will proceed to meet each other, and being on the same side of the cord will conspire at their place of union to produce a single resultant pulse, in which the molecules of the cord will depart from their places of rest by the sum of the distances of the same molecules in the component pulses. These component pulses will, however, immediately separate, and proceed towards the fixed ends, where they will be reflected as before, and return to meet again, having once more changed sides. The point of second meeting will be

Fig. 55.

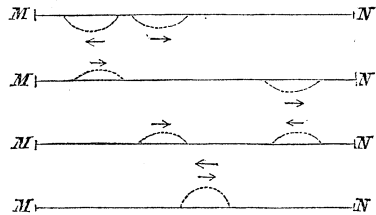

at the place of primitive disturbance, from which the waves will depart, as before, to undergo the same round; and thus, but for the resistance of the air and want of perfect elasticity in the cord, the latter would vibrate for ever. But every pulse communicated to the air, is an elimination from the cord of so much of its *living force*, and as this must soon become exhausted, the cord will come to rest.

Whole length of cord divided into two parts;

§ 96. Suppose the whole length of the cord  $MN$ , to be denoted by  $L = l_i + l'$ , of which  $l_i$  represents the distance  $OM$ , from the point of primitive disturbance  $O$ , to the fixed obstacle on one side, and  $l'$  the distance  $ON$  to the obstacle on the opposite side. Then denoting the time of describing  $l'$  by  $t'$ , and that of describing  $l_i$  by  $t_i$ , we have

Fig. 56.

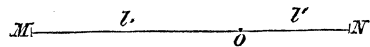

$$\begin{aligned}l' &= V \cdot t', \\l_i &= V \cdot t_i;\end{aligned}$$

Lengths of the  
parts;

whence

$$\begin{aligned}t' &= \frac{l'}{V}, \\t_i &= \frac{l_i}{V};\end{aligned}$$

Times required  
for a pulse to pass  
along them.

the first pulse being reflected at  $N$ , will describe the entire length  $l' + l_i$  in the reverse direction in the time

$$t' + t_i = \frac{l'}{V} + \frac{l_i}{V};$$

Time in which  
the first pulse  
describes the  
whole length;

and the second pulse being reflected at  $M$ , will describe the entire length  $l' + l_i$ , in the same time, or

$$t' + t_i = \frac{l'}{V} + \frac{l_i}{V};$$

The same for the  
second pulse;

the first pulse being reflected a second time at  $M$ , will describe the length  $l_i$  in the time

$$t_i = \frac{l_i}{V}$$

Time in which  
first pulse passes  
over second part;

and the second pulse being reflected a second time at  $N$ , will describe the distance  $l'$ , in the time

$$t' = \frac{l'}{V};$$

That in which  
second pulse  
passes over first  
part;

and at the expiration of all these times the pulses will

Pulses return to starting point;

be at their first starting point, and each having been twice reflected, they will be on the same side of the cord that they were originally ; they will, therefore, produce a resultant pulse precisely the same, abating the qualification due to the air and imperfect elasticity, as that produced by the initial impulse. Hence, if  $T$  denote the time of one complete vibration of the cord, that is to say, the interval between the instant of primitive disturbance and that at which the cord resumes its initial condition, we shall have, by taking the half sum of these several intervals—because both pulses are moving during the same time,

Conspire and produce a resultant pulse;

Time of vibration of the cord;

$$T = 2 (t' + t_1) = \frac{2 (l' + l_1)}{V} = \frac{2 L}{V}$$

and replacing  $V$  by its value, Equation (34),

The same reduced.

$$T = \frac{2 L}{\sqrt{2 g L_1}} \dots \dots \dots (36)$$

Example;

*Example.* Taking the example of § 94, in which  $L = 73$ , and  $2 L_1 = 1036,83$  feet, we find

Result.

$$T = \frac{2 \cdot 73}{\sqrt{32,18 \cdot 1036,83}} = 0,799.$$

Experiments;

§ 97. The truth of the foregoing theory has been fully confirmed by the experiments of WEBER. He stretched a very uniform and flexible cotton thread fifty-one feet two inches in length, weighing 864 grains, horizontally, by a known weight. The thread was struck at six inches from the end, and the time of the wave's running a certain number of times over the length of the string, backward and forward, carefully noted by means of a stop-watch that marked thirds (the sixtieth part of a second).



The mean of a great many trials, agreeing well with Mean of results each other, gave the results in the following table :

Tension in grains.	Length run over by the wave.	Time in thirds.	Time of running over the length $\overset{f}{102,33}$ in thirds by observation.	Time by calculation from the formula $T = \frac{2L}{\sqrt{2gL}}$ .
10023	$\overset{f}{102,4}$	46	46	46,012
10023	204,7	92	46	46,012
10023	409,4	184	46	46,012
33292	409,4	99	24,72	25,246
69408	409,4	65	16,25	17,485

Table.

A more complete confirmation could not have been desired. The slight discrepancies are doubtless owing to a want of perfect uniformity in so long a thread, which must necessarily have formed a *catenary* of sensible curvature.

Denote by  $N$  the number of vibrations performed in a given time  $T$ , then will

$$T = \frac{T_1}{N}$$

Time of one vibration of the cord;

which substituted for  $T$  in Equation (36) gives, after taking the reciprocal of both members,

$$\frac{N}{T_1} = \frac{\sqrt{2g L_1}}{2L} \dots \dots (37).$$

Reciprocal of the same.

In the foregoing equations  $2L$ , denotes the length of the cord of which the weight measures the tension. Denote this weight by  $W$ , the diameter of the cord by  $D$ , and its density by  $d$ ; then will

$$W = \pi \cdot \frac{D^2}{4} \cdot 2L \cdot d \cdot g$$

Weight of cord whose length measures the tension;

whence

Length of half  
this cord;

$$L_1 = \frac{2 W}{\pi \cdot D^2 \cdot d \cdot g}$$

which substituted in Equations (36) and (37), give

Time of  
vibration;

$$T = \sqrt{\pi} \cdot \frac{D \cdot L \cdot \sqrt{d}}{\sqrt{W}} \dots \dots \dots (38)$$

Its reciprocal;

$$\frac{N}{T_1} = \frac{1}{\sqrt{\pi}} \cdot \frac{\sqrt{W}}{D \cdot L \cdot \sqrt{d}}, \dots \dots \dots (39)$$

Rule first;

from which it appears that, *the time of vibration of a tense cord varies as its length, diameter and square root of its density, directly; and the square root of the stretching force, inversely.* And that, *the number of vibrations performed by a tense cord in a given time, varies as the square root of the stretching force directly, and the diameter, length and square root of the density inversely.*

Rule second.

Vibrating cord  
fixed at both  
ends and struck  
in the middle;

§ 98. The tense cord *MN* being fixed at both ends and in a state of vibration, ap-

Fig. 57.

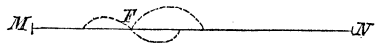

ply the finger, or any other partially obstructing cause, at the middle point *F*, and then withdraw it. The law of Equation (34), will be suddenly interrupted at this point, the progressing pulse will be resolved into two, one of which will continue to move in the same direction and on the same side of the cord, while the other will be reflected and return along the opposite side. These component pulses having equal distances to travel before they reach the ends, will be reflected at the fixed points at the same instant, return on opposite sides of the cord, and meet in the centre. They will,

Primitive pulse  
resolved into  
two;

therefore, solicit simultaneously the central point  $O$ , in opposite directions, and if the pulses be equal, they will wholly interfere at that point, which must, therefore, remain stationary.

The effect of the reciprocal action of the two waves being to fix the point  $O$ , these waves will both be totally reflected there, will return to the ends, be again reflected, return to the centre, from which they will be thrown back towards the ends, and so on till the living force of the cord is totally expended upon the air. Thus the two portions  $MO$  and  $ON$  of the cord may vibrate as though the point  $O$  had been originally fixed.

The two reflected pulses interfere at the middle of the cord;

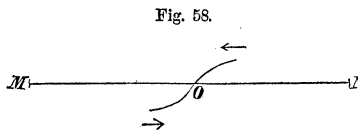

Fig. 58.

Are thence again reflected and so on.

If the finger be applied but for an instant at  $O$ , at a distance from  $M$  equal to one-third of the whole length  $MN$ , while the wave is progressing from  $M$  towards  $O$ , the latter

will be resolved, as before, into two component waves, one of which will continue to move towards  $N$  on the same side of the cord, the other will return to  $M$  on the opposite side. The distance  $MO$  being equal to one-half of  $ON$ , the return component will be wholly reflected and change sides at  $M$ , and come back to the point  $O$  by the time the direct component arrives at  $N$ , where the latter will be totally reflected and pass to the opposite side of the cord. The component waves being now on opposite sides of the cord, and moving towards each other, one starting from  $O$  and the other from  $N$ , will meet at  $O'$ , half way from  $O$  to  $N$ , making  $NO'$  equal to one-third of  $MN$ . Here

Primitive pulse resolved into two;

Component pulses interfere;

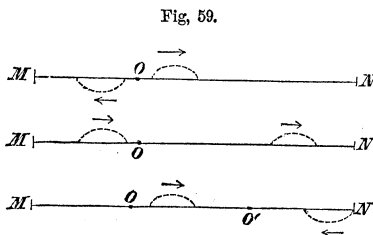

Fig. 59.

Finger applied at one third the whole length from the end;

they will interfere, be totally reflected, and proceed from

Are again reflected;

Again meet at their starting point and so on.

Finger kept on the cord;

One reflected component resolved into two;

Reciprocal action between these two sets of components;

Cord broken up into portions, each one vibrating.

Nodal points.

$O'$  as they did from  $O$ ; they will meet again in this latter point and there be totally reflected, and thus each component wave will be made to describe, as long as the cord retains any of its living force, alternately one-third on one side and two thirds on the opposite side of the entire length of the cord, as though the point  $O$  were to become alternately fixed at  $O$  and  $O'$ , after every reflexion at  $M$  and  $N$ .

Were the finger to be kept at the point  $O$ , till the first reflected component returned to that point, this compo-

nent would be there subdivided, giving rise to a second return as well as a second onward component; the latter would meet the first onward component at  $O'$ , and by its action upon it resolve this also into two components, the onward one of which would meet the second return component at  $O$ , and being on opposite sides would interfere and hold this point at rest. Thus the whole cord may be broken up into three equal parts, each of which will vibrate as though the points of division,  $O$  and  $O'$ , had been stationary or fixed.

A similar explanation would show that if the finger were applied at any other point of which the distance from one of the fixed ends were an aliquot part of the whole length of the cord, the cord would in like manner be broken up, as it were, into equal aliquot portions, each of which would vibrate as though its extremities were fixed.

Molecules or particles of a vibrating body thus rendered stationary by the simultaneous action of opposing waves or pulses, are called *Nodal* points. The interme-

Fig. 59.

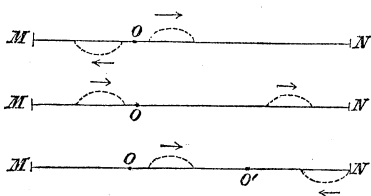
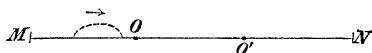

Fig. 60.



diating portions which vibrate, are termed *bellies*, or *ventral segments*.

§ 99. If  $L$ , denote, as before, the entire length of the cord, and  $n$ , the number of ventral segments into which it divides itself, then will the number of its nodes be  $n - 1$ , and the length of each segment,

$$\frac{L}{n}; \quad \text{Length of a segment.}$$

which substituted for  $L$  in Equation (36), gives for the time of vibration,

$$T = \frac{2L}{n\sqrt{2g.L}}, \quad \dots \dots \dots (40), \quad \text{Time of vibration;}$$

and in Equation (37), the number of vibrations in the time  $T$ ,

$$\frac{N}{T} = \frac{n\sqrt{2g.L}}{2L} \quad \text{Number in time } T;$$

and for the number in one second, by making  $T$ , equal to one second,

$$N = \frac{n\sqrt{2g.L}}{2L} \quad \dots \dots \dots (41). \quad \text{Number in one second.}$$

All of this is confirmed by experience. If the string of a violin, or violincello, while maintained in vibration by the action of the bow, be lightly touched by the finger, or a feather, exactly in the middle or at one-third of its length, from either end, it will not cease to vibrate, but its vibrations will be diminished in extent and increased in frequency, and a note will become audible, more faint but more acute than the original, or *fundamental* note, as it is called, and corresponding, in the former case, to

Above deductions confirmed by experience;

illustrated by the violin;

a double, and in the latter, to a triple rapidity of vibration. The note heard in the first case being, in the scale of musical intervals, an eighth or octave, and in the second a twelfth, above the fundamental tone. If a small piece of paper cut in the form of an inverted V, be set astride on the string, it will be violently agitated or thrown off if placed on the middle of a ventral segment, but at the node will ride quietly as though the string were at rest. The sounds thus produced are termed *Harmonics*.

Harmonics.

Coexistence and superposition of small motions;

§ 100. But further, according to the principle of the coexistence and superposition of small motions, referred to in § 56, any number of the various modes of vibration of which a cord is susceptible, may be going on simultaneously.

Its application illustrated;

Thus, if we suppose a mode of vibration represented by figure (a), in which there is no node, and another of the same cord represented by figure (b), with one node, to be going on at the same time, there will be a resultant vibration represented by the curve in figure (c), of

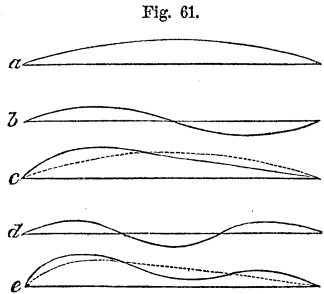

Explanation;

which the ordinates are equal to the algebraic sum of the corresponding ordinates of the curves in figures (a) and (b). If a third mode of vibration, represented by figure (d), be superposed upon the other two, there will arise a resultant vibration represented by the curve in figure (e), of which the ordinates will be equal to the algebraic sum of the corresponding ordinates in figures (a), (b) and (d), or, which is the same thing, the algebraic sum of the corresponding ordinates of figures (c) and (d).

Results confirmed by experience.

This is also confirmed by experience. It was long known to musicians, that besides the fundamental note

of a string, an experienced ear could detect in its sound, Harmonic sounds; when in motion, especially when very lightly touched in certain points, other notes related to the fundamental one by fixed laws of harmony, and which are therefore called harmonic sounds. They are the very sounds that may be heard by the production of distinct nodes as explained in § 99, and thus insulated as it were from the fundamental and other coexisting sounds.

§ 101. The *Monochord* is an instrument adapted to exhibit these and other phenomena of vibrating strings. It consists of a single string of catgut or metallic wire stretched over two fixed and well defined edges towards its extremities, which effectually terminate its vibrations in the direction of its length; one end is permanently fixed, and to the other is attached a weight which determines the tension. The interval between the two edges is graduated into aliquot parts, The monochord; and the instrument is provided with a movable *bridge* or piece of wood capable of being placed at any point of the graduated scale, and abutting firmly against the string so as to stop its vibrations, and divide it into two equal or unequal parts, Essential parts: as the case may be.

By the aid of this instrument may readily be found Its use; the number of vibrations which corresponds to any given note of any particular instrument, as a piano-forte, for instance. To this end, it will only be necessary to know, when the note of the monochord is the same as that of the instrument, the distance  $L$  between the edges, the stretching weight, and the weight of a unit's length of the string. The quotient obtained by dividing the former of these weights by the latter will give the value of  $2L$ , in Equation (37), and making  $T$ , equal to one second in that Equation, we have for the solution of the question

$$N = \frac{\sqrt{2gL}}{2L} \dots \dots \dots (42) \text{ Practical formula.}$$

Number of impulses corresponding to any higher note.

This gives the number of impulses made upon the ear in a second, corresponding to the fundamental note. To obtain the number which answers to any note *sharper*, *higher*, or more *acute*, we have but to apply the bridge and slide it to some position such that the portion of the cord between it and one of the edges gives the note in question; the scale will make known  $L$ , which in Equation (42), will give the number  $N$ .

Harmonic tones produced by causing air in motion to impinge against a stretched cord.

§ 102. The contact of a stretched cord with solid substances is not the only means of producing its fundamental and harmonic tones. The sonorous pulses proceeding from a vibrating cord are but the consequences of repeated conflicts between the elastic force of the cord and that of the air. The former impresses upon the air a certain amount of living force, and the latter by its reaction transmits this living force through the atmosphere to a distance. Reverse the process. Impress upon the air the same motion, and subject a stretched cord to its influence. Action and reaction only change names, and the cord must take up the motion of the air. Two

Two cords near together, and the shorter made to vibrate;

cords equally stretched, and in all other respects similar, but the length of one only a half, a third, or any aliquot part of the other, being placed side by side, and the shorter put in motion, the longer will soon assume a mode of vibration by which it will be divided into ventral segments, each equal to the length of the shorter cord. The sonorous pulses diverging from the shorter cord will arrive at the longer; and the molecules in the first of these pulses will, in their forward movement, press upon the stationary cord and give it a slight motion in their own direction. On the retreat of these molecules, the excess of aerial condensation will change to the opposite side of the cord; the latter will yield to the action of this inverted force and that of its own elasticity, and pass to some position on the opposite side of its place of rest, where being met by a second onward pulse, it will be thrown back in the direction of

Its vibrations will be transferred to the longer cord;



its first motion, and thus made to undergo the same round as before.

This process being repeated a number of times, the cord will be set in full and audible vibration. But these vibrations will obviously be *synchronal with the aerial pulsations, and therefore, with the vibrations of the shorter cord*, a condition that can only be fulfilled by the longer cord breaking up, as it were, into portions of which the lengths are equal to the length of the shorter cord; for, the tension, diameter and density, of the cords being the same, the times can only be equal, Equation (38), when the vibrating lengths are equal. All motions of the longer cord which are inconsistent with this, though they may be excited for the moment by one pulsation, will be extinguished by the subsequent one. Hence, if two cords can have any mode of vibration in common, that mode may be excited in either of them, and that only, by exciting it in the other. For example, if two cords, in all other respects alike, have lengths which are to each other in the proportion of 2 to 3, and if either be set in motion, the mode of vibration corresponding to a division of the first into two and of the second into three ventral segments, will, if it exist in the one, be communicated by sympathy to the other. Indeed, if it do not originally exist, it will, after awhile establish itself; for, all the circumstances which may favor such a division, however minute, will have their effect preserved and continually accumulated, and thus become sensible.

Synchronal vibrations;

Longer cord is in effect broken up;

Illustration.

And it is important to remark that whether the primitive portion disturbed be large or small, whether it occupy the whole string at once or run along it like a bulge; whether it be a single curve, or composed of several ventral segments with intervening nodal points, we must not forget that the motion of a string with fixed ends is no other than an undulation or pulse continually *doubled back upon itself*, and retained within the limits of the cord instead of running off both ways to infinity.

Motion of a string with fixed ends is analogous to a pulse retained within certain limits.

Vibrations  
seldom confined  
to the same  
plane;

Orbits described  
by particles may  
be observed;

§ 103. It is very seldom that the vibrations of a string can lie in the same plane. They most commonly consist of rotations more or less complicated, except when produced by the sawing of a bow across the string. The actual orbit described by any one molecule may be made matter of ocular inspection by throwing the solar rays through a narrow slit so as to form a thin sheet of light. A polished wire stretched in such manner as to penetrate this sheet at right angles, will appear, when stationary, as a bright spot where it pierces the light, but when in motion, the point of intersection will form a continued luminous orbit, just as a live coal whirled round appears like a circle of fire. The figures exhibit specimens of such orbits observed by Dr. YOUNG.

Fig. 62.

Specimens.

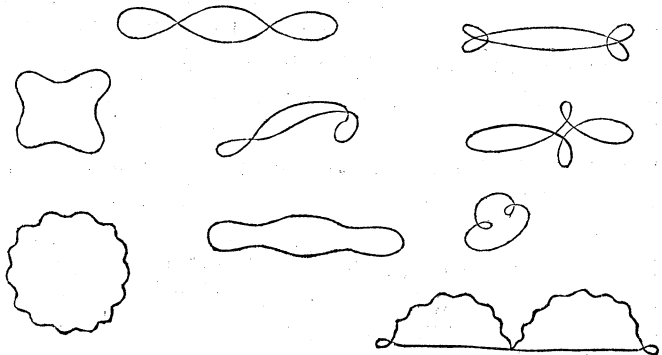

#### VIBRATING COLUMN OF AIR OF DEFINITE EXTENT.

Vibrating  
column of air of  
definite extent;

§ 104. The circumstances of the molecular vibrations of a stretched cord of indefinite extent, are, as we have seen, similar to those of a sounding column of air; and the facts which have been stated respecting a vibrating cord are equally true of a vibrating column of air of definite extent.

Thus, if such a cylindrical column be enclosed in a pipe  $AB = L$ , stopped at both ends by immovable stoppers, and an impulse be communicated in the direction  $CA$ , to one of its sections  $C$ , at the distance  $AC = l$ , from the end  $A$ , and  $BC = l'$ , from the end  $B$ , this impulse will, § 69, give rise to two pulses running in opposite directions. In the pulse from  $C$  to  $A$  the air will be condensed, and in that from  $C$  to  $B$  it will be rarefied. These pulses will be reflected at the stoppers, and the condensed pulse, after passing over the distance  $l$  before and  $l'$  after reflexion, will meet the rarefied pulse at the distance  $l$  from the end  $B$ , and produce a compound agitation in the section  $C'$  similar to that of the original disturbance; thence the partial pulses will separate, and after each undergoing another reflexion will unite in their original point of departure, constituting, as it were, a repetition of the first impulse, and so on, till the pulses are destroyed by the gradual transmission of the whole of their living forces through the substance of the tube to the open air.

If the section first set in motion be maintained in a state of vibration synchronous with the return of the reflected pulses, it will unite with and reinforce them at every return, and the result will be a clear and strong musical sound, resulting from the exact combination of the original periodic impulse with its echos.

§ 105. Let us suppose the section first set in motion and so maintained, to be exactly in the middle of the pipe. Then, when once the periodic pulsation of the contained air is established, the motion will consist of a constant and regular fluctu-

Fig. 63.

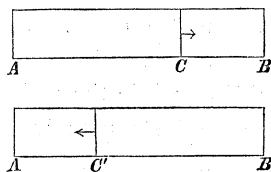

Tube closed at both ends, containing air;

Impulse communicated to a section in direction of the length of the tube;

Two pulses will be started running in opposite directions;

Pulses gradually destroyed.

Consequence of maintaining in vibration the section first disturbed.

Fig. 64.

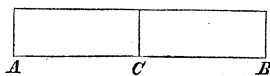

Middle section maintained in vibration;

Air condensed in one half and rarefied in the other;

ation to and fro of the whole mass, the air being always condensed within one-half of the pipe while it is rarefied in the other. The greatest excursions from their places of rest will be made by the molecules in the middle, while the molecules at the ends abutting against the solid stoppers will have the least motion, the excursion made by each intermediate molecule being greater in proportion as it is nearer the centre. On the other hand, the rarefactions and condensations are greatest at the extremities and diminish as we approach the middle, where they are the least.

Positions of greatest and least condensations and rarefactions;

Several columns end to end;

Now, conceive several such columns of vibrating air to be equal and to be placed end to end, so that the condensed portions shall be turned towards each other; it is plain that all the stoppers, except the extreme ones, may be removed without in anywise sensibly changing the interior motions, and there will result a single column of air broken up into equal portions vibrating in a manner similar to that of the ventral segments of a tense cord,

Illustration;

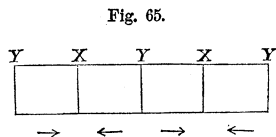

Nodes;

§ 98, the *nodes* being at *X*

Ventral segments;

and *Y*, where there will be alternately a maximum and minimum of condensation, the *bellies* lying between — in the middle of which the condensation will be the least. It is also obvious that the distance *XX*, between two alternate nodes, will be the shortest distance from any one section of air to another having the same phase, and that this distance answers to the length of a wave of the same pitch propagated in an indefinite column of air.

Distance between two alternate nodes.

§ 106. At *C*, half way between two consecutive nodes, or in the middle of one of the cylinders *AB*, let an opening be made; and sup-

An opening in the middle of a segment;

Fig. 66.

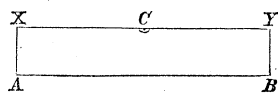

pose a vibrating body to be inserted whose vibrations are executed in equal times with those in which the excursions to and fro of the included aerial sections are performed in the stopped pipe. Its vibrations will be communicated to those of the contained air, the latter will be maintained and strengthened, and the sound from the pipe will become full and clear. Such an aperture is called an *embouchure*.

Next conceive one-half  $BC$ , of the cylinder  $AB$ , to be removed, and in its place a disc substituted exactly closing the aperture,

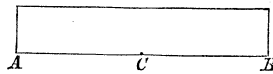

Fig. 67.

And a vibrating body introduced;  
Embouchure.  
One half of the cylinder replaced by a vibrating disc;

and maintained by some external cause in a state of constant vibration, such, that the performance of one complete vibration, going and returning, shall occupy as much time as a sonorous pulse would take to traverse the whole length of the stopped pipe  $AB$ , or double that required for the half pipe  $AC$ . Its first impulse on the air will be propagated along the half pipe  $CA$ , and reflected at the stopped end  $A$ , and will again reach the disc just as the latter is commencing its second impulse. But the absolute velocity of the disc in its vibrations being excessively minute compared with that of sound, the reflected pulse will undergo a second reflexion at the disc as though it were a fixed stopper. It will, therefore, in its return exactly coincide

Reflected pulse will coincide with the second impulse of the disc, and so on.

and conspire with the second impulse of the disc, and the same process being repeated at every impulse, each will be combined with all its echos, and a musical tone will be drawn from the pipe vastly superior to that which the disc vibrating alone in the open air could produce. This is the simplest instance of the *resonance* of a cavity. Now, it is manifestly of no importance whether the pulses reflected from the closed end  $A$  of the semi-pipe undergo a second reflexion at the disc and are so turned back, or whether we regard the disc as penetrable by the pulse, and suppose the latter to

Resonance of a cavity.

Same effects will follow if the pulse pass through the disc and be reflected at the other end.

run on and be reflected at the extremity *B* of the other half of the entire tube, and on its return again to pass freely through the disc and be again reflected at the end *A*. The sound will be the same on the principle of the superposition of vibrations. Thus the fundamental sound of a pipe open at one end is the same as that of a pipe closed at both ends and of double the length, and has the same pitch as that due to waves propagated in the open air, and of which the length of each is four times the length of the pipe open at one end.

Experimental illustration ;

§ 107. The mode here supposed of exciting and sustaining the vibrations of a column of air in an open tube may easily be put in practice. Take a common tuning-

fork and by means of sealing wax fasten a circular disc of card on one of its branches, sufficiently large to nearly cover the open end of a pipe. The upper joint of a flute with the mouth hole stop-

Tuning fork and pipe ;

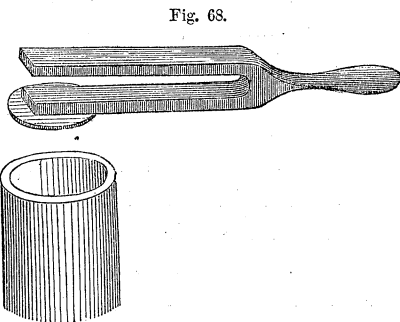

ped will answer well for the purpose ; it may be tuned in unison, that is, made of proper length by the sliding stopper. The fork being set in vibration by a blow on the unloaded branch, and held so as to bring the disc just over the mouth of the pipe, a note of great clearness and strength will be heard. Indeed, a flute may be made to “*speak*” perfectly well by holding a vibrating tuning-fork close to the embouchure, while the fingering proper to the note of the fork is at the same time performed.

Flute made to speak.

§ 108. But the most usual method of exciting the vibrations of a column of air in a pipe is by blowing across the open end, or across an opening made in the side

or by introducing a current of air into it through a small aperture of a peculiar construction called a "reed," provided with a "tongue," or flexible elastic plate which nearly stops the aperture, and which is alternately forced away by the current of air and brought back by its own elasticity, thus producing a continued and regularly periodic series of interruptions to the uniformity of the stream, and a sound in the pipe corresponding to their frequency.

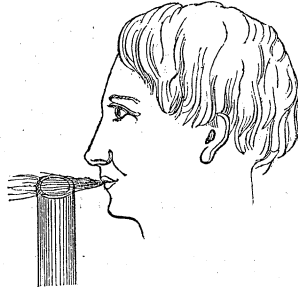

Resonance of a pipe produced by a reed;

Except, however, the reed be so constructed as to be in unison with some one of the possible modes of vibration of the column of air in the pipe, the sound of the reed only will be heard, the resonance of the pipe will not be called into play, and the pipe will not speak; or will speak but feebly and imperfectly and yield a false tone.

Conditions to be fulfilled.

§ 109. Let us consider what takes place when the vibrations of a column of air are produced by blowing across the open end of a pipe or an aperture in the side. The current of air being so directed as to graze the opposite edge, a small portion will be caught and turned aside down the pipe, thus giving a first impulse to the contained air and propagating down it a pulse in which the air is slightly condensed. This will be reflected at the end as an echo and return to the aperture where the condensation will go off, the section condensed expanding into the free atmosphere. But in so doing it lifts up and for a moment diverts from its course the impinging current, and thus suspends its impulse upon the edge of the aperture. The moment the condensation has escaped the current resumes its former course and again touches the opposite edge, creates there a second condensation and propagates down the pipe another pulse, and

Effect of blowing across the open end of a pipe;

The production of sound explained;

Current alternately grazes and misses the edge.

so on. Thus the current passing over the end or aperture is kept in a constant state of fluttering agitation, alternately grazing and passing free of its edge at regular intervals equal to those in which the sonorous pulse can run over twice the length of the pipe; or more generally, in which the condensation and rarefaction recur in virtue of any of the modes of vibration of which the column of air in the pipe is susceptible.

Point of maximum excursions of molecules;

§ 110. In general, whenever there is a free communication opened between the column of air in a pipe and the free atmosphere, that point becomes a point of maximum excursion of the vibrating molecules, or the middle of a ventral segment. At such a point the rarefaction and condensation assume their smallest possible values by the air reducing itself constantly to an equilibrium of pressure with the external air. Hence, if the pipe speak at all, it will take such a mode of vibration as to satisfy this condition, but, consistently with this, it may divide itself into any number of ventral segments. But here there is a practical difference between the affections of a vibrating aerial column and those of a tense cord. In the case of the cord both ends in practice must be fixed to secure the requisite elasticity; this the air possesses in its natural state, and to make the cases analogous we must suppose the cord to be extended in one direction to infinity, so that its pulses like those of the aerial column may run off indefinitely never to return.

Vibrations of a column of air and of a cord;

Cases made analogous.

Can be no half segments in cords with fixed ends;

§ 111. In cords with fixed extremities all the ventral segments must of necessity be complete, no half segment can exist. In pipes it is otherwise. The air in a pipe closed at one end vibrates as a half, not as a whole of such a segment. It is owing to this that a pipe open at both ends can, if properly excited, yield a

Not so with pipes;

Fig. 70.

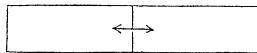



musical sound. The column of air vibrates in the mode represented in the figure, in which there is a node in the middle, and each ventral segment is only half a complete one. Node in the middle of the entire segment.

§ 112. To find the time of vibration or the number of vibrations in a given time corresponding to any mode of vibration, denote by  $m$  the number of nodes in a pipe open at both ends; the number of complete ventral segments between them will be Pipe open at both ends;

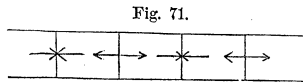

$$m - 1;$$

Number of complete ventral segments;

and denoting the length of the pipe in feet by  $L''$ , the length of each complete ventral segment will be

$$\frac{L''}{m};$$

Length of each segment;

and denoting the velocity of sound by  $V$ , and the time required for the sonorous pulse to traverse one segment by  $T$ , we shall have

$$T = \frac{1}{m} \cdot \frac{L''}{V} \dots \dots \dots (43)$$

Time of describing one segment;

and this is the time of vibration of the middle section of the segment to which the sound corresponds.

The number of vibrations per second being  $N$ , there will result

$$N = \frac{1}{T} = m \cdot \frac{V}{L''} \dots \dots \dots (44)$$

Number of vibrations in a second;

and the pitches of the series of tones which the pipe can be made to deliver will be expressed by the values

Pitches of the tones delivered by the pipe.

of  $N$ , determined by making successively  $m = 1, m = 2, m = 3, \&c.$ , or by

$$1. \frac{V}{L''}, 2. \frac{V}{L''}, 3. \frac{V}{L''}, \&c.$$

Pipe closed at one end;

§ 113. In the case of a pipe stopped at one end, the closed end must be regarded as a node; and denoting, as before, the number of nodes by  $m$ , the number of complete ventral segments will be  $m - 1$ , and one half segment at the open end, or

Fig. 72.

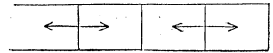

Number of entire segments;

$$m - 1 + \frac{1}{2} = \frac{2m - 1}{2};$$

and the length of each complete one, in feet, will be,

Length of each;

$$\frac{2L''}{2m - 1};$$

and the time  $T$ , required for a sonorous pulse to traverse each segment, will be given by

Time of describing one segment;

$$T = \frac{2}{2m - 1} \cdot \frac{L''}{V} \dots \dots (45)$$

and the pitch by

Pitch, or number of vibrations per second;

$$N = \frac{2m - 1}{2} \cdot \frac{V}{L''} \dots \dots (46)$$

and making  $m = 1, m = 2, m = 3, \&c.$ , the pitches of the tones will become

Series of pitches.

$$\frac{1}{2} \cdot \frac{V}{L''}; \frac{3}{2} \cdot \frac{V}{L''}; \frac{5}{2} \cdot \frac{V}{L''}; \&c.$$

§ 114. Lastly, in the case of a pipe stopped at both ends, the number of nodes, including the two ends, being  $m$ , the number of ventral segments will be  $m - 1$ ; the length in feet of each will be

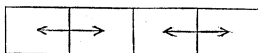

Fig. 73.

Pipe closed at both ends;

$$\frac{L_{\text{ii}}}{m - 1};$$

Length of each segment;

the time,

$$T = \frac{1}{m - 1} \cdot \frac{L_{\text{ii}}}{V}; \dots \dots \dots (47)$$

Time of describing one segment,

and the pitch,

$$N = (m - 1) \cdot \frac{V}{L_{\text{ii}}}; \dots \dots \dots (48)$$

Pitch, or number of vibrations per second;

and the series of pitches,

$$1. \frac{V}{L_{\text{ii}}}; 2. \frac{V}{L_{\text{ii}}}; 3. \frac{V}{L_{\text{ii}}}; \&c. \dots \dots \dots (49)$$

Series of pitches.

Taking, therefore, the number of vibrations performed in the fundamental note in one second as unity, the series of harmonics will run thus :

- |  |                     |                      |
|--|---------------------|----------------------|
| In a pipe stopped at both ends . . .                   | 1, 2, 3, 4, 5, &c.  | Series of harmonics. |
| “ “ “ open at both ends . . .                          | 1, 2, 3, 4, 5, &c.  |                      |
| “ “ “ stopped at one end and open at the other } . . . | 1, 3, 5, 7, 9, &c.; |                      |

it being recalled that, Equations (44), (46), and (48), in the last series, the fundamental note is an octave lower than in the other two.

These sounds produced by blowing into a pipe;

To produce these sounds by blowing into a pipe, it

Fundamental tone heard first; will only be necessary to begin with as gentle a blast as will make the pipe speak, and to augment its force gradually. The fundamental tone will first be heard, which will increase in loudness till suddenly it starts up an octave; that is, passes the interval between notes whose vibrations are as one to two. By adapting an organ-bellows to regulate the blast, M. Bior succeeded in drawing from a pipe all the harmonic notes represented by the series of natural numbers up to 12, inclusive, except 9 and 10; the reason for failing to produce these two is not stated.

Biot's experiments;

Explanation of these results.

The rationale of this continued subdivision of a vibrating column as the force of the blast increases is obvious. A quick, sharp current of air is not so easily turned aside from its course as a slow one, and when thrown into a ripple by any obstacle will undulate more rapidly. Consequently, on increasing the force of the blast a period will arrive in which the current *cannot* be diverted from its course and return to it as *slowly* as required for the production of the fundamental note, and the next higher harmonic will be excited.

The air is the sounding body;

Verification.

§ 115. That it is the air which is the sounding body and not the material of the pipe, appears from the fact that the kind, thickness, or other peculiarities of the latter, make no difference in the tone in regard to pitch. A pipe of paper, lead, glass, or wood, of the same dimensions, gives, under the same circumstances, the same pitch. The *qualities* of the tone are often different, but this is owing to the feeble vibrations of the molecules of the material of the pipe produced by those of the contained air.

§ 116. Putting the two values of  $N$ , in Equations (41) and (46), equal, we find,

Equation.

$$\frac{2m-1}{2} \cdot \frac{V}{L''} = \frac{n \cdot \sqrt{2g} L_1}{2L}$$

whence

$$V = \frac{n}{2m-1} \cdot \frac{L_i \sqrt{2g L_i}}{L} \dots \dots (50) \text{ Velocity of sound in a gas;}$$

and making  $m$  and  $n$  each unity,

$$V = \frac{L_i \sqrt{2g L_i}}{L} \dots \dots (51) \text{ Same reduced;}$$

which furnishes a ready means of finding the velocity of sound in any gas or vapor. For this purpose, fill a pipe of known length with the gas in question, and set it to vibrating by any proper means, so as to call forth its fundamental tone. Adjust the bridges of a *Mono-chord* so that the fundamental tone of its string shall have to the ear the same pitch; measure the length of the string between the bridges and substitute this length for  $L$  in Equation (51), and the velocity sought becomes known. It was by this method that CHLADNI, VARNEES, FRAMEYER and MOLL ascertained the velocity of sound in various media.

For a detailed account of the structure and management of the embouchures of pipes, and a vast amount of interesting matter on the subject of reeds, &c., &c., the reader is referred to Sir JOHN HERSCHEL's most valuable Monograph of Sound, articles 197 to 207, inclusive, as published in Vol. IV. of the Encyclopedia Metropolitana:

Practical use of the above formula.

Account of pipes, reeds, &c.

## VIBRATIONS OF ELASTIC BARS.

Vibrations of bars;

Transversal and longitudinal;

Laws governing the pitch in transversal vibrations;

Means of producing these vibrations in bars.

Longitudinal vibrations in bars;

§ 117. Bars of a cylindrical or prismatic shape are susceptible of sonorous vibrations as well as cords, and columns of air. But as such bodies are nearly equally elastic in all directions, transversely as well as longitudinally, their vibrations do not obey the same laws as those of strings. Transversal vibrations may be excited by striking a bar crosswise, and longitudinal vibrations by striking it in the direction of its length.

In bars made of the same substance, the acuteness of the pitch in transversal vibrations is directly as the thickness, and inversely as the square of the length of the bar. In bars made of different substances, it is found that the degree of the body's elasticity greatly influences the character of the pitch; thus steel gives a higher pitch than brass.

To produce these vibrations, the bar may be either secured at both ends, or its ends may be made merely to rest on some fixed objects; or one end may be fastened while the other is free, or lastly, both ends may be free, the rods being supported at two points.

We have an illustration of these kinds of vibrations in the jews-harp, musical boxes, &c.

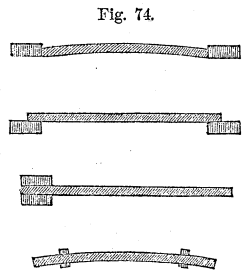

§ 118. When a bar is struck upon one of its ends in the direction of its length, the blow will give rise to a condensed pulse, which will proceed towards the other end like that of a column of air. It will be reflected back and forth alternately at the two ends, according to the principles of § 106 and § 107, and this will continue till its living force is wholly transmitted to the

air and wasted in space. If the rod be of glass, the sound emitted will be extremely acute unless its length be very great; much more so than in the case of a column of air of the same length. The reason of this is, the greater velocity with which sound is propagated in solids than in air. When the bar is short the reflexions at the ends, which determine the successive impulses upon the air and therefore the pitch, succeed each other with great rapidity. The velocity in cast iron, for example, being  $10\frac{1}{2}$  times that in air, a rod of this metal will yield a fundamental sound when longitudinally excited, identical with that of an organ-pipe of  $\frac{1}{10.5}$  of its length, stopped at both ends, or  $\frac{1}{21}$  of its length, open at one end.

The laws of longitudinal vibrations have nothing in common with the transversal, except that the acuteness of the sound emitted varies inversely as the length of the bar, the reason of which is obvious. The sounds produced by the longitudinal vibrations are, without exception, higher than those yielded by the transverse vibrations of the same body. They are little if at all influenced by the thickness, or, in the case of wires of considerable thickness, by tension. As in the case of transversal vibrations, the sounds emitted from bars of equal dimensions depend upon the nature of the material.

Longitudinal vibrations may be generated in elastic bars, by holding them in the middle between two fingers, and rubbing repeatedly one of the ends with the fingers of the other hand. In experimenting on glass tubes the friction-apparatus represented in the figure will be found convenient:  $a, a$ , are two pieces of wood hollowed out, having their cavity padded with cloth or leather;

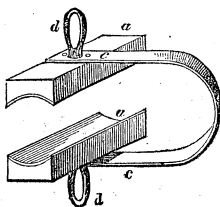

Fig. 75.

Longitudinal vibrations produced;

Solid rods give more acute sounds than columns of air;

Glass, steel, &c.

Laws of longitudinal and transversal vibrations differ;

Friction apparatus;

$c c$ , is a steel spring connecting them, and  $d, d$ , are two rings intended to receive the fingers with which the friction is excited. Moisten the padding with spirit of wine, and sprinkle on it a little finely pulverised pumice-stone. If metal or wooden bars are used, the readiest mode will be for the operator to put on a leather glove, on the thumb and index finger of which is some pounded resin, and with these to rub the rods.

Nodal points found;

The existence of nodal points may be verified by sliding small paper rings loosely on the rod.

Musical instruments.

These vibratory movements have been applied to musical purposes in some instruments. KAUFMANN'S *Harmornichord* and CHLADNI'S *Euphon* act on this principle.

Vibrations produced in bars by rotation.

§ 119. Beside the two species of vibration described already, elastic rods admit of a third, viz., that by *rotation*. It is most easily generated in cylindrical bodies, by securing one end in a vice, and communicating to the other a rotatory motion by means of a bow or by friction. An alternate expansion and contraction ensue in a direction perpendicular to its axis. Different high and low notes succeed each other, of which, as yet, no use has been made in music.

#### OF THE VIBRATIONS OF ELASTIC PLATES AND BELLS.

Vibrations produced in plates;

If elastic plates, of glass or metal in particular, be held tightly either by the fingers or by means of a clamp, at any one point, and the bow of a violin be drawn across the edge of the plate, sonorous undulations are immediately produced.

These oscillations resemble those of elastic rods, inas-

Fig. 75.

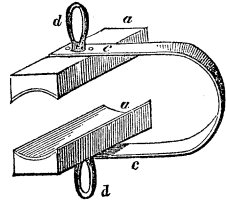



much as the surface is divided into a greater or less number of perfectly symmetrical parts, and such as are continuous, vibrate in opposite directions.

The boundary lines of these several parts are all in a state of repose, and form *nodal lines*; their position depends on the places at which the plate is held and excited, as one of these nodal lines invariably runs through the point at which the plate is held, whilst the plate itself receives the vibratory motion at the other point. These lines form certain peculiar figures, called, after their discoverer, CHLADNI'S *Sonorous Figures*.

To make these figures visible, and to render them permanent, strew some light sand or dust over the plate; they may also be seen if a small quantity of water be poured on the plate, nay, even by the rays of light falling on it. WHEATSTONE remarks that, in using the last-named mode, still more delicate divisions in the figures were observable.

These sonorous figures are composed sometimes of right lines, sometimes of curves either parallel to or intersecting each other. The shape of the plate greatly affects them, as they are differently arranged, according as it may be a square, a rectangle, a triangle, a circle, an ellipse, or some other figure. A perfectly distinct and well-defined figure is produced only when the plate gives a very clear sound.

By experiments made on such plates the following laws were detected by CHLADNI:

1. Any particular pitch will always produce the same figure with the same plate; but a small change may often be produced in the figure by slightly changing the place at which the plate is held without causing any difference in the pitch. If the pitch be changed, the existing figure disappears at once, and a new one arranges itself.

2. The gravest pitch any plate gives is accompanied by the simplest figure, and the higher the pitch the more complex the figure, *i. e.* the more nodal lines there will be.

Third law.

3. If similar plates of various sizes be treated in the same manner, similar figures will be generated in each; by the same treatment, we mean that they shall be held at the same point, and that the bow shall pass over corresponding points in each. The pitches will, however, differ, for the larger plate will give out the graver sound; and if their dimensions be equal, the stronger will give the acuter pitch.

Experimental illustration;

§ 120. If the plates be strewed with fine sand, and held at the point *a*, whilst the bow be made to pass at *b*, the figures here depicted will in each case be produced.

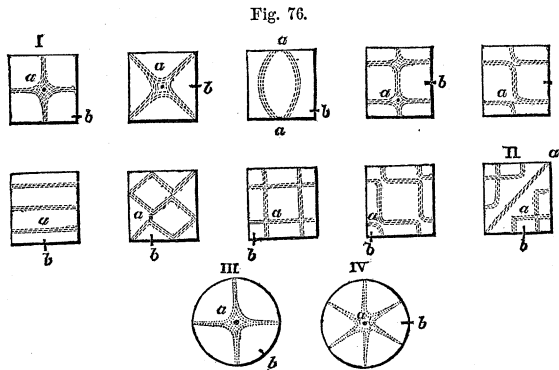

Union of several plates of equal size;

A striking effect is obtained by making the same figure on several plates of equal size and similar form, and then so arranging them as to make one figure on a larger scale. The figure thus produced will be both a *compound* and *connected* one, and such as may not unfrequently be met with on a large plate.

If a large square be formed out of four squares, bearing the figures I. and II., we shall have the following :

Fig. 77.

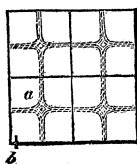
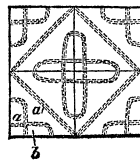

Fig. 78.



The effects.

If the large square plates be held at  $a$ , touched at  $a'$ , Particular case; and a bow be drawn across at  $b$ , similar compound figures will be generated.

*Cymbals*, the Chinese *Tam-tam* or *Gong*, &c., are Examples; practical applications of sonorous plates.

§ 121. The vibrating motions of sonorous bells resemble those of circular plates. In this case, too, the most acute pitch is accompanied by the most complex figure. Sonorous bells;

To render these vibrations visible, fill a bell-shaped glass rather more than half full of water; draw a violin bow across the rim, and at the same time touch the glass at two opposite points of the rim with the fingers. The surface of the water will acquire an undulatory motion, and to make the sonorous figures permanent, strew the surface of the water with any light and exceedingly fine powder, as *semen lycopodii*. If the point excited by the bow be at a distance of  $45^\circ$  from that touched by the finger, a four rayed star marked III. of the last article will result; but if the distance be  $30^\circ$ ,  $60^\circ$ , or  $90^\circ$ , the six-rayed star, marked IV., will appear. Means of making these acoustic figures visible;

Such a cup gives musical sounds when rubbed with the moistened finger. The vibrations of the glass in this case result from torsion, and this is the principle of the well known finger glass. They give musical sounds.

#### COMMUNICATION OF VIBRATIONS.

§ 122. The numerous experiments of M. SAVART abundantly show that the molecular motions of one body are communicated to another, when there exist between them any intervening media, and this the more effectually as the connection is the more perfect. But not only this; they also show that the molecules of the neighboring bodies are agitated by motions both similar in period and parallel in direction to those of the original source of motion. Communication of molecular motion; Its peculiarity;

tion. Of these experiments we have only room for such as have a direct bearing upon the nature and structure of our organs of hearing.

Experimental Illustration; Effect when the glass and membrane are parallel;

§ 123. Take a thin membrane, moistened tissue paper will answer every purpose, and stretch it over the mouth of a common bowl or finger glass, place it in a horizontal position and strew fine sand over its surface. Hold a glass plate, covered with fine sand or dust, horizontally and directly over the membrane, and set it in vibration so as to form CHLADNI'S acoustic figures; these figures will be immediately and exactly imitated in the sand on the membrane, and this will be the case to whatever lateral position within the sphere of sufficient action to move the particles of sand, the plate may be shifted, provided it retain its parallelism to the membrane.

Effect when inclined to one another;

§ 124. But instead of shifting the plate laterally, let its plane be inclined to the horizon. The figures on the membrane will change though the vibrations of the plate remain unaltered, and the change will be greater, the greater the inclination of the plane of the plate. And when it becomes perpendicular to the horizon and therefore to the surface of the membrane, the figures on the latter will be transformed into a system of straight lines parallel to the common intersection of the two planes; and the particles of sand, instead of dancing up and down, will creep in opposite directions to meet on these lines. One of these lines always passes through the centre, and the whole system is analogous to what would be produced by attaching a cord to the centre of the plate, and, having stretched it very obliquely, setting it in vibration by a bow drawn parallel to the surface. In a word, the vibrations of the membrane are now parallel to its surface, and they preserve this character unchanged, however the plate be shifted laterally, provided its plane be kept vertical. If the plate be made to revolve about its vertical diameter, the nodal lines on the membrane will rotate, following exactly the motions of the plate.

When perpendicular to one another;

When shifted laterally;

When the plate is revolved about its vertical diameter.

§ 125. Nothing can be more decisive or instructive Inference; than this experiment. It shows us that the motions of the aerial molecules in every part of the spherical wave propagated from a vibrating centre, instead of diverging like radii in all directions, so as to be always perpendicular to the wave surface, may be parallel to each other and to the wave surface. The same holds good in liquids also. Principle of transversal vibration;

§ 126. So long as the sound of the plate, its mode of vibration, its inclination to the plane of the membrane, and the tension of the membrane continue unchanged, the nodal figure on the membrane will continue the same; but if either of these be varied, the membrane Conditions to insure permanence of figure; will not cease to vibrate, but the figure on it will be changed accordingly. Let us consider separately the effects of these changes.

§ 127. All other things remaining the same, let the pitch of the sounding plate be altered, either by loading Difference between a membrane and rigid lamina; it or changing its size. The membrane will still vibrate, *differing in this respect from a rigid lamina, which can only vibrate by sympathy with sounds corresponding to its own subdivisions.* The membrane will vibrate in sympathy with any sound, but every particular sound will be accompanied by its own particular nodal figure, and as the pitch varies, the figure will vary. Thus, if a slow air be played on a flute near the membrane, each note Illustration. will call up its particular form, which the next will efface to establish its own.

§ 128. Next suppose the figure of the plate so to vary Change of figure of the plate; as to change its nodal figures; those on the membrane will also vary; and if the same note be produced by different subdivisions of different sized plates, the nodal figures on the membrane will also be different.

Effect of change  
of tension;

§ 129. If the tension of the membrane be varied ever so little, material changes will take place in its nodal figures. Hygrometric variations are sufficient to produce these changes. Indeed, the fluctuations arising from this cause were so troublesome in the case of tissue paper, that it became necessary to coat the upper surface with a thin film of varnish. By far the best substance for exhibiting the results of these beautiful experiments is varnished paper. Moisture diminishes the cohesion of the fibres, and renders them nearly independent of each other, and sensible alike to all impulses.

Effect of  
moisture

Secondary nodal  
lines;

Inference;

Explanation;

§ 130. Between the nodal lines formed by the coarser particles of sand, others are occasionally observed, formed only of the finest dust of microscopic dimensions. This is a most important fact, as it goes to show that different and higher modes of subdivision coexist with the more elementary divisions which produce the principal figures. The more minute particles are proportionally more resisted by the air than the coarser ones, and are thus prevented from making those great leaps which throw the coarser ones into their nodal arrangement. They rise and fall with the greater divisions of the surface, and are only affected by those minute waves which have a smaller amplitude of excursion and occur more frequently, and form their figures as though the others did not exist. These secondary figures often appear as concentric rings between the primary ones, and frequently the centre of the whole system is occupied as a nodal point.

Sensibility of  
some  
membranes;

Exploring  
membranes

§ 131. So sensitive are some varieties of stretched membrane to the influence of molecular motion that they have been employed with success in detecting the existence and exploring the extent and limits of the most delicate, continuous and oppositely vibrating portions of air. When so employed they are called *exploring mem-*

*branes*. The most highly interesting application of the properties of stretched membrane is in the “*membrana tympani*” of the ear. Application of the properties of stretched membrane;

Fig. 79.

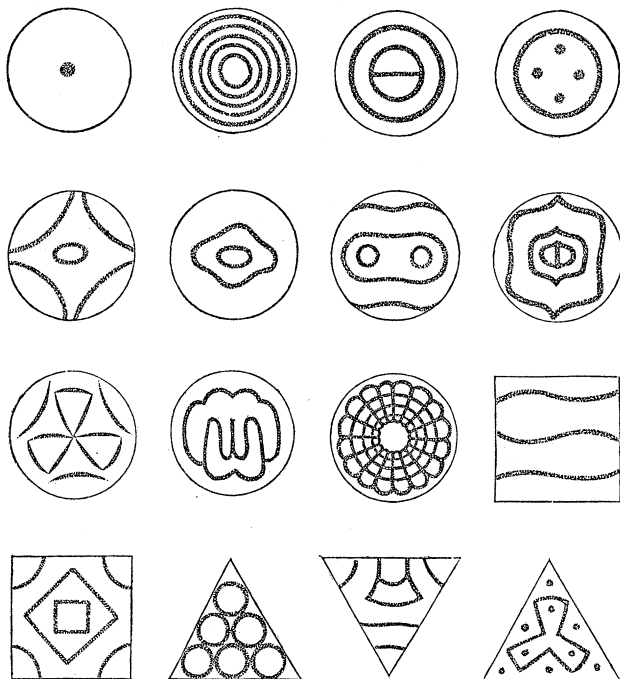

Illustrations;

Illustrations;

THE EAR.

§ 132. The auditory apparatus, called the ear, is a collection of canals, chambers, and tense membranes, whose office is to collect and convey to the seat of hearing, the vibrations impressed upon the air by sonorous bodies. Essential parts of the ear;

Beginning on the exterior and proceeding inwards,

- Wing; we find a cartilaginous funnel *AA*, called the *wing* ;
- Auditory duct; a canal *bb*, called the *auditory duct*, leading to an interior chamber *BB*, called the *cavity of the drum* ; and behind this a system of canals of considerable complexity, called the *labyrinth*, consisting of three semi-circular tubular arches *m, m, m*, originating and terminating in a common hall *n*,
- Cavity of the drum; called the *vestibule*, which communicates with the cavity of the drum by a small opening *l*, called the *fenestra ovalis*, and is prolonged in the opposite direction into a spiral cavity *o*, called the *conchlea*. The auditory duct is closed at its junction with the cavity of the drum by a tense
- Labyrinth; membrane *r*, called the *drum of the ear*, as is also the fenestra ovalis by a similar membrane. The whole cavity of the labyrinth is filled with a liquid in which are immersed the branches of the *auditory nerve*, wherein is supposed to reside the immediate seat of the first impression of sound. Within the cavity of the drum are four small bones united by articulations so as to form a continuous chain ; the first *f*, is called the *hammer*, the second *g*, the *anvil*, the third *i*, the *ball*, (os orbicularis), and the fourth *k*, the *stirrup*, from the resemblance which its shape bears to that of the common stirrup. The handle of the hammer is attached to the drum, and the stirrup to the membrane which closes the fenestra ovalis ; and thus the aerial vibrations, first collected by the funnel-shaped wing of the ear, and transmitted through the auditory duct to the drum, are conducted onwards by the articulated bones to the auditory nerve in the labyrinth, which receives them at the window of the vestibule. The cavity of the drum is connected with that
- Vestibule; of the mouth by a canal *d*, called the *Eustachian tube*,
- Fenestra ovalis and conchlea;
- Drum of the ear;
- Auditory nerve;
- Hammer, anvil, ball and stirrup;
- Eustachian tube;

Fig. 80.

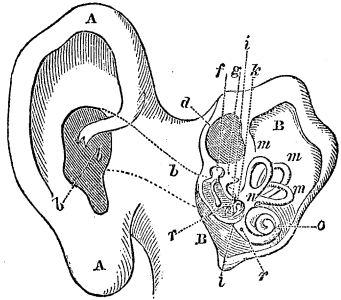



which serves to keep the cavity of the drum filled with Its use.  
 air of uniform density and temperature; a condition which  
 appears to be necessary in order that the different parts  
 may perform their functions with accuracy. If this be  
 stopped, deafness is said to ensue, but as Dr. WOLLASTON  
 has shown, only to sounds within certain limits of pitch.  
 If the membrane which closes the labyrinth be pierced Deafness  
 and its fluid let out, complete and irremediable deaf- produced.  
 ness ensues. From some experiments of M. FLOURENS  
 on the ears of birds, it appears that the nerves en-  
 closed in the several arched canals of the labyrinth have  
 other uses besides serving as organs of hearing, and are Other uses of the  
 instrumental, in some mysterious way, in giving animals nerves of the  
 the faculty of balancing themselves on their feet and ear.  
 directing their motions.

#### MUSIC, CHORDS, INTERVALS, HARMONY, SCALE AND TEMPERAMENT.

§ 133. Our impression of the pitch of a musical sound Circumstances  
 depends, as we have seen, entirely upon the number that affect our  
 of its vibrations in a given time. Two sounds whose impression of a  
 vibrations are performed with equal rapidity, whatever musical sound;  
 be their difference in intensity and quality, affect us  
 with the sentiment of accordance, which we call *uni-*  
*son*, and impress us with the idea that they are simi-  
 lar. This we express by saying that their pitch is the  
 same, or that they are the same note. The impulses Effect of two  
 which they send to the ear through the medium of sounds in unison;  
 the air, occurring with equal frequency, blend and form  
 a compound impulse, differing in quality and intensity  
 from either of its components, but not in the frequency of  
 its recurrence, and we judge of it as of a single note  
 of intermediate quality only.

But when two notes not in unison are sounded to- Of two not in  
unison:

Concord or  
discord.

gether, most persons distinctly perceive both, and can separate them in idea, and attend to one without the other. But besides this, the mind receives an impression from them jointly which it does not receive from either when sounded singly even in close succession; an impression of *concord* or of *discord*, as the case may be, and hence the mind is pleased with some combinations, displeased with others, and it even regards many as harsh and grating.

Harmony, chord,  
melody.

§ 134. The union of simultaneous and concordant sounds, is called *Harmony*. Every group of simultaneous and concordant sounds, is called a *Chord* in harmony. A succession of single sounds makes *Melody*. To discover and discuss the laws of harmony and melody, is the object of musical science; to apply these laws to the production of certain effects in musical composition, is the object of musical art. Science and art, thus employed, constitute that department of knowledge properly called *Music*.

Music.

Concordant  
sounds;

Now it is invariably found that the concordant sounds are those, and those only, in which the number of vibrations in the same time are in some simple ratio to each other, as 1 to 2, 1 to 3, 1 to 4, 2 to 3, &c., and that the concord is more pleasing the lower the terms of the ratio are and the less they differ from each other. While, on the other hand, such notes as arise from vibrations which bear no simple ratio to each other, as 8 to 15, for instance, produce, when sounded together, a sense of discord, and are unpleasant. By the constitution of the ear, ratios in which 7 and the higher primes occur are not agreeable; why, cannot be told, but simplicity must end somewhere, and in music this seems to be about the point. This is the natural foundation of all harmony.

Discordant  
sounds;

Limit of  
simplicity in  
music.

§ 135. The relative effect of any two sounds is found to be always the same as that of any other two in which the ratio of the vibrations is the same. Thus sounds of

which the vibrations are respectively 12 and 18, produce the same effect as those whose vibrations are 40 and 60, for

Compound sounds which produce the same effect;

$$\frac{18}{12} = \frac{60}{40} = \frac{3}{2};$$

and we say that according as the first and second sounded together, are pleasant or unpleasant, so are the third and fourth; also, if an air beginning on the first sound require an immediate transition to the second, then, the same air beginning on the third will require an immediate transition to the fourth.

§ 136. The relative pitch of two sounds is called an *interval*; its numerical value is expressed in terms of the graver sound, represented by the number of its vibrations in a given time, taken as unity. The value of an interval is, therefore, always found by dividing the number of vibrations of the acuter note in a given time by the number of vibrations of the graver note in the same time; thus, the interval of two sounds, one of which is produced by two and the other by three vibrations in the same time, has for its measure  $\frac{3}{2}$ . If 18, 23, and 30, be the numbers of vibrations of three sounds in the same time, and we wish to find a fourth sound which shall be as much above the third as the second is above the first, we say,

Interval;

Its numerical value found;

Examples;

$$18 : 23 :: 30 : x = \frac{30 \cdot 23}{18} = 38\frac{1}{3}.$$

§ 137. Next to *unison*, wherein the vibrations of the two sounds are in the ratio of 1 to 1, the most satisfactory *concord* is that in which the vibrations are in the ratio of 1 to 2. The effect of this is not only pleasing, but it always gives rise to the idea of sameness; insomuch that if two instruments were made to play together in such manner that the sounds of the one should always

Vibrations in the ratio of 1 to 2;

Give the impression of different shades of the same air;

be of twice as many vibrations as the simultaneous sounds of the other, they would be universally admitted to be playing the same air, with only that sort of difference which is heard when a man and a boy sing the same tune together.

Two tense strings whose vibrations are in the ratio of 1 to 2;

Now, take a tense string, and call the sound emitted from it  $C$ , and, for the reasons given above, let the sound from a string of double the number of vibrations be called  $C'$ . Let us seek for the simplest fractions which lie between 1 and 2, up to the prime 7, and we shall find,

$$\frac{3}{2}, \frac{4}{3}, \frac{5}{3}, \frac{5}{4}, \frac{6}{4} = \frac{3}{2}, \frac{6}{5},$$

Series of vibrations that will produce agreeable musical sounds.

and these, arranged in the order of magnitude, give, after placing 1 and 2 on the extremes,

$$1, \frac{6}{5}, \frac{5}{4}, \frac{4}{3}, \frac{3}{2}, \frac{5}{3}, 2.$$

A set of tense strings, or of pipes, so arranged that the first makes one vibration while the second makes  $\frac{6}{5}$  of a vibration, the third  $\frac{5}{4}$  of a vibration, and so on to the last, which makes 2, will emit sounds every one of which will be agreeable when sounded with the first.

Sounds which are pleasing and those which are not so.

§ 138. But it is found that the frequent repetition of sounds which are very near to each other is not pleasing to an uncultivated ear, and that the frequent repetition of sounds too far from each other is not pleasing to the ear after a little cultivation.

Taking the intervals of the above series, we find that from the

Examination of the above series;

$$\begin{aligned} \text{1st to 2d is, } & \frac{6}{5} \div 1 = \frac{6}{5}; \\ \text{2d to 3d is } & \frac{5}{4} \div \frac{6}{5} = \frac{25}{24}; \\ \text{3d to 4th is } & \frac{4}{3} \div \frac{5}{4} = \frac{16}{15}; \\ \text{4th to 5th is } & \frac{3}{2} \div \frac{4}{3} = \frac{9}{8}; \\ \text{5th to 6th is } & \frac{5}{3} \div \frac{3}{2} = \frac{10}{9}; \\ \text{6th to 7th is } & 2 \div \frac{5}{3} = \frac{6}{5}; \end{aligned}$$

The interval between the 1st and 2d, and that between the 6th and 7th are too great, while the interval between the 2d and 3d is too small for frequent repetition. A new sound must, therefore, be substituted for the second one of the scale, and of such value as to increase the interval between the second and third and diminish that between the first and second, while an additional sound must be interpolated between the 6th and 7th. Denote the first of these by  $x$  and the second by  $y$ , then will the series of ratios stand,

$$1, x, \frac{5}{4}, \frac{4}{3}, \frac{3}{2}, \frac{5}{3}, y, 2;$$

Defects in this series of sounds;

Additions required;

Form of an improved series;

making seven in all, for the octave is but the same note with a different pitch.

But upon what principle shall the values of these new sounds be determined, seeing we cannot have any more simple consonances with the fundamental sound whose vibrations are represented by 1? The answer is, we must take those sounds which make the *simplest* consonances while they give with the remaining sounds the *greatest number* of consonances.

Principles by which the series is improved;

The consonance indicated by the interval from the

$$4\text{th to } 8\text{th is } 2 \div \frac{4}{3} = \frac{3}{2};$$

$$5\text{th to } 8\text{th is } 2 \div \frac{3}{2} = \frac{4}{3};$$

$$4\text{th to } 6\text{th is } \frac{5}{3} \div \frac{4}{3} = \frac{5}{4}.$$

Consonances;

Now, let the sound  $x$ , have between it and the 5th an interval equal to that between the 5th and the 8th; then will

First supposition;

$$\frac{3}{2} \div x = \frac{4}{3},$$

whence

$$x = \frac{9}{8};$$

Consequence;

and the first three sounds of the series will stand  $1, \frac{9}{8}, \frac{5}{4}$ ,

First three sounds;

Intervals. giving intervals  $\frac{9}{8}$  and  $\frac{1^0}{9}$ , already found in another part of the series.

Second supposition; Again, let the interval between the 5th and 7th be equal to that between the 4th and 6th, and we shall have

$$y \div \frac{3}{2} = \frac{5}{4},$$

and

Consequence;  $y = \frac{1^5}{8};$

Last three sounds thus making the last three sounds  $\frac{5}{3}$ ,  $\frac{1^5}{8}$  and 2, and giving their intervals. ing the consecutive intervals of  $\frac{9}{8}$  and  $\frac{1^6}{1^5}$ , both of which are found in another part of the series. Replacing  $x$  and  $y$  by their values, we have

Diatonic scale;  $C, D, E, F, G, A, B, C'$   
 $1, \frac{9}{8}, \frac{5}{4}, \frac{4}{3}, \frac{3}{2}, \frac{5}{3}, \frac{1^5}{8}, 2,$  or multiplying by 24  
 $24, 27, 30, 32, 36, 40, 45, 48,$   
 1st, 2d, 3d, 4th, 5th, 6th, 7th, 8th.

Its effect universally agreeable; This is called the natural, or *diatonic scale*. When all its sounds are made to follow each other in order, either upwards or downwards, the effect is universally acknowledged to be pleasing, and all civilized nations have agreed in adopting it as the foundation of their music.

Note, its name, and place indicated; Each sound in the scale is called a *note*, and takes the name of the letter immediately above it; and its place in the order of acuteness from the fundamental note is expressed by the ordinal number below it. Thus, counting the vibrations of the fundamental note unity, the note whose vibrations are  $\frac{5}{3}$ , is named *E*, and it is a *third* above *C*, regarded as the fundamental note; in like manner the note whose vibrations are  $\frac{5}{3}$ , is *A*, and it is a sixth above *C*. The 8th from the fundamental note, or *C'*, is called an *octave* above *C*. Again, we say *A*, is a fourth above *E*, and *E*, is a fourth below *A*, as would be

Illustrations;

manifest by simply sliding the scale to the right or inverting it, so as to bring the number 1, under the note of reference regarded as the fundamental note. Confirmed by reference to the scale.

§ 139. This diatonic scale, which is obtained from the series of sounds affording the simplest concords with the fundamental note, after one alteration on account of the too great proximity of two concordant notes, and one interpolation on account of the too great distance of two others, has both of the essential qualities of repetition and variety. Thus, writing *CD*, for the interval from *C* to *D*, and using like notation for the others, and writing the names which have been adopted by musicians for the several intervals, we have the following Essential qualities of the diatonic scale;

TABLE.

<i>CD</i> = <i>F'G</i> = <i>AB</i> . . .	= $\frac{9}{8}$ ; major tone.
<i>DE</i> = <i>GA</i> . . . . .	= $\frac{10}{9}$ ; minor tone, $\frac{9}{10}$ of a major.
<i>EF</i> = <i>BC'</i> . . . . .	= $\frac{16}{15}$ ; diatonic semitone.
<i>CE</i> = <i>FA</i> = <i>GB</i> . . .	= $\frac{5}{4}$ ; major third.
<i>EG</i> = <i>AC'</i> . . . . .	= $\frac{6}{5}$ ; minor third.
<i>DF</i> . . . . .	= $\frac{32}{27}$ ; $\frac{8}{9}$ of minor third.
<i>CF</i> = <i>DG</i> = <i>EA</i> = <i>GC'</i> = $\frac{4}{3}$ ;	fourth.
<i>FB</i> . . . . .	= $\frac{45}{32}$ ; flattened fifth.*
<i>CG</i> = <i>EB</i> = <i>FC'</i> . . .	= $\frac{3}{2}$ ; fifth.
<i>DA</i> . . . . .	= $\frac{40}{27}$ ; $\frac{8}{9}$ of a fifth.
<i>CA</i> = <i>DB</i> . . . . .	= $\frac{5}{3}$ ; sixth.
<i>EC'</i> . . . . .	= $\frac{8}{5}$ ; minor sixth.
<i>CB</i> . . . . .	= $\frac{15}{8}$ ; seventh.*
<i>DC'</i> . . . . .	= $\frac{16}{9}$ ; flattened seventh.†
<i>CC'</i> . . . . .	= 2; octave.

Table of intervals formed from the diatonic scale.

We observe here three different intervals between consecutive notes, viz.: first, that from *C* to *D* = *F'* to *G*

\* An inharmonious interval when the notes are sounded together.  
 † Decidedly more harmonious than the seventh.

Major tone; =  $A$  to  $B = \frac{9}{8}$ , and called a *major tone*; second, that from  $D$  to  $E = G$  to  $A = \frac{10}{9}$ , called a *minor tone*; and  
 Minor tone; third, that from  $E$  to  $F = B$  to  $C' = \frac{15}{13}$ , called, though improperly, a *diatonic semitone*, being in fact much greater than half of either a major or minor tone.  
 Diatonic semitone or limma This interval is also called by some authors a *limma*.

§ 140. When the vibrations are less numerous than 16 a second (M. SAVART says 7 or 8), the ear loses the impression of continued sound, and in proportion as the vibrations increase in number beyond this, it first perceives a fluttering noise, then a quick rattle, then a succession of distinct sounds capable of being counted. On the other hand, when the frequency of the vibrations exceeds the limit of 24000 a second, all sensation, according to M. SAVART, is lost; a shrill squeak or chirp is only heard, and according to the observation of Dr. WOLLASTON, some individuals, otherwise no way inclined to deafness, are altogether insensible to very acute sounds, while others are painfully affected by them. It is probable, however, that it is not alone the *frequency* of the vibrations which renders shrill sounds inaudible, but also the diminution of intensity which, from the nature of sounding bodies, must ever accompany a rapid vibration among their elements. No doubt if a hundred thousand hard blows per second could be regularly struck by a hammer upon an anvil at precisely equal intervals, they would be heard as a deafening shriek; but in natural sounds the impulses lose in intensity more than they gain in number, and thus the sound grows more and more feeble till it ceases to be heard.

Least number of vibrations to produce continuous sound;  
 Greatest number;  
 Peculiarities of certain individuals;  
 Causes which render sounds inaudible.  
 Diatonic scale may be continued in both directions;  
 Practical limits.

If we add to the diatonic scale on both sides the octaves of all its tones, above and below, and again the octaves of these, and so on, we may continue it indefinitely upwards and downwards. But the considerations above show that we shall soon reach practical limits in both directions, growing out of the limited powers of the ear.



§ 141. By the aid of the ascending and descending series of sounds thus obtained, pieces of music which are perfectly pleasing may be played, and they are said to be in the *key* of that note which is taken as the *Key*; fundamental, sometimes called the *tonic* note of the scale, and of which the vibrations are represented by 1. And if such pieces be analyzed they will be found to consist chiefly if not entirely of triple or quadruple combinations of several simultaneous sounds called *chords*; such as the following:

$C, D, E, F, G, A, B, C', D', E', F', G', A', B', C''$   
 $1, \frac{9}{8}, \frac{5}{4}, \frac{4}{3}, \frac{3}{2}, \frac{5}{3}, \frac{15}{8}, 2, \frac{16}{8}, \frac{10}{4}, \frac{8}{3}, \frac{6}{2}, \frac{10}{3}, \frac{30}{8}, 4.$   
 1st, 2d, 3d, 4th, 5th, 6th, 7th, 8th, 9th, 10th, 11th, 12th, 13th, 14th, 15th.

1st. The common or fundamental *chord*, called also the *chord of the tonic*, which consists of the 1st, 3d and 5th; or the 3d, 5th and octave. This is the most harmonious and satisfactory chord in music, and when sounded the ear is satisfied and requires nothing further. It is, therefore, more frequently heard than any other, and its continued recurrence in a piece of music determines the key in which the piece is played.

2d. The *chord of the dominant*. The *fifth* of the key note is called the *dominant*, by reason of its oft recurring importance in harmonic combinations of a given key. The chord of the dominant is constructed like that of the tonic, but on the dominant as a fundamental note, and consists of the 5th, 7th and 9th, being the 5th and 7th of one scale, and the 2d on the next following scale of octaves; or, replacing the latter note by its octave below, the notes of this chord will be 2d, 5th and 7th.

3d. The *chord of the sub-dominant*; that is, the chord constructed upon the 4th note next below the dominant. It consists of the 4th, 6th and 8th; or, replacing the latter note by its octave below, the notes of this chord become the 1st, 4th and 6th.

False close.

4th. The *false close*, which is the chord of the 6th, its notes being 6th, 8th and 10th, or replacing the last two notes by their octaves below, 1st, 3d and 6th. The term false close arises from this, viz.: A piece of music frequently before its termination (which is always on the fundamental chord) comes to a momentary close on this chord, which pleases only for a short time, and requires the strain to be taken up again and closed as usual, to give full satisfaction.

Dissonance of the 7th.

5th. The *dissonance of the 7th*, or the combination of the 2d, 4th, 5th and 7th. It consists of four notes, and is the common chord of the dominant with the note immediately below it, or the 7th *in order* above it.

Short pieces of music;

§ 142. With these chords and a few others, music may be arranged in short pieces so as to possess considerable variety, but long pieces would appear monotonous. In the latter the fundamental note would occur so often as to appear to pervade the whole composition, and the ear would require a change of key to avoid the feeling of tedium which would naturally arise from such a cause. This change of *key* is called *modulation*. But the change is not possible without introducing other notes than those already enumerated.

Change of key or modulation, avoids monotony;

Suppose, for example, it were desirable to change from the key of *C* to that of *G*. The chord of the tonic in the key of *C* is composed of the notes *C E G*; in the key of *G*, of the notes *G B D'*, giving the intervals,

Example for illustration;

$$C E = G B = \frac{5}{4} \text{ and } C G = G D' = \frac{3}{2}.$$

In the chord of the dominant, in the key of *C*, the notes are *G B D'*, giving the intervals,

$$G B = \frac{5}{4}, \text{ and } G D' = \frac{3}{2},$$

the same as before. But the chord of the dominant in the key of *G*, if it could be formed at all from existing

notes, would consist of  $D', F', A'$ , giving the intervals Necessity for other notes, shown;

$$D' F' = \frac{3}{2} \cdot \frac{2}{7}, \text{ and } D' A' = \frac{4}{2} \cdot \frac{9}{7},$$

which are very different from the intervals of the common chord to which they ought to be equal; and in order that we may be able to make them equal, we must have other notes for the purpose.

Now  $D'$ , being the dominant of  $G$ , must be the commencement of the interval, and cannot be altered; What the new notes must replace; new notes must, therefore, be substituted for  $F'$  and  $A'$ . Denote the vibrations of the new notes by  $x$  and  $y$ ; then, passing to the octave below to avoid the common factor 2, we must have,

$$\frac{x}{D} = \frac{5}{4}, \text{ and } \frac{y}{D} = \frac{3}{2};$$
To find the new notes;

whence, substituting the value  $\frac{9}{8}$  for  $D$ ,

$$x = \frac{9}{8} \cdot \frac{5}{4} \text{ and } y = \frac{9}{8} \cdot \frac{3}{2}.$$

That is to say, a change from the key of  $C$  to that of  $G$ , requires for the formation of the chord of the dominant in the latter key, two new notes, whose vibrations would be represented respectively by the ratios  $\frac{5}{4}$  and  $\frac{3}{2}$  multiplied by the vibrations in the dominant of  $G$ . Now, as any note may be taken as the key note, and as the dominant changes with the latter, the number Multiplicity of new notes must be avoided; of requisite notes would be so numerous as to render the generality of musical instruments excessively complicated and unmanageable. It becomes necessary, therefore, to inquire how the number may be reduced, and what are the fewest notes that will answer.

For this purpose we remark, that if we multiply the values of  $x$  and  $y$  by 24, to reduce them to the same unit as that of the scale of whole numbers in § 138, we find

How this is  
accomplished;

$$24 x = \frac{9}{8} \cdot \frac{5}{4} \cdot 24 = 33\frac{3}{4};$$

$$24 y = \frac{9}{8} \cdot \frac{3}{2} \cdot 24 = 40\frac{1}{2}.$$

Place of first  
new note  
determined;

In the scale just referred to we find the numbers 32 and 36, so that the note whose vibrations are  $x$ , is almost half way between these two notes, and may be interpolated at that place. It will, therefore, stand between  $F$  and  $G$ , and is designated in music either by the sign  $\sharp$ , *sharp*, or  $\flat$ , *flat*, according as it takes the name of the first or second of these letters. Thus it is written either  $\sharp F$ , or  $\flat G$ .

Sharp, flat;

Place of second  
new note;

With regard to the note whose vibrations are  $y$ , and of which the value is  $40\frac{1}{2}$ , it comes so near to the note  $A$ , whose value in the same scale is 40, that the ear can hardly distinguish the difference between them, so that the latter may be used for it; and though a small error of one vibration in 80 is introduced in using  $A$  as the dominant of  $D$ , yet it is not fatal to harmony, and it is far better to encounter it than to multiply pipes or strings to our instruments for its sake. Besides, these errors are modified and in a great measure subdued, by what is called *temperament*, of which the foregoing is the origin.

Temperament.

§ 143. The highest note of the perfect chord of the dominant of  $G$ , is three perfect fifths above  $C$ , and the note  $A'$ , which we have adopted in its place, is the octave of the 6th above  $C$ . The vibrations of the first are denoted, by  $(\frac{3}{2})^3 = \frac{27}{8}$ , and of the second, by  $2 \cdot \frac{5}{3} = \frac{10}{3}$ ; and the interval between will be

$$\frac{27}{8} \div \frac{10}{3} = \frac{81}{80}.$$

Comma in music. This interval of two notes, one of which rises three perfect fifths, and the other an octave of the 6th above the same origin is called, in music, a *comma*.

§ 144. Were any other note selected for the fundamental one, similar changes would be required; and no two keys can agree in giving identically the same scale. All, however, may be satisfied by the interpolation of a new note within each of the intervals of the major and minor tones in the scale of article (138), thus,

$$C, \text{ or } \left. \begin{matrix} \#C \\ \flat D \end{matrix} \right\}, D, \text{ or } \left. \begin{matrix} \#D \\ \flat E \end{matrix} \right\}, E, F, \text{ or } \left. \begin{matrix} \#F \\ \flat G \end{matrix} \right\}, G, \text{ or } \left. \begin{matrix} \#G \\ \flat A \end{matrix} \right\}, A, \text{ or } \left. \begin{matrix} \#A \\ \flat B \end{matrix} \right\}, B, C';$$

Interpolation required;

and the scale thus obtained is called the *Chromatic* Chromatic scale; scale.

§ 145. But what shall be the numerical values of the interpolated notes? If it were desirable to make the scale of article (138), which is in the key of *C*, (the vibrations of this note being represented by unity,) as perfect as possible, at the expense of the others, there would be but little difficulty, as the mere bisection of the larger intervals would possibly answer every practical purpose, and  $\#C = \flat D$ , might be represented by  $\sqrt{1 \cdot \frac{9}{8}}$ ;  $\#D = \flat E$ , by  $\sqrt{\frac{9}{8} \cdot \frac{5}{4}}$ , and so on; but as in practice no such preference is given to this particular key, and as variety is purposely studied, we are obliged to depart from the pure and perfect diatonic scale; and to do so with the least possible offence to the ear, is the object of a *system of temperament*. If the ear required perfect concords, there could be no music but a very limited and monotonous one. But this is not the case; perfect harmony is never heard, and if it were, would be appreciated only by the most refined ears; and it is this fortunate circumstance which renders musical composition, in the exquisite and complicated state in which it at present exists, possible.

§ 146. To ascertain to what extent the ear will bear a departure from exact consonance, let us see what takes

Extent to which  
the ear can bear  
a departure from  
exact  
consonance;

Explanation;

Beats.

place when two notes nearly but not quite in unison or concord are sounded together. Suppose two equal and similar strings to be equally drawn aside from their positions of rest and abandoned at the same instant, and suppose one to make 100 vibrations while the other makes 101, and that both are at the same distance from the ear. Their first vibrations will conspire in producing sound waves of double the force of either singly, and the impression on the ear will be double. But on the 50th vibration, one will have gained half a vibration, and the motions of the aerial molecules produced by the co-existing waves from both strings will no longer be in the same but in opposite directions; and this being sensibly the case for several vibrations, there will be an interference and a moment of silence. As the vibrations continue, there will be a further gain, and at the 100th this gain will amount to one whole vibration, when the waves will again conspire, and the sound have recovered its maximum intensity. These alternate reinforcements and subsidences of sound are called *beats*.

Let  $n$ , denote the number of vibrations in which one string gains or loses one vibration on the other,  $m$  the number of vibrations per second made by the quicker, and  $t$ , the interval between the beats, then will

$$m : n :: 1^s : t$$

Example for  
illustration.

whence

$$t = \frac{n}{m};$$

from which it is obvious that the nearer two notes approach to exact unison, the longer will be the interval between the beats.

Effect of perfect  
concord;

§ 147. And here it may be proper to remark upon the effect produced in perfect concords and in those

only which are perfect. If one note make  $m$  vibrations while another makes  $n$ , it is obvious that if the vibrations begin together, the  $m$ th vibration of the one will conspire with the  $n$ th of the other, and the effect upon the ear of these conspiring vibrations will be similar to that of a third set of which each individual vibration conspires with every  $m$ th vibration of the one and every  $n$ th vibration of the other of the concordant notes. This third set will give rise to a note graver than either of the others, and its pitch will, Equation (41), be the same as that of a fundamental note of which the concordant notes may be regarded as harmonics. This graver note is called the *resultant*, and those from which it arises, *components*. Let  $m = 3$  and  $n = 2$ , then, see scale of article (138), will the concord be a perfect fifth, and the resultant note will be an octave below the graver of the two components.

These effects for two concordant notes explained and illustrated;

Resultant and components.

What is true of two notes in perfect accordance may be shown to be equally true of several, and hence the explanation of this curious fact, viz.: that if several strings or pipes be so tuned as to be exactly harmonics of one of them, that is, if their vibrations be in the ratios 1, 2, 3, 4, &c., then, if all or any number of them be sounded together, there will be heard but one note, and that the fundamental note. For, all being harmonics of the note 1, if we combine them two and two we shall find comparatively few but what will give resultants which, with the individual notes, will be lost in the united effect or resultant of *all* the component sounds. But to produce this effect the strings or pipes must be tuned perfectly to strict harmonics. The effect can never take place on the strings of a piano-forte, since they are always tempered.

Above considerations applied to several concordant notes;

Explanation of effects.

§ 148. Now, to resume the question of temperament: If we count the notes in the chromatic scale of article (144), we shall find thirteen, and consequently twelve intervals. Hence, if we would have a scale exactly similar in all its parts, and which would admit of playing equally

Temperament resumed;

Scale that would well in any key, the question of temperament would re-  
 play equally well duce to that of inserting 11 geometrical means between  
 in any key; the extremes 1 and 2, and the scale would stand,

$$1, 2^{\frac{1}{12}}, 2^{\frac{2}{12}}, 2^{\frac{3}{12}}, \dots 2^{\frac{11}{12}}, 2.$$

Iso-harmonic  
 scale.

The values of the mean terms are readily computed by  
 logarithms. This scale, which is one of perfectly equal  
 intervals, is called the *Iso-harmonic scale*.

Examination of  
 the chromatic  
 scale and table of  
 intervals;

§ 149. If we examine the chromatic scale and table of  
 intervals in article (139), we shall find that the interval  
 from *E* to *F*, and from *B* to *C'*, are semitones, and that  
 in a perfect fifth there are, therefore, seven, and in an  
 octave twelve semitones. If, then, we reckon upwards  
 by fifths, we shall, after twelve steps, come to a note  
 in the ascending scale of octaves of the same name as  
 that from which we set out. Beginning with *C*, for  
 example, we shall, after the twelfth remove, arrive at  
 another *C*; or, which amounts to the same thing, if we  
 ascend by two-fifths from *C* and descend an octave, we  
 fall upon *D*; in like manner, rising by two-fifths from  
*D* and falling an octave, we fall upon *E*, and this pro-  
 cess being sufficiently repeated, we finally reach *C'*, the  
 octave of *C*.

Ascending the  
 scale by fifths;

Ascending by  
 major thirds.

Again, from the same scale and table, we see that  
 in a major third, that is, from *C* to *E*, there are four  
 semitones, and hence, if we ascend the scale by major  
 thirds we shall, after three steps, arrive at the octave  
 of the note from which we started.

Value of a fifth,  
 of a major third,  
 and of an octave.

The value of a fifth is  $\frac{3}{2}$ , of a major third  $\frac{5}{4}$ , and of  
 an octave 2. Now, there is no power of  $\frac{3}{2}$  or of  $\frac{5}{4}$  equal  
 to any power of 2, and hence there is no series of  
 steps by perfect fifths or major thirds that can lead to  
 any one of the octaves of the fundamental note. Were  
 the chromatic scale perfect, twelve perfect fifths should  
 be equal to seven octaves, and three major thirds to



one octave; but, as just remarked, neither of these can be true of perfect fifths or major thirds, for  $(\frac{3}{2})^{12} = 129,74$ , and  $2^7 = 128$ , giving a difference of nearly one vibration in every 64; and  $(\frac{5}{4})^3 = 1,953$ , instead of two. So that, if we reckon upwards by major thirds, we fall continually short; if by fifths, we surpass the octave. The excess in this latter case is called the *wolf*, a name suggested, no doubt, by the fact that the thing which bears it has been hunted and chased through every part of the scale in the vain hope of getting rid of it. In consequence, it has been proposed to diminish all the fifths equally, making a fifth, instead of  $\frac{3}{2}$ , to be equal to  $2^{\frac{7}{12}}$ , and tuning regularly upwards by such fifths, and from the notes so tuned, downwards by perfect octaves. This constitutes what is called the system of *equal temperament*.

Reckoning upwards by major thirds, or by fifths;

The wolf;

System of equal temperament;

Identical with the iso-harmonic;

Its defects, and the remedy.

In this system the notes must all be represented by the different powers of  $2^{\frac{1}{12}}$ , and the system itself is identical with the Iso-harmonic. Theoretically, it is the simplest possible. It has, however, one radical fault; it gives all the keys one and the same character. In any other system of temperament some intervals, though of the same denomination, must differ by a minute quantity from each other, and this difference falling in one part of the scale on one key and in a different part on another, gives a peculiar quality to each, and becomes a source of pleasing variety.

Some have supposed that temperament only applies to instruments with keys and fixed notes. This is a mistake. Singers, violin players, and all others who can pass through every gradation of tone, must all temper, or they could never keep in tune with each other, or with themselves. Any one who should keep ascending by fifths and descending by thirds or octaves, would soon find his fundamental pitch grow sharper and sharper, till he could neither sing nor play; and two violin players accompanying each other and arriving at the

General application of temperament;

Illustrations.

the same note by different intervals, would find a continued want of agreement.

Construction of a table;

§ 150. If we take the logarithms of the fractions which express the intervals from the fundamental note to that of any other in the diatonic scale, we shall find, after multiplying each logarithm by 1000, to avoid fractions, taking the product to the nearest whole number, and then the successive differences between these, the following

TABLE.

From	Intervals.	Ra- tios.	Logarithms.	AP- prox.	Differences.
<i>C</i> to <i>C</i>	0	1	0,00000	0	
<i>C</i> to <i>D</i>	major tone	$\frac{9}{8}$	0,05115	51	51 = <i>T</i> = maj. tone
<i>C</i> to <i>E</i>	major third	$\frac{5}{4}$	0,09691	97	46 = <i>t</i> = minor tone
<i>C</i> to <i>F</i>	minor fourth	$\frac{4}{3}$	0,12494	125	28 = $\theta$ = limma
<i>C</i> to <i>G</i>	major fifth	$\frac{3}{2}$	0,17609	176	51 = <i>T</i> = maj. tone
<i>C</i> to <i>A</i>	major sixth	$\frac{5}{3}$	0,22185	222	46 = <i>t</i> = minor tone
<i>C</i> to <i>B</i>	major seventh	$\frac{7}{4}$	0,27300	273	51 = <i>T</i> = maj. tone
<i>C</i> to <i>C'</i>	octave	2	0,30103	301	28 = $\theta$ = limma

Table;

Its accuracy;

The approximate values for the intervals are true to the 500th of a tone, an interval far too small for the nicest ear to distinguish; these values may, therefore, be used in all musical calculations when no very high powers of them are taken. Since the logarithm of any interval is equal to the logarithm of the higher, diminished by that of the lower note, the numbers in the column of differences may be taken to represent the values of the sequence intervals, or intervals between the consecutive notes expressed in equal parts of a scale of which it takes 301 parts to measure an octave.

Its use;

Three intervals and their notation;

And we here perceive again the three different kinds of intervals referred to in article (139). They are denoted in the table above by the characters *T*, *t*, and  $\theta$ , their values being respectively 51, 46 and 28, corresponding to the fractions  $\frac{9}{8}$ ,  $\frac{5}{4}$  and  $\frac{4}{3}$  of the article just cited. These intervals give rise to what is called the *enharmonic diesis*, which is the interval between the sharp of one note and the flat of that next above it, and enables us to understand the distinction between

Enharmonic diesis;

flats and sharps; a distinction essential to perfect harmony, but which can only be maintained in practice in organs and other complicated instruments which admit of great variety of keys and pedals, or in stringed instruments or in the voice, where all gradations of tone may be produced.

To understand this distinction, suppose in the course of a piece of music it be desirable to modulate from the key of *C* to that of *F*, its subdominant. To make the new scale of *F* perfect, its intervals should be the same and succeed each other in the same order as in the original key of *C*. That is, setting out from *F*, the sequence of intervals should be *T t θ T t T θ*, as in the table. Now, this sequence does not take place in the unaltered scale of *C*, when we set out from any note but *C*, and if we prolong this scale backward to *F*, the notes will stand

<i>F</i>	<i>G</i>	<i>A</i>	<i>B</i>	<i>C</i>	<i>D</i>	<i>E</i>	<i>F'</i>	Notes as they stand erroneously;
<i>T</i>	<i>t</i>	<i>T</i>	<i>θ</i>	<i>T</i>	<i>t</i>	<i>θ</i>	<i>θ</i>	

whereas they should stand,

<i>F</i>	<i>G</i>	<i>A</i>	<i>B</i>	<i>C</i>	<i>D</i>	<i>E</i>	<i>F'</i>	Notes as they should stand;
<i>T</i>	<i>t</i>	<i>θ</i>	<i>T</i>	<i>t</i>	<i>T</i>	<i>θ</i>	<i>θ</i>	

The first two intervals are the same in both. The next two will agree if we flatten the note *B*, so as to invert the intervals, or make,

$${}^bB - A = \theta = 28; \quad \text{To make the next two agree;}$$

and

$$C - {}^bB = T = 51;$$

giving by addition

Supposition;  $C - A = T + \theta = 51 + 28 = 79 =$  major third.

The quantity by which  $B$  must be flattened for this purpose is obviously

Consequence;  $T - \theta = 51 - 28 = 23;$

Interpolation necessary to render the two scales nearly perfect in one particular case.

and this is the amount by which, *in this case*, a note differs from its flat. As to the remaining three intervals, the difference between  $T$  and  $t$  being small, amounting only to 5, (which answers to the logarithm of a comma  $\frac{3}{16}$ ;) the sequence  $T t \theta$  is hardly distinguishable from  $t T \theta$ , and if the note  $D$  be tempered flat by an interval  $= \frac{T-t}{2}$ , or half a comma, this sequence will

in both cases be the same, and our two scales of  $C$  and  $F$  will be rendered as perfect as the nature of the case will permit by the interpolation of only one new note.

Another case supposed;

But, on the other hand, suppose we would modulate from  $C$  to  $B$ . In this case the scale of  $C$  will stand

Scale as it stands in this case;

$B$	$C$	$D$	$E$	$F$	$G$	$A$	$B'$
$\theta$	$T$	$t$	$\theta$	$T$	$t$	$T$	$T$

whereas it should be

Scale as it should stand;

$B$	$\#C$	$\#D$	$E$	$\#F$	$\#G$	$\#A$	$B'$
$T$	$t$	$\theta$	$T$	$t$	$T$	$\theta$	$\theta$

The intervals from  $B$  to  $E$ , and from  $E$  to  $B$ , are the only ones that are equal, and to make the others equal would require  $C, D, F, G$  and  $A$  to be sharpened, and consequently the introduction of no less than five new notes. But to confine ourselves to the change from  $A$  to  $\#A$  we have

Conclusions.

$$B - A = T = 51;$$

Particular case taken.

and

$$B - \#A = \theta = 28;$$

consequently, by subtraction,

$$A - \#A = 23 = B - \flat B,$$

Result;

as before determined. But since the whole interval from  $B$  to  $A = T = 51$ , is more than double this interval, the flattened note  $\flat B$ , will lie nearer to  $B$ , and the sharpened note  $\#A$  nearer to the lower one  $A$  than a note arbitrarily interpolated half way between  $A$  and  $B$ , (to answer both purposes approximately,) would be, and thus a gap or *diesis*, as it is called, would be left between  $\#A$  and  $\flat B$ . Explanation; Diesis left in this case;

The diesis in this case only amounts to  $T - 2(T - \theta)$  =  $51 - 46 = 5$ , equal to a comma, or the tenth part of a major tone  $T$ ; in other cases it would be greater. But in all cases the interval between any note and *its sharp* is considered to be equal to that between the same note and *its flat*. What it amounts to.

§ 151. Taking each note of the diatonic scale as the fundamental or key note in succession, we shall find, by the same mode of comparison, the following sets of notes in the several scales—the accent at the top of the letter denoting one octave above the key note. Each note of the diatonic scale taken as the key note;

Names of the Keys.		
$C, D, E, F, G, A, B, C'$	(natural, $C$ )	
$D, E, \#F, G, A, B, \#C, D'$	(two sharps, $D$ )	Sets of notes thus found.
$E, \#F, \#G, A, B, \#C, \#D, E'$	(four sharps, $E$ )	
$F, G, A, \flat B, C, D, E, F'$	(one flat, $F$ )	
$G, A, B, C, D, E, \#F, G'$	(one sharp, $G$ )	
$A, B, \#C, D, E, \#F, \#G, A'$	(three sharps, $A$ )	
$B, \#C, \#D, E, \#F, \#G, \#A, B'$	(five sharps, $B$ )	

These scales defective by two sharps;

In these scales which have the natural notes of the diatonic scale for the key, there are but five sharps, whereas there should be seven. Where are the other two? If we take  $\#F$  and  $\#C$  as the key notes, we shall find

Result of a particular supposition.

$\#F, \#G, \#A, B, \#C, \#D, \#E, \#F'$ . (six sharps,  $\#F'$ )  
 $\#C, \#D, \#E, \#F, \#G, \#A, \#B, \#C'$ . (seven sharps,  $\#C'$ )

Names of the Keys.

In like manner, constructing a diatonic scale on  $bB$ , and on each new flat as it is successively introduced, we find the following, in which the accent at the bottom of a letter denotes one octave below the key.

Same for another supposition.

$B, C, D, bE, F, G, A, bB$ . (two flats,  $bB$ )  
 $bE, F, G, bA, bB, C', D', bE'$ . (three flats,  $bE'$ )  
 $bA, bB, C, bD, bE, F, G, bA$ . (four flats,  $bA$ )  
 $bD, bE, F, bG, bA, bB, C', bD'$ . (five flats,  $bD'$ )  
 $bG, bA, bB, bC', bD', bE', F', bG'$ . (six flats,  $bG'$ )  
 $bC, bD, bE, bF, bG, bA, bB, bC'$ . (seven flats,  $bC'$ )

Names of the Keys.

Several systems of temperament have been devised;

§ 152. Assuming the principle that the interval between any note and its sharp is to be equal to that between the same note and its flat, a variety of systems of temperament have been devised for producing the best harmony by a system of twenty-one fixed notes, viz: the seven notes of the diatonic scale with their seven sharps and seven flats. Among the most remarkable systems may be mentioned those of HUYGENS, SMITH, YOUNG and LAGIER, for an account of which the reader is referred to the Encyclopædia Metropolitana, article, Sound. Vol. IV., page 797.

Some of the most remarkable systems.

Peculiarity of the piano-forte.

§ 153. But the piano-forte, an instrument in almost universal use, and of the highest interest to all lovers of music, admits of only twelve keys from any one note to its octave, and a temperament must be devised which will accommodate itself to this condition.

We have already spoken of the division of the octave into twelve equal parts, and have seen that this makes the fifths all too flat, the thirds all too sharp, and gives a harmony equally imperfect in all the keys. It is urged in favor of equal temperament that all the keys are made equally good, and that in no one does the temperament amount to a striking defect; also, that in the orchestra there is little chance of any uniform temperament if it be not this. Against equal temperament it is urged, however, as before stated, that it takes away all distinctive character from the different keys, and after all, leaves no one of them perfect. A piano-forte perfectly tuned by the system of equal temperament has to some persons a certain insipidity which only wears off as the effect of this tuning disappears; insomuch that the best phase of the instrument is exhibited during the period which precedes its becoming disagreeably out of tune, or, more properly, while it is assuming a state of *maltonation*; for, the transition is only a change from equal to unequal temperament, in which the several keys begin to exhibit variety of character, until maltonation arrives and makes the instrument offensive.

Arguments in favor of equal temperament;

Against equal temperament.

Illustration by the piano-forte

The best practicable way of obtaining a given temperament, equal or unequal, is by means of the monochord. The proper lengths of the strings of this instrument, to form the required notes, are first calculated, and afterwards those of the instrument to be tuned are brought into unison with them. No tuner can get an equal temperament by trial; so that the question in practice generally lies between all sorts of approximations to equal temperament, and as many approximations to some other temperament.

Use of the monochord;

General aim in practice.

§ 154. The mode of proceeding by approximation to equal temperament is simply to tune all the fifths a little flat; and the following order is the most usual. The first letters represent the note already tuned, the second the one which is to be tuned from it; a chord in parenthesis

The most usual order of proceeding;

First step, by tuning fork; represents a trial that should be made on notes already tuned, to test the success of the operations as far as it has gone. The first step is to put *C'* in tune by the *tuning fork*;

Trials indicated; *C'*; *C' C*; *C G*; *G G<sub>i</sub>*; *G<sub>i</sub> D*; *D A*; *A A<sub>i</sub>*; *A<sub>i</sub> E*; (*C E G*); *E B*; (*C E G*; *D G B*); *B B<sub>i</sub>*; *B<sub>i</sub> #F*; (*D #F A*); *#F #F<sub>i</sub>*; *#F<sub>i</sub> #C*: (*A<sub>i</sub> #C E*); *#C #G*; (*E #G B*); *C' F*; (*F A C'*); *F #A<sub>i</sub>*; (*#A<sub>i</sub> D F*); *#A<sub>i</sub> #A*; (*#A<sub>i</sub> #D*); (*#D G #A*); *#D #G*; (*#G C #D*).

Explanation of method, and of results that should be obtained; All the semitones are written as sharps whether tuned from above or below. Since the fifths are all to be a little too small in their intervals, the upper notes must be flattened when tuned from below, and the lower notes sharpened when tuned from above. In the preceding, the octave *C C'* is completely tuned, and also the adjacent interval *#F<sub>i</sub> C*. The rest of the instrument is tuned by octaves. The thirds should come out a little sharper than perfect, as the several trials are made, and when this does not happen, some of the preceding fifths are not equal. The parts which are first tuned by fifths, and from which all the others are tuned by octaves, are called *bearings*.

Bearings.

Remark on unequal temperament; § 155. In unequal temperament, some of the keys are kept more free from error than others, both for the sake of variety and because keys with five or six sharps or flats are comparatively but little used; these latter keys are left less perfect, and this is called throwing the *wolf* into these keys. From equal intervals to those which produce what has been called maltonation, there is abundant room for the advocates of unequal temperament to select that particular system most congenial to the views of each, and, accordingly, many systems have been proposed. Of these we shall only mention two, Smith's system; viz.: that denominated by Dr. SMITH *the system of mean*



tones, and that which bears the name of its author, Dr. YOUNG.

The system of mean tones supposes the octave divided into five equal tones, of which we shall denote the value of each by  $a$ , and two equal limmas, each having the value  $\beta$ , succeeding each other in the order  $a a \beta a a a \beta$  instead of  $T t \theta T t T \theta$ , as in the diatonic scale, and such that the thirds shall be perfect, and the fifths tempered a little flat. These conditions are sufficient to determine the values of  $a$  and  $\beta$ , for,

$$\begin{aligned} 5 a + 2 \beta &= 1 \text{ octave} = 3 T + 2 t + 2 \theta \\ 2 a &= 1 \text{ third} = T + t \end{aligned}$$

whence

$$\alpha = \frac{T+t}{2}; \beta = \theta + \frac{T-t}{4};$$

Use of this system explained and illustrated;

and substituting the values from the table

$$\alpha = \frac{51 + 46}{2} = 48,5; \beta = 28 + \frac{51 - 46}{4} = 28,125$$

and since the interval from the 1st to the 5th of the scale is

$$3 \alpha + \beta = 2 T + t + \theta - \frac{T-t}{4};$$

the fifth by this scale is flatter than the perfect fifth by the quantity  $\frac{1}{4}(T-t)$ , that is, by a quarter of a comma. In this system the sharps and flats are inserted by bisecting the larger intervals.

Dr. YOUNG'S first system is as follows, viz.: Tune downwards from the key note six perfect fifths, then upwards from the key note six imperfect fifths, dividing the excess of twelve perfect fifths, above seven octaves,

Explanation.

equally among the imperfect fifths, and observing to ascend in the first case, and descend in the second, by octaves, when necessary, to keep between the key note and its octave.

Scale of the Chinese, Hindoos, &c.

§ 156. If we take from the diatonic scale the notes *F*, and *B*, which rise from those immediately preceding them by semitones, there will remain *C*, *D*, *E*, *G*, *A* and *C'* for all the sounds of the octave. This is the original scale of the Chinese, Hindoos, the Eastern Islands and the nations of Northern Europe. It is the scale of the Scotch and Irish music, and the Chinese have preserved it to the present time. The character of this scale is exhibited by playing on the black keys alone of the piano-forte.

Effect of small intervals.

§ 157. The effect of making an interval smaller is to give the consonance a more plaintive character. It may easily be observed, for example, that the intervals of the minor third, *E G*, and minor sixth, *E C'* on any instrument, have a sad or plaintive effect as compared with the major third, *C E*, and major sixth, *C A*. Almost all persons in ordinary conversation are constantly varying the tone in which they speak, and making intervals which approach to musical correctness, and the effect of sorrow, regret, and the like, is to make these intervals minor. Any one with a musical ear, noticing the method of saying "*I cannot*," pronounced as a determination of the will, and comparing the same uttered as an expression of regret for want of ability, will understand what is here meant. Why this is so, no one can tell. But the association exists, and resort is had to those modifications of the diatonic scale which are known from experience to produce the emotions here referred to. The results of these modifications, of which there are several, are called *Minor Scales*, in contradistinction to the diatonic, which is called the Major Scale. The change from a minor to the major scale is one of the most effective of musical resources.

Principles of music applied in conversation.

Minor scales.

If we return to the fundamental note  $C$  and its consonances, viz. :

$$C \quad \flat E \quad E \quad F \quad G \quad A \quad C'$$

$$1 \quad , \quad \frac{6}{5} \quad , \quad \frac{5}{4} \quad , \quad \frac{4}{3} \quad , \quad \frac{3}{2} \quad , \quad \frac{5}{3} \quad , \quad 2 ;$$

Fundamental  
note and its  
consonances ;

and instead of rejecting  $\flat E$  as too near to  $E$ , we discard this latter note, and finish by inserting  $D$  and  $B$  of the diatonic scale, we shall have what is called the common *ascending* minor scale, as follows :

$$C \quad , \quad D \quad , \quad \flat E \quad , \quad F \quad , \quad G \quad , \quad A \quad , \quad B \quad , \quad C'$$

$$1 \quad , \quad \frac{9}{8} \quad , \quad \frac{6}{5} \quad , \quad \frac{4}{3} \quad , \quad \frac{3}{2} \quad , \quad \frac{5}{3} \quad , \quad \frac{1.5}{2} \quad , \quad 2.$$

Ascending minor  
scale ;

But it is not easy to recognize this as a minor scale in descent, because, in going from  $C'$  to  $C$ , there is no distinction between it and the major scale till we come to  $\flat E$ , or until the scale has produced its principal effect upon the ear. To remedy this,  $A$  and  $B$  are both lowered a semitone ; that is,  $A$  is made  $\flat A$ , and  $B$  is made  $\flat B$ , thus making  $\flat A$  a fourth to  $\flat E$ , and  $\flat B$  a fifth to  $\flat E$ , and giving

$$C \quad , \quad D \quad , \quad \flat E \quad , \quad F \quad , \quad G \quad , \quad \flat A \quad , \quad \flat B \quad , \quad C'$$

$$1 \quad , \quad \frac{9}{8} \quad , \quad \frac{6}{5} \quad , \quad \frac{4}{3} \quad , \quad \frac{3}{2} \quad , \quad \frac{3}{5} \quad , \quad \frac{9}{5} \quad , \quad 2 ;$$

which being reversed, is called the common mode of *descending* the minor scale.

Again, if we retain  $B$  of the major scale and lower  $A$ , we have

$$C \quad , \quad D \quad , \quad \flat E \quad , \quad F \quad , \quad G \quad , \quad \flat A \quad , \quad B \quad , \quad C'$$

$$1 \quad , \quad \frac{9}{8} \quad , \quad \frac{6}{5} \quad , \quad \frac{4}{3} \quad , \quad \frac{3}{2} \quad , \quad \frac{3}{5} \quad , \quad \frac{1.5}{2} \quad , \quad 2,$$

which is a mild and pleasing scale both in ascent and descent, notwithstanding the wide interval between  $\flat A$  and  $B$ . Its harmonics are more easy and natural than the other, and SCHNEIDER makes it, in his Elements of

Schneider's  
principal minor  
scale.

Harmony, a principal minor scale, and treats all others as incidental deviations.

Any system of temperament may be examined by the scale;

§ 158. We shall now show how we may, from the theory of the scale, examine any system of temperament; and as the method will be rendered the more obvious by applying it to a particular example, we shall take the system of Dr. YOUNG just described.

Let all the intervals be expressed in *mean semitones*, as the unit. There being twelve semitones in the octave, we have one semitone equal to the logarithm of 2 divided by 12, or

$$\frac{0,30103}{12} = 0,0250858;$$

Method explained;

and dividing the logarithm of the major tone =  $\frac{2}{3}$ , that of the minor tone =  $\frac{1}{3}$ , that of the diatonic semitone =  $\frac{1}{12}$ , and the excess of twelve perfect fifths over seven octaves = 0,00588 by this value of the mean semitone, we shall find

System of Dr. Young taken;

1 major tone	= 2,039100	mean semitones,
1 minor tone	= 1,824037	“ “
1 diatonic semitone	= 1,117313	“ “
Excess of 12 fifths over 7 octaves	= 0,234600	“

In tuning upwards, each fifth is to be flattened by one-sixth of 0,234600, or by 0,039100. In the equal temperament the wolf is replaced by twelve equal whelps; here by six, but of double the size.

Now, a perfect fifth is composed of

Example for illustration;

2 major tones	= 4,078200
1 minor tone	= 1,824037
1 diatonic semitone	= 1,117313
Perfect fifth	= 7,019550
Deduct . . .	0,039100
Flattened fifth	= 6,980450

Then taking *C* for the key note,

<i>C'</i> . . 12,00000	<i>C</i> . . 0,00000	Example continued;
-5 <sup>th</sup> . . 7,01955	+5 <sup>th</sup> . . 6,98045	
<i>F'</i> . . 4,98045 . (1)	<i>G</i> . . 6,98045 . (1)	
+8 <sup>th</sup> . . 12	+5 . . 6,98045	
<i>F''</i> . . 16,98045	<i>D'</i> . . 13,96090	
-5 <sup>th</sup> . . 7,01955	-8 <sup>th</sup> . . 12	
# <i>A</i> . . 9,96090 . (2)	<i>D</i> . . 1,96090 . (2)	
-5 <sup>th</sup> . . 7,01955	+5 <sup>th</sup> . . 6,98045	
# <i>D</i> . . 2,94135 . (3)	<i>A</i> . . 8,94135 . (3)	
+8 <sup>th</sup> . . 12	+5 <sup>th</sup> . . 6,98045	
# <i>D'</i> . . 14,94135	<i>E'</i> . . 15,92180	
-5 <sup>th</sup> . . 7,01955	-8 <sup>th</sup> . . 12	
# <i>G</i> . . 7,92180 . (4)	<i>E</i> . . 3,92180 . (4)	The same;
-5 <sup>th</sup> . . 7,01855	+5 <sup>th</sup> . . 6,98045	
# <i>C</i> . . 0,90225 . (5)	<i>B</i> . . 10,90225 . (5)	
+8 <sup>th</sup> . . 12	+5 <sup>th</sup> . . 6,98045	
# <i>C'</i> . . 12,90225	# <i>F''</i> . . 17,88270	
-5 <sup>th</sup> . . 7,01955	-8 <sup>th</sup> . . 12	
# <i>F'</i> . . 5,88270 . (6)	# <i>F</i> . . 5,88270 . (6)	

Collecting these intervals for all the notes from *C* to *C'*, we have

<i>C</i> . . . 0,00000	# <i>F'</i> . . . 5,88270	Results collected.
# <i>C</i> . . . 0,90225	<i>G</i> . . . 6,98045	
<i>D</i> . . . 1,96090	# <i>G</i> . . . 7,92180	
# <i>D</i> . . . 2,94135	<i>A</i> . . . 8,94135	
<i>E</i> . . . 3,92180	# <i>A</i> . . . 9,96090	
<i>F</i> . . . 4,98045	<i>B</i> . . . 10,90225	

As the most important chord is that of the tonic, we form our idea of the effect of each key, from the effect of the temperament upon this chord, judging of the character of the key by the amount and direction of

Explanation; the temperament upon the third and fifth, which with the key make, as we have seen, the chord in question. Now, a major third is composed of

1 major tone	=	2,03910	mean semitones,
1 minor tone	=	1,82404	“ “
Value of a major third;		Major third . . . 3,86314	“ “

A minor third is composed of

1 major tone	=	2,03910	mean semitones,
1 diatonic semitone	=	1,11731	“ “
Value of a minor third;		Minor third . . . 3,15641	“ “

and hence the intervals for the chord of the tonic are

For a major key . . . 3,86314 and 7,01955  
 “ minor “ . . . 3,15641 and 7,01955.

Conclusions.

Method of examining any particular key.

To examine any particular key, take the numbers from the preceding table opposite the notes of the tonic chord, adding twelve to make the octave when necessary; subtract the number of the key note from each of the other two, and the remainders will give the tempered intervals; from these remainders subtract the correct intervals above, and these second remainders will give the amount and direction of the temperament. For example, let us examine the key of *A*; we find

<i>A</i> . 8,94135; # <i>C'</i> . 12,90225; <i>E'</i> . 15,92180					
	<table style="margin-left: auto; margin-right: auto;"> <tr> <td style="padding-right: 20px;">8,94135</td> <td style="padding-right: 20px;">8,94135</td> </tr> <tr> <td style="border-top: 1px solid black;"></td> <td style="border-top: 1px solid black;"></td> </tr> </table>	8,94135	8,94135		
8,94135	8,94135				
Tempered intervals	3,96090 . . . 6,98045				
Perfect intervals	. . . 3,86314 . . . 7,01955				
Temperaments	. . + 0,09776 . . - 0,03910				

Example for illustration.

whence we see that the first interval is sharper and the second flatter than perfect, the sign +, indicating sharper, and the sign -, flatter.

# ELEMENTS OF OPTICS.

---

§ 1. THE principle by whose agency we derive our sensations of external objects through the sense of sight, is called LIGHT; and that branch of Natural Philosophy which treats of the nature and properties of light, is called OPTICS.

Light;

Optics.

§ 2. There exists throughout space an extremely attenuated and highly elastic medium called *ether*. This ether permeates all bodies, and the pulsations or waves propagated through it, constitute the principle of light. The eye admitting the free passage of the ethereal waves into it, the sensation of sight arises from the motions which these waves communicate to certain nerves which are spread over a portion of the internal surface of that organ; we therefore *see* by a principle in every respect analogous to that by which we *hear*; the only difference being in the nature of the medium employed to impress upon us the motions proper to excite these different kinds of sensations. In the former case it is the ether agitating the nerves of the eye, in the latter, the air communicating its vibrations to the nerves of the ear.

Principle of light;

Sensation of sight produced;

Analogy between the sensations of sight and sound.

§ 3. Some bodies, as the sun, stars, &c., possess, in their ordinary condition, the power of exciting light, while many others do not. The first are called *self-luminous*, and the second *non-luminous* bodies. All substances, however, become self-luminous when their temperature is sufficiently elevated, or when in a state

Self-luminous bodies;

Non-luminous bodies;

Insects that possess the power of exciting light.

of chemical transition; and some organisms, as the glow-worm, fire-fly, and the like, are provided with an apparatus capable of exciting ethereal undulations and of becoming self-luminous when thrown into a state of vibration by these insects.

Self-luminous bodies visible;

Self-luminous bodies are seen in consequence of the light proceeding directly from them; whereas, non-luminous bodies only become visible because of the light which they receive from bodies of the self-luminous class, and reflect from their surfaces.

Non-luminous rendered so.

Medium.

§ 4. Whatever affords a passage to light is called a *medium*. Glass, water, air, vacuum, &c., are media.

Waves of light spherical in homogeneous media;

§ 5. Waves of light, like those of sound, proceed from any disturbed molecule as a centre, with a constant velocity in all directions, through media of homogeneous density. The front of the luminous wave in such media is, therefore, always on the surface of a sphere whose centre is at the place of primitive disturbance, and whose radius is equal to the velocity of propagation multiplied into the time since the wave began. Thus, if a molecule of ether be disturbed at  $C$ , and the velocity of propagation be denoted by  $V$ , and the time elapsed since the disturbance by  $t$ , then will the front of the wave at the expiration of this time be upon the surface of a sphere whose centre is at  $C$  and radius  $CA = V. t$ .

Geometrical illustration.

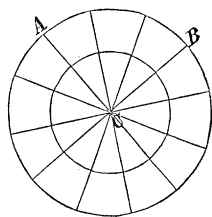

Fig. 1.

Wave front not spherical in heterogeneous media.

If the medium through which the wave moves be not homogeneous, the shape of the wave front will not be spherical, but will vary from that figure in proportion as the medium departs from perfect homogeneousness.

§ 6. The circumstances attending the propagation of luminous and sonorous waves are similar. The intensity



of light, like that of sound, depends upon, and is directly proportional to the amount of molecular displacement. It is, therefore, Acoustics, § 53, inversely proportional to the square of the distance from the original luminous source.

Intensity of light.

§ 7. We have seen, Acoustics, § 16, that in wave propagation through a homogeneous medium, the displacement of a molecule  $O$ , from its place of rest at one time, becomes a source of displacement at a subsequent time for an indefinite number of molecules situated on the surface of a sphere  $MN$ , whose centre is at  $O$ , and of which the radius is equal to  $V.t$ ; that these numerous disturbances become in their turn so many sources of disturbance for any single molecule as  $O'$ , in front of the wave, and that the amount of  $O'$ 's displacement from its place of rest will be found by compounding the displacements due to all these sources, after estimating the amount due to each separately.

To demonstrate the rectilinear propagation of light in homogeneous media;

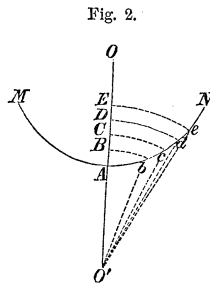

Fig. 2.

To ascertain the effect of this process of composition, denote by  $\lambda$ , the length of a luminous wave; join  $O$  and  $O'$  by a right line, and take the distances  $AB = BC = CD = DE = \frac{1}{2}\lambda$ , and with  $O'$  as a centre and the distances  $O'B, O'C, O'D, O'E$ , &c., successively as radii, describe the arcs  $Bb, Cc, Dd, Ee$ , &c., cutting the section of the wave  $MN$ , in the points  $b, c, d, e$ , &c. Now, regarding the several molecules in the portions  $Ab, bc, cd, de$ , &c., of the great wave, as so many centres of disturbance, it is obvious that the secondary waves sent to the molecule  $O'$ , from those which occupy corresponding positions, on each pair of consecutive portions, will be in complete discordance, and therefore, Acoustics, § 59, that the joint effects of any two consecutive portions will be to destroy one another, provided

Geometrical construction and explanation;

Joint effects of two consecutive portions of the main wave;

Portions of the main wave remote from the straight line destroy each other ;

the waves from these portions be equal in number and give equal molecular displacements. And it is easy to see that this is the case with respect to the portions remote from *A*. For, the magnitude of the displacement of *O'*, caused by any two consecutive portions, depends—first, upon the relative magnitudes of these portions, and secondly, upon their difference of distance from *O'*. With respect to the former, it is obvious, from the construction, that *Ab* is greater than *bc*, *bc* than *cd*, *cd* than *de*, and so on ; but that the successive differences go on continually diminishing, and that the magnitudes of,

Displacement of an assumed particle due to those portions of the main wave in the immediate vicinity of the right line joining it with the luminous origin ;

ing portions, approach indefinitely to equality as they recede from the point *A*. For corresponding points in consecutive portions, the difference of distance, which is  $\frac{1}{2}\lambda$ , never exceeds, as we shall see, 0,000013 of an inch ; so that the portions of the main wave remote from the straight line *OO'*, destroy each other's effects, and the displacement of *O'*, will be entirely due to those parts of the great wave in the neighborhood of the line connecting the point *O'* with the luminous origin.

Portion producing the greatest effect ;

Of these parts *A b* produces, of course, the greatest effect, being both the largest and least oblique to *OO'*. The effects of the neighboring portions are, however, sensible, and we shall have occasion, under the head of CHROMATICS, to observe some important phenomena to which they give rise. In the mean time we cannot fail to perceive one remarkable consequence of this explanation, viz.: that if the alternate portions *bc*, *de*, &c., whose effects are, relatively to the others, negative, be stopped, the total effect upon *O'* will be augmented, and the light there will be literally increased by intercepting a portion of the wave. All of which we shall have occasion to see fully confirmed by experiment. For the present our conclusion is, that *in a homogeneous medium, the apparent effects of light are propagated from one point to another in a right line*; that the sensible effects of light cannot, like those of sound, be propa-

Effects of the other portions.

Conclusion.

gated round corners, and that optic shadows must run up to the right line drawn from the luminous source tangent to the edges of objects which cast them.\*

Light not propagated round corners.

§ 8. Any line  $RR$ , which pierces the wave surface perpendicularly, is called a *ray of light*. A ray, therefore, is obviously a line along which the successive effects of light occur.

When the wave surface becomes a plane, the rays will be parallel, and a collection of such rays is called a *beam of light*.

When the wave surface is spherical, the rays will have a common point at the centre of curvature, and a collection of such rays is called a *pencil of light*.

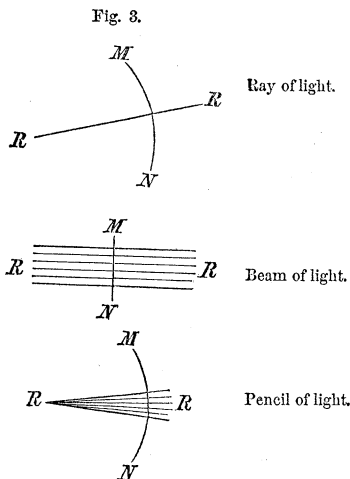

REFLEXION AND REFRACTION OF LIGHT.

§ 9. The reciprocal action between the molecules of various substances and those of the ether which pervades them, causes the latter fluid to exist in a state of different elasticity and density in different bodies.

Reflexion and refraction of light;

By reference to Equation (3), Acoustics, we recall that the wave velocity increases with the elasticity of the medium and decreases with its density; and, § 71, same subject, shows us, that when a wave is incident upon the boundary of a medium of different density from that in which it is moving, it will be resolved into two component waves, one of which will be driven back from the bounding surface, while the other will be transmitted and conducted through the new medium. Light, like sound, will, therefore, be *reflected* and *refracted*, and according to the same laws.

Follow the same laws as sound;

\*See Appendix No. 1.

And the circumstances of incident and deviated light determined by the same equation.

§ 10. And resuming Equation (29), Acoustics, which is

$$\sin. \varphi = \frac{V}{V'} \cdot \sin. \varphi' \dots \dots (1)$$

we may determine all the circumstances of velocity and direction of incident, reflected and refracted light. In this equation  $V$ , denotes the velocity of light in the first, and  $V'$ , its velocity in the second medium;  $\varphi$ , the angle of incidence, and  $\varphi'$ , that of refraction.

§ 11. Let us here repeat the notation of § 71, Acoustics. The surface which separates the two media, and of which  $M N$ , represents a section by a normal plane, is called the *deviating surface*; and, supposing the wave to be moving from  $S$  towards  $D$ ,  $W W$  is called the *incident*,  $W' W'$  the *reflected*, and  $W'' W''$  the *refracted wave*; and the normals to these, viz.:  $S D$ ,

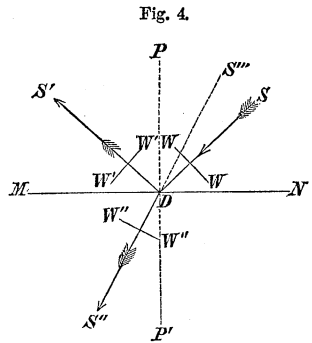

Fig. 4.

Deviating surface;

Incident, reflected, refracted wave;

Incident, reflected, refracted ray;

Angle of incidence, of reflexion, of refraction.

$D S'$  and  $D S''$ , are called, respectively, the *incident*, *reflected*, and *refracted ray*; the ray  $D S'$  is said to be deviated by reflexion, and  $D S''$  by refraction; also drawing the normal  $P P'$  to the deviating surface, the angle  $P D S$ , which the incident ray makes with this normal, is called the *angle of incidence*; the angle  $P D S'$ , which the reflected ray makes with the normal, is called the *angle of reflexion*, and the angle  $P D S'' = P' D S''$ , which the refracted ray makes with the normal, is called the *angle of refraction*.

How these angles are estimated;

§ 12. These angles are always estimated from that part of the normal drawn through the point of incidence of the ray, which lies in the medium of the incident wave.

They are accounted positive when on the same side of the normal as the incident ray, and negative when on the opposite side. Thus, the angle of incidence  $PDS$ , is always positive, as also the angle of refraction  $PDS'''$ , while the angle of reflexion  $PDS'$ , will always be negative, since the velocity of the reflected light must be counted negative, the reflected wave being driven back from the deviating surface.

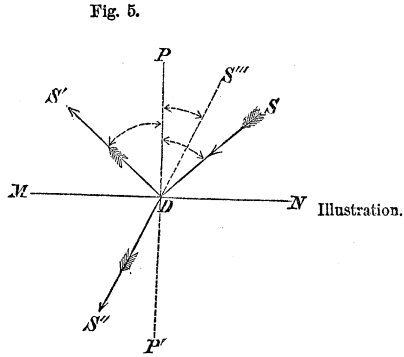

§ 13. When the deviating surface is curved, we conceive a tangent plane drawn to it at the point of incidence, and treat this plane as the deviating surface for that portion of the wave which is incident immediately about the tangential point.

§ 14. The angle which any ray after deviation, makes with the prolongation of the same ray before incidence, is called the *deviation*. Thus,  $S^{iv}DS'$  is the deviation by reflexion; and  $S''DS''$ , the deviation by refraction.

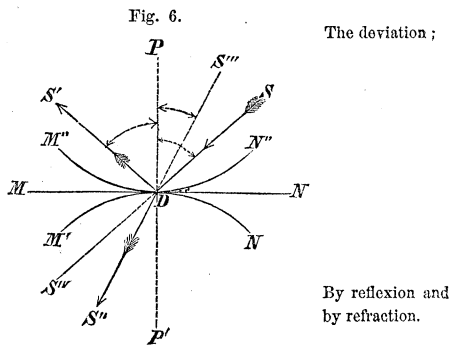

§ 15. If we make

$$\frac{V}{V'} = m, \dots \dots \dots (2)$$

Equation (1) becomes

Equation applicable to refraction;

$$\sin \varphi = m \sin \varphi' \dots \dots \dots (3)$$

which answers to any refracted ray.

For the reflected ray,  $V$  becomes equal to  $-V'$ , and

$$-1 = m;$$

this in Equation (3) gives

Equation applicable to reflexion;

$$\sin \varphi = -\sin \varphi' \dots \dots \dots (4)$$

which applies to all cases of reflexion. And generally we may consider the Equation

General equation for all deviations.

$$\sin \varphi = m \sin \varphi' \dots \dots \dots (5)$$

as applicable to all cases of deviation, observing to make  $m$ , equal to minus unity in cases of reflexion.

Catoptrics and Dioptrics.

§ 16. The circumstances attending the deviation of the component waves into which an incident wave is resolved at a deviating surface, being in general different, gave rise to two distinct branches of optics, called *Catoptrics* and *Dioptrics*, the former treating of reflected, and the latter of refracted light. But by the generalization expressed in Equation (5), this division may be avoided, the discussions made more general, and much space and labor saved.

Index of refraction;

§ 17. The quantity  $m$ , is called the index of refraction. It is the ratio of the velocity of the incident to that of the deviated light, which is equal to the ratio of the sine of the angle of incidence to the sine of the angle

of refraction or of reflexion, according as  $m$  is positive or minus unity.

The numerical value of  $m$ , has been determined experimentally for a great variety of substances, solids, liquids and gases, on the supposition that the deviating surface separates the various substances from a vacuum. It is found to be constant for the same medium, but variable from one medium to another. And as a general rule, it is *greater* than unity when light passes from any medium to another of greater density, as from air to water, from water to glass; and *less* than unity when light passes from one medium to another less dense, as from water to air.

Value of refractive index under different circumstances.

There is a remarkable exception to this rule in the case of combustible substances, these always refracting more than other substances of the same density.

Exception to the general rule.

From what has been said, it is obvious that a ray of light on leaving any medium and entering one more dense, will, in general, be bent towards the normal to the deviating surface, while the reverse will be the case when the medium into which the ray passes is less dense than the other.

Light deviated with respect to the normal.

§ 18. If all bodies possessed equal density, the value of  $m$ , or the index of refraction, might be taken as the measure of the refractive power of the substance to which it belongs, but this not being the case, it has been shown, that if the expression of the *law according to which all substances act upon light be of the same form*, the refractive power will be proportional to the excess of the square of the index of refraction above unity, divided by the specific gravity. Calling  $n$ , the absolute refractive power,  $m$ , the index of refraction,  $S$ , the specific gravity, and  $A$ , a constant co-efficient, we shall have according to this rule,

Refractive power of different substances;

$$n = A \cdot \frac{m^2 - 1}{S} \dots \dots \dots (6).$$

Its value in any case;

Refractive indices and powers determined by experiment;

The following table shows the value of  $m$ , and  $n$ , for the different substances named, the value of  $m$  being taken on the passage of light from a vacuum.

TABLE  
OF REFRACTIVE INDICES AND REFRACTIVE POWERS.

Table of refractive indices and powers.

Substances.	$m$	$n = \frac{m^2 - 1}{S}$
Chromate of Lead,	{ 2,97	1,0436
	{ 2,50	
Realgar,	2,55	1,666
Diamond,	2,45	1,4566
Glass-flint,	1,57	0,7986
Glass Crown,	1,52	
Oil of Cassia,	1,63	1,3308
Oil of Olives,	1,47	1,2607
Quartz,	1,54	0,5415
Muriatic Acid,	1,40	
Water,	1,33	0,7845
Ice,	1,30	
Hydrogen,	1,000138	3,0953
Oxygen,	1,000272	0,3799
Atmospheric Air,	1,000294	0,4528

DEVIATION OF LIGHT AT PLANE SURFACES.

Deviation of light at plane surfaces;

Illustration and explanation;

§ 19. Let  $MN$ , be a deviating surface, separating any medium  $B$ , from a vacuum  $A$ . A ray of light  $SD$ , being incident at  $D$ , will be deviated according to the law expressed by Equation (3),

$$\sin \varphi = m \sin \varphi',$$

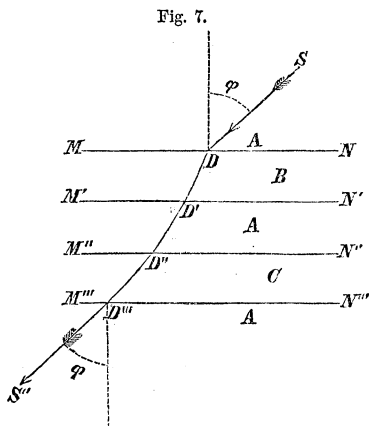



$m$ , being the index of refraction of the medium  $B$ . The refracted ray  $D D'$ , meeting a second surface  $M' N'$ , parallel to the first, and passing again into a vacuum, will be refracted so as to satisfy the Equation,

$$\sin \phi' = m' \sin \phi'',$$

the angle of incidence  $\phi'$ , on the second surface being the same as that of refraction at the first, and  $m'$ , the index of refraction from the medium  $B$  to the vacuum. But, in this case, Equation (2),

$$m' = \frac{V'}{V} = \frac{1}{m};$$

Index of refraction from medium to vacuum;

whence, substituting this value of  $m'$ , and multiplying the two preceding Equations together, we obtain,

$$\sin \phi = \sin \phi'',$$

Operations performed;

that is, the ray after passing a medium bounded by parallel plane faces, is not ultimately deviated, but remains parallel to its first direction.

Conclusion in words.

The ray  $D'' D'''$ , being supposed to traverse a second medium bounded by parallel plane faces, and of which the refractive index is  $m''$ , will undergo no deviation; and the same may be said of any number of media bounded by such faces. If, now, the spaces between the media be diminished indefinitely so as to bring them into actual contact, there will still be no deviation, and we find that a wave will emerge from a medium, arranged in parallel strata, parallel to its position before entrance.

Same true for any number of media bounded by parallel plane faces.

To find the relative index of refraction;

§ 20. Let us next suppose a ray to traverse two media *A* and *B*, bounded by plane parallel faces, the media being in contact, and having their refractive indices denoted by *m* and *m'* respectively; we shall have, by calling *m''*, the index of refraction of the second, or denser medium in reference to the first,

Fig. 8.

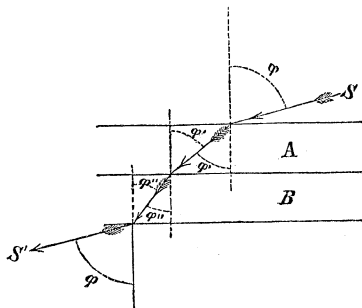

Equations applicable to the deviations;

$$\begin{aligned} \sin \phi &= m \sin \phi' \\ \sin \phi' &= m'' \sin \phi'' \quad . . . . . (7) \\ \sin \phi'' &= \frac{1}{m'} \sin \phi. \end{aligned}$$

Multiplying these Equations together, there will result

Result of operations;

$$m'' = \frac{m'}{m} . . . . . (7)'$$

Rule.

That is to say, to find the index of refraction in the case of a ray passing from any one medium to another, *divide the index of the second by that of the first referred to a vacuum*. The index thus obtained is called the *relative index*.

Example;

*Example.* What is the relative index of air and crown glass, the light entering the latter from the former? The tabular index of crown glass is 1,52, and that of air is 1,0003, whence

Result.

$$m'' = \frac{1,5200}{1,0003} = 1,52.$$

§ 21. If a ray pass from a medium to another more dense, the index  $m''$  will be greater than unity, and from equation (7), we shall have

$$\sin \phi' > \sin \phi'';$$

and if  $\sin \phi'$  be taken a maximum, or the angle of incidence be  $90^\circ$ , equation (7) will give,

$$\frac{1}{m''} = \sin \phi'' \dots \dots \dots (8)$$

from which results a maximum limit to the angle of refraction. If  $m''$  be taken equal to 1,52 for the atmosphere and crown glass,

$$\sin \phi'' = 0,657,$$

or

$$\phi'' = 41^\circ 5' 30'', \text{ nearly};$$

Example,  
atmosphere and  
crown glass;

for air and water,  $m'' = 1,33$ , and

Atmosphere and  
water;

$$\phi'' = 48^\circ 15';$$

that is to say, the greatest angle of refraction which can exist when light passes from air into crown glass, is  $41^\circ 5' 30''$ ; and from air into water,  $48^\circ 15'$ .

If the ray pass from a medium to another less dense,

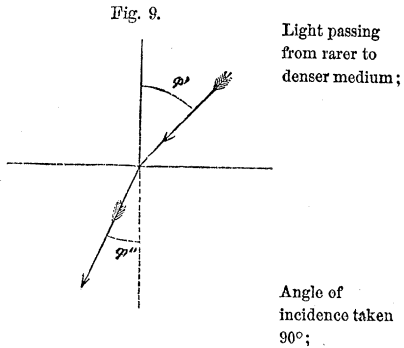

Light passing from denser to rarer medium;

$m''$  will be less than unity, and equal to the reciprocal of its former value; Equation (7) will then give

$$\sin \phi'' > \sin \phi' ;$$

Angle of refraction taken  $90^\circ$ ;

taking the maximum value for  $\sin \phi'' = 1$ , we shall obtain from the same Equation,

Fig. 10.

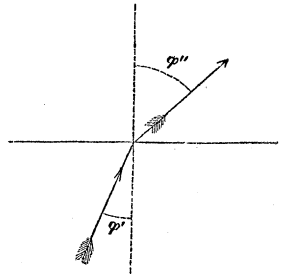

Consequence;

$$\sin \phi' = \frac{1}{m''}, \dots \dots \dots (9)$$

Analogy;

this value for the sine of the angle of incidence, which corresponds to the greatest angle of refraction when light passes from any medium to one less dense, is the same as that found before for the greatest angle of refraction, when the incidence was taken a maximum, in the passage of light from one medium to another of greater density.

Examples;

In the case of air and glass, it is 0,657; corresponding to an angle of  $41^\circ 5' 30''$ ; for air and water, the angle is  $48^\circ 15'$ .

Conclusion;

If the angle  $\phi'$  be taken greater than that whose sine is  $\frac{1}{m''}$ , the angle of refraction, or emergence from the denser medium, will be imaginary, and the light will be *wholly reflected* at the deviating surface. This maximum value for  $\phi'$  is called the *angle of total reflexion*. Light cannot, therefore, pass out of crown glass into air under a greater angle of incidence than  $41^\circ 5' 30''$ , nor out of water into air under a greater angle than  $48^\circ 15'$ .

Angle of total reflexion.

§ 22. The *maximum limit of refraction*, and the cases of *total reflexion*, are attended with many interesting

results. If an eye be placed in a more refracting medium than the atmosphere, as that of a fish under water, it will perceive, by the limit of refraction, all objects in the horizon elevated in the air, and brought within  $48^{\circ} 15'$  of the zenith, while some objects in the water would appear to occupy the belt included between this limit and the horizon by total reflexion.

Those remarkable cases of *mirage*, where objects are seen suspended in the air, and oftentimes inverted, are explained by ordinary refraction and total reflexion. The phenomena of mirage most frequently occur when there intervenes between the suspended object and spectator a large expanse of water or wet prairie, and towards the close of a hot and sultry day, when the air is calm, so that the different strata may arrange themselves according to their different densities. When the wind rises the phenomena cease.

Appearances due to the limit of refraction and total reflexion;

Those due to ordinary refraction and total reflexion.

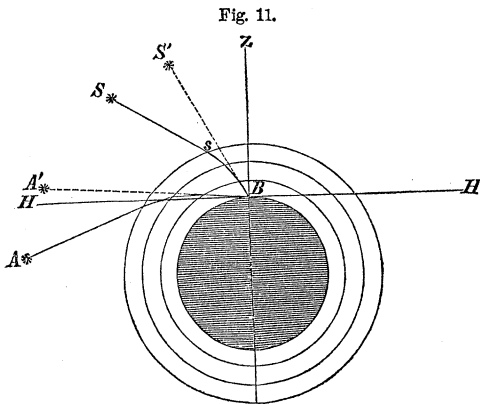

Illustration,

It is well known that in the ordinary state of the atmosphere, its density decreases as we ascend; a ray of light, therefore, entering the atmosphere at  $S$ , would undergo a series of refractions, and reach the eye at  $B$ , with an increased inclination to the surface of the earth; and would appear to come from a point,  $S'$ , in the heavens above that at  $S$ , occupied by a body from which it pro-

Apparent effect of the atmosphere on the positions of celestial bodies:

ceeded. Hence, the effect of the atmosphere is to increase apparently the altitudes of all the heavenly bodies.

Relative index determined by total reflexion;

§ 23. DR. WOLLASTON suggested a method, founded on the limit of *total reflexion*, to determine the relative indices and refractive powers of different substances. If the angle of incidence,  $\phi'$ , be measured by any device, Equation (9) will give,

$$m'' = \frac{1}{\sin \phi'}$$

And thence the refractive power.

from which, Equation (7)', we find the absolute index, knowing that of air; and the refractive power may then be deduced from Equation (6).

Optical prism;

§ 24. The deviating surfaces have, thus far, been supposed parallel. If they be inclined to each other, as  $MN, MN'$ , we shall have what is called an *optical prism*, which consists of any refracting substance bounded by plane surfaces intersecting each other.

Fig. 12.

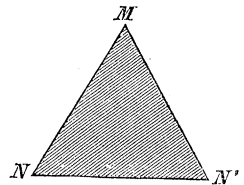

Deviating planes and refracting angle.

$MN$  and  $MN'$ , are called the *deviating planes*, and the angle under which they are inclined, is called the *refracting angle* of the prism.

Deviation of a ray of light in passing through a prism;

§ 25. To find the deviation of a ray of light in passing through a prism, let  $SD$  be the incident,  $DD'$  the first, and  $D'S'$  the second refracted ray. The total deviation will be  $S'E S''$ ,

Fig. 13.

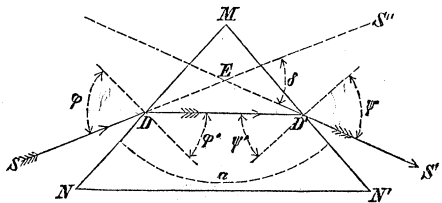

which denote by  $\delta$ ; then, calling the refracting angle of the prism  $a$ , and adopting the notation of the figure, we shall have

$$\delta = \angle ED'D' + \angle ED'D = \varphi - \varphi' + \psi - \psi' = \varphi + \psi - (\varphi' + \psi') \quad \text{Equations;}$$

$$180^\circ \text{ or } \pi = a + \angle MD'D' + \angle MD'D = a + \frac{\pi}{2} - \varphi' + \frac{\pi}{2} - \psi'$$

or

$$a = \psi' + \varphi' \quad \dots \dots \dots (10) \text{ Refracting angle;}$$

hence

$$\delta = \varphi + \psi - a \quad \dots \dots \dots (11) \text{ Deviation;}$$

The deviation of a ray of light in passing through a prism, is, therefore, equal to the *sum of the angles of incidence and emergence, diminished by the refracting angle of the prism.* Rule.

The refracting angle for the same prism being constant, the deviation will depend upon the angles of incidence and emergence. Deviation for same prism depends upon.

Now, from Equations (11), (10), (3), and

$$\sin \psi = m \sin \psi', \quad \dots \dots \dots (3')$$

by a simple process of the calculus, or by trial, it may be shown, that when the angles of incidence and emergence are equal, the deviation will be a minimum, or the least possible.\* Condition for minimum deviation;

Making  $\varphi$  equal to  $\psi$ , in Equations (11) and (10), we find,

\*See Appendix No. 2.

Its use;

$$\begin{aligned} \varphi &= \frac{1}{2}(\alpha + \delta) \\ \varphi' &= \frac{1}{2}\alpha \end{aligned}$$

which substituted in Equation (3) give

Formula for refractive index.

$$m = \frac{\sin \frac{1}{2}(\alpha + \delta)}{\sin \frac{1}{2}\alpha}; \dots \dots \dots (12)$$

we have, therefore, only to measure the deviation when a minimum, to find the index of refraction of the medium of which the prism is made, supposing its refracting angle known.

Application of the formula.

This furnishes one of the best methods by which the refractive powers of different substances may be found. If the substance be a liquid, we may unite two plane glasses, making any angle with each other, by means of a little cement along their edges, and place the liquid between them where it will be held in sufficient quantity by capillary attraction.

Incident ray normal to first surface;

§ 26. When the ray is incident at right angles upon the first surface, we have,

$$\begin{aligned} \varphi &= 0, \\ \varphi' &= 0, \end{aligned}$$

and from Equations (10) and (11), there result,

Consequences;

$$\begin{aligned} \delta &= \downarrow - \alpha, \\ \alpha &= \downarrow' \end{aligned}$$

whence

Final result.

$$\sin(\alpha + \delta) = m \sin \alpha \dots \dots \dots (13)$$

Deviation at plane surfaces by refraction, will be again referred to in a subsequent part of the text.



§ 27. Let  $MN$ ,  $MN'$ , be two plane reflectors, meeting in a line projected in  $M$ ;  $SD$ , a ray incident at the point  $D$ , and contained in a plane perpendicular to the intersection of the reflectors; this ray will be deviated at the point  $D$ , of the first reflector, again at the point  $D'$ , of the second, and so on.

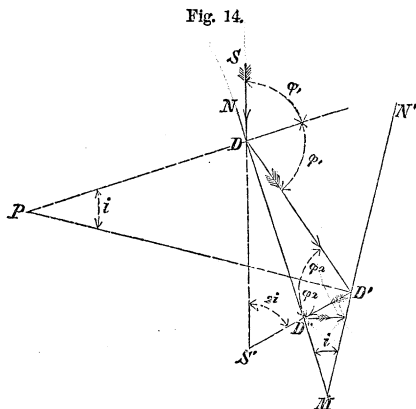

Deviations of a ray of light by two plane reflectors, the plane of incidence being normal to their intersection;

Required the circumstances attending these deviations.

Call the first angle of incidence  $\varphi_1$

- second, . . . . .  $\varphi_2$
- third . . . . .  $\varphi_3$
- &c.,
- $n^{\text{th}}$  . . . . .  $\varphi_n$

Notation;

In the triangle  $PD D'$ , the angle at  $P$  is equal to the inclination of the reflectors, which denote by  $i$ , and we shall have

$$\left. \begin{aligned} \varphi_1 - \varphi_2 &= i, \\ \varphi_2 - \varphi_3 &= i, \\ \varphi_3 - \varphi_4 &= i, \\ &\dots \dots \dots \\ \varphi_{n-2} - \varphi_{n-1} &= i, \\ \varphi_{n-1} - \varphi_n &= i; \end{aligned} \right\} \dots \dots \dots (14)$$

Equations from the figure;

and by addition,

$$\begin{aligned} \varphi_1 - \varphi_n &= \overline{n-1} \cdot i \\ \varphi_n &= \varphi_1 - \overline{n-1} \cdot i \dots \dots \dots (15) \end{aligned}$$

Sum of these equations;

If  $\phi_1$  be a multiple of  $i$ ;

If  $\phi_1$  be any multiple of  $i$ , as  $\overline{n-1} \cdot i$ ,

$$\phi_1 - \overline{n-1} \cdot i = 0, \dots \dots \dots (16)$$

The ray will return upon itself.

that is to say, the  $n$ th incidence will be perpendicular to the reflector, and the ray will, consequently, return upon itself.

Example first;

*Example 1st.* Suppose the angle made by the reflectors to be  $6^\circ$ , and the first angle of incidence, or  $\phi_1 = 60^\circ$ ; required the number of reflexions before the ray retraces its course.

These values in Equation (16), give,

Data;

$$60^\circ - \overline{n-1} \cdot 6^\circ = 0$$

or,

Result.

$$n = 11.$$

Example second;

*Example 2d.* The angle of the reflectors being  $15^\circ$ , and the first angle of incidence  $80^\circ$ , required the *fourth* angle of incidence.

These values in Equation (15), give

Result.

$$\begin{aligned} \phi_4 &= 80^\circ - \overline{4-1} \cdot 15^\circ \\ \phi_4 &= 35^\circ \end{aligned}$$

If  $\phi_1$  be not a multiple of  $i$ ;

there will be some value for  $n$  that will make  $\overline{n-1} \cdot i$ , greater than  $\phi_1$ , in which case,  $\phi_1 - \overline{n-1} \cdot i$ , will be negative; that is, at the  $n$ th incidence, the ray will be on the opposite side of the perpendicular. It will therefore return, but not, as before, by the same path.

The ray will not return by the same path;

*Example 3d.* The angle of the reflectors being  $7^\circ$ , the Example third; first angle of incidence  $69^\circ$ , required the number of reflexions before the ray returns, and the first angle of incidence of the returning ray. These values in Equation (15), reduce it to

$$\phi_n = 69^\circ - \overline{n - 1} \cdot 7^\circ = 76^\circ - 7^\circ \cdot n.$$

If  $n = 10$ ,

$$\phi_n = 76^\circ - 70^\circ = 6^\circ. \qquad \text{Suppositions;}$$

If  $n = 11$ ,

$$\phi_n = 76^\circ - 77^\circ = -1^\circ. \qquad \text{Result.}$$

or the ray begins to return at the eleventh incidence and the angle of incidence is  $1^\circ$ .

It is obvious that the angle of incidence of the returning ray will increase at every deviation; there will, therefore, be some value of the increased angle which will either be equal to or greater than  $90^\circ$ . In the first case, Remarks. the ray will be reflected by one of the reflectors into a direction parallel to the other, and in the second, this last reflexion will give the ray such a direction that it will meet the other reflector only on being produced back.

§ 28. Adding the first two Equations in group (14), we have

$$\phi_1 - \phi_3 = 2i, \qquad \text{Angle made by the incident ray and the same ray after two reflexions;}$$

or

$$SS'D' = 2i.$$

That is, the angle made by the incident ray and the

Equal to double the angle made by the reflectors.

same ray after two reflexions, is equal to double the angle of the reflectors. It follows, therefore, that if the angle of the reflectors be increased or diminished by giving motion to one of the reflectors, the angular velocity of the reflected ray will be double that of the reflector.

Application of this principle.

This is the principle upon which reflecting instruments for the measurement of angles are constructed.

DEVIATION OF LIGHT AT SPHERICAL SURFACES.

Deviation of light at spherical surfaces;

§ 29. Let  $MDO N$ , be a section of a spherical surface separating two media of different densities, as air and glass, having its centre at  $C$ , on the line  $OC$ , which will be called the axis of the deviating surface;

Illustration and notation;

$F'D$  a ray of light, incident at  $D$ , and  $DS$ , the direction of this ray after deviation, which being produced back will intersect the axis at  $F''$ . The point  $O$ , where the axis meets the surface, is called the *vertex*, which will, for the present, be taken as the origin.

Fig. 15.

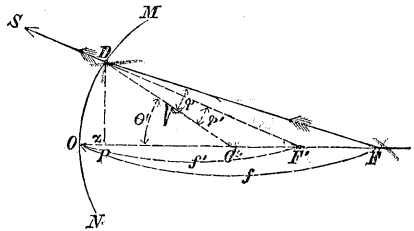

Vertex.

Call  $FD$ ,  $u$ ;  $F'D$ ,  $u'$ ;  $CD$ ,  $r$ ;  $OF'$ ,  $f'$ ;  $OF$ ,  $f$ ; and the angle  $OCD$ ,  $\theta$ .

Rule first;

Now, *distances estimated in the direction of wave propagation, from any origin whatever, are always negative; those estimated in the contrary direction, positive.*

Rule second.

And, *when light is incident on a concave surface, the radius of curvature is always positive; when incident on a convex surface, negative.*

In the triangle  $CDF$ , we have the relation,

$$\frac{\sin \phi}{\sin \theta} = \frac{f - r}{u}$$

and in the triangle  $CD F'$ ,

Equations from the figure;

$$\frac{\sin \theta}{\sin \phi'} = \frac{u'}{f' - r}.$$

These combined with

Combined with the general equation of deviation;

$$\sin \phi = m \sin \phi',$$

give

$$m u . (f' - r) = u' (f - r) \dots (17)$$

The first of these triangles will also give,

$$u^2 = (f - r)^2 + r^2 + 2 (f - r) . r . \cos \theta$$

Other equations from the figure;

and the second,

$$u'^2 = (f' - r)^2 + r^2 + 2 (f' - r) . r . \cos \theta.$$

These latter Equations by reduction become,

$$\begin{aligned} u^2 &= f^2 - 2r(f-r) . \text{versin } \theta; \\ u'^2 &= f'^2 - 2r(f'-r) . \text{versin } \theta. \end{aligned}$$

These latter reduced;

Denoting the versin  $\theta$  by  $z$ , and eliminating  $u$  and  $u'$ , between these equations and Equation (17), there will result,

$$(f-r) . \sqrt{f'^2 - 2r(f'-r) . z} = m(f'-r) . \sqrt{f^2 - 2r(f-r) . z} \quad (18)$$

General equation for finding the intersection of deviated rays with the axis.

This is a general Equation for finding the intersection of deviated rays with the axis. The relation between  $f$  and  $f'$  is somewhat complicated, and it is obvious that if  $f$  be made constant, the value of  $f'$  will vary for different values of  $\theta$ ; that is to say, *if a pencil of rays proceed from a point on the axis, they will, after deviation, meet the axis in different points, depending upon the distance of the point of incidence from the vertex.*

Conclusion for a pencil of indefinite size.

SMALL DIRECT PENCIL.

Small direct pencil;

§ 30. A pencil of light having its central ray coincident with the axis of the deviating surface, is called a *direct pencil*; and if such a pencil be taken very small, the quantity  $z$ , in Equation (18), will be so small that the products of which it is a factor may, without material error, be omitted. This will reduce Equation (18) to

$$(f - r) \cdot f' = m \cdot (f' - r) \cdot f$$

General equation made applicable to this case;

Equation for a small direct pencil;

or

$$f' = \frac{m r f}{(m - 1) \cdot f + r} \dots \dots \dots (19)$$

and taking the reciprocal,

Reciprocal of the same;

$$\frac{1}{f'} = \frac{m - 1}{m r} + \frac{1}{m \cdot f} \dots \dots \dots (20)$$

If  $f$  be constant, or the rays all proceed from the same point  $F$  on the axis before deviation,  $f'$  will also be constant for the same medium and curvature, and all the rays after deviation will meet in

Conclusion for a small direct pencil.

Fig. 16.

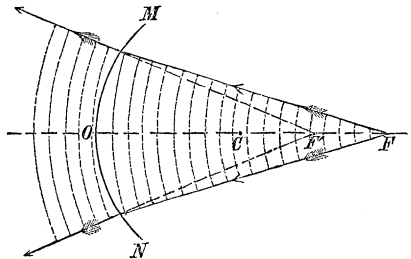
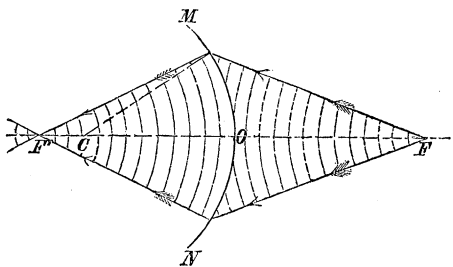

Fig. 17.



some other point  $F'$  on the axis. The first of these points is called a *radiant*, and the second a *focus*; and because of the mutual dependence of these points upon each other with respect to their positions, they are called *conjugate foci*, and the distances  $f$  and  $f'$ , are called *conjugate focal distances*. Since the wave surface is always normal to the rays, the light will proceed from the radiant in a spherical wave before deviation, and *from* or *to* the focus in a wave of like shape after deviation, according as the deviated rays meet the axis on being produced back, or in their onward course beyond the deviating surface. In the first case, the focus has but an apparent existence, and is said to be *virtual*; in the second it actually exists, and is said to be *real*. The radiant is also said to be *virtual* when the wave proceeds, (or, which is the same thing, the rays converge) to a point before deviation.

Radiant and focus;

Conjugate foci and conjugate focal distances;

Real and virtual foci;

Virtual radiant.

§ 31. Luminous waves, like waves of sound, Acoustics § 53, become more and more diffused in proportion as they recede further and further from the place of primitive disturbance, provided their *convexities* continue to be turned to the front, and more and more concentrated after they have been so deviated as to turn their *concavities* to the front. In other words, the living force of the wave molecules, which determines the intensity of light, will become less and less for divergent, and greater and greater for convergent rays.

Living force of molecules, or intensity of light decreases for diverging, and increases for converging rays.

That portion of the living force imparted to the ethereal molecules at any one place, as a radiant, and which proceeds upon a spherical segment embraced by the bounding rays of a small direct pencil, can, therefore, Equations (19) and (20), be concentrated upon the ethereal molecules at another place, as a focus, by the action of a spherical deviating surface; and the focus, whether real or virtual, becomes a source of light as well as the radiant, and is as distinctly visible. When the focus is real, the deviated wave first becomes concentrated in, and subsequently

Living force of particles on a spherical segment concentrated into a focus;

And the focus becomes a source of light.

Whence the deviated wave proceeds for real and for virtual foci.

emanates from it; when virtual, the deviated wave proceeds only from the deviating surface, but with dimensions the same as though it had departed from the virtual focus.

§ 32. If the ray which is deviated at the first, be incident upon a second surface  $M'N'$ , having a radius  $r'$ , and situated at a distance  $t$ , from the first, measured on the axis, we may

First deviated ray incident upon a second surface;

suppose this ray to have proceeded originally from  $F''$ ; and denoting the distance from the new vertex  $O'$ , to the point  $F''$ , in which this ray, after deviation at the second surface, meets the axis, by  $f''$ , and the index of refraction of the second medium by  $m'$ , we shall have from Equation (20),

Fig. 18.

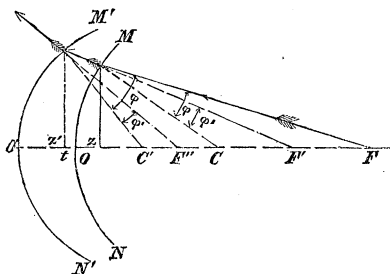

Equation applicable to the second deviation;

$$\frac{1}{f''} = \frac{m' - 1}{m' r'} + \frac{1}{m' (f' + t)} \dots (21)$$

Fig. 19.

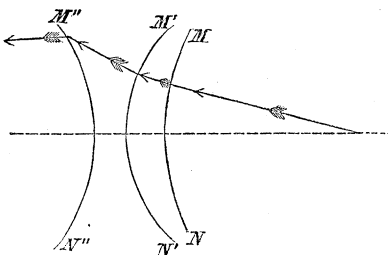

Second deviated ray incident upon a third surface;

And by the same process for a third deviating surface,

Equation applicable to the third deviation;

$$\frac{1}{f''' } = \frac{m'' - 1}{m'' r''} + \frac{1}{m'' (f'' + t')} \dots (22)$$



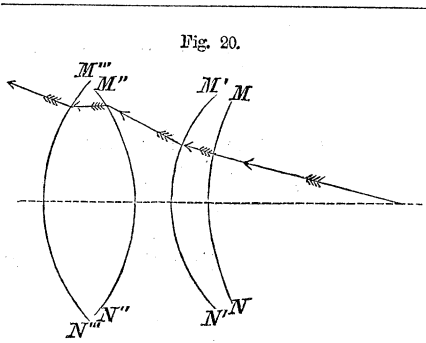

Fig. 20.

Third deviated ray incident upon a fourth surface;

And for a fourth,

$$\frac{1}{f''''} = \frac{(m''' - 1)}{m''' r'''} + \frac{1}{m''' (f''' + t'')} \dots (23)$$

Equation applicable to the fourth deviation, and so on.

And so on for any number of surfaces, the law being manifest.

§ 33. The value of  $f' + t$ , deduced from Equation (20) and substituted in Equation (21), will give a direct relation between  $f''$  and  $f$ , in terms of  $r, r', m, m'$  and  $t$ ; and the value of  $f'' + t'$  found from this derived equation and substituted in Equation (22) will give a direct relation between  $f'''$  and  $f$ , in terms of  $r, r', r'', m, m', m'', t$  and  $t'$ ; and by the same process of elimination a direct relation may be found between the radiant distance  $f$  and the final focal distance  $f''''\dots n$ .

Direct relation found between the first radiant distance and final focal distance.

§ 34. But in practice the distance  $t$ , is so small that it may, without sensible error, be neglected. Omitting  $t$ , we shall find that the first member of each of the preceding equations becomes a factor in the last term of the second member of that which immediately follows it, and proceeding to eliminate these factors by their values, we obtain from Equations (20) and (21)

Practical relation between these distances, omitting  $t$ ;

$$\frac{1}{f''} = \frac{m' - 1}{m' r'} + \frac{1}{m'} \left\{ \frac{m - 1}{m r} + \frac{1}{m f} \right\}; \dots (24)$$

Resulting equation for two surfaces,

Relation between conjugate focal distances for three surfaces, omitting  $t$ ;

this value of  $\frac{1}{f''}$ , substituted in Equation (22), gives,

$$\frac{1}{f'''} = \frac{m''-1}{m'' r''} + \frac{1}{m''} \left\{ \frac{m'-1}{m' r'} + \frac{1}{m'} \left( \frac{m-1}{m r} + \frac{1}{m f} \right) \right\} \quad (25)$$

and this value of  $\frac{1}{f''}$ , in Equation (23), gives,

Same for four surfaces, and so on.

$$\frac{1}{f''''} = \frac{m'''-1}{m''' r'''} + \frac{1}{m'''} \left[ \frac{m''-1}{m'' r''} + \frac{1}{m''} \left\{ \frac{m'-1}{m' r'} + \frac{1}{m'} \left( \frac{m-1}{m r} + \frac{1}{m f} \right) \right\} \right] \quad (26)$$

and so on for additional surfaces.

Medium between second and third, &c. surfaces, supposed the same as that of incident light;

§ 35. If we now suppose the medium between the *second* and *third*, *fourth* and *fifth*, *sixth* and *seventh*, &c., deviating surfaces, the same as that in which the light moved before the first deviation, we shall have the case of a number of refracting media bounded by spherical surfaces, situated in a homogeneous medium, such as the atmosphere, for example, and nearly in contact. Hence,

Corresponding values of refractive indices;

$$m' = \frac{1}{m}; \quad m''' = \frac{1}{m''}; \quad m'''' = \frac{1}{m'''}, \quad \&c.$$

and the foregoing Equations reduce to

Resulting equations for two, three, four, &c. surfaces.

$$\frac{1}{f''} = (m-1) \cdot \left\{ \frac{1}{r} - \frac{1}{r'} \right\} + \frac{1}{f} \quad \dots \dots \dots (27)$$

$$\frac{1}{f'''} = \frac{m''-1}{m'' r''} + \frac{1}{m''} \left\{ \frac{1}{m-1} \cdot \left( \frac{1}{r} - \frac{1}{r'} \right) + \frac{1}{f} \right\} \quad \dots \dots (28)$$

$$\frac{1}{f''''} = \frac{m'''-1}{m''' r'''} \cdot \left( \frac{1}{r''} - \frac{1}{r'''} \right) + \frac{1}{m-1} \cdot \left( \frac{1}{r} - \frac{1}{r'} \right) + \frac{1}{f} \quad (29)$$

&c., &c.

§ 36. Any medium bounded by curved surfaces and used for the purpose of deviating light by refraction, is called a *lens*. Equation (27) relates, therefore, to the deviation of a small pencil of light by a single spherical lens;  $f$ , denoting the distance of the radiant, and  $f''$ , that of the focus from the lens. Equation (28), relates to the refraction or deviation by a single lens and a second medium of indefinite extent bounded on one side by a spherical surface nearly in contact with the lens. Equation (29), relates to deviation by two spherical lenses close together,  $f$  and  $f''''$  denoting, as before, the radiant and focal distances.

Lens defined;  
Equations applicable to one, two, &c. lenses.

§ 37. If the rays be parallel before the first deviation,  $f$  will be infinite, or  $\frac{1}{f} = 0$ , and Equations (20), (27), (28), and (29), will reduce to

Incident rays supposed parallel;

$$\frac{1}{f'} = \frac{m-1}{m r};$$

$$\frac{1}{f''} = \frac{1}{m-1} \cdot \left( \frac{1}{r} - \frac{1}{r'} \right);$$

$$\frac{1}{f'''} = \frac{m''-1}{m'' r''} + \frac{1}{m''} \left[ \frac{1}{m-1} \cdot \left( \frac{1}{r} - \frac{1}{r'} \right) \right];$$

$$\frac{1}{f''''} = \frac{1}{m''-1} \cdot \left( \frac{1}{r''} - \frac{1}{r'''} \right) + \frac{1}{m-1} \cdot \left( \frac{1}{r} - \frac{1}{r'} \right);$$

&c., &c.

Resulting form of the preceding equations;

The values of  $f'$ ,  $f''$ ,  $f'''$ ,  $f''''$ , &c., deduced from these Equations, are called the *principal focal distances*, being the *focal* distances for parallel rays. Denoting these distances by  $F'$ ,  $F''$ ,  $F'''$ , &c., and  $\left( \frac{1}{r} - \frac{1}{r'} \right)$ ,  $\left( \frac{1}{r''} - \frac{1}{r'''} \right)$  &c., by  $\frac{1}{\rho}$ ,  $\frac{1}{\rho''}$ ,  $\frac{1}{\rho''''}$ , &c., we shall have the following table, viz. :

Principal focal distance.

Table of reciprocals of principal focal distances;

$$\left. \begin{aligned}
 \frac{1}{F'} &= \frac{m-1}{m r} \\
 \frac{1}{F''} &= \frac{m-1}{\rho} \\
 \frac{1}{F'''} &= \frac{m''-1}{m'' r''} + \frac{1}{m''} \left( \frac{m-1}{\rho} \right) \\
 \frac{1}{F''''} &= \frac{m''-1}{\rho''} + \frac{m-1}{\rho} \\
 \frac{1}{F''''' } &= \frac{m''''-1}{m'''' r''''} + \frac{1}{m''''} \left( \frac{m''-1}{\rho''} + \frac{m-1}{\rho} \right) \\
 \frac{1}{F''''''} &= \frac{m''''-1}{\rho''''} + \frac{m''-1}{\rho''} + \frac{m-1}{\rho} \\
 &\&c., \&c., \&c.
 \end{aligned} \right\} \dots (30)$$

Rule.

An examination of the alternate formulas of the above table, beginning with the second, leads to this result, viz., *that the reciprocal of the principal focal distance of any combination of lenses, is equal to the sum of the reciprocals of the principal focal distances of the lenses taken separately*; which may be expressed in a general way by the Equation,

$$\frac{1}{F'} = \Sigma \left( \frac{1}{F'} \right) \dots \dots \dots (31)$$

Value for the reciprocal of the principal focal distance of any combination of lenses.

wherein  $\left( \frac{1}{F'} \right)$ , denotes the reciprocal of the principal focal distance of any one lens in the combination, the Greek letter  $\Sigma$ , that the algebraic sum of these is to be taken, and  $\frac{1}{F'}$ , the reciprocal for the combination.

First members of group (30) substituted in preceding equations:

Substituting the first member of the first Equation, in group (30), and the first members of the alternate Equations, beginning with the second, for their corresponding values in Equations (20), (27), (29), &c., we finally obtain,

$$\frac{1}{f'} = \frac{1}{F'} + \frac{1}{mf} \dots \dots \dots (32)$$

$$\frac{1}{f''} = \frac{1}{F''} + \frac{1}{f} \dots \dots \dots (33)$$

$$\frac{1}{f'''} = \frac{1}{F'''} + \frac{1}{f} \dots \dots \dots (34)$$

$$\frac{1}{f''''} = \frac{1}{F''''} + \frac{1}{f} \dots \dots \dots (35)$$

Resulting equations for the discussion of the deviation of light by one or more lenses or by a single surface.

Equations (33), (34), and (35), are of a convenient form for discussing the circumstances attending the deviation of light by refraction through a single lens, or a combination of lenses placed close together; and Equation (32), the deviation at a single surface.

§ 38. The several terms of these Equations are the reciprocals of elements involved in the discussions which

To find relative measures for the vergency of incident and deviated rays;

are to follow. The pencil of light being small, the versed sine of half the arc  $DD'$ , has been disregarded, and the arc itself may be regarded as coinciding with the tangent line at the vertex  $O$ , and as

Fig. 21.

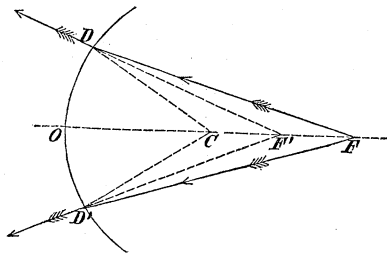

Rays supposed to diverge both before and after deviation, and are taken;

having been described about either of the points  $C$ ,  $F'$ , or  $F$ , as a centre, indifferently; and denoting the length of the arc  $OD$  by  $\alpha$ , and the number of degrees in this arc when referred to the centre  $F'$ , corresponding to the radius  $f$ , by  $n$ , we shall have the proportion,

$$2\pi \cdot f : 360^\circ :: \alpha : n;$$

whence,

$$n = \frac{\alpha \cdot 360^\circ}{2\pi} \cdot \frac{1}{f}$$

Number of degrees in this arc referred to the centre  $F'$ ;

in which  $\pi$  denotes the ratio of the diameter of a circle to its circumference.

When this arc  $\alpha$  is referred to the centre  $F'$ , corresponding to a radius  $f'$ , its number of degrees, denoted by  $n'$ , becomes,

Number of degrees in same arc referred to the centre  $F'$ ;

$$n' = \frac{\alpha \cdot 360^\circ}{2 \pi} \cdot \frac{1}{f'}$$

and dividing the first of these Equations by the second, we find,

Ratio of the above values;

$$\frac{n}{n'} = \frac{\frac{1}{f}}{\frac{1}{f'}}$$

Conclusion for diverging rays.

whence we conclude that  $\frac{1}{f}$  and  $\frac{1}{f'}$  measure the *relative divergence* of the incident and deviated rays.

When the deviated rays meet the axis at  $F'$ , on the opposite side of the deviating surface from the radiant, the value  $f'$ , being laid off in a contrary direction from the

Fig. 22.

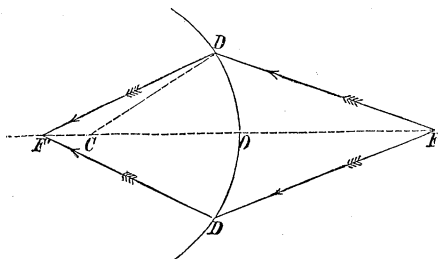

Conclusion for converging rays;

vertex  $O$ , becomes negative, and the relative measure  $\frac{1}{f'}$ , for the convergence of these rays will be negative. Again, if the incident rays converge to a point  $F$ , before deviation,  $f$  for the same reason, would be negative, and the measure for the corresponding convergence would be negative. And, generally, we shall find that, referring the radiant and focal distances to the

vertex as an origin, divergence will be measured by a positive and convergence by a negative quantity; and for convenience we shall, therefore, hereafter employ the general term *vergency* to express either of these conditions of the rays, indifferently.

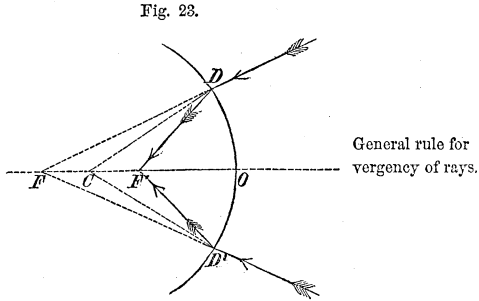

§ 39. *The power of a lens is its greater or less capacity to deviate the rays that pass through it.* Power of a lens;

In Equations (33), (34), (35,) &c.,  $\frac{1}{F''}$ ,  $\frac{1}{F'''}$ ,  $\frac{1}{F''''}$ , &c., will measure the vergency of parallel rays after deviation; and as these measures are expressed in functions of the indices of refraction, and  $\frac{1}{\rho}$ , or  $\left(\frac{1}{r} - \frac{1}{r'}\right)$  &c., they will be constant for the same media and curvature, and may be employed as terms of comparison for the other two terms which enter into the Equations to which they respectively belong.

From what has been said, it is apparent that  $\frac{1}{F}$ , in Equation (31), will measure the vergency of parallel rays after deviation by any combination of spherical lenses whatever, and will consequently be the measure of the *power of the combination*; and as  $\left(\frac{1}{F}\right)$ , is the measure of the power of any one lens of the combination, we have this rule for finding the power of any system of lenses, viz. : *Find the power of each lens separately, and take the algebraic sum of the whole.* Measure of the power of a lens or combination of lenses;

§ 40. It will be convenient to express the relation in Equations (32), (33), (34), &c., by referring to the centre Rule.

To find a relation between the conjugate focal distances when the centre of curvature is taken as the origin;

of curvature of the deviating surfaces as an origin. For this purpose, let  $OD$  be a section of the deviating surface, and denote the distances of the radiant and focal points from the centre  $C$ , by  $c$  and  $c'$ , respectively; we have by inspection,

Fig. 24.

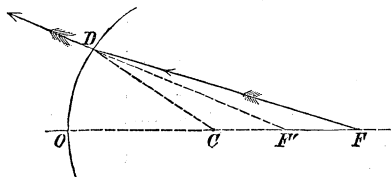

Substitutions and reductions;

$$f = r + c,$$

$$f' = r + c',$$

which in Equation (19), give, after reduction,

Relation for one surface;

$$\frac{1}{c'} = \frac{m - 1}{r} + \frac{m}{c} \dots \dots \dots (36)$$

and for a second deviating surface whose centre of curvature is at a distance  $t$ , from that of the first, we obtain from Equation (36),

For a second surface;

$$\frac{1}{c''} = \frac{m' - 1}{r'} + \frac{m'}{c' - t} \dots \dots \dots (37)$$

and for a third, whose centre is at a distance  $t'$ , from that of the second,

For a third surface;

$$\frac{1}{c'''} = \frac{m'' - 1}{r''} + \frac{m''}{c'' - t'} \dots \dots \dots (38)$$

Relations for a lens, &c.

$c'$  being eliminated between Equations (36) and (37), a relation between  $c$  and  $c''$ , will result; in like manner,  $c''$  being made to disappear by means of this derived equation and Equation (38), there will result an equation in terms of  $c'''$  and  $c$ , and so for others.

§ 41. Retaining the thickness  $t$ , of the medium between



the two deviating surfaces to which Equations (19) and (21) relate, we obtain from the first by adding  $t$ , to both members and reducing to a common denominator,

$$f' + t = \frac{m r f + (m - 1 \cdot f + r) t}{m - 1 \cdot f + r};$$

and this substituted in Eq. (21), at the same time making  $m' = \frac{1}{m}$ , which is supposing the ray to pass into the first medium after having traversed the medium bounded by the two deviating surfaces, that Equation reduces to,

$$\frac{1}{f''} = \frac{1 - m}{r'} + \frac{m(m - 1 \cdot f + r)}{m r f + (f \cdot m - 1 + r) t} \dots (39)$$

Retaining  $t$ , for two surfaces;

And suppose these surfaces to bound a medium immersed in another;

Final relation for a single lens retaining  $t$ .

which gives a direct relation between the conjugate focal distances in the case of light deviated by a single lens.

APPLICATION OF THE PRECEDING THEORY TO THE DEVIATION OF LIGHT BY REFRACTION THROUGH THE VARIOUS KINDS OF SPHERICAL LENSES.

§ 42. A lens has been defined to be, any medium bounded by curved surfaces, used for the purpose of deviating light by refraction; the surfaces are generally spherical.

$A$ , called a *double convex* lens, is bounded by two spherical surfaces, having their centres and the surfaces to which they correspond, on opposite sides of the lens. When the

Fig. 25.

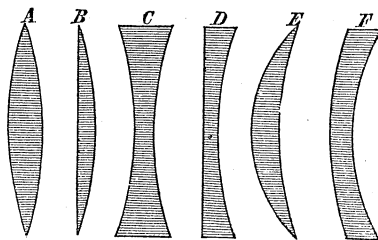

Geometrical representations of the spherical lenses.

Application of the preceding theory to the various spherical lenses.

Double convex lens;

curvature of the two surfaces is the same, the lens is said to be equally convex.

Plano-convex;

*B*, is a lens with one of its faces plane, the other spherical, this latter face and its centre being on opposite sides of the lens, and is called a *plano-convex lens*.

Double concave;

*C*, is a *double concave lens*; each curved face and its centre lying on the same side of the lens.

Plano-concave;

*D*, is a *plano-concave lens*, having one face plane and the other concave.

Meniscus;

*E*, has one face concave and the other convex, the convex face having the greater curvature; this lens is called a *meniscus*.

Concavo-convex.

*F*, like the meniscus, has one face concave and the other convex, but the concave face has the greater curvature; this is called a *concavo-convex lens*.

The line containing the centres of the spherical surfaces, is called the axis.

Fig. 25.

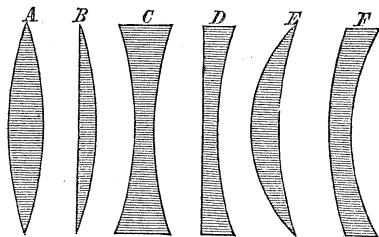

Different cases arise from the signs of the radii;

§ 43. A moment's consideration will show that all the circumstances of vergency attending the deviation of light by any one of these lenses, will be made known by Equation (33), it being only necessary to note the different cases arising out of the various combinations of surfaces by which the lenses are formed; these cases depend upon the *signs* of the *radii*.

Rule for signs of radii;

Equations (33), (34), (35), &c., were deduced on the supposition that *r* is positive, the concave side of the surface being turned towards incident light; it will, of course, § 29, be negative when the convex side is turned in the same direction. Besides, *f* was taken positive for a *real radiant*, or when the rays are supposed to diverge from any point upon the axis of the lens, before deviation; on the contrary, it will become negative when

the rays are received by the deviating surface in a state of convergence to a point behind the lens. The signs of  $f'$ ,  $f''$ , &c., will be positive when the deviated rays meet the axis on being produced back. The foci are then virtual. When the rays meet the axis on the opposite side of the lens or lenses,  $f'$ ,  $f''$ , &c., become negative, and will correspond to *real* foci.

And of conjugate focal distances.

The several lenses may be characterized as follows :

1	<i>Double Convex</i> , . . . . .	$-r$ and $+r'$	} (A) Characteristics of the various lenses.
2	<i>Plano-Convex</i> , convex side to incident light,	$-r$ and $+r' = \infty$	
	<i>Do.</i> plane side to incident light, . .	$+r = \infty$ and $+r'$	
3	<i>Meniscus</i> , convex side turned to incident light, . .	$r < r'$ , $-r$ , $-r'$	
	<i>Same</i> , concave side do. do.	$r > r'$ , $+r$ , $+r'$	
4	<i>Double Concave</i> , . . . . .	$+r$ , $-r'$	
5	<i>Plano-Concave</i> , concave side to incident light, .	$+r$ , $+r' = \infty$	
	<i>Same</i> , plane side to do. do.	$+r = \infty$ , and $-r'$	
6	<i>Concavo-Convex</i> , concave side to incident light, .	$r < r'$ , $+r$ , $+r'$	
	<i>Same</i> , reversed, . .	$r > r'$ , $-r$ , $-r'$	

§ 44. To discuss the properties of any one of these lenses, resume Equation (33), determine the sign of  $\frac{1}{F''}$ , by reference to its general value in Equations (30), and the table above, and then proceed to make various suppositions in regard to the position of the radiant and deduce the corresponding places of the focus.

Discussion of the properties of any lens.

Fig. 24.

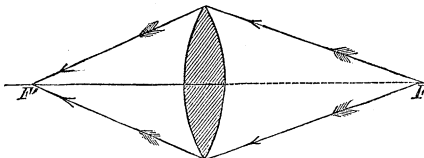

Double convex lens taken as an example;

§ 45. As an example, let us take the double convex lens.

Equation (33), is

General equation;

$$\frac{1}{f''} = \frac{1}{F''} + \frac{1}{f}$$

and, Equation (30), and Table (A),

Value for reciprocal of principal focal distance;

$$\frac{1}{F''} = \frac{m-1}{\rho} = -\frac{1}{m-1} \left( \frac{1}{r} + \frac{1}{r'} \right),$$

and as long as  $m > 1$ , we shall have,

Equation for discussion;

$$\frac{1}{f''} = -\frac{1}{F''} + \frac{1}{f} \dots \dots \dots (40)$$

For  $\frac{1}{F''} > \frac{1}{f}$ , or  $f > F''$ ,  $f''$  will be negative, and

the vergency of the deviated rays will be negative. That is to say, if a wave proceed from a point

Real radiants between principal focus and infinity;

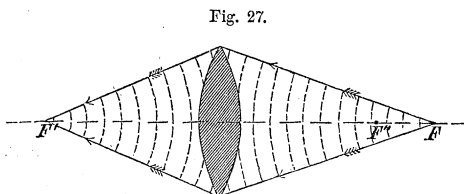

Give real focal.

upon the axis in front of the lens between the limits  $F''$ , the principal focus, and infinity, it will be concentrated after deviation, into a point upon the same line behind, and the focus will be real.

For  $\frac{1}{F''} < \frac{1}{f}$ , or

$f < F''$ ,  $f''$  will be positive, and the vergency of the deviated rays will be positive. That is, if the wave proceed from a point in front and situated be-

Real radiants within the principal focus;

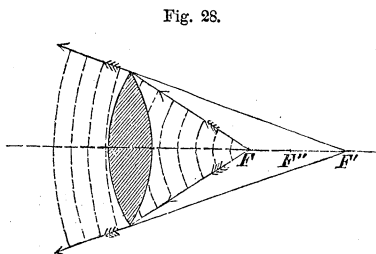

tween the lens and the principal focus, it will, after deviation, proceed from some other point in front, and the focus will be virtual.

For  $\frac{1}{F''} = \frac{1}{f}$ , or  $f = F''$ ,  $\frac{1}{f''} = 0$ , or  $f'' = \infty$ .

That is, the vergency of the deviated rays will be zero, and a spherical wave proceeding from the principal focus will be converted, by deviation, into a plane wave which can only be concentrated into a point at an infinite distance.

Fig. 29.

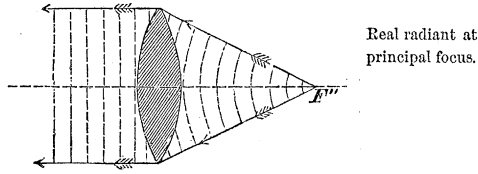

If the rays be received by the lens in a state of convergence to a point behind, that is, if the concavity of the wave be turned to the front before deviation, then  $\frac{1}{f}$  or  $f$  will be negative, and Equation (40), becomes

$$\frac{1}{f''} = - \left( \frac{1}{F''} + \frac{1}{f} \right),$$

The equation becomes :

Fig. 30.

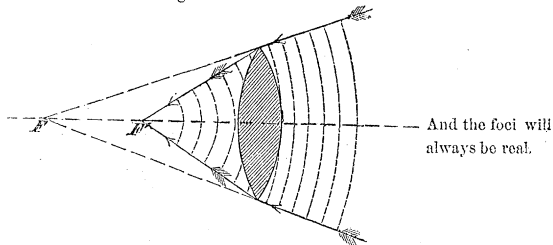

and the vergency of the deviated rays will always be negative. In other words, to whatever point behind the lens the wave may be tending to concentration before deviation, the deviation will cause it to concentrate in some other point behind.

If the rays proceed from a point in front and at the distance of twice the principal focal distance,  $f$  becomes equal to  $2 F''$ , and Equation (40) reduces to

Real radiant at distance equal to  $2 F''$ ;

The focus will be real and at a distance behind the lens equal to  $2 F''$ .

$$\frac{1}{f''} = -\frac{1}{F''} + \frac{1}{2 F''} = -\frac{1}{2 F''},$$

OR

$$f'' = -2 F''$$

and the wave will be concentrated at the same distance behind the lens.

Fig. 27.

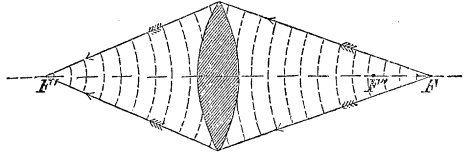

Divergence of rays decreased;

For all cases of positive vergency, both before and after deviation, we find

$$\frac{1}{f''} < \frac{1}{f};$$

which shows us that a positive vergency will be diminished by the deviation.

And convergence increased;

For all cases of negative vergency, we find numerically

$$\frac{1}{f''} > \frac{1}{f},$$

but algebraically,

$$\frac{1}{f''} < \frac{1}{f}.$$

Hence the effect of a convex lens is to concentrate the light.

That is to say, when the rays diverge before deviation, they will diverge less after; and when they converge before deviation, they will converge more after. Hence we conclude, that the tendency of a convex lens is to *collect* the rays, or concentrate the waves of light deviated by it.

The focal distance of the double convex lens is given by Equation (27),

$$f'' = \frac{f \cdot r \cdot r'}{r r' - f(m-1)(r+r')} \quad \text{Focal distance;}$$

If the lens be supposed of glass,  $m = \frac{3}{2}$ , nearly, and

$$f'' = -\frac{2 f r r'}{f \cdot (r + r') - 2 r r'}. \quad \text{For lens of glass;}$$

If the lens be equally convex,  $r = r'$ , and

$$f'' = -\frac{f \cdot r}{f - r}; \quad \text{For lens equally convex;}$$

and if the rays be supposed parallel before deviation,  $f = \infty$ , and

$$f'' = -r. \quad \text{For parallel rays.}$$

§ 46. Each of the other lenses described may be subjected to a similar discussion. This being done, the results will conform to those exhibited in the following

T A B L E

Lens.	Incident pencil.	$\frac{1}{f''}$	Sign of $f''$	Refrac.pencil.	Table for convex and concave lenses.
Convex $-F''$	{ Diverging $+f$ }	{ $-\frac{1}{F''} + \frac{1}{f}$ }	{ $f > F''$ } { - }	{ Converges.	
			{ $f < F''$ } { $f'' > f$ }	{ Diverges less.	
	{ Converging $-f$ }	{ $-\frac{1}{F''} - \frac{1}{f}$ }	{ $f'' < f$ }	{ Converges more.	
Concave $+F''$	{ Diverging $+f$ }	{ $\frac{1}{F''} + \frac{1}{f}$ }	{ $f'' < f$ }	{ Diverges more.	
	{ Converging $-f$ }	{ $\frac{1}{F''} - \frac{1}{f}$ }	{ $f > F''$ } { + }	{ Diverges.	
			{ $f < F''$ } { $f'' > f$ }	{ Converges less.	

Convex lenses collect, and concave lenses disperse the light.

A similar table may also be constructed by formula (34), for a combination of any of the spherical lenses taken two and two, and by formula (35), for any combination taken three and three, and so on.

In general, it may be inferred from the preceding table, that convex lenses tend to collect the incident rays, while concave lenses, on the contrary, tend to scatter them.

To construct the focus;

§ 47. Transposing, in Equation (33),  $\frac{1}{f}$  to the first member, we get

$$\frac{1}{f''} - \frac{1}{f} = \frac{1}{F''}$$

which shows that the vergency after, diminished by that before deviation, gives a constant vergency measured by the power of the lens. Hence, to construct the *focus*,

draw the extreme ray  $FD$ , and from the point  $D$ , the line  $DH$ , making with the incident ray  $FD$ , produced, the angle  $HDK$ , equal to the power of the lens;  $DH$  will be the deviated ray, and the

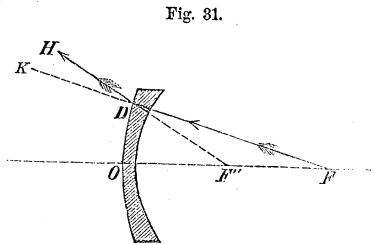

Fig. 31.

Illustration;

point  $F''$ , where it meets the axis, will be the focus. For, in the triangle  $FD F''$ , the angle  $D F'' O$ , measured by  $\frac{1}{f''}$ , diminished by  $D F F''$ , measured

Interpretation.

by  $\frac{1}{f}$ , is equal to  $HDK$ , measured by  $\frac{1}{F''}$ ; which is the geometric interpretation of the above equation.

Conjugate foci supposed in motion;

§ 48. Suppose the conjugate foci to be in motion, and denote any two consecutive values of  $f$  by  $x$  and  $x'$ ,



and the corresponding values of  $f''$  by  $y$  and  $y'$ , then Notation and equations;  
Equation (33),

$$\frac{1}{y} = \frac{1}{F''} + \frac{1}{x},$$

$$\frac{1}{y'} = \frac{1}{F''} + \frac{1}{x'};$$

subtracting the second from the first we find,

$$\frac{1}{y} - \frac{1}{y'} = \frac{1}{x} - \frac{1}{x'};$$
Transformations and reductions;

reducing to a common denominator, and writing for the products  $y y'$  and  $x x'$ , the quantities  $f''^2$  and  $f^2$ , to which they will be sensibly equal, the Equation becomes

$$\frac{y' - y}{f''^2} = \frac{x' - x}{f^2};$$

and dividing by the interval of time  $t$ , during which Time  $t$ , introduced;  
the change from  $x$  to  $x'$  takes place, which is the same as that from  $y$  to  $y'$ , we have

$$\frac{y' - y}{t} \cdot \frac{1}{f''^2} = \frac{x' - x}{t} \cdot \frac{1}{f^2}$$

or,

$$\frac{V''}{f''^2} = \frac{V}{f^2}; \dots \dots \dots (41)$$
Relation between conjugate focal distances and velocities of conjugate foci;

in which  $V$  denotes the velocity of the radiant, and  $V''$  that of its conjugate focus; and since the denominators must always be positive, being squares, the signs of the two velocities must always be alike. Whence we conclude, that in lenses a change in the place of the radiant will always be accompanied by a change of its conjugate in the same direction, and that the rate of change in the one will be to that of the other as the squares of their respective distances from the lens directly. This has an important application in the action of lenses when employed to form images.

Conclude, that in lenses conjugate foci always move in same direction.

If the lens be a sphere.

§ 49. If the lens be a sphere,  $m' = \frac{1}{m}$ ,  $t = 0$ , and  $\frac{1}{c'}$ , from Equation (36), being substituted in Equation (37), we obtain

$$\frac{1}{c''} = -\frac{2(m-1)}{mr} + \frac{1}{c} \dots \dots \dots (42)$$

§ 50. If in Equation (20), we make  $r$  infinite, we get

Deviation at a plane surface by refraction;

$$\frac{1}{f'} = \frac{1}{mf}$$

or,

$$mf = f',$$

which answers to the case of a small pencil deviated at a plane surface separating two media of different densities, as air and water. On the supposition that the

Radiant in denser medium;

radiant is in the denser medium,  $m$  becomes  $\frac{1}{m}$ , and

this in the preceding Equation gives

$$f = mf';$$

that is, to an eye situated without this medium, the distance of the radiant from the deviating surface will appear diminished in the ratio of unity to the relative index of refraction of the ray in passing from the denser to the rarer medium. This accounts for the apparent elevation above their true positions of all bodies beneath the surface of fluids, as the bottom of a vessel partly filled with water, and the apparent bending of a straight stick at the surface when partly immersed in the same fluid.

Illustration;

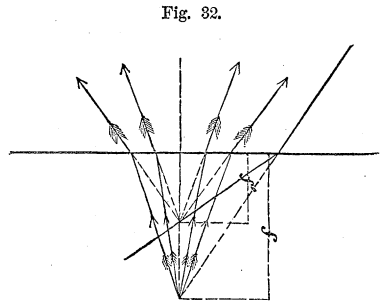

Fig. 32.

Appearances accounted for.

APPLICATION TO THE DEVIATION OF LIGHT  
BY SPHERICAL REFLECTORS.

§ 51. In reflexion, we have only to consider one deviating surface. Equation (20) applies here by making  $m = -1$ , which reduces it to, Equation applicable to a spherical concave reflector;

$$\frac{1}{f'} = \frac{2}{r} - \frac{1}{f} \dots \dots \dots (43)$$

But two cases can arise, and these are distinguished by the sign of the radius. The reflector may be concave towards incident light, in which case  $r$  will be positive, or it may be convex towards the same direction, when  $r$  will be negative. Equation (43) relates to the first case, which will now be discussed.

If the incident rays be parallel,  $\frac{1}{f} = 0$ , and Incident rays parallel;

$$\frac{1}{f'} = \frac{2}{r}$$

or,

$$f' = \frac{r}{2} = F'$$

Fig. 33.

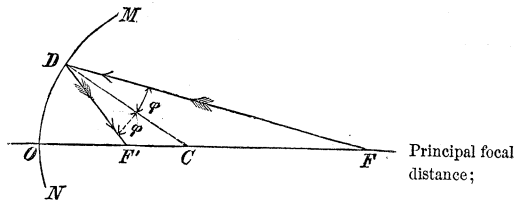

Hence the principal focal distance is equal to *half radius*, and Equation (43), reduces to

$$\frac{1}{f'} = \frac{1}{F'} - \frac{1}{f} \dots \dots \dots (44) \text{ Equation for discussion;}$$

Now, this Equation is only concerned with the reflected wave, and if this wave be concentrated at all after deviation, it must be upon that part of the axis on the side of the incident light, and hence  $f'$ , for a

Real radiants  
beyond the  
principal focus;

real focus must be positive, and for a virtual focus negative.

As long as  $\frac{1}{F'} > \frac{1}{f}$ , or  $f > F'$ ,  $f'$  will be positive, and the vergency of the deviated rays will be positive; that is, a wave proceeding from a point in front of the reflector between the principal focus and infinity will, after deviation, be concentrated into some other point in front.

Real radiants  
within the  
principal focus;

When  $\frac{1}{F'} < \frac{1}{f}$ , or  $f < F'$ ,  $f'$  will be negative, and the vergency will be negative; in other words, a wave proceeding from a point on the axis between the vertex and principal focus, will never be concentrated after deviation, but will appear to proceed from a virtual focus behind.

If the radiant be at the centre of curvature,  $f = 2 F'$ , and

Radiant at the  
centre of  
curvature.

$$f' = 2 F' = r;$$

that is, a wave proceeding from the centre of curvature will, after deviation, return to that point.

For

Real radiants  
beyond the  
centre;

$$f > 2 F', \text{ or } f > r;$$

we have

$$\frac{1}{f'} > \frac{1}{2 F'}, \text{ or } f' < r;$$

Give real foci  
between the  
centre and  
principal focus;

or the focus will be between the reflector and centre, and since  $\frac{1}{F'} - \frac{1}{f} < \frac{1}{F'}$ , we find  $\frac{1}{f'} < \frac{1}{F'}$ , or  $f' > F'$ ; so that the focus will be found between the centre and principal focus.

If

$$f < 2F', \text{ or } f < r;$$

Real radiants  
between the  
centre and  
principal focus;

then will

$$\frac{1}{f'} < \frac{1}{2F'}, \text{ or } f' > r;$$

Give real foci  
beyond the  
centre;

that is, the focus will be at a greater distance from the reflector than the centre.

When  $f = F'$ , we shall have  $\frac{1}{f'} = 0$ ; that is, the vergency will be zero, which shows that a spherical wave proceeding from the principal focus will be transformed by deviation into a plane wave, which can only be concentrated at a distance  $f' = \infty$ .

Real radiant at  
the principal  
focus.

If the vergency before incidence be negative,  $f$  will be negative, and Equation (44), becomes

$$\frac{1}{f'} = \frac{1}{F'} + \frac{1}{f} \dots \dots \dots (45) \text{ Virtual radiants,}$$

Hence,  $f'$  will always be positive, and the vergency positive; that is, when a wave is proceeding to concentration in a point behind a concave reflector, it will, after deviation, be concentrated into some other point in front.

Always give real  
foci.

Equations (44) and (45), show that  $\frac{1}{f'}$ , which measures the vergency of deviated rays, is always algebraically greater than  $\frac{1}{f}$ , which measures the vergency of

Concave  
reflectors.  
analogous to  
convex lenses.

the incident rays. Hence, concave reflectors, like convex lenses, tend to collect the rays of light which are deviated by them.

Different cases in reflectors ;

§ 52. By discussing the several cases that will arise in attributing different signs to  $r$  and  $f$ , and various values to the latter, we shall find the results in the following

T A B L E.

Table for convex and concave reflectors;	Reflector	Incident pencil.	$\frac{1}{f'}$	Sign of $\frac{1}{f'}$	Reflect. pencil
{	Concave $+F'$	{ Diverging $+f$ }	{ $\frac{1}{F'} - \frac{1}{f}$ }	{ $f > F'$ , } { + }	{ Converges }
				{ $f < F'$ , } { $f' > f$ }	{ Diverges less. }
	{ Converging $-f$ }	{ $\frac{1}{F'} + \frac{1}{f}$ }	{ $f' < f$ }	{ Converges more. }	
	Convex $-F'$	{ Diverging $+f$ }	{ $-\frac{1}{F'} - \frac{1}{f}$ }	{ $f' < f$ }	{ Diverges more. }
{ Converging $-f$ }		{ $-\frac{1}{F'} + \frac{1}{f}$ }	{ $f \geq F'$ , } { - }	{ Diverges. }	
			{ $f < F'$ , } { $f' > f$ }	{ Converges less. }	

Conclusions.

from which we perceive that convex reflectors tend to scatter the rays and concave reflectors to collect them.

§ 53. If  $\frac{1}{f}$ , in Equation (44), be transferred to the first member, we find

$$\frac{1}{f'} + \frac{1}{f} = \frac{1}{F'}$$

Sum of the vergencies after and before deviation constant;

which shows that the vergency after, increased by that before deviation, is a constant vergency, which is measured by the power of the reflector; and to construct

the focus, draw the extreme ray  $FD$ , and the line  $DF'$ , making with the incident ray the angle  $FDF'$  equal to the power of the reflector, the point  $F'$ , where this line meets the axis, will be the focus. The reason is obvious.

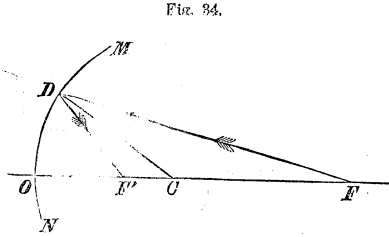

FIG. 34.

Construction of foci for reflectors.

§ 54. By a process entirely similar to that of § 48, we may find from Equation (44), which appertains equally to a concave or convex reflector by assigning to  $\frac{1}{F'}$  its proper sign,

For reflectors conjugate foci move in opposite directions.

$$\frac{V'}{f'^2} = -\frac{V}{f^2} \dots \dots \dots (46)$$

and because  $V'$  and  $V$  have contrary signs, we conclude that the conjugate foci in the case of spherical reflectors proceed, when in motion, in opposite directions.

§ 55. Equation (43), by making  $r$  infinite, reduces to

$$\frac{1}{f'} = -\frac{1}{f}$$

Deviation by reflexion at plane surfaces;

or,

$$f' = -f,$$

Which shows, that in all cases of deviation of a pencil by a plane reflector, the divergence or convergence will not be altered; and if the rays diverge before deviation, they will appear after deviation to proceed from a point as far behind the reflector as the real radiant is in front; but if they converge before deviation, they will be brought to a focus as far in front as the virtual radiant is behind the reflector.

Conclusion.

SPHERICAL ABERRATION, CAUSTICS, AND ASTIGMATISM.

Spherical aberration;

§ 56. Thus far the discussion has been conducted upon the supposition that the pencil is very small, and that  $z$ , the versed-sine of the angle  $\theta$ , included between the axis and the radius drawn to the point of incidence of the extreme rays of the pencil, is so small, that all the products of which it is a factor may be neglected. If, however,  $z$  be retained, and Equation (18) be solved with reference to  $f'$ , the value of this latter quantity will be expressed in terms of  $m$ ,  $f$ ,  $r$  and  $z$ , and may be written

$$f'_z = M_z; \dots \dots \dots (47)$$

Incident pencil not small;

and if the semi-arc of the deviating surface, denoted by  $\theta$ , and of which  $z$  is the versed-sine, be made to vary from zero to any magnitude sufficient to embrace the exterior rays of any definite pencil,

Illustration;

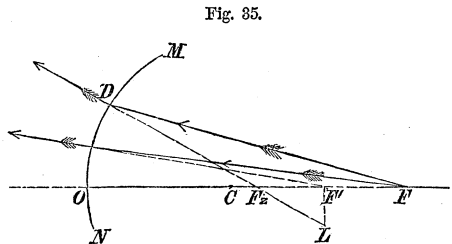

Fig. 35.

it is obvious that  $f'_z$ , must have an infinite number of values, and that each value will give the focus for those rays only which make up the *surface* of a cone and are incident at equal distances from the vertex. This wandering of the deviated rays from a single focus is called *aberration*, and when caused by a spherical deviating surface, as it is in the case under consideration and in practice generally, it is called *spherical aberration*. When estimated in the direction of the axis, it is called *longitudinal*, and at right angles to the axis, *lateral* aberration.

Longitudinal aberration;

If we represent the second member of Equation (19) by  $M$ , that Equation may be written

Lateral aberration;

$$f' = M \dots \dots \dots (19)'$$



and subtracting this from Equation (47), we find

$$f'_z - f' = M_z - M \dots \dots \dots (48)$$

Measure of longitudinal and lateral aberration, and their laws of variation;

in which the first member denotes the length of the portion  $F'F'_z$ , of the axis along which the different foci will be distributed, and will measure the longitudinal aberration. The lateral aberration is measured by the length of the line  $F'L$ , drawn through the focus of the rays near the axis of the pencil and perpendicular to the axis of the deviating surface. The linear length of the arc,  $OD = r \cdot \theta$ , is called the *radius of aperture*, and it is found that in all cases of ordinary practice, the longitudinal aberration varies as the square, and the lateral aberration as the cube of the radius of aperture.

Radius of aperture.

If in Equation (48), we make  $m = -1$ , we shall have the longitudinal aberration for a spherical reflector.

Aberration for a reflector.

If the value of  $f'_z$  in Equation (47), be substituted for  $f$  in Equation (18), and we write  $f''$  for  $f'$ , then solve the equation with reference to  $f''$ , still retaining  $z$ , and take the difference between this value of  $f''$  and that given by Equation (27), we shall find the longitudinal aberration for a single lens; and that for any number of lenses placed close together might be found by the same process.

Aberration for a lens.

§ 57. We perceive that a spherical wave of any considerable extent deviated at a spherical surface, will not, in general, be concentrated at, nor will it appear to proceed from, the same point; but if we conceive the wave to be divided into an indefinite number of elementary zones by planes perpendicular to the axis of the deviating surface, each zone will have its particular point of concentration or of diffusion, according as the foci are real or virtual. Moreover, longitudinal aberration diminishes the focal distance, that is, in general,  $f'_z$  is less than  $f'$ , and the deviated rays which are in the same plane and on the same side of the axis, will intersect

General effects of spherical aberration;

Effect of longitudinal aberration;

each other before they do this latter line. Thus, if  $F'D$

Fig. 36.

Geometrical illustration;

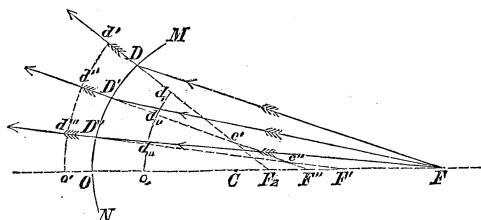

Explanation of the figure;

be the exterior, and  $F'D$  its consecutive incident ray,  $D F_2$  and  $D' F''$ , the corresponding deviated rays, these latter will intersect each other at some point as  $c'$ , on the same side of the axis  $O F$ ; in like manner, if  $D'' F''$  be the next consecutive deviated ray to  $D' F''$ , it will intersect this latter in same point as  $c''$ , and so for other deviated rays up to that one which coincides with the axis. The locus of these intersections  $c'$ ,  $c''$ , &c., is called a *caustic curve*; and if the curve be revolved about the axis  $O F$ , it will generate a *caustic surface*. This surface will spring from the focus of the axial rays at  $F'$ , as a vertex, and open out into a trumpet-shaped tube towards the deviating surface.

Caustic curve;

Caustic surface;

Section of the deviated wave by a plane through the axis of the surface;

The deviated wave will no longer be spherical, but will be of such shape that its section  $d' d'' d''' o'$ , by a plane through the axis of the deviating surface, will be the involute of the section  $c' c'' F'$ , by the same plane, of the caustic surface, taken as an evolute.

If after deviation the wave approach the caustic, the

latter will be *real*, being formed by the doubling over, as it were, of the deviated wave upon itself, thus producing at the cusp  $c'$  double the ethereal agitation due

Fig. 37.

When the caustic will be real.

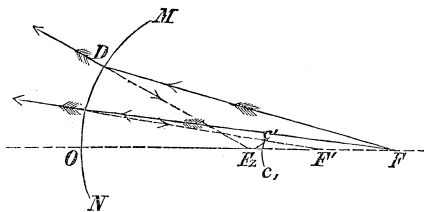

to either segment  $F_2 c'$  or  $c' e$ , separately. If, on the contrary, the wave recede from the caustic on being deviated, the caustic will be virtual. Caustics are finely illustrated on the surface of milk when the light is reflected upon it from the interior edge of the vessel in which it is contained.

Virtual caustic.

Illustration.

§ 58. We have only spoken of a pencil of light whose radiant is on the axis, which is usually called a *direct pencil*. When the radiant is off the axis, the axial ray of the pencil becomes oblique to the deviating surface, and the pencil is said to be *oblique*. In the case of an oblique pencil, however small, the deviated rays will not, in general, meet the axis as in the case of the direct pencil, but will all intersect two lines at right angles to each other and not situated in the same plane. These lines are called *focal lines*, and the property of the deviated rays by which all of them intersect both of these lines, is called *astigmatism*.

Oblique pencil;

Focal lines;

Astigmatism.

§ 59. It is, generally, not possible to deviate a spherical wave of sensible magnitude by a single lens or surface of spherical form without aberration, and yet the practical difficulties in grinding lenses and reflectors to any other figure render it necessary to adhere to this shape. Fortunately, however, two or more lenses may be so united that the aberration of one shall counteract that of another, and light may thus be deviated without aberration. When such combinations are used, a wave proceeding from one point may be made by deviation to proceed from, or concentrate in, some other point. Such points are called *aplanatic foci*, and the combinations which produce them are said to be *aplanatic*.

Aberration  
destroyed;Aplanatic foci,  
and  
combinations.

OBLIQUE PENCIL THROUGH THE OPTICAL CENTRE.

Oblique pencil through the optical centre;

§ 60. We have seen, article (19), that a ray undergoes no ultimate deviation when it passes through a medium bounded by two parallel planes. If, then, in the case of an oblique pencil the rays diverge sufficiently to cover the entire face of a lens, there may always be found one at least which will enter and leave the lens at points where tangent planes to its surfaces are parallel. This ray being taken as the axis of a very small pencil proceeding from the assumed radiant, will contain the focus of the others, the distance of which from the lens, in very moderate obliquities, will be measured by  $f''$ , given in Equation (27). This is obvious from the fact that in the immediate vicinity of the tangential points the surfaces, which are spherical, will be symmetrical in respect to the line which joins them.

Explanation.

To find where the ray referred to intersects the axis of the lens after deviation at the first surface, let  $M N N' M'$  represent a section of a concavo-convex lens, of which the radius  $CO$  of the first surface is  $r$ , and  $C'O'$  of the second is  $r'$ ;  $SP$  and  $S'P'$  the traces of two parallel tangent planes. Denote by  $t$  the distance  $OO'$ , between the surfaces measured on the axis, and by  $e$  the distance  $QK$ , from the first surface to the intersection of the line joining the tangential points  $P, P'$ , with the axis. Then, since the radii  $CP$  and  $C'P'$ , drawn to the tangential points, must be parallel, the similar triangles  $CPK$  and  $C'P'K$ , will give the relation,

To find the optical centre of a lens or a surface;

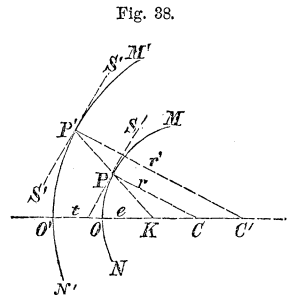

Fig. 38.

Relation from figure;

$$\frac{CO}{CK} = \frac{C'O'}{C'K}$$

and replacing these quantities by their values,

$$\frac{r}{r - e} = \frac{r'}{r' - t - e}$$

Same in other terms ;

from which we find

$$e = \frac{r t}{r' - r} = \frac{r}{\frac{r'}{t} - \frac{r}{t}} \dots \dots \dots (49)$$

Result.

But this value of  $e$  is constant, whence we infer that all rays which emerge from a lens parallel to their directions before entering it, proceed after deviation at the first surface in directions having a common point on the axis. This point is called the *optical centre*, and may lie between the surfaces or not, depending upon the figure of the lens.

If we suppose but one deviating surface, then the medium behind must be of indefinite extent, in which case  $r'$  and  $t$  will become infinite and sensibly equal, and Equation (49) reduces to

$$e = r.$$

That is to say, *the optical centre of a single deviating surface is at the centre of curvature.*

If the lens be double concave, the radius  $r'$  becomes negative, and the value of  $e$ , in Equation (49), becomes

$$e = - \frac{r t}{r' + r},$$

and if the faces be equally concave,  $r$  will equal  $r'$ , and

$$e = - \frac{t}{2}.$$

That is, the optical centre is midway between the faces.

Optical centre defined.

Optical centre of a single surface ;

Of a double concave lens ;

Of a double  
convex lens;

If the lens be double and equally convex,  $r$  becomes negative, and the result will be the same as above.

In the case of a meniscus with its concave face turned towards incident light, the radii will both be positive, and  $r > r'$ , whence

Of a meniscus;

$$e = - \frac{r t}{r - r'}.$$

In a plano-convex lens having its plane face turned towards incident light,  $r$  will be infinite, and  $r'$  finite and positive, and

Of a  
plano-convex  
lens.

$$e = - t.$$

which brings the optical centre to the vertex of the curved face. The student may determine in the same way the optical centre of the other lenses.

#### OPTICAL IMAGES.

Optical images;

§ 61. The surface of every luminous body is made up of a vast number of radiants, from each of which waves of light proceed in all directions. These waves cross each other; and if any deviating surface be presented, it becomes the common base of a multitude of pencils, whose vertices are the radiants which make up the surface of the body. Some one ray of each of these pencils will pass through the optical centre of the surface, and those rays in the immediate vicinity of this one constituting a small pencil will be brought to a focus upon it as an axis, and hence for each radiant in the surface of the body there will be a corresponding conjugate. These conjugate foci make up a second luminous surface, from which waves will proceed as from the original body; and this surface is called

Explanatory  
remarks;

an *image of the body*, because to an eye so situated as to receive these new waves, the object, though often modified in shape and size, will seem to occupy the position of the new surface. Image of a body defined;

An optical image is, therefore, an assemblage of foci conjugate to a series of contiguous radiants on the surface of some object; and its formation consists, in so deviating portions of the waves of light which proceed from the object, as either to concentrate them in some new positions from which they may proceed as from the object itself, or to cause them to move from these new positions without having at any time occupied them. Optical image defined; Its formation consists in;  
 In the first case the image will be real and in the second virtual. Real image;  
 In general, but a part of each wave can be deviated by the use of spherical deviating surfaces to satisfy these conditions, for those portions remote from the undeveloped ray of each pencil cannot, in consequence of aberration and astigmatism, be brought to accurate vergency. Virtual image.

§ 62. To ascertain the relation between an object and its image, let us suppose the deviation to be produced by a lens, so thin that its thickness may be neglected, which is the usual case in practice. The optical centre  $G$ , may be taken as the origin of coordinates. To find the relation between an object and its image formed by a lens;

Fig. 39.

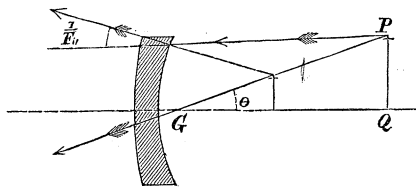

writing this quantity for  $f$ , in Equation (33), which we may do without sensible error, we get

$$f'' = \frac{F''}{1 + \frac{F''}{l}} \dots \dots \dots (50)$$

Conjugate corresponding to an assumed radiant point.

Section of the object assumed to be a right line; Let the object be a plane, perpendicular to the axis of the lens; its section will be a right line  $PQ$ . Call  $\theta$ , the angle included between the axis of any oblique pencil and the axis of the lens. When the pencil becomes direct,  $\theta$  will be zero, and  $l$  will equal  $f$ . But, generally, we have

General relation; 
$$l = \frac{f}{\cos \theta};$$

this in Equation (50), reduces it to

Equation of the image of a right line; 
$$f'' = \frac{F''}{1 + \frac{F''}{f} \cos \theta} \dots \dots \dots (51)$$

which is the polar equation of the image referred to the optical centre as a pole. It is the same in form as the polar equation of a conic section, which is

Is the same in form as that of a conic section; 
$$r = \frac{A(1 - e^2)}{1 + e \cos v}.$$

Conclusion; Whence we conclude that the image of a straight line perpendicular to the axis of the lens which forms it, is a conic section, and comparing the two Equations, we find,

$$f'' = r,$$

Equations compared; 
$$F'' = A(1 - e^2) = \frac{B^2}{A}, \dots \dots \dots (52)$$

$$e = \frac{F''}{f}, \dots \dots \dots (53)$$

$$\theta = v.$$



For the same lens,  $F''$  is constant; its value  $\frac{B^2}{A}$ , in Equation (52), which is the radius of curvature at the vertex, is also constant.

Equation (53) shows that the image of a right line will be one of the conic sections;

From Equation (53), it is easily seen that the curve will be the arc of a circle, ellipse, parabola, hyperbola, or a right line, one of the varieties of the hyperbola, according as

$$\frac{F''}{f} = 0,$$

$$\frac{F''}{f} < 1,$$

$$\frac{F''}{f} = 1,$$

$$\frac{F''}{f} > 1,$$

$$\frac{F''}{f} = \infty,$$

Conditions for the different conic sections.

or according as the distance of the object is infinite; greater than the principal focal distance of the lens; equal to this distance; less than this distance; or zero.

If the section  $PQ$  be supposed to revolve about the axis of the lens, it will generate a plane, and the image a curved surface whose nature will depend upon the distance of the object.

We have seen that a positive value for  $f''$ , answers to a virtual, and a negative value to a real focus; so, if the points of the image be indicated by positive values for  $f''$ , the image will be virtual; if by negative values, real. For a concave lens,  $F''$  is positive, and Equation (51), answers to this case. For a convex lens,  $F''$  is negative, and Equation (51), becomes

Sign of the focal distance for a lens, will indicate whether the image is real or virtual.

Image will be real for a convex lens as long as the object is beyond the principal focus;

$$f'' = - \frac{F''}{1 - \frac{F''}{f} \cos \theta} \dots \dots (54)$$

and the image will always be real as long as

$$\frac{F''}{f} \cos \theta < 1,$$

or

$$\frac{f}{\cos \theta} > F''.$$

That is, if from the optical centre, with a radius equal to the principal focal distance, we describe the arc of a circle, and this arc cut the object, the image of all that part of the object included between the points of intersection *A* and *A'* will be virtual, while that of the parts without these limits will be real; if the distance of the object exceed that of the principal focus, the whole image will be real.

Illustration.

Fig. 40.

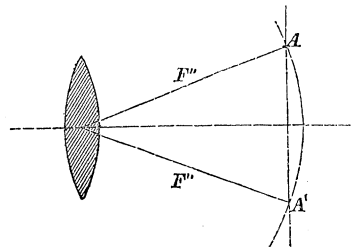

§ 63. Multiplying both members of Equation (51), by  $\sin \theta$ , it becomes

Equation (51) transformed;

$$f'' \cdot \sin \theta = \frac{F'' \cdot f \cdot \tan \theta}{\frac{f}{\cos \theta} + F''} \dots \dots (55)$$

the positive side of the axis as long as  $\theta$  is positive and less than  $90^\circ$ ;  $f'' \sin \theta$ , is the distance of the extreme limit of the image of this portion of the object from the axis; and writing

$$\begin{aligned} f \tan \theta &= \delta, \\ f'' \sin \theta &= \delta'', \end{aligned} \qquad \text{Substitutions;}$$

Equation (55) becomes, after dividing both members by  $f \tan \theta$ ,

$$\frac{\delta''}{\delta} = \frac{F''}{\frac{f}{\cos \theta} + F''}. \qquad \text{Equation (55) transformed;}$$

If the linear dimensions of the object be small as compared with its distance from the optical centre, we may write unity for  $\cos \theta$ , the image will, § 48, and Eq. (52), sensibly coincide with  $\delta''$ , and the above equation reduces to

$$\frac{\delta''}{\delta} = \frac{F''}{f + F''} \dots \dots \dots (56).$$

In which the essential signs of all the quantities correspond to a concave lens. For a convex lens,  $F''$  is negative, and Equation (56) becomes

$$\frac{\delta''}{\delta} = - \frac{F''}{f - F''} \dots \dots \dots (57). \qquad \text{Equation for a convex lens;}$$

Equations (51) and (56), show that the image of every real object formed by a *concave* lens is virtual, erect, and less than the object, while Equations (54) and (57), show that the image of every real object formed by a *convex* lens is real as long as the object is beyond the principal focus, is inverted, and less or greater than the object, depending upon the distance of the latter from

Explanation of terms;

Object small as compared with its distance from optical centre;

Images formed by concave and convex lenses.

When the image will be equal to the object;

the optical centre. When the distance of the object is twice that of the principal focus, Equation (57) becomes

$$\frac{\delta''}{\delta} = - 1,$$

Other cases.

and the object and image are equal in size. When the object is within twice the principal focal distance, it is less, and when beyond this same distance it is greater than the image.

Relation between linear dimensions of the object and image;

§ 64. If we make  $\theta$  equal to nothing in Equation (51),  $f''$  will coincide with the axis of the lens, its length will measure the distance of the image from the optical centre, while  $f$  will measure that of the object on the same line. Denoting these distances by  $D''$  and  $D$ , respectively, substituting them in Equation (51), clearing the fraction in the second member, and dividing both members by  $D$ , we find

$$\frac{D''}{D} = \frac{F''}{f + F''},$$

which, in Equation (56), gives

$$\frac{\delta''}{\delta} = \frac{D''}{D} . . . . . (58)$$

Same in words.

That is to say, the corresponding linear dimensions of an object and of its image are to each other directly as their respective distances from the optical centre.

Image formed by deviation at a single surface;

§ 65. If an image be formed by deviation at a single surface, its points will be readily found by means of Equation (36); the optical centre, in this case, being at the centre of curvature § 60.

Writing  $f$  for  $c$ , and  $f'$  for  $c'$ , that Equation becomes

$$\frac{1}{f'} = \frac{m-1}{r} + \frac{m}{f}; \quad \text{Equation applicable;}$$

making  $f = \infty$ ,

$$\frac{1}{f'} = \frac{m-1}{r} = \frac{1}{F_1} \dots \dots \dots (59) \text{ Principal focal distance;}$$

hence,

$$\frac{1}{f'} = \frac{1}{F_1} + \frac{m}{f}; \quad \text{Equation for discussion;}$$

or,

$$f' = \frac{f F_1}{f + m F_1} = \frac{F_1}{1 + \frac{m F_1}{f}}. \quad \text{Same in another form;}$$

For an oblique pencil passing through the optical centre, we have, on the supposition that the object is a right line perpendicular to the axis of the surface,

$$f' = \frac{F_1}{1 + \frac{m F_1}{f} \cos \theta} \dots \dots \dots (60) \text{ Same for an oblique pencil through the optical centre.}$$

wherein  $\frac{\cos \theta}{f} = \frac{1}{l}$ , as in article (62).

§ 66. If the image be formed by reflexion,  $m = -1$ , and Equation (60) becomes

$$f' = - \frac{F_1}{1 + \frac{F_1}{f} \cos \theta} \dots \dots \dots (61) \text{ Image formed by reflexion;}$$

Illustration; since for a concave reflector,  $F'$ , Eq. (59), becomes negative. This is a polar equation of a conic section, the nature of which will result from the relation of  $F'$  to  $f$ . It will, § 62, be an ellipse, parabola, or hyperbola, according as

Fig. 41.

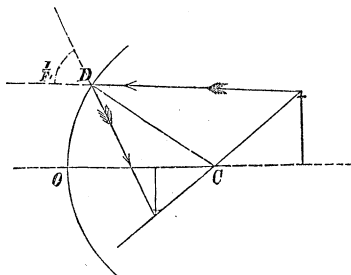

Image of a right line will be a conic section.

$$f > F'; f = F'; \text{ or } f < F'.$$

Relation between dimensions of object and image.

§ 67. By a process entirely similar to that of § 63 and § 64, we shall find that *the linear dimension of the object is to the corresponding dimension of the image, as the distance of the object from the centre is to that of the image from the same point.* And a moment's reflection will show us that all real images must be in front, while all virtual images must be behind the reflector.

§ 68. We get the point in which the image cuts the axis by making

Equation for discussing a concave reflector;

$$\theta = 0,$$

OR

$$f' = - \frac{F'}{1 + \frac{F'}{f}} = - \frac{f}{\frac{f}{F'} + 1} \dots (62)$$

Interpretation of results;

This value of  $f'$  being negative, the image will be found on the left of the centre, the distance  $f$  having been taken positive to the right. As long as  $f$  is positive, the image will lie between the centre and reflector,  $f'$  will be less than  $f$ , and the image, consequently, less than the object. When  $f$  is zero,  $f'$  will also equal zero, and the object and image will be equal and occupy

the centre. When  $f$  becomes negative, or the object passes between the centre and reflector,  $f'$  will be positive as long as  $f < F'$ , and the image will pass without,  $f'$  will be greater than  $f$ , or the image will be greater than the object. When  $f$ , being still negative, is equal to  $F'$ , or the object is in the principal focus, the image will be infinitely distant. The object still approaching the reflector,  $f$  will be greater than  $F'$ ;  $f'$  becomes negative again and the image will approach the reflector from behind it, and will be greater than the object till  $f = 2 F'$ , or the object be in contact with the reflector, when  $f'$  will equal  $f$ , and the image and object be of the same size.

Positions and relative size of the image when the object is between the centre and the vertex.

§ 69. When the reflector is convex,  $r$  is negative, the principal focal distance  $F'$ , Equation (59), is positive, and Equation (60) becomes

Convex reflector;

$$f' = \frac{F'}{1 - \frac{F'}{f} \cos \theta} \dots \dots \dots (63)$$

Equation applicable;

and making  $\theta = 0$ ,

$$f' = \frac{f}{\frac{f}{F'} - 1} \dots \dots \dots (64)$$

Equation for discussion;

This value of  $f'$  is always positive, greater than  $F'$ , and less than  $2 F'$ , for all values of  $f$ , between  $2 F'$  and infinity, or for any position of the object from the surface of the reflector to a point infinitely distant in front. In the latter position,  $f'$  is equal to  $F'$ , or the image is in the principal focus. It follows also, that the image, which will always be virtual for real objects, will be elliptical, erect, and smaller than the object.

Relations between the object and image for real objects;

§ 70. If we make  $f$  positive, greater than  $F'$ , and less than  $2 F'$ , the object will be virtual; the image real, erect, and greater than the object.

Same for virtual objects.

OF THE EYE AND OF VISION.

The eye; § 71. The eye is a collection of refractive media which concentrate the waves of light proceeding from every point of an external object, on a tissue of delicate nerves, called the retina, there forming an image, from which, by some process unknown, our perception of the object arises. These media are contained in a globular envelope composed of four coatings, two of which, very unequal in extent, make up the external enclosure of the eye, the others serving as lining to the larger of these two.

Four coatings envelop the refractive media;

Fig. 42.

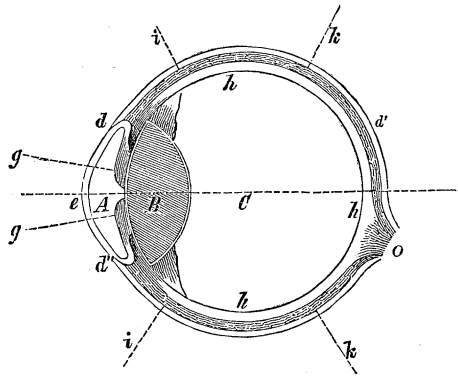

Graphic representation of the eye;

Shape of the eye; The shape of the eye is spherical except immediately in front, where it projects beyond the spherical form, as indicated at  $d e d''$ , which represents a section of the human eye through the axis by a horizontal plane. This part is called the *cornea*, and is in shape a segment of an ellipsoid of revolution about its transverse axis which coincides with the axis of the eye, and which has to the conjugate axis, the ratio of 1,3. It is a strong, horny, and delicately transparent coat.

The cornea;

Immediately behind the cornea, and in contact with



it, is the first refractive medium, called the *aqueous humour*, which is found to consist of nearly pure water, holding a little muriate of soda and gelatine in solution, with a very slight quantity of albumen. Its refractive index is found to be very nearly the same as that of water, viz. : 1,336, and parallel rays having the direction of the axis of the eye will, in consequence of the figure of the cornea, after deviation at the surface of this humour, converge accurately to a single point.

At the posterior surface of the chamber *A*, in contact with the aqueous humour, is the *iris*, *g g*, which is a circular opaque diaphragm, consisting of muscular fibres by whose contraction or expansion an aperture in the centre, called the *pupil*, is diminished or increased according to the supply of light. The object of the pupil seems to be, to moderate the illumination of the image on the retina. The iris is seen through the cornea, and gives the eye its color.

In a small transparent bag or capsule, immediately behind the iris and in contact with it, closing up the pupil, and thereby completing the chamber of the aqueous, lies the *crystalline humour*, *B*; it is a double convex lens of unequal curvature, that of the anterior surface being least; its density towards the axis is found to be greater than at the edge, which corrects the spherical aberration that would otherwise exist; its mean refractive index is 1,384, and it contains a much greater portion of albumen and gelatine than the other humours.

The posterior chamber *C*, of the eye, is filled with the *vitreous humour*, whose composition and specific gravity differ but little from the aqueous. Its refractive index is 1,339.

At the final focus for parallel rays deviated by these humours, and constituting the posterior surface of the chamber *C*, is the *retina*, *h h h*, which is a net-work of nerves of exceeding delicacy, all proceeding from one great branch *O*, called the *optic nerve*, that enters the eye

Fig. 42.

Graphic  
representation of  
the eye;

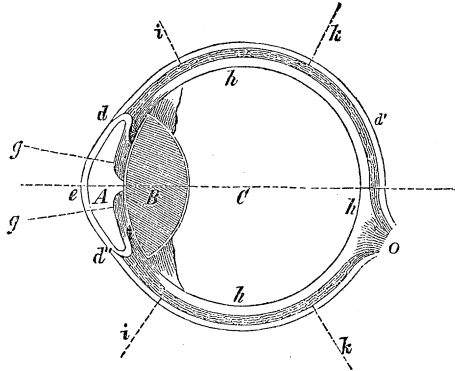

obliquely on the side of the axis towards the nose. The retina lines the whole of the chamber *C*, as far as *i i*, where the capsule of the crystalline commences.

Choroid coat;

Just behind the retina is the *choroid coat*, *k k*, covered with a very black velvety pigment, upon which the nerves of the retina rest. The office of this pigment appears to be to absorb the light which enters the eye as soon as it has excited the retina, thus preventing internal reflexion and consequent confusion of vision.

Sclerotic coat;

The next and last in order is the *sclerotic coat*, which is a thick, tough envelope *d d' d''*, uniting with the cornea at *d d'*, and constituting what is called the white of the eye. It is to this coating that the muscles are attached which give motion to the whole body of the eye.

Inverted images  
formed on the  
retina;

From the description of the eye, and what is said in article (62), it is obvious that inverted images of external objects are formed on the retina. This may easily be seen by removing the posterior coating of the eye of any recently killed animal and exposing the retina and choroid coating from behind. The distinctness of these images, and consequently of our perceptions of the objects from which they arise, must depend upon the distance

of the retina from the crystalline lens. The habitual position of the retina, in a perfect eye, is nearly at the focus for parallel rays deviated by all the humours, because the diameter of the pupil is so small compared with the distance of objects at which we ordinarily look, that the rays constituting each of the pencils employed in the formation of the internal images may be regarded as parallel. But we see objects distinctly at the distance of a few inches, and as the focal length of a system of lenses, such as those of the eye, Equation (25), increases with the diminution of the distance of the radiant or object, it is certain that the eye must possess the power of self-adjustment, by which either the retina may be made to recede from the crystalline humour and the eye lengthen in the direction of the axis, or the curvature of the lenses themselves altered so as to give greater convergency to the rays. The precise mode of this adjustment does not seem to be understood. There is a limit, however, with regard to distance, within which vision becomes indistinct; this limit is usually set down at *six inches*, though it varies with different eyes. The relation between the focal distances expressed in Equation (25), for when the radiant or object is brought within a few inches, the corresponding conjugate or image is thrown behind the point to which the retina may be brought by the adjusting power of the eye.

Habitual position  
of the retina;

Eye possesses the  
power of  
self-adjustment;

Limit of distinct  
vision;

With age the cornea loses a portion of its convexity, the power of the eye is, in consequence, diminished, and distinct images are no longer formed on the retina, the rays tending to a focus behind it. Persons possessing such eyes are said to be *long sighted*, because they see objects better at a distance; and this defect is remedied by *convex* glasses, which restore the lost power, and with it, distinct vision.

Long sightedness  
and its remedy;

The opposite defect arising from too great convexity in the cornea is also very common, particularly in young persons. The power of the eye being too great, the

Short sightedness  
and its remedy.

image is formed in the vitreous humour in front of the retina, and the remedy is in the use of *concave* glasses. Cases are said to have occurred, however, in which the prominence of the cornea was so great as to render the convenient application of this remedy impossible, and relief was found in the removal of the crystalline lens, a process common in cases of cataract, where the crystalline loses its transparency and obstructs the free passage of light to the retina.

Images on the  
retina are  
inverted;

The fact that inverted images are formed upon the retina, and we, nevertheless, see objects erect, has given rise to a good deal of discussion. Without attempting to go behind the retina to ascertain what passes there, it is believed that the solution of the difficulty is found in this simple statement, viz.: *that we look at the object, not at the image.* This supposes that every point in an image on the retina, produces, without reference to its neighboring points, the sensation of the existence of the corresponding point in the object, the position of which the mind locates somewhere in the axis of the pencil of rays of which this point is the vertex; all the axes cross at the optical centre of the eye, which is just within the pupil, and although the lowest point of an object will, in consequence, agitate by its waves the highest point of the retina affected, and the highest point of the object the lowest of the retina, yet the sensations being referred back along the axes, the points will appear in their true positions and the object to which they belong erect. In short, instead of the mind contemplating the relative positions of the points in the image, the image is the exciting cause that brings the mind to the contemplation of the points in the object.

But objects  
appear erect;

Explanation of  
the above.

Base of the optic  
nerve insensible  
to light.

It may be proper to remark here, that the base of the optic nerve, where it enters the eye, is totally insensible to the stimulus of light, and the reason assigned for this is, that at this point the nerve is not yet divided into those very minute fibres which are capable of being affected by this delicate agent.

§ 72. *The apparent magnitude of an object is determined by the extent of retina covered by its image.* Apparent magnitude of an object determined;

Fig. 43.

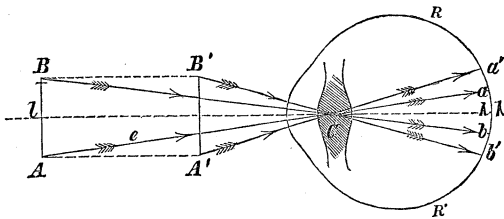

If, therefore,  $RR'$  be a section of the retina, by a plane through the optical centre  $C$ , of the eye, and  $AB = l$ ,  $a'b = \lambda$ , the linear dimensions of an object and its image in the same plane, we shall have, from the similar triangles  $CAB$  and  $Ca'b$ ,

$$\lambda = -Ca \cdot \frac{l}{\epsilon} \dots \dots \dots (65)$$

Dimension of image of an object on the retina;

denoting by  $\epsilon$ , the distance of the object. And for any other object whose linear dimension is  $l'$  and distance  $\epsilon_1$ , calling the corresponding dimension of the image  $\lambda_1$ ,

$$\lambda_1 = -Ca \cdot \frac{l'}{\epsilon_1},$$

Same for a second object;

and since  $Ca$  is constant, or very nearly so,

$$\lambda : \lambda_1 :: \frac{l}{\epsilon} : \frac{l'}{\epsilon_1},$$

Proportion;

that is, *the apparent linear dimensions of objects are as their real dimensions directly, and distances from the eye inversely.* But  $\frac{l}{\epsilon}$ , may be taken as the measure of the angle  $BCA = bCa$ , which is called the *visual an-* Rule first;

Rule second; *gle*, and hence *the apparent linear magnitudes of objects are said to be directly proportional to their visual angles.*

Small and large objects may, therefore, be made to appear of equal dimensions by a proper adjustment of their distances from the eye. For example, if  $\lambda = \lambda'$ , we have

Example for illustration;

$$\frac{l}{s} = \frac{l'}{s'}$$

or,

$$s' = \frac{l' \cdot s}{l};$$

Numerical data; and if  $l = 1000$  feet,  $s = 20000$ , and  $l' = 0,1$  of a foot, or little more than an inch,

Result.

$$s' = \frac{20000 \cdot 0,1}{1000} = 2 \text{ feet,}$$

the distance of the small object at which its apparent magnitude will be as great as that of an object ten thousand times larger, at the distance of 20000 feet.

#### MICROSCOPES AND TELESCOPES.

Microscopes;

§ 73. From what has just been said, it would appear that there is no limit beyond which an object may not be magnified by diminishing its distance from the optical centre of the eye. But when an object passes within the limit of distinct vision, what is gained in its apparent increase of size, is lost in the confusion with which it is seen. If, however, while the object is too near to be distinctly visible, some refractive medium be interposed to assist the eye in bending the rays to foci upon its retina, distinct vision will be restored, and the magnifying process may

Explanatory remarks;

be continued. Such a medium is called a *single microscope*, and usually consists of a lens, whose principal focal distance is negative and numerically less than the limit of distinct vision.

To illustrate the operation of this instrument, let  $MN$  be a section of a double convex lens whose optical centre is  $C$ ;

Fig. 44.

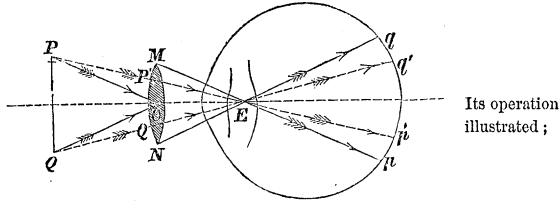

Its operation illustrated;

$QP$  an object in front and at a distance from  $C$  equal to the principal focal distance of the lens;  $E$  the optical centre of the eye, at any distance behind the lens.

The rays  $QC$  and  $PC$ , containing the optical centre, will undergo no deviation, and all the rays proceeding from the points  $Q$  and  $P$ , will be respectively parallel to these rays after passing the lens; some rays, as  $NE$  from  $Q$ , and  $ME$  from  $P$ , will pass through the optical centre of the eye, and will belong to two beams of light whose boundaries will be determined by the pupil, and whose foci will be at  $q$  and  $p$  on the retina, giving the visual angle,

$$MEN = PCQ;$$

Relation from same;

or the apparent magnitude of the object  $PQ$ , the same as if the optical centre of the eye were at that of the lens. And this will always be the case when an object occupies the principal focus of a lens whatever the distance of the eye, provided the latter be within the field of the rays.

Without the lens, the visual angle is  $QEP < PCQ$ ; hence, the apparent magnitude of the object will be increased by the lens.

Calling  $\lambda$  and  $\lambda_1$ , the apparent magnitudes of the object as seen with, and without the lens, we shall have,

Magnitudes of an object with and without the lens compared;

$$\lambda : \lambda_i :: \frac{P Q}{C Q} : \frac{P Q}{E Q} :: \frac{1}{C Q} : \frac{1}{E Q}.$$

or, by using the notation employed in Equation (33), and calling  $E Q$ , the limit of distinct vision, unity,

$$\frac{\lambda}{\lambda_i} = \frac{1}{F''} = -(m-1) \left( \frac{1}{r} + \frac{1}{r'} \right) \quad \dots \quad (66)$$

When the lens may be used as a single microscope;

As long as  $F'' < 1$ , or the principal focal length of the lens is less than the limit of distinct vision, the apparent size of the object will be increased, and the lens may be used as a single microscope.

What is meant by the magnifying power of a single microscope;

We can now understand what is meant by the power of a lens or combination of lenses, referred to at the close of article (39).  $\frac{1}{F''}$ , which was there said to measure the power of a lens, we see from Equation (66), expresses the apparent magnitude of an object referred to that at the limit of distinct vision, taken as unity; and whatever has been demonstrated of the powers of lenses generally, is true of magnifying powers. Thus, in Equation (31), we have the magnifying power of any combination of lenses equal to the algebraic sum of the magnifying powers taken separately. Should any of the individuals of the combination be concave, they will enter with signs contrary to those of the opposite curvature.

Rule for magnifying power of a single microscope;

*The power of a single microscope is, Equation (66), equal to the limit of distinct vision divided by its principal focal distance, and the numerical value of the power will be greater as the refractive index and curvature are greater.*

§ 74. To obtain a general expression for the visual angle under which the *image* of an object formed by a lens, and having any position in reference to the eye,



is seen, let  $QP$ , be an object in front of a concave lens. From  $P$ , draw through the optical centre  $E$ , the line  $PE$ ; from  $P$ , draw the extreme ray  $PM$ , and from

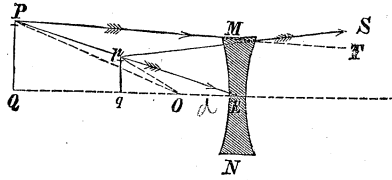

Fig. 45.

To find the visual angle under which an image formed by a lens is seen;

$M$  draw  $MS$ , making with  $PM$  produced the angle  $SMT$  equal to the power of the lens; then will, § 47,  $MS$  be the corresponding deviated ray, and its intersection  $p$ , with the ray  $PE$ , through the optical centre, will be a point in the image; from  $p$ , draw  $pq$ , parallel to  $PQ$ , till it is cut by the ray  $QE$ , through the other extreme of the object and optical centre;  $pq$  will be the image. Let  $O$ , be the optical centre of the eye; then denoting the visual angle  $pOq$  by  $A$ , we have,

$$A = \frac{qp}{Oq} = \frac{QP}{Eq - OE};$$

Value of visual angle;

and representing the distances  $QE$  by  $f$ ,  $Eq$  by  $f''$ , and  $EO$  by  $d$ , we find,

$$qp = QP \cdot \frac{f''}{f}; \quad Eq - EO = f'' - d;$$

and hence

$$A = \frac{QP}{f} \cdot \frac{f''}{f'' - d};$$

Same in other terms;

and denoting the visual angle  $PEQ$  by  $A'$ ,

$$\frac{A}{A'} = \frac{f''}{f'' - d} = \frac{1}{1 - \frac{d}{f''}} \dots \dots (67)$$

Ratio of visual angles with and without the lens,

Sign of this ratio depends upon;

Eye placed so as to see the image formed by a concave lens;

Equation corresponding to this case;

Real image formed by a convex lens;

Equation corresponding;

Distinct vision supposed possible for all positions of the eye.

The angles  $A$  and  $A'$  will have contrary signs when on opposite sides of the axis of the deviating surface. The relation expressed by this equation answers to a concave lens in which  $f''$  will, Equation (27), be positive for a real object. Moreover,  $d$  is positive, the eye being on the same side of the lens as the object; but that the image may be seen the eye must be on the opposite side, in which case  $d$  will be negative, and the Equation becomes

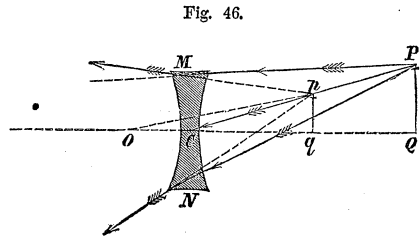

$$\frac{A}{A'} = \frac{1}{1 + \frac{d}{f''}}; \dots \dots \dots (68)$$

whence we conclude that objects will always appear diminished when seen through concave lenses.

If the lens be convex and the object be situated beyond its principal focus  $f''$  will be negative, and Equation (68) becomes

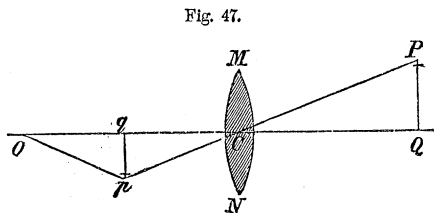

$$\frac{A}{A'} = \frac{1}{1 - \frac{d}{f''}}; \dots \dots \dots (69)$$

and supposing distinct vision possible for all positions of the eye, it appears,

1st. That when the object is at a distance from the lens greater than that of the principal focus, in which case there will be a real image, the lens will make no difference in the apparent magnitude of the object, provided the eye is situated at a distance from the lens equal to twice that of the image.

2d. At all positions for the eye between this limit and the image, the apparent magnitude of the object is increased by the lens.

3d. At a position half way between this limit and the lens, the apparent magnitude of the object would be infinite.

4th. The eye being placed at a distance greater than twice that of the image, the apparent magnitude of the object will be diminished by the lens.

5th. When the distance of the object from the lens is equal to that of the principal focus, in which case becomes infinite, the apparent magnitude will be the same as though the eye were situated at the optical centre of the lens, no matter what its actual distance behind the lens.

§ 75. The visual angle under which the image formed by a reflector is seen, is found in the same way. Thus, let

$PQ$  be an object in front of a convex reflector  $MN$ . From the extreme point  $P$ , of the object, and through the optical centre  $C$ , draw the ray  $PC$ ; from the same point  $P$ , draw to the extreme of the reflector the ray  $PM$ , and from  $M$  draw  $MS$ , making with  $PM$ , the angle  $PM S$  equal to the power of the reflector;  $MS$  will, § 53, be the deviated ray, and its intersection with  $PC$ , will give the image of the point

To find the visual angle under which an image formed by a reflector is seen;

Fig. 48.

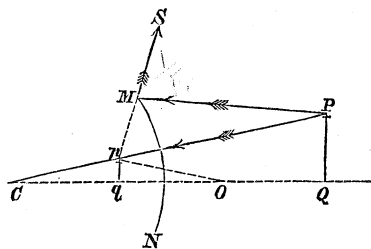

Explanation;

Construction of the image formed by a reflector;

*P.* Draw  $p q$ , parallel to  $P Q$ , till it is intersected by  $Q C$ , drawn through the opposite extreme of the object and optical centre, and we have the image. Let the optical centre of the eye be at  $O$ ; then, denoting the visual angle  $p O q$  by  $A$ , will

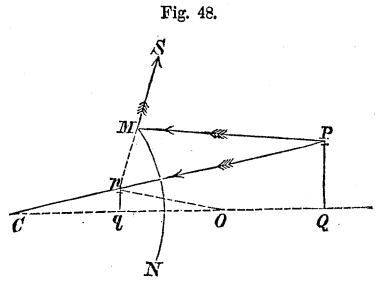

Value of visual angle with the reflector;

$$A = \frac{q P}{O q} = \frac{Q P}{C Q} \cdot \frac{C q}{O q};$$

and representing, as before,  $C Q$ ,  $C q$ , and  $C O$ , by  $f$ ,  $f'$ , and  $d$ , respectively, and the visual angle  $\frac{P Q}{C Q}$  by  $A'$ , we have

Ratio of visual angles with and without the reflector.

$$\frac{A}{A'} = \frac{f'}{d-f'} \dots \dots \dots (70)$$

We shall not stop to discuss this Equation.

In practice distinct vision is not possible for all positions of the eye;

§ 76. We have supposed, in the preceding discussion, distinct vision to be possible for all positions of the eye; but this we know depends upon the state of convergence or divergence of the rays. If, however, the image, when one is formed, instead of being seen by the naked eye, be viewed by the aid of another lens, so placed that the rays composing each pencil proceeding from the object shall, after the second deviation, be parallel, or within such limits of vergency that the eye can command them, the object will always be seen distinctly, and either larger or smaller than it would appear to the unassisted eye, depending upon the magnitude of the image, and the power of the lens used to view it.

And the image is therefore viewed through an eye lens.

As most eyes see distinctly with plane waves or parallel rays, this second lens is usually so placed that the image shall occupy its principal focus; and where this is the case, we have seen that the apparent magnitude of the image will be the same as though the eye were at its optical centre.

Fig. 49.

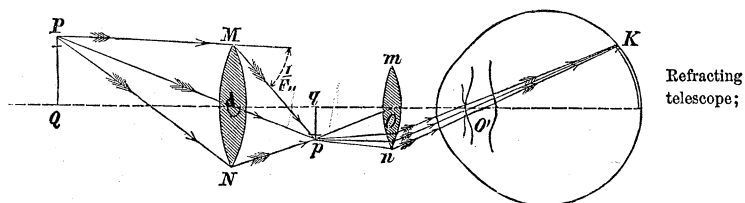

The image  $p q$ , being in the principal focus of the lens  $m n$ , draw from the point  $p$ , the line  $p O$ , to the optical centre of this lens; the rays from  $p$  will, § 73, be deviated parallel to this line, and the line  $O' K$ , through the optical centre  $O'$  of the eye, parallel to  $p O$ , will determine by its intersection  $K$ , with the retina, the place upon that membrane of the image of the point  $P$ .

Calling the principal focal distance of this lens,  $(F_{mn})$ ;  $d$ , in Equation (67), will equal  $f'' + (F_{mn})$ , and that equation will become, by first making  $f''$  and  $d$  negative and then replacing  $d$  by this value,

$$\frac{A}{A'} = - \frac{f''}{(F_{mn})} \dots \dots \dots (71)$$

General equation made applicable to this telescope;

and if the object  $P Q$ , be so distant that the rays composing each of the small pencils whose common base is  $M N$ , may be regarded as parallel,  $f''$  becomes  $F_{mn}$ , and we have,

$$\frac{A}{A'} = - \frac{F_{mn}}{(F_{mn})} \dots \dots \dots (72)$$

Ratio of visual angles for parallel rays;

Fig. 49.

Refracting telescope;

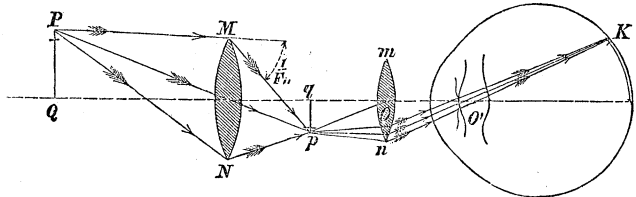

Compound microscope;

Field and eye lenses;

Rule for magnifying power.

Objects appear inverted.

Equation (71) involves the principles of the *compound refracting microscope*, and *refracting telescope*; and Equation (72), which is a particular case of (71), relates to the *astronomical refracting telescope*. The lens  $MN$ , next the object, is called the *object or field lens*, and  $mn$ , the *eye lens*. The magnifying power in the first case, is equal to the *distance of the image from the field lens divided by the principal focal length of the eye lens*; and in the second, to the *principal focal length of the field lens, divided by that of the eye lens*.

The ratio of  $A$  to  $A'$ , being negative, shows that objects appear inverted through these instruments, the visual angles of corresponding parts of the object and image being on opposite sides of the axis.

Galilean telescope;

§ 77. If instead of a convex, a concave lens be used for the eye lens, the combination will be of the form used by GALILEO, who invented this instrument in 1609. In this construction, the eye lens is placed in front of the image at a distance equal to that of its principal focus, so that the rays composing each pencil shall emerge from it parallel.

Construction of image on the retina;

Draw through the point  $p$ , where the image of  $P$  would be formed, the line  $pO$ , to the optical centre  $O$  of the eye lens, and through the optical centre  $O'$  of the eye, the line  $O'K$  parallel to  $pO$ , its intersection  $K$ , with the retina will give the image of the point  $P$  on the back part of the eye.

Fig. 50.

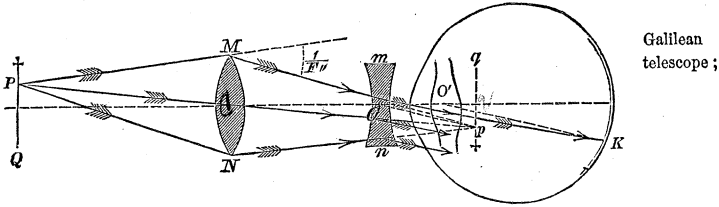

Galilean telescope ;

The rule for finding the magnifying power of this instrument is the same as in the former case; for we have,

$$d = f'' - (F''_u);$$

which in Equation (67), after making  $f''$ , and  $d$ , negative, gives

$$\frac{A}{A'} = \frac{f''}{(F''_u)}; \dots \dots \dots (73) \text{ Ratio of visual angles;}$$

and for parallel rays,

$$\frac{A}{A'} = \frac{F''_u}{(F''_u)} \dots \dots \dots (74) \text{ Same for parallel rays;}$$

The second member being positive, shows that objects seen through the Galilean telescope appear erect.

§ 78. If we divide both numerator and denominator of Equation (72), by  $F''_u \cdot (F''_u)$ , it becomes,

$$\frac{A}{A'} = - \frac{1}{\frac{(F''_u)}{F''_u}},$$

Magnifying power in terms of the powers of the lenses;

and denoting by  $L$ , the power of the field, and by  $l$ , that of the eye lens, we have

$$\frac{A}{A'} = - \frac{l}{L} \dots \dots \dots (75) \text{ Ratio of visual angles;}$$

Rule for magnifying power.

that is, the magnifying power of the astronomical telescope is equal to *the quotient arising from dividing the power of the eye lens by that of the field lens.*

Fig. 51.

Geometrical illustration of the field of view;

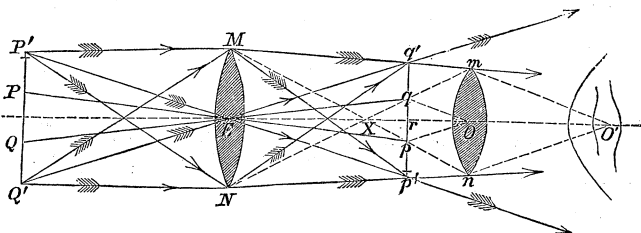

General explanation;

§ 79. If  $E$ , be the optical centre of the field, and  $O$  that of the eye lens of an astronomical telescope, the line  $EO$ , passing through the points  $E$  and  $O$ , is called the axis of the instrument. Let  $Q'P'$  be any object whose centre is in this axis, and  $q'p'$  its image. Now, in order that all points in the object may appear equally bright, it is obvious from the figure, that the lens must be large enough to embrace as many rays from the points  $P'$  and  $Q'$ , as from the intermediate points. It is not so in the figure; a portion, if not all the rays from those points will be excluded from the eye, and the object, in consequence, appear less luminous about the exterior than towards the centre, the brightness increasing to a certain boundary, within which all points will appear equally bright. The angle subtended at the centre of the field lens, by the greatest line that can be drawn within this boundary, is called *the field of view*. To find this angle, draw  $mN$  and  $Mn$  to the opposite extremes of the lenses, intersecting the image in  $p$  and  $q$ , and the axis in  $X$ ; then will  $p q$  be the extent of the image of which all the parts will appear equally bright. Draw  $qEQ$  and  $pEP$ ; the angle  $PEQ = pEq$ , is the field of view, which will be denoted by  $\xi$ ;

Field of view;

Determined by construction;

First form of its value;

$$\xi = \frac{pq}{f''} \dots \dots \dots (76)$$



but

$$pq = \frac{m n}{X O} \cdot X r \dots \dots \dots (77) \quad \text{Transformations;}$$

to find  $XO$  and  $Xr$ , call the diameter  $MN$  of the object lens  $\alpha$ , that of the eye lens  $\beta$ , and we have

$$\begin{aligned} \alpha : \beta &:: EX : XO && \text{Proportions;} \\ \alpha + \beta : \beta &:: EX + XO : XO \end{aligned}$$

hence,

$$XO = \frac{\beta}{\alpha + \beta} \cdot (f'' + (F''));$$

and in the same manner,

$$EX = \frac{\alpha}{\alpha + \beta} \cdot (f'' + (F'')); \quad \text{Relations from the figure;}$$

$$Xr = f'' - EX = f'' - \frac{\alpha}{\alpha + \beta} \cdot (f'' + (F'')) = \frac{\beta f'' - \alpha (F'')}{\alpha + \beta};$$

these values in Equation (77), give

$$pq = \frac{\beta f'' - \alpha (F'')}{f'' + (F'')}, \quad \text{Substitutions;}$$

and this in Equation (76), gives, by introducing the powers of the lenses,

$$\xi = L \cdot \frac{\beta l - \alpha L}{l + L} \dots \dots \dots (78) \quad \text{Final value for field of view.}$$

The rays of each of the several pencils emerging from the eye lens parallel, will be in condition to afford dis-

Fig. 51.

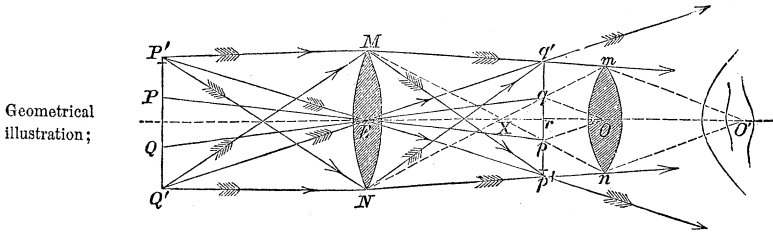

Geometrical illustration;

Proper position for the eye indicated in telescopes;

inct vision, and the extreme rays  $m O'$  and  $n O'$ , will be received by an eye whose optical centre is situated at  $O'$ . If the eye be at a greater or less distance than  $O'$ , from the eye lens, these rays will be excluded, and the field of view will be contracted by an improper position of the eye. It is on this account that the tube containing the eye lens of a telescope usually projects a short distance behind to indicate the proper position for the eye.

From the similar triangles  $p O q$  and  $m O' n$ , we have

Distance of optical centre of the eye from that of the eye lens;

$$O O' = \frac{m n}{p q} \cdot r O = \frac{\beta (L + l)}{\beta l - \alpha L} \cdot (F_{II}) \dots \dots (79)$$

Position of the eye for the Galilean telescope;

This also applies to the Galilean instrument, by changing the sign of  $l$ , which will render  $O O'$ , negative. The eye should, therefore, be in front of the eye-glass in order that it may not, by its position, diminish the field of view; but as this is impossible, the closer it is placed to the eye-glass the better.

Arrangement for changing the distance between the lenses.

When the telescope is directed to objects at different distances, the position of the image, Equation (27), will vary, and the distance between the lenses must also be changed. This is accomplished by means of two tubes which move freely one within the other, the larger usually supporting the object and the smaller the eye lens.

Terrestrial telescope;

§ 80. The *terrestrial telescope* is a common astronomical telescope with the addition of what is termed an

*erecting piece*, which consists of a tube supporting at each end a convex lens. The length of this piece should be such as to preserve entire the field of view, and its position so adjusted that the image formed by the object glass, shall occupy the principal focus of the first lens of the erecting piece, as indicated in the figure,

Fig. 52.

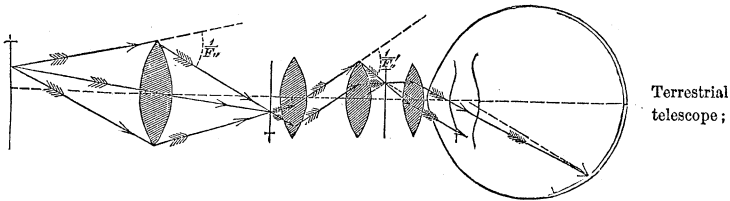

in which case a second image will be formed in the principal focus of the second lens of the erecting piece, and the corresponding linear dimensions of these images will be to each other as their distances from the lenses whose principal foci they occupy, Equation (72). These images being viewed through the same eye lens, viz.: that of the telescope, their apparent, will be directly as their real magnitudes. Hence, denoting by  $A$  and  $A''$  the visual angles subtended at the optical centre of the eye lens by the first and second images respectively; by  $l'$  and  $l''$  the powers of the first and second lenses of the erecting piece, we have,

$$\frac{A''}{A} = -\frac{F'_{e11}}{F'_{e1}} = -\frac{l'}{l''};$$

Relation between the two images formed;  
Ratio of their visual angles at the optical centre of the eye lens;

in which  $F'_{e1}$  and  $F'_{e11}$ , are the principal focal lengths of the first and second lenses. Multiplying this by Equation (75), member by member, we have for the magnifying power of the terrestrial telescope,

$$\frac{A''}{A'} = \frac{l}{L} \cdot \frac{l'}{l''}.$$

Magnifying power of the terrestrial telescope.

Objects appear erect.

And since the ratio of  $A''$  to  $A'$  is positive, objects will appear through this instrument erect.

Compound microscope;

§ 81. If, now, the object approach the field lens,  $f''$ , in Equation (71), will increase, and the magnifying power become proportionably greater; but this would require the tube containing the eye lens to be drawn out to obtain distinct vision, and to an extent much beyond the limits of convenience if the object were very near. This difficulty is avoided by increasing the power of the object lens, as is obvious from Equation (54); and when this is carried to the extent required for very great proximity, the instrument becomes a *compound microscope*, which is employed to examine minute objects. The com-

Fig. 53.

Compound microscope;

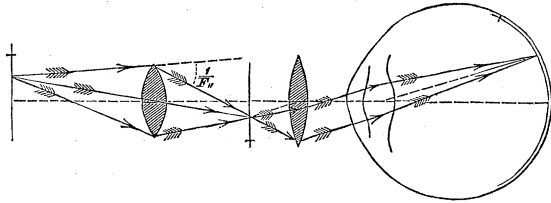

Same in principle as refracting telescope;

compound microscope not differing in principle from the telescope, its magnifying power is given by the Equation (68.)

Its magnifying power;

$$\frac{A}{A'} = \frac{f''}{(F'')} = \frac{1}{(F'')} \cdot \frac{1}{\frac{1}{f''}};$$

and substituting for  $\frac{1}{f''}$  its value in Equation (40), we have for a convex object lens

Same in a different form;

$$\frac{A}{A'} = \frac{1}{(F'')} \cdot \frac{1}{\frac{1}{f} - \frac{1}{F''}};$$

or, writing  $D$  for  $\frac{1}{f}$ ; and representing, as before, the powers of the field and eye lenses by  $L$  and  $l$ ,

$$\frac{A}{A'} = \frac{l}{D - L};$$

Final value for magnifying power;

from which it is obvious that the magnifying power may be varied to any extent by properly regulating the position of the object; but a change in the position of the object would require a change in the position of the eye-glass, and two adjustments would, therefore, be necessary, which would be inconvenient. For this reason, it is usual to leave the distance between the lenses unaltered and to vary only the distance of the object to suit distinct vision. It is, however, convenient to have the power of changing the distance between the glasses, as by that a choice of magnifying powers between certain limits may be obtained, and for this purpose the object and eye glasses are set in different tubes.

May be varied;

Usual practice;

Object and eye glasses in different tubes.

Fig. 54.

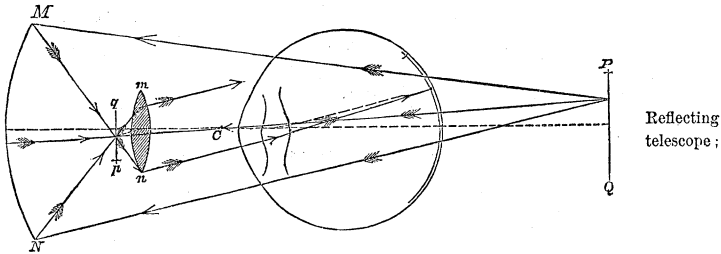

§ 82. If the field lens of the astronomical telescope be replaced by a field reflector  $MN$ , whose optical centre is at  $C$ , as indicated in the figure, we have the common *astronomical reflecting telescope*.  $C$  being the optical centre,  $d$  becomes equal to  $f' - (F'_{ii})$ , and Equation (70), becomes, by first changing the sign of  $f'$ , and then substituting this value for  $d$ ,

Explanation;

Magnifying power for terrestrial objects;

$$\frac{A}{A'} = - \frac{f'}{(F'_{II})}$$

and for plane waves or parallel rays,

Same for celestial objects.

$$\frac{A}{A'} = - \frac{F'_I}{(F'_{II})} \dots \dots \dots (80)$$

hence, the rule for the magnifying power is the same as for the refracting telescope.

To obviate the interception of light by the observer's head;

The figure represents a reflecting telescope of the simplest construction, and it is obvious that the head of the observer would intercept the whole of the incident light, if the reflector were small, and a considerable portion even in the case of a large one; to obviate this, it is usual to turn the axis a little obliquely, so that the image may be thrown to one side, where it may be viewed without any appreciable loss of light. By this arrangement, the image would, of course, be distorted, but in very large instruments, employed to view faint and very distant objects, it is not sufficient to cause much if any inconvenience. This is Herschel's instrument.

Herschel's instrument.

§ 83. The obstruction of light is in a great measure avoided in the Gregorian telescope, of which an idea may be formed from the figure.

Fig. 55.

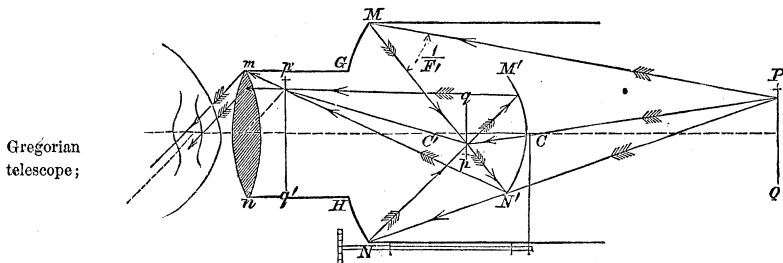

Gregorian telescope;

*M N* is a concave spherical reflector, of which the optical centre is at *C*, and having a circular aperture *G H*; an

image  $p q$  of any distant object  $P Q$ , is formed by it as before; the rays from the image are received by a second concave spherical reflector, much smaller than the first, and whose optical centre is at  $C'$ ; a second image  $p' q'$ , is formed by this small reflector, in or near the aperture of the large reflector and is there viewed through the eye lens  $m n$ . The distance of the small reflector from the first image must be greater than its principal focal distance, and so regulated that the second image will be thrown in front of the eye lens, and in its principal focus. In order to regulate this distance, the small reflector is supported by a rod that passes through a longitudinal slit in the tube of the instrument, the rod being connected with a screw, as represented in the figure, by means of which a motion in the direction of the axis may be communicated to it.

Second image formed by a small concave reflector;

Position of the small reflector;

Device for regulating it.

The apparent magnitude of the images  $p q$  and  $p' q'$ , as seen through the same eye-glass at the distance of its principal focus, are as their real magnitudes; and the latter are as the distances of these images from the centre of the small reflector, § 67. But by Equation (36), making  $m = -1$ , and recollecting that in the case before us,  $c$  is negative, we have, calling  $F_2$ , the principal focal distance of the second reflector,

Relation between the two images formed;

$$\frac{1}{c'} = -\frac{1}{F_2} + \frac{1}{c}$$

Same expressed analytically;

whence

$$c' = \frac{F_2 c}{F_2 - c}$$

dividing by  $-c$ ,

$$\frac{c'}{c} = -\frac{F_2}{F_2 - c} = \frac{A''}{A}$$

Same in other terms;

which, being multiplied by Equation (80), member by member, gives for the magnifying power of this telescope,

Magnifying power of Gregorian telescope;

$$\frac{A''}{A'} = \frac{F_1}{(F''_1)} \cdot \frac{F_2}{F_2 - c} \dots \dots (81)$$

May be varied.

whence, this ratio being positive, the object will appear erect; its apparent magnitude may be made as great as we please by giving a motion to the small reflector which shall cause its principal focus to approach the first image, and drawing out, at the same time, the eye lens to keep the second image in its principal focus.

Objects appear erect.

Cassegrainian telescope;

§ 84. If the small reflector be made *convex* instead of concave, we have the modification proposed by M. CASSEGRAIN, and called the *Cassegrainian telescope*, which is represented in the figure. Its magnifying power is

Fig. 56.

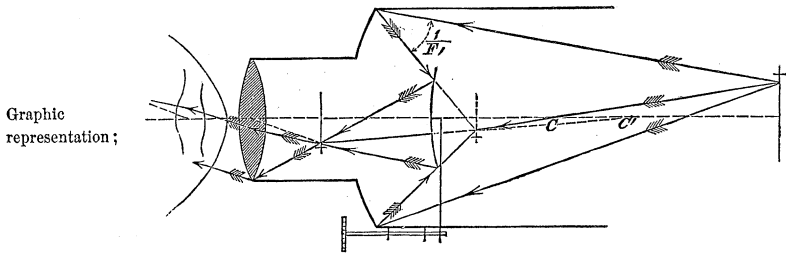

Graphic representation;

given by Equation (81), by changing the signs of  $F_2$  and  $c$ , which will give,

Magnifying power;

$$\frac{A''}{A'} = - \frac{F_1}{(F''_1)} \cdot \frac{F_2}{c - F_2} \dots \dots (82)$$

Objects appear inverted.

and because the ratio of  $A''$  to  $A'$  is negative, objects seen through this telescope with ordinary eye pieces, appear inverted.



§ 85. Sir ISAAC NEWTON substituted for the small curved reflector a plane one inclined under an angle of  $45^\circ$  to the axis of the instrument, and so placed as to intercept the rays before the image is formed. The vergency not being affected by reflexion at plane surfaces, § 55, the image is formed on one side, and viewed through the lens supported by a small tube inserted in the side of

Fig. 57.

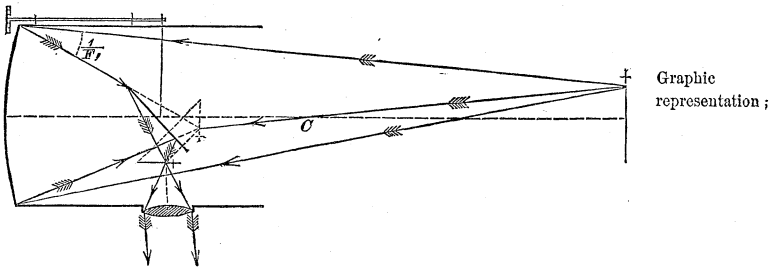

the main tube of the telescope. The magnifying power of the Newtonian telescope is given by Equation (81) or (82), by making  $F_2$  infinite, in which case  $c$ , becomes equal to  $2 F_2$ , the distance of the first image from the optical centre of the small reflector being sensibly equal to the radius of curvature. This gives

$$\frac{A''}{A'} = - \frac{F_1}{(F_2)} \dots \dots \dots (83).$$

Magnifying power found;

Its value,

DYNAMETER.

Dynameter

§ 86. If any telescope, properly adjusted to view distant objects, be directed towards the heavens, the field lens may be regarded as a luminous object whose image will be formed by the eye lens. The distance of

Distance of object;

the object in this case will be the sum of the principal focal distances or  $F'' + (F''')$ , and this being substituted for  $f$ , in Equation (57), we get, by inverting and reducing,

Relation between object and image;

$$\frac{\delta}{\delta''} = - \frac{F''}{(F''')} ; \dots \dots \dots (84)$$

Rule.

hence, *any linear dimension of the object glass of a telescope, divided by the corresponding linear dimension of its image, as formed by the eye glass, is equal to the magnifying power of the telescope.* This is the principle of the *Dynameter*, a beautiful little instrument used to measure the magnifying power of telescopes.

Fig. 53.

Illustration ;

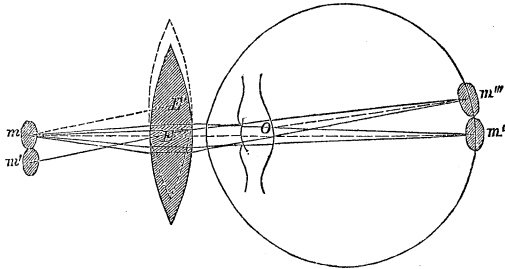

Construction of the dynameter explained ;

One disk supposed to be moved tangent to the other ;

To understand its construction, let us suppose two luminous circular disks, a tenth of an inch in diameter, to be placed one exactly over the other in the principal focus  $m$  of a lens  $E$ , and with their planes at right angles to its axis; an image of the common centre of the disks will be formed on the retina of an eye viewing them through the lens, at  $m''$ . If one of the disks be moved to the position  $m'$ , so that its circumference be tangent to that of the other, the image of its centre will be at  $m'''$ , determined by drawing from  $O$ , the optical centre of the eye, a line parallel to that joining

the optical centre of the lens and the centre of the movable disk, article (73); the images will be tangent to each other, and the movable disk will have passed over a distance equal to its diameter, viz.: one tenth of an inch. We now take but one disk, and suppose the lens divided into two equal parts by a plane passing through its axis; as long as the semi-lenses occupy a position wherein they constitute a single lens, an image of the disk will be formed as before at  $m''$ ; but when one of the semi-lenses is brought into the position denoted by the dotted lines in the figure, having its optical centre at  $E'$ , in a line through  $m$ , parallel to  $m' E$ , two images, tangent to each other, will again be formed; for, all the rays from the centre of the disk, refracted by the semi-lens in this second position, will be parallel to  $m E'$ , and  $O m'''$ , is one of these rays. It is obvious also, that the distance  $E E'$ , through which the movable semi-lens has passed, is equal to the diameter of the disk.

Take one disk and suppose the lens divided;

Move one half the lens;

Fig. 50.

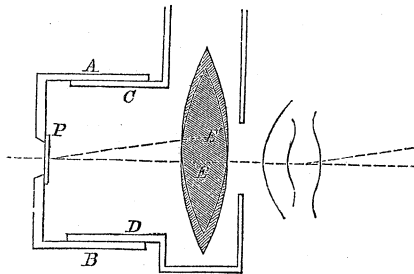

Essential parts of the dynamometer;

Fig. 60.

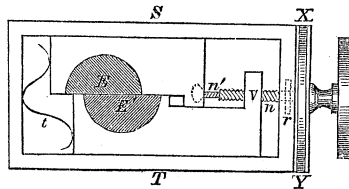

Arrangement for moving the semi-lenses;

The dynamometer consists of two tubes  $A B$ , and  $C D$ , moving freely one within the other, the larger having a metallic base with an aperture in the centre, over which, to qualify the light, is placed a thin slip of *mother-of-pearl*  $P$ . In the opposite end of the smaller tube, two semi-lenses  $E E'$ , are made to move by each other by means of an ar-

Illustration ;

Graduated screw head ;

Spring ;

Value of one entire turn of screw head ;

Value of one division.

Method of using the dynameter ;

rangement indicated in the figure, wherein  $n$  is a right-handed screw with, say, fifty threads to an inch;  $n'$  is a left-handed screw, with the same number of threads, which works in the former about a common axis, and is fastened to the frame that carries the semi-lens  $E$ . The screw  $n$ , is rendered stationary as regards longitudinal motion, by a shoulder that turns freely within the top of the frame  $ST$  at  $r$ , and works in a nut at  $V$ , connected with a frame that carries the semi-lens  $E'$ ; this screw is provided with a large circular head  $XY$ , graduated into one hundred equal parts, which may be read by means of an index at  $X$  or  $Y$ , on the frame of the instrument. At  $t$ , is a spring that serves to press the frames against their respective screws, to prevent loss of motion when a change of direction in turning takes place.

Fig. 60.

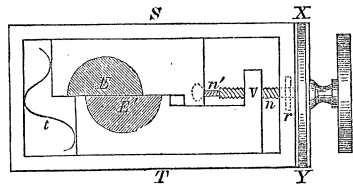

When the graduated head is turned once round to the right, the semi-lens  $E'$ , is drawn up  $\frac{1}{50}$  of an inch, while the semi-lens  $E$ , is thrust in an opposite direction through the same distance, making in all a separation of the optical centres of  $\frac{1}{25}$  of an inch, and the semi-lenses are kept symmetrical with regard to the centre of the instrument. If the screw had been turned through but one division on the head, the separation would have been  $\frac{1}{100}$  of  $\frac{1}{25}$  or  $\frac{1}{2500}$  of an inch.

To use the instrument, direct the telescope, whose power is to be measured, to some distant object, as a star, and adjust it to distinct vision; turn it off the object, and apply the dynameter with the pearl end next the eye lens, and an image of the object lens will be seen; turn the graduated head, supposed to stand at zero, till two images appear and become tangent to each other; read the number of divisions passed over, and multiply it by  $\frac{1}{2500}$ , the pro-

duct will give the diameter of the image in inches. Measure by an accurate scale, the diameter of the visible portion of the object glass, which being divided by the measure of its image just found, will give the magnifying power. The index will indicate zero, if the dynameter be properly adjusted, when the semi-lenses have their optical centres coincident. This little instrument is the more valuable, because it gives, by an easy process, the magnifying power of any telescope, however complicated.

Magnifying power of telescope found.

CAMERA LUCIDA.

§ 87. This little instrument, the invention of Dr. WOL- Camera lucida ;  
LASTON, is of great assistance in drawing from nature. In its simplest form, it consists of a glass prism, a section

of which is represented by  $ABCD$ , with one right angle at  $A$ , and the opposite angle  $C$ ,  $135^\circ$ . Rays proceeding from a point of any object  $S$ , in front of the face  $AD$ , enter this face without undergoing any material deviation, and being received in succession by the faces  $DC$  and  $CB$  within the limits of total reflexion, they are

reflected, and finally leave the face  $BA$ , in nearly the same state of divergence as when they left the object  $S$ . The eye  $E$ , being so placed that the edge  $B$  of the prism shall bisect the pupil, will receive these rays and bring them to a focus  $r$ , on the retina, at the same time that

Fig. 61.

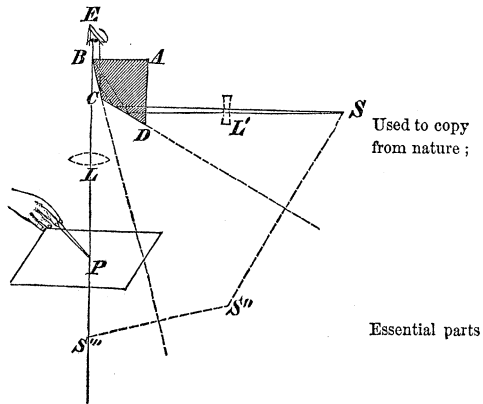

Used to copy from nature ;

Essential parts

Explanation ;

Action of the camera lucida in forming images;

it will receive through the half of the pupil not covered by the prism, rays proceeding from the point  $P$ , of a pencil, placed below on a sheet of paper, and bring them also to the same focus  $r$ ; so that the point in the object and point of the pencil will appear to coincide on the paper, the whole of which will be seen through the uncovered half of the pupil, and a picture of the object may thus be traced by bringing the pencil in succession in apparent contact with its various parts.

Linear dimensions of object and image.

The linear dimensions of the picture will be to those of the

object, as the distance of the camera from the paper, to its distance from the object, nearly.

Use of convex or concave lens with the camera lucida;

If the paper be very near, the eye may not have power to bring the rays proceeding from the pencil to the same focus with those from the object; this difficulty is obviated by the use of a convex lens at  $L$ , or a concave one at  $L'$ ; the effect of the former being to reduce the divergence of the rays from the pencil to the same degree with that of those from the object, and of the latter, to increase the divergence of the rays from the object, and render it the same with that of the rays from the pencil. The camera lucida is constructed of various forms, having reference to the facility of using it, the optical principle being the same in all.

The instrument has various forms.

Fig. 61.

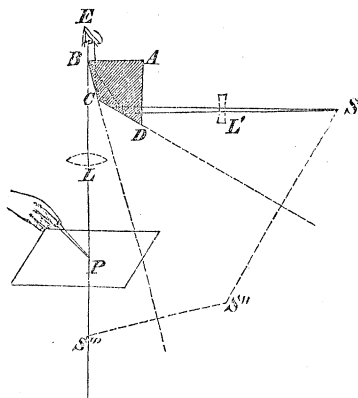

## CAMERA OBSCURA.

§ 88. This instrument is also used to copy from Camera obscura; nature, and like the camera lucida, has various forms, one of the best of which is represented in the figure.

$ABC$  is a *prismatic lens*, which is nothing more than a triangular prism with one or both of its refracting faces ground to spherical surfaces; it is set in a small box resting on a cylindrical tube  $tv$ , that moves freely in a similar tube in the top of a dark chamber, formed by up-rights or legs, about which is suspended a cotton cloth rendered impervious to light by some opaque size. On one face of the box  $mn$ , containing the prismatic lens, is an opening to admit the light from any object in front of

the instrument, and on one side the cloth has been omitted in the figure to show a table  $XY$ , supported by the uprights, on which the paper is placed to receive the picture. Now, the rays from any point in an object  $S$ , will enter the face  $AC$  of the prismatic lens, be totally reflected by  $AB$ , and brought by  $CB$ , to a focus on the paper, from which, owing to the minute irregularities of its surface, they will be reflected in all directions; and thus a picture of the external object  $S$  will be painted at  $S'$ , which may easily be traced by a person situated within the folds of the cloth forming the dark chamber. The effect of the prismatic lens being the same as that of a convex lens, except that the former

Fig. 62.

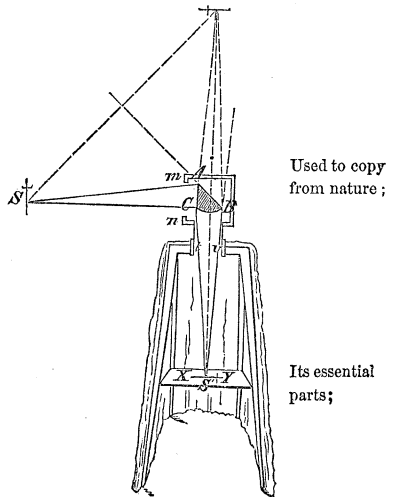

Its action in forming images explained;

Construction of the image;

changes the direction of the axis of a pencil deviated by it, it is obvious that the surface of the paper should be spherical. The image of the object is brought accurately to the table  $XY$ , by means of the tube  $tv$ , which admits of a vertical motion in the top of the chamber; this tube also admits of a horizontal motion, the purpose of which is, to take in different objects in succession without changing the position of the body of the instrument.

Means of adjusting;

Method of using.

Fig. 62.

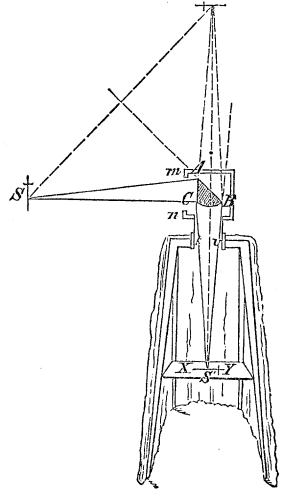

THE MAGIC LANTERN.

Magic lantern;

§ 89. This consists of a small close chamber, from one side of which proceeds a tube containing usually two convex lenses  $A$  and  $B$ , with an intermediate opening for a glass slide  $C$ , which may be moved freely in a direction at right angles to the common axis of the lenses. Within the chamber is an Argand lamp  $D$ ,

Essential parts;

Fig. 63.

Graphic representation;

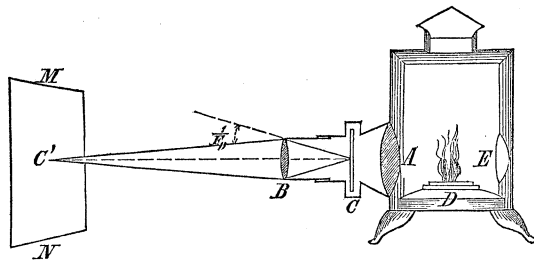

behind which is a concave reflector  $E$ . The rays pro-



ceeding from any point in a figure, painted with some transparent pigment upon the glass slide and strongly illuminated by the lens  $A$ , upon which the direct light from the lamp, as well as that from the reflector  $E$ , is concentrated, will be brought to a focus by the lens  $B$ , on a screen  $MN$ , placed at a distance in front of the instrument; here the light being reflected will proceed as from a new radiant, and a magnified image of the figure will thus appear upon the screen. Should the screen be partially transparent, a portion of the light will be transmitted, and the image will be visible to an observer behind it.

The linear dimensions of the object or figure, will be to those of the image, as their respective distances from the lens  $B$ ; if, therefore, the lens  $B$  be mounted in a tube which admits of a free motion in that containing the lens  $A$ , its distance from the figure may be varied at pleasure, and the image on the screen made larger or smaller, the instrument, at the same time, being so moved as to keep the screen in the conjugate corresponding to the focus occupied by the glass slide. The instrument with an arrangement by which this can be accomplished, is called the *phantasmagoria*. In order, however, that the deception may be complete, there must be some device to regulate the light, so that the illumination of the image may be increased with its increase of size, not diminished, as it would be without such contrivance.

#### SOLAR MICROSCOPE.

§ 90. This is the same as the magic lantern, except that the light of the sun is used instead of that from

Optical principles of the instrument explained;

Relation between the dimensions of the object and image;

Phantasmagoria.

Solar microscope;

Solar microscope;

a lamp. *DE*, is a long reflector on the outside of a window shutter, in which there is a hole occupied by the tube containing the lenses.

Fig. 64.

Essential parts and manner of using.

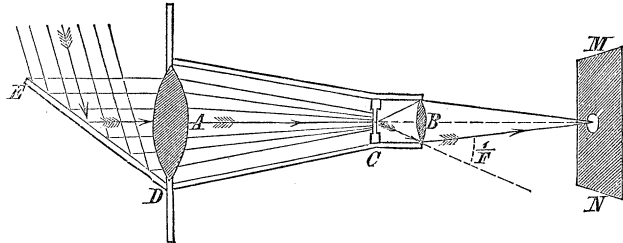

The object to be exhibited is placed near the focus of the illuminating lens *A*, so as to be perfectly enlightened and not burnt, which would be the case were it at the focus.

CHROMATICS.

Chromatics;

§ 91. *Chromatics* is a name given to that branch of optics which treats of *Color*. Color is to light what pitch and harmony are to sound. We have seen, in Acoustics, that by the principle of the coexistence and superposition of small motions, any number of sonorous waves may exist at the same time and place, and produce, through the organs of hearing, an impression different from that produced by either of the waves when acting singly. The united tones proceeding from the various voices of a full choir of music, for example, impress the ear very differently from the insulated note of the acute treble, the medium tenor, or the full, deep-toned bass; and as each voice is partially or wholly suppressed in succession from a full strain of concordant sounds, while others are reinforced, the mind

Color in light corresponds to pitch and harmony in sound;

Explanatory remarks;

marks the change, and attributes to it a distinct and specific character. Analogy between the action of sonorous and luminous waves;

So it is with the luminous waves which act upon the organs of sight. These come to us from the sun, and other self-luminous bodies, of every variety of length capable of affecting the eye; they coexist and are superposed upon the retina, and by their united influence give us the impression of *white* light; and when one after another of these waves is enfeebled, while others are strengthened, each new combination gives us a different impression, and each impression we call a *color*. White light produced;

The longest waves capable of affecting the eye correspond to *red*, and the shortest to *violet* or *lavender grey*.

But how are individual waves either suppressed or separated from the group which produce the sensation of white light? The answer is, by the principles of *interference* and of *unequal refrangibility*. Principles which produce colors.

COLOR BY INTERFERENCE.

*Colors of Gratings.*

§ 92. Recalling the explanation of § 7, let  $MN$  be a wave front proceeding from a source  $O$ . Assume any point  $O_r$ , in front of the wave, and draw the straight line  $O_r O$ . Take the distance  $AB$  equal to half the length  $\lambda_r$ , of the longest, and  $AB'$  equal to half the length  $\lambda_o$ , of the shortest wave capable of affecting

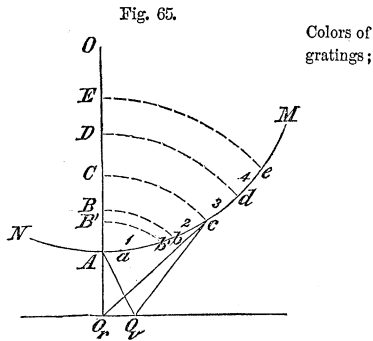

the organs of sight; and make  $BC = CD = AB = \frac{1}{2}\lambda_r$ . Construction of figure:

With  $O_r$  as a centre, and the radii  $O_r B'$ ,  $O_r B$ ,  $O_r C$ ,

Colors of gratings;

$O_r D$ , &c., describe arcs cutting the wave front in  $b', b, c, d$ , &c.; then will the portions  $A b, b c, c d$ , &c., in the immediate vicinity of  $A$ , partially, and those remote from the same point, wholly, *interfere*, § 7, and neutralize each other's effects at  $O_r$ ; for, at this point the secondary waves from the successive points of the

Construction of figure;

Even numbered portions of main wave opposed to the odd portions.

Consequence of stopping the even portions;

Effect of longest waves most increased at  $O_r$ ;

Effect of shortest waves most increased at  $O_v$ ;

portion  $A b$ , beginning at  $A$ , will be opposed to those from the corresponding points in the portion  $b c$ , beginning at  $b$ , being in opposite phases; and it is plain that if the several portions be numbered in order from  $A$ , that those distinguished by the even will be opposed to those designated by the odd numbers, the odd portions tending to displace the molecule at  $O_r$  in one direction, and the even ones in the opposite direction.

Now, conceive the even portions  $b c, d e$ , &c., to be stopped by the interposition of some opaque screen; the odd portions no longer being neutralized, will have full effect upon  $O_r$ , which will become greatly more luminous by the conspiring action of the longest waves—that is, by the waves whose length is  $\lambda_r$ . But the shortest secondary waves proceeding to  $O_r$  from the portion  $b b'$ , on one end of  $A b$ , will interfere and neutralize those from an equal portion  $A a$ , at the other end, so that the effect of the longest waves at  $O_r$ , will be increased in a much greater proportion than that of the shortest.

From the construction  $O_r c - O_r A = \lambda_r$ . Take a point  $O_v$ , such that  $O_v c - O_v A = \lambda_v$ , then will the point  $O_v$ , for the same reasons, receive the greatest possible disturbance from the action of the shortest waves which are here in the same phase, while the effect of the longest waves, at this point, will be less than at  $O_r$ , being no longer in the same phase. The effect of the waves whose

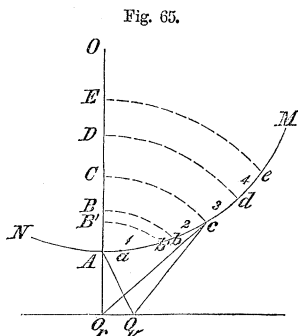
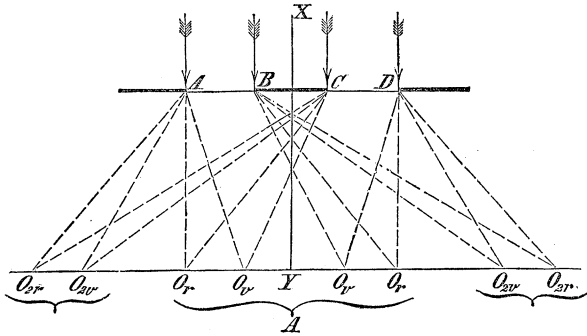

Fig. 65.

lengths are intermediate between  $\lambda_r$  and  $\lambda_v$ , will have their preponderance upon molecules between these two points, and the space  $O_r, O_v$ , should exhibit corresponding effects. And this is found by experiment to be the case. For when a grating is formed by fine parallel wires, or by a series of fine furrows cut in the face of a piece of well polished glass, and held in front of any luminous source, there will be formed upon a screen placed behind, a series of richly colored fringes, separated by dark intervals, and arranged along a line perpendicular to the furrows. The furrows intercept the light, while the intermediate spaces between permit it to pass; the former correspond to the even and the latter to the odd portions of the luminous wave referred to above, and form, as it were, a series of parallel linear

Effects of furrows cut in plane glass

Fig. 66.



Illustration,

radiants. The molecules  $O_r, O_{2r}$ , &c., where the longest waves prevail, exhibit red, and those at  $O_v, O_{2v}$ , &c., where the shortest preponderate, violet or lavender grey, the molecules between exhibiting orange, yellow, green, blue and indigo, in the order named, beginning at the red. The line  $X Y$ , being drawn from the luminous source to the middle of an opaque portion of the grating, the first fringe on either side of this line is formed by secondary waves whose radii differ by  $\lambda$ , the second by  $2\lambda$ , the third by  $3\lambda$ , and so on; that is, every fringe is

Explanation of the colors.

Collateral fringes. formed by the conspiring of secondary waves whose radii differ by some even multiple of  $\frac{1}{2}\lambda$ , while the dark spaces between are produced by the opposition of waves of which the radii differ by some odd multiple of  $\frac{1}{2}\lambda$ .

§ 93. If the furrowed glass be interposed between the eye at  $O$ , and any luminous source  $L$ , say a small hole in a window shutter, the latter will appear flanked on either side by similar fringes with intermediate dark spaces between also arranged on a right line perpendicular to the direction of the furrows, the red appearing on the outside, the violet on the inside, with the other colours in the order just named between. And to an eye at  $O'$ , so placed as to receive the light reflected from the ridges of plane

Effects of light transmitted through furrowed glass;

Effects of light reflected from the same;

Fraunhofer and Barton's experiments.

glass between the furrows, the whole furrowed space will appear covered by the most beautiful irised hues which change with every change of position of the eye.

By means of a fine diamond point, FRAUNHOFER succeeded in forming a ruled surface of glass in which the striæ were actually invisible under the most powerful microscope, the interval of the furrows being only  $\frac{1}{30000}$  of an inch. In some furrowed surfaces produced by Mr. BARTON, the lines are so close that 10000 of them would occupy only the space of an inch in breadth. The light reflected from surfaces so minutely divided, exhibits the purest colors of which we have any knowledge. Similar appearances are exhibited when light is reflected

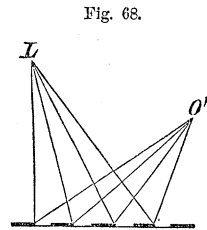
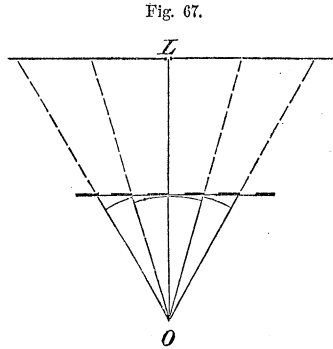

from metallic surfaces which have been polished by a coarse powder, and from surfaces of glass over which the finger is passed after being moistened by the breath.

The beautiful colors of *mother of pearl* are natural instances of the same phenomena. This substance is composed of a vast number of thin layers, which are gradually and successively deposited within the shell of the oyster, each layer taking the form of the preceding. When it is wrought, therefore, the natural joints are cut through in a great number of sinuous lines, and the resulting surface, however highly polished, is covered by an immense number of undulating ridges formed by the outcropping edges of the layers. These striæ may be observed by the aid of a powerful microscope, although they are so close that 5000 of them occupy but a single inch. That they are the cause of the brilliant colors displayed by this substance has been placed beyond doubt by Sir DAVID BREWSTER, who received from an impression of the surface of pearl on soft wax the same display of colors as from the pearl itself.

Effects of the striæ on mother of pearl.

Experiment of Sir David Brewster.

§ 94. Knowing the space  $AC$ , occupied by a single furrow and one of its adjacent transparent intervals, it will be easy to find the lengths of the waves which correspond to the different colors. For this purpose we remark,

Remark 1st.

1. That the first colored fringe  $F_1$ , seen through the glass on either side of the luminous source  $L$  is formed by secondary waves whose radii differ by  $\lambda$ , the second  $F_2$  by  $2\lambda$ , the third by  $3\lambda$  and so on, and are called respec-

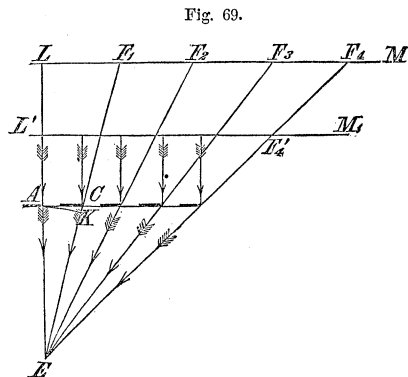

Fig. 69.

Fringes of different orders.

Remark 2d.

Distance of the fringe of any order.

Explanation.

Wave length.

Same in different terms.

tively fringes of the *first, second, third, &c.*, order.

2. The angular distance of a fringe of any order from the luminous source  $L$ , is sensibly equal to the angular distance of the fringe of the first order, multiplied by the

number which marks the order of that fringe. For example, the angular distance  $LEF_3$  of the fringe of the 3d order, is equal to the angular distance  $LEF_1$ , multiplied by 3.

The actual distance of the projection of the fringe of any given order from the luminous source will be proportional to the distance of the furrowed glass from the same source.  $LF_4$ , for instance, is obviously greater than  $L'F'_4$ , and is proportional to  $EL$ .

Now, with centre  $E$  and radius  $EA$ , describe the arc  $AK$ . The distance  $CK$  will be equal to  $\lambda$ , or the length of the wave corresponding to the color seen along the line  $EC$ ;  $AKC$  may be regarded as a right angled triangle, and the angle  $CAK$  as equal to the angle  $AEC$ , which is the angular distance of the particular color in question from the luminous source. And denoting the sum of the widths of a single transparent and furrowed part by  $S$ , and the angle  $AEC$  by  $D$ , we find

$$\lambda = S \cdot \sin D.$$

And because the angle  $D$  is exceedingly small, its arc will be sensibly equal to its sine, and the above may be written

$$\lambda = S \cdot D \dots \dots \dots (85)$$

Fig. 69.

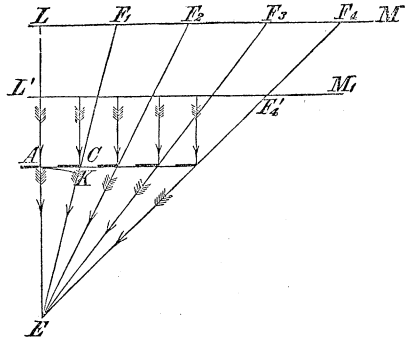



From which it appears that  $D$  will be greater in proportion as  $\lambda$  is greater; and that the colors of each fringe which correspond to the longest waves will, therefore, be found at the greatest distance from the luminous source.

To find  $\lambda$ , we have only to find  $S$  and  $D$ . The former is known from the cutting of the furrows, and M. RABINET has given a very simple method for determining the latter. It is as follows.

§ 95. Let  $A$  and  $B$  be two candles, or still better, two narrow openings in a plate of metal held before a window, the one,  $B$ , a little more elevated than the other;  $Pp$ , a perpendicular to  $AB$  at its middle point  $P$ , and  $R R'$ , the furrowed glass placed somewhere upon  $Pp$ , and held so that the furrows shall be perpendicular to  $AB$ . On placing the eye at  $E$ , and looking through the glass, we shall see the two candles or openings by direct view, and each of them flanked

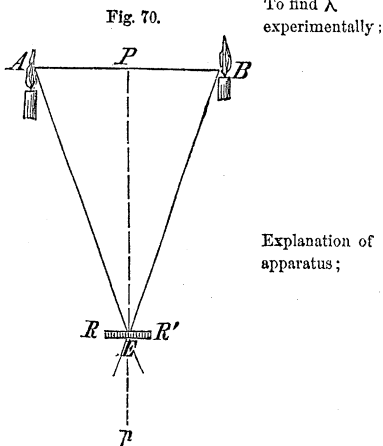

on either side by a series of fringes, those about  $B$  being higher than those about  $A$ . By moving the glass  $RR'$ , to or from the candles, the red, or any other color of the fringes on the left of  $B$ , may be brought accurately over the same color of the fringes to the right of  $A$ . These coincidences, however numerous, may be established because of the law of the angular and true distances of the fringes from their respective luminous sources referred to in the preceding article, provided the angle  $BEA$ , does not exceed 5 or 6 degrees.

Denote by  $n$ , the number of coincidences of any particular color between  $A$  and  $B$ ; there will be  $n + 1$

Colors corresponding to longest waves furthest from luminous source.

To find  $\lambda$  experimentally;

Explanation of apparatus;

Coincidences of same color produced;

Notation;

Graphic representation ;

fringes from  $A$  to  $B$  in estimating from  $A$ , for one of the fringes belonging to  $A$  will cover or fall upon the candle  $B$ . The angle  $AEB$  will, therefore, be equal to  $(n + 1) \cdot D$ ; and its half  $PEA$ , to  $\frac{n + 1}{2} \cdot D$ . But in the right angled triangle  $PEA$ , we have

Proportion from figure ;

$$EP : PA :: 1 : \tan \frac{n + 1}{2} \cdot D.$$

whence

Same in form of an equation ;

$$\tan \frac{n + 1}{2} \cdot D = \frac{PA}{PE}.$$

As long as  $PEA$  does not exceed two or three degrees its tangent may be taken equal to its arc, and we may write

Equation for small angle ;

$$\frac{n + 1}{2} \cdot D = \frac{PA}{PE}.$$

whence, denoting  $AB$  by  $b$ , and  $PE$  by  $d$ ,

Notation ;

$$D = \frac{b}{(n + 1) \cdot d}.$$

Substitution ;

and this value in Equation (85), gives

First form of value for  $\lambda$  ;

$$\lambda = \frac{S \cdot b}{(n + 1) \cdot d} \cdot \dots \dots \dots (86)$$

Fig. 70.

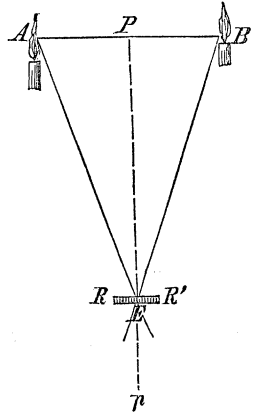

and denoting by  $c$ , the number of furrows in an inch, we shall have

$$S = \frac{1}{c},$$

and this in Equation (86), finally gives

Substitution;

$$\lambda = \frac{b}{c \cdot (n + 1) \cdot d} \dots \dots \dots (87) \text{ Final value for } \lambda;$$

whence this rule, viz: *Augment the number of coincidences between the candles by unity; multiply this sum by the number of furrows in an inch, and this product by the distance, in inches, of the glass from the plane of the candles, and divide the distance, in inches, between the candles by this product; the quotient will be the length in inches of the wave, corresponding to the color with reference to which the coincidences are made.*

By the application of this rule in the manner indicated, we find, when the experiments are made in the atmosphere, the results in the following

T A B L E .

Colors.	Length of $\lambda$ in parts of an inch.	Number of $\lambda$ in one inch.
Extreme red, - - - - -	0,0000266	37640
Orange, - - - - -	0,0000240	41610
Yellow, - - - - -	0,0000227	44000
Green, - - - - -	0,0000211	47460
Blue, - - - - -	0,0000196	51110
Indigo, - - - - -	0,0000185	54070
Extreme violet, - - -	0,0000167	59750

Tabular results of experiments;

To find the distance of any particular fringe from the central line;

Illustration ;

§ 96. Let us now determine the distances of the fringes from the central line  $XY$ . They depend upon the sum  $AC = S$ , of the width of one opaque and one adjacent transparent interval, and upon the distance  $XY$ , of the screen from the grating.

Fig. 71.

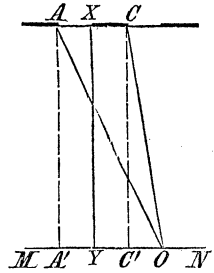

The place  $O$ , of the fringe of any order, say the  $n$ th, is determined by the condition that the difference of its distances  $AO$  and  $CO$ , from  $A$  and  $C$ , is an integer multiple of the length  $\lambda$ , of the wave of the particular color considered. Now, drawing the lines  $AA'$  and  $CC'$ , parallel to  $XY$ , and denoting the distance  $XY$  by  $d$ , and  $YO$ , by  $x$ , we find

Equations from the figure ;

$$AO = \sqrt{d^2 + (x + \frac{1}{2}S)^2} = d + \frac{(x + \frac{1}{2}S)^2}{2d},$$

$$CO = \sqrt{d^2 + (x - \frac{1}{2}S)^2} = d + \frac{(x - \frac{1}{2}S)^2}{2d};$$

the distance  $d$ , being very great in comparison with  $x$  and  $S$ .

Hence,

Difference between these equations ;

$$AO - CO = \frac{(x + \frac{1}{2}S)^2 - (x - \frac{1}{2}S)^2}{2d} = \frac{S \cdot x}{d}.$$

But this difference is equal to  $n\lambda$ ; that is,

Equal to  $n\lambda$  ;

$$\frac{S \cdot x}{d} = n\lambda.$$

whence

Value for distance of any fringe from central line.

$$x = \frac{n \cdot \lambda \cdot d}{S} \dots \dots \dots (88)$$

From which it appears that that the fringes will be crowded together more and more in proportion as  $d$  decreases relatively to  $S$ , or  $S$  increases relatively to  $d$ —a result confirmed by experience, for when the screen is either made to approach the grating, or the furrows are increased in size, the fringes will be observed to contract and crowd in upon the centre  $Y$ , till they become so narrow as not to be perceptible.

Conditions that will cause the fringes to crowd towards the centre.

§ 97. Again, let  $\lambda_r$  and  $\lambda_v$ , denote the lengths of the waves which give red and violet colors respectively; then will Equation (88) give

$$x_r = \frac{n \cdot d \cdot \lambda_r}{S},$$

$$x_v = \frac{n \cdot d \cdot \lambda_v}{S}.$$

Distances of the red and violet colors of the  $n$ th fringe from the centre

In which, because  $\lambda_r$  is greater than  $\lambda_v$ ,  $x_r$ , which denotes the distance from  $Y$  to the red color of the  $n$ th fringe, will be greater than  $x_v$ , which represents the distance of the corresponding violet color from the same point.

Subtracting the second from the first, we get

The colors separate from each other;

$$x_r - x_v = \frac{n \cdot d}{S} (\lambda_r - \lambda_v) \dots \dots (89)$$

From which we see that the different colors will separate more and more as the fringe to which they belong recedes from the centre  $Y$ . The black intervals will, therefore, be encroached upon, and at no great distance from  $Y$  will disappear.

And the dark intervals finally disappear.

To find the order of the last insulated fringe, denote by  $x_{n+1}$  and  $x_n$  the distances of the  $(n+1)$ th and  $n$ th fringes from  $Y$ ; and by  $\lambda_r$  the length of the wave for red, then will Equation (88) give

To find the order of the last insulated fringe;

Notation and equations ;

$$x_{n+1} = \frac{(n+1) \cdot \lambda_r \cdot d}{S}$$

$$x_n = \frac{n \cdot \lambda_r \cdot d}{S}$$

whence, taking the difference, we obtain for the interval between the reds of two consecutive fringes,

Interval between the reds of two consecutive fringes ;

$$x_{n+1} - x_n = \frac{\lambda_r \cdot d}{S}$$

and placing the second member of this Equation and that of Equation (89) equal, we find

$$\frac{n \cdot d}{S} \cdot (\lambda_r - \lambda_v) = \frac{\lambda_r \cdot d}{S}$$

whence

Order of the last insulated fringe.

$$n = \frac{\lambda_r}{\lambda_r - \lambda_v} \cdot \dots \dots \dots (90)$$

That is to say, the order of the last insulated fringe is denoted by the number of units in the quotient arising from dividing the length of the red wave by the difference of the lengths of the red and violet waves.

Experimental illustration.

This result is beautifully illustrated by interposing between the screen and grating some medium which will arrest all the waves but those which correspond to a particular color. When this is done, the fringes will be greatly multiplied in number beyond that of the  $n$ th order determined by Equation (90).

Experiment performed in vacuum ;

§ 98. Thus far the waves have been supposed to proceed, after passing the grating, in the atmosphere. But when the experiment is performed in vacuum, with the same grating and same position of the screen, the fringes are found to dilate and separate from each other ; when performed in a medium of greater density than the air, as

in water or glass, the fringes are reduced in width and crowded towards the centre; and what is remarkable, and important to observe, this latter effect is found, by careful experiments, to be *exactly proportional to the index of refraction of the medium as referred to that of atmospheric air.*

Experiments performed in a denser medium than air;  
Conclusion.

Now, referring to Equation (88), it is easy to see that this change in the position and width of the fringes can only arise from a change in  $\lambda$ , which denotes the length of the waves, since  $S$  and  $d$  are, by the conditions of the experiment, constant; and from the relations of  $\alpha$  and  $\lambda$ , in that Equation, it follows that the length of luminous waves of the same color are shorter in proportion as the indexes of refraction of the media in which they exist are greater. But, Equation (2), these indexes vary inversely as the velocities of wave propagation, and hence *the lengths of the waves are directly proportional to the velocities with which they are transmitted through different media.* The cause by which the lengths of the waves are thus altered in the direct proportion to their velocities, is called *the principle of wave acceleration and retardation.*

Cause of the change in position and width of the fringes;  
Lengths of waves in different media;

Principle of wave acceleration and retardation.

§ 99. Returning to the experiment in air; if a very thin plate of glass be interposed in front of one of the grate openings, and parallel to the plane of the grating, the whole system of fringes will be shifted towards the side of the interposed glass. If an exactly similar plate be placed in front of the other opening, and parallel to the first plate, the fringes will be restored to their original position. If one of the plates be slightly inclined, so as to cause the waves passing through it to traverse a greater thickness, the fringes will all move towards that side, and by gradually increasing the inclination, they will pass entirely out of sight.

Effect of interposing a plate of glass under different conditions.

Taking plates of any other medium, possessing a greater refractive index than glass, and of the same

Effect of interposing a plate of any medium.

thickness as before, it is found that the effects just noticed will be increased, and in the direct ratio of the refractive indexes of the media.

Effect on the lengths of the rays:

In the shifting of the fringes, it is evident that the lengths of the rays which correspond to the central one are made unequal, and that the differences as to lengths existing among the rays which appertain to the other fringes, are not the same as before the interposition of the medium. We will now investigate this change.

This last effect investigated;

For this purpose, let the waves from both openings pass through a prism of any medium, as glass, having a very small refracting angle,

Illustration;

$i$ , the first face being held parallel to the plane of the grating.

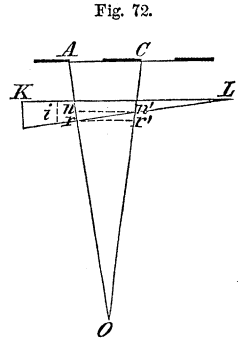

The thickness of the prism traversed by two interfering waves will be different; call this difference, which is  $rn$  in the figure,  $d$ . Draw  $nn'$ , parallel to  $KL$ ; with  $O$ , as a centre and  $Or$  as a radius, describe the arc  $rr'$ . It is obvious that the number of waves in the length  $An + Or$  will

Explanation;

be equal to the number in the length  $Cn' + Or'$ , since the circumstances are the same in both routes; the only difference, if there be any, must lie in the paths  $nr$  and  $n'r'$ . Since the angle made by the rays  $AO$  and  $CO$ , is very small, these rays will enter the first surface under very small angles of incidence, and both being refracted towards the perpendicular, their direction through the prism will be nearly normal to that surface; hence, denoting by  $b$ , the distance  $nr'$ , we have

Equation from figure;

$$d = b \cdot \sin i;$$

but under the above supposition, the angle of incidence at the second surface will be equal to  $i$ ; and denoting



the corresponding angle of refraction by  $\varphi$ , we also get

$$\sin \varphi = m \sin i;$$

Equation for  
the deviation

in which  $m$  is the relative index for glass.

Denoting the distance  $n' r'$  by  $d'$ , we have, because  $r r'$  is very small,

Notation and  
equations ;

$$d' = b \cdot \sin \varphi = b \cdot m \cdot \sin i = m d = \frac{V}{V'} \cdot d$$

in which  $V$  denotes the velocity of the waves within the air, and  $V'$  that in the glass, and from which we find

$$d : d' :: V' : V;$$

Proportion;

that is, the distances  $r n$  and  $r' n'$ , are directly proportional to the velocities with which they are traversed by the waves; they must, therefore, be passed over in the same time; and because the lengths of the waves in the glass and air are proportional to the velocities of wave propagation in the same, there will be the same number of waves in  $n r$  as in  $n' r'$ , and, therefore, in the entire route from  $A$  to  $O$  as from  $C$  to  $O$ ; so that the difference of routes of the interfering waves, as estimated by the number of waves in the routes, will be the same as before, though the linear difference will be different.

Conclusions.

Before leaving this subject, it may be remarked, that the lengths of waves answering to different colors have been computed by means of Equation (88), after carefully measuring the distances  $x$  and  $d$ , and were found to agree in all respects with the results given in the table of § 95.

Confirmation of  
the tabular  
results of § 95.

## COLORED FRINGES OF SHADOWS AND APERTURES.

Shadows of objects in pencils of light usually bordered by three fringes;

§ 100. When an object is placed in a pencil, such as may be formed by admitting light through a very small aperture into a dark chamber, or by a convex lens, and the shadow of the object is received upon a screen, it is found to be bordered externally by fringes, usually three in number, at decreasing distances from each other, each fringe being made up of different colors. These fringes are parallel to the outlines of the shadow, except when the latter terminate in a salient angle, in which case they curve around it; or when the outlines form a re-entering angle, and then the fringes cross and run up to the shadow on each side.

Positions of these fringes.

Colors of the fringes in white light.

In white light, the colors of the fringes, reckoning from the shadow, are, in the first, black, violet, deep blue, light blue, green, yellow, and red; in the second, blue, yellow, and red; and in the third, pale blue, pale yellow, and pale red.

Peculiarities of the fringes in homogeneous light.

In homogeneous light, the fringes increase in number and are alternately dark and bright. In passing from one color to another, they vary in width, being broadest in red and narrowest in violet; and it is from the partial superposition of these and the remaining colors, that the different colors arise when the experiment is made with white light.

Fringes independent of the nature of the body.

These fringes are entirely independent of the nature and figure of the body whose shadow they surround, being the same when formed by a mass of platina or a bubble of air—by the back or edge of a razor.

Measurements of the fringes show;

The shadow being received upon a convex lens, behind which is placed a micrometer, the linear elements of the fringes may be measured to any desired degree of accuracy. These measurements show:

First;

1st. That the distances between the fringes and the shadow diminish as the lens approaches the body, and

finally vanish, so that the fringes have their origin close to the edge of the body.

2d. That the locus of each fringe is an hyperboloid Second; of revolution, terminating near the edge of the body.

3d. That, the distance of the lens from the body re- Third; maining the same, the fringes will be more dilated, as the body approaches the luminous point.

It is also found, that when the luminous point is in- Effect of creased so as to become an appreciable circle, the fringes increasing the formed by the light proceeding from each of its points luminous point. overlap and confuse one another, obliterating the colors and forming a penumbra, which consists of a ring whose brightness varies from the edge of the shadow, where it is least, to its exterior boundary, where it is greatest.

§ 101. If the size of the body be much reduced in Effect of one direction, parallel to the screen or plane of the lens, reducing the the shadow will be found to consist of bright and dark size of the body fringes parallel to the length of the body, a bright fringe parallel to the occupying the centre. If the body be small and of a screen; circular form, having its plane parallel to that of the screen, the shadow will be made up of a series of concentric bright and dark circles, having a bright spot in their centre.

As the body diminishes in size, the stripes diminish Appearances as in number and increase in width, till all disappear but the body the central illumination. The reverse effect will arise diminishes. either on increasing the size of the body, or diminishing its distance from the screen.

§ 102. If a portion of the pencil be transmitted through Pencil admitted a small and well defined circular aperture and received through a small upon a screen, concentric rings will also be produced; circular aperture. and if the transmitted portion be viewed through a convex lens, the hole will appear as a bright spot, encircled by rings of the most vivid colors, which undergo a great variety of changes, both as regards tint and linear dimensions, in varying the distance of the lens from the aper-

ture, and that of the aperture from the radiant or luminous point.

Light transmitted through two circular apertures close together.

When the light is transmitted through two very small apertures, close together, rings corresponding to each will be formed as before, and in addition there will be found a number of straight parallel fringes between the centres of the circles, and at right angles to the line joining them; two other sets of parallel fringes will also be seen in the form of St. Andrew's cross proceeding from the space between the centres; and by multiplying the number of the apertures and varying their relative dimensions, a set of phenomena arise of exceeding brilliancy and beauty.

Cause of the colored fringes of shadows and apertures.

§ 103. The colored fringes of shadows and small apertures, as well as all appearances referred to under this head, are caused by *interference*;<sup>\*</sup> the interference taking place between the secondary waves from the edges of the body or aperture and those from that portion of the primitive wave which is not intercepted.

Names originally applied to them.

These phenomena were at one time called the *inflection* or *diffraction of light*, and were supposed to arise from some peculiar action exerted by the edges of bodies on the rays as they passed near them.

Effect of increasing the refracting index of the medium.

If the refractive index of the medium in which the experiments are performed be increased, the phenomena indicate a diminution in the lengths of the waves in the same ratio.

#### COLORS OF THIN PLATES.

All media exhibit colors when reduced to thin films;

§ 104. Transparent, and indeed all media, when reduced to very thin films, are found to exhibit colors which vary with the thickness of the film. These are called the *colors of thin plates*, and the easiest way to exhibit them is by means of a soap bubble blown from the end of a quill or the bowl of a common smoking

<sup>\*</sup>See Appendix No. 1.

pipe. As the bubble increases in diameter, and the fluid envelope is reduced in thickness at the top by gradual subsidence toward the bottom, many colored and concentric rings will be seen around the point of least thickness. At this point, the color will be found to change, first appearing white, then passing through blue to perfect blackness, the rings the while dilating till the bubble is destroyed.

The same is true of any other medium, whether gaseous, liquid, or solid.

These different colors being exhibited upon the same plate of variable thickness, no single color can be identified with its chemical composition. When of uniform thickness, a single color only will be seen, and this will change as the thickness of the plate changes.

A thin plate is very conveniently formed of air; and for this purpose, let  $AB$ , be a plano-convex, and  $CD$  a plano-concave lens, placed

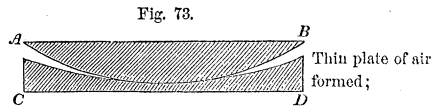

one upon the other, as represented in the figure. When this arrangement is viewed on either of the plane faces by reflected light, colors will be seen in the form of concentric circles about the point of contact, which, should the pressure be sufficient, will be totally black. If viewed by transmitted light, rings whose colors when united with those of the first, form white light, and which colors are, therefore, said to be *complementary*, will appear about the central spot, which will now be perfectly white. With waves of a single length, as yellow, these rings are alternately bright and dark, beginning with the central spot; and by reflected light, dark and bright. They are broadest and have the greatest diameter in the red, and narrowest with least diameter in the violet; the breadths and diameters in the other colors being intermediate and varying in magnitude in the order of the spectrum from red to violet. It is by the superposition of these rings, or the waves

Familiar exhibition of the colors of thin plates;

When the plate is of uniform thickness;

Thin plate of air formed;

Appearances by reflected light;

By transmitted light;

Effects due to waves of a single length;

Newton's scale; which produce them, that the different colors appear in common light.

These colors, which are of different orders as regards tint, constitute what is called Newton's scale; and by reflected light, occur as follows, beginning with the central spot.

- First order;      *1st order.* Black, very faint blue, brilliant white, yellow, orange and red.
- Second;          *2d order.* Dark violet, blue, yellow-green, bright yellow, crimson and red.
- Third;            *3d order.* Purple, blue, rich green, fine yellow, pink and crimson.
- Fourth, &c.;      *4th order.* Dull blue-green, pale yellow-pink, and red.  
                          *5th order.* Pale blue-green, white and pink.  
                          *6th order.* Pale blue-green, pale pink.
- Seventh.         *7th order.* The same as 6th, very faint. The other orders being too faint to be distinguishable.

Waves which interfere to produce the colors by reflexion;

These colors arise from the interference of waves reflected from the first, with those reflected from the second surface of the air plate.

Suppose a small beam incident perpendicularly or nearly so, on the first surface  $MN$  of the plate, where the thickness is  $t$ . A part  $AO$  will be reflected back, the rest  $AB$ , being transmitted, will

traverse the thickness  $t$ . At the second surface, again a part  $BC$ , is reflected, and the reflected portion returning through the thickness  $t$ , will emerge at the first surface in the direction  $CO$ , and be superposed on that first reflected at this surface, and these will either conspire and reinforce each other or will interfere and partially or wholly neutralize each other, according to any of the conditions explained in § 7, depending upon the differ-

Fig. 74.

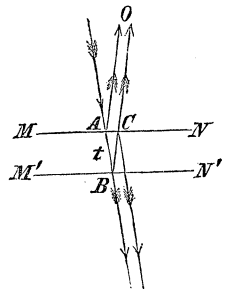

Illustration and explanation;

ence of route  $2t$ . Whenever  $2t$  is equal to any even multiple of  $\frac{1}{2}\lambda$ , for any color, this color will be increased, and when equal to any odd multiple of  $\frac{1}{2}\lambda$ , it will be suppressed. Now,  $2t$ , will vary from a value sensibly nothing to one equal to many times  $\lambda$ , for even the longest waves, in passing outward from the point in which the spherical surfaces are tangent to each other, and hence the colored fringes and the intermediate dark rings.

But the portion reflected at the second surface will, in part, be again reflected at the first, and will traverse the thickness  $t$ , a third time, and emerge below superposed upon the portion first transmitted at the second surface. The difference of route of these portions will also be  $2t$ , so that the effects should be the same on either side of the lenses. Experiment shows, however, that this is not the case, for wherever there is total darkness by reflexion, there is a maximum of brightness by transmission. Hence, there must be *half a wave length subtracted from the route at each internal reflexion*; the cause of the loss being a change in density and elasticity at the surfaces of contact of the glass and air. This will give for the interfering rays, in case of reflected rings, a difference of route expressed by

$$2t + \frac{\lambda}{2};$$

This difference accounted for; Difference of route for reflected rings;

and for the transmitted,

$$2t + \lambda.$$

Same for transmitted rings.

To ascertain the value of  $t$ , at the different rings, call  $d$ , the diameter  $PH$ , of one of them, as determined by actual measurement;  $r$  and  $r'$  the radii of the surfaces,  $v$  and  $v'$ , the corresponding versed sines of the arcs whose sines  $PH$  and  $P'H'$ , are equal to the semi-diameter of the ring in question.

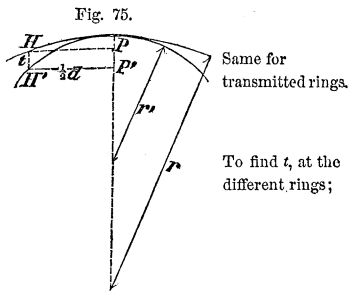

Then, for very small arcs, we have

Equation from  
the figure ;

$$v = \frac{\left(\frac{d}{2}\right)^2}{2r};$$

and

Another  
equation ;

$$v' = \frac{\left(\frac{d}{2}\right)^2}{2r'};$$

whence.

Value of  $t$ ;

$$t = v' - v = \frac{d^2}{8} \left( \frac{1}{r'} - \frac{1}{r} \right).$$

Same for first  
bright ring ;

Law of variation  
of diameters of  
dark and bright  
rings ;

In this way NEWTON found the thickness at the brightest part of the first ring nearest the central black spot, to be 0,00000561 of an inch. He also found the diameters of the darkest rings to be as the square roots of the even numbers 0, 2, 4, 6, &c., and those of the brightest as the square roots of the odd numbers 1, 3, 5, 7, &c. The radii of the surfaces being great compared with the diameters of the rings, the value of  $t$  at the alternate points of greatest obscurity and illumination are as the natural numbers

Law of variation  
of  $t$ , at the dark  
and bright rings ;

$$0, 1, 2 ; 3, 4, \text{ \&c.},$$

Rule.

hence, the value of  $t$ , just found, multiplied by these numbers, will give the thickness at the different rings.

Above results  
compared with  
 $\lambda$  for yellow ;

On comparing the value for the thickness at the first bright ring, with the numbers in the table of article (95), it will be found just equal to one-fourth of the interval denoted by  $\lambda$ , for the yellow ray, which is the most illuminating of the elements of white light.

Taking this value for  $t$ , we shall have for the difference



of route for the interfering rays producing the dark rings by reflexion, including the central black spot, Difference of route for the dark reflected rings;

$$\frac{\lambda}{2}, \frac{3\lambda}{2}, \frac{5\lambda}{2}, \frac{7\lambda}{2}, \text{ \&c.},$$

these being the even multiples of  $\frac{1}{2}\lambda$ , increased by  $\frac{1}{2}\lambda$  for the retardation caused by one internal reflexion.

The odd multiples, increased by  $\frac{1}{2}\lambda$ , give

$$\lambda, 2\lambda, 3\lambda, \text{ \&c.}$$

Same for the bright reflected rings.

The transmitted rings will be complementary to those seen by reflexion.

The phenomena we have just considered are equally produced, whatever may be the medium interposed between the glasses, the only difference being in the contraction or expansion of the rings, depending upon the refractive index of the medium. It is found that as the refractive index of the medium increases, the diameter of the rings will decrease, which might have been inferred from article (99). Same phenomena produced by different media.

§ 105. If any one of the rings at a particular color be conceived to be expanded in all directions in the plane of the ring and to retain the same thickness, it is obvious that the plate thus produced would present the same color over its entire surface. If a second plate of the same thickness and material be placed behind this one, it would act upon the waves transmitted through the first just as the latter did upon the incident waves, and the same would be true of any number of plates, so that a body made up of a series of such plates would present a uniform, distinct, and characteristic color. These considerations, in connection with those relating to the color of minute gratings or striæ, furnish an explanation of the colors of natural bodies. Colors of natural bodies explained.

COLORS OF INCLINED GLASS PLATES.

Colors of inclined glass plates;

Circumstances attending the deviation of light by such plates;

Emergent waves will generally have travelled routes differing in length;

Two will emerge after having travelled different routes of equal length;

Illustration;

§ 106. If a luminous object be viewed through two plates of glass of precisely equal thickness, slightly inclined to each other, it will be evident that besides the transmitted image, there will be a number of images formed by the successive reflexions between the glasses. The first or brightest of these is formed by the waves which have all undergone two reflexions and at different pairs of the four surfaces. On entering the first plate they undergo a partial reflexion at every surface they successively encounter, each of the reflected waves undergoing a similar series of partial reflections at each surface. Thus it will appear evident that the different portions into which the waves have been separated must go through a length of route differing by the length of the interval between the glasses and the thickness of the glasses, or the different multiples of those which they have respectively traversed. They will, therefore, *in general*, emerge after traversing routes which differ by considerable quantities.

Among these portions, however, there are two which, (if we abstract the very small difference in the interval between the glasses at the points where they respectively pass,) will have gone through *different routes of precisely equal length*. These two waves will be,

1st. One which passes directly through the first plate  $AB$ , equal to  $t$ , and through the interval  $BC$ , equal to  $i$ , between the plates, is then reflected at  $C$ , in the first surface of the second plate, returns along  $CD$ , equal to  $i$ , and a thickness  $DE$ , equal to the first, or  $t$ ;

Fig. 76.

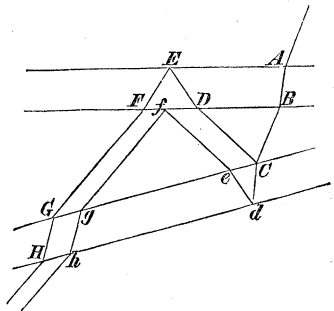

at the first surface it is reflected again and passes the whole system  $EF + FG + GH$ , equal to  $2t + i$ ; or Explanation; upon the whole, it has travelled over  $4t + 3i$ .

2d. Another portion proceeds directly through the whole  $AB + BC + Cd$ , equal to  $2t + i$ , is reflected at  $d$ , in the last surface, retraces the distance  $de + ef$ , equal to  $t + i$ , is reflected at the second surface of the first glass and pursuing the course  $fg + gh$ , equal to  $i + t$ , emerges after having, on the whole, passed through  $4t + 3i$ , or a route exactly equal in length to that of the former, neglecting, as before, the difference in  $i$ .

It will be seen that out of all the possible combina- No other waves will fulfil this condition; tions of different successive reflexions, these two are the only ones which will give routes precisely equal; all the others will differ by quantities amounting to some multiple of  $t$  or  $i$ . If we now recur to the small difference in the interval  $i$ , for the points at which the rays respectively pass, it is obvious that by slightly altering the inclination of the plates we may diminish the difference of Method of exhibiting colored fringes. routes to any amount, and may consequently make them differ by half a wave length, or any multiple of the same; and we shall thus produce colored fringes separated by dark bands, parallel to the intersection of the planes of the glasses.

COLORS OF THICK PLATES.

§ 107. Another phenomenon, which depends upon the same principle, and called the colors of *thick plates*, will be readily understood from preceding considerations.

The effect is observed to take place under these circumstances, viz. : Light being transmitted through a small hole  $A$ , in a screen, and allowed to fall upon a spherical con-

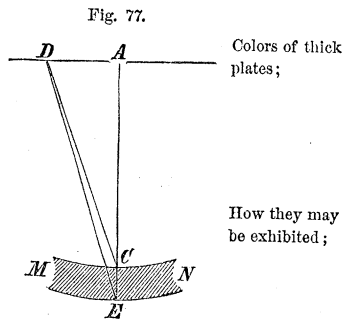

Illustration and explanation;

cave glass reflector  $M N$ , with concentric surfaces, the back being silvered, and its centre of curvature situated at the aperture, there will be formed upon the screen about the aperture a series of *colored rings*, or in luminous waves of a single length, alternate bright and dark circles. These become faint and disappear if the distance of the screen

Facts with regard to these colors;

How produced.

be increased or diminished beyond a small difference from its original position. They diminish in diameter as the glass is thicker. They arise from the interference of the waves reflected from the back surface with those reflected from the front.

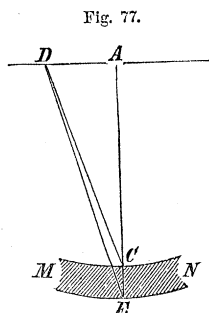

Fig. 77.

Notation;

Denote by  $y$ , the radius  $A D$ , of one of the rings, either dark or bright; by  $t$ , the thickness  $C E$ , of the reflector; and by  $r$ , the radius  $A C$ . The equivalent interval to  $t$ , in air will be  $m t$ , in which  $m$  denotes the relative index of refraction of air and glass. Then

Equation;

$$C D = \sqrt{r^2 + y^2} = r + \frac{y^2}{2r},$$

neglecting the 4th and higher powers of  $y$ .

In like manner,

Another;

$$E D = \sqrt{(m t + r)^2 + y^2} = m t + r + \frac{y^2}{2(m t + r)};$$

and since the difference of the routes  $A C + C E + E D$ , and  $A C + C D$ , must equal some multiple of one-half the wave length, we have, because  $A C$  is the same in both routes,

Difference of routes equal to some multiple of  $\frac{1}{2} \lambda$ .

$$m t + m t + r + \frac{y^2}{2(m t + r)} - r - \frac{y^2}{2r} = n \cdot \frac{1}{2} \lambda.$$

whence

$$y = \sqrt{\frac{(4mt - n\lambda) \cdot r \cdot (mt + r)}{mt}},$$

Value for radius  
of the assumed  
ring;

and neglecting  $m^2 t^2$ , being insignificant as compared with  $r$ ,

$$y = r \sqrt{\frac{(4mt - n\lambda)}{mt}} \dots \dots (91)$$

Same reduced.

This accords precisely with the most exact measurements of Sir ISAAC NEWTON.

COLOR FROM UNEQUAL REFRACTIBILITY.

§ 108. By a process unsuited to an elementary work like the present, it is found that the velocity of wave propagation through any elastic medium is given by the following equation, viz.:

$$V = H \cdot \frac{\sin \frac{r}{\lambda} \cdot n \cdot \pi}{\frac{r}{\lambda} \cdot n \cdot \pi} \dots \dots (92)$$

General value for  
velocity of wave  
propagation in  
any elastic  
medium;

in which  $V$ , denotes the velocity of wave propagation;  $H$ , a function of the elasticity and density of the medium;  $r$ , the distance between the adjacent molecules;  $\lambda$ , the length of the wave;  $n$ , a function of the inclination of the ray to the line joining the acting molecules. Now, when  $r$  is very small in comparison to  $\lambda$ , the arc of which the sine enters the last factor above will be small; the ratio of the sine to its arc will be equal to unity, and the velocity will be simply equal to  $H$ . In other words, when the distances between the consecutive molecules of the medium are small compared to the wave lengths, the velocity becomes the same for waves of all lengths.

Explanation of  
the terms;  
  
When the  
velocity will be  
the same for  
waves of all  
lengths;

This is the case with sonorous waves ;

This is the case with *sonorous* waves, Equation (3), Acoustics, whose lengths vary from several inches to several feet; compared to which distances those between the consecutive molecules of *air* may be regarded as insignificant.

But is not true for luminous waves ;

§ 109. In the *ethereal medium*, whose vibrations produce light, however, as it exists in the various forms of natural bodies, the above conditions do not obtain. In the ether of the atmosphere, for example, the luminous waves, we have seen, vary in length from 0,0000167 to 0,0000266 of an inch, compared to which distances those between the adjacent molecules have a sensible value; the last factor in Equation (92), cannot, therefore, be unity, and the velocity of wave propagation must depend upon the wave length. A consideration of the

Velocity greatest for red and least for violet waves. Refractive index varies with the wave length ;

equation shows that the velocity will be greatest for the red and least for the violet waves.

The index of refraction of any substance is, Equation (2), the ratio of the velocity of the luminous wave through the ether of a Torricellian vacuum to that through the ether of the body. And the relative index of two bodies is the ratio of the velocities through their respective ethers. Hence, both the absolute and relative indices vary with the wave lengths, being greatest in lavender grey and least in red, those of violet, indigo, blue, green, yellow, and orange, lying intermediate between these.

Is greatest for lavender grey and least for red. Effect of an oblique incidence of white light.

When, therefore, the waves which constitute white light fall obliquely and simultaneously upon the face of a new medium, they will all be deviated on account of the change of density and elasticity of the ether which they then encounter, and the intromitted waves will be *unequally* deviated, because of their difference of wave length; these waves will, hence, separate from each other and proceed in different directions; and, if intercepted by any reflecting surface, as a screen, will exhibit thereon their respective colors.

§ 110. This is well illustrated by the action of an optical prism. Let a beam  $SS'$ , of solar light, be admitted into a dark room through a small hole in a window shutter, and received upon a screen  $XY$ ; it will exhibit a round luminous spot at  $T$ , in the direction of  $SS'$  produced; but if the face of a refracting prism  $ABC$ , be interposed, the spot  $T$  will disappear, and there will be formed upon the screen an elongated image of the sun, variously and beautifully colored, beginning with *red* on the side of the refracting angle  $A$ , of the prism, and passing in succession through *orange, yellow, green, blue, indigo*, and terminating in *violet and lavender grey*, making eight in all. These colors are not separated by well-defined boundaries, but run imperceptibly into each other; nor are the colored spaces of the same length. The following table exhibits the relative lengths of these spaces as obtained by Sir ISAAC NEWTON with the glass prism used by him, and by FRAUNHOFER, with a prism made of flint glass.

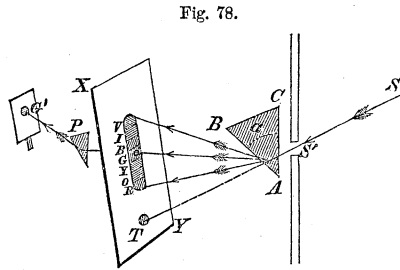

Fig. 78.

Experimental illustration;

Beam of white light caused to pass through a prism;

Colors produced;

	Newton.	Fraunhofer.	
Red	45	56	Relative lengths of the colored spaces;
Orange	27	27	
Yellow	48	27	
Green	60	46	
Blue	60	48	
Indigo	40	47	
Violet and lavender grey,	80	109	
Total length,	360	360	

This property of luminous waves by which they possess different indices of refraction and are deviated Unequal refrangibility;

Solar spectrum. through different angles for the same angle of incidence, is called the *unequal refrangibility of light*; and the colored image thence arising is called the *solar spectrum*.

Effect of admitting the light through a narrow slit;

§ 111. When the light is admitted through a very narrow slit parallel to the refracting edge of the prism, and the prism is of pure homogeneous glass and held in the position of minimum deviation, § 25, the whole spectrum appears marked by dark and bright lines, all parallel to the slit, some being broader and better defined and

Fig. 79.



more conspicuous than others. With an ordinary prism of flint glass, the eye distinguishes about twelve; FRAUNHOFER, with a fine prism of his own glass, distinguished, by the aid of a telescope, six hundred. Certain of these lines are at unequal intervals, which also differ for different media, though they are of the same order and in the same colored spaces. They differ essentially with the light employed: the light of the clouds, of the Moon, and of Venus, show them exactly as in the direct light of the sun. The bright fixed stars give lines peculiar to themselves, as also do electric lights. The light of flames shows none, or at least only certain dark intervals under peculiar circumstances. These lines furnish the means of measuring the refractive indices of different media for different colors.

Effect varies with the light

Use of these lines;

Number of primary colors considered;

§ 112. A question often proposed, as to the number of primary colors, can only be answered with reference to the *sense* in which it is asked. If it be meant to apply to the number of tints distinguishable in the spectrum, this will be a matter of individual judgment to different eyes. NEWTON distinguished *seven*, Sir JOHN HERSCHEL *eight*, Sir DAVID BREWSTER *three*; but perhaps most observers would admit that it is impossible to fix on any definite number, since the light appears to go through



every possible shade of color, from the deep red to faint violet or lavender grey. If we understand the question as applying to the number of definite points at each of which a wave of different length occurs, their number must be considered as *infinite*. These waves resolve themselves into eight classes, distinguished by the color they excite in the mind, the same color of different shades being produced by waves whose lengths vary between certain limits.

Colors of the solar spectrum resolved into eight classes.

§ 113. To find the index of refraction for any one of these different colors, let *A* be a refracting prism, made of any transparent medium; *m n*, a graduated circle, to the centre of which a small telescope is

To find the refractive index for any color;

Fig. 80.

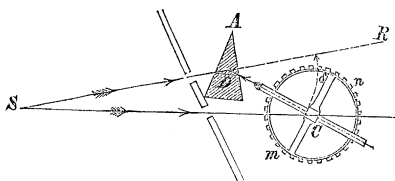

attached in such a manner that its line of collimation shall move in a plane parallel to that of the graduated circle, which is held in a position at right angles to the edges of the prism. The telescope, being provided at its solar focus with a fine wire perpendicular to the plane of the circle, is directed to some distant source of light, and the reading of the vernier noted. It is then directed so as to receive the colored rays from the prism, and the reading again noted when the prism is turned to the position giving the deviation a minimum. We shall then have

Explanation;

$$RDC = \delta = DCS + DSC$$

Value of  $\delta$ ;

or neglecting the very small angle subtended by *DC* at the distance of the object,

$$\delta = DCS,$$

Same reduced;

Middle of spectrum taken for the mean refractive index.

which is the difference of the readings; and this in Equation (12), will give the value of  $m$ .

If the color occupying the middle of the spectrum be taken, we shall find the value of  $m$ , which answers to what is called the mean deviation, and which is the same as that given in the table of article 18.

Any color deviated a second time.

If a hole be made in the screen, Fig. (78,) at any one of the colors, as green, for example, and this color, after passing through, be deviated by a second prism  $P$ , no further separation of the waves will be found to take place, but a green image, of the shape and size of the hole in the first screen, will be formed upon a second screen held behind at  $G'$ .

Result of reuniting the colors of the spectrum.

The colors of the spectrum being received, each upon a separate mirror, may, by varying the relative position of the mirrors, be reunited, by reflexion, on a screen at  $W$ , where a white spot will be formed as though it were illuminated with common light.

Fig. 81.

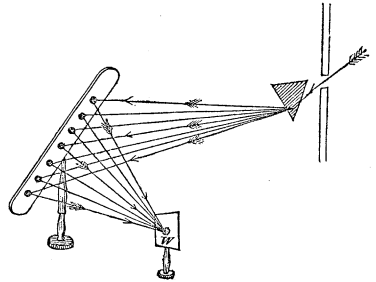

## DISPERSION OF LIGHT.

Dispersion of light;

§ 114. From what has just been explained, it appears that the waves which constitute white light may be separated from each other by refraction. The act of such separation is called the *dispersion* of light, and that property of any medium by which this is performed, is called its *dispersive power*.

Dispersive power.

§ 115. Supposing the light to be incident under a very

small angle on any prism, we may replace the sine of the angle of incidence and that of refraction by the arcs, and we shall have from Equations (10), (3) and (3)', by accenting the refractive index and refracting angle of the prism,

$$\varphi + \psi = m' (\varphi' + \psi') = m' \cdot \alpha' \quad \text{Equations combined;}$$

and this in Equation (11), by accenting  $\delta$ , gives

$$\delta' = (m' - 1) \cdot \alpha', \dots \dots \dots (93) \quad \text{Equation for one prism;}$$

from which it appears that the deviation will increase with the refractive index and refracting angle of the prism.

For a second prism, we have in like manner,

$$\delta'' = (m'' - 1) \cdot \alpha'' \quad \text{Same for a second prism;}$$

and the same for others; and for a number  $n$  of prisms we have, by taking the sum of all the deviations, and denoting the total deviation by  $\delta_n$ ,

$$\delta_n = (m' - 1)\alpha' + (m'' - 1)\alpha'' + (m''' - 1)\alpha''' \dots (m_n - 1)\alpha_n \dots (94) \quad \text{Same for any number.}$$

in which, as long as the index of refraction exceeds unity, the terms will have the same sign when the refracting angles of the prisms are turned in the same direction, but contrary signs when these angles are turned in opposite directions.

In the case of two prisms whose refracting angles are turned in opposite directions, Equation (94) becomes

$$\delta_2 = (m' - 1) \alpha' - (m'' - 1) \alpha'' \quad \text{Two prisms with refracting angles in opposite directions.}$$

and if  $\delta_2$  be zero, or there be no final deviation, we have

$$(m' - 1) \alpha' - (m'' - 1) \alpha'' = 0$$

OR

Condition that will produce no deviation for a particular color.

$$\frac{m' - 1}{m'' - 1} = \frac{\alpha''}{\alpha'}$$

whence we see, that if the refracting angles of two prisms be in the inverse ratio of the excess of the indices of refraction of any wave above unity, this wave will not be finally deviated by the action of both prisms.

To find the dispersive power of any medium;

§ 116. Resuming Equation (94), and denoting the deviation  $T n V$ , of the violet,  $T n R$ , of the red, and  $T n G$ , of the green waves by  $\delta_v$ ,  $\delta_r$ , and  $\delta_g$ , respectively, the green being the mean of the spectrum, we have

Fig. 82.

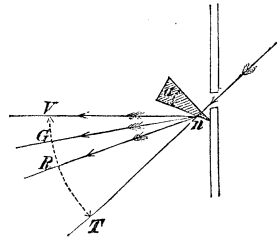

Equations for the extreme and mean colors;

$$\begin{aligned} \delta_v &= (m'_v - 1) \alpha', \\ \delta_r &= (m'_r - 1) \alpha', \\ \delta_g &= (m'_g - 1) \alpha'; \end{aligned}$$

in which  $m'_v$ ,  $m'_r$ , and  $m'_g$ , denote respectively the indices of refraction of the violet, red, and green waves.

Subtracting the second from the first, and dividing by the third, there will result

Reductions;

$$\frac{\delta_v - \delta_r}{\delta_g} = \frac{m'_v - m'_r}{m'_g - 1} \dots \dots \dots (95)$$

whence, the quotient arising from dividing the angle  $R n V$ , subtended by the spectrum, by the angle  $T n G$ , of mean deviation, is constant for the same medium, and is therefore taken as the measure of the dispersive power of the medium. And denoting this quotient by  $D$ , the foregoing Equation gives, omitting the accents,

Notation;

$$D = \frac{m_v - m_r}{m_g - 1} \dots \dots \dots (96) \quad \text{Value for dispersive power.}$$

By this formula, after finding the values of  $m_v$ ,  $m_r$ , and  $m_g$ , in the manner indicated, the dispersive powers of the substances named in the following table, as well as those of many others, were obtained.

TABLE OF DISPERSIVE POWERS.

Substances.	$\frac{m_v - m_r}{m_g - 1}$	$m_v - m_r$
Realgar melted,	0,267	0,394
Chromate of Lead,	0,262	0,388
Oil of Cassia,	0,139	0,089
Flint Glass,	0,050	0,032
Crown Glass,	0,033	0,018
Olive Oil,	0,038	0,018
Water,	0,035	0,012
Muriatic Acid,	0,043	0,016

Table of dispersive powers.

There is a circumstance connected with this subject which has been already alluded to, and which should be carefully noticed, owing to its importance in the construction of lenses. If the lengths of spectra formed by two prisms of different media be the same, the colored spaces in the one will not, in general, be equal in length to the corresponding spaces of the other. This circumstance has been called the *irrationality of dispersion*.

Irrationality of dispersion.

§ 117. It is one of the popular, and at first view plausible, objections to the theory, just explained, of the constitution of white light, and especially of the unequal velocities of waves of different lengths, that a star when shut out from view, by the interposition between it and the earth of any opaque and non-luminous body, should exhibit at its disappearance tints of color due to the successive elimination from its light of the red, orange, yellow, and so on, in the order of the spectrum, while at

Objection to the foregoing theory of the constitution of white light ;

Objection answered.

its reappearance it should present the complementary hues of these tints in the reverse order as to time; whereas no such phenomena are found to take place. The objection, however, assumes what we have no right to grant, viz.: that the relations of the wave lengths to the distances between the adjacent molecules in the great atmosphere of ether which connects us with the planetary and stellar regions, are the same as in the ether which pervades the bodies that make up the materials of the earth. But we have just seen that the wave lengths, as a general rule, diminish as the densities of the bodies in whose ether the waves exist, increase, while, on the contrary, the distances between the ethereal molecules may increase.

Conclusion drawn from known principles;

It would be more consonant to the principles of induction, to adopt the law expressed by Equation (92), which is but the simple consequence of known physical principles, and conclude from the non-appearance of color at the occultation of a star, that the distances between the ethereal molecules which occupy the celestial regions are insignificant in comparison to the wave lengths. This would bring the final waves at disappearance, of whatever length, all to the spectator at the same instant; and the same being true of the first waves at reappearance, there should be no color.

And appearances thus accounted for.

### CHROMATIC ABERRATION.

Chromatic aberration;

§ 118. It follows from the unequal refragibility of the elements of white light, that the action of a lens will be, to separate these el-

Illustration;

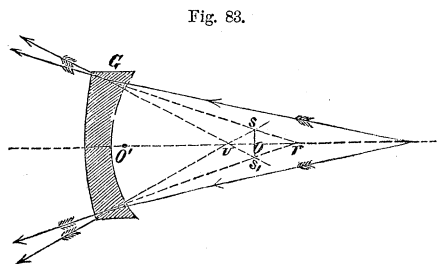

elements and direct them to different foci, since the value of  $f''$ , in Equation (27), depends upon that of  $m$ . Substituting in that equation  $\frac{1}{\rho}$  for  $\left(\frac{1}{r} - \frac{1}{r'}\right)$ , in the case of a spherical lens; and writing  $f_v$  and  $f_r$ , for the focal distances of the violet and red rays, we obtain

$$\frac{1}{f_v} = (m_v - 1) \cdot \frac{1}{\rho} + \frac{1}{f}$$

$$\frac{1}{f_r} = (m_r - 1) \cdot \frac{1}{\rho} + \frac{1}{f}$$

Elements of white light deviated to different foci;  
  
Relation between the conjugate focal distances for red and violet;

in which  $m_v$ , being greater than  $m_r$ ,  $f_v$ , will be less than  $f_r$ , and the violet rays will be brought to a focus soonest. This departure from accurate convergence, caused by the unequal refrangibility of the elements of white light, when deviated by a lens, is called *chromatic aberration*, and depends upon the nature of the lens and not on its figure. It is measured, along the axis of the lens, by the value of  $f_r - f_v$ . Its measure.

Chromatic aberration defined;

The intersection of the cone of violet rays, with that of the red rays, will give what is called the *circle of least chromatic aberration*. The diameter and position of this circle can readily be found. From the point  $s$ , demit the perpendicular  $sO = y$ , to the axis; this will divide  $f_r - f_v$ , into two parts  $VO = x$ , and  $Or = w$ ; and calling the radius of aperture of the lens  $a$ , we shall obtain from the similar triangles of the figure,

Circle of least chromatic aberration;

$$\frac{y}{a} = \frac{w}{f_r} = \frac{x}{f_v}$$

Relations from the figure;

whence we deduce

$$w + x = f_r - f_v = \frac{y}{a} (f_r + f_v)$$

Same reduced;

Radius of circle  
of least  
chromatic  
aberration; OR

$$y = a \frac{f_r - f_v}{f_r + f_v} \dots \dots \dots (97)$$

The denominator of this expression is equal to twice the mean value of  $f''$ , and therefore,

Diameter of  
the same;

$$2y = a (f_r - f_v) \cdot \frac{1}{f''};$$

and from Equation (27), we have

$$\frac{1}{f_v} - \frac{1}{f_r} = \frac{m_v - 1}{\rho} - \frac{m_r - 1}{\rho} = \frac{m_v - m_r}{\rho},$$

OR

Measure of  
chromatic  
aberration.

$$f_r - f_v = \frac{m_v - m_r}{\rho} \cdot f''^2,$$

by substituting  $f''^2$ , for  $f_r \cdot f_v$ , to which it is nearly equal.

Substituting the value of  $\rho$ , from second equation of group (30), the above becomes

Same in a  
different form;

$$f_r - f_v = \frac{m_v - m_r}{m - 1} \cdot \frac{f''^2}{F''}.$$

hence,

Final value for  
diameter of  
circle of least  
chromatic  
aberration.

$$2y = a \cdot \frac{m_v - m_r}{m - 1} \cdot \frac{f''}{F''} = a \cdot D \cdot \frac{f''}{F''} \dots \dots (98)$$

In the case of parallel rays, the last factor is unity, from which we conclude, that *the diameter of the circle of least chromatic aberration is equal to the radius of aperture of the lens, multiplied by the dispersive power.*

The distance of this circle from the lens is,



$$f_v + x = f_v + \frac{f_v \cdot y}{a},$$

Distance of this circle from the lens ;

replacing  $\frac{y}{a}$  by its value in Equation (97), we have

$$f_v + x = \frac{2f_v f_r}{f_r + f_v} \dots \dots \dots (99)$$

The same reduced.

The effect of chromatic aberration is to give color to the image of an object, and to produce confusion of vision in consequence of the different degrees of convergence in the differently colored waves proceeding from the same point of an object. The vertices of the cones composed of the rays of these waves, lying in the axis, every section perpendicular to this line will have its brightest point in the centre, and the yellow waves converging nearly to the mean focus, and having by far the greatest illuminating property, the bad effects which would otherwise arise from this aberration are in part destroyed. Besides, these effects may be lessened by reducing the aperture of the lens, though not in the same degree as those arising from spherical aberration.

Effect of chromatic aberration ;

In part destroyed ;

May be diminished.

ACHROMATISM.

§ 119. It is, then, impossible, by the use of a single homogeneous lens, to deviate the different waves of white light accurately to a single focus, and, consequently, impossible, by the use of such a lens, to form a colorless image of any object ; both, however, may be done by the union of two or more lenses of different dispersive powers. The principle according to which this may be accomplished, is termed *Achromatism*, and the combination is said to be *achromatic*.

Achromatism ;

Achromatic combination.

Let us suppose two lenses of different dispersive powers placed close together. The focus of the combination will,

Two lenses  
taken;

Equation (34), and the fourth Equation of group (30), for any one of the elementary colors as red, be given by

Focus for red;

$$\frac{1}{f_r''} = \frac{m_r - 1}{\rho} + \frac{m_r' - 1}{\rho'} + \frac{1}{f} :$$

and for violet,

Focus for violet;

$$\frac{1}{f_v''} = \frac{m_v - 1}{\rho} + \frac{m_v' - 1}{\rho'} + \frac{1}{f} ;$$

If  $f_r''$  and  $f_v''$ , were equal, the chromatic aberration, as regards these colors, would be destroyed; equating them we have,

Equating these  
focal distances;

$$(m_r - 1) \rho' + (m_r' - 1) \rho = (m_v - 1) \rho' + (m_v' - 1) \rho$$

whence,

Relation  
obtained;

$$\frac{\rho}{\rho'} = \frac{(m_v - 1) - (m_r - 1)}{(m_r' - 1) - (m_v' - 1)} = - \frac{m_v - m_r}{m_v' - m_r'} ,$$

the second member being negative, because  $m_v'$ , is greater than  $m_r'$ .

Multiplying both members of this equation by  $\frac{m' - 1}{m - 1}$ , it may be put under the form,

Same in a  
different form;

$$\frac{\frac{m' - 1}{\rho'}}{\frac{m - 1}{\rho}} = - \frac{\frac{m_v - m_r}{m - 1}}{\frac{m_v' - m_r'}{m' - 1}} \dots \dots (100)$$

Explanation of  
the result;

The second member expresses the ratio of the dispersive powers of the media, and the first, the inverse ratio of the powers of the lenses for the mean waves; this being negative, one of the lenses must be concave, the other convex; and the powers of the lenses being inversely

as the focal distances, we conclude, that *chromatic aberration*, as regards red and violet, may be destroyed by uniting a concave with a convex lens, the principal focal lengths being taken in the ratio of their dispersive powers.

The usual practice is to unite a convex lens of crown glass with a concave lens of flint glass, the focal distance of the first being to that of the second as 33 to 50, these numbers expressing the relative dispersive powers as determined by experiment; (see Table § 116). The convex lens should have the greater power, and, therefore, be constructed of the crown-glass; otherwise, the effect of the combination would be the same as that of a concave lens with which it is impossible to form a real image of a real object.

Rule for constructing an achromatic lens for red and violet;  
Usual combination;  
Convex lens should have the greater power;

Fig. 84.

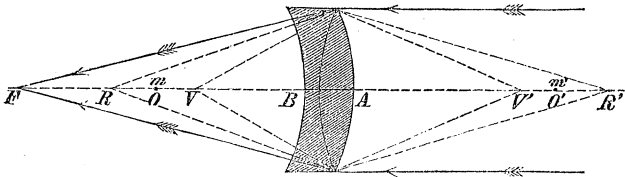

Illustration ;

To illustrate : let parallel rays be received by the lens A ; its action alone would be, to spread the different colors over the space VR, whose central point m, is distant from A, 33 units of measure, (say inches), the violet being at V, and the red at R; the action of the lens B, alone would be, to disperse the rays as though they proceeded from different points of the line V'R', whose central point m', is distant from B, 50 inches, the violet appearing to proceed from V', and the red from R'; and the effect of their united action would be, to concentrate the red and violet at F, whose distance from the lens is equal to the value of F, deduced from the formula

Explanation of the action of the compound lens;

$$\frac{1}{F} = -\frac{1}{33} + \frac{1}{50} = -\frac{1}{97,06} \text{ inches.}$$

Example;

Point in which  
red and violet  
would be united ;

$$F' = - 97, 06 \text{ inches.}$$

Fig. 84.

Geometrical  
illustration ;

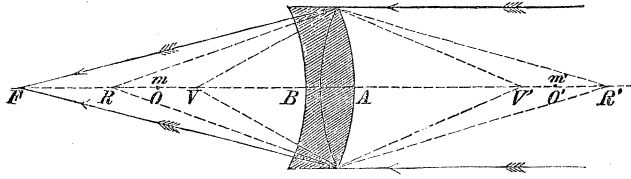

Why the other  
colors would not  
generally be  
concentrated in  
the same point ;

Now, any one of the colors, orange for example, at  $O$ , in the space  $RV$ , which is thrown by the convex lens in advance of the centre  $m$ , and the same color at  $O'$  in the space  $V'R'$ , which is thrown by the concave lens behind the centre  $m'$ , will, it is obvious, be united with the violet and red at  $F'$ , by the joint action of both lenses ; and the same would be true of any other color, but for the *irrationality of dispersion* of the media of which these lenses are composed, which prevents it, and hence an image formed by such a combination of lenses will be fringed with color ; the colors of the fringe constituting what is called a *secondary spectrum*. An additional lens is sometimes introduced to complete the achromaticity of this arrangement.

Secondary  
spectrum.

Substances  
which fulfil the  
conditions for  
perfect  
achromaticity ;

§ 120. If two lenses, constructed of media between which there is no irrationality of dispersion, be united according to the conditions of Equation (100), the combination will be perfectly achromatic. It is found that between a certain mixture of muriate of antimony with muriatic acid, and crown-glass, and between crown-glass and mercury in a solution of sal ammoniac, there is little or no irrationality of dispersion. These substances have therefore been used in the construction of compound lenses which are perfectly achromatic. The figure

represents a section of one of these, consisting of two double convex lenses of crown-glass, holding between them, by means of a glass cylinder, a solution of the muriate in the shape of a double concave lens, the whole combined agreeably to the relations expressed by Equation (100). The focal distance of the convex lenses is determined from Equation (31).

Fig. 85.

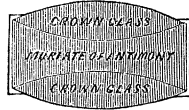

Representation of an achromatic lens;

§ 121. From Equation (98), we infer, that the circle of least chromatic aberration is independent of the focal length of the lens, and will be constant, provided the aperture be not changed. Now, by increasing the focal length of the object glass of any telescope, the eye lens remaining the same, the image is magnified; it follows, therefore, that by increasing the focal length of the field lens, we may obtain an image so much enlarged that the color will almost disappear in comparison. Besides, an increase of focal length is attended with a diminution of the spherical aberration. This explains why, when single lenses only were used as field lenses, they were of such enormous focal length, some of them being as much as a hundred to a hundred and fifty feet. The use of achromatic combinations has rendered such lengths unnecessary, and reduced to convenient limits, instruments of much greater power than any formerly made with single lenses.

Circle of least chromatic aberration independent of focal length;

Telescopes formerly very long;

Modern ones shorter.

INTERNAL REFLEXION.

§ 122. Whenever the waves of light in their motion through any medium meet with a change of density and elasticity, they will be both reflected and refracted. In consequence, objects seen by reflexion from a plate of

Internal reflexion;

When objects seen by reflexion from glass appear double;

glass, in the atmosphere, appear double when the faces of the glass are not parallel, there being an image formed by reflexion from each face. The image from the second surface will be brighter in proportion as the obliquity or angle of incidence of the incident waves becomes greater. If the second surface of the glass be placed in contact with water, the brightness of the image from that surface will be diminished; if olive oil be substituted for the water, the diminution will be greater, and if the oil be replaced by pitch, softened by heat to produce accurate contact, the image will disappear. If, now, the contact be made with oil of cassia, the image will be restored; if with sulphur, the image will be brighter than with oil of cassia, and if with mercury or an amalgam, as in the common looking-glass, still brighter, much more so indeed than the image from the first surface.

Relative brightness of the images when the second surface is in contact with various substances;

The mean refractive indices of these substances are as follows :

Refractive indices of these substances;

Air, - - - - -	1,0002
Water, - - - - -	1,336
Olive Oil, - - -	1,470
Pitch, - - -	1,531 to 1,586
Plate Glass, - - -	1,514 to 1,583
Oil of Cassia, - - -	1,641
Sulphur, - - -	2,148

Indices compared with the index for plate glass;

Taking the differences between the index of refraction for plate glass and those for the other substances of the table, and comparing these differences with the foregoing statement, we are made acquainted with the fact, which is found to be general, viz. : that when two media are in perfect contact, the intensity of the light reflected at their common surface will be less, the nearer their refractive indices approach to equality; and when these are exactly equal, reflexion will cease altogether. This is an obvious consequence of the rationale of reflexion, given in Acoustics, § 71.

Conclusion.

§ 123. Different substances, we have seen, have, in general, different dispersive powers. Two media may, therefore, be placed in contact, for each of which the same color, as red, for example, may have the same index of refraction, while for the other elements of white light, the indices may be different; when this is the case, according to what has just been said, the red would be wholly transmitted, while portions of the other colors would be reflected and impart to the image from the second surface the hue of the reflected beam; and this would always occur, unless the media in contact possessed the same refractive and dispersive powers.

Owing to a difference of dispersive power the light will not all be transmitted at the second surface.

#### ABSORPTION OF LIGHT.

§ 124. The waves of light which enter any body are not transmitted without diminution; but in consequence of a want of perfect elasticity due to the reciprocal action of the molecules of the ether and the particles of the body, and owing to the absence of perfect contact of the elements of bodies, these waves undergo a series of internal reflexions which give rise, as in the case of sound, to interferences and consequent loss of intensity. This action of bodies upon light is called *absorption*.

Absorption of light;

How produced.

The quantity absorbed is found to vary not only from one medium to another, but also in the same medium for different colors; this will appear by viewing the prismatic spectrum through a plate of almost any transparent, colored medium, such as a piece of *small blue glass*, when the relative intensity of the colors will appear altered, some colors being almost wholly transmitted, while others will disappear or become very faint. Each color may, therefore, be said to have, with respect to every medium, its peculiar *index of transparency* as well as of refraction.

Quantity absorbed varies;

Index of transparency;

Quantity absorbed depends upon ;

The quantity of each color transmitted, is found to depend, in a remarkable degree, upon the thickness of the medium ; for, if the glass just referred to be extremely thin, all the colors are seen ; but if the thickness be about  $\frac{1}{20}$  of an inch, the spectrum will appear in detached portions, separated by broad and perfectly black intervals, the rays corresponding to these intervals being totally absorbed. If the thickness be diminished, the dark spaces will be partially illuminated ; but if the thickness be increased, all the colors between the extreme *red* and *violet* will disappear.

Extreme colors transmitted longest.

Herschel's hypothesis to account for the extinction of a homogeneous wave ;

Sir JOHN HERSCHEL conceived that the simplest hypothesis with regard to the extinction of a wave of homogeneous light, passing through a homogeneous medium is, that for every equal thickness of the medium traversed, an equal aliquot part of the intensity which up to that time had escaped absorption, is extinguished.

That is, if the  $\frac{n}{m}$ -th part of the whole intensity, which will be called  $c$ , of any homogeneous wave which enters a medium, be absorbed on passing through a thickness unity, there will remain,

Portion transmitted through a unit of thickness ;

$$c - \frac{n}{m} c = \frac{m-n}{m} c ;$$

and if the  $\frac{n}{m}$ -th part of this remainder be absorbed in passing through the next unit of thickness, there will remain

Portion transmitted through two units ;

$$\frac{m-n}{m} c - \frac{n(m-n)}{m^2} c = \frac{m-n^2}{m^2} c,$$

and through the third unit,

Through three units ;

$$\frac{m-n^2}{m^2} c - \frac{n(m-n)^2}{m^3} c = \left( \frac{m-n}{m} \right)^3 c,$$



and through the whole thickness denoted by  $t$  units,

$$\left(\frac{m-n}{m}\right)^{t-1} \cdot c - \frac{n}{m} \left(\frac{m-n}{m}\right)^{t-1} \cdot c = \left(\frac{m-n}{m}\right)^t \cdot c.$$

Through  $t$  units  
of thickness;

So that, calling  $c$  the intensity of the extreme red waves in white light,  $c'$  that of the next degree of refrangibility,  $c''$  that of the next, and so on, the incident light will, according to Sir J. H., be represented in intensity by

$$c + c' + c'' + c''' + \&c.$$

Intensity of  
incident light;

and the intensity of the transmitted light, after traversing a thickness  $t$ , by

$$c y^t + c' y'^t + c'' y''^t + \&c. \quad . \quad . \quad . \quad (101)$$

That of  
transmitted  
light;

Wherein  $y$ , represents the fraction  $\frac{m-n}{m}$ , which will depend upon the waves and the medium, and will, of course, vary from one term to another.

From this it is obvious, that total extinction will be impossible for any medium of finite thickness; but if the fraction  $y$ , be small, then a moderate thickness, which enters as an exponent, will reduce the fraction to a value perfectly insensible.

Total extinction  
impossible  
for finite  
thickness;

Numerical values of the fractions  $y, y', y'', \&c.$ , may be called the *indices of transparency* of the different waves for the medium in question.

Indices of  
transparency.

There is no body in nature perfectly transparent, though all are more or less so. Gold, one of the densest of metals, may be beaten out so thin as to admit the passage of light through it: the most opaque of bodies, charcoal, becomes one of the most beautifully transparent under a different state of aggregation, as in the diamond, "and all colored bodies, however deep their hues and however seemingly opaque, must necessarily be rendered visible by waves which have entered their surface; for if reflected at their surfaces they would all appear white

No body in  
nature perfectly  
transparent;

Colors of bodies  
not superficial;

alike. Were the colors of bodies strictly superficial, no variation in their thickness could affect their hues; but so far is this from being the case, that all colored bodies, however intense their tint, become paler by diminution of thickness. Thus, the powders of all colored bodies, or the streak they leave when rubbed on substances harder than themselves, have much paler colors than the same bodies in mass."

Powders and  
streaks.

THE RAINBOW.

Rainbow defined;

§ 125. The rainbow is a circular arch, frequently seen in the heavens during a shower of rain, in a direction from the observer opposite to that of the sun.

If  $ABC$ , be a section of a prism of water at right angles to its length by a vertical plane, and  $Sr$  a beam of light proceeding from the sun; a part of the latter will be refracted at  $r$ , reflected at  $D$ , and again refracted

Illustration by  
prisms of water;

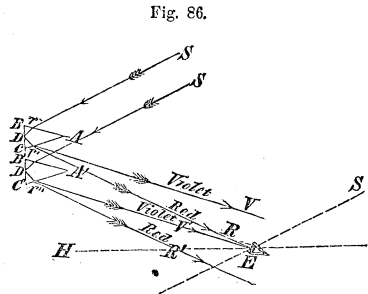

at  $r'$ , where the constituent elements of white light, which had been separated at  $r$ , will be made further divergent, the red taking the direction of  $r'R$ , and the violet the direction  $r'V$ , making, because of its greater refractive index, a greater angle than the red with the normal to the refracting surface at  $r'$ . To an observer whose eye is situated at  $E$ , the point  $r'$  will appear red, the other colors passing above the eye; and if the prism be depressed so as to occupy the position  $A'B'C'$ , making  $r''V'$ , parallel to  $r'V$ , the point  $r''$  would appear of a violet hue, the remaining colors from this position of the

Order in which  
the colors will  
appear in the  
primary bow;

prism falling below the eye. In passing from the first to the second position, the prism would, therefore, present, in succession, all the colors of the solar spectrum. If, now, the faces of the prism be regarded as tangent planes to a spherical drop of water at the points where the two refractions and intermediate reflexion take place, the prism may be abandoned and a drop of water substituted without altering the effect; and a number of these drops existing at the same time in the successive positions occupied by the prism in its descent, would exhibit a series of colors in the order of the spectrum with the red at the top.

Prisms replaced by drops of water;

A line  $ES$ , passing through the eye and the sun, is always parallel to the incident rays; and if the vertical plane revolve about this line, the drops will describe concentric circles, in crossing which, the rain in its descent will exhibit all the colors in the form of concentric arches having a common centre on the line joining the eye and the sun, produced in front of the observer. When this line passes below the horizon, which will always be the case when the sun is above it, the bow will be less than a semi-circle; when it is in the horizon, the bow will be semi-circular.

Axis of revolution for vertical plane;

When the bow is semi-circular, &c.

Fig. 87.

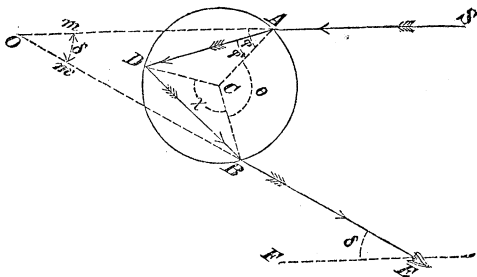

Illustration for primary bow,

To find the angle subtended at the eye by the radii of these colored arches, let  $ABD$ , be a section of a drop of rain through its centre;  $SA$  the incident,  $AD$  the

To find the angle subtended at the eye by the radii of the colored arches;

Fig. 87.

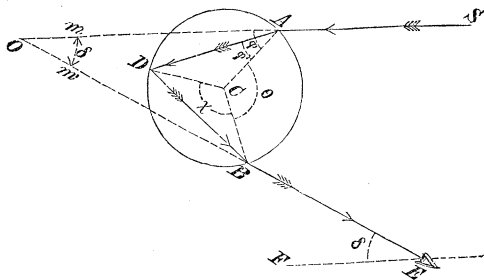

Illustration for primary bow;

Notation;

refracted,  $DB$  the reflected, and  $BR$  the emergent ray. Call the angle  $CAm = \varphi$ , the angle of incidence,  $\varphi'$ , and the angle  $CAD = \varphi'$ ; the angles subtended by the equal chords  $AD$  and  $DB$ ,  $\chi$ ; and the angle  $ACB$ ,  $\theta$ . Then we shall have

Equation for one internal reflexion;

$$\theta = 2\pi - 2\chi;$$

and if there be two internal reflexions, there will be three equal chords, in which case,

For two internal reflexions;

$$\theta = 2\pi - 3\chi;$$

and generally, for  $n$  internal reflexions,

For  $n$  internal reflexions;

$$\theta = 2\pi - \overline{n+1} \cdot \chi \dots \dots \dots (102)$$

but in each of the triangles whose bases are the equal chords, and common vertex the centre of the drop,

Angle subtended by the equal chords;

$$\chi = \pi - 2\varphi'$$

and this, in Equation (102), gives, on reduction,

Substitution;

$$\theta = 2(n+1)\varphi' - (n-1)\pi \dots \dots \dots (103)$$

Because the chords are all equal, the last angle of incidence  $CB D$ , within the drop in Fig. (87), or  $CB D'$ ,

in Fig. (88), is equal to the angle of refraction  $CAD$ , Angle of emergence equal to angle of incidence ; and hence the angle of emergence  $CBm'$ , is equal to the angle of incidence  $CAm$ .

The angle  $AOB$ , in Fig. (87), is the supplement of the total deviation of the emergent from the incident ray, and is equal to the angle  $BEF$ , subtended by the radius of the bow; in Fig. (88), it is the excess of total deviation above  $180^\circ$ . References to figures ;

Calling this angle  $\delta$ , we shall have Notation and equation ;

$$\delta = \mp (2\varphi - \theta) ;$$

Fig. 88.

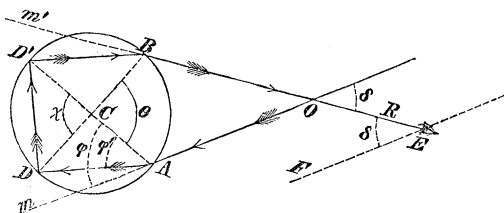

Illustration for secondary bow ;

the upper sign referring to Fig. (87), and the lower to Fig. (88); replacing  $\theta$ , by its value in Equation (103), the above reduces to

$$\delta = \mp (2\varphi - 2(n + 1)\varphi' + \overline{n - 1} \cdot \pi) \quad . \quad (104) \quad \text{General value for radius of a colored arch ;}$$

this, with equation

$$\sin \varphi = m \cdot \sin \varphi', \quad . \quad . \quad . \quad (105) \quad \text{From which the radius of any particular color can be found ;}$$

will enable us to determine the value of  $\delta$ , when  $\varphi$  and  $m$  are given for any particular color.

For any value of  $\varphi$ , assumed arbitrarily,  $\delta$  will, in general, correspond to rays of the same color so much diffused as to produce little or no impression upon the eye; but if  $\varphi$  be taken such as to give  $\delta$  a maximum or mini-

What waves appertain to the rainbow.

mum, then will the rays corresponding to  $m$ , emerge parallel, or nearly so, for a small variation in the angle  $\varphi$  on either side of that from which this maximum or minimum value of  $\delta$  results; hence, the waves which enter the eye in this case will be sufficiently copious to produce the impression of color, and these are the waves that appertain to the rainbow.

§ 126. By an easy process of the calculus it is found that the relation which will satisfy these conditions, is

Relation that will fulfil the conditions for color;

$$\frac{1}{n + 1} = \frac{\cos \varphi}{m \cos \varphi'}$$

Clearing the fraction, squaring both members, adding

$$m^2 \sin^2 \varphi' = \sin^2 \varphi$$

and reducing, we get

Corresponding angle of incidence:

$$\cos \varphi = \sqrt{\frac{m^2 - 1}{n^2 + 2n}} \dots \dots \dots (106)$$

For one internal reflexion, which answers to Fig. (87),

Same for one internal reflexion;

$$\cos \varphi = \sqrt{\frac{m^2 - 1}{3}}$$

and substituting in succession the values of  $m$ , answering to the different colors for water, we shall have values for  $\varphi$ , and consequently for  $\varphi'$ , Equation (105), which substituted in Equation (104), will give the angles subtended by the radii of the colored arches which make up what is called the *primary bow*.

Radii of the colors of primary bow deduced;

For red,  $m = 1,3333$ , hence

Example, red of the primary;

$$\begin{aligned} \cos \varphi &= 0,5092 = \cos 59^\circ 21', \\ \sin \varphi &= \sqrt{1 - \cos^2 \varphi} = 0,8603; \\ &\text{See Appendix No. 8.} \end{aligned}$$

this last, in Equation (105), gives

Substitution and  
reduction;

$$\varphi' = 40^\circ 11',$$

and these values of  $\varphi$  and  $\varphi'$ , in Equation (104), give

$$\delta = -118^\circ 42' + 160^\circ 44' = 42^\circ 02'.$$

Value of  $\delta$ ;

For the violet,  $m = 1,3456$ ,

$$\cos \varphi = 0,5199 = \cos 58^\circ 41\frac{1}{2}',$$

Example, violet  
of the primary;

$$\sin \varphi = 0,8543,$$

$$\varphi' = 39^\circ 25',$$

$$\delta' = -117^\circ 23' + 157^\circ 40' = 40^\circ 17';$$

Value of  $\delta'$ ;

hence, the width of the primary bow is

$$\delta - \delta' = 42^\circ 02' - 40^\circ 17' = 1^\circ 45'.$$

Width of primary  
bow.

If there be two internal reflexions, as in Fig. (88), we shall, by making  $n = 2$ , find

$$\cos \varphi = \sqrt{\frac{m^2 - 1}{8}}$$

Solution for two  
internal  
reflexions;

and obtain, by a process entirely similar, the elements of what is called the *secondary bow*.

Secondary bow;

For the red rays,

$$\delta = 50^\circ 57',$$

Value of  $\delta$ ;

violet,

$$\delta' = 54^\circ 07',$$

Value of  $\delta'$ ;

and

$$\delta' - \delta = 3^\circ 10';$$

Width of  
secondary bow;

Arrangement of the colors in the two bows;

the value of  $\delta'$  in the secondary, being greater than  $\delta$ , the violet will occupy the outside, and the colors, therefore, be arranged in an order the reverse of that in the primary.

Space between them;

Taking the difference between the values of  $\delta$  in the primary and secondary bows, we will obtain the space between them, which is  $50^\circ 57' - 42^\circ 02' = 8^\circ 55'$ . The solar disk being about  $32'$ , the width of both bows must be increased by this quantity, the solution having been made upon the supposition that the light flows from a point. The primary is, therefore,  $2^\circ 17'$  in width, and the secondary  $3^\circ 42'$ . The half of  $32'$  being added to the radius of the red in the primary, will give  $42^\circ 18'$ ,

When these bows will be invisible;

hence, if the sun be more than that height above the horizon, this bow cannot be seen. When higher than  $54^\circ 23'$ , no part of the secondary will be visible.

To find elements of a tertiary bow;

By substituting in Equation (106), 3 for  $n$ , we might find the radii of a third bow, which would be found to encircle the sun at the distance of about  $43^\circ 50'$ ; but the proximity of the sun, together with the great loss of light arising from so many reflexions, renders this bow so faint as to produce no impression; it is, therefore, never seen.

Tertiary not seen.

Fig. 89.

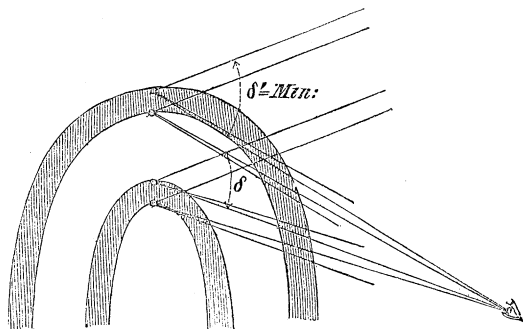

Illustration for the primary and secondary bows;

$\delta$ : a maximum for the primary and minimum for the secondary;

§ 127. By means of the calculus it is easily shown that  $\delta$ , in Equation (104), is a maximum for the primary and a minimum for the secondary. This explains the



remarkable fact that the space between these bows always appears darker than any other part of the heavens in the vicinity of the bow ; for, no light twice refracted and once reflected can reach the eye till the drops arrive at the primary, and none which is twice refracted and twice reflected, can arrive at the eye after the drops pass the secondary ; hence, while the drops are descending in the space between the bows, the light twice refracted with one or two intermediate reflexions, will pass, the first above, and the second below or in front of the observer.

Remarkable appearance of the heavens between these bows accounted for.

The same discussion will, of course, apply to the *lunar* rainbow which is sometimes seen.

§ 128. Luminous and colored rings, called *halos*, are occasionally seen about the sun and moon; the most remarkable of these are generally at distances of about twenty-two and forty-five degrees from these luminaries, and may be accounted for upon the principle of unequal refrangibility of light. They most commonly occur in cold climates. It is known that ice crystallizes in minute prisms, having angles of  $60^\circ$  and sometimes  $90^\circ$ ; these floating in the atmosphere constitute a kind of mist, and having their axes in all possible directions, a number will always be found perpendicular to each plane passing through the sun or moon, and the eye of the observer. One of these planes is indicated in the Figure.

Halos :

Their appearance accounted for ;

$Sm$ , being a beam of light parallel to  $SE$ , drawn through the sun and the eye, and incident upon the face of a prism whose refracting angle is  $90^\circ$  or  $60^\circ$ ,

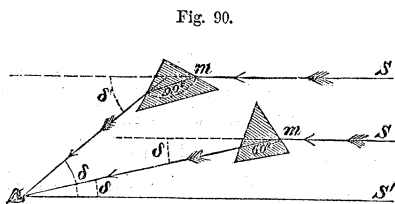

Illustration and explanation ;

we shall have the value of  $\delta$ , corresponding to a minimum from Equation (12), by substituting the proper values of  $m$  for ice. The mean value being 1,31, we have

Example first,

$$\sin \frac{1}{2} (\delta + 60^\circ) = 1,31 . \sin 30^\circ$$

$$\frac{1}{2} \delta = 40^\circ 55' 10'' - 30^\circ = 10^\circ 55' 10''$$

$$\delta = 21^\circ 50' 20''$$

and

Example second;

$$\sin \frac{1}{2} (\delta + 90^\circ) = 1,31 . \sin 45^\circ$$

$$\frac{1}{2} \delta = 67^\circ 52' - 45^\circ = 22^\circ 52'$$

$$\delta = 45^\circ 44'.$$

Other phenomena of a similar nature will be noticed hereafter.

#### POLARIZATION OF LIGHT.

Retrospective  
view of the  
phenomena of  
unpolarized  
light.

§ 129. We have thus far been concerned with the propagation of luminous waves through homogeneous media, with the deviation which these waves undergo on meeting with a change of density, and with the superposition of two or more waves, by which their effects are increased, diminished, or totally destroyed. We now come to a class of optical phenomena whose explanation depends upon considerations affecting the particular mode of molecular vibrations in these waves.

Remarks on the  
disturbance of  
molecular  
equilibrium;

When an ethereal molecule is displaced from its position of equilibrium, the forces of the neighboring molecules are no longer balanced, and their resultant tends to drive the displaced molecule back to its position of rest. The displacement being supposed very small in comparison with the distance between the molecules, the forces thus excited will, we have seen in Acoustics, be

proportional to the displacement; and according to principles explained in Mechanics, the trajectory described by the molecule will be an ellipse whose centre coincides with the position of equilibrium. Hence, the vibration of the ethereal molecules is, in general, elliptic, and the nature of the light thence arising depends upon the relative directions and magnitudes of the axes. These elliptic vibrations are in planes parallel to the wave front, and consequently transverse to the direction of wave propagation. The axes of the ellipses may either preserve constantly the same direction in their respective planes, or may be continually shifting. In the former case the light is said to be *polarized*; in the latter, it is unpolarized or common light.

A disturbed molecule in general, describes an ellipse;

Distinction between polarized and common light.

§ 130. The relative magnitude of the axes of the ellipses determines the nature of the polarization. When the axes are equal the ellipses become circles, and the light is said to be *circularly polarized*, when the lesser axis vanishes, the ellipse becomes a right line, and the light is said to be *plane polarized*—the vibrations being in this case confined to a single plane passing normally through the wave front. In intermediate cases the polarization is called *elliptical*, and its character may vary indefinitely between the two extremes of plane and circular polarization.

Nature of the polarization determined;

Circular, plane, and elliptical polarization.

The term polarization in optics has come to be a misnomer. It was introduced before the theory of luminous undulations had gained much favor with the scientific world; and was intended at the time of its adoption to express certain fancied affections, analogous to the polarities of a magnet, conceived to exist in the material emanations which, according to NEWTON, constituted the essence of light. It would be better were it replaced by some other term more expressive of the actual condition of the light; but at present this seems to be impossible, owing to its very general acceptance, and it is accordingly retained.

Use of the term polarization explained.

Illustration by a stretched cord;

§ 131. To conceive the manner in which an undulation may be propagated by transversal vibrations, imagine a cord stretched horizontally, one end being attached to a fixed point and the other held in the hand. If the latter extremity be made to vibrate by moving the hand up and down, each particle of the cord will, in succession, be thrown into a similar state of vibration, and a series of waves will be propagated along the cord with a constant velocity. The vibrations of each succeeding particle of the cord being similar to that of the first, will all be performed in the same plane, and the whole will represent the state of the ethereal particles along a *plane polarized* wave. The plane of vibration is called the *plane of polarization*.

State of the ethereal particles in a plane polarized wave;

If, after a certain number of vibrations in the vertical plane, the extremity of the cord be made to vibrate in some other plane, and then in another,—and so on in rapid succession—each particle of the cord will, after a certain time, proportional to its distance from the hand, assume in succession all these varied vibrations; and the whole cord instead of taking the form of a curve lying in *one plane*, will be thrown into a species of *helical curve*, depending on the nature of the original disturbance. Such is the condition of the ethereal molecules in waves of common or *unpolarized* light.

Condition of the ethereal particles in common light.

Undulation propagated by transversal vibrations.

When, therefore, we admit a connection among the molecules of ether, similar to that which exists among the particles of the cord, there is no difficulty in conceiving how a vibration may be propagated in a direction perpendicular to that in which it is executed. The particles of ether, it is true, are not held together by cohesive forces like those of a cord, but the molecular forces which subsist among them, are of the same kind, and produce similar effects. Neither the particles of the cord nor the ethereal molecules are in contact.

§ 132. These illustrations being understood, conceive a transversal vibration to proceed from a disturbed mole-

cule at  $A$ , towards  $C$ , and suppose the vibration to take place in the plane of the paper, and let  $M N$  be the front of the wave at the expiration of any time  $t$ , after the beginning of motion. The displacement  $x$ , of the molecule at  $C$ , will, § 55, Acoustics, be given by the equation

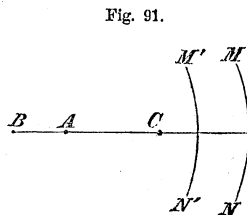

Fig. 91.

Transversal vibration supposed to proceed from a disturbed particle at  $A$ ;

$$x = \frac{a}{c} \cdot \sin \left( 2 \pi \cdot \frac{Vt - c}{\lambda} \right)$$

Consequent displacement of another particle at  $C$ ;

in which  $a$  denotes the amplitude of the disturbance at unit's distance from  $A$ ;  $c$ , the distance from  $A$  to  $C$ ;  $V$ , the velocity of wave propagation, and  $\lambda$  the length of the wave.

At the same instant, suppose a second transversal vibration to proceed from any other point, as  $B$ , towards  $C$ , the vibrations in the latter case being perpendicular to the former, and let  $M' N'$  be the front of the wave at the expiration of the same time  $t$ , as above. The displacement  $y$ , of the molecule  $C$ , due to this action, will be given by the equation

$$y = \frac{b}{c_i} \cdot \sin \left( 2 \pi \cdot \frac{Vt - c_i}{\lambda} \right)$$

Displacement of the same particle at  $C$ ;

in which  $b$  denotes the amplitude of the disturbance at unit's distance from  $B$ , and  $c_i$ , the disturbance from  $B$  to  $C$ .

Dividing these equations respectively by the coefficient of the circular function in the second member, we obtain the equations,

$$2 \pi \cdot \frac{Vt - c}{\lambda} = \arcsin \left( \sin = \frac{cx}{a} \right),$$

$$2 \pi \cdot \frac{Vt - c_i}{\lambda} = \arcsin \left( \sin = \frac{c_i y}{b} \right);$$

Equations obtained from these displacements;

the cosines of these arcs will be respectively

Cosines of these arcs ;

$$\sqrt{1 - \frac{c^2 x^2}{a^2}}, \text{ and } \sqrt{1 - \frac{c_i^2 y^2}{b^2}}.$$

Subtracting the second of these equations from the first, we find,

Combining these equations and reducing ;

$$\frac{2\pi}{\lambda} \cdot (c_i - c) = \arccos\left(\sin = \frac{c x}{a}\right) - \arccos\left(\sin = \frac{c_i y}{b}\right).$$

Taking the cosine of each member of the equation, and recollecting that the cosine of the difference of two arcs is equal to the sum of the rectangles of the cosines and sines, we find, after a slight reduction,

We obtain the equation of an ellipse ;

$$\frac{c_i^2}{b^2} y^2 + \frac{c^2}{a^2} x^2 - 2 \cos \frac{2\pi}{\lambda} (c_i - c) \cdot \frac{c}{a} x \cdot \frac{c_i}{b} y = \sin^2 \frac{2\pi}{\lambda} (c_i - c) \quad (107)$$

which is an equation of an ellipse referred to its centre.

Light elliptically polarized ;

The axes of the ellipses in this case preserving the same direction, the light will, from what we have already said, be *elliptically* polarized, and is obviously compounded of two waves plane polarized in planes at right angles to each other.

When

Supposition in Equation (107) ;

$$c_i - c = \frac{\lambda}{4}, \text{ and } \frac{c}{a} = \frac{c_i}{b},$$

Equation (107), reduces to

Which reduces it to the equation of a circle ;

$$x^2 + y^2 = a^2 ; \quad . . . . . (108)$$

the equation of a circle, and the light becomes *circularly* polarized, being compounded of two plane polarized waves of equal intensity, having their planes of polarization at right angles to each other. In this latter case, the light

Light circularly polarized ;

will possess many of the properties of common light, but will differ from it in some important particulars to be noticed presently.

Common light may be regarded as compounded of two waves polarized in planes perpendicular to each other;

§ 133. The difference between polarized and common light being, that in the former, the axes of the ellipses de-

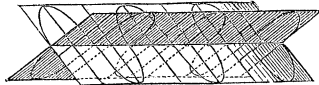

Fig. 92.

scribed by the molecules remain parallel, while in the latter they are incessantly changing their directions; common light, like elliptically polarized light, may be regarded as compounded of two plane polarized waves, of which the planes of polarization are at right angles to each other. When these component vibrations are separated, each component becomes plane polarized light. This separation may be effected, either by causing these component vibrations to take different directions by ordinary reflexion and refraction, by the retardation or acceleration of one over the other, as in the case of double refraction, soon to be explained, or by absorbing one and permitting the other to pass unobstructed.

Effect of separating these component waves :

Different ways of causing this separation.

POLARIZATION BY REFLEXION AND REFRACTION.

§ 134. It is ascertained that when a wave of common light is incident on any *transparent* medium of uniform density, under a certain angle of incidence, called the *polarizing angle*, the resolution above referred to, takes place; the reflected and refracted waves become plane polarized, the former in the plane of reflexion, and the latter in a plane at right angles to it. Both waves lose almost entirely the power of being again reflected or refracted when the surface of a second deviating medium is presented to either in a particular manner.

Polarization by reflexion and by refraction;

Introductory remarks;

Fig. 93.

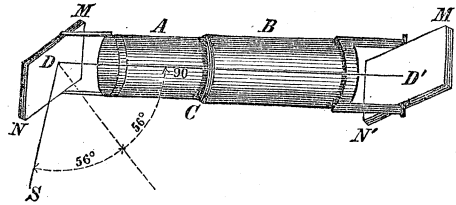

Experimental illustration;

Explanation of apparatus;

Thus,  $MN$  and  $M'N'$ , representing two plates of glass, mounted upon swing frames, attached to two tubes  $A$  and  $B$ , which move freely one within the other about a common axis, let the beam  $SD$ , of homogeneous light, be received upon the first under an angle of incidence equal to  $56^\circ$ ; reflexion and refraction will take place according to the ordinary law, and if the reflected beam  $DD'$ , which is supposed to coincide with the common axis of the tubes, be incident upon the second reflector under the same angle of incidence, *the reflector being perpendicular to the plane of first reflexion*, it will be totally reflected, there being none refracted.

Appearance when the analyzer is perpendicular to the plane of first reflexion;

The same when the analyzer is revolved through any angle less than  $90^\circ$ ;

But if the tube  $B$ , be turned about its axis, the tube  $A$  being at rest, the angle of incidence on the glass  $M'N'$ , will remain unchanged, refraction

Fig. 94.

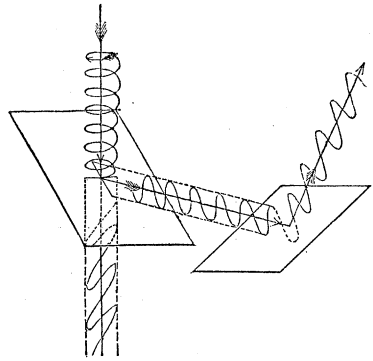
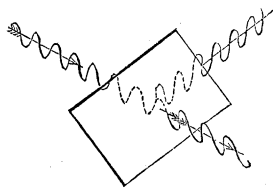

Fig. 95.





will begin, and the refracted portion will increase while the reflected portion will diminish, till the tube *B* has been turned through an angle equal to  $90^\circ$ , as indicated by the graduated circle *C*, on the

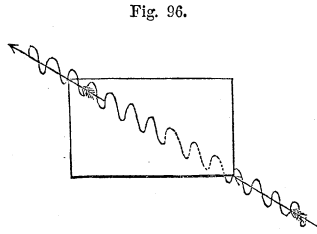

Fig. 96.

The same for a revolution through  $90^\circ$ ;

tube *A*; in which position of the reflector, the beam will be totally refracted. Continuing to turn the tube *B*, the reflexion from *M' N'* will increase, and the refraction will decrease, till the angle is equal to  $180^\circ$ , when the plane of the first reflexion will be again perpendicular to *M' N'*, and the whole beam will be reflected; beyond this, reflexion will again diminish, and refraction increase, till the angle becomes  $270^\circ$ , when the beam will be totally refracted; after passing this point, the same phenomena will recur, and in the same order, as in the second quadrant, till the tube is revolved through  $360^\circ$ , when the restoration of the reflected wave will be complete. The same phenomena would have occurred had the second reflector been presented to the refracted component of the original incident wave on its emergence from the first plate of glass.

Appearances when the analyzer is revolved through the other three quadrants.

Same phenomena exhibited by the refracted wave.

It is important to remark in this connection, that the molecular vibrations in the wave reflected from, and in that transmitted through the second reflector, take place, the former in the plane of second reflexion and the latter in a plane at right angles to it; and that the effect of the second reflector is, therefore, to twist, as it were, the planes of polarization of these component waves in opposite directions, that of the reflected wave through an angle which measures the rotation of the second reflector about the axis of the tubes, and that of the refracted wave through an angle which is its complement.

Important remark.

It thus appears that a beam of homogeneous light reflected from, or refracted through, a plate of glass, being incident under an angle equal to  $56^\circ$ , immediately

Characteristics of plane polarized light.

acquires *opposite* properties, with respect to reflexion and refraction, on sides distant from each other equal to  $90^\circ$ , measuring around the beam; and the *same* properties at distances of  $180^\circ$ ; and these among other properties distinguish plane polarized light.

Effects when the angle of incidence differs from that of polarization.

We have supposed the angle of incidence  $56^\circ$ , if it were less or greater than this, similar effects would be observed, though less in degree; or, in other words, the waves first deviated would be elliptically polarized, the eccentricity of the elliptical orbit increasing as the angle approaches more and more to that of polarization.

Fig. 93.

Apparatus.

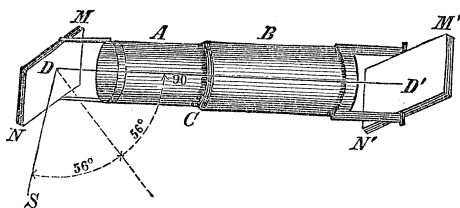

Position of the plane of polarization determined;

The plate  $MN$  is called the *polarizer*, and  $M'N'$ , the *analyzer*. The position of the plane of polarization in any plane polarized wave, is readily ascertained by the total reflexion which takes place from the analyzer, when, the polarized beam being incident under the polarizing angle, the plane of the analyzer is perpendicular to it. Starting from this position of the analyzer, with respect to the plane of polarization, and calling  $\alpha$ , the angle between the plane of polarization and that of second incidence, which is equal to the angle through which the analyzer has at any time been turned about the first reflected or polarized beam;  $A$ , the intensity of this beam, and  $I$ , the variable intensity of that reflected from the analyzer in its various positions, the formula

Analyzer revolved;

Intensity of reflected beam;

$$I = A \cos^2 \alpha, \quad \dots \dots \dots (109)$$

will express, for uncrystallized media, the law according to which a polarized beam will be reflected from the analyzer when the angle of incidence is equal to that of polarization. Law expressed by formula;

According to this law, if we conceive a wave of common light as it emanates from any self-luminous body, to be compounded of two waves polarized in planes at right angles to each other, that is, supposing the orbital motion of the molecules to arise, as they will, from two component rectilinear motions at right angles to each other, Equation (107), we should have for the intensity of reflexion from a reflector, This law applied to common light;

$$I + I' = A \cdot \cos^2 \alpha + A \cdot \cos^2 (90^\circ - \alpha) = A, \quad \text{Consequence;}$$

in which  $I$  and  $I'$ , denote the intensity of reflexion of the two component polarized waves; whence, the intensity of the reflected wave will be the same on whatever side of the incident beam the analyzer be presented. Conclusion;

§ 135. What has been said of the effects of glass on light is equally true of other transparent homogeneous media, except that the polarizing angle, which is constant for the same substance, differs for different bodies. Polarizing angle varies with the medium.

It is found, from very numerous observations, that the tangent of the maximum polarizing angle is always equal to the refractive index of the reflecting medium taken in reference to that in which the wave is reflected; thus, calling the relative index  $m$ , and the polarizing angle  $\varphi$ , we shall have, Rule.

$$\tan \varphi = m. \quad \dots \dots \dots (110) \quad \text{Same in form of an equation;}$$

*Example.* Let it be required to find the polarizing angle when light is moving in water and reflected from glass. The refractive indices for water and glass are 1,336 and 1,525, respectively, hence, Example;

Numerical data;

$$m = \frac{1,525}{1,336} = 1,1415 = \tan \varphi,$$

OR

Result.

$$\varphi = 48^\circ 47'.$$

Supposition;

If the refractive indices of the media were equal, we should have

$$m = 1$$

and

Consequence.

$$\varphi = 45^\circ.$$

The following are the values of  $\varphi$ , for the different substances named, the wave being reflected in air.

Table of  
polarizing angles.

Water, - - - - -	53° 11'
Crown glass, - - - -	56° 55'
Plate glass, - - - -	57° 45'
Oil of Cassia, - - - -	58° 39'
Diamond, - - - - -	68° 6'

No perfect  
polarization for  
white light;

And a tint will  
be reflected from  
the analyzer;

What is  
understood by  
polarizing angle  
for white light;

§ 136. It is obvious that according to the law expressed by Equation (110), there can be no such thing as perfect polarization by reflexion in white light, since the refractive index is not the same for the different colors; and hence there can never be total absence of light at the analyzer; but *a certain tint will be reflected, whose intensity will depend upon the dispersive power of the medium.* For bodies of very high refractive powers, which are also, in general, highly dispersive, we must, therefore, understand by the polarizing angle for white light, that angle of incidence at which the reflected light approaches nearest to perfect polarization. This angle being ascertained for opaque bodies by experiment, the

relation expressed by Equation (110), furnishes the means of ascertaining their refractive indices. Thus, the maximum polarizing angle for steel is a little over  $71^\circ$ , the natural tangent of which is 2,85, which is, therefore, according to the law, its refractive index; the polarizing angle for mercury is about  $76^\circ 30'$ , and its refractive index, consequently, 4,16.

Method of finding the refractive indices of opaque bodies.

§ 137. We have spoken, thus far, only of the action at the *first* surface of the glass plate; it is found that the light reflected at the *second* surface is as perfectly polarized as that reflected at the first, and in the same plane, when the faces of the plate are parallel. This is a consequence of the same law for,

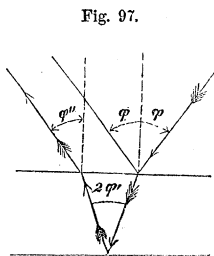

Fig. 97.

Light reflected at the second surface also polarized;

$$m = \tan \varphi = \frac{\sin \varphi}{\cos \varphi} = \frac{\sin \varphi}{\sin \varphi'}$$

Equation;

hence,

$$\cos \varphi = \sin \varphi'$$

Relation;

or  $\varphi'$  is the complement of  $\varphi$ , and the first reflected beam is perpendicular to the first refracted.

Moreover,

$$\frac{1}{m} = \frac{1}{\tan \varphi} = \cot \varphi = \tan \varphi'$$

but  $\frac{1}{m}$  is the index of the wave passing out of the glass;

hence  $\varphi'$  is the maximum polarizing angle for the second surface.

Polarizing angle for second surface found;

If a series of parallel plates be employed in the form

Effect of a pile of plates. of a pile, the light reflected from the second surfaces coming off polarized in the same plane, a polarized beam of great intensity may be obtained. This intensity can, however, never exceed half that of the incident beam, no matter how great the number of plates employed.

Effect of repeating the reflexions at angles different from that of polarization.

§ 138. Although a wave of homogeneous light is but elliptically polarized when reflected once at an angle differing from that of polarization, yet by repeating the reflexions a sufficient number of times, the ellipse may be reduced to a right line, in which case the light will be plane polarized; and in doing this, it is not necessary that the reflexions take place at the same angle of incidence, but some may be above and some below the polarizing angle. In general, the number of reflexions will increase as the angle of incidence recedes from that of polarization on either side.

The same remarks will apply to light polarized by refraction.

#### POLARIZATION BY ABSORPTION.

Polarization by absorption;

§ 139. A plate of *Tourmaline*, about  $\frac{1}{20}$  of an inch thick, cut parallel to the axis, possesses the property of intercepting that component of white light whose vibrations take place in a plane parallel to the axis, and of transmitting the other. This latter will, of course, be polarized in a plane at right angles to the axis of the crystal. If, therefore, light previously plane polarized, be incident upon the plate with its plane of polarization perpendicular to the axis, it will be wholly transmitted; but if parallel, it will be wholly absorbed or intercepted. This is another property

Experiment with a plate of tourmaline;

Fig. 98.

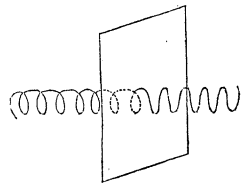

by which plane polarized light may be distinguished. Hence, two plates of tourmaline form a most convenient apparatus for experimenting with polarized light when so arranged as to be capable of turning about a common axis, the one being used to polarize light, the other to analyze it. Plates of agate and some varieties of quartz possess similar properties.

A characteristic of plane polarized light ;

Apparatus of tourmaline plates.

### DOUBLE REFRACTION.

§ 140. In treating of the transmission of light through different media, we have regarded the ether of the latter as possessing the same density and the same elasticity in all directions; in which case the luminous waves proceeding from any point, will always be spherical. But there is a large class of bodies in which neither of the above conditions exists. This class embraces all crystallized media except those whose primitive form is the *cube*, the *octohedron*, and the *rhomboidal dodecahedron*; also all animal substances among whose particles there is a tendency to regular arrangement; and, in general, all solids in a state of unequal compression or dilatation.

Bodies in which luminous waves will always be spherical :

Those in which this will not be the case;

The elastic force of the ether within such bodies differs in different directions; and whether we suppose the vibrating medium is the ether alone, or that the molecules of the body itself also partake of the vibrating movement, there will obviously be such a connection between the parts of the solid and those of the medium, that the velocity of wave propagation will, Equation (17), Acoustics, be different in different directions.

Peculiarities of this latter class:

When a disturbance is produced in a medium of the kind above referred to, and any one of the molecules displaced from its position of rest, the resultant of all the elastic forces which resist the displacement, will not, in general, act in the direction of the displacement, as in the case of homogeneous bodies, and will not, therefore, drive

Resultant reaction not generally in the direction of the disturbance ;

There are three rectangular directions along which the reactions are in the direction of the displacement;

the displaced molecule directly back to its place of equilibrium. It is shown, however, that there are *three* directions at right angles to each other, in every medium of this nature, along any of which, if the particles be displaced, the elastic forces do act *in the direction of the displacement*, whatever be the law of the disturbance; and in crystalline bodies these directions are invariable throughout the entire extent of the substances. Indeed, the principles of crystallization lead us to admit that the arrangement of the molecules of the crystalline body is similar in all parallel lines throughout the crystal; and the same property must belong to the ether within it, if, as we have every reason to presume, its elasticity be dependent on that of the crystal. These three directions are denominated the *axes of elasticity*, and are supposed to be the axes of symmetry with respect to crystalline form.

Axes of elasticity;

Surface of elasticity;

If on each of these axes and on every line diverging from the same origin, portions be taken which are as the square roots of the elastic forces in their directions, the locus of the extremities of these portions will be a surface, which is called a surface of elasticity. Its equation is,

Its equation.

$$r^2 = a^2 \cos^2 \alpha + b^2 \cos^2 \beta + c^2 \cos^2 \gamma, \quad (111)$$

in which  $a^2$ ,  $b^2$ , and  $c^2$ , denote the elasticities in the direction of the three axes;  $r$ , the radius vector of the surface, and  $\alpha$ ,  $\beta$ , and  $\gamma$ , the angles which it makes with the axes.

Effect of a difference of elasticity in different directions;

§ 141. In consequence of this difference of elasticity in different directions, certain bodies which possess it, resolve the orbital motions of the molecules in common light, into two rectilinear vibrations at right angles to each other, and transmit them with different velocities, and therefore in different directions; thus giving rise to two distinct transmitted waves for each single incident



wave. The phenomenon presented by any medium of thus dividing a wave of light which enters it, is called *double refraction*. The shape of the component waves will be determined by the elasticities which their particular vibrations call into action. The direction of the molecular motions in one set may be such as to develop, in some crystals, the action of an equal elasticity throughout their entire substance, while the motions in the other set may have such direction as to give rise to the exertion of an elasticity varying with a change of route through the crystal. In the first case, the component wave will, as we have seen, be spherical; in the second, it may have any shape whatever depending upon the law which regulates the density and elasticity.

Double refraction defined;

Shape of the component waves dependent upon;

One of the most remarkable bodies in this respect is *Iceland Spar*, which is a carbonate of lime, and is found in crystals of various shapes, all of which may be reduced by cleavage to a *regular obtuse rhomboid*, this being its primitive form, or the form of its ultimate particles. This rhomboid has six acute and two obtuse angles, and the diagonal *AB*, Fig. (99), joining the latter, which is the shortest that can be drawn in the figure, is called the *axis of double refraction*, or *optical axis* of the crystal; it is so called, because when the wave, on entering the crystal, is propagated along this line, no double refraction is observed;

Iceland spar;

Fig. 99.

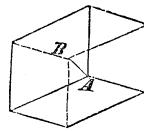

Optical axis;

the component waves in this case moving with different velocities along the same route and preserving their fronts parallel to each other. But this rhomb may be divided into an indefinite number of similar elementary rhombs each having an axis parallel to *AB*, it would, thence, follow that whenever a plane wave takes a direction *parallel* to *AB*, there should be no double refraction; and this is confirmed by observation.

Its peculiar property;

By optical axis is meant a direction.

By an axis of double refraction, we are to understand,

Ordinary and extraordinary waves.

therefore, merely a *direction*, determined in the present case by joining the obtuse solid angles of the rhomb.

Whenever the refracted wave takes a direction different from the axis, its components will not only take different velocities, but their wave fronts will become inclined to each other, one being refracted according to the ordinary law of the sines, the other according to some extraordinary law yet to be explained; the first is called the *ordinary wave*, the other, the *extraordinary wave*.

Plane of principal section;

Any plane drawn through the crystal, parallel to the axis, is called a *plane of principal section*, and the peculiar property of such a plane is, that whenever it contains the ordinary ray, it will also contain the extraordinary ray; in other words, if a principal section, drawn through the point of incidence, coincide with the plane of incidence, it will contain both rays. Whenever these planes are inclined to each other, the extraordinary ray will not be in the same plane with the incident and ordinary rays, except in the case where the incident plane is perpendicular to the axis, and consequently at right angles to every principal section possessed by the crystal, when the incident, ordinary and extraordinary rays will again be found in the same plane.

When the incident ordinary and extraordinary rays will be in the same plane.

Uniaxal and biaxal crystals.

§ 142. Doubly refracting crystals that possess but one axis of double refraction, are called *uniaxal*; very many crystals are, however, found to possess two such axes, and are called *biaxal*; but in the latter class it has been ascertained that there is, in fact, no ordinary wave.

Double refraction in a particular instance considered:

§ 143. To show how double refraction takes place in a particular instance, take, for example, the simple case of a beam of light proceeding from an indefinitely distant point, and falling *perpendicularly* on the surface of an uniaxal crystal, cut *parallel to the axis*. The incident wave being plane, and parallel to the surface of the crystal, the vibrations are also parallel to the same surface, and will be resolved into two component vibra-

tions, the one *parallel* and the other *perpendicular* to the axis of the crystal. Now, the elasticity brought into play by these two sets of vibrations being different, they will be propagated with different velocities; and there will be two waves within the crystal polarized in planes at right angles to each other. If the second face of the crystal be *parallel* to the first, the two waves will emerge parallel, resuming the velocity which they had before incidence; they will, therefore, be unequally accelerated, but will retain their parallelism after emergence, the only effect being to cause one to lag behind the other. But when the second face of the crystal is oblique to the first, it will also be oblique to the wave fronts, and this obliquity will make their unequal change of velocity apparent by causing the waves to take different directions; there will, in this case, be double refraction at emergence.

Two plane polarized waves within the crystal;

If the second surface be parallel to the first, no double refraction observed;

If the second surface be oblique to the first, double refraction will appear.

§ 144. One of the component waves in Iceland spar is propagated equally in all directions, and is, therefore, spherical in form when proceeding from a point in the crystal; the other is propagated unequally in different directions, the form of the wave being that of an oblate spheroid of revolution, whose shorter axis coincides with the optical axis of the crystal; resembling the case taken for illustration in § 42 of Acoustics.

Form of the component waves in Iceland spar.

Now, the radius of the ellipsoidal wave is always greater than that of the spherical wave, except when the refracted ray coincides with the axis; and these radii being described in the same time, may be taken as the measures of the velocities of wave propagation in the extraordinary and ordinary waves. The refractive index being equal to the ratio of the velocity before incidence, to that within the crystal, the extraordinary index will be variable, and less than the ordinary index. But the index of refraction being

Relation between the radii of the ordinary and extraordinary waves;

Fig. 100.

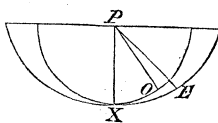

Extraordinary index variable;

When the extraordinary index will be a minimum.

also equal to the ratio of the sine of the angle of incidence to that of refraction, the extraordinary ray must always be *thrown further from* the axis than the ordinary ray; and the extraordinary index of refraction will have its *minimum* value when the *extraordinary* ray is perpendicular to the axis.

Rock crystal;

§ 145. With *rock crystal*, which occurs in the form of hexagonal prisms, terminated with six-sided pyramids, the case is just reversed; the ellipsoidal wave is prolate, its longer axis coinciding with the optical axis of the prism, and being equal in length to the radius of the spherical wave; the extraordinary ray is always found between the ordinary ray and the axis, as if *drawn towards* the latter; and the extraordinary index is a

Properties the reverse of those of Iceland spar;

*maximum* when the *extraordinary* ray is perpendicular to the axis. These circumstances have given rise to a division of doubly refracting substances into two classes distinguished by their axes, which are said to be *positive* when the extraordinary ray is between the ordinary ray and the axis, as in the case of rock crystal; and *negative*, when the positions of these rays are reversed with respect to the axis, as in Iceland spar.

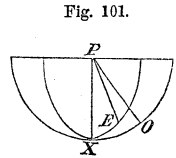

Doubly refracting substances classified.

To find any value of the extraordinary index between the maximum and minimum.

§ 146. Having ascertained by experiment the value of the ordinary index, which will be represented by  $m_o$ , and the maximum or minimum value of the extraordinary index, according as the crystal has a positive or negative axis, which will be represented by  $m_e$ ; then, denoting the space described by the wave before incidence, in the same time that the radius vector of the extraordinary wave is described, by unity, will the extraordinary index between  $m_o$ , and  $m_e$ , be found by the following law.

Let an ellipsoid of revolution, Fig. (102), be conceived,

having its centre  $C$ , at the point, of incidence, its axis of revolution coincident with the optical axis  $CX$ , of the crystal, and its polar to its equatorial radius in the inverse ratio of the ordinary, to the minimum or maximum value of

Fig. 102.

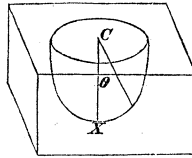

Rule;

the extraordinary index of refraction, according as the crystal belongs to the negative or positive class. Then, in all positions of the extraordinary ray, its index is equal to the reciprocal of its length contained between the centre and surface of the ellipsoid.

Value of extraordinary index.

The equation of a section of this surface through the axis, referred to the centre, is

$$A^2 y^2 + B^2 x^2 = A^2 B^2,$$

Equation of a section of the surface;

and calling  $r$ , the length of the extraordinary ray between the centre and the surface, and  $\theta$ , its angle of inclination with the optical axis, it reduces to

$$r = \frac{AB}{\sqrt{A^2 \sin^2 \theta + B^2 \cos^2 \theta}} = \frac{AB}{\sqrt{B^2 + (A^2 - B^2) \sin^2 \theta}};$$

Value of radius vector;

denoting by  $m_e$ , the value of the extraordinary index sought, we have

$$m_e = \frac{1}{r} = \sqrt{\frac{1}{A^2} + \left(\frac{1}{B^2} - \frac{1}{A^2}\right) \sin^2 \theta} \quad \dots (112)$$

Value of extraordinary index;

in which

$$A = \frac{1}{m_o},$$

$$B = \frac{1}{m_e}.$$

Notation;

Nature of crystal determined.

It is obvious that the coefficient of  $\sin^2 \theta$ , is positive or negative according as the axis is positive or negative; hence, the coefficient of  $\sin^2 \theta$ , determines the nature of the crystal.

To find experimentally the maximum and minimum values of the extraordinary index.

§ 147. To determine the value of  $m_o$  and  $m_e$ , in any particular instance, it is in the first place known that the index of the extraordinary ray will be constant and equal to its maximum or minimum value, according to the nature of the body, when refracted in a plane at right angles to the optical axis; it is only necessary, therefore, to convert the crystal, by grinding, into a prism whose refracting faces shall be parallel to the axis, when both the ordinary and extraordinary index may be ascertained by the method explained in § (25). To distinguish between the rays, it will, in general, be sufficient to move the prism so as to give the plane of incidence a slight inclination to its length, as in that case the extraordinary ray will be thrown out of this plane, and thus become known.

In Iceland spar,

These values for Iceland spar;

$$m_o = 1,6543,$$

$$m_e = 1,4833;$$

hence,

Its nature deduced from formula (112);

$$A = 0,60449,$$

$$B = 0,67417;$$

the ellipsoid is, therefore, oblate; and the coefficient of  $\sin^2 \theta$ , negative. Tourmaline, beryl, emerald, apatite, &c., also belong to this class. Quartz, ice, zircon, oxide of tin, &c., give the coefficient of  $\sin^2 \theta$  positive; they are, therefore, of the positive class, and the ellipsoid is prolate.

Other substances classified.

§ 148. If a plane wave  $W W'$ , of common light be incident on the upper surface of a crystal of Iceland spar to which it is parallel, this wave will be resolved into two components, one of which will take the direction of and be normal to an oblique line  $P e$ , and will be refracted according to the extraordinary law; the other will preserve its original

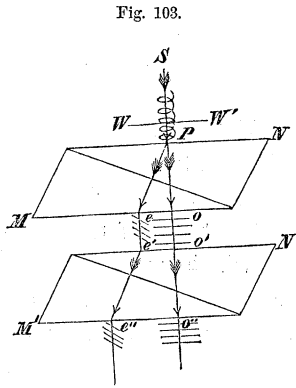

Plane wave of common light incident upon a crystal of Iceland spar;

course and pass through without deviation. These waves will both leave the crystal normal to that plane of principal section which is perpendicular to its upper face, the waves themselves becoming parallel; each will be plane polarized, the plane of polarization of the ordinary wave coinciding with the plane of principal section just named, and that of the extraordinary wave being at right angles to it.

Effect of this crystal.

If these component waves be received upon the upper surface of a second crystal of the same kind, and whose optical axis is parallel to that of the first, they will take the directions  $e' e''$  and  $o' o''$ , parallel, respectively, to the directions  $P e$ , and  $P o$ , and will not be again divided, the first undergoing extraordinary, and the latter ordinary refraction; and if the crystals be of equal thickness, the distance  $e'' o''$ , will be double  $e o$ . If either or both of the component waves whose directions are  $e e'$ , and  $o o'$ , had been polarized by reflexion, refraction or absorption, the action of the second prism would have been the same; this is, therefore, another characteristic property of plane polarized light, viz.: that it will not undergo double refraction when its plane of polarization is either *parallel* or *perpendicular* to the plane of principal section; being in the former case wholly refracted according to the *ordinary*, and the latter according to the *extraordi-*

Emergent waves received upon a second crystal of Iceland spar;

Another characteristic of plane polarized light.

Reverse true for *nary* law. The reverse would have been the case if the positive crystals. crystal, like quartz, had possessed a positive axis.

The second crystal supposed to turn on its base;

§ 149. When the crystal  $M' N'$ , is turned around on its base so that the principal sections of the crystals, which are normal to the upper surfaces, make an angle with each other, each of the component waves of which the directions are  $oo'$  and  $ee'$ , will be again divided into an ordinary and extraordinary wave, whose relative intensities will depend upon the inclination of the principal sections to each other. To avoid complication, let us suppose the wave moving along  $Pe$ , to be arrested by sticking a piece of wafer to the lower surface of the first crystal at  $e$ ; then will the intensities of the portions into which the wave moving along  $oo'$ , is divided by the second crystal, be expressed by the formulas

Effect on the ordinary wave;

Effect on the ordinary wave;

$$\left. \begin{aligned} O_o &= A \cdot \cos^2 \alpha \\ O_e &= A \cdot \sin^2 \alpha \end{aligned} \right\} \cdot (113)$$

Wherein  $A$  represents the intensity of the wave  $oo'$ ;

Fig. 103.

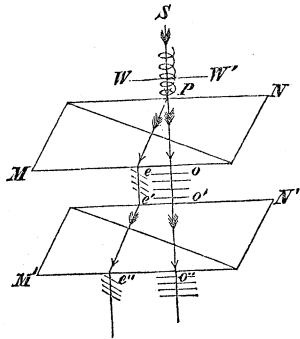

Fig. 104.

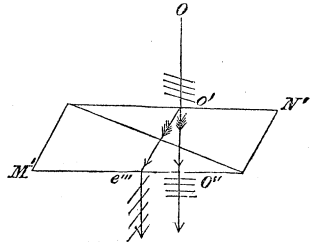
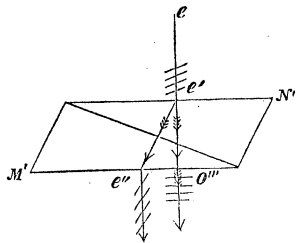

Fig. 105.





$\alpha$ , the angle made by the principal sections of the crystals;  $O_o$ , the intensity of the ordinarily refracted wave; and  $O_e$ , that of the wave refracted according to the extraordinary law.

Removing the wafer from  $e$ , and calling  $E_e$  and  $E_o$  the intensities of the extraordinary and ordinary waves into which the wave moving on  $P_e$  is separated by the second crystal, and  $B$  its intensity on leaving the first crystal, we shall, in like manner, have

$$\left. \begin{aligned} E_e &= B \cdot \cos^2 \alpha \\ E_o &= B \cdot \sin^2 \alpha \end{aligned} \right\} \dots \dots \dots (114) \quad \begin{array}{l} \text{Components of} \\ \text{the extraordinary} \\ \text{wave;} \end{array}$$

Taking the sum of the four emergent waves, there will result,

$$O_o + O_e + E_e + E_o = A + B. \quad \begin{array}{l} \text{Sum of the four} \\ \text{emergent waves.} \end{array}$$

The waves  $O_o$  and  $O_e$ , in Equations (113), are always found to be polarized, the former in the plane of principal section of the second crystal, the latter in a plane at right angles to it; and the same remark being applicable to  $E_o$  and  $E_e$ , in Equations (114), it follows that the planes of polarization of  $O_o$  and  $E_o$  will be parallel to each other, as also those of  $O_e$  and  $E_e$ .

Positions of the planes of polarization.

CIRCULAR POLARIZATION.

§ 150. We have seen, § 132, in what circular polarization consists. The best method of producing this, is by means of what is called *Fresnel's rhomb*, which consists of a parallelepipedon of St. Gobain's glass cut so that

Circular polarization produced;

Fresnel's rhomb; the angles  $M$  and  $M'$  shall each be equal to  $54\frac{1}{2}^\circ$ . When a plane polarized wave is incident upon the face  $MN$ ,

Fig. 106.

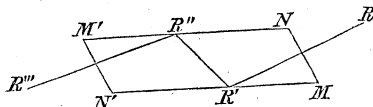

parallel to its front, this wave will be totally reflected at  $R'$  and  $R''$ , and will emerge parallel to the face  $M'N'$ . If the plane of polarization be inclined at an angle of  $45^\circ$  to the plane of reflexion, the component waves will have the same intensity, their difference of phase after two reflexions will be found equal to one-fourth of a wave length, and the emergent light will, therefore, Equations (107) and (108), be *circularly polarized*.

Light circularly polarized.

Effect of transmitting the emergent wave through a second rhomb.

If the emergent wave be now made to undergo two more total reflexions, in the same plane and at the same angle, by transmitting it through a second rhomb, placed parallel to the first, it will emerge *plane polarized*; and its plane of polarization will be inclined  $45^\circ$  on the other side of the plane of reflexion.

Circularly polarized light distinguished from common, and from plane polarized light.

This property enables us to distinguish at once a circularly polarized wave from a wave of common light; *the former becomes plane polarized by two total reflexions, at an angle of  $54\frac{1}{2}^\circ$* . On the other hand, it is at once distinguished from plane polarized light, by the circumstance that it is divided into two waves of equal intensity by a doubly refracting crystal, whatever be the position of the plane of principal section.

Effect of metallic reflectors on plane polarized light.

§ 151. We might naturally conjecture that the effects produced by *metals* upon the reflected light would be analogous to the phenomena of total reflexion by glass and other transparent substances,—there being no transmitted wave in either case. It is accordingly found that when a plane polarized wave is incident upon a metallic reflector, the reflected light is *elliptically polarized*; the laws of the phenomena are, however, different from those of total reflexion from transparent media.

§ 152. It has been observed, that when a polarized wave is passed through a doubly refracting crystal in the direction of its optical axis, it undergoes no change, the analyzer producing the same effect after as before transmission on being offered to the same side of the ray.

To this, however, there are some remarkable exceptions, one of the most conspicuous of which is exhibited by rock crystal, or quartz. When the analyzer is in the position affording no reflexion, the interposition of a crystal of this substance will restore a portion of light, and to cause it to disappear, the analyzer must be turned through *a certain angle* about the ray, the magnitude of this angle depending upon the thickness of the interposed quartz. As the thickness of the mineral is increased, the rotation of the analyzer must be continued. The plane of polarization is thus twisted into a surface of double curvature resembling the turns of an auger, or the surface generated by the rotation of one right line about another perpendicular to it, at the same time that it has a motion of translation along this second line.

It has been found that for a given thickness, the arc of rotation necessary to bring the analyzer into the position of evanescence is different for the differently colored waves, this arc being given by the formula

$$r = \frac{k t}{\lambda^2};$$

Formula for a single substance;

in which  $r$  represents the arc,  $k$  a constant,  $t$  the thickness, and  $\lambda$  the wave length for the particular color.

It has also been ascertained, that for some specimens of quartz, it was necessary to turn the analyzer in one direction, while for others, in an opposite direction, and that a singular connection exists between this property and the right or left handed direction in which certain small faces of the crystal lean around the summit of the variety called plagiedral quartz.

Other bodies, besides quartz, possess the same property,

Other bodies possess the same property ;

but in different degrees ; and if two of these bodies be interposed, the arc of rotation is that due to the sum or difference of their thicknesses, according as they exert their effects in the same or opposite directions. Or more generally,

Formula for a combination ;

$$R T = r t + r' t' + r'' t'' + \&c.,$$

Notation explained ;

in which  $R$  is the rotation due to the combination ;  $T$  its entire thickness ;  $r, r', \&c.$ , and  $t, t', \&c.$ , the corresponding quantities answering to the several individuals of the combination ; the products entering the expression with the same or different signs, according as the different media tend to turn the plane of polarization in the same or different directions. This formula is found to hold good not only with solid crystals, but also with liquids possessing this property, when mixed together.

Applies also to liquids.

#### CHROMATICS OF POLARIZED LIGHT.

Introductory remarks ;

§ 153. Having explained the general phenomena of polarization and double refraction, we pass to the consideration of the effects produced when polarized light is transmitted through crystalline substances. The phenomena displayed in such cases, are among the most splendid in optics ; and when we consider that through these phenomena we are enabled almost to view the interior structure and molecular arrangement of natural bodies, the importance of the subject will be apparent.

First discoveries.

The first discoveries in this department of science were made by ARAGO, in the year 1811, and the subject has since been successfully prosecuted by some of the first philosophers of Europe.

§ 154. We have seen that when a wave of light, polarized by reflexion, is incident upon the analyzer under the polarizing angle, no reflexion will take place when

the plane of incidence on the analyzer is perpendicular to that on the polarizer. Now, if between the two reflectors we interpose a plate of any double-refracting substance, the power of reflexion at the analyzer is suddenly restored, and a portion of the light is reflected, the quantity depending on the position of the interposed crystal; and by this property the double-refracting structure has been detected in a vast variety of substances, in which the separation of the two waves was too small to be directly perceived.

Effect of transmitting polarized light through a double-refracting crystal.

§ 155. In order to analyze this phenomenon, let the crystalline plate be placed so as to receive the polarized wave parallel to its surface, and let it be turned round in its own plane. We shall then observe that there are two positions of the plate in which the light totally disappears, and the reflected wave vanishes, just as if no crystal had been interposed. These two positions are at right angles to one another; and they are those in which the *principal section* of the crystal *coincides with the plane of first reflexion*, or is *perpendicular to it*. When the plate is turned round, from either of these positions, the light gradually increases, until the principal section is inclined at an angle of  $45^\circ$  to the plane of first reflexion, when it becomes a *maximum*.

These effects analyzed by turning the crystal in its own plane;

When no light is reflected from the analyzer;

When the amount is a maximum.

§ 156. In these experiments the reflected light is *white*. But if the interposed crystalline plate be very thin, the most gorgeous colors appear, which vary with every change of inclination of the plate to the polarized wave. *Mica* and *sulphate of lime* are very appropriate for the exhibition of these beautiful phenomena, because they can be readily divided by cleavage into laminæ of almost any required thinness. If a thin plate of either of these substances be placed so as to receive the polarized wave parallel to its surface, and be then turned round in its own plane, the tint does not change, but varies only in intensity; the color *vanishing* altogether when the prin-

Colors produced by very thin plates;

Mica and sulphate of lime;

Appearances exhibited by using these substances;

When the light disappears and when it is a maximum.

pal section of the crystal coincides with the plane of primitive polarization, or is perpendicular to it,—and, reaching a *maximum*, when it is inclined to the plane of primitive polarization at an angle of  $45^\circ$ .

The crystal fixed and the analyzer turned ;

§ 157. If, on the other hand, the crystal be fixed, and the analyzer be turned, so as to vary the inclination of the plane of the second reflexion to that of the first, the color will be observed to pass, through every grade of the same tint, into the complementary color ; it being always found that the light reflected in any one position of the analyzer is *complementary*, both in color and intensity, to that which it reflects in a position  $90^\circ$  from the former. This curious relation will appear more evidently, if we substitute a double refracting prism for the analyzer ; for the two waves refracted by the prism have their planes of polarization—one coinciding with the principal section of the prism, and the other at right angles to it, and are therefore in the same condition as the light reflected by the analyzer, with its plane of reflexion successively in these two positions. In this manner the complementary colors are seen together, and may be easily compared. But the accuracy of the relation stated is completely established by making these two waves partially overlap ; for, whatever be their separate tints, it will be found that the part in which they are superposed is absolutely *white*.

Positions giving complementary colors.

Doublerefracting crystal substituted for the analyzer ;

Effect of causing the tints to overlap.

Effect of plates of variable thicknesses ;

§ 158. When laminae of different thicknesses are interposed between the polarizer and analyzer, so as to receive the polarized wave parallel to their surfaces, the tints are found to vary with the thickness. The colors produced by plates of the same crystal, of different thicknesses, follow, in fact, the same law as the colors reflected from *thin plates* of air ; the tints *rising in the scale* as the thickness is diminished, until finally, when this thickness is reduced below a certain limit, the colors disappear altogether, and the central space appears *black*, as

Law followed by the colors ;

when the crystal is removed. The thickness producing corresponding tints is, however, much greater in crystal-  
 line plates exposed to polarized light, than in thin plates  
 of air, or any other medium of homogeneous structure. Results of experiments;  
 The *black of the first order* appears in a plate of sul-  
 phate of lime, when the thickness is the  $\frac{1}{20000}$  of an inch;  
 between  $\frac{1}{20000}$  and  $\frac{1}{5000}$  of an inch, we have the whole  
 succession of colors of Newton's scale; and when the  
 thickness exceeds the latter limit, the transmitted light  
 is always *white*. The tint produced by a plate of mica, Effects of different substances compared.  
 in polarized light, is the same as that reflected from a  
 plate of air of only the  $\frac{1}{4000}$ th part of the thickness.

The same subject has been investigated for *oblique* in-  
 cidences, and the laws which connect the tint developed Oblique incidences.  
 with the number of wave lengths and parts of a length  
 within the crystal, for a wave of given refrangibility,  
 have been determined, both for uniaxal and biaxal crys-  
 tals.

§ 159. Let us now apply the principles already estab-  
 lished, to explain the appearances. Application of preceding principles;

It has been shown, that a wave of common light, on  
 entering a crystalline plate, is resolved into two waves,  
 which traverse the crystal with different velocities, and in  
 different directions. One of these waves, therefore, will  
 lag behind the other, and they will be in *different phases*  
 of vibration at emergence. When the plate is thin, this Preliminary remarks;  
*retardation* of one wave upon the other will amount only  
 to a few wave lengths and parts of a length; and it  
 would, therefore, appear that we have here all the condi-  
 tions necessary for their *interference*, and the consequent  
 production of color.

But here we are met by a difficulty. So far as this An apparent difficulty arises;  
 explanation goes, the phenomena of interference and of  
 color should be produced by the crystalline plate alone,  
 and in common light, without either polarizing or ana-  
 lyzing plate. Such, however, is not the fact; and the  
 real difficulty in this case is,—not so much to explain

Its solution ; how the phenomena *are* produced, as to show why they are *not always* produced.

In seeking for a solution of this difficulty, it may be remarked, that the two waves, whose interference is supposed to produce the observed results, are not precisely in the condition of those whose interference we have hitherto examined; they are *polarized*, and in *planes* at right angles to each other. We are led, then, to inquire whether there is anything peculiar to the interference of polarized waves which may influence these results; and the answer to this inquiry will be found to remove the difficulty.

Inquiry suggested.

Experimental researches on the interference of polarized light;

§ 160. The subject of the *interference of polarized light* was examined, with reference to this question, by FRESNEL and ARAGO, and its laws experimentally developed. It was found that two waves of light, *polarized in the same plane*, interfere and produce fringes, under the same circumstances as two waves of common light;—that when the planes of polarization of the two waves are *inclined* to each other, the interference is diminished, and the fringes decrease in intensity; and that, finally, when the angle between these planes is a *right angle*, no fringes whatever are produced, and the waves no longer interfere at all. These facts may be established by taking a plate of tourmaline which has been carefully worked to a uniform thickness, cutting it in two, and placing one-half in the path of each of the interfering waves. It will be thus found that the intensity of the fringes depends on the relative position of the axes of the tourmalines. When these axes are parallel, and consequently the two waves polarized in the same plane, the fringes are best defined; they decrease in intensity when the axes of the tourmalines are *inclined* to one another; and, finally, they vanish altogether when these axes form a *right angle*.

Rules deduced.

Experimental illustration.

§ 161. The non-interference of waves, polarized in



planes at right angles to one another, is a necessary result of the mechanical theory of *transversal* vibrations. In fact, it is a mathematical consequence of that theory, that the intensity of the resultant light in that case is *constant*, and equal to the *sum* of the intensities of the two component waves, whatever be the phases of vibration in which they meet.

Experiments confirm the mechanical theory of transversal vibrations.

But although the intensity of the light does not vary with the phase of the component vibrations, the character of the resulting vibration will. It appears from Equation (107), that two rectilinear and rectangular vibrations compose a single vibration, which will be also *rectilinear* when the phases of the component vibrations differ by an exact number of semi-wave lengths; that, in all other cases, the resulting vibration will be *elliptic*; and that the ellipse will become a *circle*, when the component vibrations have equal amplitudes, and the difference of their phases is an odd multiple of a quarter of a wave length. These results have been completely confirmed by experiment.

Results of this theory and their experimental confirmation.

In the above mentioned law we find the explanation of the fact, that no phenomena of interference or color are produced, under ordinary circumstances, by the two waves which emerge from a crystalline plate,—for these waves are polarized in planes at right angles to one another; and we see that, to produce the phenomena of color in perfection, the planes of polarization of the two waves must be brought to coincide by the analyzer.

Apparent difficulty of § 159 removed.

§ 162. FRESNEL and ARAGO discovered, further, that two waves polarized in planes at right angles to each other, will not interfere, even when their planes of polarization are made to coincide, unless they belong to a wave, the whole of which was originally *polarized in one plane*; and that, in the interference of waves which had undergone double refraction, *half a wave length* must be supposed to be *lost* or *gained*, in passing from the ordinary to the extraordinary system,—just as in the transi-

Law deduced from experiment;

Another confirmation of the theory of transversal vibrations ;

tion from the reflected to the transmitted system, in the colors formed by thin plates.

Experiment detailed ;

The principle of the allowance of half a wave length is a beautiful and simple consequence of the theory of transversal vibrations. In fact, the vibration of the wave incident on the crystal is resolved into two within it, at right angles to one another,—one in the plane of principal section, and the other in a plane perpendicular to it. Each of these must be again resolved, in two fixed directions which are also perpendicular ; and it will easily appear from the process of resolution, that, of the four components into which the original vibration is thus resolved, the pair in one of the final directions must *conspire*, while in the other, at right angles to it, they are opposed. Accordingly, if the vibrations of the one pair be regarded as coincident, those of the other must *differ by half a wave length*. Hence, when the plane of reflexion of the analyzer coincides successively with these two positions, the colors, which result from the interference of the portions *in the plane of reflexion*, those in the perpendicular plane being not reflected, will be *complementary*.

Complementary colors.

Office of the polarizer ;

§ 163. The former of the two laws explains the office of the polarizer in the phenomena. To account mechanically for the non-interference of the two waves, when the light incident upon the crystal is unpolarized, we may, § 133, regard a wave of common light as composed of two waves of equal intensity, polarized in planes at right angles to one another, and whose vibrations are therefore perpendicular. Each of these vibrations, when resolved into two within the crystal, and these two again resolved in the plane of reflexion of the analyzer, will exhibit the phenomena of interference. But the amount of retardation will differ by half a wave length in the two cases ; the tints produced will therefore be complementary, and the light resulting from their union will be white.

Explanation of appearances.

§ 164. The preceding laws of interference being kept in mind, the reason of all the phenomena is apparent. The wave is originally polarized in a single plane, by means of the polarizer; it is then resolved into two waves within the crystal, which are polarized in planes at right angles to each other; and these are finally reduced to the same plane by means of the analyzer. The two waves will, therefore, interfere, and the resulting tint will depend on the *retardation* of one of the waves behind the other, produced by the difference of the velocities with which they traverse the crystal.

Reason of the  
phenomena;

Resultant tint  
dependent upon;

§ 165. It is plain, Equation (107), that the light issuing from the crystal is, in general, *elliptically polarized*, inasmuch as it is the resultant of two waves, in which the vibrations are at right angles, and differ in phase. Hence, when homogeneous light is used, and the emergent wave is analyzed with a double-refracting prism, the two waves into which it is divided vary in intensity as the prism is turned, neither, in general, ever vanishing. When, however, the thickness of the crystal is such that the difference of phase of the two waves is an *exact number of semi-wave lengths*, they will constitute a *plane polarized* wave at emergence,—the plane of polarization either coinciding with the plane of primitive polarization, or making an equal angle with the principal section of the crystal on the other side, according as the difference of phase is an even or odd multiple of half a wave length. Accordingly, one of the waves into which the light is divided by the analyzing prism, will vanish in two positions of its principal section; and it is manifest that the successive thicknesses of the crystalline plate, at which this takes place, form a series in arithmetical progression. On the other hand, when the difference of phase is a *quarter of a wave length*, or an odd multiple of that quantity,—and when, at the same time, the principal section of the crystal is inclined at an angle of  $45^\circ$  to the plane of primitive polarization—the emergent light will be

Emergent light,  
in general is  
elliptically  
polarized;

When the  
thickness gives  
the difference of  
phase an exact  
number of  
semi-wave  
lengths;

When the  
difference of  
phase is a  
quarter of a  
wave length,

Circular polarization perfect for one color only.

*circularly polarized*. This is one of the simplest means of obtaining a circularly polarized wave; but it has the disadvantage, that the required interval of phase can only be exact for waves of one particular length, and that, therefore, the circular polarization is perfect only for one particular color.

Color may be produced with thick plates;

§ 166. We have seen that the phenomena of color are only produced when the crystalline plate is thin. In thick plates, where the difference of phase of the two waves contains a great many wave lengths, the tints of different orders come to be superposed (as in the case of NEWTON'S rings, where the thickness of the plate of air is considerable), and the resulting light is white. The phenomena of color may still, however, be produced in thick plates, by superposing two of them in such a manner, that the wave which has the greater velocity in the first shall have the less in the second. We have only to place the plates with their principal sections *perpendicular* or *parallel*, according as the crystals to which they belong are of the *same*, or of *opposite* denominations. Thus, if both the crystals be positive, or both negative, they are to be placed with their principal sections perpendicular; and on the other hand, these sections should be parallel, when one of the crystals is positive and the other negative. The reason of this is evident.

Method explained.

Effects produced when a polarized wave traverses a uniaxial crystal;

§ 167. Let us now consider the effects produced when a polarized wave traverses a *uniaxial* crystal, in various directions inclined to the axis at small angles; and let us suppose, for more simplicity, that the crystalline plate is cut in a direction perpendicular to the axis.

Let  $ABCD$  be the plate, and  $E$  the place of the eye. The visible portion of the emergent beam will form a cone,  $AEB$ , whose vertex coincides

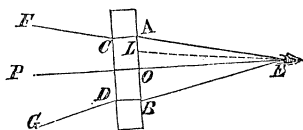

Fig. 107.

with the place of the eye, and axis  $EO$ , with the axis of the crystal. The ray which traverses the crystal in the direction of the axis,  $POE$ , will undergo no change whatever; and will consequently be reflected or not from the analyzing plate, according as the plane of reflexion there coincides with, or is perpendicular to, the plane of first reflexion. But the other rays composing the cone will be modified in their passage through the crystal, and the changes which they will undergo will depend on their inclination to the optical axis, and on the position of the principal section with respect to the plane of primitive polarization.

Ray coinciding with the axis undergoes no change;

Other rays will be modified.

Let the circle represent the section of the emergent cone of rays made by the surface  $AB$  of the crystal; and let  $MM'$  and  $NN'$ , be two lines drawn through its centre at right angles, being the intersection of the same surface by the plane of primitive polarization, and by the perpendicular plane, respectively. Now, the vibrations which emerge at any

point of these lines will not be resolved into two within the crystal, nor will their places of polarization, that is, of vibration, be altered; because the principal section of

Vibrations that will not be resolved;

Fig. 108.

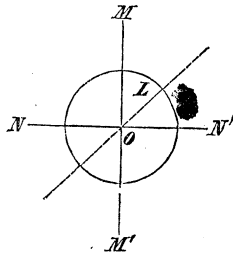

Section of the emergent pencil by the face of the crystal;

Fig. 109.

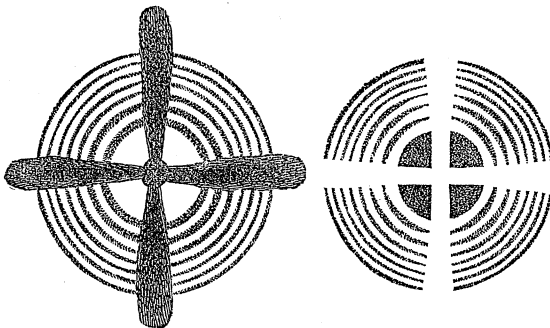

Illustrations;

Fig. 100.

Illustrations;

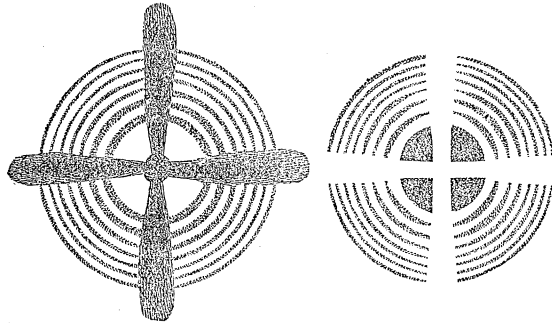

Vibrations that will not be resolved;

the crystal, for these vibrations, in the one case coincides with the plane of primitive polarization, and in the other is perpendicular to it. These waves, therefore, will be reflected, or not, from the analyzer, according as the plane of reflexion there coincides with, or is perpendicular to, the plane of first reflexion. In the latter case, a *black cross* will be displayed on the screen, and in the former a white one.

White or black cross.

Vibrations that will be resolved;

But the case is different with the vibrations which emerge at any other point, such as *L*. The principal section of the crystal for these vibrations, neither coincides with, nor is perpendicular to, the plane of primitive polarization; and consequently the incident polarized wave will be resolved into two, within the crystal, whose planes of polarization are respectively parallel and perpendicular to the principal section *OL*. The vibrations in these two

Fig. 107.

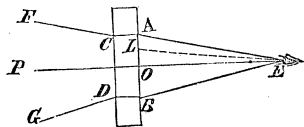

Reduced to the same plane by the analyzer, and interfere.

waves are reduced to the same plane by means of the analyzer; they will, therefore, interfere, and the extent of that interference will depend upon their difference of phase.

Now, the difference of phase of the two waves varies with the interval of retardation. When this interval is an odd multiple of half a wave length, the two waves will be in complete discordance; and, on the other hand, they will be in complete accordance, and will unite their strength, when the retardation is an even multiple of the same quantity. The successive dark and bright lines will, therefore, be arranged in circles.

Extent of interference dependent on difference of phase.

§ 168. We have been speaking here of *homogeneous* light. When white or compound light is used, the rings of different colors will be partially superposed, and the result will be a series of iris-colored rings separated by dark intervals. All the phenomena, in fact, with the exception of the cross, are similar to those of NEWTON'S rings; and we now see that they are both cases of the same fertile principle,—the principle of interference. These rings are exhibited even in *thick* crystals, because the difference of the velocities of the two waves is very small for rays slightly inclined to the optic axis.

Phenomena produced with white light.

Analogous to Newton's rings

Fig. 110.

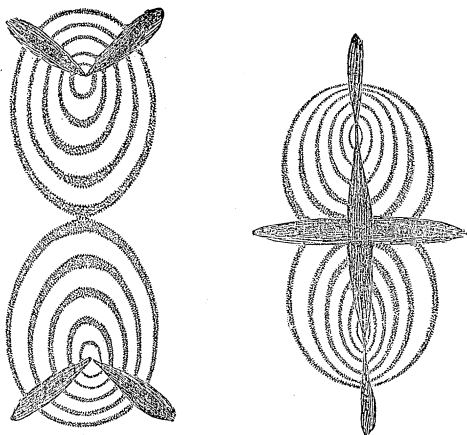

Illustrations ;

§ 169. We will now consider briefly the case of *biaxial* crystals. Let a plate of such a crystal be cut perpen-

Effects of biaxal  
crystals.

dicularly to the line bisecting the optic axes, and let it be interposed, as before, between the polarizer and analyzer. In this case, the bright and dark bands will no longer be disposed in circles, as in the former, but will form curves which are symmetrical with respect to the lines drawn from the eye in the direction of the two axes. The points of the same band are those for which the *interval of retardation* of the two waves, is *constant*.

Lemniscatæ and  
their  
fundamental  
property;

The curve formed by each band is the *Lemniscata* of JAMES BERNOULLI,—the fundamental property of which is, that the product of the radii vectores, drawn from any point to two fixed poles, is a constant quantity. The exactness of this law has been verified, in the most complete manner, by the measurements of Sir JOHN HERSCHEL. The constant varies from one curve to another,—being proportional to the interval of retardation, and increasing, therefore, as the numbers of the natural series for the successive dark bands; for different plates of the same substance, the constant varies inversely as the thickness.

Form of the  
dark brushes  
determined.

The form of the *dark brushes*, which cross the entire system of rings, is determined by the law which governs the planes of polarization of the emergent waves. It may be shown that two such dark curves, in general, pass through each pole; and that they are *rectangular hyperbolas*, whose common centre is the middle point of the line which connects the projections of the two axes.

END OF OPTICS.



# APPENDIX.

## No. I.

Suppose a general wave front, sensibly plane, to have reached an opening  $AB$ , in a partition  $MN$ ; it is proposed to find the displacement which it will produce in a molecule situated behind and anywhere, as at  $O$ , on the arc of a semi-circle  $MON$ , of which the plane is normal to the partition, and the centre at the middle point of the opening.

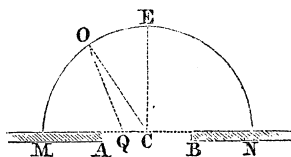

Take any molecule as  $Q$ ; draw  $OQ$  and  $OC$ ; make  $CO = r$ ;  $QO = y$ ;  $CQ = z$ ;  $CA = b$ ; the angle  $OCQ = \theta$ ; and denote the whole displacement at  $O$  by  $D$ , then

$$y = \sqrt{r^2 - 2r \cos \theta z + z^2},$$

and by Maclaurin's formula,

$$y = r - \cos \theta \cdot z + \frac{\sin^2 \theta}{2r} \cdot z^2 - \&c. \quad \dots \quad (a)$$

The displacement at  $O$ , produced by the wave from  $Q$ , will, Eq. (19), be

$$\frac{a}{y} \cdot \sin \left[ 2\pi \frac{Vt - y}{\lambda} \right];$$

and from the molecules in the distance  $dz$ ,

$$\frac{a dz}{y} \cdot \sin \left[ 2\pi \cdot \frac{Vt - y}{\lambda} \right];$$

and from those in the entire distance  $AB$ ,

$$D = \int_{-b}^{+b} \frac{a \cdot dz}{y} \cdot \sin \left[ 2\pi \cdot \frac{Vt - y}{\lambda} \right] \cdot \dots \quad (b)$$

To facilitate the integration, suppose the greatest value of  $z$  to be very small

as compared to  $r$ , and also the greatest displacements at  $O$ , by the partial waves from the molecules on  $A B$ , to be equal to one another, then will, Equation (a),

$$y = r - \cos \theta z,$$

and writing  $r$  for  $y$  in the coefficient of the circular function, Equation (b) becomes,

$$D = \frac{a}{r} \int_{-b}^{+b} \sin \frac{2\pi}{\lambda} (Vt - r + \cos \theta z) dz;$$

and performing the integration without regard to limits,

$$D = -\frac{a\lambda}{2\pi r \cos \theta} \cdot \cos \frac{2\pi}{\lambda} (Vt - r + \cos \theta z);$$

and between the limits  $-b$  and  $+b$ ,

$$D = \frac{a\lambda}{2\pi r \cos \theta} \cdot \left[ \cos \frac{2\pi}{\lambda} (Vt - r - \cos \theta b) - \cos \frac{2\pi}{\lambda} (Vt - r + \cos \theta b) \right];$$

or,

$$D = \frac{a\lambda}{\pi r \cos \theta} \cdot \sin \frac{2\pi b \cos \theta}{\lambda} \cdot \sin \left[ 2\pi \cdot \frac{Vt - r}{\lambda} \right].$$

This represents a displacement whose maximum is

$$D_i = \frac{a\lambda}{\pi r \cos \theta} \cdot \sin \frac{2\pi b \cos \theta}{\lambda}, \quad \dots \dots \dots (c)$$

and which, therefore, determines the intensity of sound in air, or of light in ether.

But this becomes zero for such values of  $\theta$ , as make  $b \cdot \cos \theta \div \lambda$ , equal to either of the following numbers, viz:

$$\frac{1}{2}, \quad \frac{3}{2}, \quad \frac{5}{2}, \quad \frac{7}{2}, \quad \&c.,$$

or which is the same thing, make  $b \cos \theta$ , equal to either of the quantities

$$\frac{\lambda}{2}, \quad \frac{3\lambda}{2}, \quad \frac{5\lambda}{2}, \quad \frac{7\lambda}{2}, \quad \&c.$$

So that, when the radius  $r$  is very great, in comparison with  $b$ , there will be upon the semicircular arc alternate places of sound or silence, light or

darkness, symmetrically disposed upon either side of the point  $E$ , corresponding to which  $\theta$  is  $90^\circ$ .

Sound decays rapidly as the distance it has travelled increases, and within the range of ordinary experience  $r$  cannot be very great. The relation assumed between  $r$  and  $b$ , to integrate Equation (b), can only be obtained, therefore, for audible sounds, by making  $b$  very small. And since  $\lambda$  may be many feet, let us take the case in which the fraction  $\frac{b}{\lambda}$  is so small as to justify the substitution of the arc

$$\frac{2\pi b \cos \theta}{\lambda},$$

in Equation (c), for its sine; in which case the intensity will be determined by

$$D_i = \frac{a\lambda}{\pi r \cos \theta} \cdot \frac{2\pi b \cos \theta}{\lambda} = \frac{2ab}{r};$$

in other words, the sound passing through a small opening will be diffused with equal intensity in every direction behind the partition.

Light follows the same law of decay as sound, but the value of  $\lambda$  for the waves of ether being extremely small, the greatest not exceeding the 0,0000266 of an inch, the limitations supposed with regard to the fraction  $\frac{b}{\lambda}$ , in the case of sound, will not apply in that of light, and there must exist the alternations of light and shade above referred to.

When  $\theta$  approaches nearly to  $90^\circ$ ,  $\cos \theta$  will be exceedingly small, and the arc  $2\pi b \cos \theta \div \lambda$  may again be substituted for its sine, in which case, Equation (c),

$$D_i' = \frac{2ab}{r};$$

which determines the intensity directly opposite the opening. The maximum value for  $D_i$  in Equation (c), will arise when

$$\sin \frac{2\pi \cdot b \cdot \cos \theta}{\lambda} = \pm 1,$$

which gives, Equation (c),

$$D_i'' = \frac{a\lambda}{\pi r \cos \theta};$$

and as the intensity of light varies as the square of the greatest displacement, § 53, we have

$$(D_i')^2 : (D_i'')^2 :: \frac{4 a^2 b^2}{r^2} : \frac{a^2 \lambda^2}{\pi^2 r^2 \cos^2 \theta};$$

whence

$$(D_i'')^2 = (D_i')^2 \cdot \frac{\lambda^2}{4 \pi^2 \cdot b^2 \cos^2 \theta} \cdot \dots \dots \dots (d)$$

Substituting the value of  $\lambda$  for the longest wave of light, it is obvious that for any appreciable value for the  $\cos \theta$ , the intensity of light becomes insignificant, and the only sensible illumination will be immediately opposite the opening. This explains the rectilinear propagation of light; and why it is, "*we may not see, and yet may hear around a corner.*"

No. II.

Differentiating Equation (11), we have

$$d \delta = d \varphi + d \psi = \left( \frac{d \psi}{d \varphi} + 1 \right) d \varphi = 0,$$

or

$$\frac{d \psi}{d \varphi} + 1 = 0; \dots \dots \dots (a)$$

differentiating Equations (3) and (3)', we obtain from them

$$\frac{d \psi}{d \varphi} = \frac{\cos \varphi}{\cos \varphi'} \cdot \frac{\cos \psi'}{\cos \psi} \cdot \frac{d \psi'}{d \varphi'}, \dots \dots \dots (b)$$

and from Equation (10),

$$\frac{d \psi'}{d \varphi'} = -1;$$

and this, combined with Equations (a) and (b), gives

$$\frac{\cos \varphi}{\cos \varphi'} \cdot \frac{\cos \psi'}{\cos \psi} = 1;$$

which will be satisfied by making

$$\varphi = \psi; \quad \varphi' = \psi'.$$

That is, the deviation becomes a minimum when the angles of incidence and of emergence are equal.

No. III.

Differentiating Equation (104), we find

$$\frac{d\delta}{d\varphi} = \mp \left[ 2 - 2(n+1) \frac{d\varphi'}{d\varphi} \right] = 0; \dots \dots \dots (a)$$

and from Equation (105),

$$\frac{d\varphi'}{d\varphi} = \frac{\cos\varphi}{m \cdot \cos\varphi'};$$

which substituted above, gives,

$$\mp \left[ 2 - 2(n+1) \frac{\cos\varphi}{m \cos\varphi'} \right] = 0;$$

whence

$$\frac{1}{n+1} = \frac{\cos\varphi}{m \cos\varphi'},$$

which is the first equation of § 126.

Differentiating Equation (a) again, we find

$$\frac{d^2\delta}{d\varphi^2} = \mp \left[ \frac{2(n+1)}{m^2} \cdot \frac{\sin\varphi'}{\cos^3\varphi'} \cdot (m^2 \cos^2\varphi' - \cos^2\varphi) \right];$$

and since  $\varphi > \varphi'$ ,  $\cos\varphi < \cos\varphi'$ ; therefore the last factor must be positive; whence  $\delta$  is a *maximum* in the primary, and a *minimum* in the secondary bow.















