



OFFICE COPY  
DO NOT REMOVE

NOV 23 1984

**1981 C.B. ANNUAL REPORT**  
**VOLUME 2A**  
**VOLUME 2 SUPPORTING DATA**



**CATHEDRAL BLUFFS SHALE OIL COMPANY**

751 HORIZON COURT

GRAND JUNCTION, COLORADO 81501

APRIL 30, 1982

TN  
859  
.C64  
1981  
v.2a







#1128742461

10 : 88074618

TN  
859  
.C64  
C3743  
1981  
V.2a

1981 C.B. ANNUAL REPORT

VOLUME 2A

Volume 2 Supporting Data

April 30, 1982

Submitted by:

CATHEDRAL BLUFFS SHALE OIL COMPANY  
751 Horizon Court  
Grand Junction, Colorado 81501

to:

Mr. Peter A. Rutledge  
Deputy Minerals Manager for Oil Shale  
Oil Shale Office  
USDI - Minerals Management Service  
131 N. 6th Street - Suite 300  
Grand Junction, Colorado 81501

BLM Library  
Denver Federal Center  
Bldg. 50, OC-521  
P.O. Box 25047  
Denver, CO 80225







FOREWORD

The 1981 C.B. ANNUAL REPORT is submitted to fulfill the requirements of Oil Shale Lease Number C-20341 as stated in Section 16(b) of the Lease, Section 1.(C)(4) of the Lease Environmental Stipulations, and Condition of Approval (No. 3) of the Detailed Development Plan issued on August 30, 1977. This report consists of the following volumes:

Volume 1 - Summary of Development Activities, Costs and Environmental Monitoring

Volume 2 - Environmental Analysis

Volume 2A - Volume 2 Supporting Data



## USERS' GUIDE TO VOLUME 2A

Volume 2A contains supporting data for the 1981 C.B. ANNUAL REPORT, VOLUME 2, ENVIRONMENTAL ANALYSIS. These data appear in the form of supporting analyses, figures, and tables.

### APPENDIX 2A

A Table of Appendices, a List of Tables, and a List of Figures, which are referenced in Volume 2 as belonging in Appendix 2A, are provided for this Appendix.

Numbers assigned to supporting appendices, tables and figures serve as a cross reference to section designations. The second- and third-level numbers correspond to the same second- and third-level section numbers in Volume 2 (e.g., Table A5.2.1-1 contains supporting data for Section 5.2.1 of Volume 2, while Appendix A5.3.2 contains supporting data for Section 5.3.2 of Volume 2). All supporting appendices, tables, and figures appear in alpha-numerical order by section number.

### APPENDICES 2B-2D

Appendices 2B to 2D are supporting reports and papers for Chapter 5 of Volume 2, Hydrology.



TABLE OF CONTENTS

	<u>Page No.</u>
Foreword . . . . .	i
Users' Guide to Volume 2A . . . . .	ii
Table of Contents . . . . .	iii
Appendix 2A Supporting Tables and Graphs for Volume 2 . . . . .	2A-1
Chapter 2.0 Tract Development Schedule and Maps . . . . .	2A2-1
Chapter 5.0 Hydrology and Water Quality . . . . .	2A5-1
Chapter 6.0 Air Quality and Meteorology . . . . .	2A6-1
Chapter 8.0 Biology . . . . .	2A8-1a
Appendix 2B <u>Geohydrological Study of Reinjection</u> <u>C-b Tract, Piceance Basin, Colorado</u> . . . . .	2B-1
Appendix 2C <u>Temperature Logging and Application of</u> <u>Downhole Temperature Logging in Hydrologic</u> <u>and Stratigraphic Evaluation, C-B Tract:</u> <u>Piceance Basin, Colorado</u> . . . . .	2C-1
Appendix 2D <u>Some Questions on Piceance Basin Hydrology</u> . . . . .	2D-1
Appendix 2E <u>Results of the Geologic Mapping Program</u> <u>During Shaft Sinking and Subsequent Station</u> <u>Development at C-B Tract</u> . . . . .	2E-1







CHAPTER 2  
Track Development Schedule and Plans

Table/Figure	Title	Page
Table 2.2-2	Component Code and Designation List, Cross-Reference	20-1

APPENDIX 2A

SUPPORTING TABLES AND GRAPHS FOR  
VOLUME 2







CHAPTER 2.0

Tract Development Schedule and Maps

<u>Table/Figure</u>	<u>Title</u>	<u>Page</u>
Table A2.2-2	Computer Code and Station I.D. Cross-Reference . . . . .	2A2-2

<u>Computer Code</u>	<u>Station I.D.</u>
BA01	150
BA02	151
BA03	152
BA04	153
BA05	154
BA06	155
BA07	156
BA08	157
BA09	158
BA10	159
BA11	160
BA12	161
BA13	162
BA14	163
BA15	164
BA16	165
BA17	166
BA18	167
BA19	168
BA20	169
BA21	170
BA22	171
BA23	172
BA24	173
BA25	174
BA26	175
BA27	176
BA28	177
BA29	178
BA30	179
BA31	180
BA32	181
BA33	182
BA34	183
BA35	184
BA36	185
BA37	186
BA38	187
BA39	188
BA40	189
BA41	190
BA42	191
BA43	192
BA44	193
BA45	194
BA46	195
BA47	196
BA48	197
BA49	198
BA50	199
BA51	200
BA52	201
BA53	202
BA54	203
BA55	204
BA56	205
BA57	206
BA58	207
BA59	208
BA60	209
BA61	210
BA62	211
BA63	212
BA64	213
BA65	214
BA66	215
BA67	216
BA68	217
BA69	218
BA70	219
BA71	220
BA72	221
BA73	222
BA74	223
BA75	224
BA76	225
BA77	226
BA78	227
BA79	228
BA80	229
BA81	230
BA82	231
BA83	232
BA84	233
BA85	234
BA86	235
BA87	236
BA88	237
BA89	238
BA90	239
BA91	240
BA92	241
BA93	242
BA94	243
BA95	244
BA96	245
BA97	246
BA98	247
BA99	248
BA00	249



Table A2.2-2  
COMPUTER CODE AND STATION I.D. CROSS-REFERENCE

I Air Quality & Meteorology

	<u>Station Designation</u>	<u>Computer Code</u>
Met. Tower:	@ Sta. 023	AA23
Trailers:	020	AB20
	021	AB21
	022	AB22
	023	AB23
	024	AB24
Acoustic Radar	Sta. 020	AC20
	021	AC21
	023	AC23
MRI and Particulates	Sta. 031	AD31
	032	AD32
	033	AD33
	041	AD41
	042	AD42
	043	AD43
	044	AD44
	056	AD56
Visibility	View I	AV01
	View II	AV02
	View III	AV03
	View IV	AV04

II Biology

<u>Program</u>	<u>General Location</u>	<u>Computer Code</u>	<u>*Analysis Code</u>
Deer Days Use	Between Hunter Cr. & Jimmy Gulch	BA01	- PJ-CH-C
		BA02	- PJ-CH-C
		BA03	- PJ-CH-C
		BA04	- PJ-CH-C
		BA05	- PJ-CH-C
		BA06	- PJ-CH-C
		BA07	- PJ-CH-C
		BA08	- PJ-CH-C
		BA09	- PJ-CH-C
	North Side, Piceance Creek	BA10	- PJ -D
		BA11	- PJ -D
		BA12	- PJ -D
		BA13	- PJ -C
		BA14	- PJ -C
		BA15	- PJ -C
		BA16	- PJ -D
South Side, Piceance Creek			



Biology (Cont'd)

<u>Program</u>	<u>General Location</u>	<u>Computer Code</u>	<u>*Analysis Code</u>
	On Tract Between Cottonwood & Scandard	BA17	- PJ-CH-C
		BA18	- PJ-CH-C
		BA19	- PJ -C
	On Tract Between Cottonwood & Sorghum	BA20	- PJ-CH-D
		BA21	- PJ-CH-D
		BA22	- PJ -D
	On Tract Between Sorghum & W. Fork Stewart	BA23	- PJ-CH-D
		BA24	- PJ
		BA25	- PJ-CH-C
	On Tract Between W. & M. Fork Stewart	BA26	- PJ -C
		BA27	- PJ -C
	On Tract Between Willow & Scandard North End	BA28	- PJ-CH-C
	On Tract Between Willow & Scandard S.E.	BA29	- PJ-CH-C
	On Tract Between Cottonwood & Sorghum North	BA30	- PJ-CH-C
	On Tract Between Cottonwood & Sorghum South	BA31	- PJ-CH-C

\*ANALYSIS CODES:

PJ-CH-C	- Pinyon Juniper, Chained, Control Station	(12)
PJ -C	- Pinyon Juniper, Control Station	( 6)
PJ-CH-D	- Pinyon Juniper, Chained, Development Station	( 3)
PJ -D	- Pinyon Juniper, Development Station	( 6)



Biology (Cont'd)

Programs: Deer Distribution & Migration and Road Kills

Mile Marker	Location	Computer Code	
		North & East of Piceance Creek Road	Meadows; South & West of Piceance Creek Road
41	White River City	BN41	BM41
40	Piceance Bridge	BN40	BM40
39	Lower Canyon	BN39	BM39
38	Piceance Canyon	BN38	BM38
37	Yellow Creek	BN37	BM37
36	Stinking Springs	BN36	BM36
35	Old Bridge	BN35	BM35
34	Little Hills Turnoff	BN34	BM34
33	Old Corrals & Buildings	BN33	BM33
32	Burk Ranch	BN32	BM32
31	Ranch	BN31	BM31
30		BN30	BM30
29		BN29	BM29
28	Bureau of Mines	BN28	BM28
27	Ryan Gulch	BN27	BM27
26	Pump Station	BN26	BM26
25		BN25	BM25
24	Rock School	BN24	BM24
23	AQ 021	BN23	BM23
22	Pat Johnson's Ranch	BN22	BM22
21	Hunter Creek	BN21	BM21
20	PL Gate	BN20	BM20
19	AQ 020	BN19	BM19
18	Sorghum, Cottonwood	BN18	BM18
17	Stewart Gulch Rd.	BN17	BM17
16	AQ Trailer 022	BN16	BM16
15	Oldland's Ranch	BN15	BM15
14	Oldland's Ranch	BN14	BM14
13	Pond and Cabin	BN13	BM13
12	Sprague Gulch	BN12	BM12
11	Cascade Gulch	BN11	BM11
10	13 Mile Gulch	BN10	BM10
9	14 Mile Gulch	BN09	BM09
8	Schutte Gulch	BN08	BM08
7	Robinson's Ranch	BN07	BM07
6		BN06	BM06
5	2 Old Cabins (35 MPH Curve)	BN05	BM05
4	McCarthy Gulch	BN04	BM04
3	Cow Creek	BN03	BM03
2	Mahogany Outcropping	BN02	BM02
1	Woodward Ranch	BN01	BM01
0	Rio Blanco Store	BN00	BM00



Biology (Cont'd)

<u>Programs</u>	<u>General Location</u>	<u>Computer Code</u>	
Deer Mortality	North Side of Piceance Creek	BD01	
		BD02	
		BD03	
		BD04	
		BD05	
	South Side of Piceance Creek	BD06	
		BD07	
		BD08	
		BD09	
		BD10	
Deer Age Class	General Area of Tract	BE01	
Coyote Abundance	8 Transects for Total for 30 miles	BF01	
	15 mi seg. near Hunter (Control)	BF02 thru BF08	
	15 mi seg. on & South of Tract (Development)		
Lagomorph Abundance	Identical Locations to deer use days	BA01 to BA31	
Small Mammals	Piceance Creek (Development)	BG01	
	On-Tract-west	BG02	
	Piceance Creek (Control)	BG03	
	On-Tract-east	BG04	
	Sprinkler Area Section B	BG05	
	Sprinkler Area (Control)	BG11	
	Sprinkler Area (Development)	BG22	
Sprinkler Area (Control)	BG33		
Avifauna	Songbirds and Gamebirds	N.W. of Tract-near Jimmy PJ-CH-C	BH01
		On-Tract-Standard PJ- -D	BH02
		On-Tract-Cottonwood PJ-CH-D	BH03
		S. of Tract-Between W&N Fork Stewart PJ- C	BH04
		Sprinkler	BH05
Raptors	The entire Tract and surrounding study areas.	BI01	
Aquatic Ecology	Benthos	USGS 09306007 (Control)	WU07
		USGS 09306058 (Development)	WU58
		USGS 09306061 (Development)	WU61
Periphyton	Piceance Creek Upstream (Control)	WP01	
		WP02	
	Piceance Creek Downstream (Development)	WP03	



Biology (Cont'd)

<u>Programs</u>	<u>General Location</u>	<u>Computer Code</u>		
Water Quality	USGS 09306061 (Development)	WU61		
Vegetation		*	**	***
Community Structure	Plots			
	Chained pinyon juniper (1978)(Dev)	BJ01	BJ11	BJ21
	Chained pinyon juniper (1978)(Cont)	BJ02	BJ12	BJ22
	Upland sagebrush (1980)(Cont)	BJ03	BJ13	BJ23
	Bottomland sagebrush (1980)(Cont)	BJ04	BJ14	BJ24
	Pinyon juniper woodland (1979)(Dev)	BJ05	BJ15	BJ25
	Pinyon juniper woodland (1979)(Cont)	BJ06	BJ16	BJ26
Herb Productivity and Utilization	Identical locations to community structure	BJ01 thru BJ26		
	<u>Plus</u>			
	60 range cages in random locations	BK01 thru BK60		
	10 cages on S. facing PJ for baseline	BK61 thru BK70		
	20 cages for fertilization assessment	BK71 thru BK90		
Shrub Productivity and Utilization	Same stations as Deer Days Use Study	BA01 thru BA31		
General Condition	By Landsat over entire Tract area	Not in computer		

- \* Fenced (8')
- \*\* Open
- \*\*\* Fenced (4')



Biology (Cont'd)

<u>Program</u>	<u>General Location</u>	<u>Computer Code</u>
Micro Climate	MC Sta. 1	BC01
	2	BC02
	3	BC03
	4	BC04
	5	BC05
	6	BC06
	7	BC07
	8	BC08
	9	BC09
	13	BC13
Traffic Count	Rio Blanco Store	BT01
	South of Cattle Guard	BT02
	Rio Blanco Lake	BT03

III Noise

	<u>Station Designation</u>	<u>Computer Code</u>
Traffic Noise	Sta. IX	NB01
	XV	NB15

IV Photography

P1	PA01
P2	PA02
P3	PA03
P4	PA04
P5	PA05
P6	PA06
P7	PA07
P8	PA08
P9	PA09
P10	PA10
P11	PA11
P12	PA12
P13	PA13
P14	PA14
P15	PA15
P16	PA16
P17	PA17
P18	PA18
P19	PA19
P20	PA20
P21	PA21
P22	PA22
P23	PA23
P24	PA24
P25	PA25



Photography

Program

Photography

General Location

Computer Code

P26

P27

P28

P29

P30

P31

P32

P33

P34

P35

PA26

PA27

PA28

PA29

PA30

PA31

PA32

PA33

PA34

PA35



V. Water

<u>Program</u>	<u>Station Designation</u>	<u>Computer Code</u>	<u>Elevation</u>
U.S.G.S. Stream Gauging Station	09304800	WU48	
	09306007	WU07	
	09306036	WU36	
	09306039	WU39	
	09306042	WU42	
	09306061	WU61	
	09306050	WU50	
	09306052	WU52	
	09306058	WU58	
	09306033	WU33	
	09306025	WU25	
	09306015	WU15	
	09306028	WU28	
	09306022	WU22	
	09306200	WU00	
	09306222	WU62	
	09306255	WU55	
Alluvial Wells	A-1	WA01	6282.2
	A-2	WA02	6284.5
	A-3	WA03	6448.6
	A-4	WA04	0000.0
	A-5	WA05	6345.0
	A-5A	WA55	6460.0
	A-5B	WA56	0000.0
	A-6	WA06	6360.0
	A-7	WA07	6383.8
	A-8	WA08	6409.0
	A-9	WA09	6540.2
	A-10	WA10	6610.6
	A-11	WA11	6503.8
A-12	WA12	6691.8	
A-13	WA13	0000.0	
Springs and Seeps	CB S-1	WS01	
	CB S-2	WS02	
	CB S-3	WS03	
	CB S-4	WS04	
	CB S-6	WS06	
	CB S-6A	WS66	
	CB S-7	WS07	
	CB S-8	WS08	
	CB S-9	WS09	
	CB S-10 (W-3)	WS10 (WS34)	
	CB Seep A	WS11	
	S-102	WS12	
	CER-1	WS21	
	B-3	WS22	
H-3	WS23		
F-3	WS24		



V. Water

<u>Program</u>	<u>Station Designation</u>	<u>Computer Code</u>	<u>Elevation</u>
Springs and Seeps (cont)	Figure 4-A	WS25	
	W-4	WS26	
	W-9	WS27	
	CER-7	WS28	
	S-9	WS29	
	P3 & P3A	WS30	
	CER-6	WS31	
	W-2 (S-9)	WS32	
	S-2	WW33	
	W-3 (CB S-10)	WS34 (WS10)	
	Figure 4	WS35	
	S-11 (S-101)	WS36	
	Oldland Spring	WS37	

Precipitation	CB-020	AB20
	CB-023	AB23
	LH	WR01
	M	WR02
	SG	WR03
	CG	WR04
	JQS	WR05
	EFPC	WR06
	EMFPC	WR07
	UCBW	WR08



V. Water (cont'd)  
Upper Aquifer Wells

<u>Before Recompletions</u>			<u>Recompletion #1</u>			<u>Recompletion #2</u>		
<u>Station</u>	<u>Code</u>	<u>Elevation</u>	<u>Station</u>	<u>Code</u>	<u>Date</u>	<u>Station</u>	<u>Code</u>	<u>Date</u>
CB-2	WX02	6737.0	CB-2	WD02	11-18-80			
CB-4	WX04	7057.3	CB-4	WE04	11-20-80			
SG-10A	WX10	6953.6	SG-10A-1	WE10	*	SG-10A-1	WG51	
			SG-10A-2	WD10	*	SG-10A-2	WE51	*
						SG-10A-Annulus	WD51	
SG-1A	WX11	6425.0	SG-1A-1	WE11	12-12-80			
			SG-1A-2	WD11	12-12-80			
SG-1-2	WX12	6428.6	SG-1-2	WD12	11-01-80			
14X-7	WX14	6909.0	14X-7-1	WD14	11-15-80			
			14X-7-2	WD15	11-15-80			
SG-17-2	WX17	7038.6				SG-17-2	WE17	11-03-80
						SG-17-3	WD17	11-03-80
						SG-17-4	WC17	11-03-80
SG-18A	WX18	7386.6	SG-18A-1	WG18	12-02-80			
			SG-18A-2	WE18	12-01-80			
			SG-18A-3	WD18	12-02-80			
SG-19	WX19	6384.4	SG-19	WD19				
SG-20	WX20	6358.0	SG-20-1	WG20	11-15-80			
			SG-20-2	WE20	11-15-80			
			SG-20-3	WD20	11-15-80			
SG-21	WX21	6813.3	SG-21-1	WH21	12-08-80			
			SG-21-2	WG21	12-08-80			
			SG-21-3	WE21	12-08-80			
			SG-21-4	WD21	12-09-80			
AT-1C-3	WX44	6906.0						
SG-11-3	WX55	6903.1				SG-11-3	WD52	10-18-80
SG-6-3	WX63	6890.7	SG-6-3	WD61	10-20-80			
SG-8-2	WX82	0000.0						
SG-9-2	WX92	6873.0	SG-9-2	WE91	12-11-80			
			SG-9-3	WD91	12-11-80			
			SG-9-4	WC91	12-12-80			
32X-12	WX32	6830.3						
33X-1	WX33	6707.1						
41X-1	WX41	6460.0						
TH75-5A	WX64	7178.0						
TH75-13A	WX65	6390.0						
TH75-18A	WX67	6740.0						
TH75-9A	WX69	7350.0						
CER RB-D-02	WX71	6580.0						
TH75-15A	WX72	6805.0						
UNION 8-1	WX73	8142.3						
COLONY 12-596	WX74	0000.0						
TH-5	WX75	7583.2						

\* Recompletion #1 not satisfactory for these strings: use #2.



V. Water (cont'd)  
Lower Aquifer Wells

<u>Before Completion</u>			<u>Recompletion #1</u>			<u>Recompletion #2</u>		
<u>Station</u>	<u>Code</u>	<u>Elevation</u>	<u>Station</u>	<u>Code</u>	<u>Date</u>	<u>Station</u>	<u>Code</u>	<u>Date</u>
CB-1	WY01	6763.4	CB-1	WD01	11-14-80			
CB-3	WY03	6743.1	CB-3	WE03	11-18-80			
SG-10	WY09	6952.5	SG-10R	WG10		SG-10	WD90	
SG-1-1	WY12	6428.8	SG-1-1	WG12	11-1-80			
SG-17-1	WY18	7038.6	SG-17-1R	WY17		SG-17-1	WG17	11-03-80
AT-1C-1	WY45	6906.0						
AT-1C-2	WY46	6906.0						
SG-11-1	WY51	6903.1	SG-11-1R	WY52		SG-11-1	WG52	10-18-80
SG-11-2	WY54	6903.1				SG-11-2	WE52	10-18-80
SG-6-1	WY61	6890.7	SG-6-1	WE61	10-20-80			
SG-6-2	WY62	6890.7	SG-6-2	WG61	10-20-80			
SG-8	WY80	6540.8	SG-8R	WY81				
SG-9-1	WY91	6873.0	SG-9-1	WG91	12-11-80			
AT-1	WY44	6909.0						
TH75-5B	WY64	7178.0						
TH75-13B	WY65	6390.0						
EQUITY-1	WY66	6286.0						
TH75-10B	WY68	6840.0						
TH75-9B	WY69	7350.0						
EQUITY-SULFUR-1A	WY70	7070.0						
CER RB-D-03	WY71	6580.0						
TH75-15B	WY72	6805.0						
TG71-3	WY75	6820.0						
TG71-5	WY76	6865.0						
GETTY 9-40	WY77	7777.8						
TG71-4	WY78	7145.0						
EQUITY BS-13	WY79	7020.0						

New Wells

<u>Station</u>	<u>Code</u>	<u>Date</u>	<u>Elevation</u>
SG-17A	WD57	12-02-80	7036.0
AT-1D-1	WG41	11-16-80	6909.0
AT-1D-2	WE41		
AT-1D-3	WD41	11-16-80	6909.0
AT-1A	WV37		6909.0
AT-1A1	WX38		6909.0
AT-1B	WV40		6909.0



V. Water (cont'd)

	<u>Before Recompletions</u>			<u>Recompletion #1</u>		
	<u>Station</u>	<u>Code</u>	<u>Elevation</u>	<u>Station</u>	<u>Code</u>	<u>Date</u>
<u>Composite Wells:</u>						
	GREENO 404	WV01	6411.0			
	OLDLAND 3	WV02	6490.0			
	GP-17X-BG	WV03				
	BUTE 25	WV04				
	LIBERTY BELL 12	WV05	7420.0			
	TOSCO WELL	WV06				
	21X12	WV07	6794.8			
	22X1	WV08	6704.1			
	43X2	WV09	6692.7			
<u>Seepage Monitoring Wells:</u>						
	32Y-12	WW32				
	31X-12	WW12	6764.0			
				31X12	WW22	11/80
	41X-13-2	WW13	6953.6			
<u>Reinjection Wells:</u>						
	22X-17	WI19				
	11X-18	WI18	6950.0			
	24X-17	WI17				
<u>Ponds:</u>						
	POND A	WN01				
	POND B	WN02				
	POND C	WN03				
	POND A SPRINGS	WN11				
	POND B SPRINGS	WN12				
	POND C SPRINGS	WN13				
	POND A INLET	WN21				
	POND B INLET	WN22				
	POND C INLET	WN23				
	POND A-B CROSSOVER	WN31				
	POND B OUTLET	WN32				
	POND C OUTLET	WN33				
	BACKWASH POND	WN04				
	BACKWASH POND SPRINGS	WN14				
	BACKWASH POND INLET	WN24				
	BACKWASH POND OUTLET	WN34				
	POND A-B DISCHARGE	WN40				
<u>Shafts:</u>						
	V/E SHAFT PROBE HOLES	WZ01				
	SERVICE SHAFT PROBE HOLES	WZ02				
	PRODUCTION SHAFT PROBE HOLES	WZ03				
	V/E SHAFT WATER RING	WZ11				
	SERVICE SHAFT WATER RING	WZ12				
	PRODUCTION SHAFT WATER RING	WZ13				



V. Water (cont'd)

<u>Before Recompletions</u>			<u>Recompletion #1</u>		
<u>Station</u>	<u>Code</u>	<u>Elevation</u>	<u>Station</u>	<u>Code</u>	<u>Date</u>
V/E SHAFT SUMP	WZ21				
SERVICE SHAFT SUMP	WZ22				
PRODUCTION SHAFT SUMP	WZ23				
V/E SHAFT	WZ31				
PRODUCTION SHAFT	WZ33				
SHAFT GROUT HOLE	WZ41				

Discharge Monitoring Stations

NO NAME GULCH	WU42
UPPER PICEANCE CREEK	WN41
LOWER PICEANCE CREEK	WN42
HUNTER CREEK	WU02
WILLOW CREEK	WU01

Mobil Wells

WELL NO. 1	MW01	6510
WELL NO. 2	MW03	6480
WELL NO. 3	MW03	6618
WELL NO. 12	MW12	6486
WELL NO. 13	MW13	6509



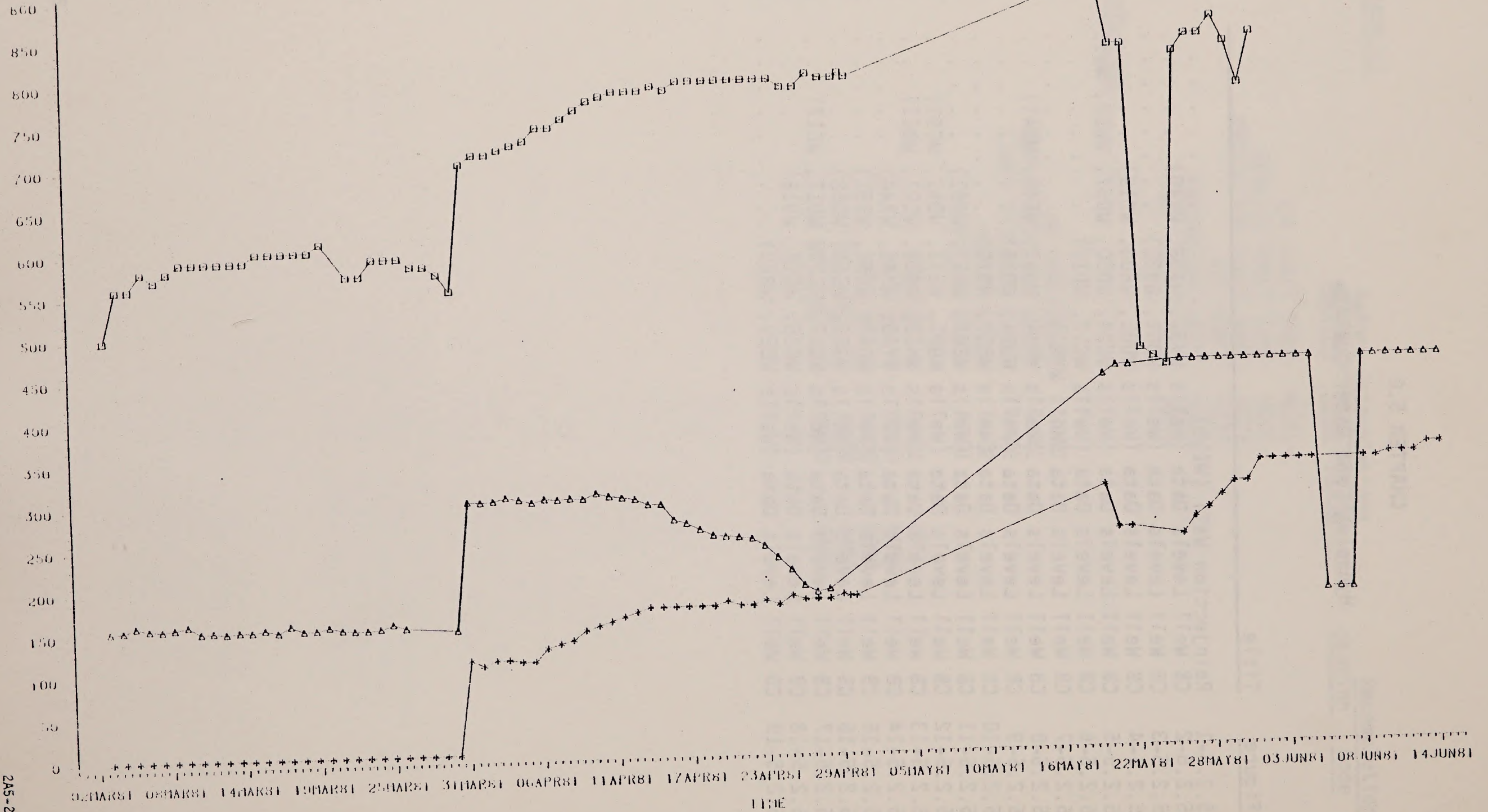
CHAPTER 5.0

Hydrology and Water Quality

<u>Table/Figure</u>	<u>Title</u>	<u>Page</u>
Figure A5.2.5-1	Reinjection Well (WI18)	2A5-2
Figure A5.2.5-2	CB Well Levels Data (Wells WV37, WX38, WV40)	2A5-3
Figure A5.2.5-3	CB Well Levels Data (Wells WD01, WX32)	2A5-4
Figure A5.2.5-4	CB Well Levels Data (Wells WD02, WE03, WD19)	2A5-5
Figure A5.2.5-5	CB Well Levels Data (Wells WE04, WD90, WD57, WW12, WW13)	2A5-6
Figure A5.2.5-6	CB Well Levels Data (Wells WG12, WD12)	2A5-7
Figure A5.2.5-7	CB Well Levels Data (Well WY81)	2A5-8
Figure A5.2.5-8	CB Well Levels Data (Wells WY44, WG41, WE41, WD41)	2A5-9
Figure A5.2.5-9	CB Well Levels Data (Wells WD14, WD15)	2A5-10
Figure A5.2.5-10	CB Well Levels Data (Wells WE11, WD11)	2A5-11
Figure A5.2.5-11	CB Well Levels Data (Wells WE61, WG61, WD61)	2A5-12
Figure A5.2.5-12	CB Well Levels Data (Wells WG91, WE91, WD91, WC91)	2A5-13
Figure A5.2.5-13	CB Well Levels Data (Wells WH21, WG21, WE21, WD21)	2A5-14
Figure A5.2.5-14	CB Well Levels Data (Wells WY45, WY46, WX44)	2A5-15
Figure A5.2.5-15	CB Well Levels Data (Wells WD51, WG51, WE51)	2A5-16
Figure A5.2.5-16	CB Well Levels Data (Wells WG52, WE52, WD52)	2A5-17
Figure A5.2.5-17	CB Well Levels Data (Wells WG17, WE17, WD17, WC17)	2A5-18
Figure A5.2.5-18	CB Well Levels Data (Wells WG18, WE18, WD18)	2A5-19
Figure A5.2.5-19	CB Well Levels Data (Wells WE20, WD20)	2A5-20



FIGURE A5.2.5-1  
REINJECTION WELL (W118)

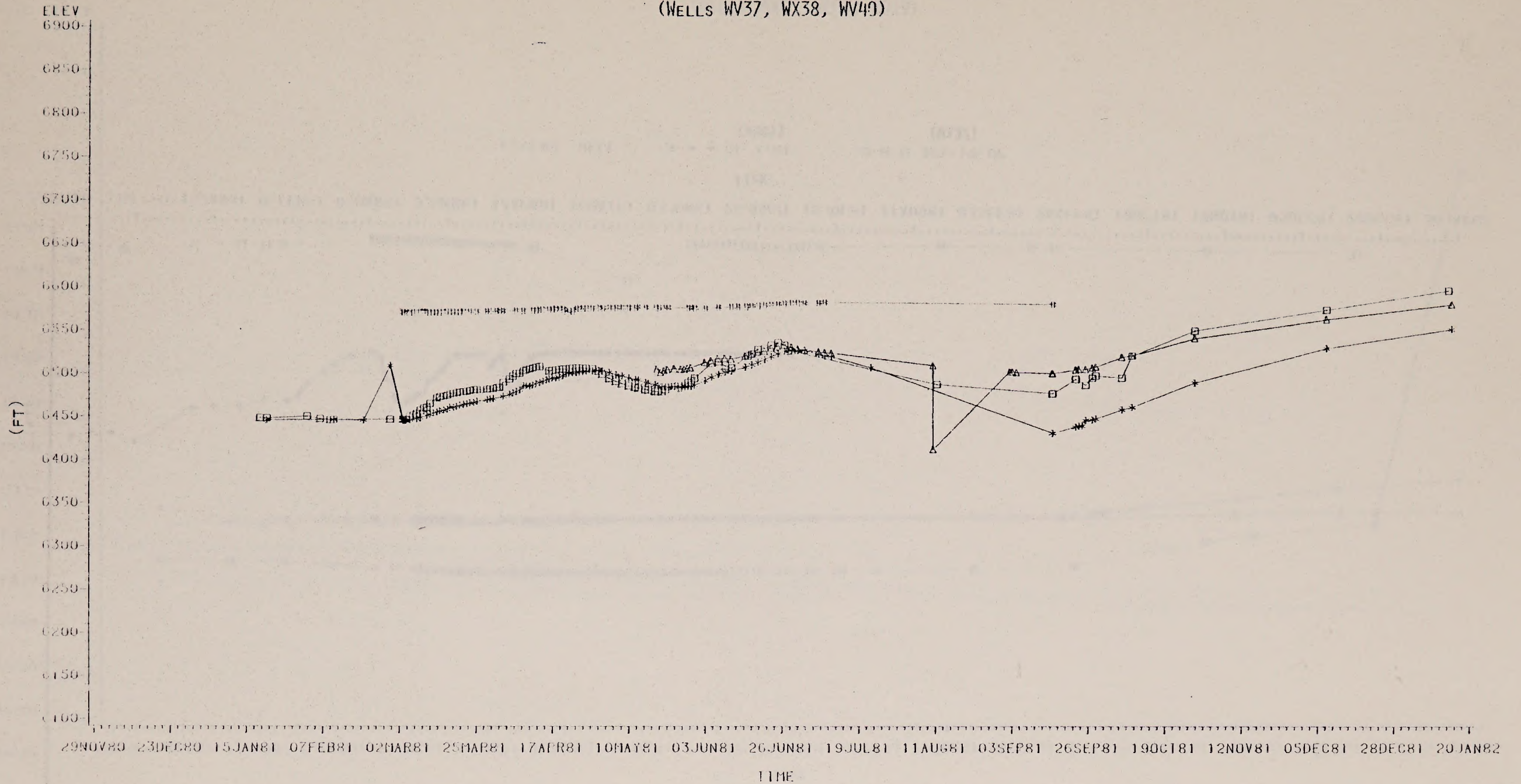


□ □ □ P11-1400      ▲-▲-▲ RATE-GPH  
 + + + P11-W118

2A5-2



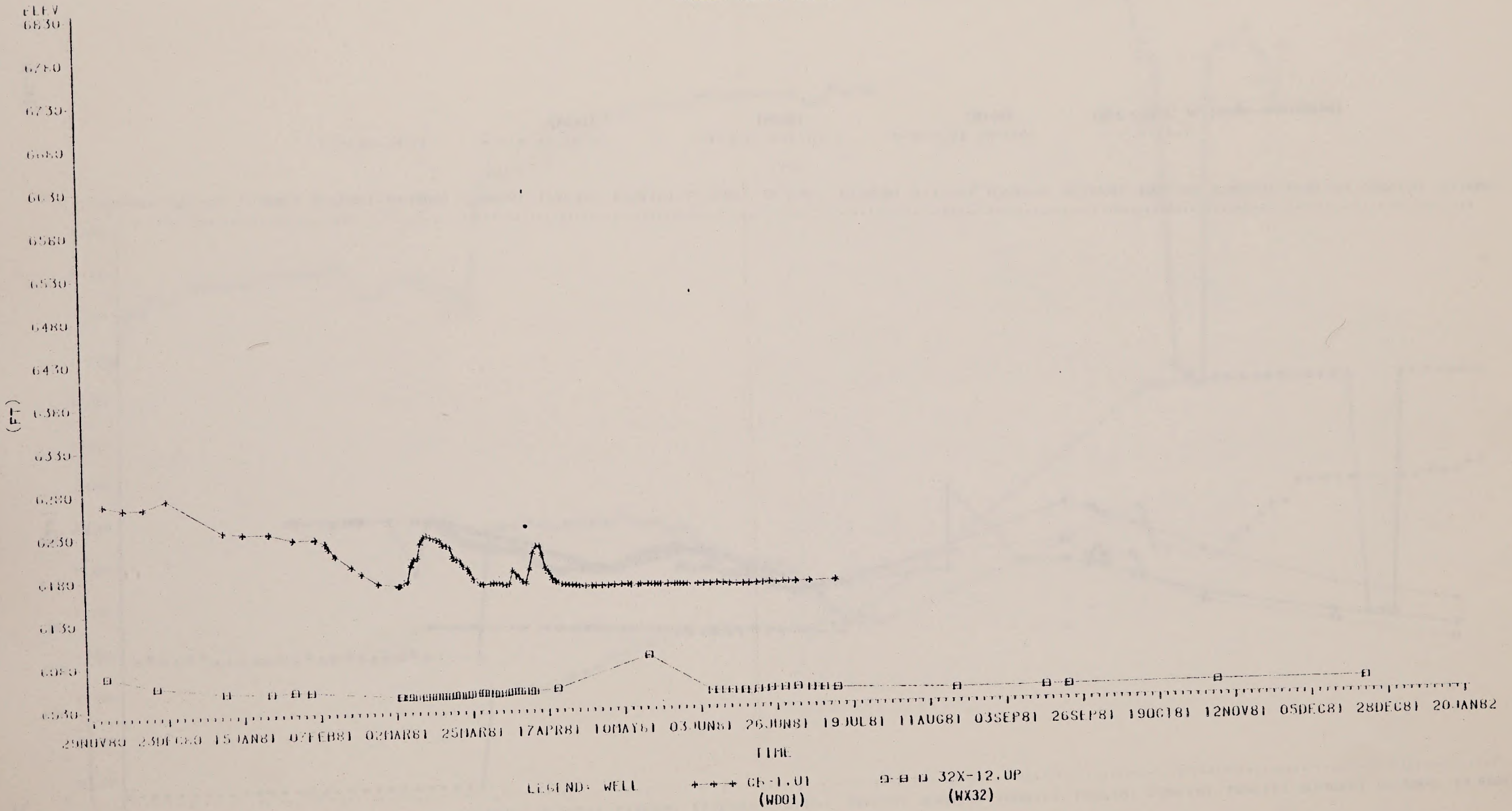
FIGURE A5.2.5-2  
 CB WELL LEVELS DATA  
 (WELLS WV37, WX38, WV49)



LEGEND: WELL    +--+ (WV37)    □-□-□ (WX38)    ▲-▲-▲ (WV49)    \*-\*-\* (71-1)  
 (Not coded, no longer monitored)



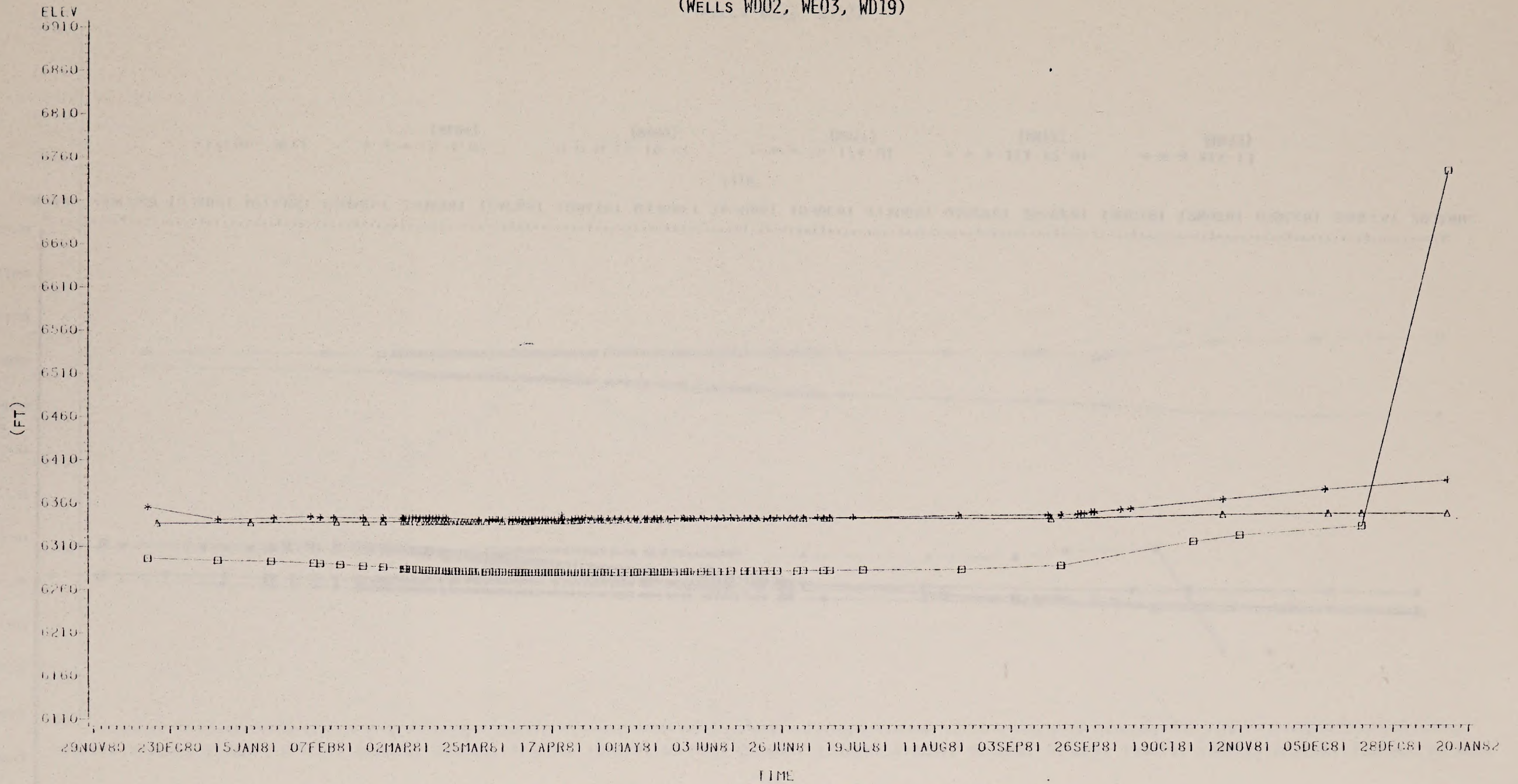
FIGURE A5.2.5-3  
 CB WELL LEVELS DATA  
 (WELLS WD01, WX32)



2A5-4



FIGURE A5.2.5-4  
 CB WELL LEVELS DATA  
 (WELLS WD02, WE03, WD19)

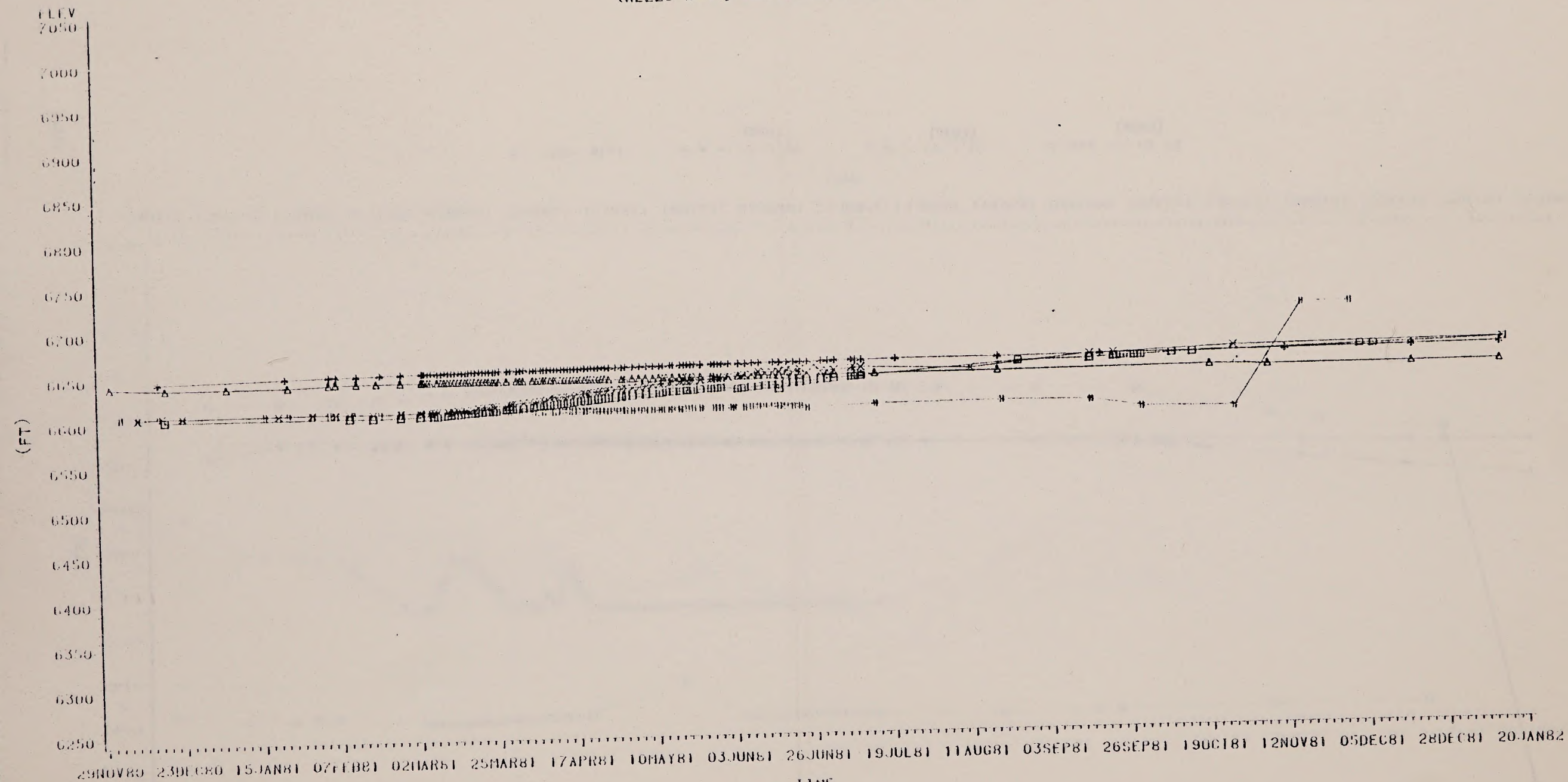


LEGEND: WELL    \*-\*-\* CB-2.01    □-□-□ CB-3.02    △-△-△ SG-19.01  
 (WD02)                    (WE03)                    (WD19)

2A5-5



FIGURE A5.2.5-5  
 CB WELL LEVELS DATA  
 (WELLS WE04, WD90, WD57, WW12, WW13)

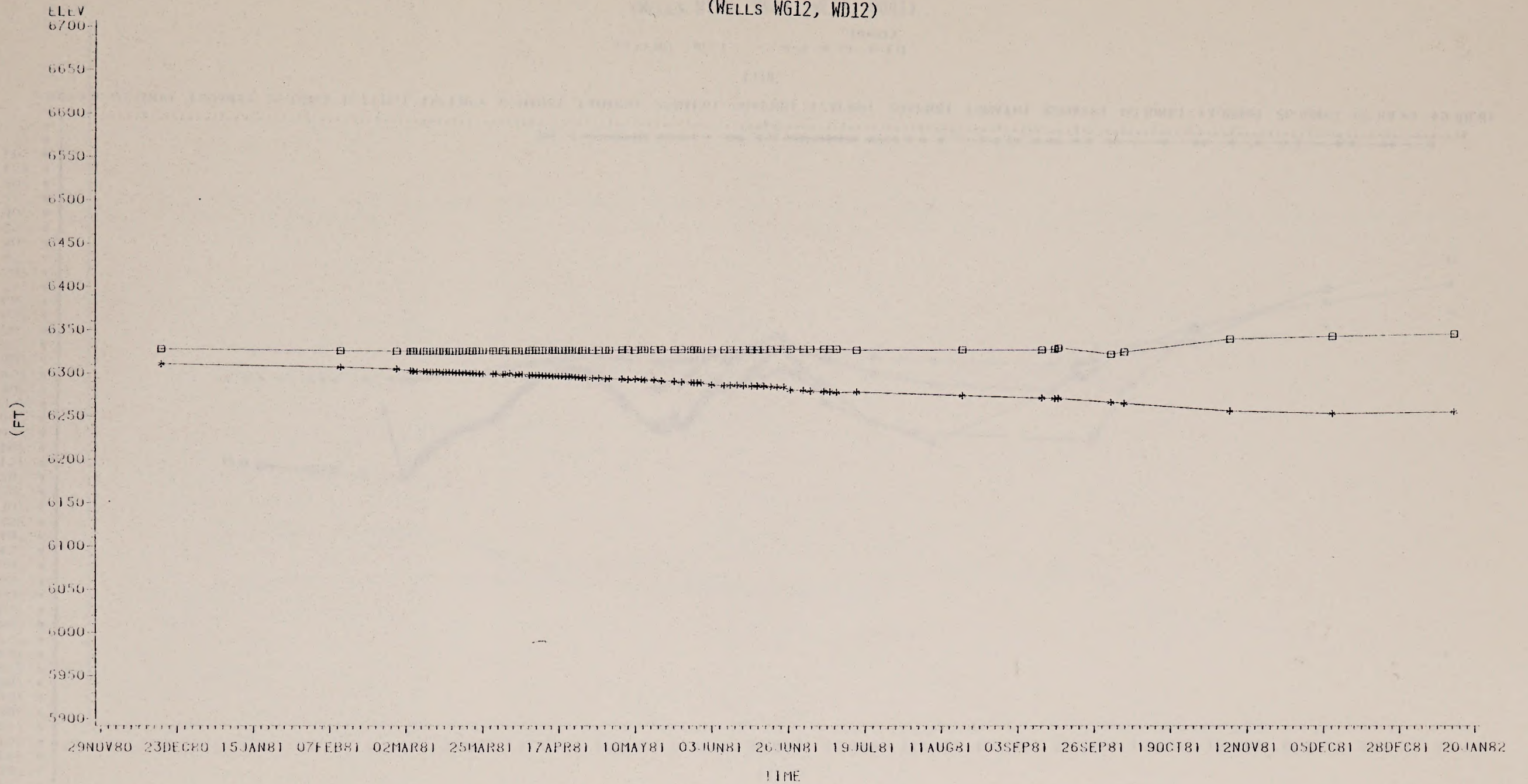


LEGEND: WELL    + + +    CB-4.02    (WE04)    □ □ □    SG-10.01    (WD90)    △-△-△    SG-17A.01    (WD57)    ○ ○ ○    31X-12.01    (WW12)    \*-\*-\*    41X-13    (WW13)

2A5-5



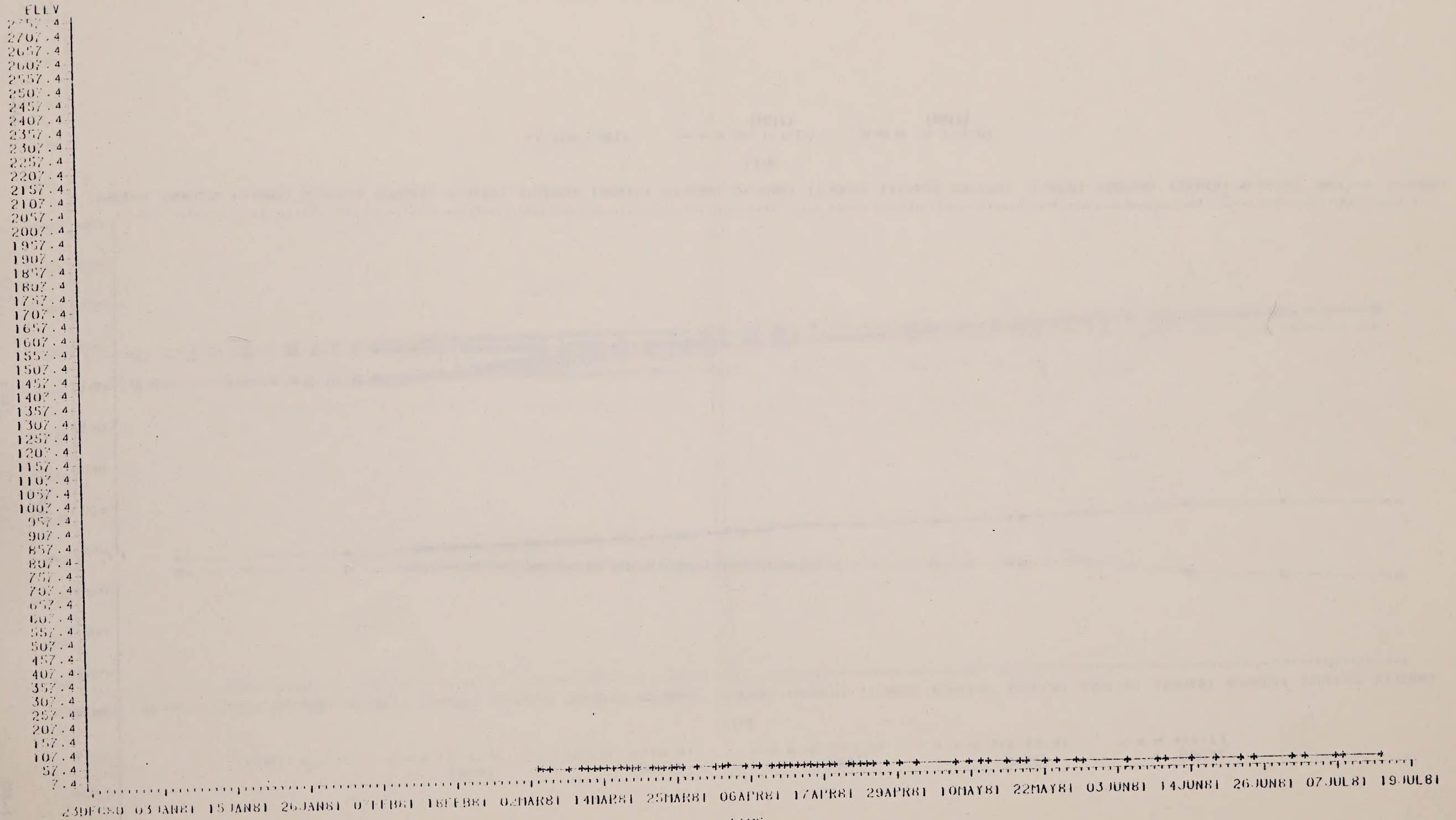
FIGURE A5.2.5-6  
 CB WELL LEVELS DATA  
 (WELLS WG12, WD12)



LEGEND: WELL \*-\*-\* SG-1-1.L3 (WG12) □-□-□ SG-1-2.U1 (WD12)



FIGURE A5.2.5-7  
 CB WELL LEVELS DATA  
 (WELL WY81)



LEGEND: WELL +--+ SUBSID (JUN 81)

GR. WIND. DEPARTS DAILY  
 1981 W 328

(1)

245-8



FIGURE A5.2.5-8

# CB WELL LEVELS DATA

(WELLS WY44, WG41, WE41, WD41)

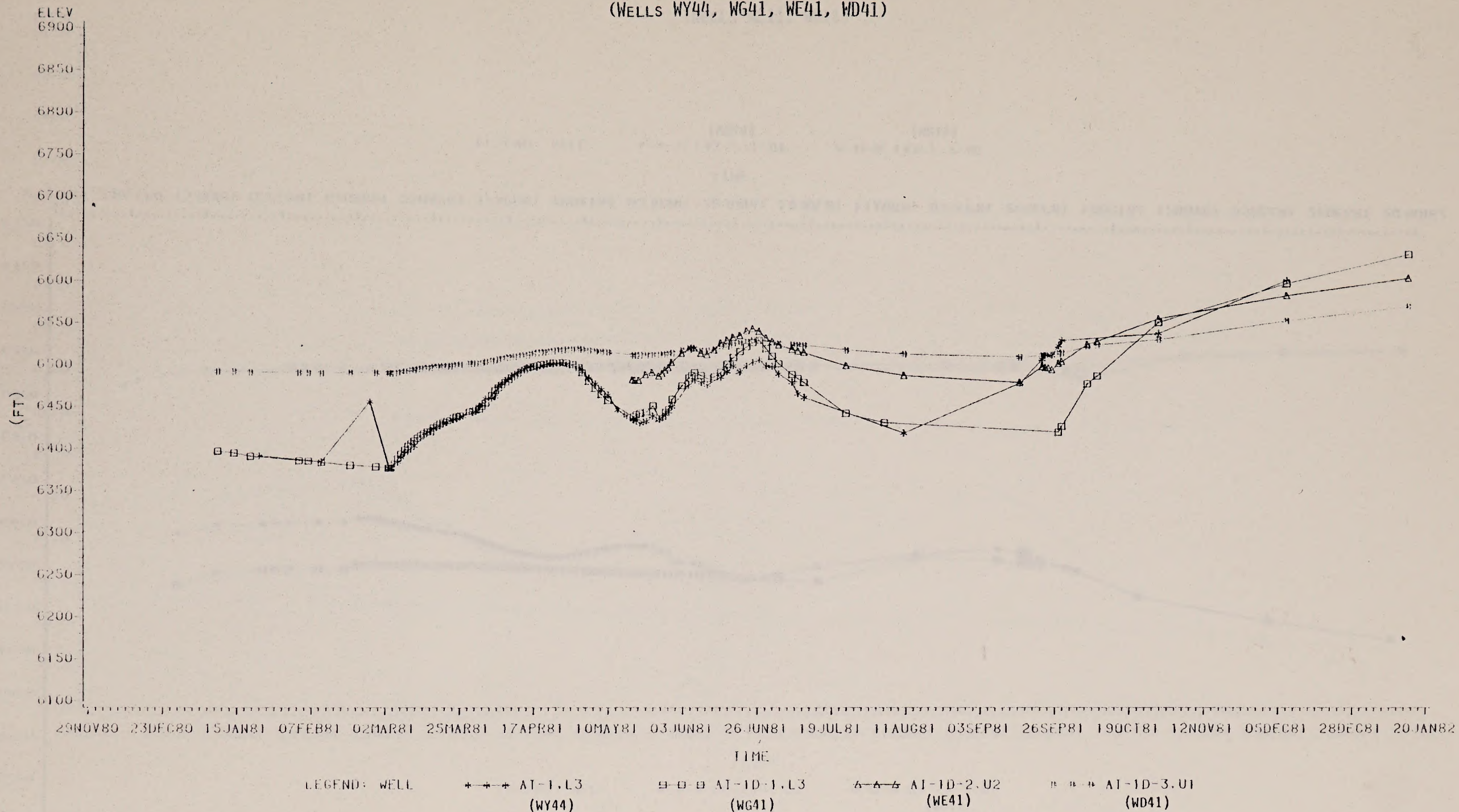




FIGURE A5.2.5-9  
 CB WELL LEVELS DATA  
 (WELLS WD14, WD15)

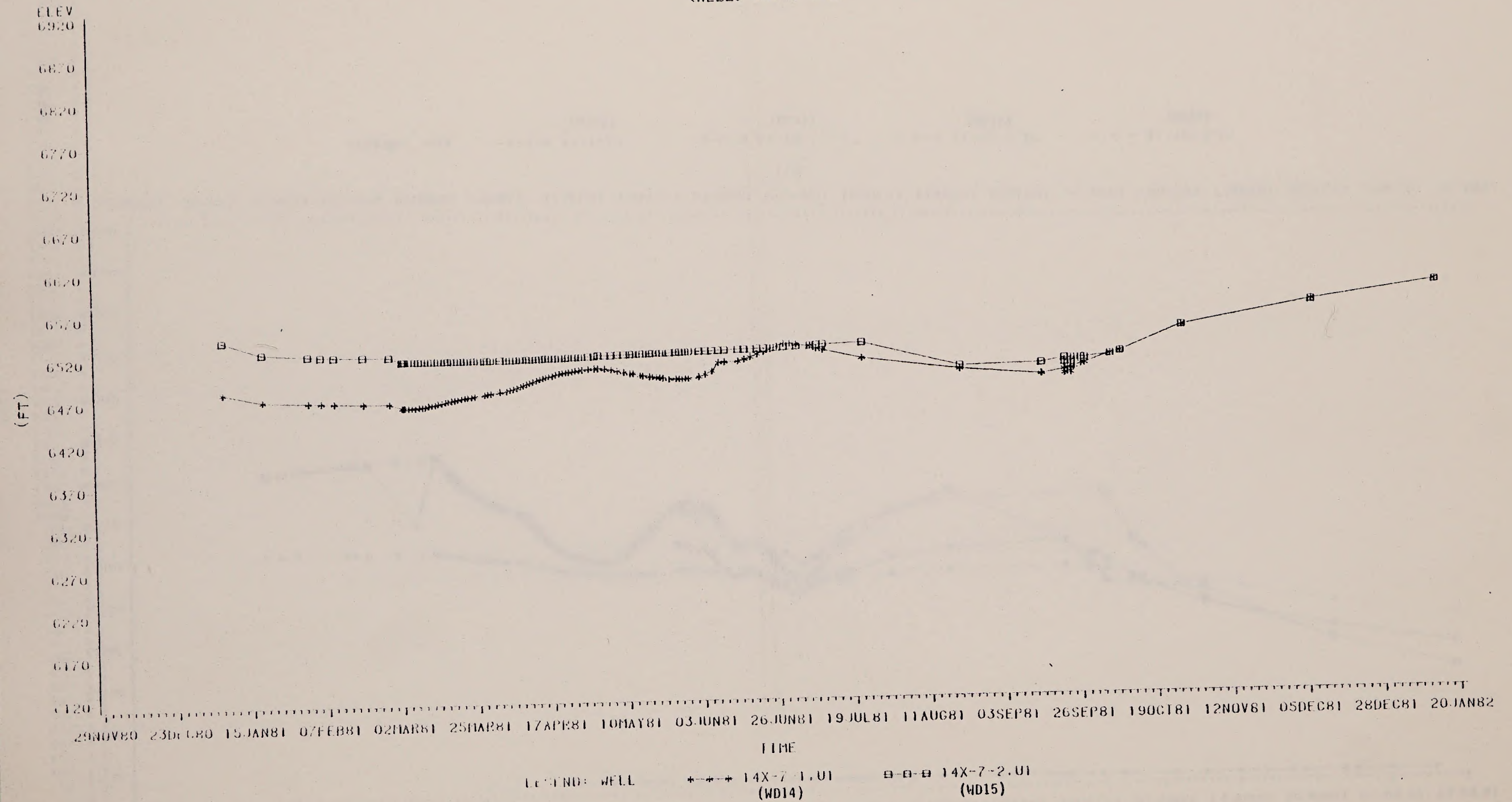
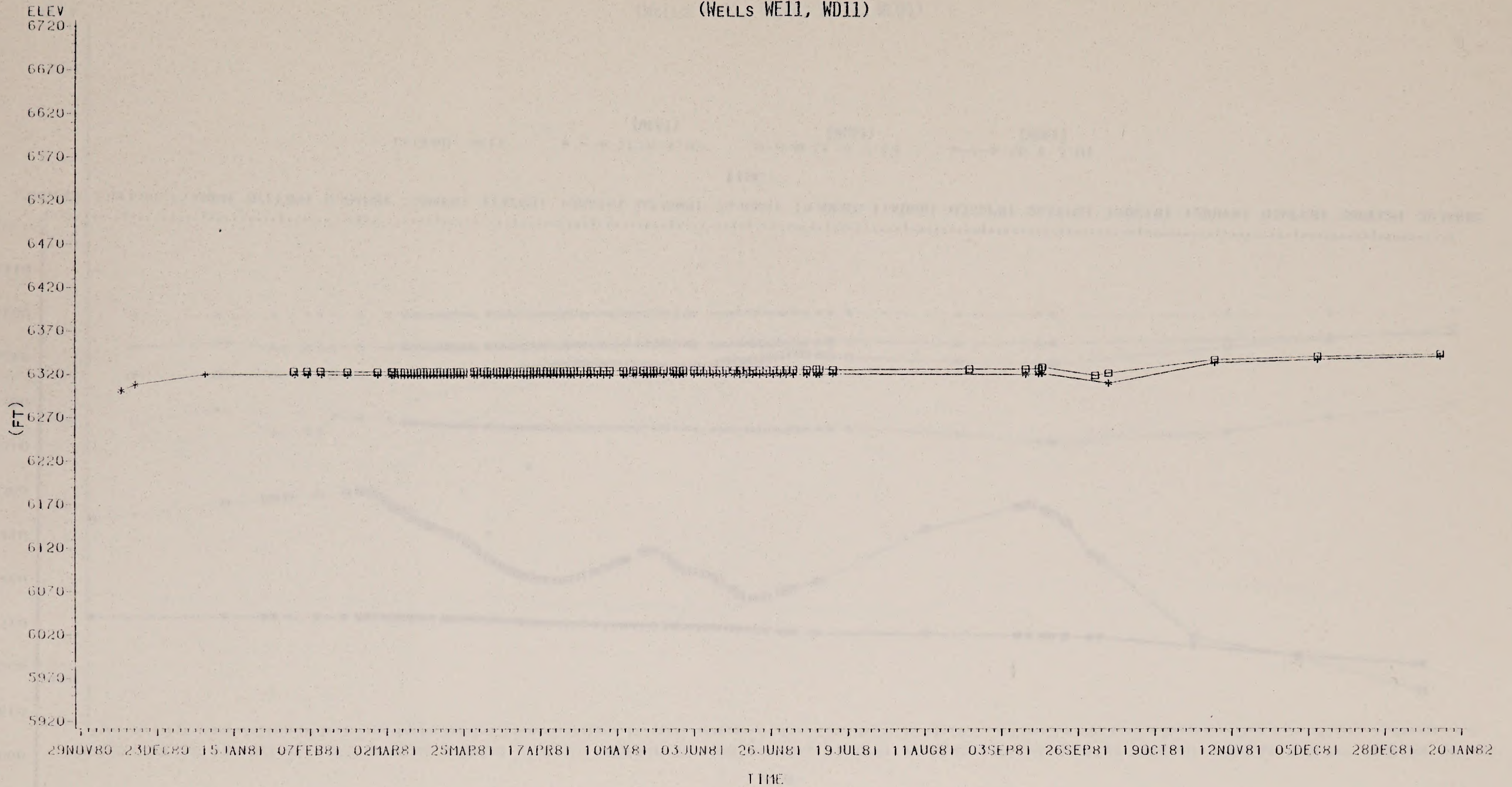




FIGURE A5.2.5-10  
 CB WELL LEVELS DATA  
 (WELLS WE11, WD11)

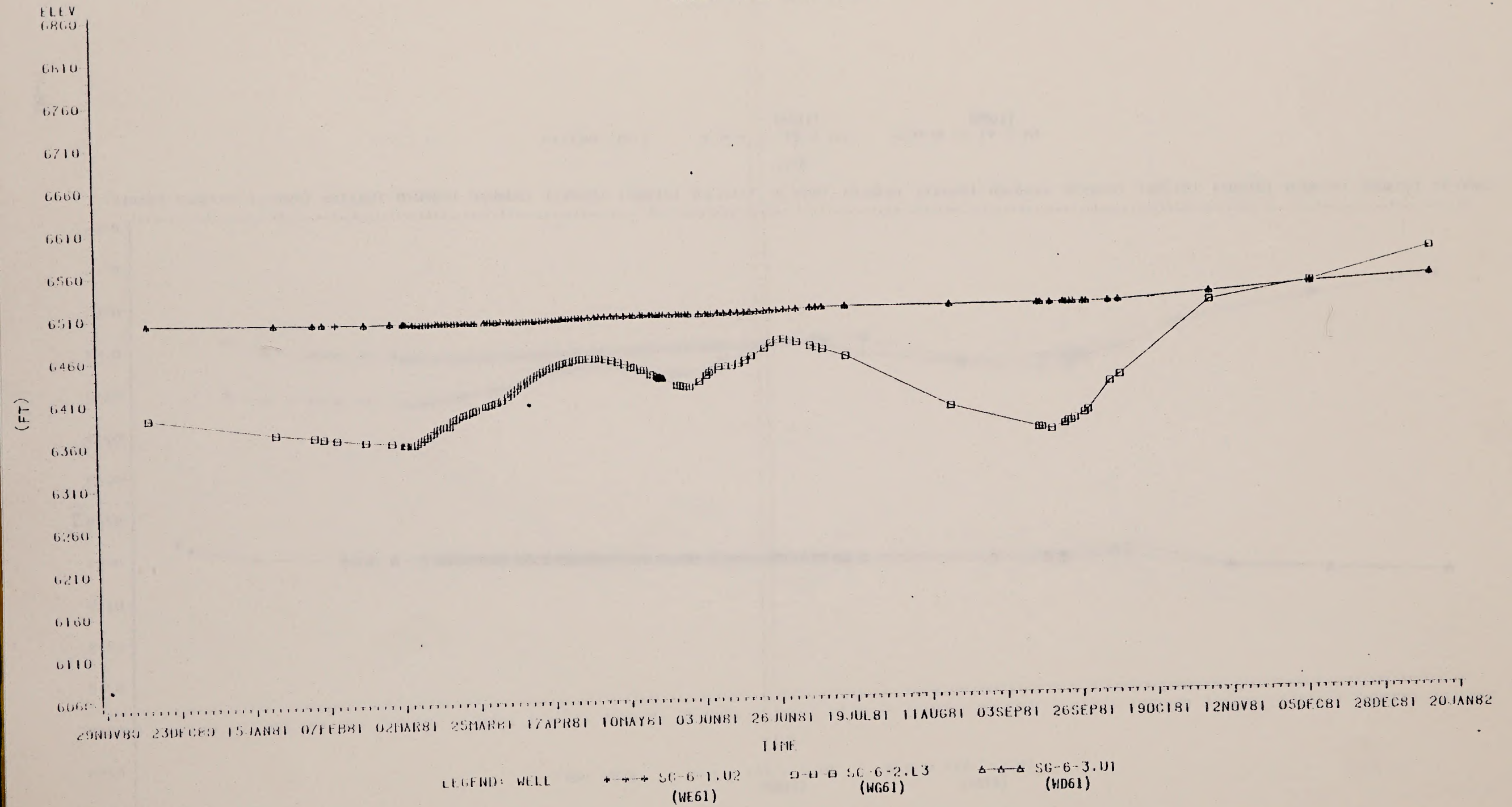


LEGEND: WELL \*-\*-\* SC-1A-1.U2 (WE11) □-□-□ SC-1A-2.U1 (WD11)

2A5-11



FIGURE A5.2.5-11  
 CB WELL LEVELS DATA  
 (WELLS WE61, WG61, WD61)

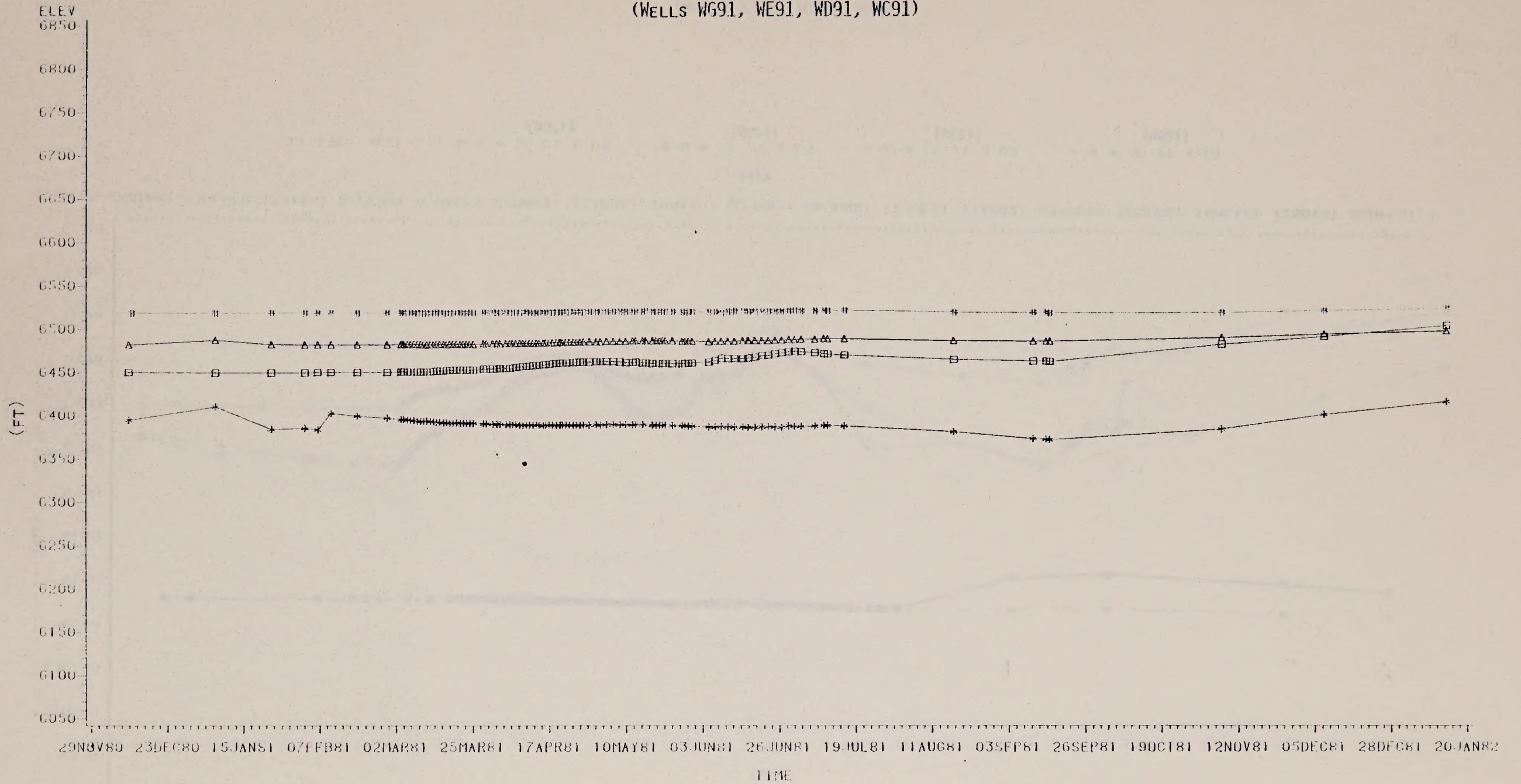


2A5-12

DATE: 11/11/81  
 BY: M. J. GIBBS, JR.  
 12/15/81



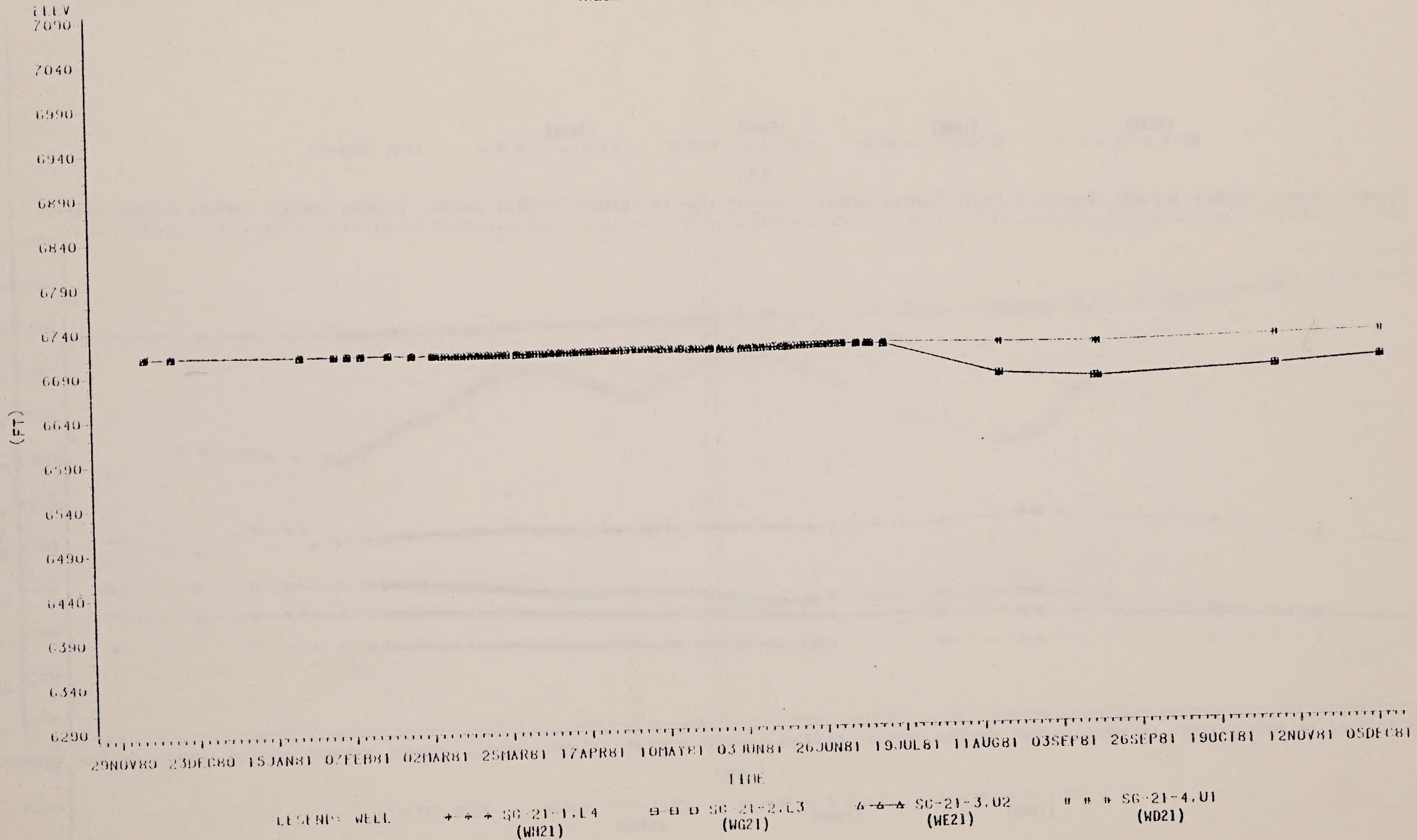
FIGURE A5.2.5-12  
 CB WELL LEVELS DATA  
 (WELLS WG91, WE91, WD91, WC91)



LEGEND: WELL    +--+ SC-9-1.L3 (WG91)    ◻◻◻ SC-9-2.U2 (WE91)    ▲▲▲ SC-9-3.U1 (WD91)    " " " SC-9-4.UN (WC91)



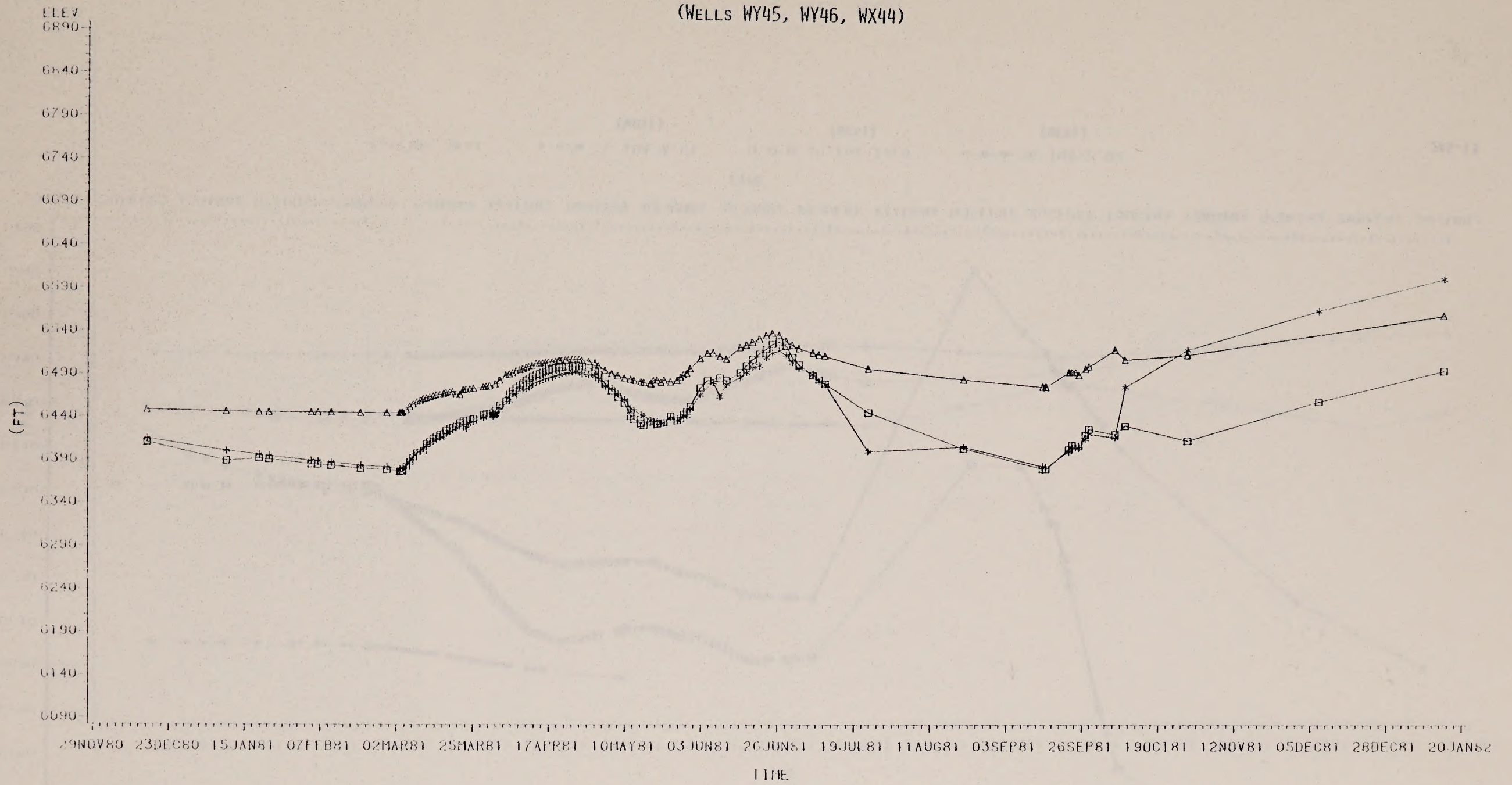
FIGURE A5.2.5-13  
**CB WELL LEVELS DATA**  
 (WELLS WH21, WG21, WE21, WD21)





# FIGURE A5.2.5-14 CB WELL LEVELS DATA

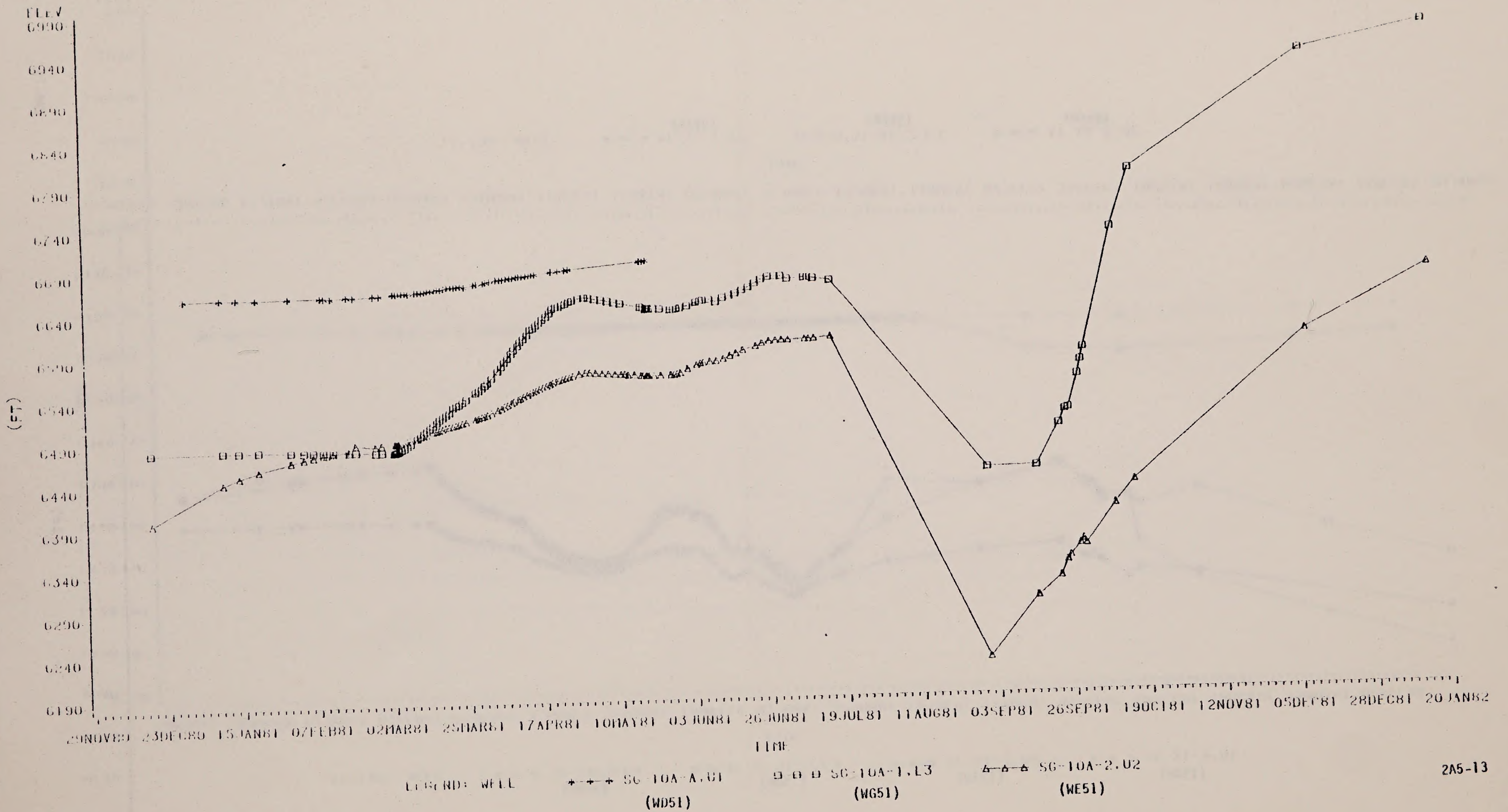
(WELLS WY45, WY46, WX44)



LEGEND: WELL    \*-\*-\* AT-1C-1.L3 (WY45)    □-□-□ AT-1C-2.L3 (WY46)    △-△-△ AT-1C-3.U2 (WX44)



FIGURE A5.2.5-15  
 CB WELL LEVELS DATA  
 (WELLS WD51, WG51, WE51)



2A5-13

2A5-16



FIGURE A5.2.5-16  
 CB WELL LEVELS DATA  
 (WELLS WG52, WE52, WD52)

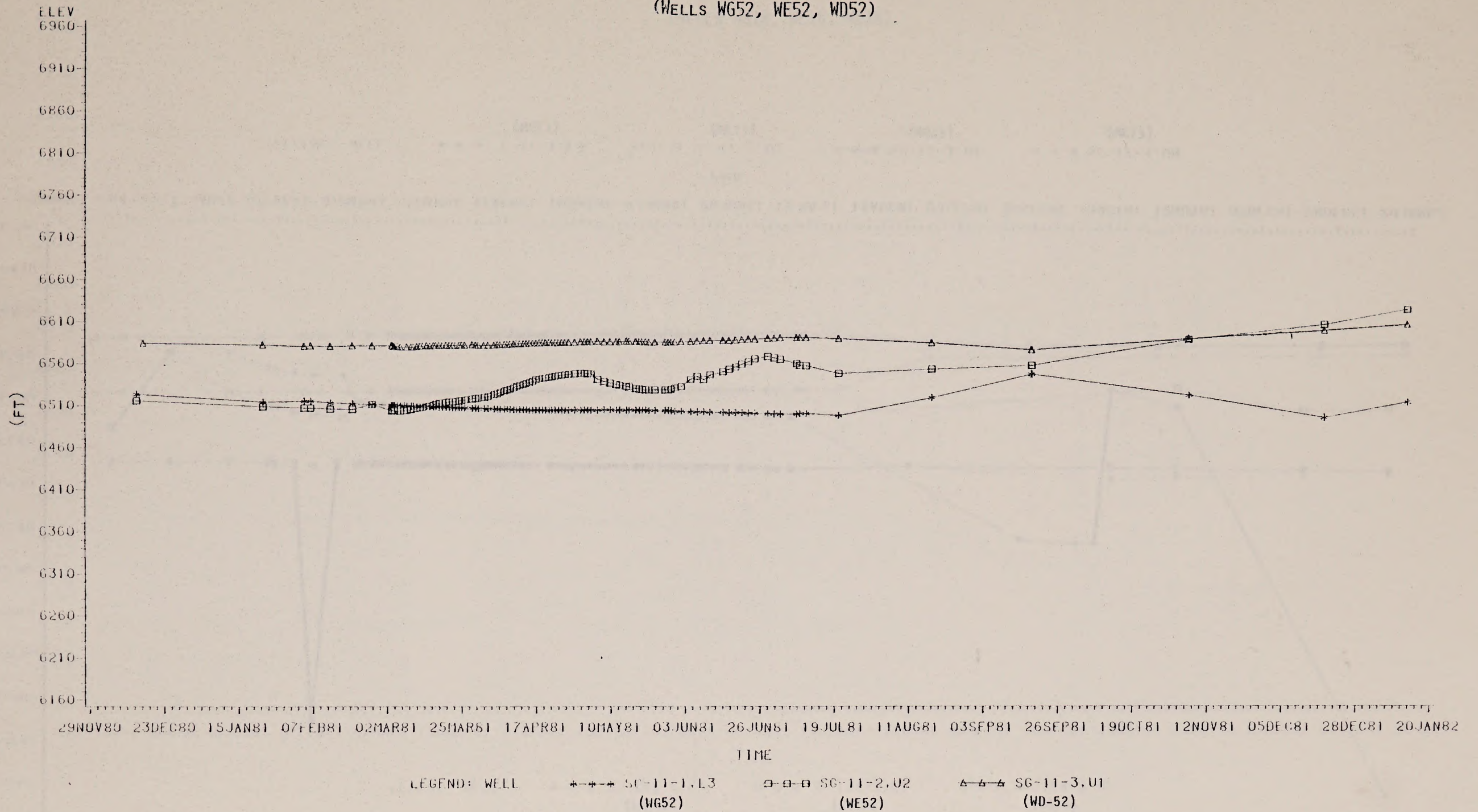
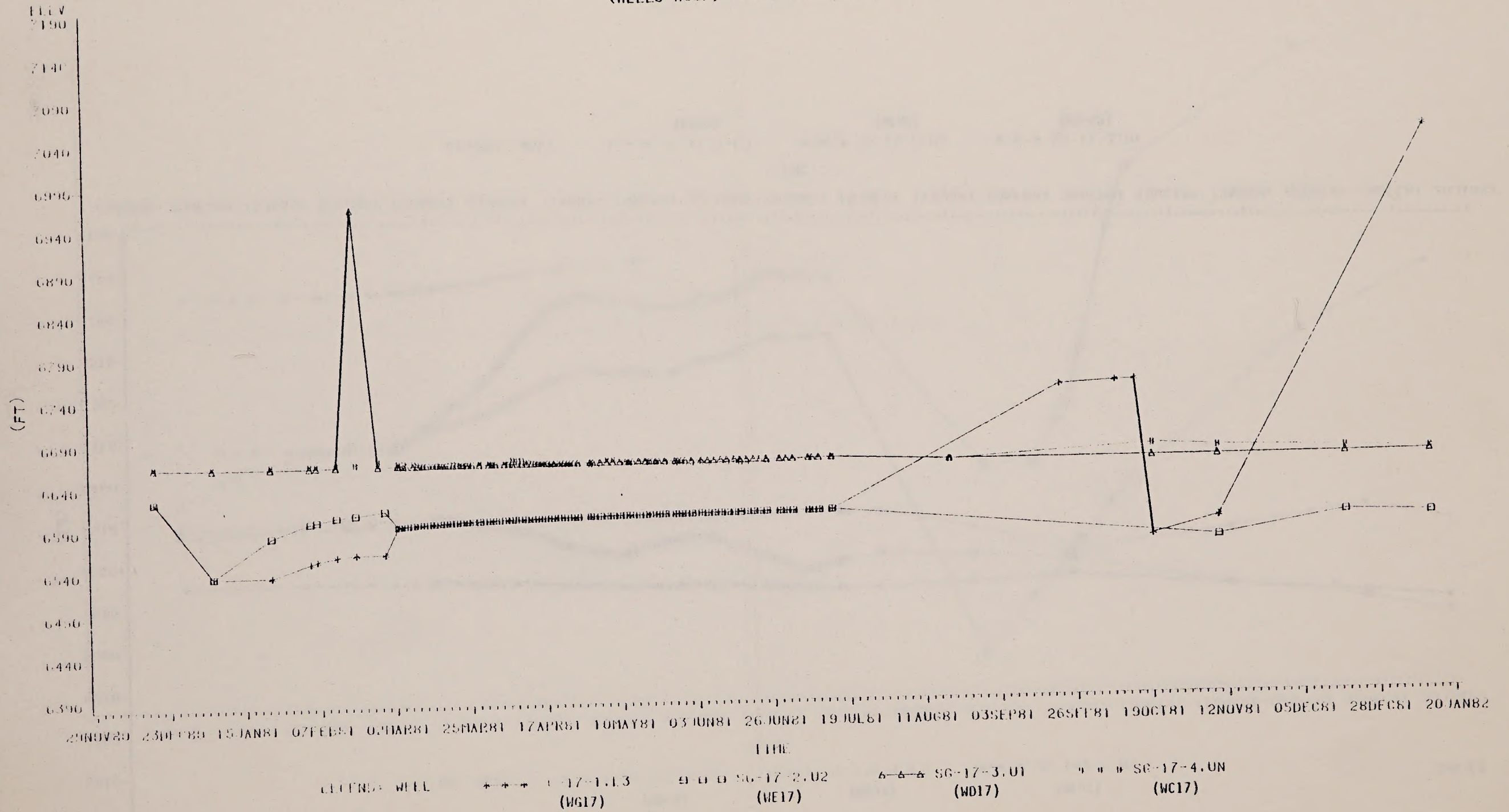




FIGURE A5.2.5-17  
 CB WELL LEVELS DATA  
 (WELLS WG17, WE17, WD17, WC17)





# FIGURE A5.2.5-18 CB WELL LEVELS DATA

(WELLS WG18, WE18, WD18)

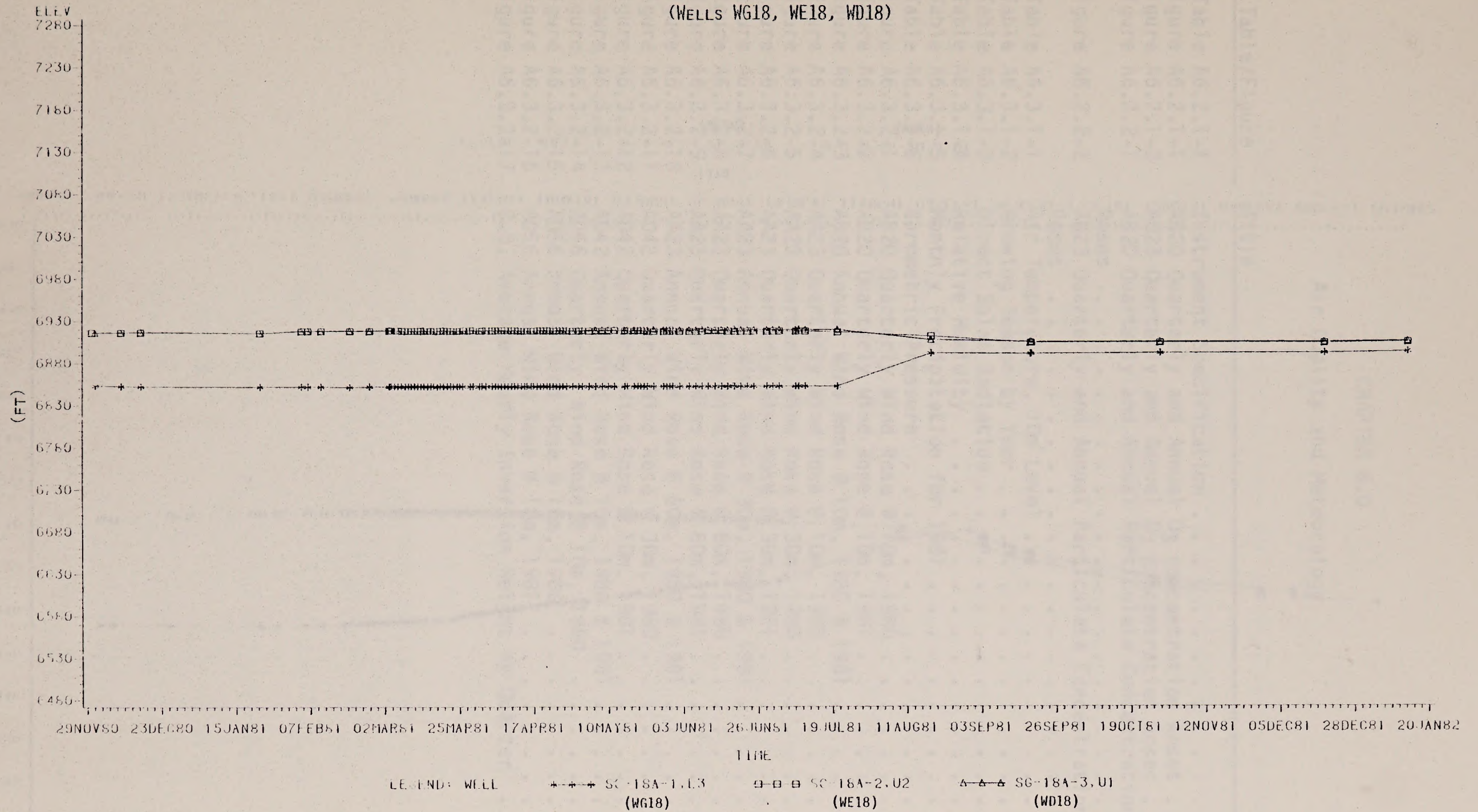
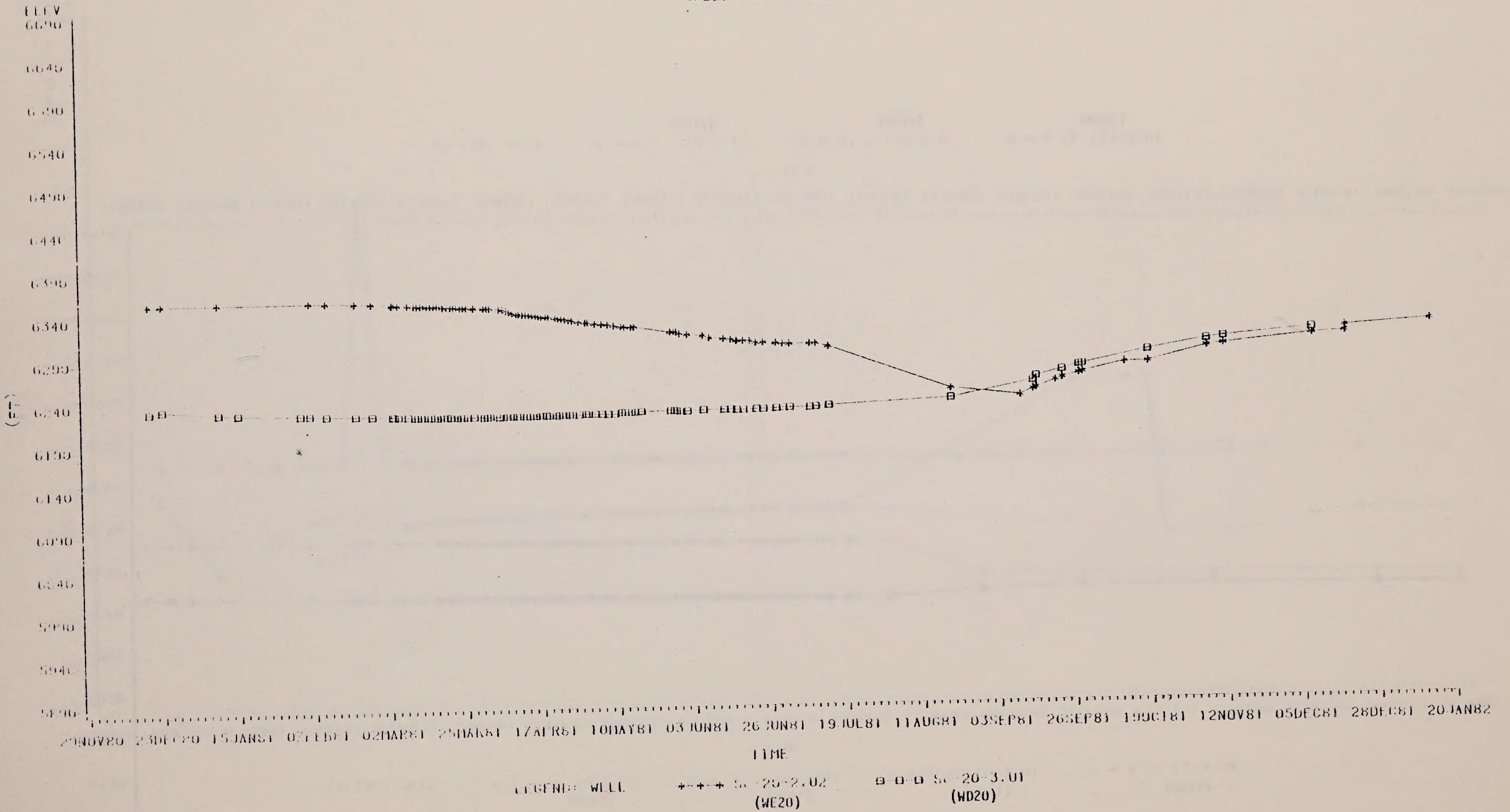




FIGURE A5.2.5-19  
 CB WELL LEVELS DATA  
 (WELLS WE20, WD20)



2A5-20



## CHAPTER 6.0

### Air Quality and Meteorology

Table/Figure	Title	Page
Table A6.2.1-1	Instrument Specification . . . . .	2A6-2
Figure A6.2.1-1	AB20 Quarterly and Annual O <sub>3</sub> Concentration Roses . .	2A6-6
Figure A6.2.1-2	AB23 Quarterly and Annual O <sub>3</sub> Concentration Roses . .	2A6-7
Figure A6.2.2-1	AB20 Quarterly and Annual Particulate Concentration Roses . . . . .	2A6-8
Figure A6.2.2-2	AB23 Quarterly and Annual Particulate Concentration Roses . . . . .	2A6-9
Table A6.3.1-1	Air Temperature, 10m Level . . . . .	2A6-10
Table A6.3.1-2	Growing Season by Year . . . . .	2A6-11
Table A6.3.1-3	Direct Solar Radiation . . . . .	2A6-12
Table A6.3.1-4	Relative Humidity . . . . .	2A6-13
Table A6.3.1-5	Monthly Precipitation for 1981 . . . . .	2A6-14
Table A6.3.1-6	Barometric Pressure . . . . .	2A6-15
Figure A6.3.2-1	AB20 Quarterly Wind Rose @ 10m, 1980 . . . . .	2A6-16
Figure A6.3.2-2	AB20 Quarterly Wind Rose @ 10m, 1981 . . . . .	2A6-17
Figure A6.3.2-3	AB20 Annual Wind Rose @ 10m, 1980 & 1981 . . . . .	2A6-18
Figure A6.3.2-4	AA23 Quarterly Wind Rose @ 10m, 1980 . . . . .	2A6-19
Figure A6.3.2-5	AA23 Quarterly Wind Rose @ 30m, 1980 . . . . .	2A6-20
Figure A6.3.2-6	AA23 Quarterly Wind Rose @ 30m, 1981 . . . . .	2A6-21
Figure A6.3.2-7	AA23 Annual Wind Rose @ 30m, 1980 & 1981 . . . . .	2A6-22
Figure A6.3.2-8	AA23 Quarterly Wind Rose @ 60m, 1980 . . . . .	2A6-23
Figure A6.3.2-9	AA23 Quarterly Wind Rose @ 60m, 1981 . . . . .	2A6-24
Figure A6.3.2-10	AA23 Annual Wind Rose @ 60m, 1980 & 1981 . . . . .	2A6-25
Figure A6.3.2-11	AD42 Quarterly Wind Rose @ 10m, 1980 . . . . .	2A6-26
Figure A6.3.2-12	AD42 Quarterly Wind Rose @ 10m, 1981 . . . . .	2A6-27
Figure A6.3.2-13	AD42 Annual Wind Rose @ 10m, 1980 & 1981 . . . . .	2A6-28
Figure A6.3.2-14	AD56 Quarterly Wind Rose @ 10m, 1980 . . . . .	2A6-29
Figure A6.3.2-15	AD56 Annual Wind Rose @ 10m, 1980 . . . . .	2A6-30
Figure A6.3.2-16	AD56 Annual Wind Rose @ 10m, 1981 . . . . .	2A6-31
Figure A6.3.2-17	C.B. Average Hourly Inversion Height by Quarter . .	2A6-32



TABLE A6.2.1-1

## INSTRUMENT SPECIFICATIONS

These specifications apply to the analyzer types and time periods indicated. In some cases, current instruments will have different specifications, generally reflecting enhanced accuracy and sensitivity.

Sulfur dioxide/hydrogen sulfide-November 1974 - March 1977 -  
Meloy SA-185-2

Range:	0 - 1 ppm (1000 ppb)
Lower Detection Limit:	.005 ppm
Noise:	± 0.5% (full scale)
Zero Drift:	± 1% per day
Span Drift:	± 1% per day
Precision:	± 1% (full scale)

March 1977 - May 1981 - Meloy SA-185-2A

Range:	0 - .5 ppm
Lower Detection Limit:	.002 ppm
Noise:	.005 ppm
Zero Drift:	.001 ppm (24 hours)
Span Drift:	3.2% (80% URL)
Precision:	.001 ppm S.D. (20% URL) .002 ppm S.D. (80% URL)

January 1982 - Present - Teco 43 Pulsed Fluorescent SO<sub>2</sub>  
May 1981 - Present - Teco 45 Pulsed Fluorescent H<sub>2</sub>S

Range:	0 - .5 ppm
Lower Detection Limit:	.002 ppm
Noise:	.001 ppm
Zero Drift: (24 hrs.)	± .005 ppm
Span Drift: (24 hrs.)	± 1%
Precision:	.005 ppm



TABLE A6.2.1-1 (cont.)

Carbon Monoxide November 1974 - August 1978 - Bendix 8200 Environmental Chromatograph

Range:	0 - 1 ppm to 0 - 100 ppm, stepped
Noise:	0.5% of full scale
Zero Drift:	< 1% per day
Span Drift:	< 1% per day
Precision:	± 1% of full scale

September 1978 - Present - Beckman Model 866 - Ambient CO Monitoring System

Range:	0 - 50 ppm
Lower Detection Limit:	0.4 ppm
Noise:	0.2 ppm S.D.
Zero Drift:	± 0.5 ppm (24 hours)
Span Drift:	± 1% full scale
Precision:	± 0.2 ppm S.D. full scale

Oxides of Nitrogen November 1974 - December 1977 - Meloy NA-520-2 Chemiluminizer

Range:	0 - .5 ppm
Lower Detection Limit:	.005 ppm
Noise:	.005 ppm
Zero Drift:	.005 ppm (24 hours)
Span Drift:	.010 ppm (24 hours)
Precision:	± 1% full scale



TABLE A6.2.1-1 (cont.)

January 1978 - Present - Monitor Labs Model 8440E Nitrogen Oxides Analyzer

Range:	0 - .5 ppm
Lower Detection Limit:	.002 ppm
Noise:	.001 ppm S.D.
Zero Drift:	< .003 ppm/7 days
Span Drift:	< 4%/7 days
Precision:	.004 ppm S.D. @ 0.1 ppm

March 1982 - Present (Station 023 Only) Monitor Labs 8840 Nitrogen Oxides Analyzer

Range:	0 - .5 ppm
Lower Detection Limit:	1.3 ppb
Noise:	@ 0 - $\pm$ 1 ppb, @ Full Scale - 2.5 ppb
Zero Drift:	$\pm$ 3 ppb (7 days)
Span Drift:	$\pm$ 4% (7 days)
Precision:	$\pm$ .8 ppb (1 std. dev.) @ 100 ppb 1 ppb (1 std. dev.) @ 400 ppb

Ozone November 1974 - March 1979 - Meloy OA-350-2 - Ozone Analyzer

Range:	0 - .5 ppm
Lower Detection Limit:	.0005 ppm
Noise:	$\pm$ .3%
Zero Drift:	$\pm$ 1% full scale/24 hours
Span Drift:	< $\pm$ full scale/24 hours
Precision:	$\pm$ 2% full scale



TABLE A6.2.1-1 (cont.)

Ozone April 1979 - April 1980 - Meloy OA-350-2R - Ozone Analyzer

Range:	0 - .5 ppm
Lower Detection Limit:	.002 ppm
Noise:	.0005 ppm @ 20% URL .002 ppm @ 80% URL
Zero Drift:	12 hours and 24 hours $\pm$ .002 ppm
Span Drift:	24 hours $\pm$ 1.5% of reading @ 20% URL $\pm$ 2.5% of reading @ 80% URL
Precision:	.001 ppm @ 20% URL @ 80% URL

1981 - Present - Dasibi 1003 - RS UV Ozone Analyzer

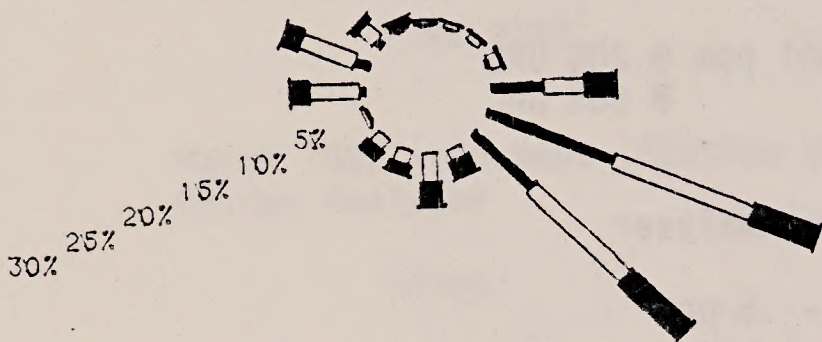
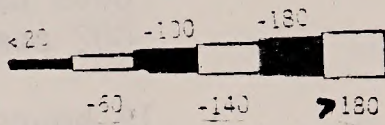
Range:	0 - .5 ppm
Lower Detection Limit:	.001 ppm
Noise:	.001 ppm
Zero Drift:	< .1%/day
Span Drift:	< .1%/day
Precision:	$\pm$ 1%



# Figure A6.2.1-1 AB20 QUARTERLY & ANNUAL O<sub>3</sub> CONCENTRATION ROSES

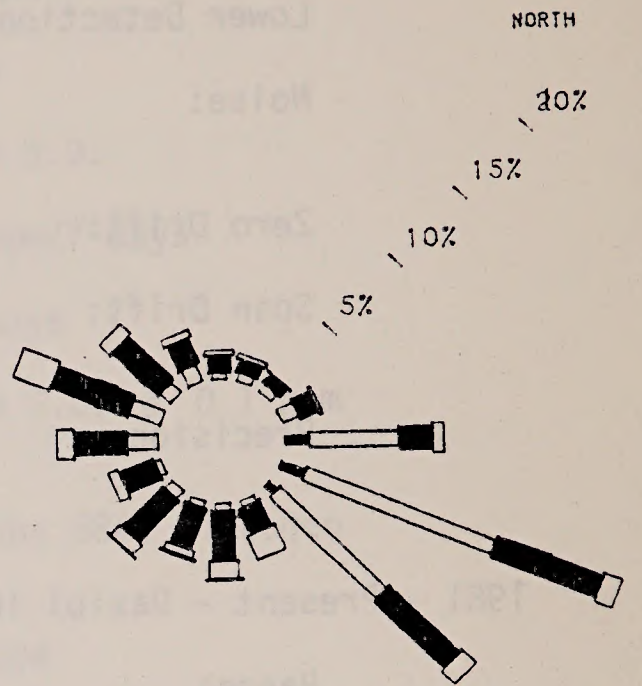
DEC 80 - FEB 81

TOTAL % OF CALMS DISTRIBUTED (6.05%)  
TOTAL NO. OF 1-HOUR SAMPLES - 2133



MAR 81 - MAY 81

TOTAL % OF CALMS DISTRIBUTED (12.4%)  
TOTAL NO. OF 1-HOUR SAMPLES - 1983

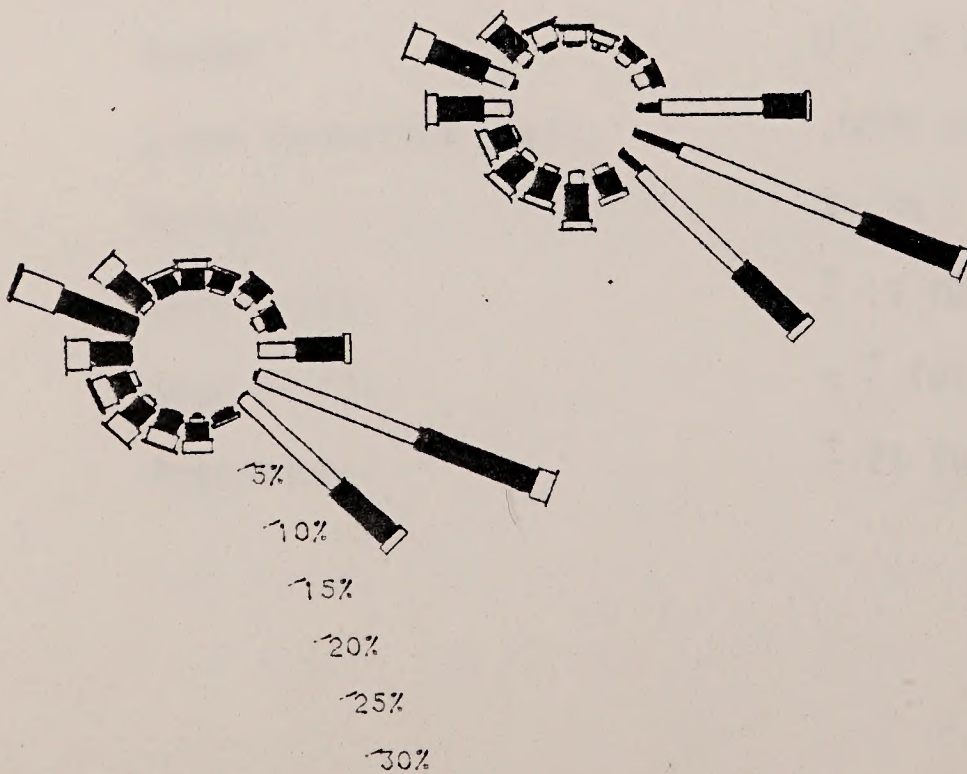


DEC 80 - NOV 81

TOTAL % OF CALMS DISTRIBUTED (7.62%)  
TOTAL NO. OF 1-HOUR SAMPLES - 8239

JUN 81 - AUG 81

TOTAL % OF CALMS DISTRIBUTED (2.06%)  
TOTAL NO. OF 1-HOUR SAMPLES - 2086



SEP 81 - NOV 81

TOTAL % OF CALMS DISTRIBUTED (10.4%)  
TOTAL NO. OF 1-HOUR SAMPLES - 3007

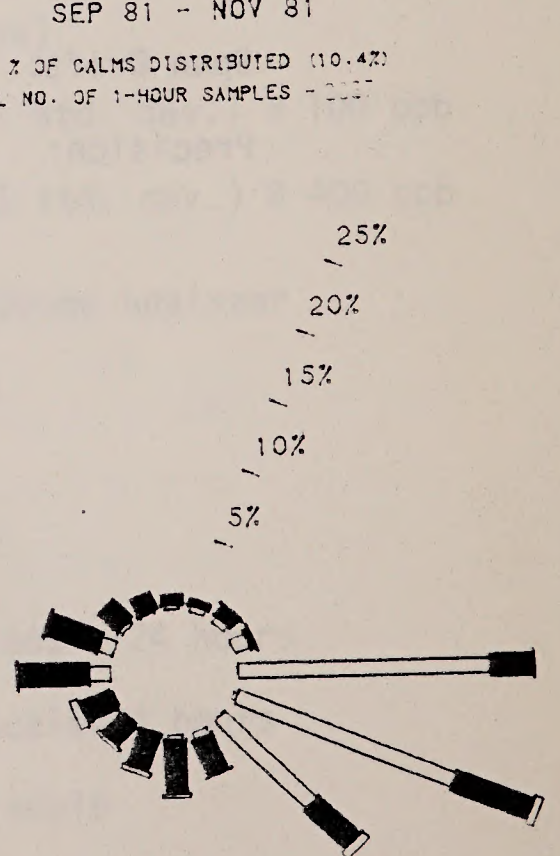
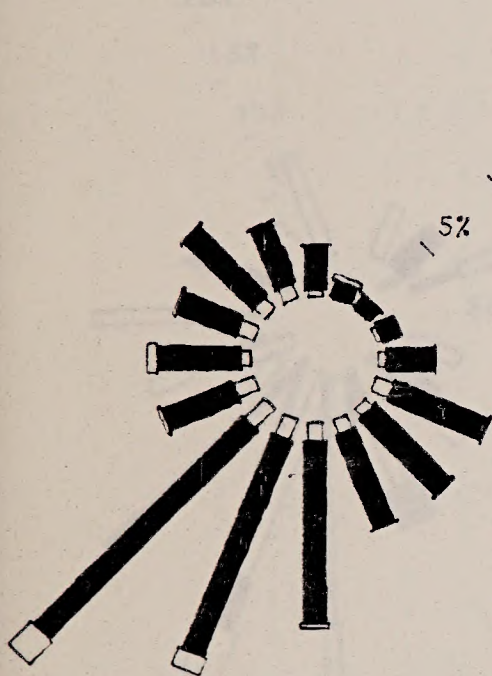




Figure A6.2.1-2  
 AB23 QUARTERLY & ANNUAL O<sub>3</sub> CONCENTRATION ROSES

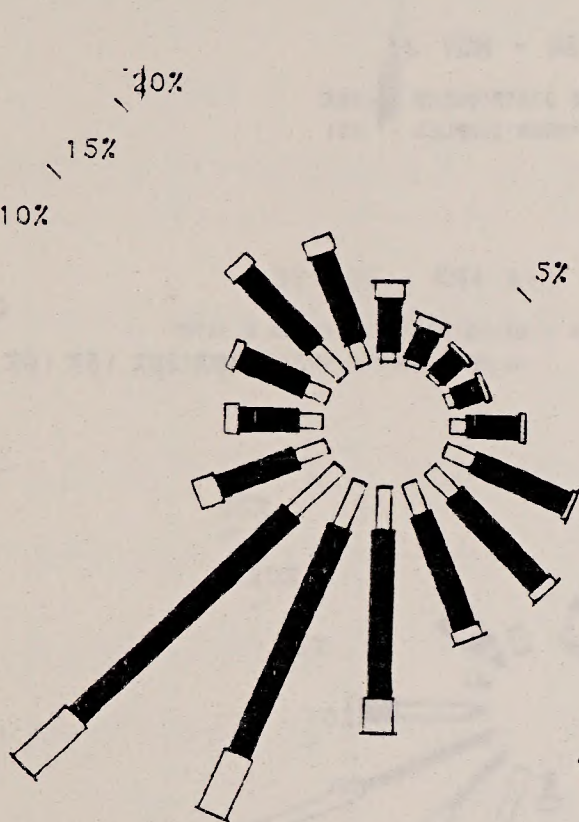
DEC 80 - FEB 81

TOTAL % OF CALMS DISTRIBUTED (2.46%)  
 TOTAL NO. OF 1-HOUR SAMPLES - 2035



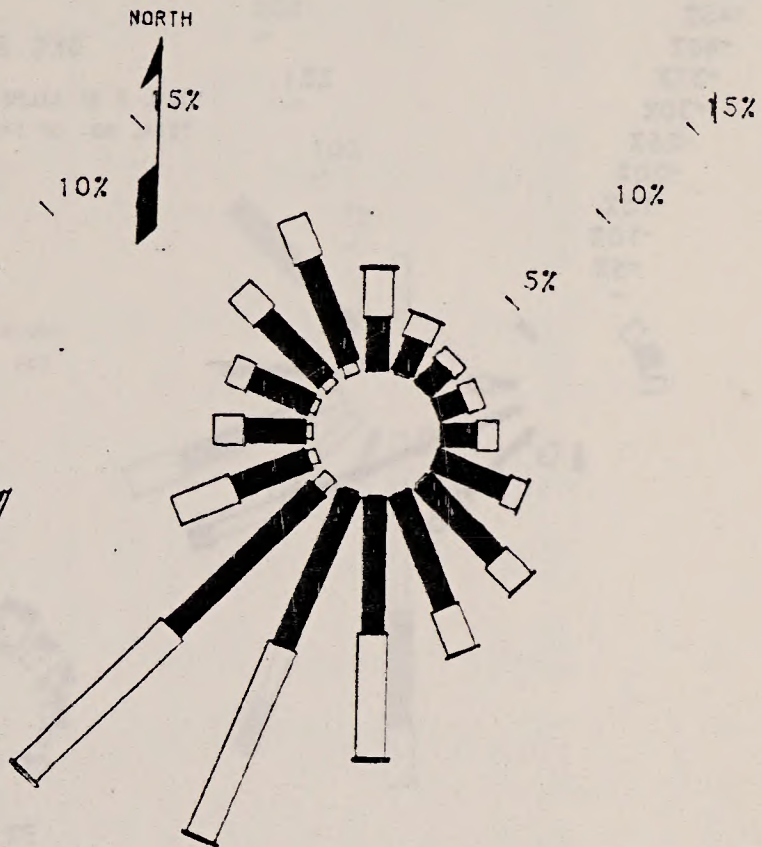
DEC 80 - NOV 81

TOTAL % OF CALMS DISTRIBUTED (1.91%)  
 TOTAL NO. OF 1-HOUR SAMPLES - 8173



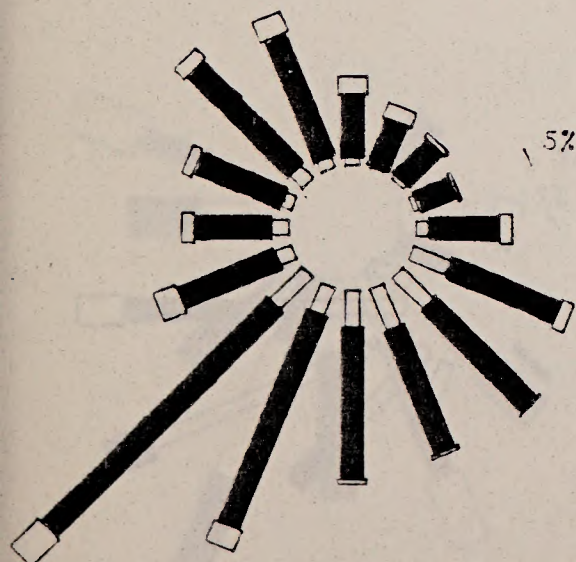
MAR 81 - MAY 81

TOTAL % OF CALMS DISTRIBUTED (1.83%)  
 TOTAL NO. OF 1-HOUR SAMPLES - 2072



JUN 81 - AUG 81

TOTAL % OF CALMS DISTRIBUTED (1.64%)  
 TOTAL NO. OF 1-HOUR SAMPLES - 1954



SEP 81 - NOV 81

TOTAL % OF CALMS DISTRIBUTED (1.75%)  
 TOTAL NO. OF 1-HOUR SAMPLES - 2112

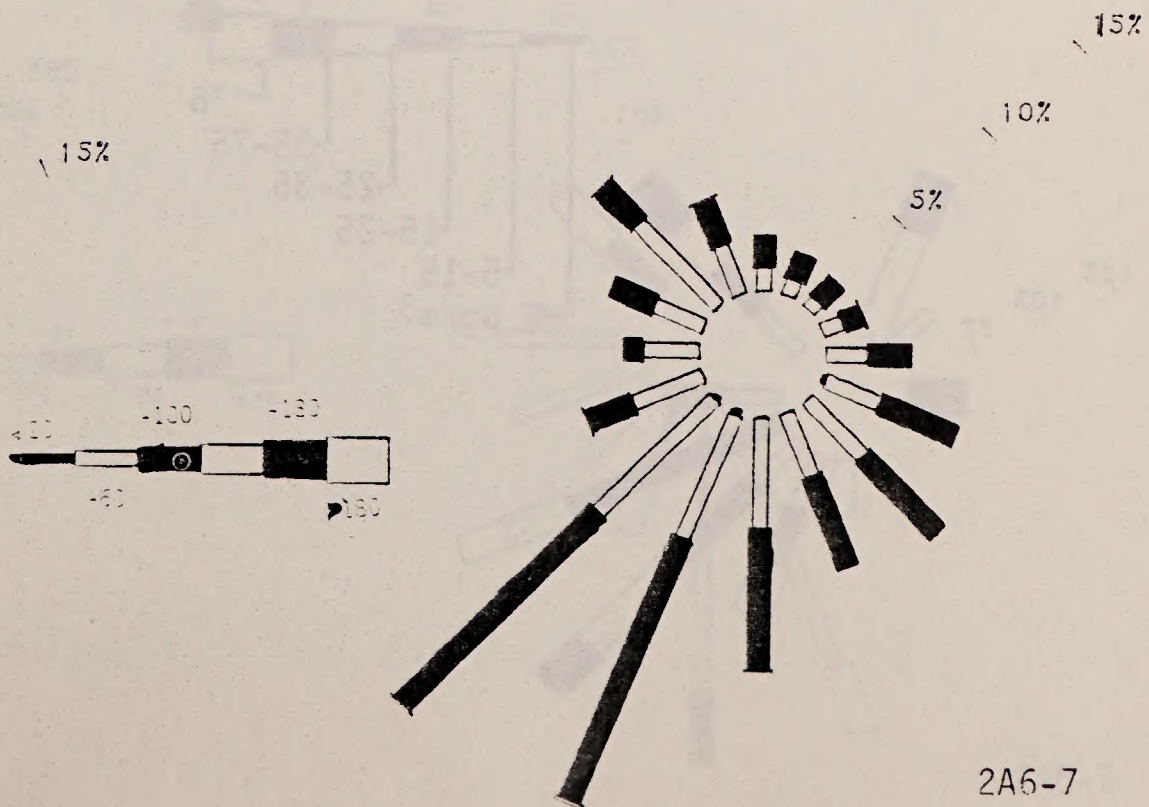
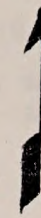




Figure A6.2.2-1

AB20 Quarterly & Annual Particulate Concentration Roses

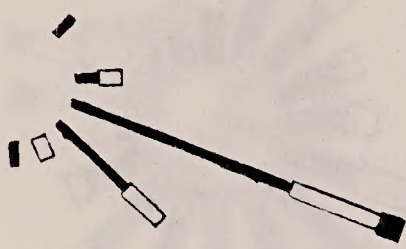
NORTH



DEC 80 - FEB 81

TOTAL % OF CALMS DISTRIBUTED (0.00%)  
TOTAL NO. OF 1-HOUR SAMPLES - 29

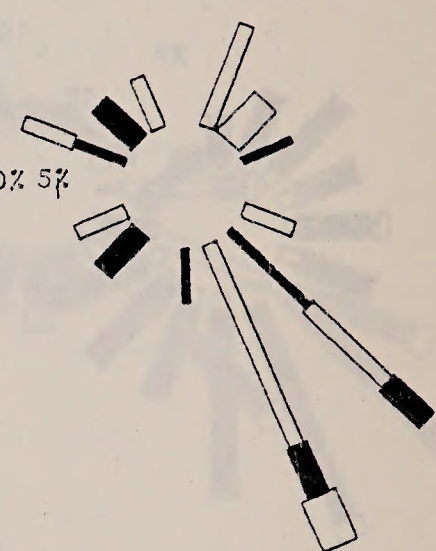
55%  
50%  
45%  
40%  
35%  
30%  
25%  
20%  
15%  
10%  
5%



MAR 81 - MAY 81

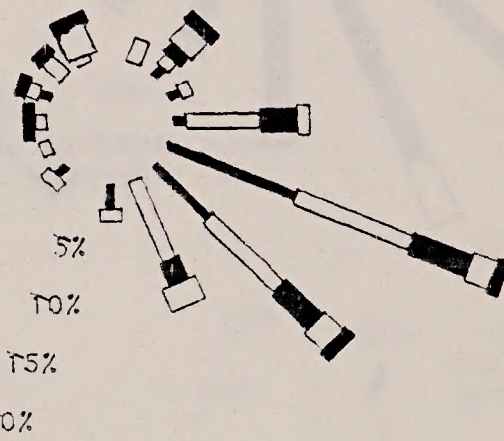
TOTAL % OF CALMS DISTRIBUTED (0.00%)  
TOTAL NO. OF 1-HOUR SAMPLES - 23

30% 25% 20% 15% 10% 5%



DEC 80 - NOV 81

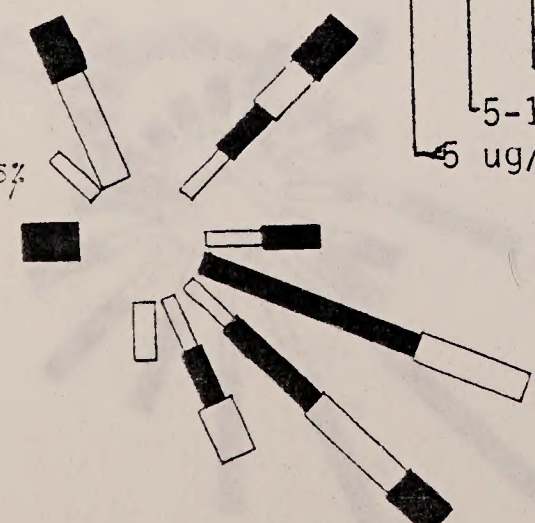
TOTAL % OF CALMS DISTRIBUTED (0.99%)  
TOTAL NO. OF 1-HOUR SAMPLES - 101



JUN 81 - AUG 81

TOTAL % OF CALMS DISTRIBUTED (0.00%)  
TOTAL NO. OF 1-HOUR SAMPLES - 26

20%  
25%  
30%



SEP 81 - NOV 81

TOTAL % OF CALMS DISTRIBUTED (4.35%)  
TOTAL NO. OF 1-HOUR SAMPLES - 23

35%  
30%  
25%  
20%  
15%  
10%  
5%

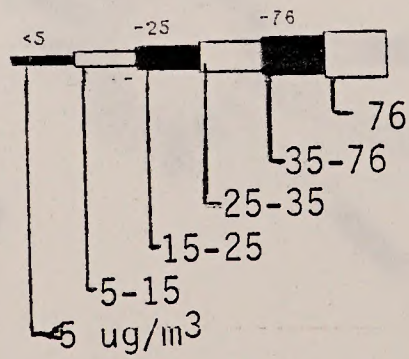
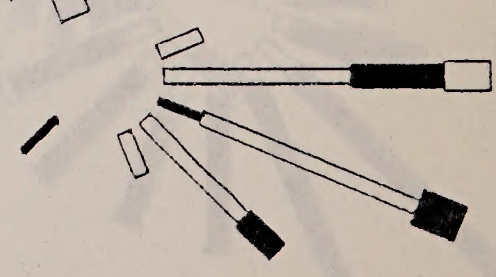


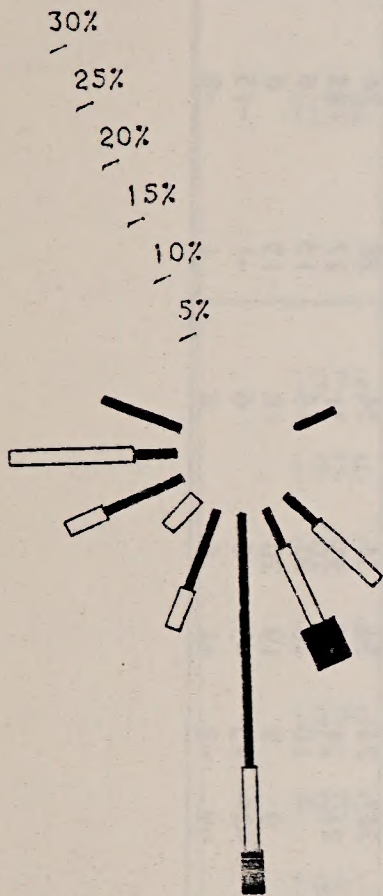


Figure A6.2.2-2

AB23 Quarterly & Annual Particulate Concentration Roses

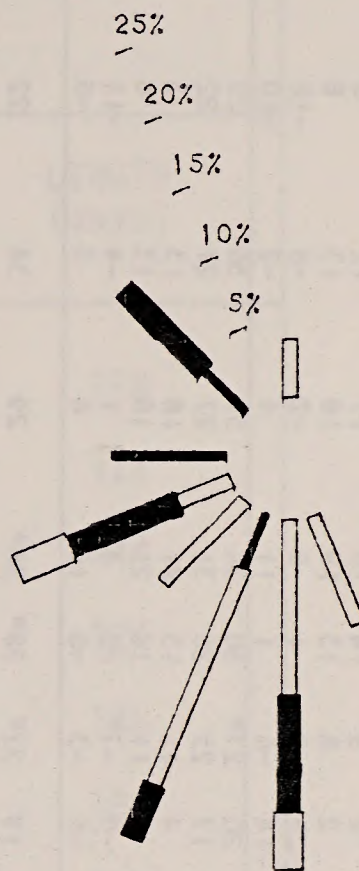
DEC 80 - FEB 81

TOTAL % OF CALMS DISTRIBUTED (0.00%)  
TOTAL NO. OF 1-HOUR SAMPLES - 30

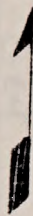


MAR 81 - MAY 81

TOTAL % OF CALMS DISTRIBUTED (0.00%)  
TOTAL NO. OF 1-HOUR SAMPLES - 26

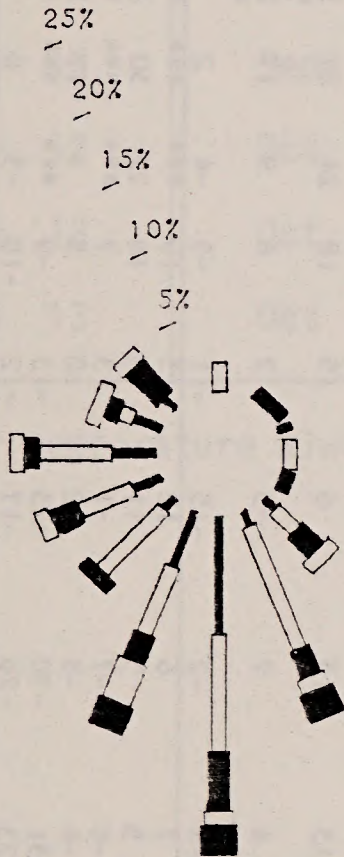


NORTH



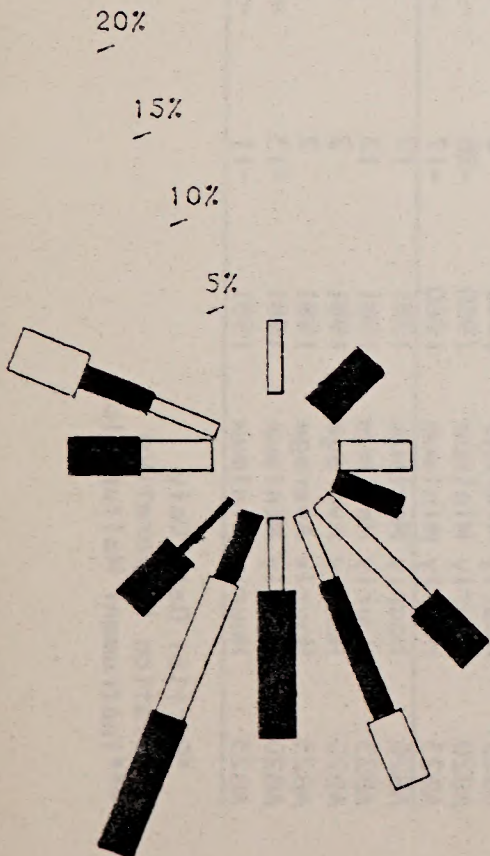
DEC 80 - NOV 81

TOTAL % OF CALMS DISTRIBUTED (0.00%)  
TOTAL NO. OF 1-HOUR SAMPLES - 103



JUN 81 - AUG 81

TOTAL % OF CALMS DISTRIBUTED (0.00%)  
TOTAL NO. OF 1-HOUR SAMPLES - 26



SEP 81 - NOV 81

TOTAL % OF CALMS DISTRIBUTED (0.00%)  
TOTAL NO. OF 1-HOUR SAMPLES - 21

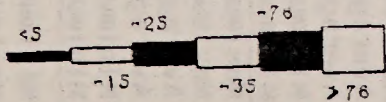
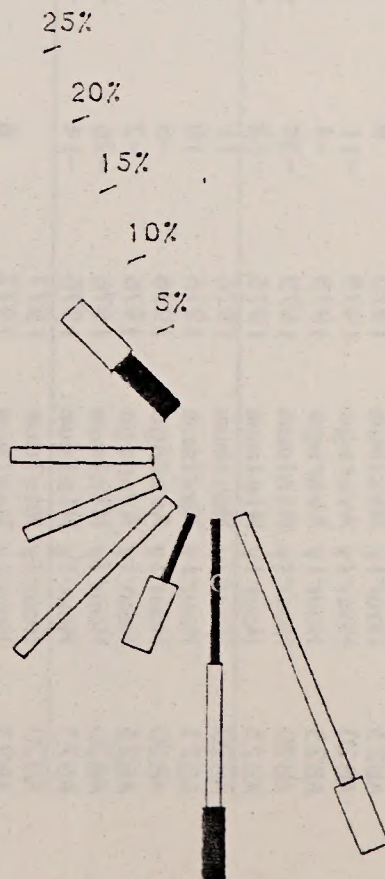




TABLE A6.3.1-1  
Air Temperature, 10m (°C)

Station	Item	Seasonal Year												Annual Maximum Average Minimum	
			December	January	February	March	April	May	June	July	August	September	October	November	32
AB20	Hourly Maximum	1975	7	10	8	15	21	26	31	32	31	28	25	18	29
AB23	Hourly Maximum	1975	9	6	6	10	20	22	28	29	28	26	22	17	4
AB20	Hourly Average	1975	-11	-9	-7	0	2	9	14	19	17	12	6	-3	6
AB23	Hourly Average	1975	-4	-5	-4	-1	2	8	13	19	18	13	8	0	-43
AB20	Hourly Minimum	1975	-34	-43	-31	-33	-28	-9	-1	6	-2	-8	-18	-27	-21
AB23	Hourly Minimum	1975	-18	-21	-18	-21	-14	-6	1	11	4	-2	-10	-16	-21
AB20	Hourly Maximum	1976	11	8	11	13	20	27*	30	34	31	30	25	**	34
AB23	Hourly Maximum	1976	10	8	9	11	17	23	28	31	27	27	22	15	31
AB20	Hourly Average	1976	-6	-9	-3	-4	4	11	15	21	18	13	3	**	7
AB23	Hourly Average	1976	-2	-4	-1	-2	6	11	16	21	18	13	6	1	-41
AB20	Hourly Minimum	1976	-26	-41	-29	-32	-9	-7*	-8	4	1	-4	-14	**	-21
AB23	Hourly Minimum	1976	-14	-21	-14	-15	-6	-3	-6	10	6	2	-9	-19	-21
AB20	Hourly Maximum	1977													34
AB23	Hourly Maximum	1977	8	7	12	12	19	22*	28*	28*	29	34	22	18	7
AB20	Hourly Average	1977													3
AB23	Hourly Average	1977	-3	-5	-2	-2	6	9*	20*	21*	19	15	5	3	-20
AB20	Hourly Minimum	1977													-17
AB23	Hourly Minimum	1977	-13	-20	-13	-16	-11	-2*	7*	11*	3	-4	-12	-17	-20
AB20	Hourly Maximum	1978													31
AB23	Hourly Maximum	1978	13	13	6	15	18	24	28	31	29	28	25	18	9
AB20	Hourly Average	1978													2
AB23	Hourly Average	1978	4	7	-3	2	6	9	17	21	18	15	10	1	-11
AB20	Hourly Minimum	1978													-16
AB23	Hourly Minimum	1978	-8	-2	-15	-11	-5	-4	2	7	2	-3	-3	-16	-16
AB20	Hourly Maximum	1979	7	6	12	13	19	***	***	***	32	31	28	13	32
AB23	Hourly Maximum	1979	5	3	11	9	18	22	30	31	35	31	28	13	35
AB20	Hourly Average	1979	-6	-7	-1	3	7	***	***	***	17	16	8	-4	
AB23	Hourly Average	1979	-6	-8	-2	0	5	9	17	20	19	17	9		
AB20	Hourly Minimum	1979	-31	-30	-23	-13	-9	***	***	***	6	-1	-16	-24	-31
AB23	Hourly Minimum	1979	-23	-26	-17	-12	-10	-3	0	9	8	1	-14	-14	-26
AB20	Hourly Maximum	1980	11	9	13	12	23	26	32	33	32	30	26	21	33
AB23	Hourly Maximum	1980	9	6	10	9	20	23	31	31	30	27	23	18	31
AB20	Hourly Average	1980	-5	-3	-1	1	6	11	18	21	19	14	7	1	7
AB23	Hourly Average	1980	-2	-4	-1	-1	5	9	19	21	19	15	7	9	8
AB20	Hourly Minimum	1980	-26	-23	-22	-16	-9	-1	1	8	3	-3	-9	-14	-26
AB23	Hourly Minimum	1980	-17	-16	-17	-13	-9	-1	3	11	4	1	-8	-5	-17
AB20	Hourly Maximum	1981	17	13	***	***	24*	24	34	34	34	28	24	17	25
AB23	Hourly Maximum	1981	13	11	***	***	*	10	18	20	18	15	6	4	10
AB20	Hourly Average	1981	2	-2	***	***									8
AB23	Hourly Average	1981	2	-1	-1	1	9	9	19	20	18	15	6	3	-6
AB20	Hourly Minimum	1981	-13	-14	***	***	-4*	-3	-3	6	6	-1	-15	-15	-6
AB23	Hourly Minimum	1981	-11	-11	-19	-8	-9	-2	-1	6	8	1	-8	-13	-6

\*Partial Data Only  
\*\*Station Inoperative  
\*\*\*Instrument Malfunction



TABLE A6.3.1-2  
 GROWING SEASON BY YEAR

YEAR	GROWING SEASON*		
	START	STOP	LENGTH (days)
1975	May 26	Sept 21	118
1976	June 14	Oct 5	111
1977	Apr 21	Sept 14	144
1978	May 15	Sept 17	124
1979	May 12	Oct 9	148
1980	May 12	Oct 15	156
1981	May 13	Oct 17	157

\*Hourly minimum air temperature always  $>0^{\circ}\text{C}$ .



TABLE A6.3.1-3

Station AB23  
Direct Solar Radiation

Month/ Year	Total Langleys For Month	Average Day- light Hr/Day	Daylight Hours Month	Uptime* Day- light Hr/Day	Daily Total/Day of The Month	
					Monthly Highest	Monthly Lowest
12/80	3638	10	310	310	194/1	23/7
1/81	4332	10	310	310	262/18	31/31
2/81	7169	11	308	308	373/23	78/1
3/81	8885	12	372	372	475/29	62/6
4/81	14054	13	390	390	610/28	217/7
5/81	6760	14	424	350	399/4	74/3
6/81	12079	15	450	300	709/16	401/28
7/81	14546	15	465	405	681/4	215/16
8/81	12508	14	434	373	623/5	214/21
9/81	10193	13	390	365	524/1	271/29
10/81	7806	12	372	362	421/1	61/24
11/81	6610	10	300	300	379/11	30/25

\*Channel "uptime" is given for reference only.



TABLE A6.3.1-4

## Relative Humidity (%)

Station	Item	Seasonal Year													Annual Maximum Average Minimum
			December	January	February	March	April	May	June	July	August	September	October	November	
AB23	Hourly Maximum	1975	100	100	100	100	100	100	100	100	87	93	100	100	100
AB23	Hourly Average	1975	69	68	72	72	67	64	54	54	29	35	40	53	56
AB23	Hourly Minimum	1975	25	26	32	37	32	28	25	28	12	16	15	19	12
AB23	Hourly Maximum	1976	90	90	89	90	98	90	99	96	100	99	94	97	100
AB23	Hourly Average	1976	62	62	57	56	53	51	44	47	50	59	51	56	54
AB23	Hourly Minimum	1976	34	25	22	23	21	24	27	29	32	32	32	32	21
AB23	Hourly Maximum	1977	96*	**	**	74*	100	**	**	**	**	99*	**	**	*
AB23	Hourly Average	1977	58*	**	**	56*	67	**	**	**	**	37*	**	**	*
AB23	Hourly Minimum	1977	30*	**	**	41*	37	**	**	**	**	15*	**	**	*
AB23	Hourly Maximum	1978	99	97	96	96	95	94	96	94	94	97	97	99	99
AB23	Hourly Average	1978	65	74	71	66	53	49	42	38	38	45	44	62	54
AB23	Hourly Minimum	1978	10	32	25	20	14	13	12	9	9	8	12	19	8
AB23	Hourly Maximum	1979	99	100	99	100	100	100	90	100	100	100	100		100
AB23	Hourly Average	1979	74	75	70	73	<75	<75	43	49	55	41	55		54
AB23	Hourly Minimum	1979	31	37	32	30	24	24	16	15	15	15	11		11
AB23	Hourly Maximum	1980	96	96	95	99	98	98	90	93	94	93	94	98	99
AB23	Hourly Average	1980	57	<75	67	66	53	61	32	42	39	42	52	58	55
AB23	Hourly Minimum	1980	17	27	18	22	14	11	12	8	8	8	7	13	7
AB23	Hourly Maximum	1981	96	99	100	99*	86	86	85	87	67	67	65	68	100
AB23	Hourly Average	1981	57	66	60	*	56	65	55	57	39	38	44	43	53
AB23	Hourly Minimum	1981	17	21	17	37*	40	42	41	42	21	21	21	21	17

\*Partial Data Only

\*\*Instrument Malfunction



TABLE A6.3.1-5  
Monthly Precipitation for 1981

Computer Code	Station	January	February	March	April	May	June	July	August	September	October	November	December
WU15	USGS 015	-	10.72	-	.56	7.04	.05	3.96	2.84	3.71	9.14	-	-
WU22	USGS 022	-	.64	4.85	1.04	7.39	1.85	2.24	3.43	4.60	8.59	-	-
WU50	USGS 050	-	10.13	-	.61	3.71	2.77	2.49	2.39	2.69	9.30	-	-
WU58	USGS 058	-	.61	2.21	3.48	4.85	2.39	6.35	3.68	1.47	9.60	-	-
WU70	USGS 070	-	-	-	-	-	-	-	-	-	-	-	-
BC01	MC Station 1	-	-	-	.14	2.80	1.10	1.00	.31	1.78	3.75	-	-
BC02	MC Station 2	-	-	-	.00	2.39	1.90	1.54	.78	1.08	3.45	-	-
BC03	MC Station 3	-	-	-	.11	2.14	1.23	1.15	.30	1.70	3.02	-	-
BC04	MC Station 4	-	-	-	.11	2.86	1.38	1.33	.36	1.61	3.41	-	-
BC05	MC Station 5	-	-	-	.00	1.65	.66	.53	.23	.88	.80	-	-
BC06	MC Station 6	-	-	-	.06	2.41	.88	.93	.24	1.59	.33	-	-
BC07	MC Station 7	-	-	-	.04	2.35	1.33	1.02	.31	1.65	3.11	-	-
BC08	MC Station 8	-	-	-	.16	.60	1.10	1.54	.29	1.38	3.48	-	-
BC09	MC Station 9	-	-	-	.09	.39	.55	.76	.22	.96	.30	-	-
BC13	MC Station 13	-	-	-	.08	2.47	1.96	1.17	.28	.80	.26	-	-
AB20	AQ Station 020	1.30	.46	4.01	1.40	7.09	2.13	3.73	2.67	1.83	10.13	-	-
AB23	AQ Station 023	1.68	.86	3.20	1.52	6.22	3.38	3.20	1.80	2.97	7.75	-	-
WR01	Little Hills	.51	1.93	7.16	.58	8.13	2.82	3.66	5.44	1.12	-	-	-
WR02	Meeker 2	.71	0.89	8.18	.99	7.54	1.83	3.23	3.30	1.19	-	-	-
WR03	Standard Gulch on Roan Plateau	1.32	1.83	6.68	1.65	7.21	1.55	1.50	4.39	3.38	8.97	-	-
WR04	Corral Gulch	2.82	1.40	9.19	2.87	7.49	.13	.28	5.87	4.50	11.73	-	-
WR05	JQS Gage	.66	5.99	4.52	2.51	9.55	6.71	6.10	7.67	1.24	10.90	-	-
WR06	East Fork Parachute Creek	1.17	6.63	5.16	2.44	10.41	4.17	4.47	2.72	2.39	11.53	-	-
WR07	East Middle Fork Parachute	2.46	1.07	-	-	7.75	6.38	4.62	1.78	2.08	8.84	-	-



TABLE A6.3.1-6

## Barometric Pressure, Millibars (Daily Extrema)

Station	Item	Seasonal Year												Annual Maximum Average Minimum	
			December	January	February	March	April	May	June	July	August	September	October	November	
AB24	Daily Maximum	1975						795	796	799	798	803	802	803	803*
AB23	Daily Maximum	1975		795	794*	790	790	792	793	794	794	799	798	800	800
AB24	Daily Average	1975						790*	791*	895	796	797	794	793*	
AB23	Daily Average	1975		786	785	782*	782	786	778*	791	792	794	791	789	787*
AB24	Daily Minimum	1975						776	781	792	792	792	782	772	772*
AB23	Daily Minimum	1975		770	777	769	771	773	778	788	789	789	782	770	770
AB24	Daily Maximum	1976	802	802	804	796	799	798	799	799	801	803	800	***	804
AB23	Daily Maximum	1976	798	799	799	793	790	795	795	796	797	799	797	798	799
AB24	Daily Average	1976	794	795	791	788	789	793*	793	796*	797	796	795	***	
AB23	Daily Average	1976	791	791	788	785	786*	790*	790	792*	793	793	792	792	790
AB24	Daily Minimum	1976	776	785	778	778	776	787	787	791	792	790	789	***	776
AB23	Daily Minimum	1976	780	781	775	775	781	784*	784	789	787	787	786	777	775
AB23	Daily Maximum	1977	798	797	797	793	796	795	795	797	796	**	**	**	798*
AB23	Daily Average	1977	790	788	790	784	789	786	791	794	794	**	**	**	790*
AB23	Daily Minimum	1977	779	773	774	771	775	776	786	789	789	**	**	**	771*
AB23	Daily Maximum	1978	**	794*	798	797	792	795	795	793	796	792	792	792	797*
AB23	Daily Average	1978	**	783*	785	786	784	784	789	787	789	785	786	783	786*
AB23	Daily Minimum	1978	**	768*	771	775	776	773	782	773	776	770	776	773	768*
AB23	Daily Maximum	1979	794	792	793	793	789	791	795	794	793	793	794		795*
AB23	Daily Average	1979	781	781	783	783	782	784	787	787	788	789	786		785
AB23	Daily Minimum	1979	766	770	771	772	766	771	776	725	783	784	773		725*
AB23	Daily Maximum	1980		792	793	790	793	789	792	793	792	793	795	795	795
AB23	Daily Average	1980		782	784	780	785	783	786	789	786	788	788	786	785
AB23	Daily Minimum	1980		766	771	773	774	773	779	784	780	781	759	775	759
AB23	Daily Maximum	1981	796	796	797	796	801	795	798	793	795	798	794	799	801
AB23	Daily Average	1981	787	786	787	788	789	785	787	788	790	788	782	784	787
AB23	Daily Minimum	1981	775	778	770	770	775	774	779	784	784	782	748	771	748

\*Partial Data Only

\*\*Instrument Malfunction

\*\*\*Station Inoperative

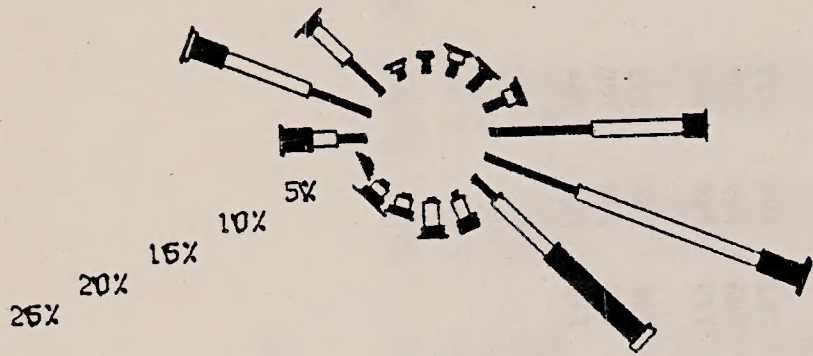


Figure A6.3.2-1

1820 QUARTERLY WIND ROSE • 10M

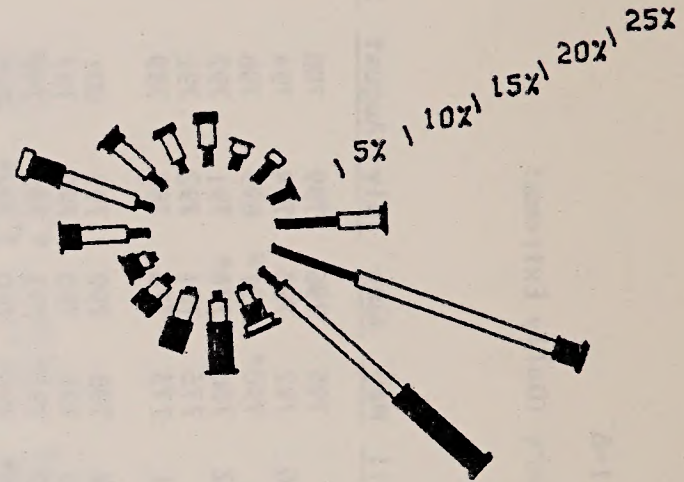
DECEMBER '79 - FEBRUARY '80

TOTAL % OF CALMS DISTRIBUTED (2.87%)  
TOTAL NO. OF 1-HOUR SAMPLES - 2172

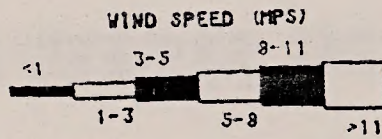


MARCH '80 - MAY '80

TOTAL % OF CALMS DISTRIBUTED (0.75%)  
TOTAL NO. OF 1-HOUR SAMPLES - 2130

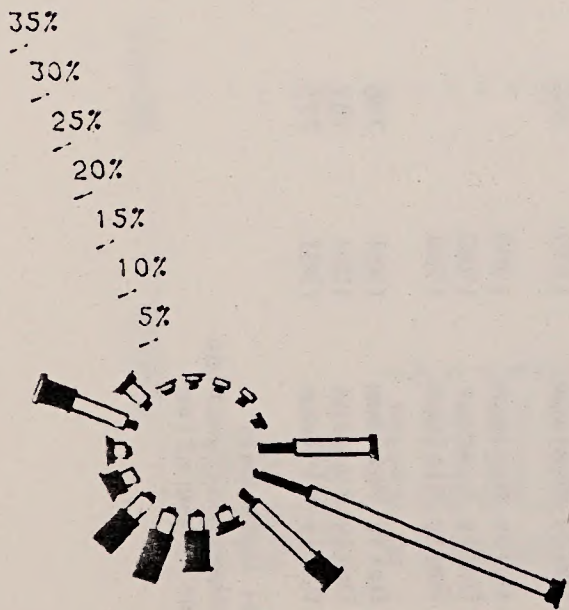


NORTH



JUNE '80 - AUG '80

TOTAL % OF CALMS DISTRIBUTED (0.00%)  
TOTAL NO. OF 1-HOUR SAMPLES - 2144



SEP '80 - NOV '80

TOTAL % OF CALMS DISTRIBUTED (0.00%)  
TOTAL NO. OF 1-HOUR SAMPLES - 2103

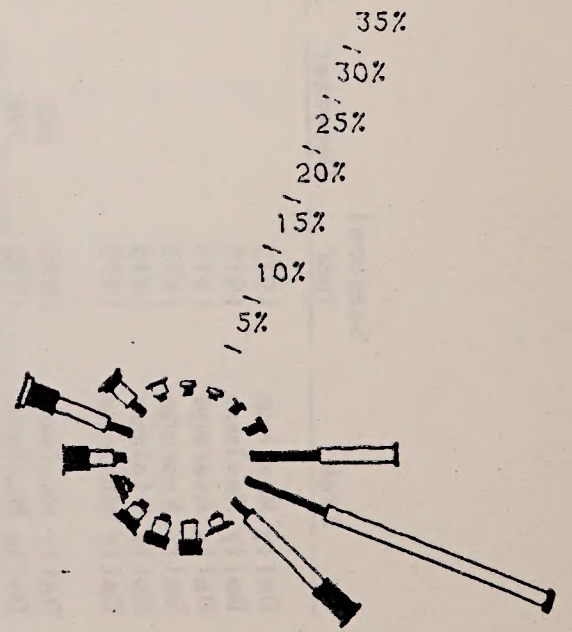


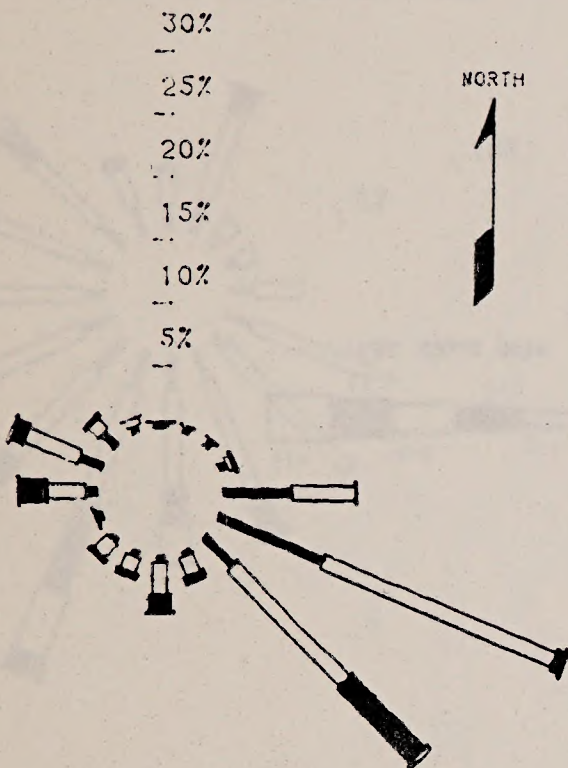


Figure A6.3.2-2

AB20 QUARTERLY WIND ROSE • 10M

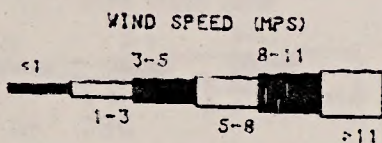
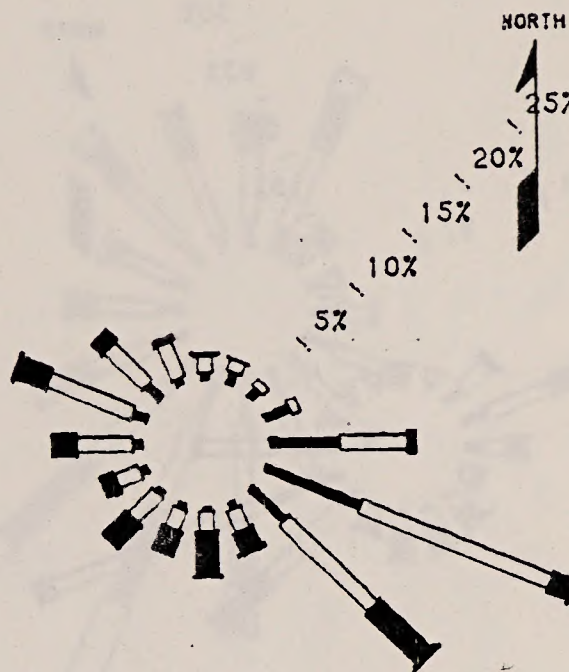
DEC '80 - FEB '81

TOTAL % OF CALMS DISTRIBUTED (0.20%)  
TOTAL NO. OF 1-HOUR SAMPLES - 2009



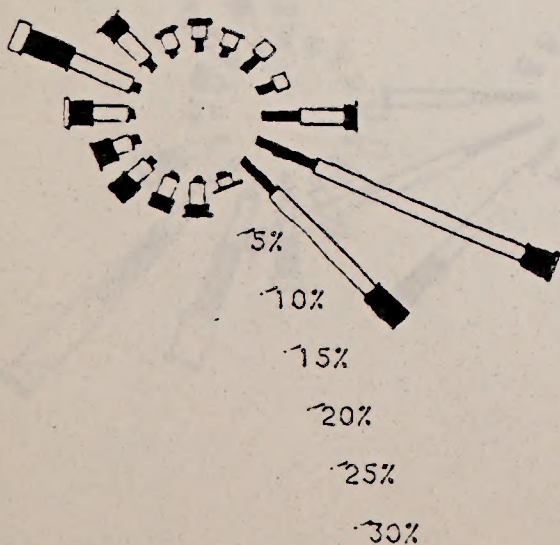
MAR '81 - MAY '81

TOTAL % OF CALMS DISTRIBUTED (0.33%)  
TOTAL NO. OF 1-HOUR SAMPLES - 1793



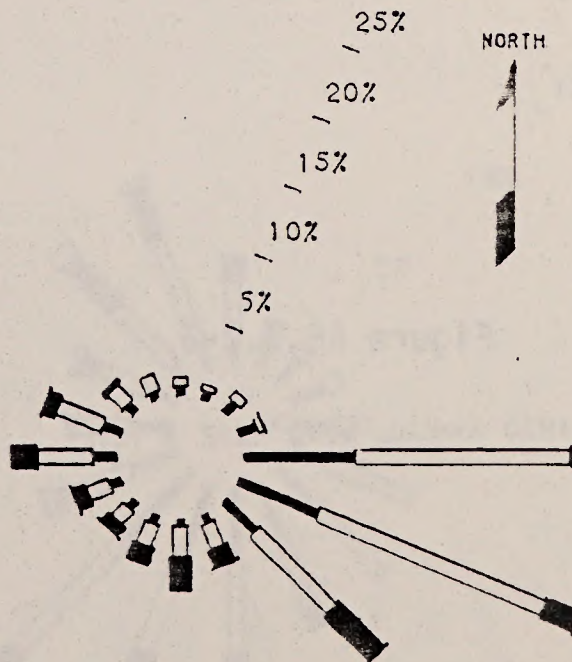
JUN '81 - AUG '81

TOTAL % OF CALMS DISTRIBUTED (0.0%)  
TOTAL NO. OF 1-HOUR SAMPLES - 2123



SEP '81 - NOV '81

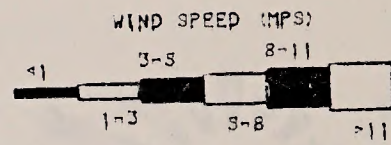
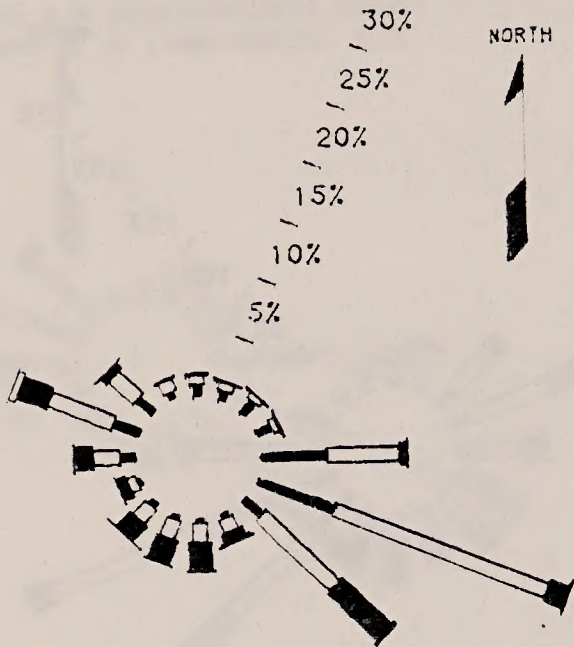
TOTAL % OF CALMS DISTRIBUTED (0.0%)  
TOTAL NO. OF 1-HOUR SAMPLES - 1828





DEC '79 - NOV '80

TOTAL % OF CALMS DISTRIBUTED (0.87%)  
TOTAL NO. OF 1-HOUR SAMPLES - 8549



DEC '80 - NOV '81

TOTAL % OF CALMS DISTRIBUTED (0.13%)  
TOTAL NO. OF 1-HOUR SAMPLES - 7753

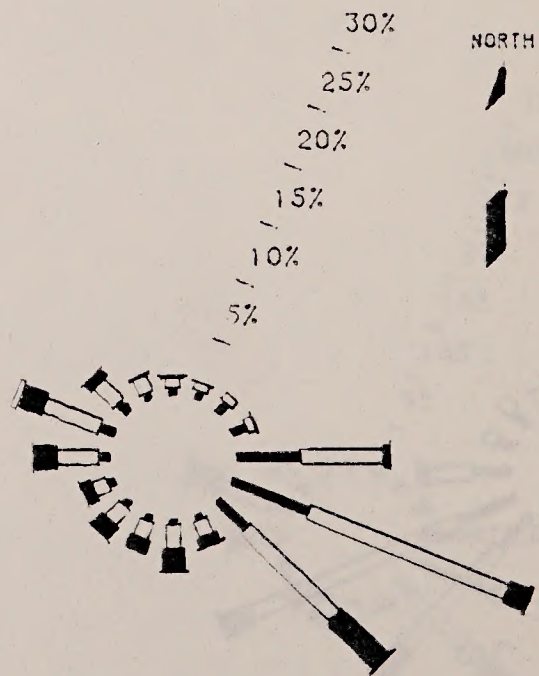


Figure A6.3.2-3

AB20 ANNUAL WIND ROSE • 10M



Figure A6.3.2-4

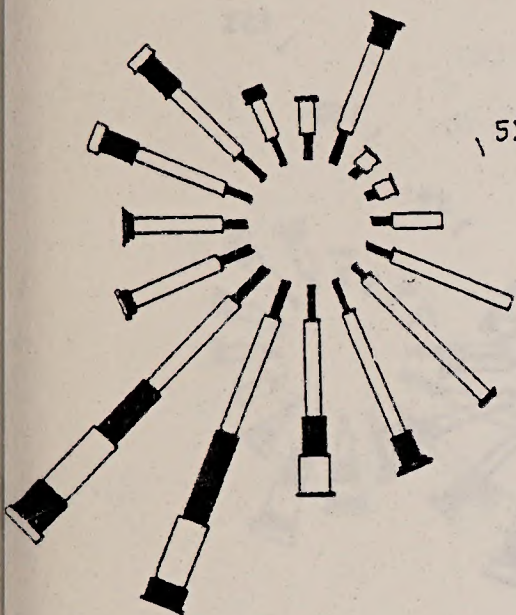
AA23 QUARTERLY WIND ROSE • 10M

DECEMBER '79 - FEBRUARY '80

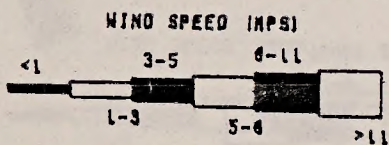
TOTAL % OF CALMS DISTRIBUTED (0.00%)  
TOTAL NO. OF 1-HOUR SAMPLES - 2118

MARCH '80 - MAY '80

TOTAL % OF CALMS DISTRIBUTED (0.00%)  
TOTAL NO. OF 1-HOUR SAMPLES - 2138



NORTH



JUNE '80 - AUG '80

TOTAL % OF CALMS DISTRIBUTED (0.00%)  
TOTAL NO. OF 1-HOUR SAMPLES - 2099

SEP '80 - NOV '80

TOTAL % OF CALMS DISTRIBUTED (0.00%)  
TOTAL NO. OF 1-HOUR SAMPLES - 2132

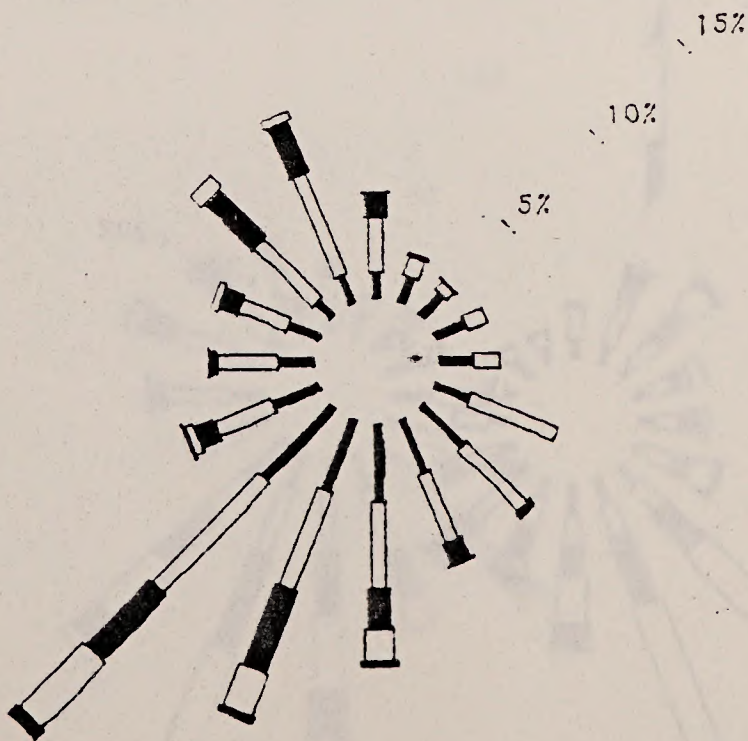
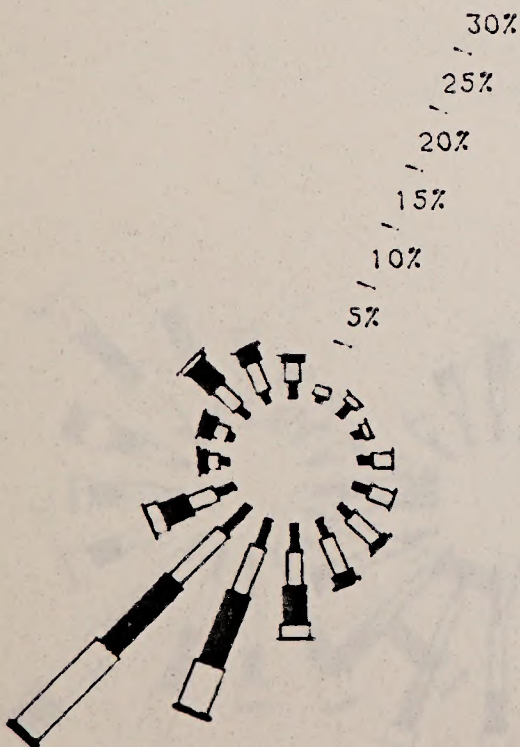


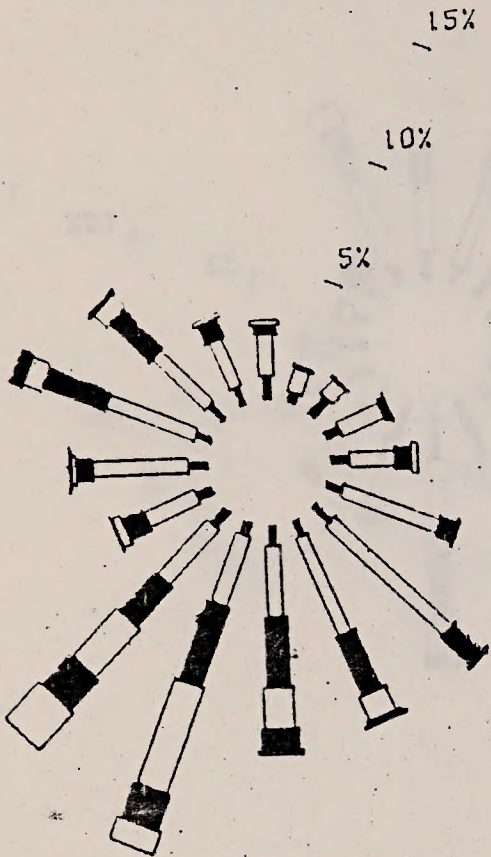


Figure A6.3.2-5

1A23 QUARTERLY WIND ROSE • 30M

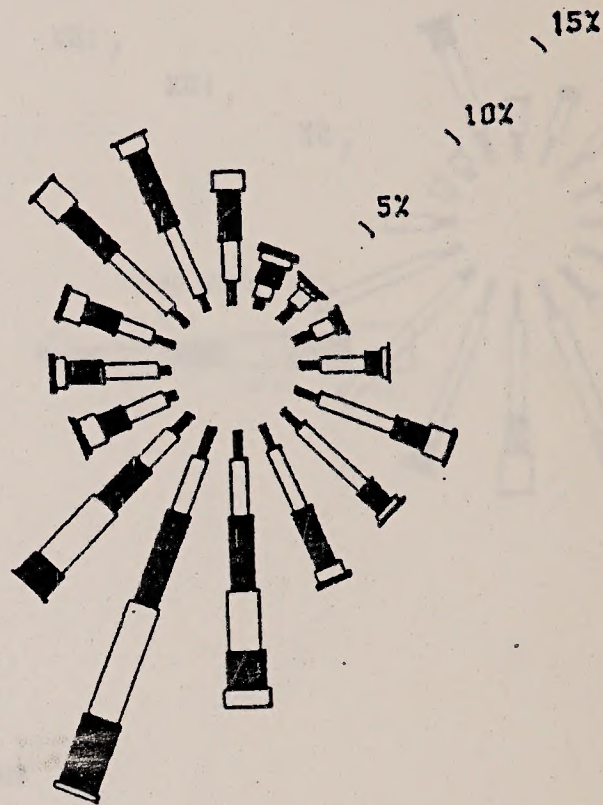
DECEMBER '79 - FEBRUARY '80

TOTAL % OF CALMS DISTRIBUTED (0.72%)  
TOTAL NO. OF 1-HOUR SAMPLES - 1952



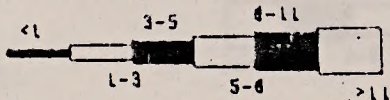
MARCH '80 - MAY '80

TOTAL % OF CALMS DISTRIBUTED (0.00%)  
TOTAL NO. OF 1-HOUR SAMPLES - 2126



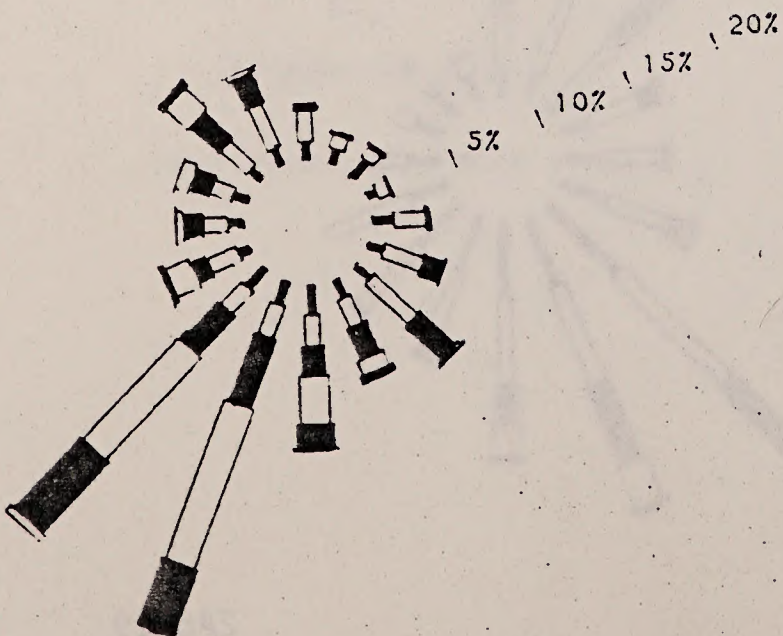
NORTH

WIND SPEED (MPS)



JUNE '80 - AUG '80

TOTAL % OF CALMS DISTRIBUTED (0.05%)  
TOTAL NO. OF 1-HOUR SAMPLES - 2098



SEP '80 - NOV '80

TOTAL % OF CALMS DISTRIBUTED (0.00%)  
TOTAL NO. OF 1-HOUR SAMPLES - 2113

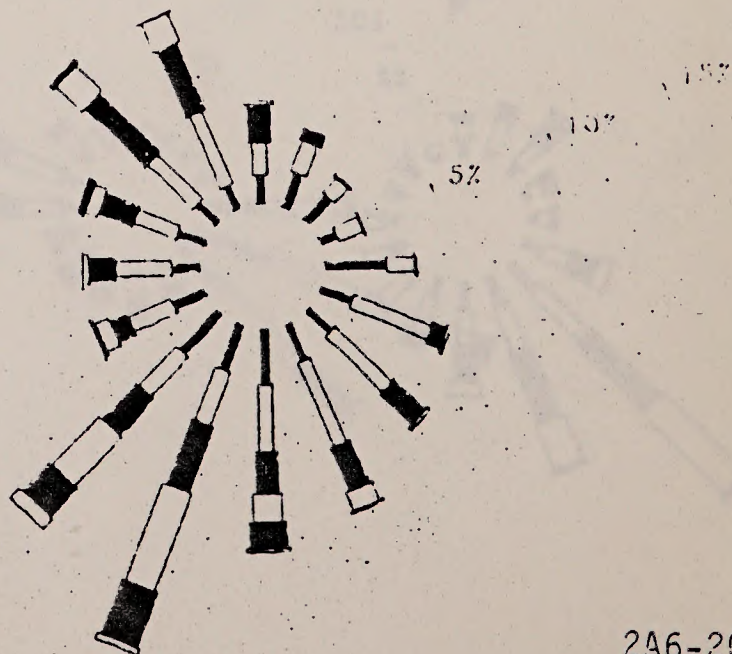


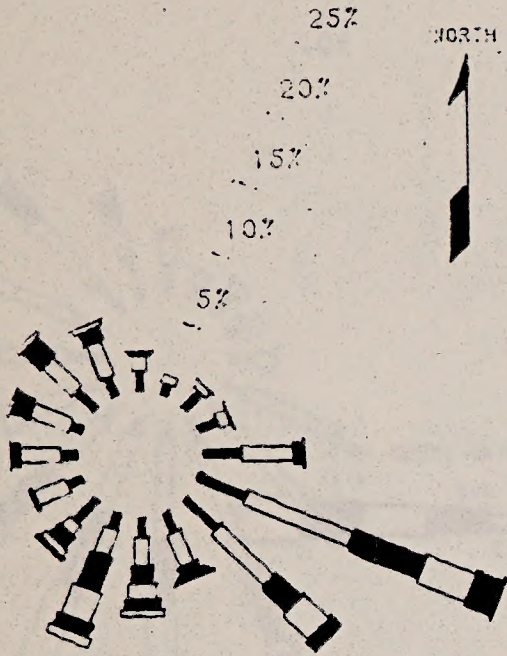


Figure A6.3.2-6

AA23 QUARTERLY WIND ROSE • 30M

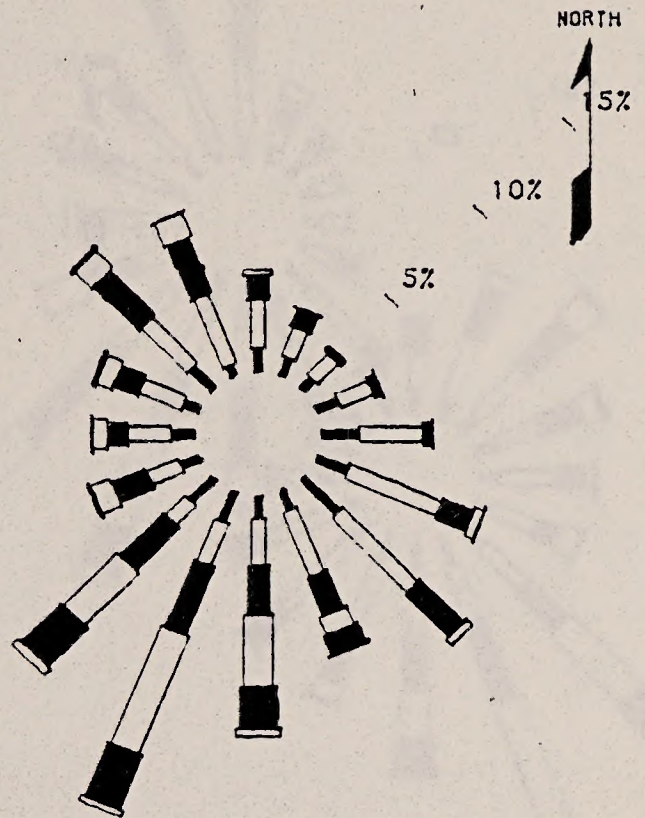
DEC '80 - FEB '81

TOTAL % OF CALMS DISTRIBUTED (0.0%)  
TOTAL NO. OF 1-HOUR SAMPLES - 1078

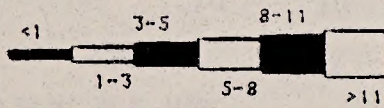


MAR '81 - MAY '81

TOTAL % OF CALMS DISTRIBUTED (0.0%)  
TOTAL NO. OF 1-HOUR SAMPLES - 2102

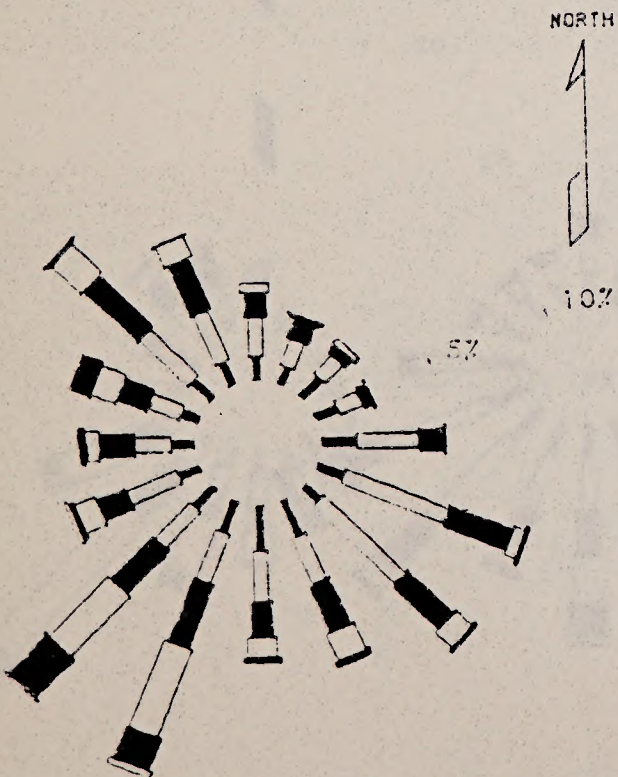


WIND SPEED (MPS)



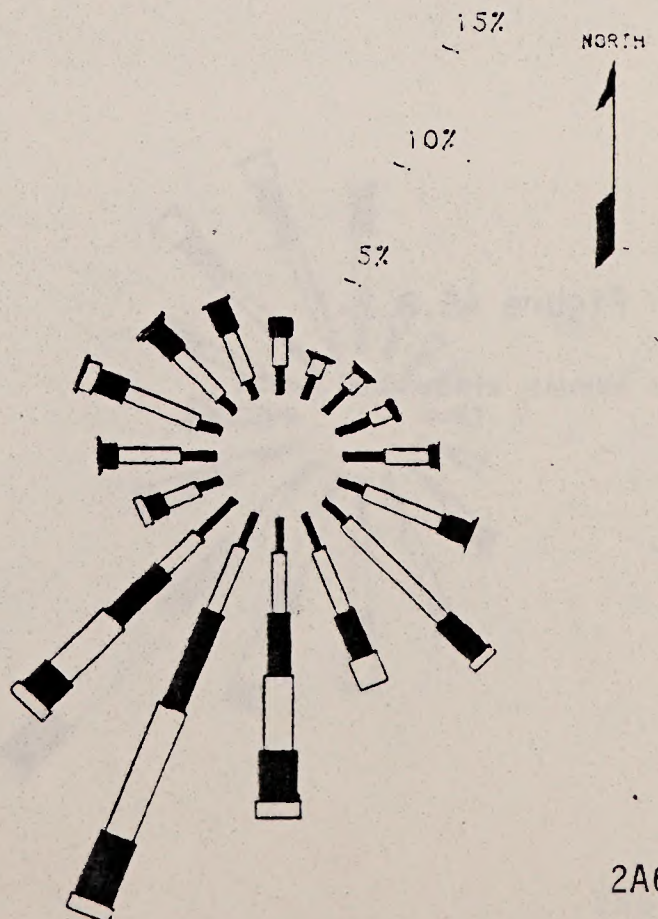
JUN '81 - AUG '81

TOTAL % OF CALMS DISTRIBUTED (0.0%)  
TOTAL NO. OF 1-HOUR SAMPLES - 1943



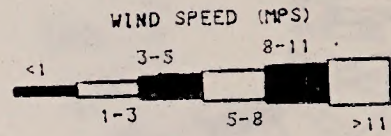
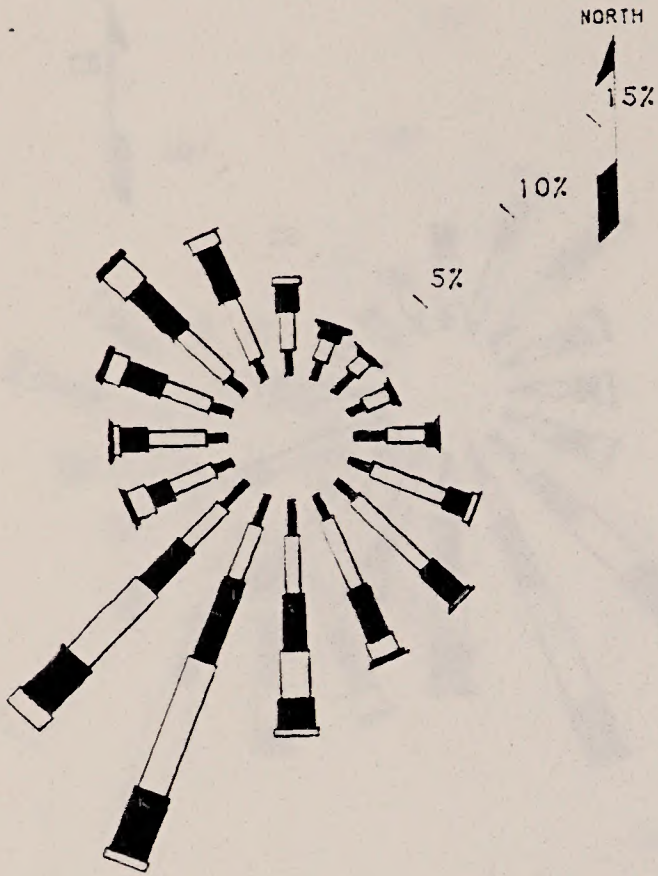
SEP '81 - NOV '81

TOTAL % OF CALMS DISTRIBUTED (0.0%)  
TOTAL NO. OF 1-HOUR SAMPLES - 2071





DEC '79 - NOV '80  
 TOTAL % OF CALMS DISTRIBUTED (0.18%)  
 TOTAL NO. OF 1-HOUR SAMPLES - 8291



DEC '80 - NOV '81  
 TOTAL % OF CALMS DISTRIBUTED (0.07%)  
 TOTAL NO. OF 1-HOUR SAMPLES - 8195

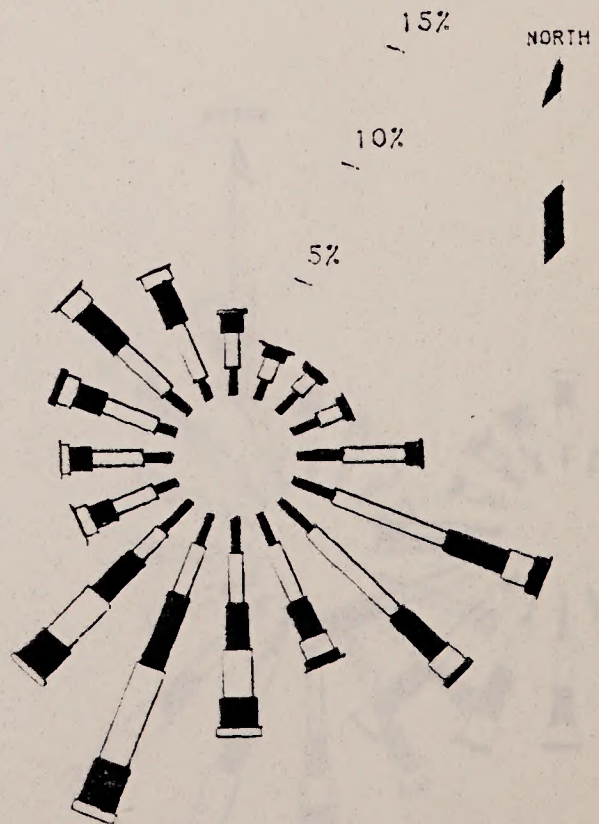


Figure A6.3.2-7  
 AA23 ANNUAL WIND ROSE • 30M

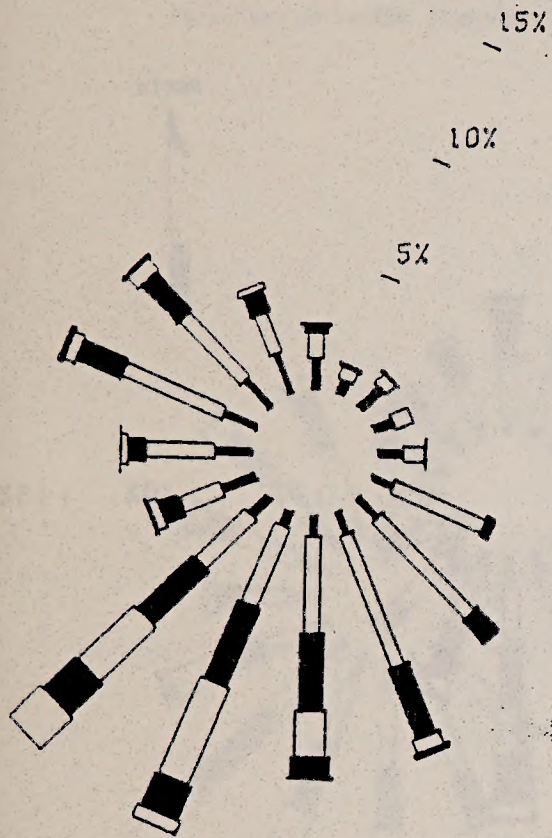


Figure A6.3.2-8

AA23 QUARTERLY WIND ROSE • 60M

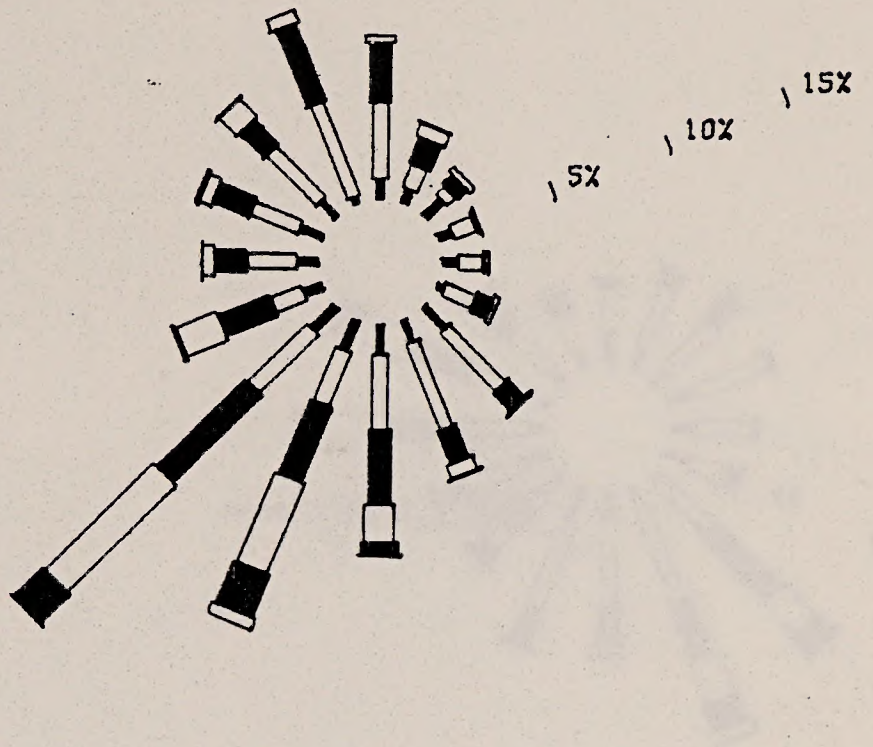
DECEMBER '79 - FEBRUARY '80

TOTAL % OF CALMS DISTRIBUTED (0.00%)  
TOTAL NO. OF 1-HOUR SAMPLES - 2105

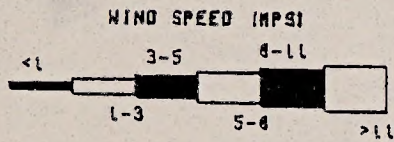


MARCH '80 - MAY '80

TOTAL % OF CALMS DISTRIBUTED (0.00%)  
TOTAL NO. OF 1-HOUR SAMPLES - 2138

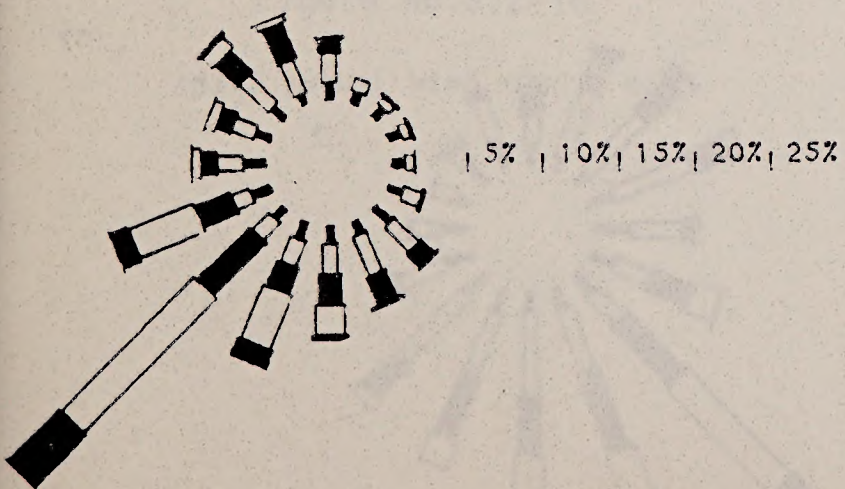


NORTH



JUNE '80 - AUG '80

TOTAL % OF CALMS DISTRIBUTED (0.00%)  
TOTAL NO. OF 1-HOUR SAMPLES - 2089



SEP '80 - NOV '80

TOTAL % OF CALMS DISTRIBUTED (0.20%)  
TOTAL NO. OF 1-HOUR SAMPLES - 2036

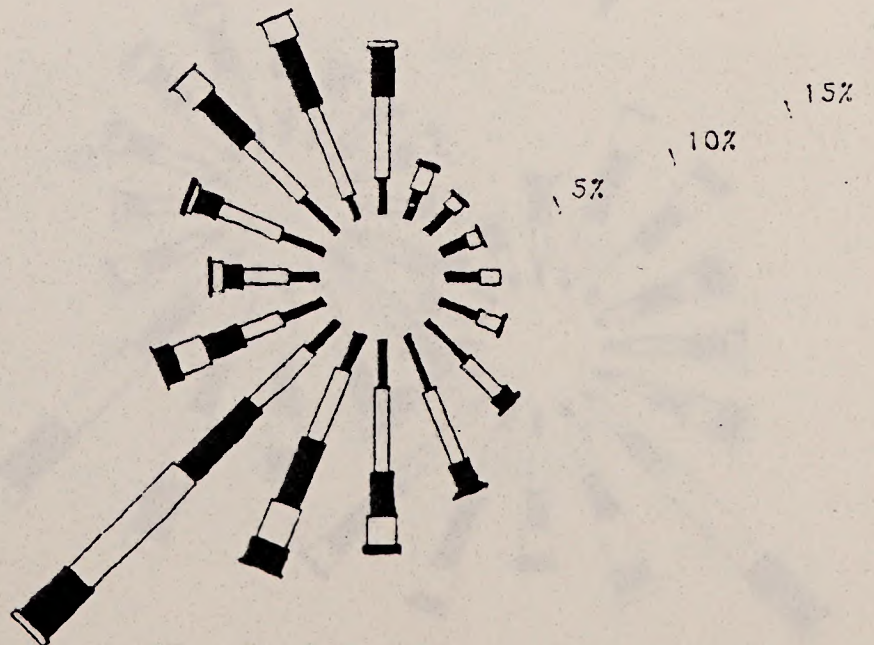




Figure A6.3.2-9

AA23 QUARTERLY WIND ROSE • 60M

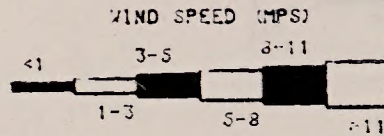
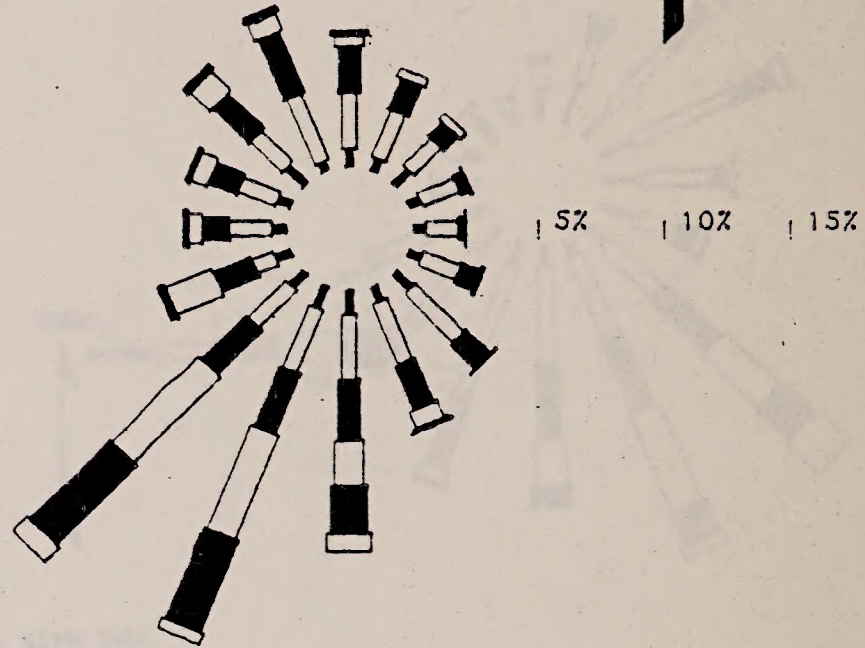
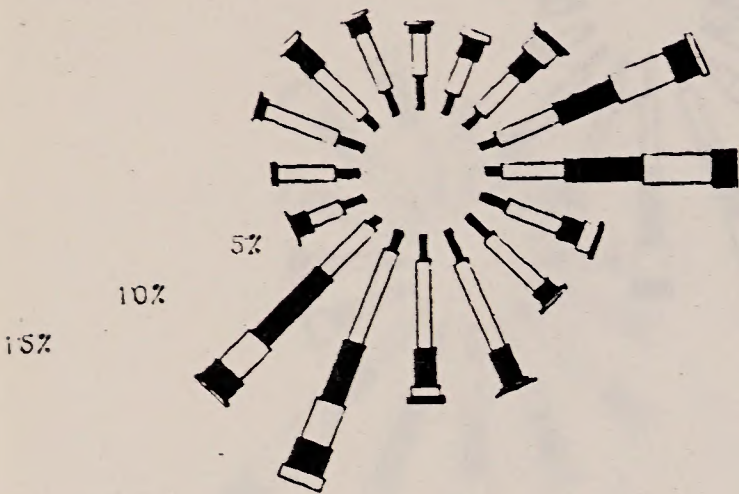
DEC '80 - FEB '81

TOTAL % OF CALMS DISTRIBUTED (0.0 %)  
TOTAL NO. OF 1-HOUR SAMPLES - 2097

MAR '81 - MAY '81

TOTAL % OF CALMS DISTRIBUTED (0.0 %)  
TOTAL NO. OF 1-HOUR SAMPLES - 2099

NORTH

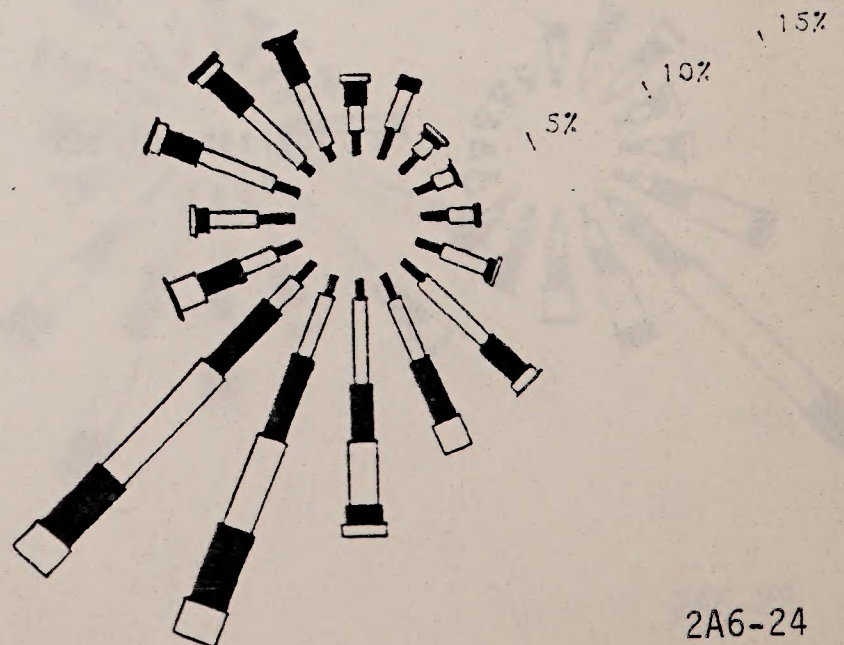
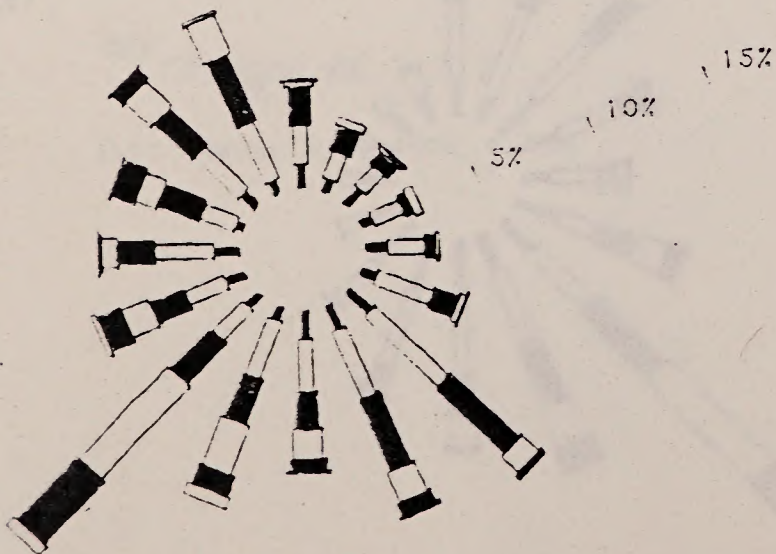


JUN '81 - AUG '81

TOTAL % OF CALMS DISTRIBUTED (0.0 %)  
TOTAL NO. OF 1-HOUR SAMPLES - 1904

SEP '81 - NOV '81

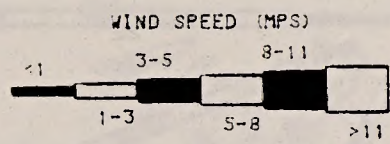
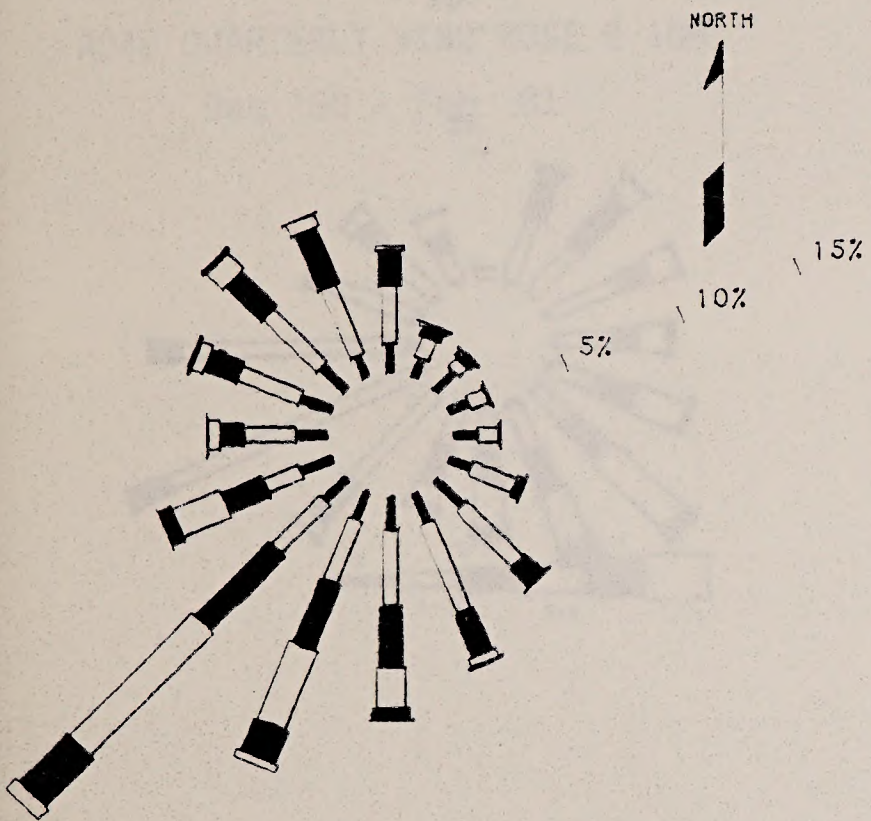
TOTAL % OF CALMS DISTRIBUTED (0.0 %)  
TOTAL NO. OF 1-HOUR SAMPLES - 1842





DEC '79 - NOV '80

TOTAL % OF CALMS DISTRIBUTED (0.05%)  
TOTAL NO. OF 1-HOUR SAMPLES - 8376



DEC '80 - NOV '81

TOTAL % OF CALMS DISTRIBUTED (1.01%)  
TOTAL NO. OF 1-HOUR SAMPLES - 8000

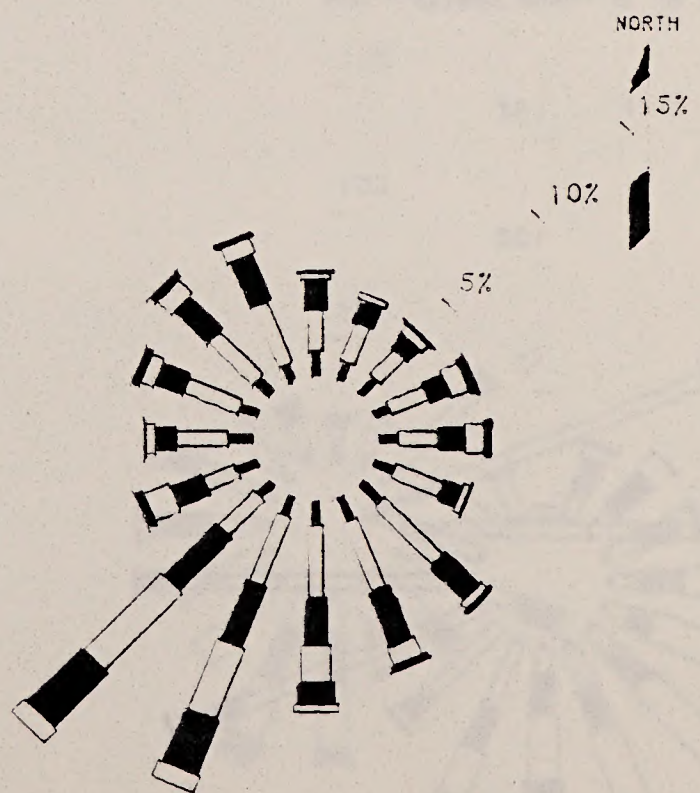


Figure A6.3.2-10

AA23 ANNUAL WIND ROSE • 60M

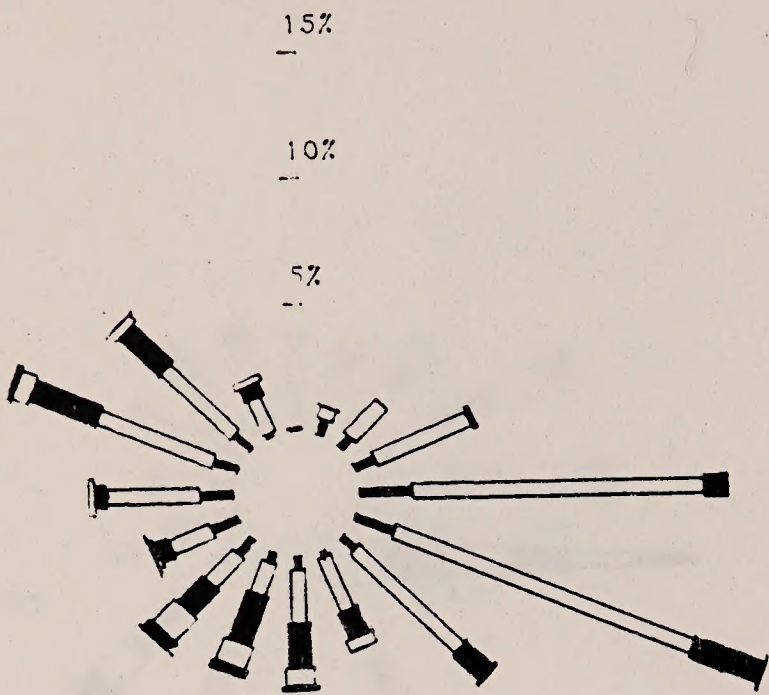


Figure A6.3.2-11

AD42 QUARTERLY WIND ROSE @ 10M

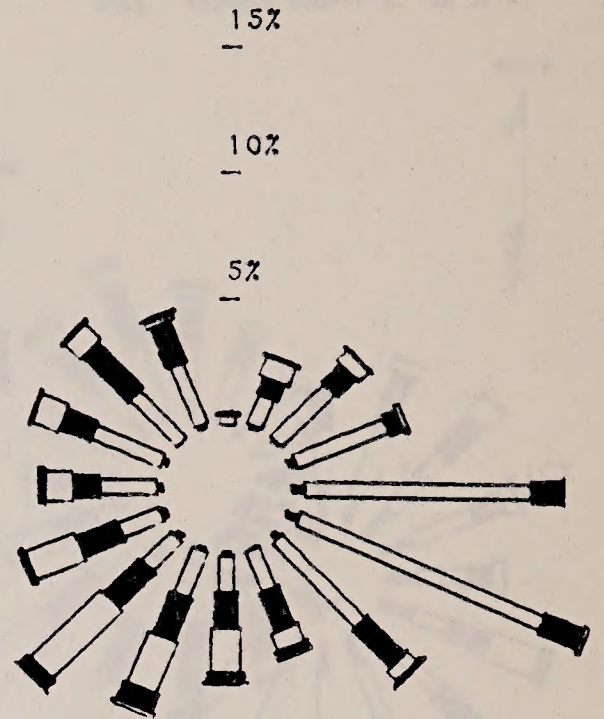
DEC '79 - FEB '80

TOTAL % OF CALMS DISTRIBUTED (0.71%)  
TOTAL NO. OF 1-HOUR SAMPLES - 1691



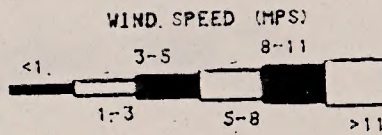
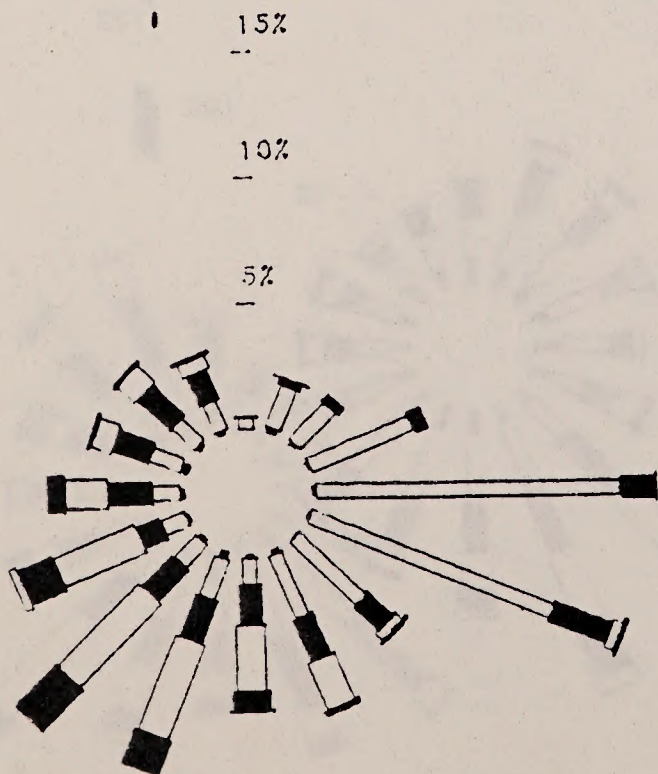
MAR '80 - MAY '80

TOTAL % OF CALMS DISTRIBUTED (1.85%)  
TOTAL NO. OF 1-HOUR SAMPLES - 2050



JUNE '80 - AUGUST '80

TOTAL % OF CALMS DISTRIBUTED (0.33%)  
TOTAL NO. OF 1-HOUR SAMPLES - 1536



SEP. '80 - NOV '80

TOTAL % OF CALMS DISTRIBUTED (0.46%)  
TOTAL NO. OF 1-HOUR SAMPLES - 1734

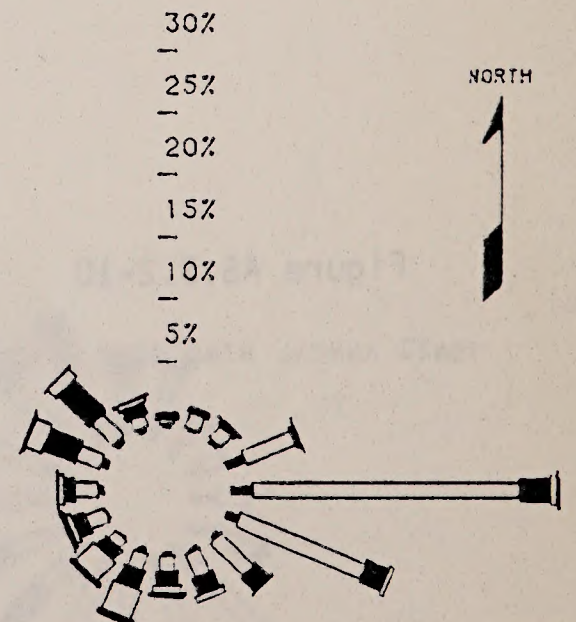
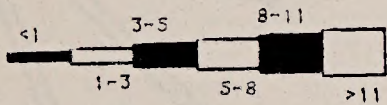




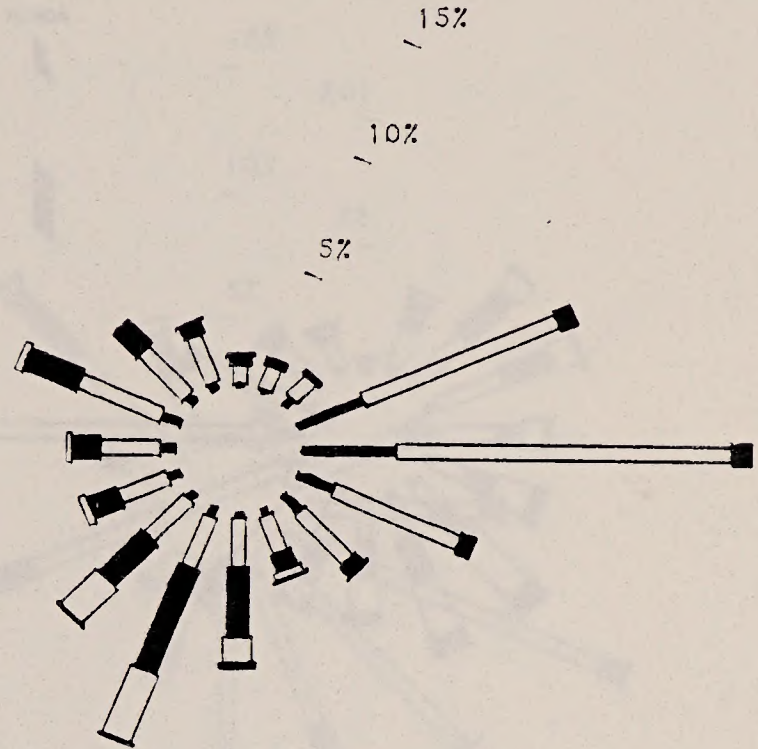
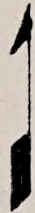
Figure A6.3.2-12  
 INSUFFICIENT DATA DURING QUARTER  
 FOR  
 AD42 QUARTERLY WIND ROSE @ 10M  
 Dec '80 - Feb '81

AD42 QUARTERLY WIND ROSE @ 10M  
 MAR '81 - MAY '81

TOTAL % OF CALMS DISTRIBUTED (5.09%)  
 TOTAL NO. OF 1-HOUR SAMPLES - 982



NORTH



AD42 QUARTERLY WIND ROSE  
 JUN '81 - AUG '81

TOTAL % OF CALMS DISTRIBUTED (0.0%)  
 TOTAL NO. OF 1-HOUR SAMPLES - 927

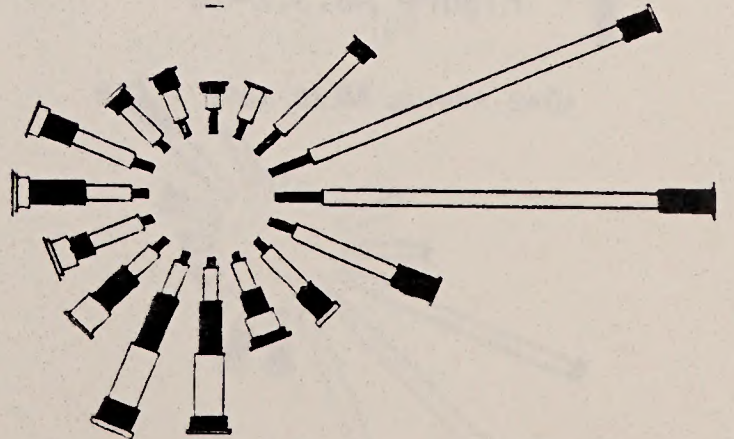
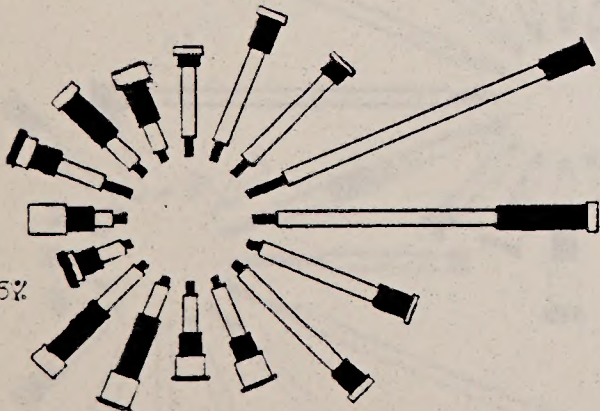
AD42 QUARTERLY WIND ROSE @ 10M  
 SEP '81 - NOV '81

TOTAL % OF CALMS DISTRIBUTED (0.0%)  
 TOTAL NO. OF 1-HOUR SAMPLES -

15%

10%

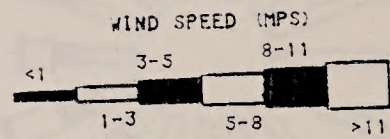
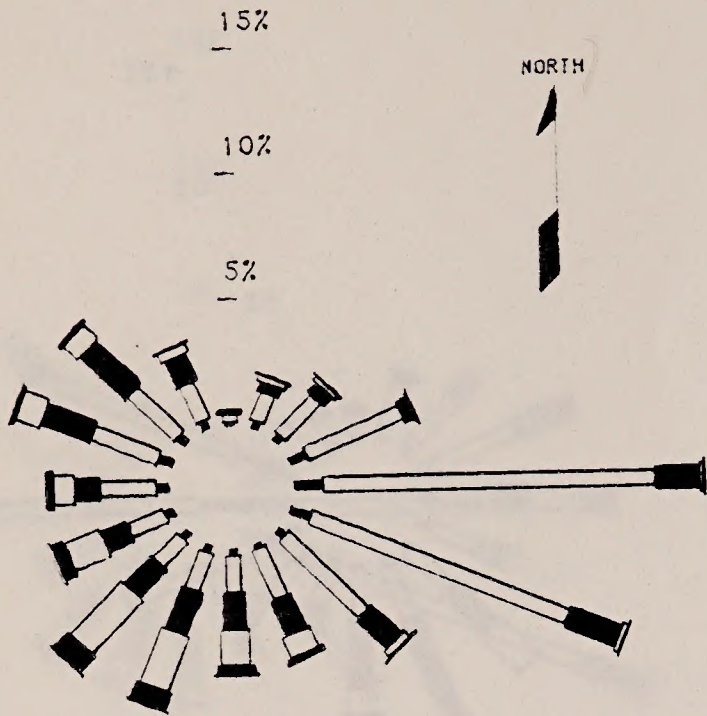
5%





DEC '79 - NOV '80

TOTAL % OF CALMS DISTRIBUTED (0.83%)  
TOTAL NO. OF 1-HOUR SAMPLES - 7011



DEC '80 - NOV '81

TOTAL % OF CALMS DISTRIBUTED (1.16%)  
TOTAL NO. OF 1-HOUR SAMPLES - 4238

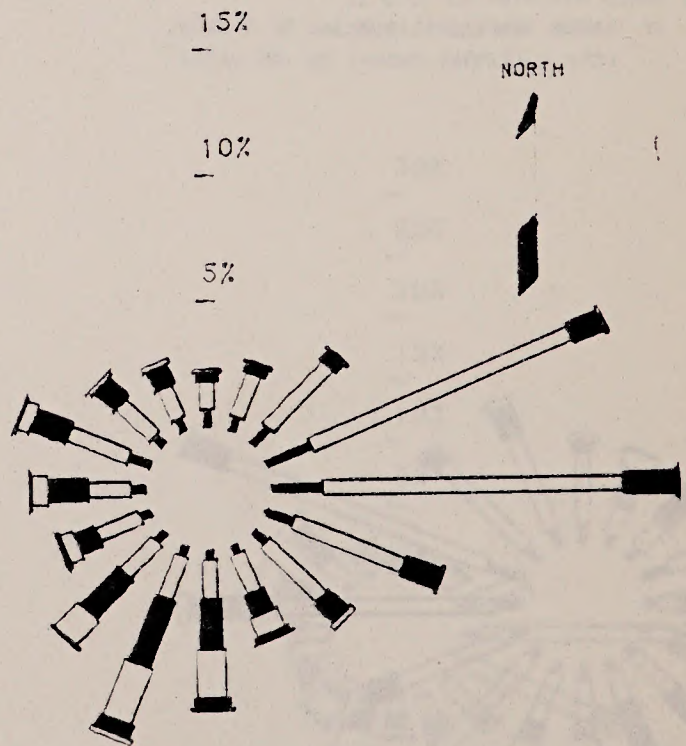


Figure A6.3.2-13

AD42 ANNUAL WIND ROSE • 10M

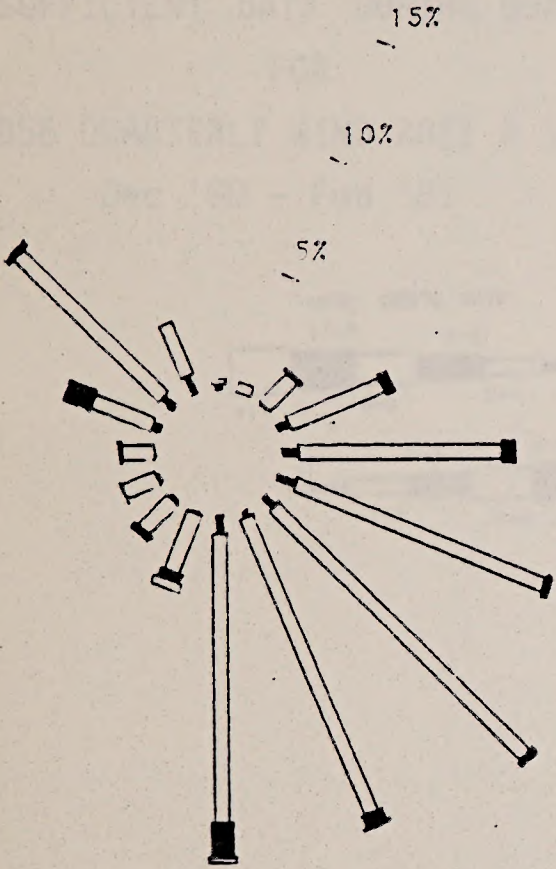


Figure A6.3.2-14

AD56 QUARTERLY WIND ROSE @ 10M

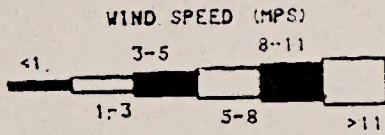
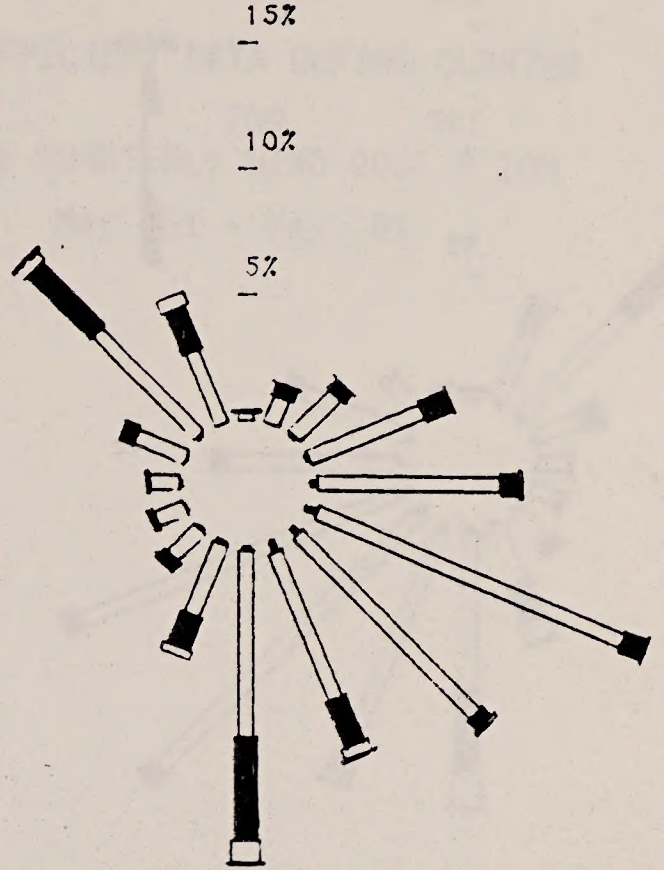
DEC '79 - FEB '80

TOTAL % OF CALMS DISTRIBUTED (4.61%)  
TOTAL NO. OF 1-HOUR SAMPLES - 1389



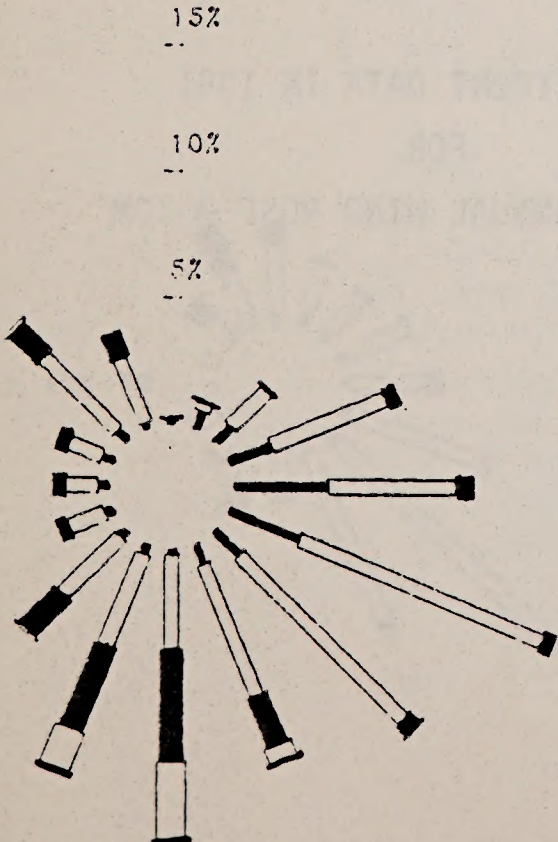
MAR '80 - MAY '80

TOTAL % OF CALMS DISTRIBUTED (3.75%)  
TOTAL NO. OF 1-HOUR SAMPLES - 2078



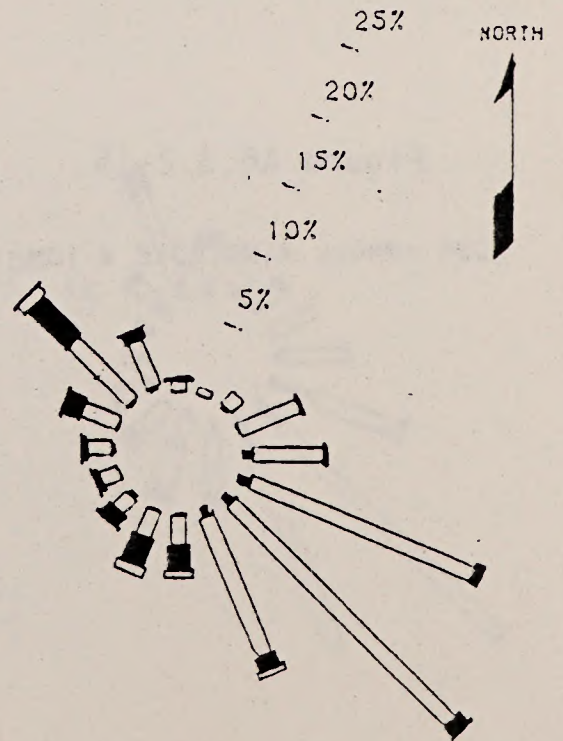
JUNE '80 - AUGUST '80

TOTAL % OF CALMS DISTRIBUTED (10.30%)  
TOTAL NO. OF 1-HOUR SAMPLES - 1397



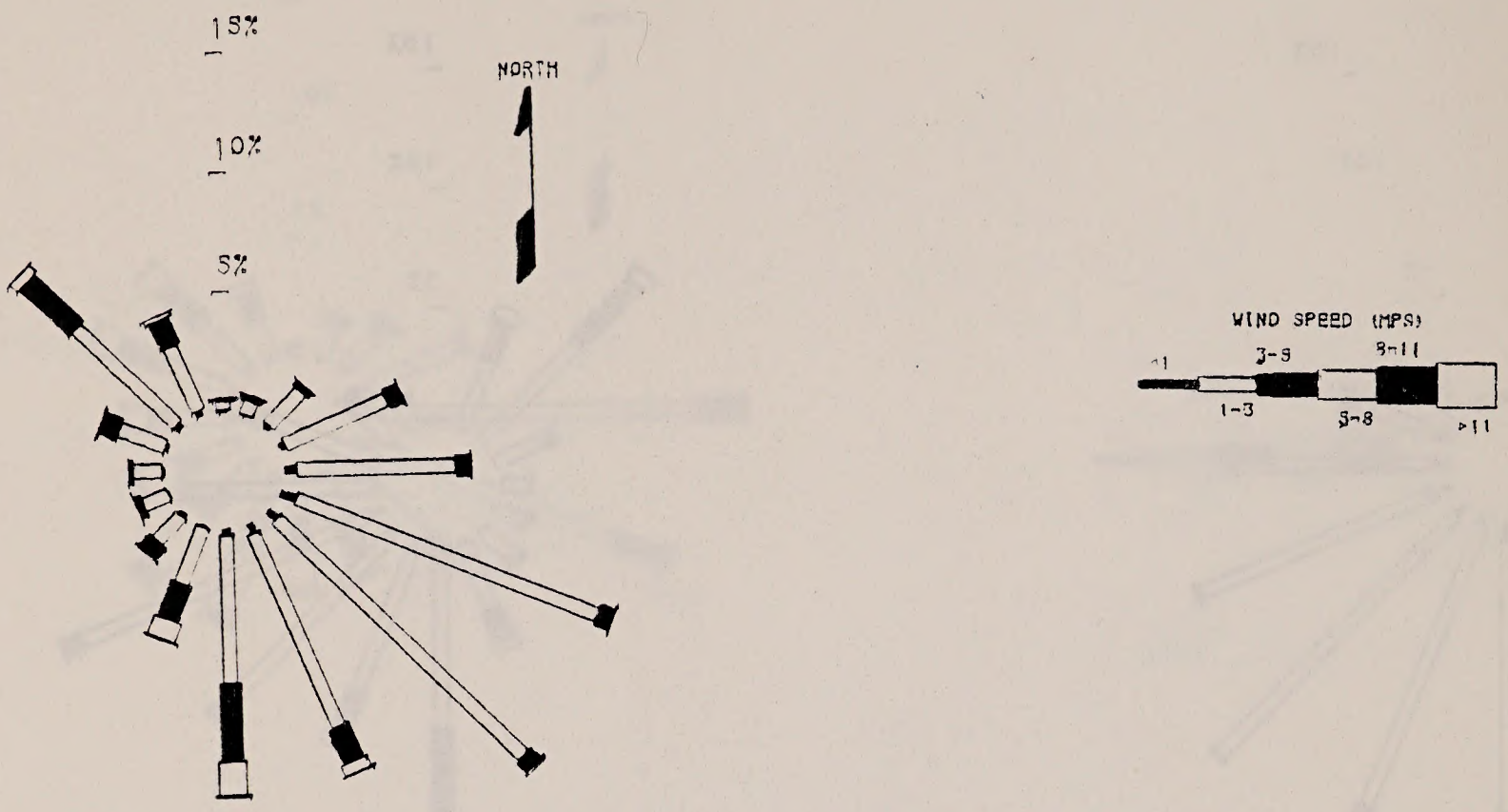
SEP. '80 - NOV '80

TOTAL % OF CALMS DISTRIBUTED (0.98%)  
TOTAL NO. OF 1-HOUR SAMPLES - 1712





TOTAL % OF CALMS DISTRIBUTED (2.41%)  
TOTAL NO. OF 1-HOUR SAMPLES = 8529



INSUFFICIENT DATA IN 1981  
FOR  
AD56 ANNUAL WIND ROSE @ 10M

Figure A6.3.2-15

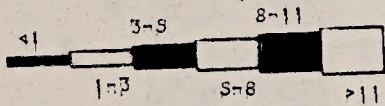
AD56 ANNUAL WIND ROSE @ 10M



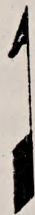
Figure A6.3.2-16

INSUFFICIENT DATA DURING QUARTER  
FOR  
AD56 QUARTERLY WIND ROSE @ 10M  
Dec '80 - Feb '81

INSUFFICIENT DATA DURING QUARTER  
FOR  
AD56 QUARTERLY WIND ROSE @ 10M  
Mar '81 - May '81



NORTH



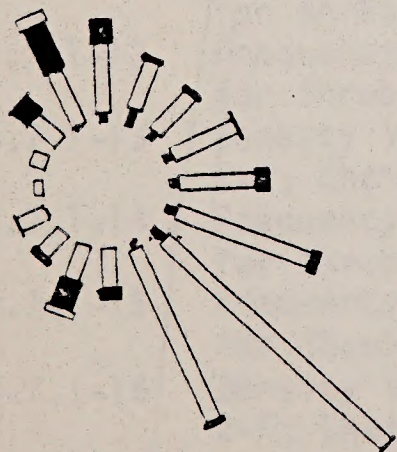
AD56 QUARTERLY WIND ROSE @ 10M  
JUN '81 - AUG '81

TOTAL % OF CALMS DISTRIBUTED (0.0 %)  
TOTAL NO. OF 1-HOUR SAMPLES - 649

AD56 QUARTERLY WIND ROSE @ 10M  
SEP '81 - NOV '81

TOTAL % OF CALMS DISTRIBUTED (0.0 %)  
TOTAL NO. OF 1-HOUR SAMPLES - 564

25% 20% 15% 10% 5%



25% 20% 15% 10% 5%

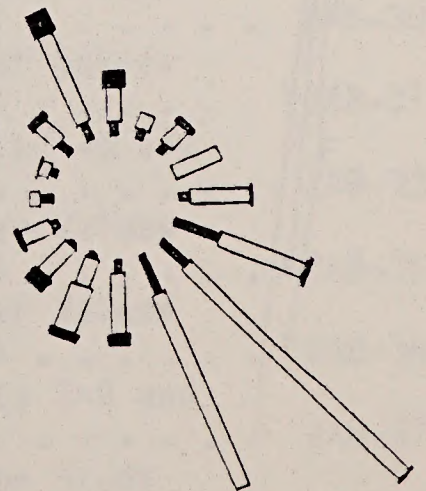
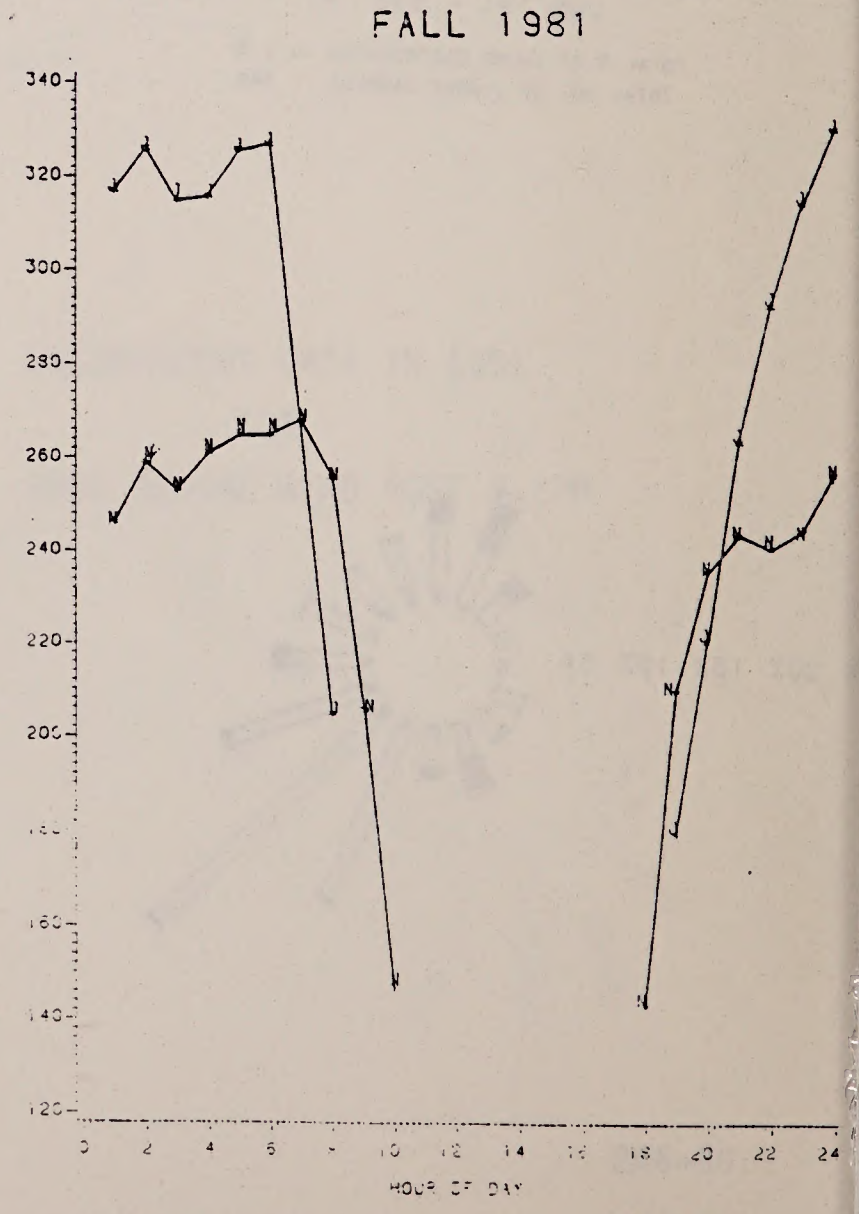
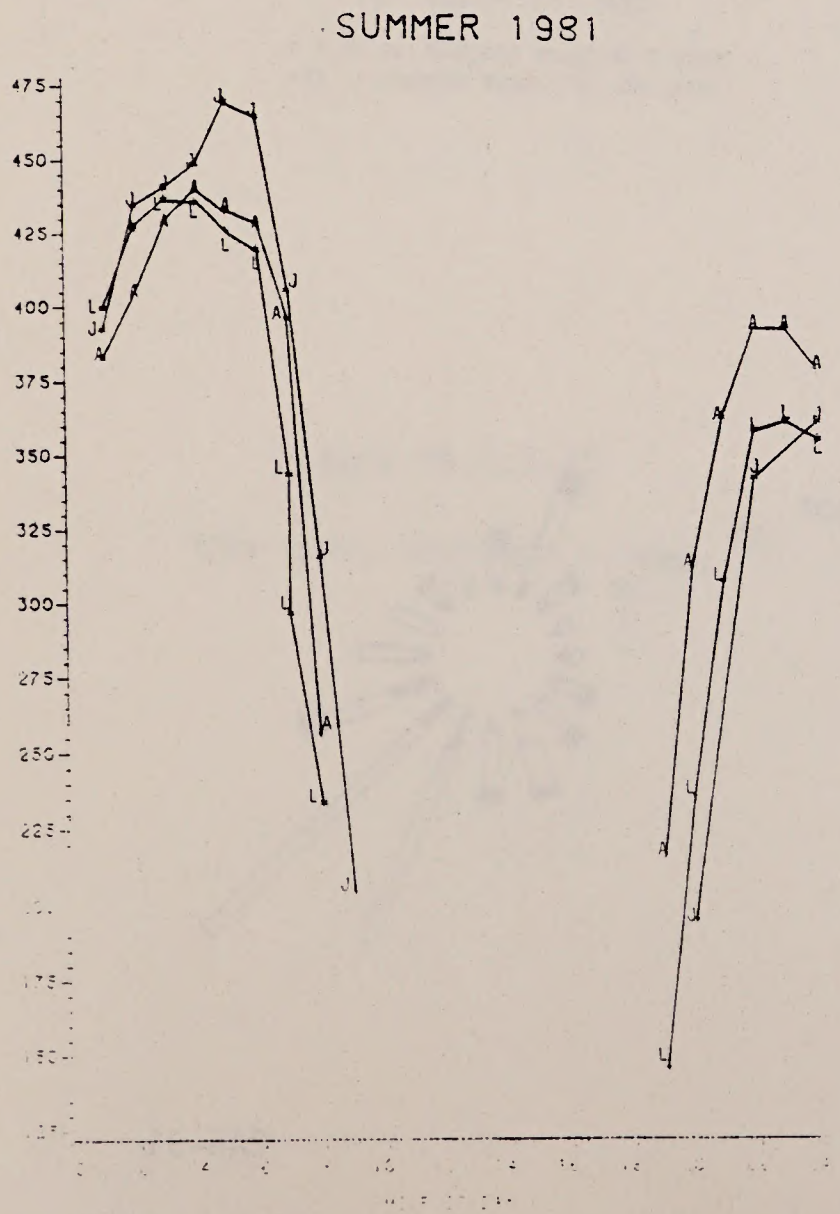
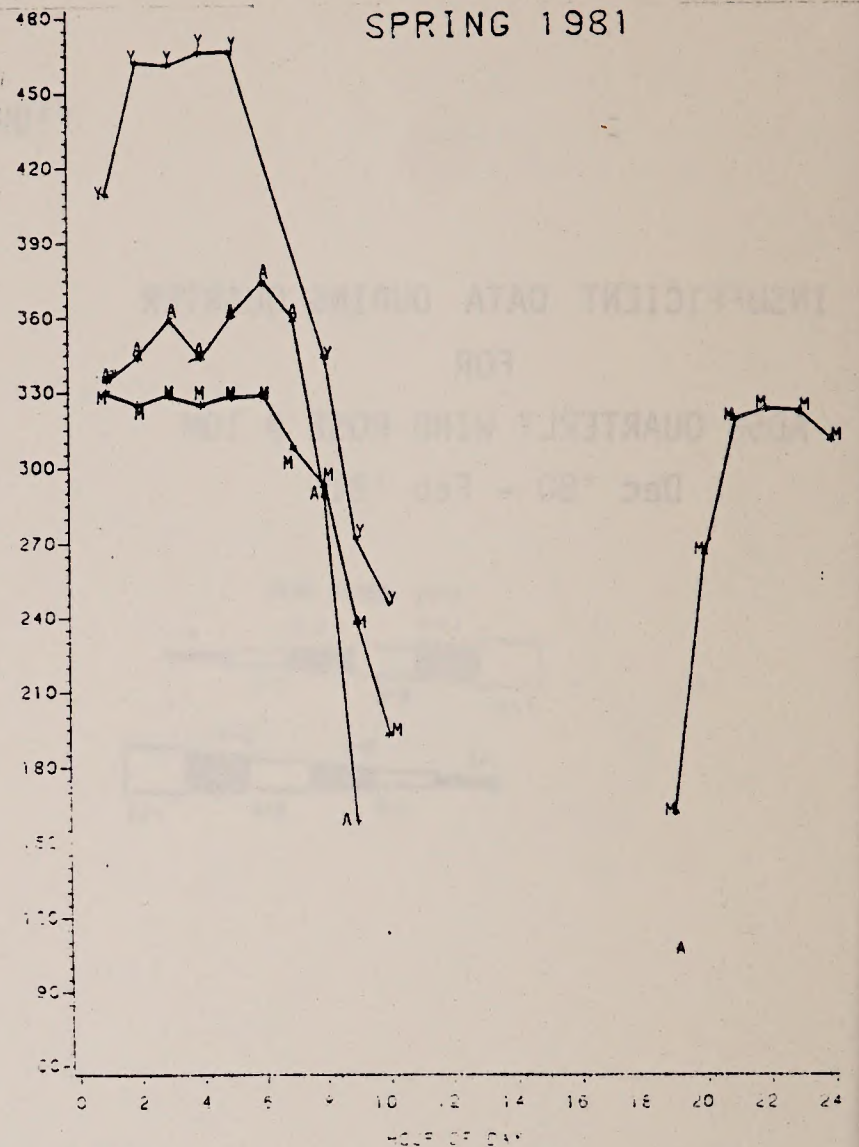
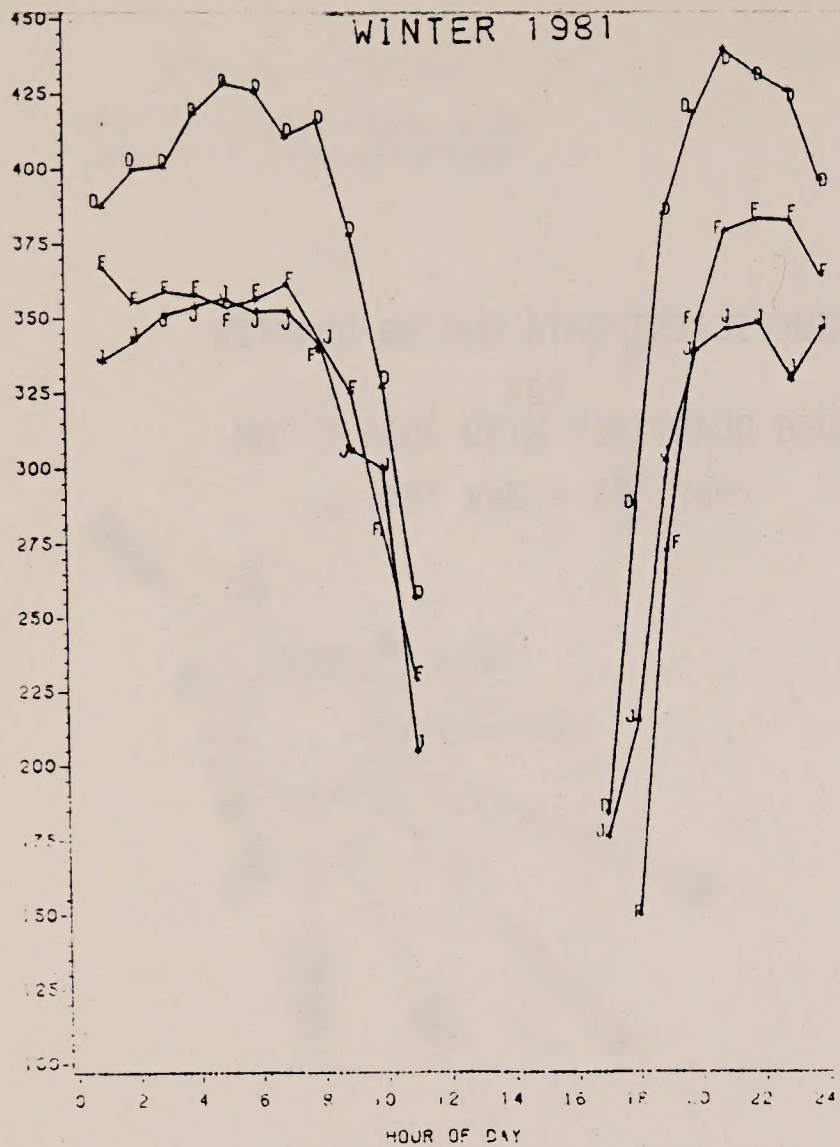




Figure A6.3.2-17

C.B. Average Hourly Inversion Height by Quarter





CHAPTER 8.0

Biology

Table/Figure	Title	Page
Table A8.2.1-1	Sagebrush Ocular Estimated - Summer 1978 . . . . .	2A8-2
Table A8.2.2-2	Sagebrush Ocular Estimated - Summer 1980 . . . . .	2A8-3
Table A8.2.2-3	Sagebrush Ocular Estimated - Summer 1981 . . . . .	2A8-4
Table A8.5.1-1	Bird Species Observed on Tract C.B. During Spring Census Period, 1981 . . . . .	2A8-5
Table A8.5.1-2	Avifauna Estimates of Species on Transect 1 (BH01) for 1981 . . . . .	2A8-7
Table A8.5.1-3	Avifauna Estimates of Species on Transect 2 (BH02) for 1981 . . . . .	2A8-8
Table A8.5.1-4	Avifauna Estimates of Species on Transect 3 (BH03) for 1981 . . . . .	2A8-9
Table A8.5.1-5	Avifauna Estimates of Species on Transect 4 (BH04) for 1981 . . . . .	2A8-10
Table A8.5.1-6	Avifauna Estimates of Species on Transect 5 (BH05) for 1981 . . . . .	2A8-11
Table A8.7.1-1	Herb Quadrat Summaries for Plot 1-0 . . . . .	2A8-12
Table A8.7.1-2	Frequency Summaries for Herb Layer Species in Plot 1-0, 1975-1981 . . . . .	2A8-14
Table A8.7.1-3	Mean Cover and Species Density Summaries for Herbaceous Quadrat Studies at Intensive Study Plots 1-0 and 1-F . . . . .	2A8-16
Table A8.7.1-4	Herb Quadrat Summaries for Plot 1-F . . . . .	2A8-17
Table A8.7.1-5	Frequency Summaries for Herb Layer Species in Plot 1-F, 1975-1981 . . . . .	2A8-19
Table A8.7.1-6	Herb Quadrat Summaries for Plot 2-0 . . . . .	2A8-21
Table A8.7.1-7	Frequency Summaries for Herb Layer Species in Plot 2-0, 1975-1981 . . . . .	2A8-23
Table A8.7.1-8	Mean Cover and Species Diversity Summaries for Herbaceous Quadrat Studies at Intensive Study Plots 2-0 and 2-F . . . . .	2A8-25
Table A8.7.1-9	Herb Quadrat Summaries for Plot 2-F . . . . .	2A8-26
Table A8.7.1-10	Frequency Summaries for Herb Layer Species in Plot 2-F, 1975-1981 . . . . .	2A8-28
Table A8.7.1-11	Frequency, Mean Cover, and Relative Cover Values for Shrub Species in Plot 1-0, 1974-1981 . . . . .	2A8-30
Table A8.7.1-12	Frequency, Mean Cover, and Relative Cover Values for Shrub Species in Plot 1-F, 1974-1981 . . . . .	2A8-31
Table A8.7.1-13	Density Values for Shrub Species at Plots 1-0 and 1-F; Chained Pinyon-Juniper Rangeland . . . . .	2A8-32
Table A8.7.1-14	Frequency, Mean Cover, and Relative Cover Values for Shrub Species in Plot 2-0, 1974-1981 . . . . .	2A8-35
Table A8.7.1-15	Frequency, Mean Cover, and Relative Cover Values for Shrub Species in plot 2-F, 1974-1981 . . . . .	2A8-36
Table A8.7.1-16	Density Values for Shrub Species at Plots 2-0 and 2-F; Chained Pinyon-Juniper Rangeland . . . . .	2A8-37
Table A8.7.1-17	Herb Quadrat Summaries for the Irrigation Study Plot . . . . .	2A8-40



<u>Table/Figure</u>	<u>Title</u>	<u>Page</u>
Table A8.7.1-18	Frequency Summaries for Herb Layer Species in the Irrigation Area Study Plot, 1980-1981 . . . . .	2A8-42
Table A8.7.1-19	Mean Cover and Species Diversity Summaries for Herbaceous Quadrat Studies at the Irrigation Intensive Study Plot . . . . .	2A8-44
Table A8.7.1-20	Mean Cover, Relative Cover, Frequency, and Density for Shrub Species in the Irrigation Intensive Study Plot . . . . .	2A8-45
Table A8.7.2-1	Oven Dry Weights for Range Cages and Adjacent Open Areas in the Pinyon-Juniper Woodland Community Type, 1981 . . . . .	2A8-47
Table A8.7.2-2	Mean Production + the Standard Error of the Mean (S.E.), Frequency, and Range of Observed Values for Clipped Plots in the Pinyon-Juniper Woodland Community Type 1981 . . . . .	2A8-48
Table A8.7.2-3	Oven Dry Weights for Range Cages and Adjacent Open Areas in the Chained Pinyon-Juniper Rangeland Community Type 1981 . . . . .	2A8-49
Table A8.7.2-4	Mean Production + the Standard Error of the Mean (S.E.) Frequency, and Range of Observed Values for Clipped Plots in the Chained Rangeland Community Type 1981 Data . . . . .	2A8-50
Table A8.7.2-5	Oven Dry Weights for Range Cages and Adjacent Open Areas in the Upland Sagebrush Community Type. 1981	2A8-51
Table A8.7.2-6	Mean Production + the Standard Error of the Mean (S.E.), Frequency, and Range of Observed Values for Clipped Plots in the Upland Sagebrush Community Type. 1981 Data . . . . .	2A8-52
Table A8.7.2-7	Oven Dry Weights for Range Cages and Adjacent Open Areas in the Bottomland Sagebrush Community Type . .	2A8-53
Table A8.7.2-8	Mean Production + the Standard Error of the Mean (S.E.), Frequency, and Range of Observed Values for Clipped Plots in the Bottomland Sagebrush Community Type. 1981 Data . . . . .	2A8-54
Table A8.7.2-9	Fresh Weight Estimates for Intensive Study Plot BJ21 (1-F), Chained Pinyon-Juniper Rangeland. July 1981	2A8-55
Table A8.7.2-10	Fresh Weight Estimates for Intensive Study Plot BJ22 (2-F), Chained Pinyon-Juniper Rangeland. July 1981	2A8-56
Table A8.7.2-11	Fresh Weight Estimates for Intensive Study Plot BJ25 (5-F), Pinyon-Juniper Woodland. July 1981 . . . . .	2A8-57
Table A8.7.2-12	Fresh Weight Estimates for Intensive Study Plot BJ26 (6-F), Pinyon-Juniper Woodland. July 1981 . . . . .	2A8-58
Table A8.7.2-13	Oven Dry Weights for Intensive Study Plot 1-F. 1981	2A8-59
Table A8.7.2-14	Oven Dry Weights for Veg Plot 5. 1981 . . . . .	2A8-60
Table A8.7.2-15	Regression Equations used for Converting Fresh Weight Estimates to Oven Dry Weights in Plot BJ21 (Plot 1). 1981 Data . . . . .	2A8-61
Table A8.7.2-16	Regression Equations used for Converting Fresh Weight Estimates to Oven Dry Weights in Plot BJ22 (Plot 2). 1981 Data . . . . .	2A8-62
Table A8.7.2-17	Regression Equations used for Converting Fresh Weight Estimates to Oven Dry Weights in Plot BJ25 (Plot 5-F). 1981 Data . . . . .	2A8-63



Table/Figure	Title	Page
Table A8.7.2-18	Regression Equations used for Converting Fresh Weight Estimates to Oven Dry Weights in Plot BJ26 (Plot 6). 1981 Data . . . . .	2A8-64
Table A8.7.2-19	Mean Production + the Standard Error of the Mean (S.E.), Frequency, and Range of Observed Values for Quadrats in Plots 1 and 2, July 1981 . . . . .	2A8-65
Table A8.7.2-20	Mean Production + the Standard Error of the Mean (S.E.), Frequency, and Range of Observed Values for Quadrats in Plots 5 and 6, July 1981 . . . . .	2A8-66
Table A8.7.2-21	Fresh Weight Estimates for Irrigation/Fertilizer Study Plots. September 1981 . . . . .	2A8-67
Table A8.7.2-22	Oven Dry Weights for Herbaceous Biomass in Fertilizer and Irrigation Treatments for Irrigation Study Plots. 1981 Data . . . . .	2A8-71
Table A8.7.2-23	Regression Equations for Converting Fresh Weight Estimates to Oven Dry Weights in the Irrigation/Fertilization Study Plots 3a, 3b, 4a, and 4b which Were Fertilized in 1980 and 1981. 1981 Data . . . . .	2A8-72
Table A8.7.2-24	Regression Equations for Converting Fresh Weight Estimates to Oven Dry Weights in the Irrigation/Fertilization Study Plots 3a, 3b, 4a, and 4b which Were Fertilized in 1980 only, and Study Plot 1a and 1b which Were Not Fertilized . . . . .	2A8-73
Table A8.7.2-25	Mean Production + the Standard Error of the Mean (S.E.), Frequency, and Range of Observed Values for Quadrats in the Irrigation/Fertilization Study Plots 1a, 1b, 3a, 3b, 4a, and 4b. . . . .	2A8-74
Table A8.7.2-26	Oven Dry Weights for Range Cage and Adjacent Open Areas in the Irrigated Chained Rangeland Community Type. 1981. . . . .	2A8-78
Table A8.7.2-27	Mean Production + the Standard of Error of the Mean (S.E.), Frequency, and Range of Observed Values for Clipped Plots in the Irrigated Area. 1981 Data. . . . .	2A8-79
Table A8.9.1-1	Herb Quadrat Summaries for Top Soil Stockpiles, which Were Seeded in the Fall of 1978 . . . . .	2A8-80
Table A8.9.1-2	Fresh Weight Estimates for Top Soil Piles. 1981 . . . . .	2A8-82
Table A8.9.1-3	Oven Dry Weight for Top Soil Piles. 1981 . . . . .	2A8-83
Table A8.9.1-4	Regression Equations for Converting Fresh Weight Estimates to Oven Dry Weights on Top Soil Storage Piles. 1981 . . . . .	2A8-84
Table A8.9.1-5	Mean Production + the Standard Error of the Mean, Frequency, and Range of Observed Values for Quadrats on Topsoil Storage Piles, 1981 . . . . .	2A8-85
Table A8.9.1-6	Summarized Data for Reference Areas (Plots 1-F and 2-F) . . . . .	2A8-86
Table A8.9.1-7	Summarized Data for Revegetated Areas (Topsoil Piles), for Calculation of Diversity in Herbaceous Layer . . . . .	2A8-87
Table A8.11.1-1	Fresh Weight Estimates for Oldland Gulch Brush Beating. 1981 . . . . .	2A8-88
Table A8.11.1-2	Fresh Weight Estimates for Gardenhire Gulch Brush Beating. 1981 . . . . .	2A8-89



<u>Table/Figure</u>	<u>Title</u>	<u>Page</u>
Table A8.11.1-3	Fresh Weight Estimates for Control Plots of Brush Beating Area. 1981 . . . . .	2A8-91
Table A8.11.1-4	Oven Dry Weight for Oldland Gulch Brush Beating Area. 1981 . . . . .	2A8-92
Table A8.11.1-5	Oven Dry Weight for Gardenhire Gulch Brush Beating Area. 1981 . . . . .	2A8-93
Table A8.11.1-6	Oven Dry Weight for Control Plots of Brush Beating Area. 1981 . . . . .	2A8-94
Table A8.11.1-7	Regression Equations for Converting Fresh Weight Estimates for Oldland Gulch Brush Beating Area. 1981	2A8-95
Table A8.11.1-8	Regression Equations Used for Converting Fresh Weight Estimates to Oven Dry Weights for Gardenhire Gulch Brush Beating Area. 1981 . . . . .	2A8-96
Table A8.11.1-9	Regression Equations Used for Converting Fresh Weight Estimates to Oven Dry Weights for Brush Beating Control Area. 1981 . . . . .	2A8-97
Table A8.11.1-10	Mean Production + Standard Error of the Mean, Frequency, and Range of Observed Values for Quadrats in Oldland Gulch Brush Beating Area, 1981 . . . . .	2A8-98
Table A8.11.1-11	Mean Production + the Standard Error of the Mean, Frequency, and Range of Observed Values for Quadrats in Gardenhire Gulch Brush Beating Area, 1981. . . . .	2A8-99
Table A8.11.1-12	Mean Production + the Standard Error of the Mean, Frequency, and Range of Observed Values for Quadrats in Control Area, 1981 . . . . .	2A8-100
Figure A8.11.3-1	Map of C-b Tract Irrigation System Layout Showing Treatment Locations . . . . .	2A8-101
Table A8.11.3-1a	Average Volumetric Soil Water Content in the Various Treatment Areas at the Beginning and End of the Irrigation Period for 1980 . . . . .	2A8-102
Table A8.11.3-1b	Average Volumetric Soil Water Content in the Various Treatment Areas after Irrigation During the 1981 Season . . . . .	2A8-103
Table A8.11.3-1c	Location and Volumetric Soil Water Content at the Beginning and End of the Season for Required Water Monitoring Treatments During 1980 . . . . .	2A8-105
Table A8.11.3-1d	Volumetric Soil Water Content in the Soil After Irrigation for the Required Water Monitoring Treatments during 1981 . . . . .	2A8-109
Table A8.11.3-2a	Mine Discharge Water Quality Including Boron, Total Dissolved Solids and Fluoride During the Irrigation Period in 1980 . . . . .	2A8-112
Table A8.11.3-2b	Mine Discharge Water Quality Including Boron, Calcium Magnesium, Potassium, Sodium, Bicarbonate, Carbonate, Fluoride, Sulfate, and Total Dissolved Solids During the Irrigation Period of 1981 . . . . .	2A8-113
Table A8.11.3-3	Values of pH, Electrical Conductivity of Saturation Extract (ECe), Exchangeable Sodium Percentage (ESP) and Boron (ppm in Saturated Extract) from Soil Samples taken June 5, December 16, 1980, and October 26, 1981.	2A8-114
Table A8.11.3-4a	Foliar Concentration of Boron, Sodium, and Fluoride in Indian Rice Grass on June 5 and December 16, 1980 .	2A8-116



<u>Table/Figure</u>	<u>Title</u>	<u>Page</u>
Table A8.11.3-4b	Foliar Concentration of Fluoride in Foliage of Indian Rice Grass on April 30, July 10, August 26, and October 26, 1981 . . . . .	2A8-117
Table A8.11.3-4c	Foliar Concentration of Boron and Sodium in Indian Rice Grass on April 30 and October 26, 1981. . . . .	2A8-118
Table A8.11.3-5a	Foliar Concentration of Boron, Sodium, and Fluoride in Western Wheat Grass on June 5 and December 16, 1980 . . . . .	2A8-119
Table A8.11.3-5b	Foliar Concentration of Fluoride in Western Wheat Grass on April 30, July 10, August 26, and October 26, 1981 . . . . .	2A8-120
Table A8.11.3-5c	Foliar Concentration of Boron and Sodium in Western Wheat Grass on April 30, and October 26, 1981. . . . .	2A8-121
Table A8.11.3-6a	Foliar Concentration of Boron, Sodium, and Fluoride in Big Sage Brush on June 5 and December 16, 1980 . . . . .	2A8-122
Table A8.11.3-6b	Foliar Concentration of Fluoride in Big Sage Brush on April 30, July 10, August 26, and October 26, 1981 . . . . .	2A8-123
Table A8.11.3-6c	Foliar Concentration of Boron and Sodium in Big Sage Brush on April 30, and October 26, 1981. . . . .	2A8-124
Table A8.11.3-7a	1980 Weather Data Summary Statistics for the C-b Tract, TRL 23 . . . . .	2A8-125
Table A8.11.3-7b	Summary of 1981 Weather Data and Calculated ET for C-b Tract, TRL 23 . . . . .	2A8-130
Table A8.11.3-8	Average Monthly Temperature, Radiation, and Calculated ET for an C-b Tract, 1981 . . . . .	2A8-134
Table A8.11.3-9	Water Application Depth at Two Typical Locations as It Varies with Distance from the 104C Rainbird Sprinkler after 6 Hours of Operation Between 20:00 Hrs July 11 to 02:00 July 12, 1981. . . . .	2A8-135



TABLE A8.2.1-1  
SAGEBRUSH OCULAR ESTIMATED - SUMMER 1978  
CHAINED P-J HABITAT

<u>Transect</u>	<u>Sample Size</u>	<u>Young</u>	<u>Mature</u>	<u>Decadent</u>	<u>Low</u>	<u>Medium</u>	<u>High</u>	<u>Shrub<sup>1</sup> Density</u>
BA01	50	10	40	---		48	2	
BA02	50	12	38	---	34	16	---	
BA03	50	11	39	---	40	10	---	
BA04	50	1	48	1	22	24	4	19
BA05	50	1	41	8	10	21	19	41
BA06	50	2	47	1	21	10	19	42
BA07	50	1	47	2	32	13	5	43
BA08	50	3	39	8	12	20	18	34
BA09	50	1	37	12	7	8	35	32
BA17	50	1	49	---	41	9	---	17
BA18	50	8	42	---	27	23	---	8
BA20	50	1	47	2	15	20	15	20
BA21	50	2	47	1	17	27	6	9
BA23	50	--	50	---	25	22	3	22
BA25	50	--	49	1	11	24	15	22
TOTAL	750	54	660	36	314	295	141	309
PERCENT		7.2	88	4.8	41.9	39.3	18.8	

PINYON JUNIPER HABITAT

<u>Transect</u>	<u>Sample Size</u>	<u>Young</u>	<u>Mature</u>	<u>Decadent</u>	<u>Low</u>	<u>Medium</u>	<u>High</u>	<u>Shrub<sup>1</sup> Density</u>
BA10	25	--	15	10	2	10	13	3
BA11	25	--	17	8	---	19	6	3
BA12	40	--	22	18	5	20	15	5
BA13	50	--	30	20	7	20	23	16
BA14	50	--	37	13	3	25	22	13
BA15	50	--	31	19	3	22	25	15
BA16	50	--	20	30	---	13	37	14
BA19	25	--	3	22	1	10	14	4
BA22	25	--	4	21	1	9	15	3
BA24	25	--	2	23	2	3	20	1
BA26	50	--	20	30	1	17	32	5
BA27	50	--	25	25	2	20	28	6
TOTAL	465	0	226	239	27	188	250	88
PERCENT			48.6	51.4	5.8	40.4	53.8	

1) Number of plants counted by using an angle gauge (40 BAF)



TABLE A.8.2.2-2  
SAGEBRUSH OCULAR ESTIMATED - SUMMER 1980  
CHAINED P-J HABITAT

<u>Transect</u>	<u>Sample Size</u>	<u>Young</u>	<u>Mature</u>	<u>Decadent</u>	<u>Low</u>	<u>Medium</u>	<u>High</u>	<u>Shrub<sup>1</sup> Density</u>
01	50	18	31	1	36	13	1	21
04	50	32	14	--	48	3	--	13
07	50	9	38	3	33	17	--	52
09	50	--	34	16	--	37	13	46
17	50	9	37	5	38	10	2	23
18	50	19	31	--	31	16	3	21
20	50	2	46	2	13	31	6	19
21	50	5	44	1	21	18	1	32
23	50	12	38	--	32	18	--	20
25	50	4	43	4	25	24	1	23
30	50	2	44	4	16	29	5	28
31	50	3	44	3	31	13	--	27
32	50	12	33	5	29	17	4	14
TOTAL	650	127	477	44	353	261	36	339
PERCENT		19.5	73.3	6.2	54	40	6	

PINYON JUNIPER HABITAT

<u>Transect</u>	<u>Sample Size</u>	<u>Young</u>	<u>Mature</u>	<u>Decadent</u>	<u>Low</u>	<u>Medium</u>	<u>High</u>	<u>Shrub<sup>1</sup> Density</u>
10	25	3	11	11	3	7	15	3
11	25	1	10	14	2	11	12	3
12	25	--	18	7	3	9	13	6
13	50	1	29	20	8	17	25	13
14	50	--	33	16	2	18	30	14
15	50	--	28	22	2	19	29	12
16	50	3	29	18	24	22	4	10
19	25	--	11	14	2	9	14	3
22	50	--	10	40	4	16	30	12
24	25	--	7	18	1	8	16	4
26	50	--	26	24	13	22	15	7
27	50	2	37	11	20	26	4	11
TOTAL	475	11	249	215	84	184	207	98
PERCENT		2.3	52.4	45.3	17.7	38.7	43.6	

1) Number of plants counted by using an angle gauge (40 BAF)



TABLE A8.2.2-3  
SAGEBRUSH OCULAR ESTIMATED - SUMMER 1981  
CHAINED P-J HABITAT

<u>Transect</u>	<u>Sample Size</u>	<u>Young</u>	<u>Mature</u>	<u>Decadent</u>	<u>Low</u>	<u>Medium</u>	<u>High</u>	<u>Shrub<sup>1</sup> Density</u>
01	50	19	31	--	35	15	--	14
04	50	17	32	1	47	2	1	10
07	50	13	37	--	40	10	--	26
09	50	4	34	12	17	24	9	40
17	50	18	32	--	40	10	--	18
18	50	14	35	1	30	17	3	14
20	50	5	45	--	20	28	2	13
21	50	11	39	--	38	11	1	24
23	50	5	45	--	37	13	--	21
25	50	4	44	2	26	21	3	17
30	50	2	48	--	20	30	--	16
31	50	16	34	--	42	8	--	27
32	50	11	38	1	30	19	1	19
TOTAL	650	187	447	17	422	208	20	259
PERCENT		28.8	68.6	2.6	64.9	32.0	3.1	

PINYON JUNIPER HABITAT

<u>Transect</u>	<u>Sample Size</u>	<u>Young</u>	<u>Mature</u>	<u>Decadent</u>	<u>Low</u>	<u>Medium</u>	<u>High</u>	<u>Shrub<sup>1</sup> Density</u>
10	25	--	20	5	13	8	4	4
11	25	1	16	8	12	10	3	3
12	25	--	19	6	15	5	5	4
13	25	--	22	3	9	12	4	7
14	25	--	20	5	5	14	6	11
15	25	--	22	3	2	12	11	4
16	50	1	42	7	31	10	9	9
19	25	--	15	10	15	5	5	4
22	50	--	33	17	19	28	3	15
24	50	4	44	2	26	21	3	17
26	50	--	33	17	31	15	4	11
27	50	--	38	12	17	30	3	8
TOTAL	425	6	324	95	195	170	60	97
PERCENT		1.4	76.2	22.4	45.9	40.0	14.1	

1) Number of plants counted by using an angle gauge (40 BAF)



## BIRD SPECIES OBSERVED ON TRACT C. B. DURING SPRING CENSUS PERIOD, 1981

ORDER FAMILY Species	Common Name <sup>1/</sup>	Observed		
		Pinyon-Juniper	Chained Pinyon-Juniper	Fly over
FALCONIFORMES FALCONIDAE <u>Falco sparverius</u>	American kestrel	X	X	
COLUMBIFORMES COLUMBIDAE <u>Zenaida macroura</u>	mourning dove	X		
TROCHILIDAE <u>Selasphorus platycercus</u>	broad-tailed hummingbird			X
PICIFORMES PICIDAE <u>Colaptes auratus</u>	common flicker		X	
PASSERIFORMES TYRANNIDAE <u>Tyrannus verticalis</u> <u>Epidonax difficilis</u>	western kingbird western flycatcher	X	X	
HIRUNDINIDAE <u>Hirundo rustica</u>	barn swallow			X
CORVIDAE <u>Gymnorhinus cyanocephalus</u> <u>Corvus corax</u>	pinyon jay common raven	X X	X	
PARIDAE <u>Parus gambeli</u> <u>Parus inornatus</u>	mountain chickadee plain titmouse	X X		
SITTIDAE <u>Sitta carolinensis</u>	white-breasted nuthatch	X		



TABLE A8.5.1-1  
 BIRD SPECIES OBSERVED ON TRACT C. B. DURING SPRING CENSUS PERIOD, 1981

ORDER	FAMILY	Species	Common Name <sup>1/</sup>	Observed		
				Pinyon-Juniper	Chained Pinyon-Juniper	Fly over
PASSERIFORMES (Cont'd.)	TROGLODYTIDAE	<u>Troglodytes aedon</u>	house wren	X		X
	TURDIDAE	<u>Turdus migratorius</u>	American robin	X		
		<u>Myndestes townsendii</u>	Townsend's solitaire	X		
		<u>Sialia currucoides</u>	mountain bluebird	X		X
	SYVIIDAE	<u>Polioptila caerules</u>	blue-gray gnatcatcher			X
	VIREONIDAE	<u>Vireo solitarius</u>	solitary vireo	X		
	PARULIDAE	<u>Dendroica coronata</u>	yellow-rumped warbler			X
		<u>Dendroica nigrescens</u>	black-throated gray warbler	X		X
	FRINGILLIDAE	<u>Carpodacus mexicanus</u>	house finch	X		
		<u>Pipilo chlorura</u>	green-tailed towhee	X		X
		<u>Poecetes gramineus</u>	vesper sparrow	X		X
		<u>Spizella passerina</u>	chipping sparrow	X		
		<u>Spizella arborea</u>	tree sparrow	X		
		<u>Spizella breweri</u>	Brewer's sparrow	X		X

<sup>1/</sup> Nomenclature follows the American Ornithologists' Union (AOU) Checklist of North American Birds (AOU 1957) and subsequent revisions (AOU 1973 and 1976).



## AVIFAUNA ESTIMATES OF SPECIES ON TRANSECT 1 (BH01) FOR 1981

Code	Name	Number of Observations	Coefficient of Determination	Density Per Hectare	Percent <sup>(1)</sup> Relative Abundance
BRSPAR	Brewer's Sparrow	18	0.49	1.125	46.11
BTWARB	Black-Throated Gray Warbler	1	1.00	0.063	2.58
GTTOWH	Green-Tailed Towhee	11	0.57	0.688	28.20
HOWREN	House Wren	3	0.50	0.188	7.70
MOBLUE	Mountain Bluebird	3	0.38	0.188	7.70
VESPER	Vesper Sparrow	3	0.57	0.188	7.70
COFLIC	Common Flicker	1	1.00	0.063	2.14
	TOTAL	40		2.440	

NOTE: NA = Means Not Available

$$(1)_{R.A.} = \frac{\text{Species density/Ha}}{\text{total density/Ha}} \times 100\%$$



TABLE A8.5.1-3

## AVIFAUNA ESTIMATES OF SPECIES ON TRANSECT 2 (BH02) FOR 1981

Code	Name	Number of Observations	Coefficient of Determination	Density Per Hectare	Percent Relative Abundance <sup>(1)</sup>
BTWARB	Black-Throated Gray Warbler	10	0.60	0.625	30.28
CHSPAR	Chipping Sparrow	4	0.34	0.250	12.11
GTTOWH	Green-tailed Towhee	1	0.31	0.063	3.05
HOWREN	House Wren	4	0.45	0.250	12.11
KESTRE	Kestrel	2	NA	0.125	6.06
MOBLUE	Mountain Bluebird	1	0.42	0.063	3.05
MOCHIC	Mountain Chickadee	6	0.56	0.375	18.17
MODOVE	Mourning Dove	2	0.74	0.125	6.06
ROBINS	Robin	1	NA	0.063	3.05
SOVIRE	Solitary Vireo	2	0.59	0.125	6.06
VESPER	Vesper Sparrow	1	0.57	0.063	3.05
	TOTAL	34		2.064	

$$(1)R.A. = \frac{\text{Species density/Ha}}{\text{total density/Ha}} \times 100\%$$



TABLE A8.5.1-4

## AVIFAUNA ESTIMATES OF SPECIES ON TRANSECT 3 (BH03) FOR 1981

Code	Name	Number of Observations	Coefficient of Determination	Density Per Hectare	Percent Relative Abundance
BGGCAT	Blue-Gray Gnat Catcher	1	0.33	0.063	2.72
BRSPAR	Brewer's Sparrow	14	0.49	0.875	37.80
COFLIC	Common Flicker	1	0.90	0.063	2.72
GTTOWH	Green-Tailed Towhee	13	0.57	0.813	35.12
HOWREN	House Wren	2	0.65	0.125	5.40
MOBLUE	Mountain Bluebird	2	0.38	0.125	5.40
PINJAY	Pinyon Jay	1	0.25	0.063	2.72
VESPER	Vesper Sparrow	2	0.57	0.125	5.40
YRWARB	Yellow-Rumped Warbler	1	0.19	0.063	2.72
	TOTAL	37		2.315	

$$(1) R.A. = \frac{\text{Species density/Ha}}{\text{total density/Ha}} \times 100\%$$



TABLE A8.5.1-5

## AVIFAUNA ESTIMATES OF SPECIES ON TRANSECT 4 (BH04) FOR 1981

Code	Name	Number of Observations	Coefficient of Determination	Density Per Hectare	Percent <sup>(1)</sup> Relative Abundance
BRSPAR	Brewer's Sparrow	1	0.75	0.063	1.97
BTWARB	Black-Throated Gray Warbler	8	0.60	0.500	15.66
CHSPAR	Chipping Sparrow	3	0.34	0.188	5.89
GTTOWH	Green-Tailed Towhee	3	0.31	0.188	5.89
HOFINC	House Finch	1	0.62	0.063	1.97
HOWREN	House Wren	1	0.47	0.063	1.97
MOBLUE	Mountain Bluebird	8	0.42	0.500	15.66
MOCHIC	Mountain Chickadee	10	0.52	0.625	19.58
ROBINS	Robin	1	NA	0.063	1.97
SOVIRE	Solitary Vireo	6	0.59	0.375	11.75
TOSOLI	Townsend's Solitaire	3	0.50	0.188	5.89
TRSPAR	Tree Sparrow	1	NA	0.188	1.97
WEFLYC	Western Flycatcher	3	NA	0.188	5.89
WBNUTH	White-Breasted Nuthatch	1	0.59	0.063	1.97
	TOTAL	50		3.192	

$$(1)R.A. = \frac{\text{Species density/Ha}}{\text{total density/Ha}} \times 100\%$$



TABLE A8.5.1-6

## AVIFAUNA ESTIMATES OF SPECIES ON TRANSECT 5 (BH05) FOR 1981

Code	Name	Number of Observations	Coefficient of Determination	Density Per Hectare	Percent <sup>(1)</sup> Relative Abundance
BRSPAR	Brewer's Sparrow	18	0.75	1.125	42.82
BTWARB	Black-Throated Gray Warbler	3	1.00	0.188	7.16
GTTOWH	Green-Tailed Towhee	8	0.57	0.500	19.03
HOWREN	House Wren	2	0.47	0.125	4.76
KESTRE	Kestrel	1	NA	0.063	2.40
MOBLUE	Mountain Bluebird	1	0.38	0.063	2.40
VESPER	Vesper Sparrow	8	0.57	0.500	19.03
YRWARB	Yellow-Rumped Warbler	<u>1</u>	0.19	<u>0.063</u>	2.40
	TOTAL	42		2.627	

NOTE: NA = Means Not Available

$$(1) R. A. = \frac{\text{Species density/Ha}}{\text{total density/Ha}} \times 100\%$$



Table A8.7.1-1

Herb quadrat summaries for Plot 1-0. Based on data from 25 permanently located quadrats. June 1981. Values in percent. "?" indicates uncertain identification.  $\pm$  values are equal to the standard error of the mean.

Species	Mean Cover (%)	Relative Cover (%)	Range of Cover Values	Frequency (%)
<b>HERBACEOUS SPECIES</b>				
<i>Agoseris glauca</i>	< 0.1	< 0.01	0- <1	4.0
<i>Agropyron desertorum</i>	3.2	30.53	0- 17	40.0
<i>Agropyron smithii</i>	0.6	5.73	0- 9	12.0
<i>Agropyron trachycaulum</i>	0.5	4.77	0- 6	16.0
<i>Antennaria rosea</i>	0.8	7.63	0- 10	20.0
<i>Arabis holboellii</i>	< 0.1	0.38	0- 1	20.0
<i>Artemisia ludoviciana</i>	0.2	1.91	0- 2	12.0
<i>Aster fendleri</i> ?	< 0.1	< 0.01	0- <1	4.0
<i>Astragalus ceramicus</i>	< 0.1	< 0.01	0- <1	8.0
<i>Astragalus diversifolius</i>	< 0.1	< 0.01	0- <1	4.0
<i>Bouteloua gracilis</i>	0.2	1.91	0- 6	4.0
<i>Bromus tectorum</i>	0.7	6.68	0- 4	84.0
<i>Carex rossii</i>	0.2	1.91	0- 4	28.0
<i>Carex</i> sp.	< 0.1	< 0.01	0- <1	4.0
<i>Chaenactis douglasii</i>	< 0.1	< 0.01	0- <1	8.0
<i>Chenopodium album</i>	< 0.1	< 0.01	0- <1	12.0
<i>Collinsia parviflora</i>	< 0.1	< 0.01	0- <1	4.0
<i>Cryptantha</i> sp.	< 0.1	< 0.01	0- <1	8.0
<i>Descurainia pinnata</i>	< 0.1	< 0.01	0- <1	4.0
<i>Gayophytum ramosissimum</i>	< 0.1	< 0.01	0- <1	12.0
<i>Lomatium orientale</i>	< 0.1	< 0.01	0- <1	8.0
<i>Lupinus argenteus</i>	< 0.1	0.38	0- 1	4.0
<i>Mentzelia dispersa</i>	< 0.1	< 0.01	0- <1	8.0
<i>Oryzopsis hymenoides</i>	1.9	18.13	0- 15	64.0
<i>Phlox longifolia</i>	< 0.1	< 0.01	0- <1	8.0
<i>Poa fendleriana</i>	0.1	0.95	0- 2	8.0
<i>Polygonum sawatchense</i>	< 0.1	< 0.01	0- <1	12.0
<i>Sitanion longifolium</i>	0.2	1.91	0- 1	32.0
<i>Stipa comata</i>	0.4	3.82	0- 5	16.0
<i>Townsendia sericea</i>	< 0.1	< 0.01	0- <1	4.0
Sub-Total	9.0			



Table A8.7.1-1 (contd.) Herb quadrat summaries for Plot 1-0.

Species	Mean Cover (%)	Relative Cover (%)	Range of Cover Values	Frequency (%)
<b>WOODY SPECIES</b>				
<i>Amelanchier</i> spp.	< 0.1	< 0.01	0- <1	4.0
<i>Artemisia tridentata</i>	< 0.1	< 0.01	0- <1	20.0
<i>Gutierrezia sarothrae</i>	0.1	0.95	0- 2	8.0
<i>Pinus edulis</i>	< 0.1	< 0.01	0- <1	4.0
<i>Purshia tridentata</i>	1.0	9.54	0- 6	32.0
<i>Symphoricarpos oreophilus</i>	0.3	2.86	0- 7	4.0
Sub-Total	1.4			
Shrub Layer Cover	17.4		0- 75	
Total Herb Cover	8.4		< 1- 22	
Total Woody in Herb Layer	1.4		0- 7	
Mosses	0.4		0- 3	
Crustose Lichen	0.6		0- 8	
Litter	75.8		10-100	
Bare Soil	20.1		0- 87	
Rock	3.2		0- 26	
	<u>Mean ± S.E.</u>		<u>Range</u>	
No. of Herb Species/m <sup>2</sup>	4.72 ± 0.43		2-10	
Total No. Species/m <sup>2</sup>	5.16 ± 0.48		2-11	



Table A8.7.1-2 Frequency summaries for herb layer species in Plot 1-0, 1975-1981. Based on data from 25 permanently located 1.0 square meter quadrats.

Species	Percent Frequency			
	1975	1976	1978	1981
<b>HERBACEOUS SPECIES</b>				
<i>Agoseris glauca</i>	8	12	16	4
<i>Agropyron desertorum</i>	44	44	40	40
<i>Agropyron smithii</i>	24	36	52	12
<i>Agropyron trachycaulum</i>	4			16
<i>Antennaria rosea</i>	20	24	20	20
<i>Arabis holboellii</i>	16	20	8	20
<i>Artemisia ludoviciana</i>	12	12	12	12
<i>Aster fendleri</i>	4	8	4	4
<i>Astragalus ceramicus</i>	8	4		8
<i>Astragalus diversifolius</i>				4
<i>Bouteloua gracilis</i>	4	4	8	4
<i>Bromus tectorum</i>	92	100	88	84
<i>Calochortus nuttallii</i>	8			
<i>Carex rossii</i>	16		20	28
<i>Carex</i> sp.	16	40		4
<i>Chaenactis douglasii</i>	12	24	24	8
<i>Chenopodium album</i>	28	12	12	12
<i>Collinsia parviflora</i>				4
<i>Crepis acuminata</i>		4		
<i>Cryptantha</i> sp.	8	4	16	8
<i>Descurainia pinnata</i>	40	12	8	4
<i>Euphorbia robusta</i>		8	8	
<i>Festuca idahoensis</i>	4	8	8	
<i>Gayophytum ramosissimum</i>	12	16	32	12
<i>Ipomopsis aggregata</i>	4	4	4	
<i>Koeleria gracilis</i>	4			
<i>Lappula redowskii</i>	8	4	12	
<i>Lepidium densiflorum</i>			4	
<i>Lomatium orientale</i>	12	4	8	8
<i>Lupinus argenteus</i>	4	4	4	4
<i>Mentzelia dispersa</i>	8		12	8
<i>Oryzopsis hymenoides</i>	48	60	76	64
<i>Phlox longifolia</i>	8	8	8	8
<i>Poa fendleriana</i>			4	8
<i>Polygonum sawatchense</i>	12	24	28	12
<i>Sitanion longifolium</i>	20	24	32	32
<i>Stipa comata</i>	20	24	28	16
<i>Taraxacum officinale</i>	4	4		
<i>Tragopogon dubius</i>	4			
<i>Townsendia sericea</i>	4	4	4	4



Table A8.7.1-2 (contd.) Frequency summaries for herb layer species in Plot 1-0.

Species	Percent Frequency			
	1975	1976	1978	1981
Unknown Grass		4	4	
<b>WOODY SPECIES</b>				
<i>Amelanchier utahensis</i>		4		4
<i>Artemisia tridentata</i>	4	16	20	20
<i>Gutierrezia sarothrae</i>	12	24	20	8
<i>Pinus edulis</i>	4	8	4	4
<i>Purshia tridentata</i>	12	16		32
<i>Symphoricarpos oreophilus</i>	8	8		4



Table A8.7.1-3 Mean cover and species diversity summaries for herbaceous quadrat studies at intensive study Plots 1-0 and 1-F.

	Plot 1-0 Mean Cover				Plot 1-F Mean Cover			
	1975	1976	1978	1981	1975	1976	1978	1981
Herb Cover	15.0	17.5	12.3	8.4	23.0	27.0	18.9	12.9
Woody Cover	0.7	1.1	0.2	1.4	0.4	1.2	0.6	0.3
Mosses	0.7	1.5	0.3	0.4	0.1	0.1	0.0	<0.1
Crustose Lichen	1.0	2.0	1.0	0.6	0.2	0.2	0.2	0.2
Foliose-Fruticose Lichen								< 0.1
Litter	63.0	62.7	76.0	75.8	70.0	76.0	77.8	81.1
Bare Soil	31.0	34.3	21.4	20.1	26.0	23.0	20.8	16.3
Rock	3.0	3.2	2.5	3.2	2.0	1.4	1.4	2.4
Mean No. of Herb Species per m <sup>2</sup>	5.4	5.6	6.3	4.7	7.0	6.6	6.5	4.9
Mean Total No. of Species per m <sup>2</sup>	5.8	6.4	6.6	5.2	7.5	7.4	6.6	5.6



Table A8.7.1-4

Herb quadrat summaries for Plot 1-F. Based on data from 25 permanently located quadrats. June 1981. Values in percent. "?" indicates uncertain identification.  $\pm$  values are equal to the standard error of the mean.

Species	Mean Cover (%)	Relative Cover (%)	Range of Cover Values	Frequency (%)
<u>HERBACEOUS SPECIES</u>				
<i>Agropyron dasystachyum</i>	3.3	23.08	0- 24	48.0
<i>Agropyron desertorum</i>	< 0.1	0.28	0- 1	4.0
<i>Agropyron smithii</i>	0.4	2.80	0- 7	16.0
<i>Antennaria parvifolia</i>	< 0.1	0.28	0- 1	8.0
<i>Antennaria rosea</i>	0.2	1.40	0- 2	12.0
<i>Arabis holboellii</i>	< 0.1	< 0.01	0- < 1	12.0
<i>Artemisia ludoviciana</i>	< 0.1	< 0.01	0- < 1	4.0
<i>Aster fendleri</i> ?	< 0.1	< 0.01	0- < 1	4.0
<i>Astragalus ceramicus</i>	< 0.1	< 0.01	0- < 1	12.0
<i>Bromus tectorum</i>	0.9	6.29	0- 12	60.0
<i>Carex rossii</i>	0.4	2.80	0- 6	28.0
<i>Castilleja chromosa</i>	< 0.1	0.28	0- 1	4.0
<i>Chenopodium album</i>	< 0.1	< 0.01	0- < 1	12.0
<i>Collinsia parviflora</i>	< 0.1	< 0.01	0- < 1	8.0
<i>Cryptantha</i> sp.	< 0.1	< 0.01	0- < 1	8.0
<i>Descurainia pinnata</i>	< 0.1	< 0.01	0- < 1	8.0
<i>Erigeron pumillus</i>	< 0.1	< 0.01	0- < 1	4.0
<i>Gayophytum ramosissimum</i>	< 0.1	< 0.01	0- < 1	4.0
<i>Haplopappus nuttallii</i>	0.2	1.40	0- 2	12.0
<i>Koeleria gracilis</i>	0.7	4.90	0- 9	28.0
<i>Lappula redowskii</i>	< 0.1	< 0.01	0- < 1	4.0
<i>Mentzelia dispersa</i>	< 0.1	< 0.01	0- < 1	4.0
<i>Oryzopsis hymenoides</i>	4.5	31.47	0- 23	72.0
<i>Phlox hoodii</i>	1.0	6.99	0- 6	32.0
<i>Physaria floribunda</i>	< 0.1	< 0.01	0- < 1	4.0
<i>Poa</i> sp.	< 0.1	< 0.01	0- < 1	4.0
<i>Poa fendleriana</i>	2.0	13.99	0- 14	40.0
<i>Senecio multilobatus</i>	< 0.1	< 0.01	0- < 1	8.0
<i>Sitanion longifolium</i>	0.2	1.40	0- 2	24.0
<i>Stipa comata</i>	< 0.1	0.28	0- 1	
<i>Zygadenus venenosus</i>	< 0.1	< 0.01	0- < 1	8.0
Sub-Total	13.8			



Table A8.7.1-4

(contd.) Herb quadrat summaries for Plot 1-F.

Species	Mean Cover (%)	Relative Cover (%)	Range of Cover Values	Frequency (%)
<b>WOODY SPECIES</b>				
<i>Artemisia tridentata</i>	0.2	1.40	0- 3	36.0
<i>Chrysothamnus nauseosus</i>	< 0.1	0.28	0- 1	4.0
<i>Gutierrezia sarothrae</i>	0.1	0.70	0- 1	24.0
<i>Pinus edulis</i>	< 0.1	< 0.01	0- < 1	44.0
Sub-Total	14.1			
Shrub Layer Cover	5.8		0- 35	
Total Herb Cover	12.9		1- 27	
Total Woody in Herb Layer	0.3		0- 3	
Mosses	< 0.1		0- < 1	
Crustose Lichen	0.2		0- 5	
Foliose-Fruticose Lichen	< 0.1		0- < 1	
Litter	81.1		45-100	
Bare Soil	16.3		4- 55	
Rock	2.4		0- 5	
	<u>Mean</u> ± <u>S.E.</u>		<u>Range</u>	
No. Herb Species/m <sup>2</sup>	4.92 ± 0.57		1-11	
Total No. Species/m <sup>2</sup>	5.60 ± 0.70		1-12	



Table A8.7.1-5. Frequency summaries for herb layer species in Plot 1-F, 1975-1981. Based on data from 25 permanently located 1.0 square meter quadrats.

Species	Percent Frequency			
	1975	1976	1978	1981
HERBACEOUS SPECIES				
<i>Agoseris glauca</i>	8	12	12	
<i>Agropyron dasystachyum</i>		4	8	48
<i>Agropyron desertorum</i>	36	36	44	4
<i>Agropyron smithii</i>	16	12	16	16
<i>Agropyron spicatum</i>	4			
<i>Antennaria parvifolia</i>	8		8	8
<i>Antennaria rosea</i>	12	32	12	12
<i>Arabis holboellii</i>	8	8	8	12
<i>Artemisia ludoviciana</i>	8	8	4	4
<i>Aster fendleri</i>	16	32	16	4
<i>Astragalus ceramicus</i>	28	32	32	12
<i>Bromus tectorum</i>	76	84	68	60
<i>Carex rossii</i>	32	32	12	28
<i>Castilleja chromosa</i>				4
<i>Chaenactis douglasii</i>	8	8	4	
<i>Chenopodium album</i>	20	8	12	12
<i>Collinsia parviflora</i>	12	8	4	8
<i>Crepis acuminata</i>		4		
<i>Cryptantha</i> sp.	24	20	4	8
<i>Delphinium nelsonii</i>			4	
<i>Descurainia pinnata</i>	24	4	8	8
<i>Draba reptans</i>			4	
<i>Erigeron pumilus</i>	20	4	4	4
<i>Erodium cicutarium</i>	4	4		
<i>Festuca idahoensis</i>	12	44	20	
<i>Gayophytum ramosissimum</i>	12		8	4
<i>Haplopappus nuttallii</i>	16	12	12	12
<i>Ipomopsis aggregata</i>		8		
<i>Koeleria gracilis</i>	32	20	28	28
<i>Lappula redowskii</i>	12	12	20	4
<i>Lepidium densiflorum</i>	8	4	4	
<i>Mentzelia dispersa</i>	8	4	8	4
<i>Microsteris micrantha</i>	8		4	
<i>Oryzopsis hymenoides</i>	64	88	84	72
<i>Phlox hoodii</i>	32	36	36	32
<i>Physaria floribunda</i>	8	8	8	4
<i>Poa fendleriana</i>	36		24	4
<i>Poa pratensis</i>	4			
<i>Polygonum douglasii</i>		12		
<i>Polygonum sawatchense</i>	4		8	
<i>Senecio multilobatus</i>	12	12	8	8



Table A8.7.1-5 (contd.) Frequency summaries for herb layer species in Plot 1-F.

Species	Percent Frequency			
	1975	1976	1978	1981
<i>Sisymbrium altissimum</i>		4		
<i>Sitanion longifolium</i>	44	40	40	24
<i>Stipa comata</i>	16	4	8	4
<i>Taraxacum officinale</i>	8		4	
<i>Tragopogon dubius</i>			4	
<i>Zygadenus venenosus</i>	4		4	8
WOODY SPECIES				
<i>Amelanchier utahensis</i>	4	4		
<i>Artemisia tridentata</i>	12	24	12	36
<i>Cercocarpus montanus</i>		4		
<i>Chrysothamnus nauseosus</i>	4	12	4	4
<i>Gutierrezia sarothrae</i>	24	28	16	24
<i>Pinus edulis</i>				4
<i>Purshia tridentata</i>		4		



Table A8.7.1-6 Herb quadrat summaries for Plot 2-0. Based on data from 25 permanently located quadrats. June 1981. Values in percent. "?" indicated uncertain identification.  $\pm$  values are equal to the standard error of the mean.

Species	Mean Cover (%)	Relative Cover (%)	Range of Cover Values	Frequency (%)
<u>HERBACEOUS SPECIES</u>				
<i>Agoseris glauca</i>	< 0.1	< 0.01	0- < 1	4.0
<i>Agropyron desertorum</i>	1.6	21.86	0- 7	44.0
<i>Agropyron smithii</i>	0.4	5.46	0- 11	20.0
<i>Antennaria rosea</i>	< 0.1	< 0.01	0- < 1	4.0
<i>Arabis holboellii</i>	< 0.1	< 0.01	0- < 1	8.0
<i>Artemisia ludoviciana</i>	< 0.1	0.55	0- 1	4.0
<i>Aster fendleri</i>	< 0.1	0.55	0- 1	20.0
<i>Aster glaucodes ?</i>	< 0.1	< 0.01	0- < 1	4.0
<i>Astragalus ceramicus</i>	< 0.1	< 0.01	0- < 1	4.0
<i>Bouteloua gracilis</i>	0.3	4.10	0- 7	8.0
<i>Bromus tectorum</i>	1.9	25.96	0- 15	96.0
<i>Carex rossii</i>	0.2	2.73	0- 5	8.0
<i>Chenopodium album</i>	< 0.1	< 0.01	0- < 1	40.0
<i>Descurainia pinnata</i>	< 0.1	< 0.01	0- < 1	8.0
<i>Eriogonum umbellatum</i>	< 0.1	< 0.01	0- < 1	4.0
<i>Gayophytum ramosissimum</i>	< 0.1	< 0.01	0- < 1	20.0
<i>Heterotheca villosa</i>	1.1	15.03	0- 27	4.0
<i>Koeleria gracilis</i>	< 0.1	0.55	0- 1	4.0
<i>Lappula redowskii</i>	< 0.1	< 0.01	0- < 1	12.0
<i>Oryzopsis hymenoides</i>	< 0.1	< 0.01	0- < 1	16.0
<i>Phlox longifolia</i>	< 0.1	< 0.01	0- < 1	12.0
<i>Poa pratensis</i>	0.2	2.73	0- 4	4.0
<i>Poa sp.</i>	0.2	2.73	0- 3	12.0
<i>Polygonum sawatchense</i>	< 0.1	< 0.01	0- < 1	4.0
<i>Sitanion longifolium</i>	0.2	2.73	0- 1	36.0
<i>Sphaeralcea coccinea</i>	0.1	1.37	0- 2	4.0
Unknown Composite	0.6	8.20	0- 15	4.0
Sub-Total	6.8			
<u>WOODY SPECIES</u>				
<i>Artemisia tridentata</i>	0.2	2.73	0- 2	44.0
<i>Chrysothamnus nauseosus</i>	0.1	1.37	0- 1	12.0
<i>Opuntia polyacantha</i>	0.1	1.37	0- 2	4.0
Sub-Total	0.4			



Table A8.7.1-6 (contd.) Herb quadrat summaries for Plot 2-0.

Species	Mean Cover (%)	Relative Cover (%)	Range of Cover Values	Frequency (%)
Shrub Layer Cover	10.9		0- 40	
Total Herb Cover	6.6		< 1- 27	
Total Woody in Herb Layer	0.4		0- 3	
Mosses	0.1		0- 3	
Crustose Lichen	0.1		0- 1	
Foliose-Fruticose Lichen	0		---	
Litter	81.8		56-100	
Bare Soil	16.0		0- 38	
Rock	2.0		0- 28	
	<u>Mean ± S.E.</u>		<u>Range</u>	
No. of Herb Species/m <sup>2</sup>	4.08 ± 0.35		1- 7	
Total No. Species/m <sup>2</sup>	4.64 ± 0.42		1- 8	



Table A8.7.1-7 Frequency summaries for herb layer species in Plot 2-0, 1975-1981. Based on data from 25 permanently located 1.0 square meter quadrats.

Species	Percent Frequency			
	1975	1976	1978	1981
HERBACEOUS SPECIES				
<i>Agoseris glauca</i>		4	4	4
<i>Agropyron desertorum</i>	36	36	36	44
<i>Agropyron smithii</i>	20	20	16	20
<i>Antennaria parvifolia</i>		4		
<i>Antennaria rosea</i>	4	4		4
<i>Arabis holboellii</i>	32	16		8
<i>Artemisia ludoviciana</i>			4	
<i>Aster fendleri</i>		60	24	20
<i>Aster glaucodes</i>		4	4	4
<i>Astragalus ceramicus</i>	8	8	4	4
<i>Bouteloua gracilis</i>	12	16	12	8
<i>Bromus tectorum</i>	100	100	96	96
<i>Carex rossii</i>	4	4	4	8
<i>Chenopodium album</i>	64	68	16	40
<i>Crepis acuminata</i>		4	8	
<i>Delphinium nelsonii</i>	4			
<i>Descurainia pinnata</i>	24	4	8	8
<i>Erigeron pumilus</i>	20			
<i>Eriogonum umbellatum</i>				4
<i>Festuca idahoensis</i>		24	16	
<i>Gayophytum ramosissimum</i>	44	40	48	20
<i>Heterotheca villosa</i>	12	4	4	4
<i>Koeleria gracilis</i>	8	4	8	4
<i>Lappula redowskii</i>	36	40	40	12
<i>Lepidium montanum</i>			4	
<i>Microsteris micrantha</i>	8	20	16	
<i>Oenothera trichocalyx</i>			4	
<i>Oryzopsis hymenoides</i>	12	8	16	16
<i>Phlox longifolia</i>	4	4	12	12
<i>Poa pratensis</i>	8	4		4
<i>Poa sp.</i>		28	8	12
<i>Polygonum sawatchense</i>	4	24	16	4
<i>Salsola iberica</i>			8	
<i>Sphaeralcea coccinea</i>	8	8	4	4
<i>Sisymbrium altissimum</i>		12	4	
<i>Sisymbrium officinale</i>		16	4	
<i>Sitanion longifolium</i>	36	44	44	36
<i>Taraxacum officinale</i>	16	8	4	
<i>Tragopogon dubius</i>			4	
Unknown Mustard	4	4	8	
Unknown Basal	4			
Unknown Composite			4	4



Table A8.7.1-7 (contd.) Frequency summaries for herb layer species in Plot 2-0.

Species	Percent Frequency			
	1975	1976	1978	1981
<b>WOODY SPECIES</b>				
<i>Amelanchier utahensis</i>	4			
<i>Artemisia tridentata</i>	4	36	28	44
<i>Chrysothamnus nauseosus</i>	16	44	24	12
<i>Chrysothamnus viscidiflorus</i>	4			
<i>Gutierrezia sarothrae</i>		8		
<i>Opuntia polyacantha</i>		4		4



Table A8.7.1-8. Mean cover and species diversity summaries for herbaceous quadrat studies at intensive study Plots 2-0 and 2-F.

	Plot 2-0 Mean Cover				Plot 2-F Mean Cover			
	1975	1976	1978	1981	1975	1976	1978	1981
Herb Cover	21.0	22.5	15.8	6.6	23.0	26.6	12.6	7.0
Woody Cover	0.4	0.4	0.4	0.4	0.2	0.2	0.3	0.2
Mosses	0.1	0.0	0.1	0.1	0.3	0.2	0.4	0.4
Crustose Lichen	0.2	0.3	0.1	0.1	1.1	1.2	0.6	0.7
Litter	69.0	81.2	82.4	81.8	64.0	78.8	81.8	80.0
Bare Soil	24.0	17.6	15.9	16.0	23.0	19.4	16.6	16.9
Rock	2.0	1.6	1.6	2.0	3.0	1.8	1.7	2.1
Mean No. of Herb Species per m <sup>2</sup>	5.6	6.2	5.0	4.1	5.2	5.4	4.4	3.5
Mean Total No. of Species per m <sup>2</sup>	5.8	7.1	5.6	4.6	5.4	6.0	5.0	4.0



Table A8.7.1-9

Herb quadrat summaries for Plot 2-F. Based on data from 25 permanently located quadrats. June 1981. Values in percent.  $\pm$  values are equal to the standard error of the mean.

Species	Mean Cover (%)	Relative Cover (%)	Range of Cover Values	Frequency (%)
<u>HERBACEOUS SPECIES</u>				
<i>Agoseris glauca</i>	< 0.1	< 0.01	0- < 1	4.0
<i>Agropyron dasystachyum</i>	0.8	10.55	0- 15	16.0
<i>Agropyron desertorum</i>	4.2	55.41	0- 21	48.0
<i>Agropyron smithii</i>	0.1	1.32	0- 1	16.0
<i>Antennaria rosea</i>	0.2	2.64	0- 3	8.0
<i>Arabis holboellii</i>	< 0.1	< 0.01	0- < 1	4.0
<i>Aster fendleri</i>	< 0.1	< 0.01	0- < 1	8.0
<i>Bouteloua gracilis</i>	0.1	1.32	0- 1	12.0
<i>Bromus tectorum</i>	0.3	3.96	0- 3	60.0
<i>Chaenactis douglasii</i>	0.1	1.32	0- 2	4.0
<i>Chenopodium album</i>	< 0.1	< 0.01	0- < 1	24.0
<i>Festuca idahoensis</i>	0.1	1.32	0- 3	8.0
<i>Gayophytum ramosissimum</i>	< 0.1	< 0.01	0- < 1	20.0
<i>Koeleria gracilis</i>	0.3	3.96	0- 4	16.0
<i>Lomatium foeniculaceum</i>	0.1	1.32	0- 1	4.0
<i>Mentzelia dispersa</i>	< 0.1	< 0.01	0- < 1	8.0
<i>Phlox longifolia</i>	< 0.1	< 0.01	0- < 1	8.0
<i>Poa pratensis</i>	0.2	2.64	0- 4	4.0
<i>Poa sp.</i>	0.1	1.32	0- 3	4.0
<i>Oryzopsis hymenoides</i>	0.4	5.28	0- 3	32.0
<i>Senecio multilobatus</i>	< 0.1	< 0.01	0- < 1	4.0
<i>Sisymbrium longifolia</i>	< 0.1	< 0.01	0- < 1	4.0
<i>Sitanion longifolium</i>	0.2	2.64	0- 4	24.0
<i>Sphaeralcea coccinea</i>	0.1	1.32	0- 1	8.0
<i>Stipa comata</i>	0.1	1.32	0- 2	4.0
Sub-Total	7.4			
<u>WOODY SPECIES</u>				
<i>Artemisia tridentata</i>	< 0.1	0.53	0- 1	24.0
<i>Cercocarpus montanus</i>	< 0.1	< 0.01	0- < 1	4.0
<i>Chrysothamnus nauseosus</i>	< 0.1	0.53	0- 1	8.0
<i>Pinus edulis</i>	0.1	1.32	0- 2	4.0
<i>Purshia tridentata</i>	< 0.1	< 0.01	0- < 1	4.0
Sub-Total	0.1			



Table A8.7.1-9 (contd.) Herb quadrat summaries for Plot 2-F.

Species	Mean Cover (%)	Relative Cover (%)	Range of Cover Values	Frequency (%)
Shrub Layer Cover	16.3		0- 75	
Total Herb Cover	7.0		0- 23	
Total Woody in Herb Layer	0.2		0- 2	
Mosses	0.4		0- 5	
Crustose Lichen	0.7		0- 8	
Foliose-Fruticose Lichens	0.0		---	
Litter	80.0		34-100	
Bare Soil	16.9		0- 65	
Rock	2.1		0- 23	
	<u>Mean</u> ± <u>S.E.</u>		<u>Range</u>	
No. of Herb Species/m <sup>2</sup>	3.52 ± 0.36		0- 7	
Total No. Species/m <sup>2</sup>	3.96 ± 0.37		1- 7	



Table A8.7.1-10 Frequency summaries for herb layer species in Plot 2-F, 1975-1981. Based on data from 25 permanently located 1.0 square meter quadrats.

Species	Percent Frequency			
	1975	1976	1978	1981
<b>HERBACEOUS SPECIES</b>				
<i>Agoseris glauca</i>	8	8	8	4
<i>Agropyron dasystachyum</i>			44	16
<i>Agropyron desertorum</i>	36	40	4	48
<i>Agropyron smithii</i>	32	28	24	16
<i>Agropyron spicatum</i>	4			
<i>Antennaria rosea</i>	12	8	4	8
<i>Arabis holboellii</i>	12	8		4
<i>Aster fendleri</i>		36	16	8
<i>Aster sp.</i>	12			
<i>Astragalus ceramicus</i>	4	4	4	
<i>Astragalus diversifolius</i>		4	4	
<i>Bouteloua gracilis</i>	12	16	16	12
<i>Brassica sp. (?)</i>	4			
<i>Bromus tectorum</i>	96	88	76	60
<i>Calochortus nuttallii</i>			4	
<i>Chaenactis douglasii</i>				4
<i>Chenopodium album</i>	24	28	20	24
<i>Collinsia parviflora</i>	8	12		
<i>Descurainia pinnata</i>	16	4		
<i>Draba reptans</i>	4			
<i>Erigeron pumilus</i>	16	4		
<i>Erysimum asperum</i>			4	
<i>Festuca idahoensis</i>	4	24	16	8
<i>Gayophytum ramosissimum</i>	36	44	32	20
<i>Heterotheca villosa</i>	8	4		
<i>Koeleria gracilis</i>	12		12	16
<i>Lappula redowskii</i>	24	24	12	
<i>Lomatium grayi</i>	4	4	4	4
<i>Mentzelia dispersa</i>	8	4	4	8
<i>Microsteris micrantha</i>	4	12	4	
<i>Phlox longifolia</i>	12	8	8	8
<i>Poa fendleriana</i>			8	
<i>Poa sp.</i>	24			4
<i>Polygonum sawatchense</i>	4	32	20	
<i>Oryzopsis hymenoides</i>	16	20	24	32
<i>Senecio multilobatus</i>				4
<i>Sisymbrium officinale</i>				4
<i>Sitanion longifolium</i>	36	40	36	24
<i>Sphaeralcea coccinea</i>	4	12	8	8
<i>Stipa comata</i>	4	4	4	4
<i>Taraxacum officinale</i>	8	8		



Table A8.7.1-10 (contd.) Frequency summaries for herb layer species in Plot 2-F.

Species	Percent Frequency			
	1975	1976	1978	1981
Unknown Mustard	4		4	
Unknown seedling		8		
WOODY SPECIES				
<i>Artemisia tridentata</i>	8	28	44	24
<i>Cercocarpus montanus</i>				4
<i>Chrysothamnus nauseosus</i>	8	24	12	8
<i>Juniperus osteosperma</i>		4		
<i>Pinus edulis</i>	4	4	4	4
<i>Purshia tridentata</i>	4	4	4	4
<i>Symphoricarpos oreophilus</i>	4			



Table A8.7.1-11 Frequency, mean cover, and relative cover values for shrub species in Plot 1-0, 1974-1981.  
Based on data from 20 10m x 4m line-strip transects.

Species	Frequency (%)				Mean Cover (%)				Relative Cover (%)			
	1974	1976	1978	1981	1974	1976	1978	1981	1974	1976	1978	1981
<i>Amelanchier</i> spp.	40	30	35	45	0.3	0.3	0.4	0.7	2.1	1.9	2.3	3.4
<i>Artemisia tridentata</i>	100	100	100	100	9.6	10.3	9.6	13.6	66.8	58.5	64.0	65.7
<i>Cercocarpus montanus</i>	65	65	70	70	0.4	0.3	0.2	0.3	3.1	1.9	1.1	1.5
<i>Chrysothamnus nauseosus</i>	30	45	40	35	0.4	0.2	0.2	0.2	2.8	1.2	1.0	1.0
<i>Chrysothamnus viscidiflorus</i>	5	15	15	25	<0.1	<0.1	<0.1	0.4	0.1	<0.1	<0.1	1.9
<i>Juniperus osteosperma</i>	40	35	45	40	0.6	0.4	2.0	0.8	3.8	2.3	13.1	3.9
<i>Juniperus scopulorum</i>	5	15		20	1.0	1.4		1.4	6.6	7.9		6.8
<i>Opuntia polyacantha</i>	20	10	35	25	<0.1	<0.1	<0.1	<0.1	<0.1	<0.1	<0.1	<0.1
<i>Pinus edulis</i>	55	70	75	75	0.8	1.6	1.2	0.9	5.5	9.2	8.1	4.4
<i>Purshia tridentata</i>	65	80	75	75	1.2	1.9	1.1	2.0	8.3	10.9	7.4	9.7
<i>Symphoricarpos oreophilus</i>	30	30	40	40	0.2	0.2	0.4	0.4	1.0	0.8	2.9	1.9
TOTAL					14.5	16.6	15.1	20.7				



Table A8.7.1-12 Frequency, mean cover, and relative cover values for shrub species in Plot 1-F. 1974 - 1981.  
Based on data from 20 10m x 4m line-strip transects.

Species	Frequency (%)				Mean Cover (%)				Relative Cover (%)			
	1974	1976	1978	1981	1974	1976	1978	1981	1974	1976	1978	1981
<i>Amelanchier</i> spp.	10	10	15	20	0.6	0.8	0.7	0.9	6.6	6.3	7.0	7.2
<i>Artemisia tridentata</i>	80	80	100	100	5.3	7.4	6.4	7.9	58.6	58.6	61.7	63.5
<i>Cercocarpus montanus</i>	50	55	50	50	0.1	0.1	0.2	0.2	1.1	0.7	1.9	1.6
<i>Chrysothamnus nauseosus</i>	50	50	55	35	1.4	1.5	1.3	0.6	15.5	12.1	12.5	4.8
<i>Chrysothamnus viscidiflorus</i>	5	5		25	< 0.1	< 0.1		0.5	< 0.1	< 0.1		4.0
<i>Juniperus osteosperma</i>	25	20	40	30	0.2	0.2	0.4	0.2	2.2	1.7	3.7	1.6
<i>Juniperus scopulorum</i>	5	5		10	< 0.1	0.1		0.2	< 0.1	1.0		1.6
<i>Opuntia polyacantha</i>	10		20	15	< 0.1		< 0.1	< 0.1	< 0.1		< 0.1	< 0.1
<i>Pinus edulis</i>	25	25	25	30	0.2	0.2	0.3	< 0.1	2.8	1.6	2.6	0.3
<i>Purshia tridentata</i>	50	65	55	60	0.6	1.6	1.0	1.8	6.6	12.5	9.5	14.5
<i>Symphoricarpos oreophilus</i>	20	20	35	35	0.1	< 0.1	0.1	0.1	1.1	< 0.1	1.1	0.8
TOTAL					8.5	11.9	10.4	12.4				



Table A8.7.1-13 Density values (No. per hectare) for shrub species at plots 1-0 and 1-F; chained pinyon-juniper rangeland. Values based on 20 10m x 4m belt transects. Height class 1 = 0.25m - 0.75m; Class 2 = 0.76m - 1.50m; Class 3 = 1.51m - 2.25m; Class 4 = >2.25m. 1974-1981.

	Height Class	Plot 1-0				Plot 1-F			
		1974	1976	1978	1981	1974	1976	1978	1981
<i>Amelanchier</i> spp.	I	162	99	163	138	25	25	88	63
	II	25	49	113	113	12	12	13	38
	III				13				13
	IV								
	Total	187	148	276	263	37	37	101	113
<i>Artemisia tridentata</i>	I	2,162	2,561	2,350	2,038	988	788	1,138	1,225
	II	712	1,074	1,363	1,875	600	724	863	1,125
	III	12	25	38	163	12	49	150	200
	IV			13				13	
	Total	2,886	3,661	3,764	4,075	1,600	1,561	2,164	2,550
<i>Artemisia</i> sp.	I								
	Total								
<i>Cercocarpus montanus</i>	I	262	375	350	275	138	138	100	50
	II	88	114	150	213	112	163	188	138
	III				25		49	63	100
	IV								
	Total	350	489	500	513	250	363	351	288
<i>Chrysothamnus nauseosus</i>	I	175	212	138	138	262	188	200	125
	II	25	12	13	38	12	62	50	50
	III								
	Total	200	224	151	175	272	250	250	175



Table A8.7.1-13 (contd.) Density values (No. per hectare) for shrub species at Plots 1-0 and 1-F.

	Height Class	Plot 1-0				Plot 1-F			
		1974	1976	1978	1981	1974	1976	1978	1981
<i>Chrysothamnus viscidiflorus</i>	I	12	49	63	125	12	12		150
	Total	12	49	63	125	12	12		150
<i>Juniperus osteosperma</i>	I	75	37	88	50	38	49	88	75
	II	62	62	75	50	50	12	38	25
	III			50	25				25
	IV			13					
	Total	137	99	226	125	88	61	126	125
<i>Juniperus scopulorum</i>	I	25	12		38	12			
	II	25	25		88				25
	III				50				
	Total	50	37		175	12			25
<i>Opuntia polyacantha</i>	I	100	25	75	113	125		50	50
	Total	100	25	75	113	125		50	50
<i>Pinus edulis</i>	I	138	188	163	113	125	114	150	125
	II	125	200	125	163	38	49	38	38
	III	38	49	63	100	12	25	13	25
	IV			25	13			13	
	Total	301	437	376	388	175	188	214	188
<i>Purshia tridentata</i>	I	588	874	938	1,063	225	299	200	275
	II	12	1,000	125	113	50	212	188	125
	III							13	25
	Total	600	1,874	1,063	1,175	275	511	401	438



Table A8.7.1-13 (contd.) Density values (No. per hectare) for shrub species at Plots 1-0 and 1-F.

	Height Class	Plot 1-0				Plot 1-F			
		1974	1976	1978	1981	1974	1976	1978	1981
<i>Symphoricarpos oreophilus</i>	I	150	262	438	363	112	62	188	200
	II			13	13		25	38	38
	Total	150	262	451	375	112	87	226	238
TOTAL		1,973	7,305	6,945	7,502	2,958	3,070	3,883	4,340



Table A8.7.1-14 Frequency, mean cover, and relative cover values for shrub species in plot 2-0, 1974-1981.  
Based on data from 20 10m x 4m line-strip transects.

Species	Frequency (%)				Mean Cover (%)				Relative Cover (%)			
	1974	1976	1978	1981	1974	1976	1978	1981	1974	1976	1978	1981
<i>Amelanchier</i> spp.	20	10	10	10	0.2	0.6	0.7	0.6	3.7	7.4	7.8	5.4
<i>Artemisia tridentata</i>	50	50	75	90	0.3	0.9	1.7	3.1	5.5	12.0	19.2	27.9
<i>Cercocarpus montanus</i>	25	25	25	25	0.3	0.2	0.2	0.3	5.5	1.9	2.5	2.7
<i>Chrysothamnus nauseosus</i>	85	90	95	95	2.6	3.4	4.2	3.3	46.7	42.8	46.9	29.7
<i>Chrysothamnus viscidiflorus</i>	5	10		55	<0.1	<0.1		1.0	<0.1	<0.1		9.0
<i>Juniperus osteosperma</i>	50	60	60	55	1.3	1.2	0.9	1.3	23.9	15.6	10.6	11.7
<i>Opuntia polyacantha</i>	35		20	20	<0.1		<0.1	<0.1	<0.1		<0.1	<0.1
<i>Pinus edulis</i>	65	60	60	65	0.8	0.5	0.3	0.6	13.8	5.9	3.7	5.4
<i>Purshia tridentata</i>	20	25	35	25	<0.1	0.6	0.4	0.6	<0.1	7.0	4.6	5.4
<i>Sumphoricarpus oreophilus</i>	10	20	35	25	0.1	0.1	0.4	0.3	0.9	0.8	4.6	2.7
TOTAL					5.6	7.5	8.8	11.1				



Table A8.7.1-15. Frequency, mean cover, and relative cover values for shrub species in Plot 2-F, 1974-1981. Based on data from 20 10m x 4m line-strip transects.

Species	Frequency (%)				Mean Cover (%)				Relative Cover (%)			
	1974	1976	1978	1981	1974	1976	1978	1981	1974	1976	1978	1981
<i>Amelanchier</i> spp.	30	10	10	10	< 0.1	< 0.1	< 0.1	< 0.1	0.5	< 0.1	< 0.1	< 0.1
<i>Artemisia tridentata</i>	35	65	70	85	1.1	1.6	2.6	3.4	11.7	11.9	17.7	22.0
<i>Artemisia</i> sp.		5				< 0.1				< 0.1		
<i>Cercocarpus montanus</i>	10	25	20	15	0.4	0.5	0.5	< 0.1	4.3	3.7	3.8	0.1
<i>Chrysothamnus nauseosus</i>	50	70	75	75	0.6	1.8	1.4	0.8	6.9	12.9	9.5	5.2
<i>Chrysothamnus viscidiflorus</i>	5	10	5	30	< 0.1	< 0.1	< 0.1	0.2	< 0.1	< 0.1	< 0.1	1.3
<i>Juniperus osteosperma</i>	70	80	85	70	2.8	4.0	3.4	5.3	30.3	28.9	23.3	34.3
<i>Juniperus scopulorum</i>				5				< 0.1				< 0.1
<i>Opuntia polyacantha</i>	10		15	25	< 0.1		< 0.1	< 0.1	< 0.1		< 0.1	0.3
<i>Pinus edulis</i>	65	65	70	70	1.2	1.9	1.9	1.4	12.2	13.6	12.8	9.1
<i>Purshia tridentata</i>	35	55	40	45	3.2	3.8	4.8	4.2	34.1	27.2	32.7	27.2
<i>Symphoricarpos oreophilus</i>		30	25	30		< 0.1	0.1	0.1		< 0.1	0.3	0.7
TOTAL					9.3	13.6	14.7	15.4				



Table A8.7.1-16 Density values (No. per hectare) for shrub species at plots 2-0 and 2-F; chained pinyon-juniper rangeland. Values based on 20 10m x 4m belt transects. Height Class I = 0.25m - 0.75m; Class 2 = 0.76m - 1.50m; Class 3 = 1.51m - 2.25m; Class 4 = >2.25m. 1974-1981.

	Height Class	Plot 2-0				Plot 2-F			
		1974	1976	1978	1981	1974	1976	1978	1981
<i>Amelanchier</i> sp.	I	62	49	38		75	25	25	
	II	12		25	38	25	12	13	
	III		12		13				13
	IV			13					25
	Total	74	61	76	50	100	37	38	38
<i>Artemisia tridentata</i>	I	138	151	575	1,250	212	388	700	1,488
	II	62	86	150	300	50	200	213	513
	III		12	25	113		49	63	125
	IV								
	Total	200	249	735	1,663	262	637	976	2,125
<i>Artemisia</i> sp.	I						12		
	Total						12		
<i>Cercocarpus montanus</i>	I	38	62	75	50	50	62	100	75
	II	25	37	13	38		12		13
	III	12	25		13	12	12		
	IV		12	13			12	26	13
	Total	75	124	101	100	62	99	126	100
<i>Chrysothamnus nauseosus</i>	I	388	1,037	1,463	1,450	175	262	213	263
	II	100	225	163	213	50	114	100	188
	III			25	13				
	Total	488	1,262	1,651	1,673	225	376	313	450



Table A8.7.1-16 (contd.) Density values (No. per hectare) for shrub species at plots 2-0 and 2-F.

	Height Class	Plot 2-0				Plot 2-F			
		1974	1976	1978	1981	1974	1976	1978	1981
<i>Chrysothamnus viscidiflorus</i>	I	12	25		275	12	25	13	75
	II								13
	Total	12	25		275	12	25	13	88
<i>Juniperus osteosperma</i>	I	75	74	75		200	138	150	75
	II	162	175	138	100	225	225	150	150
	III	12	37	50	88	12	37	88	100
	IV					12	25	13	25
	Total	249	286	263	188	449	425	401	350
<i>Juniperus scopulorum</i>	I								13
	II								13
	Total								26
<i>Opuntia polyacantha</i>	I	200		35	88	100		38	113
	Total	200		35	88	100		38	113
<i>Pinus edulis</i>	I	212	114	138	63	162	212	188	150
	II	75	126	75	75	138	225	113	113
	III	25	49	50	125	38	86	125	113
	IV		12	38	25			38	38
	Total	312	301	301	288	338	523	464	413
<i>Purshia tridentata</i>	I	88	74	88	100	225	175	213	238
	II	12	37	13	38	125	249	288	275
	III		12	13				50	25
	Total	100	123	114	138	350	424	551	538



Table A8.7.1-16. (contd.) Density values (No. per hectare) for shrub species at plots 2-0 and 2-F.

	Height Class	Plot 2-0				Plot 2-F			
		1974	1976	1978	1981	1974	1976	1978	1981
<i>Symphoricarpos oreophilus</i>	I	112	99	188	188		49	125	138
	II			13	13		37	50	125
	Total	112	99	201	200		86	175	263
TOTAL		1,822	2,530	3,477	4,663	1,898	2,644	3,095	4,491



Table A8.7.1-17

Herb quadrat summaries for the Irrigation Study Plot.  
Based on data from 25 permanently located quadrats.  
June 1981. Values in percent. "?" indicates uncertain  
identification. ± values are equal to the standard error  
of the mean.

Species	Mean Cover (%)	Relative Cover (%)	Range of Cover Values	Frequency (%)
<b>HERBACEOUS SPECIES</b>				
<i>Agoseris glauca</i>	<0.1	0.24	0- 1	32.0
<i>Agropyron dasystachyum</i>	0.5	3.02	0- 5	16.0
<i>Agropyron desertorum</i>	0.6	3.63	0- 7	20.0
<i>Agropyron smithii</i>	2.2	13.30	0- 12	48.0
<i>Agropyron trachycaulum</i>	2.0	12.09	0- 15	32.0
<i>Antennaria parviflora</i>	<0.1	0.24	0- 1	4.0
<i>Antennaria rosea</i>	0.6	3.63	0- 7	36.0
<i>Arabis holboellii</i>	<0.1	<0.01	0- <1	4.0
<i>Aster fendleri</i>	<0.1	0.24	0- 1	8.0
<i>Astragalus ceramicus</i>	<0.1	<0.01	0- <1	8.0
<i>Bouteloua gracilis</i>	<0.1	<0.01	0- <1	4.0
<i>Bromus tectorum</i>	2.1	12.70	< 1- 15	100.0
<i>Carex</i> spp.	<0.1	<0.01	0- <1	4.0
<i>Chaenactis douglasii</i>	<0.1	0.24	0- 1	24.0
<i>Chenopodium album</i>	<0.1	0.24	0- 1	12.0
<i>Collinsia parviflora</i>	<0.1	<0.01	0- <1	4.0
<i>Crepis acuminata</i>	0.1	0.60	0- 1	8.0
<i>Cryptantha</i> spp.	0.1	0.60	0- 1	12.0
<i>Descurainia pinnata</i>	<0.1	<0.01	0- <1	12.0
<i>Erysimum asperum</i>	0.1	0.60	0- 1	32.0
<i>Gayophytum ramosissimum</i>	<0.1	<0.01	0- <1	4.0
<i>Gilia aggregata</i>	<0.1	<0.01	0- <1	4.0
<i>Haplopappus nuttallii</i>	<0.1	<0.01	0- <1	4.0
<i>Heterotheca villosa</i>	0.6	3.63	0- 3	40.0
<i>Koeleria gracilis</i>	0.7	4.23	0- 4	48.0
<i>Mentzelia dispersa</i>	<0.1	<0.01	0- <1	8.0
<i>Oryzopsis hymenoides</i>	2.4	14.51	0- 18	40.0
<i>Penstemon caespitosus</i>	0.2	1.21	0- 2	12.0
<i>Penstemon fremontii</i> ?	<0.1	<0.01	0- <1	4.0
<i>Phlox hoodii</i>	0.5	3.02	0- 5	36.0
<i>Phlox longifolia</i>	0.1	0.60	0- 1	32.0
<i>Physaria floribunda</i>	0.1	0.60	0- 1	28.0
<i>Poa fendleriana</i> ?	1.3	7.86	0- 10	28.0
<i>Polygonum sawatchense</i>	<0.1	<0.01	0- <1	16.0
<i>Salsola iberica</i>	<0.1	<0.01	0- <1	8.0
<i>Senecio</i> spp.	<0.1	<0.01	0- <1	4.0



Table ,A8.7.1-17 (contd.) Herb quadrat summaries for the Irrigation Study Plot.

Species	Mean Cover (%)	Relative Cover (%)	Range of Cover Values	Frequency (%)
<u>HERBACEOUS SPECIES (contd.)</u>				
<i>Sitanion longifolium</i>	0.8	4.84	0- 4	40.0
<i>Stipa comata</i>	0.1	0.60	0- 3	4.0
<i>Sphaeralcea coccinea</i>	0.6	3.63	0- 7	20.0
<i>Taraxacum officinale</i>	0.1	0.60	0- 3	16.0
Sub-Total	15.8			
<u>WOODY SPECIES</u>				
<i>Artemisia tridentata</i>	0.3	1.81	0- 5	52.0
<i>Chrysothamnus viscidiflorus</i>	< 0.1	0.24	0- 1	4.0
<i>Gutierrezia sarothrae</i>	0.2	1.21	0- 3	24.0
Sub-Total	0.5			
Total Shrub Layer Cover	9.8		0- 45	
Total Herb Cover	14.4		1- 26	
Total Woody in Herb Layer	0.6		0- 5	
Mosses	0.2		0- 3	
Crustose Lichens	0.4		0- 3	
Litter	84.2		46-100	
Bare Soil	12.5		0- 36	
Rock	3.1		0- 25	
	<u>Mean ± S.E.</u>		<u>Range</u>	
No. of Herb Species/m <sup>2</sup>	8.16 ± 0.65		2-16	
Total No. Species/m <sup>2</sup>	8.96 ± 0.72		2-17	



Table A8.7.1-18 Frequency summaries for herb layer species in the Irrigation Area Study Plot, 1980-1981. Based on data from 25 permanently located 1.0 square meter quadrats.

Species	Percent 1980	Frequency 1981
<b>HERBACEOUS SPECIES</b>		
<i>Agoseris glauca</i>	16	32
<i>Agropyron dasystachyum</i>		16
<i>Agropyron desertorum</i>		20
<i>Agropyron smithii</i>	56	48
<i>Agropyron trachycaulum</i>	28	32
<i>Antennaria parvifolia</i>		4
<i>Antennaria rosea</i>	28	36
<i>Arabis holboellii</i>	12	4
<i>Aster fendleri</i>	12	8
<i>Aster glaucodes</i>	4	
<i>Astragalus ceramicus</i>		8
<i>Bouteloua gracilis</i>		4
<i>Bromus tectorum</i>	96	100
<i>Carex rossii</i>	4	
<i>Carex</i> sp.		4
<i>Chaenactis douglasii</i>	16	24
<i>Chenopodium album</i>	24	12
<i>Collinsia parviflora</i>	20	4
<i>Crepis acuminata</i>		8
<i>Cryptantha</i> sp.	4	12
<i>Descurainia pinnata</i>	8	12
<i>Erigeron pumilus</i>	8	
<i>Erysimum asperum</i>		32
<i>Gayophytum ramosissimum</i>	44	4
<i>Haplopappus nuttallii</i>		4
<i>Heterotheca villosa</i>	36	40
<i>Ipomopsis aggregata</i>	4	4
<i>Koeleria gracilis</i>	44	48
<i>Lappula redowskii</i>	4	
<i>Mentzelia dispersa</i>		8
<i>Microsteris micrantha</i>	8	
<i>Oryzopsis hymenoides</i>	36	40
<i>Penstemon caespitosus</i>	16	12
<i>Penstemon fremontii</i>	4	4
<i>Phlox hoodii</i>	48	36
<i>Phlox longifolia</i>	28	32
<i>Physaria floribunda</i>	20	28
<i>Poa fendleriana</i>	40	28
<i>Polygonum sawatchense</i>	36	16
<i>Salsola iberica</i>		8



Table A8.7.1-18. (contd.) Frequency summaries for herb layer species in the Irrigation Area Study Plot.

Species	Percent 1980	Frequency 1981
<i>Senecio</i> sp.		4
<i>Sitanion longifolium</i>	48	40
<i>Sphaeralcea coccinea</i>	16	20
<i>Stipa comata</i>	12	4
<i>Taraxacum officinale</i>	12	16
<i>Townsendia sericea</i>	12	
Unknown Mustard	4	
 <u>WOODY SPECIES</u>		
<i>Artemisia tridentata</i>	44	52
<i>Chrysothamnus viscidiflorus</i>	8	4
<i>Gutierrezia sarothrae</i>		24



Table A8.7.1-19 Mean cover and species diversity summaries for herbaceous quadrat studies at the irrigation intensive study plot.

	Mean Cover	
	1980	1981
Herb Cover	10.0	14.4
Woody Cover	0.3	0.6
Mosses	0.1	0.2
Crustose Lichen	0.5	0.4
Litter	80.0	84.2
Bare Soil	15.7	12.5
Rock	3.8	3.1
Mean No. of Herb Species per m <sup>2</sup>	8.1	8.2
Mean Total No. Of Species per m <sup>2</sup>	8.6	9.0



Table A8.7.1-20 Mean cover, relative cover, frequency, and density for shrub species in the Irrigation intensive study plot. 1981 data. Height Class I = 0.25m-0.75m; Class II = 0.76-1.50m; Class III = 1.51-2.25m; Class IV = > 2.25m. Values based on data from 20 10mx4m line strip transects.

	Height Class	Mean Cover (%)	Relative Cover (%)	Frequency (%)	Density (No. of Individuals/ha)
<i>Amelanchier</i> spp.	Total	<0.1	<0.01	5.0	13
	I				13
<i>Artemisia tridentata</i>	Total	2.8	19.86	90.0	1,288
	I				738
	II				538
	III				13
<i>Chrysothamnus nauseosus</i>	Total	< 0.1	< 0.01	35.0	125
	I				88
	II				38
<i>Chrysothamnus viscidiflorus</i>	Total	0.7	4.96	70.0	563
	I				550
	II				13
<i>Juniperus osteosperma</i>	Total	2.3	16.31	80.0	500
	I				113
	II				250
	III				113
	IV				25
<i>Juniperus scopulorum</i>	Total	<0.1	< 0.01	10.0	38
	I				25
	II				13



Table A8.7.1-20 (contd.) Mean cover, relative cover, frequency, and density for shrub species in the Irrigation intensive study plot.

	Height Class	Mean Cover (%)	Relative Cover (%)	Frequency (%)	Density (No. of Individuals/ha)
<i>Opuntia polyacantha</i>	Total I	< 0.1	< 0.01	30.0	163
<i>Pinus edulis</i>	Total	0.8	5.67	70.0	325
	I				125
	II				125
	III				75
<i>Purshia tridentata</i>	Total	0.9	6.38	20.0	263
	I				250
	II				13
<i>Ribes</i> spp.	Total	< 0.1	< 0.01	5.0	25
	I				
	II				25
<i>Symphoricarpos oreophilus</i>	Total	6.6	46.81	35.0	463
	I				263
	II				200
TOTAL		14.1			3,766



Table A8.7.2-1 Oven dry weights (grams/m<sup>2</sup>) for range cages and adjacent open areas in the pinyon-juniper woodland community type. 1981

Quadrat Number	<i>Agropyron smithii</i>	<i>Oryzopsis hymenoides</i>	<i>Bromus tectorum</i>	Perennial Grasses	Perennial Forbs	Annual Forbs	Half Shrubs	Total Biomass
46	-	-	1.75	0.63	-	-	-	2.38
47	-	-	-	4.53	0.88	-	-	5.41
48	-	1.64	-	0.90	-	-	-	2.54
49	-	0.16	-	1.41	0.21	-	-	1.78
50	-	-	-	1.98	2.03	-	-	4.01
51	1.41	-	-	2.12	5.15	-	-	8.68
52	4.34	-	-	3.30	1.44	-	8.55	17.63
53	-	1.80	-	5.60	0.57	-	-	7.97
54	-	1.53	0.01	2.22	0.50	-	-	4.26
55	3.70	-	0.06	2.83	0.11	0.03	-	6.73
56	0.20	-	0.02	5.28	0.74	-	-	6.24
57	0.58	-	-	8.32	1.67	-	-	10.57
58	-	-	-	4.96	13.07	-	-	18.03
59	6.38	-	-	4.59	0.84	-	-	11.81
60	-	-	-	8.24	0.95	-	-	9.19
<hr/>								
46	-	-	2.05	-	-	0.06	-	2.11
47	-	-	-	4.23	0.24	0.16	-	4.63
48	-	1.50	-	-	0.13	0.08	-	1.71
49	-	1.51	-	1.53	0.07	-	-	3.11
50	-	-	-	0.71	0.02	-	-	0.73
51	0.23	-	-	1.57	3.14	-	-	4.94
52	2.02	-	-	0.98	-	-	-	3.00
53	-	0.58	0.20	5.07	0.97	-	-	6.82
54	-	9.45	-	1.00	0.19	0.01	-	10.65
55	5.70	-	0.49	2.52	0.11	0.07	-	8.89
56	1.38	-	-	-	1.05	-	-	2.43
57	0.54	-	-	3.55	0.98	-	-	5.07
58	-	-	-	2.96	14.74	-	1.00	18.70
59	2.43	0.88	-	0.89	0.06	0.02	-	4.28
60	-	1.53	0.03	10.84	-	-	-	12.40



Table A8.7.2-2

Mean production (grams/m<sup>2</sup>) + the standard error of the mean (S.E.), frequency, and range of observed values for clipped plots in the pinyon-juniper woodland community type. 1981 Data

	Mean + S.E.	Sample Size	Frequency (%)	Range of Values
<u>OPEN AREAS</u>				
<i>Agropyron smithii</i>	0.82 ± 0.41	15	40	0-5.70
<i>Bromus tectorum</i>	0.18 ± 0.14	15	27	0-2.05
<i>Oryzopsis hymenoides</i>	1.03 ± 0.62	15	40	0-9.45
Perennial Grasses	2.39 ± 0.73	15	80	0-10.84
Perennial Forbs	1.45 ± 0.97	15	80	0-14.74
Annual Forbs	0.03 ± 0.01	15	40	0-0.16
Half Shrubs	0.07 ± 0.07	15	7	0-1.00
Total Biomass	5.96 ± 1.26	15		0.73-18.70
<u>FENCED PLOTS</u>				
<i>Agropyron smithii</i>	1.11 ± 0.52	15	40	0-6.38
<i>Bromus tectorum</i>	0.12 ± 0.11	15	27	0-1.75
<i>Oryzopsis hymenoides</i>	0.34 ± 0.18	15	27	0-1.80
Perennial Grasses	3.79 ± 0.63	15	100	0.63-8.32
Perennial Forbs	1.88 ± 0.86	15	87	0-13.07
Annual Forbs	0.002 ± 0.002	15	7	0-0.03
Half Shrubs	0.57 ± 0.57	15	7	0-8.55
Total Biomass	7.81 ± 1.30	15		1.78-18.03



Table A8.7.2-3

Oven dry weights (grams/m<sup>2</sup>) for range cages and adjacent open areas in the chained pinyon-juniper rangeland community type. 1981

Quadrat Number	<i>Agropyron smithii</i>	<i>Dryzopsis hymenoides</i>	<i>Bromus tectorum</i>	Perennial Grasses	Perennial Forbs	Annual Forbs	Half Shrubs	Total Biomass
61	8.28	-	0.02	15.20	0.50	-	-	24.00
62	-	28.81	2.06	54.01	-	0.01	-	84.89
63	4.95	4.10	0.08	5.03	-	-	-	14.16
64	10.00	-	-	17.11	5.85	-	-	32.96
65	-	-	0.02	65.72	0.71	0.03	-	66.48
66	45.06	-	0.09	7.05	14.26	0.01	-	66.47
67	15.09	-	0.11	30.97	27.31	0.37	-	73.85
68	-	42.08	0.03	7.19	8.49	-	-	57.79
69	8.34	-	0.41	7.52	3.15	0.22	-	19.64
70	-	0.81	0.51	5.95	8.80	-	-	16.07
71	2.74	2.05	-	24.16	2.73	0.02	-	31.70
72	2.35	-	-	45.23	-	-	-	47.58
73	6.82	-	-	34.82	3.69	0.09	-	45.42
74	15.79	-	9.94	3.10	7.34	2.06	-	38.23
75	8.62	-	1.99	18.27	2.83	-	3.56	35.27
61	1.25	-	0.03	11.08	0.58	0.02	-	12.96
62	-	0.90	-	10.24	0.62	-	-	11.76
63	2.11	-	.04	-	0.57	-	-	2.72
64	6.12	-	-	7.26	5.98	-	-	19.36
65	0.68	-	0.06	9.31	0.02	0.02	-	10.09
66	4.09	-	0.14	9.88	11.91	0.04	-	26.06
67	5.39	-	-	4.18	0.84	-	-	10.41
68	-	5.94	-	5.78	1.58	-	-	13.30
69	12.33	-	0.30	1.49	4.03	1.14	1.58	20.87
70	-	-	0.84	3.35	6.95	-	-	11.14
71	0.60	0.98	-	5.85	0.46	-	-	7.89
72	2.24	-	-	9.26	3.63	0.06	-	15.19
73	3.21	-	4.23	26.72	8.00	0.02	-	42.18
74	10.25	1.32	0.34	1.95	8.40	0.20	-	22.46
75	3.95	-	0.12	2.96	17.92	-	-	24.95



Table A8.7.2-4 Mean production (grams/m<sup>2</sup>) ± the standard error of the mean (S.E.), frequency, and range of observed values for clipped plots in the chained rangeland community type. 1981 Data

	Mean + S.E.	Sample Size	Frequency (%)	Range of Values
<u>OPEN AREAS</u>				
<i>Agropyron smithii</i>	3.48 ± 0.97	15	80	0-12.33
<i>Bromus tectorum</i>	0.46 ± 0.28	15	60	0-4.23
<i>Oryzopsis hymenoides</i>	0.61 ± 0.40	15	27	0-5.94
Perennial Grasses	7.29 ± 1.66	15	93	0-11.08
Perennial Forbs	4.90 ± 1.31	15	100	0.02-17.92
Annual Forbs	0.24 ± 0.10	15	47	0-1.14
Half Shrubs	0.11 ± 0.11	15	7	0-1.58
Total Biomass	16.76 ± 2.49	15		2.72-42.18
<u>FENCED PLOTS</u>				
<i>Agropyron smithii</i>	8.54 ± 2.94	15	73	0-45.06
<i>Bromus tectorum</i>	1.02 ± 0.66	15	73	0-9.94
<i>Oryzopsis hymenoides</i>	5.19 ± 3.25	15	33	0-42.08
Perennial Grasses	22.76 ± 5.05	15	100	3.10-65.72
Perennial Forbs	5.71 ± 1.87	15	80	0-27.31
Annual Forbs	0.19 ± 0.14	15	53	0-2.81
Half Shrubs	0.28 ± 0.28	15	7	0-3.56
Total Biomass	43.63 ± 5.70	15		16.07-84.89



Table A8.7.2-5

Oven dry weights (grams/m<sup>2</sup>) for range cages and adjacent open areas in the upland sagebrush community type. 1981

Quadrat Number	<i>Agropyron smithii</i>	<i>Oryzopsis hymenoides</i>	<i>Bromus tectorum</i>	Perennial Grasses	Perennial Forbs	Annual Forbs	Half Shrubs	Total Biomass
76	3.70	-	-	12.98	9.43	-	-	26.11
77	17.16	-	-	14.70	6.53	-	-	38.39
78	6.23	-	-	15.83	16.00	0.19	-	38.25
79	10.96	-	-	29.33	7.20	0.09	-	47.58
80	7.51	-	-	18.44	15.08	-	-	41.03
81	11.41	-	0.07	26.24	5.46	-	-	43.18
82	1.54	-	-	14.18	0.87	-	-	16.59
83	12.11	-	-	14.25	12.38	-	3.44	42.18
84	2.54	-	-	19.70	12.77	-	-	35.01
85	0.15	-	-	20.12	8.82	-	-	29.09
86	2.49	-	0.03	29.24	20.01	-	-	51.77
87	13.92	-	-	-	4.11	-	7.30	25.33
88	11.52	1.52	-	20.31	21.18	-	5.80	60.33
89	4.09	-	0.04	20.61	6.58	0.02	0.43	31.77
90	8.24	-	-	18.48	13.97	-	-	40.69
<hr/>								
76	2.05	-	-	13.38	1.29	-	-	16.72
77	6.81	-	-	10.02	2.71	-	-	19.54
78	4.04	-	-	9.29	20.31	0.02	-	33.66
79	2.89	-	-	8.65	11.56	-	-	23.10
80	3.10	-	-	6.19	5.95	-	-	15.24
81	1.00	-	0.03	8.09	1.12	-	-	10.24
82	6.68	-	-	10.01	-	-	-	16.69
83	9.76	-	-	7.21	17.0	0.09	2.96	37.02
84	1.53	-	-	6.51	3.62	-	-	11.66
85	0.78	-	-	9.97	17.49	-	-	28.24
86	1.05	-	20.54	-	24.72	-	0.25	46.56
87	23.85	-	-	4.55	0.60	-	-	29.00
88	17.33	-	-	10.27	18.16	-	-	45.76
89	6.57	0.51	-	9.53	2.73	-	2.63	21.97
90	4.78	-	-	4.84	10.52	-	-	20.14



Table A8.7.2-6 Mean production (grams/m<sup>2</sup>) + the standard error of the mean (S.E.), frequency, and range of observed values for clipped plots in the upland sagebrush community type. 1981 Data

	Mean + S.E.	Sample Size	Frequency (%)	Range of Values
<u>OPEN AREAS</u>				
<i>Agropyron smithii</i>	6.15 ± 1.69	15	100	0.78-23.85
<i>Bromus tectorum</i>	1.37 ± 1.37	15	13	0-20.54
<i>Oryzopsis hymenoides</i>	0.03 ± 0.03	15	7	0-0.51
Perennial Grasses	7.90 ± 0.82	15	93	0-13.38
Perennial Forbs	9.19 ± 2.18	15	93	0-24.72
Annual Forbs	0.01 ± 0.01	15	13	0-0.09
Half Shrubs	0.39 ± 0.25	15	20	0-2.96
Total Biomass	25.04 ± 2.96	15		10.24-46.56
<u>FENCED PLOTS</u>				
<i>Agropyron smithii</i>	7.57 ± 1.32	15	100	0.15-13.92
<i>Bromus tectorum</i>	0.01 ± 0.01	15	20	0-0.07
<i>Oryzopsis hymenoides</i>	0.10 ± 0.10	15	7	0-1.52
Perennial Grasses	17.96 ± 1.76	15	93	0-29.33
Perennial Forbs	10.70 ± 1.51	15	100	0.87-21.18
Annual Forbs	0.02 ± 0.01	15	20	0-0.19
Half Shrubs	1.13 ± 0.62	15	27	0-7.30
Total Biomass	37.82 ± 2.87	15		16.59-60.33



Table A8.7.2-7 Oven dry weights (grams/m<sup>2</sup>) for range cages and adjacent open areas in the bottomland sagebrush community type. 1981

Quadrat Number	<i>Agropyron smithii</i>	<i>Oryzopsis hymenoides</i>	<i>Bromus tectorum</i>	Perennial Grasses	Perennial Forbs	Annual Forbs	Half Shrubs	Total Biomass
31	0.46	-	8.36	11.62	-	0.22	-	20.66
32	-	-	2.50	1.67	0.94	2.00	-	7.11
33	-	-	-	7.35	-	0.04	-	7.39
34	-	-	0.43	0.06	20.04	-	-	20.53
35	-	-	1.30	-	2.58	-	-	3.88
36	6.88	-	1.62	-	3.51	3.68	-	15.69
37	1.09	3.87	-	-	-	0.51	-	5.47
38	-	13.70	-	30.41	0.24	0.30	-	44.65
39	2.30	-	-	14.57	30.84	7.48	-	55.19
40	-	-	49.78	6.68	2.15	3.25	-	61.86
41	1.42	-	0.15	6.68	6.53	0.98	-	15.76
42	0.49	-	1.23	5.47	1.62	1.10	-	9.91
43	-	0.11	0.29	6.45	2.38	-	-	9.23
44	-	-	0.20	99.22	0.93	0.15	-	100.50
45	-	-	11.73	70.86	24.77	20.92	-	128.28
31	-	-	1.70	1.86	-	0.08	-	3.64
32	0.89	-	0.75	3.62	1.83	0.11	-	7.20
33	-	-	0.03	2.75	-	-	-	2.78
34	-	-	-	1.20	40.21	3.73	-	45.14
35	-	2.66	0.56	0.93	2.16	0.04	-	6.35
36	-	1.71	-	-	3.55	0.46	-	5.72
37	0.26	8.78	0.11	-	3.27	0.17	-	12.59
38	-	-	1.16	4.50	4.24	0.13	-	10.03
39	2.66	-	-	4.20	42.98	2.74	-	52.58
40	-	-	0.97	7.16	0.70	0.15	-	8.98
41	2.96	-	0.57	-	-	0.33	-	3.86
42	-	-	1.24	3.70	0.06	-	-	5.00
43	-	-	0.02	1.24	2.04	-	-	3.30
44	-	-	-	24.07	1.98	1.56	-	27.61
45	0.87	-	0.58	23.68	-	4.81	-	29.94



Table A8.7.2-8 Mean production (grams/m<sup>2</sup>) + the standard error of the mean (S.E.), frequency, and range of observed values for clipped plots in the bottomland sagebrush community type. 1981 Data

	Mean + S.E.	Sample Size	Frequency (%)	Range of Values
<u>OPEN AREAS</u>				
<i>Agropyron smithii</i>	0.51 ± 0.25	15	33	0-2.96
<i>Bromus tectorum</i>	0.51 ± 0.14	15	80	0-1.70
<i>Oryzopsis hymenoides</i>	0.88 ± 0.60	15	20	0-8.78
Perennial Grasses	5.26 ± 2.02	15	80	0-24.07
Perennial Forbs	9.37 ± 4.13	15	73	0-42.98
Annual Forbs	0.95 ± 0.40	15	80	0-4.81
Total Biomass	14.98 ± 4.16	15		2.78-52.58
<u>FENCED PLOTS</u>				
<i>Agropyron smithii</i>	0.84 ± 0.47	15	40	0-6.88
<i>Bromus tectorum</i>	5.17 ± 3.31	15	73	0-49.78
<i>Oryzopsis hymenoides</i>	1.18 ± 0.93	15	20	0-13.70
Perennial Grasses	21.75 ± 8.04	15	80	0-99.22
Perennial Forbs	6.44 ± 2.60	15	80	0-30.84
Annual Forbs	2.71 ± 1.40	15	80	0-20.92
Total Biomass	33.74 ± 9.76	15		3.88-128.28



Table A8.7.2-9

Fresh weight estimates (grams) for intensive study plot BJ21 (1-F), chained pinyon-juniper rangeland. July 1981

Quadrat Number	1 26	2 27	3 28	4 29	5 30	6 31	7 32	8 33	9 34	10 35	11 36	12 37	13 38	14 39	15 40	16 41	17 42	18 43	19 44	20 45	21 46	22 47	23 48	24 49	25 50		
<i>Agropyron smithii</i>					9							15			1					4	8						
<i>Bromus tectorum</i>		3		<1 <1	<1 <1			<1				2		5	2	<1		<1 <1	4		<1 <1	1	<1 4	<1	1	<1 <1	1
<i>Oryzopsis hymenoides</i>	4 8	17 18		6 15	16 1	3 3			7 23	3 20	9	13 3				15 6	48 9		19 14	9	8			27 18		4 2	19 17
Perennial Grasses	3 2	58 21	111 19	23 10	5 2	27 1	54 4	18 48	2 108	64 5	11 41	65 76	78 8	72 35	6 36	3 14	44 12	29 34	5 41	11 46	3 51	12 24	10 3	52 3	3 6		
Annual Grasses																											
Perennial Forbs		5								1	7	8		1		1	6	4			9	4	8		18	11	
Annual Forbs			2	1	5	2	<1				3	22								1	<1	14	4	1			
Half Shrubs					3 10						7										4						
Total Biomass	7 10	83 39	111 21	29 26	24 27	30 6	54 28	18 48	12 108	74 28	40 43	80 101	79 23	72 36	22 42	61 24	48 12	48 49	14 42	37 46	15 79	47 51	10 44	74 5	33 24		



Table A8.7.2-10

Fresh weight estimates (grams) for intensive study plot BJ22 (2-F), chained pinyon-juniper range-land. July 1981

Quadrat Number	1 26	2 27	3 28	4 29	5 30	6 31	7 32	8 33	9 34	10 35	11 36	12 37	13 38	14 39	15 40	16 41	17 42	18 43	19 44	20 45	21 46	22 47	23 48	24 49	25 50	
<i>Agropyron smithii</i>	22	22	1	2	3	3			3	23		4	25	15	10		10	22						19	3	4
<i>Bromus tectorum</i>	2	2	3	<1	28	7	28	<1	<1	1	1	14	22	1	1	1	1	1	5	1	1	5	1	<1	<1	<1
	26	8	1	2	<1	2	4	<1	<1	<1	<1	2	1	2	6	<1	2	11	18	1	<1	1	1	3	3	
<i>Oryzopsis hymenoides</i>				19		20	58		1	1			2	1	52										1	5
			13				15				14					3										
Perennial Grasses	13	27	41	1				11	1		1	23	14	17	28	3		16	91	24	2	6			7	
	2	10		11	2	27	9	28	17	21	11	22	2	88	1	5		8	9	22	20	21	15	52	5	
Annual Grasses																										
Perennial Forbs	14	1	10	11	1	6	4	3	11	3			9	16	4	2			1	4	103		39	7	3	
			18	2		12		15			11	12		6	39	29				38	1	1			6	
Annual Forbs	1	2	<1		4	<1	2	<1		<1	1	1	1	3	<1	<1	<1	1	<1	<1	<1	7	2		2	
		1	1		1	1	<1	<1		<1	1	1	1	1	<1	<1	<1	1	<1	<1	<1		5		1	
Half Shrubs																										
Total Biomass	51	32	55	31	36	33	111	14	16	28	2	38	48	38	85	16	23	17	97	29	106	18	61	13	12	
	29	41	33	17	3	45	28	43	19	22	37	40	29	112	57	38	2	20	28	67	21	23	25	59	20	



Table A8.7.2-11 Fresh weight estimates (grams) for intensive study plot BJ25 (5-F), pinyon-juniper woodland. July 1981

Quadrat Number	1 26	2 27	3 28	4 29	5 30	6 31	7 32	8 33	9 34	10 35	11 36	12 37	13 38	14 39	15 40	16 41	17 42	18 43	19 44	20 45	21 46	22 47	23 48	24 49	25 50		
<i>Agropyron smithii</i>				9	5	5	4		3	14			1						4	2			2		2		
<i>Bromus tectorum</i>	<1	2 <1	1				<1	2	<1			1	1						<1	1	<1	<1	<1		<1		
<i>Oryzopsis hymenoides</i>	6		21	2 4	52						5		7	7							4	58	14		6		
Perennial Grasses	37 2	4 2	3 7	10 10	10 1	5 8	12 6	19 11	25 10	8 64	6 25	68 1	18 5		16	5 2	10 4	23	11	10				1	2	12 48	4 41
Annual Grasses																											
Perennial Forbs	1		2 1		1 2	<1 1		<1 2	<1 <1	1			3 1					1 3		<1			1		5	7 1	
Annual Forbs		<1 <1				<1	1		<1	<1		1	<1		<1	<1	<1	<1	<1	<1	<1	<1	<1	<1	<1		
Half Shrubs																										2	
Total Biomass	44 2	6 14	27 8	11 14	68 3	10 10	13 12	21 11	28 10	23 65	11 26	70 2	29 6	7 16	5 9	10 9	24 29	11 22	14 24	7 123	58 31	15 36	2 19	12 57	4 42		

2A8-57



Table A8.7.2-12 Fresh weight estimates (grams) for intensive study plot BJ26 (6-F), pinyon-juniper woodland July 1981

Quadrat Number	1 26	2 27	3 28	4 29	5 30	6 31	7 32	8 33	9 34	10 35	11 36	12 37	13 38	14 39	15 40	16 41	17 42	18 43	19 44	20 45	21 46	22 47	23 48	24 49	25 50	
<i>Agropyron smithii</i>			2				2	4			2						2		2	2	1	1				
<i>Bromus tectorum</i>																	<1									
<i>Oryzopsis hymenoides</i>			8		2					19		16	1			4	4		2			6	11		4	2
Perennial Grasses	12 20	22 4		26 14	19 9	8 21	16 17	28 11	33 13	3 12	28 3	7 11	13 5	24 21	12 53	18 22	32 2	16 2	9 2	27 18	2 11	9 2	2 10	26 25	15 12	
Annual Grasses																										
Perennial Forbs	21 2	6	<1		3 7	3 1		1 2	1 <1	5		4 2		2	<1 <1	2 3	1 8	3 <1	<1	1			3 5	<1 2	3	2
Annual Forbs	<1		<1	<1	<1	<1	1		<1	<1	<1			<1	<1	<1	<1	<1				<1			<1	
Half Shrubs																			2							
Total Biomass	33 22	28 4	8 15	26 23	22 12	8 22	17 21	33 11	34 13	27 12	28 6	27 13	14 5	26 21	12 53	24 25	39 10	21 6	11 4	29 18	9 14	20 9	2 12	29 29	17 14	



Table A8.7.2-13 Oven dry weights (grams/m<sup>2</sup>) for intensive study plot 1-F. 1981

Quadrat Number	<i>Agropyron smithii</i>	<i>Bromus tectorum</i>	<i>Oryzopsis hymenoides</i>	Perennial Grasses	Perennial Forbs	Annual Forbs	Half Shrubs	Total Biomass
2	-	1.90	7.98	25.96	2.38	-	-	38.22
3	-	-	-	84.12	-	-	-	84.12
12	-	0.83	6.03	35.95	-	-	-	42.81
17	-	-	-	17.66	2.30	-	-	19.96
26	-	-	6.20	0.24	-	-	-	6.44
29	-	0.33	9.29	5.37	0.23	-	-	15.22
37	-	-	0.52	39.62	8.74	-	-	48.88
39	-	-	0.20	13.83	-	-	-	14.03
45	-	-	-	17.85	0.09	-	-	17.94
46	-	1.38	10.38	15.59	10.76	-	-	38.11

Oven dry weights (grams/m<sup>2</sup>) for Veg Plot 2. 1981

7	-	35.28	38.30	-	1.06	11.89	-	86.53
13	-	20.49	0.57	5.21	3.81	0.12	-	30.20
16	3.55	0.34	-	0.48	0.42	0.02	-	4.81
19	-	3.46	-	51.52	0.03	0.07	-	55.08
20	-	1.12	-	10.65	1.60	-	-	13.37
21	-	0.75	-	1.72	40.26	-	-	42.73
33	-	0.02	-	18.91	7.42	0.03	-	26.38
37	1.26	1.19	-	15.21	5.33	-	-	22.99
38	10.57	0.25	-	0.69	-	0.24	-	11.75
45	4.19	0.80	-	10.86	17.32	0.03	-	33.02



Table A8.7.2-14 Oven dry weights (grams/m<sup>2</sup>) for Veg Plot 5. 1981

Quadrat Number	<i>Agropyron smithii</i>	<i>Bromus tectorum</i>	<i>Oryzopsis hymenoides</i>	Perennial Grasses	Perennial Forbs	Annual Forbs	Half Shrubs	Total Biomass
5	2.61	-	22.70	2.53	0.36	-	-	28.20
13	0.14	0.02	2.79	8.27	0.54	0.07	-	11.83
15	-	-	-	1.39	-	0.04	-	1.43
27	-	0.03	7.02	0.09	0.06	0.02	-	7.22
28	-	-	-	4.32	0.13	-	-	4.45
32	0.81	-	-	3.93	0.27	-	-	5.01
40	-	0.02	4.25	0.08	-	0.02	-	4.37
43	-	-	11.61	-	-	-	-	11.61
45	-	-	-	99.55	-	0.02	-	99.57
49	-	0.02	-	30.85	4.87	-	0.59	36.33

Oven dry weights (grams/m<sup>2</sup>) for Veg Plot 6. 1981

5	-	-	-	8.19	1.69	0.03	-	9.91
9	-	-	-	16.16	0.09	0.02	-	16.27
12	-	-	8.53	4.70	1.83	-	-	15.06
16	-	-	2.18	6.96	0.45	0.06	-	9.65
20	0.23	-	-	11.01	0.56	-	-	11.80
25	-	-	0.57	5.00	-	-	-	5.57
26	-	-	-	6.99	1.38	-	-	8.37
31	-	-	-	11.73	1.14	0.10	-	12.97
44	0.90	-	-	1.49	-	-	-	2.39
49	-	-	3.41	12.43	-	-	-	15.84



Table A8.7.2-15 Regression Equations used for converting fresh weight estimates to oven dry weights in Plot BJ21 (Plot 1). 1981 Data

Species/ Species Group	Regression Equations	Correlation Coefficient
<i>Agropyron smithii</i>	$y = 0.32 x + 0.34$	0.83
<i>Bromus tectorum</i>	$y = 0.34 x + 0.34$	0.83
<i>Oryzopsis hymenoides</i>	$y = 0.56 x + 0.48$	0.83
Perennial Grasses	$y = 0.72 x - 10.12$	0.94
Perennial Forbs	$y = 0.48 x + 0.41$	0.90
Annual Forbs		
Half Shrubs		



Table A8.7.2-16 Regression equations used for converting fresh weight estimates to oven dry weights in Plot BJ22 (Plot 2). 1981 Data

Species/ Species Group	Regression Equations	Correlation Coefficient
<i>Agropyron smithii</i>	$y = 0.41 x + 33$	0.97
<i>Bromus tectorum</i>	$y = 1.16 x - 0.85$	0.99
<i>Oryopsis hymenoides</i>	$y = 0.67 x - 0.78$	1.00
Perennial Grasses	$y = 0.58 x - 0.50$	0.99
Perennial Forbs	$y = 0.40 x + 0.31$	0.99
Annual Forbs	$y = 0.57 x - 0.14$	0.99



Table A8.7.2-17 Regression equations used for converting fresh weight estimates to oven dry weights in Plot BJ25 (Plot 5-F). 1981 Data

Species/ Species Group	Regression Equations	Correlation Coefficient
<i>Agropyron smithii</i>	$y = 0.52 x - 0.57$	0.86
<i>Bromus tectorum</i>	$y = 1.00 x - 0.08$	1.00
<i>Oryzopsis hymenoides</i>	$y = 0.42 x + 1.40$	0.99
Perennial Grasses	$y = 0.81 x - 3.28$	0.99
Perennial Forbs	$y = 0.76 x - 0.85$	0.96
Annual Forbs	$y = 0.05 x + 0.02$	0.92



Table A8.7.2-18 Regression equations used for converting fresh weight estimates to oven dry weights in Plot BJ26 (Plot 6). 1981 Data

Species/ Species Group	Regression Equations	Correlation Coefficient
<i>Agropyron smithii</i>	$y = 0.67 x - 0.44$	1.00
<i>Bromus tectorum</i>		
<i>Oryzopsis hymenoides</i>	$y = 0.52 x + 0.26$	0.97
Perennial Grasses	$y = 0.45 x + 0.09$	0.93
Perennial Forbs	$y = 0.445 x + 0.13$	0.77
Annual Forbs	$y = 0.68 x - 0.03$	0.92



Table A8.7.2-19. Mean production  $\pm$  the standard error of the mean (S.E.), frequency, and range of observed values for quadrats in Plots 1 and 2, July 1981. Based on data derived from regression equations. Production values in grams/m<sup>2</sup>.

Species/ Species Group	Mean $\pm$ S.E.	Sample Size	Frequency (%)	Range of Values
<u>PLOT 1</u>				
<i>Agropyron smithii</i>	0.38 $\pm$ 0.17	50	12	0 - 6.41
<i>Bromus tectorum</i>	0.34 $\pm$ 0.07	50	50	0 - 2.04
<i>Oryzopsis hymenoides</i>	5.19 $\pm$ 0.85	50	68	0 - 27.36
Other Perennial Grasses	15.96 $\pm$ 7.07	50	100	0.08- 63.88
Perennial Forbs	1.56 $\pm$ 0.35	50	52	0 - 10.97
Annual Forbs	< 0.01 $\pm$ < 0.01	50	8	0 - 0.05
Half Shrubs	0.26 $\pm$ 0.14	50	8	0 - 5.21
Total	23.69 $\pm$ 2.17	50	100	3.21- 63.88
<u>PLOT 2</u>				
<i>Agropyron smithii</i>	1.75 $\pm$ 0.44	50	38	0 - 10.47
<i>Bromus tectorum</i>	4.47 $\pm$ 1.20	50	100	0.05- 31.63
<i>Oryzopsis hymenoides</i>	2.55 $\pm$ 1.07	50	28	0 - 38.08
Other Perennial Grasses	8.11 $\pm$ 1.58	50	82	0 - 52.28
Perennial Forbs	3.74 $\pm$ 0.97	50	66	0 - 41.51
Annual Forbs	0.65 $\pm$ 0.25	50	76	0 - 11.83
Total	21.27 $\pm$ 2.31	50	100	0.41- 83.45



Table - A8.7.2-20 Mean production  $\pm$  the standard error of the mean (S.E.), frequency, and range of observed values for quadrats in Plots 5 and 6, July 1981. Based on data derived from regression equations. Production values in grams/m<sup>2</sup>.

Species/ Species Group	Mean $\pm$ S.E.	Sample Size	Frequency (%)	Range of Values
<u>PLOT 5</u>				
<i>Agropyron smithii</i>	0.41 $\pm$ 0.17	50	22	0 - 6.71
<i>Bromus tectorum</i>	0.25 $\pm$ 0.07	50	50	0 - 1.92
<i>Oryzopsis hymenoides</i>	3.13 $\pm$ 0.81	50	38	0 -25.26
Other Perennial Grasses	6.53 $\pm$ 1.41	50	86	0 -55.44
Perennial Forbs	0.36 $\pm$ 0.09	50	42	0 - 3.28
Annual Forbs	0.02 $\pm$ < 0.01	50	46	0 - 0.07
Half Shrubs	0.02 $\pm$ 0.02	50	2	0 - 1.03
Total	10.72 $\pm$ 1.44	50	100	0.99-55.47
<u>PLOT 6</u>				
<i>Agropyron smithii</i>	0.20 $\pm$ 0.06	50	22	0 - 2.24
<i>Bromus tectorum</i>	0.01 $\pm$ < 0.01	50	2	0 - 0.02
<i>Oryzopsis hymenoides</i>	0.88 $\pm$ 0.30	50	24	0 -10.14
Other Perennial Grasses	6.75 $\pm$ 0.66	50	98	0 -23.94
Perennial Forbs	0.94 $\pm$ 0.22	50	66	0 - 9.58
Annual Forbs	0.03 $\pm$ 0.01	50	46	0 - 0.65
Half Shrubs	0.02 $\pm$ 0.02	50	2	0 - 1.03
Total	8.82 $\pm$ 0.67	50	100	1.17-24.16



Table A8.7.2-21 Fresh weight estimates (grams/0.10 meter) for irrigation/fertilizer study plots. September 1981.

Treatment Number	3a															3a														
Fertilizer Level (Lbs/Acre) N,P	100,100															100,100														
Year Fertilizer Applied	1980 only															1980 & 1981														
Sprinkler Time Set	18 hrs.															18 hrs.														
Quadrat Number	1	2	3	4	5	6	7	8	9	10	11	12	13	14	15	1	2	3	4	5	6	7	8	9	10	11	12	13	14	15
<i>Agropyron smithii</i>	32	23	11	9	20	19	34	16	25	18	15	9	26	22	17	33	20	34	19	29	34	28	16	27	38	42	31	17	32	8
<i>Oryzopsis hymenoides</i>	--	--	--	--	--	--	--	--	--	--	--	--	--	--	--	--	--	--	--	--	--	--	--	--	--	--	--	--	--	--
<i>Bromus tectorum</i>	--	--	--	--	--	--	--	--	--	--	--	--	--	--	--	--	--	--	--	--	--	--	--	--	--	--	<1	--	1	--
Perennial Grasses	7	8	3	2	2	1	4	8	5	15	6	1	5	6	5	12	7	4	5	8	11	1	10	7	4	1	2	4	4	15
Perennial Forbs	--	6	2	5	1	2	1	2	--	<1	1	5	4	<1	5	--	1	--	2	3	2	2	--	--	--	--	--	--	2	
Annual Forbs	<1	--	--	--	--	--	--	--	--	--	--	--	--	--	--	--	--	--	--	--	2	--	--	--	--	--	3	4	1	--
Half Shrubs	--	--	--	--	4	--	--	--	--	--	--	--	--	--	--	--	--	2	--	--	--	--	--	--	--	--	--	2	2	
TOTAL	39	37	16	16	27	22	39	26	30	33	22	15	35	28	27	45	28	40	26	40	49	31	26	34	42	43	36	25	38	27



Table A8.7.2-21 (con'd) Fresh weight estimates (grams/0.10 meter) for irrigation/fertilizer study plots. September 1981.

3b																3b															
Treatment Number	3b															3b															
Fertilizer Level (Lbs/Acre) N,P	100,100															100,100															
Year Fertilizer Applied	1980 only															1980 & 1981															
Sprinkler Time Set	12 hrs.															12 hrs.															
Quadrat Number	1	2	3	4	5	6	7	8	9	10	11	12	13	14	15	1	2	3	4	5	6	7	8	9	10	11	12	13	14	15	
<i>Agropyron smithii</i>	--	7	--	--	--	--	7	--	3	14	7	10	3	10	7	7	--	--	--	--	--	11	17	5	20	4	2	6	--	--	
<i>Oryzopsis hymenoides</i>	1	--	--	6	4	6	2	1	--	--	--	--	--	--	--	--	25	--	1	3	--	--	--	--	--	--	--	--	--	3	
<i>Bromus tectorum</i>	--	--	1	<1	1	<1	2	3	1	--	--	<1	--	<1	--	4	--	4	5	<1	4	--	<1	4	--	--	3	--	--	<1	
Perennial Grasses	2	12	11	2	6	3	4	8	12	--	--	--	8	5	7	2	14	4	9	9	6	10	--	15	7	15	11	7	11	4	
Perennial Forbs	16	--	--	--	2	3	--	10	2	1	1	--	--	3	<1	<1	3	<1	3	--	--	--	1	--	--	--	4	--	--	--	
Annual Forbs	--	<1	--	--	--	--	--	2	<1	--	--	--	5	--	--	--	<1	--	--	--	--	--	--	--	--	1	--	--	--	--	
Half Shrubs	8	--	--	--	--	--	--	--	--	--	3	--	--	--	--	--	--	--	--	--	--	--	--	--	--	--	--	--	--	--	
TOTAL	27	19	12	8	13	12	15	24	18	15	8	13	16	18	14	13	42	8	18	12	10	21	18	24	27	20	20	13	11	7	



Table A8.7.2-21 (contd) Fresh weight estimates (grams/0.10 meter) for irrigation/fertilizer study plots. September 1981.

Treatment Number	4a															4a														
Fertilizer Level (Lbs/Acre) N,P	200,100															200,100														
Year Fertilizer Applied	1980 & 1981															1980														
Sprinkler Time Set	18 hrs.															18 hrs.														
Quadrat Number	1	2	3	4	5	6	7	8	9	10	11	12	13	14	15	1	2	3	4	5	6	7	8	9	10	11	12	13	14	15
<i>Agropyron smithii</i>	58	31	33	27	25	10	35	30	52	19	18	10	23	22	28	17	15	18	13	10	18	17	12	6	6	7	15	28	11	39
<i>Oryzopsis hymenoides</i>	--	--	--	--	--	--	--	--	--	--	--	--	--	--	--	--	--	--	--	--	--	--	--	--	--	--	--	--	--	--
<i>Bromus tectorum</i>	--	--	--	--	--	--	--	--	--	--	--	--	--	--	--	--	--	--	--	--	--	--	--	--	--	--	--	--	--	--
Perennial Grasses	42	7	5	12	11	18	21	15	--	8	16	9	12	2	12	8	7	20	11	5	13	2	14	5	11	8	3	5	20	4
Perennial Forbs	--	3	--	2	4	10	3	--	--	2	--	--	--	3	--	--	1	1	<1	10	--	--	4	1	4	5	--	--	--	<1
Annual Forbs	--	--	--	--	--	--	--	--	--	<1	2	--	--	--	--	4	--	<1	--	--	--	7	--	--	--	2	--	1	--	1
Half Shrubs	--	--	--	--	--	--	--	--	--	--	--	10	--	--	8	--	--	--	--	--	--	--	--	--	--	--	--	--	--	--
TOTAL	100	41	38	41	40	38	59	45	52	29	36	29	35	27	48	29	23	39	24	25	31	26	30	12	21	22	18	33	31	44



Table A8.7.2-21 (contd) Fresh weight estimates (grams/0.10 meter) for irrigation/fertilizer study plots. September 1981.

Treatment Number	4b															4b														
Fertilizer Level (Lbs/Acre) N,P	200,100															200,100														
Year Fertilizer Applied	1980 only															1980 & 1981														
Sprinkler Time Set	12 hrs.															12 hrs.														
Quadrat Number	1	2	3	4	5	6	7	8	9	10	11	12	13	14	15	1	2	3	4	5	6	7	8	9	10	11	12	13	14	15
<i>Agropyron smithii</i>	24	--	14	8	--	4	4	--	10	11	31	3	3	10	5	12	3	28	8	21	--	--	10	10	--	12	--	--	--	16
<i>Oryzopsis hymenoides</i>	--	--	--	--	--	--	--	--	--	--	--	2	--	--	--	--	2	--	19	--	12	7	2	--	--	<1	5	--	16	8
<i>Bromus tectorum</i>	2	2	--	--	4	<1	2	--	--	<1	1	--	--	--	2	--	--	2	1	--	3	10	8	--	--	--	6	--	--	<1
Perennial Grasses	11	12	13	1	7	4	6	12	--	12	--	7	9	--	2	<1	12	3	--	10	--	--	4	6	10	9	2	27	--	3
Perennial Forbs	2	4	1	1	--	10	2	--	4	--	--	8	--	--	--	24	12	--	--	5	2	--	9	--	17	--	<1	18	--	--
Annual Forbs	--	--	--	--	--	--	--	3	--	--	<1	--	1	--	--	--	--	--	--	--	--	--	--	--	--	--	--	--	--	--
Half Shrubs	--	--	--	--	--	--	--	--	--	--	--	--	--	--	--	--	--	--	--	--	--	--	4	--	--	--	--	--	--	--
TOTAL	39	18	28	10	11	18	14	15	14	23	32	20	13	10	9	36	29	33	27	36	17	17	37	16	27	21	13	45	16	27



Table A8.7.2-22 Oven dry weights (grams/0.10m<sup>2</sup>) for herbaceous biomass in fertilizer and irrigation treatments for irrigation study plots. 1981 Data

Treatment Number	Year(s) Fertilized	Quadrat Number	<i>Agropyron smithii</i>	<i>Bromus tectorum</i>	<i>Oryzopsis hymenoides</i>	Perennial Grasses	Perennial Forbs	Annual Forbs	Half Shrubs	Total Biomass
1a	N/F	1	-	0.10	-	3.17	0.04	-	-	3.31
1a	N/F	3	3.38	-	-	-	-	-	-	3.38
1a	N/F	12	-	-	3.29	-	-	-	2.88	6.17
1b	N/F	1	2.05	-	-	-	0.21	-	0.98	3.24
1b	N/F	8	1.38	0.03	0.16	0.74	1.04	-	-	3.35
3a	1980	1	12.38	-	-	1.80	-	0.02	-	14.20
3a	1980	2	10.53	-	-	2.06	1.95	-	-	14.54
3a	1980	12	2.91	-	-	0.13	1.34	-	-	4.38
3b	1980	1	-	-	0.26	0.31	4.71	-	1.65	6.93
3b	1980	4	-	0.21	2.01	0.95	-	-	-	3.17
3b	1980	11	2.66	-	-	-	0.06	-	-	2.72
4a	1980	1	4.70	-	-	3.12	-	0.79	-	8.61
4a	1980	5	2.36	-	-	1.83	2.21	-	-	6.40
4a	1980	8	4.40	-	-	4.95	1.70	-	-	11.05
4a	1980	15	12.10	-	-	0.55	0.03	0.37	-	13.05
4b	1980	1	5.09	0.06	-	2.69	0.27	-	-	8.11
4b	1980	4	2.31	-	-	0.03	0.06	-	-	2.40
4b	1980	9	2.89	-	-	-	0.85	-	-	3.74
3a	1980-81	1	13.56	-	-	3.79	-	-	-	17.35
3a	1980-81	4	7.26	-	-	1.28	0.96	-	-	9.50
3a	1980-81	12	10.88	0.14	-	0.82	-	0.66	-	12.50
3b	1980-81	1	1.61	0.83	-	0.37	0.03	-	-	2.84
3b	1980-81	2	-	-	8.48	4.62	1.15	0.02	-	14.27
3b	1980-81	15	-	0.04	1.40	1.11	-	-	-	2.55
4a	1980-81	1	13.57	-	-	8.48	-	-	-	22.05
4a	1980-81	2	11.84	-	-	1.84	0.84	-	-	14.52
4a	1980-81	4	10.20	-	-	4.21	0.52	-	-	14.93
4a	1980-81	12	-	-	-	-	-	-	1.94	1.94
4b	1980-81	1	4.97	-	-	0.03	4.91	-	-	9.91
4b	1980-81	5	9.86	-	-	3.22	1.94	-	-	15.02
4b	1980-81	12	-	1.64	2.23	1.00	0.05	-	-	4.92



Table A8.7.2-23 Regression Equations for converting fresh weight estimates to oven dry weights in the irrigation/fertilization study plots 3a, 3b, 4a, and 4b which were fertilized in 1980 and 1981. 1981 Data

Species/ Species Group	Regression Equations	Correlation Coefficient
<i>Agropyron smithii</i>	$y = 0.23 x + 3.33$	0.84
<i>Bromus tectorum</i>	$y = 0.33 x - 0.02$	0.95
<i>Oryzopsis hymenoides</i>	$y = 0.33 x + 0.21$	0.99
Perennial Grasses	$y = 0.21 x + 0.62$	0.96
Perennial Forbs	$y = 0.20 x + 0.34$	0.98
Annual Forbs	$y = 0.22 x - 0.002$	1.00
Half Shrubs *	$y = 0.59 x - 2.69$	0.94

\* Insufficient data, used regression equations calculated from study plots fertilized in 1980 only.



Table A8.7.2-24 Regression Equations for converting fresh weight estimates to oven dry weights in the irrigation/fertilization study plots 3a, 3b, 4a, and 4b which were fertilized in 1980 only, and study plot 1a and 1b which were not fertilized.

Species/ Species Group	Regression Equations	Correlation Coefficient
<i>Agropyron smithii</i>	$y = 0.35 x - 0.45$	0.93
<i>Bromus tectorum</i> *	$y = 0.33 x - 0.02$	0.95
<i>Oryzopsis hymenoides</i>	$y = 0.34 x - 0.12$	0.99
Perennial Grasses	$y = 0.28 x + 0.07$	0.92
Perennial Forbs	$y = 0.29 x - 0.13$	0.97
Annual Forbs	$y = 0.18 x + 0.08$	0.97
Half Shrubs	$y = 0.59 x - 2.69$	0.94

\* Insufficient data, used regression equations calculated from study plots fertilized in 1980 and 1981.



Table A8.7.2-25 Mean production  $\pm$  the standard error of the mean (S.E.), frequency, and range of observed values for quadrats in the irrigation/fertilization study plots 1a, 1b, 3a, 3b, 4a, and 4b. Based on data derived from regression equations. Production values in grams/m<sup>2</sup>

Species/ Species Group	Mean $\pm$ S.E.	Sample Size	Frequency (%)	Range of Values
<b>UNFERTILIZED</b>				
<u>Site 1a</u>				
<i>Agropyron smithii</i>	20.70 $\pm$ 6.14	15	53.3	0 - 76.00
<i>Bromus tectorum</i>	1.29 $\pm$ 0.68	15	46.7	0 - 9.70
<i>Oryzopsis hymenoides</i>	3.24 $\pm$ 2.36	15	13.3	0 - 32.80
Perennial Grasses	15.96 $\pm$ 4.73	15	66.7	0 - 62.30
Perennial Forbs	1.92 $\pm$ 1.05	15	40.0	0 - 13.20
Annual Forbs	0.53 $\pm$ 0.53	15	6.7	0 - 8.00
Half Shrubs	2.15 $\pm$ 1.69	15	13.3	0 - 24.80
Total Biomass	45.79 $\pm$ 4.03	15	100.0	23.20- 76.00
<u>Site 1b</u>				
<i>Agropyron smithii</i>	8.47 $\pm$ 3.86	15	40.0	0 - 51.50
<i>Bromus tectorum</i>	2.18 $\pm$ 1.33	15	40.0	0 - 16.30
<i>Oryzopsis hymenoides</i>	7.64 $\pm$ 3.21	15	53.3	0 - 39.60
Perennial Grasses	17.50 $\pm$ 3.75	15	73.3	0 - 45.50
Perennial Forbs	5.51 $\pm$ 1.80	15	66.7	0 - 24.80
Annual Forbs	0.07 $\pm$ 0.07	15	6.7	0 - 0.98
Half Shrubs	1.07 $\pm$ 1.07	15	6.7	0 - 16.10
Total Biomass	42.44 $\pm$ 2.99	15	100.0	27.80 - 65.50



Table A8.7.2-25 (contd.) Mean production  $\pm$  the standard error of the mean (S.E.), frequency, and range of observed values.

Species/ Species Group	Mean $\pm$ S.E.	Sample Size	Frequency (%)	Range of Values
<b>FERTILIZED 1980</b>				
<u>Site 3a</u>				
<i>Agropyron smithii</i>	64.57 $\pm$ 6.79	15	100.0	27.00-114.50
Perennial Grasses	15.23 $\pm$ 2.58	15	100.0	3.50- 42.70
Perennial Forbs	5.63 $\pm$ 1.51	15	86.7	0 - 16.10
Annual Forbs	0.07 $\pm$ 0.07	15	6.7	0 - 0.98
Total Biomass	85.50 $\pm$ 7.28	15	100.0	43.70-128.80
<u>Site 3b</u>				
<i>Agropyron smithii</i>	13.17 $\pm$ 3.72	15	53.3	0 - 44.50
<i>Bromus tectorum</i>	1.72 $\pm$ 0.75	15	60.0	0 - 9.70
<i>Oryzopsis hymenoides</i>	4.05 $\pm$ 1.81	15	40.0	0 - 19.20
Perennial Grasses	15.49 $\pm$ 3.12	15	80.0	0 - 34.30
Perennial Forbs	6.66 $\pm$ 3.30	15	60.0	0 - 45.10
Annual Forbs	1.08 $\pm$ 0.69	15	26.7	0 - 9.80
Total Biomass	42.17 $\pm$ 3.14	15	100.0	21.60- 67.10
<u>Site 4a</u>				
<i>Agropyron smithii</i>	49.63 $\pm$ 7.82	15	100.0	16.50-132.00
Perennial Grasses	26.09 $\pm$ 4.12	15	100.0	6.30- 56.70
Perennial Forbs	4.43 $\pm$ 2.03	15	60.0	0 - 27.70
Annual Forbs	2.13 $\pm$ 1.00	15	40.0	0 - 13.40
Total Biomass	82.28 $\pm$ 7.24	15	100.0	32.80-146.60



Table A8.7.2-25 (contd.) Mean production  $\pm$  the standard error of the mean (S.E.), frequency, and range of observed values.

Species/ Species Group	Mean $\pm$ S.E.	Sample Size	Frequency (%)	Range of Values
<u>Site 4b</u>				
<i>Agropyron smithii</i>	26.03 $\pm$ 7.85	15	80.0	0 - 104.00
<i>Bromus tectorum</i>	2.79 $\pm$ 1.04	15	53.3	0 - 13.00
<i>Oryzopsis hymenoides</i>	0.37 $\pm$ 0.37	15	6.7	0 - 5.60
Perennial Grasses	18.48 $\pm$ 3.63	15	80.0	0 - 37.10
Perennial Forbs	5.49 $\pm$ 2.24	15	53.3	0 - 27.70
Annual Forbs	0.65 $\pm$ 0.44	15	20.0	0 - 6.20
Total Biomass	53.81 $\pm$ 7.58	15	100.0	25.70- 121.90
FERTILIZED 1980 and 1981				
<u>Site 3a</u>				
<i>Agropyron smithii</i>	95.86 $\pm$ 5.54	15	100.0	51.70- 129.90
<i>Bromus tectorum</i>	0.21 $\pm$ 0.21	15	13.3	0 - 3.10
Perennial Grasses	19.50 $\pm$ 2.27	15	100.0	8.30- 37.70
Perennial Forbs	2.96 $\pm$ 0.99	15	40.0	0 - 9.40
Annual Forbs	1.47 $\pm$ 0.73	15	26.7	0 - 8.78
Half Shrubs	1.48 $\pm$ 0.79	15	20.0	0 - 7.40
Total Biomass	121.48 $\pm$ 4.65	15	100.0	95.80- 152.60



Table A8.7.2-25 (contd.) Mean production  $\pm$  the standard error of the mean (S.E.), frequency, and range of observed values for quadrats.

Species/ Species Group	Mean $\pm$ S.E.	Sample Size	Frequency (%)	Range of Values
<u>Site 3b</u>				
<i>Agropyron smithii</i>	28.80 $\pm$ 7.69	15	53.3	0 - 79.30
<i>Bromus tectorum</i>	5.22 $\pm$ 1.73	15	60.0	0 - 16.30
<i>Oryzopsis hymenoides</i>	7.60 $\pm$ 5.61	15	26.7	0 - 84.60
Perennial Grasses	23.15 $\pm$ 2.72	15	93.3	0 - 37.70
Perennial Forbs	2.85 $\pm$ 1.07	15	40.0	0 - 11.40
Annual Forbs	0.16 $\pm$ 0.15	15	13.3	0 - 2.18
Total Biomass	67.78 $\pm$ 8.07	15	100.0	26.70-129.80
<u>Site 4a</u>				
<i>Agropyron smithii</i>	97.85 $\pm$ 7.88	15	100.0	56.30-166.70
Perennial Grasses	32.39 $\pm$ 5.54	15	93.3	0 - 94.40
Perennial Forbs	5.19 $\pm$ 1.76	15	46.7	0 - 23.40
Annual Forbs	0.31 $\pm$ 0.29	15	13.3	0 - 4.38
Half Shrubs	2.85 $\pm$ 1.95	15	13.3	0 - 23.40
Total Biomass	138.59 $\pm$ 10.09	15	100.0	81.40-261.10
<u>Site 4b</u>				
<i>Agropyron smithii</i>	38.38 $\pm$ 9.02	15	60.0	0 - 97.70
<i>Bromus tectorum</i>	6.53 $\pm$ 2.80	15	46.7	0 - 32.80
<i>Oryzopsis hymenoides</i>	16.90 $\pm$ 5.61	15	60.0	0 - 64.80
Perennial Grasses	16.60 $\pm$ 4.34	15	73.3	0 - 62.90
Perennial Forbs	13.43 $\pm$ 4.55	15	53.3	0 - 51.40
Half Shrubs	0.76 $\pm$ 0.76	15	6.7	0 - 11.40
Total Biomass	92.60 $\pm$ 7.61	15	100.0	52.20-138.60



Table A8.7.2-26 Oven dry weights (grams/m<sup>2</sup>) for range cage and adjacent open areas in the irrigated chained rangeland community type. 1981

	Quadrat Number	<i>Agropyron smithii</i>	<i>Oryzopsis hymenoides</i>	<i>Bromus tectorum</i>	Perennial Grasses	Perennial Forbs	Annual Forbs	Half Shrubs	Total Biomass
FENCED	1	90.26	54.93	8.24	11.88	0.01	0.03	14.95	180.30
	2	266.12	0.53	-	-	0.02	.07	-	266.74
	3	-	26.16	0.14	63.80	26.05	-	3.18	119.33
	4	38.07	24.38	0.21	15.69	15.14	0.48	-	93.97
	5	-	21.57	0.41	84.43	48.76	-	-	155.17
	6	-	9.94	0.05	75.73	12.33	-	5.73	103.78
	7	-	6.52	0.16	37.94	2.66	-	-	47.28
	8	7.66	-	-	66.33	22.38	-	-	96.37
	9	53.75	-	32.21	73.65	1.57	5.05	-	166.23
	10	57.71	0.24	-	6.93	8.80	-	-	73.68
	11	-	-	-	61.95	1.93	-	-	63.88
	12	-	30.83	1.27	9.48	18.02	-	-	59.60
	13	21.79	-	11.41	163.83	10.91	-	-	207.94
	14	42.97	18.28	5.17	42.88	0.21	-	-	109.51
	15	97.32	-	-	38.50	22.22	-	-	158.04
OPEN	1	65.57	0.23	0.93	10.16	0.26	2.21	-	79.36
	2	77.91	-	-	4.79	10.69	-	-	93.39
	3	-	5.96	4.30	34.92	14.85	-	-	60.03
	4	-	9.10	-	61.22	1.53	-	-	71.85
	5	-	-	.03	40.19	5.45	-	3.04	48.71
	6	-	-	-	31.17	7.64	-	-	38.81
	7	-	5.63	0.13	9.07	3.29	-	-	18.12
	8	-	4.48	0.68	29.21	9.29	-	2.05	45.71
	9	39.62	7.84	2.91	5.87	13.20	9.55	-	78.99
	10	40.20	-	-	0.44	14.62	-	1.86	57.12
	11	-	12.43	0.68	5.11	1.87	-	-	20.09
	12	-	31.78	1.29	0.89	11.74	-	-	45.70
	13	0.51	1.82	1.05	52.39	0.40	-	-	56.17
	14	28.79	-	0.29	7.80	44.27	-	-	81.15
	15	22.26	-	-	17.25	9.55	-	-	49.06



Table A8.7.2-27 Mean Production (gram/m<sup>2</sup>) + the standard of error of the mean (S.E.), frequency, and range of observed values for clipped plots in the Irrigated Area. 1981 Data

Species	Mean $\pm$ S.E.	Sample Size	Frequency (%)	Range of Values
<u>OPEN AREAS</u>				
<i>Agropyron smithii</i>	18.32 $\pm$ 6.85	15	47	0-77.91
<i>Bromus tectorum</i>	0.82 $\pm$ 0.32	15	67	0-4.30
<i>Oryzopsis hymenoides</i>	8.81 $\pm$ 2.42	15	60	0-31.78
Perennial Grasses	20.70 $\pm$ 5.05	15	100	0.44-61.22
Perennial Forbs	9.91 $\pm$ 2.79	15	100	0.26-44.27
Annual Forbs	0.78 $\pm$ 0.64	15	13	0-9.55
Half Shrubs	0.46 $\pm$ 0.26	15	20	0-3.04
Total Biomass	56.28 $\pm$ 5.65	15	100	18.12-93.39
<u>FENCED PLOTS</u>				
<i>Agropyron smithii</i>	45.04 $\pm$ 18.00	15	60	0-266.12
<i>Bromus tectorum</i>	3.95 $\pm$ 2.21	15	67	0-32.21
<i>Oryzopsis hymenoides</i>	12.89 $\pm$ 4.19	15	67	0-54.93
Perennial Grasses	50.20 $\pm$ 10.89	15	93	0-163.83
Perennial Forbs	12.73 $\pm$ 3.47	15	100	0.01-48.76
Annual Forbs	0.38 $\pm$ 0.34	15	27	0-5.05
Half Shrubs	1.59 $\pm$ 1.04	15	20	0-14.95
Total Biomass	126.79 $\pm$ 15.87	15	100	47.28-266.74



Table A8.9.1-1

Herb quadrat summaries for Top Soil Stockpiles, which were seeded in the fall of 1978. Based on data from 25 permanently located quadrats. 1981. Values in percents  $\pm$  values are equal to the standard error of the mean.

Species	Mean Cover	Relative Cover	Range of Cover Values	Frequency
<u>Herbaceous species</u>				
<i>Agropyron cristatum</i>	1.40	6.34	0-4	60
<i>Agropyron intermedium</i>	1.64	7.43	0-8	48
<i>Agropyron intermedium</i> var. <i>trichophorum</i>	2.52	11.42	0-11	56
<i>Agropyron smithii</i>	4.56	20.66	0-15	88
<i>Agropyron spicatum</i> var. <i>inerme</i>	0.61	2.76	0-4	52
<i>Bromus inermis</i>	0.04	0.18	0-1	8
<i>Bromus tectorum</i>	<0.01	<0.01	0-<1	8
<i>Oryzopsis hymenoides</i>	0.08	0.36	0-1	8
<i>Hedysarum boreale</i>	4.28	19.39	0-23	52
<i>Medicago sativa</i>	<0.01	<0.01	0-<1	8
<i>Melilotus</i> spp.	4.22	19.19	0-27	52
<i>Linum lewisii</i>	<0.01	<0.01	0-<1	8
<i>Penstemon</i> spp.	<0.01	<0.01	0-<1	4
<i>Salsoa iberica</i>	0.99	4.49	0-4	92
<i>Kochia iranica</i>	1.47	6.66	0-25	60
<i>Chenopodium album</i>	<0.01	<0.01	0-<1	8
<i>Teraxacum officinale</i>	0.04	0.18	0-1	4
<i>Erigeron</i> spp.	<0.01	<0.01	0-<1	4
<i>Astragalus ceramicus</i>	<0.01	<0.01	0-<1	8
<i>Lactuca serriola</i>	0.13	0.58	0-2	20
<u>Woody species</u>				
<i>Cercocarpus montanus</i>	<0.01	<0.01	0-<1	8
<i>Purshia tridentata</i>	0.09	0.41	0-1	20
Total Herb Cover	21.98		8-38	
Total Woody Cover in Herb Layer	0.10		0-1	



Table A8.9.1-1  
(Cont'd)

Herb quadrat summaries for Top Soil Stockpiles, which were seeded in the fall of 1978. Based on data from 25 permanently located quadrats. 1981. Values in percents  $\pm$  values are equal to the standard error of the mean.

Species	Mean Cover	Relative Cover	Range of Cover Values	Frequency
Litter	79.00		52-97	
Bare Soil	18.28		0-46	
Rock	2.72		0-10	

	Mean $\pm$ S.E.	Range
No. of Herb Species/m <sup>2</sup>	6.40 $\pm$ 0.31	5-9
Total Species/m <sup>2</sup>	6.68 $\pm$ 0.35	5-10



Table A8.9.1-2 Fresh weight estimates (grams) for Top Soil Piles. 1981

Quadrat Number	1	2	3	4	5	6	7	8	9	10	11	12	13	14	15	16	17	18	19	20	21	22	23	24	25
<i>Agropyron</i> <i>spp.</i>	28	95	162	45	98	201	119	37	109	65	184	244	120	123	21	238	311	44	161	39	232	240	258	3	48
Perennial Grasses	--	--	--	2	--	1	---	--	2	--	---	---	---	---	---	---	---	---	---	---	---	---	---	---	---
<i>Bromus</i> <i>tectorum</i>	--	--	--	--	--	---	---	---	---	---	---	---	---	2	---	---	---	---	---	---	---	---	---	---	---
<i>Oryzopsis</i> <i>hymenoides</i>	--	--	--	4	6	1	---	---	---	---	---	---	---	---	---	---	---	---	---	---	---	---	---	---	---
Perennial Forbs	65	87	21	18	3	4	72	70	92	--	8	28	62	6	--	14	5	--	---	--	32	2	4	---	290
Annual Forbs	19	7	8	5	93	<1	1	10	9	8	4	7	1	9	33	1	---	6	2	8	9	<1	1	22	4
Biennial Forbs ( <i>Melilotus</i> spp.)	1	--	--	2	--	---	---	---	---	---	---	---	---	215	203	4	2	192	8	185	91	4	68	294	52



Table A8.9.1-3 Oven dry weight (grams/m<sup>2</sup>) for Top Soil Piles. 1981

Species	Quadrat Numbers									
	1	3	5	7	9	14	17	18	21	25
<i>Protophyton</i> spp.	21.65	90.91	47.61	50.15	58.94	77.07	166.06	25.61	129.85	33.14
<i>Myzopsis ymenoides</i>	-----	-----	2.43	-----	-----	-----	-----	-----	-----	-----
<i>Comus sectorum</i>	-----	-----	-----	-----	-----	-----	-----	-----	-----	-----
Perennial grasses	-----	-----	-----	-----	1.06	-----	-----	-----	-----	-----
Perennial forbs	16.96	5.75	0.70	19.17	38.25	1.38	2.73	-----	13.24	145.54
Perennial forbs	-----	-----	-----	-----	-----	70.45	0.27	116.09	38.57	19.49
Annual forbs	8.47	1.83	26.43	0.02	3.74	4.01	-----	1.40	3.92	2.61
Total Biomass	47.08	98.49	77.17	69.34	101.99	152.91	169.06	143.10	143.09	200.78
TOTAL BIOMASS										



Table A8.9.1-4 Regression equations for converting fresh weight estimates to oven dry weights on Top Soil Storage Piles. 1981.

Species/Species Group	Regression Equation	Correlation Coefficient
<i>Agropyron spp.</i>	$y = 0.53 x + 2.93$	0.99
<i>Oryzopsis hymenoides</i>	$y = 0.34 x + 0.37$	1.00
<i>Bromus tectorum</i>	*	
Perennial grasses	$y = 0.34 x + 0.37$	1.00
Perennial forbs	$y = 0.50 x - 5.71$	0.99
Biennial forbs ( <i>Melilotus spp.</i> )	$y = 0.45 x - 0.60$	0.90
Annual forbs	$y = 0.28 x + 0.97$	0.99

\* No oven dry weight data.



Table A8.9.1-5 Mean production  $\pm$  the standard error of the mean (S. E.), frequency, and range of observed values for quadrats on Topsoil Storage Piles, 1981. Based of data derived<sub>2</sub> from regression equations. Production values in grams/m<sup>2</sup>.

Species/Species Group	Mean $\pm$ S. E.	Sample Size	Frequency (%)	Range of Values
<u>Agropyron</u> spp.	71.30 $\pm$ 9.43	25	100	4.52-167.76
Perennial grasses	0.11 $\pm$ 0.06	25	12	0-1.05
<u>Bromus tectorum</u>	0.06 $\pm$ 0.06	25	4	0-1.50
<u>Oryzopsis hymenoides</u>	0.17 $\pm$ 0.10	25	12	0-2.41
Perennial forbs	14.90 $\pm$ 5.80	25	72	0-27.01
Biennial forbs ( <u>Melilotus</u> spp.)	23.47 $\pm$ 7.87	25	56	0-131.70
Annual forbs	3.75 $\pm$ 1.07	25	96	0-27.01
TOTAL	113.76 $\pm$ 8.63	25		34.84-192.55



Table A8.9.1-6 Summarized Data for Reference Areas (Plots 1-F and 2-F).  
For calculation of diversity in herbaceous layer.

Species	ABSOLUTE COVER		RELATIVE COVER		Pi		Weighted Pi	-Pi log Pi	% Contribution to Diversity
	Plot 1-F	Plot 2-F	Plot 1-F	Plot 2-F	1-F	2-F			
<i>Agropyron dasystachyum</i>	3.3	0.8	23.08	10.55	.0080	.2802	0.1444	0.1214	12.4*
<i>Agropyron desertorum</i>	<0.1	4.2	0.28	55.41	.0429	.5541	0.2980	0.1567	16.0*
<i>Agropyron smithii</i>	0.4	0.1	2.80	1.32	.0010	.0132	0.0071	0.0153	1.6
<i>Antennaria parvifolia</i>	<0.1	-	0.28	-	.0028	-	0.0014	0.0040	0.4
<i>Antennaria rosea</i>	0.2	0.2	1.40	2.64	.0140	.0264	0.0202	0.0342	3.5
<i>Bouteloua gracilis</i>	-	0.1	-	1.32	-	.0132	0.0066	0.0144	1.5
<i>Bromus tectorum</i>	0.9	0.3	6.29	3.69	.0629	.0369	0.0499	0.0650	6.6*
<i>Carex rossii</i>	0.4	-	2.80	-	.0280	-	0.0140	0.0260	2.6
<i>Castilleja chromosa</i>	<0.1	-	0.28	-	.0024	-	0.0014	0.0040	0.4
<i>Chaenactis douglassii</i>	-	0.1	-	1.32	-	.0132	0.0066	0.0144	1.5
<i>Festuca idahoensis</i>	-	0.1	-	1.32	-	.0132	0.0066	0.0144	1.5
<i>Haplopappus nuttallii</i>	0.2	-	1.40	-	.0140	-	0.0070	0.0150	1.5
<i>Koeleria gracilis</i>	0.7	0.3	4.90	3.96	.0490	.0396	0.0443	0.0600	6.1*
<i>Lomatium foeniculacoum</i>	-	0.1	-	1.32	-	.0132	0.0066	0.0144	1.5
<i>Oryzopsis hymenoides</i>	4.5	0.4	31.47	5.28	.3147	.0528	0.1837	0.1352	13.8*
<i>Phlox hoodii</i>	1.0	-	6.99	-	.0699	-	0.0349	0.0509	5.2*
<i>Poa pratensis</i>	-	0.2	-	2.64	-	.0264	0.0132	0.0248	2.5
<i>Poa spp</i>	<0.1	0.1	<0.01	1.32	-	.0132	0.0066	0.0144	1.5
<i>Poa fendleriana</i>	2.0	-	13.99	-	.1399	-	0.0699	0.0808	8.2*
<i>Sitanion longifolium</i>	0.2	0.2	1.40	2.64	.0140	.0264	0.0202	0.0342	3.5
<i>Sphaeralcea coccinea</i>	-	0.1	-	1.32	-	.0132	0.0066	0.0144	1.5
<i>Stipa comata</i>	-	0.1	-	1.32	-	.0132	0.0066	0.0144	1.5
<i>Artemisia tridentata</i>	0.2	<0.1	1.40	0.53	.0140	.0053	0.0096	0.0194	2.0
<i>Chrysothamnus nauseosus</i>	<0.1	<0.1	0.28	0.53	.0028	.0053	0.0040	0.0096	0.9
<i>Gutierrezia sarothrae</i>	0.1	-	0.70	-	.0070	-	0.0035	0.0086	0.8
<i>Pinus edulis</i>	-	0.1	-	1.32	-	.0136	0.0066	0.0144	1.5
							1.0	0.9803(H)	100.0

\* Seven species account for approximately 70% of the diversity index.



Table A8.9.1-7 Summarized Data for Revegetated Areas (Topsoil Piles), for Calculation of Diversity in Herbaceous Layer.

Species	Absolute Cover	Relative Cover	Pi	Weighted Pi	-Pi log Pi	% Contribution to Diversity
<i>Agropyron cristatum</i>	1.40	6.34	.0634	.0634	0.0759	8.36*
<i>Agropyron intermedium</i>	1.64	7.43	.0743	.0743	0.0839	9.24*
<i>Agropyron intermedium vac trichophorum</i>	2.52	11.42	.1142	.1142	0.1076	11.85*
<i>Agropyron smithii</i>	4.56	20.66	.2066	.2066	0.1415	15.59*
<i>Agropyron spicatum var inerme</i>	0.61	2.76	.0276	.0276	0.0430	4.74
<i>Bromus inremis</i>	0.04	0.18	.0018	.0018	0.0049	0.54
<i>Oryzopsis hymenoides</i>	0.08	0.36	.0036	.0036	0.0088	0.97
<i>Hedysarum boreale</i>	4.28	19.39	.1939	.1939	0.1381	15.21*
<i>Melilotus spp</i>	4.22	19.19	.1919	.1919	0.1376	15.16*
<i>Salsoa iberica</i>	0.99	4.49	.0449	.0449	0.0605	6.66*
<i>Kochia iranica</i>	1.47	6.66	.0666	.0666	0.0784	8.63*
<i>Teraxacum officinale</i>	0.04	0.18	.0018	.0018	0.0049	0.54
<i>Lactuca serriola</i>	0.13	0.58	.0058	.0058	0.0130	1.43
<i>Purshia tridentata</i>	0.09	0.41	.0041	.0041	0.0098	1.08
TOTAL:				1.000	.9079(H)	100.00

\* Eight species account for approximately 90% of the diversity index.



Table A8.11.1-1 Fresh weight estimates (grams) for Oldland Gulch Brush Beating. 1981

Quadrat Number	1	2	3	4	5	6	7	8	9	10	11	12	13	14	15	16	17	18	19	20	21	22	23	24	25
<i>Agropyron cristatum</i>	45	26	54	14	71	4	--	4	15	2	--	--	15	37	--	--	--	--	--	--	--	--	2	--	--
<i>Agropyron smithii</i>	84	--	36	76	10	112	80	23	78	67	88	9	68	52	14	30	16	18	54	52	98	54	104	--	19
<i>Agropyron trachycaulum</i>	--	--	--	--	--	--	--	--	18	--	--	21	34	--	--	--	--	63	--	--	--	--	--	--	--
<i>Bromus tectorum</i>	10	10	2	3	14	3	--	<1	<1	1	<1	2	--	2	<1	--	<1	1	<1	3	1	2	1	<1	15
<i>Elymus cinereus</i>	--	--	--	--	--	--	--	--	--	--	--	--	--	--	--	--	--	--	--	--	--	48	--	--	--
<i>Elymus junceus</i>	--	32	19	--	13	--	--	--	--	--	--	--	--	5	--	--	--	--	--	--	--	--	--	--	--
<i>Oryzopsis hymenoides</i>	--	63	29	--	21	--	--	40	9	38	--	54	--	8	--	14	--	--	--	4	9	60	--	--	8
<i>Poa spp.</i>	--	--	--	--	--	--	--	--	--	--	--	--	--	--	--	--	--	4	--	--	--	--	--	--	--
<i>Sitanion hystrix</i>	--	--	--	--	--	--	--	--	--	--	--	--	--	2	--	--	--	--	--	--	--	--	--	5	--
<i>Sporobolus cryptandrus</i>	--	--	--	--	--	--	--	--	--	--	--	--	--	--	--	--	--	--	--	--	--	2	--	--	--
<i>Stipa comata</i>	--	--	--	--	--	18	73	--	--	--	--	--	--	--	94	62	30	--	31	--	--	55	2	88	13
<i>Chenopodium spp.</i>	8	22	2	7	1	--	--	--	--	2	--	<1	<1	--	--	--	3	<1	--	4	<1	5	1	1	2
<i>Descurainia pinnata</i>	--	--	--	--	--	--	--	<1	1	1	--	3	--	--	--	<1	--	--	<1	<1	<1	<1	<1	<1	--
<i>Lappula redowski</i>	--	--	<1	2	--	<1	--	--	--	--	--	--	--	--	--	--	--	--	<1	--	--	--	--	--	--
<i>Lepidium montanum</i>	--	--	--	--	6	--	--	--	6	--	--	--	--	--	--	--	--	--	--	--	--	--	8	--	--
<i>Penstemon spp.</i>	--	--	--	--	--	--	--	28	--	--	--	--	--	--	--	--	--	--	--	--	--	--	--	--	--
Unknown mustard	42	--	--	--	12	--	--	--	--	--	--	--	--	--	--	--	3	--	--	--	--	--	--	--	--

2A8-88



Table A8.11.1-2 Fresh weight estimates (grams) for Gardenhire Gulch Brush Beating. 1981

Quadrat Number	1	2	3	4	5	6	7	8	9	10	11	12	13	14	15	16	17	18	19	20	21	22	23	24	25
<i>Agropyron Cristatum</i>	22	---	---	--	--	--	--	3	--	--	10	13	1	--	--	--	--	--	---	---	--	--	15	5	28
<i>Agropyron smithii</i>	15	---	103	60	4	9	93	--	9	--	11	---	48	73	64	--	75	13	---	62	7	32	51	20	10
<i>Agropyron trachycaulum</i>	--	---	---	11	6	--	--	--	67	--	--	---	--	--	--	--	--	65	---	--	--	--	--	--	--
<i>Bouteloua gracilis</i>	3	---	---	--	--	2	8	--	---	---	--	---	38	--	--	--	--	--	---	---	--	--	3	--	4
<i>Bromus inermis</i>	--	---	---	--	--	--	--	--	---	---	--	---	--	--	--	--	--	--	---	---	--	--	--	--	--
<i>Bromus tectorum</i>	16	---	2	1	2	1	2	48	1	21	13	113	7	5	3	29	2	1	42	2	33	21	3	11	20
<i>Elymus cinereus</i>	--	---	---	--	--	--	--	--	---	---	--	---	--	--	--	--	--	--	116	--	--	--	--	--	--
<i>Elymus junceus</i>	--	---	---	--	--	--	--	--	--	--	24	---	--	--	--	--	--	--	---	---	--	--	--	--	14
<i>Oryzopsis hymenoides</i>	34	15	---	8	--	--	--	10	9	--	14	---	--	--	11	--	--	--	14	--	16	2	12	45	9
<i>Sitanion hystrix</i>	8	---	---	--	--	--	--	--	---	---	--	---	--	--	--	--	--	--	---	---	5	--	--	--	--
<i>Sporobolus cryptandrus</i>	--	29	---	--	--	--	--	--	---	---	--	---	--	--	--	--	--	--	---	7	--	--	5	6	--
<i>Stipa comata</i>	21	104	---	75	68	84	--	--	---	---	--	---	--	--	--	--	--	--	---	---	--	--	--	--	--

2A8-89



Table A8.11.1-2(contd) Fresh weight estimates (grams) for Gardenhire Gulch Brush Beating. 1981

Quadrat Number	1	2	3	4	5	6	7	8	9	10	11	12	13	14	15	16	17	18	19	20	21	22	23	24	25
Unknown mustard	--	---	---	--	--	--	--	--	--	10	--	---	---	7	--	--	--	--	5	--	6	--	--	--	--
<i>Chenopodium</i> spp.	2	2	<1	--	--	<1	1	2	--	--	4	---	5	4	--	15	1	1	49	18	22	6	2	1	4
<i>Kochia</i> spp.	13	3	---	--	--	--	--	14	--	--	21	---	2	--	--	--	--	<1	14	1	--	--	--	--	--
<i>Euphorbia</i> spp.	--	---	---	--	--	--	---	---	---	---	---	---	---	---	---	2	--	--	---	---	1	--	--	--	--
<i>Lappula redowski</i>	--	---	---	--	--	--	--	--	--	--	--	---	---	--	<1	--	--	--	---	---	--	--	--	--	--
<i>Melilotus</i> spp.	--	---	---	--	--	--	--	6	--	--	--	---	1	--	--	--	--	--	---	---	--	--	--	--	1
<i>Salsola iberia</i>	52	3	<1	--	--	--	1	11	1	--	8	.8	2	<1	--	12	1	1	47	--	20	1	1	--	<1



Table A8.11.1-3 Fresh weight estimates (grams) for Control plots of Brush beating Area. 1981

Quadrat Number	1	2	3	4	5	6	7	8	9	10	11	12	13	14	15	16	17	18	19	20	21	22	23	24	25	
<i>Agropyron smithii</i>	52	--	24	1	31	--	--	8	--	--	21	--	24	18	9	44	34	5	39	23	20	35	22	--	62	
<i>Agrapyron trachycaulum</i>	--	--	10	--	--	--	--	--	--	--	--	--	10	--	--	--	--	--	--	8	--	--	--	--	--	
<i>Bouteloua gracilis</i>	--	14	--	--	--	4	--	--	2	5	11	8	2	--	--	--	--	--	2	--	--	--	--	--	4	
<i>Bromus tectorum</i>	--	2	2	<1	<1	1	1	--	<1	6	4	5	8	2	11	--	--	<1	--	--	--	--	--	<1	1	<1
<i>Oryzopsis hymenoides</i>	--	<1	--	4	--	--	--	--	2	40	--	22	--	13	--	--	--	--	--	--	18	33	--	7	11	
<i>Sitanion hystrix</i>	--	--	--	--	--	--	--	--	--	--	--	--	--	--	--	--	--	--	3	--	--	--	--	--	--	
<i>Sporobolus cryptandrus</i>	--	--	--	--	--	--	--	--	--	--	--	--	--	--	--	--	--	--	--	--	--	--	--	5	--	
<i>Stipa comata</i>	10	1	--	--	23	67	42	5	15	--	--	--	--	--	21	20	8	19	--	28	28	--	--	--	10	
<i>Artemesia ludoviciana</i>	--	--	--	--	--	--	--	--	--	--	--	--	--	--	--	--	--	--	--	--	--	2	--	--	--	
<i>Aster spp.</i>	--	--	--	--	--	6	--	--	--	--	--	--	--	--	--	--	--	--	--	--	1	--	--	--	--	
<i>Chenapodium spp.</i>	--	--	1	--	--	--	--	--	--	<1	--	--	--	8	4	--	--	<1	--	--	--	--	--	--	--	
<i>Descuriana pinnata</i>	--	--	<1	--	--	--	--	--	--	--	--	--	--	--	--	--	--	--	--	--	--	--	--	--	--	
<i>Lappula redowski</i>	--	--	<1	--	--	--	--	--	--	--	--	--	--	--	--	--	--	--	--	--	--	--	--	--	--	
<i>Lepidium montanum</i>	--	--	--	5	--	--	--	--	--	--	--	--	--	--	--	--	--	--	--	--	--	--	--	--	--	
<i>Penstemon spp.</i>	--	--	--	--	--	--	--	--	--	--	--	--	--	--	--	--	--	--	--	--	--	--	2	--	--	
<i>Sphaeralcea coccinea</i>	--	--	--	--	--	--	--	--	--	--	--	--	--	--	--	--	5	--	--	--	--	2	--	--	--	
Unknown mustard	--	--	--	--	--	--	--	--	--	--	--	--	--	--	--	2	--	--	--	--	2	3	--	--	--	



Table A8.11.1-4 Oven dry weight (grams/m<sup>2</sup>) for Oldland Gulch Brush Beating Area. 1981

Species	Quadrat Numbers						
	1	2	3	8	14	15	22
<i>Agropyron cristatum</i>	17.24	19.67	27.98	0.80	18.96	-----	-----
<i>Agropyron smithii</i>	48.82	-----	24.31	12.04	25.34	11.57	24.38
<i>Agropyron trachycaulum</i>	-----	-----	-----	-----	-----	-----	-----
<i>Bromus tectorum</i>	9.11	13.49	1.33	0.85	0.42	0.59	0.87
<i>Elymus cinereus</i>	-----	-----	-----	-----	-----	-----	28.31
<i>Elymus junceus</i>	-----	14.80	11.10	-----	1.02	-----	-----
<i>Oryzopsis hymenoides</i>	-----	35.75	12.80	27.77	2.35	-----	46.85
<i>Poa spp.</i>	-----	-----	-----	-----	-----	-----	-----
<i>Sitanion hystrix</i>	-----	-----	-----	-----	0.5	-----	-----
<i>Sporobolus cryptandrus</i>	-----	-----	-----	-----	-----	-----	-----
<i>Stipa comata</i>	-----	-----	-----	33.62	-----	67.42	35.30
<i>Chenopodium spp.</i>	1.08	8.48	0.33	-----	-----	-----	1.26
<i>Descurainia pinnata</i>	-----	-----	-----	0.04	-----	-----	0.10
<i>Lappula redowski</i>	-----	-----	0.11	-----	-----	-----	-----
<i>Lepidium montanum</i>	-----	-----	-----	-----	-----	-----	-----
<i>Penstemon spp.</i>	-----	-----	-----	9.12	-----	-----	-----
Unknown mustard	26.43	-----	-----	-----	-----	-----	-----
<b>TOTAL BIOMASS</b>	<b>99.68</b>	<b>92.19</b>	<b>77.96</b>	<b>89.24</b>	<b>48.59</b>	<b>79.58</b>	<b>137.07</b>



Table A8.11.1-5 Oven dry weight (grams/m<sup>2</sup>) for Gardenhire Gulch Brush Beating Area. 1981

Species	Quadrat Numbers						
	1	2	3	4	12	13	19
<i>Agropyron cristatum</i>	13.63	-----	-----	-----	8.60	0.21	-----
<i>Agropyron smithii</i>	9.45	-----	60.66	39.31	-----	44.11	-----
<i>Agropyron trachycaulum</i>	-----	-----	-----	3.49	-----	-----	-----
<i>Bouteloua gracilis</i>	1.84	-----	-----	-----	-----	30.66	-----
<i>Bromus inermis</i>	-----	-----	-----	-----	-----	-----	-----
<i>Bromus tectorum</i>	16.59	-----	1.09	0.96	100.02	11.64	61.98
<i>Elymus cinereus</i>	-----	-----	-----	-----	-----	-----	77.00
<i>Elymus junceus</i>	-----	-----	-----	-----	-----	-----	-----
<i>Oryzopsis hymenoides</i>	25.49	3.51	-----	7.06	-----	-----	8.27
<i>Sitanion hystrix</i>	6.18	-----	-----	-----	-----	-----	-----
<i>Sporobolus cryptandrus</i>	-----	7.07	-----	-----	-----	-----	-----
<i>Stipa comata</i>	10.66	58.87	-----	37.34	-----	-----	-----
<i>Chenopodium spp.</i>	0.44	0.41	0.02	-----	-----	2.05	15.07
<i>Kochia spp.</i>	4.50	0.72	-----	-----	-----	0.20	7.56
<i>Euphorbia spp.</i>	-----	-----	-----	-----	-----	-----	-----
<i>Lappula redowski</i>	-----	-----	-----	-----	-----	-----	-----
<i>Melilotus spp.</i>	-----	-----	-----	-----	-----	0.14	-----
<i>Salsoa iberica</i>	18.89	0.36	0.04	-----	1.64	0.46	10.37
Unknown mustard	-----	-----	-----	-----	-----	-----	1.56
TOTAL BIOMASS	107.67	70.94	61.81	88.16	110.26	89.47	181.81



Table A8.11.1-6 Oven dry weight (grams/m<sup>2</sup>) for Control plots of Brush Beating Area. 198

Species	Quadrat Numbers						
	1	2	7	10	13	16	22
<i>Agropyron smithii</i>	23.43	-----	-----	-----	12.71	37.40	17.98
<i>Agropyron trachycaulum</i>	-----	-----	-----	-----	5.37	-----	-----
<i>Bouteloua gracilis</i>	-----	10.00	-----	4.58	0.16	-----	-----
<i>Bromus tectorum</i>	-----	1.37	0.33	6.92	5.38	-----	-----
<i>Oryzopsis hymenoides</i>	-----	0.39	-----	30.61	-----	-----	19.95
<i>Sitanion hystrix</i>	-----	-----	-----	-----	-----	-----	-----
<i>Sporobolus cryptandrus</i>	-----	-----	-----	-----	-----	-----	-----
<i>Stipa comata</i>	3.47	0.41	19.46	-----	-----	10.80	-----
<i>Artemisia ludoviciana</i>	-----	-----	-----	-----	-----	-----	0.45
<i>Aster spp.</i>	-----	-----	-----	-----	-----	-----	-----
<i>Chenopodium spp.</i>	-----	-----	-----	-----	-----	-----	-----
<i>Descuriana pinnata</i>	-----	-----	-----	-----	-----	-----	-----
<i>Lappula redowski</i>	-----	-----	-----	-----	-----	-----	-----
<i>Lepidium montanum</i>	-----	-----	-----	-----	-----	-----	-----
<i>Penstemon spp.</i>	-----	-----	-----	-----	-----	-----	-----
<i>Sphaeralcea coccinea</i>	-----	-----	-----	-----	-----	-----	0.33
Unknown mustard	-----	-----	-----	-----	-----	0.66	1.38
<b>TOTAL BIOMASS</b>	26.90	12.17	19.79	42.11	23.62	48.86	40.09



Table A8.11.1-7 Regression equations for converting fresh weight estimates for Oldland Gulch Brush Beating Area. 1981.

Species	Regression Equation	Correlation Coefficient
<i>Agropyron cristatum</i>	$y = 0.46 x + 1.51$	0.90
<i>Agropyron smithii</i>	$y = 0.48 x + 3.04$	0.96
<i>Agropyron trachycaulum</i>	**	
<i>Bromus tectorum</i>	$y = 1.15 x - 0.51$	0.95
<i>Elymus junceus</i>	$y = 0.51 x - 0.60$	0.97
<i>Oryzopsis hymenoides</i>	$y = 0.74 x - 4.66$	0.95
<i>Poa</i> spp.	*	
<i>Sitanion hystrix</i>	**	
<i>Sporobolus cryptandrus</i>	**	
<i>Stipa comata</i>	$y = 0.84 x - 7.10$	0.87
<i>Chenopodium</i> spp.	$y = 0.42 x - 1.11$	0.98
<i>Descurainia pinnata</i>	***	
<i>Lappula redowski</i>	***	
<i>Lepidium montanum</i>	***	
Unknown mustard	***	

\* Insufficient data, used equation for *Bromus tectorum*.

\*\* Insufficient data, used equation for *Elymus junceus*.

\*\*\* Insufficient data, used equation for *Chenopodium* spp.



Table A8.11.1-8 Regression equations used for converting fresh weight estimates to oven dry weights for Gardenhire Gulch Brush Beating Area. 1981.

Species	Regression Equation	Correlation Coefficient
<i>Agropyron cristatum</i>	$y = 0.64 x - 0.23$	0.99
<i>Agropyron smithii</i>	$y = 0.55 x + 7.19$	0.94
<i>Agropyron trachycaulum</i>	*	
<i>Bouteloua gracilis</i>	$y = 0.82 x - 0.63$	1.00
<i>Bromus tectorum</i>	$y = 0.90 x + 4.86$	0.97
<i>Elymus junceus</i>	*	
<i>Oryzopsis hymenoides</i>	$y = 0.80 x - 3.12$	0.92
<i>Sitanion hystrix</i>	*	
<i>Sporobolus cryptandrus</i>	*	
<i>Stipa comata</i>	$y = 0.59 x - 2.37$	0.99
<i>Chenopodium spp.</i>	$y = 0.31 x - 0.08$	0.99
<i>Kochia spp.</i>	$y = 0.52 x - 0.89$	0.95
<i>Euphorbia spp.</i>	**	
<i>Melilotus spp.</i>	**	
<i>Salsoa iberica</i>	$y = 0.37 x + 0.30$	0.90
Unknown mustard	**	

\* Insufficient data, used equation for *Agropyron cristatum*.

\*\* Insufficient data, used equation for *Salsoa iberica*.



Table A8.11.1-9 Regression equations used for converting fresh weight estimates to oven dry weights for Brush Beating Control Area. 1981.

Species	Regression Equation	Correlation Coefficient
<i>Agropyron smithii</i>	$y = 0.58 x + 0.43$	0.66
<i>Agropyron trachycaulum</i>	*	
<i>Bouteloua gracilis</i>	$y = 0.77 x - 0.47$	0.98
<i>Bromus tectorum</i>	$y = 0.86 x - 0.15$	0.90
<i>Oryzopsis hymenoides</i>	$y = 0.71 x - 0.23$	0.98
<i>Sitanion hystrix</i>	*	
<i>Sporobolus cryptandrus</i>	*	
<i>Stipa comata</i>	$y = 0.48 x - 0.18$	0.99
<i>Aster spp.</i>	**	
<i>Chenopodium spp.</i>	**	
<i>Sphaeralcea coccinea</i>	**	
Unknown mustard	$y = 0.72 x - 0.78$	

\* Insufficient data, used equation for *Agropyron smithii*.

\*\* Insufficient data, used equation for Unknown mustard.



Table A8.11.1-10

Mean Production  $\pm$  the standard error of the mean (S. E.), frequency, and range of observed values for quadrats in Oldland Gulch Brush Beating Area, 1981. Based on data derived from regression equations. Production values in grams/m<sup>2</sup>.

Species	Mean $\pm$ S. E.	Sample Size	Frequency (%)	Range of Values
<i>Agropyron cristatum</i>	6.04 $\pm$ 1.90	25	48	0-34.17
<i>Agropyron smithii</i>	26.64 $\pm$ 3.40	25	92	0-56.80
<i>Agropyron trachycaulum</i>	2.68 $\pm$ 1.46	25	16	0-31.54
<i>Bromus tectorum</i>	3.20 $\pm$ 1.10	25	88	0-16.74
<i>Elymus junceus</i>	1.40 $\pm$ 0.75	25	16	0-15.72
<i>Elymus cinerius</i>	1.13 $\pm$ 1.13	25	4	0-28.31
<i>Oryzopsis hymenoides</i>	10.10 $\pm$ 3.00	25	52	0-41.96
<i>Poa</i> spp.	0.16 $\pm$ 0.16	25	4	0-4.09
<i>Sitanion hystrix</i>	0.09 $\pm$ 0.07	25	8	0-1.95
<i>Sporobolus cryptandrus</i>	0.01 $\pm$ 0.01	25	4	0-0.42
<i>Stipa comata</i>	13.50 $\pm$ 4.70	25	44	0-71.86
<i>henopodium</i> spp.	0.70 $\pm$ 0.30	25	64	0-8.13
<i>Sescurainia pinnata</i>	0.05 $\pm$ 0.02	25	40	0-0.42
<i>Lappula redowski</i>	0.03 $\pm$ 0.03	25	16	0-0.84
<i>Lepidium montanum</i>	0.20 $\pm$ 0.10	25	12	0-2.25
<i>Penstemon</i> spp.	0.36 $\pm$ 0.36	25	4	0-9.12
Unknown mustard	0.82 $\pm$ 0.61	25	12	0-16.53
TOTAL	63.07 $\pm$ 4.61	25		16.60-110.6



Table A8.11.1-11

Mean production  $\pm$  the standard error of the mean (S. E.), frequency, and range of observed values for quadrats in Gardenhire Gulch Brush Beating Area, 1981. Based on data derived from regression equations. Production values in grams/meter<sup>2</sup>.

Species	Mean $\pm$ S. E.	Sample Size	Frequency (%)	Range of Values
<i>Agropyron cristatum</i>	2.41 $\pm$ 0.97	25	32	0-17.69
<i>Agropyron smithii</i>	22.16 $\pm$ 3.88	25	76	0-63.84
<i>Agropyron trachycaulum</i>	2.07 $\pm$ 1.66	25	12	0-41.37
<i>Bouteloua gracilis</i>	1.75 $\pm$ 1.20	25	24	0-30.53
<i>Bromus tectorum</i>	19.02 $\pm$ 4.42	25	96	0-48.06
<i>Elymus cinerius</i>	3.08 $\pm$ 3.08	25	4	0-77.00
<i>Elymus junceus</i>	1.79 $\pm$ 1.05	25	8	0-15.13
<i>Oryzopsis hymenoides</i>	4.87 $\pm$ 1.60	25	52	0-32.88
<i>Sitanion hystrix</i>	0.31 $\pm$ 0.22	25	8	0-4.89
<i>Sporobolus cryptandrus</i>	1.17 $\pm$ 0.75	25	16	0-18.33
<i>Stipa comata</i>	7.83 $\pm$ 3.52	25	20	0-58.99
<i>Chenopodium spp.</i>	1.67 $\pm$ 0.71	25	76	0-6.74
<i>Kochia spp.</i>	1.20 $\pm$ 0.50	25	32	0-6.39
<i>Euphorbia spp.</i>	0.07 $\pm$ 0.05	25	8	0-1.04
<i>Lappula redowski</i>	0.01 $\pm$ 0.01	25	4	0-0.25
<i>Melilotus spp.</i>	0.15 $\pm$ 0.03	25	12	0-2.52
<i>Salsoa iberica</i>	2.71 $\pm$ 1.03	25	72	0-19.54
Unknown mustard	0.50 $\pm$ 0.20	25	12	0-4.00
TOTAL	68.73 $\pm$ 4.52			27.76-117.91



Table A8.11.1-12

Mean production  $\pm$  the standard error of the mean (S. E.), frequency, and range of observed values for quadrats in Control Area (for comparison to Brush Beating Areas), 1981. Based on data derived from regression equations. Production values in grams/m<sup>2</sup>.

Species	Mean $\pm$ S. E.	Sample Size	Frequency (%)	Range of Values
<i>Agropyron smithii</i>	11.26 $\pm$ 2.12	25	72	0-36.39
<i>Agropyron trachycaulum</i>	0.70 $\pm$ 0.40	25	12	0-6.23
<i>Bouteloua gracilis</i>	1.43 $\pm$ 0.50	25	36	0-10.31
<i>Bromus tectorum</i>	1.43 $\pm$ 0.49	25	68	0-9.31
<i>Oryzopsis hymenoides</i>	3.83 $\pm$ 1.50	25	40	0-28.17
<i>Sitanion hystrix</i>	0.08 $\pm$ 0.08	25	4	0-2.17
<i>Sporobolus cryptandrus</i>	0.13 $\pm$ 0.13	25	4	0-3.33
<i>Stipa comata</i>	5.60 $\pm$ 1.50	25	56	0-31.98
<i>Artemesia ludoviciana</i>	0.02 $\pm$ 0.02	25	4	0-0.45
<i>Aster</i> spp.	0.31 $\pm$ 0.22	25	8	0-4.32
<i>Chenapodium</i> spp.	0.37 $\pm$ 0.21	25	20	0-4.98
<i>Descuriana pinnata</i>	0.01 $\pm$ 0.01	25	4	0-0.25
<i>Lappula redowski</i>	0.01 $\pm$ 0.01	25	4	0-0.25
<i>Lepidium montanum</i>	0.11 $\pm$ 0.11	25	4	0-2.82
<i>Penstemon</i> spp.	0.03 $\pm$ 0.03	25	4	0-0.66
<i>Sphaeralcea coccinea</i>	0.14 $\pm$ 0.11	25	8	0-3.48
Unknown mustard	0.11 $\pm$ 0.06	25	12	0-1.38
TOTAL	25.41 $\pm$ 2.65	25		1.33-51.29



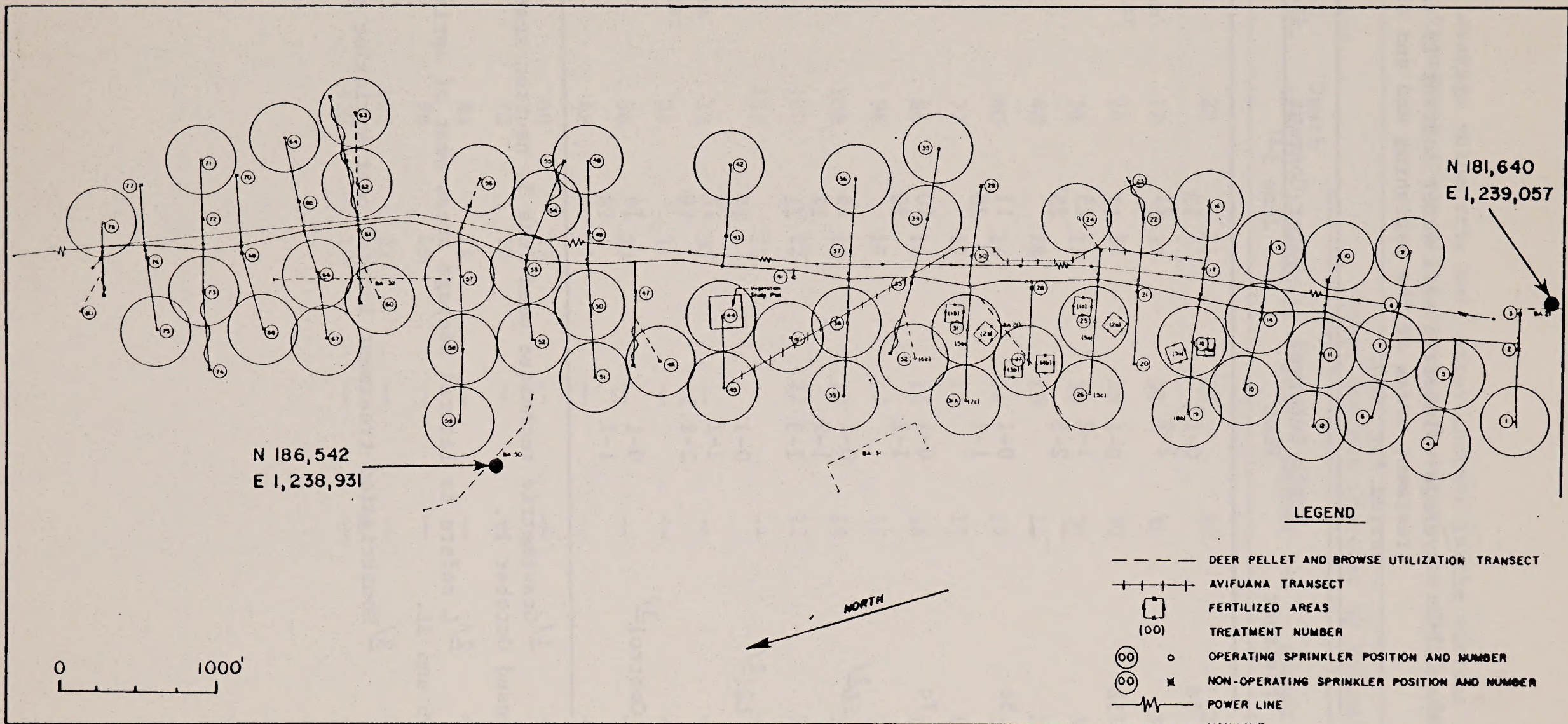


Figure A8.11.3-1 Map of C-b Tract irrigation system layout showing treatment locations.



Table A8.11.3-1a Average volumetric soil water content in the various treatment areas at the beginning and end of the irrigation period for 1980.

Treatment	Depth Interval Feet	Water Content (Percent by Volume)	
		June 5 <sup>1/</sup>	October 17
5a	0-1	13	30
	1-2	21	34
5b	0-1	17	30
	1-2	25	33
	2-3	25	--
5c	0-1	11	20
	1-2	20	19
7c	0-1	10	24
	1-2	20	25
L6 <sup>2/</sup>	0-1	16	17
	1-2	17	16
	2-3	21	--
L21 <sup>2/</sup>	0-1	15	15
	1-2	17	18
	2-2.5	19	--
Control <sup>3/</sup>	0-1	14	13
	1-2	18	12

<sup>1/</sup> Gravimetric technique used June 5, neutron scattering method used October 17.

<sup>2/</sup> L refers to lateral seepage areas west of sprinkler laterals 6 and 21.

<sup>3/</sup> Nonirrigated treatment located near sprinkler site 21.



Table A8.11.3-1b Average volumetric soil water content in the various treatment areas after irrigation during the 1981 season.

Treatment and Location of Access Tube	Depth (in.)	Water Content (Percent by Volume)			
		June 25-27	July	August 3-5	August 19-24
4a	25	21	25	22	24
4a 25' from sprinkler #18	12	33	31	31	32
	24	30	29	30	30
	36	27	30	30	30
	48	28	29	28	28
	60	24	24	24	25
	72	17	17	17	17
	84	14	14	14	14
	96	17	17	17	17
	108	19	19	19	19
	120	22	22	22	23
	132	21	--	--	--
4a 75' from sprinkler #18	12	30	--	--	--
	24	31	--	--	--
	36	23	--	--	--
	48	27	--	--	--
	60	27	--	--	--
	72	20	--	--	--
	84	14	--	--	--
	96	19	--	--	--
	108	22	--	--	--
	120	18	--	--	--



Table A8.11.3-1b Continued

Treatment and Location of Access Tube	Depth (in)	Water Content (Percent by Volume)			
		June 25-27	July	August 3-5	August 19-24
4a 100' from sprinkler #18	12	--	29	29	30
	24	--	29	31	27
	36	--	24	22	22
	48	--	27	19	27
	60	--	26	17	26
	72	--	20	17	20
	84	--	14	18	14
	96	--	16	23	16
	108	--	19	25	20
	120	--	22	17	22
4b	19	17	23	18	21
5a	18	--	34	37	--
5a 100' from sprinkler #25	12	--	27	29	--
	24	--	31	31	--
	36	--	22	22	--
	48	--	19	19	--
	60	--	17	17	--
	72	--	17	17	--
	84	--	18	18	--
	96	--	23	23	--
	108	--	24	25	--
	120	--	17	17	--
5b	20	--	31	32	34
5c	20	17	17	17	17
7c	17	17	17	17	19
L6	15	--	15	--	--
L21	18	--	16	--	--



Table A8.11.3-1c Location and volumetric soil water content at the beginning and end of the season for required water monitoring treatments during 1980.

Treatment and Replication	Depth Involved (feet)	Location #		Water Content	
		Bearing Clockwise From North (degrees)	Distance to Sprinkler (meters)	100 x cm water/cm soil June 5†	October 17††
4a1	0-1	245	22.9	16	16
	1-2			22	--
	2-3			21	25
	3-4			25	--
4a2	0-1	236.5	26.0	21	28
	1-2			19	30
4a3	0-1	236.5	30.0	11	27
	1-2			22	25
	2-3			23	--
	3-4			24	--
4a4	0-1	240.0	33.1	16	26
	1-2			24	20
4b1	0-1	190	42.0	15	21
	1-2			26	21
4b2	0-1	201	39.4	17	18
	1-2			23	16
4b3	0-1	202	38.0	18	19
	1-2			28	17
4b4	0-1	204	38.0	16	18
	1-2			21	16
5a1	0-1	41	10.6	15	34
	1-2			19	33
5a2	0-1	29	15.8	15	34
	1-2			20	39
5a3	0-1	12.5	24.1	10	31
	1-2			21	33
5a4	0-1	341	25.3	12	22
	1-2			25	30



Table A8.11.3-1c Continued

Treatment and Replication	Depth Involved (feet)	Location #		Water Content	
		Bearing Clockwise From North (degrees)	Distance to Sprinkler (meters)	100 x cm water/cm soil	June 5† October 17††
5b1	0-1	50	30	14	30
	1-2			32	34
	2-2.5			23	--
5b2	0-1	47.5	28.6	22	35
	1-2			25	36
5b3	0-1	50.0	25.9	13	33
	1-2			23	37
	2-2.5			25	--
5b4	0-1	54	20.6	15	30
	1-2			25	34
	2-2.5			27	--
5b5	0-1	35.5	24.1	19	28
	1-2			27	32
	2-2.5			24	--
5b6	0-1	35	24.1	17	29
	1-2			26	33
5b7	0-1	34.5	24.1	17	28
	1-1.5			25	32
5b8	0-1	32.0	21.3	12	31
	1-2			23	33
5b9	0-1	24.5	22.2	20	28
	1-2			21	29
5b10	0-1	19	24.8	19	27
	1.5			23	30
5c1	0-1	132	30.5	8	17
	1-2			15	16
5c2	0-1	124.5	27.1	11	20
	1-2			--	17
5c3	0-1	116.5	24.8	16	22
	1-2			18	22



Table A8.11.3-1c Continued

Treatment and Replication	Depth Involved (feet)	Location #		Water Content	
		Bearing Clockwise From North (degrees)	Distance to Sprinkler (meters)	100 x cm water/cm soil June 5†	October 17††
5c4	0-1	111.0	22.8	11	20
	1-2			14	19
7c1	0-1	151	30.0	10	23
	1-1.5			24	25
7c2	0-1	172	28.0	14	--
	1-1.5			16	22
7c3	0-1	174	29.7	7	22
	1-2			21	19
7c4	0-1	202	31.0	9	27
	1-2			19	32
L61*	0-1			17	14
	1-2			17	12
	2-3			21	--
L62	0-1			14	22
	1-1.5			14	22
L63	0-1			16	16
	1-1.5			15	17
L64	0-1			16	15
	1-1.5			22	14
L211*	0-1			14	14
	1-2			14	14
L212	0-1			--	18
	1-1.5			--	17
L213	0-1			16	24
	1-1.5			20	25
L214	0-1			17	25
	1-2			14	27
L215	0-1			12	22
	1-2			23	24
	2-2.5			19	--



Table A8.11.3-1c Continued.

Treatment and Replication	Depth Involved (feet)	Location #		Water Content	
		Bearing Clockwise From North (degrees)	Distance to Sprinkler (meters)	June 5†	October 17††
C1**	0-1	300	36	18	11
	1-2			20	10
C2	0-1	303	38	12	12
	1-2			15	11
C3	0-1	302	39	14	14
	1-1.5			12	12
C4	0-1	302	40	14	13
	1-1.5			25	13

# See Appendix Table A8.11.3-9 for typical water distribution around sprinkler.

† Gravimetric method using bulk density -  $1.1 \text{ g cm}^{-3}$

†† Campbell Pacific Hydroprobe calibration Eq: percent volumetric water content =  $2.7137 + 18.400 (\text{count} \div \text{standard count})$

\*L6 and L21 refer to lateral seepage areas west of sprinkler laterals 6 and 21.

\*\*Unirrigated controls.



Table A8.11.3-1d Volumetric soil water content in the soil after irrigation for the required water monitoring treatments during 1981.

Treatment* and Replication	Depth (inches)	Water Content (100x cm water/cm soil)				
		June 25-27	July	August 3-5	August 19-24	
4a	1	30	18	25	19	24
	2	18	25	28	23	26
	3	19	21	29	25	28
	4	34	18	19	20	19
4b	1	16	17	25**	19	20
	2	24	14	16	15	18
	3	17	17	25	20	24
	4	17	18	26	19	22
5a	1	18	--	34	35	--
	2	18	--	39	41	--
	3	18	--	36	38	--
	4	18	--	28	33	--
5b	1	uprooted (23")	--	--	--	--
	2	21	--	34	36	33
	3	23	--	35	37	33
	4	24	--	31	32	32
	5	21	--	30	31	29
	6	18	--	31	32	30
	7	18	--	31	31	29
	8	18	--	32	32	33
	9	18	--	29	29	26
	10	18	--	29	30	27
5c	1	24	16	17**	15	16
	2	19	17	17	17	17
	3	18	18	17	16	19
	4	18	19	19	18	18
7c	1	16	14	14	15	15
	2	17	18	17	17	19
	3	17	18	18	18	19
	4	18	18	18	17	25
C***	1	19	--	--	--	--
	2	21	--	--	--	--
	3	18	--	--	--	--
	4	18	--	--	--	--



Table A8.11.3-1d Continued.

Treatment* and Replication	Depth (inches)	Water Content (100 x cm water/cm soil)			
		June 25-27	July	August 3-5	August 19-24
4a deep 25' from sprinkler #18	12	33	31	31	32
	24	30	29	30	30
	36	27	30	30	30
	48	28	29	28	28
	60	24	24	24	25
	72	17	17	17	17
	84	14	14	14	14
	96	17	17	17	17
	108	19	19	19	19
	120	22	22	22	23
4a deep 75' from sprinkler #18	12	30	--	--	--
	24	31	--	--	--
	36	23	--	--	--
	48	27	--	--	--
	60	27	--	--	--
	72	20	--	--	--
	84	14	--	--	--
	96	16	--	--	--
	108	19	--	--	--
	120	22	--	--	--
4a deep 100' from sprinkler #18	12	--	29	29	30
	24	--	29	31	27
	36	--	24	22	22
	48	--	27	19	27
	60	--	26	17	26
	72	--	20	17	20
	84	--	14	18	14
	96	--	16	23	16
	108	--	19	25	20
	120	--	22	17	22
5a deep 100' from sprinkler #25	12	--	27	29	--
	24	--	31	31	--
	36	--	22	22	--
	48	--	19	19	--
	60	--	17	17	--
	72	--	17	17	--
	84	--	18	18	--
	96	--	23	23	--
	108	--	24	25	--
	120	--	17	17	--



Table A8.11.3-1d Continued.

Treatment* and Replication	Depth (inches)	Water Content (100 x cm water/cm soil)			
		June 15-17	July	August 3-5	August 19-24
L6**	17	--	13	--	--
	15	--	17	--	--
	15	--	17	--	--
	15	--	13	--	--
L21	18	--	14	--	--
	18	--	15	--	--
	17	--	16	--	--
	18	--	17	--	--
	20	--	18	--	--

\* Locations of treatment and replication in relation to sprinkler stand, are given in Table A8.11.3-1c and in Figure A8.11.3-1.

\*\* Received 0.35" precipitation between irrigation and measurement.

\*\*\* Unirrigated controls.



Table A8.11.3-2a Mine discharge water quality including boron, total dissolved solids and fluoride during the irrigation period in 1980.

Date	Boron (mg/l)	Total Dissolved Solids (mg/l)	Fluoride (mg/l)
7-7	0.6	1200	19
7-16	0.5	1200	17
7-24	0.5	1300	19
8-11	0.7	1400	18
8-18	0.6	1500	17
9-3	0.7	1700	17
9-11	0.8	1500	19
9-18	0.7	1600	16
9-26	0.7	1600	18
10-3	0.4	1700	16
10-9	0.7	1500	15
10-20	0.8	1700	17
10-23	0.9	1400	20
10-30	0.9	1700	16



Table A8.11.3-2b Mine discharge water quality including boron, calcium, magnesium, potassium, sodium, bicarbonate, carbonate, chloride, fluoride, sulfate, and total dissolved solids during the irrigation period in 1981.

Date	Cycle	Ca	Ma	K	Na	HCO <sub>3</sub>	CO <sub>3</sub>	Cl	SO <sub>4</sub>	B	F	TDS
		(me/l)									(ppm)	
6-24	1	--	--	--	--	--	--	--	--	0.6	19	1300
7-20	2	0.33	0.43	0.18	22.6	12.9	6.6	1.9	0.7	0.9	19	1300
8-5	3	0.33	0.44	0.09	25.2	11.1	8.8	0.2	1.0	0.8	19	1300
8-26	5	0.39	0.42	0.12	24.3	13.4	1.8	0.3	5.6	0.7	19	1300



Table A8.11.3-3 Values of pH, electrical conductivity of saturation extract (ECe), exchangeable sodium percentage (ESP), and boron (ppm in saturated extract) from soils samples taken June 5, December 16, 1980, and October 26, 1981.

Treatment and Replication	Depth Interval Feet	pH			ECe			ESP			Boron		
		(log [H])			(mmhos/cm)			(% )			(ppm)		
		June	Dec	Oct	June	Dec	Oct	June	Dec	Oct	June	Dec	Oct
5a1	0-1	8.0	8.3	8.6	0.6	0.9	1.9	<1	6	14	0.38	0.41	0.3
	1-2	7.9	--	8.7	0.8	--	1.0	<1	--	5	0.50	--	.1
5a2	0-1	7.8	8.4	8.5	0.9	1.1	2.2	<1	7	13	0.74	0.47	*
	1-2	7.7	--	8.3	1.0	--	1.8	<1	--	8	0.74	--	*
5a3	0-1	7.6	8.5	8.7	1.2	1.1	1.8	<1	11	15	1.04	0.46	*
	1-1.5	8.0	--	8.6	0.8	--	1.4	<1	--	15	0.63	--	*
5a4	0-1	7.5	8.2	8.8	1.0	1.4	1.7	<1	8	9	1.00	2.16	*
	1-2	8.0	--	--	0.5	--	--	<1	--	--	0.50	--	--
5b1	0-1	7.9	8.2	8.5	0.6	0.8	1.3	<1	8	11	0.52	0.19	--
	1-2	7.7	--	8.4	0.8	--	0.8	<1	--	4	0.57	--	.1
	2-2.5	8.2	--	8.4	0.5	--	0.9	<1	--	3	0.34	--	.1
5b2	0-1	7.5	8.5	8.7	1.4	1.0	1.31	<1	8	11	2.01	0.86	--
	1-2	--	--	8.2	--	--	1.2	--	--	2	--	--	--
5b3	0-1	7.9	8.3	8.8	0.9	0.7	1.1	<1	5	9	1.20	0.17	*
	1-2	7.9	--	8.5	0.7	--	0.8	<1	--	4	0.62	--	.1
	2-2.5	7.7	--	--	1.0	--	--	<1	--	--	1.36	--	--
5b4	0-1	7.8	8.2	8.7	0.5	0.7	1.1	<1	3	9	0.51	0.16	0.3
	1-2	7.9	--	8.5	0.6	--	0.7	<1	--	2	0.67	--	.1
	2-2.5	8.3	--	--	0.6	--	--	<1	--	--	0.55	--	--



Table A8.11.3-3 Continued

Treatment and Replication	Depth Interval Feet	pH (log [H])			ECe (mmhos/cm)			ESP (%)			Boron (ppm)		
		June	Dec	Oct	June	Dec	Oct	June	Dec	Oct	June	Dec	Oct
		5c1	0-0.5	--	8.3	--	--	1.0	--	--	10	--	--
	0.5-1	7.5	--	8.7	0.4	--	0.7	<1	--	7	0.28	--	<.1
	1-2	7.8	--	8.3	0.4	--	0.7	<1	--	3	0.23	--	<.1
5c2	0-1	6.9	8.1	8.6	0.4	0.5	0.9	<1	2	7	0.44	0.10	0.2
	1-2	7.6	--	8.2	0.3	--	0.8	<1	--	2	0.27	--	0.1
5c3	0-1	7.3	8.0	8.2	0.5	0.4	0.8	<1	3	6	0.39	0.08	1.0
	1-2	7.8	--	8.4	0.4	--	1.0	<1	--	3	0.29	--	0.2
5c4	0-0.5	--	8.3	--	--	2.2	--	--	8	--	--	1.37	--
	0.5-1	7.5	--	8.4	0.4	--	0.8	<1	--	7	0.20	--	0.2
	1-2	7.9	--	8.4	0.4	--	0.7	<1	--	1	0.24	--	<.1
7c1	0-0.5	--	8.7	--	--	0.5	--	--	7	--	--	0.33	--
	0.5-1	7.9	--	8.6	0.4	--	1.0	<1	--	7	0.54	--	0.7
	1-1.5	7.7	--	8.6	0.5	--	1.1	<1	--	3	0.62	--	0.4
7c2	0-1	7.7	--	8.6	0.5	--	0.9	<1	--	5	0.57	--	0.7
	1-1.5	7.7	--	--	0.8	--	--	<1	--	--	0.78	--	--
7c3	0-1	7.7	--	8.6	0.8	--	1.0	<1	--	6	0.74	--	0.9
	1-2	8.5	--	--	1.7	--	--	15	--	--	4.43	--	--
7c4	0-1	8.3	8.4	8.9	0.7	0.5	0.9	4	2	8	0.80	0.10	--
	1-2	8.6	--	--	1.5	--	--	12	--	--	1.44	--	--
C1**	0-1	--	--	8.0	--	--	0.5	--	--	<1	--	--	<.1
C2	0-1	--	--	7.7	--	--	0.8	--	--	<1	--	--	<.1
	1-2	--	--	8.0	--	--	0.4	--	--	<1	--	--	<.1
C3	0-1	--	--	7.9	--	--	0.7	--	--	1	--	--	<.1
	1-2	--	--	8.2	--	--	0.3	--	--	<1	--	--	<.1
C4	0-1	--	--	8.0	--	--	1.1	--	--	6	--	--	<.1
	1-2	--	--	8.5	--	--	0.7	--	--	3	--	--	<.1

\* Colored extract could not analyze for boron.

\*\* Unirrigated controls.



Table A8.11.3-4a Foliar concentration of boron, sodium, and fluoride in Indian rice grass on June 5 and December 16, 1980.

Treatment and Replication	Boron (ppm)		Sodium (ppm)		Fluoride (ppm)		
	June	Dec	June	Dec	June	Dec	
5b	1	118.1	90.8	28.8	308.0	6.5	13.8
	2	82.3	0.0	35.2	1627.0	4.1	9.7
	3	186.2	30.5	7.4	537.6	2.6	7.9
	4	62.9	4.3	8.5	265.6	1.8	11.2
	5	11.0	22.8	42.9	546.9	0.9	20.4
6b	1	15.6	125.0	18.6	582.5	0.0	35.6
	2	33.2	38.1	3.4	727.3	1.0	35.7
	3	51.4	23.7	19.5	481.0	1.1	49.2
	4	--	100.2	--	648.0	--	52.3
	5	--	143.5	--	539.0	--	24.6
7c	1	22.8	39.1	23.7	623.7	0.0	41.3
	2	109.6	41.4	6.2	305.2	1.0	48.2
	3	112.1	43.8	11.0	481.7	0.0	36.0
	4	--	--	--	1121.5	--	58.9
	5	--	--	--	775.4	--	44.3
8b	1	--	--	--	--	--	--
	2	--	--	--	--	--	--
	3	--	--	--	--	--	--
	4	--	--	--	--	--	--
	5	--	--	--	--	--	--



Table A8.11.3-4b Foliar concentration of fluoride in foliage of Indian rice grass on April 30, July 10, August 26, and October 26, 1981.

Treatment and Replication	Fluoride (ppm)				
	April	July	August	October	
5b	1	0.2	10.9	63.8	19.6
	2	0.2	11.9	47.4	22.4
	3	0.2	11.4	42.2	23.1
	4	0.2	8.6	42.9	23.2
	5	0.2	5.9	55.4	23.0
6b	1	3.0	6.9	97.0	29.0
	2	3.7	7.5	151.7	41.3
	3	3.0	12.0	104.9	48.4
	4	3.1	8.4	142.4	56.5
	5	3.1	10.5	82.3	35.0
7c	1	1.5	39.4	193.9	65.5
	2	2.9	52.1	122.3	41.1
	3	0.2	42.6	110.5	56.0
	4	1.5	58.4	77.7	50.0
	5	0.3	29.6	133.3	56.3
8b	1	--	--	--	--
	2	--	--	--	--
	3	--	--	--	--
	4	--	--	--	--
	5	--	--	--	--
C	1*	0.3	--	--	16.3
	2	0.3	--	--	14.4
	3	0.3	--	--	21.7
	4	0.4	--	--	21.7
	5	0.4	--	--	11.0

\* Unirrigated controls.



Table A8.11.3-4c Foliar concentration of boron and sodium in Indian rice grass on April 30 and October 26, 1981.

Treatment and Replication	Boron (ppm)		Sodium (ppm)		
	April	Oct.	April	Oct.	
5b	1	11.9	2.6	7.8	1659.9
	2	11.8	1.9	20.6	1290.6
	3	5.3	2.3	28.1	2327.9
	4	13.9	1.8	12.0	1347.1
	5	7.7	2.1	7.0	1516.0
6b	1	32.5	1.7	7.8	1490.4
	2	37.5	1.9	37.7	1779.7
	3	14.5	2.5	19.1	2426.7
	4	19.4	2.0	9.5	2716.8
	5	24.5	2.3	9.7	2519.4
7c	1	24.2	1.7	8.7	2069.1
	2	--	3.2	15.7	1877.6
	3	22.6	1.7	12.3	1549.3
	4	17.4	1.9	8.2	1777.0
	5	10.4	1.7	15.7	1650.6
8b	1	--	--	--	--
	2	--	--	--	--
	3	--	--	--	--
	4	--	--	--	--
	5	--	--	--	--
C	1*	9.1	2.3	8.7	484.0
	2	10.2	1.8	19.2	282.2
	3	11.1	2.4	27.1	591.2
	4	10.1	2.2	13.6	543.4
	5	32.7	1.7	11.1	543.4

\* Unirrigated controls.



Table A8.11.3-5a Foliar concentration of boron, sodium, and fluoride in western wheat grass on June 5 and December 16, 1980.

Treatment and Replication	Boron (ppm)		Sodium (ppm)		Fluoride (ppm)		
	June	Dec.	June	Dec.	June	Dec.	
5b	1	34.6	17.8	15.8	317.0	4.2	14.3
	2	4.3	83.4	55.5	1069.2	2.4	19.1
	3	28.2	48.3	25.0	2151.4	1.9	56.1
	4	60.8	12.0	28.8	434.2	0.9	24.3
	5	172.5	0	46.0	808.9	0.8	23.9
6b	1	21.1	91.7	21.1	328.9	13.0	27.5
	2	15.9	99.1	214.2	769.9	11.0	34.9
	3	31.5	16.2	49.5	345.9	8.4	53.5
	4	--	10.4	--	721.0	--	52.6
	5	--	11.0	--	421.6	--	38.6
7c	1	56.0	42.1	53.9	716.7	1.0	50.9
	2	36.6	27.8	32.5	707.7	1.1	55.5
	3	33.3	28.7	49.0	643.0	0	37.5
	4	--	0	--	946.8	--	48.7
	5	--	48.4	--	552.5	--	32.3
8b	1	39.9	89.0	46.8	681.5	--	30.2
	2	93.8	69.4	66.3	311.3	0.8	44.7
	3	80.4	34.9	< 0.01	533.8	0	32.0
	4	--	13.9	--	253.3	--	20.8
	5	--	--	--	440.5	--	33.2



Table A8.11.3-5b Foliar concentration of fluoride in western wheat grass on April 30, July 10, August 26, and October 26, 1981.

Treatment and Replication	Fluoride (ppm)				
	April	July	August	October	
5b	1	6.7	2.8	49.1	13.9
	2	3.3	15.9	64.4	18.8
	3	5.3	15.7	49.4	75.3
	4	2.9	8.9	47.5	26.3
	5	4.4	10.7	44.1	15.2
6b	1	2.8	11.9	63.2	27.1
	2	2.0	6.8	72.2	21.5
	3	0	7.4	90.6	23.6
	4	0	6.7	75.8	16.8
	5	0.2	10.3	108.0	25.5
7c	1	2.0	34.0	141.4	41.4
	2	1.1	61.4	186.8	51.8
	3	2.3	37.6	113.8	33.9
	4	5.3	39.4	77.8	32.1
	5	2.2	20.6	133.8	33.0
8b	1	0.9	6.8	41.0	26.8
	2	2.0	6.3	37.2	24.3
	3	3.0	8.6	45.4	33.1
	4	4.8	9.0	37.9	27.3
	5	3.0	9.0	46.2	22.8
C	1*	2.4	--	--	13.0
	2	3.4	--	--	24.7
	3	1.8	--	--	39.5
	4	0.2	--	--	28.8
	5	0.2	--	--	12.9

\*Unirrigated controls.



Table A8.11.3-5c Foliar concentration of boron and sodium in western wheat grass on April 30, and October 26, 1981.

Treatment and Replication	Boron (ppm)		Sodium (ppm)		
	April	Oct.	April	Oct.	
5b	1	3.9	2.7	10.8	366.4
	2	11.3	2.0	9.7	356.4
	3	5.8	1.9	10.1	2309.1*
	4	6.3	3.5	22.1	398.8
	5	33.9	2.1	21.2	295.9
6b	1	14.0	2.1	7.3	312.9
	2	75.3	1.9	21.4	389.6
	3	29.5	1.9	7.6	356.0
	4	26.0	2.1	9.9	369.1
	5	21.5	2.5	15.5	399.5
7c	1	21.1	4.2	13.8	1385.2
	2	16.1	11.7	16.8	602.9
	3	37.6	5.8	10.2	406.7
	4	30.1	4.2	16.5	356.4
	5	11.6	1.6	13.9	380.2
8b	1	5.4	2.7	18.9	167.8
	2	7.5	2.9	12.1	413.3
	3	10.1	3.3	9.6	368.3
	4	12.2	2.5	18.2	510.7
	5	9.6	2.3	18.0	493.7
C**	1	14.6	2.1	16.6	244.6
	2	5.1	2.2	12.2	91.0
	3	6.8	2.2	8.9	349.8
	4	7.1	2.5	13.4	325.2
	5	10.7	1.9	7.1	53.4

\* Omitted in calculation of average.

\*\* Unirrigated control.



Table A8.11.3-6a Foliar concentration of boron, sodium, and fluoride in big sage brush on June 5 and December 16, 1980.

Treatment and Replication	Boron (ppm)		Sodium (ppm)		Fluoride (ppm)		
	June	Dec.	June	Dec.	June	Dec.	
5b	1	103.9	149.1	46.0	1133.6	1.2	7.9
	2	136.4	117.0	36.2	603.1	0.0	11.0
	3	96.5	60.5	49.2	393.0	0.0	9.0
	4	205.1	180.1	48.2	306.6	0.0	7.9
	5	61.9	58.2	23.3	881.3	0.0	8.2
6b	1	21.8	143.1	62.2	724.6	4.5	23.2
	2	58.2	173.4	55.3	510.9	3.3	16.4
	3	71.4	84.7	67.3	523.7	0.9	14.4
	4	--	58.8	--	277.6	--	23.1
	5	--	74.1	--	829.3	--	5.2
7c	1	69.7	131.8	26.4	1679.0	0.9	26.8
	2	108.6	184.0	681.5	254.1	0.0	17.9
	3	59.0	83.0	4893.0	1814.6	0.2	17.5
	4	--	213.7	--	1468.3	--	13.8
	5	--	79.4	--	280.0	--	14.2
8b	1	84.8	96.5	74.5	826.5	0.0	13.9
	2	443.9	140.3	44.9	504.1	0.0	10.7
	3	147.6	125.6	61.7	682.6	0.0	10.2
	4	--	105.0	--	1568.0	--	9.0
	5	--	40.8	--	435.7	--	9.0



Table A8.11.3-6b Foliar concentration of fluoride in big sage brush on April 30, July 10, August 26, and October 26, 1981.

Treatment and Replication	Fluoride (ppm)				
	April	July	August	October	
5b	1	4.4	16.9	155.6	15.9
	2	5.9	21.6	159.2	14.6
	3	4.7	16.5	88.3	10.5
	4	6.2	29.8	103.8	11.2
	5	7.8	14.9	107.7	13.6
6b	1	11.9	8.8	162.0	25.5
	2	9.6	8.9	86.8	23.2
	3	15.0	12.1	181.3	25.4
	4	14.6	16.3	109.9	24.9
	5	9.8	12.3	115.7	22.6
7c	1	5.9	118.9	208.9	63.1
	2	10.9	149.9	213.6	19.1
	3	10.7	145.8	154.8	13.6
	4	10.2	172.1	177.8	19.7
	5	6.9	53.6	183.3	19.2
8b	1	3.9	10.2	50.9	16.9
	2	0.2	10.0	63.2	21.2
	3	2.0	8.6	36.8	15.2
	4	12.4	7.3	68.9	11.0
	5	4.0	7.2	58.5	19.4
C	1*	0.3	--	--	9.0
	2	0.3	--	--	10.5
	3	0.3	--	--	8.6
	4	0.3	--	--	12.1
	5	0.3	--	--	11.8

\*Unirrigated controls.



Table A8.11.3-6c Foliar concentration of boron and sodium in big sage brush on April 30, and October 26, 1981.

Treatment and Replication	Boron (ppm)		Sodium (ppm)		
	April	October	April	October	
5b	1	130.1	94.0	25.5	394.9
	2	150.5	91.9	12.8	136.8
	3	69.1	50.2	10.9	116.4
	4	69.6	100.7	16.4	123.3
	5	186.2	101.3	23.7	302.3
6b	1	62.0	40.2	54.5	539.6
	2	221.7	19.8	20.8	278.3
	3	29.9	41.4	9.5	500.7
	4	10.1	42.2	15.1	219.8
	5	138.7	85.1	20.6	421.4
7c	1	98.3	60.1	22.2	1636.2
	2	--	44.7	26.1	264.3
	3	158.5	26.4	146.2	545.4
	4	186.9	21.4	44.6	545.2
	5	--	90.2	17.5	185.3
8b	1	50.0	50.1	26.5	85.2
	2	78.1	41.1	8.3	34.0
	3	125.0	100.0	32.8	212.4
	4	32.5	75.0	31.9	383.4
	5	125.0	86.6	19.3	71.9
C	1*	153.8	14.1	7.0	71.9
	2	9.8	14.1	10.3	40.9
	3	96.3	26.3	15.3	44.0
	4	152.3	26.4	13.2	105.9
	5	132.7	27.2	18.4	26.9

\*Unirrigated controls.



Table A8.11.3-7a

1980 weather data summary statistics for the  
C-b Tract, TRL 23.

TEMPERATURE (DEG F)		RH (%)		SOLAR RADIATION (LANGLEYS)	
DATE	TIME	MN_TMP	MX_TMP	TOT_SR	MEAN_RH
01JUL80	AM	57	74	248.1	52.0000
01JUL80	PM	56	60	12.4	89.9167
02JUL80	AM	54	65	196.8	82.5833
02JUL80	PM	54	59	3.2	85.8333
03JUL80	AM	63	76	389.1	44.7500
03JUL80	PM	53	72	15.9	67.0000
04JUL80	AM	57	71	145.4	25.1667
04JUL80	PM	51	58	16.7	55.2500
05JUL80	AM	.	.	.	13.2500
05JUL80	PM	.	.	.	25.2500
06JUL80	AM	.	.	.	15.3333
06JUL80	PM	.	.	.	23.0833
07JUL80	AM	64	77	85.4	37.2500
07JUL80	PM	57	61	0.0	57.8333
08JUL80	AM	62	75	415.2	38.4167
08JUL80	PM	54	70	15.9	74.6667
09JUL80	AM	63	80	323.2	32.7500
09JUL80	PM	52	76	16.3	63.5833
10JUL80	AM	71	81	332.3	31.7500
10JUL80	PM	62	73	15.1	51.5000
11JUL80	AM	70	82	334.4	34.0000
11JUL80	PM	64	78	14.8	45.5833
12JUL80	AM	68	78	151.2	39.9167
12JUL80	PM	66	67	5.5	45.1667
13JUL80	AM	55	73	200.7	58.0833
13JUL80	PM	55	63	5.5	74.1667
14JUL80	AM	60	75	404.7	43.3333
14JUL80	PM	52	71	5.5	61.8333
15JUL80	AM	68	80	426.0	16.8333
15JUL80	PM	60	73	15.9	23.4167
16JUL80	AM	63	83	409.4	25.5000
16JUL80	PM	56	78	14.3	30.8333
17JUL80	AM	70	85	421.0	21.0000
17JUL80	PM	61	78	14.3	26.0833
18JUL80	AM	65	85	414.6	28.2500
18JUL80	PM	57	79	13.9	30.1667
19JUL80	AM	69	83	374.7	24.1667
19JUL80	PM	67	76	2.3	25.0000
20JUL80	AM	64	83	401.4	29.0833
20JUL80	PM	57	78	13.9	38.7500
21JUL80	AM	65	84	417.5	26.3333
21JUL80	PM	59	80	13.9	32.6667
22JUL80	AM	71	87	385.1	27.0833
22JUL80	PM	63	81	13.9	29.9167
23JUL80	AM	71	80	154.2	44.0833
23JUL80	PM	65	71	10.5	51.3333
24JUL80	AM	64	78	251.2	47.7500
24JUL80	PM	58	65	7.1	71.0000
25JUL80	AM	61	79	321.0	50.5000
25JUL80	PM	55	72	12.8	65.7500
26JUL80	AM	61	84	371.7	37.0000
26JUL80	PM	55	74	13.2	43.2500
27JUL80	AM	66	83	414.6	30.7500
27JUL80	PM	60	79	12.4	30.4167
28JUL80	AM	72	88	308.6	25.5000



Table A8.11.3-7a Continued.

TEMPERATURE (DEG F)		RH (%)		SOLAR RADIATION (LANGLEYS)	
DATE	TIME	MN_TMP	MX_TMP	TOT_SR	MEAN_RH
28 JUL 80	PM	62	81	19.0	26.0000
29 JUL 80	AM	66	87	233.8	30.4167
29 JUL 80	PM	61	77	22.6	46.9167
30 JUL 80	AM	65	77	260.2	51.8333
30 JUL 80	PM	60	69	10.5	70.8333
31 JUL 80	AM	63	81	361.4	50.0833
31 JUL 80	PM	58.1	79.8	11.7	47.0833
01 AUG 80	AM	68	82	260.3	42.1667
01 AUG 80	PM	61	70	8.6	47.8333
02 AUG 80	AM	65	82	337.7	31.1667
02 AUG 80	PM	58	78	11.3	64.1667
03 AUG 80	AM	65	83	312.4	31.9167
03 AUG 80	PM	61	74	9.7	34.6667
04 AUG 80	AM	62	81	410.8	19.9167
04 AUG 80	PM	55	73	11.7	33.4167
05 AUG 80	AM	65	83	389.9	28.5000
05 AUG 80	PM	56	76	3.5	32.3333
06 AUG 80	AM	73	83	396.7	27.7500
06 AUG 80	PM	66	76	10.5	32.5000
07 AUG 80	AM	74	85	392.7	25.0000
07 AUG 80	PM	64	79	10.5	33.6667
08 AUG 80	AM	73	86	386.6	26.2500
08 AUG 80	PM	65	78	10.5	33.9167
09 AUG 80	AM	72	83	316.7	34.3333
09 AUG 80	PM	65	78	10.1	39.6667
10 AUG 80	AM	64	83	391.9	28.4167
10 AUG 80	PM	59	77	9.3	36.3333
11 AUG 80	AM	61	83	394.6	20.7500
11 AUG 80	PM	55	77	10.5	24.5833
12 AUG 80	AM	68	85	301.3	29.0833
12 AUG 80	PM	61	67	10.1	35.8333
13 AUG 80	AM	62	79	193.7	47.3333
13 AUG 80	PM	58	63	8.9	70.6667
14 AUG 80	AM	62	77	290.0	47.0000
14 AUG 80	PM	57	72	9.0	62.9167
15 AUG 80	AM	53	69	295.4	51.7273
15 AUG 80	PM	53	56	0.0	79.4167
16 AUG 80	AM	55	66	195.3	46.1667
16 AUG 80	PM	50	63	7.4	71.7500
17 AUG 80	AM	56	75	315.8	28.7500
17 AUG 80	PM	46	67	7.8	64.8333
18 AUG 80	AM	67	76	385.8	17.6667
18 AUG 80	PM	60	69	8.6	27.9167
19 AUG 80	AM	55	69	312.4	25.4167
19 AUG 80	PM	47	63	8.9	42.9167
20 AUG 80	AM	48	68	379.4	34.5833
20 AUG 80	PM	40	63	8.6	58.3333
21 AUG 80	AM	52	75	375.5	26.6667
21 AUG 80	PM	45	69	8.6	32.1667
22 AUG 80	AM	64	80	364.8	19.3000
22 AUG 80	PM	57	70	8.2	31.0833
23 AUG 80	AM	63	72	256.0	60.5000
23 AUG 80	PM	53	67	1.9	65.2500
24 AUG 80	AM	54	67	202.7	.
24 AUG 80	PM	53	60	2.3	.



Table A8.11.3-7a Continued.

TEMPERATURE (DEG F)		RH (%)		SOLAR RADIATION (LANGLEYS)	
DATE	TIME	MN_TMP	MX_TMP	TOT_SR	MEAN_RH
25AUG80	AM	53	68	191.9	.
25AUG80	PM	51	56	5.4	.
26AUG80	AM	53	69	321.0	.
26AUG80	PM	51	55	6.2	.
27AUG80	AM	57	74	331.3	.
27AUG80	PM	50	66	7.0	.
28AUG80	AM	65	75	363.2	.
28AUG80	PM	59	66	7.4	.
29AUG80	AM	64	70	248.9	14.2000
29AUG80	PM	58	65	3.5	18.4000
30AUG80	AM	59	71	221.0	20.3333
30AUG80	PM	53	64	3.9	27.5833
31AUG80	AM	47	64	187.9	35.5833
31AUG80	PM	44	55	6.2	65.3333
01SEP80	AM	51	71	346.0	24.2500
01SEP80	PM	43	65	7.0	60.6667
02SEP80	AM	62	74	346.1	20.7500
02SEP80	PM	52	65	6.2	37.6667
03SEP80	AM	64	76	303.2	20.4167
03SEP80	PM	60	67	5.8	29.5000
04SEP80	AM	57	78	311.2	24.9167
04SEP80	PM	51	71	5.8	41.5833
05SEP80	AM	60	81	274.3	23.5000
05SEP80	PM	54	73	5.4	33.7500
06SEP80	AM	60	76	217.6	41.4167
06SEP80	PM	57	66	2.3	59.6667
07SEP80	AM	62	69	155.1	52.7500
07SEP80	PM	56	60	3.9	78.5000
08SEP80	AM	53	60	132.2	82.5833
08SEP80	PM	52	58	0.8	86.5000
09SEP80	AM	50	60	83.3	81.2500
09SEP80	PM	49	56	1.2	90.2500
10SEP80	AM	52	65	116.3	75.2500
10SEP80	PM	49	56	1.6	82.7500
11SEP80	AM	53	62	260.1	47.0000
11SEP80	PM	47	56	4.7	71.2500
12SEP80	AM	51	63	139.3	56.7500
12SEP80	PM	48	62	3.5	77.0833
13SEP80	AM	60	76	205.1	23.9167
13SEP80	PM	55	68	2.3	51.6667
14SEP80	AM	59	71	235.5	24.5000
14SEP80	PM	56	63	4.3	37.0833
15SEP80	AM	57	72	292.2	26.0833
15SEP80	PM	52	63	4.3	45.5833
16SEP80	AM	60	69	311.5	23.4167
16SEP80	PM	57	62	2.7	41.5833
17SEP80	AM	54	72	313.3	23.0000
17SEP80	PM	50	62	4.3	39.9167
18SEP80	AM	58	77	281.1	23.5000
18SEP80	PM	51	71	4.3	34.8333
19SEP80	AM	65	75	189.3	23.0000
19SEP80	PM	46	67	3.9	38.5000
20SEP80	AM	42	65	302.0	36.9167
20SEP80	PM	39	57	6.2	63.0000
21SEP80	AM	49	64	241.8	22.3333



Table A8.11.3-7a Continued.

TEMPERATURE (DEG F)		RH (%)		SOLAR RADIATION (LANGLEYS)	
DATE	TIME	MN_TMP	MX_TMP	TOT_SR	MEAN_RH
21SEP80	PM	42	55	3.5	48.2500
22SEP80	AM	37	59	302.6	32.2500
22SEP80	PM	34	51	3.5	62.0833
23SEP80	AM	41	65	295.8	23.1667
23SEP80	PM	38	55	3.5	37.1667
24SEP80	AM	44	64	294.7	33.3333
24SEP80	PM	41	56	3.1	40.7500
25SEP80	AM	42	67	291.5	28.5833
25SEP80	PM	39	58	3.1	34.6667
26SEP80	AM	52	71	287.9	25.4167
26SEP80	PM	46	60	3.1	37.1667
27SEP80	AM	55	70	191.7	29.2500
27SEP80	PM	54	61	2.7	38.7500
28SEP80	AM	54	71	163.1	28.8333
28SEP80	PM	52	62	2.7	41.0000
29SEP80	AM	51	70	282.1	26.0000
29SEP80	PM	49	63	2.7	35.6667
30SEP80	AM	52	78	274.8	22.4167
30SEP80	PM	49	65	2.7	32.6667
01OCT80	AM	51	74	272.5	26.9167
01OCT80	PM	51	64	2.3	31.5000
02OCT80	AM	41	63	272.5	39.2500
02OCT80	PM	39	56	1.9	39.1667
03OCT80	AM	44	69	247.1	29.4167
03OCT80	PM	43	61	0.0	37.0833
04OCT80	AM	49	71	268.7	26.1667
04OCT80	PM	48	62	2.3	32.7500
05OCT80	AM	52	70	260.5	30.5000
05OCT80	PM	50	61	1.9	30.5000
06OCT80	AM	49	72	256.1	34.2500
06OCT80	PM	47	63	1.9	35.6667
07OCT80	AM	52	73	256.9	29.8333
07OCT80	PM	47	65	1.9	33.5000
08OCT80	AM	50	73	248.1	32.9167
08OCT80	PM	49	65	1.6	32.1667
09OCT80	AM	49	71	249.9	31.0000
09OCT80	PM	47	59	1.6	29.9167
10OCT80	AM	39	64	247.7	44.5000
10OCT80	PM	38	54	1.6	38.5000
11OCT80	AM	48	70	232.5	29.3333
11OCT80	PM	44	58	1.6	39.0000
12OCT80	AM	44	62	101.2	59.5833
12OCT80	PM	46	57	0.8	54.0000
13OCT80	AM	44	56	224.1	53.6667
13OCT80	PM	41	50	0.4	76.4167
14OCT80	AM	38	54	123.2	64.0000
14OCT80	PM	37	46	3.1	90.4167
15OCT80	AM	33	40	150.5	56.9167
15OCT80	PM	32 *	38	0.4	82.9167
16OCT80	AM	26	33	108.8	86.6667
16OCT80	PM	27	32	0.4	89.7500
17OCT80	AM	31	38	123.8	72.0000
17OCT80	PM	29	32	0.4	90.0833
18OCT80	AM	33	42	109.4	66.7500
18OCT80	PM	31	37	0.4	83.9167

\* Frost starts here



Table A8.11.3-7a Continued.

TEMPERATURE (DEG F)		RH (%)		SOLAR RADIATION (LANGLEYS)		
DATE	TIME	MN_TMP	MX_TMP	TOT_SR	MEAN_RH	
19OCT80	AM	32	51	235.7	52.9167	
19OCT80	PM	31	42	1.9	80.6667	
20OCT80	AM	32	54	233.7	50.1667	
20OCT80	PM	33	44	2.3	79.4167	
21OCT80	AM	36	53	224.6	38.7500	
21OCT80	PM	35	42	0.8	66.3333	
22OCT80	AM	41	54	199.2	36.6667	
22OCT80	PM	30	42	0.4	48.2500	
23OCT80	AM	21	36	222.3	54.9167	
23OCT80	PM	20	30	0.8	57.5000	
24OCT80	AM	26	47	220.9	34.6667	
24OCT80	PM	24	36	0.8	59.9167	
25OCT80	AM	32	55	220.2	18.9167	
25OCT80	PM	31	44	0.4	36.1667	
26OCT80	AM	35	46	85.4	44.9167	
26OCT80	PM	31	44	0.0	55.8333	
27OCT80	AM	26	29	51.2	89.6667	
27OCT80	PM	21	31	0.0	87.3333	
28OCT80	AM	19	32	147.8	65.8333	
28OCT80	PM	17	28	0.4	84.8333	
29OCT80	AM	23	45	219.4	45.3333	
29OCT80	PM	21	37	0.8	79.9167	
30OCT80	AM	34	56	200.7	36.7500	
30OCT80	PM	33	43	0.4	63.9167	
31OCT80	AM	39	57	173.6	34.1667	
31OCT80	PM	38	45	0.0	56.4167	



Table A8.11.3-7b Summary of 1981 weather data and calculated ET for C-b Tract, TRL 23.

Date	Mean Temperature (°C)	Solar Radiation (Langley's/day)	Sum ET (mm)	Precipitation (mm)
June 1	--	--	--	--
2	--	--	--	7.6
3	11.6	--	--	1.3
4	13.2	--	--	--
5	16.2	--	--	--
6	20.2	--	--	--
7	21.3	--	--	--
8	23.3	561.6	6.5	--
9	21.6	578.4	12.7	--
10	20.3	651.0	19.5	--
11	19.9	680.4	26.5	--
12	22.2	703.8	34.4	--
13	14.0	646.8	39.7	--
14	4.7	435.6	41.8	--
15	8.6	695.4	46.2	--
16	14.7	708.6	52.2	--
17	19.0	498.5	57.1	--
18	16.5	557.4	62.2	--
19	20.4	664.8	69.1	--
20	21.8	576.0	75.5	--
21	22.4	669.6	83.0	--
22	21.7	696.0	90.6	--
23	23.3	445.2	95.8	--
24	23.1	672.6	103.8	--
25	23.4	586.2	110.3	--
26	23.8	664.8	118.0	6.3
27	19.3	518.4	123.3	3.0
28	16.3	400.8	126.9	15.5
29	--	--	--	--
30	--	--	--	--
July 1	14.2	273.0	129.1	1.0
2	17.0	526.2	134.0	--
3	17.5	480.6	138.5	--
4	19.5	681.0	145.4	--
5	23.3	666.6	153.1	--



Table A8.11.3-7b Continued.

Date	Mean Temperature (°C)	Solar Radiation (Langley's/day)	Sum ET (mm)	Precipitation (mm)	
July	6	24.8	635.4	160.7	--
	7	--	--	--	--
	8	25.1	686.4	169.1	0.5
	9	19.5	392.4	173.1	4.8
	10	18.8	538.8	178.4	--
	11	20.9	463.2	183.4	3.8
	12	18.3	335.4	186.7	0.5
	13	17.7	287.4	189.4	3.8
	14	21.2	512.4	195.0	--
	15	21.6	639.6	202.0	--
	16	18.8	119.4	204.1	--
	17	15.9	234.0	206.1	6.3
	18	18.3	454.2	212.1	0.8
	19	21.0	666.0	219.3	--
	20	23.0	658.2	226.8	--
	21	24.4	663.6	234.8	--
	22	24.0	603.0	241.8	--
	23	19.7	519.6	247.1	1.5
	24	17.6	531.6	252.2	5.1
	25	17.3	574.8	257.6	2.0
	26	15.3	485.4	261.8	1.8
	27	16.2	640.2	267.6	--
	28	20.8	579.0	273.8	--
	29	23.2	528.0	284.5	--
	30	23.2	528.0	284.5	--
	31	--	--	--	--
Aug.	1	--	--	--	--
	2	--	--	--	--
	3	25.5	536.7	291.2	--
	4	23.7	603.6	298.2	--
	5	23.6	622.8	305.5	--
	6	20.9	618.0	312.1	--
	7	19.8	613.8	318.4	--
	8	20.0	553.8	324.2	--
	9	17.5	604.8	329.9	--
	10	11.2	172.8	331.1	5.3



Table A8.11.3-7b Continued.

Date	Mean Temperature (°C)	Solar Radiation (Langley's/day)	Sum ET (mm)	Precipitation (mm)
Aug. 11	12.3	216.6	332.7	---
12	13.5	395.4	335.9	2.3
13	14.5	338.4	338.7	---
14	16.5	303.0	341.5	---
15	16.3	248.4	343.7	---
16	18.2	537.0	348.9	---
17	19.0	563.4	354.6	---
18	19.7	498.6	359.7	---
19	20.6	430.8	364.3	---
20	21.4	433.8	369.0	---
21	16.4	213.6	370.9	---
22	17.4	700.2	375.5	---
23	19.4	407.4	379.7	---
24	18.1	278.8	382.3	8.6
25	20.2	505.2	387.5	---
26	20.1	523.8	392.9	---
27	19.6	453.6	397.5	---
28	19.9	417.0	401.9	---
29	18.2	385.2	405.6	1.8
30	15.8	421.8	409.3	---
31	16.6	436.2	413.3	---
Sept. 1	17.9	524.4	418.3	---
2	18.8	403.8	422.3	1.0
3	16.7	334.2	425.4	---
4	19.6	514.2	430.6	---
5	14.4	150.6	431.8	8.9
6	11.6	178.2	433.2	0.8
7	12.6	279.0	435.3	---
8	15.7	477.0	439.5	---
9	14.7	276.6	441.8	3.8
10	11.6	187.2	443.2	---
11	12.7	14.4	443.3	---
12	14.3	349.8	446.9	---
13	15.0	395.4	449.5	2.5
14	14.8	301.8	452.9	---
15	16.6	447.6	455.5	---



Table A8.11.3-7b Continued.

Date	Mean Temperature (°C)	Solar Radiation (Langley's/day)	Sum ET (mm)	Precipitation (mm)
Sept. 16	15.5	453.6	459.5	--
17	15.0	486.0	463.5	--
18	17.2	480.6	467.7	--
19	17.1	333.0	472.2	1.3
20	16.1	112.3	475.3	--
21	16.6	381.6	476.2	1.3
22	17.2	444.6	479.7	--
23	17.6	394.8	483.8	--
24	14.7	163.6	48.76	10.2
25	13.5	338.4	489.0	--
26	10.8	453.0	491.7	--
27	15.4	435.0	494.9	--
28	17.5	444.0	499.0	--
29	17.2	271.2	501.6	--
30	12.3	329.4	504.1	--



Table A8.11.3-8 Average monthly temperature, radiation, and calculated ET for an C-b Tract, 1981.

Month	Temperature °C		Radiation Langley's/day		ET gpm/acre
April	9.0	(11.1)*	468.5	(546)*	2.2
May	9.0	(16.7)	349.3	(615)	1.7
June	19.0	(21.7)	600.6	(708)	4.5
July	20.0	(25.6)	510.1	(676)	3.9
August	18.0	(24.4)	449.5	(595)	3.2
September	15.0	(20.0)	345.2	(514)	2.2
October	6.0	(12.8)	259.2	(373)	1.0

\*Averages from long term records taken from "Climatic Atlas of the United States" for Grand Junction, Colorado. Average radiation for the months of April through September 1980 at Grand Junction was 538, 536, 735, 633, 577, and 425 Langley's/day, respectively.



Table A8.11.3-9

Water application depth at two typical locations as it varies with distance from the 104C Rainbird sprinkler after 6 hours of operation between 20:00 hrs July 11 to 02:00 July 12, 1981. (Rainfall during period = 0.15 inches; Wind 100-120° from north, ave. 10 mph with gusts to 20 mph.)

Distance From Sprinkler Meters	Depth of Water Caught (cm)							
	Direction from Sprinkler Head							
	South	West	North	East	South	West	North	East
0.0	--	--	--	--				
2.5	5.22	4.60	6.20	5.36				
7.5	F*	F	F	5.93				
12.5	4.93	F	F	4.09				
17.5	3.57	4.66	6.36	3.87				
22.5	3.66	4.47	6.66	3.97				
27.5	4.39	4.47	6.17	3.58				
32.5	4.86	4.42	6.09	3.28				
37.5	4.81	4.59	5.45	2.96				
42.5	4.00	4.62	3.91	2.21				
47.5	3.40	5.52	3.01	1.58				
52.5	2.87	4.96	1.91	0.84				
57.5	1.52	3.58	0.98	0.45				
	67.0 m	0	73 m	0	67 m	0	60 m	0
0.0	--	--	--	--				
2.5	6.32	4.06	4.78	5.72				
7.5	6.51	6.42	6.90	6.32				
12.5	5.66	6.17	6.17	4.81				
17.5	5.19	4.51	4.51	4.51				
22.5	5.30	4.48	4.32	4.66				
27.5	--	5.02	4.39	4.41				
32.5	5.72	--	3.99	4.51				
37.5	5.43	--	2.89	3.69				
42.5	4.99	4.14	2.39	3.19				
47.5	4.59	3.85	1.81	2.33				
52.5	3.81	2.90	1.10	1.35				
57.5	2.06	1.55	0.47	0.57				
	60 m	0	62 m	0	60 m	0	62 m	0







TABLE OF CONTENTS

Page

INTRODUCTION

General Statement

Background

Quality Factors

Water Use in the Basin

Potential for Salinity Before Reclamation

DESIGN AND OPERATION OF THE REINJECTION AND

MONITORING PROGRAM

Reinjection Well

Monitoring Well

Designation

APPENDIX 2B

GEOHYDROLOGICAL STUDY OF REINJECTION

C-5 TRACT

PICEANCE BASIN, COLORADO



GEOHYDROLOGICAL STUDY OF REINJECTION

C-b TRACT

PICEANCE BASIN, COLORADO

GEO THERMAL SURVEYS, INC.

21 January 1981



## TABLE OF CONTENTS

	Page
INTRODUCTION	1
General Statement	1
Background	1
Aquifer System	1
Water Make in the Shafts	3
Potentiometric Surfaces Before Reinjection	6
DESIGN AND OPERATION OF THE REINJECTION AND MONITORING PROGRAM	7
Reinjection Well	7
Monitoring Wells	13
Distribution	13
Horizons Monitored	13
Water Level Sensors	14
DATA COLLECTED	20
Water Level Measurements	20
Temperature Logging	20
Water Quality	20
DATA ANALYSIS	21
Downhole Thermal Gradients	21
Water Levels	24
Records of Individual Monitors -	
Characteristic Curve	24
Upc1/Uinta	28
Upc2	29
Lpc3	29
Transmissivity	29
Response of Cb-1	32
Potentiometric Surface Changes -	
Constant Base	33
General Statement	33
Upc1/Uinta	34
Upc2	38
Lpc3	42
Potentiometric Surface Changes -	
Changing Base	42
General Statement and Method	42
Upc1/Uinta	46
Upc2	55
Lpc3	55



## LIST OF FIGURES

Figure		Page
1	GENERALIZED STRATIGRAPHY - Cb TRACT	2
2	REINJECTION MONITORING WELL LOCATION, Cb TRACT	4
3	CUMULATIVE MINE WATER MAKE	5
4	POTENTIOMETRIC SURFACE BEFORE RECOMPLETION, ALL WELLS	8
5a	POTENTIOMETRIC SURFACE AFTER RECOMPLETION, Upc1 WELLS	9
5b	POTENTIOMETRIC SURFACE AFTER RECOMPLETION, Upc2 WELLS	10
5c	POTENTIOMETRIC SURFACE AFTER RECOMPLETION, Lpc3 WELLS	11
6	REINJECTION WELL	12
7	WATER LEVEL SENSOR	19
8	AQUIFER CHARACTERISTICS BASED ON THERMAL LOGGING	22
9a	REINJECTION POTENTIOMETRIC SURFACE DIFFERENCE MAP, Upc1, B WELLS, 3/30-3/3/81	35
9b	REINJECTION POTENTIOMETRIC SURFACE DIFFERENCE MAP, Upc1, B WELLS, 4/29-3/3/81	36
9c	REINJECTION POTENTIOMETRIC SURFACE DIFFERENCE MAP, Upc1, B WELLS, 6/24-3/3/81	37
10a	REINJECTION POTENTIOMETRIC SURFACE DIFFERENCE MAP, Upc2, B WELLS, 3/30-3/3/81	39
10b	REINJECTION POTENTIOMETRIC SURFACE DIFFERENCE MAP, Upc2, B WELLS, 4/29-3/3/81	40
10c	REINJECTION POTENTIOMETRIC SURFACE DIFFERENCE MAP, Upc2, B WELLS, 6/24-3/3/81	41
11a	REINJECTION POTENTIOMETRIC SURFACE DIFFERENCE MAP, Lpc3, B WELLS, 3/30-3/3/81	43
11b	REINJECTION POTENTIOMETRIC SURFACE DIFFERENCE MAP, Lpc3, B WELLS, 4/29-3/3/81	44
11c	REINJECTION POTENTIOMETRIC SURFACE DIFFERENCE MAP, Lpc3, B WELLS, 6/24-3/3/81	45
12a	CHANGE IN WATER LEVELS FROM THOSE EXPECTED WITHOUT REINJECTION, UINTA WELLS, AFTER 60 DAYS OF REINJECTION	51
12b	CHANGE IN WATER LEVELS FROM THOSE EXPECTED WITHOUT REINJECTION, UINTA WELLS, AFTER 90 DAYS OF REINJECTION	52
12c	CHANGE IN WATER LEVELS FROM THOSE EXPECTED WITHOUT REINJECTION, Upc1 & UINTA COMPOSITE WELLS, AFTER 60 DAYS OF REINJECTION	53
12d	CHANGE IN WATER LEVELS FROM THOSE EXPECTED WITHOUT REINJECTION, Upc1 & UINTA COMPOSITE WELLS, AFTER 90 DAYS OF REINJECTION	54



Figure

Page

13a	CHANGE IN WATER LEVELS FROM THOSE EXPECTED WITHOUT REINJECTION, Upc2 WELLS, AFTER 30 DAYS OF REINJECTION	56
13b	CHANGE IN WATER LEVELS FROM THOSE EXPECTED WITHOUT REINJECTION, Upc2 WELLS, AFTER 90 DAYS OF REINJECTION	57
14a	CHANGE IN WATER LEVELS FROM THOSE EXPECTED WITHOUT REINJECTION, Lpc3 WELLS, AFTER 30 DAYS OF REINJECTION	58
14b	CHANGE IN WATER LEVELS FROM THOSE EXPECTED WITHOUT REINJECTION, Lpc3 WELLS, AFTER 90 DAYS OF REINJECTION	59

HYDROGRAPHS OF INDIVIDUAL MONITORS

APPENDIX

A1-1	SG-1A-2	A1-26	SG-19
A1-2	SG-9-3	A1-27	AT-1D-2
A1-3	SG-9-4	A1-28	32X-12
A1-4	SG-10	A1-29	SG-1-1
A1-5	SG-10A-A	A1-30	SG-6-2
A1-6	SG-11-3	A1-31	SG-9-1
A1-7	SG-17-3	A1-32	SG-10A-1
A1-8	SG-17-4	A1-33	SG-10A-1
A1-9	SG-17A	A1-34	SG-11-1
A1-10	CB-2	A1-35	SG-18A-1
A1-11	TG71-1	A1-36	AT-1
A1-12	14X-7-1	A1-37	AT-1C-1
A1-13	14X-7-2	A1-38	AT-1C-2
A1-14	31X-12	A1-39	AT-1D-1
A1-15	41X-13	A1-40	SG-11-2
A1-16	SG-1-2	A1-41	AT-1A-1
A1-17	SG-20-3	A1-42	AT-1C-3
A1-18	AT-1D-3	A1-43	SG-6-1,3
A1-19	SG-1A-1	A1-44	SG-8
A1-20	SG-9-2	A1-45	SG-17-1,2
A1-21	SG-10A-2	A1-46	SG-18A-2,3
A1-22	AT-1A	A1-47	SG-20-1,2
A1-23	CB-1	A1-48	SG-21-1,2,3,4
A1-24	CB-3	A1-49	AT-1B-1,2,3
A1-25	CB-4		



	Page
Water Quality	60
Uinta	60
Upcl	60
Upcl/Uinta; Composite Wells	63
Upcl2	63
Lpc3	68
Lpc4	68
CONCLUSIONS AND SPECIAL INTERPRETATIONS	71
Vertical Thermal Gradients	71
Upcl/Uinta	71
Four Senators Zone	71
Upcl2	71
Mahogany Zone	71
Lpc3	71
R-5	72
Lpc4	72
Records of Individual Monitors	72
Elevations of the Potentiometric Surfaces	73
Before Reinjection	73
During Reinjection	73
Implications	73
Summary	74
Transmissivity	76
Effects on Springs, Seeps, and Surface Flows	76
Relation to the Layered Models	76
Anisotropy	77
Effect on the Environment and on the Mining	77
Uinta and Upcl	78
Effects on Alluvial Wells (to October 1981)	79



FIGURE 1  
GENERALIZED STRATIGRAPHY  
C-B TRACT

LIST OF TABLES

Table		Page
1	THE AQUIFER MONITORING SYSTEM AT C-b	15-18
2a	RECORDS OF INDIVIDUAL MONITORS-Upc1	25
2b	RECORDS OF INDIVIDUAL MONITORS-Upc2	26
2c	RECORDS OF INDIVIDUAL MONITORS-Lpc3	27
3	TRANSMISSIVITIES AND STORAGE VALUES	31
4	C-b POTENTIOMETRIC SURFACE ELEVATIONS EXPECTED WITHOUT REINJECTION	47-50
5	STATISTICAL PARAMETERS OF WATER QUALITY, UINTA FORMATION	61-62
6	STATISTICAL PARAMETERS OF WATER QUALITY, Upc1/UINTA COMPOSITES	64-65
7	STATISTICAL PARAMETERS OF WATER QUALITY, Upc2	66-67
8	STATISTICAL PARAMETERS OF WATER QUALITY, Lpc3	69-70



## INTRODUCTION

### General Statement

This report describes some of the activities and results of a program of water injection into bedrock aquifers at the C-b Tract. The water was derived from shaft sinking and related activities in the northwestern part of the Tract. It was reinjected through a specially designed well, 11X-18, central part of the Tract.

The injection period was planned for ninety days in three increasing rates each thirty days long. After establishing baseline conditions, response to injection was monitored in wells open to different horizons in the bedrock.

The engineering and engineering hydrological aspects of the program are described by other consultants in their reports. This report is geohydrological in nature and interpretations, and represents a step in furthering the understanding of the geohydrology of the C-b Tract and its surroundings.

In this report, several topics of special interest are treated. Where unique solutions are not possible, alternate hypotheses are presented.

### Background

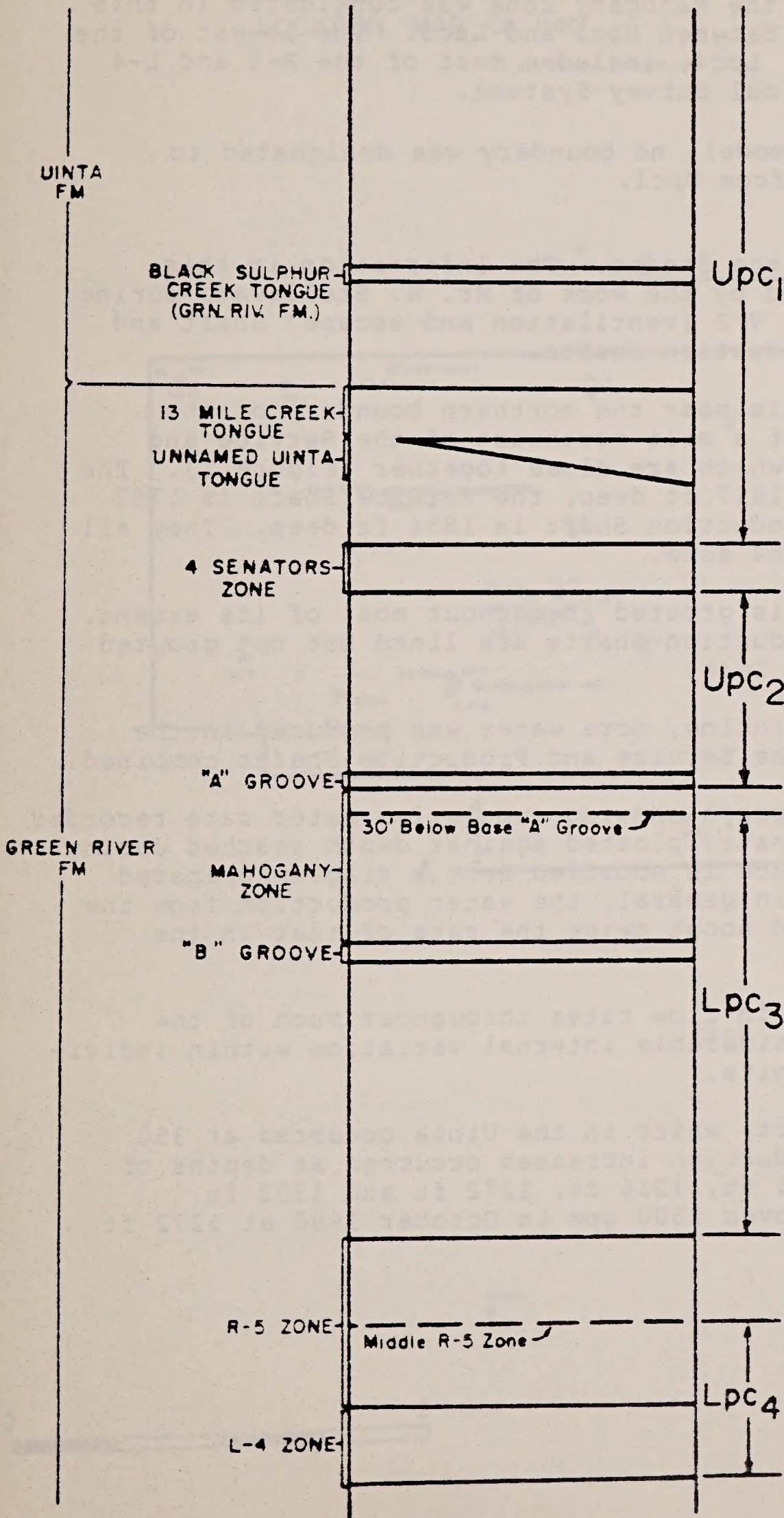
Aquifer System. Figure 1 shows the arrangement of aquifers and aquicludes (or aquitards) as proposed by Mr. David Newell, formerly with the engineering firm of Energy Consulting Associates, Denver, Colorado. It employs the terms Upc1, Upc2, Lpc3 and Lpc4, representing in descending order four aquifer identifications in the Upper Parachute Creek and Lower Parachute Creek Formations.

The model was derived in 1978 from the two exploratory core holes that preceded the sinking of the V/E Shaft and the Service and Production Shafts. Water producing and non-water producing zones were identified by pump-spinner tests run in the core holes.

From the pump-spinner tests, the Four Senators zone was considered an aquiclude or aquitard between Upc1 and Upc2 .



# FIGURE 1 GENERALIZED STRATIGRAPHY Cb TRACT





The Mahogany Zone which has for many years been considered an aquiclude or an aquitard, showed water production in its lower part during the pump-spinner tests. Therefore, only the upper 25 ft of the Mahogany Zone was considered in this model as a barrier between Upc2 and Lpc3. The lowest of the four aquifer units, Lpc4, includes most of the R-5 and L-4 zones (U.S. Geological Survey System).

In the Newell model, no boundary was designated to separate the Uinta from Upc1.

Water Make in the Shafts. The information in this section was provided by the work of Mr. N. Stellavato during the sinking of the V/E (ventilation and escape) Shaft and the Service and Production Shafts.

The V/E Shaft is near the northern boundary of the Tract and about half a mile northeast of the Service and Production Shafts, which are close together (Figure 2). The V/E Shaft is about 1617 ft deep, the Service Shaft is 1757 ft deep, and the Production Shaft is 1856 ft deep. They all terminate in the Lpc4 zone.

The V/E Shaft is grouted throughout most of its extent. The Service and Production Shafts are lined but not grouted and are designed to leak.

During shaft sinking, more water was produced in the V/E Shaft than in the Service and Production Shafts combined.

Figure 3 is a graph showing cumulative water rate recorded in the shafts (ordinate) plotted against depth reached during drilling. This figure is modified from a diagram prepared by N. Stellavato. In general, the water production from the V/E Shaft maintained about twice the rate of that in the other two shafts.

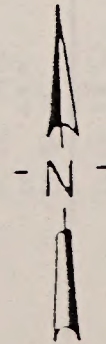
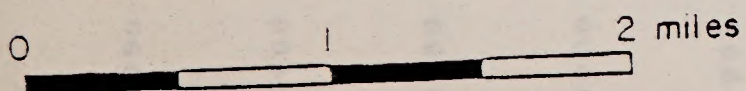
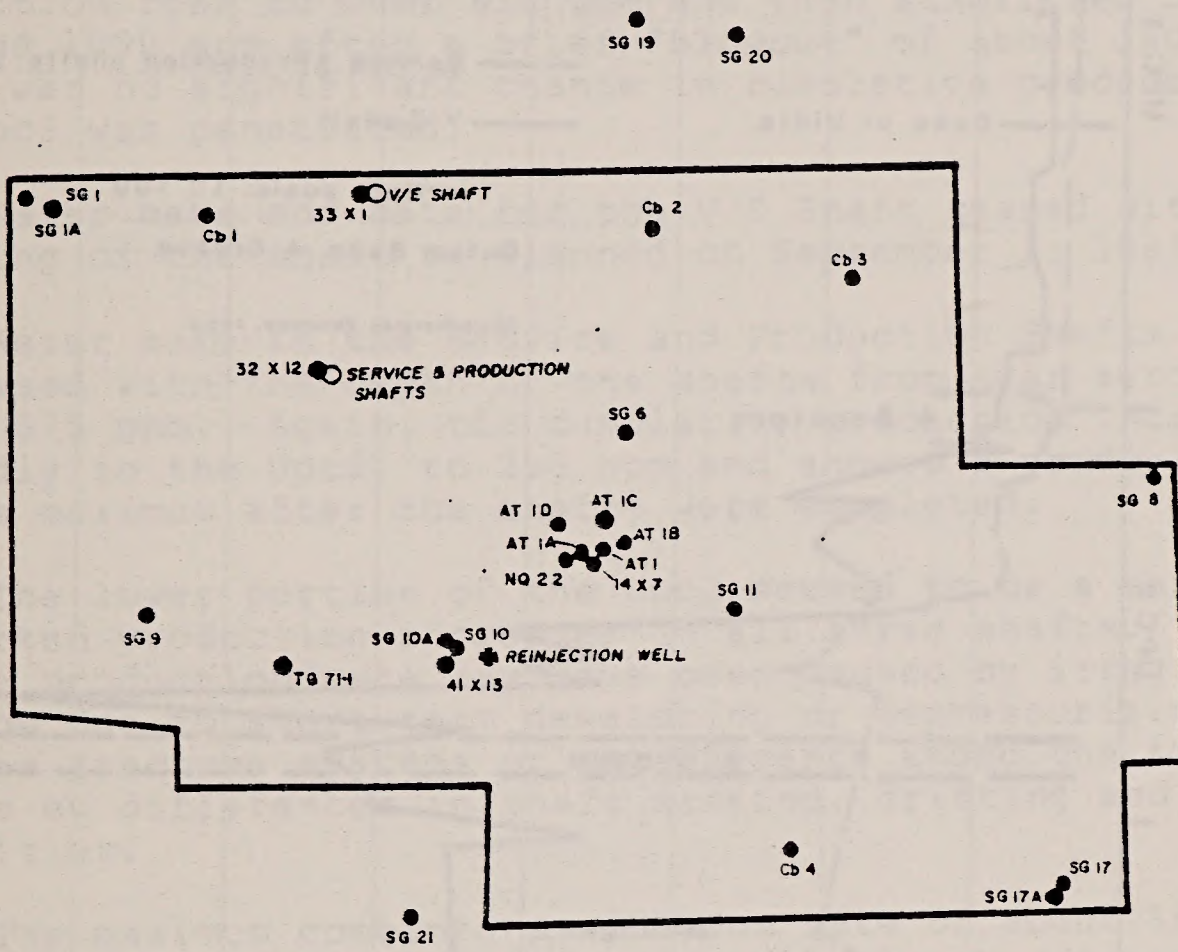
Irregularities in flow rates throughout much of the depth indicates considerable internal variation within individual ground water units.

In the V/E Shaft, water in the Uinta occurred at 350 ft. Significant production increases occurred at depths of 665 ft, 809 ft, 1120 ft, 1216 ft, 1272 ft and 1302 ft. Production rose to over 1500 gpm in October 1980 at 1272 ft depth.

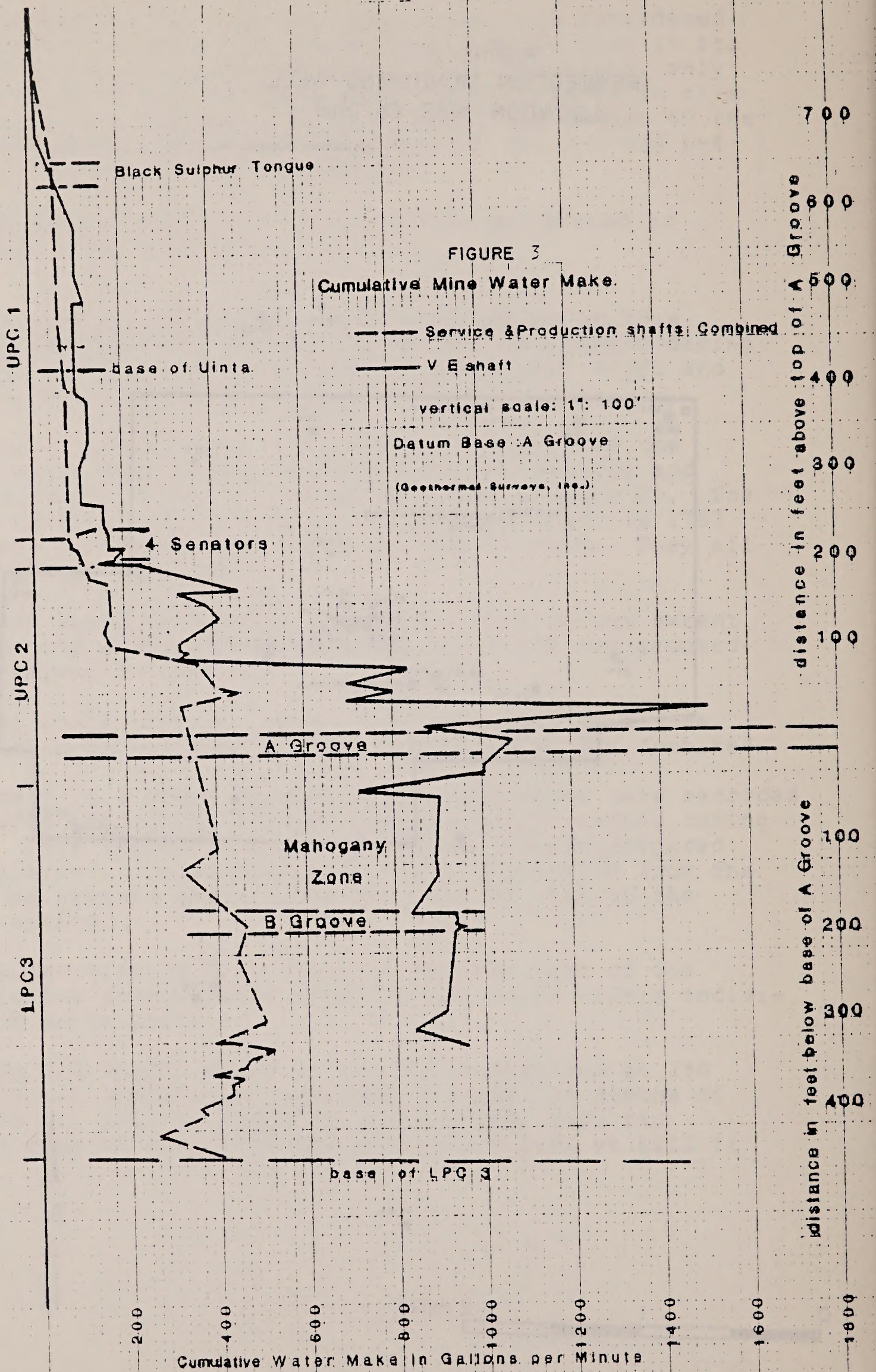


FIGURE 2  
REINJECTION MONITORING WELL  
LOCATION MAP, Cb Tract

GEOTHERMAL SURVEYS, INC.









In the Service and Production Shafts, water production began at about 365 ft depth. Significant increases in production occurred around 889 ft, 1200 ft, 1281 ft, 1531 ft, and 1852 ft depth.

Water make in the V/E Shaft gradually trended upward from encounter in the Uinta to around 400 gpm in the middle of the Upc2 (elev. 5580'). In the deeper part of the UPC2 production rose to over 830 gpm and then stabilized between 725 and 1000 gpm after a brief "blowout" of about 1600 gpm. There was no significant change in cumulative production as the Lpc3 was penetrated.

Water make and data for the V/E Shaft ceased with the flooding of the shaft as planned on September 2, 1981.

Water make in the Service and Production Shafts gradually increased with the depth of the shafts from near zero to about 575 gpm. Again, the cumulative production increased markedly in the Upc2, to 230 gpm and showed a gradual increase to its maximum after the shafts were completed.

The lower portion of the Upc2 seemed to be a threshold to marked production increases in all three shafts. Decreases in the production rate may have been caused by irregularities in flow due to short-term dewatering or depressurizing of complex fracture systems or interference among the three shafts by differences in shaft sinking, drifting and pumping activities.

The maximum combined production rate of about 1600 gpm occurred during the temporary blowout. In the deeper parts of the shafts, the general production rate was about 900 gpm in the V/E Shaft, and about 500 gpm in the Service and Production Shafts combined.

Temporary surging of water from fractures and vugs shortly after release by drilling was reported by N. Stellavato as a common occurrence, and this was also observed in the shafts by J.H. Birman.

Potentiometric Surfaces Before Reinjection. Occidental had been measuring water levels on and off the Tract for many years prior to reinjection. This provided a general understanding of potentiometric water levels within the bedrock.



In order to improve this understanding and to relate the observations more closely to the four aquifer model, D. Newell worked out a program to recomplete many of the wells. The recompletion program was finished a few months before the start of reinjection.

Figures 4 and 5a-c are computer-drawn potentiometric contour maps respectively before and after recompletion. They provide a base against which the reinjection results can be interpreted.

Because the water is controlled largely by complex fracture porosity and because the well completions are not in the same exact horizons the results must be considered general.

Long term potentiometric configurations prior to reinjection showed an overall slope to the north. Another long term configuration is a trough in the potentiometric surface extending and sloping to the northwest.

## DESIGN AND OPERATION OF THE REINJECTION AND MONITORING PROGRAM

### Reinjection Well

The injection program was planned in three consecutive stages of 30 days each. The rates were to be at 150 gpm, 300 gpm, and 450 gpm, respectively.

The location of the reinjection well (11X-18) is shown in Figure 2. Figure 6 shows the construction of the reinjection well. The zone open to reinjection extends from 1102 ft depth to 1771 ft depth. Therefore, the reinjection was into the Upc2 and Lpc3 zones..

The water for reinjection was derived from the shafts and transported to Ponds A and B where it was treated according to the normal procedure in those ponds. From there it was piped to Pond C, which is about 200 ft from the reinjection well. From Pond C the water was passed through a series of



FIGURE 4  
ALL WELLS  
APRIL, 1980

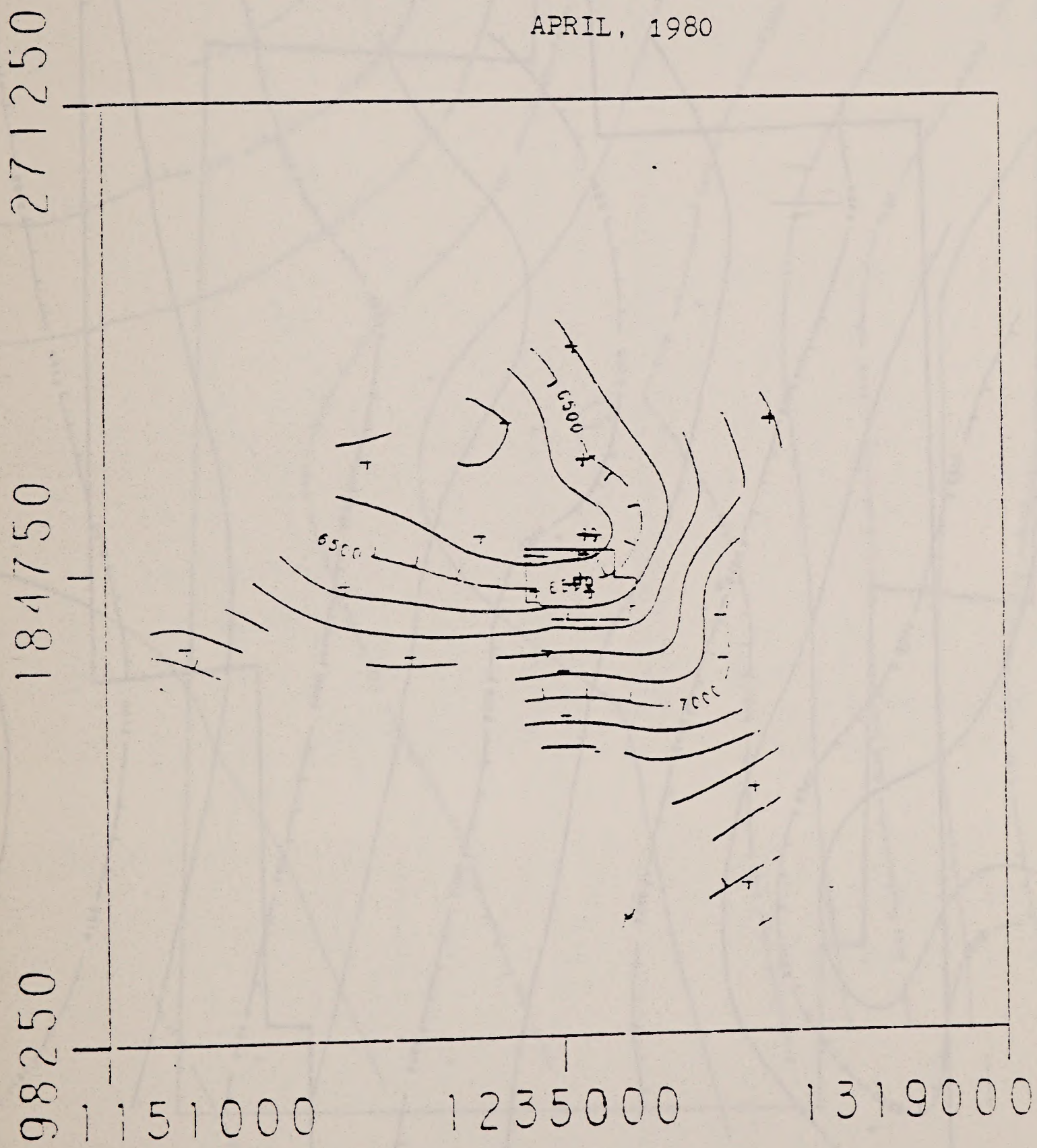




FIGURE 5a

POTENTIOMETRIC SURFACE AFTER RECOMPLETION - UPC1 WELLS  
Units (feet)

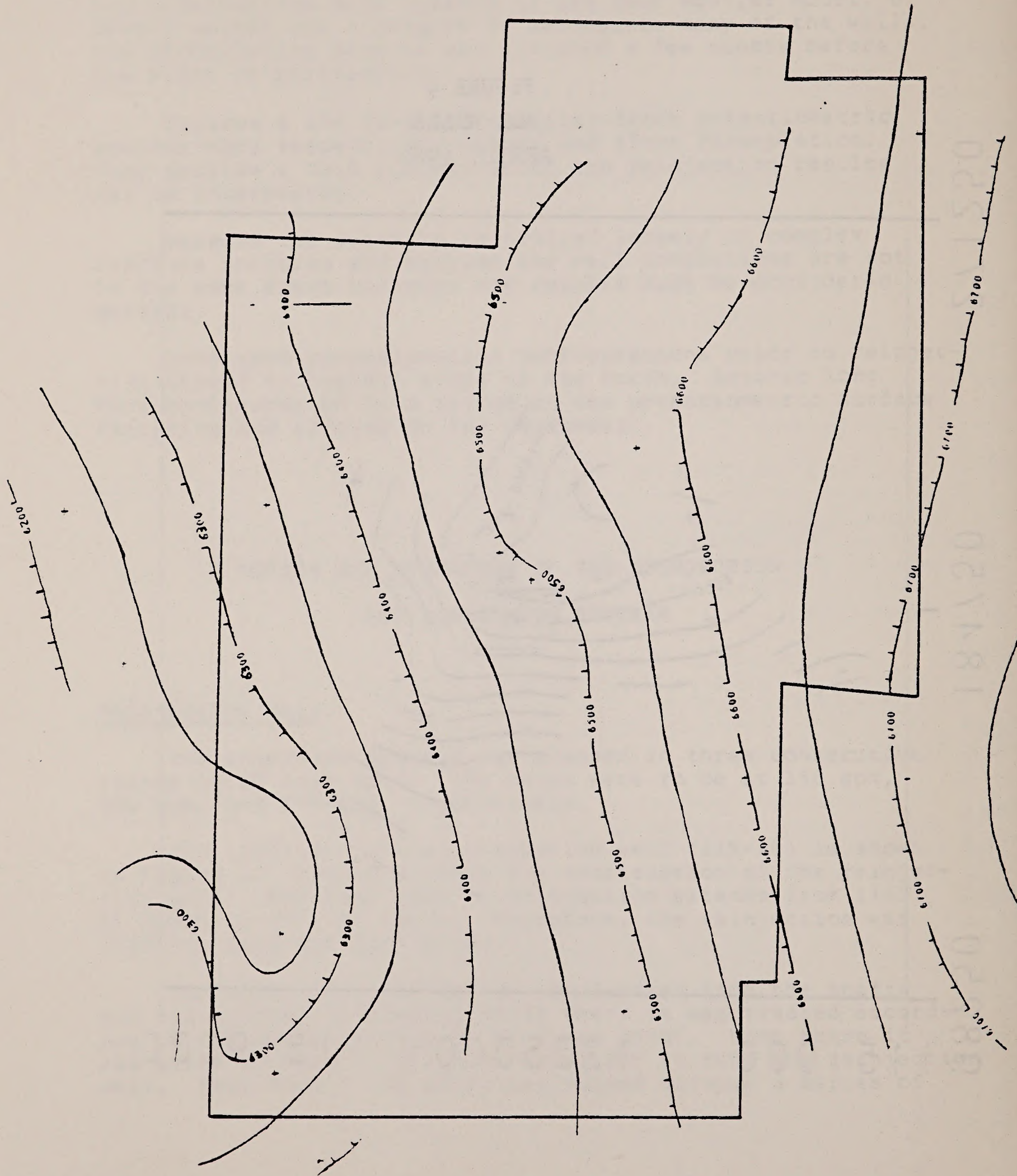




FIGURE 5b

POTENTIOMETRIC SURFACE AFTER RECOMPLETION - UPC2 WELLS  
Units (feet)

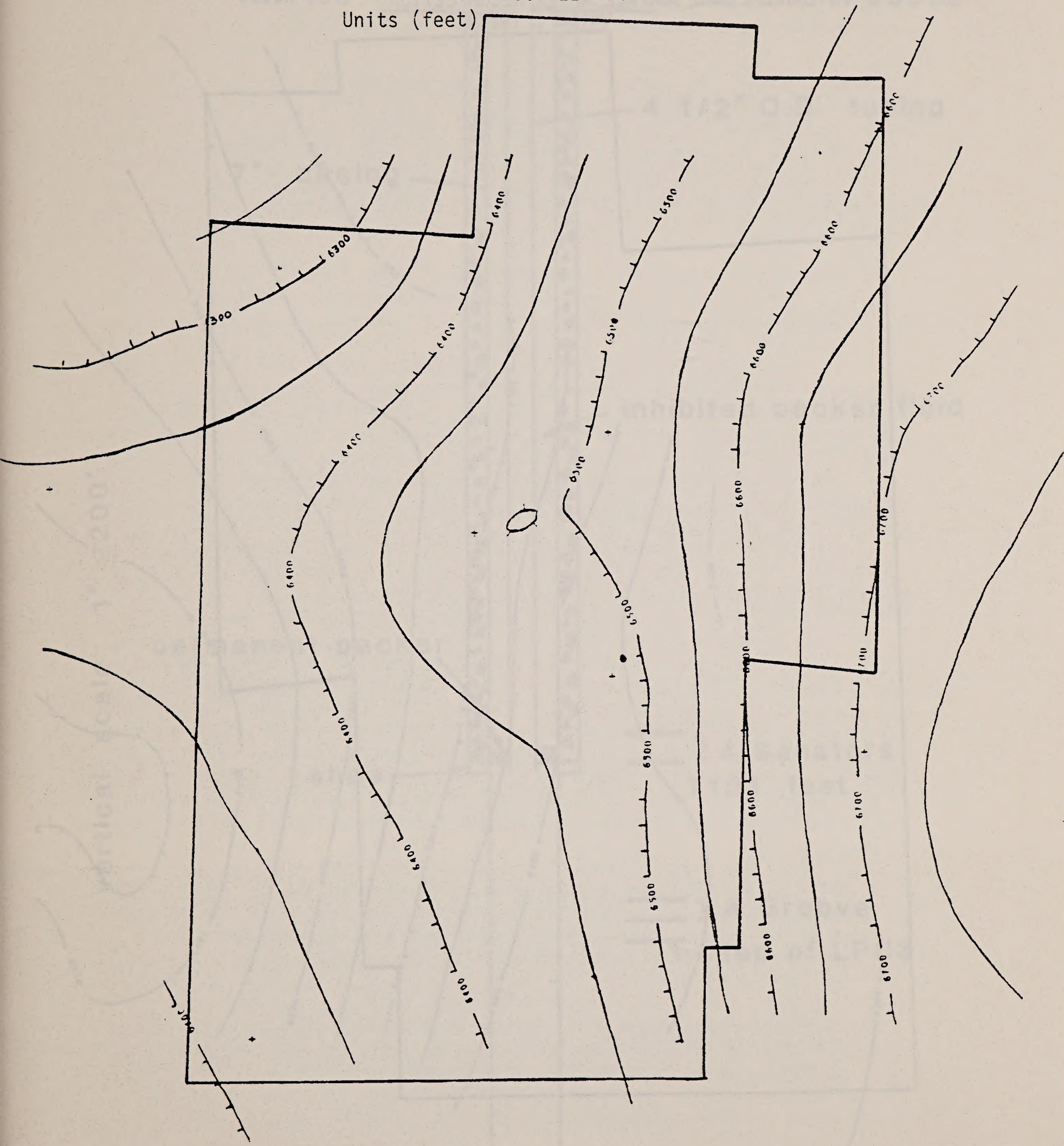




FIGURE 5c

POTENTIOMETRIC SURFACE AFTER RECOMPLETION - LPC3 WELLS  
Units ( feet ) .

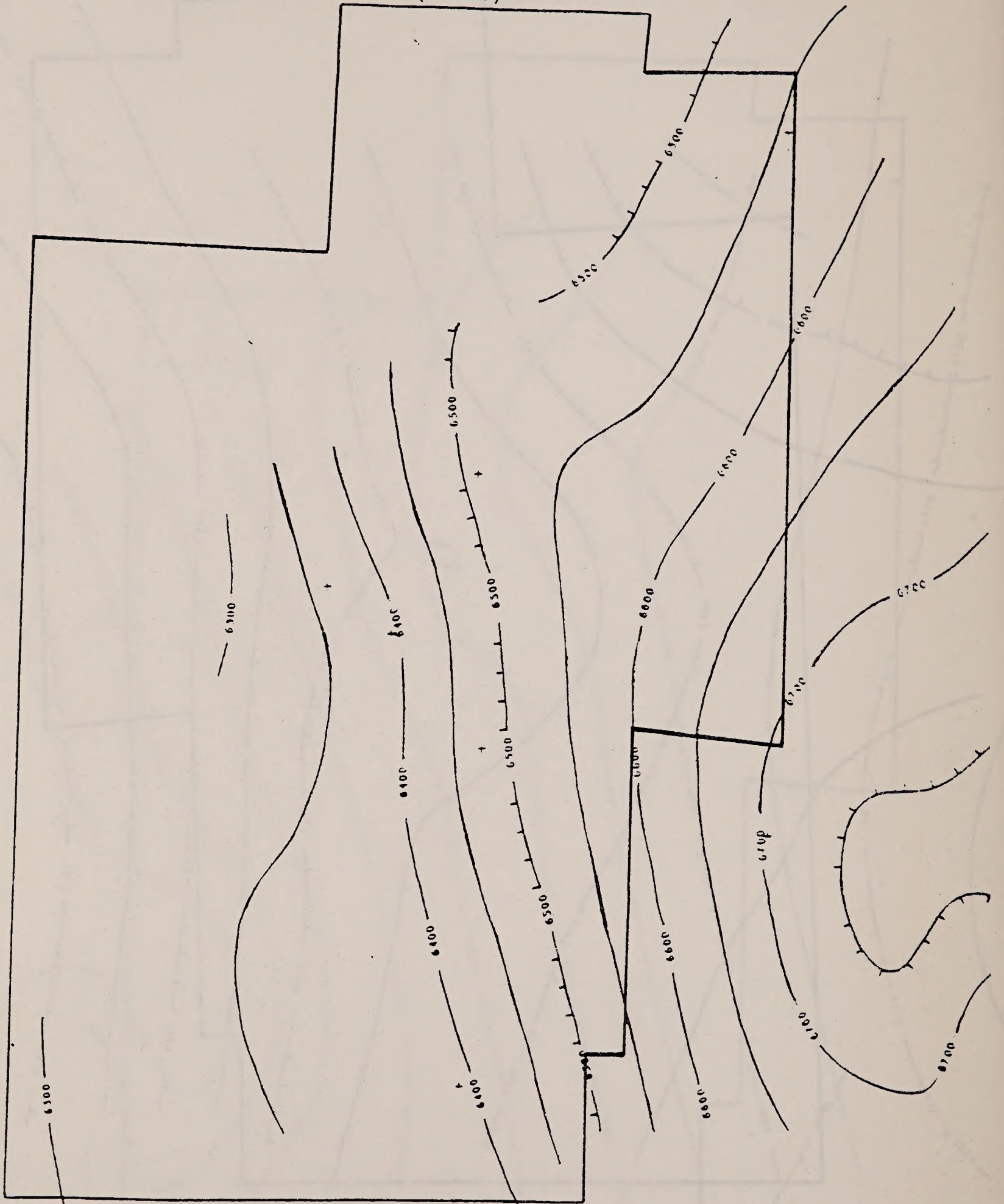
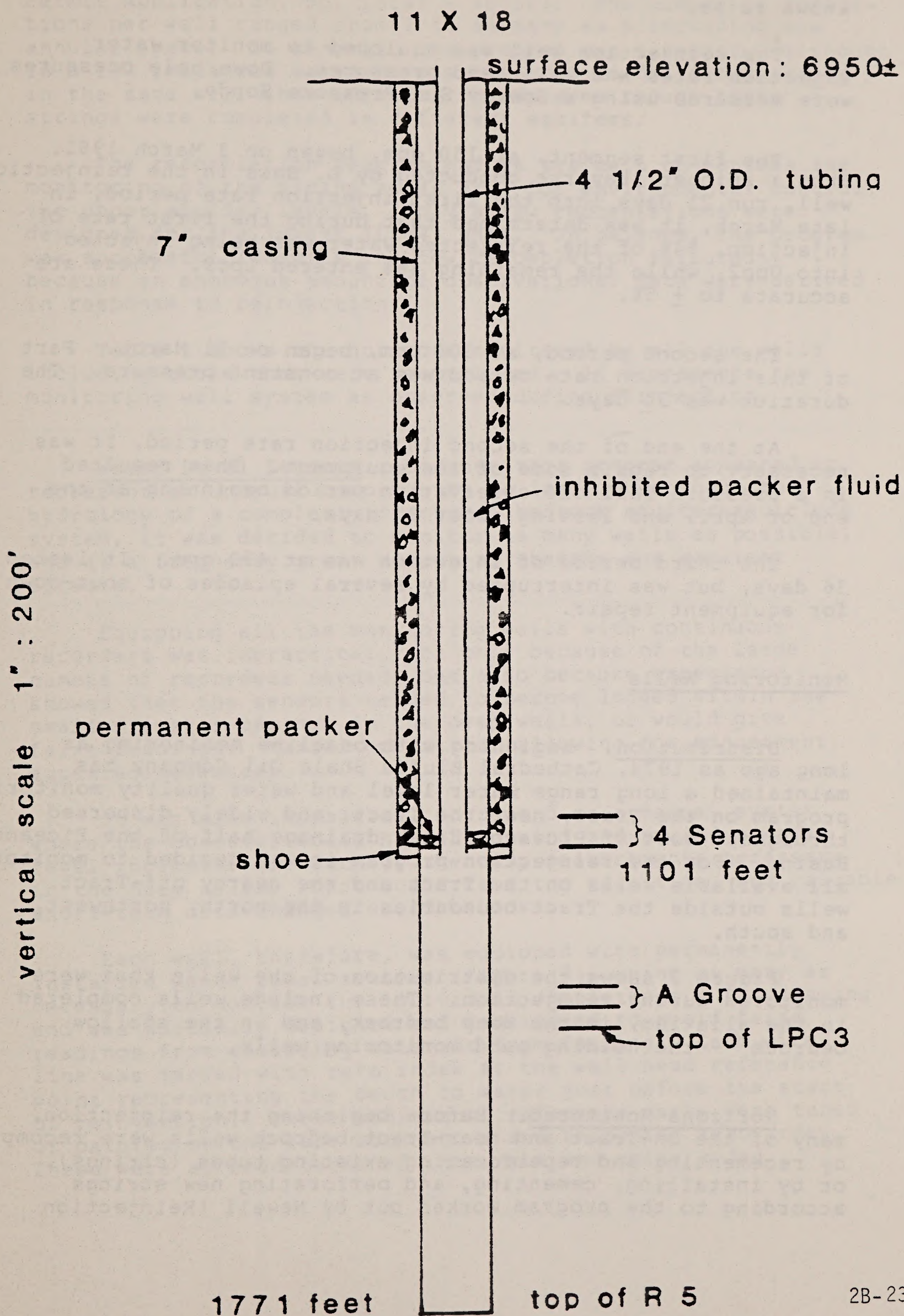




FIGURE 6





control filters and pumped into the reinjection well at known rates.

The reinjection well was equipped to monitor water injection rates and well head pressures. Down hole pressures were measured using a Sperry Sun Pressure Sonde.

The first segment, at 150 gpm, began on 3 March 1981. From a spinner traverse conducted by D. Bass in the reinjection well, run 21 days into the first injection rate period, in late March, it was determined that during the first rate of injection, 54% of the reinjected water was being injected into Upc2, while the remaining 46% entered Lpc3. These are accurate to  $\pm 5\%$ .

The second period, at 300 gpm, began on 31 March. Part of this injection rate period was at constant pressure. The duration was 30 days.

At the end of the second injection rate period, it was necessary to repair some of the equipment. This resulted in a pressure fall off observation period beginning at the end of April and lasting about 20 days.

The third period of injection was at 450 gpm. It lasted 36 days, but was interrupted by several episodes of shut-down for equipment repair.

### Monitoring Wells

Distribution. Beginning with baseline monitoring as long ago as 1974, Cathedral Bluffs Shale Oil Company has maintained a long range water level and water quality monitoring program on the Tract, near the Tract, and widely dispersed throughout most of Piceance Creek drainage half of the Piceance Basin. For the reinjection program it was decided to monitor all available wells on the Tract and the nearby off-Tract wells outside the Tract boundaries in the north, northwest, and south.

Figure 2 shows the distribution of the wells that were monitored during reinjection. These include wells completed in the alluvium, in the deep bedrock, and in the shallow bedrock -- the holding pond monitoring wells.

Horizons Monitored. Before beginning the reinjection, many of the on-Tract and near-Tract bedrock wells were recompleted by recementing and reperforating existing tubes (strings), or by installing, cementing, and perforating new strings according to the program worked out by Newell (Reinjection



Permit Application, pp. 10.47 - 10.50). The number of completions per well ranged from 1 to as many as 5 including the annular space. In general, the program was successful although in a few instances water levels measured in different stages in the same well show identical heads even though these strings were completed in different aquifers.

The recompletion program had as its main objectives the monitoring of the mining zones and, for environmental control, the upper aquifer levels. Only a few recompletions were designed for the lowest (Lpc4) unit. On balance, the program was successful (despite the few recompletion failures), because an enormous amount of observational data were derived in response to reinjection.

Table I shows the horizons monitored by all the wells including those that were recompleted. It represents the monitoring well system as observed during reinjection.

Water Level Sensors. Because this program appeared to represent an unusual opportunity to learn more about the hydrology of a complexly fractured bedrock aquifer-aquiclude system, it was decided to monitor as many wells as possible, and at a frequency great enough to observe the earliest effects.

Equipping all the monitoring wells with continuous recorders was impractical, not only because of the large number of recorders needed, but also because experience showed that the sensors tended to become lodged within the small-diameter casings in the deep wells, or would give false readings. Manual operation, allowing for adjustment, appeared necessary.

It was also impractical to depend on a manual system where the observer would have to unwind and rewind a water level indicator for each of the many measurements necessary in the deep wells. That would take too much time, and valuable short-term data changes would be lost.

Each well, therefore, was equipped with permanently installed water level sensors (Figure 7), using as many as necessary to monitor the individual completions. The sensing end was specially designed and fabricated to avoid false readings from cascading water or from fouling. Each wire line was marked with zero index at the well head reference point representing the depth to water just before the start of reinjection. Three additional reference marks were taped or painted on the wire both above and below the zero index. These were at predetermined intervals and color coded.



TABLE 1

## THE AQUIFER MONITORING SYSTEM AT C-b

Prior to Recompletion

After Recompletion

Well/ String	Perfora- tion	Formation Monitored	Collar Elev.	1981 Com- puter Code	Recomple- tion Date	Monitored Interval	Formation Monitored	Change in Aquifer Monitored
CB-1	1540-2079	LPC3&LPC4	6760	WD01	11-12-80	1075/1275	UPC2	yes
CB-2	1126/1320	UPC2&LPC3	6737	WD02	11-14-80	Above 1050	UPC1/Uinta	yes
CB-3	unknown	TD 2123	6743	WE03	11-15-80	1128/1240	UPC2	yes
CB-4	1190-1324	UPC2&LPC3	7054	WE04	11-11-80	1094/1194	UPC2	yes
SG1-1	1071-1726	LPC3&LPC4	6428	WG12	11-1-80	1071/1440	LPC3	yes
SG1-2	874-990	UPC2	6428	WD12	10-31-80	Above 717	Composite- UPC1/Uinta	yes
SG1A-1	above 1180	LPC3	6426	WE11	11-12-80	780/980	UPC2	yes
SG1A-2	new		6426	WD11	10-31-80	450/500	Uinta	yes
SG6-1	1625-2208	LPC3&LPC4	6888	WE61	10-20-80	1100/1300	UPC2	yes
SG6-2	1430-1470	LPC3	6888	WG61		1430/1470	LPC3	no
SG6-3	1100-1193	UPC2	6888	WD61	10-17-80	Above 864	Composite- UPC1/Uinta	yes
SG8	949-1650	UPC2, LPC3 LPC4	6538	WY81		949-1650		no
SG9-1	1316-2324	LPC3	6870	WG91	10-20-80	1316-1646	LPC3	no
SG9-2A	1054-1210	UPC2	6870	WE91	10-14-80	1055-1210	UPC2	no
SG9-3	new		6870	WD91	10-15-80	720-770	Uinta	
SG9-4	new		6870	WC91	10-13-80	Above 500	Uinta	



TABLE 1 (CONT'D.)

Prior to Recompletion				After Recompletion				
Well/ String	Perfora- tion	Formation Monitored	Collar Elev.	1981 Com- puter Code	Recomple- tion Date	Monitored Interval	Formation Monitored	Change in Aquifer Monitored
SG10	1425-1510	LPC3&LPC4	6950		5-20-79	510-530	Uinta	yes
SG10A-1	above 1300	LPC3	6950	WG51	5-20-79	1360-1490	LPC3	no
SG10A-2	new		6950	WE51	5-20-79	1099-1149	UPC2	yes
annulus	new				5-20-79	Above 360	Uinta	yes
SG11-1	1580-1870	LPC3&LPC4	6900	WG52	10-18-80	1580-1650	LPC3	yes
SG11-2	1385-1435	LPC3	6900	WE52	10-18-80	1070-1270	UPC2	yes
SG11-3	1100-1290	UPC2	6900	WD52	10-18-80	Above 862	UPC1/Uinta	yes
SG17-1	1292-2254	LPC3&LPC4	7039	WG17	10-21-80	1292-1624	LPC3	yes
SG17-2	1088-1228	UPC2	7039	WE17	11-2-80	1030-1084	UPC2	yes
SG17-3	new		7039	WD17	11-2-80	696-746	Uinta	
SG17-4	new		7039	WC17	11-2-80	Above 566	Uinta	
SG17A	new		7036	WD57	10-30-80	Above 450	Uinta	
SG18A-1	1224-1330	UPC2	7383	WG18	11-17-80	1355-1776	LPC3	yes
SG18A-2	new		7383	WE18	11-17-80	1135-1300	UPC2	yes
SG18A-3	new		7383	WD18	11-17-80	Above 103	Composite- Uinta/UPC1 & UPC2	yes



TABLE 1 (CONT'D.)

Prior to Recompletion				After Recompletion				
Well/ String	Perfora- tion	Formation Monitored	Collar Elev.	1981 Com- puter Code	Recomple- tion Date	Monitored Interval	Formation Monitored	Change in Aquifer Monitored
SG19	composite	Uinta, UPC1,UPC2	6384		11-80	193-233, 744, 781- 981	Inactive	
SG19	Inactive							
SG20-1	737-797	UPC1	6358	WG20	11-14-80	1100-1440	Inactive	yes
SG20-2	new		6358	WE20	11-15-80	870-940	UPC2	
SG20-3	new		6358	WD20	11-15-80	Above 861	Composite- UPC1/Uinta	
SG21-1	886-1036	UPC2	6811	WH21	11-3-80	1520-1630	LPC4	
SG21-2	new		6811	WG21	11-10-80	1050-1430	LPC3	
SG21-3	new		6811	WE21	11-11-80	820-1000	UPC2	
SG21-4	new		6811	WD21	11-20-80	Above 792	UPC1/Uinta	
14X7-1	TD 957	UPC1	6914	WD14	11-15-80	850-900	Uinta	yes
14X7-2	new		6914	WD15	11-15-80	388-438	Uinta	
AT1	1430-1700	LPC3	6909	WY44		1430-1700	LPC3	no
AT1A	1350-1590	LPC3	6909			1170	UPC2	yes
AT1A-1	1257-1341	UPC2&LPC3	6909			1257-1341	UPC2	no
AT1B-1	1360-1430	LPC3	6909			1360-1430	LPC3	no
AT1B-2	No		6909					

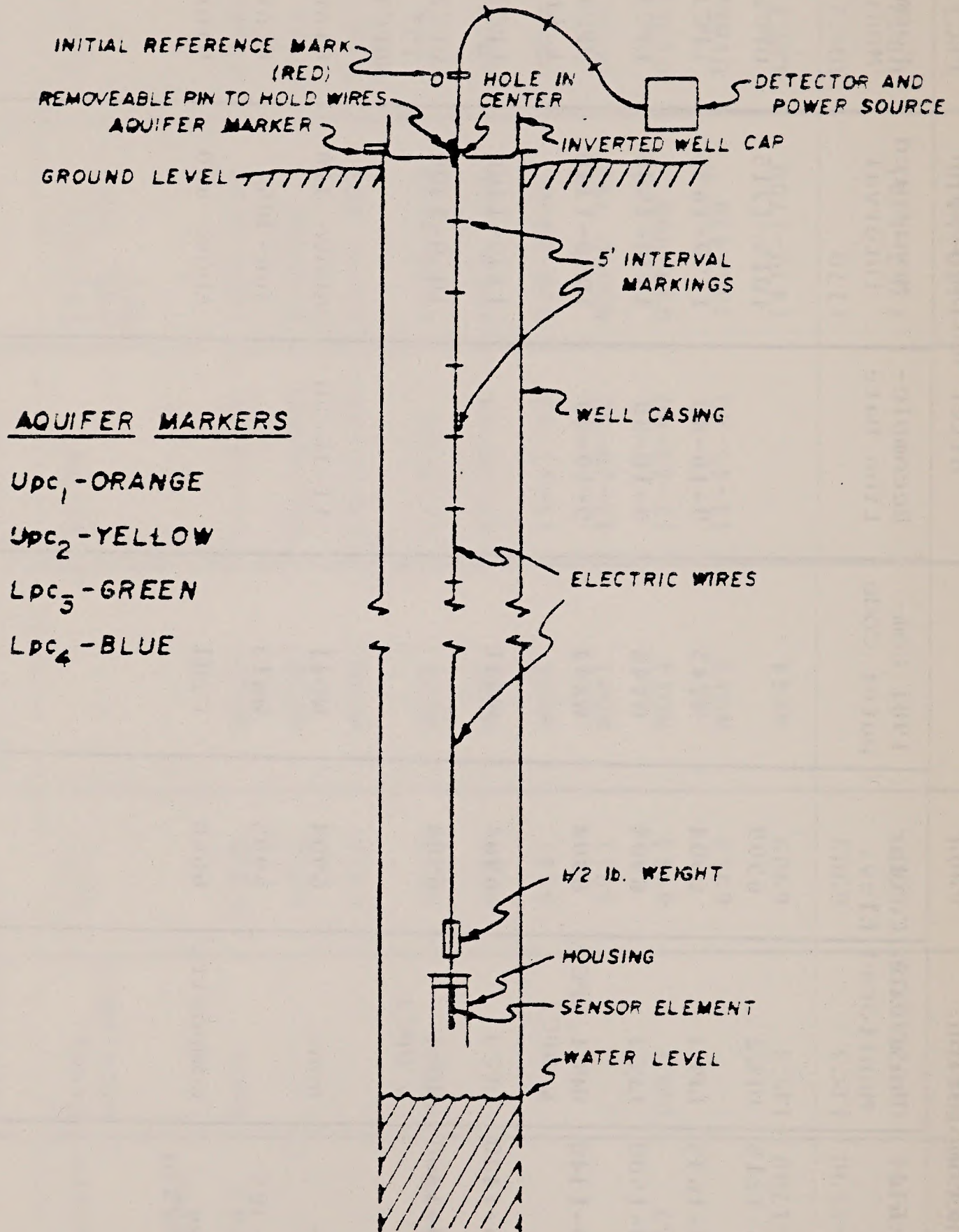


TABLE 1 (CONT'D.)

Prior to Recompletion				After Recompletion				
Well/ String	Perfora- tion	Formation Monitored	Collar Elev.	1981 Com- puter Code	Recomple- tion Date	Monitored Interval	Formation Monitored	Change in Aquifer Monitored
AT1B-3	1015-1215	UPC2	6909			1015-1215	UPC2	no
AT1C-1	1550-1635	LPC3	6904	WY45	9-10-80	1550-1635	LPC3	no
AT1C-2	1430-1500	LPC3	6904	WY46	9-10-80	1430-1500	LPC3	no
AT1C-3	1050-1340	UPC1, LPC3 & UPC2	6904	WX44	9-10-80	1050-1340	UPC1, UPC2 & LPC3	no
AT1D-1	1335-1480	LPC3	6904	WG41		1335-1480	LPC3	no
AT1D-2	1050-1300	UPC1 & UPC2	6904			1050-1300	UPC2 & 15' of UPC1	no
AT1D-3	none	none	6904	WD41	11-16-80	Above 310	Uinta	yes
41X13	366-385		6905	WW13		366-385	Uinta	no
TG71-1	above 126-2530	composite	6660	C201		Above 680	Uinta	no



# FIGURE 7 WATER LEVEL SENSOR



GEOTHERMAL SURVEYS, INC.



Some of the wells were equipped with continuous recorders. These were the alluvial wells, some of the larger diameter deep bedrock wells near the reinjection well, and 32X-12, the deep corehole monitoring the Service and Production Shafts.

In supporting this system Cathedral Bluffs Shale Oil Company has provided data which we believe will make a unique contribution to the understanding of Piceance Basin hydrology. This report should be considered only a first step in the interpretations and analyses that may ultimately be made.

## DATA COLLECTED

### Water Level Measurements

Prior to the Reinjection Test, water levels were measured monthly in all bedrock monitors and weekly in a few key monitors. Two weeks before the beginning of the test, a program of daily measurement was instituted. This schedule was maintained until the beginning of June. Measurements were then taken every two to three weeks, except during the filling of the VE Shaft when daily reading was briefly reinstated.

A few wells (AT1C-1, AT1D-1, SG10A-Ann, SG10A-1, SG10A-2 and SG6-2) were monitored intensively at the beginning and/or at the step-up points of the test.

### Temperature Logging

Before reinjection began, a series of down-hole temperature logs was made in several of the wells. This was done by lowering a calibrated thermistor probe into each well, stopping at predetermined intervals, allowing the sensor to reach equilibrium and making a reading.

The objectives were to learn more about individual aquifer zones and to recognize intervals of cross flow as indicated by changes in the normal thermal gradient.

### Water Quality

In order to avoid disturbing the water level data base before the start of reinjection, swabbing the wells to obtain samples for quality had to be discontinued. Because of



unavoidable delays in starting the reinjection, no water quality samples were able to be obtained during late fall, winter and spring of 1980-1981.

The last quality measurements before reinjections were made in June, 1980. The first quality samples after reinjection were made in July, 1981.

## DATA ANALYSIS

### Downhole Thermal Gradients

Thermal logging of thirteen monitoring wells on the C-b Tract was done by Geothermal Surveys, Inc. between October, 1980 and January, 1981. The purpose was to determine, if possible, aquifer units of relatively high flow and aquitards of relatively low flow or no flow.

The downhole thermal logging technique consists of lowering a cable mounted, precisely calibrated thermistor probe in selected monitoring wells. Electrical resistances at equilibrium were measured at depth intervals of 20 ft, using a Wheatstone bridge. Data were converted to temperature using a calibration curve generated for the individual thermistor probe.

Profiles of temperature versus depth were plotted and analyzed to determine relative flow characteristics. Zones of low or reversed temperature gradient normally indicate active ground water movement. Zones of high temperature gradient normally indicate little or no ground water movement. Vertical flow across strata is usually indicated by zero gradient.

Results of the thermal logging are presented in Figure 8, in columnar form with a generalized stratigraphic section showing the four aquifer concept of Newell for the C-b Tract area. Depths have been adjusted to the generalized stratigraphy using the base of the A-Groove as datum, and the stratigraphic picks of Newell and Beard.

Figure 8 shows that ground water flow in the Uinta Formation and Parachute Creek Member of the Green River Formation ranges widely among monitoring wells. This is as expected where flow is probably controlled to a large extent by fractures rather than by lithology entirely. However, some stratigraphic zones of relatively high and low flow were revealed by the thermal logging.



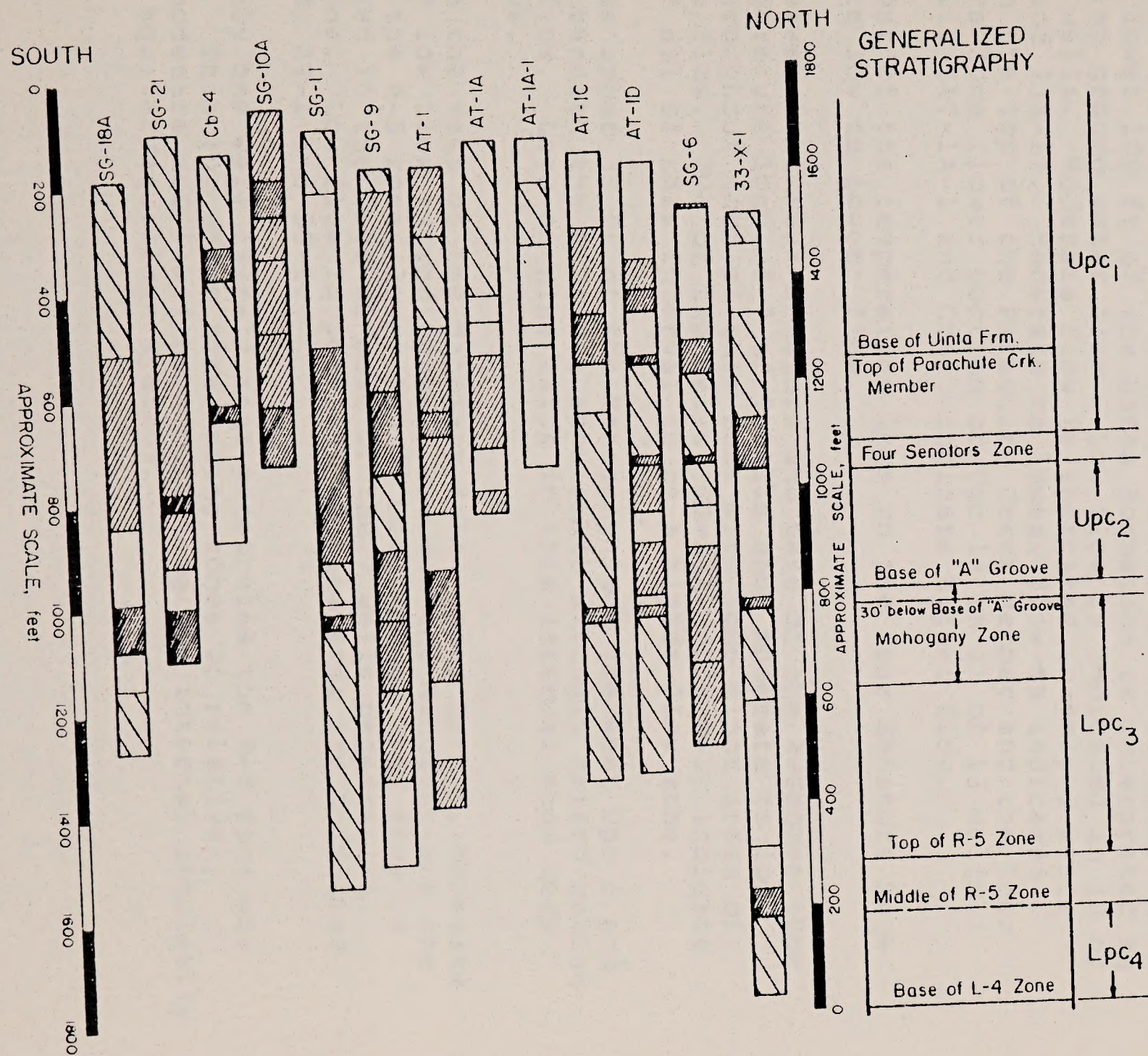






FIGURE 8  
AQUIFER CHARACTERISTICS  
BASED ON THERMAL LOGGING

FLOW TERMS ARE RELATIVE

-  HIGHEST FLOW INDICATED
-  MODERATE FLOW (INTERBEDDED HIGH AND LOW FLOW ZONES INDICATED)
-  LOW FLOW INDICATED
-  LOWEST FLOW INDICATED







In this entire discussion that follows the terms high flow, low flow, and moderate flow are relative only. They imply no numerical rate values whatsoever. The term "high flow" can refer to rates of a few feet per year or small fractions of a foot per year or any other value relative to the other terms.

The results seem reasonable in most wells except AT-1A-1. Here, relatively high flow is indicated throughout almost the entire section, suggesting cross flow (vertical) at the Aquifer Test Pad. This, too, is as expected; there are several open holes in the Aquifer Test Pad area that can provide vertical communication among the different units.

Most of the Upc 1 thermal logs exhibit relatively moderate to high flow in 9 of 13 wells and low flow in 3 wells. Much of the lower 100 ft of the Uinta Formation is interpreted as retarding ground water flow. Low flow is indicated in 10 of the 13 wells. Moderate flow is indicated in only 2 wells (Cb-4 and 33X-1). Moderate to lowest flow is indicated between the top of the Parachute Creek Member and the Four Senators Zone (lower portion of Upc 1) in 11 of 13 wells. Two wells (AT-1A-1 and Cb-4) indicate higher flow.

Most of the temperature logs in the Four Senators Zone indicate low to lowest flow.

Between the Four Senators and base of the A-Groove (Upc 2) temperature logs of 7 of 9 wells show moderate to low flow throughout most of this zone with some minor areas of highest flow. Two of the wells (SG-18A and 33X-1) indicate most or all of this interval to be a higher flow zone.

The upper 30 ft of the Mahogany Zone (between Upc 2 and Lpc 3) beneath the A-Groove appears to strongly retard ground water flow. Logs of nine wells in this interval show very low flow.

In the rest of the Mahogany Zone (upper Lpc 3), moderate to very low flow is indicated. Between the Mahogany and the top of the R-5 zone (lower Lpc 3) moderate to high flow is indicated in the logs of most of the 7 wells penetrating this zone. Low flow in portions of this area are indicated in SG-9, AT-1 and SG-6.

Only one well (33X-1) that penetrates the R-5 zone was logged. This log shows alternating zones of relatively high, moderate and low flow, indicating the internal complexity of the aquifer/aquiclude systems.



In summary, the temperature logging supports the general aquifer-aquitard-aquiclude system suggested by Newell, with modifications in detail. Except for the Aquifer Test Pad, most of the flow is lateral rather than across the units.

The temperature results indicate that water flow is controlled both by fractures and by lithology. The lithologic control is not, except for the leached vuggy zones, due primarily to porous medium conditions. It is because rocks of different lithologic character cause differences in the frequency, orientations, and openness of fractures. Thus, there is a crude stratigraphic arrangement of the distribution of fractures.

Temperatures in many of the wells were logged again after reinjection. Pre- and post-injection changes were recorded within the target aquifer zones, but not in most of the formations above the injection zones. This is discussed in the section on Conclusions and Special Interpretations.

### Water Levels

Records of Individual Monitors - Characteristic Curve.  
Records of daily water level readings were computer graphed (Appendix I). In many monitors a curve is seen which presents a rapid response to the injection pattern. This appears to be a pressure response because of its rapidity. This curve is referred to in this section as the Characteristic Curve.

The Characteristic Curve has four limbs: The first positively sloped segment is interpreted as a response to the first 23 days of reinjection when the injection rate was fairly constant at an average of 155 gallons per minute. The second limb is at first more positively sloped and then rapidly decreases to a slope of zero. During this time, reinjection rate was increased to three hundred gallons per minute for fifteen days and then declined to one hundred eighty five gallons per minute for twelve days. Following this, there was no injection for twenty days. The third limb of the curve reflects this with a sharply negative slope. The fourth limb is again positively sloped and reflects the fourth period of reinjection which was generally maintained at 445 gpm. For a three day period during the middle of the fourth period the injection rate dropped to 171 gpm, and this drop is reflected in the hydrographs of many of the monitors.

For each aquifer, Table 2 shows the type of response seen during reinjection and the magnitude of that response. It also gives the magnitude and direction of change of water level in the period July 10, to September 6, 1981. Increasing water levels are shown as unassigned numbers to the nearest foot; decreasing water levels are shown preceded by a minus sign.



Records of Individual Monitors  
a) UPC1

<u>Well No.</u>	<u>Type of Curve</u>	<u>Change During Reinjection (ft) 3/3-6/30/81</u>	<u>Change After Reinjection (ft) 6/30/81-9/81</u>
AT1-A-1	Characteristic Curve	79	-45
(UPC1-UPC2)			
AT1-D-3	Characteristic Curve	36	-17
C-b 2	No Trend	0	2
SG1-2	Subdued Characteristic Curve	2	-01
SG1A-2	Subdued Characteristic Curve	2	0
SG10	Characteristic Curve	30	15
SG10A-A	Characteristic Curve	32	--
SG11-3	Subdued Characteristic Curve	9	--
SG17-3	No Trend	0	-04
SG17-4	Irregularly Downward	-06	2
SG17-A	No Trend	0	1
SG18A-3	No Trend	0	-13
SG19	Subdued Characteristic	4	--
SG20-3	Subdued Characteristic	3	8
SG21-4	Subdued Characteristic	3	-04
SG6-3	Subdued Characteristic Curve (communications with 6-1)	7	2
SG9-3	Subdued Characteristic Curve	5	-01
SG9-4	Slight Upward Trend	1	-02
14X7-1	Characteristic	66	-39
14X7-2	Subdued Characteristic	8	-25
32X12 (Upper Aquifer)		1	-05
71-1	Subdued Characteristic Curve	10	--
41X13	Generally Smoothly Upward	37	12



## b) UPC2

<u>Well No.</u>	<u>Type of Curve</u>	<u>Change During Reinjection (ft) 3/3-6/30/81</u>	<u>Change After Reinjection (ft) 6/30/81-9/81</u>
AT-1A	Characteristic Curve	81	-110
ATIC-3	Characteristic Curve	79	-46
AT10-2	Characteristic Curve	45	-45
C-b 1	Irregular	-05	--
C-b 3	Generally Smoothly Downward	-03	2
C-b 4	Generally Smoothly Upward	4	1
SG1A-1	Generally Smoothly Upward	1	-03
SG10A-2	Characteristic Curve	110	-359
SG11-2	Characteristic Curve	63	-07
SG17-2	Smoothly Upward (Communicates with 17-1)	11	--
SG18A-2	No Trend (Communicates with 18-3)	-01	-13
SG20-2	Irregularly Downward	-54	-72
SG21-3	Subdued Characteristic Curve (Communicates with 21-2, 4)	3	-40
SG6-1	Subdued Characteristic Curve (Communicates with 6-3)	7	2
SG9-2	Subdued Characteristic Curve	23	-11



## c) LPC3

<u>Well No.</u>	<u>Type of Curve</u>	<u>Change During Reinjection (ft) 3/3-6/30/81</u>	<u>Change After Reinjection (ft) 6/30/81-9/81</u>
AT-1	Characteristic Curve	121	-10
AT1C-1	Characteristic Curve	124	-116
AT1C-2	Characteristic Curve	132	-129
SG1-1	Generally Downward	-23	-08
SG10A-1	Characteristic Curve	167	-195
SG11-1	Generally Downward	-11	62
SG17-1	Smoothly Upward (Communicates with 17-2)	11	--
SG18A-1	No Trend	0	39
SG21-2	Subdued Characteristic Curve (Communicates with 21-3, 4)	3	-41
SG6-2	Characteristic Curve	113	-98
SG9-1	Smoothly Downward	-08	-14



Upcl/Uinta. A response for the present attributed to reinjection can be discerned in 15 of 23 Upcl/Uinta monitors. This response, except around the injection well and at the Aquifer Test Pad, is subdued, ranging from 1 to 10 ft.

Wells which showed no trend were C-b 2, SG 17-3, SG 17-A, and SG 18-A-3. The lack of response may be a function of the distance from the injection well. Only SG 17-4 showed a drop in water level of 6 ft while 71-1 and 9-4 showed smoothly increasing curves of 10 and 1 ft, respectively.

Since the end of injection under pressure, most wells which responded have shown declines in water level.

There are several alternative explanations for the response in Upcl: (1) the confining formations above the zones of injection are aquitards rather than aquicludes; (2) some of the monitoring wells are leaky through or around the sealed intervals; and (3) open holes at the Aquifer Test Pad and elsewhere are providing communication across the confining layers.

It is likely that all three are responsible to some degree. We have direct evidence that some of the monitoring wells are communicating across horizons supposed to have been sealed (identical head measurements in strings monitoring different horizons). We also have strong evidence that the Aquifer Test Pad is providing communication; larger water level changes occur in some of the Aquifer Test Pad wells than at the Reinjection monitoring wells. If the only reason for the Upcl response were inefficiency of the overlying aquicludes, we would expect a fall-off in the magnitude of response more or less radially or with increasing distance from the Reinjection Well. This did not seem to happen.

Nevertheless, some leakage across the overlying tight horizons is to be expected, given the extent of fracturing. A significant response in 41X-13, the seepage monitor for Pond C similar and only a little less in magnitude than in SG-10, suggests that there is some cross-communicating here. The confinement efficiency of the shallower layers is extremely important to prediction of long-range effects. It will continue to be studied as reinjection continues and as the detailed geology of the Upcl/Uinta becomes better understood.

Tentatively, we suggest an alternative explanation for the response in Upcl at 41X-13, the Pond C monitor. The rise in water levels in the Upcl zones monitored by this well may be due to infiltration from Pond C downward through open near-surface fractures in the Uinta. In favor of this explanation are the facts that 41X-13 does not show the characteristic pressure-response curve, but is generally smooth upward, and after reinjection was finished a rise was still occurring. Against this hypothesis is that water quality data in 41X-13 do not appear similar to the water in Pond C. More study is in order.



It should be kept in mind that if upward leakage across the aquicludes occurred into Upc1 during the reinjection, it does not automatically follow that this would occur during the mining, as zones of depressuring and dewatering expand laterally from the mine.

Upc2. The wells which monitor Upc 2 generally showed a pressure response, the highest response (110 ft) being close to the injection well. Response at the aquifer test pad ranged from 45 to 81 ft.

C-b 1 showed a very irregular hydrograph. This is discussed after the section on transmissivity calculations.

Where Upc2 monitors communicated with Upc1/Uinta monitors, the response was usually subdued, similar to the Upc1/Uinta response. This can be seen in the records of SG21-3 and SG6-1. Water levels in C-b 4, SG 1A-1 and SG 17-2 increased smoothly (1-11 ft), while C-b 3 declined smoothly (3 ft). SG20-2 showed an irregular decline of 54 ft.

Since injection under pressure ceased, most wells have shown significant declines equal to or greater than the responses.

Lpc3. The pressure response was seen in 6 of 11 wells. Of the wells which showed no change in water levels or declined, SG 1-1, SG 10A-1 may have been at too great a distance to show a response to reinjection and SG 17-1 is known to communicate with an upper aquifer monitor. SG 11-1 and 9-1 represent a problem, however, since in both cases upper aquifer monitors showed response to injection. Since injection has ceased SG 11-1 has risen by 62 ft, indicating a delayed response while 9-1 has continued to decline. The wells which showed a response have declined since injection to around baseline levels.

### Transmissivity

The purpose of this section is to determine the transmissivity of different aquifers on C-b Tract using data obtained by monitoring of observation wells.

Tiab and Kumar (1980, pp. 1465-1470), proposed a method for analyzing injection pressure data. They developed a method for a line-source solution to the diffusivity equation for the transient pressure response at an observation well. When the equation is solved for a formation storage term (p. 1466) it gives an expression

$$S = \phi ch = \frac{2}{e} \frac{q}{p'_m} \frac{1}{r^2}$$

The equation for transmissivity is

$$T = \frac{kh}{\mu} = \frac{r^2}{tm} S$$



Where

$c$  = effective isothermal compressibility,  $\text{psi}^{-1}$

$e$  = 2.718

$h$  = formation thickness, ft

$p'_m$  = maximum in time rate of change of pressure,  
 $\text{p}/\text{ft}^2/\text{day}$

$q$  = injection rate,  $\text{ft}^3/\text{day}$

$S$  = storage coefficient, ft/psi

$t_m$  = time at which  $p'_m$  occurs, day

$T$  = transmissivity,  $\frac{\text{ft}^3}{\text{day ft}}$

$\mu$  = fluid viscosity, cp

$\phi$  = formation porosity, dimensionless

$r$  = radial distance, ft

The transmissivity was determined by thirteen monitoring wells located on C-b Tract which responded in the first 30 days to the change of the pressure in the reinjection well. The parameters which had to be evaluated by the existing data are the injection rate  $q$ , the distance from the injection point  $r$ , the time of arrival of the impulse  $t_m$  and the maximum change in the pressure  $p'_m$ . For the injection rate was adopted constant rate of  $28877 \text{ ft}^3/\text{day}$  as for the upper aquifer  $U1+U2+U3+U4$  its value is  $0.54q$  and for lower aquifer  $L1+L2+L3$  is  $0.46q$ . The change of the pressure was determined by the available computerized data. The time of arrival and the distance from the point of injection were determined for each well separately.

The well designation and the results from computing the transmissivity and storage are given in Table 3. The average value for the transmissivity for the  $U_{pc2}$  is 1370 and for the  $L_{pc3}$  is 288. These results are fairly close to those given by Tipton and Kalmbach (1977, p.26), of 1218 gpd/ft for upper aquifer and 311 gpd/ft for lower aquifer, which indicates that the present method deserves closer attention and further investigation for its applicability in similar cases. It could be a useful tool for analyzing separation of the different formations on the basis of their transmissivity and storage coefficient. More detailed differentiation of the aquifer zones by transmissivity at this time is not possible due to insufficient data.



TABLE 3

Well and String	Computer Code	Fm	S psi ft	T (Gal/Day/Ft)
U P P E R A Q U I F E R				
ATIA	WV37	U2	$3.2 \times 10^{-5}$	1566.05
ATIA-1	WX38	U1+U2	$3 \times 10^{-5}$	722.41
ATIC-3	WX44	U1+U2+U3	$9.7 \times 10^{-6}$	1992.04
ATID-3	WD41	U1-U2	$2.3 \times 10^{-5}$	1915.59
SG10A-2	WE51	U2	$2.4 \times 10^{-3}$	887.98
SG11-2	WE52	U2	$4.8 \times 10^{-6}$	815.16
14X7-1	WD14	U1	--	1833.77
			$\bar{S}_U = 1.8 \times 10^{-5}$	$\bar{T}_U = 1649.17$
L O W E R A Q U I F E R				
AT-1	WY44	L3	$6.0 \times 10^{-6}$	325.02
ATIC-1	WY45	L3	$4.6 \times 10^{-5}$	145.39
ATIC-2	WY46	L3	$3.6 \times 10^{-6}$	272.95
ATID-1	WG41	L3	$6.0 \times 10^{-6}$	287.37
SG6-2	WG61	L3	$3.7 \times 10^{-6}$	523.68
SC10A-2	WG51	L3	$5.5 \times 10^{-6}$	173.56
			$\bar{S}_L = 1.2 \times 10^{-5}$	$\bar{T}_L = 287.99$

Ref: Tiab, Djebbar and Anil Kumar; Application of the  $p_D'$  Function to Interference Analysis, Journal of Petroleum Technology; August, 1980; pp. 1465-1470.



Response of Cb-1. Cb-1 is located 7800 ft northwest of the reinjection well. The most rapid increase in its water level occurred on the third day after starting the reinjection. Using the solution of the diffusivity equation given by Tiab and Kumar (1980, p. 1467), for the transmissivity T

$$T = \frac{\lambda}{e} \frac{q}{p'_m t_m}$$

we derive a value for the transmissivity which is not reasonable --  
 $T = 46,052$  gal/day/ft.

If we select a more realistic value for the transmissivity, this this would be the highest value calculated for the tract:  $T = 1921$ , and then:

$$t_m = \frac{\lambda}{e} \frac{q}{p'_m T} = 72 \text{ days}$$

Using a double value  $T = 4000$  gal/ft/day, the time of response,  $t_m = 35$  days. This is a longer period than the time of fluctuation of the water level in Cb-1 after the beginning of the reinjection. Based on transmissivities, therefore, these results show clearly that it is not reasonable to expect any causal connection between the starting time of reinjection and the rise of the water level in well Cb-1.

Considering that the well is located 2100 ft from the area of the shafts it is more likely that an event related to activity in the shafts, rather than the reinjection, caused the anomalous behavior.

Inspection of the long term hydrograph of Cb-1 shows two peaks related closely in time to the first two steps of reinjection. A third peak corresponding to the third step is not present. The two peaks in the hydrograph are moderately in trend with a long term decline in the water level beginning several months before reinjection. The two peaks are bounded by deep troughs well below the levels of the preceding hydrograph trends.

It is our present interpretation that it is the troughs rather than the peaks that represent unusual events in the hydrographs, and that these are most likely related to episodes of increased water production in the shafts, such as blowouts that occurred in the V/E Shaft and during Ignition Level Development.



## Potentiometric Surface Changes - Constant Base

General Statement. Because the monitoring wells are not evenly distributed throughout the Tract; because the completion intervals are not identical from well to well; and because some of the completions appeared to have failed -- producing identical heads for different aquifer horizons, it is not possible to make detailed interpretations with confidence about the configurations of the zones of influence from reinjection.

It was found after recompletion that there were no available monitors for the Lpc4 hydrologic unit. Moreover, there were two independent activities in operation: dewatering at the shafts and leakage into the Uinta Formation at Pond C. These would be expected to modify the shapes of the zones of influence produced by reinjection alone.

Nevertheless general, more or less qualitative, statements can be made about each monitoring unit observed. The results if used with caution can help direct future studies based on the reinjection test, and the interpretations that can be made as reinjection is done in the future.

In the present study, we have not incorporated the water levels in the shafts -- the pumping levels represented by the shaft floor elevations at each time of observation. To do so would have imposed so severe an anomaly that subtle trends in the area of the Reinjection Well and the Aquifer Test Pad might have been eliminated. Moreover, until more is known about the shape of the dewatered zone around the grouted V/E Shaft and the non-grouted Service and Production Shafts, the detailed configuration in the area of the shafts will remain in doubt. This is being rectified with the new corehole monitors now available near the shafts and a new study incorporating the effects of the shafts will be possible.

As defined previously, the Upcl unit extends into and includes part of the Uinta Formation. However, because the Uinta Formation is geologically different from the Parachute Creek Formation, we have decided to treat it separately. Therefore some of the statements in this report refer to those wells that monitor only the Uinta. Unless so stated, the two are treated together.

The contoured elevations of the potentiometric surfaces and the changes in these elevations were done by computer in the Grand Junction Office.



Upcl/Uinta. Figures 9a, b and c are computer plots showing the changes in the water levels through time during reinjection. The contours represent the changes in feet during the reinjection period from their levels at the beginning of reinjection.

These plots eliminate those wells in which identical heads were recorded from separate completions in different units. We do not know at this time whether identical heads result from problems with recompletion or whether there is natural communication among the aquifer units at those sites.

These plots show a slight tendency for a northwesterly trend; a northeasterly trend appeared to develop by the end of reinjection Step 2. During Step 3, which was not continuous due to numerous shut-downs, the northwesterly trend appeared to recur.

The greatest change in water levels shown by these plots at the end of the test was about 80 ft, at the aquifer test pad, as compared with about 25 ft at the reinjection site. There was no significant off-Tract effect. If the contoured configuration is real, the reinjection effect in Upcl extended throughout an area about 2 1/2 miles long northwesterly and 1 1/2 miles broad northeasterly. The rate of response throughout an area of this size indicates that the Upcl hydrologic unit is confined, as expected.

In inspecting these plots it should be kept in mind that these are differences in the potentiometric water levels, not elevations of the potentiometric surface. Thus the contoured highs centered in the aquifer test pad rather than around the reinjection well in the later parts of the program can be understood as greater relative changes there than at the reinjection well.

The northwesterly trend, as shown by the February 1 - March 3 plot, (Figure 5a), was present before reinjection began. Details, such as the negative closure around the aquifer test pad rather than around the dewatered shafts, may be an artifact of the contouring due to the lack of evenly distributed data points. If later information shows that the closure around the aquifer test pad is real, this would have to be explained by downward leakage at that site in response to general depressurizing by the dewatering of the shafts. Although we consider this unlikely at present, this concept should not be discounted given the large number of drillholes at the aquifer test pad.

The foregoing discussion refers to potentiometric plots in which are eliminated all wells in which problems occur, such as communications among different aquifers. If those wells are included, the contoured potentiometric changes



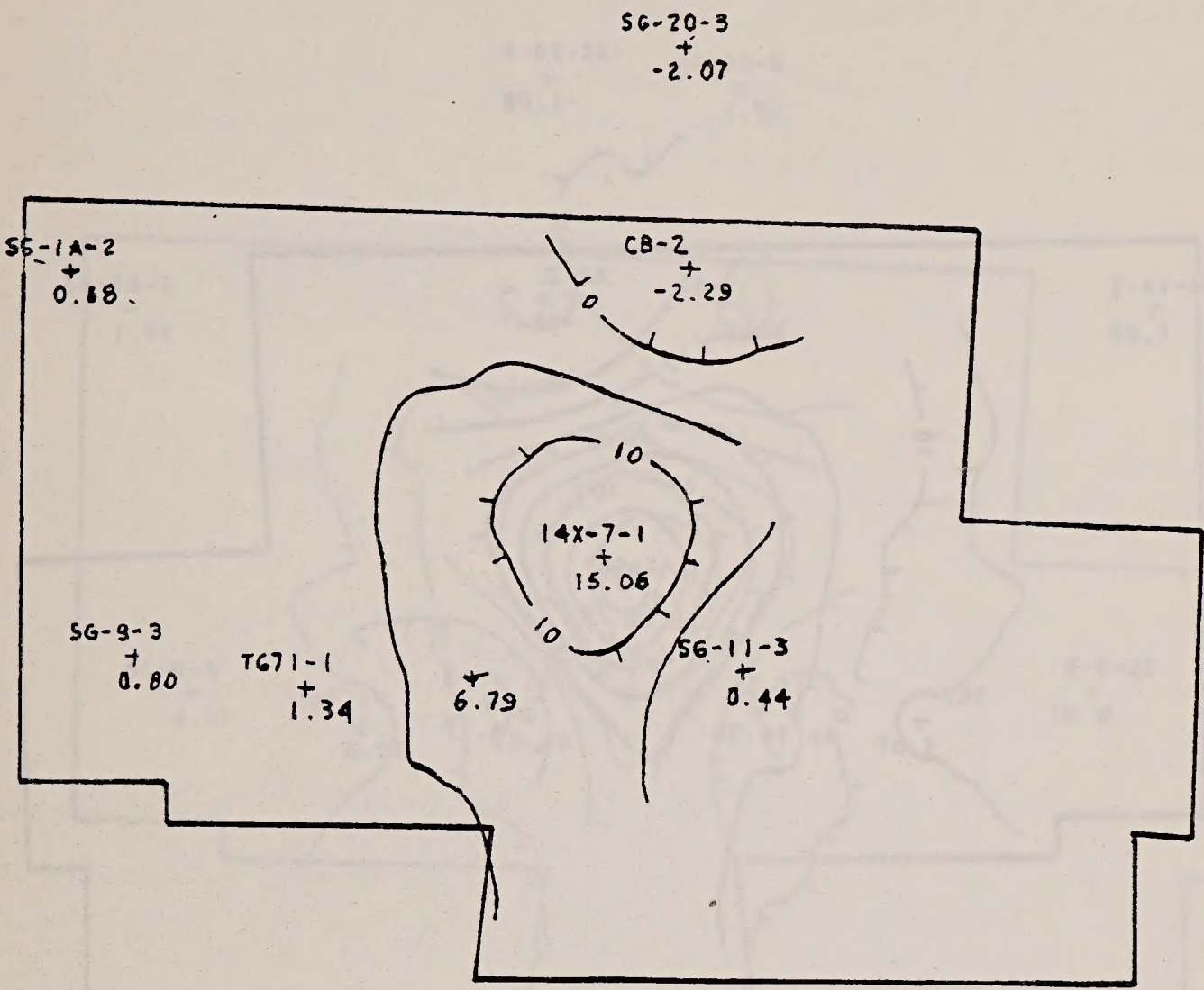


FIGURE 9a  
 REINJECTION POTENTIOMETRIC SURFACE DIFFERENCE MAP FOR MARCH 30 - MARCH 3  
 UPC1, B WELLS  
 Contour Intervals = 5.0'



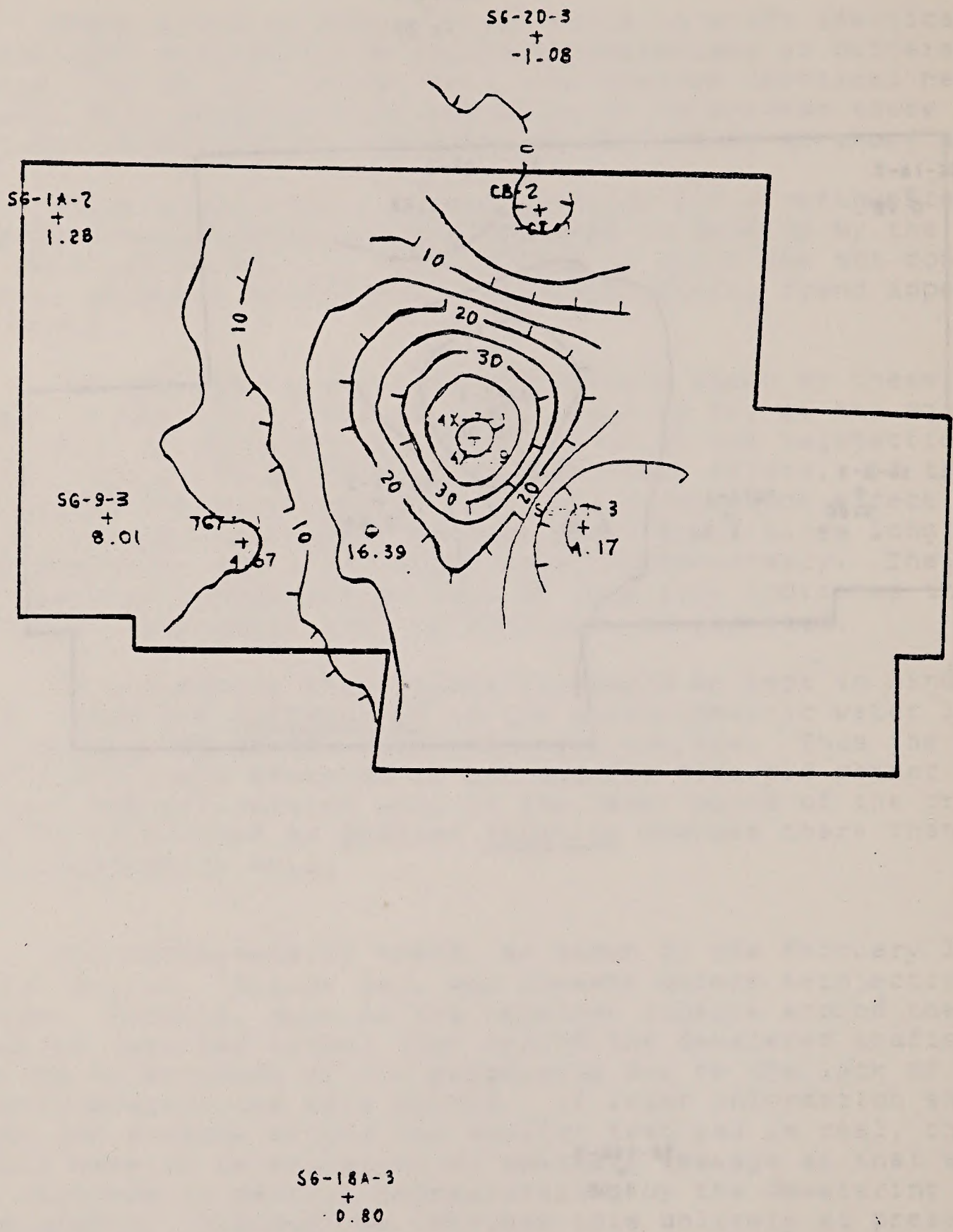


FIGURE 9b  
 REINJECTION POTENTIOMETRIC SURFACE DIFFERENCE MAP FOR APRIL 29 - MARCH 3  
 UPC1, B WELLS

Contour Intervals = 5.0'



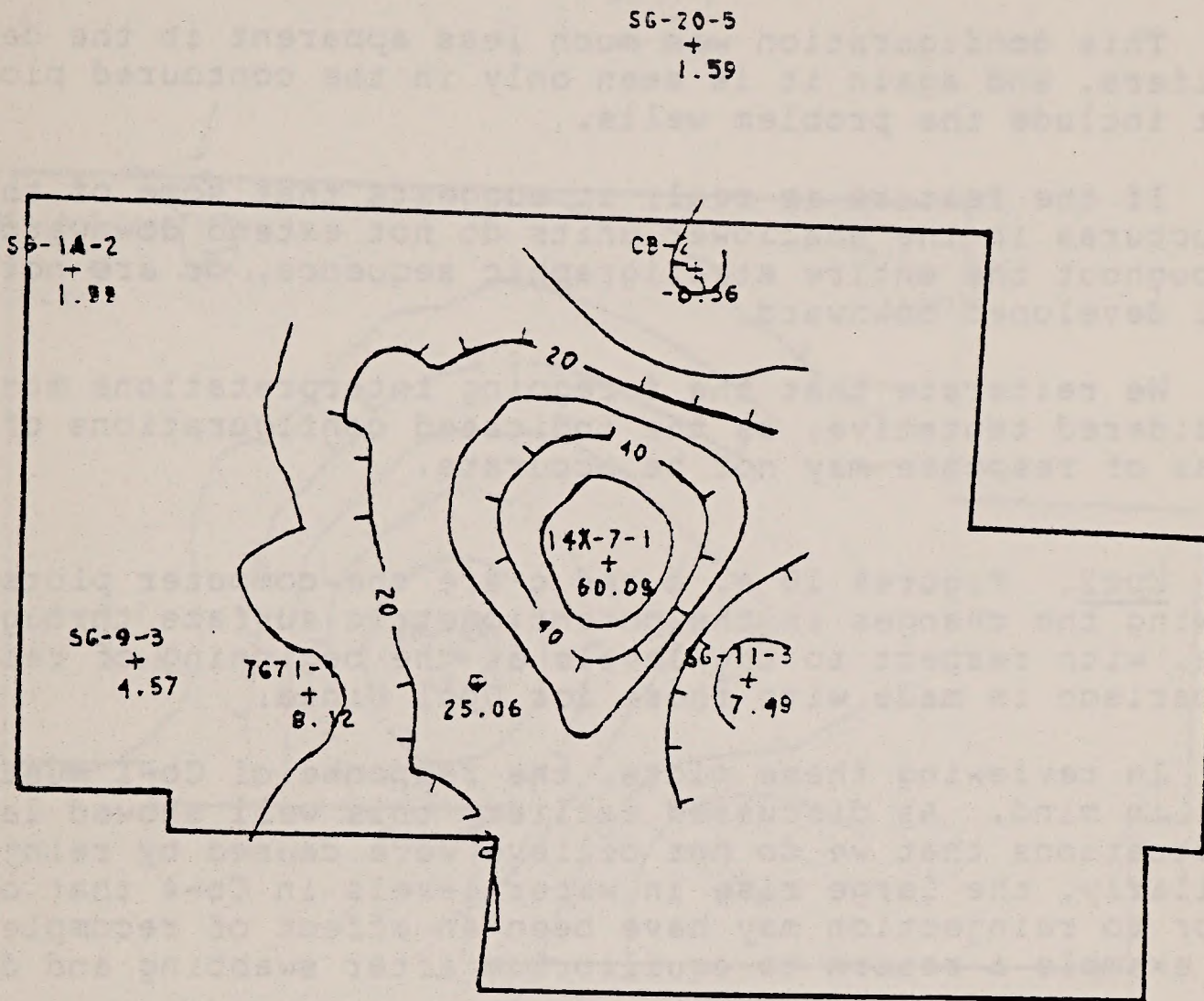


FIGURE 9c  
 REINJECTION POTENTIOMETRIC SURFACE DIFFERENCE MAP FOR JUNE 24 - MARCH 3  
 UPC1, B WELLS

Contour Intervals = 10.0'



show a well defined trend extending northwest and southeast from the Aquifer Test Pad. The high is asymmetric, being steepest along its northern margin. If this is real, a barrier is suggested, perhaps a northwest-trending fracture zone extending diagonally across the C-b Tract.

This configuration was much less apparent in the deeper aquifers, and again it is seen only in the contoured plots that include the problem wells.

If the feature is real, it suggests that some of the structures in the shallower units do not extend downward throughout the entire stratigraphic sequence, or are not as well developed downward.

We reiterate that the foregoing interpretations must be considered tentative, as the indicated configurations of the areas of response may not be accurate.

Upc2. Figures 10 a, b and c are the computer plots showing the changes in the potentiometric surface through time, with respect to the levels at the beginning of reinjection. Comparison is made with those for Upc1 Uinta.

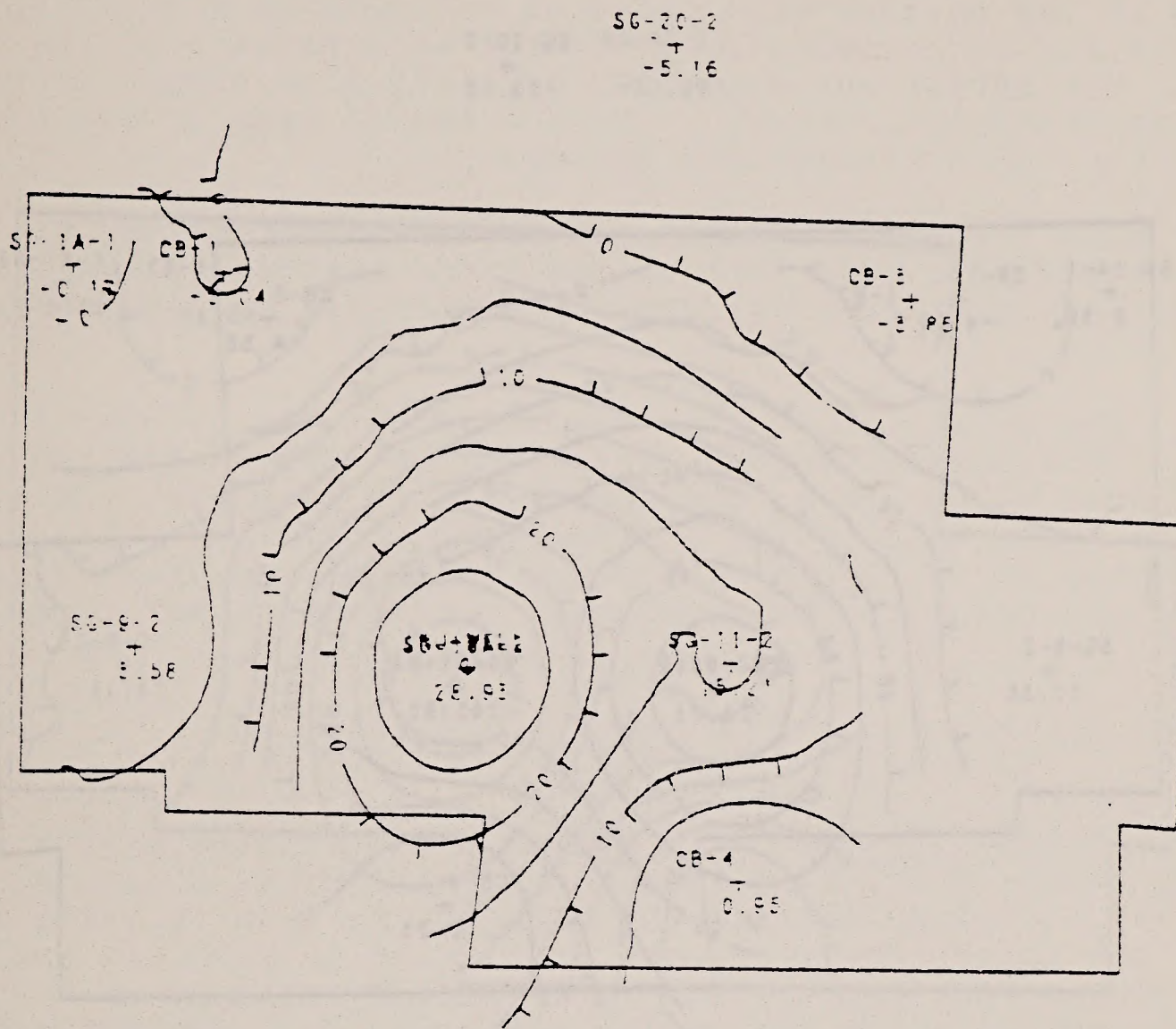
In reviewing these plots, the response of Cb-1 must be kept in mind. As discussed earlier, this well showed large fluctuations that we do not believe were caused by reinjection. Similarly, the large rise in water levels in Cb-4 that occurred prior to reinjection may have been an effect of recompletion, for example a return to equilibrium after swabbing and dewatering.

The greatest change in water levels shown in these plots was at the injection site, nearly 110 ft above the beginning levels. Except for a rise of about 3 ft at SG-21, there was no significant off-Tract effect. SG-21 was eliminated in these plots because of uncertainty that it was monitoring Upc2. Most of the effect of reinjection in Upc2 appeared to extend about a mile or a mile and a half from the reinjection site.

With problem wells eliminated, the northwesterly trend is not evident in this unit. Even with the problem wells included, the northwesterly trend is slight. This suggests that the barrier inferred from the Upc1-Uinta results does not extend through Upc2. Based on independent evidence from other studies, there is reason to believe that some of the fractures in the Uinta Formation do not extend into the Parachute Creek Formation.



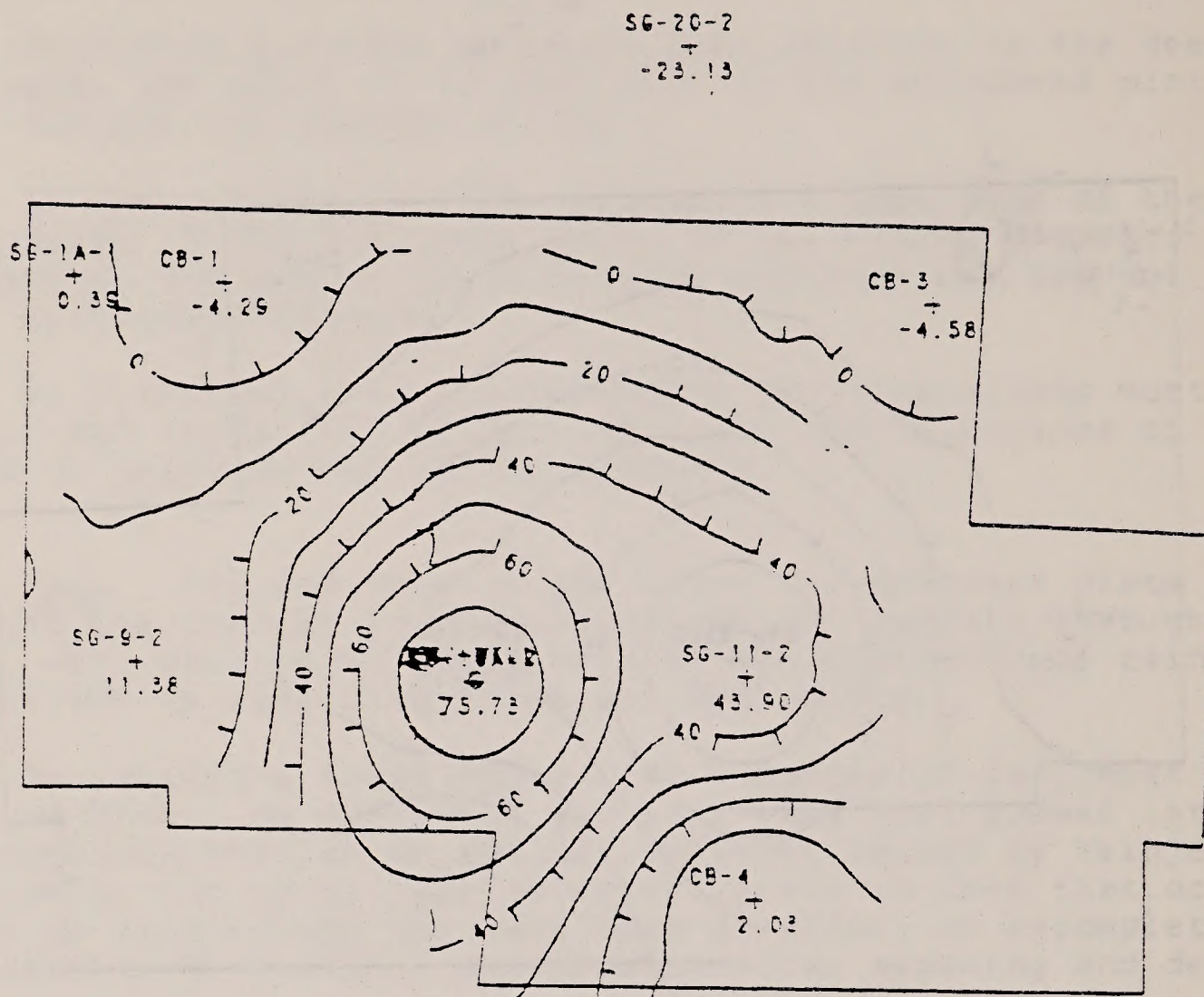
FIGURE 10a



REINJECTION POTENTIOMETRIC SURFACE DIFFERENCE MAP  
FOR MAR30-MAR5 UPO2, B WELLS CNTR. INT = 5.0'



FIGURE 10b



REINJECTION POTENTIOMETRIC SURFACE DIFFERENCE MAP  
FOR APR29-MAR3 UPC2, B WELLS CNTR INT = 10.0'







Lpc3. 11 a, b and c show the potentiometric plots for the Lpc3 monitors. Fewer control wells were available than in the other units.

With suspect wells included, the results showed a rapid rise in the aquifer test pad area followed by a build-up around the injection site. In the earlier part of the test, the effect was essentially radial with slight northwesterly and northeasterly trends. By the end of Step 2, the northwesterly trend became more apparent.

With the problem wells eliminated (Figures 11a, b, c), the trends were more northeasterly and northerly, but so few wells were available that the trends cannot be considered reliable.

The maximum head rise was 167 ft at the reinjection site. The maximum extent of the significantly affected zone was about two miles in the northwesterly direction and about a mile and a half in the northeasterly direction. The easterly extension to SG-11 did not occur, and there was more off-Tract extension to the south than in the two upper units.

#### Potentiometric Surface Changes - Changing Base

General Statement and Method. Because the shafts were still being dewatered during the three months of reinjection, a brief study was made of the reinjection results using as a base the potentiometric level that would be expected had reinjection not taken place. This study assumed that the water levels in the monitoring wells would have continued to decline in the same manner that they declined prior to the start of reinjection.

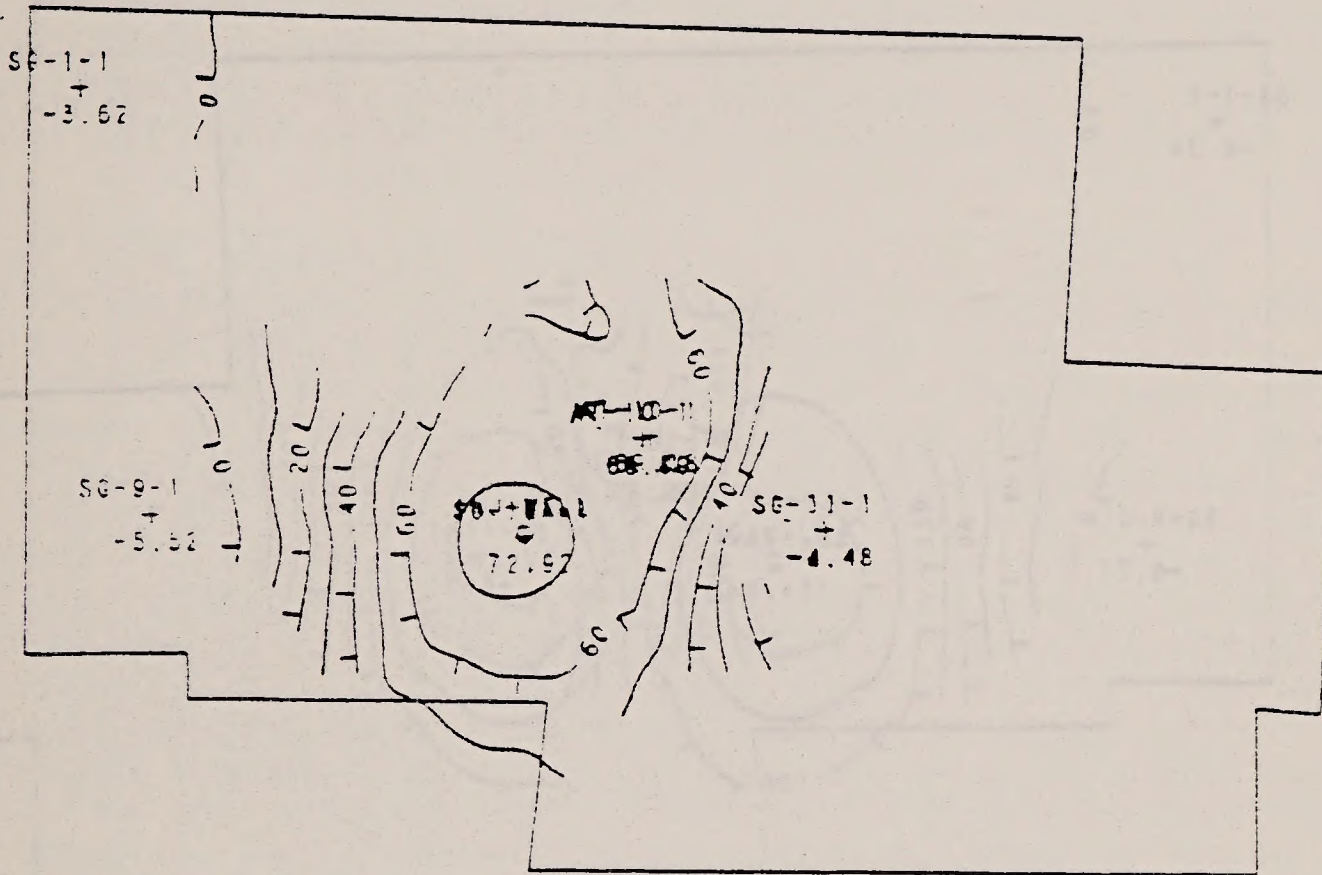
Two factors were taken into consideration for projecting the declining water levels. One was the water level data for each well since its recompletion. The other was the fact that the total amount of water produced from the three shafts had ceased to increase near the beginning of the year, and was keeping roughly constant. Thus the deepening and expansion of the zone of influence around the shafts was slowing down and would eventually be effectively stopped; thus without any outside interference, the zone of influence would attain a constant size and shape.

The effect of this on the water levels in each of the wells would be a gradual decrease in the rate of drawdown until the water level remained constant.

The mathematical expression of such a decreasing rate of decline is an inverse-log curve. Therefore, an inverse-log curve was fitted to the data from many of the wells, as



FIGURE 11a

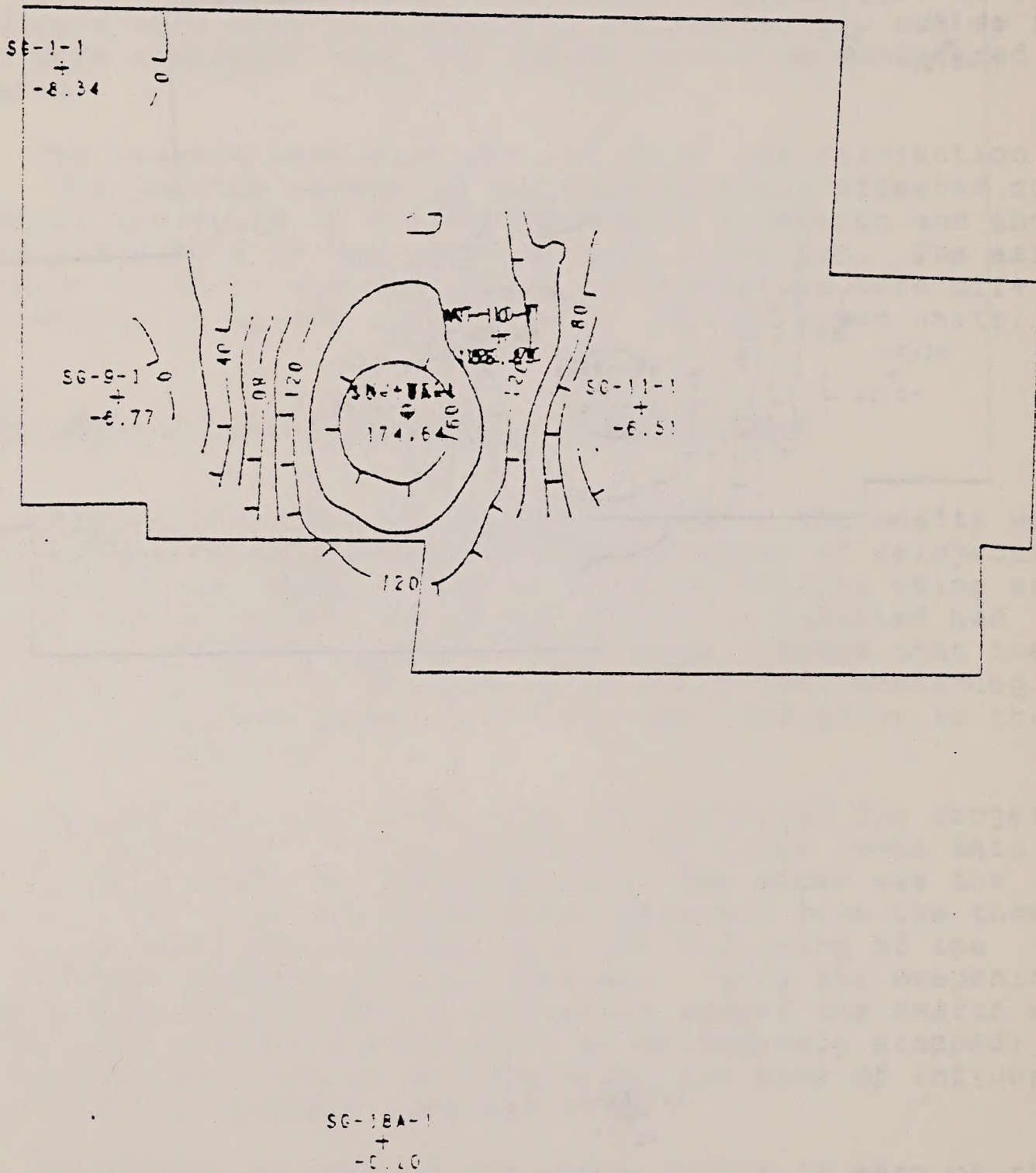


SG-18A-1  
-0.07

REINJECTION POTENTIOMETRIC SURFACE DIFFERENCE MAP  
FOR MAR30-MAR3 LPC3, B WELLS CNTR INT = 10.0'



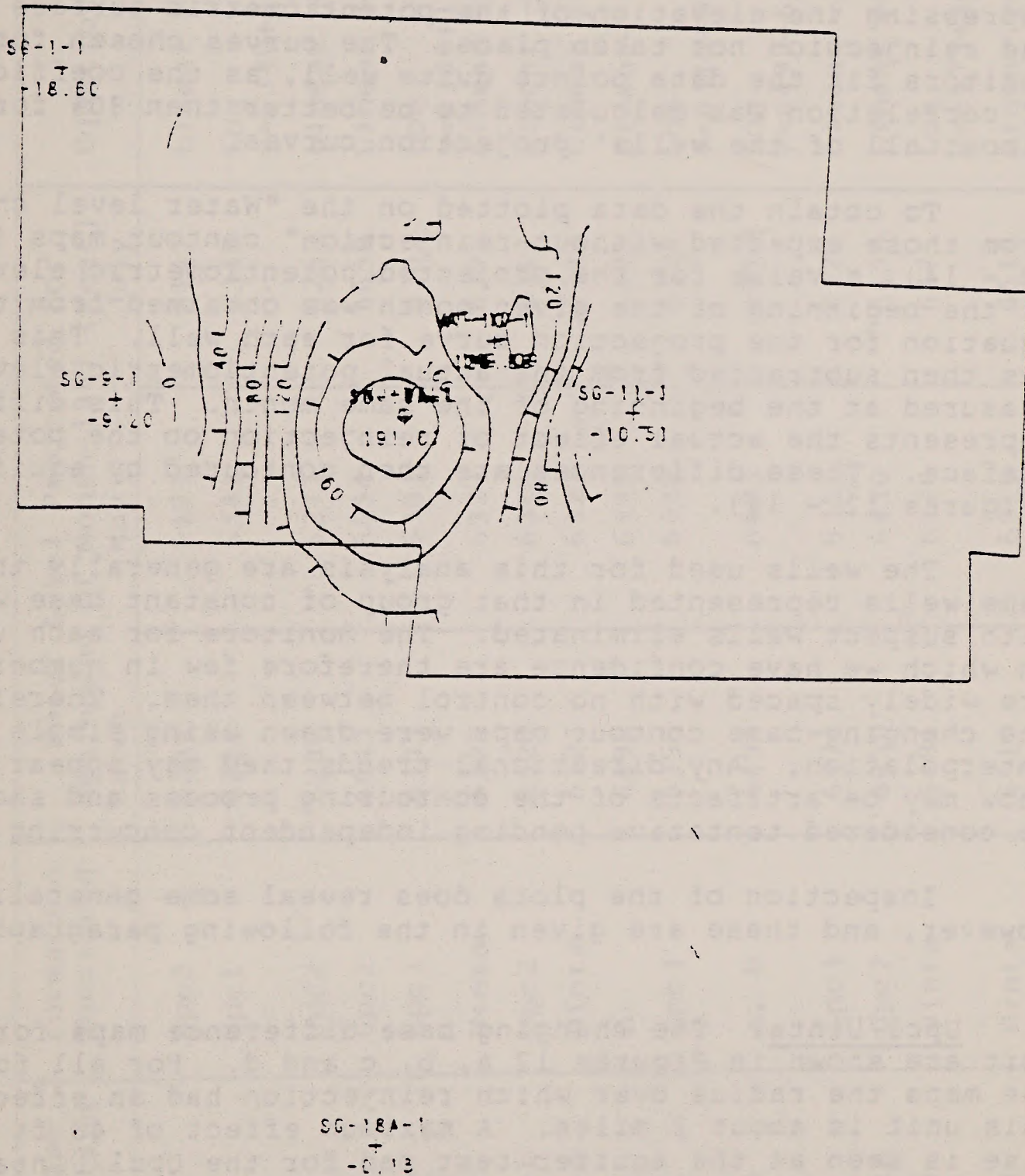
FIGURE 11b



REINJECTION POTENTIOMETRIC SURFACE DIFFERENCE MAP  
 FOR APR29-MAR3 LPC3, B WELLS CNTR INT = 20.0'



FIGURE 11c



REINJECTION POTENTIOMETRIC SURFACE DIFFERENCE MAP  
 FOR JUN24-MAR3 LPC3, B WELLS - CNTR INT = 20.0'



shown in Table 4. If, however, inspection of the water-level data for a well indicated that it had a linear trend, a linear trend was used for the projection.

Several wells showed almost no change in their water levels and were given a constant projected level. A few wells had rising trends, either linear or logarithmic, and these were used in their projections. The water level data for each monitoring well acquired since recompletion but before reinjection were statistically analyzed using the least-square method of regression to obtain an equation expressing the elevation of the potentiometric surface expected had reinjection not taken place. The curves chosen for the monitors fit the data points quite well, as the coefficient of correlation was calculated to be better than 80% for almost all of the wells' projection curves.

To obtain the data plotted on the "Water level changes from those expected without reinjection" contour maps (Figures 12 - 14), a value for the projected potentiometric elevation at the beginning of the given month was obtained from the equation for the projection curve for each well. This value was then subtracted from the actual potentiometric elevation measured at the beginning of the same month. This difference represents the actual effect of reinjection on the potentiometric surface. These differences are then contoured by aquifer (Figures 12 - 14).

The wells used for this analysis are generally the same wells represented in that group of constant base wells with suspect wells eliminated. The monitors for each unit in which we have confidence are therefore few in number and are widely spaced with no control between them. Therefore, the changing-base contour maps were drawn using simple linear interpolation. Any directional trends they may appear to show may be artifacts of the contouring process and should be considered tentative pending independent concurring evidence.

Inspection of the plots does reveal some generalities, however, and these are given in the following paragraphs.

Upcl/Uinta. The changing base difference maps for this unit are shown in Figures 12 a, b, c and d. For all four of the maps the radius over which reinjection had an effect on this unit is about 2 miles. A maximum effect of 43 ft of rise is seen at the aquifer test pad for the Upcl/Uinta. The maps show that the effect of reinjection at the aquifer test pad was the same as or greater than the effect at the reinjection well. Thus, as with the constant base examination, it appears that flow upward from the Upc2 into the Upcl was greater at the aquifer test pad than at the reinjection well. This is reasonable because the Four Senators aquiclude is perforated by many wells at the aquifer test pad.



TABLE 4

## CB POTENTIOMETRIC SURFACE ELEVATIONS EXPECTED WITHOUT REINJECTION

Computer Code	Well Name and String	Formation Monitored	Water Level Projected for Beginning of Month-1981 (Feet)			Equation Used *	Correlation Coefficient
			March	May	July		
WD01	Cb-1	Upc2	6209	6177	6147	Linear -15.3/mo.	-0.73
WD02	Cb-2	Upc1	6342	6341	6340	Log $y=6340+12.3e^{-0.54m}$	-0.93
WE03	Cb-3	Upc2	6286	6277	6269	Linear -4.3/mo.	-1.0
WE04	Cb-4	Upc2	6649	6654	6659	Linear +2.6/mo.	0.99
WG12	SG-1-1	Lpc3	6305	6303	6302	Log $y=6300+11.8e^{-0.26m}$	-0.99
WD12	SG-1-2	Uinta	6325	6323	6321	Linear -1/mo.	-- c
WE11	SG-1A-1	Upc2	6320	6318	6317	Linear -0.8/mo.	-0.99
WD11	SG-1A-2	Uinta	6323	6323	6323	Linear $y=6323$	--
WE61	SG-6-1	b	6498	6495	6491	Linear -1.7/mo.	-0.97
WG61	SG-6-2	Lpc3	6355	6338	6328	Log $y=6310+91.1e^{-0.23m}$	-1.0
WD61	SG-6-3	a, b	6494	6493	6492	Log $y=6490+6.2e^{0.15m}$	--
WG91	SG-9-1	Lpc3	6374	6351	6329	Linear -11.2/mo.	-0.71
WE91	SG-9-2A	Upc2	6450	6450	6450	Linear $y=6450$	--
WD91	SG-9-3	Uinta	6481	6476	6475	Log $y=6475+20.1e^{-0.57m}$	-0.87
WC91	SG-9-4	Uinta	6519	6519	6519	Linear $y=6519$	--
WD90	SG-10	Uinta	6601e	6600	6600	Linear $y=6600$	--
WG51	SG-10A-1	Lpc3	6478	6476	6475	Log $y=6465+13.0e^{-0.1m}$	-0.85

-47-



TABLE 4 (CONT'D.)

Computer Code	Well Name and String	Formation Monitored	Water Level Projected for Beginning of Month-1981 (Feet)			Equation Used *	Correlation Coefficient
			March	May	July		
WE51	SG-10A-2	Upc2	6492	6501	6502	Log - rise drops by 37%/mo.	-- c
WD51	SG-10A-A	Uinta	6658	6658	6658	Linear $y=6658$	--
WG52	SG-11-1	Lpc3	6511	6502	6493	Linear -4.5/mo.	-0.96
WE52	SG-11-2	Upc2	6520	6522	6524	Linear +1/mo.	0.36c
WD52	SG-11-3	Uinta	6580	6577	6575	Log $y=6570+13.5e^{-0.13m}$	--
WG17	SG-17-1	b	--	--	--	d	--
WE17	SG-17-2	b	--	--	--	d	--
WD17	SG-17-3	b	6663e	6662	6662	Linear $y=6662$	--
WC17	SG-17-4	b	6666	6671	6675	Linear +2.3/mo.	0.82
WD57	SG-17A	Uinta	6641	6641	6641	Linear $y=6641$	--
WG18	SG-18A-1	Lpc3	6352	6852	6852	Linear $y=6852$	--
WE18	SG-18A-2	Upc2	6918e	6917	6917	Linear $y=6917$	--
WD18	SG-18A-3	Upcl & Uinta a	6917	6918	6918	Linear +0.25/mo.	--
WD19	SG-19	h	--	--	--	d	--
WG20	SG-20-1	h	--	--	--	d	--
WE20	SG-20-2	b	6355	6348	6341	Linear -3.3/mo.	-0.99
WD20	SG-20-3	Upcl & Uinta a	6225	6216	6207	Linear -4.4/mo.	-0.95
WH21	SG-21-1	b	--	--	--	d	--
WG21	SG-21-2	b	--	--	--	d	--
WE21	SG-21-3	b	--	--	--	d	--
WO21	SG-21-4	b	6706	6705	6704	Log $y=6700+8.9e^{-0.13m}$	-0.94



TABLE 4 (CONT'D.)

Computer Code	Well Name and String	Formation Monitored	Water Level Projected for Beginning of Month-1981 (Feet)			Equation Used *	Correlation Coefficient
			March	May	July		
WD14	14X7-1	Uinta	6465	6459	6457	Log $y=6455+36.6e^{-0.46m}$	-0.93
WD15	14X7-2	Uinta	6520	6510	6507	Log $y=6505+49.4e^{-0.45m}$	-0.88
WY44	AT-1	Lpc3	6378	6368	6364	Log $y=6360+61.1e^{-0.40m}$	--
WV37	AT-1A	Upc2	6445	6445	6445	Linear $y=6445$	c
WX38	AT-1A1	Upc2 a	--	--	--	d	--
WY45	AT-1C-1	Lpc3	6381	6368	6360	Log $y=6350+73.2e^{-0.28m}$	-1.0
WY46	AT-1C-2	Lpc31	6377	6366	6356	Log $y=6320+90.2e^{-0.13m}$	-0.97
WX44	AT-1C-3	Upc1, Upc2 & Lpc3 a	6443	6437	6435	Log $y=6430+90.4e^{-0.18m}$	-0.99
WG41	AT-1D-1	Lpc3	6373	6361	6356	Log $Y=6350+63.4e^{-0.34m}$	-1.0
E	AT-1D-2	Upc1 & Upc2 a	--	--	--	d	--
WD41	AT-1D-3	Upc1 & Uinta a	6485	6485	6485	Linear $y=6485$	--
WY81	SG-8	a	--	--	--	g	--
WW22	31X12	a	--	--	--	d	--
WX32	32X12	a	6040	6040	6040	Linear $y=6040$	c
WW13	41X13	Uinta	6605	6605	6605	Linear $y=6605$	--
C201	TG71-1	Uinta	6569	6564	6559	Linear -2.5/mo.	-0.88

NOTES:

(See next page)

-43-

2B-61



TABLE 4 (CONT'D.)

a Composite monitor.

b String communicates with another string in well.

c Projection based on very few data points.

\*m = the number of the month (1 for January, 2 for February, etc.), 1981.

y = potentiometric surface elevation.

d No projection made due to lack of valid post-recompletion data.

e Actual value for beginning of March deviates from level trend.

f No computer code.

g Flowing well, no pressure data.

h Completion unknown.



FIGURE 12a

Uinté Wells

after 60 days of ReInjection

Change in Water Levels From Those Expected Without ReInjection

● ReInjection Well  
Contour Interval 10 ft.

● SQ 10A Monitor Well in this Aquifer Zone  
● Monitor Well of Other Aquifer Zones  
GEO THERMAL SURVEYS, INC.

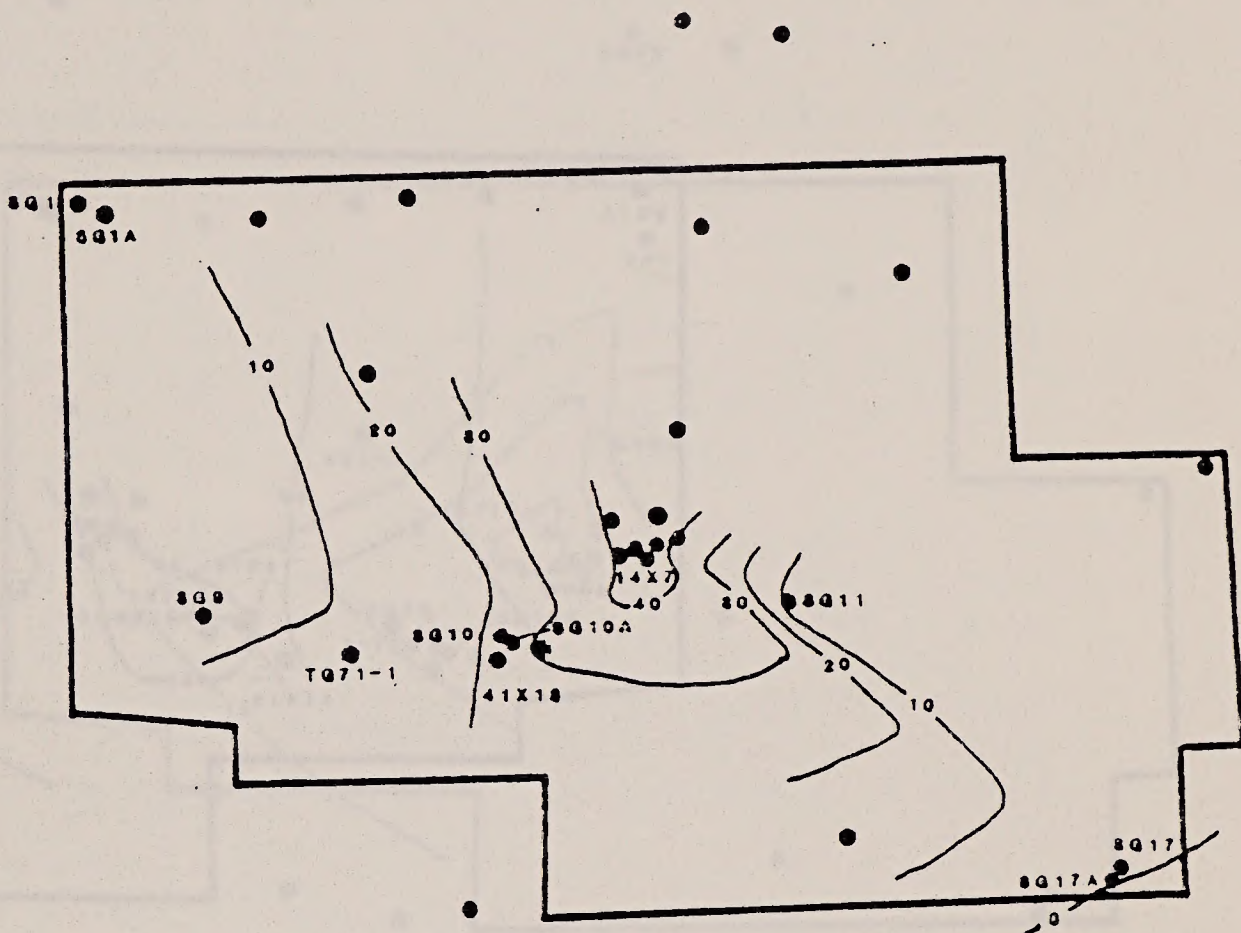




FIGURE 12b

Uinta Wells

after 90 days of ReInjection

Change in Water Levels From Those Expected Without ReInjection

◆ ReInjection Well  
Contour Interval 10 ft.

● Monitor Well in this Aquifer Zone  
● Monitor Well of Other Aquifer Zones

GEOTHERMAL SURVEYS, INC.

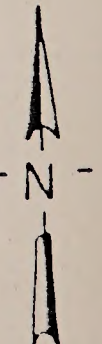
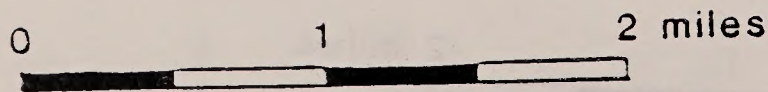
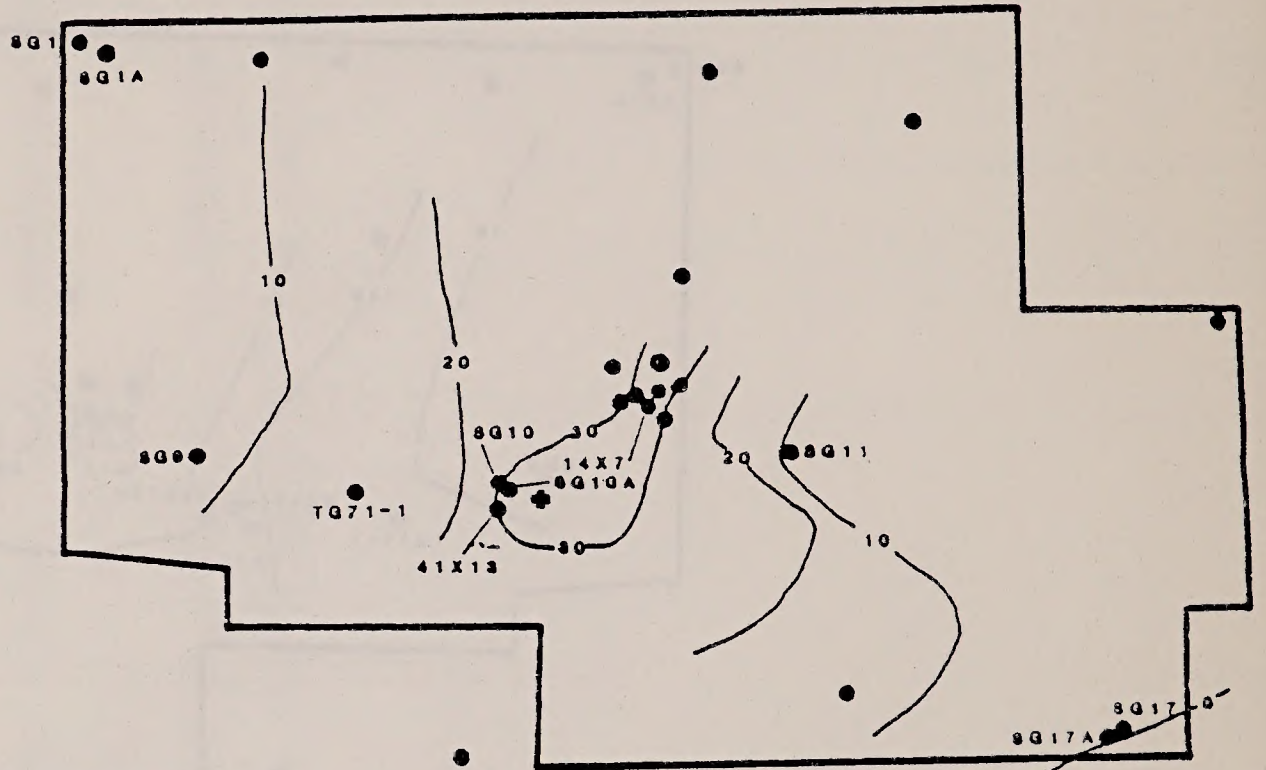




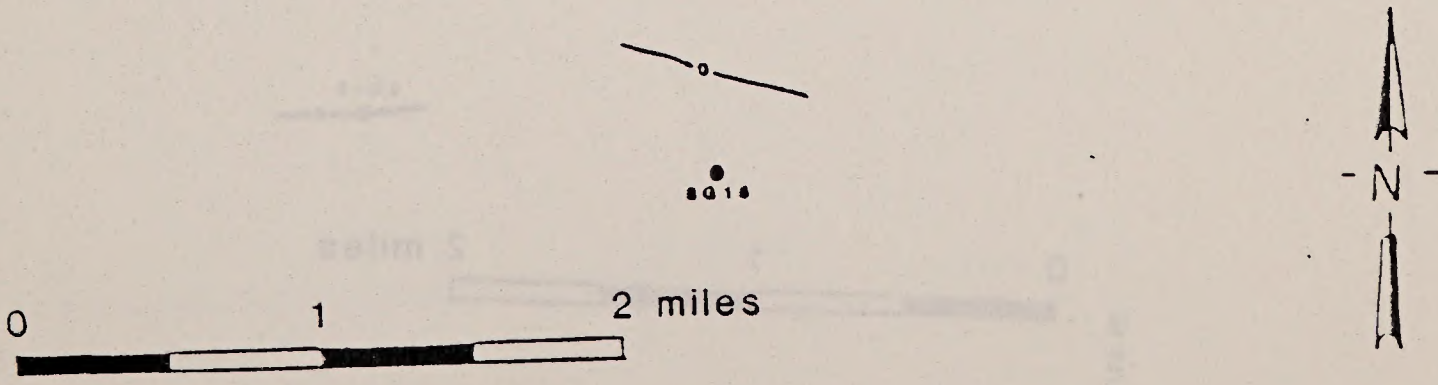
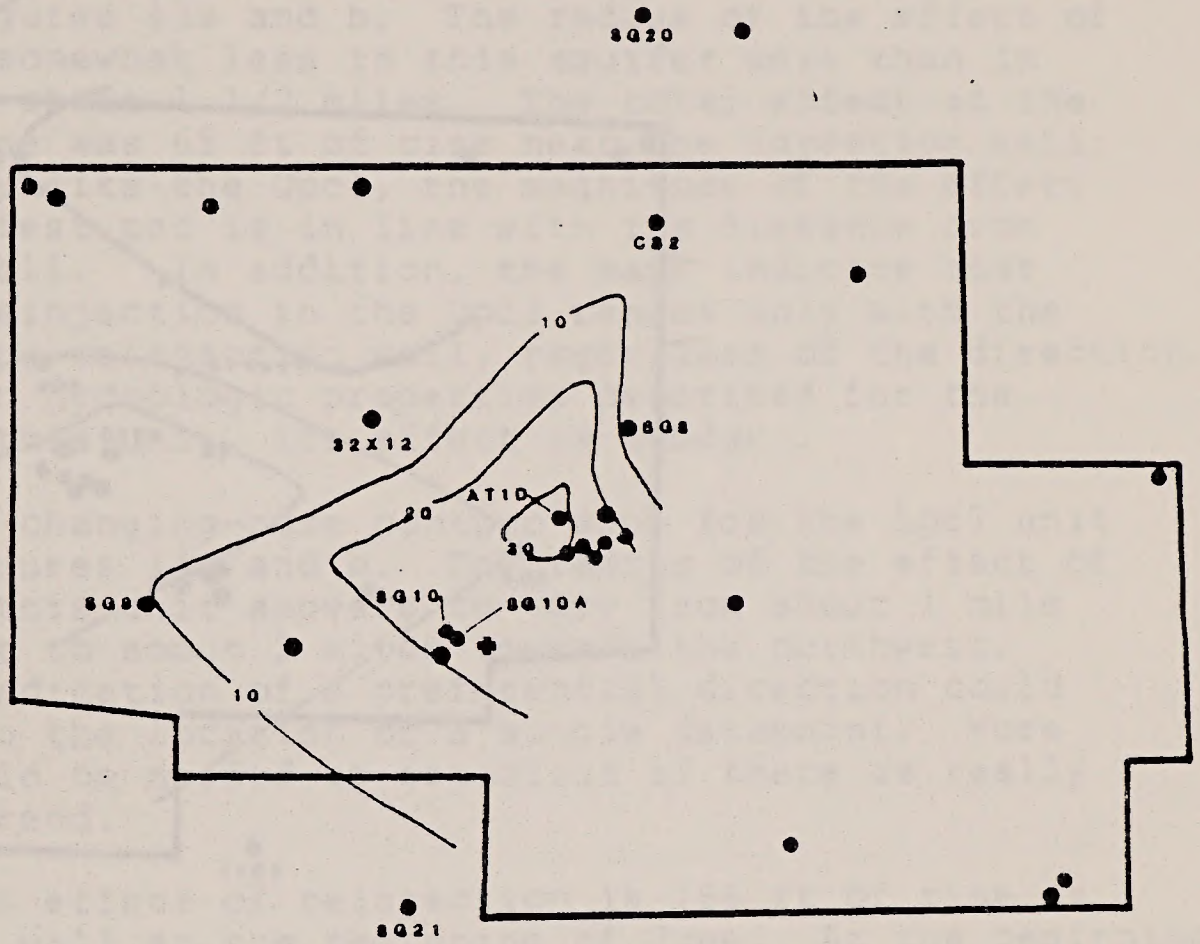
FIGURE 12c

Upc 1 & Uinta Composite Wells

after 60 days of Reinjection

Change in Water Levels From Those Expected Without Reinjection

- ◆ Reinjection Well
  - Monitor Well in this Aquifer Zone
  - Monitor Well of Other Aquifer Zones
- Contour Interval 10 ft.
- GEOTHERMAL SURVEYS, INC.



2R-67/68



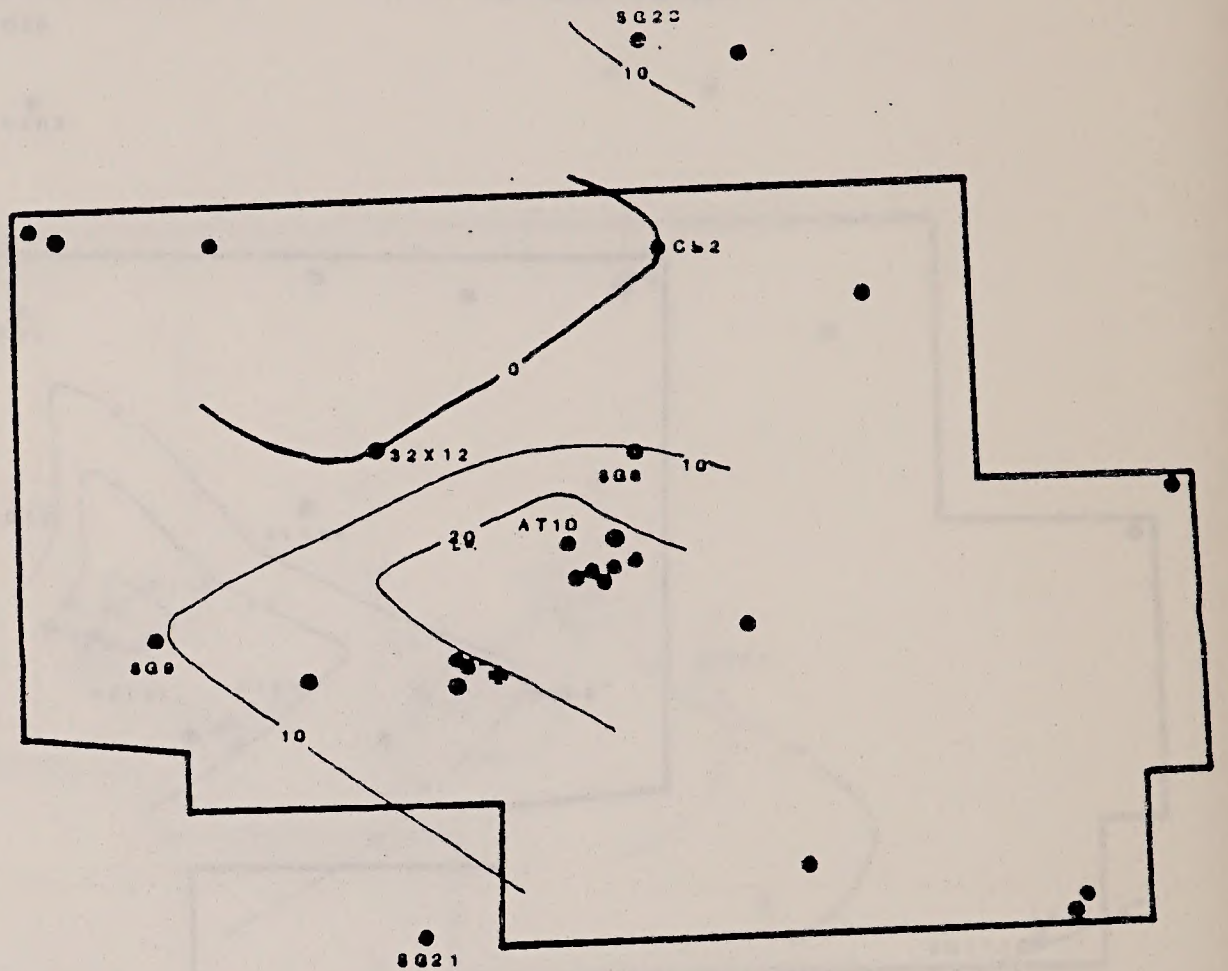
FIGURE 12d

Upc 1 & Uinta Composite Wells  
after 90 days of Reinjection

Change in Water Levels From Those Expected Without Reinjection

◆ ReInjection Well  
Contour Interval 10 ft.

● SG 10A Monitor Well in this Aquifer Zone  
● Monitor Well of Other Aquifer Zones  
GEO THERMAL SURVEYS, INC.





An additional feature indicated by this study is the greater change in the effect to the east of the aquifer test pad than in other directions. This can be seen on Figures 12 a, b, c and d. It suggests a change in the hydrologic properties of this unit eastward from the aquifer test pad. This could be caused by structures such as a tight gouge-filled fracture, or a tuffaceous dike; or by a change in lithology.

Upc2. The changing-base contour maps for the Upc2 unit are shown in Figures 13a and b. The radius of the effect of reinjection is somewhat less in this aquifer unit than in the Upc1, being about 1 1/2 miles. The total effect at the beginning of June was 65 ft of rise near the injection well. For this unit, unlike the Upc1, the magnitude of the effect at the aquifer test pad is in line with its distance from the injection well. In addition, the maps indicate that the effect of reinjection in the Upc2 ranges only with the distance from the reinjection well, regardless of the direction. If the change in hydrologic properties described for the Upc1 exists in this unit, its effect is subdued.

Lpc3. The changing-base contour maps for the Lpc3 unit are shown in Figures 14a and b. The radius of the effect of reinjection in this unit appears to vary from about 1 mile towards the east to about 2 miles towards the northwest. However, this indication of a preferential direction could be due solely to the location of a single datapoint. More information would be needed to establish if there is really a directional trend.

The maximum effect of reinjection is 166 ft of rise at the reinjection well at the beginning of June. At the beginning of April, however, the effect at the aquifer test pad was about 10 ft higher than the effect at the injection well. Even in June the effects at the aquifer test pad did not seem to conform to its distance from the reinjection well. This implies anisotropy with a directional hydraulic conductivity increase from the reinjection well to the aquifer test pad. In addition, the increased change in the effect seen for the Upc1 to the east of the aquifer test pad is also evident for this unit, indicating that a similar hydrological control may also be present in the Lpc3.







FIGURE 13a

Upc 2 Wells

after 30 days of Reinjection

Change in Water Levels From Those Expected Without Reinjection

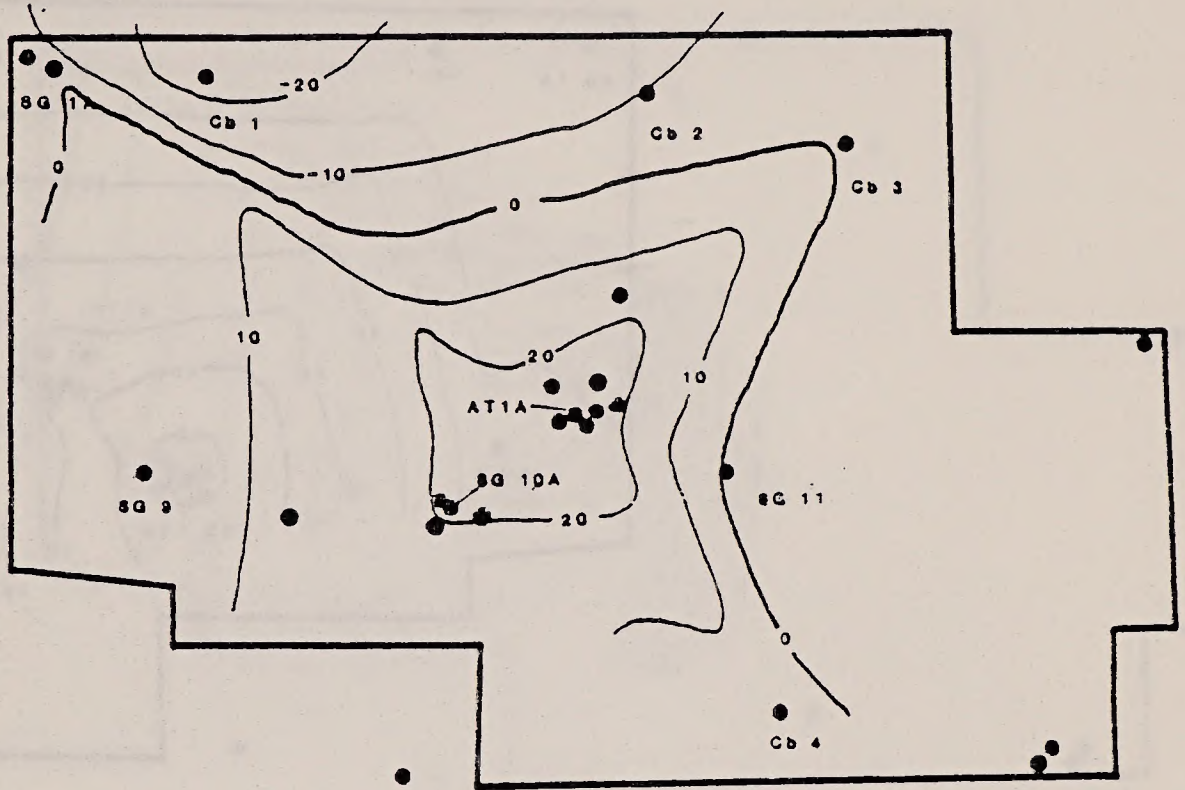
◆ Reinjection Well

Contour Interval 10 ft.

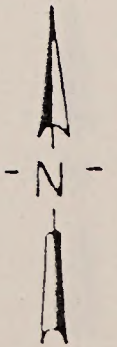
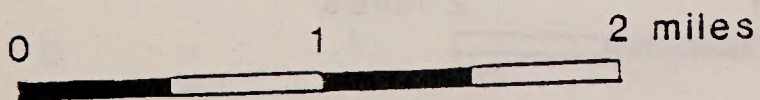
● SG 10A Monitor Well in this Aquifer Zone

● Monitor Well of Other Aquifer Zones

GEOTHERMAL SURVEYS, INC.



SG 18A



2B-73174



FIGURE 13b

Upc 2 Wells

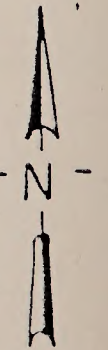
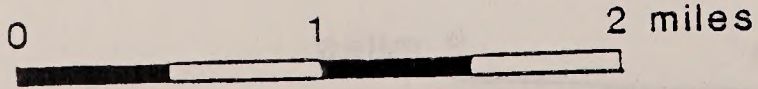
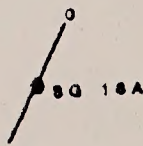
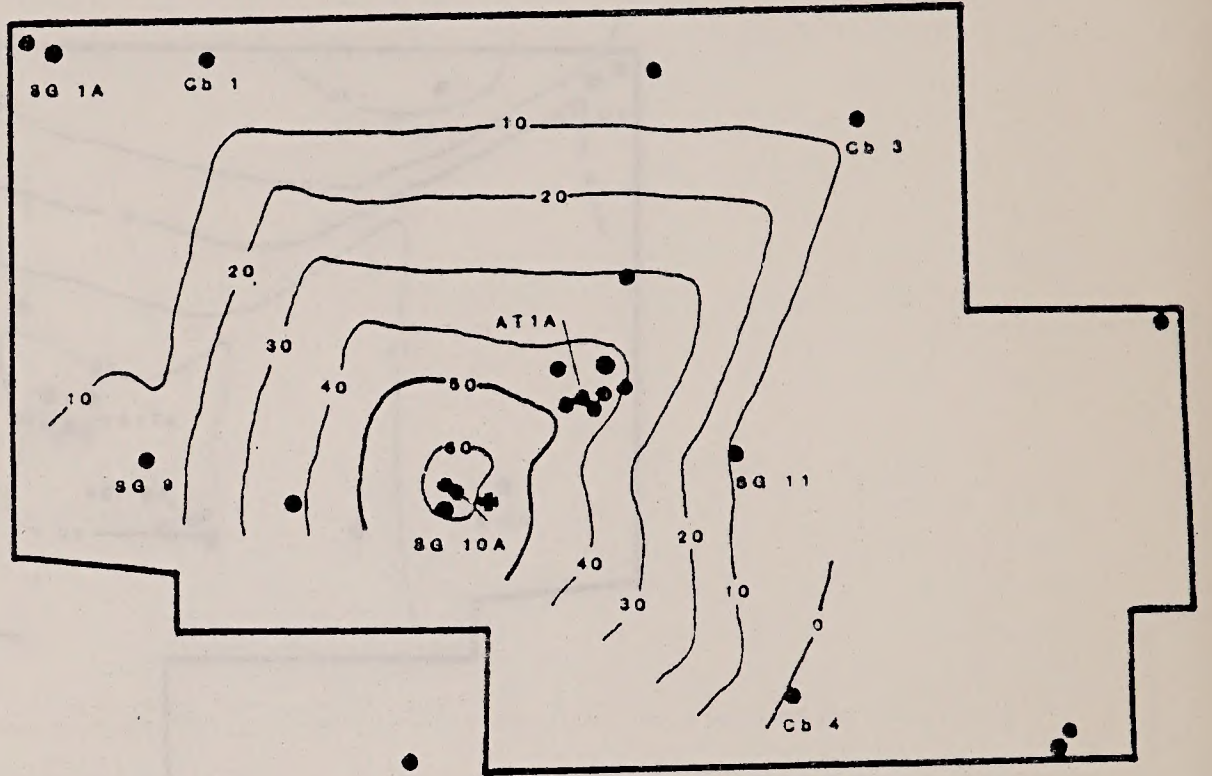
after 90 days of ReInjection

Change in Water Levels From Those Expected Without ReInjection

◆ ReInjection Well  
Contour Interval 10 ft.

● SG 10A Monitor Well in this Aquifer Zone  
● Monitor Well of Other Aquifer Zones

GEOTHERMAL SURVEYS, INC.



28-75/76



FIGURE 14a

Lpc 3 Wells

after 30 days of Reinjection

Change in Water Levels From Those Expected Without Reinjection

◆ ReInjection Well

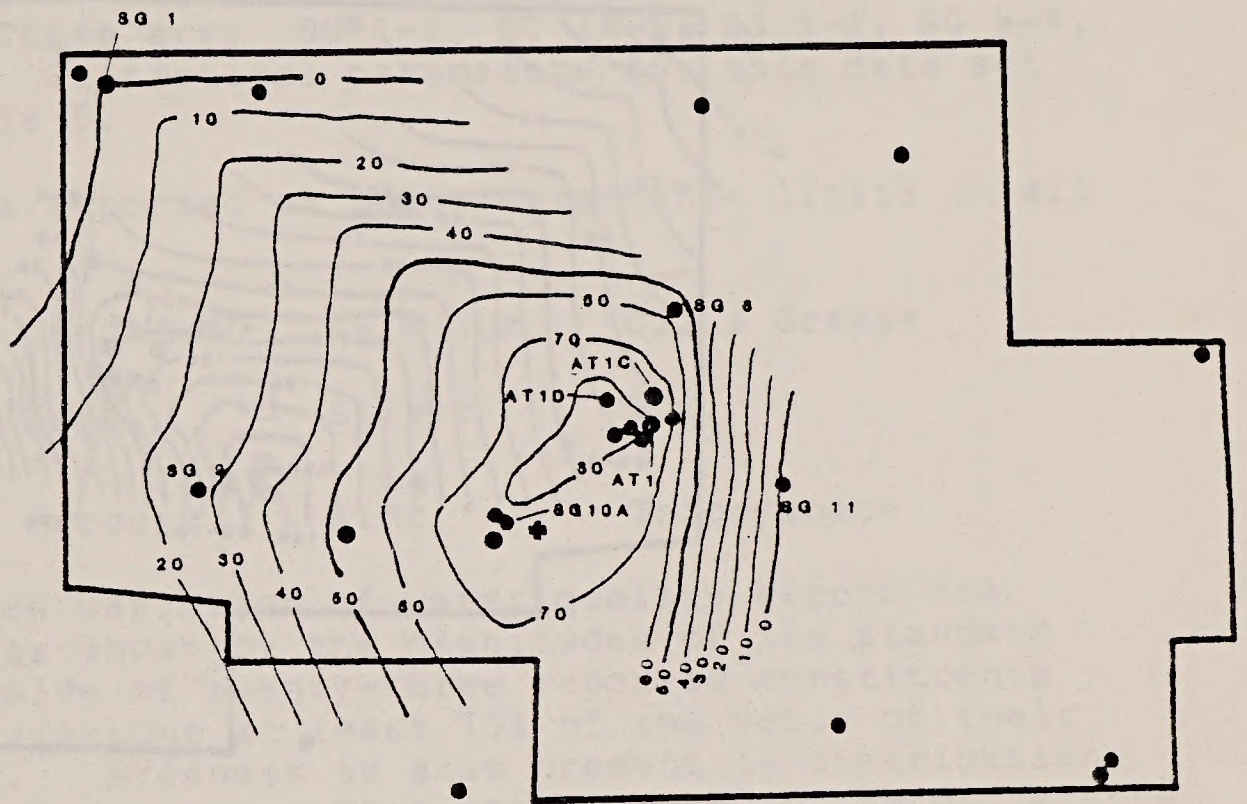
● SG 10A

● Monitor Well in this Aquifer Zone

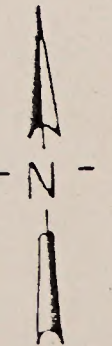
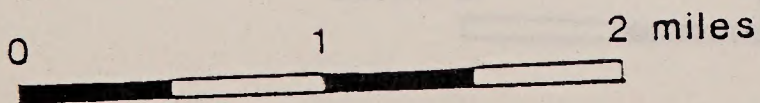
Contour Interval 10 ft.

● Monitor Well of Other Aquifer Zones

GEOTHERMAL SURVEYS, INC.



SG 15



2B-77178



FIGURE 14b

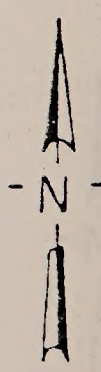
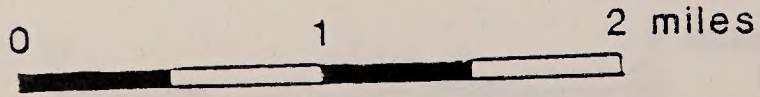
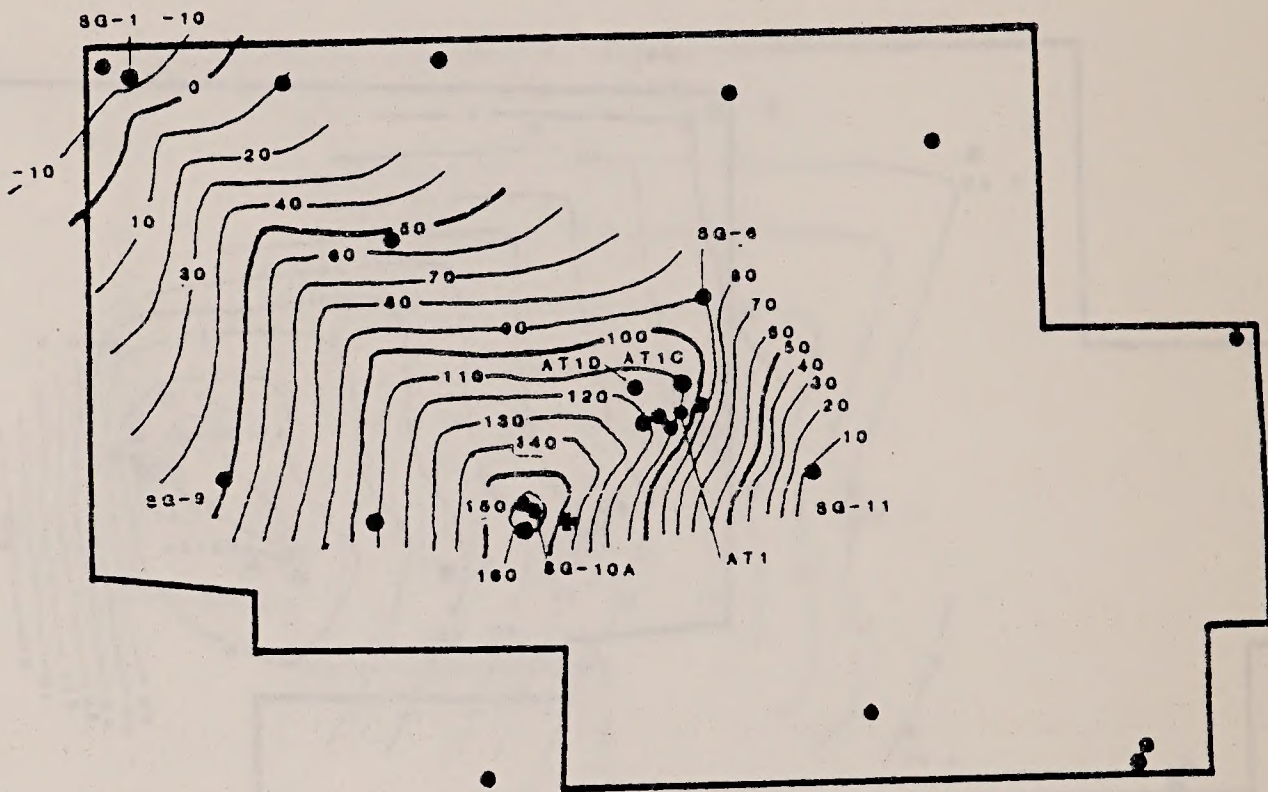
Lpc 3 Wells

after 90 days of ReInjection

Change in Water Levels From Those Expected Without ReInjection

- ◆ ReInjection Well
  - Monitor Well in this Aquifer Zone
  - Monitor Well of Other Aquifer Zones
- Contour Interval 10 ft.

GEOTHERMAL SURVEYS, INC.



28-79/80



## Water Quality

Data from water quality analyses of samples taken prior to and after reinjection have been examined to see whether quality changes attributable to reinjection activities have occurred. Water quality data may also be useful as a discriminator of aquifers. However, because of the scarcity of data, conclusions must be drawn with caution.

Upcl/Uinta. Water analysis reports of samples taken in July, 1981 from six wells which monitor the Upcl/Uinta formation are available. These are: SG 1-2, SG 1A-2, SG 9-3, SG 9-4, SG 11-3, AT1D-3. Statistical parameters for this data set are shown in Table 5.

Constituents reported at below detectable limits in all samples are:

Aluminum	Chromium	Selenium	Oil & Grease
Arsenic	Lead	Silver	BOD <sub>5</sub>
Barium	Mercury	Zinc	Thiocyanate

There is wide variation of water quality within the Uinta Formation as shown by the magnitudes of the standard deviations: Twelve of twenty-three reported constituents have standard deviations at least 75% of the value of their respective means. Skewness is also present in distributions of 11 of the constituents. This can be seen in the difference between the mean and the median.

One well, SG-9, has two Uinta monitors completed at different depths. Although samples from these two monitors show varying magnitudes of a few constituents such as iron, chloride and ammonia, when the data are adjusted and tested using a paired t-test, they are not significantly different at the 95% confidence level.

Upcl. Two analyses are available of water samples taken from Upcl monitors in July, 1981. One of these, SG 21-3, is known to be communicating with monitors at other depths or other aquifers as seen by identical water levels in the four monitors. It is, therefore, considered unreliable. Only Cb-2 can be used as being representative of Upcl water quality.



TABLE 5

## Statistical Parameters of Water Quality

## UPC 1/UINTA FORMATION

Constituent (mg/l)	N (No. of Wells)	$\bar{X}$ Mean	S Standard Deviation	Range		Median (Incl. BDL Samples)	Mode
				Minimum	Maximum		
Boron	6	.22	.12	.1	.4	.2	--
Calcium	6	47.8	52.7	6.8	120	21.0	--
Copper	1	.02	--	--	--	--	--
Iron	5	.30	.34	.04	.8	.08	--
Lithium	5	.16	.13	.05	.3	.08	--
Magnesium	6	56.0	39.0	21	120	42	--
Manganese	3	1.09	1.66	.06	.3	.04	--
Molybdenum	5	.02	.01	.01	.04	.02	.02
Nickel	2	.02	.01	.02	.03	.02	--
Potassium	6	23.5	24.1	3.2	54	14	--
Sodium	6	218	37	180	270	210	190
Strontium	6	9.7	9.9	.5	23.0	7.9	--
Bicarbonate	5	282	231	30	530	220	--
Carbonate	4	206	111	66	300	118	--
Bromide	2	.15	.07	.1	.2	.15	--
Chloride	5	67	89	10	240	38	10
Fluoride	5	1.2	.9	.1	2.5	.85	--
Ammonia	6	.97	.83	.3	2.3	.7	.3



TABLE 5 (CONT'D.)

Constituent (mg/l)	N (No. of Wells)	$\bar{X}$ Mean	s Standard Deviation	Range		Median (Incl. BDL Samples)	Mode
				Minimum	Maximum		
Kjeldahl	6	1.3	1.1	.4	3.4	.8	.6
Nitrate	1	1.1	--	--	--	--	--
COD	2	93	24	76	110	--	--
Phenol	5	.015	.012	.002	.031	.012	.02
Silica	5	13	9	2	22	12	22
Sulfate	6	412	241	220	720	290	720
Diss.Org. Carbon	6	14	7	5	26	15	16



Upcl/Uinta Unit; Composite Wells. Five monitors are completed in both the Uinta and Upcl. Statistical parameters from the analysis reports are shown on Table 6. These monitors all show no detectable levels of:

Aluminum	Chromium	Selenium	Thiocyanate
Arsenic	Mercury	Silver	BOD <sub>5</sub>
Barium	Lead	Nitrate	

Bromide and nickel were measured above their detectable limits (0.10 mg/l and 0.2 mg/l respectively) in three and four samples in this set. Only two Uinta samples contained detectable levels of these elements.

Upc2. Reports of samples taken in July, 1981 from three Upc 2 monitors are available. The monitors are SG 6-1, Cb-4 and SG 11-2. These show no detectable levels of the following constituents:

Aluminum	Lead	Selenium	BOD <sub>5</sub>
Copper			
Arsenic	Mercury	Silver	COD
Barium	Molybdenum	Zinc	Oil & Grease
Chromium	Nickel	Nitrate	Thiocyanate

A set of five reports of samples drawn from Upc2 in 1980 is available. These showed below detectable limits of the following constituents in one or more samples as shown:

<u>Constituent</u>	<u>No. of Samples</u>
Barium	2
Copper	1
Lead	3
Mercury	1
Molybdenum	3
Nickel	1
Selenium	1
Zinc	5



TABLE 6

## Statistical Parameters of Water Quality

## UPCI/UINTA COMPOSITES

Constituent (mg/l)	N (No. of Samples)	$\bar{X}$ Mean	s Standard Deviation	Range		Median (Incl. BDL Samples)	Mode
				Minimum	Maximum		
Boron	5	.16	.06	.1	.2	.2	.2
Calcium	5	56.7	43.0	7.5	110	45	--
Copper	1	.02	--	--	--	--	--
Iron	3	.29	.22	.07	.50	.07	--
Lithium	4	.10	.07	.05	.20	.07	--
Magnesium	5	68	22	46	97	63	--
Manganese	5	.20	.15	.04	.40	.2	--
Molybdenum	4	.03	.03	.01	.07	.02	.02
Nickel	4	.03	.01	.02	.05	.03	.03
Potassium	5	3.3	1.7	.6	5.0	3.2	3.2
Sodium	5	194	34	160	250	190	190
Strontium	5	14	9	.6	23	14	--
Zinc	1	.08	--	--	--	--	--
Bicarbonate	5	384	82	240	440	410	--
Carbonate	2	118	74	66	170	118	--
Bromide	3	.5	.4	.2	.9	.4	--
Chloride	5	18	16	6.1	47	12	--
Fluoride	5	1.3	1.2	.10	2.5	1.8	.10



TABLE 6 (CONT'D.)

Constituent (mg/l)	N (No. of Samples)	$\bar{X}$ Mean	s Standard Deviation	Range		Median (Incl. BDL Samples)	Mode
				Minimum	Maximum		
Ammonia	5	.4	.12	.3	.6	.4	--
Kjeldahl	5	.58	.13	.4	.7	.6	.7
COD	3	162	61	110	229	110	--
Oil & Grease	2	64	62	20	108	10	--
Phenol	4	.019	.018	.002	.038	.004	--
Silica	4	19	5	12	22	20	--
Sulfate	5	416	231	220	720	270	--
Diss. Org. Carbon	4	18	13	5	32	10	--

-55-



TABLE 7

## Statistical Parameters of Water Quality

UPC2

Constituent (mg/l)	N (No. of Samples)	$\bar{X}$ Mean	s Standard Deviation	Range		Median (Incl. BDL Samples)	Mode
				Minimum	Maximum		
Boron	2	.4	.3	.2	.6	.4	--
Calcium	3	50.6	43.1	5.9	92	54	--
Iron	3	.39	.61	.03	1.1	.04	--
Lithium	1	.07	--	--	--	--	--
Magnesium	3	47.7	45.0	4.1	94	45	--
Manganese	2	.2	--	--	--	.2	.2
Potassium	3	4.1	.40	3.9	4.6	3.9	3.9
Sodium	3	187	50	140	240	180	--
Strontium	3	9.4	11.0	1.9	22	4.4	--
Bicarbonate	3	443	85	380	540	410	--
Carbonate	1	66	--	--	--	--	--
Bromide	1	.8	--	--	--	--	--
Chloride	3	9.5	4.7	4.5	14	10	--
Fluoride	3	6.8	11.5	.1	20	.2	--
Ammonia	3	.45	.50	.04	1.0	.3	--
Kjeldahl	2	1.1	.42	.8	1.4	1.1	--
Phenol	2	.006	.006	.001	.01	.006	--







A comparison of two Upc2 means of those constituents which were above detection limits was made using a paired t-test. At the 95% confidence level there was no significant difference between the means of these two data sets.

Lpc3. Analysis reports of samples drawn from seven Lpc3 monitors are available. These are SG 1-1, AT1C-2, AT1D-1, SG 11-1, SG 9-1, SG 6-2, AT1C-1 species reported at or below detection levels in all seven samples:

Aluminum	Lead	Silver	Oil & Grease
Chromium	Mercury	Zinc	BOD <sub>5</sub>
Copper	Selenium	Nitrate	Bromide

Statistical parameters of the constituents are shown in Table 8.

Detectable in 1980 and not in 1981 were:

Zinc	Selenium
Lead	BOD <sub>5</sub>
Oil & Grease	

Detectable in 1981 and not in 1980 are:

Phenol
Nickel

Lpc4. Only one sample is available from Lpc4. This was taken from SG 21-1 which is known to communicate with other aquifers and is not considered representative of water quality in Lpc4.

A single set of lower aquifer water quality data is available from June, 1980. This section includes analysis from five wells. These wells, Cb-1, SG 10, SG 17-1, SG 11-1 and SG 1-1, were composite Lpc3, Lpc4 monitors. These samples show great variation, but in general are considerably higher in values for sodium, chloride, fluoride, bicarbonate, and barium than the 1981 analyses from Lpc3 monitors. Sulfates show much lower levels than in the shallower aquifers and phenol is not detected.



TABLE 8  
Statistical Parameters of Water Quality  
LPC3

Constituent	N (No. of Samples)	X Mean	s Standard Deviation	Range		Median (Incl. BDL Samples)	Mode
				Minimum	Maximum		
Arsenic	1	.02	--	--	--	.8	--
Barium	2	.8	0	--	--	.8	--
Boron	7	2.1	2.0	.6	5.7	.8	.8
Calcium	7	8.2	7.9	3.9	26	5.5	--
Iron	4	.06	.03	.03	.1	.03	--
Lithium	4	.4	.3	.06	.6	.06	--
Magnesium	7	7.3	10.0	3.0	30	3.4	--
Manganese	6	.05	.02	.02	.07	.06	--
Molybdenum	6	.04	.04	.01	.1	.02	--
Nickel	2	.02	0	--	--	--	--
Potassium	7	9.8	5.0	5	20	8.4	--
Sodium	7	557	480	300	1600	310	--
Strontium	7	1.9	.5	1.4	2.6	2.0	--
Bicarbonate	7	86.7	558	440	2000	590	--
Carbonate	7	221	260	68	800	120	--
Chloride	7	42	51	4.2	69	11	--
Fluoride	7	19.2	9.6	.2	32	20	--



TABLE 8 (CONT'D.)

Constituent	N (No. of Samples)	X Mean	S Standard Deviation	Range		Median (Incl. BDL Samples)	Mode
				Minimum	Maximum		
Ammonia	7	1.8	.8	1.1	3.2	1.4	--
Kjedahl	7	2.1	1.0	1.1	3.4	1.7	--
COD	3	80	16	64	96	250	--
Phenol	6	.01	.006	.003	.019	.005	--
Silica	6	12	3.3	9	15	12	--
Sulfate	6	44	54	7	150	30	--
DOC	7	15	11	3	38	14	--



## CONCLUSIONS AND SPECIAL INTERPRETATIONS

### Vertical Thermal Gradients

As indicated by the downhole thermal logs, there is considerable range in ground water activity from well to well within the same hydrologic unit. The flow is controlled both by fractures and by general lithology, which in turn influences the fracture patterns. In the discussions which follow, the terms low, moderate, and high referring to flow are used in a relative sense only.

Upcl/Uinta. Most of the Uinta Formation (Upcl) shows moderate to high flow. The lower 100 ft of the Uinta indicates low to lowest flows in most wells, which is interpreted as retarding ground water flow somewhat in most areas. This interval may represent a barrier which separates the Uinta hydrologically from the Upcl.

In the upper Parachute Creek Member above the Four Senators Zone, the thermal logs indicate that flow varies widely from highest to lowest.

Four Senators Zone. The thermal logs throughout this zone indicate low to lowest flow except in AT-1C, AT-1A and Cb-4, where moderate to highest flow is indicated. From these logs, the Four Senators Zone appears to represent an effective aquitard.

Upc2. Between the Four Senators Zone and the base of the "A" groove, moderate to low flow is indicated by the thermal logs, except in SG-18A and 33-X-1 which indicate highest flow in this interval.

Mahogany Zone. From the base of the "A" groove to 30 ft below the base, an interval of consistent lowest flow is noted. This interval is believed to retard ground water flow strongly and is likely the major aquitard separating the Upc2 and Lpc3.

Lpc3. From below the top 30 ft of the Mahogany Zone to the top of the R-5 Zone, low to moderate to high flow is indicated by the logs, with flow increasing with depth in the lower portion beneath the Mahogany Zone.



R-5. Lowest flow is indicated in the 50 ft above the middle of the R-5 Zone, between Lpc3 and Lpc4, based on the one thermal log (33-X-1) that included this interval. This may represent the effective aquitard between Lpc3 and Lpc4.

Lpc4. Between the middle of the R-5 Zone and the total depth of 33-X-1, moderate flow is indicated by the thermal log.

In summary, the thermal logs indicate a hydrologic sequence that relates moderately well with the Newell format, based in turn on the pump-spinner results of 33-X-1 and 32-X-12. Major aquitard and/or aquiclude conditions are indicated in the lower Uinta, the Four Senators, the Upper Mahogany and within the R-5 Zone. Other barriers may also be present.

It should be pointed out that most of the flow indicated by the temperature logs is lateral rather than vertical, remaining within the more permeable units.

Exceptions to the general statements discussed in the preceding paragraphs are the wells in the Aquifer Test Pad. Here, moderate to high flow is indicated throughout most intervals. This is believed due to the more-than-normal cross flow in the Aquifer Test Pad caused by the presence of open holes.

#### Records of Individual Monitors

The pressure response was seen in most of the on-tract and nearby off-tract wells. The magnitude of response was greatest in Lpc3, moderate in Upc2 and least in Upc1/Uinta. Based on the character of the response, we believe that the Aquifer Test Pad is largely responsible.

Of the wells that did not show response to the reinjection, the failure in many cases can be attributed to distance between the injection well and the monitor. In other cases, where water levels decreased during reinjection, these decreases may be due to their proximity to the shafts where water was being withdrawn at an average rate of about 1400 gpm during the reinjection period.

Two pairs which monitor Upc2 and Lpc3 showed response to reinjection in the Upc2 monitor and failure to respond in



the Lpc3 monitor. These are SG-11 and SG-9. Possible explanations are relief of pressure in Lpc3 due to upward or downward flow, or barriers in Lpc3 to transmission of the pressure wave. In SG-11 the Lpc3 monitor has shown a significant increase in water level since the completion of the reinjection monitoring program. The Lpc3 monitor in SG-9 has continued to show a decline.

### Elevations of the Potentiometric Surfaces

Before Reinjection. Figures 5a, b and c show the contoured elevations of the potentiometric surfaces for Upcl/Uinta, Upc2, and Upc3 in February 1981. They show the northerly slope of the potentiometric surface. Differences in configuration may be due to differences in the distribution of the data points -- the monitoring wells. Only the Upcl/Uinta plot shows a depression near the shafts, provided by data from Cb-1. For the other plots there were no data available from the shafts.

In general, the pre-reinjection data away from the near vicinity of the shafts show a range of about 300 ft in the potentiometric surface elevation. The highest elevations were at the southern boundary of the Tract. Here, the Upcl/Uinta surface was the highest and Lpc3 was the lowest. The Upcl/Uinta head was as much as 100 ft higher than Lpc3. Similar relationships occurred through the central part of the Tract.

During Reinjection. Figures 9a, b and c show the elevations of the potentiometric surface on April 19, 1981, after a month and a half of reinjection and well into Step 2.

For Upcl/Uinta, a little change had occurred since the February readings in head elevation, generally slight, throughout the Tract. For Upc2 and Lpc3, however, the differences were marked.

In the central part of the Tract, some of the head relationships were now reversed. Upc2 heads were at higher elevation than Upcl/Uinta, and some of the Lpc3 heads were above those of both Upc2 and Upcl/Uinta. This was especially true in the area of the aquifer test pad and the reinjection site.

Implications. If leaky aquitard conditions occur throughout the Tract, then the head relationships before reinjection suggest that the vertical component of bedrock water movement is downward under normal conditions. If the heads caused by reinjection are reversed, then the vertical component of



bedrock water, if leakage occurred, movement would be upward.

It is significant that so little change occurred in the Upcl/Uinta potentiometric surface when significant changes occurred in Upc2 and Lpc3. This suggests that there is little hydrologic continuity between the shallower and the deep formations. This study will be continued for the later and post-reinjection observations, and will be the subject of a later report.

Summary. The largest head increases in each of the hydrologic units were: 79 ft in Upcl/Uinta (30 ft at the injection site, and 79 ft in the Aquifer Test Pad); 110 ft in Upc2; and 167 ft in Lpc3.

The lateral extents of the affected zones were on the order of 1 to 2 miles, centered around the injection site, and remaining mostly within the Tract.

Most of the off-Tract extension was to the south, perhaps as much as a mile. Off-Tract extension to this distance is not reliable, as this is based partly on wells with questionable completions.

The indicated amount of spread of the zone of influence increased in the order of increasing depth of the hydrologic units. The smallest extension was in the Upcl/Uinta; the largest was in Lpc3.

Northwesterly and northeasterly trends were indicated. The northwesterly trend was most definite in Upcl/Uinta, shown best in the plots that included wells with questionable completions. The northeasterly trends were better shown in the plots using only reliable wells. Because these were fewer, and irregularly spaced, the northeasterly trends, like the northwesterly trends, must be considered tentative.

In Upcl/Uinta there was more than twice as much head increase at the Aquifer Test Pad as at the injection site. Possible explanations are: (1) there was some upward leakage through the aquitards; (2) Upcl at the injection site was pressurized not from the injection well directly, but through the much-perforated aquifer test pad; (3) leakage occurred via poorly completed wells; or (4) a combination of these processes.

A hypothesis considered earlier, but now considered unlikely, is that the rise in Upcl/Uinta near the injection well was due to infiltration from Pond C. Given the magnitude of the rise and the short time involved, we do not consider this a likely explanation, at least for the present. Further



study of post-reinjection data, should provide the correct solution. Based on the change in shape of the potentiometric surface through time, we tentatively prefer the second hypothesis - pressurization via the Aquifer Test Pad.

The analysis made for a changing base provided generally similar conclusions. Using this approach the indicated radius over which reinjection had the effect of raising the potentiometric surface elevation was not greater than 2 miles from the injection well. This places the effect entirely on-Tract except for the areas immediately to the south. The magnitude of the effect increased with depth, from 43 ft of rise in the Upc1, through 65 ft in the Upc2, to 166 ft in the Lpc3. Three discontinuities in the hydrologic properties of these units are also indicated. The first is a structure retarding the flow of water eastward from the Aquifer Test Pad in the Upc1. The second is a similar structure at the same location in the Lpc3. The third is a possible area of relatively higher hydraulic conductivity between the reinjection well and the Aquifer Test Pad in the Lpc3. Such discontinuities are not evident in the Upc2. Additionally, the data for the Upc1 give evidence for increased vertical permeability across the Four Senators Zone at the Aquifer Test Pad. This is probably due to the many wells which have been drilled there.



## Transmissivity

A method using interference analysis was used in deriving transmissivity values, as discussed on pp. 29 of this report. Results are given in Table 3.

Values ranged from 722 gpd/ft to 1992 gpd/ft in Upc1 and Upc2, and averaged 1650 gpd/ft. More of the values clearly attributable to Upc2 were lower than those clearly attributable to Upc1 or to combinations of both units.

Values in the Lpc3 ranged from 145 gpd/ft to 524 gpd/ft. The average was 288 gpd/ft.

These values conform reasonably with those derived by other workers using different methods of derivation. The overall results are that these are not high-yielding aquifers, that there is a general decrease in transmissivity with depth; and that the gross hydro-stratigraphic format proposed by Newell is reasonable.

## Effects on Springs, Seeps, and Surface Flows

Variations in these processes have been occurring long before the reinjection test. They are mostly related to climate and to agricultural diversions. Given the nature of response in Upc1/Uinta (the smallest of the three) and its localization well within the Tract and especially around the Aquifer Test Pad, it is very unlikely that springs and surface flows could be affected.

No changes in flow patterns during the time of reinjection can be attributed to the reinjection activity. Longer-range studies in which the effects of climate, agricultural diversions, and discharges are removed may in time determine whether the reinjection test caused changes. At present, there is no evidence that it has.

## Relation to the Layered Models

The results support a layered model in which stratigraphy grossly dominates, modified extensively by fractures. The Newell model consisting of four hydrologic units separated by three aquitards or aquicludes and the USGS five layer model are reasonably similar.

With the data at hand, neither can be favored over the other. It is likely that as more information becomes available, the hydrologic models will become increasingly complex, both as to the number of layers and in their lateral continuity or discontinuity.



## Anisotropy

With the scarcity and the irregular distribution of data points, no statements can be made with confidence regarding anisotropy. Based on all the evidence, not just the reinjection data, there appears to be two principal directions: Northwest-erly and north-northeasterly. These, if they exist, are probably fracture controlled.

There is some reason to believe that anisotropy may be different within the individual aquifers. The northeasterly trends, for example, may be an upper aquifer phenomenon, controlled by shallower fracture systems. There may also exist barriers to flow in some aquifers that are not seen in others, evidenced by the delayed response to reinjection in SG11-1, an Lpc3 monitor.

There is, of course, anisotropy in another sense -- the difference between horizontal and vertical permeability. An assumption could be made that horizontal permeability is greater than vertical permeability, due to stratification. Because fracture systems greatly influence flow in the Piceance Basin, the relationship is complex.

## Effect on the Environment and on the Mining

At present, we have no evidence that the reinjection done so far has caused any effects on alluvial wells, springs, or surface flows. As reinjection in the future would come from an ever enlarging zone from which water was being removed, and because barriers to vertical flow exist, it would seem that the major problem would not be to keep the reinjected water from reaching the surface, but from reaching the mine.

With respect to quantity, there is one aspect of reinjection that is positive in the sense of environmental protection. Many believe that the dewatering operations done with the mining will eventually draw down and dry up the surface streams, such as Piceance Creek. Reinjection, of course, is in the nature of preventing that from happening.

It would seem that a balance needs to be reached among three factors:

1. Do not inject so much that outflow occurs to the surface.
2. Inject as much as possible so that drying up of surface streams, springs, etc., is prevented or reduced.



3. Consume enough in the mining operations to achieve the balance in (1) and (2).

With respect to quality, reinjection is in the direction of environmental protection if the water being reinjected is poorer in quality than the surface or near surface water. If it is better in quality, or can be made better, then deliberately shallow reinjection can improve the nature of attainable ground water.

Given the relatively high transmissivity values in Upcl/Uinta there may be some reason to consider selective reinjection in the Uinta Formation to improve the Uinta ground water, to prevent the loss of surface water, and to help keep the mining area dewatered. This will take further investigation of the shallower aquicludes or aquitards, and a better definition of the ratio of horizontal to vertical permeability.

#### Uinta and Upcl

The Uinta Formation is distinguished from the Parachute Creek Formation on the basis of lithology. The temperature gradients responsive to hydrology, support the concept that the Uinta Formation is distinct from the remainder of Upcl.

The concept can neither be supported nor denied on the basis of water quality or head response to reinjection. This is because of the irregular and sparse distribution of the data points (monitoring wells).

Some of the Uinta wells were affected by reinjection. This was discussed in earlier sections. One likely reason is upward flow in the Aquifer Test Pad across the aquitards.

Based on all the evidence to date, we believe that the Uinta Formation is confined in its lower part and unconfined in its shallower part. The Black Sulphur Tongue of the Green River Formation may be the principal confining layer with the Uinta Formation.

If the upper part of the Uinta Formation is being recharged by Piceance Creek above the Black Sulphur Tongue, there is additional reason to consider the lower formations now included in Upcl as separate from the Uinta.



## Effects on Alluvial Wells (to October 1981)

The alluvial wells showed no overall noticeable effects of the reinjection test. Wells along Piceance Creek (A-1, A-2, A-3, A-6, A-7) showed lower levels of 1 ft to 2 ft in 1981 from March through September than in 1980. This is believed to be in response to low precipitations during the past water year, and rises of 2 ft to 4 ft since late 1978 were attenuated in these wells. Wells in the eastern part of the Cb-Tract (in the upper areas to the watershed) showed slight (1 ft or less) lowering in level and rises of 2 ft to 4 ft since late 1978 are continuing.

In Little Gardenhire Gulch, Wells A-5, A-5a, and A-5b showed considerable fluctuations. This is normal for these wells which are in the direct line of discharge from Ponds A and B. Well A-12 in the southeastern part of the Tract showed an anomalous rate of increase from March to June, 1981. Inasmuch as a similar anomalous rise occurred in 1978, because the well is 9300 ft from the reinjection site, across two major drainages, and up-gradient, we do not consider its behavior to be due to reinjection.

In Little Gardenhire Gulch, Wells A-5, A-5a, and A-5b showed considerable fluctuations. This is normal for these wells which are in the direct line of discharge from Ponds A and B. Well A-12 in the southeastern part of the Tract showed an anomalous rate of increase from March to June, 1981. Inasmuch as a similar anomalous rise occurred in 1978, because the well is 9300 ft from the reinjection site, across two major drainages, and up-gradient, we do not consider its behavior to be due to reinjection.



FIGURE A1-1

# CB RE-INJECT DATA SG-1A-2

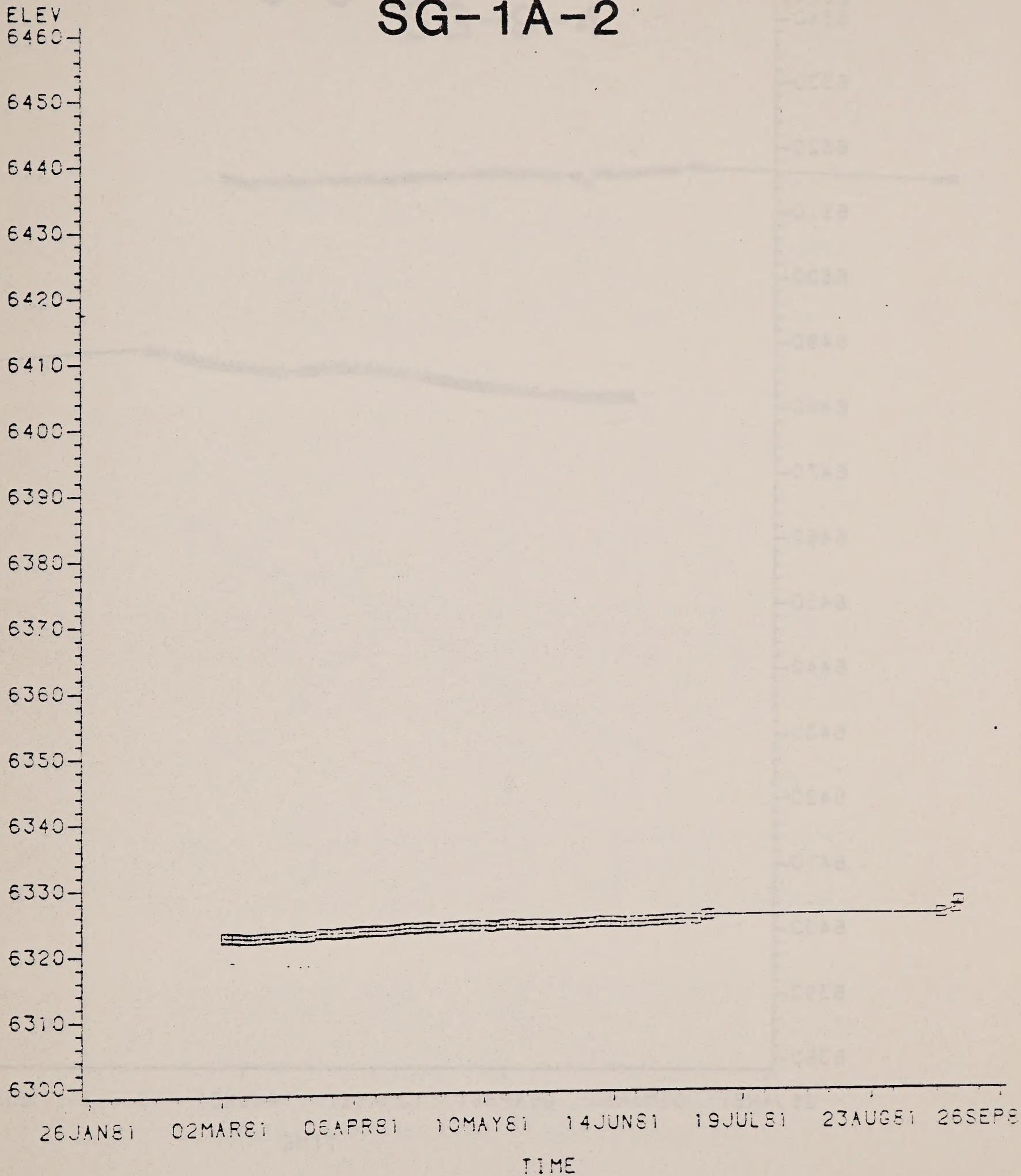




FIGURE A1-2

# CB RE-INJECT DATA

## SG-9-3

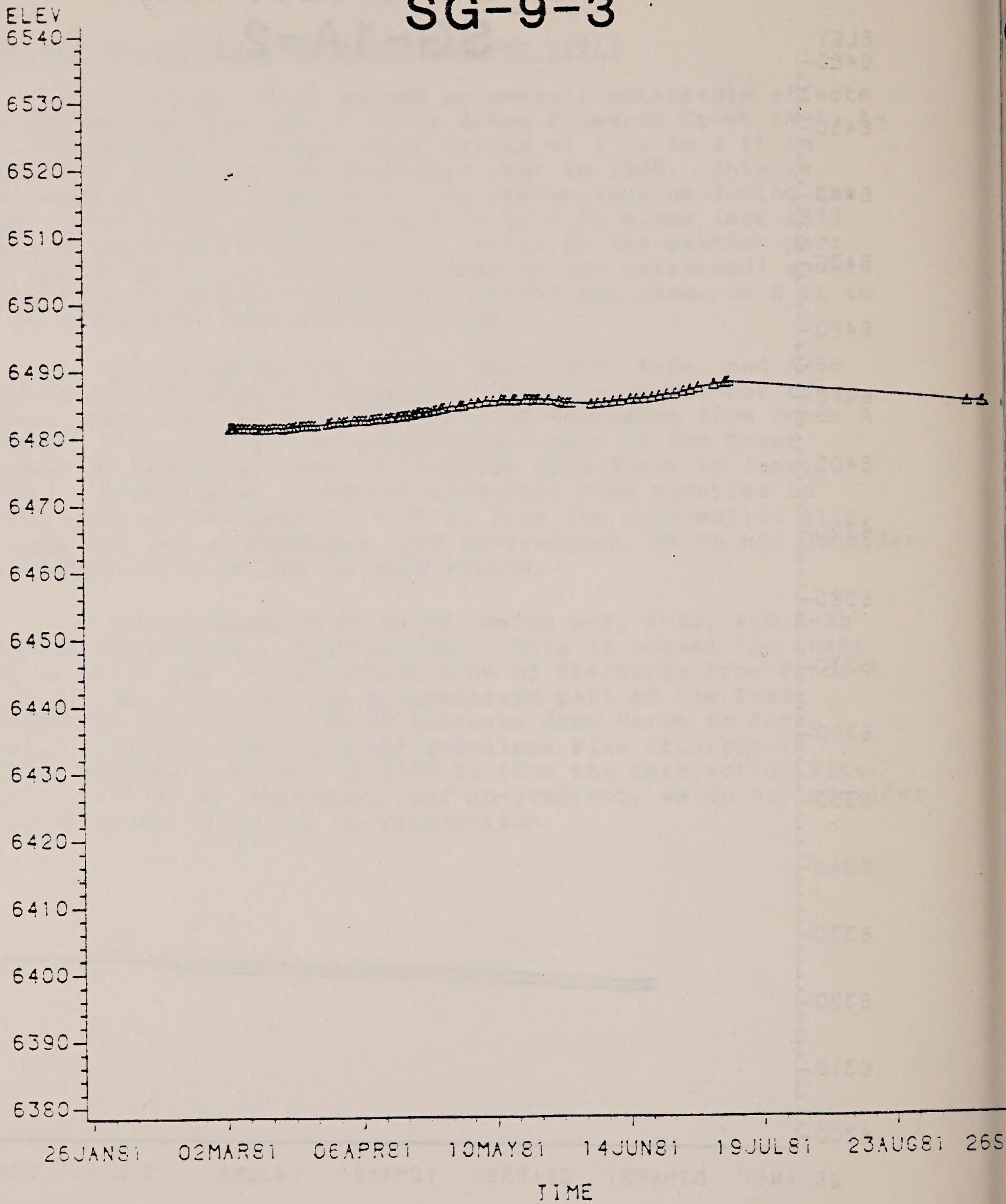




FIGURE A1-3

CB RE-INJECT DATA

SG-9-4

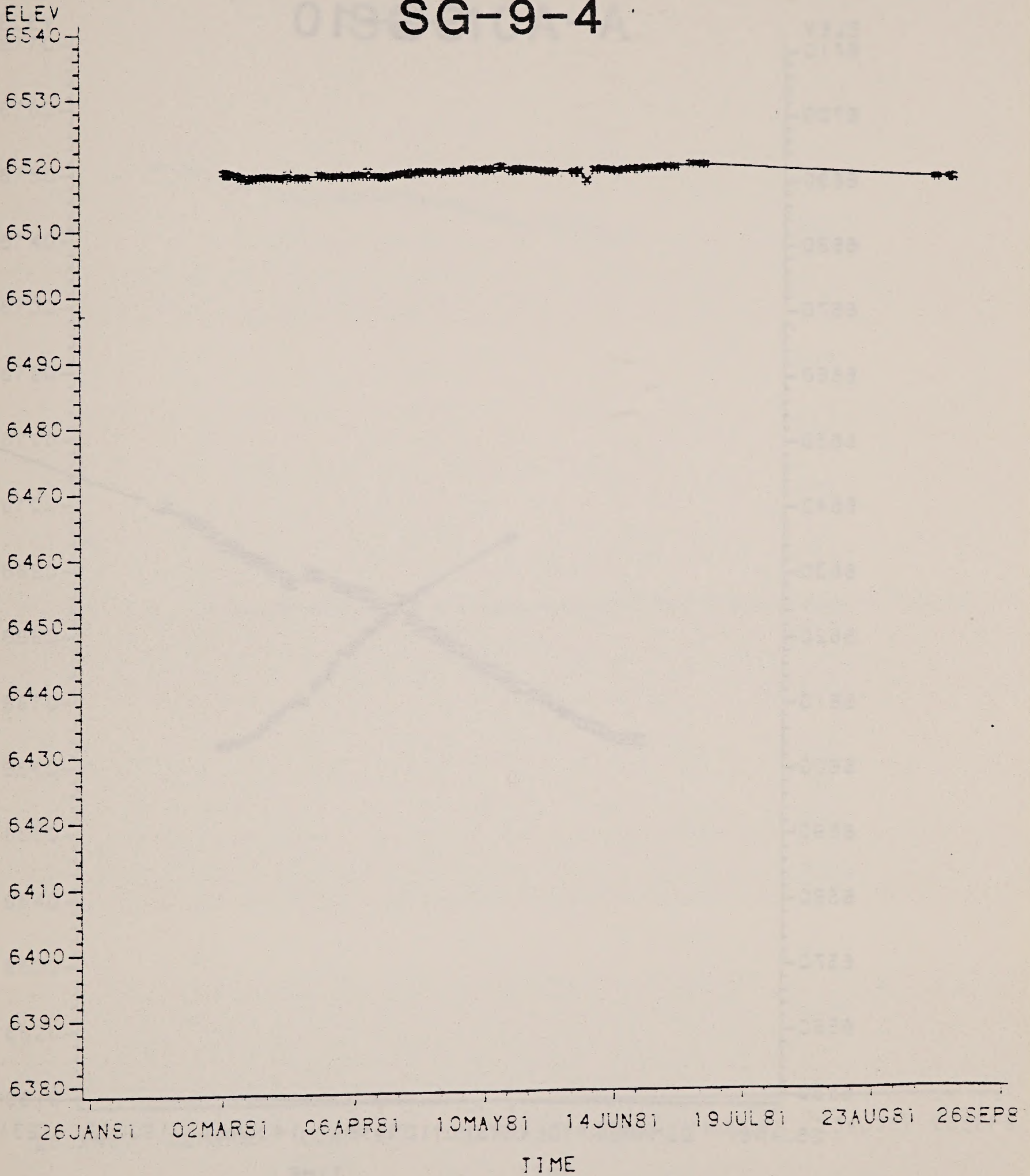




FIGURE A1-4

# CB RE-INJECT DATA SG-10

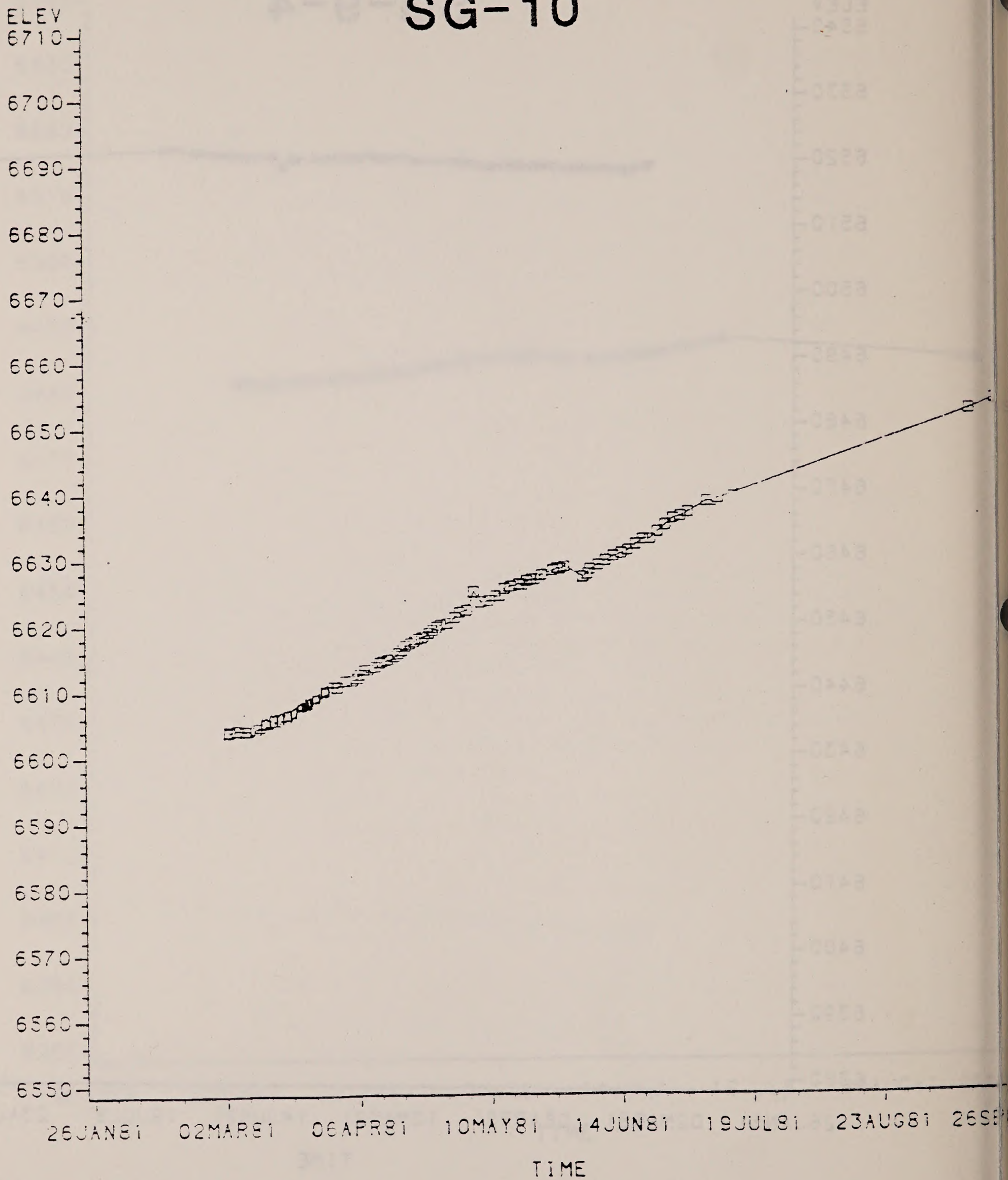




FIGURE A1-5

# CB RE-INJECT DATA SG-10A-A

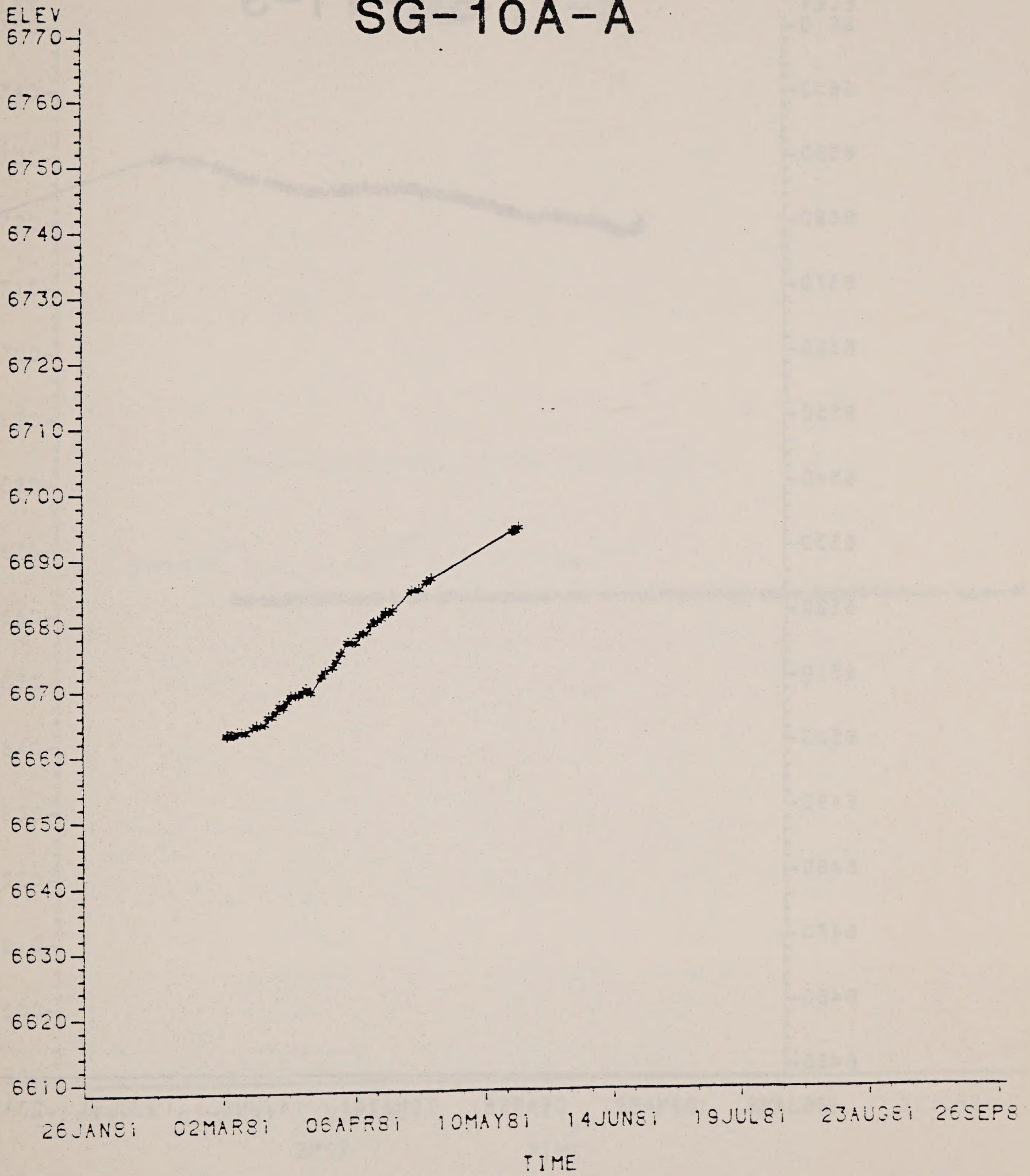




FIGURE A1-6

# CB RE-INJECT DATA SG-11-3

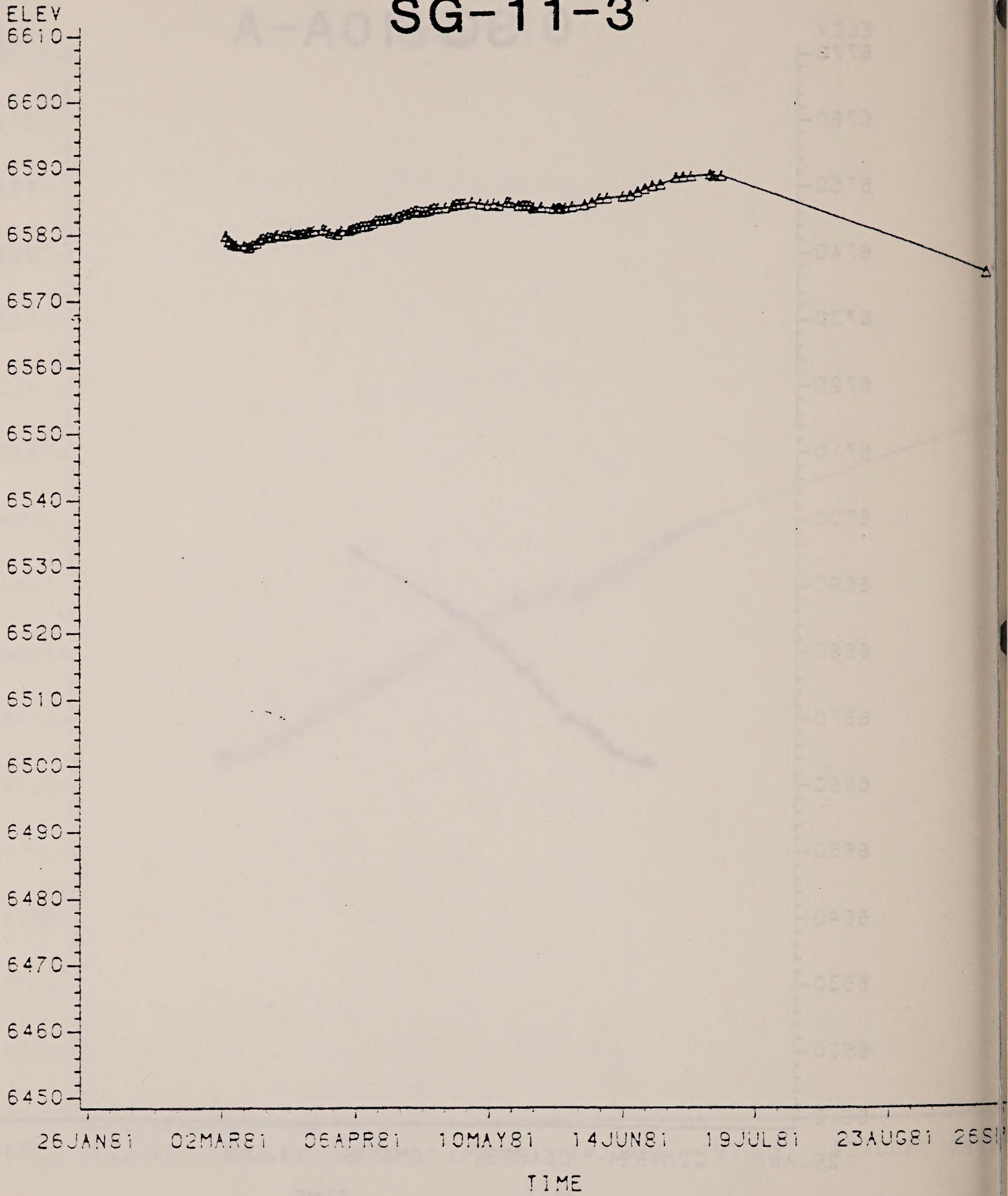




FIGURE A1-7

CB RE-INJECT DATA  
SG-17-3

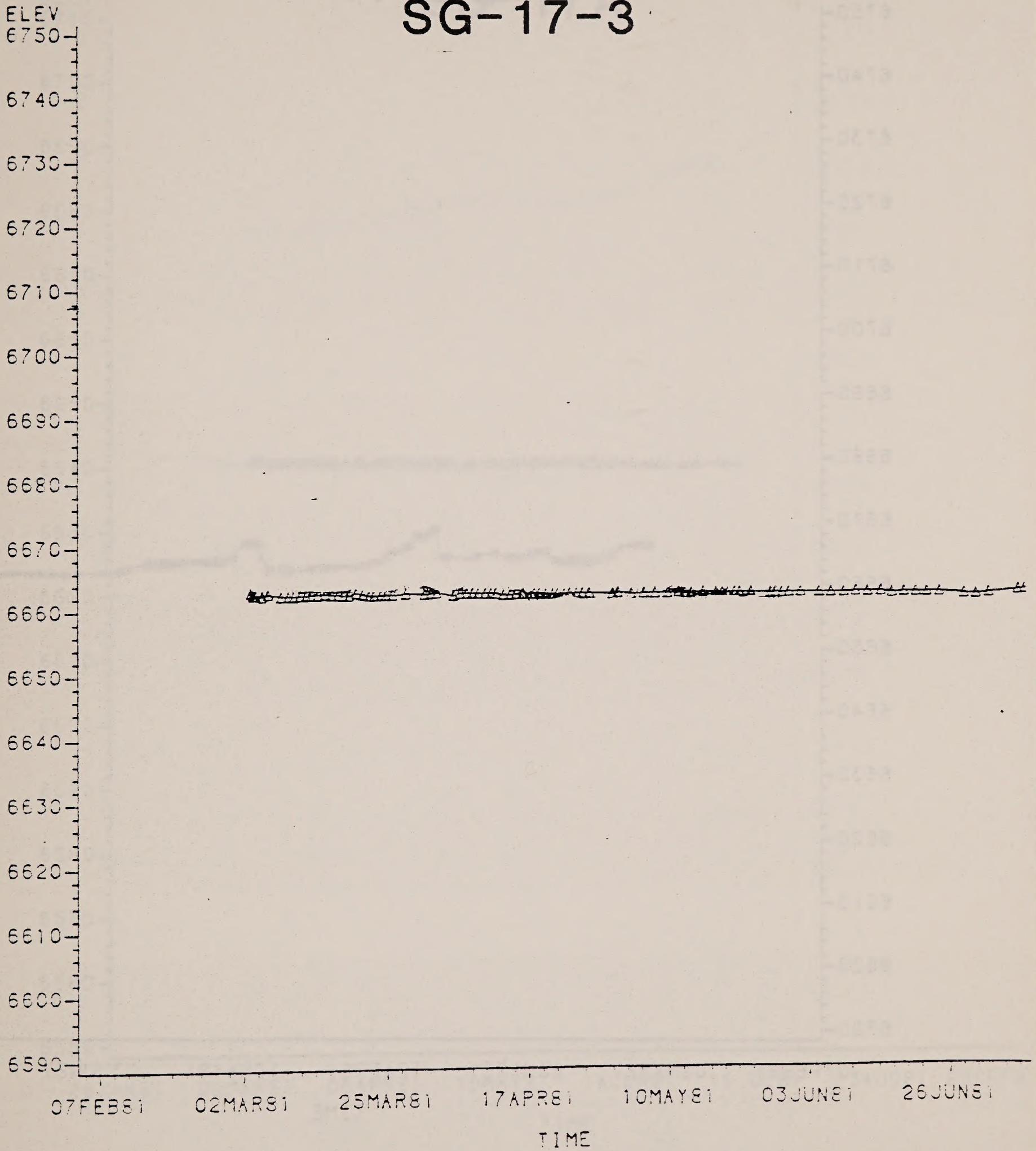




FIGURE A1-8

CB RE-INJECT DATA

SG-17-4

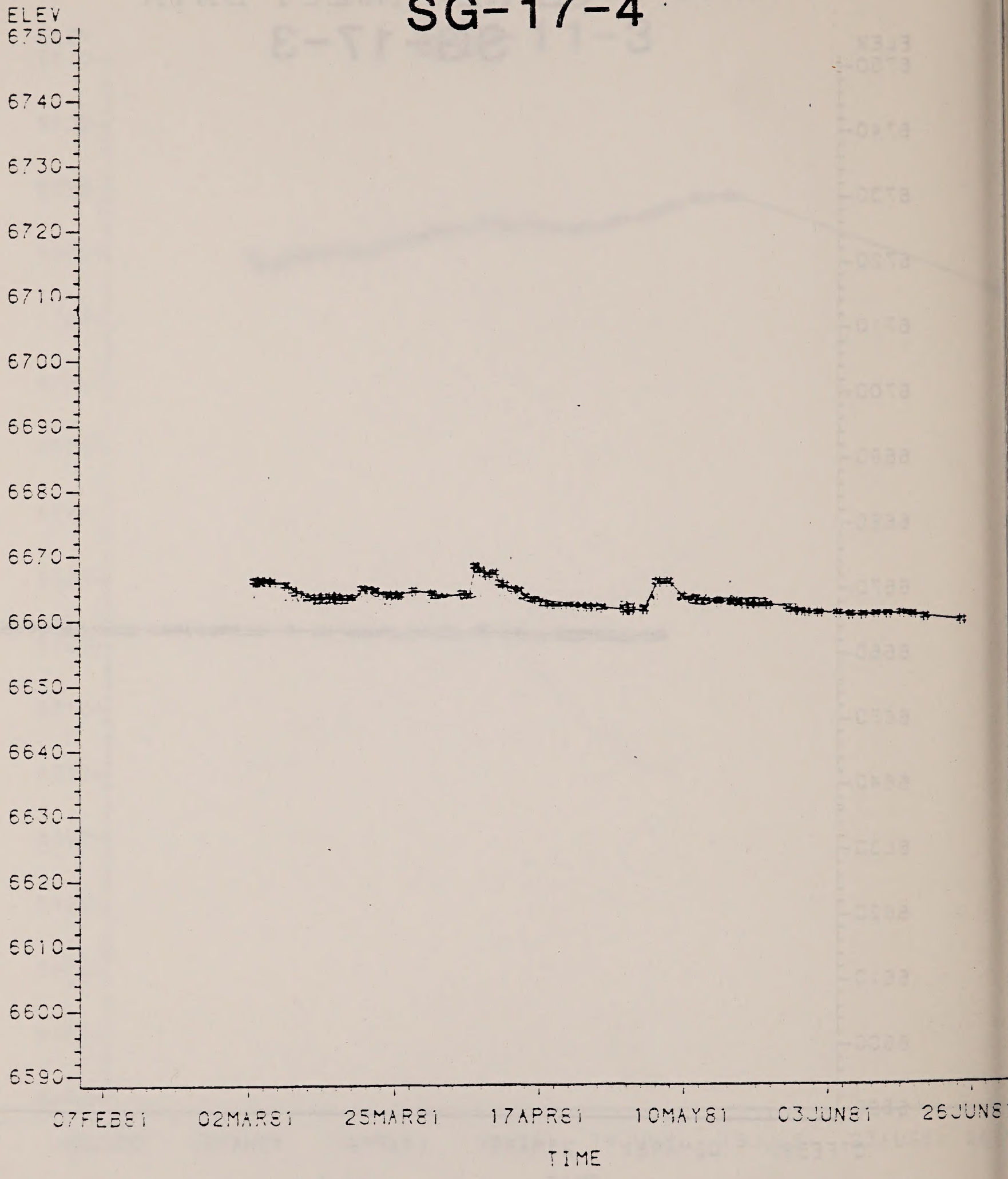




FIGURE A1-9

# CB RE-INJECT DATA SG-17A

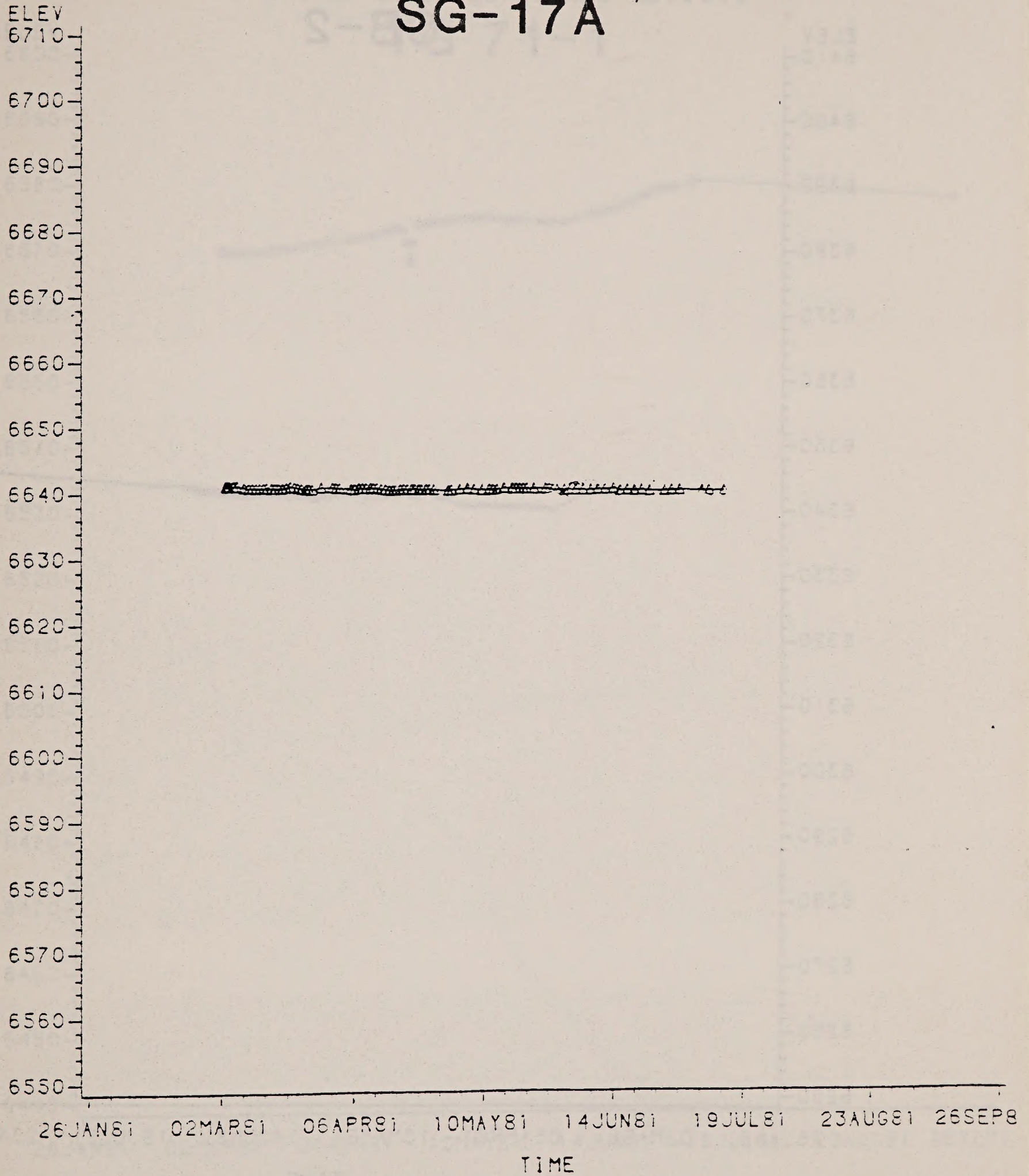




FIGURE A1-10

CB RE-INJECT DATA

CB-2

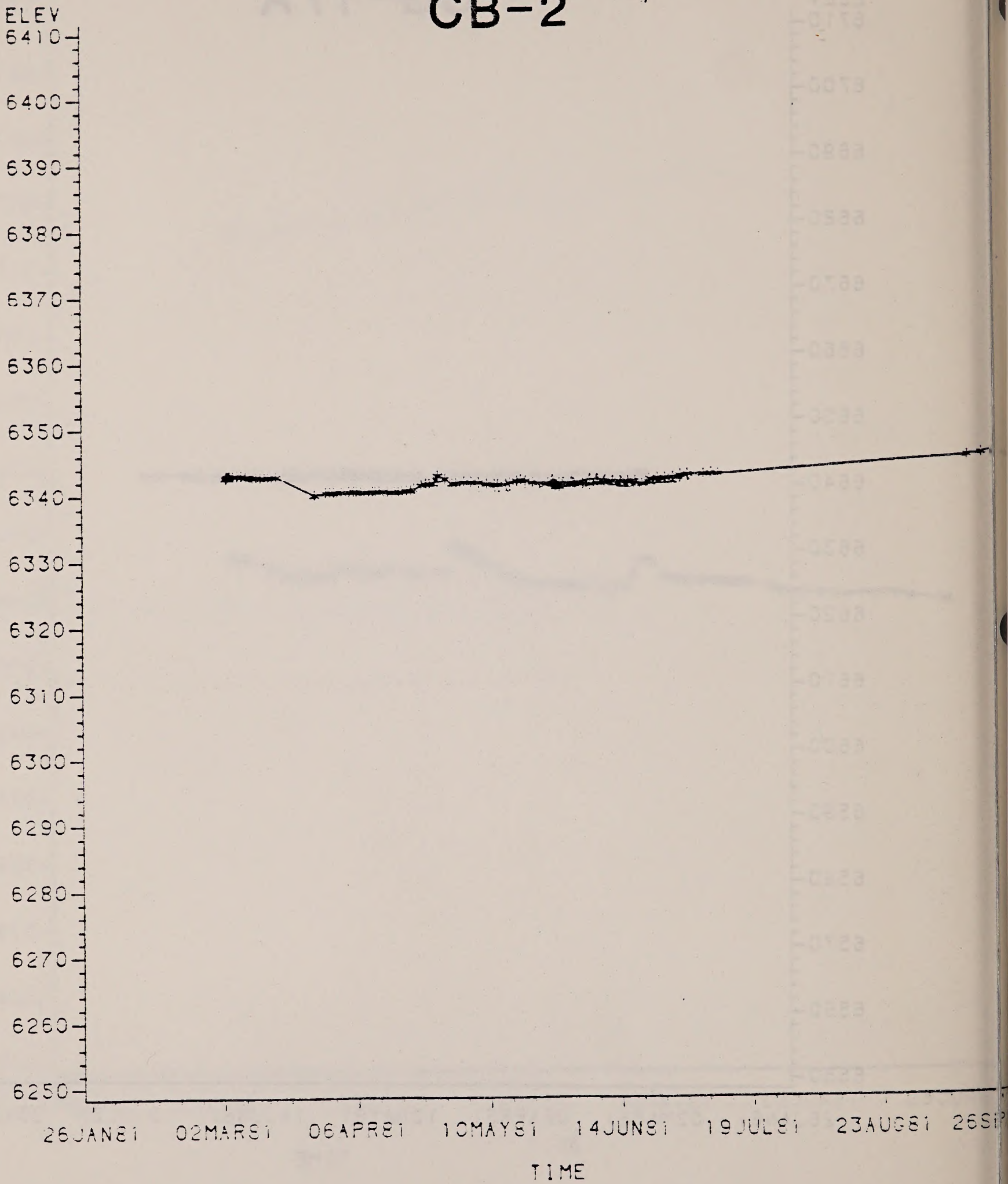




FIGURE A1-11

# CB RE-INJECT DATA TG 71-1

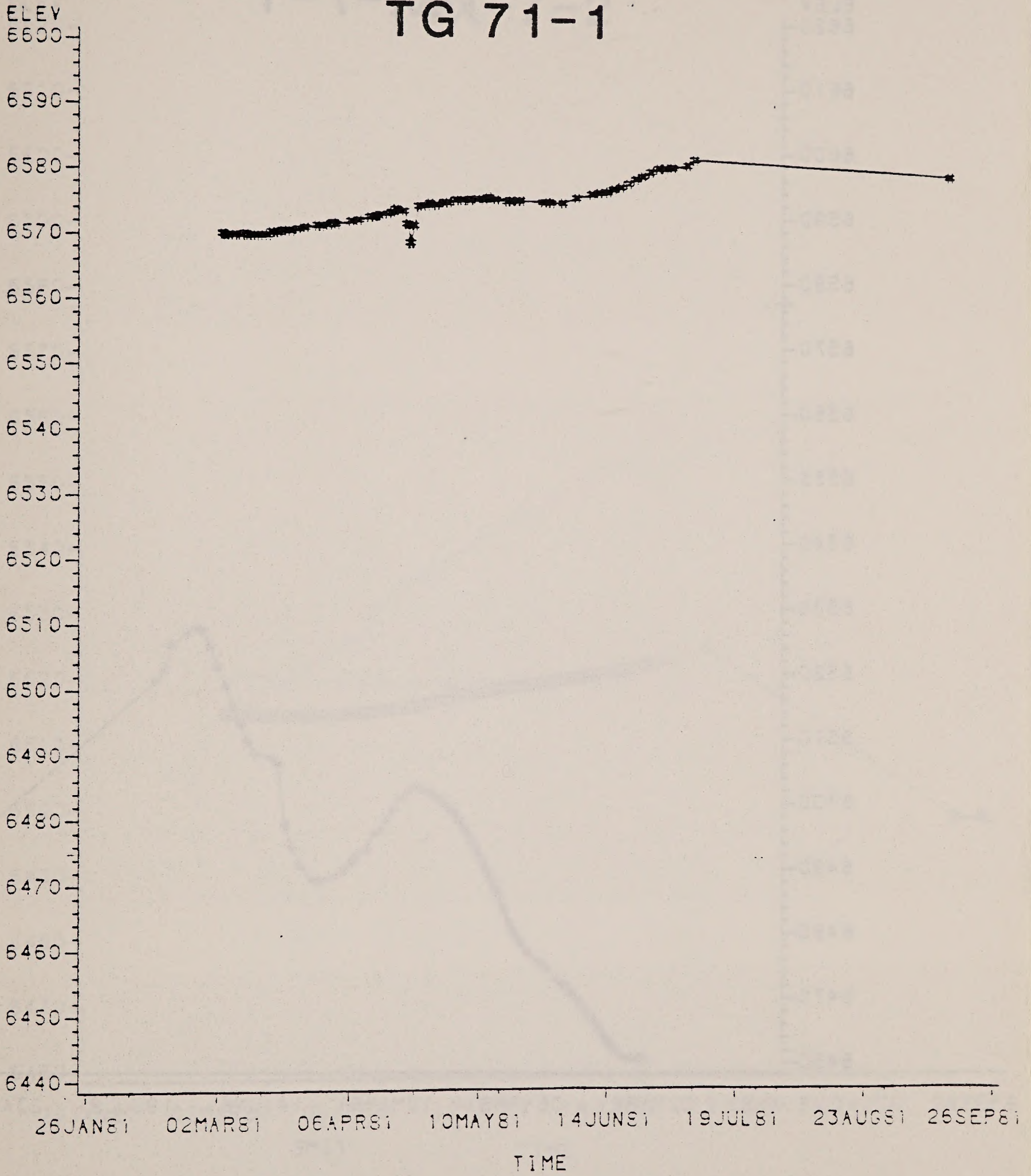




FIGURE A1-12

CB RE-INJECT DATA

14X-7-1

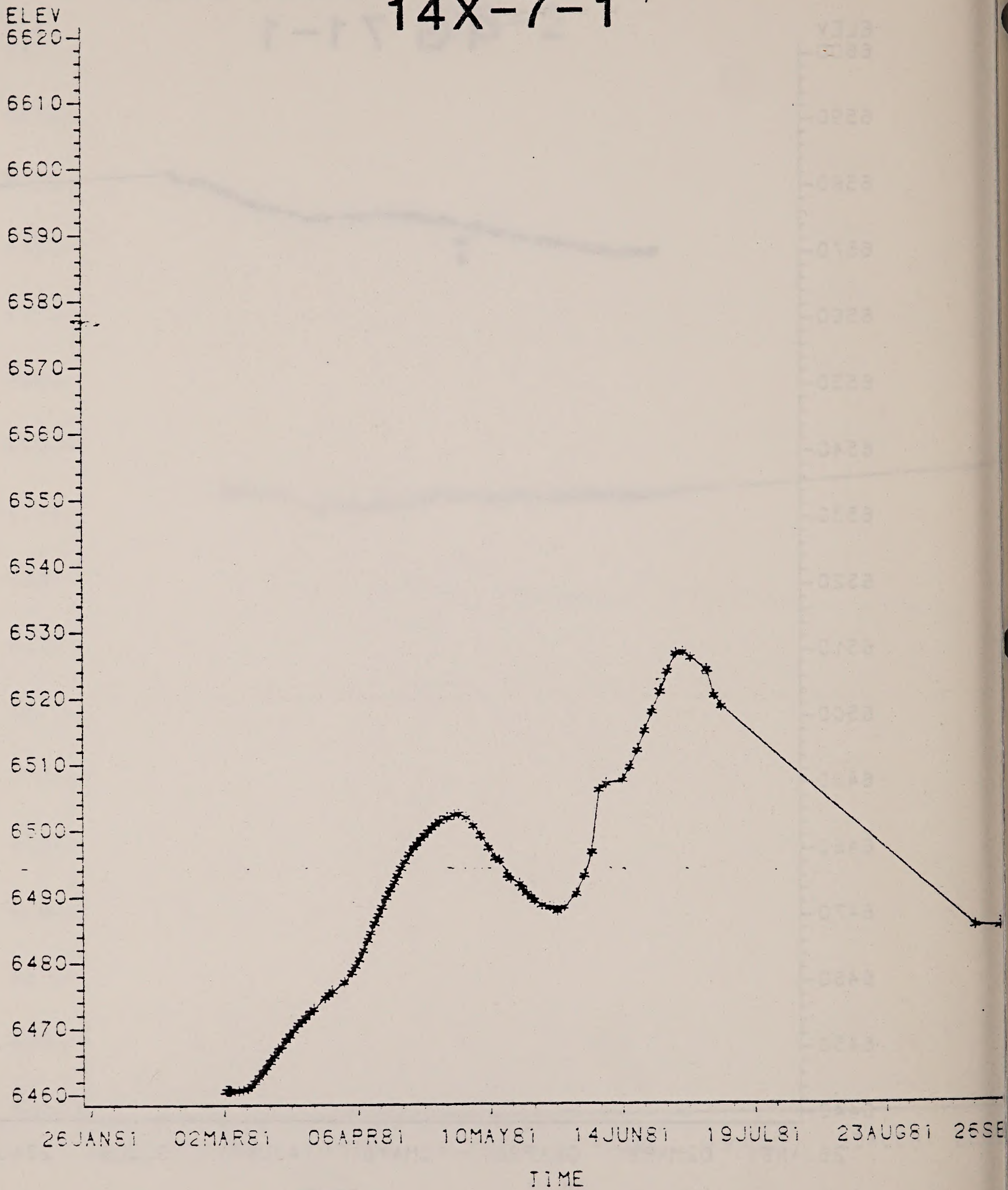




FIGURE A1-13

# CB RE-INJECT DATA 14X-7-2

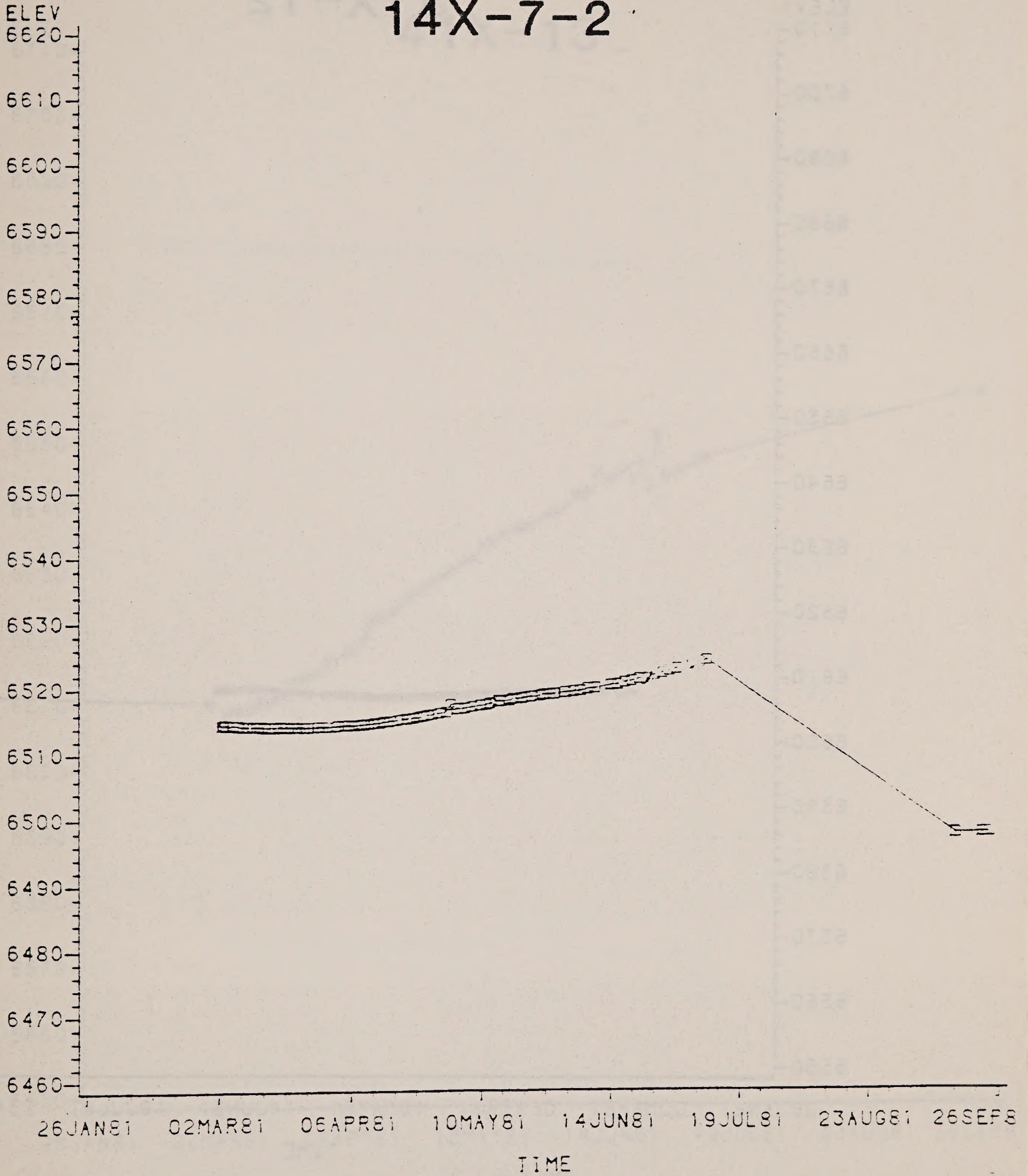




FIGURE A1-14

# CB RE-INJECT DATA 31X-12

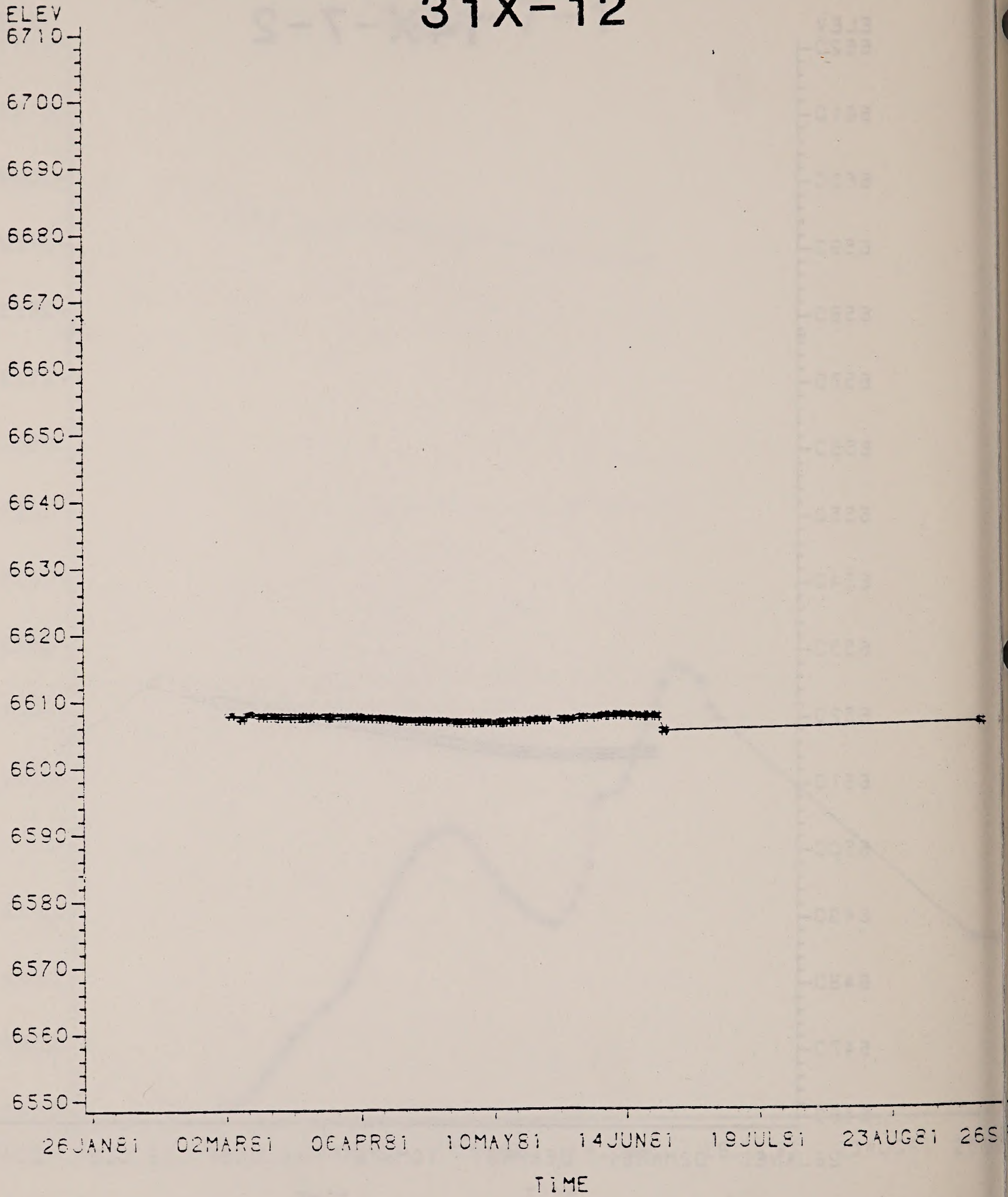




FIGURE A1-15

# CB RE-INJECT DATA 41X-13

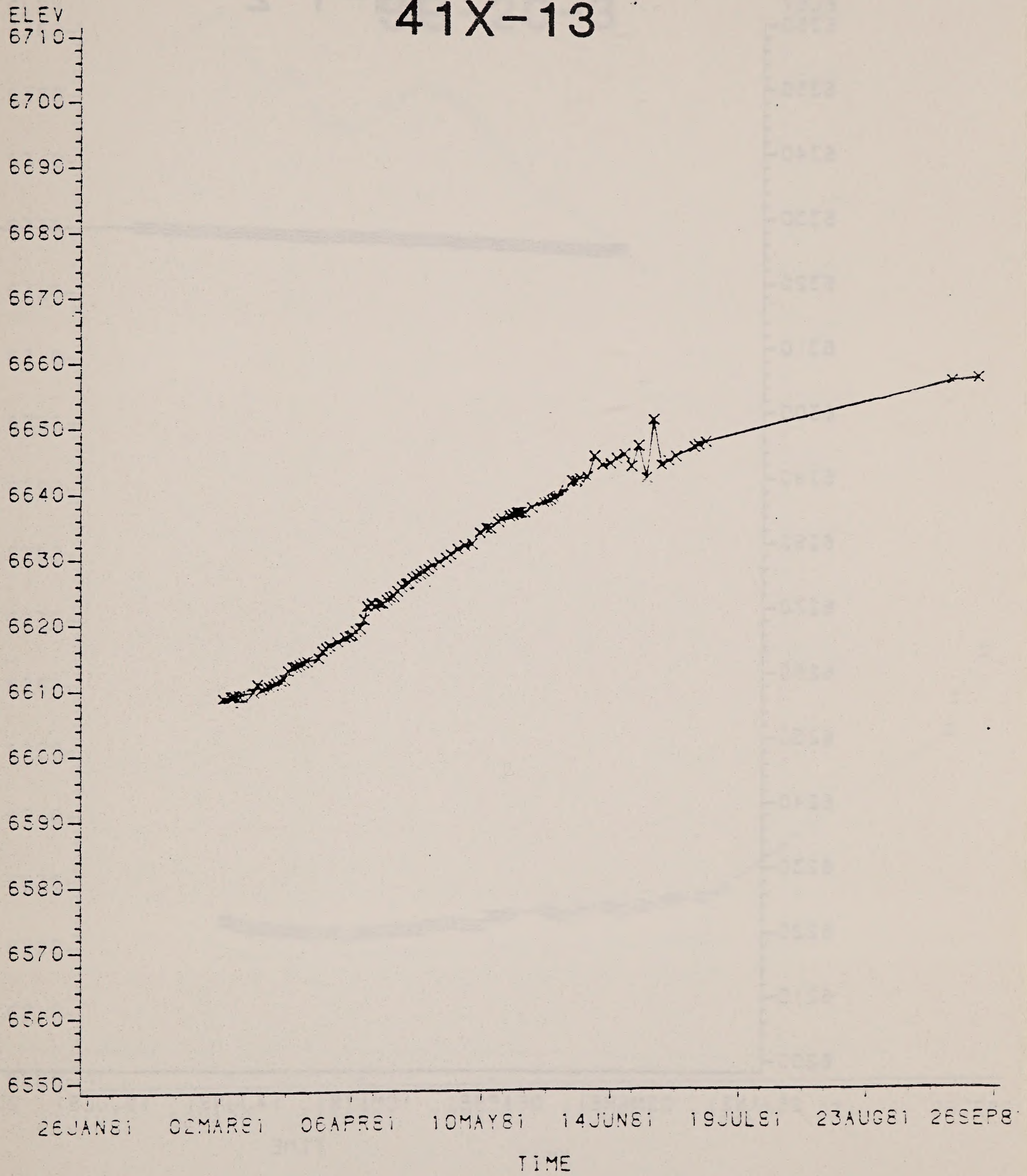




FIGURE A1-16

CB RE-INJECT DATA

SG-1-2

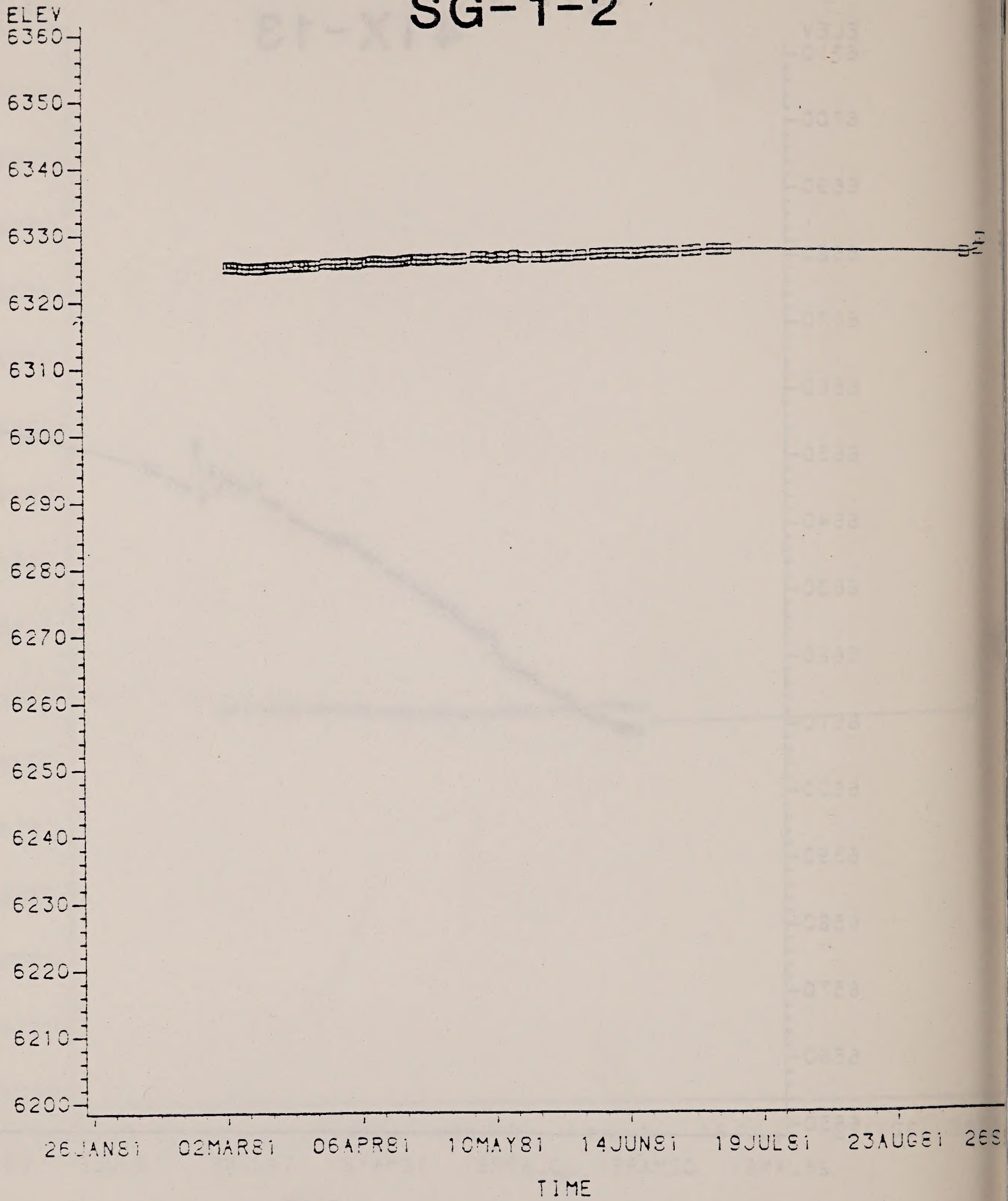




FIGURE A1-17

# CB RE-INJECT DATA SG-20-3

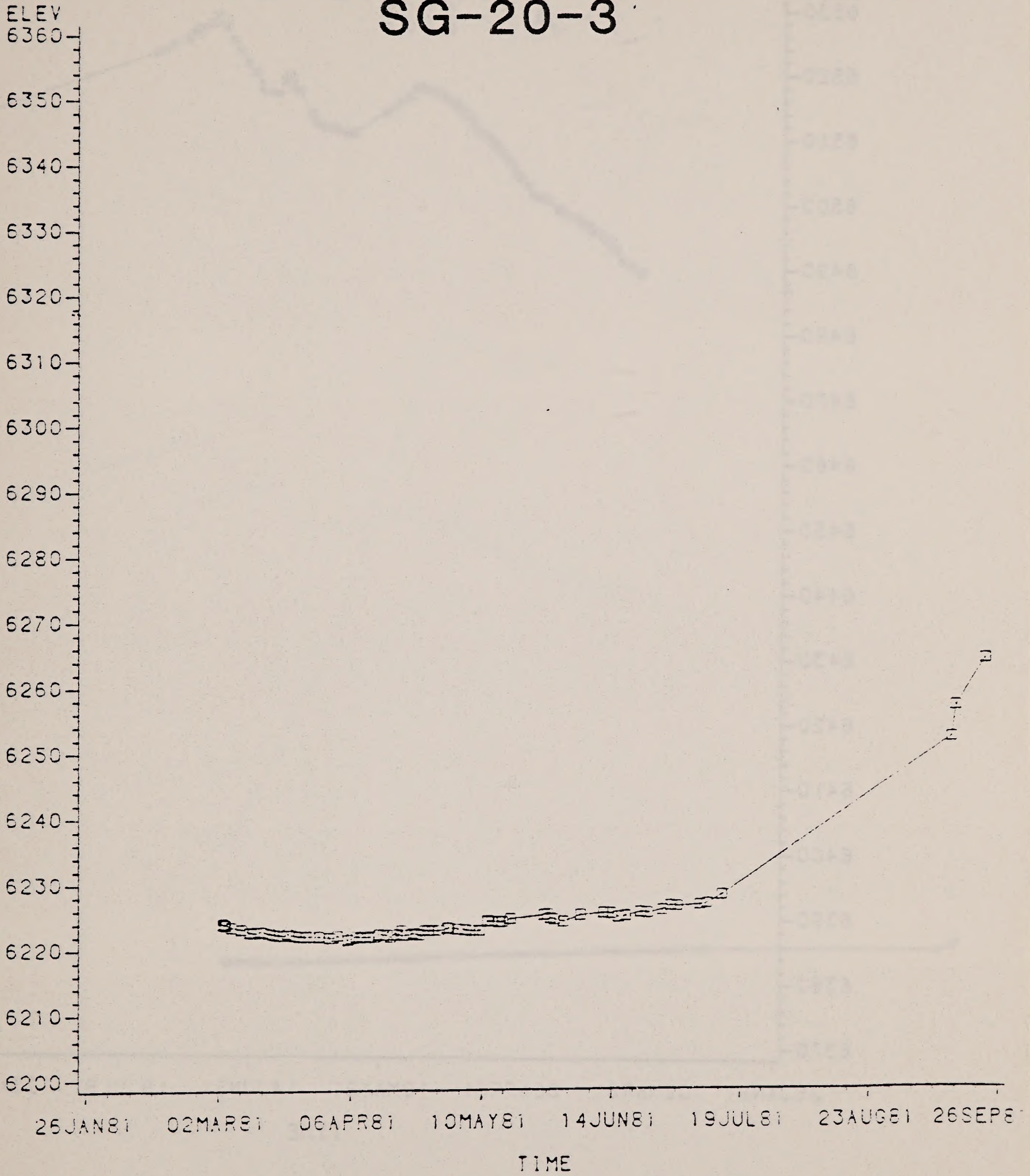




FIGURE A1-18

# CB RE-INJECT DATA AT-1D-3

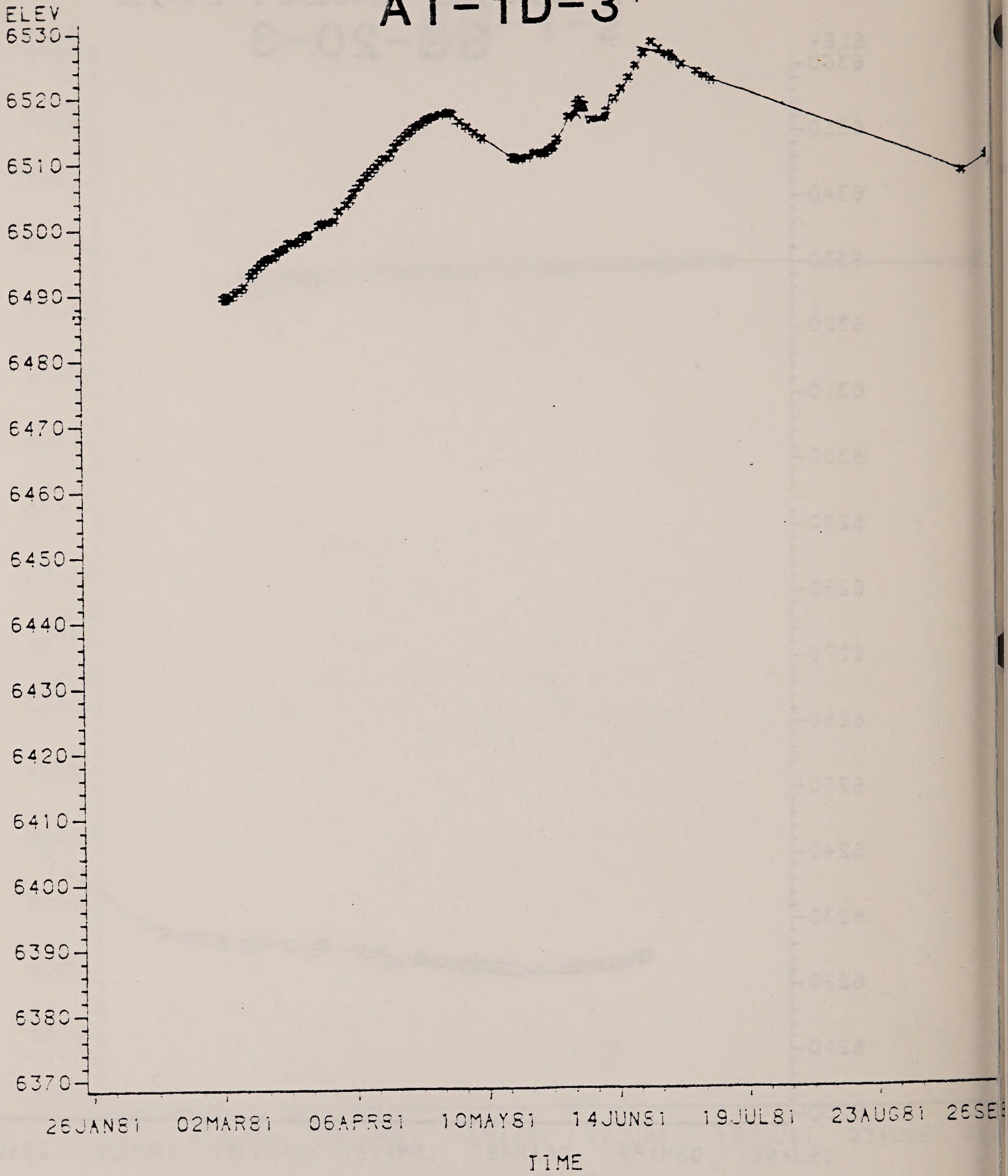




FIGURE A1-19

CB RE-INJECT DATA

SG-1A-1

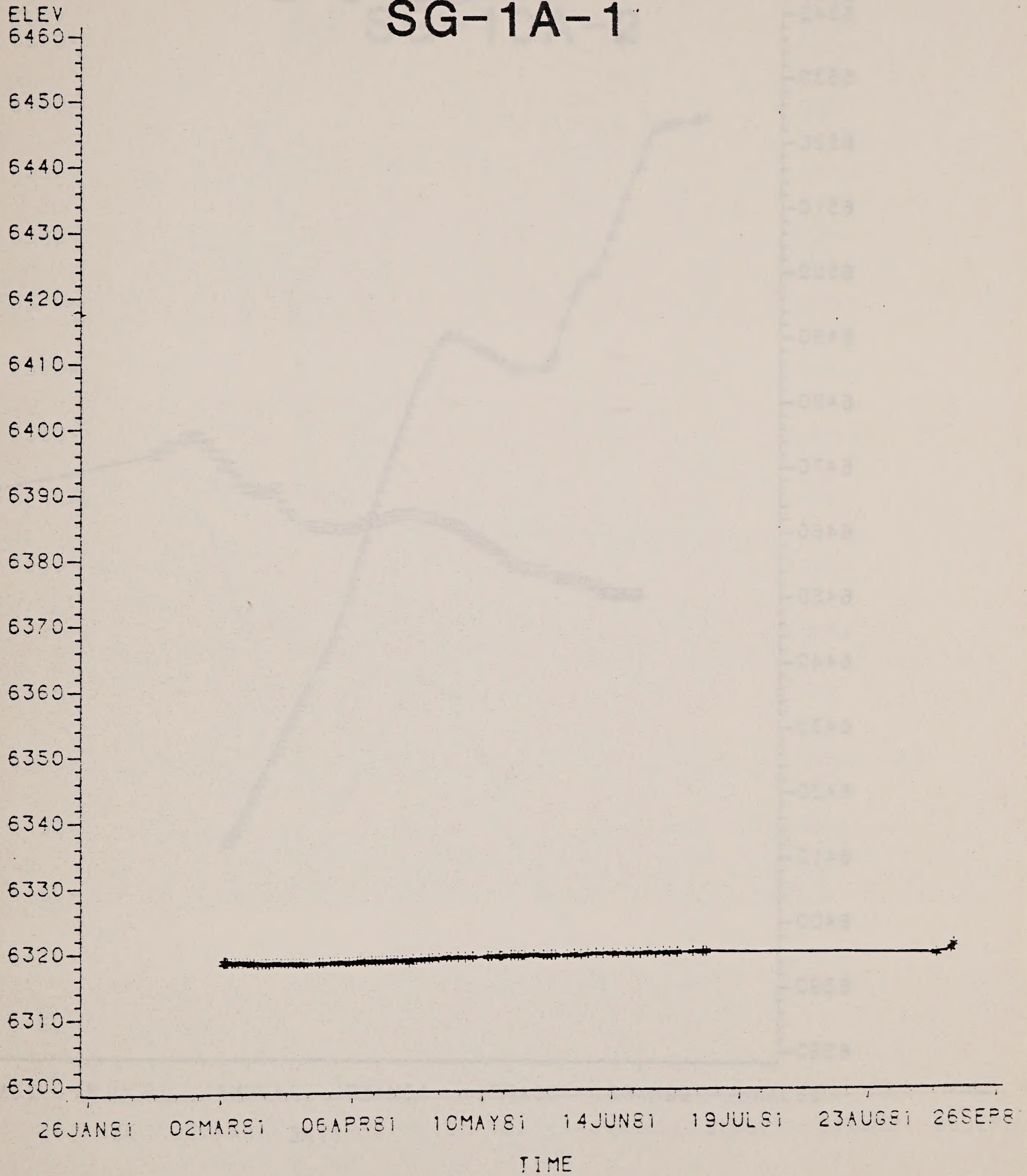




FIGURE A1-20

# CB RE-INJECT DATA

## SG-9-2

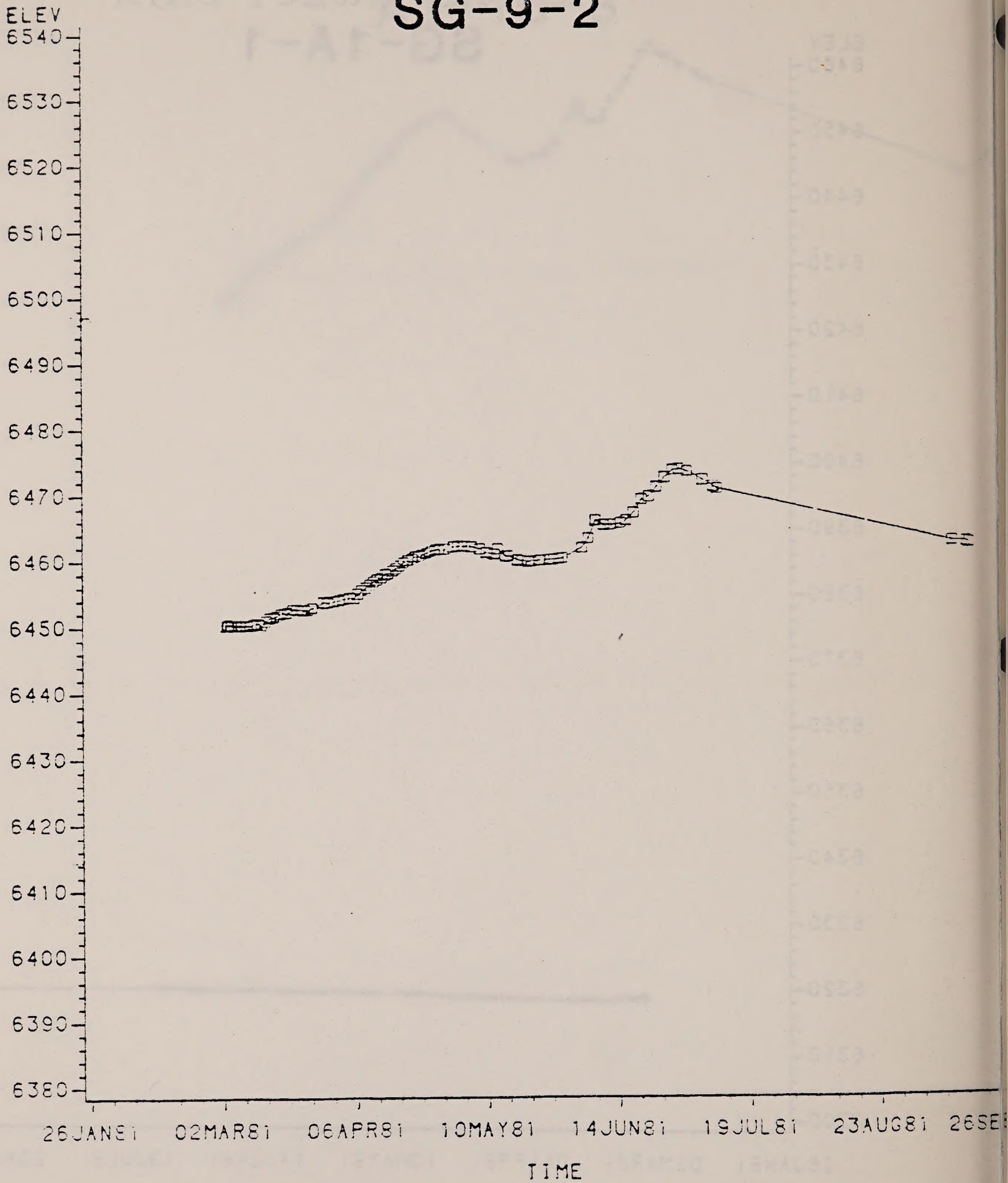




FIGURE A1-21

ATAD TO      CB RE-INJECT DATA  
A1      **SG-10A-2**

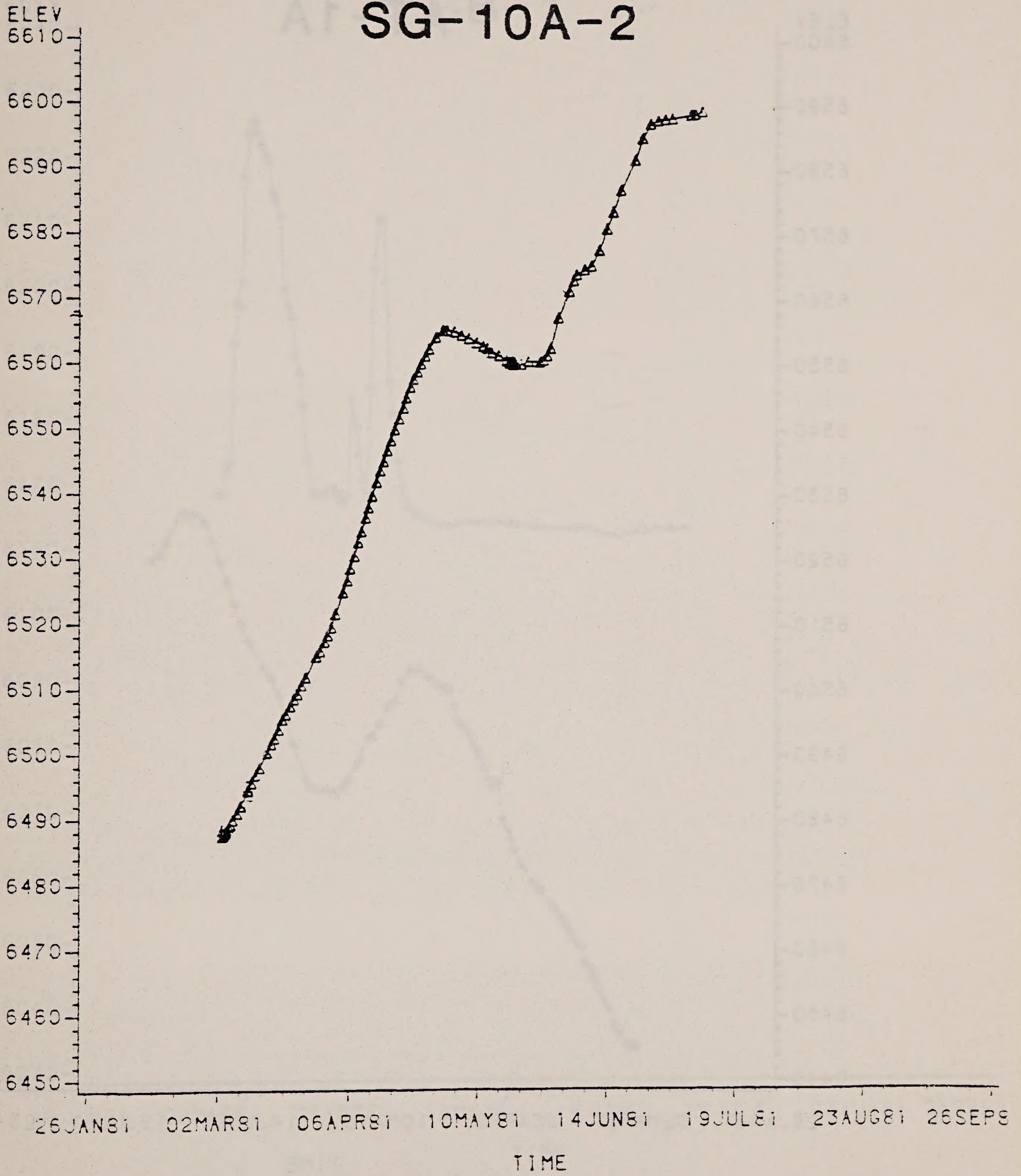




FIGURE A1-22

CB RE-INJECT DATA

AT-1A

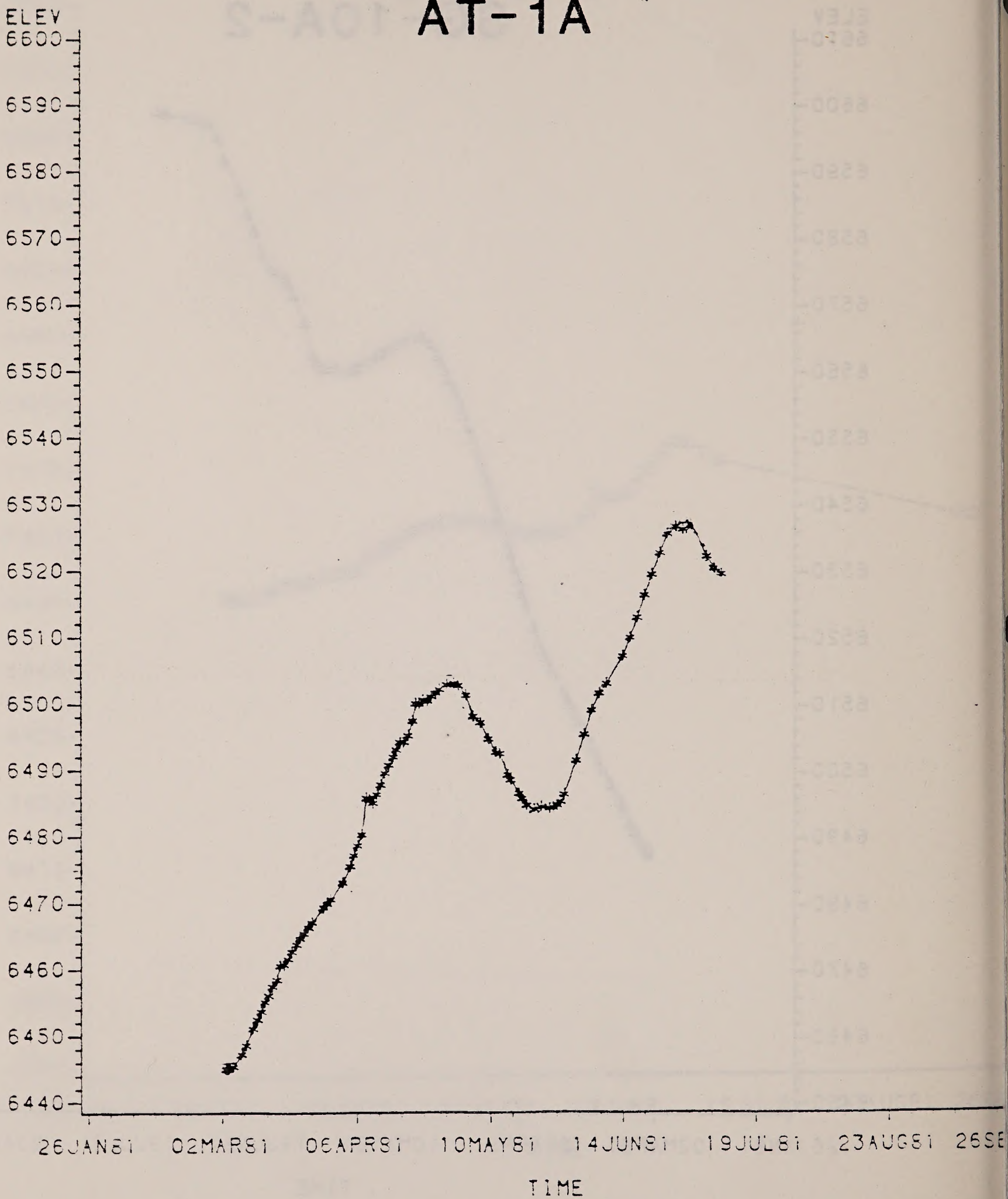




FIGURE A1-23

# CB RE-INJECT DATA CB-1

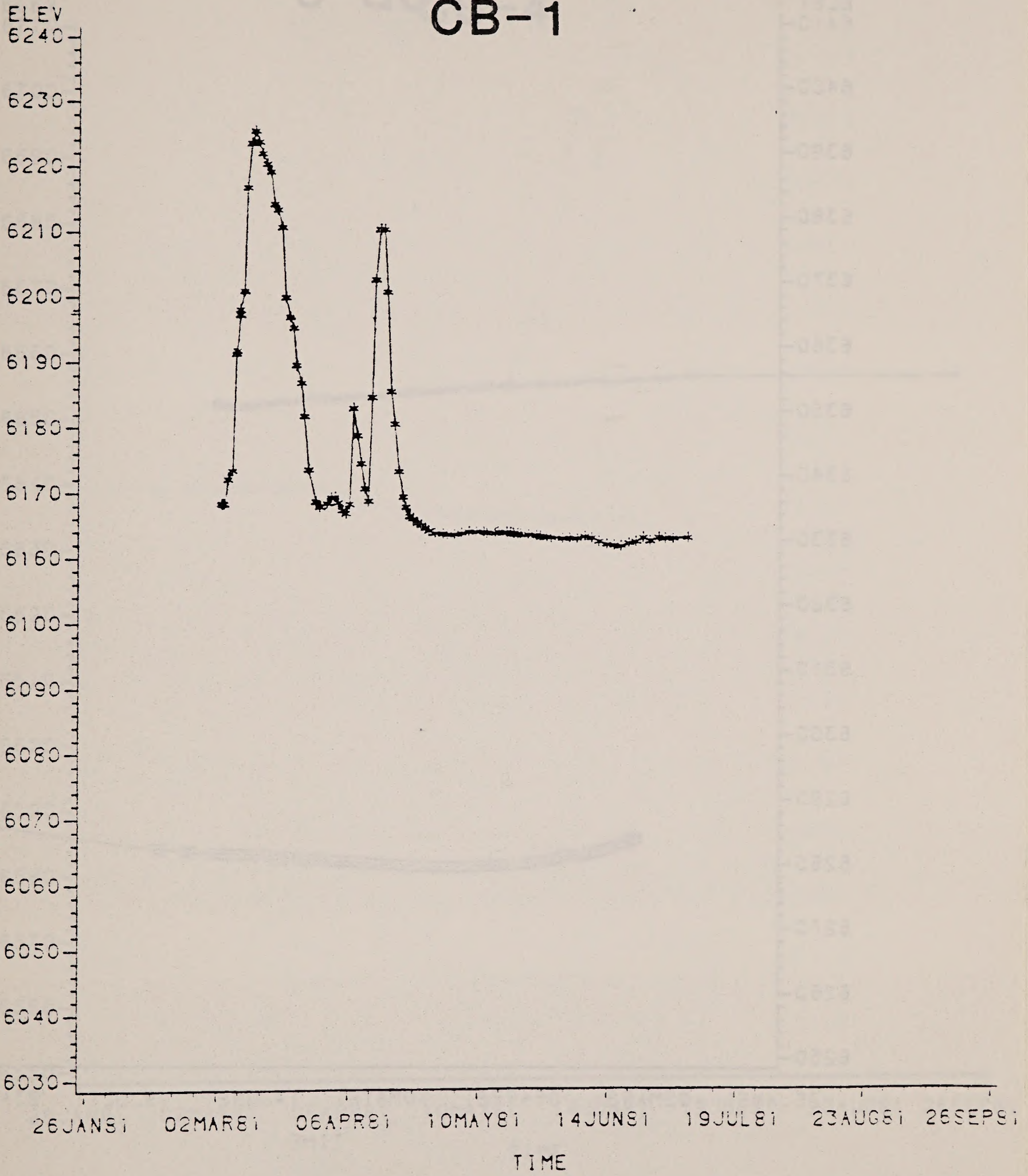




FIGURE A1-24

# CB RE-INJECT DATA CB-3

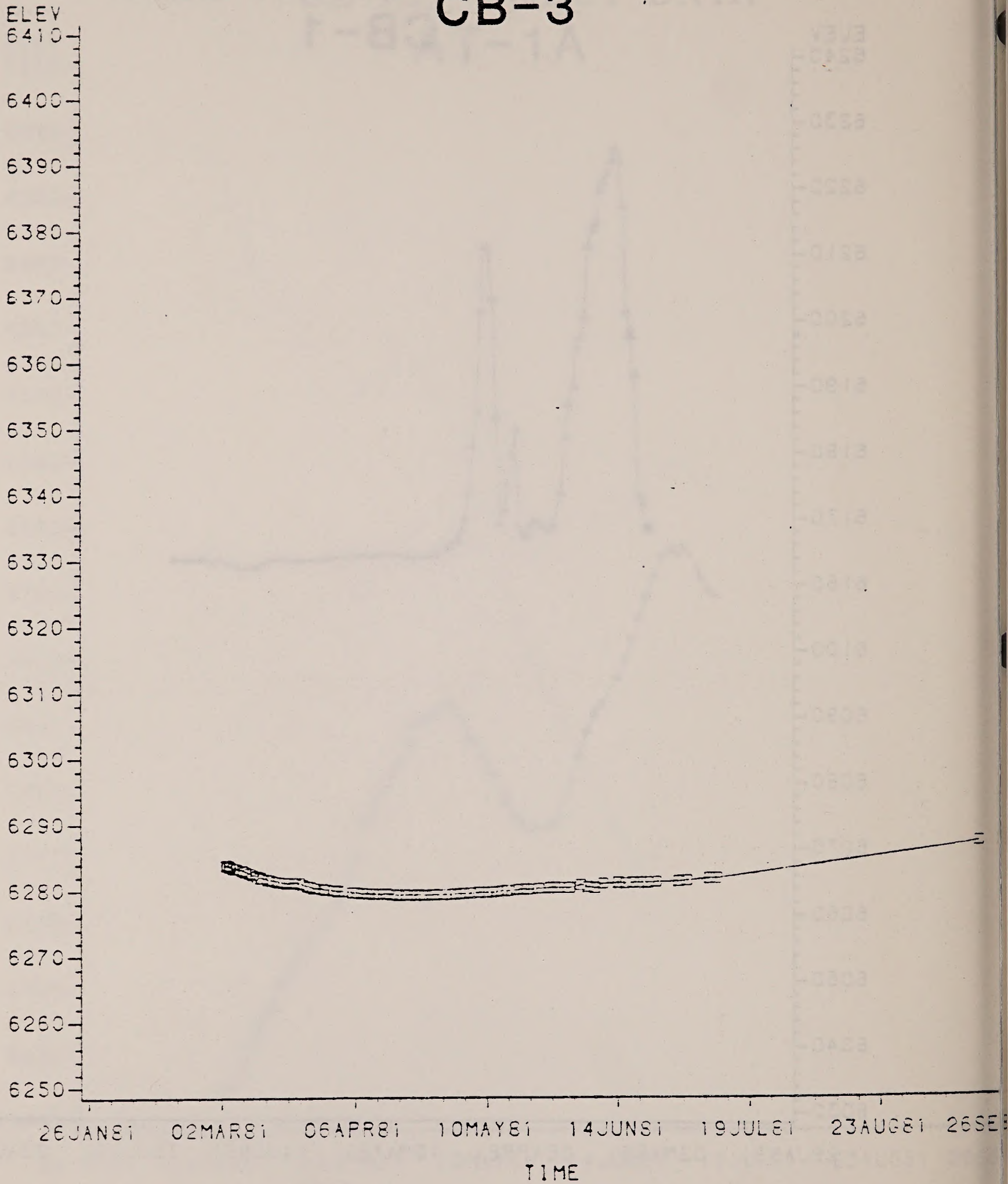




FIGURE A1-25

# CB RE-INJECT DATA

## CB-4

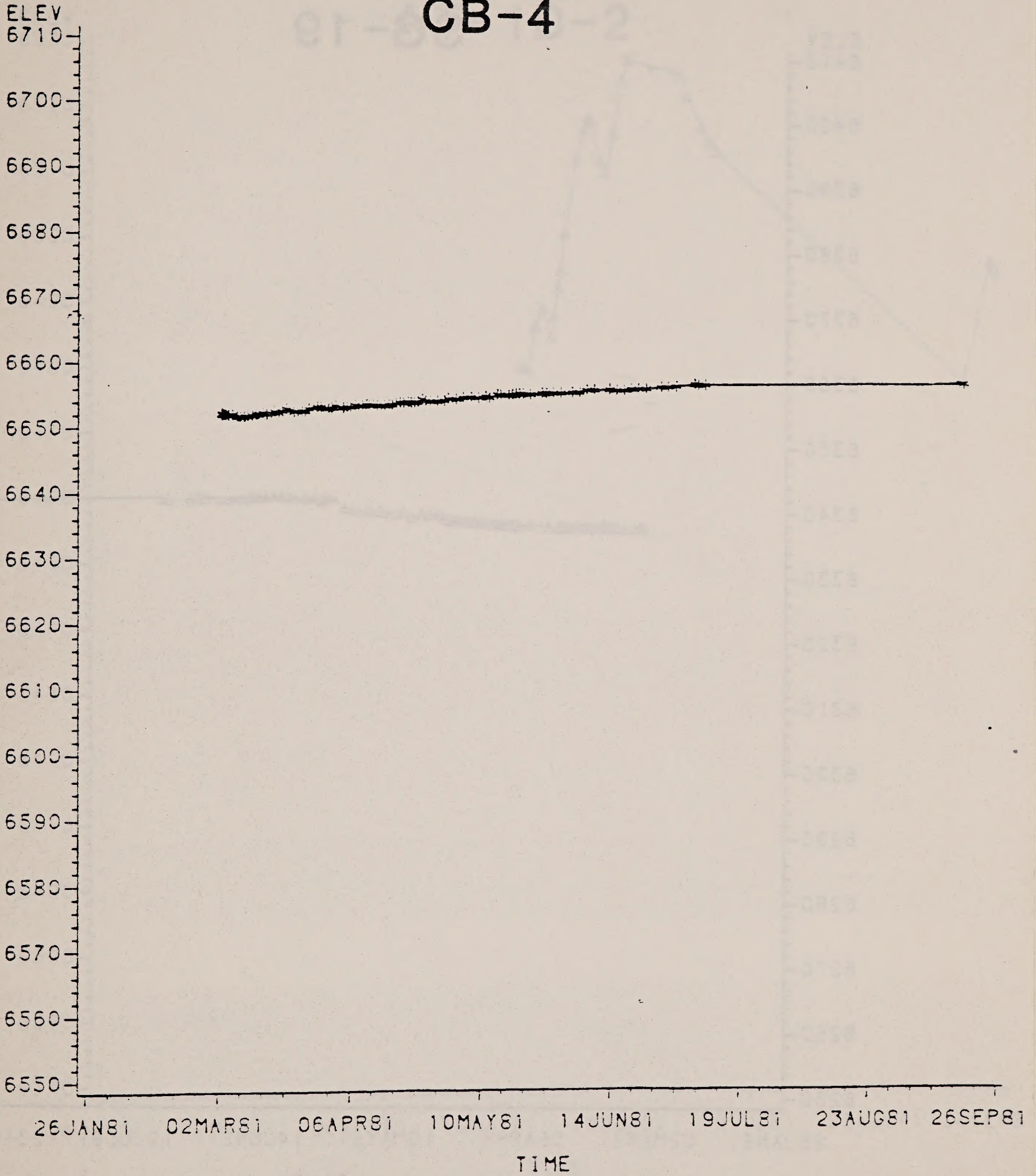




FIGURE A1-26

# CB RE-INJECT DATA SG-19

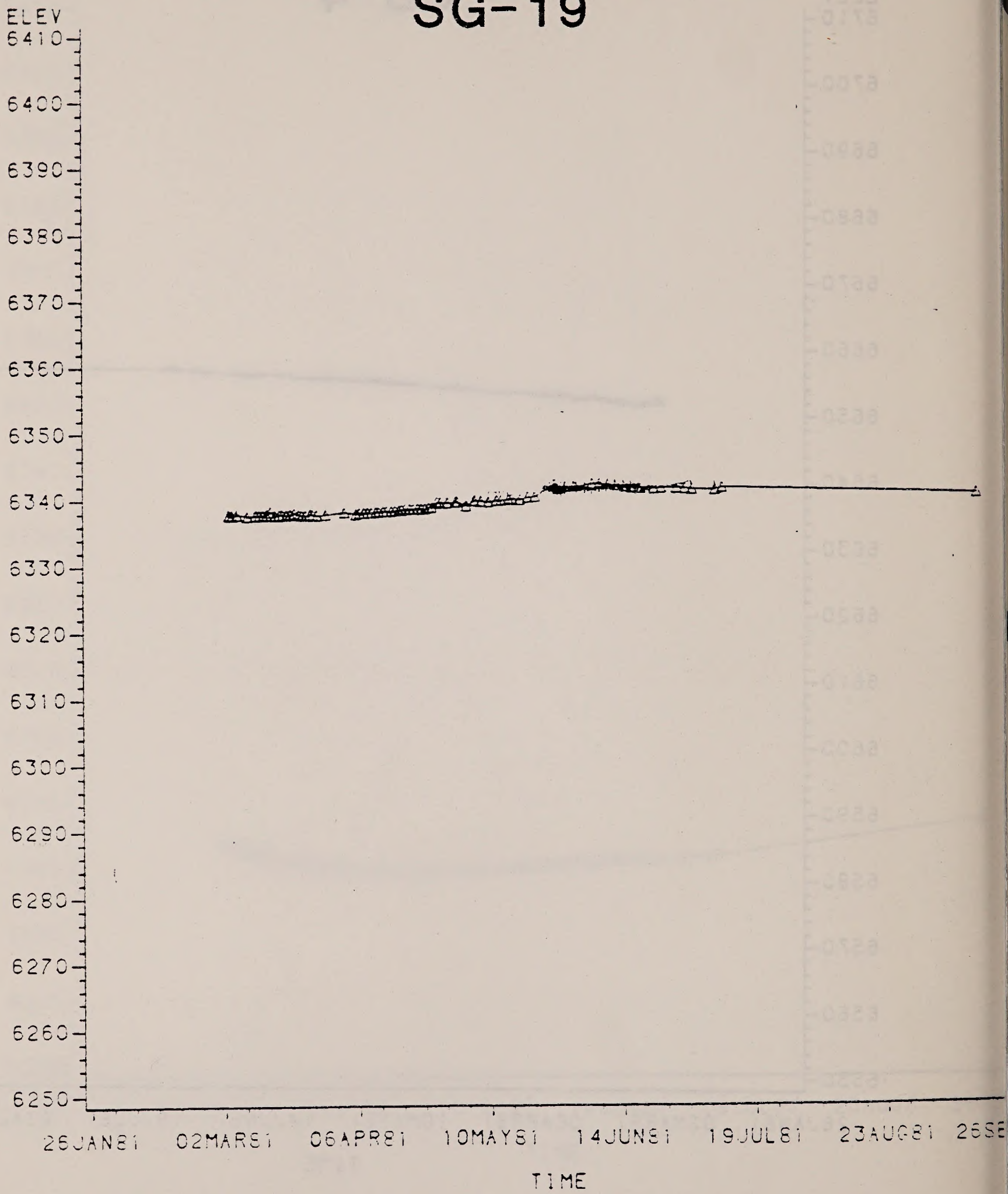




FIGURE A1-27

CB RE-INJECT DATA

AT-1D-2

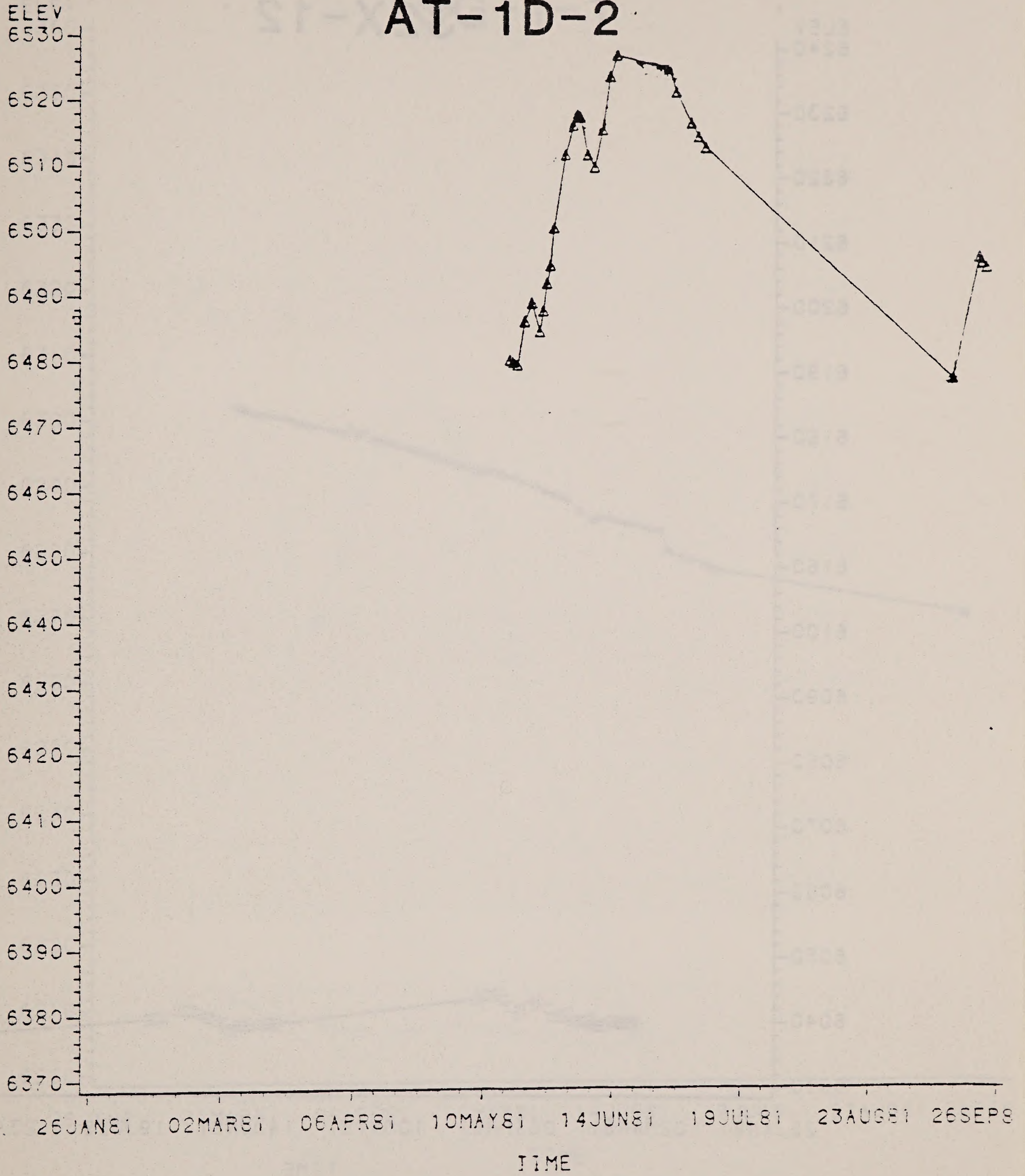




FIGURE A1-28

# CB RE-INJECT DATA

## 32X-12

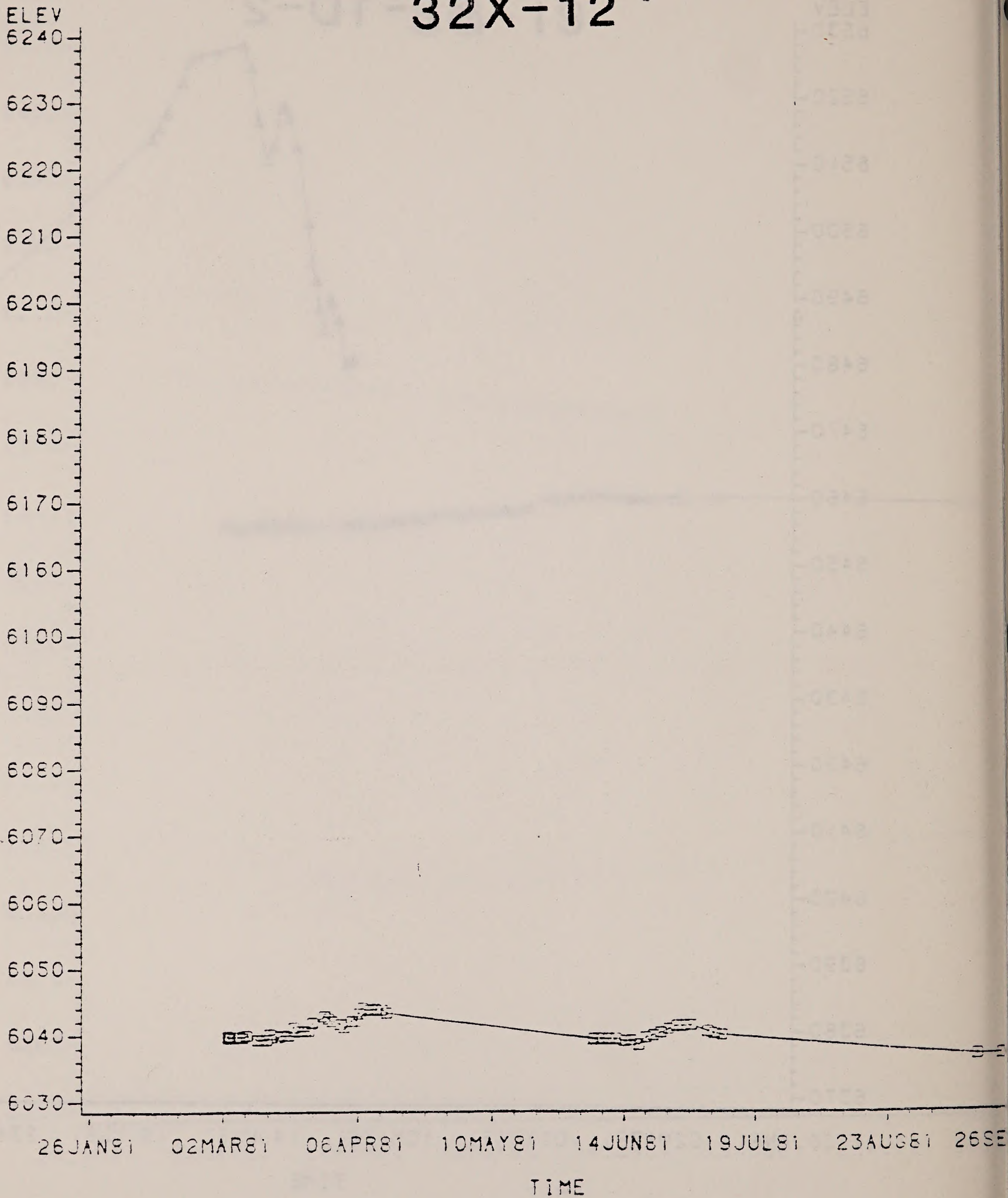
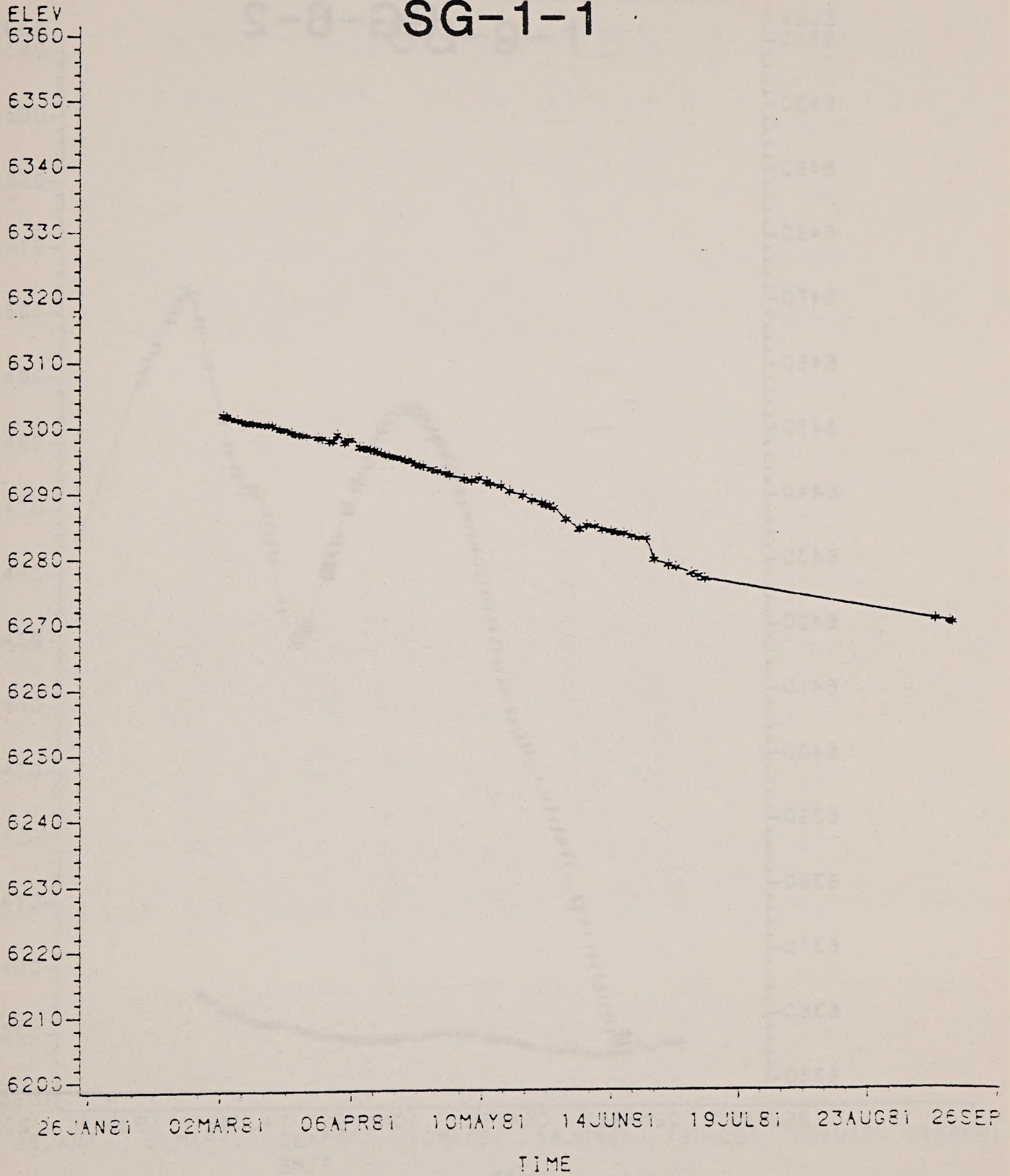




FIGURE A1-29

CB RE-INJECT DATA

**SG-1-1**





# CB RE-INJECT DATA

## SG-6-2

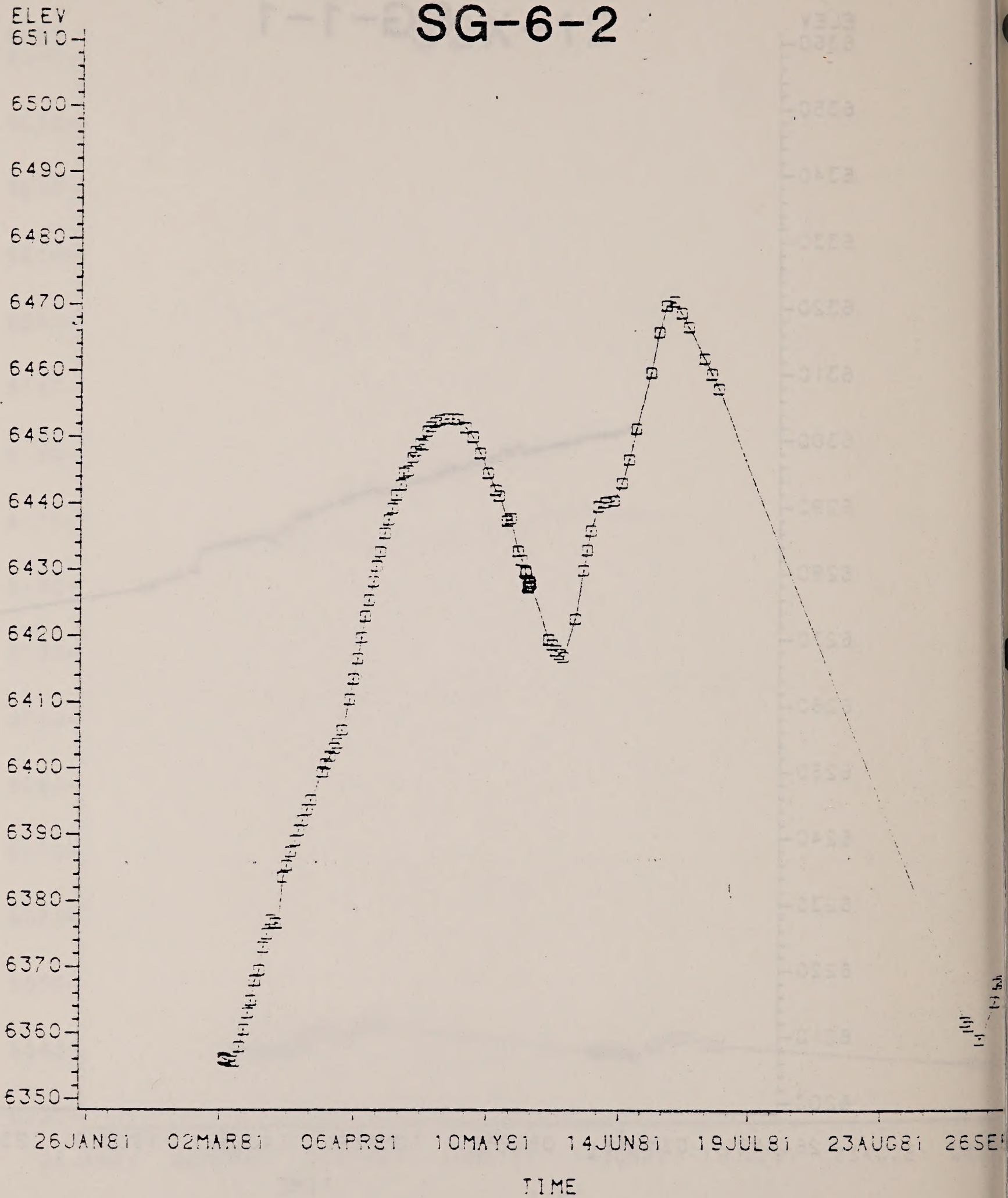




FIGURE A1-31

CB RE-INJECT DATA

SG-9-1

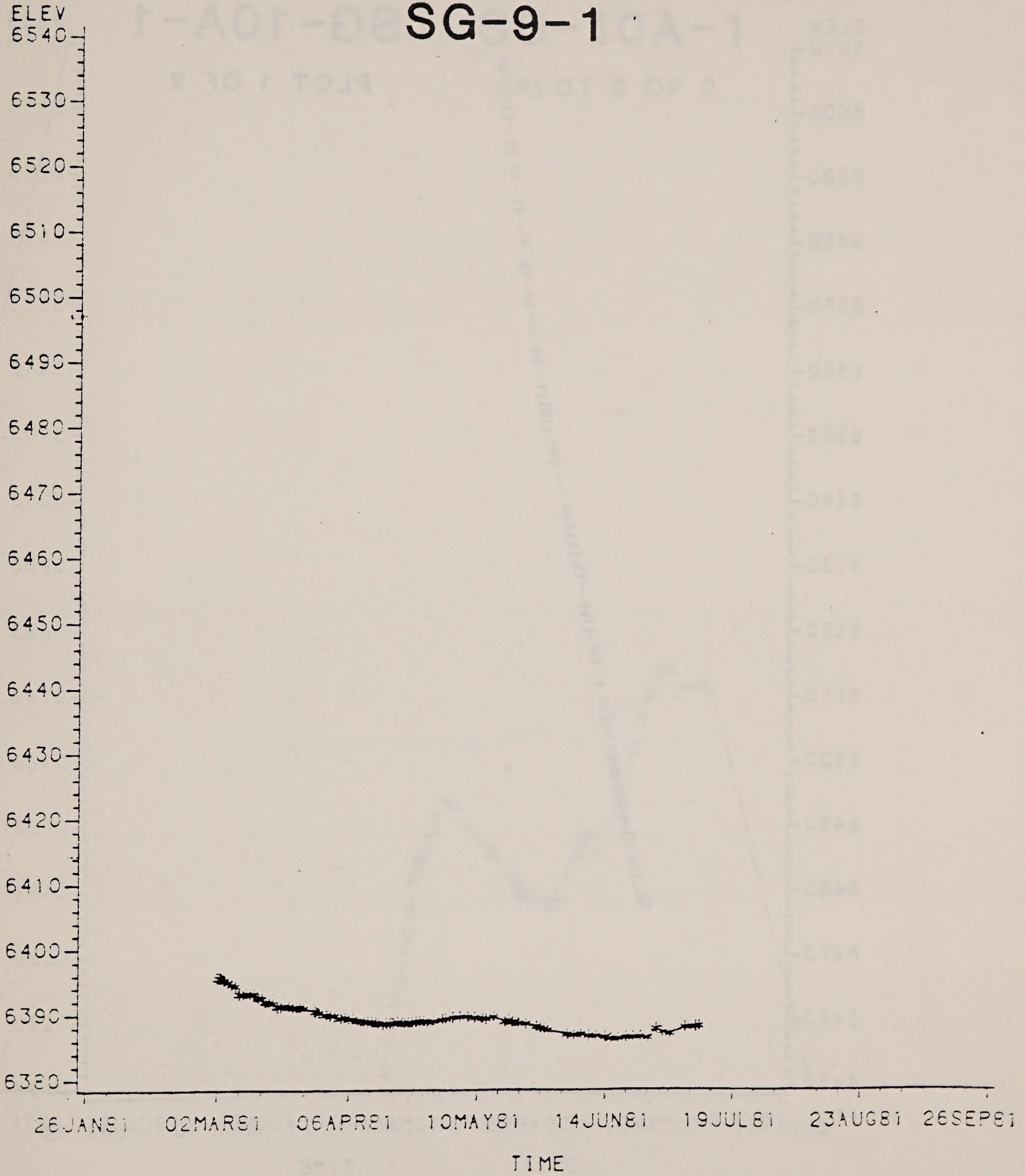




FIGURE A1-32

CB RE-INJECT DATA

SG-10A-1

PLOT 1 OF 2

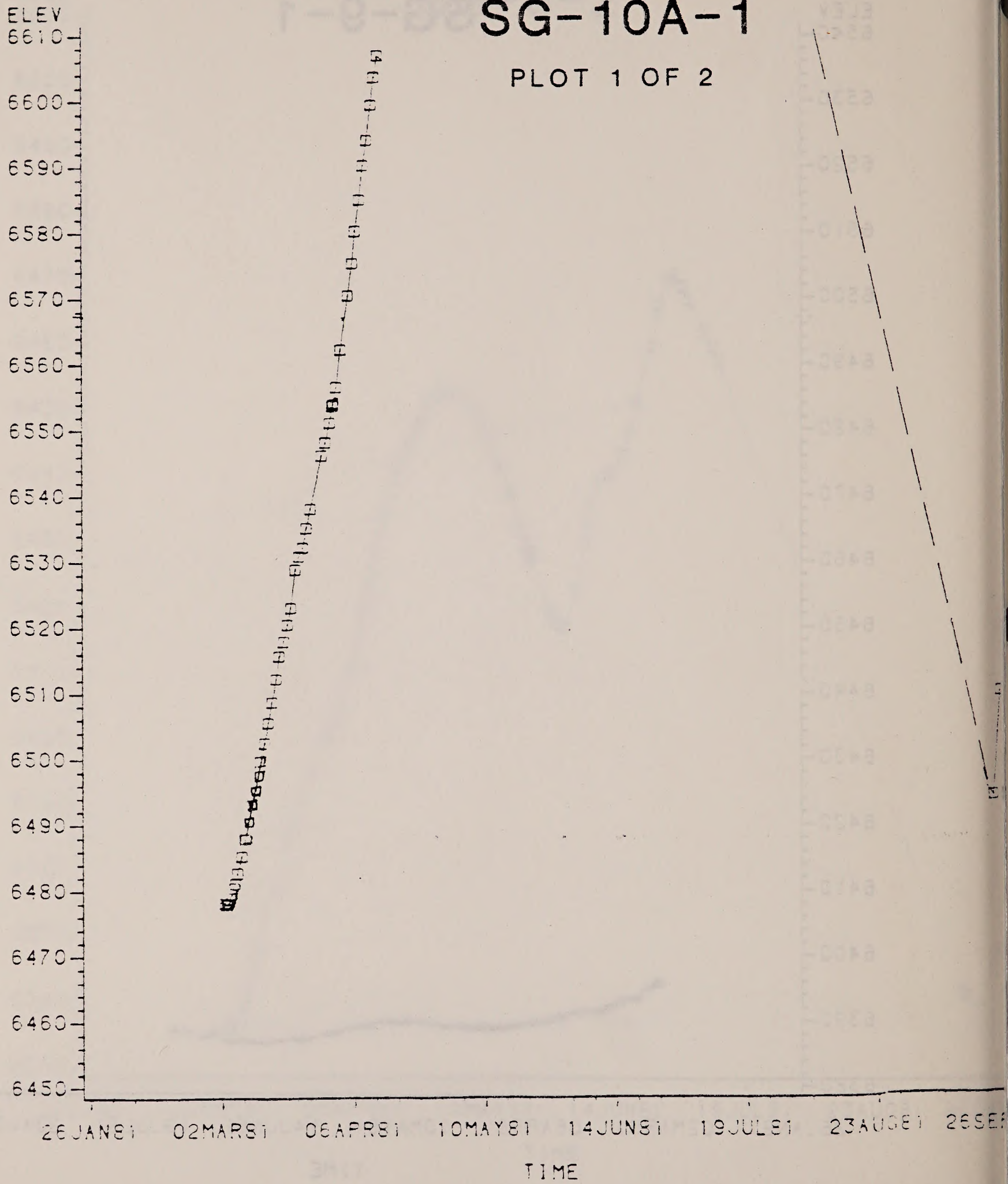




FIGURE A1-33

CB RE-INJECT DATA

**SG-10A-1**

PLOT 2 OF 2

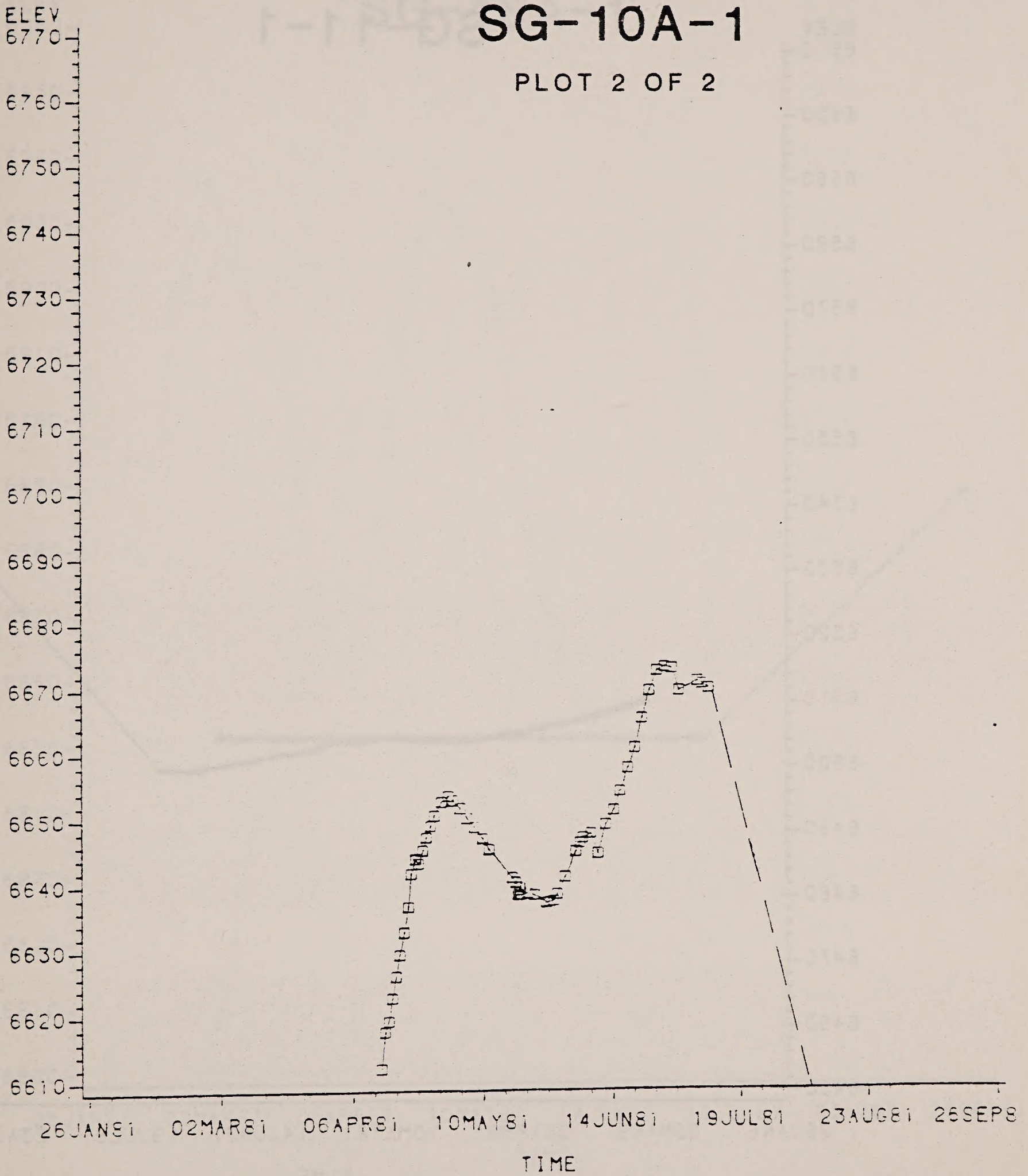




FIGURE A1-34

# CB RE-INJECT DATA SG-11-1

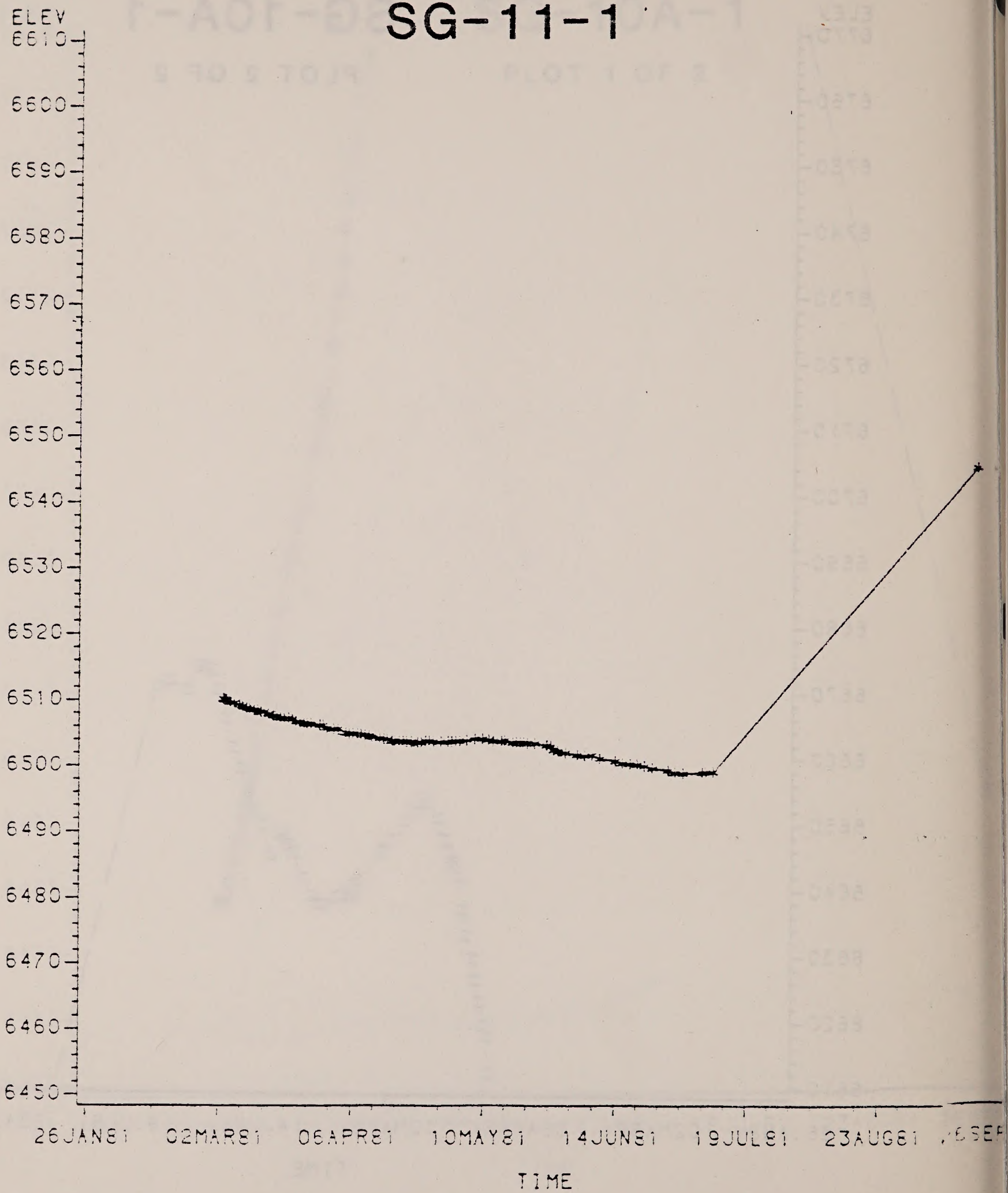




FIGURE A1-35 .

# CB RE-INJECT DATA SG-18A-1

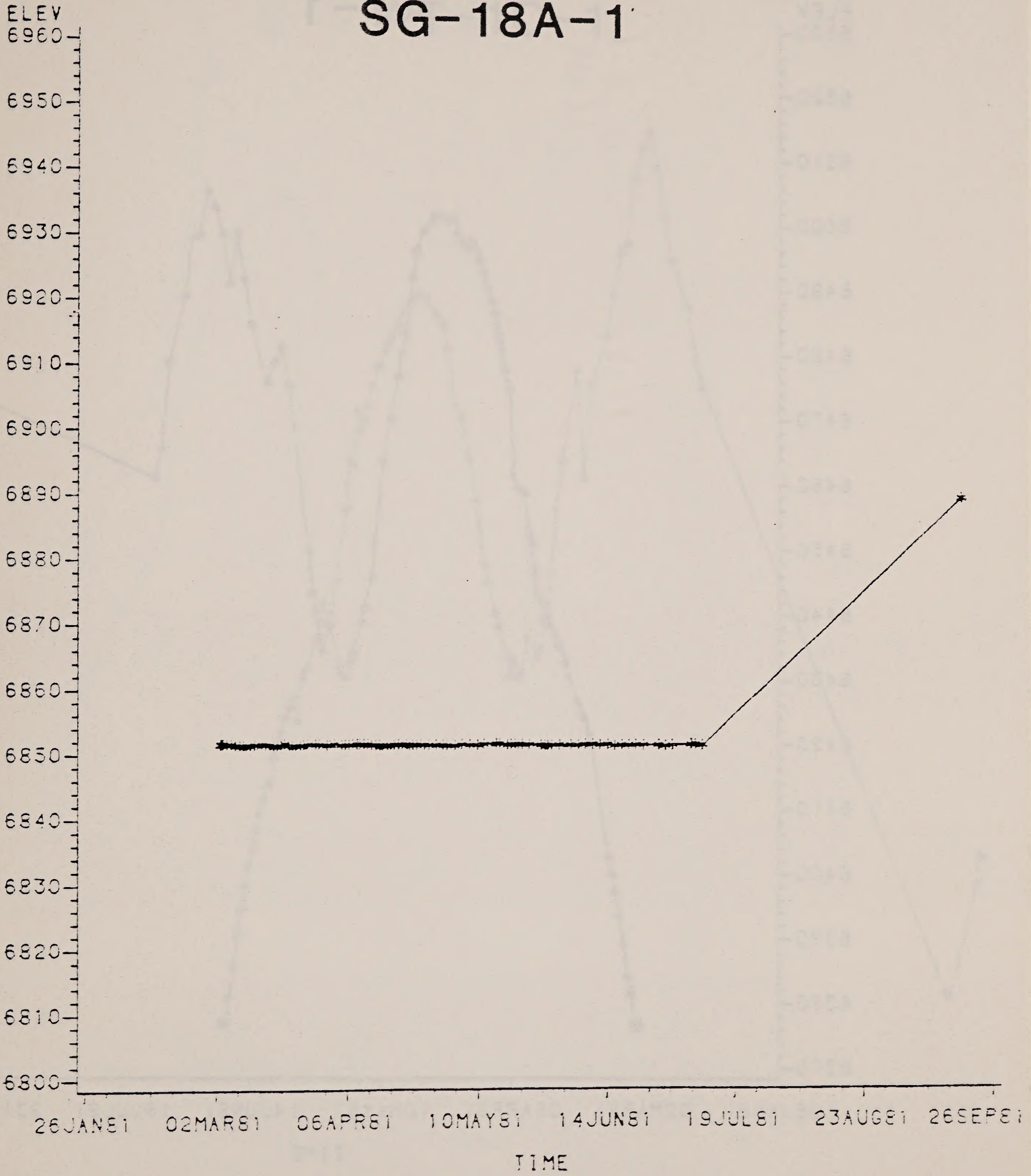




FIGURE A1-36

# CB RE-INJECT DATA AT-1

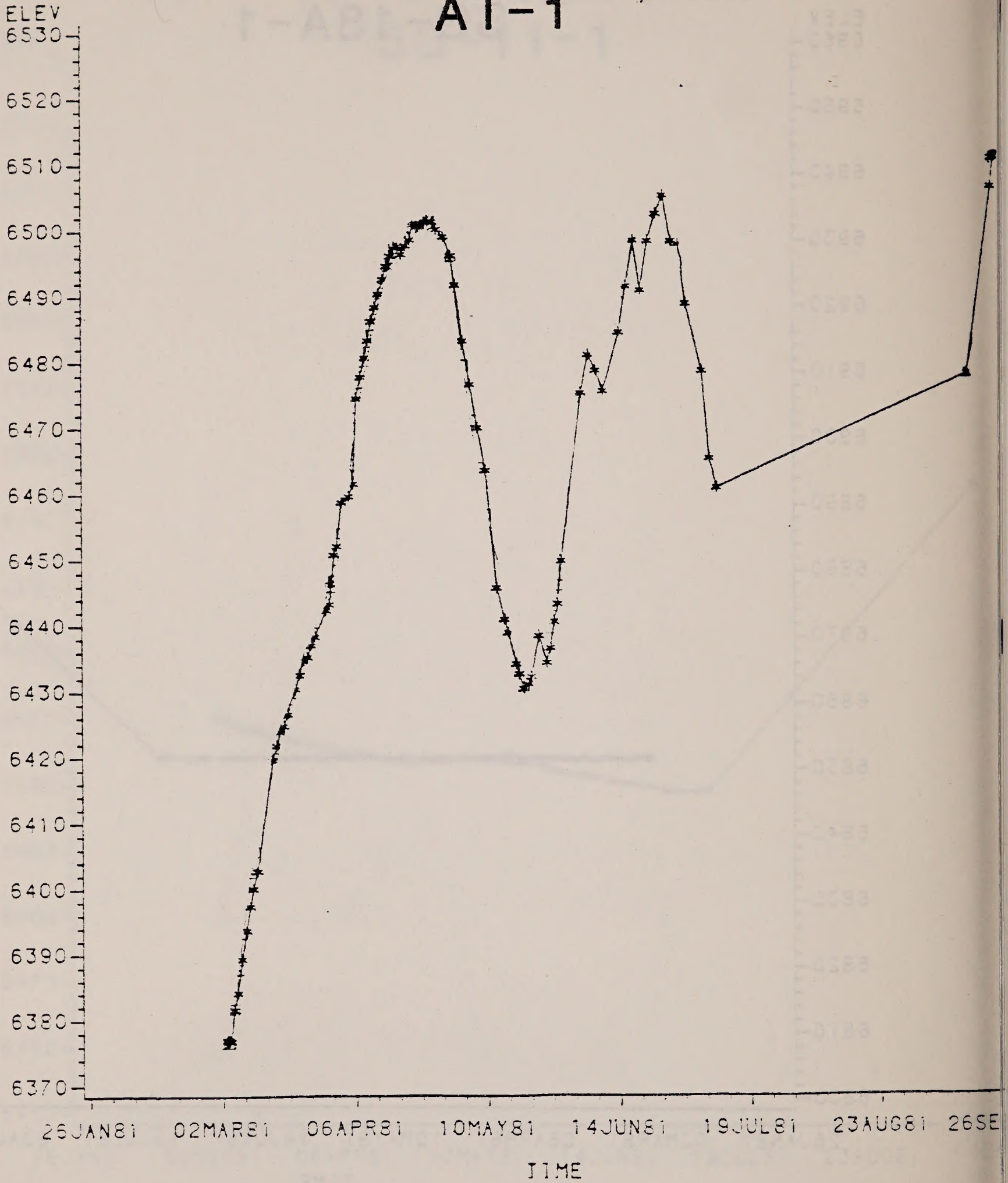




FIGURE A1-37

CB RE-INJECT DATA  
AT-1C-1

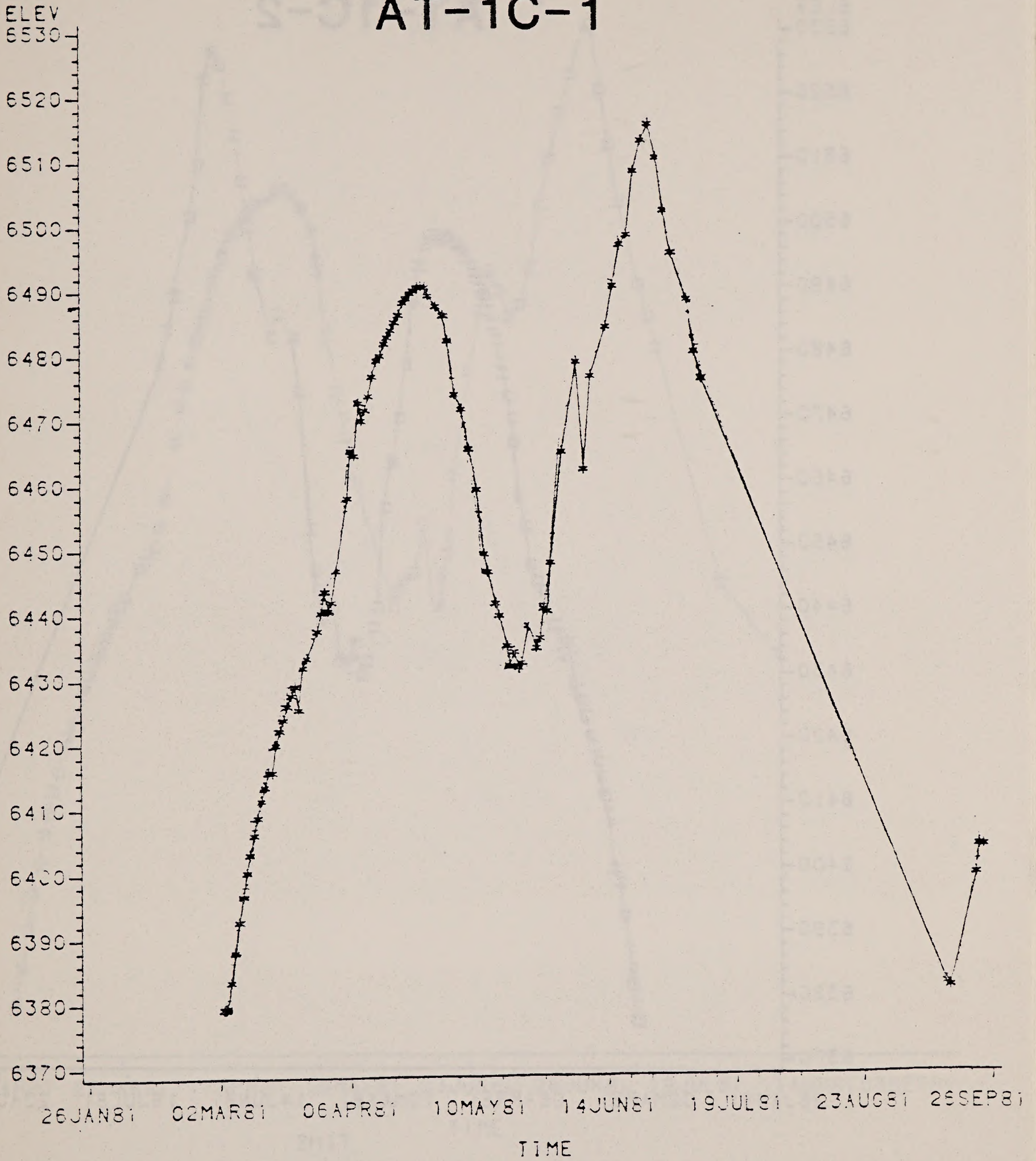




FIGURE A1-38

# CB RE-INJECT DATA AT-1C-2

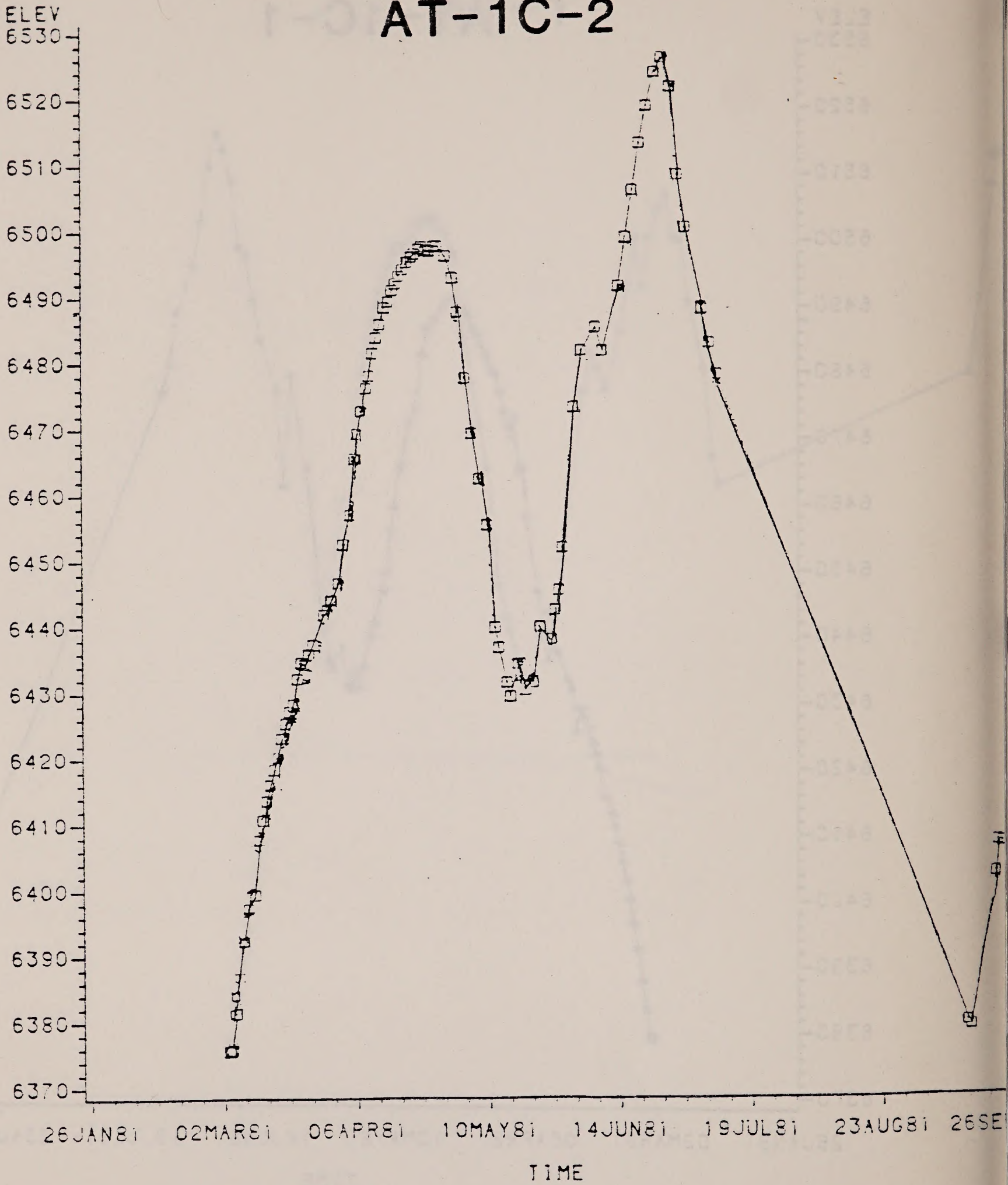




FIGURE A1-39  
CB RE-INJECT DATA  
AT-1D-1

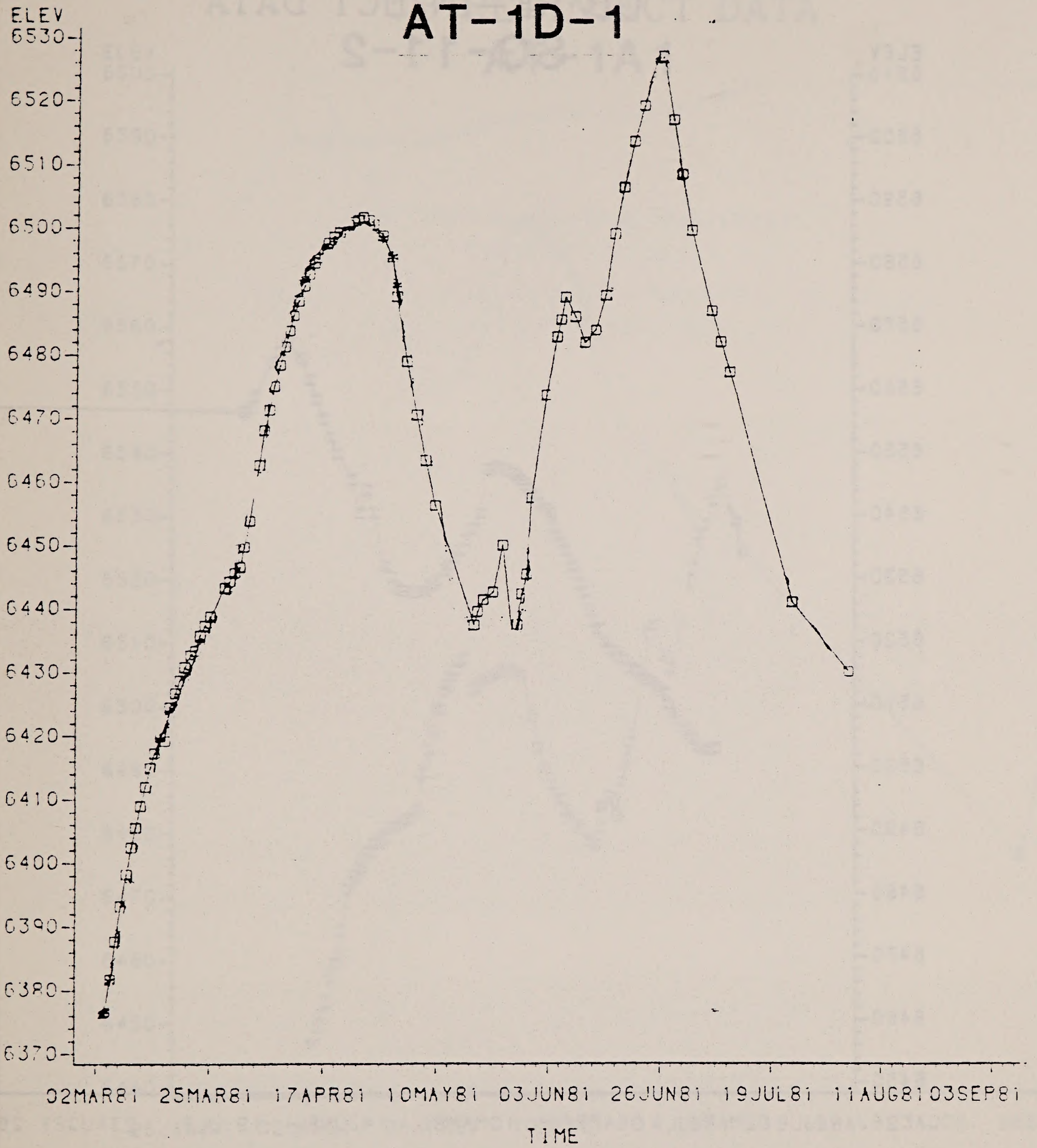




FIGURE A1-40

# CB RE-INJECT DATA SG-11-2

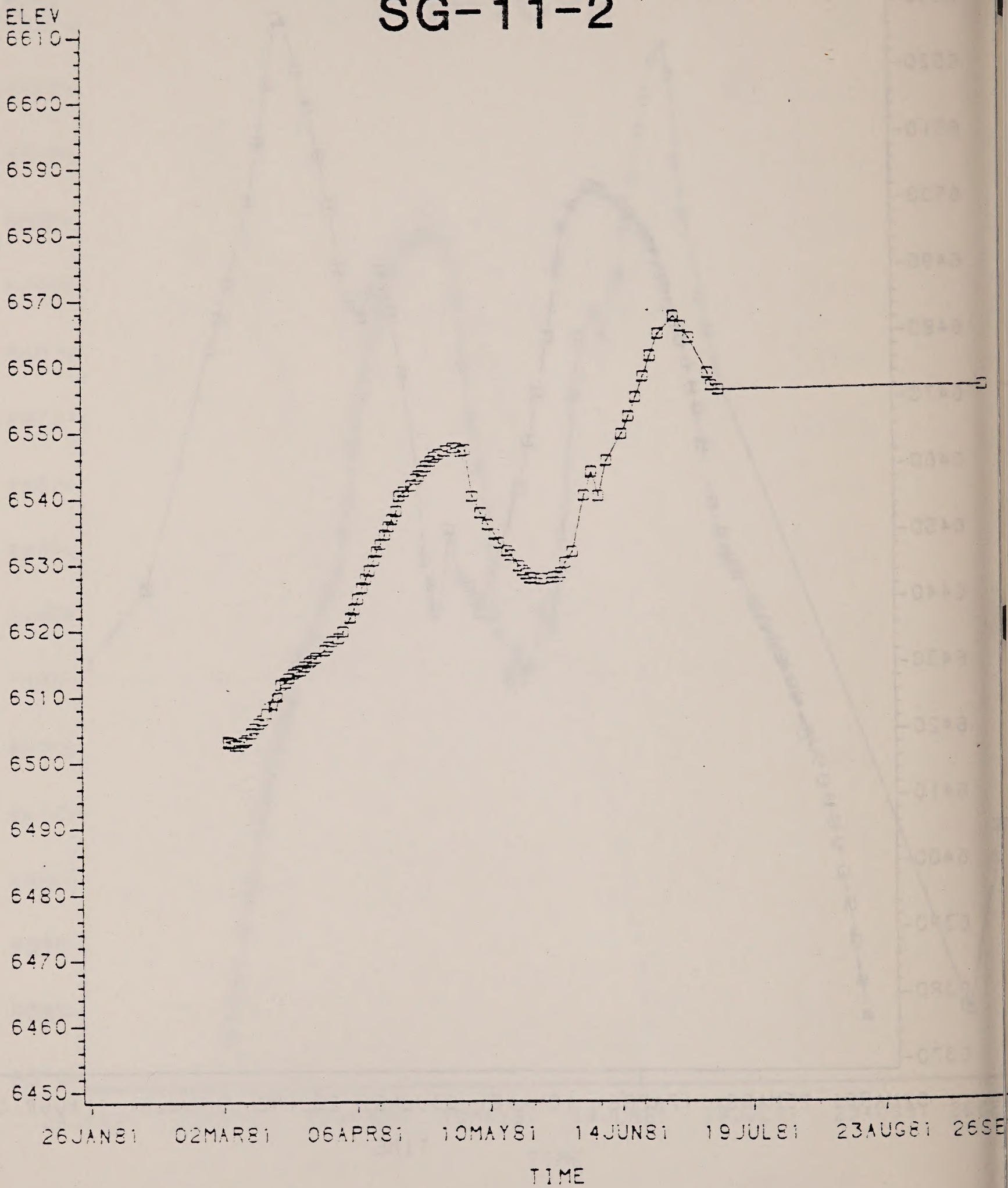




FIGURE A1-41

# CB RE-INJECT DATA AT-1A1

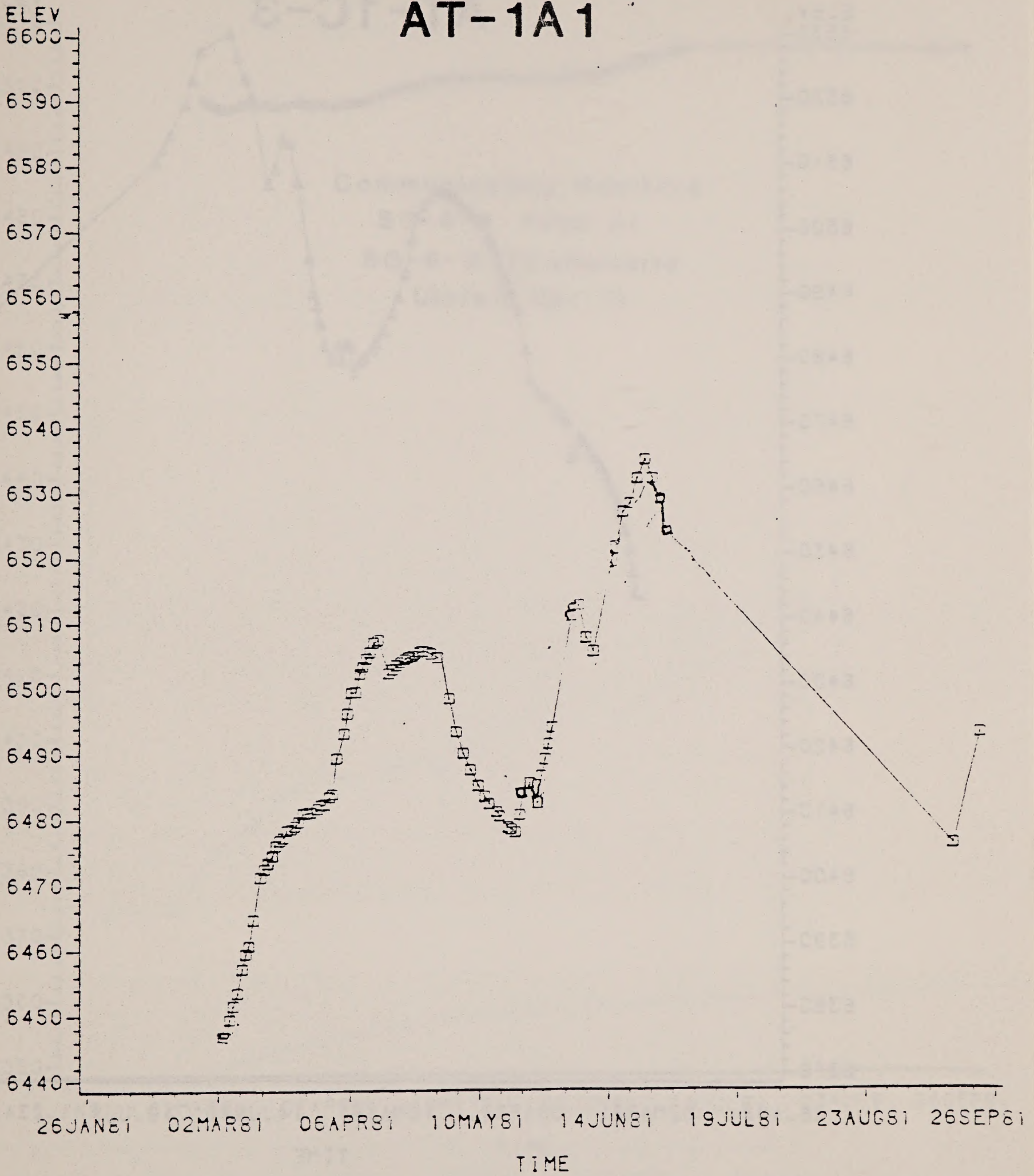




FIGURE A1-42

# CB RE-INJECT DATA AT-1C-3

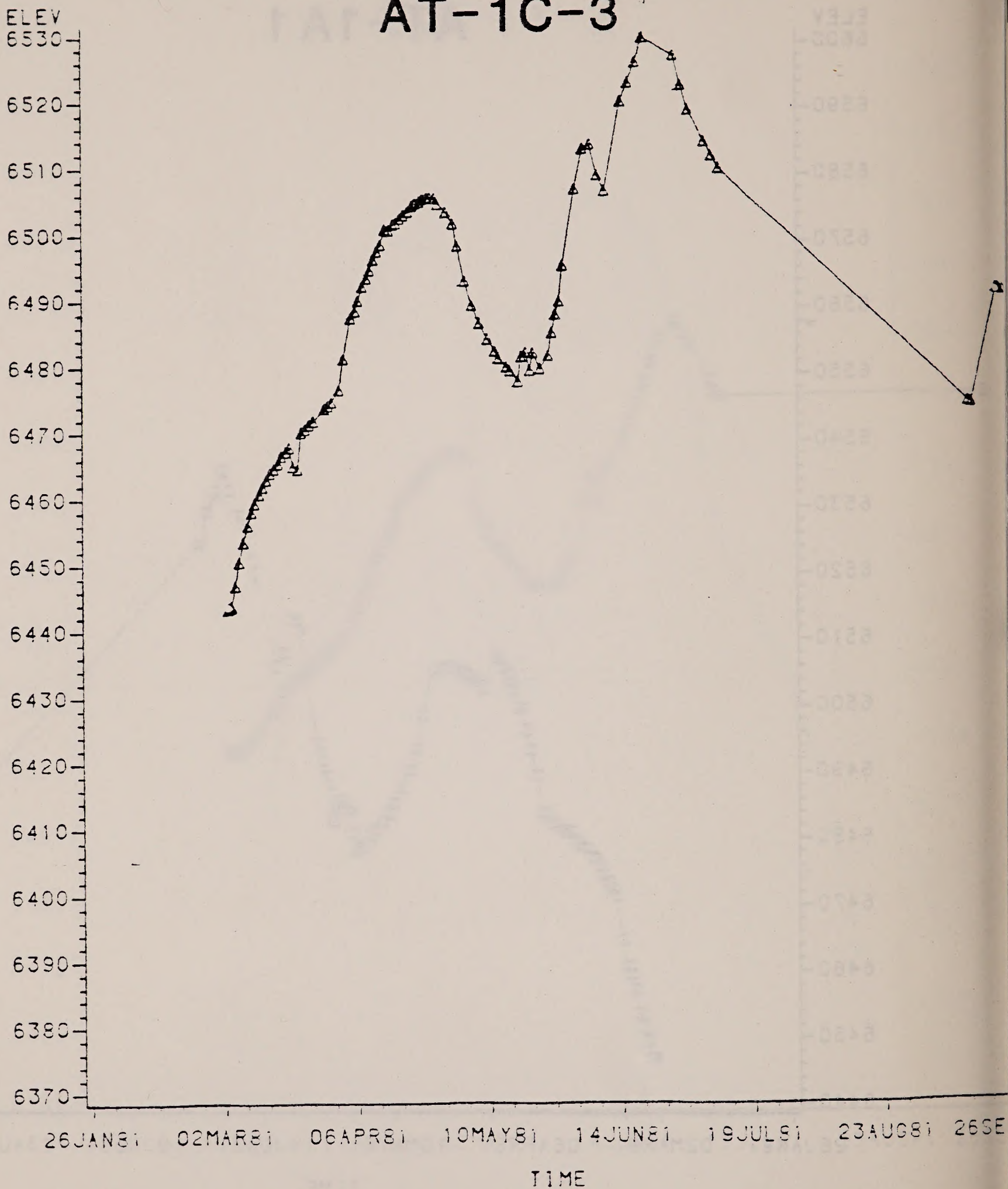




FIGURE A1-43

# CB RE-INJECT DATA

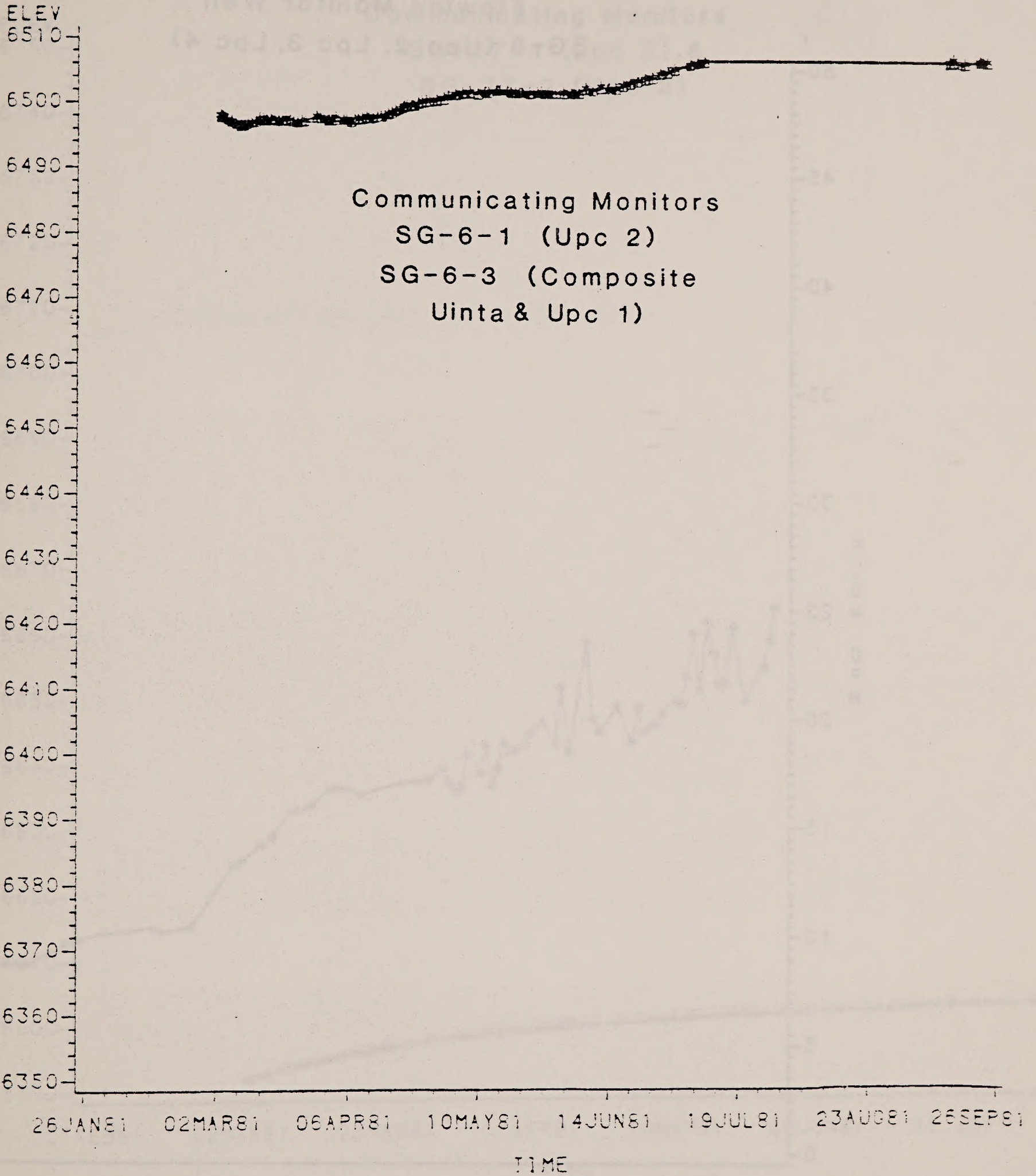




FIGURE A1-44

# CB RE-INJECT DATA

Flowing Monitor Well

SG-8 (Upc 2, Lpc 3, Lpc 4)

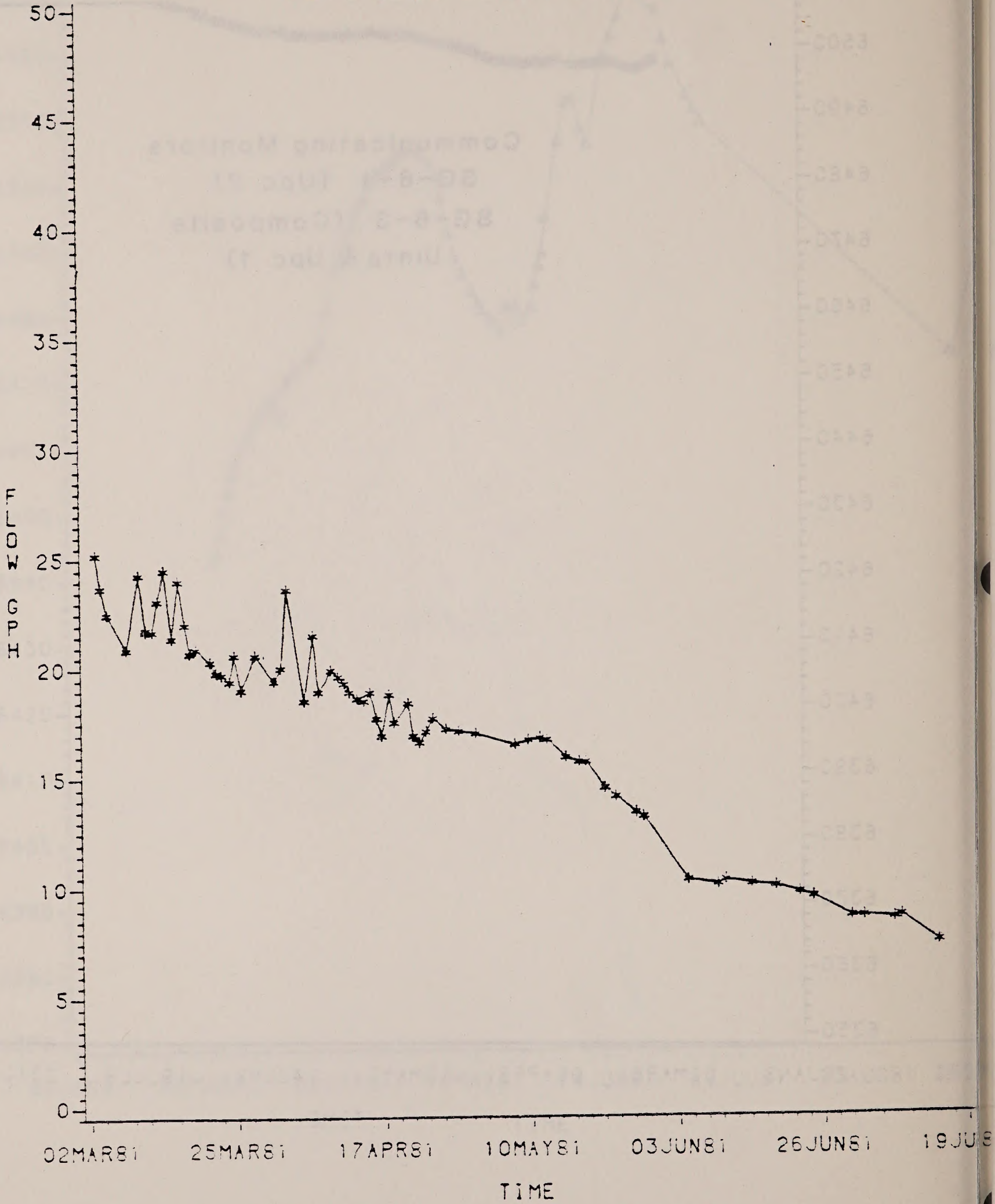




FIGURE A1-45

# CB RE-INJECT DATA

Communicating Monitors

SG-17-1 (Lpc 3) &

SG-17-2 (Upc 2)

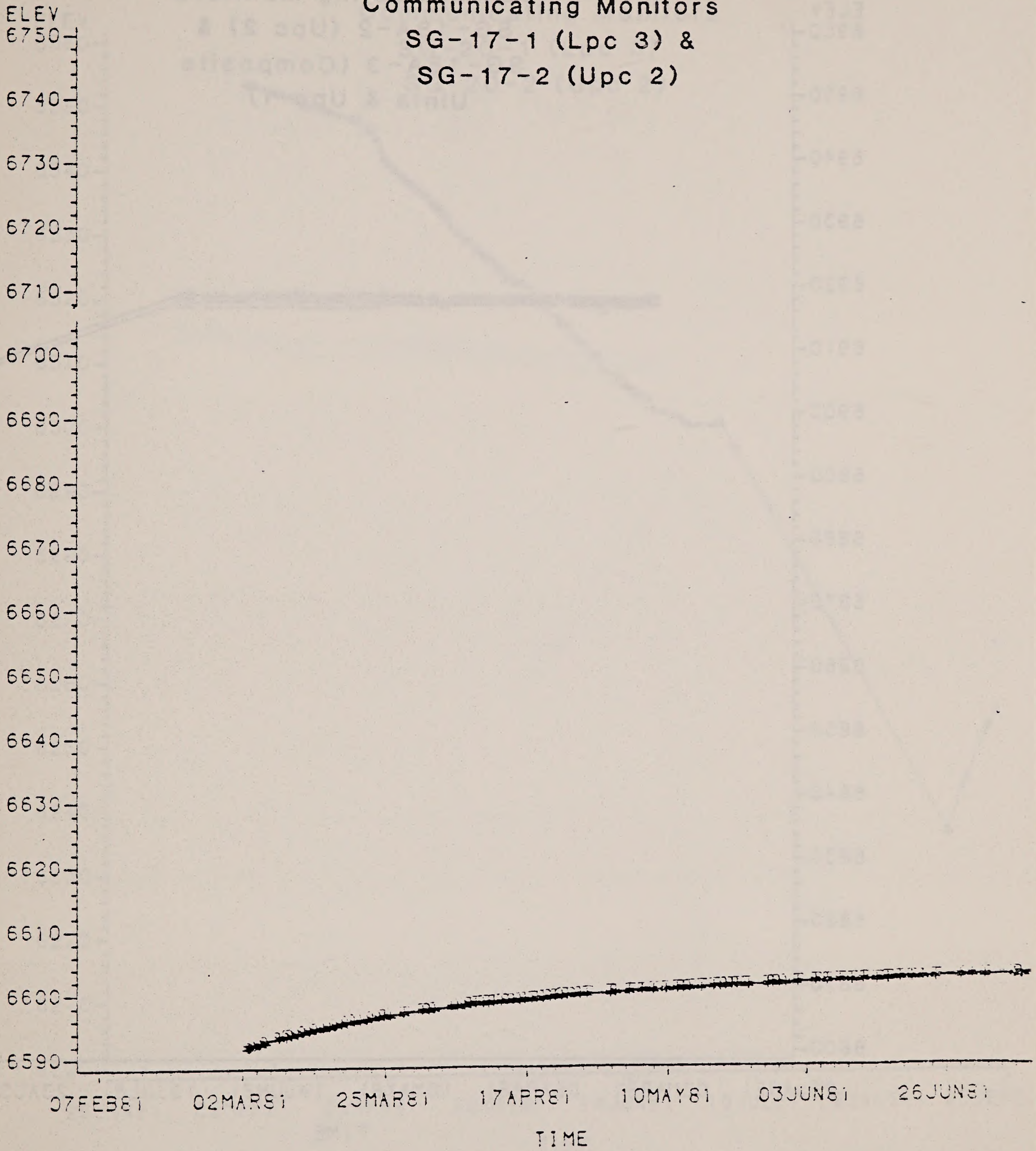




FIGURE A1-46

# CB RE-INJECT DATA

Communicating Monitors

SG-18A-2 (Upc 2) &

SG-18A-3 (Composite  
Uinta & Upc 1)

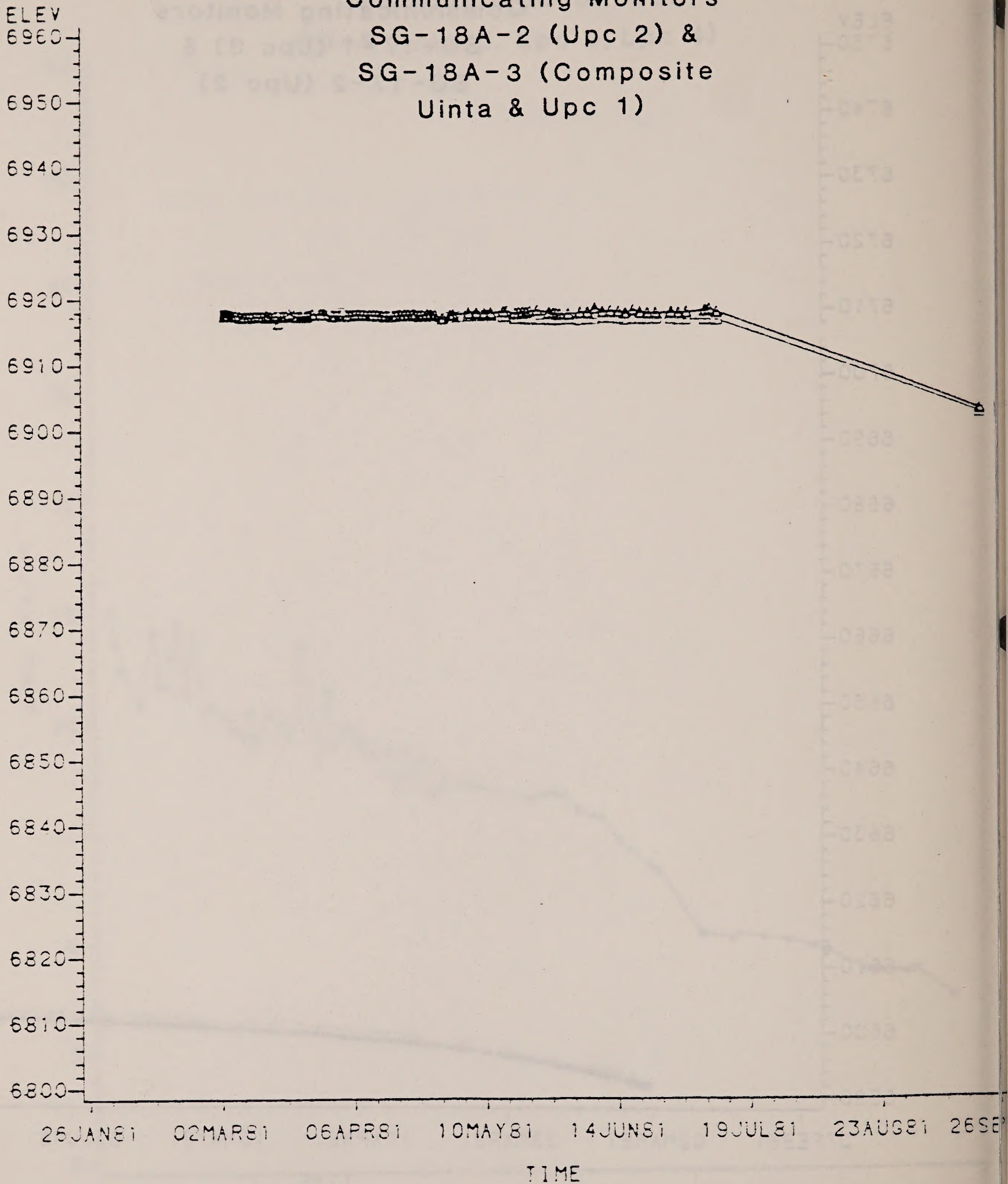




FIGURE A1-47

# CB RE-INJECT DATA

Communicating Monitors

SG-20-1 (Lpc 3)

SG-20-2 (Upc 2)

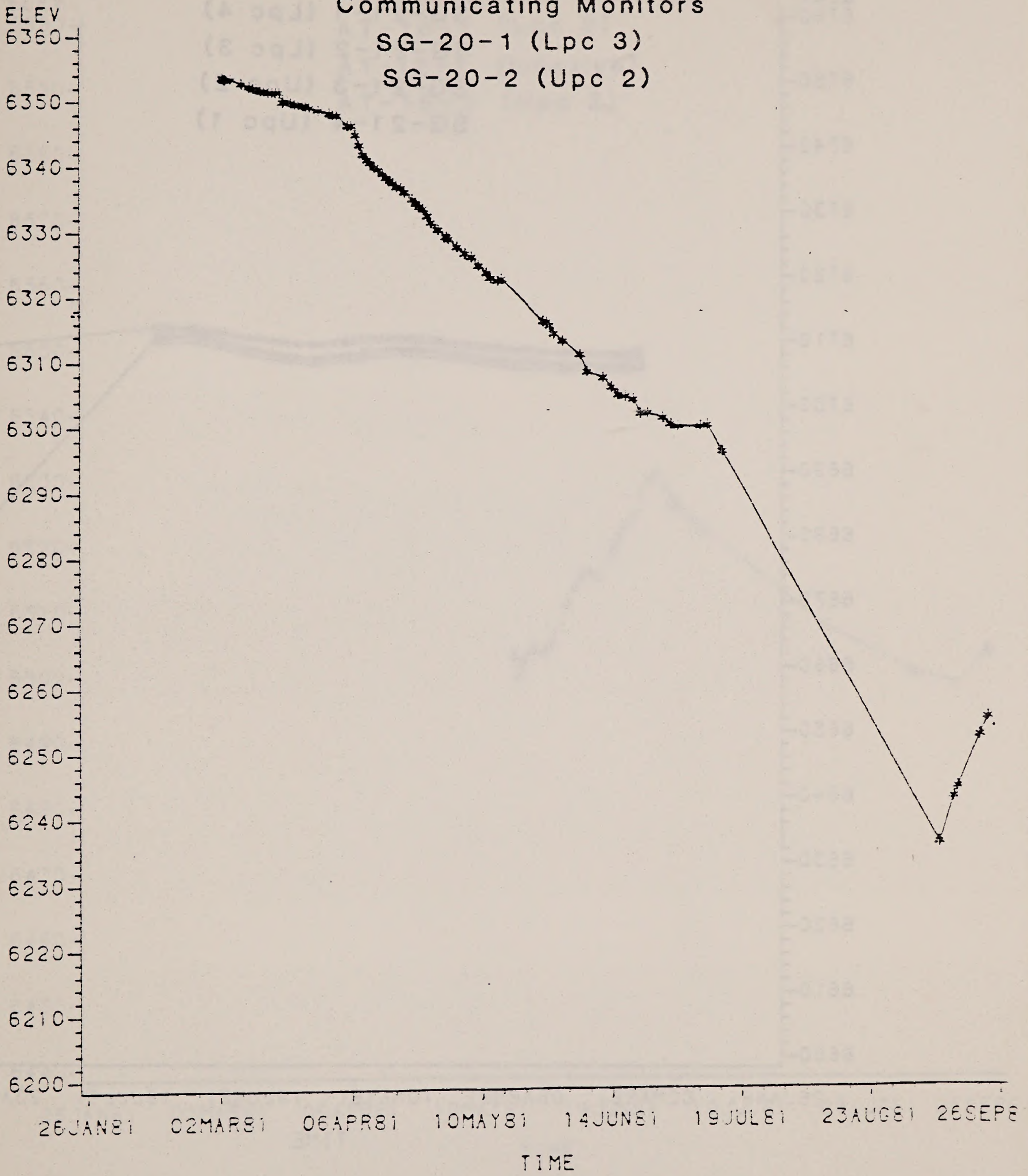




FIGURE A1-48

# CB RE-INJECT DATA

Communicating Monitors

- SG-21-1 (Lpc 4)
- SG-21-2 (Lpc 3)
- SG-21-3 (Upc 2)
- SG-21-4 (Upc 1)

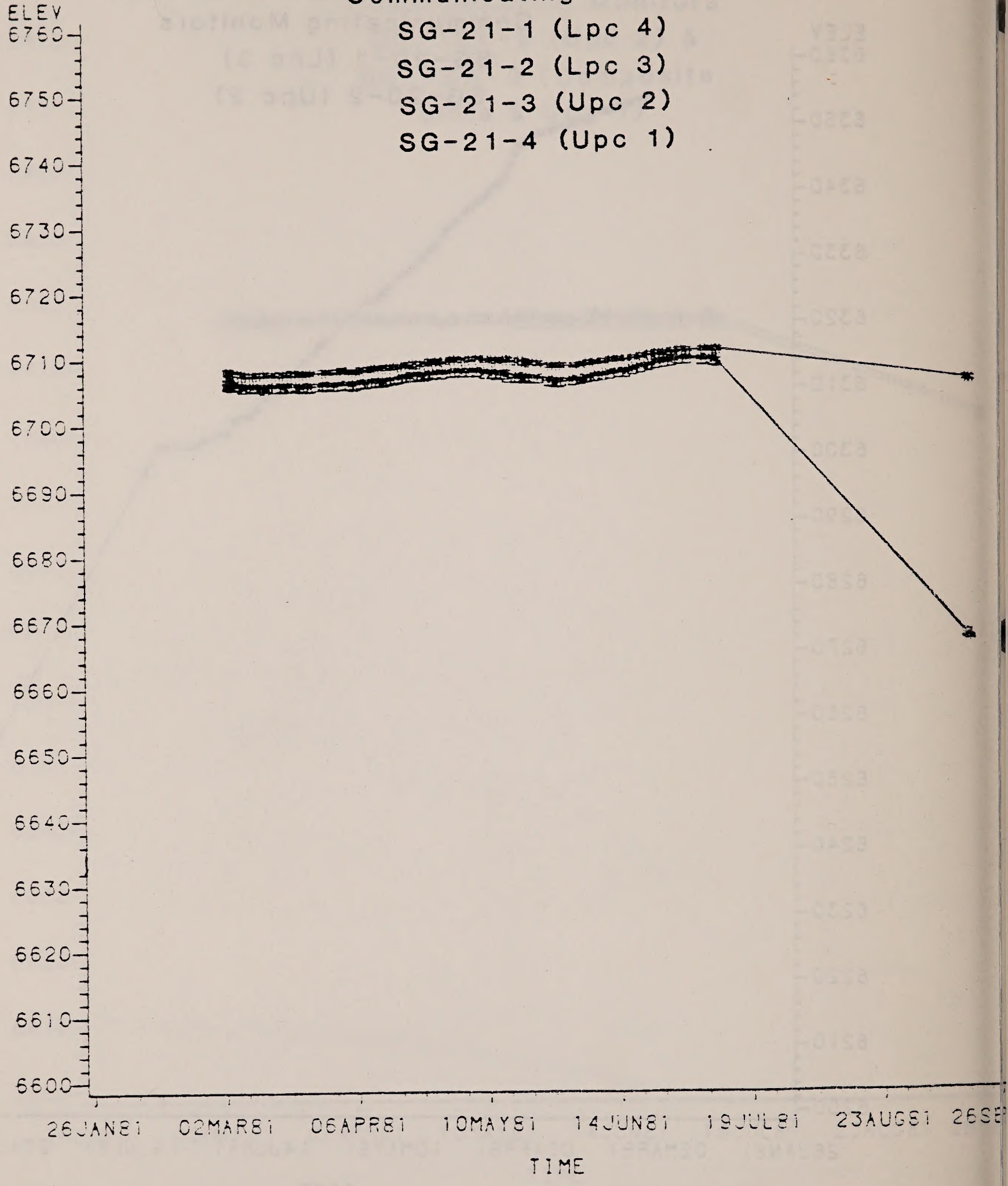




FIGURE A1-49

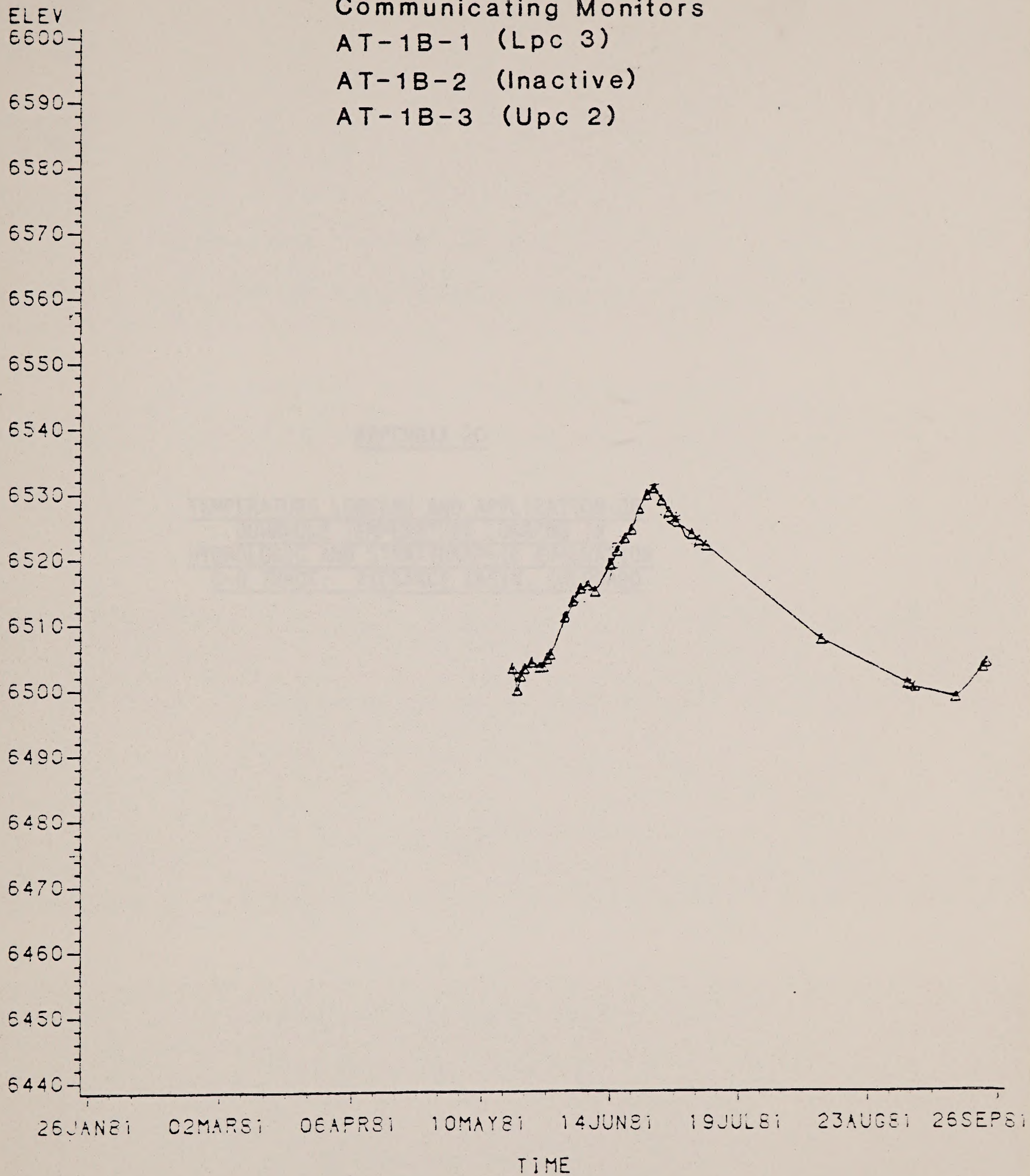
# CB RE-INJECT DATA

Communicating Monitors

AT-1B-1 (Lpc 3)

AT-1B-2 (Inactive)

AT-1B-3 (Upc 2)









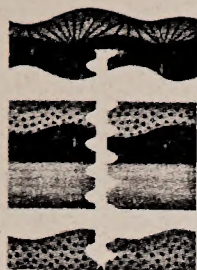
APPENDIX 2C

TEMPERATURE LOGGING AND APPLICATION OF  
DOWNHOLE TEMPERATURE LOGGING IN  
HYDROLOGIC AND STRATIGRAPHIC EVALUATION  
C-B TRACT: PICEANCE BASIN, COLORADO









**GSI**

GEOTHERMAL  
SURVEYS, INC.

TEMPERATURE LOGGING AND APPLICATION OF  
DOWNHOLE TEMPERATURE LOGGING  
IN  
HYDROLOGIC AND STRATIGRAPHIC EVALUATION  
C-B TRACT: PICEANCE BASIN, COLORADO

G. T. Pavlov  
Geophysicist

Geothermal Surveys, Inc.  
99 Pasadena Avenue  
South Pasadena, California

J. H. Birman, President  
R.G. 994

Prepared for:

Occidental Oil Shale, Inc.  
751 Horizon Court  
Grand Junction, Colorado

19 February 1982







TABLE OF CONTENTS

	Page
Introduction -----	1
Basis of Interpretation -----	1
Data Analysis -----	3
Conclusions -----	5
Discussion and Recommendations -----	6



## INTRODUCTION

This report discusses the application of downhole temperature logging in differentiating hydrologic/stratigraphic units based on thermal characteristics of the rocks and possible time-related changes in the heat flow.

A downhole thermal log is made by lowering a cable mounted, low mass, thermistor probe down a well. Thermal probes manufactured by Geothermal Surveys, Inc. contain individually calibrated platinum thermistors with accuracies of plus or minus 0.02°C. Electrical resistance readings are taken with a Wheatstone Bridge after the sensors reach equilibrium with the surrounding material. Thus readings are from discrete points and not averaged over distance as with a continuous thermal log. The reading interval is chosen to acquire the desired selectivity of measurement.

## BASIS OF INTERPRETATION

The temperature value at any point beneath the depth of influence of the annual heat wave depends on three factors: the absolute elevation, the regional temperature field and the local disturbance of that field.

The elevation and the regional temperature field will be expressed in the overall temperature gradient in the area. This gradient is believed to be produced by differences in the regional heat flux in the Earth's crust, taking place mainly by conductive heat transfer. The local disturbances caused by convective and advective heat transfer are not important in the overall temperature gradient because their effects attenuate with distance.

The local temperature changes are produced predominantly by conduction, convection and forced convection or advection.

In conductive heat transfer the heat flux is described by Fourier's Law (Incropera, F.P. and DeWitt, D.P., Fundamentals of Heat Transfer, New York, John Wiley & Sons, 1981)

$$q_c'' = -k \nabla T$$



where  $q_c''$  is the conductive heat flux,  $\nabla$  is three-dimensional del operator, and  $T$  is the scalar temperature field.

The coefficient in the heat diffusion law characterizes the transport properties at the media which depends on the physical structure, texture and the state of matter which includes the presence of fluids and gases. That coefficient is referred to as a thermal conductivity and can be defined from the upper equation as

$$k = q_c'' / (\partial T / \partial x)$$

From this definition, it follows that for a constant temperature gradient the conductive heat flow increases with increase of thermal conductivity.

The convective heat transfer occurs within a fluid or a gas due to combined effect of conduction and bulk motion of the media. The rate equation for this mode of heat transfer is known as Newton's Law of Cooling

$$q_v'' = h (T_s - T_\infty)$$

where  $q_v''$  is the convective heat flux,  $T_s$  is the temperature of the solid phase of the material, and  $T_\infty$  is the temperature of the liquid or gas state within the system. The heat transfer coefficient depends on conditions in the boundary layer, which depends on the surface geometry, the nature of fluid motion, and the fluid thermodynamics and transport properties.

Forced convection, or advection, is a special case of convective heat transfer which includes fluid mechanics.

The summarized equation for the heat flux  $q''$  is

$$q'' = q_c'' + q_v''$$

where  $q''$  is the convective and advective heat flux.

Because of insufficient data for the purpose of interpretation in the present report, a simplification was made utilizing the vertical thermal gradient  $T'$

$$T' = \frac{\partial T}{\partial z}$$



For our particular purpose, in which the downhole temperature readings were taken at  $Z = 20$  ft intervals, it is possible to express the equation in finite values

$$T' = \frac{\Delta T}{\Delta Z}$$

#### DATA ANALYSIS

The accompanying figure presenting a temperature gradient profile across wells SG18A, SG21 and AT1 illustrates the application of the method. The values for the thermal gradient are presented with intervals of 0.01 degree Celsius per foot. The isolines of equal temperature gradient were drawn between the wells. The stratigraphy at the wells is from Beard (1981).

The larger values of the gradient indicate areas with low heat flow rates, and the smaller gradient values are correlated with high heat flow rate. No specific rates of ground water flow are implied by the heat flow rates.

The mean overall thermal gradient is accepted to be about  $1.0 \times 10^{-2}$  °C/ft. This gradient value occurs throughout the largest part of the presented cross section. In the Uinta Formation the deviations of this value are insignificant, which indicates minor aquifer activity.

Considerable changes in the heat flow are indicated in the uppermost hundred feet of the Green River Formation. Right above the Four Senators stratigraphic unit, between wells SG18A and SG21-1 is a zone with very low aquifer activity.

Between the Four Senators and the A-Groove is the zone of highest indicated aquifer activity for this profile.

The heat flow between wells SG21 and AT1 indicates more uniform temperature distribution at the time of logging. The mean overall thermal gradient is predominant in this part of the cross section.

There is some inconsistency between the thermal stratigraphy and the lithologic stratigraphy as defined by Beard (1981). The difference cannot be resolved by the present scope of work. Possible explanations include errors in depth measurements or undefined thermal characteristics of the rock types due to variations in texture, fracture distribution, or fluid content (air, water, hydrocarbons).



In reducing the field data, it was assumed that the overall temperature gradient is the same for all parts of the study area. However, if differences do occur in the gradient at the individual wells, this will result in some shifting of the thermal stratigraphy upward or downward. To avoid this error, more detailed analysis of the temperature field would have to be done.

To more precisely correlate the temperature field with the geology of the area, there should be further investigations of the thermal properties and the heat transfer into the different stratigraphic units. Some investigation of the regional temperature field is also necessary.

Well AT1-1 does not show significant aquifer activity in the Uinta Formation. That part of the temperature field had a mean gradient of  $1.12 \times 10^{-2}$  before reinjection and  $1.039 \times 10^{-2}$  °C/ft after commencing reinjection. The slight cooling trend could be ascribed to the injected water, but the effect is slight and a confident interpretation regarding it cannot be made at this time.

Between the Four Senators and the A-Groove is a zone of high aquifer activity, indicated by the temperature gradient which drops to  $5.5 \times 10^{-3}$  °C/ft. In the last 400 feet there also occurs some aquifer activity with a similar gradient.

The thermal log indicates significant changes in the heat flux after the beginning of reinjection below the A-Groove. The temperature after reinjection was about 4°C cooler. This can be explained by increasing advective heat transfer caused by the injected water.

The temperature gradient in the Uinta Formation at Well SG6 shows significant heat transfer (the value is  $1.5 \times 10^{-3}$  °C/ft). That activity rose ceases about 100 ft above the top of the Parachute Creek Member. The rest of the curve does not show any significant change of the heat flux and has mean gradient  $1.86 \times 10^{-2}$ .

The temperature gradient in the upper part of the curve shows some decrease after the reinjection ( $1.3 \times 10^{-3}$  °C/ft) which could be an indication of a slight penetration of the injected water into Uinta Formation. The temperature gradient in the rest of the curve is  $1.83 \times 10^{-2}$  °C/ft which is not significantly lower than the first measurement. The behavior of the temperature field does not show change in the heat flux. This suggests that at the time of the second reading well SG6 was not affected by the injected water.



The temperature curve of well SG9-1 does not indicate any significant change in the heat flux above the A-Groove. It has a mean gradient of  $1.39 \times 10^{-2}$  °C/ft. Between the A-Groove and the B-Groove the temperature increases to the higher temperature of Mahogany Zone.

The temperature gradient above the A-Groove after reinjection is  $1.45 \times 10^{-2}$  °C/ft. The more significant change of the temperature is observed below the B-Groove (2°C cooler) which suggests that the reinjection has affected part of the Mahogany Zone.

The mean gradient for Uinta Formation before reinjection for Well SG11 was  $3 \times 10^{-3}$  °C/ft, which indicates a high rate of heat transfer. The rest of the curve has mean gradient of  $1.75 \times 10^{-2}$  °C/ft.

After the reinjection the temperature gradient for Uinta Formation is the same  $3 \times 10^{-3}$  °C/ft. A large change, however, is indicated in the entire penetrated thickness of Green River Formation. The mean temperature gradient is  $1.56 \times 10^{-2}$  °C/ft. The cooling effect of the injected water is 6°C at the lower end of the temperature curve. This indicates a significant response of the injection below Upcl.

#### CONCLUSIONS

1. Vertical temperature gradients measured in wells on the C-b Tract show relationship to the stratigraphy.
2. The relationship to the stratigraphic units (lithology) is not exact but is modified by the presence and movement of fluid.
3. The overall gradients in the Uinta Formation are distinctly different from those in the Parachute Creek Formation.
4. Effects of Reinjection are clearly seen in the gradients of some of the wells logged before and after Reinjection, such as in SG-9 below the B-Groove and in SG-11 below the Uinta Formation.
5. The extent to which temperature-indicated differences in aquifer activity were found in before and after Reinjection indicates the utility of this technique for monitoring the effects of dewatering and reinjection at the C-b Tract.



## DISCUSSION AND RECOMMENDATIONS

The analyses done for this report used only a few of the temperature logs made on the C-b Tract. Many additional gradient logs are now available that can be analyzed without further field work.

Moreover, since this work was done, we have separated the Uinta aquifer(s) from Upcl, and we have reason to believe that much of the ground water activity is within the Uinta Formation rather than the deep bedrock. Item 3 of our conclusions appears to support this concept.

It would seem reasonable, therefore, to analyze the already available thermal logs to investigate where most of the ground water movement is occurring both in a vertical sense and throughout the Tract by correlating the temperature results well-to-well.

In particular, we expect that the thermal gradient technique will be one of the few methods for distinguishing the water level changes in monitoring wells due to pressure effects from those due to mass transfer of fluids through the rocks.

We recommend, therefore, a program as follows:

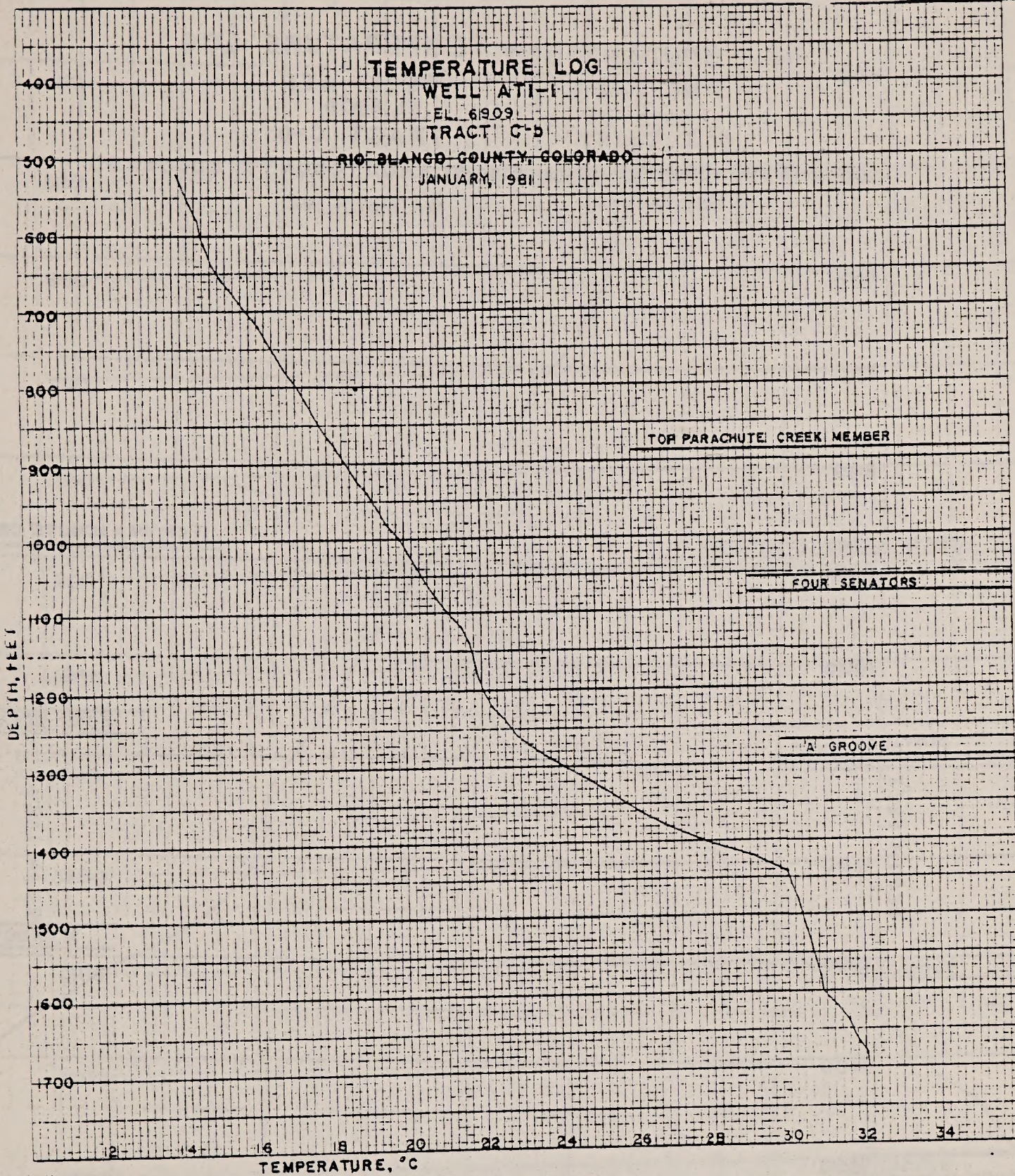
1. Complete the type of analysis described in this report for the remaining thermal logs.
2. Upgrade the analysis of all the logs by determining and removing the overall gradients to determine the local anomalies, and to adjust the gradient configuration to the stratigraphy.
3. Compare the results before and after Reinjection
  - a. with respect to Uinta vs Parachute Creek aquifer activity
  - b. within the individual units throughout the stratigraphic section
  - c. with respect to cross-formational leakage, as at the Aquifer Test Pad
  - d. make well-to-well correlations of gradient-indicated aquifer activity throughout the Tract.



4. Compare the results with the temperature logs made early in the history of the Tract, in order to identify what general changes, if any, have occurred since the beginning of shaft sinking.
5. Before Tract activity returns to normal, obtain and analyze at least one and preferably two sets of temperature logs in wells selected as key indicators from the previous steps. The two sets should be widely spaced in time, at least six months and perhaps a year apart.

This will complete the baseline data set for monitoring any time after the Tract activity begins.







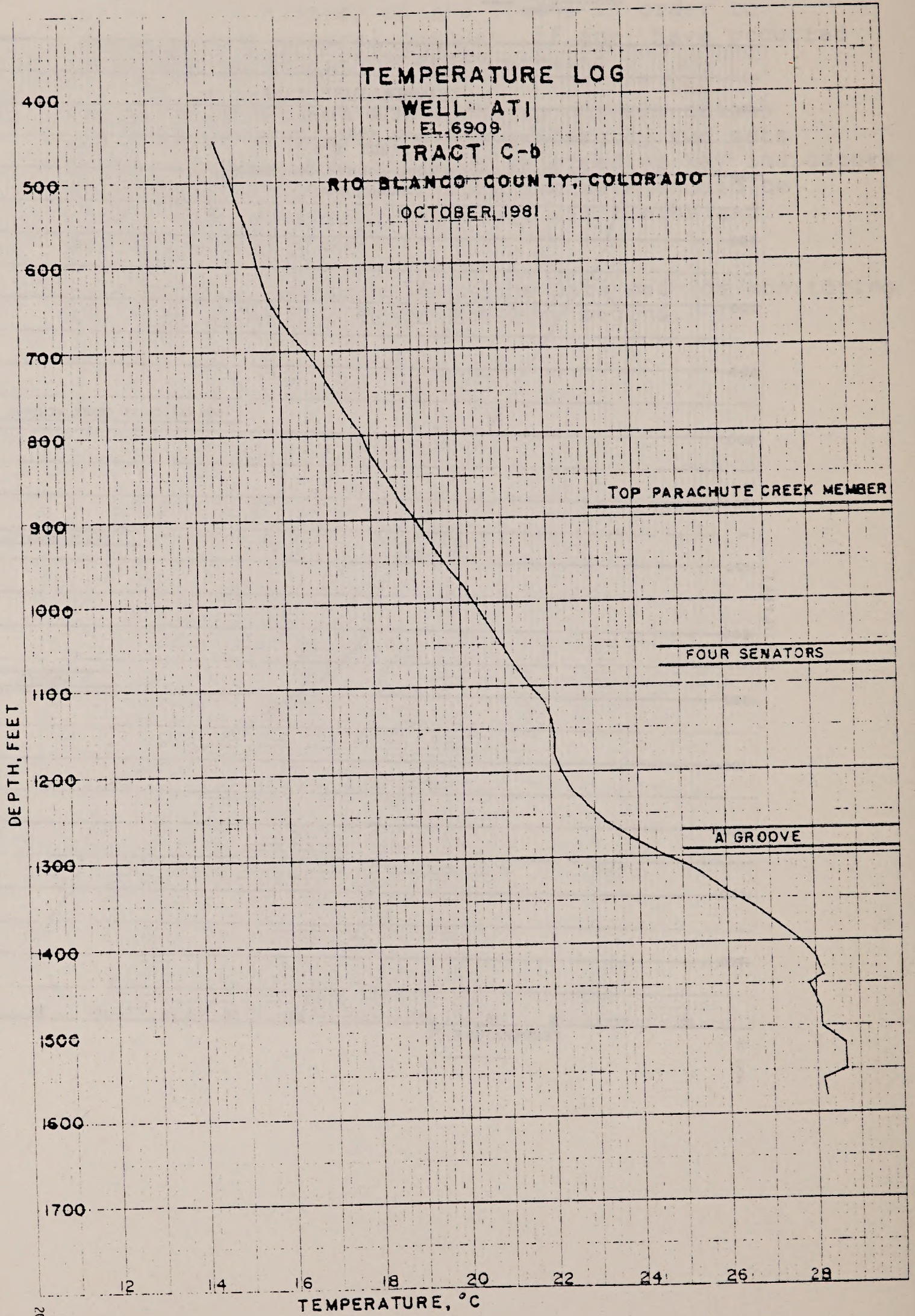
TEMPERATURE LOG

WELL AT1  
EL. 6909

TRACT C-b

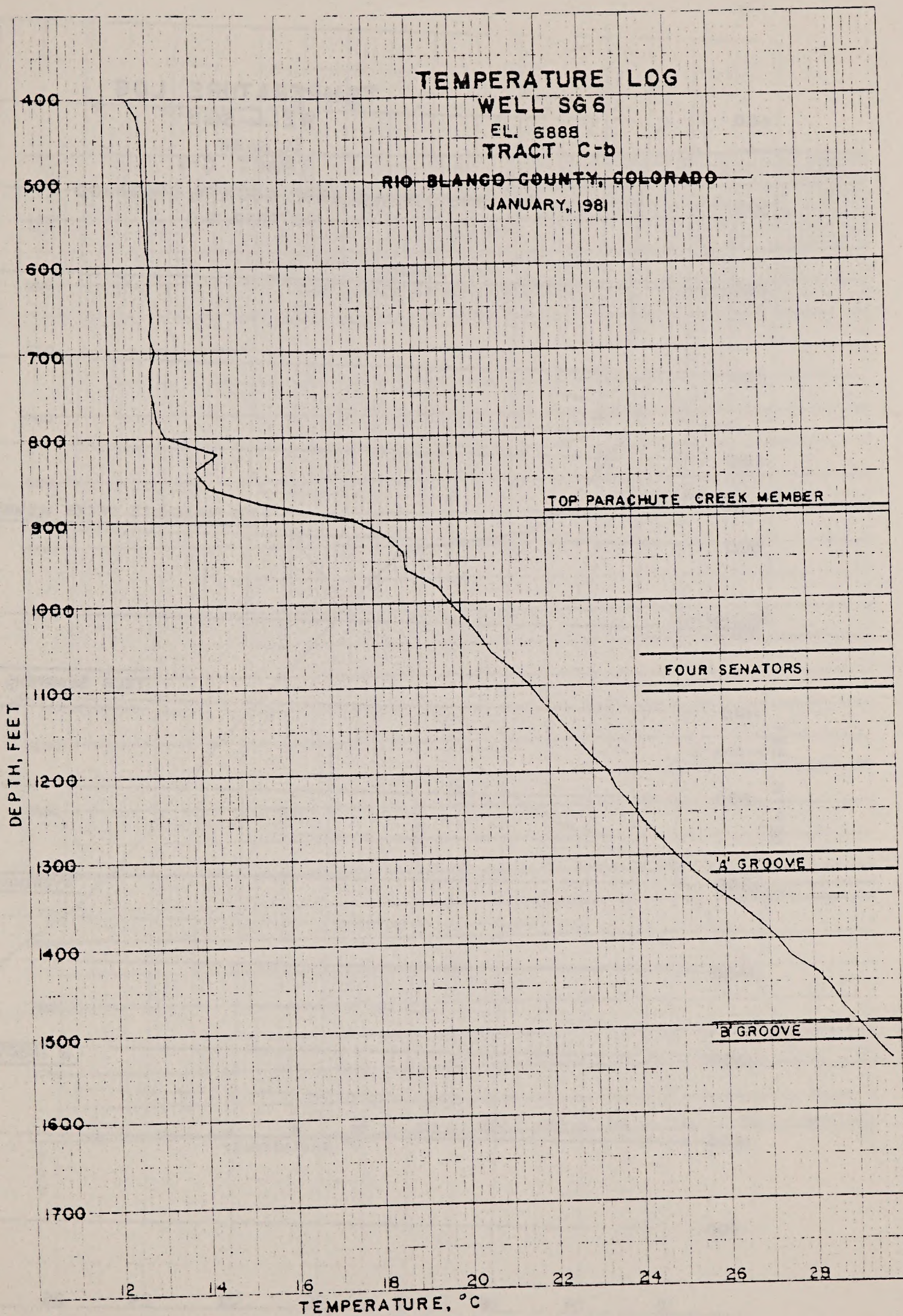
RIO BLANCO COUNTY, COLORADO

OCTOBER, 1981

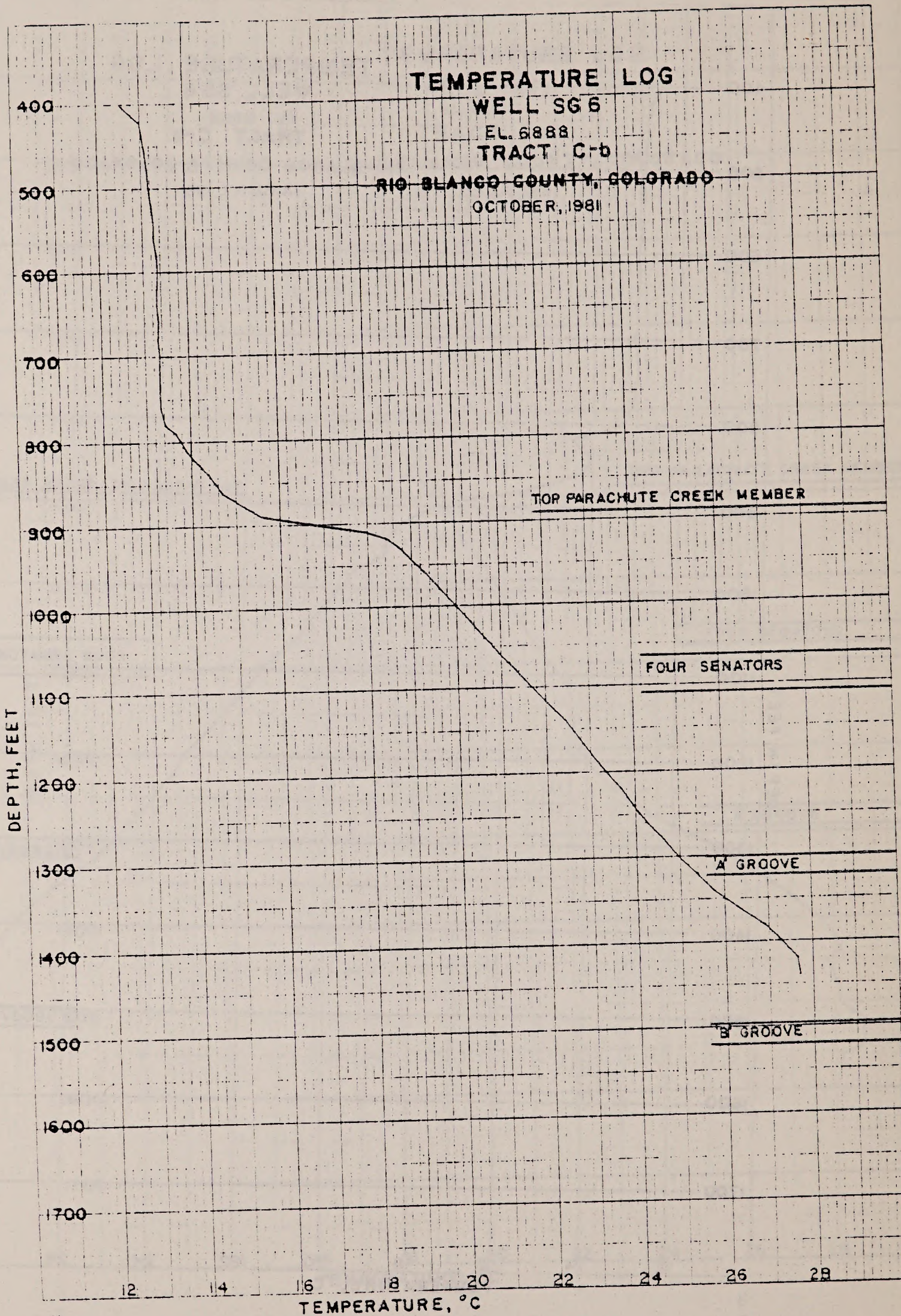


20-15/16

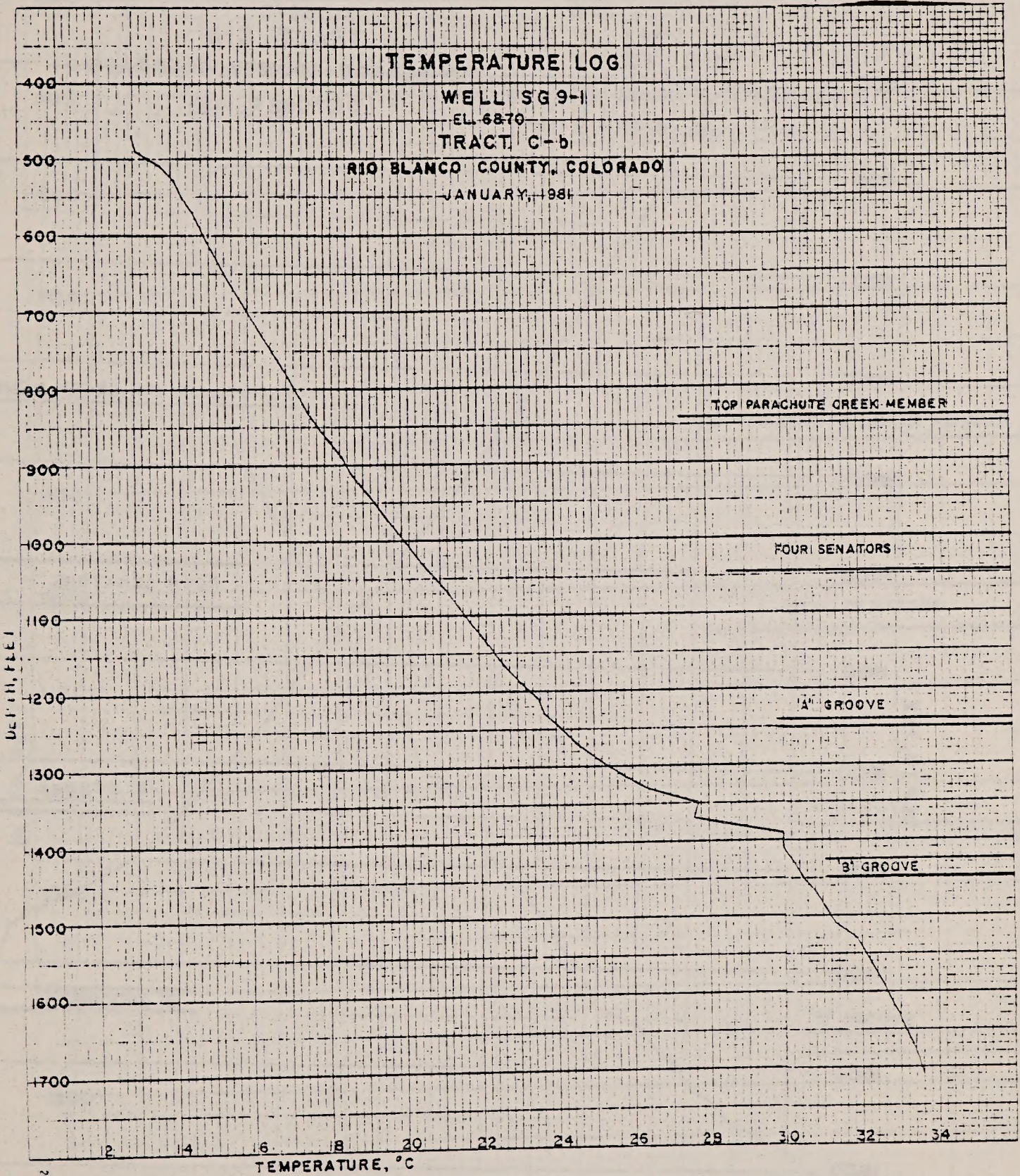






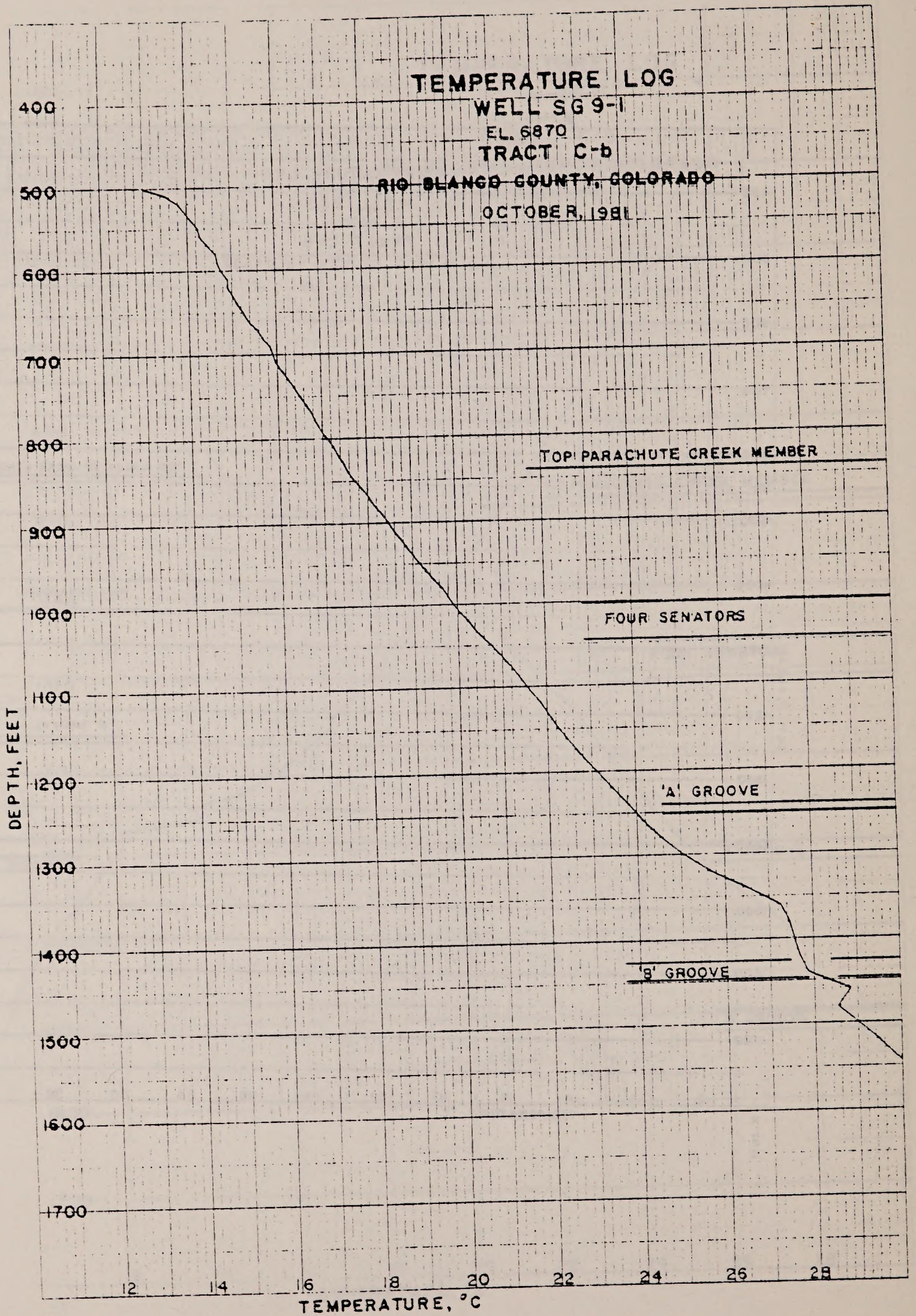






20-21/22

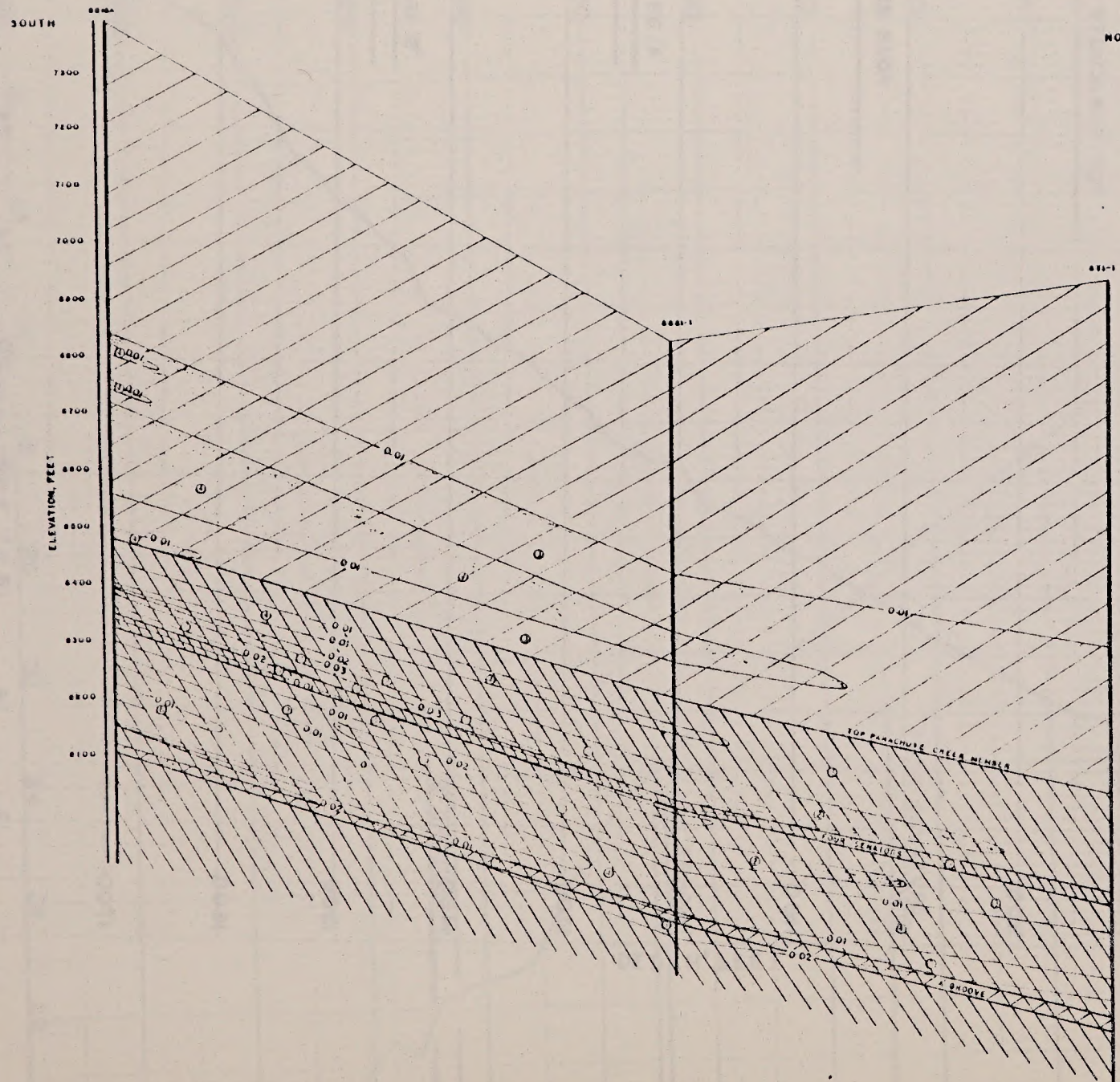












TEMPERATURE GRADIENT PROFILE  
 WELLS SG18A, SG21-I, AT1-1  
 TRACT C-6  
 RIO BLANCO COUNTY, COLORADO  
 JANUARY, 1981

**LEGEND**

TEMPERATURE GRADIENT, °C/FT <small>(No specific flow rate values implied)</small>		STRATIGRAPHIC UNITS	
LOWER FLOW RATE	0.03		UINTA FORMATION
	0.02		GREEN RIVER FORMATION
	0.01		FOUR SENATORS
	0.00		'A' BROOGE
	-0.01		
HIGHER FLOW RATE	0.03		
	0.02		
	0.01		
	0.00		
	-0.01		

CONTOUR INTERVAL 0.01 °C/FT  
 HORIZONTAL SCALE 1"=1000'  
 VERTICAL SCALE 1"=100'

Geothermal Services, Inc.



Some Questions on Piceance Basin Hydrology

Joseph A. Bierman  
Geological Services, Inc.  
Salt Lake City, Utah

ABSTRACT

Most of the ground water in the Piceance Creek Basin, Colorado, may be in shallow weathered limestone and shale formations, and not in significant contact with deeper unconsolidated aquifers of the underlying Green River Formation. Ground water movement in the deeper aquifers may be exceedingly slow.

APPENDIX 2D

SOME QUESTIONS ON PICEANCE BASIN HYDROLOGY

The Piceance Creek Basin in northwestern Colorado is a large, roughly rectangular area about 100 miles long and 50 miles wide. It is bounded by the Front Range to the east and the Wind River Range to the west. The basin is underlain by the Green River Formation, which is a thick sequence of unconsolidated sandstones, shales, and limestones. The basin is a major source of coal and natural gas in the state of Colorado. The hydrology of the basin is complex, and there are many questions that need to be answered. The following are some of the questions that have been raised:

1. How much ground water is there in the basin? 2. Where is the ground water located? 3. How is the ground water recharged? 4. How is the ground water discharged? 5. How is the ground water used? 6. How is the ground water quality affected by coal mining and gas production? 7. How is the ground water quality affected by oil and gas production? 8. How is the ground water quality affected by agriculture? 9. How is the ground water quality affected by urban development? 10. How is the ground water quality affected by climate change?







## Some Questions on Piceance Basin Hydrology

by

Joseph H. Birman  
Geothermal Surveys, Inc.  
South Pasadena, California

### Abstract

Most of the ground water in the Piceance Creek Basin, Colorado, may be in shallow aquifers (alluvium and Uinta Formation) and not in significant contact with deeper bedrock aquifers of the underlying Green River Formation. Ground water movement in the deeper aquifers may be exceedingly slow.

This paper presents a set of working hypotheses alternate to some of the concepts that seem to be held at present in Piceance Basin hydrology. If these hypotheses are correct, mining in and beneath the Mahogany Zone of the C-b Tract should be possible without hazard to the usable ground water, the springs, and the streams. We present these ideas not to teach but to learn. We hope to test them until we can accept them with confidence or until we must reject them for better interpretations.

Very little of this interpretation is new. It is an extrapolation of some established concepts and a little modification of others using existing data. In brief, it holds that lateral ground water migration within much of the Green River Formation is so slow as to be, in practical effect, non-moving; that away from through-going faults the deep ground water is not in significant communication with



the near-surface water; that some of the water in the Green River Formation is ancient and is not being actively recharged now; and that the leaching of the Green River Formation may have occurred in ancient times, after which through-going continuity of open space was destroyed.

The underlined statements which follow are tentative working hypotheses, followed by some explanatory discussion including some useful references. The geohydrologic setting of the Piceance Basin has been described in many publications and need not be repeated here.

1. Lateral or intraformational migration of ground water may be extremely slow. Drill stem test data are available from drillhole SG-17 in the southeastern corner of the C-b Tract (1, p.5). In 33 intervals over a total depth range of 1638 ft, measured hydraulic conductivities range from 0.02 gal/day ft<sup>2</sup> to 4.1 gal/day ft<sup>2</sup>.

On the C-b Tract, the hydraulic gradient for both the Upper Aquifer and Lower Aquifer is reported to be about 100 ft/mile (12, p.70-71).

Substituting these values in Darcy's Law,  $v = Ki$ , where  $v$  is Darcy or discharge velocity (2, p.81, 82) (3, p.16) (4, p.116, 117), and  $i$  is hydraulic gradient, the range of Darcy velocities is 0.018 ft/yr to 3.79 ft/yr.



These are the extreme limits, and if other things are held equal, are not real. To arrive at the actual velocities through the rock mass, the Ki function is divided by porosity as the Bernoulli Principle must apply. The real velocities are thus greater than the Darcy velocities by orders of magnitude depending on what values for porosity are used and assuming that discharge remains the same.

For the Piceance Basin this seems too simple an approach. All the hydraulic factors are related -- discharge, gradient, hydraulic conductivity, and porosity. Of these factors, effective porosity is one of the most difficult to assess, but ranges from 0.1 to less than 0.01 (5, p.10) have been used, and in very tight formations the porosity can be extremely low. Although porosity does affect hydraulic conductivity (normally as porosity decreases, hydraulic conductivity also decreases), the relationship is highly complex (6, p.60-61, 89-90; 8, p.4-5).

It seems unreasonable that an equivalent thickness of Mahogany will carry the same discharge and at faster rate than the A-Groove, especially as the potential (7, p.155-164) to drive water through smaller and smaller pore spaces is limited by the elevation of the Roan Plateau or whatever area is the principal source of recharge.



If most of the water is carried in the alluvium and the Uinta Formation, the deeper beds of the Green River Formation may be characterized by little discharge and low velocity.

For these reasons, it is worthwhile to examine the extent to which the limiting Darcy velocities may be approached in the real sense.

The drill stem tests provide the lowest Darcy velocity values. The highest Darcy velocity values were from transmissivity calculations based on data from a reinjection program at the C-b Tract in the spring of 1981. From the reinjection tests the range of Darcy velocities derived in the Green River Formation is 0.55 ft/yr to 16.4 ft/yr (9, p.29, 31) (10, p.1465-1470). The transmissivity values which provide these velocities are in reasonable agreement with or larger than transmissivity values based on other approaches such as test pumping on the C-b Tract (11, p.26).

2. Given the range of Darcy velocity values, the maximum time for water to travel across the Piceance Basin within the deep bedrock aquifers of the Green River Formation might be measured in thousands of years or even greater orders of magnitude. Maps of the potentiometric surface for the Upper Aquifer and the Lower Aquifer are provided by the U.S. Geological Survey (12, p.32) (13, p.30,31).



It is about 30 miles from the south or southeast rim of the Piceance Basin to the White River, south of which the beds of the Green River Formation are exposed. The potentiometric surface is steeper at the C-b Tract than throughout most of the Piceance Basin. Therefore velocity values derived for the C-b Tract should be reasonably representative and may be conservative.

Using the data, the shortest limiting time for ground water in the deep aquifers to move across the Piceance Basin is 9600 years (reinjection analysis). The longest limiting time is 8.8 million years (drill stem test SG-17). Again, the values represent extreme or limiting cases based on the Darcy velocity not the actual velocity. The actual velocities would be greater depending on what porosity values are used.

3. Except along through-going fault zones, vertical leakage across the stratigraphic units in the Green River Formation may be insignificant. There are several categories of evidence that bear this out.

Geologically the layered arrangement of strata, and the fact that the layers are arranged essentially horizontal, inhibits downward or upward ground water migration. While it is true that the ground water is in the fractures, it is



also true that the fractures are largely controlled by the rock type. Brittle marlstones are able to hold open fractures to some depth. Oil-rich shales are not.

Water in different strata show differences in chemistry. These differences do not change continuously downward, but increase and decrease with depth. This means that if vertical leakage is occurring it is not sufficient to smooth out or eliminate the differences in water chemistry.

During shaft sinking, large differences were found in rates of water production from different horizons. As with water chemistry, there was not a continuous change downward. There were increases and decreases in rate, and some intervals were completely dry.

There are well pairs at or near the C-b Tract in which wells completed in alluvium show no drawdown while companion wells completed in the bedrock show much drawdown. Such is the case with alluvial/bedrock pairs WA-06/SG-20 and WA-07/SG-19. If leakage downward from the alluvium is occurring into the deep bedrock it is still too slight to be discerned after more than a year of observed drawdown in the bedrock wells.



In well 32X-12, completed in the Upper Aquifer, water stands about 800 ft below the surface. Ninety feet from this well are the Service and Production Shafts, now about 1800 ft deep. These shafts have undergone dewatering since the beginning of sinking in March 1979. The shafts are lined but not sealed and are designed to leak. The fact that water still occurs in a "partially penetrating" observation well so close to the two great (more than 30 ft diameter) "production wells" is strong evidence that both the horizontal and vertical hydraulic conductivities are extremely small.

Using a statistical approach (4, p.100) and the hydraulic conductivity values from the drill stem tests of SG-17, the vertical permeability is about one-tenth the horizontal permeability. However, because this is based on horizontal permeability data, the true vertical permeability is likely to be even smaller.

Leakance studies using the Neuman and Witherspoon equation (14) were made by General Electric Company - Tempo in a study for the Environmental Protection Agency (15, p.88, 90). They report (p.88): "Leakance values, estimated from type-curve matching (Table 5-7), were small, showing that the water level in any aquifer was not affected by pumping any other aquifer. A computer solution of the Neuman and Witherspoon leaky aquifer equation was developed which indicated that the vertical hydraulic conductivity was less than  $5 \times 10^{-7}$ ." (cm/sec)

Perhaps the most striking evidence of non-communication between shallow aquifers and the deep bedrock is that some



horizons encountered during shaft sinking were absolutely dry (N. Stellavato, personal communication, many times, 1980, 1981), even though the overlying bedrock contained water. These dry horizons must be considered as not reached by either vertical leakage nor by horizontal migration from vertical leaky zones elsewhere.

4. The leached zone may represent an ancient event.

During sinking of the shafts large vugs were found, some of which were dry and some of which contained water that flowed strongly for a short time and then stopped.

If the vugs are interconnected from source to outlet, and if there is active recharge to the deep formations, they should still contain water and the water should continue to flow into the opened shaft. That some vugs were found to be dry and that others flowed strongly and then stopped, suggests that the vugs are not interconnected from recharge source to outlet, but that at least some of the water in the deeper formations, if not connate, may have been trapped there for a very long time.

Donnell (16, p.861) shows unconformable relationships among some of the formations. This implies erosion, and therefore leaching may have occurred shortly after the depositing of any of the saline deposits. If so, later blanketing by the overlying formations would tend to seal off and isolate some of the leached zones.



Such processes would provide today, long after the Eocene, a system of partially interconnected vugs and channels showing the effects of earlier activity, able to contain water but not able to transmit water for long distances.

This would also provide high transmissivity values for short term tests, but this would not necessarily indicate that through-basin flow at high velocity is going on.

5. Some upward leakage does occur from the deep aquifers to the shallow formations in the stream bottoms in the northern part of the basin; this leakage is likely controlled by major faults. Through-going faults are mapped (16) across Black Sulphur Creek and across Piceance Creek near the mouth of Ryan Gulch. Recent mapping by Beard (22) shows faulting in the north rim of the basin, with directional trends across Piceance and Yellow Creeks.

It is in such localities that upward leakage could occur and may have been occurring for a long time. In such areas, soils with higher salinities may be due to upward leakage and deposition at the surface.

In these localities, the salines are not excessively thick even though they have been exposed for a very long time (except for stream alluvium there are no post-Eocene



deposits). This implies that unless flushing at the surface is going on, the upward leakage to the surface is either a very recent event or it goes on at an extremely slow rate.

6. Most of the springs may be from very shallow sources. Many of the springs in the C-b Tract area show very short-term changes in flow rates, are along exposed stratigraphic horizons in the bedrock, or are along the bedrock-alluvial contact.

If the slow ground water migration rates as described in the foregoing paragraphs are correct, it is difficult to believe that short-term changes in flow rates can occur in springs that are outlets of the deep aquifers.

The C-b area springs may be derived from two shallow sources. One source, from the high peripheral areas may provide water to the major springs via the shallow formations. In addition, some of the springs may be fed by water that infiltrates into the near-surface fractures in the bedrock ridges, maintains high mounds of saturated storage during wet periods, and feeds the springs along adjacent slopes and valley bottoms. During dry periods, these storage mounds are lowered and the springs may reduce in flow or go dry.



In this concept some of the springs are controlled very locally by bedrock, by near surface fracture distribution, and by short-term changes in climate. Others are sustained by long term and long distance migration in the shallow formations.

7. The Uinta Formation may contain both unconfined and confined ground water in the C-b area, and may be responsible for much of the recharge to Piceance Creek and its tributaries. Recent geologic mapping (T. Beard, personal communication, November-December, 1981) shows that the Black Sulphur Tongue sub-crops beneath the alluvium of Piceance Creek north of the C-b Tract and dips southerly beneath the Tract. The layers above and below the Black Sulphur Tongue are thus in position to receive infiltration from (or provide water to) Piceance Creek in the north, from surrounding areas in the south and east, and by downward seepage from above. The Black Sulphur Tongue appears to be the uppermost significant confining layer, and above this the water is unconfined.

It seems likely that confined water occurs in the Uinta Formation between the Black Sulphur Tongue and the Thirteen Mile Creek Tongue at the base, and that it is this confined water in the lower Uinta Formation, recharged from the higher slopes to the south, the north, and the east that can provide significant recharge to Piceance Creek.



In this concept, the flow of Piceance Creek and its tributaries near the C-b Tract is derived mostly from surface runoff, from shallow-source springs, and from the Uinta aquifers.

8. That the potentiometric contours bend around Piceance Creek is not necessarily due to upward leakage from the bedrock aquifers. An interpretation held by many is that this configuration of the potentiometric surface shows that the deep bedrock aquifers discharge into Piceance Creek along most of its length. Piceance Creek is thus acting as a drain for the deep aquifers and thus depresses the potentiometric surface. This is reasonable, but there may be another explanation.

The potentiometric contours closely resemble any set of structure contours in the Piceance Basin. The Piceance Dome north of Piceance Creek is quite well defined by the potentiometric contours, and Piceance Creek flows almost along the structural downwarp axis of the basin.

The potentiometric configuration may reflect a combination of structural control of the ground water and very slow migration not upward into Piceance Creek, but outward into the White River through the Green River outcrops. We agree with the U.S. Geological Survey (12, p.30) that fracturing should be greatest along the structural axis of the basin.



If fractures are more abundant in the competent beds and less abundant in the incompetent (oil-rich) beds, the entire axial zone should thus drain laterally more efficiently than the limbs (17, p.93) toward the outlet region south of the White River, while maintaining confining integrity in the vertical direction, except where locally cut by faults.

We suggest this concept to explain the configuration of the potentiometric surface because it appears to explain why the major tributaries to Piceance Creek do not similarly have to be interpreted as drains for upward leakage, nor does Yellow Creek which, second to Piceance Creek, is the largest drainage in the Piceance Basin. Zones of upward ground water potential (13, p.33) are indicated in the lower and upper Yellow Creek system, yet the published maps do not show the potentiometric contours bending around this stream.

9. The deep bedrock aquifers in the Piceance Basin may have experienced relatively little flushing since the end of Uinta time. If the ground water migration rates are very long as suggested in this interpretation (Item 2), the ground water does not course rapidly through the deep formations, and at least in some of the formations there may have been few or no transits through the system.



10. Of the recharge that does occur to the deep bedrock a significant proportion may enter the upturned Green River Beds along the eastern rim of the Basin. At least for the Piceance Creek part of the Piceance Basin, the deep bedrock aquifers are exposed along the eastern margin. It would seem that the easiest way for water to enter these formations is along the upturned eroded edges of the beds, and from infiltration from uppermost Piceance Creek and its tributaries which flow directly upon them or where the alluvium is coarse-grained and thin.

11. At the C-b Tract, vertical leakage if it occurs as a result of mining, would be downward. Based on many wells, the head elevations for the Lower Aquifer horizons are slightly lower than are the heads in the Upper Aquifer horizons.

Therefore, we would expect that during and after mining and abandonment of retorts, there should be no leakage upward from the retorts into the shallower formations. if the overlying aquicludes have not been broken and the shallow aquifers have not been dewatered.

12. From the mining zone at the C-b Tract lateral migration if it occurs, should have no effect on quantity and quality of the usable ground water. From the C-b Tract it is 8 miles to the nearest expected zone of upward leakage



to the surface. This is where through-going faults intersect the structural axis of the basin near the mouth of Ryan Gulch (12, Plate 1).

The fastest Darcy velocities (our own work based on reinjection) and the slowest Darcy velocities (drill stem tests, SG-17) if used as limits and extrapolated across this distance give indicated times of 2,600 years and 3,250,000 years respectively to reach this locality. The actual times, of course, would depend on what values are used for the other hydraulic parameters. The Darcy velocities are so slow, however, that even if the average linear real velocities are higher by an order of magnitude or more, and if the drill stem test results are more accurate than our own interpretations, the time to reach the locality may be measured in thousands to tens of thousands of years or even more.

Some criticisms of this interpretation are that with fracture porosity, discharge can be quite large because it varies with the cube of fracture width (18, p.1016). A second is that fingering (19, p.906-908) that can occur in a cracked porous medium may take place locally in some of the formations.

However, there is another aspect of the problem that should be considered. What we are largely concerned with is not simply the established steady-state transport condition,



but the time for first arrival from a source of potential contamination to where it can become a hazard. In a region as large as the Piceance Basin, a mining area even as large as the C-b Tract can be considered more or less a point source. Flows emanating from such areas after abandonment should be subject to the laws of dispersion (20, p.848-853) and the processes of matrix diffusion (21, p.720-728). It would seem that the time for first arrival of a contaminant could be extremely long.

- - - - -

The foregoing analysis contains some surprisingly large numbers in regard to the migration time of water through the Piceance Basin. The times are so large that they appear unrealistic, and they probably are. Yet they are based on observed data, and their validity can be tested. It seems reasonable to consider the time ranges stated here as extreme limits, and that what actually occurs is at some intermediate value.

Whatever the final results, the time for water migration through the Piceance Basin seems to be long, and the geohydrologic setting seems to favor protection of the environment. These conditions appear to occur widely throughout the Piceance Basin, and this should be of interest to other developers of oil from shale in the Piceance Basin.



Finally, the excellent work by the U.S. Geological Survey, and by other organizations (23, 24), in developing models for ground water flow and solute transport are based on the best data available to them at the time. By responding to their repeated requests for data, we can greatly help them in improving their models. Their willingness to do this and their receptivity to new ideas is obvious to any of us who have worked in the Piceance Basin.



## REFERENCES

1. Energy Consulting Associates (1977), Drill Stem Test Analysis, Tract C-b. Report to Occidental Oil Shale, unpublished; Denver Colorado; p.1-81.
2. Todd, D.K., Groundwater Hydrology, John Wiley (1980); p.1-535.
3. Freeze, R. and Cherry, J., Groundwater, Prentice-Hall (1979); p.1-604.
4. Fetter, C., Applied Hydrogeology (1980), Charles E. Merrill; p.1-488.
5. Chestnut, D. and Cox, D. (1977), The dependence of aquifer storage coefficients on porosity in low porosity media: Report to Occidental Oil Shale, Inc., Unpublished, Denver, Colorado; p.1-14.
6. Scheidegger (1957), The physics of flow through porous media, MacMillan Company, p.1-231.
7. Domenico, P. (1972), Concepts and models in groundwater hydrology, McGraw Hill; p.1-405.
8. Dagan, G. (1979), The generalization of Darcy's Law for nonuniform flows; Water Resources Research; Vol. 15, p.1-7.
9. Geothermal Surveys, Inc. (1981), Geohydrologic study of reinjection, Tract C-b, Piceance Basin, Colorado; Report to Occidental Oil Shale, unpublished; p.1-82.
10. Tiab, Djebbar, and Anil Kumar (1980), Application of the p' function to interference analysis; Journal of Petroleum Technology, August 1980, p.1465-1470.
11. Tipton and Kalmbach, Inc. (1977), Hydrology, mine dewatering, water use, and augmentation; Report to Occidental Oil Shale, Inc., unpublished; Denver, Colorado; U.S.G.S. Professional Paper 908, p.1-84.
12. Weeks, J. and Others (1974), Simulated effects of oil-shale development on the hydrology of Piceance Basin, Colorado: U.S. Geological Survey Professional Paper 908; p.1-84.
13. Robson, S. and Saulnier, G. (1980), Hydrogeochemistry and simulated solute transport, Piceance Basin, Northwestern Colorado; U.S.G.S. Open File Report 80-72; p.1-89.



14. Neuman, S. and Witherspoon, P. (1972), Field determination of the hydraulic properties of leaky multiple aquifer systems: Water Resources Research, Vol. 8, p.1284-1298.
15. General Electric Company - Tempo (1980), Monitoring groundwater quality, the impact of in-situ oil shale retorting: Contract No. 68-03-2449, for Environmental Monitoring Systems Laboratory, Office of Research and Development, U.S. EPA, Las Vegas, Nevada; p.1-280.
16. Donnell, J. (1961), Tertiary Geology and oil shale resources of the Piceance Creek Basin between the Colorado and White Rivers, Northwestern Colorado: U.S. Geological Survey Bulletin 1082-L; p.835-891.
17. Stearns, D. and Friedman, M. (1972), Reservoirs in fractured rock, in: Fracture-Controlled Production, AAPG Reprint No. 21; Kostura, J. and Ravenscroft, eds.; p.174-106.
18. Witherspoon, P. and Others (1980), Validity of cubic law for fluid flow in a deformable rock fracture; Water Resources Research, Vol. 16, p.1016-1024..
19. Verma, A. (1970), Fingero imbibition in artificial replenishment of ground water through cracked porous media; Water Resources Research: Vol. 6, p.906-911.
20. Hubbert, M. King (1940), The theory of ground-water motion: Jour. Geol., Vol. 48, p.785-944.
21. Grisak, G. and Pickens, J. (1980), Solute transport through fractured media; 1. The effect of matrix diffusion: Water Resources Research, Vol. 16, p.719-730.
22. Beard, T.N. (1981), Geologic framework, Tract C-b area, Rio Blanco County, Colorado. Report to Cathedral Bluffs Shale Oil Company; p.1-13 with maps and tables.
23. Fox, J.P., Water-related impacts of in-situ oil shale processing, Lawrence Berkeley Laboratory Report No. LBL-6300, 1981.
24. Mehran, M., Narasimhan, T., and Fox, J.P. (1980), An investigation of dewatering for the modified in-situ retorting process, Piceance Creek Basin, Colorado: Lawrence Berkeley Laboratory Report No. LBL-11519, 105 pp.







APPENDIX 2E

RESULTS OF THE GEOLOGIC MAPPING PROGRAM DURING SHAFT SINKING  
AND SUBSEQUENT STATION DEVELOPMENT AT C-B TRACT







RESULTS OF THE GEOLOGIC MAPPING PROGRAM DURING SHAFT SINKING  
AND SUBSEQUENT STATION DEVELOPMENT AT C-B TRACT

Nick Stellavato  
Cathedral Bluffs Shale Oil Co.  
P. O. Box 2687  
Grand Junction, Colorado 81502

ABSTRACT

Geologic and hydrologic studies of the Piceance Basin have taken place over the past 50 years from core data, well log data, outcrop data, and sub-surface mapping in the mines that exist around the perimeter of the basin. From this data the sub-surface geology and hydrology was inferred. The sinking of three large diameter shafts at C-b presented a unique opportunity to physically map the subsurface under Tract C-b. Geologic and hydrologic data was collected in the shafts and also in the laterally developed stations off the shafts. Photographs were taken during this development to document the geologic and hydrologic observations made of the subsurface in the shafts.

INTRODUCTION

The shaft sinking operation at C-b Tract provided an opportunity to not only map the entire vertical geologic section of the Uinta Formation from the surface to the mid R-5 Zone but to also observe and record the natural groundwater conditions that exist prior to the advent of mining and dewatering. Because of its important influence on shaft sinking, mine design and subsidence, water handling facilities, and environmental considerations, a geologic and hydrologic mapping program was initiated in July 1979.

Previous to shaft sinking, all subsurface interpretations were based on approximately 30 cored and drilled holes on and around C-b Tract. The proposed three large-diameter shafts and the associated lateral workings off the shafts presented the first opportunity to observe and map the exposed rock formations and compare this data with the previous corehole data. Table 1 is a summary of all stations in the three shafts and their corresponding elevations and depths. The following list covers the major points included in the mapping program:

1. Rock Types
2. Major Structural Features

- A. Joints and Fractures
  - a. Dips
  - b. Orientation
  - c. Planar or non-planar
  - d. Open or closed
  - e. Coatings
- B. Breccia Zones
  - a. Collapse
  - b. Fracture
- C. Vuggy Zones
- D. Folding
3. Water Conditions
  - A. Water-Bearing Intervals
    - a. Flows and pressures
    - b. Water quality samples
4. Stratigraphic Horizons Penetrated
  - A. Uinta Formation
    - a. Basal - Transitional Zone
  - B. Top Parachute Creek Formation
  - C. Four Senators Zone
  - D. Interval Four Senators to A-Groove
  - E. A-Groove
  - F. Mahogany Zone
  - G. B-Groove
  - H. Lower Oil Shale Zones, R-6, L-5, R-5

VENTILATION/ESCAPE SHAFT

Cathedral Bluffs Shale Oil Company commenced sinking three large-diameter shafts in January 1979 following construction of permanent headframes. The smallest of the shafts was located on the north edge of the C-b Tract. This shaft is called the Ventilation/Escape (V/E) shaft and has a 15-ft. inside completed diameter. It is concrete-lined but the lining is not designed for hydrostatic pressure. The V/E shaft was collared at an elevation of +6,705-ft. and its total depth was 1,617-ft. (elevation 5,088-ft.), corresponding stratigraphically to the base of the R-6 Zone. Small pump stations



were cut laterally from the shaft at elevations of 6,490-ft. (215-ft. depth) and 6,090-ft. (615-ft. depth); with larger stations developed at 5,745-ft. (960-ft. depth) at the base of the Uinta Formation; 5,655-ft. (1,050-ft. depth) at the base of the Four Senators; 5,533-ft. (1,171-ft. depth) called the Ignition Level development midway between the Four Senators and A-Groove; 5,396-ft. (1,309-ft. depth) called the Upper Void Level located 40-ft. below the A-Groove, with the Mahogany Marker exposed in this station. The final two stations developed were the Intermediate Void Level at an elevation of 5,245-ft. (1,460-ft. depth) located in the B-Groove and the Lower Void Level at an elevation of 5,133-ft. (1,572-ft. depth) located in the mid R-6 Zone. The small pump stations that were developed at 215-ft. and 615-ft., were only excavated 50-ft. laterally off the shaft but still afforded the opportunity to collect fracture and water data. The larger stations, however, permitted more extensive data collection. These stations were excavated laterally in two directions off the shaft; and in the case of the 960-ft. pump station, Ignition Level, Upper Void Level (UVL), Intermediate Void Level (IVL), and

taken for lab analysis. After this, grout (cement) was pumped into the zone to seal off the water. By using this probing procedure, uncontaminated and unmixed water samples were obtained. As sinking progressed after each grout cover, observations could be made as to what geologic setting existed where water was encountered, and ultimately compared to the corehole geologic and hydrologic data for better understanding of corehole data.

#### SERVICE AND PRODUCTION SHAFTS

The Service and Production shafts are located 3,600-ft. directly south of the V/E shaft (Figure 1). The Service shaft is 300-ft. North of the Production shaft and is the larger of these two shafts. It has an inside diameter of 34-ft. and is concrete lined from the surface (elevation 6,829-ft.) to the bottom (elevation 5,067-ft; 1,763-ft. depth). As in the case of all shafts at C-b, the concrete lining is not designed to withstand hydrostatic head, but designed to leak. The second of the two big shafts is the Production Shaft which has a diameter of 29-ft. It has a collar elevation of 6,829-ft. and bottoms out an an elevation of

TABLE 1. SHAFT STATIONS AT C-B TRACT

<u>Station</u>	<u>Service Shaft</u> <u>Elev. - Depth</u>	<u>Production Shaft</u> <u>Elev. - Depth</u>	<u>Ventilation/Escape</u> <u>Elev. - Depth</u>
Collar	6,829' - 0'	6,829' - 0'	6,705' - 0'
960 Pump Station			5,745' - 960'
Mid Shaft	6,095' - 734'	6,095' - 734'	
Ignition Level	5,644' - 1,185'	5,647' - 1,181'	5,533' - 1,171'
Upper Void Level	5,481' - 1,348'	5,487' - 1,342	5,396' - 1,309'
Intermediate Void	5,341' - 1,488'	5,346' - 1,483'	5,245' - 1,460'
Lower Void Level	5,202' - 1,627'	5,208' - 1,620'	5,133' - 1,572'
Shaft Bottom	5,067' - 1,763'	4,962' - 1,867'	5,084' - 1,621'

Lower Void Level (LVL), extensive data was collected. Hydrologic data was also collected in these stations, but the bulk of hydrologic information was obtained during probing and subsequent grouting phases during sinking to quantify and mitigate any surprises of high water inflow and/or methane emissions.

At the V/E shaft, it was known from previous data from Corehole 33X-1 located 90-ft. west of the shaft that water and gas would exist as sinking progressed. A series of probe holes were drilled ahead of sinking, and if water was encountered, its pressure was recorded and a water quality sample was

4,962-ft. (1,867-ft. depth). The majority of all geologic data was collected in these two shafts due to their large size, ease of access, and because these two shafts are connected on all levels. Figure 2 is an isometric view of the levels and the amount of drifting associated with each. Geologic data was collected in each opening and compared with Corehole 32X-12 which was drilled 90-ft. west of the Production shaft in 1977. This corehole and Corehole 33X-1 near the V/E shaft provided excellent data for reference during sinking.



Each hole was cored from the surface through the R-4 Zone. Detailed geologic, hydrologic, and gas evolution data was collected from these holes and proved invaluable during shaft sinking.

#### JOINT DATA

Joint data was collected in all three shafts. Table 2 summarizes all joint data collected in each station development from the Uinta Formation to the Upper Mahogany Zone. No data was collected in the Intermediate Void Level and Lower Void Level due to the determination that joints, although still present, did not control rock quality. Leaching and other structural anomalies exhibited more control at these levels than did fracturing. These features will be discussed later. Also included in this table are surface joint measurements taken at 89 stations on and around C-b Tract for comparison. As can be seen from the V/E shaft data, dips in each set tend to steepen with depth. The major  $N75^{\circ}W$ , set in the basin dipping  $66^{\circ}NE$  steepens to  $85^{\circ}NE$  at the 1170-ft. level then to  $90^{\circ}$  at the Upper Void Level. The lower part of the table shows data taken in the major stations of the Service/Production shafts. A large

number of measurements were possible in these stations due to the size of excavation which took place. As was indicated in the V/E shaft, dips steepened with depth in the section. The major joint set mapped in the Mid-shaft Station (14% of observations)  $N68^{\circ}W$ ,  $55^{\circ}NE$ , steepened to  $69^{\circ}NE$  at the 1180-ft. level and to  $83^{\circ}NE$  at the Upper Void Level. Definite steepening in the Upper Void Level took place at the Mahogany Marker. Joints changed dips from  $69^{\circ}-70^{\circ}$  to  $83^{\circ}-90^{\circ}$  one foot above the marker. Figures 3 through 5 illustrate the type of jointing observed in the three major stations. Figure 3 shows typical Uinta jointing which has large planar faces extending greater than 50-ft. vertically and laterally. Figures 4 and 16 show these same joint sets at the 1180-ft. level (Ignition Level) in the oil shales of the zone between the A-Groove and Four Senators. Joints here are shorter due to the alternating rich and lean oil shale beds. Joints tend to truncate at rich beds and persist in lean beds. Figure 5 shows these same northwest joints at the Upper Void Level.

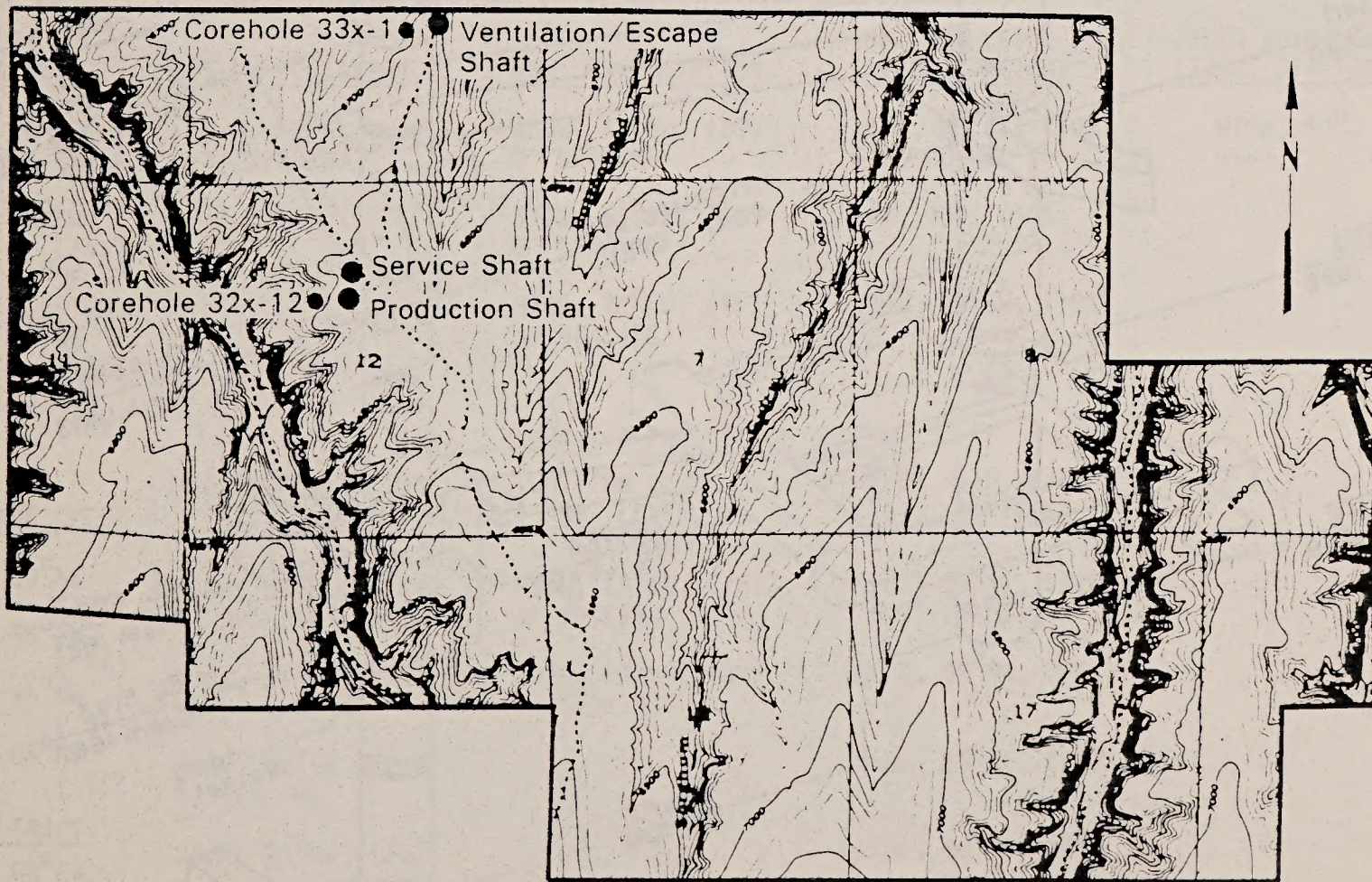


Figure 1. Plan map of C-b tract showing location of shafts.



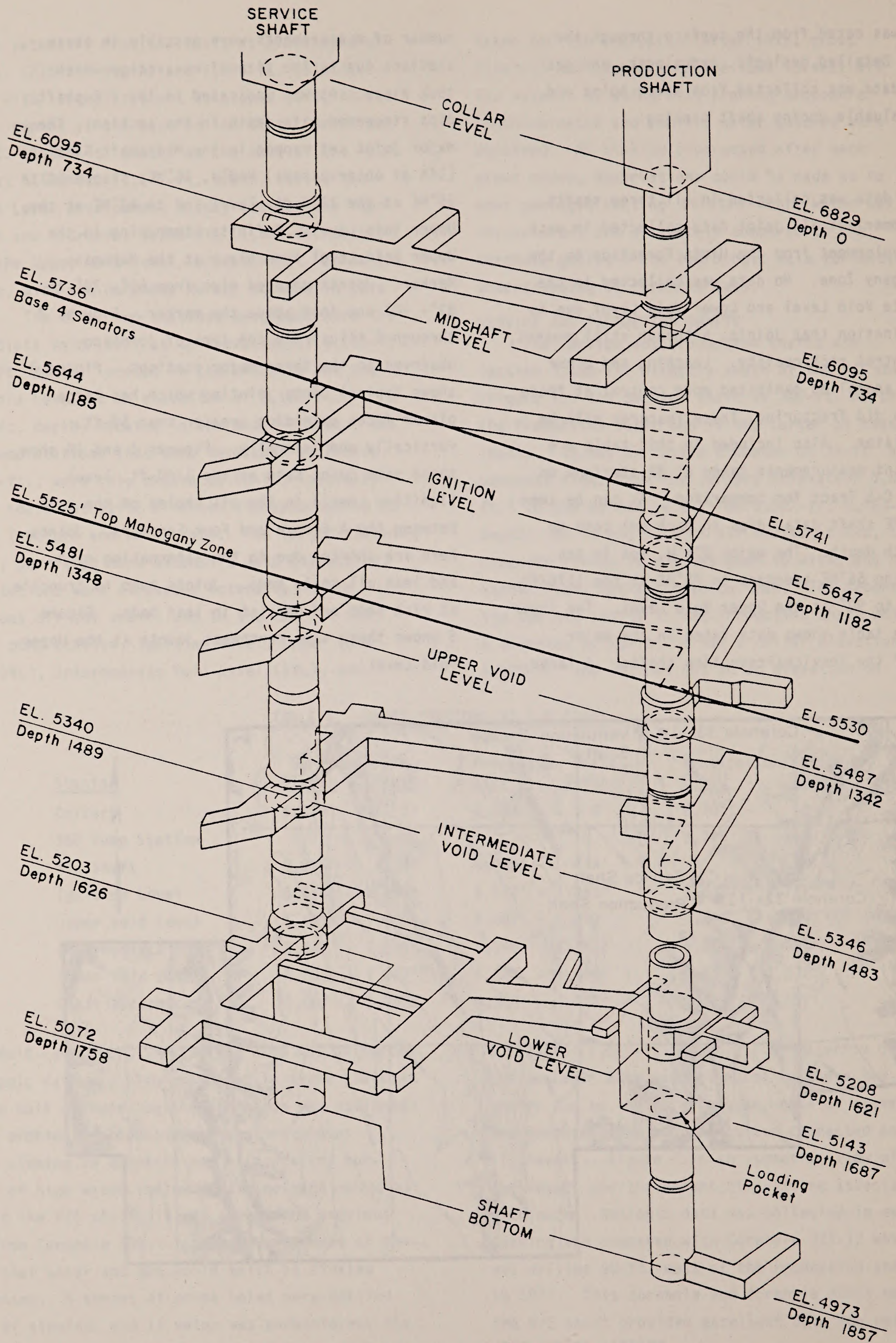


Figure 2. Isometric of Service and Production shafts and station layout.



As previously mentioned, the dips of these joints changed at the Mahogany Marker. Figure 6 shows this dip change; a large dip face (60°-70°) cuts across the photo and at the bottom of the photo changes dip to 85°-90°. Another observation concerns the lack of water in the Upper Void Level as compared to the levels higher in the section. This will be discussed later in the hydrology section. Schmidt equal-area pole plots of the measured joint lines in the shaft stations and three plots of data taken on out-crop north of Piceance Creek, south of Piceance Creek around C-b Tract, and data measured on C-b Tract are shown in Figures 7, 8, and 9. These plots show that the major joint sets seen on the outcrop are basically the same sets seen in the subsurface. Dips of joints tend to be steep on outcrop (70°- 90°), become shallower in the subsurface in the Mid-Uinta (50°- 70°), (Figure 10) then steepen with depth in the Parachute Creek member oil shales (Figures 11, 12, and 13). Another feature illustrated is that dips are steeper at the V/E shaft area on the north edge of C-b, than at the Service/Production shaft area. This feature may be due to the V/E shaft being near to the axis

of the Hunter Creek Syncline whereas the Service/ Production shafts are located on its gently dipping south limb. Dips tend to steepen near the axis of fold structures and are shallower on the limbs.

#### STRUCTURAL ANOMALIES

The structural setting of C-b, as determined from core data, indicated beds striking eastwest and dipping to the north at approximately 150-ft. per mile. As sinking progressed into the oil shale section, some interesting structural features became evident. The first anomaly encountered was the tuff injection dikes exposed during station development. As noted previously in the joint data, the major sets were the west to northwest striking ones. But the north-east striking minor sets were the ones which the tuff dikes tended to follow. As the Ignition Level off the Production shaft was started, the first dike was encountered. Figure 14 of the Ignition Level (Service/Production shafts) development shows this first dike and an other intersecting dike encountered in the north-south

TABLE 2. SUMMARY OF CB JOINT DATA-VENTILATION/ESCAPE SHAFT

SURFACE* MEASUREMENTS	615 PUMP STATION	960' PUMP STATION	IGNITION LEVEL (1170' STATION)	UPPER VOID LEVEL (1300' STATION)
NORTH OF PICEANCE CREEK	E-W, 62°N, - 3' SPACING	N69W, 69°SW, (28%) 3' SPACING	N87W, 85°NE, (10%) 6' SPACING	N70W, 90°, - ---
N50W, 35°SW (14%)		N78W, 62°NE, (6%) 6' SPACING	E-W, 90°, (10%)	
N87E, 65°SE (10%)		N70E, 75°NW, (6%) 4' SPACING	N30W, 80°SW, (10%)	
N57W, 60°NE (8%)				
N82W, 65°NE (8%)				
		<u>SERVICE PRODUCTION SHAFTS</u>		
SOUTH OF PICEANCE CREEK	MID SHAFT STATION (736' LEVEL)	IGNITION LEVEL (1180' LEVEL)	UPPER VOID LEVEL (1345' STATION)	
N75W, 60°NE (14%)	N68W, 55°NE, (14%) 4' SPACING	N59W, 69°NE, (16%) 6' SPACING	N76W, 83°NE, (12%) 2'-6' SPACING	
N66W, 55°SW (6%)	N86W, 51°SW, (7%) 16.5' SPACING	N77W, 60°SW, (8%) 6' SPACING	N57E, 85°NW, (9%) ---	
N81E, 45°NW (5%)	N55W, 54°SW (6%) 7' SPACING		N60E, 85°SE, (8%) ---	
N89W, 65°NE (5%)			N78E, 82°NW, (8%) 6' SPACING	
ON CB TRACT	N32E, 85°NW, (7%) 2' SPACING		E-W, 90°, (7%)	
N72W, 88°SW (18%)				
N72W, 88°NE (10%)				

\*FROM AMEUDO AND EVEY, NOVEMBER 1975, PLATE 6

EXPLANATION OF DATA: STRIKE, DIP  
SPACINGS (% OF OBSERVATIONS)



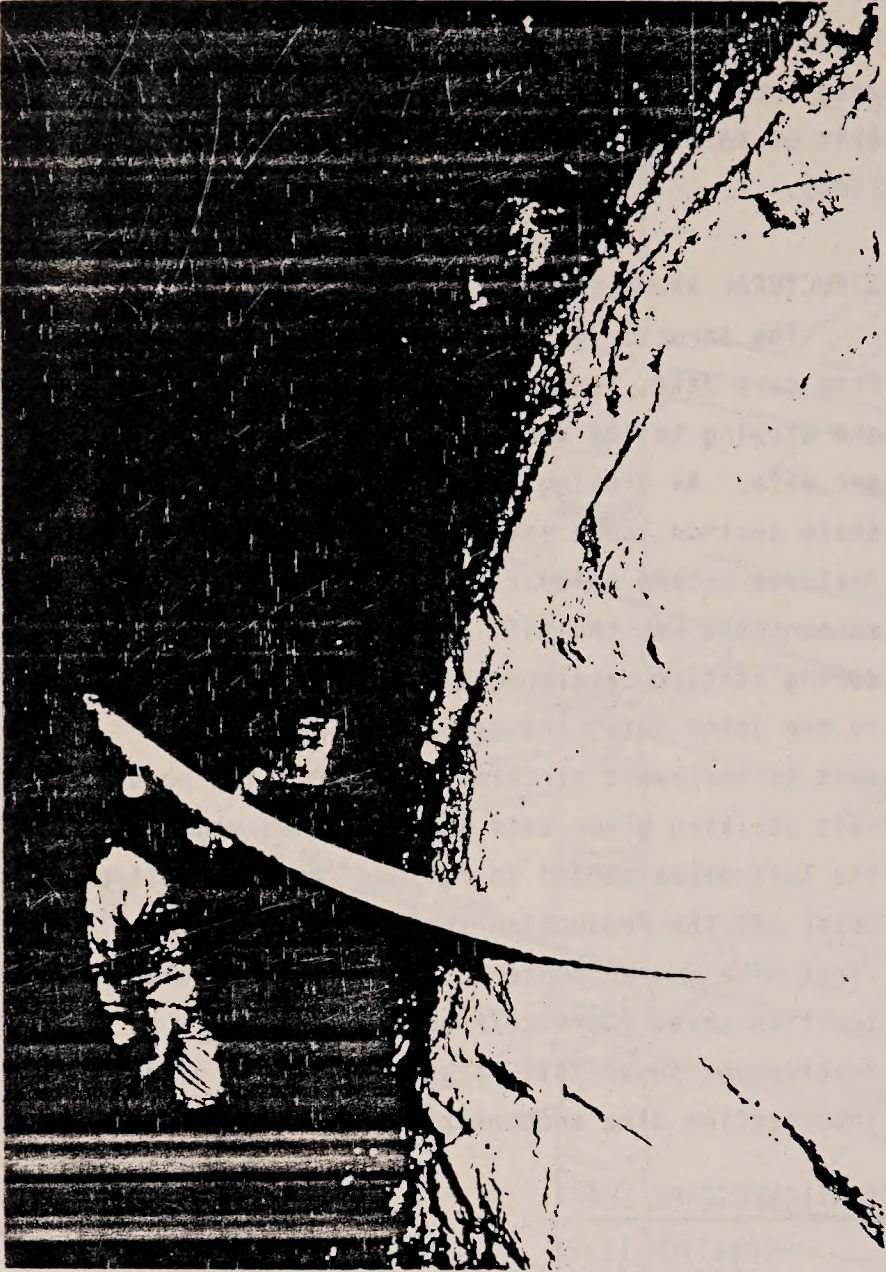


Figure 3  
Typical Uinta Formation  
Mid Shaft Station



Figure 4. Ignition Level Jointing - Service/Production Shafts





Figure 5. Upper Mahogany Jointing - Upper Void Level



Figure 6. Dip change in Upper Mahogany Zone - 1 foot above Mahogany Marker



connecting drift. This first dike trended N50°E and had a variable dip and the second dike trended N75°W. At the shaft, the northeast trending dike dipped 70° to the northwest, became vertical at the ore pass southwest corner but dipped to the southeast in the lower half of the ore pass east wall. Figures 15 and 16 show this dike on the east wall of the ore pass. Also note in these pictures the fracture sets. The dike followed the southeast dipping set then vertical. The southeast set must have existed previous to the northwest dipping set since it is offset by the northwest dipping set. Injection also occurred after the oil shales were compact enough to break. As can be seen in the pictures, the rich oil shale beds are jointed with the northwest dipping fractures. After some degree of compaction of the oil shale, emplacement of the dike was from below as indicated by the upturned beds adjacent to the dike. The dike-oil shale contact was abrupt with the dike face smooth, except where the main dike formed a large pod, approximately 5-ft. across. In this area, the oil shale dike contact was irregular and jagged leading to another possible theory that this pod is filling a leached vug, thus postdating leaching. Again at the sill of the ore

pocket, a small leached vug contained some dike material.

Figure 17 is a plan map of the Production shaft Upper Void Level Station some 150-ft. below the Ignition Level. As in the Ignition Level, tuff dikes were encountered. However, in this station the dikes are approximately 3-inches to 1-foot thick and more numerous. All dikes, except for one, follow the N35°E to N70°E trend and have steep dips. The lone exception was mapped trending N45°W and dipping 78°NE and intersected the NE dikes in the wall of the Production shaft. Figures 18 and 19 are typical of the dikes in this station. In both of these, the contact is abrupt and smooth at the roof of the station but toward the sill the dike becomes irregular and tends to wander around. Figure 20 shows one of the dikes as it intersects the Mahogany Marker. The dike-oil shale contact is highly irregular and did not seem to follow any set of fractures. The marker was not a source of the tuff since it did not thin where a dike cut across it. The marker remained 6 to 8 inches thick when

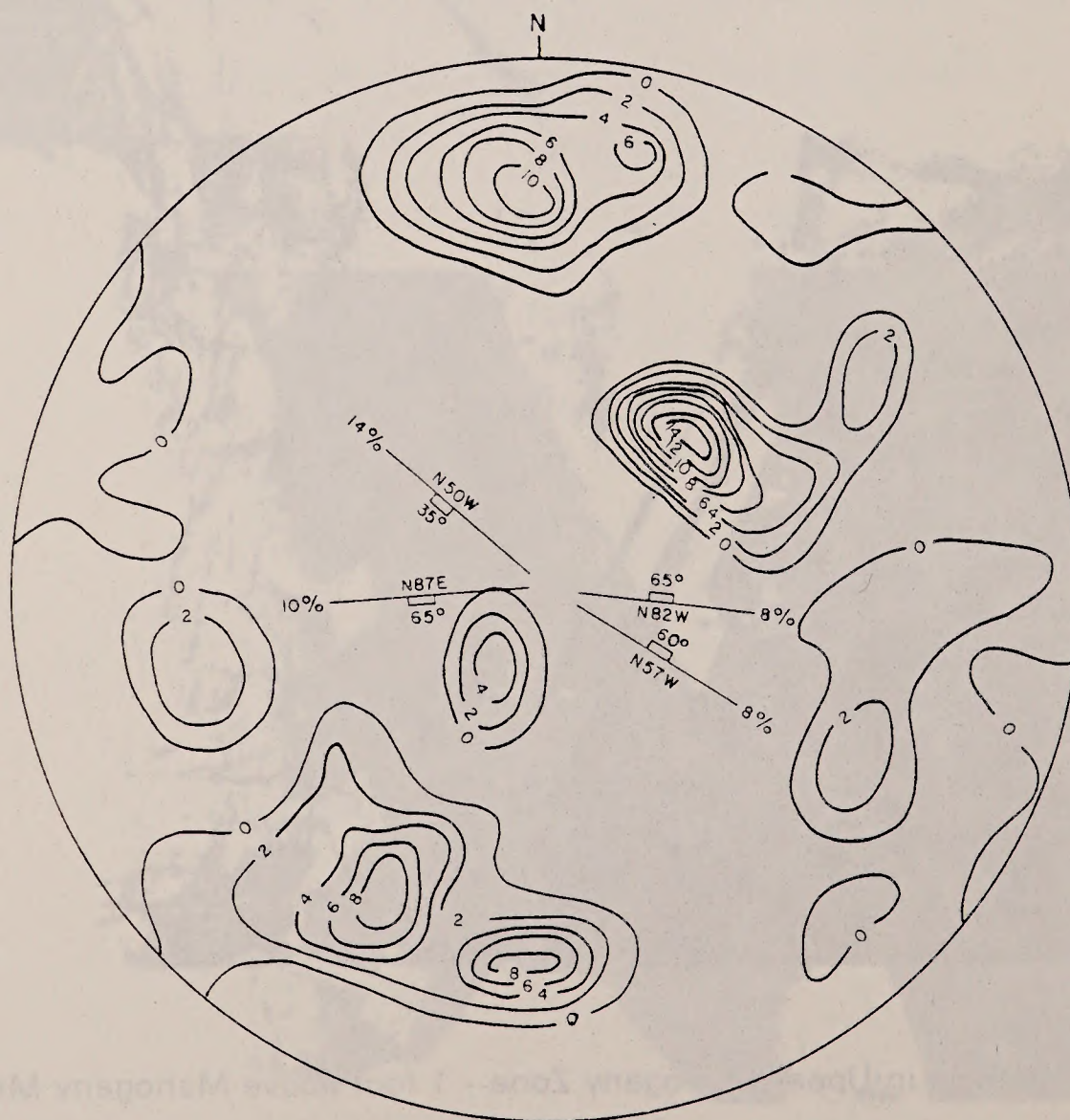


Figure 7. Surface jointing north of Piceance Creek (From Amuedo and Ivey, 1975)



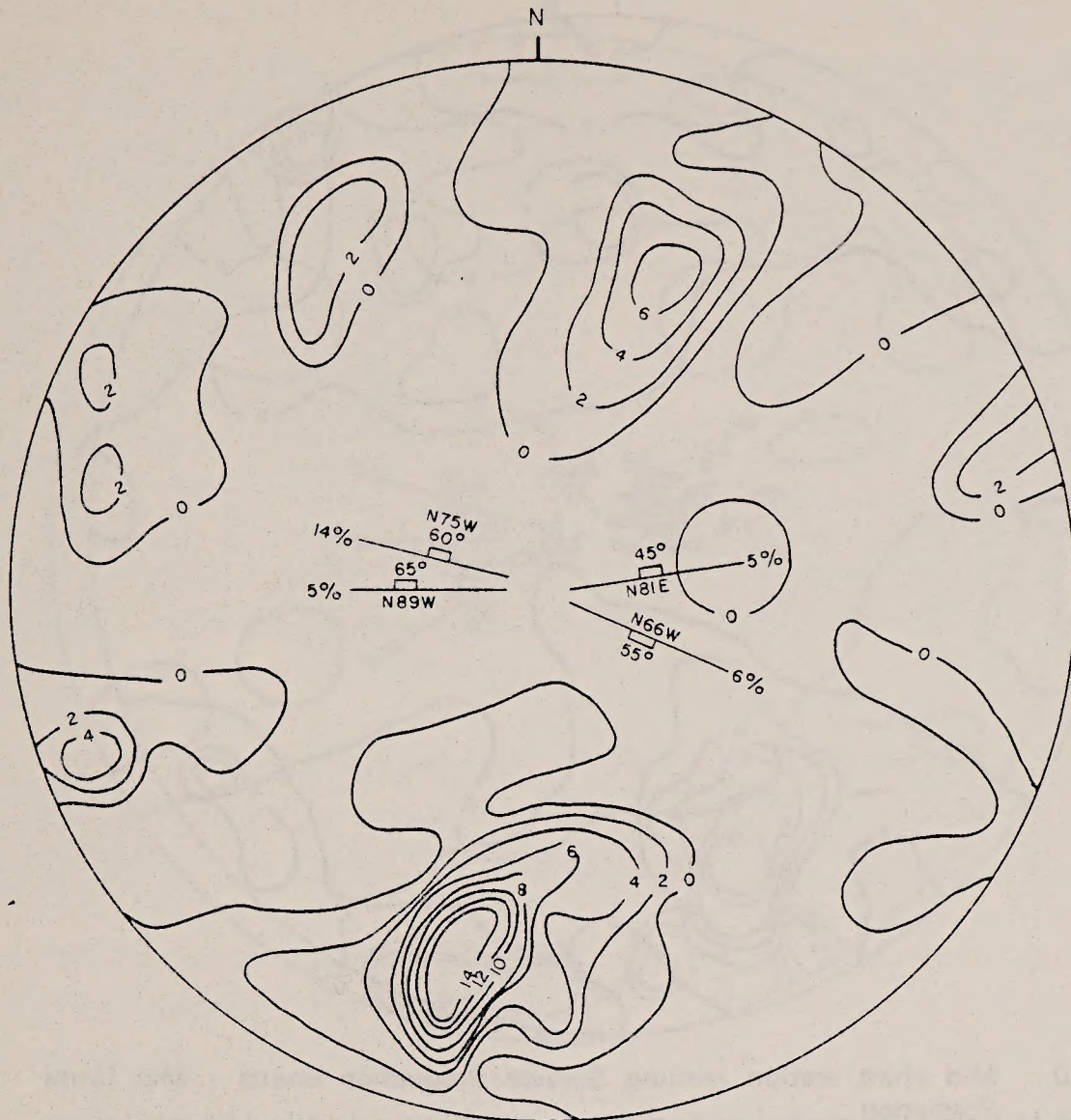


Figure 8. Surface jointing south of Piceance Creek - around C-b tract (From Amuedo and Ivey, 1975)

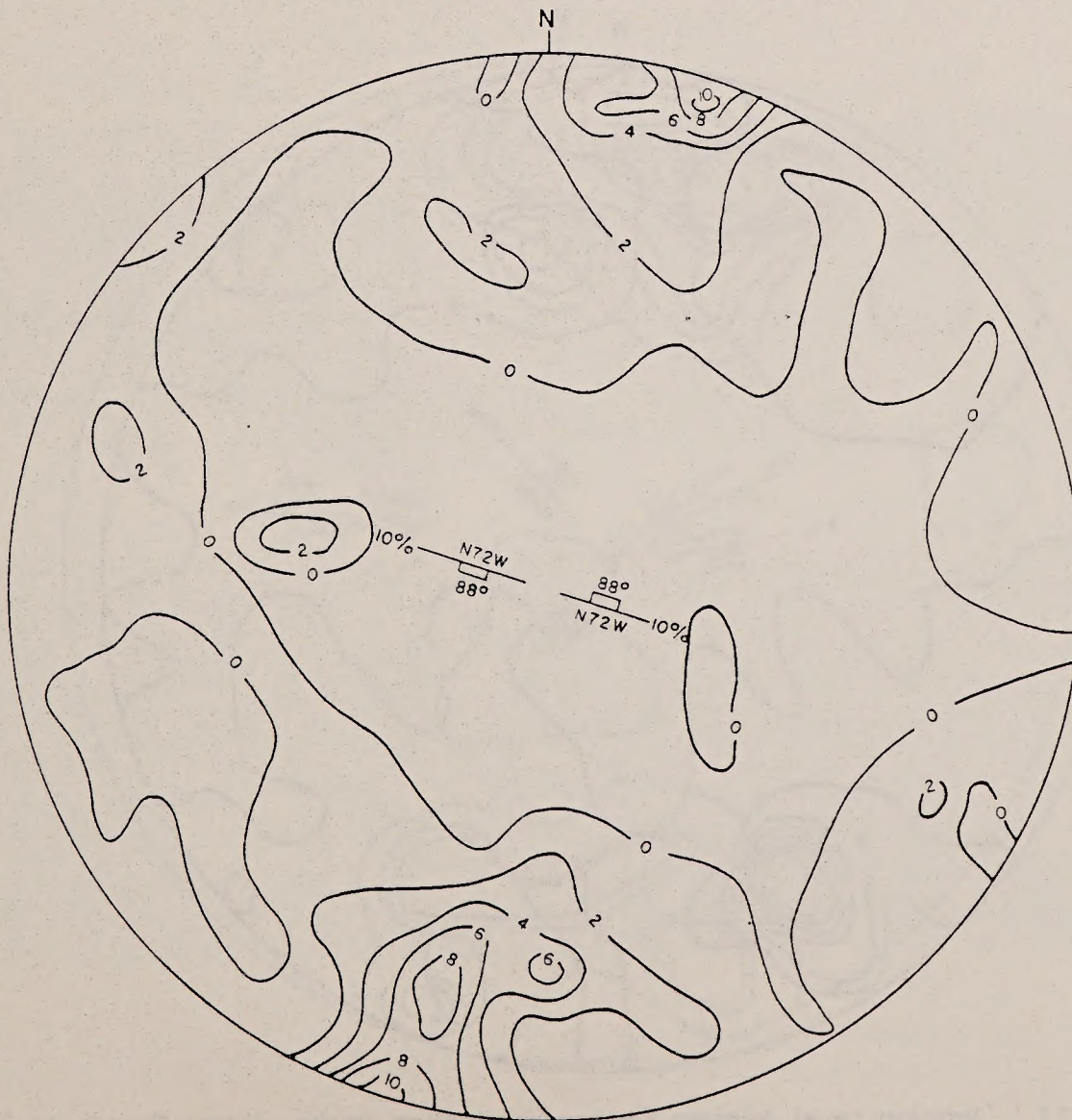


Figure 9. Surface jointing on C-b tract (From Amuedo and Ivey, 1975)



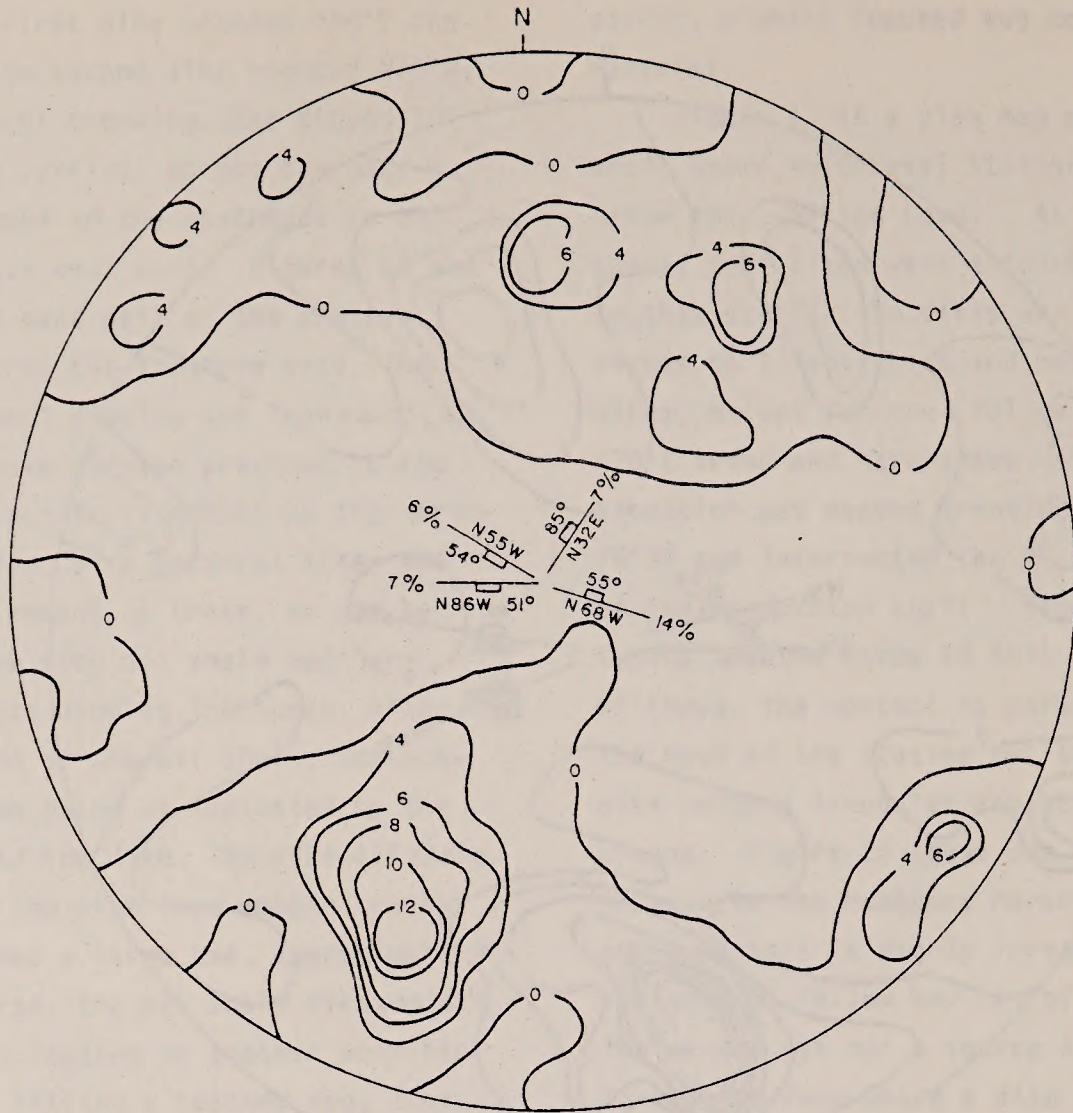


Figure 10. Mid shaft station jointing Service/Production shafts - Mid Unit Formation



Figure 11. Ignition Level Jointing Service/Production shafts - Upper Parachute Creek Member



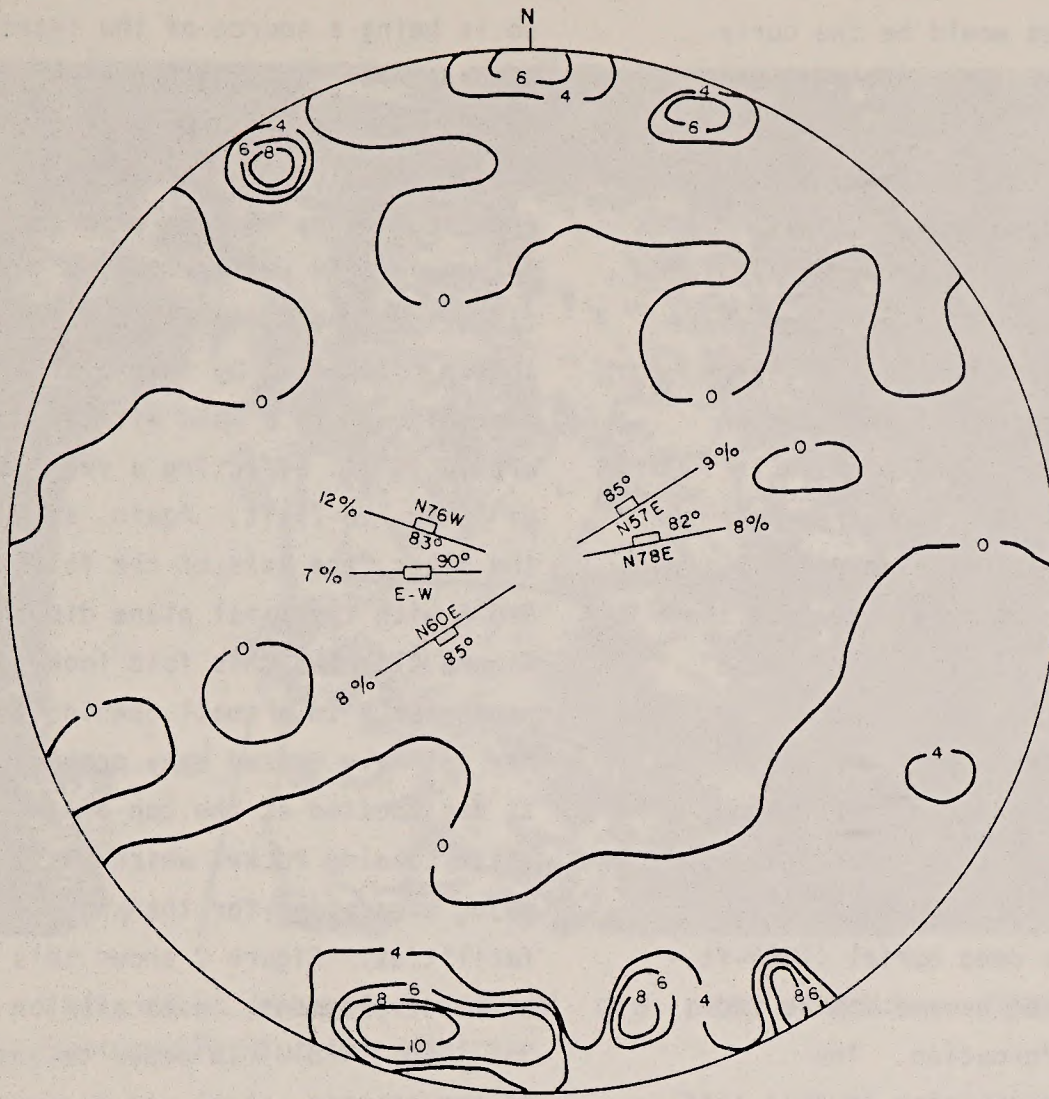


Figure 12. Upper Void Level Jointing Service/Production shafts - Upper Mahogany Zone

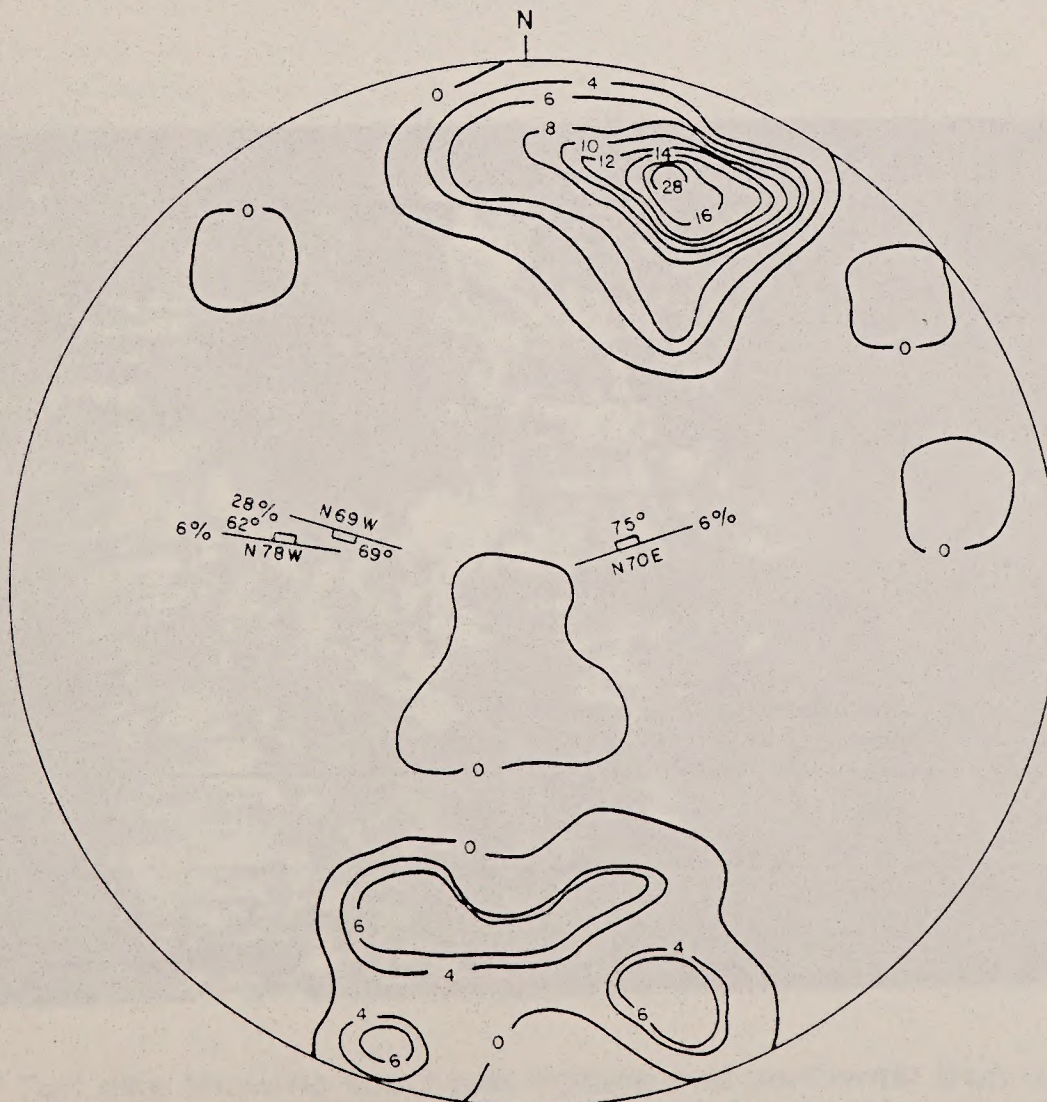


Figure 13. 960 Pump station jointing Ventilation/Escape shaft - Upper Parachute Creek Member



measured in all three shafts. The next possible source of tuff for these dikes would be the curly-bedded tuff as reported by John Donnell, 1961 and J. Ward Smith, Personal Communication. This tuff bed has been mapped up to 18-inches thick with characteristic thickening and thinning. It is stratigraphically located in the Lower Mahogany immediately above the B-Groove. As the Intermediate Void Level at the B-Groove was excavated, a 3-inch thick trace of the dike was mapped in the station roof but could not be traced down the walls. It became highly irregular until it disappeared near the top of the station, which is located immediately above the B-Groove. More importantly, however, the curly-bedded tuff has not been detected at C-b in any of the cores taken near the shafts and was not observed in either of the three shafts. Also, during coring in 1981, a dike was cored into in the Upper Mahogany Zone in a well located 2,000-feet west of the V/E shaft. Again, no curly-bedded tuff was observed in the core. Due to deep burial (1400-ft.-1500-ft.) at C-b, the curly bed became mobile and was injected throughout the formation. The characteristic thickening and thinning of this tuff,

wherever it has been mapped, is most likely due to it being a source of the injection tuff dikes mapped throughout the basin and in the Uinta basin. The thinning occurring as it became mobile and migrated laterally, then being injected in any fissure or crack which existed.

As stated earlier in the joint data section, the Lower Void Level rock quality was no longer controlled by the joint sets but was overshadowed by a fold with an amplitude around 10-ft. affecting a vertical section of 50-ft. to 75-ft. Again, as in the case of the dikes, the axis of the fold trended  $N40^{\circ}E$  with the axial plane dipping  $55^{\circ}NW$ . Figure 21 shows this fold looking to the northeast. In a small opening this fold may not have caused many problems but it was located at the top of the Production Shaft Loading Pocket which was an area of major excavation for the shaft rock loading facilities. Figure 2 shows this Lower Void Level development, an excavation of 35' x 65' x 75'. In order to ensure integrity of the station, steel and concrete arches were

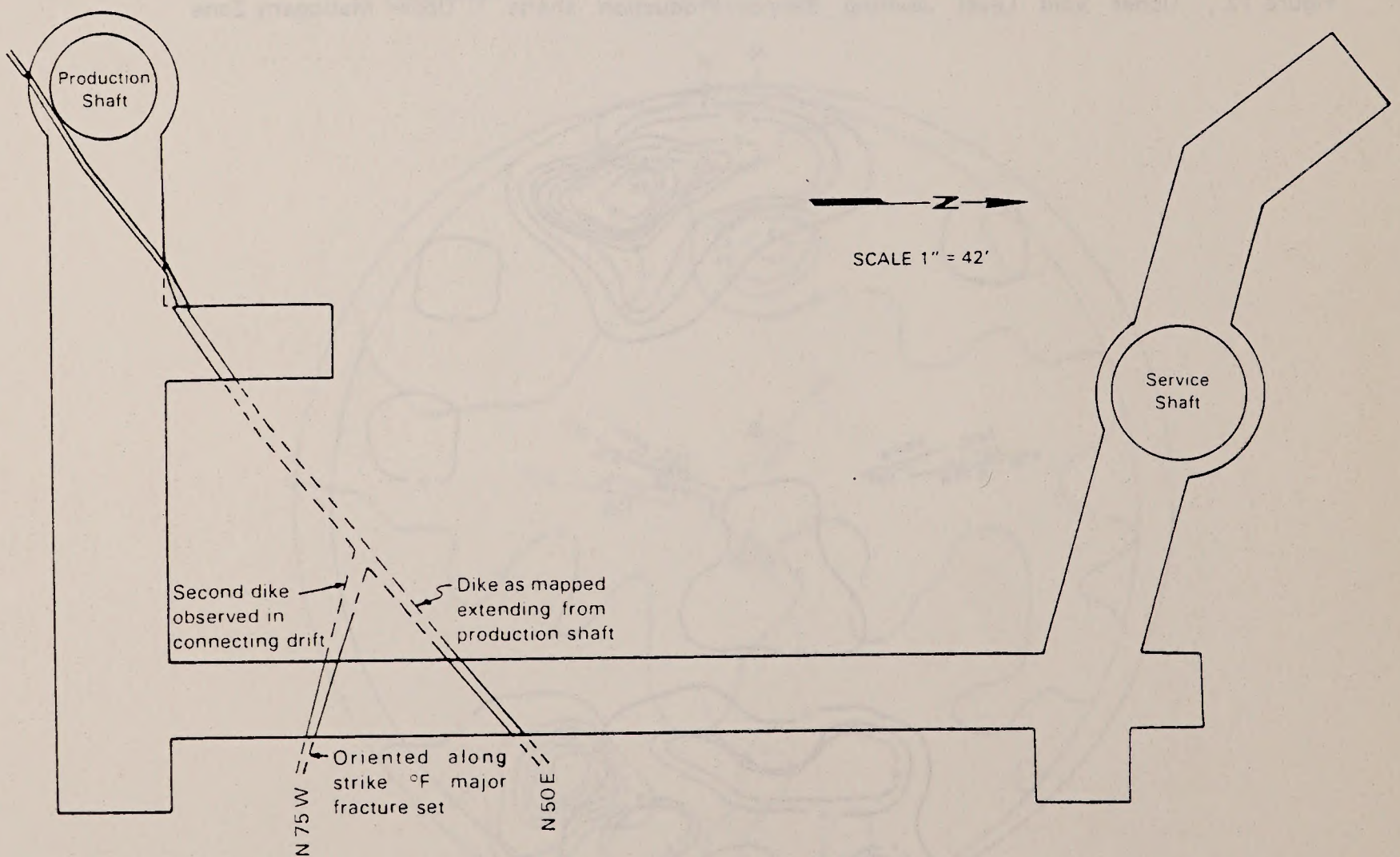


Figure 14. Plan view of Ignition Level station - Service/Production Shafts showing tuff dikes





Figure 15. Tuff dike in east wall of ore pass cutout - Ignition Level, Service/Production shafts

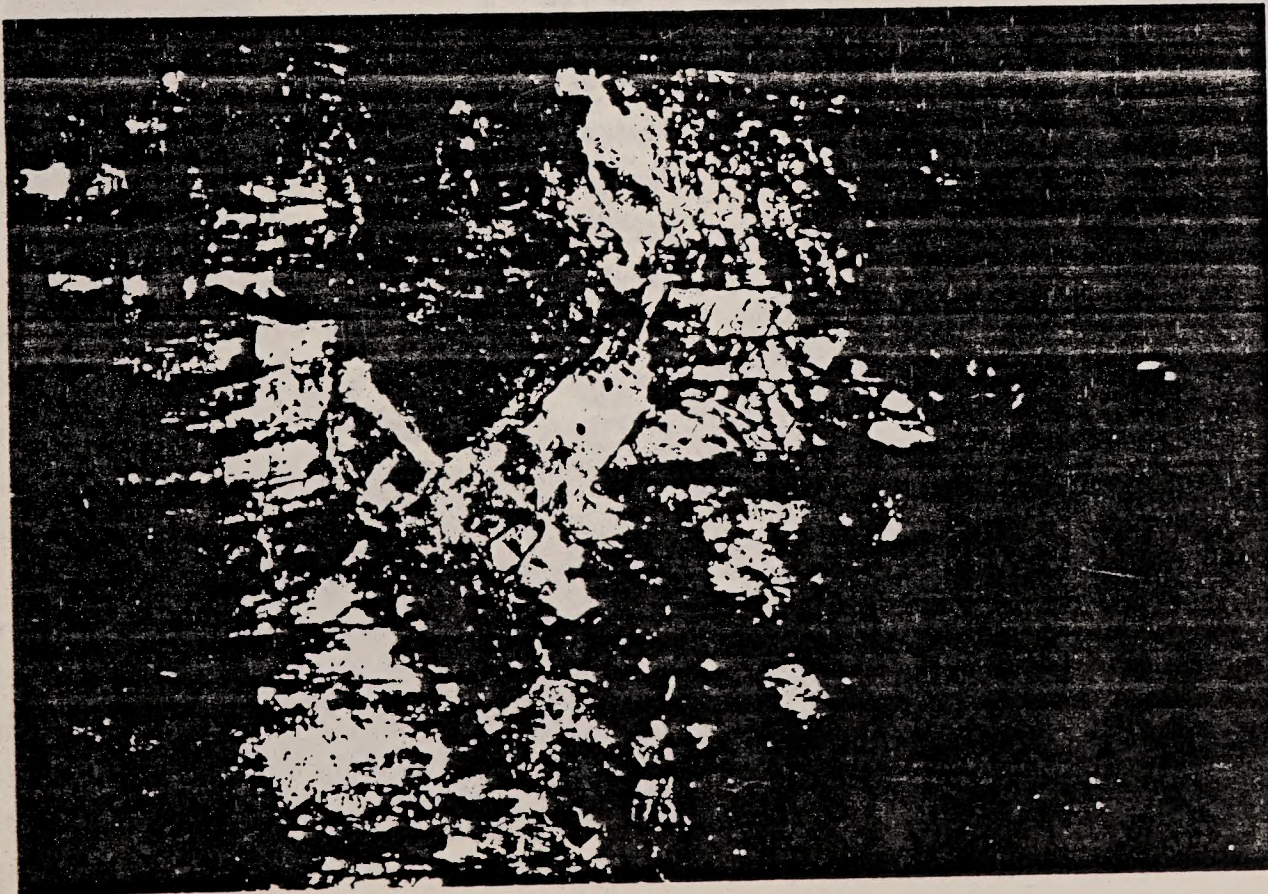


Figure 16. Tuff dike showing southeast dipping and northwest dipping joint sets.



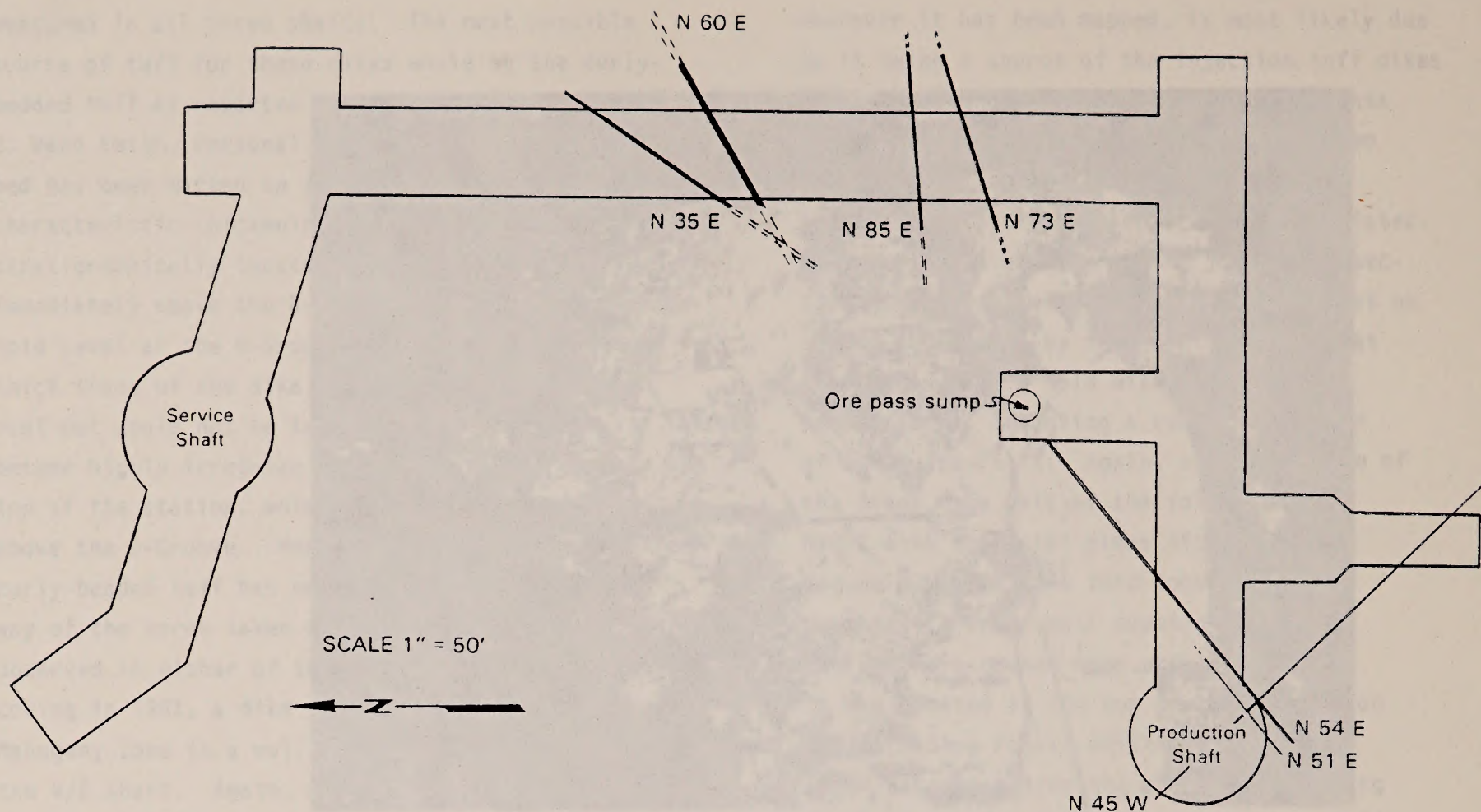


Figure 17. Plan view of Upper Void Level - Service/Production shafts showing tuff dikes

installed at the top of the development where the folding was encountered, (Figure 22). This area was mapped in detail and the fold was not encountered in any of the other drifts opened. The beds in the fold were affected according to grade. The rich oil shale beds were folded but not broken. However, the lean beds between the rich beds were crushed and would thicken and thin and then pinch out. Figure 23 is a view south from the shaft; the light gray (lean beds) pinch out whereas the dark (rich beds) are continuous. Joints can be seen in the roof but do not extend down the walls. The occurrence of the northeast trending folding is further indication of subtle northeast folding superimposed on the gentle north-dipping structure at C-b. With more dense drilling, this trend seems to become more apparent.

#### SHAFT HYDROLOGY

This paper is not an indepth hydrologic study of the C-b Tract. It reports some water flow observations associated with the geology of the three shafts. Each shaft had its own different character and provided a great deal of information.

Data presented here will be only major observations associated with water.

1977 testing of the two pre-shaft coreholes, 33X-1 at the V/E shaft and 32X-12 at the Production shaft, indicated the V/E shaft would make more water than the Service and Production shafts. However, actual water production in all shafts was lower than predicted. It was estimated the V/E shaft would produce 1500-2000 GPM and the Service/Production shafts each another 500-1000 GPM. Maximum water production from the V/E shaft was 950 GPM and 500 GPM from the Service/Production shafts combined. Table 3 shows the water production of the Service/Production shafts and V/E shaft related to depth and activity in the shaft.

Return water production from Corehole 32X-12, located 90-ft. west of the Production shaft, reached a maximum of 600 GPM during drilling. The maximum flow from the Service/Production shafts combined was 460 GPM with the greatest increase occurring at the Ignition Level, located stratigraphically in the water production zone between the Four Senators and





Figure 18. 1 foot wide tuff dike in roof of the Upper Void Level.

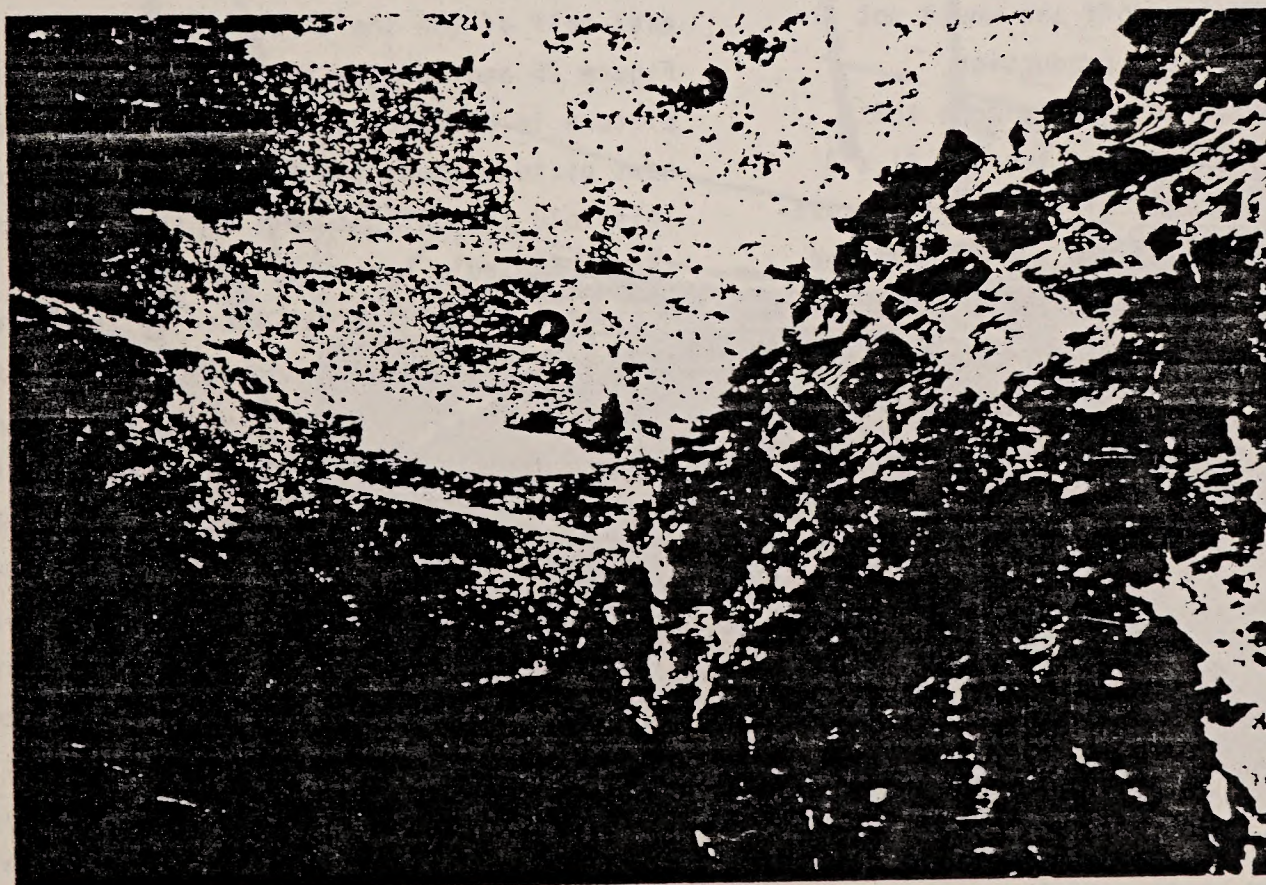


Figure 19. 3 inch wide tuff dike in roof of Upper Void Level.



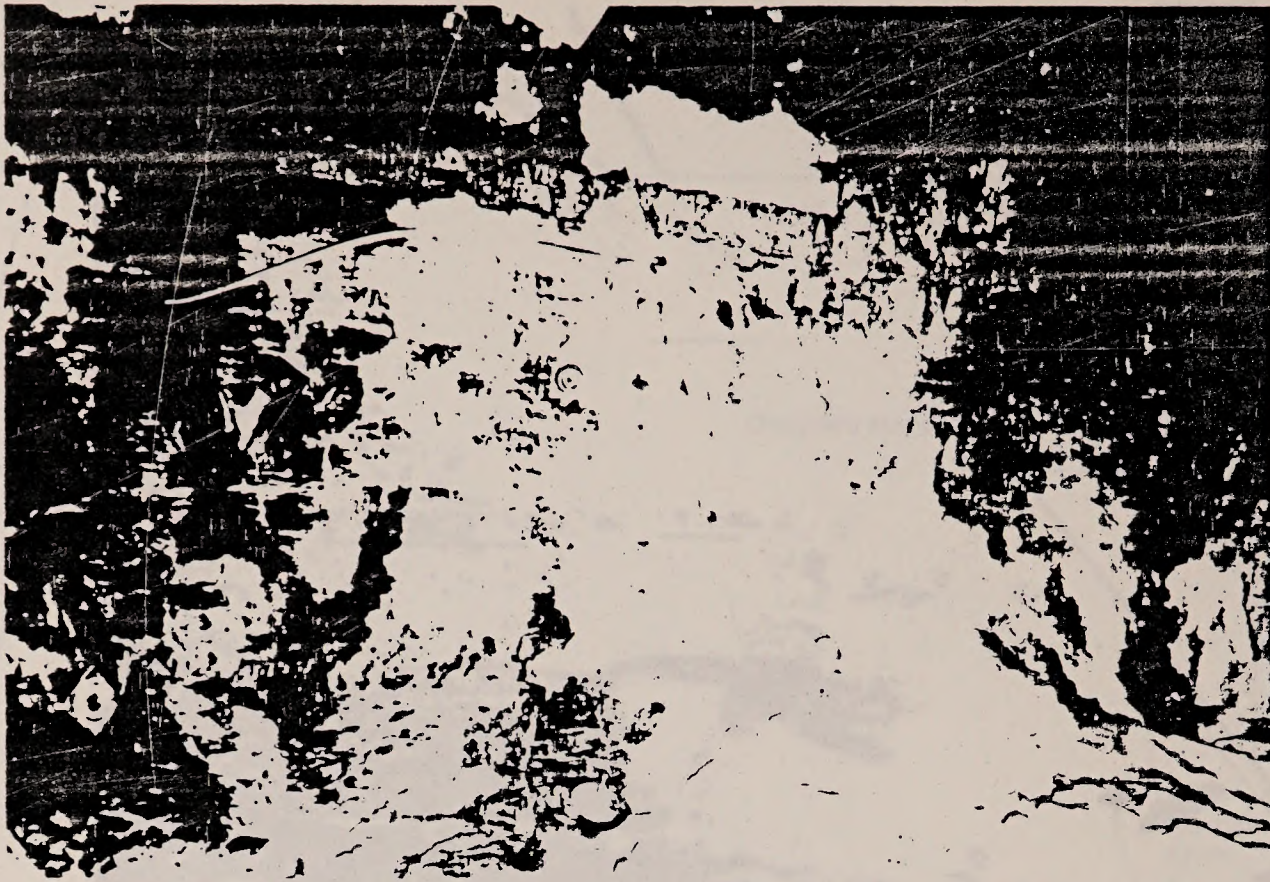


Figure 20. Tuff dike intersecting the Mahogany Marker in Upper Void Level - Service/Production shafts

A-Groove. Flows increase from 75 GPM to 390 GPM from fractures and fracture brecciated zones. Most leached vugs encountered in mining were dry. Those containing water drained off and would not contribute any additional water production. Figure 24 is a vug encountered in this zone that produced no water. This particular vug was 4' x 3' and extended back into the wall of the shaft approximately 5-feet. The largest leached vug encountered, also dry, was 10-ft. high by 7-ft. wide and was connected to smaller vugs which extended upward around 15-ft. An additional 50 GPM was encountered in the B-Groove (Intermediate Void Level) but no major production throughout the remainder of sinking.

Higher inflows were encountered at the V/E shaft as shown in Table 3. As seen at the Service/Production shafts, the zone between the Four Senators and A-Groove produces the majority of water influx. Flows from the base of the Four Senators increased from 165 GPM to 830 GPM above the A-Groove. Heavily jointed ground accounted for the majority of water influx. At the Ignition Level, joints cutting through leached vugs, fracture brecciated rock and rock bolt holes intersecting fractures produced 90% of the water. As sinking progressed, an unexpected

high inflow of water was encountered at the A-Groove. A series of three small folds confined to the 15-ft. of A-Groove rock on the east-half of the shaft were mined into; Figure 25 and 26 show these folds. The first picture is of the southernmost folding and the next picture shows the largest of the three. At this fold the unlined wall of the shaft excavation released a large quantity of gas and water. Estimates of the initial water influx were of 1500 GPM, with upwards of 1600 CFM of methane. Within 24 hours, the water had declined to 200 GPM and gas to 55 CFM. The fold which produced the water (shown in Figure 26) was a small 1' x 1' channel that extended to the east approximately 25-ft., then turned southeast. Monitoring wells completed in this zone around the area responded to this influx of water within a couple of hours. The third fold was located in the northeast quadrant of the shaft but only produced 5 to 10 GPM. Figure 27 shows this fold in the lean thin bedded A-Groove. The left-half of this picture shows the horizontal oil shale beds but the right-half shows the beds after being sharply folded (Chevron-type fold).





Figure 21. Fold in Lower Void Level - loading pocket, Production shaft

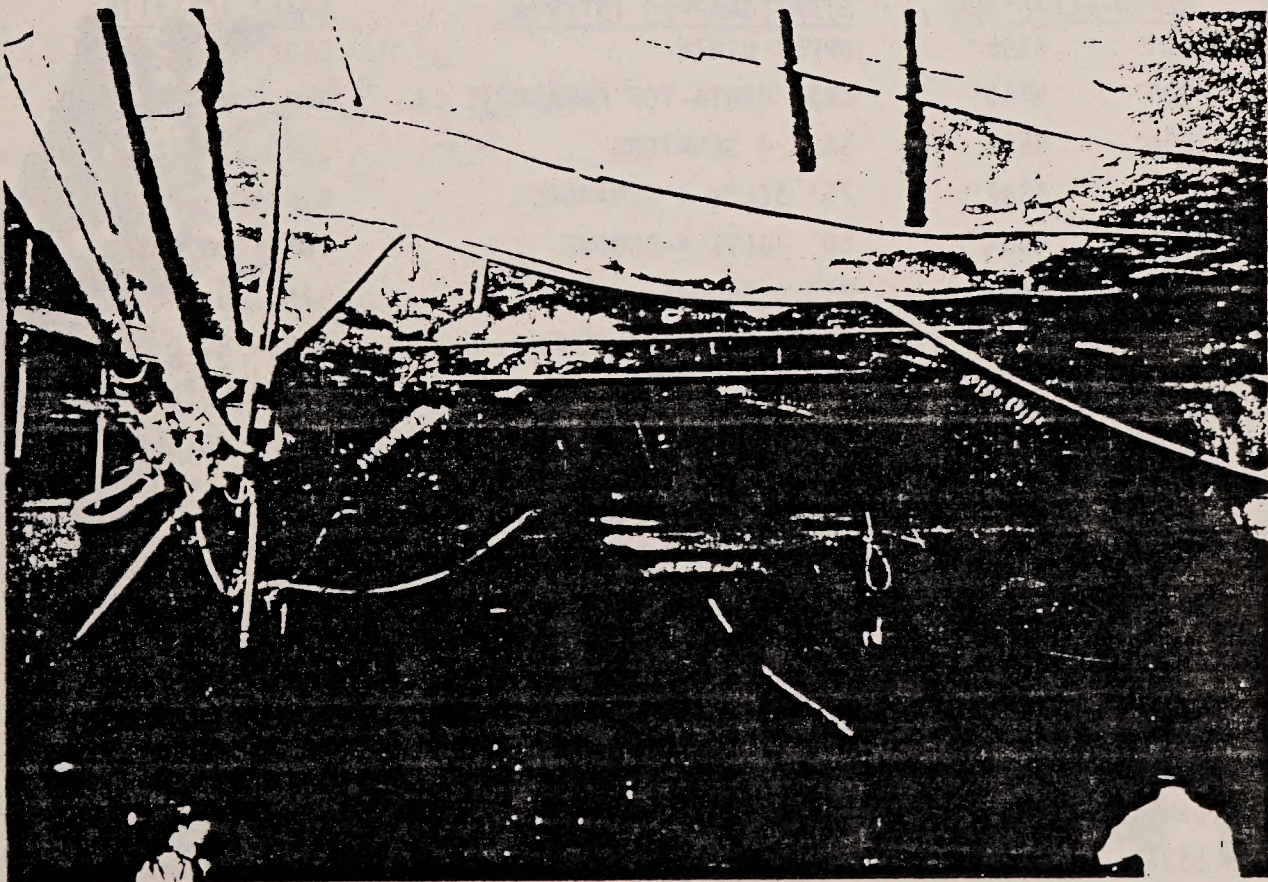


Figure 22. Steel arches at the top of the loading pocket - Lower Void Level





Figure 23. View south at the lower void level. Joints at roof do not extend down walls.

TABLE 3.

		<u>VENTILATION/ESCAPE SHAFT</u>		
		<u>WATER PRODUCTION</u>		
<u>WATER PRODUCTION</u>	<u>DEPTH-ELEVATION</u>	<u>STRATIGRAPHIC INTERVAL</u>		<u>SHAFT ACTIVITY</u>
10 GPM	310' 6395'	UPPER UINTA		SINKING
165 GPM	960' 5745'	BASE UINTA-TOP PARACHUTE CR.		960 PUMP STATION
245 GPM	1050' 5655	BASE 4 SENATORS		1050 STATION
410 GPM	1123' 5582'	75' BELOW 4 SENATORS		SINKING
830 GPM	1171' 5534'	80' ABOVE A-GROOVE		IGNITION LEVEL
1060 GPM	1262' 5443	MID A-GROOVE		SINKING-ENCOUNTERED WATER & GAS
740 GPM	1308' 5396'	UPPER MAHOGANY ZONE		UPPER VOID LEVEL
940 GPM	1460' 5245'	B-GROOVE		INTERMEDIATE VOID LEVEL
930 GPM	1573' 5133'	MID R-6 ZONE		LOWER VOID LEVEL
		<u>SERVICE AND PRODUCTION SHAFTS</u>		
		<u>WATER PRODUCTION</u>		
<u>WATER PRODUCTION</u>	<u>DEPTH-ELEVATION</u>	<u>STRATIGRAPHIC INTERVAL</u>		<u>SHAFT ACTIVITY</u>
20 GPM	370' 6459'	UPPER UINTA		SINKING
75 GPM	730' 6099	MID UINTA		MID SHAFT STATION
300 GPM	1185' 5644'	MID 4 SENATORS TO A-GROOVE		IGNITION LEVEL
390 GPM	1348' 5481'	UPPER MAHOGANY ZONE		UPPER VOID LEVEL
460 GPM	1489' 5341'	B-GROOVE		INTERMEDIATE VOID LEVEL
460 GPM	1624' 5202'	LOWER R-6 ZONE		LOWER VOID LEVEL
450 GPM	1864' 4966'	MID R-5 ZONE		BOTTOM OF PRODUCTION SHAFT



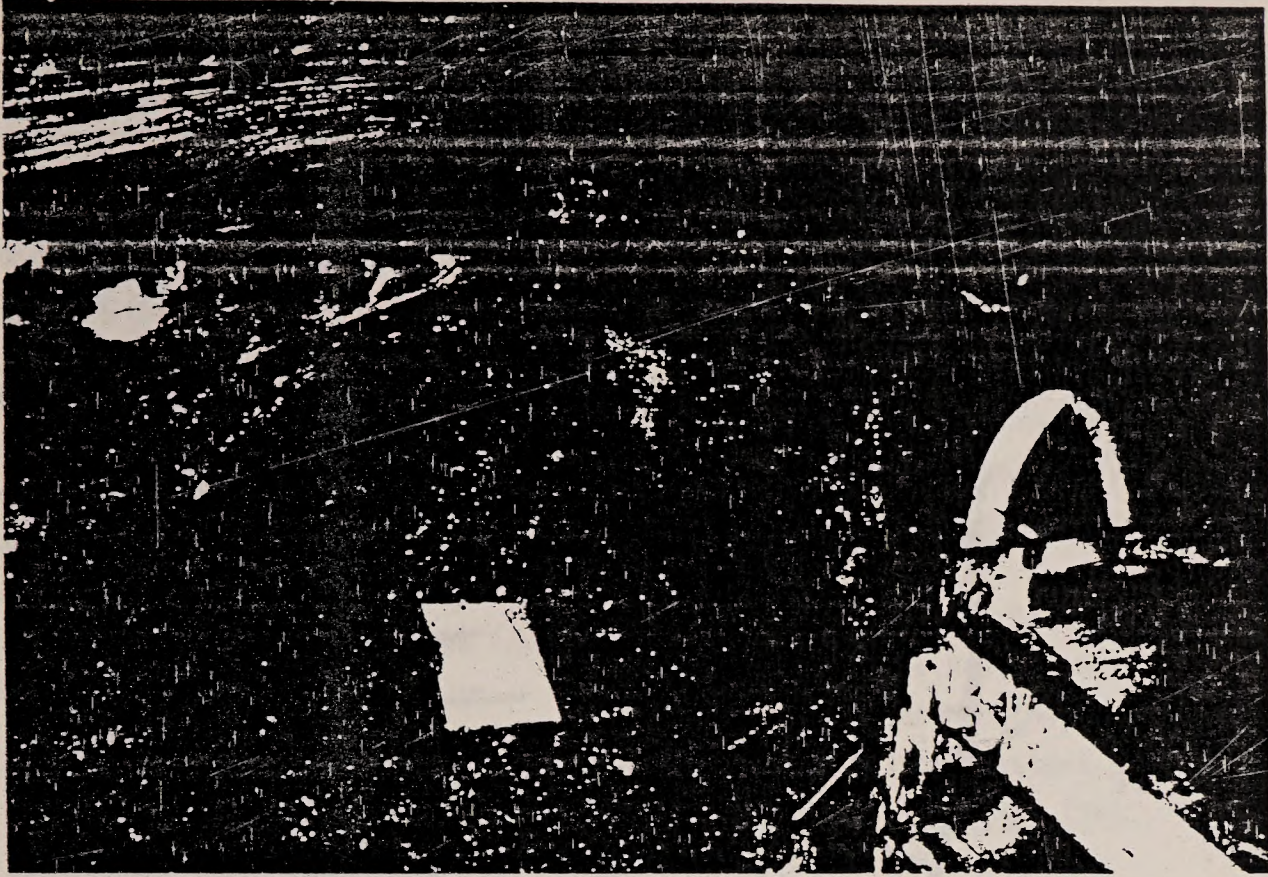


Figure 24. Large vug in Production shaft in the zone between the 4 senators and A-groove.



Figure 25. Southernmost fold in A-groove at Ventilation/Escape Shaft.





Figure 26. Largest fold in A-groove (Ventilation/Escape shaft) shown making 250 gpm water.

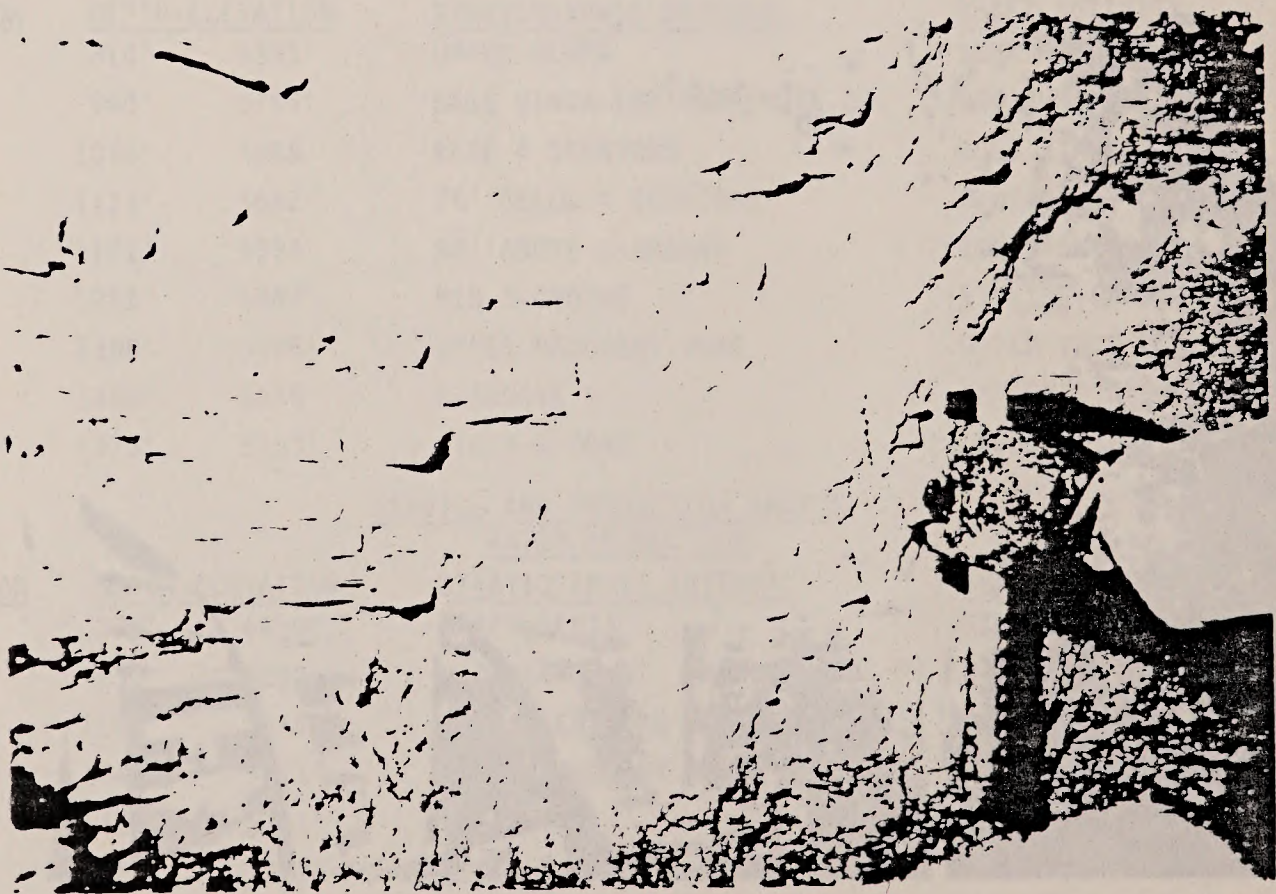


Figure 27. Small (Chevron type) fold in A-groove lean thin bedded oil shale, produced 5-10 gpm water.



The western half of the shaft, however, was undisturbed with all beds essentially horizontal.

Sinking progressed to the Upper Void Level which is located 25-ft. below the A-Groove. Although water production from the zones above this station was 1060 GPM, water produced in the Upper Void Level was zero, with the only water entering the station coming down the shaft or entering through rock bolt holes (Figure 28). This demonstrates that the Upper Mahogany is a tight restriction to vertical movement of water through the system. Joints, although present, are tight and do not permit water to move freely along them. The Lower Mahogany and R-6 Zones produced the remainder of the total water production for the shaft. As part of the total flow, the lower zones did not contain substantial quantities in storage.

#### SUMMARY

Joint data collected in the three C-b shafts agrees with data collected on the surface. The major northwest trending joint sets present on the surface are also present in the subsurface, however, the dips of each set steepen with depth. The dips at the surface range from 60° to vertical whereas in the Mid-Uinta Formation, dips are 50°-55°, then steepen in the upper Parachute Creek to 69°, then to vertical in the Upper Mahogany Zone. Below the Mahogany in the R-5 and R-6 Zones, the northwest trending joints are still present but do not control rock quality. Joints in the lower zones tend to be curved and discontinuous.

Folding and tuff dikes were encountered in the subsurface at C-b. Trends of the folds and dikes followed the northeast, minor fracture sets. These features caused rock quality problems when present.

Water in-flow to the shafts was less than predictions. Very little water was encountered below the Upper Mahogany Zone with the major production from the upper oil shale zones. The upper Mahogany Zone acts as a tight restriction to vertical water movement as do numerous other rich oil shale zones above the Mahogany Zone. The major of these upper zones above the Mahogany being the Four Senators Zone.

#### ACKNOWLEDGEMENTS

The author would like to acknowledge Bob Ward of Occidental Oil Shale, Inc., for his assistance

during underground mapping by recording data and collecting samples. Also, Irving Studebaker of Occidental and Tom Beard (Consultant) for lively discussion of geologic and hydrologic data. Finally, the assistance by Eric Denham of Occidental for computer processing of joint and water data.

#### REFERENCES

Amuedo, C. and Ivey, J., "Surface Geologic Mapping Program C-b Tract, Rio Blanco County, Colorado, November, 1975."

Donnell, John R., "Tertiary Geology and Oil Shale Resources of Piceance Creek Basin Between the Colorado and White Rivers Northwestern Colorado", GSA Bulletin 1082-L, 1961.



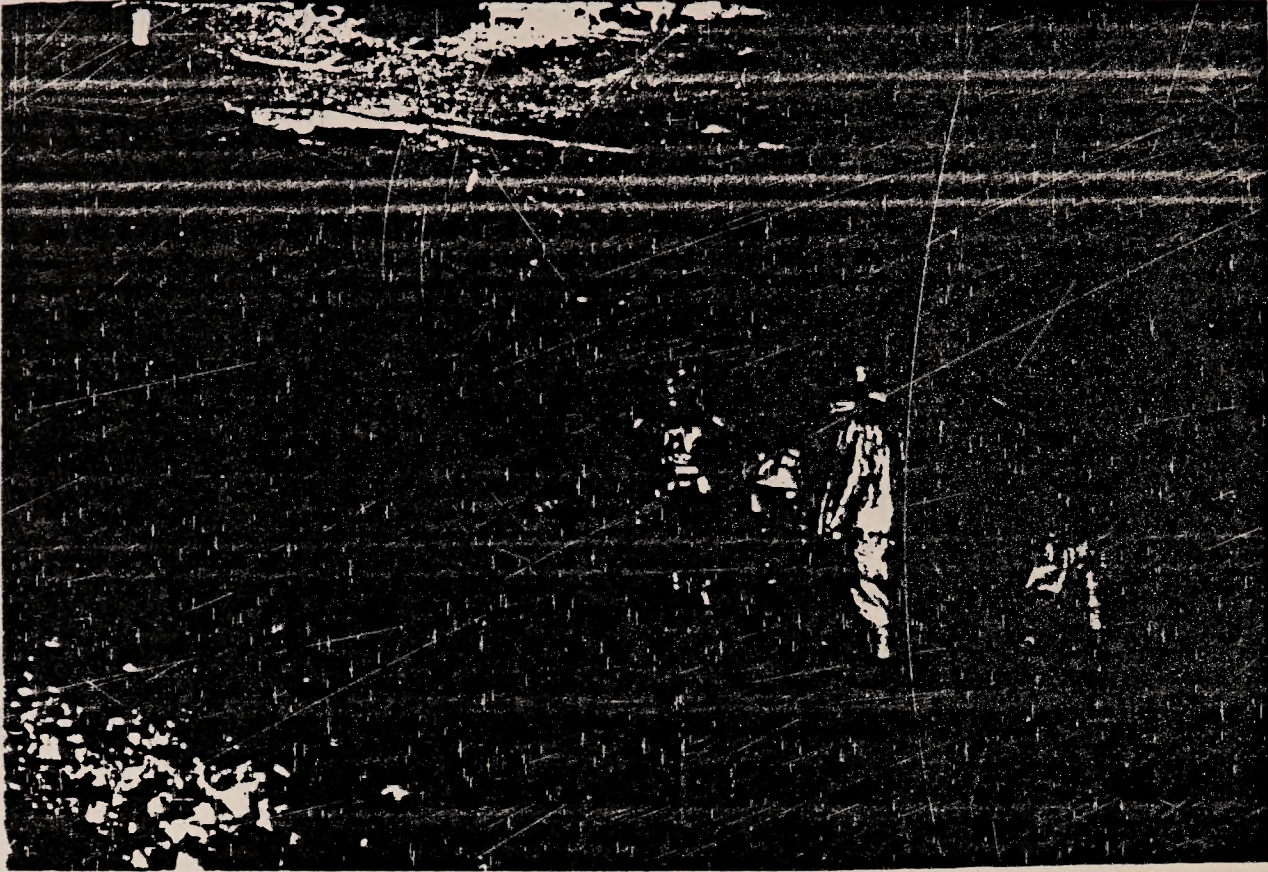


Figure 28. Dry Upper Void Level (Ventilation/Escape shaft) excavation. Fractures can be seen in roof but are tight and dry.



