

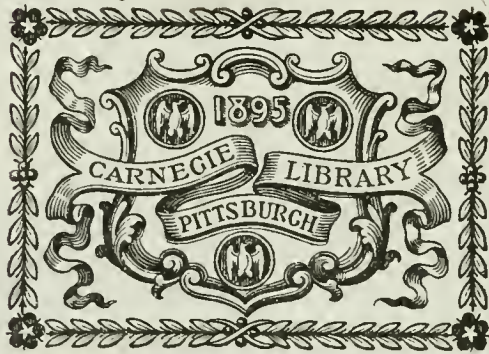

Class 95625.0⁵ Book R 1574
175







THE AMERICAN ENGINEER

AND RAILROAD JOURNAL.

R. M. VAN ARSDALE, Proprietor.

G. M. BASFORD, Editor.

E. E. SILK Associate Editor

Published Monthly at 140 Nassau Street, New York.

INDEX TO VOLUME LXXV.—1901.

Issue.	Pages.	Issue.	Pages.	Issue.	Pages.
January	1 to 34	May	135 to 166	September	271 to 302
February	35 to 68	June	167 to 206	October	303 to 334
March	69 to 100	July	207 to 238	November	335 to 366
April	101 to 134	August	239 to 270	December	367 to 398

(The asterisk indicates that the article is illustrated.)

Acceleration and Momentum, Cole.....	167*	Ballast Car, Steel, U. P. Ry.....	140*	Car, 80,000 lbs. Low Drop Bottom, C. & N. W. Ry.....	46*
Accidents, Report of.....	244	Ball-Bearing Center Plates.....	258	Car, 80,000 lbs. Oil Tank, A. T. & S. F. Ry.....	34*
Acetylene, Car Lighting.....	375	Ball-Bearing Side Bearings.....	46*	Cars, 60,000 lbs. Coke, C. & O. Ry.....	8*
Air Brake Equalizing Valve, Morris'.....	114*	Baltimore & Ohio R. R. Locomotive.....	283*	Car, Ballast, Steel, U. P. Ry.....	10*
Air Brake Equipment in U. S.....	275	Barnes Exhaust Pipe.....	121	Car Bolsters and Side Bearings.....	345
Air Brake Hose Specifications.....	233	Bates, Onward, Personal.....	65*	Car Bolster, 50-Ton Coal Car, N. & W. Ry.....	45*
Air Brake Inspector, The.....	245	Bell, J. Snowden, Patents.....	196	Car, Box, Steel Underframe, Erie R. R.....	138*
Air Brakes, Maintenance of.....	91, 171	Bent on Locomotive Gas Analysis.....	108*	Car, Brill's Convertible.....	217*
Air Brake Skipping Tests.....	84	Bentel & Margadant Boring Machines.....	25*	Car, Cafe-Parlor, Grand Trunk Ry.....	29*
Air Brake Triple Valve Test.....	95	Bentel & Margadant Planing Machine.....	322*	Car Center Plates, Design of.....	6*
Air Brake Triple Valves.....	230*	Best's Oil Fuel Apparatus.....	294*	Car Channels.....	371*
Air, Compressed, Cost of Cars.....	49	Bloomington Shops, C. & A. R. R.....	110*	Cars, Coal and Ore, A. C. & F. Co.....	151*
Air Fans for Passenger Cars.....	330	Blowers, Power Required by.....	22	Car, Coal, 50-Ton, L. & N. Ry.....	319*
Air Pump Exhaust for Car Heating.....	129*	Blue Printing by Electric Light.....	275*	Car, Composite 50-Ton, L. & N. Ry.....	319*
Air Supply, Locomotive Fireboxes.....	51	Body Bolster, L. & N. Ry, 50-Ton.....	310*	Cars, Compressed Air, Operating Cost.....	49
Ajax Metal Co. Tests of Metals.....	357, 365	Boiler Explosions, Momentum Theory.....	153	Car Construction, Metal Frames.....	240
Altruism in the Shop.....	153	Boiler, Locomotive, B. & O. R. R.....	46*	Car Construction, Importance of Lightness.....	105
Aluminum Thermit.....	353	Boiler, Locomotive, L. S. & M. S. Ry.....	71*	Cars, Cost of Cleaning Passenger.....	351
Aluminum at Paris Exposition.....	148	Boiler, Locomotive, New York Central.....	273*	Car Design, Importance of Lightness.....	351
American and English Clearances.....	90*	Boiler, Locomotive, N. P. Ry.....	273*	Cars, Dining, New, C. B. & Q. R. R.....	116*, 155*
American Blower Co. Exhibit.....	259	Boiler Performance, Goss on.....	383	Car Door Fastener, "The Prairie".....	26*
American Car & Foundry Co. Car.....	151, 279*	Boiler, Serpollet's.....	383	Car Doors, Varnish Rack for.....	18*
American Engineer Tests, Data for.....	297*	Boiler Shell Chart, Fry.....	152*	Car Draft Gear. See Draft Gear.....	
American Engineer Tests on Draft Appliances.....	184, 303, 318, 335, 354, 367	Boiler Tests, Locomotive, Goss.....	2*	Car Equalizer Springs, L. V. R. R.....	61*
American Locomotives in England.....	251	Boiler Tube Chart, Weights.....	64*	Car Framing, Steel, N. & W. Ry.....	44*
American Locomotive Co.....	185	Boiler Tubes, Methods of Setting.....	209, 270	Car Furniture, Steel Frame, Erie R. R.....	133*
American Locomotive Co. Officers.....	215	Boilers, Water Tube vs. Cylindrical.....	278	Car Heating by Air Pump Exhaust.....	123*
American Locomotive Co. Locomotive.....	271*, 329*	Boiler, Wide Firebox, C. B. & Q. R. R.....	157*	Car Heating and Ventilation, P. R. R.....	177*
American Machinery Export Co. Incorporated.....	65	Bolster for 50-Ton Cars, L. & N. Ry.....	310*	Cars, Large, Problem in England.....	19
American Railway Association.....	347	Bolster for 50-Ton Car, N. & W. Ry.....	45*	Cars, Loading to Full Capacity.....	252
American Ry. Association, Standard Car.....	394	Bolsters and Side Bearings.....	345	Cars, Ore and Coal, A. C. & F. Co.....	151*
American Soc. M. E., House for.....	86, 350, 385	Book Notices.....	33, 66, 98, 133, 164, 204, 225, 260, 301, 332, 365, 396	Car Painting, Cost by Spray and Brush.....	214
American Society of M. E. Convention.....	214	Boon, J. M., Traction Increases.....	120*	Cars, P. R. R. Parlor.....	212
American Society of Mechanical Engineers.....	17	Boring Machine.....	257	Cars, Possibility of Standardizing.....	257
Anthracite Grates, McIntosh.....	191	Box Car, Steel Underframe, Erie R. R.....	139*	Cars, Progress in Capacity.....	184*
Anthracite Culm Burning, Lloyd.....	197	Brakes for Locomotive Trucks.....	53	Car Repairs Increasing.....	375
Antz, Convenient Car Shop Devices.....	13*	Brake Shoes by Sargent Co.....	257	Car Sanitation.....	41
Apprenticeship, Baldwin Locomotive Works.....	309, 314	Brake Shoes, Laboratory Tests.....	210, 268*	Car Sanitation, Dr. J. N. Hurty.....	58
Apprentices in Railroad Shops, Walt.....	170	Brake Skipping Tests.....	84	Car Shop Devices, Antz.....	15*
Ash Elevator, Pneumatic.....	307*	Brake Tests, Burlington.....	77	Car Shops, Fond du Lac.....	146*
Association for Testing Materials.....	229	Brake Wheel, Folding, C. & N. W. Ry.....	359*	Car Shops, N. Y., N. H. & H. R. R., at Readville.....	40*
Atchison, T. & S. F. Ry. Shops.....	189*	Brass Foundry, A Well-arranged.....	327*	Car Shops, N. Y., N. H. & H. R. R.....	75*
Atchison, Oil Fuel on.....	186*	Brill Convertible Car.....	217*	Car Side Bearings and Bolsters.....	345
Atchison Pushing Locomotive.....	283*	Bronze Staybolts in France.....	296*	Car Siding and Flooring, Sizes of.....	226
Atchison, T. & S. F. Ry. Tank Car.....	343*	Brooks Locomotive Works, Locomotive.....	69*, 101*	Car Sills, Splicing of.....	242*
Atchison, T. & S. F. Ry. Mogul Locomotive.....	113*	Buda, Ill., Water Softening Plant.....	344	Car Springs, Report on.....	231*
Atchison, T. & S. F. Ry. Prairie Type Locomotive.....	372*	Bullock Motor Driving a Press.....	66*	Car, Standard Dimensions of.....	359, 394
Atchison, T. & S. F. Ry. 10-Wheel Locomotive.....	373*	Bullock Motor Driving Bending Rolls.....	162*	Car, Standard M. C. B.....	384
Atchison, T. & S. F. Draft Gear Tests.....	115	Bullock-Wagner "Pan-American" Exhibit.....	239	Car, Steel, and M. C. B. Ass'n.....	152*
Atlantic Type Locomotive, B. & O. R. R.....	46*	Burners For Oil, Santa Fe.....	388*	Cars, Steel, Am. S. F. Co.....	156*
Atlantic Type Locomotive, C. R. I. & P. Ry.....	101*	Burnishing Car Axles.....	94, 300	Car, Steel Frame Box, N. P. Ry.....	107*
Atlantic Type Locomotive, C. M. & St. P. Ry.....	313*	Burtis, A. B., Personal Notice.....	31	Car, Steel Underframe, Box, Erie R. R.....	133*
Atlantic Type Locomotive, N. Y. C. & H. R. R. R.....	35*	Bush, Management of Men.....	351	Car, Steel, Woodcock's.....	123*
Axles, Burnishing of.....	94, 300	Bush on Future of M. C. B. Association.....	207	Car Stress, Diagram for, N. & W. Ry.....	45*
Axles, Chemical Composition of.....	269*	Butler, A. G. & Co., Leather Fillets.....	255*	Car, Tank for Oil, A. T. & S. F. Ry.....	345*
Axles, Composition of Steel.....	211	Cafe Car, Grand Trunk Ry.....	20*	Car, Test Weight, C. & A. R. R.....	156*
Axles, Driving, Middle Bearings for.....	61*	Canadian Pacific Roundhouses.....	352*	Car, The "Handy".....	92*
Axle Tungs for Double Lathes.....	18*	Cast Iron Wheels. See Wheels.....		Car, The Large Steel, Morris'.....	1
Babbitt Metal, Effect of Heat on.....	328	Cast Iron Wheels, M. C. B. Report.....	235*	Car, The Standard Box.....	152, 371
Babcock & Wilcox Co. Trade Name.....	356, 360	Cast Steel End Sills for Cars.....	280*	Car Truck. See Truck.....	
Baldwin Locomotive Works, Apprenticeship.....	309, 319	Cast Steel Locomotive Frames.....	287*	Car Truck, C. & N. W. Ry.....	6*
Baldwin Locomotive Works, Locomotive.....	154*, 46*, 54*, 113*, 135*, 205*, 213*, 323*, 372	Car, 100,000 lbs. Coal, Vanderbilt.....	338	Car Truck, Haskell's Pressed Steel.....	366*
Baldwin Locomotive Works, Output.....	61	Car, 100,000 lbs. Coal, L. & N. Ry.....	310*	Car Truck, Steel Frame, Passenger.....	12*
Baldwin Locomotive Works, Throttle Valve.....	96*	Car, 100,000 lbs. Drop Bottom Gondola, E. J. & E. R. R.....	279*	Car Truck, Steel, Passenger.....	52*
		Car, 100,000 lbs. Coal, N. & W. Ry.....	42*	Car Trucks, Squareness of.....	127*
		Car, 100,000 lbs. Ore, Copper Range Ry.....	151*	Car Truck, Wright Steel.....	250*
		Car, 100,000 lbs. Ore, C. M. & St. P. Ry.....	125*	Cars, Weight and Capacity Table.....	33*
		Cars, 100,000 lbs., Woodcock.....	213*	Car Window Fixtures, Edwards'.....	27*
		Car, 100,000 lbs., Woodcock's, Hopper.....	128	Car, Woodcock's Steel Hopper.....	123*
		Cars, 100,000 lbs., C. & A. R. R.....	156	Car, Vanderbilt's 50-Ton Hopper.....	33*
		Car, 80,000 lbs. Box, C. & O. Ry.....	382*	Car Ventilation, P. R. R.....	177*
		Car, 80,000 lbs. Coal.....	151*	Cars, Volume of Loads on.....	57*
				Carbon Paint, Monolith.....	124
				Cast Iron Wheels Have Reached Their Limits.....	118

"Lake Shore" Steel Truck and Platform.....	12*
Lehigh Valley Equalizer Springs.....	61*
Lehigh Valley Locomotive Classification.....	120
Lehigh Valley Passenger Station.....	163
Light Cars, Importance of.....	351
Link Motion and Piston Valves.....	189*
Liquid Fuel.....	243, 248, 249
Liquid Fuel for Locomotives.....	292*
Liquid Fuel, Paper on.....	48
Lloyd, Anthracite Culum Burning.....	197
Localized Deflection in Structures.....	51
Locomotive, Atlantic Type, C., M. & St. P. Ry.....	313*
Locomotive, Atlantic Type, B. & O. R. Ry.....	46*
Locomotive, Balanced Compound, 4-Cylinder.....	318
Locomotive, Chautauqua Type, C., R. I. & P. Ry.....	101*
Locomotives, 4-Cylinder Compound.....	318
Locomotive, 8-Wheel, D., L. & W. R. Ry.....	141*
Locomotive, 8-Wheel New York Central.....	8*
Locomotive, Mogul, A., T. & S. F. Ry.....	113*
Locomotive, 10-Wheel, A., T. & S. F. Ry.....	373*
Locomotive, 10-Wheel Compound, Union Pacific Ry.....	54*
Locomotive, 10-Wheel, for New Zealand.....	297*
Locomotive, 10-Wheel, New Zealand.....	329*
Locomotive, Consolidation Pushing, Atchafalaya.....	289*
Locomotive, Consolidation, U. P. Ry.....	15*
Locomotive, Consolidation, Vanderbilt, E. R. & P. Ry.....	323*
Locomotive, Consolidation, N. Y. Central.....	53*
Locomotive, Consolidation Tandem Compound.....	271*
Locomotive, Prairie Type, L. S. & M. S. Ry.....	69*
Locomotive, Prairie Type, C., B. & Q. R. Ry.....	135*
Locomotive, Prairie Type, A., T. & S. F. Ry.....	372*
Locomotive, Compound Freight, N. Y. Central.....	83*
Locomotive, Compound Balanced.....	355
Locomotive, Compound, 3-Cylinder.....	359
Locomotive, Compound, C., M. & St. P. Ry.....	313*
Locomotive, Compound, in Buenos Aires.....	348
Locomotives of the Future, Vauchlain.....	169
Locomotives, American and English.....	85
Locomotives, American in England.....	251
Locomotives, American in India.....	278
Locomotives, American on English Roads.....	183
Locomotive Blow-off Valve, Homestead.....	66*
Locomotive Boiler, A., T. & S. F. Ry.....	114*
Locomotive Boiler, B. & O. R. Ry.....	46*
Locomotive Boiler, C., R. I. & P. Ry.....	102*
Locomotive Boilers, Lagged with Air.....	41
Locomotive Boiler, New York Central.....	36*
Locomotive Boiler, L. S. & M. S. Ry.....	71*
Locomotive Boiler, N. P. Ry.....	273*
Locomotive Boiler Performance, Goss.....	28*
Locomotive Boiler Tubes.....	270
Locomotive Boiler, Wide Firebox.....	137*
Locomotive Boiler, Wide Firebox, D., L. & W. R. Ry.....	144*
Locomotive Boiler Records, Formulae for.....	28*, 30
Locomotive Boilers, Weight of Water in.....	346*
Locomotives, Building, by Railroads.....	182
Locomotive Characteristics, Henderson.....	172*
Locomotive Chart of Speeds.....	60*
Locomotive, Class J, L. S. & M. S. Ry.....	69*
Locomotive Sand, Dryer for.....	273*
Locomotive Classification.....	209, 228
Locomotive Classification, L. V. R. Ry.....	119
Locomotive Classification, Whyte's.....	21
Locomotive Classification, Whyte's.....	55
Locomotive Coal, Selection of, Forney.....	185
Locomotive Coal Consumption, Forney.....	185
Locomotives, Combustion in.....	51
Locomotive Compound, See Compound.....	
Locomotive, Compressed Air.....	63*
Locomotive, Connecting Rod Ends.....	56*
Locomotives, Cost of Repairs of Compounds.....	348
Locomotive Cylinders.....	274
Locomotive Cylinder Heads.....	275*
Locomotive Cylinders, L. S. & M. S. Ry.....	73*
Locomotive Design, F. J. Cole.....	167*
Locomotive Design, Marshall.....	11
Locomotive Designs, Three Typical.....	86
Locomotive Draft Appliance Tests, See Engineer.....	
Locomotive Driving Axles, Middle Bearings for.....	61*
Locomotive Driving Wheels, Speed Chart.....	60*, 285
Locomotive Economy, Forney.....	185
Locomotive Exhaust Nozzle, Variable.....	354*
Locomotive Exhaust Pipe, Barnes.....	283*
Locomotive Failures, Importance of.....	109
Locomotives, Feed Heaters, Forney.....	185
Locomotive Feed Water Heater.....	226*
Locomotive Firebox, C., R. I. & P. Ry.....	104*
Locomotive Fireboxes, Cylindrical.....	55*
Locomotive Fireboxes, Wide.....	370
Locomotive Fireboxes, Tests of Wide and Narrow.....	358*
Locomotive Firebox, Wide, D., L. & W. R. Ry.....	144*
Locomotive Fireboxes, Wide, Delano.....	183
Locomotives for France, Baldwin.....	5
Locomotive Frames, Design of.....	149*
Locomotive Frames, Cast Steel, 149*, 287*, 356	
Locomotive Frames, N. P. Ry.....	274*
Locomotive Frames, C., R. I. & P. Ry.....	103*
Locomotive Frames, L. S. & M. S. Ry.....	71*
Locomotive Frames, New York Central.....	36*
Locomotive Frame, Prairie Type.....	136*
Locomotive Frame Quickly Repaired.....	253
Locomotive Frames, Squareness of.....	127*
Locomotive Fuel Economy Report.....	226*
Locomotive Fuel in Sweden.....	375
Locomotive Fuel Consumption, Henderson.....	172*
Locomotive Fuel Tests, D., L. & W. R. Ry.....	198
Locomotive Gas Analysis.....	108*, 118
Locomotive Grates and Gas Analysis.....	108*
Locomotive Grates, Fine Anthracite.....	191
Locomotive Grates, L. S. & M. S. Ry.....	74*
Locomotives, Heating Surface and Weight.....	80, 154
Locomotive Horse Power, Henderson.....	172*
Locomotive, for Inspection, C. B. & Q.....	241*
Locomotives, Large, on Illinois Central.....	343*, 350
Locomotives, Light & Heavy, Tests, 343*, 350	
Locomotive Loads and Grades, Henderson.....	172*
Locomotive, Loading by Tonnage.....	308
Locomotive Losses of Power.....	283*
Locomotive Lubricator for Valves.....	20*
Locomotive Mileage (M. M. Report).....	267
Locomotive Museum, Purdue University.....	7
Locomotive, Narrow Gauge, New Zealand.....	329*
Locomotives, Number Built, Baldwin Locomotive Works.....	61
Locomotives, Number in Service.....	244
Locomotives, Oil Burning, Santa Fe.....	356*
Locomotives, Oil Fuel for.....	292*
Locomotive, Old, in England.....	258
Locomotive Operation and Mileage.....	267
Locomotives, Passenger, Three Notable.....	86
Locomotive Piston, B. & O. R. Ry.....	47*
Locomotive Pistons, New Design.....	357*
Locomotive Piston Rod, Hollow, B. & O. R. Ry.....	47*
Locomotive Pistons, Tandem Compound.....	275*
Locomotive Piston Valve, 48*, 79*, 189, 276*	
Locomotive Power Chart.....	316*
Locomotives, Progress in Capacity.....	184*
Locomotive Ratings, A Caution.....	252
Locomotive Relief Valves.....	273*
Locomotive Repairs, Cost of Compound.....	348
Locomotive Repairs, Remarkable.....	86
Locomotive, Representative Designs.....	253
Locomotive Roundhouse, See Roundhouse.....	
Locomotive Saddle and Frame Braces.....	121*
Locomotive Sand, Dryer for.....	315*
Locomotive Shop, Roundhouse.....	306*
Locomotive Shops, C. R. R. of N. J.....	340*
Locomotive Shops, Fond du Lac.....	146*
Locomotives, Speed Chart for.....	60*
Locomotive Speed Tables.....	285
Locomotive Statistics, Bureau.....	194
Locomotive Superheaters for, Forney.....	186
Locomotive, Switching, D., L. & W. R. Ry.....	91*
Locomotives, Table of Dimensions.....	54*
Locomotive, Tandem Compound.....	271*
Locomotive Tank Well and Strainer.....	157*
Locomotive Tender for Oil Fuel.....	387*
Locomotive Tests of Light and Heavy, J. C. R. R.....	343*, 350
Locomotive Tests, D., L. & W. R. Ry.....	198
Locomotive Tests, M. C. R. R.....	379*
Locomotive Testing Plants, Quayle.....	151
Locomotive Throttles and Dry Steam.....	385
Locomotive Tonnage Rating, 49, 245, 262*, 308	
Locomotive Tonnage Rating, So. P. Ry.....	191
Locomotive Traction Increaser.....	39*, 82, 120*, 312*
Locomotive Tractive Power Chart.....	376*
Locomotive Tractive Power at Various Speeds.....	172*
Locomotive Truck Brakes.....	53
Locomotive Truck, Radial.....	74*
Locomotive Trucks, Radial, Machining of.....	360*
Locomotive Tubes 19 ft. Long.....	70*
Locomotives, Types of.....	16, 195*
Locomotive Valve Lubricator, Johnson's.....	20*
Locomotive Valve Motion and Piston Valves.....	189*
Locomotive Valve Motion, L. V. R. Ry.....	218*
Locomotive Valve Motion, Passenger.....	239*
Locomotive Valve Motion, By Herr.....	277
Locomotive Valve Setting, Table of.....	39
Locomotive, Vanderbilt.....	205*, 323*
Locomotive Variable Exhaust Nozzle.....	95*
Locomotive Water Scoop, N. Y. C.....	143*
Locomotive Water Service, C. & A. R. Ry.....	246*
Locomotive Weight and Heating Surface.....	154
Locomotives, Weight and Power.....	318
Locomotive Works Consolidations.....	185
Lonie, J. H., Volume of Coal Loads.....	57*
Louisville & N. Ry., 50-Ton Coal Car.....	310*
Lubrication, Forced.....	149*
Lubricating Pumps, Force Feed.....	331*
Lubrication, Pumps for.....	50
Lubrication of Driving Boxes.....	4*
Lubricator for Locomotive Valves.....	20*
Lunkenheimer Co. at "Pan-American".....	332
Lunkenheimer's Hand Oil Pump.....	66*
Lunkenheimer Lubricators.....	215
M. M. Association Convention.....	207, 220
Machinery, Depreciation of.....	84
Machine Shop at Roundhouse.....	307*
Machine Tools at "Pan-American" Exposition.....	298
Mail Service, Annual Report.....	15
Malleable Iron Oil Cup.....	251*
Mammoth Carbon Paint.....	124
Manganese Bronze Staybolts.....	296*
Manhattan Ry. Power Plant.....	140
Marine Engineering Progress.....	339
Marshall, W. H., on Locomotive Design.....	11
Master Mechanics' Association Scholarships.....	84, 86
M. C. B. Association Convention.....	210, 220
M. C. B. Association, Future of, Bush.....	207
M. C. B. Couplers, Improved.....	266*
M. C. B. Standard Box Car.....	354
McConnell, Joseph H., Personal.....	169
McIntosh, Wm., Anthracite Grates.....	191
Mechanical Draft, Sturtevant Co.....	392
Mechanical Stokers vs. Hand Firing.....	255
Melville, on The Slide Rule.....	325
Men, Management of, Bush.....	351
Metal Window Casings.....	32*
Middle Bearings for Driving Axles.....	61*
Mileage of Locomotives (M. M. Report).....	267
Mogul Locomotive, A., T. & S. F. Ry.....	113*
Molding Machine, Fay & Egan.....	216*
Momentum and Acceleration, Cole.....	167*
Momentum Grades, Cole.....	167*
Morris' Equalizing Air Brake Valve.....	111*
Morris, Presidential Address.....	207
Morris, W. S., on Steel Cars.....	16
Morris, W. S., The Large Steel Car.....	1
Motive Power Opportunity, Morris, 181*, 185*	
Motive Power Problems, Kruttschnitt.....	170
Motors, Selection of, for Shops.....	88
Multiple Drilling Machine, Bausch.....	65*
Narrow-Gauge Locomotive.....	329*
Nernst Lamp, The.....	288
New York Central Compound Consolidation Locomotive.....	83*
New York Central 8-Wheel Locomotive.....	8*
New York Central R. Ry. Locomotive.....	35*
New York Central Traction Increaser.....	39*
New York Central Tunnel.....	286
New York Central Valve Motion.....	239*
New York Central Water Scoops.....	143*
New York Central Water Scoop Tests.....	302*
New York, N. H. & H. R. Ry. Car Shops.....	78*
New York, N. H. & H. R. Ry., Readville Shops.....	46*
New York, O. & W. R. Ry., Middle Bearing Driving Axles.....	61*
Niagara Falls, Good Engineering at.....	375
Norfolk & Western 50-Ton Coal Car.....	42*
Northern Pacific Tandem Compound Locomotive.....	271*
Norwood System of Ball-Bearing Slide Bearings and Center Plates.....	268
Oil Cup, Fouque's.....	251*
Oil Cups, Improvement in.....	21*
Oil Cups of Tropenas Steel.....	258*
Oil Engine Tests.....	94
Oil Fuel in Texas and California.....	248
Oil Fuel for Locomotives.....	292*, 374*, 377
Oil Fuel for Locomotives.....	356*
Oil Fuel in Southwest.....	243
Oil Fuel, Long Runs with.....	249
Oil Fuel, Paper on.....	4*
Oil House, Monon Ry.....	58*
Oil Pump, Lunkenheimer.....	64*
Oil Tank Car, A., T. & S. F. Ry.....	348*
Open Door Policy, The.....	186
Ore Car, 100,000 lbs., C., M. & St. P. Ry.....	125*
Organization, Elements of.....	246*
Otto Gas Engine Co. Water Stations.....	260*
Packing for Oil Boxes.....	244
Packing Ring Joints, Cox.....	19*
Painting, Cost by Spray and Brush.....	89
Paint for Freight Cars.....	124
Paint, Mammoth Carbon.....	143
Paint, Removal of Old.....	62*, 190
Pan-American Exposition.....	24
Papers, Changes Among the Railroad.....	95
Papers, Use of Technical.....	363*
Paragon Drawing Pen.....	23*
Parson's Steam Turbine.....	105
Passenger Cars, Cost of Cleaning.....	12*
Passenger Car Platform, Steel.....	58
Passenger Car Sanitation, Hurty.....	242*
Passenger Car Sills, Splicing of.....	129
Passenger Car Truck, L. S. & M. S. Ry.....	52*
Passenger Car Truck, Steel.....	177*
Passenger Car Ventilation, P. R. Ry.....	52*
Passenger Locomotives, See Locomotives.....	
Passenger Locomotives, A., T. & S. F. Ry.....	372*
Passenger Locomotive, Atlantic Type, B. & O. R. Ry.....	46*
Passenger Locomotive, C., R. I. & P. Ry.....	101*
Passenger Locomotive, L. S. & M. S. Ry.....	69*
Passenger Locomotive, N. Y. C. & H. R. Ry.....	35*
Passenger Locomotive Types, Gaines.....	195*
Passenger Locomotive, U. P. Ry.....	54*
Passenger Locomotives, Valve Motion.....	239*
Patents by Railroad Men, Bell.....	196
Pennsylvania Coal Co. Purchased.....	22
Pennsylvania R. Ry. Car Ventilation.....	177*
Pennsylvania Station in Pittsburgh.....	362*
Pension System, C. & N. W. Ry.....	49
"Perfect" Leather Fillet.....	258*
Performance of Locomotive Boilers.....	28*
Personals—23, 57, 92, 123, 157, 193, 204, 221, 253, 301, 328, 329, 393	
Pintsch Lighting, Progress.....	65
Piston, Locomotive, B. & O. R. Ry.....	47*
Pistons, New, C. R. R. of N. J.....	357*
Piston Packing Rings, Cox.....	19*
Piston Rod, Hollow, B. & O. R. Ry.....	47*
Piston, Tandem Compound.....	275*
Piston Valves and Link Motion.....	189*
Piston Valve, Baldwin, B. & O. R. Ry.....	45*
Piston Valve.....	73*, 189, 271*
Piston Valve Locomotives, Table of.....	189
Piston Valve, L. S. & M. S. Ry.....	73*
Piston Valves, Tandem Compound.....	276*
Pittsburgh Union Station.....	362*
Planing, Matching and Dressing Machine.....	332*
Plant System, Springy Valve Gears.....	320*
Plant System Variable Nozzle.....	95*
Plastic Bronze, Ajax Metal Co.....	357, 365
Platform, Steel for Passenger Cars, L. S. & M. S. Ry.....	12*
Pneumatic Ash Elevator.....	307*

Porter, H. K., Co., Compressed Air Locomotive	63*	Spring Suspension for Steel Truck	52*	Train Resistance on Grades and Levels	167*
Pomery's Tonnage Rating Chart	126*	Standard Coupler Co. Draft Gear	122*	Train Speeds, Economical, Henderson	172*
Powdered Coal and Smokelessness	240	Standard Coupler Co., Friction Draft Gear	390*	Triangles for Draftsmen	97
Powdered Coal Fuel	77	Star Brass Mfg. Co. Indicator	364*	Triple Valves, Cleaning of Rhodes	171
Powell's Throttle Valve	259*	Starbuck, G. F., Locomotive Fireboxes	55*	Triple Valve, Hibbard, Tests	230*
Power, Cheap, Westinghouse	331	Station, P. R., in Pittsburgh	362*	Triple Valve Test	95
Power Plant, N. Y. Rapid Transit	333	Stationary Boiler and Fuel Economy	162	Trucks. See Cars.	
Power Plant, Manhattan Ry.	140	Stationary Engine Practice	213	Truck, 4-Wheel Passenger, L. S. & M. S. Ry.	12*
Prairie Type Locomotive, C. B. & Q. R. R.	135*	Staybolts, Manganese Bronze	296*	Trucks, Passenger Car, Holst for	161*
Prairie Type Locomotives, L. S. & M. S. Ry.	69*	Staybolt Stud Nut	96*	Truck, Haskell's Pressed Steel	393*
Prairie Type Locomotives, A. T. & S. F. Ry.	372*	Steam Consumption, Low	77	Truck, Radial, for Locomotives	74*
Pressed Steel Box Car, U. P. Ry.	107*	Steam, Dryness of, in Locomotives, Goss	28*	Trucks, Squareness of	127*
Pressed Steel Car Co. Box Car	139*	Steam Jet and Draft	60	Truck, Steel, Passenger Cars	52*
Pressed Steel Car Co. Ballast Car	140*	Steam, Moisture in	212	Truck, Steel, Passenger, L. S. & M. S. Ry.	12*
Pressed Steel Car Co. Car	107*	Steam Production, Economical	60	Truck Brakes, Locomotive	53
Pressed Steel Cars, Output of	219	Steam Turbines	211	Truck for 50-Ton Coal Cars	289*
Pressed Steel Truck, Haskell's	393*	Steam Turbine, Description	23*	Trucks, Radial, Machinery of	360*
Progress in Marine Engineering	330	Steam Turbine, Progress of	49	Truck, Trailer for Prairie Type	137*
Property Rights in Trade Names	359, 360	Steam Turbines, Record of	57	Truck, Wright's Steel	259*
Pullman Practice, Splicing of Sills	242*	Standard Box Car, The	389, 394	Trains, Fast, Restricted in France	45
Purdue University, Change of Courses	141	Steel Car. See Cars.		Tropenas Oil Cnps	258*
Purdue University Locomotive Museum	7	Steel Cars, Am. S. F. Co.	156*	Tropenas Process of Casting Steel	32
Quayle Locomotive Testing Plants	191	Steel Cars, Coal and Ore	151*	Tubes, Best Method of Setting	270
Quereau Locomotive Statistics	199	Steel Cars, Morris on	16	Tubes, Chart of Weights and Lengths	64*
Rate of Combustion in Locomotives, Goss	28*	Steel Car, 50-Ton, E. J. & E. R. R.	279*	Tubes, Inspection of Interior	71*
Readville Shops, N. Y., N. H. & H. R. R.	40*, 78*	Steel Cars, 50-Ton Woodcock	213*	Turbine, Parson's, Steam	23*
Radial Locomotive Truck	74*	Steel Cars, Large Shipment of	261	Turbine Steamer "King Edward"	285*
Railroads and Locomotive Building	182	Steel Cars Not Fully Loaded	251*	Turntables, Power for Turning	362
Railroad Earnings of U. S.	278	Steel Car, The Large, Morris	1	Types of Locomotives	21, 51, 55
Railroad Men, Demand for	355	Steel Castings, Tropenas Process	32	Types of Locomotives, Gaines	195*
Railroad Owned by "Uncle Sam"	239	Steel Castings, for Locomotive Frames	152	Types of Locomotives, Selection of	16
Rails, Steel, for	247	Steel for Rails	247	Union Pacific Ry. Consol. Locomotive	15*
"Railway Master Mechanic," New Form	63*	Steel Frame Passenger Truck	52*	Union Pacific Ry. Passenger Locomotive	54*
Rating of Locomotives	245	Steel Underframe Box Car, Erie R. R.	139*	Union Pacific Ry. Steel Frame Box Car	107*
Readville Shops, N. Y., N. H. & H. R. R.	40*, 78*	Stillman, Howard, Fuel Oils	248	Union Pacific Steel Ballast Car	140*
Reese, F. F., Cylinder Saddles	121*	Stillman Water Treating Problem	194, 281	Up-to-Date Roundhouse	305*
Relief Valves, Cylinder	273*	Storage Battery, Edison's	255	Vacuum Cement and Pulley Cover	161
Report of Interstate Commission	244	Storage Batteries, Power and Weight	45	Valve, Equalizing, for Double Headers	114*
Resistance on Grades and Levels	167*	Stud Nut for Staybolt	96*	Valve Gear Improvement, Plant System	320*
Reversing Tap Holder	97*	Sturtevant Co. Mechanical Draft	363	Valve Lubricator for Locomotives	20*
Rhodes, G. W., Maintenance of Air Brakes	171	Sturtevant Motor	395*	Valve Motion, Excellent Measurements	239*
Rip Saw, Fay & Egan Co.	363*	Sturtevant Generating Set	132*, 300*	Valve Motion, L. S. & M. S. Ry.	76*
Riveting and Splicing	299	Sturtevant Roundhouse Heating System	25*	Valve Motion, By Herr	377
Riveting Tower, Bloomington Shops	112*	Subordinates, Encouragement of	50	Valve Motions, Passenger Locomotives	239*
Rogers Locomotive Works Closed	22	Suburban Service by Water	14	Valve Motion Transmission Bar, L. V. R. R.	218*
Roundhouse Appreciated	240	Success, The Secret of	346	Valve, Piston, for 48", 78", 189"	189*
Roundhouse, Clinton, Ia., C. & N. W. Ry.	25*	Superheated Steam, Economy of	145	Valves, Relief, By-Pass and Starting	275*
Roundhouse, Collinwood	305*	Superheated Steam Plant	77	Valve Setting Measurements, Table	39
Roundhouses, Fireproof, C. P. Ry.	352*	Superheating for Locomotives, Forney	185	Vanderbilt Boiler, B. R. & P. Ry.	323*
Roundhouse, Report M. M. Ass'n	227	Switching Locomotive, D. L. & W. R. R.	91*	Vanderbilt's 50-Ton Coal Car	338*
Roundhouse, The "Up-to-Date"	210	Switch, Reinforced, Weir's	132*	Vanderbilt Locomotive	205*, 323*
Roundhouse Ventilation	248	Symington, Cotton vs. Wool Waste	244	Vanderbilt, Cornelius, Paper on Boilers	45
Rules for Inspection of Safety Appliances	256	Symington's Journal Box	292*, 395*	Vaulain Compound Locomotive, C. M. & St. P. Ry.	313*
Safety Appliance Inspection Rules	256	Table of Heating Surface and Weights	154	Vaulain's Locomotive Propose	169
Sand Chute and Elevator	315*	Table of Speeds by Driving Wheels	285	Varnish Rack for Car Doors	18*
Sand Dryer, Rotary, C. M. & St. P. Ry.	315*	Tables of Locomotive Speeds	285	Vaughan's Analysis Draft Appliances	303
Sand Drying	370	Tandem Compound Locomotive, N. P. Ry.	271*	Ventilation of Passenger Cars, P. R. R.	177*
Sanderson on Topeka Shops	186*	Tandem Compound Locomotives	286	Vestibule Trap Doors, Edwars	161*
Sanitary Car Designs	41	Tank Car for Water and Oil	348*	Vitrified Wheel Co., Emery Wheels	98
Sargent Co. and Tropenas Process	32	Tank Well and Strainer	157*	Wages, Horizontal Increase of	86
Sargent Coupling	216*	Tap Holder, Reversing	97*	Wait, Apprentices in R. R. Shops	170
Sawdust as Fuel, Value of	257*	Technical Education, Value of	95	Waste, Cotton vs. Wool for Packing	244
Saw, Rip, Fay & Egan Co.	363*	Technical Papers, Use of	95	Water Analysis, Before and After Treatment	345
Schenectady Locomotive Works, Fire at	131	Tender for Oil Fuel, Atchison	387*	Water, Car, for, A. T. & S. F. Ry.	348*
Schenectady Locomotive Works Locomotive	35*, 83*, 131, 144	Tender Tank Water, Scoop Tests	392*	Water in Boilers, Chart of Weight of	340*
Schenectady Locomotive Works Traction Increaser	39*	Tender Tank Well and Strainer	357*	Water Purifier, Kennicutt	344*
Schoen, C. T., Resignation of	48	Tender, Vanderbilt's, I. C. R. R.	205*	Water Purification Problem, Stillman	194, 281
Scoop, Water, for Locomotive Tenders	143*	Tender Water Scoops. See Water		Water Purification	307, 317
Seley, C. A., 50-Ton Coal Car	42*	Tender Water Scoop, N. Y. C.	143*	Water Scoop, N. Y. Central	142*
Seley on Link Motion and Piston Valves	189*	Ten-Wheel Locomotive, A. T. & S. F. Ry.	373*	Water Scoop Tests, N. Y. C.	392*
Sessions' Friction Draft Gear	123*	Ten-Wheel Locomotive, I. C. R. R.	205*	Water Scoops, Theory of	378*
Sessions' Friction Draft Gear	390*	Ten-Wheel Locomotive, Compound, U. P. Ry.	54*	Water Service, C. & A. R. R.	246*
Side Bearings and Bolsters	345	Ten-Wheel Locomotive for New Zealand	297*	Water Softening, C. B. & Q. R. R.	344*
Shops, Advantage of Roomy	353	Tests of Draft Gears, A. T. & S. F. Ry.	115	Water Tanks, C. & H. R. R.	246*
Shops, Altruism in	153	Tests, Heavy and Light Locomotive, M. C. R. R.	379*	Water Treatment, Commercial Side	194
Shops, Car, C. R. R. of N. J.	340*	Tests of Heavy & Light Locomotives, I. C. R. R.	343*, 350	Water Treatment Problem, Stillman	251
Shops, Car Department, N. Y., N. H. & H. R. R., at Readville	40*	Tests of Compound Locomotive	379*	Watson, E. P., on American Railways	344
Shops, Car Department, N. Y., N. H. & H. R. R.	78*	Tests of Locomotive Boilers, Goss	28*	Watson & Stillman Hydraulic Presses	159*
Shops, Colorado & Southern, at Denver	10*	Tests on Locomotive Draft Appliances. See Draft		Weights and Heating Surface of Locomotives	89, 151
Shops, Concrete Construction of	340*	Tests of M. C. B. Couplers	266*	Weight of Water in Boilers, Chart of	346*
Shops, Cost Systems	205	Testing Plants, Locomotive, Quayle	181	West, G. W., Three-Bearing Driving Axles	61*
Shops, C. R. R. of N. J.	340*	Thompson's Locomotive Speed Chart	60*	Westinghouse Electric Brake	254*
Shop Floors, N. Y., N. H. & H. R. R.	78	Throttle Valve, Improved	96*	Westinghouse Friction Draft Gear	203, 361
Shop Plan, Readville, N. Y., N. H. & H. R. R.	40*	Throttle Valve, Powell's	250*	Westinghouse Gas Engine, Large	94*
Shops, Fond du Lac	146*	Tip Top Duplicator	129	Westinghouse on Cheap Power	331
Shop Improvements, Bloomington, C. & A. R. R.	110*	Tools and Roomy Shops	353	Wheels, Breakage of Flanges	51
Shops, Locomotive and Car, Topeka	186*	Ton-Mileage Locomotive Statistics	199, 209	Wheels, Cast Iron for Heavy Cars	51, 371
Shops, Topeka, Sanderson	186*	Tonnage Rating by Henderson	262*	Wheels, Cast Iron, M. C. B. Report	235*
Shops, Track Arrangements in	163	Tonnage Rating, Canadian Pacific	49	Wheels, Cast Iron vs. Steel Tired	208, 211
Shops, at Roundhouse	305*	Tonnage Rating Chart, Loaded and Empty Cars	126*	Wheels, Cast Steel Driving	530
Sills, Splicing of Long Car	242*	Tonnage Rating of Locomotives	245	Wheels, Driving Flanges on	530
Slide Rule, The, by Melville	325	Tonnage Rating, Paper on	210	Wheel Flanges, Breakage of	581
Soule, R. H., Filing System	85	Tonnage Rating Results, So. P. Ry.	191	Wheels, Have Cast Iron Reached Their Limits?	118
Southern Pacific, Firebox Tests	358*	Tonnage Rating, Southern Pacific	308	Whyte, F. M., Locomotive Classification	55
Southern Pacific, Tonnage Rating	191, 308	Topeka Shop Extensions	186*	Wide and Narrow Fireboxes, Tests	358*
Snow's Tank Valves	246*	Toppa and Co. Car Door Fastener	298*	Wide Firebox. See Firebox	
Speeds, Economical, of Trains, Henderson	172*	Toppa & Co. Water Purifier	344*	Window Casings, Metal	32*
Speeds of Train in Locomotive Rating	245	Tracings, Making Erasures on	246	Window Fixtures, Edwars	27*
Speeds, Restricted, in France	45	Track Apprenticeship, I. C. R. R.	322	Wireless Telegraphy	84
Speed Tables for Locomotives	285	Track Arrangements in Shops	103	Wisconsin Central, Fond du Lac Shops	146*
Springs for Cars, M. C. B. Ass'n	231*	Track Scales for Locomotive Coal	288	Wood, S. H. & Co., Mortiser	151*
Springs for Equalizers, L. V. R. R.	61*	Track Tank Water Scoop	See Water	Woodcock's 50-Ton Steel Car	128*, 213*
Springs, Large Capacity Draft Gear	324*	Track Tank Water Scoop Tests	392*	Wood-working Machinery	257*, 332*
		Traction Increaser New York Central	39*	Wood-working Machinery, Planer	360*
		Traction Increasers	82, 120*, 372*	Worthington, Results of Tonnage Rating	191
		Tractive Power Chart, Fry	316*	Worthington on Tonnage Rating	245
		Tractive Power of Locomotives	283*	Worthington on Tonnage Rating	308
		Trade Names, Property Rights in	356, 360	Wright, R. G., Steel Truck	260*
		Trains, Cost of High Speed	209, 224		
		Trains, "Pittsburgh Special," P. R. R.	14		

AMERICAN ENGINEER AND RAILROAD JOURNAL.

JANUARY, 1901.

CONTENTS.

ILLUSTRATED ARTICLES :	Page	Page	
The Large Steel Car	1	The Dayton Twin-Spring Draft Gear.....	30
Effective Lubrication of Driving Boxes	4	Metal Window Casings	32
Center Plates, by Edward Grafstrom.....	6	Electric Conduct Applied to Cable Railways.....	34
New "Empire State Express" Locomotive.....	8	ARTICLES NOT ILLUSTRATED :	
Low Drop-Bottom Gondola Car, 80,000 Pounds Capacity.....	9	Baldwin Locomotives for France, A New Record on the Lehigh Valley	5
Now Shops of the Colorado & Southern Railway.....	10	Locomotive Museum	7
Four-Wheel Steel Frame Truck and Steel Frame Draft Gear.....	12	Broad View of Locomotive Design	11
Vauclain Compound Consolidation Locomotives.....	15	High Speed Suburban Service by Water.....	14
Some Convenient Car Shop Devices, by Oscar Antz.....	18	Changes Among the Railroad Papers.....	14
Improved Joint for Piston Packing Rings	19	United States Mail Service	15
Cafe-Parlor Car for Fast Express Service.....	20	American Society of Mechanical Engineers.....	17
Johnson's Locomotive Valve Lubricator	20	Locomotive Classification.....	21
An Improvement in Oil Cups.....	21	Arrangement of Views on Drawings.....	21
Westinghouse-Parsons Steam Turbine.....	23	Small Steel Castings and the Tropenas Process	32
A Modern Roundhouse.....	25	EDITORIALS:	
Self-Opening Car Windows	27	Position of the Large Steel Car in Railroad Improvements	16
Tests of the Boiler of the Purdue Locomotive, by W. F. M. Goss	23	Wheel Arrangement for the Future Heavy Passenger Locomotives.....	16
		Center Plates and Side Bearings	16

THE LARGE STEEL CAR.

Its Development and Position in the Business of Railroads.

By W. S. Morris,

Superintendent Motive Power, Chesapeake & Ohio Railway.

As we observe the different avenues of progress in locomotive and car construction, one cannot help but be taken with the general fitness of detail which seems to prevail with engineers in the design of cars and locomotives. The tendency toward increased weight and tractive power in machines is on the other hand met by the car problem, "Of carrying the greatest amount of paying load with a minimum tare and without sacrifice of strength or durability."

A casual glance at the motive power of this country will show an increase of from 25 to 50 per cent. in capacity over engines of ten years ago, and the train load has increased in as great rate as the railroads changed from the car unit to a ton unit. For example:

In 1890 the heaviest consolidation engine in use on our mountain freight trains on the Chesapeake & Ohio had 114,000 lbs. upon the drivers and developed a tractive power of 28,800 lbs., with 21 by 24-in. cylinders and carrying 160 lbs. steam pressure. In 1895 a machine with 121,700 lbs. on the drivers was introduced, and in 1899, the present "G6" consolidation engine, having 172,500 lbs. on drivers, with cylinders 22 by 28 ins. and a tractive power of 41,150 lbs., with 200 lbs. of steam, has displaced the machines of earlier birth—an actual increase of tractive force of engines since 1890 of 12,350 lbs., or 33 per cent.

The heavier trains now handled soon developed the fact that stronger cars, better draft rigging and more complete braking power were necessary. Extended experience in the design and

construction of the wooden car with its accompaniments had established well-seated prejudices, and it is not to be wondered at, that other experiences, absolutely convincing in their nature, must be weighed before the new car may be realized, as it displaces to an enormous extent well-established practices that have appealed to our best judgment and yet wield a very strong influence under certain conditions.

In my own experience on some of the Western roads the use of wood for fuel for locomotives furnished means of livelihood for the inhabitants, and the great virgin forests being at the very door of the railroad shop, metal for car construction was only introduced where timber could not be used. I can well remember when the requirements of one of our prominent Western roads for freight-car construction necessitated the carrying of all timber four years before it would be accepted in car construction. What would a car cost to-day under these specifications, and would it be possible to get it at all?

The responsible operating officer has only too well realized the experiences that demonstrate, without further experiment, that design for construction must almost reach the line of indestructibility and yet accomplish maximum carrying results, and the factor of safety must be as high as reasonable weights will admit.

Every railroad yard tells its own story of rough handling, and accidental or service damage; but with the M. C. B. coupler eliminating the necessity of manual direction of the coupling link and pin, the old-time operator or switchman witnesses many a disastrous shock and shiver of timbers, greatly exaggerated, no doubt, from the very fact that he is not obliged to go between the cars to make the coupling, thus almost, if not quite, establishing a ready bumping post of each individual car in busy shifting, thus sacrificing wooden parts that have served for many years and have been considered ample in their respective dimensions.

Metal draft rigging has been introduced in connection with wooden framing and numbers of buffing arrangements are offered to relieve destruction upon the wooden car, all indicating their useful advantages, but when by fierce competition freight rates were reduced to a figure that invited loss under old methods, the unit of train tons forced the issue between the respective conditions of car construction, and the result simmered down to the combination that is best suited in weight for maximum carrying capacity.

It is interesting to follow the evolution of the freight car from its early introduction, when about 7,000 lbs. and a four-wheeled car was considered the proper "goods wagon," up to our time, and note what the development of commerce has forced upon the engineer for provision to meet its transportation demands. Coal cars in 1860 carried five tons, and merchandise cars were built to carry about the same weight; and, as late as 1865, 15,000 lbs. was considered an ordinary load for a box car. I can remember, as an apprentice, in 1874, fitting wheels for new box cars, the weight of which was about 19,000 lbs. and their capacity fourteen tons; the twenty-ton car introducing itself in 1876; the twenty-five ton in 1883, and the thirty-ton car in 1885; but not until 1895 was the forty-ton car thought necessary, while now we have the fifty-ton car, made of steel, carrying 10 per cent. above its marked capacity, the tare being less than 25 per cent. of the total weight of car and lading.

In this country the use of steel cars is of but recent date, notwithstanding for almost forty years patents have been taken out for cars made entirely of metal or of wood and metal.

In 1869 R. Montgomery, of New York City, patented a metal car in which corrugated iron was used extensively to form the uprights and roof supports in the form of an arch, and this car was covered with corrugated iron. The floor was formed of arched corrugated iron, set between the transverse girders of the under frame. Such cars seem not to have been used extensively. In 1870, G. C. Bestor patented a passenger car having commercial-shaped metal uprights, mainly channel

bars, with a covering of sheet metal on the inside, outside, top and bottom, so as to form air spaces, and he called this a fire-proof car. In 1884, J. T. Goodfellow produced a car with a tubular trussed underframe and wooden body. In 1889, Hughes patented a car having an underframe made of rolled and trussed sections, trussed steel uprights and plates riveted to the uprights. In 1876, Kimball, of Philadelphia, patented a car with a metal frame, to which the wooden sidings were attached. In 1863, Merrill also patented a car with a metal underframe and metal body frame, to which uprights were then attached. In 1888, H. C. Hodges, of Detroit, patented a very ingenious car, with a steel underframe and having a body constructed with sheet metal uprights, having vertical grooves for stiffening and strengthening purposes. In 1892, Burton, of Wichita, Kan., patented a freight car having a metal frame for the box and a wooden or metal covering. In 1889, M. A. Zurcher patented a railway car having a trussed frame in the nature of a bridge truss, supported at each end by a truck. This ingenious bridge construction applied to railway cars, however, did not come into general practice, more than did any of the other cars heretofore described.

C. T. Schoen, of the Pressed Steel Car Company, in 1890 patented a pressed angle piece for the corners of wooden cars. In 1890 appears his first patent, taken jointly with J. M. Hansen, for a car with a steel frame and vertical plates riveted to the same and strengthened by means of rolled metal. Mr. Schoen has patented a number of cars, the essential features of which are the use of pressed steel for the side-walls, uprights, struts, etc.

F. H. Rapley, of the Fox Pressed Steel Equipment Company, patented a car having side walls formed of flanged metal riveted together and thus forming the side of the underframe.

In 1900, Coolbaugh & Dingertz patented their car, which was exhibited at Saratoga, having a steel underframe, a body frame of rolled metal sections riveted together through the flanges and secured to the corners in corner posts adapted especially for the purpose. The American Car and Foundry Company have built a few cars with a frame made up of built-up struts, posts and braces of rolled iron, and supporting a hopped body of extreme height.

The only steel car that has been used extensively is the "Schoen" car of the well-known type, both as a hopper and a gondola. A characteristic feature of the "Schoen" car is that everything is made of pressed steel.

Combination wood and metal are to-day offered by some constructors in a conservative way. Channel frames and plates are now in common use in freight-car construction; but pressed steel shapes at the present time have evidently captured the greater number of freight cars constructed wholly of metal, introducing itself in such uneven proportions with all others as to warrant its adoption without further timidity on the part of the railroads.

One bears many criticisms when bold enough to adopt the new methods, among which are the oxidation and the necessary repairs from casualty being the paramount forecasts of what must be provided for in shop practice; but the ability of the steel car to carry a paying load with a minimum tare and its stability to withstand abuse without actual derailment no one seems to question.

Deterioration due to oxidation cannot at this time be absolutely determined for the steel car, but it is reasonably estimated to be within economical limits when the car earnings of the equipment are compared. As to repairs, the evolution of our bridges and ships can be cited as a comprehensive example of the change of treatment in shop practice.

Car shops and workmen adapted and trained for wood working can be gradually adapted and prepared to meet the new requirements, as the later car construction and repairs introduce themselves, without any serious realization of plant extravagance. Woodworkers will readily turn their hands to metal and render quite equal results, a fact demonstrated in our ten-

der frame shops, originally arranged to build wooden frames, but now working metal entirely when new frames are substituted.

It is true the majority of steel cars now in service are built for coal, ore and like traffic, and what better argument can be advanced for their graduation into other classes of freight equipment? Surely no more severe service can be imagined.

The latest production of wooden car for heavy carrying capacity we have presented in the "Canda" 100,000-lb. capacity box and coal car, which appeals to me as the ideal of wood construction, and in its makeup no effort has been spared in selecting the very best material obtainable, in order to promote strength and the reduction of sizes for a minimum tare. The engineering ability displayed in the combination of the "Canda" car has certainly produced symmetrical results and is a credit to the designer, and yet the question of the life of this car under varying conditions of weather and severe service under heavy loads does not indicate the same stability as that of the steel car, but it does indicate a positive limit to which careful engineering can go in the direction of wood combination in a freight car, while the field of the steel car is limited only by the superstructures and roadway over which they may be operated.

It will be observed in comparing metal designs for freight cars that a structural car made exclusively of standard shapes will necessarily have excessive dimensions if an evil of great consequence is avoided, that of an abnormal number of rivets. which, of course, means increased tare, and while it is true that the structural car will act as a most important factor in the lines of competition in the advent of the metal car, it must be admitted that pressed steel enhances uniformity and strength in girders, without waste of material for car shapes, and a reduction of weight is effected by its selection for freight-car construction.

Some very interesting information is presented by the president of one of the roads using pressed steel cars extensively, and no doubt indicates definitely the true value of that combination. The opinion reads as follows:

"The advantages of the steel car over the 60,000 capacity wooden gondola are so numerous that it is almost impossible to enumerate them. The cost of maintaining the running repairs to wooden cars is greater, and in order to verify this statement it will only be necessary to take for example, 46 of the steel cars to carry the tonnage that 72 wooden 60,000 capacity cars would carry. It therefore cuts down time and expense in the inspection, oiling, and the wearing of the following parts: rails, wheels, brasses, axles, couplers, brake shoes and also in lubrication.

"The comparative cost of repairs due to wrecked cars would be 33 per cent. in favor of the wooden cars; however, this is more than off-set by the fact that what would damage or destroy a wooden car would not damage a steel car to any extent; in other words, the annual cost of repairs to steel cars on account of wrecks would be much less than that of the wooden cars, and if the steel cars were used entirely, the number of wrecked cars would be greatly diminished.

"The saving made and the advantages to be derived in transportation by the use of the steel cars as against the wooden cars are hard to calculate or determine exactly, but we find from a test made that in order to move 1,500 tons of freight in wooden 60,000 capacity cars we are obliged to move 62 more tons of dead weight than if the freight was in steel cars. It would take 30 steel hopper cars to move this, while it would require 47 60,000 capacity wooden cars. The percentage in favor of the use of steel hoppers in length of train would be, therefore, about 28 per cent., or 17 cars. The train expense in handling this tonnage would be the same, but as we increase the tonnage, we decrease train expenses, for example: We could handle 2,000 tons of freight in the steel cars with the same expense that we would have in handling 1,500 tons in wooden 60,000 capacity cars and would require seven cars less;

in other words, we find that 2,000 tons of freight can be moved in 40 steel cars, while it would take 47 wooden 60,000 capacity cars to move 1,500 tons. There would, however, be 112 more tons of dead weight.

"The relative cost of handling the two classes of cars at mines and terminals, of course, is greatly in favor of the steel cars in switching, side-track room and loading, each steel car holding 20 tons more. It would take 10 steel cars for 500 tons, while it would take 17 wooden 60,000 capacity cars for the same tonnage. The expense of loading would be decreased at least 10 per cent., caused by the movement of cars and switching additional cars. The cost of unloading at docks aggregates about 30 per cent. less in favor of the steel car, while the saving in switching and side-track room would be at least 25 per cent. Returning empties to the mines for loading, for the same expense we can move 60 steel cars (dead weight 1,050 tons) as we would have in moving 50 wooden cars of the same capacity (dead weight, 1,050 tons). In other words, we can move a train of steel cars with a carrying capacity of 3,000 tons for the same expense as to move a train of wooden cars with a carrying capacity of 2,500 tons. The cost of transportation in handling 40 steel cars containing 2,000 tons of freight would be the same as 1,500 tons loaded in wooden 60,000 capacity cars. The earnings per train mile would be, for steel cars \$11, and for wooden cars \$6.59; that is, we would have the same expense in transportation to earn \$6.59 per train mile in wooden cars that we would have to earn \$11 per train mile in steel cars, or a difference of \$4.41 per train mile in favor of the steel cars. This simply refers to the train expenses and not to the wear and tear on the extra wooden cars that would be necessary to handle 1,500 tons as against 2,000 tons in steel cars.

"We demonstrate the saving in power, wages, cars, oil, etc., as follows: We will take 1,000 loads to be moved in steel hoppers and the 60,000 capacity wooden gondolas. To move this number of loads, containing 62,500 tons in steel cars, would require 25 trains; to move the same tonnage in wooden cars would require 31 trains and 1,457 cars. The dead weight of the steel cars would be 17,500 tons, and of the wooden cars 18,213. Therefore, to move the same tonnage in the different kinds of cars it will require 1,457 60,000 capacity wooden cars with a dead weight of 18,213 tons, and 1,000 steel hoppers with a dead weight of 17,484 tons, a saving of six trains and 729 tons less dead weight in favor of the steel cars."

Some very attractive deductions are made in a paper by Henrik V. Loss, presented to the International Railway Congress at Paris last summer, entitled "A New Epoch in the History of Railway Transportation," which I recommend to railroad officers for careful reading if they contemplate equipment of high-carrying capacity and minimum dead weight. In conclusion it may also be of interest to present the following extracts from a report upon "Cars of Large Capacity," made by General Manager Loree, of the Pennsylvania Lines, to the same congress.

The large car, from a weight-carrying standpoint, seems every way desirable for many lines that have special traffic, such as ore, coal, stone, brick and metal, where the cars can be made to carry full loads in at least one direction. Every railroad of importance in the United States has spent large sums of money in reducing grades, improving alignment and remodeling yards. The weights of locomotives are being constantly increased, and to get the greatest earning power from these locomotives, and to secure the benefit of the large sums expended in improvements of road, it is necessary to have cars that will carry the greatest possible load without increasing the length.

There is a very large tonnage of ore and coal handled between the Great Lakes and the furnaces and mines located 150 to 200 miles distant therefrom. The ore is brought from Lake Superior regions in vessels, and transported from the various ports of Lake Erie to furnaces, from 50 to 60 per cent.

being forwarded direct from the vessels to the furnaces in cars without first being stored at the docks. These vessels a few years ago were of a maximum capacity of from 2,500 to 3,000 tons; now they carry as much as 8,500 tons. A quick despatch is required on the part of the vessel owner, which, under conditions prevailing five years ago, would be impossible, but by the use of the 100,000-lb. capacity car it has been accomplished, and the railroad companies are handling a much heavier tonnage over the same tracks, and, notwithstanding the earnings per ton-mile have been greatly cut down, they have been able to maintain a margin of profit.

A careful record taken of nearly 200,000 cars handled on two lines of railway leading from Pittsburg to two of the principal ports of Lake Erie shows that it was possible to secure the following loads for their cars:

- Ore, 108 per cent. of marked capacity.
- Coal, 82 per cent. of marked capacity.
- 3,616 of the 100,000-lb. capacity cars showed an average lading carried of 93 per cent.
- 136 of the 70,000-lb. capacity cars showed an average lading carried of 91 per cent.
- 6,727 of the 70,000-lb. capacity cars showed an average lading carried of 97 per cent.

Thus proving most conclusively that it was true economy under such conditions to build cars of greater capacity than 60,000 lbs.

The advantages gained by reducing the length of the train for a given tonnage, which are secured by the use of large capacity cars, are:

First.—The friction and atmospheric resistance are lessened, and by bringing the moving load closer to the locomotive it can be handled with greater ease.

Second.—A less number of cars and locomotives are required to move a given tonnage, saving interest on capital and car service, and lessening the empty-car movement in the direction contrary to the heavy-traffic movement.

Third.—The necessity of increasing the capacity of the main lines, freight yards and shops is avoided, and at the same time the cost of switching is reduced.

Fourth.—A large saving in wages results from the decreased number of trains.

Mr. Loree further says: "In 1895 the capacity was again increased by the building on the part of the Pennsylvania Lines West of Pittsburg of a large number of 70,000-lb. capacity self-clearing cars for the lake coal and ore trade; the forerunner of the 100,000-lb. capacity steel car, built on the same general lines, and which is now the recognized standard car for this class of traffic. It is largely by these means that the railroads have been able to reduce the cost per ton mile to a figure thought to be impossible several years ago."

On the line which I am connected with, the Chesapeake & Ohio, we started with the 80,000-lb. capacity wood car in 1897, building 100 self-clearing hopper bottom gondolas, since which time we have built of the same capacity 1,000 in 1898, 800 in 1899, and 1,500 in 1900. Our last order for new coal car equipment being 600 of the pressed steel 100,000-lb. capacity self-clearing hopper bottom C. & O. type coal cars.

The transmission of electric power over a line 153 miles long has been successfully accomplished by the Snoqualmie Falls Power Company, at Seattle, Wash. This plant is second in size to that at Niagara, the present output being 10,000 horse-power, which is distributed in and around Seattle and Tacoma. For the long distance test the various lines were coupled together in a continuous circuit beginning at the falls, running to Seattle, back to the falls, thence to Tacoma and back again to the falls. In regular service the transmission is 32 miles to Seattle and 44 miles to Tacoma. The current was furnished by a Westinghouse 1,500 kw. generator. The voltage was 30,000 with a total drop of 25 per cent.

EFFECTIVE LUBRICATION OF DRIVING BOXES.

It is generally understood by many who have experimented with methods of lubrication whereby oil is introduced at the sides of driving axle brasses, that an improvement may be made upon the admission of oil at the top or most heavily loaded portion of the bearing. It is also considered desirable to avoid the use of the oil cavity and oil holes at the top altogether. The problem is to introduce oil at the side or lightly loaded portions without danger of obstruction of the oil grooves by dirt and waste. In our October number, page 315, an interesting car journal brass was illustrated, which seems to be suggestive in this connection, in that it does not employ oil holes or grooves of any kind to get oil to the bearing surface (the holes in the top of the bearing being used merely to circulate the oil). We do not see why the same plan should not succeed in driving boxes. It is a very simple device and is apparently worth trying.

On many roads the top oiling method is still in use, but many admit that the arguments for side oiling are strong. They are

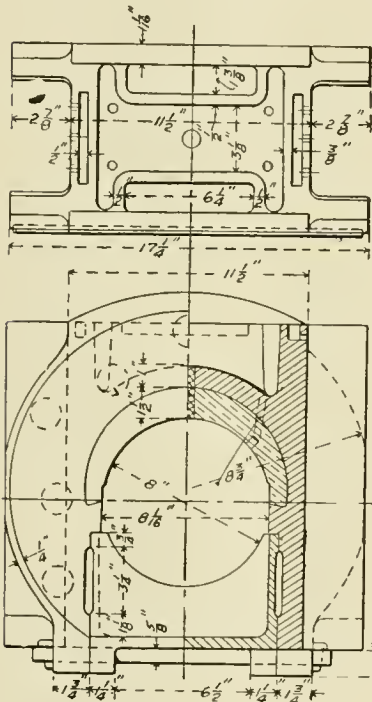

Fig. 1.

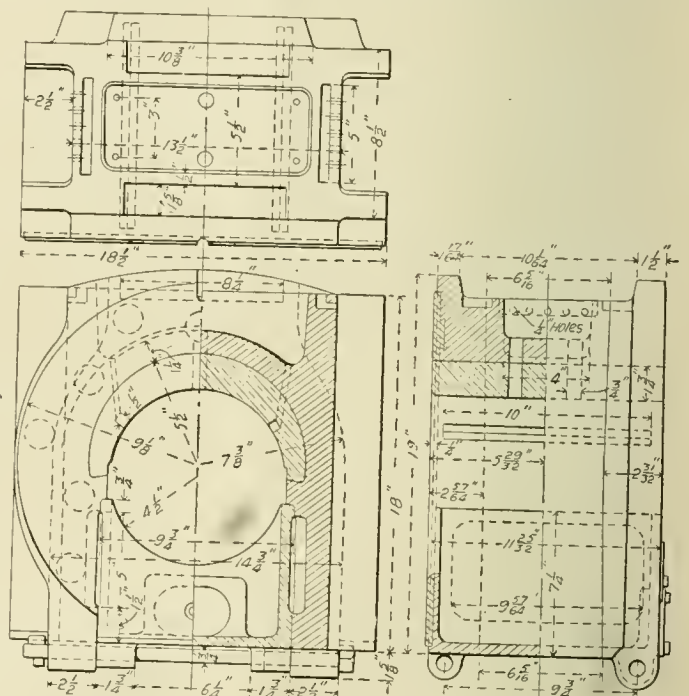

Fig. 2.

watching experiments in this direction before trying it themselves. To them the accompanying engravings will be interesting because they bring out several ideas which seem important.

The Master Mechanics' Association committee, reporting upon this subject last June, recommended slotting out the shells of driving brasses $1\frac{1}{4}$ ins. above the center of the axle, when its diameter is 9 ins., and others in proportion. For the location of the oil grooves at the sides they recommended cutting them $15/16$ ins. above the top of the clearance or $2\frac{9}{16}$ ins. above the center of a 9-in. axle. This would locate the grooves a little below points 45 degrees from the top of the bearing. It is desirable to place the grooves in zones of light pressure and yet get them high enough to prevent the oil from passing down past the journal altogether, which would occur if the grooves are too near the lower edges of the bearings. This mistake of placing them too low has been made in several cases and, when raised, satisfactory results were given at once. This change was recently made on five heavy consolidation engines which were giving a great deal of trouble, and the heating seems to be entirely overcome.

It will be seen on referring to Fig. 4 that but one groove

for side oiling is used on passenger engines on the Lake Shore and this is at the rear of the journal. For this service a simple groove will probably answer, because the engines very seldom, if ever, run backward. The groove at the front of the journal probably does no harm in forward running, but it may be expected to waste oil and carry it directly to the cellar.

Closely associated with the location of the oil grooves is the matter of cutting away the bearing surfaces of the brasses at the sides near the center of the axle, where no weight can be carried. This part of the brass does not serve any useful purpose. Its presence tends to scrape the oil from the journal and to cause the bearing to grip the journal when heated. It is not needed even when the brakes are applied.

The accompanying engravings illustrate several arrangements of the oiling grooves and clearances. A cast steel driving box for 8 by 9-in. journals is shown in Fig. 1, and a cast iron box for 9 by 12-in. journals in Fig. 2, both of these being by the Schenectady Locomotive Works. Fig. 3 is an $8\frac{1}{2}$ by 12-in. driving box of the Lake Shore & Michigan Southern. Fig. 4 is the brass for that design, and Fig. 5 illustrates a driving

brass of the Chicago Great Western with side oiling but no clearances.

Figs. 1 and 3 show two different ideas as to the shape of the clearances at the lower edges of the brass. In Fig. 1 these are straight, vertical cuts, extending $\frac{3}{4}$ in. above the center of the journal, while in Fig. 3 the clearances are radial and extend $1\frac{1}{2}$ ins. above the center. The radial form of Fig. 3 was preferred on the Lake Shore to the straight clearance, because it gives a cavity of uniform width between the brass and the journal. When the clearance is cut with vertical sides it produces a cavity which is wider on top than at the bottom. We do not know whether waste and dirt have actually collected in the straight cut clearances, but the radial cutting was done to avoid cavities which grow larger above the bottom of the brass with a view of guarding against such a possible difficulty.

In the Schenectady bearings the oiling is all done through the side grooves, which are located $3\frac{3}{4}$ ins. from the top of the 8-in. and $4\frac{1}{4}$ in. in the 9-in. journal, these distances being measured along the arc of the bearing surface. These grooves extend across the brass and terminate about $\frac{7}{8}$ in. from the edges. There is no opening at the top of the brass; what may at first to appear to be an oil hole here is a $\frac{3}{4}$ -in. brass pin

CENTER PLATES.

By Edward Grafstrom,

Mechanical Engineer Atchison, Topeka & Santa Fe Railway.

In the evolution of car design no detail of importance has been given less attention than the center plate. From the first plain sheet-iron plate with which the contact surface of the bolsters once was covered to prevent wear and give support to the king bolt, to the grooved, cupped or flanged types of to-day, there has been no transitory stage, but the increased train speed and freight-car capacity has demanded the abolishment of cast iron and made more reliable metals a necessity. The contour of the center plates seems to have been left to chance, or to the pattern-maker's or draughtsman's taste. Not until quite recently, since pressed steel center plates came into use, was it found advisable on some of the more progressive roads to define the contours, in order to avoid crushing or distortion under the heavy loads of the present day. The purpose sought was to obtain designs that could be reproduced in dies without injuring the metal, and little or no heed was given to what would otherwise be the most advantageous contour.

Such was the situation when the M. C. B. Association

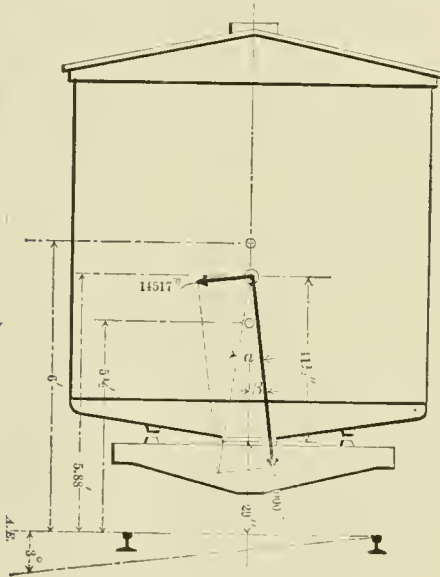

Fig. 1

charged a committee with the investigation of the subject last year. The report of this committee at the last convention shows a variety of opinions prevailing among car-builders, and the prejudices which will have to be overcome before any decisive action can be taken by the association on the subject. Further than this, the report contains suggestions as to the stiffness, dimensions and shape of center plates. Considering these suggestions in order, the first one being dependent on and subordinate to the others, can be disposed of here with the remark that the report covers the ground fully. As far as the dimensions of the center plates are concerned, however, the report is open to dispute.

Without stating the reasons for doing so, the committee assumes that a pressure of 400 lbs. to the square inch of bearing surface should be the rule for determining the dimensions of center plates. If the committee aimed to avoid the crushing of the metal, it need only be said that ten times the amount stated should not have been feared. If it was intended to avoid excessive wear, the committee's own observations, that the movement of the center plates on an 18 degree curve was imperceptible, seem to make this precaution unnecessary. The same applies to heating. Friction

did not form a basis for determining the pressure per square inch, for the report gives as an excuse for the generous bearing surface recommended that "the friction is as the weight to the number of inches on which it is distributed," which is supposed to mean that the friction is independent of the areas in contact, notwithstanding that in case of a large center bearing the friction has a greater leverage than with a smaller one.

The suggestion of this committee to establish 400 lbs. per square inch as a general rule for center plates appears most striking if taken in connection with the report of the com-

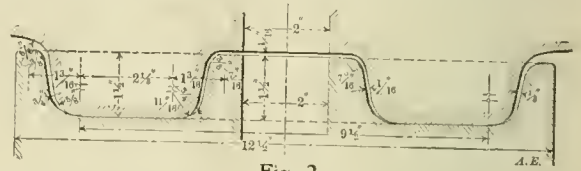

Fig. 2

mittee on side bearings, following immediately upon it, in which the opinion was expressed that 800 lbs. per square inch is considered proper. It should also be noted that that committee used a center plate with 1,405 lbs. pressure per square inch with very fair results. These differences would naturally lead one to think that within reasonable limits the pressure has nothing to do with the size of the center plate, or, in other words, a center plate good enough for a 60,000-lb. car will also answer for a 100,000-lb. car, providing that its thickness is sufficient to sustain the weight without bending or breaking. The convenience of having an interchangeable center plate for all equipment is indisputable. What, then, should the size of such a center plate be?

The tests which the committee on side bearings made show conclusively the advantage of carrying the load on the center plates with a clearance between the side bearings. If the center plates are sufficiently large for the resultant of the weight and the centrifugal force on curves to fall within the contact surfaces, all reasonable demands ought to be met. Though the momentum of the car may cause it to tilt over on the side bearing momentarily when entering a sharp curve, it would regain its equilibrium on the center plate at once. The first question is, therefore, to determine the angular deflection of the line of strain resulting from the combined forces which act on a car on a curve.

The accompanying diagram, Fig. 1, shows the position of a box car on a curve. The reason for selecting a box car is that its center of gravity is located higher and its centrifugal force on a curve is more in proportion to its weight than in other classes of freight cars. The speed of the car is assumed not to exceed 50 miles per hour; for such a speed a minimum curvature of 1,000 ft. is generally conceded to be good main-line practice. The outside rail is assumed to be elevated to

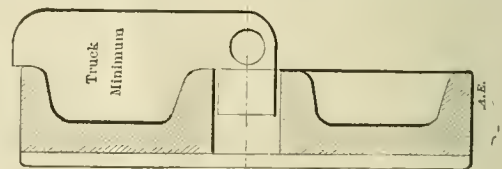

Fig. 3

an angle of 3 degrees, which is also believed to be in accordance with good practice. The center of gravity of the ordinary box car body, empty, has experimentally been found to be located about 5 1/2 ft. above the rail, and the center of gravity of the lading to be about 6 ft. The car body is assumed to weigh 21,000 lbs., and the lading is taken at 66,000 lbs. This makes a total weight of 87,000 lbs., with a resultant center of gravity located at a height of 5.88 ft.

An 80,000-lb. box car might have been selected instead, but,

as the principal difference of construction lies in the size of the floor sills, and in the deeper floor trussing, and as these cars are generally longer in order to carry the increased tonnage, the center of gravity will be found to come lower. The same applies to an 80,000-lb. gondola car, and also to a 100,000-lb. hopper car on which the load carried in the hopper below the floor lowers the center of gravity somewhat. For these reasons it is believed that a 60,000-lb. box car will give a fair average value for the purpose of this calculation.

For a speed of 50 miles per hour the centrifugal force of the car under consideration will be found to be 14,517 lbs. From the equation $87,000 \tan \alpha = 14,517$, α will be found to be 9 deg. 30 min. Subtracting from this the angle β , which is equal to the angle of elevation of the outside rail, or 3 deg., there remains 6 deg. 30 min. The contact surfaces of the center plates are generally about 29 ins. above the rail; subtracting this from 5.88 ft. leaves $41\frac{1}{2}$ ins. from the common center of gravity to the contact surfaces. This multiplied by the tangent for 6 deg. 30 min. gives the deviation of the line of pressure from the center line of the car in the plane of the center plates' contact surfaces, and will be found to be $4\frac{3}{4}$ ins. Twice that amount, or $9\frac{1}{2}$ ins., will therefore be the necessary diameter of the contact surfaces of the center plates, under the conditions named.

The writer has designed a set of center plates based upon these calculations, illustrated in Fig. 2. The diameter of the

manufacturers. With the clearance mentioned this variation is not sufficient to cause a body center plate of the maximum size to bind with a truck center plate of a minimum size. The use of these gauges is shown in Fig. 3.

Considering, finally, the cup or ball shape center plate, there is no need of adding anything to the committee's condemnation of this form. Attention should be called to the fact, however, that with this style of center plate the friction increases as the radius of the bearing surface decreases, if the outside diameter of the latter remains the same, just as a tapering plug valve turns with more difficulty the less taper it has. To further illustrate this, take the center plate shown in Fig. 4, which in form and dimensions represents a common type in use on thousands of cars. By applying the principle of the parallelogram of forces, the weight, W , on the center plate may be divided into a number of components distributed in the conical plane, A, B, C, the sum of all of which will be found to be 12 per cent. more than W itself, and as the friction is proportionate to the pressure, it follows that the resistance to curving is 12 per cent. greater with a center plate of the form and dimensions shown than with a flat center plate of the same outside diameter.

A LOCOMOTIVE MUSEUM.

The trustees of Purdue University recognize the fact that certain classes of locomotives which have long done service on American roads are now giving way to newer and heavier machines. In the natural order of events the old will be converted into scrap, and unless an effort is made to preserve them, designs which have been familiar to past generations will completely disappear. The occasion calls for a collection of typical machines and it is believed that it is not inappropriate that Purdue should take the initiative in forming one. In accomplishing its purpose, the University must necessarily depend upon the co-operation of railway companies. It asks, therefore, that roads having engines which for any reason are distinctive, consider the advisability of preserving a sample at Purdue. It is not expected that engines will be offered so long as they are useful to the roads owning them, but only that as engines are put out of service, one be sent to Purdue, instead of being scrapped. It is not asked that any transfer of ownership be made. The University is prepared to agree to meet transfer charges, to house and to otherwise care for engines thus deposited, and to hold the same at all times subject to the order of the owner. The fact should be noted that it is not the purpose of the University to collect engines for the purpose of securing numbers. The engine to be desirable must be distinctively different from others of the collection.

Three engines have already been secured. One of these is to come as a gift from a Western road, which for the present desires its name to be unknown. It is of the 8-wheeled American type, as built thirty years ago. It represents the class of engine which first performed the transcontinental service of our country. The second engine is to come through the courtesy of the Baltimore & Ohio Railway and represents the "camel-back" type, which has so long been in service upon that road. The third is the English engine "James Tolman," which was exhibited at the World's Fair in 1893, and which has since been in the keeping of the Chicago, Milwaukee & St. Paul Railway. There is needed of the old class of engines one of the single-driver type and one having inside cylinders; also, types of switching engines. As time goes on a representative of the higher class of mogul and consolidation will doubtless be obtainable.

For the accommodation of such engines as have already been assured, a rough shed will be provided; but in time it is hoped that a suitable engineering museum building will be provided which will serve as a place of deposit for the very large amount of museum material which is now either the property of Purdue or has been intrusted to its keeping.

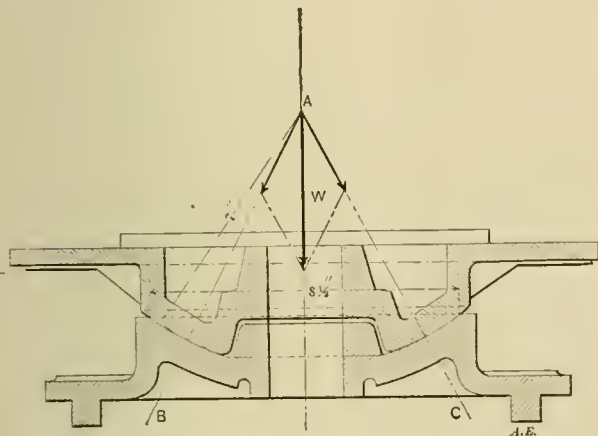
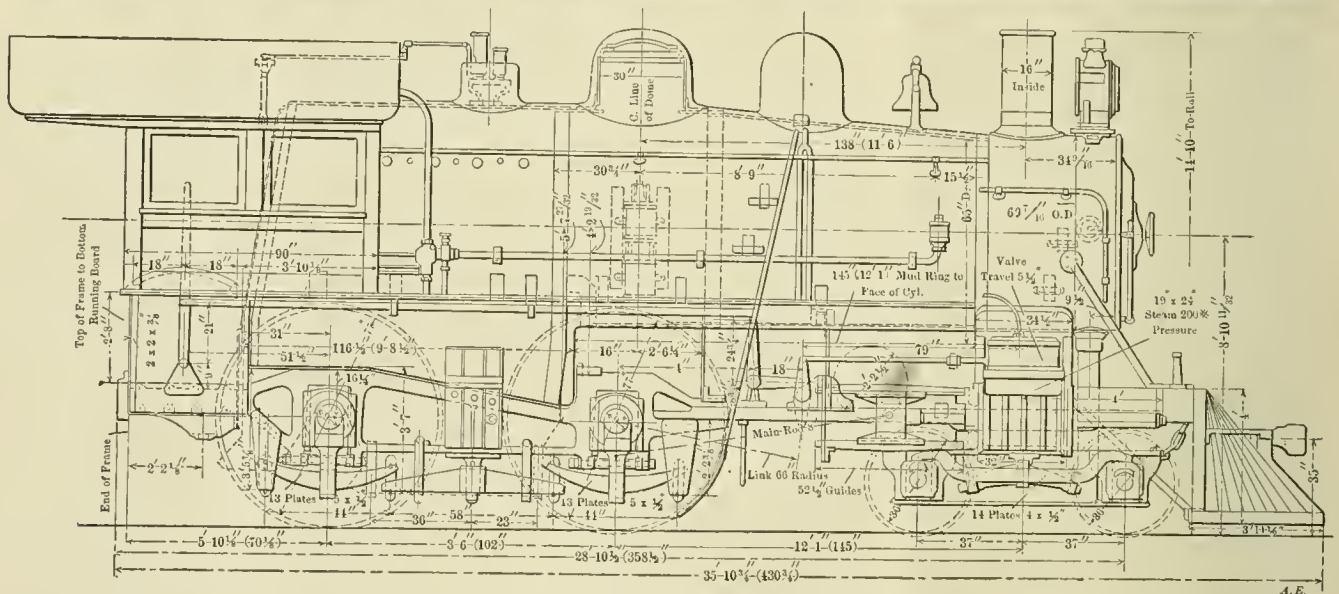
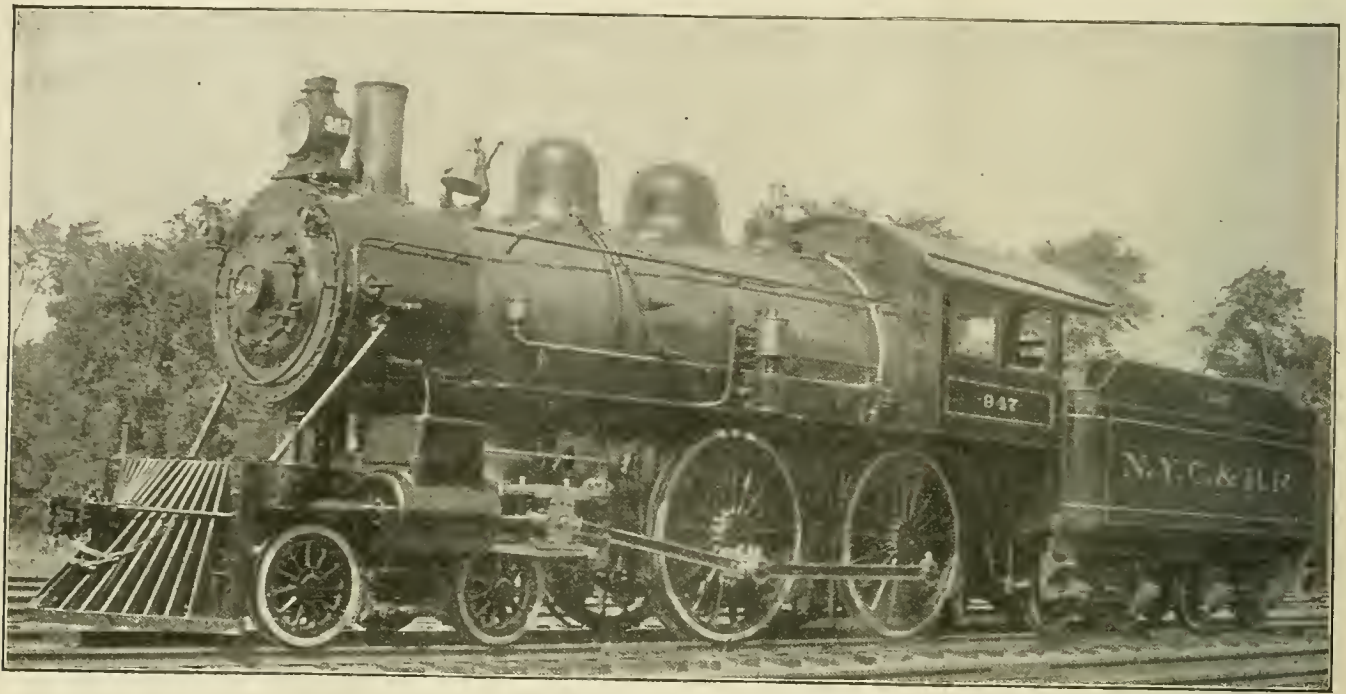

Fig. 4

bearing surfaces is $9\frac{1}{2}$ ins., and the outside width is $12\frac{1}{2}$ ins. The actual bearing surface of each is 50 sq. ins., and the approximate static pressure is 870 lbs. per square inch. The guiding surfaces are made sloping sufficiently to enable these center plates to be reproduced either as castings or in pressed steel. The concave fillets in the truck center plate are of a larger radius than the corresponding corners of the body center plate, the object being that if the car body is jolted to one side, the body center plate will commence to climb up on the fillet in the truck center plate, whereby the side thrust will be expended before the guiding surfaces of the center plates come together with the force of a blow, on the same principle as the fillet of a wheel flange is made of a larger radius than a corner of the rail head. The clearance between the center plates is only $1/16$ in. at the hub, while it is $1/8$ in. at the rim, and the guiding is therefore done at the hub, where the friction has the shortest leverage. Center plates of this pattern and of these dimensions have been introduced to some extent on three important railroads under cars of from 60,000 to 80,000 lbs. capacity, as well as under heavy tenders, the total number in use so far being approximately 4,000 cars and tenders.

In order to insure a good fit a set of templets or gauges has been devised for ascertaining the maximum or minimum dimensions permissible, a variation of $1/32$ in. from the normal contour, or a total variation of $1/16$ in. being allowed the



EMPIRE STATE EXPRESS LOCOMOTIVE.

NEW YORK CENTRAL & HUDSON RIVER R. R.

MR. A. M. WAITT, *Superintendent of Motive Power and Rolling Stock.*

NEW "EMPIRE STATE EXPRESS" LOCOMOTIVE.

New York Central & Hudson River Railroad.

This engine is described with a feeling that in a sense it is the last of its race. It is difficult to realize the progress of locomotive design until, in glancing over recent notable engines, one is struck with the passing of the 8-wheel type. The appreciation of boiler power has led to a reluctant discarding of this type for the hardest passenger service, but the type still occupies an important place in other service, and if very fast, light trains were as common in this country as in England and France, the 8-wheel engine would undoubtedly remain the favorite. The tendency, however, in this country is toward heavier trains.

Mr. A. M. Waitt, of the New York Central, recently designed and built the handsome engine of this type which is illustrated in the accompanying engraving. It is an improvement upon the similar designs which have been widely known as representing Mr. Buchanan's idea of a passenger engine, and which have hauled the Empire State Express for a number of years. It

was found necessary to strengthen the frames and enlarge the boilers, and this led to an entirely new engine, with the same sized cylinders and driving wheels as before. The boiler is 65 ins. in diameter, it has a sloping back head and radial staying, the heating surface being 2,404 sq. ft., which, with the exception of the passenger engines of the Chicago & Northwestern (described on page 224 of our July issue, 1899), is the largest for 8 wheels of which we have record. The Northwestern engine has 2,507 sq. ft. The heating surface of the earlier engines was 1,900 sq. ft. The grate area of the new one is 30.7 sq. ft., which is the same as before. The total weight of the engine is 146,400 lbs., and that on drivers 94,400 lbs. The tender weighs 108,000 lbs. Only one of these engines has been built, but there is another under way. For this particular train the service given has been very satisfactory, but it hardly need be said that this is an indication that this famous train is not difficult to handle. The boiler, cylinders, frames and tender were built at the Schenectady Locomotive Works, the work having been completed at the Depew Shops of the road. Mr. Waitt changed from the four-bar to the alligator cross-head and improved the engine in many ways, but without making radical changes.

LOW DROP-BOTTOM GONDOLA CAR, 80,000 LBS. CAPACITY.

Chicago & Northwestern Railway.

This new car is interesting because of the trussing, the depth of the body bolsters, the use of three needle beams, the stiffening of the siding, and, chiefly, because the design has been approved for adoption on the Chicago & Northwestern; the Chicago, St. Paul, Minneapolis & Omaha; the Fremont,

The drop doors, eight in number, close flush with the lower faces of the side sills. They are hinged to the three needle beams as shown in the side elevation and section. Mr. Schroyer has obtained unusual depths of trussing of the car body and also of the body bolsters. The lower bearings of the truss rods are 33 ins. below the upper faces of the side sills and four of the six truss rods support all of the needle beams. The trussing is clearly shown in the side view and transverse

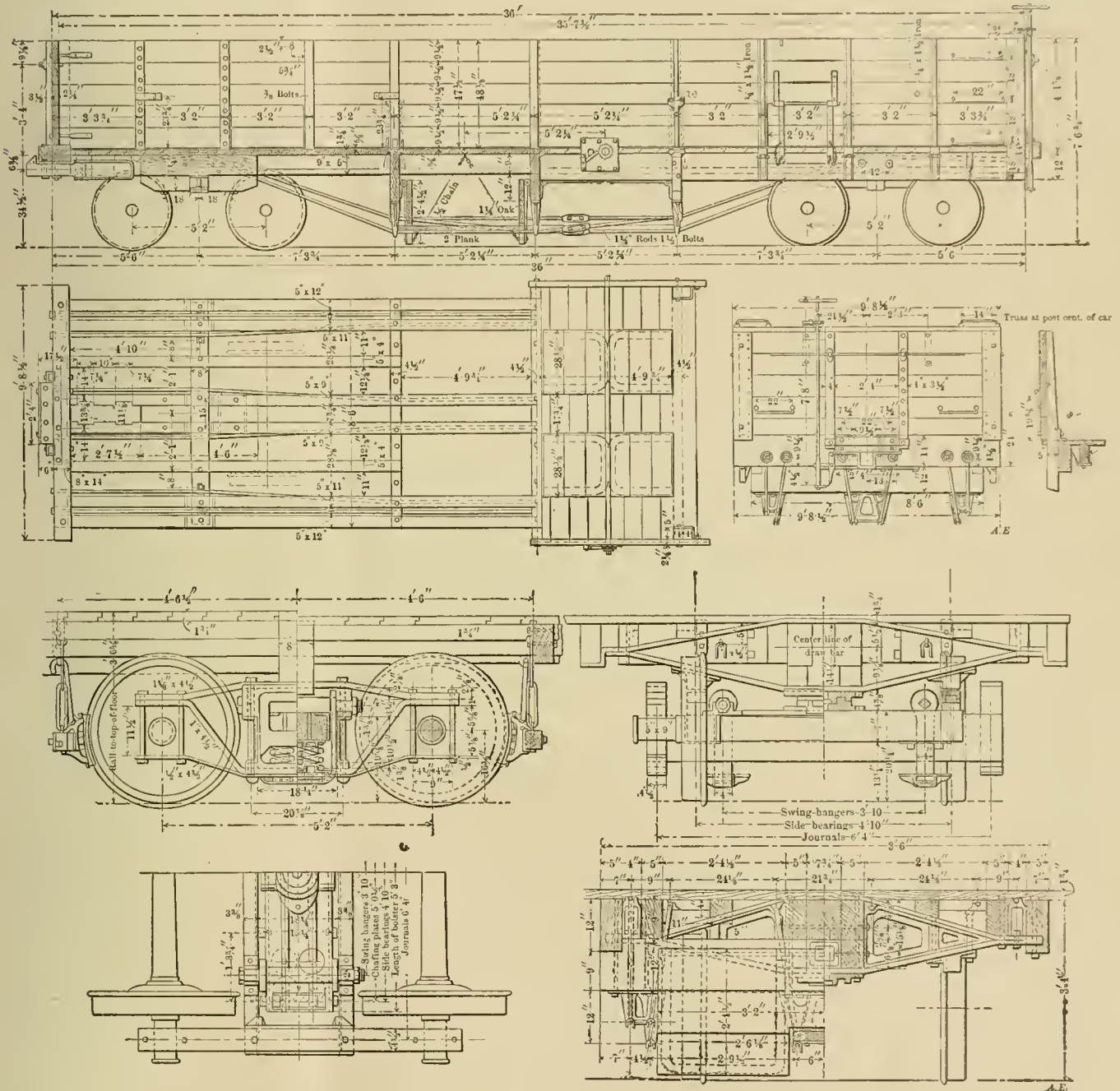

Low Drop-Bottom Gondola Cars, 80,000 Pounds Capacity.

CHICAGO & NORTHWESTERN RAILWAY.

MR. C. A. SCHROYER, Superintendent Car Department.

Elkhorn & Missouri Valley, and the Sioux City and Pacific lines, all of which are allied with the Chicago & Northwestern. The drawings have been received through the courtesy of Mr. C. A. Schroyer, Superintendent of the Car Department of the last-mentioned road:

Chief Dimensions of the Cars.

Length over end sills.....	36 ft. 0 ins.
Width over side sills.....	8 ft. 6 ins.
Length inside of box.....	35 ft. 7 1/2 ins.
Width inside box.....	9 ft. 4 ins.
Height, rail to top of sides.....	7 ft. 6 1/2 ins.
Height of siding.....	4 ft. 1/8 in.
Cubical capacity.....	1,365 cu. ft.

section. The needle beams are 4 1/2 by 12 ins. in section. The side sills are 5 by 12 ins.; the outside intermediates and the center sills, 5 by 9 ins., and there are also two 4 by 5-in. sills at each end of the car between the end sills and the outer needle beams. The queen posts at the center of the car are braced by a 2-in. plank shown in the side and end views.

The body bolsters are 15 1/8 ins. deep. The top plate is 7/8 by 8 ins., with 4-in. shoulders at the ends, and the lower plate is 1 1/8 by 8 ins. The bolster plates are held apart by a large casting, and there is also a filling casting between the bolster

filling blocks. The center sills are reinforced at the draft rigging by $\frac{3}{8}$ by 7-in. plates 4 ft. 6 ins. long.

In addition to the drop doors the car has two side doors at diagonally opposite corners, one of which is shown in the side view. All of the longitudinal sills are of long-leaf yellow pine, the end sills, needle beams, buffer blocks and stakes are of white oak, and the siding of Norway pine. The bracing of the side stakes is shown in one of the detail views.

In the drawing of the truck another form of bolster is shown which is a little shallower than the one mentioned, but this view is reproduced to illustrate the swing motion truck without the sand plank, a plan followed by Mr. Schroyer for several years. This is a low truck. It brings the floor of the gondola car 3 ft. 6 ins. from the rail, and the same truck with a box car makes this distance 3 ft. $5\frac{3}{4}$ ins. Other details will be apparent in the drawings.

NEW SHOPS OF THE COLORADO & SOUTHERN RAILWAY.

Denver, Colorado.

An entirely new car and locomotive-shop plant has been constructed by this road at Seventh Street, near the Union Station in Denver. In view of the fact that plans are being pre-

pared on several roads for new shops, a description of this plant is particularly timely.

The distance from the Union Station is about a half mile, and the shops and switching yards are brought together in the same plot. The office building containing the offices of Mr. A. L. Humphrey, Superintendent of Motive Power of the road, and the Master Mechanic, is a building 38 ft. 5 ins. x 64 ft., the store department being housed in an adjoining building 32 ft. 3 ins. by 101 ft. in size, with a platform 48 ft. in width and extending about 225 ft. beyond the end of the storehouse, where it terminates with an incline leading into two low platforms, 16 ft. wide by 150 ft. long. The transfer table, which is 70 ft. wide and 400 ft. long, extends the full length of the machine and car shops and reaches to the storehouse platform.

The machine shop has a transverse track arrangement and is 125 ft. by 323 ft. 5 ins. in size. At the south end the blacksmith shop occupies a length of 57 ft., and adjoining the blacksmith shop is the power house. A 50-ton, 65-ft. traveling crane will be erected in the locomotive shop. There are 12 tracks with concrete pits in the erecting shop, and opposite each track is a door sliding vertically.

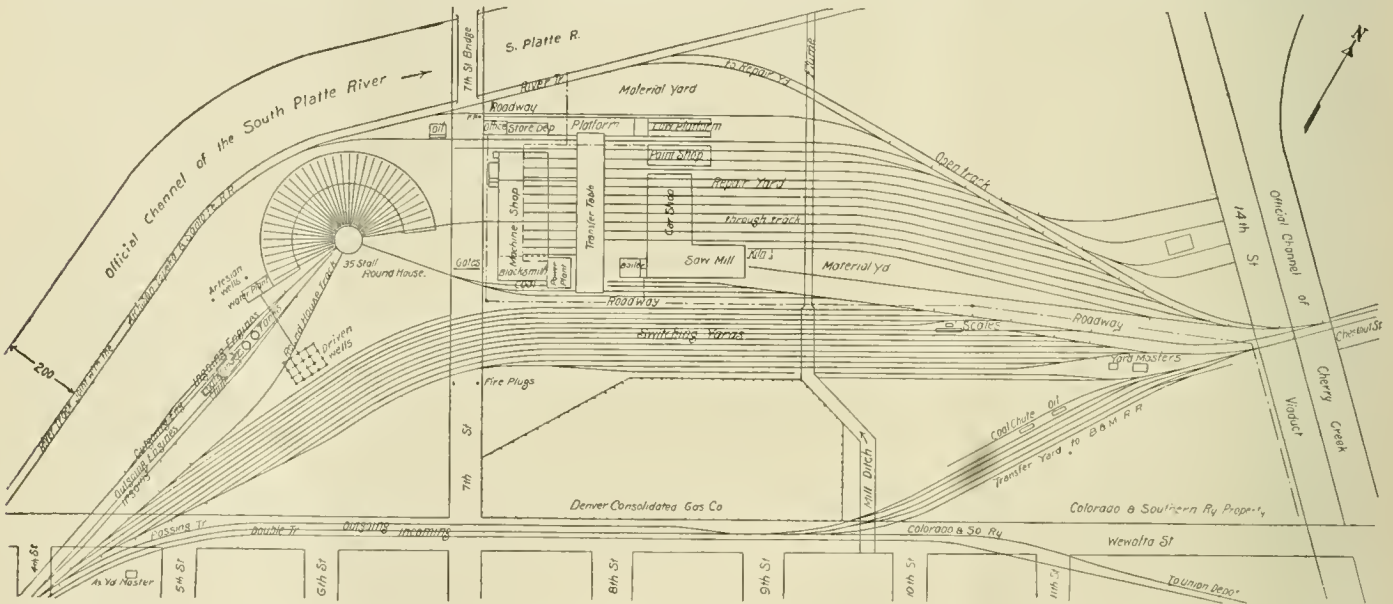

Plan of New Shops of the Colorado & Southern Railway at Denver, Colo.

pared on several roads for new shops, a description of this plant is particularly timely.

The distance from the Union Station is about a half mile, and the shops and switching yards are brought together in the same plot. The office building containing the offices of Mr. A. L. Humphrey, Superintendent of Motive Power of the road, and the Master Mechanic, is a building 38 ft. 5 ins. x 64 ft., the store department being housed in an adjoining building 32 ft. 3 ins. by 101 ft. in size, with a platform 48 ft. in width and extending about 225 ft. beyond the end of the storehouse, where it terminates with an incline leading into two low platforms, 16 ft. wide by 150 ft. long. The transfer table, which is 70 ft. wide and 400 ft. long, extends the full length of the machine and car shops and reaches to the storehouse platform.

The machine shop has a transverse track arrangement and is 125 ft. by 323 ft. 5 ins. in size. At the south end the blacksmith shop occupies a length of 57 ft., and adjoining the blacksmith shop is the power house. A 50-ton, 65-ft. traveling crane will be erected in the locomotive shop. There are 12 tracks with concrete pits in the erecting shop, and opposite each track is a door sliding vertically.

transfer table pit. The transfer table has a speed of 175 ft. per minute when carrying a 240,000-lb. engine. A capacity of 1,200 cu. ft. of free air per minute is provided for in two Rand air compressors in the power house.

The saw mill and car shop form an L-shape building, the saw mill being 50 ft. by 244 ft., the shape of the building and the arrangement of the machinery being such as to permit the material to pass through it continuously from end to end without unnecessary handling. A somewhat unusual plan is followed by placing the car-wheel machinery, wheel press and nut-tapping machines on one side of this building in order to get it out of the machine shop and locate it near the car work. In the mill the power is distributed entirely by motors. The mill has a cement floor.

7 ft. of the surface of the ground. It is raised by two 1,000-gal. pumps in a small building adjoining the round house. The tanks shown on the plan each have a capacity of 50,000 gals. The water from the driven wells is used for washing out boilers and for the lavatories, which are, by the way, unusually complete, while the water for boiler use comes from two artesian wells near the pump house, which are sunk to a depth of 700 ft. From these the water is raised to the second tank by an air lift. The arrangement of the tracks leading to the round house is indicated clearly in the engraving.

The plans and construction were carried out by Mr. H. W. Cowan, Chief Engineer, with the co-operation of Mr. A. L. Humphrey, Superintendent of Motive Power. Special care has been taken with the lighting of the buildings, which is seen in the fact that the pits in the erecting shop are all fitted for lamp connections to avoid the use of torches. The other details of lighting are equally complete. This is mentioned, however, because it is unusual.

The entire work of construction has been accomplished since last July.

A BROAD VIEW OF LOCOMOTIVE DESIGN.

Building for the Future.

An Address by W. H. Marshall.

Because of his thorough appreciation of the necessity for considering the needs of the future in view of the rapid advances in the requirements of locomotives, and his well-balanced ideas concerning the subject in general, an address delivered recently by Mr. W. H. Marshall, Superintendent of Motive Power of the Lake Shore & Michigan Southern Railroad, before the students of Purdue University, is an exceedingly important contribution at this time. We regret that we cannot reproduce it in full, but shall, however, attempt to indicate its most important points.

After briefly mentioning the advance in the capacity of locomotives during the past ten years, Mr. Marshall considers the question of design as influenced by the demand for increasing the proportion of revenue freight to the total load hauled, than which in all the field of railroad expenditures no greater possibilities of saving exist. This is the direction in which the largest economies are to be effected, and it explains the remarkable increase in the size of locomotives. If motive power officials perform their full portion of this work they will accomplish more in the reduction of expenses for the companies they serve than can be achieved through shop practices and routine work of their departments, important as these are.

When large freight power is wanted, the first question is, how heavy shall the engine be? The author of the paper is positive upon this point, and says: "If the finances will permit it, the spirit of conservatism should not prevent the transition by a single step to the most powerful engine the road can use. Unless the physical condition of the road establishes other limits, I would say as a general proposition that the road should not only build the largest engines that can be used advantageously to-day, but, if possible, should meet the conditions that will prevail in the future, say five or ten years from to-day."

He directs attention to the fact that the length of trains being limited, the lighter capacity cars will disappear in the time mentioned, and trains will be composed of 30, 40 and 50-ton cars, which will require an engine weighing, say, 170,000 lbs. on the drivers. The tendency to improve the loading of freight cars is an additional reason for building heavy engines. Considering the life of a locomotive as 20 years, we ought not to build merely for to-day, but for years in advance.

The next important item is the selection of the type. After determining the number of driving wheels required, the question of the truck remains. Mr. Marshall is satisfied with the safety of the two-wheel leading truck, and the question of

design, then, rests upon whether the limit of weight is that upon the driving wheels or the total weight of the engine. Where weight on drivers is limited, and not the total weight of the engine, the four-wheel truck permits of increasing the boiler capacity. It is stated as a general proposition that a four-wheel leading truck should not be used in any modern design of heavy freight engines unless it is employed to increase the boiler capacity through additional weight which can not be placed upon the driving wheels.

The question of speed of fast freight trains next receives attention. The author believes that speeds of 25 and 30 miles an hour can be handled better with a large engine than with a small one, provided proper care is taken in the matter of details of construction. For moderate grades he considers 62 or 63 ins. a satisfactory diameter of the driving wheels, and reports excellent service with wheels of this diameter under consolidation engines of the Lake Shore road, which have now been running more than a year. While the larger wheels require large cylinders and additional strength in the frames and running gear, and on this account involve additional weight, a substantial gain is had from the fact that the motion of the machinery is slower for a given speed, which saves in maintenance and reduces engine failures. He considers the advantages to lie greatly in favor of the large wheel.

It is noted that the eight-wheel type is unable to meet the demands of the heaviest fast passenger service. More wheels are required, and the question is: "After the eight-wheel engine, what next?" In his answer to this question Mr. Marshall makes what appears to us to be a most important and thoughtful suggestion, which is commended to the consideration of those who are now working out designs for new passenger locomotives. Far sightedness in this connection is needed. While giving a high place to the recent Atlantic-type designs, Mr. Marshall believes that ultimately the limited amount of weight of this type for tractive purposes will lead to the adoption of some other type of engine for the heaviest of passenger service. For this work three pairs of drivers are needed. The question is often asked why so much tractive weight is necessary when it can be utilized to the utmost only in getting away from stations, the mean pressure of the pistons being too small at high speeds to utilize greater tractive weight. Mr. Marshall reasons that without it engines can not start trains of from 12 to 15 cars without taking slack, and to back one of these heavy engines against a passenger train until all the draft springs are compressed and then reverse it suddenly, allowing it to surge ahead, is not only destructive to the couplers throughout the train, but is very unpleasant to passengers. Furthermore, after the train is in motion the weight on two pairs of drivers is not sufficient to utilize the full cylinder power from the first quarter of a mile from the station if the rail is slippery. These two conditions occasionally involve serious loss of time, which must be made up.

The ten-wheel design would be preferred if it were possible to get a wide grate over driving wheels of, say, more than 72 ins. in diameter, but Mr. Marshall is thoroughly convinced of the importance of six coupled wheels combined with the wide grate, and with large driving wheels would prefer an arrangement of wheels similar to that of the Prairie type of the Burlington.

While there are many other important parts of the address which we would like to comment upon, the ones already mentioned seem to be most vital, and others will be referred to later.

The selection of Saratoga as the location of the next conventions of the Master Mechanics' and Master Car Builders' Associations will please all concerned, because, all things considered, it is the most satisfactory meeting-place. This year the order of the conventions is to be reversed, and the Master Mechanics' Association is to hold its sessions first. They will begin on Wednesday, and the Master Car Builders on the following Monday, with Sunday between the two conventions. At the executive committee meeting at which these details were arranged the committee on draft gear was authorized to spend \$1,500 in securing information for its report, and a valuable presentation of the subject is thus assured. There can hardly be a more important topic before the association this year than that of draft gear.

FOUR-WHEEL STEEL FRAME TRUCK AND STEEL FRAME DRAFT GEAR

For Passenger Equipment. Lake Shore & Michigan Southern Railway.

Passenger trucks for heavy cars have received considerable attention of late and several designs have been prepared with

In the accompanying engraving, made from drawings received through the courtesy of Mr. H. F. Ball, Mechanical Engineer of the Lake Shore & Michigan Southern, this idea has been developed further and steel frame construction used in place of wood. This design is in a degree experimental, but it seems to be well carried out and is promising of still further development. The first consideration was to secure a stiff frame which

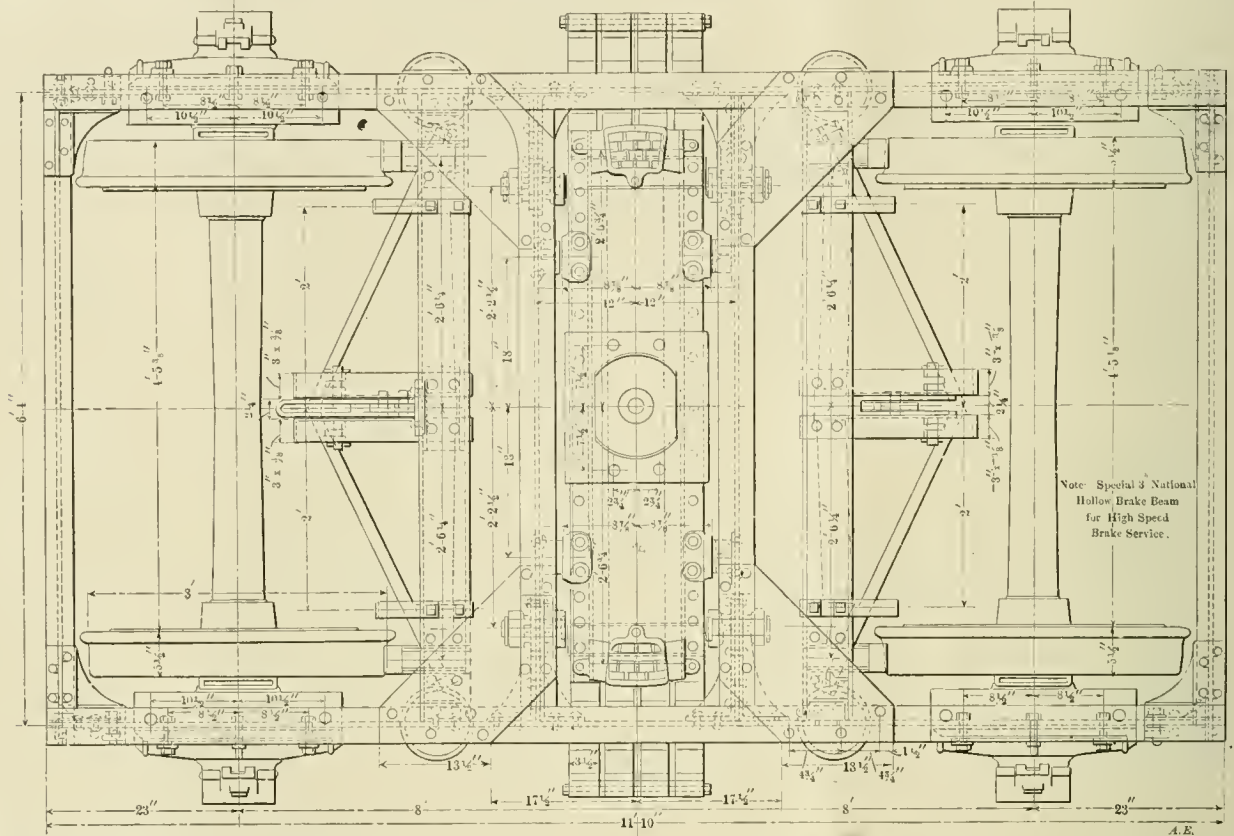

a view of improvement in this important element in car design. There is an evident desire to get down to a four-wheel truck and to this without sacrifice of safety, the 5 by 9 in. axle is employed. There has been no attempt, so far as we know, by any railroad in this country to make any change in the general plan of spring and equalizer suspension, the usual construction in this respect being followed. Saving in weight and first cost of trucks is desired and this is accomplished by a reduction in the number of parts, such as frame stiffeners, wheels, axles, boxes and bearings. The four-wheel truck recently designed and constructed for the Illinois Central and illustrated on page 306 of our October number indicates in a general way the tendency.

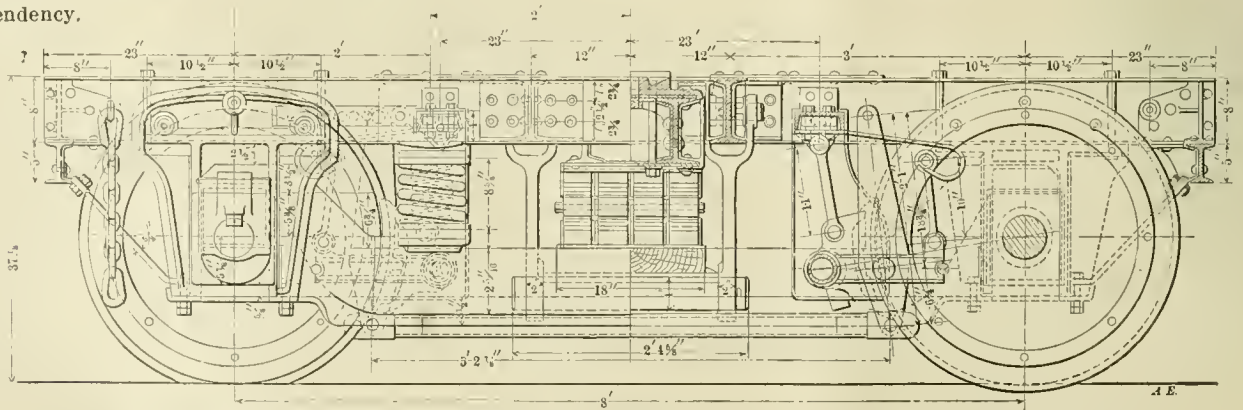
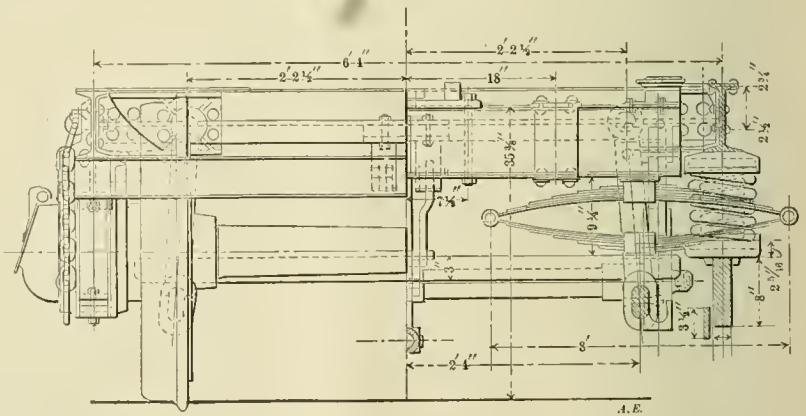

Four-Wheel Steel Frame Truck, Lake Shore & Michigan Southern Ry.—Plan Side Elevation and Section.

tween centers and the ends are welded in. The pedestals are of the usual form, except as to their upper parts, which are shaped to make secure joints with the side frames. They have a full bearing on the lower faces of the frames, and are slipped into place from the side of the frame and securely bolted from the outside, their form being shown in the detail drawing. Attention should be called to the bracing of the frame, this and the methods of securing the joints of the members being clearly indicated in the engravings. These trucks were designed for use under postal cars. The brake beams are the special 3-in. National hollow type for the high-speed brake.

We also show drawings of a new steel platform and draft gear for passenger equipment on this road. This draft gear has only three essential parts—two 6-in. draft channels and a steel casting secured between them. It is illustrated as applied to postal cars. At the outer ends of the draft arms substantial cast steel brackets are fitted. These are best shown in the end view and elevation. By means of these castings, in which the safety chain draft rods and springs are attached, the pulling stresses from the safety chains will still be carried by the draft beams in the event of the breaking or parting of the couplers.

HIGH-SPEED SUBURBAN SERVICE BY WATER.

An interesting development of high-speed marine suburban service for New York City is promised for next summer. Mr. A. S. Guerber, a wealthy resident of Nyack-on-Hudson, has placed with Mr. Charles D. Mosher, the naval architect, an order for three fast twin-screw passenger steamers to run from New York to Nyack, stopping at Yonkers, Dobb's Ferry and Tarrytown. The distance is 30 miles by water, and the boats, with a speed of 35 miles an hour, are to make the trip in an hour, including all stops. According to the "American Shipbuilder" the boats will be of steel throughout, 150 ft. long, 15 ft. beam and 4½ ft. draught. The hulls will be divided into seven water-tight compartments, and each boat will accommodate 250 passengers. They will have a women's saloon 30 ft. long by 14 ft. wide, and a broad companionway will lead to the women's boudoir on the deck below. The men's saloon will be 55 ft. long by 14 ft. wide, and below it will be the smoking room. Above the saloons will be a promenade deck, extending nearly the whole length of the vessels, where the life boats will be swung. The lighting will be by electricity throughout. The models will be graceful, with sharp bows. The machinery will consist of twin quadruple-expansion engines of 4,000 horse-power and complete auxiliary machinery. In this way a high-speed marine suburban service of considerable interest will be installed and the plan appears likely to become popular, especially to those who are now obliged to brave the discomforts of smoky, dark, hot tunnels in which New York abounds.

Mr. Mosher is known by a number of successful high-speed boats: "Norwood," "Ellide," which made 35 knots; the "Arrow," which is expected to make 40 miles, and others.

CHANGES AMONG THE RAILROAD PAPERS.

Mr. Willard A. Smith, who has owned and conducted the "Railway and Engineering Review" for many years, and has been closely identified with technical railroad newspaper work, has decided to resign from the management of the Cloud Steel Truck Company and return to the direct management of that publication. While for several years his attention has been directed in other lines, including an important commission in the Chicago World's Fair, the Paris Exposition and the supply of railroad equipment, he has retained his interest in journal-

ism and we welcome his return to active management of the journal which represents his life work.

Mr. Bruce V. Crandall, who has for several years managed the "Railway and Engineering Review," the "Railway Master Mechanic" and the "Official Railway List," of Chicago, has severed his connection with the first-named publication and bought the "Railway Master Mechanic" and the "Official Railway List." Mr. Walter D. Crosman, who has so ably conducted the "Railway Master Mechanic," will continue in editorial charge, and his marked ability, combined with Mr. Crandall's attributes as a business man, assure an increased success to the publications.

The "Railroad Car Journal," in its December issue, announces that with the next issue it will change its name and character and merge into a new publication, entitled "Railroad Equipment," with a new policy and field. The "Railroad Car Journal" was established in 1891 and has been devoted exclusively to the car departments of railroads. Its field was becoming too small, and the editorial announcement states that its exclusive character had become prejudicial to its standing and value because of the transition which has placed the car departments in a subordinate position under motive power officers. This led to the decision to enlarge its field to include railroad equipment of every class. Its leading feature will be a department entitled "The Railroad Digest," which will present abstracts of all articles appearing in the railroad journals of the world, with particular reference to the construction, maintenance and operation of railroad equipment. Mr. Albert G. Glover, who has had a wide newspaper experience, and Mr. Edward A. Phillips, formerly editor of the "Railroad Car Journal," assisted by Mr. G. S. Hodgins, will conduct the new publication, and we wish them and "Railroad Equipment" success in the new enterprise.

A copy of the J. G. Brill Company's 1901 catalogue, illustrating and describing their patented round-corner seat-end panel for open cars, has been received. The pamphlet, besides giving full-page half-tone engravings of several styles of open cars, shows line engravings, reproduced from working drawings, of the details of the round-end seat and its application. By making car seats with a round end the objection to the ordinary seat panel and the cross-seat open car in general is largely removed. Many advantages are given for this new idea of round-end seat, one of which is the ease of entering the car. Instead of the sharp projecting corners, the openings from the sides of the car are funnel-shaped. The safety to passengers is increased, the car has the same capacity as the old style, and in stormy weather dryer seats will result from the ease of operating the curtains, which drop to the floor. The car makes quicker time on account of the greater ease with which people may enter and leave, and the appearance of the car is improved. The catalogue also gives a list of the more important railways using these panels on open cars.

"The Pittsburgh Special"—a new train, No. 24—was established Nov. 25th on the Pennsylvania Lines. This train, which is now running daily from Chicago to Pittsburgh, is for Pittsburgh passengers from Chicago and the West, and is made up of drawing-room, buffet, sleeping car and coaches. It leaves the Chicago Union Station at 8.00 every evening and arrives in Pittsburgh at 8.30 the next morning. Lunch or light supper is served after leaving Chicago, and a light breakfast may be enjoyed before arrival at Pittsburgh. This special has no connection east of Pittsburgh, so that only tickets from Chicago to Pittsburgh and intermediate stations at which this train is scheduled to stop will be honored on it. The Pennsylvania Lines have also increased their through car service between Toledo and Washington, D. C., by a new sleeping-car line. The new service offers an opportunity to leave Toledo at 5.08 P. M. and arrive in Washington at 1.00 P. M. the following day.

VAUCLAIN COMPOUND CONSOLIDATION LOCOMOTIVES.

Union Pacific Railway.

Deliveries on a large order of 60 Vauclain compound consolidation locomotives for the Union Pacific Railway have begun by the Baldwin Locomotive Works, one of the engines being illustrated in the accompanying engraving. These engines are powerful, but

Engine truck wheels, journals	6 x 10 ins.
Wheel base, driving	15 ft. 3 ins.
Wheel base, rigid	15 ft. 3 ins.
Wheel base, total engine	23 ft. 11 ins.
Wheel base, total engine and tender.....	53 ft. 5 1/2 ins.
Weight on drivers	161,020 lbs.
Weight on truck	24,300 lbs.
Weight, total engine	185,320 lbs.
Weight, total engine and tender.....	305,000 lbs.
Tender, diameter of wheels.....	33 ins.
Tender, journals	5 x 9 ins.
Tender, tank capacity.....	6,000 gals.

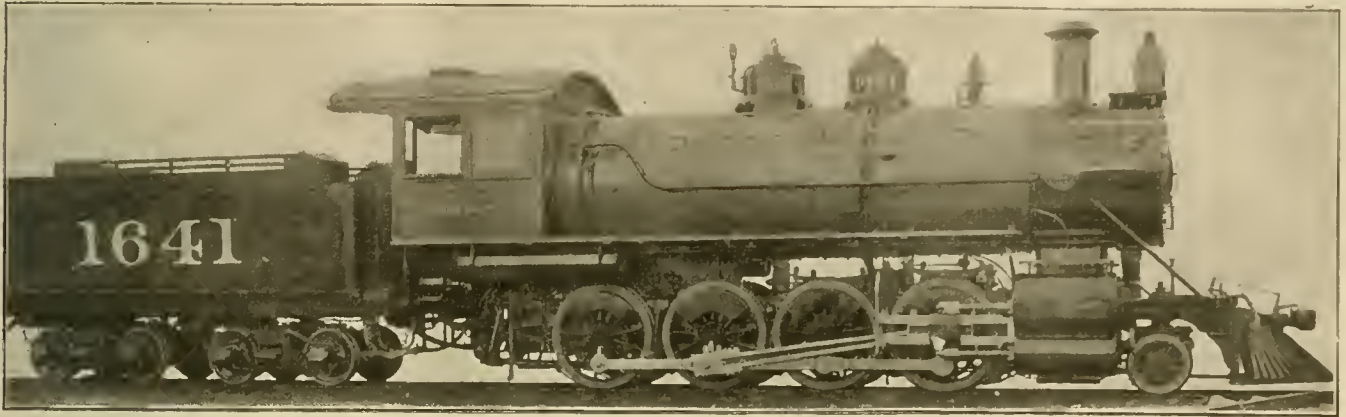

CONSOLIDATION COMPOUND LOCOMOTIVE, UNION PACIFIC RAILWAY.

J. H. McCONNELL, Superintendent Motive Power.

BALDWIN LOCOMOTIVE WORKS, Builders.

Wheel: Driving.....	57 in.;	Cylinders: 16 1/2 and 26x30 in. engine truck.....	30 in.;	Boiler pressure ..	200 lbs.	tender wheels.....	33 in.
Weights: Total of engine.....	185,320 lbs.;	on drivers.....	161,020 lbs.;	total engine and tender	305,000 lbs.		
Grate area and tubes: Grate area.....	33.8 sq. ft.	Tubes.....	321 2 in.; 13 ft. 6 in. long.	depth, front.....	74 in.;	back.....	71 in.
Firebox: Length.....	120 in.;	width.....	40 in.;	Diameter.....	72 in.		
Boiler: type, straight.....	radial staying.	arch tubes.....	25.6 sq. ft.;	total.....	2,475.5 sq. ft.		
Heating surface: Tubes	2,255 sq. ft.;	firebox.....	194.9 sq. ft.;	engine and tender.....	53 ft. 5 1/2 in.		
Wheel base: Driving.....	15 ft. 3 ins.;	total of engine	23 ft. 11 ins.;	water capacity.....	6,000 gals.		
	Tender: Eight-wheel;						

their chief interest centers in their being the first compounds to be used on this road. In various ways the design indicates the ideas of the builders, and it was probably considered best to leave the builders as far as possible unhampered as to details, in order to secure a perfectly fair demonstration of the abilities of the compound. The boiler has an extended smokebox, but a short one, with only room enough for the ciuder spout, in front of the saddle. These engines are to be used on various portions of the road, and on account of their power, as well as the compounding, they will probably prove a great relief in the handling of the present heavy traffic. These engines are designed for a maximum curvature of 10 degs. All of the driving wheels are flanged.

This road is also receiving a lot of 10 very heavy compound passenger locomotives of the 10-wheel type, which we shall illustrate in a future issue.

The principal dimensions of the freight engines are given in the following table, for which, as well as the photograph, we are indebted to the builders:

Baldwin Consolidation Freight Compounds.
Union Pacific Railway.

Cylinders, diameter, high-pressure	15 1/2 ins.
Cylinders, diameter, low-pressure	26 ins.
Cylinders, stroke.....	30 ins.
Cylinders, valve	Balanced piston
Boiler, diameter	72 ins.
Boiler, thickness of sheets.....	11/16 in. and 3/4 in.
Boiler, working pressure	200 lbs.
Boiler, fuel	Soft coal
Firebox, material	Steel
Firebox, length	120 3/16 ins.
Firebox, width	40 1/2 ins.
Firebox, depth	Front, 74 1/4 ins.; back, 71 1/4 ins.
Firebox, thickness of sheets.....	Sides 5/16 in., back 5/16 in., crown 3/8 in., tube 1/2 in.
Tubes, number	321
Tubes, diameter	2 ins.
Tubes, length	13 ft. 6 ins.
Heating surface, firebox	194.9 sq. ft.
Heating surface, tubes	2,255 sq. ft.
Heating surface, fire-brick tubes	2,425.6 sq. ft.
Heating surface, total	2,475.5 sq. ft.
Grate area	33.8 sq. ft.
Driving wheels, diameter outside	57 ins.
Driving wheels, diameter of center.....	50 ins.
Driving wheels, journals	9 x 10 ins.
Engine truck wheels, diameter	30 ins.

A bill for the adoption of the metric system by the United States Government has been favorably reported to Congress by the committee on coinage, weights and measures. It provides for the adoption of the metric units January 1, 1903, for use by all the government departments except in the completion of the surveys of public lands. Russia has recently officially adopted the system, and if the bill is enacted, England will remain the only important civilized nation yet to take such action.

UNITED STATES MAIL SERVICE.

The annual report of Second Assistant Postmaster-General Shallenberger shows that during the year ending June 30, 1900, the expenditures for the inland transportation of mails was \$55,146,059, and for foreign mails service \$2,014,537, a total of \$57,160,597. The Star routes numbered 22,834, of an aggregate length of 260,857 miles, and the service cost \$5,133,378. The railroad routes numbered 2,668, of a length of 179,982 miles, and cost \$33,424,982. The most expensive service was the pneumatic tube service, which cost \$222,226 for five routes of 8 miles in length, or nearly \$30,000 per mile. At the close of the year there were 1,268 lines of traveling post-offices (railroad, steamboat, electric and cable cars), covering 178,960 miles in length; the number of clerks employed was 8,974; annual miles travelled by them in crews, 200,672,785; adding to this the closed pouch and express pouch services, the grand total of miles travelled was 305,436,095. The number of whole cars and apartments in use and in reserve was 3,658. In addition to these there were 25 cars on electric and cable lines and 72 apartments on steamboat lines. It is estimated that there were handled by railway postal clerks during the year 7,363,-191,360 pieces of first-class matter and 6,429,415,800 of all other classes of matter, making a total of 13,792,607,160 pieces. In addition to this there were handled by railway postal clerks 18,-128,063 packages and cases of registered matter, 1,100,423 through registered packages, and 621,712 inner registered sacks, in all 19,850,198. During the year there were 1,355,464 errors reported as made by clerks in the distribution of this mail, the ratio being one error to 10,175 correct.

(Established 1832)

AMERICAN ENGINEER AND RAILROAD JOURNAL.

PUBLISHED MONTHLY

BY

R. M. VAN ARSDALE,

J. S. BONSALE, Business Manager.

MORSE BUILDING.....NEW YORK

G. M. BASFORD, Editor.

E. E. SILK, Associate Editor.

JANUARY, 1901.

Subscription.—\$2.00 a year for the United States and Canada; \$2.50 a year for Foreign Countries embraced in the Universal Postal Union. Remit by Express Money Order, Draft or Post Office Order. Subscriptions for this paper will be received and copies kept for sale by the Post Office News Co., 217 Dearborn St., Chicago, Ill. Damrell & Upham, 283 Washington St., Boston, Mass. Philip Roeder, 307 North Fourth St., St. Louis, Mo. R. S. Davis & Co., 346 Fifth Ave., Pittsburg, Pa.

EDITORIAL ANNOUNCEMENTS.

Advertisements.—Nothing will be inserted in this journal for pay, EXCEPT IN THE ADVERTISING PAGES. The reading pages will contain only such matter as we consider of interest to our readers.

Special Notice.—As the AMERICAN ENGINEER AND RAILROAD JOURNAL is printed and ready for mailing on the last day of the month, correspondence, advertisements, etc., intended for insertion must be received not later than the 20th day of each month.

Contributions.—Articles relating to railway rolling stock construction and management and kindred topics, by those who are practically acquainted with these subjects, are specially desired. Also early notices of official changes, and additions of new equipment for the road or the shop, by purchase or construction.

To Subscribers.—The AMERICAN ENGINEER AND RAILROAD JOURNAL is mailed regularly to every subscriber each month. Any subscriber who fails to receive his paper ought at once to notify the postmaster at the office of delivery, and in case the paper is not then obtained this office should be notified, so that the missing paper may be supplied. When a subscriber changes his address he ought to notify this office at once, so that the paper may be sent to the proper destination.

The paper may be obtained and subscriptions for it sent to the following agencies: Chicago, Post Office News Co., 217 Dearborn Street. London, Eng., Sampson Low, Marston & Co., Limited St. Dunstan's House, Fetter Lane, E. C.

In his article in this issue Mr. W. S. Morris, of the Chesapeake & Ohio, adds a strong statement to the facts which tend to place the large capacity steel car in the foremost rank of railroad improvements. He speaks in no uncertain tone of the influence of this movement and, being known as a careful man, his testimony will have weight with those who are still in doubt. Where the traffic is suitable for these cars they will pay handsomely. Where 80 or 90 miles per day may be had from them on an average in regular service they will pay for themselves in a few years. We are specially interested in his comparisons of earnings per train mile for steel and wooden cars at \$11 and \$6.59, a difference of \$4.41 in favor of steel cars, for the same train expense in both cases. He says that the cost of transportation in handling 40 steel cars containing 2,000 tons of freight would be the same as 1,500 tons loaded in 60,000-lb. capacity wooden cars. He also offers striking figures when he shows that 1,000 loads carried in 100,000-lb. and 60,000-lb. cars would mean 25 trains for the steel cars and 31 trains for wooden ones, a saving of six trains and 729 tons of dead weight. This shows in a graphic way the reason why the large steel cars have made such remarkable progress in three years.

The selection of type or wheel arrangement for locomotives for fast and heavy passenger service involves most interesting questions, promising important developments in the near future. It is relatively easy to haul fast and light trains, but fast and heavy ones furnish the problem and require great tractive power as well as sustained boiler capacity. For a large proportion of present passenger traffic the able Atlantic type engines, which we have illustrated recently, suffice, but it is a question whether it is not advisable to use the same number of wheels and couple six of them instead of four where starting power is now or is likely to become in the immediate future an important consideration. Mr. Marshall's idea, commented upon elsewhere in this issue, seems to us to be timely, viz., to build for the future and use six coupled wheels for heavy passenger engines. This is specially applicable to roads where double-heading is practiced, and in general it may be stated that for heavy work three pairs of drivers are necessary. If this is granted, the 10-wheel engine is the first arrangement to suggest itself, and then the wide firebox comes up for consideration. In our October number, of last year, page 312, Mr. Gaines, Mechanical Engineer of the Lehigh Valley, presents a design for 10-wheel engines soon to be built for that road which seems likely to exert an important influence upon future practice, because it combines a wide firebox with 72-in. wheels, but Mr. Gaines goes still further in this direction and believes that there is no objection to using the same arrangement with 84-in. drivers, for either soft or hard coal. The engines referred to were illustrated in outline in the article mentioned, and while they have not yet been built, there is no reasonable doubt of their performance. Those who consider it necessary to provide ample depth as well as width in fireboxes will look askance at the wide grate over the large wheels, but it may prove that there is enough to be gained from the wide grate and the arrangement of six coupled wheels and a four-wheel truck to overbalance a possible loss due to the lack of depth. We shall give our readers further information about the Lehigh Valley engines when they are built and running.

Next in importance to the improvement of draft gear among the subjects to come before the Master Car Builders' Association this year is that of center plates and side bearings, and the latter subject merits careful attention, because of the wide difference of opinions expressed by two committees last year. In this issue Mr. Grafstrom indicates the possibility of applying thoughtful study to the design of center plates, and what is more, he presents a design which is giving satisfactory service under 4,000 cars and tenders. His suggestions are worked out carefully and put into the form of practice, and in cars of large as well as small capacity. He even includes gauges for measuring the amount of allowable variation in the contour, and has, in short, applied to this subject the attention which it deserves and has not, to our knowledge, before received. Others are thinking about it, however, and rather radical suggestions have been made, one of which is in the direction of using center plates of very large diameters, even as large as 24 ins., with a view of making them serve to a degree to take some of the work ordinarily expected of the side bearings. This whole question is in such a state as to open the way for a logical and practicable method of carrying the weights of cars to the trucks so as to avoid friction of turning and permit the trucks to become square with the tracks after coming out of a curve. The work before the committee this year is therefore most important, and there is an opportunity to settle some of the disputed points in which side bearings, center plates and bolsters have a part. The difficulties lie not so much with large capacity steel cars as with the vastly larger proportion of equipment of smaller capacity in the form of wooden cars, and as this forms the greater number of cars in use, it is a question in which all are interested, and one which has to do with the entire end structure of cars. It is not by any means an easy problem.

AMERICAN SOCIETY OF MECHANICAL ENGINEERS.

Forty-second Annual Meeting.

The first session of the forty-second meeting of the American Society of Mechanical Engineers was opened Tuesday evening, December 4th, at the society rooms, 12 West Thirty-first street, New York, with an unusually large attendance. The annual address, "Some Landmarks in the History of Rolling Mills," was delivered by President C. H. Morgan, who presented in a very comprehensive manner the growth of the industry of rolling mills and its influence on the railroads and civilization. The early part of the second session was taken up with the business of the society and the annual election of officers. The election resulted as follows: President, Samuel T. Wellman, of Cleveland, O.; Vice-Presidents, Arthur M. Waitt of New York, James M. Dodge of Philadelphia and Ambrose Swasey of Cleveland; Treasurer, William H. Wiley, New York; Secretary, F. R. Hutton, New York.

On Thursday the fourth session was held at Havemeyer Hall of Columbia University, upon special invitation from President Low. After the reading of papers in the morning the society was the guest of the university for the remainder of the day.

The first paper presented at this meeting was "Comparison of Rules for Calculating the Strength of Steam Boilers," by Mr. H. De B. Parsons. Both the paper and the discussion which followed showed clearly the differences in the several rules now used in determining the strength of the different parts of a steam boiler. The sentiment was that the United States Government rules are faulty and that it is better to use the foreign rules, or those of the American insurance companies. A motion was passed to the effect that the council consider the appointment of a committee to look into the matter of adopting uniform rules.

Mr. Charles T. Porter, in his paper, "A Record of the Early Period of High-Speed Engineering," traced the early history of the high-speed engine by an interesting account of the life of the late John F. Allen, who had to do directly with the development of the high-speed engine, and bringing into practice the steam engine indicator.

"The Steam Engine of Maximum Simplicity and Highest Thermal Efficiency," a paper by Dr. R. H. Thurston, was a history of the development of the steam turbine, giving definite facts as to the efficiency established by various tests, and was discussed from the standpoint of cost, exacting work required to build steam turbines and their application to marine propulsion.

Mr. Wm. Sangster, in his paper, "Note on Centrifugal Fans for Cupolas and Forges," lays much stress on the importance of the method of applying fans to widely differing installations, and as to establishing a fixed rule covering the ground for all installations, it would be impossible. The paper offers several formulas for computing the power required by centrifugal fans in cupola and forge practice, treating separately cupola fans, forge fans and smoke exhausters. The relation of outlet pressure to outlet area of fans was also considered.

Considerable discussion, both oral and written, followed the presentation of Mr. F. W. Dean's paper on "A Power Plant of the Massachusetts General Hospital." The paper, though criticised from the standpoint of certain features of the plant, was valuable in that it brought out from those present the experiences in up-to-date operations.

The next paper presented was on the "Construction of Contracts," by Mr. R. P. Bolton, and contained a copy of the "Uniform Contract," adopted and recommended by the Institute of Architects and National Association of Builders, which the author severely criticises and also suggests necessary conditions which should be included in this contract.

The concluding paper of the evening was that of Mr. E. T. Adams, "An American Central Valve Engine," which received a careful and somewhat limited discussion. The paper is a descriptive argument in favor of the principal characteristics

of the central valve engine. The author tells what an engine of this type, designed for a wide field of service, should be. The engine must have moderate speed, must be of the vertical type, because it requires less floor space, single-acting, to comply with limited head room; it must have a central valve, because it allows ample port opening with very low clearance and affords practically perfect drainage of the cylinders, and it must be compound if the gain in economy shall justify the expense. The paper also gives a brief description of the valve gear.

As was previously announced, the Thursday morning session was held at Havemeyer Hall, Columbia University, and the first paper of the morning being a description of "A Mechanical Integrator Used in Connection with a Spring Dynamometer," by M. H. Wickhorst, designed by the author for use on the Chicago, Burlington & Quincy Railroad dynamometer car for the purpose of automatically and autographically showing the average drawbar pull. The mechanical integrator consists of a registering wheel, which slides backward and forward in sympathy with the dynamometer springs, and a circular disk, making in this case nearly three revolutions per mile, and on which the registering wheel slides. The registering wheel is a small steel wheel 2 ins. in diameter, and the disk is brass, 11 ins. in diameter. The wheel is so placed that when there is no compression of the springs it stands on the center of the disk. Its plane is at all times at right angles to the line of motion of the spring compression. Thus the farther the wheel gets from the center of the disk, the more revolutions will it make for a given number of revolutions of the disk. The sliding of the wheel back and forth on the disk causes no revolving of the wheel. Only the turning of the disk causes the wheel to revolve, and in proportion to the distance the wheel is from the center of the disk. The discussion on this paper was with regard to the interpretation of these records, which were not explained fully in the paper. Mr. R. H. Soule offered a ready means of reading such diagrams.

Mr. C. A. Read's paper presented "An Apparatus for Dynamically Testing Steam Engine Indicators" and brought out a discussion on the care of indicators, methods of allowing for errors after the errors were determined and the advisability of oiling the piston of an indicator.

The following paper, "A New Recording Air Pyrometer," by Mr. W. H. Bristol, was descriptive of an instrument invented by him for measuring temperatures of high ranges, and to give continuous records of changes of such temperatures on a moving chart. The paper was a most interesting one, as was evident from the liberal discussion which followed its presentation. The highest temperature at which the author has had experience with his instrument is about 2,200 degrees Fahrenheit, but he says he sees no reason why it should not be successful up to 3,000 degrees Fahrenheit.

Mr. F. M. Wheeler then read his paper, entitled, "Comparative Value of Different Arrangements of Suction Air Chambers on Pumps," in which he shows that an air chamber is just as necessary on the suction end of a pump as on the delivery end, if the noise and severe effect of water-hammer is to be avoided. He also insists on the importance of the proper location of the air chamber.

The opening paper of the final session was that of Prof. W. F. M. Goss, on "Tests of the Boiler of the Purdue Locomotive." This was a valuable paper and is printed in abstract in another part of this issue.

The next paper was by Mr. W. B. Gregory on "Tests of Centrifugal Pumps," which gives by diagrams the results obtained from tests made on two centrifugal pumps, one with a 2½-in. suction pipe and a discharge pipe 2 ins. in diameter. The large pump had a discharge pipe of 25 ins. and two suction pipes, each 36 ins. in diameter.

Mr. W. J. Keep then presented a paper on the "Hardness or the Workability of Metals," in which he considers the development and results of a machine perfected by himself for

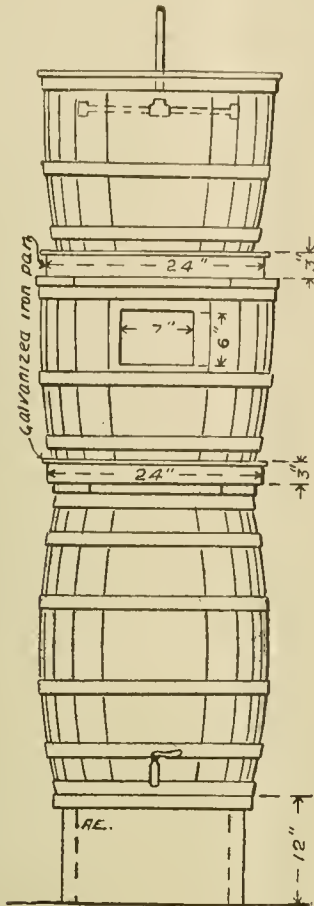

Fig. 2.—Apparatus for Saturating Water with Salt for Baker Heaters.

To prevent the salt-water from running over the sides and the salt crystallizing there, making a very untidy appearance, galvanized iron pans are placed under the two short barrels, the center of the pans being dished and provided with a large hole or a number of small ones for the water to pass through.

Surfaces which, after being varnished, are placed in a horizontal position until the varnish is "set," always present a better and more uniform appearance than when they are dried in vertical positions. In most paint shops where passenger car work is done racks are provided for drying the sash and blinds horizontally, but the doors are usually put in a vertical position as soon as the varnish has been applied.

The appliance shown in Fig. 3 allows the doors to be varnished in a horizontal position and to be left there after being varnished, and any reasonable number of doors can be superimposed on one another without occupying more than a small amount of space. The arrangement consists of two horses about 12 ins. high, made of light wood, each provided at its ends with two beveled pieces on which the door rests, touching only at the corners; the two posts on the ends of the horses project high enough above the door to allow other supports, made like the tops of the horses, to be placed upon these, to take another door; pins and corresponding holes in the top and bottom of these supports prevent their moving after being placed in position. The number of doors which can thus be placed is limited only by the height at which they can conveniently be handled without taking up more floor space than enough for one door.

IMPROVED JOINT FOR PISTON PACKING RINGS.

The accompanying engravings illustrate a new form of joint for piston packing rings, designed and patented by Mr. Millard F. Cox, Chief Draftsman of the Richmond Locomotive Works. Its purpose is to free the ordinary split packing rings, particularly of large pistons, from the difficulties of leakage and the wear caused by the access of the steam to the ends of the rings at the joints. This pressure tends to expand the rings and wear the cylinders, particularly at the ends, where the steam pressure is greatest.

The engravings make the construction clear. At the ends of the packing rings a socket is cut in the piston, into which a plug fits loosely enough to permit of self-adjustment, and this

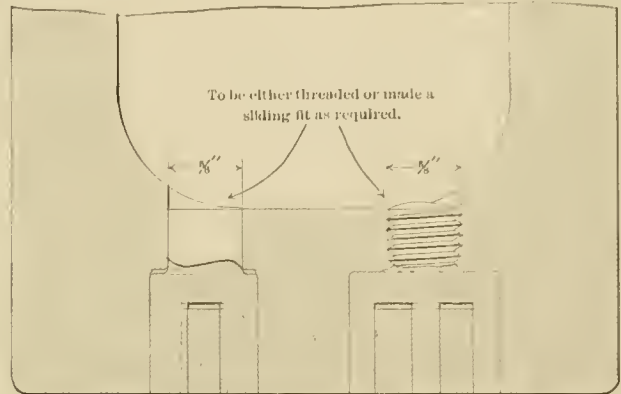

Fig. 4 This style used with narrow rings.

Fig. 5 This style used with wide rings.

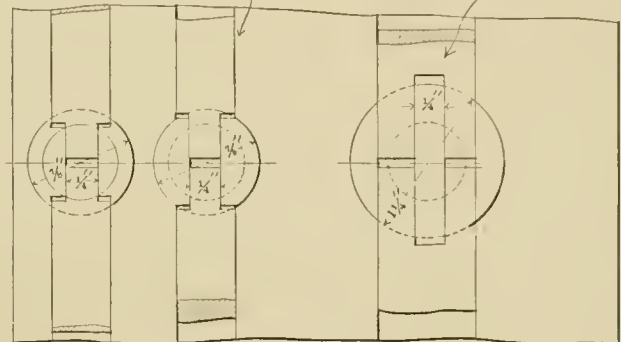

Fig. 1

Fig. 2

Fig. 3

A.E.

plug is cut to receive the ends of the rings, as shown in Figs. 1 and 2, or as in Fig. 3. In Fig. 3 the plug has a rib across its central portion, and the rings are slotted to fit it closely. Upon the back of the plug is an extension, shown in Figs. 4 and 5. This fits a hole made smaller than the main cavity and it serves to assist in centering the larger hole, while the extension increases the effectiveness of the bearing of the plug. The plug may be threaded into this hole, as indicated in Fig. 5, which illustrates the construction used with wide rings. It will be seen that this joint, as shown in Figs. 1 to 4 inclusive, forms essentially a part of the packing ring. It may adapt itself to outward or inward movements of the ring, and yet be tight against leakage, and the ends of the rings are not exposed to the steam pressure. The walls of the plugs are fitted flush with the wearing surfaces of the rings.

Large cars for English railroad conditions came up again in Mr. J. A. F. Aspinall's presidential address before the Liverpool Engineering Society. It appears that, however desirable they are from an operating standpoint, the coal operators control the situation. The railroads own about 677,000 cars and the private coal companies own about 550,000. The docks and unloading facilities are all adapted to present equipment and it will be a difficult matter to change.

CORRESPONDENCE.

LOCOMOTIVE CLASSIFICATION.

To the Editor:

Your article on this subject in your October issue is both timely and forceful, and, as it seems to me, a complete and perfect remedy for the confusion which we have already reached is found in the suggestion of Mr. F. M. Whyte, which you present. It possesses the controlling merits of being logical, simple, and covering the ground so fully and clearly as to be incapable of doubt or misunderstanding by anyone of ordinary intelligence, and I can see no reason why it should not be at once and universally adopted. It is not, to my mind, open to any unfavorable criticism, and I do not think that any suggestion of a better plan can be offered.

One of the abuses of the present arbitrary nomenclature which has lately become prominent, not merely in journals which do not pretend to be technical, but also in those which are strictly so, is the misuse of the word "consolidated" for "consolidation," and of "mogul" when referring to a ten-wheel six-coupled engine. The eight-coupled engine with two-wheel leading truck (2-8-0 under Mr. Whyte's classification) has no feature, either structural or operative, to which the word "consolidated" would be applicable in any sense, and it is a matter of common knowledge that the type took its name from that of the first engine constructed with such a disposition of wheels—i.e., the "Consolidation," which was built by the Baldwin Locomotive Works for the Lehigh Valley Railroad in 1866. While engines of this and of the "Atlantic" type have ten wheels, they have never, so far as I have observed, been termed "ten-wheel" engines, and the latter designation has been, from the first, applied to six-coupled engines with four-wheeled leading trucks. That type has been so long and so universally known as the "ten-wheel," that either ignorance or carelessness must be the only basis for the comparatively recent practice of calling them "moguls," particularly in view of the fact that the six-coupled engine with two-wheeled leading truck has been known as a "mogul" ever since the first one was built.

While the present nomenclature may be of some slight value for mere advertising purposes, it presents no identifying characteristics, and with the production of new designs, tends additionally to confusion. An intelligent and reasonable system, such as that proposed by Mr. Whyte, should by all means be substituted for it.

J. Snowden Bell.

Pittsburgh, December 8, 1900.

To the Editor:

In offering a criticism of the very simple yet ingenious scheme of locomotive classification devised by Mr. Whyte, and described on page 374 of your December number, 1900, the writer is reminded of the lesson of the "importance of some things" thrust upon the engineer, who, meeting with an accident crippling his tender, wired to headquarters for instructions. The order, to "disconnect, load some wood on a flat car, couple and proceed," was concise, if not logical.

The tender, which we are so prone to lose sight of, is a necessary adjunct to a locomotive and its form is variable. The ease with which it may be embodied in such a classification system seems to me one of the arguments favoring its adoption. Again we have the outside connected engines and our foreign cousins have the inside. Further, quoting, "the tendency is to give a type designation to a new design the only peculiarity of which is the outside or inside journals of the trailing wheels."

$$4 - 2 - 2$$

Taking all into consideration, we would write $\frac{4-2-2}{6}$, as

representing an engine with 4-wheel truck-single pair inside connected drivers, with a pair of trailers with inside bearings,

with a 6-wheel tender; where $\frac{4+4+2}{4, 4}$ would represent a type

with 4-wheel leading truck, 4 outside connected drivers, a pair of trailers with outside bearings, with the regulation tender.

Here the numerator gives the engine, the denominator the tender. The minus sign before the drivers indicating inside

connections, before trailers means inside bearings, and the plus sign the outside in each case. The bob-tail engine would then

$$\frac{6}{0}$$

G. S. Edmonds,
Mechanical Engineer,
Delaware & Hudson Co.

Green Island, N. Y., December 5, 1900.

AN IMPROVEMENT IN OIL CUPS.

To the Editor:

Being a reader of your paper and knowing that it falls into the hands of all the thinking and leading railroad men who seem to be looking for everything that is new and good, I thought a new device which I saw the other day might be of some interest to your readers.

There is a guide oil cup being used on some of our largest railroads with great economy in oil and meets with great favor among the engineers, and unless I am mistaken it has never been illustrated.

I happened to see this cup one day in strolling around a neighboring engine house and obtained all of its good points from one of the engineers who had a full set on his engine. He stated that it was the cleanest cup he ever saw and the most

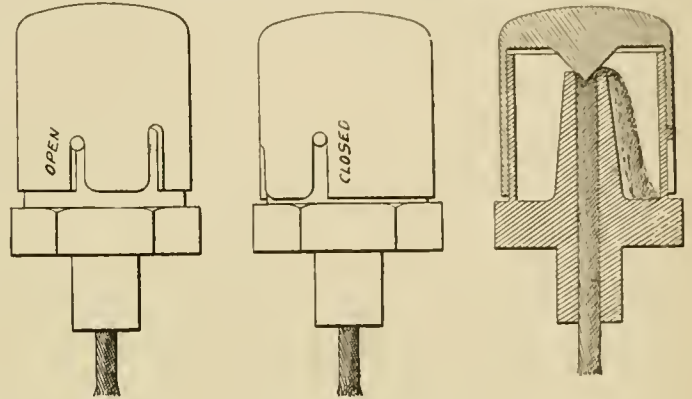

A Simple Rod Cup.

convenient, with nothing to get out of repair; it requires no tools, not even for adjusting, and is a positive feeder. To start or stop the flow of oil one has merely to raise the cover, change its position and drop it again. The number of miles run per pint of oil with this cup, comparing it with any other cup of the same size, is about 900 miles against 150.

I enclose you a pencil sketch of the cup showing its simplicity. You will readily see that it needs only the raising and lowering of the cover of the oil cup by hand to regulate the flow of oil. When the cup is feeding the cover is raised off the wick and seat, resting on the pin in the short slot. To stop the cup from feeding the cover is changed so that the pin will be in the long slot, the cover falling by gravity, resting on the wick and seat.

The cup I notice has been patented and is being introduced by J. S. Coffin as General Agent, Franklin, Pa.

Locomotive Engineer.

ARRANGEMENT OF VIEWS ON DRAWINGS.

To the Editor:

Bad practice prevails in a good many drawing-rooms in the matter of placing the several views on a drawing. I refer to the placing of the plan beneath the elevation. The most natural place for a plan view in relation to an elevation is above, not beneath it, and the reason is this: A drawing, which is always read by its two or three views, is more easily and quickly read when the projecting points of two views are brought nearer together. As an example of this, take the simplest of objects, a lead-pencil 8 ins. in length, sharpened to a point 1-16 in. in diameter. Placing the pencil in an upright position for the elevation, and then drawing the plan beneath it, throws the 1-16 in. circle representing the pencil point in the plan over 8 ins. from its projected lines in the elevation; whereas, if the plan had been placed over the elevation, the projected points would have been very near to each other. The same thing is true in the drawing of almost any object. If the placing of the plan view over the elevation is correct, then

following the same practice it would be correct to place an end view at that end of the elevation for which it is intended to represent, so that one's eye would not be obliged to traverse the entire length of the object to get the points projected. I think this point is worth the attention of those who have drawings to make or the supervision of those who make them.

A. H. Weston,
Chief Draftsman,
Atlantic Coast Line.

The purchase of the Pennsylvania Coal Company by the Morgan interests is a very important move, because it defers or possibly completely stops the building of an independent road to carry Pennsylvania coal to tide-water. The plan was to build a line 95 miles long from Hawley, Pa., to Rondout, N. Y., the right of way acquired being that of the old and disused Delaware & Hudson Canal. The purchase of the coal property has probably settled the question, and the road is not likely to be built. It seems absurd to consider the construction of more roads when the coal fields are so abundantly supplied.

The Rogers Locomotive Works, which were formally closed December 1, have recently been the subject of negotiation which may lead to their being started up again, but at this date nothing has been definitely decided. It is interesting to note in the American Railroad Journal (the predecessor of The American Engineer and Railroad Journal), of December 24, 1836, an announcement of the addition to the plant of Messrs. Rogers, Ketchum & Grosvenor of Paterson, of a department for building locomotives. For 64 years the name of "Rogers" has figured prominently in railroad circles of this country and abroad. The announcement referred to contained the prediction that "In a few years we shall not see an imported locomotive on an American railroad." In these days of extensive exportation of locomotives it is difficult to realize that this country was ever dependent for them upon England. The first locomotive by these works was finished in 1837.

In his paper at the last meeting of the American Society of Mechanical Engineers Mr. William Sangster presented some interesting facts regarding fan blower practice in connection with cupola furnaces and forges. He points out that "in hardly any other class of machinery is the method of application of so great importance as it is in the case of centrifugal fans. The conditions of one installation are usually so different from those of any other that hard and fast rules are out of the question." Briefly summarized, he shows that the horse-power required to produce blast for a cupola is equal to three-tenths of the number of tons melted per hour multiplied by the pressure of blast in ounces per square inch. For forge blast an allowance of one-quarter horse-power may be made per forge, and for exhausting smoke therefrom the power required will be 0.44 horse-power per forge.

PERSONALS.

Mr. Walter J. Thomas has been appointed Master Mechanic of the Chesapeake & Ohio at Louisville, Ky.

Mr. Edward Needham has been appointed Assistant Master Mechanic of the Wabash shops at Decatur, Ill.

Mr. J. J. Monahan, has been appointed Master Mechanic on the Louisville & Nashville, with headquarters at Memphis.

Mr. Thos. S. Stevens has been appointed Signal Engineer of the Atchison, Topeka & Santa Fe, to succeed Mr. J. S. Hobson, resigned.

Mr. Thos. D. Moore, General Superintendent and Purchasing Agent of the Cheat Valley Railway, with office at Manheim, W. Va., has resigned.

Mr. D. Witherspoon has been appointed Master Mechanic and Master Car Builder of the Washburn, Bayfield & Iron River, with headquarters at Washburn, Wis.

Mr. S. K. Dickerson has resigned as Master Mechanic of the Lake Shore & Michigan Southern at Cleveland, O., to take a similar position on the Atchison, Topeka & Santa Fe.

Mr. F. C. Gates, Purchasing Agent of the Wheeling & Lake Erie, has resigned and Mr. J. T. Stark, under the supervision of President Blickensderfer, will perform the duties of that office.

Mr. W. A. George, General Foreman of the shops of the Colorado Midland at Colorado Springs, Colo., has been appointed Master Mechanic of the Colorado & Southern at Denver, Colo.

Mr. R. A. Dugan, heretofore Purchasing Agent of the Elgin, Joliet & Eastern, has been appointed Assistant General Manager of this company and the Chicago, Lake Shore & Eastern, with headquarters at Joliet, Ill.

Mr. E. E. Hudson, Master Mechanic of the Cleveland, Cincinnati, Chicago & St. Louis, at Bellefontaine, O., has resigned and will go to Cleveland, O., to take charge of the shops of the Lake Shore & Michigan Southern.

Mr. N. Kirby, Master Mechanic of the Mobile & Ohio at Tuscaloosa, Ala., has been appointed Master Mechanic at Whistler, Ala., vice Mr. D. O. Smith, resigned. Mr. T. E. Harwell, heretofore Foreman at Okolona, Miss., succeeds Mr. Kirby, with headquarters at Tuscaloosa.

Mr. W. J. Underwood, formerly General Superintendent, has been appointed Assistant General Manager of the Chicago, Milwaukee & St. Paul Railway, and Mr. C. A. Goodnow succeeds him as General Superintendent. Both have been connected with this road for a number of years.

Mr. L. S. Chadwick, formerly Superintendent of the Ball Bearing Company, of Boston, and later with the International Time Recording Company, has accepted the position of Superintendent of the Searchmont Motor Company, of Philadelphia. Mr. Chadwick's experience after graduating from Purdue University in 1899 has been such as to make him well fitted for his new duties.

Mr. Angus Brown, who recently resigned as Superintendent of Motive Power of the Wisconsin Central, was tendered a farewell banquet and reception on November 29 by the employes of that road. During the evening Mr. Brown was presented with an embossed copy of a set of resolutions adopted by the railway men's organizations, as a token of the high regard in which he was held by those who had worked under him.

Mr. William Swanston, Master Mechanic of the Pittsburg Cincinnati, Chicago & St. Louis at Indianapolis, Ind., who has been in continuous railway service for over fifty years, will retire on January 1st, under the provisions of the pension plan. Mr. Swanston is seventy-three years of age and has earned a high place in the esteem of a great many friends. He is one of the best-known motive power officers of the Pennsylvania system.

Mr. J. S. Turner, Superintendent of Motive Power of the Fitchburg Railroad, has been appointed Superintendent of Motive Power and Equipment of the Toledo, St. Louis & Western Railroad, with headquarters at Frankford, Ind., effective January 1. Mr. Turner is equipped with a wide and valuable experience on the Pennsylvania, the Mexican Central, West Virginia Central, Colorado & Southern, and the Fitchburg roads. He is a valuable acquisition to the "Clover Leaf."

THE WESTINGHOUSE-PARSONS STEAM TURBINE.

While the steam turbine is one of the most interesting of recent steam power developments, comparatively little has been published upon the theory of the machines. For this reason and because of the apparent success of its introduction into this country, an elaborate paper upon the general subject of steam turbines, recently read by Mr. Francis Hodgkinson before the Engineers' Society of Western Pennsylvania is especially timely. Mr. Hodgkinson was identified with Mr. Chas. A. Parsons in the development of the turbine in England, and

house-Parsons steam turbine. The steam enters at the governor valve and arrives at the chamber A, and passes out to the right through the turbine blades, eventually arriving at the exhaust chamber B. The blades are shown in Fig. 3, the steam passing first a set of stationary blades and impinging on the moving blades, driving them around, and so on. On the left of the steam inlet are shown revolving balance pistons, C, one corresponding to each of the cylinders in the turbine, which, according to size, may be from one to four in number. The steam at A presses against the turbine and goes through, doing work. It also presses in the reverse direction, but cannot pass the piston C; but at the same time the pressure, so far as the steam at A is concerned, is equal and opposite, so

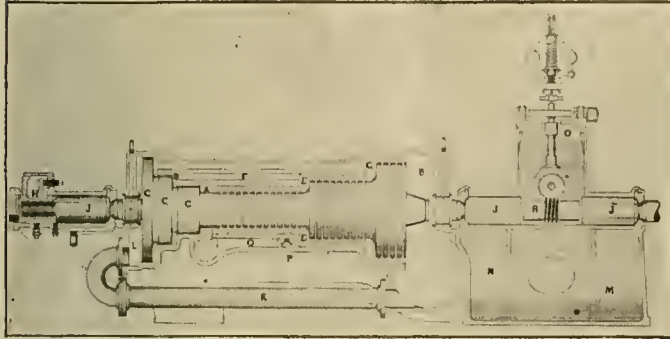

Fig. 1.

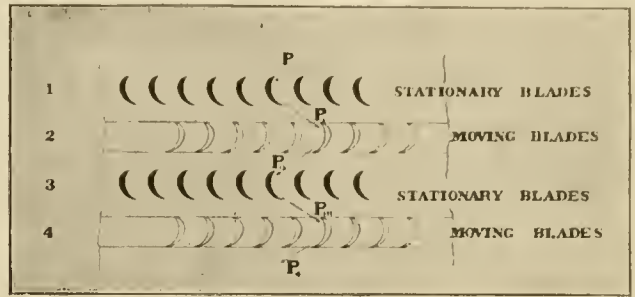

Fig. 3.

under his direction the Westinghouse Machine Company has adapted Mr. Parsons' practice to American conditions.

From the historical part of the paper it appears that the origin of the steam turbine dates back to 120 B. C. Banca's machine was made in A. D. 1629, while the reciprocating engine came in 1705. One of the earliest of Mr. Parsons' experiments with a 20-horse-power turbine, constructed on the lines of Hero's engine, showed a steam consumption of 40 lbs. per brake horse-power, and it is remarkable that Hero's engine was more economical than any engine produced for twenty centuries later.

The author of the paper confines his attention to the De Laval and Parsons systems. The former employs several jets of steam impinging against curved blades set in a single ring, the entire expansion of the steam taking place at the jets. This necessitates enormously high speeds and requires gearing

that the shaft is not subjected to any end thrust. The pressure at D is equal to that at E by reason of the balance port F, so, similarly, so far as the steam pressure at E is concerned, there is no end thrust. This same fact also applies to G. The area of the balance pistons is so arranged that no matter what the load may be, or what the steam pressure or exhaust pressure may be, the correct balance is preserved and the shaft has no end thrust whatsoever. The thrust or adjustment bearing (for it has no thrust) is in two halves, the lower half capable of adjustment in one direction, the upper one in the reverse.

There is obviously some leakage past the pistons, but it is found to be very small. Centrifugal force seems to have something to do with keeping down this leakage. The particles endeavoring to escape have to pass radially inward in going through the small clearance. It is supposed then, that the

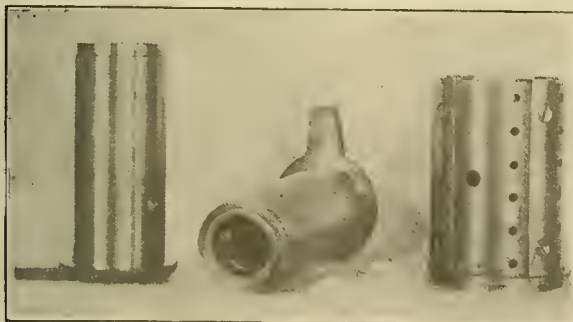

Fig. 2.

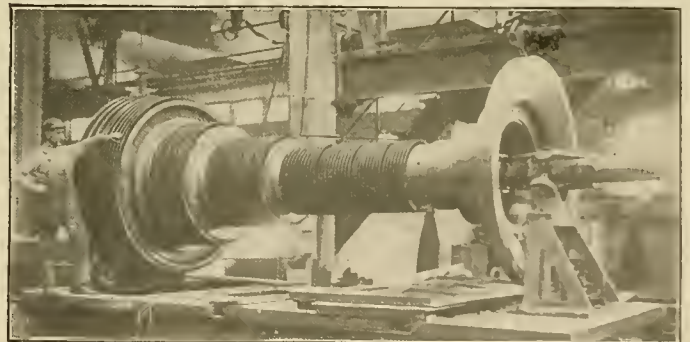

Fig. 4.

to bring the speeds down so that they can be used. It is presumed that the reader is familiar with the two types. The De Laval turbines run at about 30,000 revolutions per minute for the smaller sizes and 10,000 revolutions for the larger ones.

Mr. Hodgkinson goes into detail to an extent which makes it impossible for us to do more than convey a general idea of his paper. We aim chiefly to present those portions which will supplement the description of the Westinghouse-Parsons steam turbine, printed on page 65 of our March issue of last year, concerning the installation at the works of the Westinghouse Air-Brake Company. By aid of the accompanying diagrams the action of the steam is made clear.

Fig. 1 is a general longitudinal section through a Westing-

house-Parsons steam turbine. The steam enters at the governor valve and arrives at the chamber A, and passes out to the right through the turbine blades, eventually arriving at the exhaust chamber B. The blades are shown in Fig. 3, the steam passing first a set of stationary blades and impinging on the moving blades, driving them around, and so on. On the left of the steam inlet are shown revolving balance pistons, C, one corresponding to each of the cylinders in the turbine, which, according to size, may be from one to four in number. The steam at A presses against the turbine and goes through, doing work. It also presses in the reverse direction, but cannot pass the piston C; but at the same time the pressure, so far as the steam at A is concerned, is equal and opposite, so

rapidly revolving pistons have the effect of throwing outward the particles with which they come in contact by reason of skin friction, so that the particles being slung outward tend to oppose the escape of the particles inward. This theory, however, is somewhat imaginary, but in view of the economy obtained, the leakage cannot be very great. At K is a pipe connecting the back of the balance pistons at L with the exhaust chamber (see Fig. 1) to insure the pressure at this point, being exactly the same as that of the exhaust. At J are shown the bearings. They are also shown separately in Fig. 2. They are unique in construction. The bearing proper is a gun-metal sleeve, which is prevented from turning by a loose-fitting dowel. Outside of this are three

concentric tubes having a small clearance between them. This clearance fills up with oil and permits a vibration of the inner shell, at the same time restraining it. The shaft, therefore, revolves about its axis of gravity instead of the geometric axis, as would be the case were the bearing of everyday construction. The journal is thus permitted to run slightly eccentric, according as the shaft may be out of balance. This form of bearing in a very remarkable manner performs the functions of De Laval's slender flexible shaft. But in this case the shaft is built as rigidly as possible, and is not liable to crystallization, which would result in eventual rupture. The bearings have ample surface, are continuously lubricated under pressure, and it has been found in practice that they do not wear. As may be seen in Fig. 2, the bearings are surrounded by an outer cast-iron sleeve, in which are fitted keys which may be shimmed up and permit of adjustment of the position of the shaft relative to the cylinder. At R, Fig. 1, is shown a flexible coupling by means of which the power of the turbine is transmitted. In small sizes the two shafts have a square cut on the ends, the coupling itself somewhat loosely fitting over these. In larger sizes it is generally a modification of this arrangement.

The governor gear and oil pumps generally receive their motion by means of a worm wheel, gearing into a worm cut on the outside of the coupling. At H is an oil reservoir, into which drains all the oil from the bearings. From there it

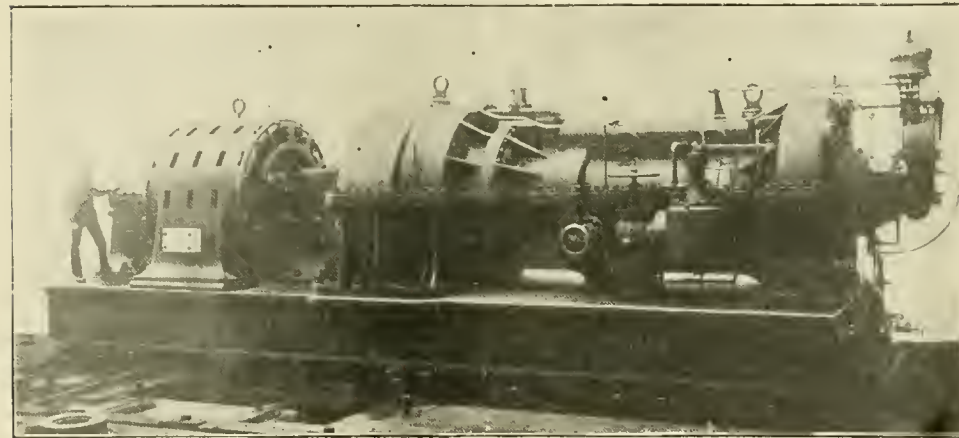

Fig. 5.

runs into the pump M, to be pumped up to the chamber O, where it forms a static head, which gives a continuous pressure of oil to the bearings. The pump is single-acting, of the simplest possible construction, that will not become deranged. The oil runs in by gravity, so that it is unlikely to fail to continue pumping.

A by-pass valve is provided, shown at P, which admits high-pressure steam by means of port Q to the steam space E. By opening this valve as much as 60 per cent. overload may be carried, and in the case of turbines operating condensing, full load may be obtained should the condenser be at any time inoperative, and the turbine allowed to exhaust into the atmosphere. Naturally, the effect of opening the by-pass valve is to reduce the economy.

The glands consist of packing rings set in grooves cut in the shaft. The rings press outward and remain stationary. Any form of frictionless packing necessarily leaks a little. In the case of the turbine exhausting into a vacuum a little less live steam is admitted between the rings by means of a small reducing valve, so that the leakage consists of a negligible quantity of live steam, instead of air, which would impair the vacuum.

While the steam admission and the construction are intensely interesting, these must be passed over with the statement that the admission valve works intermittently, the duration of the opening depending upon the governor. With this admission there is no wire-drawing of the steam, and the ad-

mission valve is continuously in motion, which guards against the possibility of its becoming stuck. As regards the regulation, it may be said that there is absolutely no variation of angular velocity in the turbine, such as is necessarily present in reciprocating engines, hence the value of turbines for running alternators in multiple. This is appreciated when we are told that a 500-horse-power turbine will run twenty minutes after the throttle is closed.

The essential parts of the turbine are the blades and buckets, which are made of hard-drawn material, securely fixed in grooves in the rotating element. Every row of these blades has passages of increased area, corresponding with the volume of the steam, this increase being obtained by increasing the height of the blades. When the limits are reached the diameter of the rotating element is increased and the steam permitted a higher velocity, which enables the blades to begin another progression. This explains the several diameters of the revolving element.

Referring to Fig. 3, the steam at pressure, P, in expanding through row 1 to pressure, P₁, converts its energy into velocity and impinges upon the moving blades, row 2. The steam then performs a second expansion in expanding through row 2, again converting its energy into velocity, but this time the energy of the efflux is to react upon the blades from which the steam issues. The same cycle is repeated in 3 and 4, and so

on until exhaust pressure is reached. The moving blades therefore receive motion from two causes, the one due to the impact of steam striking them, the other due to the reaction of the steam leaving them.

In a 300-kilowatt unit the turbine has 31,073 blades, of which 16,095 are on the moving element. The pressure that each of them exerts on the shaft varies from 0.89 to 1.04 ozs. The economy of the turbine of the size just mentioned may be taken at 14 lbs. of steam per indicated horse-power when running at full load, and the figures taken from a service test at the Wilmerding Shops were given in the American

Engineer, April, 1900, page 116. Professor Thurston has recently recorded experiments showing that with 37 degrees of super-heat the capacity of a small turbine was doubled. This indicates that even better results may be expected in the future.

Fig. 4 illustrates the complete revolving element of a 3,000-horse-power turbine, which is now being erected in the power house of the Hartford Electric Light Company. This illustration gives an excellent idea of the arrangement of the moving blades and their enormous number. The weight of the revolving part is 28,000 lbs.; it is 19 ft. 8 ins. over all and its largest diameter is 6 ft. This will be direct-connected to a 1,500 kilowatt generator, and this is the largest steam turbine ever built.

The steam turbine, while not universally applicable for the work done by ordinary steam engines, appears to be particularly well adapted to the driving of electrical generators, where uniform speed is required, as for alternating-current machines.

The paper concludes with a summary of the progress of the steam turbine in marine propulsion. The author of the paper states that in a power house in England, containing eleven turbines of from 75 to 150 kilowatts each, the cost of repairs and renewals amounted to 26 cents per kilowatt per annum, including all repairs to boilers, turbines, condensers, pumps, generators and electrical apparatus.

The Cambria Steel Company has taken up the manufacture of steel cars.

A MODERN HOUNDHOUSE,

Chicago & Northwestern Railway, at Clinton, Ia.

The large and thoroughly equipped roundhouse plant of the Chicago & Northwestern Railway at Clinton, Ia., is an example of improvement in a direction toward which comparatively

interesting. There are 48 stalls and two spaces, the plans providing for doubling the capacity when necessary. The house is 375 ft. in outside diameter, the interior wall being 207 ft. in diameter and the turntable 70 ft. long. The tracks provide for two entrances for engines, the coal, sand and ash apparatus being conveniently located. When completed there will be three cinder pits, as shown in the plan. The shop is 60 x 150

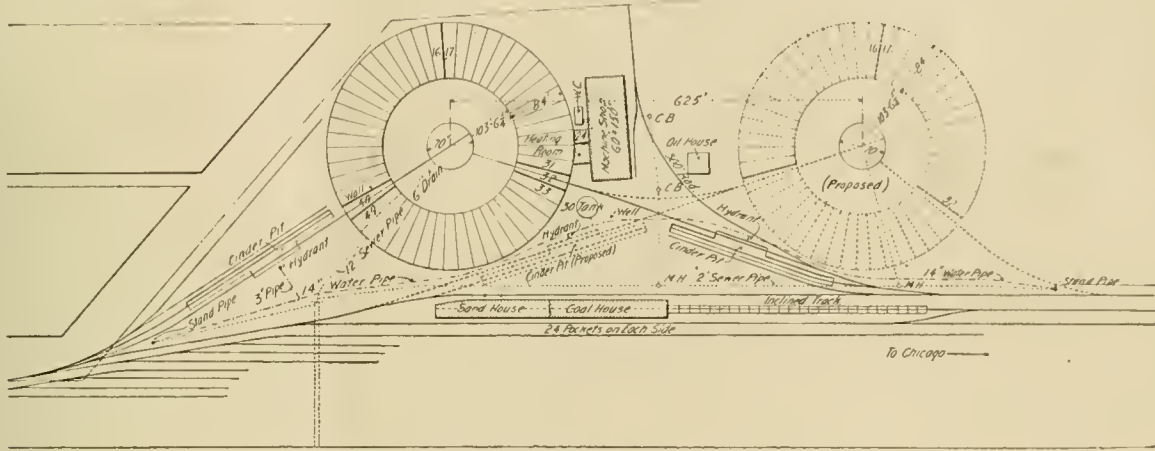

Roundhouse Plant.—Chicago & Northwestern Railway, Clinton, Iowa.
Plan of Tracks, Roundhouse and Proposed Extension.

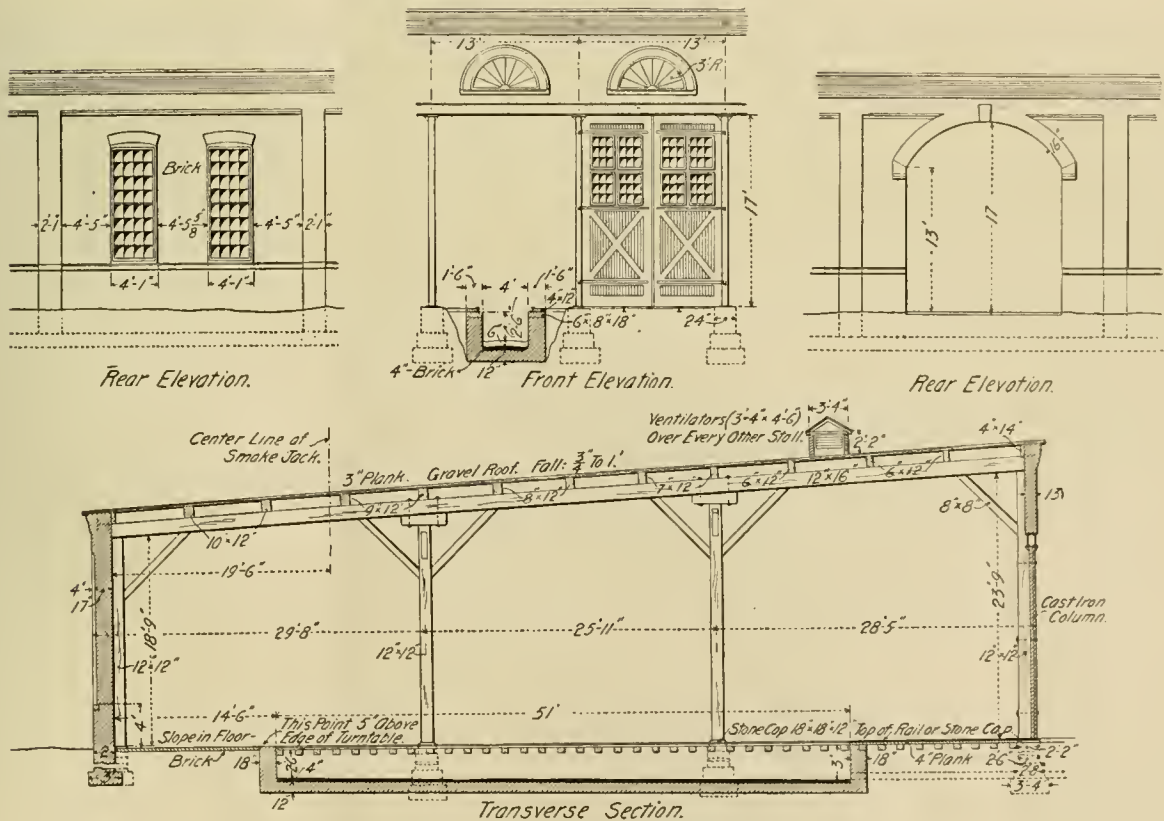

Sections and Details of Building.

little attention has heretofore been given, and because of its influence upon the service of locomotives it is an important one.

This plant replaces an old one, and the development of business necessitated thorough and ample facilities for about 80 locomotives a day, Clinton being a terminal for two divisions and a branch line. The house itself and its equipment, the adjacent shops, the coal and sand chutes and ash pit are all

ft. in size and behind it is the oil house, the arrangement being such as to eventually bring these buildings between the two roundhouses.

The accompanying engravings illustrate the construction in detail and present the chief dimensions. The outer walls are of brick, upon rubble masonry foundations, the inner walls being of cast-iron columns at 13-ft. centers, between the rectangu-

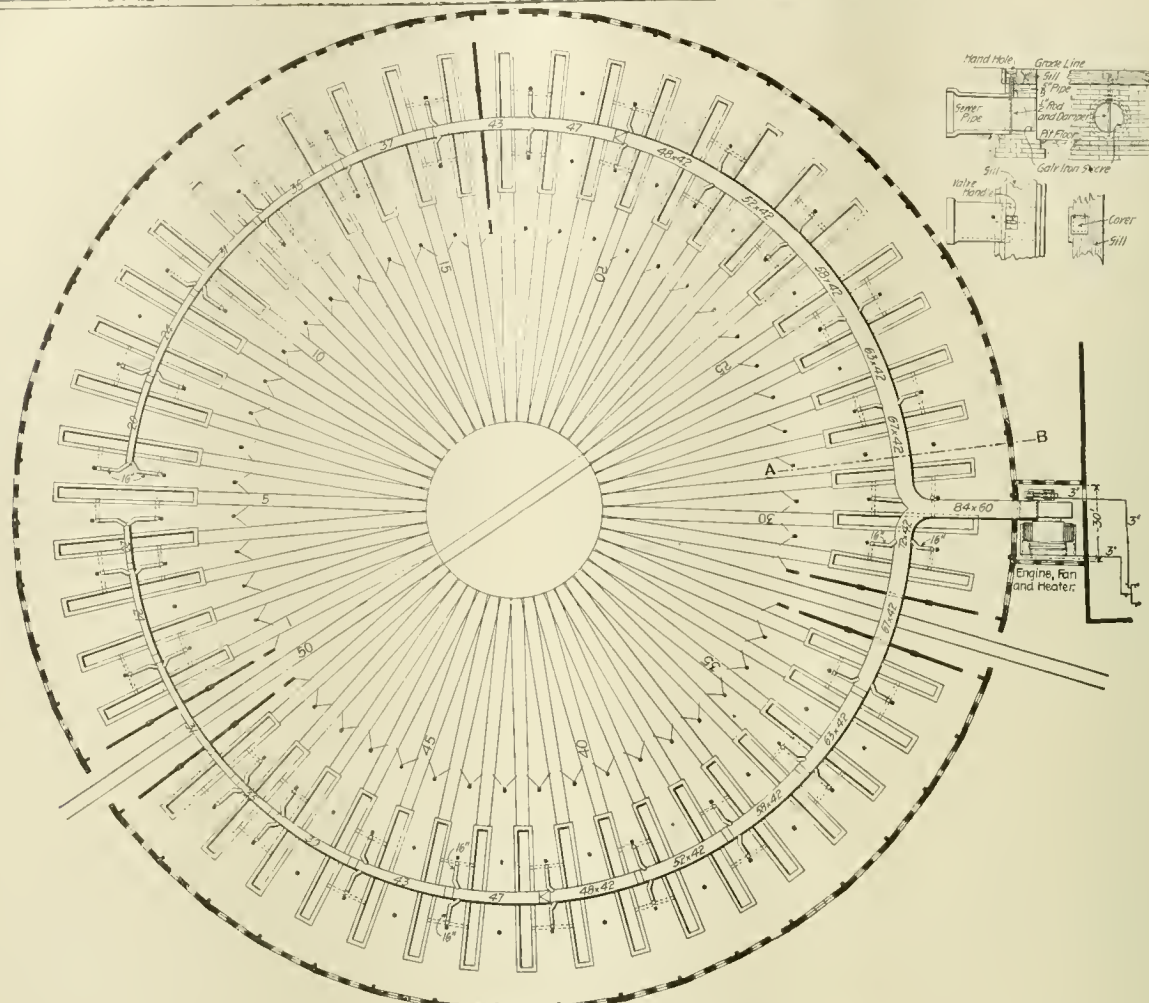

Plan of Building and Heating System.

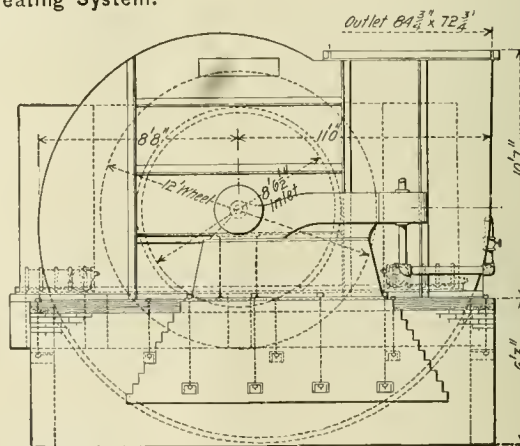
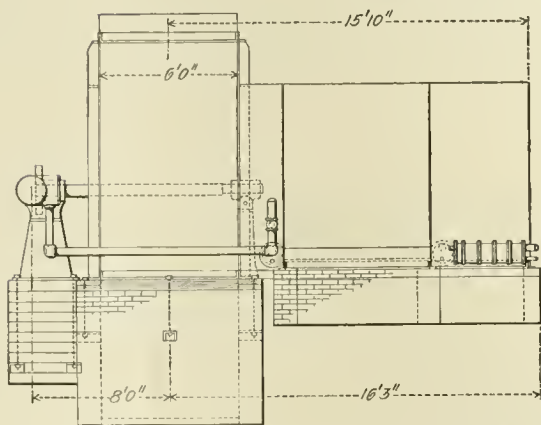

Sturtevant Fan and Heater.

Clinton Roundhouse Plant.—Chicago & Northwestern Railway.

lar doors, which are 17 ft. high. The columns support 10-in. channels, upon which the inner brick wall is laid over the doors. The roof is of 3-in. plank upon timber framing. It slopes $\frac{3}{4}$ in. to the foot and is covered with gravel roofing. Every second stall has a wooden ventilator and each stall a cast-iron smoke jack. The pits are 51 ft. long, the sides and ends are of rubble masonry and the floors of brick, sloped toward the turntable for drainage. The floor between the pits is of hard-burned brick. Water and compressed air are carried by pipes to each pit, and the pits are all fitted with pipe connections to receive the steam and water blown off from the engines. The ash hoist was illustrated in our issue of September, 1900, page 278. It was designed by Mr. G. R. Henderson, Assistant Superintendent Motive Power of the road, and is reported to be very satisfactory.

The shop is well equipped with machinery and it serves to relieve the repair shops of a large amount of small work. The oil house, 33 by 35 ft., has underground tanks, from which the oil is raised by air pressure.

The heating system is an admirable feature. It not only renders the buildings comfortable and ventilates them, but in the winter months serves in an important way to facilitate the turning out of engines by rapidly melting the ice and snow from the running gear by introducing heated air in the pits and directly under the engines. The B. F. Sturtevant Company, of Boston, were the contractors for this system, of which our engravings illustrate the arrangement. A small building between the roundhouse and shop contains the Sturtevant steel plate fan wheel, 12 ft. in diameter, placed in a steel-plate casing with an upward discharge. A direct-connected $11\frac{1}{2}$ by 16

iii. horizontal Sturtevant engine drives the fan, and its exhaust steam is used to furnish a part or the whole of the heat for the buildings, depending upon the severity of the weather. The fan is independent of other machinery, and its speed may be regulated as desired. Air is drawn by the fan through a heater having 20,000 ft. of 1-in. pipe built of Sturtevant sections in three groups and inclosed in a steel-plate casing. From the heater the air is led to a large horizontal duct of galvanized iron, which branches in both directions about the building over the centers of the pits and near the roof, where it is out of the

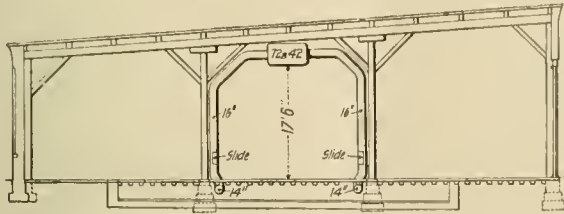

Arrangement of Air Outlets in the Pits. Section at A. B.

way. The divisions meet at the side opposite the fan, and branch pipes are led downward along the sides of the vertical posts and divide below the floor so as to connect with pipes leading to the pits on each side. The vertical pipes are also out of the way and protected by the roof posts. There are more than 50 of these branch pipes, each having a damper, the circulation of air being all that can be desired. Each branch pipe to a pit has a damper and hot air may be locally delivered in large volumes in order to melt snow and ice from the engines. The hot air is also dry and readily absorbs moisture, all of which tends to assist in reducing the delays due to roundhouse work.

One of the advantages of this system of heating lies in the concentration of the heating surface in a small fire-proof casing. The heating surface used in this way is less than would be needed by direct methods, and the fuel consumption correspondingly smaller. In moderate weather the exhaust steam from the fan engine is sufficient for heating, so that the engine is run without appreciable expense, and in colder weather live steam is used in the remainder of the heater. It is, however, customary in ordinary mill practice, where there is an abundance of exhaust steam, to utilize it in the heater, which is readily done without producing back pressure on the main engines. The ease of control of the temperature is remarkable.

The rapidity with which the Marconi system of wireless telegraphy has been developed into a practical and commercial success is remarkable and very unusual. It is not often that an inventor lives to see the recognition and commercial adoption of his invention, as has been the case in this instance, and this fact serves to draw increased attention to the subject. The Admiralty of Great Britain tested it thoroughly and has decided to install Marconi's apparatus in thirty-two English war-vessels. Doubtless the mercantile marine will soon follow suit and it is likely to come into use in coastwise signaling. The United States navy cannot long do without it in view of these facts, and it seems to be an excellent subject for thorough investigation also by the army. In the English navy tests the system worked successfully between Portland and Portsmouth, sixty-five miles, with the high land of St. Albans Head intervening between the two terminals. In view of the fact that the English Admiralty is one of the most conservative official bodies in the world and that its satisfaction is so positively expressed, seems to indicate that this system has very swiftly passed its experimental stage.

The new station of the New York Central at Albany was used for the first time December 17. The work has been in progress for several years, and included track elevation and the construction of a subway for the passengers of the Delaware & Hudson. Its cost was about \$1,000,000.

SELF-OPENING CAR WINDOWS.

The Edwards Window Fixtures.

Some greatly appreciated devices recently developed for opening car windows are those known as the Edwards window fixtures. These fixtures have met with much favor on the Pennsylvania and New York Central & Hudson River Railroads, where a large number of coaches have been equipped with them.

It will be seen from Fig. 1 that the window sash is supported by a linen mat, M, which is fastened at the lower

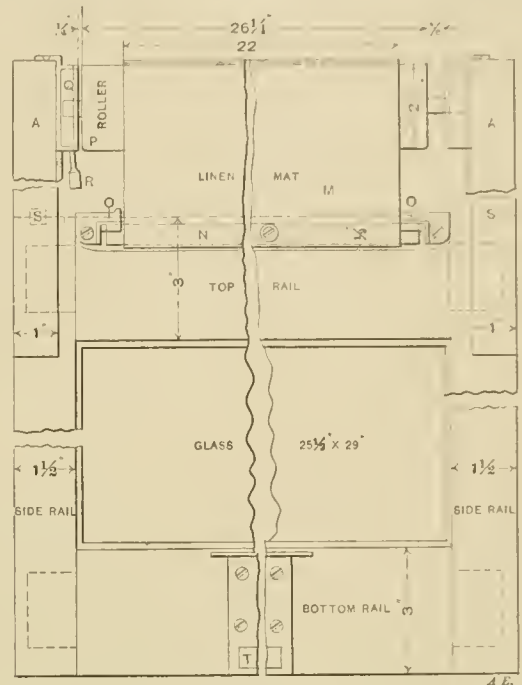

Fig. 1.—Car Window Equipped With Edwards Window Fixtures.

end to the top rail of the window by a brass strip, N, held in position by two small clamps, O. The upper end of the mat is wound around the roller, P, which is given sufficient tension to lift the sash when the sash is free to move. To regulate the tension of the roller there is a

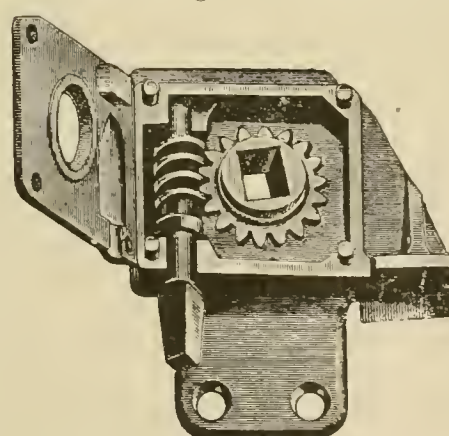

Fig. 2.—Roller Tightener.

worm gear shown in Fig. 2, which is manipulated by the screw, R, Fig. 1. By pressing slightly together a pair of thumb-catches placed on the window sill, the sash will travel steadily upward until it strikes the top of the frame, where two rubber stops S, are placed. By means of friction strips pressing against the side rails of the window and operated by the thumb-catch, the window can be opened to any desired height. In connection with the thumb-catch is a small bar which slides into the slot, T, when the window is closed, and locks it in that position. These friction strips, adjusting themselves as they do, keep any dust or cold air from entering the car, and also take up any shrinkage or swelling of the wood, thus preventing the sash from binding and allowing it to move freely when the pressure is removed. This device adds greatly to the comfort and good-will of passengers, as everyone must know who has the good fortune to ride in cars equipped with it.

TESTS OF THE BOILER OF THE PURDUE LOCOMOTIVE.

By W. F. M. Goss.

The results obtained from a series of 35 tests on the boiler of the Purdue locomotive are of rare importance and will be valuable in future matters having to do with locomotive boilers. These tests were made as part of the regular work of the senior students in Mechanical Engineering, at the Purdue Locomotive Testing Laboratory, and are recorded by Professor Goss in an admirable paper before the American Society of Mechanical Engineers, of which the following is a condensed presentation. The locomotive upon which the tests were made is now known as "Schenectady No. 1," and is of the 8-wheel type, having a total weight of 85,000 lbs. The boiler, which is designed to carry a pressure of 140 lbs., is of the ordinary crown bar type with a narrow firebox and no brick arch. It has a

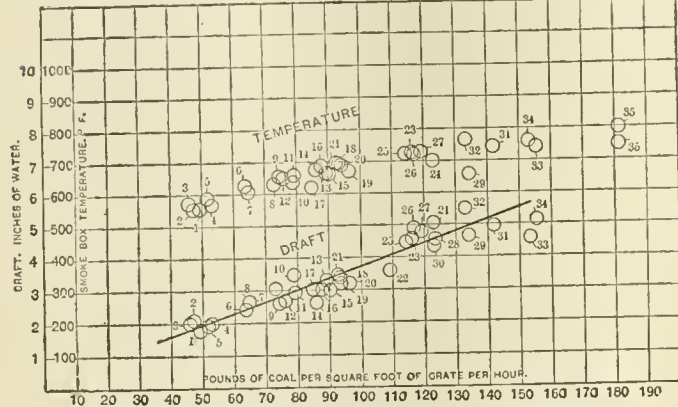

Fig. 1.—Coal, Draught and Smoke Box Temperature.

total heating surface of 1,347 sq. ft., of which 132.1 sq. ft. is in the firebox and 1,204.3 sq. ft. in the tubes. The grate area is 17.25 sq. ft., the ratio of heating surface to grate area 7.81, and the ratio of steam space to entire cubical capacity of the boiler is 0.29.

These tests were run immediately following the re-establishment of the testing plant, after its damage by fire, in February, 1894.

The results presented are averages obtained from observations taken at five-minute intervals. In most cases the individual observations were checked by two different observers using separate instruments, or they have been taken by one observer and checked by some form of automatic recording instrument. All derived results have been calculated by two or more independent workers.

Evaporation.

In actual evaporation one test shows that nearly 15,000 lbs. of water were delivered to the boiler and presumably evapo-

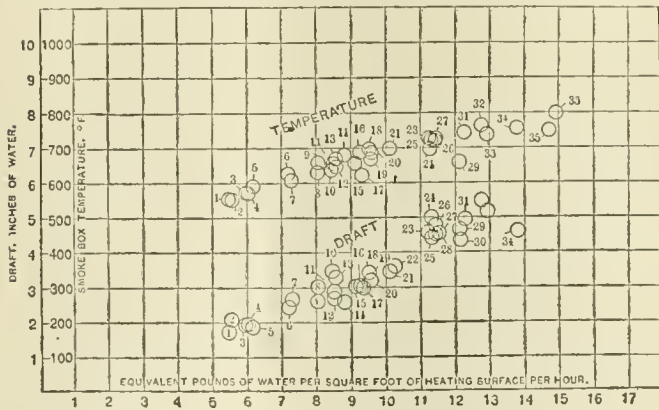

Fig. 2.—Water, Draught and Smoke Box Temperature.

rated each hour, or, approximately, 250 lbs. per minute. This rate of very nearly a barrel a minute is sufficient to evaporate an amount of water equal to the full water capacity of the boiler in 34 minutes. At this rate, had the injectors ceased in their action, the water level would have fallen between the upper and the middle gauges at the rate of 1 in. each minute.

The quality of the steam is shown to improve as the rate of evaporation is increased, although variations in individual results are so great that they do not fall in any well-defined line. It has been shown by Professor Jacobus that almost all moisture which may be intermixed with steam passing a horizontal pipe separates itself from the steam by gravitation, and forms a rill in the bottom of the pipe, the steam above being approximately dry. Experiments by the writer, involving a visual examination of the steam space of the boiler while in action, revealed no haze or mist above the surface of the water,

thus sustaining the conclusion that the steam within the steam space of the boiler is ordinarily dry and saturated; the water is present as water, and the steam as steam. They are not intermixed. If this is true, the steam which passes the throttle of a locomotive should be expected to be dry, and it would be entirely so if it were not that the violence of the circulation projects small beads of water upward, far beyond the general surface. Some of these enter the throttle with the steam. This action explains why the moisture increases with the power of the boiler, and makes it not unreasonable to assume that the purity of the water in the boiler may actually affect the quality of the steam. The comparative dryness of the steam under all conditions is a fact worthy of emphasis, for the locomotive is often credited with carrying over a great deal of water to the cylinders. The tests show that this does not happen under constant conditions of running. When it

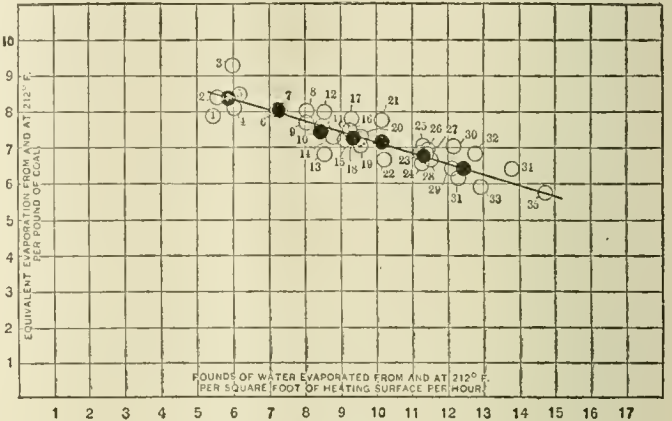

Fig. 3.—Rate of Evaporation and Efficiency.

occurs it is probably the result of too high a water level or of a sudden demand upon the boiler.

Power of Boiler.

The water evaporated per foot of grate surface varies from less than 400 to more than 1,000 lbs. per hour. These figures reflect well the intensity of the furnace action, which must provide for the combustion of sufficient fuel to produce such a result. Similarly the weight of water evaporated per square foot of heating surface varies from 5½ to nearly 15 lbs. per hour, the maximum rate being nearly the equivalent of a boiler horse-power for every 2 ft. of heating surface in the boiler.

Coal and Combustible.

The coal used for all tests was Indiana block and the amount fired per hour is between the limits of 729 lbs. and 3,133 lbs.

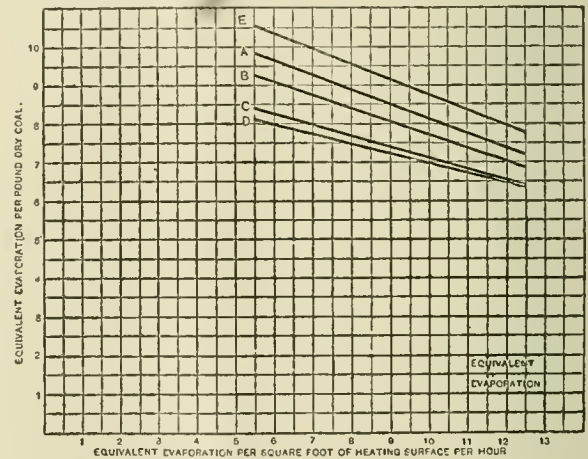

Fig. 4.—Evaporation and Efficiency for Five Samples of Coal.

Five tests have a rate of less than half a ton per hour, and twelve have a greater rate than one ton per hour. The rate per square foot of grate per hour ranges from 49 to 182, values—the significance of which appears when it is considered that in naval service, under forced draught, the rate seldom exceeds 60 lbs. per hour. The coal burned per foot of heating surface per hour varies from 0.7 to 2.6 lbs.

Draft, Ratio of Combustion and Smoke-Box Temperature.

For the tests reported, the average draft varies from 1.7 ins. to 7.5 ins. Other things being equal, the capacity of the jet as a means for producing draught is nearly proportional to the weight of steam discharged per unit of time.

The relation of reduction of pressure in the smoke-box to coal burned per square foot of grate surface is well shown by Fig. 1, and the relation of pressure reduction in smoke-box,

and evaporation per square foot of heating surface by Fig. 2. The first diagram, Fig. 1, represents the effect of changes in the draught condition, on combustion, and the second (Fig. 2) upon the evaporative power of the boiler. In both diagrams the points representing individual tests fall irregularly. An approximation to the mean curve, representing draught and rate of combustion, is shown by the straight line (Fig. 1) which is represented by the equation,

$$D = .037 G \dots\dots\dots (1)$$

in which D is the draught in inches of water, and G is the pounds of coal per square foot of grate per hour.

The smoke-box temperature, as affected by changes in the rate of combustion, is shown by Fig. 1, and as affected by changes in the rate of evaporation by Fig. 2. From these figures it will be seen that as the power of the boiler is increased the smoke-box temperature rises; also that, as in the case of the draught, the points representing individual tests fall irregularly. It should be noticed, however, that the smoke-box temperature is lower than it is usually assumed to be. It varies from 550 degrees to 798, a range which, considering the variation in the rate of combustion, is not great. Ideal conditions should make the smoke-box temperature a function of the rate of combustion, but under actual conditions the relationship, as it appears in Fig. 1, is not without variation. Smoke-box temperatures, plotted with evaporation, are given in Fig. 2. As evaporation is more directly a function of the heat passing the tubes than of furnace action, this comparison does not necessarily involve inequalities in the action of the grate. For this reason the points should be expected to fall more nearly in line, but at the scale chosen for the diagram it must be confessed that the actual difference is not great.

Evaporative Performance.

Table I. shows the actual evaporation per pound of dry coal (column 40) to vary from 6½ lbs. of water for the lightest power test to 4.77 for the heaviest. Columns 41 and 42 show respectively the evaporation from and at 212 degrees Fahr. for each pound of dry coal, assuming the quality of the steam to be that shown by the calorimeter, and assuming all steam generated to have been dry and saturated. In a similar manner columns 43 and 44 show the equivalent evaporation per pound of combustible. Referring to the equivalent evaporation per pound of coal as it would ordinarily be calculated (column 41), it will be seen that for the lightest power test the evaporation was 7.83 lbs. of coal, and that it is diminished greatly, but somewhat irregularly, as the rate of evaporation increases, until, when the power of the boiler becomes maximum, it is reduced to 5.71, a loss of 27 per cent. The equivalent evaporation per pound of coal for the several tests (column 41) and the rate of evaporation, as represented by the pounds of water evaporated per foot of heating surface per hour are

TABLE I. Evaporative Performance.

Consecutive Number.	Duration of Test in Minutes	Evaporation. Total Water divided by total Coal.	Equivalent Evap. from and at 212° F. Per Pound of Dry Coal.			
			Assuming quality of Steam as shown by Column.	Assuming all Water delivered to have been complete-ly evaporated into Dry Steam.	Assuming quality of Steam as complete-ly evaporated into Dry Steam.	Assuming all Water delivered to have been complete-ly evaporated into Dry Steam.
		40	41	42	43	44
1	240	6.50	7.83	7.86	8.70	8.7
2	190	6.90	8.31	8.35	9.24	9.28
3	180	7.67	9.15	9.26	10.17	10.29
4	255	6.70	8.05	8.10	8.95	9.00
5	180	6.98	8.37	8.44	9.31	9.38
6	180	6.63	7.95	8.00	8.84	8.89
7	240	6.61	7.95	7.99	8.84	8.88
8	180	6.44	7.74	7.99	8.61	8.66
9	180	6.31	7.61	7.66	8.45	8.51
10	140	6.26	7.54	7.58	8.38	8.42
11	180	6.26	7.54	7.58	8.38	8.42
12	150	6.62	7.96	7.99	8.83	8.88
13	170	5.62	6.75	6.79	7.50	7.54
14	120	6.00	7.17	7.24	7.95	8.04
15	160	5.95	7.12	7.20	7.92	8.00
16	170	6.19	7.41	7.48	8.24	8.31
17	170	6.44	7.72	7.80	8.53	8.66
18	180	5.99	7.18	7.23	7.98	8.04
19	120	5.83	6.98	7.03	7.76	7.81
20	160	5.98	7.18	7.25	7.97	8.05
21	120	6.40	7.68	7.75	8.54	8.62
22	120	5.51	6.59	6.66	7.33	7.40
23	150	5.69	6.81	6.86	7.57	7.63
24	180	5.40	6.47	6.53	7.18	7.26
25	180	5.79	6.94	7.00	7.72	7.78
26	140	5.75	6.87	6.95	7.63	7.73
27	160	5.63	6.74	6.80	7.49	7.56
28	120	5.50	6.59	6.65	7.32	7.39
29	160	5.31	6.35	6.42	7.06	7.13
30	120	5.82	6.95	7.03	7.73	7.81
31	140	5.09	6.09	6.14	6.77	6.83
32	122.5	5.64	6.76	6.82	7.51	6.57
33	120	4.86	5.86	5.90	6.52	6.55
34	68	5.31	6.34	6.40	7.04	7.11
35	120	4.77	5.71	5.76	6.36	6.39

plotted in Fig. 3. From the points of this diagram an effort has been made to locate a curve which should show the relation of the evaporative efficiency to the rate of evaporation. The method adopted may be described as follows:

The several points were separated into nine groups, those of

each group representing tests of nearly the same power. The grouping is as follows:

- 1st group, (test) 1, 2, 3, 4, 5; 2d group, (test) 6, 7; 3d group, (test) 8, 9, 10, 11, 12, 13, 14; 4th group, (test) 15, 16, 17, 18, 19, 20; 5th group, (test) 21, 22; 6th group, (test) 23, 24, 25, 26, 27, 28; 7th group, (test) 29, 30, 31, 32, 33; 8th group, (test) 34; 9th group, (test) 35.

The centers of the first seven groups have been determined and their location is shown on the diagram by solid black spots. A straight line drawn as nearly as possible through the points thus located is assumed to show the relationship sought. There are but two centers of groups that are as much as 1 per cent. away from this line, and four touch it within one-tenth of one per cent. Before attempting a more critical examination of the line thus located, we may inquire why so many of the joints representing individual tests and shown

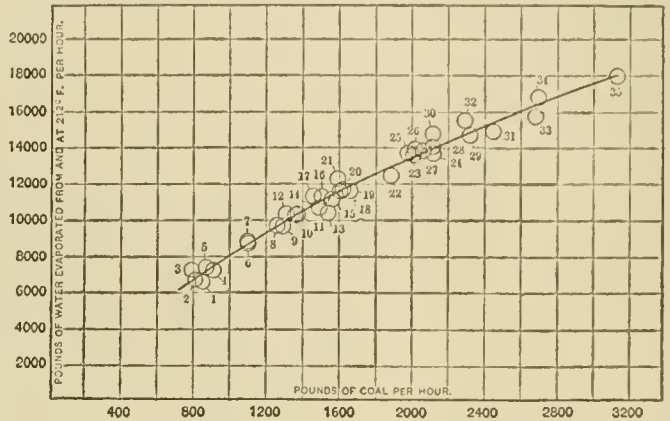

Fig. 5.—Combustion and Evaporation.

upon the diagram by light circles, fall at so great a distance from it. The facts in the case are as follows:

- 11 points or 31% of the whole agree with the curve within 1%
- 15 points or 43% of the whole agree with the curve within 2%
- 18 points or 51% of the whole agree with the curve within 3%
- 21 points or 60% of the whole agree with the curve within 4%
- 24 points or 69% of the whole agree with the curve within 5%
- 27 points or 77% of the whole agree with the curve within 6%

There is a widespread feeling among motive-power men that the character of the exhaust has much to do with the efficiency of the furnace action; that a heavy exhaust incident to slow running will have a different effect upon the fire than the lighter but more rapid action attending higher speeds, though the draft, as registered by a gauge in the smoke-box, may read the same. It was but natural, therefore, to first look to the engine conditions for an explanation of the irregularities in the efficiency of the boiler. The result of such a study tends to disprove the commonly accepted theory, and justifies the conclusion that, with a given vacuum in the smoke-box, the action of the boiler is quite independent of the manner in which the vacuum is maintained, whether by slow heavy beats or quicker, lighter pulsations.

Thus a comparison of the 11 tests that agree with the mean curve (Fig. 3) within 1 per cent. with the 11 tests which have the greatest divergence from it, reveals the fact that the tests of the latter class are, for the most part, those in which the firing of the boiler was difficult. The greater part of the tests of this group are either tests at very low power, for which only a light fire could be maintained without danger of losing steam at the safety valve, or tests at high speeds, when the

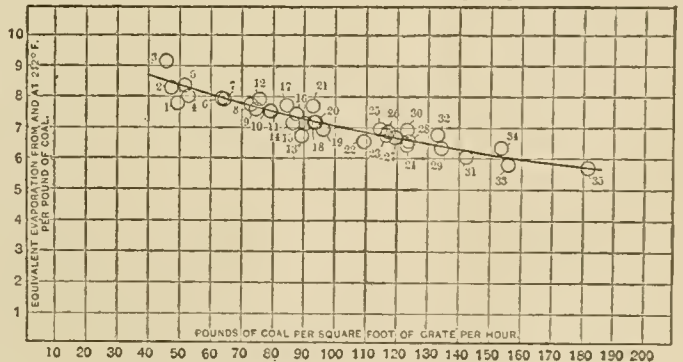

Fig. 6.—Rate of Combustion and Efficiency.

work of firing was hard and difficult. Included in this group also is one test under low boiler pressure, which is to be regarded as a light power test. On the other hand, those which agree most nearly with the curve are, for the most part, tests at medium load, which were easily fired.

Power and Efficiency.

Referring again to Fig. 3, it will be noted that the ordinates in this diagram represent the evaporative efficiency of the boiler, and the abscissae the rate of evaporation. The manner

in which the line assumed to represent the mean of these points was drawn has already been described. The equation for the line is

$$E = 10.08 - .296 H \dots\dots\dots (2)$$

in which E is the pounds of water evaporated from and at 212 degrees per pound of coal, and H the pounds evaporated per square foot of heating surface per hour. This equation and others derived from it are assumed to represent the average performance of the boiler when using Indiana block coal. By its use it is possible to obtain a coal record from the water rate, no weighing being done of the fuel as consumed. Defence for such a practice is to be found in the comparative ease with which the water record is obtained, and in the fact that the coal consumption, as determined from the equation, is a more consistent factor than can ordinarily be obtained experimentally from a few tests. The form of the equation will, doubtless hold for all boilers of similar design with that tested, but the constants may change with the proportions of the boiler, and will of necessity change with the character of the fuel employed.

Efficiency as Affected by Quality of Fuel.

The evaporation obtained from 5 different samples of fuel, designated as A, B, C, D and E, is shown in Fig. 4. In this connection it is of interest to note that the lines E, A, B, C, D converge, and it may be assumed that if D and C were sufficiently extended they would meet; that is, if the rate of evaporation were made sufficiently high, both the good and the poor coal would give the same evaporation.

The general conclusion deduced is that the higher the power to which a boiler is forced, the smaller is the fraction of the total heat developed which can be absorbed by the heating surface. If forced to very high power, the amount of heat utilized out of all that is available becomes so small that slight variations in the amount available do not measurably affect the amount utilized. If carried to extreme limits, it will doubtless appear that the line represented by equation 2, Fig. 3, is in fact not straight, though, within limits which are sufficiently broad to cover all practical cases, it may probably be so considered. The form of this, and other similar lines, is the subject of discussion in a preceding paragraph.

Derived Relations.

Fig. 5 shows the relation between the rate of evaporation and the rate of combustion for the 35 tests. The relation of water evaporated per pound of coal and pounds of coal consumed per ft. of grate per hour is shown by Fig. 6.

Conclusions.

1. The steam delivery by the boiler, tested under constant conditions of running, as shown by calorimeter attached to dome, is at all times nearly dry, the entrained moisture rarely equaling 1.5 per cent., and being generally much less than this. While the relationship can not be perfectly defined, it appears that the entrained moisture increases slightly as the rate of evaporation is increased.

2. The maximum power at which the boiler was worked with Brazil block coal was such as gave 30-boiler horse-power for each foot of grate, and .427 horse-power for each foot of heating surface. Experiments with other fuels indicate that these values may be increased by the use of a better coal by about 15 per cent., giving maximum values, which, in round numbers, are 35 horse-power per foot of grate and .5 horse-power per foot of heating surface. For the type of boiler experimented upon, and under conditions of constant running, these values may be accepted as near the maximum.

3. The maximum rate of combustion reached was 182 pounds of coal per foot of grate per hour, which is equivalent to 2.6 pounds per foot of heating surface.

4. The maximum draft for any test was that for which the average value was 7.5 inches. If D is the reduction of pressure in the smoke-box measured in inches of water, and G the pounds of coal burned per foot of grate per hour, then

$$D = .037 G.$$

Also, if W be the total weight of water evaporated per hour, the draft necessary to produce a given evaporation is represented by the equation,

$$D = \frac{.00214 W}{10.08 - .000244 W}$$

These equations apply to the boiler tested when using Indiana block coal.

5. Smoke-box temperature ranges from 550 degrees Fahr. to 800 degrees Fahr., values which are lower than those which are often assumed to prevail.

6. The evaporative efficiency of the boiler as affected by different rates of evaporation is expressed by the equation,

$$E = 10.08 - .296 H,$$

in which E is the pounds of water evaporated from and at 212 degrees per pound of coal, and H the pounds of water evaporated from and at 212 degrees per square foot of heating surface per hour; this for the boiler tested using Indiana block coal, and for values of H of not less than 5 or greater than 15. By different coals the constants will vary, results which are near the minimum being expressed by

$$E \text{ min.} = 9.4 - .024 H,$$

and results near the maximum by

$$E \text{ max.} = 12.9 - .041 H.$$

7. The evaporative efficiency of the boiler as affected by different rates of combustion is expressed by the equation,

$$E = \frac{10.08}{1 + .00421 G},$$

in which E, as before, is the pounds of water evaporated from and at 212 degrees per pound of coal, and G the pounds of coal burned per foot of grate per hour; this for the boiler tested using Indiana block coal.

8. The relation of coal burned to water evaporated is expressed by the equation,

$$C = \frac{W}{10.08 - .000244 W},$$

in which C is the total pounds of coal burned per hour, and W the total pounds of water evaporated from and at 212 degrees per hour; this for the boiler tested using Indiana block coal.

9. The condition of running the engines, whether with long or short cut-off, or at high or low speed, does not appear to affect the efficiency of the boiler of a locomotive, except in so far as it affects the average value of the draft.

10. The efficiency of the boiler of a locomotive, as disclosed by two different tests, for which all conditions of running are the same, may vary considerably, due doubtless to inequalities in the firing.

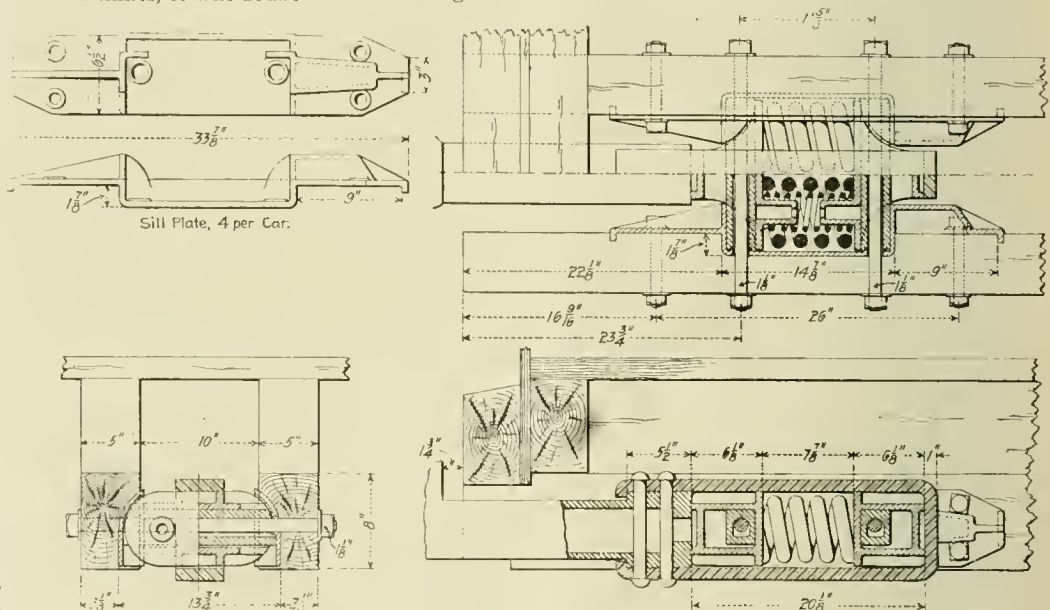

The Dayton Twin-Spring Draft Gear.

THE DAYTON TWIN-SPRING DRAFT GEAR.

To meet the demand for draft gear of increased strength and capacity, a new design employing twin springs has been placed on the market by the Dayton Malleable Iron Company. It is adapted to both steel and wooden cars and to wooden and malleable-iron draft sills, the arrangement for wooden sills being illustrated in the accompanying engraving.

The essentials are sill plates, stop bars and followers. The sill plates are gained into the draft timbers to a depth of 1 1/4 ins. and secured to them by four bolts each. Each sill plate has a lip at each end, gained into the draft sills, giving four points at which the stresses are received. The length of the sill plates, 34 ins., distributes the strains over a large area, and they are not concentrated at any one point. Their length also renders the frictional resistance between the plates and the sills important.

The stop bars are rectangular and are cast with an opening through the center. They remain in a stationary position and are rigidly secured to the sill plates and draft timbers by a 1 1/2-in. bolt which extends through each stop bar, sill plate, and draft sill. The only duty of these bolts is that of binding the

draft sills together and carrying the weight of the back end of the coupler, the tail strap and springs.

Each follower has a rectangular horizontal opening through which the stop bars are passed. In a perpendicular direction the opening is made with sufficient clearance to allow the followers free movement, while in a horizontal direction it is made $2\frac{1}{4}$ ins. greater than the width of the stop bar. Each spring is supported at its ends by a boss cast on each follower. The length of these bosses is such that while the springs are without load the distance between the bosses is $17\frac{1}{4}$ ins. A travel of 2 ins. is required to close the springs, and therefore the bosses come in contact before the spring is fully closed.

Under buffing strains the rear stop bar receives the load and the forward follower travels loosely over its stop bar and compresses the springs. The forward stop bar receives all pulling strains, and it may be noted that the sill plates are both heavily ribbed for withstanding strains in the direction in which they

which was one of the most successful in meeting the rigorous punishment described by Mr. Sanderson in his paper which we referred to on page 374 last month. In the discussion of the paper Mr. Street stated that in a service test a car loaded with 55,700 lbs. of scrap iron was thrown against another similarly loaded with 51,600 lbs., both having the Dayton draft gear. The speed in one test was as high as 16.4 miles per hour, and while the cars were rendered unfit for further service, the damage to the draft gear was confined to a slight bending of the followers and stop bars.

Two tests in the 300,000-lb. testing machine at Purdue University were also recorded. The loads were applied to the end of the coupler with the knuckle removed, and although the capacity of the machine was exhausted in the case of the malleable draft sills, the rigging was yet in condition to be used after the test. And when a load of 250,000 lbs. was left on the rigging for 12 hours, after the test, the permanent

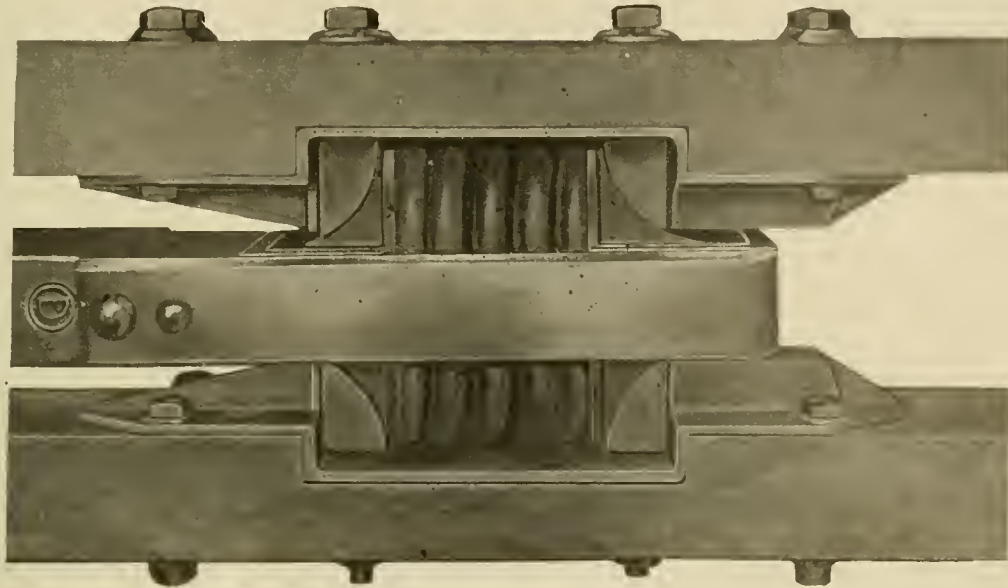

The Dayton Twin-Spring Draft Gear—Inverted Plan.

are applied. These ribs extend inwardly to a point beyond the center of each spring, and therefore the strains applied to the stop bars and followers are crushing strains. The ribs on the rear end of each sill plate form a box which gives great strength and at the same time furnishes a guide to prevent the tail strap having too much side play.

In working out this design three objects have been sought, namely, to eliminate bending and shearing strains; to keep the number of parts at the minimum; and to bind the draft sills together. These objects seem to have been attained. The bending and shearing strains which are so destructive have been reduced to direct crushing strains. The rigging complete per car, as furnished by the makers, consists of four sill plates, four stop bars and four followers. This leaves the railroad to furnish only two tail straps, four springs and 20 bolts per car. Special attention is directed to the fact that the bolts which pass through the stop bars bind the draft sills rigidly against spreading. This is essential to the success of draft rigging. Many failures are caused by the draft timbers being forced apart and split or broken, owing to the side and twisting strains, which many forms of draft gear are not designed to meet.

The special claims made for the rigging are that it can be easily and quickly inspected, all parts being in plain view; that it can be quickly put up and taken down, and also that it can be applied to a car at a lower cost than any other good double rigging. This draft gear is fully protected by patents, and is manufactured and sold by the Dayton Malleable Iron Company, Dayton, Ohio.

The proceedings of the Western Railway Club for November, 1900, contain interesting references to this draft gear,

set was but 0.65 in. and one follower plate was cracked and bent and the stop bars were slightly bent. A test on the draft gear with wooden sills developed a strength of the draft rigging exceeding that of the sills. The draft rigging withstood a load of 220,000 lbs. without producing a failure of a single part of the draft gear proper.

Wherever double spring draft gear has been used the number of failures of draft attachments and couplers have been reduced materially and there is no doubt that a material and necessary addition of strength may be obtained in this way. On one road, having 700 cars equipped with the Dayton draft gear in use since last March, the draft gear and coupler failures are reported to "amount to practically nothing." Thus far there have been no reported failures of this gear employing malleable draft sills, and the opinion that these are necessary in wooden cars is undoubtedly growing.

Mr. A. B. Burtis has resigned from the Lowe Brothers Company, where he had charge of their railway department, and has connected himself with the Mammoth Carbon Paint Company as general manager. This company will manufacture, extensively, carbon and other paints for railroads, electric roads, bridges, marine and structural work. Their dry color plant is located in the West and offices and works for grinding in New York and Cincinnati. We are informed on good authority that this company have inexhaustible mines of a high-grade carbon, which pigment has been in the hands of experts for several years. Fully 2,000 comparative tests have been made—besides a large number of buildings have been painted with it during the past few years—but they have demonstrated beyond question its value as a pigment. Mr. Burtis has a very large experience in manufacturing and selling all kinds of paints, especially for railroad uses, is well known among railway people and is thoroughly acquainted with the necessities of their work.

METAL WINDOW CASINGS.

Applied to Railway Cars and Locomotive Cabs.

Those who have had to do with car and cab windows have undoubtedly felt the need of a window casing that is weather proof, dust proof, rattle proof and in which the sash can be moved with perfect ease at all times without regard to the state of the weather. The metallic window casing shown in the

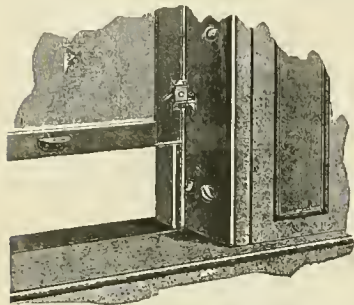

Car Window with Metallic Casings.

engraving is perfectly simple; two elastic metallic casings are secured to the window frame, and grooves made in the sash to fit the rounded edges of the metallic casings. The grooves embrace the sides of the sash between the two elastic casings with sufficient pressure to make a tight joint, on both the inner and outer sides of the sash, excluding fine cinders, wind

and cold and yet always moving with perfect freedom and ease. This casing can be applied to car windows of any style, old or new, and at an expense that is small, as compared with the great advantage derived from their application. It is also applied to locomotive cabs, steamships and dwelling houses. The finish it gives is pleasing and adds greatly to the general appearance of the window.

This invention is secured by patents owned by the Metallic Window Casing Company, who are prepared to sell the right to use and furnish the material ready to be applied to any form or style of window, and guarantee their perfect operation. Information will be furnished upon application to the Metallic Window Casing Company, 154 Congress street, Boston, Mass.

"Where the New Century Will Really Begin" is the title of a small pamphlet received from the Joseph Dixon Crucible Company. This very interesting article is by John Ritchie, Jr., and is a reprint from the Ladies' Home Journal. The latter part of the booklet is taken up with the evolution of school pencils, pointing out the improvements witnessed in the last half century in the equipment of public education. It starts back with the day of the "plummet," a bit of soft lead, which was hammered out into stick form. The Joseph Dixon Crucible Company has sought to find the best graphite ores for pencil making that the earth afforded, and the softest, straightest-grained wood for casings. They have used their every effort that the leads in their pencils might be a little smoother, a little tougher and a little blacker.

Locomotive Sanders.—A catalogue of the devices controlled and manufactured by the American Locomotive Sander Company has been distributed for the purpose of explaining their action and increasing the convenience of ordering. Reliance is now placed upon sanders in order to increase the starting power of heavy locomotives, and their development has become an important factor in modern improvements. These devices serve to place the sand where it is needed, to give a constant supply delivered automatically, and economize in sand by avoiding waste. Incidentally they also serve to reduce tire and rail wear. They have also become very important in the stopping of heavy trains with the air brake, and thus contribute not a little to the safety of railroad operation. This pamphlet of 30 pages brings the subject up to date and shows the most approved apparatus to meet all conditions of service; the Leach "A," "B" and "D" sanders, the "She" sander, and also Sherburne's arrangement for automatic sanding used in connection with the air-brake valve. The engravings are unusually fine in execution and the best use has been made of transparent views, whereby the construction and methods of attachment are clearly brought out. Copies of the catalogue will be sent upon application to the American Locomotive Sander Company, Philadelphia, Pa.

SMALL STEEL CASTINGS AND THE TROPENAS PROCESS.

Until recently the manufacturers of cast steel have not sought orders for small castings because of the difficulty of securing satisfactory work, especially when the patterns are intricate. The Sargent Company of Chicago, for example, has preferred large work, but last March this concern adopted the Tropenas process and installed it at their works at Chicago Heights, Ill., whereby small castings may be made. Good results are insured and it may be expected that many machinery parts formerly forged will now be made of cast steel. It appears that this process is an important metallurgical improvement.

This method was adopted after several years of experience with open-hearth and crucible steel plants, and after a careful study of the subject of steel-making at home and abroad, where the Tropenas process is in successful operation in some forty different plants. The Tropenas process consists in the use of special converters in which pig iron and selected scrap, previously melted in a cupola, are subjected to an air-blast of 3 to 4 lbs. pressure per square inch, directed horizontally across the top of the molten bath. This action generates intense heat by the combustion of the metalloids in the pig iron, and after a period varying from 16 to 20 minutes, depending on the quantity of the charge used, there remains in the converter a bath of nearly pure iron. Addition is made of ferromanganese or ferro-silicon, or both, to bring up the silicon, manganese and carbon contents to the specified proportions, when the metal is drawn off into a ladle and poured. The process is very simple and the product very regular.

The peculiar advantage claimed for the Tropenas process is that the resultant metal is much better and consequently more fluid than that produced by any other method, and it is this which makes it valuable in the manufacture of small and intricate castings, as it can be poured over the lip of the ladle in as small a stream as desired, and will run through thin sections, producing solid castings free from pinholes and cracks. Any grade of metal is readily produced by varying the additions. It is consequently valuable not only in the production of low carbon steel of the maximum permeability, so much desired in electrical castings, but also in the production of special grades of hard steel for mining machinery parts and other purposes.

The plant at Chicago Heights is in successful operation, producing from 20 to 30 tons of castings per day, with a much larger available capacity. All classes of general machinery, railroad, mining and electrical castings, are turned out, believed to be fully equal in physical properties and chemical composition to the best open-hearth steel. The castings are sound and solid, with a smooth surface, and the metal will stand forging and welding.

Miscellaneous castings, unless otherwise specified, are made of mild steel which is tough and machines readily, having a tensile strength per square inch of from 65,000 to 75,000 with an elongation of 20 to 30 per cent. Tropenas steel castings are solid and true to pattern, equalling in every respect the forgings which they are intended to replace, and they can be furnished in much less time and at a lower cost, especially where special dies and appliances for forging must be made.

Wherever possible, all patterns are molded by machinery, which insures uniformity. Every attention is devoted to securing the best result both in quality and workmanship. All kinds of work in the shape of special castings for automobile construction, general railroad, mining, electrical and machinery parts, where lightness and strength are desired, can be made in Tropenas steel.

Information on the subject of small and special steel castings, from one pound in weight up, may be had by addressing the Sargent Company, Old Colony Building, Chicago, Ill.

A special money card is being sent out by the American School of Correspondence, Boston, Mass., to be used by engineers and others desiring to examine their instruction papers and text books. The card contains a place where a silver twenty-five-cent piece may be inserted and securely sealed. This card contains, also, a place for name and address and the text book wanted. It can be placed in an envelope and addressed to the school without further trouble. Anyone wishing to examine any of the instruction papers of this school should send for one of these cards in order to send the money safely.

BOOKS AND PAMPHLETS.

Proceedings of the Thirty-first Annual Convention of the Master Car and Locomotive Painters' Association. Held at Detroit, Mich., September, 1900. Published for the Association by the Railroad Car Journal, New York, 1900.

This volume contains, in addition to the constitution, list of officers and members and rules of order, the proceedings and discussions of many interesting papers. It is bound in cloth and has 148 pages with an index. Copies can be procured from the Secretary, Mr. Robert McKeon, Erie Railroad, Kent, Ohio.

Injectors: Their Theory, Construction and Working. By W. W. F. Pullen, Professor of Engineering at the South Western Polytechnic, London, S. W. Second edition, illustrated. New York: D. Van Nostrand Company, 23 Murray Street. 1900. Price, \$2.00.

Very little printed information upon the subject of injectors is at hand. Those books treating of the steam engine as a whole or in part seem to fall short when they come to the subject of injectors. This volume of 187 pages, illustrated, is devoted entirely to the construction and working of injectors. In order that the reader may follow more appreciatively the different stages of development of the steam injector, the author has reserved the historical portion until he has discussed at some length the theory. The first chapter opens with a popular explanation of the action of the steam injector, which is followed by a mathematical investigation of the velocity of efflux of the steam jet. The exhaust injector, while similar to the ordinary live steam apparatus, except in dimensions, has been treated separately, together with compound injectors and the ejector condenser. The whole book is given a very consecutive arrangement which will assist those who may not be quite familiar with the mathematics used in the discussion. In this second edition advantage has been taken to describe and illustrate the latest patterns of injectors. The illustrations are not good, but the book as a whole is the most complete we have seen. It is, however, written from the English standpoint.

Progress of Invention in the Nineteenth Century. By Edward W. Byrn, A. M. Large octavo, 480 pages, illustrated. Munn & Company, 361 Broadway, New York. 1900. Price, \$3.

This is a collection of thirty-five chapters upon progress in as many different directions, in the century now closing. It is popular in style and, while necessarily rather fragmentary, because of its scope, it is a book one will often find convenient in fixing the dates of discoveries or inventions which mark turning-points in the world's progress. The work contains a chronological record of the leading inventions based upon the Patent Office documents. The subject matter may be divided into several general heads, such as electricity, steam, printing, development of machinery, medicine, lighting, engineering, textile machinery, artificial ice, liquid air and minor inventions. It does not pretend to be exhaustive, but it does present the "state of the art" in each chapter and marks the contrast which shows what has been accomplished in this century. In a number of the chapters one recognizes engravings which have appeared in the pages of the Scientific American, but the book is not in any sense a reprint from that journal.

Catechism on the Combustion of Coal and Preventing of Smoke. A Practical Treatise for Engineers, Firemen and Others Interested in Fuel Economy and Suppression of Smoke from Stationary Boilers and Locomotives. By William M. Barr, M. E. Pages, 350, illustrated. Published by Norman W. Henley & Company, 132 Nassau Street, New York, 1900. Price, \$1.50.

This book places before engineers and firemen at a moderate price an excellent treatment of the subject of combustion from the standpoints of economical use of fuel and prevention of smoke. The form of a catechism was adopted because of its directness and compactness of expression. It does not pretend to be a work for mechanical engineers, yet it will be convenient for reference with regard to fuels and a number of recent improvements in furnaces made with a view of smokeless and economical combustion. The author aimed to make the work complete in itself and evidently did not intend it for a text-book for continuous study, but rather a reference book in which to look up the various phases of the general subject of combustion. The divisions into chapters are as follows: Fuels, elementary data, the atmosphere, combustion, products of combustion, heat developed by combustion, fuel analysis,

heating power of fuels, steam generation, stationary furnace details, locomotive furnace details, chimneys and mechanical draft and spontaneous combustion. In the part devoted to the locomotive the author has included instructions to firemen as adopted by the mechanical department of the C., N. O. & T. P. R. R., the devices for smoke prevention of the Locomotive Smoke Preventer Company, the brick arch, the Strong and Wootten boilers, Mr. Quereau's papers on exhaust arrangements, the Southern Pacific front end and fire door, and the methods of the Southern Pacific Railway in burning liquid fuel. The treatment of the subject is what would be expected of a writer who is competent to treat his subject for the mechanical engineer and who adapts his style and information to the needs of men who manage boilers and are not necessarily men of high education. The book will probably have a large sale. It will be valuable to all who use steam or are responsible for its economical generation.

Specifications for Steel Bridges. By J. A. Waddell, M. Am. Soc. C. E. Published by John Wiley & Sons, New York, 1900.

This volume of 178 pages is practically a reproduction of chapters XIV. to XIX. inclusive, of Mr. Waddell's "De Pontibus," which was published nearly three years ago. They have been extended and modified somewhat so as to bring them up to the latest railroad requirements and best shop practice. The subjects treated in this book are as follows: General specifications governing the designing of steel bridges and viaducts and the superstructure of elevated railroads, specifications for railroad draw-spans, general specifications governing the designing of steel highway bridges and viaducts, specifications for highway draw-spans, general specifications governing the manufacture, shipment and erection of steel bridges, trestles, viaducts and elevated railroads, and the compromise system of live loads for railway bridges and the equivalents. There are also eighteen tables useful to the draughtsman and the designer and ten diagrams of engine loadings, equivalent uniform loads, etc. A complete index of twenty-two pages adds value to the book. Besides the usual specifications for bridges, much additional information is given that will be of value to engineers who have not had the years of experience which the author shows by his treatment of the subject. There are points, however, which will arouse criticism among engineers; for instance, the paragraphs covering the spacing for guard-timbers on railroad bridges. The clause covering the spacing of the inner guard-timber requires 5 ins. clear between gauge-plan of main rail and outer face of guard-timber; also the outer guard-timbers are placed with 12 ins. between gauge-plane of main rail and inner face of guard-timber.

Mr. Ira G. Hedrick, Consulting Engineer, Kansas City, Mo., says: "We have been using these specifications exclusively in our practice for nearly four years, and we find that they are complete in every particular, and are applicable to steel bridges of all types, lengths and loadings. In my opinion, they are the most thorough, concise and complete specifications yet published. This conclusion is based upon several years of actual use, and after having employed a great many other bridge specifications."

EQUIPMENT AND MANUFACTURING NOTES.

The New York Central is to order 100 new locomotives to meet the demands of increased business.

The steel rail manufacturers in Pittsburg authorize the announcement that they have contracted to furnish fully 1,000,000 tons of steel rails in 1901. Some of the manufacturers have already contracted to the utmost limit of their plants for the next six months. The New York Central has placed an order for 80,000 tons of steel rails to be delivered early in the year.

The Richmond Locomotive Works has just secured an order from the Norfolk & Western Railroad for 10 Class "W" 21 by 30-in. consolidation locomotives with piston valves. The principal dimensions of these engines are as follows: Driving wheels, 56 ins.; driving wheel base, 15 ft. 6 ins.; total wheel-base, 23 ft. 11 ins.; weight in working order, about 170,000 lbs.; weight on drivers, 150,000 lbs.; capacity of tank, 5,000 gallons.

In order to provide facilities for conducting its rapidly increasing local business, the B. F. Sturtevant Company has just removed its Chicago office to much larger quarters at 281-289 South Clinton Street.

The Paris agent of the Rand Drill Company reports that the compressors and drills which were exhibited at the exposition have been sold. The large Corliss compound compressor which supplied compressed air to all the American exhibits at Vincennes was purchased by the firm of Messrs. J. & A. Niclausse, the manufacturers of the Niclausse water-tube boilers, by whom it is to be used for the operation of pneumatic tools in their extensive establishment.

A recent issue of the "Jernbanebladet," a railroad journal published in Sweden, reports that the 20-in. and 31-in. by 24-in. two-cylinder compound 10-wheeled freight locomotives, which the Swedish State Railways purchased from the Richmond Locomotive Works during 1899, are so satisfactory that the Railway Administration has decided to adopt the Richmond system of compounding on their lines, and have ordered 29 compound engines of that type to be built in their own shops. This is a good achievement for American locomotives, which are gradually working their way into all countries of the world.

The Richmond Locomotive Works have just received an order from the Chesapeake & Ohio Railway Company for 25 22-in. by 28-in. Class G-6 consolidation locomotives, making 50 engines in all of the same type and design. These engines are exact duplicates of the 25 machines the Richmond Works now have under construction for the C. & O. Ry. The principal dimensions are: Cylinders, 22 ins. by 28 ins.; drivers, 56 ins.; driving wheel base, 17 ins.; total wheel-base, 25 ft. 3 ins.; diameter of boiler, 70 ins.; steam pressure, 200 lbs.; weight on drivers, 165,000 lbs.; total weight, 184,000 lbs.; total weight of tender loaded, 103,000 lbs.; tender, 6,000 gallons capacity.

The large addition to the machine shop and the new building provided for the brass foundry, boxing and brass polishing department of the Bullock Electric Manufacturing Company, which are nearing completion, will increase the floor space and improve the facilities to such an extent that the capacity of the works will be nearly doubled. Many large contracts have been recently received from both home and abroad, and this company states that the present outlook for business during 1901 is even better than during the past four years. Their bulletin No. 37, issued recently, shows numerous views in these works and the various types of machines manufactured; also a large list of the purchasers of the Bullock apparatus.

Mr. Walter B. Snow, of the B. F. Sturtevant Company, Boston, Mass., in a recent address in that city, summed up the features of the blower system of mechanical draft for heating and ventilating as follows: "The entire heating surface is centrally located, inclosed in a fireproof casing and placed under the control of a single individual, thereby avoiding the possibility of damage by leakage or freezing, incident to a scattered system of steam piping and radiators. The heater itself is adapted for the use of either live or exhaust steam, and provision is made for utilizing the exhaust of the fan engine, thereby reducing the cost of operation to practically nothing. At all times ample and positive ventilation may be provided with air temperature to the desired degree. Absolute control may be had over the quality and quantity of air supplied. It may be filtered and cleansed, heated or cooled, dried or moistened at will. By means of the hot and cold system, the temperature of the air admitted to any given apartment may be instantly and radically changed without the employment of supplementary heating surface. The pressure created within the building is sufficient to cause all leakage to be outward, preventing cold inward drafts and avoiding the possibility of drawing air from any polluting source within the building itself. By returning the air, using live steam in the heater and operating the fan at maximum speed, a building may be heated up with great rapidity. The area of heating surface is only one-third to one-fifth that required with direct radiation, while the primary cost and operating expenses of a fan is far less than that of any other device for moving the same amount of air."

ELECTRIC CONDUIT APPLIED TO CABLE RAILWAYS.

The K. A. K. Systems.

In this system the conduit rails are supported on channels which are secured to cast-iron yokes. Steel plates are placed directly upon the top of the yoke with one side turned at right angles to form the drip into the conduit. The insulators support malleable castings, on which lips are provided to close around the conduit feeder tubing, which is of iron pipe lined with treated wood.

The conductor rails are bolted to malleable castings, and the conductors are bonded at the ends by heavy flexible copper strips. Provision is made for contraction and expansion in the joints, and also for slight movements of the insulators. The trolley contacts are made by two springs of flat steel on spring bases. They carry cast-iron shoes on their lower ends for making contact with the conductor rails, and as they are simple and inexpensive, renewals may be cheaply made. The springs are carried in opposite directions at their lower ends; they pass through and are supported in insulating material, which is protected by the steel covering, this being fitted loosely in

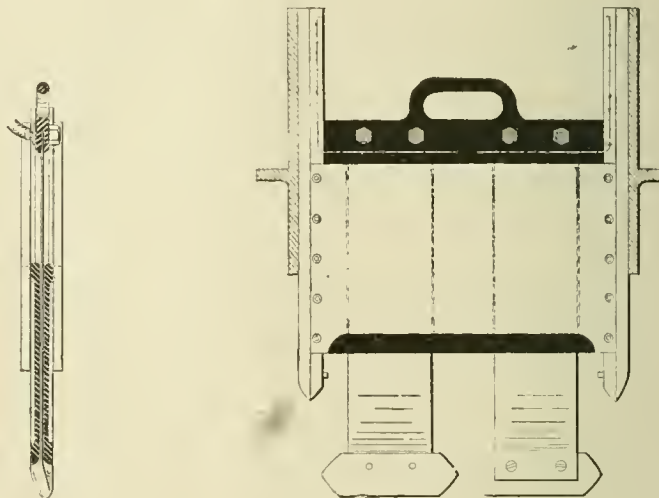

the base, which is permanently secured to the car truck. The springs are fastened at the top by means of the insulating fiber strips and pass loosely through the insulations of the casing.

The trolley is raised from the slot by means of the handle on the top of the insulating strip. This raises the springs and draws the shoes away from the conductor rails and brings them together at the bottom of the casing. The casing and the shoes are then drawn from the slot. In this system manholes are provided from 300 to 500 ft. apart. In these the fuse connections are placed and provisions are made for draining the conduit into the sewer. The fuse connections are made with heavy copper wire on insulated screw handles which may be readily detached or replaced without danger. The conductor rails end at the manholes and at these points they are connected to the feeders through the fuses. This construction renders it easy to locate defective insulation, it also prevents disabling the whole line or large part of the line because a grounding of one of the conductors disables one section only. With the return feed system electrolysis and its serious consequences are entirely prevented.

Besides this conduit system, which is owned and controlled by Mr. O. S. Kelley, A. S. Krotz and W. P. Allen, these gentlemen have a covered third-rail system, both of which are fully protected by United States patents. Information concerning the system may be obtained from Mr. O. S. Kelley, Springfield Ohio.

AMERICAN ENGINEER AND RAILROAD JOURNAL

FEBRUARY, 1901.

CONTENTS.

ILLUSTRATED ARTICLES :	Page	Page	
"Central Atlantic" Type Passenger Locomotive, with Traction Increaser.....	35	Hinson Draft Gear..... 61	
New Car Shops, N. Y., N. H. & H. R. R.R.....	41	Multiple Drilling Machinery... 65	
Composite Hopper Coal Cars, 100,000 Pounds Capacity, N. & W. Ry.....	42	Universal Hand Oil Pump..... 66	
Compound "Atlantic" Type Passenger Locomotive, B. & O. R. R.....	47	Motor-Driven Blanking Press... 66	
Steel Frame Passenger Truck... Convenient Oil House, C. I. & L. Ry.....	52	Homestead Valves..... 66	
Heavy 10-Wheel Compound Passenger Locomotive, U. P. Ry.....	54	ARTICLES NOT ILLUSTRATED :	
Study in Locomotive Fireboxes. Design of Connecting Rod Ends. Volume of Load on Ballast or Coal Cars.....	55	Liquid Fuel..... 18	
Graphical Method of Obtaining the Speed of Locomotives.....	56	New Method of Tonnage Rating in Freight Service..... 49	
Standard Equalizer Springs, L. V. R. R.....	61	Pension System, C. & N. W. Ry. Cost of Operating Compressed Air Cars..... 49	
Middle Bearings on Driving Axles.....	61	Locomotive Truck Brake..... 53	
Pan-American Exposition.....	62	Logical Locomotive Classification..... 55	
Compressed Air Locomotive. Length and Weight of Boiler Tubes, by F. K. Caswell.....	63	Passenger Coach Sanitation, by J. N. Hurty..... 58	
		EDITORIALS:	
		Progress in Gas Engines..... 50	
		Use of Sight Feed Lubricator.. 50	
		Rating of Locomotives..... 50	
		Records of Experience of Draftsman..... 50	
		Study of Conditions of Combustion in Locomotive Fireboxes.. 51	
		Localized Deflections in Built Up Structures..... 51	
		Cast Iron Wheels for Heavy Coal Cars..... 51	

"CENTRAL ATLANTIC" TYPE PASSENGER LOCOMOTIVE.

With Traction Increaser.

New York Central & Hudson River Railroad.

Built by Schenectady Locomotive Works.

This engine is a notable one which is sure to attract a great deal of attention, not only because of its large capacity but because it represents a development of a four-coupled engine with an unusual amount of tractive weight, the limits of which are by no means exhausted in this case. It stands for a high development of the "Atlantic" type, which is a wheel arrangement at this time exceedingly popular for fast passenger service.

Mr. Waitt had in mind, first of all, boiler power sufficient to insure 200 lbs. steam pressure under all conditions of service, and to secure this a wide, short grate with a large area was used, supplemented by a larger heating surface than has ever before been given to a passenger locomotive. The heating surface is only 598 sq. ft. smaller than that of the Lehigh Valley consolidation pushing engines, which have 4,103 sq. ft. This design does not appear to indicate opposition to the 10-wheel engine as a type, but it represents a desire to use but four coupled wheels in this service. To carry the weight involved in this able boiler, ten wheels were necessary and the "Atlantic" type was selected. To secure to this type the advantage of a six-coupled engine in tractive weight for starting, a traction increaser is used whereby a portion of the truck and trailer weights may be temporarily transferred to the driving wheels in starting. In this lies the chief point of interest in the design. To these features large wheels, large cylinders, 12-in. piston valves with unusually large steam passages are added.

The first of these engines completed weighed 176,000 lbs. The weight on drivers was 94,800 lbs., exactly 200 lbs. less than the calculation; the weight on the trucks was 42,600 lbs. and on the trailers 38,600 lbs. The total weight of the Chicago & Northwestern engine is 160,000 lbs., with 90,000 lbs. on the

drivers. The heating surface of the Northwestern engine is 3,015 sq. ft. (See American Engineer, August, 1900, page 237.)

The traction increaser attachment is illustrated in the drawings. It changes the fulcrums of the equalizers between the rear driving wheels and the trailers, thereby changing the distribution of weight. The position of the center of gravity of the engine is not changed, but the center of support is moved ahead, which transfers 12,000 lbs. from the truck and trailers to the driving wheels, making the weight on drivers about 107,000 lbs. when it is in use. It is obvious that any desired increase may be effected by selecting the proper distance through which the equalizer fulcrums are moved.

The fulcrums are not actually moved; the normal fulcrums are exchanged for others 5½ ins. further ahead by means of a pair of 8 by 12-in. air-brake cylinders operating through levers, as shown in the detail drawing. The normal fulcrums seat in steel castings bolted to the supplemental plate frames at the front of the firebox. The other fulcrums are made by a cross bar which in its normal position is held above the equalizers and long enough to extend across over both equalizers. This bar is carried by links attached to the air cylinder levers, and when air pressure is applied from the cab the cylinders push the cross bar down to its seats on top of the equalizers and transfer the weight as described. The air cylinders have sufficient stroke to take the weight entirely off the normal fulcrums. Vertical slabs 10½ ins wide, bolted to the frames and tied together across the engine, carry the air cylinders. The drawings also illustrate the guides for the air cylinder levers and the other details. The rear ends of the air cylinder levers are forked and their fulcrums are links bearing on pins through lugs in the equalizer fulcrum casting. This device was worked out by the Schenectady Locomotive Works and it appears to have been very well done. To remind the engineer to throw off the traction increaser after starting, a small air whistle is attached to the air pipe. It will blow while the device is in use.

In general, the engine is similar in appearance to the "Northwestern" type, but its capacity is greater. It has the same valve motion, the same general arrangement of boiler, frames and outside bearings for the trailers. The crank pins, axles and piston rods have enlarged ends for wheel and cross-head fits. The driving axle journals are 9½ by 12 ins. and those of the trailer axle are 8 by 14 ins., with 9¼-in. wheel fits. The trailer boxes are provided with a cored passage for cooling water, whereby the bearings may be cooled without putting water directly on them, and in addition to this, water may be run into the interior of the boxes and upon the journals if necessary.

The boiler is supported by two shoes at each side under the mud ring, by a plate from the front face of the foot plate to the back head and upon a cast steel cross tie between the frames under the front end of the mud ring. The foot plate is of cast steel, very light, well ribbed and thoroughly bolted. The back end structure is stiffened by a thorough bolt of steel 1¾ ins. in diameter, through the foot plate and all four sections of the frames. There are an unusual number of cross ties to the frames, amounting to eleven in all. These are: The foot plate, a bar in front of the trailer boxes, another at the rear of the equalizer fulcrums, a cast steel bar across under the front end of the firebox, a tie over the rear driving boxes, another under the rear driving boxes, another back of the lifter shaft boxes, one at the bottoms of the forward driving pedestals, the guide yoke, the cylinders and the bumper. With these precautions there should be no breakage of cylinders. The boiler is 70½ ins. in diameter and its center is 111 ins. above the rail. It is plentifully supplied with wash-out plugs and has a mud drum in front of the firebox. The brake shoes are at the rear of the drivers and trailers and the truck wheels also have brakes. The driving brake cylinders are in front of the guide yoke. Vacuum and combina-

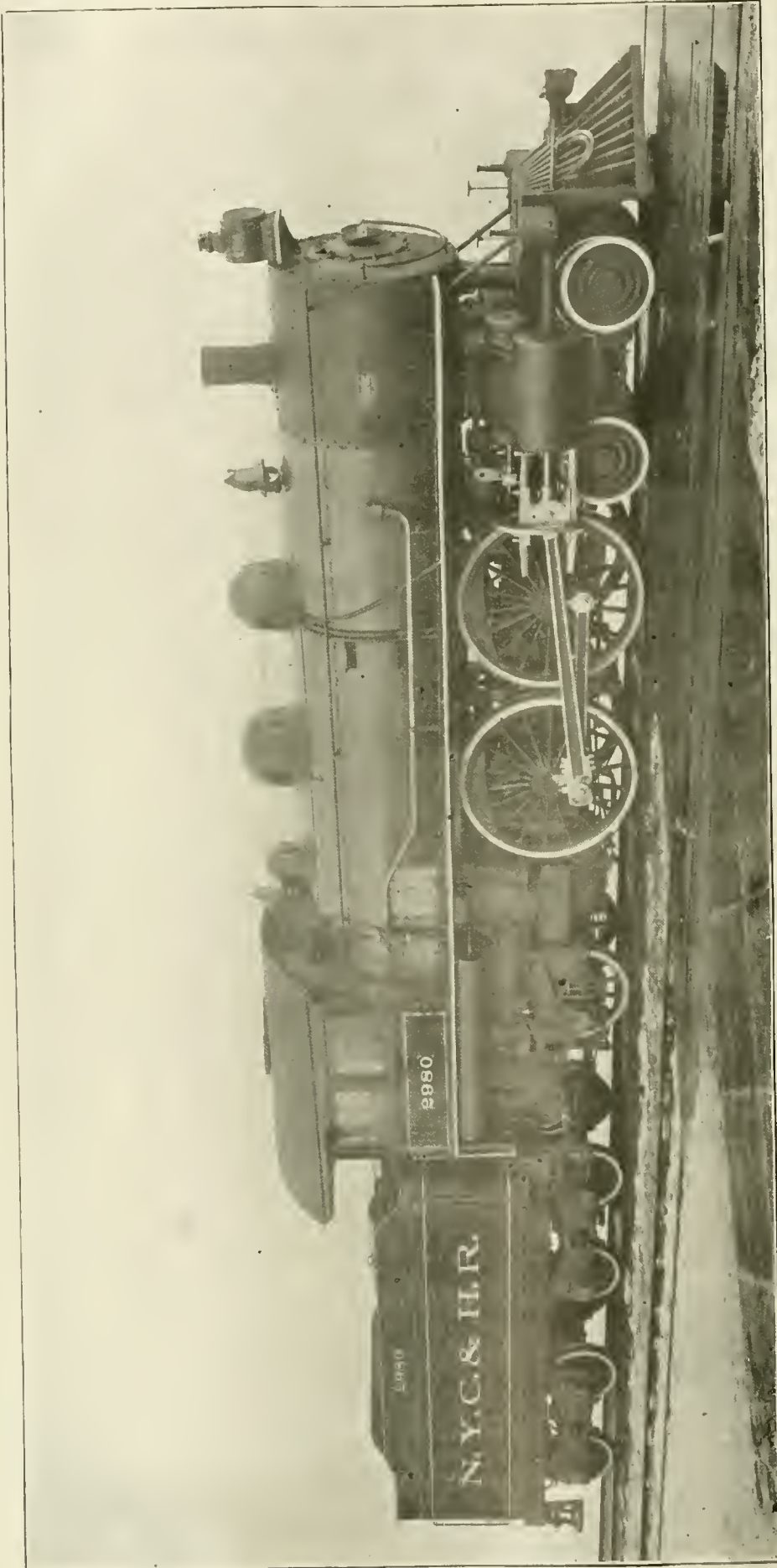

"CENTRAL ATLANTIC" TYPE HEAVY PASSENGER LOCOMOTIVE.—NEW YORK CENTRAL & HUDSON RIVER RAILROAD.

A. M. WAITT, Superintendent of Motive Power and Rolling Stock.

SCHENECTADY LOCOMOTIVE WORKS, Builders.

Wheel: Driving.....	21 x 26 in.	Boiler pressure.....	206 lbs	tender wheels.....	36 in.
Weights: Total of engine.....	176,000 lbs.;	trailing.....	50 in.;	total engine and tender.....	224,900 lbs.
Grate area and tubes: Grate area.....	width.....	Tubes.....	80 1/4 in.;	back.....	390-2 in.—16 ft. long.
Firebox: Length.....	3,298.08 sq. ft.;	depth of front.....	Diameter.....	total.....	72 in.
Boiler: type, straight.....	7 ft.;	total of engine.....	207.09 sq. ft.;	engine and tender.....	3,505.17 sq. ft.
Heating surface: Tubes.....	Eight-wheel;	water capacity.....	27 ft. 3 in.;	coal capacity.....	53 ft. 0 in.
Wheel base: Driving.....					

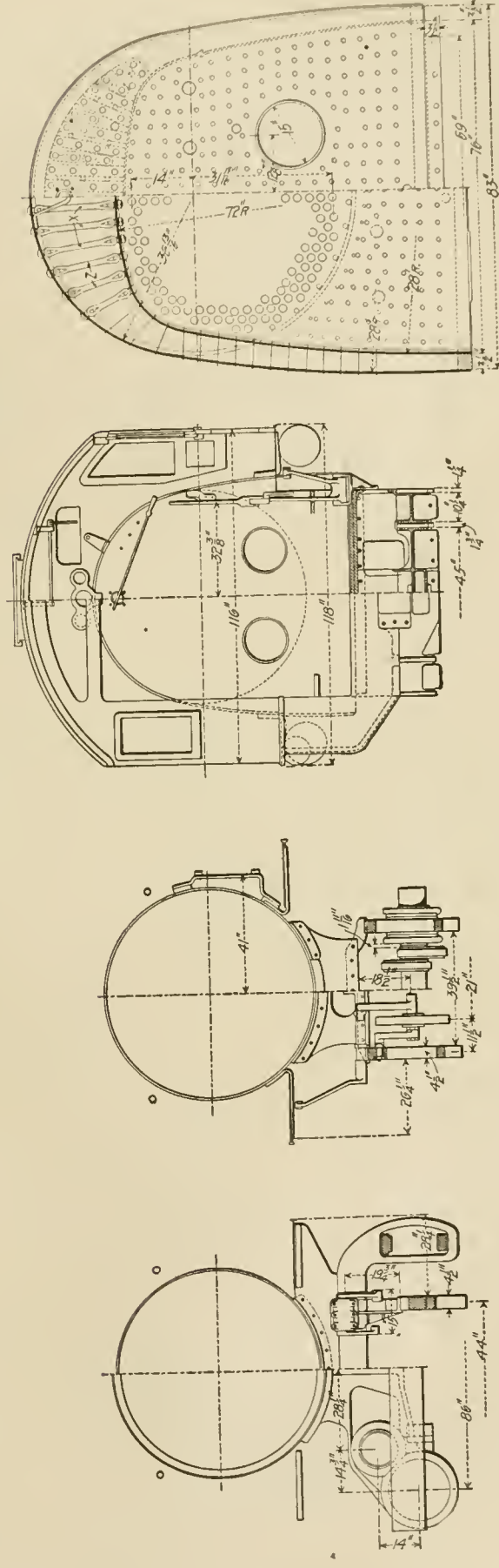
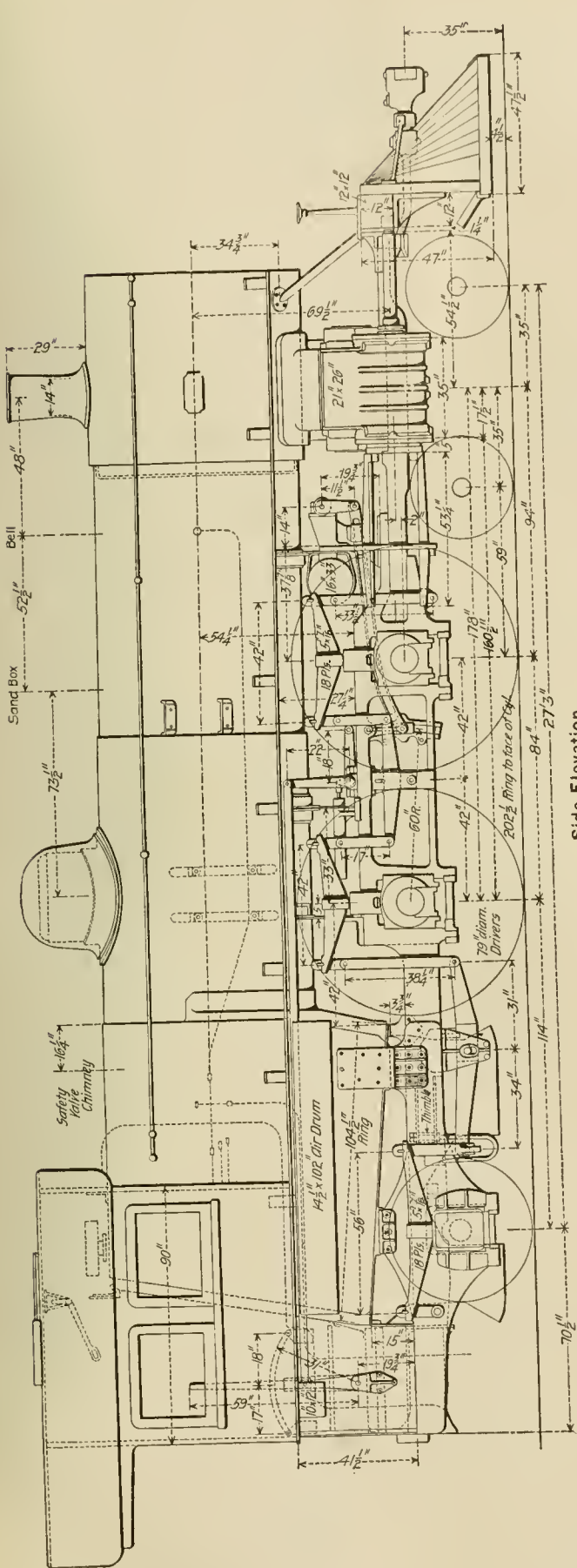

Half Rear and Front Elevations and Sections.
 "Central Atlantic" Type Passenger Locomotive—New York Central & Hudson River Railroad.

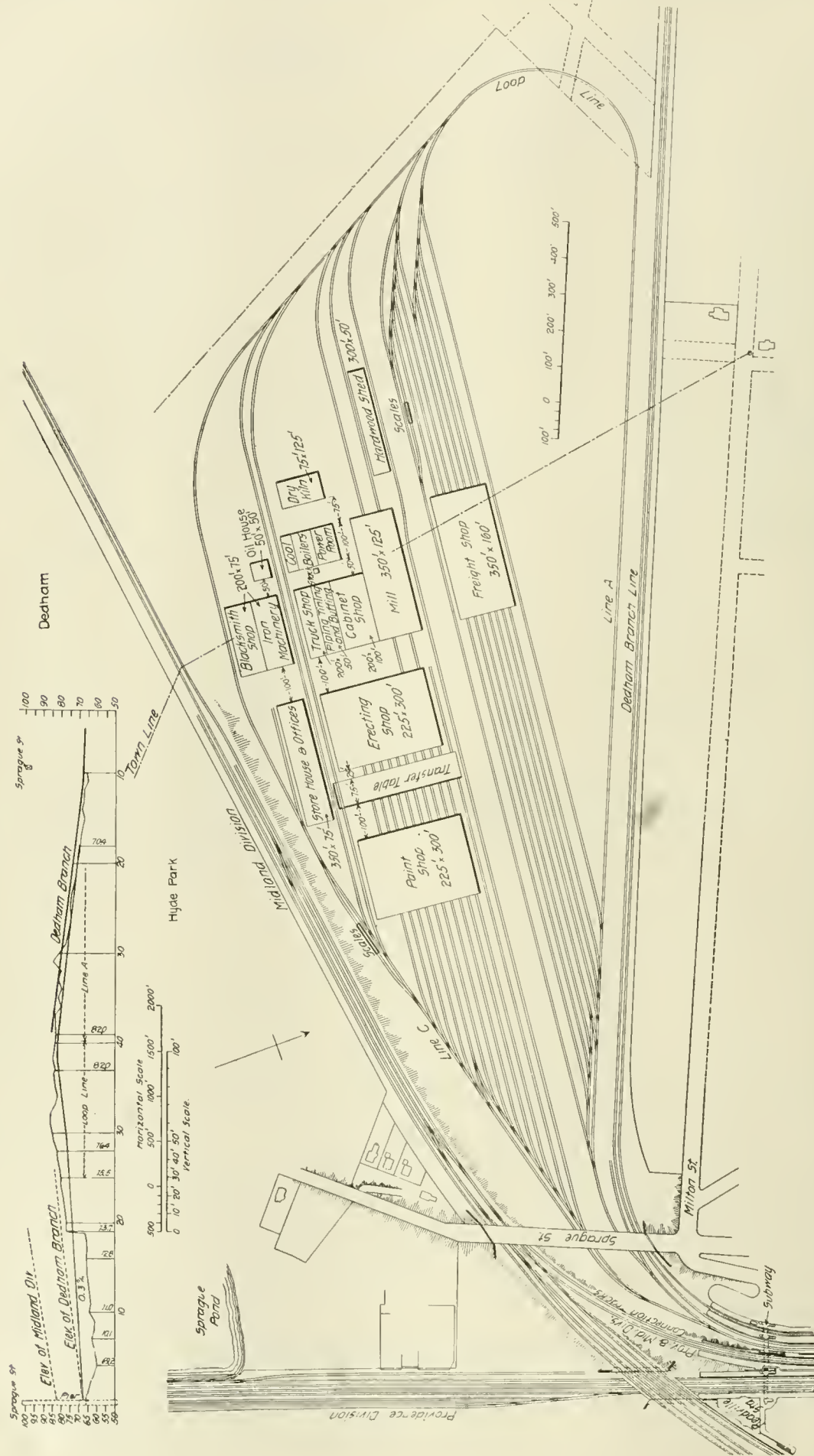

New Car Shop Plant, New York, New Haven & Hartford Railroad, at Readville, Mass.

W. P. APPEYARD, Master Car Builder.

JOHN HENNET, Superintendent Motive Power.

C. M. INOERSOLL, JR., Chief Engineer.

NEW CAR SHOPS.

New York, New Haven & Hartford Railroad.

Large Plant Exclusively for Cars At Readville, Mass.

With Electric Distribution of Power.

A few of the peculiar conditions affecting the operation of the New York, New Haven & Hartford Railroad are the following: Its total mileage is 2,060 and the longest direct run, from New York to Boston, is 232 miles. The total number of passenger trains, averaging five cars each, is 1,970 every 24 hours and this employs but 1,860 cars. The road has 13,000 freight cars of its own and handles from 50,000 to 60,000 foreign freight cars per day, which means that the car department must maintain nearly 75,000 freight cars and 1,860 passenger equipment cars, of which 120 are parlor or sleeping cars owned and operated by the road. The road is made up of a number of short lines, each having previously operated its own shop equipment, a method which has been followed until it now becomes necessary to concentrate the heavy car work at one place, while light work will be done at two others—East Hartford and New Haven. For the large shop plant, Readville, nine miles from Boston, was selected because of its convenience. An angle between the Midland division and the Dedham branch offered 70 acres in a favorable shape with good track facilities and the possibility of extending a track by a loop entirely around the grounds. In this space shops having a capacity for 180 passenger cars, for all classes of repairs that include varnishing, and 1,000 freight cars for general repairs per month are to be provided, the plant being exclusively for car work. A combination of locomotive and car shops was considered here because, being on the main line to New York and also on the Midland division (formerly the New York & New England) the location was equally favorable for locomotive work, but the car plant was considered large enough to justify complete separation of the work.

The shops provide for the housing of 60 passenger cars and 60 freight cars at one time. The plan illustrates the arrangement of the buildings with the passage or "Midway" 100 ft. wide between the freight repair tracks and the shops. This is a roadway which will always be kept open and will be most valuable in fire protection, the fire precautions being well worked out. The buildings are as follows:

Paint shop	225 x 300 ft.
Erecting shop	225 x 300 ft.
Storehouse and offices	75 x 350 ft.
Blacksmith shop	75 x 200 ft.
Truck shop	50 x 200 ft.
Piping, tin and buffing	50 x 200 ft.
Cabinet shop	100 x 200 ft.
Mill	125 x 350 ft.
Freight shop	160 x 350 ft.
Oil house	50 x 50 ft.
Power house	100 x 150 ft.
Dry kiln	75 x 125 ft.
Hardwood shed	50 x 300 ft.

In the passenger car shops there are 10 tracks at 24 ft. centers, each holding three cars, making 60 cars in all. These shops are exactly alike, with a second story in the south ends for the varnish rooms, upholstery shop and toilet rooms. The details of the buildings will be taken up in a future article, the present purpose being to direct attention to the general plan. Between the paint shop and the transfer table the tracks have a length of 100 ft. This space will be used for stripping and scrubbing cars and for storage while waiting to get into the shops. This space also permits of clearing the erecting shop promptly without waiting for cars to be removed from the paint shop tracks.

The shops requiring machinery are grouped together in a very compact space with a 100-ft. passage between them and the erecting shop and storehouse. The power distribution is to be entirely by electricity and in this passage a small electric trolley will serve the shops and take material in push cars to tracks leading to the shops where it is to be

used. The freight repair shop comes also to this line and is of the same length as the mill. The freight shop is between two yards. It has seven tracks at 20-ft. centers and, as stated, will house 60 cars at a time. It is the intention to place bad order cars in the yard at the east end of this shop and have them move progressively to the right through the shop and out to the yard at the west end. The yard at the east end of the shop will hold about 500 cars. The freight work is therefore near the shops and material may be delivered easily from the other shops and the mill. The lumber yard is west of the dry kiln and the mill, this part of the plant being laid out with a view of progressive movement of material to and through the mill with no backward or side steps, and while the plant is very large the "magnificent distances" of some recent shop plant plans have been avoided. The whole plant, in fact, embodies the progressive movement idea throughout as the plan clearly indicates.

It is the intention to dismantle passenger cars on the track south of the erecting shop. The trucks will then go to the truck shop, which will have two electric traveling cranes and the cars will be taken to the erecting shop on low trucks. The arrangement of buildings throughout is such as to save unnecessary handling of material. The oil house, iron machine shop, truck shop, store house and coal bin of the power house are all served by two parallel tracks. All wheel work and heavy parts and stores may be most conveniently handled here and the buildings used for light work are placed where they are most convenient. The hardwood shed and dry kiln are very large buildings of their kinds, which is necessary because of the large amount of cabinet work on the sleepers and parlor cars; this also necessitated a large cabinet shop.

The steam pipes for heating the buildings will be carried overhead and this also applies to all piping, as far as it may be treated in this way.

These plans were decided upon by Mr. John Henney, Superintendent Motive Power, and Mr. W. P. Appleyard, Master Car Builder, in co-operation with Mr. C. M. Ingersoll, Jr., Chief Engineer. We are indebted to these gentlemen for information and drawings, and we expect to describe the buildings and other features of the plant in future articles. The plant is an important one and its arrangement and also the interesting details will be suggestive to others who are engaged upon such problems. We expect to completely describe the buildings and the machinery in two subsequent articles. That concerning the machinery will be reserved until the work is completed.

That French locomotive boilers are not lagged with heat insulating material is rather surprising. We are told in the "Railroad Gazette," that instead of providing non-conducting material under the jacket, an air space of 2 or 3 ins. in thickness is left between the jacket and the boiler for the purpose of saving loss of heat. This is a convenient and cheap heat insulation but its efficiency depends largely upon the tightness of the jacket. A few leaks or a circulation of air will destroy its efficiency. In fact, the leakage of air from the jacket impairs the value of all boiler coverings and must be carefully guarded.

A reform in the interest of healthful conditions of railroad travel has begun on the Chesapeake & Ohio by the removal of fret, grillwork and other dust depositories from its passenger cars. It is done without sacrifice of art in ornamentation and the result is altogether an improvement. The good work should not stop until all plush, heavy hangings, carpets and fuzzy blankets are removed from parlor and sleeping cars. These should give place to materials which may be washed or disinfected at the end of every trip. Specialists insist that this reform is necessary. It seems reasonable, and we have no doubt that too little attention is given to these precautions. The fact that the improvements tend in the direction of economy should help the good work along.



100,000 Pounds Capacity Composite Hopper Coal Cars, with Steel Framing—Norfolk & Western Railway.

W. H. LEWIS, *Superintendent Motive Power.*

C. A. SELBY, *Mechanical Engineer.*

COMPOSITE HOPPER COAL CARS 100,000 POUNDS CAPACITY.

With Steel Frames and Wooden Hoppers.
Norfolk & Western Railway.

About eighteen months ago the Norfolk & Western Railway began building 50-ton capacity cars having steel underframing and wooden hoppers, illustrations and description of the design were given in the June, 1899, issue of the *American Engineer*, page 187.

One thousand of these cars were built at the Roanoke shops of this company, and have been in their exclusive service, not leaving their line. These cars are run in solid trains between the mines in West Virginia and tidewater, producing a remarkable car mileage, as high as 2,600 miles per month.

Their design may be described briefly as follows: The carrying members are 15-in., 33-lb. steel channels with a built-in bolster of plates and bars. The side planks of the box or hopper are bolted to wooden posts, which are secured to the side sills with cast-iron pockets and bolts. The inclined chute planks are of oak and three pairs of doors are hung from hinge bars extending across the car, which are supported by strap bolts riveted to the sills. The doors are operated by winding shafts with ratchet wheels on the sides of the cars, the chains winding on grooves in the wheels. The end doors have check chains to limit their opening and direct the flow of the coal to suit the openings in the unloading docks. The weight of these cars when new was about 40,000 lbs., but at the present time, owing to the drying out of the lumber, their weight averages about 39,500 lbs.

The April, 1900, issue of the *American Engineer* illustrated another style of composite car in use on the Norfolk & Western. This is a 40-ton, flat-bottom, drop-door gondola, and is a radical departure in car design. The heavy side sill and the wooden stakes of the previous design are omitted, and the sides of the car are supported by a steel truss, of which the top coping angle and the side sill are respectively the top and bottom chords and the verticals and diagonals are 5-in. channels, taking the place of the stakes, and to these the side planks are attached. The saving in weight by the use of the truss is over 1,000 lbs. per car as compared with the heavy sill design with wooden stakes.

The holsters of these cars are very strong, both for carrying and for resisting side bearing thrust which is very severe on this road, owing to heavy curvature. Five hundred of these cars are in service and have given perfect satisfaction, no defect in the design having become apparent.

The success of the truss feature of these cars in reducing weight and cost has brought about its introduction into a revised plan for 50-ton cars, which has recently been made, and a sample car built. The working drawings and an illustration from a photograph of the car are shown herewith, by courtesy of Mr. W. H. Lewis, Superintendent of Motive Power of the Norfolk & Western. The Roanoke shops have begun the construction of a large order (we believe 900) of these cars. This car and the 40-ton gondola were designed by Mr. C. A. Selby, Mechanical Engineer of the Norfolk & Western, and they represent original ideas in the use of structural steel in car construction.

A comparison of the three cars mentioned is given herewith in tabular form, and in explanation of the high lading of the gondola it may be stated that much of the coal that is carried by the Norfolk & Western exceeds the generally recognized standard of weight of 54 lbs. per cubic foot, and it was found that the usual tipple lading would often exceed the marked capacity of the car and the customary 10 per cent. excess. It was, therefore, decided to raise the stenciling to 85,000 lbs., and allow the 10 per cent. The weighmasters' books show frequent loadings of 93,000 in these cars. The average lading of the 50-ton cars is about 105,000, although 109,000 and a few cases of 110,000 lbs. have been reported on arrival at the coal piers. The loading of the sample car here illustrated was done by hand at Roanoke with wet coal, and weighed 112,000 lbs., light weight 38,000 lbs., total 150,000 lbs.

Class Designation.	GG.	HF.	HG.
Marked capacity (excess allowance, 10%)	85,000	100,000	100,000
Cubical contents, even full, cu. ft.....	1,336.76	1,598.92	1,698.86
Maximum service load	93,000	110,000	110,000
Weight of two trucks.....	14,300	15,500	15,500
Weight of body	18,200	24,400	22,500
Av. weight of car, complete, new.....	32,500	39,900	38,000

The new 50-ton cars have the following general dimensions:

Length over body	31 ft. 1/2 in.
Length over end sills.....	33 ft. 1/2 in.
Width over body (not including stakes).....	9 ft. 2 in.
Distance between truck centers.....	21 ft. 6 1/2 in.

The construction of the steel frame is clearly shown by the

COMPOUND "ATLANTIC" TYPE PASSENGER LOCOMOTIVE.

With Wide Firebox.

Baltimore & Ohio Railroad.

The adoption of the wide firebox for burning soft coal by the Baltimore & Ohio is interesting from the fact that this road has had a long and extensive experience with large grate areas for hard coal. This design is particularly noteworthy also because of the combination of wide grates and compound cylinders with the "Atlantic" type of wheel arrangement. It should prove altogether favorable and reports indicate that the expectations are being realized. With a total weight of not quite 150,000 lbs. the total heating surface is 2,663 sq. ft., which is almost the same as that of the 10-wheel locomotives of the Great Northern Railway built in 1898 which weigh 166,000 lbs. The Baltimore & Ohio engine has more heating surface for its weight than any design of this type of which we have record, and this indicates a successful effort to save weight elsewhere in order to increase the boiler capacity.

Our engravings illustrate the end elevation and sections, the boiler and firebox, the low-pressure piston and hollow piston rod, the perforated pipe valve yoke, upon the end of which a relief valve is mounted, and the piston valve with L-shaped rings. The dimensioned drawings and the following table render an extended description unnecessary:

General Dimensions.

Fuel	Soft coal
Cylinders	15 and 25 by 28 ins.
Driving wheels, diameter	78 ins.
Wheel base, total of engine	25 ft. 7 ins.
Wheel base, driving	6 ft. 9 ins.
Wheel base, total (engine and tender)	52 ft. 6 1/2 ins.
Length over all, engine	40 ft. 5 ins.
Length over all, total, engine and tender	62 ft. 6 1/2 ins.
Height center of boiler above rails	8 ft. 7 ins.
Height of stack above rails	14 ft. 6 1/2 ins.
Weight on drivers	83,400 lbs.
Weight on truck wheels	37,940 lbs.
Weight on trailing wheels	23,260 lbs.
Weight, total	149,600 lbs.
Weight tender, loaded, about	100,000 lbs.
Heating surface, firebox	150 sq. ft.
Heating surface, tubes	2,513 sq. ft.
Heating surface, total	2,663 sq. ft.
Grate area	42.5 sq. ft.
Truck wheels, diameter	33 ins.
Journals, driving axle	8 1/2 x 12 ins.
Journals, truck axle	5 1/2 x 10 ins.

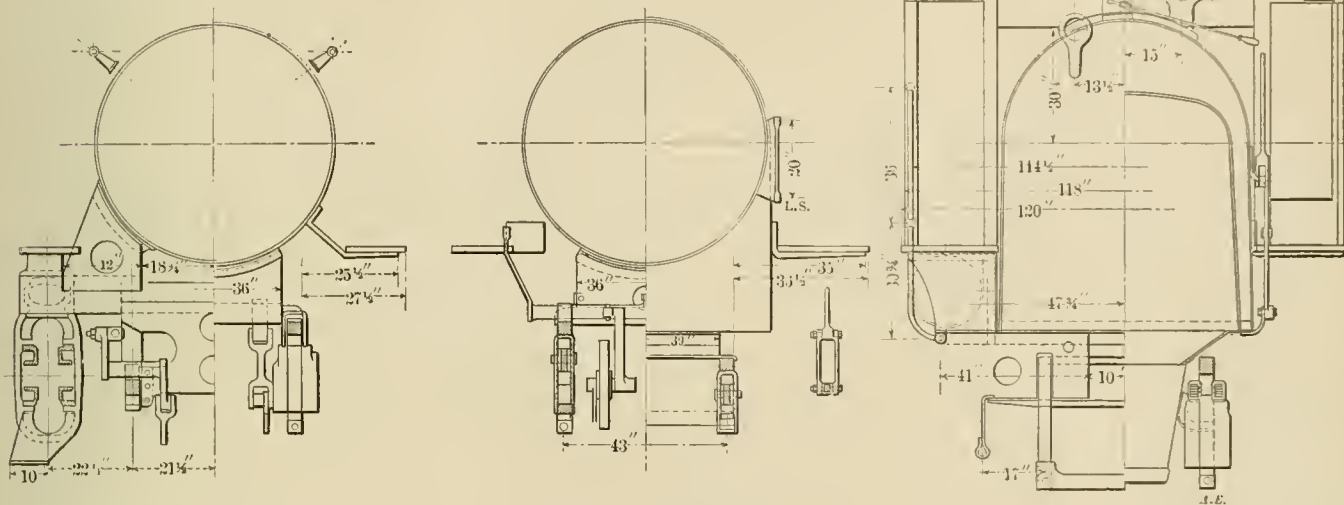

Top of Rail

Sections and End Elevations.

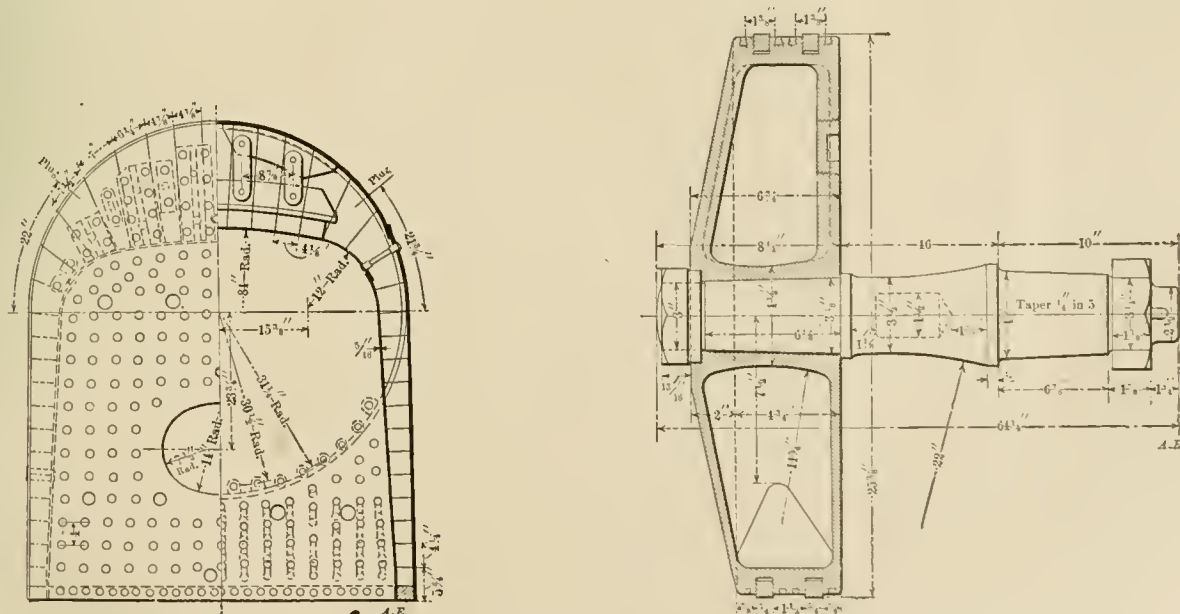

Transverse Section of Firebox.

Low Pressure Piston and Hollow Piston Rod.

Compound "Atlantic Type" Passenger Locomotive—Baltimore & Ohio Railroad.

LIQUID FUEL.

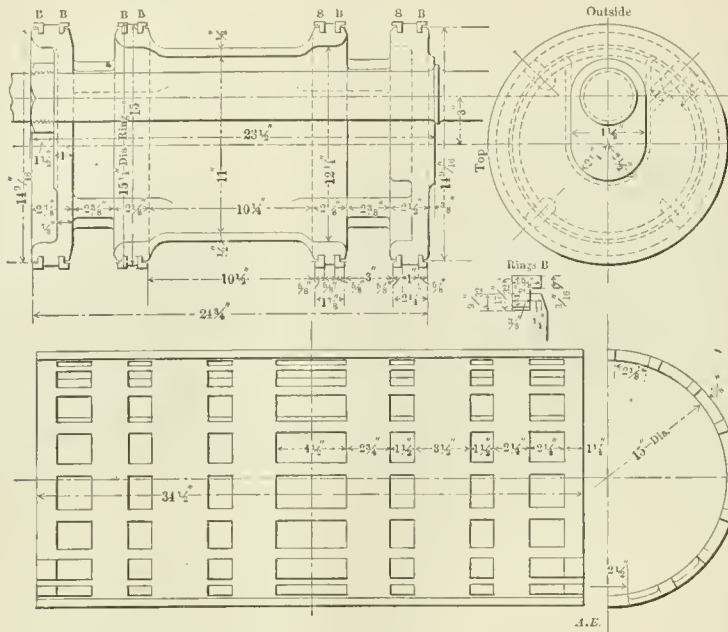

Piston Valve.

This subject has recently come afresh before the French Society of Civil Engineers with special reference to the establishment of supply stations for ships of war. The Institution of Civil Engineers presents the following abstract of a paper by Mr. H. Guerin in "Genie Civil":

Evidence exists of the increased use of liquid fuel in British vessels trading in the Far East, the installation of a charging station at Suez having been authorized by the Egyptian Government, and for railway and other purposes in Russia, America and other countries. The author refers to articles in Vols. xxxiv., xx., xxiv., viii., xxi., xxxv. and xxxvi. of the "Genie Civil," and to a paper in the "Engineering and Mining Journal" of New York, by H. Tweddle, which describes the best methods of using this fuel and of which this article is to some extent a resume. The best results have been obtained by the use of crude petroleum.

The proportions of carbon, hydrogen and oxygen in various hydrocarbons and their calorific power (in calories per kilogram) are given in the following table:

	C.	H.	O.	Calorific power.
Light petroleum oil—American....	86.834	13.107	10,913
Refined	85.481	14.216	0.293	11,047
Petroleum spirit.....	80.583	15.101	4.316	11,086
Crude petroleum.....	83.012	13.889	3.099	11,094
Light oil from Baku.....	86.700	12.944	10,843
Petroleum from the Caucasus.....	84.906	11.636	10,328
Ozokerite from Boryslaw.....	83.510	14.440	11,163

To realize the theoretical calorific power and the highest temperature of combustion it is necessary to supply to the combustible the exact quantity of air furnishing the necessary amount of oxygen, and to have the most intimate possible contact between the air and the fuel. Consequently gaseous fuel offers the best conditions for obtaining the best result, liquid fuel the next, and powdered solid fuel the next in order, although in practice excess of air, deposits of soot and other causes prevent more than a moiety of the useful effect being realized, especially in the case of coal firing. The methods of using fuel in the liquid form are, however, the most simple of all, and hence the repeated efforts toward a more general introduction of this kind of fuel.

Various forms of injectors or "pulverizers," which have been from time to time proposed and introduced, are enumerated by the author, and the effects of different forms of jets on the completeness of the pulverization of the oil and its admixture with the air are discussed. The most suitable form of flame for a given furnace or process depends upon the quality of the oil and on the purpose to which the heat of combustion is to be applied.

Tweddle has found by experiment that in order to obtain the highest possible temperature from liquid fuel it is necessary to burn it in fire-brick combustion chambers of limited capacity, and that for evaporative effects an injector worked by steam is preferable to one using an air-jet, which is more suitable for reheating, forge and other furnaces of that class. The author introduced the use of petroleum fuel on the Oroya Railway in Peru in the year 1890, where experiments had to be conducted under unfavorable conditions. Starting from sea-level at Callao, the railway crosses the Andes at an altitude of 4,250 meters, with a total length of about 160 kilometers. The gradients and curves are consequently against the realization of a high duty. Nevertheless, the consumption of oil was little over half that of coal for the same work, although the calorific power of the oil as compared with that of coal was only as 1.4 is to 1.

Mr. Charles T. Schoen has resigned from the presidency of the Pressed Steel Car Company, and Mr. F. N. Hoffstot, of Pittsburg, has been elected to succeed him. Mr. Hoffstot has been a director in the company since its incorporation.

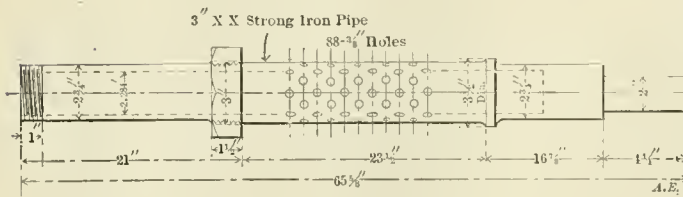

Perforated Pipe Valve Yoke.

Main crank pin	6 1/2 x 6 1/2 ins.
Piston rod diameter.....	3 1/2 ins.
Main rod, length center to center.....	10 ft. 9 5/8 ins.
Steam ports, length.....	34 ins.
Steam ports, width.....	1 1/2 ins.
Exhaust ports, length.....	34 ins.
Exhaust ports, width.....	4 3/8 ins.
Bridge, width.....	3 1/2 and 2 3/4 ins.
Valves, kind of.....	Piston
Valves, greatest travel.....	5 3/4 ins.
Valves, outside lap.....	H. P., 7/8 in., L. P., 5/8 in.
Valves, inside, clearance.....	H. P., 1/2 in., L. P., 1/4 in.
Valves, lead in full gear.....	H. P., 0, L. P., 1/2 in.
Boiler, working steam pressure.....	200 lbs.
Boiler, thickness of material in barrel.....	11/16 and 5/8 in.
Thickness of tube sheets.....	1/2 in.
Thickness of crown sheet.....	3/8 in.
Crown sheet stayed with.....	Radial stays
Dome, diameter.....	31 1/2 ins.
Firebox, length.....	8 ft. 5 15/16 ins.
Firebox, width.....	5 ft. 1/2 in.
Firebox, depth front.....	64 ins.
Firebox, depth back.....	62 ins.
Firebox, thickness of sheets.....	5/16 in.
Firebox, water space, width.....	Front 4 ins., sides 3 ins., back 3 ins.
Tubes, number.....	300
Tubes, outside diameter.....	2 ins.
Tubes, length over sheets.....	16 ft. 1 in.
Smokebox, diameter.....	63 ins.
Smokebox, length.....	65 ins.
Exhaust nozzle.....	Double
Netting, size of mesh or perforation.....	2 1/2 x 2 1/2 ins.
Stack.....	Straight
Stack, diameter.....	18 ins.

Tender.

Type	Eight-wheel
Tank capacity for water.....	5,000 gallons
Coal capacity	8 tons
Type of underframe.....	Wood
Type of truck	Barber
Type of truck spring.....	Elliptic
Diameter of truck wheels.....	36 ins.
Diameter and length of axle journals.....	5 x 9 ins.
Distance between centers of journals.....	76 ins.
Diameter of wheel fit on axle.....	6 3/8 ins.
Diameter of center of axle.....	5 3/8 ins.
Type of truck bolster.....	Barber
Length of tender frame over bumpers.....	22 ft. 2 ins.
Length of tank.....	20 ft.
Width of tank.....	8 ft. 8 ins.
Height of tank, not including collar.....	5 ft. 5 ins.
Height of tank over collar.....	6 ft. 1 in.

A NEW METHOD OF TONNAGE RATING IN FREIGHT SERVICE.

In October last the Canadian Pacific Railway put into effect a new method of tonnage rating which seems to be successful in the application of a new idea based upon the fact that the resistance per ton of loaded cars is less than of empty ones. Mr. Thomas Tait, General Manager of the road, described the plan in a paper read at the January meeting of the New York Railroad Club which should be studied by our readers who are engaged upon this problem. Probably the secretary can furnish copies.

This plan goes much farther than to reckon cars as empty or loaded; it takes into account the proportion of load to tare, the variation having greatly increased of late through the introduction of cars of large capacity. Experience on this road has demonstrated:

First—That the haulage capacity of engines from station to station in each direction should be based on a uniform proportion of tare weight to gross weight behind the tender.

Second—That in loading engines the resistance of every train, as compared with that of a train having this uniform proportion of tare, should be determined.

After investigating it was decided to adopt one-third (two tons of contents to one ton of tare weight), as the uniform proportion of tare weight to gross weight behind the tender to be used in the new schedules of haulage capacity in freight train service. These schedules of haulage capacity of locomotives in freight train service show the number of tons which each class of engine can take from station to station in each direction in a train, the tare weight of which is one-third the gross weight behind the tender.

The locomotives are classified according to their hauling capacity, each class being designated by its percentage of haulage capacity—the standard ten-wheel freight engines being termed "100 per cent." engines; more powerful engines, "140 per cent.," "150 per cent.," etc.; lighter engines, "60 per cent.," "65 per cent.," etc. Five per cent. of haulage capacity represents approximately a drawbar pull of 1,000 lbs. at seven miles per hour, which is the speed over grade summits on which the haulage capacity of engines has been based. The drawbar pull which any engine can exert is thus easily ascertained if its percentage of haulage capacity is known, or vice versa. In these schedules the ruling grade on each section is clearly indicated, as is also the increased tonnage (passing load), if any, which can be taken if the train does not stop at a station.

The capacities of the engines were carefully determined by a dynamometer car and other schedules were prepared for use in making up trains. These contain figures which permit of accurately loading an engine, when the hauling capacity is known, so that the exact amount of tonnage for a train may be selected, the weights of cars and their loads being known. The schedules are compiled on the basis that empty cars require 30 per cent. more power than the same tonnage in fully loaded cars. The load, as shown by this chart, is termed "equivalent tonnage," it is not the "actual tonnage" in the sense of being the actual weight of the cars and loads.

In the use of the system allowances are made for speeds, various conditions of weather and rails. The experience of the Canadian Pacific seems to indicate the value of the system, and while at first glance it appears rather complicated, the author of the paper states that it is really not so and that the results already obtained warrant still further extension of it.

The steam turbine has made considerable progress in Continental Europe. We are told by the "Mechanical Engineer" that in Sweden, where the Laval turbine originated, there are 1,000 in use. The French Laval Company has sold 600 since 1894, and they are used in positions of responsibility in French naval vessels and in other government service.

PENSION SYSTEM.

Chicago & Northwestern Railway.

A system of pensioning the employes of the Chicago & Northwestern Railway Company was put into effect January 1, 1901, by the new Pension Board of that road. The rules adopted affect two classes of employes in the service of the company. Those who have reached the age of seventy years and have been in service thirty years are to be retired and pensioned, and those having acquired the age of sixty-five to sixty-nine years and have become incapacitated, may be retired and pensioned after thirty or more years of service. This applies to employes of all the roads owned or controlled by the Chicago & Northwestern. The length of service will be reckoned from the date of entering the service of these roads either before or after the control or acquisition by the Chicago & Northwestern, and the amount given will be for each year of service, 1 per cent. of the average monthly pay for the ten years preceding retirement, and will be paid monthly until the death of the recipient of the pension. Should the aggregate allowance for this purpose exceed \$200,000, a new rate will be established proportionately reducing the allowances. Hereafter persons over thirty-five years of age will not be taken into the service of the company, unless for some service requiring professional and special qualifications, and then it must be only upon the approval of the Board of Directors. Those having been retired on the pension allowance are not hindered from engaging in other business if it is not detrimental to the interests of the company. For comparison with the Pennsylvania system of pensioning our readers are referred to page 295 of the volume of this paper for 1899, where a description of that system is given. These plans for caring for aged employes cannot fail to improve the relations between the road and its men, and it is hoped that the idea will spread and become a fixed principle among American railroads.

COST OF OPERATING COMPRESSED AIR CARS.

The accompany figures, which appeared in the January issue of "Compressed Air," are the running expenses of 20 compressed-air cars during a period of 47 days on the 28th and 29th street air lines, New York:

Summary.	
Total round trips	17,197
Total mileage	94,533.5
Total passengers carried	1,017,269
Average number of passengers per trip.....	59.15
Average number cars running.....	17.5
Average number daily trips per car.....	17.2
Average number miles per day per car.....	94.6

The following total cost of operating these 20 compressed-air cars, under present conditions, is computed on a basis of 1,750 miles per day:

	Cents per car mile.
Repairs: Including material, supervision, and nine men, adjusting valves, piping brakes, rods, brasses, labor, etc., \$35 per day	2.
Charging Station: Including oil, waste, foreman, charging gang (two shifts), oilers, cleaners, etc., \$28 per day.....	1.60
Power House: Including engineers, coal passers, pipe fitter, machinist, oilers, etc., and 16 tons coal per day, oil, waste, etc., \$32.50 per day.....	4.71
Cents per car mile.....	8.31
Conductors and motormen, inspectors, roadbed, ties and timber, removing snow, salaries of officers, switches, material, etc.	9.11
Cents per car mile.....	17.42

These cars are not operated under the most favorable circumstances, as the charging and power plant has a capacity for 60 or 80 cars, and would, if running more nearly its capacity, reduce considerably the cost of operation. The Compressed Air Company estimate this cost at 13.57 cents per car mile under uniform conditions. These figures compare very closely with those of the electric system with a greatly cheapened roadbed in favor of the compressed-air service.

(Established 1832)
**AMERICAN
 ENGINEER**
 AND
RAILROAD JOURNAL.

PUBLISHED MONTHLY

BY
 R. M. VAN ARSDALE,

J. S. BONSALL, Business Manager.

MORSE BUILDING.....NEW YORK

G. M. BASFORD, Editor.

E. E. SILK, Associate Editor.

FEBRUARY, 1901.

Subscription.—\$2.00 a year for the United States and Canada; \$2.50 a year to Foreign Countries embraced in the Universal Postal Union. Remit by Express Money Order, Draft or Post Office Order. Subscriptions for this paper will be received and copies kept for sale by the Post Office News Co., 217 Dearborn St., Chicago, Ill. Damrell & Upham, 283 Washington St., Boston, Mass. Philip Roeder, 307 North Fourth St., St. Louis, Mo. R. S. Davis & Co., 346 Fifth Ave., Pittsburg, Pa. Century News Co., 6 Third St. S., Minneapolis, Minn.

EDITORIAL ANNOUNCEMENTS.

Advertisements.—Nothing will be inserted in this journal for pay, EXCEPT IN THE ADVERTISING PAGES. The reading pages will contain only such matter as we consider of interest to our readers.

Special Notice.—As the AMERICAN ENGINEER AND RAILROAD JOURNAL is printed and ready for mailing on the last day of the month, correspondence, advertisements, etc., intended for insertion must be received not later than the 20th day of each month.

Contributions.—Articles relating to railway rolling stock construction and management and kindred topics, by those who are practically acquainted with these subjects, are specially desired. Also early notices of official changes, and additions of new equipment for the road or the shop, by purchase or construction.

To Subscribers.—The AMERICAN ENGINEER AND RAILROAD JOURNAL is mailed regularly to every subscriber each month. Any subscriber who fails to receive his paper ought at once to notify the postmaster at the office of delivery, and in case the paper is not then obtained this office should be notified, so that the missing paper may be supplied. When a subscriber changes his address he ought to notify this office at once, so that the paper may be sent to the proper destination.

The paper may be obtained and subscriptions for it sent to the following agencies: Chicago, Post Office News Co., 217 Dearborn Street. London, Eng., Sampson Low, Marston & Co., Limited St. Dunstan's House, Fetter Lane, E. C.

Progress in the development of the gas engine is clearly indicated in a comparison of the last two international expositions. In 1893, at the World's Fair in Chicago, the largest gas engine was one of 35 horse-power, while at Paris the largest was rated at 1,000 horse-power, and this engine had but a single cylinder. Blast-furnace gas has been used extensively in Belgium for running gas engines, the power for blowing the furnaces and for other purposes being supplied from what was previously a waste product. The Pennsylvania Steel Company are preparing to develop this idea at their works at Steelton, and it will without doubt exert a marked effect upon gas-engine practice in this country. The use of gas engines is increasing as their advantages are better known and understood; almost all types are made to use oil as well as gas, and with the advent of small, easily-managed gas producers, the internal-combustion engine is made available for many purposes as the most convenient and the cheapest power producer. The oil or gasolene engine is specially attractive for a great deal of intermittent work, such as operating turntables, transfer tables, ash and coal hoists, running shears and punches in places where it is not convenient to carry wires or pipes. It is making its way on its merits, but appreciation seems to grow rather slowly. No new shop plan

should be prepared without at least a careful consideration of the gas engine. There are reasons for belief that a satisfactory double-acting cut-off-governing gas engine is at hand, at least Mr. C. E. Sargent's recent paper before the American Society of Mechanical Engineers gives hope of such an attainment, and altogether the gas-engine subject seems to be gaining ground in a promising and practical way.

In European steam engine practice the sight feed lubricator, so generally used in this country, has given place to the simple force-pump method of distributing oil, particularly in cases where the oil must be delivered against steam pressure. Experiments which are now under way in the west seem to indicate very promising results with the same idea when applied to locomotives for the lubrication of valves. With a small pump worked from the valve stem a positive and properly regulated feed is obtained, with the certainty that the oil gets to the valve and that it gets there at once. This experiment may lead to the use of a rather substantial little oil pump with feeding tubes running to the piston rod and valve stem packing as well as the top of the steam chest.

Locomotives are often classified, for tonnage rating, in proportion to their tractive power. The unit chosen for the 100 per cent. rating may be any engine, even if not by any means the one of greatest power, and we occasionally hear of engines of 140 and 160 per cent., and from these down to 50 per cent. In this connection a correspondent recently offered a thoughtful suggestion that the most powerful engine on the road should be rated at 100 per cent. and the others would often range down even to 28 per cent. He considered it important to change the number with each increase in capacity brought in by new locomotives, always considering the most powerful as the 100 per cent. engine. His object is to emphasize the weakness of the small and light engines by designating them as 28 or 25 per cent., and thus bring them into such prominence for their inadequacy that it will be easier to get rid of them. This appears to be an excellent suggestion. It is probable that it will pay to change the number with each improvement rather than to be handicapped by a lot of inefficient engines.

Successful management of important enterprises of all kinds involves the direction of the abilities of subordinates and those who accomplish most owe most to the work of others. Their secret is in their knowledge of men and the appointment of the right man for each part of the work. The complete idea is expressed by "organization." It involves the discovery of special ability of all kinds and, necessarily, a knowledge of the available men. No success can be permanent which does not provide for the advancement of worthy men already in the service, because, with the rank and file discouraged by the continued policy of importing superiors, the ultimate efficiency must suffer. The managing officer of one of the large locomotive works recently made an appointment which seems right and wise. A man was wanted for some specially important work in the shop which required familiarity with the methods in vogue and made it desirable to select one already in the employ of the company. A record of the experience of every young man in the plant, including the drawing room, was taken. This had never been done before and it revealed a large amount of experience which was not known or expected, the result being that exactly the experience desired was discovered in one of the draftsmen. This man was a loss in the drawing room, but he was saved from the death of a draftsman, the special work was well done and the atmosphere of the drafting room changed with the improved prospects of that department. Managers who appreciate this policy will never lack efficient subordinates and they will seldom if ever need to go outside of their own organization for even the most important and responsible assistants. Railroad presidents and heads of departments can not afford to be too busy to think of these things.

The study of conditions of combustion in locomotive fire-boxes recorded by Mr. A. Bement in our November number emphasizes the importance of intelligent design and careful use of ash-pan dampers for the control of air admission below the fire. The ease and convenience with which the composition of fine gases may be continuously observed by aid of modern apparatus should lead to a great increase of interest in the subject of combustion which is one worthy of the best thought.

Additional air supply above the fire is required, especially by large engines with relatively small grates, and it may be had by leaving the fire door partially open, the amount being determined by experiment. But there is danger of overdoing in the direction of air supply with the enlargement of grates and this is a good reason for considering the gas analysis method of studying the action of the firebox. The suggestion of this method by Mr. Bement should be carefully considered. While this is a period of unusual activity in locomotive development, it is a time for caution and intelligence. The wide grate is bound to come out right in the end, but the study of the relations between certain coals and certain grates will be greatly facilitated by gas analysis work which is now possible to conduct by aid of the testing plant.

Air admission is important in the round-house as well as on the road. At many terminals fires are banked without reference to the fact that there is a right and wrong way. On many roads the hard service keeps the round-house forces unusually busy with tube leakage and kindred troubles, and this is sure to develop weakness in round-house practice where it exists. Tubes suffer severely when the fires are banked at the back end of the firebox if the front damper is left open. It is important to bank fires at the front end and keep the dampers closed in order to prevent the cold air from pouring through the tubes as will occur in the other practice. It is also advisable to place tight dampers in the smoke jacks of round-houses where the jacks are made to be drawn down to fit the stacks or to cover the stacks with a board or other tight cover while the engine is standing in the round-house with the fire banked. This occasions very little inconvenience, and it seems to be thoroughly worth while.

LOCALIZED DEFLECTIONS IN BUILT-UP STRUCTURES.

The real strength of an engineering structure is its ability to withstand continuous service without undue deflection or fracture, and is not necessarily measured by the greatest single load which it will safely carry. Sometimes the real strength may be increased by a decrease in what may be called the apparent strength. For example, a piston rod, subject to slight bending, may be actually strengthened by weakening it to permit it to adapt itself to the bending. Deflection cannot safely be disregarded, and this is specially true of composite or built-up structures. In some kinds of designing, as in machine tools, deflection must be absolutely prevented, but in general it may be said that good engineering consists in the use of sufficient material to permit of safe deflections and in the distribution of the material in such a way as to prevent the localization of the movements. In built-up structures this localization is most likely to occur, and is most difficult to manage. Locomotive frames and metal trucks for heavy freight cars are good examples of this. In the former mere size of the section will not always suffice, because the improvement of the cylinder attachments to the frames and a general stiffening up of the front ends may localize the service flexure at some point in the rear and cause breakage in a frame which is ample to meet static loads and shocks. In metal car trucks there is a strong temptation toward excessive rigidity in the connections between the side frames and the transoms. These

structures must necessarily deflect to some extent, and if the joint is made stiff the deformation is likely to localize in this case in the transom, near the joint, and result ultimately in fracture. Those of our readers who have seen the pile of broken trucks which inspired these comments already appreciate the point we make, and to others this suggestion is offered: that the localizing of deflection must be guarded against in designs of this kind. All this may also be said of boilers, in which the increase of pressures has brought about new conditions which were not important or did not exist at all in the days of lower pressures. The concentration of stresses in boilers is most noticeable in the deformation caused by the attachment of the angle braces for the back heads and for tube sheets. These braces are sometimes short, the feet attachments to the plates small in area, and the angle of pull such as to draw down the outside sheets locally. In back-head bracing this may cause the crown stays of a radial firebox to leak and it may open the seam near which the front braces are secured. These, while not serious, are important in that they indicate a direction for thought in designing. Flexibility must be provided where it is needed, and it is usually necessary to distribute the flexure in order to prevent it from occurring within too small a space.

CAST IRON WHEELS FOR HEAVY COAL CARS.

Present experience with coal and ore cars of large capacity seems to indicate that the limit of the cast iron wheel has been reached, unless a change in form is made or the wheel flanges are in some way relieved in service. The breakage of wheels, and particularly of flanges, under 50-ton cars has created a great deal of anxiety of late, and the question of the necessity for steel-tired wheels for this service is now seriously raised. It has been said that the cars are too heavy and that there will be a general reduction from 50 tons to 40 tons as the maximum capacity. This probably will not be done as long as railroad managements are able to obtain the benefits of 50-ton loads in one or both directions in cars making an average of 2,000 to 2,600 total miles per month, which is now being done. There seems to be no question of the firm establishment of the 50-ton car, and the wheels must be made to carry them. Cast iron wheels for these cars have been strengthened at the hub to the point of withstanding a wheel press pressure of 110 tons upon a mandrel, and they have, in at least one case, been increased in weight to 690 lbs. for the purpose of overcoming breakages in the plates, but the breakage of flanges is not so easy to stop. The opinion that the limits of strength of the flanges of cast iron wheels of the present standard contour has been reached is growing among those having the widest experience with these cars. It seems to be necessary to increase the thickness of the flange as it stood before 1894 or to take up the steel-tired wheel. Perhaps $\frac{1}{8}$ in. more metal in the thickness of the flange will be enough. It is, of course, desirable on account of the low cost to make the cast-iron wheel strong enough, and efforts will be made in that direction. This question will undoubtedly receive attention at the convention next summer, but instead of being confined to engine trucks the relative safety of the two types of wheel needs to be considered also from the standpoint of cars. Several broken flanges coming to our notice had blue fractures showing the influence of the brakes on mountain grades. This is troublesome in the East as well as in the West. It is evident that the near approach to 75 tons of car and load, brings up new factors in the matter of wheels. It occurs to us that perhaps the general use of rigid trucks has a bearing upon the flange breakage and the suggestion of a return to the swing motion truck for such heavy cars seems to be a reasonable one. It would undoubtedly serve to reduce the shocks to which rigid trucks must necessarily subject the wheel flanges.

STEEL FRAME PASSENGER TRUCK,

With Springs Over Journal Boxes.

In response to a request for information concerning the spring suspension of four-wheel trucks on foreign roads the accompanying engravings, illustrating a recent design by the Chemin de Fer du Nord, have been prepared. Several American roads are investigating the passenger truck question, hoping to be able to substitute a four for a six-wheel design for heavy cars, the object being to save weight and expense. Thus

French cars to which the present engravings apply, but would guess about 70,000 lbs.

This French truck, with a wheel base of 8 ft. 2½ ins., has pressed steel side frames, ¾ in. thick, with pressed channel end sills 5/16 in. thick and 1-beam transoms. Gussets are plentiful and the frame has longitudinals and diagonals for additional stiffening. The fastening appears to be altogether by rivets.

The spring suspension is made clear by the engravings. The track bolster, swing links, and elliptic springs on the sand plank are not far different from our practice, except as to the details which are elaborately worked out in the original draw-

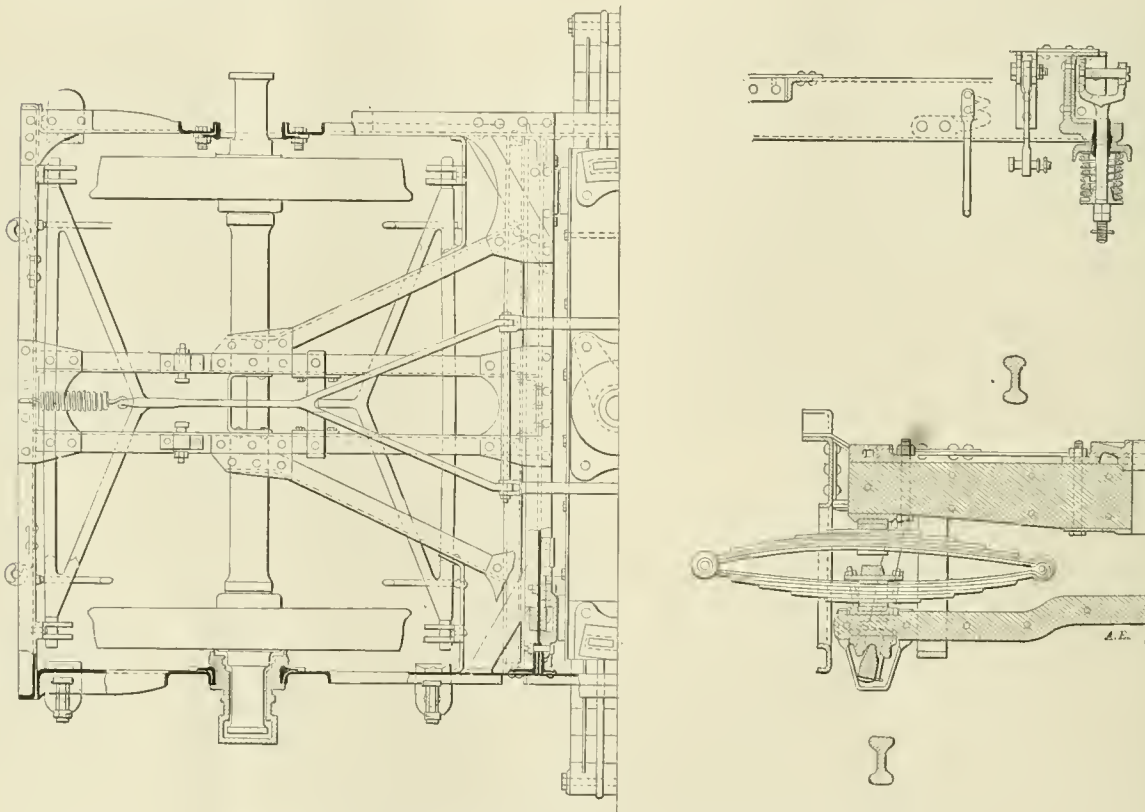
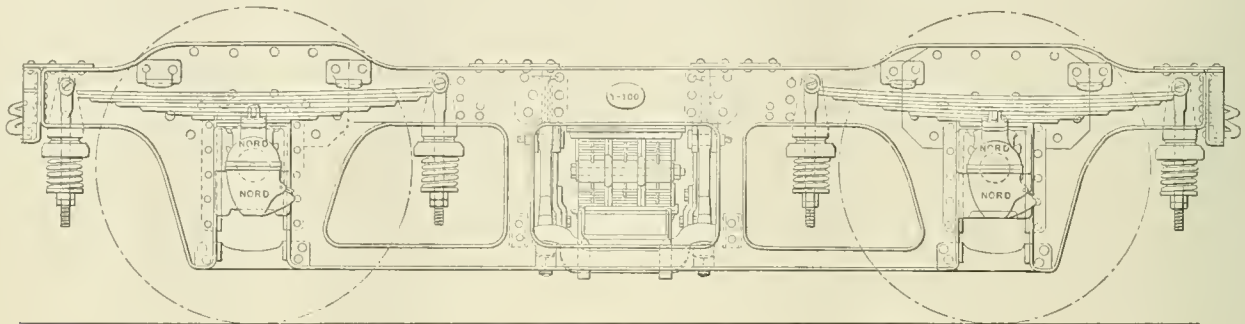

Steel Frame Passenger Truck with Leaf Springs Over the Journals.

far the designs of four-wheel trucks for this purpose (American Engineer, October, 1900, page 306, and January, 1901, page 12) have employed the usual form of equalizers, and if the fear that the good riding qualities of the six-wheel trucks are to be sacrificed is well founded, this French design with long springs over the journal boxes will be suggestive. It serves to raise the question whether the equalizer is necessary with present conditions of trucks, and it appears to be worth while to consider an adaptation of this form of spring suspension to American conditions for a trial at least. If the springs over the boxes are made long enough the riding qualities should be satisfactory. The Swiss truck, a sketch of which was shown on page 290 of our September number last year, is in use under cars weighing 75,000 lbs. We do not know the weight of the

ings. The links are inclined, approaching each other at the top ends, which may be criticised, but it is to the springs over the boxes that attention is specially attracted. Four long, flat springs bear on the boxes, and these support the frame by means of hangers supplied with coiled "Timmis" springs at their ends. The hangers are forked at their upper ends, and the load is carried to the coil springs by means of bronze sleeves, giving essentially a ball and socket connection. A uniform flexibility of the springs was sought for, in order to secure isochronal vibrations and render the oscillations uniform and easy. The dampening action of the leaf springs appears to be another important factor in this truck, and this is specially worthy of attention. The whole effect desired was that which would make the suspension of the car correspond to that of a hammock as far as the horizontal reactions are concerned.

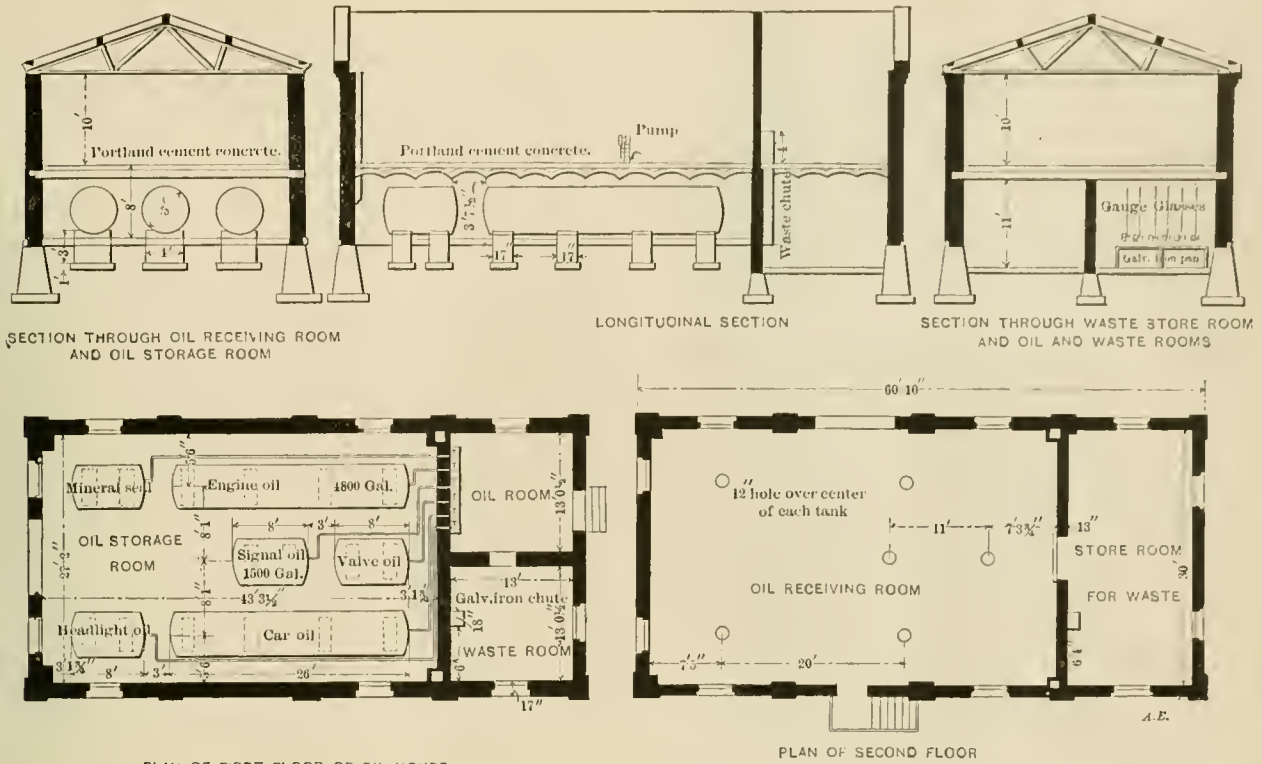

Oil House, Chicago, Indianapolis & Louisville Railway Lafayette, Ind.

A CONVENIENT OIL HOUSE.

Chicago, Indianapolis & Louisville Railway.

We have lately received several inquiries concerning the construction of oil houses from officers who are engaged in arranging plans for new shops, and the tendency seems to be to secure a plan which will permit of handling the oil to as great an extent as possible by gravity. An excellent system, which has been in use for a number of years at the Lafayette shops of the Chicago, Indianapolis & Louisville, the "Monon Route," is illustrated in the accompanying engraving made from a drawing especially prepared for us by Mr. H. Monkhouse, Superintendent of Motive Power of that road.

The merit of the plan is in the use of gravity flow for handling the oil throughout, although the operation of unloading from tank cars may be facilitated by air pressure when desired. The oil tank cars are received upon an elevated trestle along one side of the building, and oil may also be delivered in barrels from cars on this trestle. The tank cars unload direct to the storage tanks in the basement of the building, and barrels may be rolled into the second story and their contents dropped into the tanks through 12-in. holes in the floor, one of these being located over the center of each of the storage tanks. The storage tanks are all piped to the oil-delivery room, and the pipes terminate over a large pan, each pipe having a gate valve and a gauge glass to show the level of the oil in the corresponding tank. The floor of the oil delivery room is 3 ft. below that of the storage room.

The second story also provides for the storage of waste, which is delivered to the waste room below through a vertical chute. The floors are all of concrete, the roof is steel, and there is nothing about the building which will burn, except the oil and waste. In the second story a pneumatic oil pump is provided for filling barrels with oil from the main storage tanks, for use in shipping barrel lots to other points on the road. With this arrangement there is no necessity for cranes, and the oil house may be cared for by one man.

We acknowledge the courtesy of Mr. Monkhouse.

LOCOMOTIVE TRUCK BRAKES.

That long distances in which to stop trains are dangerous and expensive is being appreciated more and more by railroads nowadays, and much attention is given to increasing the tractive effort of locomotives, by increasing the weight and adding extra driving wheels, and by the use of traction increasers, to get trains out of the stations and over the road in a hurry. It therefore seems all the more necessary that absolute control be had over such trains by the application of the highest possible braking power to every wheel. In a recent bulletin issued by the Westinghouse Air Brake Company the proportion of available braking weight carried by the locomotive truck, under prevailing practice, was given as follows:

- For a two-car train, about 15 per cent.
- For a three-car train, about 12 per cent.
- For a four-car train, about 10½ per cent.
- For a five-car train, about 9 per cent.
- For a six-car train, about 8 per cent.

To increase the braking power of a 6-car train nearly 8 per cent. by truck brakes, means that we are able to lessen the distance about 1/12 that ordinarily required for stopping the train. This is worth consideration for the same reason that high acceleration is advantageous as a factor in the saving of fuel, because the maximum speed to be maintained between stops in order to make schedule time is lower. A high rate of retardation must also decrease the possibilities of damage to property and loss of life. This is not only true of through passenger and suburban service, but of fast freight service, particularly on roads with steep grades. Inasmuch as it is often the last few feet that count most in a collision, the truck brake should not be neglected.

Charles L. Gately, Manager of the Railroad Department of the New York Belting and Packing Company, recently resigned that position to become Manager of the Railroad Department of the Manhattan Rubber Manufacturing Company, with office at 18 Vesey street, New York City.

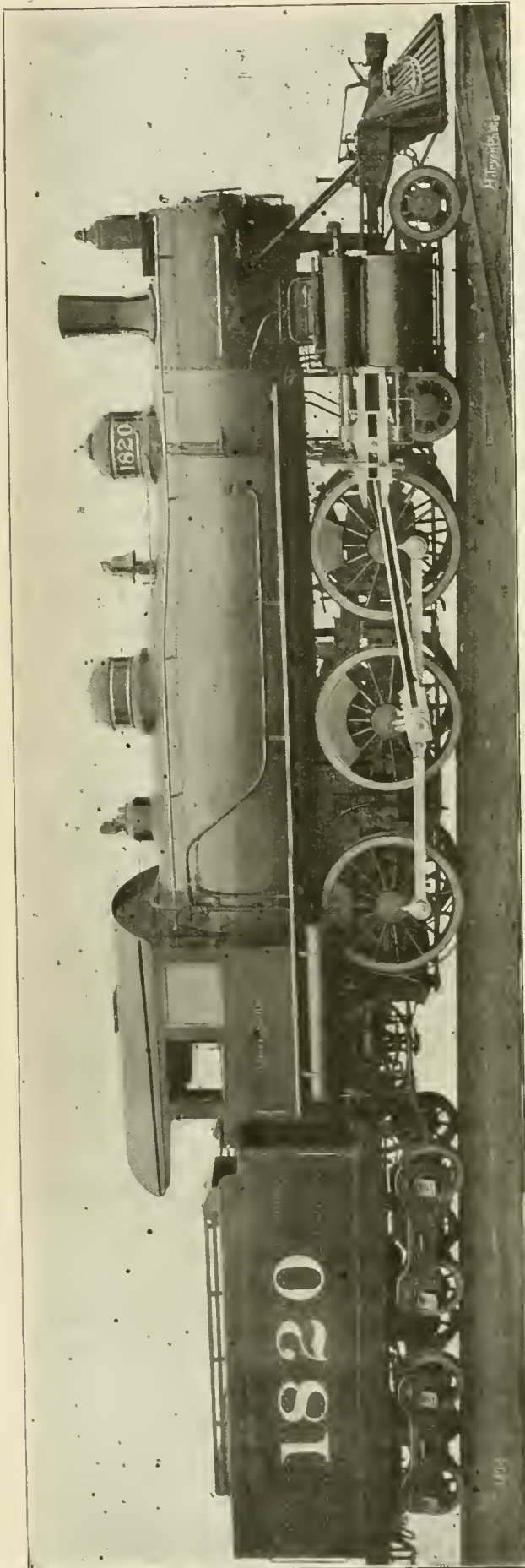

J. H. McCONNELL, Superintendent Motive Power. Heavy Ten-Wheel Compound Passenger Locomotive—Union Pacific Railway. BALDWIN LOCOMOTIVE WORKS, Builders.

HEAVY 10-WHEEL COMPOUND PASSENGER LOCOMOTIVE.

Union Pacific Railway.

Built by the Baldwin Locomotive Works.

Last month we described the new Vaucain compound, consolidation freight locomotives, of which sixty have just been built for the Union Pacific Railway, and we now illustrate one of twenty 10-wheel compound passenger engines for the same road which are the heaviest of their type ever built and very nearly as heavy as the freight engines. They weigh but 1,080 lbs. less than the consolidation engines and in heating surface have not been exceeded by any engines of the 10-wheel type of which we have record.

With this great boiler power combined with compound cylinders these engines will unquestionably greatly reduce the amount of double-heading which strong winds, long grades and severe weather conditions have rendered necessary on this road. The engines seem to have the characteristics of the Baldwin design throughout, which was probably done to give them every advantage in the first use of the compound principle on this road. Ten of these engines have 69-in. and the other ten 72-in. driving wheels. The leading dimensions of three recent 10-wheel engines are interesting for comparison.

Comparison of Large Ten-Wheel Locomotives.

Road.....	Lake Shore. Brooks.	D., L. & W. Brooks.	U. P. Baldwin.
Builder.....	Brooks.	Brooks.	Baldwin.
Weight on drivers.....	133,000 lbs.	137,000 lbs.	142,000 lbs.
Total weight.....	171,800 lbs.	179,000 lbs.	184,240 lbs.
Drivers.....	80 ins.	69 $\frac{3}{4}$ ins.	69 and 72 ins.
Cylinders.....	20 x 28 ins.	20 x 28 ins.	15 $\frac{1}{2}$ and 26 x 28 ins.
Heating surface.....	2,917 sq. ft.	2,700 sq. ft.	3,011 sq. ft.
Grate area.....	33.6 sq. ft.	34.2 sq. ft.	32 sq. ft.
Reference to American Engineer.....	Nov., 1899, page 343.	Sept., 1900, page 272.	Present issue.

The following additional information concerning the Union Pacific engines, together with the photograph, are presented by courtesy of the builders:

Vaucain Ten-Wheel Compound Passenger Locomotives.
Union Pacific Railroad.

Gauge	4 ft. 8 $\frac{1}{2}$ ins.
Fuel	Soft coal
Weight on driving wheels.....	142,440 lbs.
Weight on truck wheels.....	41,800 lbs.
Weight, total.....	184,240 lbs.
Wheel base, total, of engine	26 ft. 9 ins.
Wheel base, driving.....	14 ft. 6 ins.
Wheel base, total engine and tender.....	54 ft. 0 ins.
Height center of boiler above rail with 72-in. drivers.....	106 $\frac{3}{4}$ ins.
Height center of boiler above rail with 69-in. drivers.....	105 $\frac{1}{4}$ ins.
Height of stack above rail with 72-in. drivers.....	15 ft. 3 ins.
Height of stack above rail with 69-in. drivers.....	15 ft. 1 $\frac{1}{2}$ ins.
Heating surface, firebox.....	186 sq. ft.
Heating surface, tubes.....	2,825 sq. ft.
Heating surface, total.....	3,011 sq. ft.
Grate area	32 sq. ft.
Driving wheels, diameter.....	69 ins. and 72 ins.
Material of driving wheel centers.....	Cast steel
Truck wheels, diameter.....	30 ins.
Driving journals.....	9 ins. by 12 ins.
Engine truck journals.....	6 $\frac{1}{2}$ ins. by 11 ins.
Main crank pin, size.....	6 $\frac{3}{4}$ ins. diameter; 6 ins. long
Parallel rod pins, main.....	7 $\frac{1}{2}$ ins. diameter; 5 $\frac{1}{4}$ ins. long; others, 5 $\frac{1}{2}$ ins. diameter by 4 ins. long
Cross-head pin	4 ins. by 4 ins.
Cylinders	15 $\frac{1}{2}$ and 26 by 28 ins.
Piston rod diameter.....	3 $\frac{3}{4}$ ins.
Main rod length, center to center.....	131 ins.
Steam ports.....	length, 29 $\frac{3}{4}$ ins.; circular width, 1 $\frac{1}{2}$ ins.
Exhaust ports	length, 29 $\frac{3}{4}$ ins.; circular width, 4 $\frac{1}{2}$ ins.
Bridges	3 ins. and 2 $\frac{3}{4}$ ins.
Valves	kind, balanced piston; travel, 5 $\frac{3}{4}$ ins.; outside lap, H. P. $\frac{3}{4}$ in.; L. P. $\frac{5}{8}$ in.; inside lap, H. P. $\frac{1}{8}$ in. negative; L. P. $\frac{1}{4}$ in. negative; lead H. P., 0 in.; L. P., $\frac{1}{8}$ in.
Boiler, type	Wagon top
Working steam pressure.....	200 lbs.
Material of boiler.....	Steel; thickness, 11/16 in. and $\frac{3}{4}$ in.
Diameter of boiler.....	66 ins.
Horizontal seams.....	Butt-jointed with double covering strips; circumference seams, double riveted
Thickness of tube sheet.....	$\frac{1}{2}$ in.; crown sheet, $\frac{3}{4}$ in.
Crown sheet stayed with.....	Radial stays
Dome, diameter	31 $\frac{1}{2}$ ins.

Tubes.....	Number, 350; material, iron, No. 11 wire gauge; diameter, 2 ins.; length, 15 ft. 6 ins.
Firebox material.....	steel; length, 118 3/16 ins.; width, 39 1/2 ins.; depth, front 79 1/2 ins.; back 67 ins.
Thickness of sheets, sides and back.....	5/16 in.
Water brick arch, supported on.....	Water tubes
Water space.....	Front, 4 ins.; sides and back, 4 ins.
Grate, kind.....	Rocking bars and drop
Smoke box.....	Diameter, 67 ins.; length, 73 ins.
Exhaust nozzle.....	Single; diameter, 5 ins.
Smoke stack.....	Cast iron; 16 ins. diameter at choke
Tender, type.....	Eight-wheel
Tank.....	Length, 238 1/2 ins.; width, 120 ins.; height, 58 ins.; collar, 10 ins.; fuel rack, 8 ins.
Tank capacity.....	6,000 gals.
Coal capacity.....	10 tons
Material of tank sheets.....	Steel; thickness, 1/4 in. by 5/16 in.
Type of frame.....	Wood
Type of truck.....	Fox pressed steel
Type of truck springs.....	Elliptic and coil
Diameter of truck wheels.....	33 ins.
Truck journals.....	5 ins. by 3 ins.
Distance between journals.....	76 ins.
Diameter of axle in wheel.....	6 3/4 ins.
Diameter of axle at center.....	5 3/4 ins.

We must not expect impossibilities of the technical schools. Their work is particularly difficult, one reason being the impossibility of keeping the schools in touch with actual conditions of the practical work of life. Mr. Walter B. Snow, of Boston, recently read an interesting paper before the Society for the Promotion of Engineering Education which has been reprinted in a pamphlet. Its title is "The Relations of the Technical School and the Manufacturer." An engineer, who is also a successful manufacturer, is in position to offer valuable suggestions on such a subject. Mr. Snow emphasizes the importance of the commercial idea throughout the education, to overcome the tendency toward a preponderance of the "theoretical" side of the student's preparation. He treats the subject from the point of view of supply and demand, the schools being the producers of young engineers, and the manufacturers are the consumers. It is made clear that men who are in contact with commercial conditions are most needed, and in order to bring this fact before students an insight into the methods and spirit of the manufacturer by means of contact with living examples is urged by Mr. Snow. It is acknowledged to be difficult for instructors to keep in touch with practice. In this connection Mr. Snow suggests a broad use of the manufacturer's catalogue. He says: "The catalogue file is the elbow companion of every progressive teacher as it is of every working engineer, and its importance has already been emphasized by your discussions of the best methods of its arrangement. But it is only one of the means at the disposal of the teacher to keep himself and his pupils in close and intelligent relationship with the manufacturer." The combination of gumption and common sense with commercial features of education, and a close study of progress as indicated in the product of the leading manufacturers, seems to us to be the most important thought in Mr. Snow's address. That men of such experience are interesting themselves in technical education cannot fail to encourage educators who are endeavoring to keep pace with the progress of engineering.

The first number of the "Railroad Digest," the successor of the "Railroad Car Journal," fully justifies the predictions that it would be attractive, comprehensive and convenient. Its entire effect is pleasing and in good taste. It contains several excellent special articles by well-known authorities, but the principal feature is its digest of recent articles in the railroad papers of the world, and in this department the editors have condensed into a small space ideas which originally appeared in a large number of long articles. For this saving of time the busy reader is grateful, and we trust the publishers will realize even more than they hope for and expect.

CORRESPONDENCE.

A STUDY IN LOCOMOTIVE FIREBOXES.

To the Editor:

The article by Mr. Gaines on the stability of locomotive fireboxes in your December issue, suggests a direction in which important improvements can be made in locomotive boilers. Measurements of "radial-stay" boilers, when pressure is applied, indicate that many fireboxes do change their shapes, to the injury of the joints, staybolts and tube sheets. Below I describe a method of investigating the stability of the firebox section.

If Mr. Gaines, in his experiment with the cylindrical parchment paper, had placed a weight on top of the paper, he would have found that, under these altered conditions, his model would have assumed an elongated section instead of a circular one. Although, with an evenly distributed fluid pressure alone, the "curve of rest" is circular, conditions can alter it to some other curve. In the case of a boiler there is the evenly distributed steam pressure, and all the staybolts are pulling on the sheet with forces that are not equal and in directions which are not all radial. It follows, then, that other curves may be the "curves of rest."

This curve is obtained when the sectional area between the

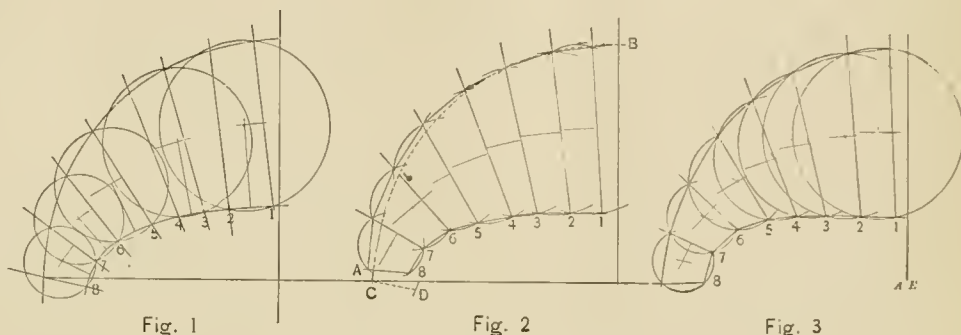

Study in Locomotive Fireboxes.

inner and outer firebox sheets is a maximum. To ascertain when this condition obtains we can consider the plates as straight between stays. Any two adjacent stays with the portions of the plates between them form a quadrilateral with fixed lengths of sides, and the area reaches a maximum when it can be inscribed in a circle. If all of these quadrilaterals can be inscribed in circles, it would seem that the "curve of rest" is obtained. It will be noted that the Belpaire boiler fulfils this condition.

Fig. 1 shows a "radial-stay" boiler, to which this test has been applied by drawing circles through three of the vertices of some of the quadrilaterals. It will be seen that these circles do not in any case pass through the fourth vertex. Fig. 2 was constructed by using the same lengths of stays as in Fig. 1, and the same spacing on the sheets. The shape of the sheets was altered, however, to make it possible to circumscribe a circle about each quadrilateral. The dotted curve AB shows the original sheet, as it was in Fig. 1. It will be noticed that the "curve of rest" is flattened somewhat from the circular arc, and it might be expected that measurements of the boiler shown in Fig. 1, when under pressure, would show that height had decreased and width increased. The staybolt CD has taken the position, 9, 8, indicating that a very great stress had been set up in the inner sheet, tending to break staybolts and destroy joints where the firebox widens. Fig. 3 was constructed by making the outer sheet the same as in Fig. 1, spacing the stays the same as in Fig. 1 in both sheets, but making the lengths of the stays and shape of the crown sheet come as they would by inscribing each quadrilateral in a circle.

G. F. Starbuck.

Waltham, Mass., December 29, 1900.

LOGICAL LOCOMOTIVE CLASSIFICATION.

To the Editor:

Lest there be some misunderstanding concerning the method of designating the types of locomotives as explained in the

be greatly increased by water in the cylinder and by excessive key driving, the importance of relieving the closing block bolts of shearing stress, as in Fig. 2, or of eliminating them altogether, as in Mr. Vogt's design, will be readily appreciated.
New York. Edward L. Coster,
A. M. Am. Soc. M. E.

PERSONALS.

Mr. G. W. Guess has been appointed Purchasing Agent of the Wayercross Air Line, with headquarters at Waycross, Ga.

General Manager George T. Jarvis, of the Wisconsin Central, has resigned and will return to the Louisville, Evansville & St. Louis.

Mr. T. H. Foque has been appointed Mechanical Superintendent of the Minneapolis, St. Paul & Sault Ste. Marie, to succeed Mr. E. A. Williams, who has resigned to become Mechanical Superintendent of the Canadian Pacific Railway.

Mr. D. J. Durrell has been appointed Mechanical Engineer of the Pittsburg, Cincinnati, Chicago & St. Louis, with headquarters at Columbus, O.

Mr. H. B. Brown, Traveling Engineer of the Baltimore & Ohio, has been appointed Master Mechanic of the shops of that road at Chicago Junction.

Mr. F. H. McGee, Master Mechanic of the Seaboard Air Line at Americus, Ga., has been made Superintendent of Motive Power of the entire system.

Mr. Carl Hagan, General Foreman of the Wheeling & Lake Erie, has been made Master Car Builder of that system, with headquarters at Cleveland, O.

Mr. T. M. Price has been appointed Master Mechanic of the Findlay, Fort Wayne & Western, with headquarters at Findlay, O., in place of Mr. H. A. Hansgen, resigned.

Mr. Samuel Miller, Assistant Master Mechanic at the Indianapolis shops of the Pennsylvania since 1899, has become Master Mechanic of these shops, succeeding William Swanston, who has retired under the pension plan.

Mr. H. E. Poronto has been appointed Purchasing Agent of the Union Stock Yard & Transit Company of Chicago, and of the Chicago Junction Railway, with office in the Exchange Building, Union Stock Yards, Chicago.

Mr. G. L. Potter, General Superintendent of Motive Power of the Pennsylvania Lines West of Pittsburg, has been appointed General Manager, to succeed Mr. L. F. Loree, who was elected to the position of Fourth Vice-President.

Mr. F. C. Gates, Purchasing Agent of the Wheeling & Lake Erie, has resigned to engage in other business. His duties, as well as those of Superintendent of Telegraph, will be assumed by Mr. J. E. Shossig, Assistant to the General Manager.

Mr. A. G. Elvin has resigned his position as Master Mechanic of the Grand Trunk Railway shops at Montreal, Que., to accept the position of Assistant Superintendent of Motive Power of the Delaware, Lackawanna & Western at Scranton, Pa.

Mr. Louis C. Todd, Division Master Mechanic of the Boston & Maine, at Lyndonville, Vt., has been appointed Master Mechanic of the Fitchburg Division of the same road, with headquarters at Charlestown, Mass., to succeed Mr. J. S. Turner, resigned.

Mr. George Thompson, Superintendent of Motive Power of the Pennsylvania Division of the New York Central, has resigned and is to be succeeded by Mr. John Howard, Superintendent of Motive Power of the Hudson River Division of the Central-Hudson system. Mr. E. A. Walton succeeds Mr. Howard as Master Mechanic at New Durham, N. J.

Mr. S. Mahmoto, Director General, and Y. Kmosheta and F. Nozawa, Directors of the Imperial Government of Railways

VOLUME OF LOAD ON BALLAST OR COAL CARS.

To the Editor:

It is often desirable to know what volume of coal, ballast or other similar material can be placed on a car of given size. It is an easy matter to find the capacity of the car level full and the volume of the heap may be computed by adding together the volumes of the two pyramids and that of the triangular prism between. But, as shown below, the whole volume can be as easily found at one operation.

In the diagram,

- Let L = length of car,
- W = width of car,
- A = height of heap,
- B = angle of heap,
- V = volume of heap.

The part of the figure between the lines CD and EF is a tri-

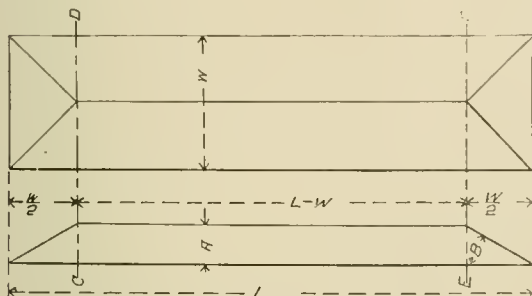

Diagram for Volume of Load on Cars.

angular prism of length (L - W) (since the angle of the slope is the same at the ends as at the sides) and the base equivalent to 1/2 AW and its volume is, therefore, 1/2 AW (L - W). The parts between the lines C-D and E-F, and the ends are equal pyramids with bases 1/2 W x W and height A and the volume of each is 1/6 AW^2, and of the two is 1/3 AW^2. Adding this to the volume of the prism we have V = 1/2 (L - W) + 1/3 AW^2 or 1/2 AW (L - 1/3 W). For A we may substitute its equivalent 1/2 W tan. B and the formula becomes V = 1/4 W^2 tan. B (L - 1/3 W). If we take B = 30°, tan. B = .57735 and V = .14439 W^2 (L - 1/3 W). Stated in words we have the rule:

Multiply the length less one-third the width by .14439 times the square of the width.

J. H. Lonie.

N. & W. Ry., Roanoke, Va.

Mr. Charles K. Thomas has resigned as special representative of the "Railway Age," having been appointed General Sales Agent of the Reliance Machine & Tool Company, of Cleveland, manufacturers of the Morgan patent bolt cutter.

In a recent letter to the New York Herald, Mr. Charles H. Cramp, the well-known shipbuilder, commenting on the necessity of forced draft in marine practice, points out that "the maximum steam generating capacity of the Scotch boiler cannot be attained without forced draft equal to 2 ins. of water in the tube with closed fire room or ash-pit, or induced draft equivalent to it. The difference between natural draft and forced draft in a Scotch boiler is usually equal to 25 or 30 per cent. of the normal. Therefore, if it is contemplated to attain with natural draft a performance equal to that of forced draft with Scotch boilers, the weights must be increased in ratio of the difference. This would be out of the question in any type of warship now worth consideration. Indeed, the time is near at hand when the same rule will be recognized as applying with equal force to the higher classes of passenger vessels."

of Japan, were on January 9 and 10 the guests of the Pennsylvania Railroad. The object of their visit was to inspect the Juniata shops and also those of the lines west of Pittsburgh. This they did in company with a party of railroad officials.

The many friends of Clement Hackney, formerly Superintendent of Machinery and Rolling Stock of the Union Pacific, will regret to learn of the news of his death, which occurred on January 6, at his home in Milwaukee, Wis., at the age of 54 years. He was born in Warrington, England, on May 16, 1846, and began his railroad career in 1860 as apprentice in the shops of the Prairie du Chien Railroad at Milwaukee, Wis. He was later with the Milwaukee Iron Company, first as Master of Transportation, then in charge of the Mechanical Department, and went to the Atchison, Topeka & Santa Fe in June, 1878, as Assistant Superintendent of Machinery, which position he held until December 1, 1885, when he became Superintendent of Machinery and Rolling Stock of the Union Pacific. He became General Manager of the Fox Pressed Steel Company in 1891, and after the absorption of that company by the Pressed Steel Car Company in 1899 was made District Manager of the latter company at Johet, which position he held until August, 1, 1900.

Mr. T. R. Browne, Master Mechanic of the Pennsylvania Railroad at Juniata, has resigned to become Works Manager of the Westinghouse Air Brake Company at Wilmerding, Pa. Mr. Browne was appointed Master Mechanic of the Juniata shops at the age of 33, and for five years has had charge of the construction of the locomotives built by the road at that plant. Mr. Browne began as a machinist apprentice in Philadelphia, and after a varied experience, chiefly in civil engineering construction, and particularly in connection with hydraulic work, he entered the employ of the Pennsylvania ten years ago as draftsman at Altoona. He was soon made assistant to Mr. H. D. Gordon, Master Mechanic of the Juniata shops, during their construction, and succeeded Mr. Gordon in that position. His experience admirably fits him for his new position, and a better choice could hardly be made. He is of the sort of men the railroads need, and while his friends congratulate him and the Westinghouse people, it is not without regret that he will no longer devote his energies directly to motive power work, in which there is so much to be done just now.

At the January meeting of the North-West Railway Club, Mr. T. A. Foque, former Secretary of the club, was selected President, in place of Mr. E. A. Williams, resigned to go to the Canadian Pacific. Mr. T. W. Flannagan, Chief Clerk of the Mechanical Department of the "Soo Line," was elected Secretary to succeed Mr. Foque. The papers read at this meeting were "Electric Traction for Heavy Railway Service," by Mr. Edward P. Burch, Electric Railway Engineer, and "A Brief History of Composite Car Wheels," by Mr. Geo. H. Bryant, of Chicago. There was a good attendance.

If, as Mr. A. Lipschitz, of the Great Northern, says in a recent number of the "Railway Age," acetylene is sure to explode if heated to the dissociating temperature of 1,432 degs. F., it is a dangerous gas for railroad car lighting. It is understood that the Great Northern is using acetylene in a piping system and tanks which are soldered with soft solder or made of a metal which will melt at a temperature below that mentioned, so that the temperature of the gas will not rise above 400 degs. in case of fire. Instead of being reassured by this precaution, one is justified in being alarmed. This is placing a great deal of dependence upon those who mix the metals. It would seem to be better to use the present prevailing Pintsch system, or, if a brighter light is wanted, go to electricity at once.

PASSENGER COACH SANITATION.*

By J. N. Hurty, M.D., Indianapolis, Ind., Secretary State Board of Health.

Professor John Fiske, in a recent essay, remarks: "Americans pride themselves on being extremely practical, yet we have not learned how to ventilate a Pullman car." In view of the havoc wrought by pulmonary tuberculosis, pneumonia and other diseases of the air passages, all largely due to lack of ventilation, this remark is calculated to lessen our conceit and cut our pride of invention to the quick.

The first step in passenger coach sanitation is sanitary construction. Angles, carvings, panels, bead work, channeling, all aid uncleanness. These further the collection of dirt and make cleaning difficult and expensive. Transom ventilation in the deck fitfully and insufficiently changes the air, and is altogether a method which is contrary to physics. Such method does not and cannot ventilate a car properly, and sometimes, as when cold air falls upon the heads and necks of passengers through the transoms, is almost worse than no ventilation. Dr. Dudley, of the Pennsylvania Company, has devised a method of introducing pure air into coaches which probably meets all conditions so far as is practicable, but the removal of the air through transoms in the deck is wrong. Dr. Dudley describes his invention now in use on the Pennsylvania system as follows:

"We have experimented with and developed a system of ventilation which promises very good results, and is a great improvement over former methods. This system consists in taking air in at diagonally opposite corners of the car, through a hood, and by means of a down-take underneath the floor of the car, to the space bounded by the outside sill, the first intermediate sill, the floor and the false bottom. This space extends the whole length of the car. From this space the air passes up through the floor into the heater boxes, the apertures in the floor being 12 ins. long by 2 ins. wide, and being located between all seats on both sides of the car. In the heater boxes the air is warmed, and from these boxes under each seat the air passes out into the car, and finally to the outside through the ventilators in the deck of the car."

The boxing of the heating pipes, as here described, is attended with material disadvantages. First, needed space, when two persons are in on seat, is taken up; second, offensive and unremovable accumulations of dirt occur within the box. While this boxing presents advantages it does not seem essential and I would do away with it.

The Dudley, or Pennsylvania method, furnishes sufficient air from the outside and warms it immediately that it enters the car. My modification would be the abolition of the boxing over the pipes, and removal of the foul air from near the floor through ducts placed within the closets and the washrooms at both ends. These ducts would be made of galvanized iron, as wide as the closet, say 36 ins., and have a depth of 8 ins. and lead upward through the roof, terminating in a hood, the ends of which are covered with stout wire netting, and within which is a light and easily swinging, deflecting leaf or plate which readily responds to wind action. This leaf will tilt in accord with the direction of the movement of the car, and thus the air forced through the hood when the car is in motion will act the same as a steam injector and aid greatly in lifting the air column. The lower end of the ventilating shaft would be raised about 8 ins. from the floor to permit the entrance of the foul air at the floor level. In order to give the duct constant draft, a branch of the heating pipes should be placed therein. This would heat the interior, cause the air column to rise, and thus create an upward draft. In addition to this, and for reserve, a Pintsch gas jet could be supplied to the interior of each duct, and this, when lighted, would serve to heat the air column and cause it to rise. Four such ventilating ducts, two at each end of the car, would have a combined cross section area of 8 sq. ft., and if the air moved upward through them at the rate of 2 cu. ft per square foot per second—a slow rate—they will remove each minute 960 cu. ft., thus effecting a complete change of air throughout the whole car, about every six minutes, supplying each passenger—60 to the car—with about 15 cu. ft. per minute. Either standing still or moving a car equipped as described would be well ventilated.

*From a paper read before the International Association of Railway Surgeons. Reprinted by "The Railway Surgeon."

Cleanliness.

Window frames and sills should be rounded, the car sides perfectly smooth, the seat frames should be perfectly plain, the seat arms never upholstered, but on the contrary made of hard polished wood or enameled iron, and round, simple and plain. The seat supports next the aisle should be simple, round, enameled iron posts. Curved, fluted and elaborate supports should not be thought of, and it would be well to do away with foot-rests, for they are not really necessary, favor dirt accumulation, and are a hindrance to cleaning. The floors should be hardwood, well filled, and kept so.

Apparently, plush must be continued and frequent renovation be depended upon to keep it as sanitary as possible. In order to accomplish this, seat frames should be skeleton and so constructed as to admit of the easy removal of the plush upholstered bottoms and backs. At present, I know of no car seat from which the backs can be readily removed. Slats or blinds should never be used at the windows. Only smooth, impervious material on automatic rollers should be tolerated. The plain, uncarved interior need not be without ornament, for painted panels, stenciling and frescoing would take their place to relieve the eye.

The strip of carpet or matting now frequently seen in car aisles should never exist. It would be allowable to have a rubber strip, which is impervious and susceptible of thorough cleaning. Hardwood, polished floors with rugs, as we have in our modern homes, would not be practicable because it would be impossible to walk about the moving car owing to slipping. To obviate this, rubber tile flooring could be laid. This would be ornamental, free from slippery smoothness, impervious and in every way practicable and excellent. On it rugs could be spread, and the easy removal of the rugs for cleaning would greatly improve sanitation.

The only way to secure fit drinking water is to sterilize, distill or filter it. It could be dispensed from water tanks, as at present, and the drinking cup should be glass; tin or metal cups should be carefully avoided. The Pennsylvania road uses glass tumblers with rounded bottoms; these are, however, always fluted. I would recommend they be perfectly smooth. Of course, careful persons carry their own drinking cups. It would be practicable for railroads to furnish small paper cups in a penny slot machine, attached to the side of water reservoirs.

The present passenger coach water-closet is a nuisance, pure and simple. Before the car has gone fifty miles it is offensive. The closet must exist, but how may its nuisance character be abolished? Of course, no matter what its construction, the closet, unless properly cared for, will be offensive, yet much remains to be done on account of better sanitary construction. It is imperative that floor and side walls of closets shall be of impervious material, and side walls perfectly plain and smooth. The porcelain hopper should be bell-shaped with the larger diameter at the bottom and the smaller diameter at the top. Such shaped hoppers would not likely become soiled and foul. Instead of receiving excreta upon the trucks, which is frequent in present construction, it should be received in removable drawers or boxes of iron, containing dry earth; and an arrangement provided whereby dry earth could be easily supplied in right quantity whenever the closet was used. If all arrangements are proper there would be no attending offense. At terminals the drawers could be removed, emptied, cleaned, and returned to place.

Cleaning and Disinfecting.

Being sanitarily constructed as described, a coach on arrival at a cleaning station should have the bottoms and backs of seats taken out and immediately placed in a steam sterilizer of sufficient capacity where they would be thoroughly sterilized and afterward dusted by means of the air blast. Or, ordinarily, they might be dusted first and then sterilized. If the seats and backs were kept in duplicate, clean sterilized seats could always be at hand. As soon as this first cleaning step has been taken, the floor of the car should be lightly sprinkled with water containing a very small amount of some efficient disinfectant (formaldehyde preferred) and then swept. Scrubbing with soap and water should then follow, the arms of the seats and all surfaces which need it should be washed and wiped and all dust taken up with damp cloths.

For car disinfection Mr. W. Garstang, Superintendent of

Motive Power of the "Big Four," has invented a giant spray. This is a strong copper can with a capacity of one gallon, provided with an atomizing tube of proper size. It is attached to the air hose, and after filling with formaldehyde the workman enters the car and proceeds to the opposite end, dragging the hose after him. He now quickly backs out, spraying the chemical onto the floor, side walls, window sills, into corners, and onto bottoms and backs of seats. The air pressure is so strong and the atomizing tube so well adjusted, that the formaldehyde is driven forth more as a nebula than a spray. By means of this nebulizing the formaldehyde gas is set free and penetrates every part of the car, effecting complete disinfection. A car thus treated does not manifest animal odors upon standing closed in the hot sun.

Sleeping Cars.

In sleepers, the men's wash and smoking room, with its carpet, its plush upholstered seats and hangings, is a veritable filth hole at the end of a trip. Let the impervious rubber tile floor of the wash room be without even a rug. Let also the rubber tile floor cover the entire car, and, if desired, use rugs between seats. The heavy curtain which hangs at the wash room entrance is all too frequently pushed aside by polluted hands. Who can doubt what result would be obtained if a bacteriological examination of such a curtain was made? A plain hardwood, highly polished door should take the place of these curtains.

The compartment sleeper solves the problem of the abolition of the berth curtain, which, as a filth collector, has few equals and no superiors. Traveling in Colorado, I once saw a consumptive wipe out his mouth with the berth curtain, after a severe attack of coughing, followed with expectoration. What magnificent collectors and distributors of pneumonia, diphtheria and like infections car curtains must be! Repeated inquiries have failed to elicit information concerning the steaming of the blankets used on sleepers. I contend these blankets should be white, and then the story of cleanliness would be quite satisfactorily told. I have learned that these blankets are frequently aired. This is well, but it is not sufficient, especially as they are aired in railroad yards where conditions are surely not good. Anything less than steam sterilization after every using cannot be acceptable. It goes without saying that the mattresses should be frequently submitted to steam sterilization.

Dining Cars.

Many surprises are in store for those who have not made sanitary inspection of dining cars. In diners carpets should never be found. The rubber tile floor should be used and extreme plainness of interior exist. The food boxes, when of wood and unlined with impervious material, are an abomination; they cannot be kept sweet. Zinc lining is not acceptable for the zinc wears away, and between it and the wood accumulations which occur, bring forth odors to taint the food and possibly to furnish unwholesome products of decomposition. Wooden slat shelves in dining car food boxes are extremely unsanitary. I have taken such wooden shelves out which exhaled sickening odors and which could not be rendered free from smell after soaking in strong formaldehyde. Cleaning and scalding seemed not to lessen the bad odor of these wooden shelves. The discoveries of Vaughn in regard to the formation of poisons in foods warn us not to trifle with wood or other absorbent material in refrigerators. The dining car food box should be made of steel boiler plate and porcelain lined; the slatted shelves should be of metal porcelain covered. Such a food box could be easily cleaned with a jet of steam or by scalding with boiling water. I would emphasize this matter concerning food boxes, for my experience in inspecting them has been disgusting.

The United States Hotel, Saratoga, N. Y., will open June 15 for the benefit of those attending the Master Mechanics' and Master Car Builders' conventions. Those who selected this hotel last year will do so again and probably also a large number in addition, especially those who appreciate the dignified, quiet comfort which Messrs. Gage and Perry so well provide. Everything will be done for the comfort and convenience of their guests and entire relief from the crowd and the exasperating delays at the table with other uncomfortable convention experiences may be had by going to this hotel.

GRAPHICAL METHOD OF OBTAINING THE SPEED OF LOCOMOTIVES.

The accompanying diagram is for use in determining the speed of a locomotive approximately, in miles per hour, by counting the revolutions of the driving wheels. This engraving, which was prepared from a drawing received through the courtesy of Mr. E. B. Thompson, Mechanical Engineer of the Chicago & Northwestern Railway, will be found convenient in indicating engines, as it is often desirable to take the cards at a certain rate of speed.

The figures along the base line of the diagram indicate the diameter of driving wheels in inches, and the figures on the

In English locomotive practice, according to Mr. Charles Rous-Marten, in "Locomotive Engineering," the year just closed has developed a disposition toward "earnest consideration" of the compound. It has also brought about an increase of boiler power of 40 per cent., and in steam pressure, 12 per cent.

To settle the comparative efficiency of centrifugal fan blowers versus steam-jet blowers for the production of boiler draft, Mr. B. R. Healey recently made some experiments upon a standard type of refuse-burning furnace having 25 sq. ft. of grate surface. He states in a recent paper read before the Society of Engineers, London, that in each case "the furnace was

got to full heat before commencing to record the results, and every care was taken to ensure precisely similar conditions for each test. The steam pipes were well covered with hair felt, the steam pressure was kept at 80 lbs. during each trial, and the blast mains and blower outlets were all 9 ins. in diameter. The first experiment was with a Korting steam-jet blower, the initial nozzle being 25-in. diameter, which gave a pressure of .20-in. water gauge. The second experiment was with a small high-speed engine geared direct to a Sturtevant centrifugal blower, and by using exactly the same weight of steam the pressure was increased to .60 in. In these two experiments the furnace gases passed through a multitubular boiler 10 ft. long and 6 ft. diameter to a stack which was 40 ft. high above the grate. Two

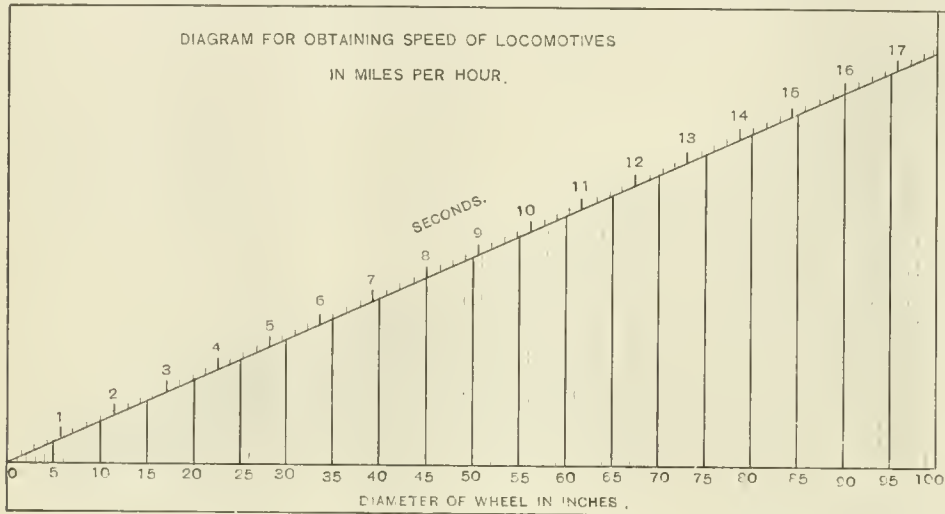

Diagram of Speed of Locomotives.

oblique line indicate seconds. To find the speed of a locomotive with 80-in. drivers, follow the base line marked "diameter of wheels in inches," until striking the ordinate marked 80. This ordinate touches the oblique line very near the point marked 14¼ seconds. By counting the number of revolutions of the driving wheel for 14¼ seconds, the result will be the speed in miles per hour that the engine is running. This method is sufficiently accurate for ordinary purposes. It is based upon the old idea of taking the speed of a train by counting the number of 30-ft. rails passed over in a space of 20 seconds.

A new process for rolling rails has been put into operation at the Edgar Thompson Steel Works, with the object of improving the quality of large rails. The process has been developed by Julian Kennedy and Thomas Morrison, and is known as the Kennedy-Morrison process. Its object is to provide for finishing the heads of rails at a lower heat without reducing the temperature at which the blooms are rolled, which is not too high for the earlier passes. It is also desirable not to decrease to too great an extent the temperature of the web and flange. The process provides an interval of time between the intermediate and finishing rolls which is just sufficient to bring each rail to the temperature which has been found to give the best results. The rail is laid on the cooling bed on its side with the head close up to the flange (or bottom) of the rail in front of it, so that the metal in the combination of two rails is about equally distributed, which allows the rails to cool gradually without causing them to become distorted. A great deal of the heat which leaves the head of the rail is absorbed in the flange of the rail adjoining it, thus keeping the temperature of the flange from being unduly lowered while the head is cooling. This is done without interfering with the rapidity or continuity of action of the mill, and it results in improving greatly the quality of the product. The process requires a special arrangement of machinery to provide this pause in the rolling. This and the machinery for operating the intermediate cooling table are fully described in "The Iron Age" of December 20, 1900.

other experiments were afterward made without the boiler, and the furnace gases passed direct to a special chimney 12 ft. high over the furnace, and it was found that with the same blast pressure the incinerating power of the furnace was as nearly as possible the same as before, which indicated the extra duty the stack has to perform when steam generators are used. A fifth experiment was made with four Korting steam-jet blowers of the same size as the one used in the first experiment. These were fixed to a sole-plate at the top of the chimney 12 ft. above the furnace and used as exhausters. The ashpit doors being open, it was found that the in-draught at the furnace doors was only .25-in. water gauge. The power of the furnace was considerably less than in the other experiments, although using four times the quantity of steam. The result was anticipated, but the experiment was made to convince certain parties of the folly of using steam-jets to any large extent in chimneys."

Less than one pound of coal per indicated horse-power per hour—to be exact, 0.97 lb.—is recorded by "Engineering," of London, for the new steamships, "Inchdune" and "Inchmarlo," on voyages between Hartlepool and Dover. These ships have Mudd's five-crank engines and a boiler pressure of 267 lbs. generated in two single-ended boilers, with Ellis and Eaves' system of induced draft. Fitted in the uptake, immediately above the level of the highest row of tubes, is the Central superheater, a device designed and patented by the Central Marine Engine Works. It consists of a series of wavy tubes through which the steam is made to pass on its way from the boiler to the engine. The steam from the boiler enters at the top, where the gases are comparatively cool, and passes out of the main steam pipe at the lower end, where the gases are hottest. A temperature of 460 degrees to 480 degrees Fahrenheit is easily obtained. Above the superheater come the air-heating tubes and casings, which, together with the fans, constitute the induced-draught system. The engines have five cylinders, of diameters respectively of 17 ins., 24 ins., 34 ins., 42 ins., and 42 ins. by 42 ins. stroke, the high-pressure valve being of the piston type, and the others flat valves.

STANDARD EQUALIZER SPRINGS.

For Passenger Equipment, Lehigh Valley Railroad.

Our attention has been called by Mr. F. F. Gaines, Mechanical Engineer, Lehigh Valley Railroad, to a very convenient

MIDDLE BEARINGS ON DRIVING AXLES.

New York, Ontario & Western Railway.

In order to overcome a serious difficulty with hot driving boxes of some mogul freight locomotives built in 1893, having 19 by 24-in. cylinders, 63-in. driving wheels and a total weight of 138,000 lbs., Mr. West, Superintendent of Motive Power of the New York, Ontario & Western, devised a third bearing for the driving axles of one of the engines to relieve the other bearings of a portion of their loads. These journals were but 8 ins. in diameter and the relief thus afforded about a year ago was so satisfactory as to lead to the application of the same plan to all the engines of that class. It has also been applied to the rear driving axle of engines of the 8-wheel type with equally good results. Mr. West states that he is now applying these bearings to new and heavier mogul engines for milk train and heavy passenger service now being built at the Cooke Locomotive Works. The device is the subject of a patent application.

The construction is clearly shown in the engraving. For the main axle a pair of pedestals are made in a short supplemental frame supported between a transverse frame brace and one of the plate boiler braces. The load is applied through stirrups under the main frames and a transverse leaf spring bearing on a step over the middle bearing. The lower view illustrates the method used on the rear axle, in which case there is not sufficient room for the pedestals and frame over the box. The bearing at the center of the main axle is 7 3/4 ins.

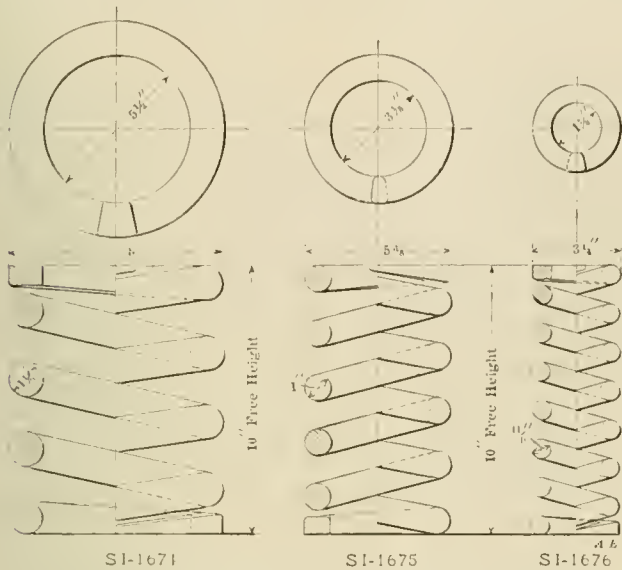

Standard Equalizer Springs, Passenger Equipment, Lehigh Valley Railway.

and compact tabulated form, used in ordering equalizer springs for passenger equipment. Over thirty different springs were formerly in use on that road for this particular equipment, but by different arrangements of the three springs shown in the engraving this number can be reduced to three. These

Spring No. 1674.

Cars having 6-wheel trucks.		Cars having 4-wheel trucks.	
Min. Car	Max. Car	Min. Car	Max. Car
Weight. 48,600	Weight. 63,800	Weight. 42,500	Weight. 57,790
Springs Nos. 1674 and 1676.			

Cars having 6-wheel trucks.		Cars having 4-wheel trucks.	
Min. Car	Max. Car	Min. Car	Max. Car
Weight. 64,600	Weight. 79,500	Weight. 58,500	Weight. 73,700
Springs Nos. 1674 and 1675.			

Cars having 6-wheel trucks.		Cars having 4-wheel trucks.	
Min. Car	Max. Car	Min. Car	Max. Car
Weight. 80,600	Weight. 95,800	Weight. 74,500	Weight. 89,700
Springs Nos. 1674, 1675 and 1676.			

Cars having 6-wheel trucks.		Cars having 4-wheel trucks.	
Min. Car	Max. Car	Min. Car	Max. Car
Weight. 96,600	Weight. 112,600	Weight. 90,500	Weight. 106,500

Specifications.

Shape number	SI-1674	SI-1675	SI-1676
Outside diameter	8 in.	5 3/8 in.	3 1/4 in.
Diameter of wire	1 1/4 in.	1 in.	11/16 in.
Free height	10 in.	10 in.	10 in.
Solid height	6 1/4 in.	6 1/4 in.	6 1/4 in.
Load at solid height, pounds	78908		
Load at 3/4 inches, pounds	78908		

All heights to be within 1/8 in. of those specified. To be free from permanent set.

springs are made 10 ins. in free height and of 1 1/4, 1 and 11/16-in. wire, with outside diameters 8, 5 3/8 and 3 1/4 ins., respectively. The accompanying tables show the different combinations of these springs for 6 and 4-wheel trucks, with the minimum and maximum car weights for each combination. In ordinary equalizer springs all can be shown in one drawing together with the tables of specifications and weights for the four combinations. This same arrangement is now being worked out for bolster springs.

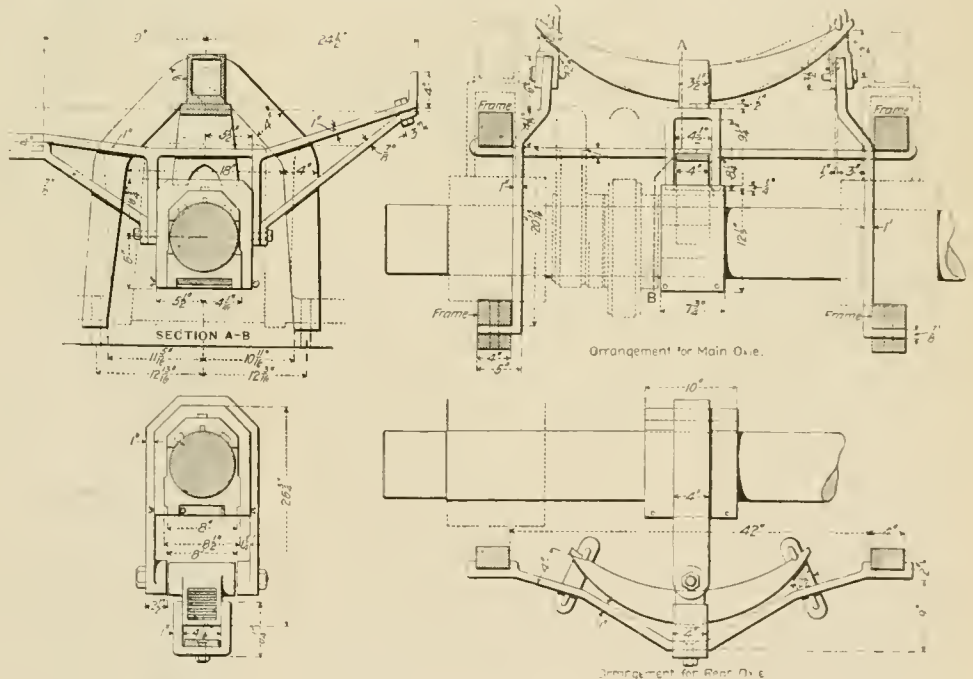

Third Bearing for Driving Wheel Axles—New York, Ontario & Western Railway.

long, which is all that could be obtained between the eccentrics, while on the rear axle a length of 10 ins. was used.

A record of 1,217 locomotives built in the year 1900 was made by the Baldwin Locomotive Works. Of these, 426 were Vulcan compounds, 363 were exported, 48 were electric, and 6 were built for compressed-air power. The aggregate weight of the locomotives was 19,277,900 lbs., or 96,388 tons, and when spare parts are included the total weight was more than 100,000 tons. If the length of each locomotive and tender is assumed to be 60 ft., the 1,217 locomotives would make a train over 13 miles long. The average weight of each engine and tender empty was 158,500 lbs., while for the year 1890 it was but 106,000 lbs., an increase of about 50 per cent.



Machinery and Transportation Building.

PAN-AMERICAN EXPOSITION.

To Open at Buffalo, New York, May 1, 1901.

This exposition, which is to celebrate the achievements of civilization in the Western Hemisphere during the past 100 years, by a display of the arts, industries, manufactures and products of the soil, mine and sea, will be opened May 1, 1901 and continue for six months. The site chosen for this purpose is in the northern part of the city of Buffalo, in the vicinity of Niagara Falls, and within a day's journey from the homes of 40,000,000 people. Of the 350 acres comprising the exposition grounds, 133 acres are picturesque park and lake lands. The architecture of the 20 or more large buildings is a liberal treatment of the Spanish Renaissance. These buildings surround 33 acres of open courts, with more than 125 original sculptured groups, and court settings of unexampled beauty.

Entering the exposition grounds by the main entrance on Lincoln Parkway, the first buildings that come to view are the Albright Gallery of Art on the left, which is designated by No. 1 in the accompanying plan of the grounds, and the park shelter and boat house, E-2, on the right. Continuing north along the park drive, the first glimpse of the New York State Building, No. 9, is caught as entrance is made to the spacious courts, which are, as shown in the engraving, to be in the form of an inverted T. Besides the structures that immediately surround these courts are buildings of a miscellaneous order. At the extreme end of the main court, and to the east side, is situated the Stadium, marked O in the engraving, which has a seating capacity for 10,000 people. The arena will have a quarter-mile track and ample space for athletic contests of all kinds. On the opposite side of the court is the Midway, comprising nearly 30 acres, to be devoted to novel entertainments, the cost of which is estimated at \$2,500,000. The state and foreign buildings are located at the right of the main entrance to the courts and occupy 15 acres. There are also music halls, cafes, band stands, live stock farms and other structures not shown in the engraving.

Of the many large buildings of great interest, the two appealing more closely to our readers are the machinery and transportation building and the electrical building. These two buildings, Nos. 12 and 13, are located one on each side of the Court of Fountains.

The electrical building is 500 x 150 ft. and the 75,000 sq. ft. of exhibition space available in this building will be divided into three divisions, namely, the service plant for the transformation and distribution of 5,000 horse-power, transmitted from Niagara Falls for lighting and power purposes; a collective exhibit of historic interest, and the commercial exhibit, showing articles possessing distinctive merit. These divisions have been subdivided into 14 groups.

One of the largest structures of the exposition is the machinery and transportation building, which is shown in the accompanying half-tone engraving. Its dimensions are 500 x 350 ft., and the architectural work of the building is a masterpiece in the style of the Spanish Renaissance. The exhibits in the machinery division will be made representative in each particular line, rather than exhaustive, and the aim will be to present exhibits possessing distinctive novelty and educational value. In the transportation exhibits some of the important features will be the automobiles and horseless carriages of every description. The rapid developments that have

taken place in trolley cars will be shown, and a fine up-to-date exhibit of railway cars and trains and interesting steam and electric locomotives will be included. Marine exhibits will show the development in lake, river and ocean navigation up to the present time. In the graphical arts, the largest exhibits

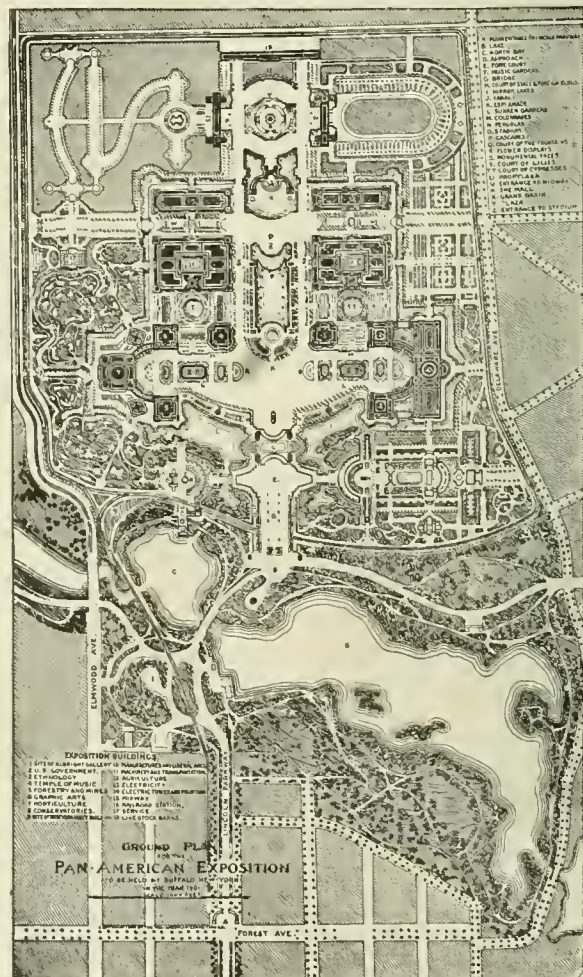

Plan of Exposition Grounds

will be those of newspaper presses, particularly the newest rotary and duplex machines. The ordnance displays will also be made in connection with the transportation exhibits as well as agricultural machinery and implements.

The most prominent feature of the exposition will undoubtedly be the brilliant electrical effects, because of the nearness

to Niagara Falls, where the greatest power plants in the world have been installed. Over 200,000 incandescent lamps will be used in lighting the courts, and it is the purpose to make this the most brilliant, fantastic and beautiful electric-lighting effect ever attempted. Much has been said about the exposition, and investigation indicates that it will not be a disappointment in any particular.

12 ins. in diameter with a 16-in. stroke. From the highest point of the locomotive down to the rail is 10 ft., the widest part about 9 ft., and the length over the bumpers is 20 ft. It has two air tanks, each 40 ins. outside diameter, with a combined capacity of 240 cu. ft., and these are designed for a working pressure of 750 lbs. Below these two large tanks and midway between the cylinders is a third tank 10 ins. in diameter and 12 ft. in length. This auxiliary tank has a capacity of 6½ cu. ft. and is fitted with a reducing valve by which the air is reduced automatically from the pressure in the main tank to 140 lbs. per square inch, the regular working pressure, in the cylinders. The engine is fitted with an air whistle, bell, track sander, inside-hung air brakes, applying to all four drivers, and is one of the largest compressed air locomotives ever built.

The plant at Iona Island consists of one locomotive, a series of charging stations along the tracks for charging the locomotive when necessary, and a complete power plant for operating the compressors. The time required in charging the locomotive is less than 30 seconds. On the success of this engine hinges an order for a number like it, to be used in the same service on the island.

Hon. Charles A. Prouty, of Washington, D. C., member of the Interstate Commerce Commission, delivered on January 21st an address before the engineering students of Purdue University. His subject was "The Railroads and the People."

The "Railway Master Mechanic" appears in new size and form in its January number. It has been changed to the standard of 9 by 12 ins. and is attractive in every way. Mr. W. D. Crosman continues as Editor, and Mr. Allen R. Cosgrove is Manager. Last month we stated that Mr. Bruce V. Crandall had purchased this publication and also the "Monthly Official Railway List." This was an error, for he has purchased the "Railway Master Mechanic" only and will conduct it as publisher. The first number under the new ownership promises increased success and improvement in every particular.

The usual causes for hot driving boxes must necessarily be understood where 75 engines are operated on a division for two months without a single delay from hot driving boxes, and yet making an average mileage of 4,157 per engine per month. Mr. M. E. Wells records this in a brief paper before the Western Railway Club. He considers constant systematic care more important than any other half-dozen remedies. It is not more oil but more care to keep the packing in good condition; not what men are instructed to do, but what they actually do, that is so important. In ten-wheel engines Mr. Wells finds it necessary to examine the front driving boxes every 510 miles, the main boxes every 1,020 and the rear ones every 1,530 miles because of that ratio in the liability of heating. The packing is thereby kept always in good condition. Mr. Wells believes the following to be factors of importance: Side oil holes, not lower than 2½ ins. above the center line of the journal; moderate pressures (5 or 6 tons) for placing bearings in driving boxes; tight-fitting oil cellars, to prevent the boxes from squeezing in at the bottom and a disposition of the cellar packing which will prevent particles of waste from being carried over the journals.

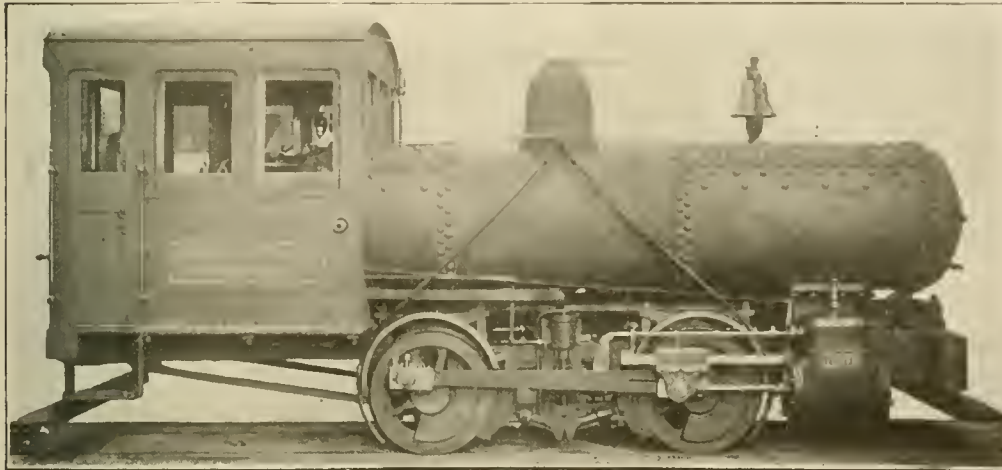

Compressed Air Locomotive—Ordnance Department, United States Navy.
Built by H. K. Porter Company, Pittsburg, Pa.

COMPRESSED AIR LOCOMOTIVE.

H. K. Porter Company.

The large compressed air locomotive illustrated in the accompanying engravings was built recently by the H. K. Porter Company and delivered, together with a complete plant for charging and operating the engine, to the Ordnance Department of the United States Navy, at Iona Island, New York, for service at the large magazines for explosives at that place. It will replace part of the old mule service on the island for

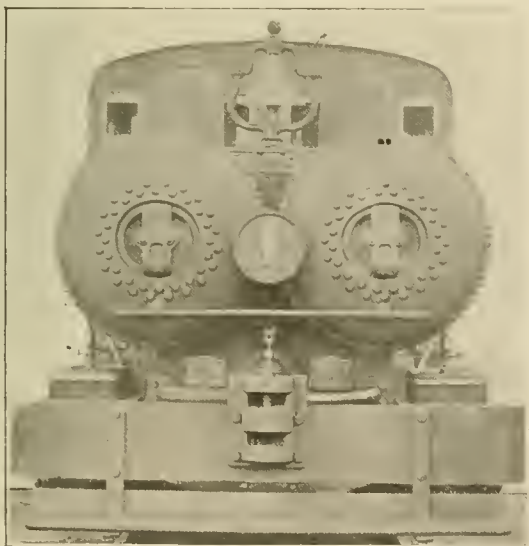

Front View of Compressed Air Locomotive.

pulling railroad cars about the ammunition storehouses. This type of locomotive was decided upon by reason of the absolute necessity of avoiding fire of any kind near the magazines.

The weight of the engine in working order is about 40,000 lbs. It is of the double tank design with four driving wheels to run on standard gauge tracks. The drivers are 30 ins. in diameter and have a rigid wheelbase of 6 ft. The cylinders are

LENGTH AND WEIGHT OF BOILER TUBES.

By F. K. Caswell.

In designing locomotives, where the weights have to be held strictly within given limits, the item of weight of boiler flues becomes an important one. Oftentimes, the change of one

THE HINSON DRAFT GEAR.

The accompanying engraving illustrates the application of the Hinson draft attachment to ore cars on the Duluth, Missabe & Northern Railway, where it has given good results in severe service for several years. The essentials are cheek castings of malleable iron or cast steel, with removable under-straps, the usual coil springs and crucible steel spring follower plates in place of the usual rigid followers. These spring follower plates have a capacity of 80,000 lbs. applied by means of the coupler and they act like the usual rigid followers, except when subjected to very heavy pulls or jerks. Such jerks are graduated by the combined elasticity of the coil and follower springs, relieving to the extent of their capacity the draft rigging and car framing from the destructive shocks which are imposed through rigid followers. In the design illustrated the follower springs are 8½ by 5¾ by 5/16-in. plates, with an initial number of ¾-in., four of these being used in each follower. Mr. Wm. Smith, Superintendent of Motive Power and Cars of the Duluth, Missabe & Northern, writes of this draft gear as follows:

"We have had it in use about three years and have 900 cars equipped with it. During this period we have only broken six of the levers in our entire equipment. We have never broken two leaves in any one follower; only one in a follower occasionally. Our business is chiefly iron ore and our

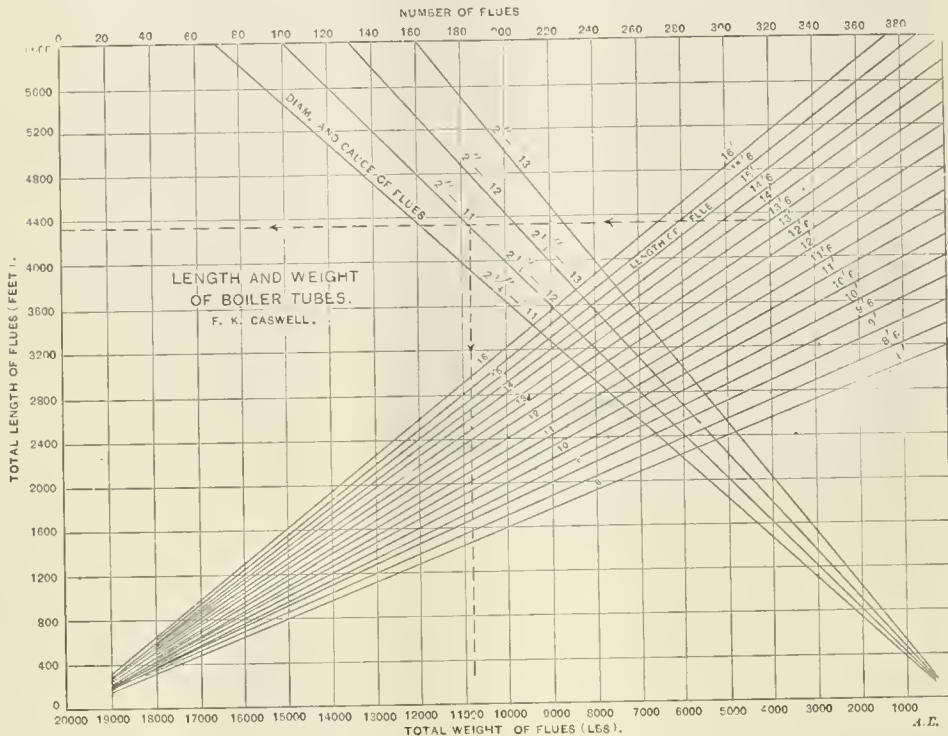

Length and Weight of Boiler Tubes.

gauge in the thickness of the flues will enable the designer to keep the weight within a given limit and yet retain the desired total heating surface.

Where weight of flues is to be figured separately for each case, considerable time is involved. To avoid this delay, and also to provide a ready means for finding the difference in weight between flues of different lengths, the accompanying chart was prepared, and is used as follows:

Starting at the top of the diagram with the given number of flues, follow the line vertically until it intersects the diagonal of the given length of flues. (For figuring weights or aggregate lengths, this length should be taken as 1 in. over the nominal lengths to allow for beading.)

Follow the horizontal line at this intersection to the left until it intersects the diagonal of the given diameter and gauge (B. W. G.), and thence to the bottom of the scale, where the total weight can be read from the scale. In making estimates it is often necessary to know the aggregate length of the flues. This figure can be obtained from the scale at the left, as indicated by the dotted lines, which for 320 2-in. flues 13 ft. 6 in. long, No. 11 B. W. G., give 4,340 ft. and 10,800 lbs. respectively.

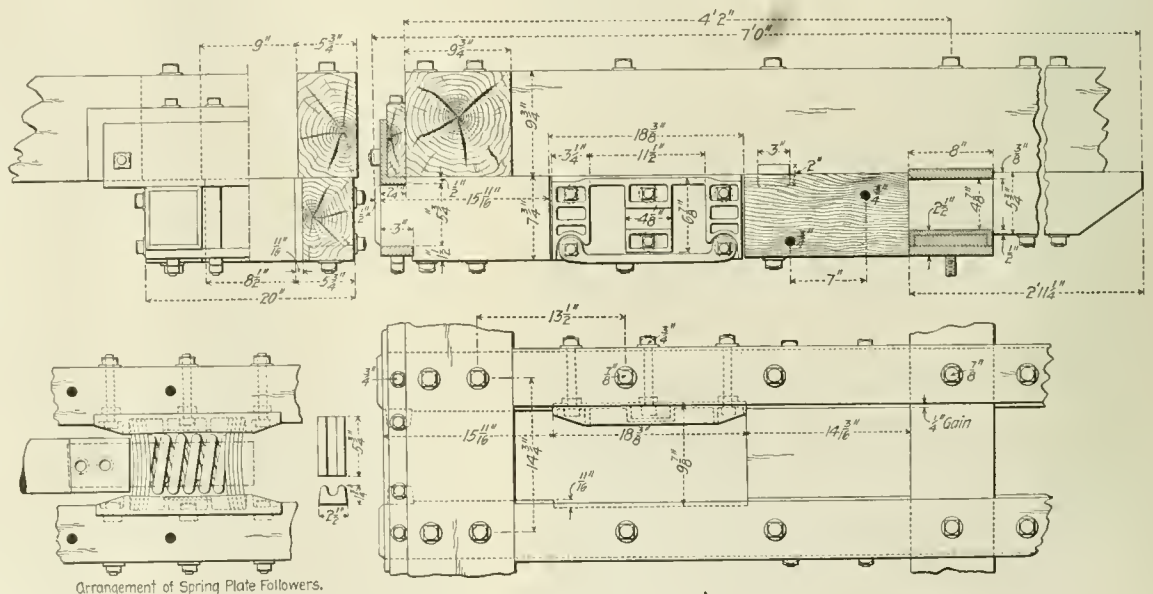

The Hinson Draft Gear Ore Cars—Duluth, Missabe & Northern Railway.

trains are very heavy, carrying on an average of 2,200 tons, and it taken a good solid draft rigging to stand this pull. We have some grades against us varying from 10 to 26 ft. to the mile and our engines are worked to their full capacity, especially with these grades. The blueprints I enclose you I think are plain enough to illustrate the design without any great explanation. It is a very easy matter to replace a spring in this attachment. You will see there is a bottom attachment, and

that by taking out a bolt it drops down, allowing free access to the bar. These followers are short and stiff and hard to compress. They cushion the shock to the draft gear, even after the coil spring is closed."

From this testimony it appears that the draft gear has already established a record and is not an experiment. It is manufactured and sold by the National Car Coupler Company, 621 Monadnock Block, Chicago, who also manufacture the other well-known car equipment devices developed by the President of the company, Mr. J. A. Hinson.

MULTIPLE DRILLING MACHINERY.

The Baush Machine Tool Company, Springfield, Mass.

The word "multiple" when applied to a drilling machine may mean much or little, depending upon the adaptability of such a machine for different kinds of work. A machine might be designed with two or more spindles for some particular work and be capable of effecting that work economically and satisfactorily. Such a machine would be a multiple drill, but

dinary drilling machine, for taking the factor of handling into account, it will drill as many more pieces in the same time as there are holes in the work.

One great advantage in this machine over some other multiple drills, is the fact that the whole head moves to and from the work by power or hand feed at the will of the operator thus allowing the work to be placed upon the bed plate or table, as desired. Another advantage is that each drill spindle is freely adjustable and independent of the others.

The field which such a machine can cover is wide and varied and a little thought will show how well adapted it is to any work of a multiple or duplicate character within its range. The sizes regularly built by the company contain four, eight, twelve, fourteen, sixteen and twenty-four spindles, or, in fact, any desired number. The larger sizes are suitable for drills up to 1½ ins. in diameter, while the smaller are designed for 1-in. drills or less. The space covered varies from a 4-in. circle in the smaller machine to 36 ins. in the larger sizes, and each machine can drill any regular or irregular layout within its capacity.

The Baush Machine Tool Company, Springfield, Mass., make a specialty of these machines which are built under the Baush & Oehring patents.

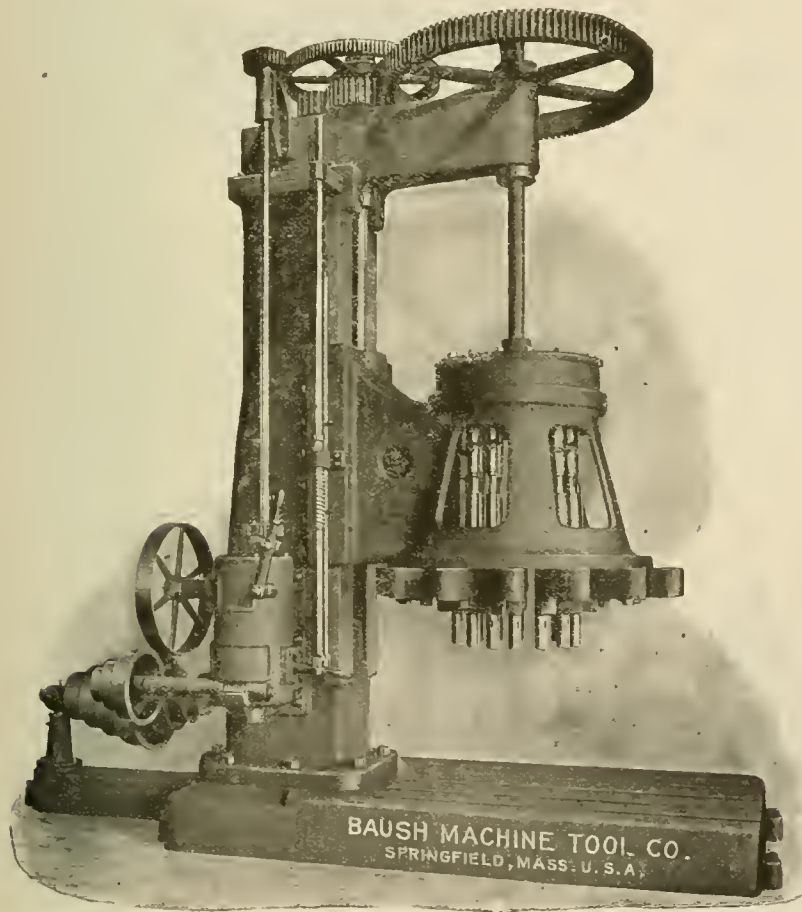

During the past year the Pintsch system of car lighting was, up to November 1, placed on 1,347 additional cars in the United States alone. This makes a total of about 16,000 cars equipped with the Pintsch compressed-gas system, of which 2,883 are Pullmans. The system is now standard on about 150 railways in the United States and Canada. And of the entire world there are not far from 100,000 cars equipped with this system. These figures would seem to indicate that the progress made during 1900, as to the adoption of the system, has been the greatest in the history of the company. The Safety Car Heating and Lighting Company, which controls in the United States and Canada the Pintsch system, has constructed during the year six gas plants, one at Albany, N. Y., one at Los Angeles, Cal., one at Jersey City, N. J., making three such works at the latter place, a large plant at Montreal, Canada, and also works at Memphis, Tenn., Texarkana, Ark., and Hamlet, N. C., making a total of 55 manufacturing plants for Pintsch gas in the United States and Canada. A further indication of the successful management of the concern is told by the fact that 8 per cent. is paid annually on its capital stock of \$3,750,000.

The Philadelphia & Reading Railway will erect a new boiler house at Reading. The structure will be of brick, one-story high, the dimensions being 31 ft. 10 ins. wide by 91 ft. 11 ins. long, supported by stone foundations and covered with granulated slag roofing. Its equipment will consist of boilers and air compressors complete, dust collector and furnace feeder. It will be located on the railway company's property on Sixth street above Oley street, in that city.

The American Machinery & Export Co., recently incorporated under the laws of New Jersey with a capital of \$250,000, has opened an office at 15 Cortlandt Street, New York City. The company will deal in all kinds of machinery, principally for export, and will make a specialty of buying for foreign railroads. Mr. Westey Meeteer, for some time Purchasing Agent of the Jackson & Sharp Co., Wilmington, Del., is Vice-President and General Manager.

A Western railroad has named one of its new sleeping cars "The Links." It will probably be filled with bunkers.

when considered as an economical tool for present-day conditions would, of course, fail to meet the claim.

If, however, a machine is so designed and constructed that while filling the requirements of a special tool, it can also without trouble or delay be adjusted to meet the necessities of other work whether its full capacity or otherwise, then such a machine becomes "multiple" in the best sense of the word and is proportionally valuable as a shop tool.

A machine which fully meets these conditions is shown in the accompanying illustration. Not only does it meet the conditions stated, but it effects a result which is not always considered at first thought and that is, that for every spindle working it is saving the time and expense of one other or-

UNIVERSAL HAND OIL PUMP.

Manufactured by The Lunkenheimer Co., Cincinnati, O.

The accompanying engraving illustrates a new form of oil pump, which is easy to fill and operate, works well under high pressure and may be attached either vertically or horizontally, by interchanging the plug marked B in the engraving, with the shank marked A. The body of the oil cup

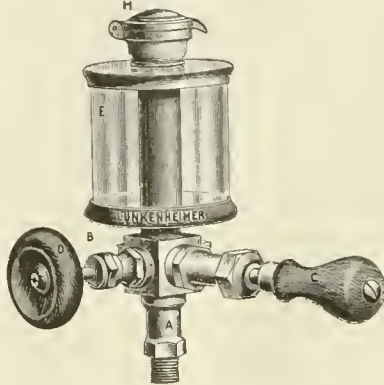

Universal Hand Oil Pump.

is glass, but may also be made of brass. All parts of the pump are well designed and constructed. The plunger is made heavy and very durable. The oil hole for filling is guarded by a removable wire gauge strainer to prevent dust or grit from entering the pump. This is in turn covered by a hinged cap, H. The finish of the pumps is brass or nickel plate, and ornamental in appearance.

MOTOR-DRIVEN BLANKING PRESS.

The blanking press shown in the accompanying engraving is operated directly by means of a Bullock motor. The machine is compact and powerful and is known as a No. 92 Toledo Punch. The motor is series wound and operated at 240 revolu-

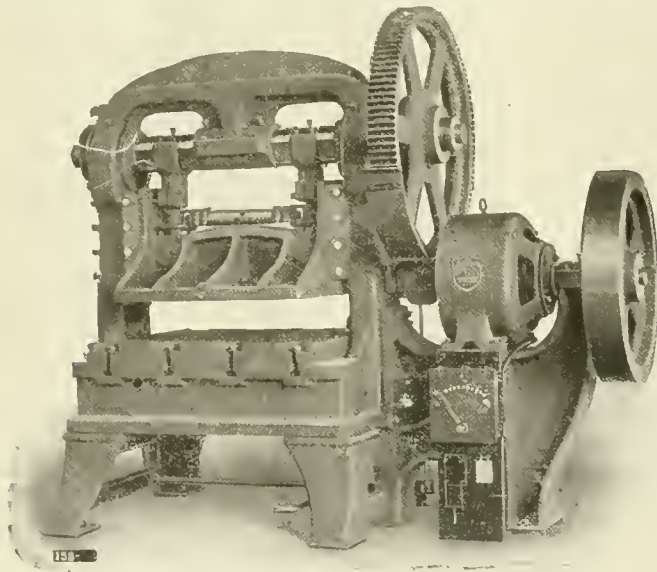

Direct Motor-Driven Blanking Press.

tions per minute, developing at that speed 4 horse-power. It is so placed on the machine that it occupies no more room than the driving pulley of a belt-driven machine. The main switch, rheostat and fuse box are mounted upon a board fastened to the motor support. This unit may be set anywhere on the floor of a shop without reference to line shafting, and from this feature it is possible to economize considerably in floor space and also to move the machine about the shop if necessary. The chief advantage of direct driving in such a case is that a machine may be placed in an outlying building or in any space in the shop over which cranes are to be operated.

HOMESTEAD VALVES.

Manufactured by the Homestead Valve Co., Pittsburg, Pa.

The Homestead valve is a balanced, self-locking valve, so constructed that the best possible service that a valve can render is done in the shortest possible time. It is provided with interlocking and releasing cams, which are operated automatically on turning the handle. The accompanying engraving is of the Homestead locomotive blow-off valve which is so constructed that when closed it is at the same time forced firmly to its seat. This is accomplished by means of a traveling cam which moves vertically in the casing above the tapered plug, but is prevented from turning by two small lugs

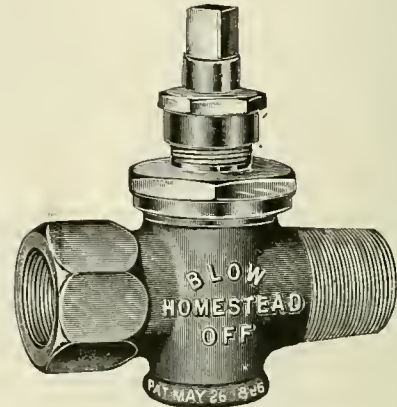

Homestead Locomotive Blow-Off Valve.

which travel in vertical slots. By turning the stem in the direction of closing, the cam is caused to move upward and take a bearing on the upper surface of the casing and thus force the plug firmly to its tapered seat. The Homestead Manufacturing Company also make straight-way, three-way and four-way valves in all sizes up to 6 ins., which are intended for high pressure, either steam, compressed air, or hydraulic. Correspondence is invited for valves of special patterns and high pressures.

BOOKS AND PAMPHLETS.

Progress in Flying Machines. By O. Chanute, C. E. 308 pages, 5¼ by 8½ ins. Price, \$2.50. Address The American Engineer and Railroad Journal, 140 Nassau St., New York.

This book, written by an engineer of long and extended experience, is a review of the experiments which have heretofore been made to achieve human flight by means of non-buoyant apparatus—that which is heavier than the air—in contradistinction to balloons whose levitation is produced by gas lighter than the atmosphere. The object which the author of the book had in mind in its preparation was to satisfy himself "whether with our present knowledge and mechanical appliances men might reasonably hope eventually to fly through the air?" This question he has answered in the affirmative. In making his investigations he aimed to gather all the records of experiments and attempts at human flight which have heretofore been made, but especially to furnish an account of the more recent achievements in that direction which make it seem less chimerical than it was a few years ago to experiment with flying machines. Having done this he has then aimed to give an explanation of the principles involved in flight and of the results thus far accomplished by others. The book contains nearly a hundred illustrations, and is the most complete and the ablest treatise on the fascinating subject to which it relates in the English, or perhaps, any other language.

Bulletin of the American Railway Engineering and Maintenance of Way Association. Vol. 2, 1900. Published by the Association, 1562 Monadnock Block, Chicago, Ill. Edited by L. C. Fritch, Secretary of the Association.

This, the first bulletin of Vol. 2, contains a very interesting paper on Locomotive Tonnage Rating on the Southern Pacific Railway (Pacific System), by the late Wm. G. Curtis, Engi-

neer of Maintenance of Way. The report was the work of a committee appointed early in 1899 by Mr. Julius Kruttschnitt, General Manager of the Southern Pacific Company, for the purpose of introducing a uniform and consistent system of locomotive tonnage rating. To put this system in form for publication as a paper before the association, Mr. John D. Isaacs, Assistant Engineer Maintenance of Way, re-arranged the experimental and theoretical investigations. The paper as presented to the society, contains, besides the general methods of calculating and practical application of the system to the single-expansion and compound locomotive, a number of extensive tables, with folding plates and diagrams. The bulletin also gives an appendix containing a synopsis of minutes of the Board meetings, list of new members, list of standing committees and mileage tables.

The Gas Engine Handbook. By E. W. Roberts, M. E. Second Edition; revised and enlarged. Published by the Gas Engine Publishing Company, Cincinnati. Price, \$1.50.

This little volume of 241 pages, $3\frac{1}{2}$ x $5\frac{1}{4}$ inches, is a manual of useful information for the designer and engineer. It does not cover the entire subject of gas engine design, but gives a sufficient number of rules and formulas to enable draftsmen to design a gas engine without difficulty. Many of the formulas given are new and have not appeared in any works by other authors. Of the twenty-five chapters of this volume, the first eight contain rules and hints, valuable not only to the designer, but to the engineer who has the care of gas engines. The following fourteen are devoted to the design of the various parts and the remaining three chapters give miscellaneous formulas, tables and the necessary operations for testing. This second edition has been revised and enlarged by way of an appendix, including some notes on two-cycle engines and especially upon their design.

Modern Locomotives. Edition of 1901. Illustrations, Specifications, and Details of Typical American and European Steam and Electric Locomotives. Large quarto size, bound in cloth, 532 pages, 837 engravings. Published by The Railroad Gazette, New York, 1901. Price, \$7.

The fourth edition of this book has just appeared. It is similar in form and arrangement to the earlier ones, and being up-to-date and the only publication of the kind, is most valuable to those who have to do with the design and management of locomotives. The work was prepared by Mr. J. C. Whitredge, Associate Editor of The Railroad Gazette. It begins with articles on subjects specially important to the designer, such as: Recent improvements in locomotives, Locomotive tests, Locomotive counterbalancing, Locomotive tests and testing plants, Experiments with exhaust apparatus and Records of fast runs. The entire work is well indexed and the subjects are grouped conveniently. This edition is specially interesting because the additional matter chiefly concerns powerful and notable engines, many of which have appeared since the 1897 edition came from the press. Tables of dimensions accompany nearly every design illustrated, and in addition to this a large number of details applicable to general practice are included. The chief features of the various well-known types of compound locomotives are presented and also of foreign, electric and compressed-air locomotives. In such a work some mistakes and criticisms of various features may be expected, but altogether the work is of such great value that these may be lightly passed over. It is a unique publication which cannot fail to win appreciation.

Motor-Driven Air Compressors.—This new catalogue, just issued by the Westinghouse Air Brake Company, illustrates and describes a line of small electrically operated air compressors for supplying compressed air for car brakes, train signals and various industrial uses. The motor and compressor, which are discussed separately, were designed to occupy the smallest possible space and are illustrated by several different views. An automatic electric pump governor is described and shown separately by a half-tone engraving and also in connection with a diagram of wiring and piping, which explains the method of connecting up the compressor to run from a direct-current trolley circuit, either on a car or in a car station. The pamphlet also gives general directions for starting the compressor and a table of weights and dimensions of the different sizes of motor-driven reciprocating air pumps, manu-

factured by the Westinghouse Air-Brake Company. The pamphlet is in the usual tasteful style of the Westinghouse companies.

"Draft Without a Chimney" is the title of an interesting little booklet of which the fourth edition has just been issued by the B. F. Sturtevant Company, Boston, Mass. This brings the total number of copies printed up to 50,000. It relates to the experience of the Sturtevant Company, in the use of a fan to produce draft without a chimney in its own works. Copies will be furnished on application.

Rubber Goods.—The Boston Belting Company, of Boston, Mass., manufacturers of all kinds of vulcanized rubber goods, have just issued a little 12-page booklet illustrating and briefly describing various styles and shapes of corrugated and perforated mats and treads for all car and steamship purposes. This company also manufacture rubber hose for every service, together with packings in great variety, gaskets, valves, washers, rubber covered rollers and Eames vacuum brake diaphragms and car vestibule diaphragms.

The Works Management Number of the "Engineering Magazine" contains a collection of valuable articles, all of which concern the problems of successful management of large industrial enterprises. It opens with descriptions of such typical establishments as those of Armstrong, Krupp, Carnegie, Westinghouse and others, followed by no less than fifteen special articles bearing upon the organization and administration which have led to successful results. It is a treatise by the best authorities and cannot fail to exert a powerful influence for improvement upon those who read it, especially if they have responsibilities of their own in the direction of the work of others. The plan of this number and its execution compels admiration. We consider it a duty to our readers to advise them to procure and study these articles. It is a veritable guide-book to the organization, administration and equipment of present-day industrial establishments, including studies of men as well as materials. The address of the "Engineering Magazine" is 120 Liberty Street, New York.

Conveying Machinery.—The Jeffrey Manufacturing Company, Columbus, O., have just issued a new special illustrated catalogue and price-list of conveying machinery, which is a pamphlet of 96 pages of engravings, with accompanying brief descriptions. The first part contains illustrations of machinery in actual service representing a general line of conveyors, elevators, steel cable conveyors, carriers and labor-saving appliances for the lumber and wood-working industries. The latter part is taken up with chains, among which are transfer, steel thimble roller, haul-up, roller carrier, drag and standard detachable chains; also various attachments for these chains, together with lists of prices. These appliances, with slight modifications, are applicable to other classes of work and this company states that estimates and plans will be furnished upon application, together with complete working drawings. Also to those interested this special catalogue No. 57 can be had by addressing the Jeffrey Manufacturing Company, Columbus, O.

Science and Technology Annual.—This annual, a copy of which has just been received, is one gotten out by the students composing the Steam and Machine Design Association and Electrical Association of Pratt Institute, Brooklyn, and is devoted chiefly to the results of some of the regular laboratory work of the first and second-year students, together with papers which they have prepared and read at the regular meetings of the two associations. This volume, which is the first book of this kind attempted by the students, is intended for circulation among their own number and among former members of the associations. This book is interesting in that it shows, from the character of the papers presented and the manner of handling laboratory reports, what the students are able to accomplish in so short a time as two years, and with the comparatively low requirements for entrance. The alumni notes given in the back of the annual are also interesting, as showing the character of positions these students are able to command after graduating from this institution. One is impressed with the demand for such sensible schools as Pratt Institute.

The Sturtevant Engine is the title of a well-illustrated catalogue of steam engines and combined generating sets, built by the Sturtevant Company, Boston, Mass., for electric light plants and general high-grade work. Among the engines illustrated and briefly described are: Automatic engines, both upright and horizontal, including single-valve, double-valve, open and closed types, and compound engines; also automatic and throttling engines and generating sets. These engines represent a development of many years, along the line of simple and compact construction, with a refinement in speed regulation. The pamphlet also gives small diagrams of the various engines, together with a table of the principal dimensions.

The Ransome & Smith Co., manufacturers of concrete mixing mills and concrete appliances, Brooklyn, N. Y., are distributing a series of blotters, one side of which are finished smooth and contain an illustration of the Ransome's Patent Drum Mixer, together with a different testimonial on each blotter, from railroad men and users of their mixers. Mr. W. A. Rogers, Engineer, Bridge and Building Department of the Chicago, Milwaukee & St. Paul Railway, says: "With this the Ransome machine, the operation is under the observation and control of the operator at all times and mixing may be carried on as long as he desires. In the writer's opinion it is impossible to mix concrete any better than it is mixed by this machine."

History of the Britannia Tubular Bridge.—In this pamphlet is printed a paper on the celebrated Britannia Tubular Bridge, by Mr. Clement E. Stretton, Consulting Engineer, Sax-Coburg House, Leicester, England. This bridge, which carries the Chester and Holyhead Railway system over the Menai Straits, was completed and opened the 21st of October, 1850, and on the celebration of its jubilee, which was attained the 20th of October, 1900, this paper was presented by the author. Besides a full-page engraving, the paper gives a general description, together with an interesting history of the construction of the bridge.

The Brill Convertible Car.—The J. G. Brill Company, of Philadelphia, have fully described in their catalogue a new form of street car for use all the year round. It contains a number of full-page engravings made from photographs of cars of this kind recently built by them. These cars when closed are, in appearance, identical with the standard closed car, and when open the points of difference between them and the ordinary open car can hardly be detected. The distinctive features of the convertible car are shown by a number of half-tone engravings of cross-sections of the car and roof. The posts are of the ordinary pattern, bent at the lower part to conform to the curve of the car side, and carry the panels and windows as well as roller curtains. These are all concealed in a pocket in the roof, out of sight, and held in place by a sash lock. The panels, which are flexible, slide in grooves in the posts, and when lowered into position close the side of the car to the height of the ordinary window rail. When the panels have been let down, the sash, which is made in two parts, hinged together, is lowered into place. Among the important advantages of the convertible car, as given in the pamphlet, are the single equipment of bodies, trucks and motors, and the saving of capital, interest and depreciation.

EQUIPMENT AND MANUFACTURING NOTES.

Mr. Jos. H. Williamson, Business Manager of the Viennet Advertising Agency, has removed his New York office from No. 127 Duane Street to room No. 719, Temple Court, where he will be pleased to see his acquaintances.

The Missouri Pacific has placed an order with the American Car & Foundry Company for 2,500 of the latest design box cars, of 60,000 pounds capacity. These cars are to have all of the best and most up-to-date devices in railroad use, among which are specified the Shickle, Harrison & Howard Iron Company's cast steel, Player trucks and body bolsters.

The Q. & C. Company and the Railroad Supply Company have consolidated and will operate under the name of the Railroad Supply Company, with D. S. Wegg as Chairman of the Board and C. F. Quincy as President. The general offices will be in the Bedford Building, Chicago, and the New York office at 106 Liberty street.

Mr. O. M. Edwards, manufacturer of the Edwards Window Fixtures, Syracuse, N. Y., held an exhibition of his devices for opening and closing car windows, at the Imperial Hotel, New York City, January 17 and 18. Models of windows were shown with these fixtures in working order, and many points of advantage were made apparent by them. The principal features of the fixtures are a torsion roller balance for raising and lowering the window sash, a worm gear to regulate the tension of the roller, friction strips bearing against the sides of the sash to make tight joints and a double thumb catch used in operating the friction strips, which secures the sash when closed and in turn allows the sash to move upward when released. Besides these window fixtures, there was on exhibition the Edwards Wide Vestibule Extension Platform Trap Doors, which are being used successfully on a number of railroads for automatically opening the traps when the catch holding the door down, is released. Mr. Edwards' models are of superior workmanship and they give an immediate impression of simplicity, durability and general satisfaction with the devices.

The Richmond Locomotive and Machine Works have just received an order from the Wabash Railroad for 50 locomotives, of which 34 are to be 2-cylinder compound moguls, 6 will be 10-wheel passenger locomotives, 6 Atlantic type passenger locomotives, and 4 switching locomotives. The mogul engines will have 19-in. by 28-in. cylinders and 56-in. driving wheels; the weight of each engine in working order will be about 130,000 lbs., of which 110,000 lbs. are on the drivers and 20,000 lbs. on the truck; the boiler is 60 ins. in diameter with 2-in. tubes, 11 ft. 4½ ins. in length; the firebox will be 108 ins. long and 42½ ins. in width, and the tank capacity 5,000 gals.

The general dimensions of the 10-wheel passenger engines are: Cylinders, 19 ins. by 28 ins.; diameter of drivers, 66 ins.; weight of engine in working order, about 147,000 lbs.; weight on drivers, about 112,000 lbs., and on truck, about 35,000 lbs.; boiler, radial stay, 62 ins. in diameter; length of firebox, 120 ins., and width, 42½ ins., and tank capacity, 5,000 gals. The switching engines will have 18-in. by 24-in. cylinders; driving wheels, 44 ins. in diameter; weight on drivers about 102,000 lbs.; radial stay boiler 60 ins. in diameter with 2-in. tubes, 10 ft. 4½ ins. in length; firebox, 84 ins. long and 33½ ins. wide, and the tank a capacity of 3,000 gals.

With the beginning of the new century, work was started in the new boiler shops of the Babcock & Wilcox Company at Bayonne, N. J., where the company purchased thirty acres of land, having a frontage of 650 ft. on the Kill von Kull, with a depth of water 25 ft. on the pier line. These works are the largest of their kind in the world. The buildings so far completed have a floor area of about 160,000 sq. ft., to which will be added at once buildings of approximately 40,000 sq. ft. floor area. The plant is equipped throughout with special tools and has been designed with the greatest care to expedite the processes of manufacture by reducing to the last degree the needless handling of material and by the use of the most approved appliances. The works of the company have hitherto been located at Elizabethport, N. J., but the growth of the business in later years made necessary an increase in productive capacity and in 1899 the company decided to build the new works now nearing completion. The site chosen is an ideal one. So large a tract of land with as desirable a water frontage close to New York City is exceedingly difficult to obtain. It consists wholly of solid ground, no piling having been used for either the buildings or the heavy foundations required for the machinery installed. A spur track from the Central Railroad of New Jersey enters the property, so that the company enjoys the best of facilities for shipping both by rail and water. The famous water-tube boilers manufactured by The Babcock & Wilcox Company have a world-wide reputation. The success of the water-tube boiler dates from the first boilers of their manufacture. In addition to the enormous business which they are doing in stationary boilers the company have in the last few years entered into the manufacture of marine water tube boilers which are now extensively used in the United States Navy, are being introduced in the British Navy and are very widely used in the merchant marine.

AMERICAN ENGINEER AND RAILROAD JOURNAL.

MARCH, 1901.

CONTENTS.

ILLUSTRATED ARTICLES:	Page	ARTICLES NOT ILLUSTRATED:	Page
New Class "J" Passenger Locomotive, L. S. & M. S. Ry.	63	Locomotive Traction Increases.	82
New Car Shops, N. Y., N. H. & H. R. R.	73	Air Brake "Skipping" Tests	84
Compound Consolidation Freight Locomotives with Wide Firebox N. Y. C. & H. R. R.	83	Electric Power Transmission	88
Busy Man's Filing System	85	Freight Car Paint	89
30-Ton Hopper Coke Cars, C. & O. R. R.	88	Ratios of Total Weight to Heating Surface in Recent Locomotives	89
Comparative Structure Gauges, Oil-Burning Switching Locomotive, D. L. & W. R. R.	91	Master Mechanics' Association Scholarships	91
The "Handy" Combination Box and Gondola Car	93	Good Use of the Technical Papers	95
Large Gas Engine in Important Service	94	Combination Triangles for Draftsmen	97
Variable Exhaust Nozzle for Locomotives	95	Porous Emery Wheels	98
Throttle Valve Taking Steam from the Top of the Dome.	96	EDITORIALS:	
A "Stunt Nut" for Screwing in Stavebolts	96	New Quarters for the American Society of Mechanical Engineers	86
Friction Sensitive Drill Press	97	Horizontal Increase in Wages	86
Reversing Tap Holder	97	Master Mechanics' Association Scholarships	86
		Three Recent Passenger Locomotives	86
		The Fate of a Draftsman	87

THE NEW CLASS "J" PASSENGER LOCOMOTIVE of the LAKE SHORE & MICHIGAN SOUTHERN RAILWAY.

Designed by W. H. Marshall, Superintendent of Motive Power.

Built by the Brooks Locomotive Works.

(With an Inset.)

We are privileged in this issue to illustrate the new passenger locomotives just completed by the Brooks Locomotive Works for the Lake Shore & Michigan Southern Railway. They were designed by Mr. W. H. Marshall, Superintendent of Motive Power of the road, and represent his views as to what is needed to meet the demands of heavy and fast passenger service. The chief aim was to secure ample power, with a reserve for emergencies, in an engine carefully designed to avoid breakdowns.

The design is bold, not in the use of uncertain factors, but in the assembling of such features as 3,343 sq. ft. of heating surface, 48½ sq. ft. of grate area, 19-ft. tubes, 20½ by 28-in. cylinders, with six coupled driving wheels 80 ins. in diameter, a pony leading truck, radial trailers and piston valves. These are skilfully combined in the handsome locomotive illustrated in the inset accompanying this issue. It gives no suggestion of the unusual factors employed—these are concealed in the symmetrical arrangement. The desire to secure a symmetrical and attractive result led to the preparation of a perspective drawing of the engine before the work was started, in order to permit of choosing harmonious proportions whenever a choice was possible. A modern passenger locomotive is thoroughly worthy of such efforts.

In the matter of large boiler capacity this engine and that of the New York Central, illustrated last month, are nearly alike, but the Lake Shore engine stands for six coupled wheels and great tractive weight available all the time and the other for four coupled wheels with additional tractive weight applied only in starting.

The basis for the new Lake Shore design was the 10-wheel, type which has been very successful on this road (American Engineer, November, 1899, page 344), for over a year. These 10-wheel engines have averaged more than 100,000 miles of

service during their first year. It was necessary to build more engines, and this offered an opportunity to considerably increase the facilities for dealing with heavy trains and secure additional reserve capacity for cold and stormy weather, accidental delays and slippery rails. The total weight was limited, and this made the problem the more difficult, necessitating extensive use of cast steel and the design of many special details for the elimination of unnecessary weight. This weight saving was very skilfully done, and the result is 52.18 lbs. of total weight per square foot of heating surface, a remarkably low figure, as the table elsewhere in this issue indicates.

The boiler is long, with a conical wagon top and sloping throat sheet and back head. It was made to fit the driving wheels, for which there was no spare room. There is but one fire door opening, but that has two doors, one opening in the



New Class "J" Passenger Locomotive.
L. S. & M. S. Railway.

other, the small one being used for firing and both being opened for cleaning fires and for access for repairs. The smaller door is 19 by 11 ins.

No special or unusual precautions were taken in the use of 19-ft. tubes; they were made of No. 11 gauge, and 2¼ ins. in diameter for the sake of stiffness. With piston valves the single deep bar front frame section brings the stresses in a direct line with the driving boxes. The front frame brace and spindle guide is of cast steel, well ribbed. At the back ends the frames again take the slab form and are well tied together by the cast-steel foot plate, in which the plate, ribs and flanges are of about the same thickness, large bunches of metal being avoided to prevent cracked castings. The cab brackets are thin plates held between two channels at the rear face of the foot plate. The boiler is supported at the firebox by two plates secured to 5-in. lugs 38 ins. long welded on the front and back of the mud ring. The one at the back head is bolted to the front face of

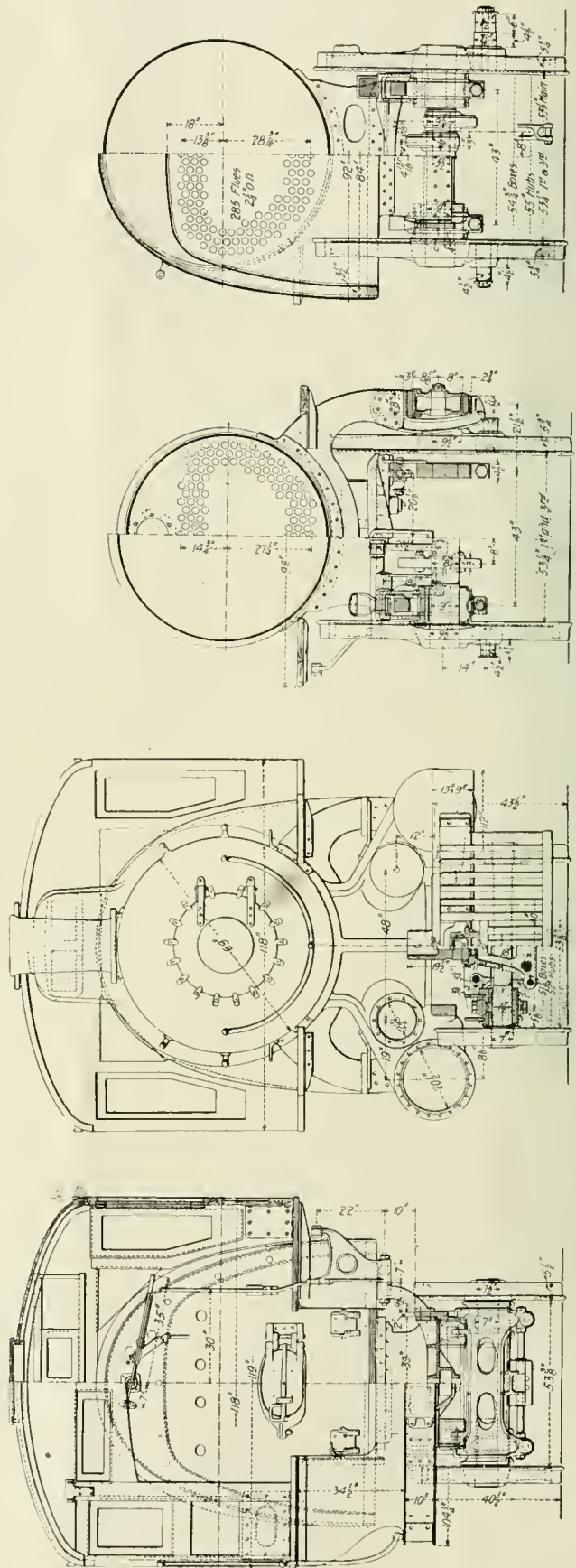
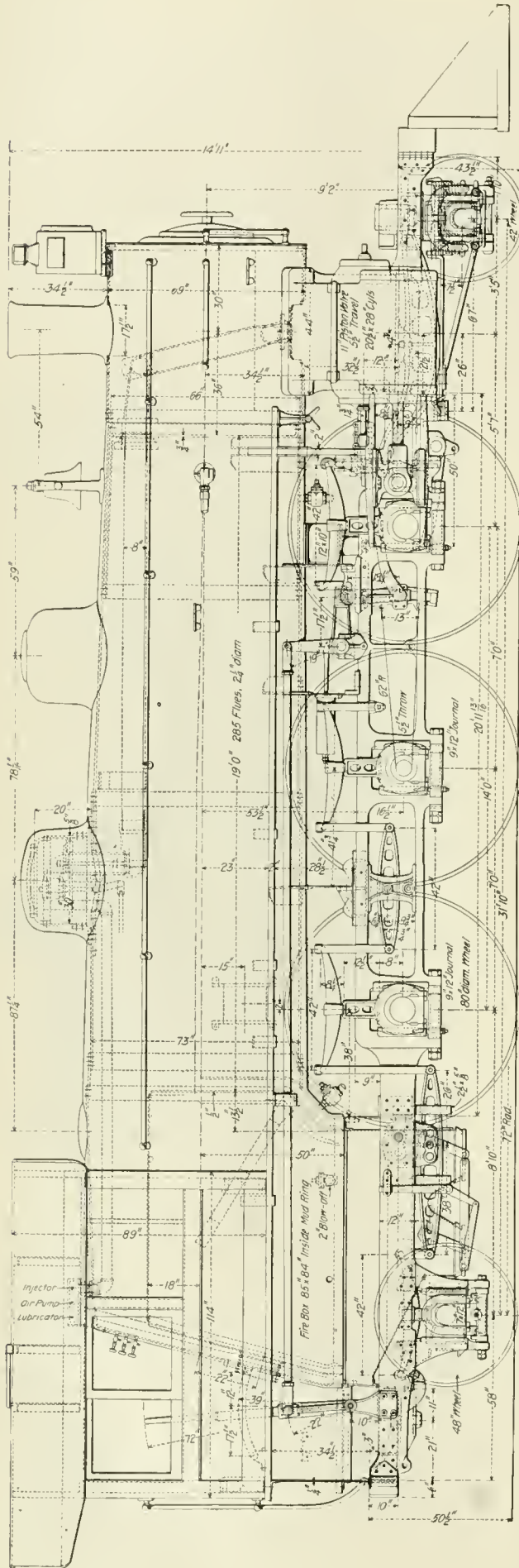

Class "J" Passenger Locomotive—Lake Shore & Michigan Southern Railway.

W. H. MARSHALL, Superintendent Motive Power.

BROOKS LOCOMOTIVE WORKS, Builders.

the foot plate, while that at the front end is carried by a cross-bar secured between the frames. These plates are free to bend to provide for expansion. There are no other furnace bearers. There are three waist sheets extending between the frames and boiler, so that, including the cylinder saddle, these parts are tied together in six places. It will be seen that these supports brace the frames at every point where the spring rigging transmits stresses to them.

The guide yoke has an unusual shape, as shown in the detail drawings. It curves under the boiler and drops outside the driving wheels in another curve, at the bottom of which is a cast-steel yoke to carry the guides. These are flat, with a long overhang, best seen in the photograph. This was a particularly difficult detail which was admirably worked out.

The driving wheels are from the same patterns as used for the large ten-wheeled engines already referred to, but slight changes were made to effect a saving in weight; these and the truck and trailer wheels all have thin spokes and look particularly light and neat. Brakes are applied only to the driving wheels, the cylinders being back of the forward axle with the cylinder levers fulcrumed in bosses on the lower faces of the frames. Everywhere weight was minimized and where possible castings were made to serve more than one purpose. The link hanger bearings, brackets for the boiler brace, back of the guide yoke, and spring hanger bearings for the front driving springs are combined in a single steel casting. The grate bearers are of pressed steel, making a packed joint with the firebox sheets and supporting also the ash pan.

Rather short main rods were necessitated by the position of the main wheels, but the ratio is 1 to 7. Piston valves with inside admission required a direct valve motion. This employs a cross head and guide bar instead of return rocker arms, a motion bar being used between the link blocks and the valve stem. The angle of this bar is not great, and the motion is very compact. It was used on the recent 10-wheel piston-valve engines of this road. The valves have L-shaped packing rings and extended valve stems. With a view of reducing the obstruction of the passage of the steam the bridges in the ports of the bushings are made narrow, as shown in the engravings. This and 5/8-in. nozzles ought to help in the matter of back pressure which is becoming manifestly important with high horse power.

The weights of the engine are as follows:

Weight on front truck.....	21,500 lbs.
Weight on drivers.....	130,000 lbs.
Weight on trailing wheels.....	23,000 lbs.
Weight, total.....	174,500 lbs.

It is, therefore, lighter than the New York Central engines, and yet the total heating surface is but 162 sq. ft. less. In order to permit of changing the distribution of weight three holes are provided for the fulcrum pins of the truck and trailer equalizers, and by changing them more or less weight as desired may be transferred from the carrying wheels to the drivers.

A part of the symmetry of outline is due to the large cab. It is surprisingly roomy, being 9 ft. 6 ins. long and 9 ft. 11 ins. wide over all, the firebox projects but 2 ft. from its front end. The curved sides of the firebox also contribute to the good appearance. The driving wheels have but 1 1/2-in. clearance between flanges and the front pair are very close to the cylinders. There was sufficient room for a pony truck in front, but not at the rear because of the ash pan. This required a radial truck as an inside journal truck was desired. The whole back end of the engine is clear and free from a heavy appearance. This radial truck gives a lateral motion of 3/4 ins. each side. The total wheel base is 31 ft. 10 ins., the longest we have on record.

Radial trucks have been used extensively abroad, they seem to offer special advantages for trailing wheels under fireboxes. A patent has been applied for upon the form used in this case, and in the recent "Chautauqua" type engines by the Brooks works, and shown in the accompanying engraving. The frame of this truck is cast steel and the boxes are malleable iron.

The boxes have spring cellars and a strong spring centering device. The wear from the load upon the ends of the radial casting is taken by case-hardened iron plates. This truck is simple and compact. We desire to draw the attention of our readers especially to this feature of the engine. It appears to curve easily and to promise very satisfactory service for this location, under the firebox. There is also good reason to be-

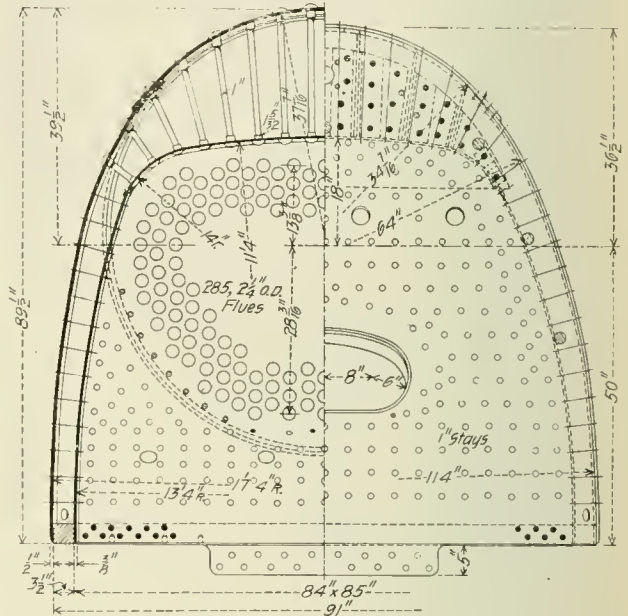

Section and Elevation of Firebox.

lieve it equally promising for the front ends of engines to replace pony trucks.

The following table gives some particulars regarding the valve setting. The saddle pins are offset 23/32 in. back and the link radius is 62 ins.

	Front.	Back.
Lead in full gear	0 in.	1/2 in.
Lead (front, 6 in.; back, 8 in.).....	3/8 in.	3/2 in.
Port opening (front, 6 in.; back, 8 in.).....	1 1/2 in.	3/8 in.
Preadmission	1 3/4 in.	3/8 in.
Exhaust opens (front, 6 in.; back, 8 in.).....	17 in.	18 1/2 in.
Cut-off, full gear.....	23 1/8 in.	23 7/8 in.

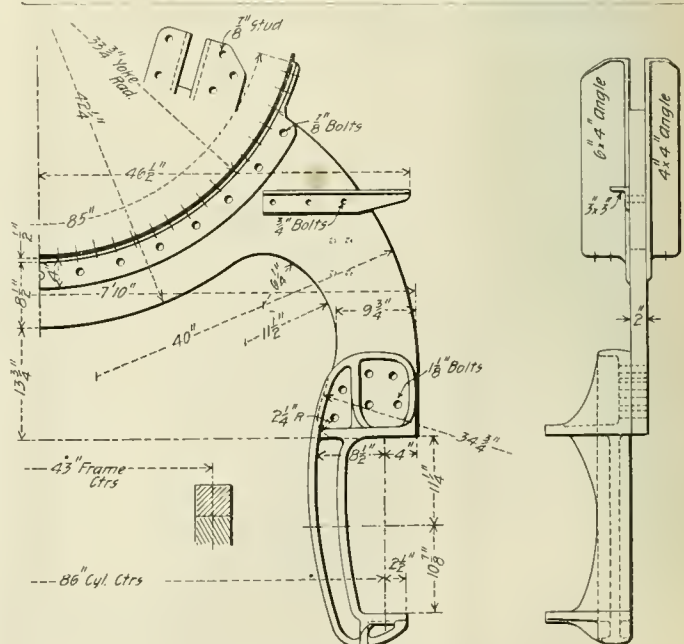

Guide Yoke. Independent of Frames.

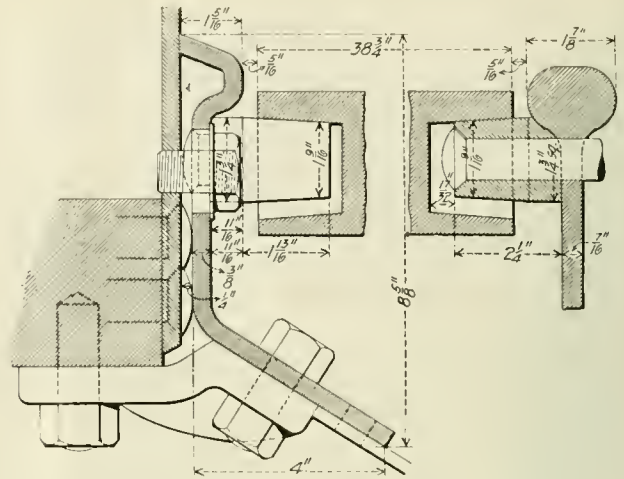
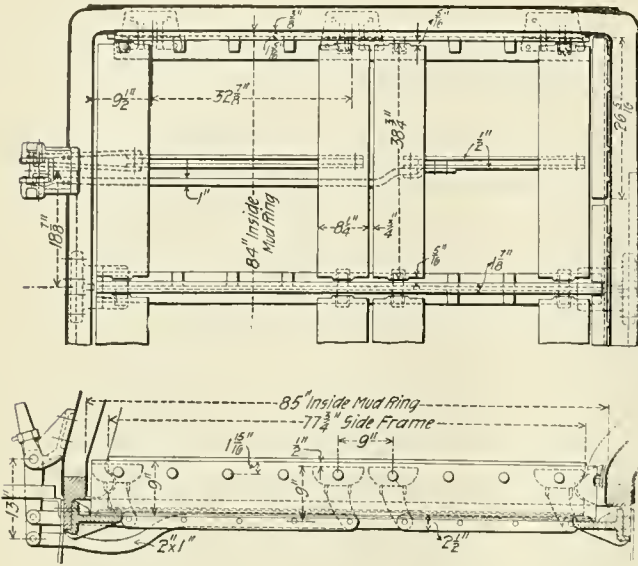

Details of Grate and Ash Pan Bearers—Pressed Steel.

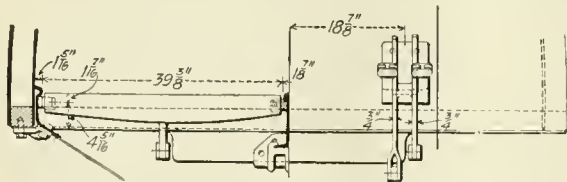

Arrangement of Grates.

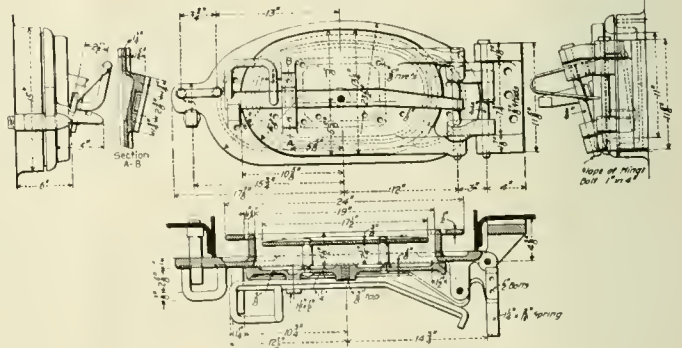

Fire Door.

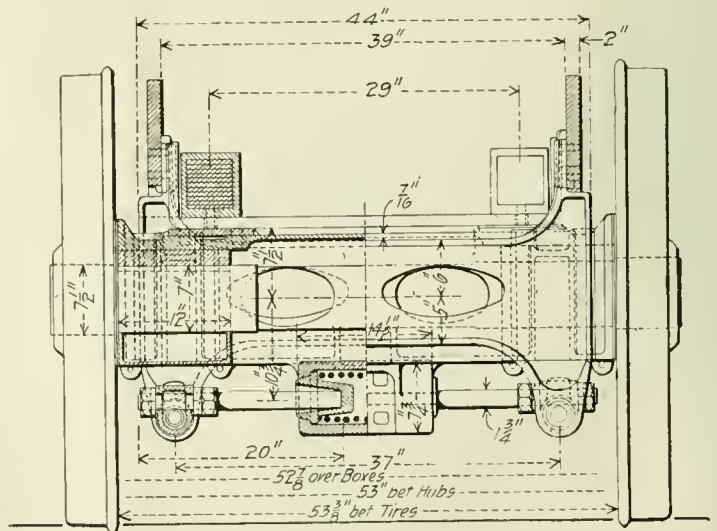
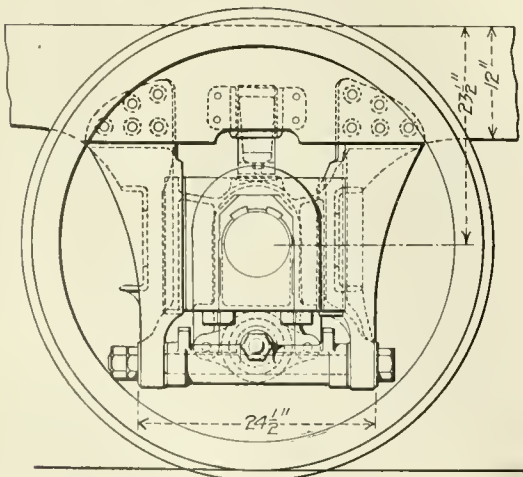
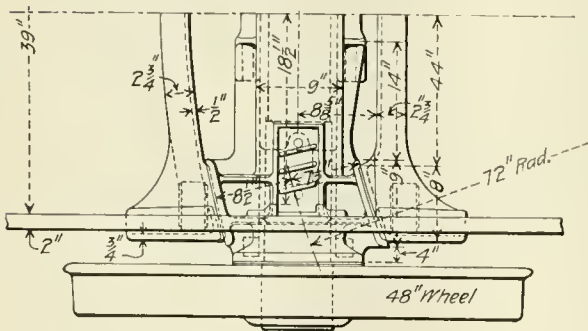

Radial Trailer Truck.

Class "J" Passenger Locomotive—Lake Shore & Michigan Southern Railway.

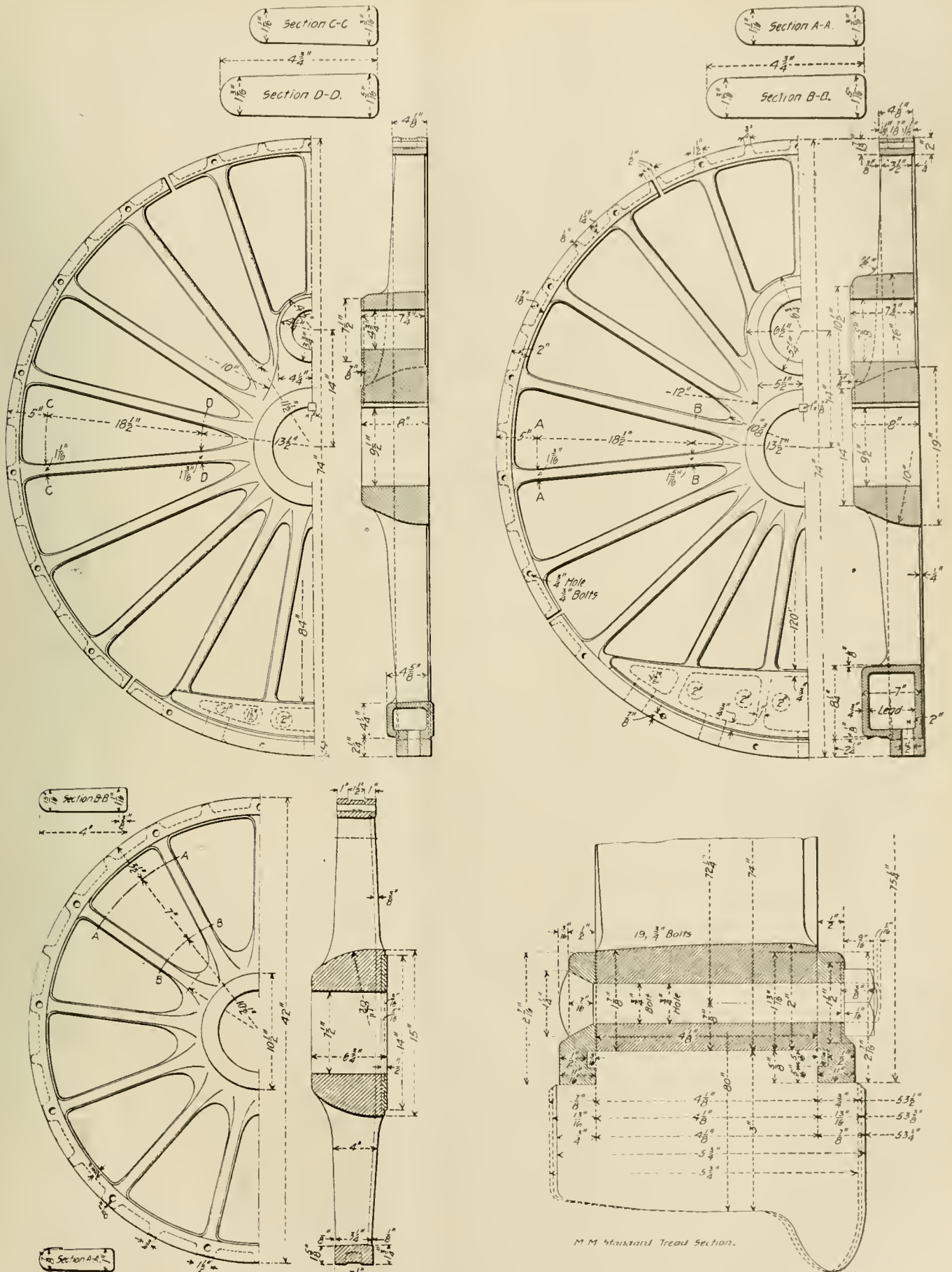

Cast Steel Driving and Truck Wheels.

Class "J" Passenger Locomotive—Lake Shore & Michigan Southern Railway.

Measurements of Valve Motion.

Admission	Internal
Valve travel51 $\frac{1}{2}$ ins.
Eccentric throw51 $\frac{1}{2}$ ins.
Lap1 $\frac{1}{8}$ ins.
Exhaust clearance62 ins.
Link radius62 $\frac{3}{4}$ ins.
Link center13 ins.
Lift of link1 $\frac{1}{2}$ ins.
Slip of link23 $\frac{3}{32}$ in.
Saddle offset	

Position.	Pre-admission.		Lead.		Port opening.		Cut-off.		Release		Closure.	
	F.	B.	F.	B.	F.	B.	F.	B.	F.	B.	F.	
Forw'd } Full gear... 0	0	0	0	1 $\frac{3}{4}$	1 $\frac{1}{2}$	23 $\frac{3}{4}$	23 $\frac{3}{4}$	26 $\frac{3}{8}$	26 $\frac{3}{8}$	17	5 $\frac{5}{8}$	8 $\frac{1}{2}$
motion. } 5-in. notch. 1 $\frac{3}{8}$	1 $\frac{3}{8}$	3 $\frac{3}{8}$	3 $\frac{3}{8}$	3 $\frac{3}{8}$	3 $\frac{3}{8}$	6	6	16 $\frac{3}{4}$	16 $\frac{3}{4}$	17	5 $\frac{5}{8}$	8 $\frac{1}{2}$
			Pos.									
Back } Full gear... 0	0	0	3 $\frac{3}{8}$	3 $\frac{3}{8}$	1 $\frac{1}{8}$	11 $\frac{1}{2}$	23 $\frac{3}{4}$	22 $\frac{3}{4}$	26 $\frac{3}{4}$	26	1 $\frac{3}{4}$	1 $\frac{3}{4}$
motion. } 8-in. notch. 7 $\frac{3}{8}$	7 $\frac{3}{8}$	7 $\frac{3}{8}$	3 $\frac{3}{8}$	3 $\frac{3}{8}$	3 $\frac{3}{8}$	3 $\frac{3}{8}$	8	8	18 $\frac{3}{4}$	18 $\frac{3}{4}$	7 $\frac{3}{8}$	7 $\frac{3}{8}$

As worthy of special mention we would call attention to the unusually large number of details made of cast steel even for these days when this material is extensively used. Even the equalizers are made of cast steel and altogether about 28,000 lbs. of this material is used in the engine. In fact, there is very little cast iron exclusive of the cylinders and grates. We would also call attention to the enlarged wheel fits for all axles and crank pins, and the care with which the frames have been braced to the boiler at all points where it receives direct vertical stresses. Many of the details, such as truck and driving boxes, shoes, wedges, pedestals, cross heads, eccentrics, eccentric straps, valves, cylinders, etc., are the same as in the 10-wheel passenger engines. The ashpan is provided with drop bottoms and has no dampers, the air openings being covered with netting. The front end is self-cleaning and has no spark hopper. The diaphragm is placed in front of the nozzles. The firebox is lagged all over. Plate gusset bracing is used for the back head and front tube sheet of the boiler. The springs are made up of very wide plates; those for the driving springs being 6 ins. and those for the trailing springs being 5 ins. in width. The tires are set as follows:

	Distance between flanges.
Wheels.	
First and third	53 $\frac{3}{8}$ ins.
Main wheels	53 $\frac{3}{8}$ ins.
Trailers	53 $\frac{3}{8}$ ins.
Truck	53 $\frac{3}{8}$ ins.

These engines will be expected to haul trains weighing from 350 to 650 tons between Buffalo and Cleveland on schedules varying from 4 hours and 15 minutes to 4 hours and 30 minutes and making four stops in a distance of 183 miles. It might be stated in explanation that none of the trains are scheduled to consist of more than 10 cars regularly, but they are frequently given additional cars so that 12 or 13 cars are not unusual in winter, and in summer trains scheduled to make the division in 4 $\frac{1}{2}$ hours have contained 15 cars and weighed 640 tons. A slow train having a schedule of 6 hours and 15 minutes, and making 22 stops, has several times had 16 cars and once was composed of 18 cars. Of course, these exceptionally large trains are unusual, but in designing these engines the idea has been to provide ample power for everyday conditions and also to be able to take such occasional trains without dividing them into two sections. One of the 10-wheel engines, already referred to, has made up in January weather 35 minutes on the 40-mile schedule of 183 miles with a train of 550 tons. It is evident that the large amount of tractive weight is important under these conditions.

The tenders are made to bring down the coal to the fireman, the slopes being carried to the front where they narrow to the coal gate. They are carried on the Brooks design of tender truck of the arch-bar type, which are noteworthy for strength. The tenders are fitted with the water scoop designed by Mr. H. F. Ball, Mechanical Engineer of the road. The details of construction were presented in our November number, 1900, page 344. This is operated by compressed air.

Two of these engines have been completed, to be followed by

11 more from the same drawings. The principal dimensions are summed up in the following table:

CLASS "J" PASSENGER LOCOMOTIVE.
Lake Shore & Michigan Southern Ry.
Description.

Gauge	4 ft. 8 $\frac{1}{2}$ ins.
Kind of fuel to be used	Bituminous coal
Weight on drivers	130,000 lbs.
Weight on truck	21,500 lbs.
Weight on trailing wheels	23,000 lbs.
Weight, total	174,500 lbs.
Weight of tender, loaded	118,000 lbs.
Wheel base, total of engine	31 ft. 10 ins.
Wheel base, driving	14 ft. 0 in.
Wheel base, total, engine and tender	57 ft. 3 $\frac{3}{4}$ ins.
Length over all, engine	43 ft. 5 ins.
Length over all, total engine and tender	65 ft. 10 $\frac{3}{8}$ ins.
Height, center of boiler above rail	9 ft. 2 ins.
Height of stack above rails	14 ft. 11 ins.
Heating surface, firebox	174 sq. ft.
Heating surface, tubes	3,169 sq. ft.
Heating surface, total	3,343 sq. ft.
Grate area	48.5 sq. ft.
Wheels, leading, diameter	42 ins.
Wheels, driving, diameter	80 ins.
Wheels, trailing, diameter	48 ins.
Material of wheel centers	All cast steel
Type of leading wheels	Two-wheel bogie
Type of trailing wheels	Radial axle
Journals, leading axle	6 $\frac{1}{2}$ ins. by 12 ins.
Wheel fit, leading axle	7 ins.
Journals, driving axle	9 ins. by 12 ins.
Wheel fit, driving axle	9 $\frac{1}{2}$ ins.
Journals, trailing axle	7 ins. by 12 ins.
Wheel fit, trailing axle	7 $\frac{1}{2}$ ins.
Cylinder, diameter	20 $\frac{1}{2}$ ins.
Cylinder stroke	28 ins.
Piston rod, diameter	3 $\frac{3}{8}$ ins.
Main rod length, center to center	99 ins.
Steam ports, length	26 $\frac{1}{2}$ ins.
Steam ports, width	2 ins.
Exhaust ports, least area	75 sq. ins.
Bridge, width	3 ins.
Valves, kind of	Piston
Valves, greatest travel	5 $\frac{1}{2}$ ins.
Valves, steam lap, (inside)	1 $\frac{1}{8}$ ins.
Valves, exhaust clearance (outside)	1 $\frac{1}{8}$ in.
Lead in full gear	Line and line in forward gear
Boiler, type of	Extended wagon top
Boiler, working steam pressure	200 lbs.
Boiler, material in barrel	Steel
Boiler, thickness of material in shell	$\frac{3}{8}$ in., 11/16 in., $\frac{3}{4}$ in., 9/16 in., $\frac{1}{2}$ in.
Boiler, thickness of tube sheet	3/4 in.
Boiler, diameter of barrel, front	66 ins.
Boiler, diameter of barrel at throat	73 ins.
Seams, kind of horizontal	Sextuple
Seams, kind of circumferential	Double and triple
Crown sheet, stayed with	Radial stays
Dome, diameter inside	30 ins.
Firebox, length	85 ins.
Firebox, width	84 ins.
Firebox, depth, front	68 ins.
Firebox, depth, back	68 ins.
Firebox, material	Steel
Firebox, thickness of sheets	Crown, $\frac{3}{8}$ in.; tube, $\frac{1}{2}$ in., side and back, $\frac{3}{8}$ in.
Firebox, brick arch	On water tubes
Firebox, mud ring, width	Back and side, 3 $\frac{1}{2}$ ins.; front, 4 ins.
Firebox, water space at top	Back, 4 $\frac{1}{2}$ ins.; sides, 5 ins.
Grates, kind of	Cast iron, rocking
Tubes, number of	285
Tubes, material	Charcoal iron
Tubes, outside diameter	2 $\frac{1}{4}$ ins.
Tubes, thickness	No. 11 B. W. G.
Tubes, length over tube sheets	19 ft. 0 in.
Smokebox, diameter outside	69 ins.
Smokebox, length from tube sheets	66 ins.
Exhaust nozzle, single or double	Single
Exhaust nozzle, variable or permanent	Permanent
Exhaust nozzle, diameter	5 $\frac{3}{8}$ ins.
Exhaust nozzle, distance of tip below center of boiler	4 ins.
Netting, wire or plate	Wire
Netting, size of mesh or perforations	2 $\frac{1}{2}$ by 2 $\frac{1}{2}$ per inch
Stack, straight or taper	Cast iron taper
Stack, least diameter	15 ins.
Stack, greatest diameter	16 $\frac{3}{8}$ ins.
Stack, height above smokebox	34 $\frac{1}{2}$ ins.
Tender.	
Type	8-wheel steel frame
Tank, type	U-shape
Tank, capacity for water	6,000 gals.
Tank, capacity for coal	11 tons
Tank, material	Steel
Tank, thickness of sheets	$\frac{1}{4}$ in.
Type of under frame	Steel channel
Type of springs	Triple elliptic
Diameter of wheels	36 ins.
Diameter and length of journals	5 $\frac{1}{2}$ ins. by 10 ins.
Distance between centers of journals	5 ft. 6 ins.
Diameter of wheel fit on axle	6 $\frac{7}{8}$ ins.
Diameter of center of axle	5 $\frac{7}{8}$ ins.
Length of tender over bumper beams	21 ft. 10 $\frac{1}{2}$ ins.
Length of tank inside	20 ft. 4 ins.
Width of tank inside	9 ft. 10 ins.
Height of tank, not including collar	60 ins.
Type of draw gear	M. C. B. coupler
Special Equipment.	
Brakes	American for drivers; Westinghouse for tender and train service
Pump	9 $\frac{1}{2}$ ins. Nathan
Sight feed lubricator	Ashton
Safety valves	Hancock
Injectors	French
Springs	Brooks Locomotive Works
Metallic packing valve stems	

An indication of the strong hold of the wide firebox upon the design of locomotives for soft coal was noticed recently in a visit to the Schenectady Locomotive Works. Fourteen out of seventeen tracks in the erecting shop were occupied by locomotives with wide fireboxes, the wide firebox engines were for four different orders, and entirely different designs.

Pulverized coal appears to have some exceedingly favorable characteristics for use as boiler fuel and prevailing high prices of oil have occasioned a number of experiments in its use in small forge shop furnaces. We have also seen rather remarkable reports of tests with it in the firebox of a locomotive. It is necessary to grind the coal to an exceedingly fine state, and as it is unsafe to store it at all the grinding must be done at the furnace as the fuel is required. The coal need not be dry. When the conditions are as they should be the combustion seems to be perfect and the heat intense. The most successful and extensive use of this fuel is in the manufacture of cement.

That exceedingly economical power production may be had with steam is well known, but that the economy of the gas engine is nearly approached by the Allis pumping engine at the Chestnut Hill pumping station of the city of Boston is brought out by "Engineering News." This engine is a triple-expansion, running at 17.2 revolutions per minute, the coal consumption being 1.062 lbs. per indicated horse-power per hour. This is believed to be the lowest coal consumption ever attained by a stationary steam plant.

The trouble which has developed from the new round bottomed M. C. B. standard journal boxes illustrates the necessity for special care in the adoption of standards in order to guard against the inconvenience of changes. It appears that in some quarters the waste used as packing for the boxes with semi-circular bottoms has been moved hoidly by the journals to the extent of cutting off the lubrication. A few projections from the casting seem to remedy the difficulty, but it seems unfortunate that this should have escaped attention in the original design.

Mr. Godfrey W. Rhodes, Assistant General Superintendent of the B. & M. R. R., delivered on Thursday, January 24th, an address before the engineering students of Purdue University. His subject was "The Burlington Brake Tests." He first described the various changes which step by step have led from the hand brake to the present high-speed brake, and briefly discussed their significance. After referring to the extent and character of the Burlington tests, he emphasized the fact that every brake which on that occasion was subjected to test had been pronounced unsatisfactory by the committee, and that all have since disappeared from service. It was worthy of note that no one had complained or had found fault with the committee because of its conclusions. Those whose apparatus had given most promise found in the results facts which served to give new ideals and to lift their practice to higher planes. The Burlington tests proved the impracticability of the buffer brakes and disclosed serious defects in the automatic air brake which at that time was in its early stages of development. The work, he said, had profited by the association of a large number of persons who were concerned in planning its details and in the final execution of the tests, the credit for the results being shared by from thirty to fifty people. The modesty with which the speaker referred to the difficulties encountered, and to the far-reaching effect of the results obtained, aroused but slight suspicion in the minds of the student audience that he was the leader in the great work he described.

Electric street cars have been known to become stalled for lack of current when upon the crossings of steam roads with a frequency which has excited curiosity as to the cause and not a little alarm as to the possible consequences. A reasonable explanation is offered by Mr. A. A. Knudson in a report upon electrolysis in Reading, Pa., which is printed in the "Engineering Record." Mr. Knudson found one particular crossing in that city to be deficient, if not altogether lacking, in the bonding of the rails. If the bonding is deficient the ground must be depended on for the return, and if that is dry the car may become stalled on what is practically an open circuit. It is evidently of the utmost importance that the rails and crossing frogs should be particularly well bonded in such cases.

A method of testing the springs of indicators by direct weighing is recorded by Mr. G. Duchesne in the "Revue de Mecanique." Mr. Duchesne was formerly associated with Professor Dwelshauvers-Dery. He recommends exposing the indicator to the heat action of the steam long enough to heat it thoroughly. The instrument is then secured by a clamp in an inverted position, so that a rod could be rested upon the piston. Weights were added in equal increments to the rod and the effect upon the spring taken on the paper. The action in increasing and decreasing the load was measured and the recovery of the spring ascertained. This appears to be a very satisfactory and an easy way to test indicator springs. It also has the advantage of eliminating errors which may be introduced by the pencil mechanism.

The most extensive superheating plant in the world has been completed by the Aachen Mining Company, at their Rothe Erde Works. Forty-two Schwoerer's super-heaters have been installed in the flues connected with a similar number of Cornish double-flued boilers having aggregate heating surface of 47,363 sq. ft. Super-heaters of the same type are also applied to a second group of twenty-four Cornish boilers, with a heating surface of 26,910 sq. ft. Very careful tests, extending over three years of day and night working, have shown the saving in fuel by the use of this plant to be from 15 to 20 per cent., coal being delivered at the works for less than \$2.20 per ton. An interesting fact in connection with the plant is that in a distance of 1,050 ft. traversed by the steam through a 24-in. pipe, a loss of only 1° C. for each 42 ft. of pipe was found.

An account is given in the "Bulletin de la Societe d'Encouragement pour l'Industrie Nationale," of an apparatus, the invention of the author and Mr. Vinsonneau, for the examination of boiler tubes. By reference to diagrams the construction and use of the apparatus is explained. It consists of a tube fixed at right angles in a chamber provided with a magnifying eye-piece. At the further end of the inspection tube, which is capable of being drawn out to suit the length of the boiler tube under examination, is an incandescent electric lamp, and an angular plane reflector which transmits the rays to a reflector inclined at a similar angle under the eye-piece. The tube in process of inspection is fixed in a traveling carrier, which permits every part of it to be examined in turn. The carrier is provided for this purpose with both a horizontal and a rotary movement. The present apparatus is designed for tubes of 6.56 ft. in length by 1½ in. in diameter, but the same principle can be applied to tubes of larger size and greater length. An apparatus for use in the case of tubes in situ has also been devised, and, by reference to a diagram, a method of employing the apparatus for the examination of the exterior surfaces of tubes is explained. It is stated that this invention has proved very satisfactory in use, and that it has often revealed defects in the interior of tubes which externally presented every appearance of soundness.—[Inst. C. E. Abstracts.]

NEW CAR SHOPS.

New York, New Haven & Hartford Railroad,

At Readville, Mass.

Details of the Buildings.

(For General Plan see American Engineer, February, 1901, page 41.)

This large shop plant, of which the buildings alone cover $8\frac{1}{2}$ acres of ground, and where 1,000 men will be employed, was described last month by aid of a ground plan. The accompanying engravings illustrate the chief details of the buildings, except the power house; this department and the machinery will be reserved for another article. Most of the principal buildings are shown in section and plan, in order to clearly indicate the methods of construction and avoid the necessity of an extended description.

Roofs.

Yellow pine is used throughout for the roof trusses. This is done because of the saving of expense, which, with so many large roofs, amounts to a large sum. The columns are also of yellow pine, except those supporting the second-story floor at the ends of the paint and erecting shops and in the mill, which are cast iron. The roof boards are white pine of varying thicknesses as shown on the plans. The two-story portions of the paint and erecting shops and the storehouse have slate roofs, all the other roofs are covered with Eastern Granite Roofing. For the slate roofs the gutters are of white pine covered with copper, the other gutters being formed in the roofing material. All the leaders are of 4-in. galvanized iron connecting with cast-iron stand-pipes 6 ft. high from the ground. The skylights are glazed with $\frac{1}{4}$ -in. rough plate glass. The roofing referred to above is the Asphalt Perfected Granite Roofing of the Eastern Granite Roofing Co.

Floors.

For the paint, erecting, iron machinery, truck, piping, cabinet and freight shops, also the mill, the floors are of 12 ins. of broken stone covered with 4 ins. of hydraulic cement concrete and topped with 2 ins. of Portland cement. The concrete is 2 parts sand, 1 part cement and 4 parts of stone that will pass a 2-in. ring. The Portland cement on top is 2 parts sand to 1 part cement and 4 parts stone that will pass a $\frac{1}{2}$ -in. ring. The top surfaces of the floors were floated off with neat Portland cement. The storehouse floor is laid on natural earth. It has 6 ins. of concrete and 1 in. of cement, in which spruce strips are laid at 2 ft. 6 in. centers. These strips are 2 ins. wide on top by 3 ins. on the bottom and $1\frac{1}{2}$ ins. thick. On these strips a 2-in. hard pine floor is nailed. In the fireproof storeroom at the end of the storehouse the floor is finished with 1 in. of Portland cement mortar instead of wood. The mill floor is of 3-in. hard pine planks laid on 6 x 6-in. timbers spaced at 24-in. centers and bedded in cinders 12 ins. deep. The cabinet shop floor is like that of the storehouse, while the power house and oil house floors are of concrete 6 ins. thick with a surface of cement 1 in. thick. In the office portion of the storehouse the floors are $\frac{7}{8}$ -in. spruce overlaid with $\frac{3}{8}$ -in. yellow pine, with one thickness of "salamander" between the floors, extending under all partitions. The floor joists are of yellow pine and are built 6 ins. into the walls and have double rows of cross bridging every 5 ft.

Painting.

All exterior exposed surfaces requiring paint have three coats of lead and oil, all tin on the roofs has a priming coat of B. P. S. "Nobrac" black paint, a second coat of "Nobrac" brown and a third coat of the same paint, black. The leaders are also painted with this brand.

Plumbing and Toilet Rooms.

This part of the work is thoroughly planned and a noteworthy feature. The wash basins are of cast iron, lined with

white enamel. The plumbing is required to conform in every respect to the building laws of the city of Boston.

Wire-work lockers, 12 x 12 ins. by 5 ft. 6 ins. high, sufficient for every workman in the entire plant are a feature of the toilet rooms, which will, without doubt, be appreciated. One of the engravings illustrates the most elaborate of these toilet rooms in connection with the erecting shop and associated departments. There are 186 lockers in this group, and each man has an individual key. The plans show their distribution, also the toilet facilities in the other buildings and their somewhat novel locations.

Heating and Ventilating.

Direct steam will be used for heating the office, storehouse, freight-car shop and oil house, the other buildings requiring heat being supplied by the fan system, using exhaust steam from the power house. The paint shop will have ducts for hot air and ventilation under the floor, with openings through the floor.

The temperatures are required to be as follows: 70 degs. in zero weather in the paint shop, storehouse, offices, cabinet shop and oil house; 60 degs. in the erecting shop, storehouse, iron machine shop; other small shops, mill, freight-car shop and engine room. The dry kiln has an independent fan system.

Water Pipe and Drainage Systems.

Fire protection was considered carefully, and a system of pipes provided especially for this service. The water supply for the paint shop, wash rooms, closets and boilers is separate from the fire line, even to the connections with the city mains. A 24-ft. 55,000 gallon tank, for storage purposes, is supported at a height of 60 ft. above the shop grade and located near the oil house. An auxiliary supply will be obtained from driven wells located near Sprague street, where a pump house will be erected. The pumps will have a capacity of 200,000 gals. in 8 hours, delivered into an 8-in. main leading to the storage tank already referred to. This pump is of the triplex type driven by an electric motor. The outside hydrants located on the pipe plan are in hose houses. They have one steamer nozzle and two $2\frac{1}{2}$ -in. hose nozzles each. This pipe plan shows the locations of the four systems of water service and drains, the sizes of the pipes and numbers of hose connections and manholes. There are two systems of drainage, one for the closets and the other for surface and roof water. In the detail drawings we show sections of the man-holes and lamp-holes and also a section of the floor of the paint shop illustrating the slopes of the floor and the drainage openings at the center of each track and midway between the tracks.

A detail section of the transfer table pit shows the drainage between the tracks. There are two rows of catch-basins across the pit, about 100 ft. from each end.

Other Details.

The foundations are all of rubble masonry, shown in the sectional drawings. The bottom stones were required to be not less than 3 ft. 6 in. long, and of various widths and depths. All the buildings and the chimney are faced with hard-burned brick, the same brick being used for the inside walls of the building. The thicknesses of the walls and the location of the buttresses are indicated in the plans.

The storehouse has a platform 4 ft. above the rail and a 30-ft. ramp at the office end. At the opposite end of the building is a fireproof storeroom 73 by 25 ft., with a 12-in. fireproof partition wall. This room is for the storage of combustible materials. Its door and window shutters are covered with tin laid over two thicknesses of sheet asbestos.

A 75-ft. transfer table will run in a pit 350 ft. long, between the two large passenger car shops. It will have a capacity of 150 tons and will be operated by a single 50-horse-power motor, giving a maximum load speed of 100 ft. per minute and a minimum load speed of 300 ft. The track stringers are 8 by 10 ins., and placed at 12-ft. centers on walls of concrete. The tim-

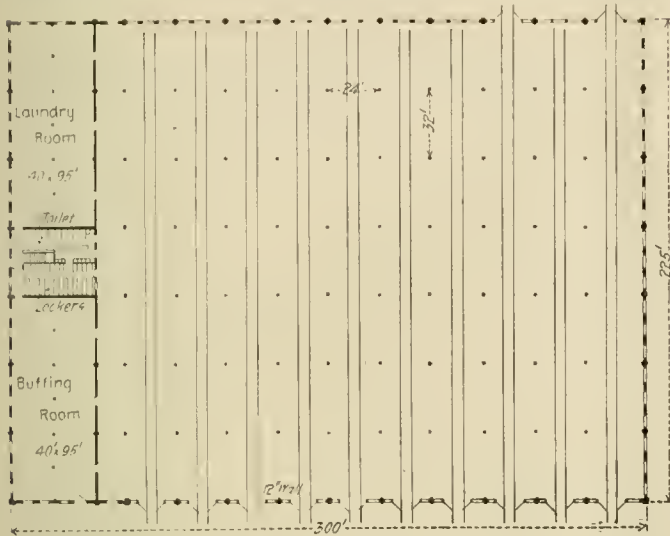

Erecting Shop.—Paint Shop Similar.

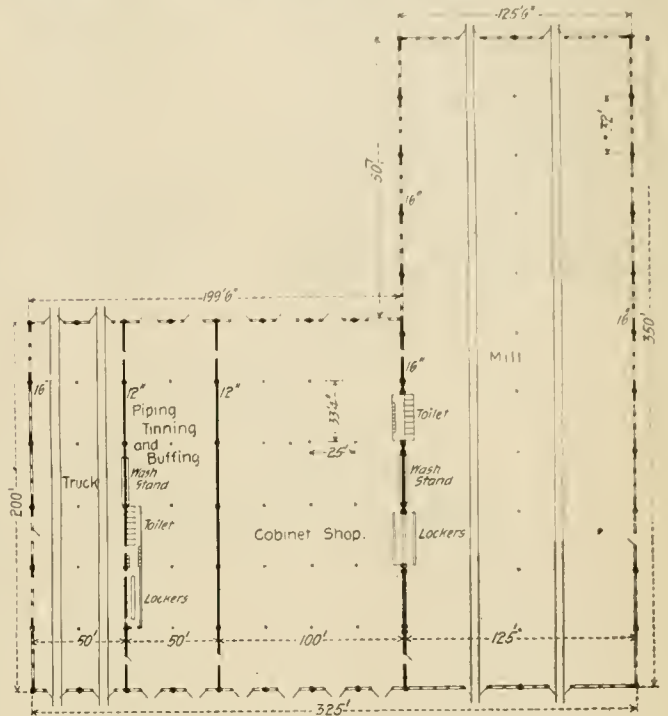
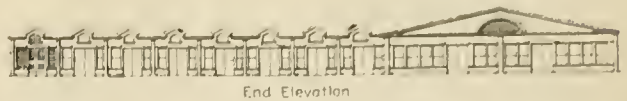

Mill, Cabinet, Pipe and Truck Shops.

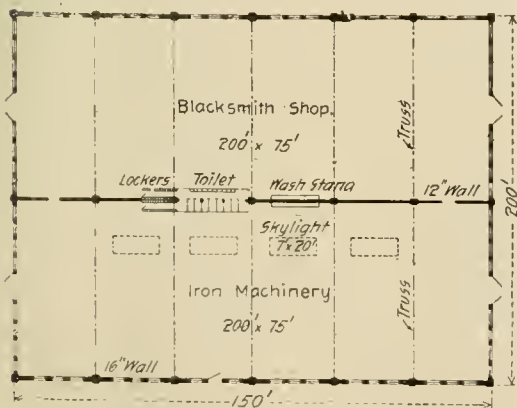
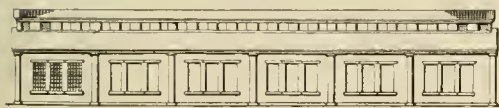

Blacksmith and Machine Shops.

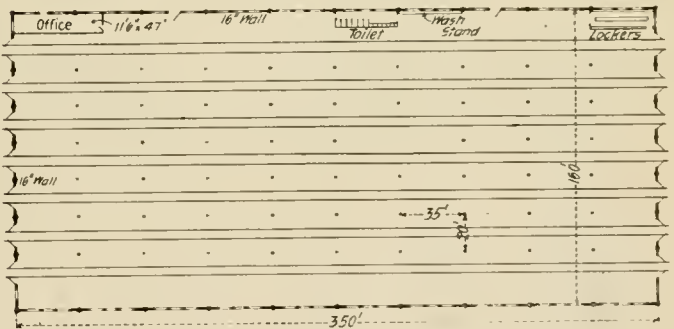

Freight Car Erecting Shop.

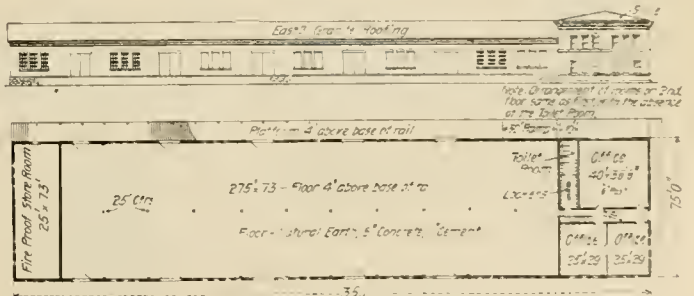

Storehouse and Offices.

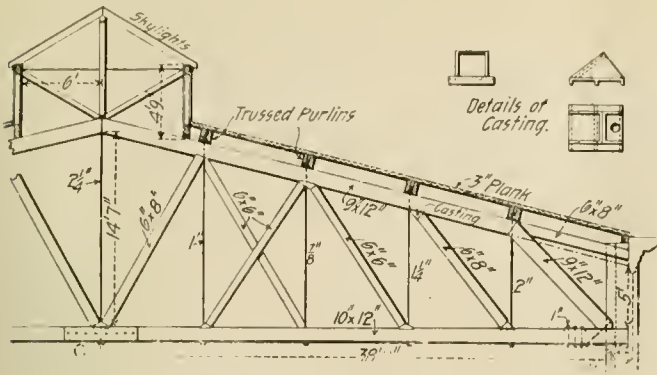

Roof of Blacksmith and Machine Shops.

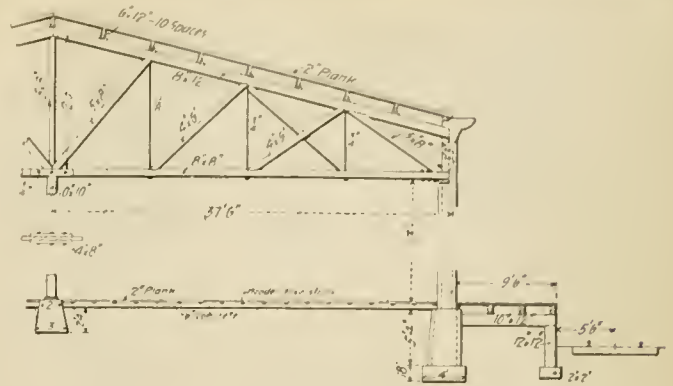

Roof and Floor of Storehouse.

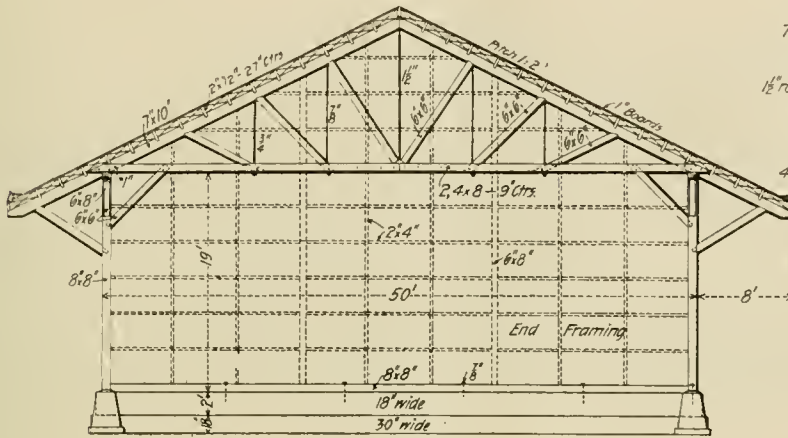

Hardwood Storage Shed.

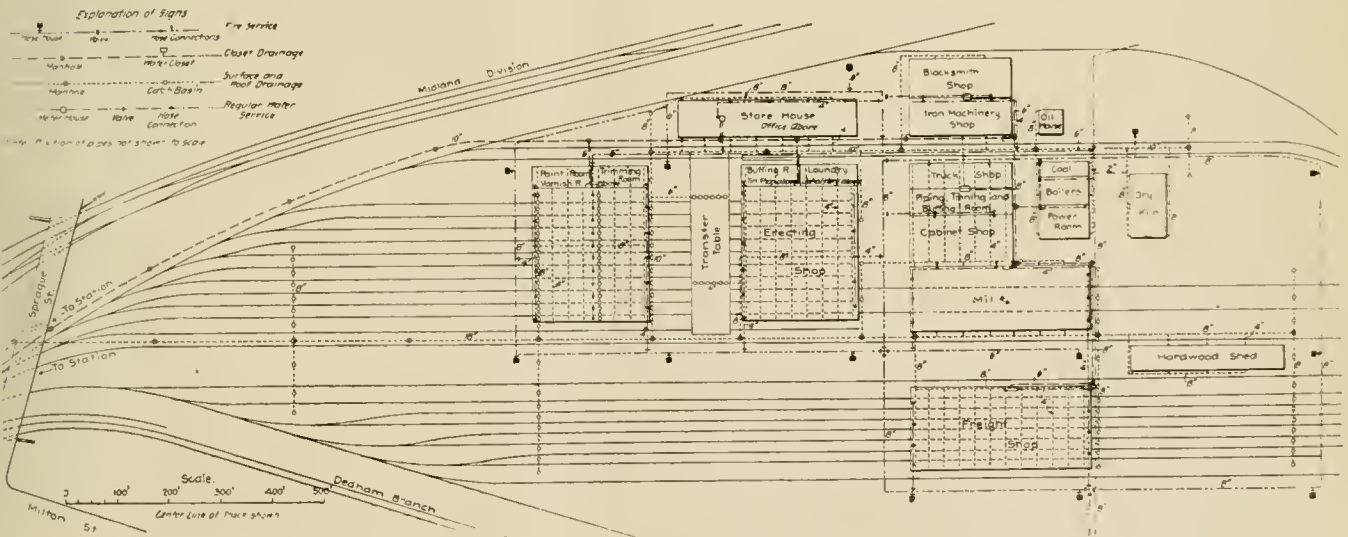
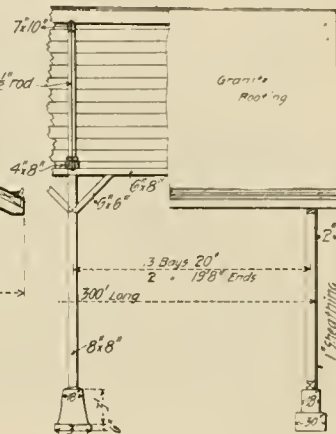

Pipe Plan for Water and Drainage.

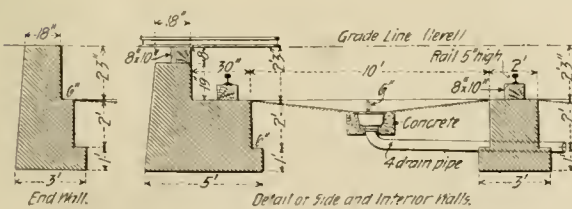

Transfer Table Pit, Drainage and Foundations.

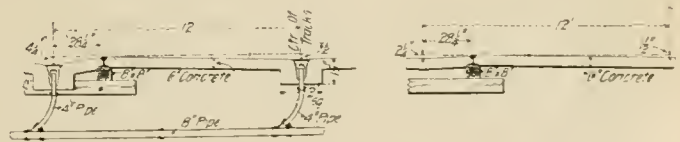

Floor Sections in Paint Shop.

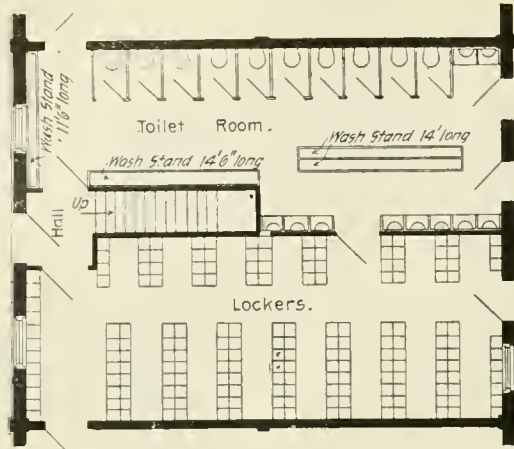

Toilet Rooms in Erecting Shop.

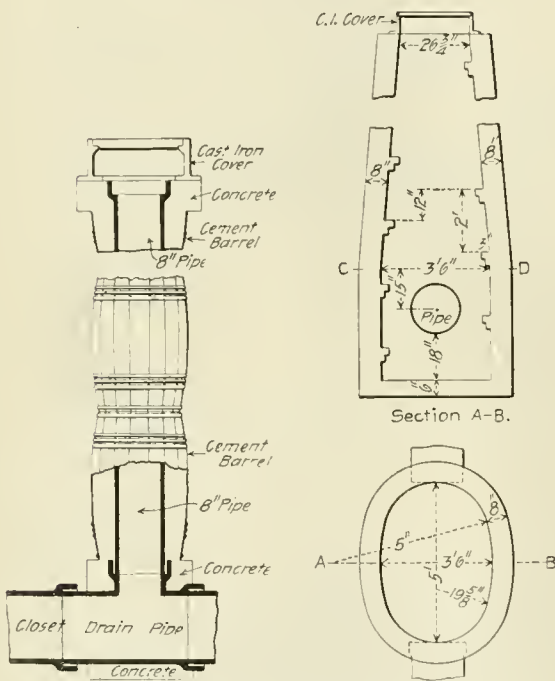

Sections of Man and Lamp Holes.

bers are anchored by 1 by 16-in. drop bolts placed about 10 ft apart.

A dry kiln 75 by 125 ft. is necessary at this plant because of the large amounts of lumber used. It is built with 12-in. brick walls and divided into rooms by fire walls.

A 20 by 25-ft. extension outside of the kiln provides for the fan from which the heated air is circulated through two 3 by 2-ft. ducts under the floor. In order to dispose of the condensation of moisture from the drying wood a large surface of cold-water piping is provided from which the drip is conducted outside of the building. A substantial framing of 12 and 18-in. I beams resting on cast-iron columns supports the upper tiers of drying lumber. There are two standard-gauge tracks running into and through this building, this being another example of the plan of the shops whereby progressive movements were sought in all operations.

A detail worthy of notice is the use of cast-iron post shoes on sockets to receive the lower ends of the roof posts in the paint and erecting shops. These have broad bases 18 ins. square and are secured to the foundations by 7/8-in. bolts. The sockets are 12 ins. deep and serve as a safeguard against displacing the posts by accidental collisions in the shops.

In order to save the reader's time the drawings are made to explain a number of features of construction which it does

not seem necessary to mention in detail, such as the forms of the roof trusses, the thickness of walls and height of the buildings under the trusses. The power plant and machinery will require an article by themselves and will be described later. The contractors for the buildings are Messrs. Horton & Hemingway, of Boston. The contracts for the equipment of the buildings are not yet awarded.

LOCOMOTIVE TRACTION INCREASERS.

About fifteen years ago traction increasers in the form of devices for temporarily transferring a portion of the weight of the tender to the driving wheels were quite common, but they soon became unpopular and disappeared from practice. They were generally applied to remedy defects in design, or "over-cylindere" engines. A committee reporting to the Master Mechanics' Association in 1887, and again in 1888, brought out unfavorable opinions and until very recently nothing more was heard of the subject. Under the conditions prevailing at that time a heavy boiler was undoubtedly the best possible traction increaser and this holds good up to the time when the limits of weight are becoming troublesome.

Interest in traction increasers is again awakened by the application of the old idea in a new way on the new locomotives built by the Schenectady Locomotive Works for the New York Central and illustrated in our February number. In this case the additional weight on the driving wheels is obtained by moving the fulcrums of the rear equalizers, and transferring about 12,000 lbs. from the trailing and truck wheels. This is to be used only at slow speeds and it is not believed to endanger the springs; neither is it likely to squeeze out the oil from the driving journals, because these are made 9 1/2 by 12 ins., presumably to guard against the effect of this additional temporary load.

The present reasons for applying the device are entirely new; they arise from a desire to use a four-coupled engine for work which may at times be beyond the capacity of four-coupled wheels unless loaded beyond the limits of weight considered by the engineering department as safe for the bridges. This is equivalent to saying that this use of the traction increaser is to avoid six-coupled wheels and to make the "Atlantic" type do the work of either the ordinary 10-wheel type or other types using 6-coupled wheels.

The traction increaser may have an important influence on passenger locomotive design, for, if successful in extending the field of the four-coupled engine, its use will become general, and if not successful it will lead at once to the conclusion that six-coupled engines are necessary for heavy and fast passenger service. By this we mean fast trains of from 13 to 16 cars. It would be pure presumption to express an opinion on the question now, but the opportunity for comparing the two ideas is at hand in the cases of the New York Central and Lake Shore engines, both of which are magnificent in their proportions and power. One stands for the "Atlantic" type with high boiler power and temporary facilities for increasing the starting power, while the other represents almost the same boiler power, but large tractive weight available all the time. There is no choice in the number of wheels and the complication of the traction device in the one case is balanced against the extra pair of driving wheels and side rods in the other.

These two locomotives are believed to be the most important which have appeared in many years. They bring up the important question: "What next?" In view of the fact that the New York Central engine is not expected to haul trains of over ten cars, it is wise for roads having to deal with heavier trains, which are constantly increasing in weight, to carefully consider the problem which the traction increaser introduces. It should not be forgotten that the latest Pullman cars weigh 125,000 lbs. and that engines now new will be in service for twenty years.

COMPOUND CONSOLIDATION FREIGHT LOCOMOTIVES WITH WIDE FIREBOX.

New York Central & Hudson River Railroad.

Built by Schenectady Locomotive Works.

Through the courtesy of Mr. A. M. Waitt, Superintendent of Motive Power of the New York Central and the builders, we illustrate a new compound freight locomotive known as the "Central Consolidation." This is a two-cylinder compound of the Schenectady Locomotive Works type, with a wide grate, large boiler and 210-lb. boiler pressure. Mr. Waitt is convinced of the value of large boiler capacity and in this engine

The following list of particulars will convey a good idea of the engine:

COMPOUND CONSOLIDATION LOCOMOTIVE.

New York Central & Hudson River R. R.

General Dimensions.

Gauge	4 ft. 8½ ins.
Fuel	Bituminous coal
Weight in working order	190,000 lbs.
Weight on drivers	161,000 lbs.
Wheel base, driving	17 ft. 6 in.
Wheel base, rigid	17 ft. 0 in.
Wheel base, total	25 ft. 9 ins.
Cylinders.	
Diameter of cylinders.....	H. P. 23 ins.; L. P. 35 ins.
Stroke of piston	32 ins.
Horizontal thickness of piston.....	H. P. 4¼ and 5¼ ins.;
	L. P. 4½ and 5½ ins.
Diameter of piston rod.....	4 ins.
Kind of piston packing.....	Cast iron rings



COMPOUND CONSOLIDATION FREIGHT LOCOMOTIVE—NEW YORK CENTRAL & HUDSON RIVER RAILROAD.

A. M. WAITT, Superintendent of Motive Power.

SCHENECTADY LOCOMOTIVE WORKS, Builders.

Wheels: Driving.....	63 in.;	Cylinders: 23 and 35 by 32 in.	Boiler Pressure.....	210 lbs.
Weights: Total of engine	190,000 lbs.;	engine truck	33 in.;	tender wheels
Grate area and tubes: Grate area	50.31 sq. ft.	on drivers	161,000 lbs.;	weight of tender empty
Fire-box: Length.....	93 in.;	width.....	75¾ in.;	depth of front
Boiler: type, straight.....	radial staying.	firebox	175.32 sq. ft.;	total
Heating surface: Tubes	3,040.81 sq. ft.;	total of engine.....	25 ft. 9 in.;	engine and tender
Wheel base: Driving	17 ft. 0 in.;	Tender: Eight-wheel;	water capacity	5,000 gals.;
				coal capacity.....
				10 tons.

has continued the policy of considering the design of the firebox from the standpoint of the fuel. The combination of large grates and compound cylinders with a large boiler should produce an engine capable of handling heavier trains than any other engine on the road. While this was desired the supply of reserve power for dealing with heavy trains in winter as well as summer was the vital question, as it is usually the combination of heavy traffic and cold weather that makes reserve capacity so desirable. This engine is intended to haul the heaviest trains handled by the present types of moguls on this road in summer and then be capable of hauling them in the worst winter weather. One of these engines has been built and 10 more will follow, but the latter installment will have 72-in. boilers, larger heating surfaces and 34 instead of 32-in. stroke, as it was found that the addition of two more wheels to the mogul design would permit of these additional contributions to the desired capacity. We present the leading dimensions of the new engine here, to be followed later by a description of the heavier class. This appearance of the compound on the New York Central is understood to be an indication that the experience with the compound mogul, which has now been in service for about a year, has been so satisfactory as to lead to a much larger scale of experiment. This engine has 63-in. driving wheels, this dimension being decided upon because it gives an increase of speed of about 5 miles per hour over a 57-in. wheel without increasing the speed in number of revolutions.

Size of steam ports.....	L. P. 23 by 2½ ins.
Size of exhaust ports.....	L. P. 23 by 3 ins.
Size of bridges	L. P. 1¾ ins.
Valves.	
Kind of slide valves.....	H. P. piston type;
	L. P. Allen-Richardson balanced
Greatest travel of slide valves.....	6 ins.
Outside lap of slide valves.....	H. P. 1¼ ins.; L. P. 1 in.
Inside clearance of slide valves.....	H. P. ¼ in.; L. P. ¼ in.
Lead of valves in full gear.....	1/32 in. blind
Wheels, Etc.	
Diameter of driving wheels outside of tire.....	63 ins.
Material of driving wheel centers.....	Cast steel
Tire held by	Shrinkage
Driving box material.....	Cast steel
Diameter and length of driving journals.....	9 ins. dia. by 12 ins.
Diameter and length of main crank pin journals.....	Main side, 7½ by 5¼ ins.; 6½ ins. dia. by 6 ins.
Diameter and length of side rod crank pin journals.....	Inter 5¼ by 4¾ ins.; F. & B. 5 ins. dia. by 3¾ ins.
Engine truck, kind	Two-wheel, swing bolster
Engine truck, journals.....	6¼ ins. dia. by 10 ins.
Diameter of engine truck wheels.....	33 ins.
Boiler.	
Style	Straight, with wide firebox
Outside diameter of first ring.....	70 ins.
Working pressure	210 lbs.
Material of barrel and outside of firebox.....	Carbon steel
Thickness of plates in barrel and outside of firebox.....	¾ in., ½ in., ⅝ in. and 13 16 in.
Horizontal seams	Butt joint, sextuple riveted,
	with welt strips inside and outside
Circumferential seams	Double riveted
Firebox, length	96 ins.
Firebox, width	75¾ ins.
Firebox, depth	Front, 71 ins.; back, 61 ins.
Firebox plates, thickness.....	Sides, 5/16 in.; back, ⅜ in.;
	crowns, ⅝ in.; tube sheet, ½ in.
Firebox, water space.....	Front, 4 ins. and 5 ins.;
	sides, 3½ ins. and 5½ ins.; back, 3½ ins. and 4½ ins.
Firebox, crown staying.....	Radial stays, 1½ in. diam

Firebox, staybolts	1 in. diam.
Tubes, material	Charcoal iron No. 12 B. W. G.
Tubes, number of	365
Tubes, diameter	2 ins.
Tubes, length over tube sheets	192 ins.
Fire brick, supported on	Water tubes
Heating surface, tubes	3,040.81 sq. ft.
Heating surface, water tubes	28.27 sq. ft.
Heating surface, firebox	148.05 sq. ft.
Heating surface, total	3,217.13 sq. ft.
Grate surface	50.31 sq. ft.
Grate, style	Rocking, N. Y. C. standard
Ash pan, style	Hopper
Exhaust pipes	Single
Exhaust nozzles	5¼ ins., 5½ ins., 5¾ ins. diam.
Smoke stack, inside diameter	15½ ins. and 14 ins.
Smoke stack, top above rail	14 ft. 9 ins.
Boiler supplied by	Two Nathan & Co. "Monitor" injectors, No. 10

Tender.

Weight, empty	46,800 lbs.
Wheels, number of	8
Wheels, diameter	33 ins.
Journals, diameter and length	5 ins. dia. by 9 ins.
Wheel base	16 ft. 6½ ins.
Tender frame	10-in. steel channels
Tender trucks	Fox pressed steel, bolster type
Water capacity	5,000 U. S. gals.
Coal capacity	10 tons
Total wheel base of engine and tender	53 ft. 9 ins.

Special Equipment.

Westinghouse-American combined brakes on drivers, tender and for train.
Westinghouse 9½-in. L. H. air pump.
Westinghouse air signal.
National hollow brake beams on tender.
Franklin sectional lagging on boiler and cylinders.
Gould coupler at front of engine and rear of tender.
Leach sand feeding apparatus.
Water scoop on tender.

What is probably the largest single shipment in the history of Southern railroads is now being moved over the Louisville & Nashville from Mount Pleasant, Tenn., to Pensacola, Fla., to be forwarded to Cuba. It consists of 2,000 carloads of rock phosphate, all in one consignment, and the magnitude of the undertaking is shown in the fact that the railroad company is under contract to deliver 200 carloads of the freight daily.

Honorable Charles A. Prouty, member of the Interstate Commerce Commission, delivered on January 21 an address before the engineering students of Purdue University. His subject was "The Relation of the Railways to the People," which he treated by presenting in outline the work of the Interstate Commerce Commission. Mr. Prouty began by calling attention to the great influence exerted by American systems upon the progress of the country and discussed the important part played by railway rates in the development of commerce. He showed how the magnitude of the interests involved demands governmental regulation of rates, and in this connection explained the work of the Interstate Commerce Commission, which is charged with the duties of supervising and regulating such affairs. The discussion was entirely impartial and was much enjoyed by the student body who were privileged to hear it.

MASTER MECHANICS' ASSOCIATION SCHOLARSHIPS.

There is now one vacancy in the Master Mechanics' Association scholarship at Stevens Institute of Technology and in June, after the graduation, there will be another. The spring entrance examinations will be held at the Institute in Hoboken, June 18 to 22 next. Candidates for the scholarships should apply to the secretary of the association, Mr. J. W. Taylor, 667 The Rookery, Chicago. The candidates for the June examinations must be sons of members or deceased members of the association, and if such do not appear for the examination the sons of other railroad employees of the mechanical department may apply for the fall examinations. The successful candidates are required to take the course in mechanical engineering. We hope soon to hear that there are young men on the waiting list for these opportunities. It seems incomprehensible that such chances for a good education should go begging for applicants.

AIR BRAKE "SKIPPING" TESTS.

These tests, which show under various conditions the limiting number of successive cars in a train which may be cut out of the air-brake service without destroying the emergency feature of the quick-acting air brake, were made upon the Master Car Builders' air-brake testing rack in the engineering laboratory of Purdue University, under the direction of Richard A. Smart, Associate Professor in Experimental Engineering, and published in the January issue of the "Railroad Digest." The failure of this emergency feature of the air-brake valve to act on those cars following an excessive number of cut-out cars is shown in these tests, and also that the number of cut-out cars can be greater at the middle and end of a train than immediately back of the tender. This is accounted for by the fact that after the emergency application has passed a number of cut-out cars in the front part of the train, the sharpness in drop in the train-line pressure is considerably reduced by the air rushing forward from the back end of the train line. It is not uncommon to see several cars, by reason of defective air-brake rigging, cut out and grouped together in different parts of a train, and it is here that it is important to know how many successive cars of this description the emergency action will skip and the best location for these cars in a train. Of the 42 tests or groups of tests that were made, 25 were with a train of thirty cars and 17 with a train of fifteen cars. The train-line pressure, with the exception of a few tests, was kept at 70 lbs., the piston travel at 8 ins., and for each of the 42 tests three applications were made. With the cut-out cars of the longer train alternately grouped in twos and threes throughout the whole length, the emergency action skipped as effectually with cars 1, 2 and 3 constituting the first group cut out as when cars 4, 5 and 6 were the first group. The greatest number that could be skipped immediately in front of the last car was nine, while with the same number cut out immediately in front of the last two cars, the quick action failed to reach the end car. In the middle of the train three cars was the limit that could be cut out. Two tests with a train-line pressure of 45 lbs. limited the number of cars that could be cut out to 8 at the end, and, alternately throughout the train, groups of two cars. Results from several tests using a 12-in. piston travel and train-line pressure of 70 and 45 lbs. were substantially the same as with a piston travel of 8 ins. and pressure of 70 lbs. With the fifteen-car train, three cars at the front and eight at the end was the limit that the emergency action would skip.

Successful wireless telegraphy over 200 miles is announced by Prof. J. A. Fleming, of London University. In a lecture delivered in Liverpool February 12, he stated that he had Marconi's permission to report that on the first day of the reign of King Edward VII. Marconi had sent messages from St. Catherine's to the Lizard, a distance of 200 miles, and that a perfect wireless communication had been established between those points.

Depreciation of machinery is treated in a recent article by Mr. R. H. Smith, in "Feilden's Magazine" (Volume, 1900, page 270). The depreciation of a machine in the course of one year is the change in the capitalized present value of its net earning power, taking into account the probable duration of its remaining life. The capitalized value of the earning value of a new machine is, if it be well chosen and skillfully placed, more than its money cost by the value of the intelligence employed in selection and placing. A mathematical expression is obtained for the depreciation of the present intrinsic and extrinsic value, and curves are plotted from which it is clear that the prevalent notion of decreasing the rate of depreciation toward the end of a machine's life is erroneous; such yearly depreciation should increase.

SUPPLEMENT T card,
to it
dif-
files,
nical
, the
usual
, not
size,
pose

\$3.00
4.20
2.40
3.00
.50
4.50

\$23.60

loule
l the
ning
s of
ound
next
next
sary
eady
' ar-
any
hem
very
The
k is
and
card
fre-
rely
sible
box
this
tory

1, of
Erie
road
lbs.
last-
that
Den-
con-
ings
line

but
d in
our
icity
with
ving
ould
died
d of
nore
ning
s of
that
mo-
nay,
rtial

DESIGNED BY 'bich



**FAST PASSENGER LOCOMOTIVE, LAKE
CL/**

DESIGNED BY W. H. MARSHALL, SUPERINTENDENT MOTIVE POWER, CLEVELAND, OHIO.

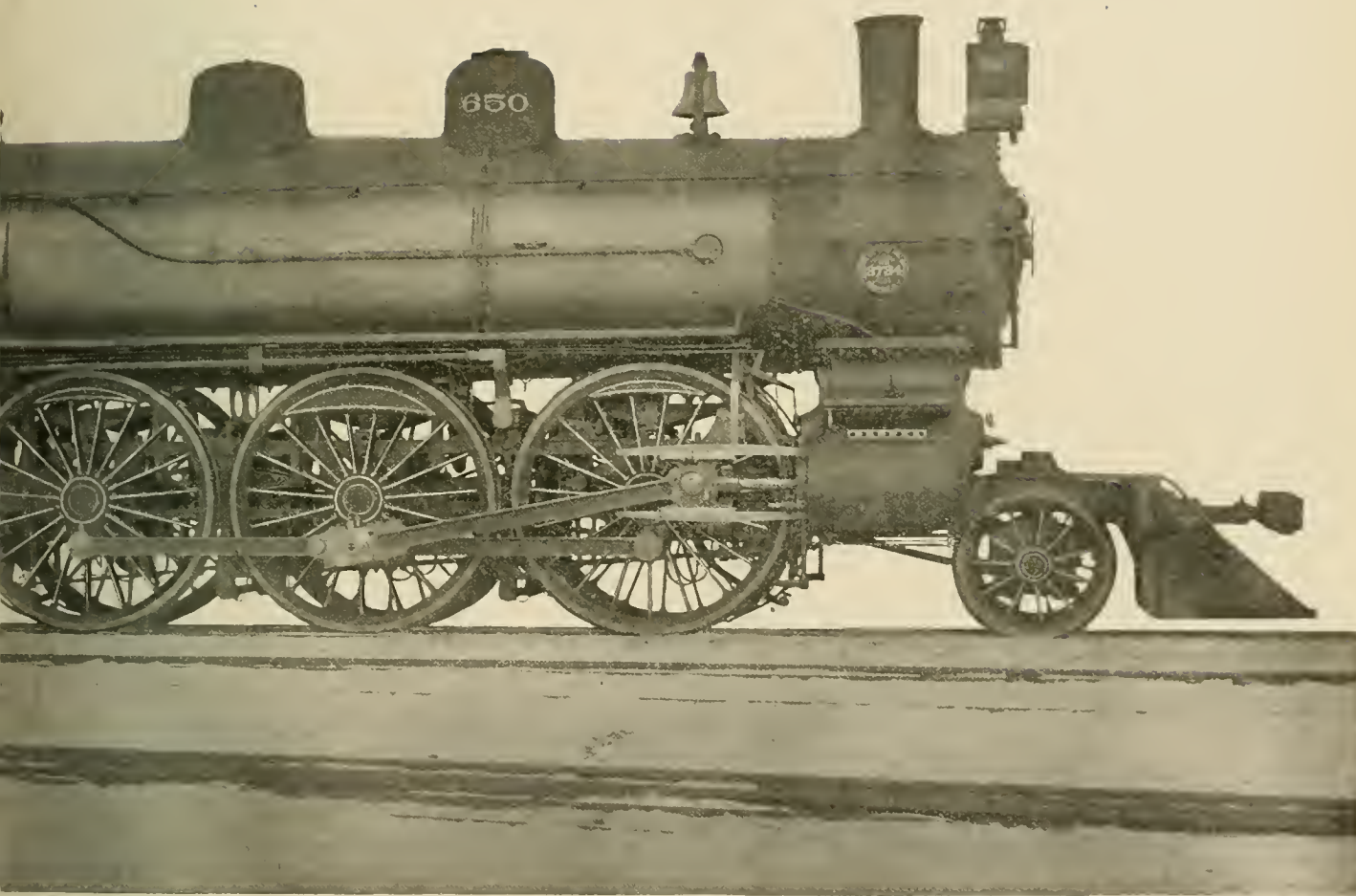

SHORE & MICHIGAN SOUTHERN RAILWAY.
CLASS "J."

BUILT BY BROOKS LOCOMOTIVE WORKS, DUNKIRK, N. Y.

Firebox, .0 AMI
Tubes, m
Tubes, m
Tubes, di
Tubes, le
Fire bric
Heating s
Heating s
Heating s
Heating s
Grate sur
Grate, st
Ash pan,
Exhaust
Exhaust
Smoke st
Smoke st
Boiler su

Weight, c
Wheels, 1
Wheels, c
Journals,
Wheel ba
Tender fr
Tender tr
Water ca
Coal cap
Total wh

Westingh
for trai
Westingh
Westingh
National
Franklin
Gould co
Leach sa
Water sc

What
of South
& Nashv
to be fo
phospha
undertak
under co

Honor
Commer
before t
subject
which I
Interstat
ing atte
tems up
portant
commerc
involved
this cor
merce C
vising a
tirely in
who we

MAST

There
tion sch
June, af
entrance
boken, .
should
Taylor,
June er
member
examin
mechan
The suc
mechan
are you
It seem
W. H
cation s

THE BUSY MAN'S FILING SYSTEM.

Nearly every engineer, whether connected with a railroad or manufacturing company, has some system of filing and indexing technical and professional information, and if he has not, will sooner or later feel the need of it. Some of the methods used are simple and serve their purpose well and, again, there are others that are not reliable, nor do they give ready access to the information sought.

Mr. R. H. Soule, Consulting Mechanical Engineer, New York, is using a system of filing to which he has given considerable thought. This method is reliable, easy of operation and is very flexible. It is not enough that an index and file should serve its purpose now, but it must be flexible in the sense that it can be developed, without any change, into a very extensive system. It has been found that three sizes of file boxes, 7 x 10 x 2½ ins., 9½ x 12¾ x 2½ ins. and 11½ x 16½ x 2½ ins., inside dimensions, constructed similar to the "National Receiving Case," but without a plate or rod in the back of the box,

<i>BoilerShops</i>	
<i>Arrangement of, by F.M. Whyte</i>	
<i>American Engr., Page 188, June 1900</i>	<i>P-144</i>
<i>Plan and sections, C. & N. W. Ry.</i>	
<i>American Engr., page 110, April 1900</i>	<i>L-96</i>
○	

Index Card—3 x 5 ins. in Size.

will accommodate the various sizes of papers, pamphlets and trade catalogues with the least waste of space. These boxes are designated by the arbitrary letters P, L and G respectively. The small file, P, is the right size for the general run of pamphlets, such as the railroad club proceedings, trade catalogues, etc., the intermediate size, L, is the most convenient for letterheads and the majority of technical papers, and the larger size, G, admits of filing the pages of the largest technical papers. These file boxes fit into a case made of plain wood, stained, and having four shelves just large enough for six files on a shelf. The first two shelves are used for the size P, the third for L and the fourth for G. For convenience in taking the files from the case small leather pull tags are fastened to the front of each box about 3 ins. from the bottom.

The location of each item of information placed in these boxes is typewritten on regular Library Bureau cards and grouped alphabetically under separate headings in a hard-wood index case, having two drawers. In looking for information, say, for example, on railroad boiler shops, the first step is to look in the index for the cards on "shops," which are separated from those on other subjects by a division card called a buff third and having the subject "Shops" written in the upper left-hand corner. If it is a reference to boiler shops which is desired, the card, being in alphabetical arrangement, will be quickly found. In the upper right-hand corner of the accompanying engraving of this card will be found the number and size of box containing the reference, which we will say is P-144. Each box as it is filled is marked on the front cover in large figures, the lowest and highest number given to the items filed in that box. It is then only a matter of turning to the given number in the file, which is marked in the upper right-hand corner of the book or clipping, together with the letter indicating the size of box. It is often necessary to cross-index an article; for instance, the subject of Electric Power Distribution at the Westinghouse Works will have one card. In that particular article tests of electrical and steam distribution

at these works may be given, which would need a second card, so that one article may have a number of cards referring to it and again one card may contain four or five references to different articles. When indexing articles not found in the files, such as contained in the "British Institution of Mechanical Engineers," the volume, page and year are also added to the card and in the upper right-hand corner, in place of the usual file number, is put a zero, indicating that that reference is not in the file. For small clippings not up to the standard size, it is convenient to have a few manila sheets for the purpose of mounting these clippings.

The cost of such a system complete is as follows:

	The Cost.
1 card index, cards and case.....	\$9.00
12 small file boxes, at 35 cents.....	4.20
6 medium file boxes, at 40 cents.....	2.40
6 large file boxes, at 50 cents.....	3.00
100 manila sheets50
1 plain stained book case.....	4.50
Total	\$23.60

When going through papers, pamphlets, etc., Mr. Soule checks with a blue pencil the articles worthy of record and the pamphlets are afterward cut up and the pages not containing the marked articles are destroyed, the remaining sheets of each paper, or in some cases two or three papers, are bound with metal binders and the whole document given the next higher number in the proper size file box. It is not necessary to make out a card for each article as it is numbered and ready to file, but this can conveniently wait until a number of articles have accumulated. The whole secret of keeping any filing system up to date is to mark the articles and get them ready for filing the first time they come to notice and every little while indexing and placing them in the proper files. The strong point about Mr. Soule's system is that the work is never done over again. The system is good indefinitely and the clippings may always be found from the cards. A card index system seems necessary to a logical plan, because frequently a single clipping may refer to a number of entirely different subjects, and with only one clipping it is impossible to find it under more than one head if it is placed in a box or envelope devoted to a single subject. The editors of this journal have adopted Mr. Soule's plan and find it satisfactory in every way.

According to statements attributed to President Newman, of the Lake Shore, improvements decided upon for the Lake Erie & Western when completed will make it second to no other road in Indiana, Ohio or Illinois. These include new steel rails, 70 lbs. to the yard, on the entire line, with new ties and heavy ballasting, rebuilding of bridges and lengthening of sidings so that the movement of trains can be expedited. No road in the Central Freight Association, Mr. Newman says, all conditions considered, is showing as large proportionate increase in earnings as the Lake Erie & Western. The relaying of the main line with new rails will take about two years.

American and English locomotives formerly differed but little in size and weight, but of recent years this has changed in a remarkable way. English designers now turn toward our practice for suggestions in the direction of increasing capacity and we can profitably turn to them for ideas in connection with getting the utmost out of each ton of weight. The following very sensible quotation from "The Engineer" (London) would be equally appropriate if reversed as to countries and applied to the adjustment of the elements to each other instead of size: "Is there, then, any reason why we should not resort more fully than we have yet done to American practice in designing the extremely powerful locomotives which the exigencies of modern traffic demand? We do not for a moment suggest that we should slavishly follow any example, or copy any locomotive; but when designing locomotives, British engineers may, we think, find in American practice direct and substantial proof that certain things may be done, the success of which might otherwise be doubtful."

(Established 1832)
**AMERICAN
 ENGINEER**
 AND
RAILROAD JOURNAL.

PUBLISHED MONTHLY

BY

R. M. VAN ARSDALE,

J. S. BONSALL, Business Manager.

MORSE BUILDING..... NEW YORK

G. M. BASFORD, Editor.

E. E. SILK, Associate Editor

MARCH, 1901.

Subscription.—\$2.00 a year for the United States and Canada; \$2.50 a year to Foreign Countries embraced in the Universal Postal Union. Remit by Express Money Order, Draft or Post Office Order. Subscriptions for this paper will be received and copies kept for sale by the Post Office News Co., 217 Dearborn St., Chicago, Ill. Damrell & Upham, 283 Washington St., Boston, Mass. Philip Roeder, 307 North Fourth St., St. Louis, Mo. R. S. Davis & Co., 346 Fifth Ave., Pittsburg, Pa. Century News Co., 6 Third St. S., Minneapolis, Minn.

EDITORIAL ANNOUNCEMENTS.

Advertisements.—Nothing will be inserted in this journal for pay, EXCEPT IN THE ADVERTISING PAGES. The reading pages will contain only such matter as we consider of interest to our readers.

Special Notice.—As the AMERICAN ENGINEER AND RAILROAD JOURNAL is printed and ready for mailing on the last day of the month, correspondence, advertisements, etc., intended for insertion must be received not later than the 20th day of each month.

Contributions.—Articles relating to railway rolling stock construction and management and kindred topics, by those who are practically acquainted with these subjects, are specially desired. Also early notices of official changes, and additions of new equipment for the road or the shop, by purchase or construction.

To Subscribers.—The AMERICAN ENGINEER AND RAILROAD JOURNAL is mailed regularly to every subscriber each month. Any subscriber who fails to receive his paper ought at once to notify the postmaster at the office of delivery, and in case the paper is not then obtained this office should be notified, so that the missing paper may be supplied. When a subscriber changes his address he ought to notify this office at once, so that the paper may be sent to the proper destination.

The paper may be obtained and subscriptions for it sent to the following agencies: Chicago, Post Office News Co., 217 Dearborn Street. London, Eng., Sampson Low, Marston & Co., Limited St. Dunstan's House, Fetter Lane, E. C.

The desirability of securing more commodious quarters for the American Society of Mechanical Engineers has long been appreciated by a large number of the members, and the temptation to follow the example of the foreign engineering institutions and the American Society of Civil Engineers in undertaking the responsibilities of a fine new building is undoubtedly strong. In an able editorial "Engineering News" comments upon the fact that the present quarters are too small for the opening meeting of each annual convention and advances arguments in favor of arranging to accommodate the mechanical engineers in the fine new building of the American Society of Civil Engineers in New York City, where there is said to be room for both. Such a movement should be slow. The mechanical engineers have been successful and have won a high place. They will advance much farther and become more influential by continuing their present state of absolute independence and any attempt to share with another organization a building not specially constructed for the needs of both is sure to be uncomfortable for the one which must be satisfied with the subordinate position. There is a homelike comfort about the society rooms on Thirty-first street which goes far to make up for the lack of room on the single night of the entire year when they are too small, and it would seem unwise to make an unsatis-

factory arrangement merely on account of that one evening. For a number of years the society may hold its opening session in a convenient hall, and when ready, the house question can be taken up as it should be, independently. It is hardly time to do this yet, because there are other and more important directions in which the energies of the organization should be exercised.

In June there will be two vacant scholarships of the Master Mechanics' Association in Stevens Institute of Technology at Hoboken. Mr. J. W. Taylor, Secretary of the Association, whose address is 667 The Rookery, Chicago, will supply information. These opportunities are offered first to sons of members of the association and afterward to the sons of employees of the mechanical department in case there are not enough applicants of the preferred class. It is difficult to understand why there are not more applicants for these scholarships. Members of the association should post bulletins in the shops to inform their young men about them.

A horizontal increase in wages is usually included in the demands of grievance committees, particularly those representing shop forces. This is usually one of the first problems a newly appointed superintendent of motive power meets if he comes from another road, and unless he is a close student of men he is likely to meet it often. On two roads having recently come under our notice, grievance committees are part of the past, because there are no grievances of the men in classes. This has been brought about by developing individual effort among the men and by placing the premium of increased wages upon merit. A horizontal increase is generally unwise, because it affects the worthy and unworthy alike, and it is likely to lead to strike after strike simply because the men are dealt with in classes. It is better to raise the wages of a good man in a group as a reward of good work. This will bring others to the foreman with claims of equality with the one who has been advanced. The reply may then be: "Yes, you are perhaps as good in every way as he; but the only way I can judge is by the results. Show that you can do as much and as good work as he and I will raise your wages in the same way." If such a plan is systematically practiced, with care and discrimination, there will probably be nothing for a grievance committee to do. This is the result on the two roads referred to. Shopmen are usually ready to respond to perfectly fair treatment. Much thought and study are needed in the handling of men, and it is safe to say that not all of the difficulties with shop labor are unavoidable.

Progress in passenger locomotive design is strikingly illustrated in this journal by the descriptions of the new Lake Shore, Union Pacific and New York Central engines, all of which are noteworthy and all aim at the utmost possible capacity and sustained power, although the conditions on these three roads are not at all alike. These engines are by three different builders and represent the views of different men, but they all show the desire to secure the greatest possible reserve power for emergencies.

The Union Pacific engine is very heavy, and but 1,080 lbs. lighter than the new consolidation freight compounds of that road illustrated in January. A mere accident in the drawing room might have reversed this order and made the passenger engine the heavier. This fact is evidence of the appreciation of great boiler power. The new Class "J" Lake Shore engine is bold throughout in its wheel arrangement and boiler design, its 19-ft. tubes and wide grate. With its combination of wheels, radial trailer trucks, wide grate, long tubes and large heating surface it is the most notable engine of the year and one from which great results may be expected.

Another novelty is the traction increaser of the new Atlantic type of the New York Central. With a large grate and heating surface and the possibility of increasing the adhesive weight in starting, this engine will be watched with great interest for excellent results. It is becoming more and more evident that the limits of capacity are yet a long way off and they appear to recede as the possibilities of increased power develop. The four-cylinder compound with divided cylinders, balanced as in French practice, is yet to be tried. At the present rate of progress we may see it sooner than we expect. At all events it is pretty well established that the compound of the future will have four cylinders. There would be no hazard in fitting the New York Central and Lake Shore engines with tandem compound cylinders.

THE FATE OF A DRAFTSMAN.

Last month in these columns a young man, promoted from the drafting room, was spoken of as having been saved from the death of a draftsman. The amount of correspondence occasioned by the expression is sufficient to indicate the necessity for saying more upon the subject.

In too many cases the drafting room is a side track into which good men hesitate to enter, and though the temptation to go into details is strong this is the fact to which attention is specially directed.

In a single week our correspondence includes three cases, any of which amply justifies these paragraphs. The first disclosed a vacancy for a first-class draftsman with technical education and training, salary \$80 per month, hours 7 a.m. to 6 p. m., with half hour for lunch. The second required an exceptional man with "college education and shop apprenticeship," and one thoroughly familiar with locomotive design and foundry work, the salary being the same as the first, but it was expressly stated that there was no hope for advancement. The third opportunity was for a chief draftsman at \$100 per month. This was clearly stated to be the limit of the position and salary, and it seems that the salary was fixed by a power above the mechanical department. Naturally, a man was not expected to stay more than a few years in the position or to get more out of it than experience and education for use elsewhere.

These and other records at our elbows indicate that the railroad mechanical draftsman has a hard time; they show how difficult it is to get good men and the reasons. During the past year there have been many calls for draftsmen and we have supplied a number of good men, but does not the very demand for men in itself indicate a solution of the whole difficulty? If the drafting room was considered a step in advancement toward other important positions, and if it was used to develop men, or rather to enable them to develop themselves, it would be full of men prepared for advancement and equipped for greater responsibilities. It is argued that railroads are not training schools, but this does not appear to be true. If drafting rooms are to have good men they must make them. One who, as a rule, looks outside of his own organization for men ready trained to his hand, is likely to be frequently disappointed and he will always be looking for men. That organization is best and most successful which best provides for its own perpetuation.

What may the drafting room offer that will attract the right kind of men, and keep them? What should the men do to place their work in an advantageous position before their superiors and lead to the proper appreciation of the department? These are questions worthy of thought on every railroad.

There is no better experience in the motive power department than that of the draftsman who is encouraged and allowed to follow up his work. There is no better place than the drafting room in which to gain an appreciation of the

commercial questions which are so vitally important, and, all things considered, this department ought to broaden and develop men. There is no better way to develop ability to take responsibility than by designing in this department. Its tendency, however, is almost altogether away from executive experience, but there is no reason to believe that a successful draftsman is necessarily a poor executive. He cannot be a good one unless given the opportunity, and we answer the first of these questions by suggesting an outlet to the talent of the drafting room. Give the men a little hope that they may go higher if they can show their ability. One good way to encourage them, and it will pay, is to give them a whole day every month in which to visit the shops or places where the results of their work are in use. Informal reports of these days, with suggestions, would be valuable to all concerned, and it would be easy, through them, to study the men with a view of making them still more useful. Do not consider this a vacation, but one of the draftsman's duties.

Because of his training for accuracy, his disinterestedness as well as his tendency to see things for himself rather than take the reports of others, the draftsman should be a most satisfactory investigator and observer. He will do much better work at the table for being occasionally sent away from it upon errands of investigation.

Not every draftsman will make a good foreman and some will always remain draftsmen. These should have the incentive of good salaries in order to develop their best efforts. A salary of \$1,500 per year is not too much for a good car or locomotive draftsman, but the railroads do not realize this as do the locomotive and car builders. They are far below the market price for the best men and these men are not luxuries, but necessities. Prevailing rates of wages are perhaps sufficient for the ordinary draftsman, but they should have hope in one direction or the other, either in the executive work or in higher development in their present line or they will be, as many are to-day, mere machines.

To the draftsman we would say that we have no sympathy with his complaint that there is no outlet for him. He may make one if he will, though it is not provided by the policy of his superiors. A young man who is determined to rise will not be kept back, even by the drafting room. It is his fault if he does not find something on the road that needs to be done and make known his ability to do it.

If the purpose of these paragraphs is understood there is no inconsistency about them. The plea is for intelligent administration of the drafting department such as to make it an attractive opportunity for young men to gain experience and advancement, and in this way improve the average as well as the expert draftsman. On the other hand, the draftsman is urged to do his part. We are heartily in sympathy with the young men who spend their evenings on designs of their own, made to meet conditions which they see about them and know to require improvement. A superior officer must be blind indeed not to see the promise of a brilliant future in a young man who will submit such a design for criticism.

Great results may be obtained by uplifting the drafting room to a place of importance and true, practical dignity.

A remarkable record for the steam turbine of 14.174 lbs. of steam per electrical horse-power-hour delivered at the switchboard has been made by a 1,000-kilowatt Parsons turbo-generator at the Electrical Supply Works of the City of Elberfeld, Germany. "Engineering," of London, in which the tests are recorded, concluded its statement as follows: "The steam turbine has had a very long fight, but it is fairly ahead of its competitors at last." It will be remembered that the best result reported for the Westinghouse-Parsons turbines at Wilmerding, and recorded on page 69 of our March, 1900, issue was 16.4 lbs. per electrical horse-power-hour.

30-TON HOPPER COKE CARS.

ELECTRIC POWER TRANSMISSION.

Chesapeake & Ohio Railway.

These coke cars were designed by Mr. W. S. Morris, Superintendent of Motive Power of the Chesapeake & Ohio, from whom we have received the drawings. They combine a number of conveniences and were evidently intended by Mr. Morris to please everybody who has occasion to use coke. They have hoppers with the usual hopper doors for those who unload on trestles, and the hopper openings may be closed by large iron

The rapid strides that electricity is taking in replacing the old style of power transmission by line shafting are no longer explained by the fact that 10 to 30 per cent. of the coal bill can be saved by the installation of electric power equipment, as that saving is now realized to be a comparatively small part of the total savings in turning out finished products. This was very forcibly emphasized by Mr. Vaucain in a recent meeting of the Franklin Institute, who placed the saving in total cost,

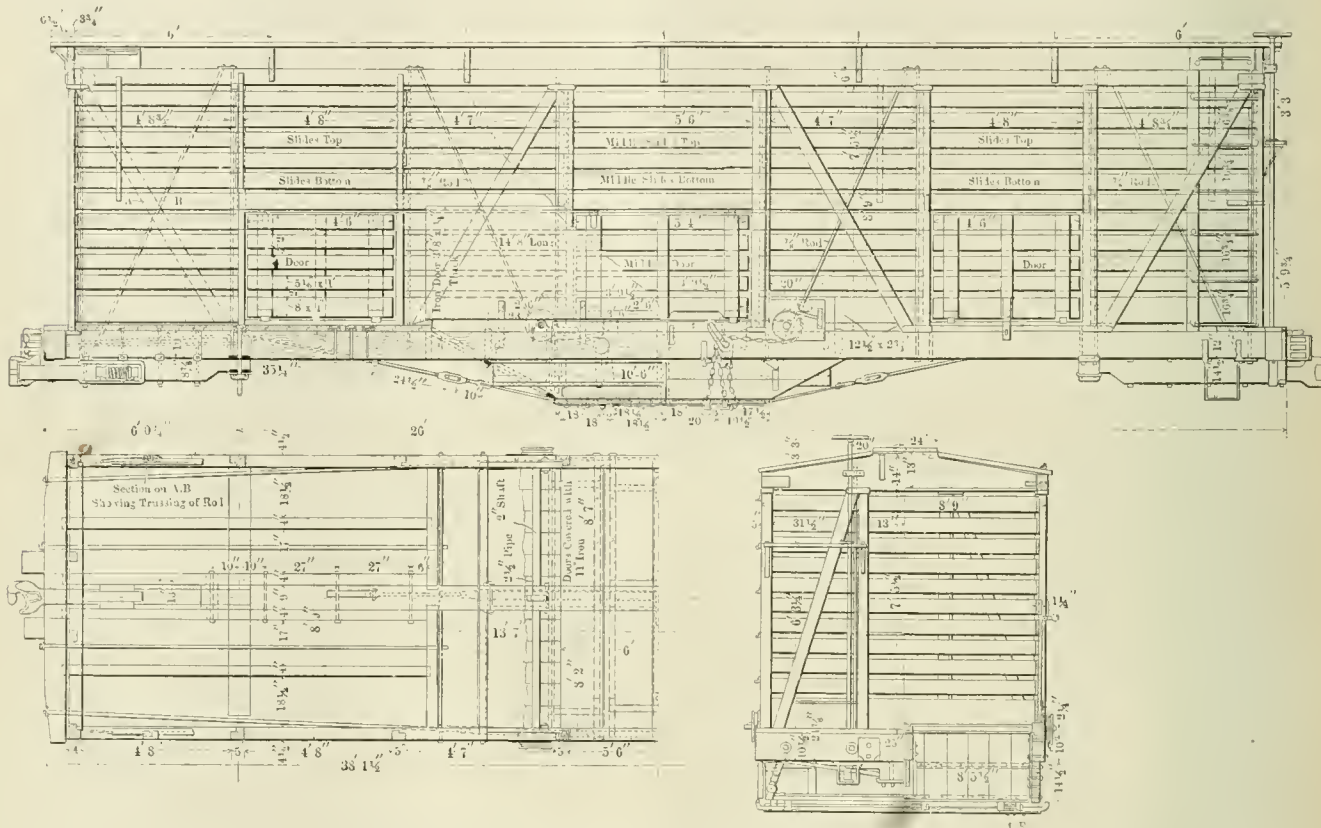

30-Ton Hopper Coke Cars—Chesapeake & Ohio Railway.

plate doors 14 ft. 8 ins. long when the load is to be discharged through the sides. In each side there are three doors below the belt rail sliding bodily to one side, and above these the slats above the belt rail may be slid to one side or the other, giving ready access to the load. The upper portions of the load may be thrown out over the sides if desired.

The side and center sills are 4 1/2 by 10' ins., the center sills being placed together with two 4 by 10-in. reinforcing sills outside of them extending to the headers at the ends of the hopper door openings. There are two through truss rods, at the side sills, and a third short truss rod under the center sills beginning about 3 ft. inside of the bolsters at each end. There is no roof, but the top rails are 3 3/4 by 6 ins. tied across the car by 2 by 14-in. carlines, carrying the running board. The length over end sills is 38 ft. 1 1/2 ins., the width outside of braces 8 ft. 9 ins., and the height from the lower face of the end sill to the brake wheel is 9 ft. 11 1/4 ins.

Mr. Morris has about 100 of these cars in service and finds them entirely satisfactory.

A striking statement with regard to the advantages of electrical operation of turrets of war vessels is made by Naval Constructor J. J. Woodward, U. S. N., in a report on tests of the electrical equipment of the battleships "Kearsarge" and "Kentucky." The sensitiveness of the turret-turning machinery made it possible to move the turrets through an angle corresponding to but 2 ins. of an arc with a radius of 3,000 ft. It is doubtful whether such a result could be had with any other power.

of the manufactured product of the Baldwin Locomotive Works, by the use of electric driving for tools and machines, at from 20 to 25 per cent., and stated that to replace the present system by belting and shafting would mean that 40 per cent. more floor space would be necessary in order to maintain the present output of five locomotives a day.

The general success that this system of driving has made in its comparatively short career is due principally to such marked advantages as cheaper construction of buildings; arrangement of machinery, with reference to the best light; saving in floor space and in handling of material; greater adaptability of tools to work; a freer use of overhead cranes for serving tools, made possible by clear head room; location of buildings with reference to general conveniences, rather than reference to transmitting power; freedom in the matter of extension of buildings; a more cleanly appearance and healthful condition of shops from better light and air, due to the absence of shafting and belting, which are means for continually stirring up dust; the variation and range of control of the speed of machine tools, and the saving of power. Of these the matter of speed control is unquestionably the principal advantage with many kinds of tools, for it is this facility that directly increases the output.

The following figures from the United States printing office, gathered since the installation of an electric drive in that establishment in 1895, show clearly the advantages of the electric system. The total cost of coal and gas in 1894, which was the year prior to the electric installation, was \$27,811.13, and for the year 1899 was \$5,614.75, leaving a difference of \$22,196.38.

The growth of the office in the four years was nearly 25 per cent., which would make the sum total in the saving of fuel about \$25,000; thus giving a gain of 16 2/3 per cent. on the investment, or, after a reduction of 6 2/3 per cent. for insurance, taxes and interest, there is left a clear gain of 10 per cent. The average earning capacity of each of the 100 presses was \$10 per day, and for 300 working days would be \$300,000. To allow a conservative estimate of 10 per cent. as the increase in production by use of electric power, would give \$30,000 as a clear gain, at which rate the entire electric plant would pay for itself in five years. While the mechanical departments did not show as large an increase in production per capita as the press-rooms, yet the output per square foot of floor space, with the same amount of help, was not less than 15 to 20 per cent. Mr. W. H. Tapley, of that office, says: "The benefits derived from electric power during five years of successful usage have financially purchased and maintained the entire electrical equipment."

The installation of an electric drive in shops and factories is accompanied by problems that are worthy of a most careful consideration and require good judgment. It requires a study of each kind of tool with reference to the character of work and output, and a careful selection of unit sizes. There are very few instances where electric motors cannot be used, and very many cases where the group system with each section of shafting driven by a single motor may be advantageously employed, but for all special tools and machines requiring three horse power or over, the tendency is toward the use of a separate motor for each machine. To adopt a single system of electric current for a shop or factory, from which all the apparatus can be operated demands a careful knowledge of the various machines and a proper installation to meet the work required of them.

The induction motor has advantages in the absence of a commutator, brushes and brush holders. It is very simple in construction, is cheap in first cost, and the only attention it requires is that of oiling. It runs at nearly constant speed, which offers special advantages for driving line shafting. As a system, the alternating current is without a doubt the only one for long-distance transmission, on account of the comparatively small amount of loss of power in the transmission line, and can be generated at low voltage, transmitted at high voltage and used at the motor at low voltage.

The direct current motors for independent tool driving have advantages in the ease with which they can be regulated and run at different speeds, to which the increase in output of a shop is largely due. The starting power is greater and the current required in starting is less than that of the induction motor. Direct currents are less complicated for lighting purposes than the three-phase system on account of the necessity of keeping the current equal in the three branches. The direct-current motors are not affected by wide or sudden variations in voltage and give good efficiencies.

Both the direct and alternating currents have their good points and work hand in hand for a common purpose. There are certain cases where one system is almost a necessity over another. For example, in long-distance transmission the alternating current is without question the better. The best operation for cranes, hoists and transfer tables is effected by the direct current, and for constant-potential, direct-current arc lamps have long shown themselves efficient, durable and satisfactory. The chief drawback to the direct current machine has been the wear of the commutator and the considerable attention they required. During the past few years much has been done to remedy that trouble, and motors are now being equipped with commutators which show a wear of but 1/64 in. per year and the use of carbon brushes, that wear only 1/32 to 3/4 of an inch per year. These important improvements place the direct-current motors fairly on a par with the alternating-current machines.

These opinions were expressed by different speakers in a discussion before the Franklin Institute of a paper by Mr. John F. Rowland, Jr., upon "Electric Distribution of Power in Workshops."

CORRESPONDENCE.

FREIGHT CAR PAINT.

To the Editor:

There is no small amount of complaint at the present time of the short life of freight car paint—that it becomes flat and dead, loses its gloss in a short time, in a month, in fact, and the one who complains, if he be an old man, will add that "they made better paint before the war." There is much truth in this.

From 1861 to 1865 linseed oil became scarce and high priced. As a substitute, rosin oil, diluted with coal oil, was largely sold, with the result that paint made of this oil lost its gloss in three weeks, although it started out with a fine gloss. The paint faded rapidly, checked, blistered, became soft and sticky in summer, cracked into small squares, and looked like white-wash, and was gone in two years, whereas pure linseed oil paint held its gloss for 90 days, and its only fault was the time it took to dry in.

After the war, when linseed oil came to a reasonable price, the sale of rosin oil diluted with coal oil dropped off. Taking advantage, however, of the poor drying qualities of linseed oil, manganese was added to the rosin oil mixture, and soon appeared under the name of a dryer, japan oil dryer, etc., and was again in favor, as the manganese gave up its oxygen and greatly hastened the drying of linseed oil. Rosin oil was worth probably 20 cents a gallon, and coal oil 8 cents, while manganese is very cheap, and thus railroads were induced to buy a lot of rosin and coal oil, which ruined the linseed oil paint with which it was mixed for the sake of getting a little manganese, which alone has any effect on the drying of linseed oil, which is shortened in life in proportion as anything else is mixed with it.

Linseed oil is often diluted or compounded in order to cut the straight market price on the pure article. Coal oil is very often used, and coal oil, cotton-seed oil, corn oil, etc., are always present in any paint oil pretending to be linseed oil, that is sold under the market price. Another favorite mixture is 40 per cent. linseed oil, 25 per cent. coal oil, and the balance rosin oil, with sufficient manganese to act as a dryer. In linseed oil paint any addition whatever of other oils or materials ruins the life just in proportion as they are used. A dryer is often necessary, and manganese is as cheap and harmless as anything that can be used. Railroads whose freight cars in a month look dead and flat, after being repainted, will find the trouble to be the use or mixture of rosin and oils cheaper than linseed with it, to cheapen it, or to act as "dryers."

CAR BUILDER.

RATIOS OF TOTAL WEIGHT TO HEATING SURFACE IN RECENT LOCOMOTIVES.

A correspondent in South America desires information concerning practice in this country with reference to proportions of cylinders, heating surface and grate area. The question brings out a feature in locomotive proportions which has not received much attention and is perhaps of general interest.

The following are the proportions recommended by the Master Mechanics' Association in 1897:

1. The ratio of grate area in square feet to total cylinder volume in cubic feet should not be less than 4 for large anthracite coal, 9 for small anthracite coal, and 3 for bituminous; all for simple locomotives.
2. The ratio of heating surface in square feet to total cylinder volume in cubic feet should not be less than 180 for large and 200 for small anthracite coal, and 200 for bituminous coal; all for simple locomotives.
3. The ratio of heating surface to grate area should not be less than 40 for large and 20 for small anthracite coal, and 60 for bituminous coal, etc.

These are, no doubt, the best limits to the ratios between these factors, but there is a growing tendency to separate the question of grates from that of heating surface and cylinder capacity, and to treat each factor by itself; the cylinders with reference to the desired hauling capacity and weight, the heating surface with reference to the weight, and the grate

area with reference to the kind and quality of fuel. In several recent designs in which the maximum power was required within fixed limits of weight, the problem centered in the heating surface, and the designers tried to get as much surface as possible. The grate question was decided by the fuel and the cylinders chiefly by the work to be done. The results apparently justify the conclusion that in future the idea of following fixed ratios will be abandoned except as a mere matter of comparison. While it is not strictly true that the steam-making capacity, and, therefore, the real power of the locomotive, depends upon the extent of heating surface, there is no question of the desirability of large heating surfaces. The larger these are, providing they are effective, the better the steam-making properties will be.

In describing the new Atlantic type locomotive for the Baltimore & Ohio Railroad last month it was noted that this engine had more heating surface for its weight than any locomotive of which we had record. This brought up the necessity for a new basis of comparing locomotives. While the statement is literally true, the ratio between the total weight and heating surface of the engine is greater than in a number of other recent designs. If the assumption that power depends upon heating surface is fair, the use that is made of the weight should form the basis of comparison. If it is not fair, a strong tendency in locomotive design of the present time is wrong. The following table reveals the relation between the total weight and the heating surface of a number of notable locomotives by several of the most prominent builders, and it may be said to show how well the weight of such locomotives has been utilized to obtain the desired heating surface.

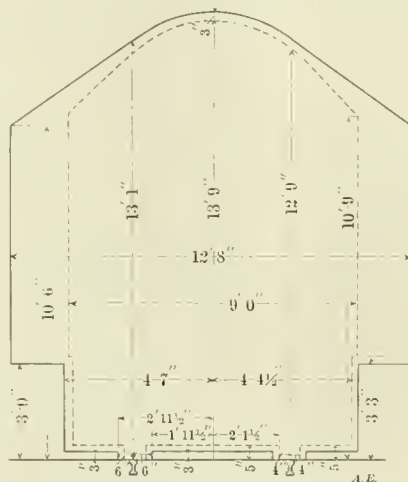

Midland Railway, England.

COMPARATIVE STRUCTURE GAUGES.

Great Northern Railway (United States) and Midland Railway, England.

The restrictions placed upon the builders of English locomotives, in consequence of the limitations caused by tunnels, bridges, platforms and buildings, is plainly evident from the accompanying engraving of the standard structure gauge of the

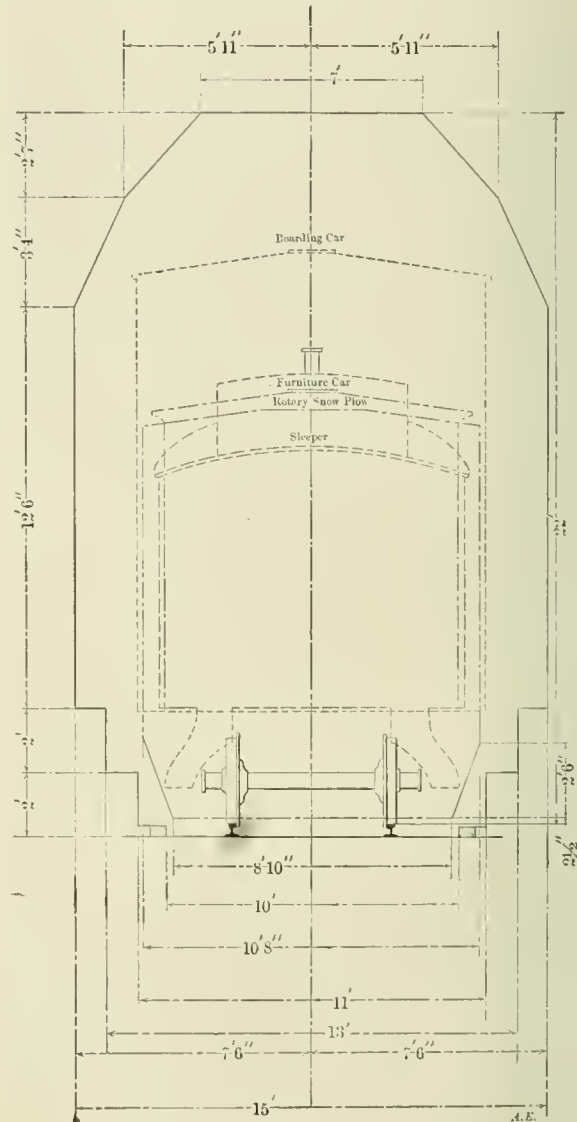

Great Northern Railway, United States.

Name of Road.	Engine Number.	Total Weight.	Total Heating Surface.	Total Weight Divided by Heating Surface.
N. Y. Central.....	2,980	176,000	3,505	50.20
Lake Shore.....	650	174,500	3,343	52.18
C. & N. W.....	1,015	160,000	3,015	53.06
L. V.....	681	225,082	4,105	54.85
B. & O.....	1,450	150,000	2,653	56.50
B., C., R. & N.....	77	158,600	2,551	62.17
C. B. & Q.....	1,591	159,000	2,500	63.60
Can. Pacific.....	209	159,000	2,401	66.00
Pennsylvania.....	820	159,000	2,401	66.00

Note.—All are passenger locomotives, except that of the Lehigh Valley.

It may be said in the light of the practice of the past few years that this is the best way to compare the work of locomotive designers, and that it reveals the skill at the drafting-table stage of locomotive construction better than any other method.

When it is noted that of the two engines standing highest in this list one is an Atlantic type with outside bearings for the trailing wheels, involving heavy supplemental frames, and the other has six-coupled wheels, it will be understood that these figures represent a great deal of engineering skill. The Lake Shore engine referred to is the new "Class J," illustrated in this issue. It should be borne in mind that three pairs of drivers and two pairs of truck wheels involve more weight in the running gear than two pairs of drivers and three pairs of truck wheels. Such a low ratio as 52.18 in a six-coupled engine and 50.20 in an "Atlantic" type are surprising and commendable.

Midland Railway of England, as compared with that of the Great Northern Railway of this country, which has one of the largest minimum cross-sections. With the two-cylinder compound locomotives of this country it is customary to flatten the cylinder casings of the low-pressure cylinders when the diameter approaches 3 ft., but with the mogul freight locomotives built recently by the Schenectady Locomotive Works for the Midland Railway, and pictured in our July, 1899, issue, it was necessary to flatten the castings of 18-in. cylinders. This shows the limitations necessarily placed on the width of English locomotives. The dotted lines in the engravings refer to the largest outside dimensions of the rolling stock of these two roads, and the solid lines the largest minimum fixed structures. Considerable difference is shown in the clearance distances, particularly in the height from rail to lowest point of fixed structures. This instance in the case of the Midland Railway is 14 ft., as against 22 ft. on the structure gauge of the Great Northern, showing that the English locomotive has about

reached its limit both in height and width with the present conditions of the structure gauge, while the roads of this country have clearance space sufficient for considerable further development of the present locomotive.

The accompanying engraving of the Midland structure gauge was prepared from a drawing received through the courtesy of Mr. S. W. Johnson, Chief Locomotive Superintendent of the Midland Railway. It should be stated here that the Great Northern diagram is an unusually large one, even for this country.

CULM-BURNING SWITCHING LOCOMOTIVES.

Delaware, Lackawanna & Western Railroad.

Mr. T. S. Lloyd, Superintendent of Motive Power of the Delaware, Lackawanna & Western Railroad, has designed new

Cylinders	19 by 24 ins.
Boiler, type	Radial stay straight top, wide firebox
Boiler, diameter at small ring62 ins.
Boiler, thickness of sheets	9/16 ins.
Boiler pressure	180 lbs.
Fuel	Fine anthracite
Firebox, material	Steel
Firebox, length	102 ins.
Firebox, width	36 ins.
Firebox, depth	Front, 58 1/4 ins.; back, 49 1/2 ins.
Firebox, thickness of sheets	Sides and back, 3/8 in.; crown, 3/4 in.; tube sheets, 9/16 in.
Tubes	Number, 270; diameter, 2 ins.; length, 12 ft.
Heating surface, firebox	170 sq. ft.
Heating surface, tubes	1,700 sq. ft.
Heating surface, total	1,870 sq. ft.
Grate area	63 sq. ft.
Driving wheels, diameter outside	51 ins.
Driving wheels, diameter centers	44 ins.
Driving axle journals	8 by 11 ins.
Wheel base, driving	12 ft.
Wheel base, rigid	12 ft.
Wheel base, engine and tender	36 ft.
Tender wheels, diameter	33 ins.
Tender journals, diameter and length	1 1/4 by 8 ins.
Tender, tank capacity	3,200 gals.

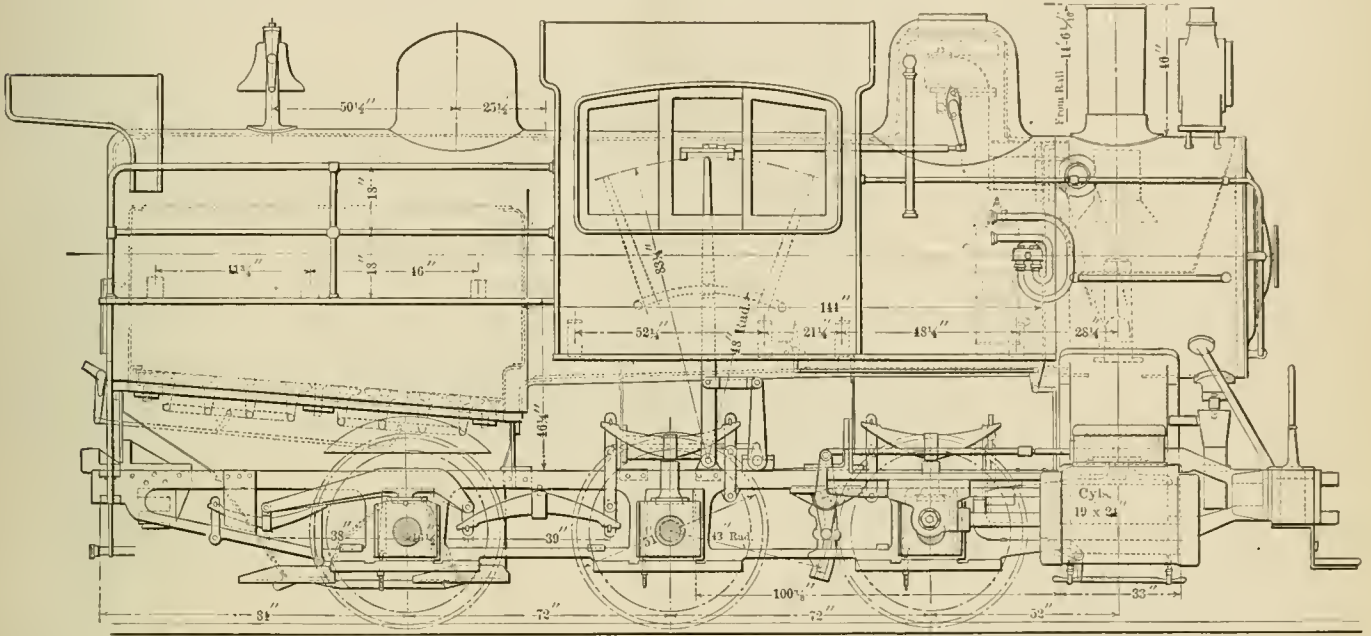

Culm-Burning Switching Locomotive—Delaware, Lackawanna & Western Railroad.

T. S. LLOYD, Superintendent Motive Power.

DICKSON LOCOMOTIVE WORKS, Builders.

six-wheel switch engines for that road embodying his ideas as to grate area and heating surface required for culm-burning with a view of economical operation which he finds exceedingly important even with low-priced fuel. An order of 14 of these engines is now under way at the Dickson Locomotive Works, Scranton, Pa. A side elevation of the design is shown here. The proportions of the engines are given in the appended table.

Special care was taken to secure uniformity of loading upon the driving wheels, the object being to obtain exactly 39,333 lbs. upon each wheel or a total of 118,000 lbs. The wide variation of weight among the wheels of a number of recent locomotives was considered objectionable. The firebox has easy curves and no straight portions and special attention was given to the boiler bracing, to distribute the stresses in order to avoid recent difficulties with the deformation of outside sheets due to concentration of the stresses of the bracing. The frames are heavy and in all particulars the design was carried out as carefully as in a road engine, which is somewhat unusual for locomotives for yard service. In the cab the same thought was applied in order to place every device used by the engineer within easy reach. This is generally receiving more attention than formerly.

General dimensions:

Weight on drivers, working order	118,000 lbs.
Weight of engine, total	118,000 lbs.
Weight, total of engine and tender	189,000 lbs.

With a conscientious persistency characteristic of the man, Mr. G. W. Rhodes is conducting a vigorous agitation looking to a proper maintenance of air-brake apparatus. He does not mince matters in the least, but in a very quiet and forcible way shows the absolute necessity for keeping air brakes in good condition. The January meeting of the Central Railway Club was devoted to this subject, the impression given being that for some reason, probably oversight, this apparatus is all but universally neglected and even the easy requirements of the M. C. B. Association as to cleaning triples once a year is not observed. That a triple valve will work at all when neglected for five years is strong evidence of good apparatus, but there is a penalty for such neglect. In the discussion referred to, Mr. Quereau told of a runaway train on a 3 per cent. mountain grade 5 miles long, the speed of which caused the engine to break 24 85-lb. steel rails in 27 places. This was due to defective maintenance of the brake apparatus. No other damage was done, but is it necessary to wait for a tragedy to awaken interest in such a question?

Plans have been prepared for a new \$2,000,000 station in Chicago for the Lake Shore and Rock Island roads, to be built on the site of the present structure. The new station will occupy the entire space between Pacific Avenue and Sherman Street, with a frontage about 30 ft. greater than that of the existing building. The waiting room is to be on the level of the elevated tracks of the Union Loop.

PERSONALS.

Mr. T. F. Brady has been appointed Master Mechanic of the Mexican Central at Chihuahua, Mexico, in place of Mr. H. W. Ridgway, resigned.

Mr. L. Larrieu has been appointed Master Car Builder of the Chicago, Rock Island & Pacific Railway, in the place of Mr. J. Randell, resigned.

Mr. H. C. Pearce is appointed Purchasing Agent of the Minneapolis, St. Paul & Sault Ste. Marie, with headquarters at Minneapolis, Minn., vice Mr. J. E. Shaughnessy, resigned.

Mr. C. W. Lee, Foreman of Locomotive Repairs of the Southern Railway at Greensboro, N. C., has been appointed Master Mechanic of the Seaboard Air Line at Raleigh, N. C.

Mr. J. Ogden Armour was at a recent meeting of the directors of the Chicago, Milwaukee & St. Paul elected a director, to fill the vacancy caused by the death of his father Philip D. Armour.

Mr. Harry Bennett has been appointed Master Mechanic of the Juniata shops of the Pennsylvania, at Altoona, Pa., to succeed Mr. T. R. Browne, resigned to become Works Manager of the Westinghouse Air Brake Company.

Mr. Edward Mahler, formerly Purchasing Agent of the New England and later in the service of the New York, New Haven & Hartford, has been appointed Purchasing Agent of the Boston Elevated in place of the late John Sever Tebbets.

Mr. Palmer C. Ricketts, Director of the Rensselaer Polytechnic Institute of Troy, N. Y., has been elected President and Trustee of that institution to succeed the Hon. J. H. Peck, resigned. Mr. Ricketts is a distinguished practical engineer and has for many years been a frequent contributor to scientific literature.

Mr. J. E. Muhlfeld, Master Mechanic of the Grand Trunk at Fort Gratiot, Mich., has been appointed Master Mechanic in charge of the locomotive shops at Montreal, Que., vice Mr. A. G. Elvin. Mr. J. McGrath has been appointed Master Mechanic in charge of the Fort Gratiot shops with headquarters at Fort Gratiot, Mich.

Mr. W. O. Thompson, Traveling Engineer of the Toledo division of the Toledo, St. Louis & Western, has been appointed Master Mechanic with office at Delphos, O., and Mr. Edward Elden, formerly with the Lake Shore & Michigan Southern, at Buffalo, becomes Master Mechanic of the St. Louis division, with office at Charleston, Ill.

The Purchasing Department of the Lake Erie & Western will be transferred about March 1st from Indianapolis, Ind., to Cleveland, O. Mr. W. F. Goltra, who has been in charge at Indianapolis, will go to Cleveland as Chief Clerk to Mr. F. H. Greene, who is Purchasing Agent of both the Lake Erie & Western and Lake Shore & Michigan Southern.

Mr. Edwin G. Russell who was, until September 1st, 1901, General Superintendent of the Delaware, Lackawanna & Western, Scranton, Pa., has been appointed Manager of the Intercolonial Railway, with headquarters at Moncton, N. B., in place of Mr. David Pottinger, who is to be Chairman of the new railway association to be created by Parliament.

Mr. Roger Atkinson, Superintendent of Rolling Stock of the Canadian Pacific, has resigned, after 19 years' service with that company. Of those 19 years, he spent 8 years as Chief Draftsman, 3 years as General Foreman, 2 years as Acting Mechanical Superintendent and 5 years as Mechanical Superin-

tendent. He was appointed Superintendent of Rolling Stock in April of last year.

M. M. Martin, for 17 years Superintendent of the Car Department of the Wabash, died at his home in Litchfield, Ill., February 12th, aged 69 years. Born at Sussex, England, on May 31, 1831, he came to this country when quite young, and at the age of 20 years entered railway service with the old Michigan Southern & Northern Indiana, at Adrian, Mich., as foreman. After serving 7 years in this capacity he was made Master Car Builder of the St. Louis, Alton & Terre Haute, which position he filled for 7 years. He also served 7 years as Master Car Builder of the Ohio & Mississippi; 1 year as Superintendent of the Indianapolis Junction; 2 years as Superintendent of the Litchfield Car Works at Litchfield, Ill.; 2 years as Master Car Builder of the Southern lines of the Illinois Central and 4 as Vice-President of the Litchfield Car & Machine Company. The last position he left in 1884 to become Superintendent of the Car Department of the Wabash.

William C. Baker, originator of the famous Baker heater, was killed on Feb. 6 by a train on the tracks of the Erie Railroad, near Montclair, N. J. Mr. Baker is best known in railroad circles by his connection with the Baker Heating Company, and his work in the matter of heating cars. During his career he had taken out something like 43 patents, of which his system of heating passenger cars by the use of steam from the locomotive, a safety explosive vent and the Baker heater, are the best known and most extensively used, both in this country and abroad. Mr. Baker was born in Dexter, Me., July 25, 1828, where he spent the early part of his life. He came to New York about 50 years ago and was the founder of the firm of Baker, Smith & Co., and later a promoter of the New York Steam Heating Company. At the time of his death he was carrying on business in his own name as successor to the Baker Heater Company. Mr. Baker is mourned by two daughters, one living at Montclair, at whose home he has been spending the winter. In all railroad circles he was known as energetic and very enterprising, and his work will not soon be forgotten by the traveling public.

During a recent trial test of the ice breaking steamship "Ermack," to penetrate ice in the Arctic Ocean, the vessel was struck in a comparatively weak underpart of her hull by a low-lying block of ice, which caused a leak. This accident occurred after she had steamed north from the north-west of Spitzbergen, breaking through fields of ice 13½ to 15½ ft. in thickness with comparative ease. It was not until several accumulations of ice 49 ft. thick and over 20 ft. high from the surface of the sea had been encountered and broken that she was disabled and compelled to return to her dock at Newcastle. The "Ermack" has a displacement of 8,000 tons and 10,000 h. p. Of the total horse-power, 2,500 is developed by the forward engine and used to drive a forward screw. This screw was found to be useless in the polar seas, so that the forward engine was not used, sufficient power being developed with the remaining engines, while running with moderate steam, to break through the hardest ice in that region. The conclusions from these tests are that an ice-breaking steamship in the Arctic Ocean must not only be strengthened in her front part down to the water line, but the whole extent below the water, and that the forward screw cannot be used in the polar seas.

A sentence of 11 years in the State prison at Thomaston, Maine, has just been imposed upon George White, of Wells, in that State, for throwing a stone through a car window and tampering with a switch. Such dangerous acts should be stopped and the report of the severe sentence should be brought to the notice of those likely to be tempted to commit them.

THE "HANDY" COMBINATION BOX AND GONDOLA CAR.

To reduce the proportion of empty to loaded car mileage is the object of a number of designs of cars with a view of rendering them convenient for various kinds of special traffic. The design known as the "Handy" car, which is controlled by Mr. C. L. Sullivan, was designed to serve both as a box and a gondola car. It has the usual large side doors and four additional doors through which the lading may be conveniently handled.

The novel features are in the construction of the sides and

but the outside sheathing extends from the belt rail to the top of the plate in the usual manner. In this construction vertical tie rods and angle braces are unnecessary and are omitted.

There is nothing unusual about the middle doors, and any form of grain door may be employed. The auxiliary doors are made to close flush with the siding and are automatically locked on the inside, rendering seals unnecessary.

A claim for superior strength for this construction as compared with an ordinary box car is based upon the use of the steel posts. A largely increased internal capacity for load-

ing is obtained by reducing the thickness of the walls from the usual 4 or 5 ins. to 2¼ or 2½ ins., and in addition to this the sides of the car are battered. Tunnel clearances deter-

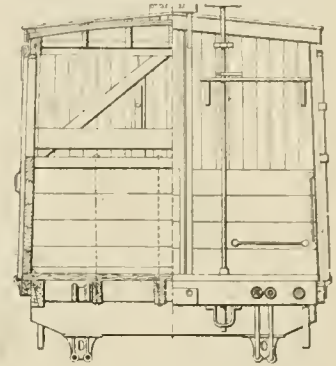

The "Handy" Combination Box and Gondola Car.

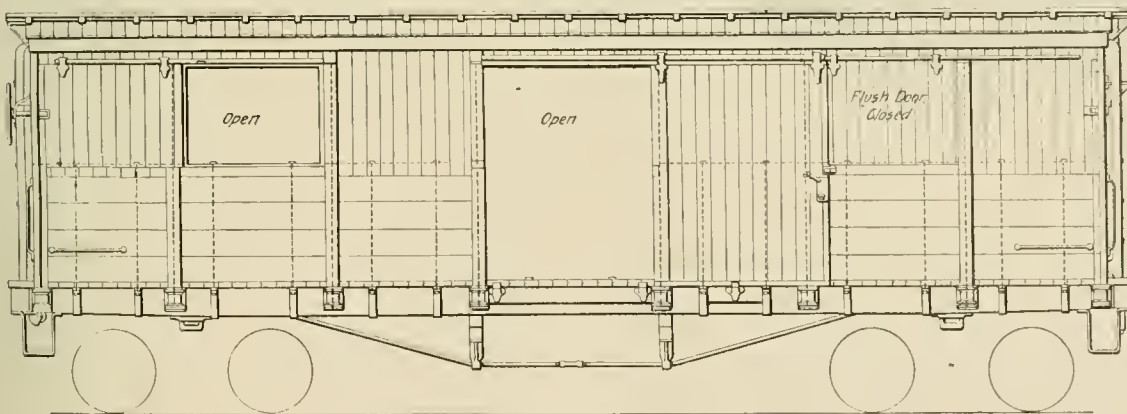

The "Handy" Combination Box and Gondola Car.

ends. The roof construction above the carlines may be of any desired form, and the same applies to the construction from the floor to the rails. Stake pockets are used to receive the ends of the posts, and the ends of the carlines are secured to the plates by malleable brackets. Angles or tees are used for the corner posts and also end, side and door posts. The siding from the belt rail down is in short lengths of 2¼-in. hoards cut in panels to fit between the steel posts; and in order to form a slot to receive the ends of the hoards, a flat plate is secured to the flanges of the angles forming the posts. Strap bolts similar to those used in gondola cars extend from the belt rail through the ends of the floor planks and through brackets secured to the side sills. The end boards are in one piece across the car. The usual inside sheathing is omitted, and the car is flush on the inside from the belt rail down;

mine the width of the roof, but instead of running the sides down vertically, the usual way in box-car construction, the sides are battered outward, making the floor from 4 to 6 ins. wider than usual. It is claimed that to secure as great volume for loading in an ordinary box car the cost would be greater than in this design; also that the use of short lengths of lumber reduces the cost \$4 or \$5 per thousand feet. The cost of the steel posts is believed to be less than that of wood for these parts. The accompanying engraving shows a photograph of a car taken after 14 months of hard service and no repairs of any kind were required, though the car was used on one of the leading trunk lines. This construction is protected by United States and foreign patents. Mr. Sullivan will be glad to furnish additional information; his address is 1425 Old Colony Building, Chicago.

A LARGE GAS ENGINE IN IMPORTANT SERVICE.

When fairly started in this country the gas engine will make rapid progress, but as yet we are far behind foreigners in appreciating it. The gas engine is not yet perfect, but there seems to be no reason for delaying longer to accept it as a reliable substitute for the steam engine. The gas producer has had a parallel development with the gas engine in other countries and we may expect equally good results here.

The leaders in the construction of large gas engines are the manufacturers of the Westinghouse engines. These are now made in sizes up to 1,500 h. p. They are in use for operating electric light and power apparatus in manufac-

switchboard and the compressed air apparatus used to start the large engine.

Instead of omitting an occasional charge of the gas and air mixture, the speed regulator, a two-ball centrifugal governor, resembling those in general use, causes the admission ports of the cylinder to be kept open for longer or shorter periods of time, thus admitting more or less of the gaseous mixture according to the demands of the loads. This is precisely analogous to steam engine practice and is claimed to produce equally good regulation. Regulation of speed, especially in the operation of electric machinery, is of first importance, and upon the attainment of this feature the success of the perfected gas engine rests.

Of vital importance also is the question of thermal efficiency, and in this regard the gas engine easily leads. Some recent tests of this type of engine in actual use show an efficiency of over 25 per cent., one horse-power-hour having been obtained repeatedly on a consumption of gas that represented only 10,000 thermal units. As this is practically twice the efficiency of the average high-grade modern steam engine, the advantage possessed in this respect by the gas engine is seen to be an important one.

In a rapidly increasing number of cases producer and furnace gases are becoming available for gas engine work. So great, indeed, is the efficiency of the gas engine and so little attention does it require that in many cases where only the relatively expensive illuminating gas is available gas engines of smaller sizes are operated

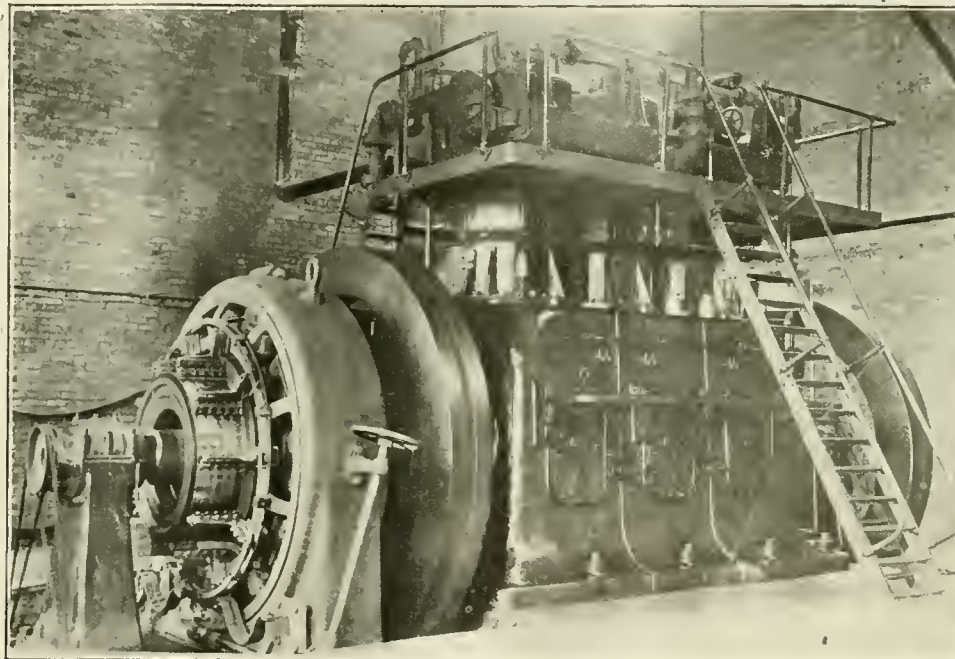

Three-Cylinder 650 H.-P. Westinghouse Gas Engine Driving a Direct-Current Generator.
Howard Axle Works, Homestead, Pa.

ories, and for driving electric street railway generators, and in general power service.

We show herewith an illustration of a Westinghouse gas engine which is now in operation at one of the Carnegie company's properties at Homestead. It is of 650 h. p., and is direct-connected to a direct-current generator, furnishing power to a large number of motors used for driving lathes and a variety of other machine tools; also electric cranes, furnace blowers, etc. Power is furthermore supplied for arc and incandescent lamps. This engine runs night and day without intermission for considerable periods, runs of 260 hours under load having been made thus far, while undoubtedly far longer runs are entirely feasible if the work demands them.

The engine is of the three-cylinder type and three ignitions occur in every two revolutions. This frequency, with a fly-wheel keyed upon each end of the shaft, suffices to give a speed regulation so close that the voltage of the direct-connected generator is maintained at a fixed point with precisely the same certainty that marks the best steam engine. The engine at Homestead is supplied with gas from the mains of the Carnegie company, so that there is no apparatus installed in connection with this power service which in any way corresponds to the boiler plant necessitated by the steam engine installation. The floor space given over to the production of 650 h. p., and its conversion into electric power measures only 29 by 11 ft., excepting the small areas occupied by the

by this means at surprisingly low running costs.

Recent tests of the Diesel oil engine described in "Engineering" showed a thermal efficiency of 30.7 per cent. This is remarkable in view of the fact that the best steam engines of about 1,000 h. p. give only 15 or 16 per cent. The mechanical efficiency of the Diesel engine was, however, low, about 30 per cent. of the power being required to operate the special air pump to give the necessary pressure of about 800 lbs. per square inch. The initial cylinder pressures were about 500 lbs. per square inch. Such high pressures obviously require the best of material and fine workmanship and all joints, including the piston packing, must be tight.

Strong endorsement was given to the practice of burnishing journals of car axles in a recent discussion before the Northwest Railway Club. Mr. Roope, of the Great Northern Railway, said: "I do not see how we can expect to get good results from axles, the journals of which have not been rolled, unless we put them in a slow train and endeavor to break them in. When a journal on a new axle is rolled and an old journal is placed alongside it, with a strong glass you cannot tell which is the old and which the new one." He also spoke of a lot of hot boxes on a car, developed before the car had gone 50 miles. Investigation showed that the journals had not been rolled. On that road a high place is given to this simple and inexpensive precaution. Why is it not a good plan for general adoption?

VARIABLE EXHAUST NOZZLE FOR LOCOMOTIVES.

GOOD USE OF THE TECHNICAL PAPERS.

Plant System.

To do away with much of the unnecessary work on the front end of locomotives, in the matter of bridging and bushing nozzle tips, Mr. Symons, Superintendent of Motive Power of the Plant System of Railways, has devised a variable exhaust nozzle, the accompanying engraving of which was prepared from drawings received through the courtesy of Mr. Symons. While no specific claims for economy are made for this device, he believes it is quite a factor in the saving of fuel and eliminating boiler repairs, both in the firebox and front end. The nozzle, which is shown in vertical section, is similar to the ordinary single-tip nozzle, with bosses on each side of the nozzle to allow the V-shaped bridge $\frac{3}{4} \times \frac{3}{4}$ in., which is shown in a horizontal position in this view, to swing vertically downward. When in the latter position, this bar or bridge fits into a $\frac{7}{8} \times 1$ -in. triangular groove in the side of the nozzle made to receive it. The section at A B shows

The practice of the Schenectady Locomotive Works concerning the technical periodical literature should be widely noted and copied. It is the duty of one of the clerks to insert a printed slip between the pages of every paper regularly received at the works and start it on its course among the officers. The slip contains the following:

Schenectady Locomotive Works.

In order to permit as many as possible to look over such current periodicals as are received by the company as soon as possible after publication, you will kindly see that this journal is forwarded from your office within two days of its receipt as directed below:

Forwarded by.	To.	Date received.	Date forwarded.
(The officers' names are printed here.)	(Names here.)

It will be filed in the correspondence room when returned and may be referred to at any time desired.

When returned to the correspondence room the various articles upon locomotive subjects are carefully indexed in a card catalogue which is kept up to date and available for reference. The papers are bound and kept in the library.

Mr. R. H. Soule introduced a somewhat similar plan on the Norfolk & Western. He kept the files of papers in his office, but, before filing them, various articles were marked and the subjects assigned to different subordinates for examination and report, with a view of ascertaining the value to that road of the suggestions contained in the practice of other roads. The articles were then indexed and the papers bound at the end of the year.

It should not be forgotten that these periodicals are prepared by men who spend all their time watching progress with a view of presenting new ideas or new applications of old ones. It is worth while to suggest the advisability of appointing to a draftsman, or other subordinate, the duty of studying the current railroad literature with a view of guarding against the escape of an idea that might profitably be applied but is now passed unnoticed because it is no one's special business to attend to it. This is one way in which the drafting room might be made more helpful.

The M. C. B. committee on triple valves have recently completed tests of a new form of triple submitted by Mr. R. Fitzgerald, General Superintendent, Chicago Junction Railway. The tests were made upon the association rack in the laboratory of Purdue University. They were conducted by Messrs. G. W. Rhodes, W. S. Morris and William McIntosh, representing the M. C. B. committee. The committee was assisted by Mr. A. J. Cota, Air Brake Instructor of the Burlington system; Mr. W. P. Huntley, Jr., Air Brake Instructor of the C. & O. R. R., and also by members of the instructional corps and by students of Purdue University. The owner of the valves was represented by Messrs. Harvey S. Park and M. W. Hihbard.

Hydraulic tools have made an important place for themselves in various branches of railroad work in the shop, on construction work and in wrecking. They, particularly hydraulic jacks, are indispensable, and it is surprising to find in a recent discussion before the Western Railway Club that these tools are considered unreliable. An implement of this kind needs care, and the character of the questions raised on the occasion referred to indicated a lack of knowledge as to even the composition of the liquid used in the jacks. They should be filled with one part of pure grain alcohol diluted with two parts of water, and then if the packing leathers are changed often enough the hydraulic jack will work. At least this is the judgment of those who take care of such tools.

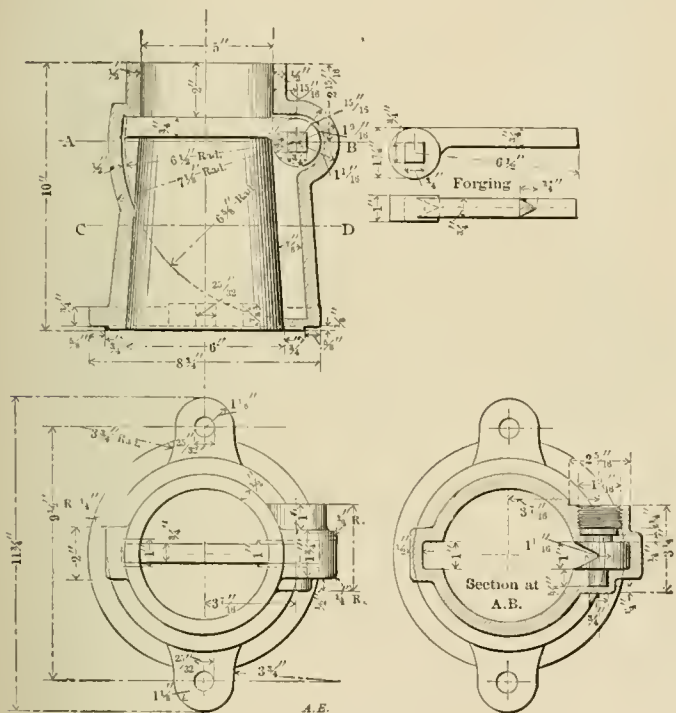

Variable Exhaust Nozzle.

the bosses cored out to admit the bridge, which is pivoted at one end on a 1 1/16-in. pin, long enough to pass through the smoke arch. This bridge is free at the other end to swing up to a horizontal position against a shoulder in the casting, or it may be turned down out of the way. This appliance is rigged with a 10-in. lever, which fits on the free end of the pin, which passes through the bridge to the outside of the smoke arch. A reach rod connecting to the lever passes through the cab to a position convenient for the engineer. Notches are made on the reach rod so as to lock the bridge in the desired position. It is obvious that the pulling power of a locomotive can be increased by reducing the back pressure to a minimum, when certain conditions are favorable to use the maximum size of opening. Cards taken from a ten-wheel passenger engine built by the Richmond Locomotive Works for the Plant System, over a year ago, and equipped with the nozzle, show a difference of from 60 to 100 indicated horse-power between the open and the closed nozzle. The device is not an expensive one to make and could be easily applied to any single-tip nozzle.

THROTTLE VALVE TAKING STEAM FROM THE TOP OF THE DOME.

Baldwin Locomotive Works.

The throttle valve illustrated by this engraving was designed with a view of taking steam from the top of the dome only, thus preventing the admission of wet steam to the dry pipe, which must necessarily occur at times with the ordinary throttle taking steam from both top and bottom of the valve. It is believed that the difference of 10 ins. in height, which is the height of the valve in this case, will have a marked effect upon the dryness of the steam.

The drawing shows the construction very clearly. The opening in the dry pipe under the valve is closed by a close-fitting

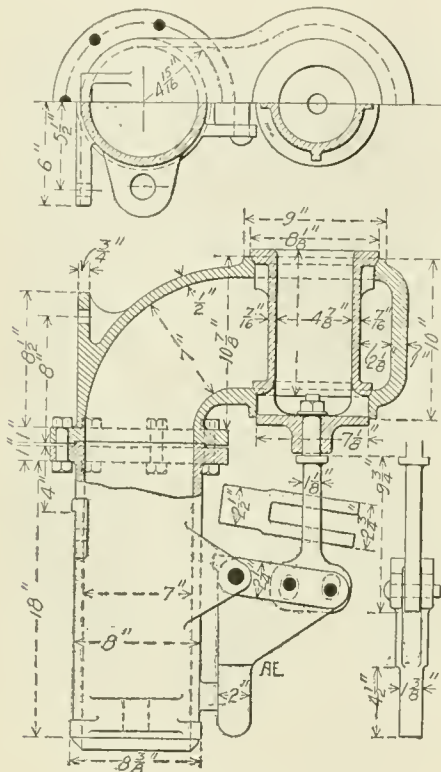

Improved Locomotive Throttle.
Baldwin Locomotive Works.

circular plate, and, by making the valve hollow, steam may enter the pipe under both the flanges of the valve, but it must all come from the space in the dome above the valve.

The engraving also shows the double pin leverage of the bell crank which operates the throttle. During the first part of the movement of opening, the bearing of the valve is upon the inner pin. This gives a greater leverage and slower motion to the valve than it has during the remainder of its motion when the outer pin takes the weight of the valve. This feature, however, is not new.

We are indebted to the Baldwin Locomotive Works for the drawing of this improved throttle, which was the subject of a patent by Mr. K. Rushton.

At the February meeting of the New York Railroad Club Mr. Willard C. Tyler read an elaborate and instructive paper upon Japan, with particular reference to the transportation facilities and national characteristics, presenting a large amount of information which has not before been put into print. The speaker spent two winters in Japan and described conditions which travelers seldom see. Mr. Tyler is a close observer and his account of the country was intensely interesting. The proceedings of the club will contain the paper in full.

A "STUD NUT" FOR SCREWING IN STAY BOLTS.

The Master Mechanics' Association last year discussed methods for screwing stay bolts into locomotive boilers, and in connection with the forms of staybolts means for turning them in without squaring the ends for wrenches were mentioned. In the discussion Mr. T. R. Browne, then of the Pennsylvania, described a simple device which he was using with good results. It is illustrated by means of the accompanying engraving, made from a sketch, and the following description is taken from the published report of the convention:

"We round off the end of the bolt to a radius which we have found to be satisfactory, and which, with the least amount of hammering on the end, will properly cause it to fill up the threads in the sheet. For the purpose of screwing in these bolts, which we do, either from the inside or outside, according

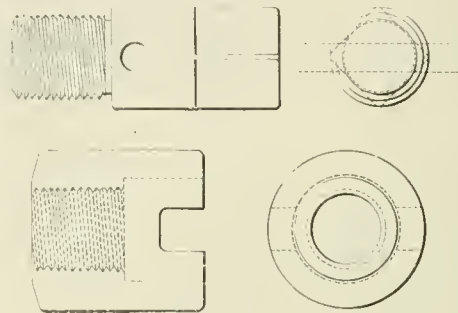

A "Stud Nut" for Staybolts.

to the angle at which they are with reference to the sheet, we have what might be called a stud nut, consisting of a sleeve tapped out in one end to suit the bolt and beveled off so as to clear the angle that the sheet forms with reference to the bolt, and in this sleeve is a plug with a square end. Through the plug and the sleeve is a tapered pin fitting a hole in the plug, and which also fits a slot in the sleeve. It is obvious that you can screw it tightly on the end of the bolt, taking up enough threads to hold, and when you unscrew it the plug will back away, leaving the sleeve stationary until the pin is brought up against the slot in the sleeve. Then the whole device can be unscrewed from the end of the bolt and used on the next bolt. Where the angle of the bolt with reference to the sheet is very great, frequently there is no thread on one side to get hold of the bolt. In cases of that kind we screw it in from the inside of the boiler."

A number of important appointments have recently been made on the faculty of the Massachusetts Institute of Technology, no less than ten instructors having been promoted to the rank of assistant professors. In the chemical department, Dr. Henry Fay becomes Assistant Professor of Analytical Chemistry and Metallography; Dr. Jas. F. Norris, Assistant Professor of Organic Chemistry; Dr. F. H. Thorp, Assistant Professor of Industrial Chemistry, and Dr. W. R. Whitney, Assistant Professor of Theoretical Chemistry and Proximate Analysis. In the department of physics, Messrs. L. Derr, C. L. Norton and Dr. G. V. Wendell were promoted Assistant Professors. The list of promotions in the department of mechanical engineering includes three Institute graduates of the class of '92—Messrs. Charles E. Fuller, William A. Johnston and Charles F. Park. All three have been connected with the Institute continuously since their graduation in work of increasing responsibility. Each of them has given instruction in drawing and in mechanical engineering laboratory work, while Messrs. Johnston and Park have also conducted classes in mechanism. Mr. Fuller and Mr. Johnston are now conducting classes in applied mechanics in addition to aiding Professor Miller in the conduct of the laboratory; Mr. Park has charge of the mechanical engineering drawing-room and is also conducting a class in mechanism.

FRICITION SENSITIVE DRILL PRESS.

Manufactured by the Knecht Bros. Company, Cincinnati, O.

There is hardly a machine in the metal working line where the speed of the working tool changes in shorter intervals than in a sensitive drill press. It is, therefore, of great importance for time and tool saving to have the speed-controlling medium instantaneous and precise. These features are embodied in the Knecht friction sensitive drill. From the accompanying engraving of this press it will be seen that the driving mechanism consists of two cones between which is held the friction roller. The power is transmitted from the lower cone to the friction roller which transfers power to the upper or spindle cone. The roller is adjusted radially with the cones. The speed of the drill spindle is increased or diminished instantly without stopping the machine, shifting belts or without the operator changing his position; by simply sliding the friction roller frame upon which is mounted the friction roller, up and down on the cones. From one extreme to the other, a distance of only 4½ ins., any imaginable number of speeds can be obtained for any size drill, from the smallest up to and including 9/16 in. More or less driving power to the drill spindle is applied as the size of the drill or the nature of the work may require. In many of the sensitive drill presses, frequent breakage of small twist drills is an annoying occurrence, while in this machine this difficulty is overcome. Power applied can be graduated to drive with equal safety the smallest or largest drills within its range, being a wonderful economy in time and a great saving in drill breakage. The cone that drives the spindle is mounted on a sleeve or bushing which extends through both bearings in the frame, the spindle being relieved thereby from any lateral pressure which enables the machine, when properly oiled, to run any length of time without heating. This spindle sleeve or bushing has thrust bearings. The bar on which the friction roller frame slides is marked with the size of drills within the range of the machine, so that the operator can get the proper speed for any drill without loss of time by simply placing the end of the roller frame at the figures on the bar corresponding to the size of the drill to be used and holding it in position by a clamping screw. This is a necessary improvement, as it allows the operation of the machine and the manipulation of the work to the best advantage in running twist drills at just the proper speed, not too high to burn them, nor too low, which would cut down the rate of production. This press is the result of many years' experience with tools of its class, and has been designed to meet all the requirements of a sensitive drill for tool-room service and all classes of light, sensitive, rapid and accurate drilling, embodying many new and original improvements that place it in the front rank as a drill of modern and perfect design, making it simple in construction and very effective in operation for light and rapid work. This drill press is a high-grade machine tool in all respects, and has proved very satisfactory to those who have it in use. Mr. A. H. Thompson, Manager "Canadian Motors," says: "The Knecht friction sensitive drill purchased some time ago is giving entire satisfaction. It does its work beautifully, in fact, we cannot speak too highly of it." Those who are interested in drill presses should write to the Knecht Brothers Company, manufacturers of machinery and tools, Beekman street, Cincinnati, O., for circular No. 4 giving a complete description.

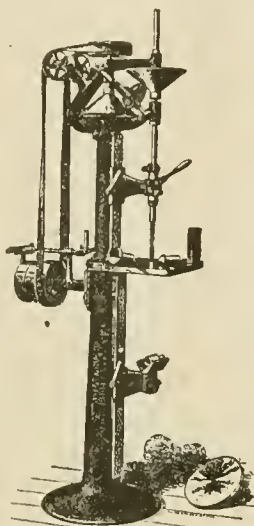

Friction Sensitive Drill.

COMBINATION TRIANGLES FOR DRAFTSMEN.

Manufactured by D. J. Kelsey, New Haven, Conn.

Mechanical draftsmen and engineering students generally will be glad to know of Mr. D. J. Kelsey's improved combination triangles, which are a means of great convenience and much time saving. The triangles are made of transparent celluloid in sizes ranging from 4 to 10 ins. They are held by a knob and well balanced, serving all angles without being reversed. They are given a slightly concave form toward the drawings, which prevents the celluloid from being scratched and also preserves the drawings. On the under surface of the larger sizes, protractors are cut, rendering the close contact of the protractor with the work very convenient for measuring or laying off angles. In the body of the triangle erasing stencils are provided, with a long, narrow slot at the bottom having thin edges. The slot is recessed so as to guide the rubber and prevent rapid wear of the slot. A simple celluloid frame is provided for these triangles whereby they may be clamped in any position, rendering the instrument an especially handy one for drawing the details and connections of lever machinery, bolt heads, screw threads, coiled springs, the teeth of worms and racks, tapers on hubs and bosses, die blocks and angle work generally. The frame has a metal edge which rests against the T-square. On the triangle alone depends its accuracy, as the frame resting against the T-square is brought up to position and clamped to the triangle, after the triangle has been set to the required angle. The parallel ruler or slipping triangles are entirely superseded by this device, which has the added advantage that it carries ruling edges for lines and their perpendiculars on any part of the drawing-board at one setting. The expense of these triangles is very small when one considers the ease and rapidity with which one is able to perform angle work, as it practically serves the place of more elaborate and expensive metal instruments with the greater advantage that it is all in one piece and not scattered over the drawing table in many pieces. An illustrated pamphlet of these instruments will be sent to draftsmen, or those who are particularly interested in draftsmen's specialties, upon application to D. J. Kelsey, 85 Cottage Street, New Haven, Conn.

REVERSING TAP HOLDER.

The accompanying engraving shows a reversing tap holder manufactured by the Ideal Machine Works, Hartford, Conn. This tool is simple and complete in itself, requiring neither a reversing belt nor special connection of any kind with the machine. It is a valuable factor in preventing the breakage of taps and will handle all sizes of machine taps up to 7/16 in.

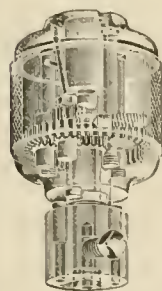

This tap-holder is attached to the spindle of a lathe or drill press with the ease and manner of the ordinary drill chuck. From the engraving it will be seen that around the body of the holder fits a loose running sleeve on the inside of which it cut an internal gear. This gear finally operates a spindle by means of two intermediate gears. The spindle extends down through the body of the holder and is so constructed at the lower end as to accommodate the various sizes of taps. The whole device is held to the machine by a driving shank which fits into a tapered hole in the top of the holder. The operation of the tool is very simple. Before it is forced up to the work or the work against the tool, the spindle is given a slight vertical movement by turning the sleeve. The two pins in the socket arrangement for receiving the taps, catch upon the two driving pins of the upper part of the holder, and feeds the tool into the work until the spindle or work holder, as the case may be, comes to a stop that has been set to regulate the depth of the work. To stop the tap the pins are

drawn off far enough to cease contact, and by a tight grip of the revolving sleeve the tap is given a reversed motion, at a speed twice as great as the forward cutting speed. These tools are much used by bicycle and typewriter manufacturers and are found to be of particular value for use in all machine shops on multiple spindle or turret drills, where work is drilled and tapped at one handling.

POROUS EMERY WHEELS.

Manufactured by the Vitrified Wheel Co., Westfield, Mass.

A composition of emery, with another cutting material for a flux, is used in this product. It is molded into any desired form such as wheels, slabs, rings, etc., and subjected to an intense heat which vitrifies the mass, giving the particles of emery and corundum a high holding power. By this process no material is used that would tend to glaze the surface of the wheel and destroy the cutting action, but the particles as they wear away, leave the wheel. Such porous wheels may be said to be self-sharpening and cut as freely when nearly used up as when first put into use. The porosity of these wheels make them best adapted to tool cutting. It is claimed that there is no disagreeable odor or dust from their use and they run equally well wet or dry. If obliged to run in oil or acid they are not injured in the least. The cutting action is rapid, and as every particle in the mixture has a cutting quality, their usefulness is prolonged. When the proper grades are selected they do not heat or burn the work. A number of different grades of wheels should be kept on hand, suitable for doing each kind of work, so that a wheel need only be used for the purpose intended, as in some cases using a wheel for a kind of work for which it is not adopted will spoil the wheel for the work that should properly be done on it, as in the case of grinding rough castings on a wheel intended for fine tools. In selecting emery wheels too much stress cannot be laid on the importance of speed at which they are to run and the particular kind of work to be ground, as a wheel might be ordered for grinding steel and unless it was specified that it was to be used for grinding either cast steel, Mushet steel, tool steel or spring steel, the wheel would be found unsuited for the work. As to speed, a wheel might be perfectly adapted for that particular kind of work, and if run at too high a speed would glaze and fill up; on the other hand it may be run so slow that the wheel would be worn away very rapidly and not give good results. If the peripheral speed be kept at about 5,500 ft. per minute the best results will be obtained. This company also manufacture wheels containing a wire web in the center. They are made by the silicate process, as the webbing used would not stand the intense heat to which the vitrified wheels are subjected. These wheels are only made when ordered specially by customers. The vitrified emery and corundum wheels are made into many standard shapes and sizes, but any other desired shapes can be had without extra charge, on receipt of drawings showing what is wanted. The Vitrified Wheel Company's catalogue gives many of the more common shapes, together with tables of sizes and prices. This illustrated catalogue is now ready for distribution.

The American Railway Engineering and Maintenance of Way Association will hold its second annual convention in Chicago March 12, 13 and 14.

Mr. W. O. Jacquette, formerly Comptroller of the Pressed Steel Car Company, with office in New York, has been appointed District Manager, with headquarters in Chicago.

Mr. Sidney A. Stephens, for many years traveling representative of the Rhode Island Locomotive Works, has been appointed agent of the Brooks Locomotive Works for the Dominion of Canada, with offices at 22 St. John Street, Montreal.

BOOKS AND PAMPHLETS.

Questions and Answers From the American Machinist. Compiled by Frank Richards. Bound in cloth, 12mo., 403 pages. Published by the American Machinist. New York, 1900. Price, \$1.50.

More than 10,000 questions have been asked by the readers of the "American Machinist" and publicly answered in the columns of that paper. Of these questions and answers, 1,088 of the more important ones of general interest and application have been put into book form. The range of topics is naturally wide and no attempt has been made at indexing farther than to divide the topics into 21 departments, such as steam boilers, steam engines, pumps, pattern-making, railroad and locomotive power transmission, etc. The criticism to be made of this volume is the lack of a thorough index. While it would be quite a task to supply such an index, yet with the vast amount of good information, it cannot be of the fullest value to a busy man, without some means of convenient reference to the information desired. The book will be of use to mechanical men in the office of the machine shop, drafting room and manufacturing establishment.

Transactions of the American Institute of Mining Engineers, Volume XXIX. February, 1899, to September, 1899, inclusive.

In addition to papers of general interest to mining engineers, this volume, No. 29, contains a number of papers relative to metallurgical and chemical investigations of timely importance, among which are: "Nickel Steel: A Synopsis of Experiment and Opinion," by D. H. Browne, giving an excellent summary of present knowledge of that material. "The Effect of Heat Treatment upon the Physical Properties and the Microstructure of Medium Carbon Steel," by R. G. Morse, is an important addition to the literature of microscopic study of steel, and is illustrated by a series of excellent photo-micrographs. "Important Results Obtained in the Past Fifteen Years With the Stiff and Heavy Rail Sections," by P. H. Dudley, gives the experience of the New York Central & Hudson River Railroad in working up to its present standard of steel rails, and the "Investigation of Magnetic Iron Ores," by F. J. Pope, gives results of a research into the composition of the hitherto undeveloped titaniferous iron ores.

Differential and Integral Calculus, with Applications for Colleges, Universities and Technical Schools. By E. W. Nichols, Professor of Mathematics in the Virginia Military Institute. Published by D. C. Heath & Co., Boston, Mass., 1900.

This book is an elementary treatise and contains 400 pages, which is about 100 pages more than the type of book which it seeks to displace. Every page gives evidence that it has been a slow evolution from the class room and not a hasty patchwork. It is a creditable piece of work by a painstaking teacher who has been accustomed to give time and emphasis to such conceptions of the differential and integral calculus—especially the former—as can be easily grasped by the beginner. One short chapter is given to the Method of Limits. With this exception the Method of Rates is used throughout the portion of the book devoted to the differential calculus. The latter is defined as the "Science of Rates." However helpful the ideas of time and motion may be in introducing a student to the calculus, this statement should be guarded. The definition is special and incomplete. The historical notes are valuable and worthy the space given to them, but the early promise of many concrete problems from nature and the arts is unfulfilled after the first few chapters. When the subject of maxima and minima is reached the problems have become the stock ones hoary with age. Technical schools at least are still left to seek out from many sources a collection of exercises embodying the most recent engineering experience. In the integral calculus reduction formulas are derived and then employed in the usual way. Yet experience shows that many special problems should be worked by the student without using these general formulas for substitution, otherwise he will rarely gain any real insight into some of the most important expedients in integration. In establishing the process known as integration between limits, the author has used a method decidedly open to criticism, and one which cannot but confuse the student. Most of the book is to be commended.

Field Manual for Engineers. By Philetus H. Philbrick, C. E., M. S., Chief Engineer, Kansas City, Watkins & Gulf Railway. First edition, 16mo, 401 pages, 152 figures. Morocco, price \$300. Published by John Wiley & Sons, New York, 1901.

It is the author's aim to present the text in a logical manner and to classify the problems for ease of reference; to express formulas with a view of simplifying numerical calculations and to extend the scope and usefulness of the tables; to present a more elaborate treatment of the problems pertaining to railway field engineering, than has hitherto appeared in such books. In the main, these aims have been accomplished, although there may, however, arise the question of proper balance between the degree of elaboration of the text and the scope of the tables at the conclusion of the book, depending upon the point of view of the critic; that is, whether the book be considered as designed primarily for the technical student or for the practicing engineer. The book contains not a few evidences that both requirements have been considered by the author, who has had a ripe experience both as engineer and teacher. For example, in pointing out the fact that logarithmic calculations are rarely used by the engineer in the field, he very consistently introduces a chapter on approximate and abbreviated computations in which are presented methods for avoiding the large waste of time in such work, which is common alike to the technical student and practicing engineer. However, the author's position in this particular would be much stronger had he included a table of squares and reciprocals in the list of tables. Doubtless this omission will be supplied in a later edition. Among the innovations in the book is the abandonment of the time-honored definition for "degree-of-curve," based on the chord, which had its origin in the necessity for straight-line measurement in laying out the curve in the field. The author assumes the ideal condition of a measurement of 100 ft. on the actual arc, by which the calculation of curve elements from his table of one-minute curve functions is made exact instead of approximate; and he also shows that sub-chord corrections are less by his method than by the original "single-chord definition." Those who are opposed to extreme refinements in field work will be likely to criticize this departure, and it seems certain that the advantages to be gained are not sufficient to justify its general adoption. The typography of the book is good, although the omission of boldface headings will prove an inconvenience. This manual ranks among the best which have appeared.

Ball-Bearing Jacks.—Mr. A. O. Norton, of 167 Oliver St., Boston, Mass., manufacturer of all kinds of heavy lifting jacks from 8 to 70 tons capacity, has sent a neat calendar for the year and a 1901 catalogue of ball-bearing jacks. The booklet illustrates the Norton double-speed ball-bearing, ball and cone-bearing, traversing and "sure drop" jacks; also cone-bearing car inspector's or journal jacks, and gives tables of sizes, weights and list of prices. The catalogue states that this company is in a position to turn out special jacks on short order and will send full information and quote prices on anything in the line of jacks.

Bearing Metals.—A new catalogue just issued by the Ajax Metal Company is entitled "Ajax Products" and is in every particular creditable. The book gives an extended discussion of the relative merits of their white metals, phosphor bronzes and the newly developed product, the "Ajax Plastic Bronze," as manufactured by them for railroad service. This metal is an alloy of copper, tin and lead, with a relatively large amount of lead, and has the very important attribute of plasticity, which gives it the best of wearing qualities. The latter part of the pamphlet is taken up with short descriptions of each of their copper and white metal products and a few finished products, including jewelers' specialties, which is a new department just established, also a reprint of a paper on the microstructure of bearing metals, by Mr. Gulliam H. Clamer, read before the Mining and Metallurgical Section of Franklin Institute, at the May, 1898, meeting, is given in full. The special engravings introduced throughout the catalogue are in the form of notable locomotives and a steamship which are equipped with Ajax bearings, four full-page engravings of the main and private offices of the company, their exhibit at the National Export Exposition at Philadelphia, the machine shop and chemical laboratory. These convey the impression of an extensive and very successful establishment.

An attractive and tastefully executed pamphlet, in fact, the best we have received this year, is that of the B. F. Sturtevant Company, Boston, Mass., devoted to a clear description of the Sturtevant system of combined heating and ventilating as it was applied to the Chicago & Northwestern round house, at Clinton, Ia. It is illustrated by seven clear and comprehensive illustrations of the round house and the blower system, and is specially noteworthy because this is the largest locomotive round house in the world.

The value of graphite as a lubricant, its nature, peculiarities and methods of application are fully considered, both scientifically and practically, in a little pamphlet issued by the Joseph Dixon Crucible Company. This is the seventh edition of the book, which has considerable new matter added to it. A copy of the pamphlet will be sent upon application to the advertising department of the Joseph Dixon Crucible Company, Jersey City, N. J.

Record of Recent Construction No. 21.—The Baldwin Locomotive Works have issued another of their attractive pamphlets illustrating recent locomotives built for home and foreign roads with tables of dimensions in French and English. It includes the recent 10-wheel and consolidation engines for the Rock Island and the Grand Trunk and simple consolidation engines for the West Virginia Central & Pittsburg, together with a number of foreign engines.

The proceedings of the tenth annual convention of the Association of Railway Superintendents of Bridges and Buildings, held in St. Louis, Mo., October 16, 17 and 18, 1900, have just been issued in the usual pamphlet form. This volume of over 300 pages gives a very concise history of the society, and the reports of the various committees and discussions in full, a number of individual papers by members of the society. Of these Mr. Walter G. Berg's paper on "The Education of Railroad Men for Subordinate Positions of Responsibility" is of particular interest, and of the reports, that of concrete masonry by W. S. Rogers is very valuable. It is the best paper on concrete we have seen. The proceedings of the association can be procured from the Secretary, Mr. S. F. Patterson, Concord, N. H.

Suspension Furnaces.—The Continental Iron Works, Brooklyn, N. Y., has issued an attractive cloth-bound catalogue of their suspension furnaces which have proved indispensable in marine boilers. Besides illustrating these corrugated suspension furnaces with both flanged and plain ends, types of flanging Morison furnaces, and removable types, the book gives a large table of working pressure, thickness of corrugated plates and rules for calculating this thickness. The Morison patent furnace front and door, for internal furnace boilers, is also illustrated and described and a partial list of steamships for which the Morison suspension furnace has been furnished.

Air Compressors.—A very complete catalogue of air compressors has just been issued by the Clayton Air Compressor Works, of Brooklyn, N. Y., manufacturers of air compressors of many types, for all pressures and purposes to which compressed air is applied. This book contains illustrated descriptions of air compressors, air receivers, vacuum pumps, carbonic-acid gas compressors and the Clayton air lift pumping system; also information regarding the transmission of compressed air and the capacity lost by air compressors in operation at various altitudes. Copies of this catalogue No. 11 will be sent to those who will address the offices of the Clayton Air Compressor Works, Havemeyer Building, 26 Cortlandt St., New York.

Steam Turbines is the title of a very attractive pamphlet issued by the Westinghouse Machine Company. It is a reprint of a paper by Mr. Francis Hodgkinson, on steam turbines, referring particularly to the Westinghouse-Parsons steam turbine. The paper was read at the November, 1900, meeting of the Engineers' Society of Western Pennsylvania and published in condensed form in the January, 1901, issue of the American Engineer and Railroad Journal. The author, who is justly considered the most eminent authority in this country on steam turbines, has in his paper given a general treatment of the subject and the pamphlet is worthy of a place in the files of all our readers.

The Stevens Institute Indicator of January, 1901, contains the best article on graphite, its origin, uses and processes of manufacture that we have seen. The author of the article is Mr. Malcolm McNaughton.

The Vitrified Wheel Company, Westfield, Mass., have put into their 1901 illustrated catalogue of emery and corundum wheels considerable information about the use of these wheels and suggestions as to the precautions to be taken in ordering. This company makes a specialty of turning out wheels to any shape desired, without extra charge. Besides cup wheels, emery cylinders and many of the special shapes of wheels for Brown & Sharpe grinding machines, the pamphlet describes a varied line of rubs, sticks, pencils, emery wheel dressers, and illustrates and describes a line of heavy grinding machines. One of the latest of these machines, and one which seems to be particularly well adapted for sawmill and all woodworking establishments, is the "Handy Grinder." To those interested in the use of emery wheels this catalogue will be sent on application to the Vitrified Wheel Company, Westfield, Mass.

"Best Form of Construction and Methods of Ventilating, Heating and General Equipment of Round Houses," is the title of a small pamphlet issued by the B. F. Sturtevant Company, Boston, Mass. The text of the pamphlet is condensed from the official proceedings of the May, 1900, meeting of the Central Railway Club and is illustrated by a full-page engraving of a section through a round house, showing water and air pipes, also the large hot-air duct necessary for the hot-blast system of heating. The pamphlet also gives a list of the round houses in which the Sturtevant system has been installed. This pamphlet contains the best of modern ideas on the subject of round houses.

The Bullock Electric Manufacturing Company has just issued bulletin No. 38, illustrating and describing electric locomotives for the use of manufacturers about their works, in handling materials. This bulletin may be had by addressing the Bullock Manufacturing Company, Cincinnati, O. This company report the following large list of sales of generators and motors for the week ending February 2: Joseph Joseph, Cincinnati, O., one 50-kw. engine type generator; Manning, Maxwell & Moore, New York, one 180-kw. engine type generator, one 35, one 50 and one 65-h.p. motors; Pittsburg Engineering Company, Pittsburg, Pa., one 30-kw. engine type generator; American Sugar Refining Company, New York, one 50-h.p. motor; John L. Thompson Est., Baltimore, Md., one 100-kw. engine type generator; The New Schuyler Apartments, one 50-kw. and one 25-kw. engine type generators; Fore River Engine Company, Quincy, Mass., 14 motors of miscellaneous sizes, making about forty Bullock motors in all which this company has purchased; U. S. Finishing Company, Greenwich, Conn., one 75-h.p. motor; Mosler Safe Company, Hamilton, O., one 35-h.p. motor; Pacific Coast Borax Company, Bayonne, N. J., one 15-h.p. motor, making about twenty Bullock motors now in operation by this company; Wolf Process Lea. Company, Sumnerdale, Pa., one machine, 80-kw. engine type; Jacob Ruppert, New York, two machines, 60-kw. generators, engine type and switchboard, together with several small motors; National Enameling and Stamping Company, Baltimore, Md., one 65-h.p. motor; Christian College, Columbia, Mo., one 17½-kw. engine type generator; Bergtheil & Young, London, Eng., one 225-kw. type "H" generator and two 60-h.p. teaser equipments for operating newspaper press; Brown Hoisting and Conveying Company, Cleveland, O., one 25-h.p. motor; Columbia Chemical Company, Barberton, O., one 42½-kw. engine type generator.

EQUIPMENT AND MANUFACTURING NOTES.

Mr. J. C. Halladay, for many years western sales agent of the Pickering Spring Co., of Philadelphia, with headquarters at the Great Northern Building, Chicago, has resigned that position to accept a position with the Chicago Pneumatic Tool Co., as manager of a new department to be established by the Chicago Pneumatic Tool Company March 1st.

Chicago Rabbeted Grain Doors were specified on 1,000 box cars for the Illinois Central Railroad, which are now being built by the American Car and Foundry Company.

Mr. Sidney A. Stephens has been appointed agent for the Ashton pop safety valves and steam gauges throughout the Dominion of Canada, with headquarters at 22 St. John Street, Montreal, Can.

The Bullock Electric Manufacturing Company has recently opened an office at Buffalo, N. Y., 657 Ellicott Square. The offices will be under the management of Francis B. Smith, an electrical engineer of wide practical experience.

Mr. S. H. Riddell has been appointed representative of the Standard Steel Works, in St. Louis and the Southwestern Territory, vice Mr. C. A. Thompson, resigned. This company has opened an office at No. 712 Security Building, St. Louis, Mo., with Mr. Riddell in charge.

Appreciation of the merits of the Chicago Rabbeted Grain Door is indicated by the following orders of box cars recently let: C., C. & St. L. Ry., 2,200 cars; C., R. I. & P. Ry., 1,500 cars; Northern Pacific, 3,000 cars; A., T. & S. F. Ry., 2,000 cars, and Rio Grande Western Ry., 100 cars upon which it was specified. Most of these cars are now under construction.

The American Blower Company, of Detroit, Mich., manufacturers of hot blast heaters, fans, blowers, engines and dry kilns, expect to begin operation in the early spring upon extensive additions to their present plant. The plans contemplate a very large addition to the steel plate fan erecting shop. This will be of steel construction throughout. A new blacksmith shop, storage warehouse and power house will be erected. The power house will be equipped with new boilers, engines, dynamos, mechanical draft apparatus, etc., all of the latest design. The entire plant will be remodeled, rearranged and equipped throughout with new cranes, hoists and all modern improvements for handling work to the best advantage. A commodious and well-appointed wash room and lockers will be provided for the men. When the improvements are completed the plant will be one of the best equipped of its kind in the country.

Lubricating devices for high-speed stationary engines receive a noticeably large amount of attention, evidence of which is seen in the following quotation from "Engineering," describing a 1,250-h.p. Delauney-Belleville engine at the Paris Exposition: A thin film of oil under pressure is maintained over all the moving surfaces in contact, so that friction, and consequently wear, is reduced in a remarkable degree, and an unusual smoothness in running is obtained even at the highest speeds. An oscillating pump driven by a crank on the motor shaft forces oil continuously into a closed receiver furnished with a safety valve. A series of pipes proceed from this receiver to the various parts of the engine requiring lubrication; these parts are made either hollow or with closed channels that conduct the oil under pressure to the various points required. It afterward flows back into the reservoir in connection with the pump, which again forces it through the whole system, so that the circulation is constant and complete.

English manufacturers have once more been distanced by American competitors, the Pressed Steel Car Company being the enterprising concern in question. When the Rand Mines, Ltd., of Cape Colony, decided to purchase 334 steel coal cars, the Pressed Steel Car Company, of Pittsburg, would have received the entire order had it not been for adverse criticisms and insinuations of disloyalty in Great Britain. These criticisms were peculiarly disagreeable on account of the Boer War, but in spite of them, 167 pressed steel hopper gondola coal cars, of 60,000 lbs. capacity, were ordered from the Pittsburg concern. On the morning of January 28th, the first consignment of 30 cars were lying alongside the Steamer "Ellerie" in Jersey City. Thirty more of the cars were shipped to Jersey City January 29th, and by February 4th, the remaining 107 cars were ready to be stowed away for the long ocean trip to Cape Town. The 167 cars made in Pittsburg will reach their destination before those made by the English competitors. They have been constructed and shipped with such dispatch that more business from the other side of the Atlantic will doubtless follow.

AMERICAN ENGINEER AND RAILROAD JOURNAL.

APRIL, 1901.

CONTENTS.

ILLUSTRATED ARTICLES:	Page	ILLUSTRATED ARTICLES:	Page
Chautauqua Type Passenger Locomotive, C. R. I. & P. Railway.....	101	Dayton Draft Gear as Applied on the A., T. & S. F. Railway.....	130
1-Ton Box Car with Steel Underframes, U. P. Railroad.....	107	New Horizontal Hollow Chisel Mortiser.....	131
Large and Small Grate Areas and Combustion, by A. Boment.....	108	Improved Direct-Current Motors.....	131
Locomotive Shop Improvements, C. & A. Railroad.....	110	A New Sturtevant Generating Set.....	132
Logal Fast Freight Locomotives, A. T. & S. F. Railway.....	113	Re-enforced Split Switches.....	132
Corris' Automatic Equalizing Check Valve.....	114	Improved Form of Pressure Oil Cup.....	133
New Dining Cars, C. B. & Q. Railroad.....	116	ARTICLES NOT ILLUSTRATED:	
Reaction Increases, by James M. Boon.....	121	The Cost of Cleaning Passenger Cars.....	105
Combination Cylinder Saddle and Frame Brace, by F. F. Reese.....	121	Engine Failures Are Becoming Exceedingly Important.....	109
Restriction Draft Gear.....	122	Road Tests of Draft Gears.....	115
Improved Ore Car, 100,000 Pounds Capacity, C. M. & St. P. Railway.....	125	Problems of a Technical Graduate.....	116
Load Rating - Loaded and Empty Cars.....	126	Locomotive Classification, by F. F. Gaines.....	119
Question of Squareness.....	127	The Fate of a Draftsman, by A. H. Weston.....	120
The Woodcock Steel Hopper Car Using Structural Shapes and Plates.....	128	"Mamolith" Carbon Paint.....	121
Featuring Passenger Trains with Exhaust Steam from the Air-Brake Pump.....	129	The "Tip Top" Duplicator.....	129
		EDITORIALS:	
		The Chilled Wheel - Has It Reached Its Limit?.....	118
		Gas Analysis Applied to Locomotives.....	118

"CHAUTAQUA" TYPE PASSENGER LOCOMOTIVE.

Chicago, Rock Island & Pacific Railway.

Built by the Brooks Locomotive Works.

A noteworthy fast passenger locomotive has been built by the Brooks Locomotive Works for the Chicago, Rock Island

of our December number of last year. The Rock Island engine is heavier and more powerful and includes several new features, such as box links, a new arrangement of the valve motion, a cast steel mud ring and a new form of ash pan openings. The Brooks radial trailer arrangement is used and the trailer journals are 8 by 4 ins. in size. A good idea of the construction was given last month in connection with the new Lake Shore engines. The trailing wheels are 51 ins. in diameter, the same as those of the first "Chautauqua" type engine.

A very direct and stiff valve motion is secured by the use of box links and straight connections with a parallel motion to pass the forward driving axle. As laid out, the slip of the links is very small and special care was taken to obtain square lead, port opening and cut-off. The side elevation and sectional drawings illustrate the valve motion clearly. In the steam chests special efforts were made to obtain free passages for the steam to reach the valve ports; the exhaust passages are also large, the least area through the cylinder casting being 75 sq. ins. The effect of this in low back pressure is seen in the cards.

The boiler drawings show the curved crown sheet, the form of the firebox, the plate angle braces at the back head and the front tube sheet; also the form of the cast steel mud ring with a 2½-in. lug all around to which the ash pan is attached. This boiler is very high. Its center is 9 ft. 7¼ ins. above the rail and but ¾ in. lower than that of the large 12-wheel locomotive built by the Brooks Works for the Illinois Central. Plates at the front and back water legs support the back end of the boiler with no shoes or pads at the sides. The mud ring slopes to give a depth of 24 in. at the throat.

The frame arrangement is like that of the earlier design referred to, with a single bar in front and with screwed bolts in the corners of the splice to prevent weaving. Other features of the frames, including the cross bracing, will be seen in the drawings.

A new design of ash pan valves or doors has been applied



"CHAUTAQUA" TYPE PASSENGER LOCOMOTIVE-CHICAGO, ROCK ISLAND & PACIFIC RAILWAY.

G. F. WILSON, Superintendent Motive Power.

BROOKS LOCOMOTIVE WORKS, Builders.

Wheels: Driving.....	78¼ in.	Cylinders: 20¼ and 26 in.	Boiler pressure.....	2.0 lbs.	
Weights: Total of engine.....	167,000 lbs.	engine truck.....	36 in.	tender wheels.....	36 in.
Grate area and tubes: Grate area.....	55.7 sq. ft.	on drivers.....	93,500 lbs.	total engine and tender.....	275,000 lbs.
Firebox: Length.....	108 in.	width.....	71 in.	15 ft. 7¾ in. long.
Boiler: type, wagon top,.....	radial staying.	depth front.....	74 in.	back.....	64 in.
Heating surface: Tubes.....	2,617 sq. ft.	firebox.....	189 sq. ft.	Diameter.....	.66 in.
Wheel base: Driving.....	7 ft. 0 in.	total of engine.....	28 ft. 8 in.	total.....	2,806 sq. ft.
Tender: Eight-wheel;		water capacity.....	5,500 gals.	engine and tender.....	53 ft. 7 in.
				coal capacity.....	8 tons.

& Pacific, which is called by the builders the "Chautauqua" type and is similar in its general features to the one for the Burlington, Cedar Rapids & Northern illustrated on page 375

to this engine. The valves are self-closing by their own weight and are operated by a rotating shaft. The mechanism is equalized so that both doors will close together and it is

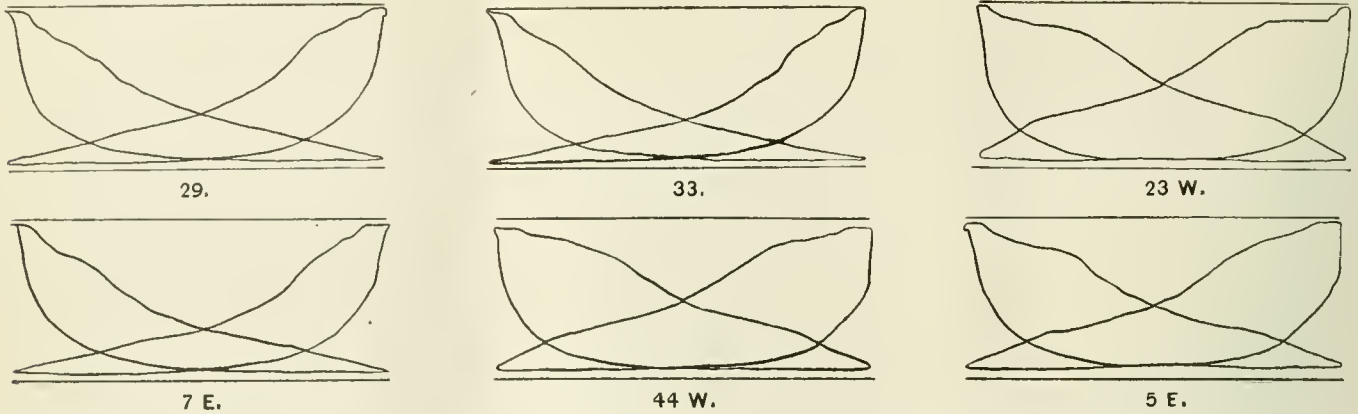

arranged to provide for slight obstructions to the closing. Patents have been applied for on this ash pan arrangement.

Among the other details the following attract attention: Cast steel equalizers with three fulcrum points for those of the trailers; cast steel "grab hook" spring hangers; a combination of two fire doors in one as in the recent Lake Shore engines; extended valve rods for the piston valves, brakes on all wheels, including the truck and trailer wheels and Fox trucks under the tender.

We have received two sets of indicator cards taken under the direction of Mr. Wilson from this engine, which are worthy of special attention in connection with the subject of high power capacity of a modern locomotive. This engine has a total heating surface of 2,806 sq. ft. and a grate area of 55.7 sq. ft. This heating surface has been exceeded by other engines, and it seems fair to say that the sustained high power is largely due to the enlarged grate area. We should say that these results add another argument in favor of the improvement in grates which is becoming so general.

Data for Indicator Cards, "Chautauqua" Type Locomotive, Chicago, Rock Island & Pacific Railway.

Card num-ber.	Boiler pressure, lbs.	Revs. per min.	Miles per hr.	Card length, inches.	Area of card.		Area of card.		Total I. H. P.*		
					M. E. P.	I. H. P.	M. E. P.	I. H. P.			
29	207	250	58.2	4	1.89	56.4	298.5	1.95	57.6	293.7	1,134.4
33	202	280	65.2	3.96	1.75	52.8	311.9	1.69	50.4	285.8	1,195.4
23W	210	160	37.2	3.88	3.00	92.4	311.9	3.03	94.8	287.3	1,193.4
7E	205	280	65.2	3.98	1.78	52.8	311.9	1.73	51.6	294.7	1,213.2
44W	203	200	46.5	3.94	2.69	81.6	342.3	2.80	85.2	347.6	1,379.8
5E	205	260	60.5	3.94	2.37	72.1	395.5	2.60	78.0	413.7	1,618.5

*On the assumption that both sides give the same power.

Valve Motion Characteristics

Valves	Improved piston
Admission	Internal
Motion	Direct, with rockers
Eccentric throw	5 1/8 ins.
Link radius	62 ins.
Link center	59 1/2 ins.
Link centers of eyes	13 ins.
Link lift	13 ins.
Link slip	Maximum, 1 1/4 ins.; at 6 ins., 1/2 in.
Saddle offset	3/16 in.
Lifter offset, top	1/2 in.
Link block above center of axle	1 1/2 ins.
Valve travel	5 3/8 ins.
Steam lap	1 1/8 ins.
Lead, forward and back	1/16 in.
Exhaust clearance	1/8 in.
Nozzle diameter	5 ins.
Steam ports	1 7/8 ins.

Cards 29 and 33 were taken from the right-hand side of the engine, on local train No. 1, March 8, 1901, consisting of 10 cars, with 120-lb. indicator spring. The valves were the same, 11 ins. piston type, with 5 1/2-in. travel in both cases, and the lap was 1 1/8 ins. On this run the exhaust clearance was 1 1/8 ins. and the valves were set with 1/32 in. lead in full gear, both forward and back. Cards 23 W and 44 W were taken on an extra freight west bound, March 6, weighing 640 tons, consisting of 30 empty and 6 loaded cars, chiefly stock cars. Cards 7 E and 5 E were taken on an east-bound extra freight on the same day, the train weighing 341 tons, consisting of 10 loaded cars. These cards were also taken from the right-hand side of the engine with the valves set for no exhaust lap but otherwise the same as before.

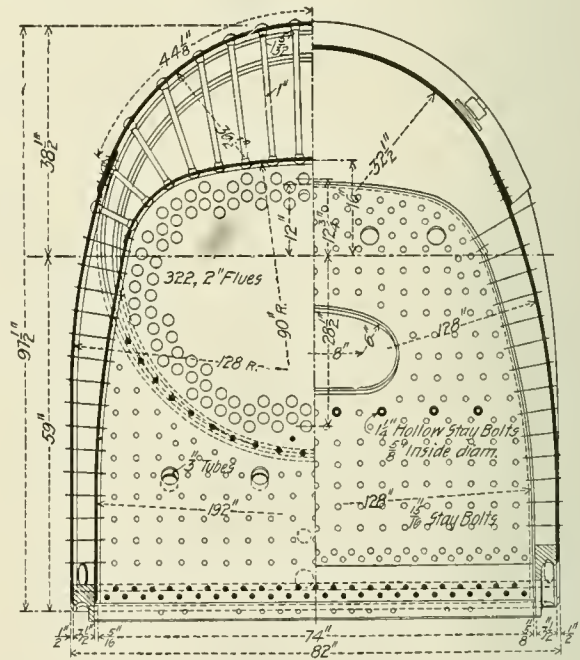

Sectional View of Firebox.

It is interesting to note that, with the assumption that the horse-power was the same on both sides of the engine, card No. 5 E gave a higher horse-power than any of the cards shown in the record of the "Northwestern" type engine of the Chicago & Northwestern given on page 335 of our November number of last year, although it does not follow that in either case the engines were doing all they could do. It is noteworthy that a locomotive has shown a capacity of 1,618 indicated horse-power at 60 miles per hour, and it is fair to assume that this power can be sustained for some time, because in the 32 indicator cards constituting this record there is no indication of failure in keeping up the high boiler pressure. We do not recall any indicator cards from a two-cylinder engine showing as great power as the last one in this table. In studying

	Pre-admission.		Lead.		Port opening.		Cut-off.		Release.		Closure.	
	Front.	Back.	Front.	Back.	Front.	Back.	Front.	Back.	Front.	Back.	Front.	Back.
Forward.												
Full gear.	in.		in.		in.		in.		in.		in.	
16 inch notch...	0		+1/8		+1 1/2		21 1/4		24 1/2		1 1/2	
12-inch notch...	1/8		1/4		5/8		12 1/4		20 1/4		5/4	
8-inch notch...	1/16		1/8		3/4		8 1/4		19 1/4		7 1/4	
6-inch notch...	1/16		1/8		1/2		6		16 1/4		9 1/4	
Back Motion.												
Full gear.	0		+1/8		1 3/4		21 1/4		24 1/4		1 1/4	
10-inch notch...	1/2		1/4		1 1/2		10		19 1/2		6 1/2	

these results it should be noted that the driving wheels are 78½ ins. in diameter. The service on this road is severe in the number of stops required of fast and heavy trains.

"Chautauqu" Type Passenger Locomotive, Chicago, Rock Island & Pacific Railway.

Description.	
Gauge	4 ft. 8½ ins.
Kind of fuel to be used	Bituminous coal
Weight on front trucks	38,000 lbs.
Weight on driving wheels	37,000 lbs.
Weight on trailing wheels	37,000 lbs.
Weight, total	162,000 lbs.
Weight, tender	108,000 lbs.

General Dimensions.

Wheel base, total of engine	28 ft. 8 ins.
Wheel base, driving	7 ft. 0 ins.
Wheel base, total engine and tender	53 ft. 7 ins.
Length over all, engine	49 ft. 8 ins.
Length over all, total engine and tender	63 ft. 9 ins.
Height, center of boiler above rail	9 ft. 7¼ ins.
Height of stack above rail	15 ft. 6 ins.
Heating surface, firebox	189 sq. ft.
Heating surface, tubes	2,617 sq. ft.
Heating surface, total	2,806 sq. ft.
Grate area	55.7 sq. ft.

Wheels and Journals.

Wheels, leading, diameter	36 ins.
Wheels, driving, diameter	78½ ins.
Wheels, trailing, diameter	51 ins.
Material of wheel centers	All cast steel
Type of leading wheels	Four-wheel swiveling and swing truck
Type of trailing wheels	Improved radial axle
Journal leading axles	6½ ins. by 11 ins.
Journal leading axles, wheel fit	6½ ins.
Journal driving axles	9 ins. by 12 ins.
Journal driving axles, wheel fit	9½ ins.
Journal trailing axles	8 ins. by 11 ins.
Journal trailing axles, wheel fit	7½ ins.

Cylinders.

Cylinder diameter	20¼ ins.
Cylinder stroke	26 ins.
Piston rod diameter	3¼ ins.
Main rod, length center to center	127 ins.
Steam ports, length	25½ ins.
Steam ports, width	1½ ins.
Exhaust ports, least area	75 sq. ins.
Bridge width	3½ ins.

Valves.

Valves, kind of	Improved piston
Valves, greatest travel	5¼ ins.
Valves, steam lap (inside)	1½ ins.
Valves, exhaust clearance (outside)	0 ins.
Lead in full gear	1/16 positive

Boiler.

Boiler type of	Wagon top
Boiler, working pressure	210 lbs.
Boiler, material in barrel	Steel
Boiler, thickness of material in shell	¾, 11/16, 9/16 and ¼ in.
Boiler, thickness in tube sheet	¾ in.
Boiler, diameter of barrel front	66 ins.
Boiler, diameter of barrel at throat	71½ ins.
Seams, kind of, horizontal	Sextuple
Seams, kind of, circumferential	Double and triple
Crown sheet stayed with	Radial stays
Dome, diameter inside	30 ins.

Firebox.

Firebox, type	Wide
Firebox, length	108 ins.
Firebox, width	74 ins.
Firebox, depth, front	74 ins.
Firebox, depth, back	64 ins.
Firebox, material	Steel
Firebox, thickness of sheets	Crown ¾ in., tube ¾ in., sides 5/16 in., back ¾ in.
Firebox, brick arch	On water tubes
Firebox, mud ring, width	Back and sides 3½ ins., front 4 ins.
Firebox, water space at top	Back 7 ins., sides 6 ins.
Grates, kind of	Cast iron, rocking
Tubes, number of	322
Tubes, material	Charcoal iron
Tubes, outside	2 ins.
Tubes, thickness	No. 11 B. W. G.
Tubes, length over tube sheets	15 ft. 7¾ ins.

Smokebox.

Smokebox, diameter, outside	69 ins.
Smokebox, length from tube sheet	64½ ins.

Other Parts.

Exhaust nozzle, single or double	Single
Exhaust nozzle, variable or permanent	Permanent
Exhaust nozzle, diameter	5½ ins.
Exhaust nozzle, distance of tip above center of boiler	1¼ ins.
Netting, wire or plate	Plate
Netting, size of mesh or perforations	3/16 in. by 1½ ins.
Stack, straight or taper	Cast iron, taper
Stack, least diameter	16 ins.
Stack, greatest diameter	19½ ins.
Stack, height above smokebox	36 ins.

Tender.

Type	Eight-wheel, steel frame
Tank, type	Gravity slide
Tank, capacity for water	5,500 gallons
Tank, capacity for coal	8 tons
Tank, material	Steel
Tank, thickness of sheets	¼ in. and 5/16 in.
Type of under frame	Steel channel
Type of trucks	Box pressed steel
Type of springs	Double elliptical and coil
Diameter of wheels	36 ins.
Diameter and length of journals	5 ins. by 9 ins.
Distance between centers of journals	5 ft. 0 in.

Diameter of wheel fit on axle	6¾ ins.
Diameter of center of axle	5¾ ins.
Length of tender over bumper beams	21 ft. 3 ins.
Length of tank inside	29 ft. 1½ ins.
Width of tank inside	19 ft. 0 in.
Height of tank, not including collar	5 ft. 0 in.
Type of draw gear	M. C. B. coupler

Special Equipment.

Brakes	American for drivers, Westinghouse for tender and train service
Pump	¾ ins.
Sight-feed lubricator	Nathan
Safety valves	Ashton
Injectors	Nathan
Springs	Scott
Metallic packing, piston rods	Jerome
Metallic packing, valve stems	Brooks Locomotive Works

THE COST OF CLEANING PASSENGER CARS.

That it costs nearly as much to clean passenger cars on the Cleveland, Cincinnati, Chicago & St. Louis Ry. as it does to paint them was a statement made by Mr. J. A. Gohen, Master Car Painter of that road, in his paper at the annual meeting of the Master Car and Locomotive Painters' Association, held at Detroit last September. He stated the cost of painting passenger cars during the year 1899 to be \$53,700.59 and \$51,721.41 for cleaning. This did not include supervision of the work in either case. To prove this statement to the satisfaction of others, Mr. Gohen gives, in a communication to the "Railroad Digest" for February, the average cost on eleven different roads, in different parts of the country for the ordinary cleaning of passenger cars at terminals, at about 60 cents per cleaning. On one road the daily cleaning per car for all classes except Pullman amounted to 65 cents, of which 61 cents represented the cost of labor and 4 cents the cost of materials used. On the C., C., C. & St. L. the average for the year 1899 was 38.6 cents for labor and 2.2 cents for material, making a total of 40.8 cents. This was for all classes, at all points and included the sweeping and dusting of local cars at intermediate points, which cost about 10 or 11 cents per car. During the month of December, 1900, there were cleaned at the Cincinnati terminal of the same road 2,494 cars of all kinds except sleepers, at a cost of \$1,317.67, an average of 52.8 cents per car. The cost of the different classes was 17.02 cents for baggage, 23.13 cents for mail cars, 40.04 cents for combination cars, 56.05 cents for coaches, \$1.22 for parlor and \$1.35 for dining cars. These cars are in daily use and are cleaned not less than 300 times a year, making the least yearly cost for cleaning \$158.40 per car, not including the materials used. This amount is undoubtedly greater than many roads are spending annually for maintaining the paint on a car.

Some interesting figures are given in a little folder issued very recently by the Compressed Air Company of New York, regarding the compressed-air cars now in operation on the Twenty-eighth and Twenty-ninth street lines of the Metropolitan Street Railway. The 20 cars now in use have during three months traveled 165,000 miles and carried 1,775,667 passengers. The total cost of maintaining this service, including repairs, charging station, power house and wages for conductors and motormen, is 17.42 cents per car-mile. The net earnings during the last quarter of 1898, when the cars were operated with horses, were \$18,107. During a similar period in 1900 the net earnings by compressed air were \$21,888. This gives an annual net increase of \$15,124 on a road only five miles in length.

The proverbial clean sweeping of a new broom is sometimes exemplified by a new appointee to an important office in the radical changes he makes, both as to methods and personnel. Mr. E. M. Herr, talking recently to the students of Purdue University, was perhaps thinking of this when he related an experience of his own in taking an important promotion. Before taking up his new duties he called on the general superintendent to ask for any instructions which might be given at the last moment. The reply was: "No instructions. The machine is running all right down there. Don't stop it until you are sure you can start it again."



40-Ton Box Car, with Steel Underframes—Union Pacific Railroad.

40-TON BOX CARS WITH STEEL UNDERFRAMES.

Union Pacific Railroad.

Built by the Pressed Steel Car Company.

An important development of the use of steel in car construction is represented by the design illustrated here by the courtesy of Mr. J. H. McConnell, Superintendent Motive Power of the Union Pacific, and the builders, the Pressed Steel Car Company. The use of steel is not entirely confined to the underframe, but the box portion is almost entirely of wood.

General Dimensions.

Capacity.....	80,000 lbs.
Light weight.....	40,300 lbs.
Cubic feet capacity.....	3,810
Length over end sills.....	41 ft. 0 in.
Length inside.....	40 ft. 0 in.
Width over side sills.....	9 ft. 6 5/8 ins.
Width inside.....	9 ft.
Width at eaves.....	10 ft. 2 ins.
Height under center of car lines.....	9 ft. 6 ins.
Height of floor from rail.....	3 ft. 7 1/4 ins.
Height of center of drawbar.....	2 ft. 10 1/4 ins.
Height over all.....	14 ft. 2 3/8 ins.
Height at eaves.....	13 ft. 3 3/8 ins.
Height of door openings.....	8 ft. 6 ins.
Width of door openings.....	5 ft. 6 ins.
Center to center of trucks.....	30 ft. 8 ins.

Pressed steel center and side sills, of the "fish-bellied" pattern peculiar to these builders, form the basis of the under-

frames, and to these pressed steel end sills are riveted, the draft gear being secured to the center sills and passing through the end sills. The draft rigging is the Pressed Steel Car Company's standard twin spring arrangement. Stiffening angles are riveted to the lower portions of the center and side sills extending a considerable distance each way from the centers. Pressed steel angles placed at 2 ft. 9 1/2-in. centers, riveted between the webs of the center and side sills and the necessary bracing at the ends, complete the metal floor system. Three 4 by 3-in. wooden stringers each side of the center of the car and additional stringers at the side sills form the basis for the floor and the box structure, as indicated in the drawings. The bolsters for the body and truck are of pressed steel.

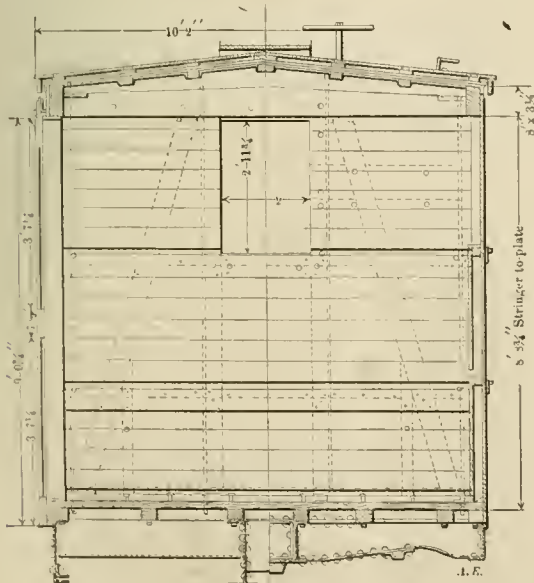

Transverse Section.

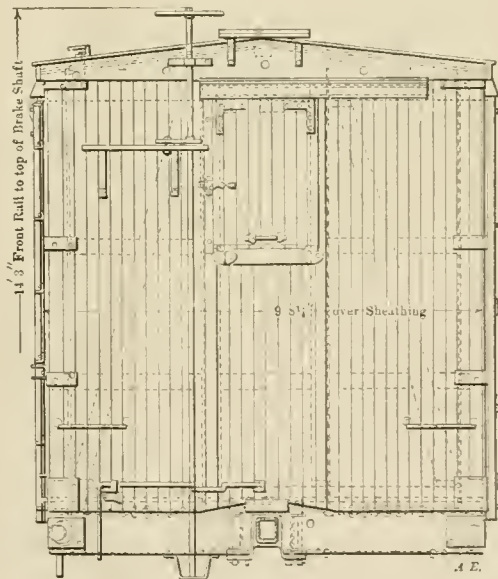

End Elevation.

Pressed steel U-section carlines with pressed sockets for the purlins are secured to the side plates at 5 ft. 3 1/2-in. centers, the plates being 8 by 3 ins. in section. A pressed steel angle extends along the outer upper corner of each side plate to form a secure attachment for the carlines. The posts and braces are 5 by 2 1/2 ins. with diagonal rods, and the side door posts are 5 by 5 1/8 ins. There are two 6 by 7/8-in. belt rails and also one of pressed steel in U-section 4 1/2 ins. deep. All bolts securing the wood-work to the underframing are 5/8 in. diameter. These cars also have 2-ft. by 2-ft. 11-in. end doors.

Fox pressed steel trucks, 33 in., 650 lbs. cast iron wheels. Buckeye couplers with 6 by 6-in. shanks, cast iron journal boxes, pressed steel brake beams and Winslow roofs constitute the special equipment of the cars.

LARGE AND SMALL GRATE AREAS AND COMBUSTION.

Studied by Gas Analysis.

Advantages of Frequent, Light Firing and Shaking of Grates.

By A. Bement.

The problem of working locomotives with small grate areas that more efficient furnace performance may be secured having been presented, I offer the following as being of interest.

It will be assumed that the larger grate areas have an advantage both in economy and capacity, or that the locomotive boiler with the correct amount of grate area may be able to deliver more horse-power with a reasonable coal consumption than those with the relatively small grates. This being true the great majority of locomotives are at a disadvantage, but they represent an enormous investment, and can neither be thrown away nor changed. Therefore if better results may be secured the subject is an inviting one.

I would also make comparisons between the performance of an engine with a small and another with a moderately large grate, both burning bituminous coal. As illustrating the matters in question I submit some data from experiments with two locomotives which are designated as Nos. 1 and 2. The experiments from which the data are taken were made on one trip with each engine over one-half of a division, with the usual train load, and over the entire division on another trip with the usual train load. The first two trips are designated as experiment No. 1 and the other two trips over the entire division as No. 2.

Experiment No. 1, Over One-half of Division.

Engine No.	1	2
Grate surface, square feet.....	30	40
Heating surface, square feet.....	2,050	1,950
Ratio grate area to cylinder volume.....	6.86	9.39
Ratio heating surface to grate area.....	68.3	48.9
Ratio heating surface to cylinder volume.....	481	447
Maximum draft over fire in inches of water.....	3.25	2.25
C O ₂ average for trip.....	11.07	11.90
O average for trip.....	4.50	6.06
C O average for trip.....	2.33	0.17
C O ₂ at end of trial.....	11.90	12.20
O at end of trial.....	2.30	5.80
C O at end of trial.....	3.30	0.50
C O ₂ maximum.....	11.90	12.20
C O maximum.....	3.30	0.50

These results will be assumed to represent average prevailing practice, because the fireman followed his own methods entirely, but it must be stated that without doubt it was better than the generally prevailing practice, because we well know firemen will do better work when experiments are being made, either unconsciously or intentionally.

It will be noted that the ratio between grate surface and draft is practically the same for each engine, the cylinder diameters were the same for each engine, but No. 1 is of 2 ins. greater stroke, and entitled to a somewhat greater train load for this reason, and because there was considerable incomplete combustion the amount of coal burned would be greater than with engine No. 2, and as the grates were not shaken in either case it follows that No. 1 would accumulate a greater quantity of ashes on 30 sq. ft. than did No. 2 on 40 sq. ft. This condition would be modified somewhat by the greater amount of ash carried out of the stack by the stronger draft of No. 1, but the character of the ash in the coal, condition of the fire at the end of the trip and the gas analysis proved that this was too small an item to be of material consequence.

This performance I think illustrates very clearly the relation between the two grates in common everyday prevailing practice. No. 2, however, has two other advantages, owing to the lower vacuum in the smokebox less fuel would be thrown out of the stack, which was, of course, an observed fact; and because of a larger exhaust nozzle there is less back pressure.

From the standpoint of the amount of incomplete combustion shown by each engine upon arrival at its destination it is probable that No. 2 could have continued over the entire division with the same manipulation of the fire with no trouble as far as steam was concerned, but not so with No. 1, because

it would no doubt suffer by low steam owing to the large accumulation of ash, which would reduce the coal burning capacity and increase the incomplete combustion.

Experiment No. 2, Over Entire Division.

Engine number	1	2
Grate surface, square feet.....	30	40
Heating surface, square feet.....	2,050	1,950
Maximum draft over fire in inches of water.....	2.25	1.62
CO ₂ average for trip.....	12.43	13.10
O average for trip.....	6.03	5.96
C O average for trip.....	0.00	0.00
CO ₂ at end of trial.....	12.50	14.00
O at end of trial.....	5.00	3.10
C O at end of trial.....	0.00	0.00
CO ₂ maximum.....	13.40	14.00
C O maximum.....	0.00	0.00
Temperature of escaping gases, average.....	850°	850°

For this experiment the exhaust nozzles were enlarged, and the method of working the fire was changed; this change consisted simply of firing light and often, and shaking the grate at brief and regular intervals. The performance is quite striking as compared with that of experiment No. 1, even more so than shown by the data, because compared with it the horse-power developed was greater; the speed higher; amount of coal burned in a given time greater; amount of air entering the fire for a given time greater; the engine steamed with great freedom and the pressure was higher, in fact at the blowing-off point under all conditions and upon arrival at the end of the

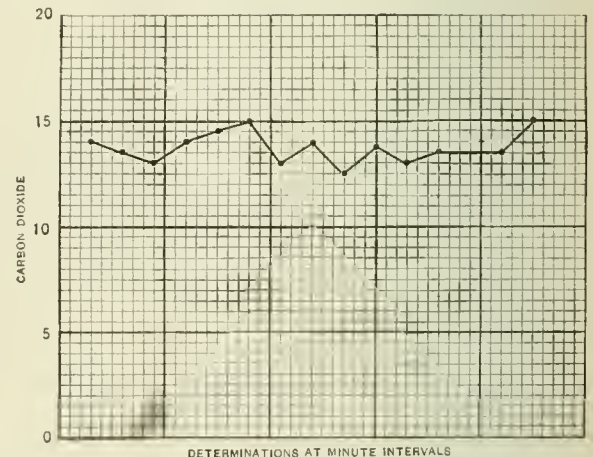

trip both engines appeared to be in condition to immediately turn around and repeat the performance, as the fire was apparently in as good condition at the finish as at the start.

Referring to the working of small grates the performance of engine No. 1 in experiments Nos. 1 and 2 should be studied, for therein lies the solution of the problem except for those especially large engines with grates but slightly enlarged, yet with very much larger boilers and cylinders. With these air may be admitted over the fire to burn CO, or producing gas, which is made. Changing exhaust nozzles, or admitting air over the fire are measures, however, which I do not consider advisable or safe to undertake without the aid of gas analysis. But grates may be shaken, and fires coaled uniformly with the usual small grates, and results will be very much improved.

Referring to experiment No. 2 as showing the relation between these two sizes of grate, it will be observed that the large grate shows a better combustion, or in other words, produces complete combustion with less air, and with 28 per cent. less "draft," which shows that the resistance to the inflow of air through the large grate is much lower, allowing the use of larger exhaust nozzles with less back pressure, a lower smokebox suction, and less fuel thrown out of the stack. This is in line with my statement in an article in the American Engineer of November, 1900, page 346.

The loss in fuel thrown out of the stack is a large item. With a good condition of combustion an evaporation of 7 lbs. of water from and at 212 deg. per pound of dry coal of 13,000 B. T. U. would be an excellent performance, with an efficiency of 53.5 per cent. If the loss by radiation, etc., is assumed to be 10 per cent., and that in the hot gases at 23, there would still be

13.5 per cent. to be accounted for in the fuel thrown out of the stack. In addition, the convenience and comfort to passengers that would result from the reduction of this loss is an item of no small importance.

The ideal condition for combustion, as far as quantity of air supply is concerned, is that the air be automatically supplied in proportion to the boiler load. This is a condition which the locomotive meets in an ideal manner. As Prof. Goss has stated in a recent paper before the American Society of Mechanical Engineers, the draft-producing power is in proportion to the weight of steam discharged in the exhaust, and as this is the same as that produced by the boiler the air supplying power is automatic. This is a matter of considerable importance, and it may be said—in view of the fact that there is a more or less general belief that a locomotive is at a serious disadvantage as compared to stationary boilers, on account of its changing load—that this lack of automatic air supply, as compared with the load, is one of the most serious difficulties experienced with stationary boiler fires.

The proper quantity of air supply being insured, it follows that there should be fed that amount of coal that will satisfy it. This coal feed should be as uniform as possible, and its quantity should be in proportion to the quantity of the air. To this end in experiment No. 2, it was first intended to keep the grate free and open, by shaking out the accumulating ash and clinker before it had time to form in large mass; and second, to keep the fire in a uniform, level and even condition, and of a depth that would be called a thin fire; third, to supply the coal at a more or less rapid rate according as the steam pressure showed a tendency to raise or lower. With this method any effort to bring down the steam pressure by working the engine harder, was met with more intense furnace action and the pressure remained unchanged; with either engine in experiment No. 2 there was no time when there was not steam enough. In fact, there was no opportunity to work the boilers at their maximum. This performance implies more care and intelligent effort on the part of the fireman, but it also means quicker and more satisfactory trips over the road for freight trains, and less delay to passenger trains, and also a saving of coal.

The quality of work performed by the firemen, in stationary practice, I have found to be such an important factor, that as a rule I am led to measure boiler horse-power by the number of men and the quality of their work, rather than by square feet of grate, and heating surface. This applies to mechanical stokers as well as to hand-fired furnaces. As a combustion-producing apparatus I consider the locomotive entitled to a position of first importance, but as with any other it must be worked at its best.

The accompanying diagram shows the carbon dioxide taken at minute intervals from engine No. 2, which illustrates a very uniform condition of combustion for a locomotive.

The foregoing data and remarks refer to running conditions, and take no account of what takes place when steam is shut off or stops are made. Under such conditions, of course, the performance is quite different, but there are times when but little coal is being burned, and for this reason the combustion losses are proportionally small. Some analyses will show these peculiar conditions, for example:

(1).....	CO ₂	11.1
	O	5.9
	CO	1.5

This was caused by steam being shut off during a portion of the time that the sample was being collected.

(2).....	CO ₂	12.1
	O	2.2
	CO	5.2

This was caused by the fire getting into very bad condition.

(3).....	CO ₂	13.9
	O	4.3
	CO	0.4

This small amount of CO resulted from some fine slack which had accumulated as the coal in the tender became low, and this was fired while the sample was gathered, otherwise combustion would have been complete, even with smaller air supply. These three analyses are not, however, from the two experiments mentioned above.

The various gas samples were uniformly gathered during a period of about ten minutes, and immediately analyzed, the results being available for guidance in the working of the fire.

ENGINE FAILURES ARE BECOMING EXCEEDINGLY IMPORTANT.

It is not long since 5,000 miles per month was satisfactory mileage for a passenger engine. Now it is often double that. The great increase in the volume of traffic makes it a serious matter to delay a train and there are also the expense of repairs and the loss of service of the engine while in the shop for repairs to be considered. A superintendent of motive power recently said that if he could do so he would build a locomotive all in one piece, because the liability of failure increased rapidly with the degree of complication. It is clear that inspection in the roundhouse must be most carefully done and that it must be extended to include everything about the locomotive. Inspectors discover many broken parts and if these are repaired or replaced without record, an excellent opportunity for improvement in the direction of reducing the difficulties is lost. Several years ago Mr. Quayle issued to the various Master Mechanics of the Chicago & Northwestern a series of blank forms upon which were printed in copying ink diagrams of eccentrics, straps, piston rods, axles, driving boxes and other parts specially likely to fail in service. These diagrams and blanks served as a record of the fracture, its character and location in each case being reported and indicated on the diagrams, and from them the drafting room secured most valuable information for guidance in increasing strength where it was most needed. The result after four or five years is pleasing, the number of parts failing having been greatly reduced as the points of weakness developed. For example, if a number of eccentric straps broke in the same or nearly the same way it was easy to locate the weakness and remedy it by the addition of material where it was necessary. The time may come when engine failures will be considered unnecessary, but at present it is an unusual record which does not show more than five failures per locomotive per year as an average, a failure in this case meaning a breakdown on anything which will cause a delay of three minutes, which cannot be made up. Close inspection and comparative records have accomplished a great improvement on several roads where systematic efforts are being made.

Mr. Joseph H. McConnell, Superintendent of Motive Power and Machinery of the Union Pacific, has resigned, and will be succeeded by Mr. Samuel Higgins, Superintendent of Motive Power of the Lehigh Valley. Mr. McConnell entered railroad service in 1861 at the age of 18 years as an apprentice in the machine shops of the Great Western, now the Wabash, at Springfield, Ill. Later he was a machinist for four years with the Chicago, Burlington & Quincy and Chicago & Alton. In 1868 he became General Foreman of the Union Pacific shops at Omaha, which position he held until 1872. From 1872 to 1885 he was Division Master Mechanic of the Union Pacific at North Platte, Neb., and from 1885 to 1886 was Master Mechanic of the Nebraska Division of the same road. The two years, 1886 to 1888, were given to mercantile pursuits, at Omaha, and during 1889 and 1890 he was occupied in reorganizing the motive power department and other special work on the Union Pacific. In February, 1891, he was appointed Superintendent of Motive Power and Machinery of that system, which position he now leaves. Mr. McConnell has had a long and remarkably successful railroad experience and feels that he has reached a point where he needs a rest. It is not known at this time to what he will direct his attention, but whatever field it may be, he has the best wishes of the American Engineer and Railroad Journal for a continued success. In the work of the Master Car Builders' Association and the Railway Master Mechanics' Association Mr. McConnell has for the past ten years been very active. His work has been recognized as valuable in the report of committees, and as President of the Railway Master Mechanics' Association during the year 1899-1900.

BLOOMINGTON SHOP IMPROVEMENTS.

Chicago & Alton Railroad.

An important part of the policy of the management of the Chicago & Alton Railroad is to improve its roadbed, rolling stock and all its facilities to an extent which will place the road in first-class condition generally. In connection with this plan the shop facilities at Bloomington are being en-

The wheel and axle shop is a part of a large car shop building, only the west end of which is to be built now. The plans provide for a length of 263 ft. when the building is completed. This building has a very high roof with a generous number of ventilators and skylights. The tracks are alternately 18 and 28 ft. centers with a material track in the center of the 28-ft. space. Seventy-pound rails are used for the work tracks and 40-lb. for the others. The roof is of slate supported on trusses of steel, except the compression members, which

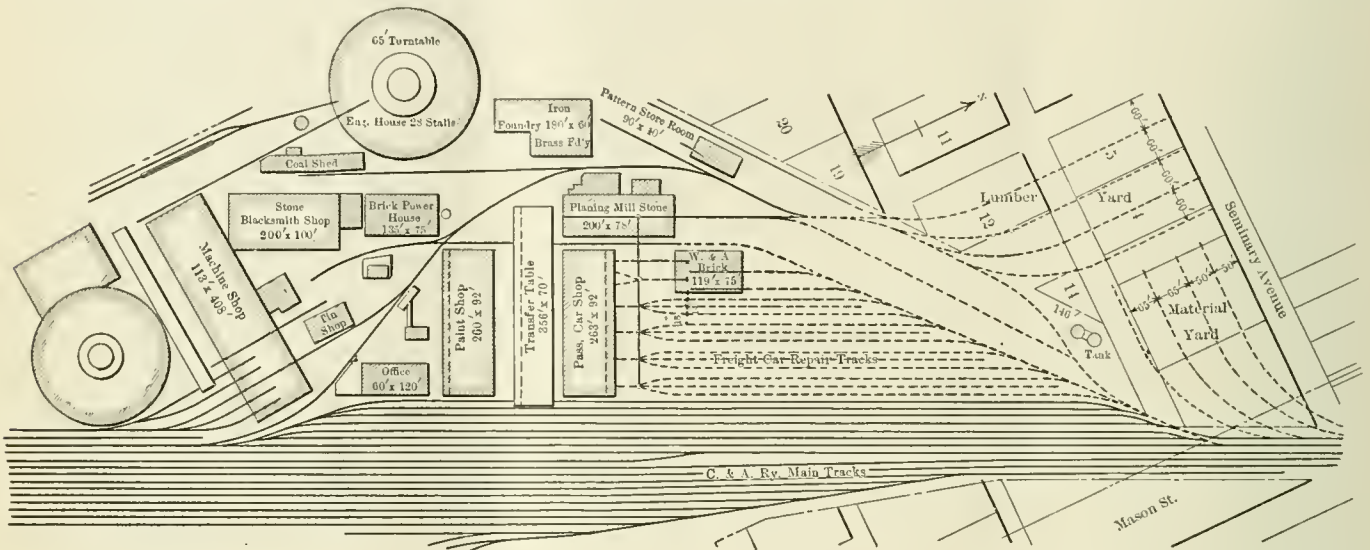

General Plan Showing Extensions

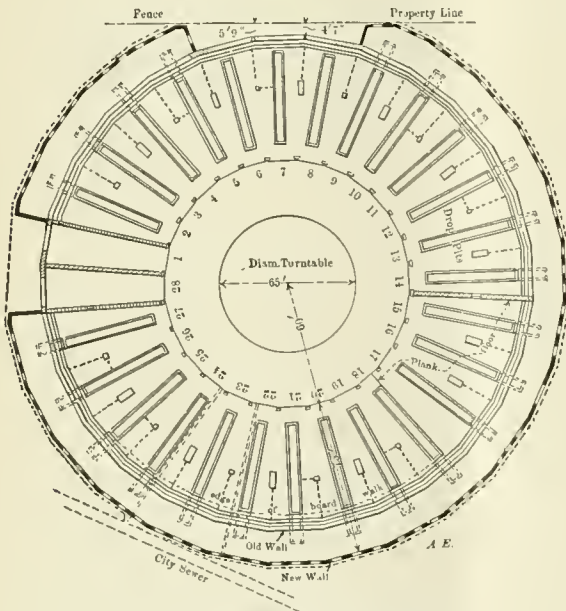

Plan of Enlarged Roundhouse.

larged and provisions are made for still further extension when it shall become necessary.

The improvements in these shops are of special interest, because they indicate methods of extending existing structures, at comparatively little expense, for the accommodation of modern equipment. The principal buildings at Bloomington were erected in 1883 and being of stone, it was desirable to use them, and but two new buildings will be erected at present. The paint shop and passenger car shop will be widened 18 ft. each, the transfer table widened from 60 to 70 ft., and the roundhouse enlarged and supplied with a 65-ft. turntable. In connection with this work a new power house, 135 by 75 ft., and a new wheel and axle shop, 114 by 75 ft., are being erected. Electricity will be used to distribute the power, and this part of the improvement will be taken up by us later.

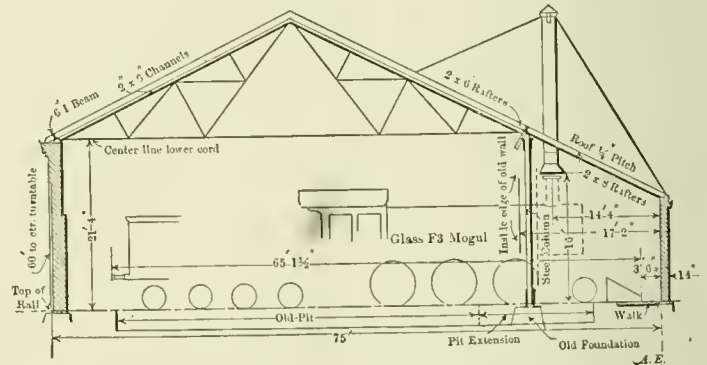

Section Through Roundhouse.

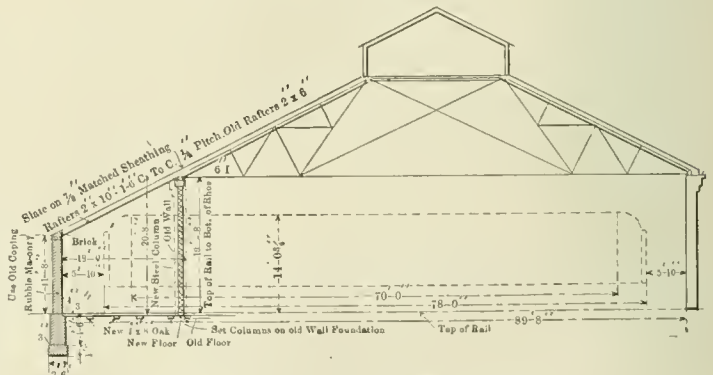

Section of Enlarged Passenger Car Shop.

are of wood. At the end to be used for machinery the bottom chords are made strong enough to support the shafting. The floor of this shop is 3-in. plank, laid on a bed of cinders 12 in. deep.

As the paint shop was only 71 ft. 8 ins. wide and a modern passenger car over vestibules requires 78 ft., an 18-ft. extension was provided, which leaves 5 ft. 10 ins. inside the walls at each end of a car of this length. One wall of this building was

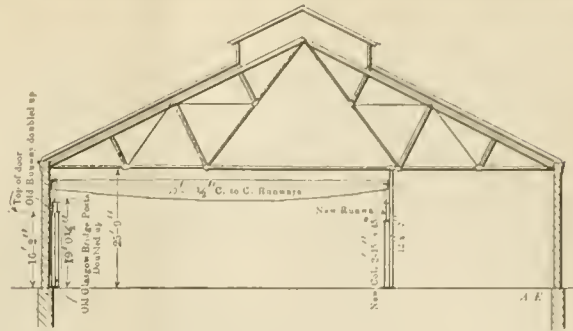
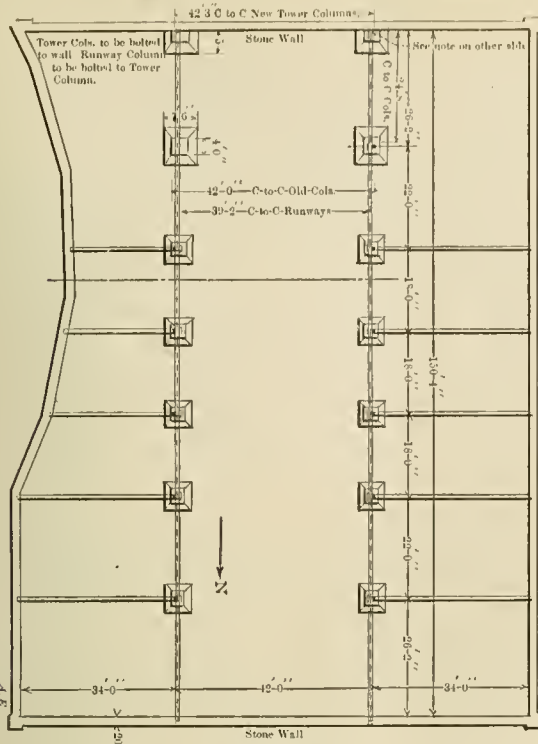

Section Through Machine and Erecting Shop.

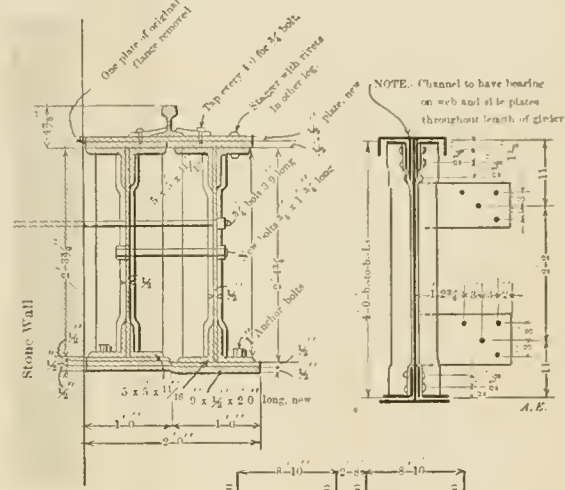

Crane Runways in Erecting Shop.

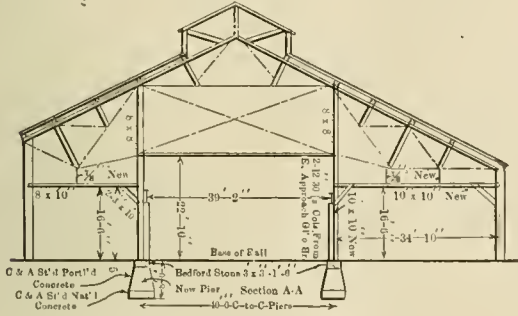

Plan and Section of Boiler Shop.

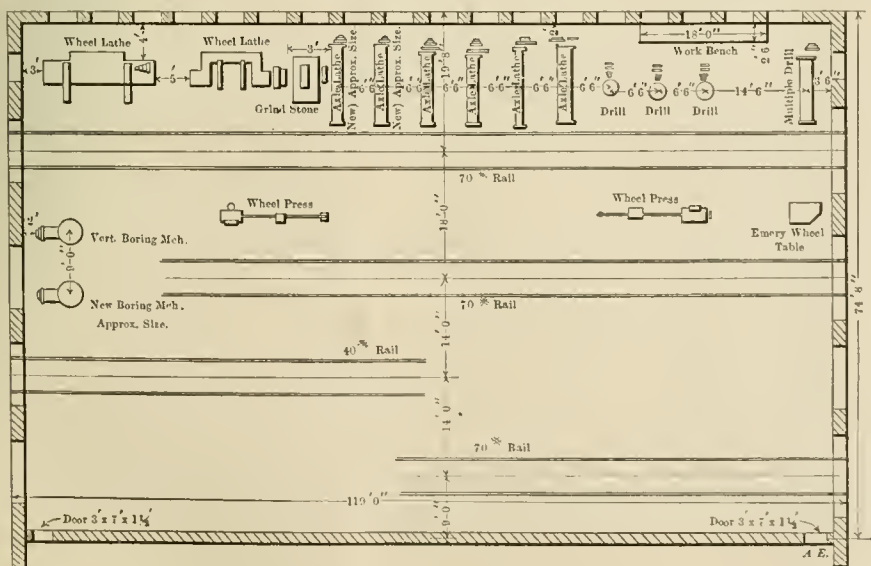
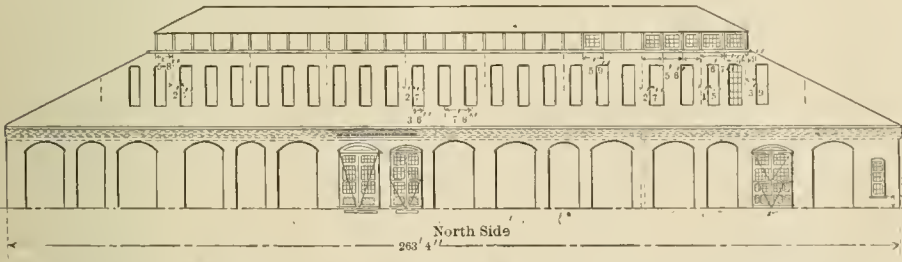

Plan and Side Elevation of New Car Shop.

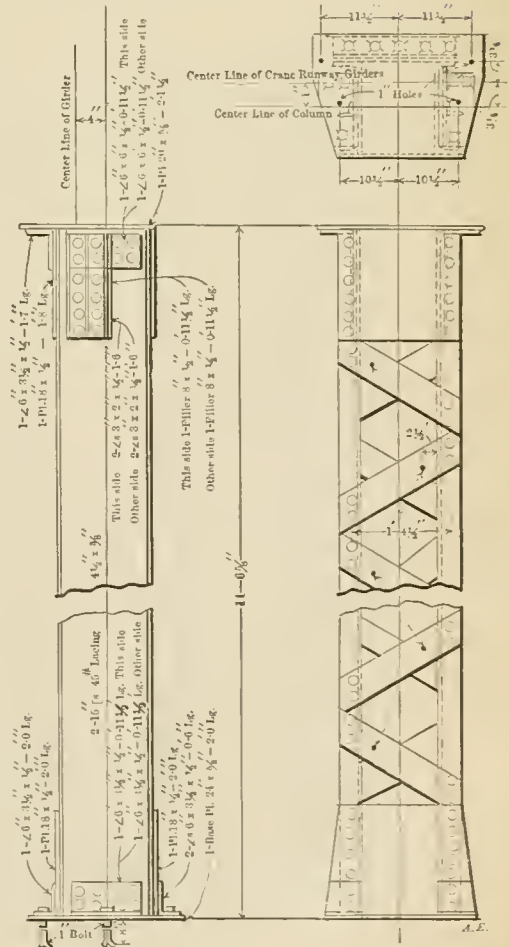

Crane Columns in Erecting Shop.

2 ins. the roof trusses were raised by a change in their lower chords, the crane columns and foundations being shown in the drawings. This shop crane runs to the end of the building where it will raise a boiler from the trucks as it is received over the transfer table and to allow it to run to the end of the building a dormer was built into the roof at the end toward the transfer table. The crane columns are made of two 12-in. channels.

A dry lumber shed is also included in the improvements.

MOGUL FAST-FREIGHT LOCOMOTIVES.

Simple and Compound with Wide Fireboxes.

Atchison, Topcka & Santa Fe Railway.

Built by The Baldwin Locomotive Works.

In freight service the general tendency seems to be toward faster trains. On this road it is necessary to provide loco-

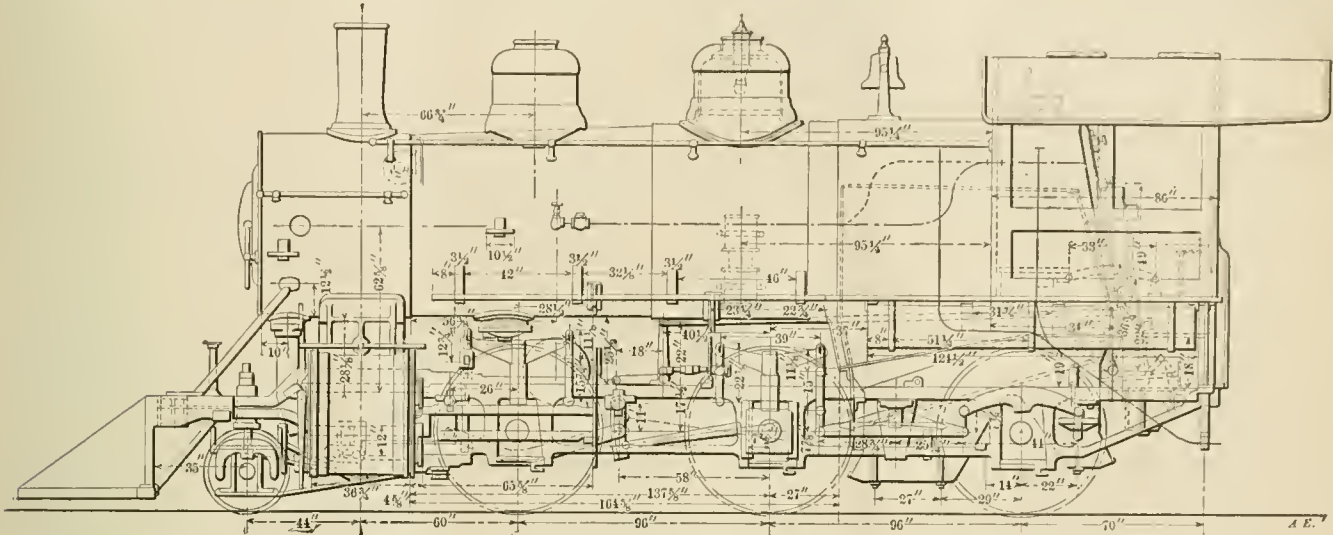

MOGUL FAST FREIGHT LOCOMOTIVE-ATCHISON, TOPEKA & SANTA FE RAILWAY.

JOHN PLAYER, Superintendent Motive Power.
R. P. C. SANDERSON, Assistant Superintendent Motive Power.

BALDWIN LOCOMOTIVE WORKS, Builders.

Wheels : Driving.....	Cylinders : 16 1/2 and 26 x 28 in.	Boiler pressure.....	200 lbs.
Weights : Total of engine.....	62 in.; 159,000 lbs.;	engine truck.....	30 in.;
Grate area and tubes: Grate area.....	48 sq. ft.	on drivers.....	135,000 lbs.;
Firebox : Length.....	100 3/4 in.;	Tubes.....	350; 2 in., 13 ft. 5 in long.
Boiler : type, wagon top.....	radial staying.	depth of, front.....	69 in.;
Heating surface : Tubes.....	2,443.4 sq. ft.;	Diameter.....	68 in
Wheel base : Driving.....	16 ft. 0 in.;	firebox.....	155 4 sq. ft.;
		total of engine.....	24 ft. 8 in.;
		Tender : water capacity.....	5,000 gals.
		total engine and tender.....	2,598.8 sq. ft.
		tender wheels.....	33 in.
		total engine and tender.....	259,000 lbs.
		back.....	54 1/2 in.

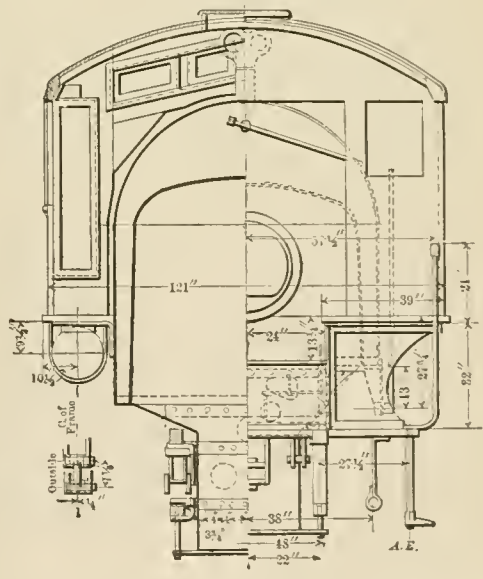
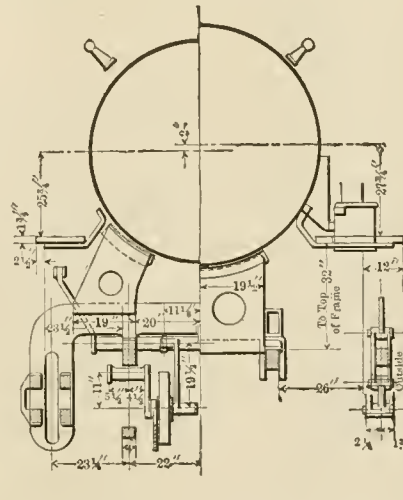
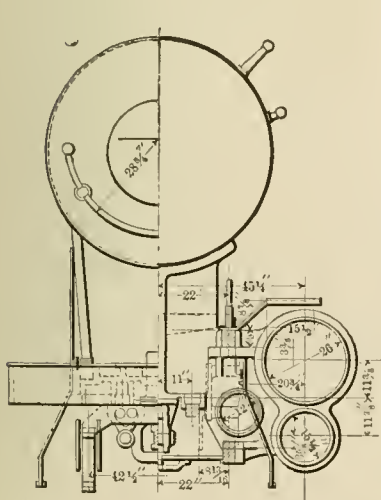

Top of Rail

Sections and Half Rear Elevation.

It is 126 by 20 ft. and has sliding doors along the whole front with slat ventilators over the doors. It has a gravel roof.

Dr. Carl Auer von Welsbach, of Vienna, Austria, has been awarded the Elliott Cresson Medal by the Franklin Institute, for his discoveries regarding the metallic oxides which may become incandescent when heated, and for the invention of the Welsbach mantle, by the use of which these metallic oxides are commercially available as sources of artificial light.

tives for freight purposes that are not far from the recent passenger designs as regards speed and capacity for sustained power. On this road freight trains must run on relatively fast schedules except on the very heavy grade districts, and the designs here shown are almost equally well adapted to deal with heavy passenger as well as freight traffic. These engines are a part of a large order, some of which are compounds, the drawings being of the compounds, while the table

the accompanying diagram, which seems to meet the requirements and permits of braking any number of cars by the leading engineer of two or three engines. Mr. Morris says he has no difficulty in braking 75 or 80 cars in this way.

Two of these valves are placed in the additional reservoir pipe on each engine, one toward the pilot and the other toward

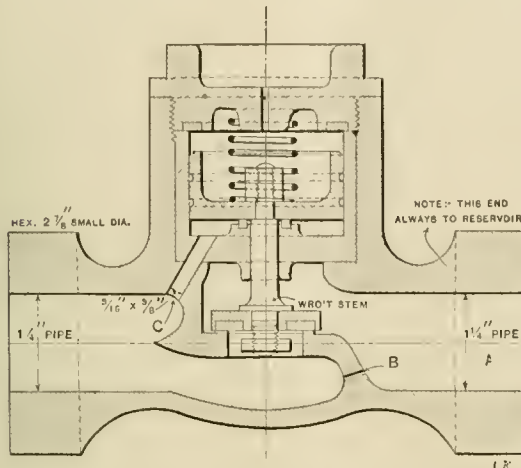

Morris' Equalizing Check Valve.

the rear end, with the end of the valve marked A in the engraving, toward the reservoir in each case.

In operation the reservoir pressure enters this valve fitting at the end, A. The large valve will be closed by the spring and pressure and held upon its seat, but the small leakage groove, B, permits the pressure to equalize through the hose connections until by means of the port C and the piston, the valve is raised from its seat and a free passage is opened for the air in the reservoirs. In case a hose bursts on a pair of couplings break the valve closes and reduces the leakage to the amount which can pass through the leakage groove, B. The piping is supplied with the usual cut-out cocks. Mr. Morris has also sent us a pipe plan for the complete equipment of the locomotive, but it is believed that the use of the valve is made clear by this description.

With this arrangement the old 8-in. air pumps do very well, although one of them alone is insufficient. Mr. Morris has applied for a patent on the device.

ROAD TESTS OF DRAFT GEARS.

Atchison, Topeka & Santa Fe Railway.

Mr. R. P. C. Sanderson, of the Atchison, Topeka & Santa Fe, has kindly sent us a copy of a report upon road tests of draft rigging which is worthy of record in the present discussion of the subject of improved draft gears. These tests were made on the Chicago division and were divided into two series.

Tests with Empty Cars.

The train was made up with twelve 80,000 lbs. capacity hopper coal cars fitted with Dayton draft gear followed by 35 hopper coal cars fitted with Miner draft gear. Speed observations were taken with a stop-watch and the following tests were made:

Tests 1 to 5 involved emergency applications from 10 to 20 miles per hour. In No. 5 the brakes were cut out of the last six cars and the caboose. Test No. 6 was an emergency application at 20 miles per hour with brakes cut out of the last 12 cars and caboose. No. 7 was at 20 miles per hour, with 18 cars at the rear cut out. No. 8 was at the same speed, but with 24 cars and the caboose cut out. In No. 9 the brakes were cut out on the first 23 cars, also on the engine and tender. The engine pulled out with wide open throttle and lever in full gear. At 10 miles per hour the angle cock on the caboose was opened wide, causing a violent emergency application on the last 24 cars and caboose. The train was brought to a

standstill with the engine stalled. No. 10 was like the previous test except that the speed was 20 miles per hour. In No. 11 handbrakes were set up hard on the caboose and last 10 cars. The engine took the slack against them and started ahead, in full gear with wide throttle. This test was repeated four times. No. 12 was made with all brakes cut in. With the train moving at 4 miles per hour, the engine was reversed to bunch the train and then the lever was put into full forward gear with the throttle wide open, causing the engine to plunge forward. This was also tried four times and the remaining test, No. 13, was an attempt by the engineman to break the train in any possible way. Several were tried but were not successful. The following results are quoted from the report:

Results.

It was found impossible to break the train in two with any of the thirteen tests referred to. There was absolutely no damage to any of the draft gears or couplers, but some of the wooden sills showed splits or cracks from the corners of the key-ways where these were grained into the wood sills. This damage, however, was quite insignificant, did not require any repairs and in nowise affected the strength or safe condition of the cars; and if steel center sills were used instead of wood, this trifling damage, of course, would not have occurred. Tests Nos. 7, 8, 9 and 10 were particularly hard on the cars. The conductor of the train refused to stay in the caboose. It was noticed that there was a good deal of recoil from the springs, and this was to be expected, as, with the play in the couplers and the compression of the springs, there was a difference in length of 15 ft. 8 ins. when the train was stretched and when it was bunched. In tests Nos. 9 and 10 the recoil was sufficient to pull the engine back several feet. In spite of all this, it was noticed with surprise that the recoil was gradual always and elastic and free from all jerk, so that this recoil is not likely to cause any damage to the draft gears. From the action of the train it is to be doubted whether the full capacity of all the 188 draft springs was ever fully exhausted.

Tests with Loaded Cars.

These were also made on the Chicago division, and two engines were used. No. 977 had 21 by 28-in. cylinders, 57-in. driving wheels and 200 lbs. steam pressure. No. 590 had 18 by 24-in. cylinders, 63-in. wheels and carried 180 lbs. steam pressure. The train was made up of 80,000-lb. hopper cars loaded with coal with the draft gear arranged as follows: 10 cars Miner, 2 cars Dayton, 16 cars Miner, 5 cars Dayton, 1 car Miner, 2 cars Dayton, 5 cars Miner, 1 car Dayton and finally the caboose. The gross weight of the train exclusive of the engines and caboose was 2,459 tons, but after two tests the load was reduced to 2,005 tons in order to come within the capacity of the engines. The remaining tests were as follows:

No. 3, the brakes were cut out on the six rear cars and the caboose, an emergency application being made at 15 miles per hour. No. 4 was like No. 3, with the cutting out of 12 cars. In No. 5 the handbrakes were set on the last 10 cars and the caboose. Both engines took the slack against them and started forward in full gear, with wide open throttles. This was repeated five times. In No. 6 the angle cock was turned on the ninth car from the rear end and the hose uncoupled between the eighth and ninth cars, thus setting the brakes on the last eight cars. The engines backed up against these and attempted to start the train with these brakes set by taking the slack with the full power of both engines. This was repeated five times, the remaining test being a number of attempts by the engineers to break the train in two in other ways, in which they failed.

Results.

With the exception of some small cracks in the wooden sills where the malleable draft arms were grained into the sills, there was absolutely no damage to any of the draft gears, springs or couplers. The cars, after the tests, were carefully inspected in the day-time by regular car inspectors who searched them thoroughly for any damage. Six of the cars used in this second test were previously used in the first test. Test No. 6 of the second series was exceptionally severe on the cars.

The report also states at this point that the empty car tests of January 23d were nearly a duplication of the Westinghouse tests made at Wall, and that the loaded car tests of January 31st were comparable with the Westinghouse tests at Wilmer-

ding, that the combined tractive power of the two Atchison engines was nearly that of the Union Railway engine at Wilmerding and that the weight of the train in the second Atchison series was in excess of that of the Wilmerding train. In referring to the Westinghouse tests it was stated in the report that the information was taken from the published accounts of the tests.

PROBLEMS OF A TECHNICAL GRADUATE.

Mr. E. M. Herr, General Manager of the Westinghouse Air Brake Company, on February 13th delivered an address before the students of Purdue University. His subject was "Some Problems in the Business Life of a Technical Graduate." Speaking from a wide experience and with a strong feeling of sympathy for his student audience, Mr. Herr was able to anticipate some of the pleasures as well as the disappointments which lie in the path of men about to graduate.

Referring to the prosperous aspect of business enterprises at the present time, he warned his audience not to relax effort if they found the problem of obtaining employment an easy one, for no true progress is made without effort, and he who is compelled by circumstances to struggle hardest is most entitled to congratulation, if progress and advancement is his object. In emphasizing the advantage to the technical graduate of a thorough shop apprenticeship, Mr. Herr discussed the necessity for reducing shop cost in manufacture and showed how necessary it was for the engineer to know for himself the details of doing work. Always remember, he said, that actually doing the planing, turning, drilling or whatever operations are to be performed on a piece of work is by no means all of the labor which the job includes. The handling to and from the tool or machine may, and in many cases does, cost more than the mechanical operations themselves. Always avoid reducing cost at the expense of either efficiency, accuracy or durability. There is often a great temptation to reduce the cost of maintenance or construction in railroad work, or the cost of a product in manufacturing, by sacrificing efficiency or durability. This may enable one to make a favorable record for a while, but so surely will eventually bring disaster and an increased cost for maintenance or operation in railroad work, or a loss of patronage and reputation in manufacturing, that one can safely condemn such practice without hesitation and in a most uncompromising way.

Speaking of the need of early accustoming oneself to carrying responsibility, Mr. Herr reminded his audience that to shirk or fail always weakens the shirker and lessens confidence, whereas every responsibility successfully borne becomes a stepping stone to greater success. In this connection he related an incident in his own experience. Having been appointed to an executive position, the details of which were new to him, he called upon the general superintendent to whom he was to report, for final instructions before proceeding to his post. In response to his questions as to whether there were any instructions to be given, he received the reply, "No instructions! The machine is running down there; don't stop it until you are sure you can start it again!"

Emphasizing the need of care and patience, the speaker cautioned the students by saying that it was easy to work when everything runs smoothly—when, to use a homely phrase, things are coming your way. But a time is likely to come when your most carefully laid plans are likely to be overturned and you fail, perhaps through no fault of your own, but apparently because some other person has been a little careless or inattentive, or has lacked judgment, with the result that your work has not materialized and you yourself are subjected to criticism. It is then very difficult to have the patience to carefully and more thoroughly than before go over the old ground and with greater pains and care reconstruct a more secure foundation, avoiding the weakness which caused the former failure, whether in man or materials, and thus finally bring success from apparent failure.

After thus inspiring his audience with the dignity of the demands which would be made upon them, Mr. Herr described in detail the organization of a large manufacturing establishment, showing the purpose of each department and the dependence of one on the other. He traced the movements which are made between the receipt of an order and the shipment of the machine ordered. In conclusion he said, "Be kind and considerate to your fellows, courteous and obedient to those in authority, and strive always to do a little more than is expected of you, and I can safely promise that there will, in your case, be no such word as fail."

NEW DINING CARS.

Chicago, Burlington & Quincy Railroad.

Through the courtesy of Mr. F. A. Delano, Superintendent of Motive Power of the Chicago, Burlington & Quincy Railroad, we have received the floor plan and drawings of the interior finish of some exceedingly interesting dining cars just completed for that road at the Pullman shops. Special attention was given to the interior decorations and finish to secure a genuine artistic effect, and the result is very pleasing. It is more striking because of being the first instance of real artistic taste in a car interior that has ever come to the writer's notice, and we shall be mistaken if it does not have an important effect upon future practice. There is nothing about the interior of the car that would look out of place in a fine house. The design is quiet and simple, there is practically no ornamentation, except on the buffet and niche. The whole scheme is an expression of quiet, elegant taste.

The floor plan shows the general arrangement, in which it will be noted that the kitchen is large and that the end opposite the kitchen is arranged with a buffet, directly opposite the

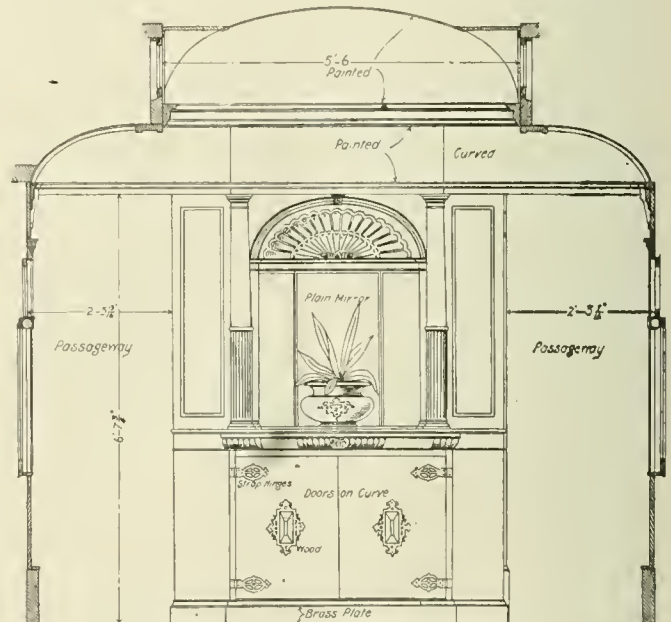

Elevation of Niche.

door. The sides of the dining room are wainscoted to a point above the large windows in very dark, almost black, Flemish oak. Above the high wainscoting and across under the roof the headlining is a strong sunflower yellow. The oak is finished without polish and is exceedingly handsome. The headlining is entirely devoid of ornamentation and the color effect with crimson window shades and carpets is exceedingly tasteful. The coat hooks and other metallic furnishings are of yellow brass. In order to break the long lines of the interior Flemish oak beams are carried up the sides and across the ceiling, as indicated in the view of the side finish. There are no curtains, merely plain shades, and above the top lines of the shades the windows are completed with stained glass in harmonizing colors. A description of the effect is difficult.

The cars are 70 ft. long, 10 ft. 4 ins. wide, and the dining room is 32 ft. 2 ins. long. There are 10 tables, 5 with 4 seats each on one side, and 5 with 2 tables each on the other. The tables are placed at 6 ft. 4 in. centers. The kitchen end of the dining room is completed by a buffet, an elevation of which is shown in one of the drawings. At the other end is a sideboard, which is also illustrated. There are five of these cars now building and we hope to illustrate them further by photographs next month.

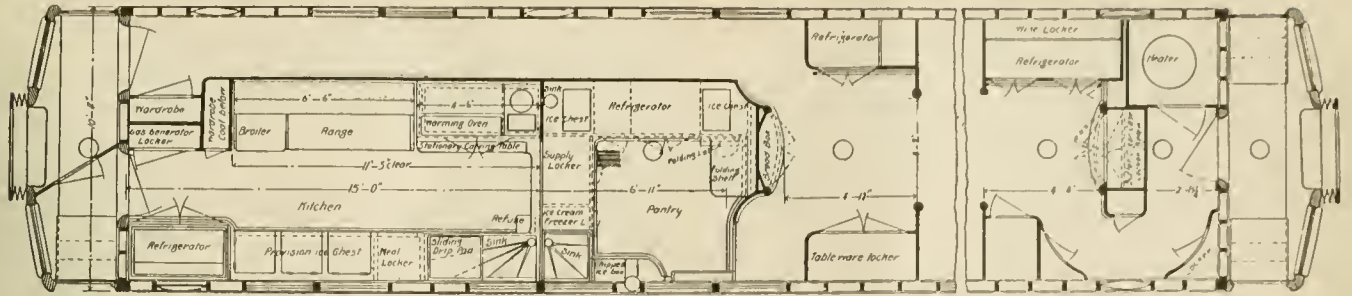

Plan of End Portions of Dining Car.

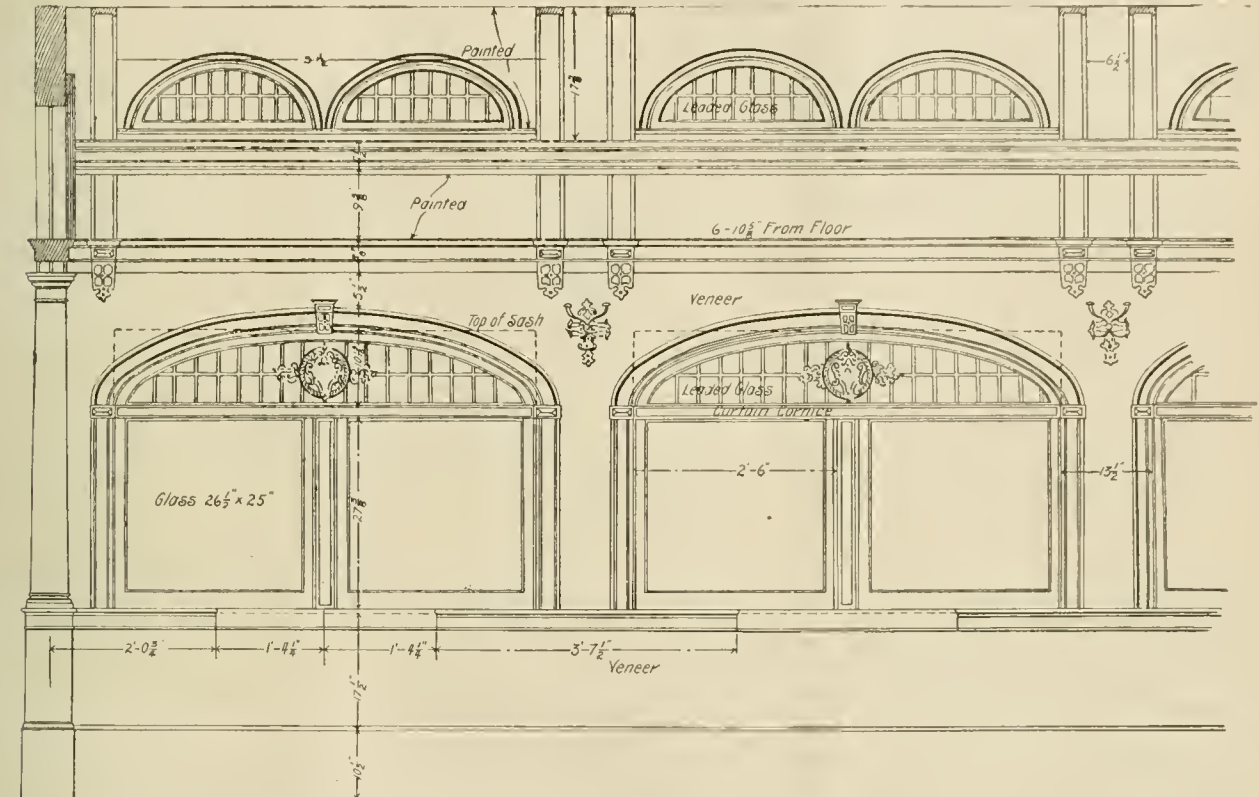

Side Finish in Dining Room.

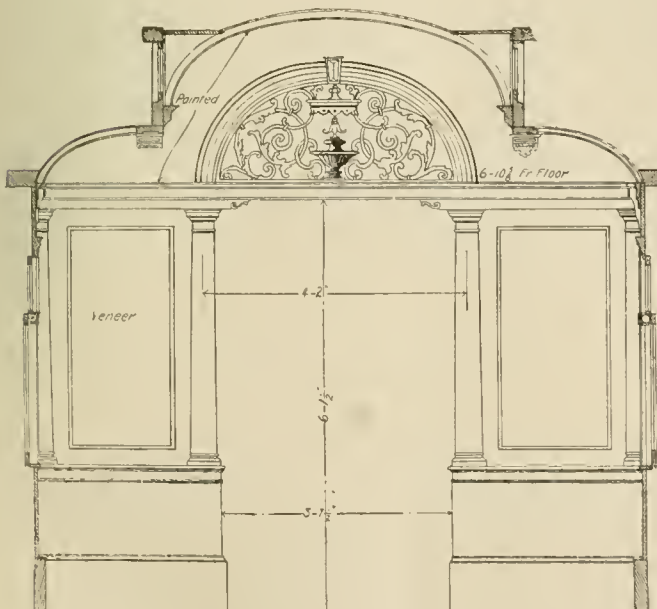

Bulkhead Partition.

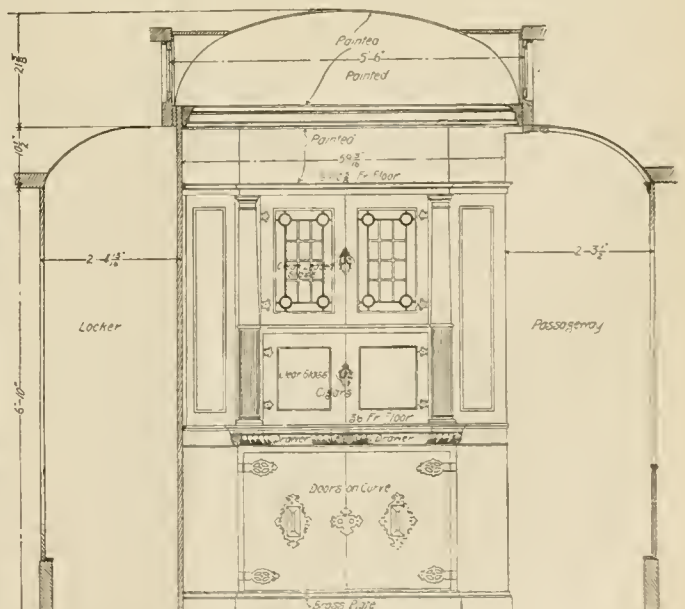

Sideboard Elevation.

New Dining Cars, Chicago, Burlington & Quincy Railroad.

(Established 1832)

AMERICAN ENGINEER AND RAILROAD JOURNAL.

PUBLISHED MONTHLY

BY
R. M. VAN ARSDALE,
J. S. BONSALL, Business Manager.
MORSE BUILDING.....NEW YORK

G. M. BASFORD, Editor.
E. E. SILK, Associate Editor

APRIL, 1901.

Subscription.—\$2.00 a year for the United States and Canada; \$2.50 a year for Foreign Countries embraced in the Universal Postal Union. Remit by Express Money Order, Draft or Post-Office Order. Subscriptions for this paper will be received and copies kept for sale by the Post Office News Co., 217 Dearborn St., Chicago, Ill.
Dumrell & Upham, 283 Washington St., Boston, Mass.
Philip Roeder, 307 North Fourth St., St. Louis, Mo.
R. S. Davis & Co., 346 Fifth Ave., Pittsburg, Pa.
Century News Co., 6 Third St. S., Minneapolis, Minn.

EDITORIAL ANNOUNCEMENTS.

Advertisements.—Nothing will be inserted in this journal for pay, EXCEPT IN THE ADVERTISING PAGES. The reading pages will contain only such matter as we consider of interest to our readers.

Special Notice.—As the AMERICAN ENGINEER AND RAILROAD JOURNAL is printed and ready for mailing on the last day of the month, correspondence, advertisements, etc., intended for insertion must be received not later than the 20th day of each month.

Contributions.—Articles relating to railway rolling stock construction and management and kindred topics, by those who are practically acquainted with these subjects, are specially desired. Also early notices of official changes, and additions of new equipment for the road or the shop, by purchase or construction.

To Subscribers.—The AMERICAN ENGINEER AND RAILROAD JOURNAL is mailed regularly to every subscriber each month. Any subscriber who fails to receive his paper ought at once to notify the postmaster at the office of delivery, and in case the paper is not then obtained this office should be notified, so that the missing paper may be supplied. When a subscriber changes his address he ought to notify this office at once, so that the paper may be sent to the proper destination.

The paper may be obtained and subscriptions for it sent to the following agencies: Chicago, Post Office News Co., 217 Dearborn Street. London, Eng., Sampson Low, Marston & Co., Limited St. Dunstan's House, Fetter Lane, E. C.

THE CHILLED WHEEL—HAS IT REACHED ITS LIMIT?

An exceedingly important question is brought forward by the breakage of wheel flanges under freight cars of 50 tons capacity. In our February number the situation was mentioned as serious, and it has not improved since that time. While the difficulty seems to be greatest on roads with severe grades it does not appear to be confined to such.

One of three things is necessary: to improve the strength of the present chilled cast-iron wheel by changes in the chemical proportions, to substitute for iron a stronger material or to relieve the wheels of the destructive stresses or influences which cause the trouble. It would not be wise to say now that the cast-iron wheel for 50-ton cars must go, but that under the present conditions as found in our investigation the present cast-iron wheel has reached its limit there can be no doubt. When a piece of a flange measuring 26 ins. in length breaks out of a wheel in one case, the entire flange breaks off in another, and many cases of fracture occur, the statements made here are seen to be justified. Our inquiry covers three important roads, and in each case the motive power officers speak of it as a source of great anxiety which is not allayed by the assurances of the makers of cast-iron wheels.

It appears that there is no opportunity to enlarge the flange because it is out of the question to change the throat space in the track frogs. There is no doubt of the value of swing motion

trucks in reducing the flange stresses. The improvement of center plates and the application of roller side bearings will also help by reducing flange wear, which, of course, leads to weakness and probably causes heating of the metal. There has been trouble elsewhere, but because the flange cannot be made thicker this part is the key to the cast-iron wheel situation.

The troublesome breakages are believed to develop from cracks originating inside of the metal, near or at the root of the chilled portion and working out to the surface. The fractures are usually, but not always, blue in color, indicating oxidation by heat, and except when inspected while the wheels are hot from a recent brake application the cracks when they come to the surface are difficult to find. This blue appearance seems to indicate that high temperature is a factor. This view is supported by the experience of one road where the effect of a heavy mountain grade is clearly noticeable. But it is not impossible that in some cases this may be traced to foundry practice.

There may be two causes for this heating. It may come from the brake shoes and it may come from flange friction and perhaps both. It has been noted that many breakages occur on flange-worn wheels, though this is not always the case. One theory is that the trouble may be overcome by improving the center plates and providing roller side bearings to make the trucks curve easily. This involves radical changes in the construction of a large number of trucks. This should be done anyway, but it is doubtful whether it will suffice. There seems to be a good basis for the theory of a flowing of the metal of the wheel due to a combination of load and stress from side thrusts which tend to cause the cracks and their development into fractures. It is, however, a curious fact that the only way in which these flange breakages have been successfully imitated experimentally has been by the application of heat.

In examining a fracture through the tread and flange of a cast-iron wheel one is impressed with the fact that there is very little gray metal at the vital part of the flange and as the chilled metal may be pulverized with a hammer it is clear that the gray iron is all that is to be depended on for strength. It seems reasonable to believe that the limit of strength was nearly reached in 40-ton cars and that the 50-ton car has merely developed the weakest spot, the flange. Three-quarters of an inch of gray iron in a flange does not appear to be enough. In the absence of experience with steel-tired wheels in freight service no one can say what they will do, but a large scale experiment will soon be tried to settle this. There can be no doubt that the steel-tired wheel will be thoroughly tried, and the question will rest simply on a basis of cost and endurance. If steel-tired wheels are used we may be sure that precautions will be taken to keep down the flange wear because of their high cost.

We desire to be perfectly fair. If the cast-iron wheel can meet the demand it is very important to know it. If not it must give place to other material. It is significant that the best authorities on the subject of cast iron wheels are the most anxious about them and the most thoroughly at a loss as to how to improve them.

GAS ANALYSIS APPLIED TO LOCOMOTIVES.

Grate area sufficient for the fuel is now thoroughly appreciated, but every bit of testimony to the advantage of large enough grates is acceptable. Mr. Bement supports the general opinion from examination of the gases and records his observations elsewhere in this issue. There are many small grates in use, however, which, as he says, cannot be changed, and these present a problem in which all are interested, viz.: How may combustion upon small grates be improved? Firing lightly and frequently has had strong advocates for a long time, and to the benefits already accorded to this practice Mr.

Bement adds the important one of economy in operation. To many his observations will not appear to be novel, but the combination of frequent and light firing with frequent shaking of the grate as a method of improving the operation of the locomotive with a small grate seems to be a very important suggestion.

Mr. Bement's tests were carried out on one of the western roads and it is surprising to have him tell us that with a grate area of 30 sq. ft. more coal could be burned than could be supplied by one fireman and yet at the end of the division the fire was in condition for the engine to take a train back at once. As a result of the light firing and frequent shaking of the grates the exhaust nozzles were at once enlarged. We shall have occasion to refer to Mr. Bement's methods later in connection with other important work, but it may be well to remark here that the study of furnace combustion by means of the analysis of the waste gases is a very important development at the present time. There is nothing new or mysterious about it. The apparatus used has been familiar to chemists for many years. It is very simple, easily manipulated and in fact requires but one observer. The determinations made are the proportion of oxygen, carbonic acid and carbonic oxide. With these the furnace action is clearly revealed and the remedy for wrong conditions may be easily applied or, at least, the conditions may usually be improved. It is extremely important that locomotives with small grates should be given the most careful consideration because they will for a long time outnumber those with wide grates.

The most important part of Mr. Bement's work thus far appears to be the fact that a great deal depends upon air supply. The improvement of very large engines having small grates seems to lie in the opening of the fire door to an extent to be indicated by the gas analysis. In some cases metallurgical furnaces have been operated with the door open all the time and with blast furnace boilers it is an advantage in some cases, when the gas comes in large volumes very rich in CO, to open the doors wide while such a condition exists.

We are told of a large plant in Indiana burning natural gas where the capacity of the mains to supply gas was exhausted and the boilers were thought to be forced to the limit of their capacity. By examining the gases it was found that more of the heat was employed in heating air which went up the chimney without accomplishing anything than was used in heating the water. This discovery led to shutting down half of the boiler plant, the remaining half then being sufficient. This was the effect of a large excess of air.

A tendency toward overdoing in the air supply should be guarded against in connection with the introduction of larger grates and this is a good reason for welcoming heartily the gas analysis method of studying locomotive combustion. Its appearance is opportune.

ing truck. A yard engine having no leading truck would omit the denominator.

The second part, or second fraction, indicates two things—the numerator, the number of pairs of coupled or driving wheels; and the denominator, the diameter of the wheel centers in inches. The letters representing the number of pairs of coupled wheels may be selected arbitrarily. Those given below represent the practice of our road and at least one locomotive builder.

- B - 1 pair of coupled wheels,
- C - 2 pairs of coupled wheels,
- D - 3 pairs of coupled wheels,
- E - 4 pairs of coupled wheels,
- F - 5 pairs of coupled wheels,
- G - 6 pairs of coupled wheels.

The third part, or third fraction, also represents two things; the numerator, the diameter (or diameters in a compound) of cylinders in inches; the denominator, the length of stroke in inches.

The fourth part, or letter, represents the type of firebox.

I - a narrow box between the frames,

T - a narrow box on top of the frames,

C - a compromise box, exceeding the width of frames and above the wheels at this point, whether driving or trailing, and up to a width of 72 ins. W is a wide box above the wheels, and over 72 ins. wide.

The classification used above for illustration indicates what is at present termed an Atlantic Type engine with a four-wheel leading truck, 74-in. wheel centers, a 20 by 26-in. cylinder, and a firebox over 72 ins. wide.

The Pennsylvania Railroad engine, class E-1, becomes class $\frac{10\ C\ 20\frac{1}{2}}{4\ 74\ 26}\ W.$

The N. Y. C. & H. R. Atlantic type becomes $\frac{10\ C\ 21}{4\ 72\ 26}\ W.$

The C. & N. W. Atlantic type becomes $\frac{10\ C\ 20}{4\ 74\ 26}\ C.$

The B. & O. Compound Atlantic type becomes $\frac{10\ C\ 15\ \&\ 25}{4\ 72\ 30}\ C.$

The C., B. & Q. Prairie type becomes $\frac{10\ D\ 19}{2\ 58\ 24}\ W.$

Such a system would at a glance not only define the type of engine, but by giving its leading dimensions, give some idea of its size and capacity. A classification plate carrying the class of the engine, and located in some accessible position, as regards observation, would be of value to both the transportation and motive power departments.

F. F. Gaines,
Mechanical Engineer, Lehigh Valley R. R.

THE FATE OF A DRAFTSMAN.

To the Editor:

I have read with a good deal of interest in the March number of the American Engineer your article entitled "The Fate of a Draftsman," and take the liberty of adding a few remarks on a subject which I know is of keen interest to the large number of draftsmen employed by railroad companies.

From the nature of drawing room work it is but following the natural order of things that good men pass through this office. In common with many other qualities the successful motive power man of to-day must possess an abundance of life and energy. A man full of life and energy is not the one to stand for more than four or five years the intensely tedious and closely confining work in the drawing room. Because good men for the reason just stated cannot be expected to remain permanently in this office, the solution of this difficulty seems to me this: Every superintendent of motive power should bring this sub-department in close touch with all other branches of his department, and make it a necessary channel for all young men in his department who are ambitious for advancement. The salary of the mechanical engineer or chief draftsman in charge of the drawing room should be amply sufficient to secure and retain for a number of years the services of a man of mechanical and executive ability who may put and keep the drawing room in the highest state of efficiency and usefulness. It is indeed to be regretted that railroad drawing rooms are

CORRESPONDENCE.

LOCOMOTIVE CLASSIFICATION, LEHIGH VALLEY RAILROAD.

To the Editor:

I have noticed lately several propositions for a system of classifying the different types of locomotives. I beg leave to submit another. It is of the following form:

$$\frac{10\ C\ 20}{4\ 74\ 26}\ W.$$

At first sight this appears very complicated and long. On the other hand, familiarity with the key renders its complexity of form unobjectionable, and as it really conveys a great deal of information beyond defining the type, its use and the memorizing of the key are worth the effort.

The first part, or first fraction, denotes the total number of wheels, and the number of wheels in the leading truck—the numerator indicating the total number of wheels under the engine; the denominator the number of wheels under the lead-

so conducted that good men hesitate to enter. The education of every mechanical engineer and motive power officer is to quite a degree incomplete until he has spent some time over the drawing table in an up-to-date drawing room, and a good man need not hesitate to enter one, because, if a good man, his time need not be longer here than is necessary to gain valuable information.

The drawing room is to a great extent an educator for the future executive officer. In what other office can be better learned the importance of system, the ability to develop and maintain standards and the great economy resulting therefrom? In what office is the habit of self-reliance and self-confidence better developed, where the practice of absolute accuracy is an every-day necessity? These are all points and qualities the appreciation of which and the possession of which are necessary to the successful motive power official.

From my own experience I would not care to have the services of a draftsman who showed no dislike to the idea of continuing as a draftsman indefinitely. There is indeed no sympathy needed for the draftsman who complains because there is no outlet for him. If there is not where he is, let him seek elsewhere. The "fate of a draftsman" is one of his own making, and viewed in that light his fate is no "fate," but his own fault.

A. H. Weston.

To the Editor:

An expression of my thoughts on the editorial, "The Fate of a Draftsman," which appeared in the March issue of the American Engineer, I hope may interest you. That the drafting office is not a field for promotion, except to a limited extent, is

mechanic who put me to work as an apprentice in a railroad shop met me several years after in a drawing office; he wanted to know why I remained in the drawing office and threw away my chances for promotion in the shop.

The promotion of the right young man from the shop will certainly be delayed if he enters the drawing office. This is not to be regretted, as the experience acquired during the delay will be the most desirable for future work. While the fear of becoming "sidetracked" is not groundless, this should not deter any ambitious mechanic from entering the drawing office, for, if he is the right sort of young man, he will have no trouble in out-shining his present-day fellow draftsmen sufficiently to be seen by those in authority. It is then that he will be selected from among the others to carry out those jobs that are outside the routine work of the office. These jobs usually cause him to take to the shop or go out on the road. Then he will have the much desired opportunity to show his ability and make himself known.

When I was in the general drawing office there was no difficulty about getting up a little discussion on most any subject during the usual noon hour debate. Then would have been the time to get up a discussion on your editorial. Since I have been taken out of the general drawing office I can't, conveniently for all, arrange to get up a discussion. Individual comments from a few of the draftsmen were that the editorial was all right, that it should be enlarged and framed, then hung up in the offices of a few of the minor officials, who seem to think that the drawing office is not a necessary adjunct to the success of the plant.

Draftsman.

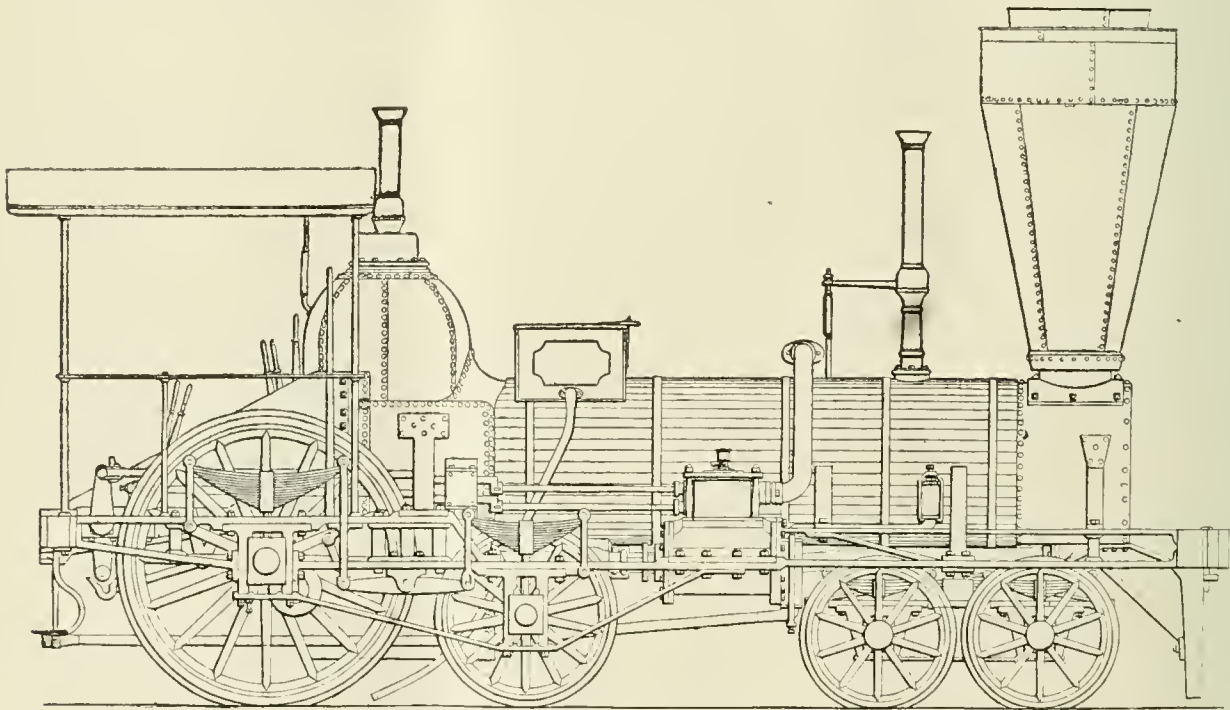

Locomotive Traction Increaser of 52 Years Ago.

quite true. This, I believe, is in a large measure due to the fact that a very large proportion of the mechanical draftsmen have taken to drafting mainly because of the desire for genteel work. Of the large number of draftsmen of my acquaintance I knew of only two who have completed a shop apprenticeship and of three others who have had about eighteen months' experience in the shop. From this it is not surprising that superintendents and master mechanics do not look to the drafting office for their shop foremen. If the accepted way to the drafting office was through a shop apprenticeship there is hardly any doubt but that a large majority of the various shop foremen would be drafting office graduates. The fear of becoming stranded in the drawing office or the certainty of delayed promotion, or both, I know have caused some shop-trained young men to forego a much desired drawing office training. And I believe these causes account for the lack of shop men in the drawing office generally. The first master

TRACTION INCREASERS.

To the Editor:

Referring to your remarks, pages 82 and 87 of the March issue, relating to locomotive traction increasers, M. W. Baldwin, of Philadelphia, the founder of the Baldwin Locomotive Works, about the year 1848 or 1849 invented and patented a traction increaser which was part of the design of an express passenger engine with single pair of drivers and leading pair of carrying wheels. This device consisted of a toggle joint with a long lever projecting up into the cab. This toggle joint was bolted to the frame and connected with the back end of the equalizer and by pulling the lever back part of the weight on the carrying wheels could be thrown on the drivers. The arrangement is shown very plainly in the line illustration herewith, which was issued by M. W. Baldwin to show the design of this class of locomotive. Four engines were built from these plans

one named Blair and one Millin, went to the Pennsylvania Railroad, then about being opened for business. One was sold to the Hudson River Railroad and one to the Vermont Central Railroad. It was reported that the Pennsylvania rebuilt the two they had and the other two were reported wrecked. The plan did not appear to have been a success, no more engines having been built from it. It is surprising that after 52 years' rest this old device, or a modification of it, should come to the front.

James M. Boon.

Chicago, March 14th, 1901.

COMBINATION CYLINDER SADDLE AND FRAME BRACE.

To the Editor:

Within the past few years it has been necessary to materially increase the height of cylinder saddles, due principally to extending fireboxes over the frames and allowing sufficient height between the top of the grate and the bottom flue. With the arrangement of firebox over the frames and between the wheels, a better opportunity is afforded to secure the boiler to the frame than in the present wide firebox engines or Wootten boilers. In the first case mentioned the firebox mud ring resting on top of the frame gives ample surface for furnace bearers, allowing for expansion, and at the same time the force tending to move the boiler longitudinally due to sudden starting, stopping and bumping, is much more restricted, owing to the friction between the parts, than in the method of supporting Wootten or wide firebox boilers by plates or links. This latter arrangement compels the cylinder saddle to absorb all strains developed by the mass of metal and the water in the boiler suddenly put in motion or brought to rest. That these strains are more severe with the Wootten than the ordinary firebox is attested by the fact that cylinders on such locomotives are at least 10 per cent. heavier than the same size cylinder for a bituminous coal burning locomotive, with the firebox between the frames.

An effort to provide for the strain on the saddle has been made by applying outside ribs, increased thickness of walls and diagonal longitudinal braces in the form of smokebox braces, extending forward and backward from center of cylinder saddles. These all tend to place an excessive weight where it is not wanted, and have not proved an efficient means to prevent movement of the parts. The large boilers and large wheels have both contributed toward making this an exceedingly difficult problem to solve. It has, however, been accomplished in some later designs by an increased length of cylinder saddles, but this is objectionable in that it lengthens the engine or shortens the flues, and at the same time greatly increases the weight of cylinders.

Knowing the value of a frame cross brace immediately in front of or behind the cylinder for absorbing transverse strains, we applied the brace shown in the engraving, which, by an addition of very little weight, does the double duty of frame cross brace and cylinder saddle support. The amount of metal required in a brace of this kind, compared with the amount of metal necessary to produce the same rigidity, distributed elsewhere, is small. This design, of course, is open to several changes to suit the different conditions imposed by the different types of locomotives. Two upright members can be used at the outer edges of the frame, or this brace can be made a

part of the center-pin guide in front of the cylinders, or used on exceptionally large locomotives, both forward and back of the cylinder saddle.

The object, however, is to brace directly to the cylinder saddle above the frame connecting it in such a manner that the strains heretofore passing through the saddle may be transmitted to the frames through other means than through the saddle itself; this arrangement allowing the cylinder to be made with the ordinary staying. The manner of fastening the brace at the frame splice makes a rigid piece of work, and will obviate the necessity of using a frame filling piece at this point.

With this form of brace we get the maximum strength and minimum amount of metal. The casting weighs 870 lbs., and we have saved about 2,000 lbs. of cast iron in the cylinders to which this has been applied, effecting a saving in weight and adding to the strength of the machine.

F. F. Reese,

Chief Draftsman, Dickson Locomotive Works.

March 14, 1901.

Mr. Onward Bates, Engineer and Superintendent of Bridges and Buildings of the Chicago, Milwaukee & St. Paul, has re-

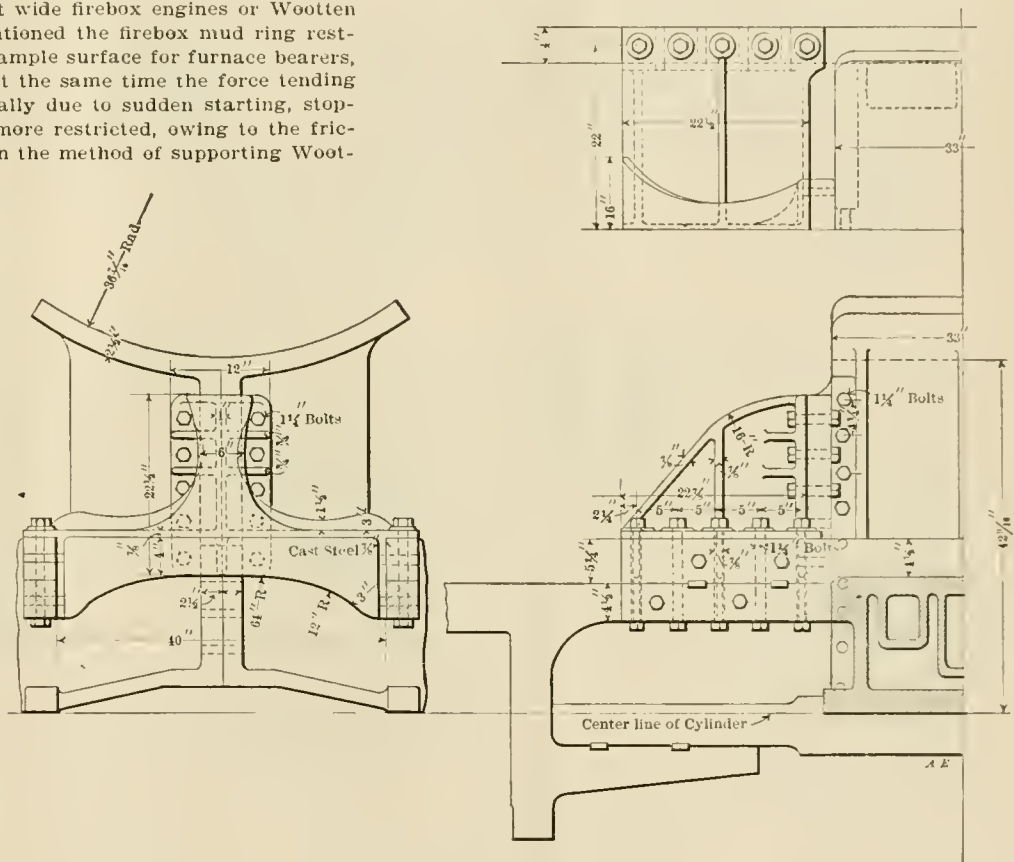

Cylinder Saddle and Frame Brace.
Dickson Locomotive Works.

signed to become a member of the firm of Bates & Rogers, Civil Engineers and Contractors, with office in the Manhattan Building, Chicago. The experience through which Mr. Bates had passed prior to his connection with the Chicago, Milwaukee & St. Paul was varied and extensive, giving him the foundation upon which he was able to build the splendid record that he has during the past 13 years with the Chicago, Milwaukee & St. Paul. In this period he has built more than 11 miles of iron and steel bridges; and culverts which made it possible to replace 44 miles of wooden bridges with earth embankments. During Mr. Bates' connection with this road it has never lost the life of a passenger through any fault of the bridges or the bridge department. Besides being a most careful designer, he was a successful organizer. Mr. Bates holds an honorary degree of Civil Engineer from the University of Wisconsin, and is a member of the American Society of Civil Engineers, Western Society of Engineers, Institution of Civil Engineers, American Railway Engineering and Maintenance of Way Association and other technical societies.

FRICION DRAFT GEAR.

The Standard Coupler Company.

Mr. H. H. Sessions, of the Standard Coupler Company, has embodied his experience and knowledge of car matters in the design illustrated by these engravings, and while experience, and that only, can prove a device of this kind the requirements sought by the designer seem to be met by this device. Instead of increasing the effect of recoil, it actually reduces it below that of ordinary spring gear. This is known as the Sessions-Standard Draft Gear.

The essentials of this gear are a malleable iron housing, a pair of malleable iron wedge blocks, a pair of wedge-ended spring barrels, two standard draft springs, two spring caps, a tie rod and the standard M. C. B. coupler and yoke. These parts are clearly indicated in the drawing, and a glance at

single nut on one end of the tie rod. This is so simple that it should require only a few minutes to make any necessary renewals or repairs. To provide for wear of the spring barrels in the housings strips of steel are inserted against which the flat portions of the barrels bear. This was done to remove all wear from the housings and render that part of the gear a permanent portion of the car structure, which will never need to be removed except in case of damage in a wreck. In buying this device the railroads will furnish only the springs, which are kept in stock in every railroad storehouse.

This arrangement does not require draft timbers, because the housing casting is bolted to the center sills and to a filling block fitted between those sills, and extending about 4 ft. back of the transom. Additional security is provided by a thrust block between the inside of the housing and the bolster and by deep lugs on the housing casting which are let into the center sills and filling block. To show the effect of the stresses produced by a drop test with reference to the recoil

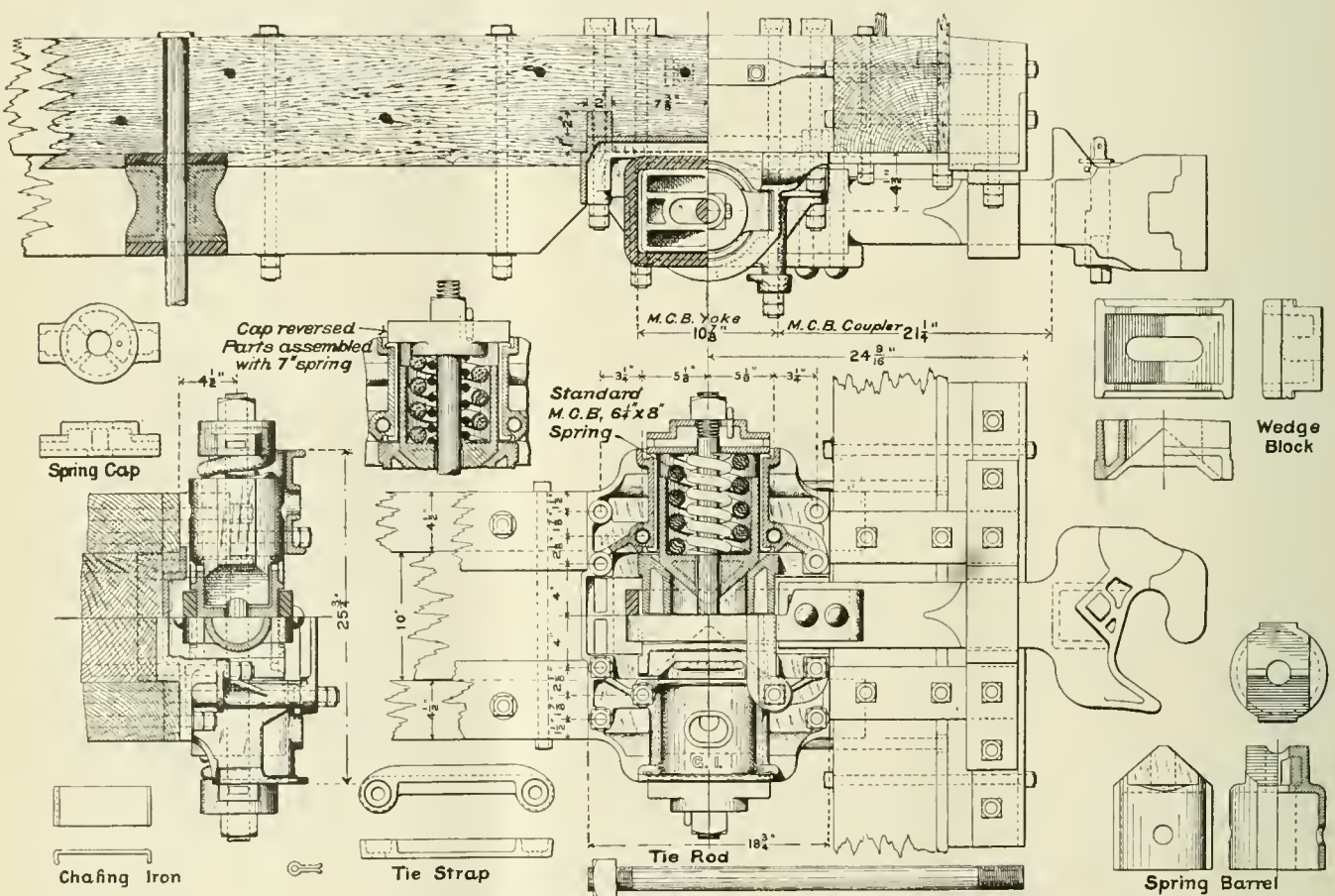

The Sessions Standard Friction Draft Gear.

the inverted plan showing the device in half section makes the application plain. By either buffing or pulling the yoke moves the wedge blocks and the inclined surfaces compress the springs within the spring barrels. The springs return the wedge blocks to their normal positions, and this without shock or recoil to the coupler, because any tendency for the coupler to pass its normal position is resisted by the spring acting on the inclined surfaces.

It is obvious that a broken spring does not prevent the action of the device, though it reduces its capacity to that of the remaining spring. In case the castings break, the 1 3/4-in. tie rod remains as a safeguard against pulling the coupler out and an idea of the care of the designer to meet the conditions of present practice is given in connection with the spring cap, which will accommodate either a 7 or an 8-in. spring, according to the way it is turned. The whole gear may be dismantled by the removal of a spring cotter and a

we have been supplied with a sketch by which is shown the recoil of a weight falling on a pair of standard draft springs laid on the anvil side by side and that of the same weight acting on the same springs through the friction draft gear. This weight was sufficient to close the springs in the first test at 7 ft. The first test gave a number of vibrations, of which four are shown, whereas the test with the friction device gave but one recoil movement. The amplitude of these movements is indicated in the diagram. While the drop on a twin spring arrangement exhausted the springs with a 2-in. movement, the same weight falling an equal height on the friction gear caused a movement of but 3/4 in. out of a possible movement of 1 1/2 ins. The parts have easy fits and in the normal condition the springs press the wedge-shaped ends of the spring barrels into the wedge blocks and are always ready for action without any lost motion to produce shocks. Angles of 40 degs. were determined by experiment as the most satisfactory.

While the development of this gear has been conservative, it has been applied to 300 cars on the Seaboard Air Line and is now being applied to a number of cars on the New York, New Haven & Hartford Railroad. We shall watch the progress of the device with interest and acquaint our readers with the results of tests which are soon to be made on the latter road. Drop tests made at the shops of the manufacturers have shown the capacity with standard springs to be about 120,000 lbs., or more than three times the capacity of the same springs when used in the ordinary way between followers, and tests made on an "Olsen" testing machine showed a final elastic resistance of more than four times the resistance of an ordinary twin spring arrangement. We append the following statement of the case by the best authority we know on car construction and operation. It presents the view of those who have developed this draft gear.

"When the average box car weighed about 22,000 to 24,000 lbs., and had a rated capacity of about 30,000 lbs. of load, single draft springs were used—that is to say, one spring to each drawbar. These

springs were from 6 to 7 ins. high and from 5½ to 6 ins. outside diameter, and their ultimate yielding resistance from 12,000 to 17,000 lbs. With locomotives having a tractive power of from 20,000 to 30,000 lbs. it is evident that in starting a train of, say, 30 loaded cars, the draft springs in the first half of the train would be exhausted, or 'bottomed,' unless some mechanical means were employed to prevent it. Several draft spring pockets were designed with limit stops for the follower plates, which prevented 'bottoming' the springs, by limiting the travel of the follower plates to something less than the compression limit of the spring. The effect of this was to impact uncushioned and destructive



Diagram showing limit of elastic resistance and recoil in drop test of Sessions-Standard Friction Draft Gear, as compared with an ordinary spring arrangement. Two standard M. C. B. springs (3½ x 8 of 12,000 lbs. capacity) used in both cases. Height of broken line shows height of drop and solid lines show recoil of drop.

impact to the car body, frequently breaking the follower plates, pockets and draft timbers. As locomotives were increased in their tractive power to haul longer trains of heavier cars, the destruction of draft timbers, and, in fact, the whole draft rigging, was so much increased that greater cushioned resistance became desirable. As the distance between the draft timbers would not readily admit of two springs being used side by side, to give greater spring resistance, many ingenious devices were designed to use two springs tandem, and in multiple, thus doubling the spring power of the single springs rigging. While this seemed the logical solution of the trouble, it was found that while the impact, or 'dead' blows, were largely diminished, the reflex action of such powerful springs was, in a long train, fully as destructive as was the impact when the single spring was used. This will be appreciated when watching a long, heavily loaded train, with the locomotive trying to start it. Several of the cars at various parts of the train will be in the reflex motion while the others, with the locomotive, will be advancing. The increased spring power must necessarily have this effect. Yet it is almost certain that in the heavier cars, or

trains, the single spring draft rigging would not be adequate to the service. Even with tandem springs of a combined power of 38,000 lbs. many of the cars in the forward part of a train, with a locomotive of the later types, would have their draft springs exhausted, yet the increased power of these springs would give a reflex action, or recoil, to a destructive degree. So it seems that while the tandem springs in this latter action are too strong, they are not strong enough in their cushioned resistance. It would appear that another principle must be employed to attain the desired result. We desire a yielding resistance considerably greater than the combined strength of the two springs used in the tandem devices, but without the quick recoil due to direct spring pressure, but with a retarded or restrained action of the springs in returning to their normal condition."

PERSONALS.

Mr. M. M. McCallister, Assistant Foreman Boilermaker of the Richmond Locomotive Works, has resigned, to accept the position of Foreman Boilermaker of the Lake Shore & Michigan Southern at Cleveland, Ohio.

Mr. James Collinson, Master Mechanic of the Gulf, Colorado & Santa Fe, at Cleburne, Tex., has been appointed Assistant Superintendent of Machinery of the Atchison, and is succeeded by Mr. Thomas Paxton, Master Mechanic of the Eastern division of that road.

Mr. Samuel Watson has been appointed Master Mechanic of the middle division of the New York Central & Hudson River, with headquarters at West Albany.

Mr. W. J. Gillingham, Signal Engineer of the Illinois Central, has resigned to take the position of General Western Agent of the Hail Signal Company, to succeed Mr. W. W. Salmon.

Mr. Ira C. Hubbell, for a number of years Purchasing Agent of the Kansas City, Pittsburg & Gulf and its successor, the Kansas City Southern, has been appointed Purchasing Agent of the Union Terminal Railway Company, of Sioux City. Mr. Hubbell will have his headquarters in the Fisher Building, Chicago.

Mr. E. Belknap has been appointed General Purchasing Agent of the Seaboard Air Line, with headquarters at Portsmouth, Va., in place of Mr. O. D. Ball.

Mr. H. D. Taylor who, for the past two years has been connected with the Calumet & Hecla Mining Company, has been appointed Superintendent of Motive Power of the Lehigh Valley, with headquarters at South Bethlehem, Pa., to succeed Mr. Samuel Higgins. Mr. Taylor was formerly in the service of the Lehigh Valley as Mechanical Engineer and as Master Mechanic of the shops at Wilkesbarre.

Mr. Samuel Higgins, Superintendent of Motive Power of the Lehigh Valley, has resigned to go to the Union Pacific in the same capacity, succeeding Mr. Joseph H. McConnell. Mr. Higgins' railway service began in 1881, when he entered the shops of the New York, Lake Erie & Western as machinist apprentice. He was in continual service with that road for 20 years, working through the responsible positions of Assistant Foreman, General Foreman, Assistant Engineer Motive Power Department, Master Mechanic and Assistant Superintendent of Motive Power. The latter position he left in 1893 to go to the Lehigh Valley.

"MAMOLITH" CARBON PAINT.

How to protect the metallic structures which have become so important in recent years is a vital question upon which the best opinions have been divided. One may consult engineering literature for the past ten years without satisfaction, because of the variety of opinions among those who have given the subject the best attention, and when attention was called to this new paint the subject was thoroughly investigated personally by a member of the staff of this journal for the purpose of presenting an intelligent statement concerning it.

"Mamoloth" is the name given in 1895 to a semi-petrified non-corrosive vegetable substance found in a locality in Arkansas believed to be the only deposit of the substance in its purity. It contains in the natural state about 85 per cent. of carbon, is free from grit and is easily reduced to powder as fine as the finest lampblack. In its development into a paint material six years have been spent in investigation and experiment, this being done very quietly and systematically until those interested were sure of their ground. Seldom, if ever before, has a new pigment been so carefully exploited and the results appear in every way promising.

Five years ago little was heard about other than lead and iron oxide paints for metal work. Opinion was vigorously divided between these pigments and much was written on the subject. Since then the carbon paints have taken prominence and they are now preferred by many for important structural work where the metal parts are permanently concealed as well as for exposed surfaces.

Among painters lampblack, ground in pure linseed oil, has been a standard of comparison, because of its "body" and durability. This, however, is expensive, and the great coloring capacity of lampblack limits its use to very dark or black colors. To use enough lampblack to secure the desired "body" involves a necessarily dark color, and this difficulty led to the examination of the carbon described here as a pigment. It was believed to offer properties of "body" equal to those of lampblack and was at the same time so weak in coloring strength that a large amount could be used with relatively light colors. On the other hand, for a protective coating for metallic structures the well-known characteristics of lampblack were expected. The tests investigated by our representative appear to indicate that these conditions are realized, although further experience seems to be needed before it can be said to be unquestionably superior to the best lampblack. There is no hesitation, however, in the statement that after two years of severe exposure it is in better condition than the best lampblack and linseed oil paint exposed under exactly similar conditions. To men experienced with paints this statement will be understood as an important one.

The pigment has reached beyond the experimental stage. It is now being extensively used for large roofs in an industrial establishment in Poplar Bluff, Mo., on a large order for large capacity cars now building for the "Big Four" by the American Car and Foundry Company, and has been used on a number of large Western railroads and by the Standard Oil Co. The paint department of this company during the past 18 months has made exhaustive tests of paints which they have manufactured from this material, all of which they have found to be entirely satisfactory. This company is probably the largest user of paint such as can be produced from Mamolith Carbon, and it is now being used in large quantities for tanks, buildings and cars. It is giving good results at their various works as a preservative paint. The Brooklyn Cooperage Company use it exclusively for buildings, docks, stacks and tanks at the following places: Brooklyn, N. Y.; Poplar Bluff, Mo.; Kane, Pa.; Oswayo, Pa.; Cross Fork, Pa.; and St. Mary's, Pa. It has been very satisfactory in all of these applications and such a large scale endorsement is important evidence of the qualities of the pigment.

The roofs in Poplar Bluff, Mo., referred to, are those of the H. D. Williams Cooperage Company. They are exposed to

exceptionally trying conditions. In the manufacture of barrels of oak the steaming of the staves produces a moist atmosphere containing tannic acid, which is exceedingly destructive to metallic roofs. Formerly two new roofs were required every three years, but the application of this paint has preserved them in good condition in some cases for six years. Upon scraping this paint with a knife it was found to be elastic, with considerable life remaining. A boiler house roof was found in excellent condition, and the paint tough and elastic after three years' exposure to steam and hot air, the roof being only about 6 ft. above the boiler shells. It was subjected to steam and sulphur fumes. These were cases of paints mixed dry and not ground in oil; they were, furthermore, single, but heavy coats. A very severe test of this paint was made last year in an exposure of 11 months upon the circulating piping in the brine tanks at the plant of the Poplar Bluff Ice Company. The pipes were sometimes in the brine and sometimes in the air, and always at low temperatures. At the end of that time the coils were changed, and the metal was found to be thoroughly protected, the paint being elastic and good. The experience in this damp climate in southern Missouri, and particularly in the cooperage plant, is nothing short of remarkable. The paint on these walls was all mixed and applied by unskilled labor, and it is known that benzine was freely used in the mixing.

In order to avoid the possibility of mistakes through non-experienced judgment, the writer examined the comparative test records in Cincinnati, with the aid of the Master Painter of one of the most prominent railroads, and of a house painter of 35 years' experience. The records cover four years, beginning with tests made on the Lake Shore & Michigan Southern, under the administration of Mr. A. M. Waitt, then General Master Car Builder. In all about 2,500 test panels have been painted and placed in a southern exposure in the smoky atmosphere of Cincinnati, Ohio. The tests were progressive, and have had an exposure of two to four years under what seem to be fair conditions. In order to examine it in another atmosphere, other similar comparisons were made at Oaks Corners, near Geneva, New York. The tests were made on 4 by 15-in. panels of pine and poplar boards, sheet steel, galvanized iron and black iron. In some of the tests steel sheets were allowed to rust for three months before the paints were applied. In the comparison the paints used were the new carbon, both crude and "burnt," iron oxides, Venetian red, ochre, red lead, white lead, lampblack and graphites. These were used alone and in combination with the new paint. For the color-fading tests, ochre and chrome yellow were used. Pure boiled linseed oil was used in most of the tests, but in some of the series other oils were tried, for example, 150 tests were made with raw oil. Four kinds of japans were also used. For each paint a clean new brush was employed, and each sample was applied to a complete set of the panels, the temperature, mixture, formula and conditions of the application being carefully recorded. Care was also taken to use panels from the same board for the different paints applied in each separate test. The lower portion of each panel had three coats and the upper portion two coats in each case. None of the paints was found sufficient when applied in a single coat.

In general the comparison showed that the new carbon pigment, both burnt and crude (the crude contains a little natural oil somewhat like that of lampblack) stood as well as any of the samples, and it is evidently a first-class article. It appears as well as the best iron oxides and lampblack when taken alone, and when combined with either of these it seems to be in better condition (after two years) than either taken alone, even the lampblack. The same applies to the tests of lead paints. Introducing the new pigment into a mixture with the other pigments improved them and helped to hold the colors, the fading of some of them being surprisingly slight.

One of the experts present was a strong advocate of iron oxides and the other of lampblack. They and the writer agreed in the conclusions presented here.

The new paint mixes, grinds and dries much better than lampblack, it does not settle in two years, it showed no corrosive action, and preserved the metallic surfaces bright and clean. No paint can eradicate rust, but this appears to arrest it. It is elastic and tough, almost like rubber, its covering qualities are good, and it did not crack in the sun. Tests covering 11 months in sea water, and practical application on roofs of buildings indicate that it has stood the action of tannic acid and steam in a severe test.

The management of the Mamolith Carbon Paint Company is in the hands of Mr. A. B. Burtis, as General Manager. He is well informed as to paints, and is widely known from his former connections with the Sherwin, Williams Company and Lowe Brothers. To those who know him the fact that he has taken it up is a strong endorsement. The address of the company is 503 Johnston Building, Cincinnati, Ohio.

IMPROVED ORE CAR, 100,000 POUNDS CAPACITY.

Chicago, Milwaukee & St. Paul Railway.

On roads having a large amount of ore traffic an interesting class of special equipment has been developed for this service which requires great strength, large carrying capacity, rapid loading and discharging facilities, simple construction and short cars to suit the ore pockets at the docks. In the Lake Superior region there are in use several designs of hopper ore cars, and by courtesy of the motive power officers of the Chi-

cago, Milwaukee & St. Paul Railway the latest improvement on that road is illustrated. This car carries 50 tons of ore and weighs 29,300 lbs., a ratio of 77 per cent of paying load. This car, built of wood, weighs but 500 lbs. more than the pressed steel ore cars of the same capacity built several years ago by the Schoen people for the Lake Superior & Ishpeming, the light weight of which was 28,800 lbs. These two designs give the highest ratio of paying load that we have seen, and the comparison is exceedingly favorable to the wooden car. The design is similar to one brought out on this road last year except that the present construction omits the backbone or cen-

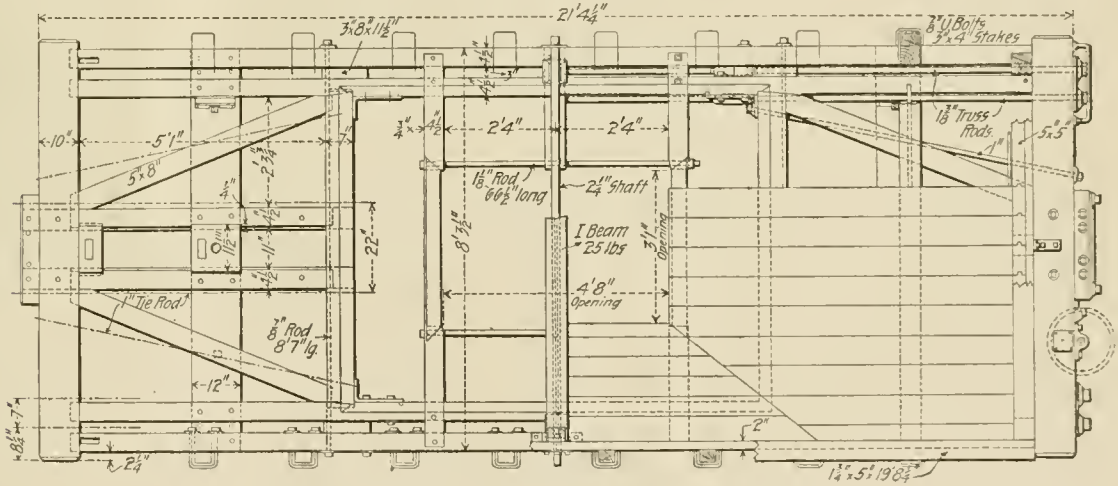
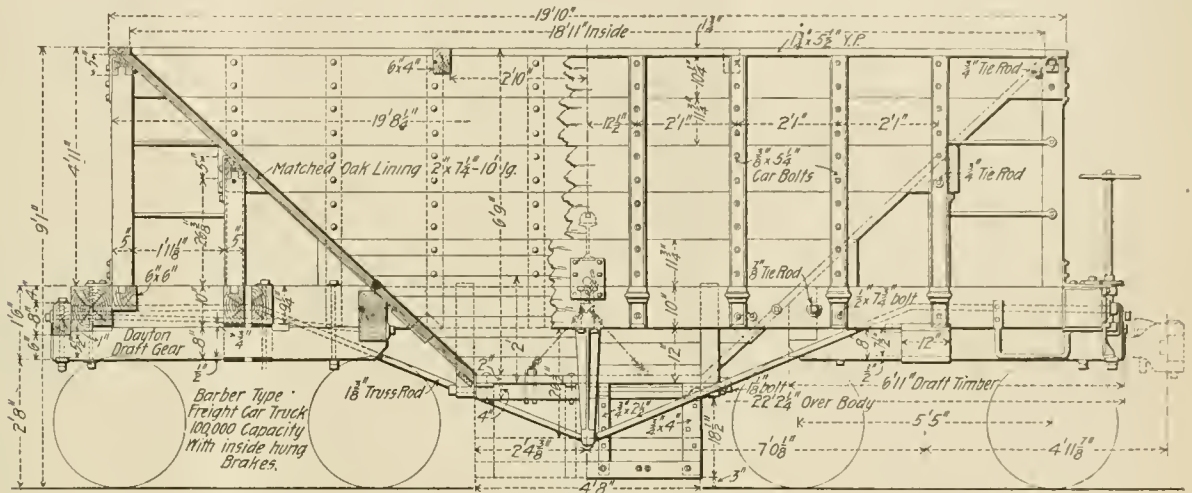

New Ore Cars, Chicago, Milwaukee & St. Paul Railway.

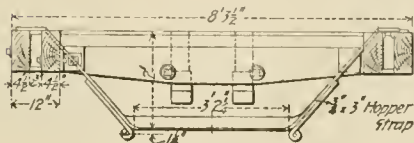

Transverse Section Near Center of Car.

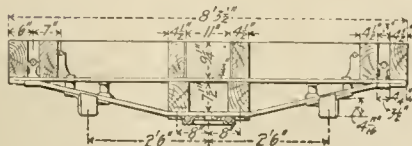

Transverse Section Near Body Bolster.

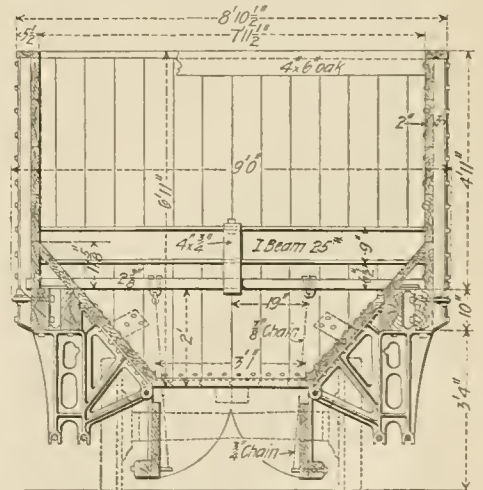

Section Through Hopper.

ter sill and leaves the center opening of the hopper entirely free for unloading. We are informed that there is no noticeable deflection of the sills when the car is loaded with 56 tons of ore.

Partial elevations and sections with a floor frame plan are presented in the engravings. There is but one hopper with the doors swinging sidewise and held by chains from a central shaft. The underframe is very "stocky" and strongly braced. There are but four through longitudinal sills and four 1 3/8 in. truss rods. These rods support malleable iron king post castings which have wings bearing against the sloping sides of the

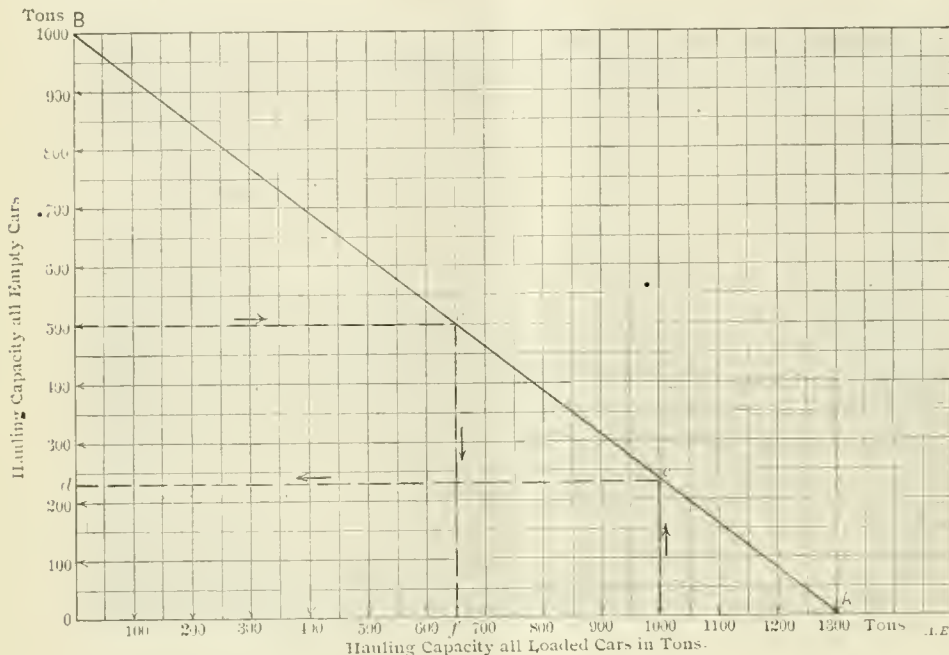

hoppers and in this way a portion of the hopper load is taken directly to the truss rods. Two 3/4 by 3 in. hopper straps, a number of transverse rods and two 4 by 6-in. cross beams tie the car across at the top of the box. A 25-lb. I-beam at the center and a pair of 7 by 12-in. cross beams at the sills furnish lateral support at the bottom and the corner bracing and tie rods are shown in the plan view. The end supports of the box are upon 6 by 6-in. cross timbers placed inside of the end sills. Draft timbers 7 ft. long are attracted to 4 1/2 by 10-in. strut sills, which are re-enforced by tie rods, and the Dayton draft rigging is attached between the draft timbers. The elevation shows the bearings at the ends of the draft timbers upon the large cross timbers. The bolsters are of the ordinary plate form 12 ins. wide. The cars are equipped with Barber 50-ton trucks, inside hung brakes and Monarch brake beams. It is evident that the entire structure is intended to withstand the roughest kind of service. The chief dimensions are summarized in the following table:

100,000-Pound Ore Car, C., M. & St. P. Ry.

Length over body.....	22 ft. 2 1/4 ins.
Length over box.....	19 ft. 10 ins.
Width, outside.....	9 ft. 10 1/2 ins.
Width, inside box.....	7 ft. 11 1/2 ins.
Height over all.....	9 ft. 1 in.
Height to under faces of sills.....	3 ft. 4 ins.
Trucks, wheel base.....	5 ft. 5 ins.
Weight, empty.....	29,300 lbs.
Cubic capacity, level full.....	567.59 cu. ft.

J. A. Fay & Egan Co., Cincinnati, Ohio, manufacturers of wood-working machinery, have taken out in the year 1900 about 100 patents. Their claims on some of these patents are being infringed by several manufacturers of wood-working machinery through ignorance or greed, and are copying their machines. Neither the J. A. Fay & Egan Co. nor the Egan Co. have had a patent suit since their consolidation in 1893, but have now retained a firm of lawyers, and it is their intention as a joint company to protect their rights in the courts.

TONNAGE RATING—LOADED AND EMPTY CARS.

To those who have not closely watched the development of tonnage rating, some of the papers and committee reports on this subject must seem exceedingly complicated. Mr. L. R. Pomeroy, of the Schenectady Locomotive Works, recently stated the fundamentals of the subject in a simple way.

If the rating of a given engine is desired and a trial train of loaded and empty cars is provided, the "commercial" capacity of this engine in both loaded and empty cars may be easily ascertained on the road. For example, let the rating be 1,300 tons of loaded cars and 1,000 tons of empties. Use cross section paper to construct a diagram as follows: Establish the point A at 1,300 tons of loads and the point B at 1,000 tons of empties. Draw a straight line between them and the diagram will show, without calculation, how to fill up the train. Suppose we have 1,000 tons of loaded cars to haul and we desire to know what tonnage in empties the engine can haul in addition, in order to complete the rated load.

From the point opposite 1,000 tons at the bottom of the diagram follow the vertical line to the diagonal at c. Then follow the horizontal line from c to d at the left-hand side of the diagram, where we find 230 tons as the amount of empties to be taken. Or if we had 500 tons of empties and desired to know how many tons of loads to take for a full train, start at 500 tons at the left and follow horizontally to the diagonal at e. Then proceed downward vertically to the base line at f, where we read 650 tons as the amount desired in loaded cars to complete the rating. Such a diagram may be constructed for each division and each class of engine. This scheme is presented as a suggestion to those who for any reason do not care to go deeply into the higher mathematics of the subject.

"Drafting Room and Shop Methods" was the subject of a paper by F. H. Ball, Mechanical Engineer, American Engine Company, New York, presented at a recent meeting of the Junior Members of the A. S. M. E., which brought out a discussion of the importance of the position of the drafting room. First considered as a place where drawings are to be made as directed by someone from outside of the office, and second as a center for the departments with which it is directly in touch. Some rules for tracings, that are worth consideration, were given as follows: Views of more than one piece should never be put on a sheet. All the views of the same piece need not be put on one sheet. Use sheets as small as practicable and still have the drawings readable. Mr. Ball believes that the draftsman and not the pattern-maker should be the one to decide how much should be allowed for finish on a casting, and gave the system employed by the American Engine Company, in which $f = 1/16$ in., $f = 1/2$ in., $F 3/16$ in., $ff = 1/4$ in., and $FF = 3/8$ in. These are placed on the drawings by the draftsmen. His idea is to make the drafting room responsible for the design of a machine, thus requiring a draftsman to follow up his own work, until it is completed in the shops. This is in accordance with our idea of what a draftsman should be, a man of all-around usefulness, competent for advancement.

The Rogers Locomotive Works, at Paterson, N. J., have been purchased by F. P. Holran, Transfer Agent of the Louisville & Nashville, and Elliott C. Smith, connected with the banking firm of Norton & Co., at 33 Wall street. These works are to be considerably improved and some extensions made to the buildings.

A QUESTION OF SQUARENESS.

Locomotive Frames and Freight Trucks—Principally Trucks.

Some things are born square, some have to be made so and kept so, and to a man accustomed to expect a locomotive to be designed with that end in view, there would appear to be some inherent tendency in the case of the average freight truck which acts in place of a premeditated design, for in many cases its construction constrains it to so slight an extent that it must pretty nearly arrange its lines to suit its own sweet will.

In a locomotive the frames are relatively stiff, thoroughly well braced at the cylinders, and, in the squarest of locomotives, the 8-wheel American type, braced again at the footplate. The footplate exercises a great influence on the maintenance of squareness; and an engine that is simply braced by the cylinders can and will get out of line far more easily from the absence of what our bridge friends would call diagonals. Fig. 1 shows the manner in which the frames must deform to allow a footplate engine to get out of line, and this the only way, provided the length of the frames does not change through bolt connections loosening. To deflect sideways, the frames must make a double bend and consequently have four times the resisting power of those in an engine built as sketched in

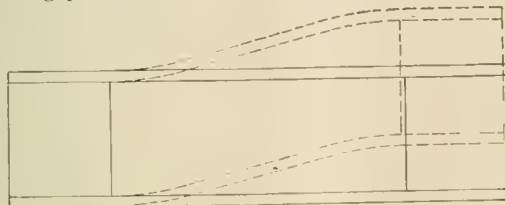

Fig. 1.

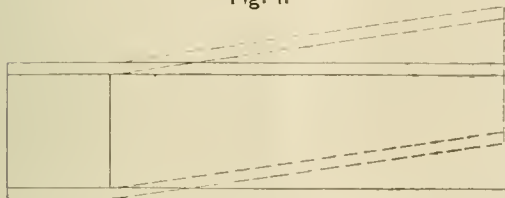

Fig. 2.

Fig. 2, where the connections at the back end are not sufficiently rigid to diagonally brace the frames. Such an engine is held in line chiefly by the boiler, and where the firebox connections are laterally weak, as in the case of wide firebox boilers supported by rocking links, the frames will frequently move sideways to a considerable extent. When the firebox is supported by expansion plates, evidence is occasionally found of heavy lateral strain being carried by the boiler, in the loosening of smokebox bolts and the rivets at the side of the front end which connect it to the barrel of the boiler. For this reason the writer has advocated a strong braced casting within the ashpan of such engines which would connect the frames and keep them from, as one well-known superintendent of motive power put it, "wiggling their hind ends."

Still, at its worst, the locomotive has its reasons for keeping square, but in the case of some freight trucks, and even passenger trucks, these reasons are more conspicuous by their absence than their presence. Take the case of the wooden frame side-swing truck. Two timbers, 4 by 12 ins., or thereabouts, are bolted to the end castings by four 5/8-in. bolts, and also take the arch bar bolts, forming a yielding backing to prevent those bolts from being tightened up properly. Fig. 3 shows the lines of the construction and also the form it takes when out of line.

Now there is evidently very little strength in such a construction to keep it from being forced out of square, and yet, in spite of this fact, such trucks are in very general and successful use. The rigid diamond truck is not much better until an iron spring plank is substituted for the wooden one, and when iron trucks are considered it is possible to arrive at an approximation of the force which is required to deflect them

out of square. In the case of the side-swing truck with iron channels riveted to the truck end castings, the resisting strength of these channels to flexure, as shown in Fig. 1, is 950 lbs. at the arch bar, adopting a 12-in. 30-lb. channel, which is common practice. In the case of the rigid truck in which the spring plank is a 12-in., 24-lb. channel, this force becomes 22,200 lbs., but the rivets connecting the spring plank to the columns then become the weak point. Allowing eight 3/4-in. rivets at each end, or four to each column, their full shearing strength is only equal to resisting a force of 3,800 lbs. at the arch bar. Now what is the force that could throw such a truck out of square? Evidently the greatest factor would be that caused by the wheels on one side having a greater running diameter than those on the other, a difference that might amount to 1/8 in. on the circumference. One wheel would then be obliged to slip, if the truck were held square, and with a load of 10,000 lbs. per wheel, 1/5 of this, or 2,000 lbs., would be at the least, the force required to slip the wheel. It might be objected that the force must be proportional to the difference in the diameters of the wheels and that it is continuous and not as large as that required to actually cause slip, but an inquiry into the force required on the assumption of continual slip will demonstrate the fallacy of such a contention. The circumference of a 33-in. wheel is about 104 ins. Taking this as that of the smaller and 104 1/8 ins. that of the larger, it would be necessary in every 104 ins. of travel to move one wheel backward 1/8 in., against a resistance of 2,000 lbs. or the work

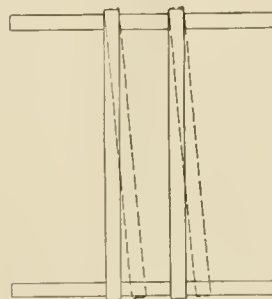

Fig. 3.

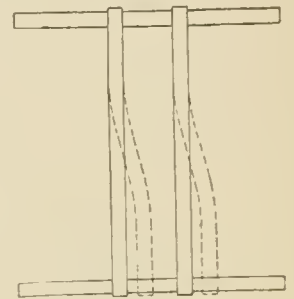

Fig. 4.

done would be $\frac{2000}{8} = 250$ inch-pounds. This would have to be done in 104 ins., a mean resistance of $\frac{250}{104} = 2.4$ lbs. Such a

force would evidently not cause a wheel to slip if applied continuously, and the variation in work with difference in diameters is accounted for by the fact that one wheel advances ahead of the other until, if the truck were strong enough, a strain is brought on it at which it slips. It then resumes its natural position and with wheels with a great difference in diameters this slip takes place more often than with those in which the difference is small, but the force required is the same in both cases, and depends simply on the weight on the wheel.

In the extreme case when both wheels on one side are in excess a strain of from 3,000 to 4,000 lbs. would thus have to be exerted to return the truck square, and but one of the constructions above considered, the rigid truck with metal spring plank, is at all strong enough, and even in that case, it can be safely said it is not strong enough for practical working. Since all such trucks are running, and running satisfactorily, evidently some other cause must be looked for to account for such a result and the most reasonable explanation is afforded by the conical form of the wheel tread.

Assume a truck with equal wheels to be a little out of square, the wheels will tend to run to one side, and in doing so will quickly cause the backward wheel to run with its flange close to the rail. This will make its running diameter greater than that of the wheel on the opposite side, and it will consequently gain on the other wheel and pass it, whereupon the reverse action would take place until the wheels settled down to run true. There would be limitations to this action, as in case the

truck was badly out, the back wheel flange might bear against the rail and prevent the wheels resuming their proper position for a considerable distance, as for instance when a car passes a crossover the wheel flange can often be heard grinding against the rail for some little time, until a lurch of the car or some similar action gives the back wheels a chance to move ahead and catch up with their companions. A difference in diameters too great to allow the conical tread to equalize matters would lead to permanent trouble, but since the difference in diameter available by the two wheels running on different parts of the tread is $\frac{1}{8}$ in. in each wheel, evidently wheels that are matched in accordance with the tape sizes will have sufficient margin for square running.

That such an action takes place was called to the writer's attention by the trucks originally used on some ballast cars. In these trucks the springs were carried on a casting on the bottom arch bar, no spring plank being used, and although diagonal tie rods were subsequently added connecting the lower ends of the column bolts, the original trucks depended entirely on the bolsters to maintain them in line, the bolster being provided with guides as usual in rigid trucks and offering but very slight resistance to any force tending to throw the truck out of square. Yet these trucks ran very satisfactorily and no trouble was experienced with them on this account. It would appear to the writer that if allowed to do so, a truck will, with fair wheel conditions, run square, and that the reason such varied arrangements have been used successfully may be attributed to this quality. What is wanted is to be sure that the trucks do not hold the wheels out of square, that they are true enough to keep in alignment, and that they are equipped with wheels that are mated in accordance with the requirements of the Master Car Builders' Association.

THE WOODCOCK STEEL HOPPER CAR USING STRUCTURAL SHAPES AND PLATES.

The superstructure of this car is made entirely of standard rolled steel shapes and plates, the design being by Mr. W. H. Woodcock, Chief Engineer of Dutilh-Smith, McMillan & Company, of Philadelphia. Two channel side sills and two I-beam center sills with strong end sills of plate and angles constitute the underframe, the draft gear being placed between the center sills. With an approximate cubical capacity of 1,810 cu. ft. the car is designed to carry a load of 105,000 lbs., the light weight being 36,980 lbs. The side plates, ridge and bottom plate are $\frac{1}{4}$ in. thick, weighing 10 lbs. per ft. As a backbone there are two 15-in. I-beam center sills tied in the center with plates and four angles placed back to back and riveted to the webs of the beams. The ridge plates are also riveted to the flanges of the beams. The side sills are 15-in. channels stiffened by the two center side plates carried down and riveted to the webs of the channels. The end sills consist of $\frac{1}{2}$ -in. plates the full width of the frame, cut out at the center for the coupler shank. They are tied to the side and center sills by angle connections and gusset plates and are re-enforced by angles riveted over and under, as shown in the drawing. Special attention was given the end sills with a view of making them stiff and strong. Several forms of hopper mechanism have been designed for this car. One employs chains for closing the doors and another uses toggles outside the doors. With the latter arrangement the doors cannot open or work loose when closed and they are easily opened or closed by the mechanism.

The top of the car is stiffened by 4 by 3-in. angles and by 4 by 2-in. verticals of T-section. The floor angles are 4 by 4 ins., the end supports are of the same size, the platform and body angles and the platform bottom angles are 4 by 3 ins. At the ends the body braces are 6-in. channels and 4 by 3-in. angles. The trucks are of the diamond type with Mr. Woodcock's special cast steel bolsters and malleable iron journal boxes for $5\frac{1}{2}$ by 10-in. journals. The designer has had a wide expe-

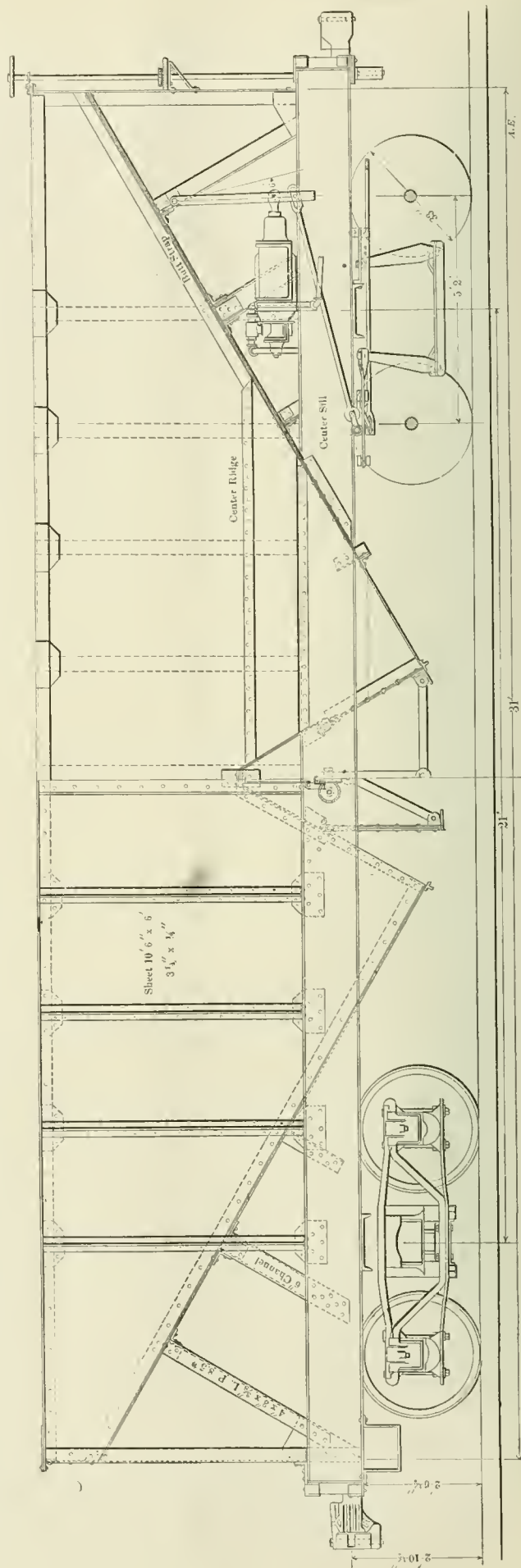

The Woodcock Steel Hopper Car Built of Structural Shapes and Plates.

rience in the manufacture and testing of metals both here and abroad and has developed a patented alloy which is specified for the truck and body bolsters. Open-hearth steel will be used which contains an alloy for the improvement of the physical qualities of the casting. By the use of this alloy the ultimate tensile strength is increased 30 per cent. and the castings are solid and free from mechanical defects. For the material of this car soft steel is specified with ultimate strength between 54,000 and 62,000 lbs., elastic limit, 50 per cent. of the ultimate strength, and an elongation of 25 per cent. in 8 ins. If basic open-hearth steel is used for the plates the phosphorus must not exceed 0.035 per cent., and if acid, it must not exceed 0.08 per cent. Other features of the design as to details are shown in the drawing.

HEATING PASSENGER TRAINS WITH EXHAUST STEAM FROM THE AIR-BRAKE PUMP.

A new system for utilizing the exhaust steam from the air pump of a locomotive for the purpose of heating passenger trains is being applied quite extensively to locomotives on the Maine Central Railroad, and is also used on other New England roads. The system is simple; consisting of a three-way cock attached to the exhaust pipe immediately in front of the pump and operated by a lever to which is attached a reach rod that passes into the cab to the engineer. Of the two pipes issuing from the three-way cock, one is connected by the ordinary exhaust pipe to a carefully jacketed reservoir

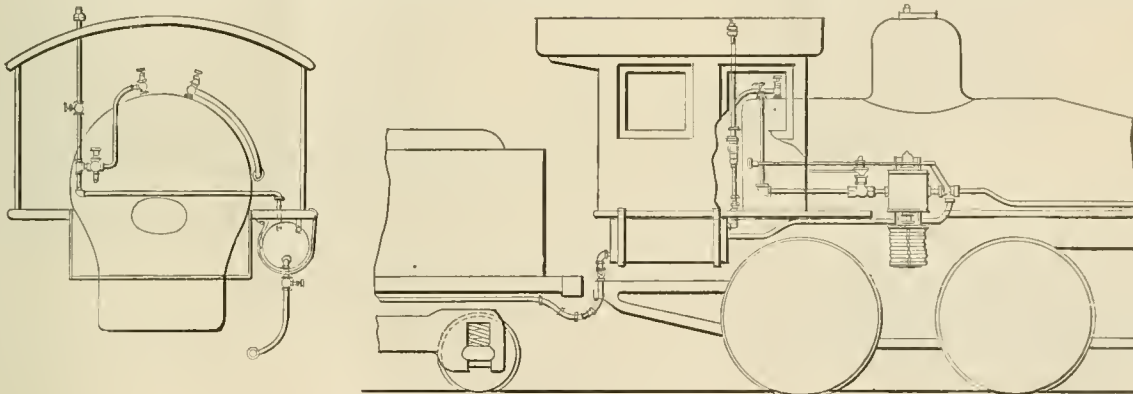

Steam Heat Piping from Air-Brake Pump.

about 40 ins. long and 20 ins. diameter, hung beneath the cab. The second exhaust pipe is connected with the smokestack. The outlet pipe to this reservoir is at the rear end near the bottom and is connected to the train steam pipe by means of a flexible hose connection.

The drawing shows the arrangement of the piping and the several parts of this apparatus, the operation of which is very simple. When the reach rod is pulled back, the exhaust steam from the pump enters the reservoir and when pushed forward it is passed to the stack. The pressure maintained in the reservoir is of course determined by the number of cars to be heated. The general rule is 20 lbs. for a train of 4 cars or less, and 4 lbs. additional for each extra car. On some of the 10-wheel engines of the Maine Central for heavy passenger service as high as 65 lbs. pressure is carried in the reservoir. This naturally raises the question as to whether the action of the pump is not blocked and some trouble experienced in maintaining the proper air pressure for the brakes. Formerly the only resistance that the pump had to overcome was the main reservoir pressure of about 90 lbs. plus the friction. This added to a pressure of, say, 30 lbs. for heating a train of six cars, would increase the resistance to be overcome. With the common use of a boiler pressure of 200 lbs., this is reported to be a very easy matter. Mr. Frank Coggin, in bringing this method of heating before the January meeting of the New England Railroad Club, said that the largest 10-wheel engines

used on the Maine Central carry a back pressure of 65 lbs. when needed. He stated that the road had never experienced the slightest difficulty in maintaining the brake pressure, nor is there much, if any, difference in the matter of time required in heating by this system and the usual method of heating direct from the boiler. In order to maintain a constant pressure in the reservoir, an automatic relief valve is placed on top of the cab and set at the desired maximum pressure.

There is also another controlling condition as to the length of train that can be heated. The number of stops will control the amount of steam the pump will furnish to the reservoir and in this respect no trouble is experienced for local trains. For heating through trains and for consideration of zero weather there is also a connection from the reducing valve of the boiler directly into the reservoir. If the pump does not furnish sufficient steam for heating, the pressure in the reservoir falls below that at which the reducing valve was set and allows steam to enter direct from the boiler to make up the deficiency. On the other hand, should the pump furnish more steam than is required to heat the train, the excess is passed off by means of the relief valve on top of the cab. In this way all the heat from the pump is utilized for heating, the supply from the boiler being used only to make up the deficiency. It is seldom necessary for local or even express trains, in moderate weather, to use the direct boiler supply. The various patents granted upon this device are owned by the Economy Car Heating Company, Portland, Me., who also have the handling of this system of heating.

THE "TIP TOP" DUPLICATOR.

The Felix F. Daus Duplicator Company, No. 5 Hanover street, New York, manufacture a duplicator which is a great time and labor saver. It requires no stencil, roller or printer's ink. It is reliable, very clean and altogether the cheapest and best duplicating apparatus for drawing-rooms and office use that we have seen. It will give from 100 to 150 distinct copies from any writing or drawing and 50 to 75 copies from typewritten copy when special typewriter ribbons are used. The duplicator consists of two rollers, one pivoted at each end of a shallow oblong case, with the printing surface between them, over which the negative paper is passed. The rolls contain five yards of negative paper and can be rolled back and forth six or eight times, when it should be replaced by another roll. Four different sizes of this apparatus are manufactured; the smallest with a printing surface $8\frac{3}{4}$ by 13 ins., and the largest size $20\frac{3}{4}$ by $23\frac{1}{2}$ ins. The following recommendations from those who have used this device speak for themselves. Mr. J. A. McCrea, Engineer Maintenance of Way, Pennsylvania Lines West of Pittsburg, says, in part: "I am very well satisfied with the working of the duplicator and have recommended its use to others." Mr. C. W. Bassett, General Passenger Agent, Pittsburg & Western Railway Company, writes: "I have made use of the new roll of paper this afternoon and find the work highly satisfactory."

NEW HORIZONTAL HOLLOW CHISEL MORTISER.

Among the very latest designs in mortising machinery is that of a horizontal hollow chisel mortiser manufactured by the S. A. Woods Machine Co., and illustrated in the accompanying engraving. In addition to the advantages possessed by other mortisers of this kind, it is equipped with many special features of convenience, which, together with its superior construction, makes it particularly well adapted to the requirements of car and railroad repair shops, wagon factories and ship-building plants. Unlike other machines of medium size, the ram or chisel carriage has a vertical adjustment instead of giving this to the table, thus ensuring more rigid support for the latter. Another of the noticeable features of the superior design is the frame of the machine, which has a base of such dimensions as to give thoroughly efficient support for the table. The carriage has a travel of $9\frac{1}{2}$ ins. and will raise a distance of 11 ins. above the table. Timbers up to 12 ins. square may be clamped, and chisels up to $1\frac{1}{2}$ ins. can be successfully used on hard wood.

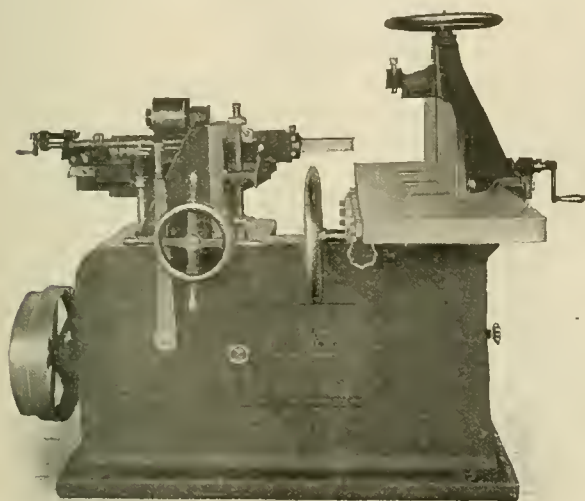

Hollow Chisel Mortiser.

S. A. Woods Machine Co., Boston, Mass.

The table has a horizontal travel of 18 ins. and is provided with patent stops for laying off double mortises. This machine is only one of a number of improved types of horizontal and vertical mortisers, besides a general line of high grade wood-working machinery manufactured by this well-known company. The builders will furnish any information that may be desired on the many special points of this horizontal hollow chisel mortiser, or any other particular kind of wood-working machine. The engraving illustrates the construction so clearly as to render more complete description unnecessary. The address of the S. A. Woods Machine Co. is South Boston, Mass.

IMPROVED DIRECT-CURRENT MOTORS.

Manufactured by the New England Motor Co., Lowell, Mass.

The distinguishing features of the direct-current motors have in the past few years been greatly improved, and in large shops where electric motors are now so generally used for power distribution their results are being appreciated. The motor shown in the accompanying engraving is one of a complete line of motors built by the New England Motor Co. for relatively slow speed and high efficiency. They do not spark, and they embody the successful features of modern multipolar design in connection with a number of special features. They are made either partially or completely enclosed, the closed form being used for dusty and damp places. A very striking feature of this machine is the method of supporting

the armature. As will be seen in the engravings, the bearings, instead of being mounted on independent end plates or brackets, are cast together in the form of a double yoke. The yoke is supported within the field magnet frame and can easily be removed or its position in the field ring changed so that the motor can be mounted in a vertical position, fastened to a wall, or at any desired angle. Slots are also provided in the casting of the field ring by which the yoke may be adjusted longitudinally or the yoke and armature removed bodily from either side, without losing the brush adjustment. The brush-holders are inside the fields and are carried by substantial lugs cast to a light, but stiff ring, which fits in the same diameter as the field cores and the yoke. This method of mounting the armature allows a ready means of centering it magnetically in the field, should the motor not be properly leveled. Without stopping the motor, two bolts can be loosened and the yoke shifted slightly in one direction or the other until the armature is brought to its proper position in the field and given the proper end play. The armature is of a standard and improved de-

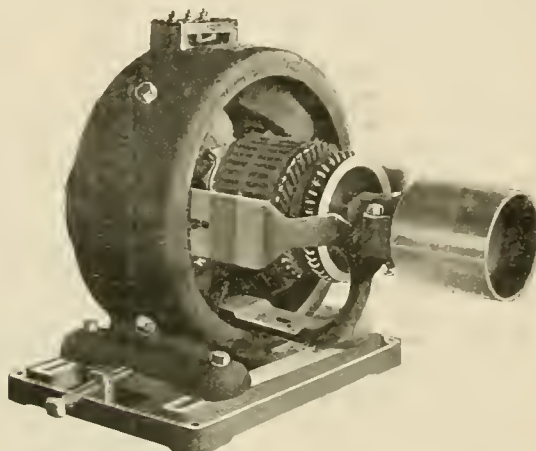

Type M. E. Motor—New England Motor Co.



Yoke and Armature, Showing Core with One Coil.

sign, built of carefully laminated annealed sheet steel of highest permeability. The commutator is made large and substantial and built with a ventilated head. The coils at the back end are securely mounted and protected by a well-finished solid protecting flange to avoid the collection of dust, dirt or oil within the coils. This company also manufacture a line of semi-enclosed and dust-proof bipolar motors, together with a complete line of slow-speed motors and generators of efficient design suitable for direct-connected service. All parts of these machines are interchangeable and durable, and the absence of outside cables gives a highly finished appearance.

The hammer shop of the Schenectady Locomotive Works, a frame building 60 by about 250 ft., was destroyed by fire Saturday, the 23d. The building and contents were insured in the Manufacturers' Mutual Insurance Companies of New England, who adjusted the loss on Monday, the 25th, and a contract was immediately let for a new building 85 by 365 ft., to be constructed of steel and brick. Meanwhile the old building will be patched up, so that several of the hammers can be started into service this week, temporarily, and with contracts let with outside forges for shapes, it is expected that the work of the Schenectady Locomotive Works will not be seriously interfered with by the loss by fire.

A NEW STURTEVANT GENERATING SET.

Modern steam engineering practice demands an engine capable of sustained operation at high speed, possessing the utmost refinement in the matter of speed regulation and developing the maximum horse-power with the minimum of weight and floor space. For many years the B. F. Sturtevant Company, of Boston, Mass., have devoted themselves to the most careful design and development of an extensive line of simple, compact and strictly high-grade engines to fulfil these requirements. Their experience in fan practice has been of untold value, for the conditions have been such as to concentrate attention upon the essential features of high speed and continuous operation. The somewhat more recent development of the fan motor by the same company has placed at its disposal a very complete line of machines ranging in capacity from ¼ to 125 h.-p. Constructed as generators and combined with the equally extensive line of engines, these form a series of generating sets which cannot be equaled for variety or adaptability.

The accompanying engraving is of a 5 x 4-in. enclosed double upright engine and a standard 12 kw. type originally designed for the generator. The engine is of the severe work of forced draft fan propulsion on the vessels of the United States Navy. The cylinders are placed side by side in the same casting, and are large in diameter as compared with the stroke, so that great power may be developed at high rotative but moderate piston speed, making the engine particularly suitable for direct connected dynamo driving. The cranks are set opposite at an angle of 180 degrees. The steam admission to both cylinders is regulated by a single piston valve, under the control of a shaft governor of the same design as that used upon the single upright engines. All moving parts subject to

ing of magnetic field and armature are such as to insure absolutely sparkless operation under all changes of load. The temperature rise after a full-load run of ten hours will not exceed 40 degrees Cent. The bearings, which are ring oiling, are built upon the ball-and-socket principle. The armature is of the barrel-wound type, the interior surface of which is perfectly smooth, offering no opportunity for the collection of oil or dust. Ventilation is effected by the use of specially-constructed vanes, forming air ducts between the laminae of the core. These convert the armature into a blower, and create a strong draft through the windings. Carbon brushes are used exclusively and are mounted in holders of the sliding socket type, having

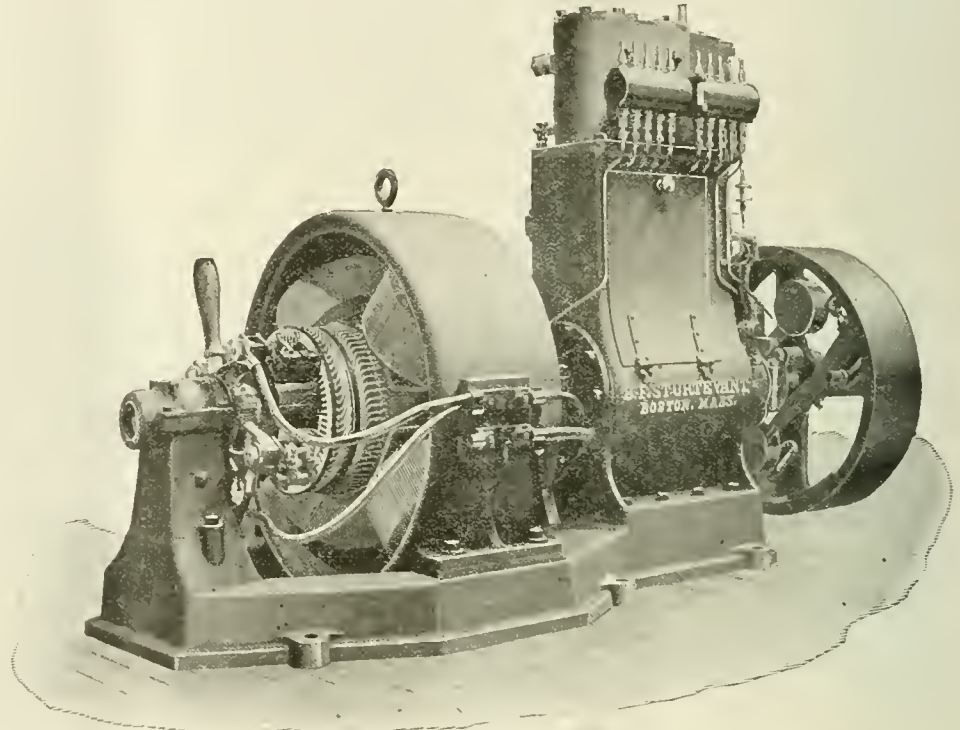

Enclosed Double Upright Engine and Standard Generator.

every facility for ready adjustment. All machines are thoroughly tested before shipment by being given a full-load run during a continuous period of six to eight hours.

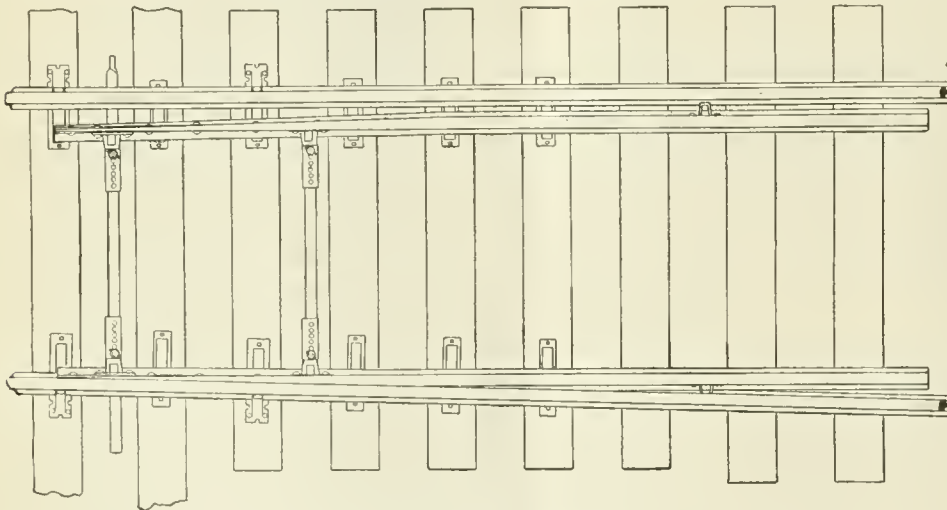

Weir Re-enforced Split Switches.

RE-ENFORCED SPLIT SWITCHES.

Since the introduction of split switches to the railroads of this country the Weir Frog Company, of Cincinnati, O., have devised a number of different designs of these popular switches. The one illustrated by the accompanying engravings is the most recent and altogether the best design. It will be seen that the switch rails are re-enforced on both sides so that if breakage should occur the re-enforcing will hold the parts together with safety to operation, until a new rail can be put in. This form of double re-enforcing is claimed to be superior to the methods of other

manufacturers who re-enforce the switch rail on one side only. In this latter method should the switch rail break the broken parts are apt to project from the line of the rail and present an obstruction, which may cause derailment, but

friction are of steel and the bearings of ample size. Automatic relief valves are provided to prevent any danger of damage by water in the cylinder. The magnet frame of the generator is of cast steel, and the shaping of the pole pieces and proportion-

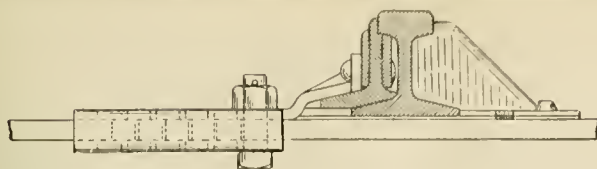

Section Showing Adjustable Head-rod and Fastening,

with the Weir method this double re-enforcing will hold the broken parts in alignment and with perfect safety to operation. The adjustment of these switches is made at the switch lugs, the latter being drilled with $1\frac{1}{4}$ -in. centers and the switch rods with $1\frac{1}{8}$ -in. centers. Owing to this difference in drilling an adjustment of $\frac{1}{8}$ in. is obtained at each movement of the switch rod. When adjustment is necessary, the bolts are withdrawn and the rods lengthened or shortened as occasion requires, thus providing for any change of gauge or wear of parts. This form of adjustment is easy and rapid. Either switch rail may be adjusted independent of the other, or both may be adjusted at the same time. Midway between the heel of the switch and where the heads of the rails diverge, a stop lug is bolted to the switch rail; this keeps the switch rail in perfect line when thrown against the stock rail. The Weir Frog Company also makes this design with one adjustable-rod.

IMPROVED FORM OF PRESSURE OIL CUP.

The improved form of oil cup which is shown in the engraving, in vertical section, has the advantage in not having the oil in the glass cylinder under pressure. This does away with the leaky joints and a possibility of the glass cylinder or reservoir being broken and thus rendering the cup useless, besides losing the oil. In this new oil cup the glass reservoir is used as an auxiliary supply in case the supply under pressure should be cut off. The pressure supply of oil is piped through the union, A, which opens into the oil duct leading to the bearing. This supply of oil is, in the matter of regulation, very simple, and easily affected by the valve, F, and is not disturbed by jarring of the machinery. The feed, when once adjusted, can be turned on or off by simply raising or lowering the lever, F. The auxiliary oiler is controlled by the cam lever, C, in the same way as the lever F. A sight-feed is placed in the base which enables the dropping oil to be clearly seen at some distance. The cup is heavy, substantial, practical, and simple in operation. All parts of the cup are made of cast brass. This oil cup is manufactured by the Lunkenheimer Company, Cincinnati, O.

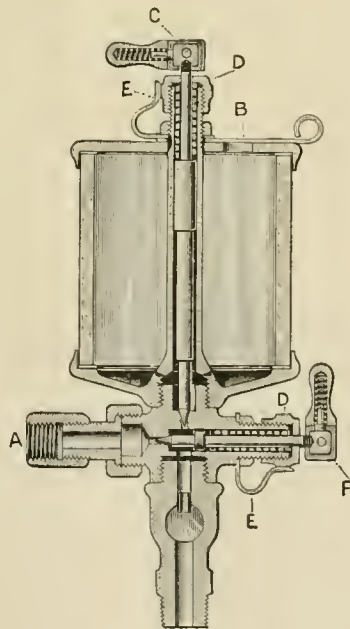

BOOKS AND PAMPHLETS.

"Monarch" Pneumatic Tools.—Some of the more recently improved Monarch pneumatic tools are illustrated in this pamphlet, which is the Standard Railway Equipment Company's latest catalogue of portable air tools. The three hammers illustrated are their size "AA" for light chipping and calking, size "A" for general run of chipping and calking, and size "B" for heavy chipping and light calking. Their Monarch long-stroke riveter, which is especially adapted to bridge erection, tank

work and steam-tight boiler work, is shown in operation in the catalogue, in connection with steel car truck work. In such service as driving boring bars, tapping, reaming and various kinds of rotary work their piston air drill is pictured, and also the Monarch wood-boring machines at work in car repair yards. This company manufacture a very efficient fine cutter that can be operated by either a No. 1 piston drill or a rotary drill of equal capacity, and furnish air compressors and air holsts of all sizes and styles, also special wire-wound air hose and hose couplings.

Grinding and Polishing Machinery.—One of the most complete catalogues of grinding machinery that has been received, is that of the Diamond Machine Co., Providence, R. I. A careful examination of this 1901 catalogue of 129 pages shows not only a number of new designs, but alterations of more or less importance in almost every one of the older machines. Many of the Diamond machines are now recognized as established types, and it has been the object of this company to perfect these machines by bringing them up to the modern requirements. Besides the more familiar grinding machines for bench work, grinding machines on columns and stands and improved surface grinders, there are illustrated in the book many interesting automatic machines for grinding saws, and knives of every description, up to 120 ins. in length. The book also presents a line of lathe grinding attachments and countershafts with patent belt shifters, suspended grinding and swing-frame polishing machines, 5 and 10-wheel grinders, and spindle and screw-feed lathes, together with various attachments, such as lathe slide rests, chucks and lathe center grinders. A description of the manufacture of carborundum and carborundum wheels introduces a chapter on polishing lathes, polishing wheels and buffs, of a great variety. Each tool and device is made reference to in a complete index in the back of the catalogue and also given a word in the telegraphic code.

The Safety Car Heating and Lighting Company, of New York, have issued a catalogue entitled "Steam Heat, Pintsch Light," a very creditable book in every way. This, their latest catalogue, has 151 pages, $8\frac{1}{4} \times 10\frac{3}{4}$ ins., is bound in green cloth, and illustrates and very briefly describes the various fittings and appliances which constitute both heating and lighting equipments. The illustrations are extensive, and in connection with the standard heating systems for both single and double circulation heaters, the standard heating system using live or exhaust steam from the locomotive and the direct steam heating system, are given large folded drawings of the floor plan showing the application of these systems to various coaches and combination cars. For particular equipments designs will be furnished on receipt of floor plan of cars showing the approximate positions of needle beams, gas tanks, equipment boxes and in a general way the position of brake cylinders. An approximate list of material required for one full equipment is given on each diagram for that particular system. Among the lighting equipment plates are a number of new and very attractive designs of lamps, such as drop bracket, drop swing bracket and combination bracket lamps; for use on the sides of the car. For detailed information relative to the systems of heating or lighting equipments, as shown in this general catalogue, will be furnished upon request at the office of the Safety Car Heating and Lighting Company, 160 Broadway, New York. This catalogue is an elaborate piece of work and is practically a text-book of car heating and lighting. The half-tone engravings are beautifully executed and the line cuts are from excellent specially prepared drawings.

Steam Boilers.—The Parker Engine Company, of San Francisco, Cal., and Drexel Building, Philadelphia, have in their 1901 catalogue of steam boilers given information about their very successful system of steam making, whereby the maximum heat is saved. In this system the progressive circulation of the feed water is from the water cylinder downward through continuous coils of tubes toward the fire and thence straight up to a separate steam chamber, thus maintaining a positive flow of the water and steam in one direction, opposite to that of the escaping gases. The claims and advantages of this boiler are fully described in the pamphlet, and are guaranteed by exceptionally high trial conditions, beside the

usual tensile and hydraulic tests. The specifications include the following: Dry steam per pound of combustible from and at 212 degrees, 11.5 lbs. Priming, foaming or lifting to be impossible, and moisture in steam not to exceed 1 per cent. under any conditions. To stand forcing to 50 per cent. above rating to date of acceptance, without leaks, or above 10 per cent. loss in economy; quick changes between no load and full load, or sudden drops in pressure from any cause; and in no case shall the circulation be reversed, the tubes overheated, or the water lifted. Ground hand hole joints to be made tight without bolts. Internal cleaning to be accomplished without shutting down, or the use of mechanical cleaners. To those interested in steam boilers, this catalogue will be found both interesting and valuable. A copy of the book can be procured by writing to the Parker Engine Company, 1041 Drexel Building, Philadelphia, Pa.

EQUIPMENT AND MANUFACTURING NOTES.

An order for pressed steel body and truck bolsters for 500 80,000-lbs. capacity cars for the Pittsburg Coal Company has been received by the Pressed Steel Car Company, of Pittsburg, Pa. The cars are being built by the Illinois Car and Equipment Company.

The Lake Shore & Michigan Southern Railway has ordered 1,500 freight cars of 80,000-lbs. capacity from the American Car and Foundry Company. The contract specifies that pressed steel body and truck bolsters shall be used in their construction. The bolsters will be furnished by the Pressed Steel Car Company, of Pittsburg.

Mr. J. W. Lowell recently resigned the position of Manager of the Railway Department of the Manhattan Rubber Manufacturing Company, New York, to become the General Sales Manager of the Woven Steel Hose and Cable Company, of Trenton, N. J., with headquarters at 32 Broadway, New York.

Simplex bolsters will be used on the 2,000 Michigan Central cars recently ordered from the American Car and Foundry Company; also 600 cars to be built for the Wheeling & Lake Erie, at the South Baltimore car shops; 400 cars for the Northern Pacific to be built at the same place, and 250 Louisville & Nashville cars to be built at the company's shops.

The Richmond Locomotive Works have just received an order from the Plant System for three six-wheel connected switching locomotives, the principal dimensions of which are as follows: Cylinders, 18 x 26 ins.; weight in working order, 108,000 lbs.; driving wheels, 50 ins. in diameter; driving wheel base, 11 ft.; 60-in. radial stay boiler; 250 tubes, 2 ins. in diameter and 12 ft. long; fire-box, 41 x 96 ins.; boiler pressure, 180 lbs. The tank capacity of the tenders is 4,000 gallons.

A new record has been established by the Pressed Steel Car Company, of Pittsburg, in the number of freight cars turned out in a day. During the week ending March 16th this company built and shipped 636 freight cars; a daily average of 106 cars. The shipments consisted of 467 hopper cars and 169 box cars.

The Standard Pneumatic Tool Company, of Chicago, manufacturers of the "Little Giant" air tools and appliances, have moved their New York offices from 619 Washington Life Building, to more commodious quarters in rooms 611, 612, 613 of the same building, this being necessitated by the increase in their business in eastern and foreign territory during the past few months. All shipments for customers in the district just mentioned will be made from New York instead of Chicago, thus expediting delivery of machines.

Mr. R. E. Janney has been appointed representative of the Sargent Company and the Railway Appliance Company in New York and the Eastern and Southern Territories. Mr. Janney will have his office at No. 1314 Havemeyer Building, Cortlandt Street, New York City, and will sell the well-known specialties of the Sargent Company, namely, open-hearth cast steel knuckles, locking parts of couplers for repairs, and a line of cast steel tools, such as car repair and machinists' hammers,

wrenches, coal picks, etc., also for the Railway Appliance Company, the Gilman Brown emergency knuckle, the O'Brien coupler, and the Sargent coupling device.

Keuffel & Esser Company, New York, have established a branch house at 303 Montgomery St., San Francisco, Cal., to accommodate the steady growth of business on the Pacific Coast. John R. Carr, which firm has been acting as their agents in San Francisco, and Mr. W. E. Holcomb, traveling representative for the Keuffel & Esser Company, in that territory will be in charge of the new branch house. A very complete line of the well-known Keuffel & Esser Company drawing materials and surveying instruments will be kept in stock, so that customers there will be provided with the same facilities for obtaining these goods as are enjoyed by those further east.

An exhibition of samples and models of the Edwards window fixtures and vestibule platform trap-doors was held at the Southern Hotel in St. Louis, March 8th and 9th, for inspection by the members of the St. Louis Railway Club and their friends. These dates were chosen as being the most convenient for those interested, as the regular meeting of the St. Louis Railway Club was held on the 8th at that hotel. The exhibit was also made at the Terminal Hotel, St. Louis, on the 11th and 12th. In comparing these devices for opening and closing car windows as developed and manufactured by Mr. O. M. Edwards, Syracuse, N. Y., with the antiquated methods that are in too common use on many railroads, one is struck with the convenience and importance of these fixtures. Not only is the operation of the windows sure and easy, but the matter of hanging the sash is very simple, and the friction strips, adjusting themselves as they do, keep out any dust or cold air from the car, and also take up shrinkage or swelling of the wood, thus preventing the sash from binding and allowing it to move freely whenever the thumb catch on the window-sill is operated. These fixtures contribute greatly to the comfort and good will of the traveler.

The following sales are reported by the Bullock Electric Manufacturing Company: Glasgow Evening News, Glasgow, Scotland, three motor generators; London Daily Express, London, Eng., three motor generators; Montreal Water & Power Company, Montreal, Can., one 400-h.p. three-phase motor; Aberdeen Journal, Aberdeen, Scotland, one 30-h.p. teaser equipment and one motor generator; Carnegie Steel Company, Pittsburg, Pa., one 25-h.p. type "H" motor; Greuner & Co., Johnstown, Pa., one 30-kw. type "I" generator; Brown & Sharpe, Providence, R. I., four type "N" motors for direct connection to machine tools; Wier Frog Company, Cincinnati, Ohio, three 10-h.p. type "N" motors; Pullman Company, Pullman, Ill., two 150-kw. type "H" generators; Mosler Safe Company, Hamilton, Ohio, one 50-h.p. type "H" motor; Susquehanna Valley Electric Company, Sydney, N. Y., one 65-kw. single-phase generator; Central Lard Company, New York City, N. Y., one 65-kw. engine type generator; Buffalo Evening News, Buffalo, N. Y., one 70-h.p. type "H" motor.

The Springfield Manufacturing Company, Bridgeport, Conn., have just moved into their new plant on Mountain Grove street. The building is of modern construction, one story high and entirely fireproof. It was designed and its construction superintended by Mr. G. W. Jackman, General Manager of the company, who has had considerable experience in the construction of buildings for manufacturing purposes. In form the building, as it faces the street, is an inverted T. The rooms forming the arms of the T are: the counting room, 20 x 15 ft.; a private office, 18 x 15 ft.; a drawing room, 15 x 25 ft., and a 100 x 25-ft. pattern room. The machine room is divided into three sections. In the center is a space 20 x 120 ft. for assembling machines, and on either side a space 20 x 100 ft. for drill presses and lathe work. Beneath the floor of the shop is a pit used as a means of ventilating and also for the line shafting which drives the machinery. In the emery-wheel department, 20 x 75 ft., are four large ovens and a hydraulic press of 300 tons capacity. This company manufacture their own gas for operating two gas engines, which furnish light and power for driving the shop tools. The design of the building was made with a view to the best means of enlarging the various departments, as the increase in the company's business demands.

AMERICAN ENGINEER AND RAILROAD JOURNAL.

MAY, 1901.

CONTENTS.

ARTICLES ILLUSTRATED :	Page	ARTICLES NOT ILLUSTRATED :	Page
New "Prairie" Type Locomotives, C., B. & Q. R. R.	135	Large Power Plant of the Manhattan Ry.	140
Furniture and Ballast Cars, Pressed Steel Car Co.	139	Steam Jets to Stop Clinkering.	141
A New Track Tank Water Scoop, N. Y. C. & H. R. R. R.	143	Aluminum at Paris Exposition 1900	148
Eight-Wheel, Wide Firebox Passenger Locomotives, D., L. & W. R. R.	141	Hot-Blast Heating	149
Locomotive and Car Shops, Wis. Central Ry.	146	Ratios of Total Weight to Heating Surface, by F. F. Gaines.	151
A Suggestion in Cast Steel Locomotive Frames	149	Four New Trains for the "Lakes Shore Limited"	155
Coal and Ore Cars, American Car and Foundry Co.	151	Vacuum Cement and Pulley Covering	161
Steel Cars by the American Steel Foundry Co.	156	The Fuel Question in Stationary Plants	162
Tank Well and Strainer	157	Track Arrangements in Erecting Shops	163
Dining Cars, C., B. & Q. R. R.	158	American School of Correspondence	166
Hydraulic Shop Tools	159		
Edwards Vestibule Platform Trap Door	161	EDITORIALS:	
Hoist for Repairing Passenger Car Trucks	161	American Railway Association	152
Electrically Driven Bending Rolls	162	Steel Castings	152
Eight-Pole Motors and Generators	163	M. C. B. Association and Steel Car Design	152
		Momentum of Boiler Explosions	152
		Practical Altruism in the Shop	153

NEW "PRAIRIE" TYPE WIDE FIREBOX LOCOMOTIVES.

Simple and Compound.

Chicago, Burlington & Quincy Railroad.

The first engines of this type designed and built by the "Burlington" road (American Engineer, April, 1900, page 103) have rendered satisfactory service both as to the details of the ar-



NEW "PRAIRIE" TYPE LOCOMOTIVES, SIMPLE AND COMPOUND—CHICAGO, BURLINGTON & QUINCY RAILROAD.

F. A. DELANO, Superintendent Motive Power.

BALDWIN LOCOMOTIVE WORKS, Builders.

Wheel: Driving	64 in.	Cylinders: 20 by 24 in.	Boiler pressure	200 lbs.	
Weights: Total of engine	171,000 lbs.	engine truck	37 1/4 in.	tender wheels	36 in.
Grate area and tubes: Grate area	42 sq. ft.	on drivers	130,000 lbs.	leading truck	14,400 lbs.
Firebox: Length	84 in.	width	72 in.	trailing truck	26,600 lbs.
Boiler: type, straight	radial staying.	depth of front	66 1/4 in.	back	17 ft. 1 in. long.
Heating surface: Tubes	2,732.7 sq. ft.	firebox	155.8 sq. ft.	Diameter	63 1/4 in.
Wheel base: Driving	12 ft. 1 in.	total of engine	28 ft. 0 in.	total	63 1/4 in.
Tender: Eight-wheel		water capacity	6,000 gals.	engine and tender	2,888.5 sq. ft.
				coal capacity	5 1/2 ft. 5 1/2 in.
					10 tons.

about 12 tons. In general the details of the frame arrangement, the equalization and the form of the trailing trucks are the same as before, but instead of placing the trailing equalizers under the truck boxes they now rest on top of them, with a saddle and side-motion rollers between. The frame cross-ties and the supplemental rear portions of the frames are substantially as before, to provide for outside journals for the trailing axle. The driving wheels are of the same diameter as before, 64 ins., and the axles are enlarged at the wheel fits.

This is an excellent example of intelligent caution in designing which should be carefully noted. Before ordering a lot of new engines with several novel features this road built a small number (we believe two), and after running them about a year embodied the experience in this present order. Aside from increasing the capacity and compounding a portion of them, the boiler shows the greatest number of changes. The heating surface is increased, but with the same grate area as before. Instead of 16-ft. tubes the new ones are 17 ft. 1 1/2 ins. long, which may be taken as an indication of a tendency toward a gradual lengthening of tubes. With this type the boiler may be kept to a low position, its center being in this case but 8 ft. from the rail level, and yet the depth under the tube sheet is 19 1/2 ins. to the bottom of the mud ring. In the width of the mud ring and the shape of the firebox sides is noted an apparently important feature, to which the wide firebox easily lends itself. At the front water leg the space is 5 ins., and at the sides and back end it is 4 ins. There is perhaps no greater need for circulation space in the wide firebox boiler, but the wide grate renders it so easy to provide greater spaces that this suggestion should be considered. Unless very close figuring on weight is required, there appears to be no reason why these water spaces should not be made even larger, say 6 ins. in front and 5 ins. at the sides and back. This would probably prolong the life of the side sheets and also exert a favorable effect upon the staybolts by increasing their length. In the section of the firebox the sides are very nearly vertical. This also is important, and probably more so with short than with long fireboxes because of its probable effect upon circulation. In a locomotive boiler the

arrangement and as to the wide firebox. This has led to the construction of 30 engines by the Baldwin Locomotive Works upon the same plan, with increased size and capacity for use on the Hannibal & St. Joseph Railroad. Six are Vaucrain compounds and the rest are simple engines with piston valves. The new design has 20 by 24-in. cylinders, and the weight is increased

side sheets just below the brick arch are probably the most active heating surfaces, and nearly vertical water legs at these points must necessarily assist circulation by permitting water to pass down on the outside. But this cannot occur if the cross-section is such as to carry the bubbles of steam, moving in approximately vertical lines, against the outside sheet because of

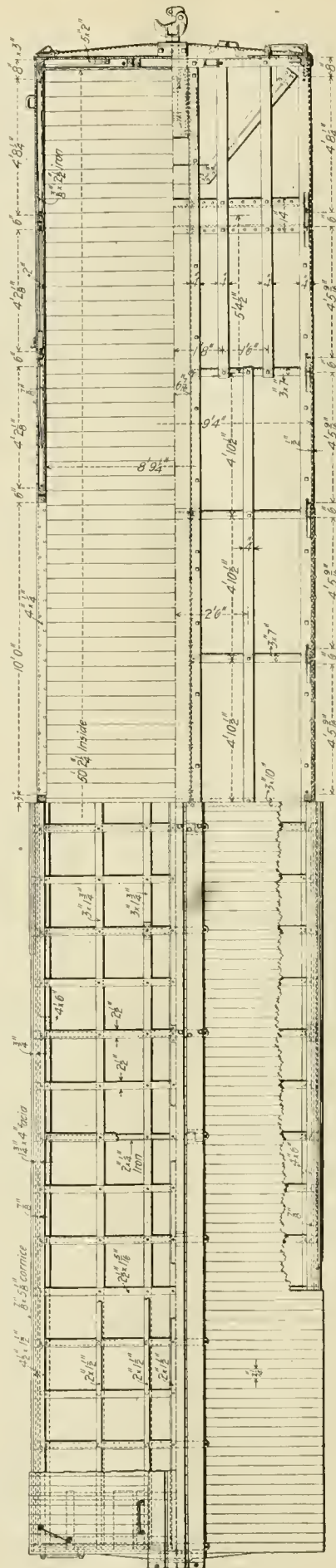
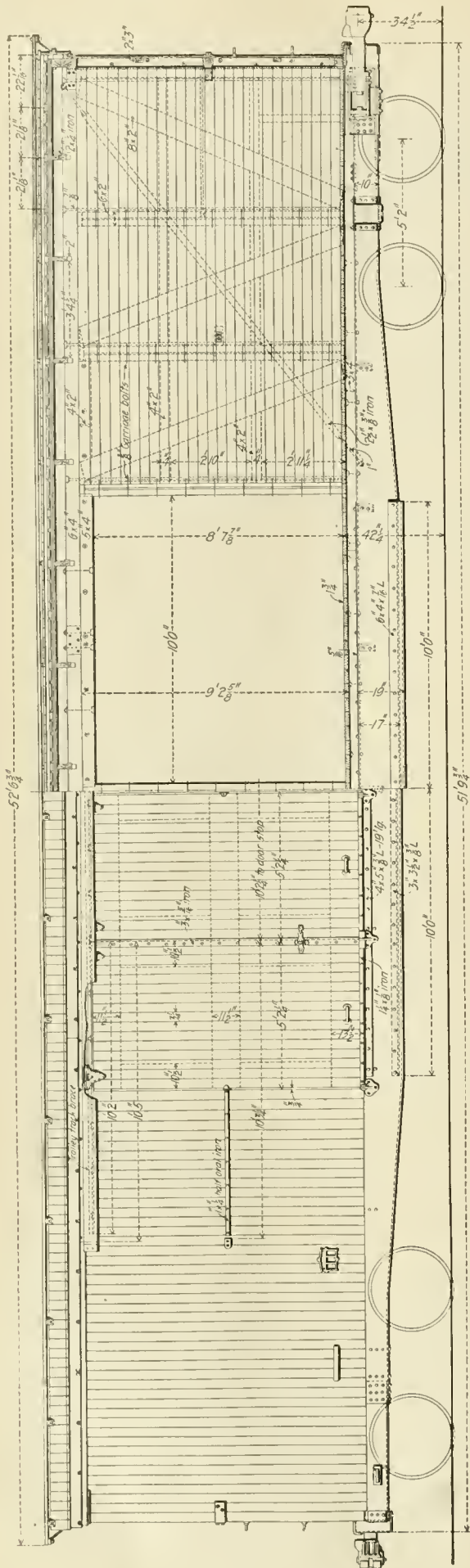

Fifty-Foot Furniture Car, with Steel Underframes—Erie Railroad.

A. E. MITCHELL, Superintendent Motive Power.

PRESSED STEEL CAR COMPANY, Builders.



Fifty-Foot Furniture Car, with Steel Underframes—Erie Railroad.

FURNITURE AND BALLAST CARS.

Pressed Steel Car Company.

FIFTY-FOOT FURNITURE CAR WITH STEEL UNDERFRAME. ERIE RAILROAD.

Last month, on page 107, a 40-ton box car with steel underframing, designed and built for the Union Pacific Railway by the Pressed Steel Car Company, was illustrated. A number of adaptations of the same general plan have been made for cars of various types, one of which, a 50-ft. furniture car, for the Erie Railroad, is illustrated by these drawings. This car has four pressed steel sills of the "fish-bellied" type, 17 ins. deep at the center and reinforced for a distance of 10 ft. each side of the center by a 4 by 6-in. pressed steel angle riveted to the lower portion of the web of each sill. At distances of 4 ft. 5 9/16 ins. between centers pressed steel channel lateral floor beams are riveted between the side and center sills to support the wooden stringers. Other details of the floor construction are shown in the drawings. In this car the corners are braced by angles at the floor and the box structure has angle braces of 2 1/2 by 3/8 in. iron drawn up between the outside stringers and the side plates by nuts. On each side there is a 10-ft. door 8 ft. 7 7/8 ins. high in the clear. The doors are double on each side of the car and "staggered" to permit of loading long material, long wagons or boats. The doors on each side come to the center line of the car as indicated in the side elevation and longitudinal section. This arrangement and the unusual width of the openings will be very convenient. The roof construction is also indicated in the drawings. In this design the underframe carries the entire load with no assistance from the upper structure.

ERIE RAILROAD FURNITURE CAR.

General Dimensions.

Length over end sills.....	51 ft. 9 3/4 ins.
Length inside of body.....	50 ft. 3 5/16 ins.
Width over all.....	9 ft. 10 1/4 ins.
Width inside.....	8 ft. 9 5/16 ins.
Height, rail to top of running board.....	14 ft. 1 in.
Height, rail to brake shaft.....	14 ft. 9 ins.
Height, rail to top of center channels.....	3 ft. 3 1/2 ins.
Height, rail to bottom of center channels at bolsters.....	2 ft. 5 1/2 ins.
Height, rail to center of couplers.....	2 ft. 10 1/2 ins.
Distance between centers of trucks.....	40 ft.
Size of journals.....	4 1/2 by 8 ins.
Wheel base of trucks.....	5 ft. 2 ins.
Centers of journals.....	6 ft. 3 ins.
Light weight of car.....	40,400 lbs.
Capacity.....	60,000 lbs.

These cars are carried on Fox pressed steel trucks with 33-in., 600-lb. wheels. They have cast iron journal boxes, Westinghouse brakes, solid pressed steel brake beams made by the Pressed Steel Car Company, and the standard twin spring draft gear of these builders. The cars are equipped with double sliding doors with Q. & C. fixtures and the Dayton

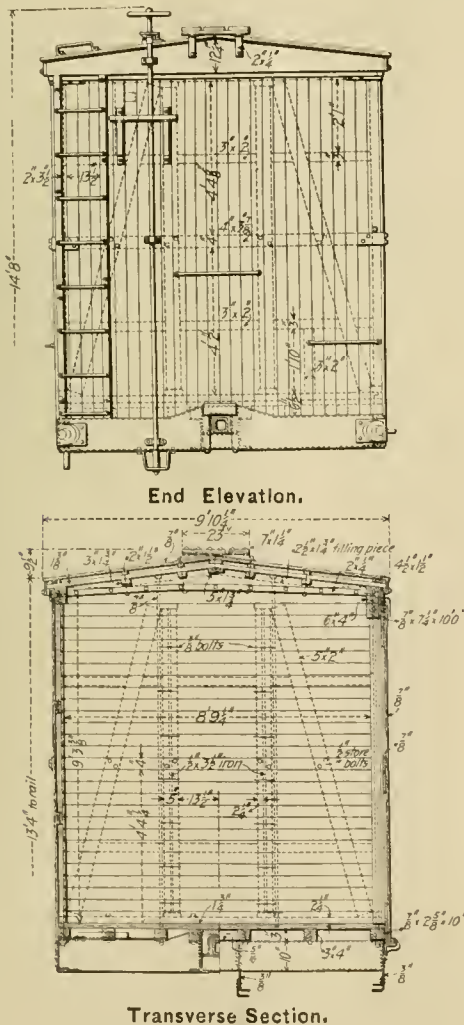

With locomotive cylinders exposed as they are to the effects of low temperature and winds of high velocity, it seems but natural that they should be protected in the best possible way from loss of heat which is much more effective at the cylinders than in the boiler. Attention has repeatedly been directed in these columns to the importance of this protection and it is hoped that before long greater care will be exercised in lagging cylinders, steam chests and saddles with the best material available. A large two-cylinder compound gave a great deal of trouble last winter in an atmosphere 50 degs. below zero Fahr., and failed to do one-half its rated duty because of this loss of heat.



Fifty-Ton Ballast Car—Union Pacific Railway.

Malleable Iron Company's door fasteners. They also have end doors at the brake shaft end of each car. The roofs are covered with the Winslow galvanized roofing.

FIFTY-TON BALLAST CAR.
Union Pacific Railway.

This car is of a unique design intended to deal with 50 tons of coal or 55 tons of ballast. It has two doors extending along each side of the full length of the bottom of the car body. These are operated in unison by a single operating shaft through the medium of a toggle lever which also operates a spreader device. This arrangement is controlled from one of the end platforms of the car, where a lever is placed on the end of the operating shaft, and the doors may be opened as much or as little as desired, while they may be closed positively at all times. In the photograph the exterior appearance of the car is shown, and also the bracing and the arrangement of the air brake cylinder and reservoir. The car is fitted with wooden extension side and end pieces which are secured to the permanent steel sides by means of removable stakes having U-shaped guides open upon the top and of such dimensions that the boards may be easily slipped in and out. Chains attached to the boards prevent them from falling to the ground when they are lifted out of the guides. This arrangement will be convenient when loading with coal, as the extension pieces may be put in place after the load has reached the level of the permanent sides. The following table gives the chief dimensions:

General Dimensions:

Length over end sills.....	40 ft. 0 in.
Length inside body.....	32 ft. 7¼ ins.
Width over all.....	9 ft. 4 ins.
Width inside of body.....	8 ft. 8½ ins.
Height from rail to top of body.....	8 ft. 3 ins.
Height to top of brake shaft.....	5 ft. 5¼ ins.
Height to top of center sills.....	3 ft. 3½ ins.
Distance between truck centers.....	31 ft. 1 in.
Size of journals.....	5½ by 10 ins.
Wheel base of trucks.....	5 ft. 6 ins.
Center of journals.....	6 ft. 5 ins.
Weight of car empty.....	37,600 lbs.
Capacity loaded with coal.....	100,000 lbs.
Capacity loaded with ballast.....	110,000 lbs.

Fireproof Stairs.—Consul General Guenther, of Frankfort, Germany, reports that on March 3 official tests of so-called fireproof stairs for apartment houses were made at the yards of one of the fire department stations in Frankfort, where intense fires had been started for the purpose. The stairs covered with plastering showed the longest resistance, and could still be used after being subjected to the fire for twenty-five minutes. Of stairs coated with fireproof paints, no tangible results could be stated, as the stairs experimented with were of great variety as to material and strength; but they were still serviceable after five or ten minutes under fire. Of the wooden stairs without fireproof paints, those of oak withstood the fire the longest.

LARGE POWER PLANT OF THE MANHATTAN RAILWAY,
New York City.

The new power station of the Manhattan Elevated Railway, New York City, will furnish electric power for the third-rail system and will displace about 225 locomotives, which last year consumed 226,924 tons of coal and 535,000,000 gallons of water. The huge proportions of this plant are made apparent by the immediate demand that will be placed upon the generators when the motive power of the road is changed from that of steam locomotives. This demand, including the lighting and heating of the trains and stations, is estimated at 60,000 electrical horse power. Each of the eight dynamos is rated at 5,000 kilowatts, and, according to "Power," they are capable of delivering at maximum load, 7,500 kilowatts or an aggregate of 80,000 electrical horse power.

The station is conveniently located near the water front of the East River, between 74th and 75th streets, and is built in the form of a trapezoid 413 ft. long on one side and 395 ft. on the other, with a uniform width of 204 ft. It is of steel construction with brown-tinted Pompeian brick walls resting on a granite rock base 26 ft. high above the foundations. The windows are 14 by 45 ft., spaced 35 ft. apart on all sides of the building. The roofs are of red tile with copper-covered monitors and the chimneys are of buff-colored brick. The station is divided longitudinally into a boiler and engine house, the latter containing a basement and main floor and the boiler house a basement and two floors devoted to the boilers and overhead coal storage. Two longitudinal division walls in the basement of the boiler house separate the pumping machinery in a central section by itself.

A 50-ton electric crane serves the main engines, and two electric cranes span the space occupied by the exciter engines.

In the engine room are eight 8,000 h.p. units furnished by the E. P. Allis Co. and are the largest units ever constructed for this kind of work. These units consist of two compounds with 44-in. horizontal high-pressure cylinders and 88-in. vertical low-pressure cylinders, with a stroke of 60 ins. and a speed of 75 revolutions per minute. The use of four cylinders and cranks placed 135 degs. apart give a turning effort sufficiently uniform to permit of dispensing with fly-wheels. The revolving field of the generator being 32 ft. in diameter and weighing about 170 tons, is sufficient to give the necessary inertia effects. Four direct-connected tandem compound engines, built by the Harris Foundry & Machine Works, are used to drive the exciters. The high-pressure cylinders are 15 ins. in diameter and the low-pressure 25 ins., with a stroke of 18 ins. These engines run at 200 revolutions per minute. A separate Worthington condenser is used for each unit. Three vertical single-acting air pumps are attached to cranks set at 120 degs. upon

a shaft operated at a speed of about 30 revolutions per minute, by a gear-connected motor. The pump cylinders are 45 by 18 ins., giving a displacement of 1,491 cu. ft. per minute, at 30 revolutions. The electric current will be generated at the main power station by three-phase Westinghouse generators, at a potential of 11,000 volts, and transmitted along three 3-in. conductor cables to seven sub-stations, where it will be transformed by step-down transformers and rotary converters to direct-current of 625 volts, for transmission to the third rail.

In the boiler plant are 64 Babcock & Wilcox units with an aggregate capacity of 32,000 h.p. Each unit has 5,243.28 sq. ft. of heating surface, and 88 sq. ft. of grate area, giving a ratio of grate area to heating surface of 1 to 59½. The boilers are designed to carry 200 lbs. pressure, and are arranged in four rows of 16 boilers each and fed by Roney stokers; the coal being piped from the overhead storage to the stokers. The economizers used in connection with the boilers are 16 in number, every four boilers being provided with an economizer. Four chimneys, 278 ft. high, together with 16 Sturtevant blowers, will furnish the draft for the 56 boilers. These blowers are 9 ft. in diameter, 4 ft. 6 ins. wide and run at 180 revolutions, with a capacity of 57,000 cu. ft. of air per minute, and will be used only for cases of emergency where it is necessary to force the boilers beyond their capacity with natural draft. The chimneys are for a height of 73 ft. above the foundation, octagonal in section, 26 ft. 6 ins. in diameter, with walls 5 ft. thick. Above the octagonal base the shaft is circular in form, varying in thickness from 32 to 8½ ins. The coal is carried by gravity bucket conveyors from a coal and ash tower erected on the river front, to the storage bins located directly over the boilers. These bins are W shaped in section and divided into three bunkers, separated from each other by an air space 35 ft. in width. The capacity of the bunkers is 15,000 tons of coal sufficient for 20 days' run. A separate conveyor is used for the ashes, which are chuted from the ash pits into dump cars and hauled by an electric locomotive to the ash hopper where they are delivered to a bucket elevator and carried to the storage bins in the tower and thence chuted into barges. The capacity of the ash storage is 1,200 cu. yds. This tower is also equipped with an automatic shovel and a coal-crusher. The coal after being crushed passes over the weighing scales into a cross-line conveyer which delivers it to the main line conveyer running to the coal bunkers. All the hoisting, crushing, weighing and conveying apparatus is operated by direct-connected motors.

The work of this plant is under the general supervision of Mr. W. E. Baker, who will be remembered as having built the intermural railway at the Columbian Exposition, in Chicago. Mr. E. D. Leavitt and Mr. L. B. Stillwell were engaged as consulting engineers. The general engineering work is in charge of Mr. George H. Pegram, Chief Engineer of the Manhattan Railway Company.

That there is a need of some recognized system of classifying locomotives is conveniently shown in a table which appeared in the April issue of the "Railroad Digest." The existing forms of wheel arrangement are classified in this table into the "Bogie" class, with four-wheel leading trucks; the "Pony" class, with two-wheel leading trucks; the "Switching" class, without a leading truck, and the "Forney" class, both with and without a leading truck. There is a logical system in these series, if the trailing wheel is not considered, but there is nevertheless an uncertainty as to the exact meaning of the type names used. These various types are also designated in a separate column of the table, by Mr. F. M. Whyte's method, which is a system of classifying that includes the whole wheel arrangement. Mr. Whyte's system is given on page 375 of the December, 1900, issue of the American Engineer and Railroad Journal and fully explained in a communication by Mr. Whyte in our issue of February, 1901, page 55, with a criticism by Mr. G. S. Edmonds in the January paper, page 21. Mr. F. F. Gaines also describes a system that not only defines the type of the engine, but gives an idea of its size and capacity. This description will be found on page 119 of the April, 1901, paper.

STEAM JETS TO STOP CLINKERING.

Admission of steam in jets into fireboxes for the improvement of combustion was practiced years ago for the purpose of mixing the gases in order to bring oxygen into intimate contact with the combustible gases. Jets of air were used for the same thing, but owing to the cooling of the furnace by the heat absorbed by the steam and that required to heat the air the resultant economy has not appeared to be great. It is possible, moreover, to have a large excess of air in the firebox and yet find a large amount of combustible gases pass off unconsumed because of imperfect mixture if the air is admitted above the fire. Unquestionably the best place for supplying air is through the grates and the fire and if there are no holes in the fire the mixture of gases is sure to be good. While steam which is admitted above the fire appears to rob the furnace of some of its heat, it does not appear likely that it will do so when admitted below the grates, and experience with automatic stokers indicates that steam admission under the grates will be worth trying on locomotives. It seems to prevent the formation of clinkers and this is a serious matter in automatic stokers. It is serious also in locomotives. The writer recently saw a mass of clinker from a locomotive firebox large enough when broken up to fill a bushel basket. Coal containing relatively large proportions of sulphur seems to give the most clinker, while some coals are free from it. The theory of the action of steam under the grates is that of dissociation in passing through the fire and the hydrogen liberated from the oxygen combines with the sulphur to form hydrogen sulphide; or, in other words, the sulphur is disposed of in a gas instead of a solid. Experiments recently made on a locomotive seem to confirm this reasoning for there has been in this case a great improvement as to the formation of clinkers.

To enlarge the opportunity of engineering students for the study of railroad problems, Purdue University has made two important changes in the course of Mechanical Engineering. Heretofore all students have during their senior year taken steam engine design, followed by general engineering design. Along with this general course will be given hereafter a course in car and locomotive design with the privilege of electing either course. The second is an additional required subject extending over a period of twenty-two weeks of the senior year. Three recitations a week will be called for, on the subject of electric power transmission dealing largely with the mechanical engineering side of power stations, of transmission lines and of motor installations. This offer of options to students in the later years of their course is practiced only by two or three of the larger technical colleges of the country and is a matter the students themselves would like to see encouraged. It might be a means of correcting some of the failures of technical graduates in the first years out of college. In many of these schools the men are educated to be professional engineers, when they really feel that they are best fitted for some particular kind of work, but without optional courses offered to them they are not given a specialty or an opportunity to study one. Some of these young men when started into practical work are not at first successful. They may take to their choice later, but it is after a large amount of shifting about and with a great deal of dissatisfaction. It is no longer a draftsman that is wanted by a railroad, but a good man to do elevation work, a man to be a fuel expert or to take up some specialty. A general course of technical training is beneficial no matter what the life work may be, but the proper preparation of a few students out of a class of many is not what is wanted so much as the education of many along the lines of their own interests and personal inclinations. These optional courses are good in themselves and it is believed that they help graduates to get into the lines of work they are best fitted for. They may, on the other hand, serve to indicate work which one is not fitted for, and that is equally important.

A NEW TRACK TANK WATER SCOOP.

For Freight and Passenger Locomotives.

New York Central & Hudson River Railroad.

Two interesting designs of track tank scoops have been brought out recently, the one on the Lake Shore & Michigan Southern, designed by Mr. H. F. Ball, Mechanical Engineer of that road, and the one illustrated in this description, designed by the motive power department of the New York Central. For the present drawings we are indebted to Mr. A. M. Waitt, Superintendent of Motive Power and Rolling Stock.

The designs are alike with respect to the provision for raising the scoop against the resistance of the water at high speed, the lower ends being made with two movable joints, but the construction and actual method of raising are quite different in the two arrangements. It becomes very important to provide properly for the thrust of water, for the horizontal thrust is considerable. We recently heard an amusing account of a test at high speed with a light engine (no train), the resistance of the water being great enough to retard the engine considerably when the scoop caught the water. Without the inertia of the train back of the tender the lifting of from 5,000 to 6,000 gallons of water in a few seconds, which represents foot pounds of work with a vengeance, slowed the engine down.

To permit of drawing the scoop out of the water against such resistances the New York Central plan, like that of the Lake Shore, employs a very short section for the dipper itself. The object being to first tilt the portion which has the least horizontal thrust upon it. The mouth section, which presents very little curved area to the water, is tilted first, and when the bottom plate of the dipper is tilted upward and forward the water striking the underside of the dipper assists in lifting the entire scoop. In the New York Central design the dipper section has stops in the lower hinge, which come to a bearing when the mouth is tilted upward and the further movement of the dipper section takes the second section along with it until the raising movement is completed.

We present two engravings of the New York Central scoop, showing two arrangements which are different in the details

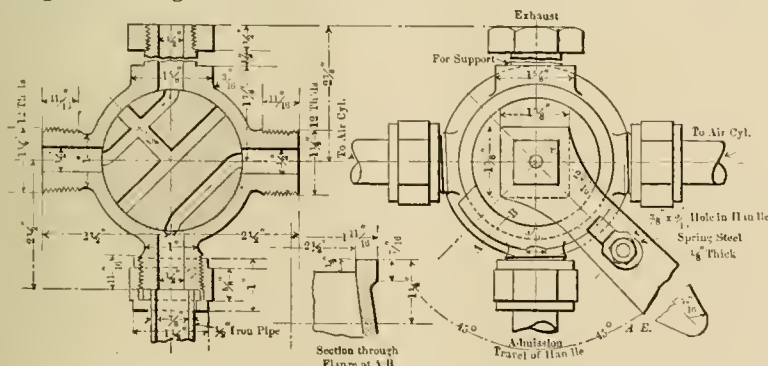

Fig. 4.

of suspension and in the arrangement of the stops in the links for limiting and controlling the action of the mouthpiece. Both are operated by air pressure, although the cylinder is shown only in Fig. 2, and both may be operated by hand, the form shown in Fig. 2 being the latest design. In Fig. 1 the links limiting the lower position of the second section are slotted and their upper ends are made adjustable in the attachment to the tender frame. In Fig. 2 the links act through the coil springs, which have three functions, to cushion the stopping of the scoop, to interpose a slight resistance to the main part of the scoop insuring the entering of the cutting edge into the water first and to assist in raising the scoop from the trough. If anything except the spring connection break, the scoop will be raised from the trough by the incline at the end of the

trough and will be supported above the rails by the springs. The thimble stops inside of the springs determine the lower position of the scoop. This attachment also provides for adjustment of the height of the scoop.

In this design no machine fitting of the scoop itself is required. The mouthpiece is left open on top in order to prevent splashing and to take advantage of the wave raised by the scoop as it passes through the water. An air cylinder and operating valve complete the apparatus. These are also illustrated. The valve is a 4-way cock with ports arranged to "bleed" both ends of the cylinder to the exhaust, to permit of operating the scoop by hand when necessary. In Fig. 4 the main air pipe is at the bottom of the drawing, the exhaust at the top and the cylinder admissions at the right and left sides. The handle of this valve is left in the middle position when the scoop is not in use. To lock the scoop the movement of the hand operating lever is blocked by a pin which must be removed before the air valve is operated.

It has been found necessary to provide a systematic method of adjusting the scoops with reference to the troughs and for this purpose the gage shown in Fig. 5 was devised. This is used as indicated in Fig. 6. When the scoop is down to its lowest point it is adjusted to be not more than $5\frac{1}{4}$ ins. below the top of the rail and this distance is provided for in the shape of the gage. When raised, the lowest point is kept at least 4 ins. above the rail level and this is measured by the swinging arm of the gage, as indicated. It is the practice of this road to inspect all the scoops every week and keep them closely adjusted.

Those who are designing water scoops in the future will find the Kiesel scoop of the Pennsylvania Railroad, illustrated in this journal in November, 1896, page 283, and the Lake Shore scoop in November, 1900, page 344. These, with the present description, bring this subject up to date and show what is believed to be the best practice.

Removal of Old Paint.—Numerous recent fires caused by the use of painters' naphtha torches have called urgent attention to this hazard. Carelessness on the part of the mechanics is, without doubt, a necessary adjunct to the torch in producing such fires; for by ordinary care in handling the torches ignition could certainly be avoided. Under the trade name of "Clyzol," a solution has been put upon the market in Paris for the purpose of removing old oil paint. If this solution is applied to a painted surface of wood or iron, upon which there may be even as many as fifteen or twenty coats of old oil paint, a saponification of the oxidized oil of the paint is effected which may be washed away in water, leaving the wood or metal clean. It is not even necessary to wait for the solution to dry, since, after it has been in contact with the paint for about ten minutes, a stream of water is sufficient to wash the whole away. Clyzol has been adopted by the Paris Omnibus Company among other large users, and would seem to have a wide

application in the cleaning of rolling stock and large iron structures before repainting. Many of the beautifully carved old oak doors in Paris, which at some period of bad taste had been painted, are now being cleaned with Clyzol and refinished in their natural state. Clyzol presents no fire hazard in its presence or use, and should be substituted for the present extremely hazardous processes of removing old paint by the use of gasoline flame, or the application of benzine or other volatile solvents.—Insurance Engineering.

It is surprising to be told that compressed air under a pressure of 100 lbs. per square inch will leak through a $1\frac{1}{16}$ -in. hole at the rate of a horse-power every five minutes or 12 horse-power per hour. Mr. W. P. Pressinger made this statement before the New York Railroad Club recently, in order to emphasize the importance of tight piping and reservoirs.

LOCOMOTIVE AND CAR SHOPS.

Wisconsin Central Railway,
Fond du Lac, Wisconsin.

We are indebted to Mr. F. C. Cleaver, Superintendent of Motive Power; Mr. R. B. Tweedy, Chief Engineer, and Mr. Angus Brown, formerly Superintendent of Motive Power of this road, for information concerning the attractive new shops just completed at Fond du Lac, Wis. The original shop plant of the road was at Stevens Point, and in 1889 the locomotive department moved to Waukesha, near Milwaukee. These plants were nearly 160 miles apart, and when it became necessary to provide increased facilities, Fond du Lac was selected, because it is 156 miles from Chicago, and permitted the road to be operated in three divisions. (1) Chicago to Fond du Lac; (2) Fond du Lac to Abbotsford, and (3) Abbotsford to Minneapolis. All the heavy repair work will now be done at Fond du Lac, the Waukesha shop will be maintained, but that at Stevens Point will be abandoned and the machinery taken to the new plant. At Fond du Lac the heavy work on 150 locomotives and 10,000 cars will be done.

A large tract of land was secured, about 3 miles from the center of Fond du Lac, and near Lake Winnebago in a location which is favorable for building a shop town. It is bounded on one side by the main line of the road, with the Chicago & Northwestern track parallel to it. The compact arrangement of the buildings is seen in the ground plan. There are three principal buildings, a locomotive shop 507 by 128 ft., and a car shop 481 by 160 ft. with a 70-ft. transfer table between, and at one end of the transfer table is the storehouse, a building with a three-story end, the upper part being occupied by offices. The plan also shows the location of the round house, coal storage plant (to be built later), the power house, and also the lumber sheds, dry kiln, scrap bins and car repair yard. This plan also indicates the location of the drains, the locker house at the entrance to the grounds and beside it a proposed club house for the employees. The water closets are near the large buildings and the washing facilities are in the locker house through which all the men pass on their way to and from work. All clothing is kept in the lockers and none is permitted to be left in the shops. The locker house is fireproof, with 600 metal ventilated lockers. The urinals are located in the shops at the center posts. They have running water and are cased in wood with doors. Instead of the usual wide space between the transfer table and the buildings on each side of it, this plan shows spaces of 20 ft. only. When locomotives are fired up for testing they are taken to the tracks at the end of the car shops where the smoke and noise of blowing pops will not inconvenience the shop or office forces and with such narrow spaces, at each side of the transfer table, there will be no temptation to litter up the short tracks outside the buildings. The buildings are of light-colored brick and very attractive. The roofs are all supported by steel trusses and steel posts.

Electric distribution is provided throughout and the power house was located where it was wanted, without reference to the other buildings. It contains two Allis-Corliss engines, one of 150 and the other of 350 h.-p. The small engine has a 16 by 42 and the larger one a 24 by 42-in. cylinder. The smaller engine is considered an auxiliary for lighting the shops, yards and station and will also be used for such over-time work as may be necessary. It drives a 100-kw. generator. The large engine has two fly wheels, taking belts for two 100-kw. generators. Three, 72 in. by 18 ft. cylindrical boilers furnish steam, the draft being secured by the Sturtevant system of forced draft used in connection with a stack which extends but 20 ft. above the roof of the building. In order to estimate the power requirements intelligently the engines at Waukesha were indicated and an allowance made for about 20 per cent. more power than at present required. All the steam and water pipes except

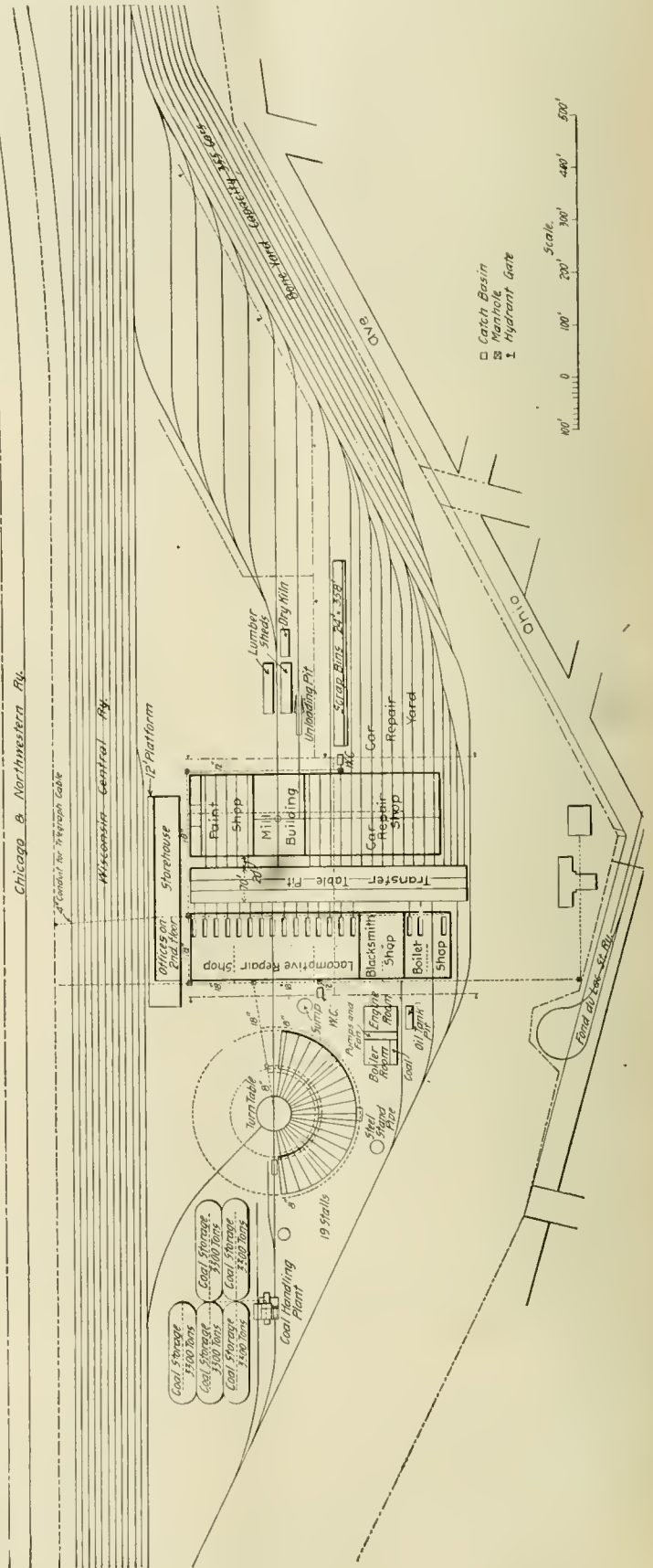

General Plan of the Fond du Lac Shops—Wisconsin Central Railway.

R. B. TWEEDY, Chief Engineer.

F. C. CLEAVER, Superintendent Motive Power.

the return steam pipes are overhead in the buildings and the outside steam pipes are overhead. The buildings are heated by the Sturtevant hot air fan system.

In the locomotive department a track runs through all the shops with a small turntable in the middle of the main shop, connecting with the round-house track. This building provides for 15 pits in the erecting shop and over them the roof trusses are shallow enough for two 30-ton rope-driven cranes which were brought from Waukesha. On the other side of the center posts two 5-ton cranes serve the heavy machinery, while a two-ton crane serves the benches. The provision for the cranes and the supports for the line shafting are shown in the sectional sketch of this shop. The line shaft is divided into three sections for the group system of driving. There are four groups in this shop, the wheel machinery, the tool room and the main portions of the shop machinery. A 40-h.-p. motor drives each section of the main shaft, and the tool room is driven by a

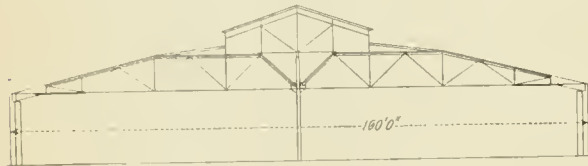

Section Through Car Repair Shop.

10-h.-p. motor, all of which are mounted overhead upon the roof trusses. Two 30-h.-p. motors in this shop drive the Sturtevant fans and two more drive the air compressors which are fitted with automatic devices for regulating the pressure. There are no individual motors on the machines of this shop.

Adjoining the locomotive shop, and separated from it by a brick wall, is the blacksmith shop, 88 ft. long. A 15-h.-p. motor drives the tools and another of the same size drives the fans, both being carried on the roof trusses. The blast is brought to the forges underground and the smoke is conducted from the 18 fires to three turrets of 6 fires each and is carried away by three stacks. The large forges and the steam hammers are served by boom cranes.

Another 88 ft. section is devoted to the hoiler shop with a brick wall partition between it and the blacksmith shop. It has three pits, a through track to the transfer table and the necessary machinery driven by a 20-h.-p. motor and a single

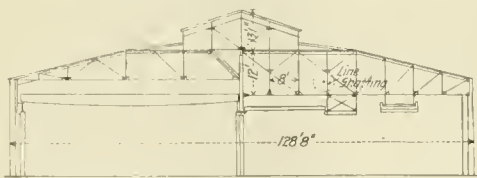

Section Through Locomotive Repair Shop.

line shaft. Outside the building and opening into it is the line rattler.

In the car department the machinery is grouped in the mill portion, which is 100 ft. long and driven by a 15-h.-p. motor, the only other motor in this building being one of 40 h.-p. for the fan system. There are 13 tracks in the car repair shop, and five in the paint shop. At the end of the building three rooms are partitioned off for upholstery, paint mixing and varnishing. For convenience the axle and wheel work for the car department is provided for in the mill, and it is served by a track from the outside of the building.

The transfer table is 70 ft. long and is driven by a 50-h.-p. motor, which is capable of driving it at almost 5 miles an hour with its load. In the round house there are at present 19 pits, but the extension of this, and, in fact, all of the buildings, is provided for. The turntable is 70 ft. long and it is to be driven by a motor.

Among the details worthy of notice is the arrangement of "Dutch" doors in all of the shops. The lower portions may be

opened to pass a truck and material without opening the entire door. All the roofs have 5-ply tarred paper, and tar with a heavy coat of gravel on top. The drainage of the grounds is admirable, as the elevation above the lake is nearly 20 ft. The main drain is 30 in. in diameter and the two branches 18 and 12 in. The roof drainage runs into 8-in. sewer pipes. These are placed in ditches about 5 ft. deep and 3 ft. wide, placed near the walls and filled with broken stone. No ice was found around the round house last winter, indicating the value of this method. The water supply is obtained from a 360-ft. well situated between the round house and erecting shop. From this the water flows through a siphon into a 30 by 30-ft. reservoir. The siphon is of 5-in. pipe and dips 30 ft. into the well and the same distance into the reservoir. It comes up to within 4 ft. from the surface of the ground. Special care was taken to secure light through a plentiful supply of skylights and clerestory windows. There are two lines of skylights on each side of each of the large buildings.

A description of the power house has been reserved for a subsequent article, when we shall fully describe the machinery in connection with the power house.

ALUMINUM AT PARIS EXPOSITION, 1900.*

The five international exhibitions held in Paris, since the first, in 1855, have served as landmarks in the history of aluminum. It made its first public appearance in the shape of a bar, lying on black velvet in a glass case, and labeled "L'argent de l'argile," "the silver from clay." That bar probably cost more than its weight in gold. The exposition of 1867 found an established industry to be represented. The metal was being sold commercially at the rate of \$12 a pound and to the quantity of 1,000 kilograms (1 long ton) a year. The important alloy with copper-aluminum bronze was then shown for the first time. In 1878 the exhibition marked only a moderate expansion of the industry. The yearly output had nearly doubled, but the selling price was the same. The 1889 exhibition marked a period of revolution in the industry. The yearly output had increased to 71 tons and the selling price of the pure metal had decreased to less than \$5 per pound; in fact, that very year it fell to nearly half that figure. The last year of the century finds the industry upon an entirely different basis. From an annual production of 70 tons it has risen to the relatively enormous figure of 7,000 tons; from a price nearly \$5 a pound to the almost incredible figure of 30 cents. Aluminum is now as really a metal of every-day life as silver, nickel, mercury, copper, brass, tin, zinc, lead or iron, though not to the same degree as several mentioned. In the United States, in 1898, only pig iron, copper, lead and zinc were produced in greater quantity than aluminum, and only pig iron, copper, lead, zinc, silver and gold surpassed it in value of output. When we wish to make a given object in metal, it can be made cheaper in aluminum than in anything else, excepting zinc, lead or iron; brass, copper and all the other metals are dearer.

It is said that the late Ulrich Eberhardt, the head of the firm of Gould & Eberhardt, machine tool builders of Newark, N. J., was made foreman of the shop while an apprentice and receiving but \$3.50 per week in wages. He spent his whole career in that one concern and never had a strike or any labor trouble.

Forced lubrication, consisting of pumping a circulation of oil to the bearings of stationary engines, was the subject of a recent discussion before the Manchester Association of Engineers. "The Engineer," in reporting the proceedings, mentions a 100-horse-power engine running at 450 revolutions per minute, night and day, for two years without any difficulty. In this case oil was forced into the bearings at a pressure of 25 lbs. per sq. in.

*From a paper by Prof. Joseph W. Richards, in Journal of the Franklin Institute.

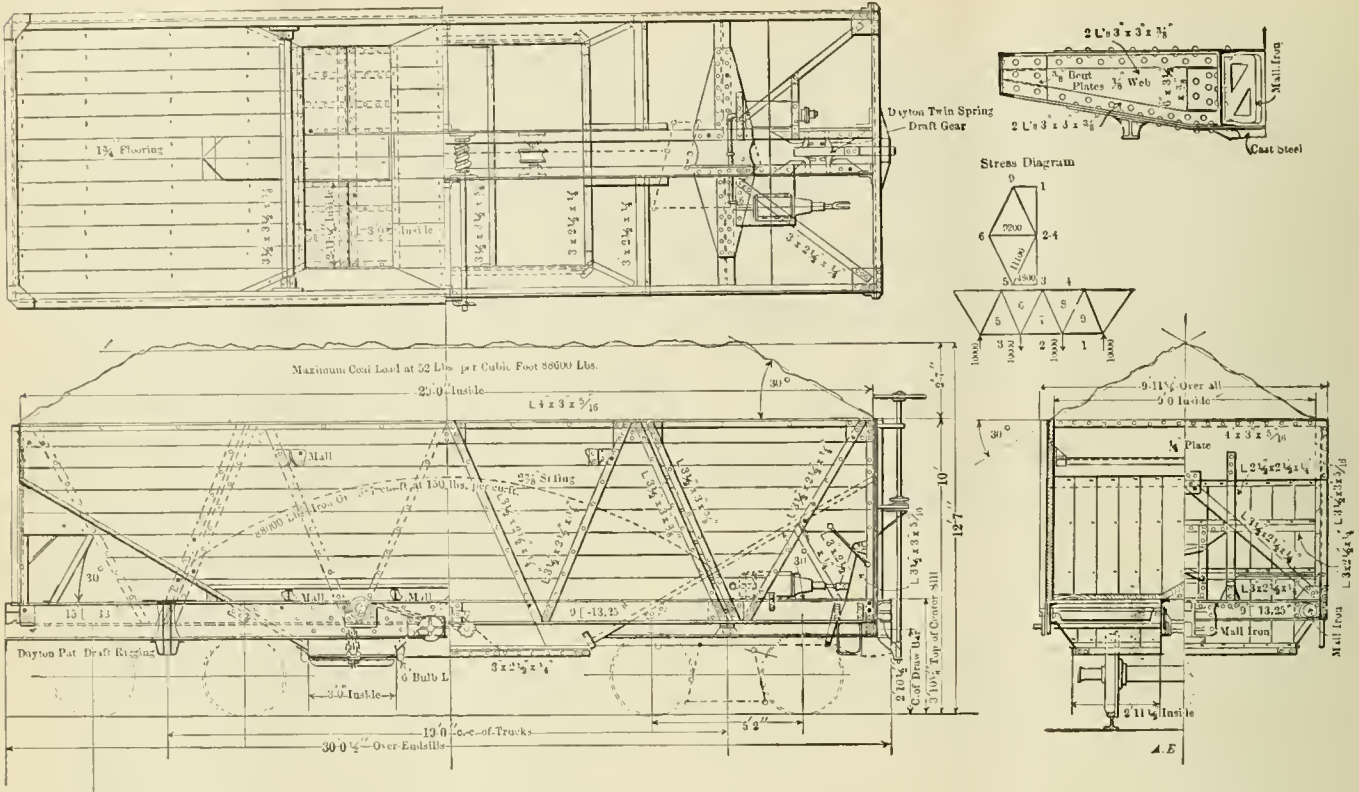

Forty-Ton Composite Coal Car.

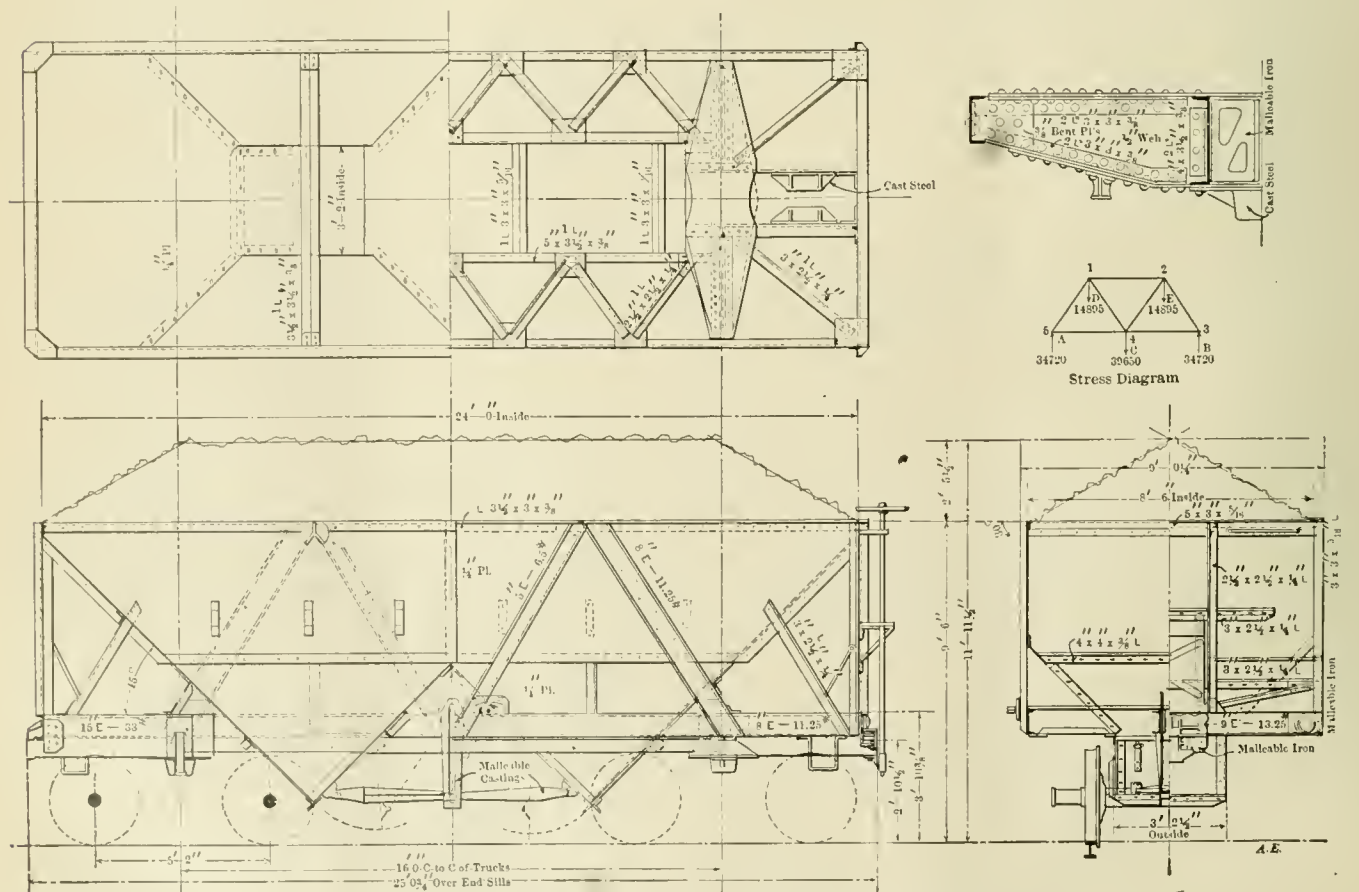

Fifty-Ton Steel Hopper Ore Car—Copper Range Railway.
New Cars with Trussed Sides—American Car & Foundry Company.

COAL AND ORE CARS.

The American Car and Foundry Company.

In the matter of distributing the loads among the members, steel car construction has usually followed the practice with wooden cars, the entire load being provided for in the underframe, the body or box being used merely to confine the load. The two coal car designs by Mr. C. A. Seley, of the Norfolk & Western Railway, illustrated in this journal in April, 1900, page 100, and February, 1901, page 42 were exceptions in that the sides were trussed to aid in carrying the load, and the success of these cars indicates the practice to be good. We are now enabled to describe two new designs by the American Car and Foundry Company, prepared under the direction of Mr. Geo. I. King, Manager of the Steel Car Department, which are built on this plan. One is an 80,000-lb. coal car which was designed for use on a large Western road, and the other a 100,000-lb. ore car for the Copper Range Railway. Both cars use structural shapes exclusively and both employ trussed side frames and built-up plate body bolsters, but the details of the underframes are very different. The cars are not heavy but there is no appearance of sacrifice of strength for the sake of lightness.

FORTY-TON COMPOSITE COAL CAR.

Designed for a Western Railway.

In this design the hopper sides and floors are of wood and the rest of the construction of steel. There are two 15-in. channel center sills, continuous from end to end, and two 9-in. channel side sills with trussed side frames of the Warren type of girder. In the drawings the sizes and sections of the various members are indicated. In a dotted line the height of a load of 88,000 lbs. of ore, at 150 lbs. per cubic foot is shown. The following table summarizes the general dimensions:

FORTY-TON COMPOSITE COAL CAR.
General Dimensions.

Length over end sills.....	30 ft. 1/2 in.
Length inside.....	29 ft. 0 in.
Height to top of side.....	10 ft. 0 ins.
Height to top of 30-degree load.....	12 ft. 7 ins.
Height to top of sills.....	3 ft. 10 1/2 ins.
Width over all.....	9 ft. 11 1/2 ins.
Width inside.....	9 ft. 0 ins.
Cubic capacity to top of sides.....	1,400 cu. ft.
Cubic capacity of 30-degree load.....	1,704 cu. ft.
Cubic capacity 30-degree load of coal at 52 lbs. per cu. ft.....	88,600 lbs.
Standard load limit.....	88,000 lbs.
Estimated weight.....	34,000 lbs.
Journals.....	.5 by 9 ins.
Total area of door openings.....	35.5 sq. ft.

In the calculations the following figures were used:

Base dead load.....	28,000 lbs.
Maximum live load.....	96,000 lbs.
Weight of trucks.....	13,400 lbs.
Deduct weight of wheels and axles.....	7,900 lbs.
Weight of truck above axles.....	5,500 lbs.
Gross body dead load.....	28,000 - 5,500 = 22,500 lbs.
Deduct for bolsters, etc.....	2,000 lbs.
Net body dead load.....	20,500 lbs.
Assumed live load.....	96,000 lbs.
Total static body load.....	96,000 + 20,500 = 116,500 lbs.
Add 50 per cent.....	58,250 lbs.
Final total load for calculation.....	174,750 lbs.
Load per cubic foot for calculation.....	103 lbs.

FIFTY-TON STEEL, HOPPER ORE CAR.

Copper Range Railway.

This car is built of steel throughout and is a novel arrangement for this service. The sides constitute a truss with 5 and 8-in. channels in the form of the letter M, with 3 1/2 by 3 by 3/8-in. top angles. Eight-inch channels are used for side sills and the center sills are not continuous between the bolsters. From the bolsters to the ends of the car are two 15-in. channels, between which the draft gear is placed. The whole structure gives the impression of being constructed from the standpoint of a bridge or structural engineer, who has a high regard for the holding capacity of rivets. Between the bolsters a floor system of angles is provided and the corners of the car are braced by angles. It is evident that the side girders

are depended upon to carry the main portions of the load and that the stresses of pulling and buffing will be received by the bolsters, end sills and side sills. The heavy construction of the bolsters is apparent in the drawings. It will be noted that the side sheets of this car do not extend down to the side sills.

Fifty-Ton Hopper Ore Car.
General Dimensions.

Length over end sills.....	25 ft. 3/4 in.
Length inside.....	24 ft. 0 in.
Height to top of sides.....	9 ft. 6 ins.
Height to top of 30-degree load.....	11 ft. 11 1/2 ins.
Height to top of sills.....	3 ft. 3/4 in.
Width over all.....	9 ft. 3/4 in.
Width inside.....	8 ft. 6 ins.
Cubic capacity to top of sides.....	907 cu. ft.
Cubic capacity to top of 30-degree load.....	1,127 cu. ft.
Maximum capacity, iron ore at 150 lbs.....	169,050 lbs.
Maximum capacity copper ore at 106 lbs.....	112,700 lbs.
Maximum capacity limestone at 85 lbs.....	95,795 lbs.
Maximum capacity coal at 52 lbs.....	58,604 lbs.
Standard load limit.....	110,000 lbs.
Estimated weight.....	30,500 lbs.
Journals.....	5 1/2 by 10 ins.

It is evident that the stresses have been carefully considered for the record of the design in this respect is included in the drawings. The assumed load is as follows:

Base dead load.....	32,000 lbs.
Maximum live load.....	120,000 lbs.
Weight of trucks.....	14,400 lbs.
Deduct weight of wheels and axles.....	8,400 lbs.
Weight of trucks except wheels and axles.....	6,000 lbs.
Gross body dead load.....	32,000 - 6,000 = 26,000 lbs.
Deduct for bolsters, etc.....	2,000 lbs.
Net body dead load.....	21,000 lbs.
Assumed live load.....	120,000 lbs.
Total static body load.....	= 120,000 + 24,000 = 144,000 lbs.
Add 50 per cent, or.....	72,000 lbs.
Final total for calculation.....	216,000 lbs.
Load per cubic foot for calculation.....	191 lbs.
Static load at end of bolster, plus 100 per cent.....	65,200 lbs.
Flange stress.....	182,500 lbs.
Stress allowed per square inch.....	15,000 lbs.

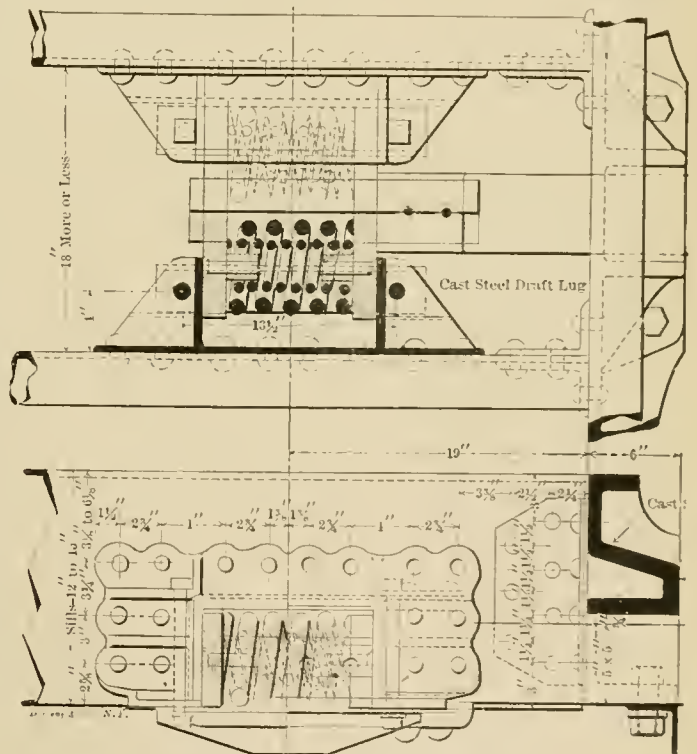

Twin Spring Standard Draft Gear.
Draft Gear.

For use in the construction steel cars of 30, 40 and 50 tons capacity these builders have designed a standard draft gear. This is a twin spring gear with cast steel draft lugs riveted to the webs of the center sills and adapted to a space of about 18 ins. between the webs, and to sills from 12 to 15 ins. high. The coal car illustrated in this connection was arranged with a view of using the Dayton Malleable Iron Company's draft rigging. The drawing of the standard draft gear illustrates the cross section of the cast steel end sill used by these builders; this, however, was not employed in either of the designs illustrated here.

(Established 1832.)

AMERICAN ENGINEER AND RAILROAD JOURNAL.

PUBLISHED MONTHLY
BY

R. M. VAN ARSDALE,

J. S. BONSALE, Business Manager.

MORSE BUILDING.....NEW YORK

G. M. BASFORD, Editor.

E. E. SILK, Associate Editor.

MAY, 1901.

Subscription.—\$2.00 a year for the United States and Canada; \$2.50 a year to Foreign Countries embraced in the Universal Postal Union.

Remit by Express Money Order, Draft or Post Office Order.

Subscriptions for this paper will be received and copies kept for sale by the

Post Office News Co., 217 Dearborn St., Chicago, Ill.

Danrett & Upham, 283 Washington St., Boston, Mass.

Philip Roeder, 507 North Fourth St., St. Louis, Mo.

R. S. Davis & Co., 346 Fifth Ave., Pittsburg, Pa.

Century News Co., 6 Third St. S., Minneapolis, Minn.

Sampson Low, Marston & Co., Limited, St. Dunstan's House, Fetter Lane,

E. C., London, England.

EDITORIAL ANNOUNCEMENTS.

Advertisements.—Nothing will be inserted in this journal for pay, EXCEPT IN THE ADVERTISING PAGES. The reading pages will contain only such matter as we consider of interest to our readers.

Contributions.—Articles relating to railway rolling stock construction and management and kindred topics, by those who are practically acquainted with these subjects, are specially desired. Also early notices of official changes, and additions of new equipment for the road or the shop, by purchase or construction.

To Subscribers.—The AMERICAN ENGINEER AND RAILROAD JOURNAL is mailed regularly to every subscriber each month. Any subscriber who fails to receive his paper ought at once to notify the postmaster at the office of delivery, and in case the paper is not then obtained this office should be notified, so that the missing paper may be supplied. When a subscriber changes his address he ought to notify this office at once, so that the paper may be sent to the proper destination.

The Standard Freight Car was advanced by the American Railway Association at the meeting in New York April 24 to a positively hopeful and promising position. Acting upon a committee report the association decided to ask the executives to take the necessary steps to change the traffic association's rules as to minimums in order to provide that there shall be no pecuniary advantage to any interest arising from the use of cars larger or smaller than the unit or standard car as recommended by the association. When this is accomplished the standard car will undoubtedly be adopted. This committee has done yeoman service and its report goes to the roots of the difficulties in a concise review of the movement. It was shown that of all the box cars in the United States but 4.1 per cent. are more than 36 ft. long. Cars 34 ft. long constitute 50 per cent. of the whole, and this compels action which will not place so large a number of cars at a disadvantage. The proposed standard car is 36 ft. long, 8 ft. 6 ins. wide and 7 ft. 6 ins. high, all inside dimensions. It is proposed that this car, with a cross-sectional area of 63.75 sq. ft. and a capacity of 2,295 cu. ft. shall be the unit of classification minimums. In order to provide for the 34 ft. cars, it is proposed that a minimum be established for their use which shall employ their capacity on the basis of a length of 34 ft.; width, 8 ft. 6 ins.; height, 7 ft. 6 ins. Cars more than 36 ft. and less than 34 ft. will be placed at a disadvantage and relatively uneconomical to the shipper. Appreciating the importance of the subject the association wisely urged the treatment of the minimums co-operatively by the various associations in such a way as to permit of taking advantage of modifications and changes which may be suggested during a period of six months. There is good reason to hope that the concluding arrangements for the standard box car may be made at the October meeting of this association.

Considerable trouble has been experienced from the use of steel castings, but there is, nevertheless, an increasing demand for them to replace those of iron, wherever an increase in strength is desired without increasing weight. No better example of this can be given than in the present problem of the design of a locomotive. The failures that have been experienced with steel castings have come chiefly from large and comparatively thin castings, as in the case of the frames of a locomotive. Many castings are sometimes made of long and poorly designed frames, in order to get a few good ones; this is due to the comparatively large shrinkage and to the absence of any movement of the castings in the sand. The molds are packed very hard for such work, and this causes the metal to pull away from the weakest point before it is cooled sufficiently to have much strength. Even frames made in two parts are not always reliable on account of the frequent occurrence of honeycomb; but with the proper care in making the mold so that the gases may pass off, and in pouring the metal from a proper height to give a pressing action as it enters the mold, this trouble is considerably decreased. A matter of most importance to the successful steel casting is in the design, avoiding altogether the bringing of a large mass of metal next to a thin part. The design should be prepared with reference to the peculiarities of the metal as well as for the work it is intended to do. By keeping a uniform section throughout the design, no trouble is experienced in the separation of the thin parts from those of greater section. Also with better foundry practice there seems to be no reason why much of the time and expense of machining can not be saved by turning out good steel castings. One of the prominent iron and steel companies manufactures shells for the Government that are cored out close enough to stand the rigid Government inspection and tests, which requires a casting that is almost perfect. The only finish put on the inside of these shells is a little grinding; the outside, of course, being turned and finished. On the recent class "J" passenger locomotive of the Lake Shore & Michigan Southern Railway about 28,000 lbs. of cast steel were used in the details of the engine, including the equalizers, foot plates and a number of parts usually made in forgings. While much has been done to develop cast steel in the last few years, there is reason to expect still more in the future from better foundry practice, and the use of steel castings will increase until the use of cast iron and forged wrought iron will be exceptional. In the matter of design we present in this issue a drawing of a locomotive frame suggesting forms for the cross sections upon which we shall be glad to have criticisms from our readers.

THE M. C. B. ASSOCIATION AND STEEL CAR DESIGN.

In the matter of steel car design the Master Car Builders' Association has thus far been little more than an interested spectator. The subject has several times come before the association in the way of committee reports, but of definite action in the form of suggestion and guidance there has been none. Up to the present time the development of steel cars has been in the hands of a few railroad men and the car builders. Perhaps this is well because of the rapid development which results from individual efforts of this kind, unhampered by limitations except those imposed by commercial conditions. Certainly the progress has been great and the results satisfactory, but it cannot be possible that there is no way in which the association can help at this stage even if it could not before. There are certain principles in car design which the association might state clearly as representing the opinions of those who maintain and operate the cars and these would probably exert a wholesome influence upon the designers and ought to prove beneficial. For example, it would be well for the association to go on record definitely with reference to the matter of supporting the entire loads upon the center plates. It would be well to know the opinion of the association with regard to the desirability of placing a portion of the load upon the side bearings. In the

matter of underframes definite action with reference to the arrangement of the sills with regard to the disposition of draft gear stresses would be very valuable just now. If it is necessary to supply a continuous draft gear by means of continuous center sills it would be wise to state the need plainly and if an arrangement of sills and bolsters whereby these stresses may be transmitted through riveted connections is admissible in cars of large capacity this should be recorded. Almost all the designs of steel cars have been arranged with a view of dispensing with truss rods, but it is by no means certain that this is the most desirable course. Another question as yet unsettled is whether or not the floor system should always be made strong enough to support the entire load independently of other parts. Should all cars be built like flat cars with a floor system sufficient for the load upon which to build gondola, hopper or box car structures, or should the sides of these cars be made in the form of trusses with a view of partaking in the duty of carrying the load? Good work may be done in a discussion of this question because it will have a vital influence on the future of car construction. In fact, all of these questions are important and there can be no doubt that the opinions of the master car builders would be the means of saving many steps in the progress of the steel car. It will doubtless be necessary to express the opinions tentatively because of the uncertainties of the paths of development, but as a guide to the workers in this field the association should at least discuss some of these questions. Unless we mistake the feelings of several prominent members some such suggestion as this will come before the next convention.

MOMENTUM THEORY OF BOILER EXPLOSIONS.

The statement is often made that if boilers are sufficiently strong they will not explode. It is generally believed, and is probably true, that boiler explosions result from weakness, but it is not safe to say that the strongest boiler possible to be made will not under certain conditions explode.

It is not long since these disasters were always mysterious, and even now one cannot say that all the mysteries have been explained. For example, why should the bursting of one boiler of a battery sometimes cause all or nearly all in the battery to explode, as sometimes occurs. This is not understood, and because of the difficulties of experimental study along this line it may never be understood. A very pertinent suggestion was recently offered editorially in "The Engineer," concerning the momentum of explosion of heated water in which an enormous amount of energy is stored. In a closed vessel the explosive energy of highly heated water is held in check by the pressure resulting from the confinement of the boiler. The argument is this: Given a tube held on end, one half filled with water at a temperature of 358 degs. F., the other half being filled with steam of the same temperature and with a total pressure of 150 lbs. Let a jet of cold water be injected into the steam space. It will condense the steam instantly and beyond question the moment the pressure is annihilated a portion of the hot water will explode into steam.

"The received idea is that there would be an instantaneous rise of pressure which would effectively prevent the further conversion of water into steam. In a word, the explosion would be stopped half-way. Is this a certainty? We venture to think that it is not; and to us it is quite conceivable that the momentum—if we may use the word—of the conversion of heat energy into mechanical energy would suffice to continue the operation, with the result that the cylindrical vessel would be burst. This result has, indeed, been obtained in another way by direct experiment. There are experiments tending in the same direction on record with a similar ending, but unfortunately, for some reason not known, the experiment may fail fifty times and then succeed. There is very good reason to believe that there is much more than appears at first sight in the theory of momentum of explosion."

If it is a fact that heated water once vigorously started

in the conversion of its heat energy into mechanical work will continue in its course until something gives way, we have an explanation of many hitherto mysterious explosions, and the theory appears to be reasonable.

PRACTICAL ALTRUISM IN THE SHOP.

During the past few years there have been so many prominent examples of successful business enterprises which have been obviously benefited by systematic efforts to improve the relations between the employer and the employed that the movement cannot fail to have been noticed by everyone, but probably few realize its general character and wide scope. There seems to be a marked reaction from previous conditions in this respect which is fast assuming noteworthy proportions. Efforts to render employment attractive and surround workmen with an atmosphere which speaks of a regard for the personal comfort and conveniences of men are being put forth in a businesslike way in various parts of the world, and the tendency is toward a feeling of greater responsibility over the lives of those who work with their hands. It is not believed that the motives are always entirely disinterested, but whatever the motive, any observer may see in different directions a desire to build comfortable, healthful, cheerful and well-lighted shops, and put a little moral responsibility into the relations between men.

There has been a good deal of this for years in such organizations as Krupp's in Germany, in various other large foreign industries and on the French railways; the idea is not new, but it is now taking a prominent place in the policies of many enterprises. We make no comment upon the methods, comparisons of details or criticisms of various effects produced by different plans, but it is to the general principle that better work is done by comfortable, contented workmen that we wish to draw attention. Never before has such attention been given to the heating, lighting and ventilation of shops and the arrangement and equipment of toilet conveniences, and in large railroad shops these factors are now so prominent that the matter calls for examination and comment. A workman in a shop where absolutely nothing is done for his comfort does not fail to become impressed with the fact that he is there for what may be got out of him and it must have its effect upon his work. As he is supposed to be a reasonable being it is fair to expect that he will respond equally to that which will put a little of something besides the mere money-paid-for-work-done idea into the relations between the parties concerned.

Some of the examples noted here may be considered unusual and extreme cases, and, perhaps, some may have been criticised already, yet they all stand for an established principle. The Browne and Sharpe, of Providence; Sherwin-Williams Co., Cleveland Hardware Co., Cleveland Twist Drill Co.; the T. B. Laycock Manufacturing Co., of Indianapolis; Acme White Lead Co., of Detroit; Gorham Manufacturing Co., Joliet Steel Works, Cleveland Cliffs Iron Co., Ishpeming, Mich.; the Draper Co., of Hopedale, Mass.; the National Cash Register Co., of Dayton, O.; the Acme Sucker Rod Co., of Toledo, and the Crane Co., of Chicago, are examples of the principle worked out in different ways, and the testimony is universally favorable to the idea. In these establishments it appears to be the rule that the grade of workmen is improving, and in some there are even "waiting lists" for ordinary unskilled labor. There must necessarily also be a corresponding improvement in the product, quality as well as quantity. The plans at most of these establishments include methods of supplying noonday lunches, well cooked and attractively served at nearly exact cost, the company furnishing the equipment and dining room, paying the cooks and providing time for the necessary number of waiters from the shop force.

It is easy to go too far and overdo an idea of this kind and no doubt this will be done, perhaps it has already been done in some cases, but this will be the exception which proves the rule, and a movement which is so sensible, profitable and right

must continue. In railroad service it has taken the form of Y. M. C. A. privileges, reading rooms, club rooms, hospital facilities, pension systems and improved conditions of the shops themselves and their surroundings. Of the efficiency and value of the railroad Y. M. C. A. the late Cornelius Vanderbilt said:

"I have for many years felt the deepest interest in this work and believe that its importance can hardly be overestimated, both to the men and the companies in whose service they are. It educates and spiritualizes; it promotes economy and thrift; it brings railroad men together with surroundings and discussions which produce the happiest results to themselves, their families and their employers."

Recent plans for new railroad shops which have come before us always indicate an increasing tendency in this direction. One of them, in addition to a good locker house with an individual clothes locker for every man in the plant and good toilet rooms, provides for a club house exclusively for the employees, to be built in order to provide a suitable place for the men to spend their noon hours and other leisure moments. In another case, where the shops are in the midst of a "shop town," the railroad company has interested itself in the village itself, in the equipment of water works, the laying out of streets, the planting of trees and many other things which will tend to attract men there and create the desire to own their homes, to become permanent. This shop has been troubled with floating men, men without families who were not content to stay anywhere more than a short time. It may become entirely different when the town is made attractive as a place to own a home.

Each case has its own peculiar conditions. Probably little that is applicable in one place may be copied from another, but there is every reason to believe that the comfortable shop and sensible way of dealing with shop employees on a strictly practical and intelligent basis will promote the best interests of the employer and earn the largest returns. It is good business policy.

CORRESPONDENCE.

RATIOS OF TOTAL WEIGHT TO HEATING SURFACE.

To the Editor of the American Engineer:

The article on page 89 of your March, 1901, issue contains considerable food for reflection. In the first place, while the relation of heating surface to weight is undoubtedly an important one, yet I am not sure but that a more valuable comparison for guidance in design, exists in the relation between heating surface and horse-power. The former comparison unless due weight were given to other factors, might at times prove misleading. What is required is a certain amount of tractive power and a boiler capable of maintaining it at the desired speed and with the desired train weight. After sufficient weight has been obtained for the desired co-efficient of adhesion, a good designer will cut off every pound of superfluous weight possible in connection with proper strength and life of the remaining machinery.

Referring to the table contained in the article in question, to show how this comparison may be misleading, it is probable that the compounding of the Lehigh Valley Engine No. 681 added about 10,000 lbs. to the total weight, over the weight of a simple engine of equivalent cylinder power. If we compare it with other simple engines as regards the ratio of total weight to heating surface, we should deduct the weight due to com-

215,082
4,105
= 52.39. As the heating surface of a compound engine is probably about 20 per cent. more effective, due to use of a less quantity of steam and better distribution, than the heating surface of a similar simple engine, it would probably be more accurate to increase the heating surface by 20 per cent. before obtaining the ratio; this would give $\frac{225,082}{4,105 + 821} = \frac{225,082}{4,926} = 45.7$ for the Lehigh Valley engine No. 681, and for the Baltimore & Ohio engine No. 1,450, $\frac{150,000}{2,663 + 533} = \frac{150,000}{3,196} = 46.93$.

It would appear from this that a comparison of ratios between total weight and heating surface is not always a true index of the merit or demerit of the design of an engine, if no account is taken of other factors which may have a very important bearing on the case.

Another train of thought started by this article was the relation between tube heating surface and firebox heating surface. I enclose a table in which is given the ratios for the engines shown in the table on page 90 of the same issue, and for an additional Atlantic type, and 10-wheel engine. The table also contains the ratios between tractive power and total heating surface, the actual heating surface in compounds being increased by 20 per cent.

Road.	Engine number.	Flue heat. surface.	Firebox heating surface.	Total heat. surface.	Total heat. surface corrected for comp'd gr.	Ratio F. H. sur. F. B. H. sur.	Tractive power.	Ratio Tractive power, total H. sur.
N. Y. C. & H.....	2,980	3,298	180	*3,478	18.32	24,674	1.095
L. S. & M. S.....	650	3,163	174	3,343	18.21	25,000	7.478
C. & N. W.....	1,015	3,817	199	3,016	14.15	22,100	7.328
L. V.....	681	3,890	215	4,105	4,926	18.19	48,400	9.826
B. & O.....	1,450	2,513	150	2,663	3,196	16.75	22,000	6.884
B. C. R. & N.....	77	2,396	156	2,552	15.26	23,400	9.170
P. R. R**.....	820	2,102	218	3,320	9.643	21,500	6.486
L. V.†.....	673	2,631	167	2,798	15.75	22,100	7.898
L. V.‡.....	801	2,533	172	2,708	3,250	14.74	28,200	8.677

*Heating surface, water bars omitted.
 †Figures given in original do not agree with previous description.
 ‡Atlantic Type; principal dimensions same as C. & N. W. engine No. 1015; total weight, 157,000.
 †See Railroad Gazette, December 28, 1900.

A large ratio would seem to indicate a small firebox in comparison to the tube length, while a low ratio would indicate a large firebox in comparison with the length of flue. It would be exceedingly interesting to know what the effect of varying the flue length and size of firebox would be on combustion and evaporation, and what would be the proper proportions between size of firebox and length of flue. This proportion with fireboxes of the same general type would be indicated by the ratio between the two heating surfaces. In a general way, it would seem that a very large box with short flues, while permitting of very thorough combustion, might have a heat loss through insufficient tube surface to absorb all the heat. On the other hand, with the other extreme, on account of the small cubic capacity of firebox and rate of combustion, there might be a loss due to the lack of space for air to mix in the proper proportions with the volatile matter of the fuel before the gases have cooled below the ignition point, or escaped from the stack. As the wider the type of firebox, the greater the weight per lineal foot of the firebox; and as the longer the flues, the greater the total heating surface; then the higher the ratio between flue heating surface and firebox heating surface, the less will be the weight of the engine per foot of heating surface, and the lower the ratio of tractive power to heating surface. This seems to be another reason why the judging of a design by the weight per square foot of heating surface, without taking into account modifying factors, would be misleading.

If the foregoing has any value, by referring to the table it would seem that the Baltimore & Ohio engine, with about an average ratio between tube and firebox heating surfaces, only has to furnish 6.884 lbs. of tractive power for each square foot of heating surface. The tractive power given is, of course, the maximum at slow speed. As the most economical point of cut-off (which should be the working point) is a certain percentage of the stroke (somewhere near 25 per cent.), the working tractive power is directly proportional to the maximum; so that the maximum tractive power can be used to a certain extent for purposes of comparison.

This basis of comparison, like the formulas determined by the Master Mechanics' Association, contains only one factor, the working force. This factor alone, without considering speed, with which the problem is so intimately connected, is of very little real value for accurately determining the correct proportions of a boiler. If, however, we combine the working force with the speed or rate of working, we then have the power. As the boiler must furnish a certain amount of power, or an amount of energy sufficient to perform a certain amount of work in a given time, it becomes apparent at once that the real basis from which the amount of heating surface should

be computed is the maximum power, and that the total heating surface of any boiler is the product of a constant, times the maximum power demanded by the service. If we take for the unit of power, a horse-power, the formula for heating surface becomes of the following form:

Total heating surface = constant \times maximum horse-power.

The maximum horse-power is easily found from the formula:

$$\text{Maximum horse-power} = \frac{\text{maximum speed} \times \text{tractive power}}{375}$$

375

The maximum speed being in miles per hour, and the tractive power being the working force necessary at the given speed, with given weight of train, and in connection with the profile of the road on which the engine is to be used. There are many well-tried formulas for the calculation of necessary tractive power under any conditions. The resistance per ton weight (of 2,000 lbs.) of train and engine for a grade is, of course, $R = .3788$ lbs. per foot rise per mile. The Baldwin formula for resistance

due to speed is accurate and simple: $R = 3 + \frac{V}{6}$, $V =$ speed in

miles per hour.

Their allowance for average curvature is the resistance due to 1.5 ft. grade per mile per degree. The sum of all resistances, times the total weight, is the total resistance which must equal the tractive power.

Of course these ratios and constants for comparison only hold good for the same general type of firebox, and a grate surface of sufficient area for the proper combustion of the class of fuel used. All of the engines in the table have a width of firebox greater than the over-all width of frames. It would be of little value to compare them in this manner with an engine having a deep narrow firebox; where, a low ratio of firebox heating surface to tube heating surface, a low ratio of tractive power to total heating surface, and a low weight of engine per square foot of heating surface, is obtainable. The best ratio of firebox heating surface to tube heating surface will probably be found to vary with the class and quality of fuel. A poor fuel, or a slow-burning fuel, such as anthracite coal, requires a larger grate surface than a free-burning bituminous coal. A large grate means a large firebox, with a proportionate reduction in total heating surface.

For purposes of comparison, and for a check in design, we need to have established the following ratios:

1. Ratio of flue heating surface to firebox heating surface.
2. Ratio of total heating surface to maximum horse-power.

Each of these ratios should be determined separately for the following conditions:

1. Wide firebox—slow burning bituminous, with high percentage of fixed carbon.
2. Wide firebox—rapid burning bituminous, with high percentage of volatile matter.
3. Narrow firebox—same fuel as in No. 1.
4. " " — " " " No. 2.
5. Wide " —anthracite.
6. Narrow " — "
7. Wide " —fine anthracite and bituminous.
8. Narrow " — " " " "

The proper allowance of the heating surface for compounds in per cent. that should be added to the actual heating surface for purposes of comparison, should be determined for use in connection with the above ratios. This work falls most properly in the sphere of the Master Mechanics' Association, and it is suggested that it be made a subject for the 1902 meeting.

The weight of engine per square foot of heating surface, for the same types and conditions, would then be an interesting and valuable quantity—to be kept as low as strength and durability will permit.

F. F. GAINES,
Mechanical Engineer,
Lehigh Valley Railroad.

The Crane Company, of Chicago, manufacturers of valves, fittings, etc., in order to increase their office facilities, will erect a modern fire-proof office building, five stories high and basement. The building will be 90 by 100 ft., and located in the vicinity of its large cast iron, malleable fittings and valve works, at Canal and 12th streets.

FOUR NEW TRAINS FOR THE "LAKE SHORE LIMITED."

The latest art in car building is to be seen in the four very elegant new trains built by the Pullman Company for the Lake Shore Limited and placed in service April 3. No effort or expense have been spared to place all of the modern comforts and conveniences at the command of the traveling public. A particularly noticeable feature in the furnishings of the cars is the absence of all heavy carvings, ornate grilles and metal work, stuffy hangings, etc.; the simplicity and quiet elegance of design, combined with the beauty of the natural wood, being relied upon entirely for decorative effect.

The trains are lighted throughout by electricity furnished from an engine and dynamo in the baggage car. The smoking and observation rooms have side reading lamps placed in a convenient location; also each section of the sleeping cars is provided with a reading lamp. Over the tables in the dining cars are side lamps and in all cars are center lamps with four 16-c.p. incandescent lights. These trains are made up of a baggage car, buffet library smoking car, dining car, three drawing-room and state-room sleeping cars and an observation compartment car. The buffet library smoking car contains a spacious smoking room, seating thirty persons, equipped with easy chairs, a library equipped with standard literature and all of the best class of periodicals, a completely appointed barber shop and bath-room, a writing desk with suitable stationery, and a buffet from which light refreshments are served. The dining car has five double tables seating four persons each and five single tables seating two each. These cars are very attractive, being finished in choice Santiago mahogany. The sleeping cars contain twelve sections and a drawing-room and a state-room, the rooms are connected by folding doors, so that they may be used separately or en suite. Ample toilet facilities are provided for both men and women. These cars are finished in vermilion wood and marquetry. The observation car has eight compartments, finished in mahogany, Circassian walnut, satinwood and prima vera. The large observation room is finished in vermilion wood and equipped with comfortable chairs, sofas and a writing desk. The services of an expert stenographer can also be procured on this car, free of charge. A large observation platform affords an exceptional opportunity to view the passing scenery.

These trains make daily trips eastbound from Chicago and Cleveland to New York and Boston via the Lake Shore & Michigan Southern, New York Central and the Boston & Albany Railways; and westbound from New York to Cleveland, Chicago and St. Louis via New York Central, Lake Shore and Big Four Railways.

"The Duties of a General Manager" was the subject of a very interesting and instructive address by Mr. L. E. Johnson, General Manager of the Norfolk & Western Railway, before the engineering students of Purdue University, April 8th. After describing briefly the organization of a railway, the character of the business which reaches the office of the general manager was discussed in detail. Some amusement was caused by incidents arising in connection with claims, and by exposing the record of a single day's work. Mr. Johnson convinced his student audience that the office of a general manager was not a sinecure. During the week ending April 20th Mr. William Kent, of New York, delivered a lecture each day before the seniors in Mechanical, Civil and Electrical Engineering. The subjects were of his own choosing, as follows: Monday, "Steam Boiler Economy"; Tuesday, "The Iron and Steel Industry"; Wednesday, "The Organization of a Manufacturing Establishment"; Thursday, "Some Engineering Problems"; Friday, "Some Elements of a Successful Engineering Career." On Wednesday afternoon he delivered a more formal address before juniors and seniors of the three schools of engineering, upon the subject of "Engineering and Economic Science."

STEEL CARS BY THE AMERICAN STEEL FOUNDRY COMPANY.

A number of types of steel cars have been designed by the American Steel Foundry Company of St. Louis, and arrangements have been made at the works at Granite City to build them in competition with other builders. The three engravings presented here illustrate the exterior appearance of a



110,000-Pound Capacity Hopper Car—Chicago & Alton Railway.

hopper car of 110,000 lbs. capacity for the Chicago & Alton, a drop bottom gondola of 80,000 lbs. for the El Paso & Northeastern and also a test weight car for the Chicago & Alton. The Delaware & Hudson has also received a number of 80,000-lb. cars exactly similar to this drop bottom gondola. Detailed descriptions of the under-frames and structural features are not available at this time. Standard rolled steel shapes and plates are used throughout, the cars, except the scale weight car, being mounted on steel trucks as made by these builders.



80,000-Pound Drop Bottom Gondola—El Paso & Northeastern Railway.



Test Weight Car—Chicago & Alton Railway.

having cast steel truck bolsters and special channel shaped arch bars.

The gondola car has substantial center sills of plates and angles, the depth at the center being 22 in., tapering at both ends. This construction permits of securing the desired depth of the sills at the center without interfering with the truck, while the draft gear is placed between the center sills. The floor plates are laid on Z-bars placed between the center sills and side plates. At the side the floor plates have additional support from angles riveted to the floor and side plates. These angles tend to stiffen the sides and to form a plate girder at the lower edge of the side plates to take the place of side sills. The bolsters are built up and riveted to the center sills which are not cut. Angles in the form of stakes are riveted to the side plates as stiffeners. These cars have four drop doors and small side doors through the side plates at each end. The gondola cars of 40 tons capacity weigh 31,000 lbs. empty.

Hopper cars without continuous center sills are novel. These cars for the Chicago & Alton are built in this way, the hopper being entirely free from obstructions inside

and the load is carried at the sides by a plate girder 30 ins. deep, with angles at the top and bottom. These girders extend the whole length of the car. The side plates of the hoppers are riveted to these girders, forming a strong arrangement. Side stakes of angles extend from the top of the sides to the bottom of the plate girder, passing the upper girder angles by offset bends. At the center of the car substantial stiffening is secured by a partition or bulkhead across from side to side, dividing the interior of the hopper in the center. The end structure is substantially braced and the draft gear is placed between short center sills which do not pass through the hopper ends. No special effort was made to secure light weight, these cars weighing, empty, 41,200 lbs.

Mr. A. J. Hitt, General Superintendent of the Chicago, Rock Island & Pacific, has been appointed General Manager, with headquarters at Chicago, effective May 1, 1901.

TANK WELL AND STRAINER.

In looking over the tenders of the new passenger engines built by the Brooks Locomotive Works for the Lake Shore & Michigan Southern Railway this tank valve and strainer was noticed, and while it is not new, its good features warrant its presentation here. This design was developed by Mr. John Player on the West Shore road a number of years ago. It combines a settling basin for mud, a tapered valve which will not lock, a large cylindrical strainer and a casing with an eas-

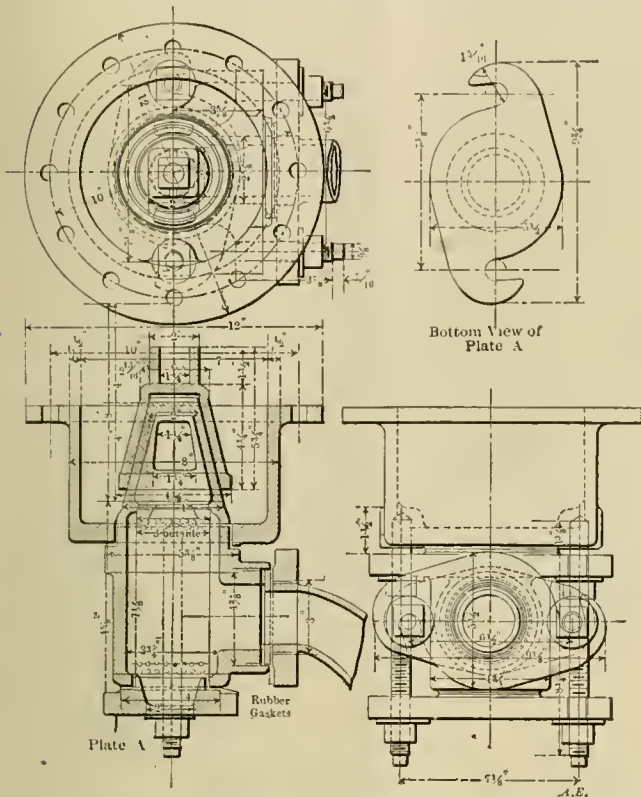

Tank Well and Strainer.

ily removable plate at the bottom. This plate may be taken off without even removing a nut. The nuts are slackened and the plate turned slightly, when the plate and strainer will come down for cleaning. The strainer has a large area, and in practice does not seem to choke the passage of the water. This design has been used extensively by the Brooks Locomotive Works.

The Celtic, launched last month, has, says "Engineering," the distinction of being the largest ship in point of tonnage that has yet been built; although in point of speed she is excelled. The Celtic represents a distinctly interesting type, which promises a large financial reward; for, with her speed of from 16 to 16½ knots, her coal bill will be very much less than that of many of her competitors on the Atlantic, while, at the same time, she is certainly not deficient in any of the comforts provided on the faster ships. In order to attain the high speed, it has been found practically impossible to carry any cargo, whereas in the Celtic something like 13,000 tons of cargo may be carried, which, while adding to the revenue, almost of necessity means a steadier, and therefore a more comfortable, sea ship for passengers. The question, however, has its other side, and there can be no doubt that for advertising purposes the fast ship is a valuable acquisition, and provided, as is pretty certain, she secures the best of the traffic, the financial results need not be unsatisfactory. This view, we know, is not universally accepted, but the North German Lloyd are probably acting on an experience which was highly satisfactory, when they ordered a vessel to equal in speed their Kaiser Wilhelm der Grosse, and another to excel in speed even the 23.36 knots of the Deutschland.

PERSONALS.

Mr. George S. Morison, Civil Engineer, New York, has changed his address to 49 Wall Street, Room 1713 Atlantic Building.

Mr. G. W. Wildin, Mechanical Engineer of the Plant System at Savannah, Ga., has been appointed to a similar position with the Central Railroad of New Jersey, with headquarters at Jersey City, N. J.

Mr. F. W. Cox, General Machinery Inspector of the Baltimore & Ohio, has resigned to accept the position of Superintendent of the Milwaukee Electric Company, with office at 296 Reed street, Milwaukee, Wis.

N. O. Whitney, Professor of Railway Engineering at the University of Wisconsin, and formerly assistant engineer of the Pennsylvania Railroad, died at Madison, Wis., March 18, at the age of 42 years.

Mr. George F. Baer, President of the Philadelphia & Reading, was elected President of the Central of New Jersey, also, at a meeting of the board of directors of that road, on April 12, succeeding Mr. J. R. Maxwell.

Mr. L. E. Butler has resigned as General Foreman of the locomotive and car department of the Missouri Pacific at Kansas City, Kan., to accept a position with the United States Metallic Packing Company, of Philadelphia.

Mr. J. A. Carney, Master Mechanic of the Chicago, Burlington & Quincy at Beardstown, Ill., is appointed Master Mechanic of the Burlington Division, with headquarters at West Burlington, Ia. Mr. A. J. Cota, Air Brake Instructor, is appointed Master Mechanic at Beardstown to succeed Mr. Carney.

Mr. George Lovelace has been appointed Purchasing Agent and Acting Manager of the Peninsular Railway, with headquarters at Shelton, Wash., in place of Mr. A. Johnson, resigned. Mr. Lovelace was formerly Master Mechanic and is succeeded in that position by Mr. Charles A. Wiss, whose headquarters are also at Shelton, Wash.

Mr. James M. Barr, Third Vice-President of the Atchison, Topeka & Santa Fe, at Chicago, has been elected to the office of First Vice-President and General Manager of the Seaboard Air Line, and will have charge of the operation and traffic. Mr. Barr is 46 years of age and has a remarkably successful railroad experience extending over a period of 23 years.

Aldaice F. Walker, Chairman of the board of directors of the Atchison, Topeka & Santa Fe, died in New York, April 12th. Mr. Walker's connection with this road began in 1894, when he was appointed receiver of the company's property. After the reorganization Mr. Walker was made chairman of the board of directors and remained in this position up to the time of his death.

Mr. James Ashworth, General Foreman of the Louisville & Nashville at Corbin, Ky., has been appointed Master Mechanic of the South & North Alabama and Birmingham Mineral divisions, with headquarters at Birmingham, Ala. Mr. J. C. Carroll, Foreman at Bowling Green, Ky., is appointed General Foreman to succeed Mr. Ashworth. Mr. Carroll is succeeded by Mr. Louis Wellisch.

Mr. F. D. Underwood, Second Vice-President and General Manager of the Baltimore & Ohio, has accepted the position of President of the Erie to succeed Mr. E. B. Thomas, who will become chairman of the board of directors. Mr. Underwood was formerly for a number of years General Manager of the Minneapolis, St. Paul & Sault Ste. Marie, and on January 15, 1899, went to the Baltimore & Ohio as General Manager, and the same year was chosen Second Vice-President.

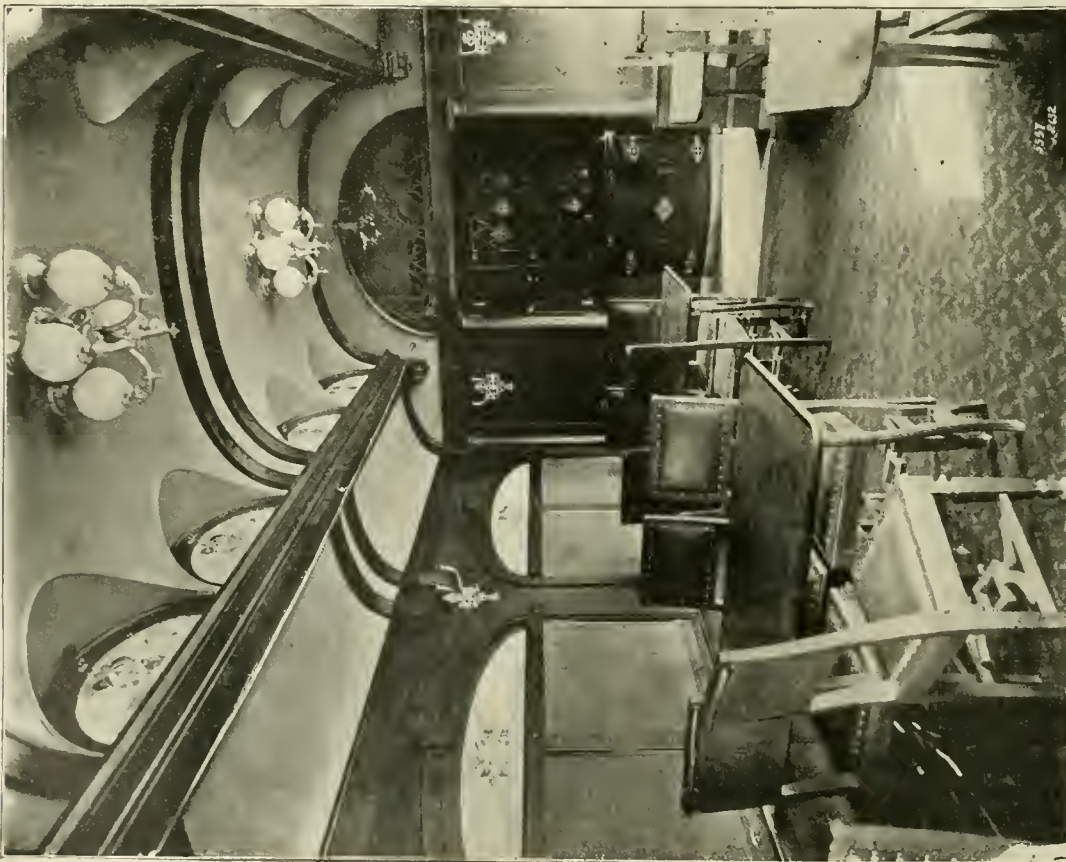
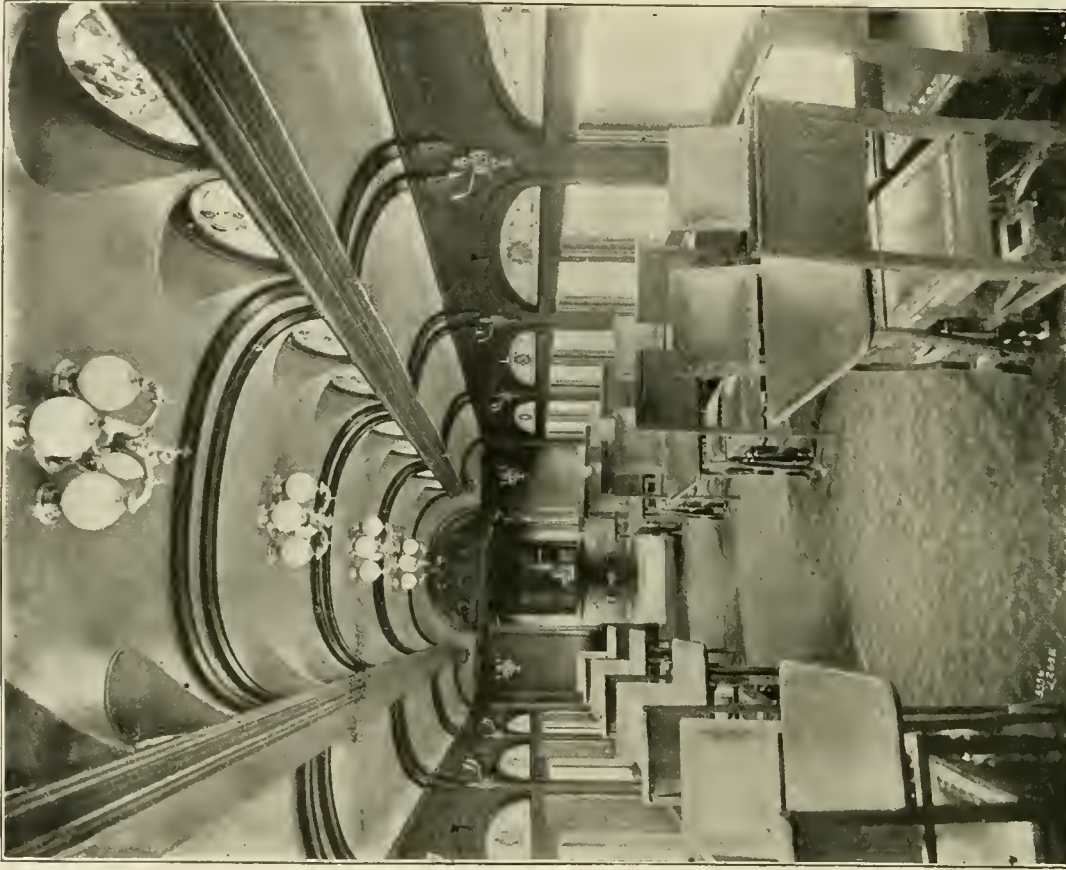

Interior Views of Dining Cars—Chicago, Burlington & Quincy Railroad.

These Engravings of the New Dining Cars for the Chicago, Burlington & Quincy Railroad, Supplement the Illustrated Description of these Cars Given on Page 116 of the April, 1901, Issue of this Paper.

HYDRAULIC SHOP TOOLS.

There is already a strong desire in railroad shops to replace steam hammers by hydraulic presses, for making large forgings. Many of the railroads are now manufacturing their own axles and the trouble experienced with such large work in the

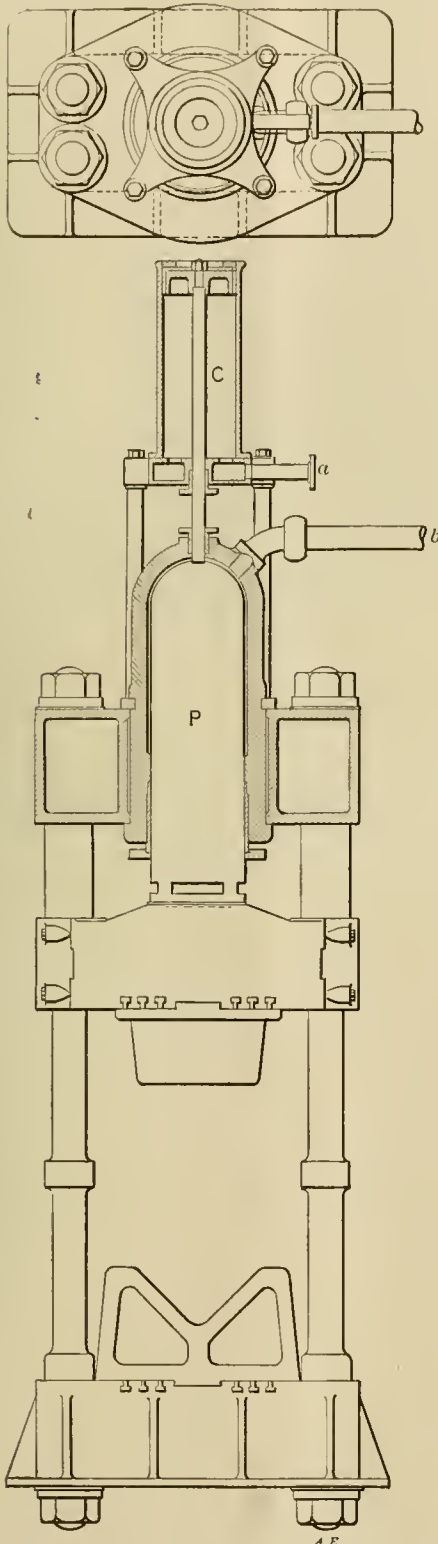

Heavy Shafting Press Suitable for Forging Axles.

use of the steam hammer is that the quick blows of the hammer affect the metal only near the surface, while the action of the press is that of squeezing, which extends through the whole mass, treating it uniformly, and the result is a much more satisfactory product. At the February meeting of the

Western Railway Club, Mr. G. S. Gillon, of New York, presented a paper on "Hydrostatic Tools in Railway Service," in the addenda of which is presented a heavy shafting press, designed by the Watson-Stillman Company, New York, in 1898, for an Eastern shop. Through the courtesy of Mr. Stillman we reproduce an engraving of this press, together with three other important hydraulic tools.

This same shafting press Mr. Stillman says is suitable for forging the standard M. C. B. axles. It was originally designed for low pressure and a long stroke, and is operated by a low-pressure pump with an air accumulator and high-pressure intensifier. The high pressure being used only on the working stroke; that is, the low-pressure pump moves the plunger to its upward position and the high-pressure acts only on the downward working stroke. The drawback cylinder marked C is single-acting, the water being forced into the cylinder through the pipe a, from the low-pressure pump, through an accumulator at a pressure of 150 lbs. per sq. in.

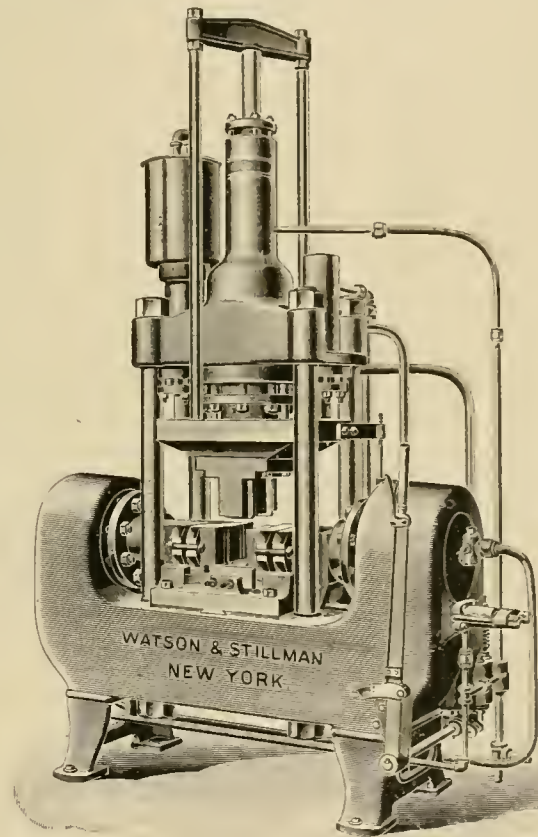

Triple Acting Forging Press.
With Independent Speed Cylinders.

The high-pressure drives the plunger P through a stroke of 16 ins. as often as 12 times a minute and exerts a pressure of 4,000 lbs. per sq. in. on the work. A more satisfactory set of valves and cylinders for operating such a press, in which the blows of the plunger can be made as frequent as the metal can be worked, is shown in the accompanying engraving, in connection with the triple-acting forging press. The movements of the plunger are all done by low pressure, the high pressure being thrown in, as the die is brought to the work, thus making a very economical machine.

This tool is itself a most valuable one for forging and is adapted to forming a large number of small articles from sheet and bar iron. There are three drawback cylinders for withdrawing the large rams, and two small cylinders placed between the rods. Besides the large reversing cylinder, speed cylinders are provided, their use permitting the employment of one high-pressure accumulator and at the same time using very little of the high-pressure water while passing through that position of the movement requiring little power. The

usual practice has been to use both high and low-pressure accumulators. The throwing of the high pressure into the large cylinder is done automatically and controlled by a collar on the valve rod at the right-hand side of the machine. The press is governed completely by special, four-spindle, balanced governing valves. To prevent improper forming of the bottom of a piece of work by too quick closing of the side cylinders, a restricted check valve is placed in each side cylinder, thus allowing free motion of the liquid one way and restricting as much as desired of the motion the other way. The press is packed from the outside under glands, avoiding the use of leather packings, as the iron parts are liable to heat by reason of the small amount of water used. This tool has a vertical movement of 8 ins. and a side movement of 1 in., each working up to 75 tons pressure. These cylinders and valves used in operating the plunger would be very satisfactory in operating such an axle press as illustrated in this article. The automatic feature would of course be abandoned and operated by hand. The expensive parts of these presses are the valves, but a hydraulic plant complete for forging axles can be installed for about \$5,000—not more than the cost of a 5,000 or 6,000-lb. steam hammer. English roads that are now using hydraulic axle presses claim that their percentage of losses is reduced as much as 40 per cent. by their use.

Axle Straightening Press.

This machine is designed with a traveling frame which runs on rollers bearing on the lower flange of the beams. The arrangement of the air pump is independent of the cylinder and is located upon a bracket fastened to the traveling frame, at a height from the floor convenient for operation. The ram has a vertical movement of 1 ins. and is provided with a rack and pinion for bringing it down to the work independently of the pump. In straightening car axles, and shafting of vari-

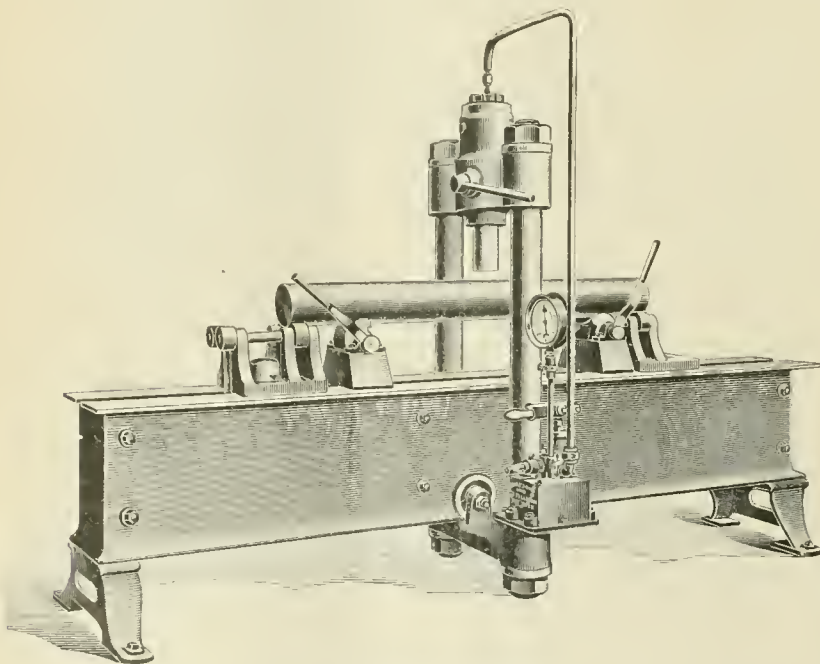

Axle Straightening Press.

ous lengths, the bending blocks and roller stands can be adjusted to any position on the beams. The rollers, when belted, revolve the work after it is dropped on the rollers, from the bending blocks, which are mounted eccentrically and bear

solidly on the beams when receiving the bending strains. The traveling frame permits the bending of a shaft at any place between the roller frames, and by moving the work endwise, a piece twice the length of the beams can be straightened. The maximum opening with a short end on the ram is 12 in., and by changing these ends any size bar can be bent.

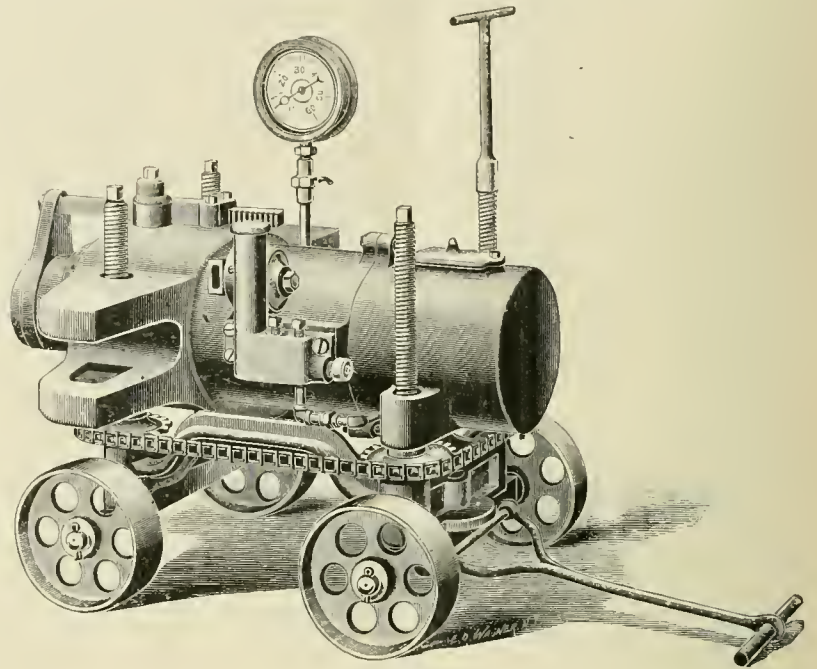

Improved Crank Pin Press.

Crank Pin Press.

To do away with any chance of springing a crank pin and forcing it home out of true, the improved press, of which an engraving is shown, was designed with its tension beam as close as possible to the work. The pump cylinders are placed immediately behind the beam and are similar in operation to a horizontal jack. To adjust the plunger and cylinders to the proper height for work, a socket wrench is used to operate the four elevating screws, placed at the four corners of the truck and all operated at one time by means of a chain passing around the four sprocket wheels. A rack and pinion, at the front of the cylinder, forces the ram up to its work, and hydraulic power is applied by the pump, which is operated by a hand lever inserted in a socket of the pump, located at the center of the press. The return motion or release of the pressure is accomplished with a small key wrench, used in the release valve stem, located a little to the right of the pump. All the larger parts of the machine are steel. The valves of the pump are made metal to metal, requiring no packing, and these are situated beneath the bonnets where they can be easily taken out for grinding or examination, when it is necessary. When pressing in crank pins, no extra appliances are required in connection with the press other than two rods and a pair of washers, but in pressing out crank pins a chuck 24 ins. long and a forcing pin are necessary.

Mr. T. R. Browne, formerly of the Pennsylvania Railroad, has pointed out in his article, on the Blacksmith Shop, page 187 of our June, 1898, issue, the advantage of hydraulic forging presses over hammer work in locomotive forgings, and has also described, on page 76 of our March, 1899, issue, the action of a very useful press for small work used at the Juniata shops.

EDWARDS VESTIBULE PLATFORM TRAP DOORS.

The typical features of the extension platform trap door illustrated in the accompanying engraving are: a torsional spring for opening and closing the door, an automatic device for releasing the catch, and a hinge running the entire width of the door. The spring is composed of two equal lengths of spring steel $\frac{3}{8}$ by $\frac{1}{4}$ in. and 28 ins. long. One end of the spring is held by the hinge, while the other end is fastened in a ratchet wheel contained in a bracket which is attached to the body of the car. By means of the ratchet wheel the torsion in the spring can be regulated to any required amount, so that the door, when the catch is released, will automatically open partially, or to a full vertical position, as desired. When in the latter position the least stress is upon the springs, and as the door is closed the torsion is increased. The weight of the door serves to give an almost equal stress of spring throughout any movement of the door. The device used in operating the catch is shown in detail and in the longitudinal section through the platform and trap door. A bell crank operated by a small movement of the pull rod located at the end of the vestibule, withdraws the catch and allows the door to open. The weight

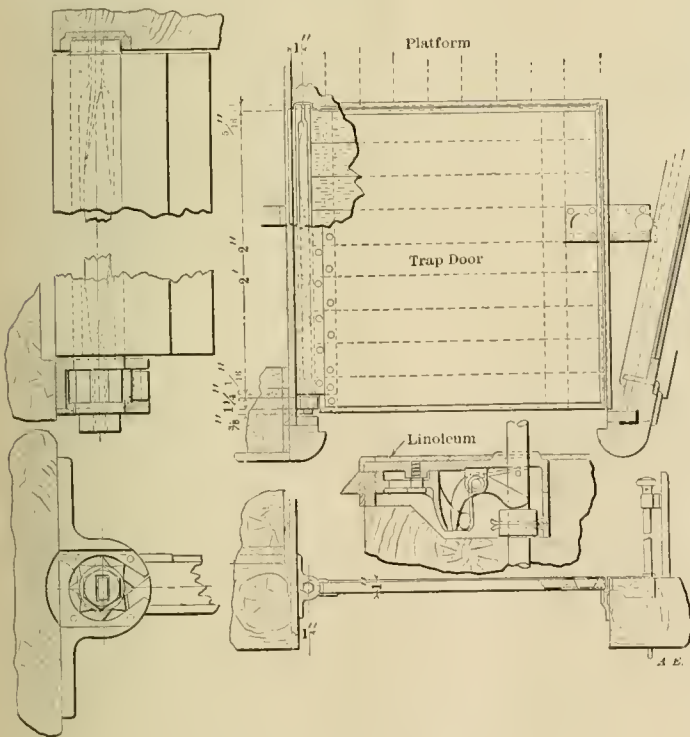

Extension Platform Trap Door.

of the pull rod, together with a spring bearing against the catch, returns it automatically to a locked position. One of several methods of applying the hinge to trap doors both with and without linoleum or rubber covering, is shown in the engraving. These trap doors have been applied to passenger cars on the Denver & Rio Grande; Southern; Ontario & Western; Atlantic & West Point; Lake Shore & Michigan Southern; Chicago, Indianapolis & Louisville; Baltimore & Ohio, and on cars now being built in the shops of the Barney & Smith Manufacturing Company, Pullman Palace Car Company and the American Car & Foundry Company. This showing speaks well for a device that has been upon the market for so short a time.

HOIST FOR REPAIRING PASSENGER CAR TRUCKS.

Lake Shore & Michigan Southern Railway.

The weight of truck frames of passenger equipment renders them exceedingly awkward to handle in the shop and they are built up of so many parts as to necessitate considerable work in overhauling. The accompanying engraving illustrates an air crane arrangement used at Cleveland at the shops of the Lake Shore & Michigan Southern, the drawing of which was received through the courtesy of Mr. W. H. Marshall, Superintendent of Motive Power. The device has been in use for several years and it has proved to be a valuable one which may be used to advantage elsewhere.

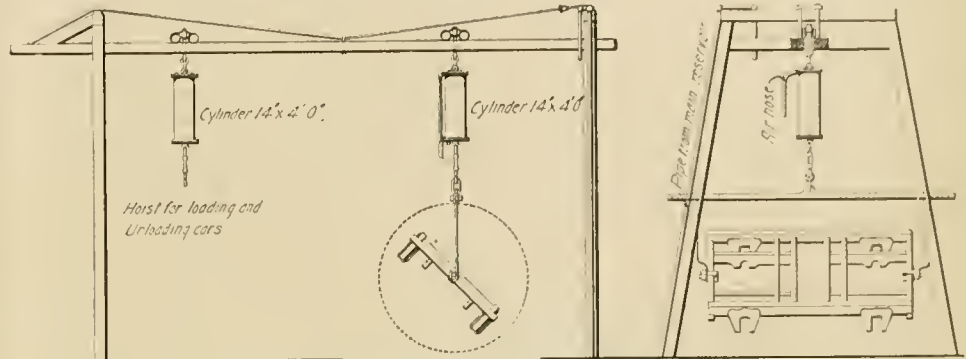

A Crane for Repairing Car Trucks.

A frame work carries a trolley bar spanning two tracks and supports two trolleys, to each of which a 14 by 48-inch air cylinder is hung. The one at the left is used for loading and unloading cars and the one at the right is fitted with a cross bar and slings, the lower ends of which are provided with swiveled clamps for supporting truck frames. These are raised by the air pressure and they may be tipped for convenience in getting at the bolts and other work on the under side of the frames. Both cylinders may be used for this work if desired. The arrangement is completed by the air hose connections and the necessary valves.

VACUUM CEMENT AND PULLEY COVERING.

The principle upon which the vacuum cement and pulley covering has been developed, is to give to a belt the quality of hugging the surface of the pulley, as this is considered more important than adhesiveness gained at the expense of corresponding resistance of the belt away from the face of the pulley in its natural line of travel. There are preparations which, while softening in their general effects, possess deteriorating agencies that harden and enamel the surface of the belt, which results in cracking and destroying the life of the leather. The Vacuum Cement and Pulley Covering Company, of 1493 Third avenue, New York, after many years of careful experiment and established record, feel able to claim the best covering in the market; a covering that prevents all belts from slipping and from which nothing comes in contact with the belt to injure it, but will prolong the life of a belt from two to three times. This pulley covering allows the use of much slacker belts and may be applied to any pulley, iron or wood, and is guaranteed for five years.

The Chicago Union Transfer Railway Company, of Chicago, have issued a notice that the switching yards of that company, now under construction in the township of Lyons, Cook County, Ill., on what was formerly known as the Stickney Tract, having connections with the Belt Railway of Chicago, the Chicago Junction Railway and the Chicago Terminal Transfer Railroad, will be known as the "Chicago Clearing Yards."

ELECTRICALLY DRIVEN BENDING ROLLS.

The plate bending rolls illustrated in the accompanying engraving are solid wrought-iron forgings having a capacity for bending plates up to 12 ft. in width and $\frac{5}{8}$ in. thick. The lower rolls are geared together, while the upper or bending roll is revolved by the friction of the plate in passing through. It is adjustable by power to suit the thickness of the plate and the radius to which it is to be bent. It has a hinged bearing at one end which may be turned down out of the way, while the other end has a long shank extending to a third support which retains the roll in position for the removal of rings or flues. This will be found a great advantage in boiler and other shops where plates are to be bent. Midway between the housings a set of supporting rollers are placed to give additional stiffness to the lower rails. For very long machines additional sets of rollers are added. The machine is firmly tied together by a heavy cast-iron sole plate. It is very strongly geared and all parts are made stiff and substantial. Suitable levers and clutches are conveniently placed for the quick and easy control of all the operations. The machine is driven by an 18-h.p. reversible, constant-speed motor, made by the Bullock Electric Manufacturing Company. For controlling the motor, an auto-

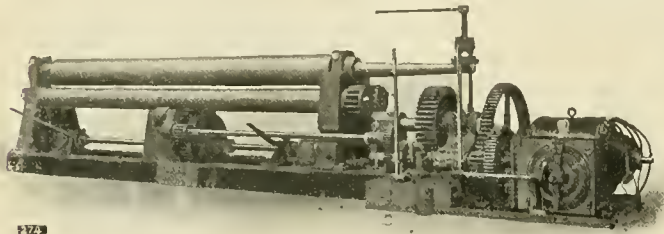

Bending Rolls Driven by Bullock Motor.

matic rheostat is used to prevent the operator from throwing on the full current too quickly and burning out the motor. The field consists of a circular yoke of special steel, with particular attention given to a reduction in weight, but this has not been at the sacrifice of efficiency. The pole pieces, built up from soft sheet steel of the highest magnetic quality, are securely bolted to the yoke. The shape of the punchings are such as to produce a saturated pole face, and this feature, coupled with carefully proportioned windings, is largely responsible for the sparkless operation of the motor. The windings, which are let into slots provided in the periphery of the armature core, are made of either copper bars or wire as best suits the requirements. The coils are machine formed, and thoroughly insulated with mica and other high-grade insulations. They are baked in steam-heated forms while under pressure, which removes all moisture and produces a perfect and very compact coil. The commutators are built from drop-forged bars of pure lake copper with selected mica insulation. They possess great durability and have an exceptionally even wearing surface for the brushes. The brush holder is simple and highly efficient, giving absolutely no trouble. It is of the reaction type; no adjustment of the brushes is necessary, and when they are once set the motor will operate in either direction without sparking and under all variations of load.

The Lehigh Valley Railroad are making extensive improvements to their Buffalo passenger station, at Washington and Scott streets, to facilitate the handling of passenger traffic to the Pan-American Exposition. Additional passenger tracks have been installed, and the capacity of the trainsheds more than doubled. The enlarged baggage room will be used solely for outgoing baggage; all incoming baggage being handled in an additional baggage room established on Scott street, adjoining the station building. To facilitate the rapid unloading of excursion trains, a 20-ft. walk has been constructed to the north of the station, projecting over the Hamburg Canal. This will obviate the necessity of having excursionists walk through the main waiting room. A commodious parcel room has been established; the space assigned to the ticket agent increased, and the improvements, now almost completed, will, it is thought, be ample to take care of the largely increased passenger business which this line expects to transact.

THE FUEL QUESTION IN STATIONARY PLANTS.

The fact that a fireman of a stationary plant may burn fuel costing from 10 to 15 times as much as his wages, the proportion varying with the locality, is sufficient reason for considering every possible means for educating him and inspiring his desire to save fuel. Mr. W. L. Abbot, of the Chicago Edison Company, in a paper before the National Electric Light Association treated this subject ably. We quote the following from his remarks on the fuel question:

The greatest possibilities for saving or wasting about a steam plant are undoubtedly in the coal pile, but as it is a dirty proposition and many of its features not well understood, the subject does not receive the consideration to which it is entitled.

The average ambitious engineer will spend much time and care on his engine to be sure that the indicator cards are perfectly symmetrical, that the points of cut-off are equal, that the release is in time and that the compression rises to meet the admission in a smooth, rounded curve. This is commendable, yet the same time spent in studying the conditions of combustion in his furnace might show him a way to make a saving in fuel fourfold greater than is possible in the final refinements of the indicator cards.

A fireman whose wages amount to, say, 20 cents an hour will burn during that time fuel costing 10 or 15 times as much as his wages. It would not be possible by any sort of driving to save half of the wages, but it is readily possible, by properly watching and instructing the fireman, to save double his wages in coal. In the first place, great care should be exercised in the selection of the coal to be used. I believe that the cheapest coal is that kind which has the greatest amount of combustible for the least amount of money, provided the furnaces are of the proper kind and ample in capacity to make the required amount of steam from them. The very cheapest kind of Illinois screenings, costing less than \$1.50 a ton, will not have less than 10,000 B. t. u. per pound, and the very best of eastern lump, costing \$4 a ton, will not have more than 14,000 B. t. u. per pound. This means, then, that for equivalent heating qualities the cheapest screenings cost about half as much as the high-grade coal.

Having selected the coal, the next problem is how to burn it properly. It is commonly understood that 12 lbs. of air are needed to properly burn 1 lb. of coal. It is also commonly supposed that in practice about twice this amount of air passes through the fire, but just how much actually passes and under what conditions are the best results obtained are impossible to determine without making analyses of the flue gases. Fortunately, this has now become a very simple operation and one which can be performed and understood by anyone competent to take charge of a large boiler room. These tests often show the most surprising and disappointing results. The analyses are made to determine the percentage of carbon dioxide in the flue gases. Under perfect conditions it can run as high as 20 per cent., but it is not unusual to find samples running as low as 2 per cent. of dioxide. This brings down the economy for two reasons: First, the gas in the firebox is diluted with an excess of cold air and cooled down, and, secondly, the amount of gas, being increased in volume, passes through the boiler more rapidly and does not give up so much of its heat. It is almost a paradox that within reasonable limits the more the gases are cooled down in the furnace by the admission of excess of air the hotter they will pass away from the boiler. The two causes of excess of air in the flue gases are, first, running boilers on too light loads, and, secondly, careless firing.

To follow intelligently the work of the individual fireman, we have installed in our boiler room a device through which is induced a small current of gas from the boiler breeching. The weight of this gas, changing with its composition, moves a pointer across a dial, thereby indicating continuously the

varying percentage of carbon dioxide in the flue gas. From this device are run individual pipes to the breeching of each boiler, and all is so arranged that samples may be drawn from several boilers and tested in a few minutes, or a continuous test may be made of the performance of any one boiler. Readings taken from this instrument at regular and short intervals, when plotted, form a curve which is a very comprehensive record of the conditions of combustion during the time of observation.

EIGHT-POLE MOTORS AND GENERATORS.

The motors of this type as manufactured by the B. F. Sturtevant Company, of Boston, Mass., and illustrated in the accompanying engraving, were primarily designed for direct-connected driving of large fans at low rotative speeds. They are therefore capable of great range of speed, and are exceptionally compact and of high efficiency. These qualities especially fit them for direct connection to machine tools. The magnet frames are of cast steel, cast iron or wrought iron, according to size or requirements. In the smallest size the field cores are cast with the frame, and the pole shoes only are removable, but, in the larger sizes readily detachable cores of wrought iron are bolted to the frame. The armatures usually employed are barrel-wound, of the toothed-hollow drum type. The laminations are of special steel plate mounted in each case upon a cast iron spider, the hub of which is extended to support the commutator. All machines except those for very low speed and high voltage are bar wound; the two-circuit type being usually adopted. This makes possible the use of a single pair of brushes where only small brush capacity is required. These machines are built in sizes from 1-100 to 50-100, the ratings being based on the horse-power delivered per 100 revolutions. The eight-pole generators are the same in design as the motors of the same type and in the larger sizes the shunt and series coils of the field windings are wound and insulated entirely separate. The brush-holder rigging for supporting the holders is so arranged that brushes of opposite polarity are carried on independent rings, which are attached to, but insulated from, a common ring which is readily detachable. On a small machine the adjustment is by hand, and on a large machine by means of a hand wheel and screw. The self-contained character of the armature and commutator especially fits both the motors and generators, to any piece of apparatus; the generators being particularly adapted for engine driven sets. The large radiating surface and thorough ventilation makes it possible to run these machines at full speed with a maximum rise in temperature not exceeding 30 degrees Cent. on the hottest part. All sizes are provided with self-aligning, ring-oiling bearings, those sizes below the 15-100 motor being supported in tripod hangers, while the larger sizes are equipped with pedestals and complete bases. The generators, like the motors, are built in ten sizes, ranging in capacity from 3 kw. to 100 kw.

Mr. C. S. Morse has been appointed Superintendent of Motive Power and Cars of the Wheeling & Lake Erie, with headquarters at Cleveland, O., vice Mr. J. B. Braden, resigned.

TRACK ARRANGEMENTS IN ERECTING SHOPS.

Crane service and the track arrangement of shops for erecting locomotives, and, in fact, the entire question of shop plans now receives more attention than it has ever had before, and the subject of shop arrangement is before many motive power officers who are thinking of prospective new work of their own in this direction. The relative merits of longitudinal and transverse track arrangements occupy attention during the earliest stages of the planning, and we have given considerable space to the views of those who have strong preferences on either side. We are inclined to think that the advocates of the longitudinal tracks and the substitution of the best crane service for the transfer table have the better side of the arguments, and in confirmation of this the following quotation is made from a communication signed "R. H. S." (Mr. R. H. Soule is believed to be the author) in a recent issue of the "Railroad Gazette":

"The suggestion that new shops may be erected on present transfer table locations is meritorious, especially for locations where new ground is not available. I am inclined to believe

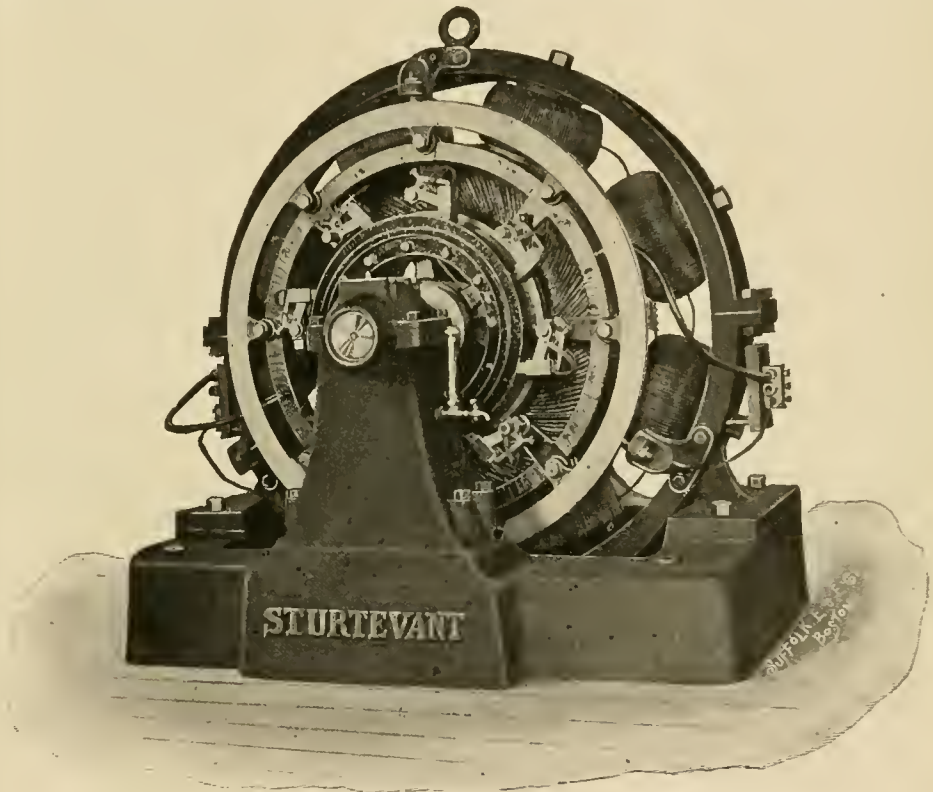

The Sturtevant Eight-Pole Motor and Generator.

that with the modern tendency to concentrate shops and locomotive repairs, the longitudinal type of locomotive repair shop will win more advocates, as time goes on, and the transverse system will be reserved for use at points where but few locomotives are handled. One advantage in the longitudinal system which I have not hitherto seen mentioned, is that each engine need only take track room suitable for its length; whereas, in the transverse system each engine must monopolize a pit or stall, and the stall tracks must necessarily be long enough for the longest engine in use at the time the shop was designed, with preferably an excess of length to provide for possible increases. One defect in the longitudinal system is that the desire to keep down the span of the traveling cranes has resulted in leaving the shop too narrow for convenient working, and for the storage of materials.

"The use of long buildings, as in recent English practice, may easily be justified, but the advantage of uniform span and uniform roof trusses should not be allowed to prevent the

use of such a particular span for each building as best promotes the economical handling of the work in that building.

"The arrangement of the new Oelwein shops of the Chicago Great Western challenges attention from the fact that unusual duty is imposed on the transfer table, which seems to be the key to the situation; and the question has been raised whether the work of the different departments may not at times be delayed waiting for transfer table service."

BOOKS AND PAMPHLETS.

Pacific Tours and Around the World. Journeys via the American and Australian Line. By Trumbull White. Issued by the Passenger Department, Santa Fe Route. Pamphlet form, fifteenth thousand, 206 pages, 8 x 5 $\frac{3}{4}$ ins., 323 illustrations and 12 maps. Printed by Rand, McNally & Company, Chicago, 1901.

This very instructive, interesting and beautifully illustrated book of journeys is issued for the purpose of attracting wider attention to the pleasures of 'round the world travel, and with a view of answering such practical questions as would naturally come to one contemplating a journey to Hawaii, Samoa, Fiji, Tahiti, New Zealand, Australia, China, Japan, the Philippines, East Indies, India, Egypt, the Holy Land, Africa, the Mediterranean, Europe and South America. It is a little surprising to know with what ease the most remote regions of the world can to-day be reached and with comforts quite as wholesome as those we have at home. All these facilities of modern travel have been placed at the command of the traveler at a comparatively small expense by the American and Australian Line, composed of the Atchison, Topeka & Santa Fe Railway system for the transcontinental journey to San Francisco, and the Oceanic Steamship Company, of San Francisco, and the Union Steamship Company, of New Zealand, from San Francisco to the other side of the world. The descriptions of the various tours offered are from the viewpoint of an American traveler and are very attractively, yet apparently truthfully, written. A great many privileges are offered to passengers purchasing through tickets, which are furnished from any point to another on this circuit around the world and at a great saving in cost to passengers buying a through ticket, instead of booking from point to point. Those who are fortunate enough to procure a copy of this book from Mr. G. T. Nicholson, Passenger Traffic Manager of the Atchison, Topeka & Santa Fe Railway systems, Chicago, will find it one of the best books of tours that has been issued.

Steam Boiler Economy. A Treatise on the Theory and Practice of Fuel Economy in the Operation of Steam Boilers. By William Kent, A. M., M. E., Consulting Engineer, Associate Editor of "Engineering News." 8vo, 458 pages, 126 illustrations. Price, \$4. Published by John Wiley & Sons, 43 East 19th street, New York, 1901.

This book treats of steam boiler economy and the subjects relating to economy. Mr. Kent is a well-known authority on this subject and is qualified by training and experience to prepare a book of this kind. It contains not a little information which is not available elsewhere. Because the author has collected from his own writings and those of others a great deal of information which is scattered and not to be easily found, this work will be found exceedingly convenient. It is such a book as one would expect from the author of the Mechanical Engineer's Pocket Book. The style is direct and concise and the chief object of the author was to meet the need for a discussion of questions of economy for steam users. To engineers its greatest value lies in the treatment of fuels and the details of combustion, including the effectiveness of furnace arrangements and heating surfaces. Its scope is very wide, as indicated by the headings, which are: Principles and definitions, fuel and combustion, coal and coal fields at home and abroad, fuels other than coal, furnaces, methods of firing, smoke prevention, mechanical stokers, forced draft, elementary principles of boiler economy, efficiency of heating surfaces, types of boilers, horse power and performance of boilers, the points of a good boiler, boiler troubles, evaporation tests, results of trials,

properties of water and steam and miscellaneous subjects. The treatment of the chemistry of fuels and the temperatures of combustion is more complete than we have seen in print before. The author's experience in the study of different fuels has been specially broad and this led him to enter thoroughly into the effects of different kinds of fuels on economy. He reviews the work of other authorities on fuel, such as Lord and Haas, Johnson, Scheurer-Kestner, Mahler and Bunte, including American and foreign coals. In the discussion of boilers the plain cylindrical boiler is taken as representing the simplest form and the author shows the relation between economy and the rate of driving. This is done in an elementary way and also mathematically including the first appearance of a formula for the efficiency of heating surface which includes the heating value of the fuel, the temperature of the water in the boiler, loss by radiation, weight of chimney gases per pound of combustible and the rate of driving. Thus all the measurable variables are included. In this Mr. Kent's chief idea is developed, viz., the comparison of results of tests of different boilers upon a really fair basis. Those who purchase and use steam boilers will derive valuable information from Chapters X. to XIII., treating of horse power, grate and heating surface proportions, the "points" of a good boiler and boiler troubles. The author gives a most sensible view of the selection of boilers. He illustrates the accepted types, all of which are good. The closing or miscellaneous chapter includes a discussion of the design of a power house plant for a small street railway and the cost of coal per boiler house power per year, with various prices of coal. The author comments upon the chaotic state of boiler practice and believes that the survival of a type will depend more upon practical questions, such as safety, maintenance, flexibility and the possibilities of forcing than upon economy because the ultimate possibilities of the economy of all types are alike. Mr. Kent believes that we now have enough types of boilers and does not expect to see new ones developed. The development in the direction of combustion of soft coal without smoke he considers the greatest improvement to be made in the future and he considers the intimate admixture of very hot air with the distilled gases the most promising method of raising the efficiencies of boilers. He advocates the use of automatic stokers and furnaces surrounded with firebrick. In the description of his "wing wall" furnace the author presents the ideal furnace conditions for economy and smokelessness. He would not attempt to prevent the formation of smoke, but by intermixture with hot air in the furnace would consume it. On page 157 the principles of smokeless combustion are clearly stated. There is scarcely a subject concerning combustion, including oil and powdered fuel, which the author has not included. The book is commended. We do not find any serious faults, although the index is somewhat disappointing.

The American Sheet Steel Company have issued a new card giving weights of the "Appolo Best Bloom" galvanized sheets. This card shows the weight of these sheets, number of sheets in a bundle and the weight per bundle in all the standard sizes and gauges from No. 10 to 30 inclusive. Copies of this card will be sent to those who will address the advertising department of the American Sheet Steel Company, Battery Park Building, New York.

A third edition of Walter B. Snow's lecture on "The Influence of Mechanical Draft Upon the Ultimate Efficiency of Steam Boilers" has just been issued by the B. F. Sturtevant Company, Boston, Mass. It treats of the different methods of application of fans for producing boiler draft, of the relative cost as compared with a chimney, of the possible economy in first cost of boilers, running expense for fuel, etc. Copies may be obtained upon application.

Log Book of the California Limited.—The Santa Fe Route has just issued the fifteenth thousand of a very attractive and artistically prepared pamphlet giving the impressions of the traveling public, journeying to California by the way of the California Limited. These impressions are from every viewpoint of the traveler. The book is interesting and somewhat out of the ordinary in the number of nice things said, for it is more common to hear the public finding fault with rather than praising a railroad.

Disc and Propeller Fans.—The B. F. Sturtevant Co., Boston, Mass., have just issued a small illustrated catalogue of their disc and propeller fans, to fill a field of service requiring low velocities and slight resistances. This catalogue is No. 116.

The decisions of the Arbitration Committee, Nos. 1 to 603 inclusive, of the Master Car Builders' Association, have been reprinted in a volume of 711 pages with index; bound in cloth similar to the reports of the proceedings. These decisions are now ready for distribution and may be procured from the Secretary, Mr. Jos. W. Taylor, 667 Rookery Building, Chicago. The price of the book is \$1.50 and postage.

Tools and Supplies for Machinists and Metal Workers.—The Hammacher, Schlemmer & Co., New York, have issued two very desirable catalogues, one on tools for machinists and metal workers and the other on bolts, screws and supplies. The latter book is No. 114 and presents a complete line of bolts and screws for all purposes and includes such other matter as descriptions, sizes, contents of packages, etc., the knowledge of which is necessary to the intelligent ordering of such goods. While this company manufactures everything in the line of factory supplies, it has not been the purpose to give in this catalogue a complete list of these supplies, but to include only such items as are generally demanded in a moderate way with bolt and screw orders. In catalogue No. 115 is presented a complete line of tools such as are ordinarily used by machinists and metal workers. All sizes of these regular goods are carried in stock and this company is particularly well-equipped to handle large orders in the best possible manner, and for all items whether shown in the catalogue or not, they solicit inquiries. These catalogues may be had by writing to Hammacher, Schlemmer & Co., 209 Bowery, New York.

EQUIPMENT AND MANUFACTURING NOTES.

The Baldwin Locomotive Works have orders for 108 large freight engines from the Pennsylvania Railroad Company.

The Pressed Steel Car Company, of Pittsburg, Pa., has received an order for pressed steel body and truck bolsters for 1,000 freight cars now being built by the Pullman Company for the Rutland Railroad. Of these, 750 cars are of 60,000 lbs. capacity and 250 of 80,000 lbs. capacity.

Mr. Charles H. Duell, Commissioner of Patents, has resigned that office to resume the practice of law. He will have associated with him Mr. William A. Megrath and Mr. Frederic P. Warfield, under the firm name of Duell, Megrath & Warfield, with office in the St. Paul Building, 220 Broadway, New York. Mr. Megrath has been connected with the patent office for fifteen years, and for the last seven years has held the position of law clerk to the commissioner. Mr. Warfield has been an assistant examiner for several years. Special attention will be given to the practice of patent, trade-mark, copyright and corporation law.

Experience has clearly demonstrated that in this climate no system of ventilation can be successfully operated by itself and independently of the method of heating that may be adopted. It is, in fact, a vital element of success that the two systems be most intimately combined, for they are clearly interdependent, and when properly applied are so interwoven in their operation and results that disunion is certain to bring about failure. For the purpose of ventilation the fan was first applied upon a practical scale about the middle of this century, but only to a limited extent, and it was not until the fan and the steam heater in marketable form were introduced by B. F. Sturtevant, of Boston, Mass., that the so-called "Blower System" became a reality. The system, of which these two elements are the most important factors, as originated by this house, has naturally been known as "The Sturtevant System." This system is at once practical, successful and economical; for, air being the natural conveyor of heat, it may, when properly warmed and supplied, perform the double office of heating and ventilating. As applied, the Sturtevant system forced the air into the apartment by the pressure or plenum method.

The Browning Manufacturing Company, of Milwaukee, Wis., have moved into their spacious new factory, which has been built to meet the urgent demands of increasing business. This company considers the matter of sizes of units, in electric driving, a most important one and has given a great deal of attention to the sizes of motors for individual machine driving and the relative capacities of generators for this style of driving in different kinds of shops. As a result they are building a line of high-grade motors and generators from $\frac{1}{2}$ to $3\frac{1}{2}$ h.p. that cover the entire range required. The new plant is running 22 out of every 24 hours, which is evidence of the demand for the Browning Company's product.

Mr. J. R. McGinley, who has for nearly twenty years been prominently identified with the Westinghouse interests, has purchased the entire capital stock, factory and real estate of the Duff Manufacturing Company, of Allegheny, Pa., and will take personal charge of the management of the Duff Company. A number of improvements will be made in the factory that will greatly increase the capacity of the present plant. Arrangements are also being made for the sale of the company's products in foreign countries.

The Keasbey & Mattison Co., owners of the patents for magnesia covering, have commenced a suit in the United States Circuit Court for the Southern District of New York, against the Philip Carey Mfg. Co., George D. Crabbs, J. E. Breese, Schoellkopf, Hartford & Hanna Co., J. F. Schoellkopf, Jr., James Hartford, W. W. Hanna, C. P. Hugo Schoellkopf and Jesse W. Starr, to restrain the defendants from making and selling magnesia covering for boilers and steam pipes containing more than 50 per cent. of magnesia, and especially coverings containing 85 per cent. of magnesia. The Keasbey & Mattison Co. respectfully request that all persons refrain from purchasing covering infringing these patents, as such purchasing must of necessity lead to suit.

Among the interesting exhibits at the Pan-American Exposition at Buffalo will be that of the Pressed Steel Car Company of Pittsburgh, Pa. This exhibit will be in the Railway Exhibit Building, located at the north end of the fair grounds, a short distance from the plaza and electric tower. It is through this building that all persons landing at the terminal station will gain access to the fair. This exhibit will occupy 200 linear feet of track space and will consist of five cars showing various types designed and built at the company's plant. The box car will be utilized as a booth and office, and will be comfortably fitted up for the accommodation of visitors. The general dimensions of these cars are as follows: Box car with steel underframing; capacity, 70,000 lbs.; weight, 36,300 lbs.; length over end sills, 36 ft. 4 $\frac{1}{4}$ ins.; width over side sill, 8 ft. 9 $\frac{3}{4}$ ins.; height from top of rail to top of running board, 12 ft. 8 ins. Fox pressed steel pedestal trucks; cast iron chilled wheels; open-hearth steel axles; Westinghouse air brakes; American type M. C. B. automatic couplers. This car is similar to the box cars of the Erie Railroad, illustrated in this issue. There will also be a steel hopper car; capacity, 80,000 lbs.; weight, 33,925 lbs.; length over end sills, 31 ft. 6 ins.; width over side stakes, 10 ft.; height from top of rail to top of body, 9 ft. 10 ins.; pressed steel diamond trucks; cast iron chilled wheels; open-hearth steel axles; New York air brakes; pressed steel brake beams; Schoen standard twin spring attachment draft rigging; Janney couplers. Hopper ore car; capacity, 100,000 lbs.; weight, 28,500 lbs.; length, 24 ft.; width, 8 ft.; height, 9 ft. 6 ins.; pressed steel diamond trucks; Bryan draft rigging; Chicago coupler. Pressed steel flat car; capacity, 100,000 lbs.; length over end sills, 40 ft.; width over stake pockets, 10 ft.; height from top of rail to top of floor, 3 ft. 10 $\frac{1}{4}$ ins.; pressed steel diamond trucks; cast iron chilled wheels; open-hearth steel axles; Westinghouse air brakes; pressed steel brake beams; Gould couplers. Pressed steel flat bottom gondola car with twin hoppers; 95,000 lbs. capacity; weight, 34,000 lbs.; length over end sills, 37 ft. 6 ins.; width over side sills, 10 ft. 2 $\frac{1}{2}$ ins.; height from top of rail to top of body, 7 ft. 5 $\frac{1}{4}$ ins.; depth of car body, 3 ft. 11 ins.; pressed steel diamond trucks; cast iron chilled wheels; open-hearth steel axles; Westinghouse air brakes; pressed steel brake beams; M. C. B. draft rigging.

The Norfolk & Western Railway have placed an order with the Richmond Locomotive Works for ten 21 by 30-in., class "W" consolidation locomotives, which are exact duplicates of the ten locomotives which are now being built at these works. The engines will weigh, in working order, 110,000 lbs. The cylinders are 21 by 30 ins. and the driving wheels 56 ins. in diameter, with a driving wheel base of 15 ft. 6 ins. and a total wheel base of 23 ft. 11 ins. The capacity of the tanks will be 5,000 gallons of water. The two 10-wheel locomotives just ordered from the Richmond Works by the California Northwestern Railway will have each a total weight of 144,000 lbs., of which 88,400 lbs. are on the drivers. The cylinders are 18 by 24 ins. and the driving wheels 56 ins. in diameter, with a driving wheel base 12 ft. 4 ins. and a total wheel base of 22 ft. 8 ins. The boilers are 56 ins. diameter with 215 2-in. tubes 12 ft. 11 ins. long. The firebox is 96 by 34 ins. and the tank capacity 3,500 gallons of water.

AMERICAN SCHOOL OF CORRESPONDENCE.

The modern development of machinery along all branches of engineering and industrial activity calls for a continually increasing grade of intelligence on the part of the individual workman. Each year the steam shovel, the electric motor and the improved machine shop equipment take away in part the physical burdens of the workman, while they place upon him a growing load of responsibility. The workman becomes less and less a mere system of muscles and should become more and more an intelligent agent of his employer. The technical schools provide admirably for the education of the designing and constructing engineer, but make no provision for the mechanic, the foreman, the practical man who remains in charge of engine and boiler rooms after the installing engineer has finished his work and the plant is in running shape. So it happens that many an important manufacturing or power plant is in the hands of employees who have little if any real knowledge of the design and construction of the machinery for which they are accountable. Such men are necessarily cheap men, for lack of the education which would give them greater wage-earning power. They are also the most expensive men, to their employers, since they lack the knowledge which would enable them to get the best results out of boiler, engine, electric generator and all the other factors in power development. To reach and educate these practical working men in ways which will add at once to their value to their employers, and hence to their wage-earning power, is the chief aim of the correspondence system of instruction. It is not suggested that this system is to take the place of a technical college education in any case where such a course is available; but to those who cannot attend technical schools this system brings the necessary practical instruction in brief, pithy lessons, carefully stripped of all unnecessary theoretical details. The American School of Correspondence, of Boston, Mass., issues sets of instruction papers and books, covering thoroughly the practical details of stationary, electrical, mechanical, marine and locomotive engineering. These courses are prepared by trained instructors of the best standing and are well illustrated. By devoting the spare minutes of each working day to the successive lessons of such a course, the student speedily advances until he has qualified himself for the diploma, which is given upon the satisfactory completion of the work. Whenever difficulties arise in following the courses of instruction, the student writes to the instructors of the school stating the points in question, and receives prompt replies, embodying full answers to his inquiries. This system of direct, personal correspondence between teacher and pupil is continued throughout the course. Many thousands of wage-earners have availed themselves of the opportunity afforded by correspondence schools and there is reason to believe that a system that follows so closely the needs of the workingman will have a still more rapid development in the future. The American School of Correspondence now has among its pupils a considerable number in foreign countries—Great Britain, India, Africa and New Zealand are largely represented. More significant still of the scope and standing of the school is the fact that among its pupils are a large number of graduates of the foremost colleges in the United States who are taking this means to add to their college training such lines of work as were not covered by their collegiate work.

Among the devices specified for the 32 new passenger cars for the Atchison, Topeka & Santa Fe Railway is the Pintsch Lighting System. This railway has conducted many experiments with other systems of car lighting, and the fact that it has been decided to use Pintsch light on these new cars is evidence of good opinion of the reliability and practicability of the compressed gas system. With these new cars in service the Atchison, Topeka & Santa Fe will have in all 106 passenger cars equipped with the Pintsch light.

The fire which visited the works of the B. F. Sturtevant Company at Jamaica Plain, Mass., April 14th proved to be far less disastrous than was first reported. Only the engine and electrical departments were injured. The power plant was started up after a delay of but one day, incident to renewing belts damaged by fire, and the entire blower, heater, forge, galvanized iron and shipping departments with the foundry and pattern shop were in full operation on that day and the shipments going forward as usual. The most serious damage occurred in the advertising department, where a large amount of printed mater was destroyed. Fortunately, however, an entirely new general catalogue was in press at the time and copies were issued on the 16th in time to meet all demands for information. New offices were established on the morning of the 15th in a nearby building and by noon the business was running as usual. With these facilities at its disposal there is no likelihood of any delay in shipments except such as may occur in the electrical and engine departments, and arrangements are already made for handling this work.

The Bullock Electric Manufacturing Company has acquired control of 15 acres of land directly opposite their present plant at East Norwood, Ohio, upon which the Norwood Foundry Company will erect a foundry building 200 by 150 ft.; a pattern storage house, 50 by 150 ft., three stories high; and a modern office structure. All of these buildings will be built of buff pressed brick with steel frames and trusses to conform to the present buildings of the Bullock Electric Manufacturing Company. The foundry will be equipped with three electric cranes, the largest of which will have a capacity of 50 tons. The side bays, which will be 25 ft. in width, will be served by hand traveling and jib cranes. The plant will be of the most modern character, and electricity will be used for power and lighting throughout. This foundry will be operated under the name of the Norwood Foundry Company, under the direction of Messrs. Hoffinghoff & Lane, of Cincinnati, but will serve primarily the needs of the Bullock Electric Manufacturing Company. The Bullock Company have also effected a combination of their selling organization with that of the Wagner Electric Manufacturing Company, of St. Louis. These two companies manufacture entirely different products, but where the product of one is used the other is likely to be necessary. The product of Bullock Company consists of a complete line of direct and alternating current machines, from a ½-h.p. motor to a 10,000-kw. generator, controllers of various types and rotary transformers. The product of the Wagner Electric Manufacturing Company covers a full line of static transformers of all types and of the largest sizes; ammeters, voltmeters, indicating wattmeters, switches, switchboards for all purposes and single-phase self-starting alternating current motors. By thus combining the forces of the two companies, they are mutually benefited, and the lines are admirably adapted to be sold by one organization, which will be under the management of Mr. E. H. Abadie, formerly Sales-Manager of the Wagner Company.

Wanted.—Copies of the American Engineer and Railroad Journal for 1900. One copy of January, one of February, two of March and one of April. Fifty cents will be paid for each sent to the Editor, 140 Nassau Street, New York.

POSITION WANTED.

Mechanical engineer with five years' experience with two prominent railroads desires position as mechanical engineer or chief draftsman. Technical graduate in both mechanical and electrical engineering. Best of references. Address "Engineer," care editor American Engineer and Railroad Journal, 140 Nassau St., New York.

AMERICAN ENGINEER AND RAILROAD JOURNAL.

JUNE, 1901.

CONTENTS.

ARTICLES ILLUSTRATED :	Page	Page
Momentum and Acceleration, by F. J. Cole ..	167	Is It Good Policy for Railroads to Build Their Own Locomotives?.....
Economical Train Speeds, by G. H. Henderson.....	172	Wide Fireboxes for Soft Coal, by F. A. Delano.....
New Ventilating System for Passenger Cars	177	Locomotive Coal Consumption, by M. N. Forney.....
The Motive Power Opportunity, by W. S. Morris.....	181	Grates for Burning Fine Anthracite Coal by W. McIntosh.....
Topeka Shop Extensions, by R. P. C. Sanderson.....	186	Results from Tonnage Rating, by B. A. Worthington.....
Link Motion and Piston Valves, by C. A. Seley.....	189	Some Phases of the Water Treating Problem, by Howard Stillman
A Boiler-Shell Chart, by Lawford H. Fry	192	Patents and Railroad Mechanical Departments, by J. Snowden Bell.....
Best Type of Engine for Heavy Fast Passenger Service, by F. F. Gaines	195	Grate Areas for Burning Culum, by T. S. Lloyd.....
Ten-Wheel Passenger Locomotive, Illinois Central R. R.....	205	Should Engine Ton Mileage be Included in Motive Power Statistics? by C. H. Quereau
ARTICLES NOT ILLUSTRATED :		The Draft Gear Situation, by Edward Grafstrom.....
A General Manager's Suggestions to Motive Power Officers, by J. Kruttschnitt.....	170	Conflicting Opinions Concerning Compound Locomotives.....
Apprentices in Railroad Shops, by A. M. Waitt.....	170	
The Maintenance of Air Brakes on Freight Cars, by G. W. Rhodes	171	EDITORIAL:
The Locomotive Testing Plant, by Robt. Quayle.....	181	American Engineer Tests, Locomotive Draft Appliances.....

LOCOMOTIVE DESIGN.*

By F. J. Cole, Assistant Mechanical Engineer, Schenectady Locomotive Works.

MOMENTUM AND ACCELERATION.

The effect of velocity to assist the tractive power of a locomotive in surmounting grades of moderate length is generally considered from two points of view, (a) the determination of the grades on a new road or the reconstruction of the grades on an old road and (b) the hauling power or tonnage rating of a locomotive on existing railroads where the ruling grades are approached at certain allowable maximum velocities. In both, the principles involved are the same, although the application is different. In this paper the argument will be confined to the maximum hauling power at varying speeds on roads already built.

In a number of tonnage tests the published data and figures were quoted to prove that under some conditions the hauling power of certain locomotives was greater than could be accounted for by the usual formulæ employed in estimating the tractive force. So that after assuming the highest mean effective pressure allowable and the lowest resistance for rolling friction, curves, etc., and making proper deductions for the weight of the engine and tender, the tonnage actually hauled was considerably in excess of the theoretical. As the resistance due to the grade is the weight actually lifted a certain number of feet in a given space, it is therefore accepted as a mathematical fact which does not admit of discussion.

It seems doubtful whether in all cases the velocity of approach, the gradually diminishing speed on the grade, and the decreased velocity at the summit have always been duly considered in relation to their effect in increasing the tractive power of the engine and enabling it to ascend grades with trains requiring a greater tractive force than that possessed by the engine. The force, momentum or kinetic energy contained or stored up in a moving body is most readily estimated by comparing it to the acceleration of gravity on a body fall-

ing freely from a height. The space through which a body will fall in one second of time from a state of rest is 16.1 ft., and the velocity at the expiration of one second is 32.2 ft. In two seconds the space fallen through is 48.3 ft. and the velocity 64.4 ft. This is expressed in the well-known formula:

$$h = \frac{V^2}{2g} = \frac{V^2}{64.4}$$

Let S = space in feet.

t = time in seconds.

K = foot-pounds.

K₂ = foot-pounds per ton.

V = final velocity in feet per second.

M = speed in miles per hour.

W = weight in pounds.

R = resistance in pounds per ton.

h = height in feet.

g = force of gravity, 32.2.

f = force in pounds.

The kinetic energy of a moving body is able to lift the body to a height equal to that through which it must fall to produce the same velocity if allowed to fall freely. For example, the energy in a train moving at 30 miles per hour is equal to lifting the whole train up vertically 30.1 ft., as 30 miles per

$$\text{hour} = \frac{30 \times 5,280}{60 \times 60} = 44 \text{ ft. per second.}$$

$$\frac{V^2}{2g} = \frac{44^2}{64.4} = 30.1 \text{ ft. fall to produce a velocity of 44 ft. per second or 30 miles per hour.}$$

So that apart from the rolling friction and the energy used in overcoming it, the lifting power for any speed can easily be determined by finding the drop in feet required to produce that speed. This is given in table No. 1.

TABLE I.

Falling bodies: Height of fall required to produce a given velocity.

M. Velocity, miles per hour.	V. Velocity, feet per second.	Fall in feet.
5.....	7.3.....	0.8
10.....	14.6.....	3.3
15.....	22.....	7.5
20.....	29.3.....	13.3
25.....	36.6.....	20.8
30.....	44.....	30.1
35.....	51.3.....	40.8
40.....	58.6.....	53.3
45.....	66.....	67.6
50.....	73.3.....	83.4
55.....	80.6.....	100.8
60.....	88.....	120.2
65.....	95.3.....	141.0
70.....	102.6.....	163.4
80.....	117.3.....	215.5
90.....	132.....	270.5
100.....	146.6.....	333.6

The kinetic energy of a moving train is also influenced by the rotative energy of the wheels and axles which absorb or give out power as their speed is accelerated or retarded. The wheels after they are in motion and spinning around like so many small fly-wheels, are sources of energy and appreciably increase the total energy of a moving train, when the speed is reduced. For modern cars, an average of 5 per cent. increase may be added to Table I. for the rotative energy of the wheels (See Wellington's "Location of Railroads," page 334, and Proceedings Railway Master Mechanics' Association, 1898, page 220, for the detailed methods of estimating the energy of rotation.) Table II. gives the kinetic energy or the height to which a moving body can be raised, for different speeds, in miles per hour plus 5 per cent. added for the rotative energy of the revolving wheels.

The resistance of loaded cars to motion on straight, level track is variously estimated by competent observers to be from 3½ to 6 lbs. per ton of 2,000 lbs., at slow speeds of say

$$10 \text{ miles per hour. The D. K. Clark formula, in which } R = \frac{M^2}{171}$$

based on the theory that the resistance increased as the square of the speed, has been known for several years to give entirely too high resistances at anything but very slow speeds. The

*For previous article see Vol. LXXIV., page 307.

TABLE II.

Kinetic Energy of a Moving Body, Plus 5 per cent. for Revolving Energy of Wheels and Axles.

$$S = 1.05 \frac{V^2}{2g} = \frac{M}{3600} = M \cdot 1.466. \quad S = \frac{1.05 \times (M \cdot 1.466)^2}{64.4} = M^2 \cdot .03508.$$

Miles per hour.	0	1	2	3	4	5	6	7	8	9
0
10	3.5	4.2	5.0	5.9	6.9	7.9	9.0	10.0	11.3	12.6
20	14.0	15.4	17.0	18.5	20.2	21.9	23.7	25.5	27.5	29.5
30	31.6	33.7	35.9	38.2	40.5	42.9	45.4	48.0	50.6	53.3
40	56.1	58.9	61.8	64.8	67.8	71.0	74.1	77.3	80.7	84.1
50	87.6	91.1	94.7	98.4	102.2	105.8	109.9	113.8	117.9	122.0
60	126.2	130.4	134.7	139.1	143.5	148.0	152.7	157.6	162.0	166.8
70	171.7	176.6	181.6	186.7	191.9	197.1	202.4	207.7	213.2	218.7
80	224.3	229.9	235.6	241.4	247.3	253.2	259.2	265.2	271.4	277.6

The above table represents the heights in feet to which a body moving at various velocities can be raised by its kinetic energy, provided the motion is retarded without friction and the revolving energy of the wheels equals 5 per cent.

"Engineering News" formula, in which $R = \frac{M}{4} + 2$, is prob-

ably used to a greater extent at present than any other. It is probable that the resistances given by this formula are too high, as the experiments conducted by the Baldwin Locomotive

Works resulted in their using the formula $R = \frac{M}{6} + 3$. The

conclusions of the late D. L. Barnes were that the resistance of passenger trains was 11 lbs. at 55, 12 lbs. at 65 and 14 lbs. at 75 miles per hour. The resistance due to grades alone is

20 lbs. per ton for each 1 per cent. of grade, or $\frac{2,000}{100} = 20$

as the entire load is lifted 1 ft. high in 100 ft. Expressed in feet per mile the resistance equals the number of feet $\times .37898$ —although the approximation of 0.38 is commonly used. Table III. gives this in convenient form.

TABLE III.

Resistance of Grades in Feet per Mile per Ton (2,000 pounds).
 $R = \text{Rise} \times .37878$.

Feet per mile.	0	1	2	3	4	5	6	7	8	9
1378	.76	1.14	1.52	1.8	2.3	2.7	3.0	3.4
10	3.8	4.2	4.6	4.9	5.3	5.6	6.1	6.5	6.8	7.2
20	7.6	8.0	8.4	8.7	9.1	9.4	9.9	10.3	10.6	11.0
30	11.4	11.8	12.2	12.5	12.9	13.2	13.7	14.1	14.4	14.8
40	15.2	15.6	16.0	16.3	16.7	17.0	17.5	17.9	18.2	18.6
50	18.9	19.4	19.8	20.1	20.5	20.8	21.3	21.7	22.0	22.4
60	22.7	23.2	23.6	23.9	24.3	24.6	25.1	25.5	25.8	26.2
70	26.5	27.0	27.4	27.7	28.1	28.4	28.9	29.3	29.6	30.0
80	30.3	30.7	31.1	31.5	31.9	32.2	32.6	33.0	33.4	33.8
90	34.1	34.5	34.9	35.3	35.6	36.0	36.4	36.8	37.2	37.5
100	37.8

Taking the resistance at slow speeds at 5 lbs. per ton, the equivalent grade on which a train if once started would just overcome the rolling friction and continue moving, at slow speed is 0.25 per cent., or 13.2 ft. per mile. This amount deducted from or added to any grade will equal the resistance of the train on straight level track.

If a train running from A to B, Fig. 1, approaches the foot of a 1 per cent. grade (52.8 ft. per mile) at 30 miles per hour and passes the summit at 5 miles per hour, the total kinetic energy absorbed is equal to raising the entire train 30.7 ft. The height for a speed of 30 miles per hour is 31.6, and for 5 miles is 0.9 ft. (see Table II.), and $31.6 - 0.9 = 30.7$. If the engine only exerts a continuous tractive force equal to the rolling friction of the train, the grade, whose total height is 30.7 ft., can be surmounted by the kinetic energy of the train alone without any assistance from the engine, except to overcome the frictional or speed resistance of the moving train.

The effect of velocity to reduce a grade whose total rise is much greater than in the preceding example is shown in Fig. 2. The result is a reduction of the 2 per cent. grade along its entire length. Suppose a train is required to pass over the summit of the grade at 5 miles per hour, when the speed of approach at H is 30 miles per hour. The actual energy is equal to raising the train 30.7 ft. as in Fig. 1. From the total height of 61.4 may be deducted 30.7 ft., so that the 2 per cent. grade can really be operated with no greater tractive effort of the engine than a 1 per cent. grade. The dotted line shows

the apparent reduction of this grade due to velocity. Had the velocity at H been 42 instead of 30 miles per hour, the entire 2 per cent. grade 3,070 ft. long having a total rise of 61.4 ft., could be surmounted by the kinetic energy alone, provided the engine exerted a uniform tractive force of $7\frac{1}{2}$ to 8 lbs. per ton, or enough to overcome the rolling friction for an average speed of $23\frac{1}{2}$ miles per hour. If a train starts from G, Fig. 2, and attains a velocity of 30 miles per hour at H after running

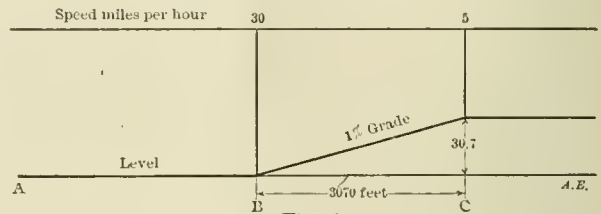

Fig. 1

3,005 ft. on straight level track, the force required to accelerate the speed from a state of rest will be 20 lbs. per ton of 2,000 lbs. (See Table IV.) To this must also be added the resistance per ton required to overcome the rolling friction. As the average speed is 15 miles per hour the resistance will equal about 6 lbs. The total force required will be 26 lbs. per ton for acceleration and rolling friction.

There is a limit to the length of grade on which the velocity of approach is beneficial; where the length is so great or the

TABLE IV.

Force and Space Required to Accelerate One Ton (2,000 lbs.) from a State of Rest to Various Velocities.

$$S = \frac{31.05 V^2}{F}$$

Velocity, miles per hour.	V. Velocity, feet per second.	V ² , Square of velocity, feet per second.	Foot pounds per ton $\frac{31.05 V^2}{F}$.	Space in feet to accelerate 1 ton (2,000 lbs.) with a uniform force of					
				5 lbs.	10 lbs.	15 lbs.	20 lbs.	25 lbs.	30 lbs.
5	7.3	53.3	1,655	331	165	110	83	66	55
10	14.6	214	6,645	1,329	664	443	332	265	221
15	22.0	484	15,028	3,005	1,502	1,001	751	601	500
20	29.3	858	26,641	5,328	2,664	1,776	1,332	1,065	888
25	36.6	1,339	41,576	8,315	4,157	2,771	2,078	1,663	1,385
30	44.0	1,936	60,113	12,022	6,011	4,007	3,005	2,404	2,003
35	51.3	2,632	81,724	16,345	8,172	5,448	4,086	3,269	2,724
40	58.6	3,434	106,626	21,325	10,662	7,108	5,033	4,265	3,551
45	66.0	4,356	135,254	27,051	13,525	9,016	6,762	5,410	4,508
50	73.3	5,373	166,832	33,366	16,683	11,122	8,342	6,673	5,561
55	80.6	6,496	201,701	40,340	20,170	13,446	10,085	8,068	6,723
60	88.0	7,744	240,451	48,090	24,045	16,030	12,023	9,618	8,015
65	95.3	9,082	281,996	56,399	28,199	18,799	14,100	11,279	9,399
70	102.6	10,527	326,863	65,372	32,686	21,791	16,343	13,074	10,895
75	109.9	12,078	375,022	75,004	37,502	25,001	18,751	15,001	12,500
80	117.3	13,759	427,186	85,437	42,718	28,479	21,359	17,087	14,239
90	132.0	17,424	541,015	108,203	54,101	36,067	27,050	21,640	18,034
100	146.6	21,491	667,295	133,459	66,729	44,486	33,364	26,691	22,243

total rise exceeds the limitations imposed by the maximum speed. It will then be found that a heavier train can be hauled at a slow steady pull than if the momentum of the train is taken into consideration, apart from the maximum power of the locomotive at 8 or 10 miles per hour. It is difficult to locate this point off-hand with great exactness for all kinds and weights of locomotives, as the principal loss of efficiency is due to the increase of piston speed causing a decrease in

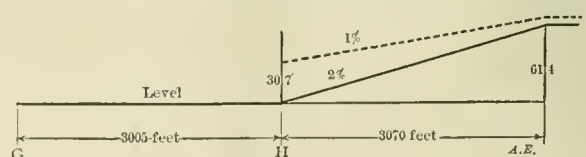

Fig. 2

the mean effective pressure in the cylinders. This in turn depends upon the diameter of drivers and stroke. When these are known the limit can easily be determined. For example, an engine with 60-in. driving wheels and 28-in. stroke will pull, we will say, 1,200 tons (including the weight of engine and tender) up a 1 per cent. grade 10,000 ft. long at slow speeds. This means a total difference of elevation of 100 ft. in a distance of 10,000 ft. Suppose the grade is approached at a maximum allowable speed of 30 miles an hour, and the summit

passed at 5 miles an hour, then the average velocity is $\frac{30 + 5}{2} = 17.5$ miles per hour and an average piston speed of

457 ft. per minute. The mean effective pressure for this piston speed will be about 68 per cent. of boiler pressure. (See Fig. 1, American Engineer, June, 1900, page 176.)

Assuming that 85 per cent. is the maximum M. E. P. at slow speeds, then there is a loss of $\frac{85 - 68}{85} = 20$ per cent., due to increase of piston speed.

The resistance of loaded cars at slow speeds on level straight track at 8 to 10 miles per hour is about 5 lbs. per ton, and at 17 or 18 miles per hour, about 6½ lbs. If the train approaches the foot of the grade at a speed of 30 miles per hour and passes the summit at 5 miles per hour, then the total kinetic energy will equal a decrease in the grade of 30.7 ft., making an apparent grade of 0.69 per cent. instead of 1.00 per cent.

At slow speeds the resistance on a 1 per cent. grade is about $20 + 5 = 25$ lbs. per ton. The resistance on 0.69 per cent. grade

$$K = \frac{W V^2}{2 g}$$

$$K = \frac{2000 V^2}{2 g} = \frac{2000 V^2}{64.4} = 31.05 V^2$$

$$f = \frac{V^2 W}{2 s g}$$

From the diagram Fig. 3 the acceleration of one ton with forces from 5 to 500 lbs. at different velocities can be readily obtained. The distance run in feet is given on the horizontal line, the velocities in miles per hour on the vertical line, the time on the straight radial lines and the force in pounds on the curved radials.

That the locomotive is likely to make remarkable progress in the immediate future is apparent to those who are in touch with the thought of leaders in this direction. Mr. S. M. Vauclain at a recent meeting of the New England Railroad Club

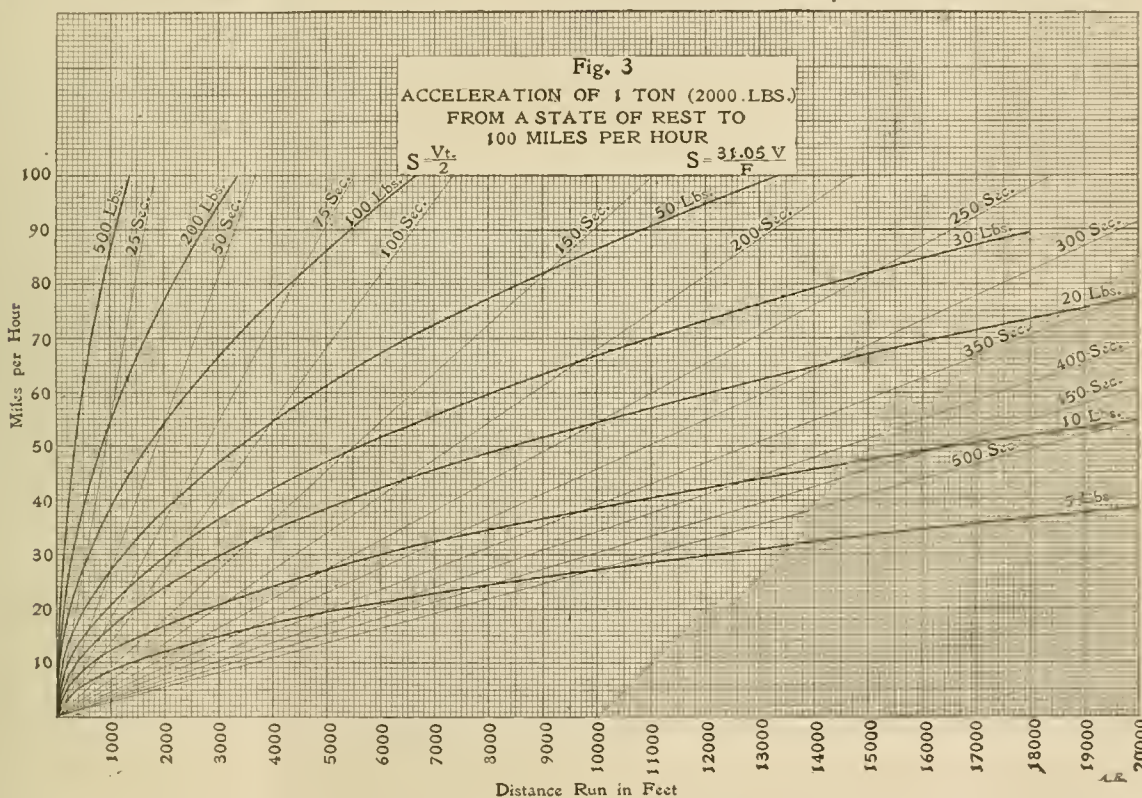

Fig. 3.

at an average speed of 17.5 miles is approximately $13.8 + 6.5 = 20.3$ lbs. per ton. Then, the percentage of decrease in resistance equals $\frac{25 - 20.3}{25} = 18.8$.

As the decrease in M. E. P. caused by higher piston speed was 20 per cent., it is obvious that no increase in weight of train can be made by approaching this grade at the speed and under the conditions named, provided ample steam can be generated by the boiler. If an up grade is preceded by a down grade considerable economy in the use of steam is of course possible by utilizing the energy gained going down to assist in overcoming or partially overcoming the ascent on the other side.

The space through which a body must pass in order to attain a given velocity when accelerated by a uniform force is equal to half the final velocity multiplied by the number of seconds:

$$S = \frac{Vt}{2}, t = \frac{S}{0.5 V} = \frac{S2}{V}$$

made some remarks which we consider prophetic. He said: "The improvement of the locomotive will embrace the further development of those features invented in the previous century, compounding of all locomotives upon some system now used, or yet to be invented, will be almost universal, the wide fire-box and tubular boiler will be carried to the limit of human ability to manage it. This will give place to the water-tube boiler, especially for high speeds. Who that is here to-night is destined to be the instrument of its introduction? Already bright minds are employed in designing a boiler of this description which can be placed on our arrangement of cylinders, underframing, wheels and machinery—a system that will give three times the heating surface for an equivalent weight. High speeds will be used for all trains carrying human freight, but long and heavy express trains will be handled with facility by the improved high-pressure compound locomotives of that period. The loading gage of our trunk lines will not prevent doubling, or even trebling, the power of locomotives for freight traffic. Double bogie engines similar to those used abroad, but on the American idea, will be employed."

A GENERAL MANAGER'S SUGGESTIONS TO MOTIVE
POWER OFFICERS.

By J. Kruttschnitt,

Fourth Vice-President and General Manager,
Southern Pacific Company.

In view of the approaching conventions of motive power officers, it may be in order to offer some suggestions as to ways in which they may assist materially in efforts to increase net earnings. It is a physical impossibility for me to offer anything like a connected article, but I will outline briefly such questions and matters as our own experience has shown to be of vital importance for successful management.

The far-reaching effects of bad water would lead me to place its improvement by chemical treatment as first in importance of the problems that confront motive power officers of the present day. The extent to which bad water will interfere with traffic and run up expenses is, I fear, hardly appreciated by either operating or motive power officers east of the Mississippi River, but on the far Western lines renewals of tubes and of fire boxes, delays to traffic through leaks and the extinguishing of fires of locomotives on the road, payments for overtime through delay, and disorganization of train service are so constantly before the management as to make the improvement of feed water a question of paramount importance. The problem, we know, is difficult, but for that very reason it is one that needs the closest and most careful study.

Tests made on freight locomotives in every-day traffic under speeds varying by 100 per cent. and loads varying by 33 per cent. seem to indicate a decided increase in ton-miles moved per pound of fuel when the speeds are high and the loads light. Trains of this character, while economizing in fuel, are wasteful as to wages; heavy trains at low speed decrease the wage expense per ton-mile enough to offset fuel increase and show besides some net economy. The indications are that the greatest economy in expenses directly proportioned to train movement should be attained with a heavily loaded train moving at moderate speed. Accurate data are desirable to show when the most economical speed and load are reached, because with present low rates and keen competition the margin between success and failure is extremely small.

To reduce the fuel bill, the following seem important:

- a. Uniform fuel over the entire divisions with intelligent adaptation on each locomotive of the draught arrangements and grate bars to burn the given coal most economically; closely followed by a careful and systematic instruction of engineers and firemen.
- b. Compounding locomotives where fuel and water are high-priced.
- c. Improving locomotive boilers by providing larger grate areas and heating surfaces so that the maximum percentage of energy of combustion may be utilized.

Reducing the cost of handling coal to a minimum by providing power coaling plants is worthy of more attention than it has ever received.

Condemning light and poorly designed locomotives and substituting modern and well-designed equipment to a greater extent than is now done, due consideration being given in each design to traffic, fuel, and grade conditions, is an important line for effort.

We need closer inspection and prompter repair of locomotives at terminals so that they may always be sent out on the line in perfect condition and after the shortest delay. This, of course, means most careful and accurate reports from engineers of defects developed en route.

Closer study of the scrap pile, whose lessons are now too often unheeded, is earnestly recommended.

A vigorous effort to push designing, adopting and maintaining of standards, reducing the number of types of couplers, is greatly needed.

Widening and clearing the horizon of view of motive power

officers and employes; leading them to recognize to a greater extent than they now do the conditions that determine the practice of keeping a locomotive on duty as long as possible after steam has been raised is important to commercial success. It has long been understood that car equipment must be kept moving to earn money; the principle applies with equal force to locomotive equipment. Some system of double crewing or pooling locomotives under present traffic conditions seems necessary. There are defects in, and objections to, the system, but motive power officers can render their companies lasting service by perfecting the system and removing or reducing the objections.

Finally, and perhaps above all, it is necessary to secure the loyal support of the entire motive power working staff from the highest to the lowest, in all measures that are prescribed by proper authority, cultivating the feeling that every man in his sphere is personally responsible for the success or failure of the department of the company in which he is employed.

APPRENTICES IN RAILROAD SHOPS.

By A. M. Waitt,

Superintendent Motive Power and Rolling Stock,
New York Central & Hudson River Railroad.

Inquiry made within a short time past develops the fact that up to the present time very little thought has been given to the subject of a systematic way of handling apprentices in railroad shops. In too many cases it would appear that the employment of apprentices had been done partly, at least, with the idea of getting labor at as low a rate of pay as possible, without considering the ultimate results of such a practice, and without considering the future welfare of the apprentice himself. In some large railroad shops a boy is taken in as an apprentice, and for about three to six months is used as a messenger, to run errands, and to sweep up around the shops. The next six months he is made use of on a holt cutter or nut tapper, and then is put to drilling for a similar period, finally, after one and a half years of his four years' term has expired, a place is found for him on a lathe or a planer. In this place the young man perhaps develops considerable ability, and it is found that at his low apprentice's rate he is doing a certain class of work much cheaper than many full-fledged machinists, and it is considered by his over-zealous foreman a good piece of management to keep the boy on these tools as long as he can. Perhaps, after three or more years have gone by, the apprentice is allowed to help on the heavy lathe or planer, and he may possibly be sent for a while to do some brass work on the light lathes. After four years' time the apprentice is turned out a "journeyman," so-called, but in reality a one-sided mechanic, being able to do a few special classes of work well, and knowing little or nothing from practical experience of the many sides of the machinist's work that might help him to be more useful to his employers and himself.

I would urge the need of railroad companies making a special point of a systematic plan of apprenticeship. Whatever may be the ultimate line of special work which the young mechanic may take up, he is best fitted for it by being given a broad view of his field of opportunity. I believe that an apprentice in a machine shop, like an aspirant for honors in athletics, should be fully developed, and fully rounded out, and not made one-sided in his development.

In order to get the best results from an apprenticeship, a well-understood plan must be adopted, and all concerned must be held to strict account for carrying out in a broad sense the spirit and detail of the system. One foundation element is that all foremen, and those in charge of shop operations, should understand that apprentices are not taken with a view of simply getting as much work out of them at a low rate of pay as can be had, but rather with the intention of making them the

best all-around mechanics possible, having in view the benefits to be derived from their thorough instruction after they become fully qualified mechanics. Conditions in different shops vary so widely that no universal schedule of apprenticeship can be laid down. I will, however, suggest what seems to me to be a good schedule for apprentices in a large railroad machine shop. I will also make some suggestions regarding the working out of such a schedule, and some reasons why some peculiar features are introduced, and some other seeming essentials omitted.

Suggested Schedule and Instructions for Employment of Machinists' Apprentices in Locomotive Department Shops.

The course for regular apprentices will cover a term of four years:

First Year.	1 month in tool room. 10 months in erecting shop, on both engine and tender work, including trucks, 1 month on bolt cutter.
Second Year.	12 months machine work. Drills, one month; lathes, three months; planers, three months; slotters, two months; milling machines and boring mills, three months.
Third Year.	3 months air-brake work, including all parts of air-brake repairs. 3 months brass work. 6 months vise work, including rod and link work.
Fourth Year.	5 months heavy machine work, including tire lathe, quartering machine, heavy planer, etc. 3 months firing on the road. 4 months in erecting shop, including practice in valve setting.

No person is to be employed as an apprentice who is under seventeen (17) years old, or who is over twenty-one (21) years old.

No person is to be employed as an apprentice who has not had a good common school education.

In the selection of apprentices, other things being equal, preference will be given to the sons of faithful employees of the company.

At the end of the four years' term of apprenticeship, if the apprentice has proven faithful, and is a good workman, he will be paid on the basis of the minimum rate of wages paid mechanics in his class of work, and he will then be advanced from time to time, as the needs of the business and the merit of his services will permit.

No apprentices are to be employed without investigation first being made, as to their education, general character and apparent fitness for the work they desire to take up.

The heads of division shops must personally see and pass upon all candidates before they enter upon their apprenticeship.

If all the railroads would enter into this idea of systematic treatment of the apprentice question we should soon have a sufficient supply of well-trained young men ready at hand for the work which is every year becoming more exacting and requiring men of special training. It is becoming more and more difficult for young men to acquire the proper training as all-around workmen owing to the tendency toward specialization in every direction. It seems necessary, therefore, for us to attend to this ourselves. We should accept the lesson from some of the well-known machinery manufacturers who have for years considered the apprenticeship question as a vitally important part of their organization to the end that we shall have an available source from which to recruit the service with young men who have a pride in their calling because of their fitness for the work and because of their being the best men from whom to ultimately select foremen and officers of greater responsibility.

This cannot be accomplished by preparing specialists, but rather by supplying opportunities for an all-around development which may be used as a stepping stone to any of the specialties of which our work is full. With this in view the apprentice should be given the greatest possible variety of work in order to permit him to select wisely the specialty at the completion of the course, and also to give him as thorough an insight as possible into the operation of the department with special reference to the dovetailing together of its various parts. With this in view it is well that the apprentices should

have the experience in firing. With this they not only obtain an excellent idea of the working of the locomotive and of its part in the operation of the road, but they also have another channel in which to direct their futures and another field in view when selecting their specialty after the completion of the course.

The reader will undoubtedly miss the drafting room in this schedule. It was left out for the reason that modern methods of operating the motive power department often require the chief drafting room to be located so as to be inaccessible to the shop forces and at the shops it is usually not necessary to provide more than a single draftsman at each of the more important plants. This renders it necessary to provide the instruction in drawing in some other way, whether this seems desirable or not, and this feature of the situation requires specially careful treatment. At most large railroad shop centers the Y. M. C. A. or the city provide evening classes, where good elementary instruction can be obtained in drafting. In localities where such instruction is available, and it is impracticable to send the apprentices of the railroad company into the drafting room, it would seem wise to make attendance at the night school, for instruction in drafting, compulsory for all apprentices.

It has been said, and it must be admitted to be a just criticism, that we devote our attention almost exclusively to the material of our profession, giving too small a proportion to the personnel, and from this fact has grown a situation in which the selection of properly qualified men for responsible positions is becoming more and more difficult.

THE MAINTENANCE OF AIR BRAKES ON FREIGHT CARS.

By G. W. Rhodes.

Assistant General Superintendent,

Burlington & Missouri River Railroad.

New equipment and material of all kinds generally must pass through a period of neglect and abuse on railroads before their full measure of advantage obtains. This is not confined to air brakes. We find the same thing in the maintenance of couplers, the use of oil, waste, the maintaining of parts on locomotives and cars, whose service depends almost entirely on the parts being intelligently bound together with properly secured bolts, nuts and keys. Even the compound locomotive has at times had a precarious existence largely because its machinery has not had the attention it requires. In the case of new machinery the cause for this is twofold.

First: When new parts, such as air brakes, are applied, in large quantities to the equipment of a railroad, it is generally through the action of the higher officials who entrust the matter of maintenance entirely to their subordinates.

Second: Subordinate officers do not know what demands the new machinery is going to make on the facilities at their command and in too many instances proper maintenance, for lack of facilities and the difficulty in obtaining them, is not possible until there is a general agitation on the subject and railroad conservatism is overcome by well-established methods in more or less general practice.

A very important and necessary movement of this kind is now progressing in the matter of maintenance of freight car air brakes. At an enormous expense, the railroads in this country of late years have been equipping their freight cars with power brakes. How to keep them up is now a most important question. The subject has been well discussed and agitated by the Central Railway Club at its November, January and March meetings of 1900 and 1901.

We propose considering two features of this question:

First: What methods should obtain to insure the cleaning of triples at least once in every 12 months?

Second: Should there be few or many cleaning stations on a railroad or system of railroads?

In regard to the first question we believe a general acceptance of the fact that triple valves are apt to be out of order if they have not been taken apart and gone over at least once in 12 months will do much to bring about the necessary reform. The decision reached by some of the Western railroads in mountainous territories—that they cannot accept cars that have not had their triples cleaned within 12 months—is a move they are warranted in because of the extreme conditions that have to be met on their grades and curves. A knowledge of this fact by freight agents when they have secured a load of transcontinental freight in the East would do much to stir up the general question of triple valve cleaning, and two or three days' time in through California business can be saved in loading through freight at Pittsburg, Philadelphia, New York and other Eastern points if agents will insist on having cars furnished that have had their triple valves cleaned within 6 months. The joint inspection at Denver is very rigid on this matter and the switching incident to a rejected car easily covers 3 days, if not more. If a railroad, owing to short mileage, had 3 days the advantage of a competing line in coast business, it would not fail to let this be known in soliciting freight. Here is an opportunity to get the same result by intelligent loading on the part of shippers. Some wide-awake roads are already availing themselves of this information.

The most important and effectual method of cleaning triples in the opinion of the writer is to keep a monthly record of the number cleaned and have this statement placed on the desk of the official who is responsible for their proper maintenance. To attempt such work without a record will never bring about the desired results. It will be a good deal like the light weights of cars whereby, through the neglect of the railroads of this country, thousands of dollars are lost every year. The chief reason for this neglect is that few railroads keep a monthly record of cars light-weighted at weighing stations and therefore they never know when any given weighing station is weighing all the cars it can or only a part. After a discussion on the importance of light weighing freight cars recently at a foremen's meeting on the Burlington road, notwithstanding the fact that no monthly tabulation of light-weighted cars have yet been made, an important weighing station increased its number of light weighings from 60 cars a week to 500!

A clear and comprehensive method of monthly triple-valve cleaning record is that described and practiced by Master Car Builder Canfield, of the D., L. & W. Railroad, which will be found in the March issue of the proceedings of the Central Railway Club. We have plenty of rules: the question is how to enforce them. Nothing is so effective as a monthly record intelligently compiled and looked after.

Let us now briefly consider the question of whether there should be few or many cleaning stations. This must depend largely on local conditions. On a line like the Burlington we favor not less than one general cleaning point on each superintendent's division, located preferably at the division shop headquarters, and in order that triple valves may be cleaned once in every 12 months we believe valve cleaners should have instructions to clean triples that have not been cleaned within 6 months and upward. Recently, in taking exception at one of our shops to the fact that they were not cleaning enough triples monthly, the Master Mechanic told me they could not clean any more even if they had more force and facilities, for they only cleaned the triples having 12 months and over of service; 10-month triples and 11-month triples were not touched. In axle limitations we have a shop limit which differs from the road limit, and it is believed the 12-month limitations for triples will be more nearly maintained if men at cleaning points are instructed to overhaul everything that has not been cleaned for six months or over. We do not favor a central cleaning point for the reason that some cars may never reach the general point, and to remove and exchange triples other than on divisions of limited length would necessitate carrying in stock many extra triples, as well as causing delays incident

to shipping. Moreover, a little competition incident to many cleaning and repairing stations has a very healthy influence in maintaining the character of the work.

These cleaning and repairing stations should be thoroughly equipped with all appliances to quickly and expeditiously do the work required, including compressed air appliances, so that after repairing or cleaning each triple may be subjected to the M. C. B. single valve test. One of the best of such cleaning stations is the one located at Western avenue, Chicago, on the C., B. & Q. Railroad. This repair shop with one man can average 3 triple valves overhauled and tested per hour or 30 per day of 10 hours.

In conclusion, to properly maintain triple valves, we advocate:

1. A road limit of 12 months.
2. A shop limit of 6 months.
3. A central cleaning station properly equipped with compressed air and triple valve cleaning and testing appliances.
4. A monthly record showing the proportion of triple valves cleaned and overhauled to the number of air braked cars owned.

ECONOMICAL TRAIN SPEEDS.

From the Fuel Standpoint.

By G. R. Henderson,

Assistant Superintendent Motive Power,
Chicago & Northwestern Railway.

Much interest has been manifested recently regarding the effect of speed of trains upon cost of operation, and particularly upon the question of fuel consumption. Numerous theoretical deductions and guesses, more or less wild, have been made as to the law of coal consumption relative to speed, but the writer believes that he was the first to make a practical demonstration of the rule of increase by means of a series of experiments with a good-sized freight locomotive. The tests were made on the "Test Plant" of the Chicago & Northwestern Railway Company at Chicago, and on the road by means of the dynamometer car belonging to the same company.

A brief account of the results of the test plant experiments was given in the American Engineer and Railroad Journal of June, 1900 (page 186), but the road tests not having been at that time undertaken, the diagrams could not be made complete. These have since been made, however, and a set of new diagrams worked up by the writer combining the results of both methods of procedure, and which, it is believed, place the results in a more convenient shape for examination and use.

As stated in the previous article, the tests were made with the standard Class R ten-wheel freight locomotive of the Chicago & Northwestern Railway, illustrated in the American Engineer and Railroad Journal in December, 1897, page 407, the principal dimensions of which are as follows:

Principal Dimensions of Class R Locomotive,
Chicago & Northwestern Railway.

Cylinders	20 ins. by 26 ins.
Driving wheels, diameter.....	63 ins.
Steam pressure.....	190 lbs.
Boiler diameter.....	64 ins.
Grate area.....	29 sq. ft.
Heating surface.....	2,332 sq. ft.
Weight on drivers.....	118,350 lbs.
Weight of engine and tender.....	260,000 lbs.
Steam ports.....	1½ by 16 ins.
Exhaust ports.....	3 by 16 ins.
Valve	Allen-American balanced
Outside lap.....	¾ in.
Inside lap.....	Line and line
Valve travel.....	5½ ins.
Lead at 6-inch cut-off.....	¼ in.

Referring now to the diagrams, No. 1 illustrates the fuel consumption at various speeds and expansions. These results were obtained by running the locomotive upon the test plant and carefully weighing the coal and measuring the water used while the engine was running for a period of considerable length at fixed speeds and cut-offs. The coal was all weighed

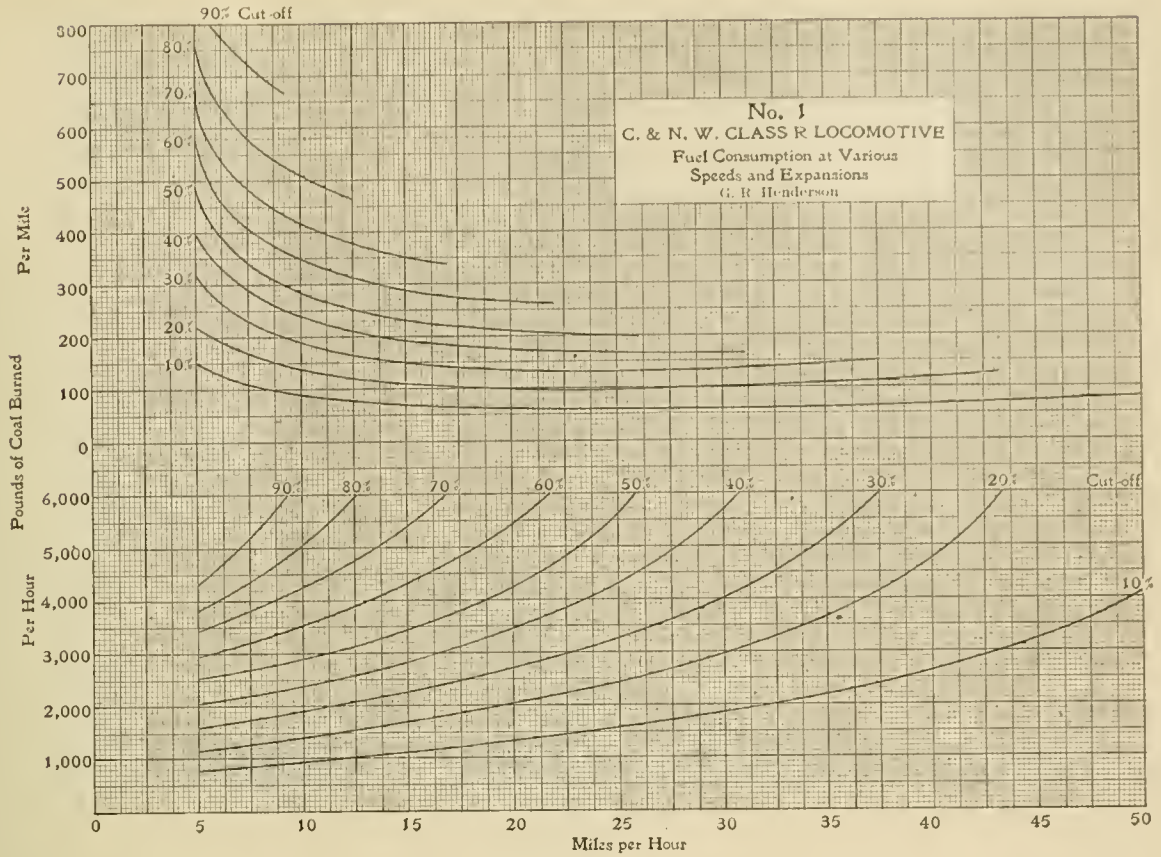

Diagram No. 1.

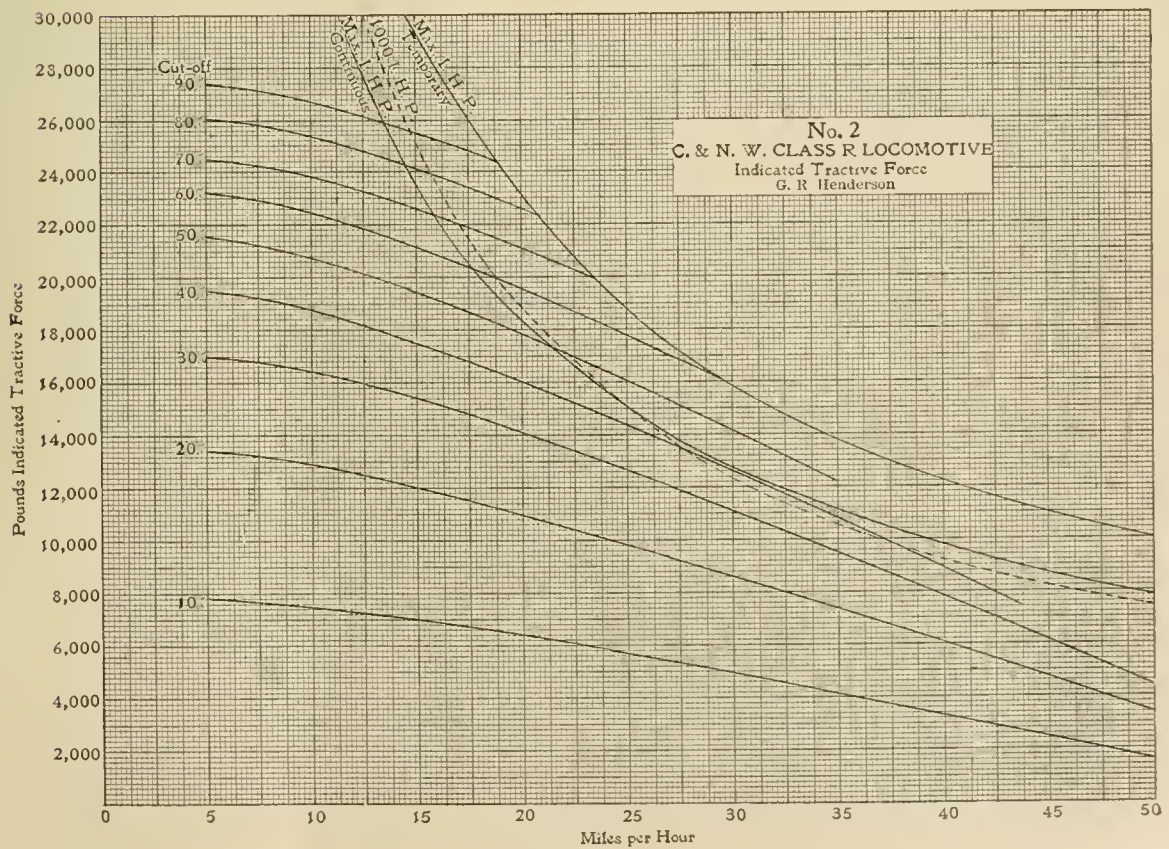

Diagram No. 2.

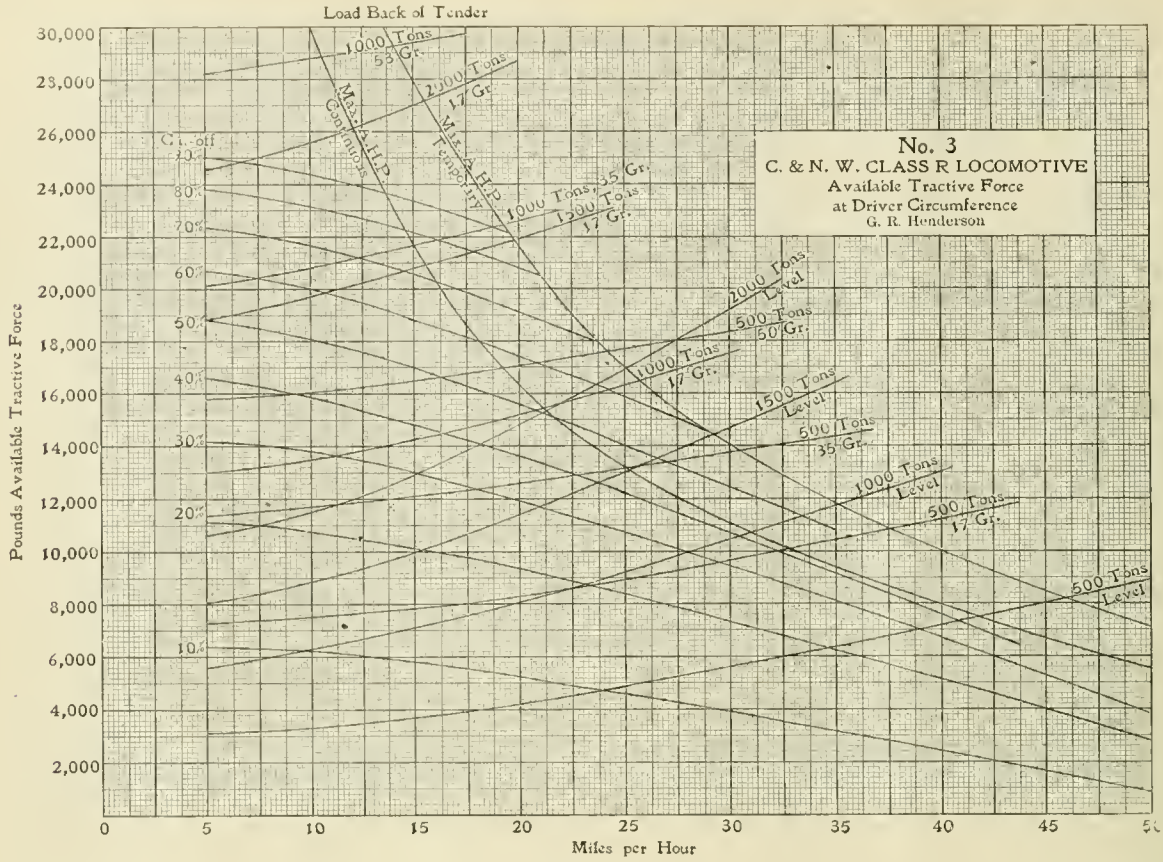

Diagram No. 3.

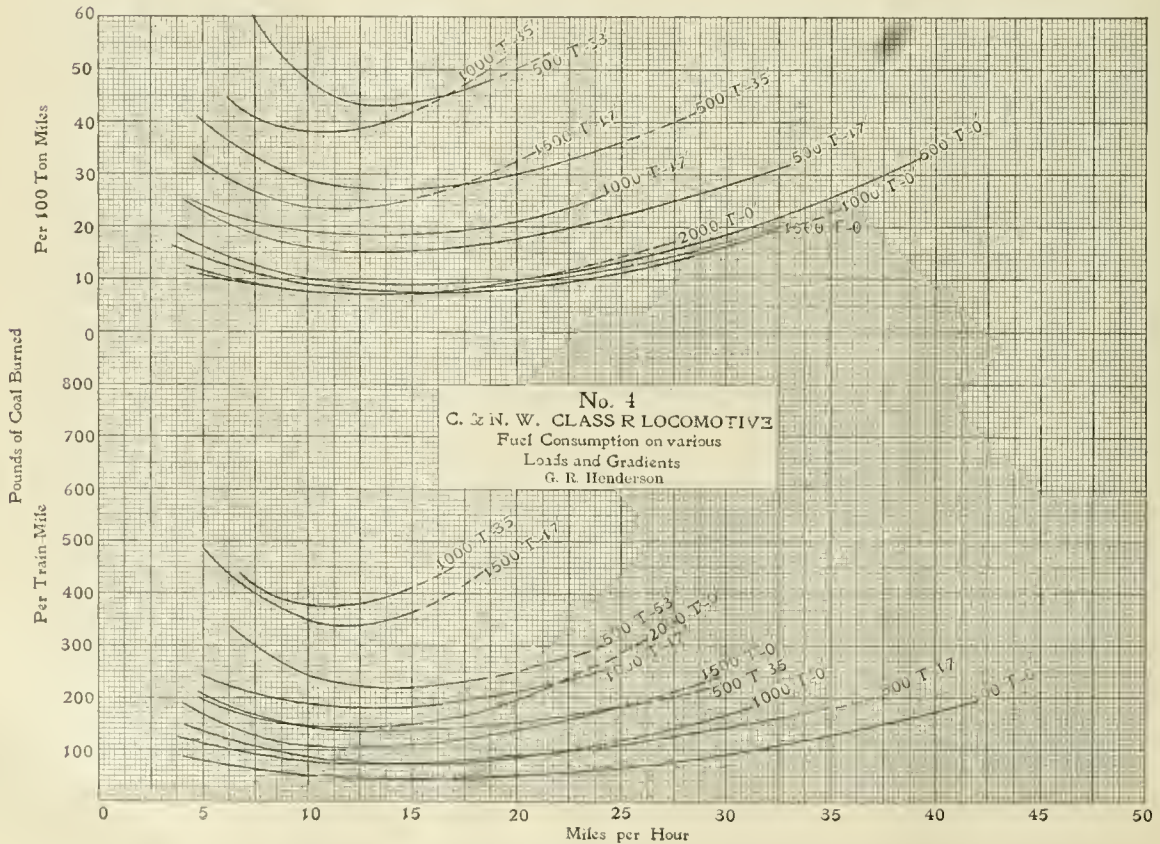

Diagram No. 4.

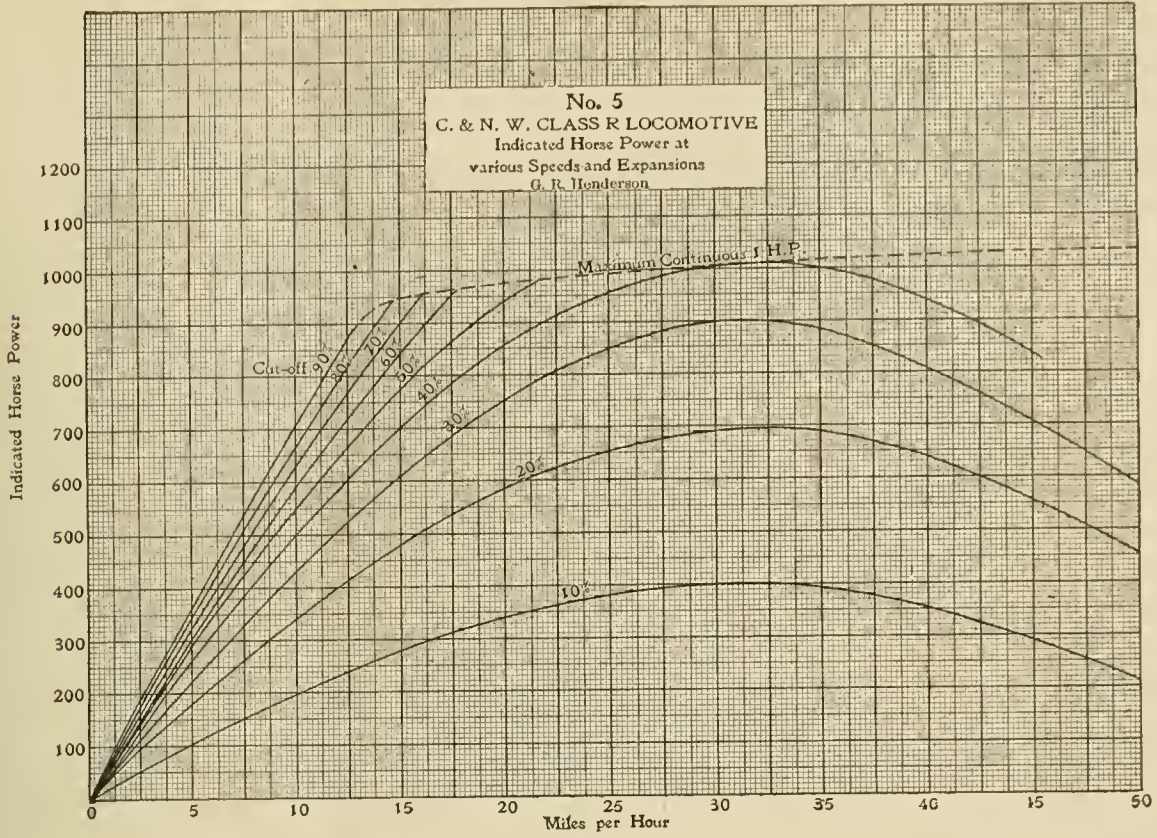

Diagram No. 5.

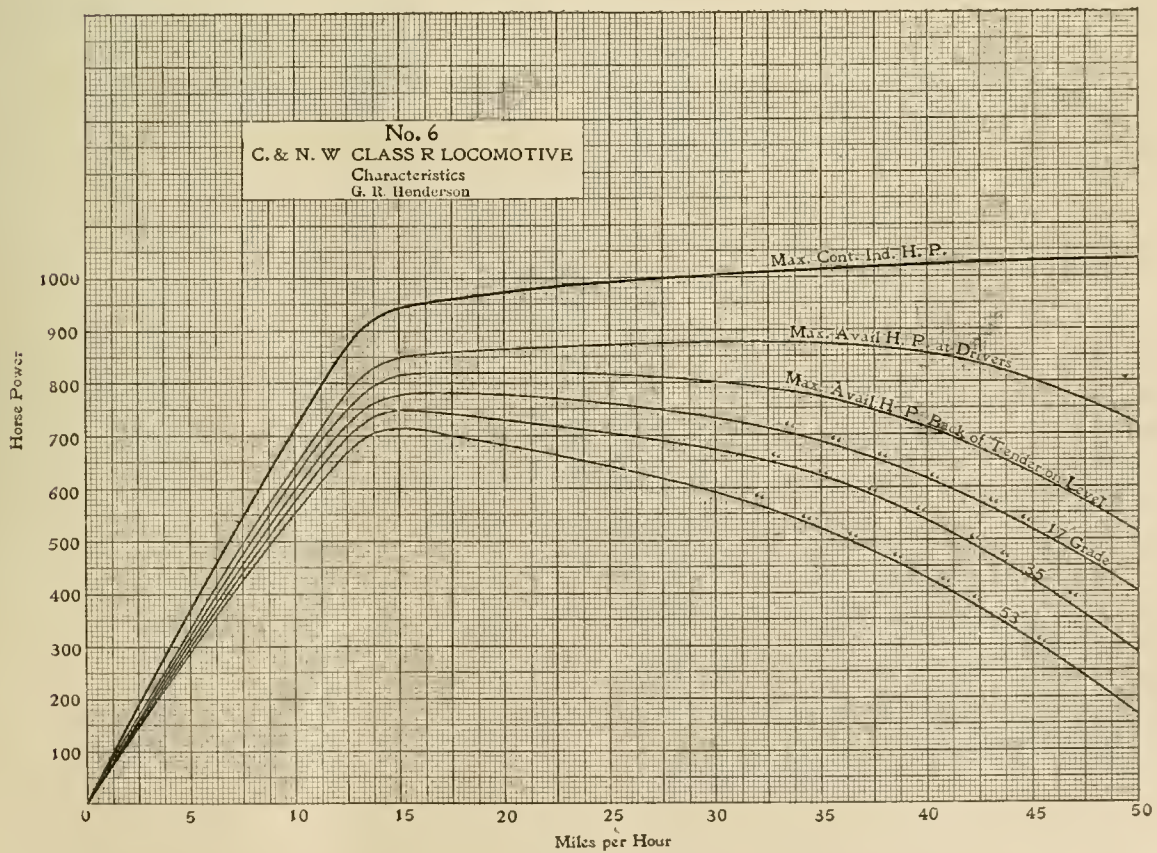

Diagram No. 6.

in a wheel-barrow just before being dumped upon the foot plate of the engine, and the water was passed through measuring tanks, carefully calibrated. A full throttle and maximum boiler pressure were maintained. The tests were run in regular series, and the results were laid off by points on cross ruled paper, and connected and interpolated to give the curves shown. From the care with which the tests were conducted, the writer feels that the results are what might be termed "commercially accurate."

The lower set of curves represents the pounds of coal consumed per hour under the different conditions. In all these diagrams the speed is shown by the abscissae. It will be noticed that 6,000 lbs. per hour was the maximum amount of fuel which it was possible to burn; this was a trifle over 200 lbs. per square foot of grate surface. The abscissa corresponding to the limit of the various curves at 6,000 lbs. denotes approximately the maximum speed which could be maintained by the boiler at the different expansions, although this is shown better on another diagram.

The upper set of curves gives the consumption per mile run, and was constructed from the lower set by dividing the several values by the speed during the test. It will be noticed that from 5 to 15 miles per hour the amount of fuel per mile decreases, but above 15 miles an hour, the quantity per mile is nearly constant at the same cut-off.

Diagram No. 2 gives the indicated tractive force for different speeds and cut-offs. These curves were worked up from the indicator cards taken on the test plant and with the dynamometer car in road service. The line marked "Max. I. H. P. Continuous" shows the maximum horse-power or tractive force which can be maintained continuously by the locomotive. It will be seen that this follows closely to the 1,000 horse-power curve, which is what would be expected from the 2,332 ft. of heating surface in the boiler, allowing 2.3 sq. ft. of heating surface per horse-power.

The line marked "Max. I. H. P. Temporary" denotes horse-power 25 per cent. in excess of the continuous horse-power line, and shows what might be obtained for a short period by closing off the injectors, thus taking advantage of the supply of heated water in the boiler, as the amount of heat used in raising cold water to the boiler temperature and pressure is about one-fourth of the total heat of evaporation under the existing conditions. It will be understood, therefore, that the latter line shows the limit which could be reached, but maintained only for a short time.

Diagram No. 3 was computed from diagram No. 2 by deducting from the indicated values the amount of internal resistance of the engine. This ranged from 8 per cent. with long cut-off to about 15 per cent. at short cut-off, and was derived from the dynamometer car test by allowing for the resistance of the engine and tender on the grade and at the speed at which the test was made. These resistances were added to the recorded drawbar pull and this was considered to be the available tractive force at the circumference of the drivers, and the curves were laid out to represent these values. The maximum available horse-power curves have the same meaning as in diagram No. 2.

The additional curves on diagram No. 3 indicate the resistance of trains of 500, 1,000, 1,500 and 2,000 tons back of the tender, on grades of 0, 17, 35 and 53 ft. to the mile. The calculations were made to include the weight of engine and tender in the resistance, so that the curves are directly comparable with the available tractive force curves. The intersection of these lines with the tractive force curves indicates what cut-off it is necessary to maintain to operate the desired trains at the designated speed. They also show the maximum conditions, and such as are beyond the power of the engine to handle.

For example, let us consider a train of 1,000 tons back of the tender on a 17-ft. grade. To operate at 10 miles an hour would require 30 per cent. cut-off; at 15 miles an hour, 40 per cent. cut-off; and at 20 miles per hour, 50 per cent. cut-off.

This would be the limit of continuous operation, but for a short distance it could make 25 miles per hour at 60 per cent. cut-off. No higher speed could be obtained with this load. These, of course, are for dead pulls, and not momentum runs. For 1,500 tons on the same grade and at speeds of 5, 10, 15 and 20 miles per hour the cut-off would be 50, 60, 70 and 90 per cent. respectively. The latter would be the limit of speed. We also can see, from the intersection of the train curves, that 1,500 tons on the level calls for the same work at 25 miles per hour as 500 tons on a 35-ft. grade; above this speed more, and below it, less power is required.

Diagram No. 4 has been constructed by combining the results shown on diagrams Nos. 1 and 3, by taking the amounts of coal needed for the conditions necessitated by the various train-loads and speeds. The lower group of curves gives the amount of coal necessary per train mile. The upper group indicates the consumption in pounds of coal per 100 ton-miles and was figured from the lower group by dividing by the weight of the train. The train weights are considered as those back of the tender. This diagram illustrates the increase in coal following an increase in speed. For instance, on a level, the amount of coal consumed per 100 ton-miles should be about 7 lbs. at 15 miles an hour, about 8 lbs. at 20 miles, 12 lbs. at 25 miles and 17 lbs. at 30 miles an hour. Thus it appears that doubling the speed more than doubles the coal consumption, when starting at 15 miles speed. It will be noticed that the minimum consumption for the various loads and grades lies between 10 and 15 miles per hour, and that the ascending portions of the curves are nearly parallel to each other, which may be interpreted as meaning that the increase in consumption due to speed is nearly the same for the various grades. There is a greater increase, however on the heavier grades. From 10 to 15 miles an hour should, therefore, be the most economical speed, as far as fuel is concerned. These tests were made in freight service, it should be remembered, but it is not clear why passenger engines would not follow a similar law. This demonstrates that it is inaccurate to compare the coal consumption of different trains without taking into consideration the speeds at which they are run.

Diagram No. 5 shows the indicated horse-power under different conditions of expansion and speed. At low speeds the horse-power increases nearly directly as the velocity, but with higher speeds the curves droop. Thirty miles per hour gives the maximum powers, and the explanation of this is that at higher speeds the steam does not have opportunity to enter the cylinder rapidly enough to maintain the mean effective pressure. The line marked "Maximum Continuous I. H. P." denotes the limit of boiler capacity.

Diagram No. 6 gives a set of "characteristics" for the Class R engine. The upper curve is the same as the one just described. The second curve gives the maximum available horse-power at the drivers, and has been produced by deducting the internal resistance of the engine from the first curve. The third has had the "rolling resistance" of the engine and tender subtracted and therefore gives a measure of power at the tender coupler. The curves for the different grades were located by further deducting the power necessary to overcome the force of gravity for the weight of the engine and tender. The last four might be termed "commercial characteristics," as they give an index of the useful work performed.

It is interesting to note that the maximum for this set is at 15 miles per hour. We would therefore conclude that this speed, 15 miles, not only is the most economical in regard to fuel consumption, but also represents the velocity at which the greatest amount of useful work can be gotten out of the engine, or where the maximum power is utilized.

Of course other questions, such as wages of train crews, interest and depreciation on equipment, etc., will modify the question of total speed economics, but it is felt that the fuel and power part of the problem will be made clearer by the graphical demonstration accompanying this study.

are believed to strengthen the car rather than weaken it.

The apertures in the floor are made by cutting slots 2 by 12 ins. through the floor itself. There is one of these slots between each two seats on both sides of the car. In the early stages of the experimental work it was thought that it might be essential to make the slot through the car floor continuous, but a little experience showed that this was unnecessary. The heating system consists of continuous radiators, rectangular in shape as is seen, fitted with fins to increase radiating surface and extends nearly the whole length of the car on each side. Under each seat is a Bundy loop attached to the main radiator, and forming a part of the heating system. These radiators, with the small steam pipes which supply them, are enclosed in a tight continuous boxing 5 by 8½ ins. inside. Under each seat is an aperture in the side of the boxing into which is fitted a galvanized iron tube 8 ins. in diameter, which encloses the Bundy loop and extends to the aisle. It will thus be seen that the cold air from the conduit between the sills is taken up through the apertures in the floor between the seats into the boxing enclosing the radiators, and must move each way from the slot in the floor horizontally, to the apertures underneath the seats, thence through the galvanized iron tube, receiving an additional increment of heat from the Bundy loop on its passage, out into the aisle of the car. From these points it disseminates through the car.

During the experimental work attempts were made to take the heated air out from the heater boxing, through registers in the sides of the boxing, into the space between each two seats. But this was found to be so objectionable to the passenger sitting next to the window that it was abandoned. Also an attempt was made to take the heated air out through apertures in the top of the boxing between each two seats, the idea being to have a current of warm air direct from the radiators pass up along the windows to neutralize their chilling effect. But it was found that this aperture served as a convenient receptacle for materials thrown in by the passengers. Still further, during the experimental work, the slots in the car floor were made 4 ins. long and spaced 4 ins. apart, and the radiators were fitted with tin shields so arranged as to keep the air in contact with the radiators as long as possible, but none of these devices worked as well as the arrangement finally adopted. The total radiating surface of the heating system is 247.24 sq. ft.

The control of the ventilating system—that is, the devices by which the amount of air taken into the car is increased or diminished—is in the ventilators situated along the center line of the upper deck. The ventilators thus far used are of the type known as the Globe ventilator, and there are six of them of the 6-in. size. They are spaced one at each end and one between each two of the five lamps. Of course the lamp ventilators also remove some air, and as these ventilators have 6-in. tubes, it was soon found that the lamp ventilators in connection with the Globe ventilators removed more air than the heating system would properly warm in severe weather; also that with the Globe ventilators closed, nearly the limit on which the system was planned, viz., 60,000 cu. ft. of fresh air per hour, would pass through the car, thus leaving the ventilating system without any control. Accordingly the lamp ventilators were partially closed by inserting diaphragms in them, leaving only a 2-in. diameter aperture for the escape of the lamp gases. This point will be referred to later.

The Globe ventilator and damper are shown in Fig. 3. It will not escape attention that the Globe ventilators may all be completely closed, except for some small leakages, or may be partly closed, or part of them may be closed and part left open, thus giving very great flexibility to the system. It will also not escape notice that thus far no reference has been made to the movable deck sash which are in so many cars, such an important element in the ventilation of the car. Upon this point it may be said that in the system of ventilation which we are describing the movable deck sash has no place. The deck sash are purposely made tight and immovable, with no detriment to the ventilation, and with very gratifying improvement in the behavior of the car lamps. Lamps which formerly gave much difficulty due to cross drafts between open deck sash can

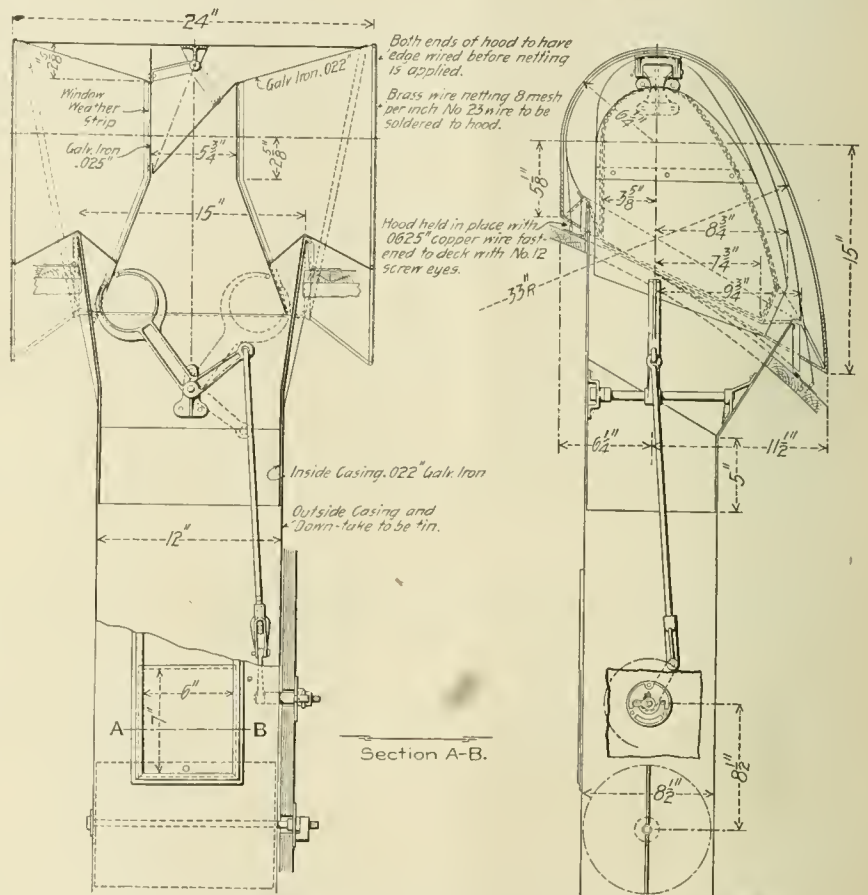

Fig. 2.—Arrangement of Intake Hood and Operating Device.

be used with very satisfactory results in cars fitted with the new ventilating system. A further marked advantage of fixed deck sash is the entire absence of cold air currents falling on the heads of the passengers, which is so unpleasant a feature of the movable deck sash. This point alone is no small item in favor of the new system, and when it is remembered that no cinders can come in through the fixed deck sash, it seems evident that the concomitant advantages of the methods adopted in this system are not inconsiderable.

The experimental work having led up to the construction above described, it remained to test the system and see what results it would give. The first tests were made to demonstrate whether the air currents would flow in the direction desired when the car is standing still. It is well known that some ventilating systems depend for the proper movement of the ventilating air currents on the movement of the car itself, and that when the car is standing still the ventilating air currents move in the wrong direction. In the system above described this difficulty, however, does not occur. It is of course fair to be said that when there is no heat in the car, and when the lamps are not lighted, there is very little movement of the ventilating air currents in either direction when the car is standing still; but definite experiments clearly show that when

there is heat in the car or when the lamps are lighted the ventilating air currents move in the direction desired. This is easily seen by holding smoking waste at the ventilators, and also, as above mentioned, by observing the motion of the air in the down-takes through the opened door. It is not difficult to see why this should be so, since the exits from the Globe

doors for a few minutes and allowing the cold air to pass out. Another point which caused some anxiety during the development of the system was soon put to test. It is well known that the construction of the Globe ventilator is such that when moving through the air on top of a car or when the wind blows past the ventilator, a suction is produced in the ventilator tube. This behavior of the Globe ventilator is one of the items relied on to cause the proper amount of ventilating air to pass through the car when in service. Moreover, the hood, when the car is in motion, acts as an injector and forces air into the car. Now it is obvious that if the exhausting action of the ventilators is in excess, there will be a slight vacuum in the car; on the other hand, if the injecting action of the hood is in excess, there will be a slight plenum in the car. In the experimental work every effort was made to secure a plenum in the car. But limitations of space inside the car, and clearances outside, rendered the efforts in this direction not quite as successful as could be desired.

It should be mentioned that experiments demonstrating whether a plenum or a vacuum exists in a car at any moment, are difficult to make, and are more or less unsatisfactory at best, and although some time has been spent over this point and a number of experiments made, the question of a plenum or a vacuum is not yet fully settled. The best that can be said is that there is no strong evidence that when the system is in normal operation there is a plenum. The tests indicate very closely a balance with a slight preponderance toward a vacuum. Such being the case, it would naturally be expected that cold air current would flow in through every available crack or crevice, and especially that contaminated air would be drawn from the closet into the body of the car. In actual practice it is found that the difficulties from cold air currents through cracks and crevices are so small as to be ignorable. The possibility of contaminated air from the closets gave more anxiety, and as a precautionary measure a 4-in. Globe ventilator was put in the roof of each closet. With this construction and with the close balance between plenum and vacuum in the car as above stated, no difficulty whatever has been experienced due to contaminated air from the closets. Indeed many and oft-repeated tests show that when the car is in motion the actual air movement is toward the closet rather than from it.

The above preliminary tests having been made, it became interesting and essential to know positively what the system would do in the way of furnishing fresh air to the cars. In order to decide this question a car fitted exactly as above described was filled with men from the shops, who were paid for their time, under the charge of a foreman so that they could be controlled in the matter of opening doors and windows and a trip was made early in December, from Altoona to Johnstown and return. Rubber bags and hand bellows were taken along with which to secure samples of the air in the car. Steam heat was necessary since the temperature outside was from 23 to 30 degs. Fahr., and neither door nor window was opened during the trip, except that after the proper samples of air had been taken at Johnstown the men were allowed some freedom, since a wait of a couple of hours must ensue before the return trip could be made. The air samples for analysis were taken by pumping air into the rubber bags by means of the hand bellows, moving from one end of the car and back again in the aisle during the operation, and taken the air from about the level of the heads of the passengers. The analyses were made immediately after the return and always the same day.

It is fair to say that during the development of the system this same trip was made a number of times, as successive modifications were tried, and during the study on this subject probably not less than thirty to forty tests of the air from cars have been made in the laboratory of the Pennsylvania Railroad Company. The final tests only are given below. In making the air analyses the carbonic acid only was determined, and from this was calculated the amount of fresh air taken through the car per hour by the ventilating system, the method used being the one described in the paper referred to in the beginning

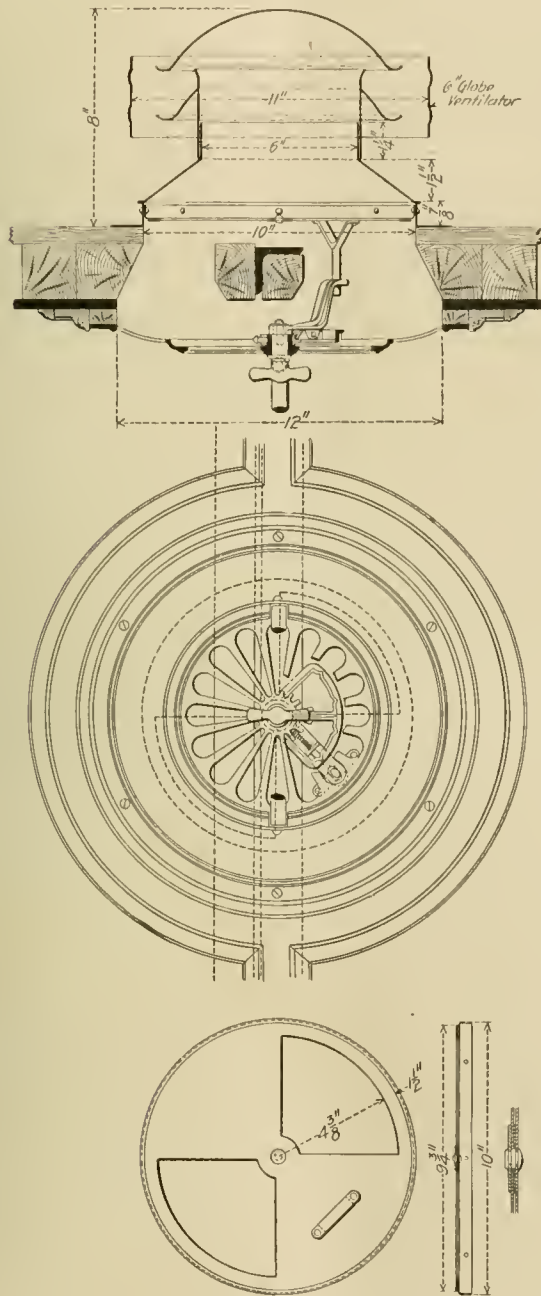

Fig. 3.-Globe Ventilator and Damper.

ventilators are nearly 2 ft. higher than the top of the hood at which the air enters. It may not be amiss to mention that when a car has been closed and standing on a siding for some time during very cold weather and is then put in a train and given heat, there is a little difficulty in getting the air currents started in the right direction. This is due to the fact that the column of cold air between the car floor and the tops of the ventilators is longer than the column of cold air from the bottom of the air conduit between the sills to the top of the hood. The difficulty is readily overcome by opening the car

of this article. The figures obtained on the trip mentioned are as follows:

	West Bound.	Per cent. of Carbonic Acid.	Cubic Feet of Air Per Car Per Hour.
All Globe Ventilators closed, Bennington.....		0.18	25,728
All Globe Ventilators open, Buttermilk Falls...		0.10	62,400
All Globe Ventilators open, standing 20 minutes at Johnstown.....		0.21	22,996
	East Bound.		
All Globe Ventilators closed, Cresson.....		0.14	37,440
All Globe Ventilators open, McGarvey.....		0.10	62,400
All Globe Ventilators open, standing 20 minutes at Altoona.....		0.20	23,400

In explanation of the figures it may be stated that the stations mentioned denote locations at which air samples were taken. Bennington, on the schedule used, is about 23 minutes from Altoona; Buttermilk Falls is about 57 minutes from Bennington, and Johnstown is about 10 minutes from Buttermilk Falls. Returning, Cresson is about 42 minutes from Johnstown; McGarvey about 20 minutes from Cresson, and Altoona about 5 minutes from McGarvey. These figures will give some idea of the interval between samples.

As has already been stated, the system was designed to supply 60,000 cu. ft. of fresh air per hour to a car, and it will be noted that when all the Globe ventilators were open, that is when the system was working normally as designed, the actual amount of fresh air obtained, was a trifle above the desired figure, as is shown by the samples taken at Buttermilk Falls and McGarvey. It should be stated that the actual amount of air supplied from time to time is affected by several conditions. The speed of the train has an influence, also the differences in temperature inside and outside of the car, and the direction and force of the wind. Just how much each of these variables amounts to is not known. It would require a number of tests under each of the varying conditions to decide these points definitely, but as the west-bound schedules was a slow one and the east-bound a more rapid one, it seems fair to assume that the system fulfils the requirements for which it was designed fairly well. It is also interesting to note that when the Globe ventilators were closed; that is, when the designed control was applied, the amount of air supplied was cut down approximately one-half, as is shown by the samples taken at Bennington and Cresson. In other words, the control makes it possible to reduce the amount of fresh air when it is desired to do so, as for example when there are few passengers in a car, or perchance in extreme cold weather, when the heating system may not be quite sufficient to warm the full amount. Finally, the samples taken at Johnstown and Altoona show what the system does, when a car is standing on the track, as at stations en route. It would, of course, not be expected that the same efficiency would be shown when the car is at rest as when it is in motion, and indeed this hardly seems essential. It will not escape notice that the difference between the amount of air supplied standing still and when the train is in motion, measures the effect of the movement of the train on the system. The tests above given were considered to indicate that the system was fairly satisfactory, as far as amount of fresh air is concerned. Two points further remain to be considered. These are the warming of the car and the exclusion of objectionable material, such as smoke and cinders.

The heating system in the cars, as above stated, embraces about 250 sq. ft. of radiating surface. It is obvious that the temperature obtained in the car from this amount of surface is a function of the steam pressure maintained in the radiators, of the amount of air taken through the heater boxing per hour and of the temperature of the outside air. Clearly it would be expected that if the amount of air supplied is constant at any given condition of the thermometer outside, the temperature inside would vary with the steam pressure; or again, if the steam pressure is constant, the thermometer outside being as above, the temperature in the car would depend on the amount of air taken in. In order to find out exactly what the system would do in the matter of car heating a car fitted as above de-

scribed, was run from Altoona to Harrisburg in January when the temperature outside during the whole trip was from 10 to 13 degs. Fahr. above zero. Thermometers were employed to measure temperature, and the car was without passengers, in order to afford opportunity for manipulation. The steam pressure maintained, although not measured on this particular car, was from readings on the gauge on the locomotive, believed to be about 20 lbs. During the trip the following points were fairly satisfactorily demonstrated: 1st, There is no difficulty whatever in keeping the car comfortably warmed in such weather with the ventilating system in full normal operation. The thermometer on the bell-cord hanger in the middle of the car, at no time throughout the whole trip showed less than 70 degs. Fahr. and most of the time was from 73 to 75 degs. Fahr., and on one occasion reached 77 degs. 2d. The distribution of heat throughout the car was entirely satisfactory. Thermometers in different parts of the car did not show differences of more than two or three degrees. 3d. Diminishing the amount of air supplied to the car, increased the temperature, which is what would be expected. Upon this latter point some further experimentation is desirable. The amount of work planned for this trip was full enough for the time, and the experiments on increased and diminished supply were not started until toward the end of the trip. The indications, however, were clearly as above stated.

An interesting feature developed during this run was in regard to the behavior of the two sides of the car. It will be remembered that there are hoods and down-takes on diagonally opposite corners of the car, one being, therefore, on the front end and the other on the rear end of the car when it is in motion; also that each down-take connects with its own radiating system, and that these are entirely independent, except that they take steam from the same point of supply. Are now both sides of the car equally efficient in supplying air when the train is in motion? The indications obtained during the trip above mentioned are that this depends largely on the direction of the wind. With the wind dead ahead, both sides seemed to be equally efficient, with the wind ahead and from the right of the line of the train movement, the right-hand side of the car seemed to be most efficient, and with the wind from the left, the left-hand side of the car seemed to do most of the ventilating. The direction of the wind was noted by observing the locomotive smoke and the movement of the air by holding delicate anemometers at the air exits in the car under the seats.

Tests subsequent to those mentioned above, seem to put beyond question the possibility of keeping the car abundantly warm during any weather, even when the ventilating system is in full normal action. Careful observations of temperature were made by a competent person during the trip from Philadelphia to Altoona, with the thermometer outside from 2 to 5 degs. Fahr. below zero most of the distance. It was easy to keep the thermometer on the bell-cord hanger 70 degs. and above. No record was made of steam pressure on the car, but 30 lbs. were used on the locomotive. An interesting feature developed during this trip, viz., the windows were heavily frosted at starting, owing to a little leak in the steam pipes while the car was being warmed up in the station. This frosting entirely disappeared in the course of an hour and a half, owing to the constant passage through the car of dry warm air.

Finally, in regard to possibilities of keeping the car warm, observations were made on a day train during the blizzard of February, 1899. This train was blocked by snow on the east end of Rockville bridge, near Harrisburg for over four hours. The location gave full sweep for the wind blowing down the Susquehanna River, and at times the cars would sway from the force of the blast. One of the five trial cars happened to be in this train, and during the time mentioned frequent observations were made on the temperature. At no time was any discomfort experienced, and at no time did the thermometer on the bell-cord hanger show less than 70 degs. Fahr.

In regard to the amount of steam required to warm the ventilated cars, no very positive data have been obtained as yet. The number of cars fitted with the new system is yet too small to make the question a very serious one. It seems evident that more steam will be required than if the cars were not ventilated, but whether this is going to make a serious drain on the locomotive or not still remains to be proven. A few through trains having from three to five ventilated cars in them have been operated with perfect success for over a year.

A single point bearing on the use of steam may be worth mentioning. At one time during the experimental work, a gauge fitted to show both pressure and vacuum was put on the radiator. As is well known, the system of heating in use is the return system, the water of condensation being taken back to the locomotive by means of a pump, which often produces a vacuum in the return pipe, which vacuum may extend into the radiator itself. On the occasion described the car was in a train moving about 40 miles an hour, the temperature outside about 20 degs. Fahr., and a very large volume of air, probably over 100,000 cu. ft. per hour, was passing through the car. The gauge on the radiator was indicating a vacuum of 5 or 6 lbs., when suddenly the train was stopped by signals. In a very short time, probably less than two minutes, the same gauge showed a pressure of 10 lbs. The explanation seems to be that while the train was moving, the heat was taken away from the radiators so rapidly by the incoming cold air that the steam condensed as fast as it was supplied, and the vacuum of the return pipe prevailed in the radiator; while, when the car stopped, the flow of air and consequently the removal of heat was so diminished that the steam supply was able to produce a pressure in the radiator. The vacuum appeared again, a short time after the train started.

In regard to the exclusion of smoke, cinders, dust, noxious gases, etc., it is to be confessed that if any of these substances are suspended in or mixed with the air which comes to the hoods, they cannot fail to be taken in along with the air. Cinders, however, of any appreciable size, are excluded by the gauze over the hoods. Small cinders that pass the gauze apparently pass out the small holes at the foot of the down-takes, or are deposited in the conduit between the sills. The location of the hoods on the top of the lower deck is believed to very greatly diminish the possibility of dust from the track being a serious source of annoyance. The smoke from the locomotive with the noxious gases which it carries is usually considerably higher than the hoods, or is diverted on one side of the train or the other by the wind. This leaves only the conditions concomitant to long smoky tunnels to be especially provided for. The closure of the valves in the down-takes and the rapid change of air in the car by the system, only about four minutes being required to completely replace the air in a car, after it has passed the tunnel, so greatly mitigate this difficulty that no serious trouble has thus far been experienced from the introduction by the ventilating system of objectionable material from without.

It may be fairly stated that practical experience with the system on this road has thus far been very gratifying. Both passengers, officers and trainmen seem to find in the new system such an amelioration of previous conditions that it is not rare for them to pronounce it a marked success. The tendency to open the windows is very greatly diminished, and the possibility of running with closed doors in the heat of summer is clearly noticeable.

One difficulty still remains to be overcome. The partial closing of the ventilators over the lamps results in a tendency to smoke the headlinings. Apparently the apertures left are not quite large enough to completely carry off the lamp gases. In order to overcome this difficulty it has been proposed to combine the Globe ventilator and lamp ventilator into one. Such combined ventilators, increasing the apertures for the escape of the lamp gases and at the same time retaining the essential control of the ventilating system, are now on trial.

THE LOCOMOTIVE TESTING PLANT.

Its Place in Railway Equipment.

By Robert Quayle,

Superintendent Motive Power, Chicago & Northwestern Railway.

While locomotive testing plants have come into somewhat extended use within the last few years, they are still few enough in number to excite interest as stationary appliances for accurately determining data in regard to the performance of locomotives.

Probably the first effort of this kind, outside of Purdue University, was made when the writer was Master Mechanic of the old Milwaukee, Lake Shore & Western Railway, at Kaukauna, when an engine truck was inverted, placed in a pit and fitted with brakes to retard the carrying wheels themselves, in order to absorb the power of the locomotive whose drivers rested upon them. The present testing plant in use at the Chicago & Northwestern shops at Chicago was built in the spring of 1895 and was complete enough to permit of making a large range of practical tests upon it, thus demonstrating the various efficiencies of a locomotive. The wheels of the present plant, upon which the drivers rest, are of large size so that the speed of retardation is slowly reduced, the diameters being practically the same as of the locomotive drivers themselves. The plant has been so often referred to and described that it is probably unnecessary to give any further details in regard to it.

The first tests on this plant were made in July, 1895, and were made principally to demonstrate the best practice in regard to settings of slide valves and the allowance of lap and lead which should be given them under different circumstances. After that a test was made comparing compound and simple engines. One of the very interesting facts brought out in a test that was made later on in the same year was that the springing of the eccentric rods would cause a remarkable decrease in the opening of the valves. This was the case with an engine which had rather long eccentric rods bent over the axles, and it was found that when the throttle was wide open the steam chest pressure caused so much friction that the port opening was reduced by a very large percentage. This led to trials with various sized ports, and it was found that with unusually long ports the friction of the valve was so much increased that there was actually much less real opening than with a shorter port and less resistance.

The test made to determine the best arrangement of front ends, in connection with the Master Mechanics' report of 1896, is too well known to require any further recapitulation, except to say that it would be practically impossible to maintain uniform conditions so necessary for such a test on anything but a stationary plant.

One quite interesting test was the comparison of two engines of the same type: one engine being pronounced a very good one and the other a very poor one. Deductions made on the testing plant showed that there was practically no difference in the work done by these two engines and that the whole question was merely an idiosyncrasy of some people connected with the handling of the engines.

Owing to the varied nature of the service when an engine is running upon the road, it is practically impossible to make tests which will give us definite information in regard to the relative value of different applications of various contrivances. The writer has frequently known cases where the difference between runs with the same device will be greater than between runs with different devices. As soon as an engine is brought into proper condition, and the reverse lever, throttle, etc., are in the desired position ready to take a test we either get a red flag or a signal is thrown up in front of the engine which compels a stop, and thus the conditions are lost, and this almost always repeats itself time and time again.

With the testing plant, however, a certain set of conditions may be maintained for an hour or more and we are thus en-

abled to accurately determine the proper adjustment of the front end, lead, diaphragm, exhaust nozzle, netting arrangement, valve setting and even the kind of lubricators or other devices and their operation may be much more satisfactorily noted than in a service or road test. Service tests, however, are not to be deprecated and the testing plant can never entirely take their place. In some recent experiments this was particularly well brought out and a combination of the two worked out in a very interesting manner.

A full set of tests was made on the standard freight engine of this road upon the testing plant, in order to obtain information in regard to the coal consumption at various speeds and expansions. These tests are described at length in this issue of the American Engineer by Mr. Henderson. The conditions were continued where possible for an hour so that the consumption of coal could be properly determined for an adequate length of time. From these, diagrams were plotted showing the consumption which might be expected under different conditions of speed and cut off. The engine was then tested with a dynamometer car upon the road and by noting the draw-bar pull which was obtained during the different conditions of speed and cut-offs we were able to deduce very closely the amount of coal needed to give various draw-bar pulls at different speeds. This was applied by working the engine up to the increased consumption of coal due to higher speeds, and this was really the prime motive in making these tests. It was found for instance that while 7 lbs. might be expected in the way of consumption per 100-ton miles at 15 miles an hour on a level, that at 30 miles an hour the consumption would be more than double or would average about 17 lbs. per 100-ton miles. With the same information we were enabled furthermore to give locomotives a proper rating, one that we are sure they can pull without difficulty, and yet which will not allow them to go underloaded. It is, of course, known that to run trains at higher speeds they must be reduced in weight, and these experiments also give us the ratio of decrease in order to maintain higher speeds on level tracks or on varying grades.

These problems are so intimately connected with the economical operation of motive power, that it is needless to give any additional examples of the results obtained from the testing plant in order to illustrate its commercial value and as its cost amounted to about \$3,000 it is unnecessary to say that we have felt more than repaid for the expenditure made upon it.

IS IT GOOD POLICY FOR RAILROADS TO BUILD THEIR OWN LOCOMOTIVES?

Obviously, the answer to this question can be found only by a careful analysis of the facts in detail for and against this policy. Dividing the problem into the following parts we have:

First, its relation to the business interests of the railroad as a common carrier. Second, the direct economy in difference of cost. Third, reduced cost of maintenance incident to a possible higher standard of workmanship, securing greater interchangeability of parts. Fourth, greater efficiency as adapted to the demands of the service.

A railroad corporation, as a common carrier, is a public servant whose business is the carriage of passengers and the hauling of freight. The latter item being by far the source of largest income and profit, and directly proportionate to the amount of manufacturing located and carried on along its lines, these manufacturing industries, therefore, constitute a patronage which is to be fostered and encouraged by every legitimate means. This fact has an important bearing on the question. As a further incidental to the faithful performance of this duty as a public servant, and that this service may be available at any time, according to demand, specially skilled employees are maintained in the various departments as a permanent force; a characteristic of every well-organized railroad.

It will be obvious that in the duties and the organization there is not only no provision logically to be made which would include the railroad as a manufacturing competitor, and that it is also a fact that any manufacturing on the part of the railroad itself, competing with a similar industry along its lines, would only antagonize and probably would result in the

loss of freight traffic. Furthermore, the amount of money saved by the best possible arrangement of organization on a railroad in the manufacture of that which could much better be purchased is a great deal less than the profits on the freight lost as a result of this policy. We have never known a case in which the railroad with its peculiar kind of skilled labor and organization could compete with the manufacturer on any article which they were attempting to make. The reasons are: First, a first-class mechanic on locomotive work, and perfectly satisfactory on that line of work, is seldom a first-class mechanic or available when compared with the class of skill characteristic of the first-class mechanic in ordinary manufacturing interests. Second, the foremen in charge of departments on a railroad are generally men who have been brought up on the railroad, and with no manufacturing instincts or experience. Third, the absence in the average railroad shops of that atmosphere of competition which is a prominent characteristic of every manufacturing interest. This almost totally eliminates that care in detail, economy in use of materials, and the multitude of small matters which are the key-notes of success or failure.

Considering cost as including only the labor, material and legitimate expenses of the plant which can be charged to output, it is an open question whether, as compared with the average manufacturing concern, a railroad ever does know exactly what a locomotive constructed by them actually costs—for this reason: The system of bookkeeping essential to the affairs in general of a railroad is not such as in all cases absolutely to identify the labor involved with the product. Even if it were true that the system of bookkeeping was the same, the reasons above given should be sufficient to indicate a very large possible difference in cost. In addition to this, there should be charged against a locomotive built by a railroad the proper proportion of cost of maintaining an engineering department incidental to the designing of the locomotive. The very creation and maintenance of this engineering department presents opportunities for the experimentation and working out of personal fancies in the designs created which quite frequently result in failure, and the cost of this also should be charged up against the locomotive. This, however, owing to the peculiar method of bookkeeping, does not show as an item of cost, and is generally paid for from the expense account. Very few railroads, indeed, are so equipped that they can assign to one shop the manufacture of all of their new locomotives, to the exclusion of repair or other work strictly incidental to maintenance. And in such shops, where this cannot be done, and the two kinds of work are carried on at the same time, the fixed force which must be maintained for emergencies and regular operative purposes constitutes practically a fixed charge, which, in the absence of anything else to charge it to, must be borne by such new work as may be turned out.

It is quite possible—in fact, in some cases we know it to be true—that there is a saving in cost of maintenance of locomotives built by a railroad company, owing to the fact that while it is not so written in the bond, it is understood that the work turned out must at any cost be interchangeable and absolutely standard. While this increases cost of manufacture in many cases, it results in less detention in repairs, a greater mileage, and reduced cost per train mile for maintenance. We think, however, that there are very few, if any, locomotive builders who cannot guarantee to produce similar work if it is insisted upon and proper drawings are furnished and thorough inspection is available. This kind of workmanship is directly the result of skilled labor and careful supervision, and it would hardly be fair to assume that the average locomotive concern is not even better equipped in this particular than any railroad. In addition to this, the competitive feature and the necessity for constant improvement in methods which will reduce cost and increase output, a necessary characteristic of their business, is greatly in favor of lower first-cost to the railroad company.

Owing to the difference in traffic demands, gradients, curvature, coal, water, etc., various modifications from one standard design are required to fulfil satisfactorily the various demands of service. And while it is true that a railroad equipped with an efficient department able to work out these problems as adapted to that particular road, it is frequently the case that the tendency of this department will be to originate rather than adopt the best existing practice, thus leading not only to expensive failures in the locomotives built, but also to wasteful delays of traffic. This is especially the case where not only are the designs made but the locomotives actually constructed by the railroad company itself. It would seem more reasonable that the locomotive builders, who are not only designing but building for railroads all over the country, and keeping records of performance of the various types of engines built, should, when supplied with the essential data, be able to furnish a more satisfactory and economical design of locomotive than the average created by the railroad company in its engineering department and at much less cost.

WIDE FIREBOXES FOR SOFT COAL.

By F. A. Delano,

Superintendent Motive Power, Chicago, Burlington & Quincy Railroad.

It has been recognized by locomotive designers for some time that the high speeds required, both in passenger and freight service, as well as the reduction of grades and the consequent handling of trains more nearly up to the maximum cylinder tractive power of locomotives, have made demands on locomotive boilers far in excess of their economic capacity. In order to meet these demands there has been a steady increase in the size of boilers, increasing the diameter in order to adequately increase the heating surface, but the chance to increase the grate area proportionately with the heating surface was limited in the ordinary bituminous coal burning engines to the available width between driving wheels (say 40 ins., putting the firebox over the frames) and a maximum length of say 9 to 10 ft., and making the total maximum grate area say 30 to 33 sq. ft.

In the summer of 1899 the Chicago, Burlington & Quincy Railroad began the construction in their own shops of four freight engines like a mogul in type, but with a trailing wheel behind, where the shell of the boiler was made long enough to place the firebox entirely behind the back drivers. While this construction compelled the use of an excessively long boiler shell, and fines of a hitherto untried length, it did admit of widening the firebox to any convenient width, still maintaining a relatively deep firebox without raising the center of the boiler to an undesirable height.

This design was rapidly followed by modifications adapted to passenger service as well as freight, prominent among which may be mentioned those of the Schenectady Locomotive Works, the Pennsylvania Railroad, the Brooks Locomotive Works, the Lake Shore Railroad and the Baldwin Locomotive Works, the examples of which are on record in this journal. The essential feature of each is the long barrel or shell of the boiler, the firebox widened to any convenient figure—thus far within the limits of $5\frac{1}{2}$ and 7 ft.—making an engine heavy at the back end and spoken of by some critics as a "Kangaroo" type. This back end has been supported on a single pony trailing truck the carrying gear for which has been the subject of a good deal of ingenious design.

The widening of the firebox beyond the limit of the width available between the driving wheels is no new thing in anthracite and "coal dirt" burning engines. It has been the practice for years to use shallow but excessively wide fireboxes, but the experience of some years ago with this firebox in handling Western bituminous coal seemed to show that the grate area was excessive and the firebox too shallow for lump coal, so that a compromise width and a more moderate total grate area, having greater depth, is coming into use, at least experimentally.

Great differences will be found between the extremes in ratios of grate area to heating surface; also between extremes in the ratios of grate area and heating surface to cylinder volume, for example: The ratio of total heating surface to grate area of about 35 to 1 with certain recently constructed Wootton type fireboxes especially designed for bituminous coal is to be found, and side by side a ratio of 110 to 1 is found in an extreme case of narrow firebox for an excessively large boiler. It seems to the writer that there might be a wise "golden mean" between these extremes and a ratio of say between 50 and 60 to 1 is recommended as being a good ratio for engines burning ordinary bituminous coal. The writer refers to ordinary bituminous screened lump and mine run coals where the coal is not very friable. For crushed coal, screened or not, and small anthracite coals, etc., a larger relative grate area would be required.

In determining the ratio of boiler capacity, as well as the

heating surface to cylinder volume, one must know the kind of service for which the engine is required. Running engines on a level road to their full cylinder tractive power requires a boiler of a very large capacity, whereas on a road with undulating grades a much smaller ratio of boiler capacity to cylinder volume can be used to advantage.

The ratio of the heating surface in square feet to the weight in pounds of one cylinder full of steam at boiler pressure gives a figure which can be used in a general way to compare different types of locomotives. I find that in comparing engines of a prominent trunk line this ratio varies all the way from 743 to 1,200. It has been found by experience with engines having a ratio below 1,000, that they have not proved very successful engines for a continuous effort; in other words, they are over-cylindered. [Editor's note.—This use of the term "over-cylindered" has no reference to the weight on the drivers.] The ratio of the latest design of "Prairie" type locomotive for this road, illustrated in the May number of the American Engineer and Railroad Journal is 1,403. This is in excess of all our earlier engines, the next in order having a ratio of 1,111 sq. ft. The lowest ratio on this road is for a consolidation locomotive designed in 1879 and very much over-cylindered for continuous grades or level track. Its ratio is 743. A ratio below 1,000 seems to be an indication that the engine is "tender."

In connection with the, so-called, moderately wide and deep firebox, a grate area of from 40 to 50 sq. ft. is readily obtainable, without making the sides of the firebox flaring or inclined outward. This grate area is only half that which has been obtained in Wootton boilers, but the firebox is considerably deeper, and the possible center of the boiler low even for high-wheeled engines.

What may we hope for this type of construction? In the first place, making the firebox shorter and wider makes it more nearly square, and even in spite of the increased area of grate an ordinary fireman can more easily cover it. Secondly, the shortening of the firebox diminishes the number of staybolts in the side, as well as increasing the thickness of the water legs on the side to any convenient figure. This ought to diminish the staybolt failures for the following reasons:

Because there are fewer staybolts.

Because the staybolts are longer.

Because the side water legs, which are supplied with water from the front barrel, from the water above the crown sheet and from the back leg, will be more readily supplied than if the side legs be long. Third, the intensity of the heat in the firebox, which should materially assist toward perfect combustion, should be greater in a nearly cubical firebox than in a long and narrow one.

The American locomotive on British railways has, aside from the prejudices of their drivers and firemen, labored from the very first under a considerable disadvantage. Mr. Charles Rous-Martin, in a recent issue of "Engineering Magazine" says, that the American engines are not the engines that the builders of this country, knowing the precise local requirements, would have designed for the class of work to which they are put; that the requirements of traffic are looked at by the designers in this country from a different point of view than that of the British designer and the result is an engine that does not represent the matured result of American experience as applied to this particular type of locomotive designing. To this may be attributed the increase in the amount of fuel that is said to be necessary for operating the American engines in a similar work with the British engines. There are, however, no records of coal consumption accessible to substantiate this statement. As to the question of repairs it is yet a little too soon to draw any conclusions, but with the exception of the matter of coal consumption it is the opinion of Mr. Rous-Martin, based upon considerable independent information, that the American engines are doing their work well and are satisfactory.

(Established 1832.)
**AMERICAN
 ENGINEER**
 AND
RAILROAD JOURNAL.

PUBLISHED MONTHLY

BY

R. M. VAN ARSDALE,

J. S. BONSALE, Business Manager.

MORSE BUILDING.....NEW YORK

G. M. BASFORD, Editor.

E. E. SILK, Associate Editor.

JUNE, 1901.

AMERICAN ENGINEER TESTS.

Locomotive Draft Appliances.

For more than two years this journal has contemplated conducting a series of tests for the purpose of furnishing information which the motive power departments of American railroads most need in solving their problems. The subject of locomotive draft appliances, or the front end problem, was selected because it is in a very unsatisfactory state. Practice in this regard seems to lead in circles, and in the absence of information applying to present conditions little if any definite progress is being made. Most excellent investigations in this direction were conducted in Hanover, Germany, in 1894, by Von Borries and Troske, and in this country in 1896 by the Master Mechanics' Association. These, however, are not applicable to the changed conditions of to-day, and we hope to supplement this excellent work and render it available to present and future designing.

Among railroad officers the idea has received an instant and encouraging response wherever it has been mentioned, and this tends to confirm the original determination to make the investigation thoroughly worthy of the subject.

As the first preliminary Mr. H. H. Vaughan, Mem. A. S. M. E. and formerly Mechanical Engineer of the Philadelphia & Reading Railway, has prepared an able analysis of the subject. We are fortunate in securing his assistance and in having the cordial interest and hearty support of Professor W. F. M. Goss, of Purdue University. Through him and the other authorities of the University the locomotive testing plant of that institution is placed at our disposal for the tests, which is sufficient promise of efficiency and thoroughness. Professor Goss has rendered a report based upon Mr. Vaughan's analysis, with recommendations as to the scope and character of the tests, and has been engaged by the American Engineer to conduct them, under our direction, the work to begin next September. The expense is to be borne by us and our columns will record his final report.

Appreciating the importance and value of suggestions from railroad officers who are in position to bring years of experience to bear upon this subject, we have invited co-operation from those who have given it special attention. On the evening of May 21, in Chicago, the preliminaries were discussed by representatives of the motive power departments of a number of prominent railroads, who met at our invitation. These included the Pennsylvania, New York Central, Chesapeake & Ohio, Lake Shore & Michigan Southern, Chicago & Northwestern; Chicago, Burlington & Quincy; Denver & Rio Grande, and Atchison, Topeka & Santa Fe. At this meeting the outline of tests was approved. These gentlemen unanimously endorsed the plan and voluntarily offered their services as a committee to do all in their power to assist in making these tests the most complete of the kind ever conducted.

It may properly be said that the enterprise is well founded, and we may even be allowed to congratulate our readers upon

the prospect of securing through our columns the complete record of the investigation. When the tests are under way we shall begin the publication of the large amount of valuable information which has already accumulated in this connection, after which the records in full will follow.

THE MOTIVE POWER OPPORTUNITY.

By W. S. Morris,

Superintendent Motive Power C. & O. Ry.,

President Master Mechanics' Association.

The fact that 40 per cent. of the operating expenses of railroads in this country come within the responsibilities of the motive power departments is ample justification, especially in the case of one connected with this branch of the service, to consider this work one of the most important factors of railway operation. All departments are but members of the whole body, and I have no desire to exact privileges for the motive power branch because of the proportion of its responsibility, but it is pleasant to be a part of the organization which presents such important possibilities.

In the matter of operation it was not long since a locomotive was merely a locomotive and a car was a car. It did not seem important that they should receive the concentrated thought and knowledge gained by years of preparation and experience, in order that their efficiency as money earners should be of the highest grade. As I understand the present situation, the operation of railroads to-day and of the future depends upon these efficiencies. In this field has appeared the most radical advancement, and in it lies the widest horizon of possible improvement. We have magnificent roadbeds to carry our equipment and we have able executives to operate it, but the locomotive and the car must be carried forward in a development which thus far surpasses all other engineering

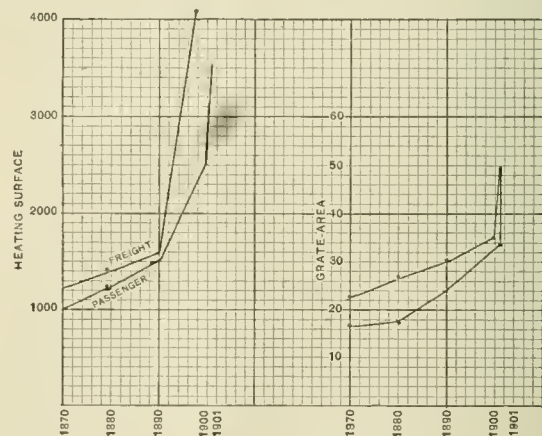

Progress in Locomotives.

progress and which bids fair, within the present official generation, to reach a state of advancement at present not dreamed of.

Having recently had occasion to look up the progress of the locomotive during the past thirty years and to put it in the form of diagrams, I include two of them here, because they indicate a tendency which will probably surprise even those who have had a hand in the performance itself, unless their attention has been directed to it as mine has been. This space of time has been covered by the experience of motive power officers who are now living and some are yet active, whose names will be found in the proceedings of the first convention of the Master Mechanics' Association. They have seen heating surfaces increase from 800 and 1,000 sq. ft. to 3,500 and 4,000 sq. ft. for passenger and freight service. They have seen boiler pressures rise from 120 to 225 lbs., and grate areas (bituminous) increase from 17 to 50 sq. ft. Tractive power has grown as well, but not in proportion. Mr. Forney expressed the opinion in the

year 1888 that in 1918 locomotives would have boilers 7½ ft. in diameter and that they would weigh 200,000 lbs. These figures have already been approached and those of weight have been passed.

The car, or carrying, problem has kept an even pace with locomotive progress. It is associated directly with the business side of transportation operation, and, "looking backward," the progress in capacities and dead weights from 1860 to the present time in freight cars can be as thoroughly appreciated from the diagrams also included. These are intended to convey ready conception of the accomplishments that have been made, and only a brief period has elapsed to indicate to the observer the financial "Eureka" to be in the heavy tonnage and concentrated load.

No one can tell what the next motive power improvements will be, but this seems to be a favorable time to consider promising suggestions of all kinds. It is my conviction that in the next few years we shall see a surprising change in the

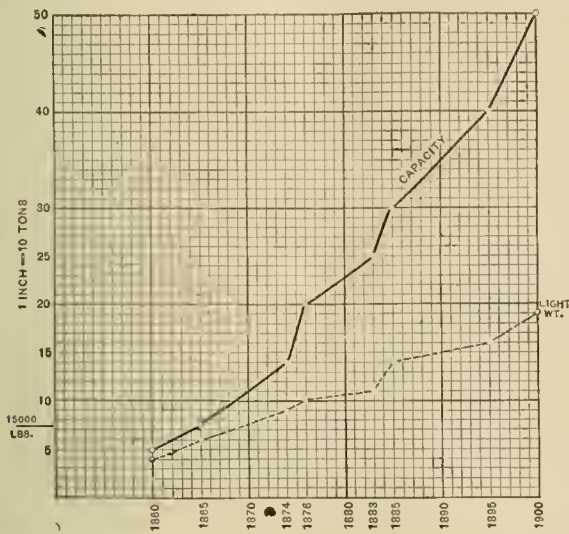

Progress in Cars.

ready acceptance of construction and the employment of principles which are not now considered at all, and that this will result from a broader appreciation of the business side of the motive power problem. If it is necessary to accept greater complications of construction in order to get the desired capacity in power, it will be done, although it would be advantageous to build locomotives and cars with the least number of parts. The men who are to have a hand in this progress are to be congratulated, for it is a work worthy of their best endeavors. The old lines cannot much longer be followed, because of limitations of size and weight. It, therefore, remains to be seen how we shall be able to get the utmost out of the weight and space that are available. This is a new era, because it requires a treatment which has not been found necessary before and here is where the progressive man with the combination of education and responsible experience will find a subject affording all he requires in the form of an opportunity. I do not mean to say that we need radical improvements to-day, but we shall grow rapidly up to the need of them.

In the stream of consolidations comes that of the locomotive builders, which includes all of the large works except the Baldwin. Under the name of the American Locomotive Company, the Brooks, Schenectady, Pittsburgh, Richmond, Cooke, Rhode Island and Manchester Locomotive Works have been consolidated. Mr. S. R. Callaway, formerly President of the New York Central & Hudson River R. R., is President of the new company. The Baldwin, Dickson and Rogers plants are not included in the combination. The combined capacity of all the builders is claimed to be 3,000 locomotives per year, of which 40 per cent. can be supplied by the Baldwin works alone.

LOCOMOTIVE COAL CONSUMPTION.

By M. N. Forney.

One of the subjects to be reported on at the coming convention of the Master Mechanics' Association has been put in the form of the inquiry, "What is the most promising direction in which to effect a reduction in locomotive coal consumption?" This, in different variants, is an old topic for discussion, and much has heretofore been written and said about it, but nevertheless it has not yet been exhausted. It ought to educe an interesting report from the committee which has it under consideration, and this in turn should lead to a profitable discussion, provided that when it becomes interesting, some dull member does not "move that the discussion be now closed."

In a general way it may be said that in a locomotive there are four available sources of economy in fuel consumption:

- (1) The coal itself—that is, its quality and combustion.
- (2) The boiler and its functions, including the generation and superheating of steam.
- (3) The engines and their use of steam.
- (4) Heat economizers or feed-water heaters.

With reference to the first it might be said of coal, as the Irishman said of whiskey, that it is all good, but some of it is better than others. As all commercial coal will generate steam, in that sense it may be said that it is good. But some kinds will generate more steam than others. As to which is the most economical depends upon its cost, and with the advent of large fireboxes poorer and cheaper qualities of fuel can be more economically used than was possible with smaller fireboxes and boilers. A great deal of careful and intelligent investigation is required to determine which of a number of different kinds and prices of coal in the long run are the cheapest to use on a railroad. Now, the surprising thing is that so few railroad companies have given any adequate attention to this subject. If, through an accident, an employee or passenger should have his toes cut off and should make a claim for damages, the most skilful legal counsel and expert testimony would be devoted to the defense of the company, and to resisting the payment of the value of the lost toes; but the cases in which railroad managers have been willing to pay anything at all to an expert to tell them how they could save a hundred or a thousand times the amount of his fees, by indicating which was the most economical coal to use, are very few. One reason for this, in some cases, is that the award of contracts for supplying coal is decided with loaded dice, and contracts are given to parties who have "influence" at headquarters. However that may be, it is certain that it would be immensely profitable to almost any railroad company to give thorough and intelligent investigation to the quality of fuel used on its line.

For an adequate discussion of the combustion of coal, a large treatise would be needed instead of a short article like this. All that will be said here is that the best appliance for the combustion of coal and the generation of steam is adequate boiler capacity; that is, sufficient heating and grate surface. The need of the latter has finally come to be appreciated. Some new problems, however, attend the use of large grates, for the reason that if their area is adequate for the maximum service demanded of the boiler, they will be much too large for moderate and minimum demands. The inference from this is that what may be called the active area of a grate should be variable. That is, we should be able to close more or less of the openings for the admission of air through the grate at will, to meet the requirements under which the engine is working. Then there should be adequate room in the firebox above the grates for the commingling of the gases to produce perfect combustion.

Our existing knowledge of the elements essential for efficiency of a locomotive boiler may be summed up by saying that a large grate, plenty of room in the firebox, and ample heating surface are most needed. Everything else seems to be merely

accessory and not essential for the economical generation of steam.

With reference to superheating, however, the case is quite different. Here we are still on the dangerous sea of experiment, but with the knowledge that there is a land which is very promising and productive beyond. It has been proved conclusively that very great theoretical economies are a possible result of superheating. It is therefore a subject well worthy of consideration and investigation.

With reference to the engines and their use of steam at the present juncture, interest will be concentrated on the question of compounding, and probably there will still be much disagreement about the saving due to that system. That a theoretical economy is possible is, of course, conceded, but what a complete debit and credit account containing all the plus and minus elements of cost and saving in the problem would show, at present, "no fellow can find out." A few years ago it was proposed in the columns of the American Engineer that the various committees who report annually to the Master Mechanics' Association should summons any of its members to appear before them to be questioned and to give testimony on the subjects under consideration. A cross-examination of some of the members of the association, with reference to the performance of compound locomotives, would be very interesting, and, it is thought, instructive. It is to be feared, however, that this proposal will not be carried out.

The limits of this article make it possible to devote but little space to the subject of feed-water heaters. That vast quantities of heat escape from the chimneys of locomotives and are wasted needs no evidence to prove. The problem is to catch it and make it useful. It has been clearly shown that with a boiler pressure of 200 lbs. and an initial temperature of feed water of 60 degrees that there will be an economy of over 1 per cent. for each 12 degrees that its temperature is raised before it enters the boiler. Smokebox temperatures of 1,200 degrees are not unusual. If the feed-water could be heated to half of that, or 600 degrees, there would be an economy of 45 per cent. To quote a Hibernian remark—"To say it is easy, but to do it!" The latter requires a large area of heating surface, as is shown in the "economizers" used on some stationary boilers. The problem on locomotives, however, is not regarded as insoluble, and is well worthy of thorough consideration by the committee and the Association.

How much to allow competitors to know of our methods and how much to try to conceal from them is a troublesome question to many people. We are in hearty sympathy with those who believe the absolutely "open-door" policy in this respect. A writer in the "American Machinist," Tecumseh Swift, recently expressed what we believe in the following words: "If you can keep your competitor always copying your work, and always looking into your ways to imitate them, you are sure to keep him a certain distance behind you—as far behind, in fact, as it is desirable to have him. Nobody living and no nation on earth can ever get ahead of anybody by following in his footsteps."

A large Allen absorption dynamometer capable of absorbing a wide range of power has, according to the "Journal of the Worcester Polytechnic Institute," been recently installed at the Willimantic, Conn., mills of the American Thread Co. It is made up of three discs each 42 ins. in diameter and $\frac{3}{8}$ in. in thickness, running in oil between $\frac{1}{16}$ in. copper plates, $46\frac{1}{2}$ ins. in diameter. The casing takes the form of a segment of a sphere on both sides of the set of discs and copper plates, and is built sufficiently heavy to stand a pressure of 120 lbs. per sq. in., although the maximum pressure used in the first tests never exceeded 25 lbs. One, two or three discs can be used, the shaft turning in the hubs of those remaining stationary. The water pressure stands upon all of the discs, but circulates only around those in use. In this way the capacity of the machine may be varied from 10-15 h.p. up to 600-700 h.p. per 100 revolutions per minute or from 2,400 to 2,800 h.p.

TOPEKA SHOP EXTENSIONS.

Atchison, Topeka & Santa Fe Railway.

By R. P. C. Sanderson, Assistant Superintendent of Machinery.

The Topeka shops of the Atchison, Topeka & Santa Fe Railway, like the historic "Topsy," have "grewed" from beginnings that were never intended for locomotive repair shops. The original main shop buildings were erected for a bridge shop; these have been added to under the pressure of continued growth, until they have reached the limits of the possible capacity of the available ground. With the growth of business and consequent increase in number of locomotives and enormous increase in the size and weight of the locomotives, it became only too evident that the shops were inadequate to keep up the work that should be done there so that further centralization of the locomotive repairs and standardizing of the repair work with consequent manufacture of interchangeable parts to gauges for use along the line could not be undertaken until further shop capacity could be provided.

While the development of the plans were in progress, earnest effort was made by improved shop methods to increase the output of the present plant, which resulted in an increase in the number of engines receiving classified general repairs from 12 per month for 1899 to 20 for January, 1901, 29 for February and 32 for March without any very material increase in the number of men employed and only a few additional machines, but this could only be done under great disadvantage for lack of cranes and proper facilities which could not be introduced into the old buildings.

There were operating reasons which made it desirable that the new shops should be located at Topeka, or a far more convenient layout could have been arranged for at some other point where land was available in greater areas at less expense. The only land to be had at Topeka, within reasonable cost limits, was to the eastward of the present freight car repair sheds and bounded by a street, by improved property and by the general freight yards, so that the problem resolved itself into one of making the best layout for the land available and not of making the most perfect arrangement regardless of land limitations. In the plan of the layout shown herewith all the buildings to the west of the smith shop are the present old shops, the car department, both freight and passenger, the storehouse and planing mill remain unchanged. The buildings marked foundries, frog and switch shop, etc., are the present old machine erecting, boiler and smith shops. There are, however, on the yards east of these buildings a number of wings and separate buildings which are to be torn down so as to make a serviceable yard for handling pig iron, scrap, coke, flasks, sand, etc., for the foundries and for rails, frogs, switches, etc., for the proposed frog and switch as well as water-service shops.

Referring to the new buildings. The blacksmith shop, now being erected, is a steel frame structure, 199 by 400 ft., very strongly built and braced. It is located next to the freight car shops and as close as possible to the storehouse, so that the car forgings, bolts, etc., can be delivered with the least possible handling direct through the small machine shop, where the threads are cut and axles turned; to the freight-car shop, or on to the storehouse for stock and shipment along the line. At A a storage for dimension bar iron is provided, at B the long bar iron is to be racked, at C the wrought iron scrap is to be stacked, cut by scrap shears driven by a motor out in the yard and prepared for fagoting. The end of the shop, D, is to be the hammer shop and will be well provided with large hammers, including a special new 5,000-lb. hammer for forging axles from scrap. All the furnaces for slabbing and forging under the heavy hammers are grouped in this end of the shop. It is the present purpose to use crude oil for fuel in these large furnaces instead of coal, the oil being atomized by compressed

air. This decision was reached because of the success in the use of fuel oil for furnace work achieved in California and on account of the recent development of the new oil fields in Southern Texas, near Beaumont. It will be noticed that provision has been made at E for bins for smith shop supplies, firebrick, etc., and that standard gauge tracks are arranged so that iron, bricks, scrap, etc., can be switched in car loads direct to the point of storage; this will reduce the handling to a minimum. The fires for heavy work are located at D near the hammers, a convenient arrangement of cranes and tramways being provided for the hammers, furnaces and large forgings.

At G all the bulldozers, bolt headers and forging machines are

mounted. At this place also pneumatic loading hoists are to be located for the shipment of axles and wheels to points along the line. Convenient access to the wheel lathes and wheel presses in this shop is provided by means of service tracks and pneumatic jack turntables, which lead to the freight car and coach shops.

Power House.—It is the present intention, although all the plans have not been completely worked out and approved, to deliver the coal by drop bottom cars to the south of the power house; it is then to be elevated by power into overhead bins carrying a couple of days' supply. From these bins the coal will pass directly into a pair of Loomis-Pettibone gas producers

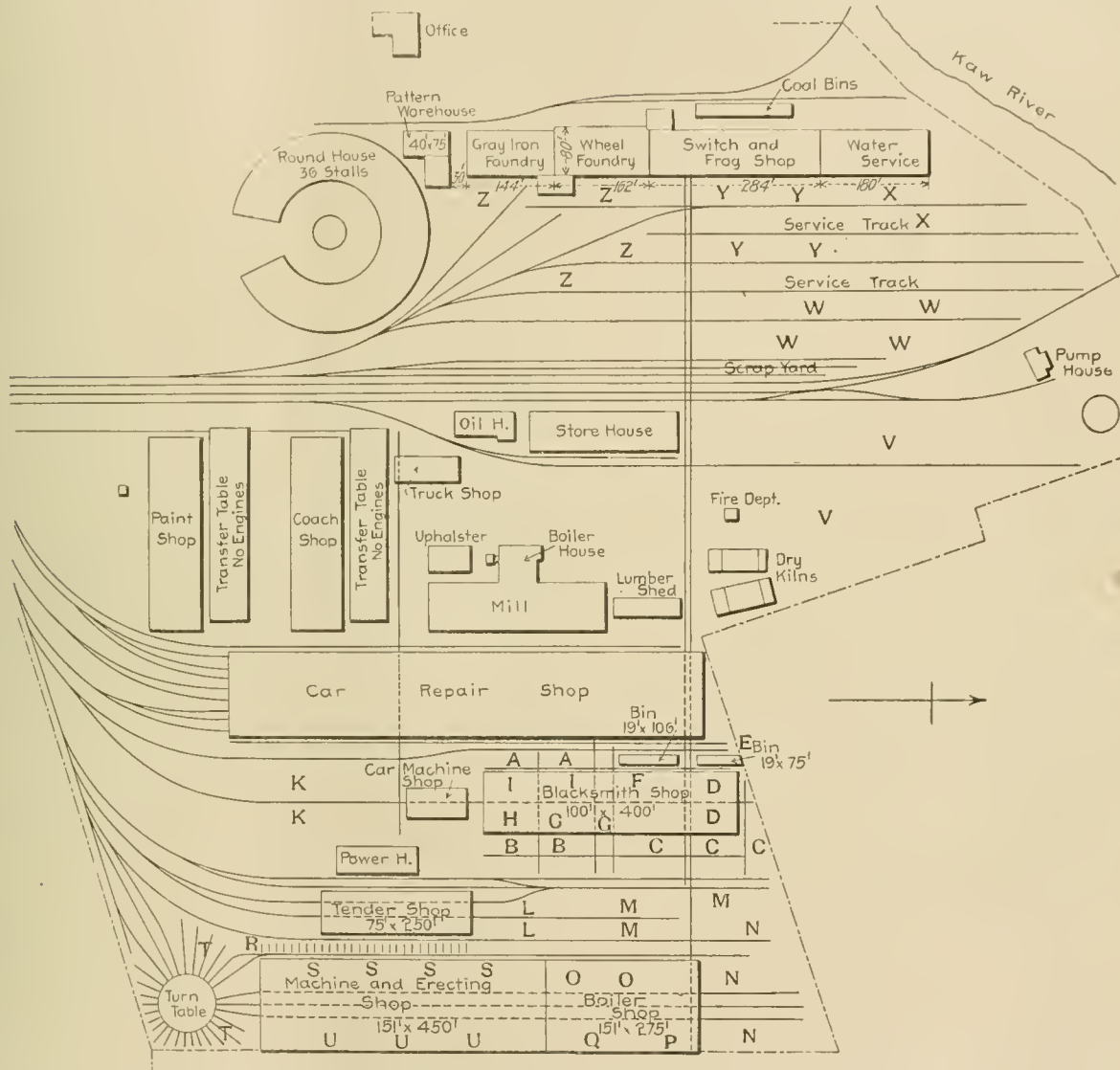

Extensive Shop Improvements, Atchison, Topeka & Santa Fe Railway.

ranked with their furnaces, service tracks being arranged for the handling of the iron from the shears to the machines and from the machines to the machine shop. At H all the spring repair work is to be done, provision being made for suitable furnaces, hammers, banding press and other spring machinery. At I, along the west side of the shop, are the forges and fires with graded sizes of steam hammers conveniently located so as to do as much of the heavy work as possible by dies and power.

The Car Machine Shop at the end of the blacksmith shop will be well equipped with single and multiple drills, punches, bolt cutters, nut tappers, axle lathes, boring mills, wheel presses and wheel lathes for steel tired wheels. Through this shop all the car forgings requiring machine finishing will pass on their way to the car shop or storehouse. The yard space, K, is intended for a wheel yard for storage and handling of new and second-hand axles and wheels, both mounted and un-

where the coal will be converted into producer and water gas, stored in separate gas holders after scrubbing and cleaning. A mixture of these gases is to be used for furnishing power in gas engines, which will be direct coupled to electric generators in the power house. This electric current is then to be used for operating the roundhouse turntable, foundry blowers and cranes, frog and switch and water service machinery, transfer tables at the car shops, machines in the smith and car machine shops, as well as all machines and cranes in the tender, machine, boiler and erecting shops, also for electric lighting of the plant and yards.

It is reasonably certain that a brake horse-power can be obtained in this way for about 1½ lbs. of slack coal, while by steam power the best that can be done with the same coal under good boilers is from 7½ to 8 lbs. of coal per brake horse-power. The surplus gas produced over what is needed for

power is to be used in the smith and boiler shops; the producer gas being used in the bulldozer and bending machine and spring furnaces as well as for the boiler plate annealing and flanging furnaces, the surplus water gas being used in the smith's fires by specially designed forges and for small furnaces where welding heat is required. In this way it is expected to very largely increase the output of the shop per man because the heats will be far more rapid and there will be little time lost waiting for heats or building and preparing fires. The resulting forgings will also be much cleaner and better and the objectionable smoke and coal gas will be avoided.

The Tender Shop is a single-story building 75 by 250 ft. This is also to be a steel-framed building, hut of lighter construction, as there will be little machinery in it. The western side of the shop over the two tracks is to be equipped with an overhead traveling crane driven electrically, for handling tender tanks, frames, ash pans and steel engine cabs. The eastern side of this shop is for building and repairing tanks, cabs, and frames and will be provided with necessary tools to be driven electrically, including a rapid working spacing punch. There will also be overhead trams for handling material. The yard space, L, is for tender tank plates, angles, tender frame and materials which will be convenient to the shop and can be unloaded there direct from the cars switched to place. The ash pans and steel cabs can be delivered direct to the erecting shop by means of narrow gauge service tracks, not shown on the plans, or handled by flat cars and switch engines over the turntable to the erecting shop. The yard space, marked M, is intended for the storage of boiler and firebox steel as well as other boiler shop material which can be unloaded direct from the cars to the racks. The plates will be carried by trams or cranes right in to the side of the main shop where the boiler work is done. The yard space, N, is for boiler scrap and materials which will come out through the end doors of the main shop and will be stacked there for cutting up, the shipment being done by light cranes direct to the cars, which can be switched there conveniently for loading up.

The Main Shop.—This building covers ground 151 ft. wide by 725 ft. long, and will be used for machine, erecting, boiler, tin, copper and pipe shops all under one roof. This building consists of a main center building with a high roof with lean-to buildings on both sides. The center building is high enough to permit the use of two heavy traveling cranes, to be driven electrically; these will serve the erecting and boiler shops and can run right through from end to end of the shop. When lifting an engine both of them will be used, but when not thus occupied they will work independently. Each crane is to have a 5-ton hoist for light, quick work in addition to the heavy hoisting gear. The western side of the shop, under the lean-to, is provided with overhead tracks running the full length. The east lean-to is for the flue work and this will be served by two 5-ton quick-running overhead electric cranes. These will serve all the heavy boiler shop tools and flanging work, and also all the heavy machine tools. In the boiler shop the space, O, is for the laying-off tables, shears, punches, drills, planers, flanging press and furnace and floor for setting up work; this latter will also be done partly in the center aisle of the boiler shop under the main cranes. The space, P, in the east lean-to is for the flue work where all this work will be done. At Q will be the riveting tower, 65 ft. high, with an overhead electric crane and a new hydraulic riveting plant, suitable for heavy work. The rest of the boiler shop space will be needed for boilers under repairs and construction. Shells and fireboxes can be thus handled entirely by cranes and swung from crane to crane, which should cheapen the cost of labor considerably.

The intention is that engines going into the shop for repairs will be taken in by two of the tracks leading to the 100-ft. turntable at the south end of the main shop, leaving the third track for outgoing engines so that they can pass without interference.

The turntable is large enough to take a short switch engine

and a large road engine without its tender. The engines going in for repairs are to enter on the two outside tracks and will be stripped under the cranes at the south end of the shop. When stripped they will be lifted off their wheels and boxes by the overhead cranes and carried down the shop to the place on the side tracks on which they will be repaired. The driving wheels left behind on the stripping stalls will be rolled back to the turntable and placed on a succession of short spur tracks which will be just long enough to each hold a set of drivers and a truck complete. There will be enough of these spurs located along the west wall of the shop to accommodate all the engines that will be in the shop at one time, each set to itself—these spurs will be in the space marked R. The wheel lathes, boring mills, axle lathes and quartering machine will be located inside the shop at S, and will be served by the light overhead crane already mentioned. The wheels can be handled by service tracks and traveling pneumatic jack trolleys direct from the spurs to the machines and back again. When engines come in for fireboxes, which will have to wait for the boiler shop, the boilers will be carried to the boiler shop by the large cranes and the skeleton run back over the turntable and stored on the radial spur tracks, T T, until the boilers are far enough advanced to be put into the erecting shop. These skeletons are to be put off and on the table and tracks by an electric capstan located on the center of the table so that no labor to speak of will be needed for this. As before mentioned, all the heavy tools will be in the west side of the shop at S, served by the overhead cranes and driven by individual motors so as to be completely independent. All the lighter repair tools will be in the east lean-to at U, run by belting from short-line shafts driven by motors, the tools being grouped together as the work requires them to be associated, each group having its own motor, so that it will be independent. Above these tools over the space U will be a second story in which all the special and other tools needed for manufacturing standard parts, brass work and oil cups, as well as the tin work, air brake work, etc., will be done; it being the intention to separate this work as far as possible from repair work proper and a separate tool room, with gauges, templates and jigs is provided for this work upstairs. There are to be two elevators serving the second floor for handling material. Engines which are ready for their wheels will be lifted across upon the center track, where their wheels have already been placed by the cranes. There they will have their rods put up and be run out for trial. As there is room for an engine hung from the cranes to pass along the shop between the middle and side tracks, there need be no interference between the incoming and outgoing engines.

There is another feature of this building which is of passing interest, namely, the roof construction. The center roof of the main building will have an A frame of usual pitch, but it is to be covered with tiles. The lean-to roof is what is known as a saw-tooth roof, with ridges running at right angles to the length of the shop; the slopes will be covered with tiles but the vertical faces of the teeth are glazed and all faced to the north. It is believed that this will give a very light shop without the usual trouble from leaky skylights—and as far as the writer knows, this is the first railroad repair shop that has been roofed in this way. The turntable was a necessity at the end of the main shop on account of the boundary lines of the land, but it will be seen that it also has its advantages in handling the engines in and out of the shop. The whole plant will be served with compressed air for hoists and pneumatic tools, and will be heated by steam and perhaps by waste gas from the gas engine exhaust. Ample water service mains, sewerage, as well as lavatories, closets, offices, etc., will be provided.

Yards.—The yard space, W, is the general scrap and wreckage yard where scrap coming in off the road will be culled, sorted, straightened and prepared for loading and delivery to the smith shop or foundry or for sale. The yard, X, will be used for water service supplies and materials, the work done in

this department is intended to consist of repairs to and manufacture of pumps, tanks, hand cars, signals and crossing gates. The yard, Y, is for frog and switch shop materials and this shop is intended to be equipped with a new outfit of special tools for repairing and perhaps making frogs, switches, switch stands, etc. The yard space, Z, is for foundry supplies and cast scrap, the intention being to fit up the gray iron foundry first as soon as the move in to the new machine and erecting shops is made, but the wheel shop question is to remain for future consideration. The yard space, V, is for lumber, of which in the west large stocks have to be carried.

The above represents the outcome in a general way of much study and thought given this problem by the writer, assisted in detail work by Mr. Ben Johnson, Engineer of Tests. The work is progressing steadily, the smith shop building being now under erection, and it is hoped in the course of 12 or 15 months to have the whole plant, at least as far as the new portion is concerned, in full operation when the output of engines should, under normal conditions, run up to 50 or 55 per month.

LINK MOTION AND PISTON VALVES.

By C. A. Seley, Mechanical Engineer, Norfolk & Western Railway.

The general type of locomotive valve motion used in this country has long been the familiar Stephenson link, acting through a rocker to impart motion to the valve, producing what is commonly known as an indirect motion, so-called on account of the reversal of the direction of action by the rocker. This feature is necessitated by the movement of the valve in relation to that of the piston; it is familiar to most readers of this journal and is shown in the diagram, Fig. 1. The main driving axle bearing the eccentrics is shown at A and the crank at B, its direction of motion being indicated. The valve is of the outside admission type and the indicated movement of the stem is to open port S, admitting steam to the front end of the cylinder for the backward stroke of the piston.

Attention is called to the relative positions of the eccentric centers shown, both being between the center of the axle and the link and the eccentric rods "open"—that is to say, not crossed. When the crank has arrived at the opposite center to that shown, the arrangement of the parts will be reversed, the rods will be crossed, both eccentric centers will be back of a vertical line through the axle center, the direction of motion of the valve will be opposite to that shown and steam will be about to be admitted to port S' for the forward stroke of the piston.

The proof of a correct valve motion is its ability to cut-off equally at half-stroke, for at this point the disturbance due to the angularity of the main rod is a maximum. This is clearly shown by the diagram, Fig. 2. The positions 2 and 4 are those of the crank when the piston is at half stroke in the back and forward movements. In one revolution, starting from position 1, it will be noted that the interval between 1 and 2, measured on the crank circle, is short as compared with that between 2 and 3, while the converse is true of the remaining intervals, from 3 to 4 being long and 4 to 1 short.

Now, it so happens, fortunately, that the irregularities of the angularity of the main rod, of the eccentric rods, the location of the eccentric rod pins back of the link center line, and the varying influence of the two eccentrics working on the link, all work together and correct each other's errors in a measure, and give a motion so nearly correct that usually a small offsetting of the link saddle pin will complete the good work and give a motion that will cut off equally at all points. This result is readily obtained in practice, with engines of normal proportions and arrangement, and we frequently see reports of valve setting showing great accuracy.

The last few years have brought into extensive use the piston valve, which required in many cases special treatment of

the valve motion. This form of valve permits either inside or outside admission of steam to the cylinders, and the advantages of the former style have led to its quite general adoption. It permits of using more direct steam passages and offers a better opportunity for the heat insulation of the passages. The valve can readily be lengthened so as to make the steam ports short and direct and reduce clearance. By placing the exhaust at the ends, on the outside, the packing of the valve stem is much simplified and the low expense of maintenance of valve stem packing against exhaust pressure is a very appealing argument in favor of inside admission valves.

Examination of many of the designs of piston valve engines brought out in the past three years show that the favorite location of the valve is in the cylinder saddle in the direct path of the steam to the cylinder. This location is relatively low, so

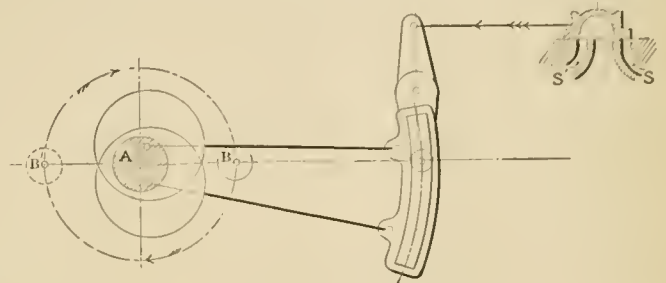

Fig. 1.

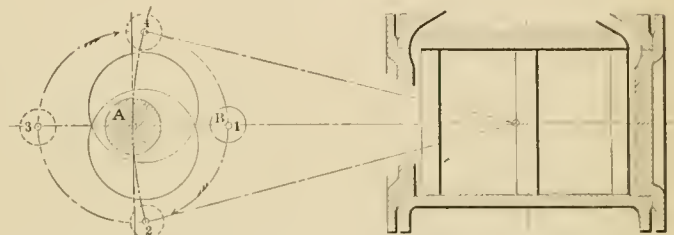

Fig. 2.

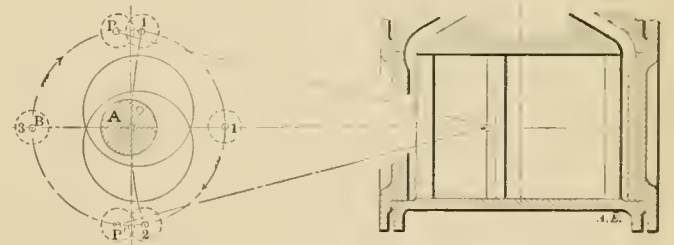

Fig. 3.

that a connection to the link can often be made without the use of a rocker, at least of the reversing type, and the resulting motion is direct. The inside admission valve, having its steam edges inside and exhaust edges outside, is opposite to the arrangement of the "D" slide valve commonly used and as shown in Fig. 1, and requires the valve to be moved in the opposite direction to perform its functions. The reversal of the motion can best be accomplished by the omission of the rocker if other considerations permit.

There may be some good reasons, however, for locating the piston valves over the cylinders of some types of locomotives. It may be that considerations due to brakes, either of reservoirs or of brake cylinders located forward, under the barrel of the boiler, render it desirable to get the valve connections outside of the frames and place the valves over the cylinders. This location also favors a stronger frame construction, which is desirable in heavy engines.

The vertical height of the valve so located is such that it is difficult to make connections for the direct motion desirable

for the inside admission valve. If a rocker and a long valve rod, located outside of the frames, are used, three considerations present themselves. One is to use an outside admission valve. The advantages of the other style have been pointed out. Another is to devise a parallel motion connection between the link and the rocker so as to make it non-reversing. The third is to reverse the motion imparted to the link so that the rocker in transmitting it will give the valve rod the proper direction of motion. This expedient requires that the eccentrics be placed, as it is called, "on the back of the axle," or in a position reversed from that ordinarily occupied by them. This new arrangement can best be appreciated by taking the arrangement shown in diagram, Fig. 1, and putting the crank pin B to position B¹, making no change in the eccentrics. It will be seen that the eccentric centers are still between the axle center and the link, and the rods are open. Therefore, the change of arrangement does not change it to a cross rod system, as might be thought without a full analysis. We do, however, get into a difficulty which will require special explanation.

As has been stated, the ordinary valve motion arrangement, used indirect with outside admission and direct with inside admission, is capable of producing perfect equalization of cutoff, and we have seen by diagram, Fig. 2, that this is done with a certain unequal arrangement of crank intervals with half cut-off.

Reversing the position of the eccentrics in relation to the crank puts the latter into a different relation with these intervals and produces an irregularity of motion which calls for additional measures for equalization of cut-off. The situation is explained by reference to diagram, Fig. 3. It will be noted from Fig. 2 that the crank in passing from position 1 to 2 travels a short interval and carries the piston to half stroke, and we will suppose the link motion to be ordinarily arranged for cut-off at that point. In Fig. 3 the eccentrics are in the same position as in Fig. 2, but the crank is starting from the opposite center. As ordinarily arranged, the cut-off would occur when the crank had travelled a short interval, or at point P, diagonally opposite from position 2, coming short of completing a half-stroke of the piston. The completion of the semi-revolution leaves the crank at position 1, while the eccentrics are now opposite to the position shown. The motion will now make a half-cut with a long interval movement of the crank, but it requires only a short interval to carry the piston to half stroke. Therefore, the crank overruns, going to position diagonally opposite position 4, or P¹. This brings the piston to the same place as before at the time of cut-off, but it is less than half stroke on the forward and more than half on the return stroke. It is therefore necessary to extend the means of equalization to cover the interval between the positions P and 4 and between P¹ and 2.

The expedients resorted to by the builders of locomotives to correct this irregularity are various, but it is believed that it is not possible to obtain as good a motion in all respects as can be had with the eccentrics normally arranged. The cut-off can be equalized by considerable offset of the link saddle pin, but generally to an amount that would not be permissible with a slide valve. The lesser weight and friction of the piston valve will permit greater off-set, but it will nevertheless result in heavy jarring of the reverse lever and also a distortion of the compression line of the indicator card, indicating that the other functions of the valve have suffered and that the results

as a whole are not as good as in the normal arrangement.

It is possible that a modified form of link will give better performance than the Stephenson type, and it is noted that some builders are doing this, but the writer has not investigated any of these forms.

In some recent designs of locomotives, non-reversing rockers are used; that is, rockers with both arms up or down. It will be well in using this feature to provide a very ample bearing for the rocker shaft, particularly as to length. With the ordinary reversing rocker, the pull or push at the bottom

PISTON VALVE LOCOMOTIVES.

Road.	Cyl.	Piston valve. (Admission.)	Location.	Motion.	Frames.	References.
G. N. Ry.	21 x 34	Outside.	14-in. Over cyl.	Indirect.	Double bar.	*Am. Eng., Jan., 1898.
N. & W.	20 x 24	Inside.	19 " Saddle.	"	Single bar.	" Feb., 1898.
W. C. Ry.	19 x 26	"	12 " "	"	"	" June, 1898.
W. C. Ry.	20 x 26	"	12 " "	"	"	" June, 1898.
G. N. Ry.	20 x 30	"	12 " "	"	"	" Oct., 1898.
O. R. & N.	19 x 30	"	10 " "	"	"	" Jan., 1899.
B. H. & P.	18 x 26	"	10 " "	"	"	" Apr., 1899.
D. R. G.	21 x 26	"	10 " "	"	"	" Sept., 1899.
I. C. Ry.	23 x 30	"	12 " "	"	"	" Oct., 1899.
D. L. & W.	21 x 32	"	12 " "	"	"	" Nov., 1899.
N. & W.	21 x 21	"	10 " "	Direct.	Double bar.	" Dec., 1899.
N. P. Ry.	22 x 30	Outside.	Over cyl.	Indirect.	"	" Dec., 1899.
(High-pressure cyl. of compound.)						
C. & A.	19 x 26	Inside.	10-in. Saddle.	Indirect.	Single bar.	" Feb., 1900.
C. B. & Q.	19 x 24	"	10 " Over cyl.	"	Double bar.	" Apr., 1900.
C. B. & Q.	20 x 24	"	10 " "	"	"	" Apr., 1900.
N. & W.	21 x 30	"	10 " "	"	"	†Loco. Eng., May, 1900.
C. & N. W.	20 x 26	"	19 " Saddle.	Direct.	Single bar.	Am. Eng., Aug., 1900.
D. L. & W.	20 x 28	"	10 " "	Indirect.	"	" Sept., 1900.
C. H. N. J.	20 x 28	"	" "	"	"	" Oct., 1900.
L. S. & M. S.	20 x 28	"	" "	"	"	Loco. Eng., Nov., 1900.
B. R. & P.	20 x 26	"	" "	"	"	Am. Eng., Nov., 1900.
B. C. R. & N.	19 x 26	"	" "	"	"	†R. Gaz., Nov. 30, 1900.
N. Y. C.	21 x 26	"	12 " "	Direct.	"	Am. Eng., Feb., 1901.
L. S. & M. S.	20 x 28	"	11 " "	"	"	" Mar., 1901.
A. T. & S. F.	20 x 28	"	10 " "	"	Double bar.	R. Gaz., Jan. 25, 1901.
B. R. & P.	20 x 26	"	" "	"	"	Am. Eng., Dec., 1900.
B. C. R. & N.	19 x 26	"	" "	"	"	R. Gaz., Nov. 10, 1900.
N. Y. O.	21 x 26	"	12 " "	"	"	Am. Eng., Feb., 1901.
L. S. & M. S.	20 x 28	"	11 " "	"	"	" Mar., 1901.
A. T. & S. F.	20 x 28	"	10 " "	"	"	R. Gaz., Jan. 25, 1901.
N. Y. C.	23 x 32	Outside.	Over cyl.	Indirect.	"	" Mar. 1, 1901.
(High-pressure cyl. of compound.)						
So. Pac.	20 x 28	Outside.	" "	"	"	" Mar. 22, 1901.
C. R. I. & P.	20 1/2 x 26	Inside.	11-in. Saddle.	Direct.	Single bar.	Am. Eng., Apr., 1901.
B. & M.	20 x 30	Outside.	Over cyl.	Indirect.	Double bar.	R. Gaz., Apr. 5, 1901.
So. Pac.	23 x 34	"	" "	"	"	" Apr. 5, 1901.
(High-pressure cyl. of compound.)						
C. B. & Q.	20 x 24	Inside.	" "	"	"	Am. Eng., May, 1901.
F. M.	23 x 26	"	10 1/2-in. Saddle.	"	Single bar.	R. Gaz., May 3, 1901.
W. C.	20 x 26	"	12 " "	"	"	" May 10, 1901.

* American Engineer and Railroad Journal. † Locomotive Engineering. ‡ Railroad Gazette.

arm is met by a resistance at the top arm, in the same direction, and the body of the rocker shaft bears its whole length against one side or the other of the box. With both arms up or down, however, the push or pull on the first arm is opposite in direction to the thrust on the driven arm and the tendency is for the shaft to bear crosswise of the box and wear at opposite corners. If both arms were in the same vertical plane there would of course be no such tendency, but with the arms at opposite ends of a shaft, a sufficient length of bearing should be provided to insure long wear, the longer, within reasonable bounds, the better.

A table is given herewith, taken from the Railway Press, and includes probably most of the piston valve engines built since the beginning of 1898. The list covers a variety of sizes and styles, so that much material for study is available for the student in this line. It indicates that the piston valve engine is being very largely adopted by a number of railroads, but it will be noted that the list does not cover the piston valve so largely and successfully used in the Vaucrain compound engines.

In conducting experiments to ascertain the value of improvements of any kind it is important that they should be so conducted as to permit of attributing the savings to the proper influences. Usually this cannot be done if several changes are made at one time. They should be made separately and the effect noted independently. It often requires careful study to correctly judge of these matters and nowhere does this apply more forcibly than in railroad practice. It is a good rule to isolate the unknown quantities by trying one change at a time, particularly in case there are several variables under consideration.

GRATES FOR BURNING FINE ANTHRACITE COAL.

By W. McIntosh, Superintendent of Motive Power, Central Railroad of New Jersey.

The advent of the large locomotive with a firebox having a grate area of from 60 to 90 sq. ft. has emphasized the desirability, if not the absolute necessity, of some mechanical means of stoking them and opens up a golden opportunity for some enterprising inventor to meet the occasion and not only reap a liberal financial reward but confer, in addition, a boon to the fireman in relieving him from severe labor and another on the railroads by furnishing the means of obtaining uniform steam pressure for every demand, extending thereby the efficiency of the locomotive and incidentally, expediting the movement of trains and traffic generally.

Were bituminous coal alone to be considered the problem would be greatly simplified. Complications arise when the "buck," "rice" and "culm" varieties of anthracite are encountered, and not to my knowledge has there been a really successful rocker grate brought out to handle this class of fuel independently of the water grate. True, there are engines running right along burning anthracite coal on forms of shaking grates without the water bars but at a considerable expense in renewals as they burn out rapidly with this fuel. These may be described as follows:

First. Sections of ribbed grates 12 ins. wide and 24 to 30 ins. long with trunnions on the ends resting on suitable frames, and, in a firebox of 80 sq. ft., divided into six separate divisions for convenience of operating.

Second. The same design of grate in longer sections and in two or four divisions, their durability diminishing in proportion to increase in length.

Third. Ribbed grates from 6 to 8 ins. wide and 4 to 5 ft. long mounted on bars running lengthwise of the firebox, the ends extending through the boiler head and square to receive the shaking lever. These are the most satisfactory of the types described, but all are short-lived and none work the fire as thoroughly as desired, having more of the waving or undulating effect upon it than the removal of the ash or clinker, as much of the fire lies dormant on the flat surface of the grate bars.

The water bar type, for many years accepted as the only reliable hard coal grate possessing lasting qualities, allowed no means whatever of shaking down the ashes and the only manner of working the fire was from the surface with a puddling bar and hoe, a very laborious and inefficient operation, especially on long runs when it is apparent that the fire must eventually become so clogged with ashes and cinders as to become practically smothered. This condition is more pronounced with the cheaper grades of fuel. When the wide firebox was first introduced the quality of coal furnished, "buck" and culm, while small and unmarketable at that time, was otherwise good coal and would burn down with a small percentage of ash. Now there is an active market for these varieties and the locomotives are being fed with washed coal from the culm banks, where it has lain for years, and, in addition to the natural deterioration, contains a large percentage of slate and other impurities that the washing does not eliminate.

On the line with which I am connected we have found a combination grate to work well. This grate is part water and part shaking. We retained every alternate water grate and between this longitudinal framing mount sections of finger grates known as the "Yingling" design. These are arranged to be shaken in four divisions and each alternate section in an opposite direction, the fingers engaging in such a manner as to dislodge and carry down all loose ashes and grind to small particles the cinders coming in contact with them, the water bars supporting the body of the fuel in the furnace and preventing excessive disturbance of the surface of the fire. It is evident that the water bars thus arranged afford protection to the finger grates as the latter, although very delicately constructed (the

body of the finger being but $\frac{3}{8}$ in. thick) seldom break and never burn out, due, no doubt, to the proportion of air space which is more than 40 per cent.

To return to my first proposition, a mechanical stoker. It may be of the Roney type or the Kincaid, the latest, or, what would be better yet, the pulverized fuel blower requiring no grate bars or ash pan, only the grinding and blowing mechanism, which might be located low enough in the tender to allow the coal to fall into it by gravity and it is not improbable that means will yet be found for safely handling the ground fuel from the coal house, where the locomotive with a hermetically sealed tank will have a supply blown in in the same manner that a gas or oil tank is filled. All that would then be required would be sufficient air pressure to blow it out again and into the furnace. If the pulverized fuel system is not yet fully developed and mechanical stokers of the ordinary type must be used, then means should be provided to operate the shaking grates by power, as quite an effort is necessary to shake them by means of ordinary hand levers and hand power and their efficiency would thereby be correspondingly reduced, for it is a difficult matter to obtain the necessary attention of the fireman when these conditions exist.

RESULTS FROM TONNAGE RATING,

Southern Pacific Company.

By B. A. Worthington,

In Charge of Tonnage Rating.

An elaborate description of the tonnage rating methods of the Southern Pacific System is contained in a paper by the writer read before the Pacific Coast Railway Club in November, 1900. The results from actual practice in improving the cost of operation are striking and the advantages of the methods are marked. These may be briefly summarized as follows:

Features of This System.

1. All through ratings are based on time and load; local ratings only are based on capacity of power.

2. Engines are classified according to power, and a separate rating is given for each engine according to the number and class, so that no figuring is necessary on the part of trainmen to determine the rating by the class to which an engine belongs.

3. Power of engines is limited by calculated traction at 10 miles per hour, when such traction does not exceed one-quarter of the driver weights. While one-quarter of the driver weight may seem high, yet it harmonizes closely with our practice.

4. Every piece of track in each direction was figured over in the Engineering Department, to arrive at the resistance offered and to determine the load that could be taken at varying speeds; based on the resistance data and energy gained from momentum, as explained in detail in the paper above referred to.

5. In addition to the rating, the rating sheets show, for the information of the dispatchers, the per cent. of load greater than rating that can be taken as a maximum between every two stations in both directions.

6. Time is an important factor with us on our long through lines and in addition to the relative efficiency attained for each train, our daily reports show the actual time consumed, including and excluding stops, enabling us to promptly locate apparently unnecessary delays.

7. A detailed monthly report is made, a copy of which is sent to each division, so that each superintendent may see what all others are doing, and as they are all practically measured with the same "measuring stick" under this system, it naturally prompts those making the poorest showing to make a strenuous effort to improve their performance.

Results Obtained.

In my paper on this subject (pages 206 and 207) I gave the

results of nine tests in actual service, which show how closely the theoretical calculations check with the practice both in point of time and load, on the basis of actual running time, excluding stops. A moment's reflection will suggest that the actual running time, excluding stops, is the true measure upon which the work performed by the locomotive should be judged, as it would be impossible to even approximate the time that might be consumed on sidings, when the engine is performing no service. On one test the variation in time was 13 minutes on a 128-mile run, and in the opposite direction only 9 minutes; another was 15 minutes on a 123-mile run; another 10 minutes on a 124-mile run over a very heavy division, helpers being used in two places, one 12 miles, the most of which is 1.9 per cent. grade and the other 26 miles, 20 miles of which is continuous 1.35 per cent. grade. In another case there was a variation of 4 minutes on a 95-mile run, and another only 24 minutes on a 124-mile run, with a train of 60 cars, 2,500 ft. long, being two-thirds empties, over a heavy division, with few sidings long enough to hold the train.

Daily reports show trains on all runs loaded up to the rating, but the preponderance of tonnage one way or the other naturally brings down the average train load in the opposite direction. Local trains, rated to capacity, usually take all there is to go and pick up and set out cars for intermediate points. These factors prevent the possibility of the general average efficiency showing 100 per cent., yet on very many runs 100 per cent. average is made in the direction in which the preponderance of tonnage runs.

As an illustration of the uniformity of this system of tonnage rating, the reports for the month of February show a variation of only four points—from 81 per cent. to 85 per cent. efficiency—in train load, the rating in each case being taken as 100 per cent., upon the seven divisions of the Pacific System, embracing both hill and valley sections, varying from a level track to 2.2 per cent. gradient on the Sacramento and Tehachapi mountains, and to 3.3 per cent. gradient on the Siskiyou mountains. For March, the average efficiency on the same seven divisions varied from 78.6 to 90 per cent.; for April, from 83 to 91 per cent. As indicative of the gradual improvement being made, the general average of all divisions, including through and local freight, was: January, 77 per cent.; February, 80 per cent.; March, 85 per cent.; April, 86 per cent. efficiency, the rating in all cases being taken as 100 per cent.

The new time-load system of tonnage rating was put in effect on July 1, 1900. Prior thereto the load was based on the capacity of the locomotives reduced arbitrarily to come within the time requirements. The results since that time as compared with last year under the old tonnage rating system, when the performance was exceptionally good, being the best in the history of the company up to that date, have been as follows on the Pacific System lines, as shown by the General Auditor's figures:

	Ton-miles of revenue freight handled.
First 8 months of this fiscal year.....	2,182,245,387
First 8 months of last fiscal year.....	1,974,056,226
An Increase in volume of 10.5 per cent.	

The total mileage of freight locomotives, including those double-heading, or helping trains, or run light in connection with them, was as follows:

	Engine Miles
First 8 months of this fiscal year.....	8,656,456
First 8 months of last fiscal year.....	8,621,107
An Increase of only 0.4 per cent.	

It will be noted that the engine miles increased only four-tenths of one per cent. in moving 10.5 per cent. more ton-miles of freight. The tons of freight moved per engine mile increased from 229 to 252 tons, the saving by heavier loading being equivalent to the movement of 873,000 engine miles in the period in question, or at the rate of 1,200,000 engine miles per annum, which is directly attributable to the new tonnage rating system, coupled with improvements in motive power and constant vigilance on the part of the management, than which there is probably none more efficient in the railway world.

A BOILER-SHELL CHART.*

By Lawford H. Fry.

In determining the strength of a locomotive boiler waist or of any other cylindrical riveted shell subjected to internal pressure the following formula is employed:

$$F = \frac{2 t p s}{D P} \dots\dots\dots(1)$$

Where

- F is the factor of safety desired,
- t is the thickness of the plate in inches,
- p is the ratio of the strength of the riveted seam to the strength of the solid plate,
- s is the ultimate tensile strength of the material in pounds per square inch,
- D is the inside diameter of the shell in inches,
- and P is the working pressure in pounds per square inch.

In work where this formula is repeatedly used, as for example, in designing locomotive boilers, it is desirable to tabulate the results obtained from the application of the formula to those cases which occur frequently. If the range of work is wide, the tabulation will be laborious to construct and unhandy to use. To take the place of a table and to facilitate all calculations regarding the strength of a cylindrical riveted shell the accompanying chart was constructed. If all but one of the factors of the formula are known the chart will automatically solve the resulting equation and give the value of the unknown factor. Since it does away with calculation it makes for ease, accuracy and rapidity of working.

An inspection of the chart will show that it consists of vertical lines corresponding to the internal diameter of the boiler, horizontal lines corresponding to the thickness of the shell, and a series of scales at the upper right-hand corner. The chart is primarily intended for locomotive boiler shell computations, consequently the scales which correspond to the factor of safety give values from 4 to 6 and a scale is given for each increment of ten pounds per square inch of boiler pressure, for pressures ranging from 140 to 220 pounds per square inch.

To use the chart a straight-edge is laid through the point of origin which is marked at the lower left-hand corner of the chart, and through the required factor of safety mark, the mark being of course chosen on the scale corresponding to the given working pressure. Then the point of intersection of the straight edge with the vertical line corresponding to the internal boiler diameter is noted; the horizontal line through this point of intersection gives the thickness of plate necessary to satisfy the conditions. It will be noticed that there are three series of horizontal lines, drawn for the sake of distinction, heavy, medium and light. Each series of lines corresponds to a type of riveted seam, as may be seen from an inspection of the left-hand end of the chart, where it will be found that the figures giving the thickness of plate are grouped in three columns, headed respectively with the designation of type of seam. Thus the heavy lines correspond to butt seams with sextuple riveting, the medium lines to butt seams with quadruple riveting, and the fine lines to double riveted lap seams.

To illustrate the use of the chart a line has been drawn through the origin and through the mark for a factor of safety of 5 on the scale of 180 lbs. per square inch boiler pressure. If we wish to determine the thickness of plate for a shell 50 ins. internal diameter to give a factor of safety of 5 with 180 lbs. per square inch pressure, we note the intersection of the above diagonal line with the line of 50 ins. boiler diameter. The point of intersection lies between two horizontal lines. The line above corresponds to a plate 1/2 in. thick with a quadruple riveted butt seam, and the line below to a 9/16 in. plate with a double riveted lap seam. Either of these two arrangements would give a satisfactory practical solution of the problem. Obviously also if the boiler diameter and thickness of sheet are

* Copyrighted by Lawford H. Fry.

given the chart may be used to determine the allowable boiler pressure. Take, for example, a shell 68 ins. inside, made of 11/16 in. plate with a double riveted butt seam. Find the intersection of the horizontal plate line and the vertical diameter line and lay a straight-edge through this point of intersection and the point of origin, and note where the straight-edge cuts the boiler pressure scales. It will be seen from the diagonal line drawn in the figure that we get a factor of safety of 4.5 for a pressure of 200 lbs. per square inch, a factor of 5 for 180 lbs. and a factor of about 5.62 for 160 lbs. Similarly if the boiler pressure and plate thickness are given the largest allowable boiler diameter can be determined.

The vertical lines are drawn so that the distance of each from the vertical base line, O Y, is proportional to the boiler diameter with which it is marked. The horizontal lines are drawn to a scale so chosen that the distance of each from the horizontal base line, O X, is proportional to the ultimate shell strength corresponding to the plate thickness and style of seam which the line represents. This ultimate shell strength is determined by inserting the particular values of plate thickness (t), and steam factor (p), in the shell strength component (110,000 t p) of equation (3). The various values of the seam factor (p) are given in the table at the lower left-hand corner of the chart. With these two elements determined, the pressure

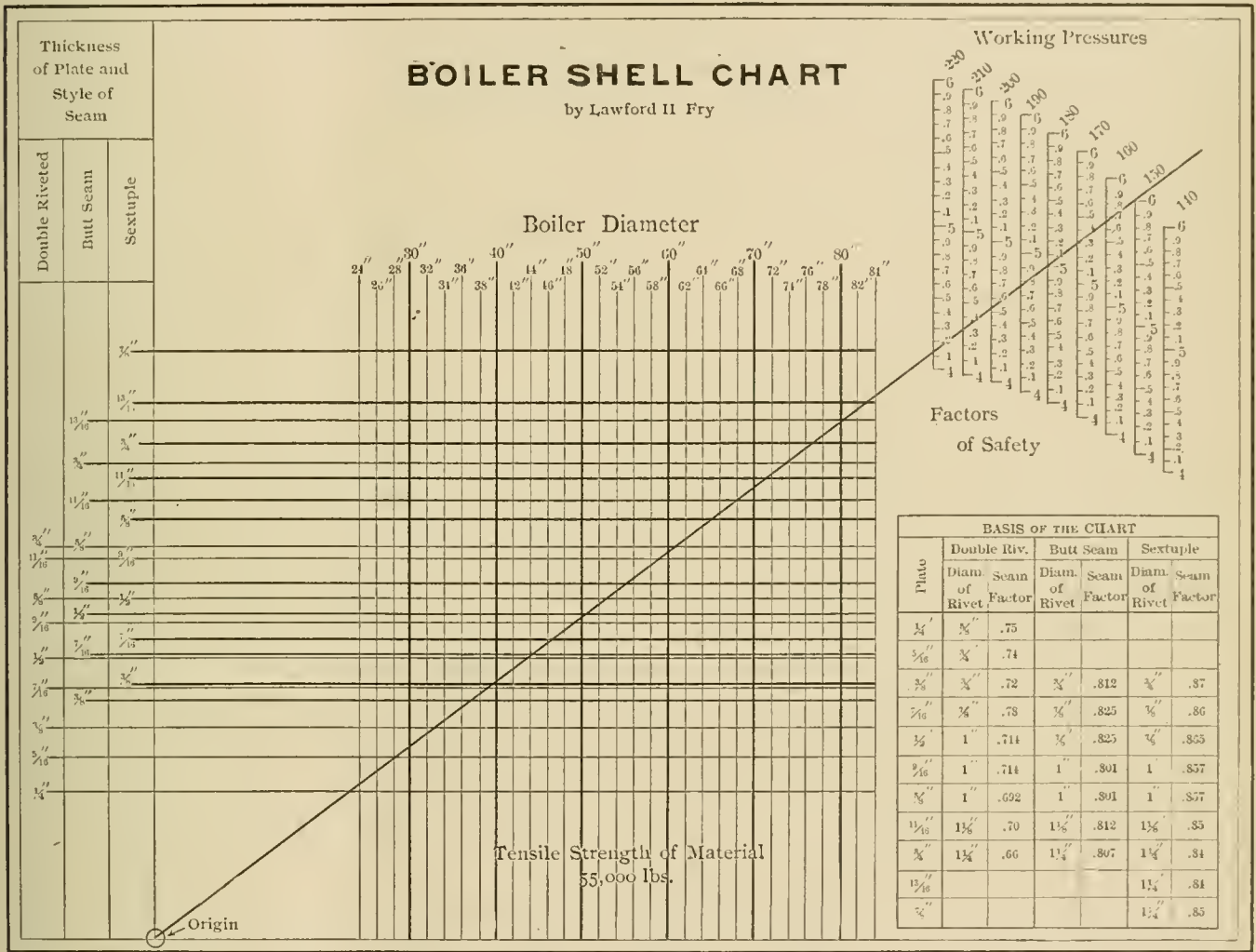

Copyrighted by L. H. Fry

A.E.

In conclusion the basis on which the chart has been constructed will be pointed out. In the first place the ultimate tensile strength of the material is taken at 55,000 lbs. per square inch. The original formula (1) then takes the form:

$$F = \frac{110,000 t}{D P} p \dots\dots\dots(2)$$

or by transposition

$$P F = \frac{110,000 t}{D} p \dots\dots\dots(3)$$

This expression divides naturally into three components:

- (a) pressure component, P F;
- (b) boiler diameter, D;
- (c) shell strength component, 110,000 t p;

each of which corresponds to one of the elements of the chart. The first step in the construction is to choose appropriate horizontal and vertical scales and draw in the corresponding lines as follows.

scales are located in a convenient position by calculation and measurement from the lines established.

Mr. Angus Brown has resigned as Master Mechanic of the Chicago Terminal Transfer Railroad Company to accept the position of Division Superintendent of Motive Power of the New York Central at West Albany.

Mr. S. P. Bush has resigned as Superintendent of Motive Power of the Chicago, Milwaukee & St. Paul to become General Manager of the Buckeye Malleable Iron & Coupler Company, Columbus, O. Mr. Bush is 37 years old and a graduate of Stevens Institute of Technology. His railroad experience began in 1884 with the Pennsylvania Lines Southwest System, where he remained until 1899. The last six years, from 1893 to 1899, he was Superintendent of Motive Power of that road, which position he left to go to the Chicago, Milwaukee & St. Paul.

SOME PHASES OF THE WATER TREATING PROBLEM.

By Howard Stillman, M. A. S. M. E. and Am. Ry. M. M. Assn.

Engineer of Tests, Southern Pacific Company.

The subject of water treatment for locomotive use in modern railroad service is one that has some very interesting phases. While the principle of water treatment by chemical precipitation seems to be the best method for reduction of scaling and corrosive matter and it is true that such a method readily accomplishes the desired result, there are some side lights on the action of water in locomotive boilers which a practical study of the subject brings out.

Generally speaking, the class of information that deals with the chemistry of water and laboratory practice does not come from those having experience on the footboard. Men who handle the throttle rarely know anything of chemistry. The two classes of men do not cross in their paths of experience and their lines are not apt to converge, yet there are some matters relating to the subject that the writer would draw attention to from the standpoint of one in position to view both the chemist and the man at the throttle. What I have to say relates to railroad service only.

Probably no subject to-day concerns the economy of the locomotive more than the character of its feed water. Some matters relating to it we understand and some we do not. The main point I would make in my discussion, is that boiler scale, while one of the greatest, is not our only trouble in locomotive feed water. Before taking up the matter of treatment let us define what we mean by bad water. There are two general classes of water that affect the service: those in which the incrustating matter predominates and those in which the soluble, non-incrustating or generally termed alkali matter is in excess. The incrustating class of waters do not necessarily trouble the engineer as they may act quietly under forced evaporation and enable him to work a good throttle and get his train over the road easily. The real trouble is revealed only when the engine is shopped with a cracked plate, corroded flues and "loads" of scale to be removed.

I give two illustrations constituting notable evidence of bad scaling waters containing comparatively little of the alkali matter referred to. These supplies are 466 miles apart and separated by an entire division. Systematic analyses of all water supplies gave the first evidence of which of them were making trouble in the boilers which were put through the shops. Locomotive engineers had for years believed the waters good, showing the following analysis:

Station	Casa Grande.	Saugus.
Location	Arizona.	California.
Source	Well.	Well.
Matter in solution.	Grains per U. S. gallons.	
Carbonate lime	4.08	11.37
Sulphate lime	32.08	23.60
Chloride lime	8.28
Carbonate magnesia	2.45	1.46
Sulphate magnesia	17.15
Chloride magnesia	7.81
Alumina and iron	.29	.12
Silica	4.49	1.69
Sulphate soda	14.34
Chloride soda	18.34	2.22
Total	77.82	71.85
Total incrustating	59.48	55.29
Total non-incrustating	18.34	16.56

The above waters are extreme types taken in illustration, and the question I would ask the chemist whose opinion is based on laboratory experience is, why did not the above waters give road service trouble from foaming and priming, if the alkalis do not cause foaming as is a stated opinion followed by the expression "boiler foaming takes place only in the presence of particles of matter suspended in the water in the boiler." It was apparent that the above waters did deposit a large quantity of matter in the boilers without foaming. It has also been written that in the laboratory, experiments have been made with boiling solutions of different qualities to induce foaming. Experiments with distilled water under con-

ditions so far removed from practice I do not consider of value. The conditions of forced steam production in the locomotive boiler under influence of pressure and corresponding heat cannot be readily reproduced in the laboratory.

Passing now to the matter of effect of water of the second general class I have referred to, namely, those containing the alkalis in excess (salts of soda and potash). I would illustrate the following waters that have been notorious for years as causing great trouble and expense from foaming and priming at the Tucson Division in Arizona, but without evidence of excessive formation of scale in the boilers shopped.

Station	Yuma.	Adonde.	Gila Bend.
Source	Colo. R.	Well.	Well.
	Matter in Solution, grains per U. S. Gallon.		
Carbonate lime	7.58	10.44	4.37
Sulphate lime	2.85	1.40	11.08
Chlorate lime	4.37
Carbonate magnesia	.75	2.56	.70
Sulphate magnesia	2.80	6.42
Chloride magnesia93	2.51
Alumina and iron	2.33	.17	.41
Silica	1.11	1.69	1.22
Sulphate soda	13.64
Chloride soda	17.66	47.12	60.65
Total	48.78	70.73	85.31
Incrustating matter	17.42	23.62	24.31
Non-incrustating matter	31.30	47.12	60.65

The expense to road operation in loss of fuel from constant blowing off, use of steam more or less saturated in cylinders and delay in road service have been considerable from use of these waters. The Adonde and Gila Bend waters are now avoided by use of water cars in freight service, carrying better water. At prevailing freight rates, however, this item of expense is considerable.

In the analyses above shown I have taken extreme cases of untreated waters, and my judgment in regard to them, as types, is that they are untreatable with commercial profit; the Casa Grande and Saugus waters, by reason of the large amount of alkali that would result from a reduction of the scale forming sulphates and chlorides they contain; the Arizona waters would not pay to treat by reason of additional alkali to the present amount that renders them unserviceable for locomotive feed water. I firmly believe in the theory that alkali matter in excess will induce foaming and priming. Matter in suspension will also produce this result, but there is evidence to prove that it is not the only cause. As to treated water, the effect of alkali when increased beyond a certain degree by reaction together with that naturally contained also goes to prove the effect of alkali.

In evidence of this I would quote the treated water at Port Los Angeles, Cal., the following being the matter contained in solution in grains per gallon:

	Before treatment.	After treatment.
Incrustating matter	39.24	10.04
Non-incrustating matter	12.31	33.63
Total	51.55	43.67

This water is supplied to a long wharf at which coal is loaded and shipped by rail, the road following along shore a few miles, then ascending a short, steep grade to the top of a bluff. In hauling coal trains to Los Angeles it is customary to take a "run" at the short grade, the summit being attained with the lever well down and full open throttle. Before treatment of the water the run was easily made without priming. After treatment the water was "light" under this severe test; a shower of water from the exhaust would follow the rapid demand for steam and the method of "doubling" the hill had to be followed. This led to so much trouble that the extent of treatment was reduced by diminishing by one half the amount of soda ash used. The result is a partly treated water showing the following matter in solution by most recent analyses:

	Before treatment.	After treatment.
Incrustating matter	42.88	20.41
Non-incrustating matter	13.24	26.48
Total	56.12	46.89

The present treated water does not form scale large in amount though the matter classed as incrustating by analysis

shows 20.41 grains per gallon, of which amount 15.05 grains are magnesium sulphate.

This brings us to another phase of the problem: To what extent does magnesium sulphate form scale after the carbonate and sulphate of lime are removed? At San Luis Obispo the treated water contains about 14 grains per gallon of magnesium sulphate with the carbonate of lime reduced to 2 grains, and sulphate of lime, none. The treated water does not form scale or corrode at this point. The total alkali amounts to 12.95 grains per gallon, which amount does not cause priming. When treatment was first established at San Luis Obispo an attempt was made to eliminate the sulphate of magnesium using 2½ lbs. of soda ash for 1,000 gals. The result was as desired, but the water primed so badly that the soda ash was reduced to 1½ lbs. The treating plant at San Luis Obispo has been in operation about three years.

In regard to the action of magnesium sulphate in natural water containing carbonate of lime in excess as usually occurs, I am confirmed in the belief, by continued experience, that it does decompose under the influence of high steam pressures and heat in boilers to produce lime sulphate and magnesium oxide. Some authorities class magnesium sulphate as non-incrustating.

To sum up the matter presented, I would urge the necessity

BEST TYPE OF ENGINE FOR HEAVY FAST PASSENGER SERVICE.

By F. F. Gaines,

Mechanical Engineer, Lehigh Valley Railroad.

The best type of engine, as regards wheel base arrangement, for any given road or run, depends upon the conditions under which it is to be operated. The length and weight of train, the speed, grade and curvature are all important factors in deciding this problem. The duration of grade, as well as the rise, also affects it. On runs where a large percentage of the distance is level or nearly so, with a few miles of heavy grade intervening, it is questionable if an engine powerful enough to handle the train on the grade should be selected. It would seem to be more economical, when track, maintenance of power, etc., are all considered, to select an engine that will do the work properly on the level, using a helper for the grade.

As a general proposition, or even as an axiom, it may be stated that the smaller the number of coupled wheels used, the faster the engine will run, and the less the cost of repairs for a given mileage—all other things being equal. That this

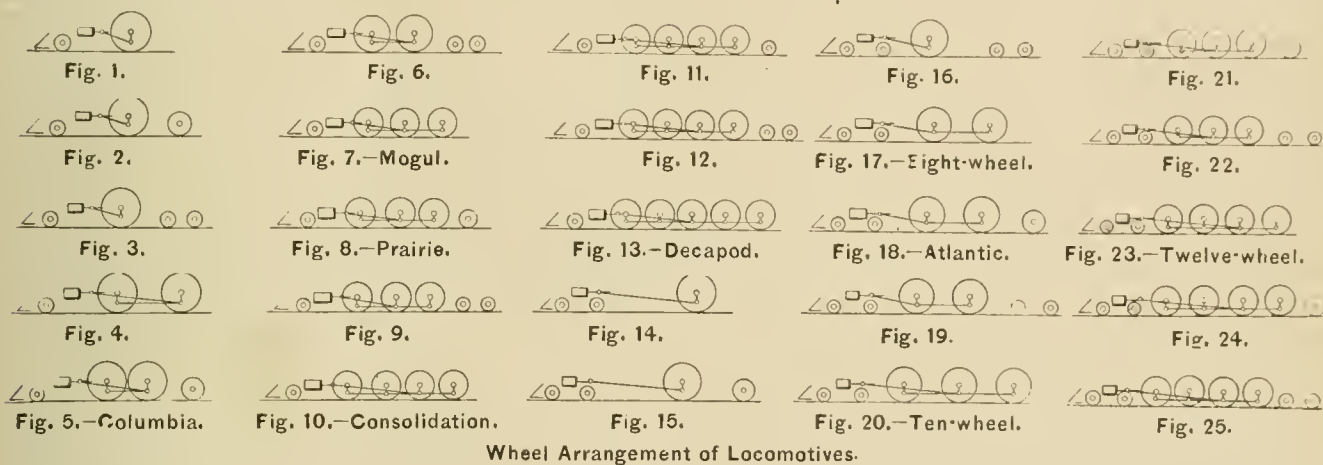

Wheel Arrangement of Locomotives.

of letting the left hand know what the right hand is doing in the matter of water treatment else the effectiveness of the locomotive may be impaired and this may become more important than the cost of repair from excess scale and corrosion.

I most certainly advocate the treatment of boiler waters for removal of excess scale and corrosive matter, but the limits I would prescribe are as follows:

Do not ordinarily attempt to treat a water containing less than 12 grains per gallon of total matter classed as incrustating unless of an unusually corrosive nature such as the unstable chlorides of lime and magnesium.

It is not commercially profitable, ordinarily, to treat a water if the total alkalies (salts of soda or potash) naturally contained and resultant, exceed 30 grains per gallon.

As above stated, I have confined my remarks to water for locomotive use only. The conditions of stationary practice are very different as I may illustrate from service tests at some future time.

is logical is seen from the facts that the greater the number of wheels coupled, the greater the flange and rolling resistance; the greater the number of parts to be maintained, such as rods and bearings, and the less the flexibility and adaptability of the machine as a whole to the varying conditions of track. As a check on theory, it has been found in actual practice that these assumptions are invariably correct.

In selecting a wheel arrangement we have the possible combination of one or more pairs of drivers, with a two or four-wheeled leading truck; a pair of trailing wheels, or a trailing truck. Several of these arrangements are shown in Figures 1 to 25 inclusive.

For high-speed passenger engines considerations of safety debar all arrangements having a two-wheeled leading truck, unless its use is an absolute necessity, due to unusually favorable circumstances. Running at high speed, the leading truck guides, or should guide, the engine. When entering a curve the side pressure on the wheel flanges is enormous, the pressure having a tendency to cause the wheel to mount the rail. The greater the weight on the truck, the greater will be the resistance to this tendency, and obviously a four-wheeled truck can safely carry twice as much weight as a two-wheeled truck, thereby doubling the probability against derailment. In these times when the legislative public is closely investigating and legislating against all features and devices that are not acknowledged the safest and best, it behooves those concerned to select only the safest devices as a precaution against possible future changes compelled by law. The four-wheeled leading truck is much more conducive to easy riding

A monster 16-in. army gun has just been completed at the Watervliet arsenal that surpasses the guns of the world in range. The noted Krupp gun recently tested in the presence of the German Emperor dropped a shell eleven miles from its initial point, but the American gun will shoot nearly 10 miles farther; its range being about 21 miles. This gun, which is to be on exhibition at the Buffalo Exposition, weighs 130 tons, is 49 ft. 2.9 in. long, with a rear diameter of 5 ft.

of the engine, as well as the lessening of oscillations at the front end, which throw a certain amount of stress on the machinery. If the side play of a two-wheeled truck is made stiff enough by springs or other arrangements to prevent these oscillations at high speeds, and when entering curves, the side thrust on the wheel flanges rises to a point where it becomes dangerous—dangerous as regards resistance of the material in the flanges against fracture and the mounting of the rail by the wheel at a low joint or other imperfection in the track. If, on the other hand, the side play is sufficiently easy to keep the flange pressure within safe limits, on any but very straight track, there is a probability of the truck not being able to do all the guiding, throwing part of this duty on the first pair of drivers, with the probable result of abnormal flange wear. From motives of both safety and economy it would seem advisable to exclude any arrangement having a two-wheel leading truck, if it is possible to use any other arrangement. These considerations dispose of Figs. 1, 2, 3, 4, 5, 6 and 7.

On account of the extra number of parts involved, and the fact that there is little or no necessity for their use, as regards carrying capacity, the use of four-wheeled trailing trucks need not be seriously considered. This excludes Figs. 9, 12, 16, 19, 22 and 25. The arrangements shown in Figs. 14 and 15 are not such as to carry a boiler of sufficient power. Of the remaining numbers, Figs. 10, 11, 13, 23 and 24 are too heavy and cumbersome for anything but very heavy trains on heavy grades, and could not be operated on account of their lack of flexibility at high speed. This series of eliminations leaves Fig. 8, or "Prairie" type; Fig. 17, or eight-wheel "American" type; Fig. 18, or "Atlantic" type; Fig. 20, or ten-wheel type, and Fig. 21, an unnamed type, for further consideration.

On account of the considerations previously mentioned, the best engine for any service will be that which with ample boiler capacity and sufficient adhesion or weight on drivers will have the smallest number of wheels, and consequently be the simplest. In this respect the eight-wheel, or "American" type, shown in Fig. 17, is unquestionably the first choice if the boiler can be carried by the wheel arrangement without overloading the journals, or giving too high a concentrated wheel load, the latter being governed by the physical condition of the track and bridges on the line. The "Atlantic" type easily comes second, as it has the same flexibility and a small number of parts, with the added advantage of much greater boiler capacity. Up to the point where it becomes a question of adhesion, in connection with a heavy drawbar pull on long, steep grades, it is a powerful type of engine which is capable of handling heavy trains at a high speed. When more adhesion than can be obtained from the weight on two pairs of drivers becomes necessary, the choice lies between the ten-wheel and "Prairie" types. The use of the latter, with a two-wheel leading truck and a short main rod, can only be justified by unusual conditions. The ten-wheeler has all of its advantages, and none of its disadvantages. Fig. 21 shows a type which, so far as I know, is not in existence. It may, however, be one of the familiar types of the future. It has some disadvantages in the long total wheel base, but it combines great boiler capacity with a well-distributed rail weight, which is often necessary on account of bridges. It would seem to be an ideal type for very heavy mountain service, heavy express or excursion trains, where a consolidation engine is sometimes necessary.

The question of choice of type becomes an easy one when the service conditions are known. A boiler with the proper ratio of maximum horse-power required, to total heating surface; with the proper ratio between flue heating surface and firebox heating surface; a grate area proportioned for the successful burning of the class of fuel to be used should be carried on a wheel arrangement that has the smallest number of coupled wheels that will provide the necessary traction and will not overload the journals or give too high a concen-

tration of rail load. From the foregoing the order of choice is as follows:

1. Eight-wheel type.
2. "Atlantic" type.
3. Ten-wheel type.
4. Type shown in Fig. 21.
5. In exceptional cases, the "Prairie" type.

It should be borne in mind that the objections to a two-wheel leading truck for fast passenger service do not hold good for an engine in freight service, as the circumstances are more favorable in the latter service.

PATENTS AND RAILROAD MECHANICAL DEPARTMENTS.

By J. Snowden Bell.

So much unnecessary litigation and expenditure have been brought about by patent claims on railroad devices that have been proved to be untenable, and so many worthy and original inventors have been sorely disappointed in their hopes of reward for what they have produced, that a general suggestion of what should be done before the question of a patent arises at all may be of some value.

The writer has found, in an extended experience in connection with the procurement and litigation of patents, that in very many cases, and specially as relating to railroad appliances, patents have been granted without any knowledge whatever, on the part of the Patent Office examiners, of what has been previously put into practice, and has not happened to be brought to their knowledge by publication or otherwise. The information of these officers is limited to what has been published, or which, if not published, they may have accidentally noticed. It is therefore entirely reasonable and proper for them to grant a patent for something which, although otherwise patentable, may have been in actual and practical service much longer than would bar the grant, but which has not been recorded in print or otherwise been made known to them.

On the other hand, there are numerous instances in which a person who has made an invention which is both a useful and a valuable improvement, and which has not been known to or used by any other person before his invention, is denied a patent, either because someone else who has obtained knowledge of it, and who is sufficiently dishonest and unscrupulous, has been shrewd enough to get ahead of him on mere technicalities, or by unreliable testimony, or because he has failed to take the proper precautions to fix the date of his invention, or to apply for a patent within the time limited by the law.

The remedies for both classes of cases seem to be simple and easy, and, while they need be stated only in general terms, they are of ready application and easy to understand. It is probable that, if they were universally applied, both the railroad associations and the patent lawyers would, to a considerable extent, be in position to feel, with Othello, that their occupation was gone, yet their loss, whether great or small, would be the gain of many, and this is the purpose we are seeking to promote.

Very many, if not nearly all, of the worthless patents under which unfounded claims of infringement have been made and may hereafter be made, against railroad companies, would never have been issued at all, and would not be issued in the future, if greater attention was paid by the officers of railroad mechanical departments and manufacturers of railroad appliances to the keeping of full and accurate records of all facts and dates relating to the origination and introduction into their service of new designs and appliances, and to bringing them, after they have been put into service and been found to be useful and practical, to the knowledge of those interested in the subject, through the medium of illustrated descriptions in print. The columns of the various railroad journals are always freely open to them for this purpose, and publications of the character referred to are both interesting and instruc-

tive. On general principles this course would obviously be desirable, and, for the purpose of establishing a barrier to the grant of patents for that which should not be patented, it is of direct and substantial value to railroad companies. It may be objected by those unfamiliar with the law, that the inventors of such designs as are really new and patentable, would, by publication, be debarred from protection for them, but such an objection is not a sound one.

The law allows an inventor two years after the date at which he has put his invention into public use, within which to make application for a United States patent on it, and, so long as he does not exceed this statutory limit, the publication of its successful reduction to practice acts in the direction of supporting his claims whenever he is prepared to make them. It is, however, to be noted that under the apparently unreasonable provisions of the patent laws of Europe, a prior publication in this country prevents a valid patent there, but it is only in exceptional cases that European patents are profitable, and the American inventor will, as a rule, find it to his interest not to spend his money on them.

The days in which a narrow-minded policy induced builders of machinery to refuse illustrations of their work to the general public are happily past, and, in most cases, the railroad or private manufacturer who gets out something new no longer wants to hide his light under a bushel. A little of the old leaven, however, remains, and the sooner it is done away with the better. When a locomotive, car, or any other appliance of new design, whether good or bad, goes on the road, it does not fail to attract attention. A two-foot rule, pencil, and sketch-book in the hands of a good draughtsman will easily get all its visible features and those that are closed up can generally be discovered. If the railroad and private shops will publish their new designs they will insure that they are put before the public in the form in which they ought to be presented, will receive the credit for them to which they are entitled, and will block the way of the patent sharp who otherwise might seek to appropriate them and fraudulently obtain a patent with which to carry on a campaign of blackmail.

The other branch of the case is that of the railroad employee who may make an invention. All new and useful improvements are not necessarily patentable ones, but as regards those that are, it is as much to the interest of the railroad company as to that of the employee, that the latter should receive the protection he is entitled to. If the improvement is valuable to the company, the company will ordinarily be glad to pay for it what it is believed to be worth. If it is not, the inventor is not harmed, but in either case the fraudulent patentee and would-be blackmailer has no opportunity.

The railroad man who makes a new design, or what he believes to be a new invention, should be careful to date all his sketches, drawings and written matter relating to it, and should make notes of his movements in the several stages of progression toward its actual use. He should keep his records in such shape as to be able to prove at a later day, if proof should happen to be required, what he did, when he did it, and who took part in, or had knowledge of, his work in the matter. If the design proves, in practice, to do so well as to lead him to believe that it would be to his interest to get a patent on it, he ought to apply for a patent within two years after it has been put in public use, and, indeed, as soon thereafter as his means will permit. He should not waste his money in filing a "caveat" (which is worse than useless) and should be on his guard against incompetent "cheap John" patent solicitors and pretended patent "brokers," who will do nothing but get a fee out of him for putting his patent on their alleged agency books, and who, in nine cases out of ten, are barefaced swindlers, who have been more than once exposed. The division Master Mechanic, or the Superintendent of Motive Power will, in most cases, be able to recommend some competent and trustworthy patent solicitor, and the solicitor will

obtain his patent for him, if the invention proves to be patentable, in regular course.

Delays are dangerous in these matters, and the inventor should also recognize that a patent is not necessarily a mine of wealth. It will not have cost him very much beyond the exercise of his ingenuity, and if he receives a fairly good offer for the patent when obtained, it is usually good policy to accept it. If the purchaser makes a profit (as he naturally expects to do), it is because he has facilities for dealing with the property which the inventor does not have, and in most cases would never be able to obtain, and it may be safely said that, in any case, the inventor will do better by devoting his attention to his regular line of work, and to the development of further improvements in it, than by speculating in patent property or dealing with it to a sufficient extent to interfere with the work or business which gives him his living.

GRATE AREAS FOR BURNING CULM.

By T. S. Lloyd,

Superintendent of Motive Power, Delaware, Lackawanna & Western Railroad.

In the use of the small sizes of anthracite coal we have found it worth while to give careful thought to the grate areas in order to permit of using as much as possible of the finer sizes such as the Nos. 1, 2 and 3 buckwheat, which are ordinarily known as buckwheat, birdseye and rice. These are by no means inferior fuels, for they contain the best of anthracite coal and are remarkably free from slate, the only problem is to furnish grate area sufficient to burn the amount of fuel required to do the work of the engines. While a little soft coal mixed with the anthracite is equivalent to a corresponding increase in grate area our efforts have been directed toward an entire elimination of bituminous coal in the anthracite engines. Large grate areas are necessary with fine coal because it runs like sand and in a deep bed leaves no interstices for air. Our object is to reduce the fuel cost by employing 62-cent coal in place of that which costs \$2.04 per ton. These are relative figures only and give the proportionate rather than the exact cost. On certain classes of engines now running (having a ratio between total cylinder volume and grate area of less than 9 to 1) we find it necessary to use about 10 per cent. of soft coal, but all of the new classes of anthracite engines use nothing but anthracite. In freight service we use No. 1 buckwheat; in switching service, Nos. 2 and 3 buckwheat, and in heavy passenger service, pea coal. The strong draft of heavy passenger service will not permit of using the finer sizes. The fine sizes are all "washed" coal taken from the culm banks and known as culm. For all new anthracite burning engines shaking grates are used, the change from the water bar grates having been most satisfactory.

We have grades averaging 80 ft. per mile, 25 miles long and 75 ft. per mile 10 miles long, with numerous other smaller slopes. Four new classes of engines have been designed for our service, the switch engine, illustrated in the American Engineer, March, 1901, page 91; an 8-wheel passenger engine, illustrated in May, 1901, page 144; a consolidation freight engine with grates 9 ft. wide and 10 ft. 6 ins. long and a consolidation engine with a moderately wide grate for soft coal. The first three of these are for hard coal, and while the heating surface is, of course, an important factor, we find that it is to a certain extent secondary to the selection of the proper grate area, as far as our immediate object is concerned. With fine coal no amount of heating surface will compensate for the lack of sufficient grate area, whereas if the grate area is right the size of the cylinder part of the modern boilers permits the introduction of sufficient tubes to insure liberal heating surface.

The first engine on this road having a wide firebox over drivers and designed to burn fine coal, was the "New York,"

old No. 102. The boiler was built in these shops, at Scranton, in 1879. The firebox was what was known as the "Swallow Tail" type, the shell of the firebox tapering down at the back to within 8 ins. of the crown sheet. The firebox was 7 ft. wide by 8 ft. 6 ins. long, giving a grate area of 59.5 sq. ft. The ratio between the total cylinder volume in cubic feet and the grate area in square feet was 8.4 to 1. The cylinders were 18-in. diameter by 24-in. stroke and when the cylinders had been bored to 18½ ins. the ratio decreased to 7.9 to 1. This engine burned fresh-mined buckwheat coal successfully, but when the cylinders had been increased to 18½ ins. in diameter, the steaming qualities of the engine were noted to deteriorate. On subsequent engines built of this type with 18 x 24-in. cylinders, we increased the size of the fireboxes to 7 ft. 6 ins. x 8 ft. 6 ins., and later to 7 ft. 6 ins. x 9 ft. and finally 7 ft. 6 ins. x 9 ft. 6 ins. The 7 ft. 6 in. x 8 ft. 6-in. firebox gave a ratio of

made a great improvement in them. As we went into heavier power with increased cylinder capacity, we found it difficult to keep up the proper ratio between grate area and total cylinder volume. Ten feet was considered a proper limit for the length of fireboxes and the limit of width of the engines was established at 9 ft. 4 ins. In 1893 we built a 10-wheel engine with 63-in. drivers for fast milk-train service. As this engine was expected to make fast time with heavy trains we decided to design a firebox with a very liberal grate area. We made the firebox 8 ft. 4 ins. wide by 10 ft. long, giving 83 1/3 sq. ft. grate area and a ratio to cylinder volume of 9.5 to 1. The firebox was 9 ft. 4 ins. wide outside of the lagging, which was then our limit. This engine proved to be an excellent steamer. Our new consolidation engines of the wide firebox type have 21 x 26 cylinders. To make the ratio of the cylinder volume to the grate area equal to our standard ratio, we made

FUEL TESTS OF 8-WHEEL LOCOMOTIVE NO. 930, DELAWARE, LACKAWANNA & WESTERN RAILROAD.
CONDUCTED BY STUDENTS OF CORNELL UNIVERSITY.

TEST NUMBERS.	1.	2.	3.	4.	5.
FUEL—POUNDS.					
Consumed on run	13,655.0	9,926.0	10,500.0	10,650.0	13,000.0
Consumed per hour while running	4,670.0	2,890.0	3,640.0	2,900.0	3,900.0
WATER—POUNDS.					
Total evaporated on run, lbs	67,100.0	54,600.0	55,400.0	69,700.0	69,000.0
Water evaporated per hour, lbs	23,000.0	18,500.0	19,200.0	18,800.0	20,780.0
Equivalent evaporation from and at 212° F. on run	82,300.0	66,700.0	67,600.0	84,700.0	84,200.0
Equivalent evaporat'n from and at 212° F. per hour	28,180.0	22,600.0	23,400.0	23,000.0	25,190.0
Boiler, h.-p.	819.0	656.0	680.0	668.0	736.0
ECONOMIC EVAPORATION.					
Water evaporated per lb. of coal on run	4.98	5.5	5.28	6.55	5.3
Equivalent evaporation from and at 212° F.	6.12	6.72	6.45	7.95	6.47
RATE OF COMBUSTION.					
Coal burned per sq. ft. grate per hour	53.3	33.0	41.5	33.19	44.6
RATE OF EVAPORATION.					
Water evap. per sq. ft. heating surface per hour	10.7	8.61	8.95	8.82	9.25
Water evap. from and at 212° F. per sq. ft. heating surface per hour	13.1	10.55	10.9	10.71	11.28
Sq. ft. heating surface per h.-p.	2.62	3.27	3.15	3.21	2.92
TRAIN DATA.					
Between Scranton and Hoboken	East. April 26, Day.	East. April 27, Day.	East. April 29, Day.	East. May 2, Day.	West. May 2, Night.
No. of cars	1 Pullman 3 coaches 1 com. smoker and baggage.	1 Pullman 2 coaches 1 com. smoker and baggage.	1 Pullman 2 coaches 1 com. smoker and baggage.	1 mail 1 express 1 coach 1 Pullman 1 smoker 1 dining car Strandsburg to New York.	4 Pullmans 1 coach 1 smoker 1 express
Estimated weight of train—tons of 2,000 lbs.	193 T.	148.0 T.	148.0 T.	212 T.	276 T.
Average steam pressure while running	177.5	182.5	180.2	153.3	182.0
Average temp. smoke box while running, F.	725	830	943
Average smoke box vacuum while run'g, ins. water	5.5	6.1	6.03
Average temp. feed water, F.	45	48	50	50	48
Average speed, M. P. H., not including stops (integration of speed recorder roll)	41.0	43.0
Average of maximum draw bar pulls, lbs.	4,200.0	3,990.0
Average (A) of maximum indicated h.-p.	832.0	936.0
Average of maximum dynamometer h.-p.	405.0	458.0
Ratio $\left\{ \begin{array}{l} \text{dynamometer h.-p.} \\ \text{indicated h.-p.} \end{array} \right.$.487	.48
Average quality of steam in dome while running	95.2%	91.9%
Average quality of steam in chest while running	96.4%	95.6%
Average quality of steam while standing still	98.5%	98.5%
Time on road	4 hrs. 1 min.	3 hrs. 53 min.	3 hrs. 53 min.	4 hrs. 33 min.	4 hrs. 10 min.
Running time	2 hrs. 55 min.	2 hrs. 57 min.	2 hrs. 53 min.	3 hrs. 41 min.	3 hrs. 20 min.
Drifting and stops	1 hr. 6 min.	0 hrs. 56 min.	1 hr. 0 min.	0 hrs. 52 min.	0 hrs. 50 min.
Condition of weather	Fine Day.	Fine Day.	Fine Day.	Cloudy.	Rained HARD.
Condition of rail	Dry.	Dry.	Dry.	Dry.	Slippery.

9 to 1. The ratio for the 7 ft. 6 in. x 9-ft. firebox was 9.56 to 1, and the 7 ft. 6 in. x 9 ft. 6-in. firebox gave a ratio of 10 to 1.

When we built the first 19 x 24 mogul in 1882 of the wide firebox type we made the ratio 9.06 to 1, the firebox being 7 ft. 6 ins. wide by 9 ft. 6 ins. long. These engines steamed so well that this firebox was adopted as a standard for 19 x 24-in. freight engines, but on 19 x 24-in. passenger engines we increased the size of the firebox to 8 ft. wide by 10 ft. long. This gave us a ratio of 10 to 1. Our first passenger engines having wide fireboxes had Wootten combustion chambers. In 1894 as an experiment we cut out the combustion chambers on all but a few of our passenger engines, with satisfactory results.

Our first 20 x 24-in. consolidation engines had fireboxes 7 ft. 6 ins. wide by 9 ft. 6 ins. long. This gave a ratio between the total cylinder volume and the grate area of 8.1 to 1. We increased the size of the fireboxes on some of these engines to 8 ft. wide by 10 ft. long, or a ratio of 9.17 to 1, and the alteration

the firebox the extreme limit in width that would insure clearance on the road, or 9 ft. wide inside and 10 ft. 6 ins. long inside. This grate area is 94.5 sq. ft. and gives a ratio of 9.4 to 1. This ratio will insure splendid steaming qualities. Our new 8-wheel passenger engines with 20 x 26 cylinders have fireboxes 8 ft. 4 ins. wide and 10 ft. 6¼ ins. long, with a grate area of 87.67 sq. ft., and a ratio of 9.3 to 1.

The increase in the ratio of the total cylinder volume to the grate area on this type of engine has been with us a gradual evolution covering a period of twenty years. We have found in actual practice that with a ratio of 9 to 1 our engines prove free steamers without the use of any bituminous coal; other roads introduce 40 per cent. and even as much as 65 per cent. of bituminous coal on account of insufficient grate area. The large grate area not only permits of the successful consumption of the finer and least valuable commercial sizes of coal, but absolutely abolishes the emission of smoke, which cannot be done where grate areas are contracted and bitumi-

nous coal is permitted to be used even with a small percentage.

The report of the committee on grates in the Master Mechanics' Association proceedings of 1897 recommends this ratio of 9 to 1 for fine anthracite fuel. The report is a consensus of opinion formulated through the experiences of this and other roads using fine anthracite fuel. A representative of one of our neighboring roads after a tour in 1894 of all roads using this fuel, stated in his report that the D., L. & W. was the only road burning fine anthracite coal on locomotives without the use of any bituminous coal.

We consider a ratio of 9 to 1 a minimum limit for fine anthracite coal for road service without a mixture of bituminous coal and as the ratio is increased the size of fuel can be decreased. We also find that as the ratio is increased a poorer quality of coal can be successfully burned. On engines engaged in switching service we find with a ratio of 8.6 to 1 that fine anthracite coal of the smallest sizes can be successfully burned without bituminous coal, as the conditions are different on these engines from those of road engines, the runs being short, large nozzles can be used and the draft effect on the fire is modified, not being as severe as on road engines operating on our heavy grades.

I include a record of recent tests on one of our passenger locomotives conducted by Mr. A. S. Tourison, Jr., assisted by other students of Cornell University. This was done in connection with a graduating thesis. The record of maximum indicated h.p. marked (A) when averaged, did not include cards taken while drifting. The water was measured by a calibrated meter and checked by tank readings. The coal was weighed on truck scales.

SHOULD ENGINE TON MILEAGE BE INCLUDED IN MOTIVE POWER STATISTICS?

By C. H. Quereau,

Assistant Superintendent Motive Power, Denver & Rio Grande Railway.

It is not necessary to make an extended argument to show that railroad managers consider statistics essential to the successful management of the properties they control, but until within a few years the careful study which its importance warrants has not been given to the basis of these statistics, or the units by which the operation of railroads are judged and controlled. While it is admitted that statistics are essential to the highest success, it is equally true, though not universally recognized, that they may easily be misleading and result in incorrect conclusions or poor operative results, either because the basis of comparison is a false one or because some essential items have been omitted.

Until recently the capacity of locomotives has been determined by the number of cars they were rated to haul. This unit has been quite generally abandoned because of the varying weights of cars, and instead locomotives are now rated by tons. Experience has shown that the use of the ton basis for moving traffic has resulted in increased train loads and fewer delays, increasing the net earnings and it can be shown that the reason for this greater efficiency of the locomotives is the fact that the ton is a more accurate measure than the car of their capacity to do work.

Comparisons based on the car are very liable to be misleading because there is no standard car and no uniform weight of lading for a car. An increase or decrease in the average weight of the cars handled during any number of years, which are to be compared for the purpose of determining whether an improvement, or the reverse, has been made, results in wrong conclusions. If the average weight of the car and its lading is less than during the period compared with, there appears to be an improvement, while in fact there is not, but rather the reverse. But if, as is more probable, the average weight per car has increased, the showing will be less favorable,

notably in the cost of delayed time, locomotive fuel and repairs, and the facts are, that instead of less favorable results, there has been an improvement, statistics to the contrary notwithstanding, because there is always a decrease in operating costs when the train load is increased, so long as the increase does not result in excessive delays. When the basis of operating is the ton the liability of such wrong conclusions largely disappears, because the ton is a constant unit of weight, and its usefulness is not seriously affected by variations in the weight or capacity of cars. In short, the ton is a more accurate measure of resistance than the car. Notwithstanding these facts, which seem self-evident when attention is called to them, a number of railroads still judge operating results by the number of cars handled per train.

Though the ton is a more accurate and satisfactory unit for operating purposes than the car, experience has shown that even the ton, though it is a basis which does not vary, does not give the desired results in all cases. The reason is this: The object aimed at in using a unit for loading locomotives is to have them always haul the heaviest possible load without stalling, or the heaviest possible load consistent with the desired speed. This object would be reached if some practicable unit could be used which had a fixed relation to the tractive power of the engines, because it is this power which we strive to gage in fixing the train load; or if there was a fixed relation between the ton and the power necessary to haul it.

Experience has demonstrated the fact that a given tonnage rating, which is all that is to be desired when made up of loads, is too heavy when composed of empties. A number of tests with a dynamometer car have shown that a given tonnage in empty cars requires from 7 per cent. to 50 per cent. more power to handle than the same weight in loaded cars; 7 per cent. more at a speed of about 10 miles an hour on a grade, and 50 per cent. more on comparatively level track at speeds approximating 25 miles an hour. A number of roads have recognized these facts and endeavored to overcome the difficulty in various ways. Several have limited the number of cars in a train; a number have added an arbitrary tonnage to the actual weight of empty cars, and a few have made careful tests with a dynamometer car to determine the resistance per ton of weight of all classes of cars, empty, partially loaded and fully loaded, and prepared tonnage rating sheets on the basis of the resistance shown by these tests. It is not necessary to discuss here which of these methods is the best. The facts are mentioned to show that, though the ton is a more accurate basis than the car, its original use has been modified because this did not furnish as accurate an operating basis as is desirable and to call attention to the fact that efforts are being made to arrive at a basis which shall measure as closely as practicable all the work to be done, or the resistance to be overcome.

It seems reasonable to conclude from these facts that it is recognized that the most desirable operating basis is that which most nearly approximates the capacity of the engine and, as nearly as practicable, includes all the resistance to be overcome; all the work to be done. It is true that usually the weight of the locomotive and waycar are not included in tonnage ratings, simply because these are always the same for a given class of each, are a constant part of freight trains and were taken into account in making the ratings originally which, if included, must be subtracted from the ratings in making up trains to determine what the weight of the train should be between the waycar and tender. Hence nothing is gained by including them and useless work is saved by omitting them. In this connection it is well to bear in mind that a tonnage rating is only a measure of a locomotive's capacity for work, and is not a measure of the work done.

When the ton was established as an operating basis for making up trains and had shown its value, it was but natural it should be considered as a basis for motive power statistics. The fact was recognized that the mile, which had been universally used as a unit of comparison, was by no means even

an approximately close measure of work, because it gave only the distance through which work was done, regardless of the capacity of the motive power and its actual performance. Its use gave the same credit to a narrow gage as to the most powerful engine built for a trip over the same length of track, whatever the load each handled. The tonnage hauled would give a more accurate measure of the work done than the mile, but it required little consideration to show that the distance over which the tonnage was handled was a very important factor in measuring the work by which to judge efficiency, for, if used, two engines handling the same tonnage would receive the same credit, though one handled it twice as far as the other. Hence, the ton-mile, which shows both the weight moved and the distance over which it is moved, thus giving a more accurate measure of the work done, has been quite generally adopted as the unit for measuring the cost of locomotive service, furnishing another illustration of the tendency of modern railroad men to measure as closely as practicable the work done as a basis of comparison; or rather an illustration of modern clear thinking.

It is interesting to recall that Watt, the inventor of the modern steam engine, that he might have a measure of the capacity of his machines, devised and used the horse-power, which may be defined as the power which will raise 33,000 lbs. 1 ft. in one minute, and contains the elements of weight, distance and time. In the evolution of the basis of railroad motive power statistics it first included only the element of distance and has but recently included that of weight, still leaving out the important item of time or speed. This lack has, however, been supplied in a measure by grouping the statistics under several heads, as passenger, freight and switching service, so that the influence of speed on the amount of work credited is largely discounted by the fact that, because of this grouping, the extremes are much less than if all classes of service were thrown together into one group. This is another instance showing the growing appreciation of the general principle that the basis of statistics should be such as to furnish the closest practical approximation and that they should include all essential items.

There has recently been started a discussion as to whether the ton-mileage of the engine should be included in the ton-mileage totals to be used in determining the efficiency of the motive power department. In view of the growing practice to use such a basis for statistics as shall approximate as closely as possible the work done, it would seem that the decision could be only an affirmative one. Still it may be of service to discuss the matter somewhat at length.

I am convinced that a majority of those who would leave the ton-mileage of the engine out of motive power statistics do not have clearly in mind the different objects in view by the general manager, the general superintendent and the superintendent of motive power in keeping statistics. I am led to this conclusion by their remarks, some of which are quoted here-with. "The essential thing for a railroad company is what an engine does behind the tender." Again, "It seems to me that the general manager of a road wants to know what the engine is doing; he wants to see how much tonnage the engines are hauling behind the tender." These statements are certainly correct, but apparently the authors draw the conclusion that "Therefore the efficiency of the motive power department should be judged on this basis." It is to the correctness of this conclusion that I take exception.

It occurs to me that the general manager, while investigating what the engines are hauling behind the tender, will not hold the superintendent of motive power responsible, if the results of the investigation are not satisfactory, but rather the general superintendent, because he is the officer who is responsible for these results and not the superintendent of motive power, who has practically no control of results "behind the tender." He would judge the capacity of the superintendent of motive power on the basis of the cost of the work for which he is responsible, which, in my opinion, cannot be de-

termined on the basis of the efficiency of the general superintendent. It seems clear that, while the general manager, the general superintendent and the superintendent of motive power have much that is of common interest and each should receive and study the statistics of all, still each has a special field which is not the same in the case of any two, and therefore one set of statistics cannot serve the best interests of all. It seems equally clear that each department should be given statistics which will serve its interests best, by which it can be judged most correctly, and only by so doing can the greatest efficiency and responsibility be reasonably expected.

The chief concern of the general manager is the relation of tonnage and revenue; that of the general superintendent the relation between theoretical and actual tonnage and between net and tare tonnage, while the superintendent of motive power should study chiefly the relation between the expenditure for which he is responsible and the output of work realized from it, whether revenue producing or not. In short, the problems of increasing net revenue, of securing the best service from engines and men while on the road, and of designing the most economical engines and keeping them at their maximum efficiency for the least money, are quite different. If this is a fair statement I cannot well see how one set of statistics can be made to do justice to all these interests. The conditions now and a few years ago are quite different. Then the profits were greater, competition not so sharp and the necessity of statistics, the best adapted to give reliable information, not so great. Under present conditions accurate knowledge, at least as accurate as one's neighbors, is essential.

It seems to me very plain that the best interests of all three can be served only by a set of statistics for each, the best adapted to judge the capacity of each, and that these can be furnished without prohibitive expense. By the use of properly prepared blanks which would show in separate columns revenue ton-miles, gross ton-miles and net ton-miles and any other items desired it is a very simple and inexpensive matter to provide the tonnage required.

It is quite probable that a considerable part of the opposition to recommending and approving the use of these sets of statistics, especially that for the motive power department, is due to the belief that the cost of furnishing the necessary ton-mileage figures will be prohibitive. An investigation will show that this fear is not well founded. In all probability the ton-mileage back of the tender will be compiled for the general superintendent. That these figures may be used as a proper basis for the statistics of the superintendent of motive power, it is only necessary that the ton-mileage of the engine be added. On the Chicago, Rock Island & Pacific this is done in the office of the superintendent of motive power and the expense is that "of one day's work per month for our statement clerk." From the Northern Pacific the information is obtained that "it must be nominal, inasmuch as no special labor is involved." The car accountant of the Burlington & Missouri River writes: "We find it difficult to say how much extra it costs to compute ton-mileage of way cars and engines, but believe that \$6 per month would cover it."

Though the ton-mileage of the engines is included in the motive power statistics of the Chicago, Burlington & Quincy and of the Southern Pacific, I have received no estimate of the cost of this work, but from the facts given believe it safe to say that the expense should not exceed \$75 per year. This item is so small because the ton-mileage for each engine is a constant for each operating district, and a table of these constants having been made, it costs only the time necessary to add them to the figures for the train back of the tender, which have already been made, to obtain the ton-mileage of the entire train.

While the superintendent of motive power may be, and should be, interested and posted in the matter of revenue ton-mileage, and the relation between theoretical and actual and between loaded and empty ton-mileage, he can control these only to a very limited extent, and therefore can be held re-

sponsible for results in these directions only indirectly. It follows therefore that his efficiency cannot be fairly judged on either of these bases. What, then, should be the basis? It is reasonable to conclude that it should be one which is a just measure of the results for which he is responsible, and hence should show the relation between the money he is responsible for and the work produced by it. In short, the cost of his department work per gross ton-mile, the ton-mileage to include all that is produced, whether revenue producing or not.

If the ton-mileage of the engine is omitted there will be no credit against which to charge wages, supplies and repairs when an engine is run over the road light, and no proper credit when hauling only a way car; no credit for these charges on account of the expense incurred because of the work necessarily done by the engine in moving itself when hauling a train. That these items frequently amount to a considerable proportion of the total will presently appear. In my opinion Mr. Rhodes, Assistant General Superintendent of the Burlington & Missouri River, sounded the keynote as to the correct line of reasoning when discussing this matter before the American Railway Master Mechanics' Association last June. He said, in part: "I believe with the men operating the head end, that a great deal of economy can be produced by getting their co-operation, and to get their co-operation you must show them figures and results to entirely secure them with you, and you must show them that your figures are fair; that is to say, that you are measuring these men properly. I believe that if you leave out a portion of the tonnage that helps to consume the coal and other materials used on the engine, you are not going to be able to put yourself in a position to say you are entirely fair in your method of measuring." If it is conceded this is a fair statement and logical reasoning when applied to the records by which engineers and firemen are judged, I can see no good reason why it is not correct when applied to the records made by the officers who are responsible for the performance of the motive power department. Nor can I see any good reason for the unnecessary expense of two sets of ton-mileage figures for this department; one including the ton-mileage of the locomotive by which to judge the efficiency of the enginemen, the other, excluding the ton-mileage of the locomotive, by which to judge the department as a whole.

It is perhaps only a coincidence that most of those who oppose including the ton-mileage of the engine are connected with railroads which operate through comparatively level country, and therefore are not familiar with the conditions confronting those connected with roads not so favorably located, but it would not be surprising if this lack of experience accounts for the position they take. Before considering their conclusion as a final one they should know that there are a number of roads with heavy and continuous grades where the use of double headers, three locomotives to a freight train, helper engines for both freight and passenger trains, and a considerable percentage of light engine mileage are necessary to economical operation; a number of districts where five car passenger trains necessitate the use of three heavy locomotives, where freight trains seldom have less than three, where light engine mileage frequently and usually reaches sixty per cent. of the total, and where more than thirty per cent. of the total ton-mileage is that made by the engines; entire divisions where the helper engine mileage is from twenty-five to forty per cent. of the total. Had these facts been understood by those who are accustomed to but one engine per train, whose passenger engines handle from ten to fourteen cars and whose freight engines haul from fifty to seventy cars, with whom the light engine mileage will average nearer six than sixty per cent. of the total and the engine ton-mileage nearer ten than thirty-five per cent., I very much doubt if they would have been quite so sure that the engine ton-mileage should not be credited to their department against which to charge their expenditure. I am quite certain they have not taken into consideration one and a half per cent.

grades seventy miles long or four per cent. grades nearly twenty-five miles long.

If the recommended practice in regard to ton-mileage for motive power statistics should omit that of the engine, I am persuaded that a number of roads which must contend with heavy grades will not be convinced of the justice of following the recommendation and decline to do so. If this is a fair estimate of the opinion prevailing on such roads, will it not considerably increase the probabilities of having the recommendation more generally adopted if the ton-mileage of the engine is included? If it is included, it seems reasonable that it would not in any way destroy the usefulness of the statistics for roads with slight grades, as shown by the opinion of the Superintendent of Motive Power of a road noted for the practically level grade over which it operates. Though at that time he was not in favor of including the ton-mileage of the engine, he said: "I think in analyzing the figures and seeing how much it amounts to, to put the weight of the engine in these ton-mile figures does not amount to one per cent. difference." This was said in regard to the influence on a comparison of the fuel records of including, as compared with excluding, the ton-mileage of the engine.

It may appear to some that an extended argument like this is a waste of time because each road will decide for itself which practice it will follow. Possibly this is true. Still, though I have no faith that the practice of comparing statistics of different roads results in bettering records, because scarcely two roads can be found where operating conditions are the same or can reasonably be made the same, such comparisons will in all probability be made, and at present such comparisons are considered of such importance that committees have been appointed by the American Railway Association, the Association of American Railway Accounting Officers and the American Railway Master Mechanics' Association to consider and report on uniform methods of preparing railway statistics.

On several occasions the argument has been made that the ton-mileage of the engine should not be included, as this would not give proper credit to unusually good locomotive designs, in which the greatest power had been obtained for the lightest gross weight of the machine. An able designer has stated the case in the following words: "I believe if we can produce an engine with the same tractive power and of lighter weight, so that the weight of the engine is replaced in part by the weight of the train, that that engine is certainly entitled to the benefit of the extra tonnage that it would haul; whereas, if we included the weight of engine and tender, there would be no extra credit for that design."

Assuming the argument is as strong as its author could possibly hope to claim, there still remains the fact that, before it is allowed to settle the question, we must decide whether the best interests of the motive power department as a whole should be sacrificed in order to give the Mechanical Engineer due credit for skill and ability. While I believe I fully appreciate the importance of good designs and their effect on the efficiency of the department, it seems to me the efficiency of the Mechanical Engineer can be properly judged without sacrificing the best interests of the department as a whole, and that this would be the result if its basis for statistics is determined by the argument just quoted. Aside from this feature of the case, I believe it can be shown that the argument is not as weighty as may at first appear.

In so far as the locomotive proper is concerned, I believe I am warranted in concluding that the steam pressure and dimensions of the cylinders and drivers are proportioned to the weight on the drivers and that the weight on the drivers determines the maximum tractive power of the machine; that the cylinder power is seldom less than 22 or more than 26 per cent. of the weight on the drivers; and that the effect of this small variation would scarcely be found whether the weight of the engine proper is included in the ton-mileage or not. It is true that on prairie roads the tractive coefficient

may be somewhat higher than on those operating on heavy grades, because with the former the maximum tractive power is seldom used except in starting, but on heavy grades the weight on the drivers determines the capacity of the locomotive most of the time, and under this condition superiority of design has little opportunity to produce a lighter engine capable of handling a heavier load. In regard to the locomotive proper I believe the following statement a fair one. Superiority of design can affect its tractive power but little, if any, because this is fixed by the weight on the drivers, though there are many opportunities to lighten the weight of the frames, cylinders and running gear so as to secure boilers of greater size and heating capacity.

As to the tender, I believe it will be conceded that its capacity for water and coal are determined by operating conditions and not by the designer; hence his field is limited to the lightest weight for a given capacity. A tender having a capacity of 10 tons of coal and 6,000 gallons of water would weigh about 110,000 lbs., ready for service, and is suitable for a locomotive having 20 by 26-in. cylinders, carrying 200 lbs. steam pressure, with drivers 63 ins. in diameter. Such an engine should easily handle 1,500 tons of train on a prairie road. The weight of the coal and water in such a tender would be 69,800 lbs., making the light weight of the tender 40,200 lbs., or 20.1 tons. Its light weight would therefore be but 1.3 per cent. of that of the train back of it, and is such a small proportion of the total that, if we assume a designer capable of accomplishing the impossible task of reducing the weight of the tender to zero, I believe it will be admitted without argument that we could not reasonably expect to find the results of his skill in our records, whether the tonnage of the tender is included in our statistics or not.

THE DRAFT GEAR SITUATION.

By Edward Graftstrom, Mechanical Engineer Atchison, Topeka & Santa Fe Railway.

Since my review of this subject in the American Engineer and Railroad Journal (June, 1900, page 185), several interesting developments have taken place which are worth the scrutiny of the Master Car Builders' Committee having this subject in charge, as furnishing data on the present state of the art.

The Westinghouse tests of the friction gear at Wall and Wilmerding have shown the possibilities of this excellent device; the tests of draft riggings under the drop testing machine at Topeka have demonstrated that there are draft riggings strong and substantial enough to satisfy the most exacting demands; and the road test of twin spring and tandem spring draft gears on the Santa Fe has been corroborated by similar tests on other roads, all of which have brought out the fact that a well-made double spring draft rigging is fully able to meet the conditions of the service of the present day.

It is to be regretted that these tests were not conducted under the official supervision of the committee, so that the results could have been reported and discussed at the coming convention. This notwithstanding these tests have become a matter of history through the medium of the railroad journals, and no member of the association with the interest of the company he serves at heart can afford to ignore them.

Few, if any, of the mechanical railroad officials will deny the superiority of the friction draft gears. Yet when the rush for new cars came this year there were few, if any, who cared to go before the management and on their own responsibility present specifications calling for the friction draft gear. The price of this device is so high compared with that of spring draft gears and the benefits accruing from it are so remote in time that no one can yet say what the return for the additional investment will actually amount to. If the friction draft gear

will lengthen the life of a car it may be fifteen years before figures will show it, and could it not then as well be ascribed to other improvements in car construction? Besides, who can tell whether or not the cars of to-day will not anyway be obsolete fifteen years hence?

If it is a question of repairs, of which the friction draft gear would have a large portion, we have at present no figures to compare it with save for single spring draft gears, for the modern double spring attachments have not yet been in service long enough to furnish figures for this purpose.

The Topeka drop test showed conclusively that some of the double spring draft gears are strong enough to promise an important reduction in the cost of maintenance of cars. This item of expense is therefore certain to be lessened with the passing of the single spring gear, be it supplanted by double springs or friction gear. The road tests on the Santa Fe and elsewhere have also demonstrated that two good springs offer a cushion sufficient to protect the car from ordinary shocks.

From this point of view the whole question resolves itself thus: What injury will this recoil, of which we have heard so much recently, do to the car? For answer let us analyze the action which takes place when two cars come together. First, the draft springs are closed up, and if the force of impact is more than what is expended in compressing them, the followers will come up against their stops before the impinging car is brought to a rest. At that moment the torsion of the springs will reassert itself, sending the cars apart until the draft springs have regained their normal free height, after which the momentum of the cars in their recoiling movement will be absorbed in compressing the springs again, this time against the other set of followers and stops. The cars now come to a rest before the springs are fully compressed or the followers brought home, and at the moment they are quiescent the springs will again commence to straighten out and pull the cars toward each other, passing their normal point and going beyond it to a still lesser extent than at first. This will be repeated until the force of impact has been entirely spent in producing oscillations in the springs, to be finally overcome by the torsion of the steel bar. It will thus be seen that the recoil in a draft rigging with double sets of followers is always acting against the same spring that caused it. With the present draft springs only a few oscillations are needed to consume the impact. Anybody can convince himself of how quickly the shock is absorbed by the springs by blocking a car and pulling out the coupler with an engine as far as it will go, and then releasing the coupler; the recoil will not reach a lead pencil held between the striking plate and the coupler horn. How the recoil can injure a car is not clear, but that it would snap the old link and pin connection in two was due to the slack and consequently to the momentum acquired by the recoiling car before the retarding influence of the spring was felt. With the limited play in the M. C. B. coupler the conditions ought to be different, however.

If this line of reasoning is accepted as logical, it follows that the recoil of the draft springs is not more injurious to the car than the recoil of the bolster springs. As long as the latter do not come together solid no damage will be done to the car or lading, and why should this not be equally true of the draft springs? According to this argument the possibilities in spring capacity of draft gears have not yet been exhausted. In point of fact, the writer believes that the main spring used in the Westinghouse friction gear would give better results as a draft spring than the present M. C. B. spring, or possibly a 10-in. spring would be more desirable. Then there is the recourse to graduated springs with a lighter inner coil which has been suggested but not yet tried as far as the writer knows.

The principal advantage of the friction gear above the spring draft gear lies consequently in its large capacity, or, in other words, in the greater resistance offered before the cars come together solid, while at the same time there is the requisite sensitiveness to light blows. By using graduated springs in

sufficient number this effect could probably be closely reproduced, but the cost of such an arrangement would perhaps come as high as that of the friction gear.

Before leaving this subject one more phase of it should be referred to which brings in the "personal element." When the M. C. B. coupler became general the enginemen felt less hesitation about hitting the cars hard in the yards while making up trains, knowing that there would be no men between them making couplings. Likewise since the friction gear became introduced on some roads it has been observed that the yard crews have developed an investigating turn of mind of their own, and when they send a cut of cars against another, and the cars are labeled "Westinghouse Friction Gear," the men try to see for themselves if what is claimed for the device is true. The writer has it from more than one source that such cars are getting rougher treatment than others in the yards, and when the superintendent of motive power has had his attention called to this diversion his explanation has been that these cars must take their chances with the rest without special protection. However, be this as it may, this practice would tend to reduce the durability of cars with friction gears and should be guarded against in the interest of the "art."

To the Editor:

The article entitled "The Draft Gear Situation," while dealing with this subject apparently in quite a comprehensive way, contains many ideas which might mislead those who have not given the subject special consideration.

It is asserted that "the tests of draft riggings under the drop testing machine at Topeka have demonstrated that there are draft riggings strong and substantial enough to satisfy the most exacting demands." The most severe punishment to which the devices tested at Topeka were put resulted from the fall of a 1,640-lb. weight through 20 ft. A simple calculation of the energy resulting from this blow will show that it is far below the capacity of a single Westinghouse friction gear, while in service two such gears, with double the capacity of a single gear, are always concerned in absorbing the energy imposed upon them when cars fitted with these devices are run in trains. The Topeka tests were not only by no means such as would determine whether or not the draft gears were substantial enough to satisfy the most exacting demands, but in these tests the gear was only tested by impact. This is manifestly inadequate as the strains set up by pulling the cars are really the most important. The draft rigging can and should generally be not required to transmit the strains arising from the impact of cars colliding, but it must take all the strains of extension. A failure here results in a break-in-two, with its attendant danger of much greater damage to cars and lading.

Again, the author makes no distinction in his comparisons between the yielding and cushioning part of the draft rigging of cars, and the attachments which secure this yielding member or members to the sills or other parts of the car structure proper, but treats them, individually and collectively, under the somewhat vague term of "draft gear." It is well known that the device called the Westinghouse Friction Draft Gear is an appliance for supplying the greatest possible yielding resistance, both in tension and compression, between the drawbar and the car structure. There can be no rivalry between this and what are called spring draft gears in the communication above mentioned, as these gears consist simply and solely in improved methods and stronger appliances for attaching the ordinary draft springs, either single or double, to the car. The friction gear is really a substitute for the draft springs and as such manifestly can be attached to the car as strongly. Laying aside then the question of the strength of attachments, the question under consideration resolves itself into one of the value of a yielding resistance, in the line of draft, of at least $4\frac{1}{4}$ times the capacity to cushion shocks and suddenly imposed strains of even the strongest double springs. This great capacity is also secured with the practical absence of recoil.

There are many locomotives running to-day the tractive power of which is more than sufficient to exhaust the capacity of the double springs on a direct pull, permitting all strains due to jerks from slack in the couplings, whether loose or

spring slack, to come as uncushioned blows or stresses upon the draft attachments. That new attachments, under these conditions, are not broken in tests signifies little in judging the value of appliances which will absorb the greatest tractive power of the heaviest locomotives, and have several times this amount of yielding resistance still left to absorb stresses and shocks due to slack, before their capacity is exhausted.

No one would think of endorsing the design of a structure or machine because it would not be destroyed by the greatest load it was to carry if imposed a few times. Mechanical structures, especially those subject to alternating stresses, must not only not fail under maximum stress, but must, like the Westinghouse friction draft gear, have a factor of safety of several times its ultimate loading when, as here, this is considered the maximum traction of the locomotive.

In regard to the effect of the recoil of the draft springs, we cannot accept the conclusion of the author that the recoil of the draft and bolster springs is comparable in action or in the effect upon the car structure. The analysis made in the article of the action of a spring under suddenly and continually applied load is quite correct and applies well to the conditions under which a bolster spring works. It is, of course, possible and often occurs that a draft spring is loaded similarly, under which conditions the author's reasoning and conclusions would apply. This, however, is by no means always the condition under which the draft spring recoils and it is that under which the recoil is disastrous which needs consideration. Let us follow the author's analysis:

"First the draft springs are closed up and if the force of impact is more than what is expended in compressing them, the followers will come up against their stops before the impinging car is brought to rest. At that moment the torsion of the springs will reassert itself, sending the cars apart until the draft springs have regained their normal free height, after which the momentum of the cars in their recoiling movement will be absorbed in compressing the springs again," etc.

Suppose now when "the impinging car is brought to a rest," in addition to the recoil of the springs, a sudden and considerable force is applied in the same direction, as often happens either from the locomotive or the inertia of other cars in motion; this force, itself perhaps almost as great as the couplings will stand, has added to it not only the energy stored in one double spring and given out in its recoil, but as many times that energy as there are springs in compression released under this condition. This rapidly accumulating force is finally expended at some point or points in the train where conditions of relative motion of the cars are different either by brakes set in the rear or different velocities of cars in one part of the train than in another, as in passing through sags or over hog-backs. It is readily seen that there is no analogy here to the action of bolster springs and it is this cumulative action, resulting from the recoil of the draft springs and increasing with their capacity, that causes the sometimes mysterious break-in-tuos in emergency stops with long trains of air-braked cars, always, as should be the case, more prevalent with empty than loaded cars.

The greater the rigidity of the car itself the more severe the results of this recoil will be and with the large increase in steel-car and underframe construction, great as the advantage in the very large capacity of the Westinghouse friction draft gear is, it is by no means certain that the absence of recoil will not prove of still greater service in lessening the expense of maintenance and improving the safety and reliability of freight train movement.

In regard to the so-called "personal element," in the first place, breakages of draft rigging in yards or in switching operations are, of course, expensive and objectionable on this account, but they do not approach in importance breakages in draft rigging on cars in trains in motion as breakages here are not, as in the former case, confined to the damage of the rigging, but may, in addition, wreck the train. Again, the same objection, viz., the "personal element," was originally urged against the use of power brakes. The train men would be reckless and approach danger points at speeds which would cause more wrecks and disasters. Such may, in some cases, have been true, but the failure to properly train and discipline employees did not stop the progress in railroad operation due to the introduction of a valuable improvement thirty years ago, nor need we fear that it will do so to-day. E. M. Herr.

CONFLICTING OPINIONS CONCERNING COMPOUND
LOCOMOTIVES.

As the compound locomotive is likely to be given considerable attention, as usual, at the approaching Master Mechanics' Convention, it will be interesting to note the following quotations taken at random from the proceedings of that association.

Mr. A. J. Pitkin (Proceedings for 1890)—I believe thoroughly in the two-cylinder type as the proper form for compounding.

Mr. P. Leeds (Proceedings for 1890)—I would not at present recommend the purchase of compound engines, * * * nor do I believe they will ever do all that is claimed for them. * * * Quoting Mr. Angus Sinclair—It is an open question, there being the most violent conflict of opinion on the subject among locomotive superintendents in Europe, where they ought to know all the comparative values. A month spent in the home of the compound locomotive took away a great deal of the faith previously held in that type of engine.

Mr. S. M. Vauclain (Proceedings for 1891)—When you come to compound standard engines with cylinders 22 x 24 ins. in diameter by 28-in. stroke, you can see that you would not have road-width enough to put a low-pressure cylinder on one side of the engine and get by on the road. I do not think anybody would want to use a 36 to 38-in. low-pressure cylinder for every-day use. We, therefore, thought we would adopt a four-cylinder arrangement, and with that idea we brought out what is called the Baldwin Compound Locomotive, of which I am the patentee. * * * We know that there is an economy in the two-cylinder compound. It was proved years ago, as far back as the original patent dates. But that economy is not sufficient so we go to the four-cylinder compound.

Mr. A. J. Pitkin (Proceedings for 1902)—I simply wish to call attention to the report sent to Mr. Gibbs by Mr. Small giving the equalization of work in the two-cylinder compounds, believing as we do thoroughly in the two-cylinder compound engine as being a case of the survival of the fittest.

Mr. J. N. Lauder (Proceedings for 1892)—But I want to say it seems to me unnecessary to build and maintain four cylinders on locomotives, with all the attending expense of repairs, when you can get equally good results out of a much simpler form of engine.

Mr. J. N. Lauder (Proceedings for 1894)—I think that the past year's experience in this country with the compound engine has plainly brought about a feeling among the railroad companies and railroad men in general, that it is very much of a question whether there is not to be a compound engine that will successfully compete with the best type of simple engine. * * * I believe we are going to get compound engines within a few years that will give us greater economy of operation than anything we have at the present time.

Mr. D. A. Wightman (Proceedings for 1895)—I am an advocate of the compound locomotive of the two-cylinder type. I think those who have closely followed what might be called the rise and fall of compound locomotives during the past three or four years have not failed to discover a growing faith in the value of double expansion. * * * The conservative reports of our European friends have been largely ignored, and in place of economies of 10 to 25 per cent., the railway officers of this country have been flooded with reports of tests showing a saving in fuel of 25 to 45 per cent.—reports in many cases so grossly misleading that as one reads and turns the pages he is surprised at not finding them signed by Ananias. These statements have doubtless accomplished, to some extent, the object sought; for it has been said that compound locomotives have been sold largely in Wall Street, so to speak; and certain it is, they have been bought sparingly upon the advice of railway master mechanics. * * * It may be unnecessary for me to add that I think the most successful double-expansion locomotive of the future will have but two cylinders.

Mr. R. H. Soule (Proceedings for 1897).—The compound locomotive is still in the balance.

Committee Report (Proceedings for 1900).—The data obtained is quite too meager to permit of drawing any definite conclusions as to what average result might be expected from the compound under any given set of conditions.

PERSONALS.

Job H. Jackson, President of the Jackson & Sharp Company, died at Wilmington, Del., May 23.

Mr. H. T. Herr has been appointed Division Master Mechanic of the Chicago & Great Western, with headquarters at St. Paul, Minn., in the place of Mr. J. M. Robb, resigned.

Mr. F. N. Hibbits, Division Superintendent of the Erie at Carbondale, Pa., has been appointed Mechanical Engineer of the Union Pacific, with headquarters at Omaha, Neb.

Mr. William Forsyth, who is well known to the readers of this journal, has joined the staff of instructors at Purdue University and will have charge of the classes in locomotive and car design.

Mr. J. F. DeVoy, Draftsman for the Brooks Locomotive Works, at Dunkirk, N. Y., has been appointed Chief Draftsman of the Chicago, Milwaukee & St. Paul, with headquarters at West Milwaukee, Wis.

Just before going to press a notice is received of the death of Frank W. Deibert, Assistant Mechanical Superintendent of the Baltimore & Ohio, at Newark, O. Mr. Deibert was formerly with the Chicago, Milwaukee & St. Paul.

Mr. R. O. Cumback, General Foreman of the locomotive department of the Central Railroad of New Jersey, has been appointed Superintendent of Cars and Machine Shops of that road, with headquarters at Elizabethport, N. J.

Mr. G. R. Henderson, who is well known to our readers, has resigned as Assistant Superintendent of Motive Power of the Chicago & Northwestern to accept a position with a similar title on the Atchison, Topeka & Santa Fe, where he succeeds Mr. R. P. C. Sanderson, recently resigned.

Mr. A. J. Ball has resigned as Assistant Superintendent of Motive Power of the Cincinnati, Hamilton & Dayton to accept the position of Superintendent of Motive Power and Equipment of the Toledo, St. Louis & Western, with headquarters at Frankford, Ind., succeeding Mr. J. S. Turner, resigned.

Mr. Samuel R. Callaway has resigned the office of President of the New York Central, to accept the presidency of the American Locomotive Company, an organization including the principal locomotive works of this country, with the exception of the Baldwin Company. Mr. Callaway is 50 years old and began a most successful railroad career in 1863, when he entered the services of the Grand Trunk Railway. Since that time he has held the offices of General Manager of the Chicago Grand Trunk, Vice-President and General Manager of the Union Pacific, President of the Toledo & Kansas City, President of the Lake Shore & Michigan Southern and of the New York Central.

BOOKS AND PAMPHLETS.

Biographical Directory of the Railway Officials of America. Edited and compiled by T. Addison Busbey, Associate Editor of the Railway Age. 1901 edition, 613 double-column pages. Published by the Railway Age, Chicago.

This volume gives in concise form the history of the professional career of every railroad man in this country who has attained an official rank. The changes and interesting developments in the career of these men are simply told by the statements of the different positions through which they have worked and the time spent in each position. The present edition contains sketches of the lives of 4,990 men, of these 1,344 did not appear in the last preceding volume of 1896, and about 1,223 of those whose names did appear in that edition have either died or entered into some other work. Many interesting things are told by an examination of the book, such as the road by which each man has traveled in preparing himself for his present position. Very few of these records show a life-long service with one company, but tell emphatically of the chances and changes of railroad life. The answers to questions usually asked of a railroad man after he has reached official rank are always interesting and instructive and for these reasons, combined with its general usefulness as a directory, makes it a volume worthy a place in every railroad office. It is well arranged and well edited.



TEN-WHEEL PASSENGER LOCOMOTIVE—ILLINOIS CENTRAL RAILROAD.
With Vanderbilt Boiler and Tender.

W. RENSIIAW, *Superintendent Motive Power.*

BALDWIN LOCOMOTIVE WORKS, *Builders.*

	Cylinders : 20 by 28 in.	Boiler pressure	180 lbs.
Wheel: Driving	63 in.; engine truck 33 in.;	tender wheels
Weights: Total of engine	167,880 lbs.; on drivers	137,040 lbs.;	total engine and tender
Grate area and tubes: Grate area	33 sq. ft.	Tubes	350-2 in. 13 ft. long.
Firebox : Length	94 in.;	Diameter	63½ in.
Boiler: type	Vanderbilt corrugated firebox.	Diameter	65 in.
Heating surface : Tubes	2,362.5 sq. ft.;	firebox	135 sq. ft.;
Wheel base: Driving	13 ft. 6 in.;	total of engine	24 ft. 4 in.;
	Tender: Eight-wheel;	water capacity	5,000 gals.;
		engine and tender	53 ft. 3 in.
		coal capacity	12 tons.

A new and improved design of the Vanderbilt boiler and a novel cylindrical tender, also built to Mr. Vanderbilt's designs, have been applied to a 10-wheel passenger locomotive recently built by the Baldwin Locomotive Works for the Illinois Central Railroad. This engine is similar in general to those of the standard 10-wheel type in use on this road since 1898. It has, however, 100 sq. ft. more heating surface and 6 sq. ft. more grate area than those of the ordinary type of boiler, the weight being correspondingly greater. In this engine the corrugated firebox is 63½ ins. in diameter, which is the largest yet constructed, the grate area being 33 sq. ft. The improvement in the boiler lies in the arrangement of the firebox and tubes with relation to the outer shell. Provisions are made in this case to receive the stresses of longitudinal expansion and contraction in straight lines. The construction of the tender is a novelty in that the cistern is cylindrical with a built-up coal space with a large capacity—12 tons—at its front end. This construction greatly simplifies the tender frame by reducing the number of longitudinal sills and bringing them close together. Lightness, strength and compact form appear to be the features of this tender. Its form seems odd at first, but it is by no means ungainly. In fact, the appearance of the engine as a whole is decidedly pleasing. We shall give our readers more of the details of this tender in a future issue. The following table contains the principal dimensions of the engine:

10-Wheel Passenger Locomotive, I. C. R. R. With Vanderbilt Boiler and Tender.
General Dimensions.

Weight on drivers	137,040 lbs.
Weight on truck	30,840 lbs.
Weight, total engine	167,880 lbs.
Weight, total engine and tender	284,000 lbs.
Cylinders, diameter	20 ins.
Cylinders, stroke	28 ins.
Cylinders, valve	American balanced
Boiler	Vanderbilt type
Boiler, diameter	65 ins.
Boiler, thickness of sheets	5/8 in. and 3/4 in.
Boiler, working pressure	180 lbs.
Boiler, fuel	Soft coal
Firebox, material	Steel
Firebox, length	94 ins.
Firebox, width	57 ins.
Firebox, diameter	63½ ins.
Firebox, thickness of sheets, sides	3/4 in.
Firebox, thickness of sheets, tube	3/4 in.
Tubes, material	Iron
Tubes, number	350
Tubes, diameter	2 ins.
Tubes, length	13 ft. 0 in.
Heating surface, firebox	135 sq. ft.
Heating surface, tubes	2,362.5 sq. ft.
Heating surface, total	2,497.5 sq. ft.
Grate area	33 sq. ft.

Driving wheels, diameter outside	63 ins.
Driving wheels, diameter of center	56 ins.
Driving wheels, journals	8½ ins. by 19 ins.
Engine truck wheels, diameter	33 ins.
Engine truck wheels, journals	5½ ins. by 12 ins.
Wheel base, driving	13 ft. 6 ins.
Wheel base, rigid	6 ft. 9 ins.
Wheel base, total engine	24 ft. 4 ins.
Wheel base, total engine and tender	53 ft. 3 ins.
Tender	Vanderbilt type
Tender, diameter of wheels	33 ins.
Tender, journals	5 ins. by 9 ins.
Tender, tank capacity	5,000 gals.
Tender, coal capacity	12 tons

No system of shop organization can be satisfactory and complete that does not show the progress of each day's work, and that does not show the cost of each piece of work, together with the general and shop establishment charges. Mr. A. Hamilton Church, in a recent issue of "Engineering Magazine," gives the following principles on which a good system should be based. Such a system should readily distinguish between incidence of indirect shop expenditure and incidence of office and sale-organization expenditure; between the incidence of shop expenditure in one shop and in another, and between different classes of work in the same shop. There should also be so close a control over the stores and shops that the present value of assets may be known at least once a month. This implies, as will be obvious to an accountant, that monthly balance-sheets must be furnished, with the advantages which a continuous audit give. There will also be, what is no less important, continuous stock-taking. The present state and cost of any order should also be known at any moment, without calculation or more than two references at the most.

To the Pan-American Exposition via the "Akron" Route.—This route is composed of the Vandalia Lines from St. Louis; the Louisville & Nashville Railroad from Nashville and Louisville; the Pennsylvania Lines from Indianapolis, Cincinnati; Dayton and Columbus, via Akron and the Erie Railroad, and is in daily operation with two through passenger trains to Buffalo each day from the places mentioned above. This route offers many advantages to tourists and a number of forms of tickets may be had, which offer various privileges. The Akron Route tickets to New York via Buffalo, over the Erie Railroad will secure the privilege of ten days' stop-over at Buffalo. This will be of particular advantage to those attending the American Railway Master Mechanics' and Master Car Builders' convention, at Saratoga Springs, June 19 to 26 inclusive.

EQUIPMENT AND MANUFACTURING NOTES.

Mr. Harry A. Norton, of the firm of A. O. Norton, Boston, is making an extensive trip abroad. He will visit the various agencies of the Norton Ball Bearing Lifting Jacks in France, Italy, Russia and Sweden.

Mr. G. E. Macklin, formerly Assistant General Sales Agent of the Pressed Steel Car Company of Pittsburgh, has recently been made General Manager of the company; and Mr. E. E. Forgeus, formerly with the Chicago Lumber Company, Chicago, has been appointed Purchasing Agent.

The Trunk Line and Central Passenger Associations have granted a reduced rate to those who will attend the Railway Master Mechanics' and Master Car Builders' conventions, at Saratoga, of a fare and one-third for the round trip. In order to get the benefit of the reduced rate it is necessary to purchase a ticket at full fare for the going trip and to obtain a certificate from the agent. This certificate when presented to the proper parties at Saratoga will entitle the purchaser to a return ticket at one-third fare.

The sale of the general machinery building shops of the Dickson Manufacturing Company to a combination of interests, also embracing the E. P. Allis Company and Fraser & Chalmers, has been completed. The Dickson Locomotive Works, formerly incorporated with the Manufacturing Company, have considerably enlarged their plant. A new forge shop is now being pushed to completion and a new foundry and erecting shop are also under construction. These extensions and improvements when finished will give a capacity to the works of 200 of the largest size modern locomotives per year. No changes are to be made in the management of the Dickson Locomotive Works by the change referred to.

One of the interesting exhibits at the Railway Master Mechanics and Master Car Builders conventions to be held this year, at Saratoga Springs, June 19 to 26, will be the Webb C. Ball Company's display of modern railroad watches. These watches are made to meet the requirements of close and fast schedules, and are products of this skilful and progressive firm. They are in every sense modern and their success as timekeepers is told by the adoption of this watch by many important railways.

The Williams safety automatic car window can be applied to old as well as new cars with very little trouble, as no part of the mechanism is above the window. The device is simple, durable, cheap and renders the window air-tight, dust-proof, free from rattle and trouble from shrinkage or swelling of the wood. The window is operated by pressing a push button placed either on top or at the side of the window sill. It can be opened to any desired height and is securely locked when in the closed position. This window is equipped with up-to-date fixtures and adds greatly to the comfort and good-will of the traveling public. By addressing Mr. Otis Williams, St. Johnsville, N. Y., any desired information regarding this automatic window will be furnished.

The Richmond Locomotive Works shipped twelve 16 x 24-in. ten-wheel passenger locomotives to the Finland State Railways, Helsingfors, Finland, on the Wilson Line steamer "Consuelo," which sailed May 3d. These locomotives are duplicates of ten engines built by the Richmond Works for the Finland State Railways last year, and this is the third order received from the same source. Two very recent orders received by these builders are for four 20 by 26-in. consolidation locomotives for the Alabama Great Southern Railroad and four 19 by 26-in. ten-wheel locomotives for the Richmond, Fredericksburg & Potomac Railroad. The principal dimensions of the Alabama Great Southern engines are as follows: Diameter of driving wheels, 58 ins.; driving wheel base 15 ft. 11 ins.; total wheel base, 23 ft. 11½ ins.; weight in working order, 142,500 lbs.; weight on drivers, 124,000 lbs.; 61-in. extended wagon top boiler; steam pressure, 200 lbs.; firebox, 102¾ by 41¾ ins.; 271 2-in.

tubes 14 ft. 4½ ins. long; tank capacity, 5,000 gallons. The principal dimensions of the Fredericksburg & Potomac engines are as follows: Diameter of driving wheels, 68 ins.; total wheel base, 24 ft. 4 ins.; driving wheel base 13 ft. 6 ins.; weight in working order, about 140,000 lbs.; weight on drivers, 102,000 lbs.; 62-in. straight top boiler; working pressure, 180 lbs.; 267 2-in. 14 ft. 5 ins. long; firebox, 96¾ by 42 ins.; capacity of tank, 4,500 gallons.

The new buildings just added to the Otto Gas Engine Works were formally opened by a reception and entertainment given to the employees, by the officers of the company. About four hundred people participated and the event was a success in every way. General good feeling was strongly manifested by the employees and the company.

The Bullock-Wagner sales organization has established a district office at No. 1624 Marquette Building, Chicago. Mr. H. B. Foster, who has for about two years served the Wagner Company as sales agent, will be in charge of the office and will have the assistance of Mr. E. W. Goldschmidt, formerly of the Western Electric Company, in covering this important field.

At a recent public discussion of the smoke nuisance in Boston Mr. Edward Atkinson predicted the passing of the tall chimney and the substitution of the low stack of large area with draft produced by mechanical means. In this development the B. F. Sturtevant Company, of Boston, Mass., are taking a prominent part. He prophesied that the next generation would regard our chimneys as monuments to our ignorance left standing because they would not pay for taking down.

There is one very prominent and favorable feature which makes the lakes of New Hampshire popular with the fishing fraternity, and that is the exceptional facilities for reaching them. The General Passenger Department of the Boston & Maine Railroad, Boston, is issuing several descriptive pamphlets on outdoor sports—namely, "Fishing and Hunting," "Lakes and Streams," "Lake Sunapee"; either of which is sent to any address upon receipt of a two-cent stamp for each book. If you are a fisherman, send for them.

A report by Lord Cromer upon the finances of Egypt for the year 1900 embodies a statement made by Major Johnstone, President of the Railway Board, regarding the supply of "goods wagons" on the Egyptian Railway. The cars referred to were designed and built for this road by the Pressed Steel Car Company of Pittsburgh. He says: "Among the improvements effected during the year which has had the greatest effect is the putting into service of two hundred 30-ton American wagons ordered by my predecessor. The result has exceeded my anticipations; the complaint of want of wagons has almost ceased to exist, partly, no doubt, because the demand is not at present so great as it has sometimes been at this season, and partly from improvements in other branches of the service, but mainly owing to a great addition to our carrying power, which is represented not only by the capacity of the wagons, but by the fact that, owing to their extreme lightness, our goods engines can draw 20 per cent. more net load in these than in our ordinary stock. The result of the purchase has been a great gain in carrying capacity obtained in a very short time at a very small cost."

The Lehigh Valley Railroad will, about June 1st, place in service a new fast passenger train to run between New York Philadelphia and Buffalo and Chicago via Niagara Falls. This train will leave New York 10 a.m.; Philadelphia, 10.30 a.m., arriving Buffalo 9 p.m.; Chicago, 1.28 p.m. Returning, train will leave Chicago 11.45 a.m., arriving New York, 4.25 p.m.; Philadelphia, 4 p.m. The train will be equipped with all new cars and will be hauled by locomotives especially designed to make fast time.

AMERICAN ENGINEER AND RAILROAD JOURNAL.

JULY, 1901.

THE FUTURE OF THE M. C. B. ASSOCIATION.

By S. P. Bush.

A Member of the Association.

[This article was written while Mr. Bush was Superintendent of Motive Power of the C. M. & St. P. Ry., and was intended for our June number.—Editor.]

The future of the M. C. B. Association is a matter of no small concern to those who regard it with any degree of interest. Up to the present time the basis of the existence of the association and its principle work has been the Rules of Car Interchange. That its work has been valuable and well done is attested by the vast number of car interchanges taking place daily with practically no delay and so few disputes as to be insignificant.

The greatest compliment upon its work lies in the fact that everything that has been done by it has been accepted by the railroads without question and at the present time nearly all of them are subscribers to the rules. But what of the future?

For the last two or three years it is fair to say that the rules have required little or no modification and the annual conventions have little to show for the time and money expended in their support. The rules have been hurried through and a few committees have been appointed, and then—adjournment. The reports of committees have not been very satisfactory as a whole, and have attracted little or no attention. Surely this cannot continue. The railroads will not permit their representatives to attend conventions that do nothing. There must be some manifest direction to the work of the association in order that it may be useful, and it is to be hoped that this will be forthcoming, for there is no want of objects to which it may turn its attention.

Standards have been adopted to some extent, but for some reason these have been few, and in many cases recommended practices have been adopted instead, on the ground that standards were not practicable. But are not all railroads that interchange cars interested in having cars for service that are strong and satisfactory in every particular having not only a few but many parts standardized by the association so that repairs can be made promptly and economically? It may be said that it is impossible to standardize many parts of the car and that few would use the standards. In answer it may be said that it is vastly more important to the railroads that cars should be kept moving in useful service than that they should be held at interchange and repair points awaiting material exactly like the original, that may require many days for its receipt. Is it not a rather narrow view to take of the question at this time? Why cannot the association do in many cases as it did in the case of the coupler in which it adopted certain principles and enough in the way of specific detail to promote interchangeability? What organization or influence is there in the country better qualified to say what constitutes good practice in car construction than the M. C. B. Association? Certainly none. Then why should not the association commence with the wheel and go to the roof and say fairly and squarely without hesitation what it considers best? It not only can but it should say and give satisfactory reasons for saying whether a truck should or should not have lateral motion, whether the bolsters should carry all of the load on the center plates, whether or not roller side bearings are right or wrong, whether the friction principle for draft gear is correct or not, what shall constitute satisfactory draft gear for cars with wooden sills and how draft timbers should be secured, etc., whether

they should pass through the body bolster or up to it and what dimensions should be used.

These are a few of the many questions which it can act upon, and having done so, the rules can be made to say that when "A" has "B's" car with broken draft gear the former can apply what the association says is satisfactory, and "B" must receive the car. The M. C. B. Association instead of standing passively by and permitting those inexperienced in car construction to direct, should itself take the initiative and say what shall be done. On the eve of many important developments such as steel construction and high-capacity car, it might with entire propriety and great advantage to the entire country lay hold firmly of the reins and mould public opinion. Finally, the convention would be vastly more interesting and valuable if the discussions of reports were not cut short but made rigorous. Committees would take greater pains in their reports if they knew that the reports were to be fully discussed and probably criticised.

MASTER MECHANICS' ASSOCIATION.*

THIRTY-FOURTH ANNUAL CONVENTION.

Saratoga, N. Y. June, 1901.

The thirty-fourth annual convention of the Association was called to order at 9 a. m. June 18, at Saratoga, New York, by Mr. William S. Morris, President of the Association. After the opening prayer by the Rev. Dr. Joseph Carey the Association was welcomed in a pleasant address by the President of the Village of Saratoga, to which Mr. George W. West, Third Vice-President, responded, suggesting Saratoga as a permanent meeting place because of its popularity with both of the Mechanical Associations.

President Morris then read his address, a thoughtful, comprehensive and inspiring review of the motive power situation, with particular reference to the important part in the development of transportation held by the members of the Association. Because of its specially valuable suggestiveness we depart from usual custom and print a considerable part of it.

ADDRESS OF PRESIDENT MORRIS.

It must indeed be a pleasure to this association to call attention to the state of the art that this congress represents. And while we are too close to the development of transportation to fully comprehend its import, years hence the last three-quarters of the past century will be looked upon as among the periods of greatest importance to humanity, for in them is contained the entire development of railroad transportation, and yet the industry of building steel freight cars, which has been established but three years, uses more steel plate than the requirements of the shipbuilding industry for the entire country.

In two years ending with 1899, the last reported upon by the Interstate Commerce Commission, the freight traffic of the country had increased 30 per cent., while the increase in population is said to have been about 2 per cent. This increased business has been handled with an increase in the number of freight locomotives of but 1.6 per cent., and in freight cars of but 6 per cent. There has been an increase of 52 per cent. in freight traffic in the past six years, and yet only 7½ per cent. increase in the number of freight cars, and 3½ per cent. in the number of freight locomotives; but of course there has been a gradual increase in the capacity of the equipment, due to the construction of larger cars and locomotives. In 1894 the average freight train load was 179.8 tons, and in 1899 it was 243.3 tons, or an increase of 35 per cent. In this time there has been an increase of 48.6 per cent. in the number of ton-miles per freight engine, and 43.3 per cent. in the number per freight car. The members of this association can fully appreciate, to accomplish this, who pulled the "laboring oar."

We see too much of the tiresome detail to get a clear view of what it all means; but the consciousness of being a part of the most important development the world has ever known

*Abstracts of the reports and papers will be found in this and the following issues.

should inspire us to-day, for much remains to be done, and in the most difficult and really scientific side of railroad transportation we are the fundamental factor. It is well that we should occasionally remind ourselves of the place we have to fill as an organization, and examine the results we attain, as an incentive to more important achievements, not forgetting the fact that this is a national association.

Under the head of "official duty" most of us need to give more attention to organization, with a view of getting our work into such shape that we can rise above the details occasionally to a level with the larger problems with which we have to deal, and to take, as it were, a birds-eye view of the department and its responsibilities. Furthermore, it ought rarely to be necessary for us to go outside to fill vacancies. To secure an organization rendering this unnecessary requires time and thought, but it will unquestionably pay. We owe it to our subordinates to encourage them by every possible promotion. The organization should begin with apprenticeship and provide for the appointment of the position of head of the department.

The motive power problem during the past year has been met successfully with machines that would have raised a storm of criticism a few years ago. The simple 8-wheel passenger machine of practically recent construction had reached the limit of size under existing conditions, and were the permanent way the only obstacle, additional concentrated axle load should, and must be avoided for reliable performance and freedom from heated bearings. In freight service a graduation from the machine of five or six years ago of 160,000 pounds to some of over 250,000 pounds further demonstrates the unusual hauling capacity that has been successfully attempted and accomplished.

The compound locomotive has been with us for several years, and as lately as 1897 it was pronounced by a former president of the association as "still in the balance." We cannot be proud of the fact that its status has not changed since then and that its place has not been defined and established. Many profess belief in compounding, but continue to order simple engines with an occasional few compounds. The compound is either good or bad; if bad, let us have none of it; but if good, we ought to study its good points systematically, and understand where it should be used and how it should be built, for no more creditable, profitable or necessary work can be undertaken by the association than an attempt to get the real merit of the compound. We should not be satisfied to let the compound drag itself wearily along into its final place in our esteem, when with present-day facilities it is easy to forecast so much intelligently and appropriately. I am tempted to say that we ought to have known our own minds before this, and if we do not, an important function of the association on this particular question has not been performed.

Under the head of boilers, to meet the conditions already alluded to in the increase of capacity of locomotives, is observed the wider fire-boxes for machines burning bituminous coal. It has been ascertained, however, that wide fireboxes designed for burning anthracite coal will not successfully operate with bituminous coal, they having limited depth and a larger grate area than was required; but with convictions that justified the wide firebox for soft coal burning engines, it has been introduced successfully. The requirements being, for large engines, a wide grate with from 45 to 60 square feet and a deep firebox; this explaining the necessity for trailing wheels.

Necessity has urged these conditions in her own way to no little extent, by the demand upon the engineer to accomplish economical means of transportation, which has been forced upon the traffic officer in many ways, through competition and legislation, with its inevitable understanding and demand for lower freight rates. Think of hauling a ton of freight one mile for 3.43 mills! This, gentlemen, was the average earning for the last fiscal year of a line I am very familiar with, and while its rate power decreased 5.25 per cent., the tons of paying freight increased 14.8 per cent. Hence, you will observe the operating fully met the necessities and the balance was on the right side of the ledger to meet fixed charges.

Thus far the locomotive has advanced prominently in weight and capacity, or in other words, brute force. We now have before us the problem of making each ton of weight stand for the maximum possible horse-power, and in this there is much to be done. It will never be possible to improve the locomotive to a point in which it will compare favorably with the best marine and stationary practice with regard to the number of pounds of

coal per indicated horse-power per hour; but in the line of its present standing, as a machine which must run on the road and be relatively inexpensive to maintain, much may yet be done in increased economy in the use of steam.

Among progressive methods which should be considered prominently at this convention is the necessity for improved facilities for quickly turning engines at terminals. Until recently it was thought that anything in the form of a roundhouse would suffice, but now passenger engines are expected to make 100,000 miles, and freight engines from 40,000 to 50,000 miles per year. Roundhouses need more attention than was formerly given to shops, and this is brought about for the best of business reasons. There is scarcely any direction, except perhaps in economies in fuel, in which our work will bring more immediate and satisfactory returns than in prompt work at terminals. In busy times terminal conveniences are more readily needed and appreciated, because idle machinery for road service is shown to be so prominently unproductive, from the fact that the quicker and better the roundhouse works the smaller will be the number of engines required.

The exact relative costs of fast and slow trains is difficult to ascertain; but this subject in itself is to my mind less important than another suggested by it, viz.: The advantage of high average speed—including time lost in stops—in other words, what is the cost of the needless delays on the road which render it necessary to run unduly fast between stations? Most trains stop unnecessarily long at stations. They must sometimes wait six, eight or even more minutes for water to run into the tender tanks through a small pipe, where one or two minutes is long enough where pipes are sufficiently large for the delivery of the water. Trains are slacked up for dangerous places which would be passed at high speeds if equipped with signals.

The motive power department is glad to do its part, but the growing severity of modern conditions demands the co-operation of all who have to do with train service in reducing wasted time. It is difficult to realize that a minute lost at a station is the same as one lost while running, yet that is the fact, and delays at stations necessitate faster running as a matter of course, and consequently a relatively higher cost is invited in operation.

In closing I would like to remind you that the remarkable changes in the ownership and control of some of our largest roads must be taken to indicate most important alterations in the situation in which we are a part, and it behooves us to watch lest we fail in some degree to appreciate what it means to the departments which we represent, and with renewed efforts we must meet the new problems in a way that will inspire confidence and insure absolute progress.

Reports of the Secretary and Treasurer indicated a satisfactory condition as to membership and finances. The total membership is 665. The balance in the treasury is \$3,712.90, with all bills paid.

Messrs. Henry A. Sprague, Reuben Wells, D. O. Shaver, Wm. Swanston, J. H. Setchel, J. M. Boon, John Hewitt, W. H. Lewis, W. A. Foster, Allan Cook, J. M. Scheer and L. B. Paxon were elected to honorary membership. The names of Messrs. F. W. Lane, of the "Railway Age," and John Player, of the Brooks Locomotive Works, were presented for letter ballot for associate membership.

DISCUSSION OF COMMITTEE REPORTS.

Relative Merits of Cast Iron and Steel Tired Wheels.

This report offered no recommendations and was evidently a disappointment. Mr. Sanderson presented a discussion of the cost side of the comparison of steel tired and cast-iron wheels. He assumed the cost of a steel-tired wheel at \$45 and that of a cast wheel at \$8, the relative mileages under 100,000 lbs. capacity cars being as 300,000 to 50,000. The average daily mileage under coal cars was 45 and 10 pairs of each kind of wheel were taken. The comparison on corresponding mileage of 1,000 miles for both showed a cost of 35.174 cents for steel-tired wheels as against 19.684 cents for cast iron. The question is whether the increased cost of steel-tired wheels was justified. It was apparent that it would pay to use the best

quality of steel wheels in comparison with cheaper ones. Mr. Mitchell believed the cast-iron wheel should have the advantage of greater life due to the use of better material at a greater cost. Mr. Leeds did not believe it possible to obtain a mileage of 300,000 from steel-tired wheels with the present type of trucks. He insisted, however, that cost was subordinate to safety.

Report on Ton-Mile Statistics.

The committee made no report and recommended that the matter be dropped. Mr. Quereau, of the committee, discussed the subject individually and presented the argument favoring the inclusion of the weight of the engine in that of the train, which was contained in his article in our June number. He was, however, opposed to the comparison of statistics because of the fact that conditions vary so greatly with regard to grades, quality of water, weight and speed of trains as to render it impossible to compare performances fairly. It was legitimate to compare the work of one division with itself for different periods of time. He suggested the desirability of placing the association on record to the effect that making strict comparisons of the statistics of various roads with varying conditions was not conducive to best results. This was put into the form of a resolution and was carried. Mr. Delano was sure that comparisons would continue to be made, although the unfairness was recognized. He thought that it was worth while to work toward an improvement of the methods of preparing statistics and was sorry to see the association go on record in this way. Mr. Quereau offered an additional resolution to the effect that it was the opinion of the association that the ton-mileage figures should include those of the engines and tenders as a credit to the motive power department. Mr. Leeds supported Mr. Quereau in an excellent argument. The second resolution was unanimously carried. The committee was continued to confer with the statistical associations and report next year.

Topical Discussions.

The Proper Method of Lubricating Locomotive Driving and Truck Axles.—Mr. G. R. Henderson opened this subject with a severe arraignment of present methods of lubricating locomotive journals which were about as bad as they could possibly be. The conditions were very severe and the difficulties great. The criticism seemed to us to indicate the desirability of forced lubrication. Mr. Symington and Mr. Rhodes favored precautions to keep dust out of the oil holes by the use of plugs.

Should Parallel Rods be in Position on Locomotives While in Transit?—Mr. Garstang opened this question by advocating the shipment of locomotives from the builder's works with these rods in place, because of convenience and also because it insured good fitting by the builders. The engineering departments objected to the absence of the rods on account of the destructive effects of the counterbalance under such conditions. A resolution was passed to the effect that the members should require the builders to deliver engines with the side rods in place.

A Classification of Locomotives.

Mr. Sanderson read his paper by abstract. It was apparent that the large number of wheel arrangements necessitated some logical system of classifying locomotives. Mr. F. F. Gaines referred to his article in the American Engineer for April, 1901, for his idea of what a classification should include. Mr. Leeds preferred the simplest possible method and would number the locomotives in classes representing the various class characteristics by the numbers. Mr. Sanderson's system was criticized because it was necessary to remember the meaning of the reference letters. Mr. Fowler argued in favor of Whyte's classification as a logical system of designating locomotives which would be understood everywhere in general reference to the wheel arrangement. Mr. Fowler offered a resolution to the effect that Mr. Whyte's classification should be endorsed by the Association. Mr. Leeds supported the resolution on the basis of the convenience of being able to intelligently indicate

the types of engines in correspondence if not otherwise valuable. The resolution was amended and the subject referred to the committee on subjects for report next year.

Cost of Running Trains at High Speed.

The difficulty in securing satisfactory data on this subject was well understood. Mr. Rhodes considered it important to know in the definite terms of the report the cost of high-speed trains. It might have the effect of checking the tendency toward faster trains. Mr. Whyte criticized the statement made by the committee that the coal consumption increases directly as the speed. This was not borne out by an analysis based on the increase of train resistance as the speed increases. Mr. Delano, whose contribution to the report we print almost in full, explained the tests made on the C., B. & Q. R. R. They were not offered as establishing a curve but as showing a tendency in regard to fuel consumption. While the tests indicated what would be expected, an increase in fuel consumption with the speed, in the discussion we think it should have been made clear that there are other questions as important as that of the fuel. The speeds of freight trains were not touched upon. Mr. Delano did not wish to be understood as objecting to increasing speed. He thought it important to know the relation between the cost and speed. There was much more to be done for the benefit of railroad managements. The committee was continued for further investigation.

The Most Satisfactory Method of Handling, Cleaning and Setting Boiler Tubes.

Mr. Rosing in presenting the report indicated a number of ways in which labor might be saved by better use of pneumatic tools. Mr. David Brown had found it desirable to apply safe ends one gage thicker than the tubes. He preferred oil furnaces for tube work because of saving the delays due to cleaning coal or coke fires. Prof. Hibbard referred to foreign practice in stretching steel tubes instead of applying safe ends. He thought it worth trying. The discussion brought out the advantages of steel tubes which were not presented in the report. Mr. Quereau reported very satisfactory experience in welding steel tubes with water glass as a flux. He considered this a satisfactory solution of the difficulty, if it was really a difficulty. Mr. A. E. Mitchell said that there was no difficulty in welding iron safe ends on steel tubes made by the Shelby Steel Tube Company. Mr. Garstang stated that he had no difficulty in welding steel safe ends to steel tubes. There was no testimony in the discussion that was in any way unfavorable to steel tubes. Mr. Rhodes spoke of the pitting of tubes which was usually due to acid in the water. He thought it would affect steel and iron alike. Mr. John Platt testified to satisfactory experience with steel tubes in English naval service, providing the material was good. Steel was, however, uncertain with regard to pitting, particularly in marine practice where distilled water was used. Mr. Symington called attention to the importance of water purification. There was no trouble in good water districts. It was evident that tube practice was backward. Exigencies of present service had caused a difficulty which was both serious and general.

What Is the Most Promising Direction in Which to Effect a Reduction in Locomotive Fuel Consumption?

Mr. Rhodes believed this to be a most important report. Fuel consumption could be reduced by many different improvements systematically followed up as is done in the matter of oil consumption by the Galena Oil Company, by stopping the waste. Mr. Rhodes advocated the employment of a specialist to improve the use of fuel on each road. Mr. Charles M. Muehnic presented interesting information concerning French practice in compound locomotives, showing the value of the four-cylinder balanced type of Mr. de Glenn, of which many are in use in Europe. It was evident from the discussion that there is to-day more intense interest than ever before in efforts to improve the economy of the locomotive. "Eternal vigilance," Mr. Humphrey said, "was the secret of success in this direction. Much may be accomplished by interesting the men, by per-

fectly fair fuel records and by education." The compound loco motive received substantial endorsement.

Feed-water heaters received prominent attention, especially in Mr. Forney's remarks. He outlined the advantages and also the difficulties connected with the problem. Professor Goss, among other good points, mentioned the effect of clearance. The steam admitted to the clearance space was not lost as it returned work to the piston on the next stroke. He considered the steam leaks from valves and fittings about locomotive boilers too important to be neglected, because of the large losses they represent.

A Practical Tonnage Rating.

Mr. Henderson's paper on this subject was very well received. We shall print it nearly in full next month. Mr. Quereau supported the author in believing that theoretical ratings would save much time in establishing practical operating ratings. In other words, office work will assist in securing the necessary data from the road. Mr. Seley considered it advisable to give to large capacity cars the advantage of the fact that their resistance per ton is less than that of lighter cars instead of increasing the rating of engines handling such cars. The discussion developed the fact that there was a question as to the relative resistances of empty and loaded cars.

Maximum Monthly Mileage Practicable and Desirable to Make.

This report recommended single and double crewing and the use of extra men in place of pooling. The discussion centered in the question of crewing. Mr. Rhodes showed that pooling permitted the selection of engines with reference to particular trains to be hauled without interfering with the runs of the men. Mr. Deems strongly endorsed pooling. When carefully arranged it was altogether satisfactory and greatly increased mileage. Mr. Quereau also supported pooling. In fact it was ably defended. It permitted an even distribution of pay and an even distribution of rest. In the discussion nothing was said that was adverse to pooling. This system had gained strength during the past year.

The Most Improved Method of Handling Locomotive Coal Prior to Unloading on the Tanks.

Mr. Rhodes spoke approvingly of the tendency toward placing the chief coaling stations convenient for engines on the main line and would provide only for switch engines at the roundhouses. It was evident that the Association approved of generous expenditure for equipment for handling coal. Mr. Waitt quoted costs for handling coal on the New York Central varying from 1.4 cents to 41 cents per ton according to the conditions. Where there was sufficient room he approved of the inclined trestle and simple coal chute not requiring machinery or shoveling. The cost by these was as low as 1 cent per ton. Where there was insufficient room conveyors were necessary. They were also necessary in case bituminous and anthracite coal were mixed before using. Mr. Delano mentioned satisfactory experience with track scales for weighing the tenders in order to secure accurate measurements of the coal.

Index of Proceedings.

The committee reported the completion of the index in a volume of 200 pages which would soon be ready for distribution. Upon this achievement the Association is to be congratulated.

An "Up-to-Date" Roundhouse.

It was made apparent by Mr. Rhodes that roundhouses should be better lighted in the daytime and a high or peak roof with skylights not only favored lighting but was an improvement as regards drainage, and while it costs more it was preferred to the flat roof. Special stress was placed upon the necessity for the best possible ventilation. The discussion was general and covered many details, it occupied more time than was given to any other subject treated at the convention and also called out the largest number of speakers, thus indicating appreciation of the importance of the best roundhouse equipment. The committee was continued.

After the election of the following officers the convention adjourned:

President, A. M. Waitt; First Vice-President, J. N. Barr; Second Vice-President, G. W. West; Third Vice-President, F. A. Delano; Treasurer, Angus Sinclair; Secretary, Jos. W. Taylor.

MASTER CAR BUILDERS' ASSOCIATION.

THIRTY-FIFTH ANNUAL CONVENTION.

Saratoga, N. Y., June, 1901.

This convention opened June 24, President Chamberlain presiding. Following the invocation by the Rev. Delos Jump and the address of welcome by President A. P. Knapp of the Village of Saratoga, with response by Mr. A. M. Waitt, the annual presidential address was read by Mr. Chamberlain. This was devoted principally to comments upon the reports of committees of the convention and the progress in the development of car construction. The secretary's report showed the total membership to be 483, a gain of 20 during the past year. The balance in the treasury, as stated by the Treasurer, Mr. Kirby, was \$9,590.48. The routine business of the convention was despatched promptly and the revision of the rules of interchange was taken up early in the opening session. The time devoted to it was less than two hours. Last year there were but 31 cases brought before the arbitration committee, an indication that the rules are working admirably. The important change this year was in the prices of cleaning triple valves and brake cylinders. It has been a rule that all M. C. B. prices should not be such as to permit of making a profit by repairs, but an exception was made in this case in order to put a premium upon the proper condition of these vital parts of the brake apparatus. The new prices are 20 cents for thoroughly cleaning a triple and the same amount for a brake cylinder. These prices are slightly above the actual cost under normal conditions and it is probable that more triples will be cleaned if even a few cents profit may be made on each one. This action is likely to have an important effect upon the condition of air brakes, to which Mr. G. W. Rhodes called attention in his article in our June number. The other changes in the rules were of less importance and were disposed of quickly.

DISCUSSION OF COMMITTEE REPORTS.

Triple Valve Tests.

Mr. Rhodes explained the tests on the Hibbard valve and laid special stress upon sensitiveness, as indicated by the disc tests, which showed that the Hibbard valve had not been designed with a complete understanding of the importance of the time requirements. In long trains the rapidity of application in the rear cars was important, because of its effect upon the shocks of application. It was apparent that the work of the committee was most thoroughly done.

Laboratory Tests of Brake Shoes.

Mr. Bush opened this subject with an explanation of the origin of the test shoes, two of which, the Lappin and Cardwell shoes, were not received from railroads and were not to be considered on the same basis as the others. They were softer shoes and not those regularly furnished to railroads by these manufacturers. The committee recommended an increase of speed for tests of shoes on steel wheels to 65 miles per hour, as being nearer present passenger service conditions. Mr. Sanderson made a distinction between friction and tire dressing. The shoe which would dress tires would naturally have the longest life. A happy medium between high friction and long life of the shoes was desired. More efficient shoes were desirable for steel wheels because they were used in passenger service. The tendency was toward a sacrifice of efficiency in order to secure long life. This being now fully understood, a change toward greater efficiency was suggested. Mr. Rhodes was afraid that the importance of the fact that brake shoes were intended to stop trains would be somewhat neglected in the desire to secure durability of brake shoes. This was the chief feature of the discussion.

The specifications submitted by the committee were modified by dividing the shoes into two groups, one for chilled wheels and one for steel wheels, increasing the speed of tests for steel wheels. They were referred to letter ballot as a standard.

"M. C. B." Couplers.

Mr. Atterbury, in introducing the report urged the members to use the worn coupler gage. There was a strong demand for a reinforcement of strength by increasing the size of coupler shanks. An increase of 76 per cent. in strength was suggested, by enlarging the shanks to a section 5 by 7 ins. Changes in the head were also proposed; they strengthen it but do not affect the contour. Changes in the present unsatisfactory test of knuckles, and also the jerk test were suggested, to the effect that dummy couplers should be used in both of these tests in order to reproduce the conditions of service. The committee also proposed a design that would make the yoke correspond in strength with the new shank. Mr. Sanderson, who had given special attention to the breakage of couplers, presented an able argument in favor of pivoting the coupler head in order to reduce the stresses of the couplers due to curving. Present construction did not provide sufficient side play. This resulted in straining trucks, platforms, causing rail wear, flange wear and incurring danger of derailment, with frequent fracture of the weakest parts. This was received with evident approval of the association and was considered an important subject for investigation by the coupler committee. Mr. Sanderson was supported by Mr. Schroyer, who had made tests showing that under severe conditions, with cars having long, overhanging ends, the stresses sometimes amounted to 57,000 lbs. Mr. Atterbury supported Mr. Sanderson in the opinion that swiveling the coupler should be considered. It was also desirable to increase the strength of couplers, through the knuckle pin hole. This might be made unnecessary by the swivel if the contours will not permit of the necessary reinforcement. The recommendations as to specifications were ordered submitted to letter ballot.

Supervision of Standards and Recommended Practice.

This report covered a number of minor details, among which changes were suggested in the standard journal boxes to prevent the journal bearings from breaking out the rear walls. Mr. Whyte showed the necessity of this in our issue of September, 1900. The recommendations were ordered submitted to letter ballot. Mr. Rhodes spoke of round bottom journal boxes, believing that the round bottomed box was not good because of the tendency of the waste to move and cause "waste grab," a source of considerable trouble.

Revision of Recommended Practice in Springs for 100,000-Pound Cars.

This committee had gone to the trouble of having sample springs tested to insure the satisfactory operation of those recommended in the report. The report also favored abundance of steel in springs. It was ordered submitted to letter ballot.

Cast Iron Wheels.

Mr. Barr considered it undesirable to permit wheel makers to use so large a proportion of old wheels in the manufacture of new wheels. This, moreover, was accompanied by the use of inferior new metal which rendered the cast iron wheel situation a serious one. Mr. Garstang read a minority report because he did not agree with the changes suggested in the report. He did not approve of light wheels, and would prefer increasing the weights. A number of speakers supported this view. The tendency to increase loads was thought to demand heavier wheels. Mr. Garstang recognized the inferiority of wheel metal and thought that "two pounds of poor metal were better than one pound." Mr. Hennessey made an eloquent appeal for better material. If wheels burst in forcing axles in place the remedy was better metal rather than more metal. Others admitted the use of poor iron, but believed it necessary to use more weight for safety under present conditions. Mr. Stark mentioned flange failures. This he considered the real question of the time. The committee was continued and instructed to report the subject of design, material and form of wheels of 60,000, 80,000 and 100,000-lb. cars, a most important piece of work.

Uniform Section of Siding and Flooring.

This committee directed its efforts toward the selection of sizes of lumber for these purposes, whereby the best possible advantage could be had in the purchase of lumber. After discussing some of the details, the recommendations were ordered submitted to letter ballot.

Air Brake Hose Specifications.

Mr. Sanderson spoke of the damage at the ends of air brake hose and believed it important to furnish reinforcement by nipple caps at the ends. The committee agreed that a very large proportion of the damage to air hose occurred at the ends because of the treatment required in forcing the couplings into place. The nipple cap prevented this. The report was submitted to letter ballot.

Chemical Composition of All-Steel Axles.

The report stood for a retention of the present proportion of carbon instead of a reduction, as was desired by some members. Mr. Gibbs supported the high carbon, and related his satisfactory experience with the earliest steel axles imported from England. They were very soft and gave much trouble. He thought the present specifications as to fiber stress were fully high enough and would insure sufficient wear. He had not found any difficulty in cooling hot journals with water, and thought that this fear was not well founded, as far as high-carbon axles were concerned. Mr. Albert L. Colby, of the Bethlehem Steel Company, was invited to address the convention. From the standpoint of the metallurgical engineer he supported the present carbon requirement. It insured the qualities needed to withstand "fatigue." He did not approve of specifying the proportion of silicon. A large number of axles would be found to have more than 0.05 silicon, the present requirement. The phosphorus and sulphur should be limited, and the manganese and silicon should be left to the manufacturer. It should be clearly stated that axles should be made by the open-hearth process. Copper in small proportions was not detrimental, and should not be mentioned in the specifications. He would like to see all unnecessary limitations stricken out of the requirements. No arguments were presented in favor of reducing the carbon. The committee recommended several changes in the dimensions of the standard axles and a new classification of the axles. These were referred to letter ballot.

Rules for Loading Long Materials.

This committee had carefully revised these rules and assembled the general instructions, avoiding repetitions. It was recommended that two separate committees be appointed to formulate rules applying to box cars and to further consider the subject of safety chains with reference to flat and gondola cars. The revised rules, except section 27, referring to safety chains, were submitted to letter ballot. To the work outlined for the new committees was added the consideration of the weight of lap lumber shipments for the benefit of the Southern lumber lines.

Index of Proceedings.

The probable cost of the index was placed at about \$1,500. It was ordered that the work should be done, to include all of the proceedings to date.

Draft Gear.

This subject was continued with the addition of two members to the committee, with the understanding that tests shall be made. Mr. Sanderson suggested the design and construction of an improved machine for drop tests. Road tests were, however, necessary in order to determine the effect of recoil. Mr. Hennessey voiced the opinion of many to the effect that the present situation in draft gear is an emergency. It was definitely stated that continuous-draft gear was necessary and that the requirements were past the possibility of wooden sills; also that the center line of draft should be well within the vertical dimensions of the center sills, in order to prevent destructive bell-crank action. Mr. Querean thought that the proportion of 75 per cent. of the cost of repairs of cars, due to

the draft gear, could be reduced to 25 per cent. by the use of a continuous-draft gear used in connection with buffer blocks. Mr. Clark described the draft gear illustrated on page 370 of our issue of December, 1900. This design brought the center line of draft at the lower face of the center sills, and by turning the end sill on its side the draft was brought nearly where it should be without cutting the end sills. Mr. Rhodes believed that the committee should take the initiative by outlining tests. Mr. Canfield spoke of the large amount of equipment now in service which required improvement, and this could not be done by changing the height of floors. Longer draft timbers extending beyond the bolsters were necessary. Several speakers thought it advisable to urge the transportation officers to insist on more considerate handling of cars. Formerly merely draft rigging was broken in the yards; now ends of cars are torn out entire because of rough treatment. Mr. Brazier stated that the New York Central was obliged to replace 3,000 couplers and 1,500 knuckles per month. The association, for some reason, failed to open the great question in the subject, viz., the necessity for increased capacity because of the increased capacity of locomotives and cars. The principles of draft gear, except that of "continuous" gear, were not presented. The committee was continued as stated.

Topical Discussions.

Mr. Rhodes presented an able argument in favor of greater care in the selection of car inspectors.

The practice of rolling or burnishing journals was adversely criticised by Messrs. Canfield and Brazier. The roller was used to press down the roughness left by the lathe tool, leaving it smooth. If in the first trip of the car the axle turned in the direction in which its axle turned while being rolled, all was well; but if it turned in the opposite direction the fibers were raised, and heating commenced. Mr. Hennessey's experience was, however, entirely favorable to the rolling process.

Mr. Pfeleger, of the Pullman Company, exhibited a splice in a car sill which had been in use under a Pullman car for nineteen years. It was a convincing argument in favor of splicing sills in passenger-car construction. Splicing permitted the use of the best timber because of the difficulty in securing satisfactory timber of sufficient length for continuous sills. The practice of splicing sills was generally indorsed by several speakers, with no adverse criticism. This subject was referred to a committee for report next year.

Election of Officers.

President, J. J. Hennessey; First Vice-President, J. W. Marden; Second Vice-President, F. W. Brazier; Third Vice-President, W. P. Appleyard; Executive Committee, T. W. Demarest, W. Renshaw, J. T. Chamberlain; Treasurer, J. Kirby; Secretary, J. W. Taylor.

Stationary engine practice has reached a high stage in the 8,000 h.p. Allis units for the Manhattan Railway of New York. The builders guarantee that the amount which a point on the circumference of the armature will lag behind the point of uniform rotation, plus the amount which it forges ahead of that point shall not exceed three-fifths of one degree of the circumference. This uniformity will be a result of the cylinder arrangement whereby the shaft will receive eight impulses per revolution. The speed of a point in the circumference of the armature, running at 75 revolutions per minute will be 1.4 miles per minute. The crank pins of these interesting engines are 18 by 18 in., and the main journals are 34 in. in diameter by 60 in. long. An economy of 13 lbs. of dry steam per indicated horse-power per hour is guaranteed. The engines occupy 2,000 sq. ft. of floor space and stand 38.3 ft. high above the floor level. Eight of these units were provided for in the original installation and the number will be increased to twelve. They are the largest stationary engines ever built. These and other details of the construction are noted in the June issue of "Power."

THE NEW PENNSYLVANIA RAILROAD STANDARD PULLMAN PARLOR CAR.

New Pullman Parlor Cars are now being placed in the service of the Pennsylvania Railroad between Philadelphia and New York. They have been constructed upon designs furnished by the Pennsylvania Railroad officials, and will be known as the Pennsylvania Standard Pullman Parlor Car. The cars are 70 ft. long, and their exterior presents the well-known Pennsylvania Railroad color—Tuscan red, with gold trimmings. They have wide vestibules. The interior is finished in highly burnished light mahogany, decorated in marquetry. The main windows are **very** wide; they are protected by shades, and the absence of any drapery about the windows or in the interior is a noticeable improvement. The upper deck of the roof is very wide, thus giving a significant appearance of unusual size to the interior and at the same time aiding materially in the ventilation. **Thirty** handsomely, yet comfortably, upholstered arm-chairs supply the seating accommodations. Lady travelers will appreciate the enlarged provision for their comfort in the addition of a dressing room fitted with mirrors and toilet requisites, in communication with the usual toilet room. At the other end of the car there are two toilet rooms for men, instead of one, as is usual. The entire decorative scheme of the interior lends a brightness and an effect of roominess to the car, which carries with it a suggestion of coolness in summer days.

Compressed air has in its comparatively short career sprung into many places of usefulness, not only as a power for operating shop and foundry tools of all descriptions, for construction and building work, but as a motive power. For this purpose it has been used successfully on streets cars in France for a number of years, and in New York and Chicago for the past two years. The United States Government, after some careful investigations and trials of compressed air locomotives, are now using them very successfully for handling ammunition about the larger magazines. Many of the manufacturers of powder use compressed air as a motive power owing to the absence of fire and its entire independence under a charge of air to run at will. Such cars or locomotives are in themselves a complete unit and can be operated as cheaply as with electricity or steam, and cheaper when the cost of special installation and maintenance is considered, for they can run on tracks of any desired gauge.

The amount of moisture in steam generated by a locomotive boiler is probably not as great as is generally believed. Experiments recently described in the American Engineer and Railroad Journal, January, 1901, page 28, indicate that the amount is usually much less than 1.5 per cent., when the locomotive is running under nearly uniform conditions. Readings taken from a calorimeter placed on one of the branch pipes in the smokebox, midway between the saddle and T-head, show less moisture than when read immediately at the steam dome of the boiler. In the latter case the amount of moisture determined from a series of 35 tests made on the boiler of the Purdue Locomotive in 1895 ranged from 0.49 to 1.62 per cent. A series of 19 tests made at an earlier date upon the same boiler operated under more constant conditions, and at lighter power, gave an average of 0.95 per cent. of moisture. These readings were taken from a calorimeter attached to one of the branch pipes. It was found that the steam in passing through the branch pipe absorbs heat from the smokebox and is delivered to the calorimeter about 0.25 of 1 per cent. dryer than at the boiler. This correction added to .95 per cent. makes the average amount of moisture in the steam for this series of tests 1.2 per cent. And this amount would seem to increase very slightly as the rate of evaporation is increased. There are conditions where considerable water passes the throttle with the steam, but this is because the water-level in the boiler is kept too high, or too sudden a demand is made upon the steam, which causes some spray to pass the throttle.

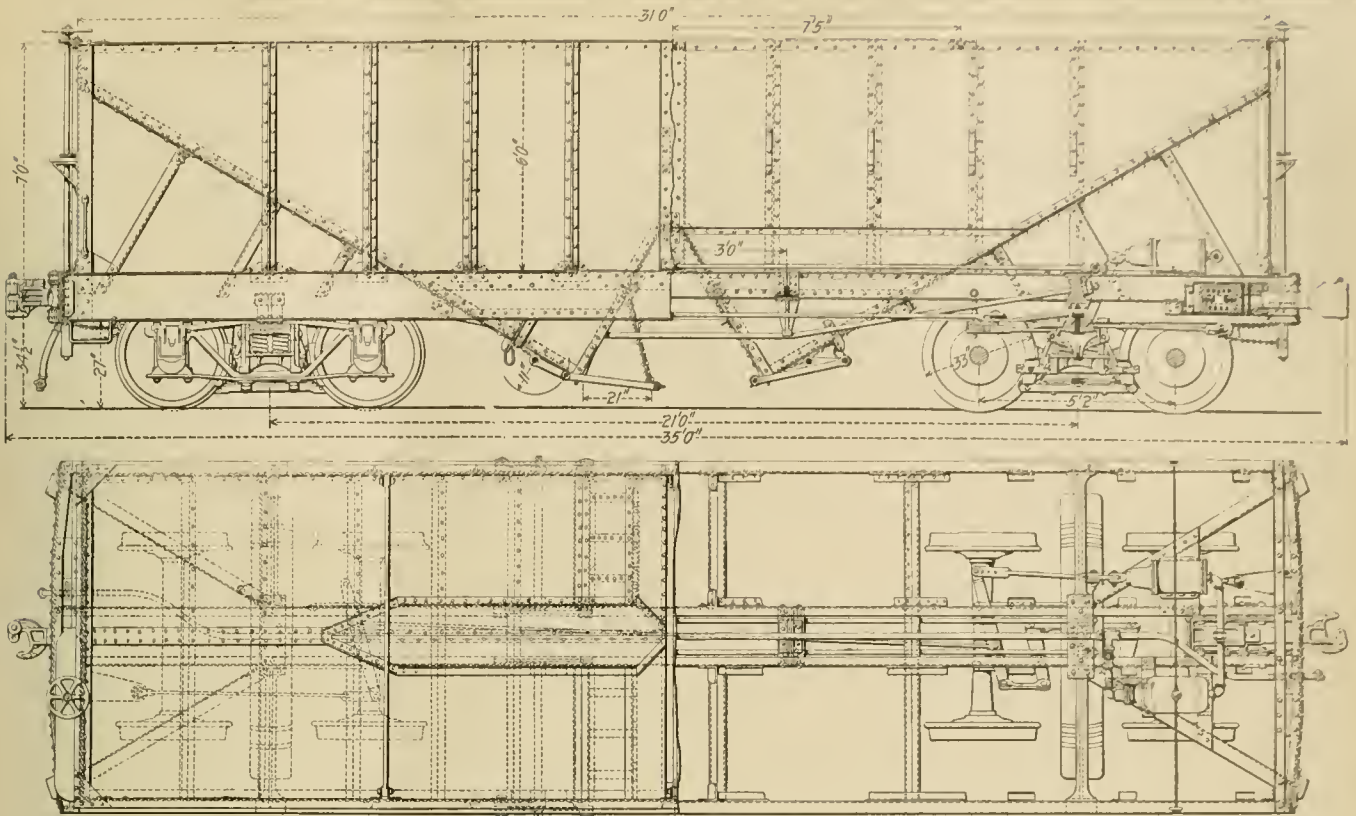

100,000 Pounds Capacity Hopper Cars, with Truss d Center Sills.
The Structural Steel Car Company.

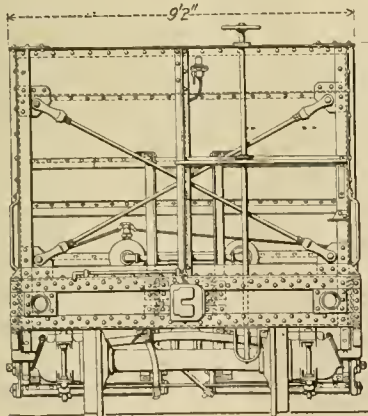

End elevation.

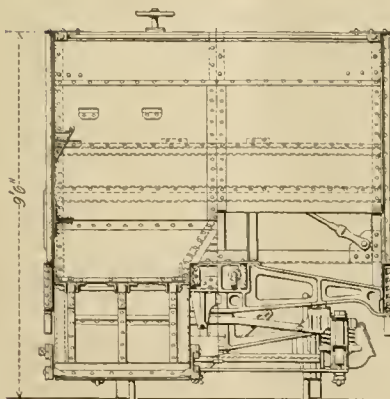

Transverse Section.

100,000 POUNDS CAPACITY STEEL HOPPER CARS.

With Trussed Center Sills.

The Structural Steel Car Company.

The specially interesting features of this design are the light weight of the car and the method of construction in which the center sills are made of light sections, reinforced by truss rods. The car is designed to carry a load of 110,000 lbs. with a capacity of 1,825 cu. ft. when filled level with the top flange angles, the estimated weight of the car being 31,400 lbs. Its length inside is 31 ft., length outside 35 ft., width outside 9 ft. 4 ins. and height, from the top of the rail to the top of the flange angles, 9 ft. 6 ins.

The side sills are of 15-in., 33-lb. channels and the center sills are 8-in., 13¾-lb. channels. These channels are trussed with two rods, which are anchored at the centers of the body bolsters, the bolsters being constructed specially to receive them and make the anchorage secure. The body bolsters are of cast-steel, fitting between the side and center sills and bringing the center plates flush with the lower edges of the side sills. The side bearings are designed to carry a part of the load permanently. They consist of radial cones, placed in the truck bolster. The bolster has seats with corresponding angles to run over the cones. The end sills are 1½-in. plates, secured and stiffened by reverse angles. The corners of the end and side sills are braced against end and corner shocks by angle braces shown in the plan view. These braces rest on lugs cast upon the body bolsters at the center sills and are riveted through bolsters and sills, thus distributing the shocks and stresses of buffing and pulling to the center and side sills. The lateral bracing is also shown in the plan view. In addition to the body bolsters there are two connections to the center sills, which serve also as seats for the struts of the truss rods and the side sills are braced by four angles at about 5-ft. centers.

The draft gear is carried by the center sills and two angles.

the whole gear being made central with the 15-in. side sills. The arrangement of the brake gear, which differs from usual construction in hopper cars, is clearly shown in the engraving. The sides of the car are supported by T section members secured to the side sills, the side plates being reinforced at these points by plates inside the car body and shown on the side elevation. The floor is carried on angles supported by other angles, arranged perpendicularly to the floor and secured to the side and center sills. There are four of these angle supports at each angle cross bearer and three cross bearers at each end of the car. Three more are placed between and below the sills. The ends are supported by angle corner posts, braced at their lower ends. The corners at the top of the car have each a T center post. The cross bracing at the end is in the form of clevis bars. These effectually tie the corners of the car, making it impossible for it to twist, which is expected to overcome the tendency for the rivets to shear and the side supports to break. Three tie rods extend across the car at the top angles.

The lower central portion of the car is divided into four compartments by the cross and central ridges, which divide the load and cause it to run to the discharging doors, one of which is shown in the open position and the other one closed. The doors may be operated separately or in pairs, as desired, the operating gear being simple and apparently effective. This gear consists of one cross shaft to each pair of doors, the shafts having side crank arms, which engage the side links and one end of each link is fastened to the door angle. The doors are kept closed and fastened by the links attached to the angle supports, as shown in the elevation drawing.

The trucks are of the diamond type with a new design of truck bolster and spring plank. The bolsters and spring planks and also the truss rod struts are of cast steel. In calculating the various stresses about the car a factor of safety of 6 was used and additional 10 per cent. was added for the increased stresses due to vibration.

These cars are to be built by the Structural Steel Car Company, recently incorporated under the laws of Ohio, and large works are now being built at Canton in that state, for the construction of this and other types of steel cars which we expect to illustrate later.

With an estimated weight of 31,400 lbs. and a load of 110,000 lbs. this car has a ratio of 78 per cent. of carrying load, which is the highest ratio which has thus far come to our attention. This car was designed by Mr. W. H. Woodcock, M. E., and Mr. R. H. Hornbrook, Member Inst. M. E., who are interested in the Structural Steel Car Company.

Among the exhibits of progressive railroad improvements at the Saratoga Conventions this year was a display of pneumatic sanders by the American Locomotive Sander Company of Philadelphia. The Leach, Sherburne, Houston, "She," Dean, Curtis and Austin sanders are all owned and manufactured by this company. They are easily applied to old or new sand boxes and can be used in combination with gravity sanders or independently as desired. They will handle sand promptly, economically and are all simple and easily understood. Each of the pneumatic sanders manufactured by this company have their advantages and are all worthy of careful consideration.

The Garry Iron & Steel Roofing Company are manufacturing a variety of pneumatic cranes, jacks and painting machines for a great variety of purposes. Their No. 2 and No. 3 cranes are mounted on hand cars and used for light work in and about railroad yards, and their No. 1 crane is for heavy work, such as unloading car trucks and wreckage. The ease and rapidity with which these cranes can be operated was shown to good advantage by actual demonstration, at Saratoga, during the conventions in June. The crane on exhibition was rigged for handling coal. It was made of channel steel and mounted on a revolving table equipped with a pneumatic brake which is used to stop the crane at any point in its circuit. The Garry Iron & Steel Roofing Company have ready for distribution a finely illustrated catalogue of these machines. Their offices are at Cleveland, O.

AMERICAN SOCIETY OF MECHANICAL ENGINEERS

Semi-Annual Convention.

The American Society of Mechanical Engineers held its spring meeting in Milwaukee, Wis., May 28th to 31st. The meeting was very successful, although the discussions were somewhat disappointing. The most important subject was the application of electricity to shop driving, introduced by a comprehensive paper by Professor W. S. Aldrich. The most important feature of the paper and discussion, and also of the paper by Mr. John Ridell on portable machine tools, was to show the value of electric driving in its influence on output. Convenient speed control made it possible to obtain higher capacity of machines, because it led to convenient attainment of the maximum cutting speeds. Professor Aldrich estimates the value of electric driving as increasing output from 30 to 40 per cent. per square foot of floor space, from 20 to 60 per cent. per machine and from 10 to 30 per cent. per man; the reduction in the cost of production being from 25 to 45 per cent.

Superheated steam was a prominent subject, introduced in papers by G. A. Hutchinson and E. H. Foster. These reviewed progress up to date and recorded very successful experience abroad, it was stated, that "A net gain in economy of 10 to 15 per cent. is a common result, while a saving of 20, 25 and even 30 per cent. is by no means uncommon." It was shown that Continental engineers are advanced in the use of superheated steam. Professor Goss thought that American engineers appreciated its possibilities, but up to this time preferred to secure the economies in easier ways. These two papers constitute a valuable record on this subject.

Papers on Drafting Room and Shop Systems by F. O. Ball, Blue Printing by Electric Light by S. L. G. Knox and Rules for a Drawing Office by A. W. Robinson, indicated the importance of the engineering department in the organization of large modern industrial establishments. Drawing-office rules must, of course, vary according to conditions, but there is much in the papers by Messrs. Ball and Robinson that is suggestive to those who find entirely different arrangements necessary. Mr. Knox described a method of making blue prints by electric light and this paper brought out the desirability of being independent of sunlight, although the electric light took much longer for printing. Messrs. Blood, Hunt and Wellman gave accounts of their successful experience with the electric light blue-print apparatus, furnished by the Pittsburg Blue Print Company.

In a paper on the Influence of Titanium on the Properties of Cast Iron and Steel, Mr. J. A. Rossi indicated a possibility that this element may become an important hardener for iron and steel. Mr. C. W. Hunt described a New Connecting Rod End, which was followed by a preliminary report of the committee appointed to codify and standardize the methods of making engine tests. This report is an exhaustive document, including tests of steam, gas and oil engines, giving forms for recording the data and results. This report was followed by that on the Standardizing of Engines and Dynamos, which indicated that the committee has received encouraging support from the builders of engines and dynamos. Of the other papers presented the one most interesting to our readers was entitled The Locomotive Exhibits at the Paris Exposition, by Professor Storm Bull. This is a record of the locomotives with a complete table comparing their dimensions and was illustrated by half-tone and line engravings.

Mr. F. H. Stillman described A Pully Press Valve. Professor Benjamin read a paper on Some Experiments on Ball Bearings, in which he stated that ball bearings should not be designed on a basis of crushing strength of the balls, because they seldom break in this way. Professor C. H. Robinson described Efficiency Tests of a 125-Horse-Power Gas Engine, which is a supplement to his paper on the same subject at the December meeting. This is a complete record and will be valuable for reference. Under the title Protection of Ferric

Structures, Mr. M. P. Wood adds to his valuable contributions to this society an elaborate discussion of paints and varnishes for the protection of iron and steel.

While there were other papers these are believed to be the most important to our readers.

The first electric railroad in Russia was placed in operation this year. It is 13½ miles in length and connects the manufacturing city of Lodz, in Russian Poland, with the neighboring towns of Zgierz and Pabianice. The road is owned by a company of Polish merchants and manufacturers and was built at a cost of \$560,000.

At a meeting of the stockholders of the American Locomotive Company the following directors were elected: Pliny Fisk, George R. Sheldon, S. R. Gallaway, W. Seward Webb, J. E. French, S. L. Schoonmaker, of New York; A. J. Pitkin, Schenectady, N. Y.; Joseph Bryan, Richmond, Va.; F. H. Stevens, Buffalo, N. Y.; Charles Miller, Franklin, Pa.; George W. Hoadley, Providence, R. I. At a meeting held by the directors the following officers were elected: President, S. R. Callaway; Vice-President, A. J. Pitkin; Second Vice-President, R. J. Cross; Secretary, Leigh Best; Treasurer, C. B. Denny; Comptroller, C. R. Patterson. The Executive Committee of the company consists of Pliny Fisk, George R. Sheldon, S. R. Callaway, A. J. Pitkin and J. E. French. Reed, Simpson, Thacher & Barnum are counsel of the company. The general offices of the company are located in the Broad Exchange Building, New York. A certificate has been filed with the Secretary of State of New York announcing an increase in the amount of capital stock from \$50,000 to \$50,000,000, of which \$25,000,000 is to be preferred stock.

There is little doubt but that considerable of the expense of machining in shops can be saved by finishing work in grinding machines, for the cost of turning the work preparatory to grinding is cheapened and the actual cost of grinding is less. This has been proved more conclusively than ever before by the Norton Plain Grinder, manufactured by the Norton Grinding Company. Samples of work ground by this new machine were exhibited at the recent conventions of the Master Mechanics' and Master Car Builders' Associations and attracted considerable attention. The excellent quality of the work and rapidity with which it can be ground is a step in advance of anything that has been accomplished in this line. The machine has entirely new features and is designed to give a great variety of table, work and wheel speeds. It will grind heavier cuts from heavier pieces than has been heretofore possible. Standard car axles are given the usual roughing cut in the lathe and the wheel fits, bearings and dust caps ground complete in one hour. The bearings after being ground are perfect cylinders with a smooth surface and no high places or spots to be worn off before the bearing will run cool. This company has just issued a desirable catalogue illustrating and describing this machine and those who are interested in the design and construction may procure the pamphlet from the offices of the Norton Grinding Company, Worcester, Mass.

The very general use of the Harrison dust guard manufactured by the Harrison Dust Guard Company, of Toledo, O., is due to the fact that it completely closes the back of the oil boxes and will stand the severest service. In the construction of the three sections of which these guards are made, the toughest kind of wood is used and the leather packing ring is made of heavy belting leather. The sections are held together by steel rods with coiled brass springs and lock nuts on the spring bolts. The improved form of this guard has the springs in the lower half of the guard, where they are better protected from sand and dirt, and instead of counter-boring the wedge strip which closes the top of the box above the guard, it is simply a symmetrical piece of wood. The durability of the Harrison guard has won for it great favor among railroad mechanics, and that it is appreciated as a thoroughly reliable guard is shown by the greatly increasing orders in the past three months for the improved form.

LUNKENHEIMER SIGHT-FEED LUBRICATOR.

The improved form of lubricator shown in the accompanying engraving is known as the "Paragon" glass body sight-feed lubricator and is used for gas, gasoline or oil engines. Referring to the sectional view of this lubricator, it will be seen that the filling arrangement consists of a slide filler, the slide A screwing down upon and around the lid or cup and has a loose plug which covers the filling hole when the slide is swung over to a closed position. This loose plug is so arranged that the wear can be adjusted by turning down the screw B. The whole construction is very heavy, and the slide can be depended upon to seat perfectly and remain tight for an indefinite period. The feed regulating mechanism may be put on or off by raising

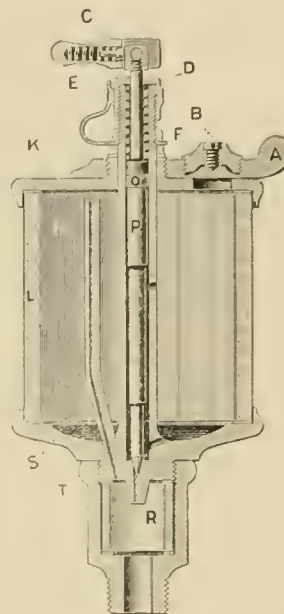

Improved Sight-Feed Lubricator.

or lowering the cam lever C. The rate of feed may be adjusted by turning the nut D, which is prevented from loosening by a spring E. This arrangement of feed may be set and turned on or off without disturbing the rate of flow. The cup is thoroughly packed both around the stem and at the top and bottom of the body and sight-feed glasses, and cannot become leaky. The parts of the cup are fastened together by the Lunkenheimer patent lock nut, which makes it impossible for the cup to jar apart, due to the shaking of the engine, and also dispenses with the annoyance of oil leaks. The construction of the lubricator is very compact and the general design such as to appeal to the users of this class of lubricator.

The exhibit of the Safety Car Heating & Lighting Company at the Saratoga conventions is specially worthy of notice and commendation. It was in the form of a section of a sleeping car, the woodwork in white and the upholstery and head lining in green. These colors harmonized with the gold of the lamp fixtures and the brilliant effect of the Pintsch gas and electric lights completed the artistic and tasteful combination.

The fact that the old plant of the New York Blower Company at Louisville, O., has been offered for sale has led to an erroneous report, to the effect that the company is out of business. This wrong impression grew out of a change that was made some time ago in the location of their factory. It was formerly at Louisville, but for the very urgent need of a much enlarged plant and better shipping facilities the company moved to Bucyrus, O., where a new model factory building had been erected. As all the manufacturing is now done at the latter place, the old Louisville buildings have been placed on the market. The New York Blower Company also has offices in New York, Boston and Chicago.

NEW MOLDING MACHINE.

The accompanying engraving illustrates a 9-in. standard molder, No. 14, manufactured by the J. A. Fay & Egan Company, Cincinnati. This new style of machine has many superior advantages over the older style, and will do more and better work. The few following special features will recommend it as a very efficient and high-grade machine.

(1.) In this machine the lower head cuts first. (2.) The table at the feeding-in end is independently adjustable. (3.) The upper feed rolls are driven downward. (4.) All pressure bars can be instantly thrown back, giving free access to the heads. (5.) The main head has outside bearings. (6.) For setting or sharpening the knives the lower head, with its bear-

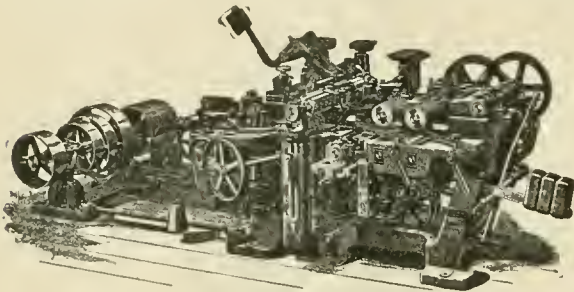

The J. A. Fay & Egan 9-Inch Molder.

ings, draws out endwise. (7.) There is a countershaft at the feeding-out end of the machine, and there is, consequently, no rubbing or cutting of belts. The J. A. Fay & Egan Company have their offices at 409 to 429 West Front Street, Cincinnati, O., and they will be pleased to furnish prices and full particulars on application.

THE SARGENT COUPLING.

The accompanying engravings illustrate an improved form of the Sargent coupling which is adapted both for pushing and pulling cars on sharp curves, especially where solid knuckles are used. It will be seen that the coupler consists of two open-hearth cast-steel dogs which engage the knuckle arms of the two coupler heads. A strong yet flexible connection is made between these dogs by means of two castings, which are curved to follow the contour lines of the M. C. B. knuckle, and are joined in the center by a pin. In operation the dogs are placed on each drawbar, just back of the knuckle pin, and the curved arms brought together around the face of

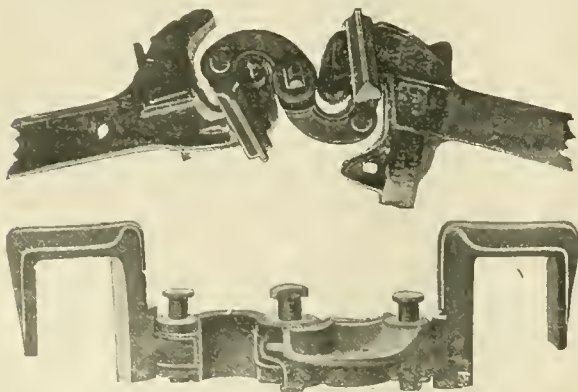

The Sargent Coupling.

each knuckle and connected. This connection permits the cars to be pushed or pulled around any curve without injury to the draft gear, and is so spaced that even on the sharpest curves from 6 to 8 ins. is allowed between the end sills of the cars.

The Philadelphia & Reading Railroad has placed an order with the Pressed Steel Car Company for 1,000 low side gondola cars and 100 flat cars, to be built entirely of steel. The gondola cars will be of 110,000 lbs. capacity, similar to the low side gondola cars already built for this road. They will be 35 ft. 10½ ins. long over end sills; 34 ft. long inside of body; 9 ft. 11¼ ins. wide over side stakes; 9 ft. 4 ins. wide inside of body; 5 ft. 3¼ ins. high from top of rail to top of body; 1 ft. 1 in. deep from floor to top of sides. The cars will be equipped with Fox pressed steel pedestal truck frames, cast-iron chilled wheels, open-hearth steel axles, Westinghouse air-brakes, pressed steel brake beams, and Chicago M. C. B. automatic couplers. The flat cars will be of 110,000 lbs. capacity and will have steel floors. They will be 35 ft. 6 ins. long over end sills; 9 ft. 6 ins. wide over side sills; 10 ft. 1¼ ins. wide over side stakes; 3 ft. 6¼ ins. high from top of rail to floor. They will be equipped with Fox pressed steel trucks; cast-iron chilled wheels, open-hearth steel axles, Westinghouse air-brakes, pressed steel brake beams and Chicago M. C. B. couplers.

The Chicago & Alton has ordered 400 steel cars from the Pressed Steel Car Company. One hundred and fifty of these will be hopped bottom gondola cars of 100,000 lbs. capacity, similar to those built for the Erie. They will weigh 35,514 lbs. and will be 31 ft. 6 ins. long over all; 30 ft. ¼ in. long inside; 10 ft. wide over all; 9 ft. 6 ins. wide inside; sides 10 ft. high above rail. The other 250 will be flat bottom gondola cars similar to the 600 cars already built for this road. They will be of 100,000 lbs. marked capacity and will weigh 35,600 lbs. They will be 43 ft. 3 ins. long over end sills; 41 ft. 9 ins. long inside; 10 ft. wide over side stakes; 9 ft. 4½ ins. wide inside; 7 ft. 8¼ ins. high from top of rail to top of body. All the cars will be equipped with gray iron journal boxes; P. R. R. draft rigging; M. C. B. journal bearings, and Schoen trucks.

An inspection of the Webb C. Ball Company's exhibit of watches at the Saratoga conventions this year revealed many special features of the Ball official standard railroad watch. The aim of the manufacturer has been to make a watch that will satisfactorily stand the rough usage of railroad men and be always reliable. It is small and very compact, being about two-thirds the thickness of an ordinary watch. The dial is made exceptionally white and marked in plain Arabic figures. The shape of the crystal and dial is such that the time can be read easily when held even at a very acute angle to the eye. The address of the Webb C. Ball Company is Cleveland, Ohio.

A very interesting line of valves were exhibited by the Homestead Valve Manufacturing Company of Pittsburgh at the recent conventions in Saratoga. Besides the initial Homestead straightway valve containing an internal locking device which marks the success of all Homestead plug valves, there was a more recent form of the original valve. There were also exhibited three-way and four-way valves, the "Homestead Junior," valve, an hydraulic valve for working cranes, presses or furnace doors, and a valve consisting of a simple cock body and a plug. In the last-named valve the plug is held in the seat in mid-open position by a spring at the bottom. In the full open and full-closed positions this valve locks the plug automatically by the addition of locking dogs or projections fastened on the lower end of the plug which effects a tight seating every time the cock is opened or closed. The Homestead valves are almost entirely of metal and have the superior advantage in that the working pressure never touches the seat but passes directly through the port.

The spiral journal bearing manufactured by the St. Louis Car Company is so constructed that that part of the bearing which does not come in contact with the journal is made of malleable iron and in the part that is abraded the best bronze bearing metal is used. This reduces the cost of the bearing without detriment to its service. The construction of the bearing is simple and practical. The bronze lining is keyed into the malleable iron back in such a manner that it can not become loose or detached while in service and is of sufficient thickness to allow the bearing to wear down very thin. This spiral journal bearing is becoming very generally introduced in this country and the manufacturers state that they have added to their works a thoroughly equipped brass foundry, babbitt metal furnaces and machine shop, and they are prepared to furnish these bearings on a large scale. These bearings were exhibited at the recent conventions in Saratoga.



The Brill Semi-Convertible Car.



Interior View of Semi-Convertible Car.

SEMI-CONVERTIBLE CAR FOR SUBURBAN SERVICE.

J. G. Brill Company, Philadelphia.

The car shown in the accompanying engravings was designed to meet the needs of high-speed suburban service both for trolley and steam roads, and has been in use for several years on high-speed electric railways. Aside from the convertible feature of the car it is particularly noteworthy on account of its lightness and strength. This should appeal to the motive-power men of steam railways who have been obliged to increase the weight of their engines in order to pull the much too heavy suburban rolling stock.

The chief object of this semi-convertible type is a satisfactory closed car in winter and one that can readily be converted into an open car for summer use by the removal of the windows and sash. While the car has no side entrance, the closed portion of the sides are much lower than the ordinary closed car, and the construction affords an advantage in the arrangement of seats.

From the accompanying engravings it will be seen that the general appearance of the car is very similar to the ordinary closed type, but its construction is radically different. The sides of the car can be made either straight or curved, as desired, but in this case requires the use of a steam-car truss plank, which is bolted to both posts and sills. The posts are made double and glued together, with a tie rod between them. The sashes are also double, and of much larger size than those ordinarily employed. They are arranged so that when it is desirable to open the car the sashes slide upward on trunnions

into pockets framed in the roof, and are entirely out of sight and out of the way. The roof does not appear, from either outside or inside, to vary materially from the ordinary standard forms, as will be seen from a glance at the interior and exterior views. Sufficient space between the lining and roof boards, however, is found to accommodate both sashes.

One of the standard objections to the use of open cars has been the fact that when once in service they had to be continued in operation until the end of the season, the expense and the time required for changing being so great that it was out of the question to attempt to provide closed cars during rains or uncomfortable storms in the summer time. The new construction is so easily operated that the changing from open to closed cars is but a matter of a few minutes and involves no extra expense.

The Economy Car Heating Company's system of heating passenger trains has been in use for the past two winters on several of the largest roads in New England with general satisfaction. This system was illustrated and described on page 129 of the April issue of this paper. It consists simply in using the exhaust steam from the air pump of a locomotive instead of drawing live steam direct from the boiler for this purpose. The economy of such a system is evident, as all the actual steam leaving the pump is utilized, as well as the latent heat in the water of condensation, and the general results are that all the heat leaving the pump is now utilized for heating purposes. This company has a circular describing their system of car heating that will be sent together with any additional information desired. The headquarters of the Economy Car Heating Company are in Portland, Me.

The latest development in metal covered sheathing for use in building railway coaches was shown in an exhibit of the Metal Plated Car & Lumber Co., of New York, at the recent convention of the Master Mechanics and Master Car Builders Associations. The exhibit consisted of a full-sized corner section of a passenger coach. The many advantages of this covering and the pleasing permanent finish which the copper takes when oxidized makes it a very satisfactory covering not only for railway cars, but steamships and structural work, and one that experience has proved in railway service to be economical. This improvement consists of covering each piece of wood sheathing, paneling, belt rails, letter boards, etc., with sheet copper. It is applied to the sheathing before it is assembled. It is applied in such a way that the metal fits "skin tight" to the wood, makes all joints absolutely water tight and gives the exterior of the car a smooth finished surface. When once this covering is applied no further expense is required in maintaining its permanent rich color, as the use of paint or varnish on the exterior of the car body is wholly unnecessary. In first cost this covering is more expensive than paint, but it offers important advantages in permanence and in the saving of time required for painting and varnishing. This system is the invention of Mr. W. P. Appleyard, Master Car Builder of the New York, New Haven & Hartford R. R.

The Metal Dust Guard Co. has placed on the market a very simple, durable and cheap dust guard, the body of which is made of one piece of heavy felt, oval in shape and braced on the sides by a broad ring of galvanized iron. The perfect fit of this guard prevents the entrance of dust and the exit of oil and gives proper protection to the bearing and journal. A block of wood is inserted in the top of the slot of the box and excludes dust at that point. The guard is free to move up and down in the box and being made in one piece sets itself to the journal. The surface of the felt in contact with the journal becomes glazed over when oil reaches it and in this case there is no wear to the felt. This company has offices at 403 Equitable Building, Baltimore, Md., and will be pleased to correspond with those interested in this felt dust guard.

The exhibit of the Lunkenheimer Company at the Master Mechanics' convention consisted of a full line of their injectors, gauge-cocks, cylinder cocks, stop and check valves and chime whistles. Of these the Lunkenheimer '99 model injector, which was shown in two full-sized sections, attracted considerable attention. This standard injector, which has just been placed on the market, differs in a number of particulars from other injectors. It is designed for high-pressure service, is not affected by variations of steam pressure and the manufacturers claim that it will start promptly and can be depended upon to work reliably at all steam pressures from 25 to 300 lbs. and higher. The company has just issued a catalogue which gives directions for placing and operating the injector. This pamphlet will be sent with any additional information desired, to those who will correspond with the Lunkenheimer Company, at Cincinnati, Ohio.

Upon a recapitulation made by the officials of the Pressed Steel Car Company of Pittsburgh, it was found that, including the cars built during May, 1901, the total number of cars shipped since the industry began four years ago is 40,578. At the present rate of production, the company will build this year nearly as many cars as have been constructed since the inception of the company. During May the total number built and shipped was 2,705, an average of a little over 100 cars for every working day. This average has been kept up for several months and the officials of the company believe that in the future the average will be even greater than it has been in the past. The enormous output of this company can best be realized when it is known that in addition to the cars built there is a large output of bolsters, truck frames, center plates, brake beams, etc., and that in May alone the consumption of steel amounted to over 40,000 tons. With this amount of steel plates and steel structural material, 13 steamers 500 ft. long, 50 ft. beam and 50 ft. deep could be constructed.

CORRESPONDENCE.

COST OF CAR PAINTING BY SPRAY AND BRUSH.

To the Editor:

There is a wide difference of opinion as to the relative merits of painting freight cars by spraying or by brush. The arguments against spraying are that contract shops do not use this method and that it wastes paint.

If properly used there is no waste of paint, as has been shown by erecting a canvas tent with canvas floor and spraying a number of cars inside the tent. The weight of the canvas before and after showed the waste of the paint, which amounted to but a few ounces.

The following test made by a large railroad system needs no comment. It shows that contract shops using brushes can not compete with the sprayer. Lucol paint was used, which has special advantages for spraying and which finishes a repainted car with one coat, giving a good uniform gloss, with no flat spots.

Cost of Spraying Cars.

The following is the test record:

Spraying.	
A. and D. car No. 1196 (in fair condition), sides and ends, 684 sq. ft. Paint used, 13 lbs.....	\$.95¼
Time required, 26 minutes.....	.06½
Total for body.....	\$1.01¾
Roof paint, 9 lbs. 3 oz.....	\$.68
Time required, 10 minutes.....	.02½
Total for sides, ends and roof.....	\$1.72¼
R. and D. car No. 3671 (in bad condition), sides and ends, 734 sq. ft. Paint required, 17 lbs. 4 oz.....	\$1.27¾
Time required, 17½ minutes.....	.04½
Total for sides and ends.....	\$1.32¼
Roof paint, 9 lbs. 3 oz.....	\$.68
Time required, 10 minutes.....	.02½
Total for sides, ends and roof.....	\$2.02¾

Several other cars were sprayed, all showing the same results as to cost within a few cents. Compare this now with the following figures given by another road using "wall" brushes and two coats of linseed oil, paste and japan dryer. The two coats were necessary to give a gloss. The car repainted was a 36-ft. box car.

Cost with Brushes.

Paint used, 12 gals., at 60 cents per gal.....	\$7.20
Time required, 3½ hours.....	.52
Total for sides, ends and roof.....	\$7.72

The \$7.72 represents the cost of applying two coats of paint. Because of the qualifications of the paint used with the sprayer but one coat was necessary. By taking half of the \$7.22, or \$3.86, and comparing it with the \$1.72¼ and \$2.02¾ a fair comparison may be had of sprayer versus brush. Car Builder.

Direct-Current Machinery.—The Bullock Electric Manufacturing Company has issued a small pamphlet for distribution at the Pan American Exposition. This souvenir catalogue illustrates a varied line of their direct-current electrical machinery, including the types "I," "H," "N" and "E" generators and motors; also type "N-I" Bullock marine generator. No detailed description is given in connection with these machines, but reference is made in each case to a certain bulletin in which that machine is fully described. These descriptive bulletins referred to will be sent to those interested in direct-current motors and generators upon request of the Bullock Electric Manufacturing Company, Cincinnati, Ohio. The pamphlet is prepared in the attractive good taste which characterizes the publications of this company.

The Railway and Engineering Review in its issue for June 15th presents an admirable inset, containing a comparison of the principal dimensions and leading particulars of prominent locomotives constructed in the United States during the last two years. The table occupies a full page and is accompanied by excellent half tones of 12 interesting designs, all of which have attracted special attention. This comparison is the most convenient we have seen and is not the least interesting feature of this excellent number.

(Established 1832.)

AMERICAN ENGINEER AND RAILROAD JOURNAL.

PUBLISHED MONTHLY

BY

R. M. VAN ARSDALE,

J. S. BONSALE, Business Manager.

MORSE BUILDING.....NEW YORK

G. M. BASFORD, Editor.

E. E. SILK, Associate Editor.

JULY, 1901.

Subscription.—\$2.00 a year for the United States and Canada; \$2.50 a year to

Foreign Countries embraced in the Universal Postal Union.

Remit by Express Money Order, Draft or Post Office Order.

Subscriptions for this paper will be received and copies kept for sale by the

Post Office News Co., 217 Dearborn St., Chicago, Ill.

Damrell & Upham, 283 Washington St., Boston, Mass.

Philip Roeder, 307 North Fourth St., St. Louis, Mo.

R. S. Davis & Co., 346 Fifth Ave., Pittsburg, Pa.

Century News Co., 6 Third St. S., Minneapolis, Minn.

Sampson Low, Marston & Co., Limited, St. Dunstan's House, Fetter Lane, E. C., London, England.

EDITORIAL ANNOUNCEMENTS.

Advertisements.—Nothing will be inserted in this journal for pay, EXCEPT IN THE ADVERTISING PAGES. The reading pages will contain only such matter as we consider of interest to our readers.

Contributions.—Articles relating to railway rolling stock construction and management and kindred topics, by those who are practically acquainted with these subjects, are specially desired. Also early notices of official changes, and additions of new equipment for the road or the shop, by purchase or construction.

To Subscribers.—The AMERICAN ENGINEER AND RAILROAD JOURNAL is mailed regularly to every subscriber each month. Any subscriber who fails to receive his paper ought at once to notify the postmaster at the office of delivery, and in case the paper is not then obtained this office should be notified, so that the missing paper may be supplied. When a subscriber changes his address he ought to notify this office at once, so that the paper may be sent to the proper destination.

IMPRESSIONS OF THE CONVENTIONS.

MASTER MECHANICS' ASSOCIATION.

The introduction of the individual papers at the Master Mechanics' Convention this year began what may become an important improvement if properly developed. Mr. Henderson's treatment of tonnage rating was what would be expected from him. It is as thorough and comprehensive as if it had been a committee report, but in this case the credit will be placed with the author. Mr. Sanderson's paper is also better than a committee report could possibly be, because it was the work of an individual and was not trimmed to meet the opinions of several members of a committee. There is much to be gained by a development of this plan, and not the least of the benefits will come to those who prepare the papers. It offers excellent opportunities for members to improve themselves. Usually the one most benefited by a paper before a technical association is the author himself.

In discussing boiler-tube practice the extent of the difficulty in keeping tubes tight, and the apparent increase of the trouble with increasing pressures and growing severity of service, indicate the necessity for something radical. The most trouble occurs in bad water districts, which points to the "treatment" of water as the most effective remedy. It is interesting to know that Mr. Kruttschnitt, Vice-President and General Manager of the Southern Pacific, in his article in our June number places water treatment as the first of his suggestions to motive-power officers. He says: "The far-reaching effects of bad water would lead me to place its improvement by chemical treatment as first in importance of the problems that confront motive-power officers of the present day."

Mr. Morris, in his presidential address, struck from the shoulder at the uncertain attitude of the association with regard to the compound locomotive. With admirable facilities at command, the status of the compound should be established, and, to quote Mr. Morris: "We should not be satisfied to let the compound drag itself wearily along into its final resting place in our esteem, when with present-day facilities it is easy to forecast so much intelligently."

In interest, time occupied, and the number of speakers, the round-house report stood first among the subjects. It is apparent that facilities for caring for locomotives at terminals must receive the best sort of attention to meet the demands of progress in operating methods. In connection with round-houses broad-minded men do not hesitate to furnish anything which will contribute to a reduction of the time lost by locomotives at terminals. It was disappointing that the discussion dealt with details instead of the fundamentals, and that nothing was said about the losses of time in caring for engines or the possibilities of reducing them.

If anyone expected a definite statement on the relative merits of cast-iron and steel-tired wheels which would settle the question of superiority and safety, he was disappointed. If the cast-iron wheel is safe in locomotive service it should not be difficult to put it into words. It is difficult to understand why, if the cast-iron wheel is all that its friends represent it to be, its friends do not come out boldly and advocate it for every service. If it is not safe for leading wheels for engine trucks, is it safe anywhere in a train? At the recent convention the views expressed in the article on page 118 of our April issue were abundantly confirmed, viz.: Cast-iron wheels must be greatly improved or they must give place to better wheels, if safety is to be insured. The situation as illuminated by the M. C. B. Association is nothing short of dangerous.

While many other features of the convention are worthy of mention, only one more will be included. It was the closing paragraph in the President's address, which was as follows: "I would like to remind you that the remarkable changes in the ownership and control of some of our largest roads must be taken to indicate most important alterations in the situation in which we are a part, and it behooves us to watch lest we fail in some degree to appreciate what it means to the departments which we represent, and with renewed efforts we must meet the new problems in a way that will inspire confidence and insure absolute progress."

An impression was left by this convention, and also by that of the M. C. B. Association, that progress in operation must be closely studied and followed by motive-power men in order that they may keep ahead of their problems.

M. C. B. ASSOCIATION.

One of the most important subjects was the draft-gear situation. It is thoroughly understood that most of the draft gear in common use is inadequate and that about 75 per cent. of the cost of car repairs goes into the maintenance of these parts. A number of important features were touched upon in the discussion, but only a few real principles were reached. There was a strong sentiment in favor of "continuous" gear, but it was not made clear that a satisfactory device of this kind was available. Continuous draft sills, or the use of center sills, was considered desirable, and there was but one mind as to the desirability of placing the line of draft at or near the neutral axis of the members of the floor system to which the draft gear is attached. There was also a general complaint concerning the rough handling of cars in yards, and many thought that the operating departments should be induced to correct the abuses. The discussion was, however, disappointing to those who hoped for a proper appreciation of the principles involved in providing for the enormous advances which have been made in the power of locomotives and the capacities of cars. These were scarcely mentioned, and the discussion turned on what should be done with old cars and the admittedly weak

gears. It was apparent that the men who understand the situation were not ready to take a hand, but if the tests of the committee are begun before the next convention, their time will come for assuming control of the discussion. A lot of educational work needs to be done in order that all of the elements of the pulling and buffing of cars may be understood. It does not appear to be appreciated that at present the entire structure of a wooden car acts as a buffer. The yielding of the whole floor system saves the day as far as these cars are concerned, but when the next step beyond the wooden underframe is taken, an entirely new condition arises which compels the provision of greater capacity in the gear. The real question is how best to provide the increased capacity. It is surprising that this was not mentioned in any way in the convention, though it was unreservedly discussed in the piazza conversations. Why do the members of this association hesitate to go on record on this subject? It seems advisable and appropriate to refer them to the criticism by Mr. Bush on the opening page of this issue.

Another live topic is the status of the cast-iron wheel. The committee on wheels recommended changes in the direction of lighter wheels, and in the discussion a marked difference of opinion was developed. It was generally admitted that wheel iron had deteriorated because of the large proportion of old wheels used in the mixtures, and it was said that wheels had been remelted a dozen and more times, a practice which was condemned. The lighter patterns were suggested with a view of requiring better iron, but those who had experienced the most difficulty wanted heavier wheels to meet the present crisis. No doubt was left in anyone's mind that something was radically wrong with cast-iron wheels. Next year a report may be expected covering the material, design, form and weight of wheels of various capacities. The association is to be congratulated on the prospect of a thorough examination of the whole question.

In connection with couplers the necessity for more lateral play at the carry-iron seemed to be the most striking factor in the discussion. It was suggested that breakage of couplers and derailments of cars, as well as flange wear of wheels, might be greatly reduced by allowing the coupler to move laterally to permit cars to pass over sharp curves without cramping the draft gear. In addition to this the whole coupler needed strengthening. This subject will come up prominently next year.

Durability is the property most generally sought in buying brake shoes. It seems to be pretty well understood that this involves the use of hard metal, which gives low braking power. The members were reminded that brakes were intended to stop trains and that it was unwise to give undue prominence to the matter of cost. The committee argued in favor of shoes hard enough to last through a long run, but soft enough to give a fair coefficient of friction. They recommended the equivalent of a hard cast-iron shoe.

It has never been the practice of this association to establish prices sufficiently high to permit of making profits in repairs. In the case of the cleaning of triple valves, however, the wisdom of such prices is apparent. It will now be easier to maintain air brakes in good order, concerning which Mr. G. W. Rhodes presented an able argument in our June number.

The discussions this year were unusually general and thoughtful, and they gave evidence of considerable advance preparation.

Mr. W. C. Brown, General Manager of the Chicago, Burlington & Quincy, has been elected Vice-President and General Manager of the Lake Shore & Michigan Southern, with office at Cleveland, O. Mr. Brown is 48 years of age, and has had a remarkably wide experience dating from 1870, when he entered the service of the Chicago, Milwaukee & St. Paul as a section hand. He advanced rapidly through various responsible positions, and in 1896 was appointed General Manager of the Chicago, Burlington & Quincy.

PERSONALS.

Charles Henry Burns, Master Mechanic of the Houston & Texas Central, died recently. He had been in the service of that company for 25 years.

Mr. J. P. Neff, Foreman of the Waseca shops of the Chicago & Northwestern, has been appointed General Foreman at Huron, S. D., succeeding A. B. Quimby.

Mr. J. J. Sullivan, General Foreman of the Louisville & Nashville shops at Louisville, has been appointed Master Mechanic, and will have charge of all mechanical matters pertaining to the terminal facilities at Louisville.

Mr. David W. Ross, for several years Chief Clerk to Vice-President Harahan, of the Illinois Central, has been appointed Purchasing Agent of that system, with headquarters at Chicago, to succeed Mr. C. A. Beck. Mr. Beck will remain in the service of the company as Chairman of the new board of pensions.

Mr. A. E. Manchester has been appointed Superintendent of Motive Power of the Chicago, Milwaukee and St. Paul, in the place of Mr. S. P. Bush, resigned, to become General Manager of the Buckeye Malleable Iron & Coupler Company. Mr. Manchester is 53 years of age, and his entire railroad career has been spent with this road. He began service in 1864 and has been consecutively 5 years Machinist, 17 years Round House Foreman, 3 years General Foreman of the Locomotive Department, 4 years Division Master Mechanic, and from 1893 to date Assistant Superintendent of Motive Power.

Mr. John W. Kendrick has been appointed Third Vice-President of the Atchison, Topeka & Santa Fe. He leaves the office of Second Vice-President of the Northern Pacific after a splendid career of 22 years with that road. Mr. Kendrick is 47 years of age, and began his railroad service with a construction party of the Northern Pacific in the Yellowstone Valley. During the past few years Mr. Kendrick has had associated with him in his work Mr. McHenry, and to these two gentlemen is due the success of the remarkable work in reconstructing the road and equipment of the Northern Pacific.

Mr. John S. Chambers has just been appointed Superintendent of Motive Power of the Atlantic Coast Line, with headquarters at Wilmington, N. C. Mr. Chambers is 43 years old, and began his railroad career in 1886 as a machinist in the shops of the Wabash, St. Louis & Pacific. Since that time he has held respectively the following positions: General Foreman, Kansas City & Northwestern; General Foreman and Master Mechanic, St. Joseph Terminal; Master Mechanic, Illinois Central; Superintendent of Motive Power, West Virginia Central & Pittsburg; Master Mechanic, Buffalo Division Lehigh Valley; Master Mechanic, Central Railroad of New Jersey, from which position he recently resigned.

Mr. William H. Newman, President of the Lake Shore & Michigan Southern, was elected President of the New York Central & Hudson River Railroad at a special meeting of the board in New York June 3 to succeed Mr. Samuel R. Callaway who resigned to accept the office of President of the American Locomotive Company. Mr. Newman began his railroad career July 1, 1869, at the age of 22, as station agent on the Texas & Pacific, at Shreveport, La., and in 1872 was appointed General Freight Agent of the same road. This position he held until 1883 when he became Traffic Manager of the Gould Southern System. From 1885 to 1887 he was Traffic Manager of the Missouri Pacific System, and then chosen Third Vice-President. He was made Third Vice-President of the Chicago & Northwestern in 1889 and in 1896 entered the services of the Great Northern as Second Vice-President in charge of traffic. This position he held until 1898 when he was called to the Presidency of the Lake Shore & Michigan Southern. He has also been re-elected to the presidency of the "Lake Shore."

BOOKS AND PAMPHLETS.

Hand Book of Patent Law, Patent Office Procedure, Trademarks and Copyrights. Published by J. A. Osborne & Co., Cleveland, O. Revised edition.

The object of this little book of 112 pages is to answer most of the questions usually asked by inventors, manufacturers and patent users. It is full of useful information and the index shows a great variety of subjects treated. Those who are interested in patents will be able to procure a copy of this pamphlet by addressing J. A. Osborne & Co., Patent Lawyers, 508 The Arcade, Cleveland, O.

Index to Engineering News for the years 1890 to 1899 Inclusive. Compiled by Mary E. Miller, Librarian, Equitable Life Assurance Society. Octavo, cloth, 324 pages. Published by Engineering News Publishing Co., St. Paul Building, New York, 1900. Price, \$2.50.

The accumulation of engineering literature is so rapid in these days as to render every work of this character exceedingly valuable. It was entrusted to a trained expert who eliminated all but the matters of permanent value and arranged the references logically and conveniently. The enterprise which prompted this undertaking is heartily commended. It renders available a large amount of valuable literature which would otherwise be lost to most busy men because of the difficulty of locating it with the usual volume indexes. The book is well printed in satisfactory type and is exceedingly creditable.

Gas and Fuel Analysis for Engineers. A compend for those interested in the economical application of fuel. By Augustus H. Gill, Assistant Professor of Gas Analysis, Massachusetts Institute of Technology. Second Edition, 89 pages, illustrated, cloth. Published by John Wiley & Sons, 43 E. 19th St., New York, 1900. Price, \$1.25.

This little book is important to those who have to do with steam boilers, because it presents in concise form the subject of chimney gas analysis which is becoming appreciated as a convenient and easy method of studying the performance of steam boiler furnaces. Its substance was given originally in the form of notes to students in mechanical and electrical engineering, which, owing to an expressed demand for a wide circulation, was prepared for book form. It is the result of six years' experience in the instruction of classes and is believed to be the only work on this subject in the English language. It is by no means merely a class text-book, but is a valuable assistant to the engineer. Boiler practice has reached a stage in which the differences between the results of various methods of abstracting heat from the furnace gases are relatively small, but the importance of proper furnace conditions is as great as ever. Because of the convenience of the method, gas analysis is the best and in many cases it is the only one for the study of furnace conditions. The author deserves great credit for this excellent and valuable work, which cannot fail to receive the appreciation of the engineer. It is commended to our readers for careful study because the improvement of combustion is one of the greatest fields open to the engineer.

Hydraulic Tools.—A new catalogue of hydraulic bending machines has just been issued by the Watson Stillman Company, New York, manufacturers of a very large line of high-pressure hydraulic tools for all purposes. This catalogue, No. 59, is devoted entirely to hydraulic bending machines. Among those illustrated and described are various styles of girder and rail benders, pipe benders and bending jacks, bar straightening presses, plate straighteners and forming presses, beam benders, sheet metal benders, garboard strake benders, shaft and car axle straighteners and improved crank pin presses. The last two machines are also illustrated on page 160 of the May issue of this paper. A new catalogue illustrating and describing hydraulic jacks has also been received. This book is a new edition of the company's former catalogue No. 54 and contains considerable additional matter. New sizes and styles of jacks have been added and certain parts have been entirely revised. These catalogues are standard size, 6x9 ins., and the pages are all given a file number, so that separate sheets describing any machine in the lists may be had upon application to the main office, 204 East Forty-third street, New York. This company has exceptional facilities for making any special machine in these lines and will be glad to correspond with those wanting tools which are not illustrated in these catalogues.

"A Step Forward" is the title of a little pamphlet just issued by the Bullock Electric Manufacturing Company, Cincinnati, announcing the consolidation of their sales departments with those of the Wagner Electric Manufacturing Company, St. Louis. This booklet also contains some information about these two companies of which a few brief remarks were given in the May issue of this paper, page 166. The new organization will be under the management of Mr. E. H. Abadie, former Sales Agent of the Wagner Company.

Brake Shoes.—This little pamphlet was prepared by the American Brake Shoe Company, Chicago. It illustrates and describes six different driving brake shoes and four styles of shoes for coaches and cars, all of which have distinguishing features. The catalogue is issued for distribution at the coming M. C. B. and M. M. conventions at Saratoga. Copies were distributed at that time. It presents in an attractive and concise manner a great deal of information concerning these well-known brake shoes.

Graphite Productions.—The Joseph Dixon Crucible Company has just issued a catalogue which covers very fully their graphite productions. In addition to a general description of the great variety of Dixon's graphite productions this catalogue contains some excellent engravings of the company's graphite works at Ticonderoga, views of the graphite mines and cedar mills and the main works at Jersey City. The press work of the pamphlet represents a high degree of perfection which, added to the other good features, make it an unusually attractive catalogue.

The Pressed Steel Car Company, of Pittsburgh, has just issued a catalogue which is the best pamphlet on steel cars that has been received at this office. The catalogue shows by many excellent engravings the latest designs of hopper, box, furniture, gondola and ballast cars with the improvements that have been developed from the results of actual service. In addition to a variety of trucks for all equipment which are shown by full-page engravings, are standard types of pressed steel body and truck bolsters, side stakes and pockets, brake beams, center plates and other pressed steel specialties for general car equipment. The book also gives tables of figures taken from daily reports showing the advantages of pressed steel cars and valuable testimonials from motive power and operating officers. The catalogue is standard size and is a good example of the best, up-to-date catalogue literature.

Air Compressors.—An illustrated pamphlet has just been issued by the Rand Drill Company, 128 Broadway, New York, giving general and detailed descriptions of their "Imperial" Type X air compressors, designed for both simple and compound, double-acting, steam and air cylinders. The pamphlet also illustrates and describes their Type XI belt driven air compressor and Type VII air compressors with duplex or compound steam cylinders and multiple stage compression cylinders. Tables of dimensions and capacities of the various sizes are also given in the catalogue.

"A. B. C." Mechanical Draft.—In this little pamphlet, which has just been issued by the American Blower Company, of Detroit, is given in a concise but comprehensive manner the advantages of mechanical draft. The book is illustrated by clear engravings of fans, blowers, steam engines, both vertical and horizontal, and the methods of applying forced and induced draft. In the back of the pamphlet are given some miscellaneous tables for handy reference from which mechanical draft plants may be designed. Catalogues giving detailed information of any particular line of this company's products will be furnished upon request at the office of the American Blower Company, Detroit, Mich.

Locomotive Inspirators and Injectors.—In this catalogue, just issued by the Hancock Inspirator Company, of Boston, are given brief illustrated descriptions of their locomotive inspirators and various attachments for the locomotive, together with the Hancock inspirator, types "A," "B," "D" and "Composite," and locomotive injectors. An important advantage of these different types of inspirators is that the repair parts of all can be replaced with one standard set of parts. In addition are illustrations of the Hancock Main Steam valve and Main Boiler valve, a new double check valve and improved hose strainer. The catalogue is very complete, covering the subject fully.

Elevating and Conveying Machinery.—The Jeffrey Manufacturing Company has just issued a circular, No. 61, of elevating and conveying machinery for mills, factories, mines, industrial and power plants. The circular illustrates a number of the ways in which their products are used. For those desiring a complete description of any line of these equipments a catalogue will be sent upon application to the Jeffrey Manufacturing Company, Columbus, Ohio.

"The Cause of Foaming in Locomotive Boilers and Other Papers" is the title of a pamphlet republished by the Industrial Water Company, of New York. It gives in concise form three valuable papers by C. Herschel Koyl, one on The Cause of Foaming in Locomotive Boilers, a second on Pure Water for Locomotives by Evaporation, and a third on The Purification of Feed-Water. The book is illustrated by several engravings, among which is a continuous and automatic water softening and purifying machine, built by this company, and a "Yaryan" multiple effect evaporator in use at the works of the Perim Coal Company, on the Red Sea. The address of the Industrial Water Company is 15 Wall street, New York.

The American Brake Company, St. Louis, has issued a 1901 catalogue illustrating and describing the American automatic slack adjuster, a device for maintaining constant and uniform piston travel in air brake cylinders, and to compensate for the varying conditions of leverage and brake shoe wear, thus insuring uniform cylinder pressure and brake shoe effect. To show the application of this slack adjuster to quick-action passenger and freight car brakes, and locomotive truck and tender brakes this catalogue contains a number of colored folding plates with explanations. The book also gives detailed illustrations of the adjuster itself and of the standard Westinghouse cylinder heads for use in connection with this device. For freight car and locomotive trucks, where there is considerable variety of construction, this company will be pleased to submit without cost, upon receipt of suitable data, working drawings of brakes with the American automatic slack adjuster applied.

Inventors' Manual: How to Make a Patent Pay. By an experienced and successful inventor. Revised and enlarged edition, including the 1900 census of the United States by counties. Bound in cloth, 119 pages. Published by Norman W. Henly & Company, 132 Nassau street, New York, 1901. Price, \$1.

This book tells how to introduce and dispose of an invention. It is a guide to the inventor in perfecting his inventions, taking out patents and disposing of them, with general hints to the inventor and patentee. Among the subjects treated are: How to invent, how to secure a good patent, how to exhibit an invention, how to interest capital, how to estimate the value of a patent, and the value of a good invention, good design, foreign patents and of small inventions. The volume also gives advice on the selling of patents, formation of stock companies, formation of limited liability companies, disposing of old patents and advice as to selling agents, forms of assignments, license and contracts, and State laws concerning patent rights. The author of the book has had a long and successful experience as an inventor and the principles of his success as laid down in this manual make it a useful book to those who have to do with patents.

EQUIPMENT AND MANUFACTURING NOTES.

The Babcock & Wilcox Company has removed its New York offices to 85 Liberty street, twelfth floor.

The coach roofs of the President's train on his recent trip to the Western coast were painted with Superior Graphite Paint furnished by the Detroit Graphite Manufacturing Company, of Detroit, Mich.

The Sargent Company on May 29 elected the following officers: Chairman of the Board, Geo. M. Sargent; President, W. D. Sargent; Vice-President and Treasurer, H. K. Gilbert; Secretary, Day McBirney.

An order for 250 steel gondola cars for use on the Government Railways of Australia in New South Wales was recently

received by the Pressed Steel Car Company, through its foreign agents, the Transportation Development Company, Inc.

The Westinghouse Air Brake Company has absorbed the Standard Air Brake Company and will manufacture air brakes for street and interurban railroads on an extensive scale. The plant of the Standard Company will be moved to Wilmerding, Pa.

The Dry Color Plant of The Mammoth Carbon Paint Company, located at Poplar Bluff, Mo., was damaged by fire on the 11th of June, loss about \$5,000. The company will rebuild immediately and will be able to handle its business without any delays, as their stock of pigments at the Cincinnati and New York works are ample to provide for filling all orders promptly until the dry color plant at Poplar Bluff is rebuilt.

Two Pedrick & Ayer air compressors will be used in a novel way at the Pan-American Exposition for supplying compressed air to a Baldwin locomotive which is to be jacked up off the track and operated in this position. The compressors are compound, automatic, belt driven and will pump the air into the boiler of the locomotive from which it will be used in the cylinders as the motive power for turning the wheels.

The transcontinental limited train of the Santa Fe System, which has heretofore been operated only through the winter months, when tourist travel is heaviest, is to be continued in service as a semi-weekly train both to San Francisco and Los Angeles. Each car on the train will be equipped with electric fans and the service in other respects will be the most desirable for a summer journey to the coast. The train leaves Chicago Tuesdays and Saturdays. East-bound it will leave San Francisco and Los Angeles Mondays and Thursdays.

It will surprise most people to discover that the population of China is greater than that of Russia, Great Britain, Germany, France, Japan and the United States combined, and that China has a population capable of bearing arms of almost 100,000,000. In those other elements which go to make up a nation's potential strength, such as vitality, endurance, indifference to discomfort, ability to subsist on the smallest rations and to thrive amid unsanitary surroundings, the Chinese are unmatched.—From No. 28 of the New York Central's "Four Track Series."

Now that the damaged portion of the old plant of the B. F. Sturtevant Company has been made habitable and the effects of the fire have been overcome, attention is being turned to the selection of another site and the consideration of plans for an entire new plant. It is more than likely that the selection of a site will be in the vicinity of Boston and it is certain that it will be one that presents the most favorable conditions as regards shipping facilities, proximity to a skilled-labor center, water supply, etc. The plant itself will of necessity consist of a power house, large foundry, blower, heater, forge, engine, electrical and galvanized iron shops with administration building and pattern shop. Between five and ten acres of floor space will undoubtedly be required to meet the present requirements, while the available land for future extensions must be from fifteen to twenty acres.

The A. S. Cameron Steam Pump Works of New York have a very fine exhibit of their pumps at the Pan-American Exposition at Buffalo. The exhibit consists of eight of the Cameron pumps showing a variety of the direct-acting type and including the following: The "regular" type for general service, the special "boiler feeder" pump, the vertical piston mining pump, vertical plunger sinking pump, the horizontal plunger station mining pump cut in sections for mule-back transportation in mountainous countries, the sectional plunger sinking pump, the vertical engine and deep well pump for artesian wells and a pump cut into sections to illustrate the mechanism and principle of operation of the Cameron type of pump. The exhibit is shown in the Machinery Division of the Transportation Building in block No. 25, and is in charge of Mr. P. E. Leahy, President of the National Association of Stationary Engineers and Consulting Engineer for the Cameron Company.

MASTER MECHANICS' ASSOCIATION.

Thirty-Fourth Annual Convention.

Abstracts of Reports.

WHAT IS THE MOST IMPROVED METHOD OF UNLOADING LOCOMOTIVE COAL PRIOR TO BEING UNLOADED ON THE TANK?

Committee—W. Garstang, T. S. Lloyd, W. E. Symons.

Your committee has endeavored to present a series of cuts that will give an excellent general idea of the different arrangements. It has been impossible to present all of the plans in detail, but it has been the aim to present in more or less detail all of the peculiar features, but only once where the same principle has been embodied in two or more plants. There has been no effort to present any data on the means of furnishing power to operate the conveyor or machinery in the plant, as location, surrounding conditions and amount of power required would have to be taken into consideration for each individual location.

For instance, when a plant is situated close to shops equipped with electric power, the electric motor is the simplest and probably the most economical. At another point where fuel is cheap and steam can be used to advantage for other purposes than hoisting, such as pumping water, no doubt the steam boiler is the cheapest arrangement, while at other points the greatest

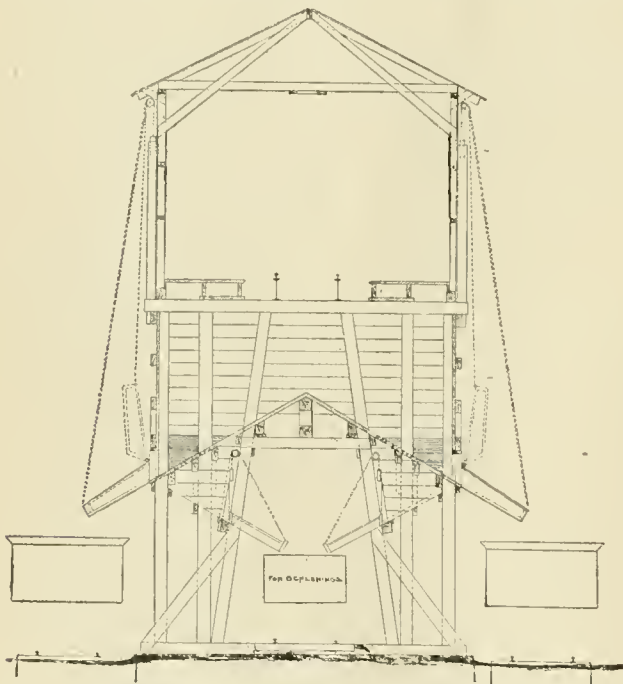

Lehigh Railroad Valley Coaling Station.

economy can be gotten by the use of the gas engine. In deciding on the kind of power, unless the plant is operated by electricity and is close enough to a shop station to have some part of the building heated by steam for the comfort of the operators, it is safe to say that the steam boiler, at least in winter months, would be the most economical, otherwise the amount of coal burned in heating stoves would probably be sufficient to operate the plant and furnish the heat also.

It is the opinion of the committee that the expense of coaling engines is governed entirely by the kind of cars in which the coal is handled, without reference to the kind of plant in which it is handled, provided the plant is one that will admit of dumping the coal to either bin or conveyor.

If the coal is received in hopper bottom or side dump cars, the cost will probably be between 1 and 3 cents per ton delivered on the tender, no matter whether the cars are pushed up an incline and dumped into pockets or whether the place of the switch engine is taken by other power operating a system of conveyors.

On the other hand, if the coal is received in gondola or box cars and has to be shoveled from the car, the cost will be from 6 to 8 cents per ton delivered on the tender, regardless of the kind of coaling station through which it is handled.

The advantages of the power plant seem to be in more independence at the coaling station, not being required to wait for switching crews, the better housing of the fuel and the ability to have large storage which can be cheaply and quickly handled. Especially important would this seem to be in winter months in locations subject to severe cold weather, when the movement of coal is often slow.

Your committee regrets not being able to furnish the cost of building the various plants shown, but members operating them can probably answer this question.

An item of importance to many roads is the ability to weigh or measure the coal to individual engines. There are four systems now in use; the first, to fill the ordinary coaling bucket which is handled on to the tender by hand or air operated crane. Second, by filling the pocket to a given mark or making the pocket of a given capacity. Third, by the balance pocket operating a dynamometer, and fourth, by having a pocket supported on scales.

Of the plans considered four commend themselves as having special advantages and would cover all general conditions: First, a cheap station operating gondola or coal cars, using the

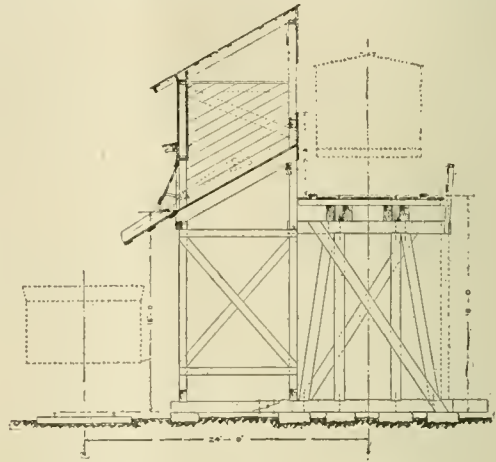

Chicago Great Western Railway Coaling Station.

bucket as a means of measuring and transferring the coal to the tender with the air-operated crane, such as is used at many small stations on the C. C. & St. L. Ry. Second, the single or double pocket of large capacity, delivering coal directly to the tender or from a measured car of small capacity, as on the Erie R. R. Third, the large pocket, the total contents of which is weighed by the dynamometer, as largely used on the Northern Pacific R. R. Fourth, the measured pocket with storage underneath and its automatic adjustment, as used on the Michigan Central R. R. This arrangement seems an ideal one, as it admits of any extension or capacity; can be operated by drop bottom, side dump, gondola or box cars; automatically weighs the coal to measure and provides large storage capacity.

COST OF RUNNING TRAINS AT HIGH SPEED.

Committee—Wm. McIntosh, G. F. Wilson, F. A. Delano.

Editor's Note.—This is a lengthy report consisting of data from various roads, but with the exception of that from Mr. Quayle of the Chicago & Northwestern and Mr. Delano of the Chicago, Burlington & Quincy, none contained results of tests. The information given by Mr. Quayle was presented in substance in the article by Mr. G. R. Henderson in the American Engineer and Railroad Journal in June, 1900, and that by Mr. Delano is given in abstract below. These two contributions are selected as being the most valuable offered by the committee.

Contributed by Mr. Delano.

I submit as evidence on this matter of cost of running trains at high speed, a report made in July, 1900, on the C. B. & Q. F. R., under my jurisdiction on fast mail train No. 15, between Chicago and Burlington, a distance of 206 miles, the schedule of the train, including stops, being fifty-one miles per hour. Three trips were made with this train and two trips were made with a dummy train of practically the same weight, but making only half the speed. The data of the tests is given fully in the report made by Mr. H. T. Wickhorst, Engineer of Tests, who had direct charge of the work, with a staff of assistants, but I would call attention to several particular features.

First. The test was made at a time of the year most favorable to low cost of train operation. Second. The train was exactly on schedule time and there was, therefore, no time to be made up and no accident or hot boxes causing a delay which had to be made up. Third. In spite of the above fact, it is interesting to note the speed at which most of the miles had to be made in order to keep the train on schedule time. It will be noted, for example, that the greater part of the distance had to be covered at a speed of sixty to sixty-five miles per hour. Fourth. It is estimated that the value of the high-speed engine on the fast mail train (weighing seventy-four tons in working order) was \$14,000, as against the value of say \$7,000 for the engine (weighing forty-one tons in working order) which handled the test train operating at only one-half the speed.

In regard to breakdowns, it is pretty apparent that there are a great many more cases of delayed trains due to hot bearings on engines and cars where the speed is excessive than where it is moderate. On some divisions of the road where speed is moderate we never have a case of hot crank pins, whereas hot crank pins and hot driving boxes are not uncommon in high-speed service.

We use our very best power in high-speed service, and in spite of this we have more failures in high-speed service than in moderate service, but just how much more I am unable to say.

I feel quite certain that the increase in speed of a few trains has a tendency to quicken the speed of all trains, first, because the men get educated or keyed up to a high speed, and secondly, because it is necessary to make high speed in order to keep out of the way of trains, even on a double-track road.

The greater speed of trains, both freight and passenger, which has come with recent years has greatly increased the requirements for large boiler capacity of freight as well as passenger engines. High speed has developed a good many weak points in the machinery of engines which under more moderate speeds gave good service. There is very little question that this enhances the first cost of the motive power, but just how much it would be difficult, if not impossible, to say. To combine speed with great tractive power is a difficult thing to accomplish because, in the nature of things, the requirements are contradictory, and in attempting to satisfy opposing conditions is of course more or less of a compromise.

Mr. Wickhorst's report is as follows:

I submit herewith dynamometer car tests made with fast mail train 15, compared with special train of the same make-up, but run at one-half the speed, the test to be made primarily to show relative drawbar pulls and speeds and also to show relative coal and water consumption. We made three tests with train 15 and two tests with the special train. The dates and make-ups of the different trains are shown on the following table:

Car.	Fast Mail Train No. 15.					
	July 20, 1900.	July 22, 1900.	July 23, 1900.			
	No.	Weight in lbs.	No.	Weight in lbs.	No.	Weight in lbs.
Dynamometer	Z	34,000	Z	34,000	Z	34,000
Baggage	707	69,400	707	69,400	707	69,400
Mail	930	73,800	930	73,800	931	74,000
Contents	914	79,600	914	79,600	915	79,300
		50,000		25,000		25,000
		376,400		351,400		351,100
Total weight behind engine tender	188.2 tons	175.7 tons	175.5 tons			
Car.	Special Train.		July 26 and 27, 1900.			
	No.	Weight in lbs.	No.	Weight in lbs.		
Dynamometer	Z	34,000	Z	34,000		
Baggage	706	65,200	706	65,200		
Mail	932	75,200	932	75,200		
Contents	913	74,400	913	74,400		
		319,700		319,700		
Total weight		159.85 tons		159.85 tons		

The weights of the cars are the actual weights. The weights of the contents or mail on train No. 15 are estimated weights. Train No. 15 was run on its regular schedule. The special train was run on a special schedule made by doubling the time between stations and stops of train No. 15. A condensed time schedule of the two trains is given below:

	No. 15.	Special.
Union depot, Chicago.....	Lv. 9.30 P. M.	8.25 A. M.
Mendota	Ar. 10.55 P. M.	11.15 A. M.
Mendota	Lv. 10.59 P. M.	11.23 A. M.
Galesburg	Ar. 12.24 A. M.	2.13 P. M.
Galesburg	Lv. 12.27 A. M.	2.19 P. M.
Burlington	Ar. 1.22 A. M.	4.09 P. M.

The train No. 15 made its regular schedule stops, which are as follows:

	Miles.
Canal and Sixteenth streets.....	1
Western avenue	4
Mendota	63
Galesburg	163
Burlington	206

The special train on July 26 was started 13 minutes behind its schedule time, leaving Chicago 8:33 as second No. 13, and besides the regular scheduled stops as per above, we were also compelled to stop on account of being blocked by No. 13 at the following points: Montgomery, Wyonet.

The special train on July 27 was started from Chicago at 8:10, 15 minutes ahead of its schedule as an extra train. On this run also we had to make stops outside of the schedule, which were as follows: Princeton, Wyonet (three times), Buda, Monmouth.

We made no attempt to correct our calculations for these extra stops. On trains No. 15 we use 'Columbia' type engine 1590. This engine has 18 by 26-in. cylinders, 200 lbs. steam pressure, 84 1/4-in. drivers (nominally), and weight on drivers 84,450 lbs.; cylinder tractive power, 17,000 lbs. On the special train we used engine 1121. This is an American type 8-wheel engine, 17 by 24-in. cylinders, 160 lbs. steam pressure, 69-in. drivers and weight on drivers 53,600 lbs.; cylinder tractive power, 13,500 lbs. The idea of using different engines in the two different kind of runs was to have the class of engine best adapted to the service in each case.

The tests consisted of determining with the dynamometer car the drawbar pulls, or, in other words, the resistances of the different trains, and also the running speeds. We also kept records of the coal used, water consumption and steam pressure. Coal used was the best grade of screened lump Illinois coal. Method of determining the amount of coal was as follows: Before the trip, the empty tender was weighed on track scales and then coaled up and reweighed. This gave us the amount of coal supplied. A small separate amount of coal was used to fire up the engine and take it from the Western avenue roundhouse to the train in the Union depot, the coal taken into account in our tests being only that required to actually run the train. At the end of the trip we weighed the coal left and thus arrived at the coal used during the trip. The method of determining the water consumption was as follows: The tank was first calibrated to determine the amount of water in the tank for each 1/4-in. height of the water. This was done by filling up the tank, placing the tender on track scales, allowing the water to run out and determining the weight at each 1/2 in. In making the test, the level of the water in the tank was determined just before starting out, then the height at arrival at Mendota, and the height after taking water at Mendota; the same at Galesburg; the level again taken on arrival at Burlington, care being taken to have the water level in the boiler the same at the end of the trip as at the beginning. The temperature of the water was also taken when starting out and also just before and after taking water. The drawbar pulls and the running speeds were recorded automatically in the dynamometer car. After making the trips, we went over the record paper and determined with a planimeter the average drawbar pull, or, in other words, the average train resistance for each half mile of each trip. We also determined the average running speed for each half mile of each trip. The work of determining the drawbar pulls and running speeds was done by Messrs. John G. Crawford and George Ristine, Jr., students of Cornell University, who took part in the tests and worked up the data and results:

It will be noticed from the various blue prints (Not reproduced here.—Editor) that the average running speed of the special trains was just about half of the speeds of train No. 15, while the average train resistance per ton was a little less than half. The water per ton-mile was about two-thirds and the coal per ton-mile was a little over half. The following tables show the results, taking the results of No. 15 as 100 per cent.:

	Train No. 15.	Special train.
Speed, miles per hour.....	100 per cent.	50.7 per cent.
Drawbar pull, per ton.....	100 "	46.5 "
Water, per ton-mile.....	100 "	65 "
Coal, per ton-mile.....	100 "	54.5 "

In general, therefore, we may say that these tests indicate the cost for power as represented by the consumption of coal and water, of running trains, increases directly as the speed, that is, if we double the speed, the coal, water and drawbar pull are likewise doubled.

I give below a table giving the coal burned per square foot of grate area per hour:

Trip. No.	Engine 1,590, Train No. 15.			Pounds of coal per square foot of grate area, per hour.	Average.
	Grate surface, square feet.	Actual running time, hours, min.	Coal, pounds.		
1	37.5	3.32	13,205	99.5	...
2	37.5	3.25	12,400	96.7	...
3	37.5	3.27	12,464	99.0	98.4
Engine 1,121, Special Train.					
4	17.25	6.39	6,223	54.4	...
5	17.25	7.00	6,070	50.3	52.23

RELATIVE MERITS OF CAST IRON AND STEEL TIRED WHEELS.

Committee—J. N. Barr, A. M. Waitt, A. L. Humphrey, H. S. Hayward, John Hickey.

Since the date of the last report of this committee there have been practically no new developments or new information obtained bearing on this subject. The committee has nothing, therefore, of value to present.

Since the last report of this committee, the question has been raised as to the expediency of the use of steel tired wheels under 100,000-lb. cars, but the data in this matter is so deficient that it cannot be properly made a subject of report.

SUBJECTS.

FOR INVESTIGATION DURING THE YEAR.

- Committee—W. H. Marshall, S. M. Vauclain, A. J. Pitkin.
1. Standard specifications for locomotive driving and truck axles.
 2. The purifying of feed-waters for locomotives.
 3. What constitutes a good locomotive terminal?
 4. The gas engine in railroad work.
 5. Water scoops and track troughs.
 6. Review of recent progress in locomotive designs, including boilers, wheel arrangements, cylinders and valve design, frames and machinery.
 7. Locomotive boilers. The Vanderbilt boiler, wide fire box, and how much grate area is desirable to obtain the best results from soft coal.
 8. Piston valves.
 9. Standard pipe fittings.
 10. Revision of standards of the association, more particularly specifications for materials.

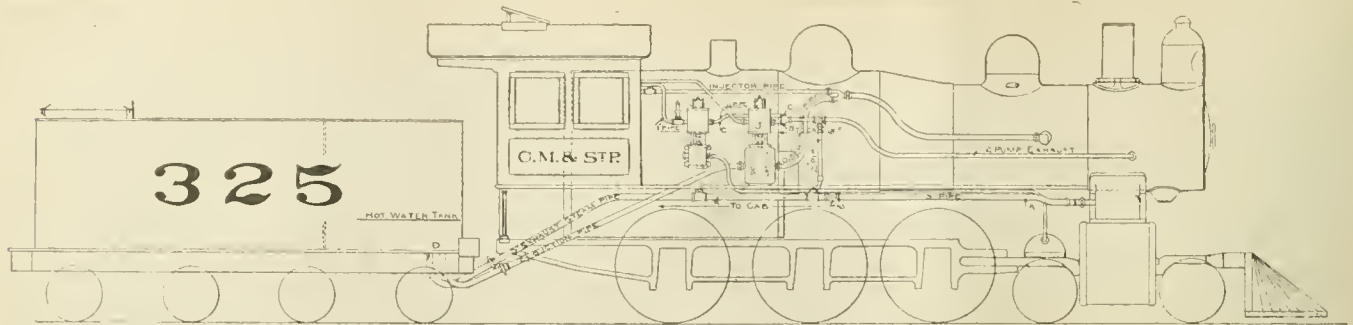

Fig. 1.—General Arrangement of Feed Water Heater.

WHAT IS THE MOST PROMISING DIRECTION IN WHICH TO EFFECT A REDUCTION IN LOCOMOTIVE FUEL CONSUMPTION?

Committee—A. E. Manchester, A. Forsyth, A. F. Stewart.

A few weeks since, in a paper and a discussion upon it before one of the Railway Clubs, in answer to a question as to the increase in the proportion of compound engines built at their works last year, as compared with four or five years previous, a prominent locomotive builder said: "After eliminating from the total number of locomotives built in our shops last year, foreign locomotives, switch engines, electric and compressed air locomotives, and various other specialties which we build, of the road engines turned out for this country seventy per cent. were compound."

Since having this subject under consideration, in conversation with another of the principal locomotive builders, he said in answer to the same question, that fifty per cent. of the road engines for this country turned out of their shops within the last year were compound.

In view of this, and from the fact that compound engines have been a topical subject of discussion at every convention for several years, and a special subject for consideration by one committee which gave a very thorough and complete report upon it, it seems to your committee that compounding has passed the questionable or experimental stage and is now so generally recognized as one of the known methods for effecting a reduction in locomotive fuel consumption as to not warrant making it a special feature of this report.

The committee is further of the opinion that the American Railway Master Mechanics' Association has so often had this matter under consideration and investigation, and such a large portion of the members have had actual experience in the operation of compound locomotives, that the Association should be prepared, and ought to, in justice to itself, give its approval or condemnation of the compound locomotive, and place itself squarely before the world as to why it does so.

In considering the advisability of the application of the compound principle to existing single expansion engines, as one of the essential features in obtaining results from compounding is high pressure steam, and as a majority of the older single expansion engines are not provided with boilers suitable for high pressures, it is doubtful whether economy would result in changing from single expansion to compound except in engines where the boilers are capable of sustaining at least 175 lbs. pressure per square inch, and a higher pressure is desirable.

If further economy by steam expansion and multiplying of cylinders be considered, it would seem proper to follow the lines suggested by a prominent engineer, who, while prophesying on the probable twentieth century improvements in locomotives, said, "We may all live to see triple, and even quadruple expansion locomotives, almost noiselessly performing their work." This may be a hint to this Association to assist in the early development along these lines, and hastening the day of further economies by appointing a committee to investigate and report on the same.

Using the exhaust steam from air pump and cylinder for heating feed water, your committee looks upon as being one of the most promising directions in which to effect a reduction in locomotive fuel consumption. This feature can be applied to existing engines, as well as new, with a moderate expense and but slight changes in existing arrangements, and is adapted to work in connection with several other fuel economizing devices, such as wide fire boxes, compounding, etc.

The average yearly temperature of water as delivered to locomotive tenders is from 50 to 60 degrees Fahr. For every 12 degrees that the temperature of the feed water is raised by exhaust steam or waste gases before the water enters the boiler, there will be a saving of one per cent. in fuel. If by the means recommended an average temperature of 200 degrees for the feed water can be maintained, a saving of twelve per cent. in fuel would result.

The method we recommend for accomplishing this is illustrated in Figs. 1 and 2, and consists of a steam pump adapted to handle hot water. The exhaust from the air pump, water pump, and a branch from the exhaust in front end, to be discharged into a partition of portion of tank, which we will designate as the hot-water tank.

The hot-water tank will have a capacity of 300 to 400 gallons of water. The partition will be water-tight, with the excep-

tion of a 1/2 inch space at the bottom, through which the water will maintain a constant level on both sides of the partition.

The exhaust from the cylinder saddles is conducted to the rear of the engine through a pipe, as shown in Fig. 1 at A; and the exhaust from the water and air pumps, as shown at B and C, joins this piping, which enters the bottom of the hot-water tank at D, and is then conducted up through the tank to the top and through a return bend back to within two inches of the bottom of the tank, where it terminates in a bell-shaped open end through which the exhaust escapes into the water.

In the exhaust pipe and between the pumps and cylinders is placed a shut-off gate at E, to close the exhaust from the cylinders to the tank if desired; also a gate at F where the pump exhausts may be cut off from the tank and delivered to the front end.

The suction pipe for water pump is arranged to draw water

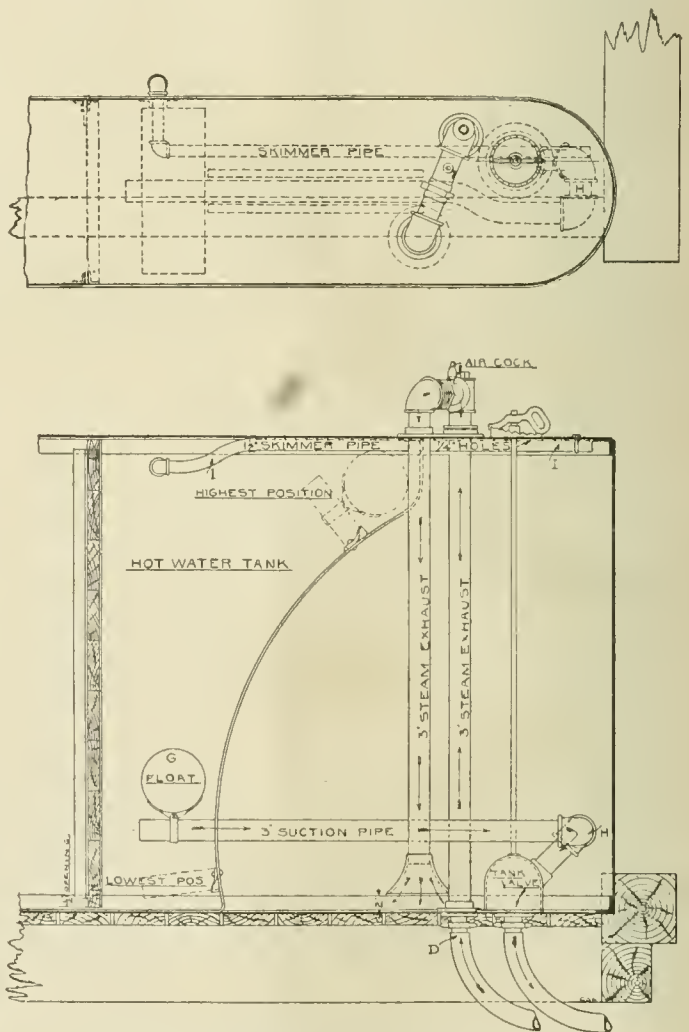

Fig. 2.—Arrangement for Exhaust Steam in Tank.

from 4 inches below the surface of the water in hot-water tank, the suction end being supported by a float or buoy, as shown in Fig. 2 at G, which rises and falls with the level of water in the tank. The other end of adjustable pipe connects with a flexible joint at H, and forms a connection through tank valve case in bottom of tank to hose and pump.

In the top of the hot-water tank is a perforated pipe, 1, which connects to the pipe running down through the coal space to the under side of tender frame. When the tank is full of water, this pipe acts as a skimmer.

The most effective way to reduce the third loss would be by the use of larger grate areas, which would afford a freer air supply and from the reduction of the resistance of the fuel bed there would be a lower suction over the fire, consequently less small fuel would be carried out with the gases. Careful manipulation of the fire with small grates will have an influence in the same direction, because the resistance through the fire would be reduced.

We cannot recommend any special device except larger grates, which, of course, would apply to new engines only; although there is an opportunity of improvement with very large engines with small grates where the necessary resistance through the fire is abnormal, or where it is impossible to get sufficient air into the fire with prevailing practice. The remedy would be to introduce air over the fire. This is not recommended, however, unless shown necessary by tests of the combustion, and its application and operation determined likewise.

Complete combustion with 12 or 13 Co may be secured in locomotives, and under these conditions, the loss in hot gases, based on their escaping at 800 degrees Fahr. would be about twenty-four per cent. Under such conditions, in stationary practice, an economizer would afford means for recovery of about ten or eleven per cent., but for several reasons such means are not applicable to locomotives. The usual locomotive as compared with the average stationary boiler and furnace furnishes an opportunity for a more efficient condition of combustion, but it has the disadvantages of a somewhat higher temperature of escaping gases, a very much greater loss in the form of solid fuel, and a very much greater radiation loss from the boiler.

The above remarks concerning excess of air do not apply to engines with extremely large grates, because with them the loss on this account may be considerable.

Improvement based on tests of the combustion products are always of importance, and there is no difficulty in demonstrating the value of such tests.

We are not prepared to recommend a definite proportion of grate to cylinder or heating surface, or the relative width to length; neither do we believe that such proportions can be correctly given and have them apply to all grades of fuel and classes of service. However, from information received from those who have had the most experience with wide fire-boxes and increased grate area, and from reports of combustion tests showing the gas analyses of different sized grates and fire-boxes, we feel warranted in placing this feature among the methods by which some improvement in fuel economy may be effected, but all the conditions should be carefully considered before a radical departure is made from the deep and narrow box.

An uneconomical feature of the large firebox and increased grate area is the heating of unnecessary excess of air in the gases. This can be kept down to a minimum by careful firing and well-fitting ash pans and dampers, if the latter be carefully manipulated. Adjustable grates, whereby the air space could be enlarged or decreased at will, might, if such a device could be made entirely reliable, better perform this part, but we know of no grate that has withstood the test of service that will fill the requirements.

Another feature is the greater amount of coal that must be burned on a large grate while the engine is standing still and the greater care required to hold the steam below the popping-off point. The safety valve, if allowed to frequently perform its function, will be very wasteful of coal. This loss has been figured out as equal to 4 lbs. of coal per second, or a small scoopful per minute.

Wide fireboxes when operating under favorable conditions and burning fuel suitable to their construction, will develop economies worthy of consideration; but in a service where much of the time is spent standing still and the fire being kept in a condition to go whenever the signal is given, enough fuel will be wasted while standing still to overcome the economies obtained while running.

Traveling engineers and firemen; light and intermittent firing; keeping a level fire; prevent excess of air in gases; perfect combustion; checking coal consumption each trip, and constant attention to details, are some of the recommendations of members as the most promising directions in which to effect a reduction in locomotive fuel consumption.

If it be possible to stimulate in the engine crew efforts equal to those obtained in a test, it will be one of the promising directions in which to effect a saving in the fuel burned in the locomotive. Assigning regular crews to engines has the effect of stimulating an interest in the work and exciting a rivalry between the men in the same class of service on different engines that must result in economy. The remark is sometimes heard that "enginemen don't own their engines any more." Would it not be to the interest of the railroad companies to revive that old-time love for the engine which formerly existed in every engine crew?

Conclusions.

After considering the several recommendations, the conclusions arrived at by your committee are that the most promising directions in which to effect a reduction in locomotive fuel consumption must be largely determined by each particular railroad for itself, the methods varying to suit the local conditions, such as class of power, fuel, service, and to what extent fuel economizing features are now successfully employed.

Many of the recommended methods are applicable only to new construction, but engines building to-day should be serviceable for twenty to twenty-five years to come, and care should be taken to incorporate in them all well developed features of economy.

As far as we have been able to learn, a reduction in fuel consumption has resulted from compounding whenever the engines were intelligently handled. This feature seems to us to be one of the most promising directions and the one that would yield the largest per cent. of saving.

Wide firebox and increased grate area under certain conditions, with the size of the firebox and grate area modified to suit the conditions, when intelligently handled, should be one of the means of effecting a reduction in locomotive fuel consumption and should be carefully considered for new road locomotives.

As to economical length for locomotive flues, we have no definite recommendation to offer; but would call attention to some of the latest designs and constructions in which one of the new features is flues of an heretofore untried length. So far as we have been able to learn, the economical length for flues has not yet been reached.

Using of the air pump and a portion of the other exhausts for heating feed water, appears to your committee to be one of the most promising directions by which to effect a reduction in locomotive fuel consumption. It is applicable to old and new construction and to all classes of service. Your committee had hoped to present to this convention something more tangible than a picture with which to back up their recommendation, but failed in the market to locate what seemed to be a satisfactory pump for the place. In our judgment, there are no requirements which cannot be met, and assume that it is only a question of showing what is wanted, together with the volume of business this feature would open up, to have the pump manufacturers bring out what is required.

All the methods referred to are worthy of consideration. Many of them are adapted to work together, each one exerting an individual influence toward fuel economy, and when aided by earnest and intelligent effort on the part of the engineer and fireman, in connection with close attention to details on the part of the Motive Power Department officials, a reduction in locomotive fuel consumption will follow.

AN "UP-TO-DATE ROUNDHOUSE."

Committee—Robert Quayle, D. Van Alstine, V. B. Lang.

As the appurtenances of the house depend entirely upon the general dimensions, your committee has concluded that the length of the roundhouse should not be less than 80 ft. in the clear. Rapid strides have been made in the design and construction of locomotives during the last few years, and it is not infrequent for us now to find a number of engines that measure from 65 to 70 ft. over all. A locomotive 70 ft. in length would only give us 10 ft. in clearance. This being divided equally would only leave 5 ft. between each wall.

Doors should have a minimum height and minimum width of 16 ft. and 12 ft. in the clear, respectively. The upper portion of the doors should have as much light as can be obtained without interfering with the strength. The window space should be as ample as considered consistent with the strength of the walls in the outer circle of the roundhouse.

Engines should head into roundhouses of modern type, first, because of the more room afforded at the outer circle of the house, where most of the work on the engines is done when headed in in this manner; second, because of the increased light that can be obtained.

Your committee would recommend that ventilators be used at least in every other stall, with a minimum dimension of 3 by 4, and not less than 2 ft. in height, and these to have the usual slats in the sides. In the northern country we recommend that a damper or drop-door be placed in the bottom of each ventilator so that they can be closed in winter time when necessary. In the southern districts of our country, it is not considered necessary to have these additional openings where they have the continuous ventilator at the highest point of the roof, which is used instead of smoke-jacks.

The length of pit should be 60 ft.; the depth of same to be governed by the type of power used on the line for which the roundhouse is being built. For example: If engines have large fireboxes, and the wheels are from 63 ins. and upward over all, we recommend that the pits be 2 ft. 6 ins. minimum depth, and 3 ft. maximum depth. If the wheels of the locomotive are low, and most of them deep fireboxes, we would recommend that the pits be 3 ft. minimum and 3 ft. 6 ins. maximum depth.

The floor of the pits under the engines should be formed to a convex surface, the center being about three inches higher than the sides, which allows workmen to work on a dry floor even if there should be some water trickling through the sides of the pit. The floor of the pit is best made of brick on edge on a concrete bed. If this is considered too expensive, it can be made of crushed stone and sand.

The drainage of the pit is a very important feature. Many modern houses have the engine pits extend to an annular pit, which is just inside of the main doors, this pit being made lower than the engine pits. This annular pit should be drained at some suitable point into the turntable pit or system of drainage. This pit should be deeper in the center than at the sides, and besides offers an opportunity, where this is desired, for stringing water and steam pipes. This pit should have loose

covers which can be removed when necessary to clean out the pit, but ordinarily form a close floor. The turntable pit should have a tile drainage to the main sewer. It should also be either paved with vitrified brick or cemented.

An up-to-date roundhouse floor should be of vitrified brick laid on edge in a bed of sand. The consensus of opinion is that the brick floor is the best, and your committee would recommend a concrete bottom and then a layer of sand in which to bed the vitrified brick. When brick is laid, the floor should be covered with a layer of sand or tar (tar preferable) to fill in the joints.

We also recommend that the water and blow-off pipes be placed in the annular pit, all other pipes to be placed overhead, with drop-pipes between every two pits, with suitable hose connections to connect with the locomotives. The blow-off pipe from the top of the dome to be connected with short pipes through the roof over each pit, connection with the engine to be made with flexible metallic joints.

The most modern method of heating at present seems to be by hot air and forced blast. In this connection the air can be taken from the roundhouse and warmed over and over again, thus reducing the cost of heating the air. While this air is generally carried in overhead ducts, your committee considers it should be investigated and determined in each case whether an underground duct would not be suitable. It is also suggested that air be taken from the boiler room, thus serving the double purpose of cooling this room and using the heat imparted to warm the roundhouse.

One arc light should be located over the center of the turntable, and not less than three 16-candle-power incandescent lamps should be placed between the pits; one about opposite the cylinders, another about opposite the cab, and the third about the center of the tank. There should also be located in convenient places in every other stall two connections for portable lamps for pit work and firebox work; all lamps to be covered with wire guards for protection.

Every roundhouse should be provided with a drop-pit for removing driving wheels, extending across two tracks; also one closer to the outer wall of the house for removing truck wheels. These pits should be so arranged that the wheels can be removed from an engine on one track, and run over to the adjacent track, and then lifted up to the floor. Jacks are preferably worked by power, air and water being the chief sources. The hydraulic power, however, has the advantage in that there is not the same elasticity and vibration that is noticeable when air is used.

When new tables are being put in, your committee would recommend that they be made at least seventy feet long and well braced. Experience shows that the long table with a load on it is more easily handled than the shorter table with the same load. This is no doubt due to the fact that you are better able to balance the engine, by having longer leverage. Your committee recommends electric power for operating turntables in preference to any other in use. If, however, there is no electrical power available, the gasoline engine can be used for this purpose very successfully. If the electric motor be used, a foot-brake is very desirable, as it will save trouble with the motor by the operator reversing the current in order to stop the table at the proper place. Such a brake will also allow the omission of the lock, as the table can be held securely by this means when the engine is moving on or off.

Your committee recommends as many wall benches supported by brackets as there are stalls, and in addition to these, several portable benches.

It is the opinion of your committee that every well-managed roundhouse should be provided with a tool-room for the care and maintenance of hand tools and supplies.

An annex should be provided to contain the necessary boiler, pumps and machine tools for making ordinary running repairs, as well as a room for supplies. We would recommend the following machinery, namely: One 30-in. engine lathe, one 12-in. engine lathe, one 30 by 30-in. planer, one 24-in. drill-press, one 20-in. shaper, one grindstone, one bolt-cutter, one screw or pneumatic press for rod bushings, one blacksmith forge and anvil, etc. Where size of the cylinder demands it, the large lathe should be increased to 36 ins.

We further recommend that the following portable tools be provided, namely: Portable crane, valve-facing machine, air motors, air drills and hammers, cylinder boring machine, valve setting apparatus, chain block and fall, hydraulic jacks, small air press, pinch bars, chains, tongs, wrenches, etc.

For handling ashes and cinders, we conclude that the cheapest arrangement, and one which is least liable to cause trouble by breaking down, is a depressed track between two tracks, the depressed track to be deep enough so that the ashes can be hoed from the cleaning floor directly into the ash cars, and the double ash tracks being merely for the purpose of having engines desiring quick treatment pass around those which may be a longer time on the pit. If, however, there is not sufficient track room for this arrangement, some mechanical device for taking care of the ashes will have to be resorted to, provided the traffic warrants the expense.

Considering the cost of fuel, labor and maintenance, your committee is of the opinion that the steam coil sand dryer is the most economical. On the question of furnishing sand to locomotives, the answers were almost unanimously in favor of elevated sand bins, the sand being elevated by compressed air or mechanical means, allowing the sand to flow into sand-boxes by gravity. In this your committee concurs.

For washing out locomotive boilers, your committee recommends that 100 lbs. pressure per square inch be used, and when

it is desirable to do this in the shortest possible time, hot water can be used advantageously.

It is the opinion of your committee that staybolts should be tested once a month. The hammer test is satisfactory when bolts are completely broken through. When only partially broken it does not tell the story. Where tell-tale holes are drilled, or hollow staybolts used, a careful inspection of the tell-tale hole for the presence of lime is considered most satisfactory. It is also desirable that a record should be kept of all such tests. In making the hammer test, about 40 or 50 lbs. of steam or air pressure should be used in boiler to separate the ends of the broken bolts.

Your committee is of the opinion that it is very necessary that a roundhouse foreman should have had practical experience as a machinist, and that if he could have some experience as either a locomotive fireman or an engineer, it would make him a better roundhouse foreman than he could be without such experience, as he would then know the conditions that exist on the road, and could therefore do more intelligent work.

A STANDARD LOCOMOTIVE CLASSIFICATION.

An Individual Paper.

By R. P. C. Sanderson.

The appearance during the past year of a number of letters and articles in the technical press, bringing forward different plans for locomotive classification, would indicate that there is need of a generally acceptable locomotive classification, and the matter presented herewith is advanced with the idea that perhaps the suggestion contained may, if not complete, at least lead to a generally acceptable plan for locomotive classification which could be adopted by the association as standard and be used by the locomotive builders as well as railroad officers in referring to locomotives, either for descriptive purposes or when referring to tonnage or speed performances.

The time-honored plan of giving class letters to the different styles of locomotives on any one railroad, the letters following one another in alphabetical order in accordance with the dates at which the different classes evolve themselves, is familiar to all of us, and while it is, to those who are brought up and educated on the particular road on which the classification is in force, as familiar as any household word, yet to an outsider the classification does not convey any information which would enable him to tell the design, power or anything else in connection with the engine. As the numbers of classes of engines have increased on larger systems, even this method of classifying engines has been found insufficient and efforts have been made to modify the same, adding figures to the letters to provide enough subdivisions to take care of different classes and styles of engines, as the alphabet was too short for the purpose.

On railway systems which have grown by aggregation, so that the classes of engines are very numerous and were not designed by any one controlling departmental head, the conditions are often perplexing. On one road that is before the writer's mind there were as many as twenty-three different classes of 8-wheel engines with cylinders 17 inches in diameter. Happily many of these have gone to that scrap pile from which no old engine ever returns. The various classes of engines, for lack of official designation, were known as "Creepers," "Klon-dikes," "Broncos," "Fan Tails," "Mud Hens," "Sea Cows," "Battle Ships," etc. As a fact, some of these names were more suggestive than the letter classification would have been, as they have originated in nicknames given the engines, on account of their failings or peculiarities, by the "sandhouse meetings."

In hunting for a suitable engine classification the different schemes brought forward in the technical journals were all considered, but found too complicated, or did not appeal to those interested, for lack of descriptiveness and general usefulness. Those based on the wheel arrangement did not convey enough information to the transportation officers, and others had to be used with a key for explanations.

For an engine classification to be generally useful it should fill, in the writer's estimation, the following requirements:

1. It should give an immediate mental picture of the style of engine.
2. It should give correct information as to the power of the engine.
3. It should designate, for the benefit of the Mechanical Department, foreman and others, the particular make of engine.

To comply with the first requirement it has seemed that the initial letter of the recognized names of the different types of engines would be the best class letter to use, thus:

E for 8-wheel engines.
T for 10-wheel engines.
V for 12-wheel engines.
C for consolidation engines.
M for mogul engines.
S for switch engines.
A for Atlantic type engines.
P for prairie type engines.

With reference to the second requirement: As to-day we are all largely interested in the tonnage haul, by divisions and so on, a figure representing the power of the engine, which would indicate to any transportation officer, whether Division Superintendent, General Superintendent, and so on, the hauling capacity of that engine over any of his grades, would be the most convenient indicator to use for the size and power of the engine.

It is suggested that for this purpose we could use the hauling capacity in tons at ten miles per hour on a straight, level track, figured under formula $H = \frac{T}{R} - W$, where "T" equals tractive

force in pounds, figured by the usual formula on a basis of eighty per cent. of boiler pressure as mean effective pressure; "R" representing 5.25 lbs., equal to the speed resistance per ton, and "W" the weight of the engine and tender in tons. This would figure out anywhere from say 2,400 tons to 7,500 or 8,000 tons, ranging from a 17-in. cylinder to a 22-in. cylinder.

As these figures will be too long for current use, and as minute refinement is unnecessary, it is believed that the first two figures, representing hundreds, would be sufficient, so that an engine classed as "T 37" would represent a 10-wheel engine of 3,700 tons hauling capacity on a straight, level track at ten miles an hour.

This would give the transportation officers all the information they would require with regard to any engine that would appear on their divisions. They would need in addition a rating sheet for each division showing—at the speeds at which the trains would have to be handled, and making allowance for all the difficulties of the division, water stops, grade slope, compensation for curvature, etc.—what the actual tonnage rating should be summer and winter for each tonnage class as given in these figures.

The mechanical department officers, however, will have to have further knowledge of the engine in that there might be several different patterns of engines of the same type and tonnage class. There might be, for instance, three or four styles of engines T 37. This can be very readily provided for by using a small letter affix to follow the tonnage rating, as "T 37 a," and "T 37 b," and so on, representing different builds and makes of engines of the same tonnage class and type.

With regard to switch engines, they are not usually figured on the basis of tonnage rating. As some further knowledge of the engines is desirable, it is therefore believed that the switch engines can be classified in the following manner, to convey a better impression of the style and class of engine:

- S 4, 4-wheel coupled switch engine, no truck.
- S 6, 6-wheel coupled switch engine, no truck.
- S 8, 8-wheel coupled switch engine, no truck.
- S T, 10-wheel switch engine.
- S C, consolidation switch engine.
- S M, mogul switch engine.

The small final letter following would ordinarily be sufficient information as to the style and build of the engine for full identification. For instance, "S 6 b."

There is one point left uncovered in this classification which the writer was not able to scheme out in the time allotted for the work and which to some may seem to be very necessary, namely, a distinction between high-wheel passenger engines and low-wheel freight engines of the same type. This would be indicated, of course, in the tonnage capacity, and the officers of any one road would soon become familiar with their engines and not need this special classification between passenger and freight. It is also rather a difficult matter to draw the line between passenger and freight on many roads, as on low-grade roads heavy passenger trains are hauled with the same sized driving wheel as fast freight trains. It might be that the use of the capital letter or a small letter would be inappropriate to designate a recognized passenger engine from a freight engine, or a different grouping of the figures on the badge could be arranged to indicate these, but this would only be clear to those seeing the emblem on the badge and could not well be conveyed by word of mouth without additional elaboration.

There is another point which will no doubt occur to some has not been properly covered, namely, that many engines of equal cylinder power may be short of heating surface and boiler capacity so that they cannot properly exert their full cylinder power. Such engines should be rated lower than other engines of equal cylinder capacity with full boiler capacity. This, of course, is a matter that can be best handled by having actual tonnage tests made of the engine, after the theoretical rating is established, and correcting the classification according to the results thus obtained.

The above, generally speaking, is the result of an effort made to apply some systematic classification to a very miscellaneous assortment of locomotives, but it has led to the thought that the idea could be developed further and applied to locomotive classification generally with advantage to all concerned.

ADVISABILITY OF THIS ASSOCIATION JOINING THE INTERNATIONAL ASSOCIATION FOR TESTING MATERIALS.

Committee—S. M. Vauclain, H. S. Hayward, T. W. Gentry.

The object of the International Association for Testing Materials is the development and unification of standard methods of tests, for the determination of those qualities of materials of construction and others which are of technological importance, and the perfection of apparatus used for that purpose.

At the instigation of John Baughlinger, director of the testing laboratory of the Technical School at Munich, formal conferences were held at Munich in 1882, Dresden in 1884, Berlin in

1886, Munich in 1888 and at Vienna in 1893, at which the above questions were discussed. The reports of these proceedings attracted wide attention, and, as a result, the International Association for Testing Materials was formally organized at a conference at Zurich, both the United States Government and the American Society of Mechanical Engineers being represented by delegates. In 1897, the second congress of the Association was held at Stockholm, at which eighteen countries were represented, the United States Government by an army and a navy officer, and the American Society of Mechanical Engineers was also represented.

The Association is working chiefly through committees, and to show the scope of the work the following is the list of subjects upon which the various committees are to render report at the next congress, in 1902:

- Problem 1.—To establish international rules and specifications for testing and inspecting iron and steel.
- Problem 2.—To establish methods of inspection and testing for determining the uniformity of individual shipments of iron and steel.
- Problem 3.—On the properties of soft steel (Flusseisen) at abnormally low temperatures.
- Problem 4.—Methods for testing welds and weldability.
- Problem 5.—Collection of data for establishing standard rules for piece tests, with special reference to axles, tires, springs, pipes, etc.
- Problem 6.—On the most practical methods for polishing and etching for the microscopic study of iron and steel.
- Problems 7 to 16.—Relate to natural and artificial building stones and their cements.
- Problem 17.—On methods for testing oil pipes.
- Problem 18.—On methods for testing the protective power of paints used on metallic structures.
- Problem 19.—On uniform methods for testing lubricants.
- Problem 20.—On the protection of wood against action of dry rot.
- Problem 21.—On the revision of the statutes.
- Problem 22.—Considering that the resolutions formed by the International Congresses of Munich, Dresden, Berlin, Vienna and Zurich for the purpose of obtaining unity in the methods of testing materials do not agree in many points with the decisions arrived at by the French commission, it is proposed that the managing committee appoint a commission which shall prepare a report upon these differences, and proposals for ways and means to abolish them.
- Problem 23.—On uniform methods for compression tests of wood.

It is also proposed to establish an international chemical laboratory at Zurich, and a committee was appointed to organize the same. The American members are Dr. Dudley, Chemist, Pennsylvania Railroad, and Professor Howe, Professor of Metallurgy, Columbia College.

The members of the council are appointed by the International Congress. The first American member was Capt. Oberlin M. Carter, the second was Mr. Gus C. Henning, and last October the present member, Prof. H. M. Howe was unanimously elected by letter ballot as the Member of the Council.

The membership of the American Section includes all of the large steel companies and representatives from the test departments of a number of railroads. The following technical associations are also members:

- American Foundrymen's Association; American Society of Mechanical Engineers; Franklin Institute; Technischer Verein.
- The most work has been accomplished by Committee No. 1, of which Mr. W. R. Webster is chairman. This committee has formulated a set of specifications for the following material:
- Bridge and Ship Material; Building Material; Rails; Boiler and Firebox Plate; Axles—driving and truck; Tires; Forgings; Steel Castings; Wire.

Specifications devoted exclusively to locomotive forgings, and for spring steel and boiler tubes will be in shape this spring.

We believe more good would result from the Master Mechanics' Association urging their specialists on testing of material to join the International Association individually or as representatives of the railroads than could be obtained by the Master Mechanics' Association joining as a body. It may also be advisable to recommend the appointment of a committee to co-operate with Committee No. 1 in the formulation of standard specifications applicable to material used in railroad work. The specifications recommended by this committee are to be discussed by the American Society of Mechanical Engineers, American Society of Civil Engineers, American Institute of Mining Engineers, the former having appointed a Committee on Tests and Method of Testing Material with which Committee No. 1 proposes to co-operate. The specifications will also be thoroughly discussed abroad and they no doubt will represent the best thought of engineers on this subject.

Your committee therefore recommends:

First: That this Association should not join the International Association until a more definite organization is effected. Second: That a committee of material experts, members of this Association, be appointed to consult with the International Council (American Section) if it desires our assistance. Third: That it would be far better for this Association to adopt the specifications agreed upon by the International Council, if a majority of our members would endorse the same, instead of becoming members of the International Council, thus leaving our Association free to depart from them at any time a majority vote would favor doing so.

(Concluded next month.)

MASTER CAR BUILDERS' ASSOCIATION.

Thirty-Fifth Annual Convention.

Abstracts of Reports.

TRIPLE VALVE TESTS.

Committee—G. W. Rhodes, A. W. Gibbs, W. S. Morris, J. O. Pattee, W. McIntosh.

During the year an air brake valve known as the "Hibbard" has been submitted to your committee for test purposes on the Association's rack at Purdue University, La Fayette, Ind. This valve is owned by Chicago interests. Fifty valves were delivered to the committee at the University, applied to the rack and made ready for test, those interested in the device having first been given an opportunity to thoroughly prove the device themselves, making such readjustments as seemed advisable. A description of the Hibbard air brake valve is as follows:

Fig. 1 shows the valve in section. The train pipe air entering the valve passes through the strainer and upward through the passage 27 in the end cap and into chambers 3 and 4 and feeds to the reservoir through the by-pass 5, the route being shown in dotted lines. The piston 8 has a single traverse and governs the release of the brake cylinder through passage 12 and by means of slide valve 9. The piston 13 has a stem 14 on whose inner end is the graduating valve 16 governing the passage 17 through the emergency valve 18. This passage communicates with the brake cylinder.

In service action both pistons move to the left, piston 8

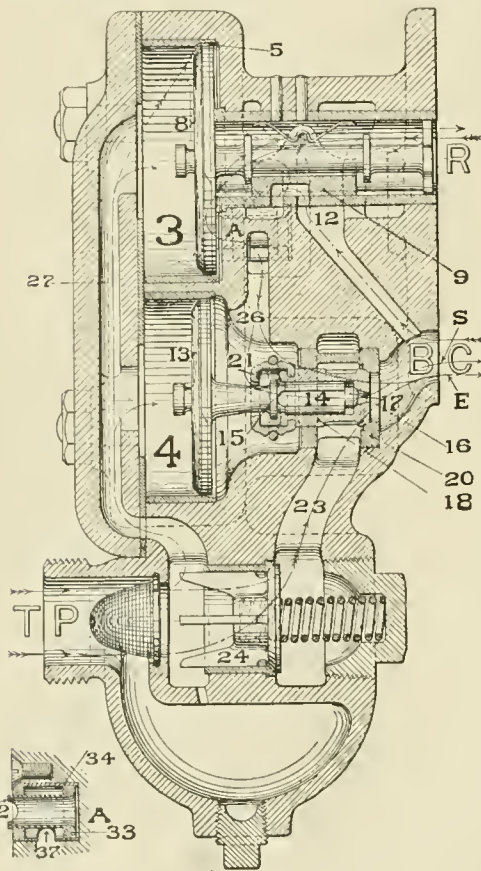

Fig. 1

making its full traverse, thereby closing the release port, and piston 13 lifting the service valve 16 from its seat and permitting the reservoir air to flow to the brake cylinder. The route of the air is shown by the line marked S. When the reservoir pressure is reduced slightly below the train pipe pressure, the piston 13 seats the service valve 16. In emergency action, pistons 8 and 13 both make full traverse. The annular ring 15 on stem 14 will abut the split collar 21, thereby closing the service route of the air, and will lift emergency valve 18 from its seat, venting the train pipe air through the strainer, past check valve 24, through passage 23, and thence direct to the brake cylinder. The route of the air is shown by line marked E. The reservoir air flows around the outside of the emergency valve 18, through bushing 20, meeting the train line air, and then enters the brake cylinder. A restoration of the train pipe pressure returns all the parts to their normal position and releases the brakes.

The part marked A is fixed in the passage 26 by means of the bushing 34, which has an opening 37 on its lower side. The tube 32 operates in the bushing and has an annular ring 33

on its inner end, the bushing and the tube making a partially air-tight closure of passage 26. The operation of these parts is as follows: When the piston 13 has opened the service valve 16, the pressure in the annular space in the bushing 34 around the tube 32 will be less than the reservoir pressure on the annular ring 33 on the tube 32, and will move the tube to the left until the ring 33 passes opening 37 in the bushing, thereby forming a direct communication from the chamber 3, on the inner side of the piston 8, to chamber 4, on the inner side of piston 13.

The function of the device A is as follows: Piston 8 and 13 being independent of each other in their movements, if the piston 8 should by any possibility stick and fail to move, and the piston 13 should move, the reservoir air would flow to the brake cylinder and to the atmosphere in case such device was not used. This device, however, prevents such action by holding the reservoir air in chamber 3 until piston 8 moves and closes the release passage. The tube 32 abuts piston 8 and cannot open the passage 26 until piston 8 has moved. This part A is not essential, as the piston 8, having a larger area than piston 13, will move first, but is used only as a matter of precaution in case piston 8 should by any possibility stick and fail to move.

Some of the claims set forth by those interested in the Hibbard valve are:

1. The slide valve having only one traverse wears the seat uniformly, thereby preventing the blow or leakage incident to the two-traverse valves when making their full traverse.
2. The area of the piston which moves the emergency valve is so proportioned to such valve that emergency action is produced only when the proper reduction is made, thereby obviating the trouble of getting too early emergency action which occurs in those valves that depend on a graduating spring.
3. The absence of springs.
4. The emergency valve, being a metallic valve, is not dissolved or affected by oil.
5. The strainer's apex is pointed against the current of air and arrests and deflects dirt, dust, etc., into a dirt chamber where the dirt is trapped out of the path of the air, and so remains until removed.
6. The simple removal of a single cap permits access to all the working parts for cleaning, oiling or overhauling.
7. The valve is from 7 to 13 lbs. lighter than those in common use.
8. Less temptation to brass thieves because the brass parts are fewer and lighter than those in general use.
9. Simplicity in construction and operation, rendering the valve comparatively inexpensive of manufacture and easily understood by operatives.

The committee offers no comments on these claims, the owners are likely to be partial to their own device, and each member of the Association can draw his own conclusions.

The Association's test plant was fully described and illustrated in the annual Proceedings of 1893. It will not be necessary to repeat the description, as there has been no material change in it. The plant was originally located at Altoona, Pa., at the shops of the Pennsylvania Railroad. During the summer of 1898 the apparatus was transferred to La Fayette, Ind., Purdue University becoming its custodian. In 1894 a series of tests with various triple valves then on the market were conducted at Altoona, the results appearing in the annual report of that year. The immediate effect of these tests was the framing of a code descriptive of what was considered essential performances in air brake valves for freight cars. This code was presented to the Association at its Alexandria Bay convention in 1895, and subsequently adopted as recommended practice.

A summary of the tests of the Hibbard valve is as follows:

- | | |
|--|---|
| Test No. 1.—To determine power of service brake..... | Meets requirements. |
| Test No. 2.—Development of power and measurement of time in emergency service..... | Meets requirements. |
| Test No. 3.—Jumping Test..... | Meets requirements as far as jumping is concerned, but fails in the time requirement on the 50th car. |
| Test No. 4.—(a) Graduating Test...
Test No. 4.—(b) Graduating Test..... | Meets requirement.
Meets requirement. |
| Test No. 5.—Disk Test—Service..... | Meets requirement. |
| Test No. 6.—Disk Test—Emergency..... | Failed in requirement. |
| Test No. 7.—Holding Test—Service..... | Meets requirement. |
| Test No. 8.—Release Test..... | Meets requirement. |
| Test No. 9.—Time Charging Reservoir..... | Failed in requirement. |
| Test No. 10.—Service followed by quick action..... | Meets requirements as far as quick action is concerned, but failed in the time requirement. |
| Test No. 11.—A Extra—Mixed Train Test of Application
No. 1..... | Results entirely satisfactory. |
| Test No. 11.—B Extra—Mixed Train Test of Application
No. 2..... | Results entirely satisfactory, including time requirement. |

Conclusions.

It will be observed that while, under a strict accounting, the Hibbard valve failed in four of the twelve tests it was subjected to, there was but one class of failure, excluding the

used in the construction of spring "A" for 60,000-lb. cars by removing two or all of the inner coils.

Springs A, B, F and G, as recommended, do not conform exactly to any springs now in service as far as known, but they are of such dimensions that they can be used in place of similar springs now in service. Of springs B, C and D there are about 200,000 in service, and from reports received they have met all requirements, and as they are correctly designed, there is no reason why failures should be anticipated.

It is believed that all of these springs will fully meet the requirements of a majority of the railroads, as well as of the manufacturers of springs, and while there may be certain constructions of trucks for which they will not be suitable, the number of such trucks is not large and they will gradually disappear.

DRAFT GEAR.

Committee—E. D. Bronner, C. M. Mendenhall, Mord Roberts, T. A. Lawes, G. F. Wilson.

The subject assigned to your committee was as follows: "Draft Gear: To report on the requirements of modern freight car draft gear to meet modern conditions; methods of attaching to sills or cars; spring capacity; sizes and strength of parts, excluding the coupler, and to submit recommendations covering principles."

Last year's committee on this subject reported the result of a circular of inquiry, so that the present committee deemed it the more advisable to proceed in a somewhat different manner. The plan of procedure has been to gather data and opinions by correspondence, supplementing this correspondence wherever possible by interviews with members and draft gear makers.

Owing to a number of unforeseen circumstances, the work of the committee was not begun as early as intended, with the result that all the work planned could not be carried out in time for a final report at this meeting. The work remaining relates chiefly to the testing of different draft gears and the submission of certain recommendations which can best be made after the tests are completed. It is proposed to make these draft gear tests this summer.

As regards draft gear for freight cars, the relative conditions now are very similar to what they were about ten years ago and prior to the adoptions of the present recommended practice of the Association for coupler attachments. These conditions were clearly set out in a paper by Mr. C. A. Schroyer before the Western Railway Club in November, 1890, and a paper by Mr. D. L. Barnes in May, 1891, before the New York Railroad Club. Then on account of increases in the size of trains the strength of the draft rigging was being exceeded. It is believed that the present M. C. B. rigging has served a good purpose, but the time has come when it must be strengthened to suit new conditions.

The draft gear failures which have been referred to in discussions during the past year seem to be chiefly breakages of the old riggings which were not designed for the work they are now called upon to do. So far as the committee has observed, several draft gears of recent design are showing good results in service. Of course, in considering any record of this kind it must be borne in mind that most of these gears are practically new and also that they are favored by the large number of old cars with weak draft rigging, which fails first and so relieves the rest of the draft gear in the train. This is mentioned here because there seems to be an impression that most of the draft gears now being applied are inadequate, which has certainly not been demonstrated up to this time.

The use of metal underframing, allowing the draft attachments to be placed between and fastened direct to the sills, is looked on as one of the most important steps which can be taken in car design favorable to the draft gear. Experience so far has shown that with metal underframes the front and back follower stops can best be lugs united in one casting with heavy connecting ribs. This gives a large area in contact with the sills and permits of the use of an ample number of rivets. In several cases where single follower lugs have been used, concentrating the strains on a small area of the sill, the webs of the sills have been badly distorted, and in other cases, where the sills have been reinforced, these single lugs have been sheared off. The committee has heard of no cases of failure of sills where both lugs were on a single casting.

Some anticipate trouble from the greater rigidity of the metal frames. To compensate in the metal underframe for the greater elasticity of wood to absorb shocks, one road proposes to place the flanges of the center sills facing each other and put long timbers in between the flanges, extending the full length of the car. To these timbers the draft attachments are then bolted. Another plan is to use a channel end sill filled with a wooden timber which carries the striking plate. Still another design has been used on small Chicago & Alton cars. In this the draft gear in buffing is reinforced by high capacity spring resistance through a range of about $\frac{1}{2}$ in. Another plan is to use spring buffers. The committee is of the opinion that the introduction of steel underframes will favor the draft rigging, eliminating the troubles from loose attachments due to the shrinkage of wood and the backing off of nuts.

What the committee considers an important principle is that with metal underframes, and wooden cars with low floors, the line of draft should be on the neutral axis of the center sills.

It is realized that it is not always possible to place the draft rigging on the neutral axis of the center sills with this construction, but this does not affect the correctness of the principle.

Where the lowering of the car floor is objectionable, the committee recommends that the draft timbers extend at least to the body bolster. There are, however, preferences for continuous draft timbers, and a design in metal, consisting of two unbroken steel channels running from end to end of the car in place of the draft timbers. This is a design of the Lake Shore & Michigan Southern Railway. Another construction recently used by the Chicago, Burlington & Quincy, puts the line of draft on a level with the bottom of the center sill; this avoids cutting away the end sill about the coupler.

There would seem to be no reason why there should not be uniformity in new car construction regarding the spacing of center sills. The present recommended practice of the association is an 8-in. sill spacing. This now seems inadequate, and on account of the general use of both twin and tandem spring arrangements it seems desirable to modify this and settle on two dimensions of sill spacing. The committee suggests 10 ins. and 14 ins. These dimensions are recommended because one or the other will take, conveniently, any of the draft riggings now being used, and will enable two lengths of follower plates to be used instead of a variety of lengths. The 10-in. center sill spacing is ample for underhung rigging of both the twin and tandem types, and the 14-in. spacing will take any rigging attached between the center sills. In metal construction this wider spacing is also required to enable the rivets at the bolsters to be machine driven. It is recommended that 10 ins. and 14 ins. be adopted as standard distances between center sills.

As showing recent practice in draft gear, drawings are presented in Appendix A (Most of these have been illustrated in our columns.—Editor) of various gears which are now on the market, or are being applied by railroads in accordance with their own designs. It will be seen that with one exception these gears are designed to pull the car from the head end, which seems to be the type of draft gear that is generally preferred, although this one gear is used extensively.

While there are two ways of receiving the pulling forces on the car, through attachments at the front end or through attachments at the rear, the principle of all draft gear as regards buffing forces is alike—i.e., the buffing strains are taken by the draft gear proper until the spring or other resistance is exhausted, when the remainder of the shock is transmitted direct to the car framing through the coupler horn or buffer blocks, if present. In the latest draft rigging, the friction gears, the capacity of the gears to absorb shocks has been increased to between 100,000 and 160,000 lbs., leaving a smaller proportion of shock to be transmitted at the coupler horn, this increased capacity being obtained with practically no recoil. It is readily conceded that the theory of the friction draft gear is correct, but few have had any experience with these gears, they have not been in service long enough to estimate their life or wearing qualities, or in any way determine whether the increased first cost and greater complication is warranted. At the present time the committee has no recommendations to make as between friction and spring gears.

Last year the draft gear committee disagreed as between the tandem and twin spring arrangements. The present committee considers that the arrangement of the springs is largely a matter of preference. Both have advantages and disadvantages. As the tandem arrangement is usually applied, the breaking of one spring does not cripple the rigging as with the twin arrangement; shorter followers can be used with the tandem; the pull is more central and it is easier fitted to old cars with the sills close together. The twin arrangement, on the other hand, permits of a shorter and lighter yoke. In some cases the long leverage of tandem yokes causes trouble by shearing off the rivets which join the yoke to the coupler. The rear spring of the tandem arrangement extends back so far from the end of the car that it cannot be inspected without going under the car, and it is doubtful if the rear spring and follower ever gets much attention from the inspectors. None of these objections are very serious, and the committee in its future recommendations will provide for the use of both twin and tandem spring arrangements. The committee is of the opinion that draft gear of the same capacity should be used on small cars as is used on cars of the largest capacity.

It is found that the M. C. B. draft gear spring, $6\frac{1}{4}$ ins. in diameter by 8 ins. high, is used generally in spring riggings; at least the dimensions are adhered to and should be retained.

AIR BRAKE HOSE SPECIFICATIONS.

Committee—Jas. Macbeth, H. F. Ball, R. N. Durborow.

It will be noted from the replies received from a number of the roads that a very large percentage of hose is removed on account of unfair usage, and while the committee was not furnished data to show at what point on the hose the failures occurred, we have had access to records which have been carefully kept for the past two or three years, which show that fully 80 per cent. of all hose renewed has failed through chafing or cutting of the inner tube at the end of the nipple or coupling. Very few roads throughout the country have any device in use or have made any provision to overcome this chafing action on the inner tube of the hose, and in view of the committee's findings in this respect, we would recommend that some suit-

able device be used to prevent the injury to the inner tube at the coupling and nipple.

The roads in using specifications are largely overcoming the troubles which they formerly experienced with air hose bursting in trains. That specifications are as necessary in the case of air brake hose as in any other important detail of car design goes without saying, if it is desired to maintain a uniformity in the grade of material purchased. The testing of hose to see that they comply with the specifications is not a difficult task, and it is urgently recommended that specifications be used by all roads in purchasing air-brake hose.

In view of the practical unanimity in essential details of the specifications presented to the committee in response to our circular of inquiry, we would recommend the following specifications for adoption as "recommended practice" of the Association. These specifications do not differ materially in general from those recommended in the able report presented by Mr. A. M. Waitt, at the convention in 1898.

Specifications for Air Brake Hose.

1. All air brake hose must be soft and pliable and not less than three ply nor more than four ply. These must be made of rubber and cotton fabric, each of the best of its kind made for the purpose; no rubber substitutes or short fiber cotton to be used.

2. Tube must be handmade, composed of three cauders of

6 The inside diameter of all 1 1/4-in. air brake hose must not be less than 1 1/4-ins. or more than 1 5/16 ins., except at the ends, which are to be enlarged 3-16 in. for a distance of 3/4 ins., the change from the smaller to the larger to be made tapering. The outside diameters must be kept within the following dimensions: The main part of hose 1 7/8 ins. to 2 ins. The enlarged ends 2 1/16 ins. to 2 3/16 ins. The hose must be finished smooth and regular in size throughout as stated above.

7. Each standard length of hose must be branded with the name of the manufacturer, year and month when made, and serial number, the initials of the railway company, and also have a table of raised letters at least 3/16 in. high to show the date of application and removal. Each lot of 200 or less hose must bear the manufacturer's serial number, commencing at 1 on the first of the year and continuing consecutively until the end of the year. For each lot of 200 or less extra hose must be furnished free of cost for test. All markings to be full and distinct and made on a thin layer of white or red rubber, vulcanized, and so applied as to be removed either by cutting with a knife or sharp instrument.

8. Test hose will be subjected to the following test: Test hose must stand for 10 minutes a pressure of 500 lbs. before bursting. Each hose must stand a shop test of 200 lbs. A section of 1 in. long will be taken from any part of the hose and the friction determined by the force and the time required to un-

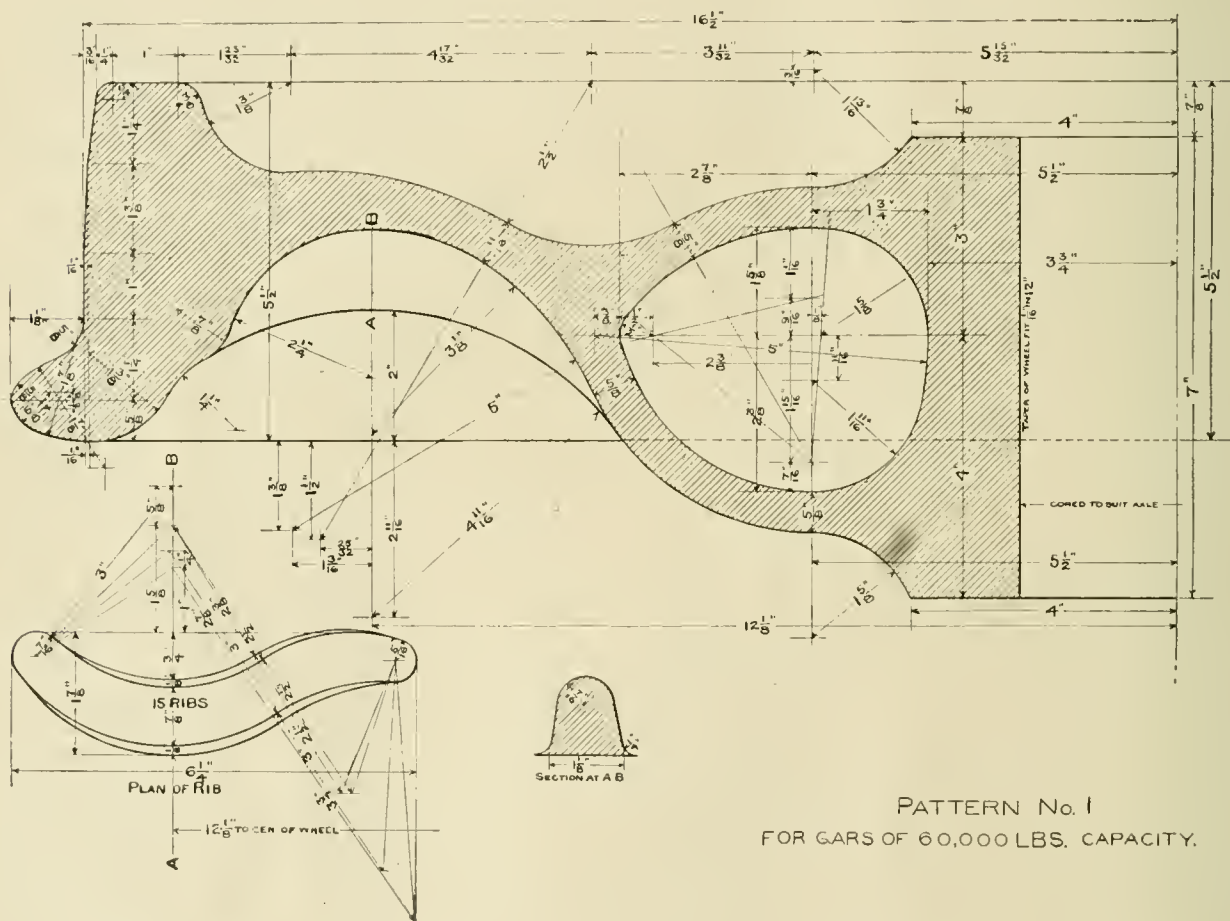

1 3/32 in. rubber. It must be free from holes and imperfections in general and must be so firmly united to the cotton fabric that it can not be separated without breaking or splitting in two. The tube must be a high quality of rubber and must be such composition as to successfully meet the requirements of the stretching test given below; the tube to be not less than 3/32 in. thick at any point.

3. The canvas or woven fabric used as wrapping for the hose to be made of long fiber cotton loosely woven, and to weigh not less than 22 oz. per yard, and to be from 38 in. to 40 in. wide. The wrapping must be frictioned on both sides and must have in addition a distinct coating or layer of gum between each ply of wrapping. The canvas wrapping to be applied on the bias.

4. The cover must be of the same quality of gum as the tube and must not be less than 1/16 in. to 1/8 in.

5. Air brake hose to be furnished in 22-in. lengths. Variations exceeding 1/4 in. in length will not be permitted. Hose must be capped on ends with not less than 1/16 in. or more than 1/8 in. rubber caps. Caps must be vulcanized on, not pasted or cemented.

wind the hose, the force to be applied at right angles to line of separation with a weight of 25 lbs. suspended from the separated end; the separation must be uniform and regular when unwinding; the average speed must not exceed 6 ins. in 10 minutes. A 1-in. section of the rubber tube or inner lining will be placed on it and stretched until the marks are 10 ins. apart, then released immediately. The piece will then be re-marked as at first and stretched 10 ins., or 400 per cent., and will remain stretched 10 minutes; it will then be released and the distance measured between the marks 10 minutes after the release. In no case must test piece show defective rubber or show a permanent set of more than 1/4-in. between the 2-in. marks. Small strips taken from the cover or friction will be taken for the same test.

9. If the test hose fails to meet the required test, the lot from which they are taken may be rejected without further examination. If the hose are satisfactory the entire lot will be examined and those complying with the test will be accepted. All rejected hose will be returned to manufacturers, they paying freight charges both ways.

CAST-IRON WHEELS.

Committee—J. N. Barr, Wm. Garstang, J. J. Hennessey, D. F. Crawford, Wm. Appa.

Your committee appointed to investigate and report on the question of locating the inner face of cast-iron wheels to the gauge point, and the thickness of metal between the bore and ring core, and to recommend minimum weights for wheels for use under 60,000, 80,000 and 100,000 pound capacity cars, begs to report as follows:

First, As to locating the inner face of hub of cast-iron wheels to the gauge point. If the outside face of the hub next to the box projects $3\frac{3}{16}$ ins. beyond the gauge point, it will allow a clearance between the face of hub and box of one inch in the normal position. The lost motion between the journal, the brass, the wedge and the box is about $\frac{3}{8}$ in. The dimensions given above will afford a clearance of at least $\frac{1}{4}$ in. between the hub and the box, when all the lost motion between the journal, the wedge, the brass and the box is fully taken up. It is the opinion of the committee that this amount of clearance

in the case, so far as this committee has information, are that wheels measuring 1 in. to $1\frac{1}{16}$ ins. between the ring core and bore, when the core is finished, have given satisfaction, and so far as the knowledge of the committee extends, it does not know of any case of failure of wheels at this point.

Third, As to the minimum weight of wheels for use under cars of 60,000, 80,000 and 100,000 lbs. capacity, it is the impression of the committee that this is intended to refer to wheels used for repairs of cars in interchange. On this basis the committee would recommend that the minimum weight of wheels used for this purpose should be as follows.

For 60,000 pounds capacity cars.....	570 pounds
For 80,000 pounds capacity cars.....	590 "
For 100,000 pounds capacity cars.....	620 "

These recommendations apply only to wheels used for the purpose of repairing foreign cars, and as to minimum weight which should be allowed. At the same time, as a matter of experience, it is the opinion that wheels of fair quality and of the weights given will afford satisfactory results.

It is also recommended that commencing September 1, 1901, wheelmakers should be required to have the nominal weight

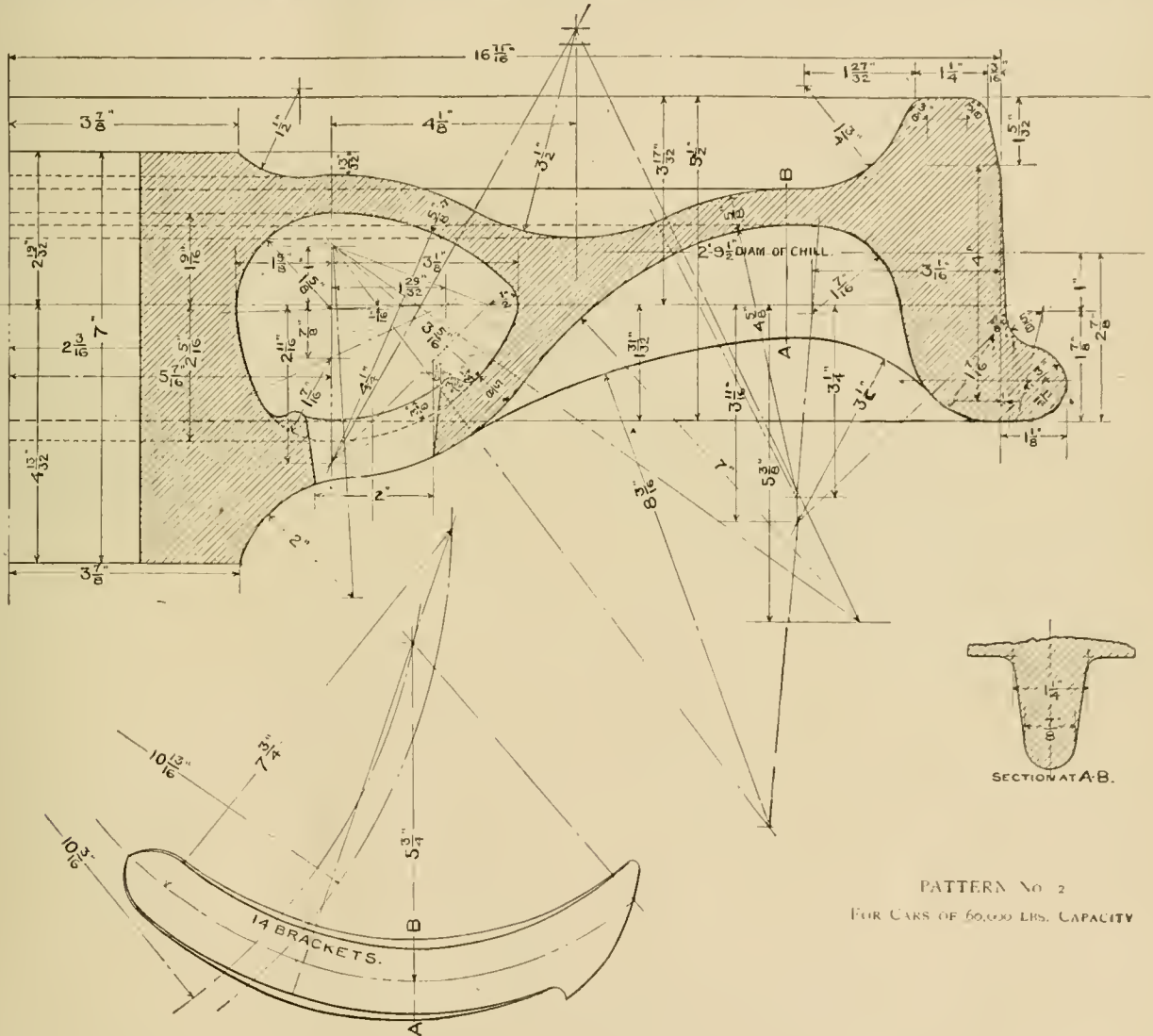

is sufficient and that no good will be obtained by increasing or decreasing this amount of clearance. So far as the templet for determining these dimensions is concerned, the committee is of the opinion that it is not practical to make the templet to locate the hub with reference to the gauge point, but that the practical method will be to lay a straight edge across the outside of rim, measuring in $15\frac{1}{16}$ in., which will give the proper location of the face of the hub. It, of course, should be determined that the pattern is so made that the wheel is $5\frac{1}{2}$ ins. over all between the inside of flange and outside of rim, before the measurements referred to above are taken. This applies to 60,000, 80,000 and 100,000 lbs. capacity cars.

Second, As to the thickness of metal between the bore and ring core. It is the opinion of the committee, based on actual experience, that any thickness greater than 1 in. is sufficient, and the committee would recommend that a thickness of $1\frac{1}{4}$ ins. between the bore and ring core after the wheel is bored, should be made standard for all sizes of wheels. The facts in

cast on them, and your committee recommends the following weights:

For 60,000 pounds capacity cars.....	575 pounds
For 80,000 pounds capacity cars.....	600 "
For 100,000 pounds capacity cars.....	625 "

The committee would also call attention to the fact that in a number of cases wheel patterns have been increased in weight by plastering on material at points which do not serve to increase the strength of the wheel, but merely to attain in the cheapest way the object of furnishing wheels of a given weight. It is extremely important, in going to a heavier wheel, to have the material so distributed that an actual increase in the strength of the wheel shall be obtained thereby.

In order to throw some light on this subject, the committee attaches to its report four drawings showing two patterns of the 60,000 lbs. capacity wheel, and two patterns of the 100,000 lbs. capacity wheel, which have been in extensive use, and which have given satisfactory results. The patterns Nos. 1 and

ferent widths can be stacked separately, uniform widths being used on different cars.

It was suggested from several quarters that the ship-lap should be so arranged that the upper part would be 1 in. thick and the lower part $\frac{3}{4}$ in. thick, so as to give greater wearing life to the floor. Your committee, however, felt that it was better not to do this, because it is desired to have the best surface up, and by making the ship-lap centrally, the best side can always be turned up, and thus make a better looking and better wearing floor, and it is assumed that when the floor is nearly worn down to the ship-lap, the flooring will have to be renewed, as it is then too thin for service in modern, heavy cars.

Siding, Roofing and Lining.

Your committee thinks it best to recommend that the same section of material be used for siding, roofing and lining, and that the tongue and groove be placed centrally, so that either side of the material can be used as a face side. The purpose of this is that both at the commercial and railroad mills all the material of this character can be run through the planers and matchers without changing knives. Then it can be assorted according to quality, the best of it being used for sid-

ing and it is believed to be wise at the present time to concede this point and agree to accept lumber for siding, roofing and lining made from the rough of the two widths, namely, 4-in. and 6-in.

(Concluded next month.)

EXHIBITORS AT THE SARATOGA CONVENTION.

The following is a list of the principal exhibitors at the recent conventions of the M. M. and M. C. B. Associations:
 American Brake Shoe Company, Chicago.
 American Locomotive Sander Company, Philadelphia, Pa.
 American Steel Foundry Company, St. Louis, Mo.
 American Watchman's Time Detector Company, The, New York, N. Y.
 Atlantic Brass Company, New York, N. Y.
 Auto Coupler and Supply Company, Cincinnati, O.
 Ball, Webb C., Company, The, Cleveland, Ohio. Watches specially adapted to the use of railroad service.
 Baltimore Ball Bearing Company, Baltimore, Md. Norwood ball side bearing, balls made from hardened steel.

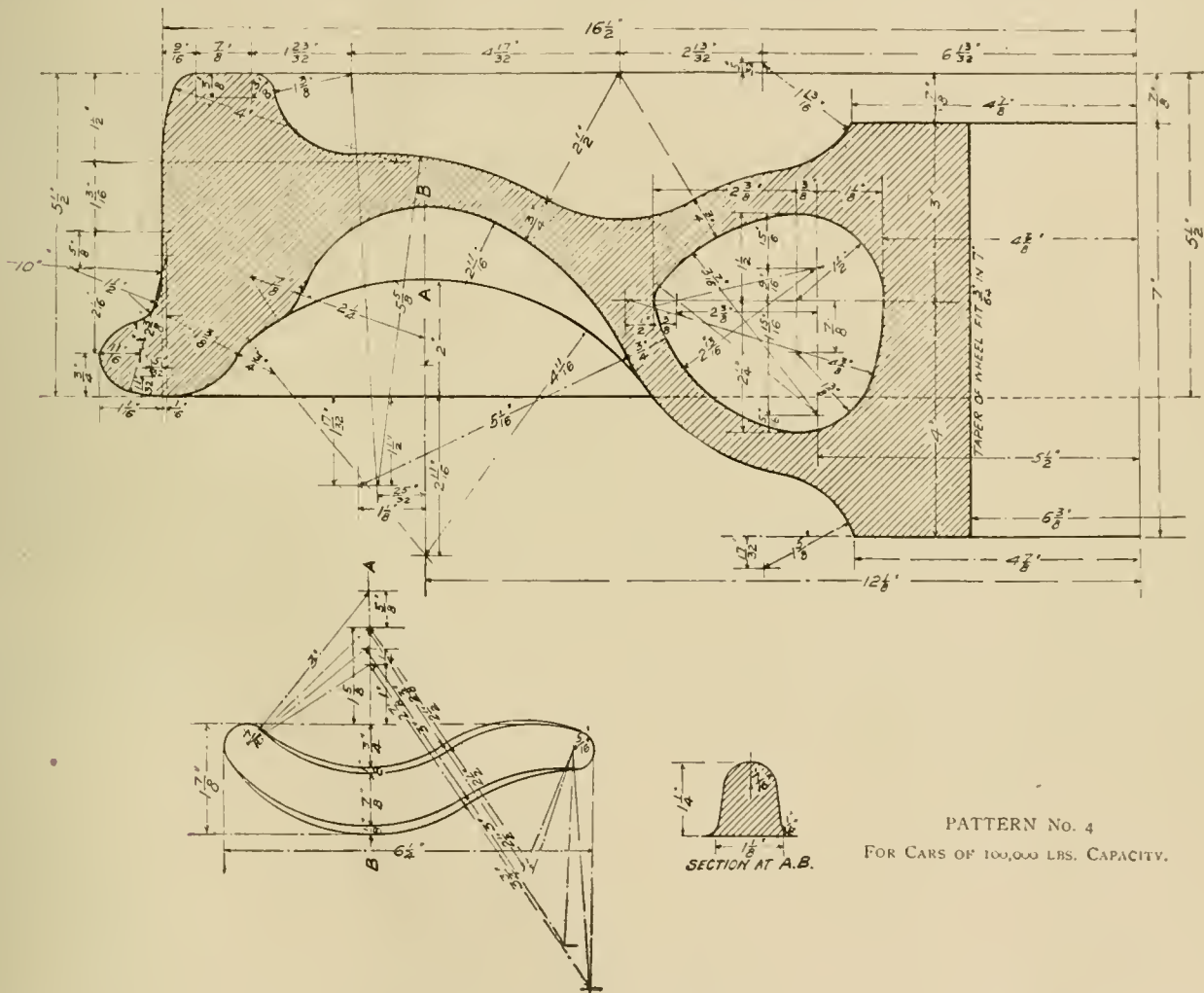

ing, the less perfect for roofing, and the poorest quality for lining. By making the tongue and groove centrally we think the roofing and lining lumber can be used with the flat surface out, while for the siding it can be used with the beveled edges out. There is no waste of labor in doing this, because cutting the bevel edges requires a second pass through the machine and does not cost anything additional. This siding, roofing, and lining is intended to be made from regular commercial 1-in. sawed stuff, and to be dressed from 6-in. and 4-in. widths to match up $5\frac{1}{4}$ -in. and $3\frac{3}{4}$ -in. By accepting material of the two widths and stacking them separately, this lumber can be obtained at a cheaper price and obtained more quickly. We find that it is the practice of many car builders to do this, using material of one width only in one car, while the roofing and lining the lumber used does not make any material difference. It is true that more nails will be required with the narrower widths, and there will be some more loss with the narrower widths on account of the additional number of joints per car, but the mill men are prepared to furnish the material already matched for less money per thousand feet. The mill men claim that it is becoming very difficult to get large quantities of lumber of the right specifications in the greater widths

Bettendorf Axle Company, Chicago, Ill. Bettendorf truck and body bolsters for 30 and 40 tons cars and structural steel underframe, press steel center still, structural steel car on the D. & H. tracks.

F. W. Bird & Son, East Walpole, Mass. Torsion proof car roofing.

R. Bliss Manufacturing Company, Pawtucket, R. I. Wood's patent safety gate.

Bordo Valve Company, Coatesville, Pa. The Bordo locomotive blow-off valve and swing joint.

The Boston Belting Company. Samples of air brake, steam and water hose.

Brill Company, J. G., Philadelphia, Pa. Car trucks.

Buckeye Malleable Iron & Coupler Company, Columbus, O. The Major automatic coupler and Buckeye draft gear attachment to be used when the link slot and pin hole is abandoned.

Butler Draw-bar Attachment Company, Cleveland, O. Various types of tandem draft attachments.

Carborundum Company, Niagara Falls, N. Y. A full line of carborundum goods, such as carborundum wheels, paper, cloth, carborundum grains and other specialties.

Chicago Pneumatic Tool Company, Chicago, Ill. Exhibiting

Chicago reversible drills in five different sizes. Boyer drill, two sizes; Chicago rotary drill, four sizes; flue cutters, flue welders, Chicago piston breast drills, Chicago rotary breast drills, Boyer long stroke riveting hammer, Boyer chipping and calking hammer, Chicago painting machine, Chicago oil rivet forges, Boyer yoke riveters, Chicago staybolt chuck, Ford dolly bars, pneumatic holder-on, Duntley drills, electric headlights and motors.

Chicago Railway Equipment Company, Chicago, Ill. National Hollow, Kewanee, Diamond and Central brake beams, Automatic Frictionless Side Bearings, and a specially adapted brake beam for high speed brake service.

Cleveland City Forge & Iron Company, Cleveland, Ohio. Turn-buckles and drawbar pockets.

Columbus Pneumatic Tool Company, Columbus, O. U. and W. piston air drills and Columbus flue cutters.

Consolidated Car Heating Company, Albany, N. Y. Steam heating apparatus under steam, steam couplers, steam traps, etc., and electrical heating apparatus.

Consolidated Railway Electric Lighting & Equipment Company, New York, N. Y. Electric lighting generating apparatus, the Lindstrom lever brake for railway cars, a combination baggage and smoking car electrically equipped and lighted, and a refrigerating car.

Crane Company, The, Chicago, Ill. The new Crane locomotive muffler pop safety valve, gun metal globe and angle valves and blow-off valves for high steam pressure.

Crosby Steam Gauge & Valve Company, Boston, Mass. Locomotive gauges, pop safety and other valves.

Dayton Malleable Iron Company, Dayton, O. Dayton draft gear, Dayton patent car door fastener, lubricating center plate, brake levers and brake wheels.

Detroit Lubricator Company, Detroit, Mich. Detroit lubricators, style 3-C, automatic steam chest plugs as shown on souvenir.

Economy Car Heating Company, Portland, Me.

Economy Railway Equipment Company, New York, N. Y. Exhibiting the Economy flush car door and the Economy exhaust nozzle.

Edwards Company, The O. M., Syracuse, N. Y. Window models showing three designs of windows comprising recent improvements, four models of extension platform trap doors for wide vestibules and open platforms for railway coaches.

Franklin Manufacturing Company, Franklin, Pa. Monarch sectional train pipe coverings and asbestos products.

Garry Iron & Steel Company, Cleveland, O. Revolving pneumatic crane.

General Electric Company, Schenectady, N. Y. Seven H. P. variable speed motor direct-connected to boring mill, illustrating method of operating machine tools by direct-connected variable speed motors.

Gould Car Coupler Company, 25 West 33d street, New York, N. Y. Showing passenger and freight slack adjusters, improved M. C. B. journal boxes, improved malleable draft rigging for freight equipment with spring buffer blocks; improved M. C. B. coupler for 100,000-lb. car and improved locomotive tender coupler for heavy equipment.

Hammett, H. G., Troy, N. Y. Richardson and Allen-Richardson balanced slide valves, oil cups, "Sansom" bell ringer, link grinders, etc.

Handy Car Equipment Company, Chicago, Ill. Full size Snow locomotive and car replacers. Also a sample Handy car.

Harrison Dust Guard Company, Toledo, O. Exhibiting the Harrison dust guard in the four following sizes: 40,000, 60,000, 80,000, 100,000 lbs. capacity, Tunks uncoupling lever.

Homestead Valve Manufacturing Company, Pittsburg, Pa. Locomotive blow-off valves.

Jackson, James W., New York, N. Y. The Nixon safety staybolt sleeve.

Keasbey & Mattison Company, Ambler, Pa. Magnesia locomotive lagging and asbestos materials, including valve and piston packings of various kinds.

Klein, August, Utica, N. Y. Replacer of derailed cars and locomotives for steam or street railroads.

Laidlaw-Dunn-Gordon Company. Models and photographs of air compressors.

Lappin Brake Shoe Company, Bloomfield N. J. Lappin brake shoes with and without steel backs, Congdon brake shoes with various types of inserts with the standard Lappin back and with the Lappin bridge back and interlocking brake shoes.

Locomotive Appliance Company, Chicago, Ill. The Allfree valve gear, Allfree cut-off adjuster, Plano convex valves and Davis system of counterbalancing locomotive driving wheels.

Lunkenheimer Company, Cincinnati, Ohio. Injectors, globe valve and swing check valves, rod caps and locomotive fittings.

Mason Regulator Company, Boston, Mass. Steam specialties and Mason locomotive reducing valves.

McCord & Co., Chicago and New York. McCord journal box, McCord spring dampener, Johnson hopper door, McKim gasket and seamless copper ferrules, Torrey anti-friction metal.

Manning, Maxwell & Moore, New York, N. Y.—Ashcroft steam pressure and vacuum gauges, air brake gauges, Consolidated pop safety valves, both incased and muffled, water relief valves, Metropolitan locomotive and stationary injectors, H-D ejectors, hose strainers and check valves, Hancock locomotive, composite and stationary inspirators, boiler washers, ejectors, main steam valves, main check valves, double check valves, hose strainers and hose couplings made in various forms.

Metal Dust Guard Company, Baltimore, Md. Metal, flax and hair felt dust guards.

Metal-plated Car and Lumber Company, New York, N. Y. Section of a metal-plated car, sheet copper.

Michigan Lubricator Company, Detroit, Mich. Michigan improved triple lubricator No. 3 and automatic steam chest plugs, also air pump cup.

Monarch Brake Beam Company, Ltd., Detroit, Mich. Monarch and Solid brake beams, and new interlocking fulcrum for the solid beam.

Moran Flexible Steam Joint Company, Louisville, Ky. Large joints and all-metal steam-heat couplings.

National Lock Washer Company, Newark, N. J. Car windows, equipped with National sash lock and balance.

National Car Coupler Company, Chicago, Ill. Freight coupler, tandem draft rigging with spring steel followers, steel platform and continuous platform buffer.

National Malleable Castings Company, Cleveland, Ohio. Tower coupler.

National Railway Specialty Company. The "N. R. S." hose clamp, the National adjustable journal bearing.

New York & Franklin Air Compressor Company, New York. A straight line steam-driven air compressor.

Norton, A. O., Boston, Mass. Ball bearing lifting jacks, journal, bridge and track jacks.

Norton Emery Wheel Company, Worcester, Mass. Piston-rod and crank-pin, ground from rough turning of lathe.

Pearson Jack Company, Boston, Mass. Pearson car replacing jacks, King bolt clamp, ratchet pulling jacks, ratchet journal jack, Goodwin brake beam clamps, U. S. car pusher.

Powers Regulator Company, Chicago, Ill. Automatic temperature regulator for railway passenger cars.

Railway Appliances Company exhibit Sargent coupling for handling cars around curves, the Gilman-Brown emergency knuckle, the O'Brien emergency knuckle, the diamond "D" knuckle of extra hardness and durability, Economic metallic packing, the Best car and engine replacer.

Railway Fuel Economy Company, New York, N. Y. The Eates fire door.

Railroad Supply Company, Chicago, Ill. Hien coupler, Hien friction gear, Avery acetylene car lighting system, pressed steel box lids.

Ramapo Foundry Company, Mahwah, N. J. Licensees for the American brake shoe.

Rand Drill Company, New York. Imperial types Nos. 10 and 11 Rand compressors.

Roller Bearing and Equipment Company, Keene, N. H. Samples of roller bearings for cars, Downing car wheel clamp for removing brasses.

St. Louis Car Company, St. Louis, Mo. Spiral journal bearings.

Safety Car Heating and Lighting Company, New York, N. Y. Exhibiting car lighting and heating apparatus. The new features are fancy deck lamps, bracket lamps, gas ranges for private cars and buoy lantern.

Sargent Company, Chicago, Ill. Steel castings of Tropenas metal, consisting of wrenches, hammers, coal picks and oil cups.

Seamless Steel Tube Company, Detroit, Mich. Seamless steel boiler tubes.

Sellers, Wm., & Co., Philadelphia, Pa. Shelby Steel Tube Company, Cleveland, O. Cold drawn seamless steel boiler tubes.

Shickle, Harrison & Howard Iron Company, St. Louis, Mo. Model of standard S. H. & H. truck and body bolster, Player truck and body bolster, Ajax truck, Leeds pilot coupler, Davis patented counterbalanced driving wheel center, also photographs of their new steel plant.

Simplex Railway Appliance Company, Chicago. Simplex bolsters for 80,000-lb. capacity cars, also for 60,000-lb. cars. Susemihl frictionless roller side bearing.

Standard Acetylene Lighting Company, Springfield, Mass. Exhibiting car "Roland."

Standard Car Truck Company, Chicago, Ill. Models of Barber trucks for steam and electric cars, models of freight car truck with center plate designed to keep out dust and cinders.

Standard Coupler Company, New York. Standard steel platforms, Session's standard friction draft gear, Standard couplers.

Standard Pneumatic Tool Company, Chicago, Ill. "Little Giant" pneumatic long stroke riveting hammer, pneumatic chipping, calking, beading hammer, piston air drills, reversible fine rolling, reaming and tapping machines, reversible boring machines, hand yoke riveter, staybolt nipper, pneumatic blow-off cock, pneumatic bell ringers, air hoists, steam pipe grinders, right angle attachment, pneumatic holder-on, pneumatic wood chiseling tool.

Star Brass Manufacturing Company, Boston, Mass. Air and steam gauges, chime whistles, pop valves, recording gauges, complete line of fittings for locomotives and steamships.

Symington, T. H., & Co., Baltimore, Md. Journal boxes and dust guards.

Thornburgh Coupler Attachment Company, Detroit, Mich. Coupler attachments for all classes of equipment, either with single, double or triple springs, with or without metal draft arms.

Western Railway Equipment Company, St. Louis. Combination lug and follower casing, Economy slack adjuster, tandem combination lug and follower, sill and carline pocket, bell ringer, Western flush door, interchangeable door, safety and security truck and casting, the Mudd sander, the Lindstrom non-freezing suction pipe, St. Louis flush door, Acme pipe clamps, Downing card holder, Acme tender pocket, lugless draft beams, side bearings.

Williams Safety Car Window Company, St. Johnsville, N. Y. Two models of car windows and two sectional models of window showing inside mechanism.

AMERICAN ENGINEER AND RAILROAD JOURNAL.

AUGUST, 1901.

CONTENTS.

ARTICLES ILLUSTRATED:	Page	Page
Valve Motion of Recent Passenger Locomotives	239	Physical Treatment of Steel for Rails..... 247
Inspection Locomotive, C. B. & O. R. R.	241	Fuel Oil in Texas and California. 248
Spliced Sills in Long Passenger Cars	242	Long Runs With Liquid Fuel... 249
New Locomotive Water Service.	245	Iceing Stations for Refrigerator Cars..... 250
New Steel Frame Truck..... 250		American Locomotives in England..... 251
Malleable Iron Oil Cup..... 251		Edison's New Storage Battery..... 255
Westinghouse Electric Brake and Heater..... 254		Mechanical Stokers vs. Hand Firing..... 255
Fuel Valve of Sawdust..... 257		Rules for Inspection of Safety Appliances..... 256
Heavy Vertical Boring Machine..... 257		Brake shoes by the American Brake Shoe Co..... 257
Tropenas Steel Oil Cups..... 258		Norwood System of Ball Bearings and Center Plates..... 258
"Perfect" Leather Fillet..... 258		Exhibit of the American Blower Co. at the Pan-American Exposition .. 259
Improved Lever-Throttle Valves..... 259		Master Mechanics' and Master Car Builders' Association Reports..... 262
Master Mechanics' and Master Car Builders' Association Reports..... 262		
ARTICLES NOT ILLUSTRATED:		EDITORIALS:
Powdered Fuel and Smoke Consumers in Germany..... 240		Steel Underframes for Wooden Cars..... 252
New Situation as to Fuel Oil..... 243		Loading of Large Capacity Cars..... 252
Interstate Commerce Commission Report..... 244		Inspection of Freight and Passenger Trains..... 252
Tonnage Rating of Locomotives..... 245		Establishing Locomotive Ratings..... 252
Position of Air-Brake Inspector..... 245		
Making Erasures on Drawings..... 246		

VALVE MOTION OF RECENT PASSENGER LOCOMOTIVES.

Remarkable Uniformity of Cut-Off.

In describing the new "Central Atlantic" type passenger engines of the New York Central on page 39 of our February number, a table of the valve-setting measurements was presented as taken from one of the engines before it left the Schenectady Locomotive Works. Because of the remarkable uniformity of the cut-off measurements, which are very nearly perfect, the subject was investigated and by permission of the builders of the engines and also of Mr. A. M. Waitt, Superintendent of Motive Power of the road, a diagram of the detail measurements of the valve motion are now presented. These

to a cut-off of 6 ins. If equal at 6 ins. it will usually be unequal at full stroke and perhaps be equal at 8 ins. The cut-off at full stroke in this case is longer than many have been able to obtain with a valve motion having 9-32 in. lead and 11-32 in. port opening at 6 ins. cut-off. In order to get this lead and port opening it has usually been considered necessary to provide 1 1/4 ins. lap and with this amount of lead the port opening and cut-off at full stroke has been decreased. For convenience the table of valve measurements is reproduced as follows:

Valve Motion Characteristics, "Central Atlantic" Type Locomotive, N. Y. C. & H. R. R. R.

No. of Notches.	Lead.		Valve opens.		Cut off.	
	Front stroke. Inches.	Back stroke. Inches.	Front stroke. Inches.	Back stroke. Inches.	Front stroke. Inches.	Back stroke. Inches.
Left	0	0	2	2	23	23 1/8
Right	0	0	2	2	23 1/8	23 3/4
1	1/8	1/8	1 1/4	1 1/4	21	21 1/2
2	3/8	3/8	1 1/2	1 1/2	19	19
3	1/2	1/2	1 3/4	1 3/4	17	17
4	5/8	5/8	2	2	15	15
5	3/4	3/4	2 1/4	2 1/4	13	13
Left	1/4 S	1/4 S	3 1/2	3 1/2	13	13
Right	1/4 F	1/4 F	7/8	7/8	11	11
6	5/8 S	5/8 S	1 1/2	1 1/2	9	9
7	3/4 S	3/4 S	1 1/2	1 1/2	6	6 1/8
8	7/8 S	7/8 S	1 1/2	1 1/2		

The following dimensions may also be convenient here:

Cylinders.....	21 by 26 ins.
Eccentric throw.....	5 3/4 ins.
Valve travel.....	6 ins.
Center of cylinder above center of axle.....	2 ins.
Saddle pin offset.....	1 in.
Steam lap.....	1 in.
Exhaust clearance.....	1/8 in.
Length of main rod.....	10 ft. 6 1/2 ins.
Admission.....	Internal
Width of port.....	1 5/8 in.
Motion hangers.....	Vertical
Radius of link.....	60 ins.

In looking up the history of this valve motion we find that it originated with Mr. G. R. Henderson, while Mechanical Engineer of the Norfolk & Western Railway. It was applied by him, very successfully, to a locomotive on that road and

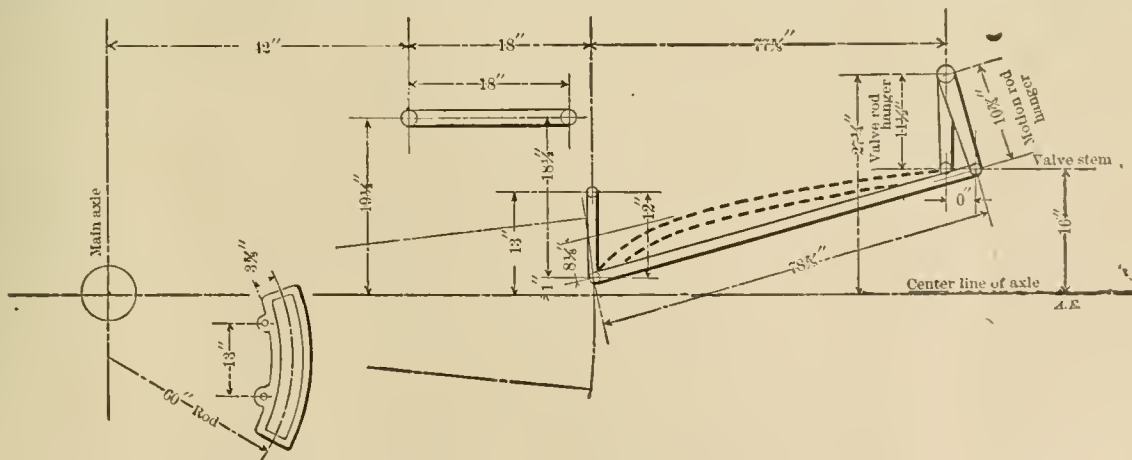

Diagram of Valve Motion—"Central Atlantic" Type Locomotive, New York Central & Hudson River Railroad. (Not to scale.)

dimensions are believed to be sufficient to enable anyone to set up the valve motion on a model for the purpose of investigating the subject for himself.

It is well known to be difficult to obtain such results as these and to get approximately equal valve opening, front and back, at full stroke or up to 15 or 16 ins. cut-off. As a rule the cut-off will not be as uniform as this table shows from full stroke

was developed into the design of the "Northwestern" type locomotives built at Schenectady last year for the Chicago & Northwestern Railway and illustrated in our August number of last year, page 237. Mr. Henderson, until very recently Assistant Superintendent of Motive Power of the Chicago & Northwestern, reports that the valve motion of these engines is very satisfactory, which is substantiated by the following tables of

measurements, also taken before the engine left the works of the builders:

Valve Motion Characteristics, "Northwestern" Type Locomotive, Chicago & Northwestern Railway.

Lead, Inches.		Valve Opening, Inches.		Cut-off, Inches.	
Front.	Back.	Front.	Back.	Front.	Back.
0	0	1 $\frac{3}{4}$	1 $\frac{3}{4}$	21 $\frac{5}{8}$	21 $\frac{5}{8}$
$\frac{1}{8}$	$\frac{1}{8}$	1 $\frac{1}{2}$	1 $\frac{1}{2}$	21	21 $\frac{5}{8}$
$\frac{3}{8}$	$\frac{3}{8}$	1 $\frac{1}{8}$	1 $\frac{5}{8}$	19	19 $\frac{3}{8}$
$\frac{1}{2}$	$\frac{1}{2}$	1 in.	1 in.	17	17 $\frac{1}{8}$
$\frac{3}{8}$	$\frac{3}{8}$	$\frac{5}{8}$	$\frac{5}{8}$	13 $\frac{1}{8}$	13 $\frac{1}{8}$
$\frac{7}{8}$	$\frac{7}{8}$	$\frac{1}{8}$	$\frac{1}{8}$	6	6

These records are taken from every engine after the valves are set in the erecting shop. They are more uniform than any we have seen and the motion by which they are produced is worthy of study.

Of late there has been a tendency toward elevating the roundhouse to its proper position as an important factor in efficient locomotive service. The change of operating methods beginning with pooling and including various plans for rapid work at terminals is now appreciated as a most important influence in the economy of the department, and the whole question of locomotive terminals will probably continue to be a vital one. New plans for roundhouses almost invariably include repair facilities, and while this is not a new idea, the inclusion of small shops in the original plans of roundhouse equipment is a sign of the times denoting the necessity for promptness and perfection in running repairs. A better class of roundhouse workmen must also be developed, and it will not be surprising if the most intelligent men of the shop will be needed. It was well said at Saratoga that "any mechanic can tell what is the matter with a driving box if it is out on the floor, but it takes more ability to locate a pound on an engine in the roundhouse and find out which box is going to give trouble." It is the ability to prevent engine failures that is now required in the roundhouse.

It seems probable that the thought now concentrated on metal car construction will eventually produce a satisfactory all metal, or at least a metallic frame, box car. It is a difficult problem and one which, as to the all-steel construction, is not likely to be popular, until the relative costs of steel and wood change materially. It is not so, however, with the steel framing and wooden body, either for box or gondola cars. The time has come for careful consideration of steel underframing for all cars and the extension of steel to the upper traming is natural and logical. This is the direction which progress is taking. All permanent advance comes in steps, and the steel underframe is unquestionably an important step which should not longer be delayed. No one questions the policy of building tender frames of steel, and the reasons are equally forcible as to cars. It is beginning to be appreciated that even with the best wooden construction the repair expenses for sills and end sills are increasing, and not alone with old and small-capacity equipment. It is even more noticeable in modern 30-ton cars, as a result of modern methods of operation in connection with the present heavy locomotives. Steel underframes increase the initial cost, but there is plenty of evidence that they will soon save this cost, and the life of a steel frame when occasionally painted is indefinite. With the adoption of the 36-ft. standard box car, which now seems certain, a very general use of steel underframes may be confidently predicted. This has already reached the drawing-room stage on several exceedingly conservative railroads. With it comes the problem of draft gear, and, on roads having an extensive grain business, that of making the 36-ft. car strong enough, as to frames and trucks, to carry 100,000 lbs. The question of the large capacity is a local one, but that of the steel underframe seems to have general application.

POWDERED FUEL AND SMOKE CONSUMERS IN GERMANY.

Two influences, the high cost of fuel and the necessity for smokelessness, have operated in Germany to increase interest in the burning of powdered fuel. Consul-General Guenther, writing from Frankfort, Germany, says that the high price of coal has made the German manufacturers disposed to listen with favor to proposals to replace their old-style furnaces by apparatus in which low-grade coal and coal dust can be burned and which, through almost complete combustion, are smoke consumers. Because of its clear statement of the principles of pulverized coal burning we are glad to print the following from Mr. Guenther's letter:

"A German imperial commission has been making experiments in the consumption of coal dust in furnaces, and a recent report makes special mention of the 'Schwarzkopf' apparatus (American Engineer and Railroad Journal, December, 1900, page 379). The Journal of the Society of Arts has also given a brief description of the same. It states that it is necessary in the first place to have a highly heated fire chamber for the ignition of the coal dust, for the higher the temperature, the quicker and more perfect will be the combustion. Contact with the boiler walls must be guarded against, as this interferes with ignition; the fire chamber must be lined with fireproof material, as it has to be kept constantly at a certain temperature. It is pointed out that such a fire chamber is not an inconvenience, but rather a special advantage in coal-dust firing, because it insures perfect combustion, a high temperature of the gases at the start, and protection against the formation of 'needle' flames. Also, after firing has ceased—for the night, for instance—the heat stored in the fireproof walls maintains steam pressure longer and steam is more quickly raised in the morning.

"The managers of State institutions have been instructed to do all they can to prevent or to consume the smoke from their fires, and, if necessary, to have smoke-consuming appliances constructed. Municipal authorities have been asked to do the same. It would seem a propitious time for American builders of smoke-consuming devices to appear on the field. I think it can easily be demonstrated that at least some American devices successfully prevent the formation of smoke and make it possible to use low grades of coal, screenings and dust, so that the cost of the plant is covered by the saving in the cost of fuel in two years. It seems to me advisable for our manufacturers of smoke-consuming furnaces to have experts investigate conditions here. I am convinced that a large and lucrative business can be established."

It is only very recently that the gas engine has become a real rival of the steam engine and the best work for both at this time is practically the same. Prof. R. H. Thurston said recently, regarding the efficiencies of these engines, that "the gas engine and steam engine have delivered a net horse-power with a consumption equivalent to about 1 lb. of good coal. The consumption of such fuel for efficiency unity would be about one-fifth of a pound per horse-power and the engines have thus both attained an efficiency, between the coal pile and the point of delivery of about 20 per cent." Looking at each engine, with a view to future progress, it is fair to presume that the gas engine has the greater possibilities. The developments that we can expect to see in the steam engine are the use of higher boiler pressures, which are becoming available with the use of water-tube boilers, and the superheating of the steam. The opportunities to reduce the wastes in a gas engine are many and it is possible that the gas engine will become so improved in the next few years as to put it in many places and for a variety of purposes, in which the steam engine is now the chief prime mover.



Inspection Locomotive—Chicago, Burlington & Quincy Railroad.

The accompanying engraving illustrates a new inspection locomotive built by the Chicago, Burlington & Quincy for the use of its General Manager. This engine is not specially novel, having been modeled after one built by the Baldwin Locomotive Works for the Philadelphia & Reading. It is much more powerful than most inspection engines and is intended to haul one or more business cars when necessary. The engine itself is an old one, rebuilt for this purpose. The boiler differs from others of the same class in having somewhat stronger construction and a straight shell, with the dome located over the firebox and with suspended crown bars. The cab and observation room are of light construction, principally of Oregon fir with an inside finish of quartered oak and a light green head lining. Special care was taken to insulate the observation room from the heat of the boiler and stack and it is said to be quite comfortable. Eight people may be accommodated in the observation room, four in revolving chairs at the sides and four on the elevated platform on top of the boiler. The engine is equipped with a pneumatic sander, pneumatic bell ringer, speed recorder and electric lights, including an electric headlight. The following list gives the principal dimensions:

Cylinders	16 ins. by 24 ins.
Diameter of drivers64 ins.
Weight on drivers.....	53,300 lbs.
Weight on trucks.....	32,300 lbs.
Total weight	85,600 lbs.
Boiler pressure	160 lbs.
Diameter of boiler, front course.....	46 1/4 ins.
Length of tubes	11 ft. 1 1/16 ins.
Diameter of tubes	1 3/4 ins.
Tube heating surface	821 sq. ft.
Firebox heating surface.....	88 1/2 sq. ft.
Total heating surface	909 1/2 sq. ft.
Width of grate	35 1/4 ins.
Length of grate66 ins.
Grate area	16.4 sq. ft.
Length of observation room in the clear.....	14 ft. 1 1/8 ins.
Width of observation room in the clear.....	9 ft.
Seating capacity	8

The manufacture of pinions for street railway motors by the pressing process has been accomplished in Brooklyn. The object is to secure toughness and durability superior to the usual cut gears. Dies are used and pinions are pressed out of cylindrical billets by a 500-ton press. It is stated that by this process a high carbon hard steel may be used. Thus far the process has been applied only to pinions.

The use of steam turbines for the propulsion of the new Clyde passenger steamship now being completed at the Denny shipyard, England, may be expected to lead to some important developments in steamship construction. This turbine vessel will ply between Fairlie, on the Ayrshire coast, and Campbeltown, on the Kintyre coast, a distance of about 40 miles. The character of the journey is such as to thoroughly test this system of propulsion not only for river but open-channel service. The vessel measures 250 ft. in length on the water line, 30 ft. beam and 11 ft. deep. It will be fitted with three separate compound turbines, one high pressure, driving a center shaft with a 4-ft. propeller, and two low-pressure turbines driving two side lines of shafting with propellers 3 ft. in diameter, working a little in advance of the center propeller. The combined power of the turbines is from 3,000 to 4,000 h.p., which is considered ample for the guaranteed speed of 20 knots an hour. A speed of 15 knots is also guaranteed when running astern. To obtain the guaranteed speed in this direction, "astern" turbines are combined with the low-pressure turbines and fitted in the exhaust casting, being permanently connected with the vacuum of the condensers. In going ahead the steam passes from the high-pressure turbine through two self-closing valves to the low-pressure turbines and then to the condensers. To go astern the side propellers are reversed by closing the ahead steam valve and opening the astern valves on each side of the vessel, admitting steam direct from the boilers to the astern turbines. For quick manouevring of the vessel the port or starboard engines can be run ahead or astern independently of each other by closing the regulating valve and two self-closing valves on the high-pressure turbines, and opening the drain valve to the condensers; the high-pressure turbine then runs idly in a vacuum and is entirely out of action. On each of the low-pressure turbines is fitted a valve which admits the steam direct from the boiler to the receivers of the low-pressure and astern turbines. By moving these valves the port or starboard turbines can be run ahead or astern as desired; the entire propelling machinery being operated from a central starting platform. Two Scotch return tubular type boilers, working under induced draft, will furnish steam at a high pressure. Had water-tube boilers been used instead of the Scotch type, the Parsons Marine Steam Turbine Company, who are responsible for the engineering success of the vessel, would have guaranteed a speed of 25 knots instead of 20 knots an hour.

SPliced SILLS IN LONG PASSENGER CARS.

The splicing of sills of long passenger cars has been practiced for a number of years with apparently no unfavorable results. The subject was introduced by Mr. H. M. Pfeleger, Mechanical Superintendent of the Pullman Company, at the

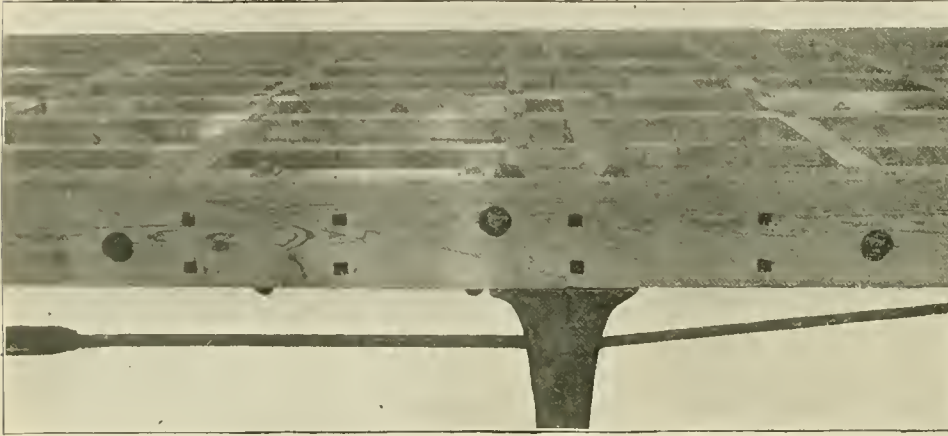

Spliced Passenger Car Sills.

recent M. C. B. convention in a topical discussion entitled: "Are there any objections to splicing all sills of long passenger equipment?" If not, how should this be done according to the best modern practice?" As a result of the discussion the question will be presented at the convention next year with recommendation. Mr. Pfeleger's comments on the practice were as follows:

The practice followed by a large number of car builders is to make one splice in the sills of cars 50 ft. and over in length, and this may be taken as a strong indication that there are no objections to splicing sills in long passenger cars; and it may be safely said that if a sill of a passenger car has one splice in it, properly made, it is as strong as a continuous sill. Practice has demonstrated that a properly spliced sill will last as long as a continuous sill, and can be safely used for both side sills and draft sills. The practice of the Pullman Company for the last twenty years has been to make one splice in each of the sills under its cars, and a careful examination of sills which have been in service for many years shows the splice to be in almost as good condition as the day applied, and no indication of having pulled apart or opened. Here is a portion of a sill which has been in continuous service since the car was built at Pullman in September, 1882, and you will note that the splice is in excellent condition after nineteen years' service.

I quote as follows from a letter of Mr. George W. West, Superintendent Motive Power of the New York, Ontario & Western Railway:

"We send you portions of two passenger car sills that have been spliced and in service for sixteen years, and have not had a wrench applied to a bolt or nut used in the splicing. Sills were removed on account of rotten end sills and the tenons on end of draw sills were slightly decayed, and we thought it advisable to remove them; the balance of the sills were as good as the day they were first applied and in as good condition as the section we send you—no indication of either dry or wet rot, and the same condition prevailed throughout the entire sill, except the tenons on the end. The original floor or deafening ceilings have never been disturbed, which is proof posi-

tive that the nuts and bolts securing the splices have never been tightened. I take this interest in the matter from the fact that I was associated with the West Shore road when duplicate coaches were furnished that company, and was very strong in my objections to the spliced sills. Experience convinces me that I was wrong in my conclusions, and that the spliced sill, if the work is well done, is fully as strong as the sill without splices. I have watched this matter very closely and have been an advocate in the conventions of allowing sills to be spliced on freight cars, and I assure you that it gives me as much pleasure as it can your company gratification to see these results."

From the foregoing, as well as our own observations, we feel safe in saying that there are no objections to splicing sills in long passenger car equipment, providing the splice is properly made, but on the other hand, there are some advantages in splicing passenger car sills, the chief of which is the better quality of lumber which is obtained in the shorter sills. A car builder can readily obtain first-class sills 40 ft. and under in length, while it is almost impossible to obtain good sills of 60 ft. or over in length. Should sills 60 ft. or over in length be ordered it would be found that delivery was very slow, and the lumber of inferior

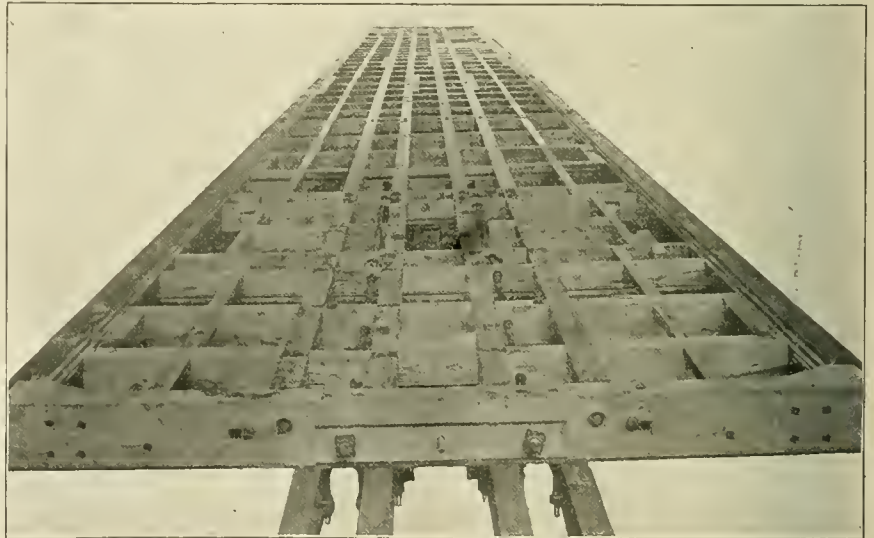

Spliced Passenger Car Sills.

quality; but, on the other hand, sills of 40 ft. or under in length can be furnished promptly by almost any lumber dealer, and a far better quality of lumber obtained.

It is cheaper to use sills with one splice made of two pieces 40 ft. or under in length, than to purchase a continuous sill about 70 ft. long, as the latter will cost from 40 to 50 per cent. more per thousand feet than the shorter sills. The cost of splicing a sill varies according to the splice made, and will run from \$1 to \$1.60 per sill. Taking a 70-ft. car, the saving in lumber by the use of spliced sills, as compared with continuous sills, would amount to \$39.70 a car—deducting the cost of splicing, \$9.60, leaves a net saving per car of \$30.10. Should it be granted that there are no objections to splicing sills on passenger cars, the question is: How should it be done according to the best modern practice?

It is our opinion that what is known as a lock splice is the best, the same as is used by a large number of railroad com-

panies in this country, and also in foreign countries, and the same kind of a splice as in the piece of sill here exhibited, and that the length of the splice should be four times the width of the sill and that the splice should be bolted together with two or more bolts. It is advisable to re-enforce the sill on the side with an oak block 2½ ins. wide, depth of sill, and about 6 ft. long, bolting the re-enforcing blocks securely to the sill, as indicated



Spliced Passenger Car Sills.

on blue print here shown. With such a splice the sill is stronger at the point of splice than at any other point, both for resisting a downward load and for cross blow or strain.

In splicing sills it is important that the splice be made over or very close to the center cross-ties or needle beams of the cars, and that the splices be divided over two center cross-ties and the second sill over the other center cross-tie, about 10 ft. away, and the third splice again over first cross-tie—thus alternating the splices of the sills above the cross-tie. In arranging the blocks or strengthening pieces on the sides of the splice of the first sill being over one sill they should be placed on the inside of the outside sill, outside of the intermediate sill and inside of the center sill, so as to counteract each other in any bending moment caused by the car being struck an end blow.

The accompanying engravings were made from photographs exhibited by Mr. Pfefer.

In steam engineering practice of all kinds it is important to know how great a measure of economy can be afforded. If locomotives, marine and stationary engines could be built on a basis of 13 lbs. of steam per indicated horse-power hour in all cases there would be a stupendous saving in the cost of fuel, but economy is often so expensive as to render it advisable to be wasteful and the best engineering skill is required to secure the proper balance in this respect. Students of engineering are apt to overestimate the real value of efficiency and they are often surprised to be told that wasteful operation is sometimes true economy. The high first cost of installation of the most efficient steam machinery for a continuously operating pumping plant is justified, whereas it would be wasteful when applied to a pump operating only a few hours per day. A cut-off of one-quarter stroke may be the most favorable as to coal consumption in a locomotive, whereas the full stroke operation of a heavily loaded engine may lead to greater economy when train and engine crew wages are considered. A quadruple expansion locomotive would undoubtedly be most economical for the operating conditions which would favor its use but who would be willing to recommend the large maintenance expense of such requirements. "How economical can we afford to be?" is an important question requiring experience and sound judgment.

THE NEW SITUATION AS TO FUEL OIL.

Probable Effect on California and Texas Roads.

In 1888 when the Pennsylvania Railroad investigated the subject of oil as fuel for its locomotives, 26,000 bbls. per day—the equivalent in heating value of 8,000 tons of coal per day, the rate of consumption of coal by that road at that time—was nearly one half the daily output of fuel oil of the United States. It was found that with oil at 30 cents per barrel it cost more to take the same train 100 miles by means of oil than by means of coal, but coal was cheap in the Pennsylvania territory. There has never been any question of the steaming qualities of locomotives when fired with oil, and there are no serious practical difficulties but many advantages in oil.

Its use depends upon the relative prices of oil and coal. It is the same question with fuel oil as with corn. When coal is high and corn is cheap it may pay to fit up to burn corn. Our readers will remember the experiments made by the University of Nebraska in 1897, when it was determined that one pound of screened Wyoming coal, costing \$6.65 per ton, evaporated 1.9 times as much water in a steam boiler as could be evaporated by one pound of a good grade of yellow corn. With coal at \$7.11 per ton it paid to burn corn at 13 cents per bushel and coal at \$5.41 was equivalent to corn at 10 cents. It is a matter of price and, with oil, also a matter of supply, which amounts really to the same thing. Of course, it would be absurd to think of burning corn on locomotives because of its bulk, but corn serves admirably as an illustration.

The four "gushers" in the newly developed Texas oil fields introduce a new element into the situation. These, the "Lucas," the "Beatty," the "Higgins" and the "Haywood," are reported to give an output "twice as great as that of all of the wells in Pennsylvania." If these are only the beginnings of Texas oil and if this output continues, the southwestern section of the country is to receive a remarkable benefit, the extent of which is not now to be foreseen. As to the qualities of the oil and its adaptability to locomotive use, readers are referred to the statements by Mr. Howard Stillman, Engineer of Tests of the Southern Pacific, which are printed elsewhere in this issue.

Among the railroads now using oil fuel extensively the most prominent are the Atchison, Topeka & Santa Fe and the Southern Pacific. Since the close of the year 1900 coal has been abandoned in favor of oil on all locomotives of the Atchison lines in California. This road, however, is much better situated with respect to coal than the Southern Pacific. The latter line of about 8,000 miles lies almost entirely in the States of California and Texas and very near the oil fields of both. Because of the absence of coal deposits west of the Sierra Nevada Mountains coal is very expensive, averaging \$4.03 per ton last year, on the Southern Pacific. As this road used 1,629,459 tons of coal last year, the ultimate possible saving by using oil at present prices may be conservatively estimated at between three and four millions of dollars per year, providing the supply is sufficient. This road paid \$6,566,751 for coal last year, which was 30 per cent. of the cost of conducting its transportation. These figures indicate the importance of the new developments in oil for only one road.

If the expectations with reference to the territorial extent of the newly found fields are realized, there may be a revolution in locomotive practice in a large and important section of the country.

The number of locomotives turned out by American builders last year was 3,153, an increase of 680, or 27.5 per cent. over 1899, when the record was also broken.

INTERSTATE COMMERCE COMMISSION REPORT.

Summaries of the thirteenth statistical report of the Interstate Commerce Commission prepared by its statistician show that in the year ending June 30, 1901, the gross earnings of the railroads in the United States covering an operated mileage of 192,556 miles, were \$1,487,044,814, being \$173,434,696 more than for the preceding fiscal year, or an increase of \$717 per mile of line operated.

Passenger revenues increased \$2,602,646; from mail, \$1,753,463; from express, \$1,660,096; miscellaneous passenger, \$473,659; freight, \$135,519,168; unclassified, \$341,556, and miscellaneous freight a decrease of \$915,892. Operating expenses aggregated \$961,428,511, an increase of \$104,459,512, or \$423 greater per mile of line. The net earnings were \$525,616,303, an increase of \$68,975,184, or \$294 per mile of line. In dividends, \$139,602,514 were declared and paid.

Freight and Passengers.

The number of passengers carried during the year was 576,865,230, an increase of 53,688,722, and the passenger mileage, 16,039,007,217, an increase of 1,447,679,604. The number of tons of freight carried was 1,101,680,238, an increase of 141,916,655, and the ton mileage, 141,599,157,270, an increase of 17,931,900,117.

The average cost of running a train one mile increased nearly 9 cents as compared with 1899, while the percentage of operating expenses to earnings shows a small decrease.

Railroad Mileage.

The total single track railway mileage of the United States on June 30, 1900, was 193,345 miles, an increase during the year of 4,051 miles, which was a greater increase than in any year since 1893.

The aggregate length of railway mileage, including tracks of all kinds, was 259,788 miles. This mileage was controlled by 2,023 railway corporations, of which 1,067 maintained operating accounts, 847 were operated independently and 220 as subsidiary.

Locomotives in Service.

During the year there was an increase of 960 in the number of locomotives in service and of 74,922 in the number of cars, the total number in use at the close of the year being 37,663 and 1,450,838, respectively.

The report shows that for each 100 miles of line 20 locomotives and 753 cars were used; that each passenger locomotive carried 58,488 persons, and that each freight locomotive carried 51,013 tons of freight, all showing an increase as compared with the previous year. During the year the 1,017,653 employees of the railways received \$577,264,841 in wages or salaries, representing 60 per cent. of the operating expenses of the roads and 39 per cent. of the gross earnings. Compared with the fiscal year 1895 the amount paid in wages and salaries showed an increase of \$131,756,580.

Railroad Accidents.

The total number of casualties to persons on account of railway accidents during the year was 53,185, of which 7,865 were fatalities and of the latter 2,550 were railway employees and 4,346 trespassers. The number of passengers killed was 249, or one passenger for each 2,316,648 carried. One passenger was injured for every 139,740 carried. The casualties, both fatalities and injuries, show a substantial comparative reduction over those of the previous year.

In the thirteen years ended June 30, 1900, 86,277 persons were killed in consequence of railway accidents and 459,027 were injured. The passengers killed numbered 3,485; injured, 37,729; employees killed, 38,340; injured, 361,799; other persons, including trespassers, killed, 54,452, and injured, 69,509.

The Central Railroad Club has been asked by the director-general of the Pan-American Exposition to take charge of the ceremonies of "Railroad Day," which has been designated as September 13. Mr. George W. West, President of that club, has appointed the following committee of arrangements: Mr. James Macbeth, Master Car Builder of the Western Division of the New York Central; Mr. W. H. Marshall, Superintendent of Motive Power of the Lake Shore; Mr. O. P. Letchworth, of the firm of Pratt & Letchworth, and Mr. Pemberton Smith, of the New York Car Wheel Works. The September meeting of the club will be held at the Exposition.

The vast dimensions of the combination of interests comprised under the name of the steel trust surprised everyone. It is a combination of combinations, including ore deposits, railroad and steamship facilities, furnaces and mills, engineering establishments and construction companies, until complete steel frames for buildings or the largest bridges may be delivered and erected without going outside of the circles of the trust for an important link in the chain. This concentration surpasses everything heretofore accomplished in the combination of railroads, but we now have a new factor in the combination, the full meaning and importance of which does not yet appear. Whether the new owners of the Pennsylvania Steel Company are the stockholders or the officers of the Pennsylvania Railroad does not matter. It is certain that this large railroad interest has taken the control of this steel corporation with \$50,000,000 capital and immense resources. Evidently the United States Steel Company is not to continue without formidable competition.

A comparison between wool and cotton waste for journal box packing, recorded by Mr. T. H. Symington in a paper before the Western Railway Club, shows that wool is more elastic than cotton in the ratio of 22 to 15. In capillarity cotton was superior to wool in the ratio of 131 to 88, and in the height to which the oil was carried by capillarity the cotton was better by the ratio of 1.72 to 1.28. In absorption and in degree and height of capillarity the cotton waste was superior, but the expansion and elasticity of the wool are important enough to lend to its use in many cases, even at a much greater expense. The trouble with cheap waste is that it disintegrates in the boxes on account of its short fiber and shoddy material. The long fiber wool does not go to pieces but retains its form and elasticity. Mr. Symington believes that if cotton waste is held mechanically up to the journal, independently of its own elasticity, and is also held in the box so that it cannot roll up in knots, it would be as efficient packing as wool, and as the cost of the cotton is so very much less than the wool, this would seem to open a field for a large saving in the operation of cars.

Improvements in shop and roundhouse ventilation have been very marked during the past few years, and it is now considered essential to spend a great deal of money in order to insure pure air at the proper temperature where "workmen" are employed. The contrast, however, between the careful treatment of this problem in shops and in drawing rooms is often striking to one who makes a practice of visiting both places. Without the least disparagement of the practice in other buildings attention should be directed to the fact that draftsmen also may be expected to do their work correspondingly cheaper in the proper atmosphere. In one case we recently found eight draftsmen working in a room about 20 by 30 feet in size, with the windows all at one side, and so arranged that no ventilation could be had without inconveniencing the men near the windows. There is no doubt that the work of that department cost from 10 to 20 per cent. more than if it were done in a properly ventilated room. At least from \$4 to \$5 could have been saved each day in the season of poorest ventilation by the expenditure of a very small sum for devices which would secure a sufficient amount of pure air. It might be accomplished in the case mentioned by the construction of an air duct in which one or two gas jets would furnish the necessary circulation, and the total cost of operation would be that of the gas consumed. There are other methods equally simple. The writer speaks with authority on this subject and sympathizes with the draughtsman who is obliged to endanger his health and his eyesight by working under improper conditions.

CORRESPONDENCE.

TONNAGE RATING OF LOCOMOTIVES.

To the Editor:

I hesitate to criticize the work of a gentleman of Mr. Henderson's acknowledged high standing, but if you care to have some points showing omissions which Mr. Henderson has made in his proposed system of tonnage rating (Mr. Henderson's paper appears almost in full in this issue.—Editor) which are essential to its success I would be glad to give you the data, but I would not like to stand in the position of criticising his work, because, as far as he has gone, his ideas are very good indeed. He has gone over the same ground that we passed over when we began to study the question of tonnage rating. The practical application of the system, however, suggests some vital points to which he makes no reference.

For instance: On a 10-hour and 50-minute schedule for 170 miles, an exceptionally long run, the time required for stops will vary from 1 hour and 30 minutes to 4 hours and 30 minutes, according to the number of trains in each direction, the length of sidings, the distance between sidings, the facilities for coaling and watering engines and the methods of handling trains on the run; hence, in calculating the load that can be taken, you must first determine by a check of the service just what time is required for stops per mile on each freight run.

As I understand Mr. Henderson, he bases his rating entirely on the limiting portion of the run. For example: If it should be a 1 per cent. grade the calculation would show that for each 1,000 lbs. of locomotive traction a load of 80 Ms. could be taken at 10 miles an hour. If it were desired to make 20 miles an hour this load would be reduced to about 60 Ms. for each unit of engine traction. This is a 25 per cent. reduction in the load to make the faster speed. While this reasoning will apply to the limiting portion of the run the same calculation applied to the entire run instead of to the limiting portion only, viz., by making a virtual profile, as suggested by Mr. Henderson, modifying the actual profile; plotting velocity heads at different points along the track and joining these velocity heads by lines that will measure the grades, the resistance from which will equal the power consumed or required by change of speed or elevation, from one terminal to the other in both directions on the run, you have data from which to make a table to show the load that can be taken at different speeds, for each section of track between every two stations in each direction. From this table a time-line can be made for a train showing the number of minutes required and the speed in miles per hour that can be made with a given load.

The value of this system may be understood by citing the above 170-mile run. Competitive traffic conditions might require two hours faster time to be made on this run, and the practice shows that 8 hours and 30 minutes out of the 10 hours and 50 minutes card time are required for running time. This would reduce the actual running time from 8 hours and 30 minutes to 6 hours and 30 minutes and would increase the average speed over the entire run from 20.3 to 26.2 miles per hour. Suppose the practice shows that 120 Ms. of load for each unit of engine traction can be taken at a speed of 20.2 miles an hour in regular daily service. Now the question arises, how many Ms of load for each unit of engine traction can be taken at an average speed of 26 miles per hour over the whole length of the run, not over the limiting portion, as it does not make so much difference what speed is made over the limiting portion of the run. By reference to the table already prepared, as outlined above, a time-line can be run in 20 minutes showing the number of Ms. of load that can be taken over the run in question in 6 hours and 30 minutes instead of 8 hours and 30 minutes, thereby giving the most economical load that can be taken within the prescribed time for the whole distance.

It is also necessary to make some check of the performance in order to determine what resistance formula will meet the requirements of the road for which the engine rating is to be made. The "Engineering News" formula and the Baldwin Locomotive Works formula referred to by Mr. Henderson were deduced from experiments on heavy rail on some of the best track in the world, and this high standard of excellence in track conditions is not to be found on most of the roads of this country. Our practice also shows that for rating purposes the cylinder traction of locomotives on heavy grade lines should be lim-

ited to about 22.5 per cent. and for valley lines 25 per cent. of the driver weight.

From the foregoing you will see that there are many practical factors to be considered in formulating a system of tonnage rating, and while the principles laid down by Mr. Henderson are correct in theory, they cannot be applied to make a successful system of tonnage rating without considering the other elements which come into the practice, as suggested above, the most important of which is the determination of the speed that can be made with a given load between every two stations from one end of the road to the other, which is really the essence of a successful system, as it is only by this means that we can arrive at the load that can be taken within the prescribed time limit with the greatest degree of economy.

B. A. Worthington,
In Charge of Tonnage Rating,
Southern Pacific Company.

POSITION OF AN AIR-BRAKE INSPECTOR.

To the Editor:

The extensive use of the air brake on locomotives and cars demands of every well-managed railroad a superior man for this particular responsibility. He is one whose knowledge and worth should be considered and respected by those whose duties are in any way connected with the handling of trains or who superintends the application and care of such equipment. The man appointed to the position of chief air-brake inspector should possess that practical part of railroading which will enable him to use the judgment and tact necessary to accomplish the best results. He should be schooled especially in the mechanical department that his knowledge of the use of the apparatus may not be questioned. Of course, his judgment or recommendation may be criticised similar to those of other officials, but having a clear understanding of this line of work an immediate tendency will be to harmonize many of the complicated and unsettled questions in his sphere.

It is frequently stated that the interests of the air brake are only allied with those more directly concerned in its care and operation, but the rapid growth of this faithful agent for fast and heavy trains has increased its importance. Our own, as well as other Governments, recognize this, and it is, therefore, of considerable consequence that the brake apparatus and its interests be closely followed by a competent person.

By way of a practical illustration, a certain division on a railway, which is not unlike many others topographically, is responsible for a large number of slid flat wheels under cars having air-brake equipment. A freight train leaving a division point in fifty cars in good condition, thirty of which on the head end have air brakes in working order. On arriving at the terminal the tenth car from the locomotive is found to have under it three pairs of slid flat wheels necessitating removal. To ascertain the cause of this difficulty the Division Superintendent does all within his power. He patiently listens, and from reports forms certain conclusions, the substance of which leaves the matter imperfectly settled, with him at least, without satisfaction. The attention of the General Superintendent is called to the wheel sliding on this particular division, and he requests of the air-brake inspector that an investigation be made for the cause of the removal of so large a number of wheels, and at the same time expresses surprise at the unnecessary expense and trouble chargeable to air.

Now one phase of the duties of the air-brake inspector and those directly under him is to determine the real cause for flattening these wheels. The trouble may be complicated, but with the proper understanding and treatment these causes for such complaints will at once grow less. This, however, involves keeping the proper remedy in stock, which is a competent person to look after the varied interests of the air brake in its application to rolling stock and maintenance, one whose position is respected by official and employe.

It is necessary that an individual be sought for special adoption in his particular line, if he will be the most proficient for a special calling. Many opinions in a matter of moment may be ventured by those whose daily duties and experience entitle them to much consideration, but guess work is not an increasing quantity in the market of the railroad world to-day, nor is it allied to the successful operation of any business.

New England.

MAKING ERASURES ON TRACINGS.

"The most successful plan that I know of for making erasures on tracings and then obliterating the effects of the erasure, is first to use an ink eraser—taking out the lines thoroughly—and then rubbing the tracing with powdered pumice stone. For this I use a piece of chamois skin, first sprinkling the cloth with the powdered stone and then rubbing thoroughly with the skin—afterwards blowing off the stone and polishing with the skin alone. I enclose a piece of cloth from which erasures have been made and which has then been treated in this way."

This paragraph was contributed by Mr. C. A. Terry, to a recent number of the "American Machinist." The editor says that Mr. Terry's results are better than anything of the kind he has ever seen. The gloss of the cloth is renewed so perfectly that only by the sharpest scrutiny can the fact that an erasure has been made be detected. It would pass ordinary inspection without the erasure being noticed.

NEW LOCOMOTIVE WATER SERVICE.

Delivering 5,000 Gallons Per Minute.

Chicago & Alton Railroad.

A number of new water tanks and cranes have been put into service on the Chicago & Alton Railroad in connection with extensive road improvements. One of these stations and one of the tanks are illustrated from photographs received from Mr. T. W. Snow, Manager of the railway department of the Otto Gas Engine Works, the contractors for this work. This represents the best development in this direction and it is important to note that owing to the large pipes and columns 5,000 gals. of water are delivered to a tender tank in one minute. To use such capacity successfully a new valve for controlling the flow at the crane has been developed and it is an essential feature of the system. The standpipes or cranes

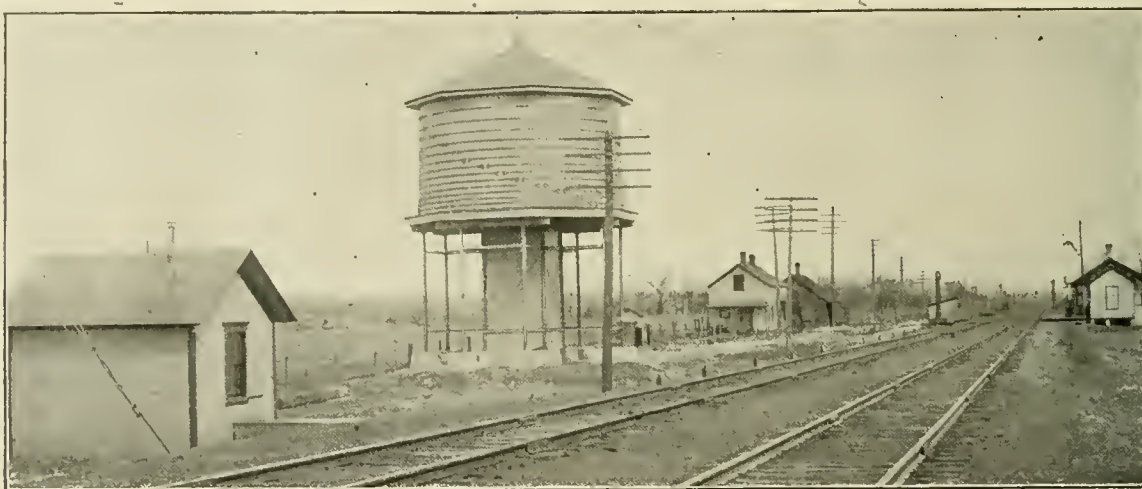

Improved Water Service, Delivering 5,000 Gallons Per Minute—Chicago & Alton Railroad.

In the selection of Mr. Potter as General Manager of the Baltimore & Ohio, Mr. Delano as General Manager of the Burlington, Mr. Morse as Third Vice-President of the Grand Trunk and Mr. H. D. Miles—formerly Signal Engineer—as Assistant Superintendent on the Michigan Central, there is a most important indication of the breaking down of traditions. These are instances of recognition of ability which should encourage all in the hope of ultimately reaching the highest position for which their life work fits them. These selections may even indicate an awakening to the need of improved methods of developing men. A thoughtful observer of the situation will be inclined to think that they do and will undoubtedly agree with us in believing that there never was a better time than the present in which to prepare for the rewards of those who can successfully manage the departments of our railroads. In the case of Mr. Miles we have an example showing that to be a thoroughly successful Signal Engineer one must have or acquire the qualifications of an operating officer. The apprentice, the draftsman and even the clerk should take courage for the present tendency toward improved business methods of railroad operation will create a greater demand for well qualified men and traditions are unquestionably breaking down.

Experiments in making coke from Western coals are being conducted at the works of the Illinois Steel Company, in Chicago. While no definite results have been announced, we are informed that the outlook is promising. If successful this will become a most important factor in steel making, which will tend toward a movement of the steel making center toward the West.

are 12 ins. in diameter, connected with the tank by a 14-in. pipe. The cranes are 600 ft. apart and the distance from the tank to the further crane is 900 ft. The pump-house is 100 ft. from the tank. These tanks are 30 ft. in diameter by 18 ft. high at the staves, holding 90,000 gals. The posts are usually 20 ft. high and supported on concrete foundations. The posts are made by bending the webs of 7-in. I-beams and riveting the central portions together, making a stiff, strong column. All the new tanks have slate roofs. In the pump-house is a 10-h.p. Otto gasoline engine direct connected to a triplex-gear pump having a capacity of 10,000 gals. per hour. The engines have electric ignition and are automatically controlled. Mr. Snow gives us the remarkable figure of one-half cent per 1,000 gals. of water pumped as the cost of fuel and lubricating oil for one of these new stations. There is no additional cost for operation because the attendance does not necessitate additional expense. Special attention is directed to the importance of the low cost of pumping and also to that of the very rapid rate of delivery of the water. The taking of water is usually the slowest operation about a train stop and under present conditions it is necessary for well understood reasons to save time in every possible way. On a long fast run if the fireman can be quickly released from attending to the water and be given a minute or two to attend to his fire and his coal an important saving would be made and the influence of changing the taking of water from the slowest to the quickest station operation would be great, though impossible to estimate in figures.

In the smaller engravings two forms of slow closing tank valves are illustrated. These were developed by Mr. T. W. Snow and F. S. Milne. With the increase in the

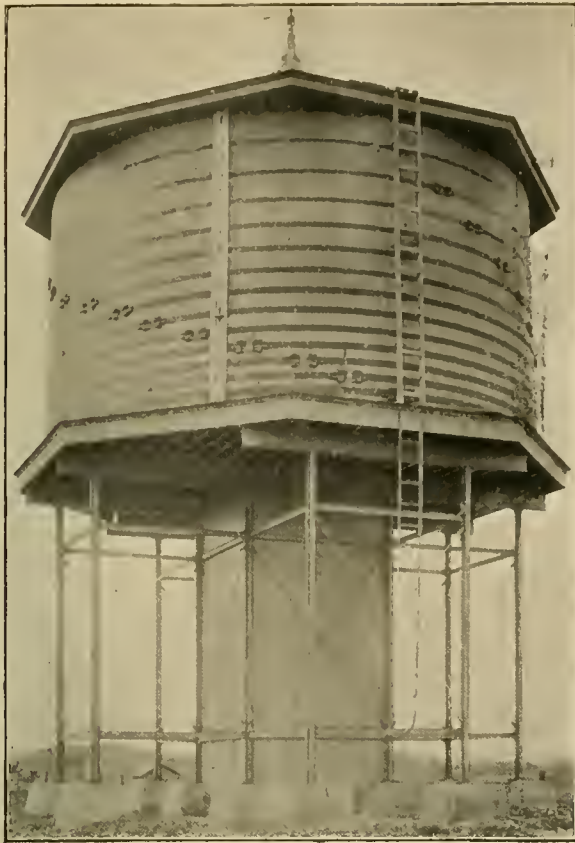

Water Tank, 90,000 Gallons Capacity.
Chicago & Alton Railroad.

diameters of the valves some slow closing device was found necessary because of the destructive shocks of the heavy columns of water. The arrangement of the new valve employs a small piston on top of the main valve.

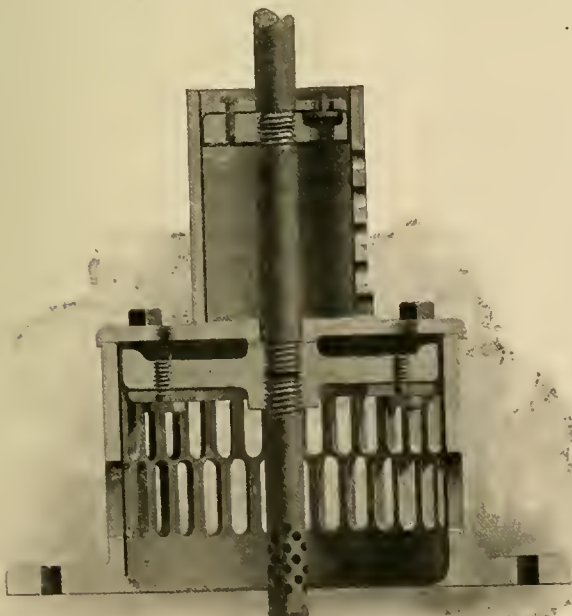

Slow-Closing Tank Outlet Valve.

This works in a cylinder in which four holes are drilled. The small cylinder fills with water and the holes offer sufficient resistance to the motion of the piston to retard its closing. In the small piston a check valve is provided which admits water to aid in the first upward movement of the piston. The valve

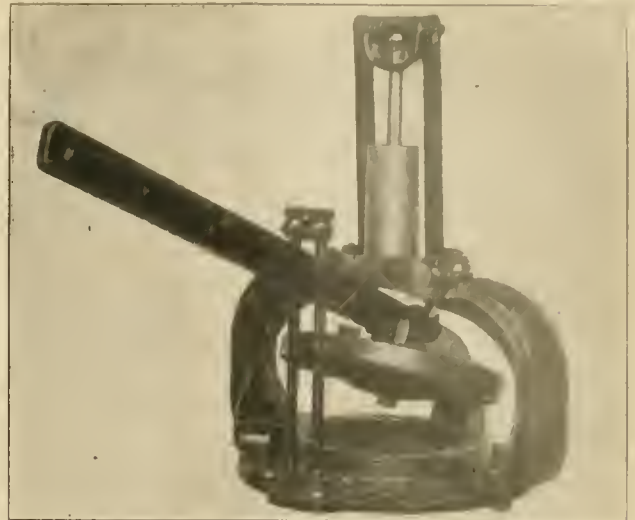

Slow-Closing Attachment for Tank Valves.

stem, which is of gas pipe, is perforated for the purpose of admitting air to the pipe below the valve in order to destroy the vacuum which would otherwise form after the closure of the valve. The dash pot shown on top of the ordinary tank valve in the other engraving is applied for the same purpose as the small piston shown in the sectional drawing of the new valve. This dash pot is $3\frac{1}{2}$ ins. in diameter and the necessary resistance is secured through $\frac{1}{8}$ -in. holes. This dash pot is connected to the main valve lever by the two links also shown in the engraving.

PHYSICAL TREATMENT OF STEEL FOR RAILS.

Much has been said regarding the chemical and physical treatment of steel while being rolled into rails, but not until recently has the physical treatment been given due consideration by the modern rolling mills, in the matter of finishing its products at a reduced temperature. It is generally conceded that old rails after being rerolled wear better than when put into a track for the first time and that smaller sections of rails give better satisfaction than do the larger sections, both for the same reason that the metal has received more working, and that at a lower temperature. Capt. Robert W. Hunt, who is the recognized authority on rails in this country, read at the February, 1901, meeting of the American Institute of Mining Engineers, held in Richmond, Va., a paper on the "Finishing Temperatures for Steel Rails."

The paper sums up the efforts that have been made by the author and many others to bring about this necessary physical treatment. As the rush of the modern mill and its tremendous productions seemed to shut out the possibility of obtaining rails rolled at lower heats, the author advocated efforts to obtain from chemical composition that which could not be had from physical treatment, and so urged harder steel in proportion to the increase of section. Good results have come from such mixtures, but the author insists that the chemical composition is secondary to the physical treatment of the metal. There have been instances in the experience of many railway engineers where they have obtained excellent service from steel rails that were made in the earlier days, whose chemical analyses revealed the fact that they had neither good nor even consistent chemical character.

Now that the large section rail has been made universally necessary by the large increase in tonnage of railway traffic and weight of rolling stock, several of the rail companies have prepared plans for the alteration of their rail mills. The Carnegie Steel Company, having carried their plans into execution, are to-day rolling rails in their modified mills. The

Pennsylvania Railroad in their orders this year for rails specify that they must be finished at a low heat. This commercial recognition of the heat and work principle, Capt. Hunt believes, was brought about by the McKenna process of renewing old rails rather than by the quantity of talking and writing that has been given the subject. Thousands of tons of rails have been renewed by the McKenna process since the plant was established in 1895, and are giving very satisfactory service. Here was an actual demonstration that could not be denied.

As to just what this temperature should be for finishing rails and how to determine it, Mr. Thomas Morrison, General Superintendent of the Carnegie Steel Company's Edgar Thomson Works, who planned and executed the alterations in their mill, thinks that the distance between the hot saws which is found to yield a rail of the desired length will be a sufficiently accurate and practical controlling factor, as to the heat at which the rail is finished. In this Capt. Hunt agrees, but also considers that the Ducretet and Lejeune pyrometer would be of considerable assistance, as it gives quick and consistent results. By the use of this instrument the temperature of finishing 80-lb. rails in most mills under the old conditions averaged 1,795 deg. F. In the McKenna renewing mill at Joliet the finishing temperature is considerably reduced.

The rails are drawn from the reheating furnace at an average temperature of 1,750 degs. F. and when leaving the finishing rolls their average temperature was 1,480 degs. On the other hand, there is a danger of finishing at too low a temperature, more so with high than with low carbon steels. If the metal is too cold it will spring the rolls and the interior of the rail will receive no work, thus rendering the rails unsatisfactory. There is a patent owned jointly by Messrs. Morrison and Julian Kennedy covering the handling of rails previous to their final pass through the rolls, that has as its principle the arrangement of the rails on the intermediate table where the finishing pass is delayed. The flange, being the thinnest part of the rail, gives off its heat more quickly than any other part, and in order to keep the flange longer at a heat sufficiently hot to roll, while the temperature of the metal in the head is reduced, the flange of one rail is placed against the head of another, so that the flanges draw heat from the heads of the rails. The head of the outside rail to be first entered in the finishing pass is exposed, but the bottom of its flange is against the head of the next rail.

This new practice of rolling rails is considered by Capt. Hunt as a revolution in rail making and justifies a change in the larger sections of rails, which would have been just as necessary under other conditions. It therefore seems wise that the standard sections of 89, 90, 95 and 100 lbs. be modified so as to obtain the best results from this heat condition and that will also be well suited for rerolling into lighter sections; adhering, of course, to all the necessary features of the sections recommended by the committee of the American Society of Civil Engineers. As the society sections are now practically standard on the railroads of this country, they should be considered as a basis on which new sections are to be designed.

In a report recently presented to the American Railway Master Mechanics' Association the following statement was made regarding the heating and ventilating of round houses: "The most modern method of heating at present seems to be by hot air and forced blast. The air can be taken from the round-house and warmed over and over again, thus reducing the cost of heating the air. While this air is generally carried in overhead ducts, your committee considers it should be investigated, and determined in each case whether an underground duct would not be suitable. It is also suggested that air be taken from the boiler room, thus serving the double purpose of cooling this room and using the heat imparted to warm the round-house."

FUEL OILS IN TEXAS AND CALIFORNIA.

Experience on the Southern Pacific Railway.

By Howard Stillman.

Engineer of Tests Southern Pacific Co.

Concerning the recent discoveries and remarkable output of oil in Texas much has been written, and because of its importance to the railroads which are able to avail themselves of this apparently enormous supply, the following valuable discussion, written for and published by the New York "Commercial" by Mr. Howard Stillman, M. A. S. M. E., Engineer of Tests of the Southern Pacific Company, is timely:

The Southern Pacific Railroad Co. has used fuel oil in locomotive service for several years, and is extending its use in proportion to the supply of this class of fuel.

As compared with coal the following data are shown in evaporative tests made with both fuels in locomotive service. Engines with which tests were made were of the same size and make and in similar service. The following figures show the results:

Service, passenger.	Fuel.	
	Summerland and Los Angeles petroleum.	Comax (bit.) coal.
Miles run	224	224
Mean number of cars in train.....	3.71	3.71
Weight of cars in train, tons.....	113.01	110.40
Actual running time, hours.....	7.55	7.63
Average steam pressure gauge, pounds.....	133	130
Temperature of feed water, deg. Fahrenheit....	66	66
Gallons water evaporated.....	6,603	5,980
Pounds water evaporated.....	55,025	49,833
Gallons oil burned.....	755
Pounds fuel burned.....	6,040	8,043
Evap. water per pound fuel.....	9.11	6.19
Evap. from and at 212 deg. F.....	10.96	7.41
Pounds fuel to evaporate one pound water from and at 212 deg. Fahrenheit.....	.09124	.1349
Equivalent of fuels for equal evaporation, lbs.....	1.00	1.48
Ditto, by measure.....	*168.9	†1
Gallons water evaporated per gallon oil.....	8.75
Miles run per ton.....	74.14	55.72
Fuel burned per hour.....	*100	†537
Total ton mileage.....	25,314	24,730
Ton miles per pound fuel.....	4.191	3.074
Ton-miles per gallon oil.....	33.53

*Gallons. †Ton.

The above items are from the record of the fuel tests made with careful attention to weights and measures.

The proximate analyses of the Comax coal is as follows:

	Per cent.
Moisture	1.90
Volatile combustible	27.08
Fixed carbon	55.38
Ash	12.50
Sulphur	3.14

Total

The fuel oil used in the test was California product from the locality named, and ranging in gravity close to 16 degrees Beaume, its flash point being about 240 degrees Fahrenheit, fire point at 290 degrees Fahrenheit. In practice it is taken at a weight of eight pounds per gallon.

The California oil varies somewhat in the gravity, but the fuel oils as obtained from the Kern, Los Angeles, Summerland, McKittrick and other fields are represented in the results above shown. They are all dark brown or black heavy asphalt oils, being more or less oxydized petroleum, very thick and viscid at temperatures below 60 degrees, and can only be handled by use of steam heating coils in the tanks or around the pipes.

The grades of California petroleum are many and should not all be confounded with the fuel oil referred to. There is a wide range in quality for refining purposes, but by the term fuel oil we mean that it is supposed to be of use for little else than fuel, and this article has to deal more particularly with such.

As to the relative cost of either coal or oil fuel, the relative values are based on the figure from the above test for equal calorific effect from and at 212 degrees; that is to say, 168.9 gallons oil equal one ton of coal, to which ratio local prices may be applied. As to effect on flues, fire boxes, etc., there is rather more trouble from leaky flues, seams, etc., than with coal fuel. This is due not to the fuel, but to more rapid temperature changes in the firebox during service with its subsequent expansions and contractions. This applies particularly to the use of

oil fuel in locomotives, because its service is so irregular in shutting off steam, stopping, starting, etc.

We have used oil fuel in stationary service many years, and it was used as fuel for a long time on the ferry steamers on San Francisco Bay, with excellent results, but was abandoned on account of possibility of accidents on crowded boats and the public were timid. The writer had occasion as a part of his duty to make occasional inspection of the oil burning boilers of steamers Solano, Oakland and Piedmont. I am prepared to make the statement that I have never seen an instance of damage to fire-box plates from use of oil fuel. Stationary boilers being regularly fired and not forced in evaporation as locomotive boilers are, do not suffer from the rapid expansions and contractions referred to.

The Texas fuel oil is in some respects quite different from the California oil. It has a gravity of about 22 degrees Beaume, flashes at 180 degrees, and fire point at 200 degrees Fahrenheit. Its commercial weight may be taken at 7.43 pounds per gallon. It is quite fluid at ordinary temperatures, and flows easily and readily in pipes, burners, etc. For refining purposes it is said by authorities to be of little value and good for little else than fuel. A quantity of this oil was hauled into Los Angeles and put to use on a freight engine in comparison with the California product. The chief variations found were as follows:

About 2 per cent. gain in evaporative effect was found in favor of the California oil, but the probabilities are that with continued use there will be little or no difference found. Theoretically, the Texas oil has the greater calorific value, owing to its containing a larger proportion of the paraffine or unoxidized oils.

In the comparative test a marked difference was found in the effect of the oil fire on the brick lining and arch of the fire-box. The California oils contain more or less water of a salty or alkali nature, the effect of the alkali being to flux and melt out the fire brick to such an extent that removals are quite an item. The Texas oil is free from alkali, and it was observed that no destructive element was present to destroy the fire-brick. The comparative fluidity of the Texas oil has already been referred to, and the difference in handling the oil was a matter of practical importance.

The smell of the burning oil or products of combustion of the Texas oil were noted by the locomotive engineer during his two weeks' experience with it. He said the odor was not as disagreeable as with the California oil. This was not as expected, owing to the quantity of sulphur in the Texas oil, but is explained by the fact that in complete combustion the sulphur is oxidized to sulphurous fumes not present in appreciable quantity.

The amount of sulphur in the Texas oil is considerable for petroleum, being determined at from 1½ to 2½ per cent. When the oil is distilled or heated below ignition point without access to air, a series of sulphuretted gases are given off, which are very disagreeable. Not so when the oil is burned in plenty of air. Oil refiners cannot make use of the petroleum containing much sulphur, and condemn the Texas oil on this account for fuel.

I wish to contradict the statement made in an Eastern oil refiner's paper that "The Texas oil would eat up the flues of an ocean steamer in once crossing the Atlantic on account of the sulphur." This statement had no foundation in fact, and I would contradict it from the following basis of observation:

The Southern Pacific Company for many years used on a portion of its lines a quality of coal known as Union, or Comax. This coal contained sulphur in considerable quantities, varying from 3 to 5 per cent. The sulphurous fumes were present in such quantity as to be objectionable to passengers and a general nuisance. Observations were made covering several years of the action of this coal on firebox plates, but I was unable to locate corrosion that could be traced to sulphur. The reason why no such corrosion can be expected is briefly explained as follows:

The fumes of dry sulphurous acid at high temperature are not corrosive to iron plates and cannot unite with them at temperature of the furnace. In presence of water and temperature less, say, than the boiling point of water, the corrosive acid is formed in time, but this condition is not found in an oil fire.

I would wish to go on record as denying any statement that the sulphur in Texas fuel oil will destroy the firebox of a marine boiler. For marine or stationary service we have never found an objection to oil fuel. When burned continuously in such service there is no complication and no better form of combustion

can be desired or better fuel devised excepting gas, of course.

A cheap source of fuel oil such as the Texas field promises has a great future for steam production. They seem to have it on tap in enormous quantities. The California product may not be able to compete with it, as the California oil generally has to be pumped from wells varying from 800 to 1,200 ft. in depth. A 10 or 50 bbl. per day well in California is rated as a good one. In Texas there are four wells that yield under pressure from below 100 times as much oil per day.

In connection with the use of Texas oil for locomotives the following quotation from an Austin correspondent of the St. Louis Globe-Democrat is interesting:

"The fact that the tests of the Beaumont oil as fuel for locomotives proved highly successful is of the greatest importance to several companies operating extensive railway systems in Texas. This is particularly true as applying to the Southern Pacific, the Atchison, Topeka & Santa Fe and the Gould lines. It is to be expected that the railroads, by buying in large quantities, as they now do coal, will be able to get fuel oil in the Beaumont field at a very low price, probably not exceeding 20 cents per barrel at Beaumont. The numerous tests which have been made show that this oil is a better steam producer for locomotives than much of the coal that is now being used. These tests have demonstrated that about 3½ barrels of oil are equal to one ton of coal for steam-producing purposes. It is asserted that 2½ barrels of the oil is equal to one ton of Indian Territory coal, which is used on most of the Texas roads. The reports made by the several railroads of Texas to the State Railroad Commission show that the total amount of coal used for locomotives on the Texas lines for the twelve months ending on June 30, 1900, was 1,716,471 tons. The price paid per ton for the coal ranged from \$1.35, for which the Paris & Great Northern obtained it, to \$5, which was the price paid by the Velasco terminal. The former road used 5,919 tons of coal during the year and the latter road only 525 tons.

"The total number of tons of coal used for locomotives by all the roads belonging to the Southern Pacific system in Texas during last year was 539,808, and the aggregate sum paid for this fuel was \$1,764,970.04. Taking the liberal estimate that it requires 3½ barrels of the Beaumont fuel oil to equal one ton of coal, it is shown that the 539,808 tons of coal are equivalent to 1,889,328 barrels of fuel oil. Inasmuch as this oil is now being sold in large lots at 20 cents per barrel, it is reasonable to suppose that the Southern Pacific will be able to contract for it at that rate or even lower. At 20 cents per barrel, the 1,889,328 barrels would cost \$377,865.60, as against \$1,764,970.04, which was the sum paid for fuel for locomotives of the Texas lines belonging to the Southern Pacific system during the twelve months ending on June 30, 1900. This would mean a saving of \$1,384,304.44 per annum in the company's fuel bill for its Texas lines alone. The cost of installing oil burners on locomotives is said to be about \$300 for each locomotive."

LONG RUNS WITH LIQUID FUEL.

Concerning liquid fuel on the Great Eastern Railway of England, Mr. James Holden recently expressed a most favorable opinion of its use on long runs. In an article in "Engineering Times" he said: "On the long runs of fast trains, which are yearly increasing in number, one of the chief difficulties is the fire, which being continuously urged for such long intervals becomes choked with dirt and ashes. With oil-burning locomotives no such trouble exists, as the supply of fuel is regular, continuous and entirely free from residue. An engine of the Great Eastern Railway (761) had on a special occasion to haul an express train from London (St. Pancras) to Scarborough and back. The total distance covered was 532 miles, the engine being in steam some twenty-four hours. The fire was untouched during the whole time, and the engine steamed as freely during the last half-hour of the run as on its initial fifty miles of the journey."

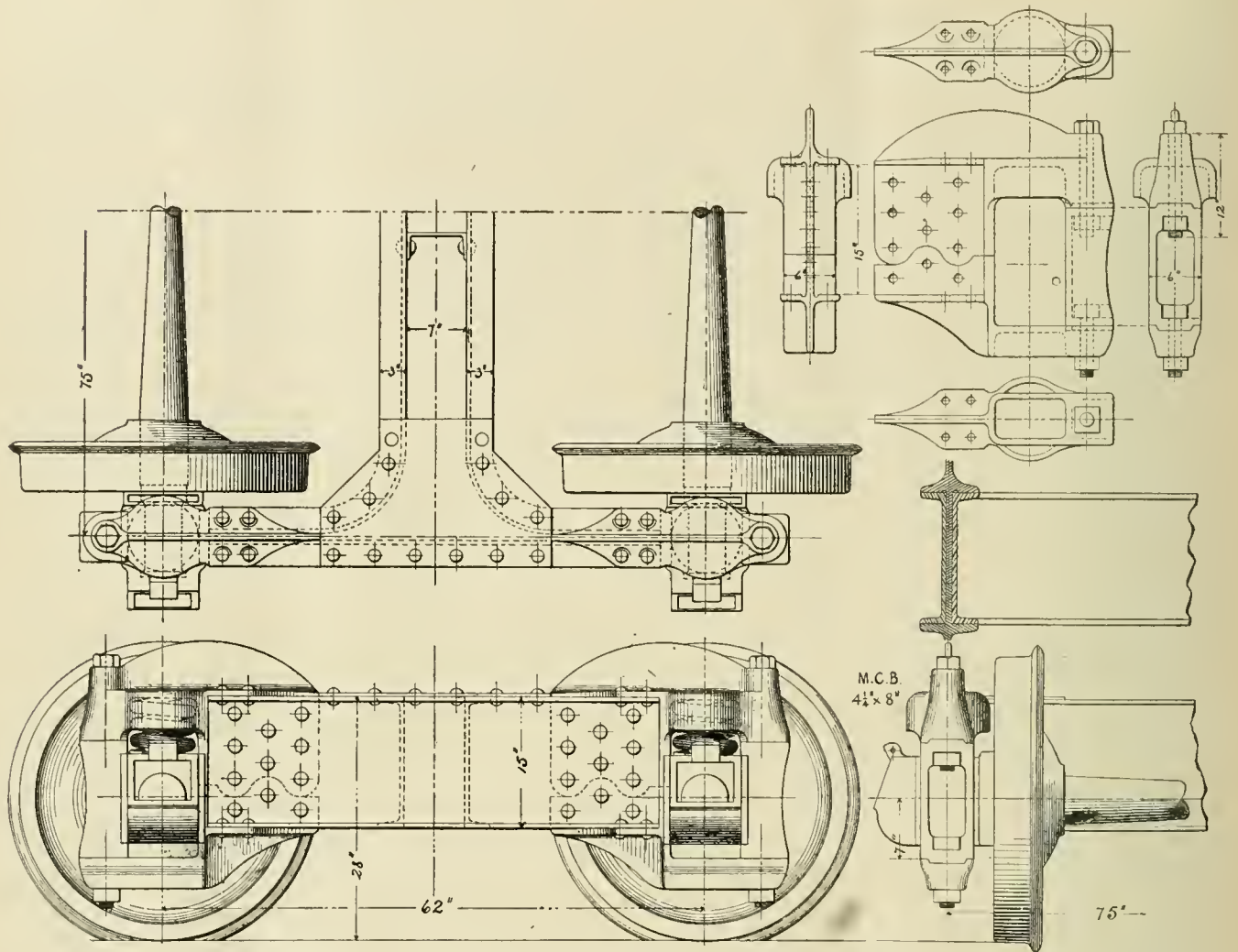

Steel Frame Pedestal Truck.

A NEW STEEL FRAME TRUCK.

The accompanying illustration shows a design for a pedestal truck which presents several novel features of construction. The main part of the frame, embracing the side pieces and transoms, consists of commercial rolled channel beams, the ends of the transoms being bent so that their extreme portions lie in planes parallel with the side pieces. Flat plates are riveted to the side pieces and transoms at their junctions to render the frame stiff and rigid and keep it square. Between the ends of the side pieces and transoms are inserted the necks of cast steel pedestals which are riveted in place. Each pedestal is cast in three pieces, the end piece being removably secured in position by two $1\frac{1}{2}$ -in. bolts. A pair of wheels can be rolled out by jacking up the frame a short distance to take the weight off the springs and removing the end pieces of the pedestals. The principal dimensions are shown in the several figures. This truck can be built in the ordinary car shop with the use of familiar tools and also can be easily repaired when necessary. The castings are simple and light and the pocket for the end of a spring adds the requisite strength where the weight is transmitted to the journal box. The designer, Mr. R. G. Wright, of Philadelphia, Pa., had in view the production of a truck which should be cheap in first cost, simple in construction, and adapted to be easily repaired in the ordinary car shop.

ICING STATIONS FOR REFRIGERATOR CARS.

A correspondent, who is an operating official, recently inquired why the principles followed in handling locomotive fuel from cars to tenders could not be applied to the icing of trains of refrigerator cars. He suggested the coal-chute idea for handling ice. Upon looking for information it was found that this was done on the Pittsburg, Fort Wayne & Chicago Ry. in the Sixteenth Street yards in Chicago several years ago. The object is to ice the cars in trains, and to do it cheaply and quickly in order to permit of forwarding the trains without delay when they are iced in transit.

The refrigerator cars are placed on the track beside a trestle which carries the ice cars, and the ice is handled from the ice cars upon a long platform which is the proper height to skid the ice into the tanks in the refrigerators. The approach to the trestle is inclined with a grade of 2.2 feet per 100 feet, and is about 590 feet long. The icing platform is 156 feet long and level, the trestle is 300 feet long and about half is on the grade. The refrigerator track is 940 feet long, which is ample for the purpose. The trestle is supported on mud sills 12 by 12 inches in section and the bents are 12 feet apart, of 12 by 12 inch timbers. The stringers under the ice track are 8 by 18 inches.

This platform has been found very satisfactory. About 350 cars are iced per month, giving from 4,000 to 4,500 pounds of ice to each car. With this arrangement the ice may be carried along the platform in a small truck in which it is broken up and then dumped into the cars.

AMERICAN LOCOMOTIVES IN ENGLAND.

In view of the great difficulty in making a comparison between two locomotives or two classes of locomotives when all concerned use their utmost endeavors to get the real facts it is not at all strange that the American locomotives on the Midland Railway of England are reported to be wasteful. The reported extra working costs over the English engine in the same service for six months are:

Fuel	20-25%
Oil	50%
Repairs	60%

As to oil and repairs nothing can be said without knowing more than we know about the conditions, but with reference to fuel we believe that there is as much as 25 per cent. variation to be expected in the adjustment of the front end arrangements to suit English coal, plus a lack of personal interest in the success of the American engines which was to be expected, because of the bitter criticisms of the policy of buying the engines in this country. No one expected the American engines to come out ahead. It would not do at all to have them beat the English machines, even if they could do so under favorable circumstances—which we decidedly doubt. This is an opportunity, however, for a most interesting locomotive study, though it may not be made. It suggests a question which American designers would profit by satisfactorily answering, viz.: Why do English engines, in general, do such good work with such small heating surfaces?

There is no profit in blindly defending one's own practice in the face of an opportunity to improve it. This affair is merely an interesting example of American methods whereby an emergency was quickly and satisfactorily met. As a comparison it is equivalent to matching our rough and ready practice of years ago with the polished and highly finished methods of a conservative and steady development under the most highly concentrated attention the locomotive has ever had. It is utterly impossible to compare present representative American and English locomotives for reasons too well known to require explanation.

We confidently believe, however, that it would be profitable for an American road to import an English engine and make a study of its operation under conditions adapted to its capacity.

The following quotation from "Engineering" illustrates a broad-minded view, which is as intelligent as it is commendable:

"In regard to the detail of fuel economy, we should not be at all surprised to find that British locomotives have a superiority. It is a question, however, whether we in this country have not made fuel economy a feature to which too much has been sacrificed. It is a detail of expenditure, doubtless an important one, but it is possible to overestimate its value. The American railway manager takes the view that a few dollars extra spent on coal is a profitable outlay if it enables an engine to do more work, better time to be kept and other economies to be secured in regard to capital expenditure and wages.

"These things, like other points raised, need working out quantitatively, so as to give a just balance on the total of expenditure and return. It may be that British engines would show a superiority. We cordially hope such might prove to be the case, but on the information we possess we are assured that American competition in nearly all branches of engineering industry is not a thing lightly to be dismissed, in the way that some optimistic persons in this country would have us dismiss it. This is more true of some other engineering products than of locomotives. Steel bridge builders, especially would do well to bear it in mind.

"It may be thought that we, like the railway officials (according to Sir Alfred Hickman), seem resolved to screen the Americans at all costs. We are careless as to such an accusation. Unlike Sir Alfred Hickman, we believe that American competition in the engineering industry is an extremely serious

question, with which British engineers must deal in a most strenuous manner, and we are of opinion that it is the height of folly to put aside unpleasant facts by cavilling criticism on details."

MALLEABLE IRON OIL CUP.

Minneapolis, St. Paul & Sault Ste. Marie Railroad.

Theft and breakage of brass oil cups is leading many to the use of cheaper materials. The description of the malleable iron oil cup devised by Mr. McIntosh, of the Central Railroad of New Jersey, illustrated on page 323 of our October number of last year, attracted the attention of Mr. T. A. Foque, Mechanical Superintendent of the "Soo" Line, and led him to send us a drawing of a design which seems to have excellent features.

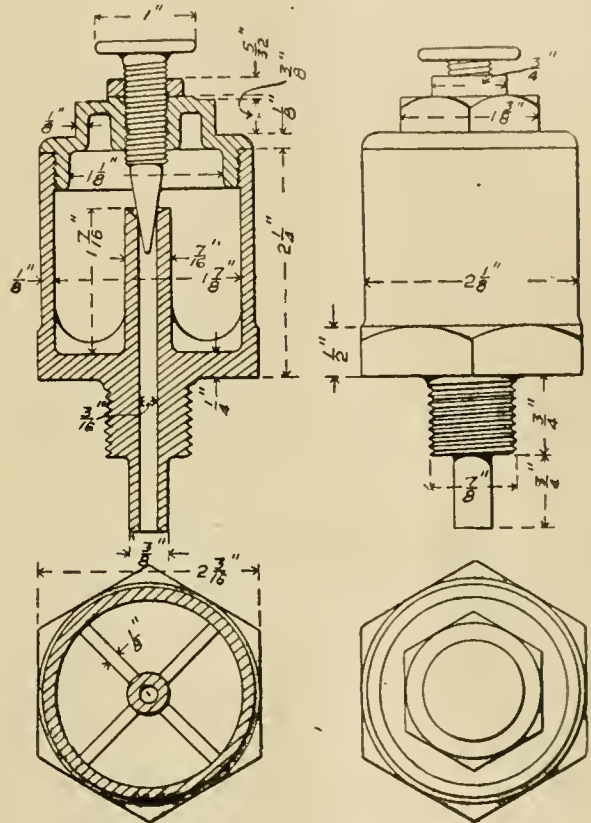

Malleable Iron Oil Cup.

This cup has a regulating needle similar to that of the New Jersey Central, but Mr. Foque has made it accessible from the outside of the oil cup without requiring the cap to be taken off in order to regulate the feed. It is held in the desired position by the lock nut on the top of the cup. This design has the additional advantage of placing the wrench at the bottom of the cup instead of the top, when screwing it into place. The desire to secure oil cups from loosening often results in too vigorous use of the wrench and the weakening of the cup if turned from the top, unless it is made very strong. Mr. Foque says that losses of oil cups by breakage and loosening from the rods are now almost unknown. His oil cup is not large, but it is found to be ample for all conditions of service.

A fast run made by the Chicago & Northwestern fast mail train June 30 from Clinton to Boone, Iowa, is worthy of record. According to the train sheet report the distance of 202 miles was made in 187 minutes actual running time, at an average speed of 64.8 miles per hour. The weight of the train exclusive of the engine was 179 tons.

(Established 1832.)
**AMERICAN
 ENGINEER**
 AND
RAILROAD JOURNAL.

PUBLISHED MONTHLY
 BY
 R. M. VAN ARSDALE,
 J. S. BONSALL, Business Manager.
 MORSE BUILDING.....NEW YORK

G. M. HASFORD, Editor.
 E. E. SILK, Associate Editor.

AUGUST, 1901.

Subscription.—\$2.00 a year for the United States and Canada; \$2.50 a year to Foreign Countries embraced in the Universal Postal Union.

Remit by Express Money Order, Draft or Post Office Order.

Subscriptions for this paper will be received and copies kept for sale by the

Post Office News Co., 217 Dearborn St., Chicago, Ill.
 Danrell & Upham, 283 Washington St., Boston, Mass.
 Philip Roeder, 507 North Fourth St., St. Louis, Mo.
 R. S. Davis & Co., 346 Fifth Ave., Pittsburg, Pa.
 Century News Co., 6 Third St. S., Minneapolis, Minn.
 Sampson Low, Marston & Co., Limited, St. Dunstan's House, Fetter Lane,
 E. C., London, England.

EDITORIAL ANNOUNCEMENTS.

Advertisements.—Nothing will be inserted in this journal for pay, EXCEPT IN THE ADVERTISING PAGES. The reading pages will contain only such matter as we consider of interest to our readers.

Contributions.—Articles relating to railway rolling stock construction and management and kindred topics, by those who are practically acquainted with these subjects, are specially desired. Also early notices of official changes, and additions of new equipment for the road or the shop, by purchase or construction.

To Subscribers.—The AMERICAN ENGINEER AND RAILROAD JOURNAL is mailed regularly to every subscriber each month. Any subscriber who fails to receive his paper ought at once to notify the postmaster at the office of delivery, and in case the paper is not then obtained this office should be notified, so that the missing paper may be supplied. When a subscriber changes his address he ought to notify this office at once, so that the paper may be sent to the proper destination.

Matters in car design are moving very rapidly just now, and when it is remembered that there have been but about four years' experience with steel cars the progress is remarkable. In addition to the many designs of cars built entirely of steel a large number of wooden cars with steel underframes have been brought out. It is in this direction that the chief development of the immediate future may be expected, and particularly now that it is practically assured that the American Railway Association is to recommend a standard car at its next convention. Much has been heard of late concerning the weaknesses and inadequacy of draft gears, but little has been heard concerning the increased expense of maintaining cars having wooden underframes. Recently a representative of this journal, in looking up the subject of steel cars, discovered that one large road has reached the conclusion that in these days of heavy trains and powerful locomotives it does not pay to build cars with wooden underframes. In investigating a large increase in the cost of repairs of wooden cars, particularly for end sills and longitudinal sills, it was found that the trouble was by no means confined to old and weak cars, but that it applied equally to well-constructed and relatively new cars of 30 tons capacity. On the other hand, steel cars of large capacity had given almost no trouble in these parts. This led to the important decision to at once establish the rule that in future construction steel underframes will be used for all standard freight cars, whatever the type. On the road referred to it is the opinion that it will not pay to continue to use wooden sills, and that present methods of operation will soon drive all roads to this conviction,

While the mechanical departments of American railroads are being crowded in the matter of capacity of locomotives, and with the present tendency will find it difficult to meet the requirements for power, it is clear that in the capacities of cars they are far ahead of the present abilities of the operating departments in the matter of loading. The increase in capacity of the freight car has not been accompanied by a corresponding increase in the loads carried, and considerable improvement will be necessary before the increased cost of 40-ton above that of 30-ton cars will be earned. A competent authority places the actual loading of cars at not above 55 per cent. of the nominal capacity, considering the railroads of the country, as a whole. It is only in grain, coal, ore or similar traffic that full loads are always insured, but by careful watching of the loading at local points the average of miscellaneous freight will gradually be raised. There is now a great waste of equipment, and the benefits to be derived from increasing car loadings will be apparent at once. They will appear in decreased car mileage, decreased train mileage, switching cost and in increased earning capacity of the entire road because of the more profitable use of facilities. The present situation is not in the least an argument for smaller cars. It is the strongest argument for larger ones. It shows, however, the deficiencies in present methods of loading.

A new and probably entirely unexpected development from the wholesale application of air brakes and improvements in modern car construction has become noticeable. With the increased number of freight cars equipped with air brakes, it is no longer necessary for the brakemen to spend a large part of their time on the top of the cars, because the brakes are handled by the engineer and the brakemen spend a large proportion of their time in the caboose. That there is a strong tendency for them to do this is unquestioned, and with the increasing lengths of trains, due to the increase in the capacity of locomotives, this has brought about a situation which may become dangerous. In fact, it has already done so. Recently a large steel shaft for a stationary engine broke loose from its fastenings on a flat car in transit over a well-known railroad and it fell across the rails of the adjoining track, just before the arrival of a passenger train going in the opposite direction. Fortunately it fell at a spot where it closed the rail circuit of the automatic signal system and put to "danger" the automatic signal controlling that track. The passenger train was stopped in time to avoid a serious accident. In this case the freight train was well supplied with air brakes and the trainmen, not being required to go over the train, were not aware of the loss of the shaft until their attention was called to it by persons not connected with the train. This incident indicates the advisability of inaugurating a systematic method of inspecting the train in order to take the place of that which was formerly done through the necessity for the man to go over the cars frequently. In passenger service a somewhat similar difficulty exists. Because of the tightness of the vestibules and the gradual increase of the lengths of runs between stops for fast trains, it is beginning to be appreciated that hot boxes are not as easily detected as formerly. Several roads have recently experienced the entire burning off of journals through failures of the trainmen to detect hot boxes in time. The vestibules render it difficult to detect them by the odor and it is evident that something new in the way of inspection is needed in passenger service also.

In establishing locomotive ratings there seems to be a tendency toward overdoing the tonnage by assigning more than a locomotive can be sure to haul satisfactorily to the operating department. It is far better to allow too much rather than too little lee-way for the condition of the weather and rail. It is also advisable to allow some elasticity as to speed so that when necessary a little spurt may be made to assist the movement of other trains. Considerable criticism of the mechanical

departments may be avoided by care in considering these variables in the preliminary ratings. There is no thing that will earn the epithet "theoretical" more quickly than to offer a rating which burdens the operation of trains.

PERSONALS.

H. L. Preston, for the past 17 years Master Car Builder of the Chicago, St. Paul, Minneapolis & Omaha, died at his home in Hudson, Wis., June 28.

Mr. Joseph O. Osgood has been appointed Chief Engineer of the Central Railroad of New Jersey to succeed Mr. J. H. Thompson, assigned to other duties.

Mr. J. H. McConnell, recently Superintendent of Motive Power and Machinery of the Union Pacific, has been appointed Manager of the Pittsburg Locomotive Works.

Mr. J. H. Stubbs, General Foreman of the Union Pacific shops at Armstrong, Kan., has been appointed Master Mechanic, with headquarters at North Platte, Neb., and will have jurisdiction over the main line of that road from Grand Island to Cheyenne.

Mr. Wm. A. Nettleton, Superintendent of Motive Power and Machinery of the Kansas City, Fort Scott & Memphis and the Kansas City, Memphis & Birmingham, has resigned and Mr. F. A. Arthur is appointed Acting Superintendent of Motive Power and Machinery.

Mr. Frank W. Morse, Superintendent of Motive Power of the Grand Trunk, has been appointed to the position of Third Vice-President and Assistant General Manager, and Mr. W. D. Robb, Master Mechanic of the Middle and Southern Divisions, is in turn appointed Acting Superintendent of Motive Power of that system.

Mr. W. S. Haines has been promoted to succeed the late F. W. Diebert as Assistant Mechanical Superintendent of the Baltimore & Ohio at Newark, Ohio. Mr. Haines is succeeded at Mount Clare by Mr. H. M. Brennan, who was formerly chief boiler inspector.

Mr. A. E. Mitchell, who has been Superintendent of Motive Power of the Erie Railway since 1892, has been appointed Mechanical Superintendent of that road and his former position has been abolished. Mr. Mitchell has had a very wide and successful experience and is one of the best-known motive power officers in this country.

Mr. Joseph Ramsey, Jr., Vice-President and General Manager of the Wabash, has been elected President of that road to succeed Mr. O. D. Ashley, made chairman of the board of directors. Mr. Ramsey has been Vice-President and General Manager of the Wabash for the past five years and was formerly General Manager of the Cleveland, Cincinnati, Chicago & St. Louis.

Mr. A. H. Fetters, has resigned his position with the Baldwin Locomotive Works to go to the Union Pacific Railroad as Chief Draftsman. He was formerly with the Erie Railroad in a similar capacity and then Assistant to Mr. T. H. Curtis, Mechanical Engineer of that road. Mr. Fetters is a graduate of Lehigh University and received his early training at the Baldwin Works where he was a draftsman for seven years.

Jacob S. Rogers who, for many years was the owner and head of the Rogers Locomotive Works, died in New York July 2, at the age of 77 years. In 1856 he took charge of the locomotive works which had been founded by his father. In 1891 Mr. Rogers placed the management in the hands of Mr. R. S. Hughes, who continued in charge until his death two years ago. At that time Mr. Rogers announced his intention to sell

or close the works in spite of the fact that they were busy and on a satisfactory paying basis. They have been sold, as recorded in these columns, and are now running.

Mr. Walter D. Crosman, who was for many years engaged in editorial work on the Railway Review, Railway Age and Railway Master Mechanic in Chicago, has resigned his editorial charge of the last-mentioned publication to become the Western Representative of the Gold Car Heating Company, with headquarters in the Rookery Building in Chicago. Mr. Crosman's long and thorough familiarity with technical railroad subjects and his exceptionally wide acquaintance will be specially valuable in his new undertaking, but we regret his loss to the profession with which he has been identified so long and so successfully. Having, however, made the decision to lay aside the arduous work of the editor, he is to be congratulated upon his new position and the Gold Company upon securing his services.

Mr. J. F. Deems, Assistant Superintendent of Motive Power of the Chicago, Burlington & Quincy, has been appointed to succeed Mr. F. A. Delano as Superintendent of Motive Power with headquarters in Chicago. Mr. Deems has had a long and successful experience on this road, his rapid progress beginning in his promotion from the position of Master Mechanic at Ottumwa, Iowa, to a similar position at Creston, about six years ago. He has long been considered as a leading motive power officer in the Middle West and is sure to be a credit to the succession of such men as Mr. Rhodes and Mr. Delano. His thorough and painstaking methods, his conscientious and business-like conduct of his work, together with fair and open handed treatment of his subordinates, we should say, are the reasons for his success. We cannot help commenting upon the desirability, of which this case is an example, of the policy of developing the staff of a department so that the advance of its chief finds a well qualified successor already in the employ of the road.

Mr. P. S. Blodgett, who has recently become General Superintendent of the New York Central, and formerly held the same position with the Lake Shore, was recently presented with a testimonial of esteem from his former associates in the form of the finest watch which the Webb C. Ball Company of Cleveland makes. The presentation was informal and the feeling leading up to it was unquestionably appreciated.

We are continually receiving requests for references of good men for positions as foremen, draftsmen, and particularly for leading draftsmen who can take complete charge of locomotive work, keeping several other draftsmen busy. We shall be glad to receive additional applications from men qualified to fill these positions and especially request the large number who have secured positions through our aid to notify us of the fact and give us their new addresses. There is no charge whatever for this service. Our object is to encourage young men and to assist in placing them advantageously. Our compensation is in the satisfaction of bringing together the men and the opportunities. The list is large and has been very valuable to many young men and to the railroads. It can be made more so if all those who desire and are qualified for better positions will meet us halfway.

A delay of but 22 hours from service for the repair of a locomotive frame by welding is a record performance described recently before the Pacific Coast Railway Club. It was done at the West Oakland shops of the Southern Pacific by aid of an oil burner. Little boxes of fire brick were built around one of the frames that was broken in two places and with an oil flame from an atomizer burner the frame was heated sufficiently for welding, the work being done without removing the frame from the engine. This engine broke down at night, 20 miles from the shop, and was back at the same place ready for work in 22 hours. The welds were under the rocker box and the work was done before the steam had died off in the boiler.

WESTINGHOUSE ELECTRIC BRAKE AND HEATER.

This apparatus combines the brake with the heater. The power of the brake is derived from magnetic track shoes and the heater derives its heat from the electric energy of the motors used as generators. The two parts of the apparatus may be used independently or together. It is a remarkably ingenious and almost ideal combination. The brake operates independently of the trolley current, a great safeguard.

The Brake.

The brake proper comprises a double shoe combined with a powerful electro-magnet, which, when energized by the car motors acting as generators, is strongly attracted to the rail by magnetic force, combined with brake heads and shoes of the ordinary type, acting directly on the wheels and constituting a wheel brake of maximum power and efficiency, and various castings and forgings for simultaneously transmitting the downward pull and resultant drag of the magnetic track brake into lateral pressure upon the wheels. The combination of these three elements in duplicate, together with the necessary tie-rods and attachments, constitutes an equipment designed for application to a four-wheel, or single-truck car; a double-truck equipment is required for an eight-wheel car. In addition to the truck equipment, a complete brake includes brake controller attachments for use when the motor controllers are not provided with braking points, and a diverter, or improved form of rheostat, for dissipating any excess of heat when the heaters are not in service.

Figs. 1 and 2 illustrate the arrangement and construction of the apparatus; also the method of attaching the brake rigging to the truck, and of suspending the track shoes and magnet frames. When the brake is not in operation the suspension springs carry the track magnets and shoes, entirely clear of the rails, and by means of their flexibility, permit the shoes to ride over any obstruction not sufficient to cause the car to

be stopped. When the brake is applied (through the saturation of the magnets with current supplied by the car motors acting as generators) three distinct effects are produced: 1. A noticeable increase in the pressure of the wheels on the track, because of the downward pull of the magnets; 2. A pronounced retardation by reason of the friction generated between the track shoes and rails; 3. A maximum braking effect on the wheels, obtained through the transmission of the resultant drag of the track shoes to the brake shoes.

The net result of these three effects is a much higher braking power than can be obtained by the use of any other brake without skidding the wheels; moreover, the feature of a powerful track brake, which, instead of decreasing the weight upon the rails at the wheels, actually increases it, is as unique as it is valuable, and it is in this feature that this brake differs from all other track brakes. Other forms have proved distinctly inferior because of their tendency to decrease the hold of the wheels upon the rails. It is highly important not to lessen but rather to increase the pressure of the wheels upon the rails in the manner obtained by the magnetic brake. While the thrust against the wheel-brake shoes, caused by the drag of the track shoe is similar to the thrust obtained in the well-known air-

brake, the magnetic brake has a decided advantage in that the brake-shoe pressure is automatically regulated by the condition of the rail surface. This is a fortunate feature, which gives the highest braking power at all times without danger of wheel-sliding.

There is still another automatic adjustment of braking effect, scarcely less interesting, if somewhat less important. It is well known that, when the motion of the car is being rapidly retarded, the forward wheels carry a somewhat greater proportion of the weight resting upon the truck: from this it follows that by placing the fixed lower fulcrum of the forward brake-shoe lever slightly above the pin connecting it with the telescope rod, as shown in Fig. 1, a brake-shoe pressure is applied to the forward wheels proportionately greater than that acting upon the rear wheels; when the car is reversed, the governing conditions are also reversed and entirely satisfactory results attained—the levers and connections being so designed that, when properly adjusted, the highest possible braking power is secured, without reference to the direction in which the car moves.

As previously explained, the track magnets are energized by current obtained from the car motors acting as generators.

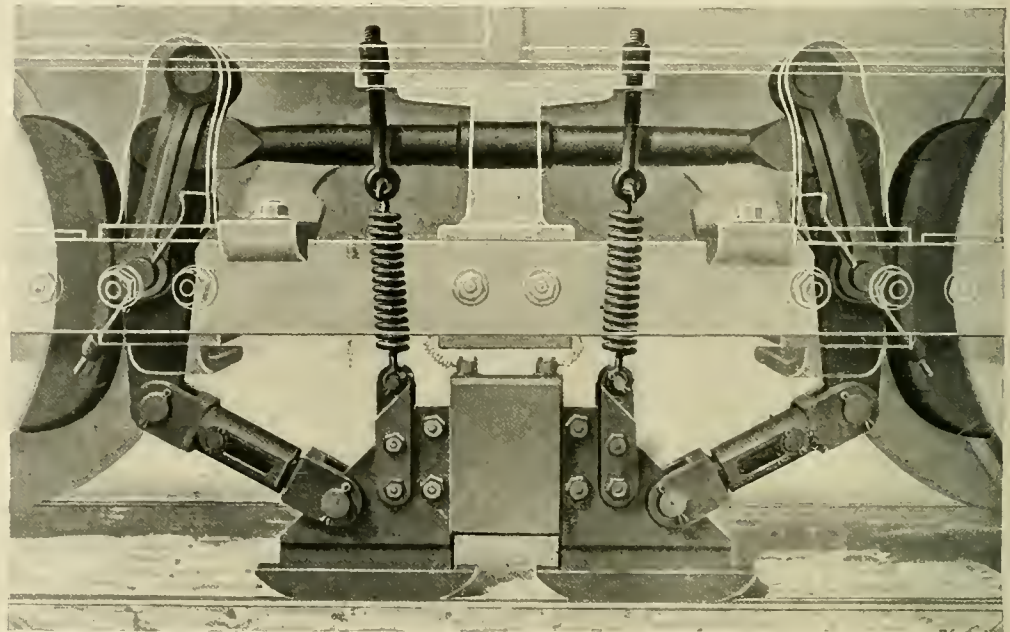

Fig. 1.

which not only obviates any expense in that connection, but also effectually prevents the possibility of accident through sudden failure of line current. The current necessary for the required magnetization is uniformly kept within safe limits by a proper adjustment of resistance always in circuit with the brakes, thus avoiding any injurious effect on the motors.

An additional advantage gained by the use of the magnetic brake is found by employing an improved form of rheostat, or diverter (which has a constant resistance regardless of the heating produced by a continuous flow of current) in the automatic control of speed down long and steep grades. This result is owing to the fact that a certain resistance in the rheostat insures a fixed current flow at a given speed; and this resistance can be readily adjusted so as to permit just enough current to pass through the track-shoe magnets to hold the car at the required speed, against the action of gravity, on any grade: any increase in speed increases the current and causes the brakes to act with greater force, while a decrease in speed instantly decreases the current and the brake action at the same time, so that the speed of a car may be automatically regulated within narrow limits regardless of changes in the gradient. This brake can be readily applied to trail cars by properly

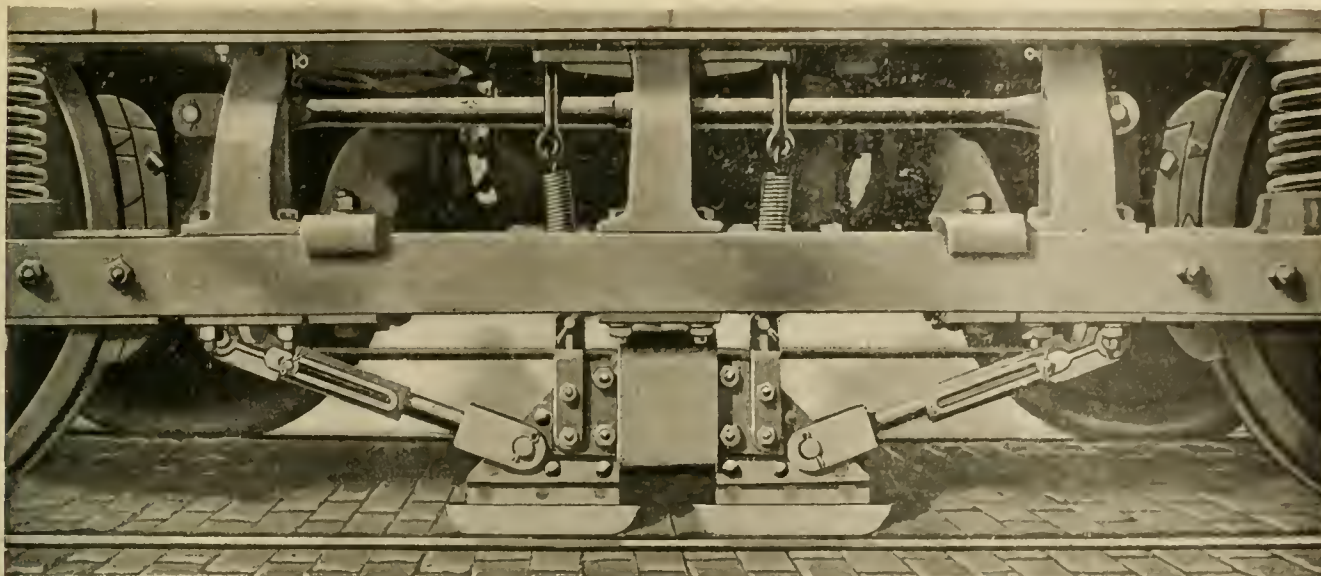

Fig. 2.

attaching the track magnets and accessories to them and connecting the magnetic coils to the wiring system of the motor car.

The Heater.

The heaters are connected with the general system of wiring by means of a suitably arranged switch, so constructed that the braking and starting currents, both of which are used for heating the car in cold weather, may be divided as desired and the whole or any portion thereof sent through the heaters, the remainder going through the proper portion of the diverter beneath the car. Whatever portion of the total actual current is flowing through the heaters flows through every section alike, which results in heating the car uniformly, no matter how small the amount of heat required. The ordinary electric car heaters, in which the heat is generated by line current, have so small a storage capacity that they are cooled to atmospheric temperature very quickly when, for any reason, the current is interrupted. An important advantage of this heater is its great capacity to store and retain heat within its mass. In the event of blockades or of the failure of line current from any cause this heat storage capacity is so great that the car is kept comfortable for an hour or more, even in severe weather.

EDISON'S NEW STORAGE BATTERY.

We believe we violate no confidence in stating that Dixon's Pure Flake Graphite forms one of the materials in Edison's new storage battery, which is attracting such marked attention throughout the world. The manner in which the graphite is used is explained by Mr. Edison as follows: "The construction of one cell is as follows: In a steel sheet a number of holes are punched—twenty-four, in fact, and in each one is placed a steel box, thin and perforated with minute holes. The active material is made in the form of briquettes, and is contained in these little steel boxes. The briquettes are condensed under a pressure of one hundred tons, which insures their being absolutely rigid. The positive briquettes are composed of a finely divided compound of iron obtained by a special chemical process, mixed with an equal portion of graphite. The graphite does not enter into any of the chemical processes, it simply assists the chemical conductivity. The negative briquette is obtained by similarly mixing finely divided nickel, also obtained by a secret process, with an equal bulk of graphite. This is solidified in the little steel boxes as in the case of the iron. These two plates, one containing twenty-four of the iron and graphite boxes, and the other twenty-four of the nickel and graphite boxes, constitute one cell of the battery. Of course, there can be as many of these cells as the experimenter desires to use. The two plates are placed in a vessel containing the potash solution, and the primary cell is complete."—"Graphite."

MECHANICAL STOKERS VS. HAND FIRING.

The efficiency of firing boilers by mechanical stokers has never approached the best performance of hand firing and there is no reason to expect them to exceed it, even if they should equal it. There are advantages, however, in favor of mechanical stokers in many plants, as they often save a large proportion of the labor. A cheaper grade of coal may be used. And the cost of repairs on the boilers is often diminished by reason of the more even temperatures. But there are many advantages offered in favor of the mechanical stoker which are based on the results obtained from comparative tests of stokers against hand firing, which are not fair comparisons, as the furnaces chosen for this purpose are usually old and inefficient ones, while the stoker furnaces are new and well laid out. We would naturally expect the stokers to prove more favorable in such cases. And again, tests unfavorable to stokers might occur if an old stoker plant was tested and then replaced by a first-class furnace arranged for hand firing.

There are few cases where an increase of efficiency in the use of coal will alone warrant the expense of stokers. Those responsible for a plant contemplating the use of stokers should then consider carefully the saving on labor, the prevention in smoke and ascertain if their use will permit of a cheaper grade of coal being burned than could be burned by hand firing. Many plants have been installed on the strength of the use of cheaper coals, when slight changes in the grates or furnaces would have enabled the cheaper coal to be burned by hand and at a much smaller expense.

In small plants containing one or two boilers there is no saving in labor and there is hardly a case in such plants where stokers will even begin to pay interest on their cost. On the other hand, many large plants, especially those running twenty-four hours a day, will show the use of one of the first-class automatic stokers to give a very satisfactory net return on the cost of its installation, by reason of the saving in labor alone.

Messrs. R. S. Hale and J. S. Codman, in an article on coal saving by means of mechanical stokers ("Mechanical World"), gives the best authentic performance of hand firing as 86.8 per cent. without the use of an economizer and an efficiency of 90 per cent. with the use of an economizer, which is, as yet too high a figure for the mechanical stoker to reach.

At a cost of between \$15,000 and \$20,000 the Boston & Maine management has again gratuitously supplied its employees with new uniforms.

RULES FOR INSPECTION OF SAFETY APPLIANCES,
 WITH CLASSIFICATION OF DEFECTS TO BE
 REPORTED.

Adopted April 1, 1901, by the Interstate Commerce Commission.

Rule 1.

A.

Previous to examining equipment, inspectors shall make themselves known to the foreman or other official of the mechanical department, or, in the absence of that officer, to the agent or other employee next in authority. In all cases have name and title of such officer or employee included in report of defective cars. Whenever practicable, the official found in charge should be invited to accompany or send a representative with the inspector, and the person so accompanying the inspector should have his attention drawn to all defects likely to endanger life or limb.

Rule 2.

B.

Report location of all curves in yards and sidings where M. C. B. coupler will not couple or remain coupled, the practice generally followed where such curves exist, and whether any special device is employed.

Rule 3.

C.

Section 1. Secure information when practicable in reference to practice of handling brakes on descending grades. Ascertain whether hand brakes are used, and to what extent.

Sec. 2. Ascertain what inspection is given to air-brake cars leaving terminals, and whether engineers are informed of exact number of air-brake cars with effective brakes.

Sec. 3. Observe closely whether air-brake defect cards are attached or not. These cards are of two kinds: One designates that the car can not be placed between air-brake cars at all, on account of certain defects; the other signifies that the car may be used with air-brake cars as a means of continuing the connection, but that the brake on that particular car is inoperative. These cards indicate defects which should be repaired promptly; report if this is done.

Sec. 4. Pay special attention to the making-up of trains with reference to the placing of air-brake cars in forward end of train.

Sec. 5. Inspect heavily loaded cars sagging in the middle for leaky air pipes.

Rule 4.

D.

Section 1. Special attention should be given to grab irons on roofs of cars, and when reporting loose grab irons, state whether secured with lag screws or bolts and to a substantial part of car frame.

Sec. 2. As loose handholds and grab irons may originate in car shops, observe closely new cars and those a few months out of shop. Report all defects found in running boards and ladders, whether constructed of iron or wood.

Sec. 3. Report as to the result of the use of pivotal couplers on locomotives assigned to switching.

Sec. 4. Note to what extent men have to go between cars to couple them during the making-up of trains. Also to what extent men step in to open or close knuckles by hand. This should be ascertained by careful observation.

Sec. 5. State whether locomotives are equipped with M. C. B. type of coupler, noting if on end of tender only or on tender and front end.

Sec. 6. State fully all particulars of any other than the M. C. B. type of coupler found on coaches or cars of all kinds.

Sec. 7. Note on report of defective cars whether your inspection was made prior to inspection by railway company's inspector, and, if possible, show disposition of cars found defective.

Defects of Couplers and Parts.

1. Broken coupler body. 2. Broken knuckle. 3. Broken knuckle pin. 4. Broken locking pin or block. 5. Bent locking pin or block. 6. Wrong locking pin or block. 7. Wrong knuckle pin. 8. Worn locking pin or block. 9. Worn couplers or knuckles, as per M. C. B. limit gauge. 10. Short guard arm. 11. All missing parts of coupler complete, except cotter pins in knuckle pins. 12. Inoperative locking pin or block.

Nos. 5, 6 and 7 are defective only when interfering with safe

operation. Nos. 8 and 9 are defective only when worn sufficiently to destroy contour line by allowing lost motion to approach the danger point as shown by M. C. B. limit gauge.

Defects to Uncoupling Mechanism.

21. Broken uncoupling lever. 22. Broken chain. 23. Broken end lock or end casting. 24. Broken inner casting or keeper. 25. Bent uncoupling lever. 26. Chain too short. 27. Chain too long. 28. Loose end lock or end casting. 29. Loose inner casting or keeper. 30. Wrong end lock or end casting. 31. Wrong inner casting or keeper. 32. Uncoupling lever improperly applied or of wrong dimensions. 33. Missing uncoupling levers, and locks or end castings, inner castings or keepers, chain, clevis or clevis pins. 34. Chains kinked, making them too short.

No. 25 is defective when interfering with its proper operation or making it difficult to operate. Nos. 28 and 29 are defective when the proper operation of the uncoupling mechanism is interfered with. Nos. 30 and 31 are defective when interfering with proper operation of uncoupling lever to the coupler for which it was designed. No. 32. Under this head report all uncoupling levers which are too long, too short, too close to cars or other parts; give details of each. Judgment should be used in connection with the defects under No. 32.

Defects of Visible Parts of Air Brakes.

41. Defective triple-valve casting. 42. Defective reservoir casting. 43. Defective cylinder casting. 44. Defective cut-out cock. 45. Defective release cock and broken release rods. 46. Defective angle cock. 47. Defective train pipe (broken or loose). 48. Defective cross-over pipe. 49. Defective hose. 50. Defective hose gasket. 51. Defective brake rigging, beams or brake shoes. 52. Defective retaining valve. 53. Defective retaining-valve pipe. 54. All missing parts. 55. Air brakes cut out; when possible give reason why. 56. Whether cylinder or triple valve has been cleaned in six months preceding. 57. Whether locomotives moving interstate traffic are equipped with driver brakes and appliances for operating the train brakes.

Note.

Defects Nos. 41, 42, 43 and 48 are such as ordinarily exist only after cars have been wrecked, but are mentioned here to define the defects of visible parts.

Defects to Handholds.

81. Handholds missing. 82. Handholds improperly applied. 83. Handholds bent. 84. Handholds broken. 85. Handholds loose.

Note.

Application of handholds and grab irons should be governed by recommended practice of the M. C. B. Association. A standard location for these parts is essential for safe operation at all times and especially at night.

Defects in Height of Drawbars.

91. Empty cars too high. 92. Empty cars too low. 93. Loaded cars too low. 94. Loaded cars too high. 95. Loose carrier iron or stirrup.

Note.

On standard-gauge roads the maximum height is 34½ ins., measured from level of tops of rails to the center of the drawbar (coupler body) or corresponding line in coupler head. Greatest variation allowed from such standard height between drawbars of empty and loaded cars is 3 inches.

On narrow-gauge roads the maximum height is 26 ins.; extreme variation allowed between drawbars of empty and loaded cars is 3 ins.

Inspectors must exercise judgment in determining defects of this class. See that car is standing on an approximately level track before measurements are taken.

Minimum height for loaded or empty cars, standard or narrow gauge, is 31½ ins. An empty car having a drawbar 31½ ins. high is defective because when loaded it must fall below the minimum of 31½ ins.

It is certainly an impressive fact that if all the standards of length in existence should by any means be lost or destroyed skilled mechanics can now reproduce these standards within the limit of error of one millionth of an inch. Such refinement is interesting to all and while its practical value is limited to the field of physical research one can but admire the skill of those who can measure and work to these limits. Professor Gale describes his methods and apparatus for doing this in recent numbers of the "American Machinist."

FUEL VALUE OF SAWDUST.

The fuel value of sawdust and pine edgings compared with Youghiogheny coal is given by Mr. F. W. Cappelen, City Engineer of Minneapolis, in a recent issue of "Ryerson's Technical Library." At the north side pumping station of that city is a battery of six corrugated boilers with Morison suspension furnaces.

The sawdust is fed automatically by a chain carrier delivering it through a hopper into an outer furnace provided with closely set grates, the bars of which are pierced with holes. The flames and gases pass from this outer furnace through an inclined steel plate extension to the boilers, thence through the Morison corrugated furnaces in the usual way. The sawdust may be quite wet and yet burn freely. A diagram of the arrangement of the furnace is presented in the accompanying engraving.

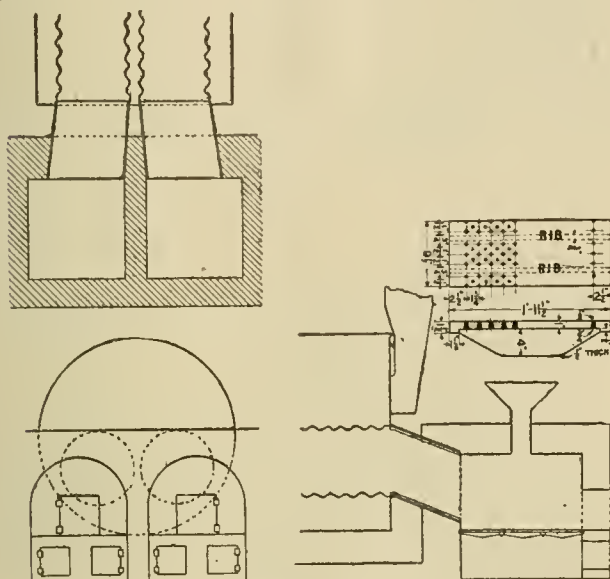

Arrangement of furnace for burning sawdust.

Mr. Cappelen gives the following figures as to the fuel value of sawdust and pine edgings, as compared with the best lump coal in the plant in question:

It requires 3.98 cords of fairly good sawdust to pump 1,000,000 gallons of water against a head of 193 ft.

It requires 1.88 cords of dry 4-ft. edgings to do the same work.

It requires 2,146 lbs. of Youghiogheny lump coal to do the same work.

This would indicate that a cord (128 cu. ft.) of sawdust had the fuel equivalent of 538 lbs. of coal, in actual practice, though the fact that the coal and the edgings are fed directly into the boiler furnace, while the sawdust is burned in an outer oven, involving a loss of heat before reaching the furnace, would show a theoretical value considerably greater.

The proposed School of Technology which is to be established in the city of Pittsburg by Mr. Andrew Carnegie will probably consist of three grades of schools to be called the Carnegie Technical College, the Carnegie Technical High School and the Carnegie Artisan Day and Evening Classes. The Technical College will teach all branches of engineering to high school graduates. The Technical High School will provide for the graduates of the grammar school instruction in foundry practice, pattern making, brass foundry, metal working, steam engine and steam boiler operation, gas manufacturing and electricity. The Day and Evening Classes will offer opportunities in technical training to those who cannot take advantage of the more complete courses. This is an outline of the report of the advisory committee appointed by the board of trustees of the Carnegie Institute of Pittsburg to prepare a plan.

BRAKE SHOES BY THE AMERICAN BRAKE SHOE COMPANY.

A little pamphlet recently issued by this company contains the following concise resume of the objects sought by each type of shoe manufactured by them:

Driving Brake Shoes.

Skeleton Steel—Maximum strength, minimum weight, maximum tire dressing.

Skeleton Steel Inserts—Strong dressing effect, strong frictional effect, durable.

Diamond "S" Skeleton—Maximum frictional effect, moderate dressing effect.

Improved Combination—Maximum durability, with strong dressing effect.

Reinforced Steel Insert (Herron) Driving Shoes—Maximum strength, strong dressing effect, durable.

"U" Shoe, Ross or Skeleton—Maximum durability, maximum frictional effect.

Coach and Car Shoes.

Flange Diamond "S"—Maximum friction, best results on tires. Unflanged Diamond "S"—Strong retarding effect, effective service, good durability.

The "U" Brake Shoe—Steel Tired and Chilled Wheels—Maximum durability, maximum strength, maximum retarding effect consistent with these.

Reinforced Steel Insert (Herron) Coach Shoe—Maximum strength, maximum durability.

HEAVY VERTICAL BORING MACHINE.

The Bentel & Margedant Co., manufacturers of wood-working machinery, have placed on the market a six-spindle car boring machine which is designed for the heaviest work in car shops and ship yards. The boring spindles shown in the accompanying illustration of this machine are each driven by an independent belt and will take augers up to 3½ ins. in diameter. This allows any of the spindles to be thrown out of motion when desired and gives a greater amount of power as no idler pulleys are used. The spindles have a vertical movement of 14 ins. and are adjustable back and forward across the width

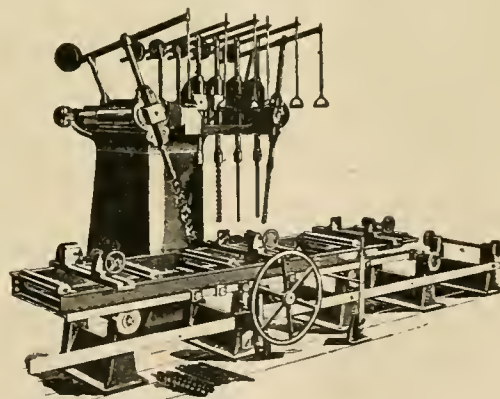

Six-Spindle Vertical Car Boring Machine.

of the table with a range of 16 ins. In addition to these movements the two outside spindles have a radial motion in either direction for boring angular holes. An automatic traveling table of any desired length from 10 to 40 ft. rests and moves on the top of large rollers placed at intervals in heavy housings. These housings all run in dove-tail slides and are adjusted by means of screws and hand-wheels. The feeding of the table is done by a heavy pinion running in a rack and driven in either direction by reversible friction pulleys. For short distances and work requiring accurate setting, a lever ratchet hand feed is provided for feeding the table. The address of the Bentel & Margedant Co. is Hamilton, Ohio.

THE NORWOOD SYSTEM OF BALL BEARINGS AND CENTER PLATES.

It was noticeable at the Saratoga convention this year that more than the usual amount of attention was paid to car side bearings and center plates. This was apparent in the number of devices exhibited and in the interest which they aroused. Among these exhibits was that of the Norwood system of ball bearings, of the Baltimore Ball Bearing Co., Baltimore, Md. The special features of the exhibit last year was the suspension

TROPENAS STEEL OIL CUPS.

The castings shown in the accompanying engraving in the form of oil cups are the most recent products of the Sargent Company, of Chicago. These cups are made by the Tropenas steel process, which produces a casting that is exceedingly tough and in cost is very reasonable. They are made in any size and shape, and with the addition to the company's Tropenas department which is now under way, a large line of these high-grade castings will be kept in stock so that orders



The Sargent Company's Tropenas Steel Oil Cups.

of the balls to keep them free from dirt and the side rolling movement, to prevent the balls from wearing flat. We are informed that these bearings are giving good results.

This year the Norwood Diamond Center Plate and Side Bearing were brought out. In this improvement four bearing points are provided for each ball because of the V-shaped channels in which the balls run. The diamond formed by these grooves gives the name to these devices. The bearing points determined by these channels prevent all motions except those in rotary directions, and lost motion is eliminated.

It is the elimination of the resistance of the trucks to turning that the most important claims for these bearings are made. It is held by these manufacturers, and this seems to be the tendency of opinion among railroad men, that by supporting the weight of a car permanently upon three points at each end, instead of upon the center plates only, that much lighter bolsters may be used. In the case of the large number of old cars now in service this will be a source of considerable saving, and in many cases improved side bearings may be the means of saving the cost of new bolsters. It is also obvious that a considerable saving in flange and rail wear will accompany the introduction of this improvement, and that the danger of derailment will be greatly reduced.

An important feature of this construction is the method of making the bearing frames, which may be used over and over again with the renewal of the wearing plates at a trifling cost. This company also proposes to make steel bolsters in which the wear from all sources will come upon renewable plates. It is obvious that the advantages here outlined apply equally well to passenger and freight cars.

Concentrated information concerning the various departments is required for the management of the enormous manufacturing enterprises of the present time. No one could manage such a colossal concern as the new steel corporation, involving hundreds of plants, fleets of ships, ranges of iron ore and miles of railroads, without a daily report of boiled down information. We are told that the General Electric Company has at Schenectady a substantial printing establishment where every night a report of the affairs, progress and status of each department concerning the work in hand is prepared for appearance each morning upon the desks of the heads of the departments. This is a striking example of present methods of manufacturing.

can be filled promptly. The engraving illustrates the toughness of the metal. A and B are the normal shapes, the others being distorted to test the metal.

"PERFECT" LEATHER FILLET.

The leather fillet manufactured by A. G. Butler, and shown in the accompanying engraving, is constructed with curved sides which form a perfect arc of a circle when applied. With ordinary fillets considerable time is lost in tacking and clamping, and also in the use of the mitre box. All these difficul-

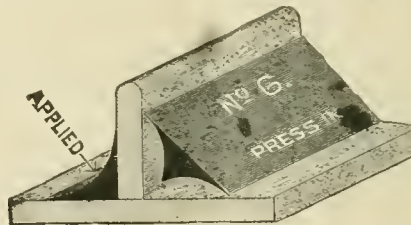

Leather Fillet with Curved Sides.

ties are dispensed with by the use of the leather fillet, and can be easily and quickly applied on single or compound curves and on straight work. They are not affected in the least by heat, cold or moisture, and their application is accomplished by a single operation. The address of the A. G. Butler Company is 285 Pearl street, New York.

An Old Locomotive at Barrow.—The Furness Railway Company in 1899 were possessed of the oldest working railway engine in the world. This engine, which is known as "Copper Knob No. 3," has been put out of service, and the company in question now propose placing it in an open building in the front of the Barrow Central Station as a memento of the early days of the railway in Furness. The engine was purchased from Messrs Bury, Curtis & Kennedy, of Liverpool, in 1846, and was thus running passenger and goods trains on the Furness railway for over 50 years. The boiler is 3 ft. 8 ins. in diameter and 11 ft. 2 ins. long, and the whole engine weighs about 19 tons. The local term "copper knob" is applied to the engine on account of the round back fire-box, the dome of which is covered with copper.—The "Mechanical Engineer."

IMPROVED LEVER THROTTLE VALVES.

In this newly improved form of valve made by the Wm. Powell Company, of Cincinnati, the construction is entirely different from all former makes of throttle valves. It is strong, durable and so nearly frictionless that its operation is very easy. In the accompanying engraving, Fig. 1 illustrates

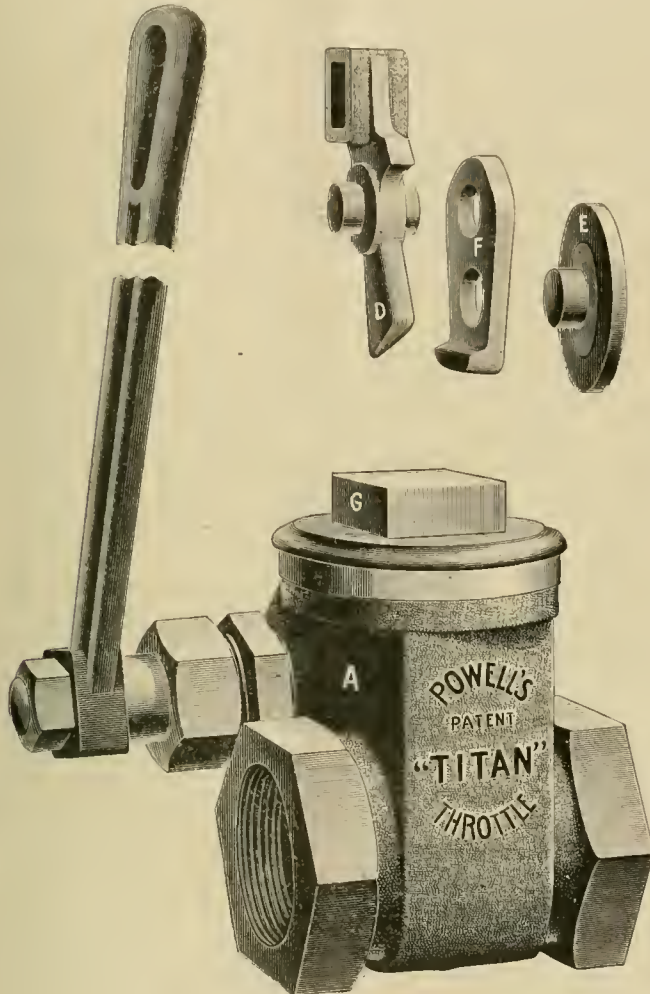

Fig. 1.

the exterior form of the body and Fig. 2 the interior working parts of the valve. The operation of this very ingenious device for opening and closing the valve is best shown by reference to the lettered parts, of which B is the spindle, C the carrier terminating in a tapering wedge, D, and F F are two

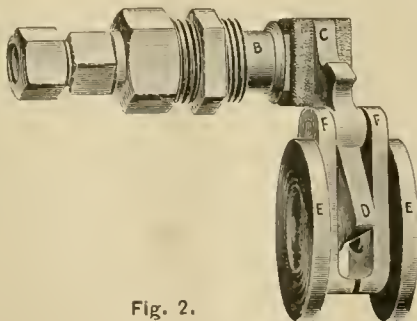

Fig. 2.

links loosely coupled to the carrier at its upper end, while the lower ends of the links engage the studs of the disks, E E. The upward movement of the carrier, C, first lifts the wedge from between the disks before they begin to move, and

as the disks fall loosely away from their seats they are carried up to full opening without friction on the seats. In the downward stroke the wedge, D, performs its work upon the disk studs as the rotation of the spindle reaches a dead center. These valves are made in bronze from $\frac{1}{2}$ to 3 ins., and in iron from 1 to 8 ins., and the parts are all interchangeable. The company manufactures two grades of these valves, the "Titan" and "Giant." The latter is designed for high working pressures.

EXHIBIT OF THE AMERICAN BLOWER COMPANY AT THE PAN-AMERICAN EXPOSITION.

In Block No. 26 of the Machinery Hall is an exhibit of heaters, engines, blowers, dry-kilns trucks and kindred other machinery, which is quite interesting and well worth the few minutes' time necessary to inspect it by anyone who has use for such machinery. Almost everyone is interested in this particular line as these devices enter into almost all branches of manufacture in some way or other. The booth is about 20 feet in height, and topped by a gable-end resting on some very prominent columns. Above this is a large painting emblematical of the American Blower. The general scheme is rendered in ivory white and deep green. Another feature which attracts a great deal of attention is a model of the widely-known and very successful "Molst-Air" dry kiln. This model has a glass side, enabling the spectator to see the exact operation of the kiln.

Besides a large 140-in full-housed steel plate fan driven by an 8 by 8-in. marine type vertical engine, coupling direct to the fan shaft is a Moorhead automatic return steam trap in operation, which clearly shows how the trap drains condensation from heating surfaces and delivers it direct to the boiler.

There is a large pressure blower mounted on a Z iron base, on the other end of which is the vertical automatic high-speed engine which drives it. They are also showing a horizontal, automatic high speed engine and a vertical low-pressure engine, as well as their well-known A.B.C. exhaust fans.

The exhibit is well worth investigating and the company assures a cordial welcome to all who will make this exhibit their headquarters.

The first thing an interested person wishes to know concerning the discussion of a subject before the Master Mechanics' or Master Car Builders' Associations is the opinions of the organizations as expressed in the proceedings. It is not always possible to put these in the form of resolutions such as "the sense of the meeting," but it would be well to cause the discussions to be reviewed by a regularly appointed individual or committee who would review the discussion on each subject. The object is to present the conclusions drawn from the report papers and remarks in the form of an exceedingly brief statement to be voted upon by the entire association as representing the opinions of the body as to those subjects. The custom of the International Railway Congress in this respect is an interesting example of this idea. Each section, after a discussion, draws up a resume which is a condensed statement of the general drift of the discussion and this is placed on record by the entire organization as representing the views expressed and the tendency indicated by the remarks. In a very short time anyone may obtain from these conclusions an excellent idea of the status of each question brought before the congress last year. Without such a system it would be necessary, at a great expense of time and patience, to go through the voluminous reports. This idea carefully carried out would add immensely to the value of all the technical railroad and engineering organizations.

Wanted—Position as chief draftsman or assistant mechanical engineer, by thoroughly experienced man on railroad work, who desires to change. Address "B.," care Editor American Engineer, 140 Nassau street, New York.

BOOKS AND PAMPHLETS.

"Burlington's Number One."—This is the title of a pamphlet of unusual artistic merit recently issued by the Passenger Department of the Chicago, Burlington & Quincy Railroad. It describes their train No. 1, a fast express running every day between Chicago and Denver, equipped with every modern convenience that adds to the comfort of the tourist. Mr. T. K. Hanna, Jr., has pictured in this booklet in a very pleasing manner the accommodations of the sleeping, chair, buffet and dining cars and the unusual accuracy in the details of these illustrations adds greatly to the attractiveness of the book. Mr. P. S. Eustis is the General Passenger Agent of the Burlington road. His address is 209 Adams street, Chicago.

Air Compressors.—The New York & Franklin Air Compressor Companies have sent a complete catalogue of their air compressors for operating pneumatic tools in shops, foundries, shipyards, mines, tunnels, quarries and for every service to which compressed air is applied. This catalogue B illustrates and describes nine different classes of compressors actuated by steam, belt, gearing, electricity or water power. It also gives some useful information regarding the comparative economy of air compressors, the selection of air compressors and the careful installation of compressed air equipment. The company in presenting this pamphlet also announce the commencement of operations in their new works at Franklin, Pa., which are modern and in every way the most proficient for the purpose of manufacturing air compressors. Their main offices are at 95 Liberty St., New York.

Boilers.—A new catalogue of corrugated furnace boilers with the Morison suspension furnace for marine and stationary use has just been issued by Joseph T. Ryerson & Son, Chicago. This corrugated furnace boiler has a very wide field of usefulness, as is shown by the catalogue, which gives in addition to the brief description of the principal features of these boilers some extensive lists of places where they are in use, and what people think of them. Their application is shown in a few instances by engravings, among which is an application of the Morison furnace to the locomotive designed by Cornelius Vanderbilt; also the design of a return flue type of locomotive boiler with Morison furnace, designed by John Player, of the A. T. & S. F. Railway. This small volume, No. 4, of the Ryerson technical library may be had by addressing Joseph T. Ryerson & Son, Chicago, Ill.

Purdue Society of Civil Engineering.—The proceedings of this society for the year 1900-1901 have been received. This, the fifth annual number of this publication, contains several creditable papers by members of the Civil Engineering class on the following subjects: Some Modern Creosoting Plants, Concrete Leveling, The American Society of Civil Engineer's Rail Section, The Equipment and Management of an Engineer's Field Party, Simple Solution of Compound Curves, Timber Beam Diagrams and Masonry Diagrams. Also a paper on The Errors of the Transverse Surveys by Prof. W. D. Pence. The price of this volume is 50 cents.

The June, 1901, issue of the Iowa Engineer, a quarterly publication devoted to the interests of the engineering departments of the Iowa State college, is an exceptionally strong number. It contains several carefully selected papers which cover a wide range of the engineering field.

"Jim Skeevers Object Lessons."—The American Brake Shoe Company has published for its licensees, the Sargent Company, the Ramapo Foundry Company and the Railway Appliances Company, a limited edition of this popular and instructive series of stories of railroad motive power work for distribution among its friends. In these "Object Lessons" Mr. John A. Hill has put into very readable form a rather severe but not unmerited commentary upon methods of managing motive power matters and the book deserves a place in the libraries of all operating officials. One who reads the first of the stories is not likely to leave the others unread and they cannot be read without pleasure and profit. This edition is attractively printed and well bound. The edition of 300 copies will doubtless be far from enough to supply the demand.

Locomotives of the Nineteenth and Twentieth Centuries is the title of the latest number of the Record of Recent Construction of the Baldwin Locomotive Works. This valuable

series of pamphlets contains many good chapters of the record of the locomotive and the one now at hand is specially worthy of thoughtful consideration. It contains the address of Mr. S. M. Vauclain, read before the New England Railroad Club last February. The early history of the locomotive was followed by aid of lantern slides prepared by Mr. J. G. Pangborn. The comments of a man of Mr. Vauclain's standing upon the probable future of the locomotive are specially worthy of attention and it is encouraging to note that he believes that the near future will bring out important developments. This pamphlet is prepared in excellent taste and is well worthy of permanent preservation.

The Santa Fe Route has just issued an illustrated pamphlet of the Pan-American Exposition and a folder containing a panoramic view of the Grand Canyon of Arizona. On the back of the folder are a number of interesting facts about the canyon, how it is most easily reached, something about hotel accommodations and a few impressions from people who have seen the Grand Canyon. The Pan-American pamphlet illustrates and describes many of the features of the exposition and how to see them; it also gives valuable suggestions to those traveling from Mexico and the Southwest to Chicago over the Santa Fe Route.

"Fire Hose," "Rubber Belting" and "Rubber-Covered Rollers" are the titles of three catalogue pamphlets received from the Boston Belting Company, 256 Devonshire street, Boston. The first contains illustrated descriptions of the various kinds of fire hose made by this company, including accessories, such as nozzles, fittings and hose racks. It also includes pertinent remarks concerning requirements and underwriters' regulations. The second contains a chapter of facts relating to rubber belting derived from an experience of more than 70 years as manufacturers. This is followed by suggestions for the transmission of power by rubber belting and a statement of the conditions most favorable to the use of rubber. Besides illustrating Forsyth's patent seamless belting and other varieties of their manufacture, the pamphlet includes several pages of valuable information and rules which will be convenient to all belt users. The third pamphlet deals with rubber-covered rollers which are made in great variety for industrial purposes. These rubber coverings are applied by a process invented by Mr. J. B. Forsyth, General Manager of the Boston Belting Company. The catalogues are standard size (6 by 9 ins.) and are admirably printed and illustrated.

Continuous Rail Joints.—The Continuous Rail Joint Company of America have produced an excellent catalogue of their rail joints, including joints for T rails, girder rails, "compromise" and insulated joints. The engravings, which are excellent, illustrate joints for eleven A. S. C. E. standard sections, twelve other sections, including the "Manning," "Dudley" and P. R. R. sections, ten girder section joints and two "compromise" joints for joining T and girder rails. The insulated joint is illustrated in connection with an S5-lb. section of the A. S. C. E. standard and we judge that the substantial support given to the joint by its form will relieve the signal engineer from a great deal of worry concerning insulations wherever these are used. The object of the continuous rail joint is to overcome the admitted defects of the ordinary angle bar and permit of overcoming the usual weakness at the rail ends and at the same time to return all of the advantages of the angle bar. The result is an angle bar and base plate in one piece and a joint which takes the form of a sleeve. This is, however, too well known to require description here. In the catalogue the right-hand pages have full-sized sections of the joints and opposite each of these is a terse paragraph outlining the advantages of this construction. This company is prepared to furnish joints to fit any rail section. The address of Mr. L. F. Braine, General Manager, is Newark, N. J.

Cheaper Than Shoe Leather.—The Santa Fe keeps a neatly bound book on its California Limited train called "The Log Book," and in this passengers record their observations and impressions of the trip, the excellence of the service, etc.—sometimes a bit of verse, sometimes a note of approval of the dining-car service. One of the latest and best of these paragraphs is given below. In it the writer demonstrates (to his own satisfaction at least) that it is cheaper to ride on the Cali-

California Limited than to walk. "The California Limited, May 30, 1901. San Francisco to Flagstaff, 855 miles, fare and sleeper \$36.40, meals and extras \$3.60, total \$40; cheaper than walking. Walking at 20 miles per day, 43 days: Meals 25 cents, lodging 25 cents, total \$43. We ride first class, save 41½ days, save shoe leather, save clothes and save \$3. Who would not ride on the California Limited?"

McGill College and University has sent its 1901-1902 catalogue, which is a volume of 384 pages giving a general description of the courses that are offered in Arts, Applied Science, Law, Medicine, Veterinary Science, together with detailed information regarding the admission of students and the requirements.

EQUIPMENT AND MANUFACTURING NOTES.

The Cleveland, Cincinnati, Chicago & St. Louis Railway is using draft springs of larger capacity than the M. C. B. spring, but of the same outside dimensions. These springs have three coils which fit closely one coil within another. The outer coil tested alone to 6 ins., requires a pressure of 16,700 lbs.; the second coil alone, 5,400 lbs., and the inner coil alone, 1,400 lbs. Compressed separately to 6 ins., the coils thus have in all 23,400 lbs. capacity, but when assembled, a little over 28,000 lbs. is required to compress the group to 6 ins. The difference is accounted for by the friction of one coil on another. This is mentioned here as showing how the capacity of a spring of the standard dimensions can be increased.

An order for new passenger equipment for the Wabash Railroad includes two baggage cars, eight combination passenger and baggage cars, thirty coaches, ten reclining chair cars, three cafe and two dining cars. Four of the combination cars, ten of the coaches and all of the chair cars, cafe and dining cars will be 70 ft. in length with wide vestibules. They will have the Martin stationary vestibule, standard six-wheel trucks, and all trucks will have steel wheels. The finish will be selected mahogany and quartered oak, but the finer cars will have selected St. Jago mahogany and the half empire deck. The lighting will be with Pintsch gas for all the ordinary cars, but for the cafe and dining and chair cars they will have the finest of electric light equipment. The dining cars will seat twenty-nine persons, with ample kitchen space; the cafe will seat eighteen persons, and will have a library and smoking room in the observation end, which will seat fourteen. Another up-to-date feature will be a private dining room for eight persons.

Northern New England is one of the most attractive summer pleasure and vacation grounds in the world. No other section can boast of scores of lakes, a hundred beaches and a whole mountain range within the meagre boundaries of a hundred miles square, yet this is what New England has, and, though there are thousands of tourists annually at these resorts, there can be accommodated hundreds of thousands more. Every nook and corner of New England is an outing resort and the Boston & Maine lines reach all of the leading ones. If you are interested in or intend to take a vacation this season you want a Boston & Maine Excursion Book. Send a postal to the General Passenger Department of the Boston & Maine Railroad, Boston.

A handsome "convertible" car forms a part of the exhibit of the J. G. Brill Company at the Pan-American Exposition. It is 28 ft. long and is equipped with the ingenious sliding panels which may be pushed up into the roof, making an "open" car or drawn down between the posts, making it an equally satisfactory "closed" car for winter service or for stormy weather in the summer season. The seats are of the walk-over pattern with an aisle between them. This is not only a very creditable exhibit, but it marks a high attainment in street car construction, for electric lines are rapidly progressing in a direction which must ultimately interest, if it does not instruct, those who are conducting the suburban service of steam roads. The car referred to is mounted on a pair of Brill "27 G" trucks.

Mr. Frederick Brotherhood has been appointed Manager of the Foreign Sales Department of The Railroad Supply Company, with headquarters at their New York Store, 106 Liberty Street.

The Monarch Brake Beam Company, Limited, of Detroit, state that the Waycott-Andrews Supply Company is no longer connected with them in any way.

Mr. Henry W. Toothe, who for a number of years represented the Midvale Steel Company and later the Chicago Pneumatic Tool Company, has taken charge of the Railway Department of the Magnolia Metal Company as sales agent, with headquarters in New York. Mr. Toothe's wide acquaintance and his thorough knowledge of the railroad requirements will make his services invaluable and this fact, with the high standing of this company and its product, lead us to congratulate both parties.

The Pan-American Exposition exhibit of the Baldwin Locomotive Works is described in a pamphlet of 32 pages. Four locomotives are exhibited, a heavy consolidation freight engine for the Lehigh Valley, a 10-wheel passenger engine with Vanderbilt boiler and tender, for the Illinois Central (see American Engineer June, 1901, page 205); a consolidation freight locomotive with a moderately wide firebox for the Buffalo & Susquehanna Railroad and an electric mining locomotive of 50 horse-power for the Berwind-White Coal Mining Company. In addition to detailed information of these engines the pamphlet describes the Baldwin Locomotive Works and contains a striking statement of their capacity. It is printed in parallel columns in English and Spanish.

The creative genius apparent in the architecture of the many buildings of the Pan-American Exposition is without equal and the effects obtained through the beautiful color decorations the most pleasing. The exhibits are well chosen and compare favorable with all other expositions. The landscape work has developed the grounds into a place of great delight. Buffalo, as a city, is a very fascinating place, and excursions can be made in every direction to localities intensely interesting, but the greatest attraction save the Exposition is Niagara Falls, which is truly one of the marvels of the world. The Boston & Maine Railroad is making every inducement possible for the benefit of the tourist to Buffalo from New England. The rates are the lowest, the routes numerous, the line the most direct and its trains the best equipped of any from Boston. The General Passenger Department of the Boston and Maine will upon application send a Pan-American folder which is full of information that will be of service to those visiting the Exposition.

A record shipment of steel cars left Pittsburg July 20 from the works of the Pressed Steel Car Company over the Baltimore & Ohio Railroad. The shipment was made to the Great Southern of Spain Railroad in Aquiles, south Spain, and comprised a solid train of thirty-two cars. The contents of the train was seventy large capacity pressed-steel hopper-ore cars, carefully packed in parts for shipment on the White Star Line steamer *Georgic*, which sailed from New York July 23. An engineer from the Pressed Steel Car Company will superintend the erection of the cars on their arrival in Spain.

The cars themselves are of 80,000-pounds capacity, and when in service will be the largest cars in use on any Spanish railroad. In some respects they differ materially from American cars. For instance, one car in ten is equipped with a shelter box for the brakeman or guard. These boxes are built of wood on the end of the car, and are so constructed that the guard has an unobstructed view of the portion of the train under his care. Other minor portions of the car, such as the hand-brake apparatus, etc., differ from American standards, but in the main the cars are similar to those built for ore roads in this country. The cars when erected will be 26 ft. 6¼ ins. long, 8 ft. wide with a height, from top of rail to top of body, of 9 ft. 9½ ins. The light weight is 29,180 lbs., and the ratio of paying load to total weight of car when loaded 75.09 per cent. The gauge of the Great Southern of Spain Railroad is considerably wider than our standard, being 5 ft. 6 ins.

MASTER MECHANICS' AND MASTER CAR BUILDERS' REPORTS, CONCLUDED FROM JULY.

PRACTICAL TONNAGE RATING.

By George R. Henderson.

[A Paper Read Before the American Railway Master Mechanics' Association.]

In 1898 the writer was chairman of a committee which reported to this Association on the subject of Tonnage Rating for locomotives. In this report it was stated that the committee believed that results could generally be secured more quickly and satisfactorily by first producing the theoretical rating and checking this up by practical tests. How far the theoretical rating will be satisfactory depends upon the care and foresight used in determining it. The committee above referred to pre-

Those who have attempted to establish ratings by means of actual tests upon the road know the many difficulties encountered and how seldom results can be satisfactorily duplicated. Variations in the weather or the steaming of the engine, the condition of the track and the train, and often the unexpected display of a danger signal throw so many obstacles in the way of successful tests that the "office method" is by many considered preferable. The writer believes that by the use of the following rules and diagrams it will be possible to rate almost

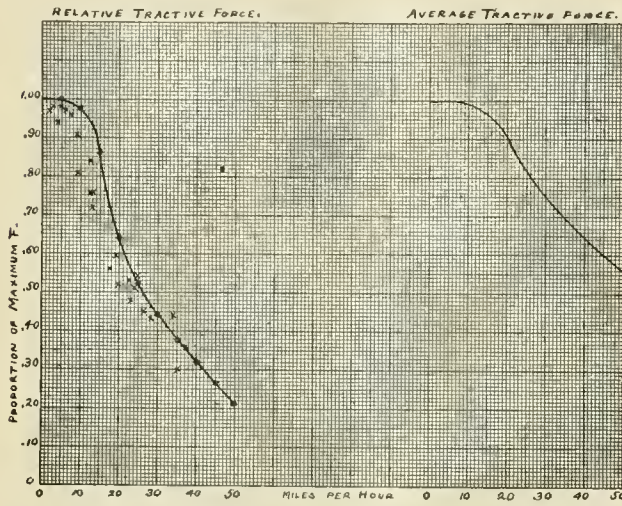

No. 1.—Tonnage Rating Diagram.

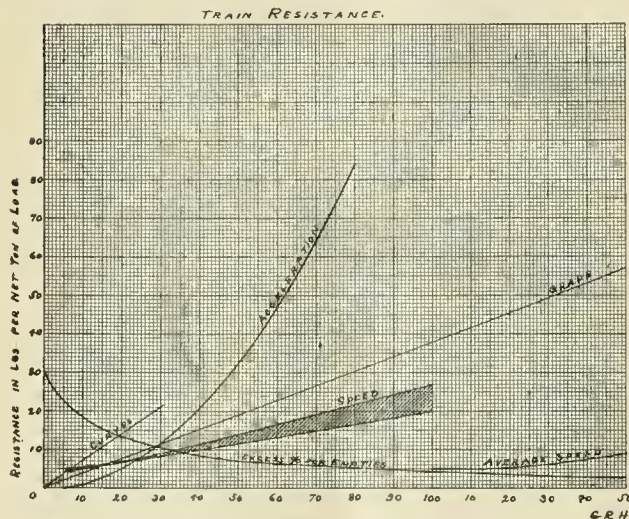

No. 2.—Tonnage Rating Diagram.

sented a number of diagrams and formulae for use in such work, but when there is much of this to be done the calculations of the various cases require a great deal of time, particularly when momentum grades and many sizes of locomotives must be considered. In fact, the writer remembers a case several years back when it occupied a force of six men for ten days to rate thirteen classes of engines over 1,500 miles of road, and this without considering momentum grades. With 5,000 miles of track and 75 varieties of locomotives, the former methods would be almost prohibitive, and this has led to the adoption of new methods by which an ordinary division of say 500 miles can be rated in from three to five hours, and for all the locomotives in service, the rating to be practically correct for momentum grades as well as "dead pulls." Empties and "time freights" may also be included with no extra labor, and thus a new division, heretofore unoperated, may be scheduled before the equipment is placed upon it. Of course there will always be cases where an increase in the speed of approach to a grade will permit a heavier rating, but it is a very easy matter to make slight variations in the schedule.

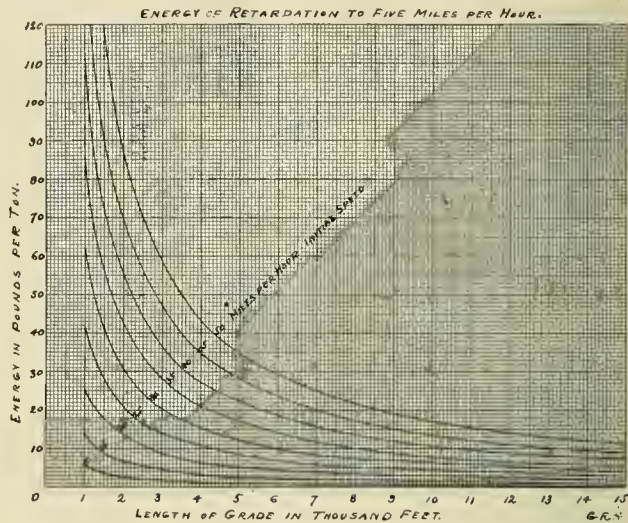

No. 3.—Tonnage Rating Diagram.

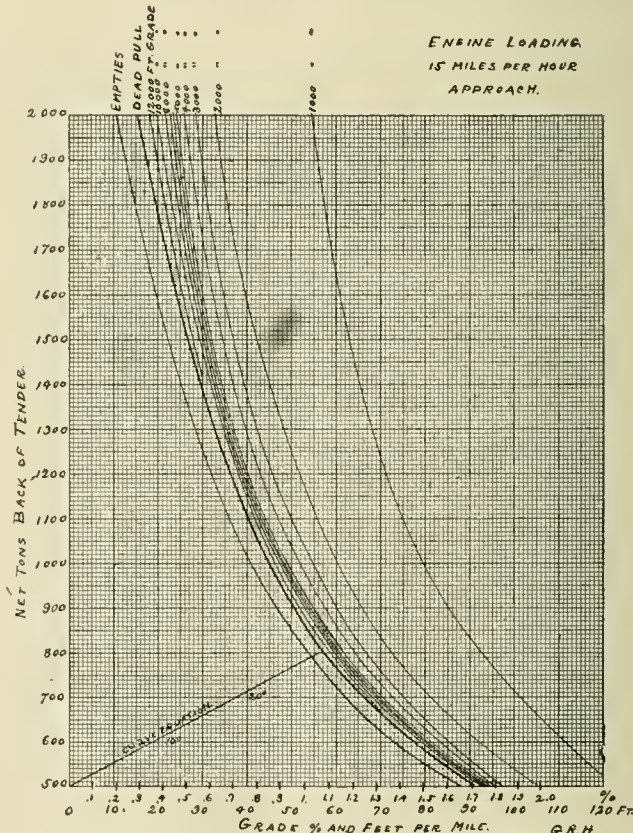

No. 4.—Tonnage Rating Diagram.

any modern engine on any profile and alignment, and with very few calculations to establish a satisfactory schedule.

Tractive Force of Locomotives.

The tractive force referred to in this article will be that available at the circumference of the drivers, and will be designated by T, and is determined as follows:

- At slow speeds, 5 to 8 miles an hour, with the reverse lever in the corner notch and a cut-off of about 90 per cent. of the stroke, pressures will be obtained about as follows:
- Initial pressure=.95 boiler pressure.
- Mean effective pressure=.91 initial pressure.
- Mean effective pressure=.86 boiler pressure.
- Allowing 8 per cent. internal friction.....=.92 M.E.P.
- Mean available pressure=.80 boiler pressure.

This allows for friction of pistons, valves, eccentrics, etc., but not the resistance to motion which must be considered with the train. For the maximum available tractive force we have for single expansion engines:

$$T = \frac{p d^2 s}{D} \dots \dots \dots (1)$$

Where p = mean available pressure in lbs. per sq. in.
 d = diameter of cylinder in inches.
 s = stroke in inches.
 D = diameter of driver in inches.

We can also write:

$$T = \frac{.8 P d^2 s}{D} \dots \dots \dots (2)$$

Where P = working boiler pressure in lbs. per sq. in.

For 2-in-cylinder compounds, when operating compound:

$$T = \frac{.8 P d_1^2 s}{D (r + 1)} \dots \dots \dots (3)$$

Where d = diameter of low-pressure cylinder in inches, r = ratio of cylinder volumes.

For 2-cylinder compounds when operating simple:

$$T = \frac{.8 P d_h^2 s}{D} \dots \dots \dots (4)$$

Where d_h = diameter of high-pressure cylinder in inches. (This, of course, assumes that the adhesion of the engine is sufficient to allow it to develop this tractive force without slipping.)

Four-cylinder compounds will give values as follows:

When operating compound:

$$T = \frac{16 P d_1^2 s}{D (r + 1)} \dots \dots \dots (5)$$

And when operating simple:

$$T = \frac{16 P d_h^2 s}{D} \dots \dots \dots (6)$$

While variations in these figures may sometimes be looked for they will generally represent safe deductions at the slow speed mentioned above.

As the speed is increased the value of T will evidently be reduced, as the boiler is generally inadequate to maintain full pressure with the lever in the corner over 5 to 8 miles per hour. In order to determine the possibilities in this direction tests were made with a dynamometer car and also by means of the Chicago & Northwestern Testing Plant, the standard 10-wheel freight engine of that road being taken for this purpose. This locomotive has the following proportions:

Cylinders (single)	20 by 26 ins.
Driving wheel diameter	63 ins.
Steam pressure	190 lbs.
Tube heating surface	2,146 sq. ft.
Firebox heating surface	186 sq. ft.
Total heating surface	2,332 sq. ft.
Grate area	29 sq. ft.
Total cylinder volume	9.5 cu. ft.
Ratio of grate area to cylinder volume3
Ratio of heating surface to cylinder volume	245
Ratio heating surface to grate area80
Weight on drivers	118,350 lbs.
Weight of engine and tender	130 tons
T (max.)	25,000 lbs.

Diagram No. 1 shows the relative tractive force at different speeds. The curve illustrates the results derived from records obtained on the "testing plant" and the crosses are plotted from the dynamometer car experiments. Thus it will be seen that the test plant gave generally the maximum T, as might be expected. In order to simplify the calculations, it is more convenient to consider the average T during the period of retardation, and the right-hand curve on diagram No. 1 gives the average T during a reduction from the speed designated by the abscissa to 5 miles per hour. The two curves of diagram No. 1 therefore present a ready means of obtaining the tractive force for a fixed or variable speed. (Of course, a large increase in the proportions of boiler to cylinder will give curves having greater ordinates for the corresponding abscissae than those shown, which are based on the class R engines as stated above.)

Resistance of Train.

Diagram No. 2 gives the curves for train resistance in accordance with the "Engineering News" and the Baldwin Locomotive

Works formulae, being respectively $2 + \frac{V}{4}$ and $3 + \frac{V}{6}$,

where V equals velocity in miles per hour, and the shaded portion of the zone shows the variation in resistance that may be met with. (In this diagram, the abscissae represent the unit of grade, speed, etc., and the ordinates the resistance.) For grades we have resistance = .38 M when M = the feet rise per mile.

Curves give a resistance equal 0.7 c, where c = degree of curvature. Acceleration (and retardation) a resistance = 0.0132 A² when A = speed attained in one mile, in miles per hour. (The latter includes rotative energy of the wheels and axles.) The "average speed" curve is used for varying speeds and gives the average resistance between the selected speed and five miles per hour.

Effect of Momentum.

By utilizing the momentum of retardation we are enabled to pull much heavier trains up a grade than we could with a dead pull only. The effect of this is to produce a virtual grade, which is less steep than the actual grade, and the weight of train which can be pulled corresponds to this virtual grade. It must

be remembered, however, as illustrated in Diagram No. 1, that at high speed the tractive force of the engine is reduced, and when we desire to figure momentum grades we must calculate on the average available tractive force during the change of speed

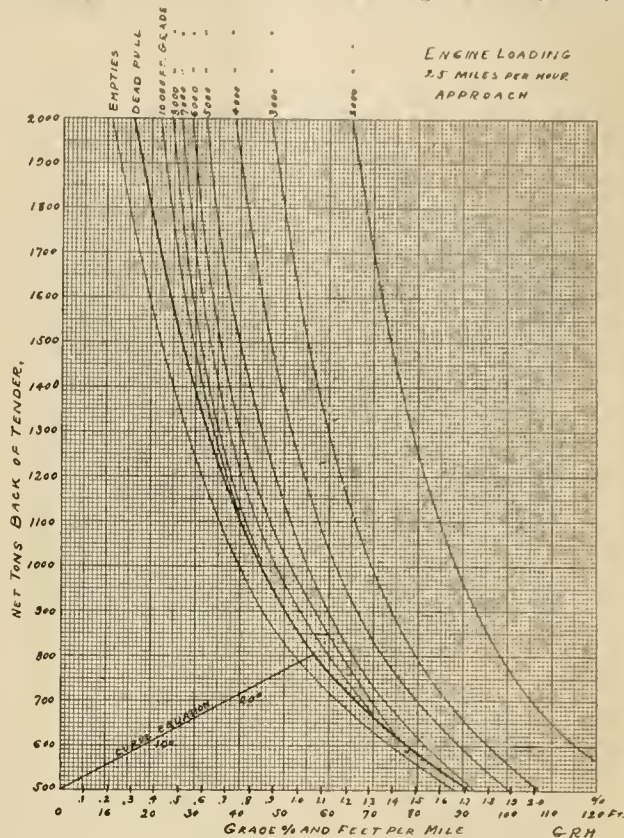

No. 5.—Tonnage Rating Diagram.

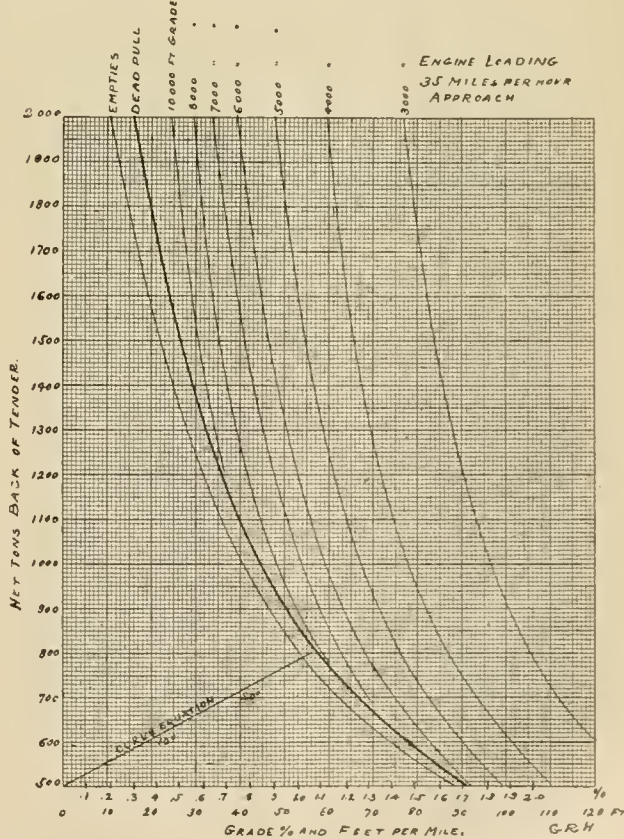

No. 6.—Tonnage Rating Diagram.

from that at the foot of the hill to, say, five miles per hour at the top. The relation of this to the maximum T can be found from the right-hand curve of Diagram No. 1. The average resistance to speed may be taken from Diagram

No. 2 and the resistance due to actual grade from the same chart. This resistance, however, is to be reduced by the amount of inertia due to retardation of train from the maximum speed to five miles per hour. The average force of inertia in pounds per ton may be expressed approximately by the formula,

$$70 \frac{V^2 - 25}{x}, \text{ where}$$

- x = initial velocity in miles per hour.
 - x = distance traversed during retardation, in feet.
- Diagram No. 3 gives a series of these curves for various values

and average speed minus the coefficient for energy due to retardation. The weight of the engine and tender must be deducted for net loading.

Effect of Empty Cars.

It has been suggested from results of experiments that an empty car has about 1.8 lbs. greater resistance per ton than a loaded car at slow speeds. If we wish to express this as a percentage of increase over loaded trains we can use the formula

$$\frac{1.8}{y + \dots}$$

for this excess $\frac{1.8}{y + \dots}$, where y = resistance due to grade. The

locus of the formula is drawn on Diagram No. 2 where the ordinate gives the excess resistance in per cent. for empties on the grade in feet per mile represented by the abscissae. Thus empty trains should be considered as having so many per cent. greater tonnage than actually the case, depending upon the grade to be ascended.

Method of Rating Engines.

The various rules enumerated above are embodied in Diagrams Nos. 4, 5 and 6, which give the tons behind tender which a Class R engine can pull on various grades. The heavy line gives the rating on a dead pull for grades of the ascent shown by the abscissae. The line marked "empties" gives the rating for empty cars.

In Diagram No. 4 the upper fine lines give the load for a speed of approach of 15 miles per hour, reducing to five miles per hour at top, and length of grade being denoted by figures at top of line. These allow for the effect of momentum and the diminished T at the higher speed. The short line at lower left-hand corner gives the ratio for equating curves and grades; thus, add to the actual grade the grade corresponding to the curvature shown for the total effective grade. For empties operated under momentum rules, from the intersection of tonnage line and "dead pull curve" follow directly down to the "empty" line, which gives the empty rating for the corresponding case. Diagram No. 5 gives the same data for a speed of approach of 25 miles per hour, and Diagram No. 6 at 35 miles.

To illustrate: The engine selected as the standard can haul 1,750 tons up a 21-ft. grade in a "dead pull." On a 34-ft. grade with a dead pull, 1,250 tons would be the limit. However, on a hill of this grade 9,000 ft. long and with a 35-mile an hour velocity at the foot, 1,450 tons can be taken up. If empties compose the train, 1,300 tons would be the allowance. By this means it is easy to rate the "standard engine" over the whole road. In order to simplify the rating of other classes, we have recourse to Diagram No. 7. This gives the load suitable for an engine having a different T when the load for the "standard" engines is known. These lines are not radial as would seem at first sight, but are parallel to radial lines whose tangents are proportional to the T of the different engines, the parallel being drawn below the radial lines by the amount corresponding to the weight of engine and tender. In this way, the loads back of tender are comparable by the diagram, whereas it would be the power at the drivers were the radial lines used. The diagram is drawn for other hypothetical engines to compare with the standard, assumed engine and tender weights being allowed, and it being further supposed that the boiler has about the same proportions relatively to the cylinder power.

Diagram No. 8 and the following table are reproduced from one of the Division Time Cards of the Chicago & Northwestern, and explain fully how the chart is used.

Class "R" Ratings for Freight Trains—Wisconsin Division.

	Dead.	Time.	Empties.
Princeton to Fond du Lac.....	860	775	800
Fond du Lac to Princeton.....	1,260	1,140	1,150
Fond du Lac to Sheboygan.....	770	630	720
Sheboygan to Fond du Lac.....	930	840	870
Fond du Lac to Milwaukee (Helper Fond du Lac to Eden).....	1,290	1,160	1,160
Milwaukee to Fond du Lac.....	1,060	960	970
Milwaukee to Chicago (Helper to Cudahy)...	1,380	1,250	1,250
Chicago to Milwaukee.....	1,440	1,300	1,280
Green Bay to Appleton Junction.....	1,440	1,300	1,280
Appleton Junction to Green Bay.....	2,000	1,800	1,600
Appleton Junction to Fond du Lac.....	2,000	1,800	1,600
Fond du Lac to Appleton Junction.....	1,380	1,250	1,250
Fond du Lac to Janesville (Helper to Oakfield).....	1,250	1,130	1,080
Janesville to Chicago.....	1,120	1,000	1,030
Chicago to Janesville.....	1,160	1,050	1,050
Belvidere to Kenosha.....	900	840	875
Kenosha to Belvidere.....	900	820	810

Rating for other than Class R engines will be obtained from diagram.

It is hardly necessary to say that an accurate knowledge of the profile and alignment is necessary to properly rate an engine, as well as the crossings, water tanks, stops and methods of operation, as these all contribute to the success of the rating.

The use of the Diagram No. 8 simplifies the transfer of engines from one division to another, as the proper loading can be determined by a glance at the diagram, when the class is known. For example, in the table given above the rating for Class R engine from Chicago to Milwaukee is 1,440 tons. On diagram No. 8 we follow down the vertical line corresponding to 1,450 tons on the upper diagonal line, and the intersection with the various diagonals gives the proper loading; for instance, Class Q, 1,160 tons; Class S-3, 950 tons, and so on. As all locomotives have the class letter painted on the cab, the proper rating is easily determined.

The ratings explained have been based on a speed of 5 to 8

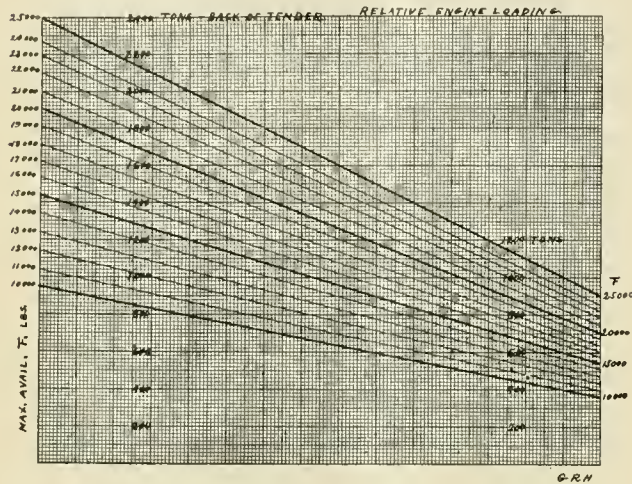

No. 7.—Tonnage Rating Diagram.

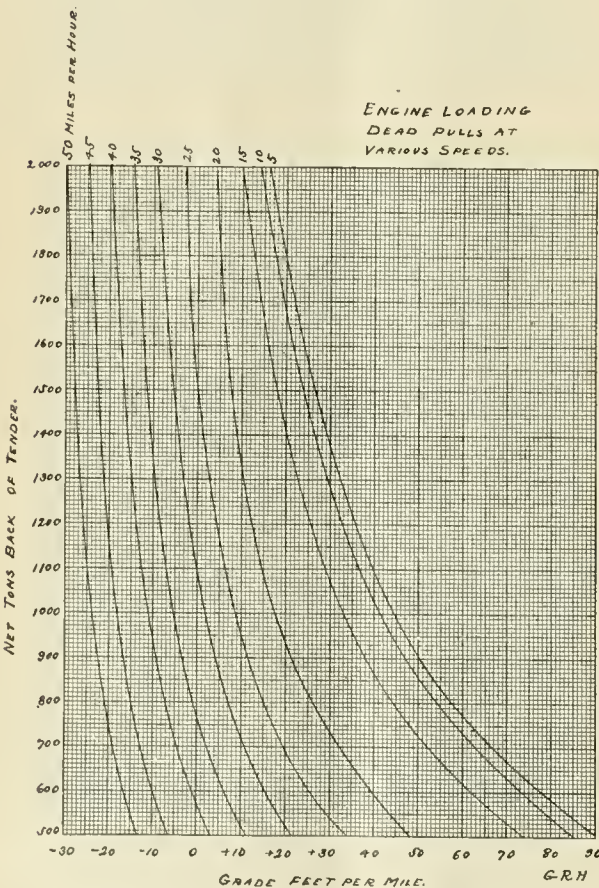

No. 9.—Tonnage Rating Diagram.

of V and x when speed is reduced to five miles per hour. This energy added to the average T represents the propelling force, and the sum of the various resistances gives the amount to be overcome by the first two forces. The equation must, of course, be made for the total weight of train multiplied by the various coefficients in pounds per ton, as the tractive force is also in pounds; as, for example, to find the weight of train, divide the average tractive force by the sum of the coefficients for grade

miles an hour for a dead pull or for a summit velocity of 5 miles an hour for momentum runs. It will often be necessary to determine what load could be hauled at a higher speed, or what speed could be obtained with the same weight of train on a

References to Letters at Left of Diagram.

- A and B: Engines Classes F2, H1, H3 and Ashland Div. A.
- C: Engines Classes B5, E1, E4, E5, H4.
- D: Ashland Div. engines Classes K, E1, E2, E3, E4, E5, F, L, D.
- E: Engines Classes A1, B2, B3.
- F and G: Engines Class D3 and Ashland Div. K5.
- H: Engines Classes A2, A3, B1, F1.
- J: Ashland Div. engines Classes K1, K2, K3, K4, N, N1.
- K: Classes A4, C2.
- L: Classes A5, C4, D1.
- M: Classes C3, C5.
- N and O: Classes B1, C6, D1a, D1b, D2a, D14 and Ashland Div. H.
- P: Class S3.
- Q and R: Classes A, C, D12, S5, S7 and Ashland Div. H and I2.
- S: Classes S1, D13.
- T: Classes S4, S6.
- U: Classes B and S2.
- V: Classes D12a and Q.
- W: Class D.
- X: R 19½ x 26 (?)
- Y: R 20 x 26.

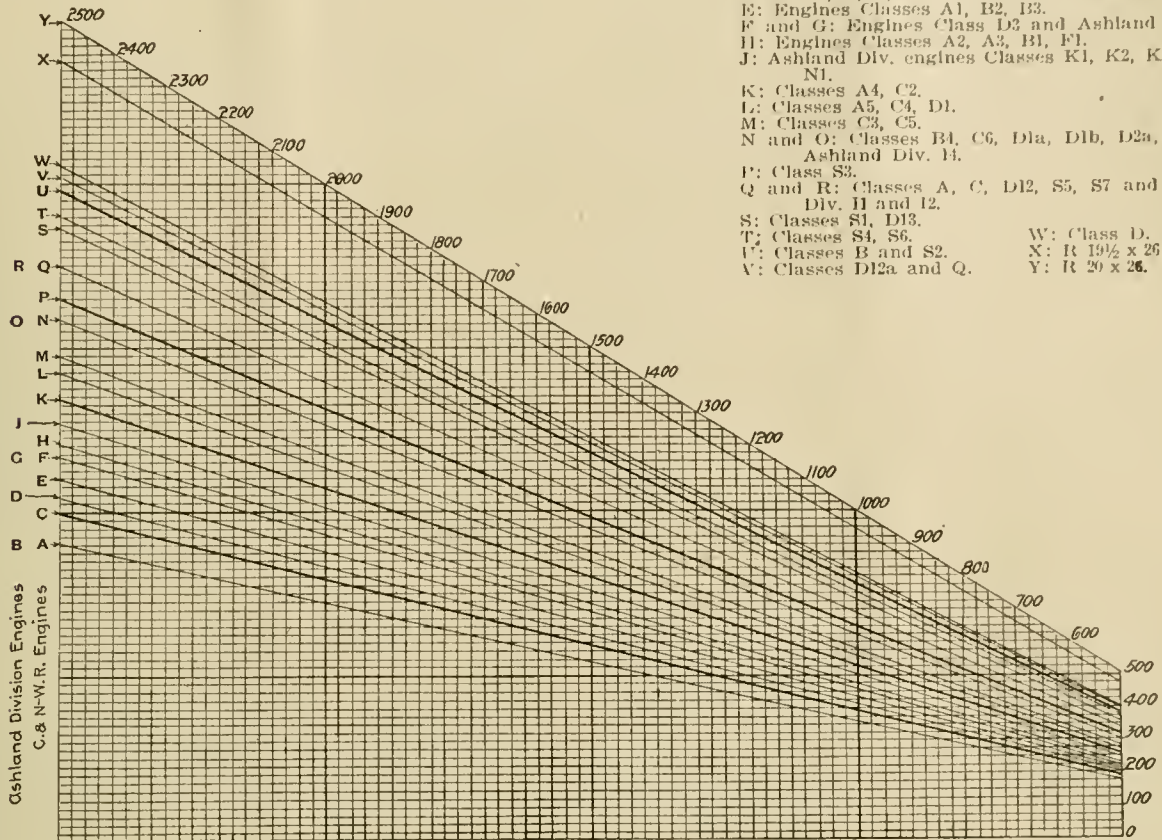

Diagram No. 8.-C. & N. W. Railway Locomotive Lading.

The vertical scale represents tonnage, four spaces to the one hundred tons. The diagonal lines represent the relative tonnage of each class of engine to that of Class R, which is the uppermost line.

To find the tonnage for any class of engine over a certain piece of road get the Class R rating for that section from the published rating on time card and follow down the nearest vertical line until it intersects the desired class line, and take the reading on the vertical scale.

For Example.—If the Class R engines are rated 1,450 tons over a certain division, Class Q should be given 1,165 tons.

grade less than the ruling grade. Diagram No. 9 has been calculated for the standard Class R engine by using the data in Diagram No. 1 for the T of the locomotive, and the train resistance from Diagram No. 2. For example, it was found above that 1,750 tons was the "dead pull" limit for a 21-ft. grade. This would be at a speed of about 5 miles an hour. If, however, it be desired to maintain a speed of 20 miles an hour on this grade the load must be reduced to 900 tons, as will be found from the intersection of the 20-mile curve with the 21-ft. grade line. Or, on the other hand, the 1,750 tons could be hauled on a 5-ft. grade at 20 miles an hour. As previously explained, these curves will be approximately correct only for locomotives having about the same cylinder and boiler ratio as the Class R engine.

SUBJECTS FOR INVESTIGATION AND REPORT AT THE CONVENTION OF 1902.

Committee—S. Higgins, W. A. Nettleton, A. E. Mitchell.

No. 1.—Standard pipe fittings.

This committee to be appointed in conjunction with a similar committee of the American Railway Master Mechanics' Association, to consider report of the Committee of the American Society of Mechanical Engineers. Mr. B. Haskell, chairman, W. H. Lewis and Thos. Fildes.

No. 2.—Progress made and the present state of the art in improved methods of car lighting. C. A. Schroyer, chairman, L. T. Canfield, A. E. Mitchell, R. P. C. Sanderson and S. P. Bush.

No. 3.—Best methods in shop practice in meeting the requirements for the maintenance of all steel cars. Probable future

shop changes necessary. W. H. Lewis, chairman, L. H. Turner, E. B. Gilbert, J. N. Barr and S. Higgins.

No. 4.—White pine and its substitutes in wooden car construction. W. E. Symons, chairman, J. J. Hennessey, A. Childs, H. J. Small and W. P. Appleyard.

No. 5.—Light weighing and stenciling of cars. F. A. Delano, chairman, D. F. Crawford and W. E. Symons.

No. 6.—Should the present cast iron wheel be changed in any manner to suit the 100,000-lb. capacity cars?

It is suggested that this committee consist of Mr. A. S. Vogt, chairman, C. M. Mendenhall and W. S. Morris. In case the Convention or Executive Committee should decide that this subject be referred to the Committee on Cast Iron Wheels, the Committee on Subjects would recommend as follows:

Substitute for No. 6. Suggestions on improved car construction gleaned from the Pan-American Exposition.

It is proposed that Mr. H. F. Ball, Mechanical Engineer of the L. S. & M. S. Railway, prepare this paper.

THE ESTABLISHMENT OF A JOINT LIBRARY IN CONNECTION WITH THE MASTER CAR BUILDERS' ASSOCIATION.

Committee—A. M. Waitt.

The matter has been carefully canvassed from the standpoint of both Associations, and as a result of the joint deliberations would report that it is deemed inexpedient at the present time to establish a joint library: First. Owing to the expense involved. Second. In all large cities excellent reference libraries are maintained, whose facilities are available to all. Third. There are comparatively few of our members who would be likely to avail themselves of such a library if established.

TESTS OF M. C. B. COUPLERS.

Committee—W. W. Atterbury, W. S. Morris, W. P. Apple-
yard, H. Monkhouse, F. A. Delano.

As a result of the experience that we have had during the past year, changes of considerable importance have been found necessary in the specifications of M. C. B. couplers, and minor changes have been thought advisable in the drop testing machine and the coupler contour gage. No changes have been found necessary in either the worn coupler gage or the twist gage, except to make the latter adaptable to the new design of coupler with increased shank.

Specifications.—The specifications in their present form have not proved as commercially practicable as is considered advisable, due partially to their lack of definiteness and to their severity, and also because there are certain portions of the specifications which, in the judgment of the committee, are unnecessary. The modifications to which the committee particularly calls attention are: First, the requirements of the specifications have been made uniform for couplers, whether of cast steel or malleable iron; second, the abandonment of the separate knuckle test. An extended experience with the M. C. B. testing machine has forcibly impressed on the committee the advantages of good, well-annealed cast steel as a material from which to make the body of the coupler; so much so that in its judgment it is inadvisable to longer retain in the specifications any preferential test for any other material. The separate knuckle test, in connection with the test of couplers is an unnecessary expense, as the knuckles are already thoroughly tested in tests 1, 3 and 4.

Drop Testing Machine.—On account of the change in the design of the standard shank, it was found necessary to widen out the sides which hold the shank in place, as well as to accommodate butts of larger dimensions than the standard.

It was also found advisable to raise the sides from 17½ ins. to 19½ ins. on account of the severity of the test with the former height.

Coupler Labels.—Experience has demonstrated the impossibility of successfully casting in steel a legible label of the present dimensions, and while ½-in. letters might be used to replace the 5/16-in. size, a simpler arrangement, similar to that used on wheels, is preferable. The label now recommended has been incorporated as a part of M. C. B. sheet "K."

Coupler Contour Gage.—With the new design coupler contour gage it was found that through the carelessness or captiousness of an inspector, a coupler could be condemned which was really within the prescribed limits. The contour between the theoretically correct and the inferior limit allowable permits so much play between the gage and the coupler head, that the guard arm gaging screw can be made to fall beyond the end of guard arm, even though the latter may be of the proper length. This screw can then be moved to the condemning position without touching the coupler. To prevent this, and to secure approximate coincidence of center lines of coupler head and gage, a spring socket and contact has been added.

Worn Coupler Gage.—There has been some criticism of an indefinite character by some members of the association, against the use of this gage. The committee realizing the im-

manner outlined by the committee, the general condition of the couplers throughout the country would be decidedly improved, but in so gradual a manner as to work no great hardship on the car owner.

Twist Gage.—On account of the proposed changes in the shank of coupler, it has been necessary to alter the design of the twist gage so as to be applicable to 5 x 5-in. or 5 x 7-in. shanks. Also so that it can be used with butts of even larger dimensions than those of the association.

Link Pin Holes and Link Locks.—The committee had hoped to have been able to present, at the present meeting, a means by which cars could be handled around curves, or on and off floats, without the use of link and pins, thus being able to abandon the link pin hole and slot in the knuckle. It has experimented with several designs of its own, as well as with some patented appliances, but as yet has not been able to find anything that successfully met all the requirements of the

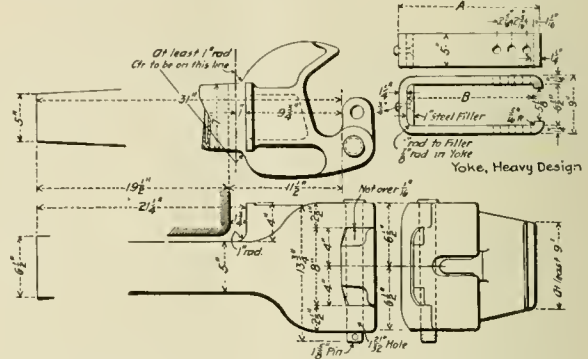

Automatic Coupler 5-in. x 7-in. Shank and Increased Head.

Proposed Heavy Coupler and Yoke.

service. It was thought that the dimensions of the link slot might be reduced, but this has been found impracticable where floats are used, and particularly so at tide water. It is, therefore the opinion of the committee that no change should be made at the present time.

Increased Dimensions of Coupler Body.—Since the last meeting of the association the committee has experimented very largely with couplers with increased shank and now presents a design of shank 5 x 7 ins. back of the head, with the larger dimension in horizontal plane, as its recommendation as standard of the association. This recommendation is made after serious consideration of the changes that will be necessitated in the various parts affected, but a change must be made to get increased strength, and the proposed change gives us this in-

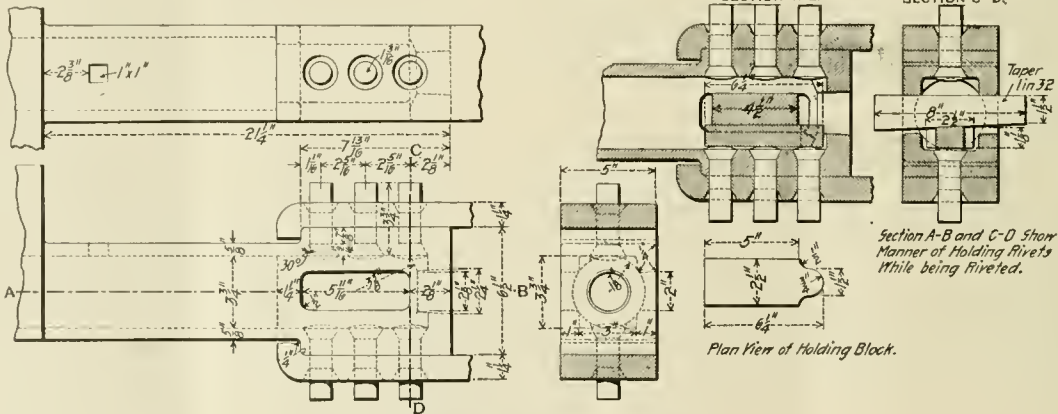

Proposed Butt for 5 x 7 in. Shank.

portance of this gage, both in its use and abuse, has had the matter particularly followed up, and as a result of a year's experience, is satisfied that no change at the present time is necessary or advisable. The committee would strongly recommend that the worn coupler gage be put in general use at repair shops and repair tracks. While this will result in the condemnation of a great many knuckle pins, locks and knuckles, it will not affect a very large number of couplers. The couplers in almost all cases are brought back to gage by the replacement of the knuckle, knuckle pin or the lock, and such couplers as are condemned will be of the short-arm type or of the long guard arm, in the event of the guard arm being seriously damaged. It is the opinion of the committee that this gage should not be used at interchange points, as, for transportation reasons, it is impracticable, its use necessitating the separation of the cars. If the various roads in the Master Car Builders' Association would conscientiously put this gage in use in the

creased strength with the least additional material, and less seriously affects the related parts than would the change to a 6 x 6-in. The committee, as a result of the guard arm tests of 179, 5 x 7-in. shanks and 58, 5 x 5-in. shanks, has found that the increase in strength is as the ratio of 23 to 13, or a gain of 76 per cent. Experience also shows us that an increase in the dimensions of the head of the coupler is necessary, and this fortunately the committee can give, without seriously affecting any of the working parts of the car. The dimensions 8¾ ins. from the back of the lug to the inside face of the knuckle should be increased to 9¾ ins., thus allowing an increase of 1 in. or more in metal through all parts of the head. The vertical dimensions of the knuckle through the knuckle pin hole have been increased to 8 ins., and of the lugs to 2½ ins., thus materially increasing the strength of all the parts. During the coming year the committee hopes to experiment with a head of these dimensions, and at the next meeting of the asso-

ciation will be prepared to give some definite figures as to its relative strength.

Increased Butt.—At the request of the Committee on Draft Gear we have seriously considered a redesign of the standard butt, retaining the present dimension of 6½ ins. as its depth, lengthening the butt so as to allow the use of a third rivet or bolt. The dimensions between the back of the butt and back of the horn have been retained as at present. The committee submits a proposed arrangement for the consideration of the association. We have always recognized the impossibility of properly riveting the yoke to the butt because of its inability to hold the rivet. The committee, therefore, in its proposed arrangement has entirely departed from the old design, and suggests an arrangement whereby the riveting can be successfully done. As the design is quite a radical departure from anything that has heretofore been used, the committee is not prepared to recommend the arrangement as standard until after a series of experiments which are being conducted has proven the correctness of the design.

Heavy Design Yoke.—The committee has prepared a design of yoke with the strength increased to correspond with that of the increased shank, and to be used in connection with the 5 x 7 shank coupler. For the coming year the committee has considerable work laid out. As previously explained, it will be necessary to experiment with the new design of head, as well as that of the proposed butt. In addition, proper gages for the butt will have to be developed, on account of the necessity for uniformity of dimensions at all points. The abandonment of the separate knuckle test in the regular specification leaves the association without a test for knuckles which may be purchased separately for repairs. The separate knuckle test has never been other than a rough test of the quality of the material. The committee is working on a method whereby knuckles can be tested with a dummy coupler, somewhat as are the knuckles in a complete coupler test at the present time. The committee has also felt for some time that the jerk test might be improved upon by introducing the impact arrangement as exemplified in the method at Purdue University, and recommended by Prof. Goss for the impact testing of material. If successful, this would make unnecessary the use of two couplers in the jerk tests, a dummy being substituted in the impact test for the second coupler.

MAXIMUM MONTHLY MILEAGE IT IS PRACTICABLE AND ADVISABLE TO MAKE; HOW BEST TO MAKE IT, BOTH IN PASSENGER AND FREIGHT SERVICE.

Committee—T. H. Symington, Mord Roberts, Geo. F. Wilson.

It is generally accepted that there is no limit to the monthly mileage it is advisable to make, consistent with proper maintenance of the power and sufficient rest for the enginemen.

It is frequently stated by practical railroad men that engines need a rest after each trip. This is not the case, as the boiler (which is the backbone or keystone of the whole machine) is more damaged by periodic contraction when cooled and expansion when heated, than by continuing to do its duty in making steam.

By getting the maximum possible mileage out of power, fewer engines are needed and a great saving is made in outlay for equipment; or, expressed differently, a locomotive is good for a certain fixed number of ton-miles and to get this return in ten years is better policy than to wait for twenty-five years. It is best to get the full service from our engines quickly so they can be replaced with more modern power. We therefore believe beyond question that the maximum mileage it is advisable to make is only limited by what is practicable.

It is impossible to theorize on the maximum mileage to be obtained on various roads, as we have all been figuring over the problem for years with very different results. The best practice as reported by thirty separate lines is given in the table below, and we can simply take these results as a high standard and endeavor to follow and improve on them.

The Best Reported Practice on Different Length Divisions.

Division.	Service.	Monthly mileage.	How engines are crewed.	Lay-overs at terminals.	
				Home.	Other.
100 miles	Passenger	7,000	Double with extra men...	30	6
100 miles	Freight	5,500	Double	8	5
125 miles	Passenger	8,300	Pooled	8	5
125 miles	Freight	6,900	Double with extra men...	9	4
150 miles	Passenger	9,000	Double with extra men...	10	4
150 miles	Freight	6,500	Double with extra men...	6	3
175 miles	Passenger	10,000	Double	32	4
175 miles	Freight	6,600	Double	10	6
200 miles	Passenger	10,500	Pooled	20	5
200 miles	Freight	6,500	Pooled	8	8

That it would be possible to improve on these results under special conditions is indicated by the fact that the average of replies from all thirty lines gives 7 hours for passenger and 6½ hours for freight as the necessary lay-over at the home terminal to properly care for the engines. The lay-over at the other terminals can theoretically be much less.

It is often possible to lengthen out divisions, and the table below indicates the great advantage of doing so. This table shows an average of practice, and each road is given the same value regardless of the number of engines on its several divisions.

Average Monthly Mileage Made on Different Length Divisions.

Service.	100-mile.	125-mile.	150-mile.	175-mile.	200-mile.
Passenger	5,037	5,695	6,487	7,071	7,331
Freight	3,720	4,253	4,416	4,753	5,125

It will be noted that the average of thirty roads would indicate that engine mileage can be increased in both passenger and freight service, in about the same proportion as divisions are lengthened from 100 to 200 miles. For various practical reasons your committee would recommend that all divisions be lengthened so that the average service will consume from eight to ten hours between terminals.

The effect of grades and curves in reducing the speed of maximum trains, and consequent lengthening of the time between terminals, greatly reduces the monthly engine mileage, and probably more money has been spent on straightening curves and reducing grades, in the last ten years than on any other improvements. It is sometimes the case that a great deal of time is necessary to get trains over a maximum grade, and the time would be greatly shortened by putting helpers at these points.

As a rule, schedules are made with reference to connections and markets, but it is frequently the case that they may be changed to better suit the motive power requirements.

The average lay-over at the home and other terminal is given in the table below as reported for thirty roads, each road being given equal value in the averages, regardless of the number of engines in service.

Average Lay-over at Home Terminal on Different Length Divisions.

Service.	100-mile.	125-mile.	150-mile.	175-mile.	200-mile.	Average.
	Hours.	Hours.	Hours.	Hours.	Hours.	Hours.
Passenger	13	14	16	18	22	16.6
Freight	12.5	12.5	14.5	10.5	19	13.8

Average Lay-over at Other Terminals on Different Length Divisions.

Service.	100-mile.	125-mile.	150-mile.	175-mile.	200-mile.	Average.
	Hours.	Hours.	Hours.	Hours.	Hours.	Hours.
Passenger	6	7	9	8	14	8.8
Freight	7	9	9	8.5	9	8.5

It will be noted that the average lay-over away from the home terminal is over eight hours for both passenger and freight engines. The reasons for this are many. It is seldom that the traffic is balanced in both directions on a division; sometimes the light mileage is in one direction and sometimes in another, and the transportation department usually prefers to have the balance of power at that end from which the business starts. Another cause of unnecessary lay-over away from the home terminal is that crews, on single crewed engines, frequently have their homes at that end of the division. We would recommend that our transportation departments arrange as far as practicable for a minimum lay-over away from the home terminal, and that crews be required to live at the point most conducive to economy of operation.

On most roads there are certain seasons when the power is taxed to its utmost, and others when engines must be laid up. When the heavy season is a short one, it would, of course, be desirable that in this season every effort be made by the transportation department to arrange especially for an absolute maximum of mileage temporarily, even though at some sacrifice to other requirements, and to the comfort or custom of the crews.

It is wonderful the increased results that are obtained sometimes by a young and inexperienced runner over an older man, because the younger man will try to get everything out of the engine that is in it. This policy will undoubtedly avoid the purchase of many locomotives, and thereby increase the mileage and revenue from what we have the balance of the year. The tables below give the average mileage for different methods of crewing on different length divisions as reported by thirty separate roads, equal value being given to each line regardless of the number of engines in service.

Average Mileage in Passenger Service for Different Methods of Crewing on Different Length Divisions.

Method of crewing.	100-mile	125-mile	150-mile	175-mile	200-mile	Average.
	Div'n.	Div'n.	Div'n.	Div'n.	Div'n.	
Single	4,066	3,980	4,276	3,833	4,000	4,051
Single with extra men	4,700	5,400	5,450	7,850	5,850
Double	5,500	6,625	8,300	9,066	8,150	7,528
Double with extra men	6,045	9,000	9,000	8,015
Pooled	6,000	5,500	8,000	9,250	7,187

Average Mileage in Freight Service for Different Methods of Crewing on Different Length Divisions.

Method of crewing.	100-mile	125-mile	150-mile	175-mile	200-mile	Average.
	Div'n.	Div'n.	Div'n.	Div'n.	Div'n.	
Single	3,274	3,450	3,600	4,108	4,000	3,567
Single with extra men	4,425	4,500	4,200	5,000	4,450
Double	4,325	6,900	5,450	8,150	4,891
Double with extra men	5,700	5,900
Pooled	3,800	3,959	4,337	4,900	6,500	4,527

Special attention is called to the average mileage on all divisions in both passenger and freight service, as reported by thirty separate roads and representing their best practice. It will be noted that the mileage increased regularly in the following order of crewing:

1. Single.
 2. Single with extra men.
 3. Pooled.
 4. Double.
 5. Double with extra men.
- The only way in the control of the machinery department to increase an engine's mileage is to reduce the necessary lay-over at terminals to a minimum.
- An average of replies from thirty separate lines gives 4,650 miles in passenger service and 3,550 miles in freight service as

the monthly maximum it is considered enginemen should be allowed to make. On the other hand an average of the same replies gives 4,250 miles in passenger service and 3,330 miles in freight service as the monthly mileage men are satisfied to make. Under normal conditions it would then seem that two men by continuous running can make regularly almost as great a monthly mileage together as is practicable for one engine.

On account of the great variation in the amount of business at different seasons on most lines, the ideal arrangement of crews would be to have a flexible system arranged to the best advantage for normal service, but capable of expansion or contraction without hardship or loss of money to the older employees.

Pooling is flexible enough, but it puts all men on exactly the same plane and they fare alike. The old experienced runner is on the same footing with new men in the same pool. Of course when the pool is contracted, the younger men are dropped out, but there are often intervening periods when the pool is kept full of men without enough work for them all. On roads where it is only practicable to make a low monthly engine mileage except during one or two very short heavy seasons, we would strongly recommend that the engines be regularly single crewed and special arrangements made during the short heavy seasons.

The most flexible arrangement of crewing with consideration for the old and more competent runners would seem as follows, for a road with varying traffic: First condition, normal, single crew. Second condition, single crew and extra men. Third condition, double crew. Fourth condition, double crew and extra men.

For a road with more regular traffic: First condition, normal, double crew. Second condition, double crew with extra men.

No one denies that where one or two men are regularly assigned to an engine, it gets more careful and systematic inspection by the enginemen, and as a rule is kept in better condition than when the engine is pooled. This is natural, as the best roundhouse practice consists in correcting little troubles before they are apparent to the inspector's eye, and human nature will not permit a runner on a pooled engine to take the pains to investigate and locate incipient troubles as if he had a personal interest in his machine. Single crewing undoubtedly provides best for the care of locomotives, but they will be very well looked after if two men are equally responsible.

For large monthly engine mileage, the roundhouse and its methods are perhaps the largest single factors in the entire question. Practically the entire function of the roundhouse, aside from hostling the engines, is to take the stitch in time that saves ninety-nine. The talent required to properly look after engines there is of a higher order than that needed in the back shop. Any mechanic can tell what is the matter with a driving box if it is out on the floor, but it takes more ability to locate a pound on an engine in the roundhouse, and find out which box is going to give trouble. We frequently see roundhouses insufficiently equipped with men and appliances for the proper handling of the work. It is the roundhouse that keeps engines in service, and we believe it is far better to thoroughly equip it with the best men and tools, before giving any serious consideration to the balance of the locomotive plant.

We believe that a thoroughly up-to-date roundhouse foreman, who has competent men under him, and who knows in detail, himself, the condition of every engine in his division, who can keep his work behind him and not ahead of him, has more to do with keeping engines in service than any man in the machinery department. He must be backed up, and when curtailments of force are necessary, his force should be the last to suffer.

Summarizing our conclusions, we recommend, for a maximum monthly engine mileage, as follows:

That short divisions be lengthened so that the average service will consume from eight to ten hours over the division one way. That there be as low a maximum grade and degree of curve as practicable, and that helping engines be placed at one or two points on a division where the grade is considerably in excess of the rest of the division. That unnecessary stops be eliminated as far as practicable by the better location of water columns.

That as far as practicable schedules be arranged to give reduced lay-over away from the home terminal. That crews be required, as far as practicable, to live at the point most conducive to economy of operation, and to keeping engines in service. That transportation officers avoid the demand for more power when during a short heavy season some other requirements of the service can be adjusted temporarily, thus avoiding the laying up of engines in normal season. That transportation officers do not make the demand for all engines to be in good order, resulting sometimes in the purchase of new power for heavy seasons, when it might be avoided, and thus provide for increased mileage in normal seasons.

That engines be double-crewed with extra men for relief when there is enough work on one engine for two men. When this is not the case, that they be single-crewed with extra men for relief. That special attention be given to the roundhouse force and equipment, and that it be the last place to suffer from reduction of force. That the very best talent in the machinery department be placed in charge of the roundhouse work, and that system alone be not depended on for results. That the inspection of engines be reported separately by the enginemen and inspectors, as a check on their attention to detail. That the roundhouse work be specialized as far as possible,

so as to avoid a division or uncertainty of responsibility. That the existing methods be overhauled so that necessary routine work will not cause engines to lose their turn. That with the change to the pooling system, adequate preparation be made for more careful inspection, and heavier charges to maintenance. That interchangeability of parts be adhered to as far as practicable in various types of engines. That we strive after simplicity of design, and adhere to what we know is all right, unless there are excellent reasons for change.

LABORATORY TESTS OF BRAKE SHOES.

Committee—S. P. Bush, R. P. C. Sanderson, Geo. Gibbs.

The last report of the committee which contained the results of tests made was presented in 1896; since that time the committee has had no report to make, except that of last year on the installation of the testing apparatus at Purdue University, and the arrangement effected between the Master Car Builders' Association and the Purdue University concerning its care and use.

At the last convention the committee was instructed; first, to make tests of any brake shoes that might be submitted to it by any railroad company belonging to the association; second, to present a specification for adoption as standard by the association which would cover the essential and most desirable features of a satisfactory brake shoe for steam railway purposes.

In compliance with the above, the committee, through the secretary of the association, gave due notice to all concerned that it would receive brake shoes for test. Arrangements were also made with Professor Goss whereby, under the direction of Professor Smart, the work of testing would be conducted in a manner exactly similar to that followed in 1896, it having been demonstrated by the committee and the university authorities

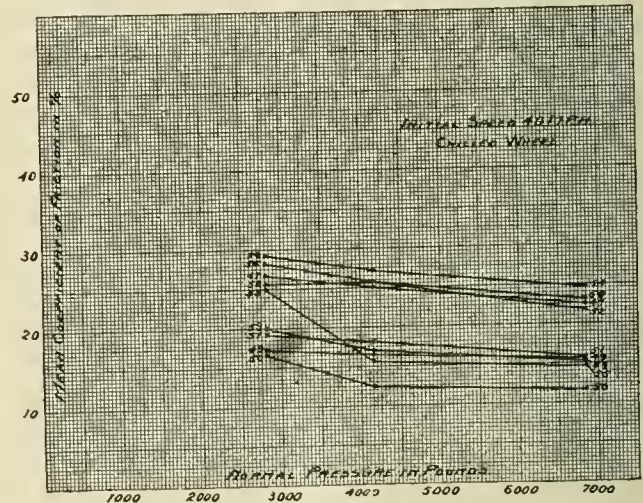

Diagram B.—Graphical Summary and Comparison.

who have used the machine frequently that the original results obtained by the committee were both accurate and reliable, and as representative as possible of actual conditions.

The shoes submitted for test and tested were as follows, the number opposite each one being the laboratory number and the number by which each shoe is designated:

Shoe.	Laboratory Number.
Lappin	47
Sargent U (Broke).....	48
Streeter	49
Corning	50
Herron	51
Cardwell	52
Ideal	53
Cardwell	54
Sargent U	55
Composite	56
Diamond S	57
Diamond S	58

Note.—Tests of Diamond S shoes could not be completed in time for printing, but will be presented at the convention.

The data in detail is shown by the tabulated statements and diagrams. The result of each, as compared with the "A" or soft cast-iron shoe originally tested by the committee, is shown by the graphical diagrams on which the solid line indicates the "A" shoe and the dotted lines the shoe indicated by the number on the margin.

It is apparent that the shoes producing the greater friction also show the greater wear, and the committee feel safe in stating that this is the general rule, which may, however, have some exceptions, and may show differences in the amount of wear for any given friction. An examination of the particles

worn from each shoe, and samples of the fractured shoes themselves, will give anyone an idea as to the causes that have produced the results in each specific case.

The committee has no knowledge as to the origin of the shoes tested, and desires to state distinctly that all brake shoes furnished under similar names may not give the same results as those tested. The committee recommends that the results shown should be regarded more as an indication of what it is possible and practicable for brake shoes made up under the various forms to produce, and that anyone desiring to be assured of getting brake shoes with a specific value as to friction, can only do so by selecting samples from time to time and having them tested, or by learning the physical qualities as developed by the character of the fracture, or by having satisfactory samples of fractured shoes with which to compare.

As to the matter of presenting a specification, it may be stated that a perfect specification should cover:

1. The mean coefficient of friction throughout the length of the stop.
2. The final coefficient of friction which is taken at a point 15 ft. from the end of the stop.
3. The initial coefficient of friction which is taken to be the highest value obtainable at a point near the beginning of the stop.

Such a specification, however, would perhaps be unnecessarily refined and complicated for practical purposes, and it seems

therefore, proposes the following specification for a brake shoe having the standard M. C. B. dimensions:

Specification.

Shoes when tested on the Master Car Builders' testing machine in effecting stops from an initial speed of forty miles an hour shall develop upon a cast-iron chilled wheel, or upon a steel-tired wheel, a mean coefficient of friction of not less than:
 25 per cent. when the brake shoe pressure is 2,808 lbs.
 22½ per cent. when the brake shoe pressure is 4,152 lbs.
 20 per cent. when the brake shoe pressure is 6,840 lbs.

The rise in the value of the coefficient of friction at the end of the stop shall be within such limits that the value of the coefficient of friction for a point of 15 ft. from the end of the stop

TABLE I.

Shoe.	Lab. Number.	Wheel.	Coeff. of Friction In Per Cent.	
			Mean—A.	Final—B.
Lappin	47	Steel.....	20.45	28.37
		Chilled.....	21.87	31.26
Streeter	49	Steel.....	21.99	26.55
		Chilled.....	16.51	24.76
Corning	50	Steel.....	14.22	20.88
		Chilled.....	13.69	22.60
Herron	51	Steel.....	18.98	25.02
		Chilled.....	17.80	25.66
Cardwell	52	Steel.....	22.91	29.29
		Chilled.....	24.42	30.64
Ideal	53	Steel.....	14.13	21.05
		Chilled.....	17.46	24.36
Cardwell	54	Steel.....	18.72	24.59
		Chilled.....	27.29	31.47
Sargent U.....	55	Steel.....	16.78	28.74
		Chilled.....	16.16	28.85
Composite	56	Steel.....	20.66	28.67
		Chilled.....	25.86	30.41
Diamond S.....	57	Steel.....	17.13	27.56
		Chilled.....	18.90	30.46
Diamond S.....	58	Steel.....	18.12	25.39
		Chilled.....	20.63	28.46

will not exceed the mean coefficient of friction by more than 7 per cent.

This specification is based upon the results obtained in the case of ordinary or reasonably hard cast iron, such as the "B" shoe of the original tests, and a good quality of composite shoe. It will be noticed that this specification does not place a maximum limit on the coefficient of friction. The committee has omitted this for the reason that it believes it is the desire of the association to encourage high frictional qualities as well as satisfactory wear. It is found that high and uniform frictional qualities are desirable in that it makes it possible to perform the operation of braking with an expenditure of less work and with lighter and less expensive brake gear. The committee believes that it is undesirable to use a brake shoe that gives a high coefficient of friction at or near the end of the stop, as this results in sliding the wheels, and in recommending that the coefficient of friction for a point 15 ft. from the end of the stop should not exceed the mean coefficient of friction by more than 7 per cent., it was intended to exclude only the worst of those that have been presented for test.

Finally, it may be stated that as development in the matter of brake shoes continues, it may be found desirable to make some modification in the specification proposed, but for the conditions existing to-day, the committee believes that it is fair and reasonable, and urges all members to pay some heed to the frictional qualities of brake shoes that they may use.

THE CHEMICAL COMPOSITION OF ALL STEEL CAR AXLES.

Committee—E. D. Nelson, C. A. Schroyer, F. A. Delano.

At the convention held in Saratoga, N. Y., in June, 1900, the question of changing the chemical composition of steel car axles, as outlined in the M. C. B. specifications, was discussed. The point made in the informal discussion held at that time was that the present specifications provided too high a proportion of carbon.

The first work of your committee was to correspond with those who had taken part in this discussion, and ascertain if possible their reasons for wishing to decrease the percentage of carbon. The result of this correspondence was that a number of instances where steel car axles had broken, were cited to your committee, with the statement that such axles had been bought in accordance with M. C. B. specifications for steel axles, at least in relation to the percentage of carbon contained in the steel. Your committee was particular to trace out these cases of reputed broken axles, and found that, although the information given was in entire good faith, a careful investigation showed quite clearly that the axles in question which had broken were not known absolutely to have been made in accordance with the chemical compositions required by the M. C. B. specifications; in fact, it was quite clear that these axles either were not bought under these or similar specifications, or else, if they were, no means had been taken to see that the axles furnished were strictly in accordance therewith. It is therefore clear to your committee that so far as these cases of broken axles are concerned, they do not furnish any evidence that the percentage of carbon allowed in the present specifications is too high. In addition to the above investigation, your committee has been in correspondence with railroad companies who have specifications for steel axles, or who have used the present M. C. B. specifications, and the matter seems to stand, so far as the opinion of those in charge of the car departments

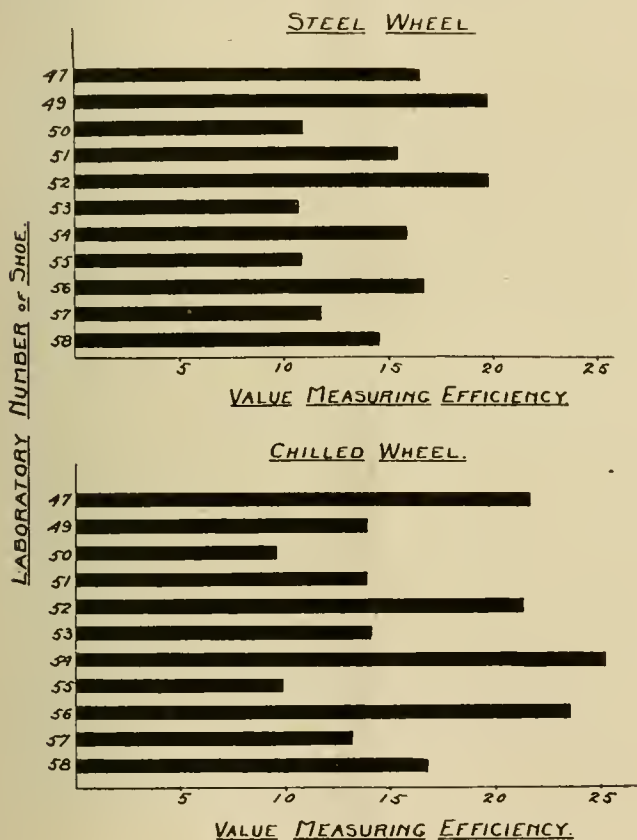

DIAGRAM C.

probable that the several factors are so related that a specification covering one or two would insure protection against failure in respect to others.

The committee is of the opinion that, to cover the frictional clause satisfactorily it will only be necessary to use two of the factors, i. e.: the mean coefficient of friction for the whole stop, and the final coefficient of friction.

The committee is also of the opinion from a review of all the data obtained from the test of the machine, that these results are more satisfactory for purposes of comparison when stops are made from a speed of forty miles per hour, and for this reason it is proposed to make this the standard speed in the proposed specification, and follow the original practice of the committee in adopting three comparative pressures, i. e.: 2,808 lbs., 4,152 lbs. and 6,840 lbs., respectively.

Considering the question as to whether it would be desirable to have a separate specification for chilled and steel-tired wheels, the committee, after reviewing the results, does not feel that such would be warranted. The results indicate plainly that a satisfactory friction can be obtained on either, although as a rule the coefficient of friction obtained on steel-tired wheels is somewhat lower than on the chilled, but inasmuch as the steel-tired wheels are used principally in passenger service, the committee is of the opinion that an effort should be made to keep the coefficient of friction up with a view of keeping the efficiency of the brakes up to a proper point. The committee,

on these railroads is concerned, that the percentage of carbon now allowed is not too high, and it is even intimated in some instances that if any change is made it should be in the direction of higher carbon.

Your committee does not feel justified in recommending any increase in the percentage of carbon above that allowed at the present time, but is strongly of the opinion that no decrease should be made and urges that the specifications in regard to chemical composition shall remain as at present. In connection with this subject, your committee desires to offer some suggestions having a bearing on the subject of the specifications.

First. As to the location of the boring to be taken from steel axles for chemical analysis. This should be distinctly defined by

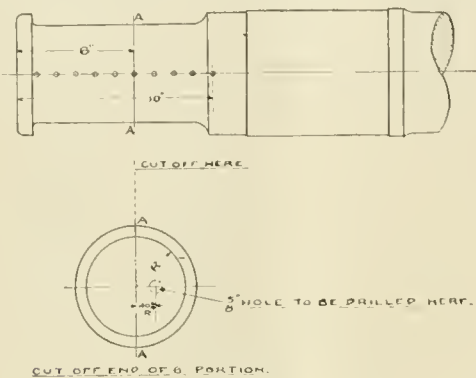

Fig. 1.

a diagram as shown in Fig. 1, attached to this report, and your committee would recommend that this be incorporated with the specifications.

Second. The present M. C. B. axles, except of the later design, have not had their dimensions determined upon the basis of uniform fiber stress between the center and the hub portion of the axle. In order to have uniform fiber stress throughout the body of the axle, it is absolutely necessary that the taper between the wheels should be straight and uniform. It has been found that some manufacturers neglect this, possibly due to a misunderstanding of the importance of this point, and your committee would recommend that a notation to this effect be placed on the standard drawing of M. C. B. axles as shown in Fig. 2.

Third. It is further thought by your committee that the question of having all steel axles rough turned should be seriously considered. Provision for this is now included in the M. C. B. specifications, but your committee thinks that sufficient emphasis is not placed on this matter by members of the association ordering steel axles. There is a decided advantage to the railroad companies in getting steel axles turned throughout their length, because it enables the inspector to determine readily whether the dimensions and contour required are strictly followed. It is thought no great opposition will be made to this practice, as the principal manufacturers are equipped for doing this work.

Fourth. M. C. B. axle "A," having journals $3\frac{3}{4}$ by 7 inches, is somewhat small at the wheel seat according to the method followed for the design of axles "C" and "D." The wheel seat of axle "A" should have a limiting diameter of $4\frac{7}{8}$ ins., and allowing $\frac{1}{4}$ in. to be turned off, the original size should be $5\frac{1}{8}$ ins. As this axle, however, was designed for cars of 40,000 lbs. ca-

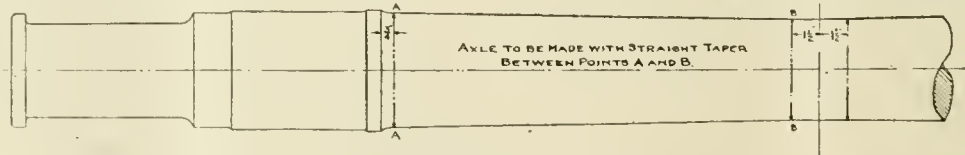

Fig. 2.

capacity, it may not be considered advisable by the association to make any changes in its design.

Fifth. Axle "B," having journals $4\frac{1}{4}$ by 8 ins., now has a wheel seat $5\frac{3}{8}$ ins. in diameter. The limiting size of wheel seat for this axle should be $5\frac{1}{2}$ ins., and allowing $\frac{1}{4}$ in. to be turned off, the original size should be $5\frac{3}{4}$ ins. The center of this axle is now $4\frac{3}{8}$ ins., and your committee would recommend that it be made $4\frac{3}{4}$ ins., in order that it shall have the same fiber stress as used in axles "C" and "D." The height of drop in the present specifications for this axle is 34 ft. This is incorrect for the axle having a center of $4\frac{3}{8}$ ins., but would be correct for this axle having a center of $4\frac{3}{4}$ ins. Therefore, the change recommended will make the size of axle consistent with the specifications, besides reducing the fiber stress, which is now somewhat greater than in the axles of later and more approved design.

Sixth. Axle "C," having journals 5 by 9 ins., now has a wheel seat $6\frac{3}{8}$ ins. As the limiting size is $6\frac{1}{4}$ ins., it is thought that the new size should be $6\frac{1}{2}$ ins., leaving the axle otherwise unchanged.

Seventh. Axle "D," having journals $5\frac{1}{2}$ by 10 ins., now has a wheel seat $6\frac{7}{8}$ ins. As the limiting size is $6\frac{3}{4}$ ins., it is thought that the new size should be 7 ins.

Eighth. In accordance with the designated standards of the association, axles "A" and "B" are specified for use under cars of 40,000 and 60,000 pounds capacity. It is only necessary to remind you of the fact that an axle is designated for carrying a definite weight to make it plain that the axles of the association should not be designated for cars of particular capacity. This is at once apparent when it is considered that under this assumption no consideration is given to the weight of the body of the car, which varies through wide limits. This is, of course, a portion of the weight carried, and together with the lading makes up the total weight carried on the car axles. Therefore, your committee would ask your consideration for a better designation of these axles, which would be as follows:

Axle "A," designed to carry 15,000 lbs. Axle "B," designed to carry 22,000 lbs. Axle "C," designed to carry 31,000 lbs. Axle "D," designed to carry 38,000 lbs.

Ninth. In conclusion, your committee feel that they should call the attention of members of the association to the desirability of ordering their axles according to the M. C. B. specifications. There are a number of railroad companies ordering steel axles and having specifications varying slightly from those of the association. It would appear to be to the advantage both of the manufacturers and of the railroad companies, to have these specifications uniform, and your committee would urge serious consideration of this question.

THE MOST SATISFACTORY METHOD OF HANDLING, CLEANING AND SETTING BOILER TUBES.

Committee—W. H. V. Rosing, A. E. Miller, C. H. Doebler.

Tubes should be cut out of both tube sheets with a power cutter and removed through dry pipe holes providing the pipe has been taken out, otherwise through a tube hole that has been reamed sufficiently large to admit of removal of tubes, according to the probable amount of hard scale they may carry. The ends remaining in the front sheet should be driven out with a pneumatic hammer and chisel. The ends remaining in back tube sheet should be removed in a similar manner. A heavier hammer, however, is needed for this, with an ordinary flat chisel about one-half inch wide, or split caulking tool. The labor of chipping off beads can be then dispensed with. They should then be taken to the rattler for the purpose of removing the scale. Safe ends should be cut off and scarfed and piled near furnace with horning anvil where the tubes should be opened and safe end applied. After this operation they should be piled convenient to welding furnace.

The safe end should be same thickness as the original tube and should be applied to the end of tube having previously received a safe end in order that the thicker end of the tube be used for welding. After weld has been made and scale scraped off, the tubes should be swaged about 5-32 in. and stood up in quicklime for annealing. They are then cut to length, and front end opened on horning anvil and are then ready to be replaced.

The committee is of the opinion that, with the average workman, it is not necessary to test the welds in tubes until they have been reset, for, with the small percentage of failures, it is more economical to remove a defective tube occasionally after having been set in boiler than to test each tube separately.

Before setting tubes, copper ferrules should be rolled into the holes of the back tube sheet and tubes driven into them. The back ends of tubes should be set with a Prosser expander and after peening over, rolled with a roller expander and beaded with a pneumatic hammer and beading tool. The front ends should be rolled with a roller expander.

The heating of tubes is accomplished with either coke, anthracite coal or oil. Either of these will produce a satisfactory

welding heat and the furnace should be arranged for heating as many tubes simultaneously as the man at the welding machine can handle without waiting for a heat. The fuel used is rather a matter of cost, according to local conditions, than of specific kind.

Where coal or coke is used it should be fed to the furnace by means of a hopper. In case of burning oil, it should be applied with a burner at both ends, especially where tubes are being heated from both sides of the furnace.

The committee recommends the scrapping weight of tubes for boilers carrying 200 lbs. boiler pressure as follows: 2-in. tubes, 1.65 lbs. per foot; $2\frac{1}{4}$ -in. tubes, 1.85 lbs. per foot. From this it is obvious that a heavier tube will have a greater percentage of service metal.

No definite information was received regarding the merits of steel tubes as compared with charcoal-iron tubes. The experience with steel tubes seems to have been very limited. The opinion of the majority favored charcoal-iron tubes from the fact that they pitted less and would hold a better bead. The principal trouble, however, was in the welding of steel tubes to steel safe ends. The committee is not prepared to say how much of this is due to the inexperience of the operator or to the metal itself.

AMERICAN ENGINEER AND RAILROAD JOURNAL.

SEPTEMBER, 1901.

CONTENTS.

ARTICLES ILLUSTRATED :	Page	ARTICLES NOT ILLUSTRATED :	Page
Four-Cylinder Tandem Compound Locomotive, Northern Pacific Ry.....	271	Some Phases of the Water-Treating Problem, by Howard Stillman	281
Fifty-Ton Steel Drop-Bottom Gondolas	279	Santa Fe Route Reading Rooms	284
The Barnes Exhaust Pipe.	283	The New Turbine Steamer "King Edward"	284
Tractive Power and Power Losses.....	283	Cost of Track Scales for Locomotive Coal.....	288
Tables of Speed of Locomotives, by R. F. Peters.....	285	The Nernst Lamp.....	288
Cast Steel Locomotive Frames ..	287	The "Pan-American".....	290
Consolidation Mountain Pushing Locomotive, A. T. & S. Fe Ry.....	289	Requirements of Electricity in Manufacturing Work.....	291
An Improvement in Journal Boxes.....	292	Machine Tools at the Pan-American Exposition	298
Some Details of Fuel Oil Burners	292	Effect of Splicing and Riveting	299
Manganese Bronze Staybolts ..	296	The Bullock-Wagner Pan-American Exhibit.....	299
Ten-Wheel Freight Locomotive with Walschaert Valve Gear..	297	Burnishing Car Journals	300
Car-Door Fastening and Ventilation.....	298	EDITORIALS:	
New Combined Planing, Matching and Jointing Machine.....	300	Track Scales for Weighing Locomotive Coal	286
A New Generating Set	300	The Tandem Compound.....	286
		The New York Central Tunnel... ..	286

FOUR-CYLINDER TANDEM COMPOUND LOCOMOTIVE.

Consolidation Type.

Northern Pacific Railway.

After a year of service on the Northern Pacific Railway the experimental four-cylinder tandem compound locomotive, built by the Schenectady Locomotive Works, has been found satisfactory and these builders are engaged upon an order for 26 for that road, the drawings of which have been supplied for this description by the American Locomotive Company. In addition to these an order for 40 of the same type has been given by the Atchison, Topeka & Santa Fe. Comments upon the selection of this type will be found in the editorial columns of this issue.

This engine will be known as Class Y2 and will be used in freight service on the Pacific division. The consolidation engines on this road of the two cylinder compound type, Class Y1 (American Engineer, Feb., 1899, page 42), have 55-in. driving wheels. With 63-in. drivers the new class will be available for fast freight.

The chief interest in this design centers in the cylinders. Only one pair of saddle castings are used, the cylinders are cast separately, the low pressure with the saddle and the high pressure cylinders being mounted upon the front faces of the low-pressure cylinders with a single head between. Piston valves are fitted to both cylinders with a continuous passage between. This forms the receiver, and by making the valves hollow, arranging the high pressure valve for inside admission, the low-pressure valve for outside admission and crossing the steam ports of the high-pressure cylinder an ingenious method of using a single valve stem and single ported valves was secured. In a compound engine the large clearances of the high pressure ports is not detrimental and this plan is simpler than those requiring a rocker to reverse the motion of the high-pressure valve or those requiring a double-ported valve on the low-pressure cylinder.

The piston rods and valve rods are continuous. To secure the high-pressure piston to the rod a nut is used instead of the key shown in the drawing. To remove the piston of the low-pressure cylinder, the high-pressure piston is removed by

taking off the nut, and the back head of the large cylinder is taken down.

When access to the low-pressure packing rings only is desired the operation is simple. The engine is placed on the back center on the side which is to be examined, the guides loosened at the back end, and the nuts removed from the back low-pressure cylinder head. This cylinder head, with the guides attached, can then be shoved back until the cylinder head comes in contact with the forward driving wheel tire. This allows sufficient space to get at the follower bolts of the low-pressure piston and permits the rings to be examined or renewed. The back ends of the guides are fastened to a separate plate which is attached to the main guide yoke by four bolts. The back end of the guides is loosened by removing these four bolts and the lining of the guides is not disturbed. Comparatively little work is thus involved in examining the low-pressure piston beyond what would be required for the low-pressure piston of a two-cylinder compound, as neither the main rod, cross-head, or high-pressure piston need be disconnected.

For packing the piston rods between the cylinders a close fitting sleeve with water grooves is used. It has a collar with ground joints fitting loosely enough between the head and the gland to take sufficient motion to accommodate the piston rod and provide for the wear of the pistons and cylinders. There is no removable or adjustable packing whatever. This idea was taken from years of successful experience with the same device in steam pumps. As this sleeve floats and has no work to do it ought to wear well, and the provision of the motion should prevent all difficulties with it. A special lubricator is provided for this bearing. The collar is always held against the head by the pressure of the steam in the high-pressure cylinder. It will be seen that very large port openings are provided, the high-pressure valve is short and the low-pressure clearances are very small.

Relief valves are used on the high and the low-pressure cylinders because of the use of piston valves on both cylinders. On the low-pressure these are attached to the steam chest itself and when open form a by-pass when drifting. On the side of the high-pressure steam chest the relief valves and starting valve are for convenience combined in one casting. These relief valves are closed when the throttle is open and when it is closed they open communication between the ends of this cylinder through the steam port. A simple plug valve working in a fore and aft direction serves as a starting valve. When starting the engine it is in the position shown in the engraving and admits steam to the exhausting side of the high-pressure cylinder, while the steam side of this cylinder takes steam through the throttle and main piston valve. This puts the high-pressure piston in equilibrium and gives boiler steam to the low-pressure piston at properly reduced pressure.

In the drawing of the frames it will be seen that there are two bars at the saddle which are brought together in front of it and both extend in a long splice to the bumper. Back of the cylinders cast-steel filling blocks are used between the frame splices and immediately back of the cylinders a substantial cross-tie is shrunk on between the frames. The character of the splices and the large number of bolts are, together with the security of the bolting of the cylinders and saddle, clearly shown in the drawing. In front of the cylinders a 1-in. plate is bolted between the frames, forming a substantial brace. The cylinder drawings show the method of conducting the steam pipe from the saddle to the high-pressure cylinder. This is also seen in the elevation and sectional views. The frames, except the front rails, are of cast steel.

In cross-section the firebox closely resembles that of the New York Central Atlantic type engines (American Engineer, February, 1901, page 37). With a slope downward of the front half of the mud ring a depth of 18 ins. below the barrel of the boiler is secured. Thick barrel and throat sheets are necessary, for the pressure on these boilers is 225 lbs. per square inch. These figures are given in the table of dimensions. The

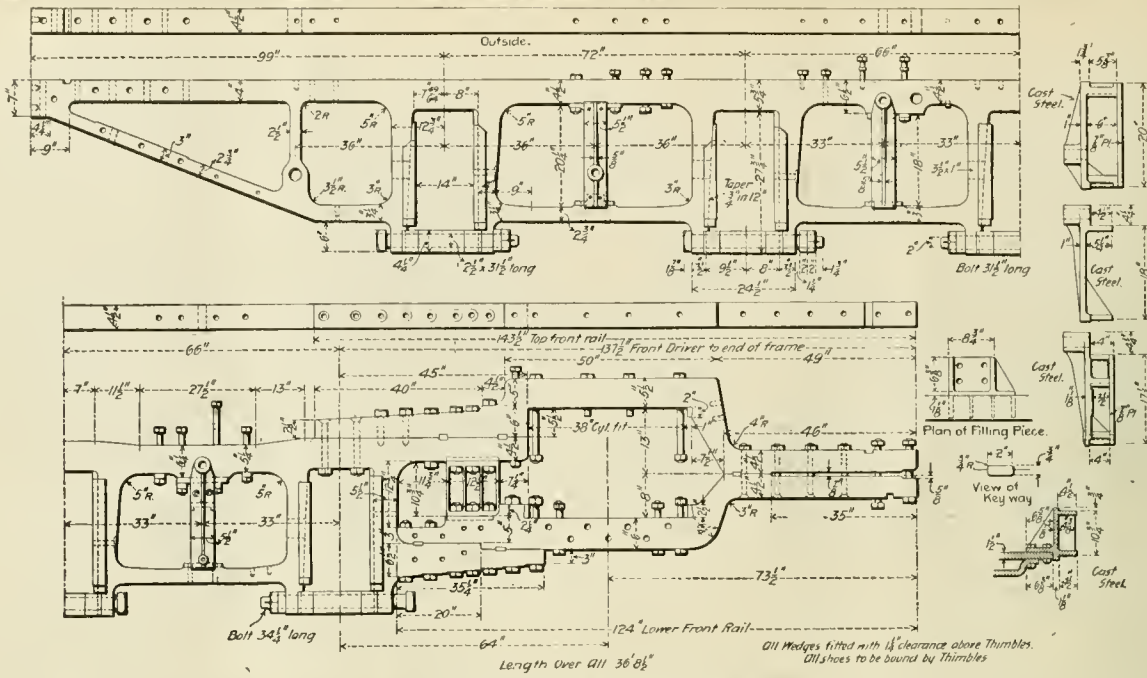

Views of Cast Steel Frames.

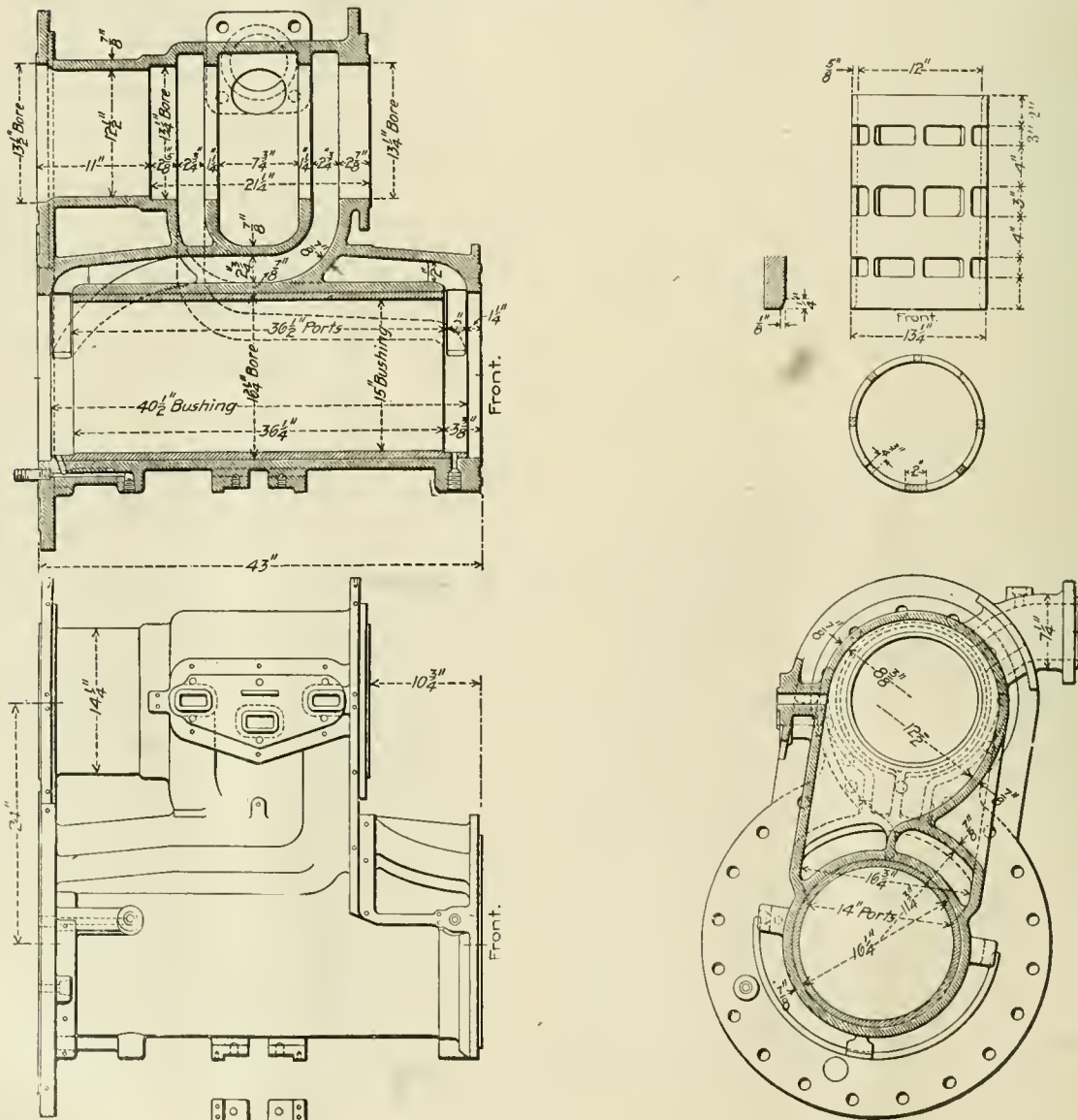

High Pressure Cylinder.
Four-Cylinder Tandem Compound Locomotive—Northern Pacific Railway.

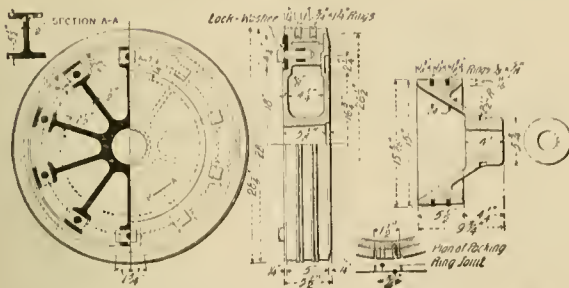

High and Low Pressure Pistons.

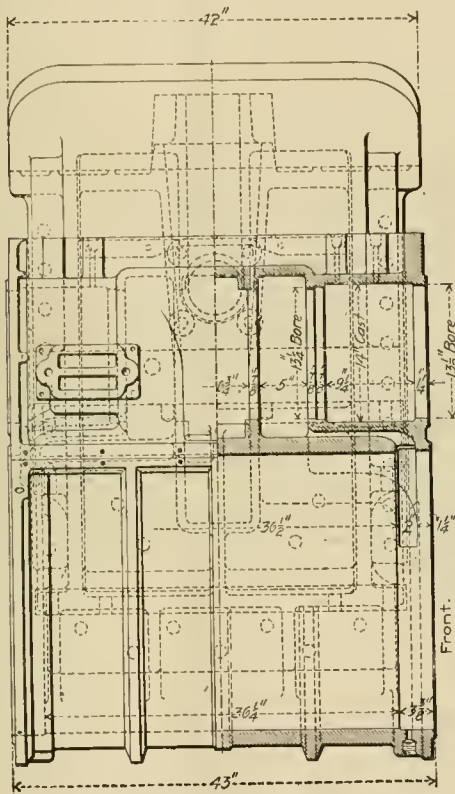
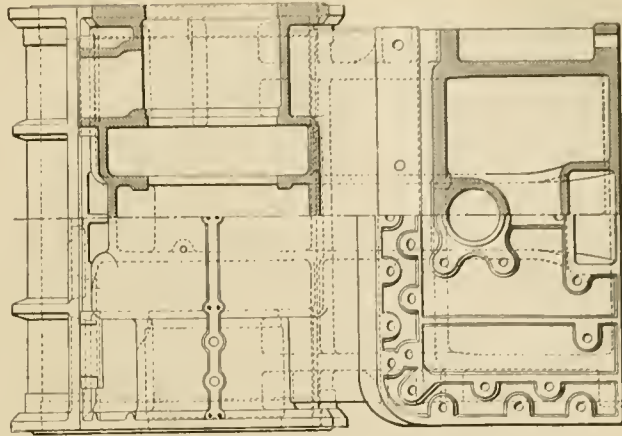

Low Pressure Cylinder.

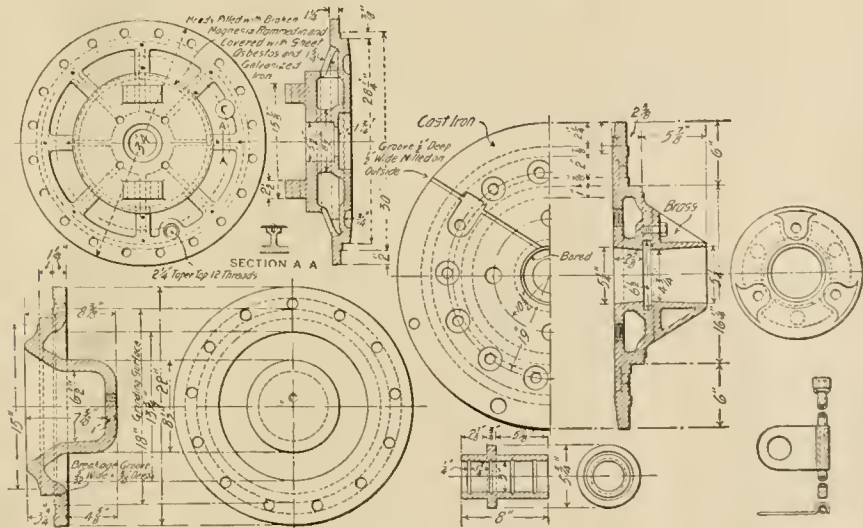
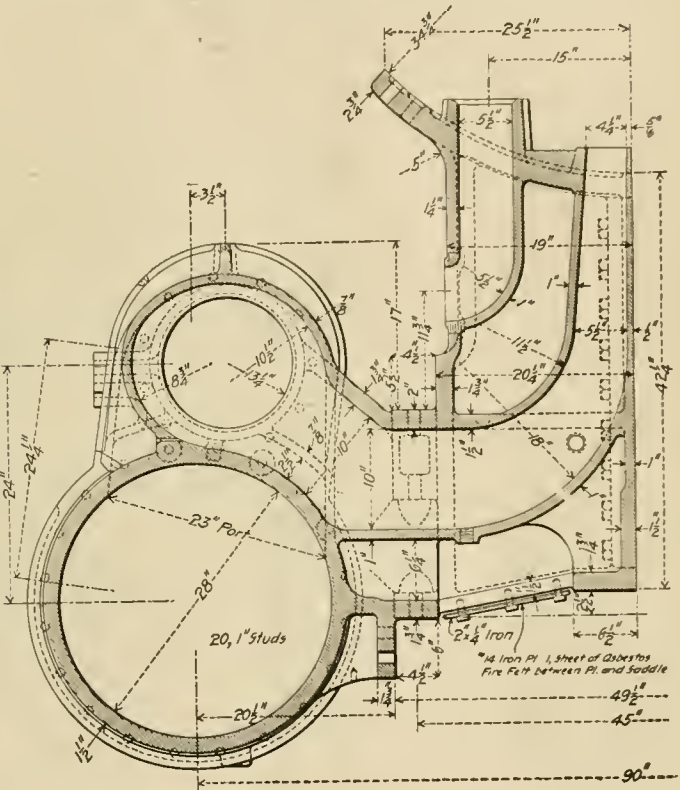

Cylinder Heads.

Four-Cylinder Tandem Compound Locomotive-Northern Pacific Railway.

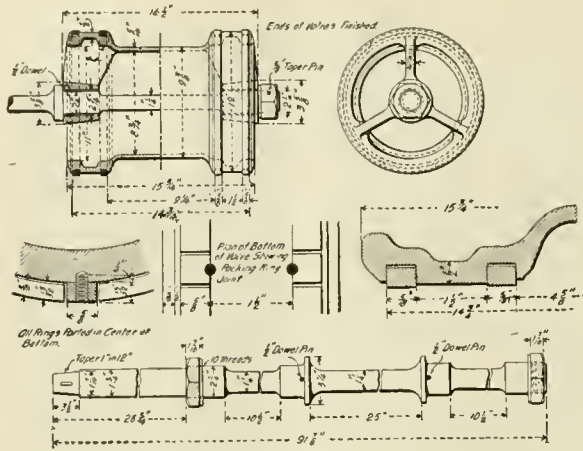

High Pressure Valve and Rod.

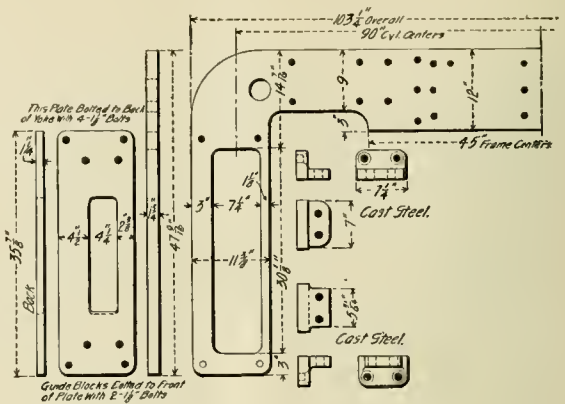

Guide Yoke.

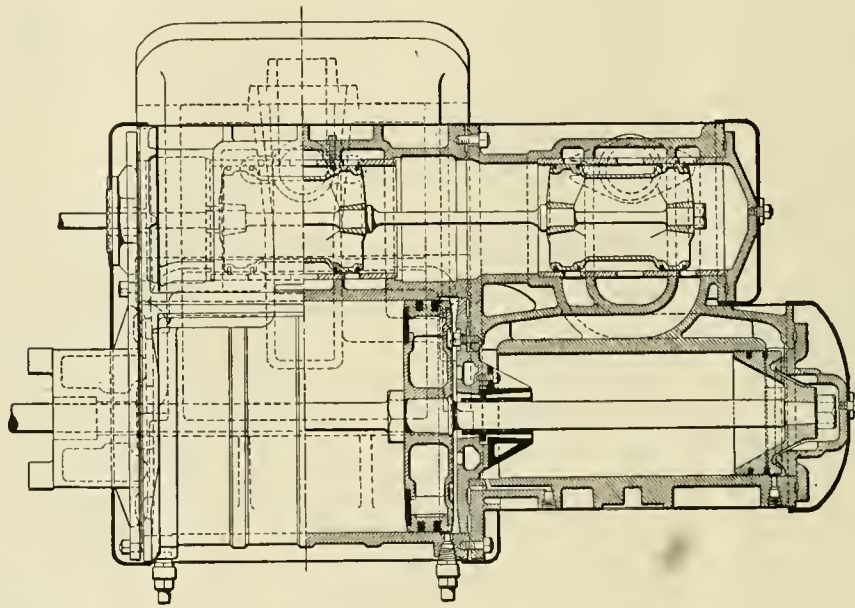

Section Through Cylinders and Steam Chests.

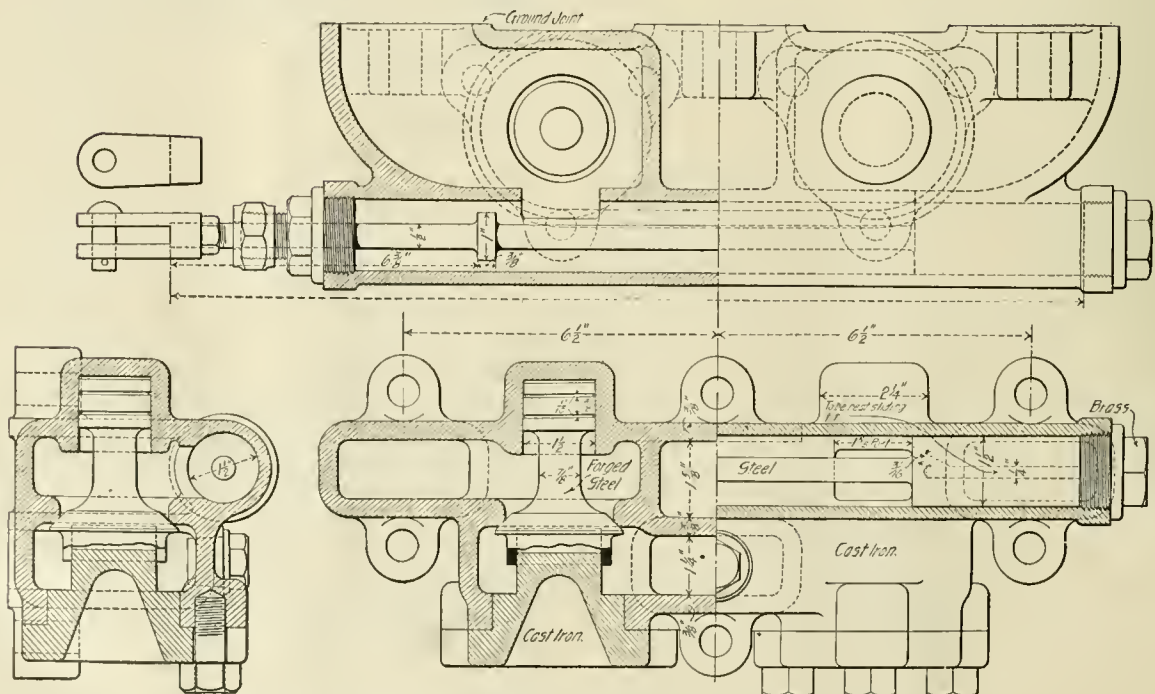

Combination By-Pass and Relief Valves for High Pressure Cylinders. Four-Cylinder Tandem Compound Locomotive—Northern Pacific Railway.

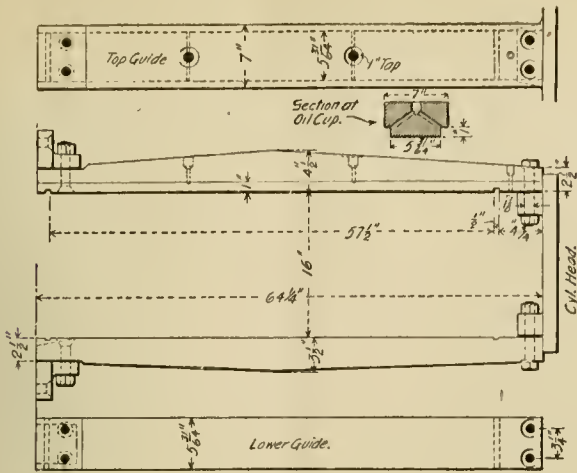

Upper and Lower Guides.

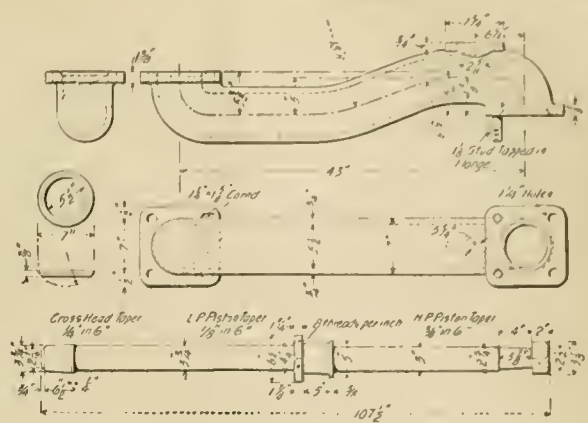

Steam Pipe and Piston Rod.

Wheels, Etc.

Diameter of driving wheels outside of tire	63 ins.
Material of driving-wheel centers	Cast steel
Tire held by	Shrinkage
Driving-box material	Main, cast steel, F. & B. steeled cast iron
Diameter and length of driving journals	main, 9 1/2 by 11 ins.
Diameter and length of main crank-pin journals	(Main side, 7 3/4 by 5 1/2 ins.) 6 1/2 by 7 ins.
Diameter and length of side rod crank-pin journals	Intermediate, 5 1/2 by 5 ins.; F. & B., 5 by 4 1/2 ins.
Engine truck, kind	Two-wheel swing bolster
Engine truck journals	6 by 11 ins.
Diameter of engine truck wheels	33 ins.
Kind of engine truck wheels	Boles steel tired

Boiler.

Style	Extended wagon top with wide firebox
Outside diameter of first ring	66 1/2 ins.
Working pressure	225 lbs.
Material of barrel and outside of firebox	Worth basic steel
Thickness of plates in barrel and outside of firebox	9/16 in., 3/8 in., 13/16 in. and 7/8 in.
Horizontal seams	Butt joint, sextuple riveted, with well strip inside and outside
Circumferential seams	Double riveted
Firebox, length	100 1 1/16 ins.
Firebox, width	75 1/4 ins.
Firebox, depth	F, 70 3/4 ins.; B, 59 3/4 ins.
Firebox, material	Carbon acid steel
Firebox plates, thickness	Sides, 3/8 in.; hack, 3/8 in.; crown, 7/16 in.; tube sheet, 9/16 in.
Firebox, water space	Front, 4 1/2 ins.; sides, 3 1/2 to 6 ins.; back, 3 1/2 to 4 1/2 ins.
Firebox, crown staying	Radial, 1 1/8 ins. diameter
Firebox, staybolts	Taylor iron, 1 in.
Tubes, material	Charcoal iron No. 12
Tubes, number of	335
Tubes, diameter	2 ins.
Tubes, length over tube sheets	16 ft.
Fire brick, supported on	Water tubes
Heating surface, tubes	2,815.03 sq. ft.
Heating surface, water tubes	26.43 sq. ft.
Heating surface, firebox	155.64 sq. ft.
Heating surface, total	2,997.10 sq. ft.
Grate surface	52.29 sq. ft.
Grate, style	Rocking
Ash pan, style	Hopper, with slides operated by steam cylinder dampers front and back

Exhaust pipes	Single
Exhaust nozzles	5 1/4 ins., 5 1/2 ins., 5 3/4 ins. diameter
Smoke stack, inside diameter	18 1/2 and 16 ins.
Smoke stack, top above rail	15 ft. 1/4 in.
Boiler supplied by	Two Hancock inspirators, Type "A." No. 10

Tender.

Weight, empty	47,000 lbs.
Wheels, number of	8
Wheels, diameter	33 ins.
Journals, diameter and length	5 by 9 ins.
Wheel base	15 ft. 8 ins.
Tender frame	10-in. steel channels
Tender trucks	Two trucks 4-wheel center-bearing double I-beam bolster
Water capacity	Tank water bottom of 5,500 U. S. gals.
Coal capacity	10 tons
Total wheel base of engine and tender	53 ft. 10 1/2 ins.
Brakes	Westinghouse-American combined on drivers, tender and for train
Air pumps	Two 9 1/2-in., with duplex governors
Water brake on cylinders	Le Chatelier
Safety valves	Three 3-in. Ashton special open pop
Blow-off cock	Little Giant
Lubricators	Michigan, 1 double and 1 triple
Sand blast	Leach D-2 double
Sectional lagging	Magnesia
Steam gauge	Ashcroft
Bell ringer	Western

boilers have two firedoors and sloping back heads. They are supported from the mud ring, as indicated in the elevation drawing.

From having followed this development in the drawing room and the shops it is evident that the greatest care has been exercised in the design of the details and before the type received the endorsement of the builders the experimental engine was put through the test of severe service, after which the present plans were prepared but without radical changes of any kind.

The valve motion gave the following measurements from engine No. 1,250 on the erecting floor of the Schenectady Locomotive Works, the uniformity of the cut-off and valve opening being specially noteworthy.

Valve Measurements.

No. of Notches.	Lead.		Valve opens.		Cut off.	
	Front stroke. Inches.	Back stroke. Inches.	Front stroke. Inches.	Back stroke. Inches.	Front stroke. Inches.	Back stroke. Inches.
Left	0	0	2 1/8	2 1/8	30 3/8	30 3/8
1 Right	0	0	2 1/8	2 1/8	30 3/8	30 3/8
2	1/16	1/16	1 1/8	1 1/8	25	25 1/8
3	1/32	1/32	3/8	3/8	23	23 3/8
4	1/4 S	1/4 S	1 1/8	1 1/8	21	21 1/8
5	1/4	1/4	5/8	5/8	19	19
Left	3/8	3/8	1 5/8 S	1 5/8	17	17
6 Right	3/8	3/8	1 5/8 S	1 5/8 S	17	17

The slip of the links in full forward motion is 15/16 in., in full back motion 11/16 in., and at half stroke 5/8 in. The valves are set line and line in both forward and hack motions and the lead at 17-in. cut-off is 9/32 in.

Tandem Compound Locomotive, Northern Pacific Railway. General Dimensions.

Gauge	4 ft. 8 1/2 ins.
Fuel	Bituminous coal
Weight in working order	198,000 lbs.
Weight on drivers	175,000 lbs.
Wheel base, driving	17 ft.
Wheel base, rigid	17 ft.
Wheel base, total	25 ft. 9 ins.

Cylinders.

Diameter of cylinders	15 and 28 ins.
Stroke of piston	34 ins.
Horizontal thickness of piston	5 1/2 ins.
Diameter of piston rod	H. P., 3 ins.; L. P., 3 3/4 ins.
Kind of piston-rod packing	Cast iron

Valves.

Kind of slide valves	Piston type
Greatest travel of slide valves	6 ins.
Outside lap of slide valves	7/8 in.
Inside clearance of slide valves	H. P., 1/4 in.; L. P., 3/8 in.
Lead of valves in full gear	Line and line F. & B., 1/4-in. lead at 1/2-in. stroke cut-off.

The Chicago & Northwestern annual report shows that in the year ending May 31, 1901, 3,701 million tons of freight were hauled with a smaller train mileage than that of 1894 when 1,989 million tons were hauled. In seven years the train load has increased from 123 tons to 232 tons. The earnings per train mile now average \$1.98 as against \$1.33 in 1894, but the rate has decreased from 1.07 cent to 0.85 cent in that time.

The arrangement employed in the General Electric works at Schenectady for blue-printing by electric light was described by Mr. H. G. Reist in a paper at the recent meeting of the American Society of Mechanical Engineers at Milwaukee. The carriages supporting the blue-printing frames are run under a metal hood a little larger in size than the printing frame, each containing two 5-ampere, 110-volt enclosed-arc lamps. The lamps in turn are supported on a small trolley arrangement and are enclosed in white opal globes. The time required for printing is three or four times as long as with bright sunlight. The cost of making prints by electric light is smaller than by sunlight, owing to the fact that the labor employed in carrying out the former method can be utilized during the entire office hours, both summer and winter, and during cloudy days. Another advantage is that with the electric equipment, blue prints may be put into the shop almost immediately after the completion of the tracing, regardless of the time of day.

The gross earnings of all the railroads in the United States reporting to R. G. Dun & Co. for July are \$50,732,912, a gain of 13.2 per cent. over last year and 25.2 per cent. over 1899. The increase continues remarkably large. Southwestern roads are still in the lead, but on all other classes earnings show a very uniform percentage of gain. The statement includes many leading systems and about one-half the total mileage of the country. It indicates a prosperous condition for the railroads and the country as well, for it shows a volume of business in all leading classes of freights greater than ever before known at this season.

In considering the introduction of a special engine for driving the fan of a heating apparatus in connection with the blower system of ventilation and heating, it should be clearly realized that a certain amount of steam being required for supply to the heater, the passage of that steam through the engine on its way to the heater entails very little loss in its heating power—so little, in fact, that the actual expense of driving the fan may be disregarded and the steam-engine cylinder may be looked upon as merely an enlargement of the steam pipe. Evidently this feature of this system has its influence on the relative cost of driving the fan by an engine or by an electric motor, for, in the employment of the latter there is no incidental return whereby the cost of power is reduced.

"Technolexicon" is the name decided upon for the trilingual technical dictionary, the compilation of which has been undertaken by the "Verein Deutscher Ingenieure." This work will be printed in English, German and French, and in three volumes, for the convenience of those who best understand only one of these languages. Appeals for co-operation have been issued, assistance being necessary from those who are familiar with the needs of various interests who will be benefited by the dictionary. All the expense of publication is to be borne by the German society acting disinterestedly, to meet the long-felt need for a satisfactory authority on technical terms. This movement is heartily commended. A dictionary of this kind will increase in value with the growing tendency toward international trade in engineering products. Its usefulness is not confined to scientists, for it is probably most needed by those who find it necessary to impart knowledge of their productions to those who think, write and talk in other languages, in which technical terms find no logical equivalent. Dr. Hubert Jansen, the editor-in-chief of the "Technolexicon," should receive the heartiest co-operation of those who need this work, and it appears to be the duty of the engineering societies to respond unreservedly. His headquarters are Dorotheenstr. 49, Berlin (N. W. 7), Germany, where all communications and contributions should be addressed.

The water-tube and cylindrical boiler controversy in the English navy led recently to a trial run of the "Hyacinth," with Bellville boilers, and the "Minerva," with cylindrical boilers, from Gibraltar home. The ships were not alike and the trial was, as should have been expected, inconclusive, although the honors are apparently given to the old type of boiler. The "Minerva" had 150 lbs., and the "Hyacinth" 250 lbs. steam pressure. Beyond demonstrating the possibilities of getting the former ship up to full speed in two hours after lighting the fires, together with the fact that her boilers and machinery gave no trouble during the run, while the Bellville boilers leaked and a fireman was scalded severely by the bursting of a tube, the trials threw no valuable light on the general subject. We are reminded by these tests of the numerous attempts to compare locomotives under "similar conditions," that is, under conditions which absolutely prevent an intelligent conclusion. By investigating one feature of a complicated problem at a time and gradually decreasing the number of unknown quantities an opinion may be formed. In this case the advocates of the water-tube boiler should defend the type from unjust condemnation because of these tests. Even if the tests had given conclusive results the case of the water-tube boiler is not weakened by a test of a boiler of this type which is not considered as a fair representative.

American locomotives on Indian railways are favorably reported upon by the Locomotive Superintendent of the Oudh & Rohilkhand Railway under date of May 17 and recorded in "Engineering News" as follows: For this road ten mogul locomotives, six wheels, coupled, with a Bisel truck, were built by the Baldwin Locomotive Works, and were delivered in May, 1900. At the end of April, 1901, these locomotives had recorded an average mileage of 23,070 miles. The only change made at first was in the grates, which did not suit Bengal coal; and new bars, with a $\frac{7}{8}$ -in. space between, were put in them. Later, certain oil-cups and the sandboxes were changed to suit Indian requirements. The chief defects pointed out by the superintendent are as follows: Eccentric sheaves came loose on axle in two engines, vacuum brake cylinder hangers of tender are put on with bolts and nuts so placed as to be impossible to get at with wrench, the nuts have to be tightened up nearly each trip; the engine-cab, while very roomy and comfortable, is not stayed sufficiently and rocks a good deal with the "constant jolting of the engine." All of these defects seem to result from a very rough track. The average coal consumption on the ten engines, from October, 1900, to March, 1901, was:

Per engine mle.....	48.29 lbs.
Per vehicle mle.....	1.92 lbs.

The new "B" class English engines do the same work as follows:

Per engine mle.....	45.25 lbs.
Per vehicle mle.....	1.94 lbs.

The cost of the American locomotives complete was \$12,614 each, with the rupee = \$0.324 each. Class "B" English locomotive cost \$14,523. The report concludes as follows: These ten engines have been working passenger trains, running at 30 to 35 miles an hour, and goods trains running at 20 miles an hour, chiefly the former, and they have done their work well. They steam capitally, and are remarkably good starters; they get away from a station with 55 loaded goods wagons (equal to about 1,300 tons) with the greatest ease. They are a little higher in coal consumption than our new "B" class. They are easily repaired, but repairs will have to be kept up, if not, they will go to pieces sooner than another engine would. They do not, as far as I can see at present, cost more in repairs than other engines, and I am very well satisfied with them.

From the figures of coal consumption given above it will be noted that the coal used per engine mile by the American locomotive is slightly greater than that of the English engines, but when more fairly compared on the basis of coal per vehicle mile a saving of the difference between 1.94 and 1.92 is shown by the American locomotive.

FIFTY-TON STEEL DROP-BOTTOM GONDOLAS.

Elgin, Joliet & Eastern Railroad.

Through the courtesy of Mr. George I. King drawings of the new 50-ton gondola coal cars now building for the Elgin, Joliet & Eastern have been received. These cars have drop bottoms with a large door opening and, due to the arrangement of the

cured by bent plates riveted to the bolsters and to the sills. The sills are not continuous and the body bolsters are not cut for the sills; they extend across the car and are reinforced by large cover plates. Instead of using heavy slide sills Mr. King has employed the sides as plate girders to assist in carrying the load and the manner of carrying out the construction indicates very careful study, which is apparent in the light weight of the car. At the ends of the central sections of the center

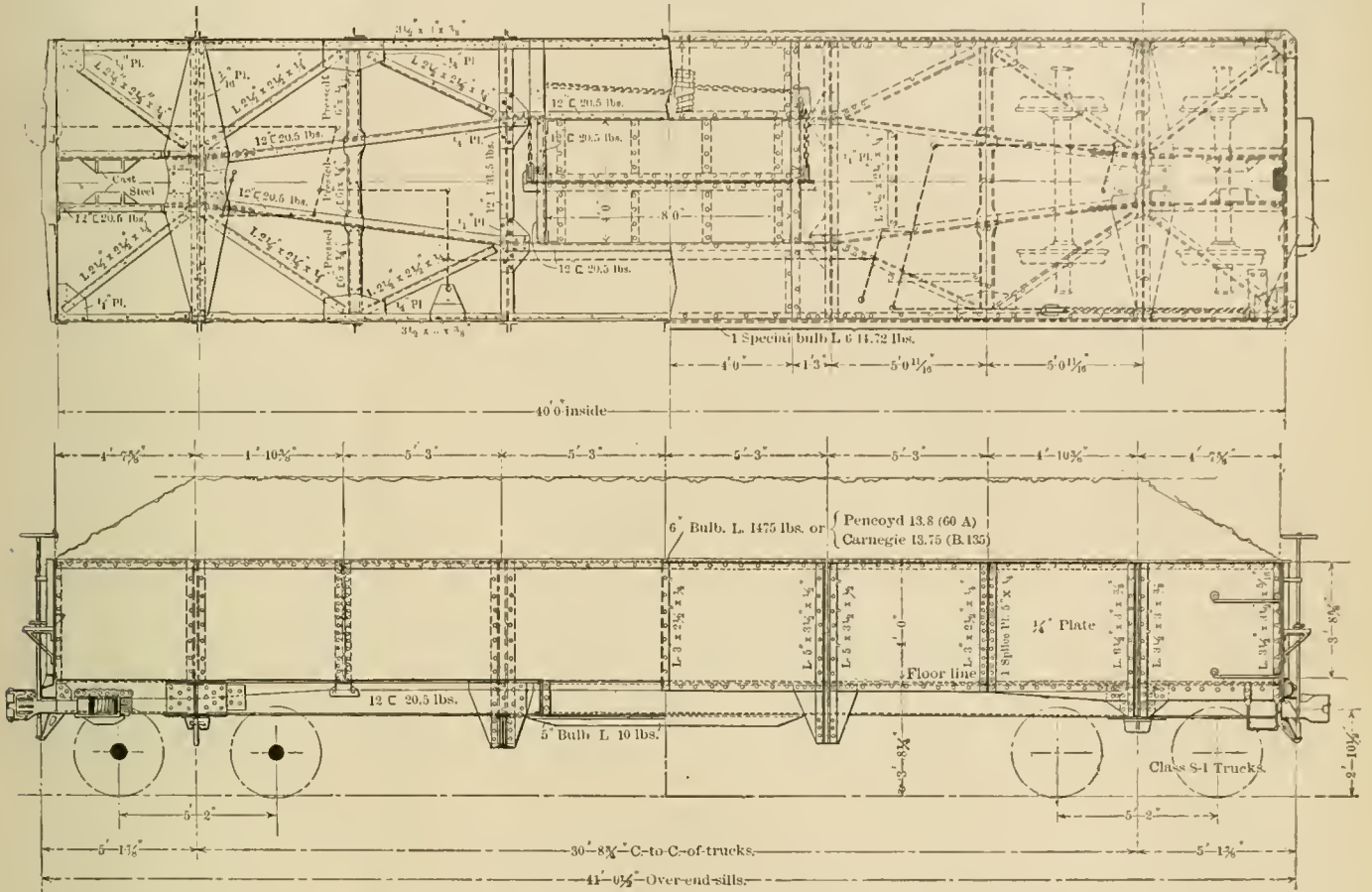

New Fifty-Ton Gondola Coal Car—Elgin, Joliet & Eastern Railroad.

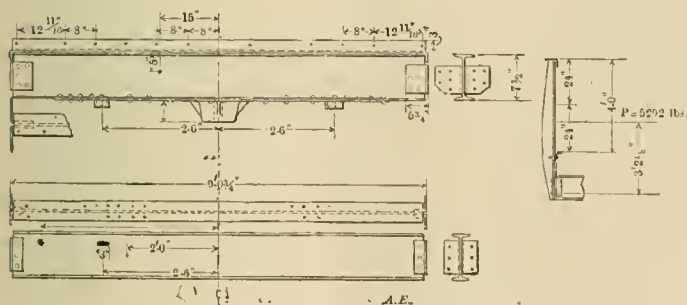

Transoms and Floor Beams.

underframe, the opening is at the center of the cars and has an area of 32 sq. ft. Instead of placing a pair of sills at the center of the car he has used an interesting composite structure which is a decided departure from previous designs. The center sills are 12 ins. 20.5 lbs. channels placed 4 ft. apart at the center of the car with their ends resting on 12-in. transverse floor beams of I-section placed 10 ft. 6 ins. apart. From these floor beams the center sills are extended by other 12-in. channels reaching as far as the body bolsters and drawn toward each other at these ends to meet the lines of the draft sills which are separate members secured at their outer ends to cast-steel end sills and at the inner ends to the bolsters. At the body bolsters, which are 12-in. I-beams, the center sills are se-

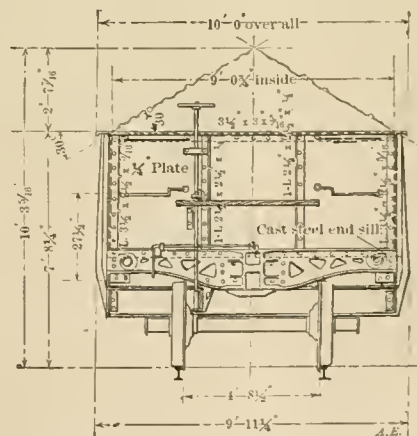

End Elevation.

sills the load is transferred to the sides by the transverse I-beams and these are secured to the side trusses by plates and double angles which are also stiffeners. At the top of the sides a special 6-in. bulb angle is used. The only departure from commercial sections discovered from the drawings are pressed channel floor supports midway between the heavy transverse I-beams and the bolsters. These were used apparently to avoid cutting the channels. Additional floor support is obtained from

From the Stress Diagram.

Assumed Loading.	
Base dead load.....	32,000 lbs.
Maximum live load.....	120,000 lbs.
Weight of trucks.....	14,400 lbs.
Deduct weight of wheels and axles.....	8,400 lbs.
Weight of truck materials above axles.....	6,000 lbs.
Gross body dead load (32,000 - 6,000).....	26,000 lbs.
Deduct for bolsters, etc.....	13,000 lbs.
Net body dead load.....	24,700 lbs.
Assumed live load.....	120,000 lbs.
Total static body load.....	144,700 lbs.
Add 50 per cent., or.....	72,350 lbs.
Final uniformly distributed load.....	217,050 lbs.
Ditto per sq. ft. floor area.....	535 lbs.
Total floor area.....	362.5 sq. ft.

Side Pressure and Side Sheet Ties.

Area of unsupported side (4 ft. by 10 ft. 6 ins.).....	42 sq. ft.
Weight of 1 cu. ft. water.....	.63 lbs.
Pressure "P," (see section) $63 \times 42 \times 2$	5,292 lbs.
Stress in (2) connection tie bolts	$\frac{5,292 \times 38.125}{20,125} = 10,025$ lbs.

Main Side Stiffeners.

Resultant pressure one set stiffeners.....	5,292 lbs.
Max. bending moment at tie connection ($5,292 \times 13$).....	95,256 lbs.
Section required at 16,400 lbs. per sq. in.....	5.1 sq. ins.
Two angles 5 by 3½ by ½ ins.....	5.98 sq. ins.

Center Sills.

Maximum moment.....	44,966 ft.-lbs.
Section required at 16,400 lbs. per sq. in.....	32.8 sq. ins.
Two 12-in. channels (20.5 lbs.).....	42.8 sq. ins.

Sides.

Maximum moment.....	82,362 ft.-lbs.
Maximum moment from concentration.....	148,536 ft.-lbs.
Total maximum moment.....	230,898 ft.-lbs.
Flange stress.....	57,724 lbs.

Bottom Flange.

Net area required (at 16,400 lbs.).....	3.41 sq. ins.
Total net area web and angles.....	3.7 sq. ins.

Top Flange

Flange stress as before.....	57,724 ft.-lbs.
Area required (at 11,000 lbs. per sq. in.).....	5.2 sq. ins.
One-sixth of net web area.....	1.66 sq. ins.
Special bulb angle.....	4.3 sq. ins.
Total area provided.....	5.96 sq. ins.

Bolster.

Static load at end plus 100 per cent.....	50,666 lbs.
Section required (at 15,000 lbs.).....	118 sq. ins.
Section provided.....	109 sq. ins.
Rivets ¾-in. in diameter required.....	18

Floor Beams.

Maximum moment (one beam).....	43,000 ft.-lbs.
Section required.....	31.5 sq. ins.
Section provided (1, 12-in. 40-lb. I-beam).....	36 sq. ins.

Signals from a 30-in. searchlight, on the electric tower of the Pan-American Exposition, were sent to Niagara Falls. July 25, by Prof. Geo. F. Sever, Superintendent of Electrical Exhibits, in the presence of the electrical jury, thus demonstrating the feasibility of this method of signalling at night. Since that time searchlight signals have been sent from Buffalo to Toronto, a distance of 58 miles, through arrangements completed by Prof. Sever in co-operation with Mr. Wm. S. Aldrich, Consulting Electrical Engineer of Toronto. The first trial was made 9.10 p.m., August 9, with clouds over Toronto. The local illumination of the overhead sky by the electric arc lights in the streets of Toronto effectually prevented any discrimination being made between the local and the Buffalo illumination of the clouds. The second trial was made August 13, with a perfectly clear atmosphere. Owing to the smoke settling down over the city, no signals could be discerned from the top of the Municipal Hall tower, Toronto. This was the prearranged objective point for both experiments. Special long-distance communication was arranged between the top of the tower and the electric tower, at the Pan-American, through the courtesy of the Bell Telephone Co., represented by Mr. Dunstan, of Toronto, so that every detail of the experiment could be followed. The special instructions were to depress the searchlight to the lake horizon, bearing on the Municipal Hall tower, Toronto; then, to sweep the horizon a definite angle, to the right and left of this bearing, and later to elevate and depress the light on the original bearing. All of these signals were very clearly discerned during the second trial by Mr. C. H. Rust, City Engineer, Toronto, with a party located on Centre Island, two miles off shore from the city.

SOME PHASES OF THE WATER-TREATING PROBLEM.

SECOND PAPER.*

By Howard Stillman, Mem. A. S. M. E.

Engineer of Tests, Southern Pacific Company.

The forced evaporation demanded of the locomotive boiler in modern railway service may be shown in many ways. An illustration of this in comparison with the same boilers had they been in stationary service may be shown from the following figures taken from locomotive service tests, which are presented simply for the purpose of showing the rate of evaporation in point of time.

Five tests at random from a series are taken covering train service under different conditions and for stationary practice. I am supposing the usual builders' rating of 30 pounds water per horse-power per hour to express the builders' rating, supposing, as we may imagine, that the boilers had effected the same rate of evaporation as if set up in stationary service instead of actual road service.

Test number	1	2	3	4	5
Size of cylinders of locomotives	Simple. 22 × 26	Compound. 23 + 35 × 32	Simple. 20 × 28	Simple. 30 × 24	Compound. 23 + 35 / 34
Service.....	Freight	Freight	Freight	Pass'g'r	Freight
Distance covered in the test, miles	239	136	329	171	196
Actual running time.	16.2 hrs	8.9 hrs	16.9 hrs	5.3 hrs	21.3 hrs
Total pounds water evaporated.	187,038	122,482	187,888	79,063	285,466
Ditto per hour.	11,515	13,760	11,060	14,918	11,748
Capacity developed by above boilers at (stationary) builders' rating of 30 lbs. water per horse power hour:					
Horse power of boiler	385	458	386	497	392

In other words, the rating of the boiler in test number one would have developed 385 horse-power if in stationary practice the rate of evaporation had been as shown. During the above test the cylinders were indicated and an average of records under full working conditions developed the following work being done by steam cylinders:

Test number	1	2	3	4	5
Mean I. H. P. full working.....	1,141	1,090	1,017	998	1,130

An average of these figures shows that the locomotive boilers in road service were at times forced in the rate of evaporation 126 per cent. above what we would consider their normal "static" rating. Nor is this all, as the total amount of water evaporated as above shown includes air pump, steam brake, blower and other work demanded in service, an amount comparatively small, however, as compared with the work of the steam cylinders.

It was my endeavor in the former paper to show that boiler waters containing considerable alkali matter (Glauber's salt and common salt) tend to prime and foam where in stationary service such waters would not cause trouble, such being one phase of the water-treating problem as applied to railway service. The forced evaporation of say 126 per cent. above stationary practice may show why such condition occurs, coupled with another consideration as follows:

We find in our most modern locomotive that the lower steam throttle opening is but 26 ins. above the water level when the gauge glass is half full and the engine on level track. The diameter of the boiler shell is 75 ins., and ample steam room is apparently provided, but the tendency to carry water over into the steam cylinders when the throttle opening is so close to the water line is most apparent. In stationary practice and boiler setting we generally find a steam drum and attachments well above the boiler shell, but the modern locomotive boiler has not room for such a device. The above considerations appear to me to largely account for the difficulty ex-

*See American Engineer, June, 1901, page 194.

perienced with foaming in locomotive boilers, and it is questionable if we had not better limit the introduction of alkali to correct the scale formation to the least amount. In my former paper I ventured a commercial limit of 30 grains per gallon (say $4\frac{1}{2}$) lbs. per 1,000 gallons), beyond which amount naturally contained, plus the reaction from chemical treatment, the profit from scale prevention is offset by a tendency to prime, the worst feature in the use of alkali water on railroads. The working disadvantages and heat losses from this cause are too well known to require discussion here.

Very interesting and exhaustive experiments have been made at Purdue University (also presented to the American Society of Mechanical Engineers) with the calorimeter to determine quality of steam furnished locomotive cylinders as to entrained water. More than $1\frac{1}{2}$ per cent. moisture was not observed, but unfortunately the quality of the water from which steam was furnished was not an element of the investigation. It is doubtful if conditions other than favorable, as to dome and throttle setting relative to the water line were maintained during the tests. Exceptional conditions are most likely to occur in main line service, and a series of investigations in this direction on alkali water would be most interesting, and in all probability would show results of widely varying nature from those obtained.

The use of some form of steam separator would be suggested were it possible to apply it to the locomotive. Some modification of throttle whereby the openings are raised to the highest possible position above the water line seems the more feasible. There are few locomotive engineers who do not recall in their experience certain engines they have handled that carried their water better than others. The difference can always be traced to the principle referred to—that a difference in boiler construction or cylinder ratio to steam space had favored the relation between supply and demand in one case more than another.

The condition or quietude, as we may express it, of a boiling mass of water within a steam boiler varies directly as the drain upon its mass. The greatest production of steam is always from the hottest portion of the mass, or adjacent to the fire-box plates, and we must expect violent ebullition in direct proportion to the demand. That the amount or degree of disturbance is again directly proportionate to the solid matter within the boiler water (soluble or insoluble) we are very sure. I have seen instances in a boiler carrying bad alkali water where the water would leave the gauge glass entirely on opening the throttle to pull out with a heavy train. Evidently the boiling mass tended to follow the direction of a drain on its evaporative capacity, the steam dome in such case having been placed well ahead on the boiler. After starting the train the closing of the throttle for a few seconds will bring the water again to its level. The practice in such districts when water gets very bad is for the engineer to occasionally close the throttle and verify the water line. No detail of his routine is of more vital importance to the engineer or of more anxious concern to him than the location of the water line.

This is a digression from the subject in hand, but I have referred to it as of great importance as a side issue to the excessive use of alkali (carbonated or in other form) to remove scale.

To what extent scale deposits affect the loss of fuel is a disputed question, and there have been so many widely different statements made that we have little of value except general principles to depend on. Any series of tests to determine the effect of the scale in heat losses must be particularly rigid in having similar conditions, eliminating all variation in condition except the scale itself. In practice absolutely uniform conditions are extremely difficult to obtain. It will be understood that I am referring to railway service. In stationary practice it is much easier to arrive at definite conclusions as between cause and effect.

As far as I have been able to observe from conducting many

boiler tests, I do not believe that a light scale formation, say not to exceed 1-16 in., has any material effect on fuel losses.

In the stationary boiler using continually the same water the scale formation will continue to increase and should be kept out. In the locomotive boiler the formation from one source may be offset or removed by water from another source. The effect of alkali on a boiler that has been scaled from use of hard water is generally disastrous. We have abundant evidence that alkali water tends to open seams and causes flues to leak, where previous scale formation had mechanically closed them. Soluble matter in a boiler is very penetrating and follows the water in all cases, hence we find the deposit from evaporated leakage on the outside of a boiler about leaking seams or stay-bolts, also the penetration and flaking off of old scale within the boiler.

From tests made on scaled boilers, I believe that very hard sulphate scale is less to be feared than loose carbonated scale, both in the danger from sudden removal in service and from its heat-conducting capacity, which is greater in proportion to its hardness.

The variations produced by the "migratory" nature of the locomotive boiler is a peculiar phase of the water problem, and that is so largely local that it can hardly be solved by general conclusions. A change of water affects boilers much as the human system is affected by a change of diet, and what is good for one condition may be bad for another.

It is not proposed here to discuss the technical side of water analysis, but there are some features of the subject that seem to be little understood by those having to deal practically with the water problem. An inorganic water analysis, as shown by the chemist, is the result of a series of experiments upon the sample to determine what the solid matter contained is, and how in probability it naturally exists. Results would be less confusing if chemists adopted the same scheme of analysis, but they sometimes vary widely, depending on the school or scheme of analysis followed. The proper expression of a water analysis should show what the contents are as bases, acids and elements, as separated by the analyst. Such an expression would, however, be Greek to the layman. He must have a more positive expression in grains per gallon, therefore the chemist gives him one based on a scheme of combination that may or may not show just how the matter exists naturally. The variation in expression by different chemists is not surprising in view of the fact that no method without most careful research can tell just how the combinations do naturally exist, and they may vary in some waters between the time of taking the sample and the opportunity of the analyst. Ordinarily the water analysis for boiler purposes should be considered as an approximation, and the chemist cannot tell exactly now it will act in the steam boiler. The specific action of salts existing is largely influenced by the presence of others. The chemist knows the influence of chlorides, for instance, on deposit, or precipitation of magnesia. As an analyst he must allow for it. The deposit of sulphate of lime or gypsum scale in a steam boiler is undoubtedly diminished if common salt is present in quantity in the water. If largely in excess it is questionable from evidence I have that much scale deposit forms.

The variation in character of water from its source is a point that should be looked into in consideration of water treatment. Generally ground water supplies do not materially vary in character, but certain cases have come under our observation where well supplies have materially changed with the season. It is not practical at the wayside tank to give a water daily analysis to find out exactly what is required, and a commercial result only can be expected. We have found cases where wide variation has existed with the season. A water should have been analyzed several times before considering what average of treatment should be adapted. Surface waters are most liable to be affected, ground less, and artesian water is least likely to vary.

speeds as based on cylinder performance, after machine friction has been deducted. Then there are other losses to be deducted. There is the rolling friction of the truck and tender which when accounted for causes the pull exerted at the drawbar to fall to the line A D. Finally, there is the wind resistance of the head of the train. Subtracting values for this from those shown by the line A D gives results which are represented by the line A E which, according to the best information we have upon the subject, shows the drawbar pull that the particular engine under discussion, which was a small engine, is capable of exerting upon a train at different speeds. It is necessary to cut off the diagram somewhere along the top (A F) because the adhesion is not sufficient to allow the drawbar stress to increase above 12,000 lbs.; and to make this diagram entirely practical, we must end it at a definite point above which, it may be assumed, the engine will not run. Such a speed might be that which is represented by 400 revolutions a minute, but for the present we will consider the diagrams as unlimited as to speed. Reasoning from facts thus presented, it is interesting to note that in the case of this particular engine, the drawbar stress runs out to nothing at a speed of less than 90 miles an hour.

If this engine were at the head of a train running at approximately 90 miles an hour, it would just cease to exert a pull on the drawbar, all its power being absorbed to carry itself along. The diagram shows, also, why it is that the pulling power of a locomotive falls off rapidly as speed is increased. It is not the indicated power that falls off, as many people have supposed, but it is because there are losses between the cylinder and the drawbar power which increase rapidly as the speed is increased. These losses are in all cases represented by the vertical distances between the curves A B and A E. It will be seen that for a speed of 20 miles an hour the vertical distance between A B and A E is small in proportion to the distance from A B to the base line; while at a speed of 60 miles an hour, the losses represented by the distance between A B and A E is about half the total pull as represented by the distance between A B and the base. At 80 miles an hour, the losses amount to practically all the power that is developed. If the facts on this diagram are kept in mind they will serve to explain results which, occurring in practice, often cause comment and surprise. Finally, I should call attention to the fact that the results disclosed by this diagram, applying as they do to a small engine, are in some respects misleading as indicating what may be expected of a modern heavy engine. Some of the losses, more particularly those resulting from atmospheric resistance, are no greater for a large engine than for one that is small, consequently in case of a large engine the reductions to be made from the initial curve are proportionately less than for a small engine. This fact constitutes one of the arguments in favor of the large engine for high-speed work.

SANTA FE ROUTE READING ROOMS.

There are now fourteen railroad reading rooms on the Santa Fe System. Seven of these are located on the A. T. & S. F. and seven on the lines west of Albuquerque. The privileges of these reading rooms consist of the latest books, the leading periodicals of the country, baths, games and lectures on scientific and social subjects by eminent educators, lectures on astronomy, chemistry, geology, physiology, sociology and kindred topics. All these privileges are absolutely free to all employees and their families and the community in the smaller towns has always been invited and welcomed. More than 10,000 books are in circulation on the Santa Fe System. About 40 per cent. of these are fiction, 25 per cent. are historical, 15 per cent. are biographical, 10 per cent. technical and the rest general. The families of the men have free use of the books and periodicals. Any employee has the privilege of ordering any book he may desire to read. On the fairest estimate at the points where these reading rooms are located 90 per cent. of the employees use them.

THE NEW TURBINE STEAMER "KING EDWARD."

Driven by Parsons' Turbines.

The "King Edward," the latest Clyde passenger steamboat, built for the purpose of trying the Parsons' steam turbine machinery for mercantile purposes, has quite justified the courage and enterprise of her owners, says "Engineering" of London.

The "King Edward" is 250 ft. long and 30 ft. wide. Her molded depth is 10 ft. 6 ins. to the main deck and 17 ft. 9 ins. to the promenade deck. The propelling machinery consists of three Parsons' steam turbines working compound. These are placed side by side. In ordinary working, and when going ahead steam is admitted from the boilers to the high-pressure turbine, where it is expanded five-fold. From thence it passes to the two low-pressure or wing turbines placed one on each side, where it is expanded 25-fold and then passes to the condensers. The total ratio of expansion is therefore no less than 125-fold. Each turbine has its own shafting, and on each of the wing shafts there are two propellers, while the center one carries only a single screw. When coming alongside a pier or maneuvering in crowded waters the wing motors alone are used, steam being admitted directly into them by suitable valves. The high-pressure turbine is then shut off, the steam-admission valve being closed, while connection between it and the low-pressure turbines is also shut off by an automatic arrangement. There are special turbines placed inside the exhaust ends of the low-pressure turbines for going astern with the wing screws. The whole of the maneuvering excepting, of course, by the rudder, is effected by the manipulation of valves in a very simple manner.

On June 26, on a mean of runs over the Skelmorlie mile, a speed of 20.48 knots was registered. The mean revolutions were 740 per minute, steam at the boilers was 150 lbs. to the square inch, and the vacuum 26½ ins. The air pressure in the stokehold was equal to 1 in. of water. The indicated horsepower was estimated at 3,500, there being, of course, no means of taking indicator diagrams with this type of motor.

The weight of the motors, condensers, with water in them, steam pipes, auxiliaries connected with the propelling machinery, shafting, propellers, etc., is 66 tons. This, we believe, is considered to be about half the weight per indicated horsepower developed of the average of the propelling machinery of paddle-boats of a similar type. So far as the turbines are concerned, it is not possible to tell whether they are running or not by placing one's hand on them. There is, however, a very slight vibration that can be felt right astern, and this is due to the propellers. Whether this can be eliminated or not remains to be seen, but certainly no vibration is set up by the main engines themselves. At the bow end motion is similar to that of a fast sailing yacht.

In regard to the fine shape of the boat, it may be pointed out that the low center of gravity of the turbine machinery gives good stability without the necessity for a hard bilge or long floor; in fact, this type of machinery lends itself readily to a form of hull conducive to high speed.

The long-distance telephone system has been adopted by the Delaware, Lackawanna and Western Railroad for controlling the movement of their trains instead of by telegraph. The road has a contract with the American Bell Telephone Company to build its own line, and is extending the double copper wire lines which already cover a considerable portion of the main road. The total miles of line now completed are about 250. The wires used are mostly No. 12 copper wire and strung on telegraph poles. The company has private exchanges in New York, Hoboken, Scranton, Binghamton, Elmira, Utica, Syracuse and Buffalo. The main exchange is at Hoboken and has 30 connections, including 13 lines to general and division officers; 7 to piers and yard offices; lines to the ticket office, the baggage room, signal towers, etc. There are also private connections to the homes of several officers of the road.

TABLES OF SPEED OF LOCOMOTIVES.

By R. F. Peters, Houston, Tex.

In taking indicator diagrams from and testing locomotives where each speed has to be taken and figured separately considerable time and work are involved. To avoid this, and also

The columns are divided into spaces of five figures each, to facilitate the finding of a number.

Starting at the top right-hand corner, 5 rev. per 10 sec. = 30 rev. per min. = 1,800 rev. per hour; opposite the number of revolutions and in the column of miles per hour, under the diameter of the driver of the locomotive, will be found the exact number of miles per hour to two decimal places. Under

DIA OF DRIVER																									REV. PER								
Number of Revolutions Per Mile																									Hour								
Number of Miles Per Hour																									Min								
Hour																									Sec								
55	56	57	58	59	60	61	62	63	64	65	66	67	68	69	70	71	72	73	74	75	76	77	78	79	80	81	82	83	84	85	1	2	10
4.90	4.99	5.08	5.10	5.24	5.35	5.44	5.53	5.62	5.71	5.80	5.89	5.98	6.06	6.16	6.24	6.33	6.42	6.51	6.60	6.69	6.78	6.87	6.96	7.05	7.14	7.22	7.32	7.40	7.49	7.58	18.00	3.0	5
5.89	5.99	6.15	6.21	6.31	6.42	6.53	6.64	6.74	6.85	6.96	7.07	7.17	7.28	7.39	7.49	7.59	7.70	7.82	7.92	8.03	8.14	8.24	8.36	8.46	8.56	8.67	8.78	8.88	8.99	9.09	21.60	3.6	6
6.87	6.99	7.12	7.24	7.37	7.49	7.62	7.74	7.87	7.99	8.12	8.24	8.37	8.49	8.62	8.75	8.89	8.99	9.12	9.24	9.36	9.49	9.62	9.75	9.87	9.99	10.11	10.24	10.36	10.49	10.61	25.20	4.2	7
7.85	7.99	8.14	8.27	8.42	8.56	8.71	8.85	8.99	9.14	9.28	9.42	9.56	9.70	9.85	9.99	10.13	10.27	10.42	10.56	10.70	10.85	10.99	11.14	11.28	11.41	11.56	11.71	11.85	11.98	12.13	28.80	4.8	8
8.83	8.99	9.15	9.31	9.48	9.64	9.81	9.96	10.12	10.28	10.44	10.60	10.76	10.92	11.08	11.23	11.39	11.56	11.72	11.88	12.04	12.20	12.36	12.52	12.69	12.85	13.00	13.17	13.33	13.50	32.40	5.4	9	
9.81	9.99	10.17	10.35	10.53	10.71	10.88	11.05	11.24	11.43	11.60	11.78	11.96	12.13	12.31	12.49	12.66	12.84	13.03	13.21	13.38	13.56	13.74	13.93	14.10	14.28	14.45	14.64	14.81	14.97	15.16	36.00	6.0	10
10.79	10.99	11.18	11.38	11.58	11.78	11.97	12.16	12.36	12.56	12.76	12.96	13.15	13.34	13.53	13.73	13.93	14.13	14.33	14.53	14.72	14.91	15.11	15.32	15.51	15.70	15.89	16.10	16.30	16.46	16.68	39.60	6.6	11
11.78	11.98	12.21	12.42	12.64	12.85	13.06	13.28	13.48	13.68	13.87	14.07	14.26	14.45	14.65	14.85	15.05	15.25	15.44	15.63	15.83	16.02	16.21	16.41	16.60	16.79	16.98	17.17	17.36	17.55	17.74	43.20	7.2	12
12.76	12.99	13.23	13.45	13.69	13.92	14.15	14.37	14.58	14.80	15.02	15.24	15.46	15.68	15.90	16.12	16.34	16.56	16.78	17.00	17.22	17.43	17.65	17.86	18.11	18.33	18.54	18.76	18.97	19.19	19.40	46.80	7.8	13
13.74	13.99	14.24	14.48	14.74	14.99	15.24	15.49	15.74	15.99	16.24	16.49	16.74	17.00	17.24	17.49	17.74	17.99	18.24	18.49	18.74	18.99	19.24	19.51	19.74	19.99	20.24	20.49	20.74	20.99	21.23	50.40	8.4	14
14.72	14.99	15.26	15.52	15.78	16.06	16.33	16.60	16.86	17.13	17.40	17.65	17.94	18.20	18.48	18.74	19.00	19.17	19.54	19.81	20.08	20.35	20.61	20.90	21.15	21.42	21.68	21.96	22.22	22.48	22.75	54.00	9.0	15
15.70	15.99	16.27	16.56	16.82	17.13	17.42	17.70	17.98	18.27	18.56	18.83	19.13	19.41	19.71	19.99	20.27	20.45	20.85	21.13	21.41	21.71	21.98	22.28	22.58	22.88	23.13	23.42	23.70	23.98	24.26	57.60	9.6	16
16.68	16.99	17.25	17.56	17.90	18.21	18.51	18.81	19.11	19.41	19.72	20.01	20.33	20.64	20.91	21.24	21.54	21.74	22.15	22.45	22.71	23.06	23.36	23.69	23.97	24.27	24.57	24.81	25.18	25.47	25.76	61.20	10.2	17
17.67	17.99	18.31	18.63	18.95	19.28	19.60	19.92	20.24	20.56	20.88	21.19	21.53	21.89	22.23	22.58	22.90	23.21	23.55	23.87	24.20	24.52	24.83	25.17	25.49	25.83	26.16	26.47	26.79	27.10	27.42	64.80	10.8	18
18.65	18.99	19.33	19.66	19.99	20.32	20.67	21.02	21.33	21.70	22.04	22.37	22.72	23.05	23.40	23.73	24.07	24.41	24.74	25.09	25.43	25.77	26.10	26.47	26.79	27.15	27.46	27.81	28.14	28.46	28.78	68.40	11.4	19
19.63	19.99	20.35	20.70	21.06	21.42	21.74	22.13	22.49	22.84	23.20	23.53	23.92	24.26	24.64	24.98	25.34	25.69	26.04	26.41	26.77	27.13	27.48	27.87	28.20	28.56	28.91	29.28	29.62	29.96	30.33	72.00	12.0	20
20.61	20.99	21.37	21.74	22.12	22.47	22.83	23.20	23.58	23.98	24.36	24.72	25.11	25.49	25.88	26.23	26.58	26.94	27.36	27.76	28.11	28.49	28.85	29.25	29.61	29.98	30.35	30.74	31.10	31.45	31.81	75.60	12.6	21
21.59	21.99	22.39	22.77	23.16	23.54	23.93	24.34	24.74	25.13	25.53	25.90	26.31	26.69	27.10	27.47	27.97	28.34	28.74	29.14	29.54	29.94	30.33	30.83	31.21	31.61	32.00	32.38	32.83	33.27	33.70	79.20	13.2	22
22.57	22.99	23.41	23.80	24.21	24.63	25.04	25.45	25.85	26.27	26.69	27.09	27.53	27.90	28.33	28.74	29.14	29.54	29.94	30.39	30.79	31.20	31.60	32.04	32.43	32.84	33.24	33.63	34.04	34.44	34.84	82.80	13.8	23
23.55	23.99	24.42	24.84	25.26	25.68	26.10	26.52	26.94	27.41	27.83	28.28	28.70	29.13	29.56	29.98	30.41	30.78	31.28	31.70	32.15	32.56	32.98	33.49	33.84	34.27	34.74	35.15	35.58	36.00	36.44	86.40	14.4	24
24.54	24.99	25.43	25.88	26.30	26.77	27.22	27.66	28.11	28.59	29.01	29.45	29.90	30.34	30.78	31.23	31.67	32.13	32.58	33.02	33.47	33.92	34.36	34.84	35.25	35.70	36.13	36.53	37.03	37.49	37.92	90.00	15.0	25
25.52	25.99	26.45	26.91	27.38	27.88	28.31	28.76	29.20	29.70	30.17	30.63	31.09	31.56	32.03	32.48	32.94	33.41	33.87	34.34	34.80	35.27	35.73	36.23	36.66	37.14	37.59	38.08	38.52	38.97	39.43	93.60	15.6	26
26.50	26.99	27.47	27.95	28.43	28.90	29.40	29.89	30.36	30.84	31.33	31.83	32.33	32.76	33.26	33.74	34.24	34.73	35.23	35.72	36.23	36.71	37.22	37.69	38.15	38.63	39.11	39.58	40.04	40.52	40.99	97.20	16.2	27
27.48	27.99	28.46	28.94	29.43	29.93	30.43	30.93	31.43	31.93	32.43	32.94	33.45	33.97	34.48	34.99	35.51	36.02	36.54	37.05	37.57	38.08	38.61	39.11	39.62	40.14	40.67	41.19	41.71	42.23	42.74	100.80	16.8	28
28.47	28.99	29.50	30.02	30.53	31.06	31.57	32.09	32.61	33.12	33.65	34.17	34.70	35.23	35.76	36.28	36.81	37.33	37.86	38.38	38.91	39.43	39.96	40.49	41.02	41.56	42.09	42.62	43.14	43.68	44.20	104.40	17.4	29
29.45	29.99	30.52	31.06	31.59	32.12	32.66	33.20	33.73	34.27	34.81	35.35	35.89	36.43	36.97	37.51	38.05	38.59	39.13	39.67	40.21	40.75	41.29	41.83	42.37	42.91	43.45	43.99	44.53	45.07	45.61	108.00	18.0	30
30.44	30.99	31.54	32.09	32.63	33.17	33.72	34.26	34.81	35.37	35.92	36.47	37.02	37.57	38.12	38.67	39.22	39.77	40.32	40.87	41.42	41.97	42.52	43.07	43.62	44.17	44.72	45.27	45.82	46.37	46.92	111.60	18.6	31
31.41	31.99	32.56	33.12	33.70	34.27	34.85	35.43	36.01	36.59	37.17	37.75	38.33	38.91	39.49	40.07	40.65	41.23	41.81	42.40	42.98	43.57	44.15	44.74	45.33	45.92	46.51	47.10	47.69	48.28	48.87	115.20	19.2	32
32.39	32.99	33.58	34.16	34.75	35.35	35.93	36.51	37.11	37.69	38.29	38.88	39.46	40.05	40.64	41.23	41.82	42.41	43.00	43.59	44.18	44.78	45.37	45.96	46.55	47.14	47.73	48.33	48.92	49.51	50.10	118.80	19.8	33
33.37	33.99	34.59	35.18	35.78	36.37	36.97	37.57	38.17	38.77	39.37	40.00	40.60	41.20	41.80	42.40	43.00	43.60	44.20	44.80	45.40	46.00	46.60	47.20	47.80	48.40	49.00	49.60	50.20	50.80	51.40	122.40	20.4	34
34.36	34.99	35.61	36.23	36.86	37.48	38.11	38.73	39.36	39.99	40.61	41.24	41.86	42.49	43.11	43.74	44.37	44.99	45.62	46.25	46.87	47.50	48.13	48.76	49.39	50.02	50.65	51.28	51.91	52.54	53.17	126.00	21.0	35
35.34	35.99	36.63	37.27	37.91	38.55	39.20	39.84	40.48	41.12	41.77	42.42	43.07	43.72	44.37	45.02	45.67	46.32	46.97	47.62	48.27	48.92	49.57	50.22	50.87	51.52	52.17	52.82	53.47	54.12	54.77	129.60	21.6	36
36.32	36.99	37.65	38.29	38.95	39.61	40.27	40.94	41.61	42.28	42.94	43.60	44.27	44.94	45.61	46.28	46.95	47.62	48.29	48.96	49.63	50.30	50.97	51.64	52.31	52.98	53.65	54.32	55.00	55.67	56.34	133.20	22.2	37
37.30	37.99	38.67	39.33	39.99	40.76	41.53	42.30	43.07	43.84	44.61	45.38	46.15	46.92	47.69	48.46	49.23	50.00	50.77	51.54	52.31	53.08	53.85	54.62	55.39	56.16	56.93	57.70	58.47	59.24	60.01	136.80	22.8	38
38.																																	

(Established 1832.)

AMERICAN ENGINEER AND RAILROAD JOURNAL.

PUBLISHED MONTHLY

BY

R. M. VAN ARSDALE,

J. S. BONSALE, Business Manager.

MORSE BUILDING.....NEW YORK

G. M. BASFORD, Editor.

E. E. SILK, Associate Editor.

SEPTEMBER, 1901.

A correspondent in another column of this issue states the cost of installing track scales for weighing locomotive coal for a road having 1,300 locomotives to be approximately \$23,000 and the cost of operation per year to be about \$41,472, which, in order to secure an advantage on the investment would call for the saving of \$42,852 per year in fuel. It is reasonable to suppose that such an installation would pay, but is it not better to construct chutes in which the coal can be handled cheaply and at the same time be weighed by the attendants as it is delivered? Such apparatus can be used in places where it is impossible to find room for track scales, and considerable attention has been concentrated upon the development of coal-weighing apparatus of this kind, which will permit of weighing the coal in the chutes themselves. Undoubtedly the traveling expert freeman is the most fruitful agent in coal saving, but he must be fortified by a system whereby the records of the enginemen can be accurate and fair, and one which will impress its fairness upon the men. Nothing can be accomplished without the hearty interest and co-operation of the men and a proper method of weighing coal is the real starting point with them. After correctly weighing the coal it must be correctly charged and the record must be understood by the men to be on this basis. What seems to be most needed is a weighing device or method of suspending large chutes whereby the coal may be weighed conveniently as it is delivered and by the coal chute attendants without additional labor costs. There is a demand for such a device now and the chutes should be built to take coal from hopper cars without shoveling.

THE TANDEM COMPOUND.

Compound locomotives with tandem cylinders are not new. They have been used experimentally on the Boston & Albany in 1883, on the North British Railway in 1885 (the locomotive taken from the wreck of the Tay Bridge was converted into this type in that year), on other foreign roads and on the Great Northern and the Atchison in this country. Until now, however, designers have not turned to this type as a solution of difficulties or as a direction in which to pursue further development. There seems to be good reason to believe the tandem to be an important step in the progress of the compound, although it is not free from objections, for example, the reciprocating parts must be heavy. Judging from opinions which have been expressed to us it seems to appeal to some who heretofore have been skeptical as to all types of compounds. There is a limit to the size of the low-pressure cylinders of the two-cylinder type and this has undoubtedly already been reached. For compounds of large capacity four cylinders therefore seem to be absolutely necessary, and it becomes merely a question as to how they shall be arranged. In this issue will be found a description of the new Schenectady Locomotive design which is interesting in itself and is a distinct mark in favor of four cylinders.

This step by the Schenectady Works does not indicate that the two-cylinder type of which so many successful examples are in service is to be abandoned. Probably many more will be built. The tandem meets some important objections and it may perhaps open the way for another step which has already been taken abroad and which several conservative American locomotive authorities now admit to be a probability in their own practice, viz., the four-cylinder arrangement of De Glehn or Webb adapted to American ideas of simplicity. These will not come into favor until found to be necessary, but there can be no doubt that they are looked upon with increasing interest in this country.

THE NEW YORK CENTRAL TUNNEL.

A grand jury investigation of the Park Avenue tunnel of the New York Central, whereby its passenger trains reach the Grand Central station, has been made on behalf of a number of residents who made a concerted complaint. After giving due regard to the expert opinions usually brought out in such cases the matter rests where it was before, the only accomplishment of the investigation being a vigorous public protest against the present situation with respect to ventilation and a renewed activity on the part of the railroad to remedy it. This is not really a tunnel, but a subway under a fashionable avenue. It has four tracks, two of them in a channel open above as much as could be done without inconveniencing the residents and at each side of this is a separate tunnel with arches opening into the central channel. This gave no great trouble when there were few trains, but now with 500 or 600 every day and many switching movements the ventilation is troublesome to passengers and the gases from the locomotives are complained of by the residents. These objections are, of course, aggravated by the extremely warm weather of this summer.

Innumerable impracticable schemes are suggested, but a careful consideration of the situation reveals a most difficult problem, for the solution of which there is no precedent. This agitation will undoubtedly hasten matters, but we state with authority that the railroad officers are not and have not been indifferent, and that they are making a thorough study of the situation, in order to reach the fundamentals and provide permanent relief. This is not a ventilation question alone. The whole problem of a busy terminal in the contracted space of a thickly settled city is involved. Suburban and through trains must be provided for. It is easy to furnish facilities for either alone, but to take care of both in such a contracted space as this terminal is a problem which at present no one knows how to solve. Something must be done soon, because of the rapid increase of traffic. Furthermore, suburban service at this station under present conditions requires locomotives heavier than were necessary for through trains a few years ago, and these schedules are among the most difficult of all to maintain.

Something radical is needed, and the conditions are such as to point toward electric traction for all but the long distance trains as the most promising suggestion. But electrical engineers have not yet shown the way to handle such traffic. Electric locomotives cannot be exchanged for the steam locomotives outside of the city, because the delay of changing would tie up the terminal. A busy yard full of switches and slips and movable point frogs is no place for electric and steam traffic to mix, therefore a separation of tracks is necessary. We are able to state positively that the officers of the New York Central are busy on this problem and are gathering information at home and abroad. Nothing has been decided upon and no one can say what will be done, but it is probable that the entire suburban districts of the three roads running into this station will be equipped for electric traction for a distance of about 50 miles from the city. These trains may be run through the outside galleries of the "tunnel" and the through trains, hauled by steam locomotives, in the central channel. In order to separate the steam and electric lines the

calculation, except for moment of inertia of section, the accompanying data of sections equal in weight are arranged as in Fig. 4. From these the absolute need of additional cross-bracing with web sections, more especially the I section, is seen, the arrangement and possible provisions for which is governed by the specific design under consideration. Frames of to-day have an average ultimate strength per square inch of original section of 60,000 to 67,000 lbs., with an elongation of 23 to 30 per cent.

(4) Under the heading of durability may be properly discussed shrinkage effects, inasmuch as upon the elimination of such depends materially the life of the frame. By nearly uniform and comparatively small thickness of metal these exist in much less intensity than with the rectangular section. Experience, however, gives rise to the suggestion of increased radii with a considerable number of the fillets. Here, almost without exception, first failures are discovered. Provision for irregularities in shrinkage, which invariably exist in the casting, would give rise to an increase in several instances of the thicknesses of the finished parts. Noting, for example, the pedestal sketch, Fig. 2, the inner web should not on this account, together with proper provision for shoe and wedge bearing surface, be made less than 2 ins. A further continuance of this thought is suggested to include bosses, etc.

The factor of safety, possibly more aptly classified under strength considerations, should with equivalent weight of section be higher with either of the web sections. The comparative thinness of the casting allows of ready and careful examination by the inspector. With the rectangular section oft-times the outer surface covers a multitude of sins, discovered only when failure of a part discloses interior honeycombing. Aside from these, each of which favor the web section, no distinctive advantage seems to exist as to durability between the several sections.

The suggestions as here given are such as appear to the designer. The scope of the discussion might be increased to a consideration of problems as they are presented to others, whose part it is to assist in the production, but such is beyond the scope of this criticism.

G. S. EDMONDS,

Mechanical Engineer, Delaware & Hudson Co.

THE COST OF TRACK SCALES FOR LOCOMOTIVE COAL.

To the Editor:

At the last convention of the Master Mechanics' Association the question was brought up regarding the best methods of saving fuel on locomotives. During the discussion some members of the committee and a number of the members thought it best, if going into this question thoroughly, to locate track scales at each coaling plant, so that the coal could be accurately weighed for each trip.

After reading over the report of the committee and more fully looking into the matter, I began to wonder what it would cost a railroad having a large number of coaling plants and operating from twelve to fifteen hundred locomotives, to place track scales at each of the important coaling plants or engine houses where coal was loaded on tenders.

If we are going thoroughly into this question, taking the committee's advice as to comparing one engine with another doing the same class of work, and one engineman with another, it is absolutely necessary, of course, to weigh the coal, as all enginemen well know that at the present time on the majority of roads the weight of coal is merely guessed at.

On a road of the size just mentioned, say, having in service an average of thirteen hundred engines, it would take at least a single set of track scales at eleven coaling plants and two sets of scales at six more coaling plants, making a total of twenty-three sets of scales to be installed at a cost of about \$1,000 each or more per set, making a total expenditure of \$23,000 for installing track scales.

After the scales have been installed, in order to get the accurate weight of the coal it will be necessary to have competent men, one by day and one by night, to take charge of each set of scales, which means sixty-four men in all, at a salary of about \$54 per month for each man, or a monthly expenditure of \$3,456 for weighmasters. Adding the amount expended for track scales, \$23,000, to the amount expended in labor at the end of the first year, \$41,472, it would amount to a total expendi-

ture of \$64,472. At least a saving of 6 per cent. on the \$23,000, the cost of installing the track scales, added to the \$41,472, the amount of money expended in labor, which would amount to \$42,852, would be necessary. This would be equivalent to a saving of 34,281 tons of coal at \$1.25 per ton.

I believe that every effort possible should be made to save fuel by keeping the coal picked up at all coaling plants, and not allow tenders to go away from the coal dock that are over-loaded, so that the coal will be falling off all along the line of the road for the first twenty-five miles. If the loading of coal is properly looked after at the coaling plants, so that none will be wasted there, or lost off the tenders on the road, and a competent man appointed, to, say, every one hundred engines, as traveling firemen, to educate the men regarding the firing of engines, it will save more coal and black smoke in three months than all the track scales, corps of clerks and expert figuring would save in three years. The old saying is: "Figures will not lie." That may be true, but neither will the figures of a number of weighmasters and a high-salaried office man bring back the coal without an expert fireman putting his hands to the shovel and teaching the men on the road how to use the coal to advantage on a locomotive. "D."

THE NERNST LAMP.

This lamp appears to be the most important recent development in electric lighting, and it is undoubtedly the most noteworthy exhibit at Buffalo, where it is shown to the public for the first time. There are over 100 400 candle-power Nernst lamps lighting the Westinghouse space in the Electrical Building. There are also several 50 candle-power lamps of the same kind, and also incandescents for comparison. This new lamp seems to be on the arc light order as to strength, and it takes less current than the incandescent.

"Glowers," resembling small diameter wires, of white material and made by a secret process, furnish the light. These are about 1¼ in. long and are placed in a horizontal plane in the lamp. They are in multiple, six being used in the 400 candle-power lamp, and only one in the 50 candle-power lamp. These glowers are non-conductors when cold, and must be heated by exterior means before they will take any current. Each glower is placed directly under a heater coil of fine iron wire, and when these coils are heated by the current the glowers also heat and begin to conduct. The arrangement for heating the glowers and automatically cutting out the heaters is ingenious and important. This is the factor making the lamp possible commercially.

When the current is turned on, the heaters and the glowers are all in multiple, but the glowers take no current because of their high resistance when cold. The heaters rapidly heat the glowers, however, and they soon begin to take some of the current. As the glowers work up toward their full conductivity a magnet, which is in series with them all, cuts the current out of the heaters and the lamp comes up to full candle power, when the glowers take all of the current. This requires about 20 seconds. Another ingenious device completes the lamp. In series with each of the glowers is a coil of iron wire sealed up in a glass tube filled with nitrogen. The purpose of these is to regulate the current through the glowers. When the current increases the iron wires heat and cut down the current to the glowers, and when it drops off the resistance of the iron decreases and the glowers receive more, the action of the iron and the glowers in regard to heat and resistance being opposite; this arrangement acts as a regulator to take care of considerable variations of current.

In the 400 candle-power lamp the glowers are good for about 900 hours and are easily renewed. These lamps will cost more to install than incandescent, but they take much less current and are cheaper to operate. Thus far they have been used with alternating currents only, but there seems to be reason to expect them to work equally well with direct current when further developed. The light is pleasing, and it causes colors to change less than incandescent lights.

CONSOLIDATION MOUNTAIN PUSHING LOCOMOTIVE.

Atchison, Topeka & Santa Fe Railway.

A heavy mountain pushing locomotive with 21 by 32-in. cylinders was designed recently by the motive power department of the Atchison, Topeka & Santa Fe Railway, under the

driving wheels and 200 lbs. steam pressure the tractive effort will be 39,000 lbs., and while the heating surface is not large for an engine of this weight it is sufficient to permit of road as well as pushing service. More than usual care was necessary in selecting the proportions of these engines and the distribution of the weight was most carefully figured in order to meet the exacting conditions existing in the territory for which they



CONSOLIDATION PUSHING LOCOMOTIVE FOR MOUNTAIN SERVICE—ATCHISON, TOPEKA & SANTA FE RAILWAY

JOHN PLAYER, Superintendent of Machinery.

Built at TOPEKA SHOPS.

Wheel: Driving.....	57 in.;	Cylinders: 21 x 32 in.	Boiler Pressure.....	200 lbs.
Weights: Total of engine	185,000 lbs.;	engine truck	30 in.;	tender wheels.....
Grate area and tubes: Grate area	35 sq. ft.	on drivers.....	166,400 lbs.;	total engine and tender.....
Fire box: Length.....	120 in.;	width.....	49 1/4 in.;	Tubes.....
Boiler: type.....	radial staying.	depth of front	73 1/4 in.;	back.....
Heating surface: Tubes.....	2,475 sq. ft.;	firebox.....	224 sq. ft.;	Diameter.....
Wheel base: Driving.....	15 ft. 4 in.;	total of engine.....	24 ft.	total.....
Tender: Eight-wheel;		water capacity.....	6,000 gals.;	engine and tender.....
				coal capacity.....
				10 tons.

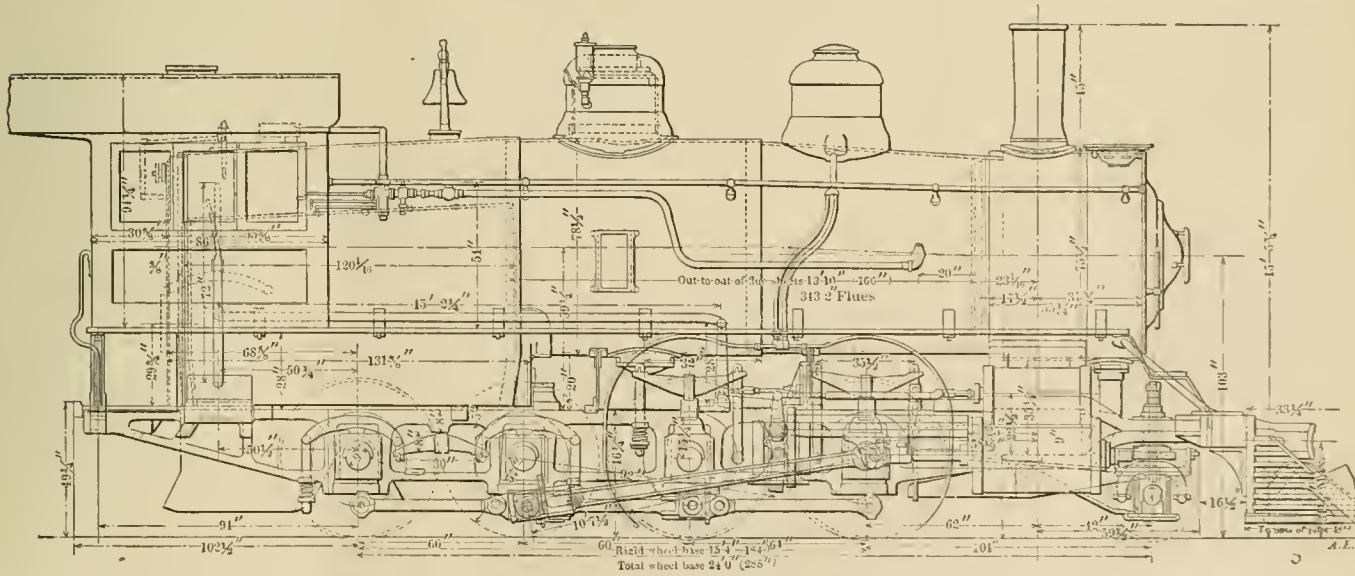

Consolidation Pushing Locomotive—Atchison, Topeka & Santa Fe Railway.

direction of Mr. John Player, Superintendent of Machinery, through whose courtesy we have received a photograph and elevation drawing. Ten of these engines are being built at the Topeka shops and the design appears to be an excellent one for this service. These engines are intended chiefly for pusher service in the Sierras of Arizona and New Mexico. They are simple engines with piston valves, radial stayed boilers and swing motion pony trucks. With 21 by 32-in. cylinders, 57-in.

are intended. Thus far they have come fully up to Mr. Player's expectations. A summary of the leading dimensions is given in the following table:

Leading Dimensions.

Gauge.....	4 ft. 8 1/2 ins.
Kind of fuel to be used.....	Bituminous coal
Weight on trucks.....	18,600 lbs.
Weight on driving wheels.....	166,400 lbs.
Weight, total.....	185,000 lbs.
Weight, tender.....	115,000 lbs.

General Dimensions.

THE "PAN-AMERICAN."

Wheel base, total of engine.....	24 ft. 0 in.
Wheel base, driving.....	15 ft. 4 ins.
Wheel base, total engine and tender.....	53 ft. 10 ins.
Length over all, engine.....	39 ft. 4½ ins.
Length over all, total engine and tender.....	65 ft. 3 ins.
Height, center of boiler above rail.....	9 ft. 7 ins.
Height of stack above rail.....	15 ft. 6 ins.
Heating surface, fire-box.....	224 sq. ft.
Heating surface, tubes.....	2,475 sq. ft.
Heating surface, total.....	2,699 sq. ft.
Grate area.....	35 sq. ft.

Wheels and Journals.

Wheels, leading, diameter.....	30 ins.
Wheels, driving, diameter.....	57 ins.
Material of wheel centers.....	Main S. C., others C. I
Type of leading wheels.....	Radial pony swing truck
Journal leading axles.....	6½ by 10½ ins.
Journal leading axles, wheel fit.....	6¼ ins.
Journal driving axles.....	9 by 10½ ins.
Journal driving axles, wheel fit.....	9 ins.

Cylinders.

Cylinder diameter.....	21 ins.
Cylinder stroke.....	32 ins.
Piston rod diameter.....	4 ins.
Main rod, length center to center.....	127¼ ins.
Steam ports, length.....	25¼ ins.
Steam ports, width.....	1½ ins.
Exhaust ports, least area.....	67 ins.
Bridge width.....	3 ins.

Valves.

Valves, kind of.....	Improved piston
Valves, greatest travel.....	6½ ins.
Valves, steam lap (outside).....	¾ in.
Valves, exhaust clearance (inside).....	0 in.
Lead in full gear.....	Line and line

Boiler.

Boiler, type of.....	Wagon top
Boiler, working pressure.....	200 lbs.
Boiler, material in barrel.....	Steel
Boiler, thickness of material in shell.....	¾-in., ¾-in.
Boiler, thickness in tube sheet.....	9/16 in.
Boiler, diameter of barrel front.....	72 ins.
Boiler, diameter of barrel at throat.....	75¼ ins.
Seams, kind of, horizontal.....	Sextuple
Seams, kind of, circumferential.....	Double
Crown sheet stayed with.....	Radial stays
Dome, diameter inside.....	30 ins.

Firebox.

Firebox, type.....	Radial stay
Firebox, length.....	120 ins.
Firebox, width.....	40¼ ins.
Firebox, depth, front.....	73¼ ins.
Firebox, depth, back.....	67¼ ins.
Firebox, material.....	Steel
Firebox, thickness of sheets.....	Crown 9/16 in., tube 9/16 in., sides ¾ in., back ¾ in.
Firebox, brick arch.....	On water tubes
Firebox, mud ring, width.....	4½ ins., all around
Firebox, water space at top.....	Back 4½ ins., sides 6½ ins.
Grates, kind of.....	Cast iron, rocking
Tubes, number of.....	345
Tubes, material.....	Charcoal iron
Tubes, outside.....	2 ins.
Tubes, thickness.....	No. 11 B. W. G.
Tubes, length over tube sheets.....	13 ft. 10 ins.

Smokebox.

Smokebox, diameter, outside.....	75½ ins.
Smokebox, length from tube sheet.....	60 13/16 ins.

Other Parts.

Exhaust nozzle, single or double.....	Single
Exhaust nozzle, variable or permanent.....	Permanent
Exhaust nozzle, diameter.....	5¼ ins.
Exhaust nozzle, distance of tip below center of boiler.....	4½ ins.
Netting, wire or plate.....	Wire
Netting, size of mesh or perforations.....	2 by 2 No. 11
Stack, straight or taper.....	Cast iron, taper
Stack, least diameter.....	15¾ ins.
Stack, greatest diameter.....	18¾ ins.
Stack, height above smokebox.....	45 ins.

Tender.

Type.....	Eight-wheel, steel frame
Tank, type.....	Gravity slide
Tank, capacity for water.....	6,000 gallons
Tank, capacity for coal.....	10 tons
Tank, material.....	Steel
Tank, thickness of sheets.....	¾ in. and 5/16 in.
Type of under frame.....	Steel channel
Type of trucks.....	Player S. C.
Type of springs.....	Double elliptical
Diameter of wheels.....	33 ins.
Diameter and length of journals.....	5 ins. by 9 ins.
Distance between centers of journals.....	62 ins.
Diameter of wheel fit on axle.....	6¾ ins.
Diameter of center of axle.....	5¾ ins.
Length of tender over bumper beams.....	23 ft. 10½ ins.
Length of tank inside.....	22 ft. 3 ins.
Width of tank inside.....	9 ft. 6 ins.
Height of tank, not including collar.....	5 ft. 0 ins.
Type of draw gear.....	M. C. B. coupler

Special Equipment.

Brakes.....	American for drivers, Westinghouse for tender and train service
Pump.....	¾ in.
Sight-feed lubricator.....	Double Nathan
Safety valves.....	Three 3½-in. Crosby
Injectors.....	Two No. 10 simplex
Metallic packing, piston rods.....	Jerome

The originators and executors of the plan of this exposition are entitled to a great deal of credit. The surroundings have a significance of their own which is deeper than that of a mere housing of the exhibits. Harmony is the underlying idea of the plan, and unusual attention has been given to detail. An impression is conveyed to the effect that our remarkable commercial development has not entirely divorced art from industry, and the beauty and grace of the combination are significant of a higher and purer ideal than that of commercial supremacy. It must exert a powerful moral influence, and even those who do not see beyond the mere exposition features cannot fail to be better for having visited it.

It is broadly and distinctively American, and presents a thoughtful record of the social, political and commercial development of this continent. It was not necessary to borrow even the architecture of older countries, and the harmony with which the work of numbers of individuals was perfected to accord with a single underlying idea is admirable. Nothing like it has ever been accomplished before and the whole scheme seems to promise greater things for the future.

The grounds should be approached from the park at the south, and the first near view should be taken from the bridge. From this point begins a scene of beauty, combining architectural, landscape, color and sculptural effects, all of which are loyal to the original conception of a harmonious whole with a most satisfactory result. Instead of uncovering crudities, close study developed the details, which are carried out faithfully and thoughtfully. A trip on the waterway reveals many features and effects which cannot be seen in any other way. It should be taken by day and again at night.

At night the most impressive effect is produced. The lighting scheme is not less artistic than the rest. The idea of the architecture is harmony, and that of the lighting is proportion. This may be understood by comparing the heights of the buildings and noting the treatment of the lights. To Mr. H. Rustin, Chief of the Mechanical and Electrical Bureau, belongs the credit of the illumination and the fascinating effect produced by the slow "turning on" of all the lights simultaneously all over the grounds at the beginning of darkness. Usually all of the eight candle-power lamps take current from Niagara, twenty miles away and these are gradually brought up to full candle power from darkness in about two minutes. They soon begin to glow perceptibly, and the effect of the gradual increase of the light until the buildings and grounds are fully illuminated by the soft light of the low candle power lamps is worth going a long distance to see. It is wonderful and beautiful. A glimpse behind the scenes, through the courtesy of Mr. Rustin, showed how this was accomplished.

At the cable house there are three water rheostats, one for each cable from Niagara. The three cables terminate in submerged electrodes in the tanks. The other electrodes are vertical plates supported at one corner by a shaft whereby they may be dipped into or entirely removed from the water, and this is accomplished by a small motor acting on the plates through worms and worm wheels. At the beginning of the illumination these removable plates are raised almost entirely out of the water, the resistance being great enough to render the lights non-luminous. The motor is then started and the plates are dipped slowly into the water without commotion beyond a lively sparking at the surface of the water. In their lowest position the movable electrodes rest in contact with the others and the lights then run at full candle power. This current is at 10,500 volts and the load is 3,730 kilowatts, which gives an idea of the boldness of this plan. An afternoon spent in the vicinity of this heavy current inspired a high degree of respect for it. It is rather impressive to see a copper cable of 300,000 circular mils burn out like a piece of fuse. From the rheostat the cables run to the General Electric transformers in

the Electricity Building, where the currents are handled by oil switches until stepped down for the lighting circuits. The extent of the lighting feature made possible by the Niagara power, is likely to be a high watermark in this direction for some time.

The Exhibits.

While the success of the Exposition does not rest entirely with the exhibits they are by no means uninteresting. Machine tools are well represented, particularly automatic and semi-automatic machinery. Many of the exhibits are running, and these merit specially careful examination. Gas and oil engines take a more prominent place than ever before in an American show, with a promise of a most important future. Large engineering work is represented by one of the Worthington condenser and air-pump units for the Manhattan Railway power house in New York. The electric manufacturing concerns content themselves with a display of apparatus, the entire Exposition being prominently an electric exhibit. The Bullock Electric Manufacturing Company have a number of generators, motors and transformers, well arranged and carefully exhibited. In the Westinghouse exhibit are two gas engines, one small one and the other of 300 horse-power, direct-connected to generator and using natural gas. In this exhibit is—to many people the most noteworthy feature of the entire Exposition—the Nernst lamp, which is described elsewhere in this issue. Taken as a whole the Westinghouse apparatus was exceedingly prominent, including the gas engines, electrical machinery, air brake, electric brake, friction buffer and electric and electro-pneumatic signaling, each appropriately shown and in nearly every case in actual operation.

The General Electric Company had an impressive exhibit, especially that used in connection with the Niagara supply of power to the Exposition.

Edison's new storage battery, which, by the way, has been withdrawn from competition, attracted a great deal of interested attention. It is not in operation, but Mr. Edison promises to take others to the exhibit which will be complete and in operation. The capacity of the one shown is $\frac{1}{8}$ h.p. and 100 ampere-hours, its weight being but $5\frac{3}{4}$ lbs.

Of twelve locomotives exhibited only two have narrow fire-boxes between the frames. The powerful passenger engines of the past year were represented by one of the Lake Shore & Michigan Southern prairie type, the "Chautauqua" type of the Brooks works, the "Central Atlantic" type of the New York Central and Michigan Central, and the Vanderbilt engine and tender of the Illinois Central. These were accompanied by the Schenectady 8-wheel passenger engines for the D., L. & W., the compound consolidated engines with wide firebox for the New York Central, the Richmond compound No. 2,427, and two Baldwin consolidation freight engines. Unfortunately these locomotives are all crowded into an entirely inadequate space, where they do not appear advantageously, although they attract a great deal of attention. The Lake Shore engine bears the following worthy inscription: "Most efficient per unit of weight and lightest per unit of power ever constructed."

No such array of powerful passenger locomotives has ever been assembled before, and had they been given the entire space in the terminal station annex they would have been considered one of the leading features of the Exposition. The enormous increase of recent years in boiler capacity is very impressive as represented in this exhibit. There is not the least suggestion of a freak in the lot; each engine represents the development of the locomotive along well understood lines toward the ultimate possibility within the prescribed limits of size and weight.

Our readers will also be interested to see the Gould electric car lighting system of the Gould Coupler Company, which is in operation with a complete equipment. Near it are the exhibits of the Simplex Railway Appliance Company, the Continuous Rail Joint Company of America, that of O. M. Edwards' car windows, the new "Major" coupler of the Buckeye

Malleable Iron & Coupler Company and that of the Standard steel wheels. The car exhibited by the J. G. Brill Company we have already described. In this department there is an attractive exhibit by the Safety Car Heating & Lighting Company.

In the machinery building on the main floor are a number of gas engines by the Otto Gas Engine Company, of Philadelphia, and also an exhibit by Mietz & Weiss, of New York. In the inner court of this building are the steam engine and other gas engine exhibits. These are likely to be missed unless the visitor is looking specially for them. The gas engines are particularly interesting and some are of considerable power, indicating substantial progress. The National Meter Company, of New York; the Alberger Company, of Buffalo; the Bessemer Gas Engine Company, Grove City, Pa.; Struthers, Wells & Co., Warren, Pa., and the Marinette Iron Works, of Marinette, Wis., are the principal exhibitors.

Struthers, Wells & Co. show a large vertical twin-cylinder engine with 21 by 24-in. cylinders, a single heavy flywheel and a very heavy bed. This engine is started by air compressed by an auxiliary pump. The attendant stated that this engine was operating with less than 10 cu. ft. of gas per net horse-power per hour. A 125-h.p. four-cycle, two-cylinder tandem gas engine is exhibited by the Alberger Company. This engine has electric ignition with adjustable timing to give variable lead. In starting, the valves are blind and the lead increases to the desired extent as the normal speed is reached. We did not see this engine running. The valves are operating positively and the governor regulates the amount of charge instead of by the "hit or miss" principle. A large standard type of Nash engine is shown by the National Metal Company. It has three vertical cylinders and is rated at 125 horse-power.

In machine tools we found a number of new developments in the form of automatic machinery and in the methods of driving. The cone pulley and inconvenient change gear are giving place to gears in nests, with convenient methods of couplings for the desired speed without the bother of shifting belts. The machine tool exhibits are briefly described in another column.

There are many other interesting exhibits, for example, the Carborundum Company and the Wm. Powell Company, but for the time we must be content to mention these. It is fitting and pleasing that the best and most complete and finished exhibit of all is that of the various departments of the United States Government.

Mr. F. W. Johnstone, Superintendent of Motive Power and Machinery of the Mexican Central Railway, has resigned to devote his entire attention to private interests in Mexico City. Mr. Johnstone has had a successful railroad experience which dates as far back as April, 1874. Since that time he has been connected with the Philadelphia, Wilmington & Baltimore, Panama, Springfield, Jackson & Pomeroy and Mexican Central Railroads, working through the positions of draftsman, machinist, foreman, assistant master mechanic and master mechanic. The latter position he held with the Springfield, Jackson & Pomeroy from 1879 to 1881, when he went to the Mexican Central in the same capacity. In 1884 he was appointed Superintendent of Motive Power and Machinery of the entire system and in this capacity he has served up to the present time. Mr. Johnstone will on the appointment of his successor open a consulting engineer's office in Mexico City, and will be associated with Mr. Rafael M. de Arozarena, under the firm name of Johnstone & Arozarena, Consulting Engineers. Mr. Arozarena is an American by birth, who has been in this country nearly twenty years. Both Mr. Johnstone and Mr. Arozarena have a wide acquaintance in the Republic of Mexico, and will be glad to serve their friends in the United States who may desire any technical information concerning Mexico.

AN IMPROVEMENT IN JOURNAL BOXES.

Recently a great deal of trouble has been found on some railroads on account of the waste getting caught between the brass and the journal, and Mr. T. H. Symington has added to his journal boxes two ribs just above the center line of the journal, as shown in the accompanying engraving.

It is quite difficult to get the every-day inspector to pack boxes properly and get enough waste on the sides of the journal without getting it too high; these upper ribs in combination with the ribs for supporting the packing and oil on the sides enable the inspector to put the waste exactly where it is wanted and absolutely prevent his getting the waste too high on the sides. After the box is packed these ribs also prevent the waste on the sides of the journal from rolling up with the journal and getting caught beneath the brass, producing what is usually known as a waste grab.

In the discussion at the Master Car Builders' Convention on the subject of standards, Mr. Rhodes remarked that he

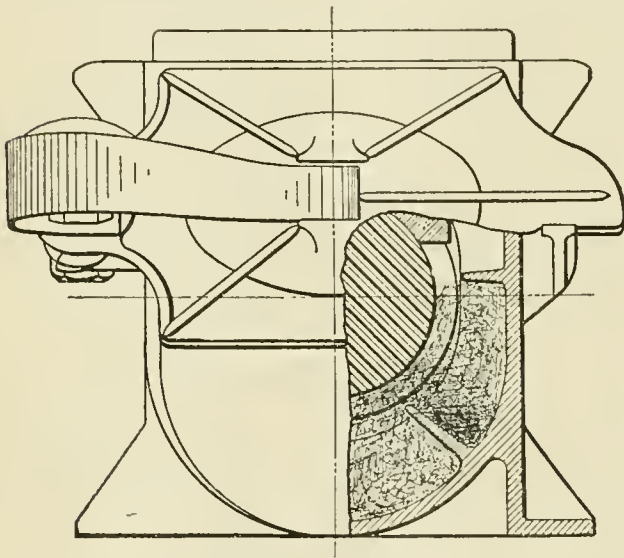

An Improvement in Journal Boxes.

thought the round bottom box was wrong construction, as it was his experience that after a run of 100 to 150 miles the waste had all rolled up on one side in the direction in which the journal was revolving, and that what these boxes then needed was not oil but attention. He further said that he thought we should have a standard box with the bottom so shaped that it would hold the waste in position.

Mr. Symington is satisfied from his own observation that the waste does not slide on the bottom of the box at all. He believes it is simply the top part of the packing that is in contact with the journal that rolls on the bottom part of the packing, and the shape of the bottom of the box has really nothing to do with it. The ribs, as shown, entirely prevent this movement of the packing in contact with the moving journal, and by their use it is thought to be impossible for an inspector to pack a box improperly.

General Superintendent J. M. Wallis, of the Pittsburgh Division of the Pennsylvania Railroad, has granted an increase in wages to the engineers of the larger locomotives. The low-rate day has been advanced from \$3.50 to \$3.70, and the high-rate day has been advanced from \$4.10 to \$4.35. The high-rate day is a run from Altoona to Pitcairn, and a low-rate day is only a partial trip. Under the new arrangement the engineers' time is to be counted from the minute they report until they are relieved.—"Railway and Locomotive Engineering."

SOME DETAILS OF FUEL OIL BURNERS.

Oil fuel has thus far had a relatively small application to locomotive service, and with the exception of a very few roads it has not been systematically employed. The recent developments of the Texas oil region seem likely to greatly extend its field and render information concerning the details of oil burning interesting in a much larger territory. At a recent meeting of the Pacific Coast Railway Club Mr. W. N. Best recorded his experience, from which the following paragraphs are taken:

If we will first consider the burning of bituminous coal, we can better understand the subject of using crude oil, or liquid fuel, for it is very important in both cases that the volatile gases should be properly consumed, as they contain remarkably high heat-producing qualities. Average bituminous coal contains about 65 per cent. of carbon, which has the same heat-generating qualities as coke, and 25 per cent. of hydro-carbons, which are of the nature of illuminating gases. About one-quarter, by weight, of the hydro-carbons is hydrogen gas, which makes the hottest fire possible, but a very high temperature is required to burn this gas, and if, from any cause, parts of the firebox become too cold for converting gas into flame, it passes away unconsumed in the form of smoke or worthless uncombined gas, and makes no more heat than superfluous air.

The loss from permitting hydro-carbon gases to pass away is two-fold; in the first place, the heat of the burning carbon has been wasted in distilling the gas from the coal, and in the second place, valuable heat-making gases have been wasted.

The combustion of one pound of hydrogen gas, if it combines with all the oxygen of the air necessary to effect perfect combustion, produces 62,000 heat units, or enough to raise about 365 lbs. of water from a tank temperature to the boiling point. The complete combustion of one pound of carbon, such as rests on the grates, after the volatile gases have been liberated, produces heat sufficient to raise about 85 lbs. of water from the tank temperature to the boiling point.

I give these figures to show how important it is to have all the volatile gases properly burned, and to bring us to realize the importance of always keeping every part of the firebox up to what is called "the igniting temperature."

I claim that it is very much easier to make perfect combustion in oil-burning locomotives than by the improved methods of burning coal. First, it is necessary to have a good burner that will atomize the oil perfectly by the steam jet striking the flow of oil from the burner, so that the point of ignition will not exceed 8 ins. from the mouth of the burner, and completely fill the firebox with flames, thereby producing and maintaining a temperature sufficient to ignite the hydro-carbon gas as well as the other gases and distribute the air which is admitted through the holes in an inverted arch to cause perfect combustion, the quantity of air admitted being regulated by dampers on each end of the ashpan.

I find that some of the hydro-carbon burners used on locomotives are entirely incapable of securing desirable results and ruin the metal of the firebox by the force of flame, similar to a flame made by a blow pipe. My attention was first called to a burner of this type some years past. By placing it under a stationary boiler the result was that the igniting point of oil was almost at the first bridge wall. The flame passing under the boiler, then through the 3-in. flues in the boiler, thence up through the smokestack, made the smokestack red with almost melting heat, when I was compelled to change it for another type of burner. You can well imagine what great injury this style of burner would do to the crown bar bolts and flues and heads of rivets that rivet the crown sheets to side sheets in the firebox. The cold air is forced into the rear of the firebox, and often a burner of this type will prove a failure, and a locomotive will smoke in spite of any efforts made by skilled and attentive firemen, and in a short time a new firebox will be required, which means unnecessary expense and creates a prejudice in the minds of many against crude oil as fuel.

This has been especially noticeable in oil-burning locomotives, for the reason that the forced intermittent draft, caused by the exhaust of the locomotive, carries air into the firebox in largely varying quantities, thus at one moment tending to chill the firebox and the contained gases and carrying a portion of them off as smoke, and at the next moment allowing certain gases to suddenly ignite and be carried through the lower flue, often resulting in a series of explosions of greater or less force, and causing injury to the lower flues by reason of unequal distribution of the heat, which causes the beads of the lower flues to become spongy and burn off, thereby causing the flues to leak.

By use of a proper atomizer the nose piece can be released from its position by the operation of a bridle. Should any scale from pipe or boiler pass into the atomizer channel, in 30 seconds it can be removed by simply uncoupling the bridle, a point I consider of great value, as it insures the best results without delay. The atomizer is also provided with an automatic condensed steam release valve, which, by means of a spiral spring, is raised from its seat, which allows the condensed steam to pass out, and when the steam is turned on the burner, the pressure of the steam closes this valve. This device prevents water from injuring the refractory walls and arch.

I use an inverted arch, similar to those used in Russia and South America, and by railroads of California and Arizona, with this exception, that the hole for the admission of air is immediately back of the front refractory wall, for these reasons:

By numerous experiments I found that this gives the best results, as the air is admitted at the wall against which the current of flame is forced, and the oxygen of the air is mixed with the volatile gases as the flames rise and pass under the refractory arch into the upper portion of the firebox. Several roads use three air cavities in the inverted arch, the two rear ones merely allowing the currents of cold air to pass up by the side sheets, which chills the firebox and escapes with the hydrogen gas out from the smokestack, the very gas of all gases which should be saved.

The inverted arch is lined with firebrick at the rear, and around the air cavity angle iron is riveted in order to hold the firebricks intact. The refractory arch consists of bricks especially designed, 9 ins. thick, fitting closely to the front refractory wall and resting upon two refractory wedges, which gives them the proper pitch, the highest portion of the arch being on an exact level with the lower flue. This arch is one-third the length of the firebox.

When I took charge of the machinery department of the Los Angeles Terminal Railway, July 17, 1899, I found the locomotives in a very bad condition, especially the fireboxes and flues. To see an engine coming at a distance, not knowing that it was burning oil, you would have imagined that it was an old style coal burner, by the amount of volatile gases escaping from the smokestack. By examination of the fireboxes I found that the same grates and grate frames were used as when engine was burning coal, the air being admitted through the grate. The arch extended from flue sheet to fully one-half the length of the firebox; the arch consisted of 66 firebricks, which required a man five hours to build, and I am informed that often a portion of them would fall down before making a 30-mile run. One by one I took the engines into the shop and equipped them with an inverted arch, refractory wall and an arch as described.

I immediately instituted a night school of instruction for the enginemen, in order that they might fully understand the proper handling of oil. At first, very few were in accord with my ideas; they imagined that if the engine did not make smoke it would indicate that too much air was being admitted in the firebox, which would certainly cause the flues and stay bolts to leak. One evening I opened the front end of an engine that had not been changed in order to show the condition of the flues. I also ascertained the amount of sand that had been

used to clean the flues that day, which was an astonishing amount. The 2-in. flues were almost filled with flaked soot; the holes through the flues would not exceed $\frac{3}{4}$ in.

The following is a comparison of the engine and car mileage and barrels of oil consumed by the old method of the Los Angeles Terminal Railway, as compared with the present method, showing the results by the saving of gases:

July, 1899—Engine mileage	20,354
Car mileage	67,016
Barrels of oil consumed to do the work.....	3,050
Cost per mile for repairs.....	.0555
July, 1900—Engine mileage	21,628
Car mileage	73,881
Barrels of oil consumed.....	3,331 $\frac{1}{4}$
Cost per mile for repairs.....	.0222

The tonnage was very much greater in July, 1900, than in July, 1899, thus making a saving of about one-third fuel oil. Thus it is seen that these valuable results come from a proper handling of the fuel oil.

On every division there should be a competent engineman, acquainted with all the grades of the division, whose duty it should be to instruct the enginemen to properly handle the oil, and at the end of every month report to instructor on combustion the name of the crew making the best record in oil saving, and due recognition by the superintendent to be given them. The burning of crude oil should not be even as injurious to the metal of a firebox as bituminous coal, for a more even heat can be attained and controlled. The cavities for admission of air in order to supply the necessary oxygen, should be carefully examined, so that they will not fill with pieces of broken firebrick.

The crude oil of 15 to 18 gravity gives the best result; is not explosive should a wreck occur, and should be as free from water as possible, as water is well known to be injurious to the refractory walls and arch.

When we first began the use of oil in locomotives in this part of the State, early in 1895, we used coils in the oil tank for the purpose of heating the oil. This was found to be a failure for these reasons: Oil of 16 gravity must be heated, and when a supply of oil was given the engine the process of heating the oil by coils was found to be too slow. A heater pipe, allowing live steam to mingle with and heat the oil, at a point near the flange connection of the oil tank which connects oil tank with burner, has been found to obtain desired results.

In conclusion, allow me to say that I confidently believe that within six months the present method of burning crude oil will be revolutionized by a new and better system, giving in every way more satisfactory results.

Mr. Best's Apparatus.

This discussion may be more easily understood by an examination of the accompanying engraving showing the apparatus referred to. Instead of the usual arrangement, the oil orifice of this burner is below the stem opening. In order to guard against clogging the burner the nozzle may be easily opened for cleaning. At the back end of the burner an automatic drainage cock is fitted to prevent an accumulation of condensed steam in the nozzle when the steam valve is closed. If water should be thrown against the brick arch when hot it would suffer considerable damage.

In the firebox an inverted arch is placed. It has an opening for air back of the front firebrick wall, this having been decided upon by experiment. The arch is lined with firebrick where the flame reaches it and it is bound with angles to prevent it from breaking down. These bricks are 9 ins. thick and made specially for this purpose. The location of the arch with reference to the flues and its length are indicated in a general way in the drawings.

The oil is carried in a tank in the coal space of the tender and flows by gravity to the burner. In passing from the tank into the delivery pipe, the oil goes through a cast iron well under the tank, where it is heated by steam from the boiler. This device insures a continuous and ready supply of heated

oil to the burner by heating it only as it is used. This well also traps the water that may be in the oil before it goes to the burner.

Test on the International & Great Northern.

Mr. W. B. Chenoweth, Mechanical Engineer of this road, has kindly sent us the following communication on this subject:

"The fuel oil question in Texas is becoming very interesting. I give, below, the performance of an 85-ton engine with 20 by 28-inch cylinders, which has been in service the past two

REQUIREMENTS OF ELECTRICITY IN MANUFACTURING WORK.

By William S. Aldrich.

From a paper read before the American Society of Mechanical Engineers.

Factories are not built in a day, but the ready extension of existing electrical supply service has increased the output from 30 to 40 per cent. per square foot of floor space. New machines and tools cannot always be obtained on telegraph order, but a resort to electric driving has increased the output of existing

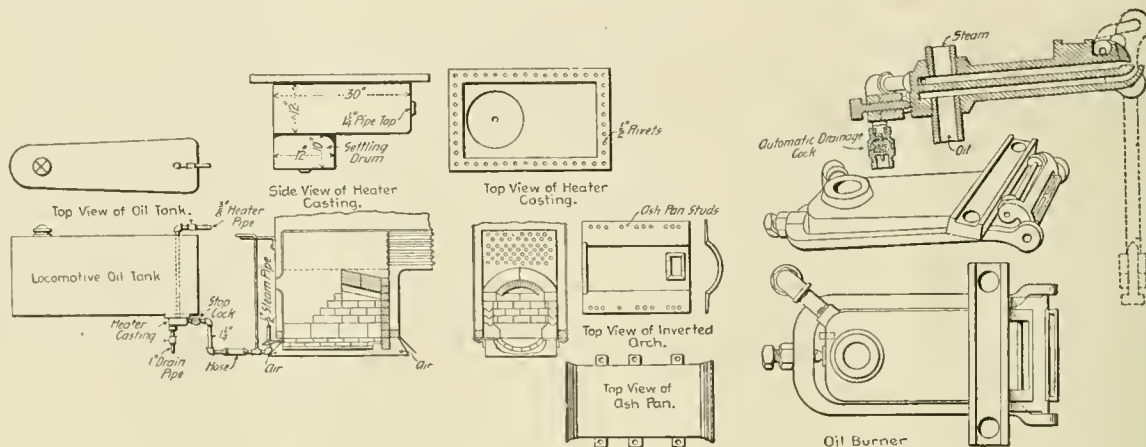

Apparatus for Burning Crude Oil—Los Angeles Terminal Railway.

weeks and is equipped with the W. N. Best oil burning system, using Beaumont oil. This engine makes a 308-mile run and the average coal consumed was $17\frac{3}{4}$ tons, or 35,500 lbs.; this means $17\frac{1}{5}$ miles per ton of coal. On the same run with the same tonnage the engine is now making the 308 miles on 17,640 lbs. of oil, a difference of 17,860 lbs. in favor of oil. According to Rankine, the well-known authority, the perfect combustion of 1 lb. of bituminous coal is equal to 15,887 heat units. The perfect combustion of 1 lb. of crude oil equals 21,735 heat units, which shows the great advantage of oil over coal.

With this engine the question was not how much steam could be made, but how much steam could be used. The engine carries 200-lb. boiler pressure and could be maintained at that pressure under any and all conditions on the trip. In going up 1 per cent. grade with a 3 deg. curve with 900 tons of freight the engine could be easily popped off while both injectors were working. There was absolutely no smoke and no odor arising from the burning oil, all the smoke being consumed.

It is argued by some that the intense heat will shorten the life of the firebox; but such arguments are not borne out in experience, because it is not the heat that injures the firebox; it is cold air, and with the use of oil the fire door is never opened.

A slight accident to the Brooklyn Bridge occurred July 24. Two of the cables and seven of the short suspension rods at the center of the bridge broke, but without any damage resulting. At the center of the bridge the suspension rods are short, and to accommodate the necessary movement of the roadway in expanding and contracting, trunnion blocks were used at their lower ends. These were so located as to be impossible to inspect and the breakage of the first rod at one of these ends was not discovered until a number had given way. These short rods are subjected to considerable movement in extremely hot or cold weather and the hot days before the discovery probably played a part in the breakage. There was no cause for alarm or for fear of disaster to the structure but no time should be lost to improve the defective details which gave the trouble.

machines from 20 to 60 per cent. Workmen may not be had for the asking, but giving them electric-driven machines has increased the output per man from 10 to 30 per cent. All of this has been developed without any strikes or other than satisfactory regulation of wages by recognized premium and price-rate systems.

It is no longer a question of the efficiency of electricity vs. shafting for power transmission. Nor is it a mere question of saving at the coal pile when only 2 or 3 per cent. of the total cost of production is to be charged to the fuel account. In many cases electricity has effected a saving during the first year that has more than paid for the change to the new system. Whether it is more or less economical than mechanical transmission depends upon circumstances. When properly installed and operated, electricity should have inherently all of the considerations in its favor.

The disciplinary value of electric driving cannot be ignored. The old easy-going belt system used to allow many a glance at the morning news, many a familiar chat during long and deep cuts. With the electric drive the operator finds it very convenient to be near his machine. The customary warning signals of slipping belts are no longer heard.

Satisfactory illumination should also be provided. No one will work by a smoky torch when he can have an arc or an incandescent lamp. Electric light must be supplied in these times in all shops where they make a practice of doing a day's work the year round. Only a little wiring is required, and a small amount of extra power is necessary at the generating plant to drive machines and tools by electricity. In many instances electric lighting has paved the way for electric driving.

This system admits of centralized or concentrated power generation, which is required for maximum economy. Distributed power generation in small and scattered units is very wasteful. The electric power plant may be located to best advantage for fuel and water supplies, conveying and transportation facilities. It may be isolated from other structures, so reducing fire risks and insurance rates, especially where the boiler house is in a separate building. The electric generating sets may be subdivided into similar and independent units. These may be operated at all times under the most economic condition of normal loads. This permits manufacturing work in any branch or section of the establishment as economically under part load as under full load, on overtime and night shifts as during the day's work. Electric light may be supplied from the power mains or from separate generators, as conditions require. In

not a few cases of the introduction of electric driving the additional saving has been more than enough to pay for all of the lighting service.

The distances are short in factory service, the electric distribution being within one building or a group of buildings. The so-called line losses are therefore usually negligible in well-designed installations. Low voltages are employed in factory transmission. From 110 to 550 volts are the accepted limits at the present time in this country, either for direct- or alternating-current working at constant potential or pressure. The economics of the various systems can be only satisfactorily discussed with reference to any given project or installation.

The following are recognized methods of distribution, for electric light or power, or both, in manufacturing work:

Two-wire and three-wire systems, for direct or alternating currents. Multi-circuit system for direct-current multi-voltage service. Single-phase, two-wire alternating current. Two-phase, three- or four-wire alternating current. Three-phase, three- or four-wire alternating current. Composite system, direct current and single-phase or two-phase alternating current on the same wires.

The design, plan, and arrangement of manufacturing establishments are not now dictated or controlled by the new electric transmission, as always has been the case with the old mechanical system. Factory and mill construction is undergoing radical changes incident to the electric transmission of power. There is now a superior adaptation of the building to manufacturing work and sanitary requirements, with higher ceilings for light, ventilation, and overhead transportation. The cost of buildings is reduced to a minimum.

The site for buildings may be chosen independent of power considerations and located on most suitable ground. There is no necessity for buildings being placed around or adjacent to the power-house, as required for mechanical connections to engines or turbines. Grouped shops may be arranged in best manner to facilitate economic production and the handling, conveying, and transportation of material and work. Detached buildings, a tendency of certain lines of modern manufacturing development, are feasible, and the work therein facilitated by electric transmission. The isolation of various shops, departments, and workrooms for manufacturing or insurance reasons may be carried to any extent with the electric system without impairing its efficiency or economy. The output per square foot of floor space is a maximum with electric transmission.

Future areas of work may be planned and arranged for with the utmost freedom and entirely irrespective of power considerations. They can be located as desired, on separate floors, in various departments or in detached buildings. Original provision for prospective development is not necessary in the electric system, but is required by shafting transmission. There is no expense for contemplated additions till they are actually installed as required.

Temporary extensions, to meet sudden demands for power at any point, are quickly made by running to the desired location electric wires or cables. These are easily removed when no longer required and as readily used elsewhere for similar purposes. The shifts are made with the least expense of time and labor in handling, and with no accompanying waste of material to suit different conditions. Auxiliary power is always at hand for emergencies and to almost any reasonable extent, on account of the reserve nature of the electric supply.

When alterations or additions in power transmission are required, it is the invariable practice in many modern shops to extend in the line of electric driving. This is notably the rule where electric supply is already at hand for either lighting or power service. In the rehabilitation of an old establishment some of the shafting transmission may usually be combined with the electric drive, as in the so-called group system. Much can be done to improve the power transmission if existing lines of shafting are divided into the most economic sectional lengths, determined by the speed, character of load, and kind of work.

For individual driving without intermediate gearing the armature of the motor is mounted on the main spindle of the machine. The power is most directly applied, with ideal adaptation of tool to work. It requires more or less special adaptation of motor to machine, with rarely any marked changes in the structural design of the latter.

For individual driving with intermediate gearing the motor is conveniently mounted on the frame of the machine and drives

it through the intervention of the ordinary gearing. It requires no special adaptation of motor to machine. Any suitable motor may be used on any machine.

With the individual drive the workman has the most perfect control of all factors entering into the economics of production. There is maximum economy in the application of power. The speed control and the output are independent of any other machine. They are no longer limited by the speed of the line shafting. Machines and tools may now be worked to the limits of their respective capacities. The productive efficiency of the machine is increased. It may be operated at all times up to the power limit, reducing time and cost of labor for any given product. The choice of the individual drive depends upon the power required, the size of the machine, the time it is in service, and the value of the product. The individual motor drive is usually adopted where the machine is in use only part of the time, and in sizes as small as two or three horse-power, and requiring wide variations in speed and power for maximum output, quite independent of the first cost. For large machines this method reduces the power losses to a minimum. It is particularly advantageous for shears, punches, and a class of repair shop tools requiring power only at intervals. The constructive details and design of direct-driven machines are not usually altered to any extent; secondary speed changes are obtained by the usual change-gear and mechanism; in special cases of large tools, a range of speeds is sometimes best provided by a special variable-speed motor.

In group driving a few large electric motors are employed, independently driving sections of shafting of most economical length. This method is thus adapted for driving a number of small machines, with no particular requirements in speed or in power; or for most economical manufacturing along special lines; or for driving any section on overtime or night shifts; or for independent driving of separate floors, departments, or detached buildings.

The maximum economy with the group system can only be secured when all of the machines so driven are in constant use, at best speeds for maximum output. This dictates grouping machines as far as practicable of the same size, style, functions, speed and power requirements, having due regard to the work to be executed. Sectionalizing the power transmission by substituting electric motors for either the main or section belts secures partial advantages of the new system side by side with the old, and is frequently resorted to in old establishments adopting new methods.

The most general requirements of factory transmission can all be met by an intelligent combination of individual and group driving. The first cost of installing the individual drive will generally be from 2 to 5 per cent. higher than for the best group system, when all other considerations are the same. The individual drive is more economical in the use of power than the group system, especially if in the latter only a limited number of grouped machines are in use at any one time, at average loads.

The extreme flexibility of the electric system invites the widest use of portable tools and appliances. A flexible heavily-armored cable gives any desirable radius of action, with no expense to maintain as a part of the transmission system, with no danger or difficulty in handling, and requiring least time and labor for any immediate shifting of tool or work. Least used tools need not occupy floor space when not in operation. Most favorable economic relations may, therefore, be secured in many lines of manufacturing work, especially of the heavier grades. Almost all required tools may be taken to and operated at the work in hand. Time is saved in not having to shift and adjust the work to the machine or tool. Several operations may be carried on at one time by bringing different tools to the work, each independently driven and operated.

In general, the following lines of inquiry should be freely investigated before choosing any system for power transmission in manufacturing work: The size of the establishment; the area to be served; the arrangement and grouping of shops, departments or buildings; the arrangement, types, and sizes of machines or tools to be driven; the variety of speeds required; the character of the loads involved; the kind of work to be executed; the economics of fuel and water supplies.

It should be possible to drive similar apparatus and motors from any point of attachment to the wiring system. Greater flexibility is thereby secured, added facilities provided for use

of portable tools, and readiest extension made of plant and distributing system at any time. Preferably have one, and only one, electric system if it can be secured by intelligent consideration of all present and the most probable future requirements. This does not necessarily imply that it is best to have one single circuit for all kinds of service required in a manufacturing establishment, as light and power; but it should not be required to use different circuits for the same service, as portable tools.

Generating sets and motor equipments should be standardized as far as possible in the case of any given establishment. These machines, as well as all their parts, should be readily obtained in duplicate at any time. This is particularly important in making additions and extensions in the group system. Electrical machinery to-day is so far standardized, and its performance predetermined, that there can be no excuse for not selecting that style and type best adapted to any given factory.

The load diagram for any machine will furnish the best data for determining the proper size of motor. It may be readily obtained under the working conditions of the machine by using a test motor.

The limit of overload is fixed by the allowable rise of temperature, and can readily be predetermined for any given electric motor. In general, the surface temperature of the motor field coils, as measured by a thermometer, should not exceed from 35 to 45 degrees C., with a maximum limit of 50 degrees C. after an overload run of from six to eighteen hours, as may be specified by the builders.

Starting load currents are of course high, and may be from two to three times the normal current, as in the case of overloads, for brief periods. Individual drives require proportionately larger motors to enable them to carry alone the heavy overloads. Group drives require only normal load motors, as it will rarely ever occur that the several grouped machines are all carrying overloads at the same instant. Motors for this service may often be much smaller than would be dictated by the combined load diagram of the machines forming the given group or section. In no case will they require to approach the maximum, or the sum of the maximum, loads of the various machines.

The speeds should be predetermined by the conditions for most economic maximum output, and so fix the range required for the electric motors. In no instance should the reverse be the case. In many cases of individual drives it may be best to secure the speed reductions mechanically, as by the ordinary change-gear. It is not necessary nor advisable in all cases to secure the same by mounting the motor armature directly on the spindle of the machine. Provide motors with speeds consistent with the range of change-gear, and gear down rather than up.

The actual normal capacity of the generator will be chiefly determined by the length of time the various motors are in use, rather than by their normal or aggregate capacity. It may happen, owing to the intermittent use of machines and motors, that the generating plant may be reduced to 50 per cent., or even to 20 per cent., of the aggregate normal capacity of the motors out in the establishment. An increase of the electrical system can only be intelligently made from a careful study of the load curves of the existing installation, and using it as a basis for comparison with the portable load curve under the proposed conditions. There should be judicious subdivision of the generating plant into units, preferably of the same size and style, that they may be readily interchanged and duplicated at any time, with one or two relay units for emergencies and extra rush seasons of work.

Separate service circuits, from the same or separate bus-bars, may be provided to advantage, for lighting and various power uses. Sub-stations, or sub-station switchboards, should be provided for separate shops, floors, departments, or buildings, making it unnecessary to run a separate set of wires back to main switchboard for each service.

As far as practicable, each unit of the generating plant should be operated at its normal capacity—additional units to be switched in as may be required by the manufacturing conditions. Rarely the case that any machine or tool is started from rest with full load upon it. Motors may be started best under the usual friction, or light loads on the machines, as in the belt systems. When the machine is brought up to proper speed, work may be thrown on to it. In this respect the practi-

cal operation of an individual electric drive follows closely that of the belt system.

It is always possible to tell exactly what is going on in an electric drive, both in kind and amount of useful work, as well as in matter of wastes and losses. Power measurements are made at any point by ammeter and voltmeter, or by a wattmeter alone. A special test motor of known performance lends itself admirably to comparative tests of the performance of machines and tools under various conditions. Workmen may know at any moment whether they are driving tools or machine to best advantage for maximum output at best speeds.

The definite power required for definite work may be determined and charged to each machine, tool, or piece of work, and so make up the shop cost of production more exactly than by any other system. The power lost in friction of individual machines when running empty may be obtained with equal facility and compared with that required in doing useful work. It will be found that the latter increases almost directly as the resistance being overcome by the machine in its operation under working conditions. The power required by the work is a small per cent. of the total power delivered to the machine.

MANGANESE BRONZE STAYBOLTS.

A careful study of the staybolt problem made by M. du Bousquet, Chief Engineer of Material and Traction of the Northern Railroad of France, is worthy of record in staybolt literature. This investigation was brought about by the serious trouble which occurred from the failure of copper staybolts almost immediately after that road had put into service some new locomotives having steam pressures as high as 199 to 213 lbs. per square inch. The breakage of these staybolts increased as the engines were continued in service.

To study this trouble, drawings of the two sides and end sheets of a boiler of this class of locomotive were sent out on the road showing by small crosses the location of each staybolt in the firebox. In every case the failure of a staybolt was marked with a circle on the drawing representing that sheet. From these reports the general office made diagrams repre-

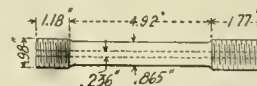

Fig. 1.

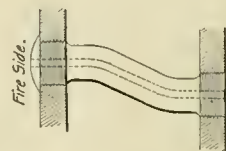
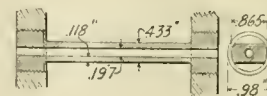

Fig. 2.



3.



Fig. 4.

sents the sheets of the firebox, only in this case the diagrams were divided into spaces of one (square) centimeter, each space representing a staybolt. By blackening a square millimeter of the space representing a particular staybolt each time a rupture occurred, a diagrammatic record of every staybolt in the firebox was obtained. This revealed at a glance the part of the firebox where the greatest number of failures occurred and furnished material on which to base an investigation. After extensive trials with copper staybolts threaded only on the ends, as shown in Fig. 1, and increasing the diameter as shown in Fig. 2 with no success, another line of experiments was undertaken, using chiefly iron and steel staybolts

reduced in cross section, as illustrated in Fig. 3. These were made first of soft steel and then of nickel steel, but with no better results.

Reports of a metal called manganese bronze led M. du Bousquet, in April, 1896, to experiment with it for use in staybolts. The results from a series of physical tests of this metal, both hot and cold, are given as follows: Pulling tests were made on specimens 0.59 in. diameter and 3.94 ins. long between the shoulders of the specimens. In the cold test the mean resistance to breaking was 44,945 lbs. per square inch, with an elongation of 39.4 per cent. At 100 degs. Cent. the breaking strength was 47,079 lbs. per square inch, elongation 34.9 per

TEN-WHEEL FREIGHT LOCOMOTIVE WITH WALSCHAERT VALVE GEAR.

Government of New Zealand Railway.

We have received from the Baldwin Locomotive Works a photograph of a design of 10-wheel freight locomotive with piston valves and the Walschaert valve gear for use in New Zealand. The engine is not large or heavy when compared with those in use in the United States, but is of special interest because of the application of this valve gear, which has important attributes which are attracting considerable attention in this country at this time, although, as far as we are informed,

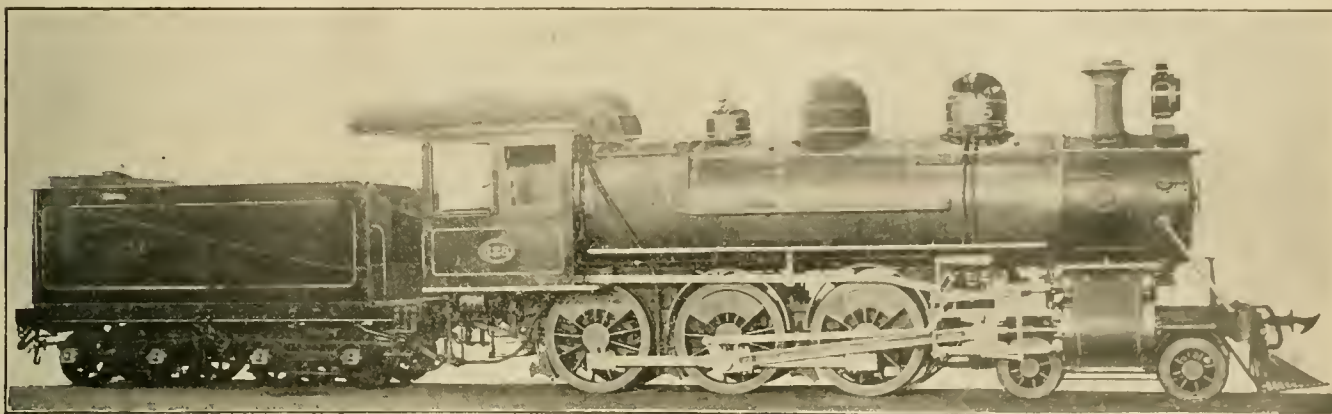

Ten-Wheel Freight Locomotive with Walschaert Valve Gear—Government of New Zealand Railway.

cent.; at 200 degs. Cent. (392 degs. Fahr.) breaking strength 44,234 lbs. per square inch, elongation 34.2 per cent. Drifting tests showed excellent quality, as did bending tests. The results showed that this manganese bronze was notably superior to copper in the cold tests and incomparably superior in the hot tests, for copper at 200 degs. Cent. breaks at 22,330 lbs. per square inch, the elongation being about 34 per cent.

Staybolts of this metal were first used in 1896 to replace the old ones made of copper, in the three upper rows of the side sheets of certain high-speed locomotives. Afterward they were used to replace all broken staybolts in about 20 passenger locomotives, and finally, in 1900, the firebox of engines Nos. 2,641 and 2,642, carrying a steam pressure of 227.5 lbs., were completely fitted with these staybolts. The Northern Railroad of Belgium has also fitted with these manganese staybolts the fireboxes of six of their new passenger locomotives having steam pressure of 213 lbs. Since the trial of these staybolts in 1896 by M. du Bousquet 3,500 have been placed in service, mostly in those parts of the firebox where frequent ruptures occurred. Records kept of these bolts showed that up to December 10, 1900, a period of about four years, not one had been found broken, and their application has greatly decreased the trouble. In the first three months of 1897 the breaking of copper staybolts in 40 locomotives was at the rate of 543 per month. In the first three months of 1898 this average had fallen to 379 per month; in the first three months of 1899 to 148, and for the first three months of 1900 to 99. An analysis of this metal revealed the fact that only copper and manganese are used, the percentage of manganese being about 3 or 4. This road is also considering the use of firebox tube sheets of manganese bronze. Another metal investigated for staybolt use on the Northern Railroad was "Stone bronze" of special composition, which seems to have given good results in England. Fig. 4 gives a design of this bolt with four slots cut in the sides to give greater flexibility. In 1898 about 130 of these staybolts were put into service on a compound locomotive carrying 199 lbs. working pressure, and as yet no ruptures have been found. The complete record of these experiments may be found in the "Revue Generale des Chemins de Fer" for March, 1901, from which this abstract is taken.

it is not yet being applied on any American road. The chief dimensions of these engines are as follows:

General Dimensions.	
Cylinders.	
Diameter	16 ins.
Stroke	20 ins.
Valve	Balanced piston
Boiler.	
Diameter	52 ins.
Thickness of sheets.....	½ in.
Working pressure	200 lbs.
Fuel	Soft coal
Firebox.	
Material	Steel
Length	76 3/16 ins.
Width	30¾ ins.
Depth	Front, 56½ ins.; back, 46½ ins.
Thickness of sheets.....	Sides, 5/16 in.; back, 5/16 in.; crown, ¾ in.; tube, ½ in.
Tubes.	
Material	Steel
Number	177
Diameter	2 ins.
Length	13 ft. 4½ ins.
Heating Surface.	
Firebox	89.7 sq. ft.
Tubes	1,230.8 sq. ft.
Total	1,320.5 sq. ft.
Grate area	16 sq. ft.
Driving Wheels.	
Diameter outside	49 ins.
Diameter of center	44 ins.
Journals	6½ by 7 ins.
Engine Truck Wheels.	
Diameter	26 ins.
Journals	4¼ by 7½ ins.
Wheel Base.	
Driving	10 ft. 0 in.
Total engine	20 ft. 11 ins.
Total engine and tender.....	42 ft. 10 ins.
Weight.	
On drivers	63,580 lbs.
On truck	20,462 lbs.
Total engine	84,042 lbs.
Total engine and tender.....	125,000 lbs.
Tender.	
Diameter of wheels.....	28 ins.
Journals	3¾ by 7 ins.
Tank capacity	2,000 gals.

The new White Star Liner "Celtic," the largest ship ever built, arrived in New York August 3d, on her first voyage. She was out eight days and made an average speed of 14.95 knots, which is likely to be raised to about 16.5 knots in future voyages. The "Celtic" is 700 ft. long, 75 ft. beam and 49 ft. deep, with passenger accommodations for 2,859, and the gross tonnage is 20,888.

MACHINE TOOLS AT THE PAN-AMERICAN EXPOSITION.

These exhibits have already been referred to in this issue in a general way, but they merit further mention individually.

The Niles-Bennet-Pond Company, of New York, are the only exhibitors of heavy machine tools. They show a 60-in. Pond planer and lathe, a 5,000-lb. Bennet steam hammer and a Bennet vertical milling machine. From the Niles works there is an 84-in. boring mill and a large direct-driven radial drill with the motor mounted on top of the column. Adjoining this space is that of the Long & Alstatter Company, of Hamilton, Ohio, who exhibit a multiple punch for punching 40 5/16-in. holes at once. They also exhibit a horizontal punch and bender, a standard 1-in. punch and a double angle shear.

American Tool Work Company, Cincinnati, Ohio.—This company has a number of their standard tools, which have been recently re-designed, among which are 2½-ft. and 5-ft. radial drills with back gears. They show a planer, motor driven, with the motor on top of the upright frame, also a 16-in. shaper with back gears, a 26-in. shaper with triple gears and several lathes.

The G. A. Gray Company, of Cincinnati, who make a specialty of planers, demonstrated the remarkable smoothness of the reversal of the beds by running them with glasses of water standing upon them. The water does not spill, although the glasses are full to the brim. One of the planers is 36 ins. and the other 30 ins. The larger one has the motor on the uprights driving through spur gears, while the motor of the smaller one is on the floor, driving by a screw. The smoothness of reversal is remarkable and attracts attention to the other features of the machines.

Bradford Machine Tool Company, Cincinnati.—This firm exhibits a number of lathes, the most noticeable of which is an engine lathe fitted with a turret attachment, which has tools for boring. They have another 21-in. engine lathe fitted with a novel feed belt tightener.

Bullard Machine Tool Company, Bridgeport, Conn.—Their machines are running and are specially well displayed. They show two turret lathes and four boring mills. All the mills are new. In the 42-in. machine a boring bar is fitted which has an adjustment by a rack and pinion in addition to that of the head. This permits of placing the tool while the feed is in gear. One of the mills has a turret and three of them have screw-cutting attachments.

The Prentiss Machine Tool & Supply Company have the most extensive exhibit, including the product of nearly a dozen machine tool makers. Among these the most prominent are the milling machines and attachments of the Cincinnati Milling Machine Company, the radial and multiple drills of the Bickford Drill & Tool Company, and the lathes of the Lodge & Shipley Company.

Prentice Brothers, Worcester, Mass., exhibit a number of drills, both radial and upright and a 24-in. engine lathe. This lathe merits careful attention. It is driven by a motor placed below the bed of the lathe, connected by gears. The motor speed is constant, all speed and gear changes being made by levers. This lathe operates so nicely that in screw cutting the tool comes to the shoulder and reverses without stopping the machine.

Pratt & Whitney, of Hartford, show about a dozen machines in operation, including several automatic screw machines making buttons for typewriters, valves for pet cocks and small bolts, also a mill machine, a 14-in. lathe, a 16-in. chasing lathe and deep hole drilling machines.

The Detrick & Harvey Machine Company, of Baltimore, exhibit a horizontal boring, milling and drilling machine, an open side planer, a nut facer and bolt cutter. The boring, milling and drilling machine will work at any angle, its work being secured to a universal table.

Becker-Brainard Milling Machine Company, Hyde Park, Mass.—This exhibit is devoted to their well-known milling machines and a new grinder for ordinary cutters, large mills with inserted teeth and for end mills. They also exhibit a new horizontal milling machine with vertical attachment.

The Cleveland Machine Screw Company, of Cleveland, have an interesting lot of automatic machines, the largest of which is an 18-in. automatic chucking machine which will take work up to a size of 18 by 18 ins., which may be held in a chuck.

The Brown & Sharpe Manufacturing Company, of Providence, exhibit machine tools, hand tools, milling machines, gear cutters and have altogether a very interesting collection.

The Norton Emery Wheel Company, Worcester, Mass., have a very attractive and instructive exhibit which includes samples of the work of the Norton grinding machine which attracted attention at the Saratoga convention. They also exhibit a large line of emery wheels, including the largest one ever made. We are informed that the Midvale Steel Company have installed these grinding machines with the intention of grinding all of their car axles.

CAR-DOOR FASTENING AND VENTILATION.

A car-door fastening devised by Mr. F. A. Delano, General Manager of the Burlington, and Mr. R. D. Smith, Master Mechanic of that road, in Chicago, has recently been brought to our attention. It was developed to meet the peculiar requirements of a combination of a hasp which may be sealed with the door in the closed position, or with it open slightly, and also may be secured by a padlock when the car is used for bonded freight. At the same time the cost was required to be low and the device simple and durable. It was also necessary that it should be proof against thieves.

The result was the device known as the "Prairie Car-Door



The Prairie Car-Door Fastener.

Fastener." It consists of a simple loop fastening attached to the door, a hasp with two hooks with seal slots, one of which engages the staple on the door post when the door is closed, and the other when the door is slightly open, and above these hooks is a loop for the padlock, whenever it is needed.

Its first cost is not greater than ordinary fastenings, it is easily sealed, and the lettering on the seal is readily seen. It may be used on regular or bonded cars, and with the car door slightly open the seal and lock are as secure as when it is closed. We do not know of any other combination of these features, and the exigencies of present-day traffic render such a device indispensable. The "Proceedings" of the Central Railway Club for May contain the following statement by Mr. H. H. Perkins, which shows the necessity for something of this sort:

"We do not have any trouble about the ventilation of box cars containing grain, but with fruit we do; the latter all goes in refrigerator cars now, which are either ventilated by leaving the ice doors open, or are practically ventilated by closing them and putting ice underneath and keeping the temperature down. Ventilated cars are very good for plums, cherries and strawberries. The New York Central has quite a number of these cars in which the doors are racked, and so the cars get good ventilation. This winter we had two refrigerator cars arrive here in Buffalo from Florida with oranges, and the heat in the cars when they arrived was over 120 degrees, and the oranges were nearly baked, while the thermometer in Buffalo was below zero. My explanation is that in Florida, at the time the oranges were loaded, it must have been a very hot day; the doors of the car were open so that the car became heated to that temperature; then the

oranges were placed in it and the doors tightly shut. Thus the car was practically an oven, and most of the oranges were ruined. In future, when we are drawing fruit from a southern climate to a northern one, in the winter, the ventilation will have to be regulated so as to let the cool air in down in Florida and shut the cold air out up here in Buffalo. Some refrigerator cars came from Baltimore, containing bananas, with ice doors open when they began the journey. Some one closed the ice doors en route. When they got here the bananas were baked. The thermometer stood at 148 degrees in those cars. We are settling the claim now."

This car-door fastener has been placed on the market by the J. S. Toppan Company, Great Northern Building, Chicago.

EFFECT OF SPICING AND RIVETING.

Extracts from a paper read before the Western Society of Engineers by Mr. Geo. S. Morison, describing tests on riveted connections.

Four bars of soft steel were constructed by the American Bridge Company at its Pencoyd works, two of which were solid bars and two of which were cut in the center and spliced. In both of the spliced bars the holes were reamed. In one of them the splices were riveted on, and in the other they were fastened with close fitting turned bolts. The bars were all made of the same steel. These four bars were all broken in the Government testing machine at the U. S. Arsenal at Watertown, Mass., in January, 1901.

The solid bars broke in the body of the bar under strains averaging 56,915 lbs. per square inch, one of them showing a total elongation of 14.7 per cent. and a reduction of area at fracture of 53.5 per cent., and the other a total elongation of 18 per cent. and a reduction of area at fracture of 54.7 per cent. Each of the spliced bars broke in the rivet or bolt hole nearest to one of the heads, and showed comparatively small elongation but a large reduction at point of fracture, the elongation being respectively 3.6 and 3.7 per cent., and the reductions 45.6 and 43.5 per cent. The metal showed signs of overstraining and had begun to draw down opposite the rivet or bolt at the other end of the splice. All this was to be expected, as the full strain was taken here on the section of the bar reduced by the hole. The net section of the riveted bar at the rivet holes, which were 0.94 in. in diameter, was 76.5 per cent. of the full section of the bar. The net section of the bolted bar at the bolt holes, which were 0.87 in. in diameter, was 78.25 per cent. of the full section of the bar.

The mean ultimate strength of the spliced bars was 46,870 lbs. measured on the original section of the unspliced bar, or 82 per cent. of the mean ultimate strength of the solid bars. The mean elastic limit of the unspliced bars, according to the official reports, was 28,500 lbs., and that of the only spliced bar reported (the riveted bar) was 25,000 lbs., or 88 per cent. of that of the solid bars. A study of the elongations as plotted would seem to indicate that the yield point of the solid bars was practically 30,000 lbs., and of the spliced bars 26,000 lbs., or 87 per cent. that of the solid. All unit stresses are referred to the original section of the bar without allowance for reduction by holes or increase by metal in splices. But the average section of the spliced bars at the hole where the fracture occurred was 23 per cent. less than that of the solid bar, so that the actual stress per square inch where the fracture occurred was 6.4 per cent. more in the spliced bar than in the solid bar. The yield point was about 12 per cent. greater. This result is in accordance with those obtained in testing short specimens of ductile metal as compared with specimens of sufficient length to allow full contraction to occur. On the other hand, the form of these test bars allowed a considerable contraction to occur at the rivet or bolt hole where they broke.

The ultimate strength of the spliced bars was about 18 per cent. and the elastic limit about 12 per cent. less than that of the solid bars.

A study of the plotted elongations shows that below a stress of 26,000 lbs. per square inch, the elongations of the riveted bar were a little less than that of the solid bars, this difference

evidently being due to the relief in the center of the bar given by the increased section of the splices.

A study of the plotted curves shows some instructive general results. Up to a 26,000-lb. stress the action of all the bars was practically the same, and if we exclude the bolted bar, the action may be said to be identical. After passing the yield point the action of the bars was practically the same until an elongation of 2 ins., or 1.25 per cent. of the gauged length, was reached. Above this the elongation of the spliced bars was considerably less than that of the solid bars, the difference being due to the larger section of the spliced portion of the bar.

In spite of the reductions in the elastic limit and ultimate strength, the action of the spliced bars was identical with the unspliced bars under all stresses which would be considered within permissible working limits on an actual structure.

On the basis of behavior under working stresses we should be justified in working the spliced bar up to the gross strain that we should put on a solid bar. On the basis of elastic limit we should be justified in working the spliced bar up to seven-eighths the gross strain we should put on a solid bar. On the basis of ultimate strength we should be justified in working the spliced bar up to nearly five-sixths the gross strain we should put on a solid bar. On the basis of net sections, after deducting for rivet or bolt holes, we should be justified in working the spliced bar up to a unit stress from 6 to 11 per cent. greater than we should put on a solid bar.

THE BULLOCK-WAGNER PAN-AMERICAN EXHIBIT.

Visitors to the electrical building of the Pan-American Exposition are attracted to a splendidly arranged exhibit of the products of the Bullock and Wagner Manufacturing Companies, by a brilliant electric sign surmounting a heavy wooden background enameled in white and gold. In the center of the sign is reproduced the Bullock shield with the words Wagner on one side and Electric on the other, flashed by incandescent lights of four different colors on each side of the sign. The exhibits of the two companies are in two distinct sections, with the machines mounted on wooden pedestals. Nine different types of direct-current motors and controllers form the Bullock company's portion of the exhibit. Of these there are two generators of 150 and 25-kw. capacity, a 30-kw. belted generator, and motors of 50, 45, 20, 10, 9 and 2 h.p. Each of these machines has several particular advantages. The motors are built with either open or closed ends and may be belted or geared. They are designed to be placed either on the floor, ceiling or wall. The printing press controller is equipped with a hand wheel, the movement of which gives all speeds from full to an inch at a time.

The Wagner exhibit consists of single-phase alternating-current motors, transformers and switchboard panels equipped with voltmeters, ammeters, wattmeters and all switchboard instruments. These panels, of which there are four, form the middle lower part of the background of the exhibit. The three alternating-current motors have capacities as follows: 30-h.p., 208 volts; 5-h.p., 140 volts, and 2-h.p., 140 volts., and are all single-phase, 60-cycle, self-starting machines.

A centrifugal governor changes the armature connections when a certain speed is reached. Of the large number of transformers exhibited there is one 175-kw., with 18,500-volt primary and 1,100-volt secondary. This is one of a lot of 25 transformers built for the McCloud River Electric Power Company, of Washington, for which the Bullock and Wagner companies have the entire electrical contract. They show a 100-kw. transformer that is a new type of machine, having the air-blast inlet and exhaust in the base. There are also exhibited transformers from 25 to 1½-kw. capacity that are of the self-cooling type. These are all filled with oil, except the 1½-kw. transformer, which is filled with a solid insulating compound that the company finds is a more rapid conductor of heat than an air chamber around the coils.

NEW COMBINED PLANING, MATCHING AND JOINTING MACHINE.

A heavy six-roll, double-cylinder planing and matching machine has just been placed on the market by the J. A. Fay & Egan Company. This is the largest and heaviest combined planer and matcher made by this company and is especially adapted for railroad car and repair shops and planing mills. It will plane material 30 ins. wide, 14 ins. thick and will work simultaneously three sides of two pieces of material of uneven thickness up to 12 ins. wide and 14 ins. thick. The frame of the machine is massive, perfectly jointed and bolted to insure rigidity. The cylinders are made from solid forged steel and slotted on all faces. The matching devices are very substantial and

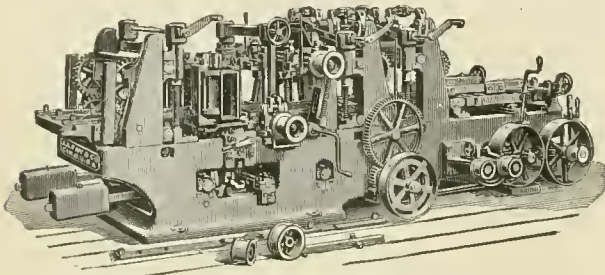

Double-Cylinder Planing and Matching Machine.

are fitted with a patent weighted matcher clip for working cross-grained and knotty lumber. This assures more rapid and accurate work. The feed rolls are eight inches in diameter, connected by a train of heavy expansion gearing with double links, heavily weighted. In the construction of the machine are embodied many devices of convenience for doing work in the most accurate and rapid manner. The builders will furnish upon application any information regarding this or any other of their special car shop wood-working machinery, and will also send free of charge their illustrated poster. The address of the J. A. Fay & Egan Company is No. 409 W. Front street, Cincinnati, Ohio.

BURNISHING CAR JOURNALS.

For a time there seemed to be but one opinion, and that favorable, concerning the advisability of burnishing or rolling the journals of car axles. At the recent M. C. B. convention the following conflicting opinions were expressed:

Mr. D. F. Crawford, of the Pennsylvania, said: "The rolling of journals has proven very advantageous, particularly in reducing materially, and in fact almost entirely eliminating, the trouble with hot boxes under new cars which are built at our own shops. In addition it has very materially reduced the number of hot journals under new cars built at outside shops, where the journals have been rolled we have had no trouble in loading the cars at once to their marked capacity, plus the usual 10 per cent. The advantages thus derived are so great that it would seem that if other roads have derived similar advantages, it might be well to have the rolled journals adopted as standard recommended practice, so that individual companies, as well as smaller railroad companies, having their cars built at outside shops, would insist on having the journals under their cars rolled, thus obviating the troubles from hot journals and loading under the capacity which has been found in the past."

Mr. Brazier, of the New York Central, stated that that road does not use the

rolling process; the journals are put into high speed lathes and polished with emery.

The opinion of Mr. Canfield, of the Philadelphia and Reading, was adverse. He said: "We do not think it is good practice to use the roller. The object of using it is to smooth the journal and roll down any particles of the iron or steel that may be standing up. It does that and would be all right if the journal always continued rolling in the same direction. But the minute you reverse the motion of the car and start it to roll the other way these particles are liable to be cut in the brass and give you trouble."

Mr. Hennessey, of the Chicago, Milwaukee & St. Paul, approved the practice: "We have had some experience in the use of rollers. We have built our equipment with exception of 500 cars, and for the last ten years rolled all the journals without any additional cost to the company. While doing the wheel fit we rolled the journal at the same time. We have had a large number of cars taken from the works and loaded them at once to half their capacity. We sometimes take the cars to the coal yards and load them to their full capacity. In something over 20,000 cars rolled we have never had one cut journal and the number of journals removed has not been worth considering."

A new process of finishing journals, that of grinding, has been recently offered and it seems to have important advantages over the rolling. It insures perfect roundness of the journals and it does not appear to be important which way they turn. Many of our readers saw the exhibit of piston rods and crank pins by the Norton Grinding Company at Saratoga.

A NEW GENERATING SET.

Within the past ten years the necessity of equipping large fans with means of driving other than by belt, has led to the design and manufacture of a line of distinctively fan engines. The rapid increase in the use of electricity as a motive power has also opened the way for the electric fan motor. Engines, generators and motors have been developed under the exacting conditions usually incident to fan practice, namely,

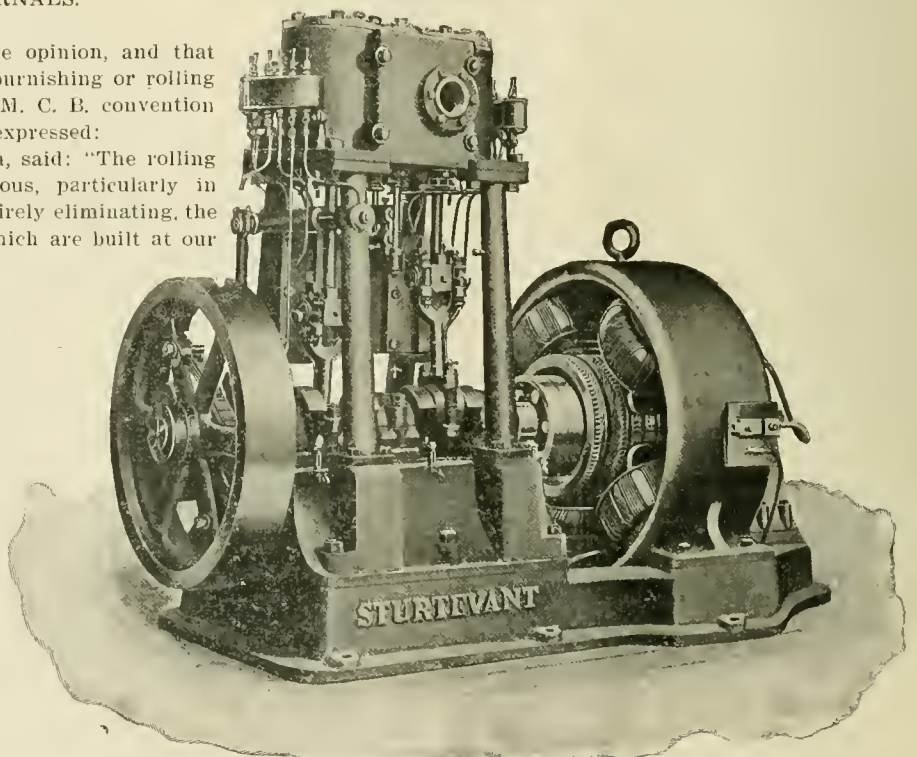

Double-Cylinder Upright Engine and Standard Generator.

high speed and constant operation requiring comparatively little attention. With these principles of a perfected generating set at hand it has been a relatively simple matter to combine them in a large line of many sizes, ranging from 1½ to 100 kilowatts.

One of the latest products of the B. F. Sturtevant Company, Boston, Mass., is illustrated in the accompanying engraving. It represents a double cylinder open type vertical engine and a 4-pole generator, both mounted upon the same bed. The engine is provided with three main journal bearings, the lower halves of which are brass bushed and provided with continuous oiling devices in connection with oil reservoirs beneath. The upright columns carry the single cylinder casting, which includes the two cylinders. Two piston valves are operated in unison by a single rocker and yoke, each regulating the admission of steam to one cylinder. They are fitted with snap rings and travel in removable bushings; the regulator is of the same general form as that used upon other types of upright engines. The cross heads are of the slipper type with projecting cross-head pins and the connecting rods have yoked cross-head ends. Both connecting rods and cross heads are of forged steel. These engines are built in sizes 8 x 5½ ins. and 9 x 5½ ins., having a rating of 47.5 and 60 h.p. respectively, and in material and workmanship are of the highest grade.

The generator is of the standard Sturtevant construction having the field cores cast on to the magnet steel frame. The bearings are of the ball-and-socket type and the armature of the barrel toothed drum type. The commutator consists of segments of pure copper secured between cast-iron flanges of spider construction which allow free circulation of air. All machines are fitted with carbon brushes mounted in holders of the sliding socket type. Each machine before being shipped is given a full load test for sufficient time to bring every part to maximum temperature, which does not exceed 40 degs. Cent. and is guaranteed to carry full rated load for ten hours without sparking at the brushes or overheating.

PERSONALS.

Mr. George H. Bussing has been appointed Master Car Builder of the Evansville & Terre Haute, with headquarters at Evansville, Ind.

Mr. Wm. J. Knox has resigned as Chief Draftsman of the Union Pacific, at Omaha, Neb., to accept a position with the Pittsburg Locomotive Works.

Mr. P. T. Dunlop, heretofore General Foreman of the Santa Fe shops at Newton, Kan., has been appointed Master Mechanic of the Gulf, Colorado & Santa Fe at Temple, Tex.

Mr. George B. Reeve, Second Vice-President and General Manager of the Grand Trunk, was elected President of the Atlantic & St. Lawrence Railway at a recent meeting of the directors of that road.

Mr. Grant Hall has been appointed Master Mechanic of the Pacific Division of the Canadian Pacific, with headquarters at Revelstoke, succeeding Mr. F. E. Hobbs, transferred to the Vancouver shops as General Foreman.

Mr. R. V. Wright, who was formerly with the Chicago Great Western at St. Paul, Minn., has been appointed Mechanical Engineer of the Pittsburg & Lake Erie, with headquarters at Pittsburg, Pa., to succeed Mr. J. H. Mitchell.

Mr. W. S. Lawless, for a number of years Foreman of water service of the Atchison, Topeka & Santa Fe, has been appointed General Foreman of the shops of that road at Topeka, Kan., in the place of Mr. F. P. Hickey, resigned.

Mr. Grant W. Lillie has resigned his position in the office of Superintendent Naval Constructor, at Newport News Ship

Building & Dry Dock Co., to accept the position of Chief Draftsman of the Oregon Short Line in the place of Mr. W. C. Halstead, resigned.

Mr. William Gell has been appointed Locomotive Foreman of the Grand Trunk at Sarnia Tunnel, to succeed Mr. W. Kennedy, who has been made Master Mechanic at Montreal in the place of Mr. J. E. Muhlfeld, who recently accepted a position with the American Locomotive Company.

Mr. R. P. C. Sanderson, formerly Assistant Superintendent of Machinery of the Atchison, Topeka & Santa Fe, has been appointed General Purchasing Agent of the Seaboard Air Line, vice Mr. E. Belknap resigned to engaged in private business. Mr. Sanderson has had a wide and valuable experience on the Norfolk & Western and Atchison, Topeka & Santa Fe Railways. He will have headquarters at Portsmouth, Va.

Prof. Arthur L. Rice, in charge of the courses in mechanics and applied electricity at Pratt Institute, has resigned his duties at that school to become assistant to the secretary of the American Society of Mechanical Engineers. Mr. Rice is a graduate from Worcester Polytechnic Institute, in the class of 1891, and took several years of post-graduate work in electricity at this school and at Cornell. He will have charge of the development of the Society's library, its employment bureau and arrangements for the winter reunions, besides relieving the secretary of routine duties.

BOOKS AND PAMPHLETS.

Index of the American Railway Master Mechanics' Association Proceedings, from Vol. I. to Vol. XXXIII., inclusive. Compiled by George L. Fowler, M. E. Under the direction of F. A. Deiano, S. P. Bush, C. M. Mendenhall, Committee. Price, \$1. (Apply to Jos. W. Taylor, Secretary, The Rookery Building, Chicago.)

This, the first complete index of the proceedings of this association, is a very satisfactory production which will be appreciated by all who have occasion to refer to the records of this organization, which constitute a technical history of the progress of the locomotive and the mechanical departments of American railroads. Its chief value comes from the fact that it renders available in convenient form the entire records and what was impossible before, a study of the whole history of some particular practice, is now made not only possible but easy. By following in general the plans of the indexes of the engineering societies the committee did wisely and Mr. Fowler's compilation is done well. It is impossible perhaps to please everybody in a work of this kind, but the faults are such as may be easily remedied in future editions. The association is congratulated upon having the index and upon having such a good one. It contains 206 pages and is bound like the published proceedings. The price is \$1.09 by mail.

Royal Wood Preserver.—This illustrated pamphlet, just issued by the Royal Wood Preserver Company, contains a short description of the cause and prevention of wood decay, together with other interesting matter regarding the treatment of wood. In railway service this preservative is used on stock, refrigerator and flat cars; railroad ties, trestle works, telegraph poles and cross arms; bridge timbers, piling, flooring and all wood-work above or below ground, in water or exposed to moisture or poor ventilation. It is self-penetrating and requires no skilled labor for its application, as this is accomplished by the use of a brush or by immersing the wood. A prominent feature of the pamphlet lies in the large number of photographic reproductions of strong testimonials, as to the merits of Royal Wood Preserver. These testimonials are from prominent firms whose knowledge is based on long continued use of this preservative. Those who use wood and are interested in lengthening its durability will find this pamphlet both valuable and interesting, and can procure a copy by addressing the Royal Wood Preserver Company, St. Louis, Mo.

Valves.—A small pamphlet has just been issued by the Homestead Valve Manufacturing Company, of Pittsburgh, Pa., describing the principal features of their locomotive blow-off, three-way, four-way and Homestead Junior valves, designed to meet every requirement of high pressure service. A brief description of how these valves operate is also embodied in the catalogue and a number of valuable testimonials from prominent firms using the Homestead valves.

A map of the Pan-American Exposition has been issued by the Westinghouse Companies, in which particular attention is directed to their exhibits. It is the best map of the grounds we have seen, and those who have not yet visited the exposition should send to the Westinghouse Company's Publication Department, Pittsburgh, Pa., for a copy.

The Knecht friction sensitive drill press is described in a small pamphlet issued by the Knecht Brothers Co., Cincinnati, Ohio. In a press of this kind, where the speed of the working tool changes in such short intervals, it is important to have the speed-controlling medium instantaneous and precise in its action. This feature, together with the driving mechanism, adjustable tension device and the simplicity and convenience of this press, are some of its points of excellence. The pamphlet also contains very favorable testimonials from railway and manufacturing companies.

Elevators and Conveyors.—A general idea of the very complete line of conveying machinery built by the Jeffrey Manufacturing Company can be gained from their little pamphlet No. 63, which has just been issued. The book is, with the exception of some short explanatory headings, a pictorial pamphlet giving photographic views of this company's elevators and conveyors in actual use; also a variety of buckets and screens for handling material of all kinds. Those who are interested in any particular line of these conveyors may procure the general descriptive catalogue by writing to the Jeffrey Manufacturing Company, Columbus, Ohio.

Carborundum.—The Carborundum Company, of Niagara Falls, N. Y., has sent a catalogue of 64 pages, containing a lecture on "The Manufacture and Development of Carborundum at Niagara Falls," delivered by Francis A. Fitzgerald, December 11, 1896, before the Franklin Institute. The pamphlet also gives additional notes on this company's products, including the characteristics of carborundum for grinding and polishing, the safety of such wheels, and their selection for high efficiency. A large list of working drawings of special wheels for well-known grinding machines are also included in the catalogue, together with a varied list of specialties, such as carborundum cloth, sharpening sticks and stones.

Bettendorf I-Beam Bolsters.—This catalogue illustrates several varieties of construction to which the Bettendorf I-beam bolster is adapted. These bolsters being made of standard I-beam sections, can be tapered to any required form to suit the standard trucks of any railway company. Particular attention is directed in this book to the construction and to the resistance which the parts of these bolsters offer in wrecks. No dependence is placed upon the rivets or connections to carry the load, as the I-beams are figured to be strong enough and are subjected to a central vertical load in a testing press sufficient to give 1 in. permanent set without any appreciable collapse at the ends. In the back of the catalogue are illustrated quite a number of photographic views and detail working drawings of various capacities of the Bettendorf double I-beam bolsters that are now in service on some of the principal railroads. This catalogue may be procured by writing to the Chicago office of the Bettendorf Axle Company, 1590 Old Colony Building, Chicago, Ill.

The Lowell Textile School catalogue for 1901-1902 presents an account of the very creditable work that is being done in that institution. The book gives a description of the five regular diploma courses offered in the theory and practical art of manufacturing all fibers known to the textile industry, also six different courses for evening students in which they can complete a thorough technical education without interfering with their daily duties. There is a woman's department, where the natural refinements of taste and skill of woman are brought out to excellent advantage in decorative art and textile design; also a commercial department for those contemplating a commercial career. The entrance qualifications of the school as given in the catalogue are low enough to admit anybody who has had an ordinary grammar school training. This school aims to aid those of the so-called "working classes" who desire to advance through the sacrifice of their otherwise spare time.

Industrial Opportunities.—This book, of 300 pages, issued by the Industrial Department of the Delaware, Lackawanna & Western Railroad, treats of all the towns on the lines of that

road, showing the population, distance from New York and from Buffalo, the leading industries, the shipping facilities, rate of taxation, cost of labor, source and price of power, value of lands suitable for manufacturing sites, and all special inducements for the location of industries along these lines. The aim of this work is not only to be of valuable assistance to manufacturers, but through the location of new industries to expand and broaden the cities and towns. Copies of the book will be forwarded on application to Mr. W. B. Hunter, Industrial Agent of the Lackawanna Railroad, at 26 Exchange Place, New York.

EQUIPMENT AND MANUFACTURING NOTES.

The Barber trucks will be used under the following new equipment: One thousand box cars to be built by the Chicago, Milwaukee & St. Paul Railway at their West Milwaukee shops; 1,000 cars to be built by the Pressed Steel Car Company for the Erie Railroad; 1,100 box cars to be built by the American Car & Foundry Company for the Delaware, Lackawanna & Western Railroad, and 10 sets for locomotive tenders now being built by the American Locomotive Works at Richmond for the Baltimore & Ohio Railway.

Mr. W. H. Bryan, of St. Louis, with offices in the Lincoln Trust Building, has been retained as Consulting Engineer by the Shickle, Harrison & Howard Iron Company of that city. Mr. Bryan is a graduate of the Washington University, and an expert in electrical and mechanical engineering. The Shickle, Harrison & Howard Company are to be congratulated on securing the services of Mr. Bryan.

The Titan throttle valve, illustrated on page 259 of our August number, may be seen at the exhibit of the manufacturers, the Wm. Powell Company, of Cincinnati, at their exhibit in the machinery building at the Pan-American Exposition at Buffalo. This company also exhibits lubricators and a large number of other steam specialties.

The Chicago Grain Door Company has recently received a large number of orders for grain door equipment, including the following: Chicago Great Western, 800 box cars; Intercolonial of Canada, 800 cars; Illinois Central, 1,300 cars; Norfolk & Western, 250 cars; Chesapeake & Ohio, 300 cars; Canadian Northern, 600 cars, and Chicago, Milwaukee & St. Paul, 2,000 cars, together with 5,000 Security Lock Brackets used in connection with outside doors.

Another foreign shipment of steel cars left Pittsburg August 9 from the works of the Pressed Steel Car Company. This time the destination of the cars is Durban, Natal, South Africa, where they will be turned over to the Zululand Railway. The shipment consists of 10 flat cars of 50,000 lbs. capacity, and is an exact duplicate of a shipment made some time ago to the same railroad. The cars are 32 ft. long, 8 ft. wide and 3 ft. 3/4 ins. high. This is the third shipment of cars to South Africa made by the Pressed Steel Car Company within the last six months.

In the exhibit of the Buckeye Malleable Iron & Coupler Company at the Pan-American Exposition is included one of their new "Major" couplers, which are nearly ready for the market. This coupler has a very interesting lock, lock set and knuckle opener, all in one piece, which is entirely protected from external injury by being placed in a cavity inside the coupler head and operated by a chain passing through a hole in the top of the coupler. The lock has a wide bearing which covers the entire face of the knuckle arm at the lock bearing, which not only gives a secure lock, but also insures good wearing qualities. The coupler is strengthened by enlarging the pivot lugs and increasing the amount of wearing surface upon the inner face of the knuckle. This company also exhibits a draft gear and a new design for attaching the pocket straps to the coupler shank, whereby the shearing of rivets will be prevented. This gear has a spring capacity of 90,000 lbs. at each end and metal draft beams are used instead of wooden ones. The manufacturers will give a guarantee with this construction which should satisfy the purchaser.

SPECIAL PARTNER WANTED, with \$25,000, to join with a reliable man of experience in developing a foreign business in Mining and Railway Equipment Specialties. Address correspondence W. K., Room 50, 105 Hudson St., New York City.

AMERICAN ENGINEER AND RAILROAD JOURNAL.

OCTOBER, 1901.

CONTENTS.

ARTICLES ILLUSTRATED :	Page	Page
An Up-to-Date Round House ...	305	High-Speed Electric Car of the
Composite Hopper Coal Cars, 100,000 Pounds Capacity ...	310	Allgemeine Electricitats Ges- ellschaft of Berlin.....
Vauclain Consolidation Com- pound Atlantic Type Passen- ger Locomotive, C. M. & St. P. Ry.....	313	Extension of the Snoqualmie Falls Power Company's Instal- lation.....
Improved Sand Dryer and Bin for Locomotive Sand	315	Water Tubes in Fireboxes, Eng- lish Practice.....
A Tractive Power Chart.....	316	What Water Softening Will Do?
Improvement of Valve Gears by Use of the Indicator.....	320	The Demand for Railroad Men..
Consolidation Freight Locomo- tive.....	323	The Slide Rule.....
Large Capacity Draft Spring ...	321	Master Mechanics' Association Committees for 1901.....
New Flue Cutting Machine.....	325	Effect of Heat on Babbitt Metal.
A Well-Arranged Brass Foundry	327	A Waste-Heat Engine.....
Ten-Wheel Narrow-Gauge Pas- senger Locomotive.....	329	A Short-Sighted Policy as to Shop Machinery.....
New Friction Draft Gear.....	330	Air Fans for Cooling and Ventil- ating Passenger Cars
Force Feed Lubricating Pumps and Dash Pot Valves ...	331	George Westinghouse on Cheap Electrical Power for Railroads
Heavy Sill Planer, Matcher and Timber Dresser.....	332	Lunkeheimer Pan-American Exhibit.....
		332
EDITORIALS:		
ARTICLES NOT ILLUSTRATED :		American Engineer Tests.....
American Engineer Tests.....	303	Weight and Power in Locomo- tives
Suggestions for the Establish- ment of a Practical System of Tonnage Rating, by B. A. Worthington	308	The Four Cylinder Balanced Compound.....
A Systematic Plan of Appren- ticeship	309	Maintenance of Air-Brake Appa- ratus
		Systematic Treatment of the Apprenticeship Problem.....

AMERICAN ENGINEER TESTS.

Locomotive Draft Appliances.

Preliminary Discussion of Existing Information.

I.

Editor's Note.—This is the first of the series of articles upon the tests of locomotive draft appliances which Professor Goss, of Purdue University, has been engaged to conduct for the American Engineer and Railroad Journal. Their purpose is to bring the information on this subject up to date and supplement what has already been done in order to render it applicable to the very large locomotives of the present time. A number of the best authorities among prominent railroad motive power officers are acting in an advisory capacity and have approved the plans on which the work has already begun. They are in close touch with the undertaking and will co-operate in the effort to reach the desired results. The railroads represented include the Pennsylvania, New York Central, Lake Shore & Michigan Southern, Chesapeake & Ohio, Norfolk & Western, Chicago & Northwestern, "Burlington," Denver & Rio Grande and the Atchison, Topeka & Santa Fe. These are all actively represented by men who have given special attention to this subject, some of them for many years. The preliminary examination of existing data, Mr. H. H. Vaughan's able analysis of previous investigations and his research into "what we know and what we want to know," is the first material to be published. It will be followed by an opinion by Prof. Goss upon the proposed tests, by a report of the meeting of the railroad officers, held in Chicago last spring, a description of the apparatus to be used, a record of the preliminary experiments, a programme of the entire series of experiments, and

by observed data, with a final report, by Prof. Goss, upon the entire subject. The circumstances surrounding this undertaking, the interest shown in it by the railroads, and the careful plan, give promise of a final report which will be a classic. We invite criticism and suggestions, and shall leave nothing undone which can in any way contribute to success and save the railroads the expense and annoyance of the large amount of individual experimenting which they are now compelled to bear because of insufficient information on the subject.

In the June, 1900, number of the American Engineer was printed an article from the pen of Mr. H. H. Vaughan, in which the need for further and more exhaustive tests on front end arrangements was discussed. At the time this paper attracted but slight attention, but it nevertheless represented in a general way the ideas of a considerable number of men who have given this subject careful study. Probably no one would resent more quickly than the members of the Master Mechanics' Association committee of 1896 on that subject themselves a statement that the results they obtained were to be regarded as final, and granted this, it is questionable whether, outside of the firebox, there is really a more important feature in the design of a locomotive than the blast producing apparatus, or one from which money expended in determining its most economical form can be so readily recovered. The series of tests carried out by the Master Mechanics' Association had without doubt paid for themselves over and over again, even to the few roads that participated in their expense, by the saving made possible through more accurate knowledge of the principles involved in the action of the blast, and if any further improvement is possible, experiments to determine its form should certainly be made.

As an illustration of the importance of this subject, we might refer to the indicator diagrams published in the American Engineer in November, 1900, which were taken from the new Chicago & Northwestern engine No. 1,017. On some of these cards the back pressure is from 20 per cent. to 25 per cent. of the mean effective pressure, in other words from 16 per cent. to 20 per cent. of the total power developed by the engine is employed in creating the draft necessary for combustion. It is certainly true that even were this back pressure not required in order to obtain sufficient pressure at the nozzle there would always be some few pounds back pressure due to the impossibility of instantly emptying a cylinder of such a size at high speeds, but this necessary loss is small in comparison with that which actually takes place, amounting in one of the cards to as much as 300 horse-power. At the same time it must be distinctly understood that the use of the word loss in the preceding statement is somewhat in error. It is not a loss in the proper sense of the word. It requires a large amount of power to maintain the vacuum in the front end of an engine which is burning coal at the rate of 5,400 lbs. per hour, which is the approximate figure given in the article, and there is no reason to suppose that this instance is an example of inefficient construction. On the contrary we have good reason for stating that the blast arrangements of this engine are in accordance with the best-known practice at the present time. Still, as there is a large amount of work to be done the power absorbed is large and any saving that can be effected in it becomes important and well worth careful consideration. A concrete example of this kind is perhaps hardly required, as it simply serves to add evidence to prove what we can take as freely granted, the importance of any improvement that might be made in our present practice, and the question that now really requires an answer is, "In what direction should further tests be made to obtain greater efficiency in blast appliances?"

Before replying to this question we believe it advisable to answer it somewhat in the Scotch fashion, by an inquiry into what is already known. A great deal of good work has already been performed in experiments on blast nozzles and in this

three series of experiments stand out as pre-eminently reliable and thorough. The experiments carried out by the Master Mechanics' Association committee of 1894 on Exhaust Nozzles and Steam Passages and those of the committee of 1896 on the same subject are in a class by themselves, having been carried out on an actual locomotive on a testing plant, while the Hanover (German) experiments of 1894, described in a paper by Inspector Troske and published in the "American Engineer" in January and the succeeding months of 1896, will always take their place as a most elaborate and careful investigation of the relation between stacks and nozzles.

The report of these latter experiments was presented by Inspector Troske in the form of a paper and opens by a historical review of previous experiments by Clark, Zeuner, Nozo & Geoffroy, Prussman & Grove, all of which is most interesting and instructive reading, although it must be confessed a good deal of the instruction is derived from the demonstration of the erroneous conclusions that can be reached by reasoning from insufficient data or from experiments that do not in every way represent actual conditions. The Hanover experiments are not entirely free from this criticism, as they were not carried out on an actual locomotive, but on a special apparatus designed to give as closely as possible similar results, and to quote from the report "the different shapes of stacks that were investigated were frequently transferred afterward to locomotives under steam and made fast, when precisely the same results were obtained." This method of checking up results obtained on the test apparatus by subsequent transference to an actual locomotive is the guarantee of the reliability of the Hanover tests, and we shall later investigate to what extent these tests confirm or disagree with those carried out by the Master Mechanics' Association committee on actual locomotives on testing plants.

There are two very important points of difference between experiments carried out on a locomotive and on any apparatus to which atmospheric air is admitted, caused by the generally high temperature of the smokebox gases. This may be taken as running from 800 degs. to 1,000 degs. and rarely as low as 600 degs. At these temperatures the weight per cubic foot is about one-third of the weight of the same gases at atmospheric temperature. We should expect from this cause alone that the action of a jet of steam would vary considerably under the two conditions, and without evidence to the contrary should certainly not consider it wise to base any conclusions on smokebox efficiencies on results obtained by apparatus in which atmospheric air is employed. Even should the results be the same in one set of conditions there is no assurance that they would be in others and while we shall refer to this subject later with reference to Troske's report, it certainly is of sufficient importance to demonstrate the advantages of experiments made on a test plant.

A second effect of the temperature of the smokebox gases is their influence on the condensation of the jet. Under ordinary conditions on a locomotive it is almost certain that no condensation of the exhaust jet takes place until after leaving the top of the stack. In fact any admixture with the smokebox gases would tend to superheat the steam in place of cooling it, and this effect is always visible at the stack of an engine in operation, where no steam is visible for several inches from the top of the stack even on the dampest day. In the Hanover experiments in which air was admitted at ordinary temperatures a very different state of affairs was experienced. To quote from the report—"when the apparatus was in blast, the stack emitted the hot condensation of the steam, while showers of water prevailed all about." From this it would appear that considerable condensation took place. In placing dependence on the Hanover experiments, therefore, it must be remembered that this influence might possibly render the results somewhat unreliable as applied to locomotive work, although its extent would very probably be small when the nozzle position was close to the stack and become of greater importance as the

distance was increased. In spite of these conditions the Hanover experiments are of considerable importance, especially so far as the shape of the stacks is concerned, and they constitute a most valuable addition to the Master Mechanics' Association series of tests.

The Master Mechanics' Association experiments of 1894, which were completed at about the same time as the Hanover tests, are valuable more from their influence and the suggestions they aroused than from any definite information which was obtained from them, although with the exception of the Hanover experiments, which had not at that time, we believe, been published in America, they furnished the first reliable demonstration of the increased efficiency obtained from the lowering of the exhaust nozzle. Owing to the apparatus used not having sufficient capacity for variation, the full investigation of this feature could not be made, but enough was done to justify the more extensive experiments of 1896 and to serve as a confirmation of the results which had been obtained in this direction on many railroads.

Other variables experimented on in 1894 were the influence of the position of the choke in the exhaust pipe, the form and size of the stack, the angle of the exhaust jet and the most advantageous length of front end. The first three of these points were subsequently more elaborately investigated in 1896, and in view of this fact the 1894 results may be taken as being entirely superseded by the later experiments, but the remarkable influence of the length of the front end, which was the subject of only a few, not entirely conclusive, tests, to the best of our knowledge has not yet been determined and so far as current practice is concerned, the experiments do not seem to be confirmed by experience in service to a sufficient extent to make the results convincing.

The 1896 tests, apart from the information obtained, are also valuable from their proof that a steady flow of steam from the nozzle gave results in every way similar to the actual discharge when the engine is running, thus confirming the assumption made in carrying out the Hanover tests. Definite results were arrived at, determining the relative efficiency of single and double nozzles, the best position of the choke in the exhaust pipe, the proper form of nozzle tip, the variation in vacuum with the position of the nozzle and several forms of stacks, and the relation between size of nozzle and vacuum. The action and form of the steam jet were investigated and a series of tests on the modifying action of the petticoat pipe was carried out without leading to any satisfactory conclusion. In all, these experiments were most complete and satisfactory so far as they went and are without question the most valuable and convincing that have ever been carried out. The Hanover experiments, however, while simply directed to three variables, namely, size of nozzle, distance of nozzle from stack and form of stack, were far more elaborate with respect to these features than the tests of the Master Mechanics' Association, as no less than five sizes of nozzles and 18 different stacks were experimented on at varying nozzle distances, in many cases each of these stacks being tested with different lengths. It is therefore of great importance to compare these experiments with those of 1896, with a view to their mutual confirmation, as in case of their substantial agreement we should have command of an amount of information that would place the relations of stack and nozzle in a position that may be taken as definitely settled, while discrepancies would indicate the direction in which further investigation is desirable.

A considerable number of other experiments have been made from time to time on this subject, but while valuable in themselves and satisfactory so far as the particular object in view was concerned, they have not been carried out in a manner that permits of their use to determine what might be termed the present state of the art, and we believe that the three series of tests above mentioned constitute all the reliable information which has so far been obtained on this subject.

(To be continued.)

AN UP-TO-DATE ROUNDHOUSE.

Lake Shore & Michigan Southern,

At Collinwood, Ohio.

At Collinwood, near Cleveland, Ohio, the Lake Shore & Michigan Southern Railway has just put into service a new roundhouse plant which is noteworthy in the completeness of its appointments and furnishes exceptional facilities for dealing with locomotives at a division terminal. The roundhouse has 35 stalls, with provision for 15 more when required and it is understood that the whole plant may be doubled in capacity by the addition of another roundhouse if that becomes necessary. The accompanying drawings illustrate the track arrangement and location of the roundhouse, the shops connecting with it, the oil, coal, ash and sand handling facilities and the locker and toilet rooms for the men. Provision is made for

admirable equipment of drop pits and of piping for blowing off and washing out boilers. In the roundhouse there are five lines of piping reaching all the pits and located overhead in the roof framing. Toward the outside of the circle is a 1½-in. blower pipe with ¾-in. outlets reaching down between the pits, convenient to the front ends. Next in order is a 4-in. water pipe with 2½-in. branches at alternate spaces between the pits; inside of this is a 5-in. blow-off pipe over the domes of the engines with 2½-in. connections through which the steam may be blown down from the boilers into an underground reservoir near the roundhouse where it condenses and heats the water used for washing out and filling boilers. A 4-in. washout pipe has 2½-in. connections between alternate pits and the piping system is completed by a 1½-in. air pipe with ½-in. branches between alternate pits whereby all the engines may be reached. The locations of all these pipes may be seen in the sectional view of the building. It will be noted that the roof trusses and posts are of wood, this being done to

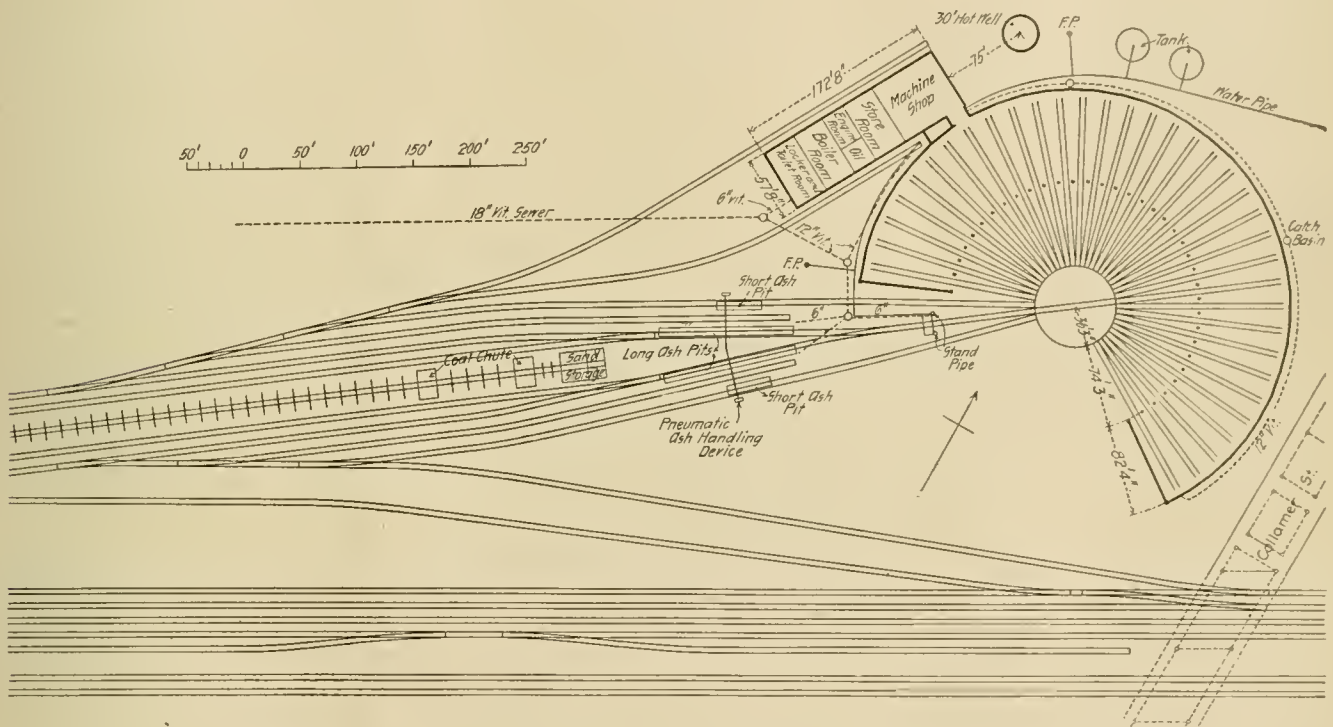

New Round House—Lake Shore & Michigan Southern Railway, at Collinwood, Ohio.

another complete roundhouse which will be placed so as to bring the machine shop and office between the two roundhouses. The chutes, ash pits and sand-house will then be duplicated.

A duplicate arrangement of tracks and ash pits provides for a congestion of the outside work and permits of taking coal, sand and water from either side of the coal chutes. Additional tracks are provided for reaching the roundhouse outside of those next to the chutes. Each of the ingoing tracks has a long ash pit sufficient for two engines and there are also two short pits for cleaning the ash pans of engines leaving the roundhouse after having remained there long enough to render cleaning necessary. At each pair of ash pits a pneumatic ash hoist is provided, one hoist serving a long and a short pit. The long pits will accommodate four engines at once, each of these pits being 120 ft. long. One of the objects of the plan is to permit of expeditious work at the terminal and the coaling, sanding and ash cleaning are progressive operations as the engines go to the house.

The turntable is 72 ft. in diameter and is driven by power. The roundhouse is one of the largest in diameter ever built. It is heated by the Sturtevant fan system and is provided with an

avoid the corrosion which would be destructive to metallic construction. A drain of 12-in. hard tile pipe encircles the building on the outside with a branch leading from the end of each pit under the wall of the building.

The shop building is entered direct from the roundhouse, with the office between the two buildings, the shop being reached by a track for coal, oil and material. At one end of the building is the machine shop, next to this is the storeroom and next the oil room, with two floors for a gravity system of supply. Even with the oil room is the engine room and beyond this the boiler room and coal storage, while the end of the building is devoted to a two-story locker room with 300 lockers for the engineers, firemen and shopmen, and the necessary toilet facilities.

Throughout, the plans provided for a reduction of the labor charges to the minimum and the treatment of the entire problem has been liberal, with a view of quick service in order to assist in securing the most favorable mileage of locomotives. One of the noteworthy features is the ash handling equipment with pneumatic hoists, so arranged as to be operated by one man and involving a small expense for masonry and superstructure. In this arrangement the locomotives may stand at

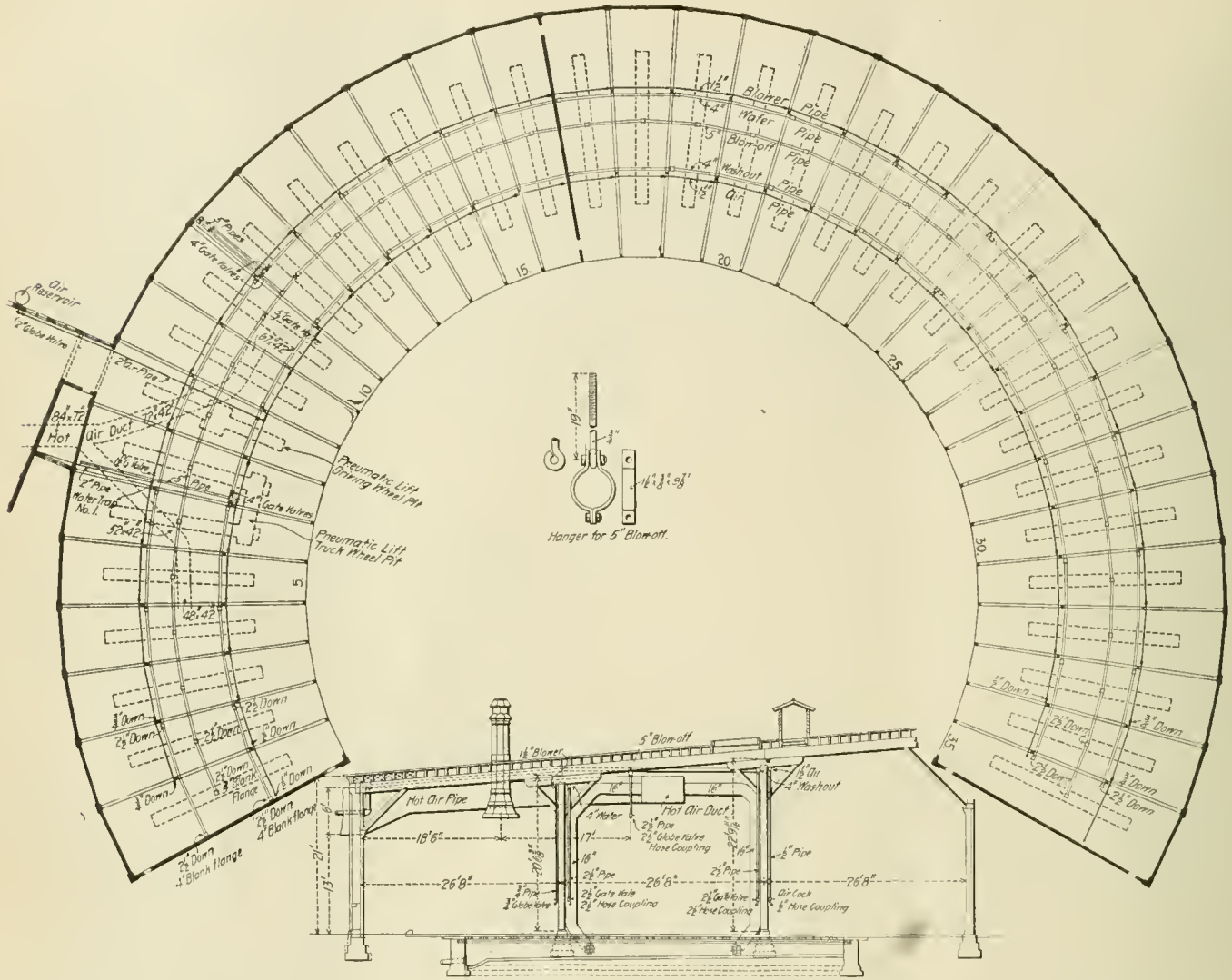

Plan and Section of House.

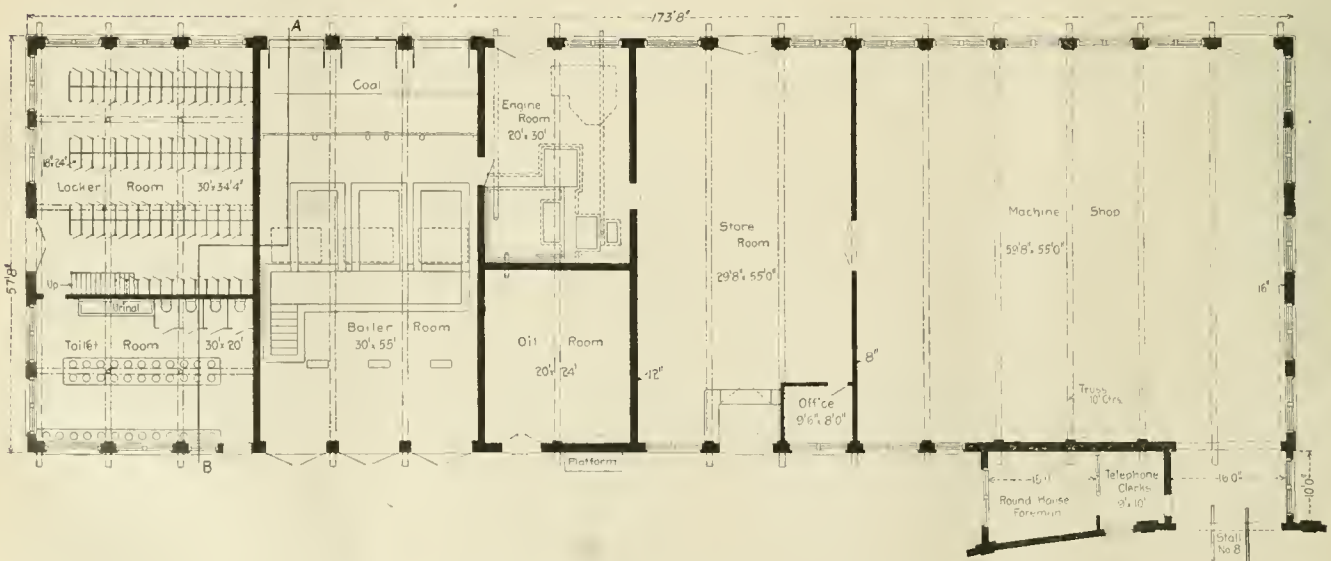

Plan of Machine Shop in Connection with Round House.

Collinwood Round House—Lake Shore & Michigan Southern Railway.

SUGGESTIONS FOR THE ESTABLISHMENT OF A PRACTICAL SYSTEM OF TONNAGE RATING.

By B. A. Worthington,

Division Superintendent, Southern Pacific Company.

Given a railroad of several divisions, moving a heavy volume of tonnage, on which it is desired to establish a practical system of tonnage rating that will produce the most economical results and that will be as free as possible of theoretical error arising from false assumptions, what is the best method of introducing such a system?

Make a check of the actual practice on each freight run to determine the best load that has been taken on both time and dead freight. Note particularly the speed over the limiting points on the run, so as to arrive at the engine piston speed, from which the traction can be closely calculated. By dividing the load into this traction the resistance can be approximately determined.

In a similar way the resistance can be determined at all points on the run without the use of a dynamometer car. It is essential that such a practical test should be made, as established resistance curves of recent years have been formulated from data obtained on track of very high standard; in fact, from particular sections of heavy rail and thoroughly ballasted track, such as the New York Central line between Albany and New York, from which I understand the "Engineering News" formula was derived. The resistance will vary according to the size of the rail and the conditions of the track, whether properly aligned, ballasted and well maintained.

To arrive at the value of momentum, Wellington's table No. 118 of "Velocity Heads," shown on pages 335 and 336 of his "Economic Theory of Railway Location," gives very accurate results which check out closely in practice.

To make the system applicable to different kinds and sizes of locomotive power, a unit of power should be established. For example, 1,000 lbs. of available locomotive traction to be considered one unit. By "available" locomotive traction I mean traction that can be utilized in service; in other words, traction that comes within the adhesive power of the engine. Then, as shown in the following paragraph, ascertain the load that can be taken at varying speeds over each section of track with one unit of power.

An "operating profile" should be constructed by checking over each section of track from the detailed track profiles, plotting the equivalent grades and velocity heads, making due allowance for resistance from curvature. The column of velocity heads will correspond to the vertical distance from which momentum alone can lift a train moving at any given velocity head against the force of gravity, and measures the work which has already been done in accelerating the train to a given speed. The method of making this operating profile is very clearly described in the "Bulletin of the American Railway Engineering and Maintenance of Way Association" for November, 1900. The equivalent profile will naturally modify the actual profile, velocity heads being plotted along the track and lines drawn joining these velocity heads, measuring the grades, the resistance from which equals the power consumed or acquired by change of speed or elevation. From these lines a table may be readily prepared showing the load that may be taken at different speeds with each unit of engine power. The question of constructive weight allowance for empty and underloaded cars should be carefully considered, as on gradient sections only the rolling and atmospheric resistance are greater per weight unit of empty cars than per weight unit of loaded cars.

With this data at hand, time lines can be readily prepared for rating purposes, but in making the operating profile it is important that no uniform assumptions should be made to apply to radically different conditions as to train lengths or as to the speed that can be attained in a given distance on gradient

sections after a start. Both of these points can be easily determined on each freight run from the check of the service suggested in the second paragraph.

With the foregoing data worked out, we are now required to make a rating on say a 120 mile freight run, with an eight-hour schedule. The first thing to be determined is the time required for stops, which necessarily must be deducted from the eight-hour schedule, as the remainder of the time really represents the work that must be performed by the locomotive. My experience teaches me that the time required for stops in actual service will vary from 25 to 30 seconds per mile on valley lines, to 2 minutes and 30 seconds on heavy grade lines, the variation being controlled by the physical characteristics of the track, the length of the sidings to hold long trains, the facilities for taking coal and water, the number of stops to be made, the method of handling train orders and the volume of tonnage moved in each direction.

Suppose we ascertain that two hours are needed for stops on the run in question, leaving six hours for actual running time. We further ascertain from the operating profile that 100 Ms of load (1 M equals 1,000 pounds) can be taken within the six hours' actual running time with each unit of engine traction, and by reference to the operating profile we make a time line for this load showing the speed in miles per hour and the number of minutes required between every two stations on the run, this information being furnished to the superintendent for his guidance in making the time card.

We next arrive at the units of power in the locomotives, which should be done by calculating the traction, limiting the traction, however, on heavy grade lines to one-fifth the driver weight and on valley lines to about 23 per cent. of the driver weight. The limit was placed at 25 per cent. on Southern Pacific lines, but is a trifle high and has a tendency to overload the engines. Suppose an engine has 20,000 lbs. of available traction, which equals 20 units. On the run in question the gross load would be twenty times the 100 Ms, or 2,000 Ms, but the net rating would be 2,000 Ms less the weight of the engine, tender and caboose, say about 1,750 Ms, which is the figure that would appear upon the rating sheet for the information of dispatchers and yardmasters.

Suitable tonnage manifest reports for conductors should be made, and suitable daily train reports for division officers should be made and sent to the general office daily, showing the train number, the freight run, the potential (required) ton mileage, the actual ton mileage, the percentage of efficiency that the actual bears to the potential, the actual running time and the total running time of the train, the character of the freight (whether time or dead freight) and explanation of variation in trainload from required rating and explanation of all delayed time.

In the general office suitable blanks should be prepared for keeping a daily record of performance on each freight run separately and a monthly report should be made and furnished each division superintendent, showing not only his performance, but the performance on all other divisions in comparison, in order that he may see what the others are doing, as this will enable him to know when he is dropping behind and tends to prompt him to keep up as high a standard of efficiency as possible.

The foregoing will give an idea of the system that has been worked out on the Pacific System lines of the Southern Pacific Company, the results from which for the fiscal year ending June 30th, 1901, during which time the tonnage rating system was under my charge, are shown by the following table.

The movement of 13 per cent. heavier volume of tonnage for 5 per cent. increase in locomotive and train mileage, with only 5.4 per cent. increase in the cost of conducting transportation, is certainly a very gratifying showing. The increase in the gross tons hauled per engine mile from 604 to 651 tons speaks for itself. When it is considered that this new system of tonnage rating is compared with a previous system that was in use for three years, the year 1900 being the best performance

in the history of the company, the full value of this new system may be better understood.

	Increase 1901 over 1900	1901.	1900.
1. Tons freight carried one mile, or revenue ton mileage	13.2 per cent.	3,401,942,407	3,001,456,642
2. Gross ton miles handled....	13.2 "	8,742,451,000	7,720,024,000
3. Freight locomotive miles....	5 "	13,434,986	12,790,358
4. Freight train miles.....	5 "	10,553,125	10,057,162
5. Total cost of conducting transportation	5.4 "	\$16,701,705	\$15,971,454
6 Per cent. conducting transportation to earnings.....		33.4	35.1
7. Conducting transportation per train mile.....		\$0.83	\$0.83
8. Earnings per freight train mile	8.5 "	\$3.05	\$2.81
9. Gross tons moved per engine mile.....	7.8 "	651	604
10. Average number cars per train	7.5 "	25.7	23.9
11. Tons freight per loaded car	2.3 "	17.57	17.18
12. Tons freight per locomotive mile	7.9 "	253.22	234.64
13. Tons freight per train.....	8 "	322.36	298.41

Anyone who has given the system of tonnage rating much thought or study will readily understand that it is impracticable to arrive at a mathematically exact system of engine rating, owing to the complexity of the conditions and constantly varying factors involved, which forces us to deal with approximations gained from the best obtainable data to be found and from our own experience. However perfect a theoretical system of tonnage rating may appear, when attempting to put it into practice many obstacles will necessarily be encountered, and the purpose of this article is simply to suggest to others a method for overcoming many of the obstacles which will be met. It is well to avoid all assumptions, as they necessarily lead to false conclusions. A check of the performance can be easily made and data that is more or less reliable can be obtained.

The foregoing is respectfully submitted in the hope that it will enable others to avoid the troublesome obstacles which we have had to overcome in establishing what seems to be the most practical system of tonnage rating in use in this country.

A SYSTEMATIC PLAN OF APPRENTICESHIP.

Baldwin Locomotive Works.

Mr. N. W. Sample, who is well known for his long service as Superintendent of Motive Power of the Denver & Rio Grande, has been placed in charge of the apprentices at the Baldwin Locomotive Works, and, since February last, has given them his entire attention. These works now employ 9,700 men, and with the completion of extensions to the plant the number will probably soon reach 12,000. Naturally such an establishment has always had apprentices. With about 90 per cent. piece-work conducted under a contract system, however, the boys did not have a fair chance and, as stated in the editorial columns of this issue, the results were far from satisfactory, and a systematic method of dealing with the problem of educating "all around" men seemed to be an absolute necessity.

The apprentices now number 750, of whom 115 are indentured under the new plan, which divides them into three classes, and the application blank indicates in the explanatory note requirements of these classes. Special prominence is given to educational qualifications in the first two classes, while a third class provides for the shop training of technical school graduates. Of the newly indentured apprentices 70 per cent. are in the first class and 15 per cent. in each of the others.

The usual legal form of indenture is followed for the first two classes. The first class requires four years' service and the age limit is placed so that the boys will finish at the age of 21 years. It is expressly stipulated that the apprentice must "faithfully attend at least two evenings in each week during the first three years of his apprenticeship, free night schools, such as during the first year will teach him elementary algebra and geometry and during the remaining two years will teach him the rudiments of mechanical drawing. * * * It

is understood that the apprentice already has a grammar-school education, or sufficient to render it unnecessary that any provision should be made for his further instruction."

The second class requires three years' service and requires advanced grammar or high school training, the upper age limit being 18 years. During the service the apprentice must "faithfully attend at least two evenings in each week during the first two years of his apprenticeship, free night schools which will teach him the rudiments of mechanical drawing."

APPRENTICE'S APPLICATION.

Burnham, Williams & Co.:

Gentlemen: I desire to become an apprentice in your employ, to learn the trade of.....
 I was.....years of age at my last birthday, which occurred on the.....day of.....19.....
 am sound in body, industrious and intelligent, having attended..... school, and have a knowledge of the following studies, viz.:

If my application is considered favorably, I am willing to be indentured for the necessary term of years.
 Respectfully yours,

Note.—Applications for indenture as first-class apprentices will be considered from boys who have had a good common school education, and are not over seventeen years and three months of age. The compensation for this class is five cents per hour, first year, seven cents per hour second year, nine cents per hour third year, and eleven cents per hour fourth year, with the further sum of \$125.00 at expiration of term of apprenticeship.

Applications for indenture as second-class apprentices will be considered from boys who have had an advanced grammar or high school training, and are not over eighteen years of age. The compensation for this class is seven cents per hour first year, nine cents per hour second year, and eleven cents per hour third year, with the further sum of \$100.00 at expiration of term of apprenticeship.

Applications for a special course of instruction, covering a period of two years, will be considered from young men over twenty-one years of age who are graduates of colleges, technical schools or scientific institutes. The compensation for this class is 13 cents per hour for the first year and 16 cents for the second.

All three classes are to be moved or changed in the shop, the first two classes every three months and the third class at their own request, subject to the approval of the superintendent. In order to arrange the moving system systematically and to keep a complete record of the work, the conduct and character of service of each, a blank form is used, a portion of which, the section for the first year, is reproduced here. These blanks, when completed, contain the record of each apprentice for his entire service, together with every foreman's opinion of him.

BALDWIN LOCOMOTIVE WORKS.

Apprentice Record.

Name....., Age.....years.....months.
 Address..... Class.....
 Date of indenture.....19..... Shop.....

First Year.					
Time.	Expires.	Em- ployed on.	Services were.	Rate per hour.	Sig. of Foreman.
1st 3 mos.
2d 3 mos.
3d 3 mos.
4th 3 mos.

Remarks.....

Note.—Apprentices will be changed from one machine or job to another once every three months. Apprentices must not be transferred from one department to another without consultation.

While not definitely stipulated, it is understood that the completion of the apprenticeship leaves the company free to offer further employment to all three classes or not, according to the need for men at the time. At this point the personal record is valuable, and it is obvious that if one who has taken the first or second grade has studied faithfully and made his value apparent he may even pass those of the third or technical class. At least there is nothing to prevent his doing so. It is generally understood that this is a possibility and that at the end of the training all apprentices will stand where their records place them.

It is too soon to say what the results will be, but whether it is an ideal system or not it is a system from which eventually a large number of thoroughly trained young men are looked for. It seems fair to expect that it will produce a large number of good men who are thoroughly imbued with the traditions and spirit of the works. One of its prominent features is that by which the problem receives the exclusive attention of a man with a wide and successful experience.

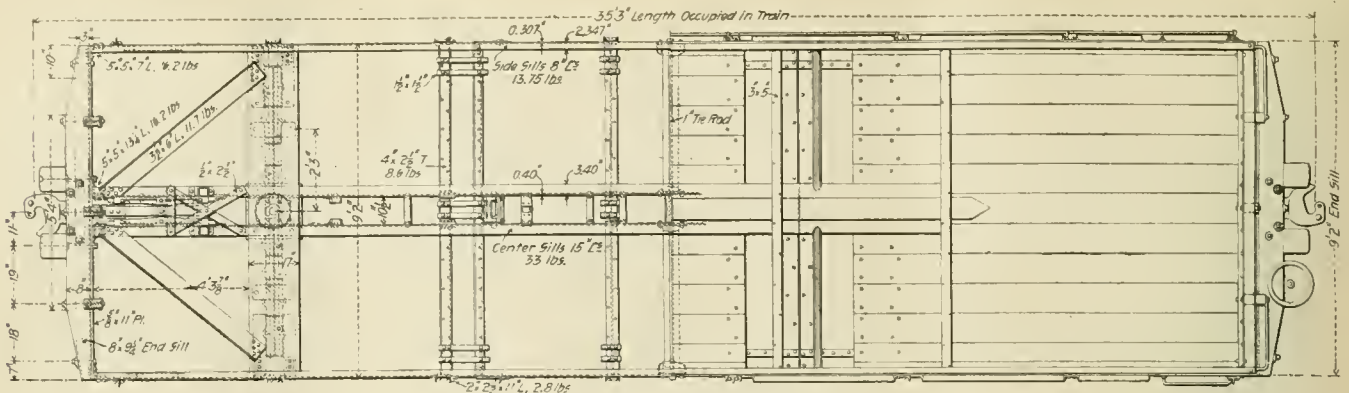

Plan View Showing Under Framing.

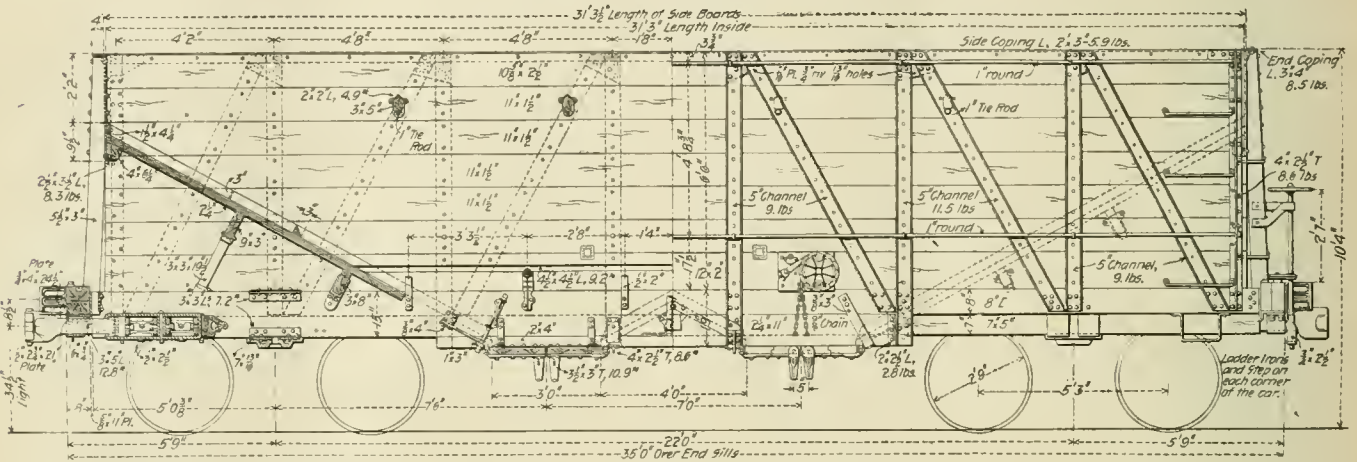

Half Longitudinal Section and Elevation.

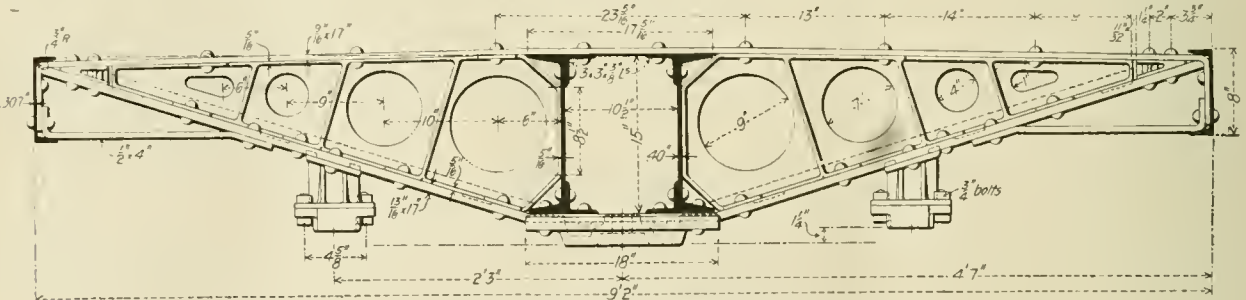

Showing Construction of Body Bolster.

100,000 Pounds Capacity Coal Cars—Louisville & Nashville Railway.

COMPOSITE HOPPER COAL CARS, 100,000 POUNDS CAPACITY.

Louisville & Nashville Railway.

Comment upon the influence upon the design of the cars developed and built last year on the Norfolk & Western (American Engineer, February, 1901, page 42) has already been made in these columns. These cars, designed by Mr. C. A. Seley, under the direction of Mr. W. H. Lewis, have been very successful and in every way have fulfilled what was expected of them. They embody steel underframes and trussed side frames of steel, with wooden hoppers, and the sides are utilized in carrying the loads with the result of securing a paying load of 74 per cent., the light weight of one of the cars being but 38,000 lbs. It is decidedly pleasing to receive the drawings of cars of similar capacity now being built on similar lines by the Louisville & Nashville Railroad at Louisville. The idea of the framing was taken from our illustrations of the Norfolk & Western car already referred to, and it was adapted in minor details to the special requirements of the L. & N. The details of the draft rigging are new, the castings being of malleable iron, which are nowhere more than 5 16 in. thick. Tandem springs

are used in connection with long malleable draft castings which are riveted to the webs of the center sills. Mr. F. A. Beckert, Mechanical Engineer of the road, who prepared the drawings under the direction of Mr. Pulaski Leeds, states that he considers the idea of the original design the best he has seen. The lumber market on the Louisville & Nashville is specially favorable to wooden construction wherever it can be used, as this line runs through the pine forests of Alabama and Georgia, and lumber is cheap with no transportation charges.

This car weighs 38,400 lbs., 400 lbs. more than that of the Norfolk & Western. Its cubical contents are 1,625 cu. ft. level full and 2,000 cu. ft. when heaped, which is about the same as the original design. This capacity is sufficient to provide for 110,000 lbs. of the lightest coal the cars will be called upon to carry.

In comparing the drawings of these two designs the use in both of 15-in. channels for center sills and 8-in. channels for side sills will be observed; also the channel sections and trusses of the side frames are alike, except as to small differences in the panel dimensions. The Louisville & Nashville car has T-iron corner posts and wide trussed doors, which are arranged in two sets with a small ridge between, instead of

having three sets of doors. Body bolsters of cars of this type must be strong, and in this detail also the construction of the Norfolk & Western has been followed. The body bolsters have 9/16 by 17-in. top members, 13/16 by 17-in. bottom members and malleable iron filling pieces extending the full length of the bolster from the center sills. The side sills are braced to the bottom members of the bolsters, as indicated in the drawings. It will be noted that the body side bearings are substantially supported by the malleable fillers. The general dimensions of the original design having been previously recorded, further description is not necessary.

In addition to 250 of these 50-ton cars this road is building 750 40-ton gondolas, weighing 34,800 lbs., and 100 40-ton flat cars weighing 28,000 lbs. For all of these cars the truck bolsters and spring planks are of cast steel. Parts of the trucks are alike for the 40 and 50-ton cars, except the axles.

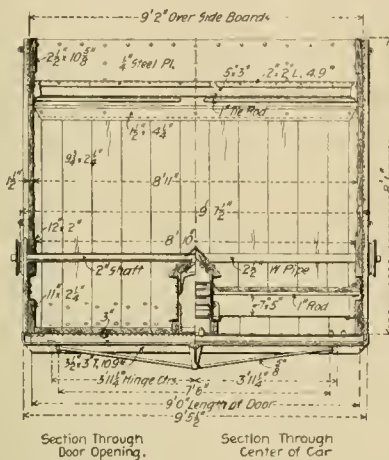

Transverse Section.

arch bars and bolsters, the trucks being the standard in use on this road.

HIGH-SPEED ELECTRIC CAR OF THE ALLGEMEINE ELECTRICITÄTS GESELLSCHAFT OF BERLIN.*

The car described in the paper is now finished, and, so far as trials and tests in the factory can give an indication of its behavior under working conditions, has answered all expectations. It was tested at a peripheral speed of the wheels of about 56 meters per second, corresponding to a car speed of 200 to 210 kilometers per hour.

The Studiengesellschaft was formed to study the technical and economical requirements of electric driving on long distance railroads. The maximum limit of speed for the trials determined upon was 200 km. an hour (124 miles). After careful consideration, it was decided to use an existing military line from Berlin to Zossen, placed by the German Military Department at the disposal of the Association. The paper relates to the construction and testing of the car, and to investigations and experiments in connection therewith. The running tests on the line will shortly commence.

The motors are attached to the car. Each car will accommodate about 50 passengers. The motors have in all a normal output of 1,000 horse-power, and a maximum output of 3,000 horse-power. The tests will show whether so much power is really necessary, and will indicate the consumption of power at different speeds, and under the influence of head or side winds.

For the working of long-distance railroads, the three-phase alternate current system could alone be considered. The gen-

eration and transmission of three-phase currents at from 40,000 to 50,000 volts pressure present no difficulty, but on the experimental line the pressure will be only 12,000 volts, the current being supplied from the central generating station of the Berlin Electricity Works, which is situated at a distance of 12½ km. from the commencement of the line. The length of the line is 24 km.

At present, transformers are placed on the car itself to transform the current down from 12,000 to 400 volts; but it is still undecided whether, in practice, it may not be better to use motors of medium voltage, say of 3,000 volts, taking the current at this pressure from the line, to which it is supplied through transformers placed in transformer houses at definite intervals along the track. In this case the transformers would reduce the pressure from 50,000 to 3,000 volts. It is well known that static transformers require no attendance as compared with rotary transformers.

The car is provided with a driver's platform at either end, from which the control is effected. All parts carrying current are placed in a special apparatus compartment, which is separated from the rest of the car by a double sheet-iron partition. The car body is carried by two bogies, each with three axles, of which the center is only a running axle, while each of the others carries a 250 horse-power motor, capable of developing a maximum of 750 horse-power. The diameter of the car wheels is 1,250 mm., and the speed about 960 r.p.m.

The weight of the electrical equipment was, in the first instance, not less than 50 tons for the required output of 3,000 horse-power, but, by modifying the construction of the starting apparatus, motors and transformers, the weight was reduced to 30 tons; but of this weight a large proportion was due to the transformers, which may possibly be dispensed with altogether hereafter.

The mechanical connection between the motors and the axles of the wheels was a matter of the greatest importance, the use of intermediate gearing being out of the question on account of wear and tear. Although from the first the object was to obtain an elastic coupling, various designs and devices were tried, in some of which the motor was rigidly attached to the axle, while in others springs were introduced. The designing of a spring attachment for use at about 1,000 r.p.m., and with an output of 750 horse-power per motor, was a difficult task. The problem was solved by connecting the motor to the wheel by an elastic coupling, and providing an elastic suspension for the motor, the springs being arranged so as to have increasing rigidity as the load increases. The motors are accordingly mounted on a hollow shaft, of which the surface speed in the bearings is nearly 15 m. per second.

Starting resistances for motors of 250 to 750 horse-power have already been used in practice, but the problem of arranging them in a confined space, for use in continuous current regulation in connection with a current of 4 x 750 horse-power, has never before been contemplated. The relative advantages of liquid and metal resistances were considered in detail. The use of the former at first seemed out of the question, while the latter involved the employment of a large number of contacts, brushes, connecting cables and resistance material, making them too heavy and cumbersome.

Four motors, each with three armature circuits, give a total of 12 phases, in each of which was inserted a resistance divided into 12 steps; but in spite of this sub-division, the regulation was found to be too jerky to be satisfactory. Ultimately a liquid starting device, that could be equally well used for large winding engines, was designed. The resistance material was a solution of soda, but the apparatus had nothing in common with the ordinary liquid starting resistance.

Taking into account the fact that a speed of 200 km. per hour was contemplated, it was arranged to provide, in addition to the Westinghouse air brake, an electrical brake which could be used either in connection with, or independently of, the source of current. The brake was so designed that it could be applied either gently or powerfully, at will.

*From a paper by O. Lasche, read before the International Engineering Congress, Glasgow.

VAUCLAIN CONSOLIDATION COMPOUND ATLANTIC TYPE PASSENGER LOCOMOTIVE—CHICAGO, MILWAUKEE & ST. PAUL RAILWAY.

A. E. MANCHESTER, *Superintendent Motive Power.*

BALDWIN LOCOMOTIVE WORKS, *Builders.*

Wheel: Driving.....	.84 in.;	Boiler pressure.....	200 lbs.	Trailers.....	51 in.
Weights: Total of engine.....	170,000 lbs.;	on drivers.....	90,000 lbs.;	tender wheels.....	38 in.
Grate area and tubes: Grate area.....	40 sq. ft.	Tubes.....	350-2 in.	total engine and tender.....	250,000 lbs.
Firebox: Length.....	8 ft. 6 in.;	width.....	5 ft. 5 in.	Depth in front.....	70 in.;
Boiler: type.....	Wagon top, radial staying.	Diameter.....	190 sq. ft.;	back.....	64 in.
Heating surface: Tubes.....	3,608 sq. ft.;	firebox.....	29 ft. 9 in.;	total.....	3,198 sq. ft.
Wheel base: Driving.....	7 ft. 3 in.;	total of engine.....	29 ft. 9 in.;	engine and tender.....	57 ft. 5½ in.
Tender: Eight-wheel;		water capacity.....	7,000 gals.;	coal capacity.....	9 tons.

For heavy passenger service the Chicago, Milwaukee & St. Paul has used VaucLain compounds of the Atlantic type for a number of years with marked success. Nine engines of the same type, with far greater power, are building at the Baldwin Locomotive Works. These are not far enough advanced to permit of showing a photograph, but the elevation drawing gives an excellent idea of their appearance. For comparison with the earlier engines the following figures are convenient and striking, because they indicate a large increase in capacity:

	No. 838.	New Class.
Heating surface.....	2,241 sq. ft.	3,198 sq. ft.
Total weight.....	140,700 lbs.	170,000 lbs.
Weight on drivers.....	71,600 lbs.	90,000 lbs.
Grate area.....	30 sq. ft.	40 sq. ft.
Cylinders.....	13 and 22 by 25 ins.	15 and 25 by 28 ins.
Drivers.....	78 ins.	84 ins.
Tubes, length.....	15 ft.	16 ft. 6 ins.
Boiler diameter.....	60 ins.	66 ins.
Tractive power.....	15,502 lbs.	20,400 lbs.

In weight on drivers, total weight, heating surface and grate area these engines are surpassed by the New York Central engines illustrated in our February issue, page 35, but the compound cylinders must be considered in comparing their power. With the increased heating surface and one-third larger grate area the boilers should be correspondingly more powerful than the earlier class on the St. Paul road, and excellent performance is expected. Without unduly lengthening the tubes, the large drivers have been accommodated by offsetting the front water leg of the firebox, as indicated in the elevation view. By forging the frames down behind the rear driving boxes the firebox is made 70 ins. deep in front and 64 ins. at the rear, with the mud ring level. We show the elevation and sections of the engine, longitudinal and cross-sections through the boiler, and a side elevation of the frames. The rear of the cab is made flush with the ends of the frames, and the back head of the boiler is vertical. Other details of the design are indicated in the following table:

General Dimensions.

Gauge.....	4 ft. 3½ ins.
Simple or compound.....	Compound
Fuel.....	Illinois soft coal
Weight on drivers.....	90,000 lbs.
Weight, total.....	170,000 lbs.
Weight, tender, loaded.....	120,000 lbs.
Note.—These weights are approximate.	
Wheel base, total of engine.....	27 ft. 11¼ ins.
Wheel base, driving.....	7 ft. 3 ins.
Wheel base, total, engine and tender.....	57 ft. 5½ ins.
Length over all, engine.....	45 ft. 11 ins.
Length over all, total, engine and tender.....	68 ft. 7 ins.
Height, center of boiler above rails.....	9 ft. 5½ ins.
Height of stack above rails.....	14 ft. 11 ins.
Heating surface, firebox.....	190 sq. ft.
Heating surface, tubes.....	3,608 sq. ft.
Heating surface, total.....	3,198 sq. ft.
Grate area.....	40 sq. ft.

Cylinders.

Cylinders, diameter.....	15 ins. and 25 ins.
Piston stroke.....	28 ins.
Piston rod, diameter.....	3¼ ins.
Kind of piston rod packing.....	United States Metallic
Main rod, length center to center.....	11 ft. 4 ins.
Steam ports, length.....	Circular, 34 ins.
Steam ports, width.....	1½ ins.
Exhaust ports, length.....	Circular, 34 ins.
Exhaust ports, width.....	4¼ ins.
Bridge, width.....	3¼ ins. and 3 ins.

Valves.

Valves, kind of.....	Balanced piston
Valves, greatest travel.....	5¼ ins.
Valves, outside lap.....	H. P., ¾ in.; L. P., ½ in.
Valves, inside clearance.....	H. P., ½ in.; L. P., ¼ in.
Valves, lead in full gear.....	H. P., 0 in.; L. P., ¼ in.

Wheels and Journals.

Drivers, diameter.....	84 ins.
Drivers, material of centers.....	Cast steel
Truck wheels, diameter.....	36 ins.
Trailing wheels, diameter.....	54 ins.
Journals, driving axle, size.....	9 ins. by 12 ins.
Journals, truck axle, size.....	6 ins. by 10 ins.
Journals, trailing axle, size.....	8½ ins. by 12 ins.
Main crank pin, size.....	6 ins. by 6½ ins.

Boiler, type of.....	Wagon top
Boiler, working steam pressure.....	200 lbs.
Boiler, material in barrel.....	Steel
Boiler, thickness of material in barrel.....	1/16 in. and ¼ in.
Boiler, diameter of barrel.....	66 ins.
Seams, kind of horizontal.....	Sextuple riveted
Seams, kind of circumferential.....	Double riveted
Thickness of tube sheets.....	½ in.
Thickness of crown sheet.....	¾ in.
Crown sheet stayed with.....	Radial stay
Dome, diameter.....	31½ ins.
Tubes, number.....	350
Tubes, material.....	Iron
Tubes, outside diameter.....	2 ins.
Tubes, length over sheets.....	16 ft. 6 ins.
Firebox.	
Firebox, length.....	8 ft. 6 ins.
Firebox, width.....	5 ft. 5½ ins.
Firebox, depth, front.....	70¼ ins.
Firebox, depth, back.....	64 ins.
Firebox, material.....	Steel
Firebox, thickness of sheets.....	5/16 in. and ¾ in.
Firebox, brick arch.....	Yes
Firebox, water space, width.....	Front, 4 ins.; sides, 3 ins.; back, 3 ins.
Grate, kind of.....	Rocking and drop plate
Other Parts.	
Exhaust nozzle.....	Double
Exhaust nozzle, diameter.....	Permanent
Exhaust nozzle, distance of tip below center of boiler.....	3¼ ins., 3½ ins., 3¾ ins.
Netting.....	Wire
Netting, size of mesh or perforation.....	3 ins. by 3 ins.
Stack.....	Straight
Stack, diameter.....	18 ins.
Stack, height above smoke box.....	2 ft. 8 ins.
Tender.	
Type.....	8-wheel swivel trucks
Tank capacity for water.....	7,000 gals.
Coal capacity.....	9 tons
Kind of material in tank.....	Steel
Thickness of tank sheets.....	¼ in. and 5/16 in.
Type of underframe, wood or iron.....	Wood
Type of truck.....	Barber
Truck with swinging motion or rigid bolster.....	Rigid
Type of truck spring.....	Coll
Diameter of truck wheels.....	38 ins.
Diameter and length of axle journals.....	5 by 9 ins.
Distance between centers of journals.....	76 ins.
Diameter of wheel fit on axle.....	6¾ ins.
Diameter of center of axle.....	5¾ ins.
Type of truck bolster.....	Barber
Type of truck transom.....	Barber
Length of tender frame over bumpers.....	290 ins.
Length of tank.....	264 ins.
Width of tank.....	118 ins.
Height of tank, not including collar.....	73 ins.

The importance of good firing in considering methods of economical operation of power plants is not always as thoroughly appreciated as it ought to be. Mr. Abbott, of the Chicago Edison Company, recently, before the Western Society of Engineers, directed attention to this as follows: "There is, as most every one of us knows, a wide difference between what can be obtained in general practice and what can be obtained on tests. You may make a series of tests on a certain fuel and the results would point, say, toward the Promised Land, and on trying them later on, under ordinary conditions, unless you have the most careful management of the boiler house, you will find your results will then point in the opposite direction. I am becoming impressed more and more with the fact that the boiler room usually does not receive the attention to which it is entitled, and that instead of spending so much attention and providing the very best superintendent for the engine room, if these were divided between the engine room and the boiler room, the results which would be obtained in the latter place would far outweigh any possible improvement which might be made in the engine room. In ordinary boiler practice the efficiency of the boilers is probably not greater than 50 per cent. and as low as 40 per cent. Good practice, however, can bring this up to 70 per cent., and in some cases as high as 80 per cent. Now, there is that chance of a possible improvement of 30 per cent., or in some cases 50 per cent., which may be made by proper attention to the work of the boiler room."

EXTENSION OF THE SNOQUALMIE FALLS POWER
COMPANY'S INSTALLATION.

Of all water-power plants in existence, this hydro-electric installation is probably the most interesting. During the last six months it has been visited by engineers and capitalists from all over the world, who speak in high praise of its correct design and the superior excellence of its mechanical operation; with a most varied service that includes electric traction, mill and factory power, as well as ordinary illumination, the entire load of the Snoqualmie system is operated in multiple, and with a regulation of less than 2 per cent. The development of this installation is largely due to the business sagacity of the company's president, Mr. Charles H. Baker.

Two years have passed since the first current from Snoqualmie Falls was carried into the cities of Seattle and Tacoma, Washington, and in this short time the initial installation has proven too small. The capacity of the plant is to be enlarged to meet the increasing demand for power in these growing western cities. At the Falls, distant 44 miles in an air line from Tacoma, and 32 miles from Seattle, are installed in a rock-excavated chamber four generating units, each consisting of a water wheel direct-connected to a 2,000-horse-power Westinghouse three-phase alternator. This power-transmission system, now generating and distributing 8,000 electrical horse-power, is to be more than doubled in capacity. At the same transmission voltage now employed, 30,000 volts, it is proposed to carry 12,000 horse-power more into the cities above mentioned, making a total output of 20,000 electrical horse-power. The electrical machinery is to be wholly furnished by the Westinghouse Electric & Manufacturing Company.

The Abner Doble Company, of San Francisco, which furnished the water-wheel equipment for the initial installation, are figuring upon placing their wheels in the new extension, and an engineer of another water-wheel concern is likewise looking into the matter. The water-wheel contract will not be let for 60 days yet. If an impact wheel is used there will be a single wheel on each end of each generator shaft, and each wheel will be driven by a single jet of water 14 ins. in diameter, the two jets combined being sufficient, under the existing head of 270 ft., to give the requisite power. The two water wheels, and the generator between, will be built on a single hollow shaft of oil-tempered nickel steel.

The present underground generating station, which is 200 ft. long, is to be lengthened out 150 ft. upstream to make room for the new installation. A new penstock is to be built, which will carry 50 per cent. more water than the old one. The transmission line, which is to parallel the old line, will require 125 tons of aluminum wire, and the order for it has already been placed. At Tacoma a large and commodious brick and stone sub-station is now being erected. The entire cost of these improvements will be in the neighborhood of \$400,000. The work is to be vigorously prosecuted, and it is expected that the first of the new generators will be delivering current into Seattle and Tacoma within the next nine months. The generating machinery will consist of three 3,000-kw. (4,000 horse-power) rotating-field generators of the two-bearing type, generating a three-phase current at 1,100 volts and 7,200 alternations. The speed is to be 100 r. p. m. Each generator will require an exciting current of 320 amperes approximately, at 125 volts. For exciting these three generators a 200-kilowatt, eight-pole, direct-current generator of the two-bearing type is to be used. At 175 r. p. m. it is to deliver, under normal load, a current of 1,600 amperes at 125 volts.

The current which is generated at 1,100 volts is to be raised to a line potential of 30,000 volts by nine 1,000-kilowatt, oil-insulated, water-cooled transformers. These are to be delta-connected on both the primary and secondary sides. It is estimated that each transformer will weigh 11,000 lbs. and require 500 gals. of oil. The switchboard to be installed is to consist of 14 panels of white marble, and is to be of the

special type furnished for the original installation. Instead of the Niagara-type single-phase indicating wattmeter in use on the present switchboard, a polyphase long-scale indicating wattmeter is to be used. Where formerly a field-plug switch was used, a double-pole field switch is to be employed. The standard equipment of synchronizing lamps is to be replaced by a single-pole plug switch mounted on the generating panel and connected to a synchroscope, which will be mounted on the multiplying panel. The increased capacity of the generators will necessitate placing three single-pole main switches instead of one three-pole main switch. The circuit-breakers, which are to be non-automatic, will be placed on an extension panel, above the main instrument panel.

The metric system.—Consul Haynes, of Rouen, under date of August 26, 1901, says that the metric system is to-day compulsory in twenty countries, representing more than 300,000,000 inhabitants—Germany, Austria-Hungary, Belgium, Spain, France, Greece, Italy, Netherlands, Portugal, Roumania, Servia, Norway, Sweden, Switzerland, Argentine Republic, Brazil, Chile, Mexico, Peru and Venezuela—and advises American exporters in dealing with any of these countries to adopt the system.

Racing automobiles have been developed in Europe to an astonishing degree, which suggests possibilities concerning the application of internal combustion motors to heavier and more important services. These machines are valueless except for racing, but the facts that in the recent Paris to Bordeaux race the winner made a schedule of 53¼ miles per hour and that the same machine later ran from Paris to Berlin, 744 miles, at an average speed of 46½ miles per hour, is most impressive as an illustration of what may be done on a rough road. The machines had 50 h.p. motors, and the speed is stated by "The Engineer" to have been as high as 70 and 75 miles per hour in places. A record of 744 miles in the net time of 16 hours 6 minutes would be very creditable for a locomotive on the best of track. The success of this race, although 110 started out of 170 machines entered, and but 45 finished, places the internal combustion motor in a favorable light after a development of but five years in this direction. Perhaps its possibilities have not yet been exhausted.

The Traveling Engineers' Association held its annual convention in Philadelphia, September 10. In discussing the subject of methods of firing locomotives, the Bates fire-door, with a narrow slit about 5 by 17 ins. in size, was strongly endorsed. This door required frequent and light firing, and the air admitted above the fire through the opening, which was never closed, seemed to have a beneficial effect on the fire. In the discussion of the subject of the relative merits of grease and oil for lubricating locomotive crank pins, it appeared that the tendency toward careless maintenance of engines under the pooling system gave the advantage to grease, which worked better than oil under unsatisfactory conditions in the rod cups. Several arguments were presented in favor of oil and better maintenance of oil cups, which would render the use of oil entirely satisfactory. The association also took up the subject of locomotive light and emphasized the importance of better attention to headlights and signal lamps than they generally received under the pooling system.

The transportation problem in Boston is a most difficult one on account of the narrow and crooked streets. On the 10.7 miles of track now operated by the Boston Elevated Railway there are 3,395 degrees of curvatures which if laid out from a common center would double on itself over nine times. The longest stretch of straight track is less than .28 of a mile. The ascending grades are as high as 5 per cent., or 264 ft. per mile, and the descending grades as high as 422 ft. per mile, or 8 per cent. In addition to the present 10.7 miles of track, of which 2.27 miles is underground in the subway and the remainder on elevated structures at each end of the road, there is nearing completion the Atlantic avenue division, having 4.69 miles of track. This will supplement the subway portion.

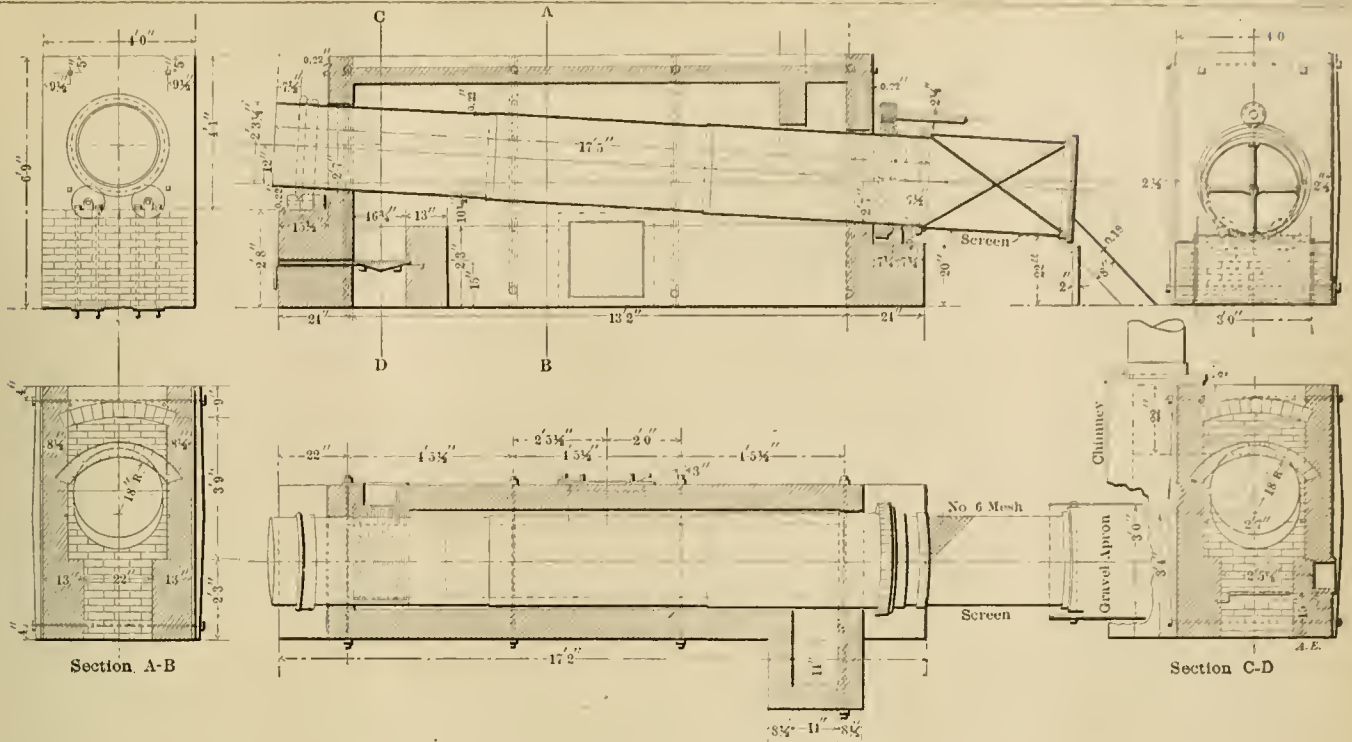

Rotary Sand Dryer—Chicago, Milwaukee & St. Paul Railway.

IMPROVED SAND DRYER AND BIN FOR LOCOMOTIVE SAND.

Chicago, Milwaukee & St. Paul Railway.

An indication of increased efforts to improve facilities for promptly dealing with locomotives at roundhouse terminals is seen in the interest which is now taken in methods of supplying an abundance of dry sand for locomotive sand boxes. The day of the old cast-iron stove which must be fed with a shovel is past on many roads, and through the kindness of Mr. A. E. Manchester, Superintendent of Motive Power, and Mr. R. R. Bradley, Mechanical Engineer of the Chicago, Milwaukee & St. Paul Railway we have received drawings of the new rotary sand dryer recently put into service on that road.

There seems to be a tendency toward the use of hotter surfaces for drying sand than can be had with steam pipes, because of the desire for quicker and more thorough drying. Steam pipes seem to work very well with crushed stone, such as the Pennsylvania road uses, but the general use of the pneumatic sander seems to require something better.

This rotary dryer was intended for a capacity of about 10 or 12 cu. yds. in 10 hours, but it has proved to be a little slower than that and the grate area will probably be increased, otherwise the device is entirely satisfactory. The dryer is a cylinder 27½ ins. in diameter and 17 ft. 5 ins. long with open ends and supported in a brick setting on rollers at an angle with the horizontal. Its operation and the arrangement of the screen at the delivering end are seen at a glance. At the ends of the cylinder, rings made of old 33-in. tires are secured, the upper one having the flange to hold the cylinder in position, while the lower one forms the attachment of the driving gear. In the inside of the cylinder angle irons are riveted in spiral form, giving about 1½ turns in the length of the barrel. These agitate the sand and also delay its movement down the cylinder. Sand is shoveled into the high end, or it may later be delivered by an automatic conveyor. It gradually works down as the cylinder revolves and falls into a hopper placed under the screen, from which it is raised to the chutes by compressed air. Large lumps, stones or other undesirable matter passes out of the end of the screen into a wheelbarrow. When the hopper is full the valve is opened and the sand allowed to fall into the cylindrical tank shown in the other drawing. From

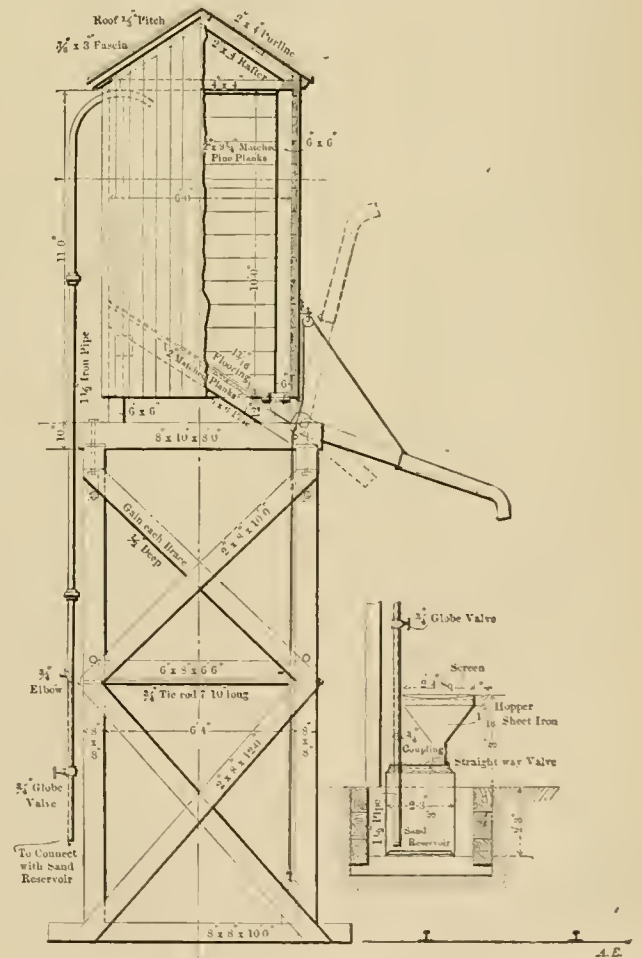

Sand Chute and Elevator.

here it is elevated into the bin by air pressure from the small pipe.

It is obvious that this dryer may be developed still further and its capacity greatly increased if necessary. For example

the return tube principle may be easily applied, and except for the attention required for the fire it may be made automatic. Several speeds may be arranged for the rotating cylinder. The idea seems to be an excellent one which is capable of still further development.

WATER TUBES IN FIREBOXES, ENGLISH PRACTICE.

On the London & South Western Railway Mr. D. Drummond, Locomotive Superintendent, about two years ago applied in-

A TRACTIVE POWER CHART.

By Lawford H. Fry.

The accompanying chart is designed as a time and labor-saving device for use in the calculation of the cylinder tractive power of a locomotive. Other charts and tables have been prepared for this purpose, but the present one has the advantage that it can be reproduced at any time with a minimum of calculation, and the tractive power of odd-sized cylinders can be readily found by interpolation.

The chart consists of vertical and horizontal lines. The vertical lines end at the top in a scale of driving wheel diameters and at the bottom in a scale of stroke lengths. The horizontal lines are in two series, the one terminating at the left of the chart in a scale of cylinder diameters, while the other series of lines ends on the right of the chart in the tractive power scale.

Having given the diameter and stroke of the cylinders and the driving wheel diameter of a locomotive, its tractive power per pound of mean effective pressure is determined from the chart by the following operation:

Pick out the lines corresponding to the given diameters of cylinders and driving wheels and follow them to their intersection. Through this point draw a diagonal line passing also through the "Origin" at the lower left-hand corner of the chart. Find the intersection of this diagonal with the vertical line corresponding to the length of stroke. The horizontal line through this point of intersection is marked on the right-hand scale with the tractive power required.

For example, to find the tractive power of a locomotive having cylinders 18 by 26 ins. and driving wheels 60 ins. in diameter. Find the intersection of the lines for 18-in. cylinder diameter and 60-in. driving wheel diameter and draw a diagonal line as shown in the figure through this point of intersection and the origin. Note the point of intersection of this diagonal with the vertical line marked 26 ins. on the length of stroke scale. This intersection is on a horizontal line marked 140 on the tractive power scale at the right of the chart. The consequent conclusion is that a locomotive of the above dimensions will develop a cylinder tractive power of 140 lbs. per pound of mean effective pressure.

As another example, which also illustrates the application of the chart to odd-sized cylinders, take the case of the high-pressure cylinders of a four-cylinder compound engine, say, 13½ by 26 ins. with 72-in. drivers. Take a point on the 72-in. driving wheel line midway between the lines for 13-in. and 14-in. cylinder diameter, and through this point draw the diagonal to the origin. Find the intersection of the diagonal with the 26-in. stroke line and follow the horizontal through this intersection to the right-hand scale. The resultant reading is 66, which is the tractive power developed by the high-pressure cylinders per pound of mean effective pressure.

In using the chart it should be noticed that the tendency is to take the intersection of the lines for cylinder diameter and

TRACTIVE POWER CHART

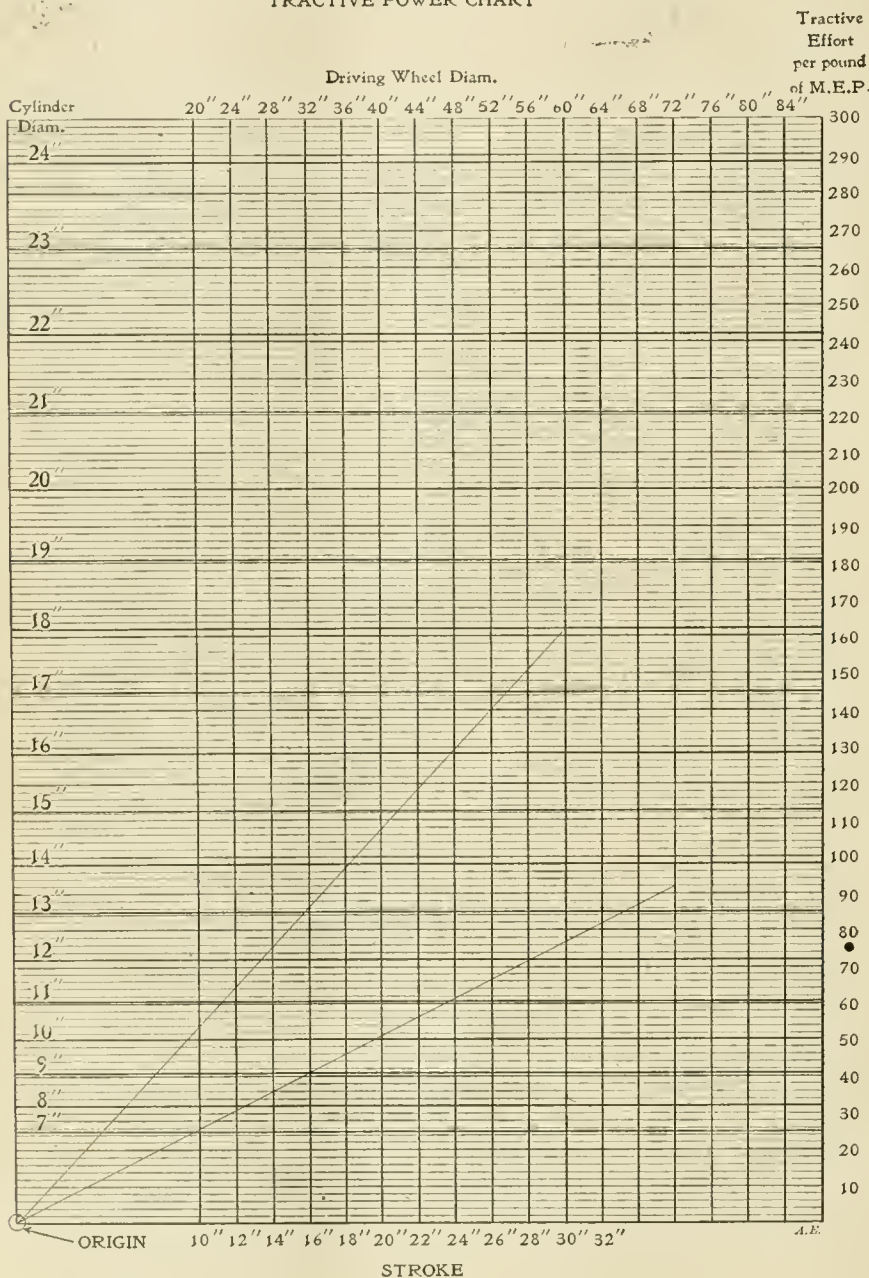

clined water tubes to the upper portion of fireboxes, and the experiment has apparently been successful. He has just repeated the application to new passenger engines. This arrangement was illustrated and described in our issues of March and July, 1899, pages 79 and 223. These tubes are arranged in two nests inclined in opposite directions, the staying being done by rods passing through a number of the tubes. About 215 sq. ft. of most valuable heating surface is secured in this way. In our illustrated description of this device it was shown that if applied to the Great Northern locomotive (American Engineer, October, 1898, page 328), about 350 sq. ft. of firebox heating surface could be provided by means of such tubes.

stroke as the starting point. This is wrong. The diagonal from the origin must pass through the intersection of the two diameter lines (diameter of cylinders and diameter of drivers).

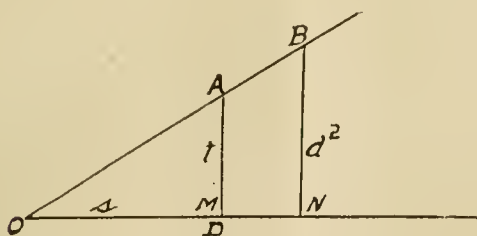

The reason for this will be evident from the following explanation of the principle of the chart:

If t = tractive power per pound of M. E. P.,
 d = diameter of cylinder,
 s = stroke of cylinder,
 and D = diameter of driving wheels,

$$\text{we have } t = \frac{d^2 s}{D} \dots\dots\dots (1)$$

$$\text{hence } \frac{t}{s} = \frac{d^2}{D} \dots\dots\dots (2)$$

Now, in two similar triangles, as OMA and ONB , obviously

$$\frac{BN}{ON} = \frac{AM}{OM} \dots\dots\dots (3)$$

Consequently if the triangles be so chosen that

BN is proportional to d^2 ,

ON is proportional to D ,

and OM is proportional to s ,

it follows from (2) and (3) that AM must be proportional to t . The chart is constructed on this principle. The vertical wheel diameter lines are drawn so that the horizontal distance from the left of the chart is proportional to the wheel diameter represented, and the cylinder diameter lines are drawn horizontally so that the distance of each from the lower base line is proportional to the square of the cylinder diameter represented. Then the stroke lines are put in. It is found convenient to use the same lines as for the wheel diameters, using a scale twice the previous one. The tractive power scale is determined by the foregoing and must be twice the scale used for the cylinder diameter. It is thus seen that the only calculation required in the construction of the chart is the determination of the values of d^2 , and with a table of squares at hand even this can be avoided.

A correspondent of the Boston Herald calls attention to the fact that the 2-ft. gauge railroads in the State of Maine now aggregate a length of 156 miles. There are seven companies: The Sandy River, Farmington to Phillips, 18 miles; Bridgton & Saco River, connecting Harrison with Hiram, 21 miles; Phillips & Rangeley, connecting the towns thus named, 29 miles; Franklin & Megantic, from Strong to Bigelow, 31 miles; Wiscasset & Quebec, connecting Wiscasset and Albion, 44 miles; Kennebec Central, connecting Randolph and Togus, 5 miles; Monson, from Monson to Monson Junction, 8 miles. These roads own 22 locomotives, 23 passenger cars and 324 baggage, freight and miscellaneous cars. It is said that charters have been granted to several other companies which intend to build railroads of this gauge. The officers of the Bridgton & Saco River say that they have inquiries from all over the United States, as well as from Europe and the West Indies, asking about their experience with the narrow gauge; and lately a party of investigators from New Orleans, Central America and South America visited Maine to inspect the railroad. The standard locomotive on the Bridgton & Saco River weighs 13 tons.

WHAT WATER SOFTENING WILL DO.

Mr. J. Kruttschult, Vice-President and General Manager of the Southern Pacific, in his article in our June number said: "The far-reaching effects of bad water would lead me to place its improvement by chemical treatment as first in importance of the problem that confront motive power officers of the present day."

There is at present an encouraging tendency toward the belief that the locomotive boiler is sufficiently taxed with its legitimate offices without also burdening it with the additional duty of clearing its own water of corrosive and scale forming ingredients. This is seen in the more general acceptance of the theory that the worst waters should be prepared for locomotive use by preliminary treatment before going into the boiler and a large increase in the number of plants for this purpose may be expected. Such convincing testimony of the value of these plants as was given by Mr. Henry Miller, Assistant Superintendent of the Burlington Route, before the St. Louis Railway Club, is worthy of attention by all who are troubled with bad locomotive feed water. Mr. Miller gave an account of two locomotives of ordinary standard construction used daily between Hannibal and Burlington. He said:

"These engines ran 12,000 miles each during the month of May of this year and are now doing the work in which four engines were formerly employed. They are kept in almost continuous service without being cooled down, are washed out only twice a month, after making over 6,000 miles, which is extraordinary, and this seems to be very near the ideal condition for engine service.

"This performance was made possible by the discovery that at a regular water station our engines were being supplied with a fine quality of water produced by a new process of filtration. (The speaker probably meant softening.—Editor.) By equipping these engines with large tanks, they were enabled to perform the service required by taking most of their water at the station above mentioned, and at one other place where the water is fair. These engines are giving almost perfect service, there is no flue trouble, foaming or other difficulty present, and the plan thus far has proven entirely successful. It has also enabled a good showing to be made in passenger mileage on the St. Louis, Keokuk & Northwestern road because in one month nearly 72,000 passenger miles were made by seven engines, averaging 10,271 miles each; therefore the importance of good water at a single station is exemplified.

"At another place on the same division, a switch engine is located, which used to go to the shop once a week for washing out, involving a 38-mile run. We found we were getting good water there, and inquiry of the boiler washer as to how much solid matter developed in washing the boiler brought the response that there was very little. This showed that we were simply going through the motions of washing out when there was no real necessity for it. The method was changed at once, and the engine now goes to the shops only once every month or six weeks, when other work is necessary."

The remarkable record of an indicated horse-power hour obtained from an expenditure of 0.88 lb. of cheap bituminous slack coal was recently obtained from producer gas in a 600 h.p. Premier gas engine. These trials were conducted by Mr. Herbert A. Humphrey, London, and the details presented in a recent paper entitled "Power Gas and Large Gas Engines," by Mr. Humphrey before the Institute of Mechanical Engineers. These results establish a new world's record for thermal efficiency attained with producer gas. The coal used was of poor quality, containing only 62 per cent. of carbon. There was no way at the time of the tests of absorbing the full power of the engine, but the author feels justified in saying that a thermal efficiency of not less than 27 per cent. would have been reached when running in regular working under full load.

(Established 1832.)

AMERICAN ENGINEER AND RAILROAD JOURNAL.

PUBLISHED MONTHLY
BY

R. M. VAN ARSDALE.

J. S. BONSALE, Business Manager.

MORSE BUILDING.....NEW YORK

G. M. BASFORD, Editor.
E. E. SILK, Associate Editor.

OCTOBER, 1901.

Subscription.—\$2.00 a year for the United States and Canada; \$2.50 a year to Foreign Countries embraced in the Universal Postal Union.

Remit by Express Money Order, Draft or Post Office Order.

Subscriptions for this paper will be received and copies kept for sale by the

Post Office News Co., 217 Dearborn St., Chicago, Ill.

Damrell & Upham, 283 Washington St., Boston, Mass.

Philip Roder, 507 North Fourth St., St. Louis, Mo.

R. S. Davis & Co., 346 Fifth Ave., Pittsburg, Pa.

Century News Co., 6 Third St. S., Minneapolis, Minn.

Sampson Low, Marston & Co., Limited, St. Dunstan's House, Fetter Lane, E. C., London, England.

EDITORIAL ANNOUNCEMENTS.

Advertisements.—Nothing will be inserted in this journal for pay, EXCEPT IN THE ADVERTISING PAGES. The reading pages will contain only such matter as we consider of interest to our readers.

Contributions.—Articles relating to railway rolling stock construction and management and kindred topics, by those who are practically acquainted with these subjects, are specially desired. Also early notices of official changes, and additions of new equipment for the road or the shop, by purchase or construction.

To Subscribers.—The AMERICAN ENGINEER AND RAILROAD JOURNAL is mailed regularly to every subscriber each month. Any subscriber who fails to receive his paper ought at once to notify the postmaster at the office of delivery, and in case the paper is not then obtained this office should be notified, so that the missing paper may be supplied. When a subscriber changes his address he ought to notify this office at once, so that the paper may be sent to the proper destination.

AMERICAN ENGINEER TESTS.

Locomotive Draft Appliances.

Preparations for the extensive series of tests on locomotive draft appliances which Professor Goss, of Purdue University, has been engaged to conduct for the American Engineer and Railroad Journal are sufficiently advanced to justify the publication of the preliminary investigation of what we know and what we want to know upon this subject, the first instalment of which is to be found in this issue.

In an undertaking of this character it is most important to make use of all existing information and to supplement it with investigations which will permit of applying to the greatest possible extent that which is already known, as well as that which is now sought for, to the conditions of locomotive practice as they exist to-day. To this end a careful analysis of the Von Borries-Troske tests and those of the Master Mechanics' Association of 1896 has been made by Mr. Vaughan. This has been reported upon by Professor Goss, and when brought before a voluntarily self-appointed committee of prominent motive power officers a general plan of procedure was selected. In accordance with this plan Professor Goss is now working, and the programme is such as to warrant the expectation of valuable results from each step in the general plan,

As the tests are to be conducted on a working locomotive and in accordance with actual conditions of practice a large amount of special apparatus will be necessary, for which the drawings have been prepared by Professor Goss, and the tests will begin at the opening of the Purdue University laboratories for the fall term.

It is our confident intention that these tests shall decide the question of "front end" construction, and solve the problem of the form and adjustment of draft appliances as applied to the large locomotives of the present time. The plan is well founded, with the approval of the best authorities among motive power officers, its execution is intrusted to Professor Goss, than whom there is no more careful and intelligent investigator and observer, and with the advisory co-operation of these railroad officials a valuable contribution to the science of the locomotive may be promised.

To the railroads it means a great saving in expenditures for fuel; to those who secure the records through our columns it will mean a relief from difficulties in working blindly; to the locomotive it may mean an increase of power without increasing weight, and to us it is a source of satisfaction in an effort to contribute to the information on so important a subject.

We invite the criticism and counsel of all who read the record.

WEIGHT AND POWER IN LOCOMOTIVES.

The strides made by the locomotive in the past five years in the direction of increased capacity have been most remarkable and these have led to improvements in operation which are without precedent. If the limits in size and weight have not been reached in some of the magnificent productions of this time, the margins are becoming narrow and many already look askance at the big engines which are now required. But the improvements in operation to which these monsters contribute reveal the necessity for something which is likely to be the most important influence in the future of this branch of engineering. The time has come for the most careful consideration of "means whereby the fireman will be enabled to shovel the maximum horse-power through the fire-door." This is not for the benefit of the fireman, though he needs some consideration, but in order to secure the utmost power within the ultimate limits of size and weight. In other words, this is a time to build locomotives in which every pound of weight will contribute the utmost possibility in power. The complications of machinery and increased cost of repairs will not stand in the way of this movement if these are necessary accompaniments. This leads to a consideration of what appears to be the most promising direction for development and in the following review editorial opinions are carefully avoided. There arguments have been presented to us from five different sources, by prominent motive-power officers in as many different parts of the country. They reflect the opinion that the four-cylinder balanced compound offers advantages sufficient to warrant a thorough trial in this country, and we present these views, confident that they are worthy of thoughtful study.

THE FOUR-CYLINDER BALANCED COMPOUND.

The compound principle has established itself securely on a basis of economy in steam. Opinions differ as to the cost of repairs, but those who are best qualified to judge believe the compound to be as cheap in maintenance as the simple engine, and others believe that if not so now this may be accomplished by further experience. However, the difference in cost of repairs is evidently less than the improvement in fuel consumption. But the matter of power is to be the chief consid-

eration, and for a given weight the compound certainly offers greater possibilities than the simple. There is no hazard in expressing the belief that the locomotive of the future must be a compound.

The two-cylinder type has made good records here and abroad. It has established itself firmly and is making friends. With two cylinders, however, the limit of size has already been reached, and this seems to indicate that another type must be selected for more powerful machines. Three cylinders have been used successfully, but for many reasons a better type seems to be available using four cylinders. In fact, the four-cylinder compound has undoubtedly the advantage over all other types, and it is in this direction that most is to be expected. Four cylinders are not popular, undoubtedly, and many would use but one cylinder in a locomotive if they could possibly get along with one. We are not now facing a question of desire, but of necessity. The large number of Vauclain engines and the recent ready acceptance of tandems have prepared the way for four-cylinder types, and they have shown that the advantage of the larger number of cylinders outweighs the objections to a larger number of parts. They have prepared the way for something with greater possibilities than either. These are steps in advance, but because they do not improve the situation with regard to reciprocating weight they are not believed to constitute the ultimate possibilities of the locomotive. To them, however, a great debt is due for convincing testimony as to the value of and necessity for four cylinders.

When the heaviest possible locomotives of prevailing types have been built, and this, perhaps, has not yet been done, the question of "what next" will arise. A four-cylinder design may be taken as a basis. If the question of counterbalancing the reciprocating parts is disposed of by a balanced engine with a crank axle and cylinders arranged in a row or after the de Glehn type, a large amount of additional weight may be placed on the drivers without increasing the damage to the track. For this reason this type of construction is believed to offer the greatest promise of the future, and within a short time this idea is expected to find ready acceptance among those who are now anxious as to how they may meet the demands for capacity.

With reference to clearances the type of construction under discussion is very favorable and there are other advantages which do not appear to be generally appreciated. One of these is the division of the steam into relatively small portions, not so much steam having to pass through any one of the ports as must pass through one of the ports of a simple engine. This means that there will be less loss of power from friction of steam, wire-drawing and back pressure. With longer cut-offs the four-cylinder compound will use the valve motion more favorably and secure larger port openings at high speeds. With more impulses in each revolution the stresses in the rods and frames will be reduced, and while there are more parts the load on each will be lighter and the parts may be made correspondingly light. With a balanced arrangement of the reciprocating parts the weight on drivers may be increased without damaging the tracks. This was mentioned before as a leading advantage. In accelerating trains there is no doubt that the French four-cylinder compounds excel all other locomotives and this attribute should be added to the others.

Increased complication and the crank axle constitute the chief disadvantages. Both of these are important, but they are likely to be found less objectionable in practice than in contemplation. It may not be necessary to come to this type of locomotive immediately, but it is believed to be the next step in progress, and much credit will come to him who has the courage to undertake a design which shall include these possibilities and yet conform to the greatest possible extent to American ideas of simplicity. It may interest our readers to know that drawings have been sent us in which the four-cylinder balanced principle has been worked out for a heavy six-coupled passenger engine and an eight-coupled freight en-

gine of two of the leading railroads, both of these locomotives having been thoroughly illustrated in this journal. This was done to show the possibilities of application to three and four axles and to indicate a method of using present valve motion.

Who will take up in a practical experiment this attractive problem?

Never before has such prominence been given to the necessity for the proper maintenance of air-brake apparatus. It is perhaps natural for busy men to overlook important matters of this character until their attention is directed to them, and because the air brake has been such a faithful servant rather too much has been expected of it, but systematic and thorough attention is now imperative. We believe this fact is appreciated, and the inauguration of equipment and systematic methods of overhauling and repair will doubtless be noticed on every side. There is an evident desire to introduce the reform without waiting for the compulsion of disaster. The Master Car Builders' Association will doubtless be a factor in this movement.

SYSTEMATIC TREATMENT OF THE APPRENTICESHIP PROBLEM.

With about 90 per cent. piece work on a contract basis, the Baldwin Locomotive Works find it necessary to provide a systematic plan for dealing with the apprentice problem. The reasons why the old methods of apprenticeship no longer meet present needs are well understood, and in order to create a supply of well qualified young men, the management of these works inaugurated a systematic plan last February. It has worked very well thus far and seems promising.

Because boys in a piece-work shop can make better wages, as compared with apprentices' pay, and because the employer can get almost as much from a boy as from a man there is a tendency for boys to learn but one operation and neglect to secure an all-around apprentice training. This is bad for the boy and for the employer. If work in his particular line is slack and he afterward loses his position, he must work as a laborer or learn some new specialty. Piece work is profitable to the employer, but it has the serious disadvantage of cutting off the supply of thoroughly trained mechanics of the old school. It limits the resources of the employee and cuts off the source of supply of the best men.

This firm realized this, and also saw the need of providing at the same time the training in practical experience of the technical school graduate. At the start Mr. N. W. Sample, who, for years was at the head of the motive power department of the Denver & Rio Grande, was placed in charge of the problem as Superintendent of Apprentices, and the system which was worked out merits the careful attention of railroad men as well as manufacturers. It possesses features which appear to be specially adapted to railroads, one of which is to put the technical school graduate on a good basis, one that is fair to him, profitable to the employer and, what is perhaps even more important, does not discourage the regular apprentice. This last qualification is stated thoughtfully, because from this class of apprentices of the past the railroads owe some of their best motive power officers of to-day. With the usual special apprentice arrangement, the regular apprentice is discouraged. He sees special advantages offered to the educated boys and he feels sure that they will be selected instead of himself for promotion. This feeling extends also to the older men of the shop and it is believed to be a serious matter.

It is to be expected that the educated boy will be the more valuable, but is it wise and right that it should be taken for granted that this is a fact? Should not the boys prove it themselves? In other words, there should be a time in the career of both kinds of apprentices when they are offered equal oppor-

tunities, provided the regular apprentice has studied and acquired an education during his shop training. This the Baldwin plan provides. It does more, it obliges the regular apprentice to study, and if he desires he may do more than is required, and by special effort may put himself on the plane of his more favored rival. Whether he does so or not is not as important as that he should have the opportunity. To this feature of this system special attention is called, for it is usually considered unimportant to safeguard the regular apprentice. At these works all apprentices, at the termination of their time, stand equally on their merits. They are hired for further service if needed, and are hired on the basis of their worth. While the special apprentice has the advantage in

IMPROVEMENT OF VALVE GEARS BY USE OF THE INDICATOR.

Plant System of Railways.

Springy valve gears, improperly balanced valves and inadequate steam and exhaust passages are now thoroughly understood in their bad effects upon the distribution of steam in locomotives, particularly in their influence in cutting down the power and in making engines "logy," but such an extreme example as this which is furnished through the kindness of Mr. W. E. Symons, Superintendent Motive Power of the Plant System of Railways, is, fortunately, seldom seen. Mr. Symons

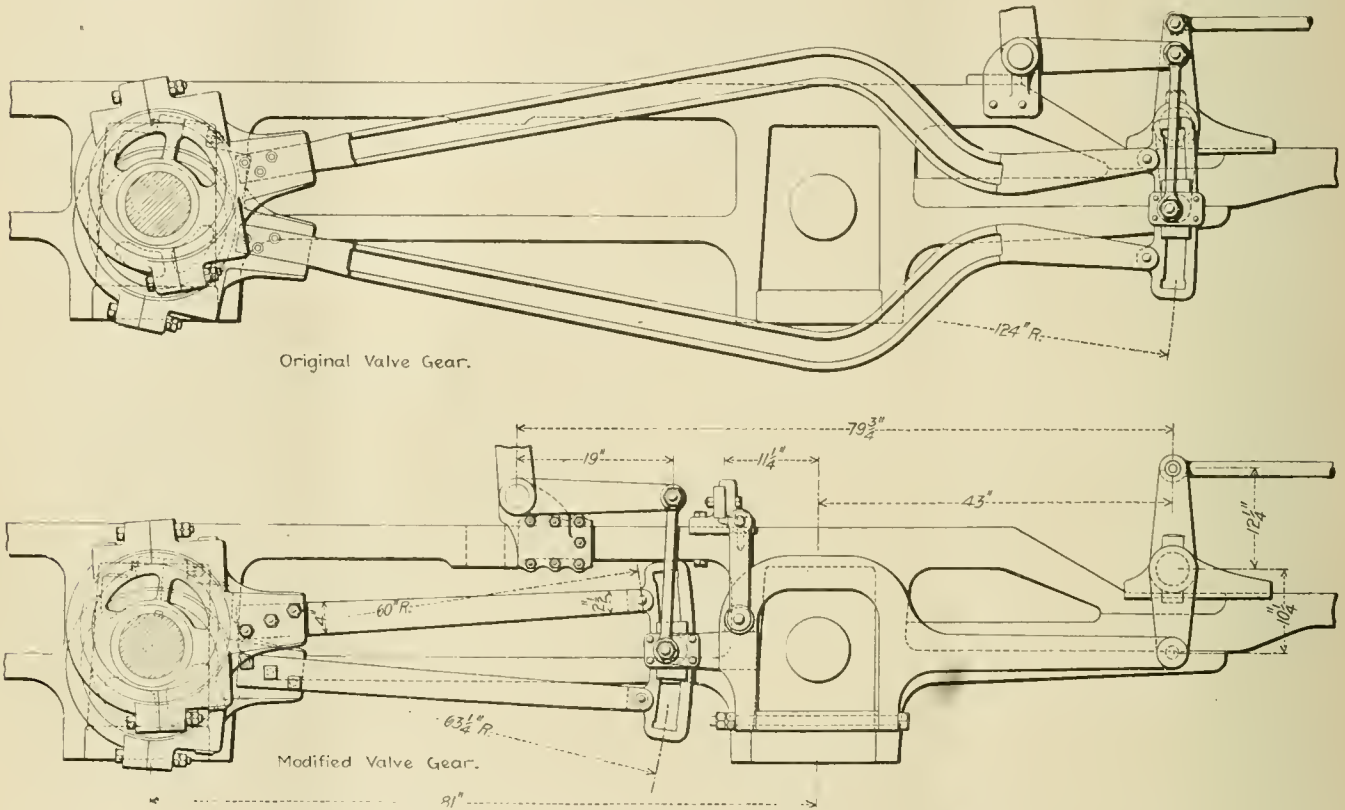

Comparison of Original and Improved Valve Gear.

education the others have an undoubted advantage in thoroughness in the shop, because of their longer contact with it.

It is fair and right and wise to treat the graduate as a trained thinker. He can acquire the shop training more quickly than the other. On the other hand, the regular apprentice is more likely to secure more thorough shop contact. The only advantage offered by the Baldwin plan to the special apprentice is the two years saving of time. In practice it seems to have a good effect upon both classes, whereas it must be admitted that the usual plan has not always produced the results expected or desired.

A study of this subject must lead to the conclusion that those who are in position to inaugurate a thorough system of recruiting the ranks of well-trained young men and are not doing so are missing an important opportunity, and failing in a real duty.

An exceedingly impressive and unprecedented tribute was paid to the memory of President McKinley on the afternoon of September 19, the day of the funeral service, by the cessation of all railroad and steamboat traffic in New York, Baltimore and Pittsburgh. By special orders, the street railroad and steamboat lines stopped traffic for five minutes during the time of the funeral service at Canton.

is a thorough believer in the generous use of the indicator and such a discovery as this justifies the opinion that this little instrument offers opportunities for usefulness in the study of valve motions which are not less important than those relating to performance tests.

Some time ago in an unusual rush of business Mr. Symons procured from one of the locomotive builders three locomotives which had been built for another road, and for some reason were not delivered. They were illustrated in "Modern Locomotives," page 253, specification No. 177, and are the only heavy ten-wheel passenger engines having trailing wheels of which we have record. They were of the two-cylinder compound type and were changed to simple engines before delivery to the Plant System. While the valve motion was known to be unsatisfactory, the state of business compelled their use at the time. Upon placing them in service it was discovered that they were very extravagant in fuel and water, and were "logy," indicating very high back pressure. At the first opportunity indicators were applied and a new valve motion designed in which four eccentric rods weighing 212 lbs. were substituted for the original ones, which weighed 980 lbs. These two forms of valve motion are illustrated in the accompanying engraving, and it is unnecessary to comment upon the comparison. The indicator revealed an astonishing amount of back pressure,

RECORDS OF VALVE GEAR-PLANT SYSTEM.

Card.	Train number.	Mile post.	Weight in tons, working order.	Weight of train in tons.	Total weight engine and train in tons.	Speed per hour, miles.	Revolutions per minute.	Boiler pressure.	M. E.	Initial pressure.	Back pressure.	I. H. P. of engine.	Scale of spring.	Miles run per ton of coal.	Gallons of water used per mile run.	Ratio in lbs. of coal used to water used.	Pounds of coal used per minute.
1a.	30	116	124	240	361	4	17	180	141.0	157.5	10.25	200.42	80	With modified valve gear. 31.4	With modified valve gear. 51.7	With modified valve gear. 17.4	With modified valve gear. 39.2
1.	53	130	121	212	336	4	17	180	161.5	169.0	2.0	229.56	100				
2a.	30	134	124	240	361	20	86	150	68.6	122.0	43.5	487.56	80	With original valve gear. 20.2	With original valve gear. 67	With original valve gear. 15.4	With original valve gear. 67.7
2.	53	1	124	212	336	20	86	175	61.7	126.5	3.0	459.76	100				
3a.	30	148	121	210	364	46	198	160	59.5	126.5	19.0	973.01	80	With original valve gear. 20.2	With original valve gear. 67	With original valve gear. 15.4	With original valve gear. 67.7
3.	53	14	121	212	336	45	194	180	53.5	171.5	5.5	855.91	100				
4a.	30	137	124	240	364	60	259	160	45.4	134.5	22.0	968.43	80	With original valve gear. 20.2	With original valve gear. 67	With original valve gear. 15.4	With original valve gear. 67.7
4.	53	59	124	212	336	60	259	180	50.5	146.5	5.5	1,077.22	100				
5a.	30	58	121	240	364	62	267	180	44.0	134.0	18.0	969.81	80	With original valve gear. 20.2	With original valve gear. 67	With original valve gear. 15.4	With original valve gear. 67.7
5.	53	87	124	212	334	65	280	180	37.0	166.0	7.0	855.00	100				

That there are fortunes annually spent for unnecessary consumption of fuel on locomotives in a condition similar to that shown by cards Nos. 1a to 4a, I feel confident, and unless railroad companies' fuel is looked after and handled a little more in the way

in which the treasurer handles his cash, this unnecessary waste will continue."

It is not necessary to add to Mr. Symons' forcible statement.

Cards 1a to 5a were taken with the original valve gear between Jacksonville and Savannah, and cards 1 to 5 with the modified gear, between Savannah and Jacksonville, the grades being about the same in both directions. These engines have 20 by 26-in. cylinders, 78-in. driving wheels, 2,103 sq. ft. of heating surface and 27.8 sq. ft. of grade area.

An important tendency toward increased capacity of British locomotives is indicated by the introduction on the Caledonian Railway of the largest locomotives ever used in that country. These engines have eight 54-in. coupled drivers and no truck wheels. The cylinders are 21 by 26 ins., and the boilers have 2,500 sq. ft. of heating surface. The engine and tender, together, weigh 228,500 lbs.

The advantage given by a technical education seldom stands out as it did in the case of an investigation brought to our attention at one of the locomotive works recently. Having under consideration the subject of tool steel, with a view of improving upon former practice without paying a large royalty for the use of patented processes one of the engineers made a study of the best treatment of steel, and developed a method of hardening a common form so that it would cut a driving axle at 45 ft. per minute with a 1/4-in. feed. In spite of all his efforts he could not get the tool steel experts of the shops to follow his directions and produce the results which he had shown them how to produce. At that plant the tool steel was

passed out of the hands of the former experts and is now treated by a bright laborer, who was taught to use the process so as to secure the capacity mentioned for the every-day work of the shop.

"Aids to navigation" along the line of the Boston Elevated Road are strikingly plentiful. They take the form of signboards, indicating where the motormen should "coast," "apply air" and "release air," and are repeated all over the road at stations and curves. By following these printed instructions there should be no difficulty in handling trains, especially with automatic block signals and short blocks. This may be a necessary precaution, but it gives an impression of a lack of perfect confidence in the judgment of the men, and this is an important factor in safe operation of railroads.

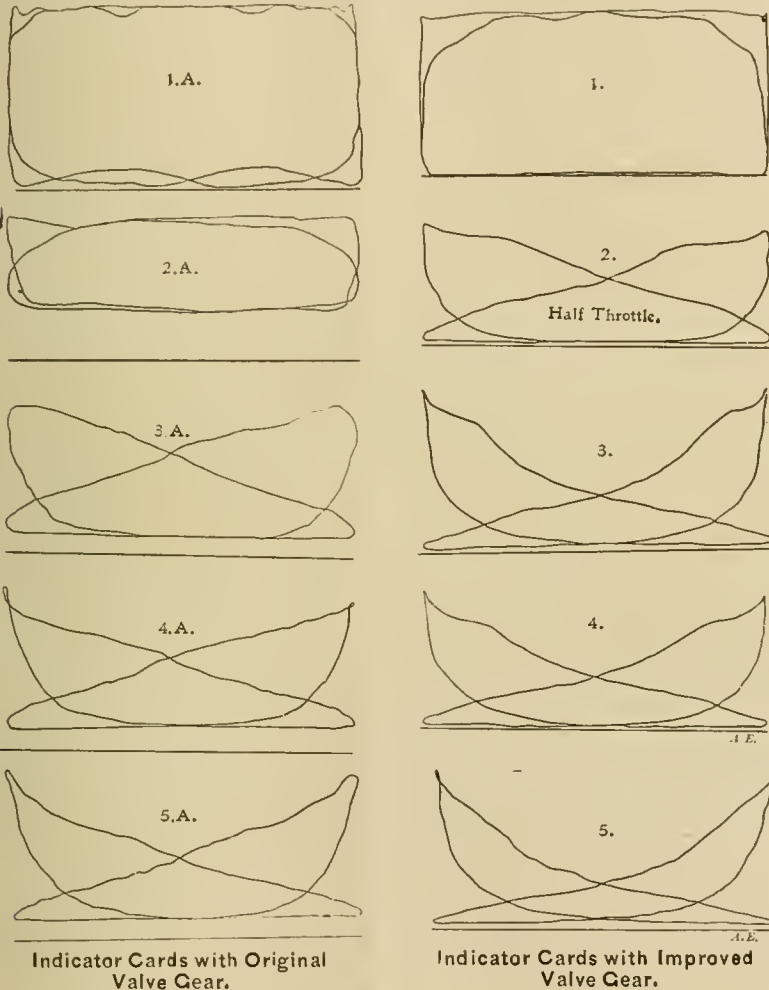

the two series of cards taken before and after the change showing the results obtained by the new gear. Other comparisons may be made by aid of the table. The original valve gear was springy, the port openings of the valves were restricted, the nozzle was too small and was opened to the extent of one inch.

Back pressures of 43 lbs., increase of mileage per ton of coal from 20 to 34, and water consumption reduced from 67 to 51.4 gals. per mile run, indicate the situation on these engines. As will be noted by the table, these comparisons, however, are not made at the same speed and not with exactly the same train load, but the difference in speed will not account for all of this loss.

Quoting from Mr. Symons' letter, "There are some forcible and one might say 'knock-down' arguments embodied in these indicator cards which cannot be too strongly commented upon for the benefit of those who are disposed to ignore the use of the indicator on a steam engine, particularly on the locomotive.

THE DEMAND FOR RAILROAD MEN.

The apprentice system as applied in the maintenance of way department of the Illinois Central Railroad appears to be very successful. It is fully described in a letter from Mr. John F. Wallace, Assistant General Manager of the road, printed in "Engineering News" (March 8, 1900, page 157). The system was introduced in May, 1897, as a result of the difficulty of securing men with the right kind of qualifications for filling responsible positions in that department. At that time this road had 39 young men on its engineering staff who were taken from the ranks of track apprentices.

Of these, 2 men had reached the rank of assistant engineers at \$100 per month, 1 as office engineer at \$88.33, 3 as transitmen at \$75, 10 as roadmen at \$60, 18 as chainmen at \$50. The track apprenticeship has been made the doorway to the engineering department, and the lower positions are filled entirely from among the track apprentices, who may or may not be college or technical school graduates. Their subsequent promotions depend entirely upon their relative fitness. Not all continue in this service. Some are attracted away by other opportunities and some move slowly because of lack of fitness. Mr. Wallace said:

"In spite of our effort and desire to fill our road department with educated, capable men, we find it difficult, whenever there is a vacancy in the higher positions, to find a suitable man to fill it. This is mainly because executive ability and the power to control men is a rare faculty. Men are born, not educated, to command, although the efficiency of the born commander is improved by education. I feel that even if we secure only one good man out of ten, the system will have been successful and will recompense us for our work and trouble in connection with it."

Mr. Wallace at our request expressed his opinion of the plan, after further experience, in a letter which has just been received, in which he said:

"The track apprenticeship system has given very satisfactory service, although these results have not been obtained along the exact lines contemplated when the system was originally installed. Our first intention was to give positions as track apprentices to the graduates of technical schools and colleges; assigning these young men to work on the sub-sections of the road, their compensation being \$1.25 per day at the beginning and gradually promote them as they prove themselves capable to fill positions as track foremen, track supervisors and road masters. It might be explained in this connection that the position of track supervisor on the Illinois Central compares with that of roadmaster on some systems, and the position of roadmaster to that of engineer of maintenance of way or general roadmaster. Track supervisors have charge of approximately 120 miles of track; roadmasters have charge of track, bridges, buildings and water supply on divisions ranging from 300 to 500 miles in extent.

"Owing to the large number of men who applied for the positions as track apprentices, and their quality, it was not considered fair to the young men to confine their promotion entirely to the position of track foremen; it was therefore made a rule of the engineering department that all vacancies in the lower ranks of that department, viz., axmen, chainmen, rodmen, etc., should be filled from among these track apprentices; the result is that the track apprenticeship has been made the door to the engineering department on the Illinois Central Railroad, and rarely has any position been filled in this department except from among these track apprentices, they being first appointed axmen or chainmen, then promoted to rodmen, instrument men and assistant engineers, as the vacancies occurred above them.

"The large amount of construction work on the system has made such drafts upon the apprentice class that these young men have rarely been kept as track apprentices more than one year, and the majority have been promoted to the engi-

neering department; several, however, after employment as chainmen, rodmen, instrument men and assistant engineers, have returned to the road department as track supervisors and roadmasters; the knowledge which they have received in the practical track work being one of the principal factors in securing these positions for them. The knowledge obtained of track work has been of material advantage to those who have continued in the engineering department, particularly those who have been engaged in the construction of yards and track facilities; it has, also, had the effect of primarily weeding out incompetent and undesirable young men and retaining only those whose enthusiasm has enabled them to go through approximately a year of hard and laborious work. Greatly to my surprise a much smaller portion of these young men have 'flunked' than was originally expected, the greater number remaining and attaining positions of responsibility."

This testimony is valuable, chiefly because it points conclusively to two facts. First, that it is exceedingly difficult to find the right men for leading positions. Second, that of all kinds of abilities, that of the executive or commander is the rarest.

During the past two years it has become apparent through the number of applications received at this office from Superintendents of Motive Power that the same thing is true of the mechanical department and that there is a demand for men with executive ability, who are able to organize forces and manage affairs of various kinds. In fact, good, experienced young men with technical training supplemented by sufficient shop and executive experience, who are ready for any position from gang or floor foremen to Superintendent of Motive Power have been sought for as they never have been before.

It may be easy to get an unlimited supply of track engineers after the method of the Illinois Central with the very low salaries already mentioned, but there can be no doubt that in the compensation question lies much of the trouble in which the mechanical department finds itself. Railroads do not pay their mechanical officers enough. It is pure absurdity to pay a locomotive runner more than a Master Mechanic, who has the charge of many runners, besides the engines and shops, and yet this is done on every side. Only a short time ago one of the best young motive power officers in the United States was lost to the railroads because he could make a great deal more money in a manufacturing concern.

The motive power department of one of our great railroads to-day demands more of its chief than is asked of managers of even the largest manufacturing establishments, and yet they leave the railroads to double their salaries in an industrial concern, and they are not to be blamed. We hope that time will correct this, but the railroads will pay a heavy price for every moment of delay. The trouble extends all along down the line, and in the large number of applications received by us from Superintendents of Motive Power, the best of men are asked for and salaries are mentioned which are ridiculously out of proportion to the requirements and responsibilities.

Railroads need to do two things for their mechanical men: Pay them better and institute such organizations as will make promotion more certain to follow ability and faithfulness.

In the demand for men with executive experience we see a suggestion for the technical school graduate.

The greatest work ever undertaken in Egypt in regard to discharging coal from steamers has just been completed in Alexandria. The machinery that towers above the surrounding ships owes its origin to Mr. Alexander E. Brown, an American engineer, who has invented a system of suspended bridge tramways, whereby colliers could be unloaded automatically in about one-quarter of the time taken by manual labor and the use of steam winches. The Egyptian Railway Administration decided to adopt this system; the present apparatus is the first that has been installed in Egypt.—Consul Long, in a letter from Cairo.

LARGE CAPACITY DRAFT SPRING

For Freight Cars.

C., C., C. & St. L. Ry.

In the recent report to the M. C. B. Association on draft gear it was stated that Mr. William Garstang, of the C., C., C. & St. L. Ry., is using draft springs of larger capacity than those of the recommended practice of the association, but without exceeding the dimensions of that practice. By courtesy of Mr. Garstang we illustrate his new spring, which has three coils instead of two, and has a capacity of 28,000 lbs., an increase of 9,000 lbs. over the usual practice. The free height of 8 ins. is retained and the outside diameter of the large coil is $6\frac{3}{8}$ ins., $\frac{1}{8}$ in. larger than before. This new spring employs coils having bars $1\frac{11}{32}$, $\frac{25}{32}$ and $\frac{15}{32}$ in. in diameter respectively and its normal weight is 40 lbs. The height when

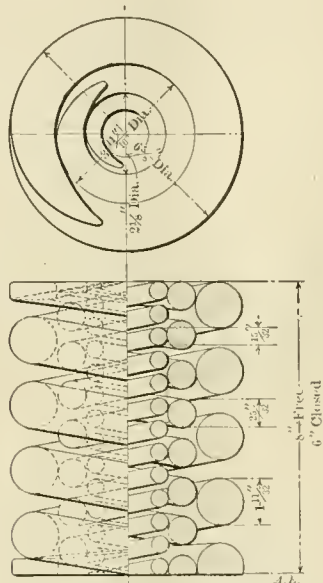

Large Capacity Draft Spring.

solid is 6 ins., and the height under a load of 28,000 lbs. is required to be $6\frac{1}{16}$ ins. It is obvious that this spring may be used in the ordinary draft gear having a yoke attachment, and that 50 per cent. increase in capacity over the usual practice is obtained very easily and cheaply. If used in a twin or tandem gear these springs would give a capacity of 60,000 lbs., a very respectable increase over the usual construction; but Mr. Garstang uses them singly on all new cars and in replacements. The outer coil tested alone to 6 ins., requires a pressure of 16,700 lbs.; the second coil alone, 5,400 lbs., and the inner coil alone, 1,400 lbs. Compressed separately to 6 ins., the coils thus have in all 23,500 lbs. capacity, but when assembled, a little over 28,000 lbs. is required to compress the group to 6 ins. The difference is accounted for by the friction of one coil on another.

A ventilating fan running backward was found by Prof. R. C. Carpenter in one of the Cornell University buildings some time ago. The fan had been operated for about three months when a cold snap came along and it proved impossible to warm the place. The fan was found in the condition stated, and the motor was reversed and not only was there an increase in the air delivery, but the amount of electric current fell off. Where it took 22 amperes to drive the fan backward, delivering very little air, it required but 12 amperes with the fan running in the right direction and delivering six or eight times as much air.—“Engineering Record.”

CORRESPONDENCE.

THE SLIDE RULE.

Most Valuable Draftsman's Assistant.

To the Editor:

“Why Don't Draftsmen Use the Slide Rule?” Speaking as one who is well acquainted with the uses of the slide rule, it is quite surprising that there is such a noticeable lack of use of this extremely handy and fairly efficient instrument among draftsmen.

I have seen draftsmen who had at times a number of calculations to make on work in connection with a locomotive elevation, that after a few hours of worry over a mass of figures, were about worn out for the remainder of the day, solely because of the mental drudgery due to following every simple but necessary step in nothing more than an ordinary calculation. On the other hand, I have seen the draftsman who used the slide rule, engaged on the same class of work, who easily did the same amount of calculating in less than one-fourth the time and with no more mental fatigue than ordinarily acquired when trying a point on an elevation. And the chances for errors are greatly reduced when using the rule. Nothing has impressed upon me more deeply the amount of labor and time saved and mental drudgery overcome by the aid of the slide rule than the conditions seen in the majority of draftsmen's note-books as compared with what is seen in the notebook of the man who uses the rule. In the notebook of the former can be found page after page of long-drawn-out examples of multiplication and division—usually three-fourths of the book's contents is composed of just such stuff as can be taken from the slide rule in a moment's time. One would imagine that draftsmen who do not use the rule would make use of the logarithm tables instead of working out long multiplication and division. I have yet to meet the draftsman who makes regular use of these tables in his work. When a calculation is noted by the draftsman who uses the slide rule all that will be found in his notebook is the formula, this followed by substituting for the letters their values in figures, then the answer, of course, all arranged algebraically. This not only saves time and labor, but simplifies matters so that they may be readily referred to without going over a whole mass of figures before getting the results desired.

Here are some of the reasons that may account for the lack of the use of the slide rule among draftsmen. Many are of the opinion that the results obtained from the rule are at best poor approximations, that the rule was devised for work that is a little better than guessing, such as rough estimating, and also useful in checking. The rule will do all this and more. As a draftsman, I have found the rule sufficiently accurate for all practical purposes, except in a very few instances. In other words, I mean that if you were to figure for stresses with the rule, say, in crank pins or a guide yoke or for the capacity of a tender tank, the results obtained would be near enough to the actual stresses in the parts named and to the actual capacity of the tank to be accepted as correct, as I have found. Of course, this is supposing you know how to use the rule well enough to read your results within the usual allowed limit for error, which is less than one-half of one per cent., or an error of 1 in every 200.

Some beginners in the use of the rule have trouble in bringing themselves to the point of accepting results from it because they are so accustomed to seeing every step in working out an example put down on paper. When they are in error they are too ready to blame the rule, whereas, the rule never makes a mistake. The varying subdivisions of the various scales are puzzling to the eye of the beginner, and there is some difficulty in becoming familiar with the arrangement. This, I believe, is the only real difficulty in learning to use the rule, but with some practice and a little patience this can be overcome. Some complain of trouble in finding the decimal point on the rule. With the few users I know and in my own case there was no trouble about this after once becoming thoroughly familiar with the subdivisions. The principal fault with beginners, I find, is that they try to learn too much on the start. Before they are able to readily read from the scales they are branching off into square and cube roots, logarithms, etc., which is entirely wrong. Beginners should confine themselves to multiplication and division until they can read the subdivisions accurately and without much hesitation, then

take to checking up results given in the many mathematical tables in reference books. These tables cannot be used too much for this work, because it is the best kind of slide rule practice.

There are also many draftsmen who hesitate about taking up the slide rule because they believe it requires an extensive knowledge of mathematics, especially a knowledge of logarithms. The scales of the slide rule are divided into a logarithmic series, arranged so they may be placed side by side and one moved over or by the other. It is in this way that the divisions or logarithms are added, thus multiplying the numbers, or subtracted and dividing the numbers. These and all the many operations on the rule are done mechanically. Anyone with a knowledge of multiplication and division can learn to perform these on the rule. Of course, the more extensive one's knowledge of mathematics the more extensive will be his application of the rule.

I prefer to use the straight slide rule, ten inches long, the sliding index of glass with a hair-line across its face; the glass is enclosed by a small aluminum frame. The improved rule with the slits through the back of the stock, which is to prevent the sliding scale from binding in the stock, should be used. With any other rule this binding will be found quite annoying, especially during damp weather. I find the straight rule more convenient to handle and its celluloid face, I believe, will stand fingering better than the cardboard of the so-called circular slide rule. The circular rule has the advantage of giving one more figure, which is desirable, and it also gives the fifth root direct without the use of logarithms, as with the straight rule.

The little pamphlet that is given with the slide rule when purchased contains all the instructions required in learning to use the rule. This may be supplemented by what has been written on the subject, and may appear from time to time in the various technical journals. That the draftsman and the up-to-date mechanic, or, in fact, anyone who has calculating to do, would be more than repaid for the time and patience spent in learning to use the rule is the least that can be said on this point. And that the draftsman who uses the rule will have a distinct advantage over his fellow draftsmen, engaged on the same class of work, but who do not make use of it, there is no doubt. It is also most likely he will agree with me in saying that the slide rule is the most valuable instrument to a draftsman that was ever laid down on the drawing board.

LAWRENCE B. MELVILLE,
Richmond Locomotive Works.

MASTER MECHANICS' ASSOCIATION COMMITTEES FOR 1901.

At a meeting of the Executive Committee of the American Railway Master Mechanics' Association held on August 15, 1901, the following committees for conducting the work of the association for the year 1901-1902 were selected:

1. Ton-Mile Statistics: H. J. Small, chairman; C. H. Quereau, W. H. Marshall, Geo. L. Fowler.
2. What is the Cost of Punning High-Speed Passenger Trains? Wm. McIntosh, chairman; J. F. Deems, G. F. Wilson, Prof. W. F. M. Goss.
3. What Should Be the Arrangement and Accessories of an Up-to-Date Roundhouse? Robert Quayle, chairman; V. B. Lang, D. Van Alstine, G. M. Basford.
4. Present Improvements in Boiler Design and Best Proportions of Heating and Grate Surface for Different Kinds of Coal: Geo. W. West, chairman; T. W. Demarest, H. D. Taylor, M. N. Forney.
5. Standard Specifications for Locomotive Driving and Truck Axles: A. E. Mitchell, chairman; S. Higgins, W. S. Morris, L. R. Pomeroy.
6. Internal Combustion Engines in Railroad Work: R. P. C. Sanderson, chairman; M. K. Barnum, C. M. Mendenhall, JOHN A. Hill.
7. Subjects: A. E. Manchester, chairman; Howard Stillman, Alfred Lovell.

In addition to the above it is expected there will be three or four papers by individual members of the association; and these, together with the topical discussions, will complete the program for the work of the next convention.

NEW FLUE CUTTING MACHINE.

A very efficient machine for cutting out flues in locomotive boilers has recently been developed at the Burnside shops of the Illinois Central Railroad. The accompanying engraving shows one of these tools for cutting 2-in. flues from the front end of a boiler. To remove a set of flues requires two of these cutters, one for the front and another for the back end of the boiler. The only differences in the two tools are the diameter of the shank which fits into the end of the tubes and the location of the knife in the shank. The cutting action is accomplished by means of a small knife, shown in the lower part of the engraving, the point of which is brought into action and withdrawn by means of a 3/8-in. pin, one end of which is off-centered in the end of a smaller shank that turns in the body of the tool, and the other end of the pin works in a groove in

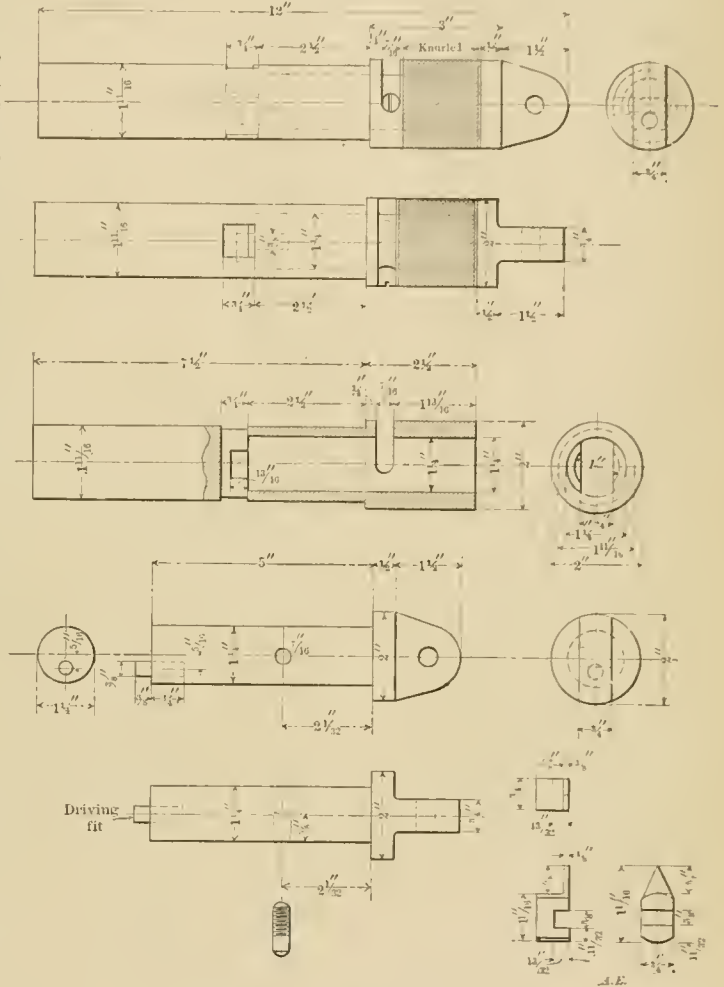

Tool for Cutting Out Boiler Flues.

the knife blade. This shank is allowed to turn through a distance of 180 degrees. When at one end of its path the cutting point is extended its full length and in the other is completely withdrawn. The path through which the shank is allowed to turn is governed by a small screw which travels in a slot in the knurled head of the tool. The machine is operated by an air motor secured to a bracket, not shown in the engraving, and having slots in the ends to make it adjustable for various sizes of smoke arches. The motor is placed centrally with the boiler shell and connected with the flue cutter by a square hollow shaft, making it telescopic, with a universal joint on each end. By this arrangement one setting of the machine will accommodate the entire set of boiler tubes. The time required in cutting out a set of 232 flues from the front end of a boiler, including the time for applying and removing the apparatus, is 1 hour and 25 minutes. We are indebted to Mr. W. H. V. Rosing, Assistant Superintendent of Machinery of the Illinois Central Railroad, for information and drawings from which this engraving was prepared. The machine is now being manufactured by F. B. Redington & Co., 340 West Monroe street, Chicago.

EFFECT OF HEAT ON BABBITT METAL

Almost any solid metal for lining bearings is called by the name "babbitt metal," while in fact few of the soft linings used have any claim whatever to that title. The genuine alloy which was compounded by John Babbitt, and which bears his name, is composed of eight parts of regulus of antimony (regulus means the pure, refined metal), four parts copper and ninety-six parts of tin.

Ordinary soft lining, so-called babbitt metal, frequently is made up of four parts lead and one part antimony. Old type metal is also used for lining, and consists of two parts lead, one part tin, and one part antimony. Britannia metal (pewter) is much used for lining, and this consists of nine parts tin and one part antimony.

It will be noted that all the alloys above described are partly of antimony, and also contain either lead or tin, both easily oxidized metals. But antimony is even more easily oxidized, and will burn in the open air if too highly heated, much like zinc. Thus, when either of the alloys described above is frequently heated, the different metals become oxidized, but burn out in different ratios to each other, thereby changing the nature of the alloy to a certain extent each time it is heated.

Genuine babbitt will probably change its form more by reheating than the alloys of antimony and lead, but the latter are reduced the most in quantity. The reason, therefore, is that the copper and tin oxidize more slowly than the antimony, which quickly burns out, leaving the babbitt much softer than it was before getting rid of some of its antimony. Lead oxidizes much more freely than either copper or tin, therefore the alloy retains more nearly its original composition when a quantity is burned off or oxidized; still the antimony burns out faster than the lead, reducing the hardness of the alloy, but not to the extent it does when mixed with tin and copper. Under proper conditions, any kind of babbitt metal may be melted, and even kept indefinitely in a molten condition without oxidation, or, in every-day language, without the forming of dross on the surface of the molten metal. To secure this result, protect the metal from the atmosphere. A layer of dirt on top of the molten metal will do it; even a layer of oxide or dross is a good preventive; therefore do not skim off the layer of oxide as it forms, but let it stay on top of the hot metal.

A very good way is to cover the metal in the ladle or melting pot with pulverized charcoal. Carbon largely retards the process of oxidation, and if some salt and soda (common washing and cooking soda) be added to the coarsely powdered charcoal, the oxide will be reduced—that is, the dross will be smelted back into the metal again.

Another preventive of oxidation of babbitt metal lies in not heating the metal too hot. For all except very small bearings where the layer of metal must run very thin, there is no need of heating the metal very hot. Just hot enough to barely char a dry pine stick, is a good rule to follow when heating babbitt metal. But whittle the stick every time the metal is tested, so that a fresh wooden surface is exposed thereto.—Modern Machinery.

In support of the principle of distribution of power and long-distance transmission by compressed air, an interesting account of the distribution system of natural gas by the Pittsburgh Company, of Pittsburgh, is published in a recent number of "Compressed Air." The West Virginia system of pipes alone contains upward of 200 miles of pipes, none of which is less than 8 in. in diameter. The entire product is forced to the city by its own well pressure, which is so regulated as to produce about 265 lbs. at the West Virginia end. There are other plants of this description in the gas regions of the United States, the lines in some cases being 70 miles long. This company has a total of about 1,300 miles of pipe, most of which is worked at a fairly high pressure. This is good evidence that air can be transmitted successfully and economically.

A WASTE-HEAT ENGINE.

The fundamental principle of this waste-heat engine is to increase the total usefulness of the ordinary condensing engine by using a part of the heat that is given off as a waste, to do useful work. This is accomplished by Professor E. Josse, of the Royal Technical High School of Berlin-Charlottenberg, by using the ordinary surface condenser, into which the steam of the engine exhausts, as a boiler for evaporating sulphur dioxide (SO₂). Part of the heat in the condensing water is thus used to evaporate the sulphur dioxide, which is in turn used to drive a vapor engine. This second engine is connected with a condenser, from which the sulphurous acid is drawn off by a little vapor pump and returned to the original condenser of the steam engine.

Sulphur dioxide vapor, at a temperature of 140 degs., which corresponds to a vacuum of 24 ins. in the cylinder of an engine, is known to have a pressure of 156.6 lbs. per square inch absolute; and at 60 degs., the temperature of the condenser cooling water, it has a pressure of 40.8 lbs. per square inch absolute. It will readily be seen that under these conditions the sulphur dioxide may be used for developing power in the cylinder in expanding from 156.5 lbs. to 40.8 lbs. per square inch.

The engine used for experimental work in this connection is a 150-horse-power triple-expansion engine, installed at the Technical High School of Berlin-Charlottenberg. It has cylinders 10 $\frac{1}{2}$ and 16 15/16 and 26 9/16 by 19 11/16 ins., the vapor cylinder having a diameter of 16 15/16 ins., and the same stroke as the steam piston. The steam condenser or vaporizer has 753 ft. of cooling surface, and the sulphur dioxide condenser 1,720 sq. ft.

Tests of the steam engine alone and of the combined engines show that the steam consumption per i. h. p.-hour was reduced to 8.34 lbs. The total output was 170 i. h. p.-hours. Of the total power of the engine about three-quarters of one per cent. is required to run the sulphur dioxide feed pump.

From the data now available, Prof. Josse believes that in large combined engines of a capacity from 1,200 to 2,000 horsepower, the steam consumption would be reduced to 7 lbs. per i. h. p.-hours, but in small steam plants, or where operation is only for a few hours each day, he does not consider this engine suitable. With the use of the waste-heat engine every precaution must be taken to have all joints and packings perfectly tight, as sulphur dioxide is readily oxidized when in the presence of atmospheric air or water, and forms sulphuric acid, which has a destructive effect on the metal. It is stated that no trouble has been experienced from this source, and examinations of both the vapor engine and condenser, after more than a year's operation, show them to be in perfect condition. One of these engines is now in operation in one of the stations of the Berlin Electric Lighting Company. The steam engines are 360 horse-power, and consume about 40 lbs. of steam per i. h. p.-hour. The vapor engine installed utilizes 175 horse-power from the waste heat of the steam engine.

Returns from the letter ballot of the M. C. B. Association on questions submitted after the recent convention, show that all of them are decided in the affirmative, that is, they are all adopted.

Mr. J. N. Barr, Mechanical Superintendent of the Baltimore & Ohio, has accepted the position of Mechanical Superintendent of the Erie. Mr. Barr has had a very successful experience, both as a mechanical officer and as an administrator. He began his railroad career in the Pennsylvania shops at Altoona. From 1885 to 1899 he held consecutively the positions of Mechanical Engineer, Superintendent of the Car Department and Superintendent of Motive Power of the Chicago, Milwaukee & St. Paul. On November 1, 1899, he became Mechanical Superintendent of the Baltimore & Ohio, which position he now leaves for his new appointment.

A WELL-ARRANGED BRASS FOUNDRY.

Special attention is being given at this time to the better equipping of brass foundries in railroad shops, and to those having the subject under consideration, the accompanying engravings, showing the general lay-out of a brass foundry that has given excellent service in a plant for making brass fittings for steam and gas, may be suggestive. This foundry, described in a recent issue of the "American Machinist," is about 45 ft. wide and 60 ft. long, and, as will be seen from Fig. 1, provision is made for six molders. Instead of the usual arrangement of troughs for holding the sand and flasks while

the advantage of plenty of sand always ready in two piles, one at the upper end and a second pile to the right of the entrance to the stall. While one heat is being poured the second pile of sand is shoveled to the back end ready for use. Such tools as are used by the molder are hung on pegs, or placed within easy reach of the operator.

In the construction of the furnaces two pulley rims marked a in Fig. 3 have been used. These rims are about 34 ins. in diameter, with a 13-in. face 1 in. thick. The top and bottom plates, b, are made of cast iron, with two bars, c, 1½ ins. thick, placed one on each side of the two bottom plates to allow space for the cast iron grate bars marked d. These grate bars

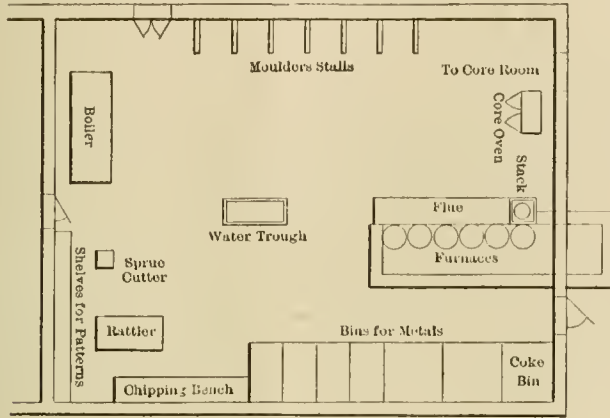

Fig. 1.—Plan View of Foundry.

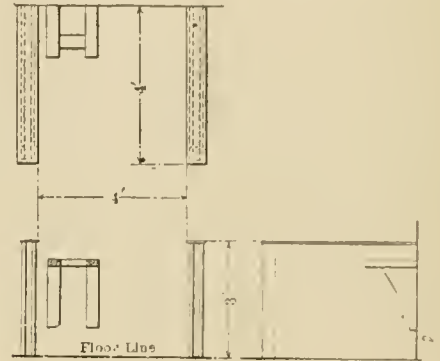

Fig. 2.—Molding Stall.

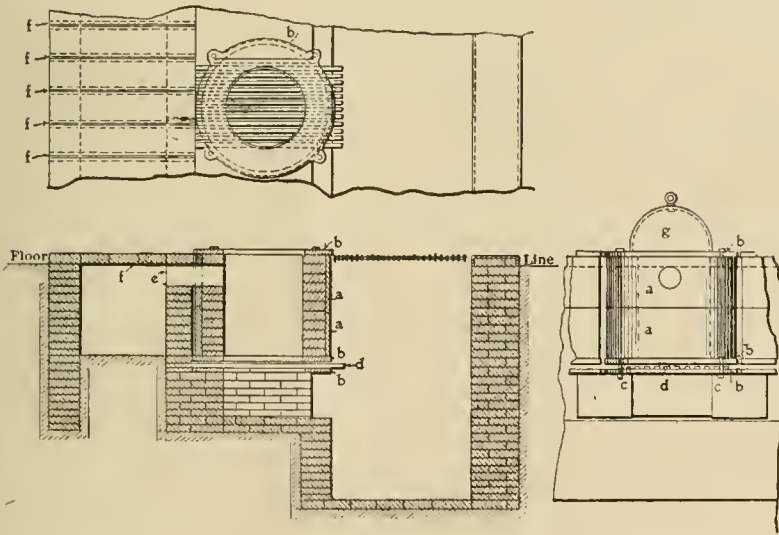

Fig. 3.—Brass Furnace.

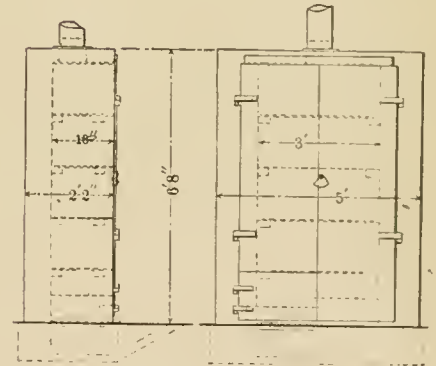

Fig. 4.—Core Oven.

the molds are being made, the stall system is used. These molding troughs, which are common in most foundries, have the objection of not holding sand enough for more than one heat, and as a molder usually puts up three heats in a day, he is obliged to use the hot sand over again, which is not conducive to the best castings and in warm weather is very trying on the men. Fig. 2 shows the arrangement of one of the molding stalls as they are used in this foundry. Each stall is 4 ft. long, 4 ft. wide and 3 ft. high, made of 1-in. hemlock plank. A bracket of 2 by 4-in. hemlock is fastened to the wall of the stall at a convenient height for the molder and the ledge on the left partition of each stall provides a place for the patterns, matches, etc., as they are taken from the mold. By this stall arrangement each molder has the advantage of a large window which furnishes plenty of light and air and also has

are 1 in. square and 40 ins. long; the ends, d, projecting beyond the furnace for the purpose of shaking or dumping the fire. The lining of the furnace is of rectangular fire-brick, which is cheaper and easier to obtain than the segmental shapes. In using the rectangular brick care should be taken to fill all the crevices with fire clay and the space between the brick and casing with pieces of old fire-brick and clay. Each of the six furnaces is connected to a large brick flue, f, by small flues, e, made of 6-in. wrought iron pipe. The main flue is built of common brick, and so constructed that six more furnaces can be built on the opposite side when necessary. To support the brick top of this flue, cast iron T-rails are used. The flue leads to a stack 20 ins. in diameter by 40 ft. high and furnishes excellent draft. In front of the furnaces, which are set upon brick piers, is a pit deep enough for a man to walk in, while

removing the ashes. The pit as shown in Fig. 1 extends outside of the building so that the handling of ashes does not come into the foundry. To keep the pit clean and free from water there should be a sewer connection, with the bottom of the pit sloping to the opening.

A very effective furnace for baking cores is shown in Fig. 4. It is very simple and can be built cheaply. The walls and top of the oven are common brick with cast-iron tee-bars used only to hold the top bricks in position. Two doors made of sheet iron are placed on the fire side so as to get at the fire without exposing the entire oven. The same pattern of cast iron grate bars is used as in the brass furnace. The shelves for holding cores may be made of 3-16 or 1/4-in. boiler plate, punched full of 3/4-in. holes or made of cast iron. In the case of the latter they do not warp, but the expense of the pattern hardly justifies their use. The fuel used for both the furnace and oven is gas-house coke and is stored away in the yard outside of the foundry; only enough for a single day's run is brought to the coke bin shown in Fig. 1, in connection with the bins for metals. The core room is attached to the main building, not shown in the engraving.

In the center of the floor of the foundry will be noticed a trough for running water used in dipping castings. To obtain a rich color such as seen on valves and cocks, it is necessary to set the color by dipping at a certain temperature, although the same color is procured in a cheaper metal by dipping in acid. The use of water has the advantage that it causes the cores to be blown out, leaving the inside of the castings clear and thus saving considerable expense. For convenience in lifting and carrying the crucibles to a clear space on the floor for skimming and making ready to carry to the molds, a trolley and chain hoist is placed over the furnace. The floor of the foundry is paved so that by sweeping each day, the brass that is spilled in pouring is saved. In this floor a hard brick is used, but for hard service the vitrified brick would doubtless be the cheaper in the end.

PERSONALS.

Mr. L. R. Johnson has been appointed Assistant Superintendent of Rolling Stock of the Canadian Pacific.

Mr. M. J. Collins has been appointed Assistant General Purchasing Agent of the Atchison, Topeka & Santa Fe system, with offices at Chicago, Ill.

Mr. D. J. Durrell, Mechanical Engineer of the Pennsylvania Lines, at Columbus, O., has been appointed Assistant Engineer of Motive Power of the Southwest system.

Mr. W. C. Dallas has been appointed Assistant Superintendent of the Locomotive and Car Department of the Missouri-Pacific system, with headquarters at St. Louis, Mo.

Mr. J. H. Watters, Master Mechanic of the Louisville & Nashville at Anniston, Ala., has resigned to accept the position of Master Mechanic of the Georgia Railroad at Augusta, Ga.

Mr. Thomas Tipton, formerly Purchasing Agent of the Rio Grande Western, has been appointed Assistant Purchasing Agent of the Denver & Rio Grande, with headquarters at Denver, Colo.

Mr. G. R. Joughins, Mechanical Superintendent of the Intercolonial, at Moncton, N. B., has resigned. Mr. Joughins was formerly Superintendent of Motive Power of the Norfolk & Southern, and has had a successful railroad experience.

Mr. Lester S. Carroll, Assistant Purchasing Agent of the Chicago & Northwestern and the Fremont, Elkhorn & Missouri Valley, has been appointed Purchasing Agent, with headquarters in Chicago, in place of Mr. Charles Hayward, resigned.

Mr. A. A. Maver has been appointed Master Mechanic, in charge of the Montreal shops of the Grand Trunk, to succeed

Mr. J. E. Muhlfield, resigned. Mr. T. A. Summerskill has been appointed Master Mechanic of the Northern Division, with headquarters at Allendale, Ont., in place of Mr. W. Ball, resigned.

Mr. A. McCormick, Master Mechanic of the Rock Island & Peoria, has been appointed Master Mechanic of the southwestern division east of the Missouri River of the Chicago, Rock Island & Pacific, to succeed Mr. John Gill, resigned. Mr. McCormick will have charge of the locomotive and car departments, with headquarters at Trenton, Mo.

Mr. C. H. Wiggin has been promoted to succeed Mr. P. M. Hammett as Assistant Superintendent of Motive Power of the Boston & Maine, with headquarters in Boston. Mr. Wiggin has been connected with this road for a number of years and in 1891 was appointed Master Mechanic at Concord, N. H., of the Concord and White Mountains divisions. He is succeeded in that position by Mr. D. E. Davis and Mr. Davis is succeeded as Master Mechanic at Boston by Mr. C. B. Smith.

Mr. Charles T. Bayless has been appointed Mechanical Engineer of the Mexican Central Railway, with headquarters in the City of Mexico, Mex. He has acted in the capacity of Mechanical Engineer for about five years under the title of Chief Draftsman. The present appointment is the first time this position has been established officially on this road. Mr. Bayless was formerly associated with the late David L. Barnes in Chicago, and had to do with a large number of designs of well-known equipment specialties.

Mr. A. E. Mitchell, Mechanical Superintendent of the Erie Railroad, and one of the best-known Motive Power officials in the railroad field to-day, has resigned after 15 years of service with that road. Prior to his service on the Erie he was an apprentice in the Baldwin Locomotive Works and Altoona shops, was afterward with the Yale & Towne Manufacturing Company, and for several years in a variety of railroad and manufacturing service. Since 1886 he has held the positions of engineer of signals, engineer of tests, mechanical engineer and superintendent of motive power of the Erie Railroad, the last title having been recently changed to mechanical superintendent.

Mr. Amos Pillsbury has retired from the position of Superintendent of Motive Power of the Maine Central at his own request after many years of faithful railroad service which began in 1852 as machinist on the New York, Hartford and Springfield Railroad. From 1853 to 1855 he worked as a machinist on the Baltimore & Ohio; from 1855 to 1880 he was machinist, general foreman and master mechanic of the Hartford, Providence & Fishkill; from 1880 to 1881 Master Mechanic of the Cleveland, Akron & Canton Railroad; from 1881 to 1885, Superintendent of Rolling Stock of the Eastern Railroad; from 1885 to 1894, General Master Mechanic of the Maine Central, and since 1894, Superintendent of Motive Power of that road.

Mr. F. D. Casanave has resigned as General Superintendent of Motive Power of the Pennsylvania Railroad to succeed Mr. J. N. Barr as Mechanical Superintendent of the Baltimore & Ohio. Mr. Casanave has been connected with the Pennsylvania since 1862, when he entered the Altoona shops as an apprentice. After completing the apprenticeship he entered the drafting room, where he remained until 1875. He served about one year as inspector of locomotives and after being detailed for special work in the department was made Assistant Master Mechanic at Altoona in 1876. From 1881 to 1887 he was Master Mechanic at Fort Wayne and from 1887 to 1893 Superintendent of Motive Power of the northwest system of the Pennsylvania Lines. In March, 1893, he was appointed General Superintendent of Motive Power of the Pennsylvania Railroad lines east of Pittsburg and Erie.

Mr. Philip M. Hammett has been appointed Superintendent of Motive Power of the Maine Central to succeed Mr. Amos Pillsbury, who retires from that office at his own request after a long term of faithful service. Mr. Hammett is 34 years of age and has a remarkable record in motive power service. After graduating from Harvard University in 1888 he completed his engineering education at the Massachusetts Institute of Technology in 1890, and entered the mechanical department of the Pennsylvania Railroad as a special apprentice. From this time his advancement has been rapid. In 1893 he was made general foreman of the Wilmington shop of the P. W. & B. Railway and in 1896 Master Mechanic of the Boston & Maine. The latter position he held for four years, until his appointment as Assistant Superintendent of Motive Power of that road in September of last year. He goes to the Maine Central with an excellent experience and preparation, both technical and practical.

TEN-WHEEL NARROW-GAUGE PASSENGER LOCOMOTIVE.

New Zealand Government Railways.

American Locomotive Company.

At the Brooks Works of the American Locomotive Company a 10-wheel passenger locomotive has just been completed for the New Zealand Government Railways. As shown by the accompanying photograph, this is a neat and attractive de-

Firebox, width	29½ ins.
Firebox, depth, front.....	56 ins.
Firebox, depth, rear.....	13 ins.
Firebox, material	Steel
Firebox, thickness of sheets.....	Crown, ¾ in.; tube, ½ in.; side and back, 5/16 in.
Firebox, brick arch.....	Self supporting
Firebox, mud ring, width.....	Back, 3 ins.; sides, 2½ ins.; front, 3½ ins.
Firebox, water space at top.....	Back, 4 ins.; sides, 4 ins.; front, 3½ ins.
Grate, kind of.....	Cast iron, stationary
Tubes, number of.....	220
Tubes, material	Steel
Tubes, outside diameter.....	1¾ ins.
Tubes, thickness	No. 13 B. W. G.
Tubes, length over tube sheet.....	12 ft. 7 1/16 ins.
Smoke box, diameter outside.....	54 ins.
Smoke box, length from tube sheet.....	55½ ins.
Exhaust nozzle	Single

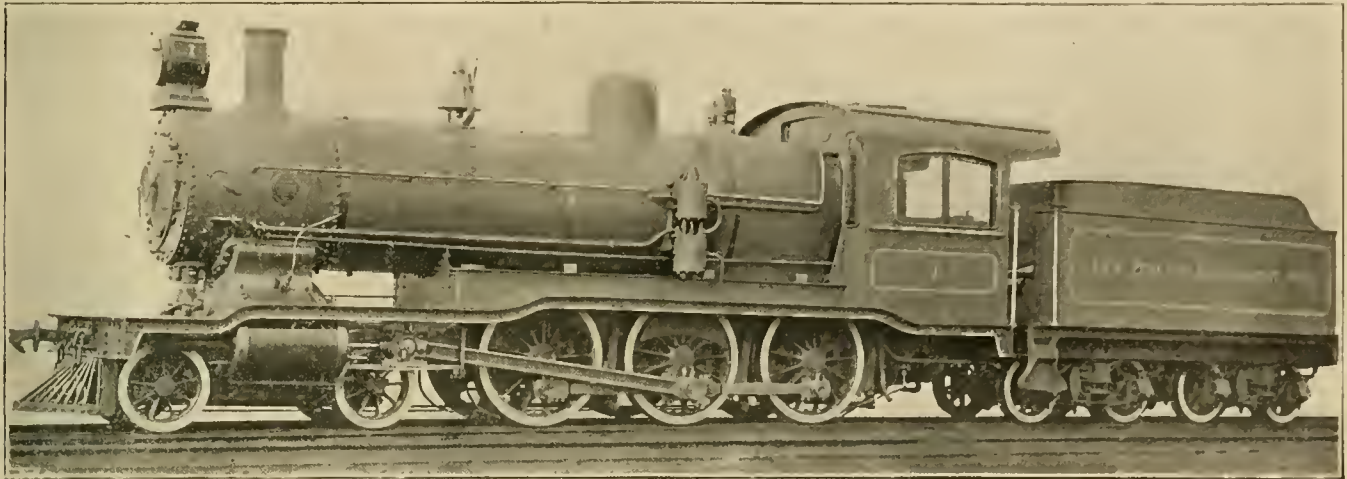

Narrow-Gauge Passenger Locomotive.—New Zealand Government Railways.

sign, somewhat heavier and larger than the Baldwin freight engine for the same road illustrated in our September number. The passenger engine has a Belpaire boiler, piston valves, extended piston rods and, except as to the running hoars, sand boxes, and the arrangement of the front deck, strongly resembles American practice in light engines. The chief dimensions are as follows:

General Dimensions.

Gauge	3 ft. 6 ins.
Kind of fuel to be used.....	Bituminous coal
Weight on drivers.....	64,500 lbs.
Weight on truck.....	27,000 lbs.
Weight, total.....	91,500 lbs.
Weight of tender, loaded.....	57,000 lbs.
Wheel base, total of engine.....	18 ft. 3 ins.
Wheel base, driving.....	10 ft. 0 in.
Wheel base, total, engine and tender.....	40 ft. 6 ins.
Length over all, engine.....	29 ft. ¾ in.
Length over all, total engine and tender.....	46 ft. 9 ins.
Height, center of boiler above rails.....	6 ft. 8½ ins.
Height of stack above rails.....	11 ft. 5½ ins.
Heating surface, firebox.....	91 sq. ft.
Heating surface, tubes.....	1,260 sq. ft.
Heating surface, total.....	1,351 sq. ft.
Grate area	16.7 sq. ft.
Drivers, diameter	50 ins.
Drivers, material of centers.....	Cast steel
Truck wheels, diameter.....	30 ins.
Journals, driving axle.....	6½ ins. by 8 ins., with enlarged wheel fit
Journals, truck axle.....	4½ ins. by 8 ins.
Main crank pin, size.....	5 ins. dia. by 4½ ins. long
Main coupling pin, size.....	5½ ins. dia. by 3¾ ins. long
Main pin, dia. wheel fit.....	5¾ ins. dia.
Cylinders, diameter	16 ins.
Piston stroke	22 ins.
Piston rod, diameter.....	2¾ ins.
Main rod, length center to center.....	115½ ins.
Steam ports, length.....	17¾ ins.
Steam ports, width.....	1¾ ins.
Exhaust ports, least area.....	25 sq. ins.
Bridge, width	23½ ins.
Valves, kind of.....	Improved piston
Valves, greatest travel.....	4¼ ins.
Valves, steam lap (inside).....	1 in.
Valves, exhaust lap or clearance (outside).....	Line and line
Lead in full gear.....	1/16 in.
Lead, constant or variable.....	Variable
Boiler, type of.....	Improved Belpaire
Boiler, working steam pressure.....	200 lbs.
Boiler, material in barrel.....	Steel
Boiler, thickness of material in shell.....	½ in., 9/16 in. and 7/16 in.
Boiler, thickness of tube sheet.....	½ in.
Boiler, diameter of barrel front.....	51 ins.
Boiler, diameter of barrel at throat.....	55¼ ins.
Boiler, diameter at back head.....	51 ins.
Crown sheet, stayed with.....	Direct stays
Dome, diameter	22 ins.
Firebox, type of.....	Sloping
Firebox, length	84 ins.

Exhaust nozzle, diameter.....	3¾ ins. and 4 ins.
Exhaust nozzle, distance of tip below center of boiler.....	1 in.
Netting, wire or plate.....	Plate
Netting, size of mesh or perforation.....	¼ in. by 1¼ in.
Stack, straight or taper.....	Taper
Stack, least diameter.....	12¼ ins.
Stack, greatest diameter.....	13¾ ins.
Stack, height above smoke box.....	30 ins.

Type	Tender.
Type	8-wheeled steel frame
Tank, type	Straight top
Tank, capacity for water.....	2,100 gals.
Tank, capacity for coal.....	5 tons

Mr. Lewis R. Pomeroy, who is well known to our readers, recently resigned his position with the Schenectady Locomotive Works to become special representative of the railway department of the General Electric Company, with office at 44 Broad street, New York. With the present activity in new shops and in rearranging old ones to secure the remarkable advantages of electrical distribution of power and the many questions which are continually arising concerning the application of electric traction to heavy railroad traffic, this field is a most important one, requiring the best attention of those who are conversant not only with the possibilities of electric machinery, but with the needs of the railroads in respect to it. Mr. Pomeroy combines these qualifications in an admirable way, and with his wide railroad acquaintance is prepared to fill a need which has long been felt. Both he and the General Electric Company are to be congratulated upon the appointment.

Mr. John E. Muhlfeld has resigned as Master Mechanic of the Montreal shops of the Grand Trunk Railway to become Superintendent of Machinery and Rolling Stock of the Intercolonial Railway, with headquarters at Moncton, N. B., to succeed Mr. G. R. Joughins, resigned. Mr. Muhlfeld is 29 years of age. He entered Purdue University in 1889, spending his summer vacations in construction work on the Peru & Detroit Railway, and as machinist and apprentice in the Fort Wayne shops of the Wabash. From 1892 to 1894 he was machinist and charginan at Fort Wayne shops. Since this time he has worked through the responsible positions of round-house foreman, general shop foreman and general foreman in charge of locomotives and cars on the same road. In 1899 he became Master Mechanic of the Grand Trunk at Port Huron, Mich., and later transferred to the Montreal shops, which position he held up to the time of his present appointment on the Intercolonial.

NEW FRICTION DRAFT GEAR.

National Car Coupler Company.

A drawing of a new design of friction draft gear upon which a patent application has been filed, has been received from Mr. J. A. Hinson, President of the National Car Coupler Company, Chicago. Its object is to increase the resistance of the draft gear to withstand the shocks of pulling and buffing in such a way as to avoid the difficulties with increased recoil which

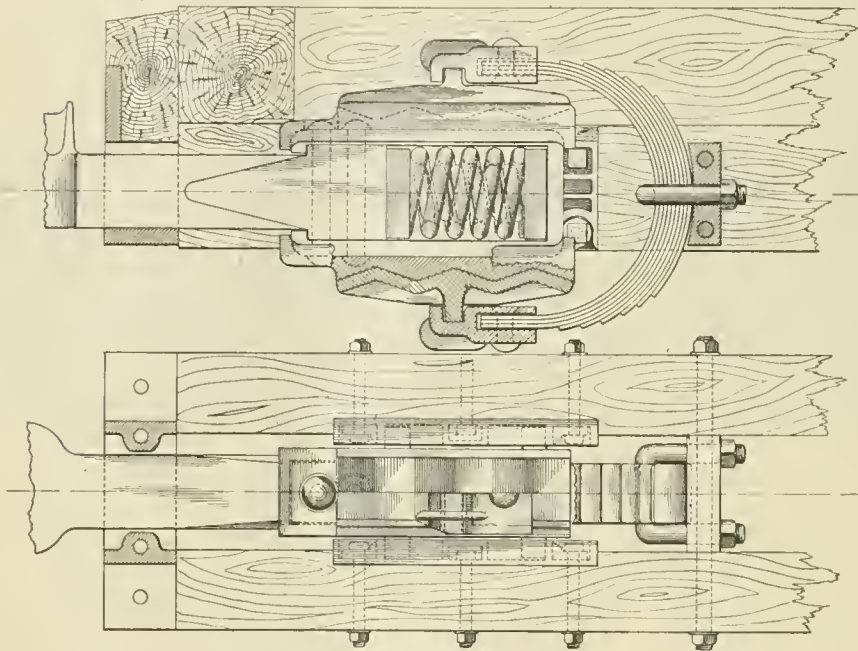

New Friction Draft Gear.

would be troublesome if the increased resistance should be introduced through the direct action of springs on the draw-bar. This construction makes use of a bow spring attached to the draft sills, the movable ends of which bear against two mating pieces with inclined faces which are capped over the draw-bar yoke. When the draw-bar is pushed or pulled, these inclines open the bent spring, causing an increased frictional resistance upon the movement of the draw-bar. The capacity of the spring may be made to suit the desired conditions. Its construction is such as to permit of attachment to any form of draft rigging using a draw-bar yoke. It has been specially designed to meet the requirements of cars now in service with inadequate draft gear, to which it may be easily applied in the shop. Further information may be had from the National Car Coupler Company, 621 Monadnock Building, Chicago.

A SHORT-SIGHTED POLICY AS TO SHOP MACHINERY.

The success of Andrew Carnegie as a manufacturer has been due in a large measure to his thorough understanding of the value of the most improved machinery and he has been spoken of as the greatest "scrapper," meaning that he has for years made apparently enormous sacrifices of good machinery simply because better and more productive machinery was available. The same is true to a greater or less degree of all manufacturers and is in marked contrast with the policy of nearly all railroads, as has been repeatedly indicated in these columns. Mr. H. F. J. Porter, of the Bethlehem Steel Company, made the following pertinent remarks on a subject closely allied to this, before the American Water Works Association recently:

"During a recent visit to the shops of one of the great trunk

lines of the country, the writer was surprised to find that although all the men he met were intelligent and progressive in their ideas, he could discover no evidence of the application of these ideas in the adoption of modern methods of organization and management in the shops. Machinery and tools were old, and evidently the work they were doing was costing much more than it could have been done for elsewhere. On inquiry for the cause of this condition of affairs, the blame was laid on the Board of Directors, which, they said, looked upon the shops as a necessary evil and merely tolerated their existence, cutting down the amount of all appropriations asked for for new equipment. The superintendent of machinery said that after many futile endeavors to obtain an outfit of air-compressor and pneumatic tools, which are now the necessary adjuncts of every modern shop of the kind, he had actually started to build the whole thing himself. He said it would cost the road ten times as much as it could be bought for and take a long time to complete, but that the road would save money over present practice. It would seem as if in this case a 'getting together' of the powers for a full discussion of the situation would have uncovered the matter and that his usefulness to the road would in the future be diverted in another direction."

This, it must be admitted, does occur far too often and it reveals a deplorable lack of appreciation of the repair shop, but with keener insight into the meaning of locomotive statistics and with the increasing watchfulness of those who are most interested in comparing the cost of repairs, the number of such cases will rapidly decrease. The exigencies of the service and the large amounts invested in modern large locomotives will work a reform in this direction. We wish that every manager would consider Mr. Porter's criticism and suggestion as to "getting together." It would hasten the reform.

AIR FANS FOR COOLING AND VENTILATING PASSENGER CARS.

A very ingenious device has just been perfected by the Safety Car Heating and Lighting Company for cooling and ventilating passenger cars. The device consists of a system of fans, two of which are placed in each car and operated by compressed air, the air being supplied by an additional air-brake pump on the locomotive. From the engine the air is conveyed through the steam pipe the length of the train.

These air fans possess many inherent advantages over other styles of fans heretofore used. One of the principal advantages is found in the fact that the air is not only stirred up by the revolution of the fans, but a considerable amount of fresh cold air is introduced into the car as long as the fans are in operation. There is no motor used in this case, as the fans are made to operate as a reaction wheel, on the same principle as a garden sprinkler is made to turn by the flow of water. The fan, complete, weighs only 6 lbs., and can be placed in any position in the car that may be desired. A train on the New York Central Railroad has just been equipped with this system, and two fans have been in operation in a Pullman car running on the Erie Railroad, between Jersey City and Tuxedo, for some time. Only good reports have been heard from all those who have looked at the device, and there is no doubt but that its introduction will result in adding greatly to the comfort of the traveling public.

FORCE FEED LUBRICATING PUMPS AND DASH POT VALVES.

The Dorn & Marcellus Company, of Philadelphia, has placed on the market a force feed lubricator pump for lubricating the cylinders of steam engines, steam pumps, steam hammers, and pumping coal oil into the bottom of boilers to remove scale; also to lubricate the different bearings on all kinds of machinery and gear tools. These pumps, of which the accompanying engraving is a representative, are composed of very few parts, made of the best material, and consequently reducing the wear of the machine to a minimum. They are positive in their action, economical, safe and reliable, and are constructed with a cam motion, which does away with teeth on the gear wheel. The power necessary for operating the pump is taken from the eccentric of the engine, the pump being set in line with some working part of the engine

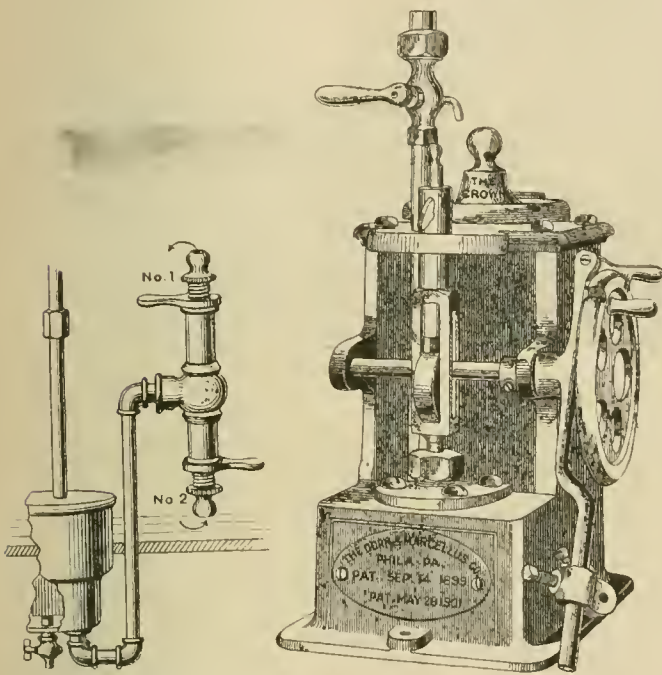

Dash Pot Valve. Automatic Lubricating Pump. Manufactured by Dorn & Marcellus Company.

with a stroke not longer than three inches. The feeding is done automatically, starting the flow of oil as the engine starts, and cutting off the supply when the engine stops. To feed the oil by the drop or a continuous stream, the stroke is varied by moving a bar on top of the piston rod, thus giving a one-quarter, one-half, full stroke, or cutting off the supply entirely. These pumps are made to hold from 1/2 to 3 gals. of oil, with one to six pumps on the same shaft, and can be operated singly or severally, saving from 40 to 50 per cent. of oil.

The dash-pot valve, also illustrated in the accompanying cut, has become standard for the governing of the vacuum pots of Corliss and Green engines and ice machines. They cut off regularly, reduce the strain on the crab claws and are particularly valuable where great variations in load are encountered. The pistons can be made to lift from 25 to 50 lbs. easily, according to the size of the engine. Every dash-pot engine, old or new, should be equipped with these valves, as they will stop dancing and pounding in an engine. They are good for years of wear, as they contain no springs and have steel ball valves. There are thousands of these valves in use, reported to be giving universal satisfaction. The address of the Dorn & Marcellus Company is Mascher and York streets, Philadelphia, where information and printed matter can be obtained by those interested in dash-pot engines.

GEORGE WESTINGHOUSE ON CHEAP ELECTRICAL POWER FOR RAILROADS.

In a letter to the London "Times" concerning the advantages of electric traction for the transportation problem of London, Mr. George Westinghouse recently offered some important observations. As to the effect upon traffic he said:

"The electric propulsion of vehicles, already well extended, admits of such radical departure from the old way as to suggest that we may, by discarding many of our old ideas and methods, have a veritable revolution in the prevailing practice. This point is illustrated by the fact that an electric railroad, upon which single cars are run at frequent intervals for a distance of about 45 miles, parallel to one of the standard railroads in the United States, is, after being two years in operation, carrying twenty times as many passengers as were formerly carried by the steam railroad between the same points."

The large amounts of power required for heavy traffic render the selection of generating methods most important, and because of his prominence in the development of the large gas engine the views of Mr. Westinghouse on the possibilities of gas engines and producers for large units should be most carefully considered. He is a thorough believer in the internal combustion engine. On this subject he says:

"Of great importance to those who invest capital in these undertakings are the facts with reference to the cheaper generation of electric energy—which means the cost of power—since the first outlay for a plant is of far less importance than the continued cost of operation. The saving to be effected by the use of large gas engines supplied by producer gas will equal an amount which will represent an interest on about twice the estimated cost of a given power station of the modern type. The far-reaching effect of the cheap production of electricity can only be appreciated by going most carefully into the subject. Suffice to say, however, that it is only by means of a much cheaper method of generating electricity than by the use of steam engines of even the best type, that one can hope to effect such economies as will justify the great railroads in operating all of their suburban trains by electricity.

"Roughly stated, the expense for fuel and labor for the production of electricity by a gas engine equipment will not be greatly above one-third of that of the highest type of steam plant, while, in comparison with the average steam plant, the fuel consumption and cost will not exceed one-quarter. The decreased cost of production of electricity by means of gas engines, as compared with the present steam engine plants, would enable a board of trade unit to be sold at so low a figure as to justify a wide use of the electric current for cooking and heating purposes.

"In discussing the importance of the cheaper generation of electricity by means of gas engines and producer gas, one is met by much scepticism and frequently by the arguments of people having contrary interests. A sufficient answer to the sceptic and the interested party is the fact that apparatus will be supplied and results guaranteed. Representatives of large interests, ignoring what has heretofore taken place, have observed that to put in a large gas engine plant would be a great experiment; but on this point one may reply that it would be a much greater experiment to now establish a modern steam engine alternating generating plant, and in view of what can be accomplished with such economies with the gas engine, a far greater risk."

Prof. E. Josse, of the Royal Technical High School, of Berlin-Charlottenberg, in order to test the relative advantages of triple and compound expansion engines where superheated steam is used, recently made a number of experiments with the intermediate cylinder cut out. The engine used was a 150-horse-power triple-expansion engine, used for electric lighting and experimental purposes at that school. The results of the tests showed the economy to be precisely the same when two cylinders were used as when all three were in service.

HEAVY SILL PLANER, MATCHER AND TIMBER
DRESSER.

The Bentel & Margedant Company.

This is not only a new machine, but is one of the largest of its kind ever built. It was designed specially for very heavy work, such as planing the four sides of car sills and dressing and matching other large timbers. It is known by the manufacturers as No. 74, and will plane two sides up to 24 by 8 ins., or four sides up to 20 by 8 ins. The design throughout is made to handle such heavy work as requires great strength and rigidity.

There are six feed rolls of large diameter, and large journals, powerfully driven by a train of large and wide-faced gears. The rolls are raised and lowered in massive housings

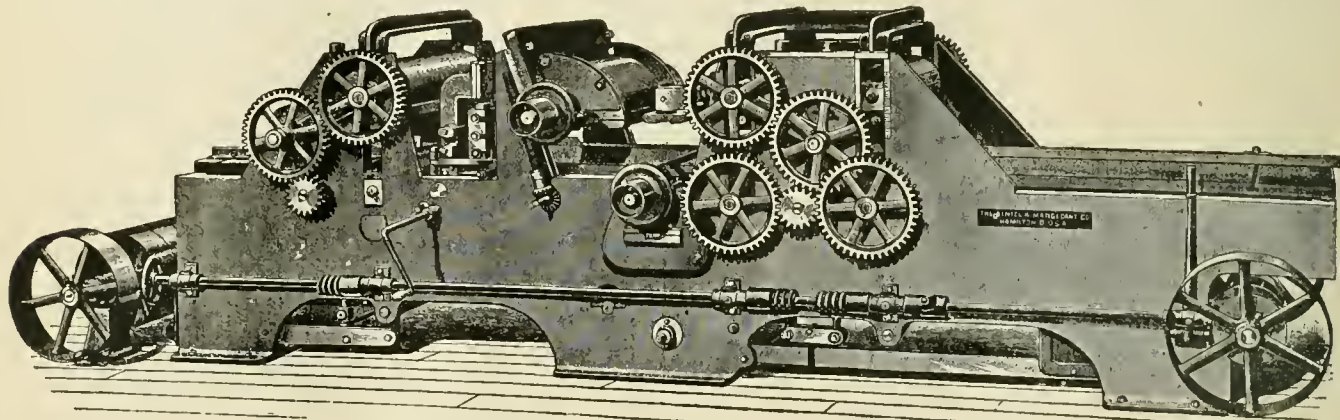

New Sill Planer, Matcher and Timber Dresser.

by means of screws and a system of levers. All the rolls are raised and lowered simultaneously by power, by the operator at the feeding end, where the lever is conveniently located.

The lower head is placed in front, and operates on the material first, which is a feature to which special attention is called, because it provides a smooth surface for the material to slide upon and a surface from which to gauge and measure. It makes a division of the cut between the two heads and allows the parts of the machine to be brought close together. The head is carried in a heavy housing, which is made to slide entirely out of the machine for convenience in sharpening the knives.

Next to the lower head is the upper one, mounted rigidly in large housings, which are raised and lowered by two large screws. The bonnet chip breaker carries an adjustable shoe on the bottom, which may be set close to the knives, or it may be swung entirely out of the way for sharpening or adjusting them.

Housings of an entirely new construction are provided for the side heads. The lower end of the mandrel runs in a step box, where it rests in oil to keep it cool. The manufacturers state positively that it runs without heating. The heads run between two boxes, the upper one being removable to give access to the heads. The tables are cast solid and are provided with gauges and fences.

There are three speed changes in the feed, giving speeds varying from 30 to 65 ft. per minute, and the adjustment of the rate is made by changing the pulleys. Including the countershaft, the whole length of the machine is 17 ft., the width over all being 5 ft. 4 ins. Its weight is about 10,000 lbs., and it is furnished with two countershafts, one at each end. Jointer heads, 8 ins. long, or high, are furnished for the side mandrels. Further information may be had from the Bentel & Margedant Company, Hamilton, Ohio.

Mr. W. S. Aldrich, who was formerly of the firm of Smith & Aldrich, Consulting Engineers, Toronto, Ont., has been appointed to the directorship of the Thomas S. Clarkson School of Technology, Potsdam, N. Y.

LUNKENHEIMER PAN-AMERICAN EXHIBIT.

Visitors to the Pan-American Exposition who are interested in a line of superior brass and iron steam specialties and engineering appliances should not fail to visit the exhibit of the Lunkenheimer Company. This very complete and interesting exhibit is installed in section 46 of the Machinery and Transportation Building. Mr. F. S. Swanberg, who is in charge of the exhibit, will be pleased to explain the merits of these specialties. Among the products exhibited is a complete line of regrinding valves, handy valves, lever throttle valves, pop safety valves, plain whistles, chime whistles, fire-alarm whistles, injectors, sight-feed lubricators, oil cups, grease cups, glass cups, glass-body oil pumps, and a complete line of brass valves and fittings for marine work, in medium and extra-heavy pat-

terns. The headquarters of the Lunkenheimer Company are in Cincinnati. The company also has branches in New York and London.

BOOKS AND PAMPHLETS.

Western Railway Club. Official Proceedings for the club year 1900-1901. Published by the Western Railway Club, Rookery Building, Chicago. Bound in cloth, standard size, 6 by 9 ins. Price, \$2.00.

The very creditable work of this club for the past club year is just issued to its members in a bound and indexed volume. This is the only railroad club that sends out its proceedings in this form, and this is an excellent way to spend the accumulated funds of the club. By this method the membership is not only increased, but the value of the membership is enhanced. Copies of the proceedings can be had by addressing the Secretary, Mr. J. W. Taylor, 667 Rookery Building, Chicago. The price of the volume is \$2, or the regular price of a year's membership.

American Railway Master Mechanics' Association. Proceedings of the Annual Convention, June, 1901. Edited by the Secretary, Mr. J. W. Taylor, Rookery Building, Chicago, Illinois.

The promptness with which the official proceedings of this association appear, in this case but twelve weeks after the close of the convention, is always a surprise. It indicates an activity by the secretary which is undoubtedly appreciated. This year, besides the reports, papers and discussions of the recent conventions, the volume contains the standards of the association complete, and a valuable record of the recommendations with reference to wheels, axles and rules for apprenticeship. In addition to these a summary has been prepared of the resolutions of the association with reference to matters of locomotive practice. These are placed in chronological order, beginning with the convention of 1873. This we consider a most important feature of this volume, and it should by all means be continued and kept up to date. In spite of the fact that the proceedings are now indexed from the beginning, the opinions of the association as established by vote may easily be overlooked, and this summary places them in convenient and readily accessible form.

Proceedings of the Air-Brake Association for 1901. Eighth Annual Convention, held at Chicago, April 30, 1901. Edited by Mr. F. M. Mellis, Secretary of the Association.

This volume of 267 pages contains, besides the regular business of the association and the president's address, the reports of the committees and the discussions in full. The subjects reported upon are as follows: The pressure retaining valve; standard form of questions and answers on the air-brake; terminal test plants; and unconnected hose vs. dummy couplings. The book is a uniform size with previous volume and is bound in paper and also in leather. The price in paper is 50 cents, and in leather 75 cents per copy.

The J. G. Brill Company, of Philadelphia, has just issued a small illustrated catalogue of snow plows for street and suburban railroads. The pamphlet presents a description of several different plows for handling snow and keeping railway tracks in working order through the most severe storms. Besides nose plows and shear plows for double track, a description of their combination electric locomotive snow plow and construction car is given, and also of the Brill track scraper. This catalogue, No. 68, is now ready for distribution.

The Boston Belting Company has just issued their new complete general catalogue of India rubber goods for all mechanical purposes. Besides the illustrations of all articles manufactured by this company and the tables of sizes and prices, the book contains a great many useful suggestions regarding the transmission of power, with rules and examples of how to find the arc of contact of a belt, the horse-power of any belt, the width required to do a given amount of work, the length of belt, directions for lacing, and other practical information concerning rubber belting. The illustrations and presswork of the book are of a high order, which, together with the very complete list of this company's products, makes it a very desirable catalogue. Those who are genuinely interested in mechanical rubber goods can procure a copy by addressing the Boston Belting Co., 256 Devonshire street, Boston, Mass.

Jeffrey Electric Locomotives.—A well-printed, finely illustrated pamphlet, received from the Jeffrey Manufacturing Company, Columbus, O., is devoted to the description of electric locomotives built by them for coal, iron, gold, copper and other mines, for steel works and other large industrial establishments. This company has made a specialty of this subject and is ready to submit specifications and guarantees upon inquiry. In addition to the illustration of locomotives and their parts, electrical equipment and mine rolling stock, the catalogue also contains information concerning other well-known specialties of this company.

Friction sensitive drill presses, with variable speed, without cone pulleys or the shifting of belts, are described in a little pamphlet by the Knecht Brothers Company, Cincinnati, O. The driving is done by an adjustable cone drive which permits of obtaining changes of speed very quickly and conveniently without requiring the operator to change his position. These machines are in satisfactory use on the New York, Ontario & Western, the Burlington & Missouri River, the Terminal Railroad of St. Louis, the Central Railroad of New Jersey, at the Richmond Locomotive Works and other establishments well known to our readers.

Ball and Roller Bearings.—We have received from Mr. W. S. Rogers, Vice-President of the Roller Bearing and Equipment Company, of Keene, N. H., a catalogue of ball and roller bearings, car side bearings and other railroad specialties, which is sure to interest our readers. Mr. Rogers is well known in connection with the Ball Bearing Company, of Boston. He continues the line of work in which he was so successful there, and has added to it the construction of roller side bearings for railroad cars of all classes and for trucks of all the well-known types. There is no better authority than Mr. Rogers in the selection of material and in methods of manufacturing. With a well-arranged factory, new machinery and workmen who have been with him for the past three years, he is in position to meet the most exacting requirements in the specialties mentioned. This catalogue contains a page of instructions to pattern makers, blacksmiths and machinists; also an advertisement and excellent engraving of a "Steamobile" upon the back cover.

The Westinghouse Pan-American Booklet.—This attractive and well-illustrated pamphlet gives a comprehensive idea of the industrial enterprise with which this company is associated, and pictures the very complete exhibits of this group of companies at the Pan-American Exposition, which occupy the central area of the electrical building and the southeast section of the railway building. These exhibits include a very large variety of electrical and railway equipment, much of which is of a new and interesting nature. The pamphlet is intended for distribution from the Westinghouse exhibits at the Pan-American.

Locomotive Data.—This very desirable little book is published by the Baldwin Locomotive Works, Philadelphia, Pa. It is pocket size, 3 by 5 ins., bound in leather, and contains 64 pages, including an index. The subjects treated in this second edition, such as the designation of different classes of locomotives, curves, curve resistance and how to find the radius of curves; hauling capacity; heating surface of tubes; horse-power; piston speed; properties of saturated steam; resistance due to speed, grade, curves, and acceleration of speed; tractive power, etc., are practically unchanged. Some new and convenient tables have been added, and an occasional short descriptive paragraph. The data brought together is of the most useful nature, making it a valuable reference book for all railroad men, and one which they will be glad to have conveniently at hand.

How to Keep Boilers Clean.—This pamphlet is issued by Leonard & McCoy, New York, and contains an illustrated description of the Hotchkiss mechanical boiler cleaner, which is a device for automatically removing all muddy solutions and sediments from the water in a boiler before they have a chance to form scale. Its application is shown to locomotive, marine, upright, flue, cylinder and tubular boilers. The pamphlet also gives some useful information on the subjects of Incrustation and Sediment in Boilers, The Care of Steam Boilers, Foaming and Priming, and The Use of Soda in Steam Boilers, together with valuable receipts, tables, etc. This pamphlet will be sent to those who will write to Leonard & McCoy, 161 Washington street, New York.

The American Steam Gauge and Valve Manufacturing Company, 188 Franklin street, Boston, has just distributed a new catalogue for 1901. It is profusely illustrated and the various specialties are briefly described. In addition to the usual improvements in former designs, this catalogue indicates additional specialties not contained in previous editions. These manufacturers give unusual attention to the testing of their product under actual working conditions, and it is said that, besides the United States Government testing equipment, there is no other equal to theirs in the country. The specialties of this catalogue include gauges and standard appliances for governing, indicating, measuring, recording and controlling steam, water, air, gas, oil and other pressures.

Electric Locomotives for Mine Haulage.—The Baldwin Locomotive Works and Westinghouse Electric & Manufacturing Company have issued jointly a catalogue of electric mine locomotives. The purpose of the book is to call attention to this most convenient and economical form of motive power for mine haulage. The catalogue illustrates a number of single and double-end electric locomotives, together with a brief description of the general features of construction of the latest and most approved types, and it also gives general information for use in determining the size and type of locomotive for general service. The latter half of the catalogue is devoted to illustrated details and a telegraphic code for use in ordering duplicate parts of locomotives. There is also inserted in the book a printed form to be filled out and sent for a preliminary estimate of the cost of electric mine haulage. The catalogue can be obtained from either the Baldwin Locomotive Works, Philadelphia, Pa., or the Westinghouse Electric & Manufacturing Company, Pittsburgh, Pa.

Graphite for Automobiles.—In this little pamphlet, issued by the Joseph Dixon Crucible Company, is printed the experiences of a number of prominent people, who have used graphite as a lubricant for steam, gas and electric automobiles. These experiences may be helpful to others who desire better running of their automobiles. Samples of this graphite compound are sent free to interested parties. The address of the Joseph Dixon Crucible Company is Jersey City, N. J.

The American Sheet Steel Company has just issued a finely-illustrated pamphlet, containing full-page engravings of a large number of their works throughout Pennsylvania and Ohio. A series of interesting views of the interior of a few of these works are also given. The last few pages of the book are devoted to tables of standard sizes of their various products, giving weights of sheets and bundles in pounds. Copies of this booklet will be sent to those who will address the advertising department of the American Sheet Steel Company, Battery Park Building, New York. It is one of the finest trade catalogues of the year.

Steam Hot Blast Heating and Drying Apparatus.—Thirty years of unrestricted progress has developed the Sturtevant products to meet the most peculiar requirements. The great diversity of sizes and arrangements is one of the essential features of these machines. This catalogue, just issued by the Sturtevant Company, shows the latest and most approved designs of exhausters and heaters, and combined fans and heaters. The construction and application of each of the various styles is described, and tables of sizes, weights and general information are given. A part of the pamphlet is given up to illustrations and descriptions of instruments for testing fan systems, and a large number of tables from which pressures in ounces may be transformed into pressures in inches of water, and vice versa. The B. F. Sturtevant Company, with address at Boston, Mass., are publishing independent treatises on ventilation and heating, and on drying, which illustrate the application of this company's apparatus for such purposes.

Summer Outings in California is the title of a very attractive pamphlet which is being distributed by the Atchison, Topeka & Santa Fe Railway. A brief description illustrated by many beautiful pictures of the coast and mountain regions of California is given in this pamphlet. The climate, cost of living and the joys of camp life are discussed. Information as to how to reach the resorts of California and the many places of interest just outside of Los Angeles and San Francisco are included, together with a large map of the Santa Fe lines, which lends its usefulness in planning these little excursions. The Santa Fe system is putting forth every effort to make their service to California the most pleasant and attractive to the large crowds of western tourists who are availing themselves of the considerably reduced rates.

EQUIPMENT AND MANUFACTURING NOTES.

Recognizing the fact that centrifugal force is proportional to the weights of the bodies in motion, and that water is nearly 1,600 times heavier than steam, the B. F. Sturtevant exhaust head was so designed that the exhaust steam is given a vigorous whirling motion within the case, thus throwing the water outward with such excessive force as to absolutely prevent its escape through the large central exit opening provided for the steam. The water, and likewise the oil, trickles quietly down the sides of the cage, which is in the shape of an inverted cone, and finally escapes through a special drip pipe at the bottom.

The Continuous Rail Joint Company of America has a complete outfit of special machinery that enables them to roll the continuous rail joint to fit perfectly any T or girder rail section used by steam or street railways. Ninety-two different rail sections are used by the one hundred and twenty-five railroads having this rail joint in successful operation. The rapid increase in engine and car loads has made the use of some form of base support necessary to give the required rigidity to the rail ends. The angle bar, while it has failed to do the work required, has yet some features that preclude its abandonment. These good features have been retained without the multiplicity of parts. The base plate, being an integral part of the joint, gives great horizontal and vertical rigidity, prevents any play between surface, and holds the rail ends in perfect line and surface. This rail joint is simple, complete and perfect in action, producing a remarkably easy riding track.

The address of the Continuous Rail Joint Company of America is 142 Market street, Newark, N. J. Circulars and full information will be sent on application.

During the week ending September 13th, the Pressed Steel Car Company shipped 628 cars, an average of 105 cars a day. The company is also making large shipments of truck frames, bolsters, brake beams, and other pressed steel specialties.

The increasing demand from railroads for locomotive injectors has made it necessary for the Lunkenheimer Company to materially increase the capacity of their injector department. Their '99 Model standard locomotive injector has been put through impartial tests that have proven the superior qualities of this machine.

In spite of the fact that large additions have been recently made to the plant of the Sargent Company at Chicago Heights, it has again been found necessary to extend them. This time it is the pattern shop which is found inadequate, owing to the large increase in the volume of business.

After severe tests with English built locomotives the American Locomotive Company has secured an order for fourteen engines for the Cape Government Railroad of South Africa. The locomotives will be built on strictly American lines.

An important victory has been won by the Westinghouse Air Brake Company in their suit against the Christensen Engineering Company for infringement of the Boyden patent on quick action triple valves, by the granting of an injunction by Judge Lacombe against the latter company. In the opinion Judge Lacombe says, in part, of the Christensen valve: "It does not present the difference in form and principle which will distinguish it from the Boyden valve."

An idea of the enormous quantity of work turned out by the Pressed Steel Car Company can be gained by the following calculations. An average of over 1,600 tons of steel are used per day, or over 500,000 tons per year. In the four years during which the manufacture of pressed-steel cars has been carried on, up to September 1, 1901, this company has used about 1,657,080,000 lbs. of iron and steel in the construction of the 46,030 cars which it has built. If these cars were placed end to end, allowing 35 ft. as the average length of the car, and 2 ft. for the couplings, they would form a continuous train 1,703,110 ft. in length, or over 322 miles. These cars would carry about 4,603,000,000 lbs. of freight, and the weight of the freight and cars combined would be 6,260,080,000 lbs., or 3,130,040 tons.

Among the railway exhibits at the Pan-American Exposition are those of the Consolidated Railway Electric Lighting and Equipment Company, of 100 Broadway, New York. The company exhibits its lights and fans on the special exhibition car of the Delaware, Lackawanna & Western, a special composite car of the Atchison, Topeka & Santa Fe, the "San Rafael," and includes also one of its refrigerator cars with its complete refrigerating equipment. The Santa Fe car is one of 106 cars equipped with this system on the road and includes fans as well as lights. These have been especially appreciated during the past season of extremely hot weather. This electric light and fan equipment may either be purchased at moderate cost by the railroads or it may be installed and maintained by the manufacturers upon a rental basis.

Mr. George W. Scott, for the past five years Mechanical Engineer of the Pullman Company, Pullman, Ill., has resigned to engage in business as consulting engineer, with office at 616 "The Rookery," Chicago, Ill. Mr. Scott has had a wide and varied experience in engineering and structural work and is well qualified to conduct a general engineering practice with reference to plans, specifications and estimates; examinations, valuations and reports of properties; investigation and development of mechanical undertakings; arrangement, construction and equipment of power plants, railroad and car shops, mills, works and factories; application of economical and cost-reducing methods in existing plants, shops and manufactories. Mr. Scott will be pleased to serve those who desire thorough, competent and responsible engineering services bearing on these subjects.

Wanted.—General foreman of the locomotive department of a large road in the Middle West desires to change. Is well educated, a practical machinist and an experienced, competent foreman. Age, 30 years, and best of references. Address C. care Editor American Engineer, 140 Nassau St., New York.

Wanted.—Position as leading locomotive draftsman by man now holding such a position, who desires to change. Address "B." care Editor American Engineer, 140 Nassau street, New York.

AMERICAN ENGINEER AND RAILROAD JOURNAL.

NOVEMBER, 1901.

CONTENTS.

ARTICLES ILLUSTRATED:	Page	ARTICLES NOT ILLUSTRATED:	Page
American Engineer Tests.....	335	A Railroad Owned and Operated by "Uncle Sam".....	338
The Vanderbilt Steel Hopper Coal Car.....	338	The Bolster vs. the Slide Bearing The Secret of Success.....	355 346
New Locomotive and Car Shops of Concrete Construction C. R. R. of N. J.....	340	Compound Locomotives on the Buenos Aires Great Southern Railway.....	349
Tests of Light and Heavy Loco- motives.....	343	Aluminum Thermit.....	353
Water Purification.....	344	Arrangement of Tools and Rooty Shops.....	353
To Determine the Weight of Water in a Boiler.....	346	The Four-Cylinder Balanced Compound.....	355
80,000 Pounds Capacity Tank Cars Fireproof Roundhouses.....	348 352	The Demand for Railroad Men... The Property Rights in a Trade Name.....	355 356 357
The American Engineer Tests... Carefully Designed Cast-Steel Locomotive Frames and Other Details.....	354 356	Tests of Ajax Plastic Bronze... Three-Cylinder Compound Loco- motive.....	356 356
New Method of Constructing Pis- tons.....	357	A Generous Employer Appreci- ated.....	359
Tests of Wide and Narrow Fire- box Locomotives.....	358	Service Record of Friction Draft Gear.....	361
A Folding Brake Wheel.....	359	Mechanical Draft.....	363
Machining Radial Locomotive Trucks.....	360	EDITORIALS:	
New Pennsylvania Union Pass- enger Station at Pittsburgh... New Paragon Drawing Pen.....	362 363	Large Freight Locomotives on the Illinois Central.....	350
A Convenient Hydrant and Hose House.....	363	Narrow and Wide Firebox Loco- motives.....	350
New Rip Saw for Car Shops The Star Steam Engine Indicator	363 364	A New House for the American Society of Mechanical Engi- neers.....	350
		The Business Problem in Car Construction.....	351
		The Duty of the Officer to His Men.....	351

AMERICAN ENGINEER TESTS.

Locomotive Draft Appliances.

II.

THE THEORIES TO BE INVESTIGATED.

A Research by H. H. Vaughan.

Member A. S. M. E.

An examination of the Hanover or Von Troske experiments discloses that they were directed almost exclusively to ascertaining the efficiency of various forms and sizes of stacks when used with nozzles of different sizes at varying distances from the stack. A few series of tests were made at different steam pressures, but as these led to the conclusion that within the limits of practical working the vacuum obtained varied directly as the pressure, all succeeding tests were made with a pressure of steam in the blast pipe of 3.94 inches of mercury; this pressure was also constant, that is to say, it was taken for granted that the action of the steam when issuing from the cylinders gave the same results as a steady jet, an assumption that was proved to be substantially correct in the experiments of the Master Mechanics' Association. It is evident, that, supposing it to be true for all forms of stacks that the vacuum varies directly as the pressure, the combination that is most efficient for any one pressure is also most efficient for all, so that in that respect the tests are complete. There is, however, another point that might have been attended to, the area through which the air was allowed to flow into the apparatus.

This was kept constant at 80.72 sq. ins., the size of the opening being determined by adjusting it until a certain combination of stack and nozzle gave the same vacuum on the apparatus, as it had been found to do previously on a locomotive. Now while this is satisfactory for that particular case, it does not appear to follow that the most efficient combination with this area would also be so for a larger or smaller area, in other words, the best combination for one size of engine is not necessarily the best for one that is larger or smaller and it is not

possible from these experiments to deduce any results were this condition varied. Experiments were also carried out to determine the advantages or otherwise of bridges in the nozzles and the form of the jet, but none that related in any way to the form of the exhaust passages below the nozzle.

In the experiments of the Master Mechanics' Association, on the other hand, only three stacks were used, and in most of the tests but one size of nozzle. The most advantageous position of this nozzle with reference to the stack was fully determined and the results obtained were confirmed for other sizes of nozzles. A number of tests were devoted to the details of the exhaust pipe; height of bridge, size of choke and form of nozzle and in these respects the results are practically final. The double nozzle, petticoat pipes, bridges in nozzles, and form of the steam jet were also experimented on, but not so completely as the other mentioned points.

In general then the two series of experiments have obtained results more or less definite as follows:

Hanover.	Master Mechanics' Association.
Varying stack with varying noz- zles at varying distances, con- stant pressure.	Three stacks with constant noz- zles at varying distance.
Effect of nozzle bridge.	Effect of nozzle bridge.
Form of jet.	Form of jet, etc.
Effect of variation of pressure.	Action of jet.
	Detail design of exhaust pipe.
	Double nozzles.
	Petticoat pipe.

It is safe to assume that as far as the Master Mechanics' experiments go they are absolutely reliable, if they are not we might as well stop at once, but for several reasons that have previously been mentioned the same cannot be said of the Hanover tests. The fact of checking up a few isolated results in practice is not sufficient to establish the truth of all other results, which may or may not be universally true, especially as the service tests so far as can be learned from the report simply showed whether stacks which had given certain results on the testing apparatus, did or did not assist in the steaming qualities of an engine. If results of several series of experiments on the test apparatus had been repeated under identical conditions in the front end of an engine and had been proven substantially true, there would be some foundation for the acceptance of all the results, but in the absence of such a verification they must, as they stand in the report, be open to question.

It is unfortunate, in many respects, that the two series of experiments are to a large extent supplemental. Work done in Hanover was only in a few instances repeated at Chicago, and even in these instances the similarity is not complete. Had the Master Mechanics' experiments been conducted with a steady jet in place of on a running engine it would have been possible to compare the vacuum obtained on the assumption that it varies as the pressure in the exhaust pipe, allowing for the area through which air could flow to the front end, but as this was not done the only comparison possible is that of the general forms of the curves obtained.

In Figs. 1, 2, 3 and 4 the results of the Hanover and Master Mechanics' experiments are shown for three series of tests in which the conditions were very nearly alike. Figs. 1 and 2 show results with 4¾-in. nozzle in both cases, the 14-in. choke stack of the Master Mechanics' Association and the 13.78-in. 1 in 12 in. conical stack of the Hanover tests. The Master Mechanics' Association stack was 52 ins. high, 12 ins. to choke, taper 1 in 11.4, the Hanover stack was 57½ ins. high, 17½ ins. to choke, taper 1 in 12, the length in both cases from choke to top of stack thus being the same, so that the stacks are practically alike. The results of the Hanover tests are compared with series A, B, C, D, E, of the Master Mechanics' Association in Fig. 1 and with series F, G, H, I in Fig. 2. Now there is no question but that in Fig. 1 the Master Mechanics' Association tests show a continued improvement up to a nozzle distance of 43 to 47 ins. in Fig. 1, and up to 45 ins. in Fig. 2, although it is true that the improvement after 30 to 35 ins. is small, while the Hanover tests show a decided and comparatively rapid drop when the nozzle distance is increased over 35 ins. The Master Mechanics' Association results are plotted direct from the

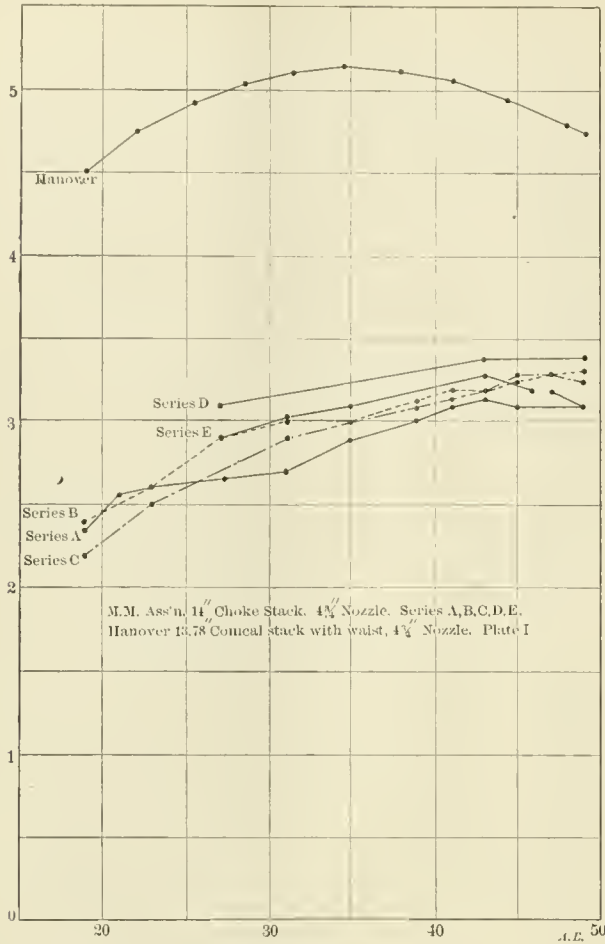

Fig. 1.

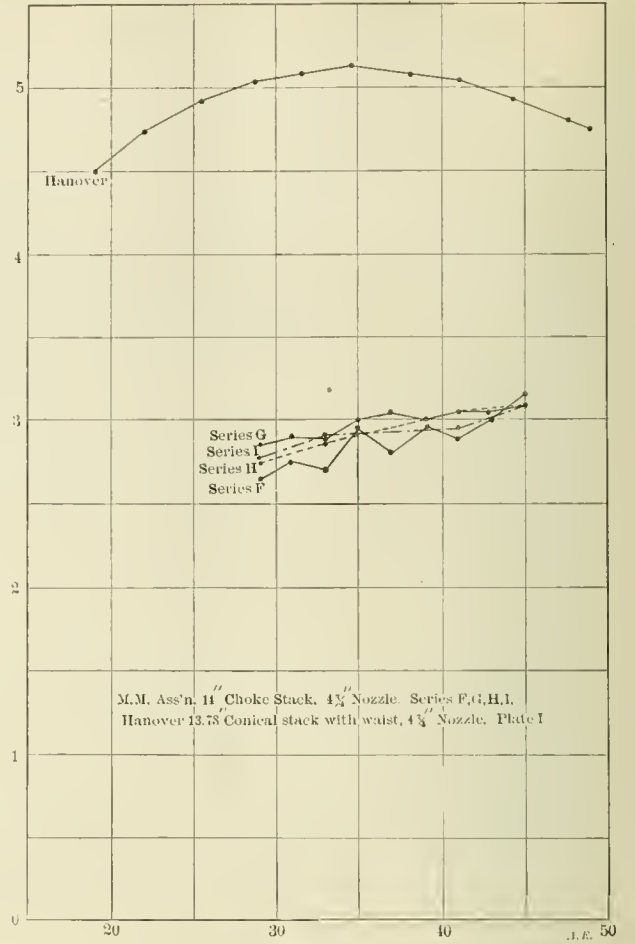

Fig. 2.

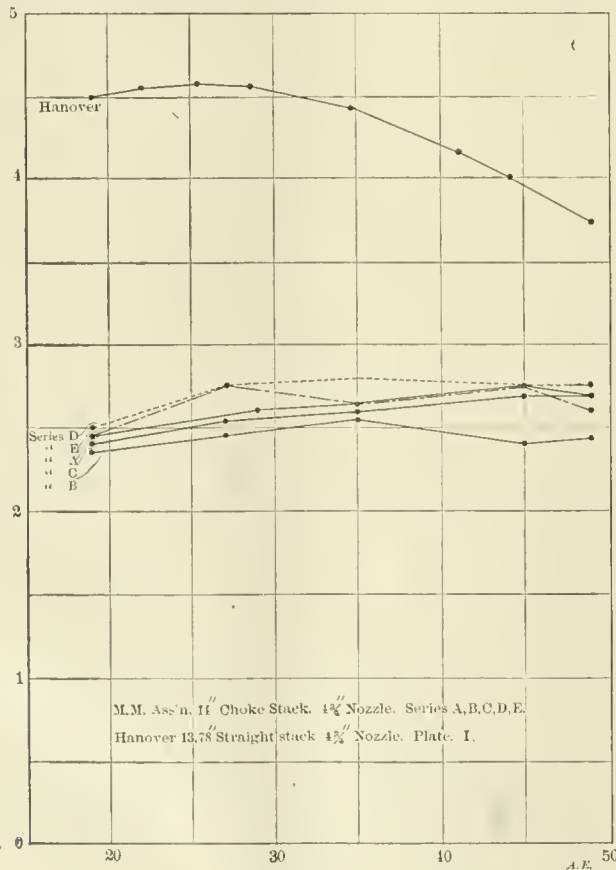

Fig. 3.

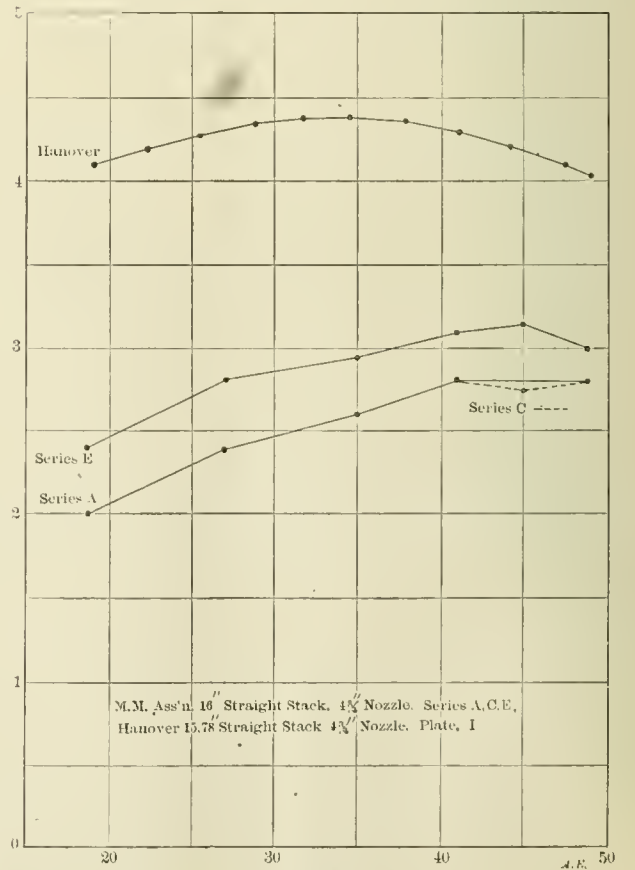

Fig. 4.

vacuum obtained; as the engine ran at a constant speed, with very nearly constant steam pressure, with the same cut-off these results are far more concordant than if the vacuum is increased in proportion to the drop in back pressure, since the back pressure given is simply the lowest point to which the exhaust line fell and does not represent the mean pressure in the exhaust pipe. If the vacuum obtained is divided by the back pressure the result is in all cases to show a still more rapid increase up to 45 ins., thus emphasizing the above statement. Fig. 3 shows the same curves for the 14-in., and Fig. 4 for the 16-in. straight stacks of the Master Mechanics' Association as compared with the 13.78-in. and 15.78-in. straight stacks on the Hanover tests. These stacks are all the same length from choke to top of stack, but with one decided difference, namely, that the Master Mechanics' Association stacks continued 14 and 16 ins. in diameter for 12 ins. from the choke until the smokebox was reached, whereas the Hanover stacks

stance in the condition shown in Plate III of the Hanover tests? And if so, how far can the results of the Hanover tests be depended on under such conditions, which are certainly those which relate to the larger types of locomotives now becoming universal. I have little hesitation in saying that with our present knowledge of the subject this question cannot be answered, yet before discussing the best method of rendering available the vast amount of information on the Hanover tests I would call attention to two more series of tests on which comparisons are possible. Fig. 5 gives the results of Master Mechanics' Association series, M, O, Q, and deductions from similar tests from Hanover Plate II by assuming the vacuum to vary with the pressure. The 14-in. choke stack is used in both cases and the double line plotted from the Hanover tests shows

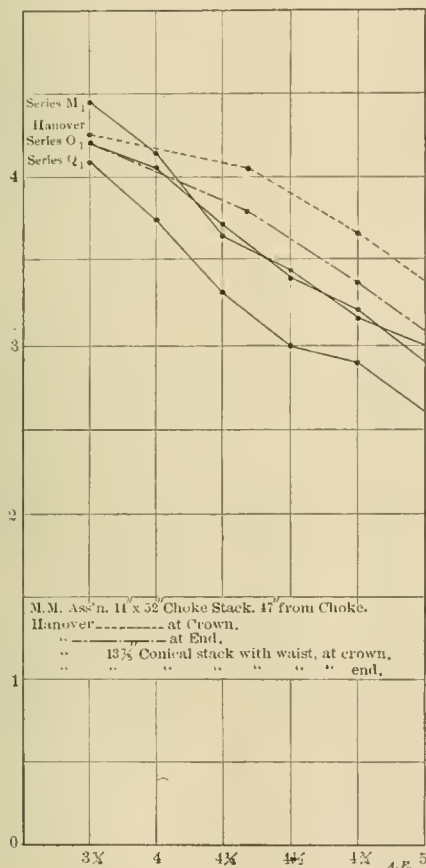

Fig. 5. American Engineer Tests of Locomotive Draft Appliances.

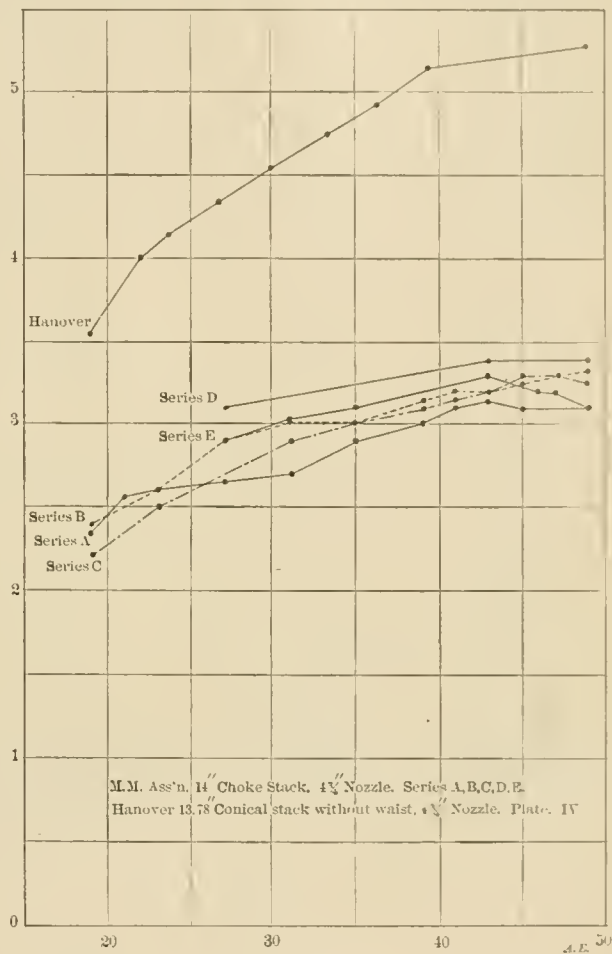

Fig. 6.

were conical, 17.59 ins. from the choke to a diameter of 17.72 ins. at the box.

After a careful study of the tests I am prepared to state that there would have been very little difference in the results had these stacks been similar to the Master Mechanics' Association form. Figs. 3 and 4 are plotted from series A, B, C, D, E in the Master Mechanics' Association experiments and show very clearly the same divergence from the Hanover results. Now while the divergence is not very serious in these particular instances, as it would simply lead to placing the nozzle rather higher than recommended in the report of the Master Mechanics' Association committee, it leads to a very much more serious question. Here is a considerable difference between results obtained on the Hanover tests apparatus and an actual locomotive, when the stack is fairly long and a small change in nozzle distance makes but little difference in the vacuum. Is this divergence going to increase and become more serious when the stack is short or of different size or when the proper nozzle distance becomes of considerable importance, as for in-

the best vacuum obtainable and also the vacuum at a nozzle distance of 49 ins. with each size of nozzle. In this case there is a very fair agreement, although in the Hanover test the vacuum does not drop as rapidly when the nozzle diameter is increased.

Fig. 6 shows the Master Mechanics' Association series, A, B, C, D, E, with the 14-in. choke stack compared with the Hanover results from a stack 13.78 ins. at the bottom with 1 in 12 taper, but without waist, and 57.7 ins. long. The nozzle distances are, however, measured from a point 17 ins. above the bottom of the stack. The curve for this stack resembles very closely that for the 14-in. choke stack and would do so almost exactly if the scale were reduced in the proportion of 5.3 to 3.3, that of the vacuum recorded at the greatest nozzle distances. While this agreement is remarkable, it is not of much use in reconciling the differences, as this stack does not resemble the Master Mechanics' Association 14-in. choke stack as nearly as the one considered in Fig. 1.

(To be Continued.)

THE VANDERBILT STEEL HOPPER COAL CAR, 100,000 POUNDS CAPACITY.

Lackawanna Iron & Steel Company.

Designed by Cornelius Vanderbilt.

Through the courtesy of the designer, Mr. Cornelius Vanderbilt, we have received drawings of a new steel hopper coal car of 100,000 lbs. capacity, to be built for the Lackawanna Iron & Steel Company. Its construction presents new and in-

In order to secure the necessary strength with minimum dead weight the side framing is constructed in the form of trusses, to render their weight available in assisting in carrying the load. This idea has been employed before, but Mr. Vanderbilt's design is the first to take advantage of the entire depth of the side from the top rail to the bottom of the hoppers for this purpose. These trusses do not end at the floor line, but extend the full depth of the sides to the bottom of the hoppers. In fact, the side frames, used in this way, render it possible to reduce the center sills to 9-inch, 25 lbs. channels and side sills are omitted entirely. Steel plate 1/4-in.

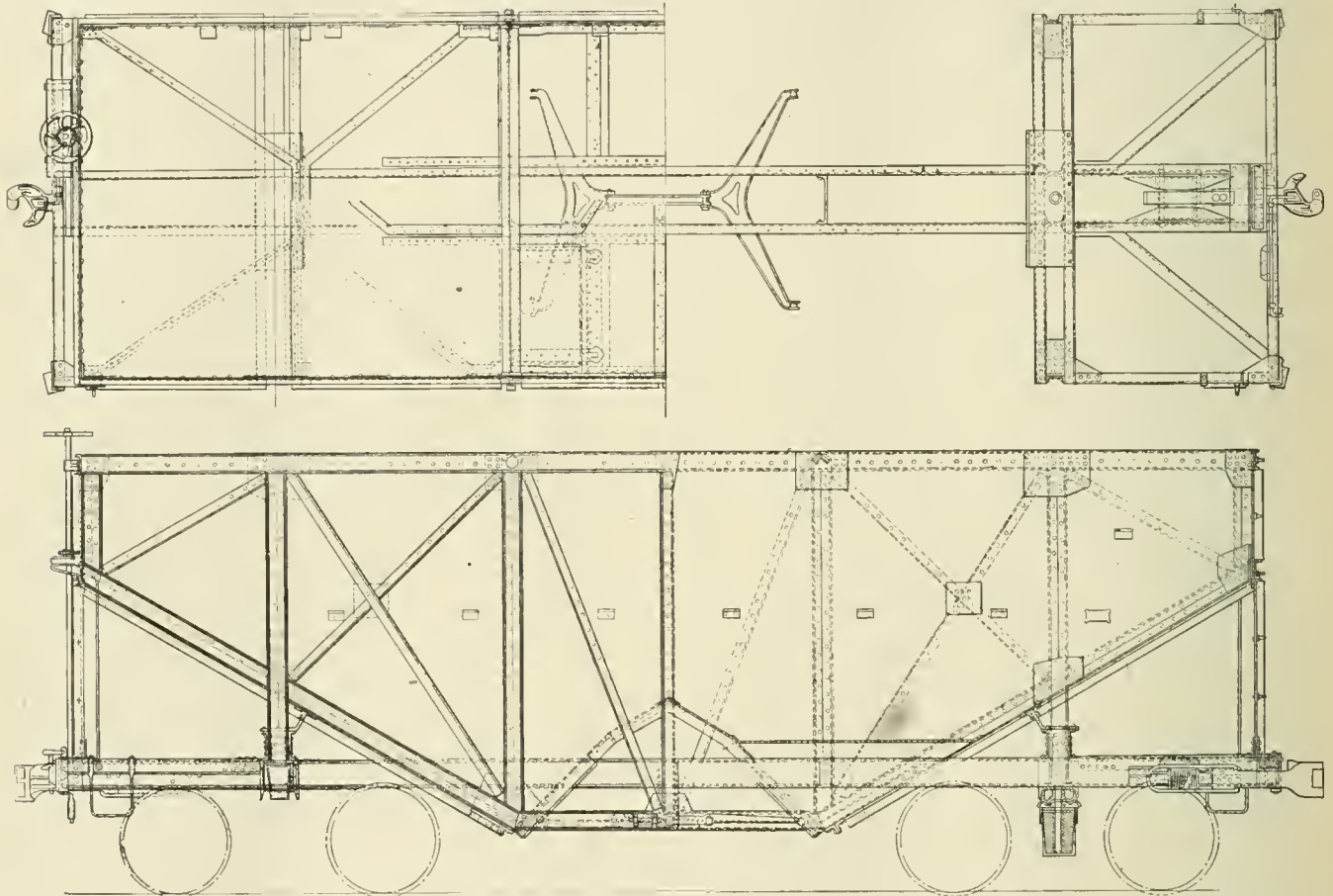

Vanderbilt Steel Hopper Coal Car—Lackawanna Iron & Steel Company.

Comparison of Fifty-Ton Steel Hopper Coal Cars.

Railroad.	Date.	Builders.	Construction.	Contents.		Coal capacity.	Light weight.	Ratio dead weight to paying load.
				30° heap.	30° heap.			
Lackawanna Iron & Steel Co.	1901	Not yet built.....	Vanderbilt, structural	2,136 cu. ft.	111,072 lbs.	36,500 lbs.	33.0 per cent.	
Norfolk & Western.....	1900	N. & W. Ry.....	Composite	2,638 cu. ft.	112,000 lbs.*	38,000 lbs.	34.0 per cent.	
Lake Shore.....	1899	Pressed Steel Car Co.	Pressed steel.....	2,072 cu. ft.	107,740 lbs.	36,600 lbs.	34.0 per cent.	
Cleveland & Pittsburgh.....	1900	Am. C. & F. Co.....	Structural	2,140 cu. ft.	111,280 lbs.	38,300 lbs.	34.4 per cent.	
Baltimore & Ohio.....	1899	Pressed Steel Car Co.	Pressed steel.....	2,127 cu. ft.	110,600 lbs.	39,325 lbs.	35.6 per cent.	
Northern Pacific.....	1898	Pressed Steel Car Co.	Pressed steel.....	1,875 cu. ft.	97,500 lbs.	34,800 lbs.	35.7 per cent.	
Baltimore & Ohio.....	Gillette-Herzog.....	Composite	1,842 cu. ft.	95,780 lbs.	37,400 lbs.	39.6 per cent.	
Erie.....	Pressed Steel Car Co.	Pressed steel.....	1,886 cu. ft.	98,072 lbs.	36,700 lbs.	37.4 per cent.	
P. R. R.....	Pressed Steel Car Co.	Pressed steel.....	2,030 cu. ft.	105,560 lbs.	36,300 lbs.	34.4 per cent.	
L. V. R. R.....	Pressed Steel Car Co.	Pressed steel.....	2,056 cu. ft.	106,912 lbs.	39,600 lbs.	37.4 per cent.	
				2,030 cu. ft.	105,560 lbs.	36,600 lbs.	34.5 per cent.	

*Actual weight of test load.

interesting features which have been patented by Mr. Vanderbilt. The construction throughout employs structural steel shapes and plates. The leading dimensions of the car are as follows:

Vanderbilt Fifty-Ton Steel Hopper Car.

Light weight.....	36,500 lbs.
Weight of body.....	24,000 lbs.
Total capacity, coal.....	111,072 lbs.
Total capacity, ore.....	120,000 lbs.
Cubical capacity (30 degrees heap).....	2,136 cu. ft.
Cubical capacity, level full.....	1,822 cu. ft.
Length, over end sills.....	31 ft. 10 1/4 ins.
Length, inside.....	30 ft. 0 ins.
Width, over all.....	9 ft. 1 1/4 ins.
Width, inside.....	9 ft. 0 ins.
Height, rail to top of brake staff.....	11 ft. 11 ins.
Height, rail to top of body.....	11 ft. 3 ins.
Height, rail to bottom of hopper.....	1 ft. 7 ins.
Height, rail to center of sills.....	3 ft. 3/4 in.

in thickness forms the body of the car and is riveted to a trussed frame of channels stiffened and braced by angles, as indicated in the drawing. All of the chord, vertical and post members are of channel section, with a liberal number of angles and gussets. There are two hoppers with ridge plates over the center sills, and at the sides of the hoppers the bottom chord is a substantial channel connecting the sloping end channels and receiving, by means of gussets at its center, three of the bracing angles. The body bolsters are built up in the form of a box girder, with a lower or compression member in the form of a large channel receiving the center plate and bent up to meet the ends of the transverse channels. The center sills pass between these two portions of the bolster. The upper plate of this box girder is bent to form an at-

tachment between two transverse angles riveted to the outer surface of the hopper plates, giving substantial support to the structure and constituting a rigid tie across the car at this point. At the ends of the body bolsters the load from the side frames is transmitted by vertical channels. The four points of support of the side frames are therefore at the ends of the bolsters and these vertical channels are riveted directly between the bolster channels. This arrangement of the bolsters, the end framing and side framing, with the various braces, may be easily understood from the drawings. At the

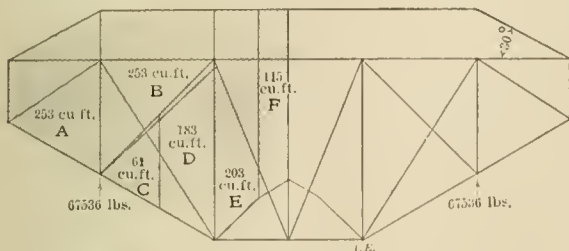

Stress Diagram.

termination of the sloping floor channels transverse channels pass across the ends of the car in such a way as to transmit end thrusts from the load to the side frame trusses. At the top of the sides and ends 6-in. channels give strength and

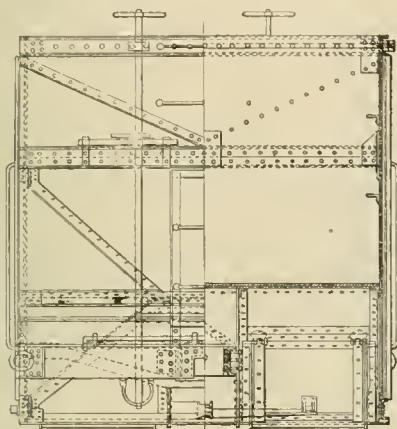

Half-Section and End Elevation of Vanderbilt Car.

stiffness. Cross ties of rods, protected by inverted angles, are provided at two points along the upper chords, while under the floor plating transverse tying is provided for the lower portions of the sides. Channels are used for end sills, with castings to reinforce the center portions and compensate for the coupler shank openings. At the corners of the underframing bracing angles are riveted to the inner faces of the end sills, reaching diagonally to the center sills. The brake cylinders are mounted under the ends of the hoppers.

This construction will be better understood by considering the usual underframe of the car as dispensed with altogether and the weight carried on the body bolsters by means of the vertical struts of the side frames, which are attached to the ends of the bolsters. The office of the center sills is merely to connect the bolsters together and to deal with the pulling and buffing stresses.

In the weight diagram the various volumes are indicated by letters as follows:

A	=	253 cu. ft.	=	11.85%	=	13,156 lbs.
B	=	253 cu. ft.	=	11.85%	=	13,156 lbs.
C	=	61 cu. ft.	=	2.85%	=	3,172 lbs.
D	=	183 cu. ft.	=	8.57%	=	9,516 lbs.
E	=	203 cu. ft.	=	9.5%	=	10,550 lbs.
F	=	115 cu. ft.	=	5.38%	=	5,980 lbs.

One-half of car,	1,068 cu. ft.	=	50%	=	55,536 lbs.
Total,	2,136 cu. ft.	=	100%	=	111,072 lbs.
Light weight of car body	=	24,000 lbs.			
Estimated weight of car,	36,500 lbs.				

This car is very light. Its estimated weight with trucks is

36,500 lbs., and a new design of truck, which is not yet ready for publication, will probably reduce this weight slightly. In order to compare its weight and capacity with other cars of this type the accompanying table has been prepared. In a comparison of this kind, including the figures of different builders, it is assumed that the weights and capacities stated by them are correct. It will be noted that the Vanderbilt car heads the list with reference to the ratio of the light weight to the paying load. The capacity of this car for ore is 120,000 lbs.

A RAILROAD OWNED AND OPERATED BY "UNCLE SAM."

The United States is operating a railroad of its own, and does not make a cent out of it from one year's end to the other. Only a few miles from New York, on the Sandy Hook peninsula, is a six-mile steam railroad with Fort Hancock as one terminal and Highland Beach as the other. This road, while limited in its rolling stock to one locomotive, one combination baggage and passenger car, and several freight cars, is in touch with the whole country, as it connects at Highland Beach with the Central Railroad of New Jersey. Large operations in the line of ordnance tests are secretly conducted at the Sandy Hook proving grounds, by the Ordnance Department at Sandy Hook, and it is the transportation of this ordnance, together with ammunition and supplies, that furnishes the bulk of business of this railroad. The passenger traffic is small, as it is limited to those having passes issued by the military authorities of the United States. Aside from the inscription, "Sandy Hook Proving Grounds," which appears on the cars and locomotive, there is nothing about the train to suggest the ownership of the road. Nevertheless, it is Uncle Sam's own railroad, with an artillery sergeant as conductor and a competent traffic manager, Colonel J. B. Burbank, who is at present in command at Fort Hancock.

In a summary of the progress of the last ten years in marine practice, in a paper recently read before the Institute of Mechanical Engineers, Mr. James McKechnie showed that this branch has made remarkable strides. He summed up his conclusions as follows: Steam pressures have been increased in the merchant marine from 15 lbs. to 197 lbs. per square inch, the maximum attained being 267 lbs. per square inch, and 300 lbs. in the naval service. The piston speed of mercantile machinery has gone up from 529 ft. to 654 ft. per minute, the maximum in merchant practice being about 900 ft., and in naval practice 960 ft. for large engines, and 1,300 ft. in torpedo boat destroyers. Boilers also yield a greater power for a given service, and thus the average power per ton of machinery has gone up from an average of 6 to about 7 indicated horse-power per ton of machinery. The net result in respect of speed is that while ten years ago the highest sustained ocean speed was 20.7 knots, it is now 23.38 knots; the highest speed for large warships was 22 knots and is now 23 knots on a trial of double the duration of those of ten years ago; the maximum speed attained by any craft was 25 knots, as compared with 36.581 knots now; while the number of ships of over 20 knots was eight in 1891 and is fifty-eight now. But probably the result of most importance, because affecting every type of ship from the tramp to the greyhound, is the reduction in the coal consumption. Ten years ago the rate for ocean voyages was 1.75 lbs. per horse-power per hour; to-day, in the most modern ships, it is about 1.5 lbs. Ten years ago one ton of cargo was carried 100 miles for 10 lbs. of fuel, whereas now, with the great increase in the size of ships and other mechanical improvements, the same work is done for about 4 lbs. of coal—a result which means a very great saving when applied to the immense fleet of over-sea carriers throughout the world.

NEW LOCOMOTIVE AND CAR SHOPS OF CONCRETE CONSTRUCTION.

Central Railroad of New Jersey.
At Elizabethport, New Jersey.

The new shops of the Central Railroad of New Jersey at Elizabethport will take care of the heavy repairs on 430 locomotives, and maintain a car equipment of 20,000 freight and 500 passenger cars. The arrangement of building was made with a view of convenience in moving cars and material from one point to another, and after much thoughtful consideration in this direction and to the future extension of every building, the arrangement shown in the accompanying engraving of the general plan of the shops was decided upon. A 60-acre plot of ground bordering on Newark Bay and only 9 miles from the Jersey City terminal was selected as a site for

tracks located between alternate repair tracks. Cars in this way will pass through the shop on certain tracks, according to the nature of their repairs, whether heavy, light or medium. An overhead trolley will carry all scrap parts from the rear end of the shop to the scrap platform, also the wheels to the wheel shop to be pressed off. Finished wheels and supplies, such as brasses and springs from the supply house, are taken in at the upper end of the repair shop, while those for the passenger car shop will be taken in car-load lots to that building. The lumber yard, dry kiln and planing mill are placed in line, so that the finished material will pass out at the rear end of the mill to the repair shop or to the passenger car shop. The latter building will be separated from the paint shop by an 80-ft. transfer table, so that cars will move in the one general direction through the paint shop out to meet the finished freight cars, and both find their way to the main line. This progressive movement has also been adhered to

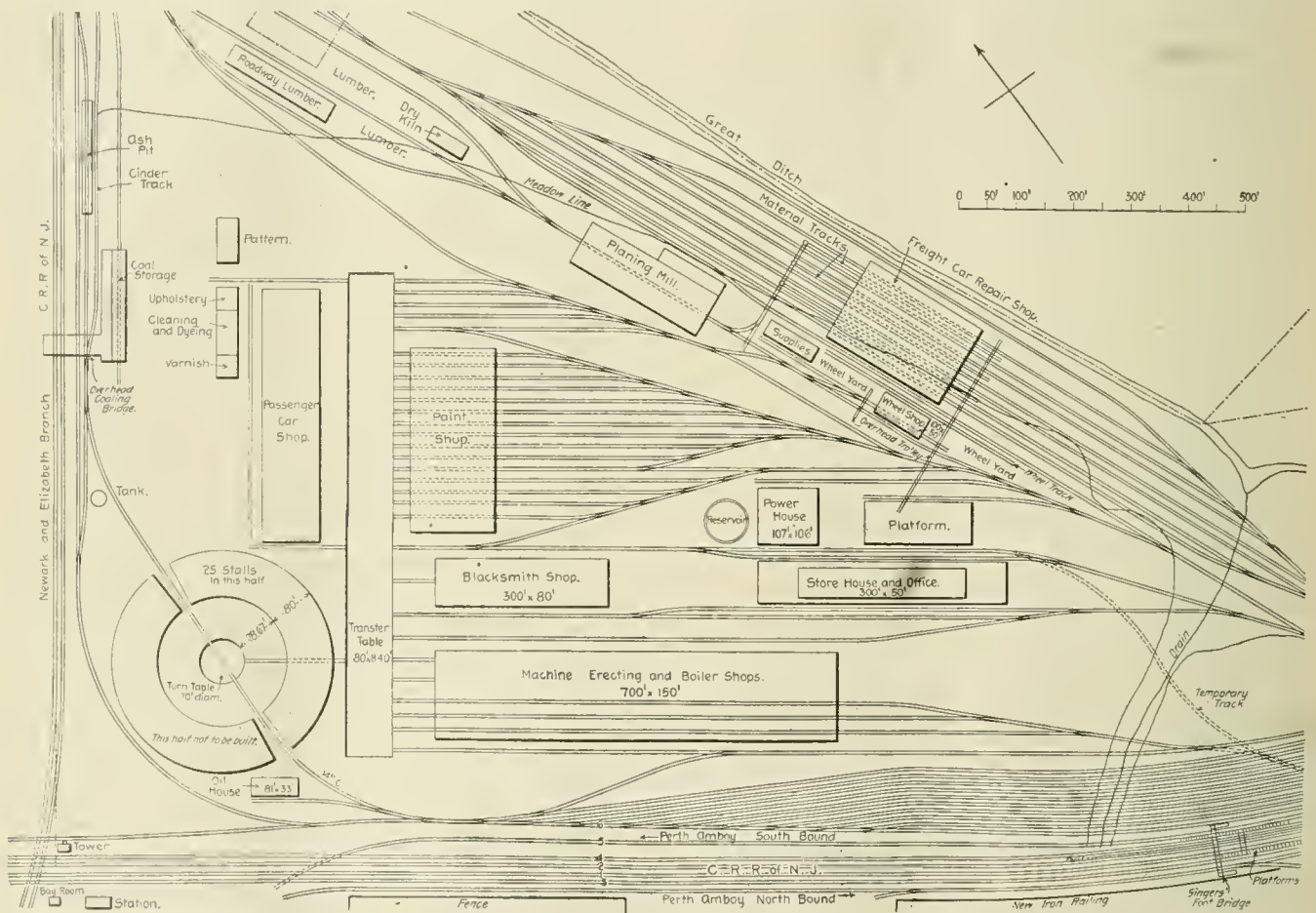

General Plan of New Locomotive and Car Shops—Central Railroad of New Jersey.

WM. McINTOSH, Superintendent of Motive Power.

G. W. WILDIN, Mechanical Engineer.

the new shops, as this is the junction of the main line with the Newark and Perth Amboy divisions. The triangular shape of the grounds, with the tracks on the main line on one side, those of the Newark division on the second, and Newark Bay on the third side, added considerably to the problems of locating the tracks and buildings in such a way that every part of the shopyard would be in easy communication with every other part. By the use of a transfer table this plan has been successfully carried out.

As empty cars will naturally collect at this junction, those needing repairs will be switched into a yard for crippled cars, not shown, in the upper part of the grounds. The tracks for this storage yard are built on the gravity principle and finally converge into a single track, which again branches out into a series of tracks before reaching the freight repair shop. Seven of the tracks will run through the shop, with material

as a principle in the locomotive shops. The buildings, including the machine, erecting and boiler shop, blacksmith shop, round house, power house, storehouse and office, oil house and transfer table, are already nearing completion. The car shops will not be built until later; at present attention is centered on the locomotive shops.

Running parallel with the main line of the road are the machine, erecting and boiler shops, which are in one building. This building is 700 by 150 ft., and is the only one of the entire group that is not of concrete construction. Its walls are brick, with a steel skeleton and concrete foundation 10 ft. wide at the base and rising to a height of 6 ft. above grade, where it tapers to a width of 2 feet at the top. A 12-in. brick wall rests on this foundation and is surmounted by a steel truss roof covered with 3-in. plank with a covering of tar and gravel. The building is formed of three bays, with longitudinal

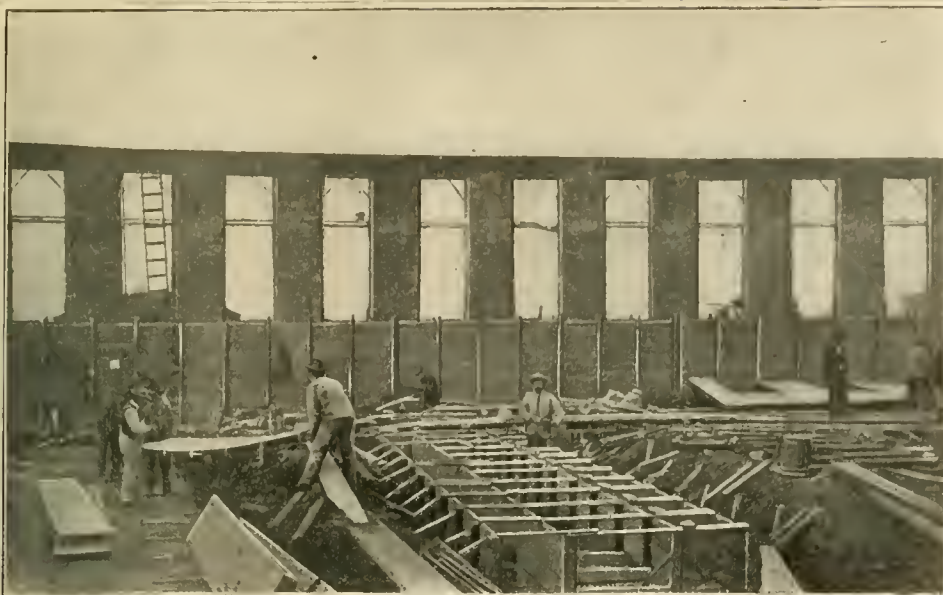

Fig. 1.

tracks connecting with the transfer table. Upon these tracks the engines will be dismantled by the aid of an efficient crane service. The description of the arrangement of machines, the foundations, which are all of concrete and expanded metal, and the crane service will be reserved for a second article to appear in connection with the power house and power distribution, which is by electricity.

The tracks on either side of the machine erecting and boiler shop and next to the blacksmith shop all lead to the transfer table. Locomotives in this way can be brought from any part of the yard or direct through the round house to the machine shop. Not

all of the tracks emerging from the rear of the paint shop will be built now, but are provided for when it becomes necessary to widen the building to accommodate more than three cars on each transverse track.

The transfer table, which is 400 x 80 ft., also serves the blacksmith shop and round house. The pit is entirely of concrete construction, in the form of parallel foundations prepared in the same manner as the pits of the round house shown in Fig. 1. The mould for the concrete pit, as will be noticed in the engraving, rests on a solid foundation of concrete. This foundation is 12 ins. in thickness, with a sheet of expanded metal at the bottom to aid in making a solid foot. Instead of

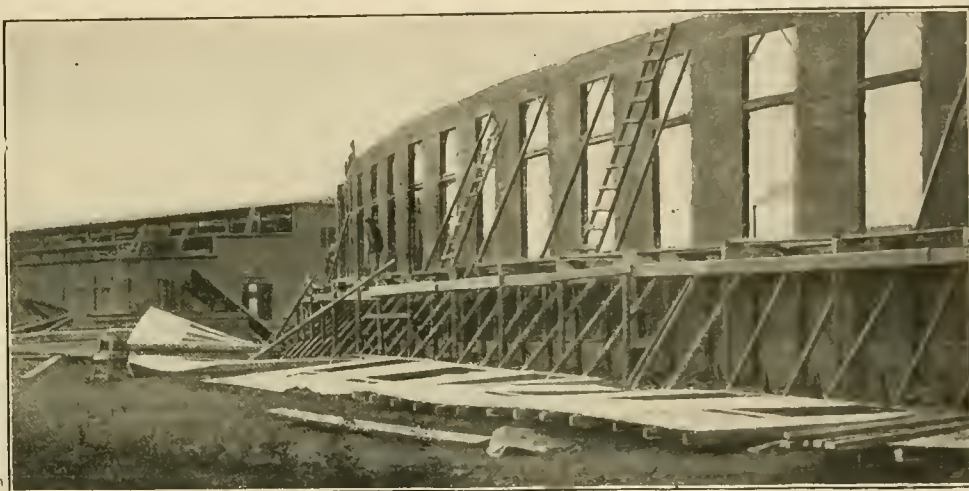

Fig. 2.

employing piling this so-called "floating" foundation is used for all foundations throughout the entire plant, as the grade at this point is not much above the tide level, and water is encountered only a few feet below the grade.

Fig. 2 shows the exterior walls of the round house, which are 8 ins. in thickness, and Fig. 3 illustrates the bracing used in constructing the wall on the west side. The house is 400 ft. in diameter and equipped with a 70-ft. electric turn table. It is designed to house 50 engines, but at the present time only half of the house is being completed. Engines in coming into the round-house must first pass over the cinder pit before taking on coal and water. This arrangement is necessary, as considerable room is required in which to handle the tools in cleaning the grates of a hard coal burning engine. In front of the round-house is the oil house, 81 by 33 ft., which is constructed entirely of concrete, the roof as well as the walls and floors.

Back of the machine, erecting and boiler shops, are the store house and office building and the blacksmith shop. The latter building is 300 ft. long and 80 ft. wide, with concrete walls 8 ins. thick surrounding a framework of steel, as illustrated in Fig. 4. The store house is 300 ft. long and 50 ft. wide, constructed entirely of concrete, with walls 4 ins. thick. One end of the building is two stories high, the upper floor of which is to be used for offices. Surrounding the building is a platform built to the height of a car door, and it is accessible from



Fig. 3.

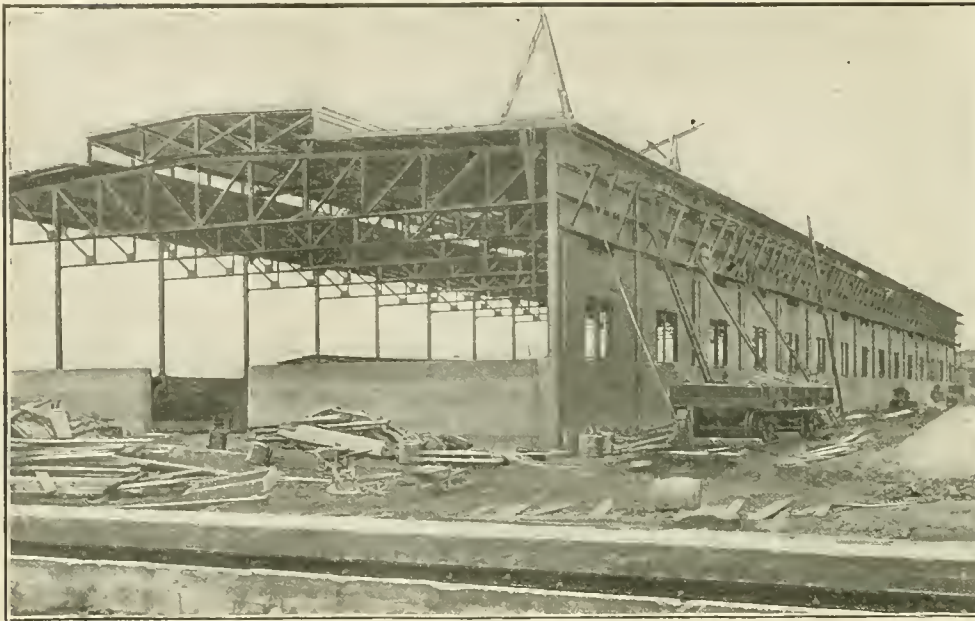

Fig. 4.

two tracks, one on either side, which lead to the transfer table.

The power house is another building, with floors, walls and roof of concrete. No attempt has been made at ornamenting any of the buildings, with the exception of the power house. This building is shown in Fig. 5 and is 107 ft. long, 106 ft. wide and 25 ft. high. A reservoir made of the same material is located at one side of the power house and will be used for storing rain water. All piping and wiring is to be placed in a concrete subway running the entire length of the machine, erecting and boiler shops. This tunnel extends through to the round house and has two branches, one to the blacksmith shop and the other to the power house.

In the present plant concrete construction has been used to the complete exclusion of masonry, except in the machine, erecting and boiler shops. Instead of using trap rock in the mixture, as is the ordinary practice in concrete construction, either cinders, furnace slag, sand and cement or gravel, sand and cement, are used. In every instance the mixture was about 4 to 1.

There appear to be good reasons for believing that concrete construction of foundations and buildings will become quite general. Cement is improving in quality and its cost is decreasing. For this construction the concrete is poured into molds made of pine boards, tongued and grooved, and, by exercising a little thought, an entire building may be constructed with a few molds and repeating small sections. In these buildings it will be noted that the walls are thin. This is an advantage offered by concrete. In the case of the west wall of the roundhouse temporary bracing is required, but this will be taken out when the round-house is completed to its full capacity of 50 stalls. Another advantage of concrete is the

fact that it may be applied by cheap labor under the direction of a competent foreman who thoroughly understands mixing the concrete. This is quite important in avoiding labor difficulties. This material may be made in any form suitable to monolithic construction. It is durable, and when properly built upon expanded metal, there seems to be no anxiety as to its strength.

For the blue prints of the general plan of these shops from which the accompanying engraving was prepared, and also information regarding the arrangement of buildings, we are indebted to Mr. Wm. McIntosh, Superintendent of Motive Power, and Mr. G. W. Wildin, Mechanical Engineer, of the Central Railroad of New Jersey. The engineer

and architect for the buildings is Mr. George Hill, of New York, who is making a specialty of concrete construction of this general character.

A new railroad club was organized in Pittsburgh October 18, known as the Railway Club of Pittsburgh, this being a large and important railroad center. The era of railroad building on a huge scale is passed and one of improvement has begun. In this the technical railroad club is an important factor. The

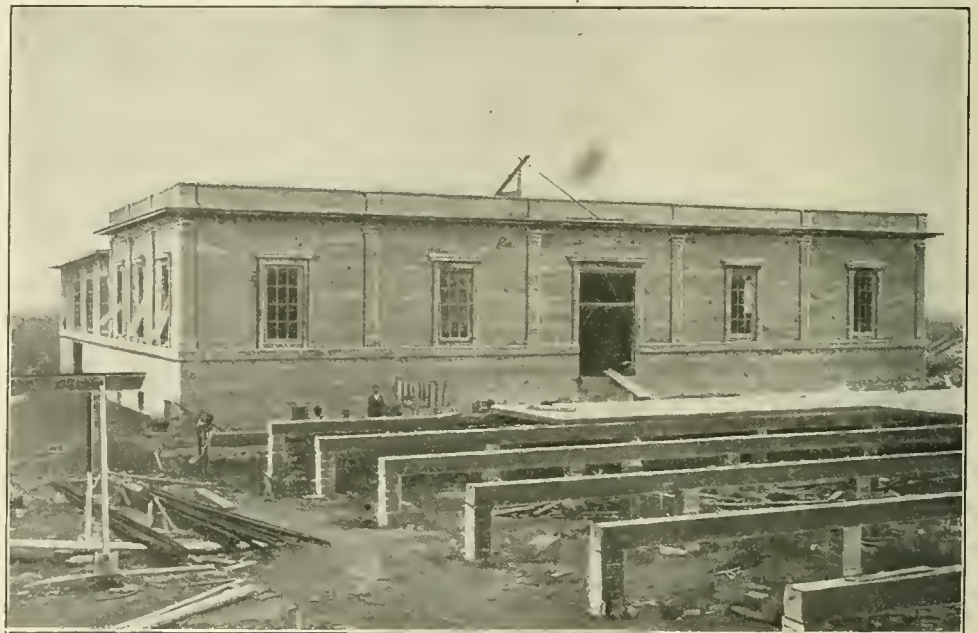

Fig. 5.

discussion of technical subjects by the men who are dealing with them individually is one of the methods of the present which means much for the future. This club begins with a membership of 50 and with the following officers: President, Mr. J. H. McConnell, General Manager of Pittsburgh Works of the American Locomotive Company; Vice-President, Mr. L. H. Turner, Superintendent of Motive Power of the Pittsburgh & Lake Erie; Secretary, Mr. J. D. Conway, of the Motive Power department of the Pittsburgh & Lake Erie; Treasurer, Mr. J. D. McIlwain; Executive Committee, Messrs. D. F. Crawford, of the Pennsylvania Lines; J. E. Simons, of the Pittsburgh Coal Company, and Mr. F. T. Hyndman, of the Pittsburgh & Western Railway.

TESTS OF LIGHT AND HEAVY LOCOMOTIVES.

Illinois Central Railroad.

Showing Heavy Locomotives to Be Advantageous When They May Be Loaded to Capacity.

With an Inset.

By the courtesy of Mr. A. W. Sullivan, Assistant Second Vice-President, and Mr. William Renshaw, Superintendent of Machinery of this road, we are permitted to describe an important test comparing heavy and light locomotives.

On the Centralia District the limiting grade is on the Makanda hill. The freight locomotives in service about three years ago had normal ratings of about 1,000 tons or less over this grade, but over the rest of the district, 104 miles long, there was no difficulty in hauling much heavier trains. To ascertain the operating advantage of heavier locomotives the Brooks and the Rogers Locomotive Works were each asked to build an engine which would pull trains of 2,000 tons over the summit. The builders were not restricted or hampered as to details. The engines were built and placed in service. The Brooks design, of the 12-wheel type, was illustrated in our issue of October, 1899, page 315, and that of the Rogers Works, of the consolidation type, in that of January, 1900, page 12. The former is the heaviest locomotive ever built, and the latter somewhat lighter. These large engines have 23 by 30-in. cylinders and carry 210 lbs. boiler pressure. Their dimensions are given in the accompanying inset.

An opportunity was offered to ascertain definitely the relative costs of operation of the new, very heavy engines and those of lighter weight which were formerly standard engines on this road. It became necessary to know positively whether or not more large engines should be built, or whether the lighter engines were to be continued as standard. This led to a road test, comparing the large engines with a 10-wheel and a mogul. The cylinders of the 10-wheel engine are 20 by 28 ins., and of the mogul 19 by 28 ins. The steam pressures of these engines are 180 and 165 lbs., respectively. As the management was in earnest to know what practice to follow, the tests were made without reference to cost or inconvenience, and the records were prepared and studied with great care.

The entire report appears in a single blue print giving diagrams of the four locomotives, a profile of the district, a table of mechanical data, transportation memoranda and the summary of results. These are reproduced entire. The profile diagram gives the stations, grades in feet per mile, elevations, curves, the mile posts, and from the diagram there appears to be but 177 ft. difference in elevation at the terminals of this district. The record also gives the analysis of the coal used.

Each of the locomotives ran 10,000 miles, requiring from 94 to 124 days for the tests. Each engine was accompanied on its 96 trips by a special apprentice, who was a technical school graduate, and these young men were under the direct supervision of Mr. W. H. V. Rosing, Assistant Superintendent of Machinery, who gave his personal attention to the work. All the trains were weighed on track scales, and one grade of coal, all from the same mine, was used throughout. It was weighed on platform scales before being delivered to the tenders. Water meters were used to measure the water, and these were checked by tank gauge measurements. The injector overflow was measured and deducted. These data were taken in order to ascertain all the conditions of operation, the final comparison being expressed in the cost in dollars and cents to haul 10,000 tons one mile.

The record speaks for itself, and is worthy of most careful study by every mechanical and operating officer, for it contains information which very few have undertaken to secure at all, and for completeness this case stands alone. We have never seen a more comprehensive record, including cost of repairs and wages.

These results need careful consideration or they will be misunderstood, and in view of the tendency toward increasing the power of locomotives the figures are exceedingly significant and valuable.

The Illinois Central probably will not build more of these heavy engines, but this decision needs explanation. In this case, because of peculiar conditions of the traffic, it was found impossible to gain the full advantage which the large engines would give if completely loaded. It was impossible to load the heavy engines up to their economical capacity without holding them for full trains, which could not be done. Whereas these engines ought to haul 1,800 tons, but 1,500 tons could be given them. Furthermore, the big engines required an extra man to assist the fireman. At this point attention should be called to the fact that these two heavy locomotives have narrow fire-boxes. If they were to be built now they would doubtless have at least 30 per cent. more grate area. Because of the significance of these figures the relative cost of hauling 10,000 tons one mile is repeated here. These figures are from the 10-wheel mogul, consolidation and 12-wheel engines in the order named.

Cost to Haul 10,000 Tons One Mile.

Engine No.	Oil and waste. Cents.	Coal. Cents.	Repairs. Cents.	Wages.		Total cost.
				Engineers and firemen. Cents.	Of trainmen. Cents.	
35	3.47	65.3	8.14	60.52	65.55	\$1.93
489	2.22	58.4	10.11	61.50	69.33	2.02
639	3.33	62.29	10.33	60.01	49.73	1.86
640	3.17	62.98	7.59	62.79	50.13	1.87

In oil and waste there is no important difference; the 10-wheel engine, however, was the most expensive in this item. The big engines cost more in fuel. In repairs the heaviest engine was the lowest, and we are informed that the relatively high repairs of engine No. 639 were not due to its being a large engine. In spite of the extra man required for each of the large engines, No. 639 had the lowest item of wages of the engine crew. It is in the saving in train-crew wages that the greatest difference appears. The train crews consisted of one conductor and two brakemen.

The heavy engines, though handicapped, operated more economically than the others, and to us the tests seem to be an unqualified proof of the correctness of the policy of building heavy locomotives—if they can be properly loaded. This is understood to be the view taken by the Illinois Central officers. No business originates between the terminals of this district, and nearly all of the traffic is time freight. Even the coal business must be hurried, because of peculiar storage conditions in Chicago. The difficulty is purely one of traffic conditions. In ore, timber or ordinary coal traffic these big engines would have stood out head and shoulders above the others instead of showing a small margin.

Incidentally, it may be worth mentioning that comparisons of this kind are impossible without the ton-mile basis for locomotive statistics.

There are many interesting facts brought out in these tables which we must leave to the reader to discover.

General interest in the American Engineer Tests on Locomotive Draft Appliances is shown by the large number of communications received from railroad officers and others interested in this subject. Because of its suggestiveness, one of these, from Mr. C. M. Muchnic, is printed in this issue. Suggestions and criticisms are acceptable, and they will receive careful consideration. It is difficult to realize the breadth of this subject, and after our thorough preliminary study of it, new phases of the problem continually appear. The extent of the work will perhaps be better understood from a statement that in studying the effect of 7 different heights of nozzles, 4 heights of stacks, 4 diameters of stacks, 2 shapes of stacks and 3 different rates of driving, as many as 672 conditions will be investigated. This is for the study of the subject of nozzles and stacks alone. Consideration of the other factors develops an increasing number of interesting conditions requiring investigation, and these will be treated in turn. In order to get at all of the factors and their relationships, a well-equipped testing plant could be kept busy for several years. There is evidence in abundance to indicate that the subject selected is one of most vital interest.

WATER PURIFICATION.

Chicago, Burlington & Quincy.

An Automatic Process.

For many years the Chicago, Burlington & Quincy has given a great deal of attention to the water supply for its locomotives. Until recently, however, efforts have been confined to a thorough study of the water and toward the selection of improved supplies when possible. At Quincy and Galesburg filter installations have been completed, the former being now in use, but the latter has not yet been put into service. At Buda, Illinois, 117 miles from Chicago, where the water contains nearly 21 grains of scale-forming solids per gallon, a new water softener has been put into service. This water is the worst used on this road in Illinois, and it is an important supply, furnishing at present about 75 locomotives per day. The normal capacity of the machine is 9,500 gallons per hour, but



Water Service on the Chicago, Burlington & Quincy.

as the rating is very conservative, the real capacity is much greater.

The most interesting and striking feature of the plant is that it is automatic and that as long as the character of the raw water does not change the machine requires attention only for the supply of chemicals and for cleaning out. A representative of this journal recently made a thorough examination of this plant and a description will undoubtedly interest our readers, because of the necessity for securing good boiler water under present conditions of locomotive service. It is unnecessary to present the reasons for this, because our readers undoubtedly appreciate the effect of had water upon the fuel account, the cost of repairs and the continuity of service of locomotives, which is such an important item when business is so heavy.

The accompanying engraving illustrates the construction and operation of the machine at Buda. The apparatus is contained in and mounted on a cylindrical shell about 12 ft. in diameter and about 40 ft. high. This is mounted on a concrete foundation and is located near three elevated storage tanks having combined capacity of about 170,000 gals. An 8-in. pipe, reaching over the top of the cylinder, brings the raw water from

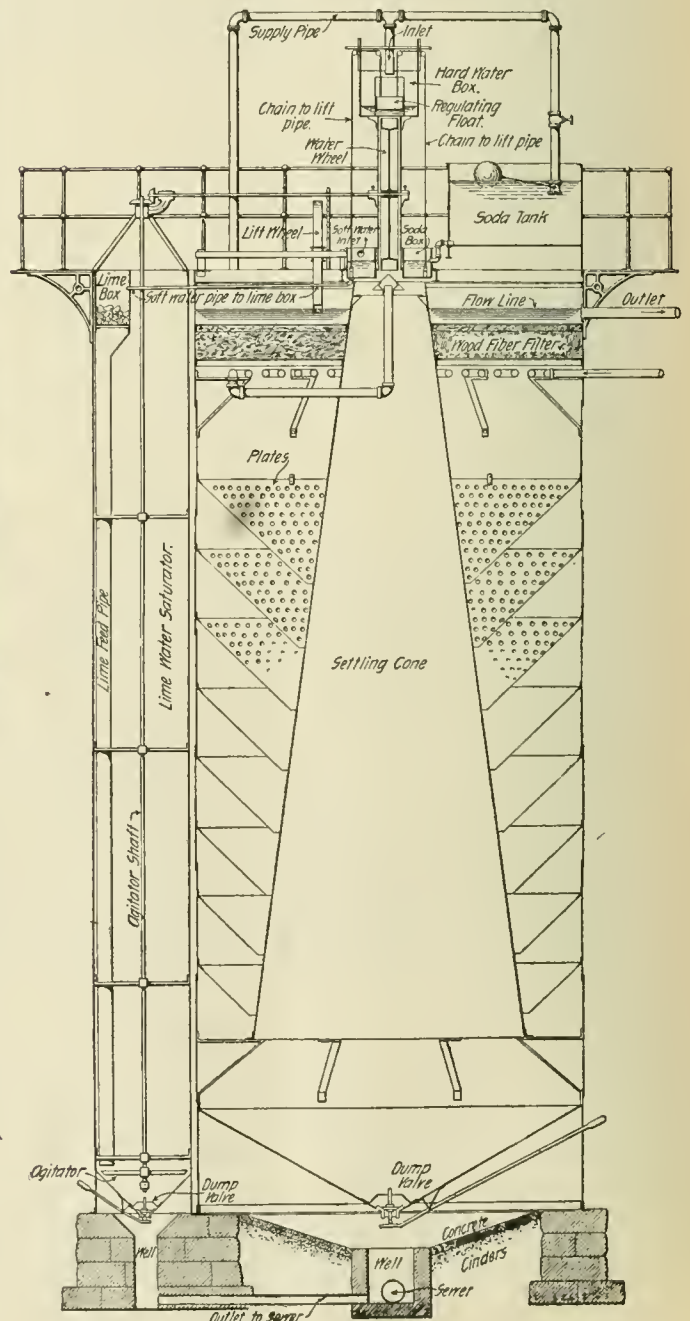
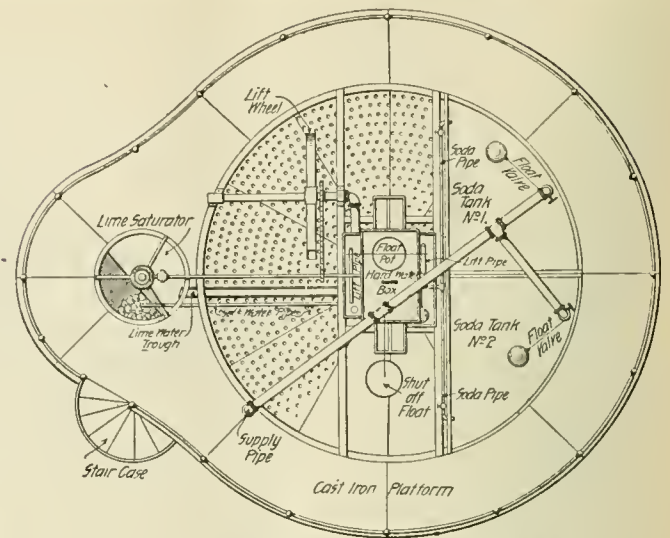

Section of Purifier.

"Coal Creek," a distance of 1 1/8 miles, the pump being located at the creek. Some of the water is from the surface, but most of it is from springs, the supply being permanent. Over this section of the road soda ash has been used in the tenders for some time, but engines taking water at this point have discontinued its use.

The water to be treated is brought to the center of the vertical cylinder, where it discharges into a hard-water box, shown in the engraving. From this box the water, on its way to the purifier, turns a water wheel from which the power required for the machine is derived. After leaving the wheel it passes to the top of the settling cone. At this point it is mixed with the treating solutions, which, in this case, are limewater and soda. Upon mixing with the chemicals lime, magnesia, iron, alumina and a portion of the silica (if the water contains it) begin to settle out, and the process continues.

Because of its shape the cone permits the water to gradually reduce its velocity, which assists in the settling. From the bottom of the settling cone the water passes up through the outer space, where the settling is continued and aided by a large number of baffle plates. Before passing to the outlets the treated water finally passes through a filter of wood fiber. The water passes through the machine without loss of head, and on its way automatically regulates the supply of the chemicals.

The lime and soda solutions are prepared separately. At one side of the main cylinder a smaller, and sometimes shorter cylinder, 25 ft. high, is secured. This is open at the top and an agitator at the bottom of a vertical shaft stirs up the contents. From the top of the lime saturator a trough takes the limewater to the top of the settling cone. A lift wheel, driven by the water wheel, raises some of the treated water into a box. From here it passes by gravity to the lime saturator through the orifice marked "soft water inlet."

On the other side of the water wheel is the soda box, which is kept full from the soda tanks by a ball valve. There are two soda tanks for use alternately. The relative amounts of soda and lime solutions are determined by the sizes of the orifices through which the solutions pass out of the small tanks at each side of the water wheel. These openings are slits in the ends of pipes. The pipes have swing joints at their fixed ends, and by raising the free ends the flow is reduced by reducing the "head." These lift pipes are controlled by a float in the hard-water box, so that the chemicals will be governed by the amount of raw water entering the machine. A valve in the main supply pipe is controlled by a float in the top of the cylinder, resting upon the treated water. This float will stop the whole machine if the water level for any reason becomes higher than the normal. At Buda the outlets open directly into the three elevated tanks, and the water flows by gravity. At the bottom of the settling cone and lime saturator the sludge is removed by valves opening into a drain. A neat cast-iron platform with a railing surrounds the top of the machine.

The effect of the process on the water is given in the following table, in which the quantities are expressed in grains per gallon:

ANALYSIS BEFORE AND AFTER TREATMENT.

	Before.	After
Sodium chloride.....	0.36	0.40
Magnesium chloride.....	0.23	none
Sodium sulphate.....	none	1.80
Alkalies (non-incrusting).....	0.59	2.20
Calcium carbonate.....	9.64	2.43
Calcium sulphate.....	3.03	0.24
Magnesium carbonate.....	7.80	0.74
Silica and iron oxide.....	0.29	0.20
Incrusting solids.....	20.76	3.61

The apparatus is the Kennicott Water Softener. It was installed under contract with the J. S. Toppan Company, Agents, 77 Jackson Boulevard, Chicago. This company is now employed upon extensive investigations of the water supply of several well-known railroads, with a view of improving the supply by treatment with their apparatus. They have installed a number of plants which are now in use.

THE BOLSTER VS. THE SIDE BEARING.

The effect of recent improvements in operation of railroads is seen in many efforts to cut down and eliminate losses which were formerly not thought of at all and were considered unavoidable. One of these is involved in the very unsatisfactory practice in connection with center plates and side bearings. These details not only influence the resistance of trains, but also the wear of wheels and rails and the safety of the flanges. Altogether the subject is perhaps second only to that of draft gear in importance in connection with car construction.

While the M. C. B. Association has twice appointed committees to report on this subject nothing definite has been accomplished except to emphasize its importance. There was no report by the committee at the recent convention, but the opinions secured in conversation with several prominent members indicate that there is a marked tendency toward a change of opinion with reference to the functions of side bearings.

With the ordinary side bearings it is necessary to provide sufficient rigidity in the bolsters to prevent bringing these bearings into contact by deflection and the question then becomes: Shall bolsters be made stiff enough to keep the side bearings apart, except as a result of rocking of the car, or shall the side bearings be utilized at all times to carry the load? If side bearings are to be depended upon for the load, relief in the matter of weight of bolsters will be had and it is becoming apparent that weight in bolsters is now a factor in car design. Some of the modern metal bolsters are holding the cars up and some are not. It will not be questioned that bolsters must not be lighter, but in many cases much heavier than they are now in order to hold the side bearings apart. Is it worth while to make them heavier if a satisfactory side bearing is available for permanent and continuous loading? The answer to this depends upon the qualities of the so-called "frictionless" side bearings. Several authorities have expressed themselves as ready to support their cars on three points at each end when they are satisfied that the proper side bearing is available. It may be inferred that these men have the various "frictionless" side bearings in trial service. If not they should begin such an investigation.

Center plate design cannot be considered independently of the side bearings. If the side bearings are kept apart through the stiffness of the bolsters the resistance of the truck to curving comes upon the center plate. It should therefore be so made as to offer the least possible resistance. On the other hand, if side bearings are improved in extent permitting of their use as permanent supports, it is inconsistent to neglect the improvement of the center plate and this view leads to the conclusion that, whatever is done as to side bearings the center plate should be made as nearly frictionless as possible. It is too late a day to require reviewing the advantages to be derived from a reduction in the resistance of trucks to turning. These are thoroughly understood.

Like draft gear, the improvement of center plates and side bearings is necessary for old as well as new cars and it is specially necessary in modern steel coal cars of the hopper type with extremely high centers of gravity. In fact, it was in connection with these high cars that the expressions of opinions referred to arose. It is immediately apparent that a high center of gravity and a 50-ton load is likely to cause large stresses on the bolsters if even a slight opening between the side bearings is permitted. In swinging at the entrance of a curve the momentum of such a load must cause excessive blows upon the bolsters as the motion is arrested by the side bearings and the shocks are aggravated by the motion at these bearings. Authenticated records of damaged bolsters support the opinion that this is likely to become a serious matter. While it is possible to provide for the ordinary deflections due to load and to use metal enough in the bolsters to carry the loads on the center plates this destructive rocking action is not to be laid, as a fault, to the bolsters, but to a defect in

side bearings whereby the motion is permitted to become destructive. A close-fitting ball or roller side bearing seems to offer a solution of this difficulty. The side bearings of such cars should be in contact and this at once necessitates the use of improved side bearings.

It should not be thought that the failure of the M. C. B. Association to discuss the subject at the recent convention indicates that it is unimportant or that the problem has been accepted as solved.

THE SECRET OF SUCCESS.

The following paragraph was received from a correspondent. It is commended to everyone who is in a responsible position in charge of the direction of the efforts of others:

TO DETERMINE THE WEIGHT OF WATER IN A BOILER.

By Lawford H. Fry.

The following method was developed as a means of determining easily and with reasonable accuracy the weight of water contained in a locomotive boiler of given dimensions. Comparisons of results calculated by this method, with actual weightings, show that the calculated results come well within the limits of accuracy required in practical work.

The process consists of two operations; first, the determination of the weight of water in the waist, and second, the determination of the weight of water surrounding the firebox.

Considering a cross-section of the waist, the area of

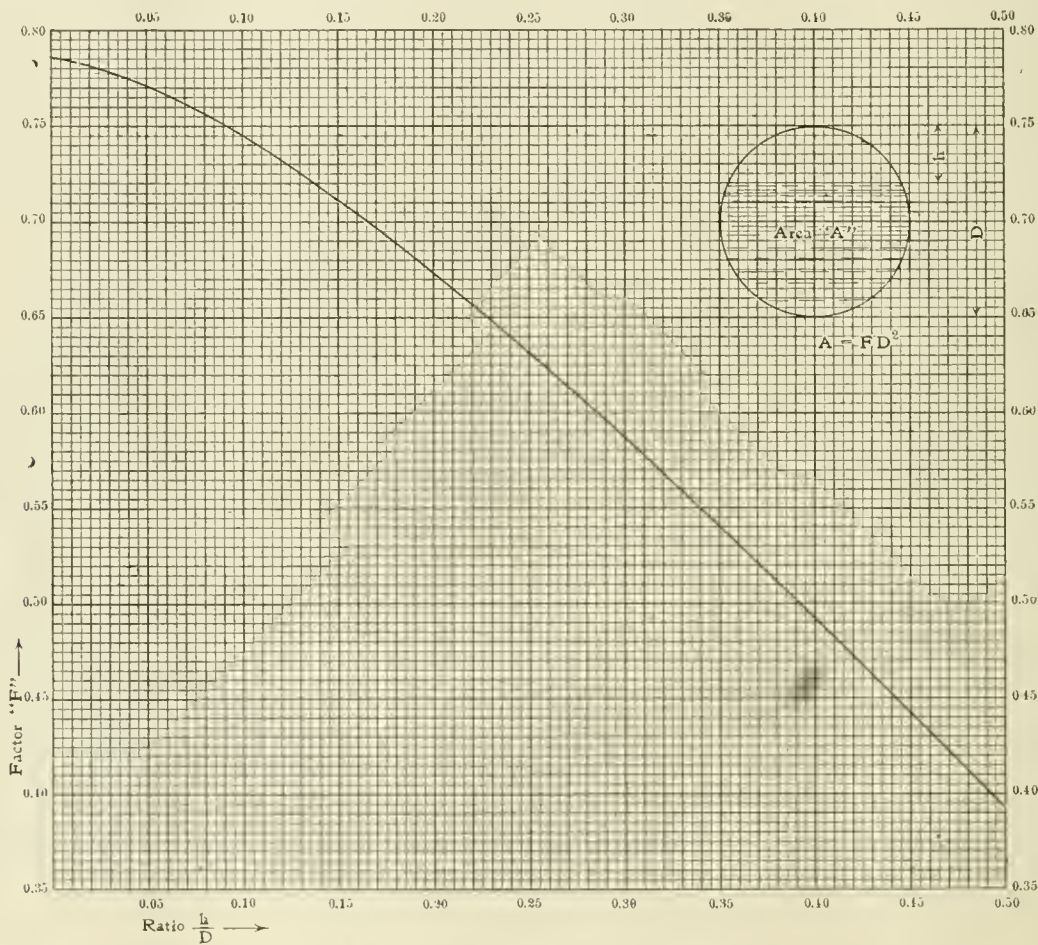

To Determine the Weight of Water in a Boiler.

"The secret of the success of the great business enterprises of the world lies in the talent of some man at the head to get folks who can do things and then let them alone to do them. It requires much less talent and genius to find the man to 'deliver the message' than to keep your hands off and let him do it. One business that the writer knows of has practically reached the limit of its expansion because the man at the head of it isn't big enough to let folks do things; he is always interfering with the method; his employees have no individuality in their work; they try to do it 'to please the old man' rather than to promote the business, but he doesn't encourage the expression of them; he overrides new suggestions because they 'cost too much,' or because he doesn't 'consider them practical' or because the man who makes the suggestion 'doesn't know anything about it.' This is a discouraging case for an employee who really wants to improve his own condition by improving the business he is in."

the water is the area of the segment below the water level, less the area of the flues. The area of the segment of a circle is obtained from the formidable formula

Area = $D^2 \left\{ \frac{\pi}{4} - \frac{4}{3} \left(\frac{h}{D} \right)^2 \sqrt{\frac{D}{h} - 0.608} \right\}$ Where "D" is the diameter of the circle and "h" is the height of the remaining segment. In the present case "D" is the inside diameter of the boiler and "h" is the height of the steam space. (Fig. 1.)

To require the solution of the expression given above for the area would be a fatal defect in a method pretending to practical application. To avoid this the curve in the accompanying chart has been arranged.

If the expression $\left\{ \frac{\pi}{4} - \frac{4}{3} \left(\frac{h}{D} \right)^2 \sqrt{\frac{D}{h} - 0.608} \right\}$ be represented by "F" the formula for the area becomes Area = $D^2 F$. This factor F, by which the square of the diameter is multiplied to give the area, is dependent only on the ratio $\frac{h}{D}$; a curve can therefore be drawn representing the relation between

The Pressed Steel Car Company's output of cars up to October 24 aggregates 50,091, enough to make a train of steel equipment over three hundred miles long.

the value of the factor and the ratio $\frac{h}{D}$. In Fig. 1 such a curve has been drawn with the values of $\frac{h}{D}$ between 0 and 0.5 as abscissæ, and the corresponding values of the factor F as ordinates. By the use of this curve then, the area of any segment of a circle can be readily found.

The area of the water section having been determined by this means, the weight of an inch length or a foot length is readily found. The area being D^2F square inches, the weight of one inch length is $0.036 D^2F$ pounds, and the weight of one foot length is $0.432 D^2F$ pounds. To save trouble the values of D^2 , $0.036 D^2$ and $0.432 D^2$ have been worked out for values of D, advancing by two inches between 24 ins. and 88 ins., and are given in Table A. The process outlined above gives the weight of water in the waist, supposing there are no tubes. The weight of water displaced by the tubes is readily found from Table B, which gives for tubes of various diameters the weight of water displaced respectively by one foot and one inch of tubes of various diameters.

It now remains to find the weight of water surrounding the

Table A.				Table A—(Continued).			
D	D ²	0.036D ²	0.432D ²	D	D ²	0.036D ²	0.432D ²
24	576	20.74	248.8	62	3,844	138.3	1,661
26	676	24.34	292.0	64	4,096	147.5	1,769
28	784	28.22	338.7	66	4,356	156.8	1,882
30	900	32.40	388.8	68	4,624	166.5	1,997
32	1,024	36.86	442.4	70	4,900	176.4	2,117
34	1,156	41.62	499.4	72	5,184	186.6	2,239
36	1,296	46.66	559.9	74	5,476	197.1	2,366
38	1,444	51.98	623.8	76	5,776	207.9	2,494
40	1,600	57.60	691.2	78	6,084	219.0	2,628
42	1,764	63.50	762.0	80	6,400	230.4	2,765
44	1,936	69.70	836.4	82	6,724	242.1	2,905
46	2,116	76.18	914.1	84	7,056	254.0	3,048
48	2,304	82.94	995.3	86	7,396	266.3	3,195
50	2,500	90.00	1,080.0	88	7,744	278.8	3,345
52	2,704	97.34	1,168				
54	2,916	105.0	1,260				
56	3,136	112.9	1,355				
60	3,600	129.6	1,555				
68	4,624	162.1	1,953				

TABLE B.			TABLE C.		
Table B—Weight of Water Displaced by Tubes.			Table C—Factor for Determining Weight of Water Surrounding Firebox.		
Tube Diameter.	Weight of Water Displaced. Per inch.	Per foot.	Pitch.	Staybolt Diameter.	Staybolt Diameter.
1 1/2"	0.063	0.763	7/8"	1"	1 1/8"
1 3/4"	0.096	1.04			
2"	0.113	1.36	4 ins.	5.05	5.00
2 1/4"	0.143	1.72	4 1/2	5.07	5.02
2 1/2"	0.177	2.12	4 3/4	5.08	5.04

firebox. To do this without a laborious calculation the volume of water is estimated by multiplying the heating surface of the firebox by the mean thickness of the surrounding water space, and making due allowance for the water displaced by the staybolts. If the heating surface is given in square feet and the mean water space thickness in inches, their product multiplied by the proper factor from Table C gives the weight of the water in pounds. This added to the weight found for the water in the waist gives the weight of the total water capacity of the boiler.

As stated at the outset the method is an approximate one, and this must necessarily be the case if the result is to be arrived at by a reasonable amount of calculation. It is, however, easy to see what assumptions are made, and thus to determine the measure of confidence of which the method is worthy. In the first place an assumption is made tending to give too heavy a result. In estimating the weight of water in the waist, the whole distance between tube sheets is taken, and in estimating the weight of water surrounding the firebox the whole firebox surface, including the tube sheet, is supposed to be overlaid with a sheet of water of the mean thickness of the water space, consequently the water between the firebox tube sheet and a vertical extension of the throat sheet is counted twice. A further tendency to an excessive result is due to the neglect to consider the water displaced by crown bars or longitudinal braces.

On the other hand, the result has a tendency to fall short, because the crown-sheet is only estimated to be overlaid by a sheet of water of the mean water space thickness, while in reality there will be considerably more water over the crown-sheet. Another item, making for a light result, is the estimation of the water by means of the surface of the inside of the firebox. Of course the surface which should be multiplied by the mean water space thickness to give the volume is a surface lying between the inner and outer surfaces of the water under consideration. There are thus two factors tending to an excess and two tending to a deficit of weight. Careful consideration has led to the belief that for practical purposes the errors may be taken to balance each other, and comparisons of calculated with actual results have gone to confirm this belief.

A concise recapitulation of the method is as follows:

- If W_w = weight in pounds of water in one foot of waist,
- D = inside diameter of boiler in inches,
- h = height of steam space in inches,
- F = factor found from curve in Fig. 1 to correspond to ratio $\frac{h}{D}$,

and A_c = factor from column 4 of Table A, to correspond to D. Then $W_w = F \times A_c$.

From this the weight of water displaced by one foot of the tubes (Table B) must be deducted, and the result multiplied by the distance between tube sheets in feet.*

Again, if W_s = weight in pounds of water surrounding the firebox,

- S = firebox heating surface in square feet,
- d = mean water space thickness in inches,
- and c = factor corresponding to stay-bolt diameter and pitch in Table C.

Then $W_s = c \times S \times d$.

The total weight of water in the boiler is the sum of the two above results.

THE AMERICAN RAILWAY ASSOCIATION.

The fall meeting of this association was held in St. Louis October 23, with a large attendance. An invitation to the International Railway Congress to hold its next convention in the United States in 1905 has been accepted, and an "American Section" will be organized to make the necessary arrangements. The committee on Standard Dimensions of Freight Cars recommended the following dimensions for standard cars: 36 ft. long; 8 ft. 6 ins. wide; 8 ft. high, with a cross section of 68 sq. ft., and cubical contents, 2,448 cu. ft.; the side-door opening to be 6 ft. wide. This car is recommended to be considered the unit for the establishment of minimum carload weights, and the necessary steps will be taken in connection with the rates to discourage the building of larger or smaller cars, but the use of smaller cars, until they are worn out, is provided for. A resolution was offered as follows: Resolved, that no box cars of larger dimensions than those prescribed for the standard car shall be hereafter constructed, and that all owners and builders of cars be officially notified of the adoption of this resolution. The recommendations were adopted and as the subject is exceedingly important it will be discussed in our next issue.

Arrangements have been made (with the Aetna Life Insurance Company, of Hartford, Conn.), by Mr. J. M. Barr, First Vice-President and General Manager of the Seaboard Air Line, to furnish accident insurance to the employees of that system at a materially reduced rate. This insurance company will have the exclusive right to solicit accident insurance on this road, and payment for insurance premiums will be made from the pay rolls only for the Aetna Company. Employees preferring to insure with other companies will be required to arrange for the payment of premiums outside of the railroad company's accounts.

*The boiler is supposed to be a straight top boiler, so that for the average inside diameter, D, the outside diameter of the first ring, can be taken. For a wagon top boiler the weight of water in the cylindrical part is found as above, while for the coned part the mean weight per foot (or inch) is equal to $1/3 (W + w + 1/3 Ww)$, W and w being respectively the weights per foot (or inch) of the sections at either end of the cone.

EIGHTY-THOUSAND POUNDS CAPACITY TANK CARS.

For Oil or Water.

Atchison, Topeka & Santa Fe Railway.

In order to deal with the oil business in Texas and to carry water for supplying locomotives in the desert districts, the Atchison, Topeka & Santa Fe has built 450 large tank cars which have a number of new features. Their capacity is 9,406 gals. when fitted with heater pipes. One hundred of them will be used to carry water for locomotive use and the rest for service in the Texas oil-fields.

Instead of resting upon the floor of a flat car, the common

to unload freely. A saving of weight would be possible if these pipes were omitted and if the plates were made thinner. In this one the body plates are 1/4 in. and the heads and dome 3/8 in. Throughout, the rivets are 1/2 in., with all seams, except the dome joints, double riveted. Seven straps secure the tank to the car body. The principal timbers are as follows:

Sills, yellow pine.....	5 by 9 ins.
End sills, yellow pine.....	8 by 12 ins.
Dead woods, white oak.....	5 by 9 by 32 ins.
Crossbeams, white oak.....	5 by 12 ins.
Cradle blocks, white oak.....	8 by 9 ins.
Head blocks, white oak.....	9 by 12 ins.

The draft rigging is the Dayton twin spring arrangement, the body holsters are of wrought iron with malleable fillers between the center sills and cast iron spacers between the upper and lower plates: the trucks are the Atchison standard

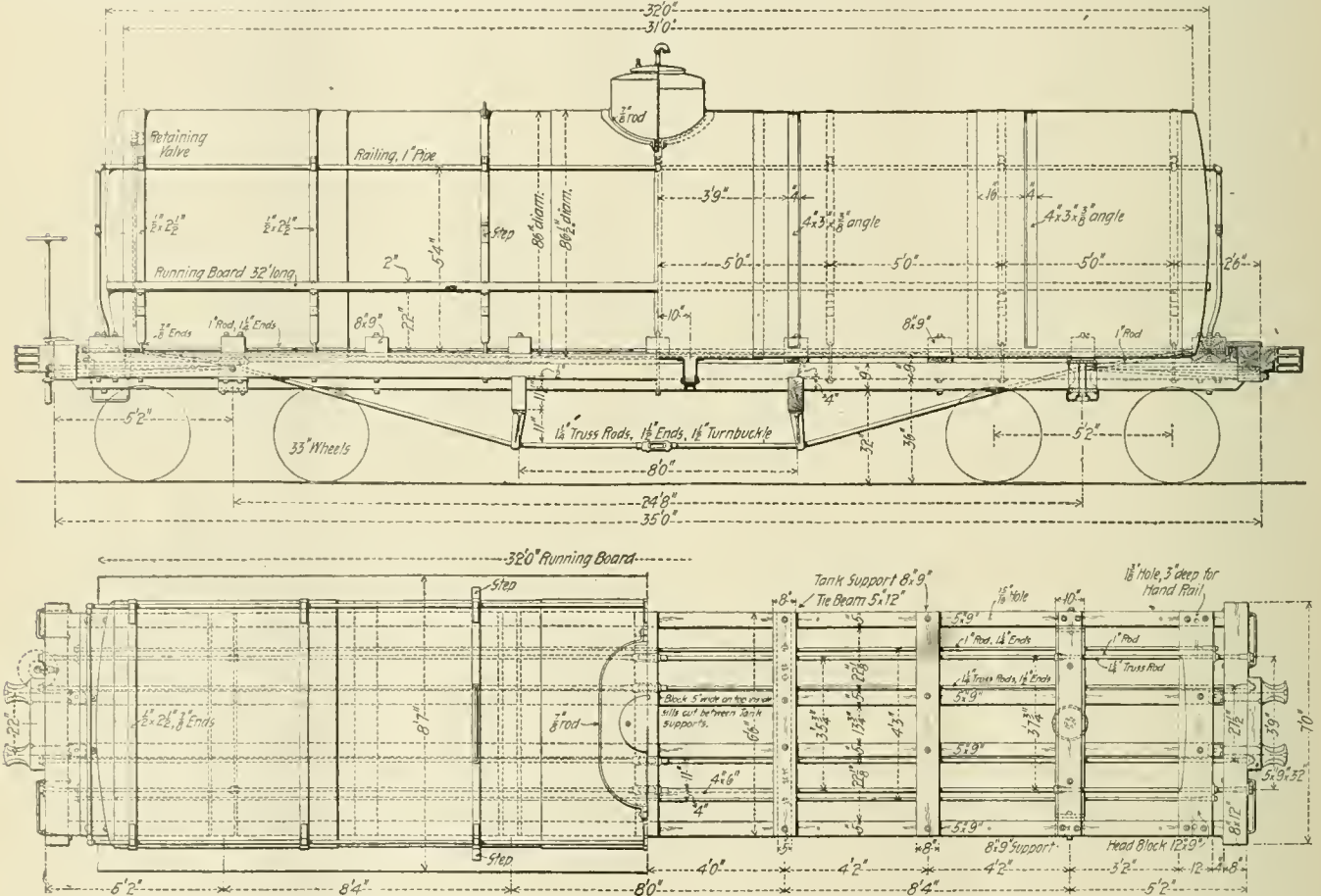

80,000 Pounds Capacity Tank Car—Atchison, Topeka & Santa Fe Railway.

practice in tank car construction, this design places the tank upon seven 8 by 9-in. white oak cradle blocks, and between two head blocks, all of which rest upon four 5 by 9-in. yellow pine longitudinal sills trussed with 1 1/4-in. truss rods. The general dimensions are as follows:

80,000-lb. Tank Car, A. T. & S. F. Railway.	
Length over end sills.....	35 ft.
Length of tank.....	32 ft.
Width over end sills.....	6 ft. 6 ins.
Width over running boards.....	8 ft. 7 ins.
Diameter of tank, outside.....	7 ft. 2 1/2 ins.
Height, rail to bottom of side sill.....	3 ft. 0 ins.
Height, rail to center of tank.....	7 ft. 2 ins.
Height, rail to top of dome.....	12 ft.
Height, rail to top of dome cap.....	12 ft. 5 ins.
Wheel base of car.....	39 ft. 10 ins.
Wheel base of trucks.....	5 ft. 2 ins.
Distance between crossbeams.....	24 ft. 8 ins.
Capacity for oil.....	9,406 gals.
Weight of tank.....	10,000 lbs.
Weight of car body.....	10,700 lbs.
Weight of trucks.....	13,400 lbs.
Total weight, with heater pipes.....	35,300 lbs.

Heater pipes are necessary for carrying California oils, because they are thick at ordinary temperatures. Beaumont oil is considerably thinner, but on cold nights it becomes too thick

Player type for 80,000-lb. cars, having 5 by 9-in. wrought iron axles, M. C. B. malleable iron journal boxes and 33-in., 600-lb. cast iron wheels. These cars were designed by the motive power department of the road at Topeka. They are being built at the shops at that point and the tanks are furnished by the Hamler Boiler and Tank Company, of Chicago.

Having discovered that a statement in the preliminary article on the American Engineer tests has done an injustice to the motive power department of the Chicago & Northwestern Railroad, we hasten to explain. The indicator cards referred to on page 303 of our October issue, which show such high back pressures, do not represent the practice of that road. For a special purpose a 4 1/2-in. exhaust nozzle was in the engine at the time of the tests, and for some reason was not removed before the cards were taken. The engines of this class usually run with a 5 1/4-in. nozzle, which would undoubtedly reduce the back pressure somewhat. We were not aware of this fact at the time, and we are glad to correct the impression which we received and probably also gave to others.

COMPOUND LOCOMOTIVES ON THE BUENOS AIRES GREAT SOUTHERN RAILWAY.

From a paper by R. Gould, read before the International Engineering Congress, Glasgow.

The question of coal consumption of locomotives becomes in countries like the Argentine Republic, which depends entirely on the imported article, a matter of paramount importance, and an endeavor to secure an economy in this respect led to the trial of the compound engine.

The type of engine adopted on the Great Southern Railway was the two-cylinder "Worsdell and Von Borries," as being the simplest arrangement, and interfering least with the duplication of parts of the standard simple engines previously in service. All these engines, both simple and compound, were

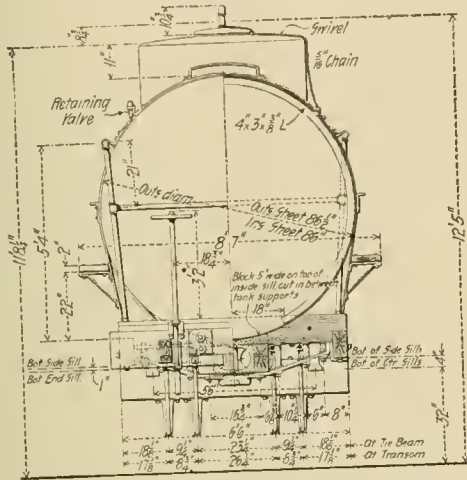

Section and End Elevation of Tank Car.

built by Messrs. Beyer, Peacock & Co., under the instructions of Messrs. Livesey, Son & Henderson, the company's consulting engineers.

The first compound engines ordered were erected in 1889, and the results obtained were so excellent that, with the exception of shunting and local traffic engines, no simple engines (either goods or passenger) have since been ordered.

The engines proved easy to handle, exhibited a high economy in coal and water, and, owing to the reduced demand on the boiler, showed less tendency to priming and scale than the original simples. As an offset against these advantages, the first compounds sometimes showed a sluggishness in starting, or an inclination to jib, due to the rapidity with which the automatic "Worsdell and von Borries" starting valve caused compounding to take place, reducing the power by cutting off the live steam from the low-pressure cylinder before (in the case of long and heavy trains) the whole weight was fully taken on the drawbars, or the whole train in motion. The defect was gotten over by an improvement made in the company's works at Buenos Aires in introducing a hollow spindle in the muchroom valve with an escape passage to the chimney, the office of the passage being to relieve the back pressure to some extent, and so delay compounding.

The effect of the alteration in the intercepting valve was to entirely obviate the tendency to jib previously experienced, and to ensure a certain and easy start, with the maximum power, while retaining the automaticity of the valve's action, a most valuable and important feature, putting it out of the power of the driver to work non-compound longer than was absolutely necessary. Some 109 engines were fitted with this improvement.

Increasing weights of trains made it necessary to do something to adapt engines—of which the company possessed a large number—to the heavier demand on their power. The boilers of some of the older engines were replaced by new and larger ones carrying high pressure, the cylinders being at the

same time changed for those of increased size, and the engines compounded. The engines have proved a great success, being from 25 to 30 per cent. more powerful than the old Class 6 which they supersede. The tabular statement attached shows the coal and lubricant consumption, and also the comparative cost of repairs for the mileages given.

The absence of heavy grades on the Buenos Aires Great Southern Railway renders it a favorable field for the compound engine, the grades of importance being in one district only, the bulk of the line being practically straight and level. The CONSUMPTION OF COAL AND LUBRICANTS FOR THE YEAR 1900.

	Passenger Engine.		Goods Engine.			
	Class 6	Class 6A	Class 6B	Class 7	Class 7A	Class 10
Coal consumed per train-mile. lbs.	36.00	28.05	29.25	55.68	45.00	40.50
Average weight of trains tons	162	166	211	621	585	526.
Average number of axles per train.	25	25.5	32.5	96	90	81
Coal consumed per axle per mile. lbs.	1.41	1.10	0.99	0.58	0.50	0.50
Lubricant consumed per 100 train-miles. lbs.	7.70	6.45	6.28	7.13	7.27	5.96
Lubricants consumed per 100 engine miles. lbs.	6.38	5.96	5.98	5.57	5.96	5.32
Ratio of coal consumed per axle per mile.	100	76.4	62.5	100	86.2	86.2

Cost of Repairs.

	Passenger Engine.		Goods Engine.	
	Class 6	Class 6A	Class 7	Class 7A
Number of engines repaired	32	24	22	43
Average cost of repairs per engine per mileage shown.	£510	£470	£198	£470
Average number of engine-miles run for above engine repairs	51,034	55,865	54,769	55,224
Average number of engine-miles run per annum	23,916	23,920	20,556	25,692

character of the traffic, with long runs and full trains as a rule, causing an approximation to the fixed load of a stationary engine, is also favorable for the compound system.

Speaking of the advance in locomotive building, Mr. A. B. Johnson, of the Baldwin Locomotive Works, says that in the next year or two the capabilities of the American-built locomotive will be increased from 25 to 35 per cent. He also insists that locomotive engineering on scientific principles has only just begun, and that the progress in the immediate future will result in a gain as great as that of the past 15 years. While the freight engine bids fair to continue its increase in weight, Mr. Johnson says of the passenger engines that "there will be no marked change in the external appearance. I should not like to see any great increase in weight. The beauty, gracefulness, the symmetry of the locomotive of the present will be retained. Such changes as will be made will be internal, that is, in the firebox, the boiler and the cylinders. The Vauclain compound locomotive, which utilizes some of the steam power which was once wasted, is coming into wide use. Possibly another step forward will be the addition of other cylinders for the further utilization of waste steam, and there is a constant effort to save the waste of coal energy, which is now so large a percentage of all the energy of consumed coal."

As to the further development of the American locomotive as a high-speed and high-power machine, Mr. E. P. Watson, in a recent issue of the "Engineering Magazine," expresses his opinion "that the greatest stumbling block is the line itself, as it exists on most American railways between important terminals."

(Established 1832.)

AMERICAN ENGINEER AND RAILROAD JOURNAL.

PUBLISHED MONTHLY

BY

R. M. VAN ARSDALE,

J. S. BONSALE, Business Manager.

MORSE BUILDINGNEW YORK

G. M. BASFORD, Editor.

E. E. SILK, Associate Editor.

NOVEMBER, 1901.

Subscription.—\$2.00 a year for the United States and Canada; \$2.50 a year to Foreign Countries embraced in the Universal Postal Union.

Remit by Express Money Order, Draft or Post Office Order.

Subscriptions for this paper will be received and copies kept for sale by the

Post Office News Co., 217 Dearborn St., Chicago, Ill.

Danrell & Upham, 283 Washington St., Boston, Mass.

Philip Roeder, 507 North Fourth St., St. Louis, Mo.

R. S. Davis & Co., 346 Fifth Ave., Pittsburg, Pa.

Century News Co., 6 Third St. S., Minneapolis, Minn.

Sampson Low, Marston & Co., Limited, St. Dunstan's House, Fetter Lane, E. C., London, England.

It has been said that the two big freight locomotives which have been running about two years on the Illinois Central are failures, and that the road will not build more of them. It is probably true that no more 110-ton engines will be built for this road at present, but it is not true that they have been failures or that they are now so considered by the management. In this issue the results of the road tests show the correct status of these engines. They operate more cheaply than the lighter engines, even under conditions which are exceedingly unfavorable. The real fact brought out by this experiment is that these engines outclass the conditions under which they operate. They do not get full trains because of the traffic conditions, they can haul more cars than the sidings can hold and they can shear off the heads of draft gear bolts at an amazing rate. These engines are powerful enough to expose the weak spots in the other factors of operation and to indicate that the locomotive is somewhat ahead of its surroundings. Having this valuable information, what is the proper view to take concerning large engines? They are economical when they may be loaded to capacity. A policy of gradually increasing the power of locomotives to keep pace with improvements in the condition of cars, sidings, bridges and operating methods is a good one. This subject is vitally important, and we shall soon be able to present figures to show the effect of a gradual increase in the power of the locomotives of another road which abundantly proves the big engine policy to be a good one.

Tests comparing narrow and wide firebox locomotives on the Southern Pacific are recorded elsewhere in this issue. The locomotives were both compounds of the same type and sizes of cylinders but not of the same weight and heating surface. As might have been expected, the wide firebox showed a decided advantage. In ton miles per pound of coal the wide firebox engine showed an improvement of 13.8 per cent. and 10.1 per cent. In equivalent evaporation of water per pound of coal the advantage was 11.8 per cent. and 17.9 per cent. The average of both tests show a gain of 12 per cent. in ton miles and 14.8 per cent. in water evaporated per pound of coal. To correctly estimate these results it must be noted that the condition of the track was unfavorable to the wide firebox and that engine undoubtedly used wet steam. Altogether the tests are probably perfectly fair and the wet steam and slippery rail may balance the advantage obtained from the more powerful boiler of the wide firebox engine. One cannot fail to be

impressed, however, with the necessity for great care in estimating the value of test records from locomotives which are slightly different in important particulars. In this case the difference of a few inches in the distance between the water line and the throttle valve opening has an important effect which cannot be correctly estimated without a calorimeter and a very elaborate series of experiments. But we have the assurance of the engineer who conducted the tests that the comparison given in the table of results is correct. This is the first instance of tests of this kind showing the value of improved fireboxes for soft coal, and we are glad to be allowed to present the record. The value of the wide firebox seems to be in the less vigorous rate of combustion. It is specially interesting to note the effect in the accumulation of cinders in the front end.

A NEW HOUSE FOR THE AMERICAN SOCIETY OF MECHANICAL ENGINEERS.

With twenty years of conservative management the American Society of Mechanical Engineers has won a high place as a technical association. Its membership has increased rapidly, and likewise its influence. At the spring meeting of this year at Milwaukee a change in the constitution was proposed which, if enacted at the winter meeting, will have an important and, it is feared, serious effect upon the future of the organization. It is proposed to increase the annual dues from \$15 to \$25 for members, and from \$10 to \$15 for juniors. In an official circular it is announced that the added funds are needed to conduct the affairs of the society without loss of efficiency and to provide for more satisfactory housing of the society and its library.

With a membership of about 2,000 and annual receipts of over \$35,000, there can be no question of the possibility of conducting the business of the organization efficiently without increasing the dues. This reason for the proposed increase may be dismissed at once and attention given to the suggestion concerning larger quarters.

The mechanical engineers' house is a pleasant, home-like place, fully adequate, except on a single night of the year. At the opening session of the winter meeting it is too small. Everyone knows the effect of heavy indebtedness on a society of this kind, and to blindly enter upon a long period of such pangs as a new house would bring seems, to say the least, unwise and a most uncomfortable change from the present situation.

If there were not other ways to meet the need this course might be justified, but the American Society of Civil Engineers has recently built an admirable house, and that, too, is used to the full capacity seldom, if at all. What is really needed is a meeting place for engineers, a house with the necessary facilities, which, by reason of the number of tenant societies, would not represent such extravagance and wastefulness. Engineers more than any other class of men should appreciate the "low efficiency" of plant of these two national societies, and they will be quick to see the advantage in a joint building. The Institute of Electrical Engineers must soon secure permanent quarters in order to accept the gift of the Latimer Clark library, which was donated on condition that a suitable place shall be provided for it. There seems to be no reason why these three societies should not enter into a tentative arrangement pending the adoption of a plan for a new house in which the libraries, reading rooms, auditoriums and administration offices may be concentrated or combined. Such a building would be invaluable as a meeting ground for engineers, and doubtless other smaller societies would be glad to have the use of it.

A tenant society in the building of another society never feels at home, and unless all were on an equal footing the joint plan would eventually fail, but by studying the problem with a broad view of ultimately bringing engineers together in their separate organizations, a satisfactory scheme should be found. A temporary arrangement could probably be made for the use

ILLINOIS CENTRAL COMPARATIVE TEST CENTRA

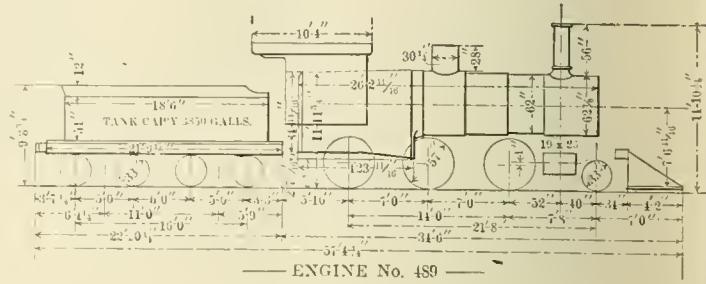
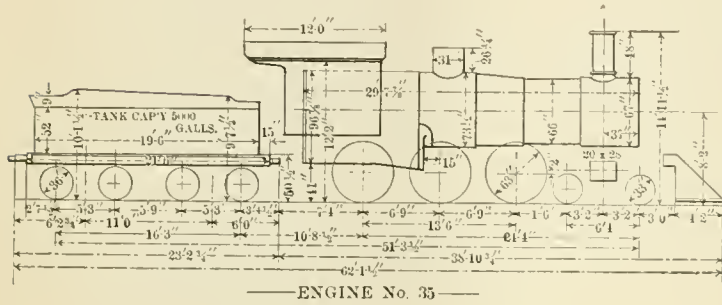

MECHANICAL

ENG. NUMBER	TYPE	BUILDER	CYLINDERS	DRIVERS	WEIGHT				
					ENGINE TRUCK	DRIVERS	TOTAL ENGINE	TOTAL TENDER	TOTAL ENG. & T.
35	10 WHEEL	ROGERS	20" x 28"	6	63	31,000	152,300	102,000	259,200
489	MOGUL	BROOKS	19" x 26"	6	57	16,900	103,400	126,000	206,000
639	CONSOL	ROGERS	23" x 30"	8	57	18,200	134,800	203,000	308,400
640	12 WHEEL	BROOKS	23" x 30"	8	57	40,050	181,400	221,450	308,400

PROFILE CENTER

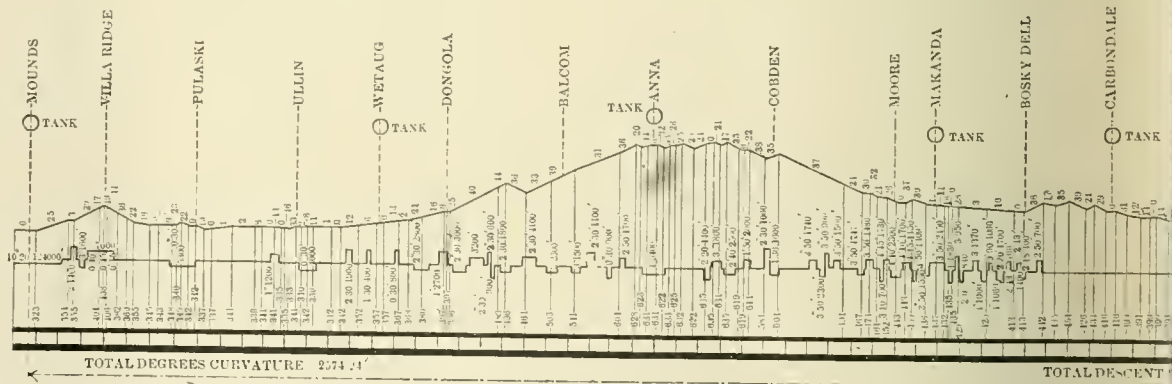

NOTES

TRAIN TONNAGE OBTAINED BY ACTUAL WEIGHT ON TRACK SCALES. ONE GRADE OF COAL USED IN ALL THE ENGINES THROUGHOUT TEST. ALL COAL USED WEIGHED ON PLATFORM SCALES WHEN LOADED ON TENDERS.
WATER MEASURED BY METERS & RECORD CHECKED BY TANK MEASUREMENTS.
OVERFLOW OF INJECTORS MEASURED & DEDUCTED.
ENGINES No. 35 & 489 EACH HAD ONE ENGINEMAN & ONE FIREMAN.
ENGINES No. 639 & 640 EACH HAD ONE ENGINEMAN & ONE FIREMAN & ONE FIREMAN'S HELPER.
TRAIN CREW WITH EACH ENGINE CONSISTED OF ONE CONDUCTOR & TWO BRAKEMEN.

TRANSPORTATION

ENG. Nos.	No. OF TRIPS	MILES RUN	AVERAGE MILES PER HOUR RUNNING TIME	TRAIN						TON MILES	TONS OF COAL USED	GALLONS OF WATER USED			
				GROSS TONNAGE IN TONS OF 2000 LBS.	LOADED CARS		EMPTY CARS		TOTAL CARS				AVERAGE CARS PER TRIP		
					NUMBER	PER-CENT	NUMBER	PER-CENT					LOAD	EMPTY	TOTAL
35	96	10,000	20.24	103,336	2480	71.22	1062	28.75	3482	26	10	36	10,763,613	565	81,7673
489	96	10,000	19.05	101,590	2183	63.84	1236	33.16	3419	23	12	35	10,573,494	608	87,6413
639	96	10,000	17.71	145,738	3144	66.38	1592	33.62	4736	33	16	49	15,173,803	915	1,424,603
640	96	10,000	17.95	145,161	3083	68.73	1734	36.27	4837	32	18	50	15,112,737	921	1,415,420

SUMMARY AND RE

ENG. Nos.	DURATION OF TEST									SHORTEST LAYOVER AT TERMINALS	LONGEST LAYOVER AT TERMINALS NOT INCLUDING REPAIRS	AVERAGE LAYOVER AT TERMINALS NOT INCLUDING REPAIRS	TIME HELD FOR REPAIRS	TIME ON ROAD					
	FROM	TO	TOTAL TIME		TIME IN SERVICE			TIME OUT OF SERVICE						RUNNING	STANDING	TOTAL	PERCENT RUNNING TO TOTAL TIME	PERCENT STANDING TO TOTAL	
			DAYS	HRS	DAYS	HRS	PER-CENT	DAYS	HRS										PER-CENT
35	MAY 3RD 1900	AUG. 6TH 1900	94	4	31	8	33.3	62	20	66.7	3 HRS. 53 MIN.	45 HRS. 36 MIN.	14 HRS. 38 MIN.	97 HRS. 30 MIN.	494 HRS.	258 HRS.	752 HRS.	65.7	34
489	MAY 6TH 1900	AUG. 14TH 1900	101	3	36	4	35.8	64	23	64.2	3 " 15 "	33 " 32 "	14 " 14 "	142 " 10 "	525 "	343 "	868 "	60.5	39
639	MAY 6TH 1900	AUG. 21TH 1900	110	23	38	11	34.7	72	12	65.3	3 " 10 "	47 " 05 "	16 " 21 "	275 " 29 "	565 "	358 "	923 "	61.2	35
640	MAY 4TH 1900	SEPT. 5TH 1900	124	3	40	20	32.9	83	7	67.1	4 " 55 "	36 " 48 "	15 " 32 "	485 " 10 "	557 "	423 "	980 "	56.8	43

RAILROAD COMPANY.

OF LOCOMOTIVES.

A DISTRICT.

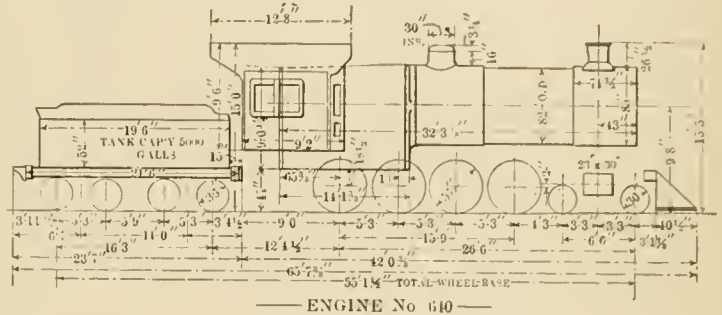
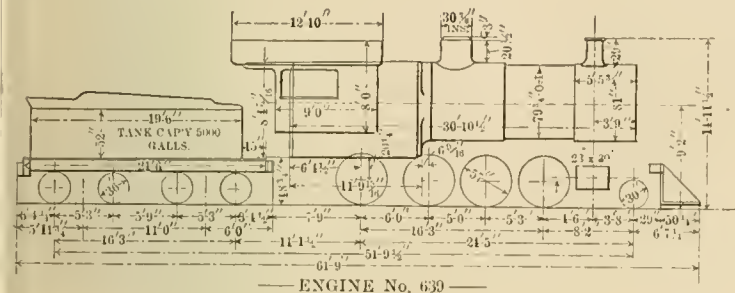

MEMORANDA.

TYPE	WORKING PRESSURE	DIA.	LENGTH		NUMBER	DIA.	LENGTH	HEATING SURFACE		GRATE AREA	
			LENGTH	WIDTH				TRUCK	FIREBOX		TOTAL
LAGONTOP	150	66"	129"	32"	304	2 1/2"	13-11"	2204	192	2396	27.22
BELPAIRE	165	62"	114"	33"	236	2 1/2"	14-1"	1338.57	173.08	1531.65	23.45
BELPAIRE	210	80"	132"	42"	417	2 1/2"	13-8"	2382	221	3203	35.50
BELPAIRE	210	82"	131"	41"	424	2 1/2"	14-8"	3237	263	3500	37.50

MEMORANDA.

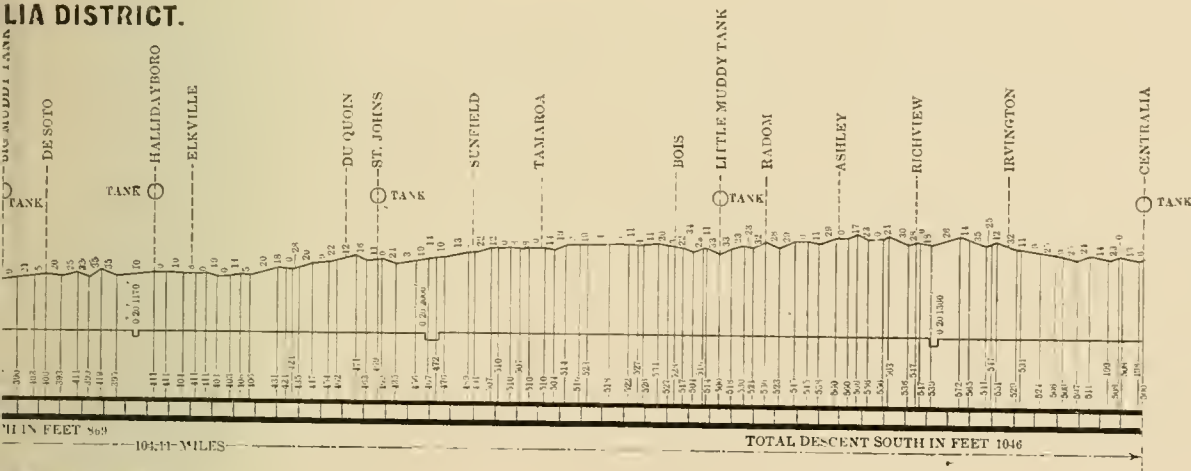

MEMORANDA.

TEMPERATURE	AVERAGE STEAM PRESSURE	POUNDS OF WATER EVAPORATED PER POUND OF COAL	MILES RUN PER TON OF COAL	TON MILES PER TON OF COAL	ITEMS OF COST					TOTAL COST
					OIL & WASTE	COAL	REPAIRS	WAGES OF ENGINE MEN AND FIREMEN	WAGES OF TRAINMEN	
72°	177	6.028	17.69	19051	\$37.39	\$595.09	\$ 87.66	\$ 651.47	\$ 705.56	\$ 2077.17
72°	163	6.063	16.41	17391	23.55	618.09	106.92	650.27	733.56	2132.39
72°	201	6.491	10.92	16582	50.57	945.23	156.76	910.53	754.56	2817.65
72°	199	6.397	10.86	16409	47.90	951.80	174.05	948.93	757.56	2820.84

ANALYSIS OF COAL USED ON TEST ENGINES

FIXED CARBON	47.86 PERCENT
VOLATILE COMBUSTIBLES	37.96 " "
WATER	6.24 " "
ASH	7.94 " "
SULPHUR	1.51 " "
B. T. U.	12622

RESULTS OF TESTS.

TONNAGE RATING	AVERAGE GROSS TRAIN TONNAGE OVER DISTRICT IN RULING GRADE	PERCENTAGE AVERAGE GROSS TRAIN TONNAGE OVER DISTRICT IN RULING GRADE	COST TO HAUL 10,000 TONS ONE MILE					POUNDS OF COAL USED TO HAUL 10,000 TONS ONE MILE	COMPARISON ON PERCENTAGE BASIS ENG. 33 BEING RATED 100%									
			OIL & WASTE	COAL	REPAIRS	WAGES OF ENGINE MEN AND FIREMEN	WAGES OF TRAINMEN		TOTAL COST	TONS OF COAL USED	TONS HAULED	TON MILES	WATER USED	POUNDS OF WATER RUN PER POUND OF COAL	MILES RUN PER TON OF COAL	POUNDS COAL USED TO HAUL 10,000 TONS ONE MILE	COST TO HAUL 10,000 TONS ONE MILE	TOTAL COST
1050	1076	102.5	3.47	55.3	8.14	60.52	65.55	\$ 1.93	1050	100	100	100	100	100	100	100	100	100
900	1057	117.4	2.22	58.4	10.11	61.50	69.38	2.02	1150	107.54	98.23	98.23	107.18	99.59	92.76	109.52	104.66	102.65
1800	1517	84.3	3.33	62.39	10.33	61.01	49.73	1.86	1206	161.95	140.96	140.96	174.44	107.68	61.72	114.86	96.37	135.64
1800	1511	83.9	3.17	62.98	7.59	62.79	50.13	1.87	1219	163.01	140.40	140.40	173.10	106.12	61.39	116.09	96.88	135.80

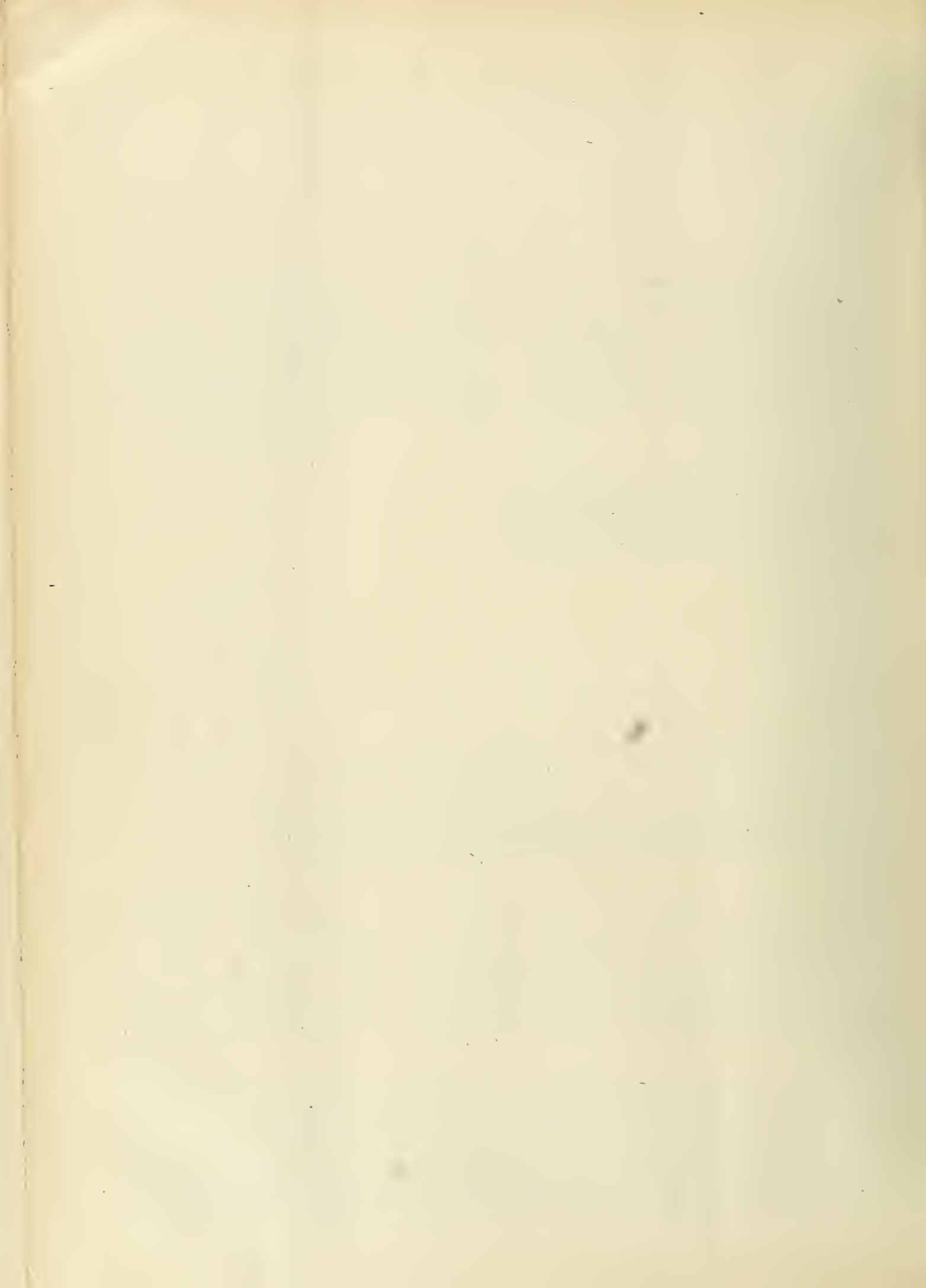

of the civil engineers' house, and if it was understood to be temporary it ought to work well. It is probable that the advantage of a joint building would soon appear to all in a favorable light, which would be a good starting point for the future. There can be no question of jealousy in such a case with such men. The value of a concentration (we do not say consolidation) of the libraries concerned and the improvement of their administration, seems sufficient to insure consideration to this arrangement. If the building of the civil engineers is found to be too small, and if it cannot be extended, the associations can then take up the problem in its broadest phase.

There is an element of injustice in the proposed increase of dues, in that the burden will fall on all members, while few will be able to obtain any direct benefit. If dues, already heavy, are increased, the society will be likely to lose many helpful members. Undoubtedly, it will tend to keep out many young men who are growing up into the profession, and this the society cannot afford to do.

Where the expenses are so heavy in proportion to the benefits every effort should be made in the direction of increased efficiency. The proposed plan of joint division of this expense presupposes the co-operation of the various societies. Whether this can be secured is not known, but it should be known before another society builds a home for itself alone. It is to be hoped that conservative counsel will prevail when this question comes up in December. It is impossible to believe that such an increase can be passed by a two-thirds vote at the annual meeting.

THE BUSINESS PROBLEM IN CAR CONSTRUCTION.

Until a few years ago car construction was one of the rough and ready arts, in which the sizes and arrangements of parts followed well established precedents, and a thorough knowledge of the exigencies of service, coupled with good judgment on the part of the builder, were all that were required. These attributes are not less necessary now that new conditions have come into the car situation, but the men who have brought car practice up to its present state find new problems which do not yield to the established methods. One of the new conditions is brought into prominence by improved operating methods which render the dead weight of the car noticeable in the financial returns. In some kinds of service this is not yet considered important, but it is evident that one of the problems of the future in this field is to produce the lightest cars which will have the strength and endurance necessary to withstand the punishment of service.

For about three years this subject has been carefully studied, and the effect is indicated by the number of applications of engineering principles to car design which are now undergoing service trials, for steel car construction cannot yet be considered as crystallized. This is a most interesting and promising stage in the development of cars, and much is to be expected of the next few years. The idea of utilizing the weight of every possible part for assisting in carrying the load has only just begun to be applied to steel cars, and this is believed to be one of the most important directions which future development can take. This is the factor in car design which offers ultimately the greatest savings possible in the operation of trains. It is intimately associated with the power and weight of locomotives, and consequently the weight of rails and strength of bridges. In spite of all that can be done to favor the locomotive, it is absolutely certain that present indications point to still heavier ones as a business necessity. This increase, however, cannot go on indefinitely. Just now it is easier to build heavier locomotives than to favor present ones by more favorable conditions, but these conditions must eventually receive attention. This applies to passenger as well as freight service, for we have now the suburban locomotive developed to a weight on driving wheels greater than the total weight of the heaviest passenger locomotive of but ten years ago, and we have freight engines now running weighing

230,000 lbs., with much heavier ones suggested, and now in the drawing room stage. There is "money" in big engines, as records from the Illinois Central published in this issue and other records still to come, indicate; but there is, perhaps, even more in lighter cars. In view of these facts every effort toward improvement in cars should be considered as an important step in advance.

In this issue is illustrated a new car designed by Cornelius Vanderbilt, which embodies one of the boldest steps ever taken in the direction which is considered so important. These cars have no underframe whatever, in the usual acceptance of the term. They have center sills, but light ones, only to provide for the draft and buffing stresses. They have no side sills, the weight of the car body and load being carried by the trussed sides and transmitted directly to the bolsters by the vertical struts of the side trusses, which are placed at the bolsters for this purpose. Trussed side frames have been used before, but never in such a way as to permit of taking advantage of the full length from the bottom of the hoppers to the top rails for obtaining trusses of the maximum possible depth. The performance of these cars in service will be closely watched. They are likely to mark a departure in steel car design.

THE DUTY OF THE OFFICER TO HIS MEN.

It is comparatively easy to direct and control the forces of nature, to build monumental engineering works, and little wonder is expressed over the greatest undertakings of this character. Much has been written concerning these things. The transactions of technical associations are filled with papers and discussions concerning them, but comparatively little has been written about men, without whose loyal assistance these works could not be accomplished. Mr. S. P. Bush read a paper before the Western Railroad Club last month in which very important suggestions were presented on the subject of men. It is one of the most important papers in the records of that club.

The development of young men to take responsibility is one of the most difficult, and yet one of the most important, duties of an officer. Even those who observe without being actually concerned in the problem can perhaps appreciate the need, if they are unable to suggest methods.

Recently, in a large manufacturing establishment, a man was needed for special duty which required a peculiar experience. Fortunately this concern made a practice of keeping a careful record of the experience of every promising employee, and a man was found in the drafting room who had all of the necessary qualifications. It hardly needs to be said that this selection was wise, and that it was good business policy. In another drafting room six places were made vacant in two months because the salaries were lower than the prevailing rates. This was on one of our most prominent railroads:

Mr. Bush speaks of "voluntary loyal effort," which counts for more than anything else in large organizations. It seems reasonable to expect a corps of men to give more loyal and unstinted service to their employers when working in an atmosphere of encouragement than when they are discouraged or disheartened. An organization which is self-sustaining by the advancement of its own members whenever an opportunity offers, is likely to secure this loyal effort. A systematic method of giving credit for suggestions and improvements is not as common as it ought to be. In the headquarters of a department recently visited an unusual example was found. For years the head of the department has kept in a book a record of the valuable suggestions offered by his subordinates. This book was not often referred to, it is true, but its existence was encouraging to the young men, who fully appreciated the fact that credit was given them for their faithfulness. This practice enlisted efforts which otherwise would not have been made.

The best men are always wanted in emergencies, and railroad work is full of emergencies. At these times a thorough ac-

quaintance with the subordinates is needed. A well-known railroad officer recently applied to us for a man for an important position, and was surprised and somewhat chagrined when one of his own men, just the one for the place, was suggested. The appointment was made, and it resulted most satisfactorily.

Many officers are not entirely satisfied with their assistants, and while there are some cases occasionally requiring "new blood," there are many others which may be improved, if not entirely corrected, by the exercise of painstaking assistance from the superior. Men do not always know how to find their own best fields, but a little effort and kindly interest may set them right.

Mr. Bush emphasizes the importance of the duty of the leader to set an example to his helpers. He says: "Among organizations as large as are often found in the railway mechanical department it would seem that enthusiastic and loyal effort

FIREPROOF ROUNDHOUSES.

Canadian Pacific Railway.

By courtesy of Mr. Tait, Manager of Transportation, and Mr. Peterson, Chief Engineer of the Canadian Pacific, the drawings of their new fireproof construction for roundhouses have been received. There is no wood about the building except the 5-in. plank floor at the pits and the mouldings at the edges of the roof; it is therefore really fireproof. This particular house has eight stalls, but the same construction would apply to larger ones. The foundations are of stone and the pits may be of either stone or brick. If of stone the pit walls are 18 ins. and if of brick 12 ins. Either brick or stone may be used also for the outer walls.

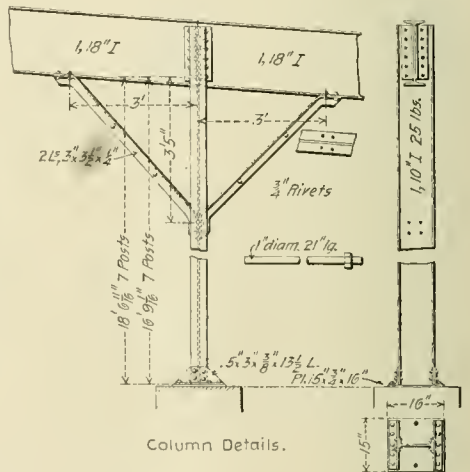
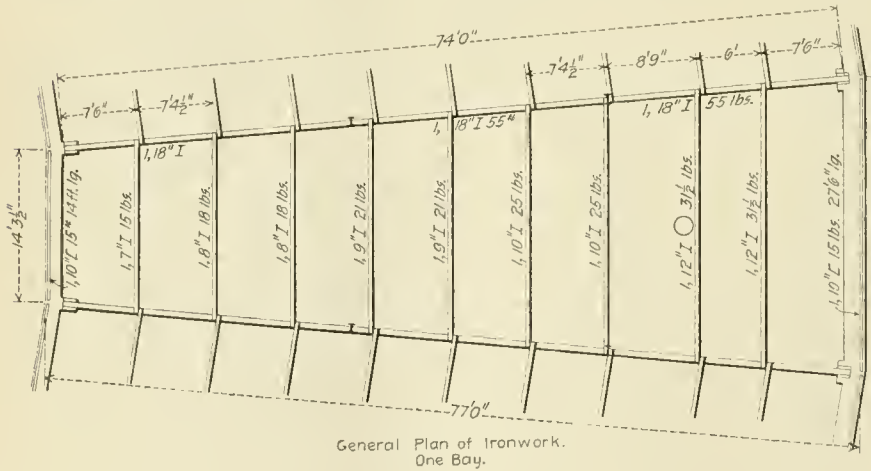
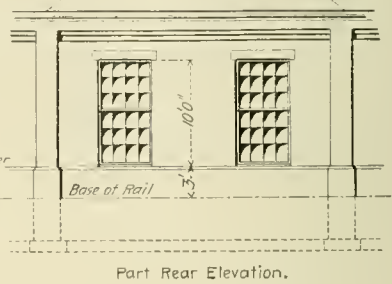
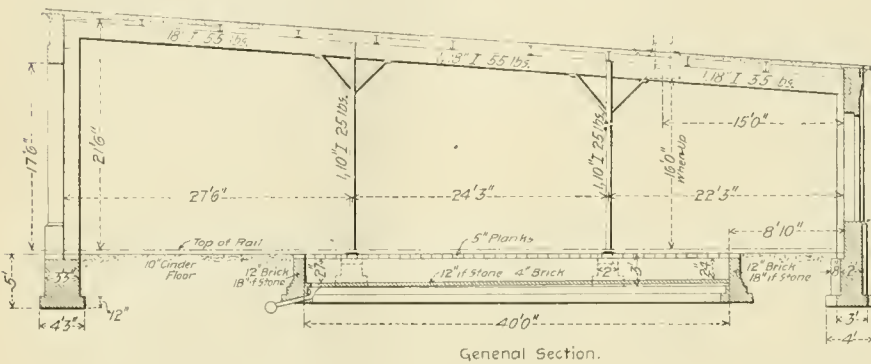

Fireproof Roundhouse—Canadian Pacific Railway.

must be a most important factor. But surely the moving spirit in bringing about such a condition, like water, cannot be expected to run from a lower level to a higher one; it must start from the higher one. This is the problem which we generally call the 'handling of men.' It applies to the leader of thousands of men, and to him who has only one.

Mr. Lucius B. Sherman has resigned as Western Manager of the "Pocket List of Railroad Officials," a position which he has held for the past five years, to become Western Manager of the "Railroad Gazette," with headquarters in the Monadnock, Chicago. Mr. Sherman has had a wide experience in newspaper work, and is one of the best and most favorably known of the advertising solicitors connected with the railroad press. The American Engineer joins his many friends in wishing him success in his new field.

Large sections of rolled shapes are used for the posts and roof beams, and upon these the roof of Roebling fireproofing is laid and covered with four-ply tar and gravel roofing. In the detail drawings the construction is clearly shown. It will be noticed that the roof members resting on the 18-in. I-beams are 7-in. I-beams at the turntable end of each section of the building and increased to 12 ins. at the outside where the span is longer. Tile pipe is used for the top portions of the smoke jacks, the lower portions, which are telescopic and movable, being of riveted sheets mounted on counterbalanced levers with three locations of the fulcrums to accommodate different lifts. A damper is placed near the bottom of the movable portion and the arm attached to the spindle engages with the roof casting or a bracket suitably placed on the roof. Except at the pits the floor is of cinders 10 ins. deep. The pits are 40 ft. long and extend to within 8 ft. of the outer wall.

ALUMINUM THERMIT.

Dr. Goldschmidt's simple process of welding, by means of his aluminum thermit, continues to attract attention abroad. "Engineering" recently described a public demonstration by the discoverer.

A mixture of powdered aluminum and iron oxide constitutes the thermit, which is kept in soldered boxes, and can be bought at the rate of less than 25 cents per pound. This mixture is perfectly harmless, and molten iron may be poured into it without starting any reaction. If, however, a primer, consisting of powdered aluminum and some peroxide, is applied the reduction commences at once. This was the first experi-

clamp the tubes together are tightened by, perhaps, 1/8 in.; a minute or two later the box frames are knocked off, and the iron and alumina also come off neatly without the slightest trouble. A beautiful weld results. An experiment with a larger tube was equally successful. Then two heavy tram rails were welded together. Boxes packed with sand had been placed about them, and the rails were held in position by two bolts, one on each side. Above the joint stood a crucible, taking about 25 lbs. of thermit and closed below by a thin plate of iron. In this instance, a little ignition powder was simply sprinkled on the top of the thermit and lighted in the usual fashion by means of a fusee. The mass soon burned its way through the under plate, and a minute or so afterward the bolts could be tightened. That practically finishes the weld. As no fishplate nor drilling is required, the Allgemeine Thermit Gesellschaft, of Essen, can weld rails on the terms usually paid for making a good joint. The process has been adopted in a good many towns, and has given great satisfaction. Some fine specimens of work done by aluminum thermit were exhibited, among them a welding of cast iron and steel, and many test bars, none of which had in the testing machine ever given way at the joint. The aluminum applied is commercial aluminum of American and other works, of 98 per cent. and more. The powdering and mixing, the manufacture of the partly magnesia-lined crucibles and box frames are all done at the Essen Works. The alumina, which results as a by-product, is an exceptionally pure corundum, which is sold to emery works. Messrs. Fox, Thicknesse, and Hull, of 32 Victoria street, S. W., are representing Dr. Goldschmidt in the United Kingdom.

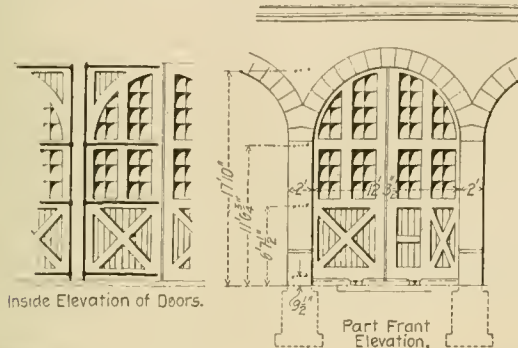

ARRANGEMENT OF TOOLS AND ROOMY SHOPS.

From a paper by William Thompson, read before the International Engineering Congress, Glasgow.

The questions of arrangement of tools and roomy shops are closely connected and interdependent, and where these have to be applied to existing buildings they become very difficult ones to settle, and in most cases the result cannot be anything more than a compromise. The question of handling material, which is the direct result of the arrangement of tools, is one which has not received the attention it deserves, simply on account of the difficulty of getting at the direct loss caused by a poor arrangement. As an example of what can be done by the consideration of these questions, it might be mentioned that after the author's firm laid down their new boiler shop, the work turned out by the light and heavy plating squads was done in 19.6 per cent. less time in the new shops than it had averaged in the old, while the machines turned out their work in 10 per cent. less time than before; the conditions in both cases as regards tools and appliances being exactly the same, except that more room was allowed.

Another example taken from the machine shop illustrates this same point very well. A group of three machines was located in the old machine shop in somewhat cramped and inconvenient position, but afterward these machines were shifted to a new machine shop and given lots of room. The results of this new arrangement are given below in the annexed table:

Machine.	—Saving—		Output	
	Time.	Money.	increased by	Per cent.
	Per cent.	Per cent.	Per cent.	Per cent.
Double-headed Horizontal Borer....	3.9	2.5	4	
H. and V. Planer.....	22.5	14	29	
Connecting-rod Lathe.....	12.8	8.3	14.7	

In this comparison the conditions were as nearly as possible the same in both cases, the machines doing the same kind of work; the same men were at the machines, and were working under the premium system in the new shop as in the old. The result was that the men made on an average—which is taken over a long period in both cases—9.3 per cent. more wages; the work was 8.3 per cent. cheaper to the firm, and 15.9 per cent. more work was got out of the same machines, due entirely to a better arrangement and more roomy location of these machines.

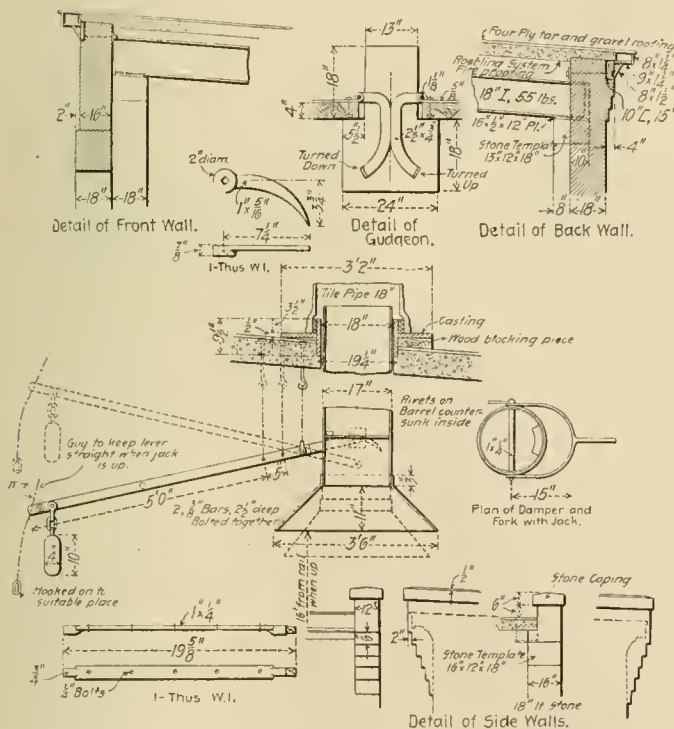

Showing Construction of Fireproof Roundhouse—Canadian Pacific Railway.

ment. A little of the ignition powder is dropped into a crucible and lighted with a common fusee. It flares up, and when thermit is gradually added, the whole mass begins to boil. A minute, or less, later, the fused alumina, which floats on the top, may be poured off, and the molten iron then made to follow. To show the intense heat, a bottomless crucible was placed on the top of an iron plate 1/2 in. or more in thickness. The reduced iron bored a hole through the plate so quickly that the plate could be handed round before the heat had spread to the edge. Then two tubes, 2 in. in diameter, were welded together endways, a box of sheet iron being loosely fitted round the joint, and another box, packed with sand, outside this. In this case the heat alone acts, the reduced iron is not wanted really. Therefore, some of the alumina is poured out first and directed against the tubes, surrounding them with a protective layer of this oxide. After a minute the bolts which

CORRESPONDENCE.

THE AMERICAN ENGINEER TESTS.

On Locomotive Draft Appliances.

To the Editor:

I have read with much interest your article on locomotive draft appliances in the October issue of your paper, and wish to join the hearty congratulations of the thousands of readers of the American Engineer in this country and abroad on the happy thought of undertaking such useful and urgently needed tests as you intend to make.

There is little doubt that the locomotive front end problem is one of the most important of those that confront the up-to-date locomotive designer. The proper function of the exhaust is so closely connected with the successful and economical performance of the boiler and of the work of the steam in the cylinders that a clear and definite knowledge of its relation to both becomes more and more necessary.

The 1896 experiments of the American Railway Master Mechanics' Association and the Von-Borries-Troske experiments of 1894, while exhaustive in themselves, have covered but a portion of the ground connected with the blast apparatus. The former have investigated the nature of the exhaust vacuum of smoke boxes, different forms of nozzles and stacks, and their relative sizes and position. The latter have been confined to the size of nozzle, distance of nozzle from stack and form of stack. While the information obtained by those tests was definite at the time and was successfully applied in actual practice on engines of that time, it is questionable whether one can be safely guided by those results in relation to modern locomotives. Besides, neither of those experiments have looked into the relation of the exhaust to the proportions of the boiler, condition and particular construction of the fire-box, and to compound working of the steam in the cylinders. With the general adoption of the wide grate, the use of the 19-ft. tube in our boilers, and with 20-ft. tubes in prospect, with about 50 per cent. of compound locomotives in actual service, which per cent. is increasing in a much greater ratio, it becomes opportune to investigate the draft appliances on new lines to suit new conditions.

It would seem that the above-mentioned elements of the locomotive are certain factors which should enter in considering the problem of exhaust nozzle proportions and efficiency. With this point in view, may I make some suggestions?

The best proportioned nozzle, in both size and form and proper position within the smoke-box, would be such that it should produce a draft sufficient to maintain an active combustion in the firebox and would offer the minimum back pressure in the cylinders. It is to be hoped that the American Engineer Tests will prove for the first time that there is a definite relation between the area of the exhaust nozzle and the length of tubes and their cross-sectional area, as well as to the cylinder capacity. It will be evident that the temperature of the smoke-box gases escaping through the long tubes will be lower than from the short tubes, given the same activity of combustion in the firebox. What should be the intensity of the exhaust compatible with the utmost economy in either case? As the size of nozzle largely determines the intensity of the exhaust, what should be the relation between the size of nozzle and length of tube? It has also been shown that the influence of the exhaust on the firebox efficiency is very great. To illustrate the point, assume an exhaust nozzle that would work most satisfactorily and economically with a fire-box having a firebrick arch, will it be wasteful in fuel consumption with the same style of box, but without an arch? What should be the size of the exhaust nozzle for wide and narrow fireboxes, and for a given intensity of combustion and when burning soft or hard coal? The efficiency of the exhaust has a close relation to the general efficiency of the boiler, and

the above factors should therefore be considered in connection with the front end problem.

The height of nozzle or its relation to the stack has been exhaustively treated in both of the above-named experiments, but in neither has there been any mention made regarding its distance from the front flue sheet. I know of at least one road where the practice is to place the exhaust nozzle and center line of stack as near the front flue sheet as possible. The mechanical officers of that road claim increased efficiency of the exhaust, without increasing the back pressure in the cylinders. It often necessitated the bending of the exhaust pipe. The smoke-boxes in question are of the extended type, have no deflector plate; the height of exhaust nozzle is about the center line of the top row of tubes, and having a wire netting across and above the nozzle, extending from end of flue sheet to the front end of the smoke-box.

Another arrangement for which great efficiency is claimed (recent German practice) is, like the above case, placing the exhaust nozzle quite near the front flue sheet and extending a circular netting from the top of the exhaust pipe flange to the base of the stack. No deflector plate is used, nor any other netting besides the one mentioned. The smoke-box is of the extended type and of medium length.

The fact that the pressure and amount of steam passing through the exhaust nozzle in a compound locomotive is less

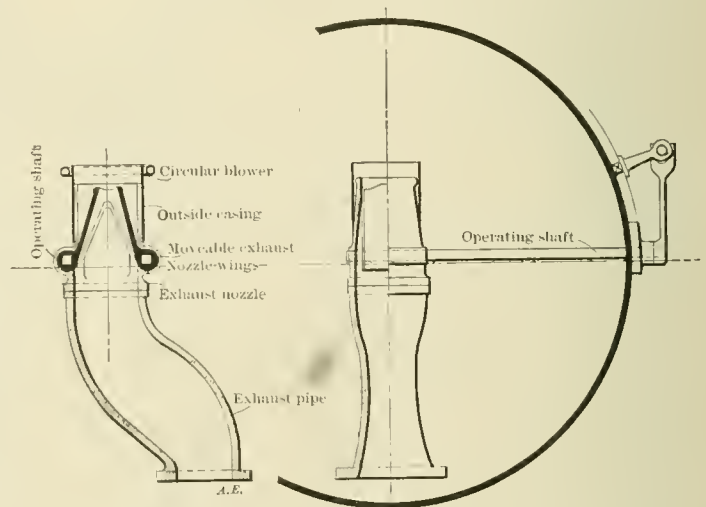

Variable Exhaust Nozzle—French 4-Cylinder Compound Locomotive.

per stroke than in the similar simple expansion engine would seem to be of enough importance to warrant investigating the proper relation of the exhaust nozzle to compound locomotives, apart from the experiments with the simple expansion engine.

It has been the practice, I believe, to proportion the exhaust nozzle for two cylinder compound locomotives by considering a pair of simple expansion cylinders that would develop the same amount of work as the two-cylinder compound. Is this safe practice? What data do we have to warrant that such proportions give the most desirable results? The same would apply to all types of four-cylinder compounds. Another point that occurs to me to be worthy of consideration in connection with the front end problem for compound locomotives is the varying pressures and quantity of steam that passes through the exhaust nozzle under different condition of service. All modern two-cylinder compound locomotives have a separate exhaust for the low-pressure cylinder, and the working of both cylinders in simple expansion is often resorted to—for instance, in starting a train from a state of rest, or when crossing difficult sections of the road, it is desirable to prevent "stalling" of the engine, or in case the high-pressure cylinder or any part of the mechanism pertaining thereto is disabled. Will the exhaust nozzle proportioned for the normal working of the engine be as efficient as when working both high and

low-pressure cylinders in simple expansion? How are we to determine the best medium? All successful compound locomotives of the two, three and four-cylinder types used to-day, and those that will come in the future, have a separate exhaust for the low-pressure cylinder or cylinders, for the reasons above mentioned? What should be the proper relation of the exhaust nozzle area to that of the cylinder capacity of the engine?

I have already intimated that in the simple expansion engine and to a much greater extent in the compound, the draft that the steam has to create is not constant and varies with the rate of combustion, degree of boiler evaporation, and speed of engine. If it were possible to adjust the exhaust so as to work most economically under those varying conditions, we should have been able to obtain the maximum efficiency from our boilers and a more economical performance of the steam in the cylinders. It is probably for this reason that European practice has been for many years, notably French, to make use of a variable exhaust. The arrangement commonly used on the Continent is illustrated in the accompanying sketch. Figs. 1 and 2 show in section an exhaust pipe provided with the variable exhaust nozzle. As will be seen from the drawings, it consists of an exhaust nozzle having two movable wings fixed to its sides. The wings are shown in the closed position; when it is desirable to increase the opening of this exhaust nozzle the hand wheel in the cab is turned and spreads the operating arms or the wings to which they are fixed through the intermediate shaft shown.

French engineers believe this to be an efficient arrangement, and the higher efficiency they obtain by its use seems to counterbalance the complication. It has been in general use for many years on the Northern Railways of France, State Railways, Eastern, Western & Southern. It has also been used on different roads in Spain and Portugal and other Continental railroads.

In closing, allow me to quote a passage from the Henry * tests and study on the evaporation of the locomotive boiler and relating to the exhaust.

"The influence of the exhaust on the power of the locomotive is so great that it would seem desirable, in spite of its effect on the boiler efficiency, to make use of all appliances permitting to increase the draft, and to vary its intensity in the largest possible limits. This is the best means to give to the power of a locomotive a great elasticity (flexibility) and afford the possibility to regulate this power in proportion to the work the engine has to do at every instant. It should, however, be borne in mind not to pass a certain limit of back pressure due to the exhaust."

CHAS. M. MUCHNIC.

Fond du Lac, Wis., October 12, 1901.

THE FOUR-CYLINDER BALANCED COMPOUND.

To the Editor:

For several years the belief has been growing upon me that we ought to thoroughly investigate the four-cylinder balanced compound locomotive in this country, but I have not before seen so many advantages outlined in its favor as appear in the editorial in the "American Engineer and Railroad Journal" for October. These I do not consider as sure of accomplishment, at least some of them, but it is safe enough to state them all as inducements for a thorough trial of the idea. It is by no means certain that the matter of repairs will be as simple as you appear to believe, and the crank axle needs a great deal of nursing before it will answer for the requirements of modern American locomotives. But that these necessarily constitute unremovable obstacles I decline to believe. I am not afraid of the crank axle.

In spite of all we can do engines must be heavy, for power must be had. Instead of making them heavier we should attack the problem of getting more power out of weights which we now have, and when track and bridge construction are up to it we may begin to think of increased weights. It is not to provide for the future so much as to reduce the present difficulties

*Etude Experimentale de la Vaporisation dans les Chaudières de Locomotives. Par M. A. Henry, Ingenieur en Chef des Ch de fer de Paris, Lyons, Mediterranee, 1894.

that this type appears to me attractive. What we most need is to be able to build eight-wheel and Atlantic type engines which will do the work of six-coupled, ten-wheel engines as these are now built. We have not yet reached the limit of the eight-wheel engine.

If we can overcome the difficulties with crank axles and obtain satisfactory valve motion with but a single pair of valves for the four cylinders, we ought to be able to increase the present wheel weights to such an extent that we can carry 100,000 lbs. on four drivers, or perhaps 120,000 lbs., without damaging the track as much as the present weights. Experiment would determine the lengths to which this may be carried, but if we can make four drivers do the work now required of six and can make six do the present work of eight, this system will be the relief we all are seeking.

You probably know that the Baldwin Locomotive Works are now building an engine to test this principle on the Plant System. It will be watched with greatest interest.

Superintendent of Motive Power.

THE DEMAND FOR RAILROAD MEN.

To the Editor:

The article from the pen of the editor in the October number of this journal on the "Demand for Railroad Men" immediately brings a question to the mind of the reader. Why do the managers of railroad companies permit the existence of a state of affairs which brings about this demand for men of business and executive ability, without the ability to meet such demand because of insufficient expenditure of money to pay for their services? The answer comes quickly to the mind of him who has had any opportunity to observe existing condition in railroad organization. The reason is clear. It is either indifference on the part of the manager, or it is because he is not permitted to carry out what his judgment dictates to be the correct policy in the matter of salaries.

A manufacturer is willing to spend money freely to make it freely, because he is an owner or part owner in his establishment, and the worth of the services of his subordinates is of vital interest to him as one of the money producing factors of his plant. The railroad operating manager is rarely an owner of the stock of the company, and therefore does not to the fullest extent share this vital interest of the manufacturer, or if he does, he is limited in his expenditure of money in salaries for department heads and their subordinates, by the board of directors. These directors are owners, but how many of them are intimately acquainted with the practical and truly economical operation of a railroad? How many of them realize the necessity of paying well for executive ability in all departments, and how such money paid out for this ability will be returned two and threefold?

Until the owners of railroad properties become the managers of such properties themselves or bring themselves in close contact with the problems involved in the operation of them, the demand for railroad men of executive ability will continue.

How little money in proportion to the large amount which leaks out in other directions is saved by the railroad company which is close on the salary question? The general manager holds down the appropriation for salaries of department heads. These department heads in turn hold down the salaries of their sub-department heads, and the heads of sub-departments are held down on the allowed salaries to their subordinates and rank and file employees. And thus it goes through the whole line, until we have an organization of men who but poorly fill their positions, every day wasting what a competent man would save, or if filling their positions well, speedily gobbled up by either a more appreciative railroad company or a manufacturer.

A. H. W.

[A complaint recently reached us from the chief draftsman of a leading road because in eight weeks he had lost six of his best draftsmen. Inquiry brought out the fact that the salary limit for draftsmen in the motive power department on that road was but \$75 per month.—Editor.]

Mr. James H. McGraw has added to his ownership of technical papers "The Engineering and Mining Journal." This journal appears in its latest issue in a new dress and promises to add attractiveness to correspond with its high standing in other respects.

THE PROPERTY RIGHTS IN A TRADE NAME.

CAREFULLY DESIGNED CAST-STEEL LOCOMOTIVE FRAMES AND OTHER DETAILS.

In the suit of The Babcock & Wilcox Company against the Joshua Hendy Machine Works a decree has been entered in the United States Court for the Northern District of California, as follows:

"That a perpetual injunction be and it is hereby issued against the respondent, the Joshua Hendy Machine Works, and its officers, agents, attorneys, servants, clerks and employees, enjoining it and them and each of them from using the name 'Babcock & Wilcox' either alone or combined with

Delaware & Hudson Company.

It has been customary to make cast-steel frames almost, if not exactly, like those forged from wrought iron. In many cases this has given entire satisfaction and in others it has not. There have been sufficient numbers of failures to draw attention to the nature of cast steel and its action in casting and cooling, and in several directions efforts have been made to design frames to suit the metal. There is no attempt to conceal the fact that the Delaware & Hudson has had trouble with cast-steel frames, the principal location of breakage being over the driving boxes. Instead of discarding this material, however, the sections were increased. There has been no trouble in welding the frames, and though the breakages have been more numerous than they should be the use of steel was continued until Mr. Slack believes he has discovered and

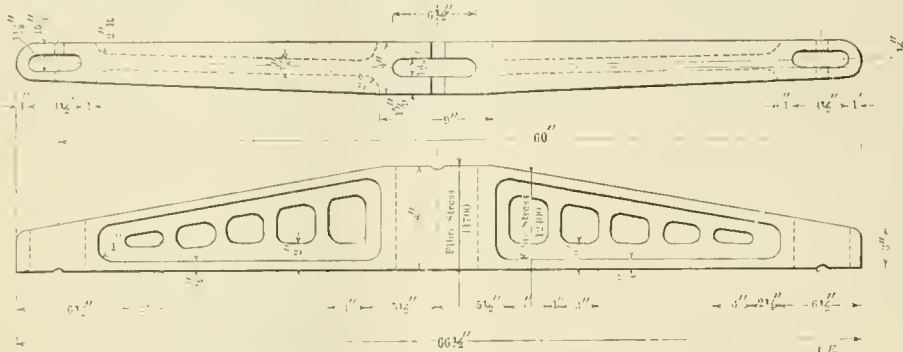

Cast-Steel Equalizer—Delaware Hudson Company.

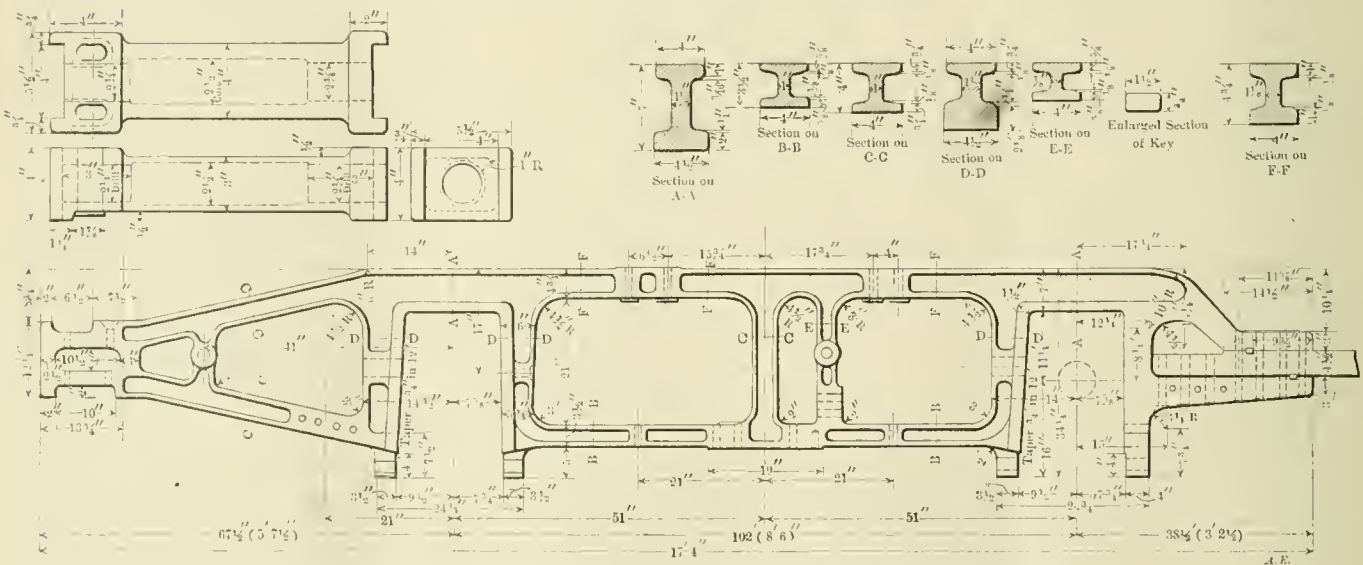
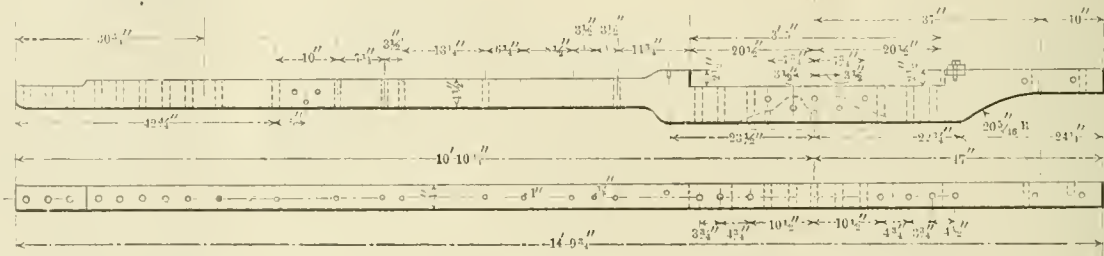

Cast-Steel Locomotive Frames—Delaware & Hudson Company.

other word or words upon or in connection with the sale or offering for sale of any boiler or other steam apparatus not manufactured by the complainant, and from stating or representing that any boiler or other steam apparatus sold or dealt in by the respondent and not manufactured by complainant is a Babcock & Wilcox boiler, and from selling or offering for sale, or passing off any such boiler or other steam apparatus, as and for boilers or steam apparatus manufactured and sold by complainant."

An important step toward the accomplishment of the "standard box car" has been taken by the American Railway Association in the adoption of standard inside dimensions.

overcome the faults of the earlier designs. All these frames are now required to be annealed, which was not done formerly. In the present design the depth over the driving boxes is 7 in.

In redesigning the Class V-3 eight-wheel passenger locomotive for this road, which was done by Mr. G. S. Edmonds, I-section frames were developed which are illustrated in the accompanying drawing. This is a revised design of the standard passenger engine of the road, having a Wootten firebox. The principal changes in the engine were an increase in the size of the boiler from 58 to 62 in., the use of piston valves and several other minor changes. This frame design is interesting in connection with the discussion of the subject in our issues of May, page 149, and September, page 287. Other cast steel

details of this engine are interesting, among which is the equalizer, which is also illustrated. This construction is light and with good material should be satisfactory; the fiber stress through the center at the fulcrum slot is 11,700 lbs. per sq. in. and at the first opening on either side of the center it is 12,400 lbs., under the loading given in this engine. The sling stay anchors are of cast steel and are cheaper than forgings. Mr. Slack considers them equally reliable if the metal is sound. In fact, this material is used very extensively in these engines, indicating complete confidence in it.

NEW METHOD OF CONSTRUCTING PISTONS.

Central Railroad of New Jersey.

Difficulties with the usual construction of locomotive pistons were discussed at the recent Master Mechanics' Association convention by Mr. Wm. McIntosh, of the Central Railroad of

easily removed there would be no necessity for the removal of the piston head, as is the common practice with the solid head with snap rings, when it becomes worn. It would only be necessary to remove the bull ring and substitute another, when the cylinders become worn to such an extent that they had to be bored. It is possible that some such easily accessible follower is in use, but it has not come to my attention. My idea of what will constitute the most satisfactory arrangement is something similar to the breech-lock of a piece of modern ordnance."

On account of the general interest in pistons at this time we obtained from Mr. McIntosh drawings of the preliminary designs suggested by Mr. R. O. Cumback, then General Foreman, under Mr. McIntosh, and of the later development as applied to a number of large engines on that road. With this construction the bull ring and packing rings are placed and the threaded fastening ring is then inserted, turned up tight and held by a 5-16 in. set screw. The fastening ring has an interrupted thread accurately cut and extending a little less than a quarter of the circumference. It may be removed by giving it a quarter turn to disengage the threads and is then free from the piston.

On a number of roads solid pistons have been substituted

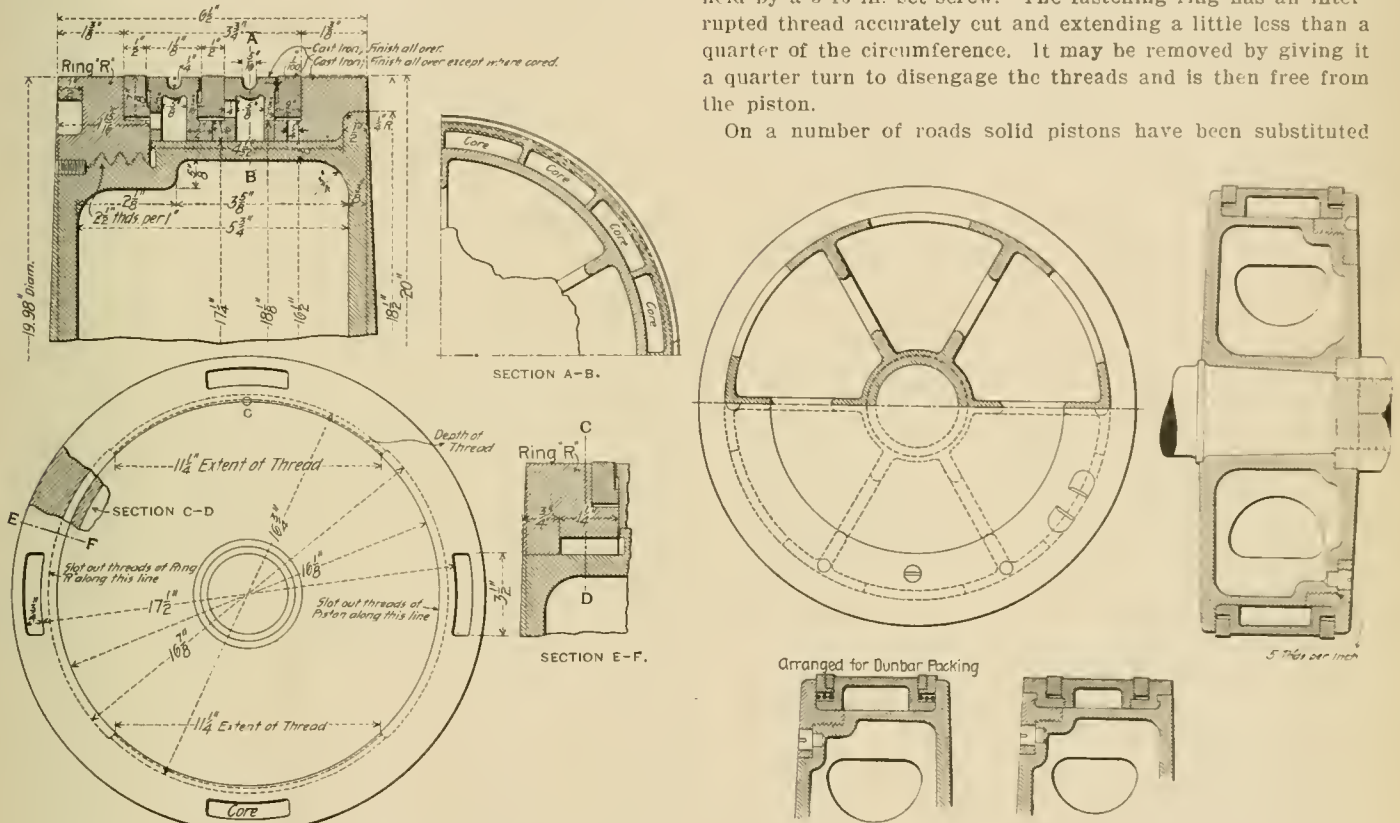

New Method of Constructing Pistons, Showing Preliminary and Completed Designs—Central Railroad of New Jersey.

New Jersey, who introduced the subject with the following topical question:

Wanted: A design of piston follower, bull ring and packing ring for cylinders of large diameter to avoid the necessity of the removal of the piston from the cylinder to change the rings, the removal of the piston on account of wear, the use of snap rings and the use of riveted followers.

Considerable difficulty had been experienced by the speaker, which was especially aggravated by the introduction of large locomotives. He said: "The piston of the solid type, equipped with snap rings, must be unkeyed from the cross-head and removed whenever necessary to change rings, and in our experience that necessity occurs quite often. If, on the other hand, it is provided with bull rings and a follower secured by plates held by bolts, there is a possibility of the bolts breaking and damaging the cylinder and cylinder heads, frequently breaking the followers and the spider or piston head also. I think all will agree that a device which will permit the easy removal of the bull rings when necessary to replace the packing would be received with pleasure, and it would seem possible that some device could be developed. With a bull ring that could be

for the bull ring after many years of experience. The design illustrated here will increase the first cost somewhat, but it appears to offer important advantages.

TESTS OF AJAX PLASTIC BRONZE.

Results of a test of Ajax plastic bronze, manufactured by the Ajax Metal Company, of Philadelphia, have been received. The test was made by Messrs. Hughes and Patterson, of Philadelphia, on a hot bar mill in severe service. Ajax plastic bronze was used for the bearings at one end of the rolls and phosphor bronze bearings at the opposite end. When the bearings were placed in position, November 15, 1900, they measured 7 7/8 in. in thickness. When taken out, February 27, 1901, the plastic bronze measured 3/8 in., and the phosphor bronze 3/8 in. On that date a new phosphor bronze bearing was applied and opposite to this the original plastic bronze bearing replaced. When compared again, April 29, the second phosphor bronze bearing was worn down to the limit of usefulness, 3/4 in., while the plastic bronze still measured 7 1/16 in. Thus the plastic bronze showed a saving of 100 per cent. over the other metal.

TESTS OF WIDE AND NARROW FIREBOX LOCOMOTIVES.

Southern Pacific Railway.

Because of the relatively large number of moderately wide firebox locomotives built during the past year the comparison obtained in a series of road tests between narrow and wide soft coal fireboxes on the Southern Pacific will interest our readers. These figures have been received through the courtesy of Mr. H. J. Small, Superintendent of Motive Power, who has

631 sq. ft. more heating surface than the other engine, which probably contributes somewhat to the good showing made by the engine with the larger grate. The log of the tests is reproduced in the accompanying table, which gives the data from each run and the averages for both engines. The train weights are exclusive of the engine, tender and caboose and represent the manifest tonnage, including the resistance of empty cars. These tests were made under ordinary service conditions except as to the measurement of coal and water. An analysis of the coal gave the following:

Analysis of Coal.

Moisture	3.67	Per cent.
Volatiles	36.74	
Carbon	51.44	
Ash	7.60	
Sulphur	0.62	
	100.00	

Indicator records were taken but are not reproduced here. The distance from Rocklin to Truckee is 97.37 miles, the profile of the division being indicated in the engraving.

Clear weather prevailed in all the tests, but the track in the snow sheds was wet with melting snow in the tests of the wide

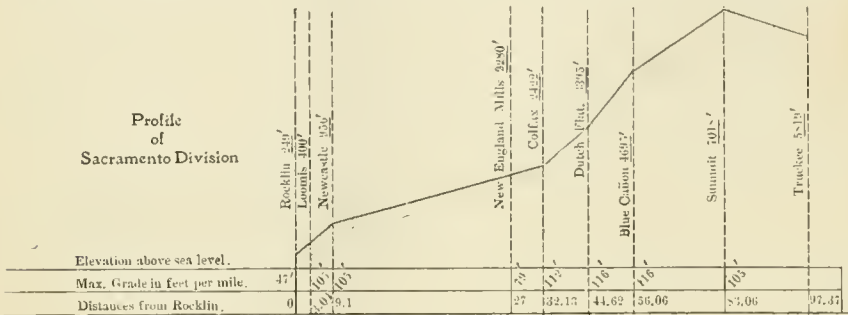

Profile of Sacramento Division.

TEST OF WIDE AND NARROW FIREBOX LOCOMOTIVES - SOUTHERN PACIFIC RAILWAY.

	Rocklin to Truckee		Rocklin to Truckee.		Totals and Averages.	
	1	2	3	4	2609 F. C.	2612 F. D.
Number of test	1	2	3	4	2609 F. C.	2612 F. D.
Number and class of engine	2509 F. C.	2612 F. D.	69 F. C.	2612 F. D.	2609 F. C.	2612 F. D.
Area of grate surface	35.3 sq. ft.	51.0 sq. ft.	35.3 sq. ft.	51.0 sq. ft.	35.3 sq. ft.	51.0 sq. ft.
Date of test	Dec. 5, 1900.	April 10, 1901.	Dec. 7, 1900	April 12, 1901.	Dec. 1900.	April, 1901.
Number of train—through freight	Extra East.	Extra East	Extra East	Extra East	Extra East.	Extra East.
Kind of coal
Schedule time between terminals	11 hrs. 5 min.	11 hrs. 5 min.	11 hrs. 5 min.	11 hrs. 5 min.	22 hrs. 10 min.	22 hrs. 10 min.
Total time of test between terminals	14 " 11 "	11 " 33 "	10 " 5 "	18 " 25 "	24 " 16 "	23 " 58 "
Actual running time between terminals	7 " 18 "	7 " 37 "	7 " 4 "	5 " 18 "	14 " 22 "	15 " 55 "
Time lost during test	6 " 53 "	3 " 56 "	5 " 1 "	4 " 7 "	9 " 4 "	8 " 5 "
Mean speed between terminals, run time	13.4 M. P. H.	12.8 M. P. H.	13.8 M. P. H.	11.8 M. P. H.	13.6 M. P. H.	12.31 M. P. H.
Number of stops made	25	14	18	18	43	32
Maximum steam pressure (gauge)	215 lbs.	220 lbs.	215 lbs.	220 lbs.	215 lbs.	220 lbs.
Minimum " "	195 "	190 "	200 "	190 "	195 "	19 "
Average " "	208 "	211 "	208 "	205 "	208 "	208 "
Average temperature of feed water	50.5 F.	50.7 F.	50.1 F.	53.7 F.	50.3 F.	53.7 F.
Gallons of water evaporated	18,215	18,683	17,141	19,101	35,362	37,787
Pounds " "	151,761	155,687	142,813	159,203	294,574	314,890
" " coal burned	25,320	22,722	22,912	20,858	48,262	43,580
" " water evaporated per lb. of coal	5.99	6.85	6.22	7.63	6.10	7.22
Equivalent evaporation from and at 212° F.	7.39	8.38	7.66	9.32	7.52	8.83
Engine miles run per ton of coal	7.41	8.626	8.54	9.40	8.00	8.99
" " 1,000 gallons of water	5.38	5.245	5.72	5.130	5.56	5.19
Number of loaded cars in train—mean	9	13	15	6.5	12.0
" " empty	26.5	12	13.25	6.0
Total number of " "	26.5	21	13	15	19.75	18.0
Weight of train in M s.	918	987	1004	1015	976	1000.8
" " tons	474	493.3	502	507.6	488	500.4
Distance run—miles between terminals	98	98	98	98	196	196
Gross ton mileage	16,452	48,343	49,196	49,745	95,618	98,078
Ton miles per gallon of water	2.550	2.588	2.869	2.604	2.705	2.596
" " pound of coal	1.835	2.128	2.145	2.385	1.982	2.251
Coal burned per sq. ft. of grate per hour mean for actual running time	95.33	53.87	90.74	45.16	93.04	49.52
Relative comparison between above engines in work done. Engine 2612 being considered at 100.						
Ton miles per gallon of water	98.9	100	110.2	100	104.2	100
" " expressed as gain per cent	Gain 1.2%	Gain 10.2%	Gain 4.2%
" " per lb. of coal	86.2	100	89.9	100	88.0	100
Ratio expressed as gain per cent	Gain 13.8%	Gain 10.1%	Gain 12.0%
Relative comparison on basis of equivalent evaporation—Boiler efficiency.						
Engine 2612 F. D. considered 100	88.2	100	82.1	100	85.2	100
Ratio expressed as gain per cent	Gain 11.8%	Gain 17.9%	Gain 14.8%

kindly sent us a report upon the subject by Mr. Howard Stillman, Engineer of Tests.

The locomotives compared are Schenectady two-cylinder compounds with 26 by 35 by 34-in. cylinders and of the mastodon type. Two trips were made with each engine in freight service on the Sacramento Division in December, 1900, and April, 1901, running between Rocklin and Truckee. A comparison of the leading features is as follows:

Number of engine	F. C. 2,609	F. D. 2,612
Diameter of drivers, ins.	57	57
Heating surface	3,027.8	3,658
Grate area	35.3	51
Heating surface per sq. ft. of grate	85.77	67.75
Weight on drivers	173,000	177,000
Size of exhaust nozzle, ins.	6	6

It will be noted that the engine with the larger grate also has

firebox engine, and was unfavorable to that engine. A considerable loss of time resulted from slippery track. Tests 1 and 2 are comparable, as the trains were mixed, having both loads and empties. Tests 3 and 4 are also comparable as both had all loaded cars. In these comparisons the wide firebox shows an advantage of 13.8 and 10.1 per cent. in ton miles per pound of coal and an advantage of 11.8 and 17.9 per cent. in equivalent evaporation of water per pound of coal. The average shows 12 per cent. advantage in ton miles and 14.8 per cent. in the amount of water evaporated per pound of coal, the two results seeming to indicate a decided advantage of the wide firebox with the large grate area, because of the more moderate rate of combustion. The front end accumulation was much less

with the wide firebox. Cinders were dumped from the front ends as follows:

Engine number.....	2,609	2,612
Test number.....	1 3	2 4
Times cinders dumped.....	3 6	1 1

It has already been pointed out that these engines are not exactly alike as to heating surface, the difference being much greater than the difference in the firebox areas would call for. This must affect the results somewhat. Considerable trouble has been experienced with an accumulation of water in the high-pressure cylinders, indicating the necessity for relief valves. This difficulty was greater with the wide firebox engine, and it was noted that the water line with the gauge glass half full was but 26 ins. below the lower throttle opening. With the rapid evaporation required of these engines it seems probable that the steam was very wet. In one case the indicator on the high-pressure cylinder was wrecked by water in the piping. While these factors all affect the results there is no doubt that the advantage of the wide firebox is about as indicated by this table.

THREE-CYLINDER COMPOUND LOCOMOTIVE.

A new type of express passenger locomotive, designed for a wide range of power, was put into service about two years ago, on the North-Eastern Railway of England, by Mr. Wilson Worsdell, Locomotive Superintendent of that road. This engine, No. 1,619, is so constructed that it can be run as a compound engine and as a simple engine using steam at an increased pressure in the low-pressure cylinders, and also using steam in the high and low-pressure cylinders at equal pressures. In the first case, when running compound, live steam is admitted to the high-pressure steam chests and also through a reducing valve to the low-pressure steam chests at a predetermined pressure. When running simple it is only necessary to compress the reducing valve spring which admits steam to the low-pressure cylinders at a high pressure, and by further compressing the reducing valve steam at full boiler pressure is admitted to both the high and low-pressure cylinders, in which case the high-pressure piston works in equilibrium. Between the steam ports of the high-pressure cylinders and the steam chest of the low-pressure cylinders, is placed a non-return valve, so that in starting the engine when the valve of the high-pressure cylinder is not in position to take steam, that the steam entering the exhaust ports from the low-pressure valve chest will not reverse the engine.

This locomotive is reported to be doing excellent work with the express trains between Newcastle and Edinburgh, a distance of 124 miles. The line has a number of grades, but they are not very heavy; the worst grade is the last mile from Edinburgh, which has a rise of 1 in 78. In running several slacks have to be made; in two cases the speed is reduced to 15 miles per hour, in another to 5 miles per hour and for the last 4 miles out of Edinburgh to 5 miles per hour. According to "Engineering" in an illustrated article regarding this locomotive, the mean of 15 trips run during September, 1898, gives the gross weight of each train as 404 tons, approximately, and the mean speed 50 miles per hour. On the 24th of that month the gross load was approximately 430 tons, and the mean speed 51.5 miles per hour. This is a good performance and required an average of 815 h.-p. to accomplish it. The total weight of the engine in working order is 53 tons and weight on drivers 35.5 tons. The high-pressure cylinder is 19 ins. in diameter by 26-in. stroke, while the low-pressure cylinders are each 20 ins. in diameter. The driving wheels are four-coupled and 7 ft. 1 in. in diameter. The total heating surface of the engine is 1,324 sq. ft.

The largest order ever taken for Magnolia Metal has just been closed by Mr. H. W. Toothe with the American Locomotive Company for the supply of all the bearing metal that this company will require for the coming year,

A FOLDING BRAKE WHEEL.

Chicago & Northwestern Railway.

For use on cars of passenger trains where the usual arrangement of the brake wheel would be in the way of vestibules, Mr. C. A. Schroyer, Superintendent of the Car Department of the Chicago & Northwestern Railway, designed the brake wheel illustrated in the accompanying engraving. The wheel is turned up out of the way when the car is coupled to one having a vestibule and when in use the brake wheel is held rigidly in place.

The wheel pivots on the pin shown in section below the center of the wheel and revolves so that the left-hand side, as seen in the engraving, moves upward and to the right. The hook

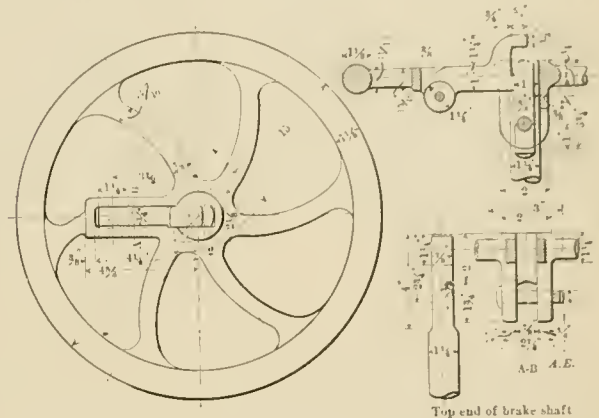

A Folding Brake Wheel—Chicago & Northwestern Railway.

on the top of the dog over the center of the brake staff is used to raise the dog so that the wheel will turn up out of the way. At the last minute we note an error in the engraving. The top of the brake staff should not be shown in the dotted lines and the cross-section of the metal in the wheel should be shown against the top of the shaft so as to indicate an abutment for the wheel to rest against. To fold the wheel over, the dog is lifted and the wheel is free to move. When returned to place the dog drops into position and locks the wheel.

A GENEROUS EMPLOYER APPRECIATED.

When so much is heard about the unreasonableness of workmen the following quotation from the president of a large trust company, printed in the New York "Times," is refreshing and even reassuring, as it records a response to considerate treatment:

"When I hear discussions of the relations existing between workmen and their employers, I invariably think of an experience my father, a manufacturer of Philadelphia, had with the men employed in a factory owned by him. At one time, some years ago, when the business in which he was engaged was being carried on with little or no profit, he continued to pay his men the established rate of wages in spite of the fact that the men employed in other factories doing the same work had had their wages considerably cut down. After this had been going on for some time he was one day waited on by a committee of his workmen, who asked to confer with him about their wages. Not unnaturally he was surprised and disappointed, believing that the men had come to make some complaint. It is easy to imagine what his astonishment was when the men informed him that they had come to insist on his reducing their wages. They said that they had been well treated in good times, and did not wish him to suffer in bad times through his generosity to them. At first he refused to make any change, but in a body they said that they would strike if he did not reduce their wages. You see, that a generous employer can find appreciation and even generosity among those whom he employs."

MACHINING RADIAL LOCOMOTIVE TRUCKS.

American Locomotive Company.

A new form of trailing trucks built at the Brooks Works of the American Locomotive Company for the Prairie type pas-

trailing wheels because of their simplicity, and it has even been suggested that they would probably be equally satisfactory for leading trucks as well, but they have not yet been tried for this purpose.

An examination of the drawings referred to will make the construction clear at a glance. The boxes are embodied in the ends of a casting which has radial bearing surfaces between the ends of two guide castings which are bolted to the frames and have at their ends radial surfaces corresponding with those of the box casting. Some question has arisen as to the difficulty of finishing these radial surfaces and by the courtesy of the builders photographs have been received showing the method of accomplishing this.

This work is done on a Bement, Miles & Co.'s planer. The nuts for the vertical feed screws are removed and guide plates with slots formed to guide the tools to the correct radial surfaces are applied. These are shown in the photographs. When fed across, the tool posts must follow the guides or radius plates. One of the photographs shows the machining of the box. When the surface or side is treated the casting is turned over upon the guide, which is shown immediately in front of the box. The guide has already been machined and serves as a chuck for

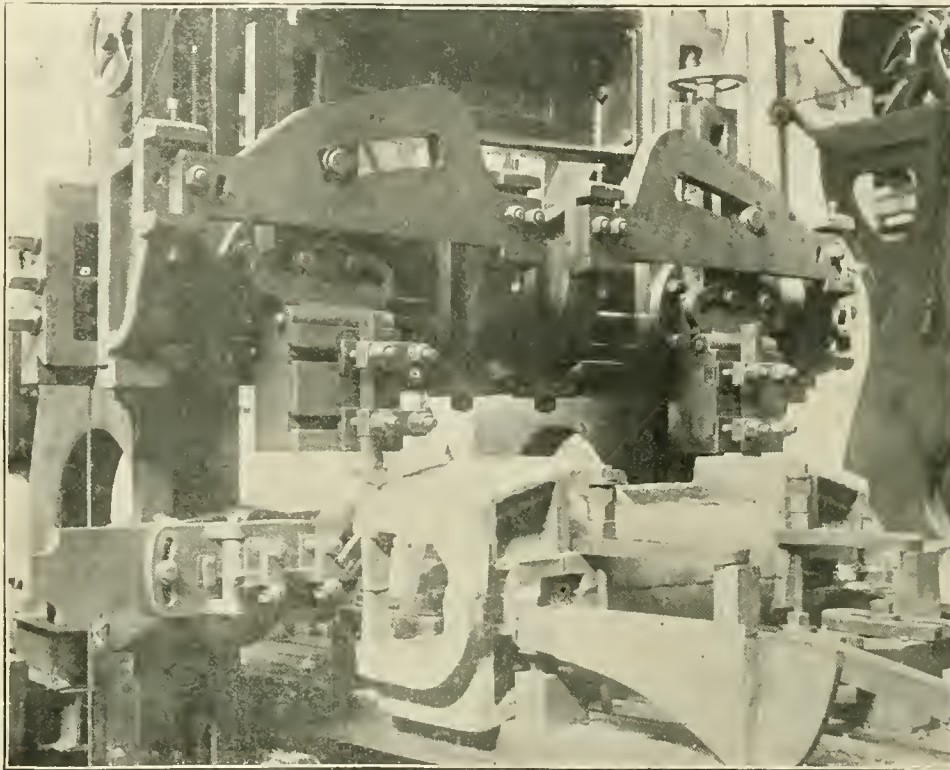

Method of Machining Radial Locomotive Trucks.

senger engines of the Lake Shore & Michigan Southern, was illustrated on page 74 of our March number of the current volume. These trucks appear to offer advantages over others for

the box when turned over for the completion of its opposite side. This method insures accuracy and it greatly facilitates what would otherwise be a much more difficult and expensive job.

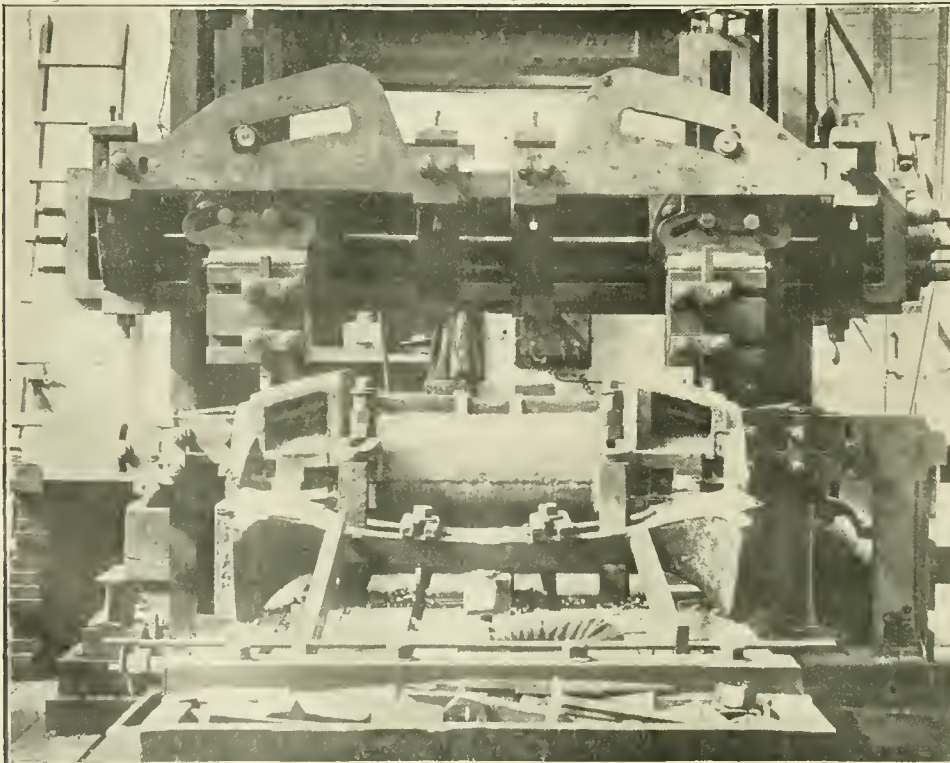

Method of Machining Radial Locomotive Trucks.

Trade names representing years of effort and large expenditures of money and years of experience for the development of a manufactured specialty, are of unquestioned value to the manufacturer and are important as a protection to the purchaser. It is a matter of simple justice that the property right in trade names should be protected from infringement, because the public has learned to regard the name as the designation of the source from which a manufactured article comes, rather than as a description of the article. It is cause for congratulation that the courts show a growing tendency to sustain the right of any concern to the exclusive use of its trade name as a proper designation of its product. Elsewhere in this issue is the record of an important decision of this character.

PERSONALS.

Mr. Charles Eddington has been appointed General Foreman of the Atchison, Topeka & Santa Fe shops at Trinidad, Colo.

Mr. E. H. Harriman, Chairman of the Executive Committee of the Southern Pacific, has been elected President of that company, to succeed Mr. C. M. Hays, resigned.

Mr. W. L. Harrison, formerly Superintendent of Shops of the St. Louis & Southwestern, at Pine Bluff, Ark., has been appointed Superintendent of the Locomotive and Car Shops of the Central Railroad of New Jersey, at Elizabethport, N. J., vice Mr. R. O. Cumback, resigned.

Mr. J. Kruttschnitt has been appointed Assistant to the President of the Southern Pacific, and will take up the duties of this office in addition to those pertaining to his office as Fourth Vice-President and General Manager. All officers heretofore reporting to the president will hereafter report to him.

Mr. Charles M. Hays, President of the Southern Pacific, has resigned. His resignation is due to a change in policy and organization of the company, owing to the change in ownership. Mr. Hays was for four years, up to January 1, 1901, General Manager of the Grand Trunk, which position he resigned to assume the Presidency of the Southern Pacific.

Prof. R. A. Smart has resigned his position in the department of experimental engineering of Purdue University and connected himself with the B. F. Sturtevant Company, of Boston, Mass., at the head of a department of experimental engineering which is being established for the purpose of investigating all problems relating to blower practice and developing new and more efficient applications of the fan blower in all lines of industry.

Mr. W. W. Wentz, Jr., who has been Acting General Superintendent of the Central Railroad of New Jersey during Mr. J. H. Olhausen's illness, has been appointed General Superintendent on account of the continued ill-health of Mr. Olhausen. Mr. Wentz will be succeeded as Superintendent of the New Jersey Central and Lehigh & Susquehanna division, by Mr. M. M. Richey, heretofore Superintendent of Terminals. The office of Superintendent of Terminals is abolished.

Joshua T. Brooks, Second Vice-President of the Pennsylvania, and of the Pittsburgh, Cincinnati, Chicago & St. Louis Railway companies, died suddenly at his residence in Salem, O., October 11, of Bright's disease, at the age of 61 years. Mr. Brooks was born at Salem in 1840. He entered railroad service in 1866 as solicitor of the Pittsburgh, Fort Wayne & Chicago, and the following year was appointed General Counsel for the Pennsylvania lines west of Pittsburg. He continued in this position until May, 1891, when he was elected Second Vice-President.

Mr. Charles M. Muchnic has been appointed Chief Draftsman in the motive power department of the Wisconsin Central Line, at Fond du Lac, Wis. He is a graduate of Drexel Institute, Philadelphia, and in 1896 entered the service of the Baldwin Locomotive Works as draftsman, after which he served two years in a similar capacity in the Brooks Locomotive Works. In 1899 he went to Europe and obtained a thorough knowledge of French and Continental locomotive practice. He was for a time connected with the Compagnie de Fives-Lille, and while abroad made a thorough study of the four-cylinder compound,

which he has put into the form of a very interesting design of this type for adaptation to American conditions. Mr. Muchnic was in charge of the exhibit of the Baldwin Locomotive Works at the Paris Exposition.

Mr. Mord Roberts, General Master Mechanic of the Louisville & Nashville, has resigned to accept the position of Superintendent of Motive Power and Machinery of the Kansas City Southern, in the place of Mr. F. Mertsheimer, resigned. Mr. Roberts is 48 years of age, and began his railroad career with the Pennsylvania in 1867 as machinists' apprentice, and later machinist, locomotive fireman and engineer. Since that time he has been connected with the St. Louis, Iron Mountain & Southern, Missouri Pacific and Louisville & Nashville, working through the positions of traveling engineer, foreman, general foreman of locomotive shops, locomotive inspector and master mechanic. He resigned the last-named position, which was with the St. Louis, Iron Mountain & Southern, in June, 1899, and a few months later was appointed General Master Mechanic of the Louisville & Nashville, which position he now leaves for his new appointment. Mr. Roberts will have headquarters at Kansas City, Mo.

SERVICE RECORD OF FRICTION DRAFT GEAR.

The results obtained from the Westinghouse friction draft gear on the Butte, Anaconda & Pacific Railway have been reported to us from the car foreman's record, after verification by the officers of that road, and are interesting in that they support the contention that draft gear needs reinforcement in the direction of pulling or extension. It is apparent that nearly all of the breakages recorded were from pulling stresses and not from compression or buffing. This is seen in the fact that the item of yokes accounts for about 30 per cent. of the breakages. The record is interesting also because it shows that the effect of improved draft gears may be seen in a short time after its application. The report is as follows:

The Butte, Anaconda and Pacific road has 520 50-ton Pressed Steel Car Company's ore cars, all of which are fitted with the Westinghouse friction draft gear and used in ore traffic between the mines in Butte and the smelters in Anaconda, Mont. The comparative records given below are for 155 of the above 520 cars, five of which were placed in service August, 1898, and the remaining 150 in June, 1900; the remainder of the 520 cars having been placed in service more recently. The couplers on these cars have 6-inch shanks, excepting the five cars first in service, which have 5-inch shanks. One of the connecting lines of the Butte, Anaconda & Pacific has a number of similar steel cars, equipped with the ordinary twin spring draft gear (not one of the patented devices now on the market), also having couplers with 6-inch shanks, and used in the coal traffic over the Butte, Anaconda & Pacific Railway, to the smelters in Anaconda and the mines in Butte.

The record of draft gear failures and mileage made for the six months from November 1, 1900, to May 1, 1901, on 50-ton steel cars, both foreign and home, on the lines of the Butte, Anaconda & Pacific Railway, is as follows:

	No. failures.		Car mileage.		Ratio of mileage.		Remarks.
	Foreign.	B. A. & P.	Foreign.	B. A. & P.	Foreign.	B. A. & P.	
1900 and 1901.							
November	18	1	14,155	149,820	1	10.3	
December	20	1	17,183	148,040	1	8.4	↑
January	18	0	23,356	139,500	1	6.2	
February	10	0	13,263	97,380	1	7.3	
March	13	1	11,637	133,640	1	11.3	↓
April	11	1	15,535	140,220	1	9.6	
	90	3					

↑Three B. A. & P. and three foreign cars had sills damaged in a collision, and two of the latter had couplers broken.

↓Friction draft-gear cylinder found cracked two weeks earlier.

It, therefore, appears that the average monthly mileage of foreign 50-ton steel cars on the Butte, Anaconda & Pacific road

was 15,738 miles, while the average monthly mileage of the Butte, Anaconda & Pacific cars was 135,650, or 8.6 times greater. The yokes on the foreign cars were of 1-in. by 4-in. iron, while nearly all of those on the B., A. & P. cars fitted with friction draft gear were 1-in. by 4½-in. iron. Of the 90 breakages of draft gear on foreign cars, 25 were broken yokes. Deducting this number on account of yokes being unlike, there were 65 couplers and knuckle breakages on foreign cars to three on the B., A. & P. cars, or more than twenty-one times as many. On an equal mileage basis, the breakages on foreign cars were 185 times as many as on the B., A. & P. cars fitted with the friction draft gear.

The assumption is that the couplers on foreign cars were of equal strength with those on the B., A. & P. cars, and as all of the former had the extra large 6-in. shank, and, therefore, were designed for especially severe service, this assumption seems amply justified. The breakages on foreign cars were divided as follows: 35 couplers, 30 knuckles, 25 yokes; total, 90.

On B., A. & P. cars but three couplers were broken, and no knuckles or yokes, this comprising the entire breakage of draft attachments in six months' service. Compared with 35 broken couplers on foreign cars and allowing for the home cars making 8.6 times greater mileage, the breakage of couplers only, on an equal mileage basis, on the foreign cars with the double spring draft gear, was 100 times as great, or 300 couplers, instead of three, would have been broken on B., A. & P. cars had they been equipped with the spring draft gear.

The saving in coupler breakages alone in six months' service by the use of friction draft gear on 155 cars, as shown by the above record, was enough to pay the entire cost of the friction draft gear with which they were equipped, the saving in broken knuckles and yokes being additional and in the nature of an increased interest—and a large one—on the investment.

The ore service on the B., A. & P. is severe, as the grades are steep, reaching 132 ft. per mile, while the locomotives are very heavy and powerful, those used between terminals being 8-wheel connected Schenectady compounds. Trains of 50 and 60 loads are handled one way and empties the other, all the air brakes on the latter rarely ever being used, resulting in additional severe strains on the draft gear.

At each terminal the powerful switch engines employed work on heavy grades, enabling them to handle but few cars at a time, which causes a great deal of switching and an unusually severe service for the draft attachments. The use of heavy locomotives on steep grades, handling cars of large capacity—conditions which are rapidly becoming common on many roads—probably accounts for the inadequacy of the spring draft gear, although of the strongest type and greatest capacity, to protect the couplers from breaking. The record at the same time brings out very clearly the great value and really indispensable character of the friction draft gear under these conditions.

Fifty thousand dollars is the sum paid for the handsomest private car in this country. It was a gift to a wealthy Western brewer by the stockholders in his company, and as a surprise on his recent return from Europe.

NEW PENNSYLVANIA UNION PASSENGER STATION AT PITTSBURGH.

After the long periods of preparation and construction, the new Union Station of the Pennsylvania in Pittsburgh is sufficiently near completion for use, and it will soon be formally put into service.

This station is of brick, 352 by 175 ft. and 11 stories in height, with a large and imposing covered entrance with a domed roof and a large train shed in the rear. Accommodations for express, baggage, mail and the kitchens are provided on the lower floor, which is reached by depressed approaches from Grant and Liberty streets. The waiting room, restaurants, toilet and smoking rooms are on the train floor level,



New Pennsylvania Union Passenger Station at Pittsburgh.

with high ceilings, offering an opportunity for exceedingly handsome decorations. Above these floors is the office building of ten stories, with accommodations for local offices and the general offices of the Pennsylvania Lines West of Pittsburgh. This colossal undertaking, including expensive track elevation, has been conducted throughout in a manner characteristic of this railroad and this is sufficient to convey the impression of a most satisfactory and handsome terminal. It is thoroughly worthy of the roads using it.

For heavy turntables the substitution of power for hand turning was recommended by a committee of the Association of Superintendents of Bridges and Buildings at their recent meeting. Electric power is preferred when it is available from near-by shops or where it may be conveniently purchased. Where electricity is not available gasoline engines are recommended. Steam power is not considered economical, though satisfactory in operation. The report on this subject presents figures showing the saving to range from \$13 to \$1.50 per day in favor of mechanical over hand power.

NEW PARAGON DRAWING PEN.

In addition to the excellent qualities which have brought the paragon pen into such general use, it now possesses an additional advantage in the way of opening the blades for cleaning, without altering its original setting. As will be noticed in the accompanying engraving, the blades are widely and instantly separated by a spring in the upper blade, when the excenter connected to the angular shank of the adjusting screw is released. On reapplying it the blades are brought to

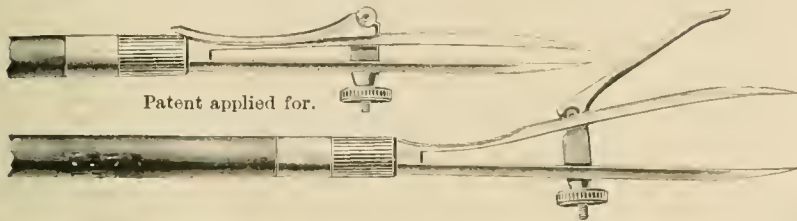

New Paragon Drawing Pen.

exactly their original position, smoothly and without jar. The adjusting screw is on the lower blade, permitting of changing the adjustment by applying one finger of the hand holding the instrument. These pens will be found a great convenience for all railroad draftsmen. They are made with ebony or aluminum handles, and may be obtained from Messrs. Keufel & Esser, 127 Fulton street, New York.

A CONVENIENT HYDRANT AND HOSE HOUSE.

The hydrant and hose house illustrated in the accompanying engraving is intended for use in shop and mill yards. Its many good features are apparent at a glance, and its details may, of course, be varied to suit various conditions. The design of the house and the arrangement of the doors provide for full and unobstructed access to and use of the hydrant and the

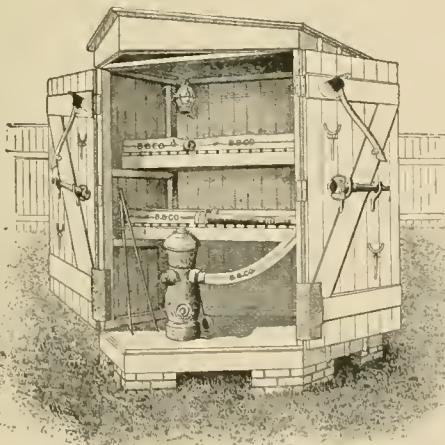

A Convenient Hydrant and Hose House.

hose. This construction is recommended by the Associated Factory Mutual Fire Insurance Company. Our engraving is taken from a catalogue on fire hose recently issued by the Boston Belting Company, 256 Devonshire street, Boston, Mass.

The specifications for the Vanderbilt cars, which are illustrated elsewhere in this issue, are unusually complete. They include Dayton twin spring draft gear; Tower couplers; Peerless air hose; Westinghouse brakes; Vanderbilt arch bar trucks; Vanderbilt bolsters and hopper door rigging; McCord Journal boxes, and the cars are to be painted with Superior Graphite Paint furnished by the Detroit Graphite Manufacturing Company.

NEW RIP SAW FOR CAR SHOPS.

Special attention has been given in the design of the rip-saw shown in the accompanying engraving, adapting it to hard and heavy work in car shops. The frame of the machine is massive and substantial, and has a large table fitted with an adjustable fence on the front end, which can be tilted to any angle up to 45 degs. and moved to the right edge of the table, leaving a distance of 22 ins. between the saw and fence. The arbor, which is gibbed to heavy ways, carries a saw up to

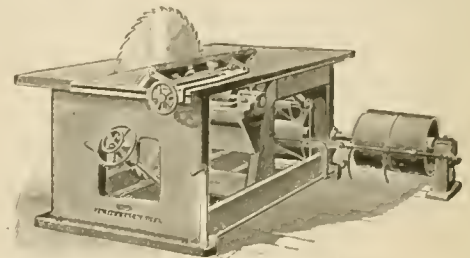

Heavy Rip Saw for Car Shops.

42 ins. in diameter, and will rip material up to 15 ins. in thickness. The frame is raised and lowered by a hand-wheel and screw, with a lock attachment for holding it in position, which also insures uniform tension of the belt. The countershaft at the back of the machine is provided with a belt-shifting attachment, by which the machine can be started and stopped at the working end.

The J. A. Fay & Egan Company, makers of this machine, will furnish further information, and will also send free their large new poster, showing this machine and other car-shop tools.

MECHANICAL DRAFT.

In the summary of advantages of mechanical draft presented in the treatise on that subject published by the B. F. Sturtevant Company, it is stated that "the very adaptability of mechanical draft is indicative of the fact that it is more flexible than that produced by the chimney, is more readily controlled and less influenced by climatic changes; while the apparatus for its production is more readily transported and has a higher potential value than a chimney. To a considerable extent these stand but as the conveniences of this method, regardless of their economies. When it is shown that increased efficiency can be secured by a method that is more convenient, the advantage of mechanical draft is established. The actual omission of the chimney is sometimes of far greater importance than would at first appear, while the readiness with which the rate of combustion may be increased is doubly appreciated when it is shown that under proper conditions the efficiency of combustion may be increased thereby. The purely economic features are presented most prominently in the ability to utilize low-grade fuels, the resultant economy being shown in numerous examples here presented. The economy in the quality of fuel consumed has, in its relation to the use of mechanical draft on shipboard, an advantage which is closely allied to that resulting from the decreased space occupied. The economic results which may be secured through the introduction of mechanical stokers and devices for utilizing the waste heat of the gases are rendered most evident under the conditions of mechanical draft production, as are also the great advantage of preventing smoke and the blessings of good ventilation as they are exemplified on shipboard. The facts that the size of a boiler plant required for a given output can be reduced when a fan is substituted for a chimney, that the cost of the mechanical draft plant is usually far less than that of the chimney draft plant, and that its operating expense is likewise less under proper conditions, all point most conclusively to the purely economic advantages of the method which it is the purpose of this book to present. When these are considered in the light of the convenience and various other advantages of mechanical draft, its evident superiority to chimney draft must be conclusively established in the mind of any one who has read these pages."

THE STAR STEAM ENGINE INDICATOR.

This name has been given to the indicator manufactured and sold by the Star Brass Manufacturing Company, of Boston, who have established a department to meet the demand for indicators.

It is similar to the Thompson indicator in appearance, and employs a pencil movement like that instrument. The lower end of the spring terminates in a ball, giving a ball and socket connection to the piston. A helical spring is used for the drum motion, and instead of a ratchet and pawl a new detent motion, employing a friction clutch, is used. This consists of a ball which is thrown into contact with a groove in the circumference of the drum base. The frame and coupling are of unusual strength, to secure rigidity where it is most needed. One of the improvements consists in the attachment of the cap at the top of the cylinder to the interior shell, within which the piston moves, rather than to the outer shell, thus securing and maintaining the most correct alignment for the motion of the piston and its rod. At the same time the interior shell

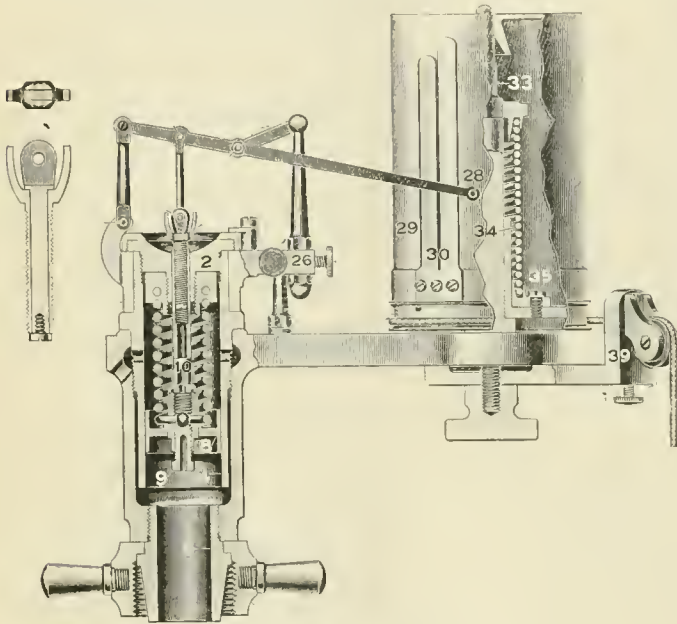

The Star Steam Engine Indicator.

is removable, as in instruments which do not possess this feature. A jacket space, filled with working steam, completely surrounds the lower part of the interior shell and secures a uniform temperature on the inside and outside of the cylinder, which insures immunity from unequal expansion.

A noticeable feature is the means for unscrewing and removing the cap from the cylinder with the parts attached to it. The cap has a milled edge of the usual construction, but the edge is protected by a hard rubber non-conducting covering. This covering can be handled with comfort to the one using it, whereas in the indicators heretofore made, as everyone who has operated an indicator knows, it is impossible to unscrew the cap without risk of burning the thumb and finger with the hot metal. Another thing which will be appreciated by those having the active handling of the instrument, is the provision of a vent tube for carrying away the waste steam and hot water which blows by the piston. This tube is attached to the side of the cylinder and it extends a sufficient distance below the body of the instrument to fully clear it, and prevent the hot water which is mixed with the steam from dripping on the hand of the operator while in the act of turning off the indicator cock.

The piston rod of this indicator is provided with an adjustable swivel-head, so planned that the position of the pencil arm can be varied and the atmospheric line drawn at any desired distance from the lower edge of the card, without going

to the trouble of removing the piston and its mechanism from the cylinder. It is simply necessary to screw the swivel-head up or down the desired amount, using the thumb and finger.

The address of the Star Brass Manufacturing Company is 108 East Dedham street, Boston.

BOOKS AND PAMPHLETS.

Universal Directory of Railway Officials. Compiled from official sources under the direction of S. Richardson Blundstone, Editor of the Railway Engineer. Published by the Directory Publishing Company, Ltd., London, 1901. E. A. Simmons, United States Representative, 697 Chauncy street, Brooklyn, N. Y. Seventh edition, 623 pages, bound in cloth. Price, \$2.50.

This directory is a necessity in every railroad office that has to do with foreign railroads. It contains a list of the railroads of the entire world, together with their mileage, gauge, equipment and officials, also a personal index of the railroad officials. This seventh annual edition has been carefully revised and brought up to date. It is somewhat enlarged, 60 pages in all having been added to the directory.

Linear Drawing and Lettering. By J. C. L. Fish, Associate Member A. S. M. E., Associate Professor of Civil Engineering in Leland Stanford, Junior, University. Published by the author. Palo Alto, California. 65 pages, 7 by 10½ ins., bound in cloth. Price \$1.00 post paid. 1901.

The aim of this book is to give the student enough training in the use of drafting instruments to enable him to construct accurate pencil drawings, make clean-cut lines and do legible lettering. Chapter I. treats of the care and use of materials. The work given in chapters II. and III. constitutes a course of 50 working hours in lineal drawing and lettering, while Chapter IV. is an introduction to drafting. Reference is made throughout the last three chapters to 50 figures which are put in the form of folded plates in the back of the book. In connection with this course of lettering the author has issued a separate blank book of specially ruled paper.

A Hand-Book for Apprenticed Machinists. Edited by Oscar J. Beale. Second edition, 141 pages, with index, bound in cloth. Published by Brown & Sharp Manufacturing Co., 1901. Price, 50 cents.

This little hand-book gives information that every young apprentice, who is serving his time at the machinists' trade, should possess. The first edition was published about two years ago by the Brown & Sharp people for the apprentices in their own shops, but there has been an increasing demand from outside for this volume, so that in this second edition enough copies were printed so that they could be placed on the market. The work does not go into mathematical details, but is comprised of hints in the care of machine tools and explanation of terms pertaining to screw threads; instruction in the figuring of gear and pulley speeds, as well as the figuring of change gears in screw cutting. Also chapters on such subjects as centering and care of centers; turning, reading a drawing, measuring and lacing a belt; signs and formulas; drilling, counter-boring, tapping and cutting speed; the screw and its parts; angles, setting a protractor and working to an angle; circular and straight line indexing, and the subdividing of threads. Copies of this hand-book can be procured from the various book dealers, or will be mailed direct from the Brown & Sharp Manufacturing Co., Providence, R. I.

Poor's Manual for 1901 has issued its advance copies of the introduction, giving a general exhibit of the railroads of the United States for the fiscal year 1900. The length of railroads completed on December 31, 1900, was 194,321.09 miles, of which 188,334 miles are represented in the returns to this valuable publication. After presenting summaries of traffic, capitalization, construction statements, in groups of States and statistics of the trunk line railways, the report presents a comparative statement of the leading trunk lines covering 60 roads, of which is said: "By this statement it appears that the 60 systems whose operations it covers controlled, in 1900, 62.8 per cent. of all the railroads in operation in the country. In other respects it shows that of the passengers carried in 1900 (584,695,935) these 60 systems carried 442,382,459, or 75.6 per cent. of the whole number, the total distance traveled by passengers on the 60 systems being 12,936,472,872 miles at an average charge of 1.993 cents per passenger per mile, against a general average for all

the roads in the Union of 2.031 cents. Of freight tonnage the companies included in the table hauled 685,908,701 tons, being 64 per cent. of the total tonnage (1,071,431,919) of all the lines in the country. Their aggregate haulage equaled 111,419,695,803 tons one mile, being 79 per cent. of the grand total, while the average charge per ton per mile was 0.713 cent, or 0.033 cent less than the general average for the whole country."

A Solid Wrought Steel Passenger Truck.—The J. G. Brill Company of Philadelphia have issued a pamphlet dated October, 1901, which is the 6th edition of their catalogue No. 80, devoted to their truck No. 27, which has been repeatedly referred to in our columns. This truck has seen six years of service and is now working satisfactorily under a great variety of conditions. It has three sets of springs, in series, all of which operate through swinging links. Changes in detail have been made, the most important being solid forged wheel pieces instead of cast steel formerly used. The pamphlet describes the truck and explains the features of its suspension. It also contains a large number of letters from those who are using these trucks; these represent a large variety of service.

Electric Motors, Generators and Generating Sets.—The B. F. Sturtevant Company, of Boston, Mass., has in the past ten years developed the electrical side of their business to a magnitude correspondingly as great as their blower department. This is evidenced in their new catalogue No. 117, which presents a large number of the standard products of their electrical department, such as 2, 4 and 8-pole motors and generators and generating sets. These are illustrated and briefly described in the pamphlet, together with sizes and tables of dimensions. The B. F. Sturtevant Company are fully equipped to meet any requirements in the way of moderate sizes of these electrical machines.

Hydraulic Jacks.—This catalogue, No. 61, just issued by the Watson-Stillman Company, is one of a large number of individual catalogues of high-grade hydraulic tools manufactured by this company for all purposes. It is devoted to both horizontal and vertical jacks, also lifting tools, and contains a general description of the construction of their improved jacks. This company carries in stock, in the form of separate sheets, printed information on all their standard hydraulic tools. These single sheets are sent out in assortments as demanded by the trade. The address of the Watson-Stillman Company is 204 East Forty-third street, New York.

EQUIPMENT AND MANUFACTURING NOTES.

A gold medal has been awarded The Continental Iron Works, of New York, Borough of Brooklyn, for the Morison suspension boiler furnaces exhibited at the Pan-American Exposition. These furnaces are in great favor for land and marine boilers. Their form of construction offers the greatest possible resistance to distortion or collapse, and a freedom from leakage not to be obtained in furnaces which consist of sectional flanged and riveted cylinders, with reinforcing rings interposed between the flanges, or any other method. The Continental Iron Works are the sole manufacturers in this country for the Morison suspension furnaces.

The Lunkenheimer Company has received recognition from the Pan-American Commissioners for the high character of their valves, lubricators and engine fittings, in the form of a gold medal.

The "Diamond S" and other brake shoes made by the American Brake Shoe Company were well represented at the recent street railway convention in an exhibit which was in charge of Mr. F. W. Sargent, Chief Engineer of the company. These shoes are well known to our readers for their peculiar construction, and use of material which combines high friction qualities with durability as far as these qualities can be combined. In our August issue of the current volume, page 257, a statement of the purposes of the various brake shoes made by this com-

pany was presented. Associated with Mr. Sargent in connection with the exhibit were Mr. O. H. Cutler, General Manager of the Ramapo Foundry Company, and also Messrs. Arthur Gmundner and W. W. Gardner.

The prompt action taken by the Chicago Pneumatic Tool Company to protect its customers from litigation and further expense in the matter of the Moffet patent No. 369,129 on portable drilling machines, which was decided in favor of the Moffet patent, by the United States Circuit Court, will no doubt be appreciated. After consultation with leading patent attorneys and a careful examination, the Chicago Pneumatic Tool Company has become convinced that the portable power drills made by itself, as well as by all other concerns, are infringements on the Moffet patent. In view of the decision this company has purchased a license under this patent, which protects all drills that have been manufactured and sold by them or shall hereafter be manufactured or sold.

A prominent railroad of this country after testing the Ajax Plastic Bronze to the extent of 13,400 brasses on cars of 100,000 lbs. capacity, made the statement that that road "has not had a train delayed on account of hot brasses since adopting Ajax Plastic Bronze." The Ajax Metal Company, of Philadelphia, has no hesitancy in saying that their plastic bronze will show a saving of 50 to 100 per cent. in mileage, and are prepared and have the privilege of furnishing the name of this road to any motive power department desiring full information.

The exhibit of the Corning Brake Shoe Company at the American Street Railway Convention, held in New York last month, consisted of an interesting collection of different types of their brake shoes for all service. Some of these shoes were the standards used by many of the electric and steam railways in New York. This shoe is one that does not cut the tire, and has a coefficient of friction that fulfills the requirements of steam and electric railway service. They are made of soft cast iron and chilled iron, which gives the shoe a uniform action. They are long lived, the cost is low in consideration of their long life, and they have ample strength to prevent breakage in service. The general office and works of the Corning Brake Shoe Company are at Corning, N. Y.

The contract for the electrical equipment of the main power house and sub-stations of the Rapid Transit Railroad of New York City was awarded, October 4, by John B. McDonald to the Westinghouse Electric & Manufacturing Company. Although the value was not made public, it is understood that at least \$1,500,000 will be expended on the equipments. Among the apparatus provided for in the contract are six 5,000-kilowatt alternators, three 250-kilowatt exciters, twenty-six 1,500-kilowatt rotary converters, seventy-eight 550-kilowatt transformers, and eight motor-generator starting sets. The third-rail system has been definitely adopted as the motor principle for the underground road. The steam plant will consist of twelve 7,500 to 11,000-horse-power engines, each of which will drive a 5,000-kilowatt generator.

A very interesting and characteristic exhibit of the Hale & Kilburn Manufacturing Company, of Philadelphia, was displayed at the recent Convention of the American Street Railway Association at Madison Square Garden, New York. One of the sections of the south gallery was fitted up in a novel way to represent a room, the walls of which were hung with canvas-lined rattan. The furnishings of the room were various styles of car seats manufactured by this company, together with different kinds of material, such as mohair plush and samples of rattan, used in upholstering work. Considerable interest was shown by railroad men in the walkover car seat, which occupied a prominent position in the exhibit. This seat is of pressed steel construction, with the number of parts reduced to a minimum. It gives 2 ins. greater seating capacity and the cushion and back are detachable. A patent oval base and single automatic shifting footrest is used in connection with the seat, which gives an entirely clear space under the seat for baggage, and greatly facilitates floor cleaning.

The fall term of Purdue University opened September 12, with a freshman class of something over 300. By the close of the first week 1,000 students were in attendance, indicating that the total enrollment for the year will exceed 1,200. Of those already enrolled 766 are taking engineering courses, and 300 are in the course of mechanical engineering. The special work of this course in locomotive and car design, inaugurated this year under the direction of Professor William Forsyth, is giving promise of flattering success.

Among the prominent firms to receive a gold medal at the Pan-American Exposition is the American Steam Gauge & Valve Manufacturing Company, the well-known manufacturers of steam specialties. Visitors at the exposition will remember their exhibit, which attracted a great deal of attention, and particularly their steam gauges and engine fittings, which won for them this medal. This company reports a continually increasing business both domestic and foreign, with capacity for dealing with all orders promptly.

The Continuous Rail Joint Company of America was well represented at the recent Annual Meeting of the American Street Railway Association, in New York. Their exhibit, which was a very interesting one, was located on the main floor of the convention hall. The continuous rail joint (which is now used on about 140 roads and applied to over 10,000 miles of track in the United States) was shown in connection with a variety of sections of T and girder rails. The base plate of this rail joint is an integral part of the joint and gives great horizontal and vertical rigidity, prevents the rail from being battered and makes the joint as strong as any part of the rail.

The Russell Snow-Plow Company, of Boston, has received orders for their snow-plows from various railroad companies, as follows: New York Central and Hudson River Railroad, two Russell double-track wing-elevator snow-plows, size No. 2; two Russell standard double-track snow-plows, size No. 2, also three Russell single-track wing-elevator snow-plows, size No. 2. Each of the above plows to be equipped with Russell air flanger, the Westinghouse air-brake and train signal, and with Gould automatic coupler. Central Railroad of New Jersey, one Russell standard double-track snow-plow, size No. 2, equipped with Westinghouse air-brake and air signal. New York, Chicago & St. Louis Railroad Company, one Russell standard single-track snow-plow, size No. 2, equipped with Russell air flanger, Westinghouse air-brake and air signal. Somerset Railway Company, one Russell standard single-track snow-plow, size No. 3. Delaware & Hudson Company, one Russell standard single-track snow-plow, size No. 2. Bangor & Aroostook Railroad Company, five Russell single-track snow-plows, size No. 2, equipped with Westinghouse train air signal. Lake Shore & Michigan Southern Railway Company, two Russell standard double-track snow-plows, size No. 4, equipped with Russell air flanger, Westinghouse air-brake and signal, and Gould automatic coupler. Grand Rapids & Indiana Railway Company, one Russell single-track wing-elevator snow-plow, size No. 2. Buffalo, Attica & Arcade Railroad Co., one Russell single-track snow-plow, "Flyer A." All of the above snow-plows will be built by the American Car and Foundry Company, many of which are now under construction.

One of the largest and most interesting exhibits at the American Street Railway Convention, held in New York, October 9 to 12, was that of the Westinghouse Electric and Manufacturing Company. Nearly one-half of the central portion of the main floor was devoted to various sizes of standard railway motors; Brill maximum traction truck, equipped with Westinghouse No. 81 railway motor; Peckham truck, equipped with two No. 49 Westinghouse railway motors; railway power station switchboards; ammeters and voltmeters, lightning arresters, switches, circuit breakers, and all switchboard instruments, together with a Brill double-track closed car, equipped with the Westinghouse magnetic brake and car-heating apparatus. The car was in actual operation on a section of inclined track in the center of the hall. The heaters are connected with the general system of wiring by means of a suitably arranged switch, so constructed that the braking and starting currents, both of which are used for heating the car in cold weather,

may be divided as desired, and the whole or any portion sent through the heaters. An important advantage of this heater is its capacity to store and retain heat within its mass. The brake consists of a double shoe, combined with a powerful electro-magnet, which, when energized, is strongly attracted to the rail. This shoe, combined with brake heads, and shoes of the ordinary type acting directly on the wheels, constitutes a wheel brake of maximum power and efficiency. The brake operates independently of the trolley current.

Keuffel & Esser Company, of New York, have been awarded a gold medal at the Pan-American Exposition for their drawing materials, mathematical and surveying instruments, the gold medal being the only one awarded in this line of manufactures.

Mr. Walter W. Davin, of Chicago, who has long been identified with, and is widely known, in connection with steam specialties, has been secured by the Shields Flexible Joints Company to take charge of their railroad interests. His headquarters are at 906 Fisher Building, Chicago. His wide acquaintance and thorough knowledge of steam specialties, as well as of the requirements of the railroad, assure the success of this department.

The Safety Car Heating and Lighting Company has been awarded a gold medal by the Pan-American Commissioners for their "Pintsch light." The company has recently put into operation plants at St. Paul, Minn., and Los Angeles, Cal., and are building new ones at El Paso and San Antonio, Tex.; Shreveport, La.; Mexico City, Mex., and Moncton, New Brunswick.

Considerable interest was shown on the part of electric and steam railroad men in the very extensive exhibit of new designs of Brill cars and trucks at the Twentieth Annual Convention of the American Street Railway Association, held last month in New York. The novel features of the new Brill convertible and semi-convertible car were shown to good advantage by full-sized sections and models. The chief object of this type of car is to have a satisfactory closed car in winter, and one that can readily be converted into an open car for summer use by the removal of the windows and sash. The side panels are made flexible, to follow the sash and glass into the roof. The posts have precisely the same external form as those of standard open and closed cars. Aside from the convertible feature of the car it is particularly noteworthy on account of its lightness and strength. Another of the Brill cars which attracted considerable attention by the visitors was the Narragansett type, which gets its name from being the first of this kind of car built for the Narragansett Pier Line. The chief features of the car aside from the design of the side sills, which are Z-shape, formed from two angle irons, the vertical side of one forming the sill proper, is that the trucks are available for use under both open and closed cars. This type of car seems to have met with considerable favor in the short time it has been on the market, as several large orders have already been placed for them.

Maine offers scenes and pleasures in the line of fishing and hunting that are all her own, and in the chase for big game she has no competitors. Deer are not only more numerous, but they grow to a much larger size, and the person who knows how to handle a gun at all is reasonably sure of his full quota of deer and moose. Although these two kinds of game are usually enough to satisfy the appetite of the average sportsman, they are by no means the only kinds of game to be found in these vast timberlands. Braces of smaller game, together with a plentiful supply of partridge and quail, have already been brought into camp in that section which lies contiguous to the Dead River and known as the Rangeley region. Bears are much more plentiful this year than ever before, and to the sportsman who enjoys this exciting sport, this portion of Maine is an especially desirable spot. The only railroad out of New England that makes direct connections for the heart of the hunting and fishing regions is the Boston & Maine. This road publishes a book called "Hunting and Fishing," that pictures these very desirable places and tells how to reach them. The pamphlet will be mailed to those sending a two-cent stamp to the General Passenger Department of the Boston & Maine, at Boston, Mass.

AMERICAN ENGINEER AND RAILROAD JOURNAL.

DECEMBER, 1901.

CONTENTS.

ARTICLES ILLUSTRATED :	Page	ARTICLES NOT ILLUSTRATED :	Page
American Engineer Tests, Locomotive Draft Appliances.....	367	Valve Motion and Steam Distribution	377
Clearances and the M. C. B. Standard Box Car	371	Completion of Siberian Ry.....	377
Prairie Type Passenger Locomotive, A., T., & S. Fe Ry.....	373	A Crooked Railroad.....	382
Ten-Wheel Passenger Locomotive, A., T., & S. Fe. Ry.....	373	Power Station of the New York Rapid Transit Ry.....	383
Theory of Locomotive Water Scoops, by I. P. Church.....	376	A New Serpentine Boiler	383
Comparative Locomotive Tests. 36-Foot, 40-ton Box Cars With End Platforms, C. & O. Ry....	382	International Railway Congress. Compressed Air As a Safe Power.....	383
Oil Fuel for Locomotives, by H. B. Gregg.....	386	Suggested Increase of Dues in the American Society of Mechanical Engineers	385
The New Sessions-Standard Friction Draft Gear	390	Upper Admission Throttle Valves and Dry Steam.....	385
Experiments with Track Tank Scoops, N. Y. C. & H. R. R. R. Pressed Steel Truck.....	392	The Standard M. C. B. Box Car. The New Sessions Friction Draft Gear.....	389
Four-Pole Enclosed Motors	395	Standard Dimensions of Box Cars.....	394
An Improved Journal Box Lid. Blank for Record of Stacks and Nozzles.....	395		
	397	EDITORIALS:	
		American Engineer Tests, Progress of the Work	381
		The Standard Box Car	384
		Advancements in Transportation Methods	385
		Blank for Record of Stacks and Nozzles....	385
		The Present Car Famine.....	385
		Remarkable Passenger Locomotives	385
ARTICLES NOT ILLUSTRATED :	Page		
M. C. B. Draft Gear Test.....	370		
New Fuel for Swedish Railroads	375		
Air-Brake Equipment of Freight Cars and Locomotives.	375		
Freight Car Repairs are Increasing.	375		

AMERICAN ENGINEER TESTS.

Locomotive Draft Appliances.

III.

THE THEORIES TO BE INVESTIGATED.

A Research by H. H. Vaughan.
Member A. S. M. E.

On carefully reading the Hanover experiments, several things appear rather questionable. Apart from the question of efficiency when larger quantities of air were admitted, which is not touched upon in the report, I should have supposed that the most efficient stack was that which with a given sized nozzle produced the greatest vacuum. If the vacuum varies directly with the pressure in the exhaust pipe, this would give the highest vacuum at all pressures if it gave it with one, although it would not of course follow directly that the stack which gave the best results with one size of nozzle would be the best stack for another size. Then if on an engine a nozzle, say $4\frac{3}{4}$ ins. in diameter, was found to give a greater draught than was necessary, the proper plan would be to enlarge the nozzle. As a matter of fact the experiments show that whatever the size of the nozzle may be the highest vacuum is obtained with a conical stack 11.8 ins. in diameter and of 1 in 6 taper, although there is very little difference between this stack and the other of the same diameter but 1 in 12 taper. This diameter of 11.8 ins. is also the smallest tested. Now in the Hanover report it is stated that the stacks having the greatest indraft of air are not the most suitable for locomotives on account of the sparks thrown, etc. By in-draft of air is practically meant vacuum obtained, and I cannot help the conclusion that the idea carried through the report is that a stack giving less vacuum is preferable to the most efficient form on this account, in place of keeping the most efficient stack and enlarging the diameter of the nozzle in such a case, and thus obtaining the lowest possible back

pressure. Fig. 5 shows clearly the reduction in vacuum found in both sets of experiments when the nozzle is enlarged and the same amount of steam discharged. This point may appear small, but the same idea is carried through the entire report and it appears to me to be founded on an erroneous way of looking at the question.

In Section III the recommendation for nozzle distance must, of course, be modified in accordance with the Master Mechanics' Association results, as shown in Figs. 1, 2, 3, 4, and it is worthy of notice that in the recommendation for the total height of stack, that this height is the distance from the top of the nozzle to the top of the stack and not simply the height of the stack itself.

In the experiments on shortened stacks the statement is made that if the nozzle distance is increased as the stack is shortened the same vacuum can be obtained. While this is true in one way, yet it should be noticed that the highest vacuum that can be obtained with a shortened stack is always less and often considerably less than that which can be obtained in the full length stack.

Several examples are given of stacks which caused spark throwing, in connection with a peculiarity of the experimental apparatus, throwing water under certain conditions. This action was cured by the substitution of stacks which gave a reduced vacuum, and the question naturally arises whether an increase of nozzle diameter would not have remedied the trouble equally as well and decreased the back pressure at the same time.

A large number of experiments on nozzles fitted with a bridge led to the endorsement of this appliance. This directly contradicts the results of the Master Mechanics' Association experiments, but the advantage or disadvantage is in any case very small.

A series of tests to determine the angle of the steam jet gave a most extraordinary result, that the angle of the jet was in all cases 1 in 2.41. As the average angle found in the Master Mechanics' Association experiments is 1 in 6.4, there is evidently some discrepancy in the method employed to measure the angle. In the Hanover tests themselves the jet could not have maintained this angle, since as the greatest vacuum with a conical stack without waist 13.78 ins. in diameter with a $4\frac{3}{4}$ -in. nozzle is obtained 30 ins. from the bottom of the stack, it is evident the jet cannot maintain any such angle, as its diameter would be 17.75 at the point at which it enters the stack.

In general, granted the fact that spark throwing does and can only arise from excessive draught, I cannot avoid the conclusion that while the results of the Hanover tests as a whole may be of great value the deductions made from those tests in the report are from a wrong standpoint and should only be used in connection with the results themselves.

The curious discrepancy in the angle formed by the steam jet in these and the Master Mechanics' Association tests appears to me of considerable importance, and careful consideration of the results in the latter instance has considerably modified my ideas of this subject, which were exceedingly hazy. At the risk of being tedious I am free to say that I had always considered the steam jet as being at some considerable pressure and that the increase in diameter of the jet was caused by the expansion from this to a lower pressure. Now this is not the case. Experiments on jets flowing through orifices of various forms from a pressure of as much as 200 lbs., show that only with the thinnest plates is there any expansion of the jet after leaving the orifice, and that when this does take place the jet is parabolic in form for a short distance. Nothing of this form is visible in the case of the jet from the exhaust pipe, and it is, therefore, certain that in this case the jet has expanded to the pressure of the gases in the front end by the time it has left the nozzle, and is really a stream of particles flowing at the velocity due to the difference of pressure in the exhaust pipe and in the smokebox. Now as this stream passes through the gases it induces movement in them and itself loses correspondingly in velocity. At constant pressure and tem-

perature the amount of steam passing any section per second must of course be constant, and this amount is the product of the area of the jet multiplied by its mean velocity, and therefore apart from any entraining action as the jet loses velocity it must spread, and it is the rate of this spreading which forms the angle of the jet, and it is not due to any expansion of the steam.

Here I wish to make a few remarks on elementary things which are simple enough, but which I have found it necessary to get quite straight in considering this subject. The difference of pressures that we are dealing with is exceedingly small. For instance, 4 ins. of water = 0.1445 lbs. per square inch. The exhaust pipe pressure in the Hanover tests, 3.94 ins. of mercury = 1.932 lbs. per square inch. The rate of flow of a gas under slightly different pressure, P_1 and P_0 , is given by

$$v^2 = \frac{2g}{W_0} (P_1 - P_0), W_0 = \text{weight of gas, all dimensions being squares, feet and seconds.}$$

The weight of steam at 14.5 lbs. per square inch is 0.0378 lbs. per cubic foot, of air at 60 degs. is 0.077 lbs. per cubic foot, or roughly double that of steam.

The velocity of flow of air from atmospheric pressure into the following vacuums is as follows in feet per second:

Vacuum, inches.	Air at 50 deg.	Air at 760 deg.
1	65	80
2	92	113
3	113	138
4	139	169
5	145	179
6	158	196

The very slight difference of pressure between the front end and the atmosphere leads to the conclusion that apart from temperature changes there is but very slight change in the volume of either gas or steam in passing out into the atmosphere. With a smokebox vacuum of 4 ins. of water the change at atmospheric pressure or from 14.555 to 14.7 lbs. per square inch is only as 100 to 101. It is therefore entirely negligible, so that if the steam jet is not condensed or superheated the same volume of stuff must pass any section per second that issues from the nozzle. Now, while the only observation made in the Hanover experiments was the angle of the jet, the Master Mechanics' Association report gives considerable information on this subject. Figs. 6 to 23 in that report give the velocity of the jet at various distances from the nozzle and axis, while Fig. 2 shows what was in the light of previous knowledge a most curious state of affairs in the vacuum found in the stack. In Flgs. 6 to 23, Figs. 9, 10, 11 give the form of jet obtained by a steady blow with low bridge pipe, and as this is the simplest condition it is the one I have attempted to analyze. In Figs. 7, 8, 9, are plotted the velocities shown in the report at distances of 11 7/8, 15 9/16 and 19 11/16 ins. from the nozzle, in each case the curve marked "a" corresponding to the least, "b" to the next and "c" to the greatest distance. The abscissae represent circular inches of area, while the ordinates represent the velocity in feet per second.

The rectangles in each figure represent the velocity of flow at the nozzle multiplied by the area in circular inches, in other words the volume of stuff per second that issues from the nozzle. Now the curious point about these diagrams is that in each case they show that considerably more stuff passes each section per second than issues from the nozzle, and this is the case in other jets shown in the Master Mechanics' Association report that I have plotted, to even a larger degree. As this cannot be due to the expansion of the jet it must be due to the entrainment of air. Not knowing the reasons for the statement in the Master Mechanics' Association report that in all the jets examined the inducing action is great and the entraining action small, I feel that my statement should be accepted conditionally, but the above fact would certainly indicate that the entraining action exists. In Figs. 10 and 11 the jets illustrated in Figs. 10 and 11 of the Master Mechanics' Association reports are plotted with the abscissae representing circular inches as before, while the ordinates are the squares of the

velocities, so that the area in these diagrams represents the energy of the jet, only sections "a" and "c" are plotted and the jet shown in Master Mechanics' Association Fig. 9 is not plotted, as since only two velocity lines are given, it is impossible to do it accurately.

In these diagrams the rectangles represent the energy of the jet on leaving the nozzles. Of course on such slight information absolute accuracy is impossible, yet remembering that air at 750 degs. weighs very nearly the same as steam, these diagrams show that the energy of the jet is constant, or that but little is lost in inducing currents, but that the velocity of the steam has been reduced by giving velocity to the gases entrained in the jet, so that the energy is the same. This point must be remembered, that when the jet leaves the nozzle it would simply flow in straight lines if the pressure of the gases enclosing it were unchanged and they offered no resistance to its motion, so that apart from inducing or entraining action the velocity of its particles cannot change without change in pressure, in which case part of the velocity is transformed into an increase in pressure. In other words, if M and P are

constant, $\frac{Mv^2}{2}$ is constant and cannot change. If velocity is imparted to other gases by entraining, M is increased and v diminished, $\frac{Mv^2}{2}$ being constant; if by induction M is constant and $\frac{Mv^2}{2}$ is diminished, the $\frac{Mv^2}{2}$ being constant if mass

of induced gases is taken into account. Now any of the figures in the Master Mechanics' Association diagrams will show that Mv is increased, and increased too much to be accounted for by the steam in the jet being heated by the smokebox gases, if indeed this could take place in the absence of great entraining action. The energy cannot be plotted for most of the jets from the data in the report, but this should be done, and if constant or increasing with the distance from the nozzle it would certainly prove that the inducing action is small.

There is another fact to support this idea. In Fig. 2 of the Master Mechanics' Association report, it is shown that the vacuum above the foot of the stack is 1.5 times that in the smokebox. The jet plotted in Fig. 8 would produce a smokebox vacuum of 2.75 ins. or a vacuum at the foot of the stack of 4.12 ins. This air is hot, and if it is at such a vacuum it must have sufficient velocity to restore it to atmospheric pressure at the top of the stack, and if we take its temperature at 765 degs. this velocity would have to be 160 ft. per second. By reference to Fig. 8 it can be seen that the velocity of the steam at the edge of the jet is only 150 ft. per second and this is at some distance from the stack; there is no evidence in the Master Mechanics' Association Fig. 2 of any change in the relation of the jet and the surrounding air until right at the top of the stack and it is unlikely that all the surrounding air in the stack is moving as rapidly as the edge of the jet. Therefore, first, it is very unlikely that this air would have sufficient energy to flow into the atmosphere unless entrained in the steam. Second, if it did have sufficient for this its velocity near the top of the stack would not be sufficient to remove enough air per second to cause the registered vacuum in the smokebox. By this I mean that the production of a vacuum in the smokebox means that a certain amount of air was removed per second. Now the firebox vacuum in these tests was one-third the smokebox vacuum. The area through which air could flow was 185 sq. ins. At a vacuum of one-third of 2 3/4, or 0.92 in., air would flow in with a velocity of about 60 ft. per second, so that apart from the great increase in volume caused by this air being heated, it must have flowed out of a 16-in. stack of 200 sq. ins. area at about 55 ft. per second if distributed over the entire area. If we consider that if this air surrounded the jet as an induced current, it could not have flowed through

at the outside over 50 to 60 ins. area, that it was expanded at any rate to 50 per cent. greater volume through heating, so that it would have had to flow under a velocity of about 270 ft. per second at the top of the stack, a velocity much greater than that of the edge of the jet, it appears to me the induction idea is untenable.

On the other hand I have attempted to make some calculations on the assumption that the energy of the jet is constant,

If V_1 is the velocity of jet on leaving the nozzle, and A_1 the area of the nozzle, we know that at any point if $A_s =$ area of steam in the jet and $A_a =$ area of air in the jet, and V is the mean velocity at that point, that $A_1 V_1 = A_s V$ since the quantity of steam passing per second is constant. Now let $A_x =$ area at that point. We know A_x at any point since the angle of the jet is assumed. Also since the energy is constant and mass of $A_s =$ twice that of A_a ,

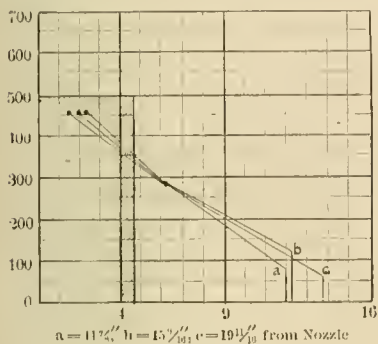

Fig. 7

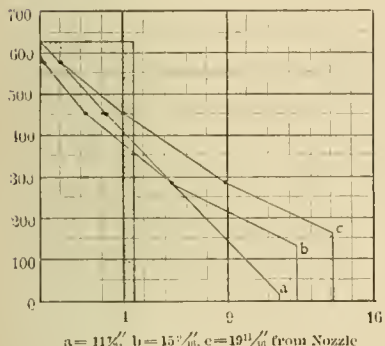

Fig. 8

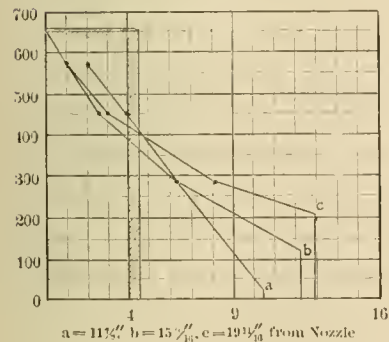

Fig. 9

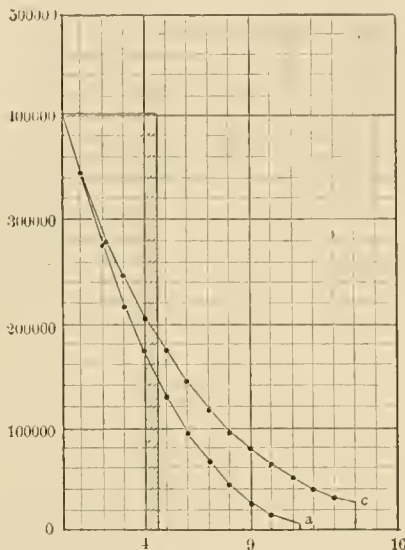

Fig. 10

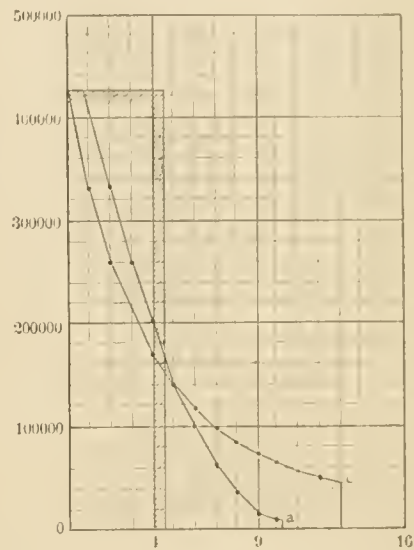

Fig. 11

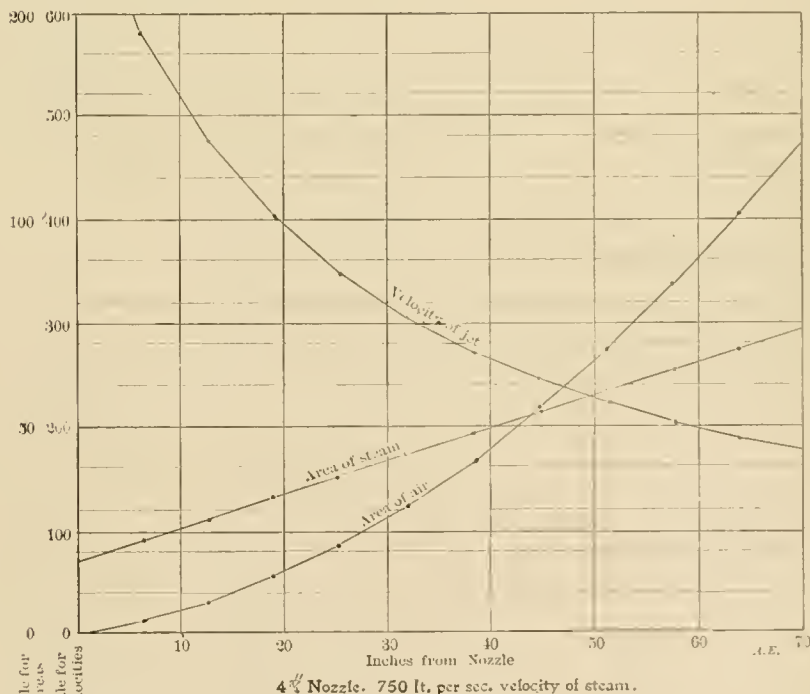

Fig. 12

American Engineer Tests On Locomotive Draft Appliances.

that the angle of the jet is 1 in 6.4, and that there is no heat transference between the steam and air, that the conditions of the Hanover tests are maintained, namely, pressure of 3.94 ins. of mercury in the exhaust pipe, and admission openings of 80.72 sq. ins. to the smokebox, and the results are rather interesting. The following calculations may be skipped, but I give them for criticism.

Air at 50 degs. is roughly twice the weight of steam, so let us adopt that proportion.

$(A_s + 2 A_a) V^2 = A_1 V_1^2$
 or since $A_s + A_a = A_x$
 $(2 A_x - A_1) V^2 = A_1 V_1^2$
 But $A_1 V_1^2 = A_1 V_1 V_1$
 so that $2 A_x V^2 - A_1 V_1 V - A_1 V_1^2 = 0$
 and from this we can find V , A_s , and A_a .
 For a nozzle 4 3/4 ins. in diameter these results are plotted in Fig. 12, taking the nozzle velocity at 750 ft. per second and numerical results are given in the attached table, in which $A_s V$

is also given (Table A). Now, $A_1 V$ is area in square inches of air multiplied by velocity in feet per second and this quantity for an opening of 80.72 sq. ins. is given, for different vacua, in Table B. Table C gives the velocity at which various mixtures of steam and air would have to flow at different vacua to have sufficient kinetic energy to restore them to atmospheric pressure.

Let us assume a vacuum of 5 ins. Table B shows that the quantity of air admitted through the opening is 11,700, Table A shows that this amount of air is entrained in the jet at 38 ins. from the nozzle and that the velocity is then 274 ft. Table C shows that this velocity is sufficient, as only 198 ft. is required with that mixture.

Here enters a condition that we do not know. While the mean velocity of the jet would be 274 ft., the velocity of the center is greater and of the edge less. We do not know what the ration between them is, although Figs. 7, 8, 9 show that the velocity rapidly equalizes as the nozzle distance increases; it

TABLE A.

Dis. from nozzle.	Diam. of jet.	Mean velocity V.	Area of jet A _x .	Area of steam A _b .	Area of Air A _a .	A _a v.
6.4	5 $\frac{3}{4}$	582	26	22.7	3.3	1,920
12.8	6 $\frac{3}{4}$	476	35.7	27.7	8	3,360
19.2	7 $\frac{3}{4}$	402	47	32.8	14.2	5,700
25.6	8 $\frac{3}{4}$	348	60	37.9	22.1	7,700
32.0	9 $\frac{3}{4}$	306	74.5	43	31.5	9,650
38.4	10 $\frac{3}{4}$	274	90	48	42	11,500
44.8	11 $\frac{3}{4}$	248	107	53	54	13,400
51.2	12 $\frac{3}{4}$	224	128	59	69	15,450
57.6	13 $\frac{3}{4}$	206	149	64	85	17,500
64.0	14 $\frac{3}{4}$	191	170.5	69	101.5	19,400

TABLE B.

Volume in square inches, one foot long of air that will flow per second through aperture 80.72 sq. ins. area, into receiver at lower pressure.

Vacuum. inches of water.	Volume per second.	Vacuum inches of water.	Volume per second.	Vacuum inches of water.	Volume per second.
1.....	5,250	3.....	9,150	5.....	11,700
2.....	7,420	4.....	10,500	6.....	12,800

TABLE C.

Velocity of flow from atmospheric pressure, to lower pressures for mixtures of steam and air.

Vacuum, inches of water.	Composition of Mixture.							
	Air 22	38	42	48	54	59	64	101.5
1	65	95	91	88	85	84	83	81
2	92	135	129	125	121	119	117	115
3	113	165	159	154	148	147	144	142
4	130	190	183	177	171	169	165	163
5	145	212	204	198	191	188	185	182
6	159	232	224	217	209	206	203	199

is, however, always less than the mean velocity. Why does this jet not go on entraining air and produce a higher vacuum? To obtain a 6-in. vacuum it would have to entrain a volume of about 12,800, corresponding to a nozzle distance of 44.8, and the mean velocity would have dropped to 248. The velocity necessary to restore the gas mixture to atmospheric pressure at the top of the stack is 209 ft. per second or 84 per cent. of the mean velocity of the jet and it can be safely said that the edge of the jet does not move at that velocity.

If conditions are such that the jet tries to take up more air part of it will not pass out to the atmosphere, but it will simply form a jacket around the jet, allowing the center portions with sufficient energy to pass out through the stack. Also note that 5 ins. is very closely the vacuum found in the Hanover test under these conditions. Now I certainly do not want to make facts fit into a theory, but considering the roughness of these calculations, there is something convincing about the correlations of these figures, and if facts would fit calculations upon generally accepted theories as closely it would be a great comfort to us all.

(To be continued.)

In drying locomotive sand by means of coils of steam pipes the pipe joints need to be kept tight or the leakage of steam will make more moisture than the dryer will be able to take out. Several examples of carelessness in this respect have been noticed in a recent examination of a number of sand houses built in connection with modern locomotive terminals.

M. C. B. DRAFT-GEAR TESTS.

A circular has been issued by the secretary of the M. C. B. Association to members of the association, and manufacturers of draft gear, outlining the plan of the committee on draft-gear tests. The committee has omitted all reference to road tests in the circular, the purpose being to first make drop tests, together with tensile and compressive tests, and afterward to take up different questions that require other methods of testing. To aid in this work Purdue University, through Professor Goss, has given the association the use of the Purdue 300,000-lb. capacity tensile and compression testing machine, and the Pennsylvania Railroad, through Mr. W. W. Atterbury, General Superintendent of Motive Power, has given the use of its drop-testing machine at Altoona, Pa. The general plan of the tests is therefore to show the relative standing of the different constructions under steady pulls and under shocks. The manner of testing is shown by engravings in this carefully-prepared circular, a copy of which can be procured from the secretary at No. 667 Rookery Building, Chicago, Ill.

The market for new cars and locomotives is remarkably active at this time. The Pennsylvania Railroad Company has placed orders with three car manufacturing companies for an aggregate of 12,000 cars. Of this immense order 11,500 are to be 100,000 lbs. capacity, and the remainder are refrigerator cars. Included in the list are 6,000 steel gondola coal cars and 1,000 box cars with steel underframing, built to the standard dimensions of the American Railway Association. All of the other cars have steel underframes. The finished locomotives turned out last month by the American Locomotive Company numbered 167, or a rate of 2,000 engines a year. The Baldwin and Rogers Locomotive Works are equally busy, and all have booked sufficient orders to keep the plants running to their utmost capacity well into next summer. Since the above was written we learn of an order for 4,000 more cars by the Pennsylvania.

Mr. George R. Henderson, Assistant Superintendent of Machinery of the Atchison, Topeka & Santa Fe, has been appointed Superintendent of Machinery to succeed Mr. John Player, effective January 1. Mr. Player retires from active service at his own request, because of ill health, and will continue with the company as Consulting Superintendent of Machinery. He has held the position of Superintendent of this department since 1890, when he left the Wisconsin Central for this position. Mr. Player has had a long record of high standing. Mr. Henderson, who is well known to our readers for his comprehensive command of motive power subjects, is one of the youngest men to be called to such an important position on an American railroad. He began with a technical education, followed by a three years' apprenticeship on the Pennsylvania at Altoona. After serving six years as a draftsman and assistant chief draftsman at Altoona he went to the Roanoke Machine Works as Assistant Superintendent. He afterward became Mechanical Engineer of the Norfolk & Western at Roanoke, and was called to the Schenectady Locomotive Works in March, 1899. Soon after this he was appointed Assistant Superintendent of Motive Power of the Chicago & Northwestern, a position which he filled with credit. Mr. Henderson was appointed Assistant Superintendent of Machinery of the "Atchison" last June, and at once showed his ability to take charge of the department. He is an example of the combination of technical engineering training with active experience, and has made an enviable reputation by his writing as well as his railroad work. He has contributed many very valuable papers and discussions to the Master Mechanics' Association, the American Society of Mechanical Engineers, and to the American Engineer and Railroad Journal.

CLEARANCES AND THE M. C. B. STANDARD BOX CAR.

Elsewhere in this issue the general features of the subject of the standard box car are discussed, and, by courtesy of Mr. A. M. Waitt, of the New York Central, we are permitted to present a comparison of clearances of several prominent roads which bears on an important feature of this question.

On many roads the clearances are sufficient to permit of using the recommended standard height of 8 ft. with no difficulty whatever, but on three roads, at least, the New York Central, New York, New Haven & Hartford and the Pennsylvania, the clearances over the running board are too small for comfort.

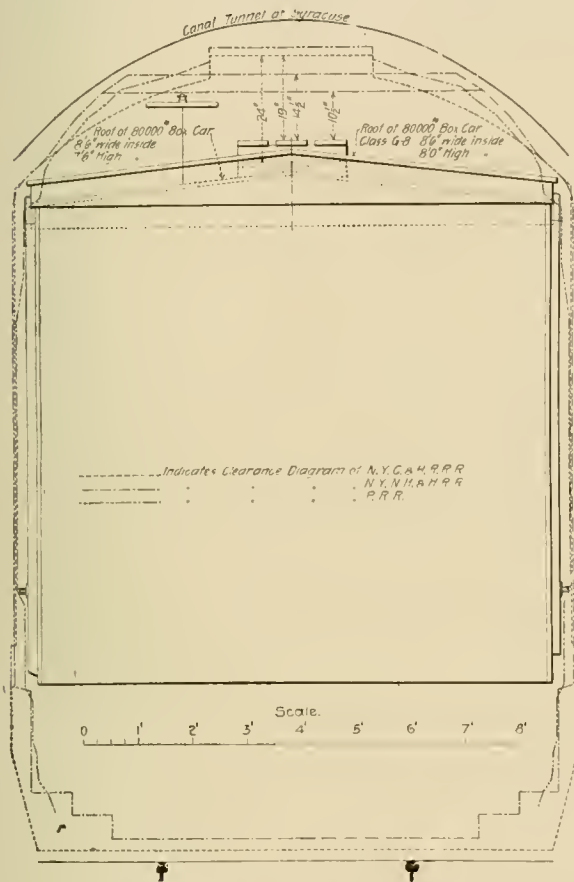

The Standard Box Car and Clearances.

It is understood that these clearances on these roads constituted the chief objection to the 8-ft. car, but, notwithstanding the difficulties, the standard has been adopted and it remains for them to be overcome. On the Pennsylvania there is trouble also at the eaves, but it is understood that the clearances at this point may be somewhat enlarged on that road by work which is now under way.

A glance at the comparative diagram, reproduced by permission of Mr. Waitt, will show what this problem amounts to. The car roof shown in solid lines was drawn to represent an 8-ft. car, and it is apparent that it exceeds the Pennsylvania clearances at the eaves and that it leaves but 19 ins. clearance over the running board. This car can run over the New York, New Haven & Hartford, but on one of the divisions its brake staff would just clear and brakemen would have but 10½ ins. over the running boards. On the other division they would have but 14½ ins. Mr. Waitt does not consider anything less than 20 ins. as safe, and on a lot of new cars for which the drawings are now under way, he has decided on a design which includes the standard interior dimensions and which, by careful attention to the roof at the eaves, comes within the Pennsylvania clearances and leaves 20 ins. over the running board on the New York Central.

Western roads whose cars never come East are not specially interested in the confined clearances of some of the lines on the Eastern seaboard, but should they ever desire to send their equipment over these lines it may be found advantageous to consider the clearances in the construction of the cars, so that they may go anywhere. From this discussion it seems possible to accomplish this result without sacrificing any principle of construction, and to show that this may be done is the object of this article.

That higher grade car wheels for large capacity cars are necessary is clear to a correspondent of the "Railway and Engineering Review," who quotes the experience of an important road as follows: "The road in question has a variety of freight cars of all capacities and was one of the first purchasers of steel cars of 100,000 lbs. capacity. An investigation of the wheel records recently ordered shows that the failure of wheels under 100,000-lb. cars as compared with 60,000-lb. cars is in the ratio of 3 to 1; and compared with 40,000-lb. cars is in the ratio of 5 to 1. This shows very clearly the relation of the load to wheel failures. It is interesting to note in this connection that the wheel records showed wheels made at various times by over sixty different foundries. Unless the wheels used under the 100,000-lb. cars were of specially poor quality, the comparative record is a fair indication and proof of the facts. As a matter of fact their record is really an epitome of the situation."

Except in a few cases of roads having peculiar conditions with reference to the cost of coal and availability of oil, there has never been more than a local interest in the use of oil for locomotive fuel. What influence the phenomenal discoveries of oil in Texas will have on the operation of railroads can only be guessed at now, but these discoveries have brought a general awakening to the possibilities of oil fuel, and if the predictions of cheap supply are fulfilled the application of oil fuel to locomotives will assume an importance which it never has had. Even where it is most extensively used it has never seemed advisable to fit up for oil burning in such a way as to render it inconvenient or expensive to return to coal. This is due to the uncertainty of the continuance of the supply, or of the relations of cost which have given the advantage to oil. There can be no doubt of the success of oil, or of the fact that its employment will tend to relieve locomotive designers of some of their present burdens. But notwithstanding its success it seems likely that the performance with oil may be greatly improved. This far it has always been burned in fireboxes which were built for coal. If the Texas fields affect the oil market as they are expected to do, it will pay to make a study of the subject with reference to the design of fireboxes so that they may be built for oil alone. It does not seem likely that the best furnaces for coal will be equally favorable to oil. If it is unnecessary to consider the grate area, and if the design of oil burning fireboxes becomes a question of volume and form, it seems probable that oil burning may exert an important influence on locomotive construction and operation. The staybolt problem may perhaps be avoided entirely by corrugated furnaces, and the physical endurance of the fireman drops out as a factor in operation. This fuel is now a general topic of discussion, and many are wondering whether they will not be able to use it. If its use becomes general its possibilities will expand, for it is reasonable to suppose that oil needs a furnace of its own. In the oil belts, at least, real oil-burning locomotives may be expected as a development of the near future.

The consumption of fuel oil by the railroads of California is at present at the rate of 3,000,000 barrels per year, and the total output of California wells is 8,000,000 barrels per year, according to a recent published statement by Dr. C. T. Deane, Secretary of the California Petroleum Miners' Association.

PRAIRIE TYPE PASSENGER LOCOMOTIVES.

Largest Ever Built.

With Traction Increaser.

Also Ten-Wheel Passenger Locomotives.

Atchison, Topeka & Santa Fe Railway.

Built by the Baldwin Locomotive Works.

Forty-five of the remarkable engines illustrated by these engravings are being built by the Baldwin Locomotive Works for the Atchison, Topeka & Santa Fe for working passenger trains over the 16-degree curves and grades of 184 ft. per mile, such as occur between Albuquerque and La Junta. These engines have about 15 per cent. more tractive power than the most powerful previous design on this road. They weigh 190,000 lbs. and have 3,738 sq. ft. of heating surface, these figures being larger than have been used in passenger locomotives. The weight on driving wheels is 135,000 lbs., the same as the Lake Shore Class J prairie type, illustrated in the March, 1901, issue of this journal, page 69. In comparing the heating surface and total weight of a number of recent designs, these Atchison engines head the list with reference to the total weight divided by the heating surface, as indicated in the following table:

Name of road.	Engine No.	Total weight.	Total weight divided by heating surface.	Total weight divided by heating surface.
Atchison	1,000	190,000	3,738	50.08
N. Y. Central	2,980	176,000	3,505	50.20
Lake Shore	650	174,500	3,543	52.18
C. & N. W.	1,015	160,000	3,015	53.06
L. V.	681	225,082	4,105	54.83
B. & O.	1,450	150,000	2,603	56.50
B., C., R. & N.	77	158,600	2,551	62.17
C., B. & Q.	1,531	159,000	2,500	63.60
Can. Pacific	203	153,000	2,401	66.00
Penn.	820	159,000	2,401	66.00

Note.—All are passenger locomotives except that of the Lehigh Valley.

These engines will be used on the most important trains, and will undoubtedly greatly reduce the amount of mountain pusher service. Among the interesting details may be noted the use of compound cylinders, 74-in. driving wheels, wide grates, 19-ft. tubes, inside journals for the trailing wheels, bent motion bars, with rockers close to the steam chests, sloping back boiler head and front water leg, plate firebox supports, 9 by 12-in. main driving journals, 10 by 12-in. journals for the other driving axles, and one of the lot of 40 engines is fitted with a traction increaser.

This is the first application of which we have record of a traction increaser to a large six-coupled engine. It is intended to increase the weight on driving wheels from 135,000 to 160,000 lbs., and for this type of engine, with divided equalization it is necessary to also divide the traction increaser. At the rear end the equalizer fulcrums are changed by a cross-bar operated by two cylinders, and a third cylinder takes weight

from the front truck by means of the lever shown. This is a bold plan, which will be watched with interest. Our engraving shows the arrangement of piping, whereby a valve controlling the application of the traction increaser is operated by the reverse lever, so that it may not be applied except when working at long cut-offs. These engines have a tractive power of 27,500 lbs., which is increased by the traction increaser to about 32,000 lbs. by the use of live steam in the low-pressure cylinders.

There is work for such engines to do on this road, where even in the comparatively level districts double-heading is frequently necessary in bad weather. This design is a part of a thoroughgoing plan of increasing the capacity of locomotives on this road, which is sure to merit the attention of all who are concerned in improving locomotive practice. The leading dimensions of these engines are recorded in the following table:

Compound Prairie Type Locomotive, Atchison, Topeka & Santa Fe Railway.

General Dimensions.	
Gauge	4 ft. 8½ ins.
Kind of fuel to be used	Soft coal
Weight on drivers	135,000 lbs.
Weight on leading truck wheels	25,000 lbs.
Weight on trailing truck wheels	30,000 lbs.
Weight, total	190,000 lbs.
Cylinders, diameter	17 and 28 ins.
Cylinders, stroke	28 ins.
Drivers, number	6
Drivers, diameter	70 ins.
Steam pressure	200 lbs.
Heating surface, tubes	3,543 sq. ft.
Heating surface, fire-box	195 sq. ft.
Heating surface, total	3,738 sq. ft.
Grate area	53.5 sq. ft.
Wheel base, total, of engine	32 ft. 2 ins.
Wheel base, driving	13 ft. 8 ins.
Length over all, engine	46 ft. 3 ins.
Length over all, engine and tender	69 ft. 7 ins.
Height, center of boiler above rail	112 ins.
Boiler, type of	Straight top
Boiler, diameter of barrel	70 ins.
Tubes, number	318
Tubes, diameter	2½ ins.
Tubes, length	228 ins.
Fire-box, width	71½ ins.
Fire-box, length	108 ins.
Fire-box, depth front	75½ ins.
Fire-box, depth back	67½ ins.
Tender, weight	112,000 lbs.
Tender, water capacity	6,000 gals.
Tender, coal capacity	10 tons
Wheel base, total (engine and tender)	57 ft. 9 ins.
Height of stack above rails	15 ft. 6 ins.
Drivers, material of centers	Cast steel
Truck wheels, diameter	Front, 21 ins.; Back, 49 ins.
Journals, driving axle, size	Main, 10 x 12 ins.; Others, 9 x 12 ins.
Journals, truck axle, size	Front, 6½ x 12 ins.; Back, 7½ x 12 ins.
Main crank pin, size	7 x 7 ins.
Piston-rod, diameter	Hollow, 4½ ins.
Kind of piston-rod packing	Metallic
Main rod, length center to center	7 ft. 8½ ins.
Steam ports, circular, length	34 ins.
Steam ports, width	1½ ins.
Exhaust ports, circular, length	34 ins.
Exhaust ports, width	1½ ins.
Bridge, width	3 and 2½ ins.
Valves, kind of	Balanced piston, 15 ins. diam.
Valves, greatest travel	5½ ins.
Valves, outside lap	H. P., 7½ in.; L. P., 5½ in.
Valves, negative inside lap	H. P., 14 in.; L. P., 8 in.
Valves, lead in full gear	H. P., 9 in.; L. P., 1 in.
Boiler, material in barrel	Steel
Boiler, thickness of material in barrel	10 and 5½ in.
Seams, kind of horizontal	Butt jointed, double covering.
Seams, kind of circumferential	Double riveted
Thickness of tube sheets	Both ½ in.
Thickness of crown sheet	9/16 in.
Crown sheet stayed with	1 in. radii stays
Dome, diameter	31½ ins.
Fire-box, material	Steel
Fire-box, thickness of sheets	Crown, sides and back, 5/16 in.
Fire-box, brick arch	Yes
Fire-box, water space, width	Front, 1½ ins.; sides, 4 ins.; back 4 ins.
Grate, kind of	Rocking, in four sections
Smoke-box, diameter	72½ ins.
Smoke-box, length	72 ins.
Exhaust nozzle	Single
Exhaust nozzle, diameter	Permanent
Exhaust nozzle, distance of tip below center of boiler	4½ and 5 ins.

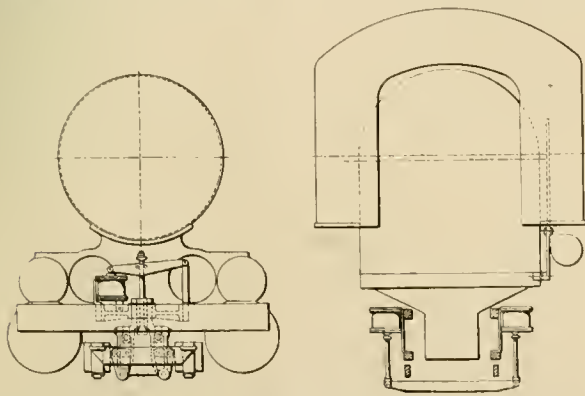

Front and Rear Elevations of Engine, Showing Arrangement of Traction Increaser Cylinders.

TEN-WHEEL OIL-BURNING PASSENGER LOCOMOTIVE.

With Vanderbilt Boiler.

These engines are also heavy, and compounds. They will burn oil, and for this fuel the Vanderbilt firebox seems to be specially well adapted. The fireboxes are 10 ft. 11 ins. long

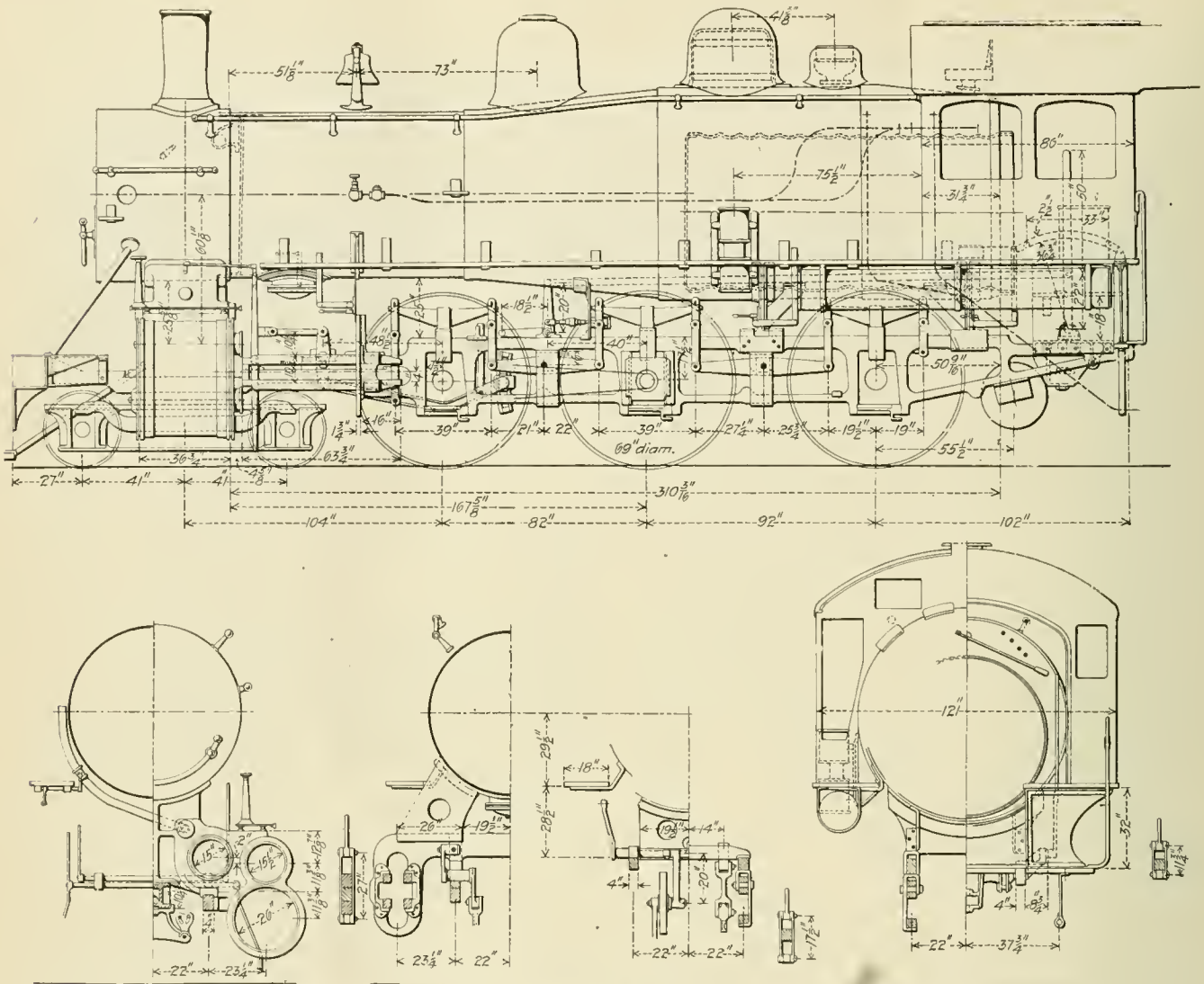

Ten-Wheel Oil Burning Passenger Locomotive—Atchison, Topeka and Santa Fe Railway.

with the necessary brick arches for oil burning. The boilers are of the wagon-top type and will carry pressures of 200 lbs. The heating surface is 2,946 sq. ft., and the engines will weigh 175,000 lbs. These engines will be used on districts which are within reach of the California and Texas oil regions. The chief dimensions of these engines are as follows:

Ten-Wheel Passenger Locomotive, Atchison, Topeka & Santa Fe Railway.

General Dimensions.

Gauge	4 ft. 8 1/2 ins.
Fuel	Oil
Weight in working order	175,000 lbs.
Weight, total engine and tender	285,000 lbs.
Weight on driving wheels about	135,000 lbs.
Weight on front truck	40,000 lbs.
Wheel base, driving	14 ft. 6 ins.
Wheel base, engine total	26 ft. 7 ins.
Wheel base, total engine and tender	56 ft. 6 1/2 ins.

Cylinders.

Diameter of cylinders	H. P., 15 1/2 ins.; L. P., 26 ins.
Stroke of piston	28 ins.
Valve, boiler	Balanced piston
Boiler, diameter	66 ins.
Thickness of sheets	5/8 and 3/4 ins.
Working pressure	200 lbs.
Fire-box	Vanderbilt
Material	Steel
Diameter	63 3/4 ins.
Thickness of sheets	Sides, 3/4 in.; back, 3/4 in.; crown, 3/4 in.; tube sheet, 1/2 in.
Tubes, material	Iron
Tubes, number of	300
Tubes, diameter	2 ins.
Tubes, length	15 ft. 0 in.
Heating surface, fire-box	135 sq. ft.
Heating surface, tubes	2,811 sq. ft.
Heating surface, total	2,946 sq. ft.
Grate area	No

Wheels, Etc.

Diameter of driving wheels outside of tire	69 ins.
Journals	9 x 12 ins.
Diameter engine truck wheels	30 ins.
Journals	6 1/2 x 10 1/2 ins.

Tender.

Wheels, diameter	34 1/4 ins.
Journals	5 x 9 ins.
Water capacity	6,000 gals.
Oil capacity	2,200 gals.

Piston valves have made many friends and are highly spoken of by those who have had wide experience with them, but opinions are not yet unanimously favorable. This is true of almost everything that is good, and in the development of the piston valve some difficulties have been encountered. One of them recently came to notice on a road having many of these valves with outside admission and the usual arrangement of the valve stem. If the pressure of the steam upon the area corresponding to the end of the valve stem remains unbalanced it always urges the valve toward the rear and with sufficient force to give considerable trouble with the steam distribution in addition to other difficulties. Not wishing to extend the valve stem through the chest and introduce another stuffing box or to change the motion for inside admission, relief was found by boring out the rear valve hushings about 3/16 in., which gave a perfect balance to the valves and overcame the trouble. This seems to be almost trivial, but we are assured that this simple device produced perfect working valves and entirely changed the opinions of the engine men. Others may have had this difficulty without thinking of this simple remedy.

NEW FUEL FOR SWEDISH RAILROADS.

Sweden imports yearly large quantities of coal and coke, and this trade is increasing steadily, in pace with the industrial activity and the building of new railroads. Several millions of dollars are annually paid out to foreign countries for fuel. The managers of the State railroads have been instructed to make trials of peat, peat charcoal, and peat briquettes as fuel for locomotives. The intention is to construct a special locomotive to be used in these experiments, and if they are successful other engines will undoubtedly be built, because peat is abundant in that country. The navy and the State railroads have also tried to use Swedish coal, but without much success; the efforts will be continued, however. Consul Bergh reports from Gottenburg as follows:

"In the new briquette factory at Elmhult, belonging to the State, experiments will be made this fall in the production of a cheap and practical fuel for Swedish railroads. In locomotive furnaces Swedish coal cannot be used alone, because it contains too much scrap and incombustible substances, which are not consumed, but form refuse and ashes. It must, therefore, be mixed with English coal, but this is becoming more and more expensive. The possibility of using Swedish coal alone is therefore ideal, and the above-mentioned factory has been built, to be employed in the attempts to make or refine Swedish coal into a good fuel. The factory will operate according to a German patented method, and has been put up under the supervision of a German. It will be started this fall, and the work will continue night and day. It is calculated that the output will be 36 briquettes per minute—that is, 51,840 per 24 hours, or 15 carloads of 10,000 kilograms per car. Experiments will first be made with 40 carloads of Swedish coal of the lowest grade.

Every little while the North German Lloyd Steamship Company adds to its already large number of floating palaces a steamer which shows in every way the progress in German naval architecture, including mechanics, art and science. Everything that is new in the way of equipment, such as electric heating, lighting, fans and wireless telegraphy, are used for the comfort and convenience of passengers. The latest production of the Vulcan Shipbuilding Company, Stettin, Germany, is the steamer "Bremen" of the North German Lloyd. This vessel was damaged in the terrible Hoboken fire of June 30, 1900. She is now in service again, with no sign of the old ship remaining. She has been lengthened 25 ft. to add more boiler power, and from the hull up the ship is entirely new. Not alone is the floating equipment of the North German Lloyd Company the most improved, but its docks at Hoboken, N. J., when completed, will be altogether the best on this or the other side of the Atlantic. The roofs, floors, sides, window frames and, in fact, every part of the docks, will be of steel, concrete or masonry. The building connecting the ends of the piers on land will be two stories high, of the same construction, with a large promenade on the second floor for the use of patrons of the line. Passenger elevators will be used for the convenience of the public, and in addition there will be a number of large double staircases inside and outside of the building. These piers will be as nearly fireproof as it is possible to make them.

Vice-President Voorhees, General Superintendent Besler and half a dozen division superintendents of the Reading Railway, had a conference recently on the subject of establishing stations for the testing of air brakes. It is probable that plants will be located for this purpose in all the principal yards of the company, and that they will be erected as soon as the necessary machinery can be secured. In this way the same attention is to be given to freight and coal cars that is now given to passenger coaches.

FREIGHT CAR REPAIRS ARE INCREASING.

Freight car repairs are increasing in cost to an extent which has led, on a number of roads, to an investigation of the causes. They are attributed chiefly to the rough handling of freight equipment, which is a result of the introduction of automatic couplers. This is a matter of grave importance and it will require action. Either the rough handling must stop or the car construction must be such as to provide for it. Probably it cannot be stopped entirely, because in busy seasons there is not time to be gentle with cars, but abuse can unquestionably be regulated. There are several ways, however, to improve the situation. The maintenance of air brake hose is beginning to be appreciated as being enormously more expensive than it ought to be. This is due to two, and, perhaps, more, causes. There seems to be an increasing tendency toward a general practice of not uncoupling the hose when cars are uncoupled, thus submitting the hose to severe strains which were intended to occur only in cases of emergency. The other cause, and it is closely related to this practice, is carelessness in maintaining the M. C. B. standards with reference to the location of train pipes and angle cocks. The second cause aggravates the first, because with properly located pipes and angle cocks the pulling apart of the couplings would do far less damage to the hose. The Car Foreman's Association of Chicago has done good service in this connection by revealing the defective condition found in a lot of 100 cars recently examined in one of the Chicago yards. This examination gave the following results:

	Per cent.
Angle cocks 13 ins. from center line of car.....	33
Angle cocks more than 13 ins. from center line of car.....	58½
Angle cocks less than 13 ins. from center line of car.....	8½
Angle cocks set at the proper angle.....	20½
Vertical angle cocks.....	39½
Turned toward track 10 degrees or over.....	12½
Turned toward proper position 10 to 20 degrees.....	17½
Total out of position.....	69½
Distance from center of train pipe to center line of coupler.....	48
Correct position.....	43½
Below center line of coupler.....	8½
Above center line of coupler.....	8½
Condition of pipe brackets:	
Proper position.....	85
Bent outward.....	15
Condition of train pipe:	
Proper position.....	94
Train pipe shifted.....	6

These cars were taken in regular order on the tracks with few exceptions. Cars which were examined at other times were in much worse condition than those shown in the report. These may appear to be trifles, but the serious consequences of break-in-tuos because of burst hose connections is sure to bring the subject before the managements of railroads before long. This feature of the trouble is far more serious than the cost of hose replacements, important as they are.

AIR-BRAKE EQUIPMENT OF FREIGHT CARS AND LOCOMOTIVES.

The American Railway Association Committee on Safety Appliances reported at the recent St. Louis meeting the following statement of the equipment of freight cars and locomotives with air brakes, including July 1, 1901:

Freight cars in service.....	1,366,458
Fitted with air brakes.....	1,012,399
Engines in service.....	35,025
Equipped with power brakes.....	34,637

New equipment, other than passenger, under contract or construction:

Freight cars to be fitted with air brakes.....	52,623
Freight cars not to be fitted with air brakes.....	0
Engines to be equipped with power brakes.....	1,298
Engines not to be equipped with power brakes.....	0

A contract has been placed for sleeping cars to run on the electric line between Cincinnati and Columbus, O.

THEORY OF LOCOMOTIVE WATER-SCOOPS.

By Professor I. P. Church, Cornell University.

For simplicity it will be assumed that the result is the same if the locomotive is stationary, while the main trough of water and its contents move underneath it with a velocity (uniform) equal to that of the locomotive in the actual case. Let this velocity be denoted by c .

First Case.—Open Trough.

Let the scoop and channel be an open trough, so that the depth of the stream of water proceeding upward along it is

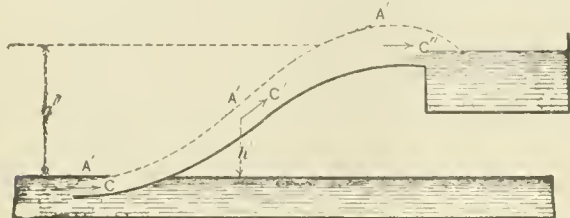

First Case—Open Pipe.

free to adjust itself in accordance with the dynamic relations of the flow.

It is well known that if a block be started with a velocity, c , along a smooth and fixed guiding surface inclining upward, it will not come to rest until a vertical height $h = \frac{c^2}{2g}$ (g being the acceleration of gravity, = 32.2 for the foot and second) above the initial point has been reached; also that at a height h' (less than h) above the starting point the velocity will have diminished to a value, c' , satisfying the relation

$$\frac{c'^2}{2g} = \frac{c^2}{2g} - h' \dots \dots \dots (1)$$

In the case of a great number of successive "blocks," or water particles, when an even or "steady" flow takes place up the open trough, the effect of a diminished velocity is to produce a thickening, or increase of depth (if width of trough is uniform) of the stream in accordance with the law

$$F'c' = Fc \dots \dots \dots (2)$$

Where F is the sectional area of the stream at the bottom (see Fig. 1), and F' that at A' , at any height h' ; since with a steady flow this product is constant.

That is (neglecting all friction for the present), the sectional area of the stream at A' , at a height h' , would be (from equations (1) and (2))

$$F' = \frac{Fc}{\sqrt{c^2 - 2gh'}} \dots \dots \dots (3)$$

and the sides of the trough (which is here assumed of uniform width) must be high enough correspondingly to prevent lateral escape of the water.

Assuming a convenient low value for the velocity c'' (not calling for too great a depth of stream) at the highest point

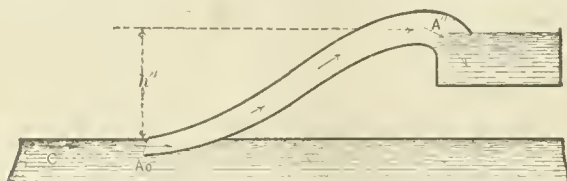

Second Case—Closed Pipe.

A'' , the greatest height to which the water could be raised, with the given velocity c at A , would be h'' ; to be computed from the equation

$$h'' = \frac{c^2}{2g} - \frac{c''^2}{2g} \dots \dots \dots (4)$$

Friction, however, modifies these results somewhat, and can be provided for in the formula by introducing a "loss of head"

(depending on the square of the velocity nearly and also on the size of the section and the depth) for each small length along the trough. This would complicate the formula extremely, so that it is better to introduce a single loss of head of the form $m \frac{c^2 + c''^2}{2g}$, making equation (4) now read

$$h'' = \frac{c^2}{2g} - \frac{c''^2}{2g} - \frac{m}{2} \frac{c^2 + c''^2}{2g} \dots \dots \dots (5)$$

The number, m , would have to be determined by experiment in each case. By reason of friction the maximum possible value of h'' would be quite a little smaller than that obtained from equation (4).

It is evident that the tip of the scoop at A must not be permitted to dip too far below the surface; i. e., too great a value must not be given to the sectional area, F' , of the stream at A , otherwise the sections above, all of which are larger than F , would become too great, and the water would overflow the sides. For example, if the tip of the trough is 12 ins. wide at A and dips 1 in. below the surface of the water, we have $F' 1-12$ of a square foot, so that if c is twelve times c'' , the value of F'' will be 1 sq. ft.; that is, the depth of the stream at A'' would be 1 ft., for the same width of trough.

The quantity of water delivered per second would be $Q = F'c'$ (in cubic feet per second, say; if c is feet per second and F' expressed in square feet). Vice versa if h'' is given as well as c and F , c'' becomes known from (5) and the corresponding area F'' can then be computed from $F'c' = F''c''$, and its value compared with the capacity of the trough at A'' .

Second Case.—Closed Pipe.

Here, a gradual increase of section (and consequent gradual diminution of velocity, assuming the pipe to flow full) should be provided, in the direction of the flow of the water; just as is done on the downstream side of the throat of a venturi meter, and also in the design of the delivery tube of a steam injector. In the venturi meter and in the injector tube the object is to enable the stream, which in the "throat" is at high velocity, and low pressure, to make its way by gradual reduction of velocity into a region where the pressure is much greater; and in the present apparatus a similar design will enable the stream to flow into a region of increasing altitude with gradually diminishing velocity. If the sectional area of the pipe were kept uniform the capacity of the device would be limited; though if the end of the pipe were dipped but slightly below the water surface a stream might be lifted which would not fill the pipe, the latter becoming in that case an open trough.

Since with a closed pipe of fixed dimensions the stream of water is no longer free to vary its own sectional area, but must take that of the pipe, assuming the pipe to have full sections at all points, the velocity of the water in the "throat" or narrow tip at A_0 has a value c_0 , in any given case, not necessarily equal to that, c , of the main body of water approaching the locomotive.

Let us first assume, however, that c_0 equals c , in order to note the conditions that must be fulfilled for the attainment of such a result. Such being the case, the water in the throat will be under atmospheric pressure and that in the section at A'' is also, and in all cases, under atmospheric pressure. For the steady flow in the pipe from A_0 to A'' , Bernoulli's fundamental theorem gives rise to the relation (see Fig. 2):

$$\frac{c^2}{2g} = h'' + \frac{c''^2}{2g} + m' \frac{c^2}{2g} \dots \dots \dots (6)$$

In which c'' is the (slow) velocity of the water at A'' and m' is a coefficient whose value may vary from 0.10 to 0.50 (judging from results of experiments with pipes and venturi meters), the term $m' \frac{c^2}{2g}$ representing the "loss of head" occurring between A and A'' . From this we obtain, after writing $c'' = \frac{Fc}{F''}$,

$$\frac{Fc}{F''}$$

as the value of that particular velocity of the locomotive for which (with the given h'' , and dimensions of pipe) the velocity

$$c = \frac{\sqrt{2gh''}}{\sqrt{1 - \left[m' + \left(\frac{F}{F''} \right)^2 \right]}}$$

of the water through the tip would be equal to that of the locomotive over the track. In other words, no water would be thrown sideways by the advancing tip, and there would be less splashing.

For example, with $h'' = 15$ ft. and $F'' =$ eight times F , and $m' = 0.10$, we find this special value of c to be about 33 ft. per second (or some 22 miles per hour for the locomotive). If the locomotive has a less speed than that given by equation (7) (with the same h and dimensions of pipe, etc.), the water would simply form a standing column in the pipe, not reaching high enough to flow into the tank.

If the speed of the locomotive were greater than that given by (7) the stream of water would probably not fill the pipe completely, but simply flow along the lower part of each section as in an open trough, the section of the stream increasing with the altitude, as already shown, but not filling the pipe except near the tip, A .

VALVE MOTION AND STEAM DISTRIBUTION.

In an admirable paper on locomotive steam distribution, read recently before the Northwest Railway Club, Mr. H. T. Herr, Division Master Mechanic of the Chicago Great Western, gave an extended description of the effect of changing the valve functions, and discussed the most important present questions in valve setting and construction. His conclusions merit thoughtful attention, with special reference to that concerning double ported valves for high speed work. This subject is soon to be thoroughly investigated by practical experiment on a western road. The summary of his conclusions is as follows:

- (1) The design of valve motion as a whole is as important as any other single element of the locomotive, and in its solution consideration should be given to the nature of the service to which the engine will ultimately be assigned, as outlined in the body of this paper.
- (2) The distribution of steam at the probable running cut-off is most important for the proper action of the valve motion and its elements.
- (3) The full gear adjustment should not be allowed to influence the setting of the valve, to the detriment of the running cut-off.
- (4) A greater reduction of lead than is generally found in practice is advisable, as is also an increased outside lap and travel.
- (5) Some form of double or multiple ported valve is valuable and should be used, especially in high speed work.
- (6) The Zeuner and harmonic valve diagrams are material aids to the solution of all slide valve problems.

The Superintendent of Motive Power of one of the most prominent Western roads desires to be put in communication with young men who have recently graduated from mechanical engineering schools and wish to enter service as special apprentices. An opportunity is offered for gaining experience and for the preparation for promotion, for which this road offers unusually favorable opportunities. This is a case in which technical education is thoroughly appreciated and where ability is sure to be recognized. It seems strange, in view of the remarkable developments of the motive power situation, that the prominent roads are not overwhelmed with applications. Young men who are soon to graduate from their technical studies and who are attracted by the opportunity mentioned here, will be placed in communication with the officer referred to, through the editor of this journal.

COMPLETION OF THE SIBERIAN RAILWAY.

The Siberian Railway is almost completed, at a total cost of about \$390,000,000. This road, of 5,542 miles, including its branches, traverses the most fruitful and comparatively populous part of Siberia and puts all Russia with her Siberian granaries and other productive powers in commercial intercourse with the countries of eastern Asia.

In selecting the shortest and most direct route from St. Petersburg, which is the western terminal, to Vladivostock, the eastern terminal, it was necessary to build more than 30 miles of bridges; the longest of these is over the Yenisei River, and is 2,940 ft. long, with spans measuring 490 ft. In spite of the difficulty of building a permanent roadway in a country so intersected by rivers, the Siberian Railway is unequalled in rapidity of construction. Work on this great transcontinental railway, which was constructed by Russians and with Russian money, began May 19, 1891, and by 1900 there had been built 3,375 miles of line, making an average of 375 miles a year.

Direct steam communication with only small gaps is now possible between the railways of Europe and Vladivostock on the Pacific coast. At this terminal a commercial port has been built in order to regulate trade with the countries of China and Japan. There is also an important branch of this railway reaching to Port Arthur on the Yellow Sea, and connecting with a regular service of steamers along the Pacific coast and the Sungari River, which flows through the most thickly populated and industrial part of Manchuria.

The passenger equipment of the road is constructed on the side corridor plan, and on account of the wide gauge track, the cars are more commodious than those of the European narrow gauge roads. The "train de Lux," which leaves Moscow for Irkutsk twice a week, is said to compare favorably with the limited trains of this country in accommodations, but not in speed. It is lighted by electricity, with both stationary and portable lamps, and each apartment has its own arrangements for ventilating and heating. In the center of each coach is a space about the size of three staterooms, which is well equipped for a lounging room. Meals are served at all hours up to midnight in a well-appointed dining car. In one end of this car, and separated from the dining room by the kitchen, is a bath-room and small gymnasium.

The southern and central sections of this road were opened for business as soon as completed, and the immediate results of both passenger and goods traffic was far greater than had been anticipated. From September, 1895, to 1899, inclusive, these two sections carried 3,352,000 passengers, 2,041,000 tons of freight and 996,000 persons emigrated to Siberia, which makes an average of about 232,000 persons a year. This all-rail connection between the Atlantic and Pacific coasts now offers to Russia advantages, both commercial and strategic, which makes the great cost of the road seem insignificant in comparison.

Through the co-operation of the mechanical and the engineering departments of the New York Central & Hudson River Railroad, Purdue University has received an exhibit of primitive railway track. This track was exposed in the course of certain excavations which have recently been in progress on the line of the old Mohawk & Hudson Railroad. Notwithstanding the fact that it had been so long covered that everybody connected with the road appears to have entirely forgotten its existence, it was found to be in a fair state of preservation. The exhibit consists of stone sleepers, stringers and rails, and altogether weighs 2,700 lbs. This section of primitive track from the State of New York will supplement an exhibit of the so-called "bull-rail" track, representing a somewhat later date, taken from the Central Railway of Georgia, and deposited with Purdue University through the courtesy of Mr. Theo. D. Kline, General Superintendent of that road.

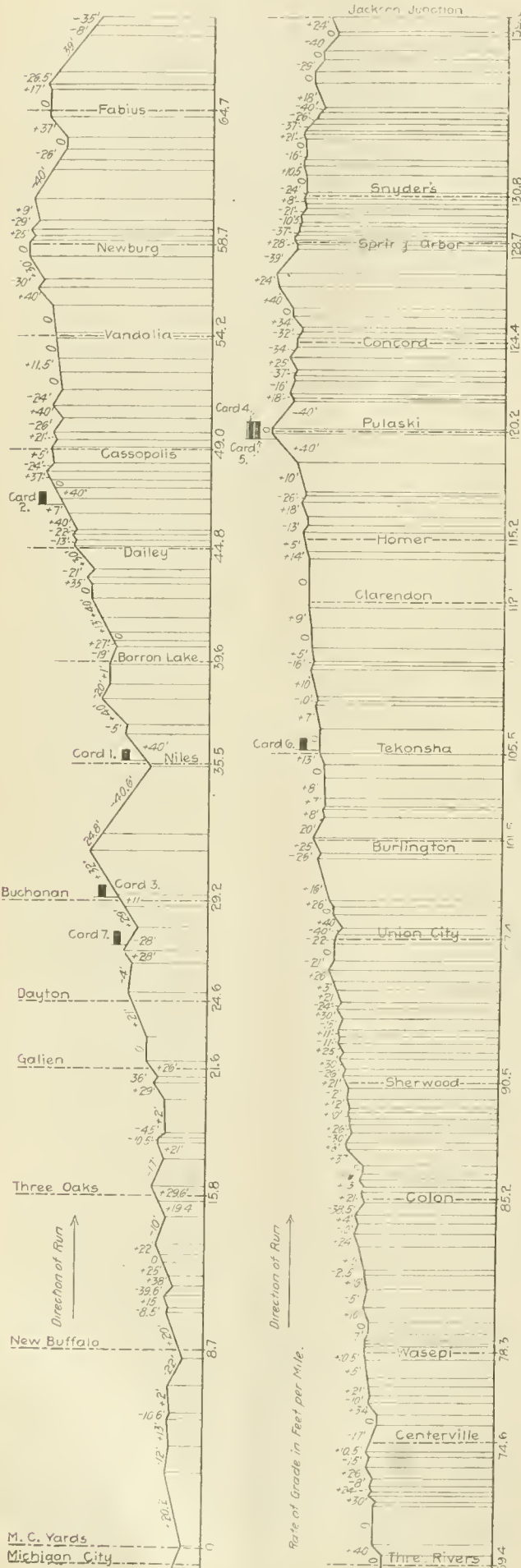

Profile of the Michigan Central—Michigan City to Jackson Junction.

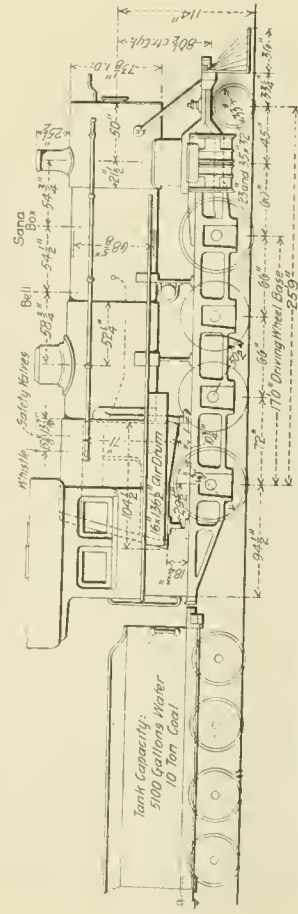

COMPOUND CONSOLIDATION LOCOMOTIVE, CLASS W.—MICHIGAN CENTRAL RAILROAD.

Cylinders..... 23 and 35 by 32 in. Boiler pressure..... 33 in. tender..... 210 lbs.
 Wheels: Driving diameter..... 63 in.; engine truck..... 33 in. tender..... 33 in.
 Weights: Total of engine..... 184,500 lbs.
 Grate area and tubes..... 964.3 sq. ft. on drivers..... 164,500 lbs.
 Firebox: Length..... 98 1/2 in.; width..... 36 1/2 in.; depth, front..... 16 ft. long.
 Boiler: type..... straight, wide firebox; Diameter..... 71 in.; back..... 61 in.
 Heating surface: Tubes..... 3,074.24 sq. ft.; water tubes..... 28.27 sq. ft.; firebox..... 148.05 sq. ft.; total..... 3,250.56 sq. ft.
 Wheel base: Driving..... 17 ft.; rigid, 17 ft. total of engine..... 25 ft. 4 in.;
 Tender..... Eight-wheel; total engine and tender..... 53 ft. 7 1/2 in.
 Tender..... water capacity..... 5,100 gals.; coal capacity..... 10 tons.

E. D. BRONNER, Superintendent Motive Power and Equipment.

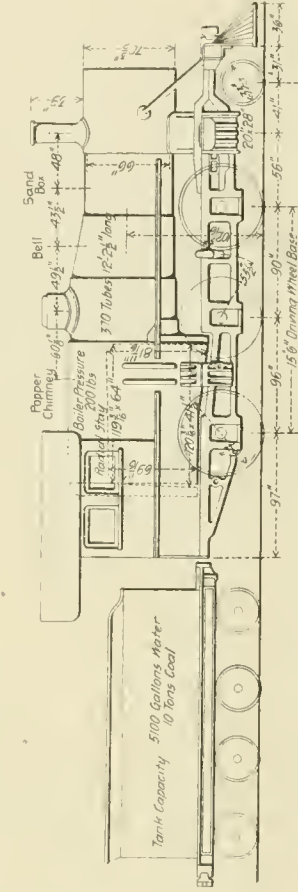

MOGUL LOCOMOTIVE, CLASS P.—MICHIGAN CENTRAL RAILROAD.

Cylinders..... 30 by 28 in. Boiler pressure..... 206 lbs.
 Wheels: Driving diameter..... 64 in.; truck wheels..... 33 in. tender wheels..... 33 in.
 Weights: Total of engine..... 162,500 lbs. on drivers..... 14,000 lbs.
 Grate area and tubes..... 934.6 sq. ft. Tubes..... 370-2 in.—12 ft. 2 1/2 in. long.
 Firebox: Length..... 120 in.; width..... 41 1/2 in.; depth, front..... 81 in.; back..... 69 in.
 Boiler: type..... radial stayed; firebox between wheels..... 34.2 sq. ft.; firebox..... 67 in.
 Heating surface: Tubes..... 2,348 sq. ft.; Arch tubes..... 2,583.8 sq. ft. total..... 5,000 sq. ft.
 Wheel base: Driving..... 15 ft. 6 in.; total wheel base..... 23 ft. 8 in.; Tender..... Eight-wheel.
 Tender..... water capacity..... 5,100 gals.; coal capacity..... 10 tons.

Comparative Locomotive Tests—Michigan Central.

G. F. PARKS, Mechanical Engineer.

COMPARATIVE LOCOMOTIVE TESTS.

Michigan Central Railroad.

Involving Compound Cylinders, Wide Firebox and a Heavy Engine.

Through the courtesy of Mr. E. D. Bronner a record of locomotive tests recently made on the Michigan Central Railroad has been received. The tests were undertaken to determine the policy of building heavier engines, and to ascertain the extent of their advantages, combined with wide fireboxes and compounding, and for short time tests are unusually interesting.

The comparison was made between a 20 by 28-in. simple mogul, weighing 162,500 lbs., and a 23 and 35 by 32-in. two-cylinder Schenectady compound consolidation, weighing 190,000 lbs., and it was so distinctly favorable to the compound as to lead to an order for 20 engines of that type, the trials having been conducted with a sample engine built for the purpose. The consolidation engine closely resembles the one by the Schenectady Locomotive Works for the New York Central, illustrated on page 83 of our March number of the current volume. The dimensions of the compound are given in the accompanying table, and the indicator cards on page 380.

In order to secure comparative information with reference to fast and slow freights the tests were made on both engines at speeds of 20 and 25 miles per hour. The record shows that these speeds were very closely followed in the eight test trains. Because of the completeness of the data the record sheet is reproduced in full. Some of the observations, such as the position of the throttle, the number of blasts of the whistle, the number of seconds of blowing off at the pops, the length of time the blower was used, and strokes of the air pump, give rather rough comparisons, but this data is valuable in comparing the conditions, and some of these figures tend to throw light on the operation of the engines and their steaming qualities. In this way a large amount of steam is accounted for in addition to that used in the cylinders. This corresponds to the large drain upon the boilers of a steam vessel for the auxiliaries. It is unusual to find so many of these figures taken in a locomotive test.

The tests were conducted by the motive power department on the West and Air Line divisions between Michigan City and Jackson Junction, a distance of 139 miles, and with east-bound trains because that was the direction of heavy freight movement. The test trains were given the right of way, and the same engineer and fireman handled both engines. With the slow trains the tonnage was made as large as possible and avoid stalling. For the mogul 1,700 tons were asked for and for the consolidation 2,000 tons for the slow trains, and because the trains were not weighed until the end of the run the mogul received less and the consolidation more than was asked for. The trains were weighed on track scales at Jackson Junction. The fast trains were of the same class of freight, but were lighter, in order to make the time. Platform scales were used for weighing the coal, and extra coal was carried in 150-lb. bags. For each run samples of the coal, which was all from the same mine, were taken and tested in a calorimeter in the laboratory of the University of Michigan at Ann Arbor. The observers were under the direction of Mr. George E. Parks, Mechanical Engineer of the road.

Comparing the speeds of the two engines it appears that with the slow trains the mogul averaged 1,646 tons, and made the run in 7 hours 16 minutes with 6½ stops. The consolidation averaged 2,075 tons and 7 hours 15 minutes with 7½ stops. The heavier engine hauled the increased tonnage and made one more stop in the same time. With the fast trains the mogul averaged 1,280 tons and made the run in 5 hours 21 minutes with 5 stops. The consolidation averaged 1,512 tons in 5 hours 35 minutes with the same number of stops. The consolidation hauled 213 more tons and required 14½ minutes

more than the mogul. The heavy engine made the schedule time on the Air Line division with 35 minutes to spare for emergencies, and is satisfactory in this respect. With the condition of these tests the following conclusions were drawn:

Conclusions.

Water Consumption.—A gain of 6.9 per cent. may be expected from the compound, as shown by the cylinders, based upon the steam consumption per indicated horse power per hour. This is smaller than would be expected, but it is apparent that the compound was overloaded.

Heat Units.—A gain of 17 per cent. is shown in favor of the compound in equivalent evaporation in terms of a given number of heat units.

Fuel Consumption.—The most important fact brought out by these tests is the gain by the compound of 22 per cent. in fuel consumption when compared on the basis of the number of heat units required to haul one ton of freight one mile.

These tests were made under specially well-selected conditions, and while they show the marked advantage of the compound it is impossible to separate this into the portions which are due to the larger boiler, larger grates and compound cylinders. It is to be regretted that the wages and items of cost could not be added to these engineering comparisons. These tests establish the compound as the better engine including all of these features, but it cannot be said that this is because of the compound feature alone. The data were taken in a thorough way, and with a fair comparison as to speeds. The cylinder and boiler performances are remarkably good, as indicated in lines 58, 62 and 64 of the table. Of course the cylinder performance affects the boiler, because good work in the cylinders causes a reduced drain upon the boiler. The wide firebox appears to good advantage in line 52, which is also due in part to the compounding. This is an important comparison, which probably has a great deal to do with the relative standing of the engines. In line 65 the water per I. H. P. per hour for the cylinders alone is remarkably low for the compound, averaging 22.56 lbs. Line 23 shows that the mogul did not steam as freely as the consolidation, and line 25 indicates that the consolidation steamed freely and that the fireman was, probably, not accustomed to the wide grate. The draft in the smokebox was less in the compound, as seen in line 38, and it was also much less in the ashpan of that engine. Line 46 shows that the consolidation was loaded much nearer to its limit than the lighter engine. Line 73 expresses the economy of the compound in terms of heat units, and this item alone might be made the subject of interesting studies in the selection of coal, as well as in locomotive design.

These tests are heartily commended, but it should be understood that these comparisons do not include the most important figures of all, the total cost in terms of a given tonnage hauled one mile. If these figures were included the true record of the heavier engine would stand out in a way which would appeal to the manager still more forcibly than the results which are given in mechanical engineering terms. The saving in train crew wages would unquestionably amount to more than that expressed in this admirable report.

COMPOUND CONSOLIDATION LOCOMOTIVE.

Michigan Central Railroad.

General Dimensions.

Gauge.....	4 ft. 8½ in.
Fuel.....	Bituminous coal
Weight in working order.....	189,000 lbs.
Weight on drivers.....	164,500 lbs.
Wheel base, driving.....	17 ft.
Wheel base, rigid.....	17 ft.
Wheel base, total.....	25 ft. 9 in.

Cylinders.

Diameter of cylinders.....	23 and 35 in.
Stroke of piston.....	32 in.
Horizontal thickness of piston.....	H.P., 4¼ in.; L.P., 4½ in.
Diameter of piston rod.....	4 in.
Kind of piston packing.....	Plain ring
Kind of rod packing.....	U. S.
Size of steam ports.....	L.P., 23 in. x 2¼ in.
Size of exhaust ports.....	L.P., 23 in. x 3 in.
Size of bridges.....	L.P., 1½ in.

Valves.	
Kind of slide valves.....	H.P., piston type; L.P., Allen-Richardson
Greatest travel of slide valves.....	6 in.
Outside lap of slide valves.....	H.P., 1 1/4 in.; L.P., 1 in.
Inside clearance of slide valves.....	H.P., 3/8 in.; L.P., 1/4 in.
Lead of valves in full gear.....	1/32 in. blind
Kind of valve stem packing.....	U. S.
Wheels, Etc.	
Diameter of driving wheels outside of tire.....	63 in.
Material of driving wheel centers.....	Cast steel
Driving box material.....	Cast steel
Diam. and length of main crank pin journals,	
Main, 9 1/2 in. x 12 in.; others, 9 in. in dia. x 12 in.	
Diam. and length of main crank pin journals,	
Main side, 7 1/2 in. x 5 1/4 in.; 6 in. dia. x 6 in.	
Diam. and length of side rod,	
Inter., 5 1/2 in. x 4 3/4 in.; F. & B., 5 in. dia. x 3 1/4 in.	
Engine truck journals.....	6 in. dia. x 12 in.
Diameter of engine truck wheels.....	33 in.
Boiler.	
Style.....	Straight, with wide firebox
Outside diameter of first ring.....	70 1/2 in.

Heating surface, water tubes.....	28 27 sq. ft.
Heating surface, firebox.....	148.05 sq. ft.
Heating surface, total.....	3,250.56 sq. ft.
Grate surface.....	50.31 sq. ft.
Grate, style.....	Rocking, in 4 sections
Ash pan.....	Hopper, with slides and lining M. C. standard
Exhaust pipes.....	Single
Exhaust nozzles.....	5 in., 5 1/4 in., 5 1/2 in. dia.
Smokestack, inside diameter.....	14 in.
Smokestack, top above rail.....	14 ft. 8 in.
Boiler supplied by.....	2 Hancock inspirators, Type A, No. 10, R. & L.
Tender.	
Weight, empty.....	44,700 lbs.
Wheels, number of.....	8
Wheels, diameter.....	33 in.
Journals, diameter and length.....	5 in. dia. x 9 in.
Wheel base.....	16 ft. 5 1/2 in.
Tender frame.....	10-in. steel channels
Tender trucks.....	Fox pressed steel
Water capacity.....	5,100 U. S. gallons
Coal.....	10 tons
Total wheel base of engine and tender.....	53 ft. 7 1/4 in.

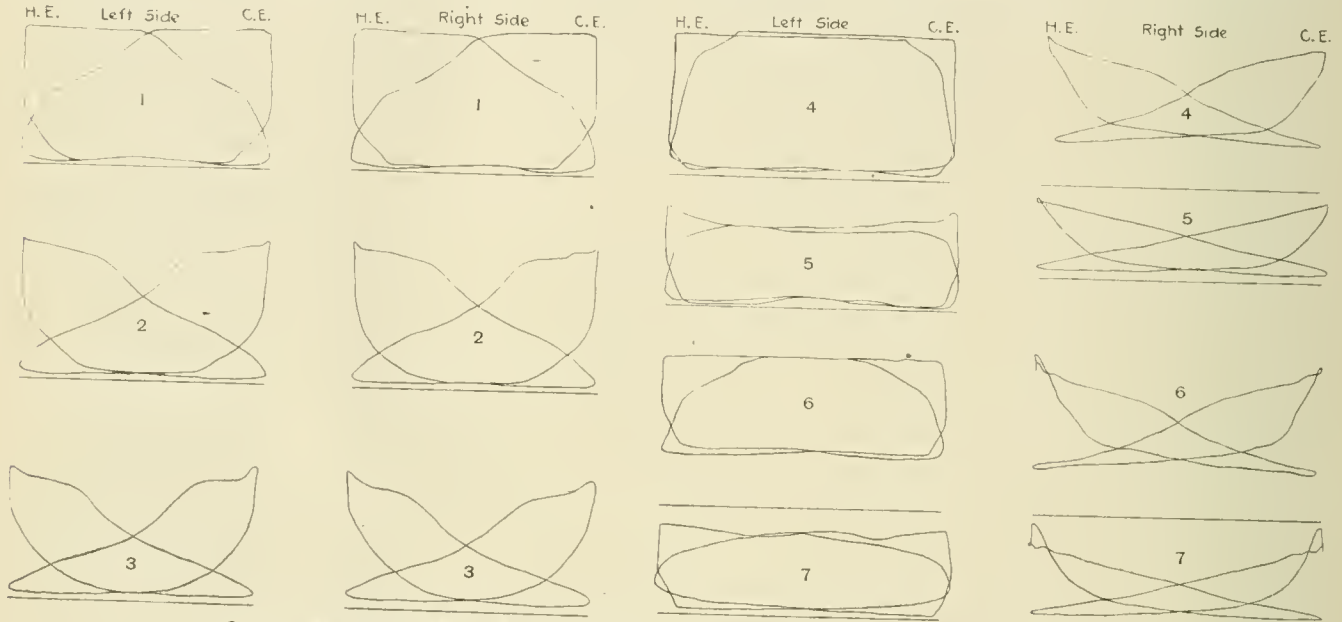

Cards Taken From Simple and Compound Locomotive—Michigan Central Railway.

Locomotive.	Number 288.			Number 590.			
	1*	2	3	Working simple.	Working compound.		
No. of card.....				4	5	6	7
Date.....	August 10, 1901.			Sept. 1, 1901.	Sept. 3, 1901.	Sept. 3, 1901.	Sept. 3, 1901.
Grade, feet per mile.....	32	7	11	40	40	0	28
Train load, tons.....	1276	1276	1276	2160	1992	1992	1992
Speed, miles per hour.....	11.5	21.5	28	4	13	27	33 1/2
Revolutions per minute.....	61	113	147	21.3	69	141	179
Steam pressure, lbs.....	200	200	190	205	210	205	210
Scale of spring, lbs per inch.....	120	120	120	120	120	120	120
Cylinder data—				{ H. P.			
Head end.....				{ L. P.			
Crank end.....	R. S. { M. E. P. 147.5	102 4	76.9	H. P. { M. E. P. 171.8	115.5	45.2	33.8
Both ends.....	I. H. P. 197.1	255.7	250	I. H. P. 121.3	265.2	213.7	211.7
Head end.....	R. S. { M. E. P. 145.4	100 6	78.1	H. P. { M. E. P. 172.2	115.1	49.3	40.2
Crank end.....	I. H. P. 191.9	248.4	251.2	I. H. P. 119.7	260.1	231.5	234.3
Both ends.....	R. S. { M. E. P. 389.0	504.1	501.2	H. P. { M. E. P. 241.0	525.3	147.2	416.0
Head end.....	L. S. { M. E. P. 145.0	99.5	74.5	L. P. { M. E. P. 64.6	60 4	23.6	17.1
Crank end.....	I. H. P. 192.6	246.9	240 7	I. H. P. 106 6	323.9	262.9	236.4
Both ends.....	L. S. { M. E. P. 146.3	100 4	74.9	L. P. { M. E. P. 66.1	61.1	24.1	17.6
Head end.....	I. H. P. 191.9	246.1	239.2	I. H. P. 104.2	325.4	266.4	241.3
Crank end.....	L. S. { M. E. P. 381.6	493.0	79.9	L. P. { I. H. P. 211.7	649.3	529.3	477.7
Total I. H. P.....				L. P. { I. H. P. 455.7	1174.6	976.5	923.7
Per cent. I. H. P. developed in L. P. cylinder.....	773.5	997.1	981.1		47.1	55.2	51.7

*Starting with helper.

Working pressure.....	210 lbs.
Thickness of plates in barrel and outside of firebox.....	3/4, 1/2, 13/16 in.
Firebox, length.....	96 1/2 in.
Firebox, width.....	75 1/2 in.
Firebox, depth.....	F, 71 in.; B, 61 in.
Firebox, material.....	Carbon steel
Firebox plates, thickness.....	
Sides, 5/16 in.; back, 3/8 in.; crown, 3/8 in.; tube sheet, 1/2 in.	
Firebox water space.....	
Front, 4 and 5 ins.; sides, 3 1/2 ins. and 5 1/2 ins.; back, 3 1/2 and 4 1/2 ins.	
Firebox crown staying.....	Radial, 1 1/4 in. diam.
Firebox staybolts.....	1 in. diam.
Tubes, material.....	Charcoal iron, No. 12
Tubes, number of.....	369
Tubes, diameter.....	2 in.
Tubes, length over tube sheets.....	16 ft.
Fire brick, supported on.....	Water tubes
Heating surface, tubes.....	3,074.24 sq. ft.

The effect upon the track of the present practice of using flanges on all of the driving wheels of locomotives was the subject of a paper by Mr. Hugh Wilson, of the "Burlington." read before the Rocky Mountain Railway Club recently. Mr. Wilson analyzed the relations between the flanges and the rails on various curves, and showed that there is in all usual cases sufficient play to relieve the rails from increased stresses. The track was really favored by the practice of abandoning blind tires. The only case in which danger occurred was when frogs were placed in the inside rail of a curve which is above about 9 degrees.

Comparative Locomotive Tests—Michigan Central Railroad.

SHOWING THE COMBINED ADVANTAGES OF COMPOUNDING, WIDE GRATES AND LARGE LOCOMOTIVES.

Type of engine	Mogul, simple				Consolidation, compound			
	20 by 28 Wagon top Narrow				23 and 35 by 32 Straight Wide			
Type of boiler	2,583.9				2,217.1			
Kind of firebox	34.6				60.2			
Area of heating surface	Single				Single			
Area of grate surface	6				6 1/4			
Kind of exhaust nozzle								
Diameter of exhaust nozzle, inches								
Average weight (tons) of engine and tender, including coal and water	126				140			
1. Date	Aug. 1	Aug. 3	Aug. 8	Aug. 10	Sept. 1	Sept. 3	Sept. 5	Sept. 7
2. Kind of coal used	Fairm't	Fairm't	Fairm't	Fairm't	Fairm't	Fairm't	Fairm't	Fairm't
3. Kind of train	Slow	Slow	Fast	Fast	Slow	Slow	Fast	Fast
4. Length of route in miles	149	149	149	149	149	149	149	149
5. Number of empty cars	6	8	7	6	10	4	2	6
6. Number of loaded cars	46	55	39	41	66	62	49	41
7. Total number of cars	52	63	46	47	66	56	51	47
8. Weight of cars in tons	1,654.45	1,638.97	1,286.01	1,275.85	2,159.62	1,991.68	1,528.68	1,495.80
9. Number of ton-miles of train load	231,623	229,455.8	180,041.4	178,619	302,347.5	278,821	214,016.2	209,425.3
10. Number of ton-miles of total load	249,263	247,095.8	197,681.4	196,259	321,947.5	298,421	233,616.2	229,025.3
11. Total number of stops made	4	9	7	3	7	8	5	6
12. Total time on the road with train, in hours and minutes	7 59 1/2	9 10	6 52 1/4	6 20 3/4	9 26 3/4	9 19 1/4	6 31 3/4	6 62
13. Total time actual running, in hours and minutes	7 02	7 30	5 18 1/2	5 23 3/4	7 39 3/4	6 51 3/4	6 42 1/2	6 28 3/4
14. Total time throttle was open, in hours and minutes	6 35 1/2	6 39 3/4	4 43	4 50 1/4	6 53 1/4	6 03	5 02	4 47
15. Total weight of coal consumed, pounds	17,398	18,979	14,759	15,848	20,192	17,191	15,095	14,622
16. Per cent. of ash as found by calorimeter test	6.37	7.24	5.98	7.26	10.20	6.44	7.91	8.57
17. Total heat of combustion as found by calorimeter test	14,756	13,934	14,354	13,283	13,157	13,880	13,202	13,419
18. Total weight of water evaporated, corrected for moisture of steam and loss at injector	131,097	141,915	112,874	113,114	160,262	145,625	126,133	121,664
19. Total weight of steam used by engine cylinders, corrected for moisture, losses at calorimeter air pump, whistle, etc.	122,166	130,239	105,317	103,604	148,765	133,069	116,561	110,694
20. Total number of strokes of the air pump	19,736	28,987	17,035	23,980	20,265	28,920	22,650	24,750
21. Total number of long whistle blasts	290	284	278	276	231	241	262	263
22. Total number of short whistle blasts	472	262	248	263	214	246	259	258
23. Total number of minutes blower was in operation	32	44	30	25	24	4	6	10
24. Total number of times the injector was started	27	31	20	15	21	17	14	17
25. Total number of seconds pops were blowing	420	228	264	138	67	664	374	626
26. Total equivalent weight of water evaporated from and at 212 degs. F., corrected for moisture in steam, etc.	156,831	170,028	135,325	135,827	193,012	175,125	161,839	146,632
27. Mean effective pressure, right side or L. P. cylinder, head end	88.24	94.25	75.75	73.83	37.99	35.31	27.16	26.39
28. Mean effective pressure, right side or L. P. cylinder, crank end	87.26	93.48	76.57	75.51	27.81	35.52	27.55	27.09
29. Mean effective pressure, left side or H. P. cylinder, head end	89.90	92.53	73.88	72.91	73.55	68.70	65.04	52.23
30. Mean effective pressure, left side or H. P. cylinder, crank end	90.28	93.43	75.82	74.67	73.25	68.59	56.72	64.57
31. Average number of revolutions per minute	115.23	108.03	148.59	143.48	101.33	113.98	137.53	145.30
32. Indicated H.-P., right side or L. P. cylinder, head end	202.25	201.29	231.70	216.27	254.39	275.93	265.50	263.63
33. Indicated H.-P., right side or L. P. cylinder, crank end	198.28	197.15	230.59	219.86	250.86	277.78	269.15	269.06
34. Indicated H.-P., left side or H. P. cylinder, head end	206.33	195.01	223.71	212.26	219.41	235.27	235.16	231.49
35. Indicated H.-P., left side or H. P. cylinder, crank end	203.86	195.18	227.43	215.95	215.70	233.00	240.80	247.47
36. Indicated horse-power whole engine	809.70	788.63	813.43	864.34	940.26	1,021.98	1,010.61	1,011.65
37. Average boiler pressure	193.1	191.1	196.7	196.1	202	209.5	203.8	208.2
38. Average draft of smokebox, in inches	5.6	6.4	5.4	4.5	4.4	4.2	4.1	4.5
39. Average draft in ash-pan, in inches	1.1	1.3	1.4	1.4	.68	.63	.47	.60
40. Average temperature of feed water, in degs.	76	74	74	72	70	71	70	70
41. Average per cent. of moisture in steam in per cent.	2.92	3.3	2.26	2.08	1.81	1.99	1.95	2.04
42. Average position of throttle (1 = wide open)	.74	.80	.81	.76	.93	.85	.89	.95
43. Average position of reverse lever in inches	9.79	10.63	8.83	8.38	18.14	17.53	16.63	14.36
44. Average speed in miles per hour	19.90	18.66	25.37	25.93	18.38	20.38	24.53	25.59
45. Maximum speed in miles per hour	38	38	42	42	35	37	37	40
46. Minimum speed at top of Buchanan Hill	8	10	17	15	2 1/2	8	15	16
47. Maximum speed at foot of Buchanan Hill	29	32	39	37	31	33	35	37
48. Minimum speed at top of Grub Hill	7	3	16	3	10	10	12	16
49. Maximum speed at foot of Grub Hill	34	26	35	33	24	30	31	32
50. Average number of strokes of air pump per minute	41.1	52.7	41.2	62.9	53.4	61.7	57.4	60
51. Pounds of coal burned per hour	2,639.6	2,863	3,129.5	3,276.4	2,931.6	2,814.4	2,999	3,056.8
52. Pounds of coal burned per square foot of grate per hour	76.28	82.74	90.44	94.7	53.3	56.5	57.6	60.7
53. Pounds of coal burned per sq. ft. of heating surf. per hr.	1.021	1.108	1.211	1.268	.911	.883	.932	.95
54. Pounds of water evaporated per hour	19,590	21,408	23,934	23,385	23,283	24,053	25,059	25,435
55. Lbs. of water evaporated per sq. ft. of heat'g surf. per hr.	7.69	8.23	9.26	9.05	7.23	7.47	7.78	7.90
56. Equivalent weight of water evaporated per hour from and at 212 degs. F.	23,784	25,649	28,694	28,080	28,023	28,946	30,166	30,634
57. Equivalent weight of water evaporated per hour from and at 212 degs. F. per sq. ft. of heating surface	9.20	9.92	11.10	10.86	8.71	8.99	9.37	9.62
58. Pounds of coal consumed per I. H. P. per hour	3.260	3.633	3.426	3.790	3.117	2.780	2.967	3.021
59. Pounds of coal consumed per ton-mile of train load	.0751	.0827	.0819	.0887	.0657	.0616	.0705	.0698
60. Pounds of coal consumed per ton-mile of total load	.0692	.0768	.0747	.0807	.0627	.0576	.0646	.0638
61. Water evaporated per pound of coal	7.53	7.47	7.64	7.13	7.94	8.46	8.35	8.32
62. Equivalent evaporation per pound of coal from and at 212 degs. F.	9.01	8.95	9.17	8.57	9.55	10.13	10.06	10.02
63. Heat imparted to each pound of steam used from average temperature of feed at average steam pressure, in British thermal units	1,155.27	1,156.97	1,157.73	1,159.65	1,162.36	1,162.11	1,162.54	1,163.03
64. Total water consumed per indicated horse-power per hour, corrected from moisture in steam	24.56	27.14	26.22	27.05	24.76	23.53	24.79	25.14
65. Water consumed per I. H. P. per hour by cylinders alone	22.89	24.91	24.44	24.78	22.94	21.52	22.91	22.87
66. Weather and condition of rail	Good	Good	Good	Good	Good	Good	Good	Good
67. Average number of heat units per pound of coal used	14,082				13,415			
68. Average equivalent number of pounds of water evaporated from and at 212 degs. F. for each 1,000 heat units in the coal	.6337				.7418			
69. Average number of pounds of steam used per horse-power per hour, cylinders only	24.255				22.565			
70. Average number of heat units used to haul one ton of freight one mile	1,156.13				900.82			
71. Per cent. gain of compound over the simple as shown in the boiler, based upon equivalent evaporation per 1,000 heat units				17.0			
72. Per cent. gain of compound over the simple as shown in the cylinders, based upon steam consumption per horse-power per hour				6.9			
73. Per cent. of gain of compound over the simple as shown in heat units required to haul one ton of freight one mile				22.0			

36-FOOT, 40-TON BOX CARS WITH END PLATFORMS.

Chesapeake & Ohio Railway.

Through the kindness of Mr. W. S. Morris, Superintendent of Motive Power, drawings for 40-ton box cars having end platforms, built for the Chesapeake & Ohio Railway, have been received. These cars are built to the originally recommended standard dimensions of the American Railway Association, viz.:

Length	36 ft. 0 in.
Width	8 ft. 6 in.
Height	7 ft. 6 in.

A car 36 ft. long, 8 ft. 6 ins. wide, and 8 ft. high (all inside

Height from rail to top brake shaft.....	13 ft. 10 1/4 in.
Height from rail to eaves.....	12 ft. 0 in.
Height from rail to center of coupler.....	2 ft. 10 1/2 in.
Center to center of trucks.....	26 ft. 1 3/4 in.
Center to center of tie timbers.....	6 ft. 6 in.

At the ends of the cars 8 by 11-in. oak end sills are placed outside of the car, and the truss rods, of which there are six, pass through them. These timbers are supplied with end-sill cover boards and form a narrow platform at each end of the car. The cars have metal bolsters and Chicago grain doors. The draft timbers are secured to the under faces of the center sills and are continuous. The draft gear is the Miner tandem arrangement with malleable draft arms. In general, the cars follow the customary prac-

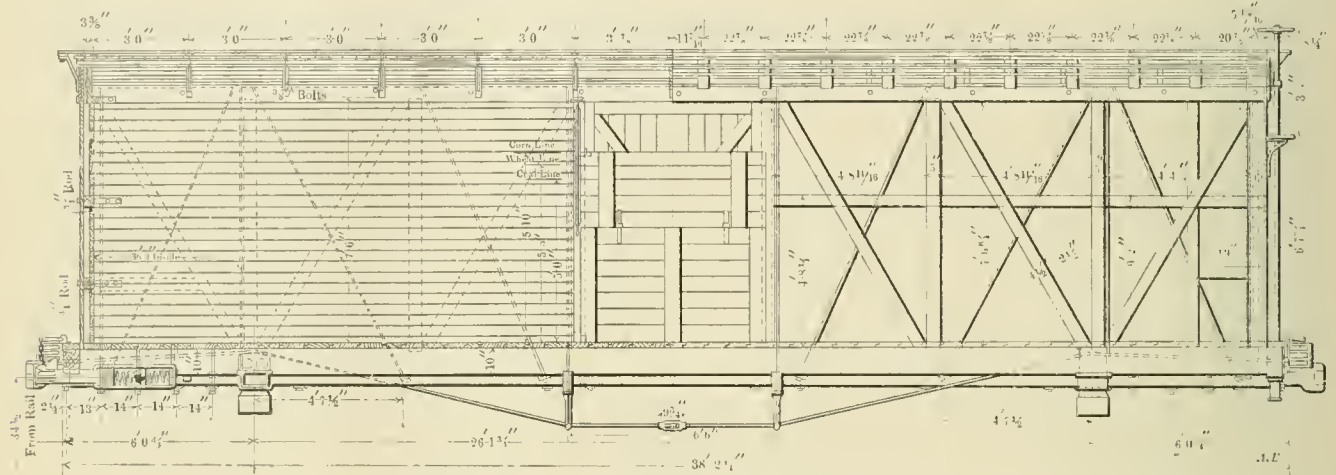

36-Foot, 40-Ton Box Car—Chesapeake & Ohio Railway.

W. S. Morris, Superintendent Motive Power.

dimensions), was originally favored by the association, but because it was subsequently stated that cars 8 ft. high (inside) could not be transported over certain lines, the height was recommended to be 7 ft. 6 ins. On April 24, 1901, the association found that the objection to the higher car had been removed, and at the St. Louis meeting, in October, as recorded elsewhere in this issue, the height of 8 ft. was adopted. These

dimensions, was originally favored by the association, but because it was subsequently stated that cars 8 ft. high (inside) could not be transported over certain lines, the height was recommended to be 7 ft. 6 ins. On April 24, 1901, the association found that the objection to the higher car had been removed, and at the St. Louis meeting, in October, as recorded elsewhere in this issue, the height of 8 ft. was adopted. These

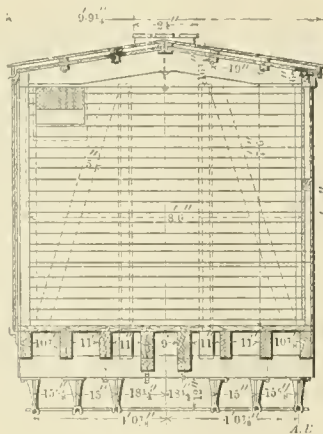

Transverse Section.

cars, therefore, do not conform to the adopted standard. The general dimensions of the cars are given in the following table:

General Dimensions.

Length of framing over end sills.....	38 ft. 3/4 in.
Length over siding.....	36 ft. 10 1/4 in.
Length inside	36 ft. 0 in.
Length over running boards.....	38 ft. 2 3/4 in.
Width over side sills.....	9 ft. 3/4 in.
Width over siding.....	9 ft. 2 1/2 in.
Width inside	8 ft. 6 in.
Width of door opening.....	5 ft. 6 in.
Height between sill and plate.....	7 ft. 6 3/4 in.
Height from floor to under side of carlines.....	7 ft. 6 in.
Height from rail to top running board.....	12 ft. 11 1/4 in.

A CROOKED RAILROAD.

The Baltimore & Ohio Railroad Company is building four miles of line in Pennsylvania, which is believed to be the crookedest railroad in the United States. This little road will extend from Boswell, Pa., to Friedens on the Somerset & Cambria branch of the Baltimore & Ohio. The air-line distance is about five miles, but the peculiar conformation of the country makes it necessary to loop a number of hills in order to get an easy grade. The new road doubles on itself four times, and at one point, after making a loop of about five miles, the road comes back to within 300 ft. of itself on a grade 50 ft. lower.

A very good run was made November 9 by the Philadelphia & Reading from Camden to Atlantic City. This special train left Camden about 1:30 P. M. with a party composed of Mr. Theodore Voorhees, First Vice-President of the road; Mr. Gibb, General Manager; Mr. Harrison, Chief Engineer; Mr. Burt, General Traffic Manager, and Mr. Newell, Docks Engineer, all of the North Eastern Railway (England). Other officials of the Reading and their friends were aboard the train. The train was made up of five cars, which weighed 235 tons behind the tender, and was hauled by the Vanclain compound Atlantic type engine No. 326. The engine has 84-in. drivers and 2,550 sq. ft. of heating surface. The run of 55 1/2 miles was made from start to stop in 46 1/2 minutes, or at the rate of 71.6 miles an hour. There were no stops, but speed was checked three times. During the run 35 miles was covered at 81 1/2 miles an hour, and the fastest single mile was made at 85.7 miles an hour. The last two miles were run to an absolute stand in 120 1/2 seconds.

POWER STATION OF THE NEW YORK RAPID TRANSIT RAILWAY.

The power to be used in operating the lines of the Rapid Transit Subway in New York City is electricity, which will be transmitted by means of the third rail system. The equipment for the power house, according to present specifications, will consist of eight entirely independent units, of which the engines and boilers have been contracted for. Each of the eight engines, to be built by the Allis-Chalmers Company, of Chicago, will have direct pipe connections to six Babcock & Wilcox boilers, provided with wrought-steel headers. These engines are of the same general type as used in the power house of the Manhattan Railway Company of New York, and described in our issue of May, 1901, page 140. They will be run at 75 revolutions per minute, and at their best efficiency will develop 75,000 h.p. The cylinders are 42 and 86 ins. in diameter, with a stroke of 60 ins., and are jacketed by steam, which passes direct from the throttle to the jackets before entering the admission valves. A pair of cylinders arranged on the compound principle are attached to each end of the main shaft by a crank, the high pressure cylinders being located in a horizontal position, while the low-pressure cylinders are vertical. In order to use superheated steam at a temperature of 500 to 550 degs. Fahr., the high-pressure cylinders are provided with poppet valves. The steam pressure to be used is from 175 to 200 lbs. The boilers are rated at 600 horse-power, and each has a heating surface of 6,200 sq. ft. They will be located on one floor of the power house, with four chimneys built upon steel structures, so as to give access to the full floor space. The boilers will be equipped with mechanical stokers, and the plant supplied with efficient coal and ash-handling machinery.

A NEW SERPOLLET BOILER.

A company is being formed for the manufacture and introduction of a new steam generator, which was described in a recent consular report.

This powerful generator, constructed by M. Serpollet, is made of cast steel, fused at 1,800 degrees C. Within it is an arrangement of non-capillary tubes, and it is in these that the instantaneous vaporization is effected without danger of escape, up to a pressure of 80 kilograms (176 lbs.). The apparatus placed in the firebox constitutes a sort of blower, allowing great facility to the fire draft. On account of its heavy construction it offers ample resistance to the pressure. It is claimed that it is not affected by immediate contact with the fire, and that capillary action is completely suppressed. By this apparatus an absolutely new departure is brought about in the generating of steam, and it is contended that its application will be of incalculable value either as a motor agent or in the employment of steam dried at hitherto unknown temperatures. Either coal, coke or petroleum may be used for fuel.

INTERNATIONAL RAILWAY CONGRESS

Meets in the United States in 1905.

Last month it was announced that at the invitation of the American Railway Association the International Railway Congress would hold its next convention in the United States. May, 1905, has been fixed as the time, and probably Washington, D. C., will be the place.

To provide an organization to manage the preparations, the American Railway Association will appoint 25 members of an "American Section," of which the executive board of the association will form the nucleus. This body will have complete charge of the convention.

This meeting will be an important one because of the opportunity it will offer foreigners to study American railroad practice, and because it will bring to this country the leading operating, engineering and motive-power men of Europe.

COMPRESSED AIR AS A SAFE POWER

Considerable attention has been called recently to compressed air explosions, so much in fact, that an impression might be given that compressed air is an unsafe power. On the contrary, it is the safest power or means of transmitting power that is in use at the present time. When we consider the great number and variety of uses to which compressed air has been applied in its comparatively short period of development, it is to be expected that some failures would occur, but it is only through ignorance of the cause of these explosions and carelessness on the part of engineers that these troubles do exist.

Compressed air installations are used with pressures up to 3,000 lbs. to the square inch, not only in every mine of any magnitude, in all tunnel work, quarries, ship-building, submarine work and for refrigerating purposes, but it has a very wide range of usefulness in all railroad and manufacturing lines. Nearly every railroad, machine, erecting, boiler shop and foundry of any size has its own compressor plant, and from all of these varied sources comparatively few accidents have been reported. As a means of safety many of the powder magazines throughout the country are using compressed air as a motive power, to the exclusion of steam and electricity. Railroad trains, both freight and passenger, are equipped with air compressors and storage tanks, and on the latter the power is used for as many as eight different purposes, such as the braking of trains, ringing bells, opening fire doors, shaking grates, sanding the rails, lifting tender water scoops, raising water in passenger coaches and operating fans for ventilation.

The reason why compressed air is a safe power is the fact that it has no reserve force, as in the case of steam boiler explosions, where the destructive effect is caused chiefly from this force, that is, the sudden conversion of large volumes of superheated water into steam, by the reduction of pressure above the water space in the boiler. In the case of air, when a vent occurs, it serves to reduce the strains. This is due not only to the expansion of the air from a smaller space into a larger one, but a rapid reduction in volume, due to the fall of temperature in expanding. The failures that have occurred in the use of compressed air can, in nearly every instance, be traced back to the ignition of oil or some inflammable substance which is used with the air. Low-test lubricating oil, for example, fed to the air cylinders, may meet with a temperature greater than that of its flashing point. In putting oil into the cylinders, any surplus that may reach the cylinders is forced out through the delivery valves into the air pipes and receivers. The products of decomposition of a large quantity of oil in the receiver would, with the air, form an explosive mixture.

Air in itself is a perfectly safe fluid, and only requires a vessel strong enough to hold it. In this respect the problem is not a serious one, as the factor of safety in the case of air may be less than for steam, water or gas, as it does not corrode the vessel, its temperature is not changed, and it causes no internal destruction.

It will thus be seen that air is the cleanest, healthiest and, except through the course of compression, is as nearly absolutely safe as any power of this kind can be.

Wireless telegraphy is likely to have a rapid development under a contract just closed by Lloyd's Agency to use the Marconi system exclusively for fourteen years for reports between vessels and their signal stations on the coasts of Great Britain and the United States.

Acetylene gas is being used to some extent on the Santa Fe System and the Chicago, Burlington & Quincy Railroad for lighting cars, and in a number of instances for locomotive headlights. Each car has its own generating plant, placed in a small cabinet 30 by 18 ins. in size. In starting, a maximum pressure of 1½ lbs. is attained, and the operating pressure is ¼ of a pound.

(Established 1832.)

AMERICAN ENGINEER AND RAILROAD JOURNAL.

PUBLISHED MONTHLY

BY

R. M. VAN ARSDALE,

J. S. BONSALL, Business Manager.

MORSE BUILDING, NEW YORK

G. M. BASFORD, Editor.

E. E. SILK, Associate Editor.

DECEMBER, 1901.

Subscription.—\$2.00 a year for the United States and Canada, \$2.50 a year in Foreign Countries embraced in the Universal Postal Union.

Remit by Express Money Order, Draft or Post Office Order.

Subscriptions for this paper will be received and copies kept for sale by the

Post Office News Co., 217 Dearborn St., Chicago, Ill.

Danvers & Upham, 283 Washington St., Boston, Mass.

Philip Roeder, 507 North Fourth St., St. Louis, Mo.

R. S. Davis & Co., 346 Fifth Ave., Pittsburg, Pa.

Century News Co., 6 Third St. S., Minneapolis, Minn.

Sampson Low, Marston & Co., Limited, St. Dunstons House, Fetter Lane,

E. C., London, England.

EDITORIAL ANNOUNCEMENTS.

Advertisements.—Nothing will be inserted in this journal for pay, EXCEPT IN THE ADVERTISING PAGES. The reading pages will contain only such matter as we consider of interest to our readers.

Contributions.—Articles relating to railway rolling stock construction and management and kindred topics, by those who are practically acquainted with these subjects, are specially desired. Also early notices of official changes, and additions of new equipment for the road or the shop, by purchase or construction.

To Subscribers.—The AMERICAN ENGINEER AND RAILROAD JOURNAL is mailed regularly to every subscriber each month. Any subscriber who fails to receive his paper ought at once to notify the postmaster at the office of delivery, and in case the paper is not then obtained this office should be notified, so that the missing paper may be supplied. When a subscriber changes his address he ought to notify this office at once, so that the paper may be sent to the proper destination.

AMERICAN ENGINEER TESTS.

Locomotive Draft Appliances.

Progress of the Work.

In order to conduct this investigation along practical lines a large amount of special apparatus is required. The first to be used is a number of draft gauges and measuring tubes for an examination and measurement of the smokebox with reference to vacuum. When this investigation is completed that of the stacks and nozzles will begin. Under the direction of Professor Goss, Professor William Forsyth has designed a series of special exhaust nozzles, seven in number, and these have been made in the shops of one of the trunk line railroads. At another railroad shop the experimental stacks are being made. Of these there will be four heights, four diameters and two shapes, straight and taper. The stacks and nozzles are designed with a view of making rapid changes in running the tests. This becomes important, considering the fact that with three rates of power the number of different conditions to be studied will be 672.

It would be impossible to conduct these tests with coal as a fuel, and of necessity oil must be used. A standard locomotive fuel-oil burner has been donated by the Atchison, Topeka & Santa Fe Railway, a steam pump to be used in connection with the burner has been furnished by the Snow Steam Pump Works,

and the Standard Oil Company has supplied fuel oil sufficient for the entire series. Preparations for receiving and storing the oil at the laboratory are nearing completion. These donations, and the assistance given by the railroads in making the stacks and nozzles, indicate the quality of the appreciation and endorsement the tests receive from the railroads and others. We wish to express our thanks for this substantial interest.

The attention of those for whom these tests are undertaken is directed to the fact that of the large number of extra copies printed less than 400 copies of the October and November issues of this journal remain. These contain the first two installments of the record of the investigation. A surprising amount of interest has been shown in this work. It has led to a large correspondence from authorities on the subject, including Herr Von Borries, of Hannover, Germany, who was intimately associated with the "Hannover Tests." Undoubtedly the demand for the present record will be as great as that of the German tests, \$12 having been offered for the 1896 volume of the American Engineer containing the translated report of the work of Von Borries and Troske. The 400 copies of the present record will be supplied to those who order them first. This is fair warning to those who demand back numbers when it is too late to furnish them.

The Master Car Builders' Association will soon prepare to attack the largest and most far-reaching problem it has ever attempted—the design of the standard box car. It is not now a question of possibility or desirability, but one of necessity, for the American Railway Association has opened the way and has given the equivalent of a positive order that the constructive features of the standard car shall be decided by the M. C. B. Association. With its own reputation at stake, the result will unquestionably be worthy of the standing and traditions of the association. Those who are best able to judge believe that "per diem" charges for car service are coming soon, and after the standard car the pooling of freight equipment is not an unreasonable hope.

While the first reason for the action of the American Railway Association was the abolition of the large car, the development of standard construction as well as standard size was a prominent object. With standard interior and exterior dimensions it follows logically that all parts which may properly be standardized should be decided upon, so that the expensive delays which present conditions involve in repairs may be avoided. There is no reason why all the timbers of wooden cars should not in future be made alike, and also the castings; in fact, all parts except those in which the element of progress must be provided for. Roofs, door attachments, trucks, draft gear, air brakes and brake beams may be left for individual selection, and even these may profitably be treated in a new way. The association may perhaps approve of certain construction of parts not standardized, and these may be used to facilitate the movement of cars and the settlement be arranged upon a definite plan. It seems to be assured that the prompt movement of cars will be the most important factor of future developments of car interchange rules.

Whatever the ultimate development of the standard car is to be, this appears to be a movement of transcendent importance. It offers an occasion to which the Master Car Builders' Association will surely rise, and one in which relatively small differences of opinion will give way for the common good.

New locomotives which are now going into service are sure to have a useful life of at least twenty or twenty-five years. Never in the history of the locomotive has any time equaled

the present with regard to rapid and radical advancements in transportation methods. With these facts in mind each new design merits the greatest study and the best possible provision for the future. A few years hence the locomotives of to-day are to be regarded as monuments of efficient engineering or the reverse. Those who appreciate this will soon stand out prominently as men who understand these problems.

On page 297 of this issue is printed a diagram with blank spaces for dimensions of the draft appliances of locomotives. We ask our readers to fill in these blanks in accordance with their practice in locomotives, for both freight and passenger service, having boilers of 64 ins. in diameter and upward. This information is sought in order to ascertain whether the experimental stacks and nozzles designed for the tests by Professors Goss and Forsyth meet all of the conditions of present practice. No apology is made for this request, because the result of the information will be most valuable to the railroads.

The present car famine is unquestionably the most serious which American railroads have ever experienced, and in spite of the fact that phenomenally large orders have been placed for new cars and the railroads are doing all they can to meet the situation, it appears to be growing worse. Not only is it impossible to supply cars, but in important centers there is difficulty in securing means to remove freight from the premises of the railroads. The car side of the question points to the imperative need of radical improvements in car service methods and this constitutes a strong argument of the "per diem" principle, which would undoubtedly serve to greatly increase the available number of cars. This alone would not meet the present need, but it would be more permanently effective than the emergency methods which are adopted after the pressure for equipment has risen. Thoughtful consideration of the situation shows the necessity for revision of the fundamentals in the factors concerned, with a view of the permanent effects of the remedies applied. Perhaps the next crisis of this kind will find the standard car, the "per diem" plan and the pooling of car equipment in use.

In this issue is printed an illustrated description of the most remarkable passenger locomotives which have yet appeared. They are of the prairie type, with large drivers, long tubes, wide fireboxes and compound cylinders, constituting a combination which will unquestionably secure large power and the ability to sustain it continuously. In weight, size and ultimate capacity these engines surpass everything which has appeared up to date, and yet there is nothing among the essentials of the design which can now be considered doubtful or questionable. A six-coupled engine, with 135,000 lbs. on driving wheels, which may be increased to 160,000 lbs. by the use of the traction increaser, and with cylinder capacity to correspond, is certainly a remarkable achievement. The theory of the traction increaser is well received, and its use on such a bold scale as this is worthy of general attention. The devices work out in a very simple and satisfactory way on an Atlantic type engine, but they must be much more complicated for the prairie type. There seems to be no reason to fear improper use of the device by the enginemen, for the experience which is now being had tends to indicate a dislike on the part of the enginemen to use it. Its application to such large locomotives for mountain service seems to be an ideal one, which is very likely to settle the status of this principle in a short time. No better illustration of the tendency toward the building of larger locomotives can be offered than this, and the influence of this design, which so closely follows the first large prairie type engine on the Lake Shore, seems likely to be strong and far-reaching. Having ordered 45 of these engines it may be said that the builders and the "Santa Fe" officers have confidence in their success.

CORRESPONDENCE.

SUGGESTED INCREASE OF DUES IN THE AMERICAN SOCIETY OF MECHANICAL ENGINEERS.

To the Editor:

The recent circular sent out by the secretary of the American Society of Mechanical Engineers calls attention to the proposal to increase the dues of regular members from \$15 to \$25 per year, and the dues of juniors from \$10 to \$15. As a member of the society, I wish to protest against this increase in dues for the full members. There is probably a large percentage of the membership that are also members of various special engineers' clubs and societies, with varying dues to pay in each. For instance, a member who is engaged in railway work will have (according to the proposed scheme) \$25 for the A. S. M. E.; \$5 for the Master Mechanics' Association; \$4 for the Master Car Builders' Association, and \$4 for Railway Clubs, with a probability of other dues, such as the Franklin Institute, International Society on Testing Materials, etc. The sum total of this, it seems to me, runs up rather large, especially for the younger members, whose position and salary are limited.

On the other hand, it would seem to me proper for both the juniors and associate members to pay the same as the regular members—\$15 per year. I think this is fully justified by the fact that the junior members receive all the advantages of the association, in the way of publications, etc., that the full members receive; and, moreover, to my personal knowledge, there are a large number of junior members who are eligible for associate or full membership, who stay in the junior grade simply on account of the difference in dues. This does not seem to me to be just or fair to the full members, and if more money is needed by the society for actual expenses, it would seem to me proper to obtain it by increasing the dues of the junior members.

If money is required for building purposes, as it undoubtedly is, it should be raised in some other manner than from the actual dues, as the building itself is of interest largely to local membership only, while members residing at a distance receive little or no benefit from it. It would also seem that those most benefited by a new building should stand the greater burden of expense. There are also, doubtless, members of the society whose financial conditions are such that a donation from them would not be felt appreciably.

I sincerely trust that, before this proposition is voted upon, the members of the society will give it due consideration and look at it from all standpoints, as I do not believe that the proposed increase is wise, as the present dues are already heavy enough. Moreover, when compared with the dues of the railway clubs and the master mechanics' and master car builders' associations, the dues are out of all proportion at present to the amount of literature received, as compared with these other organizations.

F. F. GAINES,

Member A. S. M. E.

UPPER ADMISSION THROTTLE VALVES AND DRY STEAM.

To the Editor:

The importance of taking steam from the cylinders from the highest possible point in a locomotive boiler, is clearly shown by Mr. Howard Stillman, Engineer of Tests of the Southern Pacific Company, in his excellent paper entitled "Some Phases of the Water-Treating Problem," published in the September issue of the American Engineer, page 281.

In the course of his article, Mr. Stillman says: "We find in our most modern locomotive that the lower steam throttle opening is but 26 ins. above the water level when the gauge glass is half full and the engine on level track. The diameter of the boiler shell is 75 ins., and ample steam room is apparently provided, but the tendency to carry water over into the steam cylinders when the throttle opening is so close to the water line is most apparent. . . . I have seen instances in a boiler carrying bad alkali water when the water would leave the gauge glass entirely on opening the throttle to pull out with a heavy train. Evidently the boiling mass tended to follow the direction of a drain on its evaporative capacity, the steam dome in such

case having been placed well ahead on the boiler. . . . The use of some form of steam separator would be suggested were it possible to apply it to the locomotive. Some modification of throttle whereby the openings are raised to the highest possible position above the water line seems the more feasible."

Drawings of two excellent throttle valves fulfilling this condition have appeared in the American Engineer during the past fifteen months, and the object of this communication is to again direct attention to them, in the hope of leading to their more general adoption. One of these throttles, designed by Mr. A. S. Vogt, Mechanical Engineer of the Pennsylvania Railroad, was illustrated on page 170 of the American Engineer for June, 1900; and its application to the "Northwestern" type express locomotives of the Chicago & Northwestern Railway was shown on page 302 of the October number of the same year. Steam is taken from the top of the dome only, which is accomplished by making the throttle hollow, and closing the usual opening in the lower part of the bonnet. The valve being hollow, there is no sacrifice of area, and its height is but $5\frac{1}{4}$ ins., or about half the usual amount. All who have seen this throttle speak in high praise of it.

The other throttle referred to was patented by Mr. K. Rush-ton, of the Baldwin Locomotive Works, and is illustrated on page 96 of the American Engineer for March of the current year. The opening in the throttle pipe below the valve is closed by a close-fitting circular plate, and the valve is hollow; steam can therefore enter the pipe under both flanges of the valve, but it is all initially supplied from the space in the dome above the valve, or from a point about 10 ins. higher than the lower steam opening of the ordinary type of throttle valve. It is probable that this increase in height of 10 ins. from the water level to the point of steam intake will appreciably augment the dryness fraction of the steam delivered to the cylinders.

The Hungarian State Railway compound "Atlantic" type express locomotive, exhibited last year at the St. Maurice-Vincennes Annexe of the Paris Exhibition, is provided with double baffle-plates placed horizontally in the steam dome below the regulator, and in view of the simplicity and ease of application of this device, and its apparent success in Continental practice, it seems well worthy of a trial in this country.

In the admirable paper entitled "Tests of the Boiler of the Purdue Locomotive," read by Prof. W. F. M. Goss at the last annual meeting of the American Society of Mechanical Engineers, the author says: "The steam delivered by the boiler, tested under constant conditions of running, as shown by calorimeter attached to dome, is at all times nearly dry, the entrained moisture rarely equaling 1.5 per cent., and being generally much less than this." These results are both valuable and somewhat surprising, but it should be remarked that constant running conditions are favorable to a high dryness fraction of the steam; the water level was probably also such as to give the best results, and the quality of the water used is not stated.

Calorimeter tests of a locomotive in heavy road service, subject to the variable demands upon the evaporative power of the boiler which such work necessarily entails, would, in all probability, show a much higher average percentage of moisture in the steam than is indicated by the above experiments, and especially so if alkali or other readily foaming water was used.

The thermodynamic losses resulting from water in the cylinders, and the danger to the cylinder covers, particularly with piston valves, are too well known to require explanation, and when it is considered that an average of five evaporation tests, taken at random by Mr. Stillman, show "that the locomotive boilers in road service were at times forced in the rate of evaporation 126 per cent. above what we would consider their normal 'static' rating," the advisability of using throttle valves of the upper admission type, and the experimental addition of steam baffle-plates, will be readily appreciated.

EDWARD L. COSTER,
A. M. Am. Soc. M. E.

25 Broad St., New York, September 4, 1901.

Very fast time was made November 16 with automobiles over the straightaway course at Ocean Parkway, Brooklyn, N. Y. H. Fournier made a mile in 51 $\frac{4}{5}$ seconds with a 40-h.p. gasoline machine, the best mile record previous to this being that of Mr. A. Winton on the Grosse Point track at Detroit last October, which was in 1.06 $\frac{2}{5}$ minute.

OIL FUEL FOR LOCOMOTIVES.

Practice on the Pacific Coast.

By H. B. Gregg, Engineer of Tests, Santa Fe Pacific Railway,
San Bernardino, Cal.

The essential equipment for the successful burning of crude oil in locomotives consists of:

A tank fitted with necessary valves and piping for storing, regulating and conducting the oil; a burner that will properly atomize it; a jet of steam or air for the atomizer; a firebox containing the proper brick work, and having an ash-pan with suitable openings to admit air for combustion.

To convert an engine from a coal to an oil burner, remove the grates and grate frames and apply an ash-pan with suitable plates or castings that will form support for brick-work, and having properly arranged air openings, with dampers to regulate the supply of air.

The Brick Work.—This usually consists of a lining of brick on the bottom of the box, a wall at the front of the box built against the flue sheet, but occasionally from six to twenty inches back, thereby forming a combustion chamber in front of the arch; and an arch, shown in Fig. 1, supported on the side walls. These walls extend around the box and form protection for the mud-ring rivets. In some engines, however, the arch brick is supported on studs, in which case the side walls extend up only to a sufficient height to protect the mud-ring rivets, the front wall in both instances being carried up to the arch. The brick arch should be built as low as possible, in order to protect the crown sheet, crown bolts and rivets from overheating.

In the arrangement shown, special attention is called to the comparatively low arch; to the fact that the bottom of the arch slopes away from the burner, so that broken pieces of brick falling down will not lodge in front of the burner and divert the flame; and to the location of the air openings, these being so arranged that the air for combustion is admitted into the lower pan through dampers, passes up through air inlets and into the fire-box directly underneath the arch, thus being heated before coming into contact with the fire-box sheets and flues.

The Burner.—The burner is bolted or clamped to the mud-ring or bottom plate in the center of the box, and set at an angle so that the oil spray will be directed under the arch. Burners in general may be classified as inside and outside atomizers. In the first class the oil and steam are mixed inside the burner, while in the second the oil and the steam do not mix until after leaving the burner. With some burners it is necessary to have a heater box, while others are made with heater and burner combined. In this system a separate heater box is fastened to the frame with the necessary piping. In this arrangement the piping and valves are so connected that live steam can be used to blow out the oil pipes, either through the burner or back through the oil tank.

It has been found by experience that a rigid pipe connection between the heater box and the burner causes the burner to get out of adjustment, due to the expansion and vibration of the pipe. To overcome this difficulty a piece of hose is inserted in the oil pipe line near the burner as shown. The steam for the atomizer and also for the heater is taken from a tee connection in the blower pipe. This pipe branches, one line going directly to the burner for the atomizer and the other through the heater box to the heater coil in the oil tank on the tender. The valves for the atomizer and heater, also the handle for the oil regulating valve, are located on the left side of the engine, convenient for the fireman.

The fire door is fitted with a clamp to hold it tightly closed. It has a hole in the center with an escutcheon plate and wing nut. This aperture is for sanding the flues, which is done occasionally on hard pulls, should the engine show a tendency to lag for steam. This method is very effective in cleaning

the gum off the flues, and is only used three or four times going over a division. The sand is applied through an elbow-shaped funnel made for the purpose. When sand is being applied by the fireman the dampers are closed and the engineer

leading to the aperture in the fire-door, the sand being blown into the fire-box by means of an air jet.

An important change in the usual front end arrangement of a coal burner when the engine is equipped for oil is the

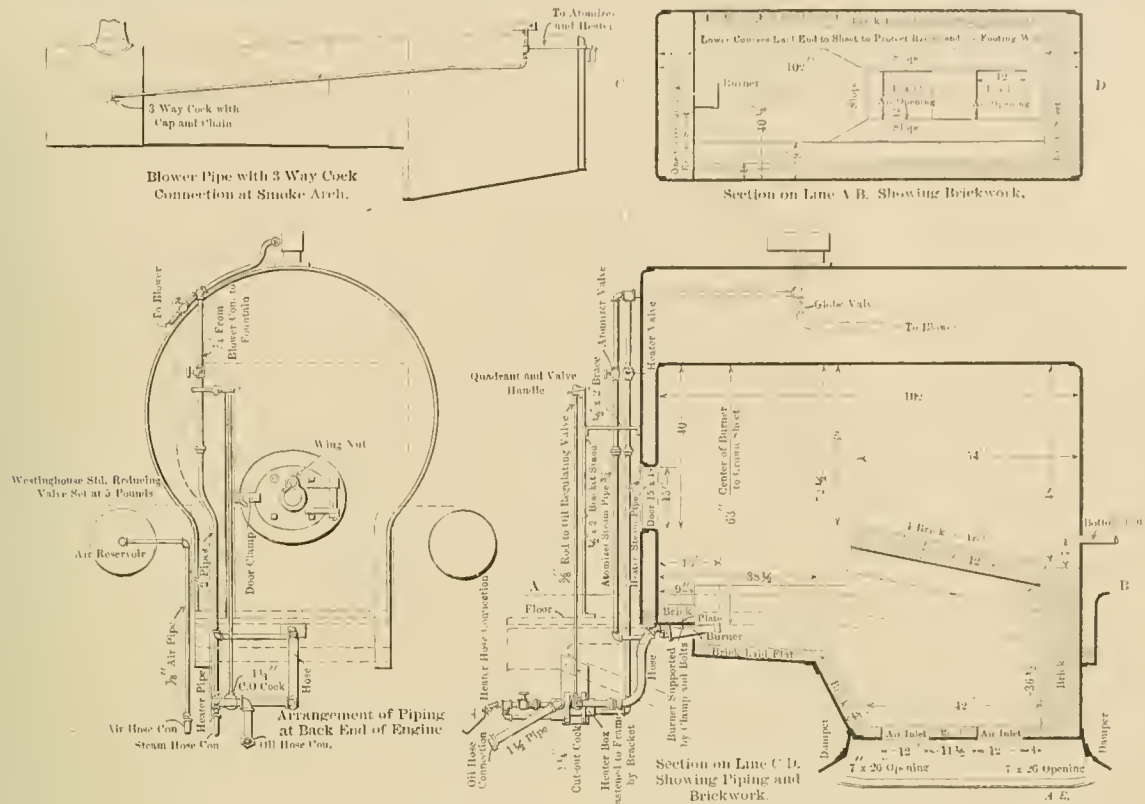

Fig. 1.—Firebox, Brick Work and Piping.

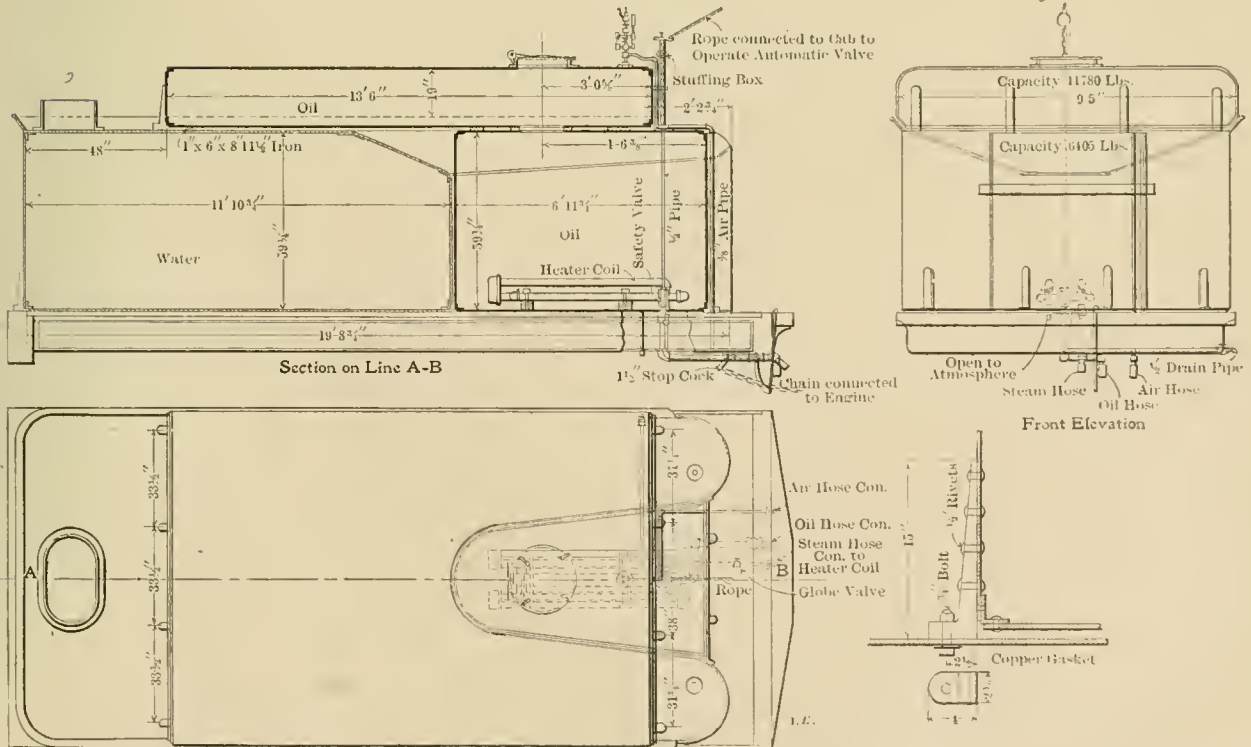

Fig. 2.—Tender, Oil Tank and Piping.
Oil Burning Locomotive—Santa Fe Pacific Railroad.

drops the reverse lever down a few notches, in order to make the sand more effective. The sand supply is carried in a box located on the tender. Another method for sanding flues is to locate the box up in the cab or on the boiler with a pipe

removal of all netting and plates. The danger from sparks with oil fuel being practically eliminated, the front end arrangement consists of only the exhaust nozzle, petticoat pipe and straight or choke stack. A special three-way cock, form-

Each fuel station is provided with a copy of the schedule of capacity of each individual tank, from which reports of oil issued to engines are made.

Cost of Oil Equipment. Following is a detailed statement of cost of labor and material in changing a 20x26 ten-wheel engine from a coal to an oil burner:

Oil reservoir, drilling, tapping, putting in place and securing	\$21.60
Automatic valve	3.90
Heater in oil tank	5.20
Heater pipes	1.20
Reducing valve	4.54
Air pipes	6.30
Burner	3.10
Heater box	3.00
Heater hose	1.40
Oil hose	2.15
Stop cocks	1.53
Regulators	2.16
Atomizers and pipes	.95
Brick walls and brick arch	42.25
Oil pipes	.55
Erecting—blacksmith, machinist and laborer	32.50
Removing coal-burning device	3.09
Building and placing ash pan, and material	14.75
Sand box and funnel	2.50
Pop and air gauge	5.05
One set of oil tanks, consisting of two tanks	174.83
	\$332.46

In general the comparative cost of handling oil fuel is estimated at 75 per cent less than coal. It is free from starting fires along the right-of-way or setting fire to equipment, and because of its freedom from cinders and black smoke is preferable for passenger service. The additional cost of repairs to brick work, flues and fireboxes, and consequently their shorter lives, is estimated at 25 per cent more in oil-burning engines than the cost of repairs to flues, fireboxes, grates, stacks and front ends in engines burning coal.

The next article on this subject will present the results of tests comparing oil with coal as fuel.

(To be Continued.)

THE STANDARD M. C. B. BOX CAR.

It Has Become a Possibility.

Time seems to cause the greatest difficulties to fade. The desirability of the adoption of a standard box car has long been appreciated, but it has appeared hopeless, because the strong influence necessary to its accomplishment has been lacking. By employing some of the energy and persistence which has resulted in the present admirable system of car interchange, the standard car may now be had in a short time, because the only serious obstacle has been removed by the adoption, last month, by the American Railway Association of the standard inside dimensions of box cars. These are a length of 36 ft., a width of 8 ft. 6 ins., a height of 8 ft., a cross sectional area of 68 sq. ft., and a cubical capacity of 2,448 cu. ft. These dimensions were adopted by the association, with but one dissenting vote, and the following resolution was unanimously adopted: Resolved, That the Master Car Builders' Association be requested to consider and adopt the required external dimensions of the Standard Box Car, based upon the interior dimensions as prescribed by the American Railway Association.

A standard size of 6 ft. as the width of the door openings has an important bearing upon the shipper's side of the question, for it appears that many of them find that this is a necessity. This dimension was settled upon to meet this need. With a large door they are prepared to get along with cars of the standard size.

There have been two obstacles to the standard car. First, the desire of the freight departments to build larger cars than their competitors own, as an inducement for the patronage of shippers; second, the opinion of many officials that their own practice in car design is superior to that of their neighbors. The first of these is removed by the decision of the operating and traffic officials to consider the 36-ft. car the unit for the establishment of minimum carload weights, and the second will be brought before the M. C. B. Association at its next convention. Furthermore, the American Railway Association has determined to continue its efforts and aid in the practical

adoption of the standard "to the end that both the best physical and the best commercial results may be accomplished."

Heretofore the shippers have found it advantageous to use the largest cars obtainable, but now the minimum weights become a penalty for the use of cars larger than the standard, and on the other hand, the use of cars smaller than the standard, until they are worn out, is provided for, as will be seen by the text of the new rules, which will be found in another column of this issue. With this preparation the M. C. B. Association will find its problem comparatively simple, and it will probably be taken up in the manner characteristic of that body in dealing with questions of such importance.

In 1896 the late D. L. Barnes said that "no M. C. B. standard of details of the woodwork of cars will ever be agreed upon." This seemed impossible then, but it is possible now. A standard for sections of siding and flooring has already been adopted, and in settling upon the necessary exterior dimensions it will be comparatively easy to extend the standards to sills, posts, braces and other timbers. While there is now a great variety in the distribution of the material, the differences in amounts for cars of the same capacity are not great. It will be necessary to determine a standard sill spacing and construction as to trussing. Fifteen years ago the Chicago, Burlington & Quincy adopted the practice of making the truss rods large enough to carry the whole live load. It should be a simple matter to determine the proper sizes and disposition of sills and truss rods to carry a given load, and practice in this respect would easily become uniform. In this connection the capacities of the standard car become important. It should be decided whether the standard car should be of 40 or 50 tons capacity, and probably both capacities will be provided for. In short, an opportunity is at hand for investigating the entire question of box cars, with a view of providing M. C. B. construction for all the steps from wooden to all-steel underframing.

A careful examination of the dimensions of a number of cars now used successfully in general interchange, leads to the opinion that the standard inside dimensions may be provided for within the limitations of present clearances. There will be no difficulty in keeping within the limits of a width of 9 ft. 10 ins. at the eaves, and a height of 12 ft. 6 ins. from the rail to the eaves. These dimensions have already been used for years for 30-ton cars. When the side bearing vs. center plate method of support is decided, it may be possible to obtain the 8-ft. inside height, with a lower roof than is now used. It may also be possible to save several inches in height by introducing pressed steel carlines.

As the standard car question now stands it is necessary for the car builders to act, because one of the primary objects of the American Railway Association was to pave the way for car construction which shall enable the railroads to obtain the benefits from the better market conditions with regard to standard timbers and the reduction of the delays in repairs now caused by the absence of such standard sizes. Careful estimates place the effect of this as amounting to a virtual increase of 5 per cent. in the amount of car equipment available for use. If lumbermen are called upon to furnish only standard timber and other lumber, they will be able to cut it specially for car work, and this must affect both the time of deliveries and the price. The difference in the items of siding and flooring has been placed at \$1 per thousand. It may be even greater when all the wooden members are standardized.

If the standard car should tend to check development or progress in new ideas it would not be an unmixed blessing, but sufficient scope for development seems to remain in such items as the trucks, bolsters, draft gear, brake beams and roof coverings. In larger matters the association will be able to keep the standard abreast of all improvements. This will be a comparatively simple matter with the sizes once established, and the problem is one of construction only, whether the material is wood or steel, or both. Other types of cars may be given the same treatment in their turn. In this work, beginning with the box car, the Master Car Builders' Association will find a field worthy of its skill and traditions. This movement accomplished, the introduction of per diem charges for the use of cars may be undertaken.

THE NEW SESSIONS-STANDARD FRICTION DRAFT GEAR.

The Standard Coupler Company.

This new draft gear is the result of a series of improvements upon the original design of friction draft gear by this company, which was illustrated on page 122 of our April number. It employs the friction principle of increasing the effectiveness of the springs, but instead of increasing the recoil, as would result from increased spring capacity alone, the recoil is actually reduced. This improvement employs standard springs and the usual arrangement of parts, it does not require special sill construction, and it effects the friction principle with the addition of but four parts to the number required by an ordinary spring gear. In the engravings are shown sectional views of the gear itself, the method of attach-

the left-hand follower bears on the barrel, and the other one, being against the wedges, presses the wedges into the bell mouth of the barrel and compresses the springs within the barrel. The parts are so made that the springs cannot be closed solid, because the cylinder is of such a length as to take the load of the followers in direct compression of itself when the wedges have moved almost to the point where the springs would close. The springs, therefore, ought to last indefinitely if made of proper material and of correct size. Angles have been chosen for the wedges which will prevent sticking. The outer wedges are in the form of equilateral triangles and may be put in without regard to the wearing surfaces. All three wedges are of cast iron with chilled faces. They are cheap and should wear well. Cast steel wearing plates are riveted to the mouth of the barrel to take the wear from the wedges, thus placing all of the wear upon easily re-

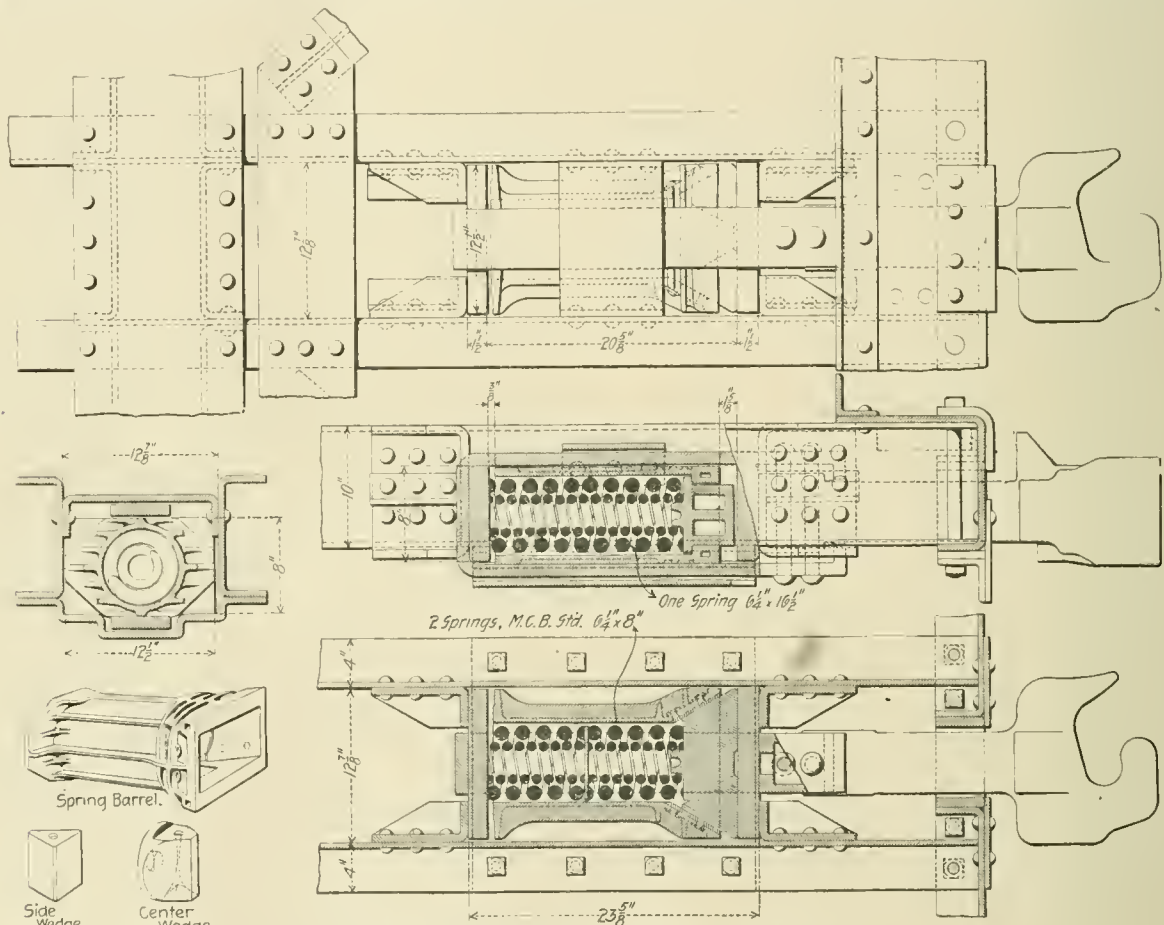

The New Sessions-Standard Friction Draft Gear.

ment to steel and wooden underframes, and details of the cheek plates and stop castings used with wooden cars.

The complete gear is shown as attached to draft construction which has been used extensively in steel cars. Either two standard M. C. B. draft springs or a single long spring of the same diameter as the standard may be used. Both arrangements are shown in the drawing. The springs are placed in a substantially ribbed malleable iron barrel through which the end of one of them projects $\frac{3}{8}$ in. toward the left-hand follower. The other end of the other spring bears against a central wedge, and between the bearing faces of this central wedge and bearing surfaces at the bell end of the barrel, two triangular wedges bear. Against the outer faces of these latter wedges the forward follower rests. In placing the parts together, the springs are given a slight initial load.

In service the followers tend to approach each other in both pulling and buffing. The first movement of $\frac{3}{8}$ in. acts upon the springs alone, because of the clearance space left at the end of the barrel. As soon as this motion is taken up

newed parts. With 2-in. motion of the followers the total spring motion, including the preliminary motion and the $\frac{1}{4}$ -in. initial compression, is $3\frac{5}{8}$ ins. On the wedges the multiplication of the motion is 2 to 1. The wedges have a free movement of $1\frac{5}{8}$ ins.

This gear may be placed between sills which are $12\frac{7}{8}$ ins. apart, and in the wooden sill attachments two methods are shown, one having cheek plates and the other with stop castings. The large area of the shoulders of these should be noted. They amount to nearly the total sectional area of the draft timbers. In the attachments the method of support is simple.

As stated, a single long spring may be used if desired. This permits of increasing the spring capacity by substituting 15/16 and $\frac{3}{4}$ -in. rods for the standard sizes. This alternative saves two pieces—the second spring and the separating plate. There may be an advantage in the cost in favor of the single spring.

Remarkable tests have been made upon this gear by a well-known railroad official, in whose judgment and impartiality

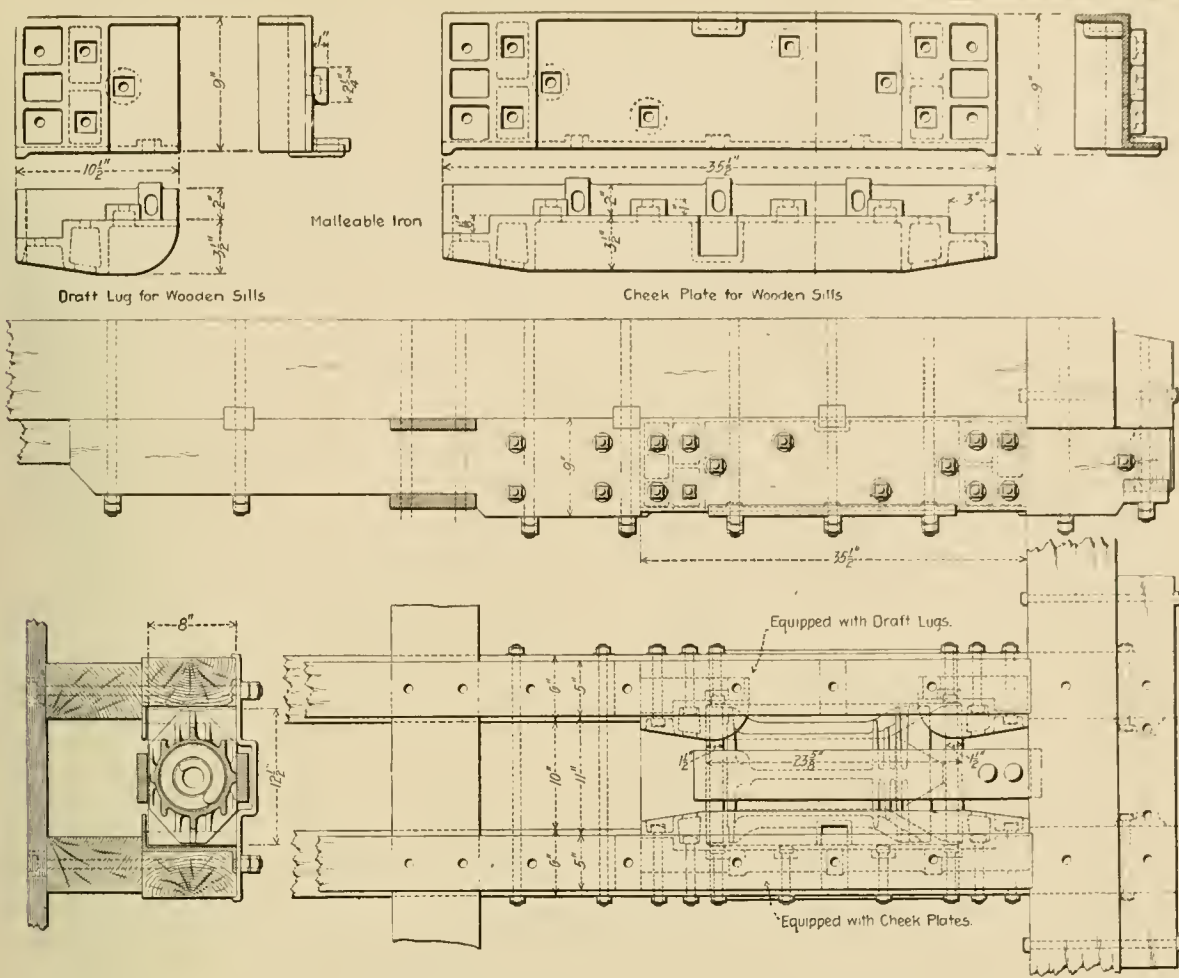

Showing Attachments for Wooden Cars.

we have every confidence. This gear and a twin spring gear of the usual type were mounted in draft attachments intended to represent the strongest construction in use under steel cars. The gears were mounted centrally with the draft sills, and in order to prevent deflection of the webs of these sills, bracing was applied. Otherwise the attachments were as shown in the complete draft gear in the large engraving. These gears were then tested under a 1,640-lb. drop, with the results indicated in the accompanying record.

In the friction gear test the first two blows were not counted; they were given to bring the parts up to a bearing; but after the blows at 2 ft. the tests were the same for both up to the

It is apparent that the effect of the wedges (the springs were alike in both tests) was to change the point of solidity of

No. of blow.	Height drop.	Sessions—Standard Friction Draft Gear.	Remarks.	
1	5 ft.	Movement of followers. 19/16 ins.	Preliminary to loosen parts to working condition.	
2	5 ft.	19/16 ins.		
3	1 ft.	5/8 in.	Slight backing of web at draft lug, visible on one side.	
4	2 ft.	1 in.		
5	3 ft.	1 1/16 ins.		
6	4 ft.	1 3/8 ins.		
7	5 ft.	1 9/16 ins.		
8	5 ft.	1 9/16 ins.		
9	6 ft.	1 3/4 ins.		
10	6 ft.	1 3/4 ins.		
11	7 ft.	1 7/8 ins.		
12	7 ft.	1 7/8 ins.		
13	8 ft.	2 ins.; Gear closed.		No change apparent.
14	9 ft.	"		Both sides showed slight buckling of channel web.
15	10 ft.	"	No change apparent.	
16	11 ft.	"	Web buckled 3/8 in.; flanges contracted 1/2 in.	
17	12 ft. 3 ins.	"	Webs buckled 7/16 in.; flanges contracted 9/16 in.	
18	12 ft. 3 ins.	"	Webs buckled 9/16 in.; flanges contracted 9/16 in. and buckled vertically.	
19	12 ft. 3 ins.	"	Sills badly distorted, equivalent to a bad wreck.	

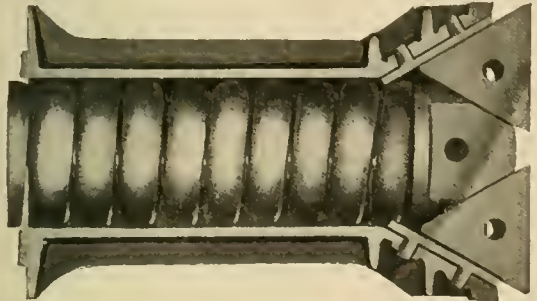

Sectional View, Showing Spring Barrel, and Wedges.

tenth and twelfth blows. It is noteworthy that the twin spring gear was closed solid and the destruction of the steel sills was begun by blows which only brought the other gear to a bearing. At the end of both tests the channels were badly crippled, notwithstanding the lateral bracing. Clamps were located 11 1/2 ins. below the face of each draft lug to prevent spreading, and 4 ins. above each of these another was applied to prevent buckling. The ends of the sills were badly crushed where they rested upon the anvil. Notwithstanding that these tests were sufficient to wreck a steel car, the friction gear, when removed, was in perfect condition.

In the tests of the friction gear the maximum recoil of the weight was but 8 ins., and usually there was but one recoil.

No. of blow.	Height drop.	Twin Spring Gear.	Remarks.
1	2 ft.	Springs closed solid.	Damage continued as above. Condition of channels about the same as when removed at end of test with Sessions Gear.
2	3 ft.		
3	4 ft.		
4	5 ft.		
5	5 ft.		
6	6 ft.		
7	6 ft.		
8	7 ft.		
9	7 ft.		
10	8 ft.		

the gear from a drop of 2 ft. to one of 8 ft. This means that the wedges act to increase the height of the drop to exhaust the Sessions gear to four times that of the ordinary gear before closing it. One of the most important facts shown by the friction gear is that the draft attachments began to fail before the gear was closed. The most remarkable feature of these tests is the fact that this high capacity is obtained with such simple construction.

Records of another test by Robert W. Hunt & Co., made on a Riehle 150-ton machine, show that when equipped with two 6¼ by 8-in. M. C. B. springs the elastic limit of the gear was not quite reached at a load of 125,200 lbs. This was the average of four tests, and at this load the springs were not closed. After taking 300,000 lbs., the limit of capacity of the machine, the gear was in perfect condition, with no deformation of the spring barrel.

EXPERIMENTS WITH TRACK TANK SCOOPS.

New York Central & Hudson River Railroad.

It is apparent that the track tank is becoming more and more necessary for both freight and passenger equipment on roads having congested traffic. Improvement of practice in this regard has been recorded in these pages, and we are now permitted to present the results of some experiments made last year on the New York Central & Hudson River Railroad, which led up to the design of water scoop which was illustrated on page 143 of our May issue of this year.

These experiments were undertaken in a study of the different forms of water scoops which were then in common use, and included the practice of four different roads. They were

indicating that the amount of water taken did not increase uniformly, and that less water was sometimes taken at the higher speeds than at lower speeds. This is probably due to the splashing of the water, which was very great in these three cases. Diagram No. 1 was taken with the line at the inside lower edge of the scoop, 2½ ins. below the top of the rail, diagram No. 2 was with a different scoop, having this distance 2¾ ins., and diagram No. 3 with a distance of 3½ ins., all of these three tenders being loaded.

At speeds of about 25 miles an hour it is safe to count upon getting about 2,000 gals. in a trough 1,400 ft. long, of which only about 1,200 ft. can be used safely. This quantity increases with the speed until the capacity of the pipe is reached, and at from 40 to 50 miles an hour about 3,500 gals. may be

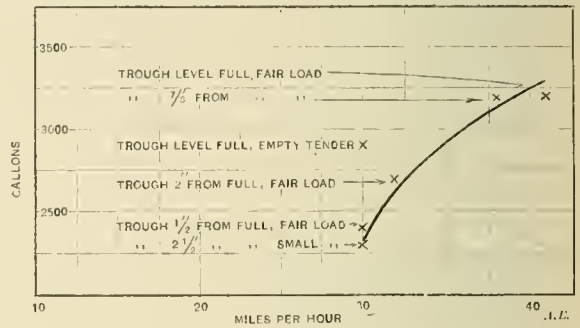

No. 5.

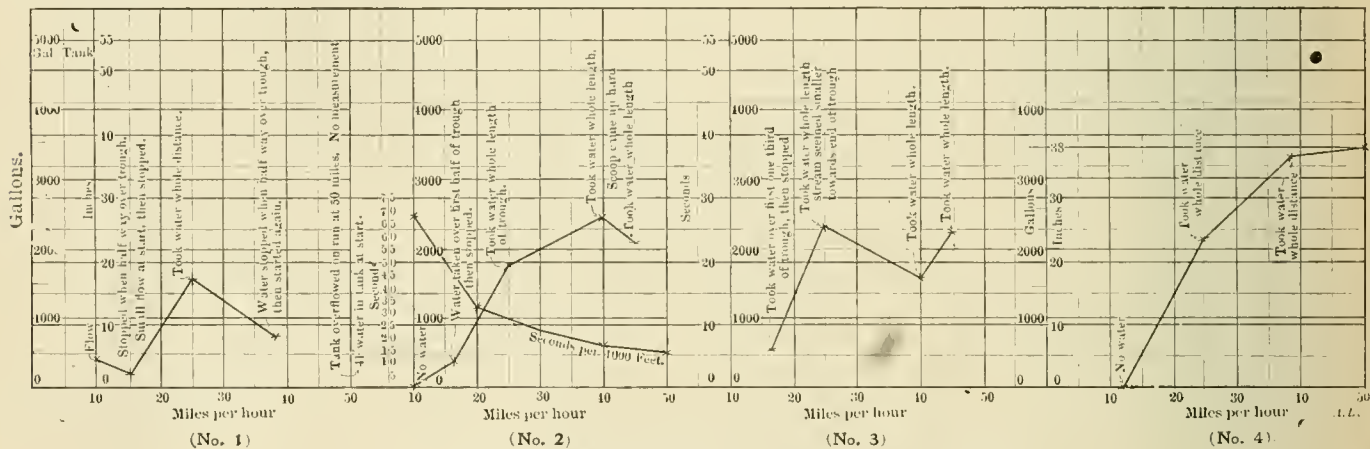

New York Central Experiments With Track Tank Water Scoops.

carried out on west-bound track No. 2, at Schenectady. The trough used is 1,400 ft. long and 7 ins. deep, its top being at about the height of the top of the rail. The different scoops were fitted to tenders, which were drawn over the trough at various speeds, and the amount of water taken at each speed was measured in the tender tank. The measurement of speed and of water taken was not done with the idea of being scientifically accurate. In a length of 1,400 ft. there was a difference of elevation of 3 ins. in the level of the trough. In this case this was due to the fact that the trough was new and the ballasting was not completed. This, however, represents the condition of troughs which may be seen in actual use. This difference of level explains the notations on the first three diagrams, showing that at the slow speeds water was taken over the first third or half of the trough, and that the flow stopped when the water became shallow.

Diagram No. 4 was taken from a scoop which was illustrated on page 283 of our November issue of 1896. The line at the inside lower edge of the mouth was 4½ ins. below the top of the rail, and the record was taken with the tender half loaded with water and fully loaded with coal. This scoop does not splash the water beyond the rails at speeds as high as 50 miles per hour, which explains its excellent action.

Test No. 1 was made with a scoop having a shield. It will be noticed that in Nos. 1, 2 and 3 the curves are irregular, in-

taken when the scoop dips into the water about 2 ins., this being the average distance, which will vary in accordance with the height of the tender and the level of the water in the tank.

It will be remembered that the new water scoop on this road differs from those with which many old locomotives are equipped by the omission of the top wall and hood. On the Lake Shore, the New York Central and the Pennsylvania, the practice is to omit these parts to reduce the splashing.

A test of the new scoop, when plotted, gave the curve shown in No. 5, which does not include high speeds. These curves are interesting in connection with the discussion of the theory of water scoops by Professor Church, which appears elsewhere in this issue. One of the great difficulties with track troughs is to keep them level. They must be given constant attention where water is taken from them frequently, because considerable water is wasted each time the scoop is used, and provision must be made to get this water away from the roadbed. The open-top scoop wastes much less water than do the scoops of earlier design, and hence, by their use the cost of maintenance of the track trough is very materially reduced.

We are indebted to Mr. A. M. Waitt, of the New York Central, for the privilege of printing these diagrams.

For previous references to track tank scoops see the following numbers of this journal: November, 1896, page 283; July, 1900, page 211; November, 1900, page 344, and May, 1901, page 143. This issue, page 376,

PRESSED STEEL TRUCK

For Cars and Tenders,
Pere Marquette Railroad.

Mr. B. Haskell, Superintendent of Motive Power of the Pere Marquette, has designed and patented the construction of pressed steel trucks, which, by his courtesy, are illustrated in these engravings. These trucks are arranged for cast steel and also pressed steel bolsters; the latter is selected for illustration.

The object was to employ pressed steel in the arch bar type of construction, which would be simple and would not require column bolts and rivets. It is believed to be amply strong, and it employs no rivets except those attaching the spring plank to the bottom bar and those securing the short tie pieces.

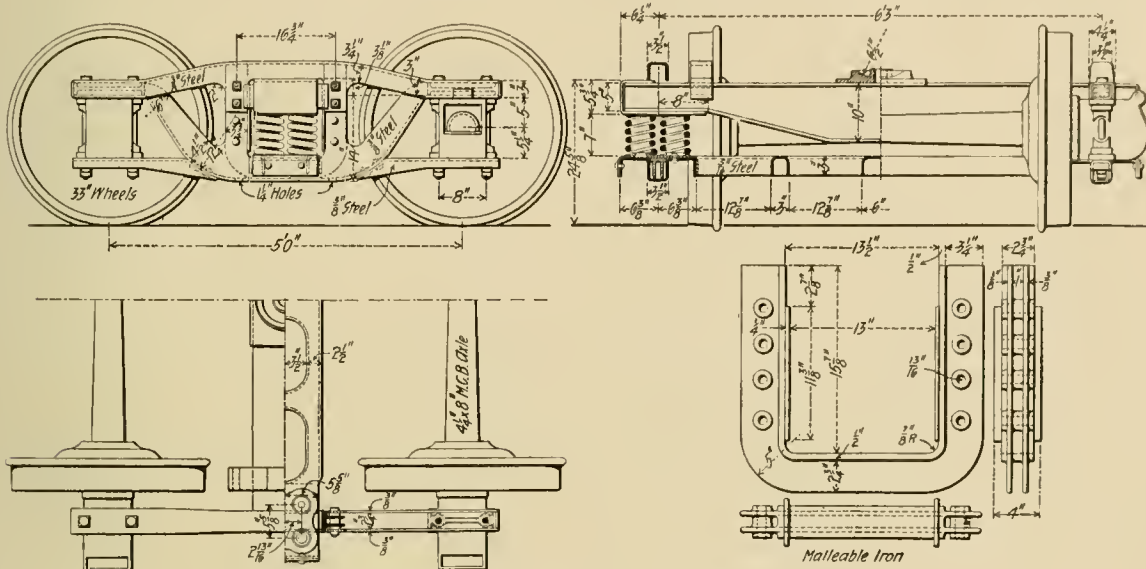

Pressed Steel Truck—Pere Marquette Railroad.

The arch bar frames are of pressed steel in U section, with the flanges of both parts turned toward each other. At the ends over the boxes the upper bar is flanged to a width which permits it to cover the ends of the lower one, and a filling casting is placed between them, through which the box bolts pass. At the opening for the end of the bolster the pressed steel portions are bolted to malleable filling blocks, which are shown in the detail view. These serve to stiffen the frames at these points and they also act as distance pieces for the bolts. The spring planks are also of pressed steel. From the inverted arch bar, the pieces of pressed steel extend to the boxes and receive the lower ends of the box bolts. For the side frames the steel plate is $\frac{3}{8}$ ins. thick, and for the spring plank $\frac{5}{16}$ in. In case it is necessary to take out the bolster, the journal box bolts are removed and also those attaching the upper member of the side frame to the casting forming the connection between the upper and lower bars. This design uses $4\frac{1}{4}$ by 8-in. journals and will first be used under box cars.

Because Mr. T. H. Symington has become connected with the Gold Car Heating Company, the impression has been received that he has severed his connection with T. H. Symington & Co., of which he remains as President. Pending the completion of tests of their specialties in various parts of the country, the business of this company will be conducted as heretofore, from the Baltimore office, under the direct supervision of Mr. Harvey Middleton, managing director. Mr. W. R. Bean has been appointed general inspector of the company, and will have charge of these tests.

PERSONALS.

Mr. E. A. Faulhaber, Treasurer and Purchasing Agent of the Tennessee Central, has removed his headquarters from St. Louis, Mo., to Nashville, Tenn.

Mr. N. B. Whitsel has been appointed Master Mechanic of the Northern Division of the Grand Trunk, with headquarters at Allendale, Ont., in place of Mr. T. A. Summerskill, resigned.

Mr. C. M. Taylor, Master Mechanic of the Atchison, Topeka & Santa Fe at La Junta, Colo., has been appointed Master Mechanic of the Rio Grande & New Mexico Division, with headquarters at Raton, N. M.

Captain A. L. Fowler has been appointed Eastern Manager of the "Railway and Engineering Review," succeeding Mr. R.

A. Bagnell, resigned. Captain Fowler will have charge of the eastern office in New York.

Mr. F. N. Risteen has been appointed Assistant Superintendent of Motive Power of the Chicago Great Western. Mr. Risteen was formerly Master Mechanic of the Fargo division of the Northern Pacific at Fargo, N. Dak.

Mr. T. A. Summerskill, Master Mechanic of the Grand Trunk at Allendale, Ont., has been appointed Superintendent of Motive Power of the Central Vermont, with headquarters at St. Albans, Vt., to succeed Mr. William Hassman, resigned.

Mr. E. M. Roberts has been appointed Superintendent of Motive Power of the Detroit Southern, with headquarters at Detroit. He was formerly Superintendent of Motive Power of the South Carolina & Georgia.

Mr. R. A. Bagnell has resigned as Advertising Manager of the Eastern department of the "Railway and Engineering Review," a position which he has held for the past three years, to accept the appointment of Western Manager of the Pocket List of Railway Officials, with headquarters in Chicago.

Mr. Ashbel Green, Purchasing Agent of the Manhattan Railroad Company, has resigned to connect himself with Thornton N. Motley & Co. Mr. Green was formerly connected with the West Shore and New York Central railroads. Mr. J. H. Canepe, Acting Supply Agent, is now filling the office of Purchasing Agent of the road.

Mr. Benjamin Johnson, Engineer of Tests of the Atchison, Topeka & Santa Fe, has resigned to accept the position of Superintendent of Motive Power and Machinery of the Mexican Central, succeeding Mr. F. W. Johnstone. Mr. Johnson entered the service of the Santa Fe as a machinist in 1879, and remained in the locomotive department in various capacities until 1888, when he accepted a position with the Westinghouse Air-Brake Company. In 1898 he returned to the "Santa Fe" as Division Master Mechanic, and since June, 1900, has been Engineer of Tests.

Mr. A. E. Mitchell, who for nine years has been identified with the Erie Railroad as Superintendent of Motive Power, has resigned to become Assistant Superintendent of Motive Power of the Chicago, Milwaukee & St. Paul, with headquarters at West Milwaukee. Mr. Mitchell has had an unusually wide and successful experience, which will be exceedingly valuable to the road whose service he enters. After graduating in mechanical engineering from the Maine State College in 1875, he entered the Baldwin Locomotive Works as an apprentice, and in 1877 went to Altoona. After serving in the test and signal departments of the Pennsylvania until 1881, he became designer of hoisting machinery for Yale & Towne at Stamford, Conn. In 1882 he went to the New York & New England Railroad and served until 1884 as chief draftsman. Following this two years were spent in the service of the French Furnace Company and the Arctic Ice Machine Company, of Cleveland. He next went to the New York, Lake Erie & Western in 1887, and after serving there as engineer of signals, engineer of tests and mechanical engineer, was appointed Superintendent of Motive Power in 1892. He has filled this position with the Erie and also the Chicago & Erie until his recent resignation. Mr. Mitchell therefore brings to his new position not only an extensive executive motive power experience, but a thorough knowledge of commercial and engineering principles, which are becoming most important in the management of motive power affairs. The "St. Paul" offers an attractive opportunity, and both Mr. Mitchell and the road are to be congratulated upon the appointment.

STANDARD DIMENSIONS OF BOX CARS.

American Railway Association.

At the recent St. Louis meeting of the American Railway Association the standard box car was advanced by an important step, which removes the greatest obstacle to its accomplishment. At that meeting a report was presented by a conference committee, which is reproduced in full as follows:

The Committee on Standard Dimensions of Box Cars respectfully presents the following report: It held a session at Mackinac Island, Mich., on August 21 and 22, 1901, at which time there were present by invitation the following representatives of traffic associations: Mr. C. E. Gill, Chairman Official Classification Committee; Mr. J. T. Ripley, Chairman Western Classification Committee; Mr. P. J. McGovern, Chairman Southern Classification Committee; Mr. John Earls, Chairman Classification Committee of the Canadian Freight Association.

Under the resolution of the association passed April 24, 1901, your committee was requested to confer with the representatives of the various traffic associations, and the recommendations herewith submitted are the result of the action of this joint conference.

A standard car of the dimensions of 36 ft. in length, 8 ft. 6 ins. in width, and 8 ft. in height, was originally favored. It was subsequently stated that cars 8 ft. in height could not be transported over certain important lines, and the height was therefore made 7 ft. 6 ins. This was adopted by the Association in April, 1901.

On April 24, 1901, the following principle was approved by the association:

"That the essential elements of the standard box car require the height and width to be as great as are permitted by the physical limitations of the important railroad clearances and the present established height of loading platforms; that the

length be determined by economy in construction, maintenance and operation and the requirements of economical stowage."

The objections to the car 8 ft. in height have now been withdrawn, and in pursuance of the principle above enunciated the following resolution is offered for adoption:

(1) Resolved, That the dimensions of the standard box car be 36 ft. in length, 8 ft. 6 ins. in width, and 8 ft. in height, all inside dimensions. Cross-section, 68 sq. ft.; capacity, 2,448 cu. ft. The side door opening to be 6 ft. in width.

After a thorough discussion of all phases of the question as affecting both the transportation and traffic departments, the following resolution was approved and recommended for adoption:

(2) Resolved, That the standard 36-ft. car be considered the unit for the establishment of minimum car-load weights; and that where necessary in any classification territory to recognize cars under 36 ft. in length, it shall be by a reduced minimum of 2½ per cent. for 35-ft. cars and 5 per cent. for cars 34 ft. or under, inside dimensions.

In the opinion of the conference committee, cars exceeding the standard dimensions are uneconomical and undesirable vehicles of transportation, and they ought not to exist. As they do exist, minimums are recommended which will permit of the use of such cars until they shall be worn out. The rate of increase of the minimum is slightly greater than the increase in the capacity of these cars, and will therefore tend to discourage their further construction. These figures have been embodied in the following resolution, which is recommended for adoption:

(3) Resolved, That for cars over 36 ft. in length the percentage of increase of the minimum weights shall be as follows:

For cars of 37 ft. and 38 ft., 10 per cent. over the minimum for the 36-ft. car. For cars of 39 ft. and 40 ft., 25 per cent. over the minimum for the 36-ft. car. For cars of 41 and 42 ft., 40 per cent. over the minimum for the 36-ft. car. For cars of 43 and 44 ft., 55 per cent. over the minimum for the 36-ft. car. For cars of 45 and 46 ft., 65 per cent. over the minimum for the 36-ft. car. For cars of 47 and 48 ft., 70 per cent. over the minimum for the 36-ft. car. For cars of 49 and 50 ft., 80 per cent. over the minimum for the 36-ft. car. For cars of over 50 ft., 150 per cent. over the minimum for the 36-ft. car.

As the alterations in the minimums above recommended may affect the revenue, your committee suggests the passage of the following:

(4) Resolved, That any diminution of revenue incident to the minimum proposed in the accompanying schedule shall be adjusted in the rate.

With improved methods of construction the carrying capacity of freight-car equipment has been constantly increasing. It is therefore recommended:

(5) Resolved, That the minimum car-load weights of heavy articles, such as iron, brick, lumber, minerals, etc., should, as fast as practicable, be advanced to the stenciled capacity of the car.

In order that the growth of the evil now under consideration may be effectually checked, the following resolution is recommended for adoption:

(6) Resolved, That no box cars of larger dimensions than those prescribed for the standard car shall be hereafter constructed, and that all owners and builders of cars be officially notified of the adoption of this resolution.

For the purpose of reference, the statistics published with the previous report of the committee on standard dimensions of box cars, together with some since obtained, are attached hereto.

These conclusions of the conference committee, which were unanimously adopted, are herewith submitted as the report of your committee to the association.

The following gentlemen were members of the committee on standard dimensions of box cars: J. J. Turner, Fourth Vice-President Pennsylvania Lines West of Pittsburgh; A. M. Waitt, Superintendent of Motive Power and Rolling Stock, New York Central & Hudson River Railroad; G. W. Rhodes, Assistant General Superintendent, Burlington & Missouri River Railroad in Nebraska; S. T. Crapo, General Manager Pere Marquette Railroad; J. J. Frey, President Florence & Cripple Creek Railroad; F. D. Underwood, President Erie Railroad; A. W. Johnston, General Superintendent New York, Chicago & St. Louis Railroad.

This report was adopted with but one dissenting vote, and then the following resolutions were adopted unanimously:

Resolved, That the Master Car Builders' Association be requested to consider and adopt the required external dimensions of the standard box car, based upon the interior dimensions as prescribed by the American Railway Association.

Resolved, That the committee on standard dimensions of box cars be continued for the purpose of aiding in the practical adoption of the standards which it has proposed, and which have been approved by the association, and that the chairman of the several classification committees be requested to act with the committee on standard dimensions of box cars, to the end that both the best physical and the best commercial results may be accomplished.

Comment upon these important steps will be found elsewhere in this issue.

FOUR-POLE ENCLOSED MOTORS.

The accompanying engraving illustrates a type of enclosed motor intended to fill all requirements for a high class medium speed machine, with all the latest and most improved features of construction. This type of machine is used by the B. F. Sturtevant Company, of Boston, in a line of bi-polar enclosed motors ranging from ¼ to 5 horse-power, inclusive, and has also been designed to complete the series, four sizes of 4-pole enclosed motors ranging from 7½ to 20 horse-power. The magnet frame of these machines is of special magnet steel and has the field cores cast with the frame. On the small sizes the ring is cast in one piece, but in larger sizes it is split to facilitate the removal of the armature, so as to reduce the weight of each individual part. The pole shoes are of cast-iron, secured to the field cores by cap screws, and are detachable to allow the field coils to be easily repaired if necessary. The bearings are of the ball-and-socket type of ring-oiling, self-aligning construction and are formed in the hemispherical

attached to the centre of the casing at the end of the shaft. In the design of this motor special care has been taken to provide for the most perfect circulation of air through the commutator and armature, and for ample radiating surface in the casings, so as to avoid all possibility of overheating. As a result machines of this type can be operated constantly for ten hours at full rated load without sparking, and with a temperature rise not exceeding 50 degrees Centigrade above that of the surrounding atmosphere. Ventilation is effected by the use of specially constructed air ducts which connect with radial ducts between the laminae of the core. These convert the armature into a blower and create a strong draft through the windings. The winding for low voltage machines is of copper bars with easy bends. High voltage machines are wire-wound with machine-formed coils. The commutator consists of drop forged segments of pure copper secured by cast-iron flanges of spider construction which allow free circulation of air. All machines are fitted with carbon brushes mounted on holders of the sliding socket type.

AN IMPROVED JOURNAL BOX LID.

On page 292 of our September number an illustrated description of the new journal box of T. H. Symington & Co. was printed. In order to provide for blows which would damage a lid hinged at the side, the new form now shown was

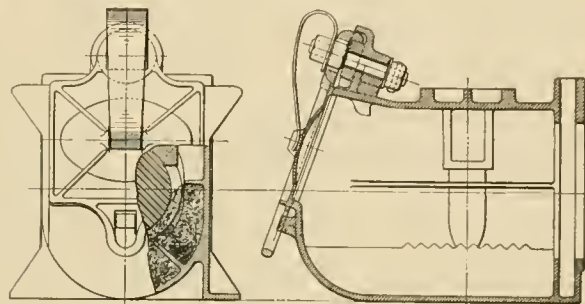

The New Symington Journal Box Lid.

developed on the same principle as the previous one. This lid has a machined joint, and the spring gives it a heavy central pressure, the spring being locked between the ends of a pivot bolt, but the hinge is upon the top of the lid, which will protect it from damage. The lid, if struck, will merely open and not break from a side blow. The lug at the bottom of the box for holding the lid in a central position when closed is slightly tapered on the sides, so that it will slide freely. In this construction no weight comes upon the pivot bolt, because the lid is supported by the solid lugs on the box and lid. The nut which forms the head of the pivot bolt is riveted in place by a ¼-in. rivet, which must be cut in order to remove this bolt. This form of lid has been adopted as standard by this company. Mr. Symington has sent us a set of his printed instructions for the moulder and core maker in making these boxes and also blanks for service records and tests of the boxes. These give the impression of completeness, and they indicate a desire on the part of the manufacturers to promote the practice

of keeping careful records of the performance of these devices. The description of the box itself, already referred to, applies to the new standard, which is not changed, except as to the attachment of the lid. The address of T. H. Symington & Co. is Fidelity Building, Baltimore, Md.

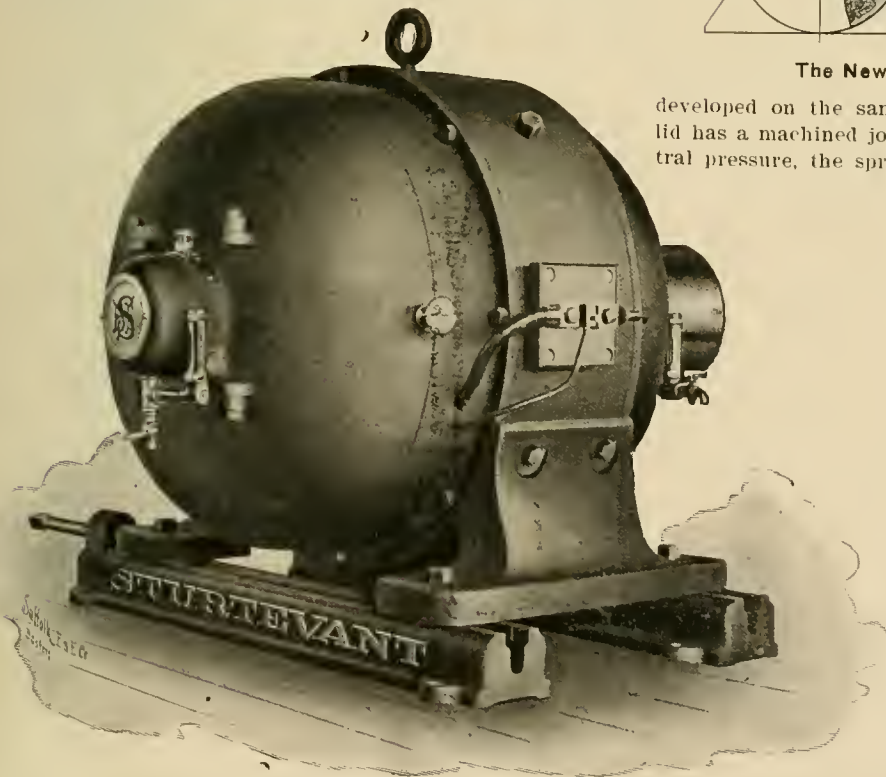

A Four-Pole Enclosed Motor.

cover casings, which are attached to the magnet ring, one upon either side. The front casing is provided with closely fitting doors which afford ready access to the brushes and other parts of the motor. The entire machine is thus rendered absolutely dust-proof and practically water proof. A removable cap is

BOOKS AND PAMPHLETS.

The Practical Engineer Pocket Book. The Practical Engineer Electrical Pocket Book, 1902. Published by The Technical Publishing Company, 31 Whitworth street, Manchester, England. Price, 1s. 6d. for each.

These handy little volumes are revised annually by the publisher of "The Practical Engineer." They give a large amount of information which is not usually found in pocket books, except the most expensive. These are sold at a low price, which cannot possibly cover the cost of printing and binding. The presence of advertisements may therefore be forgiven. The "Pocket Book" is now in its fourteenth edition and includes new matter with reference to gas engines which will be useful to designers and users of these engines. It also contains new matter concerning the use of Mond gas on a commercial scale. Among new features are sections dealing with mechanical refrigeration, photo-copying of drawings and motor vehicles, these having been treated by men specially versed in these subjects.

The "Electrical Pocket Book" is of the same general character as its older companion. It now appears in its third edition, containing many additional tables and presenting tables and other information concerning wiring, electrical machinery and power transmission.

Parallel Table of Logarithms and Squares, of Feet and Inches. By Constantine Smoley. Size, 5 by 6 ins. 212 pages. Price, \$3.00. Published by the Engineering News Publishing Company, New York, 1901.

As indicated by the title, the book presents in parallel columns both the squares and the logarithms, of feet and inches, from zero to 50 feet, by steps of 1/32 of an inch. This is the first appearance in a book of this scope of a case where the steps have been made so small as 1/32 of an inch. It is believed that it is also the first time that the logarithms have been given in parallel columns with the squares. This latter feature, of course, greatly facilitates all computations involving the foot, the inch and the customary division of the inch. The book also contains a five-place logarithm table of the numbers from zero to 1,000, and the more important mathematical constants with their logarithms. Several pages are devoted to an explanation of the logarithms and numerous problems worked out illustrating the applications of the main tables of the book. On the whole, it is a valuable addition to that class of reference books that makes for accuracy in results and economy of time for the engineer or architect.

Master Car Builders' Association. Proceedings of the Convention of June, 1901. Edited by the Secretary, Mr. J. W. Taylor, 667 The Rookery Building, Chicago.

This volume contains the usual information concerning membership, standing committees, subjects for the next convention, the constitution and the proceedings of the recent convention. This year the record covers 597 pages and 30 folded plates of the standards and recommended practices of the association. Among other subjects it includes important reports on coupler tests and draft gear, with the discussions. It is the largest volume ever published by the association, and is in the customary style and binding. Considering the fact that the results of the letter ballot are included in the volume, it appears in a remarkably short time after the convention.

Manning, Maxwell & Moore, Catalogue for 1902. An Illustrated Catalogue of Railway, Steamship, Machinist, Factory, Mill and Electric Supplies. Size, 9 by 12 ins.; 1,056 pages. Published by Messrs. Manning, Maxwell & Moore, 85 Liberty street, New York.

One of these subjects alone would require a large volume, but the representation of all of these branches of mechanical activity in one catalogue results in a work of magnificent proportions which undoubtedly has no parallel in industrial literature. An idea of its comprehensive character is obtained from a glance at the 38-page index of this catalogue. It contains illustrated descriptions and instructions for ordering all of the supplies ordinarily required in the various lines mentioned, and nothing could reflect the character and importance of such a firm as does a catalogue of this kind. Their catalogue of machine tools issued in the current year covers over 700 pages and supplements the present volume.

Transactions of the American Institute of Mining Engineers, Vol. XXX.—These papers are of the usual interest and value, and deal particularly with: 1st, Ores and minerals as regards their origin, formation, development and distribution, as well as various methods of mining. 2d, Metallurgical data regarding cast iron, especially as to its structure, with excellent illustrative photomicrographs, and concerning influence of silicon. 3d, Chemical investigations, including a comprehensive study of the electromotive force of metals in cyanide solutions, with results from the modern electrolytic theory. 4th, Surveying instruments, mining and solar, with cuts showing the gradual evolution up to the present time.

Methods of Chemical Analysis and Foundry Chemistry. By Frank L. Crobaugh. Published by Whitworth Bros. Co., Cleveland, O., 1901. Price, \$1.50.

The book gives a concise and simple statement of many of the best standard methods in present use in iron and steel laboratories, and also a statement of the influence of chemical composition upon the qualities of cast iron, with general information regarding foundry practice. It is a useful reference book for any iron or steel chemist.

Poor's Manual for 1901. Thirty-fourth Annual Number. The Handbook and Official Organ of the Railroad System of the Country and of Every Interest Connected with It. Royal octavo, cloth, 1,900 pages, with maps. H. V. & H. W. Poor, 44 Broad street, New York. Price, \$10.00.

This invaluable publication, which began 33 years ago in a volume of 442 pages, representing a mileage of 39,250, has grown to 1,900 pages, containing statements of 3,691 corporations, covering a mileage of 194,321. These statements are official, because they are all revised in the proof by the railroad companies before publication, and they present at a glance information which would otherwise be beyond the reach of people actively engaged in affairs, as it is a compilation by experts after a vast amount of laborious research. Steam railroad statistics occupy the most prominent place in this record, and next in importance is the city and suburban system of railways, which has been revolutionized by the introduction of electric traction and is now undergoing a most extraordinary development. In the manual the statements of these roads are presented in the same comprehensive form as those of the steam lines. Most of the railroads do not cover more than two years in their comparisons, and when it is necessary to make comprehensive comparisons for a series of years, this manual is the only publication which may be consulted with confidence. It has been customary to give, from time to time, exhaustive analyses of the affairs of important companies by carefully prepared historical statements. In this volume is such a study, which was referred to in our November number. As a result of its continuous publication, this work preserves the histories, records and statistics of all the railroads ever built in this country, and in this field alone it has done monumental service to not only the railroads, but to the investor, the historian and the public. Another valuable feature of the work lies in the officially revised maps of the leading railroad systems, whereby the geographical importance of the lines is emphasized. Not the least of the valuable features of this publication is the promptness of its appearance and the presentation of statistics of the finances and resources of the United States and State municipal indebtedness. So closely are the railroad interests identified with the progress and prosperity of the nation that a record of this kind has become an index of the public welfare. It is a work with a history of its own, and is a chronicle of the greatest development the world has ever seen.

The new catalogue just issued by the Chicago Pneumatic Tool Company is an elaborate pamphlet on the subject of pneumatic appliances. It contains no long descriptions of the machines, but presents many large clear engravings showing the tools of these manufacturers in operation on recently constructed buildings and other prominent structural work. The great variety of service to which these tools are put is forcibly shown by the excellent engravings of this catalogue. The Commissioners at the Pan-American Exposition awarded this company the only gold medal for pneumatic tools, and also a silver medal for their exhibit.

Railroad.

Date,

American Engineer Tests of Locomotive Draft Appliances.

Data Concerning Practice With Large Locomotives.

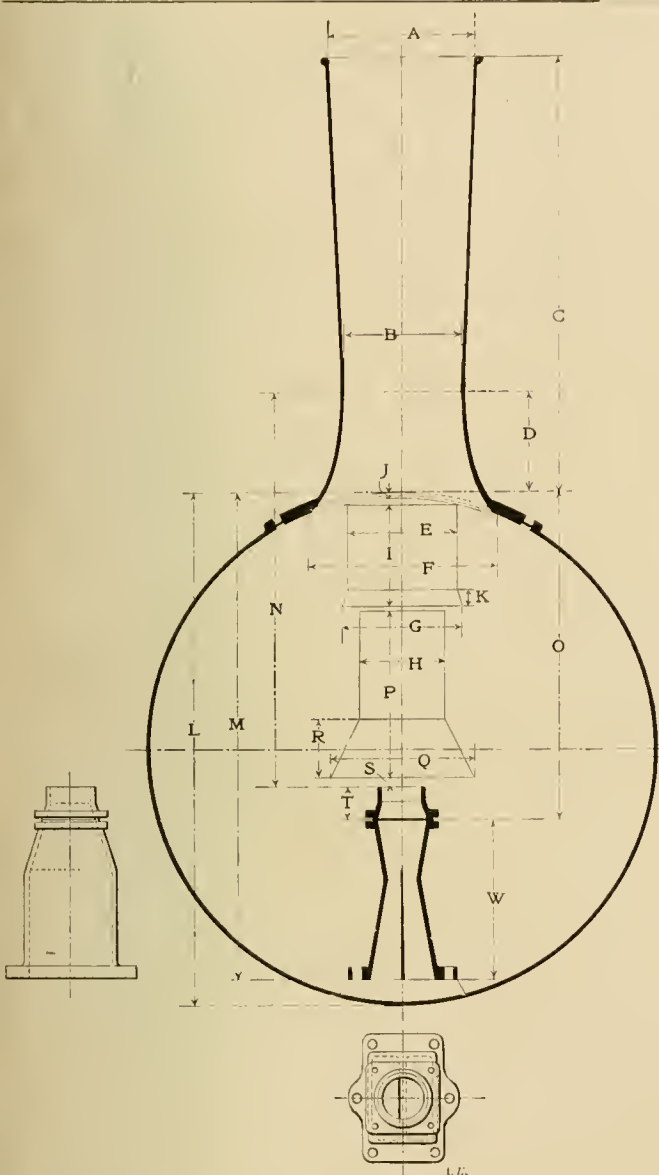

	Passenger Engines, 64-In. Boilers and Up- wards.	Freight Engines, 64-In. Boilers and Up- wards.
L.....		
A.....		
B.....		
C.....		
D.....		
E.....		
F.....		
G.....		
H.....		
I.....		
J.....		
K.....		
M.....		
N.....		
O.....		
P.....		
Q.....		
R.....		
S.....		
T.....		
W.....		
Cylinders..		
Drivers, dia.		

Remarks—

We are sending copies of this diagram to the members of the motive power officers' committee and others who are following these tests, in order to secure data with reference to present practice in draft appliances for large engines. Those who do not receive this in another way will confer a favor upon us and aid in the investigation which Professor Goss is making for us by kindly filling out this information pertaining to their practice and sending the page to the editor of this journal, 140 Nassau street, New York.

Mr. William Durham Sargent, President of the American Brake Shoe Company, and also of the Sargent Company, has been elected President of the National Founders' Association. In addition to the many inventions of improvements in brake shoes, Mr. Sargent is known as one of the most prominent manufacturers of cast steel, and for the successful development in this country of the Tropenas steel casting process.

Mr. T. H. Symington, formerly Superintendent of Motive Power of the Atlantic Coast Line, and later President of the T. H. Symington & Co., Baltimore, has accepted a position as representative of the Gold Car Heating Company, of New York and Chicago. He remains President of the Symington Company.

The development of the steel car industry cannot be better illustrated than by the fact that the Pressed Steel Car Company built in 1897 501 cars; 1898, 2,931 cars; 1899, 9,624 cars; 1900, 16,671 cars; up to and including November, 1901, 23,381 cars, making a total of 53,106 cars.

Mr. Joseph H. Washburn has been appointed manager of the Roller Bearing and Equipment Company, of Keene, N. H. He was formerly draftsman for the Ball Bearing Company of Boston, under Mr. W. S. Rogers. Mr. Rogers appointed him in accordance with his policy of taking young men into his service and giving them important responsibilities. The effect of this policy is clearly shown in every enterprise with which Mr. Rogers has been connected.

EQUIPMENT AND MANUFACTURING NOTES.

Officers of the American Locomotive Company say that plans have been made to double the capacity of the company's most important plants in consequence of the unprecedented demand for locomotives. This demand comes from all parts of the world. Plans were made some time ago for enlarging the works at Schenectady, and the work is nearly completed. Now the details are being arranged for extensive additions to the Brooks works at Dunkirk.

Mr. Charles T. Schoen, former president and founder of the Pressed Steel Car Company, has resigned as chairman of the board of directors, and his son, E. A. Schoen, has resigned as one of the directors. The Schoens will devote their time to starting the \$5,000,000 plant which is to manufacture rolled steel car wheels at Allequippa, near Pittsburg. It is reported that they have sold nearly all their stock in the Pressed Steel Car Company.

The extent to which the Alexander engine and car replacer is used on railroads of this and other countries is forcibly shown by a large number of specimen orders received by that company, reproduced in one of their recent pamphlets. This booklet is devoted entirely to these printed orders and to valuable testimonials from prominent railroad officials. A pair of these replacers are sent for trial and approval at the manufacturer's expense. The address of the Alexander Car Replacer Manufacturing Company is Scranton, Pa.

The Billings & Spencer Company, Hartford, Conn., report largely increased demand for their machinery and drop forgings of special design. Their facilities for making these are not surpassed anywhere. The attention of our readers is specially directed to the following tools, the excellence of which is guaranteed by the name of the manufacturers: Adjustable wrenches, 10, 14 and 18 ins. in size, shown on page 14 of the Billings & Spencer Catalogue, carbon tongs on page 18; genuine Parker ratchet drill, railroad Parker ratchet drills, and Billings double action ratchets; drop forged lathe dogs with straight and bent tails; clamp dogs, drop forged machinists' clamps, screw drivers, calipers, gauges and machinists' hammers, shown on pages 44 and 45 of the catalogue. These hammers are of excellent quality, and the "B and S" and machinists' wrenches are noted for their high grade. A large line of machine wrenches is shown on pages 60 to 77, and another specialty of this company is the manufacture of special and standard eyebolts.

The principle of applying cork insets to brake shoes is well known to our readers through the tests by the Master Car Builders' Association committee on laboratory tests, which were recorded on page 269 of our August number of the current volume and by other previous references. We are informed positively by Mr. W. W. Whitcomb, of the Allston Foundry Company, the manufacturers, that the cork does not burn in the shoes under the action of the brakes. Mr. Whitcomb has recently applied the insets of cork to the rims of belt pulleys with what appear to be remarkable results, although the tests are not yet completed. In the Worcester Polytechnic Institute Journal of October, 1901, is an account of the tests which are being conducted on these pulleys at that laboratory. The pulleys are of cast iron or of wood. In their faces corks 1 in. in diameter are inserted. These corks are about 2½ ins. apart on the circumference of the pulley and distributed across the face to give a uniform bearing surface to the belt. The corks are forced into cocked sockets less than ½ in. deep, and protrude slightly above the smooth face of the pulley. Results of the tests show that when the belt is in the least favorable condition for the "Compo" or iron pulley with cork inserts, this pulley carries more load with allowable slip than any of the others, and when the belt is in the least favorable condition (i. e., dry) for the plain iron, wood, and wood with leather face, the increase in favor of the "Compo" or iron pulley with cork inserts, is more marked. From the average results of over one hundred tests, the "Compo" or iron pulley with cork inserts at a point of 2 per cent. slip (which is considered allowable in commercial practice) shows an increase in its power transmitting capacity of 51 per cent. over the plain iron pulley.

Wood's patent car grate has been adopted for all the cars of the Boston Elevated Railway, and for this service a new form of folding gate, 5 ft. 6 ins. high, will be used. These gates are also in use on the New York Central; New York, New Haven & Hartford; the Boston & Maine, and other roads. They are manufactured by the R. Bliss Manufacturing Company, Pawtucket, R. I.

The Colburn Machine Tool Company are breaking ground for extensive buildings for the manufacture of specially designed machine tools for railroad and car shops, at Third and Buffalo streets, Franklin, Pa. The Lake Shore & Michigan Southern Railway will run their tracks through the yard in order to give the concern good shipping facilities. The plant will be modern in every detail, and is excellently located.

The Fowler Elastic Enamel Paint Company, of 390 Wabash avenue, Chicago, have entered the railroad field vigorously. This company has made tests on the cars of two well-known railroads, and the results are exceedingly promising in this most exacting service. The special claims made for their paint are elasticity, durability and decreased cost.

The growth of the Pintsch lighting system in the Dominion of Canada has been especially rapid in the past two years and is now being speedily introduced into service in Mexico. During October and part of November the Mexican Central Railroad has ordered Pintsch light equipment for 52 cars and it is probable that all their better class of cars will be equipped with that system as rapidly as they are put into the shops for general repairs. Work is now in progress on a Pintsch manufacturing plant in the City of Mexico. This work is being constructed for the Mexican Central Railroad, but it is likely that it will supply other Mexican railroads entering that city, and it is presumable that all such roads will soon be using this improved method of lighting. In the Dominion of Canada the recent point of activity, so far as this light is concerned, has been at Moncton, N. B., where a plant will be erected for supplying gas to the Intercolonial Railway. About 50 per cent. of the serviceable passenger cars belonging to the roads in the United States are now equipped with the Pintsch light, and this percentage is being rapidly increased each year. During the year 1900 the addition was one of the largest since the gas was first introduced into this country. This method of car lighting was not pushed so vigorously in either Canada or Mexico as it has been in the United States, for these countries were not under control of the American company until within a comparatively short time. Now the same active and successful efforts are being employed, both to the north and south of the United States, by the American company, and it is very probable that the percentage of gas lighted cars in those countries will soon come up to the point attained in the United States.

The total number of cars, locomotives, buoys, etc., throughout the world now equipped with the Pintsch system of lighting is given in the following table, which shows, up to May, 1901, an increase during the past year of 7,482 cars, 451 locomotives, 30 gas works and 124 buoys and beacons.

Countries.	Cars.	Loco- motives.	Gas Works.	Buoys & Beacons.
Germany	38,218	4,285	71	98
Denmark	45	...	3	21
England	18,611	18	87	272
France	6,618	...	27	240
Holland	3,318	5	10	83
Italy	1,528	...	5	15
Switzerland	380	2	1	...
Austria	3,777	...	10	1
Russia	2,845	102	13	13
Sweden	591	29	4	2
Servia	169
Bulgaria	98	...	1	...
Turkey	112
Egypt	2	...	3	112
Canada	75	...	2	60
Brazil	974	3	1	33
Argentina	1,046	...	10	2
Chili	46	...	2	...
India	8,058	...	16	...
Australia	2,053	...	13	29
United States	17,000	...	54	162
Japan	100	...	2	4
China	1	15
Total	105,661	4,472	336	1,162





CARNEGIE LIBRARY OF PITTSBURGH



3 1812 04296 1046